

# Radio **E**lectronics

MARCH 1992

TECHNOLOGY - VIDEO - STEREO - COMPUTERS - SERVICE

Bring the world of music to your computer with this easy-to-build **MIDI INTERFACE** for your PC

Build our single-chip **SOLID-STATE VOICE RECORDER**

How to become a **CERTIFIED ELECTRONIC TECHNICIAN**

Build our **SCANNER CONVERTER** and give your scanner unrestricted coverage of the 800-MHz band!

Keep tabs on your telephone bills with our **INTELLIGENT PHONE-LINE MONITOR**

Learn how to work with 7-segment **DECODER/DRIVER IC's**

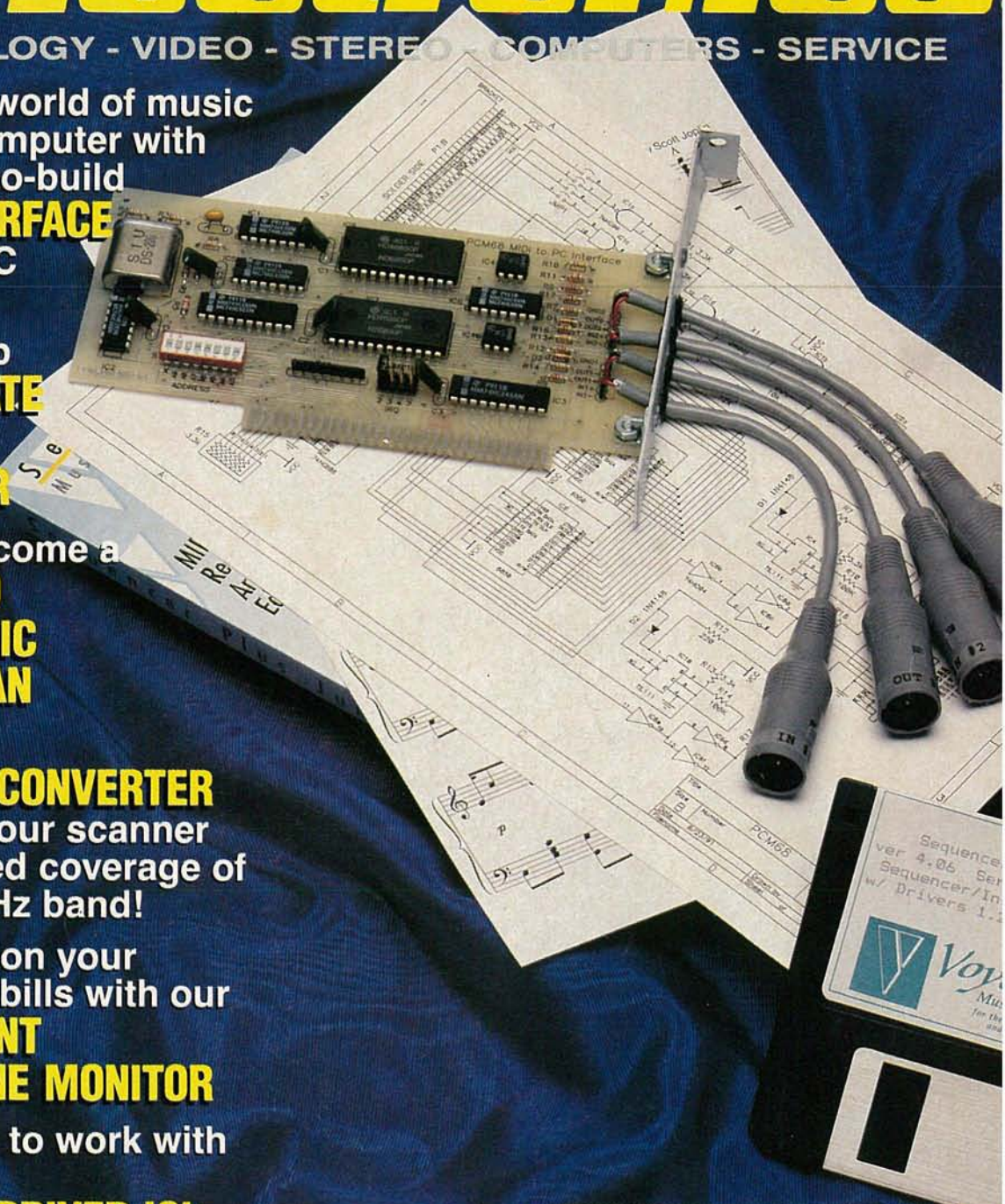

\$2.95 U.S.  
\$3.75 CAN

A **GERNSBACK** PUBLICATION

\*\*\*\*\* CAR-RT SORT \*\* CRO3  
750456HRR5165MD93 03 97  
NOV 93  
RB

# We Only Skimped On The Price

Introducing The Fluke Series 10—From \$69.<sup>95</sup>

**Actual size:** Easy to carry, easy to use.

**New! V Chek™:** For fast accurate checks on power sources and supplies, set your meter on V Chek—and let it do the rest. V Chek will determine continuity/ohms; if voltage is present, it will *automatically* change modes to measure AC or DC volts, whichever is detected. For most initial troubleshooting checks, here's the only setting you need to make.

**Autorangeing with manual option:** Your choice, depending on your situation.

**Sleep Mode:** Shuts itself off if you forget, extending long battery life even further.

**New! Slide switch and a few pushbuttons control all functions:** Designed for true one-hand operation.

**Fast, accurate tests and measurements:** AC and DC voltage measurements to 600 volts, ohms to 40 MΩ; audible continuity test; and diode test.

**Fluke quality:** Made in the USA by Fluke, with the same rugged reliability that's made us the world leader in digital multimeters. Count on hard-working high performance—and a two-year warranty to back it up.

**Large, easy-to-read display:** 4000 count digital readout.

**New! Min/Max record with relative time stamp and Continuity Capture** Makes intermittent problems easier to find. Records highs and lows—and "time stamps" when they occurred. Continuity mode, opens or shorts a as 250 μs are captured and display

**Capacitance:** Autorangeing from .001 μF to 9999 μF. No need to carry a dedicated capacitance meter.

**For high performance at Fluke's lowest price your hands on the new Series 10.** Stop by your local Fluke distributor and feel what a power difference the right multimeter makes—at right price. For a free product brochure or the of your nearest distributor, call 1-800-87-FLUKE.



Fluke 10	Fluke 11	Fluke 12
\$69.95*	\$79.95*	\$89.95*
4000 count digital display	V Chek™ Capacitance .001 to 9999 μF	V Chek™ Min/Max record with relative time stamp
1.5% basic dc volts accuracy	4000 count digital display	Continuity Capture™
2.9% basic ac volts accuracy	0.9% basic dc volts accuracy	Capacitance .001 to 9999 μF
1.5% basic ohms accuracy	1.9% basic ac volts accuracy	4000 count digital display
Fast continuity beeper	0.9% basic ohms accuracy	0.9% basic dc volts accuracy
Diode Test	Fast continuity beeper	1.9% basic ac volts accuracy
Sleep Mode	Diode Test	0.9% basic dc volts accuracy
Two-year warranty	Sleep Mode	Fast continuity beeper
	Two-year warranty	Diode Test
		Sleep Mode
		Two-year warranty

\*Suggested U.S. list price.

Optional holster tilt-stand available.



The New Series 10.  
A Small Price For A Fluke

FLUKE AND PHILIP  
THE T & M ALLIANCE

©1991 John Fluke Mfg. Co., Inc. Prices and specifications subject to change. Ad no. 00130.

**FLUKE®**

**Safety—a Fluke standard:** Designed to meet UL1244, IEC 1010, CSA and VDE safety requirements; extensive overload protection built in.

**Audible Continuity:** To perform fast continuity checks, just listen for the beep; no need to watch the display.

**New! TL75 Hard Point™ Test Leads:** Comfort grip with extra strong tips for extended service life.

## BUILD THIS

- 33 MIDI INTERFACE FOR YOUR PC**  
Bring the world of music to your PC.  
**John Simonton**
- 41 SCANNER CONVERTER**  
Get unrestricted coverage of the 800-MHz band!  
**William Sheets and Rudolf F. Graf**
- 53 INTELLIGENT PHONE-LINE MONITOR**  
The Digi-Call logs your phone/fax/modem usage automatically.  
**Thomas E. Black**
- 59 SINGLE-CHIP MESSAGING SYSTEM**  
Add audio-storage capability to your next project!  
**Richard D. Tenney**

## TECHNOLOGY

- 16 MARCH 10: ELECTRONIC TECHNICIAN'S DAY**  
How you can become a Certified Electronic Technician.  
**Larry Steckler, EHF, CET**
- 46 ELECTRONIC TEMPERATURE MEASUREMENT**  
A look at temperature and how it's measured electronically.  
**Harry L. Trietley**
- 65 WORKING WITH LED DISPLAY DRIVERS**  
An in-depth look at LED display drivers.  
**Ray Marston**

## DEPARTMENTS

- |  |  |
|--|--|
| <ul style="list-style-type: none"><li><b>6 VIDEO NEWS</b><br/>What's new in this fast-changing field.<br/><b>David Lachenbruch</b></li><li><b>24 EQUIPMENT REPORTS</b><br/>Dallas Semiconductor's Touch Memory Starter Kit</li><li><b>73 HARDWARE HACKER</b><br/>Using the IC Master, and more.<br/><b>Don Lancaster</b></li></ul> | <ul style="list-style-type: none"><li><b>80 AUDIO UPDATE</b><br/>AES: Audio fact and fantasy.<br/><b>Larry Klein</b></li><li><b>82 DRAWING BOARD</b><br/>Our oscilloscope is shaping up nicely.<br/><b>Robert Grossblatt</b></li><li><b>90 COMPUTER CONNECTIONS</b><br/>Industry evolution.<br/><b>Jeff Holtzman</b></li></ul> |
|--|--|



### SINGLE-CHIP MESSAGING SYSTEM

Our one-chip voice messaging system makes it easy to add audio-storage capability to your next project!

**PAGE 53**



Log telephone/modem/fax usage automatically and inexpensively with our intelligent phone-line monitor.

**PAGE 59**

## AND MORE

- 102 Advertising and Sales Offices**
- 102 Advertising Index**
- 12 Ask R-E**
- 14 Letters**
- 93 Market Center**
- 30 New Lit**
- 26 New Products**
- 4 What's News**

## ON THE COVER



The Musical Instrument Digital Interface, or MIDI, brings together music and computers, and allows a single musician to create the sounds of an entire orchestra. But you don't have to be a professional musician, or have a small fortune's worth of computer and musical hardware, to take advantage of MIDI. Instruments with MIDI interfaces have become common and affordable. Our MIDI interface is a low-cost solution for beginners, and serious users will find it easy to upgrade to meet their needs. For more information, turn to page 33.

## COMING NEXT MONTH

**THE APRIL ISSUE  
GOES ON SALE  
MARCH 5.**

### **BUILD AN AUTO STEREO AMPLIFIER**

This high-power, hi-fi car stereo amp is an excellent amplifier design course.

### **CABLE-TV SNOOPER STOPPER**

Protect yourself against cable-TV snooping!

### **BUILD THE DIGI-CALL**

Construction details for our intelligent phone-line monitor.

### **CIRCUIT COOKBOOK**

More on 7-segment decoder/driver IC's.

As a service to readers, RADIO-ELECTRONICS publishes available plans or information relating to newsworthy products, techniques and scientific and technological developments. Because of possible variances in the quality and condition of materials and workmanship used by readers, RADIO-ELECTRONICS disclaims any responsibility for the safe and proper functioning of reader-built projects based upon or from plans or information published in this magazine.

Since some of the equipment and circuitry described in RADIO-ELECTRONICS may relate to or be covered by U.S. patents, RADIO-ELECTRONICS disclaims any liability for the infringement of such patents by the making, using, or selling of any such equipment or circuitry, and suggests that anyone interested in such projects consult a patent attorney.

RADIO-ELECTRONICS, (ISSN 0033-7862) March 1992. Published monthly by Gernsback Publications, Inc., 500-B Bi-County Boulevard, Farmingdale, NY 11735. Second-Class Postage paid at Farmingdale, NY and additional mailing offices. Second-Class mail registration No. R125166280, authorized at Toronto, Canada. One-year subscription rate U.S.A. and possessions \$17.97, Canada \$25.65 (includes G.S.T. Canadian Goods and Services Tax Registration No. R125166280), all other countries \$26.97. All subscription orders payable in U.S.A. funds only, via international postal money order or check drawn on a U.S.A. bank. Single copies \$2.95. © 1992 by Gernsback Publications, Inc. All rights reserved. Printed in U.S.A.

**POSTMASTER:** Please send address changes to RADIO-ELECTRONICS, Subscription Dept., Box 55115, Boulder, CO 80321-5115.

A stamped self-addressed envelope must accompany all submitted manuscripts and/or artwork or photographs if their return is desired should they be rejected. We disclaim any responsibility for the loss or damage of manuscripts and/or artwork or photographs while in our possession or otherwise.

## Radio Electronics

Hugo Gernsback (1884-1967) founder

Larry Steckler, EHF, CET,  
editor-in-chief and publisher

### EDITORIAL DEPARTMENT

Brian C. Fenton, editor  
Marc Spiwak, associate editor  
Neil Sclater, associate editor  
Teri Scaduto, assistant editor  
Jeffrey K. Holtzman  
computer editor  
Robert Grossblatt, circuits editor  
Larry Klein, audio editor  
David Lachenbruch  
contributing editor  
Don Lancaster  
contributing editor  
Kathy Terenzi, editorial assistant

### ART DEPARTMENT

Andre Duzant, art director  
Injae Lee, illustrator  
Russell C. Truelson, illustrator

### PRODUCTION DEPARTMENT

Ruby M. Yee, production director  
Janice Box  
editorial production  
Karen S. Brown  
advertising production  
Marcella Amoroso  
production assistant

### CIRCULATION DEPARTMENT

Jacqueline P. Cheeseboro  
circulation director  
Wendy Alanko  
circulation analyst  
Theresa Lombardo  
circulation assistant  
Michele Torrillo,  
reprint bookstore

Typography by Mates Graphics  
Cover photo by Diversified Photo  
Services

Radio-Electronics is indexed  
*Applied Science & Technology Ind.*  
and *Readers Guide to Periodical Literature*.

Microfilm & Microfiche editions available. Contact circulation department for details.

**Advertising Sales Offices listed on page 106.**

Radio-Electronics Executive and  
Administrative Offices  
1-516-293-3000.

Subscriber Customer Service:  
1-800-288-0652.

Order Entry for New Subscribers:  
1-800-999-7139.

The  
Audit  
Bureau  
of Circulation



## THE PARTS PLACE<sup>SM</sup>

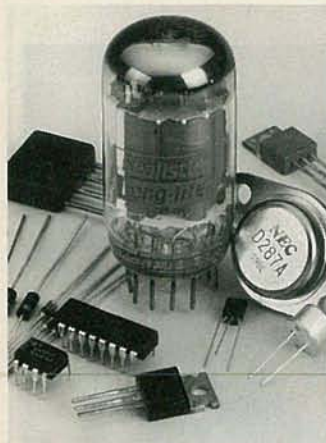

### Super Selection! Try Our Special-Order Hotline

Your local Radio Shack stocks over 1000 popular electronic components. Plus, we can special-order over 10,000 items from our main warehouse—ICs, semiconductors, tubes, crystals, phono cartridges and styli, popular modules, even SAMS\* manuals. There are no postage charges or minimum requirements for this service. Come in today for details!

### NEW! Micronta<sup>®</sup> LCD Digital Multimeter

With big display and protective rubber holster. Autoranging with manual override, high-speed sampling. Has data hold, 33-dot analog bargraph, 200  $\mu$ A low-current range and continuity sounder. Fold-out stand/hanger. Measures to 1000 VDC, 700 VAC, 10A AC/DC, 30 megohms resistance. Batteries extra. #22-167 ..... 69.95

NEW!

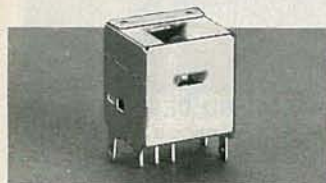

**Infrared Detector Module.** A ready-to-use IR receiver for remote-control projects. Combines detector, limiter and demodulator in a compact 3-lead package. 5VDC. With data. #276-137 ..... 3.49



(1) **Pulsing Buzzer.** Extra-loud! 3 to 28 VDC. #273-066 ..... 4.29  
 (2) **"Ding-Dong" Chime.** For doorbell, entry alert. Requires 6 to 18 VDC. #273-071 ..... 8.99  
 (3) **Mini Buzzer.** Efficient! Draws 7 mA at 12VDC. #273-074 ..... 2.99



(1) **High-Speed 12VDC Motor.** Up to 15,200 RPM with no load. About 2" long (including shaft). #273-255 ..... 2.99  
 (2) **Low-Voltage Motor.** For projects and solar power demos. 1 1/2 to 3VDC. #273-223 ..... 99¢



**Mini Audio Amplifier.** With built-in speaker. Use to boost computer audio, signal tracing and more. Has a high-gain IC circuit, 1/8" headphone jack, 1/8" input jack and volume control. Battery extra. #277-1008 ..... 11.95



(1) **4-Conductor Double Shielded Cable.** 30 feet. For audio or data hookups. #278-777 ..... 7.95  
 (2) **12-Foot "Business Machine" Power Cord.** #278-1261 ..... 5.99  
 (3) **6-Ft. Version of Fig. 2.** 90° connector. #278-1260 ..... 5.99



(1) **Binding Posts/BNC Adapter.** For dependable test instrument hookups. #274-715 ..... 8.95  
 (2) **Binding Post to Banana Plugs.** Stackable. Includes one red and one black. #274-716 ..... Set 4.95

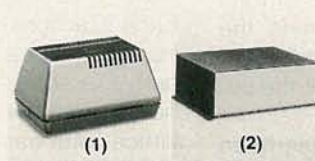

(1) **Power Supply Project Case.** Vented 2 1/2 x 4 5/8 x 3 1/4" molded box. #270-287 ..... 3.99  
 (2) **Deluxe Project Box.** 3 1/16 x 8 1/4 x 6 1/8". All metal. With protective rubber feet. #270-274, 10.79  
**20 different enclosures in stock!**



**Infrared Detector Card.** Detects normally invisible IR light. Fast way to confirm output from remote controls, infrared LEDs or laser in CD and video players. Great for science projects, too! #276-099 ..... 5.95



**Portable Shortwave Antenna.** Boosts reception on worldband portables! Clips to rod antenna. Wire extends up to 23 feet. Winds up on pocket-size reel for storage and travel. #278-1374 ..... 8.95

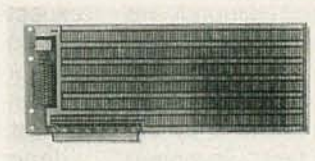

**PC/XT Experimenter's Circuit Card.** Premium epoxy prototyping board fits computer's XT bus connector. Plated-through holes. 3 7/8 x 10 1/16 x 1/16". Accepts D-sub at right. #276-1598 ..... 29.95



**Right-Angle D-Sub 25 Female Connector.** Ideal for use with card at left. Radio Shack has solder-type and IDC solderless connectors for computer and printer hookups. #276-1504 ..... 2.49

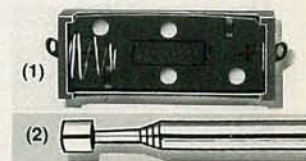

(1) **Holder for Type "N" Battery.** #270-405 ..... 59¢  
**16 different holders in stock!**  
 (2) **Telescoping Antenna.** 17 3/4". Six sections. #270-1409 ..... 2.59  
**16 different antennas in stock!**

Since 1921 Radio Shack has been the place to obtain up-to-date electronic parts as well as quality tools, test equipment and accessories at low prices. Our nearly 7000 locations are ready to serve you—NOBODY COMPARES

Prices apply at participating Radio Shack stores and dealers. Radio Shack is a division of Tandy Corporation

**Radio Shack<sup>®</sup>** SINCE 1921  
**AMERICA'S TECHNOLOGY STORE<sup>SM</sup>**

# WHAT'S NEWS

*A review of the latest happenings in electronics.*

## Petal power?

Electrical engineers at the Georgia Institute of Technology (Atlanta, GA), with support from the U.S. Joint Services Electronics Program, have discovered that adding serrations shaped like flower petals to the outer edges of satellite dishes can significantly improve their performance by reducing unwanted "sidelobe" radiation—energy that is unintentionally scattered by the dishes. Reducing it minimizes the chance that antennas will interfere with each other or send signals in undesired directions, both of which could cause problems for future telecommunications satellites that will be placed much closer together in geosynchronous orbit.

The edge treatment, for which Georgia Tech has applied for a patent, allows designers to customize the serration design for specific applications, taking into account such factors as how much gain will be lost to reduce the sidelobe levels. The optimal length for the serrations seems to be about 10 times the wavelength the dish is designed to reflect. It isn't necessary for the petals to be of uniform size.

The petal-edge design has been incorporated in an outdoor compact range recently build for the U.S. Army's Electronic Proving Grounds

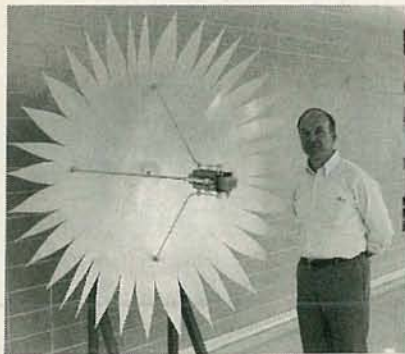

**DR. EDWARD B. JOY, PROFESSOR OF ELECTRICAL ENGINEERING at Georgia Tech, shows antenna dish with flower petal edges that improve the antenna's performance.**

at Fort Huachuca, AZ, and at least one manufacturer of compact antenna ranges has already adopted the technology. The edges will add little to the manufacturing costs of dishes, and could even be retrofitted onto existing dishes, although such modified dishes would require alterations to the feed systems.

## Harder than diamonds?

High-resolution x-ray measurements performed by scientists at Ford Motor Company (Dearborn, MI), show that gem-quality diamonds synthesized by scientists at GE Research and Development Center (Schenectady, NY) contain more atoms per cubic centimeter at room temperature than any other solid known to exist on earth. The diamonds, which are composed almost totally of the isotope Carbon-13, are of greater crystalline perfection than any found in nature, and range up to three carats.

Carbon exists as two stable isotopes: Carbon-12 and Carbon-13. Each Carbon-13 atom is slightly heavier than its Carbon-12 counterpart. Diamond is composed of carbon atoms arranged in a regular lattice, with each atom at the same small distance from its neighbors. The regular lattice, small distance between atoms, and very strong carbon-to-carbon bond, account for diamond's unsurpassed hardness. Natural diamonds contain 99% Carbon-12 and only 1% of Carbon-13, while the synthesized diamonds are made of 99% Carbon-13 and 1% Carbon-12.

A proprietary two-step process invented in the late 1980's by GE scientists involves, first, a low-pressure chemical vapor deposition technique to produce aggregates of small diamonds with the desired isotopic composition, and second, dissolving and recrystallizing the aggregate into gem-quality diamonds weighing a carat or more.

The Ford experiments showed

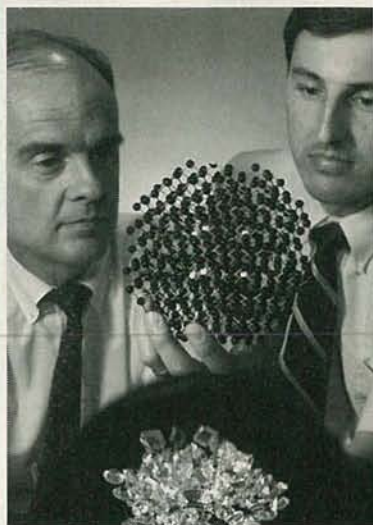

**GE RESEARCH AND DEVELOPMENT Center scientists examine a model of atomic structure of a diamond synthesized from 99% Carbon-13. The diamonds, shown in the foreground, come out to be harder than natural diamond, currently the world's hardest material.**

that, as Carbon-13 interaction increased, the interatomic distance or lattice constant, decreased slightly. Some scientists speculate that the smaller lattice constant could make the GE diamond even harder than natural diamonds.

Also revealed by the Ford experiments is that the GE diamond crystal quality approaches that of the best man-made semiconductor crystals. Because improved crystal quality translates to improved electronic properties, that discovery is expected to stimulate the development of electronic devices based on diamonds. Laboratory studies have shown that synthesized gem diamonds can be electronically "doped" by the incorporation of small amounts of boron, which transforms it from an insulator into a semiconductor.

GE manufactures diamond for use in the electronics industry as well as diamond abrasives for machining, grinding, sawing, and drilling applications.

# WHAT YOUR TOOLS SAY ABOUT YOU.

## "ULTIMATE PROFESSIONAL"

Here's the newest family member: the 60 MHz Tek 224. It's as rugged, reliable and easy to use as the rest of the 220 Series—and extended bandwidth makes it the logical choice for computer service professionals.

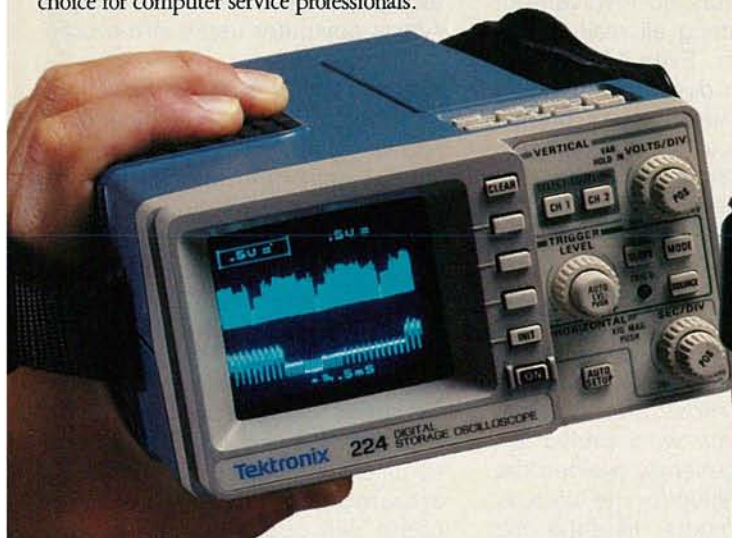

## "ACE TROUBLESHOOTER"

The Tek 222 is everything a service scope ought to be. Lightweight. Rugged. Fully programmable. Floatable to  $\pm 400$  V. Two channels, 10 MHz, Auto Setup and Auto Trigger make it easy finding trouble—fast.



## "RUGGED SURVIVALIST"

Tek's 222PS Power Scout™ offers the field-proven performance of the 222, *plus* it's rated 600 VAC, 850 VDC and 6 kV peak surge. Perfect for circuit measurements requiring extra protection—and a few added guts.

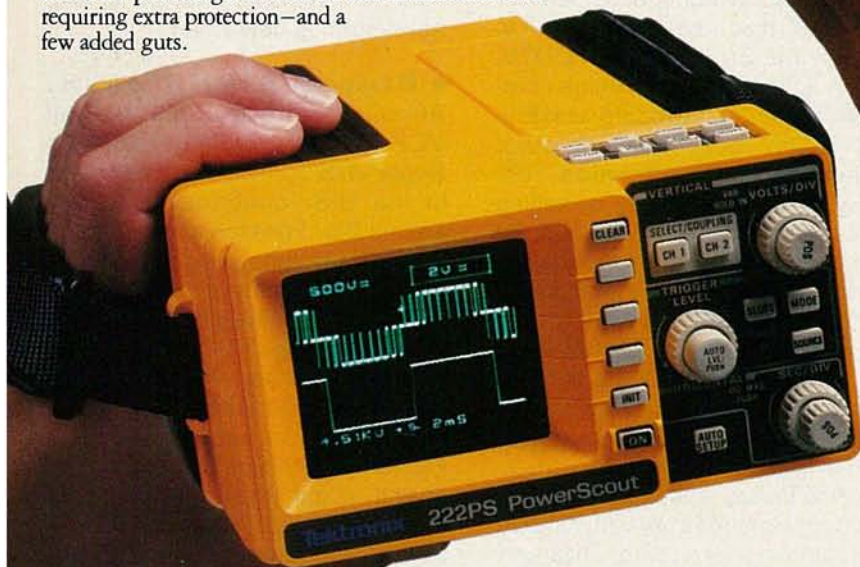

They're just 4½ pounds. U.L. certified. And start at \$2450. 220 Series handheld oscilloscopes—all with Tek's exclusive IsolatedChannel™ architecture—are the service tools the professionals use. There's one with you written all over it. To order, contact your Tek representative or distributor. Or just call Tek direct: 1-800-426-2200

**Tektronix**

Test and Measurement

# VIDEO NEWS

*What's new in the fast-changing video industry.*

DAVID LACHENBRUCH

## ● "Use it or lose it."

Anticipating the arrival of HDTV, the FCC is preparing new allocation of TV channels to permit broadcasters to simulcast in standard NTSC and HDTV during a long transitional period. The FCC has found that there will probably be enough channels in most markets to allot those extra frequencies to broadcasters who are planning to transmit in HDTV. However, there is some fear that broadcasters, hesitant because of the expense of converting to HDTV, might merely sit on the extra channels. Thus, the Commission's chairman, Alfred Sikes, has warned that broadcasters won't be allowed to dally and that the UHF spectrum space that broadcasters don't use after a respectable period of time could well be turned over to land mobile services. The FCC is asking a number of questions to prepare for HDTV, including how long stations should continue broadcasting in NTSC after the arrival of high definition.

● **Two-lens camcorder.** One of the last holdouts against the 8mm video format—Sharp Electronics—has come into the fold in a big way. It has introduced two camcorders with dual-lens systems. Each of the compact, palm-sized models are virtually two cameras in one. One lens provides a fixed-focus, wide-angle picture, the other an 8:1 zoom system. The wide-angle lens gives a 62° field of view, and switching from one lens to the other provides "instant 12:1 zoom," according to Sharp. The system provides a number of special effects. It can be used for picture-in-picture, with both lens and CCD operating systems operating at the same time, or the user can "wipe" from one lens to the other. The basic model has monophonic sound and a monochrome viewfinder, while the higher priced model has stereo audio and a color LCD viewer.

With Sharp's addition of 8mm (it will continue to offer VHS camcorders as well), only JVC—the inventor of VHS—has no involvement with 8mm, among all major camcorder makers. Even Matsushita Electric, which doesn't offer 8mm camcorders under its own brands (Panasonic, Quasar, and National), manufactures 8mm camcorders on a private-label basis of other brands.

● **Home multimedia.** Nobody has really defined the word "multimedia," which is largely used to describe CD-ROM computer products to which interactive video has been added. Those offering non-computer items with similar attributes have generally avoided the word. The question for the future is whether multimedia will enter the home as a computer or as an attachment for the common TV set. Although there are many approaches to multimedia via the computer, so far only two systems have been introduced that use the family TV. Those are Commodore's CDTV, which is based on the Amiga computer but has no keyboard, and Philips' CD-I, launched with great fanfare (**Radio-Electronics**, February 1992) reportedly is selling well. Philips recently announced agreement with Motion Picture Experts Group (MPEG), a standards-setting body, on a standard to add full-motion video to CD-I. All CD-I players have a port for the addition of a chip to provide full-motion, full-screen video. Philips promises the plug-in chip by mid-year.

While Philips is attempting to appeal to the entire family with its CD-I programming—including children's activities, adult games, and reference materials—Commodore says it will begin next year to offer special-interest interactive packages, including MIDI (musical instrument digital interface) selections for audio enthusiasts and titling and captioning software for videomakers.

Commodore also plans to bridge the gap between TV-based and computer-based multimedia by offering a CDTV drive to the 750,000 Amiga computer users in the U.S.

● **Full HDTV schedule.** High definition broadcasting is now on a regular schedule in Japan, the satellite-delivered Hi-Vision signal being transmitted for eight hours daily, though the broadcasts are still billed as "experimental." So-called "regular" HDTV broadcasting is still three years off. Japan's analog HDTV system has been under development for more than 20 years. TV sets to receive and display the broadcasts in full HDTV still cost about \$30,000, and HDTV VCRs are around \$115,000, although costs will come down. Already some private broadcasters in Japan (as opposed to the public NHK network, which developed Hi-Vision) are calling the Japanese system an "interim" measure until a truly digital system is developed.

● **Bigger S-VHS push.** Although more than 20% of VCRs sold in Japan are in the Super-VHS format, the proportion in the U.S. continues to hover around 2%. Panasonic now plans a major campaign around S-VHS with lower prices—a strategy already being followed by JVC, which is now shipping an S-VHS deck carrying a "nationally advertised price of \$799," about \$500 less than the cheapest model last year. Although Panasonic's pricing hadn't been revealed at our press time, it is expected to be at least in line with JVC's. In addition, Panasonic will bring S-VHS into more complex VHS compatibility by making its entire VHS line S-VHS "playback compatible"—meaning that its standard VHS decks will be able to play S-VHS tapes as well as standard VHS (although with only standard VHS resolution). **R**



# Afford. Ability.

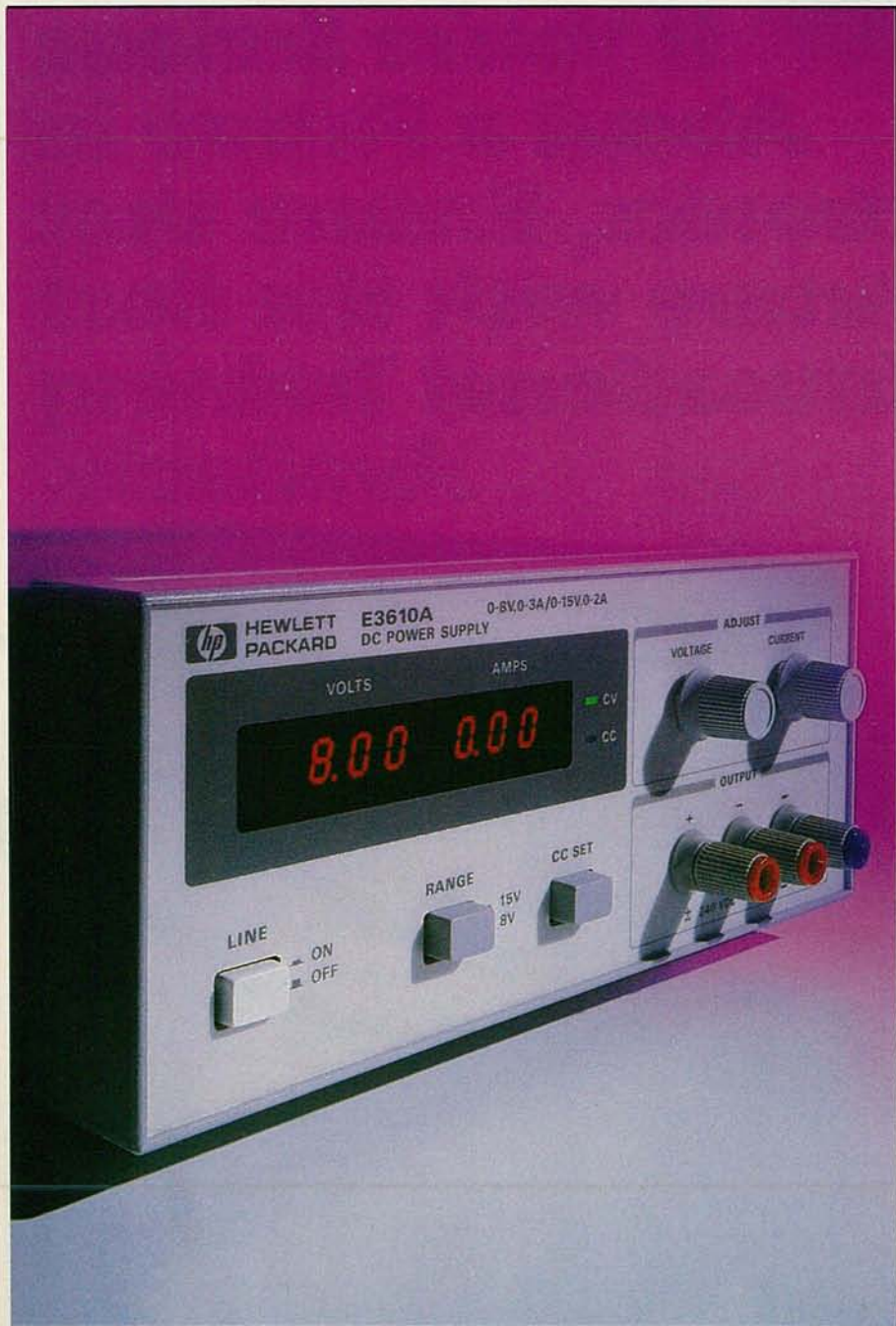

## In a dc power supply.

Now, put a dependable, 30-watt dc power supply on your bench for just **\$300\***. You'll get the low noise your work demands (200  $\mu$ V rms). Constant-voltage or constant-current operation. And built-in reliability ensured by conservative design margins and rigorous environmental testing.

Outstanding value in a dc power supply. It's just one in a full line of basic instruments developed by HP to give you uncompromising performance at an affordable price.



To order, call **HP DIRECT**,  
1-800-452-4844,† Ext. TW13.

We'll ship your order the day it's received. Instruments come with a sixty-day, money-back guarantee.

All you need is a company purchase order or credit card.



HP 30-watt power supplies		E3610A	E3611A	E3612A
Output	Range 1	8V, 3A	20V, 1.50A	60V, 0.50A
	Range 2	15V, 2A	35V, 0.85A	120V, 0.25A
Load or line regulation		0.01% + 2 mV		
Ripple and noise (10 Hz-10 MHz)		200 $\mu$ V rms/2 mV p-p		

There is a better way.



**HEWLETT  
PACKARD**

\* U.S. list price.

† In Canada call 1-800-387-3867, Dept. 442.

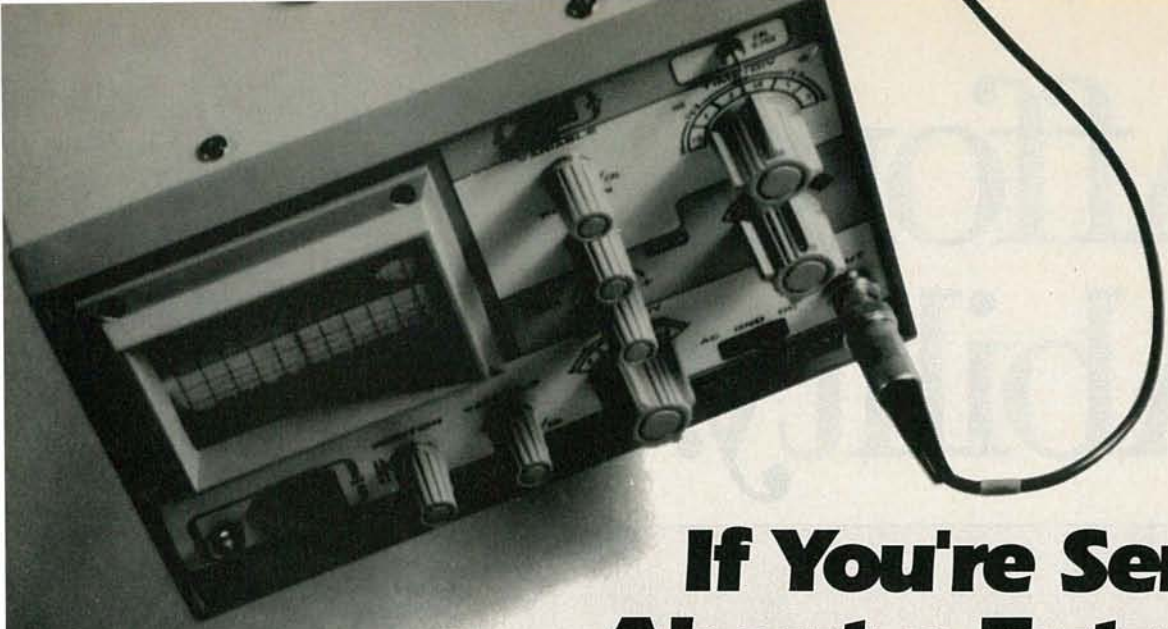

# If You're Serious About a Future in Electronics, Ensure that Your Future with the Best Educational Training Available.

## FREE!

SEND FOR YOUR CIE HOME  
STUDY COURSE CATALOG AND  
RECEIVE A FREE 24 PAGE CIE  
ELECTRONICS SYMBOL HANDBOOK!

Includes hundreds of the most frequently  
used electronic symbols. Published by  
CIE exclusively for our students and  
alumni. Yours free when you  
request a CIE Course Catalog.

electronics

ELECTRONICS SYMBOL  
HANDBOOK

### Procedure

Figure 16 shows the circuit diagram for this experiment. You'll note that pin numbers for the IC aren't included on the diagram. For those, you'll have to refer to Fig. 17, which shows pertinent 74151A data. For the data inputs, you'll use an eight-pole DIP switch in conjunction with 10 k $\Omega$  pull-up resistors. For the Select and Strobe lines, finally, you'll use the trainer data switches.

1. With the power off, mount the 74151A IC and the DIP switch on the breadboard.
2. Connect the eight 10 k $\Omega$  resistors to the DIP switch as shown in Fig. 16. Connect the opposite end of each of these resistors to the +5 V supply. The second terminal of each switch is to be connected to trainer ground.
3. Connect the IC  $V_{CC}$  pin to +5 V, connect the GND to trainer ground.
4. Next, connect the trainer data switches to the Select and Strobe inputs on the IC, using Fig. 17 as a guide. Initially, set SW1 through SW4 to 1.
5. Connect the trainer Y LED to the Y output, and connect the W LED to the W output.

Fig. 16 Circuit for Experiment 2

Fig. 17 Pin diagram for 74151A

7. Turn the power on. The Y LED on your trainer should be off, and the W LED should be on. If you don't observe these conditions, turn off the power and check your connections.
8. From the present input conditions on the inputs, you can see that the input will be enabled.
9. Set the appropriate DIP switch H1 (1000), and verify your prediction. Record your results in terms of the selected input D, where a valid number of the selected data lines in the appropriate space in the truth table in Fig. 18.

If you want to learn about electronics, and earn a good income with that knowledge then CIE is your best educational value.

CIE's reputation as the world leader in home study electronics is based solely on the success of our graduates. And we've earned that reputation with an unconditional commitment to provide our students with the very best electronics training.

Just ask any of the 50,000-plus graduates of the Cleveland Institute of Electronics who are working in high-paying positions with aerospace, computer, medical, automotive and communication firms throughout the world.

They'll tell you success didn't come easy...but, it did come....thanks to CIE. And today, a career in electronics offers more opportunities and greater rewards than ever before.

### CIE'S COMMITTED TO BEING THE BEST....IN ONE AREA....ELECTRONICS.

CIE isn't another be-everything-to-everybody school. We teach only one subject and we believe we're the best at what we do. Also, CIE is accredited by the National Home Study Council. And with more than a 1,000 graduates each year, we're the largest home study school specializing exclusively in electronics. CIE has been training career-minded students like yourself for nearly 60 years and we're the best at our subject .....  
**ELECTRONICS ... BECAUSE IT'S THE ONLY SUBJECT WE TEACH!**

### WHY CHOOSE CIE FOR YOUR TRAINING?

150,000 successful graduates from every country around the world.

Only CIE rewards you for fast study. CIE offers an Associate Degree program based on actual study time used. The faster you complete your degree the less your overall tuition.

State-of-the-art laboratory equipment is yours to keep and it comes assembled, ready for hands-on experiments.

Approved for educational benefits under the G.I. Bill for veterans and other eligible persons.

Upon graduation, CIE offers free preparation to pass the Certified Electronics Technician Exams.



### CIE PROVIDES YOU WITH A LEARNING METHOD SO GOOD, IT'S PATENTED.

CIE's Auto-programmed lessons are a proven learning method for building valuable electronics career skills. Each lesson is designed to take you step-by-step and principle-by-principle. And while all CIE lessons are designed for independent study, CIE's instructors are personally available to assist you with just a toll-free call. The result is practical training... the kind of experience you can put to work in today's marketplace.

### LEARN BY DOING...WITH STATE-OF-THE-ART FACILITIES AND EQUIPMENT.

In 1969, CIE pioneered the first Electronics Laboratory course and in 1984, the first Microprocessor Laboratory course. Today, no other home study school can match CIE's state-of-the-art equipment and training. And all your laboratory equipment, books, and lessons are included in your tuition. It's all yours to use while you study at home and for on-the-job after graduation.

### PERSONALIZED TRAINING....TO MATCH YOUR BACKGROUND.

While some of our students have a working knowledge of electronics others are just starting out. That's why we've developed twelve career courses and an A.A.S. Degree program to choose from. So, even if your not sure which electronics career is best for you, CIE can get you started with

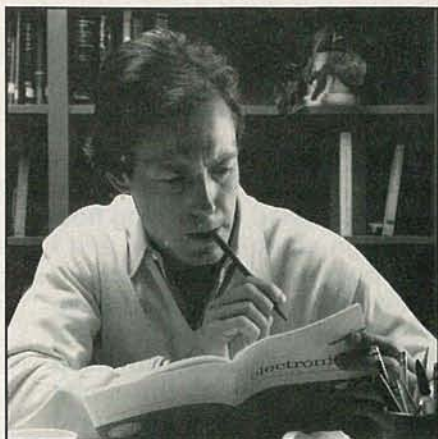

core lessons applicable to all areas of electronics. And every CIE course you take earns you credit towards completion of your Associate in Applied Science Degree. So you can work toward your degree in stages or as fast as you wish. In fact, CIE is the only school that actually rewards you for fast study, which can save you thousands of dollars.

**SEND TODAY FOR YOUR CIE COURSE CATALOG AND WE'LL SEND YOU A FREE 24 PAGE CIE ELECTRONICS SYMBOL HANDBOOK!**

**YES!** I want to get started.

Send me my CIE school catalog including details about the Associate Degree Program. (For your convenience, CIE will have a representative contact you - there is no obligation.)

AE36

Name: \_\_\_\_\_

Address: \_\_\_\_\_

City: \_\_\_\_\_ State: \_\_\_\_\_

Zip: \_\_\_\_\_ Age: \_\_\_\_\_

Phone No. ( \_\_\_\_\_ ) \_\_\_\_\_

Check box for G.I. Bulletin Benefits

Veteran  Active Duty



**CLEVELAND INSTITUTE OF ELECTRONICS**

1776 East 17th Street  
 Cleveland, Ohio 44114  
 (216) 781-9400



A school of thousands.  
 A class of one.  
 Since 1934.

# ASK R-E

Write to Ask R-E, Radio-Electronics, 500-B Bi-County Blvd., Farmingdale, NY 11735

## VIDEO FADER

I'm interested in learning how to design video hardware and I have been working on a circuit that would cause a video image to fade as I turn a potentiometer. I've tried several ideas but keep running up against the same problem. As I cause the signal to fade, it always starts to mess up horizontally and vertically before the image disappears completely. I'm not asking you to design the circuit for me, but I sure could use some advice. Do you have any idea what I'm doing wrong?—D. Koetting, St. Louis, MO

It's always a pleasure to answer a letter from someone who understands that the only way to learn is to make mistakes and work out the answers with a minimum of help and a maximum of brainwork.

I've studied your schematics and you've been making the same mistake each time. Each design you've done assumes that the video signal is similar to audio in that all the information contained in the signal is

spread equally throughout the signal's entire voltage range. The video signal is extremely complex and different parts of it are reserved for different purposes. A typical line of video is shown in Fig. 1. Notice that the line is divided horizontally between the picture information (want to fade), and the control information (want to leave alone).

The only thing wrong with the designs you sent me is that they all treat the two parts of the video signal equally. By dropping the voltage level of the entire line of video, you're cutting the level of the control information in the horizontal interval as well. For your designs to work properly, your circuit must distinguish electronically between the picture and the control information in the horizontal interval.

This is the same problem that every television has and, as you would expect, there are one-chip solutions to the problem. National Semiconductor and other manufacturers have a range of chips available that can separate picture and sync. If you want to build something

of your own to handle this problem the answer will become evident when you realize that in a standard NTSC signal (1 volt peak-to-peak) the picture data lives above 300 millivolts and the sync information lives below that. You didn't ask for a specific design, but remember that in a 5 volt TTL land, the picture information will be seen as a high and sync will be seen as a low.

Once you work out that part of the problem, you have to use the sync signal to gate your fade circuit. Reducing the picture to 300 millivolts will make it disappear completely, and passing the whole signal during the sync interval will steady the image as it fades away on the screen.

## EGA-VGA ADAPTER

I have an AT clone and recently I upgraded my video card from EGA to VGA but I am saving to buy myself an analog VGA monitor. The problem I having at the moment is that my old EGA monitor has a nine-pin connector and the VGA card has

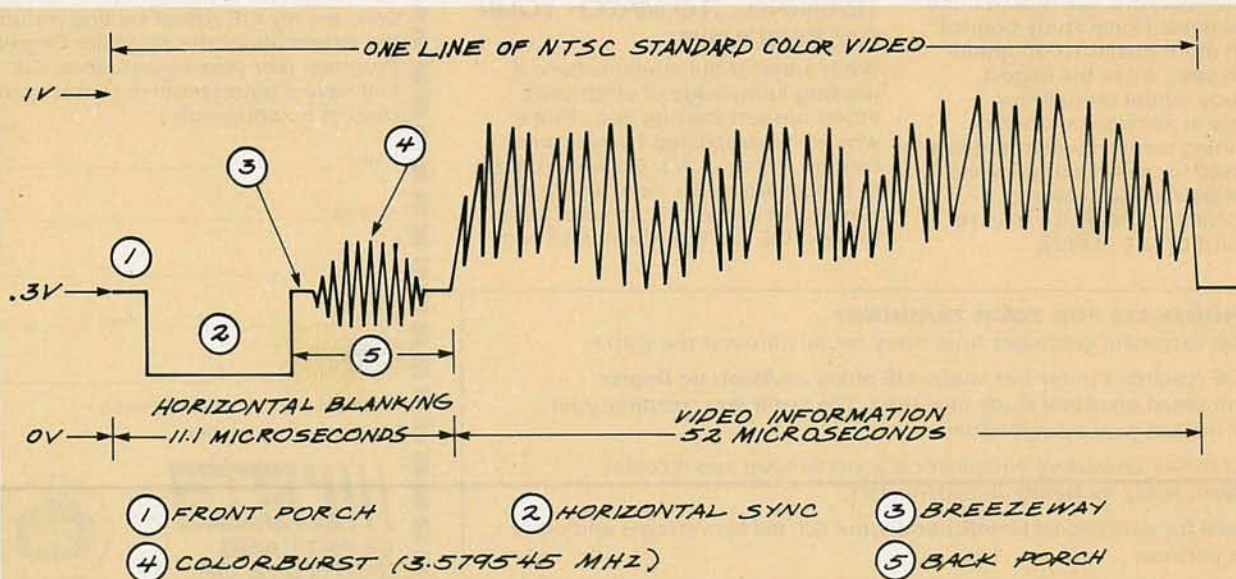

FIG. 1—THE VIDEO SIGNAL is extremely complex and different parts of it are reserved for different purposes. A typical line of video is divided horizontally between the picture information and the control information.

**TABLE 1  
IBM 15-PIN VGA CONNECTOR  
PINOUTS**

Pin #	Function
1	Red Video
2	Green Video
3	Blue Video
4	Not Used
5	Ground
6	Red Ground
7	Green Ground
8	Blue Ground
9	No Pin
10	Sync Ground
11	Monitor ID (not used)
12	Monitor ID
13	Horizontal Sync
14	Vertical Sync
15	Not Used

Monochrome VGA monitors get their signal from Green Video on pin #2 and connect pin #12 to ground. Color VGA monitors leave pin #12 open. This allows the VGA card to detect the type of monitor it's driving when the computer is first turned on.

shown in Table 2. Making one of these adapters is easy but the fifteen-pin connectors are a pain in the neck to work with. If I were faced with your problem, I'd spring for a ready-made adapter.

While the adapter is standard, there's no guarantee that you can use it safely in your system. The EGA monitor you have is probably designed to handle only the standard EGA-level signals, and the VGA card you bought can probably drive only VGA-type analog monitors. Even if you were able to get past the problem with signal levels (and type), you'd still be left with the problem of the scan rate.

The standard EGA horizontal scan rate is about 21 kHz, while the regular VGA scan rate is considerably higher—about 31 kHz—and this is root of the problem. Trying to drive a monitor designed to scan at 21 kHz with a horizontal frequency 10 kHz higher will undoubtedly

**TABLE 2  
PINOUTS OF THE NINE- TO FIFTEEN-PIN IBM VIDEO ADAPTER**

Nine Pin Connector		Fifteen Pin Connector	
Pin #	Function	Pin #	Function
1	Red Video	1	Red Video
2	Green Video	2	Green Video
3	Blue Video	3	Blue Video
4	Horizontal Sync	13	Horizontal Sync
5	Vertical Sync	14	Vertical Sync
6	Red Ground	6	Red Ground
7	Green Ground	7	Green Ground
8	Blue Ground	8	Blue Ground
9	Sync Ground	10	Sync Ground
		5	Ground

**a fifteen-pin connector. I know I can't see VGA-quality video on my monitor, but is there a standard for making an adapter to go from the fifteen pins on my card to the nine pins on my monitor?—F. Gisher, Benjamin, IN**

At the risk of sounding completely mysterious, I have to tell you that the answer to your question is yes (maybe), and no (sort of). Even though VGA is an established standard, there are some important parts of it that aren't standardized.

Nine-to-fifteen pin adapters are sold by a lot of people. The pinout for the VGA's fifteen-pin connector is shown in Table 1, and the nine-to-fifteen pin adapter pinouts are

damage the horizontal deflection circuitry in the EGA monitor.

Some VGA cards—such as the ones from ATI—have hardware on them specifically designed to drive everything from monochrome to CGA to EGA monitors. In essence, while they look like a VGA card to both your computer and software, they can look like a variety of video cards to your monitor. Read your VGA card manual carefully and, if it doesn't specifically state that it can drive an EGA monitor, forget the idea and buy a VGA monitor.

By the way, the nine-to-fifteen-pin adapters are normally used for multisync monitors that can handle both analog (VGA) and TTL video signals.

R-E

# FREE HEATH CATALOG



**New and innovative electronics that make your life easier, safer and more secure, including:**

- The world's largest and most varied selection of home lighting controls.
- Home security, safety and whole-house automation systems.
- The Heath Most Accurate Clock, accurate to +/- 10 milliseconds.
- Heath's own Advanced Weather Computer for precision weather display and analysis.

**And, the best electronics home study programs you'll find anywhere (the best value, too) including:**

- ✓ New Computer-Aided Instruction (CAI) courses in basic electronics for accelerated, interactive learning.
- ✓ Video courses you can watch from the comfort of your easy chair.
- ✓ Courses that let you start at the level that's right for you and continue at your own pace.
- ✓ Courses from Heathkit Educational Systems, accredited and licensed as a premier electronics educator.
- ✓ Continuing Education Units (CEUs) awarded on successful completion of most Heath courses.

To receive your FREE Heath Catalog, fill in your name and address below and mail TODAY!

To: Heath Company  
Dept. 020-150  
Benton Harbor, MI 49022

Name \_\_\_\_\_

Address \_\_\_\_\_

City \_\_\_\_\_

State/Zip \_\_\_\_\_

CL-808

CIRCLE 86 ON FREE INFORMATION CARD

# LETTERS

Write to Letters, Radio-Electronics, 500-B Bi-County Blvd., Farmingdale, NY 11735

## A REAL SOAP OPERA

**Radio-Electronics** readers might be interested to know that radio musical comedy is still alive and well in the 1990's. ZBS Foundation has produced "Dishpan Fantasy," a modern comic opera that is available to public radio stations as two half-hour programs. The format might be reminiscent of the past, but the plot and production methods are strictly contemporary. The story line blends bits of feminism with fantasy, comedy, love, and self-discovery. The music ranges from classical to rock'n'roll, from 50's cocktail lounge songs to African drums and whistles. The voices of two opera singers were used to create the seven characters in the opera. By running the singers' voices through a processor, the producer, Tim Clark, was able to create a cartoon-like quality. Using samplers and synthesizers, sound effects and environmental background noises were added. The "Finale" music-writing program was used for composing the opera, and the "Performer" program was used for the preliminary rough mix that

allowed the singers to hear their parts with full orchestration. After the voices were recorded on a multi-track, Clark went back and added the music that was in the computer in the Performer program. Besides simplifying production, computer technology offered one big plus: Listeners can hear every word. Clark was able to rearrange the vocals and instrumentation so that the singers' words were always clearly understood. Check local public radio programming schedules for broadcast times of "Dishpan Fantasy."

KATHY GRONAU

ZBS Foundation

*If "Dishpan Fantasy" isn't being broadcast in your listening area, you can order it on a 72-minute audio cassette for \$12.95 directly from ZBS Foundation, RR#1 Box 1201, Ft. Edward, NY 12828-9713. Their phone number is 800-662-3345.—Editor*

## ONE READER'S OPINION

I'm writing to let you know that you're doing a great job. I work as an electrical engineer in the automotive field at a major R&D outfit during the day, and work towards my masters in E.E. at night. My job requires that I stay on the leading edge of technology and be informed on the latest techniques, applications, and discoveries. **Radio-Electronics** has been a great help in meeting those requirements. I can't emphasize enough that education is a priority for success and must be a lifetime commitment. I've always preached to other electronics students that **Radio-Electronics** is an excellent source of information. I love to study the "Build This" projects, admiring some of the designs—and catching some of the errors. The technology articles provide an excellent review. The various departments keep getting better, and I hate it when I don't have time to read them all.

One suggestion for improvement: I'd like to see a section **Radio-Electronics** devoted to testing your electronic skills. Perhaps it could be a one-page test covering a different topic each month, that readers could take and quiz themselves. Taking such tests really keeps you on your toes.

Keep up the good work!

J. KEITH DAVIS

San Antonio, TX

## ADC FOR YOUR PC IMPROVEMENTS

The surface temperature problem: "Experimenting with ADC for your PC" (**Radio-Electronics**, January 1992) should not have its handle filled with epoxy or silicone, as this will increase heat transfer between the sensor and the handle, thus decreasing response time and decreasing accuracy. The top of the TO-92 case should also be filed to increase contact area and heat transfer between the sensor and the measured surface.

At the low-temperature dew point gathering point, be sure not to record the voltage until the ice cube is wet from its own melting. An ice cube just out of a freezer could have a temperature well below 0°C.

At the high-temperature dew point gathering point, the probe should not be immersed if it's to be used as a surface probe. Place it against the outer flat side of the container boiling water, just below the water level. Bring the water to a rolling boil, reduce the heat slowly, and record the voltage just as active bubble production ceases.

A rolling boil can be more than 1°C above the true boiling point which is also greatly affected by barometric pressure. Pure water boils at less than 95°C in Denver under the influence of a low-pressure system, and at more than 101°C at sea level under the influence of a high-pressure system.

The current uncorrected barometric



metric pressure can be obtained from your nearest airport or weather bureau. For every 0.1 inch of mercury above or below 29.92 inches, adding or subtracting 0.1°C from 100°C will be quite close.

For immersion probe construction, on the other hand, thermal isolation of the sensor from the handle is of little concern, but moisture proofing is important. For the low-temperature point, immerse the probe in a constantly stirred slurry of chipped ice and water using +0.3°C instead of 0.0°C as the temperature. At the boiling point, don't pour the water into another container. It will lose several degrees in the process. Immerse the probe to just above the bottom of the container, making temperature corrections and voltage recordings as outlined above.

DAN A. NIEMI  
Gwinn, MI

#### SCRAMBLER/DESCRAMBLER REQUEST

It has been several years since my service training in electronics. As a matter of fact, my education was very complete—on tubes, that is. I've just recently regained my interest in electronics as a hobby for my golden (silicon?) years. After making a bunch of doo-dads directly from simple schematics, I would like to get back into designing my own circuitry as I did in days of yore.

In the meantime, while my knowledge is getting modernized, I would greatly appreciate plans for a simple solid-state scrambler/decrypter. The parameters could be very limited, since it only has to be variable to give four or five "channels" and an audio band (even just the frequencies of the human voice).

It's hard to believe the changes that have come to pass. Picking up my first subscription copy since dropping out years ago is like starting to learn a foreign language that your distant relative spoke in your youth. In any case, it is satisfying to see that the quality of **Radio-Electronics** has not suffered.

LEN BOULTER  
Prince Rupert, B.C.  
Canada

Keep reading—we're working on just such a project!—Editor R-E

## Does Your Frequency Counter Give Honest Answers?



**B+K PRECISION frequency counters are conservatively rated and designed for accuracy.**

Before you buy a counter, compare specs and ask questions... Does high-input sensitivity come at the expense of false readings with no input? Is time base drift specified per year, or just per month? From 0° to 50° C, or only at room temperature? B+K PRECISION's rugged, lab-grade counters have guaranteed specs. They'll perform as promised, every time. You can count on B+K!

#### 1.3GHz 8-digit Multifunction Counter

- Frequency, period, period average, and totalize functions
- 1.0 PPM TCXO time base
- 10 mV rms max. sensitivity
- Optional accessory antenna
- 0.1 Hz max. resolution
- Remote start-stop

Model 1856 **\$495.00**

#### 175 MHz 8-digit Universal Counter

- Frequency, period, period average, totalize, frequency ratio, and time-interval function
- 10 PPM time base
- 20 mV rms max. sensitivity
- Optional accessory antenna
- 0.1 Hz max. resolution

Model 1823 **\$395.00**

For detailed specifications on the complete line of B+K PRECISION frequency counters or immediate delivery, contact your local distributor or B+K PRECISION.



**BK PRECISION**  
MAXTEC INTERNATIONAL CORP.

Domestic and International Sales  
6470 W. Cortland St., Chicago, IL 60635  
312-889-1448 • FAX: 312-794-9740

CIRCLE 77 ON FREE INFORMATION CARD

NO COMPLICATED ELECTRONICS, NO EXPENSIVE INSTRUMENTS:

## Home study course shows you how to make good money in VCR repair.

An amazing fact: you can do more than four out of five VCR repairs with ordinary tools and basic fix-it procedures. Our home study program shows you how.

Learn all of the systems, mechanisms, and parts of almost all brands of VCRs. With *no* expensive instruments. *No* complicated electronics. *No* fancy workshop. The step-by-step texts and close personal attention from your instructor make learning easy.



Texts, course materials, and tool kit are sent to your home. Graduate ready to make up to \$50.00 or more per hour in your own spare-time or full-time business.

**Send today for your free career booklet. Or call 800-223-4542**



Name \_\_\_\_\_  
Address \_\_\_\_\_  
City \_\_\_\_\_ State \_\_\_\_\_ Zip \_\_\_\_\_

### The School of VCR Repair

2245 Perimeter Park, Dept. VC342, Atlanta, Georgia 30341



# MARCI

LARRY STECKLER, EHF/CET, Editor-in-Chief

IF YOU MAINTAIN, REPAIR OR UPGRADE electronic equipment you should become a Certified Electronics Technician (CET). Here's how you can become someone special.

On behalf of its more than 32,000 Certified Technicians, Ernie Curtis, CET, Chairman of the International Society of Certified Electronics Technicians, has declared Tuesday, March 10, 1992, "Electronics Technicians Day."

"The electronics technician," stated Curtis, "is responsible for keeping today's electronics-dependent society operating. Without this highly-skilled and specially-trained corps of electronics technicians, breakdowns in modern complex electronics would quickly bring our world to a sparking halt. Our intention," Curtis continues,

"is to focus international recognition on the high standards of performance and excellence maintained by professional electronics technicians."

Over 100 IS CET Certification Test Administrators have volunteered to give tests during the week of March 8 through 14, 1992 to honor Electronics Technicians Day. The complete list of all of these test sites is published in the pages that follow this article. In 1991, the 30,000th CET, Robert Bruce Bottoms, CET was an IS CET member who used T-Day 1991 to upgrade from Associate to Journeyman. Bottoms, an employee of United Parcel Service, attended the 1991 IS CET convention in Reno, Nevada, and addressed an enthusiastic audience about his desire to represent a new generation of CET's.

## What is IS CET?

As the proud electronics technicians division of the National

Electronics Sales & Service Dealers Association (NESDA), IS CET was founded in 1970 as a committee of Certified Electronics Technicians, whose main purpose was to foster respect and admiration for the profession. By maintaining rigorous standards in its certification program, IS CET is able to separate the highly skilled and knowledgeable technicians from those with less experience. IS CET's main functions include direction and administration of the CET program, the national appreciation and training program, the technical information training upgrading programs, and serviceability programs.

The CET program was designed to measure the degree of theoretical knowledge and practical proficiency of practicing technicians. A technician with a CET certificate is thought of as the industry as one who possesses the training and expertise necessary to perform his job with professional competence. Since its inception, the program has continued to gain acceptance by technical manufacturers, and consumers. Many organizations require their technical employees to be certified by IS CET.

## Technician skills

Just keeping up with the changes that seem to occur daily in new equipment is a time task. To be able to service the latest electronics equipment with its new circuitry, new components, and new principles is a difficult challenge. Today's electronics technicians must constantly learn, constantly acquire new theoretical and practical skills, and constantly develop new techniques. They must become familiar with



AT THE IS CET CONVENTION, the current IS CET chairman, Ernie Curtis, CET (left) accepts the gavel from outgoing chairman, Leonard Bowdre, CET.



# 10: ELECTRONICS TECHNICIANS DAY

kinds of test equipment and new servicing techniques to repair the latest electronics engineering marvels.

Perhaps this was best summed up by Leonard Bowdre, CET, ISCET's Immediate Past Chairman, when he said, "I marvel at the exponential changes in electronics since my introduction to it in 1946. The new techniques, devices, and technology that have appeared in the last two years alone are mind-boggling. With what today's technicians must know, I think they must be the most qualified, most underpaid, and the least recognized in the world's work force."

## The CET exam

To become certified by ISCET, the electronics technician must pass both a 75-question Associate-level CET test, and a 75-question Journeyman-level test. To pass, the candidate must score a grade of 75% or better. An electronics technician or student with less than four years of experience may apply for the Associate-level exam only, which covers the following subjects:

- Basic Mathematics
- DC Circuits
- AC Circuits
- Transistors and Semiconductors
- Electronic Components
- Instruments
- Tests and Measurements
- Troubleshooting and Network Analysis

A fully certified technician must have four or more years of education or experience in electronics and must pass, in addition to the Associate-level test, one or more of the Journeyman options available in specialized

fields of electronics. The Journeyman options that are available are:

- Consumer—Subjects covered include antennas and transmission lines, digital and linear circuits in consumer products, TV and VCR servicing problems, and the use of test equipment.
- Industrial—Subjects include transducers, switches, power factor, differential amplifiers, closed-loop feedback, basic logic circuits and functions, elements of numeric control, thyratrons, and SCR controls.
- Communications—This test covers two-way radio transceiver theory and servicing, receivers, transmitters, basic communications theory, deviation sensitivity, quieting, and troubleshooting.
- FCC Legal—This is a 25-question optional exam cover-

ing FCC regulations. Applicants who take the associate exam, the Communication option, and the FCC Legal exams will receive a general radio-telephone license.

- Computer—This test covers operation of computer systems with basic emphasis on hardware. Subjects covered include basic arithmetic and logic operations, computer organization, input and output equipment, and memory and storage. Some knowledge of software and programming is required, and the ability to explain troubleshooting procedure is also required.

- Audio—Products covered in this option include turntables, tape decks, compact discs, and



**TRAINING NEVER STOPS** for electronic technicians. Here Ernie Curtis, CET and other ISCET Members learn about the latest developments in digital electronics.

radios. The exam consists of both digital and analog sections, amplifiers and sound quality, system set-up, speaker installation, and troubleshooting audio systems.

● **Medical**—The priorities of this option are electrical safety and accuracy of calibration for electromedical instruments. The technician must be familiar with the basic vocabulary of medical instrumentation, telemetry, measurements, and differential and operational amplifier applications.

● **Radar**—A general knowledge of both pulsed and continuous-wave radar is necessary to take this Journeyman option. The test covers transmitters and receivers, CRT display systems and their power supplies, and antennas, transmission lines and their characteristics.

● **Video**—The rapidly growing field of video is covered by this exam. The technician needs to know NTSC standards, video basics, test signals, and the operation of both the electronic and mechanical systems in

VCR's. Also covered are 8mm video, camcorders, cameras and monitors, and the micro-processors used in video products

### Fees and difficulty

The fee for the CET exam is \$25.00, which includes both the Associate exam and any one Journeyman option, if taken in one sitting. If the Journeyman option is taken separately from the Associate exam, each test is \$25.00. Each additional Journeyman option is \$25.00. If you fail any portion, the first retake is free, after a 60-day waiting period. The fee for any additional retake is \$12.50. If you choose to take the FCC Legal exam after you have successfully completed the Communications option, there is an additional fee of \$10.00. Don't underestimate the difficulty of the CET exam. Every year only 30% of those who take a CET test pass—it is not an easy test!

The best way to prepare for this exam is to study diligently. Tab Books publishes *The CET*

*Study Guide* by Sam Wils which will help you prepare both tests. ISCET also has a tional study guides available a nominal fee.

If after reading this article you're interested in taking CET exam and joining the g ing ranks of Certified Electronics Technicians, con any one of ISCET's volun test administrators listed this article for details. exams are scheduled to be g during the week of Marc through 14, 1992. For any a tional information you m need, contact ISCET at 2 West Berry St., Fort Worth, 76109; phone 1-817-921-91

### Join the professionals

You're already competen electronics or you wouldn' reading this magazine and article. You need to gain the ognition you deserve. To dc take the CET challenge and 32,000 other electronics pr onals. Become a CET. worth the effort and you des the recognition.

## ISCET CERTIFIED ADMINISTRATORS FOR CET EXAM

David L. Bryan, CET Alabama Aviat. & Tech. Coll. PO Box 1209 Ozark, AL 36360 (205) 774-5113	H.J. Paine, CET 4631 E. 8th St. Tucson, AZ 85711 (602) 881-6784	Romualdo Malarayap, CET ITT Technical Institute 1530 W. Cameron Ave. W. Covina, CA 91706 (818) 960-8681	Dr. Kenneth L. Wilson, CET San Diego City College 1313-12th Ave. San Diego, CA 92101 (619) 230-2601	Daniel J. Shea, CET Conn. School of Electronics 586 Ella Grasso Blvd. New Haven, CT 06519 (203) 624-2121	Daniel B. Mundy, C Norman's Electroni 3653 Clairmont Rd Atlanta, GA 30341 (404) 451-5057
David L. McCann, CET 64 Steele Lane Loxley, AL 36651 (205) 343-8200	Russell Scarpelli, CET 10529 W. Dessert Forst. Crle. Sun City, AZ 85351 (602) 972-3854	David Marson, CET California Youth Authority PO Box 1245 Paso de Robles, CA 93447-1245 (805) 238-4040 Ext 428	Don Winchel, CET M & D Electronics PO Box 123 Smartville, CA 95977 (916) 639-2477	William S. Brooks, CET 7112 N. Habana Ave. Tampa, FL 33614-4365 (813) 933-1793	James Peek, CET Panasonic 4245 E International Norcross, GA 3006 (404) 717-6858
Delores Rasberry Herzing Institute 1218 South 20th St. Birmingham, AL 35205 (205) 933-8536	Silvino Alonso Calif. Business Inst. 3550 Johnson Ave. El Monte, CA 91731 (818) 444-7779	Michael R. Miller, CET California Mens Colony-West PO Box 8103-Education Dept. Slo, CA 93403-0006 (805) 543-2700 Ext 7143	John F. McMullen, CET Denver Inst. of Tech. Inc. 7350 N. Broadway Denver, CO 80221 (303) 426-1808	Edward Guary, CET Eddy's Radio & TV Service 1110 NE 4th Ave. Fl. Lauderdale, FL 33304 (305) 763-2964	W.R. Rooks, CET Shiloh Rd. Rt.6 Box 181 Americus, GA 3170 (912) 928-0283 Ex
Ricky G. Reaves, CET Shoals Comm. Coll. PO Box 2545 Muscle Shoals, AL 35662 (205) 381-2813	Billy J. Edmonds, CET 1311-16th St. Baywood, CA 93402 (805) 543-2700 Ext 7772	Peter J. Moreno, CET ITT Technical Institute 630 E. Brier Dr., #150 San Bernardino, CA 92408 (714) 889-3800	Albert Moses, CET PO Box 188 Cheswold, DE 19936 (302) 571-5402	Ronald A. Handlon, CET Nec. Bauder College 7955 NW 12 St. Miami, FL 33126 (305) 477-0251	Ebin Shepard, CET Bloomfield TV Svs 2481 Rocky Creek Macon, GA 31206 (912) 788-5281
R. T. Van Iderstine, CET Southwest State Tech. College 925 Dauphin Island Pkwy. Mobile, AL 36605 (205) 947-4441	Howard Bardach, CET The Audio Specialist 4381 Tujungua Ave. Studio City, CA 91604 (818) 763-3009	Kevin J. Price, CET NEC 825 E. Hospitality Ln. San Bernardino, CA 92408 (714) 885-3896	George W. Shaiffer, CET 38 N Dartmouth Widefield, CO 80911 (719) 392-1000	Karl A. Hunter, CET 13850 Ketch Cove Dr. Jacksonville, FL 32224-1143 (904) 633-8143	James P. Van Sant Pickens Tech. 240 Burnt Mountai Jasper, GA 30143 (404) 692-3411
Alison J. Fletcher, CET Southern Tech. College 7601 Scott Hamilton Little Rock, AR 72209 (501) 565-7000	John V. Craig, CET 531 W. Hueneeme Rd. Oxnard, CA 93033 (805) 982-5228	Parviz Shams Southern Calif. Inst. of Tech. 10600 Katella Ave. Anaheim, CA 92804 (714) 520-5552	John F. Stackhouse, CET ITT 2121 South Blackhawk Aurora, CO 80014 (303) 695-1913	John Steven Richards, CET ITT Technical Institute 2600 Lake Lucien Dr., #140 Maitland, FL 32751 (407) 660-2900	Mei Streeter Lewis Clark St. col 8th Ave. at 6th St. Lewiston, ID 83501 (208) 799-2255
Dennis P. Blum, CET Phoenix Inst. of Tech. 2555 E. University Dr. Phoenix, AZ 85034 (602) 244-8111	Max B. Free California Med. Facility 2100 Peabody Rd. Vacaville, CA 95696-4000 (707) 448-6841 Ext 3355	Fredrick J. Smith, CET Ed. Dept. Calif. Mens Clin. PO Box 8101 San Luis Obispo, CA 93409-0003 (805) 772-2009	Anthony R. Valdez, CET 1919 Rolling Hill Rd. Cortex, CO 81321 (303) 565-8457	J.J. Villademoros, CET ITT Technical Institute 5225 Memorial Highway Tampa, FL 33634-7350 (813) 885-2244	Douglas E. Minter, American College 1300 W. Washingto Bloomington, IL 61 (309) 828-5151
Frank Grabiec, CET Dyna-tronics 1704 E. Claremont Phoenix, AZ 85016 (602) 279-3791	Robert A. Johnson, CET Ameritech Colleges 4600 Ashe Rd., #313 Bakersfield, CA 93313 (805) 835-9225	Phillip G. Stephens Matsushita Reg. Tech. Center 6550 Katella Ave. Cypress, CA 90630 (714) 895-7435	John E. DePalma, CET Conn. School of Electronics 586 Ella Grasso Blvd. New Haven, CT 06519 (203) 624-2121	Roy Chastain, CET N.G.T.I. 197 N. Box 65 Clarkesville, GA 30523-0065 (404) 754-7751 Ext. 334	F.A. Schwarzkopf, Triton College, Rm 2000 Fifth Ave. River Grove, IL 60 (312) 767-4126

Today's top-paying programming jobs go to those skilled in both C++ and Windows

# NRI's new training in Programming in C++ with Windows lets you combine two of today's hottest programming skills into one great new career!

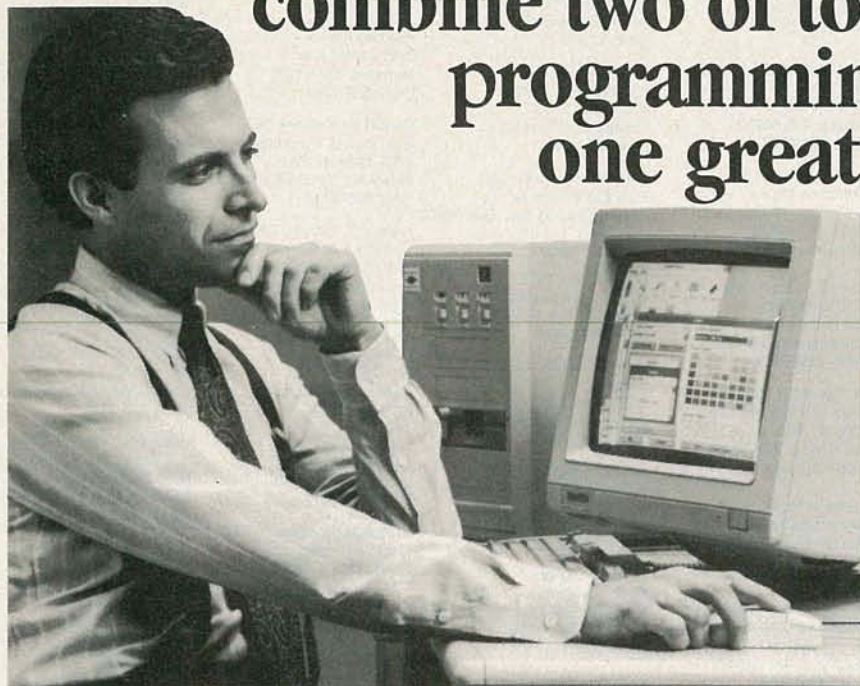

Like never before, organizations everywhere are paying top dollar for PC programmers who can combine the power of object-oriented C++ with the new freedom and ease of Windows to create in-demand software for business, industry, or consumer applications.

Pick up the classified section in any major newspaper and you'll see: C++ programming and the ability to create PC programs for a Windows environment top the list of job skills today's employers demand.

Now you can take advantage of today's hottest programming opportunities with NRI's new at-home training — Programming in C++ with Windows. It's the right training at the right time. And the only training that gives you everything you need to succeed today on the job, in a new career, or in a full- or part-time programming business of your own.

## Get hands-on training with a 386sx-based mini-tower computer system

NRI knows: To program in C++ and create Windows applications, you need to work with a state-of-the-art computer system. That's why NRI gives you hands-on experience with a 386sx-based mini-tower computer — yours to train with and keep! Only a computer this powerful and fast would do. Best of all, your computer system comes complete

Get practical experience with a powerful 386sx-based computer, VGA color monitor, 3 meg RAM, 40 meg IDE hard drive, enhanced keyboard and mouse, and professional software ... all yours to train with and keep!

with VGA color monitor, enhanced keyboard and mouse, 40 meg IDE hard drive, and three full megabytes of RAM.

This outstanding computer system gives you the memory, speed, and power you need to take advantage of all the features of your C++ compiler and Windows software ... and develop the kind of quality software programs today's employers and consumers demand. But hardware is just part of what makes NRI training so good ...

## Master object-oriented programming using Borland Turbo C++<sup>®</sup>

With NRI you learn at home, at a comfortable pace. NRI's Discovery Learning Method takes you step-by-step from computer basics to advanced programming in C++, today's hottest object-oriented programming language. As you

work with the top-rated Borland Turbo C++ compiler included in your course, you master object-oriented programming methods — gaining the practical experience and design expertise that will save you time and make future programming fast and easy.

You discover for yourself how this in-demand language allows you the freedom to write real-world applications that rival software produced by top-paid design teams — from stand-alone graphics and word processing packages to spreadsheets, text editors, database managers, and more! But that's still not all...

## Learn to program for the exciting visual environment of Microsoft<sup>®</sup> Windows<sup>™</sup>

With NRI training you take command of today's newest design techniques as you master programming skills for Windows — using both C++ and the built-in functions and routines of your Microsoft Windows software.

As you actually build your own software application, you develop hands-on experience with Windows' easy-to-use features — including graphics, memory management, multitasking, data exchange, and more!

Soon you're ready to use your computer and know-how to create fast, functional programs — complete with on-screen graphics, custom cursors, images, icons, and all the other Windows features you need to build high-performance software that meets today's competitive business needs.

## Send for your FREE NRI catalog today!

Discover how NRI can give you the computer know-how you need for success. If the coupon is missing, write to NRI Schools, McGraw-Hill Continuing Education Center, 4401 Connecticut Avenue, NW, Washington, DC 20008.

## SEND COUPON TODAY FOR FREE NRI CATALOG!

**NRI** Schools

McGraw-Hill Continuing Education Center  
4401 Connecticut Avenue, NW, Washington, DC 20008



Yes! Send me the FREE catalog I've checked and show me how NRI can give me the state-of-the-art computer training I need for advancement, extra income, or a business of my own!

Check one FREE catalog only

PROGRAMMING IN C++ WITH WINDOWS

PC Troubleshooter

PC Applications Specialist

Other computer career training:

Computer Programming

Desktop Publishing and Design

Bookkeeping and Accounting

Name \_\_\_\_\_ Age \_\_\_\_\_

Address \_\_\_\_\_

City \_\_\_\_\_ State \_\_\_\_\_ Zip \_\_\_\_\_

Accredited Member, National Home Study Council

5415-032



- George Sopocko, CET  
The Radio TV Lab  
5631 W Irving Park Rd.  
Chicago, IL 60634  
(312) 545-3622
- Paul K. Tan, CET  
155 Augusta St.  
Oak Park, IL 60302-1678  
(312) 848-6327
- Frank Teskey, CET  
F.J. Teskey Enterprises  
3094 Lafayette Rd.  
Indianapolis, IN 46222  
(317) 926-2639
- Leonard E. Bowdre, CET  
15 SE Thornton Ave.  
Des Moines, IA 50315  
(515) 964-6484
- James E. Boyer, CET  
Western Ia. Tech. Comm. Coll.  
4647 Stone Ave.  
Sioux City, IA 51102  
(712) 274-6279
- Donnin G. Custer, CET  
West Ia. Tech. Comm. College  
PO Box 265-4647 Stone Ave.  
Sioux City, IA 51102-0265  
(712) 274-6279
- Michael L. Baughman, CET  
KS City Area Vo. Tech.  
2220 N 59th St.  
Kansas City, KS 66104  
(913) 334-1000 Ext 48
- Stanley Creitz, CET  
NCK Area Vocat. Tech.  
PO Box 507, West Campus D  
Beloit, KS 67420  
(913) 738-2279
- Dr. G.W. Ko, CET  
550 N. Fountain  
Wichita, KS 67208  
(316) 686-4864
- John E. Krier, CET  
1606 Timothy  
Wichita, KS 67212-3812  
(316) 722-4041
- Michael Dixon, CET  
Somerset Vo. Tech. School  
714 Airport Rd.  
Somerset, KY 42501  
(606) 679-4303
- Sanford N. Dotson, CET  
Lexington Elect. Tech.  
3340 Holwyn Rd.  
Lexington, KY 40503  
(606) 223-9608
- Edward J. Kimmel, CET  
Kimmel Electronics  
2061 Eastern Parkway  
Louisville, KY 40204  
(502) 451-3457
- Jerry D. Middleton, CET  
2906 New Haven Ct.  
Flatwoods, KY 41139  
(606) 836-4736
- Edward M. Ondo, CET  
Cumberland Vally Health Cntr.  
PO Box 187  
Pineville, KY 40977  
(606) 337-3094
- Jack B. Sellards, CET  
Jack's TV & Appliances  
509 Knox St.  
Barbourville, KY 40906  
(606) 546-5224
- Lamarr W. Ritchie, CET  
Hazard State Vo-Tech. School  
101 Vo-Tech  
Hazard, KY 41701  
(606) 436-3101
- Dr. I.F. Creel, CET  
Sullivan Tech. Inst.  
1710 Sullivan Dr.  
Bogalusa, LA 70427  
(504) 732-6640
- W.H. Hartzfeldt, CET  
Delta-Quachita Vo. Tech.  
609 Vocational Pkwy.  
W. Monroe, LA 71291  
(318) 396-7431
- M.G. McCann Jr., CET  
McCann Electronics  
100 Division St.  
Metairie, LA 70001  
(504) 837-7272
- James R. Sorrels, CET/CSM  
110 Oakridge Dr.  
Shreveport, LA 71106-7113  
(318) 686-4637
- Gordon L. Burgess, CET  
Gard Northern Paper Div.  
Main St.  
E. Millinocket, ME 04430  
(207) 746-9912 Ext. 1300
- Carl F. Miller, CET  
5114 Baltimore Ave.  
Hyattsville, MD 20781  
(301) 864-5750
- Earl Tickler, CET  
Rets. Tech. Trng. Center  
1520 S. Caton Ave.  
Baltimore, MD 21227  
(301) 644-6400
- Robert A. Cluffetti, CET  
444 Fairmount St.  
Fitchburg, MA 01420  
(508) 834-2052
- Frank Serra, CET  
Serra's TV Video  
1686 Massachusetts Ave.  
Cambridge, MA 02138  
(617) 492-2667
- Bob Bellers, CET  
Washtenaw Comm. College  
4800 E Huron River Dr.  
Ann Arbor, MI 48106  
(313) 973-3316
- John P. Borris, CET  
St. Clair Cnty Comm. College  
323 Erie St.  
Port Huron, MI 48060  
(313) 984-3881 Ext 305
- Dr. Joel Goldberg, CET  
Macomb Community College  
14500 12 Mile Rd.  
Warren, MI 48093  
(313) 445-7373
- Gerald H. Heyn, CET  
55 E. Jackpine St., Lot 113  
Gwinn, MI 49841  
(906) 346-6396
- E. Eugene Ranta, CET  
Macomb Comm. College  
14500 Twelve Mile Rd.  
Warren, MI 48093  
(313) 445-7343
- Willard Rush, CET  
Oakland College  
3361 Aspen-6304  
Orion, MI 48359  
(313) 333-2531
- John Baldwin, CET  
Faribault Campus  
1225 SW 3rd St.  
Faribault, MN 55021  
(504) 334-3965 Ext 129
- Larry Geissler, CET  
3706 Chambersburg  
Duluth MN 55811  
(218) 722-9356
- Steven M. Brumfield, CET  
Southern Technical College  
2305 Lakeland Dr.  
Jackson, MS 39208  
(601) 932-7809
- Marion B. Denny Jr., CET  
Audio-Video Service  
1405 Corinne St.  
Hattiesburg, MS 39401  
(601) 545-7606
- James D. Everett, CET  
Platte County Avt. School  
PO Box 1700  
Platte City, MO 64079  
(816) 329-4646
- Annabel L. Gooch  
Davis Hart Mavts.  
905 N. Wade St.  
Mexico, MO 65265  
(314) 581-5684
- Gregory J. Nesbo, CET  
440 1st Ave.  
Havre, MT 59501  
(406) 265-8459
- Jack Hopson, CET  
First Television Service  
5214 Center  
Omaha, NE 68106  
(402) 551-4868
- James Belanger, CET  
Beltronics Inc.  
19 Proctor Hill Rd., Box 330  
Hollis, NH 03049  
(603) 465-2422
- Joseph T. Szumowski, CET  
JTS Electronics  
412 Pomona Rd.  
Cinnaminson, NJ 08077  
(609) 829-9669
- Dr. Ronald P. Hartman  
Tech. Training Institute  
1320 S. Solano  
Las Cruces, NM 88001  
(505) 522-6533
- Anthony Abram, CET  
Bryan Stratton elect. tech.  
1028 Main St.  
Buffalo, NY 14202  
(716) 884-9120
- Joseph A. Passaretti, CET  
Pyramid Electronics Ltd.  
353 E 76th St.  
New York, NY 10021  
(212) 628-6500
- Larry Steckler,EHF/CET  
Radio Electronics Magazine  
500 B Bi-county Blvd.  
Farmingdale, NY 11735  
(516) 293-3000
- Fred H. Freeman Jr.  
Reynolds Elect. & Engrn. Co.  
PO Box 98521  
Las Vegas, NV 89193-8521  
(702) 295-1915
- Linda Dickinson  
Craven Community College  
PO Box 952  
Havelock, NC 28532  
(919) 447-1141
- William H. Mast, CET  
Appalachian State Univ.  
Dept. of Ind. Ed. & Tech.  
Boone, NC 28607  
(704) 262-6352
- Melvin E. Talbert, CET  
Heilig Meyer Service Co.  
PO Box 64189-2858, Owen Dr.  
Fayetteville, NC 28306-0189  
(919) 483-0801
- Lloyd G. Chale, CET  
301-3rd St. East  
Fargo, ND 58078  
(701) 282-0430 Ext 220
- Lawrence M. Delonais, CET  
National Education Center  
1660 Martin Rd.  
Mogadore, OH 44260  
(216) 628-3115 Ext. 19
- A.C.Falcione, CET  
Falcon Electronics, Inc.  
3266 Kent Rd.  
Stow, OH 44224  
(216) 688-2451
- Andrew M. Flock, CET  
Hickok Tech. Institute  
5100 Pearl Rd.  
Cleveland, OH 44129-1240  
(216) 351-4600
- David J. Garwacki, CET  
Sales & Service  
4846 Oak Glen Dr.  
Toledo, OH 43613-3048  
(419) 475-9221
- J.R. Manchester, CET  
University of Akron  
PO Box 61, Buckingham Center  
Akron, OH 44309  
(216) 972-7575
- Bary G. Rathbun, CET  
ETI Technical College  
4300 Euclid Ave.  
Cleveland, OH 44103  
(216) 431-4300
- Rod Schlingerman, CET  
PVS Electronics Inc.  
3949 Cleveland Ave., Box 24400  
Columbus, OH 43224  
(614) 471-9010
- Donald Sisk, CET  
1650 Cobble Gate Ln.  
Reynoldsburg, OH 43068  
(614) 866-5667
- John E. Valerio, CET  
Sencore  
612 Lovers Lane  
Stuebenville, OH 43952  
(614) 264-3001
- J.S. Glosemeyer, CET  
East Okla. County Vo. Tech.  
4601 N. Choctaw Rd.  
Choctaw, OK 73020  
(405) 390-9591
- Dr. Bess Jenkins  
Redlands Comm. College  
Box 370-1300 Country Club Rd.  
El Reno, OK 73036  
(405) 262-2552
- Hubert L. Wood  
College of Americas of Tulsa  
2514 East 71st St.  
Tulsa, OK 74136  
(918) 496-8324
- Roy W. Yonce  
Tec-Ed Corporation  
PO Box 470992  
Tulsa, OK 74147  
(918) 663-9500
- George W. Day, CET  
Douglas Education Svc. Dept.  
1871 NE Stephens St.  
Roseburg, OR 97470  
(503) 440-4774
- William H. Manny, CET  
Round-Up Electronics Inc.  
2927 Riverside  
Pendleton, OR 97801  
(503) 276-3152
- John F. Grzesiak, CET  
27 Lighthouse St.  
Erie, PA 16507-1937  
(814) 459-2519
- Gene Hedgepeth, CET  
Technics Service Labs.  
RD 4-639 E. Alberdeen Rd.  
Mountaintop, PA 18707  
(717) 868-6566
- L.A. Leibensperger, CET  
Lincoln Tech. Institute  
5151 Tilghman St.  
Allentown, PA 18104  
(215) 398-5300
- Thomas Plant, CET  
ETG of Rhode Island  
29 Dean St.  
Pawtucket, RI 02861  
(401) 723-3500 Ext. 333
- Stanley A. Salter, CET  
826 Bat Blossom  
Sumter, SC 29150  
(803) 469-3022
- Donald Haag, CET  
RR 3, Box 92  
Watertown, SD 57201  
(605) 886-8932
- Charles Daugherty, CET  
Electronic Service Center  
166 First St. NE  
Cleveland, TN 37311  
(615) 472-0359
- Ross Hutcherson, CET  
781 Iron Workers Rd.  
Clarksville, TN 37043-7911  
(615) 368-9440
- Herman Patrick  
3715 Lamar Ave.  
Memphis, TN 38118  
(901) 362-8368
- Ronald R. Rackley, CET  
Tenn Inst. of Electronics  
3203 Tazewell Pike  
Knoxville, TN 37918-2530  
(615) 368-9422
- William S. Warren, CET/CSM  
Warren's Audio-Video Service  
2540 Sutherland Ave.  
Knoxville, TN 37919  
(615) 546-1121
- Earl W. Hines, CET  
Star Rt. 1 Box 1-A  
1710 Lamar  
Sweetwater, TX 79556  
(915) 235-1849
- Loren R. Hodge  
3614-28th St.  
Lubbock, TX 79410  
(806) 795-8617
- Joseph H. Hudson Jr., CET  
1500 Yarborough Dr.  
Sherman, TX 75090-5545  
(214) 892-9356
- ISCET  
2708 West Berry St.  
Fort Worth, TX 76109  
(817) 921-9101
- Charles W. Kelley, CET  
7805 Estates Way  
Rowlett, TX 75088  
(214) 475-4406
- Gerald Martin, CET  
3347 Falcon Grove  
San Antonio, TX 78247  
(512) 496-1134
- J.W. (Dub) Newson, CET  
Advanced Electronics, Inc.  
1310 19th St.  
Lubbock, TX 79401  
(806) 763-8246
- Arthur J. Ruppert, CET  
30217 St. Andrews  
Georgetown, TX 78628  
(512) 495-1679
- Elizabeth Sheets  
American Commercial College  
2007 34th St.  
Lubbock, TX 79411  
(806) 747-4339
- Frank Sosolik Jr., CET  
T.S.T.I. Servicing Dept.  
Box 154454  
Waco, TX 76715  
(817) 867-4883
- Thomas C. Underwood, CET  
Sony Service Company  
3201 Premier, #100  
Irving, TX 75063  
(214) 550-5266
- Leonard M. Cowherd, CET  
Piedmont Tech. Ed. Center  
PO Box 999  
Culpeper, VA 22701  
(703) 825-0476
- Russell R. Offhaus, CET  
PO Box 1116  
Chincoteague, VA 23336  
(804) 336-5980
- Jame Richerson, CET  
Blue Ridge Comm. Colle  
Box 80  
Weyers Cave, VA 24486  
(703) 885-5960 Ext 276
- Jim Teeters, CET  
2937 E. Malden Ave.  
Norfolk, VA 23518  
(804) 428-5772
- Cary D. Thomas Jr., CET  
2209 Eastover Dr.  
S Boston, VA 24592  
(804) 572-6474
- M.B. Hixenbaugh, CET  
B N H Service  
3635 S. Lawrence  
Tacoma, WA 98409  
(206) 475-8861
- Leonard Laabs, CET  
Walla Walla College  
204 S. College Ave.  
College Place, WA 9932  
(509) 527-2712
- Carl E. McDonald, CET  
Sun Tech  
417 S 6th  
Sunnyside, WA 98944  
(509) 837-8800
- Arthur B. Mitchell, CET  
922 N. 97th St.  
Seattle, WA 98103-3210  
(206) 525-8331
- Ralph E. Oscanor, CET  
ITT Technical Institute  
N. 1050 Argonne Rd.  
Spokane, WA 99212  
(509) 926-2900
- Cecil C. Poe, CET  
1012 McClain Dr.  
Sunnyside, WA 98944-1  
(509) 839-3995
- Ted Rodriguez, CET  
Skagit Valley College  
2405 College Way  
Mt. Vernon, WA 98273  
(206) 428-1248
- James C. Shambow, CE  
ITT Technical Institute  
12720 Gateway Dr., Suit  
Seattle, WA 98168-3333  
(206) 244-3300
- Duane Busby, CET  
Motorla Computer Syste  
2027 Sherman Ave.  
Madison, WI 53704  
(608) 244-0339
- Larry Geissler, CET  
Indian head Tech. Colle  
600 N. 21st St.  
Superior, WI 54880  
(715) 394-6677 Ext. 275
- Jacob Klein, CET  
Northcentral Tech. Colle  
1000 Campus Ave.  
Wausau, WI 54401  
(715) 675-3331 Ext. 265
- David E. Nida  
National Education Cen  
5514 Big Tylor Rd.  
Cross Lanes, WV 2531  
(304) 776-6290 Ext. 24
- W. Clem Small  
RT 1, Box 64-1  
Weybridge, VT 05753  
(802) 545-2141
- Robert Ing, CET  
Atropos Telecom  
PO Box 378 Postal Sta  
Toronto, Ontario,  
Canada M4A-2N9  
(416) 580-7508
- Antonio M. Avellanosa  
MPTITI  
YMCA Building  
Baguio City, Philippines  
Phone# 442-6532

# Take Any 3 PROFESSIONAL BOOKS for only \$9.95

when you join the **ELECTRONICS ENGINEERS' BOOK CLUB**

values to \$121.40



9255 \$97.50  
Counts as 3



8225P \$19.95

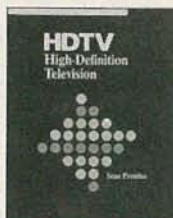

3272 \$24.95



9832 \$36.95



003957-7 \$49.95  
Counts as 2



3557 \$29.95

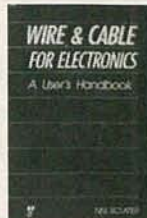

3787 \$29.95



3279 \$36.95  
Counts as 2



3205 \$24.95



9340 \$44.95  
Counts as 2



3212 \$34.95

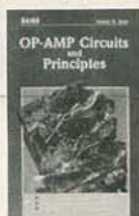

9401P \$19.95



3138 \$60.00  
Counts as 2



2672 \$49.50



033559-1 \$29.95



3102 \$49.95  
Counts as 2



9244P \$18.95



3365 \$34.95



2962P \$17.95

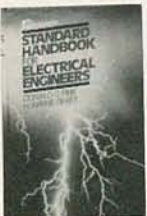

020975-8 \$99.50  
Counts as 3



3199 \$52.00  
Counts as 2



3321P \$16.95



9354 \$39.95  
Counts as 2



3710 \$32.95



071231-X \$54.95  
Counts as 2



3540 \$26.95

## How the Club Works

**YOUR BENEFITS:** You get 3 books for \$9.95 plus shipping and handling when you join. You keep on saving with discounts of up to 50% off as a member.

**YOUR PROFESSIONAL BOOKSTORE BY MAIL:** Every 3-4 weeks, you will receive the Electronics Engineers' Book Club News describing the Main Selection and Alternates, as well as bonus offers and special sales, with scores of titles to choose from.

**AUTOMATIC ORDER:** If you want the Main Selection, do nothing and it will be sent to you automatically. If you prefer another selection, or no selection at all, simply indicate your choice on the reply form provided. You will have at least 10 days to decide. As a member, you agree to purchase at least 3 books within the next 2 years and may resign at any time thereafter.

**BONUS BOOKS:** Starting immediately, you will be eligible for our *Bonus Book Plan*, with savings of up to 80% off publishers' prices.

**IRONCLAD NO-RISK GUARANTEE:** If not satisfied with your books, return them within 10 days without obligation!

**EXCEPTIONAL QUALITY:** All books are quality publishers' editions especially selected by our Editorial Board. (Publishers' Prices Shown)

The Electronics Engineers and Designers Book Club and the Electronics and Control Engineers' Book Club have joined forces to bring you all the best titles from the most prominent electronics publishers.

## ELECTRONICS ENGINEERS' BOOK CLUB

Blue Ridge Summit, PA 17294-0860

**YES!** Please accept my membership in the ELECTRONICS ENGINEER'S BOOK CLUB and send the 3 volumes listed below, billing me \$9.95. If not satisfied, I may return the books within ten days without obligation and have my membership cancelled. I agree to purchase at least 3 books at regular Club Prices during the next 2 years, and may resign any time thereafter. A shipping/handling charge and sales tax will be added to all orders.

\_\_\_\_\_

Name \_\_\_\_\_

Address \_\_\_\_\_

City \_\_\_\_\_

State \_\_\_\_\_ Zip \_\_\_\_\_ Phone \_\_\_\_\_

Valid for new members only. Foreign applicants will receive special ordering instructions. Canada must remit in U.S. currency. This order subject to acceptance by the Electronics Engineers' Book Club. RPIF392

## EQUIPMENT REPORTS

### Dallas Semiconductor Touch Memory Starter Kit

*The electronic equivalent of the Post-It note.*



CIRCLE 10 ON FREE INFORMATION CARD

People were once naive enough to believe that computers and other office-automation equipment would bring about the "paperless office." We haven't heard anyone suggest such a thing for some time, but Dallas Semiconductor (4401 South Beltwood Parkway, Dallas, TX 75244) might have come up with a way to replace a good deal of paper with silicon chips. Their DS199x *Touch Memory* devices are non-volatile memory packaged in a button-shaped can. They can be read or written with a momentary contact. We recently had the opportunity to examine the devices and see how they work, using Dallas Semiconductor's *DS9092K Touch Memory Starter Kit*.

Touch Memory is available in two main configurations: One is ROM only, the other is a combination of ROM and battery-backed RAM. The ROM-only device would be used primarily for electronic identification. If attached to an employee ID badge, for example, it could be used to permit access to secure areas of a building. The ROM/RAM device could be used for a good deal more. In manufacturing, for instance a Touch Memory could be attached to the device being manufactured. It could contain proper calibration settings for the assembly technician to read. The technician could then input the results of the calibration tests into the Touch

Memory, along with his identification and a date stamp.

The potential applications aren't limited to electronics and manufacturing. Imagine if your checked airline baggage was identified by a small Touch Memory tag that not only contained your destination, but your name, address, flight itinerary, and the name of each baggage handler who handled your luggage—including the one who put your bags on the flight to Bogata instead of Boston.

The Touch Memory Starter Kit is a good way to get a feel for what Touch products can do. It includes five assorted Touch Memories, a Touch Memory probe (for reading and writing the devices) an adapter that lets you attach the probe to the serial port of a PC, and a floppy disk that contains the interface software.

Three of the five included Touch Memory devices are DS1990 "Touch Serial Numbers." They contain a 64-bit ROM into which is written an 8-bit family code, a 48-bit serial number, and an 8-bit CRC (cyclical redundancy check). One of the devices is mounted to a key fob, while the other two are mounted on a "peel and stick" sheet. Two DS1991 touch memories are also provided. They contain 3 384-bit blocks of non-volatile RAM and a 64-bit ROM.

The probe included with the evaluation kit is strictly for evaluation—it's not packaged with any

handle or base, and instead, has a probe on the end of a pair of wires. The other end of the wire is terminated with a RJ-11 modular telephone jack. That, in turn, plugs into an adapter that converts the RJ-11 jack to a pin D-type connector for a PC serial port, as well as converting the computer's RS-232 interface into a single, bi-directional data line.

The probe doesn't have to be held good to get across its strong point, however. Most important, it's very forgiving of how it's positioned on the memory. One of the reasons the memory is packaged in a round "MicroCan" is because the curved edges can guide the probe for self-alignment. The one-wire data transfer is what helps to make the Touch Memory rugged. The top of the device is the data connection, while the edge and bottom is ground. Data is transferred at speeds up to 100 kilobits per second, which seems instantaneous for small memories.

Even with fast data rates, it's likely that a momentary contact will be interrupted before a data transfer is complete. However, the Touch Memory uses two verification techniques to ensure data integrity. First, data is written to a scratchpad memory and verified before it is transferred to memory. If the connection is broken early, the scratchpad contents won't be transferred to the main memory, so the integrity of the previous memory is maintained. A CRC check is also performed on data.

The non-volatile memory will last for five or ten years—the life of the built-in lithium battery. The stainless-steel case is resistant to corrosion from moisture, acid, and plain old dirt.

From what we've seen of this self-stick data carrier, we think that we may be seeing fewer bar codes and a bit less paper. If you'd like to get an idea of how they work, the Touch Memory Starter Kit is available for \$75.

# ONCE YOU'VE GOT IT DESIGNED, YOU'VE GOT IT MADE.

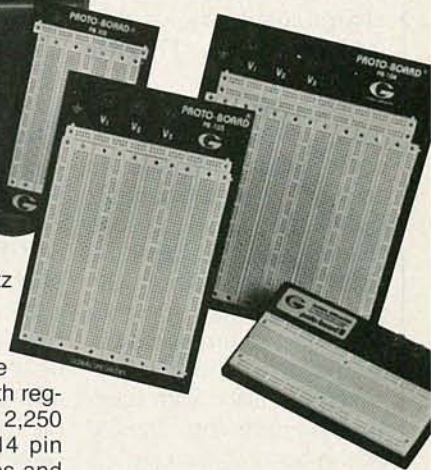
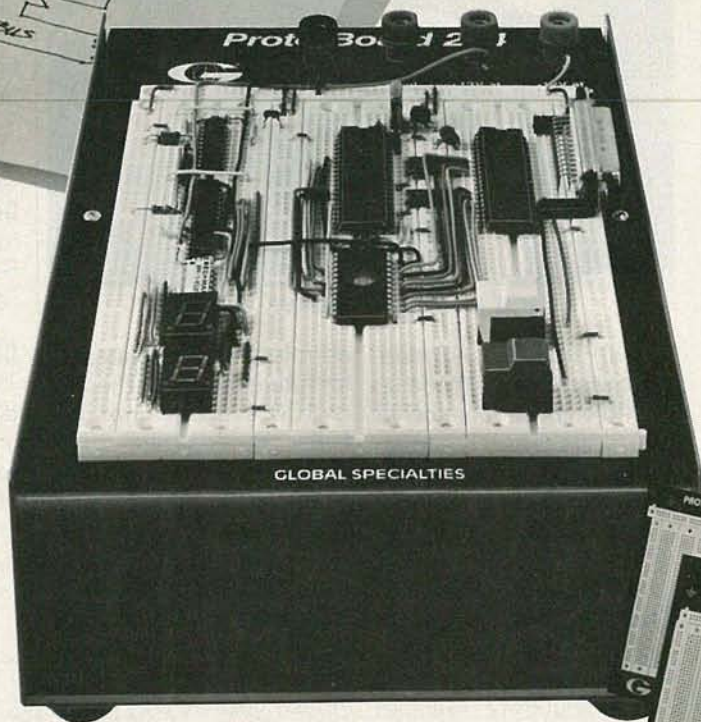
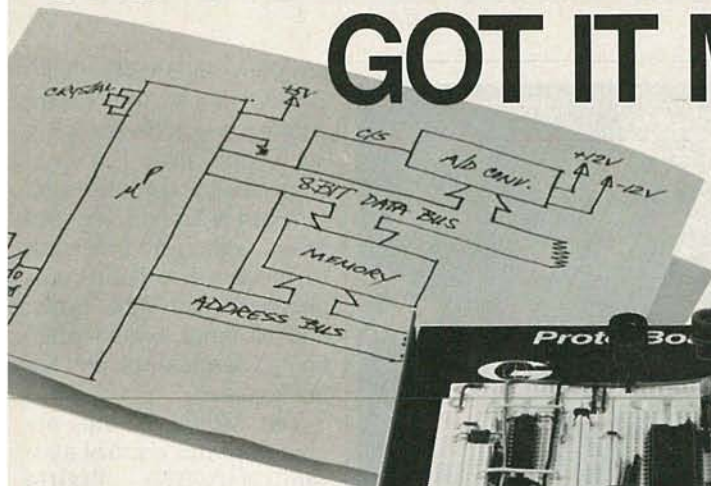

Now you can take those hot, new logic or block design diagrams, and quickly, easily bring them up to reality...in minutes...without solder!

Build circuits as fast as you can think. Test. Modify. Expand. Without burned-out parts or burnt fingers. Save time, money...and prove that you know that you're talking about... before you use your CAD.

Specify PROTO BOARD Brand. Today's recognized Standard for Quality in breadboarding. Here are five expandable breadboards, offering countless arrays of solderless sockets and bus strips that emulate pc board layouts. Pop in components. Pop them out again. Microprocessors. Memory. Large DIPs. Tiny discretes. Makes no difference. The patented aluminum backplane lets you work at

frequencies from DC to half-a-GigaHertz or 500MHz.

**Need power?** A powered PROTO BOARD Brand offers up to triple voltage power supplies, +5V, +12V, -12V, with regulated/current limited DC power. Over 2,250 tie points with 24 IC capacity and 14 pin DIPs. Super for TTL, CMOS, Op-Amps and microprocessor circuits. And lots more.

Best of all, your hassle-free American-made PROTO BOARD Brand comes with an unlimited lifetime guarantee on all the breadboard sockets. Prices are so modest, you'll wonder why you waited this long to specify PROTO BOARD Brand. Order today.



**GLOBAL  
SPECIALTIES**

*Easy does it!*<sup>TM</sup>



Call toll-free for details  
**1-800-572-1028**

Global Specialties. An Interplex Electronics Company.  
70 Fulton Terrace. New Haven, CT 06512.  
Telephone: (203) 624-3103. © Interplex Electronics 1989.  
All Global Specialties breadboarding products made in USA

CIRCLE 186 ON FREE INFORMATION CARD

A0010

# NEW PRODUCTS

Use the Free Information Card for more details on these products.

## HANDHELD DIGITIZING SCOPE.

According to Tektronix, its *Model 224* 60-MHz handheld digital oscilloscope is the fastest in the industry. It allows electronic service technicians to troubleshoot high-speed TTL circuits with a battery-operated unit, avionics technicians to get the power of a digitizing scope in the cockpit, and military-maintenance personnel to perform accurate equipment servicing in remote land or under-sea operations. The *224's* TV triggering capabilities allow video repairmen to monitor and troubleshoot a wide range of imaging systems. The unit weighs just 4.4 pounds, and two rechargeable batteries provide three hours of reliable operation.

The *224's* dual-channel design allows input-to-output comparisons and its unique "Isolated Channel" architecture, in which each channel is isolated from the other channel and from earth ground, makes truly safe floating measurements (as opposed to other handhelds that claim safe floating measurements simply on the basis of their plastic



CIRCLE 16 ON FREE INFORMATION CARD

cases). True floating measurements can be made up to 400 volts per channel or 800 volts peak-to-peak, without risk to the operator or to the device under test.

Like the other members of Tektronix's popular 222 family of portable digitizing oscilloscopes, the *224* features a clear, bright CRT display; ease of use; and PC compatibility. AutoSet and Autolevel Trigger allow effortless acquisition and display of signals. Up to four front-panel setups can be defined and stored in memory, then recalled at the touch of a button. Four waveforms can be stored

as reference templates or for future analysis. The *224* is 100% programmable from the RS232C port. When linked by modem, the *224* can be controlled remotely from a PC equipped with Tek's Virtual Instrument Software (CAT200). The scope's controls can be manipulated at the keyboard or mouse, just as they would be handled manually on the instrument.

The *224* handheld digitizing scope costs \$2750.—**Tektronix, Inc.**, Test & Measurement Group, P.O. Box 1520, Pittsfield, MA 01202; Phone: 1-800-426-2200.

## DATA-ACQUISITION AND CONTROL SYSTEM FOR PC'S.

Claimed to be the lowest-priced general-purpose data-acquisition and control system for personal computers, Prairie Digital's *Model 30* is available for XT's, AT's, 386's, and PS/2 model 30's. The system's printed-circuit board

plugs into the PC's expansion bus and occupies a 1/4 slot. The unit includes

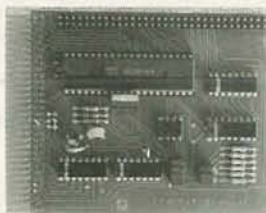

CIRCLE 17 ON FREE INFORMATION CARD

24 lines of programmable digital input/output; an 8-channel, 8-bit A/D converter; and a 12-bit CMOS counter. (An 8-channel, 30-volt, 0.5-amp driver is available for an additional \$5.) The system communicates with the PC via four I/O memory locations and is easily interfaced to all popular languages. Sample

programs in BASIC, C, BASIC, and Assembly language are included on a 5.25-inch floppy disk. The data acquisition and control system can be used to control relays, lights, and motors to measure temperature, pressure, and light level, and to input switch positions, thermostats, and other signals.

The *Model 30* data acquisition and control system costs \$79.—**Prairie Digital, Inc.**, 846 Seventh Street, Prairie Sac, WI 53578; Phone: 608-643-8599.

## DIGITAL CLAMP-ON METER.

The *ACD-11* autoranging digital clamp-on meter directly measures AC current, voltage, and resistance. Measurements shown on a large, easy-read, 1/2-inch display. Current range is indicated by



CIRCLE 18 ON FREE INFORMATION CARD

letters "O.L." appear on the display. The instrument features circuit protection to 550 volts and a low-battery indicator. It



a maximum jaw opening of 2.14 inches. The ACD-11 meter comes with a wrist strap, a removable belt clip, a 9V battery, safety test leads, a carrying case, and instructions.

The ACD-11 clamp-on volt/amp/ohmmeter has a list price of \$119.95.—

**Amprobe Instruments**, 630 Merrick Road, P.O. Box 329, Lynbrook, NY 11563; Phone: 615-593-5600; Fax: 516-593-5682.

**MONOLITHIC OP-AMP.** With a unity gain bandwidth of 140 MHz, Analog Devices' AD811 is the industry's fastest monolithic operational amplifier operating from a  $\pm 15V$  supply. Video specifications such as gain flatness, which ensures broadcast-quality signal transmission, and differential gain and phase, which

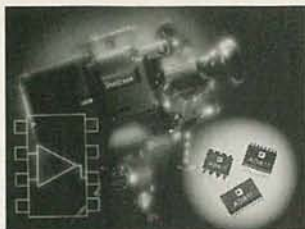

CIRCLE 19 ON FREE INFORMATION CARD

are critical for video cameras, multimedia systems, and special-effects units, are optimized. The AD811's output is capable of driving two back-terminated 75-ohm cables, making the device well-suited as a line driver in video routers or distribution amplifiers. The AD811 current feedback amplifier meets stringent HDTV video specifications, and offers the transient response characteristics needed for high-speed pulsed applications such as infrared imaging

and digital oscilloscopes. When used as a buffer for analog-to-digital or digital-to-analog converters, the AD811 offers low distortion and, as a result of the current feedback design, a wide bandwidth over a large range of gains. The amplifier operates from power supplies ranging from  $\pm 4.5V$  to  $\pm 18V$ , with a minimum output drive current of 100 mA. The video-speed op-amp is available specified over the industrial ( $-40^{\circ}C$  to  $+85^{\circ}C$ ) and military ( $-55^{\circ}C$  to  $+125^{\circ}C$ ) temperature ranges. Package options include an 8-pin plastic DIP, 16- and 20-pin SOIC, 8-pin Cerdip, or 20-pin LCC.

Specified over the industrial temperature range and packaged in an 8-pin plastic DIP, the AD811 costs \$3.35 in hundreds or \$2.85

in thousands.—**Analog Devices**, Literature Center, 70 Shawmut Road, Canton, MA 02021; Fax: 617-821-4273 (for applications assistance, contact Jay Cormier, Analog Devices, Inc., 804 Woburn Street, Wilmington, MA 01887; Phone: 617-937-2507).

**SMT PICK-AND-PLACE SYSTEM.** Designed for prototyping or low-volume production of surface-mount boards, O.K. Industries' SMT-880 Series Manual Pick and Place System provides up to three times greater throughput with substantially improved accuracy over hand placement. The operator chooses a component from the loose-component carousel or the stick or tape feeders, picks

# Train at HOME to be an Electronics Technician!

As the demand for computers and microprocessors in business, manufacturing and communications continues to grow, so does the need for qualified technicians. It's not unusual for experienced technicians to earn from \$30,000 to more than \$40,000 a year.\* Now through Peoples College of Independent Studies you can train for this exciting field without interrupting your job or home life.

## Choose From Five Programs of Study

- Electronics & Microprocessor Technology
- Industrial Electronics & Microprocessor Technology
- Communications Electronics with Microprocessor Technology
- Computer Servicing & Electronics Technology
- Specialized Associate Degree In Electronics Technology

## Professional Equipment Is Included

Depending on the program you select, you'll perfect your skills using this advanced equipment, included in the price of tuition:

- IBM-Compatible Personal Computer
- Digital Multimeter
- Digital Logic Probe
- Elenco Oscilloscope
- Portable Cellular Telephone

(\* Source: U.S. Bureau of Labor Statistics)



## Exclusive Extras That Enhance Your Training

Peoples College introduces some training firsts to make your learning experience more complete:

- Accelerated Learning System — a scientifically proven study system that helps you learn faster and easier than ever before.
- Video Tutor Training Tapes — give you a permanent, visual record of informative lectures and close-up demonstrations.
- Experience Labs — professionally designed experiments that give you hands-on "bench" experience.
- Industry Certification Training Guide — provided with four of our programs. Prepares you for examinations you may take for your professional license or certification.

## Easy Payment Plans — No Finance Charges

To help you get started on your education, Peoples College has reduced tuition rates and offers low monthly payment plans with no finance fees. So don't delay, call or write for more information today!

## For COLOR CATALOG Mail Coupon or Call TOLL FREE 1-800-765-7247

Programs offered only in United States, Canada, Puerto Rico and Virgin Islands. No Obligation. No sales person will call.

Our programs are accredited by the Accrediting Commission of the National Home Study Council

YES! I would like to know more about your training programs. Send a catalog to:

Name \_\_\_\_\_  
 Address \_\_\_\_\_  
 City \_\_\_\_\_  
 State \_\_\_\_\_ Zip \_\_\_\_\_

Phone # \_\_\_\_\_  
**PEOPLES COLLEGE**  
 OF INDEPENDENT STUDIES  
 233 Academy Drive • P.O. Box 421768  
 Kissimmee, FL 34742-1768  
 Member, D.L. Peoples Group R0392



CIRCLE 20 ON FREE INFORMATION CARD

it up with the vacuum head, and then guides it with the free-floating X-Y-Z arm to the appropriate position on the board. A control knob on the vacuum head provides theta rotation to ensure proper component orientation. When the component is lowered, the vacuum head automatically releases it when contact with the board is made.

The *SMT-800* provides a total working area of 8 x 12 inches, with an adjustable board holder. The system comes complete with an ESD-safe carousel vacuum pump and a movable hand rest that glides over the board holder and provides the user with a stable, fatigue-relieving platform. For easy compatibility with larger automatic machines, optional tape and stick feeders mount on the vise. Other options include a lighted magnifier with four diopter lenses to assist in component alignment. The system is available for 115-volt or 230-volt operation.

Prices for the *SMT-800* pick-and-place system start at \$3495.—**O.K. Industries**, 4 Executive Plaza, Yonkers, NY 10701; Phone: 914-969-6800.

**PLCC QUAD CLIP KIT.** The selection of test adapters included in ITT Pomona's *Model 5515A PLCC Quad Clip Kit* was specifically chosen to test the most popular surface-mounted plastic leaded chip carriers (PCC and PLCC) with "J" leads (JEDEC MO-047 and

MO-052). The design of each test adapter incorporates a "snap ring" that allows the quad clip to fit directly onto an IC and provides simultaneous access to all the pins of the surface-mount device for hands-free testing. The wipe action of the snapping design, as it is pushed down with normal force into position against the contact, wedges against the IC for a tight fit and assures a good connection.

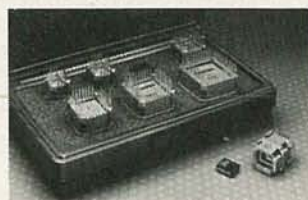

CIRCLE 21 ON FREE INFORMATION CARD

The kit contains seven items: one each 20-, 28-, 32- (7 x 9, EEPROM), 44-, 52, 68-, and 84-pin Pomona Quad Clip test adapters. All the adapters have gold-plated center contacts, silver-plated bodies, and 0.064mm (0.025-inch) square pins staggered on 2.54mm (0.100-inch) centers. The kit is packaged in a durable, reusable plastic case.

The *5515A PLCC Quad Clip Kit* costs \$245.—**ITT Pomona Electronics**, 1500 East Ninth Street, P.O. Box 2767, Pomona, CA 91769; Phone: 714-469-2900; Fax: 714-629-3317.

**CONTROLLERS/INDICATORS.** For start, stop, or limit control of a wide range of process variables, Simpson Electronics has introduced the *Hawk Series* of controllers/indicators that fit in a 1/8 DIN cutout. The series offers high accuracy and ease of installation in electrical, chemical, petrochemical, and other process industries. The controllers accept AC and DC

voltage and current, 4–20-mA DC, 1–5V DC resistance, 3-wire potentiometer, frequency, and tachometer (RPM) inputs. RTD inputs may be two-, three-, or four-wire configuration. The Hawk models also accept several thermocouple types, including J, K, R, and S, which input without calibration or internal hardware changes. The compact units are AC or DC powered and are housed in impact-resistant, flame-retardant, plastic cases. Their front-panel keypads are used to program, set, or check the operating parameters of hysteresis, time delay, and set point, as well as alarm levels and relay settings. A user password prevents unauthorized program access. Each instrument also features a highly visible, 0.51-inch, red LED display; plug-in circuit boards for user-selected functions; dual set point with optional



CIRCLE 22 ON FREE INFORMATION CARD

dual relays; a fast, easy, input terminal block that can be unplugged; and an edge-type connector for analog and digital output options.

The *Hawk Series* of controllers/indicators are priced starting at \$199.—**Simpson Electric Company**, 833 Dundee Avenue, Elgin, IL 60120-3090; Phone: 708-697-2260; Fax: 708-697-2272.

**PC AUDIO CONTROL SOFTWARE.** Voyetra's *Sound Central*, a software utility for Windows 3.0, provides a convenient way to control



CIRCLE 23 ON FREE INFORMATION CARD

every aspect of sound generated by PC sound card or Multimedia PC's (MPC) graphical audio editor can be used to audition and edit digital waveforms, the VOC or .WAV form and modify them with special effects as echo, data compression, bit resolution, and sample-rate conversion. A MIDI song file editor provides control over major parameters in a MIDI song file so that music generated by the can be manipulated—instance, re-orchestrate, lengthened, or shortened. The full-featured CD "control panel" provides a convenient way to sort, view, and play CD audio tracks. A mixer control panel provides access to all of the MPC's mixer functions, including input/output control levels and line/monitor settings. Also included are a MIDI file maker and a "patch editor" for the MPC's FM synthesis.

*Sound Central* audio control software has a suggested retail price of \$199.95.—**Voyetra Technologies**, 333 Fifth Avenue, Pelham, NY 10803; Phone: 1-800-233-9377; 914-738-4500; Fax: 914-738-6946.

**OSCILLOSCOPE PRO SWITCH.** Providing a simple way to observe and compare waveforms at different points in a circuit, Micro

# DON'T GAMBLE

when you want the best

## 1 Reasons To Buy OPTOELECTRONICS' MODEL 3000

1. RANGE- 10Hz to 3GHz.
2. Hi-Speed ASIC (Application Specific Integrated Circuit) State-Of-The-Art.
3. 256 Times Faster than other hand held counters.
4. 10 Digit LCD. Readability even in Bright Sunlight.
5. 6 Functions - Frequency, Period, Ratio, Time Interval, Average and Prescale.
6. RF Signal Strength Bargraph - 16 Segment, Zero & Full Scale Adjust. Excellent for locating Hidden Transmitters.
7. Four extremely Fast Gate Times .01, .1, 1, 10 sec.
8. Dual High Impedance Amplifiers.
9. Maximized Sensitivity
10. Hold Switch - Locks in measurements FAST.
11.  $\pm 1$ PPM Accuracy
12. Direct Count - 1Hz resolution to 220MHz
13. Sensitivity <1mv 10MHz - 200MHz, <5mv - 2GHz.
14. Single Shot Time Interval 100ns, .1ns averaged.
15. Push-button Input, Gate & Function selection.
16. Extruded Aluminum Enclosure.
17. NiCad & Charger Included.
18. Low Battery Indicator.
19. 1 Year Parts & Labor Warranty
20. 30 day Money Back Guarantee.
21. OPTOELECTRONICS backs this with our 18 Years of Dependability & Service.

**All this and more for the Low Price - \$375.**

### Also Available at Special Package Price:

For A Limited Time Only  
Model 3000, Backlight/Beeper, Carry  
Case & TA-100s Whip Antenna

**All this for only \$449.**

#### OPTIONS:

**TCXO 30**  $\pm .2$ ppm TCXO .....\$100.

**BLB30**

Back light & two step audible signal level indicator ..\$ 75.

**CC30** Carry Case .....\$ 15.

**TA100S** Telescoping Whip Antenna .....\$ 12.



# OPTOELECTRONICS

Factory Direct Order Line

## 1-800-327-5912

305)771-2050 • FAX(305) • 2052 5821 NE 14th Ave. • Ft. Lauderdale, FL 33334

% Ship/Shandling (Max. \$10) U.S. & Canada. 15% outside continental U.S. Visa & Master Card Accepted.

CIRCLE 180 ON FREE INFORMATION CARD

### YOU CAN'T LOSE!



**CIRCLE 24 ON FREE INFORMATION CARD**

Engineering's *MV103* oscilloscope probe switch accepts two scope probes and attaches to the oscilloscope input. The accessory allows the user to easily select either of the two probes with the flip of a switch. With the *MV103*, a dual-channel scope can accept four separate inputs without performance degradation. High-frequency relay technology provides high isolation and low insertion loss. Compact all-metal design provides excel-

lent shielding and allows the *MV103* to be installed directly on the input BNC connector of the oscilloscope. The switch can also be used as a standalone, general-purpose RF switch.

The *MV103* oscilloscope probe switch costs \$275.00—**Microvolt Engineering**, P.O. Box 777, Tustin, CA 92680; Phone: 714-544-3441.

**EMI/RFI FILTERS.** When controlling electromagnetic and radio frequency interference to the environment and complying with FCC regulations on maximum level emissions are concerns, the *601 Series* of surface-mount resistor-capacitor networks from Bourns provide a simple

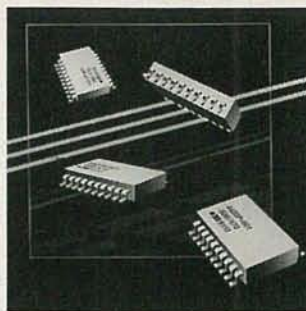

**CIRCLE 25 ON FREE INFORMATION CARD**

solution. Shielding is required between the RS232 connector and the input/output drivers in electronic equipment. The *601 Series* of low-pass filters prevent the transmission of high-frequency noise components and are especially effective on lines to external connectors. Featuring a T-configuration of 16 re-

sistors in series and 8 capacitors bused to a common ground, the surface-mounted RC networks suppress high-frequency EMI/RFI noise for up to eight separate lines. Smaller than inductive-type filters, the devices are packaged in wide-body cases. Typical applications for the filters are in personal computers, data terminals, test equipment, process controllers and high-frequency suppression into or out of electronic equipment.

Prices for the *601 Series* of surface-mount EMI/RFI filters begin at \$2.15 each in quantities of 10,000 pieces.—**Bourns Network Inc.**, 1400 North 100 West, Logan, UT 84301; Phone: 801-750-7200.

## NEW LIT

Use The Free Information Card for fast response.

**HOW TO GET ANYTHING ON ANYBODY: BOOK II; by Lee Lapin.** ISECO, Inc., 2228 South El Camino Real #349; San Mateo, CA 94403; Phone: 415-513-5549; Fax: 415-578-8741; \$38.00 postpaid (plus 8% sales tax on California orders).

If the words "espionage" and "spying" bring to mind James Bond (or Maxwell Smart), you're living a couple of decades in the past. These days, just about everyone can snoop (or be snooped upon), thanks to the huge assortment of personal surveillance devices now available. Subtitled "The Encyclopedia of Personal Surveillance," this book provides a guided tour of audio surveillance, including unconventional bugs,

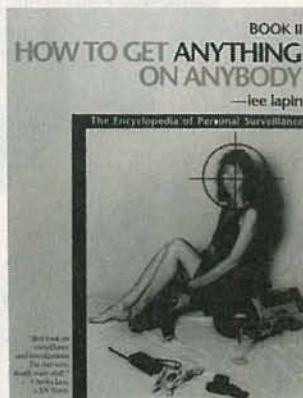

**CIRCLE 40 ON FREE INFORMATION CARD**

parallel and serial taps, carrier-current bugs, and IR and encrypted transmitters; acoustic analysis and hardwiring, including how to purchase and how to plant super-sensitive sub-miniature microphones; video surveillance using

special cameras and trick lenses hidden in everyday items, inexpensive wireless systems, and using TV's as surveillance devices; and cellular telephone operations and intercepts. The book also explains how to tail someone, how to obtain confidential phone-company records, how to see and hear through walls, how to use infrared devices for night vision, and how to tap into a phone with no equipment. It describes the art of surveillance photography, and shows how to put together a complete dossier on anybody. Also included are legal guidelines and the addresses of more than 200 suppliers of surveillance and counter-surveillance gear.

**COMPUTER VIRUSES AND DATA PROTECTION; by R. Burger.** Abacus, 5370 52nd Street SE, Grand Rapids, MI 49503; Phone: 616-698-0330; Fax: 616-698-0325; \$19.95.

Computer viruses—programs with the potential to destroy data and disable computer systems—can be quite costly in terms of lost time, data, and money. The best protection against such viruses is education—learning what steps to take to minimize or avoid losses. Intended as a general guide rather than a reference work, this book aims to teach readers about all kinds of computer viruses to allow them to protect themselves. Beginning with a short history of viruses and a descriptor



CIRCLE 39 ON FREE INFORMATION CARD

how a virus can gain control over a computer, the book explains how viruses are created and how to remove them from a system. It explores the design and function of viral programs, and includes sample program listings in BASIC, Pascal, and machine language as well as examples of viral software manipulation. The book outlines the protection options available, and provides practical advice about what to do when your PC is infected. Along with examples of protection viruses and strategies, a simple virus-detection program is provided. In addition, the book explains how to design virus-proof operating systems.

**HOME REMOTE-CONTROL & AUTOMATION PROJECTS (SECOND EDITION);** by Delton T. Horn. TAB Books, Division of McGraw-Hill Inc., Blue Ridge Summit, PA 17294-0850; Phone: 1-800-822-8138; \$18.95.

Besides being practical and educational, the projects described in this book are sure to impress your friends and family. Remote-control and automation projects can also save you both time and money, by letting electronics do the job for you. Although the emphasis is on the practical—in the form of 77 different projects—the book does provide background information on the basics of remote control, mechanical devices, motors, sensors, digitally-controlled

potentiometer IC's, and building and safety procedures. The projects themselves fall into 11 categories: lighting, doors and windows, temperature control, liquid control, audio and video, telephone, motor control, electronic switching, timers, wireless control, and computer con-



CIRCLE 38 ON FREE INFORMATION CARD

trol. The second edition presents 15 all-new projects and updates and improvements of the original projects. Each project is accompanied by a circuit drawing and a parts list, and most are fairly simple to build. Most of them can also be adapted in various ways to meet other, custom applications.

**TROUBLESHOOTING AND REPAIRING FAX MACHINES;** by Gordon McComb. TAB Books, Division of McGraw-Hill Inc., Blue Ridge Summit, PA 17294-0850; Tel. 1-800-822-8138; \$16.95.

It stands to reason that as soon as an electronic device becomes a necessity in our homes or offices, the need arises for people who know how to maintain and repair that device. This book was written to provide that know-how to the non-technical fax owner. By following its instructions, and using a few inexpensive tools, consumers should be able to keep their fax machines in proper working order—and to recognize a major problem that must be handled by a

professional repair person. Aimed at non-technical folks, the book provides plenty of background information about how fax machines work. Most of the book is devoted to the troubleshooting and repair of mechanical problems, which account for about 85% of fax breakdowns. Full coverage of the major electronic subsystems—power supplies, solenoid controls, etc.—is also provided. Because most problems that occur with fax machines involve such things as dirty switch contacts or printing elements, broken wires, aging rubber belts and rollers, and damaged paper, preventative maintenance is emphasized. Simple illustrated instructions show how to clean and lubricate the paper path, light-sensitive reader bar, thermal printing mechanism, paper



CIRCLE 37 ON FREE INFORMATION CARD

cutter, fluorescent lamp, and front-panel controls. The book also explains how to diagnose and fix bad phone connections and printing and transmission errors. Emergency first-aid procedures in case of fire or water damage are detailed. An entire chapter is devoted to troubleshooting flowcharts illustrating the proper steps to follow to locate and solve problems.

**MS-DOS 5 QUICK REFERENCE;** by Timothy S. Stanley. Que, 11711 North College Avenue, Suite 140, Carmel, IN 46032; Tel: 1-317-573-2500; \$9.95.

This slim volume puts the essentials of MS-DOS 5 at your fingertips, providing an instant reference to critical commands and procedures, batch files, the



CIRCLE 36 ON FREE INFORMATION CARD

DOS Editor, and error messages. Short on documentation, but full of practical pointers, the book is intended as a supplement to a full-size MS-DOS guide. It explains the proper use of primary DOS functions, as well as advice on how to avoid making serious errors.

In a compact, easy-to-use format, the book explains the proper DOS commands to use for specific operations. The book is arranged alphabetically by command. Each command name is accompanied by an explanation of its purpose, followed by the syntax needed to invoke the command and the rules for its use. Examples are provided for some of the commands. Separate sections provide in-depth coverage of batch files, the DOS Editor, MS-DOS messages, and error messages. A "DOS Survival Guide" lists specific procedures and the commands needed to invoke them.

# Now! Experience the electronics behind the MIDI revolution as you build your own computer-controlled music center

Only NRI's innovative, at-home training in Electronic Music Technology gives you hands-on experience with the equipment that's revolutionizing the music industry—Atari ST Series computer with built-in MIDI ports, Casio HT-3000 synthesizer with advanced MIDI operations, and ingenious MIDI software that links computer keyboard to synthesizer keyboard—all yours to train with and keep!

This year, over \$1.5 billion worth of digital electronic music instruments, from keyboards to drum machines, will be sold in the U.S. alone. Enthusiasts everywhere—professional musicians and recording technicians, even people who have never touched a musical instrument before—are discovering the excitement of today's electronic music technology.

At the heart of this excitement is MIDI (Musical Instrument Digital Interface), an innovation that's transformed musical instruments into the ultimate computer peripherals...and opened up a whole new world of opportunity for the person who knows how to use, program, and service this extraordinary new digital equipment.

Now NRI's breakthrough Electronic Music Technology course puts you at the forefront of this booming new technology with exclusive training built around a MIDI-equipped computer, MIDI synthesizer, and MIDI software you keep.

## Dynamic new technology opens up new career opportunities

The opportunities are unlimited for the person who's trained to take advantage of today's electronic music phenomenon. Now you can prepare for a high-paying career as a sound engineer, recording engineer, or road technician... even start your own business selling and servicing today's high-tech musical instruments. Or simply unleash your own musical creativity with the breakthrough training and equipment only NRI gives you.

## Only NRI gives you hands-on training with today's MIDI technology

The Atari ST Series computer included in your course becomes the heart of your own



computer-controlled music center.

With its tremendous power, superior graphics capabilities, and built-in MIDI interface, the 16/32-bit Atari ST has almost overnight become the computer of choice for today's most knowledgeable electronic musicians.

Your Casio HT-3000 synthesizer features a five-octave, MIDI-compatible digital keyboard with built-in monitor speakers, advanced tone editing and writing, pattern memory, keyboard split, tone and rhythm banks, chord memory, and dozens more state-of-the-art capabilities.

Plus you get ingeniously designed MIDI software that opens up amazing new creative and technical possibilities... you actually build your own 4-input audio mixer/amplifier...and you test the electronic circuits at the core of today's new equipment



*NRI training includes an Atari ST computer, Casio synthesizer, exclusive MIDI software, and much more—all yours to train with and keep! (TV not supplied)*

with the hand-held digital multimeter also included in your course.

## No previous electronics or music experience necessary

No matter what your background NRI gives you the skills you need to take advantage of today's opportunities in electronic music technology.

With your experienced NRI instructor always available to help, you master the basics of electronic theory step by step, gaining the full understanding of electronics that's now so essential for technicians and musicians alike.

You move on to analyze sound generation techniques, digital logic, microprocessor fundamentals, and sampling and recording techniques... ultimately getting first-hand experience with today's explosive new technology as you

explore MIDI, waveshaping, patching, sequencing, mixing, special effects, and much more.

Plus, even if you've never been involved with music before, NRI gives you enough basic training in music theory and musical notation to appreciate the creative potential and far-reaching applications of today's electronic music equipment.

## Send today for FREE catalog

If the coupon is missing, write to NRI Schools, McGraw-Hill Continuing Education Center, 4401 Connecticut Avenue, NW, Washington, DC 20008.

### NRI Schools

McGraw-Hill Continuing Education Center  
4401 Connecticut Avenue, NW, Washington, DC 20008



Check One FREE Catalog Only

- |  |  |
|--|--|
| <input type="checkbox"/> Electronic Music Technology | <input type="checkbox"/> Computer Programming          |
| <input type="checkbox"/> Microcomputer Servicing     | <input type="checkbox"/> Desktop Publishing and Design |
| <input type="checkbox"/> TV/Video/Audio Servicing    | <input type="checkbox"/> Fiction/Nonfiction Writing    |
| <input type="checkbox"/> Security Electronics        | <input type="checkbox"/> Bookkeeping & Accounting      |
| <input type="checkbox"/> Basic Electronics           |  |

For Career courses approved under GI bill  check for details.

Name \_\_\_\_\_ Age \_\_\_\_\_

Address \_\_\_\_\_

City/State/Zip \_\_\_\_\_

Accredited Member, National Home Study Council

3-032

# BUILD THIS MIDI INTERFACE FOR YOUR PC

*Bring the world of music to your PC with this versatile and inexpensive MIDI interface.*



JOHN SIMONTON

AFTER A LONG-TERM FLIRTATION, the marriage of computers and musical instruments has been consummated, thanks to MIDI, the Musical Instrument Digital Interface. The fruits of this union are sequencer programs with the look and feel of a multi-track recording studio. Using those and other PC-based tools, a single musician in a back bedroom can produce recordings that only a few years ago required orchestras and an office staff.

Professional musicians aren't the only ones to benefit—you can too. Instruments with MIDI interfaces are so common that even your local discount store probably has several to choose from. The only thing standing between you and the artistic gratification of writing and performing like the philharmonic is the interface from your PC to the MIDI world, so let's take care of that little detail right now. We'll show you how to build a MIDI interface that is both low-cost for the beginner and upgradable for the serious user. With little further delay we begin, but first...

## A little history

The MIDI specification, which was written with low-cost hardware in mind, allows us to use an HD6850P Universal Asynchronous Receiver Transmitter (UART) chip. The 6850 is older than the hills, readily available, inexpensive, and easily produces the 31.25 kilobaud signal that is required for MIDI. The basis of our MIDI interface is that UART assigned to one of the PC's output ports. For more information on MIDI, see **Radio-Electronics**, August 1989.

The most frequent MIDI commands are NOTE ON and NOTE OFF as keys are pressed and released. Those messages happen relatively infrequently; even when a chord is played, there is generally a slight delay between the individual notes. But the protocol also has provisions for continuous controllers such as pitch wheels and foot pedals, and the messages that signal that kind of activity can really spew out data. With nothing more than a UART for an interface, the original IBM PC, with its 4.77-MHz 8088 MPU and 8

bit bus, is just slightly too slow to handle MIDI at the maximum rate possible. It's not so much of a problem for the avocational user, but in a professional environment with lots of equipment, there is the possibility that data can be lost. Losing a little pitch wheel information isn't usually the end of the world, but if a NOTE ON or NOTE OFF command comes in the middle of it, missing that data is a very big deal.

The first widely accepted MIDI interface to overcome that problem was the MPU-401 made by Roland. It has its own dedicated processor and memory, and gets around the lost-data problem by maintaining a first-in-first-out (FIFO) buffer for the MIDI data

FIG. 1—TWO 6850 UART's are the heart of our MIDI interface. The circuit can be built in either a single-port version for the beginner or dual-port for the more experienced.

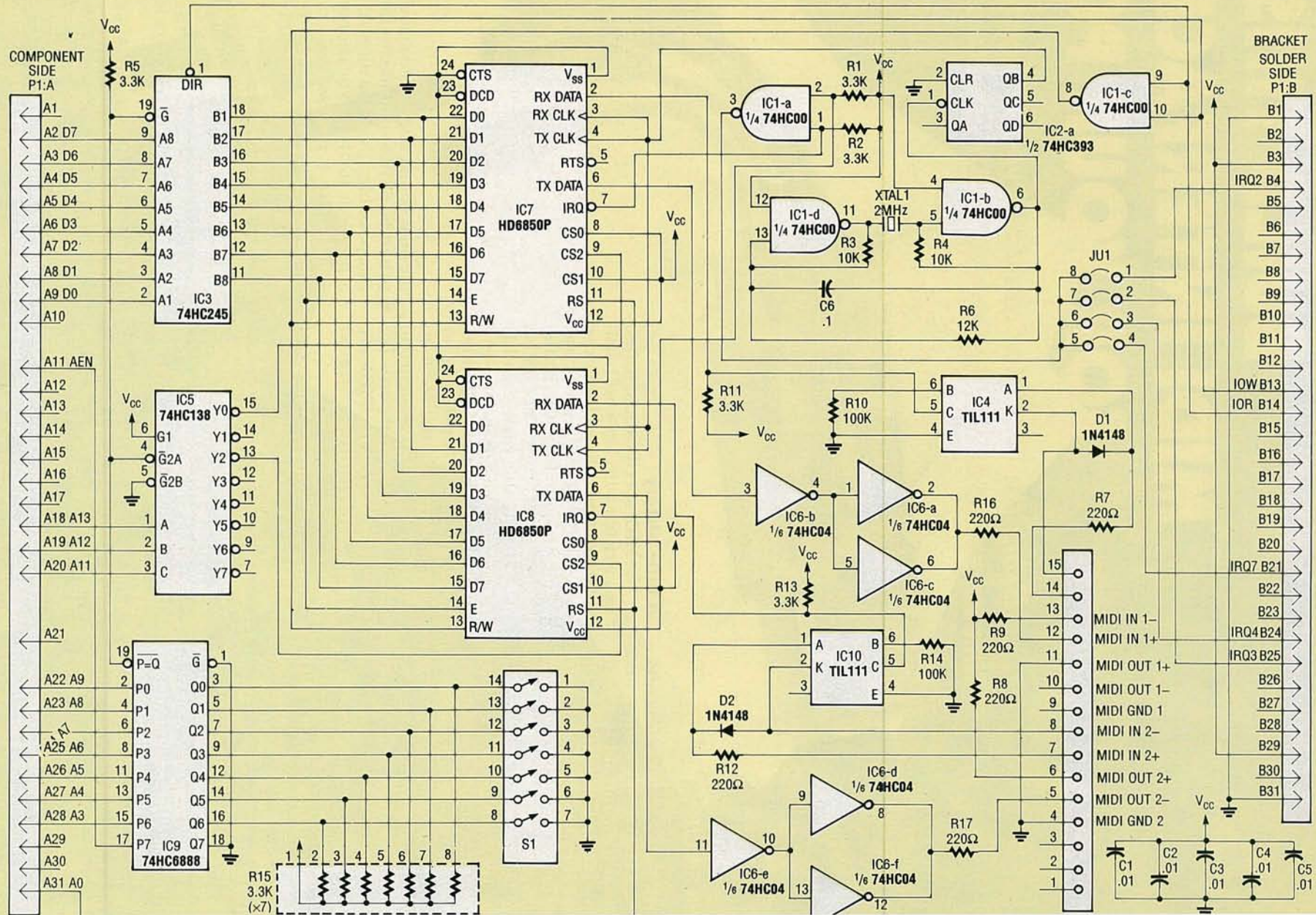



received. It also does some tricks such as data filtering and providing a metronome.

All well and good, but the introduction of the first XT-class

## PARTS LIST

All resistors are 1/8-watt, 5%, unless otherwise noted.

R1, R2, R5, R11, R13\*—3300 ohms

R3, R4—10,000 ohms

R6—12,000 ohms

R7, R8\*, R9, R12\*, R16, R17\*—220 ohms

R10, R14\*—100,000 ohms

R15—3300 ohms × 7, 8-pin SIP

### Capacitors

C1—C5—0.01 μF, Mylar

C6—0.1 μF, Mylar

### Semiconductors

IC1—74HC00 quad NAND gate

IC2—74HC393 dual 4-bit binary counter

IC3—74HC245 octal transceiver

IC4, IC10\*—TIL111 opto-coupler

IC5—74HC138 3-to-8 line decoder

IC6—74HC04 hex inverter

IC7, IC8\*—6850 UART

IC9—74HC688 8-bit magnitude comparator

D1, D2\*—1N4148 silicon diode

### Other components

J1, J2, J3\*, J4\*—inline 5-pin female DIN connector

JU1—8-pin IDC header w/jumper blocks

S1—7-position DIP switch

XTAL1—2 MHz crystal

**Note:** Components marked with a "\*" are optional for a second MIDI in/out.

**Miscellaneous:** Printed circuit board, hold-down bracket, wire, solder, etc.

**Note:** The following are available from PAIA Electronics, Inc., 3200 Teakwood Ln., Edmond, OK 73013 (405) 340-6300:

- PCM68pc double-sided, plated thru, PC board and bracket—\$24.95

- PCM68k kit of all parts needed to build the single-port interface, including PC board, bracket, wire, MIDI jacks, etc.—\$49.95

- PCM68ex expander parts for adding second MIDI port—\$14.95

- MIDIPAC MIDI starter set consisting of PCM68k interface kit and Voyetra SPJr. 64-track polyphonic sequencer software for PC/clones—\$99.00

Add \$3.00 P&H per order.

PC made an intelligent interface unnecessary because the computer alone was fast enough to handle the throughput. As faster and more powerful PC's have become available, the need for an intelligent interface has decreased until finally the MPU-401 has technically become a bottle-neck in the system (though you would never notice that the interface is slowing things down).

What has turned out to be a noticeable problem to serious users is the bandwidth limitation of the MIDI channel itself. The solution to that problem has been multiple, separate In and Out jacks, equivalent to multiple interface cards. And here the MPU-401 runs into serious problems. Synchronizing multiple 401's is not trivial—and worse than that, each has to have its own slot and dedicated interrupt. Interrupts and slots, is there anything more precious in the PC world? You can switch MPU-401's into a "dumb" mode so that several of them share an interrupt. But then you have expensive UART's and serious slot depletion.

So, having faster computers and the need for lower-cost multi-port interfaces has started a resurgence of interest in UART's, and all software publishers support them. De-facto standards being what they are, the MPU-401 "standard" continues to hang on. But meanwhile, really hip "power users" are stepping back in time to just the sort of card that we'll come up with here.

### Design analysis

The 6850 UART's, which are the heart of our MIDI interface, are shown as IC7 and, optionally, IC8 in the schematic Fig. 1. The circuit can be built in either a single-port version for the beginner or dual-port version for the more demanding user. Much of the rest of the circuitry is concerned with decoding addresses and managing control lines on the PC's slot.

The lowest-order address line (A0) directly drives the RS (REGISTER SELECT) pins (pin 11) of the UART's to allow selection

of either Status/Control or Data registers internal to the chip. We'll look at what those registers do when we test the interface. The next two address lines (A1 and A2) are not used, so each chip occupies 8 bytes of space consisting of four 2-byte chunks which overlay one another.

The next seven address lines (A3-A9) are routed to one set of inputs on IC9, a 74HC688 8-bit magnitude comparator. The other "side" of IC9 connects to DIP switch S1 and seven pull-up resistors in SIP-network R15. When the pattern of bits from the address bus matches the pattern of bits set by S1, pin 19 is pulled low. Notice that the 8th input to IC9 (Q7, pin 18) is grounded on one side and connects to the slot's AEN on the other (P7, pin 17). An address match will be valid only when AEN (ADDRESS ENABLE) is low, indicating that it's not the DMA controller that has the bus.

An address match does two things. It strobes IC3, a 74HC245 transceiver, which routes data either from the slot to the card or from the card to the slot depending on the direction selected by the  $\overline{\text{IOR}}$  (I/O READ) line (which connects to the DIR pin (pin 1) of the chip). It also enables IC5, a 74HC138 3-to-8 line decoder which does the final address decoding for UART selection. UART IC7 is selected when A11-A13 match the pattern 0h, and IC8 is selected when the pattern is 2h.  $\overline{\text{IOW}}$  (I/O WRITE) ties to the RW pins of the UART's to select either a read or write to the chips.

The  $\overline{\text{IRQ}}$  (INTERRUPT REQUEST) output pins of the two UART's are pulled up by R1 and R2 and combined by NAND gate IC1-c so that an interrupt request by either of them shows up on a line which can be routed to IRQ2, IRQ3, IRQ4, or IRQ7 depending on the placement of jumper JU1. Subsequently, the software will poll the two UART's to determine which of them generated the interrupt.

A 500-kHz transmit and receive clock starts out with the oscillator formed by the two NAND gates IC1-b and IC1-d. The

frequency of the oscillator is set to 2 MHz by crystal XTAL1 which is then divided by 4 in one section of the 74HC393 dual 4-bit binary counter IC2.

Two TIL111 opto-couplers (IC4 and IC10) are used on the MIDI inputs to prevent grounds through the path. A continuous ground on the MIDI inputs would likely duplicate a similar ground at the audio inputs and outputs, leading to circulating ground currents and noisy audio. The TIL111's are not the fastest opto's in the world, but are more than fast enough for this application and less expensive than their faster brothers. On the MIDI outputs, two inverter stages from IC6 are paralleled to increase drive current capabilities.

### Assembly

Because things run fairly slowly on slot I/O operations of even the fastest PC, there are no extraordinarily high frequencies involved on the PCM68. That means that prototyping boards and wire-wrap can be used to put together a card if you like. Be careful, though; 0.8-inch spacing between slots in a PC doesn't leave a lot of room for wire-wrap pins. And a misplaced conductor can cause a lot of damage in no time at all. It should go without saying that the shortest possible wires should be used to get a signal from the card edge to the IC it connects to.

Of course it's always best to use a PC board for any project, and you can either make your own from the foil patterns we've provided, or purchase a ready-made board from the source mentioned in the parts list.

A parts-placement diagram is shown in Fig. 2. IC sockets can be used, but certainly are not necessary. Note that if you've elected to put together the single MIDI in/out configuration, you can leave out the following parts: IC8, IC10, D2, R8, R12-R14, and R17.

Since PC-slot access holes weren't designed with MIDI in mind, they typically aren't wide enough for DIN connectors to peek through. Current practice

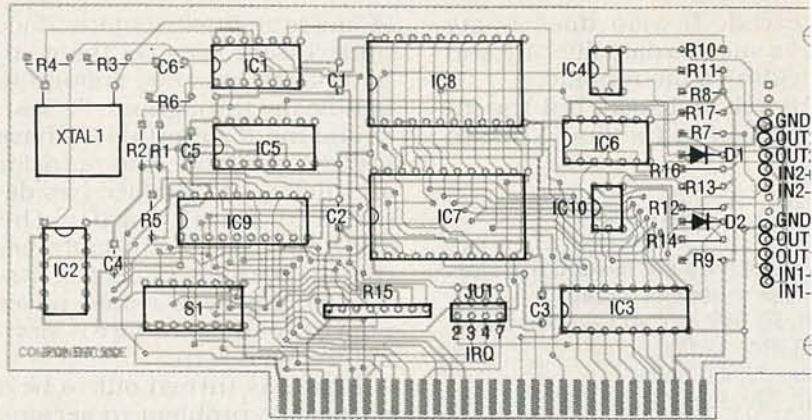

FIG. 2—PARTS-PLACEMENT DIAGRAM. If you've elected to put together the single MIDI in/out configuration, you can leave out IC8, IC10, D2, R8, R12-R14, and R17.

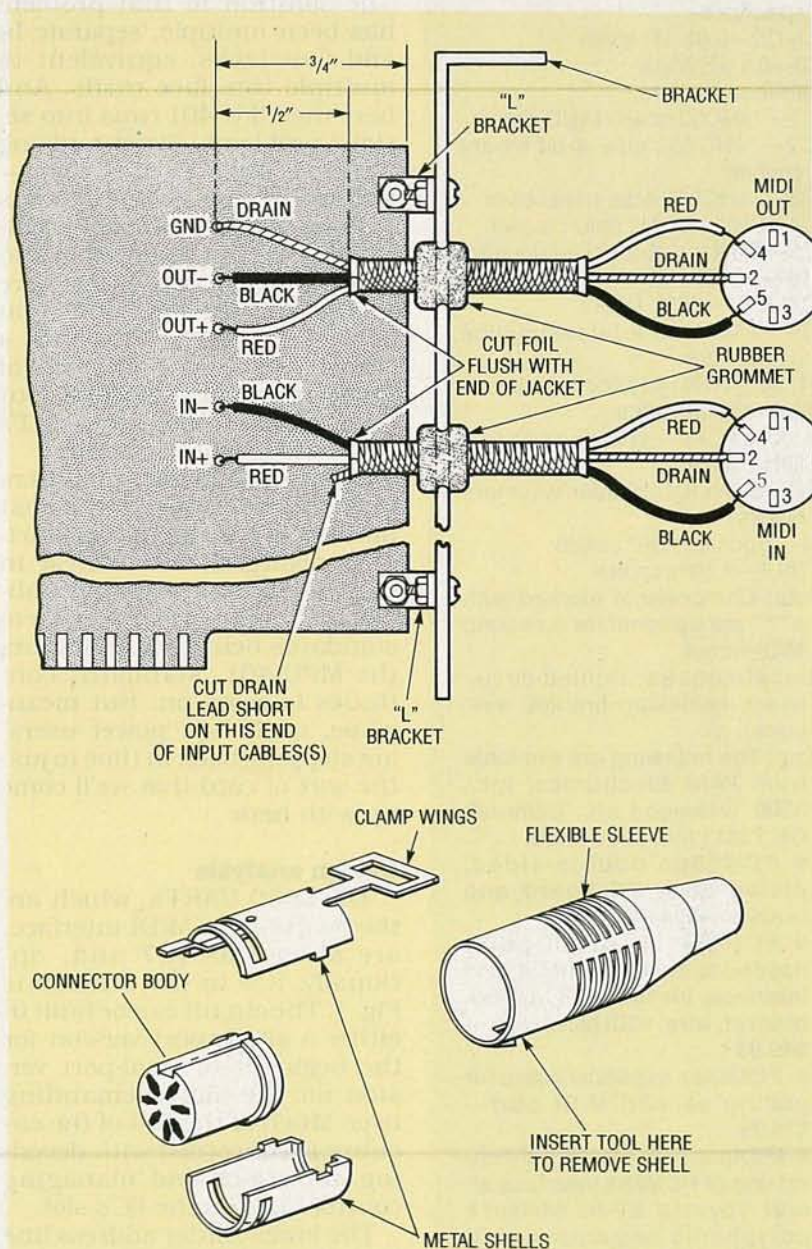

FIG. 3—PC-SLOT ACCESS HOLES aren't wide enough for DIN connectors, so we have in-line female connectors out on pig-tails. Labeling the connectors will make it easy to tell them apart.

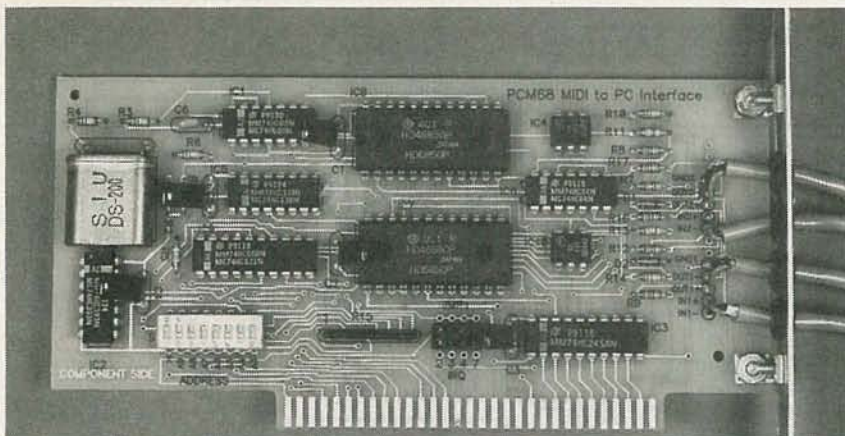

FIG. 4—THE COMPLETED PROTOTYPE CARD. The MIDI jacks are wired directly to the circuit board using shielded twisted pair.

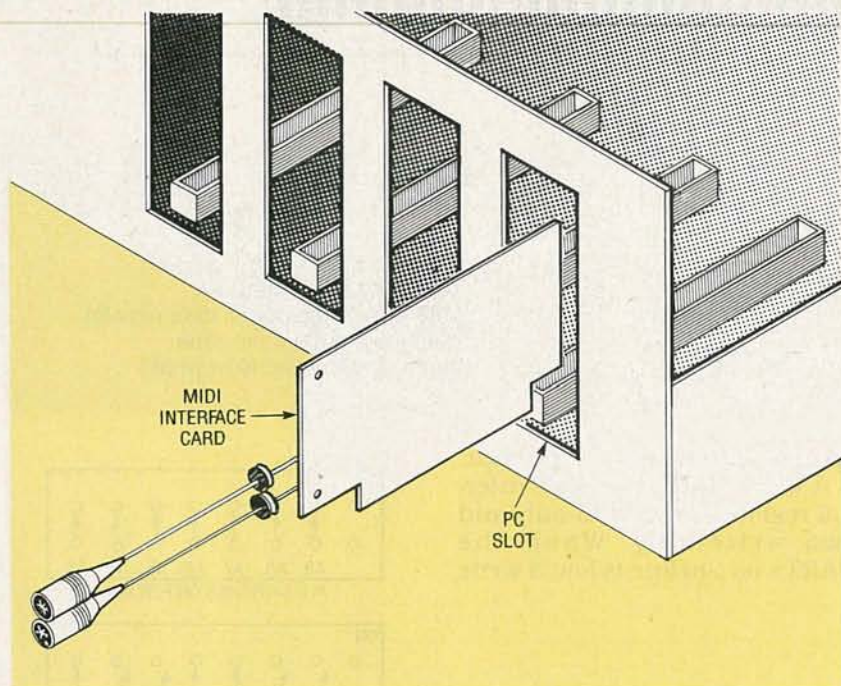

FIG. 5—THE CARD FITS through the computer's rear slot.

on many interfaces is simply to hang in-line female connectors out on pig-tails and that's what we'll do here. The circuit board end of those connections can be soldered directly to the circuit board. Use 6-inch lengths of shielded, twisted pair; see Fig. 3. Note that while the shield's drain wire (the wire that connects to the shield itself) is soldered to pin 2 of all the DIN connectors, it connects to the circuit board ground only on the MIDI outputs. Be sure to slide a ¼-inch rubber grommet onto each wire as shown in Fig. 3 before soldering both ends of the wires. It's a good idea to label

the connectors, as they are all identical and it will be hard to tell them apart once things are sealed up. Figure 4 shows the completed prototype card.

### Installation

When it comes time to install the card in your PC, you'll notice right away that the DIN connectors won't fit through the hole in the back of the case. But by now you've probably also noticed that the interface is somewhat smaller than a usual card, and that's because the card itself is designed to fit through the rear of the PC (see Fig. 5).

A hold-down bracket for the PCM68, shown in Fig. 6, can be fabricated from any material that's handy; ours is bent from 0.040-inch aluminum. After the card is slipped through the access hole in the case, the bracket mounts to the card with two small "L" brackets, and the rubber grommets that you slid onto the wires during assembly fit into the notches in the bracket. Finally, push the card down into the selected slot and secure the whole affair with the traditional screw at the top.

### Address/interrupt selection

The I/O addresses that the MIDI channels on the PCM68 occupy are selected by DIP-switch S1. It's fairly common for software to default to an address of h330 for the first set of connectors, and Fig. 7 shows the setting of the switches for that situation. If it turns out that there is a conflict, the switches can be set to any address from h0–h3f8. Any software that you select will have some provisions outlined in the owner's manual for changing the port address.

If you've built the interface with two ports, the second pair of inputs and outputs will be at the base address set by S1 plus 1000h. If the first port is at 330h, the second port will be at 1330h.

For interrupts, IRQ2 is normal, and placing a jumper at that location on JU1 will set the card that way (see Fig. 8). If there's a conflict, the jumper can be set to send interrupts to IRQ4 (COM2), IRQ3 (COM1), and IRQ7 (LPT). That's about the order you should try them in if you have to search for one that's unused. Your software will probably default to IRQ2 (or possibly IRQ9 which is re-directed to IRQ2 in AT's) and will definitely have some provisions for changing the default if needed.

### Testing

Your software will have a complete test of the interface, but we'll do some simple tests here that will give you a feel for what's going on and confirm that things are working properly. In-

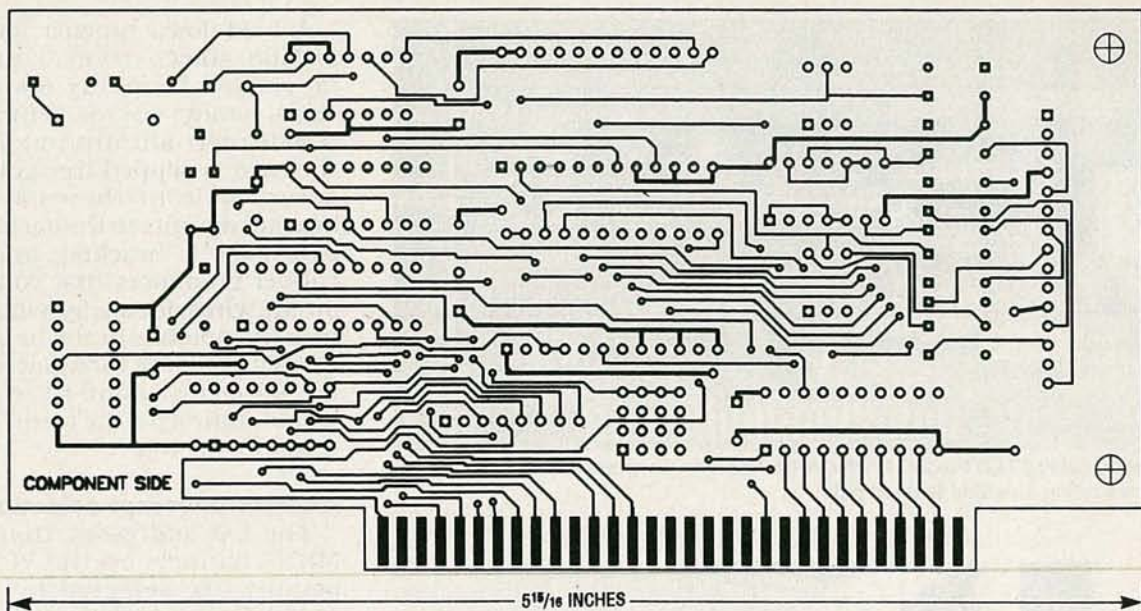

COMPONENT SIDE of the MIDI interface card.

interface tests check to see that data sent from the output side appear at the input side, so the first step is to connect the input to the output with a MIDI jumper cable.

We'll use DOS's handy do-all tool, DEBUG, to directly control the UART and see that it can talk to itself—one of the few cases where that is an indication of sanity. After making sure that DEBUG exists somewhere in the path of your system, invoke it by simply typing "debug" at the DOS prompt. DEBUG re-

sponds with its own "-" prompt. A 6850 UART has four internal registers; two read-only and two write-only. When the UART's RS (A0) line is low, a write

TABLE 1

```
>debug
-o 330 03
-o 330 15
-o 331 aa
-i 331
AA
```

This resets the UART  
/16, 8 data bits, 1 stop bit  
Write hAA to the output data register  
Read the input data register  
Alright, a response! Now what?

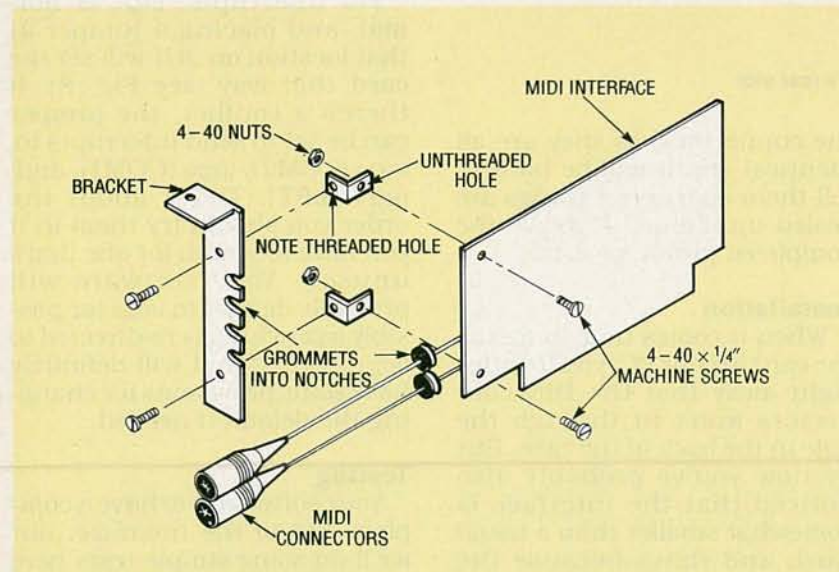

FIG. 6—A HOLD-DOWN BRACKET was fabricated from 0.040-inch aluminum. After the card is slipped through the access hole in the case, the bracket mounts to the card with two small "L" brackets.

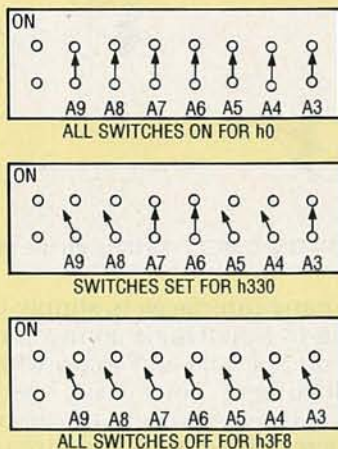
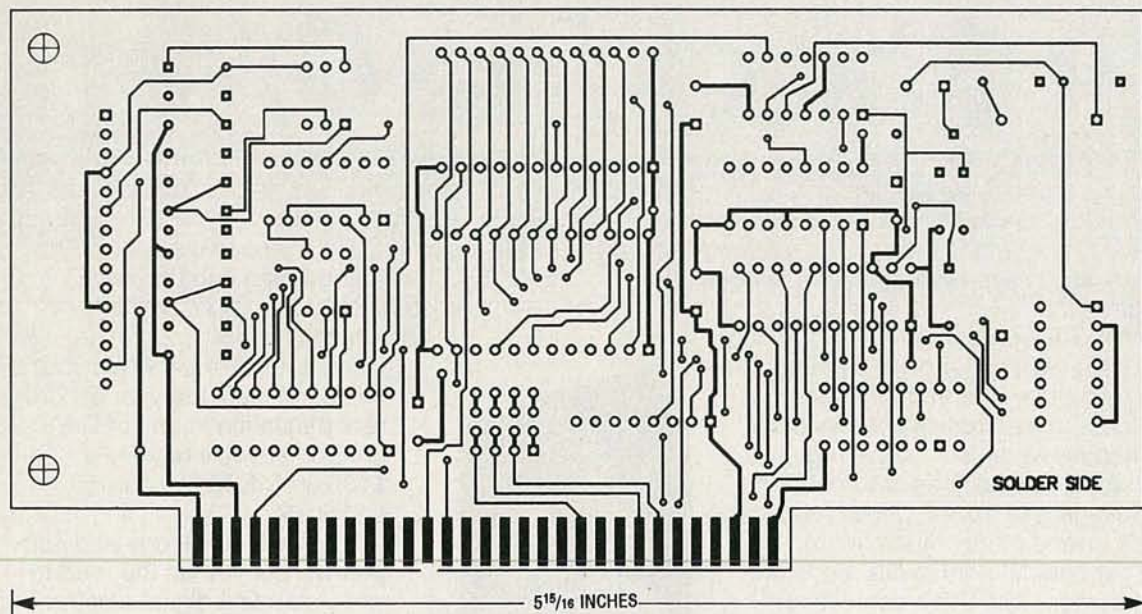

FIG. 7—THE I/O ADDRESSES that the MIDI channels on the PCM68 occupy are selected by DIP-switch S1. Setting the address DIP switches as shown here puts the interface on port h330.

operation puts data into the Control Register which sets the chip's operating parameters; and a read brings back the contents of a Status Register which is information on whether the transmit and receive registers



SOLDER SIDE of the MIDI interface card.

are empty or full. One address higher up (rs high) are the Data Registers, and writing to that address sends data out on the serial output, while reading brings back anything which has been received from the serial input.

Unlike some interface chips, a 6850 has no hardware reset line. Instead, a "reset word" is written into the Control Register. The first part of our test will be to do that by entering "o 330 03" from the keyboard. To DEBUG that means to write (output) the datum 03h to the port at address 330h. "03" is the reset word and if you have set up the base address to be other than 330h you will want to change that part of your entry.

The next instruction will be "o 330 15," and that writes a byte to the Control Register, which sets the UART to a mode of 8 data bits and one stop bit and sets the internal frequency divider on the transmit and receive clocks to divide by 16.

Now we output a byte by typing "o 331 aa" which writes the datum hAA to the Data Register of the UART, which in turn sends the data out serially. To see that the data was received, the entry "i 331" reads (inputs) from port h331 and should cause the screen to display "AA." The test process is summarized in Table 1.

The pattern in Table 1 shows how you can write whatever data you like with "o 331 xx" and check to see that the data was received with "i 331." The second port, if you have one, can be checked by writing the reset and setup words to h1330 and writing and reading data to h1331.

### Using the interface

After installing your software following its publisher's instructions and fully testing the interface using their tests,

you're ready to plug things together and start composing and recording. As you become more involved with MIDI, you'll realize that there are a lot of different ways to hook things up, depending on what you're going to be doing. But the simplest configuration for the beginner is simply to use MIDI patch cords to connect the MIDI output of your keyboard to the MIDI input of the PCM68 and vice versa.

The keyboard that you choose may have its own means of enabling MIDI, such as a slide switch which has a "MIDI" position or something similar. Of course that switch should be set appropriately. More professional instruments might have more exotic capabilities such as re-mapping the keyboard or other controllers onto different MIDI channels, but you'll learn about those things as you go along.

MIDI can be dealt with at a fairly low level for the beginner, yet it offers the capability of becoming as complex as you like. A good place to start learning is "All About MIDI" in the August 1989 issue of **Radio-Electronics**. And for a really well done treatment of MIDI (not only the technical details but also the user side of it), try reading *MIDI for Musicians* by Craig Anderton, published by Amsco Publications.

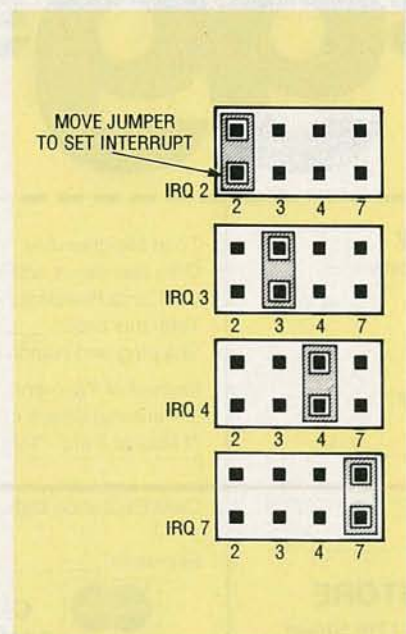

FIG.8—JU1 SETS THE INTERRUPT (see text).

# A Shocking Offer!

Now for the first time in CIE's 56 year history you do not have to be enrolled at CIE to receive our Electronics and Electricity Lesson Modules. Available for a limited time to non-students for the shockingly low introductory price of only \$99.50.

With CIE's patented AUTO-PROGRAMMED method of learning you'll quickly learn and then master the basics of electronics and electricity and then move on to ... soldering techniques, applications of Kirchhoff's law, voltage and power, printed circuit boards ... and much, much, more.

Your commitment to CIE ends with your payment, but CIE's commitment to your success just begins when you receive your lessons, exams, binder and equipment. This special price includes the benefits CIE normally extends to its students and graduates.

You'll receive CIE Bookstore privileges, a patented learning method, access to CIE's student, faculty and alumni electronic bulletin board and a free issue of CIE's school newspaper "The Electron". 24-Hour grading and unlimited access to CIE's faculty is available on an optional basis.

And best of all, when you decide to continue your electronics education in any of CIE's programs, you'll receive a \$100.00 CIE tuition credit certificate.

All this knowledge and support will put you on the road to understanding digital electronics, microprocessing principles, computer systems, telecommunications, and much, much, more.

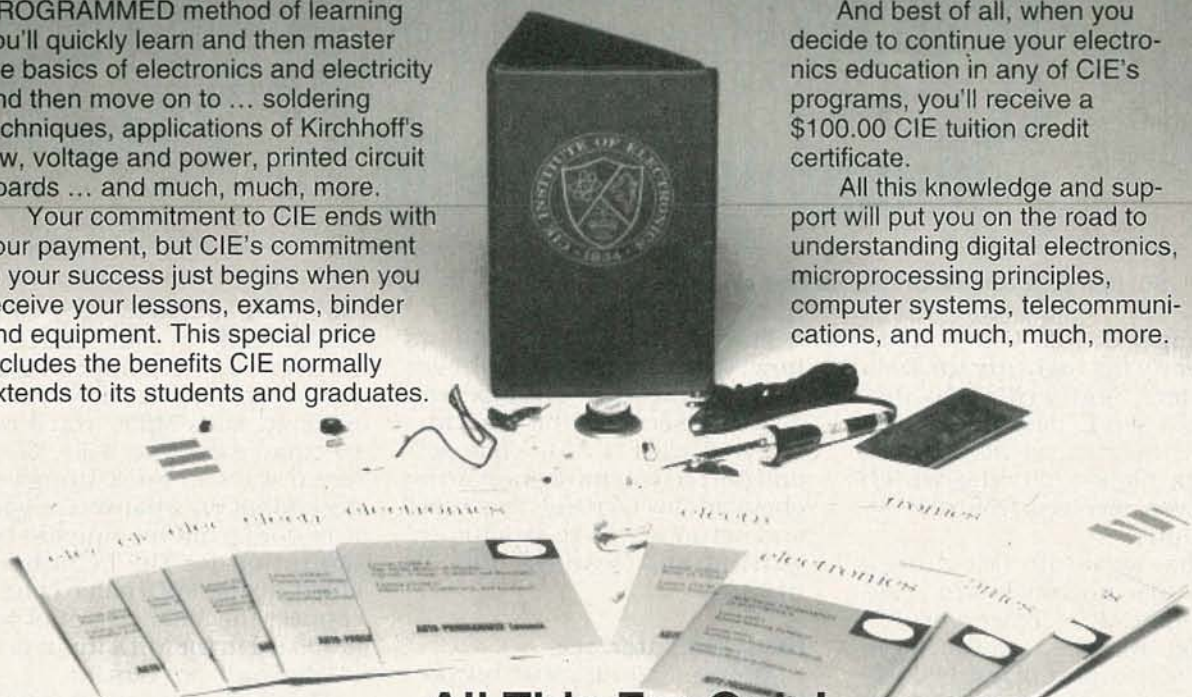

- Free Issue of "The Electron"
- Build your personal burglar alarm
- Theory and hands-on training lessons and exams covering "current and voltage" through "printed circuit boards"
- CIE Bookstore privileges
- Patent learning method
- Electronic Bulletin Board privileges

All This For Only!

# \$99<sup>50</sup>

• A \$100.00 CIE TUITION CREDIT CERTIFICATE

**Yes, send me CIE's Introductory Electronic and Electricity Lessons and Equipment.** A7303

Name: \_\_\_\_\_

Street: \_\_\_\_\_ Apt. #: \_\_\_\_\_

City: \_\_\_\_\_

State: \_\_\_\_\_ Zip: \_\_\_\_\_

Age: \_\_\_\_\_ Phone (\_\_\_\_) \_\_\_\_\_

Total Merchandise: \_\_\_\_\_ \$99.50

Ohio Residents add 7% Sales Tax: \_\_\_\_\_

California Residents add 6 1/2% Sales Tax: \_\_\_\_\_

Total this order: \_\_\_\_\_

Shipping and Handling Charges: \_\_\_\_\_ \$5.00

Method of Payment: Amount Enclosed: \$ \_\_\_\_\_

Personal Check or Money Order

Master Card  Visa

\_\_\_\_\_

Card Expiration Date: \_\_\_\_\_

Signature: \_\_\_\_\_



**BOOKSTORE**  
1776 East 17th Street  
Cleveland, Ohio 44114



**CHARGE BY PHONE!**

9 AM to 4:30 PM Eastern Time;

1-800-321-2155 ext. 7303; In Ohio 1-800-523-9109 ext. 730



### WARNING!

Please note that unauthorized wire and electronic communications interception and interception of oral communications is illegal under Federal and State Law. In addition Federal Law renders illegal the intentional manufacturing, assembling, possessing, or selling any electronic, mechanical, or other device, knowing or having reason to know that the design of such device renders it primarily useful for the purpose of surreptitious interception or wire, oral, or electronic communications. Federal law imposes both civil and criminal penalties for violations of the applicable statutes. Thus, the use of the Scanner Converter described in this article is intended for and should be restricted to educational, scientific, and/or informational purposes. This is not intended to constitute legal advice and readers are advised to obtain independent advice as to the propriety of their use thereof based upon their individual circumstances and jurisdictions.

# SCANNER CONVERTER

***We'll be converting those  
800-1000 MHz signals down to  
400-500 MHz in no time at all.***



**WILLIAM SHEETS and RUDOLF F. GRAF**

WE ARE IN THE MIDDLE OF BUILDING our scanner converter—it's a device that allows the reception of signals from 800-1000 MHz on any scanner that covers frequencies in the 400-500 MHz range. Last month we discussed the scanner converter's circuitry. This month we are going to build the unit and get it working properly.

### Construction

If you are going to make your own PC board from the foil patterns we've provided, you must use G-10 type PC material,  $\frac{1}{16}$ -inch thick, with a dielectric constant of 4.8. There's nothing inherently special about the common material except that

the printed inductors and filters were designed around it. If other PC-board material is used, the printed inductors and filters will not have the proper electrical characteristics. Because of the high frequencies involved, don't substitute components or change the layout. Also, when drilling the holes in the board, use the solder-side foil pattern as a drilling guide, and drill through any hole you see even if you don't see one on the component side. The parts layout is shown in Fig. 1. Note that a piece of wire must be inserted and soldered on both sides anywhere you see an "X" in Fig. 1.

The resistors should be in-

stalled while installing all jumpers, which are made from component-lead clippings. To ensure solid grounding, all components that have grounded leads, especially the trimmer capacitors, must be soldered top and bottom.

Coils L7, L8, and L9 are made from #22 enameled wire wound tightly on an 8-32 screw. See the parts list for coil-winding details. Coil L16, as shown in Fig. 2, is only a loop of wire and not at all critical, and L6 and L15 are simply ferrite beads placed over a length of wire, also shown in Fig. 2. Coil L14 is similar, although this time a ferrite bead is placed over one lead of R20, again as shown in Fig. 2. Coil

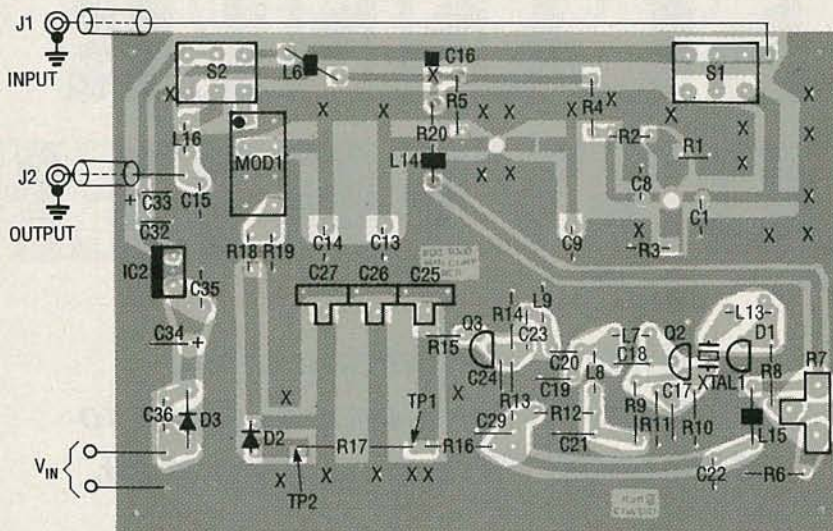

FIG. 1—PARTS LAYOUT. Note that a piece of wire must be inserted and soldered on both sides of the board anywhere you see an "X." The chip components mount on the solder side as shown in Fig. 3.

L13 is an RF choke and should have a ferrite core for a high "Q" value.

Slide switches S1 and S2 should be mounted very close to the PC board, with leads 1/8-inch or less, measured from the top surface of the PC board. Mixer MOD1 is a prepackaged diode bridge balanced mixer; the blue dot on MOD1 indicates pin 1. Note that IC1, Q1, and all chip capacitors are installed on the solder side of the PC board as shown in Fig. 3. However, do not yet install IC1 or Q1-Q3. You can install the chip capacitors after all regular capacitors are installed on top of the board.

Install IC2 and D1-D3. Now connect power (12 VAC or 15-25 VDC), place S2 in the "on" position, and connect a voltmeter to

TP3. You should see around +12 volts  $\pm 0.5$  volt. If not, fix the problem before proceeding. Check your work for shorts, solder bridges, missing solder connections, etc., and then install the remaining semiconductor devices, observing the polarity on all of them. Watch the lead configurations of IC1 and Q1 once soldered in, they are difficult to remove without damaging them.

Keep all coaxial leads going to the PC board very short. Solder them to the board as shown in Fig. 4 for best operation. The two slide switches (S1 and S2) must be ganged together. You can use the method shown in Fig. 5 or devise your own.

The converter board can

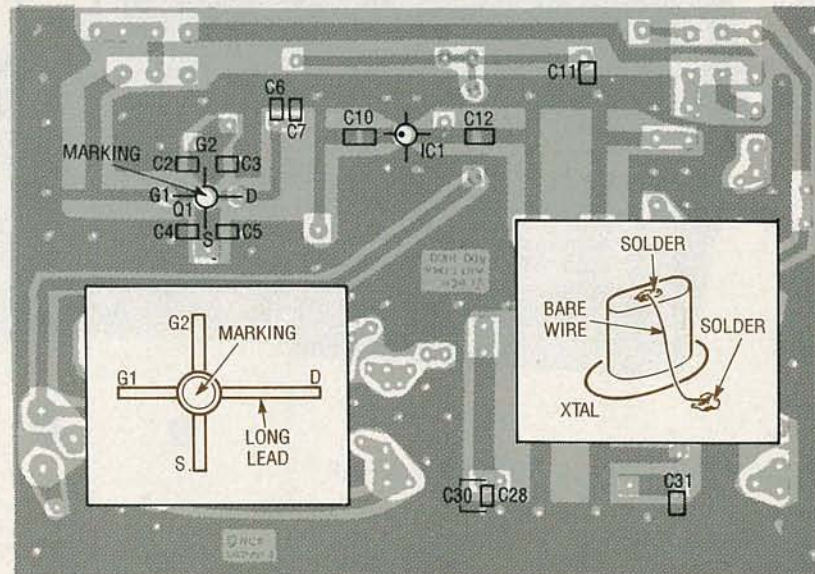

FIG. 3—COMPONENTS IC1, Q1, and all chip capacitors are installed on the solder side of the PC board. Note how to position Q1 and how to ground XTAL1.

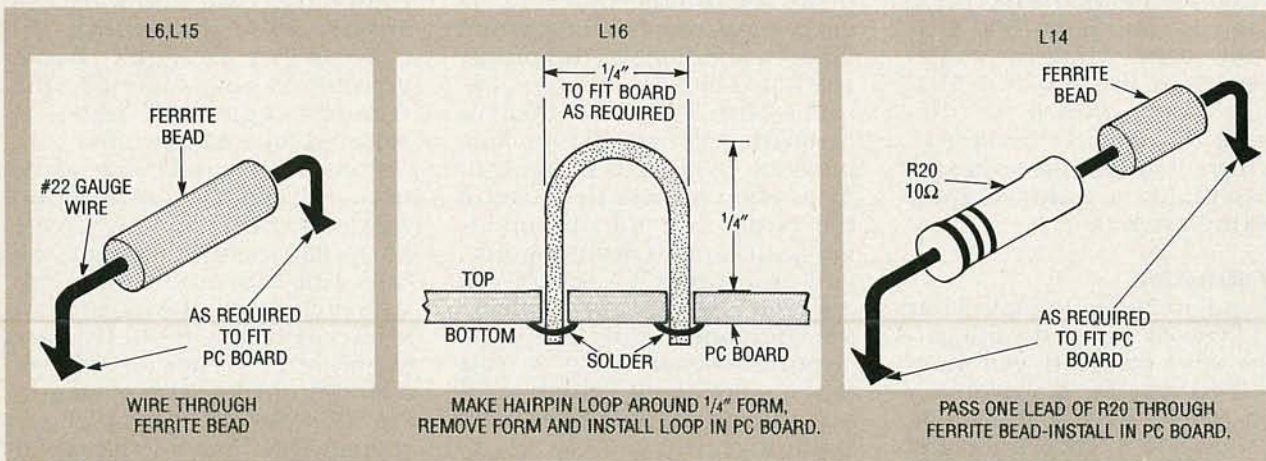

FIG. 2—COILS L6 AND L15 are ferrite beads placed over a length of wire, L16 is just a loop of wire, and L14 is a ferrite bead placed over one lead of R20.



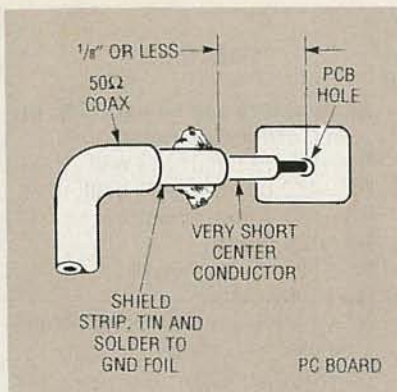

FIG. 4—ALL COAXIAL LEADS going to the PC board must be kept as short as possible. Solder them to the board as shown here.

mounted in a case with enough room for a 12-volt transformer. You can also mount the board inside an existing scanner, if +15 volts at 100 mA is available. If you have a regulated +12-volt supply, you can use it for power by connecting the +12 volts to the junction of C32, C33, and S2-b—in this case you can omit IC2, C34–C36, and D3 from the circuit. Figure 6 shows the inside of the completed prototype.

### Tune and align

To align the scanner converter you'll need a VOM, a 100-MHz

or higher frequency counter, and a non metallic screwdriver. Preset all trimmer capacitors as shown in Fig. 7, and set the slugs halfway in L7, L8, and L9.

First check all wiring for shorts, opens, and correct component orientation. Then connect either +14-volts DC or 12-volts AC to the power input and check for the following voltages:

- Junction of C16, L6, and R20 for +12 volts  $\pm 0.5$  volt
- Source of Q1 (the junction of C4, C5, and R3) for +1 to +2 volts
- Drain of Q1 (the hot side C8) for +10 to +11 volts
- Gate 2 of Q1 (the junction of R1 and R2) for +1.5 to +2.5 volts
- Output of IC1 (the junction of R5 and C12) for +5 volts  $\pm 1$  volt
- Wiper of R7 for +10 to +15 volts (vary the setting of R1)
- Junction of R8 and D1 for +10 to +15 volts
- Emitter of Q2 for +1.5 to +3 volts
- Collector of Q2 for +10 to +11.5 volts
- Collector of Q3 for +8 to +12 volts
- TP2 for -1 to +1 volt

Do not proceed any further until those voltages are obtained. Slight variations outside the stated ranges might be acceptable, but any major ones should be investigated. Table 1 gives some troubleshooting hints.

Couple a frequency counter to L7 using a 2-turn wire loop as shown in Fig. 8. Set R7 in the center of its range and adjust L7 for a 50-MHz reading. Vary R7 and see if you can obtain about  $\pm 1$ -kHz variation. Use the non-metallic screwdriver.

Couple a frequency counter to L9 using a 2-turn loop, and connect a VOM between TP1 (negative lead) and TP2 (positive lead). Adjust L8 and L9 for maximum voltage reading, which should be between 2 and 3 volts. Check to see that your counter reading is about 100 MHz.

Make sure that you have set trimmer capacitors C25, C26, and C27 according to Fig. 7 for coverage of either 800–900 or 900–1000 MHz. Connect a voltmeter to TP2 and adjust C25,

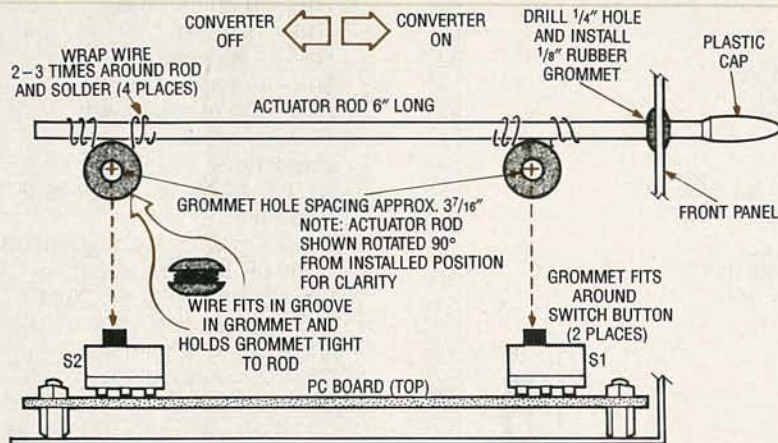

FIG. 5—ACTUATOR ROD S1/S2 CONSTRUCTION. The two slide switches (S1 and S2) must be ganged together. This method uses a brass rod or coat-hanger wire and rubber grommets. You can also devise your own method of ganging them together.

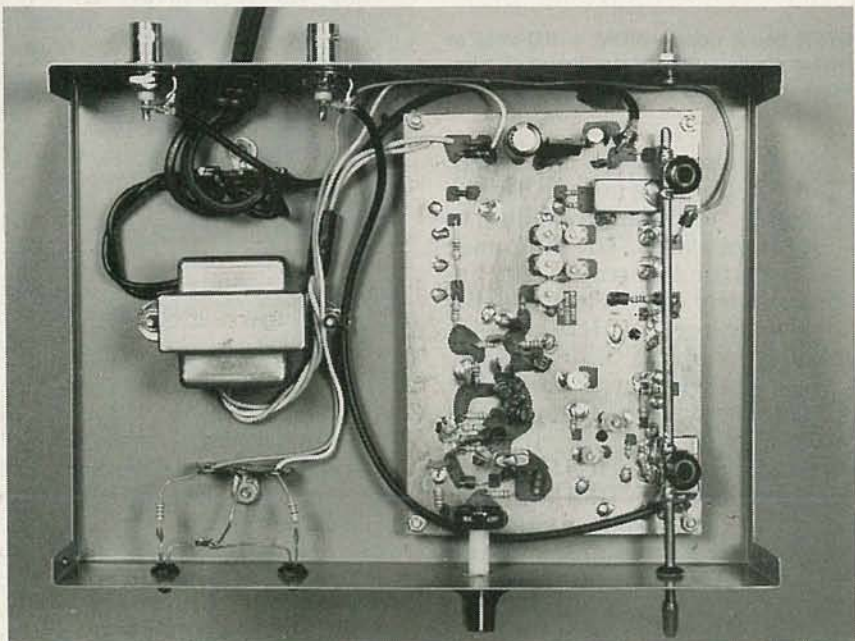

FIG. 6—THE INSIDE OF THE PROTOTYPE UNIT. The converter board can be mounted in a case along with a 12-volt transformer.

## PARTS LIST

All resistors are 1/4-watt, 5%, less otherwise noted.

- R1—100,000 ohms, 1/8-watt
- R2—470,000 ohms, 1/8-watt
- R3—180 ohms, 1/8-watt
- R4—180 ohms
- R5—390 ohms, 1/8-watt
- R6—1000 ohms
- R7—10,000 ohms, trimmer potentiometer with shaft
- R8—10,000 ohms
- R9—15,000 ohms
- R10—3900 ohms
- R11—330 ohms
- R12—100 ohms
- R13—15,000 ohms
- R14—2200 ohms
- R15—10 ohms, 1/8-watt
- R16—47 ohms
- R17—1 megohm
- R18—15 ohms, 1/8-watt
- R19—390 ohms, 1/8-watt
- R20—10 ohms

### Capacitors

- C1, C8, C9, C13, C14—1–5 pF trimmer
- C2–C7, C10–C12, C16, C28, C30—100 pF, 50 volts, chip
- C15—5.6 pF NPO  $\pm 0.25$  pF
- C17—100 pF NPO, 5%
- C18—39 pF NPO, 5%
- C19—22 pF NPO, 5%
- C20—2.2 pF NPO,  $\pm 0.25$  pF
- C21, C29—470 pF  $\pm 20\%$ , disc
- C22, C30, C32, C35, C36—0.1  $\mu$ F, 50 volts, GMV disc
- C23—33 pF NPO  $\pm 5\%$
- C24—56 pF NPO  $\pm 5\%$
- C25–C27—2–10 pF trimmer
- C33—10  $\mu$ F/16 volts, electrolytic
- C34—470  $\mu$ F/25 volts, electrolytic

### Semiconductors

- IC1—MAR-1 UHF amplifier
- IC2—7812 +12-volt regulator
- D1—MV2107 varactor diode
- D2—HP5082-2800 hot carrier diode
- D3—1N4007 rectifier diode
- Q1—NE25137 dual-gate GaAsFET
- Q2—2N3563 VHF NPN transistor
- Q3—MPS3866 VHF NPN transistor

Preset C1, C8, C9, C13 and C14 as shown in Fig. 7, and connect output J2 to a scanner tuner in the vicinity of 500 MHz (470–530 MHz will do). Now, set the scanner in a "search" mode and tune as to gradually tune from low end to the high end of the range. Find a suitable signal and align the RF stages. If you have access to a signal generator,

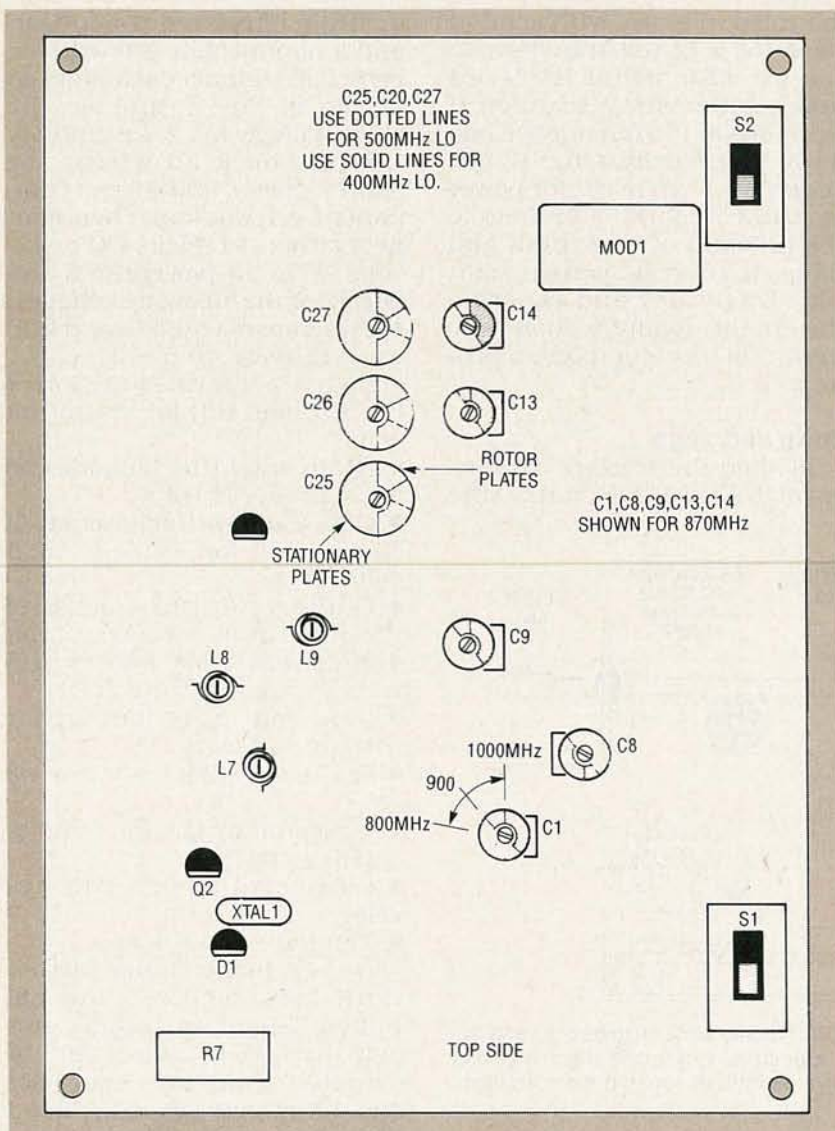

FIG. 7—TO ALIGN THE SCANNER CONVERTER you'll need a VOM, a 100-MHz or higher frequency counter, and an insulated non-metallic screwdriver. Preset all trimmer capacitors as shown here, and set the slugs halfway in L7, L8, and L9.

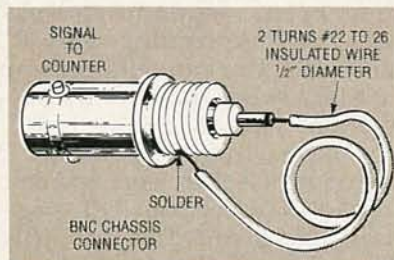

FIG. 8—COUPLE A FREQUENCY COUNTER to L7 using a 2-turn wire loop as shown here.

C26, and C27 for the greatest reading. Short the base of Q2 to ground; the reading at TP2 should be about +0.2 volt. With the short removed, the reading should drop and ideally even go negative, to about -0.1 to

-0.15 volts. Adjust C25, C26, and C27 to go as far negative as possible. You should be able to obtain zero volts. The difference between the two readings is approximately the local oscillator injection level at R18, which should be about 0.3 volt RMS.

Use the counter to check the frequency of the signal at the junction of R18 and R19. It should be within a few kilohertz of either 400 or 500 MHz. Potentiometer R7 should vary the frequency  $\pm 5$  kHz or more. Adjust L7 so that R7 can do that, and also so that R7 is in the middle of its range when either 400 or 500 MHz is produced.

Connect an antenna to J1.

LED1—green light-emitting diode (optional)

LED2—red light-emitting diode (optional)

#### Inductors

L1–L5, L10–L12—part of PC-board etching

L6, L15—ferrite bead on wire jumper (see Fig. 2)

L7—0.2–0.32  $\mu$ H (9½ turns #22 enameled wire wound on 8-32 screw with ferrite slug, Cambion part # 515-3225-06-21-00)

L8, L9—0.05–0.1  $\mu$ H (3½ turns #22 enameled wire wound on 8-32 screw with ferrite slug, Cambion part # 515-3225-06-21-00)

L13—1.0  $\mu$ H RF choke

L14—ferrite bead over lead of R20 (see Fig. 2)

L16—½-turn #22 enameled wire on ¼-inch form (see Fig. 2)

#### Other components

J1, J2—female BNC connector

MOD1—MCL SBL-IX mixer module

S1, S2—DPDT PC-mount slide switch

XTAL1—50-MHz 3rd overtone crystal

**Miscellaneous:** PC board, small-diameter 50-ohm coaxial cable, project case, 14.5–24-volt DC or 12-volt AC, 350-mA transformer (see text), hardware as required, brass rod or wire, two ¼-inch rubber grommets, line cord if required, solder, etc.

**Note:** The following items are available from North Country Radio, PO Box 53, Wykagyl Station, New Rochelle, NY 10804:

- Converter kit including all parts except case and transformer—\$67.50 + \$3.50 S&H
- PC board only—\$13.50 + \$3.50 S&H
- Transformer—\$9.50 + \$3.50 S&H

New York State residents must add appropriate sales tax.

the 900-MHz range, use it (connected to J1) as a signal source.

On a weak signal, peak C1, C8, C9, C13, and C14 for best signal-to-noise ratio. If you use an off-the-air signal, the signal may disappear before you are through.

Do not mistake a stray 470–530 MHz signal that may leak into your scanner for 900

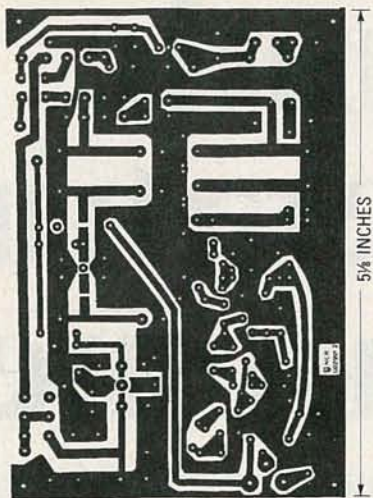

COMPONENT SIDE of the scanner converter board. Board shown half size.

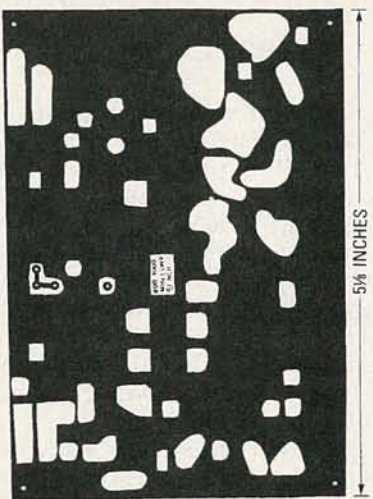

SOLDER SIDE of the scanner converter board. Board shown half size.

MHz. To check this, turn off the converter using the built-in switch. If the signal is false, it will get stronger. If it is a real 900-MHz signal, it will disappear when the converter is turned off. You can re-peak the converter at any time on any part of the frequency range. Typical RF bandwidth is 40 MHz at the 3 dB points. Signals will be heard 10 to 20 MHz beyond those limits, so if you use the converter for, say 800–825 MHz and 851–868 MHz (most common), you can peak the converter in the middle (825 MHz) and still get satisfactory performance. It is possible to “stagger tune” the circuits to increase bandwidth, although you will lose some gain. R-E

## Earn Your B.S. Degree in ELECTRONICS or COMPUTERS



### By Studying at Home

Grantham College of Engineering, now in our 41st year, is highly experienced in “distance education”—teaching by correspondence—through printed materials, computer material, fax, and phone.

No commuting to class. Study at your own pace, while continuing on your present job. Learn from easy-to-understand but complete and thorough lesson materials, with additional help from our instructors.

Our Computer B.S. Degree Program includes courses in BASIC, PASCAL and C languages — as well as Assembly Language, MS DOS, CAD, Robotics, and much more.

Our Electronics B.S. Degree Program includes courses in Solid-State Circuit Analysis and Design, Control Systems, Analog/Digital Communications, Microwave Engr, and much more.

An important part of being prepared to *move up* is holding the right college degree, and the absolutely necessary part is knowing your field. Grantham can help you both ways—to learn more and to earn your degree in the process.

Write or phone for our free catalog. Toll free, 1-800-955-2527, or see mailing address below.

Accredited by  
the Accrediting Commission of the  
National Home Study Council

**GRANTHAM**  
**College of Engineering**  
Grantham College Road  
Slidell, LA 70460

# Electronic Temperature Measurement



*What is temperature and how can it be measured electronically?*

HARRY L. TRIETLEY

TEMPERATURE IS PERHAPS THE most common of all physical measurements. From weather forecasts to industrial processes to patient monitoring, its measurement pervades our lives. Yet, unless our jobs directly involve temperature measurement, most of us don't give much thought to what temperature is or how it's measured. In this article we will look briefly at how temperature is defined and survey the field of electronic temperature measurement. We'll then begin an in-depth study of temperature sensors and application circuits, closing with a look at noncontact infrared thermometry.

## What is temperature?

Any grade school science student knows that heat is molecular motion. The hotter something is, the faster its molecules move; absolute zero is defined as the point where all molecular motion ceases. All well and good but, since we can't see molecules move, how do we measure temperature?

The bedrock standard used by the NIST (National Institute of Standards and Technology, formerly the National Bureau of Standards) is based on the perfect gas law. The law states that as temperature rises, either the pressure or volume of the gas

must increase in proportion. Mathematically,  $P \times V = kT$ , where  $P$  = pressure,  $V$  = volume,  $T$  = absolute temperature, and  $k$  is a constant. Doubling the molecular velocity in a constant volume results in twice as many molecular collisions per second, or twice the pressure. At absolute zero a perfect gas would collapse to zero volume and pressure.

Figure 1 illustrates the concept of a constant-volume helium gas thermometer. (Perfect gases do not exist, but helium comes close.) A mercury manometer—a device used for measuring the pressure of gasses and vapors—with an adjustable reservoir measures the gas pressure of a helium-filled bulb. As temperature changes, a plunger in the reservoir is adjusted to maintain the left leg of the manometer at a constant height, thus maintaining the helium at a constant volume. When a vacuum is pulled above the right leg, the mercury height indicates the gas pressure, and thus the temperature of the helium.

The concept sounds simple, but precision measurements are difficult. Temperature affects the volume of the bulb and the interconnecting tube is not at the same temperature as the bulb. Also, the relatively small

change in mercury level, plus the meniscus of the mercury surface, limits measurement accuracy. On top of all that, corrections must be made for helium's deviations from the perfect gas law. Therefore, gas law thermometry is used primarily by national standards laboratories such as the NIST.

## Temperature scales

Companies and laboratories which manufacture or calibrate thermometers need a more practical standard. For that reason, the International Temperature Scale (ITS) was established. Previously known as the International Practical Temperature Scale to distinguish it from the fundamental gas-law scale, it is regularly reviewed and revised by international conferences involving a number of national standards laboratories. The latest revision, published in 1990, is known as ITS-90.

The scale begins with a series of agreed-upon fundamental temperatures, or fixed points. The freezing (or melting) point—or, in some cases, a variation known as the triple point—of certain high-purity materials have been assigned precise temperature values by agreement among the participating labs. Figure 2 shows

a typical fixed-point cell. A graphite crucible containing a high-purity metal is sealed in a quartz envelope filled with argon or some other inert gas.

Table 1 lists several fixed points. The freezing point of silver, for example, has been assigned the value of 1234.93 Kelvin (absolute) or 660.323 degrees Celsius. Water's triple point, which can be controlled more precisely than the freezing point, is defined to be 273.16K or 0.01°C.

(The triple point is like the freezing point, except that the material is sealed in an evacuated glass container. Instead of being at atmospheric pressure, the water sees only its own vapor pressure. Since the freezing point is affected by both air pressure and contamination, the triple point is more repeatable. The term, "triple point," refers to the fact that the material is in three-phase equilibrium—vapor, liquid, and solid.)

To make the scale practical it is necessary to have sensors that can interpolate between the defined fixed points. ITS-90 defines several such sensors, covering various portions of the scale.

The "center" of the scale, between the hydrogen triple point and the silver freezing point, is interpolated using high-grade resistance thermometers known as SPRT's (Standard Platinum Resistance Thermometers). SPRT's are carefully constructed of high-purity platinum wire, wound and assembled with a minimum of support so as to be strain-free. The thermometers are calibrated at three or more fixed points, then used between those temperatures. Their R versus T equations are very complex and must be handled by computers. Figure 3 shows a SPRT enclosed in a Pyrex sheath.

The very low end of the scale, down to 0.65K, is defined by Helium gas-law thermometry. Several overlapping ranges are defined, each with its own set of complex equations and tables. At the high end, temperatures above the silver freezing point

are defined using radiation thermometry. We'll look at radiation thermometry next month, but basically it makes use of the fact that infrared or optical radiation increases with temperature. (The older IPTS also used thermocouples made of platinum alloys to define part of the temperature scale, but this was dropped in the 1990 revision.)

### Commercial sensors

For the balance of this article we'll examine and compare commercial temperature sensors: thermocouples, resistance thermometers, thermistors, and silicon (IC) sensors. Let's begin with a quick survey; Table 2 compares their characteristics, while Fig. 4 shows operating ranges and accuracies.

Incidentally, for a first-rate mail-order source of temperature sensors, instruments, and information contact Omega Engineering, One Omega Drive, Box 4047, Stamford, CT 06907, 1-800-826-6342 (CT and international, 203-359-1660).

Thermocouples are nothing more than two dissimilar metals joined together. When connected, an EMF is produced which increases (approximately linearly) with temperature. The thermocouple's sensitivity, linearity, and temperature range depend on the metals used.

Over the years several types of thermocouples have emerged as standards. In the US the NIST publishes millivolt-versus-temperature tables for eight types, identified by letter codes. Five (types J, K, T, E, and N), made from base-metal alloys, cover varying temperature ranges and applications. Sensitivities are typically tens of microvolts per degree C. The other three (types R, S, and B) are formed of platinum and platinum alloys. Obviously expensive, they are the most stable and repeatable of thermocouples, and most often used for high-temperature work, but their sensitivities are lower.

Thermocouple wire and probes made to these standards are available from a number of manufacturers and distributors. In addition, some

manufacturers produce special thermocouples for high temperature, cryogenic, and other specialized applications. Most common of these are tungsten alloy thermocouples which allow measurements as high as 2315°C (4200°F).

A resistance thermometer (commonly called an RTD, or Resistance Temperature Device) consists of a coil of fine-gauge wire or metal film. Most metals change resistance with temperature, but platinum or nickel are most often used to make RTD's. RTD's generally are more stable, accurate, and sensitive than thermocouples, but are limited to lower temperatures. Platinum RTD's are the most stable and accurate and cover the highest temperature range.

Nickel's lower cost has made it attractive for moderate-temperature industrial applications; however, recent advances in the art of manufacturing platinum-film elements (similar in principle to metal-film resistors) has eliminated the cost advantage of nickel. Other metals, primarily copper and an alloy named Balco, are sometimes used as well.

Thermistors are probably somewhat familiar to most readers. Unlike thermocouples and RTD's, they are highly sensitive, highly nonlinear, and cover limited temperature ranges. Positive temperature coefficient (PTC) thermistors exist, but those best suited to temperature measurement are negative temperature coefficient (NTC) devices which decrease in resistance by about 3 to 5% per °C. Thermistors offer the widest variety of sizes, shapes, accuracies, and prices of any commercial temperature sensors.

Integrated circuit (IC) temperature sensors are newest and easiest for most experimenters to apply. They are sensitive and linear, and interface easily to op-amps and A/D converters. On the flip side, IC's have not become as standardized as other sensors. Precisely-calibrated (selected) grades tend to get expensive. Their temperature range is about the same as ep-

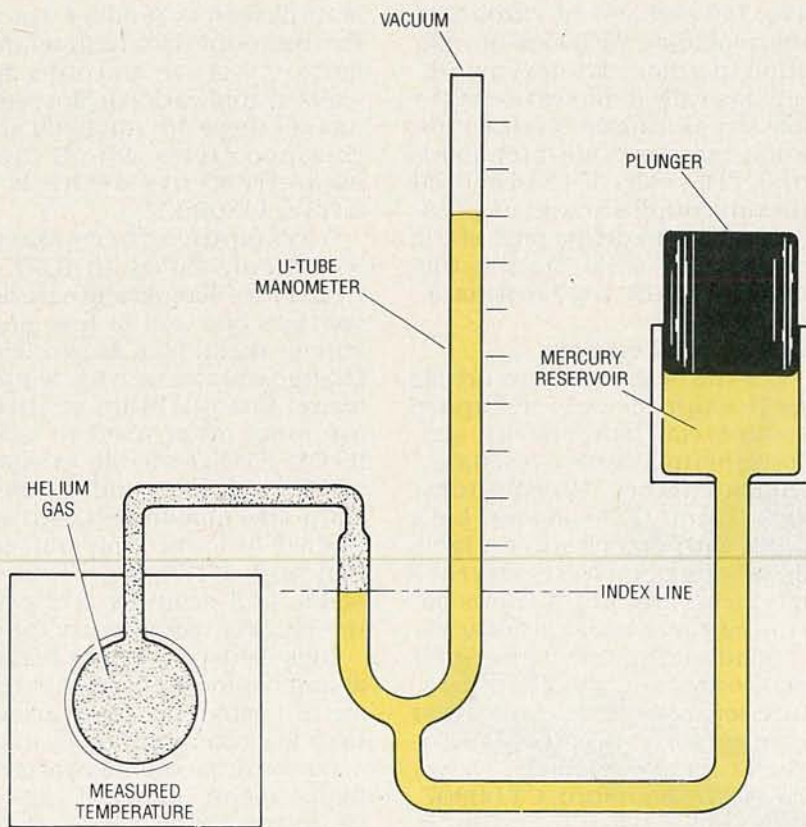

FIG. 1—CONSTANT-VOLUME GAS THERMOMETER. The plunger is adjusted to maintain the left leg of the manometer at the index line as the gas pressure changes.

TABLE 1

Fixed Point	Temp (K)	Temp (°C)
Hydrogen Triple Point	13.8033	-259.3467
Neon Triple Point	24.5561	-248.5939
Oxygen Triple Point	54.3584	-218.7916
Argon Triple Point	83.8058	-189.3442
Mercury Triple Point	234.3156	-38.8344
Water Triple Point	273.16	0.01
Gallium Melt Point	302.9146	29.7646
Indium Freeze Point	429.7485	156.5985
Tin Freeze Point	505.078	231.928
Zinc Freeze Point	692.677	419.527
Aluminum Freeze Point	933.473	660.323
Silver Freeze Point	1234.93	961.78
Gold Freeze Point	1337.33	1064.18
Copper Freeze Point	1357.77	1084.62

oxy-coated thermistors.

### Which sensor is best?

It depends upon temperature, application and accuracy. At high temperatures thermocouples may be the only choice. Best accuracy generally is given by platinum RTD's, although precision thermistors may excel near room temperature. Thermistors, because of their high sensitivity, are superb in narrow-range applications such as

medical thermometers. Thermistors and IC's both serve well for moderate accuracy measurements and temperature compensation applications.

IC's and, to a lesser extent, RTD's offer limited package selections. For small size and fast response, glass-bead thermistors are available in diameters from 0.014 down to 0.005 inch while uninsulated thermocouple wire is available down to 0.0005-inch diameter. At the

other end of the scale, thermistor washers and discs are offered with diameters up to 1/2 inch. Thermocouple wires are available to 14 AWG and even larger, with insulations ranging from PVC to ceramic fibers. Surface temperatures may be measured by ribbon style thermocouples, or thermocouple wires may be welded directly to metal surfaces.

Now that our survey is complete, let's look at each in detail.

### IC sensors

Forward-biased silicon diodes and base-emitter junctions have often been used to measure temperature. At room temperature, a forward-bias



FIG. 2—FIXED POINT CELL. The graphite crucible, visible through the quartz enclosure, contains a high-purity metal. (Courtesy of YSI Inc.)

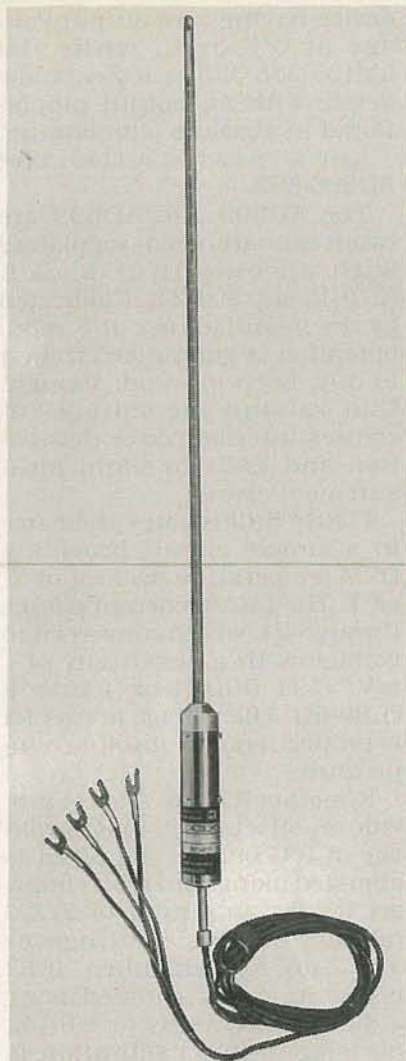

FIG. 3—STANDARDS-QUALITY SPRT, assembled into a quartz sheath. (Courtesy of YSI Inc.)

junction drops about 0.7 volts, with a negative temperature coefficient of approximately  $-2\text{mV}/^\circ\text{C}$ . The exact voltage and temperature coefficient depends upon the junction's geometry, current density, and other factors.

Precise calibration requires individual measurement of each diode or transistor at known temperatures. The basic equation for a P-N junction is:

$$I = I_0 \left( e^{\frac{qV}{kT}} - 1 \right)$$

where  $q$  is the charge of an electron,  $k$  is a physical constant known as the Boltzmann constant, and  $T$  is the absolute temperature (Kelvins).  $I_0$  is a

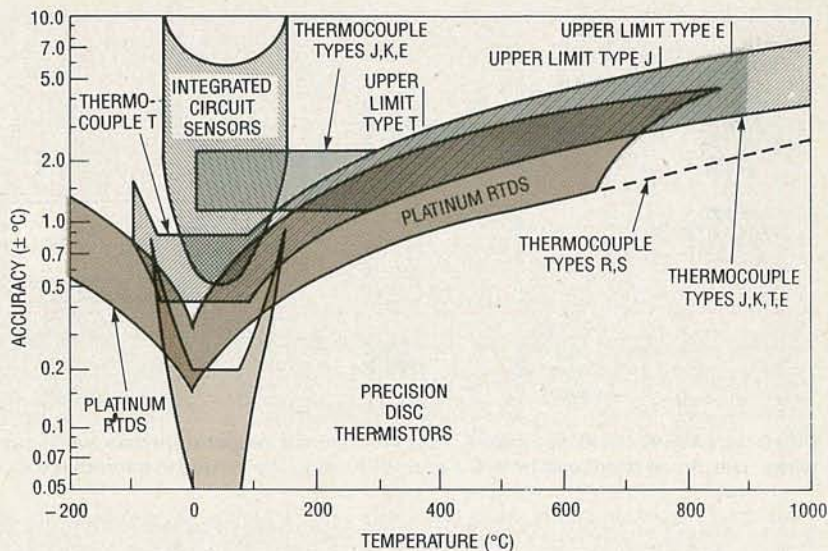

FIG. 4—THE "BEST" TEMPERATURE SENSOR depends on the temperature range and accuracy required.

TABLE 2—SENSOR COMPARISON CHART

Sensor Type	Typical Sensitivity	Temperature Range	Midrange Accuracy	Non-Linearity
Base Metal Thermocouples Types J, K, T, E, N	40 to 70 $\mu\text{V}/^\circ\text{C}$	$-270$ to $1372^\circ\text{C}$	1.1 to $2.2^\circ\text{C}$	1 to 5%
Platinum Alloy Thermocouples Types R, S, B	7 to 12 $\mu\text{V}/^\circ\text{C}$	$-50$ to $1820^\circ\text{C}$	0.6 to $1.5^\circ\text{C}$	1 to 5%
Tungsten Alloy Thermocouples	10 to 21 $\mu\text{V}/^\circ\text{C}$	$-17$ to $2315^\circ\text{C}$	$4.5^\circ\text{C}$	2 to 7%
Platinum Resistance Thermometers (100 $\Omega$ )	$0.4\Omega/^\circ\text{C}$	$-200$ to $650^\circ\text{C}$	0.1 to $0.25^\circ\text{C}$	1 to 3%
Nickel Resistance Thermometers (100 $\Omega$ )	$0.7\Omega/^\circ\text{C}$	$-60$ to $180^\circ\text{C}$	$0.4^\circ\text{C}$	1 to 5%
Precision Disc Thermistors	$-3$ to $-5\%$ $^\circ\text{C}$	$-80$ to $150^\circ\text{C}$	0.1 to $0.2^\circ\text{C}$	Inherently Nonlinear
Glass Bead Thermistors	$-3$ to $-5\%$ $^\circ\text{C}$	$-60$ to $300^\circ\text{C}$	Noninterchangeable	Inherently Nonlinear
Integrated Circuit Sensors	$1\mu\text{A}/^\circ\text{C}$ or $1$ to $10\text{mV}/^\circ\text{C}$	$-50$ to $150^\circ\text{C}$	0.5 to $5^\circ\text{C}$	0.3 to 3% $^\circ\text{C}$

constant, basically equal to the reverse-biased leakage current. At room temperature, the quantity  $kT/q$  is about 26 mV. Under normal forward-biased conditions the  $-1$  term is insignificant and can be ignored, so:

$$I \approx I_0 e^{\frac{qV}{kT}}$$

so

$$\ln \left( \frac{I}{I_0} \right) = V$$

An IC temperature sensor's operation is based on the dif-

ference between two base-emitter voltage drops where the junction currents are maintained at a constant ratio,  $I_2/I_1$ . Applying a little algebra to that equation shows that the voltage difference is given by:

$$V_2 - V_1 = \frac{kT}{q} \ln \left( \frac{I_2}{I_1} \right)$$

Circuits within the IC use that difference to create an output voltage or current which is proportional to temperature.

Table 3 lists four IC's. The AD590 and AD592 behave iden-

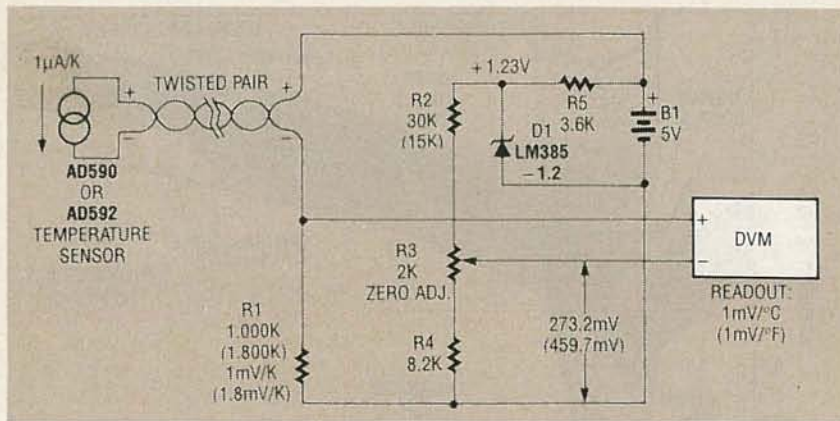

FIG. 5—AN AD590 OR AD592 makes it easy to transmit temperature data over a pair of wires. The circuit produces 1mV/°C (or 1mV/°F using the values in parentheses).

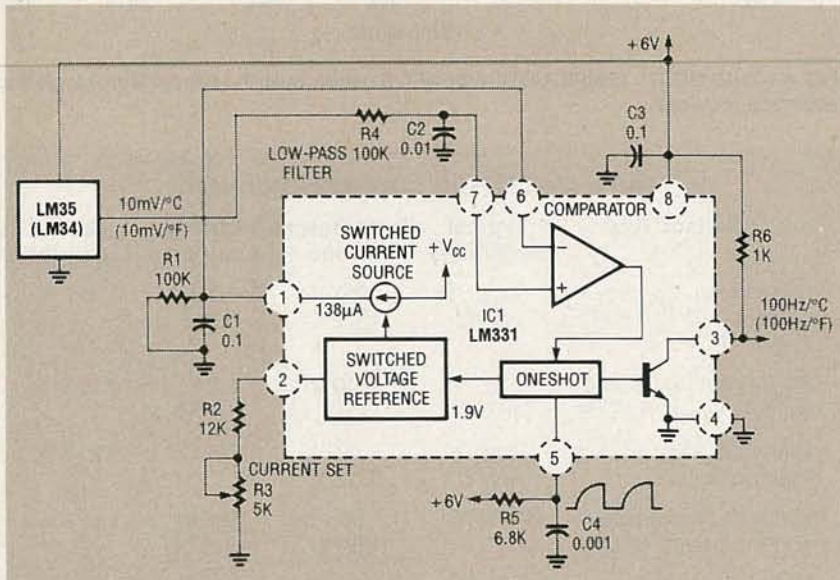

FIG. 6—AN LM35 OR LM34 PLUS A V/F IC produces a frequency proportional to temperature.

TABLE 3—TEMPERATURE SENSORS

Type & Mfr	Description	Available Ranges	Available Accuracies
AD590: Analog Devices, Harris	Two terminal current source 1 $\mu$ A/K	-55 to 150°C	1.7 to 10°C (0.5 to 5°C @ 25°C)
AD592: Analog Devices	Two terminal current source 1 $\mu$ A/K	-25 to 105°C	1 to 3.5°C (0.5 to 2.5°C @ 0 to 70°C)
LM34, LM35: National	Three terminal current source 10mV/°F (LM34) 10mV/°C (LM35)	-55 to 150°C	1.5 to 2°C (0.5 to 1°C @ 25°C)
LM135/235/335: National	Two terminal voltage regulator 10mV/K, calibratable	-40 to 100°C -40 to 125°C -55 to 150°C	2.7 to 9°C (1 to 6°C @ 25°C) without user calibration

tically, but the newer AD592 is less expensive (plastic TO-92 case), covers a narrower range,

and, over that range, offers tighter accuracy. National's LM34/LM35 is a three-terminal

device having zero output voltage at 0°F or C, while the LM135/235/335 is a Zener-like device with an output proportional to absolute temperature. Let's start with the AD590/592.

The AD590 and AD592 are two-terminal current regulators with an output of 1  $\mu$ A (273.15  $\mu$ A at 0°C). Calibrated by the manufacturer at 5 volt operation is guaranteed from 0 to 30V. Keep in mind, though, that raising the voltage increases internal power dissipation and leads to slight measurement errors.

Figure 5 illustrates their use in a simple circuit providing a DVM temperature readout in °C or °F. The 1  $\mu$ A/K current passes through R1, which converts its voltage with a sensitivity of 1 mV/°C (1.000K) or 1 mV/°F (1.800K). The voltage across R1 is proportional to absolute temperature.

Resistors R2, R3, and R4 provide an offset equal to R1's voltage at 0°C or 0°F. The offset is adjusted using the DVM: simply set R3 for an output of 273 mV for Celsius readings or 459.7 mV for Fahrenheit. If the DVM is purchased (or trimmed using a digital ohmmeter) to  $\pm 0.1\%$ , no temperature calibration is required to achieve the IC's rated accuracy.

If you want to achieve superior accuracy using a lower grade (looser tolerance) IC, you can make R1 adjustable. Place the IC at a known temperature, connect the DVM across R1, and adjust it for the correct reading based on 1 mV/degree. (Suggestion: place the IC in a closed-end sheath and let it come to equilibrium in a stirred ice-water bath. Trim R1 until the voltage across it is 273.2 at 0

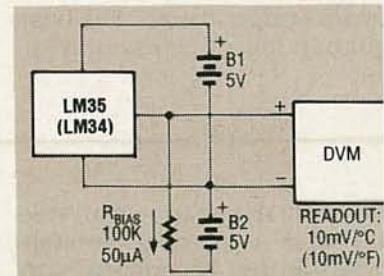

FIG. 7—A NEGATIVE BIAS is needed for readings below zero degrees.



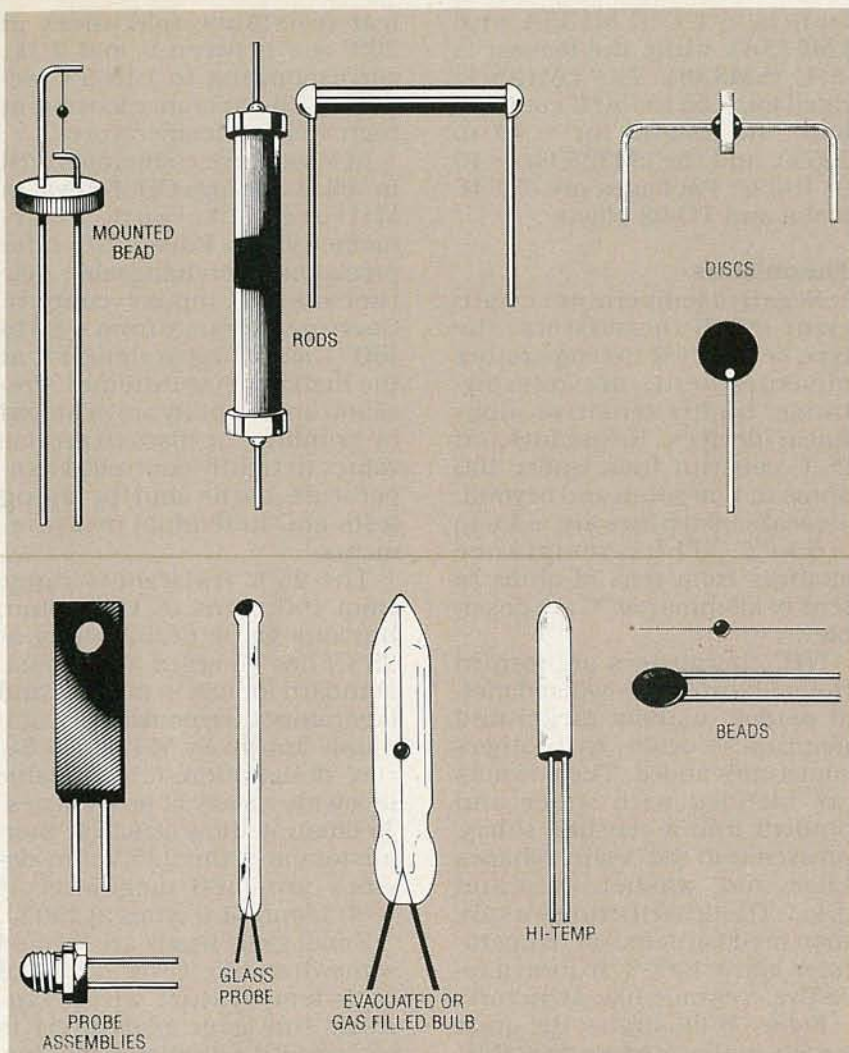

FIG. 8—A BROAD VARIETY of thermistor styles are available. Shown here are some of the more common ones.

TABLE 4—THERMISTOR CHARACTERISTICS

Thermistor Type	Available Resistances	Mid-Range Accuracy	Typical Temperature Range
Low Cost	100 ohms to 200K	5 to 20% (1 to 5°C)	-50 to 150°C
Precision Interchangeable Disc	100 ohms to 1 megohm	0.1 to 0.2°C (0.5 to 1%)	-80 to 150°C
Glass Bead	200 ohms to 1 megohm	20% (5°C)	-60 to 300°C
Glass Coated Interchangeable Disc	2.2K to 30K	0.05 to 0.2°C (0.2 to 1%)	-80 to 250°C

or 491.7 mV at 32°F.) Adjust R3 as described earlier.

The AD590 is available in several grades from  $\pm 5^\circ\text{C}$  (AD590J) to  $\pm 0.5^\circ\text{C}$  at  $25^\circ\text{C}$  (AD590M). The AD592's guaranteed  $25^\circ\text{C}$  accuracies range from  $\pm 2.5^\circ\text{C}$  (AD592AN) to

$\pm 0.5^\circ\text{C}$  (AD592CD). The AD590 is available in TO-52 transistor can or flat-pack enclosures, while the AD592 is sold in a TO-92 plastic transistor package. Both are sold as un-packaged, trimmed chips.

National's LM34/35 series is

even easier to use. A three-terminal IC, it outputs 10 mV/°F (LM34) or 10 mV/°C (LM35) and is zero-based (zero millivolts at zero degrees). All that is needed to read temperature is a DVM and a battery or voltage source (anywhere from 4 to 30 volts).

Figure 6 combines an LM34 or LM35 with an LM331 voltage-to-frequency converter to provide a frequency proportional to temperature. The component values shown produce an output of 100 Hz/degree (10 kHz at 100°F or C). For more information on the LM331 and other V/F converters see "V/F Converters," **Radio-Electronics**, June 1991.

As with the AD590/592, no temperature calibration is necessary. To calibrate it, you temporarily disconnect the sensor, provide a precise 1.000 volt input, and adjust R3 for 10.00-kHz output. No zero adjustment is necessary. For improved accuracy using loose-tolerance IC's, you can place the IC at an accurately-known temperature near the high end of its range and adjust R3 for the proper output.

The LM34/35 needs a negative bias to track temperatures below zero. Figure 7 shows the basics: the IC is powered by a positive supply, but a negative bias current of approximately 50  $\mu\text{A}$  is added to the output.

The LM35 is available with temperature ranges of  $-55$  to  $150^\circ\text{C}$ ,  $-40$  to  $110^\circ\text{C}$  (suffix C), and  $0$  to  $100^\circ\text{C}$  (suffix D), and with  $25^\circ\text{C}$  guaranteed accuracies of  $\pm 1^\circ\text{C}$  and  $\pm 0.5^\circ\text{C}$  (suffix A). Similar grades are available for the LM34 Fahrenheit version. Packages are TO-46 metal and TO-92 plastic. The last IC in the table is National's LM135/235/335 series.

The LM135 operates as a Zener-like two-terminal voltage regulator IC, similar to an LM185 reference. A third terminal allows a potentiometer to be added for user calibration. The bias or "Zener" current may be anywhere from 400  $\mu\text{A}$  to 5 mA. Its output is proportional to absolute temperature, 10 mV/K (2.73 volts at  $0^\circ\text{C}$ ).

The tightest  $25^\circ\text{C}$  guaranteed accuracy without user calibra-

## DIGITAL VIDEO STABILIZER ELIMINATES ALL VIDEO COPYGUARDS



While watching rental movies, you will notice annoying periodic color darkening, color shift, unwanted lines, flashing or jagged edges. This is caused by the copy protection jamming signals embedded in the video tape, such as Macrovision copy protection. THE DIGITAL VIDEO STABILIZER: RXII COMPLETELY ELIMINATES ALL COPY PROTECTIONS AND JAMMING SIGNALS AND BRINGS YOU CRYSTAL CLEAR PICTURES.

### FEATURES

- Easy to use and a snap to install
- State-of-the-art Microchip technology
- 100% automatic
- Compatible to all types of VCRs and TVs
- The best and most exciting Video Stabilizer in the market
- Light weight (8 ounces) and compact (1x3.5x5")
- Uses a standard 9 Volt battery (last 1-2 years)
- Fast UPS delivery
- Air shipping available
- UNCONDITIONAL 30 day money back guarantee
- 1 year warranty

### WARNING

THE DIGITAL VIDEO STABILIZER IS INTENDED FOR PRIVATE HOME USE ONLY. IT IS NOT INTENDED TO COPY RENTAL MOVIES OR COPYRIGHTED VIDEO TAPES THAT MAY CONSTITUTE COPYRIGHT INFRINGEMENT.

(Dealers Welcome)  
**FREE 20P Catalog**

To Order: \$59.95 ea +\$4 for p & h  
Visa, M/C, COD Mon-Fri: 9-6 EST

**1-800-445-9285 ext. 6383**

SCO Electronics Inc. Dept. 6383  
581 W. MERRICK RD. VALLEY STREAM, NY 11580

CIRCLE 187 ON FREE INFORMATION CARD

## CABLE TV DESCRAMBLERS How You Can Save Money on Cable Rental Fees

### Bullet Proof



1 Unit 5+

**BEST Super Tri-Bi Auto/**  
Var. Gain Adjustment \$119.95...\$85  
Jerrold Super Tri-Bi... \$109.95...\$79  
Scientific Atlanta... \$109...\$79  
Pioneer... \$109...\$79  
Panasonic TZPC145... \$99.95...\$79  
Stargate Converter... \$95...\$69  
Digital Video Stabilizer... \$59.95...\$29  
Wireless Video Sender... \$59.95...\$49.95

**US Cable'll Beat  
Anyone's Price  
Advertised in  
this Magazine!**

**30 Day Money Back Guarantee**  
**FREE 20 page Catalog**

Visa, M/C, COD or send money order to:

**U.S. Cable TV Inc.** Dept. 5383  
4100 N. Powerline Rd., Bldg. F-4  
Pompano Beach, FL 33073

**1-800-772-6244 ext. 5383**

**For Our Record**

I, the undersigned, do hereby declare under penalty of perjury that all products purchased, now and in the future, will only be used on Cable TV systems with proper authorization from local officials or cable company officials in accordance with all applicable federal and state laws. FEDERAL AND VARIOUS STATE LAWS PROVIDE FOR SUBSTANTIAL CRIMINAL AND CIVIL PENALTIES FOR UNAUTHORIZED USE.

Date: \_\_\_\_\_

Signed: \_\_\_\_\_

**No Florida Sales!**

CIRCLE 188 ON FREE INFORMATION CARD

tion is  $\pm 1^\circ\text{C}$  (LM135A and LM235A), while the loosest is  $\pm 1^\circ\text{C}$  (LM335). The LM135 is rated for  $-55$  to  $150^\circ\text{C}$  continuous, the LM235 for  $-40$  to  $125^\circ\text{C}$ , and the LM335 for  $-40$  to  $100^\circ\text{C}$ . Packages are TO-46 metal and TO-92 plastic.

### Thermistors

Negative temperature coefficient (NTC) thermistors, the type best suited to temperature measurement, are narrow-range, highly sensitive, non-linear devices. Resistances at  $25^\circ\text{C}$  can run from under 100 ohms to 1 megohm and beyond. Typical sensitivities are  $-3\%$  to  $-5\%/^\circ\text{C}$ . Thus resistance changes from tens of ohms to tens of kilohms per  $^\circ\text{C}$  are possible.

NTC thermistors are formed from mixtures of powdered metal oxides, usually nickel and manganese oxides with others sometimes added. The powders are blended with water and binders into a clay-like slurry, pressed into the desired shapes (disc, rod, washer, etc.) and dried. The dried thermistors are then fired (sintered) at temperatures above  $1000^\circ\text{C}$  to form a resistive, ceramic-like structure.

Figure 8 illustrates the great variety of thermistors available. Most common for temperature measurement applications are epoxy-coated discs, generally under 0.1-inch in diameter. Similarly-sized glass-coated discs perform at higher temperatures. Bead thermistors, both glass-coated and bare, offer small size and fast response. Sizes vary from around 0.05 inch down to 0.005 inch. At the other end of the spectrum, thermistor rods are available as well as disc and washer shapes up to 1-inch diameter. In addition, several manufacturers offer thermistor sensor assemblies ranging from straight-stick probes to bolt-on and surface-mount assemblies to transistor cans.

Specifications vary greatly, but Table 4 summarizes several types. Thermistors have a reputation of being not too accurate or stable—and that is true of most inexpensive devices. Typ-

ical resistance tolerances  $25^\circ\text{C}$  are between 5 and 20 corresponding to 1 to  $5^\circ\text{C}$  accuracy. The tolerance loosens high and low temperatures.

At least three companies (3 in Yellow Springs OH, Fenwal Milford MA, and Theometrics in Edison NJ) offer precision interchangeable disc thermistors (epoxy coated). Covering the range from  $-80$  to  $150^\circ\text{C}$ , loosening to about  $1^\circ\text{C}$  at the high and low extremes. Precision and stability are achieved by grinding the discs to precise values in tightly-controlled temperature baths and by aging tests and individual measurements.

The  $25^\circ\text{C}$  resistances range from 100 ohms to 1 megohm, but one value (2252 ohms at  $25^\circ\text{C}$ ) has emerged as a quasi-standard for use in medical and laboratory thermometers. Commonly known by YSI's "400 series" designation, it is available in a wide variety of probe styles. To illustrate how sensitive thermistors are, the 2252-ohm devices are 1.66 megohms at  $-80^\circ\text{C}$  and 41.9 ohms at  $150^\circ\text{C}$ .

Small glass beads are formed somewhat differently. A pair of high-temperature wires (typically fine-gage platinum) coated with a droplet of the slurry, fired, and then dipped in molten glass. The result is a high-temperature device which is typically more stable than epoxy-coated discs but which cannot be ground or trimmed. precision applications thermistors may be supplied by manufacturer with individual test measurements. For interchangeability, the manufacturer may select and press two thermistors in parallel to match a specific calibration curve. Glass beads generally specified to about  $300^\circ\text{C}$ .

Next month we'll look at some thermistor application circuits then move on to resistance thermometers and thermocouples. We will conclude with a look at noncontact radiation thermometry. If you want to study thermistors in detail, look for **Radio-Electronics'** three-part series, "All About Thermistors," January—March 1985.

# INTELLIGENT PHONE-LINE MONITOR

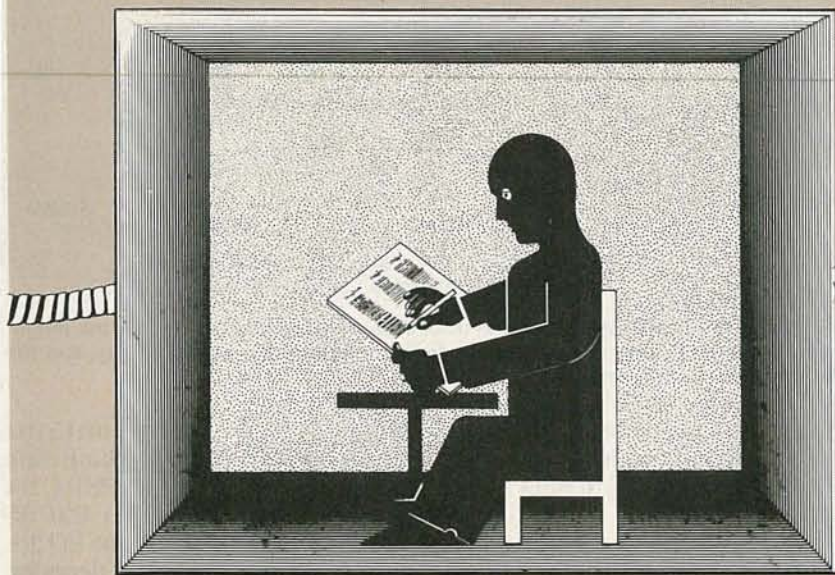

THOMAS E. BLACK

***Log telephone/modem/fax usage automatically and inexpensively with our intelligent phone-line monitor.***

RESOLVING MONTHLY TELEPHONE bills can be a struggle, especially in a shared household. It seems that there are always some long-distance calls that we would like to dispute (did someone really call Oshkosh, Wisconsin?) One solution is to maintain a telephone log on paper, but doing so requires personal discipline that may be hard to keep up. Managing telephone usage is a problem that extends into the office, too. Knowing how long you spoke to each caller is a necessity if you bill for your time. If only one could log all phone calls automatically!

As a matter of fact, there is: Digi-Call (Digital Call Auto-Logger). This unobtrusive device can solve your telephone-management troubles. Digi-Call is a microprocessor-based system that connects to any standard telephone outlet and passively waits for incoming or outgoing calls. When you make an outgoing call, Digi-Call silently logs the time, telephone number, call length, and other vital information. When you receive an incoming call, Digi-Call records the time, call length, number of rings before answering, and more. A four-digit account-cod-

ing system optionally allows you to associate each call with a particular client, user, or housemate simply by pressing the appropriate code any time during the conversation. Digi-Call can work with both rotary and *Touch-Tone* phones, but the account-management feature is available only on tone phones.

Digi-Call's intelligence is provided by an 8-bit microprocessor, 32K of RAM, and 8K of EPROM-based realtime software. Digi-Call's internal RAM allows it to record more than 1550 calls without user intervention; audible and visual

alarms signal when RAM is full. A rechargeable battery ensures that data will not be lost because of a power interruption. A built-in serial interface allows all data to be uploaded to a PC where sophisticated host software provides data analysis and reporting in a friendly, menu-based system with context-sensitive help screens. Data is stored in standard format for analysis by spreadsheet and database programs.

A complete kit of parts is available for about \$170; a commercial-quality PC board is also available, as are hard to find parts. All software is available from the author and the R-E BBS (516-293-2883, 1200/2400, 8N1) as a self-extracting ZIP file called DIGICALL.EXE.

A brief summary of Digi-Call's features is shown in Table 1.

### Circuit overview

A block diagram of the circuit is shown in Fig. 1. Intelligence is provided by IC9, an 80C31. That popular 40-pin Intel device contains an 8-bit CPU, 128 bytes of internal RAM, 32 programmable I/O ports, two timer/event counters, serial input and output lines, and 64K address spaces each for program and data memory. Telephone interface circuitry cleans up the audio and feeds it to DTMF (Dual-Tone, Multi-Frequency) decoder IC2, which drives a parallel input/output (PIO) expander, IC8. The line interface also provides a digital interrupt signal so that the microprocessor will know when something is happening on the line. A MAX232 buffers serial inputs and outputs from the microprocessor and provides RS-232 signal levels from a 5-volt supply; several lines from the PIO drive serial-control lines DTR (Data Terminal Ready) and CTS (Clear to Send).

Miscellaneous functions performed by the 8031 include driving several LED's for status indication, and monitoring the PWRON line from the power supply. When there is a power outage, the microprocessor senses and signals that fact both audibly and visually.

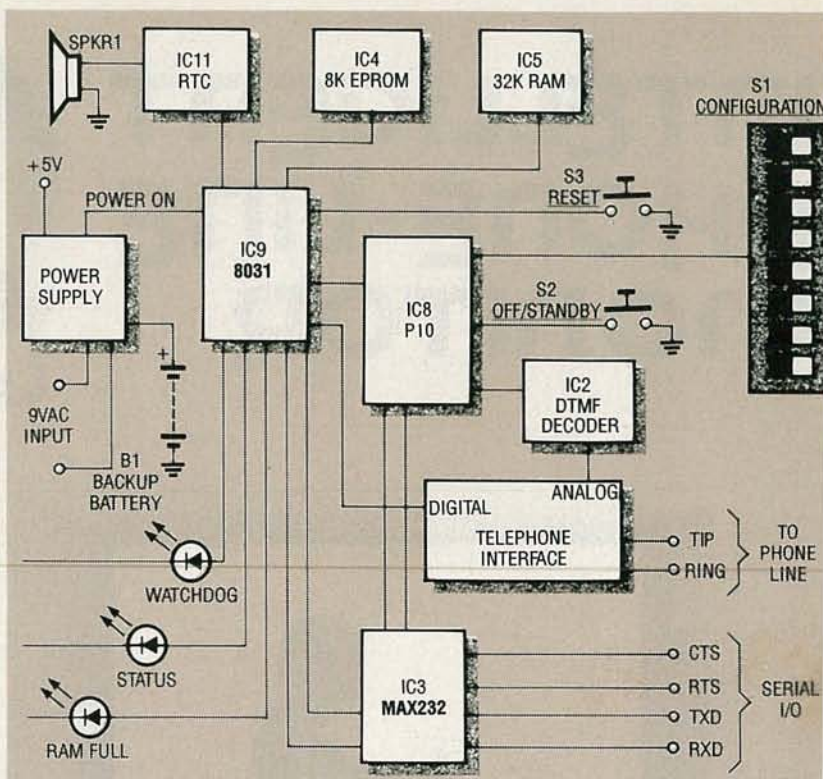

FIG. 1—BLOCK DIAGRAM shows the three major sections of the circuit: the microprocessor and memory circuit, the phone-line interface, the power supply, and the switches, LED's, and speaker.

Support components include IC4 and IC5, which provide 8K of program and 32K of data storage, respectively. A real-time clock (IC11) allows the unit to record time and data of each call

accurately; it also contains some RAM for intermediate data storage, and drives SPKR1 for audible signalling. An 82C10 (IC8) provides 24 bits of I/O interfacing the DTMF decoder configuration switch S1, and the serial I/O control lines (DTR and CTS).

TABLE 1—DIGICALL FEATURES

- Stand-alone operation while recording calls
- PC interface uses standard serial COM port
- Turn-on chime reminder
- Real time clock
- 32K buffer stores more than 1550 calls
- Built-in hardware diagnostic utilities
- Battery backup with alarm
- RAM full visual/audible alarm
- Data sorting, formatting and printing features
- Hardcopy and disk file report output
- Export feature compatible with many spreadsheet programs
- Supports popular PC/XT/AT video formats, including 50-line VGA color
- Account Group Recording (9999 accounts)
- Total Cost less than \$200

### Circuit details

Due to its size, the schema cannot be presented in one piece. Instead we present it in several sections: microprocessor, memory, and decoding (Fig. 2); telephone interface (Fig. 3); miscellaneous (Fig. 4); and power supply (Fig. 5). We start with the microprocessor section.

The 8031 requires an 8-bit latch (a 74HCT373) to demultiplex the low-order memory address. The latch holds the address presented by the microprocessor on the falling edge of the ALE (IC9, pin 30). Whenever ALE is low, those same 8 bits function as the data bus.

The 8031 has separate 64K program and data spaces. The data space consists of 32K

## PARTS LIST

### All resistors are 1/4-watt, 5%, unless otherwise noted

R1, R2—100,000 ohms  
 R3, R10, R13—470,000 ohms  
 R4—R6—22,000 ohms  
 R7, R14—470 ohms  
 R8—56,000 ohms  
 R9, R11, R12, R28—47,000 ohms  
 R15—1 megohm  
 R21, R23, R25—220 ohms  
 R17—10,000 ohms  
 R18, R29—1000 ohms  
 R19—100 ohms  
 R20, R22, R24—10,000 ohms  
 R30—10 megohms  
 R31—470 ohms, 1/2 watt

### Capacitors

C1, C2—0.001  $\mu$ F, 100 volts, polyester, radial lead  
 C3, C14—0.01  $\mu$ F, 100 volts, polyester, radial lead  
 C4, C7, C15—C21, C28, C31, C32—0.1  $\mu$ F, 50 volts, monolithic, radial lead  
 C5, C6, C8—C13, C22, C25, C33—10  $\mu$ F, 16 volts, electrolytic, radial lead  
 C23, C24, C27—27 pF, 100 volts, ceramic  
 C26—5–35 pF, variable, top adjust, 5 mm, PCB mount  
 C29—1000  $\mu$ F, 16 volts, electrolytic, axial lead

### Semiconductors

BR1—DB103, 200 volts, 1 amp, bridge rectifier, DIP package  
 BR2—W005M, 50 volts, 1 amp, bridge rectifier  
 LED1, LED2—Not used  
 LED3, LED5—LED, red, T-1 $\frac{3}{4}$   
 LED4—LED, green, T-1 $\frac{3}{4}$   
 D1—D7—1N4148 or 1N914 switching diode  
 D8—1N4732A, 4.7 volts, 1 watt, Zener diode  
 D9, D10—1N4001, 50 volts, 1 amp, rectifier  
 Q1—Q4—2N2222, general-purpose transistor  
 IC1—LM324, low-power op-amp  
 IC2—75T204 (SSI204) or 75T202 (SSI202) DTMF decoder (see text)  
 IC3—MAX232 or ICL232, 5-volt RS-232 driver  
 IC4—27C64-2, 8K CMOS EPROM

IC5—M5M5256A or HM62256LP-15, 32K  $\times$  8 static RAM  
 IC6—74HCT373, CMOS 8-bit latch  
 IC7—74HCT138, CMOS 3-to-8 line decoder  
 IC8—82C55A, CMOS peripheral interface  
 IC9—80C31 or 80C32, CMOS microprocessor  
 IC10—74HCT14, CMOS hex inverter  
 IC11—MC146818A, realtime clock with RAM (see text)  
 IC12—LM2940T, 5 volts, 1 amp, low-power regulator

### Other Components

B1—6 Ni-Cd AA Cells, 400–600 mAh  
 P1—6-pin, 0.1" header connector  
 SPKR1—8-ohms, 1 $\frac{1}{2}$ "  
 S1—8-position DIP switch  
 S2—SPST, normally open, momentary, PC board mount  
 S3—SPST, normally open, momentary, panel mount  
 XTAL1—3.58 MHz, HC-18  
 XTAL2—11.0592 MHz, HC-18  
 XTAL3—4.194 MHz, HC-18  
 MOV1—ERZ-C07DK201U, 130 volts, 400 amps, ZNR surge suppressor

**Miscellaneous:** 6-cell AA battery holder, TO-220 heatsink, wall transformer (8–9 VAC, 300–1000 mA), PC board, IC sockets, enclosure (8.25  $\times$  6.25  $\times$  2), modular telephone line cord, assembly hardware, software.

**Note: The following parts are available from Digital Products Company, Attn: Thomas E. Black, 134 Windstar Circle, Folsom, CA 95630: Complete kit of PC-board and parts without enclosure, \$169.95; printed circuit board #DC001, \$42.50; 75T204 DTMF decoder \$14.50, programmed EPROM, \$16.50, software on disk (5.25" only), \$7.50. All orders add \$3.75 S&H. CA residents add CA tax. U.S. funds only, no foreign shipments. Personal and business checks allow 3–4 weeks. No COD's or bank cards accepted. Prices subject to change.**

vals, i.e., the realtime clock is addressed at C000h, the PIO at C100h, and the remaining outputs are unused.

Current time and date are maintained by realtime clock IC11, an MC146818A, which also has a simple square-wave tone generator and 50 bytes of RAM. The RAM serves as a buffer for incoming RS-232 data; Digi-Call uses the square-wave generator portion for audible signalling.

The EPROM (IC4) contains all system code; it is accessed beginning at 0000h whenever PSEN is low.

### Telephone interface

The key to Digi-Call's operation is its telephone interface, shown in Fig. 3. Note that this circuit uses two separate grounds: analog and digital. Electrically, they meet at a common point near the power-supply ground. To avoid noise problems, the two ground circuits must remain separate except where they meet at the power supply. (Our PC board ensures that that is so.)

Digi-Call determines the status of the phone line by watching the voltages present on it. A standard phone line sits at -48-volts DC when not in use (when it is on-hook). When the phone is in use (when it is off-hook) the nominal voltage is about -7-volts DC. When the phone rings, a 90-volt, 20-Hz AC signal appears across the line.

When you dial a number using a rotary-dial phone (or the pulse-dial option on a modern phone, modem, or fax machine), what happens is that the device interrupts phone-line current, thereby causing line voltage to swing between the off- and the on-hook voltages. For instance, dialing the digit "9" causes nine oscillations between the two voltages, usually at a rate of about ten pulses per second. Rather than interrupt the flow of current, pushbutton phones usually send DTMF tones, which we will describe momentarily.

The telephone interface connects to the phone line at the tip

static RAM (IC5), which occupies the lower 32K of memory. The realtime clock (IC11), and the peripheral interface (IC8)

share the upper 16K of the address space, as decoded by IC7, beginning at C000h. Outputs of IC7 are enabled at 100h inter-

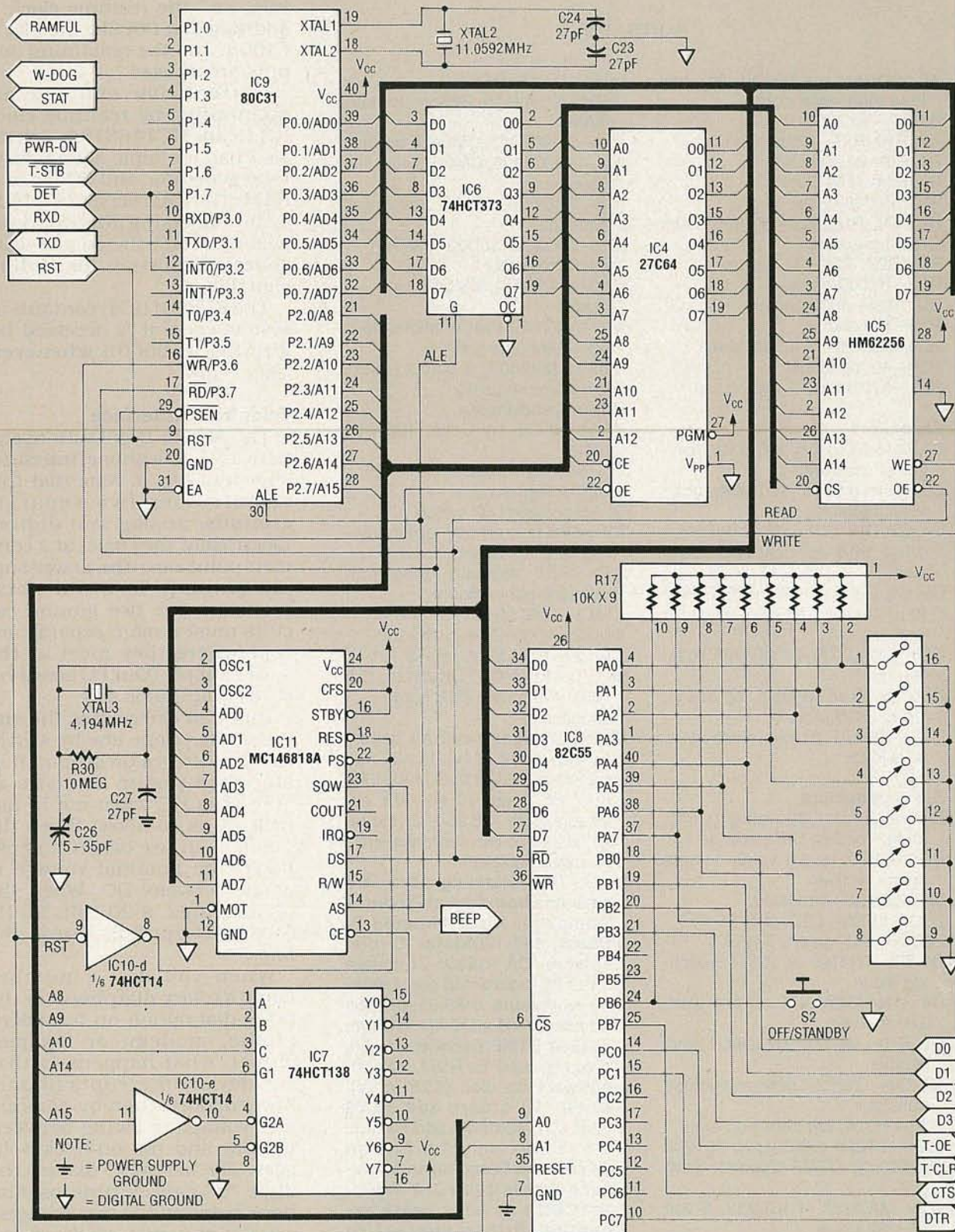

FIG. 2—DETAILS OF THE MICROPROCESSOR/MEMORY CIRCUIT, which consists of an 80C31 microprocessor, 32K of static RAM, and 8K of EPROM-based realtime software.

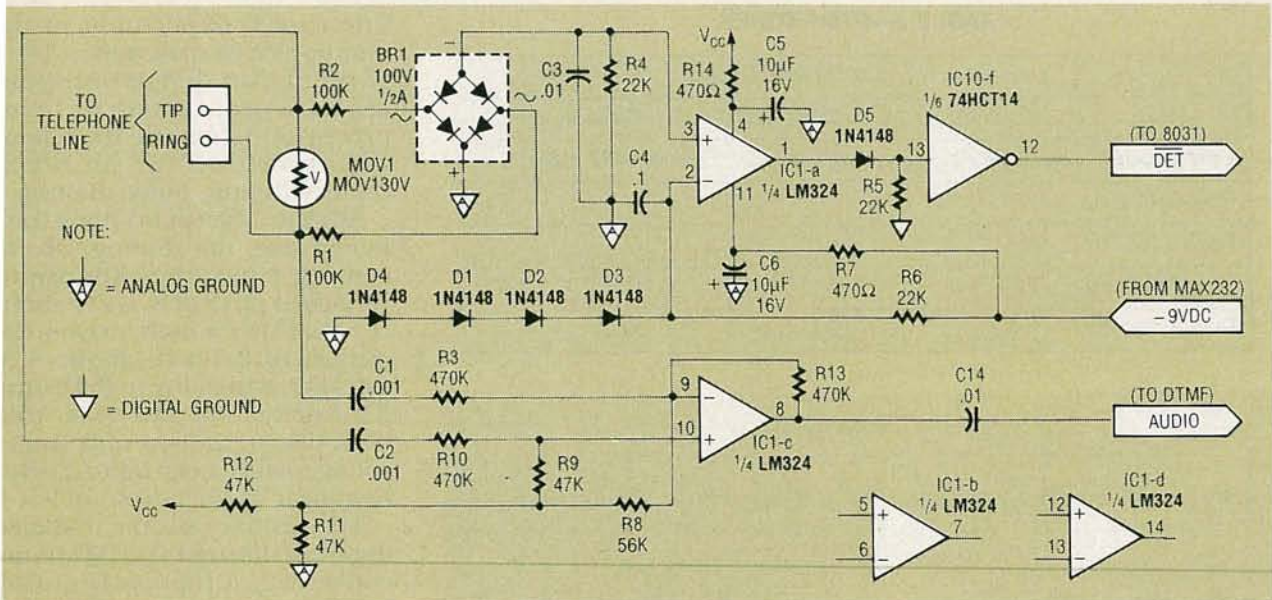

FIG. 3—TELEPHONE-LINE INTERFACE presents a high-impedance interface to avoid line loading. Note the use of separate analog and digital grounds.

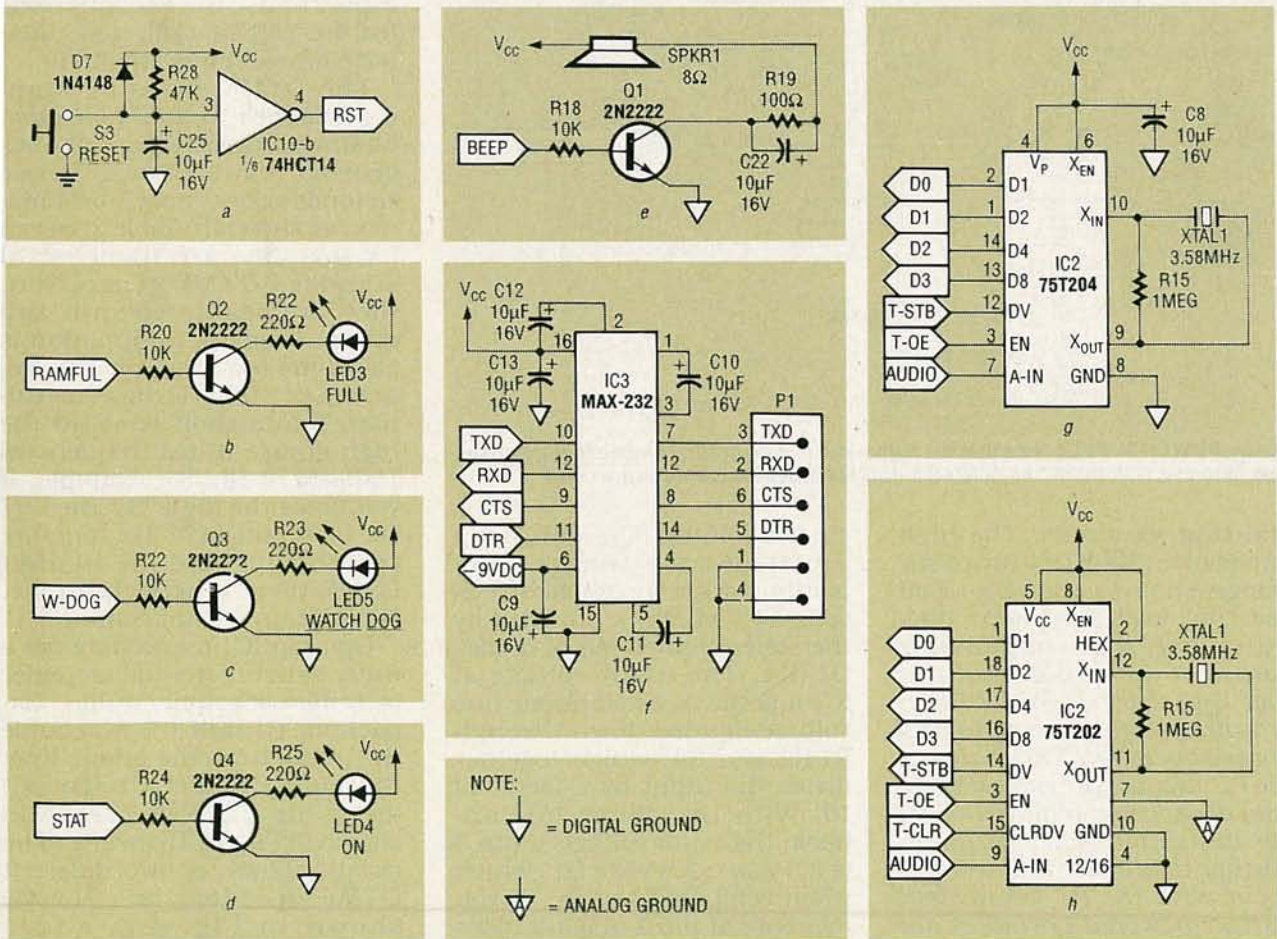

FIG. 4—MISCELLANEOUS CIRCUITS: (a) shows the reset circuit; (b), (c), and (d) show the status LED drivers; (e) shows the speaker driver; (f) shows the RS-232 interface; (g) and (h) show the DTMF interfaces. Use only one of (g) or (h), depending on the availability of DTMF decoder IC's.

TABLE 2—DTMF TONES

	High Group		
	Column 0	Column 1	Column 2
<b>Low Group</b>	1209 Hz	1336 Hz	1477 Hz
Row 0, 697 Hz	1	2	3
Row 1, 770 Hz	4	5	6
Row 2, 852 Hz	7	8	9
Row 3, 941 Hz	*	0	#

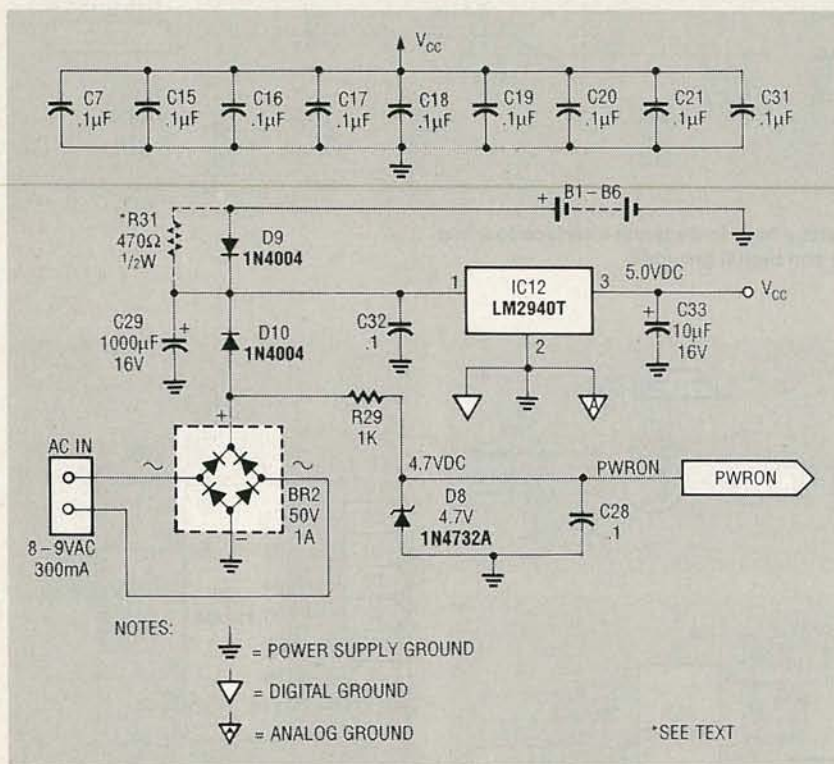

FIG. 5—POWER SUPPLY. Note that the digital and analog grounds come together here. Also note that R31 should be deleted if nonrechargeable batteries are used.

and ring terminals. The high impedance (200K) nature of our design ensures that Digi-Call does not load the phone line. *Note: The high-impedance nature of the circuit requires that Digi-Call be isolated from grounded equipment during normal operation. Only connect the PC's serial port cable during data downloads; remove the cable immediately when done. Further data recording will not occur with the PC connected! Battery-powered portables are exempt from this limitation.*

Surge absorber MOV1 provides protection against lightning strikes. Bridge rectifier BR1 provides polarity protection; BR1 also rectifies the AC

ringer voltage. Op-amp IC1-a functions as a voltage comparator with a threshold of -2-volts DC, which is provided by the series connection of diodes D1-D4. The input voltage at IC1-a is the rectified phone line voltage divided down through R1/R2 and R4, which together divide the input by a factor of 10. With the phone line on-hook, the input voltage at pin 3 of IC1-a is -4.8-volts DC, which when compared to the -2-volt reference at pin 2 of IC1-a, drives the pin-1 output to about -9-volts DC. Diode D5 blocks this negative voltage, which would harm IC1-f; that input is normally pulled low by R5. The output of IC1-f,  $\overline{DET}$ , drives the

interrupt 0 ( $\overline{INT0}$ ) input of the microprocessor, as well as bit of input port 1. The interrupt feature helps the microprocessor determine the following states: off- or on-hook, phone-ringing, pulse dialing.

All states except on-hook (i.e., not in use, not dialing, no incoming ring) force the input voltage at pin 3 of IC1-a to about -1-volt DC, which drives the output of IC1-a to about +5-volts DC, which through D5 and IC1-f drives  $\overline{DET}$  low. Note that both dialing pulses and ringing voltages will cause digital pulses to appear at the output of IC1-f.

The primary source of dial digits is through the DTMF decoder, IC2. Although Digi-Call can recognize pulse-dialed digits, tone dialing is faster, and now the standard dialing practice in most areas. Also, if you expect to use the Account Call feature of Digi-Call, you must have tone-dialing capability.

The DTMF encoding standard defines 16 dual-tone combinations, but standard phones generate only 12 of them. The 12 tones arise from a 3-by-4 matrix, as shown in Table 2. Several frequencies are involved in standard DTMF generation; they are separated into two groups. The row information is called the low group; it has frequencies 697-941 Hz. The column information is called the high group; it has frequencies 1209-1477 Hz. For example, you press the digit "3," the 697 Hz tone and 1477 Hz tone are combined. (Note: In 16-digit DTMF, there is an eighth tone, 1633 Hz, in a third column.)

Op-amp IC1-c functions as a unity-gain differential amplifier to buffer telephone audio. Capacitors C1 and C2 AC-couple the audio from the phone line to the pin-8 output of IC1-c ( $A_{UF}$ ), which drives the DTMF decoder (IC3, shown in Figure 4) directly. This circuit allows for two different DTMF decoders, a 75T201, shown in Fig. 4-g, and a 75T202, shown in Fig. 4-h. The PC board allows use of either. The DTMF decoder incorporates switched-capacitor filtering to separate the low- and

continued on page



TALKING DEVICES SEEM TO BE ALL around us today. Virtually everywhere we go we're being spoken to by vending machines, arcade games, toys, cars, and even computer-spoken junk phone calls! There seems to be no limit to applications for devices that mimic the human voice, but the quality of the voice emanating from most talking devices has several serious flaws. It's usually monotone, lacking the natural inflection of real speech, and has less than adequate enunciation. In other words, most machine speech sounds robotic." Worse yet is the necessity of programming a ROM (Read Only Memory) in order to change the message. It's obvious that the standard solutions are less than ideal.

The ISD 1016 Single-Chip Voice Messaging System (Information Storage Devices, Inc., Austin, TX) eliminates all those drawbacks while at the same time introducing several features and functions which greatly enhance its versatility and simplify system design.

#### Features

As the industry's first non-volatile analog storage chip, the ISD 1016 can record and play back up to 16 seconds of analog, or "audio" information. All analog signal conditioning circuits, amplification, and digital control circuits are contained in the single 28-pin package. Therefore, a complete voice record/playback system can be implemented by simply connecting an external microphone and speaker, and a few capacitors, resistors, and switches to the analog storage chip.

Several configuration options are available including multiple message, continuous repeat, and fast forward. These options are in addition to, but mutually exclusive of, the message addressing mode, which allows the user to directly address any segment of the analog storage array. By offering capabilities such as direct analog input, analog storage, and analog output, the ISD 1016 provides a high-grade voice record and playback system.



RICHARD D. TENNEY

# SINGLE-CHIP MESSAGING SYSTEM

***Our one-chip voice messaging system makes it easy to add audio-storage capability to your next project!***

## Novel approach

Key to the ISD 1016 is the unique method of storing the analog signal. Conventional circuits first sample the incoming analog signal and send it to an A/D converter that provides a digital output, typically eight bits wide, which is proportional to the amplitude of the incoming signal. Therefore, this method requires at least eight bits of storage per sample. Playback of the data requires that the eight bits of digital data be sent to a D/A converter to reproduce the original analog signal.

The ISD 1016 eliminates the A/D and D/A conversions by using CMOS EEPROM (Electrically Erasable Programmable Read Only Memory) technology and storing the sampled data as an analog level in the

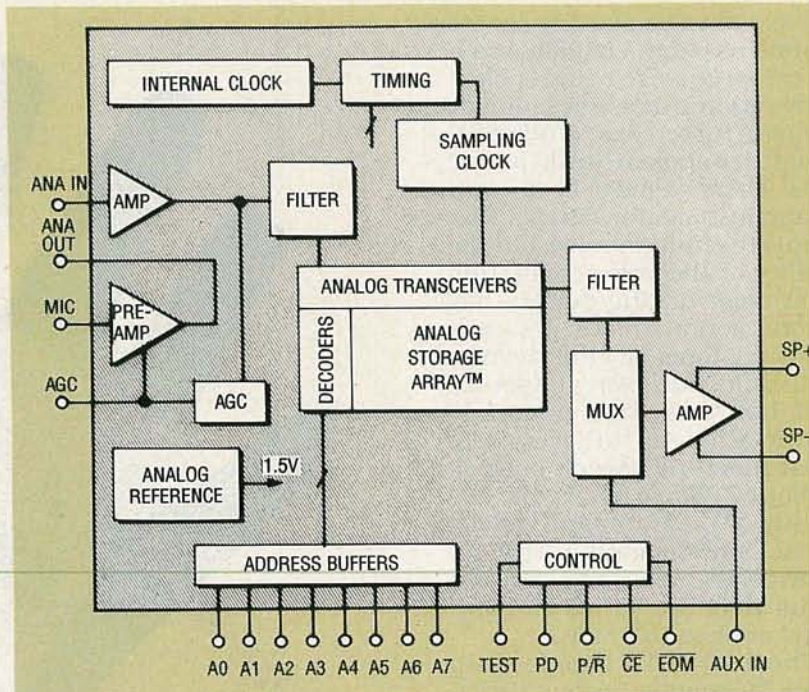

FIG. 1—FUNCTIONAL BLOCK DIAGRAM OF THE ISD 1016. The microphone signal is capacitively coupled to the input preamp, and the gain of the preamp is dynamically adjusted by the AGC circuit.

## PARTS LIST

All resistors are 1/4-watt, 10%, unless otherwise noted.

R1—2000 ohms

R2—10,000 ohms

R3—470,000 ohms

R4—1000 ohms × 9, 10-pin SIP resistor

### Capacitors

C1, C4—22  $\mu$ F, 16 volts, tantalum

C2, C6—0.1  $\mu$ F, ceramic

C3—4.7  $\mu$ F, 16 volts tantalum

C5—0.22  $\mu$ F, polystyrene

C7—1  $\mu$ F, 16 volts, tantalum

### Semiconductors

IC1—ISD 1016 Voice Messaging System

### Other components

S1—S3—SPDT miniature slide switch

S4—8 position DIP switch

MIC1—miniature electret microphone

Miscellaneous: 28-pin IC socket, 16-ohm speaker, power source of at least 5 volts, wire, solder, etc.

**Note:** The following items are available from R. Tenney, 33 Eastmeadow Way, Manchester, N.H. 03109:

• ISD 1016 IC—\$35.00

• Etched and drilled PC board—\$9.75

• A kit of all parts except speaker—\$55.00.

Please add \$2.50 postage and handling.

EEPROM storage array. This method requires only one cell per sample and has the added advantage of being nonvolatile. The signal can be stored for ten or more years without power.

## How it works

Figure 1 shows the functional block diagram of the ISD 1016. The microphone signal is capacitively coupled to the input preamp. The gain of the preamp is dynamically adjusted by the AGC (Automatic Gain Control) circuit, which reduces the gain of the preamp for large input signal levels, and increases it for lower-level signals, thereby expanding the range of input signal levels that can be accommodated without distortion.

The output of the preamp is then coupled to an additional amplifier stage through an external capacitor. This stage has two main functions. One is to provide an input to the AGC circuitry so it can adjust the gain of the preamp according to the strength of the incoming signal. The second role of this stage is to drive the filter network which will remove noise and other unwanted signals outside of its passband.

The gain-adjusted and filtered signal is then fed to the analog transceivers. In the record mode, these transceivers take their input from the input filter and send the signal to the analog storage array. In playback mode they take their input from the analog storage array and send it to the output filter and amplifier.

Timing circuitry internally synchronizes the operation of the analog storage array and the analog transceivers, and also generates the sampling clock. The analog input signal is sampled at that clock at an 8-kHz rate, which is adequate for an audio passband of 3.4 kHz (about the same as a telephone), and is stored in the analog storage array as a voltage level. During playback, the storage array outputs the sampled and stored signal to the output filter via the analog transceivers. This filtered signal is then sent to one input of the analog multiplexer, which selects one of its two inputs to drive the power amp. In playback mode, the stored message will be selected, amplified, and sent to the speaker. When no record mode, and not play

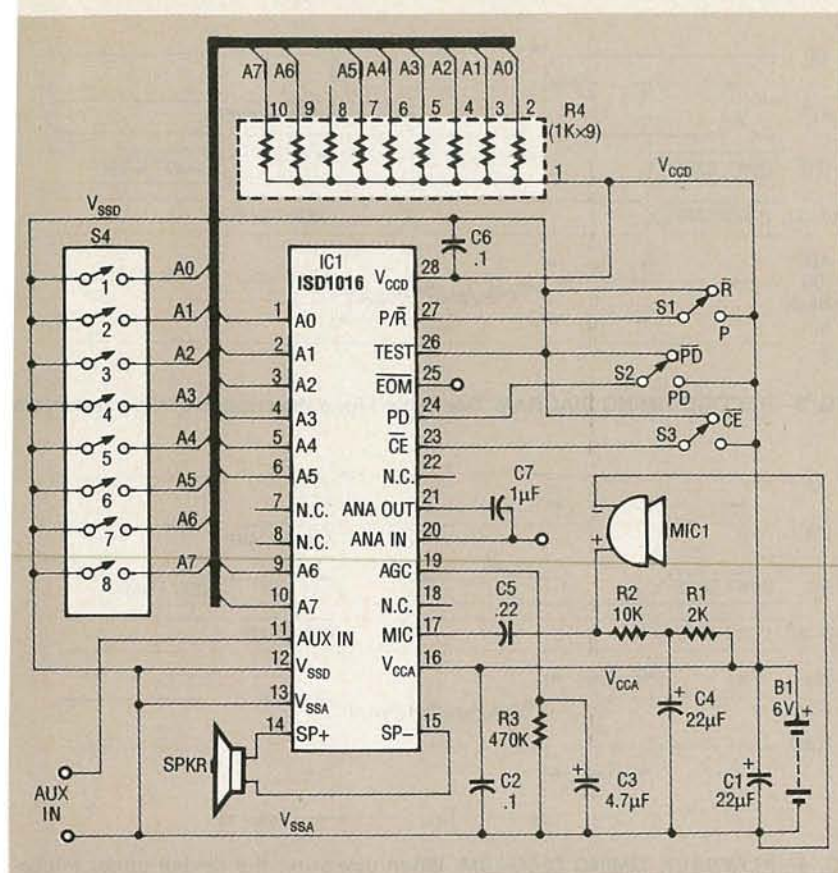

FIG. 2—SCHEMATIC DIAGRAM of the complete voice recording and playback system capable of storing up to 16 seconds of telephone-grade audio.

back a message, the multiplexer will select the auxiliary input as its source, thus allowing us to take advantage of the output amplifier when the ISD 1016 is otherwise idle.

### Circuit details

Figure 2 shows the schematic diagram of a complete voice recording and playback system that is capable of storing up to 16 seconds of telephone-grade audio. Before we go over the schematic, let's go over the pin functions of the ISD 1016 to make it easier to understand the overall operation of the circuit.

- **Microphone Input (MIC), pin 17**—An external microphone is coupled to this input through a series capacitor. The value of the capacitor and the 10K internal resistance of the input determines the low-frequency cutoff for the ISD 1016. A good-quality omni-directional electret microphone is recommended. Its impedance should

be about 1K, sensitivity 64 dB, frequency response 50 Hz to 8 kHz, and S/N ratio greater than 40 dB. Refer to the parts list for sources.

- **Analog Out (ANA OUT), pin 21**—The amplified analog input signal appears on the analog output pin. The gain of the preamp is determined by the voltage level at the AGC pin. Maximum gain is about 24 dB for low-level signals.

- **Analog Input (ANA IN), pin 20**—This pin has two roles. The analog output (pin 21) of the preamp can be coupled via an external capacitor to this analog input pin. The value of the capacitor and the 2.7K input resistance of this input pin can provide additional cutoff at the low-frequency end of the passband. Alternatively, this pin can be used to input analog signals other than the microphone signal.

- **Automatic Gain Control (AGC), pin 19**—As described in the section on the block diagram, the

AGC circuit will dynamically adjust the gain of the preamp. Peak output voltages of the preamp will be detected and charge an external capacitor. The time it takes for the capacitor to charge to a level that will start to reduce the gain of the preamp (about 1.8V) is known as the "attack time," and is determined by the value of the capacitor and the 5K internal resistance of the AGC input. The "release time" of the AGC is determined by this capacitor in parallel with an external resistor.

- **Speaker Outputs (SP+), pin 14 and (SP-), pin 15**—The ISD 1016 can directly drive speakers with impedances as low as 16 ohms. The maximum output power of 50 mW is achieved when the speaker is connected between these two pins. In that configuration no coupling capacitor is required. The device can be used in a single-ended configuration; however, an AC coupling capacitor must be used and the output power will be reduced to about 12 mW. While recording, the speaker outputs are disabled. An 8-ohm speaker can be used, but the volume will be louder and some audio distortion can result.

- **Power Down (PD), pin 24**—This pin serves two purposes in the operation of the chip. First, it provides a low-power mode when the ISD 1016 is at idle (not recording or playing back) and the pin is high. The second function of this pin is to provide a means to reset the address counter. Whenever the ISD 1016 reaches overflow (after 16 seconds total record or playback time) the address counter is at its maximum recording count (9Fh) and an  $\overline{\text{EOM}}$  (end of message) pulse will be generated. Activating  $\overline{\text{CE}}$  (chip enable) will not restart the device until PD was cycled high and low. NOTE: When recording multiple messages, the user should terminate each message by disabling  $\overline{\text{CE}}$  while keeping PD low. That will prevent the address counters from getting reset to zero at the start of the subsequent message, thereby causing the previous message to be overwritten.

- **Chip Enable ( $\overline{CE}$ ), pin 23**—When taken low, this pin enables all playback and record operations. The address and play/record inputs that meet the setup time (300 ns) are latched on this falling edge. When this pin is taken high, the ISD 1016 is deselected and the auxiliary input is selected as the input to the output power amp.

- **Play/Record ( $P/\overline{R}$ ), pin 27**—The state of this input is latched into the ISD 1016 on the falling edge of  $\overline{CE}$  (along with the address inputs ( $A0-A7$ )). A logic high selects playback mode and a logic low selects a record operation. The message to be played will start at the address latched when  $\overline{CE}$  went low. The message will continue until an  $\overline{EOM}$  (end of message) is encountered on pin 25. The  $\overline{EOM}$  bit is automatically inserted during a record operation when the storage area is full or when the record operation is terminated by PD going low or  $\overline{CE}$  going high. If multiple messages have been recorded,  $\overline{CE}$  should be pulsed low for the device to play back a single message. If  $\overline{CE}$  is held low (active), all the stored messages will be played back in sequence.

- **Address Inputs ( $A0-A7$ ), pins 1-6, 9, 10**—Two functions are performed by the address inputs: mode and option selection, and message address. The ISD 1016 has two modes of operation, Address Mode and Configuration Mode. Address bits 6 and 7 determine which mode will be selected. If either bit 6 or bit 7 is low, Address Mode will be selected. In that mode the address pins specify the starting address of the operation to be performed. If both address 6 and 7 are high, the configuration mode is selected. Table 3 lists the configuration mode options. Of the options listed, continuous repeat and multiple message recording can be of the most use to the experimenter. Further details of their use can be found in the section on "Modes of Operation."

- **End Of Message ( $\overline{EOM}$ ), pin 25**—At the end of each recorded message, an  $\overline{EOM}$  marker is automatically inserted in a non-volatile register. The  $\overline{EOM}$  output

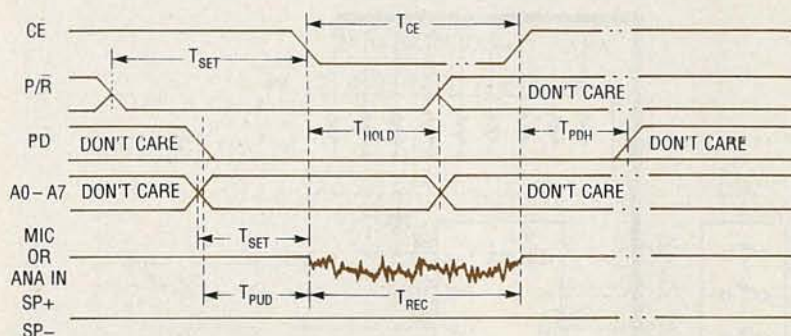

FIG. 3—RECORD TIMING DIAGRAM. See Table 1 for a description of the parameters.

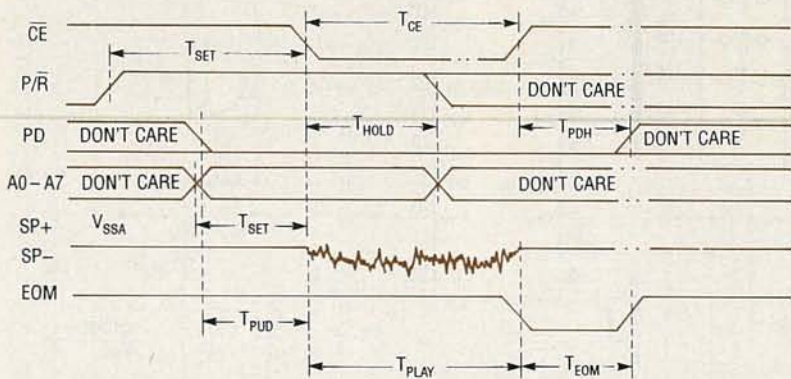

FIG. 4—PLAYBACK TIMING DIAGRAM. When operating the device under microprocessor control or other high-speed device, these parameters must be considered.

will go low at the end of each message and at message overflow. The width of the negative pulse is 12.5 ms minimum. Another function of  $\overline{EOM}$  is as a low-power indicator. If power to the chip should drop below 3.5V,  $\overline{EOM}$  will be forced low and the ISD 1016 placed in playback mode. This feature helps prevent recording while in an unreliable power condition.

- **Auxiliary Input (AUX IN), pin 11**—As explained earlier, AUX IN is selected as the input to the output power amplifier when either  $\overline{EOM}$  is true or  $\overline{CE}$  is not true, thus allowing us to take advantage of the amplifier for other uses when the ISD 1016 is otherwise inactive.

- **5-volt Analog and Digital Power Inputs ( $V_{CCA}$ ), pin 16 and ( $V_{CCD}$ ), pin 28**—The ISD 1016 voice messaging system chip incorporates both digital and analog circuitry. The digital circuitry generates considerable noise from rapid switching of gates within the device, as does any other digital device. The noise is

easily detected by the analog circuitry and can, therefore, be recorded as noise in the analog signal. For that reason, separate power and ground buses are provided for the analog and digital portions of the device. In that manner, currents flowing in the digital portions of the device cannot cause significant voltage fluctuations in the analog power buses. The two power pins should be connected together as close as possible to the power source. That is the location where the two power buses should be connected together. If another direct connection between  $V_{CCA}$  and  $V_{CCD}$  were to be made at any other point, a "loop" would be formed and slight voltage differences between the two points would cause unwanted currents to flow in this loop, providing another source of noise.

- **Analog and Digital Ground Connections ( $V_{SSA}$ ), pin 13 and ( $V_{SSD}$ ), pin 12**—NOTE: The ground connections for the ISD 1016 do not conform to a standard.

TABLE 1—TIMING & VOLTAGE PARAMETERS

Symbol	Parameter	Value
FS	Sampling Freq.	8 kHz
BW	Bandwidth	3400 Hz typ.
P <sub>OUT</sub>	Speaker Output Power	50 mW max.
V <sub>IN1</sub>	Mic Input Voltage	20 mV max. p-p
V <sub>IN2</sub>	Ana Input Voltage	80 mV max. p-p
V <sub>IN3</sub>	Aux Input Voltage	1.25 V max. p-p
T <sub>SET</sub>	Control/Address Set-up	300 ns min.
T <sub>HOLD</sub>	Control/Address Hold	0 ns max.
T <sub>CE</sub>	$\overline{CE}$ Record Time	100 ns min.
T <sub>PUD</sub>	Power Up Delay	25 ms min.
T <sub>PDH</sub>	Power Down Hold	0 ns min.
T <sub>REC</sub>	Record Time	16 s max.
T <sub>PLAY</sub>	Playback Time	16 s max.
T <sub>EOM</sub>	EOM Pulse Width	12.5 ms typ.

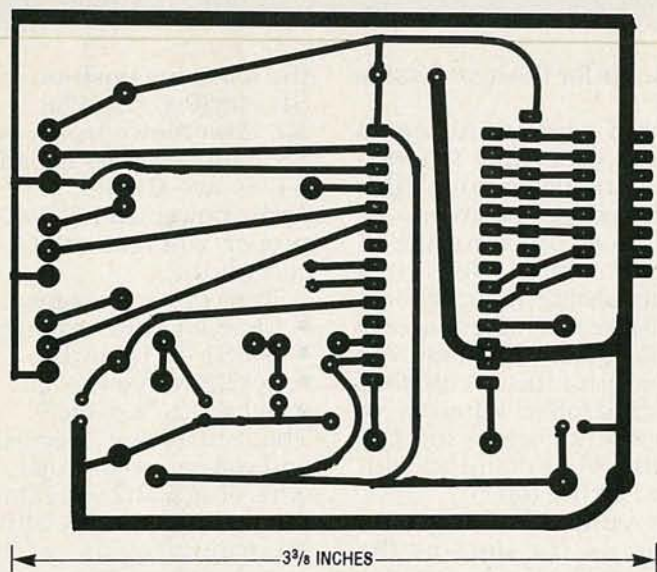

FOIL PATTERN for the voice messaging system.

standard 28-pin DIP.  $V_{SSA}$  and  $V_{SSD}$  are the return paths for the analog and digital sections of the device, respectively. Follow precautions similar to those described for the power inputs. Pins 12 and 13 should be tied together at the package, and power should be decoupled using 0.1  $\mu$ F capacitors between  $V_{CC}$  and  $V_{SS}$ , as close as possible to the package, for both analog and digital power.

• Test Input, pin 26 (TEST)—This pin is used during the manufacturing operation prior to product shipment. For proper device operation this pin *must* be tied low.

Now that we have a better understanding of how the ISD 1016 works, let's go over the schematic (Fig. 2). Resistors R1

and R2 supply the microphone bias for the electret microphone (MIC1) recommended in the parts list. Capacitor C4 provides microphone decoupling and C5 provides input coupling and DC blocking for the microphone while also acting as a single-pole, low-frequency cutoff filter. Capacitor C7 provides AC coupling between the preamp output and the input amplifier, and also provides additional low-frequency cutoff.

Resistor R3 and capacitor C3 provide the AGC attack/release time constants. For strong input signals, the AGC circuit internal to the ISD 1016 starts charging C3. If the signal remains strong long enough for C3 to reach the AGC threshold level (about 1.8V), the gain of

the preamp is reduced to prevent it from being overdriven. If the input signal level decreases, C3 starts to discharge through R3, thus increasing the gain of the preamp for low-level signals.

Capacitor C1 provides  $V_{CC}$  decoupling, C2 is the  $V_{CCA}$  high-frequency decoupling capacitor, and C6 provides the same function for  $V_{CCD}$ . C1 should be located as close to the supply as possible, and C2 should be as close to IC1 as possible. Switches S1, S2, and S3 provide the control functions for PLAYBACK/RECORD, POWERDOWN, and CHIP ENABLE inputs respectively.

Resistor R4 is a SIP (Single-Inline-Package) containing nine resistors, one of which is not used. Those pull-up resistors are used so we can implement the address switches with an inexpensive eight-position DIP switch (S4) instead of eight individual switches.

The output amplifier of the ISD 1016 is designed to drive a 16-ohm speaker; a standard 8-ohm speaker can be used, but you'll end up with slightly louder volume, slightly greater power dissipation, and some distortion. In general, the better the quality of the speaker, the better the sound quality.

### Timing diagrams

Figures 3 and 4 show the timing diagrams for the record and playback modes respectively. The parameters referenced are shown in Table 1. When operating the device manually, parameters such as setup and hold times are met by simply following the recommended procedures outlined later in this article. When operating the device under microprocessor control or other high-speed device, these parameters must be considered when controlling the chip. For example, to set up for a record operation the address lines should be set by one instruction and the  $\overline{CE}$  line set by a subsequent instruction to ensure the 300-ns control/address setup time ( $T_{SET}$ ) is met.

### Construction

A complete kit of parts, including an etched and drilled

PC board, is available from the source in the parts list. A foil pattern is provided here if you would like to make your own board. None of the component values are critical, but be sure to leave pins 7, 8, 18, and 22 unconnected, no matter what you do.

If you're making your own layout, some simple guidelines should be followed for best results. Note that  $V_{CCA}$  and  $V_{CCD}$  should be connected at one point only, right where power enters the board. Likewise,  $V_{SSA}$  and  $V_{SSD}$  should be connected together right at pins 12 and 13 of IC1. That isolates the analog signal and ground paths from the digital paths, thus reducing noise. Also, the analog components should be physically separated from the digital

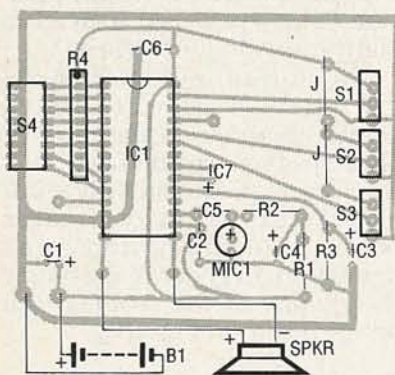

**FIG. 5—PARTS PLACEMENT DIAGRAM.** Mounting the DIP switch (S4) in a socket will give you convenient access to the address lines if you wish to control the circuit with a microcontroller. Be sure to position switch #1 of the DIP switch at the top.

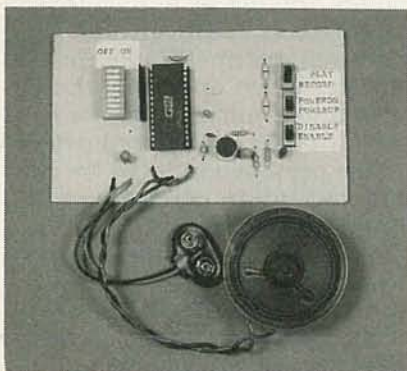

**FIG. 6—THE COMPLETED PROTOTYPE.** The 9-volt battery clip attaches to a 4-AA cell holder that has a matching connector; the prototype voice messaging system, therefore, is powered from a total of 6 volts.

Function	Address Bit	Use
Playback chip enable level activated	5	Provide switch debounce
Message start pointer reset only play/record changed	4	Recording multiple messages
Continuous repeat of message	3	Continuous repeat at $\overline{EOM}$ encounter
During playback $\overline{EOM}$ pulses low at overflow only	2	Concatenate chips for longer messages
$\overline{EOM}$ markers deleted by next message	1	Assures that $\overline{EOM}$ markers are cleaned up when recording over message
Fast forward (speaker output is disabled)	0	Selecting messages when address is unknown

components for those very same reasons.

Figure 5 shows the parts placement diagram. The ISD 1016 (IC1) should be mounted in a 28-pin socket, which can be installed now, but leave the IC out for the moment. DIP switch S4 should also be mounted in a socket to give convenient access to the address lines should you wish to control the circuit with a microcontroller. Whether or not you use a socket, the DIP switch should be mounted with switch #1 at the top.

Next mount SIP resistor R4 (with pin 1—the dot—at the top), followed by the various capacitors, discrete resistors, and the microphone. Be certain to observe polarity when installing C1, C3, C4, C7, and the microphone. Next mount switches S1–S3 and the leads for the speaker and the power source. (The prototype uses a standard 9-volt battery clip and a 4-AA cell holder that snaps onto the 9-volt clip.) Figure 6 shows the completed prototype.

After all components have been mounted, check for any shorts or solder bridges, and verify proper orientation of all components. After these checks have been made, install IC1 in its socket verifying proper orientation, and connect a speaker to the speaker terminals.

### Operation

Before connecting power to the circuit, set all switches to

the following positions:

- S1, Play/Record—Play
- S2, Powerdown/Up—Down
- S3, Chip Enable—Disable
- S4, A0–A7—Closed

Apply power and check for the proper voltages at IC1 before continuing.

To record a message:

- Close all switches on S4.
- Set S1 to "Record."
- Set S2 to "Power up."
- Set S3 to "Enable."

That starts the "Record" timer and you can record up to 16 seconds of speech by speaking in the microphone, as with a tape recorder. Speak with your mouth close to the microphone in a normal voice. When you finish recording your message you should:

- Set S3 to "disable."
- Set S2 to "Powerdown."
- Set S1 to "Play."

To play back a message:

- Set S1 to "Play."
- Set S2 to "Power up."
- Toggle S3 to the "Enable" position and back to the "Disable" position.

Your pre-recorded message now play back and stop at the end. When the message is complete, set S2 to the "Powerdown" position.

### Addressing mode

The ISD 1016 has two mutually exclusive modes of operation: the "Addressing Mode" and the "Configuration Mode." The addressing mode is selected

*continued on page*

IT'S EASIER THAN YOU THINK TO DESIGN LED display drivers with National Semiconductor's LM391X and LM2917 series IC's. In this article, we'll show you how to use those IC's to build moving-dot and bar-graph voltmeters as well as frequency-to-voltage converters. We'll also give you an introduction to binary coded decimal (BCD) to 7-segment decoder/driver circuits that are commonly used in electronics design.

### LM391X-series basics

National Semiconductor's LM391X dot/bar display drivers are versatile 18-pin DIP IC's that can be used to drive up to 10 LED's in either dot or bar mode. The three members of the LM391X display driver series are the LM3914, LM3915, and LM3916. All three versions use the same basic internal circuitry, as shown in Fig. 1, but have different output scaling modes, as shown in Table 1.

The LM3914 is a linearly-scaled device that's intended for use in LED voltmeters, with the number of lit LED's being directly proportional to the input voltage (pin 5). The LM3915 is a logarithmically-scaled device that's intended for use in power meters, and spans a range of 0-30 dB in ten 3-dB steps. Finally, the LM3916 is a semi-logarithmically-scaled device that's intended for use in volume-unit (VU) meters.

Figure 1 shows an LM3914 used in a simple 10-LED voltmeter, which ranges from 0 to 1.25 volts DC. The LM3914 has 10 internal comparators, each with its non-inverting terminal connected to a specific tap on a floating, precision, 10-stage, internal resistive voltage-divider. The inverting terminals on all ten of the comparators are fed by a unity-gain buffer on pin 5. Each comparator is externally accessible, and can sink up to 30 milliamps. The sink currents are internally limited, and are externally pre-set via R1.

The LM3914 also has a floating 1.25-volt DC reference between pins 7 and 8, externally connected to the 10-stage internal voltage divider on pins 4 and

# WORKING WITH LED DISPLAY DRIVERS

*Let's take an in-depth look at  
LED display drivers.*

RAY MARSTON

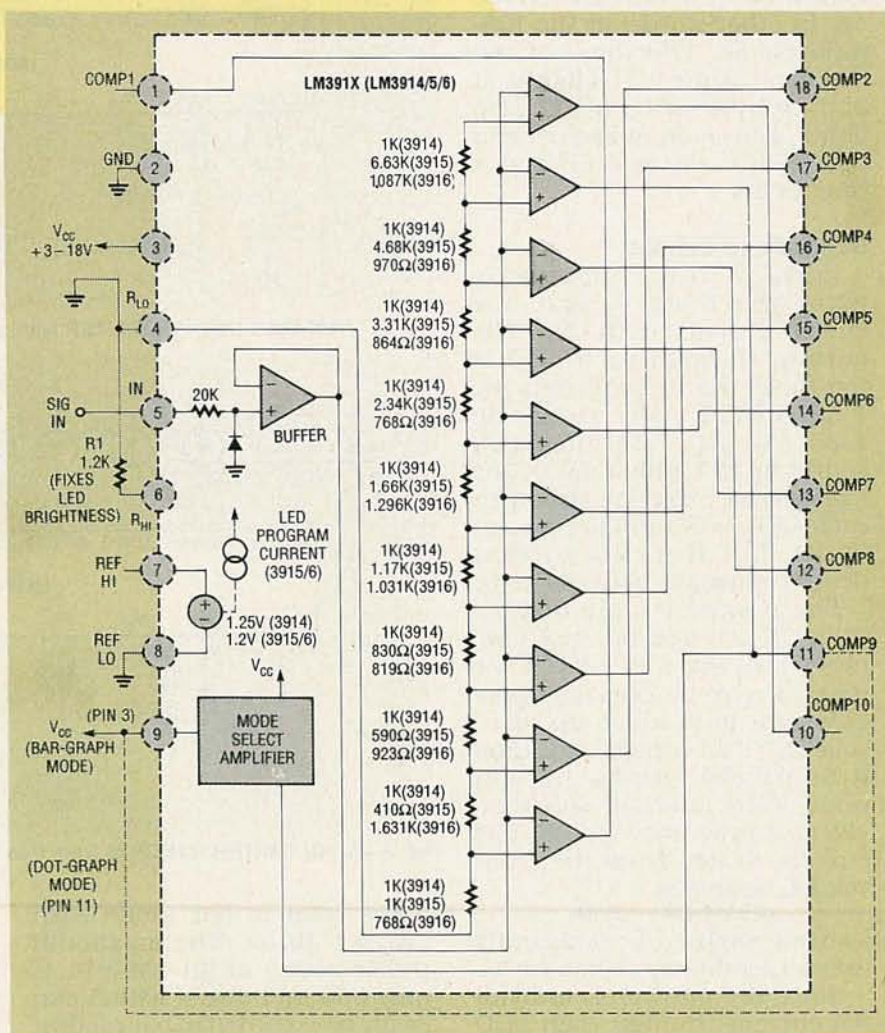

FIG. 1—INTERNAL CIRCUIT OF THE LM3914, with connections for making a 10-LED, 0 to 1.25 volts DC, linear meter using either dot or bar mode.

COURTESY NATIONAL SEMICONDUCTOR

6. Pins 4 and 8 are grounded, so that the bottom of the 10-stage internal voltage divider is at ground, and the top is at 1.25 volts DC. The LM3914 also has an internal logic network that can be used to select either moving-dot or bar-graph mode.

If the LM3914 is set for bar mode, the 1.25-volt DC reference is connected across the 10-stage internal voltage divider. Because of the linear scaling of that divider, each succeeding inverting comparator input has an additional 0.125 volts DC applied to it.

When there is no signal on the input, pin 5 is at ground, all 10 internal comparators are disabled, and LED's 1-10 are off. With a slowly rising signal on the input, the voltage increases to 1.25 volts DC, and an LED lights for each 125-millivolt increment, until LED's 1-10 are on. In other words, at the 125-millivolt DC threshold of the first comparator, LED1 lights, at 250 millivolts DC, LED2 also lights, and so on. When used in dot mode, only one LED at a time lights.

### Some finer details

In Fig. 1, R1 is connected between pins 6 and 4, fixing the current through each LED. The current through each LED is ten times that drawn from the 1.25-volt DC reference. The 1.25-volt DC reference can source up to 3 milliamps, so the maximum current through each LED is 30 milliamps, set by R1, but the LED current doesn't normally get that high.

The nominal value of 1.25 volts DC can also be varied between 1.20 and 1.32 volts DC, or its value can be externally programmed to produce up to 12 volts DC. If R1 equals 1.2K, then R1 in parallel with the full 10K value of the internal voltage divider is equivalent to 1.07K. The current drawn from the 1.25-volt DC source is

$$1.25 \text{ V} / 1.07\text{K} = 1.2 \text{ mA},$$

so that each LED nominally draws 12 milliamps when it's lit.

Since the maximum individual current through each LED is 30 milliamps, then the LM3914 draws up to 300 milli-

TABLE 1—COMPARISON OF TYPICAL INPUT THRESHOLDS FOR THE LM391X IC FAMILY

LED	LM3914	LM3915		LM3916		
	V	V	dB	V	dB	VU
1	1.000	0.447	-27	0.708	-23	-20
2	2.000	0.631	-24	2.239	-13	-10
3	3.000	0.891	-21	3.162	-10	-7
4	4.000	1.259	-18	3.981	-8	-5
5	5.000	1.778	-15	5.012	-6	-3
6	6.000	2.512	-12	6.310	-4	-1
7	7.000	3.548	-9	7.079	-3	0
8	8.000	5.012	-6	7.943	-2	+1
9	9.000	7.079	-3	8.913	-1	+2
10	10.000	10.00	0	10.000	0	+3

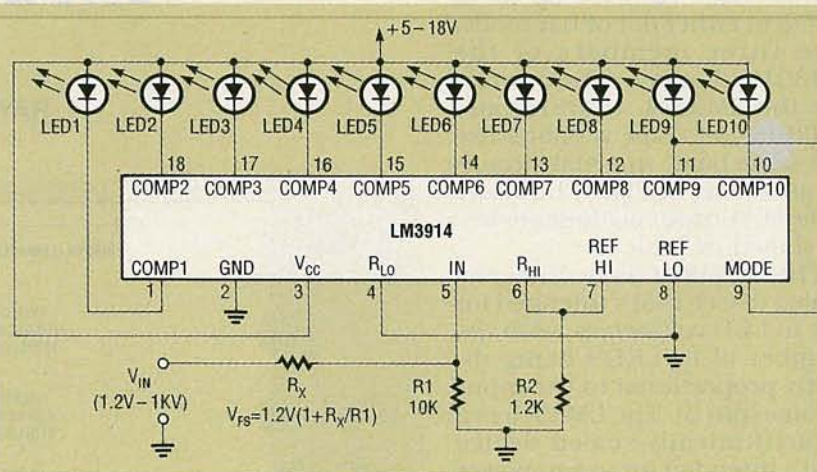

FIG. 2—A MOVING-DOT VOLTMETER with a range of 1.25 volts to 1 kilovolt DC.

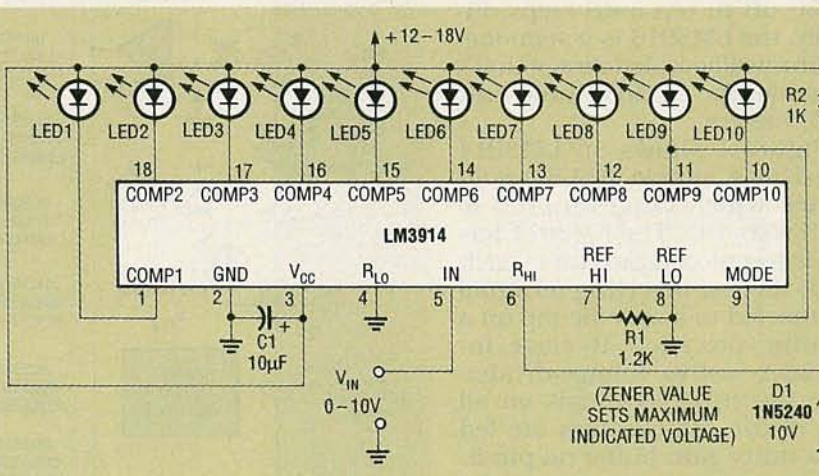

FIG. 3—A VOLTMETER RANGING from 0 to 10 volts DC using an external reference

amps total in bar mode with LED's 1-10 on. The maximum power rating of an LM3914 is only 660 milliwatts, which can easily be exceeded in bar mode if you're not careful. The LM391X series runs on a supply of 3-25

volts DC, and the LED's can use the same voltage supply, or they can use an independent supply for minimal IC heat dissipation.

The internal voltage divider is floating, with both ends externally available for maximum



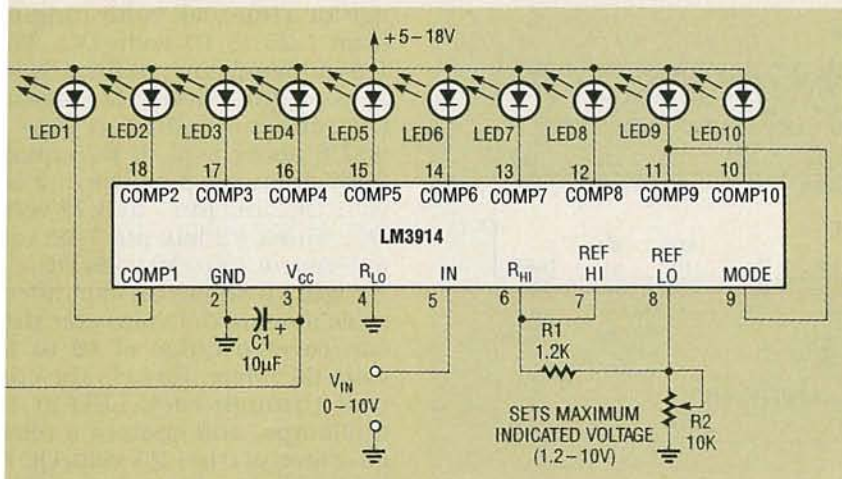

FIG. 4—AN ALTERNATE VARIABLE-RANGE voltmeter that can allow a variation in the maximum value of its range from +1.25 to 10 volts DC.

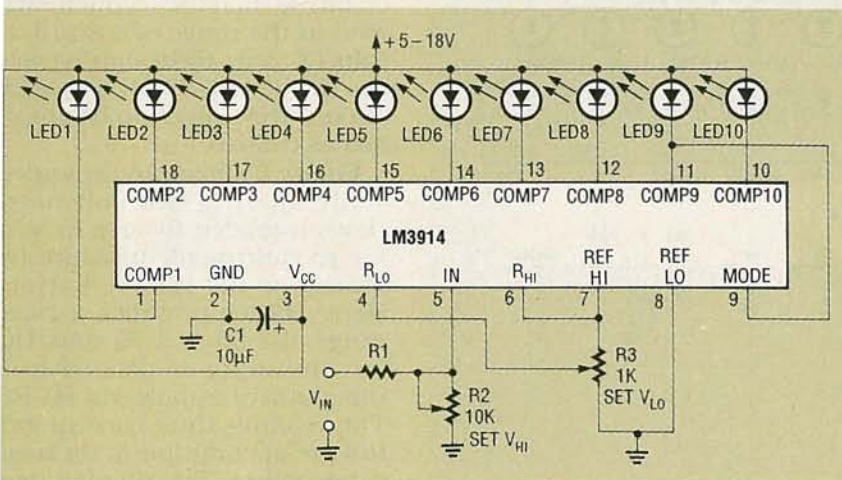

FIG. 5—AN EXPANDED-SCALE MOVING-DOT voltmeter that ranges from 10 to 15 volts DC.

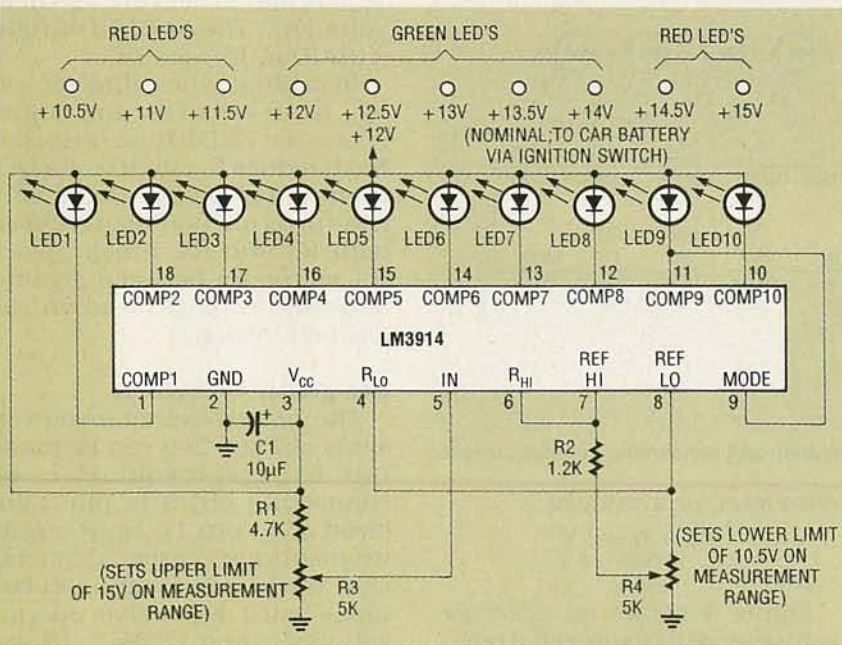

FIG. 6—AN EXPANDED-SCALE DOT-GRAPH voltmeter for use with a car battery.

versatility, and it can be powered by either the internal reference or an external source. If pin 6 is connected to 10 volts DC, then the LM3914 becomes a voltmeter ranging from 0 to +10-volts DC if pin 4 is grounded, or a restricted-range DC voltmeter ranging from 5 to 10 volts DC if pin 4 is connected to 5 volts DC.

The only constraint is that pin 4 cannot go more than 2 volts below  $V_{CC}$ . The input is fully protected against overloads up to  $\pm 35$  volts DC.

As we mentioned earlier, the major difference between the three members of the LM391X family is in the weighting of the ten-stage internal voltage dividers. In the LM3914, the values are equal, producing a ten-step linear display. In the LM3915, the values are logarithmically-weighted, producing a log display spanning 30 dB in ten 3-dB steps. The values are semi-logarithmically weighted in the LM3916, producing a volume unit (VU) meter display. Let's now examine some LM391X applications, focusing on the LM3914.

### Moving-dot voltmeters

Figures 2–6 show the LM3914 used in various 10-LED moving-dot voltmeters. In all of them, pin 9 is connected to pin 11, and a 10  $\mu$ F capacitor is connected between pins 2 and 3 for stability.

Figure 2 shows a variable-range moving-dot voltmeter that can cover a range of 1.25 volts to 1 kilovolt DC. The low ends of the internal reference and the 10-stage internal voltage divider are grounded, while the top ends are joined. The voltmeter has a basic full-scale sensitivity of 1.25 volts DC, with variable ranging provided by voltage divider  $R_x$ - $R_1$ . When  $R_x$  equals 0 ohms, the full-scale value is 1.25 volts DC, and when  $R_x$  equals 90K, the full-scale value is 12.5 volts DC. Also,  $R_2$  is connected across the internal reference and sets the current through each LED at 10 milliamps, as before.

Figure 3 shows a fixed-range moving-dot voltmeter that can

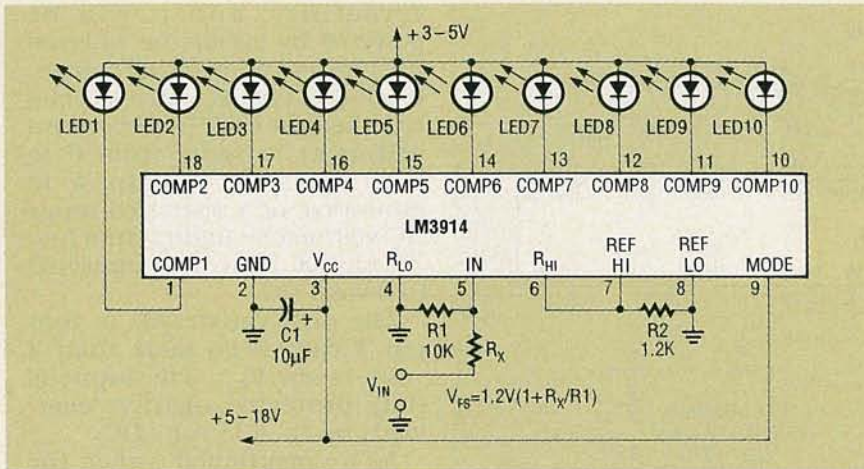

FIG. 7—A BAR-GRAPH VOLTMETER USING a separate supply for LED's 1-10.

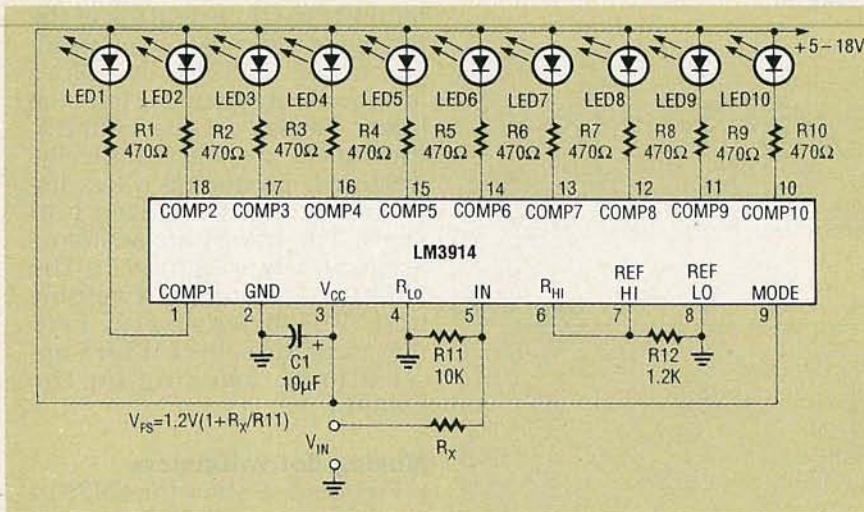

FIG. 8—A BAR-GRAPH VOLTMETER USING a common supply for both IC1 and LED's 1-10.

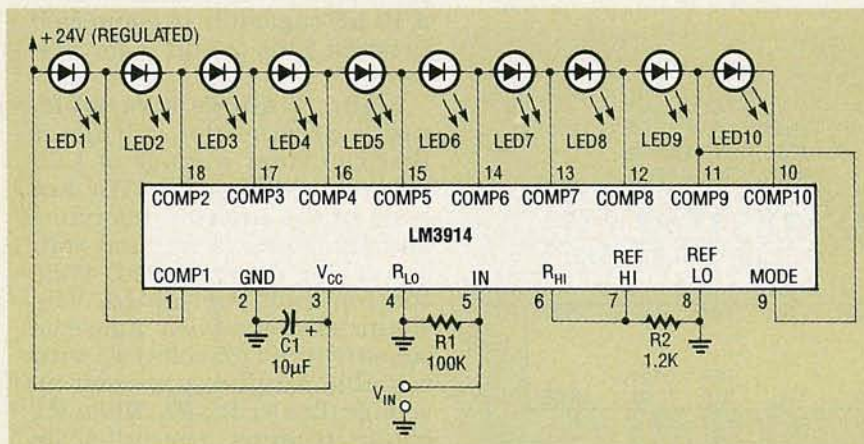

FIG. 9—A BAR-GRAPH USING dot-mode operation and consuming minimal current.

cover a range of 0 to 10 volts DC. It uses an external Zener diode reference D1 going to the top of the 10-stage internal voltage divider for a 10-volt DC reference. Also, the supply must be at least 2 volts DC above the Zener refer-

ence level, or a value of

$$V_{CC} = V_{D1} + 2V \\ = 10V + 2V \\ = 12V.$$

Figure 4 shows an alternate voltmeter with its internal reference providing a variable volt-

age for a full-scale value ranging from 1.25 to 10 volts DC. The 1.2-milliamp current fixed by goes to ground via R2, raising the reference value on pins 7 and 8 above zero. If R2 equals 2.4K, then pin 8 will be at 2.4 volts DC, and pin 7 at 3.75 volts DC. Thus, R2 lets pin 7 be varied from 1.25 to 10 volts DC.

Figure 5 shows an expanded scale moving-dot voltmeter that can cover a range of 10 to 100 volts DC. Here, R3 sets the current through each LED at milliamperes, and enables a reference level of 0 to 1.25-volts DC to be set on pin 4, the low end of the 10-stage internal voltage divider. If R3 is set for 0.8 volts on pin 4, then the voltmeter will read in the range of 0.8 to 10 volts DC only. By designing a voltage divider R1-R2 for a specific circuit, the range can be amplified as desired.

Figure 6 shows an expanded scale moving-dot voltmeter that's intended for use in your car to continually measure the status of its 12-volt battery. Here, R2-R4 provides a battery range of 2.50 to 3.75 volts DC, but the input is derived from the positive supply via R1. The reading thus corresponds to a pre-set multiple of the battery range value. The display uses red and green LEDs, with green LEDs lighting when  $V_{CC}$  range is within 12 to 15 volts DC. The red LEDs light with 10 to 15 volts DC.

To calibrate the voltmeter,  $V_{CC}$  to 15 volts DC, and adjust R3 so that LED10 just turns on. Next, reduce  $V_{CC}$  to 10 volts DC, then adjust R4 so that LED1 just turns on, and then recalibrate both R3 and R4. Finally, place the voltmeter between ground and the 12-volt-DC lead on the ignition switch.

### Bar-graph voltmeters

The moving-dot voltmeter versions of Figs. 2-6 can be modified into bar-graph voltmeters by connecting pin 9 to pin 3 instead of to pin 11. However, as we mentioned earlier, don't exceed the IC power rating in dot mode with excessive output voltages when LEDs 1-10 are on. Figure 7 is a bar-graph v

eter that uses a separate supply for its ten LED's. Most LED's drop about 2 volts

when on, so one way around that problem is to use a separate 3 to 5-volt DC source for them,

as shown in Fig. 7. Figure 8 is another variation of the bar-graph voltmeter using the same supply for the LM3914 and the ten LED's. If you use the same supply to operate both the IC and the LED's, then be sure to use a current-limiting resistor in series with each LED as shown in Fig. 8, so the IC output terminals saturate when they are lit.

Figure 9 shows another bar-graph display, one that doesn't exhibit excessive power loss. Here, LED's 1-10 are all in series, but each one is connected to an individual IC output, and the IC is in dot mode. Thus, if LED5 was on, its current would be drawn through LED's 1-4, so LED's 1-5 would also be on, creating a bar-graph display. In that case, the total current through all of the LED's is that of a single LED, so the total power dissipation is very low.

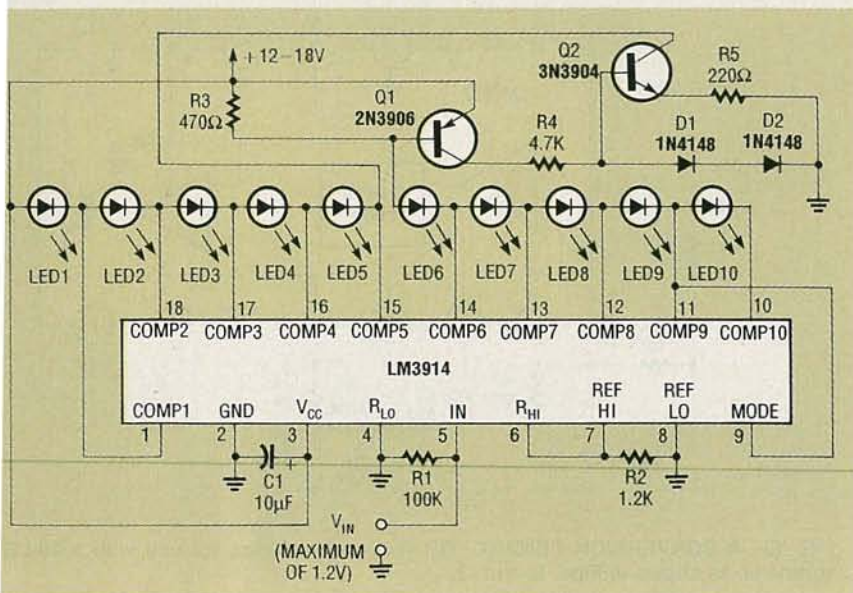

FIG. 10—A MODIFICATION OF THE VERSION in Fig. 9, using an unregulated 12 to 18-ohm DC supply.

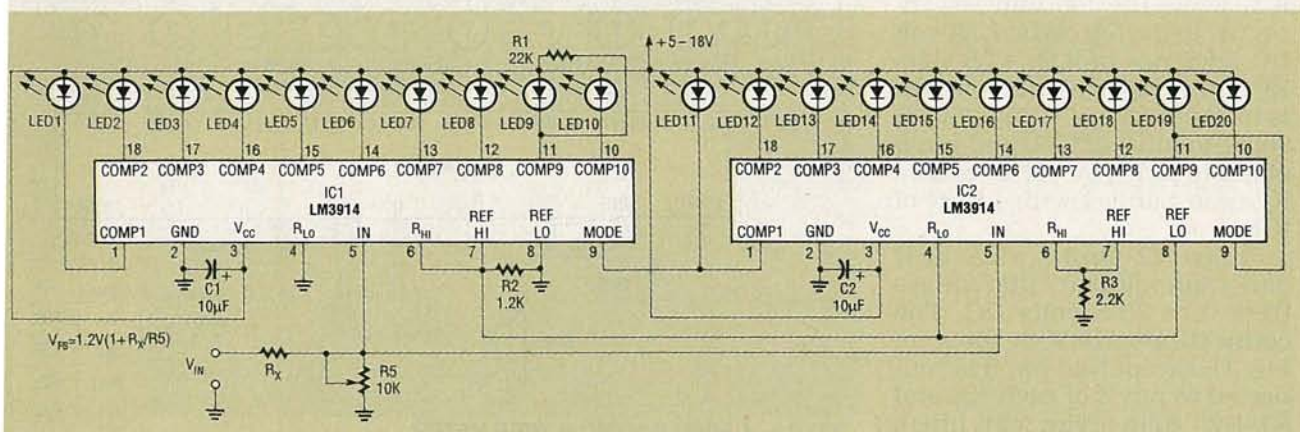

FIG. 11—A MOVING-DOT 20-LED VOLTMETER that ranges from 0 to 2.56 volts DC when  $R_x$  equals 0 ohms.

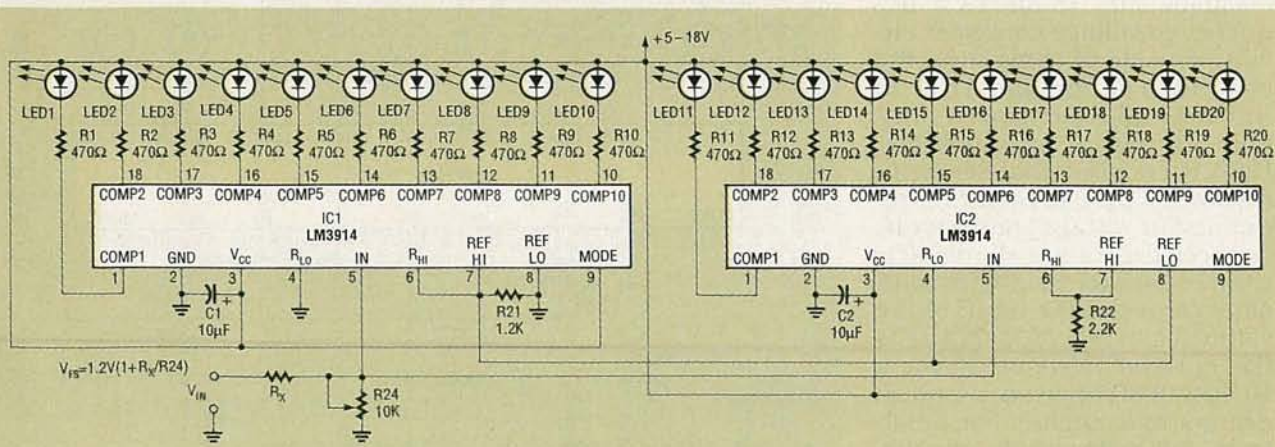

FIG. 12—A BAR-GRAPH 20-LED VOLTMETER that ranges from 0 to 2.56 volts DC when  $R_x$  equals 0 ohms.

The supply for the LED's has to be greater than the sum of the total drop with LED's 1-10 on, but within the voltage limits of the IC. Here the  $V_{CC}$  is a regulated value of 24 volts.

Figure 10 shows a modification of Fig. 9, using an unregulated  $V_{CC}$  ranging between 12 and 18 volts. In that case, LED's 1-10 are split into two chains, with Q1 and Q2 switching LED's 1-5 on when any of LED's 6-10 are active; the maximum total current through the LED's is twice that of a single LED.

### The 20-LED voltmeter

The circuit in Fig. 11 uses two LM3914's in a 20-LED moving-dot voltmeter. The inputs of IC1 and IC2 go in parallel, but IC1 reads 0 to 1.25 volts DC, while IC2 reads 1.25 to 2.50 volts DC.

For the latter range, the low end of the 10-stage internal voltage divider in IC2 is connected to the 1.25-volt DC reference of IC1, while the top end is connected to the top of the 1.25-volt DC reference of IC2, 1.25 volts DC above that of IC1. The circuit is in dot mode, with pin 9 of IC1 going to pin 1 of IC2, and pin 9 of IC2 to pin 11 of IC2; note that R1 is in parallel with LED9 of IC1.

Figure 12 shows a 20-LED bar-graph voltmeter that ranges from 0 to 2.56 volts DC. The connections are like those of Fig. 11, except that pin 9 is connected to pin 3 of each IC, and R1-R20 go in series with LED's 1-20 to reduce power dissipation.

Finally, Fig. 13 shows a frequency-to-voltage converter circuit, capable of converting the circuits in either Figs. 11 or 12 into a 20-LED tachometer suitable for use in automobiles. Here, IC1 is a National Semiconductor LM2917 monolithic frequency-to-voltage converter IC connected between the vehicle contact-breaker points (used in older cars) and the input of the voltmeter. In Fig. 13,  $0.022 \mu\text{F}$  is the optimal value of C2 for a 10,000-RPM range on a 4-cylinder, 4-stroke engine. For much lower full-scale speeds, the value of C2 might need to be changed for vehicles that have

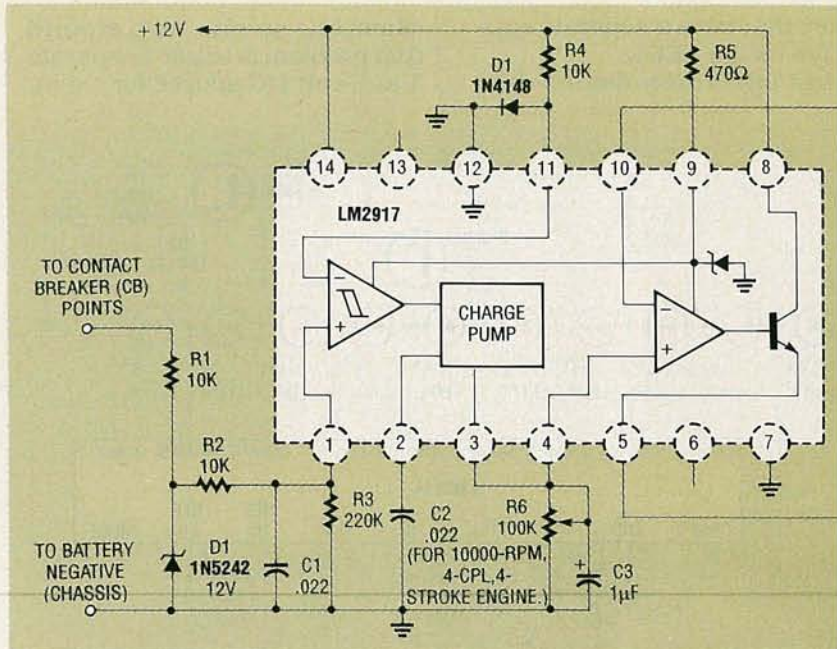

FIG. 13—A CONVERSION CIRCUIT FOR A car tachometer, for use with a 20-LED voltmeter, as shown in Figs. 11 and 12.

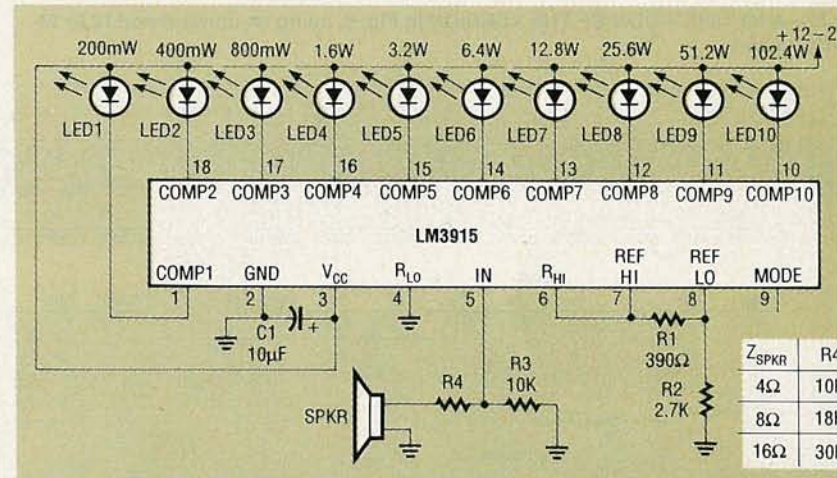

FIG. 14—A SIMPLE AUDIO POWER METER.

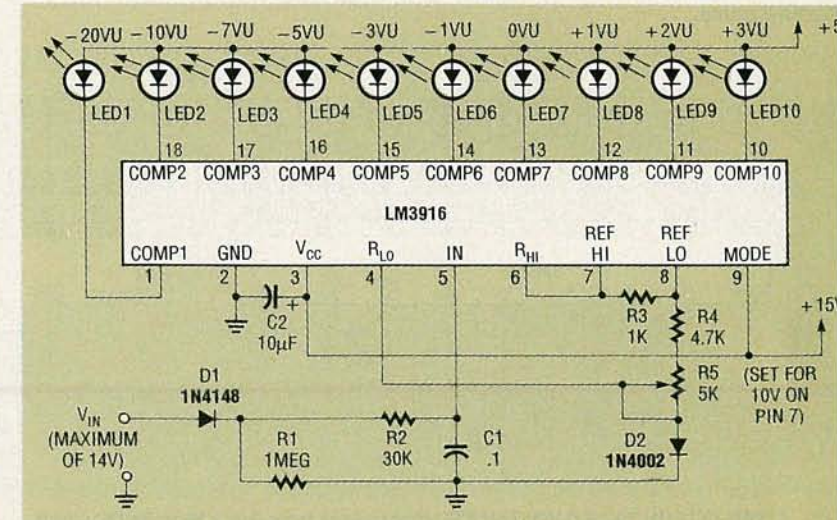

FIG. 15—A SIMPLE VOLUME-UNIT (VU) METER.

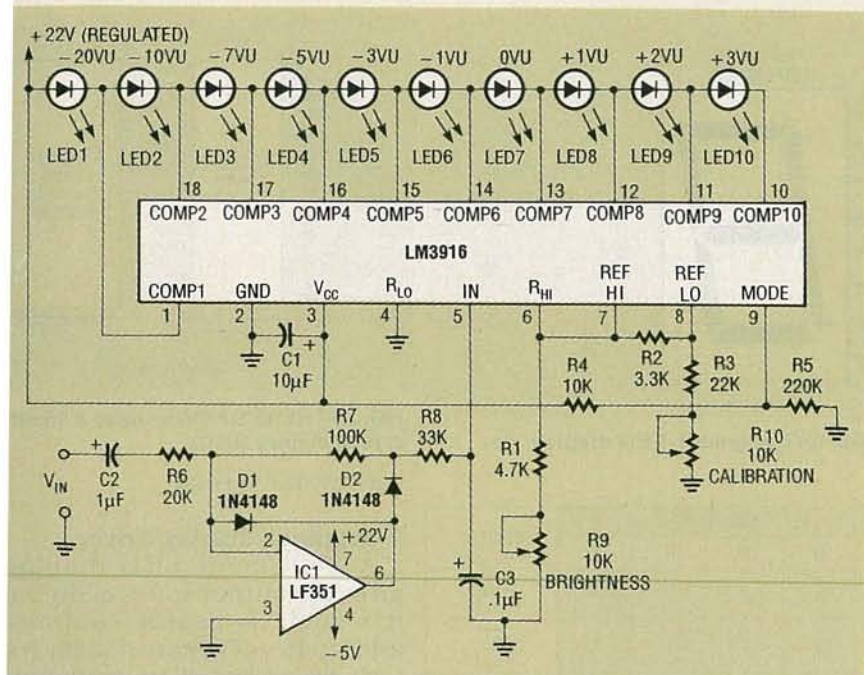

FIG. 16—A PRECISION VU METER with low current drain.

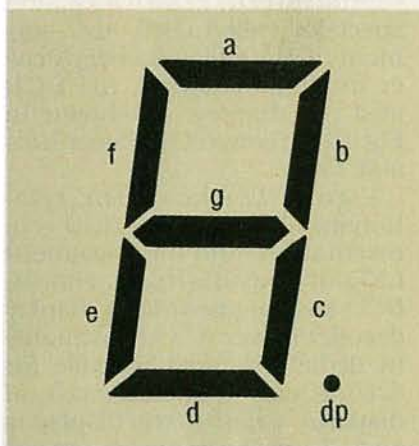

FIG. 17—THE STANDARD CONFIGURATION for a 7-segment LED display.

SEGMENTS							DISPLAY	SEGMENTS							DISPLAY
a	b	c	d	e	f	g		a	b	c	d	e	f	g	
1	1	1	1	1	1	0		1	1	1	1	1	1	1	
0	1	1	0	0	0	0		1	1	1	0	0	1	1	
1	1	0	1	1	0	1		1	1	1	0	1	1	1	
1	1	1	1	0	0	1		0	0	1	1	1	1	1	
0	1	1	0	0	1	1		1	0	0	1	1	1	0	
1	0	1	1	0	1	1		0	1	1	1	1	0	1	
1	0	1	1	1	1	1		1	0	0	1	1	1	1	
1	1	1	0	0	0	0		1	0	0	0	1	1	1	

FIG. 18—THE TRUTH TABLE for a 7-segment LED display.

six or more cylinders.

### LM3915 and LM3916 circuits

The LM3915 logarithmic and LM3916 semi-logarithmic versions basically work the same way as the LM3914, and can be directly substituted in most of the circuits shown in Figs. 2-12. The LM3915 and LM3916 will give an LED meter reading for an AC signal going to the input, and respond only to positive halves of the signal, with the number of LED's lit being proportional to the instantaneous peak value. The IC should be in dot mode, and set

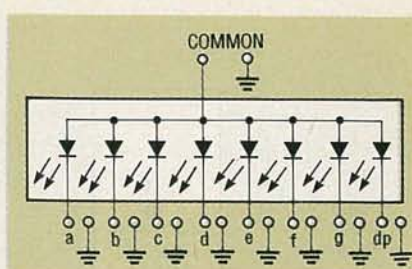

FIG. 19—THE SCHEMATIC OF a common-anode 7-segment LED display.

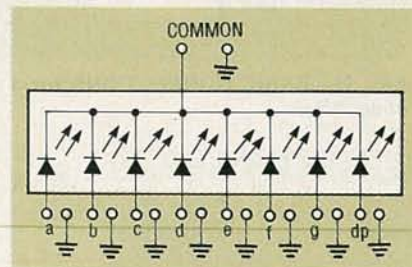

FIG. 20—THE SCHEMATIC OF a common-cathode 7-segment LED display.

for 30 milliamps of LED drive.

Figure 14 shows an LM3915-based audio power meter. Pin 9 is left open for dot mode, and R1 equals 390 ohms, for an LED current of 30 milliamps. The range of the audio power meter is 200 milliwatts-100 watts. A better approach is to half-wave rectify the signal on the input and feed in the resulting DC, as shown in the VU-meter circuits of Figs. 15 and 16.

Figure 15, a simple volume-unit (VU) meter, uses an LM3915 in bar mode; the signal at the input is rectified by D1 and filtered by R1-R2-C1, with D2 compensating for the forward drop of D1. Figure 16, a precision VU meter offering low current drain, uses an LM3916, with the combination of IC1-D1-D2 acting as a precision half-wave rectifier.

Also, LED's 1-10 are in series, and IC2 is in dot mode, giving a low-power bar-graph display. To calibrate the audio power meter, adjust R10 for 10 volts DC on pin 7; R9 controls the level of display brightness.

### The 7-segment LED display

Alphanumeric displays are used in electronics, in digital watches, pocket calculators, and in test equipment such as multimeters and frequency counters. The most common

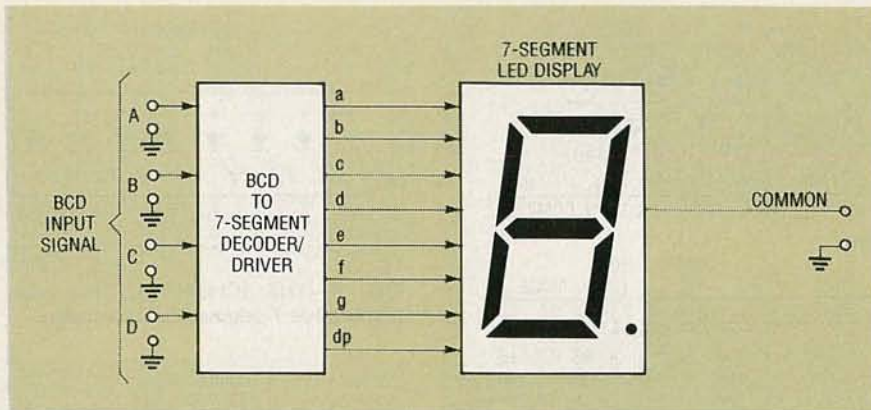

FIG. 21—BASIC CONNECTIONS for a BCD-to-7-segment LED-display decoder/driver.

BCD SIGNAL				DISPLAY	BCD SIGNAL				DISPLAY
D	C	B	A		D	C	B	A	
0	0	0	0		0	1	0	1	
0	0	0	1		0	1	1	0	
0	0	1	0		0	1	1	1	
0	0	1	1		1	0	0	0	
0	1	0	0		1	0	0	1	

FIG. 22—THE TRUTH TABLE of a BCD-to-7-segment LED-display decoder/driver.

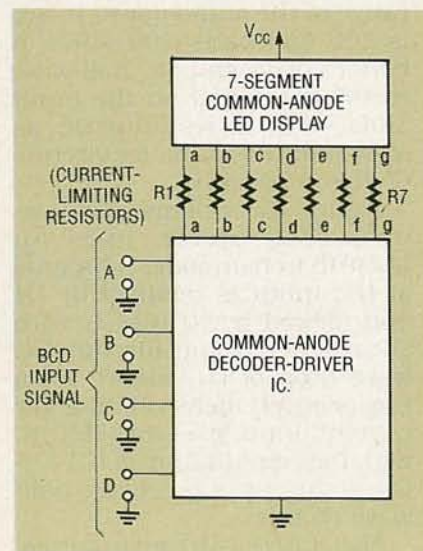

FIG. 23—HERE'S HOW to drive a common-anode 7-segment LED display.

type of alphanumeric display is the 7-segment LED or LCD display, as shown in Fig. 17. The segments are labeled a-g, and the decimal point is labeled dp. You can display either the digits 0-9, or the letters A-F (a mixture of upper and lower case letters), as shown in Fig. 18.

Most 7-segment LED displays need at least nine external con-

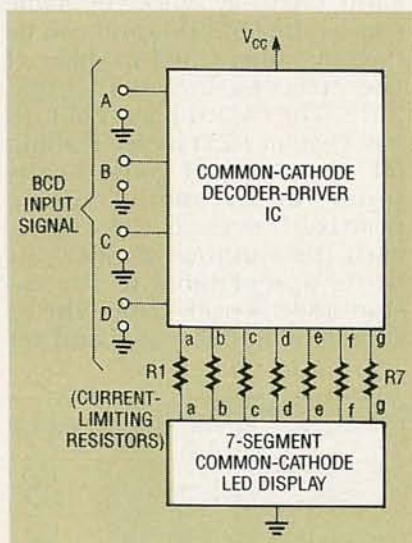

FIG. 24—HERE'S HOW to drive a common-cathode 7-segment LED display.

nections. Seven of those connections access the segments, one the decimal point, and the eighth is common. If the display is an LED type, the seven segments are arranged as shown in Figs. 19 and 20. A common-anode version (Fig. 19) has all LED anodes going to common, while a common-cathode version (Fig. 20) is configured in

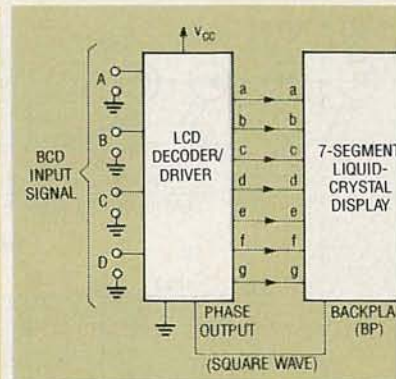

FIG. 25—HERE'S HOW to drive a liquid crystal display (LCD).

the reverse format.

### 7-segment display/driver

A 7-segment LED display gives the output states of digit IC's such as decade counter and latches. They are usually internally arranged in 4-bit binary-coded decimal (BCD), and cannot directly drive a display. A special IC called a BCD-to-7-segment LED-display decoder/driver must go between the BCD and the display, as shown in Fig. 21, to convert BCD to a suitable form.

Figure 22 shows the relationship between the BCD representation, and the 7-segment LED display digits. Normal BCD-to-7-segment LED-display decoder/driver IC's are available in dedicated form suitable for driving only a special class of displays, whether the display is an LCD, or a common-anode or common-cathode LED display. Figures 23-25 show how suitable BCD-to-7-segment LED-display decoder/driver IC's are connected.

Figures 23 and 24 show how to drive common-anode and common-cathode 7-segment LED displays. Note that if the BCD-to-7-segment LED-display decoder/driver IC outputs are unbuffered, as is the case in many TTL IC's, a resistor in series with each segment limits current; most CMOS IC's have such resistors internally. In Fig. 23 you can see how to drive a common-anode LED display. The common or backplane (BP) display terminal is driven with a symmetric square wave which is derived from the phase output terminal.

# HARDWARE HACKER

Using the IC Master; wavelets update; another caller-ID chip; musical note frequencies; and piano and organ resources.

DON LANCASTER

Several commercial products are starting to appear using that great *Rohm* BA-1404 FM stereo transmitter circuit. In particular, check out the *Pioneer* CD-M-1 and the *Sony* XA7A CD to auto radio adapters. Dealer cost is in the \$42 range.

What they do is let you play the output of a CD player through your existing car radio and audio system. The stereo channels are accepted by the BA-1404 IC and converted to a miniature but quite high-quality FM "broadcast" signal. You unplug your antenna, plug in your adapter, and then plug the antenna back into the adapter. Presto. Your CD audio now appears on the FM dial on your choice of one of two pushbutton-selected low-end channels.

As we've found out in the past, sloppily breadboarded BA-1404 chips tend to drift and mistune so much that they are unacceptable to most of the newer synthesized FM receivers that demand perfectly on-channel signals. While the ultimate way to stabilize an FM transmitter is to use a frequency-locked loop against a crystal reference, Pioneer and Sony both seem to have gone a simpler route.

Apparently they are just using a rigid and well-shielded design, tight supply regulation, and careful temperature compensation instead. They seem interested in a very low-level signal on a controlled cable, and they also do not see any antenna coupling or loading effects.

I will present more on those two beasts after I get a chance to test them. Either one of them should hack beautifully into a FM stereo wireless broadcaster circuit.

## Wavelets update

We've had bunches of requests for lots more wavelet information. So, here is a summary of where we seem to be.

Wavelets are a stunning new set of math tools that are having a strong impact on just about every region of advanced scientific study. While the keenest interest in wavelets now lies in video compression, wavelets are being applied to everything from cardiology and seismology to animal vision—and everything in between.

Wavelets are a newer method of analyzing any complex set of signals and extracting useful information from those signals. Unlike the ancient *Fourier Transform*, wavelets have both *global* and *local* properties that let you selectively zoom in on signal portions of interest. For instance, good old Fourier is quite superb at working with the top and the bottom of a square wave. But the sides give it fits. Instead of Fourier's "one-size-fits-all," wavelets let you apply lots of detail only where needed.

Wavelets tend to work in a "log" manner rather than in that "linear" fashion of Fourier. This lets you pick up any fine details when wanted. Wavelets are also great at doing the "big lumps first." That becomes handy in decompressing pictures, where your crude (but complete) picture initially appears and detail gets added later. It also gives you the ability to select the amount of needed detail on the fly.

One detailed book on wavelets is *Wavelets and their Applications*, as published by *Jones and Bartlett*.

## NEED HELP?

Phone or write your **Hardware Hacker** questions directly to:  
Don Lancaster  
**Synergetics**  
Box 809  
Thatcher, AZ 85552  
(602) 428-4073

The topics thoroughly covered include wavelet fundamentals, video compression, digital signal processing, numeric analysis, and a bunch of advanced subjects. Sadly, the volume is written by math freaks for math freaks. It tends to run roughshod over mere mortals. But it is there and certainly is the precise center of the emerging wavelet universe.

One tad less formidable wavelet summary tutorial and bibliography appears in *IEEE-SP* (Signal Processing) magazine for October 1991 on pages 14–38. Note that there are dozens of different monthly IEEE publications. Make sure you get the right one.

For a useful collection of freebie reprints on wavelets for video compression, hardware chips, and design software, contact the folks at *Aware*. Wavelets do video compression far simpler, far faster, and with far fewer artifacts than the older (and now largely obsolete) DCT (discrete cosine transform) compression transforms. Their hardware is also far cleaner and more likely to be standard.

Finally, I have posted some great IBM wavelet shareware on my *GEnie* PSRT as the file #365 WAVELET.PAK. You can call (800) 638-9636 for your connect information.

## A new caller-ID circuit

*Motorola* has just introduced an exciting new phone-caller identification chip called the MC145447. Free samples are available. They also have a very convenient but somewhat overpriced \$100 evaluation kit breadboard that gives you a full telephone-to-computer serial interface.

Figure 1 shows one of many possible circuits. This one is intended for continuous powering.

Compared to the earlier chips,

the MC145447 includes internal ring detection, and it apparently can be used without an expensive coupling transformer. It optionally strips off that ID header and provides only "real" message bits. That's the difference between their *raw* data output (the entire caller-ID byte sequence) and the *cooked* data (only the useful bytes) message strings.

Note that those two 500-pF input capacitors must be closely matched and rated to at least 1500 volts. A varistor and the normal part-68 interface should precede the circuit. The output levels are TTL- or CMOS-compatible, but have to be suitably translated to be sent over a RS-232 serial cable or data line.

The crystal used is the standard for colorburst frequency, available for under a dollar through several of our **Radio-Electronics** advertisers.

Naturally, your caller-ID service must already be provided by your phone company before either the

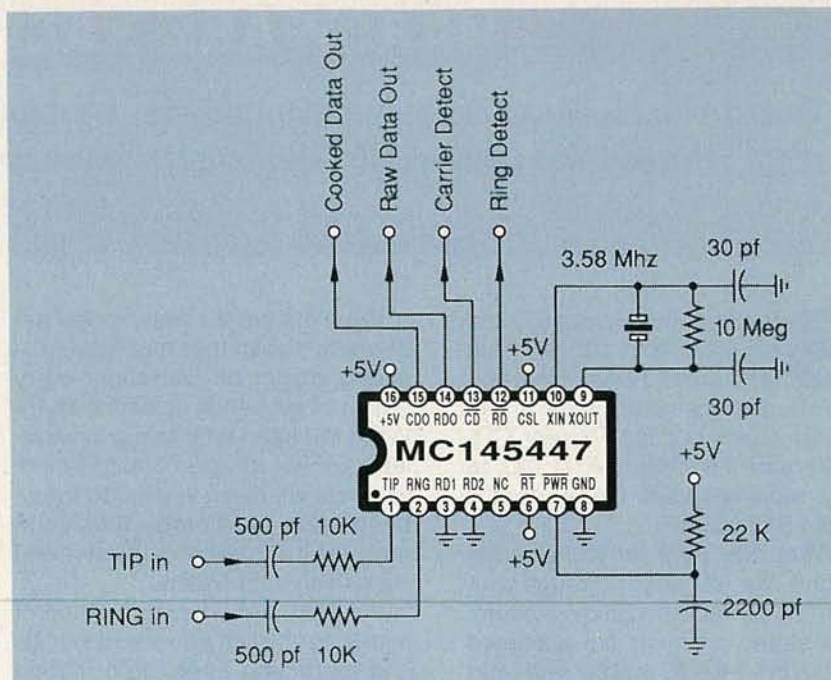

**FIG. 1—ANOTHER CALLER ID CIRCUIT** uses the brand new Motorola MC145447. Features include internal ring detection and data header stripping. Free samples available. The service has to be available from your local phone company before the chip can be used.

chip or the evaluation kit will work. If the service is not yet available, suitable machine language emulation software can easily be written for nearly any computer. The game paddle port on an Apple IIe is absolutely ideal as a fake source of ID coding signals.

We'll be seeing much more on this chip and suitable emulation software after I get a better chance to test it more thoroughly. The obvious thing to do is to "steal" enough power off a computer's RS-232 interface lines to eliminate any need for a stand-alone power supply. Internal power-down features of the MC145447 can greatly simplify this task. Stay tuned for more details.

### The IC Master

Identifying the maker of an integrated circuit from just the part number can be tricky, especially if you are mistakenly reading the date code instead. As you have probably found out on your own, *Radio Shack* has a useful *Semiconductor Reference Guide* available for \$4.

We've already seen that the two leading sources of service, repair, and replacement semiconductors are *NTE* and *ECG*. Parts and training

specific to *RCA* and *GE* products are also available through *Thomson Consumer Electronics Publications*. This is an extension of the old "S" series of replacement parts.

But the place to go for information on integrated circuit part numbers and cross references is the three-volume set known as the *Master* which is published by the *Hearst Business Communications* folks. The set is not cheap—it costs \$160.

Hearst also publishes the *Electronic Products* magazine, and their *EEM (Electronic Engine Master Catalog)* directories. Both of these are free to qualified subscribers. But note that *EEM* and *IC Master* are two totally different and separate sets of references

### Top-octave generators

This topic is more in the realm of "whatever happened to..." than anything else. But we still get a lot of helpline calls concerning *top-octave generators*, especially in the *Mostek* MK50240 family. The bottom line: They're long out of date. They also have recently become possibly difficult to get.

The traditional western music scale is based upon twelve equal

## NEW FROM DON LANCASTER

### HARDWARE HACKER STUFF

Hardware Hacker Reprints II or III	24.50
Midnight Engineering Reprints	16.50
Incredible Secret Money Machine	18.50
CMOS Cookbook	24.50
TTL Cookbook	24.50
Active Filter Cookbook	19.50
Micro Cookbook vol I or II	19.50
Lancaster Classics Library	109.50
AppleWriter Cookbook	19.50

### POSTSCRIPT STUFF

Ask The Guru Reprints I, II or III	24.50
LaserWriter Secrets (Ile/Mac/PC)	29.50
PostScript Show & Tell	39.50
Intro to PostScript VHS Video	39.50
PostScript Beginner Stuff	39.50
PostScript Cookbook (Adobe)	16.50
PostScript Ref. Manual II (Adobe)	28.50
PostScript Program Design (Adobe)	22.50
Type I Font Format (Adobe)	15.50
LaserWriter Reference (Apple)	19.50
Real World Postscript (Roth)	22.50
PostScript Visual Approach (Smith)	22.50
Thinking in PostScript (Reid)	22.50
Undst PS Pgrmmg (Holtzgang)	26.50
The Whole Works (all PostScript)	349.50

### BOOK-ON-DEMAND STUFF

Book-on-demand resource kit	39.50
GENie PSRT sampler (Ile/Mac/PC)	39.50

FREE VOICE HELPLINE VISA/MC

## SYNERGETICS

Box 809-RE  
Thatcher, AZ 85552  
(602) 428-4073



	octave 0	octave 1	octave 2	octave 3	octave 4	octave 5	octave 6	octave 7	octave 8
<b>B</b>	30.868	61.735	123.47	246.94	493.88	987.77	1975.5	3951.1	7902.1
<b>A#</b>	29.135	58.270	116.54	233.08	466.16	932.33	1864.7	3729.3	7458.6
<b>A</b>	27.500	55.000	110.00	220.00	440.00	880.00	1760.0	3520.0	7040.0
<b>G#</b>	25.957	51.913	103.83	207.65	415.30	830.61	1661.2	3322.4	6644.9
<b>G</b>	24.500	48.999	97.999	196.00	392.00	783.99	1568.0	3136.0	6271.9
<b>F#</b>	23.125	46.249	92.499	185.00	369.99	739.99	1480.0	2960.0	5919.9
<b>F</b>	21.827	43.654	87.307	174.61	349.23	698.46	1396.9	2793.8	5587.7
<b>E</b>	20.602	41.203	82.407	164.81	329.63	659.26	1318.5	2637.0	5274.0
<b>D#</b>	19.445	38.891	77.782	155.56	311.13	622.25	1244.5	2489.0	4978.0
<b>D</b>	18.354	36.708	73.416	146.83	293.66	587.33	1174.7	2349.3	4698.6
<b>C#</b>	17.324	34.648	69.296	138.59	277.18	554.37	1108.7	2217.5	4434.9
<b>C</b>	16.352	32.703	65.406	130.81	261.63	523.25	1046.5	2093.0	4186.0

FIG. 2—THE STANDARD FREQUENCIES of the Western 12-note equally tempered music scale. It applies to most electronic and conventional musical instruments EXCEPT the piano. Piano keyboards must be "stretched" because of a piano's non-harmonic overtones.

tempered notes per octave. (An octave is a 2:1 frequency interval.) Each note is related by the twelfth

root of two, or 1.059 times the frequency of its neighbor.

The notes, of course, are lettered as C, C#, D, D#, E, F, F#, G, G#,

A, A#, B, and back around to the next C, one octave higher. The traditional organ people number the octaves from zero up through eight. The usual "standard pitch" frequency reference sets note A4 to precisely 440.0 Hertz.

The usual twelve-note-per-octave equally tempered frequencies appear in Fig. 2.

Because all of the music note frequencies are irrational, they have to be approximated. One way to do that is to take a high-frequency clock and divide it down by magic numbers which can hit the needed accuracy. Musicians define the interval between notes as one *semitone*, and further define *one percent* of a semitone as a *cent*. A one-cent frequency error is approximately 0.06 percent.

Reasonably trained individuals usually can spot a three-cent frequency error, while the best of professional musicians can resolve a single cent. Thus, the relative frequency accuracy of all the notes

**PIANO AND ORGAN RESOURCES**  
**Devtronics**  
 6101 Warehouse Way  
 Sacramento, CA 95826  
 (916) 381-6203  
 CIRCLE 301 ON FREE INFORMATION CARD

**Jrnl Audio Engineering Soc**  
 60 East 42nd Street, Rm 2520  
 New York City, NY 10165  
 (212) 661-2355  
 CIRCLE 302 ON FREE INFORMATION CARD

**MIX Bookshelf**  
 6400 Hollis Street, Ste 12  
 Emeryville, CA 94608  
 (800) 233-9604  
 CIRCLE 303 ON FREE INFORMATION CARD

**PAIA Electronics**  
 3200 Teakwood Lane  
 Edmond, OK 73013  
 (405) 340-6300  
 CIRCLE 304 ON FREE INFORMATION CARD

**Player Piano Company**  
 704 East Douglas  
 Wichita, KS 67202  
 (316) 263-3241  
 CIRCLE 305 ON FREE INFORMATION CARD

**Tuners Supply**  
 88-94 Wheatland Street  
 Somerville, MA 02145  
 (800) 247-0702  
 CIRCLE 306 ON FREE INFORMATION CARD

## No Better Probe Ever at this Price!

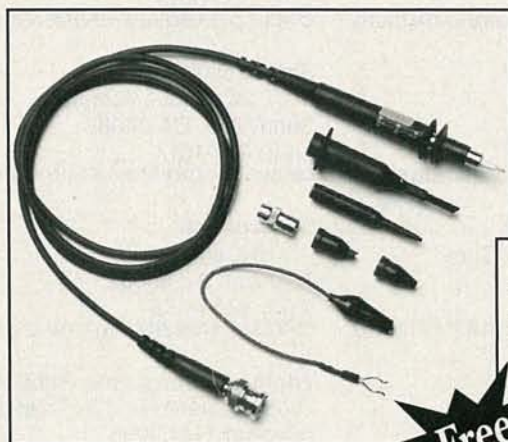

Shown here  
 Model SP150 Switchable 1x-10x .... \$49

**Risetime less than 1.5 nsec.**

- **Universal**  
Works with all oscilloscopes
- **Rugged**  
Flexible cable lasts longer-  
Replaceable ground lead
- **Economical**  
Substantial savings compared to  
OEM probes
- **10 Day Return Policy**  
Guaranteed performance and quality

**TEST  
 PROBES, INC.**

**TPI**

9178 Brown Deer Road, San Diego, CA 92121  
 Toll Free 1-800-368-5719

CIRCLE 123 ON FREE INFORMATION CARD

## NAMES AND NUMBERS

### Aircraft Designs

25380 Boots Road  
Monterey, CA 93940  
(408) 649-6212  
CIRCLE 307 ON FREE INFORMATION CARD

### Antique Electronic Supply

6221 South Maple Avenue  
Tempe, AZ 85283  
(602) 820-5411  
CIRCLE 308 ON FREE INFORMATION CARD

### ARclad

PO Box 100  
Glen Rock, PA 17327  
(717) 235-7979  
CIRCLE 309 ON FREE INFORMATION CARD

### Astex

35 Cabot Road  
Woburn, MA 01801  
(617) 933-5560  
CIRCLE 310 ON FREE INFORMATION CARD

### Aware

One Memorial Drive  
Cambridge, MA 02142  
(617) 577-1700  
CIRCLE 311 ON FREE INFORMATION CARD

### ECG/Philips

PO Box 3277  
Williamsport, PA 17701  
(717) 323-4691  
CIRCLE 312 ON FREE INFORMATION CARD

### EMC Technology

PO Box D  
Gainesville, VA 22065  
(703) 347-0030  
CIRCLE 313 ON FREE INFORMATION CARD

### GENie

401 North Washington Street  
Rockville, MD 20850  
(800) 638-9636  
CIRCLE 314 ON FREE INFORMATION CARD

### IC Master/Hearst

645 Stewart Avenue  
Garden City, NY 11530  
(516) 227-1300  
CIRCLE 315 ON FREE INFORMATION CARD

### IEEE/Signal Processing

445 Hoes Lane  
Piscataway, NJ 08855  
(908) 981-0060  
CIRCLE 316 ON FREE INFORMATION CARD

### ITW/Fastex

226 Gerry Drive  
Wood Dale, IL 60191  
(708) 350-8200  
CIRCLE 317 ON FREE INFORMATION CARD

### Jones & Bartlett

20 Park Plaza  
Boston, MA 02116  
(617) 482-3900  
CIRCLE 318 ON FREE INFORMATION CARD

### Media Magic

PO Box 507  
Nicasio, CA 94946  
(415) 662-2426  
CIRCLE 319 ON FREE INFORMATION CARD

### Motorola

PO Box 1466  
Austin, TX 78767  
(800) 521-6274  
CIRCLE 320 ON FREE INFORMATION CARD

### NTE Electronics

44 Farrand Street  
Bloomfield, NJ 07003  
(201) 748-5089  
CIRCLE 321 ON FREE INFORMATION CARD

### Rohm

PO Box 19681-631  
Irvine, CA 92713  
(714) 855-0819  
CIRCLE 322 ON FREE INFORMATION CARD

### Signetics/Philips

811 East Arques Avenue  
Sunnyvale, CA 94088  
(800) 227-1817  
CIRCLE 323 ON FREE INFORMATION CARD

### Synergetics

PO Box 809  
Thatcher, AZ 85552  
(602) 428-4073  
CIRCLE 324 ON FREE INFORMATION CARD

### Thomson Consumer Publicitns

2000 Clements Bridge Road  
Deptford, NJ 08096  
(609) 853-2417  
CIRCLE 325 ON FREE INFORMATION CARD

### Voltek

100 Shepard Street  
Lawrence, MA 01843  
(508) 685-2557  
CIRCLE 326 ON FREE INFORMATION CARD

The 12 equally tempered musical keys repeat each **OCTAVE**, or 2:1 frequency interval.

This means each note is related to its neighbor by a geometric ratio of the **12th** root of two, or **1.05946:1**

Only this "magic" sequence of 8-bit divisors is good enough to let all of the notes sound good together...

**232 219 207 195 184 174 164  
155 146 138 130 123 116**

Here is the better 9-bit "magic" sequence used by the MK50240..

**478 451 426 402 379 358 338  
319 301 284 268 253 239**

**FIG. 3—EQUALLY TEMPERED NOTES are irrational, so only this one "magic" 8-bit sequence of division ratios can a good enough approximation.**

octave generator works. This is old N-channel integrated circuit runs on a single 12-volt supply. input clock of 2.000240 MHz is required. The clock can be obtained from a crystal for an absolute reference, or it can be variable for pitch blending or keyboard stretch variations. Thirteen outputs are provided, giving you all the notes of highest octave, plus a spare C octave lower.

To generate lower notes, you either divide down the input clock for a single octave, or else add output dividers to generate the entire music keyboard as shown in Fig.

Hackers have long ago found other exciting uses for top-octave generators, which include musician's pitch references, piano tuners, aides, meditation, and musical toys.

Perhaps one of the most off-wall new-age uses involved John Monton's *chord egg*. Polyphonic chords obtained from a lower pitch top-octave generator were chosen at random and routed to a stereo headset. With suitable delay and phasing techniques, the apparent source of the stereo sound was forced *between* your ears, and the chords literally bounce around *inside* your head. A few chord effects remain available through PAIA electronics.

Assembly details for a traditional top-octave generator music module system appeared long ago in the June 1976 issue of *Popular Electronics*.

should be better than 0.06 percent.

To get all of the notes to sound well together, well-chosen "magic" division ratios must be used. Figure 3 shows some detail. Of all the possible 8-bit divisor values, only the

unique sequence of 116 123 ... 232 is good enough for a three-cent worst-case accuracy. If you have more bits available, then other sequences are also usable.

Figure 4 shows you how a top-

Inputs and outputs are 12 volt square waves

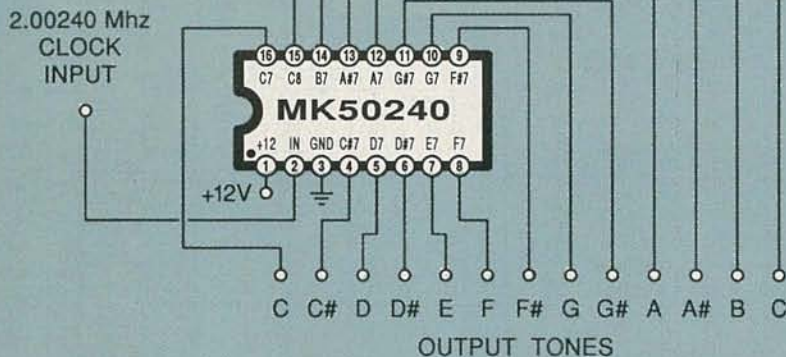

FIG. 4—TOP OCTAVE GENERATOR integrated circuits produce all the needed notes of the musical scale. Input or output lines can be binarily divided for lower octaves. Sadly, these chips are getting hard to find.

There are several reasons why the top-octave generators are no longer popular. The "locked in" nature of octave-shifted notes sound as a single richer tone, rather than as a separate pair of chorused voices. Having all the notes sound-

ing continuously in the background can lead to serious system noise problems. Zillions of wires are needed because the keyboard is usually non-scanned. The envelope and voicing opportunities are also severely limited.

But the main reason is that MIDI-based and all-digital sampled synthesizers do a much better job with a far cheaper, a far simpler, and far cleaner system architecture. Moreover, they are infinitely more flexible and sound much better than anything else.

At any rate, new sources of top-octave generators seem to be long gone. A very few of the original chips may remain available through PAIA or Devtronix on a catch-as-catch-can basis. It should also be possible to fake the top-octave generators with programmable gate array devices. The FPGA costs are dropping rapidly enough to make this possible.

Note that any pitch reference must be a nearly pure sine wave. Any higher harmonics will fool the ear and also cause potential tuning problems.

Finally, if any of you out there know of any secret stashes of this one-time great chip, be sure to let all of us know.

Try the

**Radio Electronics**

bulletin board system

(RE-BBS)  
516-293-2283

The more you use it the more useful it becomes.

We support 1200 and 2400 baud operation.

Parameters: 8N1 (8 data bits, no parity, 1 stop bit) or 7E1 (7 data bits, even parity, 1 stop bit).

Add yourself to our user files to increase your access.

Communicate with other R-E readers.

Leave your comments on R-E with the SYSOP.

RE-BBS  
516-293-2283

## Be an FCC LICENSED ELECTRONIC TECHNICIAN!



No costly school. No commuting to class. The Original Home-Study course prepares you for the "FCC Commercial Radiotelephone License." This valuable license is your professional "ticket" to thousands of exciting jobs in Communications, Radio-TV, Microwave, Maritime, Radar, Avionics and more...even start your own business! You don't need a college degree to qualify, but you do need an FCC License.

**No Need to Quit Your Job or Go To School** This proven course is easy, fast and low cost! **GUARANTEED PASS**—You get your FCC License or money refunded. **Send for FREE facts now. MAIL COUPON TODAY!**

### COMMAND PRODUCTIONS

FCC LICENSE TRAINING, Dept. 90  
P.O. Box 2824, San Francisco, CA 94126  
Please rush FREE details immediately!

NAME \_\_\_\_\_  
ADDRESS \_\_\_\_\_  
CITY \_\_\_\_\_ STATE \_\_\_\_\_ ZIP \_\_\_\_\_

## QUALITY TV & VCR PARTS

### SEMICONDUCTORS



2SC1172B	STK0080	\$16.95ea
2SD869 10/up	STK4273	\$9.95ea (10min)
2SD1398	STR30120	\$3.95ea
2SD1426		



### REPLACEMENT FLYBACKS

154-074E	GOLDSTAR	\$19.95ea
154-040A	GOLDSTAR	\$19.95ea
FCC1415AL	SAMSUNG	\$19.95ea
3214003	EMERSON	\$24.50ea
TLF14423F	PANASONIC	\$29.95ea
TLF14530F	PANASONIC	\$29.95ea
2434391	HITACHI	\$34.95ea



### IDLERS

164113	RCA	\$3.50ea (10min)
NPL Y0111GEZZ	SHARP	\$10.95ea
NPL Y0006GEZZ	REPLACEMENT	\$2.95ea
143-0-4204-00400	REPLACEMENT	\$4.95ea



### POPULAR PARTS

526A	TRIPLER	\$9.95ea
4-1164-031600	SANYO RF MODULATOR	\$17.95ea
100M/50V	RADIAL	20/for \$10.00
4.7M/250V	RADIAL	10/for \$5.50
1000M/200V	SNAP-IN	5/for \$12.50
47M/50V	RADIAL	10/for \$4.50



**MET ELECTRONICS**

975 JAYMOR ROAD  
SOUTHAMPTON, PA 18966

CALL TOLLFREE  
1-800-628-1118  
FAX# 215-364-8554



CIRCLE 89 ON FREE INFORMATION CARD

# SUPER LONG PLAY TAPE RECORDERS

12 Hour Model —  
USES 120 TAPE  
\$119.00\*

Modified Panasonic Slimline, high quality AC-DC provide 6 continuous hours of quality recording & playback on each side of cassette for 12 hours total. Includes • Voice level control • Digital counter, etc. TDK -120 Cassette Furnished.



## PHONE RECORDING ADAPTER

Records calls automatically. All Solid state connects to your telephone jack and tape recorder. Starts recording when phone is lifted. Stops when you hang up.



\$28.50\*

FCC APPROVED

## VOX VOICE ACTIVATED CONTROL SWITCH

Solid state. Self contained. Adjustable sensitivity. Voices or other sounds automatically activate and control recorder. Uses either recorder or remote mike. \$28.50\*



\* Add for ship. & handling. Phone Adapter & Vox \$2.00 each. Recorders \$5.00 each. Calif. Res. add tax. Mail order, VISA, M/C, COD's OK. Money Back Guarantee. Quantity discounts available. Dealer inquiries invited. Free data.

AMC SALES INC. Dept. A 9335 Lubec Street  
Box 928, Downey, CA 90241  
Phones (310) 869-8519 1-800-926-2488  
FAX (310) 923-1478  
Mon-Fri 8-5 PAC. TIME

CIRCLE 108 ON FREE INFORMATION CARD

Save on cable rental fees!  
**CABLE TV  
DESCRAMBLERS  
WE'LL BEAT  
ANY PRICE!**

JERROLD-TOCOM-ZENITH  
HAMLIN-OAK-PIONEER  
SCIENTIFIC ATLANTA

- 24 HOUR SHIPMENTS!
- MONEY BACK GUARANTEE!
- QUANTITY DISCOUNTS!

MASTER CARD / AMEX / VISA / C.O.D.



Have make and model number of equipment used in your area ready

CALL TOLL-FREE  
**1-800-284-8432**

**CABLE WAREHOUSE**  
10117 West Oakland Park Blvd., Suite  
515, Sunrise, FL 33351  
NO FLORIDA SALES

CIRCLE 184 ON FREE INFORMATION CARD

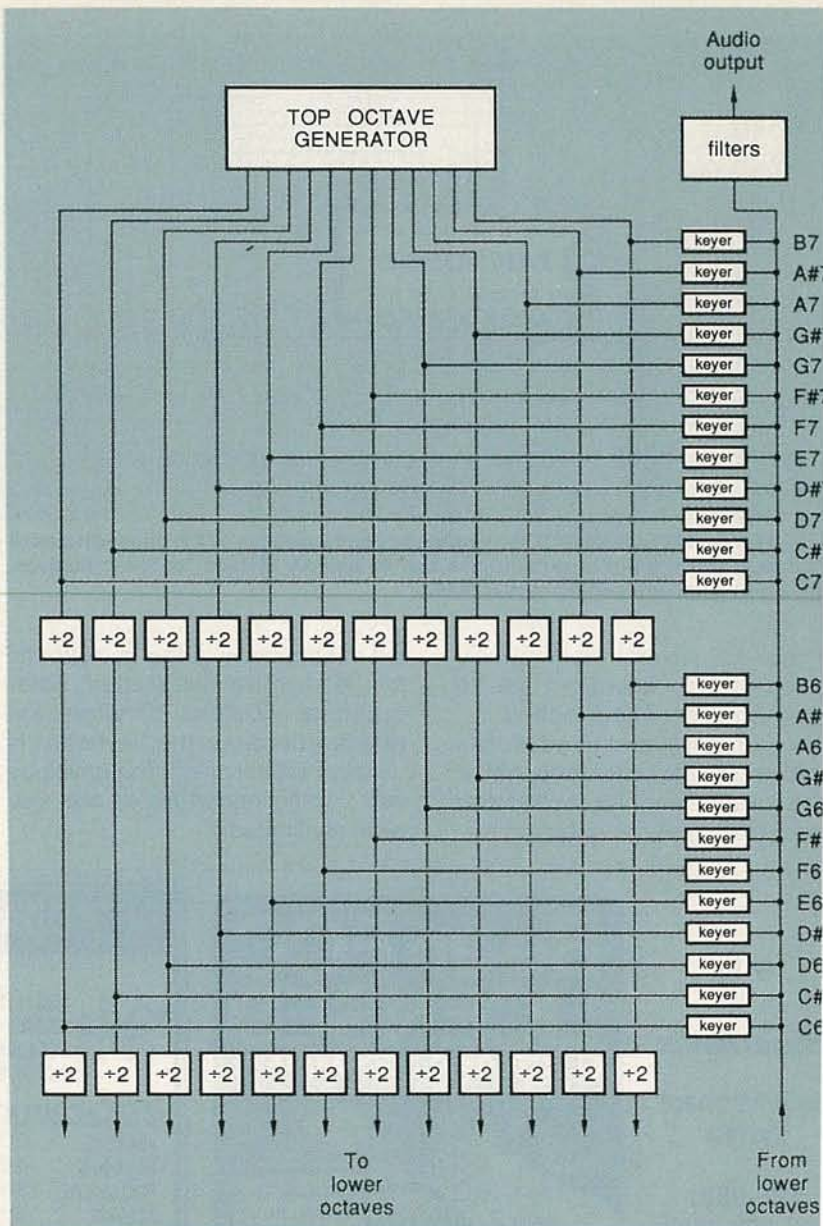

FIG. 5—A TRADITIONAL ELECTRONIC ORGAN architecture using top octave generators and dividers. Today's MIDI-based sampled synthesizer circuits can produce much better sound far simpler and in an infinitely wider variety.

### Piano and organ resources

I thought I'd gather together some traditional music names and numbers for this month's resource sidebar. For piano tuning materials and supplies try *Tuner's Supply*, while the best source for antique instrument parts and data is the *Player Piano Company*. And a good horse's mouth book is *Piano Tuning and Allied Arts*.

Note that piano tuning is (1) a lot harder than it appears; (2) a minuscule, unprofitable, and rapidly declining market; and (3) an easy way to cause irreparable damage.

Note also that most piano keys are never tuned to all their "correct" frequencies. Instead, the keyboard has to be "stretched" to allow for the non-harmonic nature of world string overtones. Keep in mind that it takes several weeks to properly tune a piano!

One classic organ kit comparison is *Devtronix*, while a company called *PAIA* offers a wide range of traditional to new age kits.

An excellent source for electronic music titles is the *MIX Books* stocked by the folks that also publish the *Electronic Musician* magazine.

ne. Fundamental synthesizer secrets can often show up first in the *Journal of the Audio Engineering Society*.

Some additional electronic music resources appear in my *Hardware Hacker II* reprints.

## New tech lit

A great "gottahave" is the *Video Data Handbook* from *Signetics Philips*, which is chock-full of digital video-interface chips, RGB digitizers, multimedia chips, sync strippers, color decoding, and all of the usual A/D and D/A conversion chips and circuits.

Speaking of multimedia, the *Media Magic* people offer a *Computers in Science and Art* catalog full of good books, tapes, and software.

A free bibliography of papers on microwave plasma applications is offered by *Astex*.

From *Antique Electronic Supply*, a 1992 wholesale catalog of supplies, books, tubes, info, and parts for the electronic collector. We've had lots of calls from experimenters trying to find Fahstock clips in this day and age. These folks are one of the few remaining suppliers.

Another trade journal on magnetic and electric shielding ideas is *EMC Technology*. And a wide selection of aircraft hacker books is available by way of *Aircraft Designs*.

This month's freebie mechanical samples include foams, films, and foils from *ARclad*, a *Foam Specifier Kit* from *Voltek*, and some self-stick bumpers from *ITW/Fastex*.

A reminder that I have recently revised my *Incredible Secret Money Machine II* and have autographed copies on hand for you when you call or write. You can get the ISMM by itself or as a portion of my *Lancaster Classics Library*.

You can also reach me via *GENie PSRT* (800) 638-9636 where you will find hundreds of downloadable files and tutorials on hardware hacking and also those midnight engineering topics.

Our usual reminder here that most of the products and services that have been mentioned appear either in the "Names and Numbers" or in the "Piano and Organ Resources" sidebars.

R-E



**CREATE INTELLIGENT PROJECTS WITH THE VERSATILE Z8 PROGRAMMABLE MICROCOMPUTER.** This powerful computer was designed for flexibility and can be used for various electronic projects. I/O Intensive. Up to 20MHz operation. Download programs or run EPROM code. Special hardware features included. Prices from **\$125.00**. Battery-backed RAM, X-assembler, and other options available. **CALL FOR FREE BROCHURE. MJS DESIGNS, INC., 1438 W. Broadway Rd., Suite B185. Tempe, AZ 85282. (602) 966-8618.**

CIRCLE 178 ON FREE INFORMATION CARD



**FREE CATALOG! ELECTRONIC TOOLS & TEST EQUIPMENT**—Jensen's new Master Catalog, available free, presents major brand name electronics tools, tool kits, and test instruments, plus unique, hard-to-find products for assembly and repair and custom field service kits available only from Jensen. All fully described and illustrated. Enjoy free technical support and rapid, post-paid delivery anywhere in the Continental USA. **JENSEN TOOLS, INC., 7815 S. 46th St., Phoenix, AZ 85044. Phone: 602-968-6231; FAX 1-800-366-9662.**

CIRCLE 115 ON FREE INFORMATION CARD



**\$495 FOR A PROGRAMMABLE DC POWER SUPPLY IS NOW A REALITY!**

- GPIB Interface Standard • Output Voltage/Current Programming & Readback • Local & Remote GPIB Operations • Remote Sense Function • Programmable Overvoltage and Overcurrent Protection • Software Calibration • Superior Line/Load Regulation • Output Enable/Disable • 3 Year Warranty.

FREE Orientation Video available. For details, call: **AMERICAN RELIANCE INC. 800-654-9838 FAX: 818-575-0801.**

CIRCLE 185 ON FREE INFORMATION CARD



**CABLE TV CONVERTERS AND DE-SCRAMBLERS** SB-3 \$79.00 TRI-BI \$95.00 MLD-\$79.00 M35B \$69.00 DRZ-DIC \$149.00. Special combos available. We ship COD. Quantity discounts. Call for pricing on other products. Dealers wanted. **FREE CATALOG.** We stand behind our products where others fail. One year warranty. **ACE PRODUCTS. P.O. Box 582, Saco, ME 04072 1 (800) 234-0726.**

CIRCLE 75 ON FREE INFORMATION CARD



**APPLIANCE REPAIR HANDBOOKS**—13 volumes by service experts; easy-to-understand diagrams, illustrations. For major appliances (air conditioners, refrigerators, washers, dryers, microwaves, etc.), elec. housewares, personal-care appliances. Basics of solid state, setting up shop, test instruments. **\$2.65 to \$5.90 each.** Free brochure. **APPLIANCE SERVICE, PO Box 789, Lombard, IL 60148. 1-(312) 932-9550.**

CIRCLE 84 ON FREE INFORMATION CARD



**TWO FOR THE PRICE OF ONE! 5 MINUTE ASSEMBLY! MONEYBACK GUARANTEE!** Attach any 3V-12V battery and have the most stable, sensitive, powerful room transmitter you can buy. Or attach to telephone line. Hear all telephone conversations—crystal clear—over 1 mile away without batteries! Use any FM radio or wideband scanner. 80-130 MHz. 100mW output! VT-75 microtransmitter chip **\$49.95 + 1.50 S&H.** VISA, MC, MO. COD's add **\$4.00.** **DECO INDUSTRIES, Box 607, Bedford Hills, NY 10507. 1-800-759-5553.**

CIRCLE 127 ON FREE INFORMATION CARD

# AUDIO UPDATE

## AES: Audio Fact and Fantasy.

LARRY KLEIN

The theme of the recent 91st Audio Engineering Society Convention held in New York—"Audio Fact and Fantasy"—was one dear to my heart. I thoroughly enjoyed both the formal sessions and the lunches and hallway conversations with some of my old friends and new acquaintances.

As I've done in years past, I intend to discuss some of the more interesting papers. But first, I'd like to set the stage, so to speak, with a recapitulation of what I see to be some of the basic problems of high-fidelity reproduction—which is what the 91st Convention was all about.

### What's the Problem?

In the very early days of hi-fi we kept talking about "concert-hall realism." Later, it came as a shock to many of the audio faithful to read that some new or rebuilt concert halls failed to achieve the "realism" supposedly inherent in live sound. In any case, how can the live listening experience ever be even approximately duplicated by scattering a dozen or more microphones throughout the ranks of a strangely grouped orchestra? And then when pop recording went multi-track, frequently done in several venues over weeks or months, the philosophical problems of duplicating a live sound that never was became intense—at least for the thinking listener.

Those and other questions arise during the process of getting the music into the storage medium. Extracting the music out again and delivering it to the ears of a listener in believable form is the other side of the coin. The success of a recording can only be judged during playback. But playback through what equipment, into what environment, and with what jury of listeners?

A recording of a live event entails a selected sampling of the sound field in the recording environment. The success of the sampling pro-

cess—which basically involves the choice and placement of microphones—depends mostly on the talent of the recording engineer. If under reasonable playback conditions the recording can produce a plausible simulation of a live sonic event, it is deemed a success.

Be aware that this thumbnail input-output description of the audio process leaves many questions unanswered. Not unexpectedly, the input part of the recording process excites far fewer passions than the playback end of things. In playback, the audiophile gets involved obsessively exploring the real or imagined effects produced by each of a wide range of components. Objectively, most electronic equipment is

really very good. Speaker quality, however, is somewhat variable from model to model and brand to brand. A third category of equipment, accessories, ranges from the sometimes helpful through the silly to the truly demented. (For further exploration of that last category, browse through virtually any issue of *The Stereophile* and *The Absolute Sound*.)

### Loudspeakers

It seems to me that amplifiers are pretty much cut and dried in the sense that competent designers can give them any desired sound quality. Although I find it strange that an engineer would deliberately introduce—or fail to eliminate—non-linearities in an amplifier design, I know for a fact that this has sometimes been done in the misguided pursuit of euphonic (ear-pleasing) effects. In any case, it's not too difficult to produce a virtually perfect amplifier, which is defined as one being free of audibly disturbing artifacts.

Loudspeakers are an altogether different ball game. Their complexities are reflected in the seemingly endless series of technical papers, experiments, and products produced over the years. The recent AES Convention provided an excellent overview of the raging controversies and unsolved problems besetting the world of loudspeakers. The essential questions confronting the loudspeaker designer are: What should a loudspeaker do, and how can the designer determine when it's doing it correctly?

A comprehensive, if somewhat weighty, overview of those speaker evaluation problems was presented by M.R. Jason of National Public Radio. I'll discuss some of the issues raised by Mr. Jason.

The listener-preference approach as a means of evaluating lo-

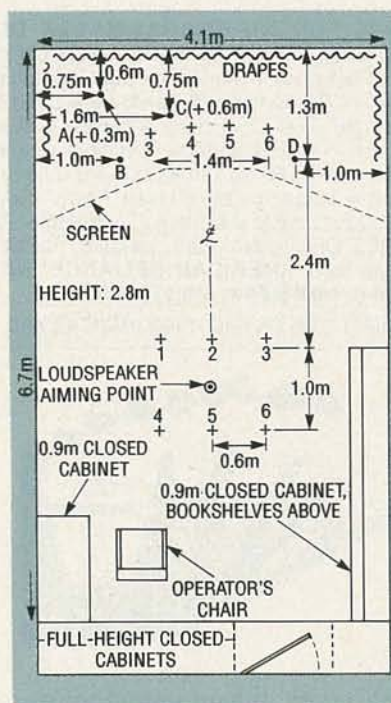

FIG. 1—THE FLOOR PLAN of the National Research Council of Canada's speaker listening room shows loudspeaker and listener locations. Loudspeakers were placed at positions 3, 4, 5, and 6 in monophonic tests, with listeners at positions 1, 3, and 5. In stereophonic tests, loudspeakers were at position B and D, and listeners at positions 2 and 5.

aker performance would seem the face of it to be an easy way to parate the good from the bad om the indifferent. But unless the aluations are based on very carel procedures and sophisticated atistical analysis, rather than sim listening tests, the results are uly to be misleading.

In fact, listener preference apars to be so unreliable an evaluaon tool that a number of reputable ademic researchers have sugested that listener-preference sts be replaced by detectable-difference tests. Those would test the ility of a listener to discriminate between a test signal and a reference signal. The thought seems to e that preference is determined by o many uncontrolled subjective ariables, while "detectability" at ast eliminates individual taste om the equation.

"Detectability" also eliminates ome of the problems of fastourier transform time-delay specometry. One of the earliest users f the technique confided to me at ne point that while the displays ere undoubtedly impressive-looking and contained lots of informaon about what was happening uring the first several milliseconds f a pulse, the exact relevance to he music-reproductive abilities of ny particular speakers was, at est, unclear.

### A Standard Listening Room

No one argues that loudspeaker performance is independent of the oom in which it is playing. Even if ou had an ideal speaker—whatver that is—the relative balance of he high and low frequencies, the evenness of the distribution of sound throughout the room, is strongly influenced, for better for worse, by the room size, proportions, wall treatments, furniture, speaker location(s), and listener positions. All of those variable have to be standardized before evaluations can be meaningful to others who are working—or listening—with a different set of conditions.

A major step toward standardization was taken in 1985, when the International Electrotechnical Commission (IEC) specified a standard listening room when it published its

recommended practice for listening tests, *Listening Tests on Loudspeakers* publication 268-13. The standard room was not, as one might suppose, derived from some mathematically optimized ideal acoustic environment. It was based, instead, on a 22 × 13.5 × 9.2-foot room, shown in Fig. 1, used for listening tests at the National Research Council of Canada in Ottawa. (The NRC roughly corresponds to the National Institute of Science and Technology in the U.S., but does far more practical research in support of various Canadian industries. The NRC test and research facilities are largely responsible for the general excellence of Canadian loudspeakers—but that's another story for another month.)

The room's acoustics were adjusted somewhat with drapes and upholstered chairs. I visited the room shortly after it had been set up and I remarked on its acoustic normalcy. It was explained that it was

intended to represent a good domestic listening environment typical of North America and Europe. Reverberation time is  $0.35 \pm .085$  seconds from 250 Hz to 4 kHz, rising to 0.85 seconds at 40 Hz and falling to 0.25 seconds at 10 kHz.

Having a common reference environment for speaker listening tests is a necessary tool, but certainly only part of what needs to be done. Without going further into the complexities of speaker evaluation, let it suffice to say that it is no easy task—and certainly not as easy as most audio publications would have you believe. Floyd Toole, formerly of the NRC, has done significant work in correlating listener evaluations with measured performance. In the view of many experts, Toole's efforts have advanced audio art significantly toward the goal of "What you hear is what you measure—and vice versa."

Next month, I'll look at some additional AES papers that I think you'll find interesting. **R-E**

## LEARN to CLEAN/ MAINTAIN/ REPAIR CAMCORDERS



**EARN \$85 AN HOUR!**

### HUGE EXPANDING MARKET!

Work from your home - part-time or full-time!  
No prior experience needed - Average mechanical ability only requirement for your success! Over 15 million camcorders in use - Over 5 million expected to be sold in 1991 alone!

It is a fact that the vast majority of camcorder malfunctions (just like VCRs!) are due to simple mechanical failure... We can show you how to easily fix those breakdowns and earn an average of \$85.00/Hr. while working at home!

**Get In Now** - Soon camcorders will be like VCRs, i.e., one in almost every home.

For a camcorder cleaning job you can earn \$65.00 for less than 30 minutes work.

For a camcorder repair job you can earn over \$100.00.

**FREE INFORMATION PACKAGE call or write:**  
Toll-Free 1-800-537-0589  
Viejo Publications, Inc.  
4470-107 Sunset Blvd. #600  
Los Angeles, CA 90027, Dept. REC

CIRCLE 182 ON FREE INFORMATION CARD

## Choose from 45 Career Opportunities!

**Get Your Specialized Associate Degree or Career Diploma at Home in Spare Time**

Now without attending college classes and with no previous experience, you can train for a money-making career...even get a Degree. Send for free facts and color brochure on employment opportunities in the field that interests you most. See how easy it is to train at home for a great career or advancement in your present job.



**CALL TOLL FREE 1-800-234-9070 Ext. 489**  
CALL ANYTIME—24 hours a day, 7 days a week.  
**OR MAIL COUPON TODAY!**

**INTERNATIONAL CORRESPONDENCE SCHOOLS**  
Dept. ADES22S, 925 Oak Street, Scranton, PA 18515

Please send me free facts, color brochure and full information on how I can study at home for the career I have chosen. No obligation. **CHECK ONE BOX ONLY!**

<p><b>ASSOCIATE IN SPECIALIZED BUSINESS DEGREE PROGRAMS</b></p> <p><input type="checkbox"/> Business Management</p> <p><input type="checkbox"/> Accounting</p> <p><input type="checkbox"/> Bus. Mgmt.—Finance Option</p> <p><input type="checkbox"/> Bus. Mgmt.—Marketing Option</p> <p><input type="checkbox"/> Applied Computer Science</p> <p><input type="checkbox"/> Hospitality Management</p>	<p><b>ASSOCIATE IN SPECIALIZED TECHNOLOGY DEGREE PROGRAMS</b></p> <p><input type="checkbox"/> Civil Engineering Technology</p> <p><input type="checkbox"/> Mechanical Engineering Technology</p> <p><input type="checkbox"/> Electrical Engineering Technology</p> <p><input type="checkbox"/> Industrial Engineering Technology</p> <p><input type="checkbox"/> Electronics Technology</p>
--	---

**CAREER DIPLOMA PROGRAMS**

<p><input type="checkbox"/> High School</p> <p><input type="checkbox"/> Auto Mechanics</p> <p><input type="checkbox"/> Surveying and Mapping</p> <p><input type="checkbox"/> Drafting</p> <p><input type="checkbox"/> Air Conditioning &amp; Refrigeration</p> <p><input type="checkbox"/> Wildlife/Forestry Conservation</p> <p><input type="checkbox"/> Police Sciences</p> <p><input type="checkbox"/> Private Security Officer</p> <p><input type="checkbox"/> Diesel Mechanics</p> <p><input type="checkbox"/> Electrician</p> <p><input type="checkbox"/> Small Business Management</p> <p><input type="checkbox"/> Gun Repair</p> <p><input type="checkbox"/> Electronics</p> <p><input type="checkbox"/> Microcomputer Repair</p> <p><input type="checkbox"/> Hotel/Restaurant Management</p> <p><input type="checkbox"/> Child Day Care</p> <p><input type="checkbox"/> Legal Assistant</p>	<p><input type="checkbox"/> Interior Decorating</p> <p><input type="checkbox"/> Bookkeeping</p> <p><input type="checkbox"/> Art</p> <p><input type="checkbox"/> Motorcycle Repair</p> <p><input type="checkbox"/> Catering/Gourmet Cooking</p> <p><input type="checkbox"/> Computer Programming</p> <p><input type="checkbox"/> Computer Programming/COBOL</p> <p><input type="checkbox"/> Personal Computer Specialist</p> <p><input type="checkbox"/> Computer-Assisted Bookkeeping</p> <p><input type="checkbox"/> Fitness &amp; Nutrition</p> <p><input type="checkbox"/> TV/VCR Repair</p> <p><input type="checkbox"/> Travel Agent</p> <p><input type="checkbox"/> Animal Care Specialist</p> <p><input type="checkbox"/> Photography</p> <p><input type="checkbox"/> Journalism/Short Story Writing</p> <p><input type="checkbox"/> Dressmaking and Design</p> <p><input type="checkbox"/> Florist</p>
--	---

Name \_\_\_\_\_ Age \_\_\_\_\_  
Address \_\_\_\_\_ Apt. # \_\_\_\_\_  
City/State \_\_\_\_\_ Zip \_\_\_\_\_  
Phone ( ) \_\_\_\_\_

# DRAWING BOARD

## Our oscilloscope is shaping up nicely.

ROBERT GROSSBLATT

If you're a regular reader of "Drawing Board," you know that the principles of design are just as important as the particulars of the circuit. Even though each series of columns winds up with a working gadget of one kind or other, the real idea behind all of it isn't to see how to design something in particular, but how to design anything in general. The real message is the method, not the minutiae.

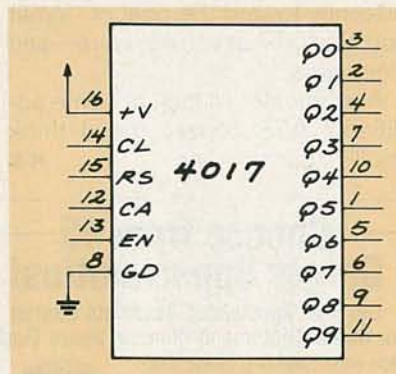

FIG. 1—THE 4017 DECADE COUNTER will be used to sequentially enable each of the LED columns at a rate chosen by the clock circuit we put together last month.

The reason for mentioning this is that we've come to the point where we're going to do the design of the horizontal driver circuit and there are lots of ways to get the job done. What we'll be doing together here is only one of them.

The job of this circuit is to sequentially enable each of the LED columns at a rate chosen by the clock circuit that we put together last month. Most small digital scopes (those with ten or less columns), use a 4017 decade counter to do this; that makes sense because it's exactly the kind of job the 4017 was designed to do. For scopes like ours where there are more than ten columns, the sequencing circuit generally gets more complex because there are no single-chip solutions to get the job done, and the 4017 wasn't really designed for sequential cascade counting. Decade counting is simply a matter of using the cascade output built into the chip, but doing sequential counting is something else altogether.

As you can see in Fig. 1, the chip

has a limited number of control puts, and there's no easy way to disable all the outputs. One output will always be enabled no matter what you do to the control lines as long as the chip is getting clock pulses.

That's not to say, however, that can't be done. After all, a 4017 is cheap, so available, and so perfect for the job, it would be a shame not to use it. All it takes is some logic glue and a bit of imaginative gating. And that's what we're going to do.

I've been using various versions of this arrangement of 4017's for years since it's a neat way to get around the ten-count limit of the 4017. As we all know, nothing is free and that goes here as well. Since the 4017 will always have one of its outputs enabled, there's no way we can string a bunch of them together sequentially and use every output on every chip. That's the reason there are three 4017's being used in Fig. 2 even though we need only twenty outputs. We lose the last output of the first 4017 and the outputs from each of the others

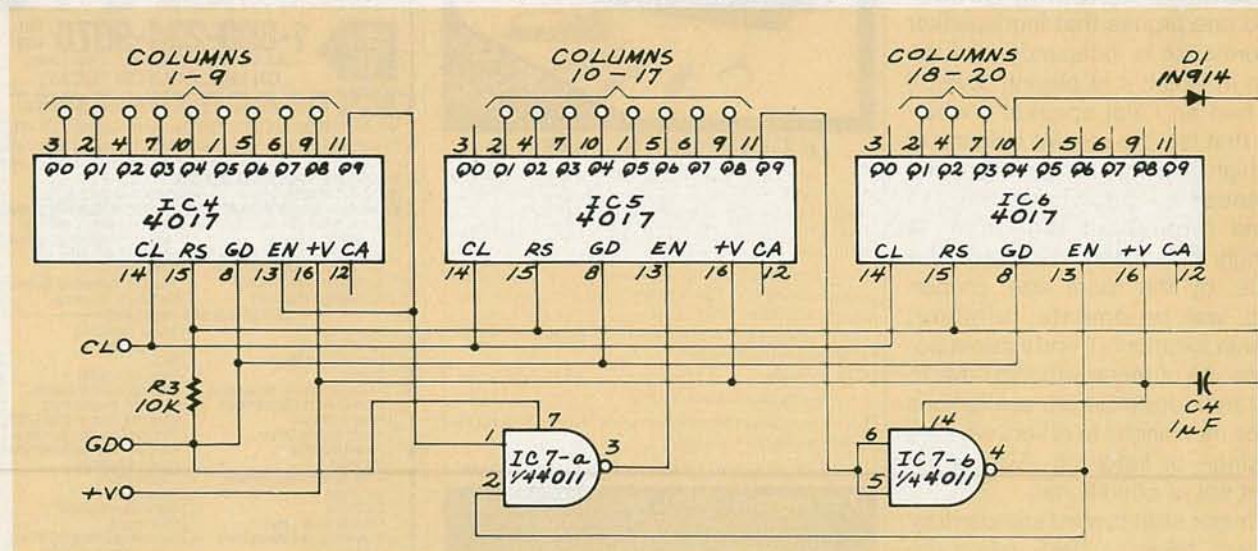
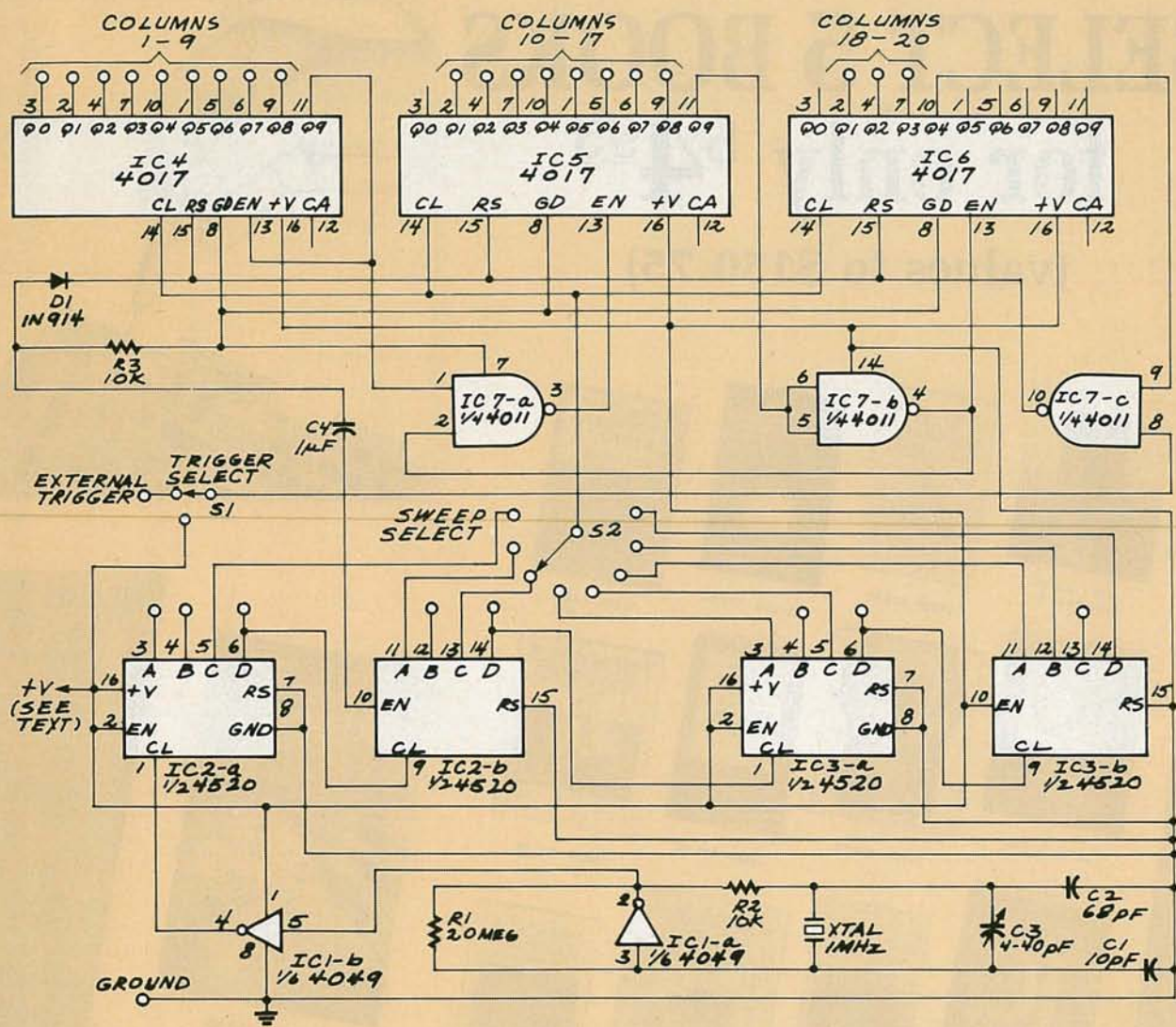

FIG. 2—BECAUSE ONE OUTPUT OF THE 4017 will always be enabled, we can't use every output on every chip. That's why there are three 4017's being used here even though we need only twenty outputs.





**FIG. 3—HERE'S OUR OSCILLOSCOPE SO FAR.** The NAND gate IC7-c is switched into the circuit in the triggered sweep mode. It resets when the trigger signal puts a high on the second leg of the NAND gate. If we want the scope to be free running, we switch the trigger leg of the gate to +V.

You should file this circuit away in our notebooks because it comes in handy when you least expect it. And for all you out there who were rained to eat absolutely everything on your plate, there are ways to reconfigure the circuit so you can use every single output of every single chip. Without going into the details, the problem is to create some sort of an external output enable control for the 4017. That can be done with buffers or transistors between the outputs of the 4017 and whatever the outputs are intended to control.

But I leave that to you. Any more of these asides and I'll wind up writing like Lawrence Sterne did in *Tristram Shandy*—digression upon

digression upon digression.

By adding Fig. 2 to the stuff we did last month, we now have a working version of the horizontal circuit we defined at the outset of this design project. It does everything we specified and, if you wire it up on a breadboard, you'll see that the only other piece you have to add is an eight-position, single-pole rotary switch (a break-before-make type), so you can select the sweep speed being fed to the common clock inputs of the 4017's.

Before we leave the horizontal section of the scope, this is a good time to talk about how the scope is going to be triggered. If you're familiar with scopes, you know that most

scopes offer you a choice of three basic ways to control the horizontal sweep: as a single shot, free-running, or triggered. Each of them is useful in different situations and, with the exception of free-running (most scopes refer to this as "normal"), the circuitry to make them happen needs some of the signals we'll be generating when we get to work on the design of our scope's vertical drive.

Any control of the horizontal sweep is directly translatable into what we do with the reset control lines of the 4017's. As you can see in Fig. 2, all the reset lines have been tied together and are controlled by

*continued on page 98*

# SELECT 5 BOOKS for only \$4<sup>95</sup>

(values to \$150.75)

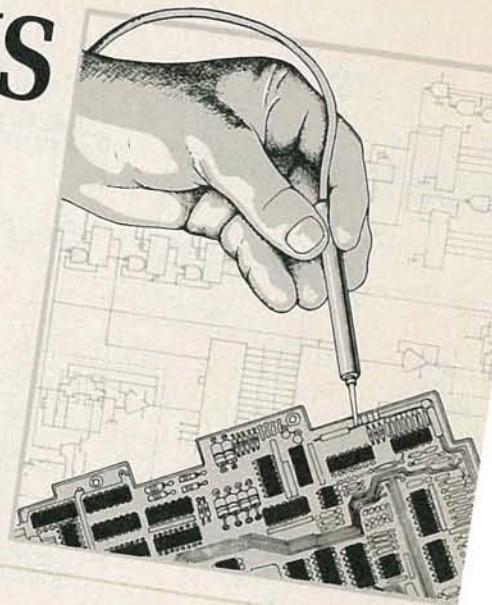

3414 \$39.95  
Counts as 2



2883P \$18.95



585120-2 \$12.95



10024 \$32.95  
Counts as 2



2613P \$17.95



3107P \$18.95



2980P \$19.95

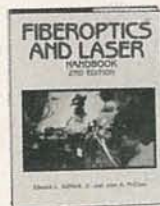

2981P \$18.95



3550 \$34.95  
Counts as 2



1367P \$24.95

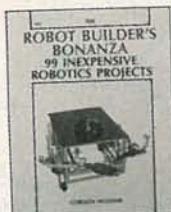

2800P \$16.95



3321P \$16.95

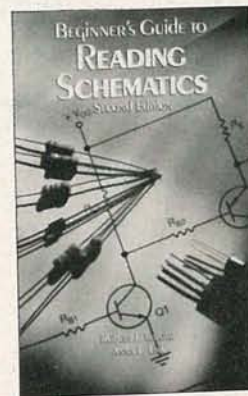

3632 \$18.95



3672 \$28.95



3145P \$12.95



3345 \$39.95



3576P \$14.95



3270 \$32.95  
Counts as 2



3241P \$16.95

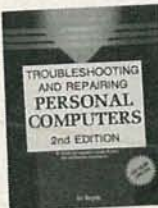

3677 \$34.95  
Counts as 2



3122P \$21.95



2880P \$14.95



3804P \$19.95



2947P \$13.95



3778 \$26.95

# Your most complete source for electronics books for over 25 years.

**Troubleshooting & Repairing VCRs** SECOND EDITION  
Gordon McComb  
3777 \$32.95  
Counts as 2

**Troubleshooting and Repairing AUDIO EQUIPMENT**  
Homer L. Davidson  
2867P \$18.95

**THE ENCYCLOPEDIA OF ELECTRONIC CIRCUITS** VOLUME ONE  
1938 \$60.00  
Counts as 3

**How to Test Almost Everything Electronic**  
2925P \$9.95

**ELECTRONIC SIGNALS AND SYSTEMS**  
3557 \$29.95  
Counts as 2

**THE CET STUDY GUIDE** 2nd Edition  
2941P \$16.95

**Design & Build ELECTRONIC POWER SUPPLIES**  
3540 \$26.95

**Electronic Troubleshooting Procedures and Servicing Techniques**  
J.A. SAN WILSON  
9370 \$38.60  
Counts as 2

**COMPUTER TECHNICIAN'S HANDBOOK** 3rd Edition  
3279 \$36.95  
Counts as 2

**EASY ELECTRONICS PROJECTS FOR TRANSCONDUCTANCE & NORTON OP AMPS**  
3455 \$25.95

**101 SOLDERLESS BREADBOARDING PROJECTS**  
39 JONAS'S BOOK  
2985 \$24.95

**MASTERING IC ELECTRONICS** Through Projects & Experiments  
3660 \$32.95  
Counts as 2

**TV REPAIR FOR BEGINNERS** FOURTH EDITION  
3627 \$29.95  
Counts as 2

**REMOTE CONTROLLED ROBOT FOR UNDER \$100**  
2617P \$9.95

**Troubleshooting & Repairing Electronic Circuits**  
3258 \$28.95

**BUILD YOUR OWN TEST EQUIPMENT** 762  
3475 \$27.95

**WIRE & CABLE FOR ELECTRONICS** A User's Handbook  
3787 \$29.95  
Counts as 2

**BUILD YOUR OWN LASER, PHASER, ION RAY GUN AND OTHER WORKING SPACE-AGE PROJECTS**  
1604P \$17.95

**MAKE BETTER VIDEOS WITH YOUR CAMCORDER** Even Complete Beginners  
3659 \$21.95

**Mastering Electronics Math** SECOND EDITION  
3589 \$27.95  
Counts as 2

**Membership Benefits • Big Savings.** In addition to this introductory offer, you keep saving substantially with members' prices of up to 50% off the publishers' prices. • **Bonus Books.** Starting immediately, you will be eligible for our Bonus Book Plan, with savings of up to 80% off publishers' prices. • **Club News Bulletins.** 15 times per year you will receive the Book Club News, describing all the current selections—mains, alternates, extras—plus bonus offers and special sales, with scores of titles to choose from. • **Automatic Order.** If you want the Main Selection, do nothing and it will be sent to you automatically. If you prefer another selection, or no book at all, simply indicate your choice on the reply form provided. You will have at least 10 days to decide. As a member, you agree to purchase at least 3 books within the next 12 months and may resign at any time thereafter. • **Ironclad No-Risk Guarantee.** If not satisfied with your books, return them within 10 days without obligation! • **Exceptional Quality.** All books are quality publishers' editions especially selected by our Editorial Board. (Publishers' Prices Shown)

All books are hardcover unless number is followed by a "P" for paperback.  
©1992 ELECTRONICS BOOK CLUB, Blue Ridge Summit, PA 17294-0810



## ELECTRONICS BOOK CLUB

Blue Ridge Summit, PA 17294-0810

YES! Please accept my membership in the Electronics Book Club and send the 5 volumes listed below, billing me \$4.95. If not satisfied, I may return the books within ten days without obligation and have my membership cancelled. I agree to purchase at least 3 books at regular Club prices during the next 12 months and may resign any time thereafter. A shipping/handling charge and sales tax will be added to all orders.

--	--	--	--

Name \_\_\_\_\_

Address \_\_\_\_\_

City \_\_\_\_\_

State \_\_\_\_\_ Zip \_\_\_\_\_ Phone \_\_\_\_\_

Signature \_\_\_\_\_

Valid for new members only. Foreign applicants will receive special ordering instructions. Canada must remit in U.S. currency. This order subject to acceptance by the Electronics Book Club.

RE392

# LEARN VCR

## CLEANING/MAINTENANCE/REPAIR

EARN UP TO \$1000 A WEEK, WORKING PART TIME FROM YOUR OWN HOME!



Secrets Revealed!

NO Special Tools or Equipment Needed.

EARN UP TO \$60 AN HOUR AND MORE!

### THE MONEY MAKING OPPORTUNITY OF THE 1990'S

IF you are able to work with common small hand tools, and are familiar with basic electronics (i.e. able to use voltmeter, understand DC electronics). . . . IF you possess average mechanical ability, and have a VCR on which to practice and learn. . . . then we can teach **YOU** VCR maintenance and repair!

**FACT:** up to 90% of ALL VCR malfunctions are due to simple MECHANICAL or ELECTRO-MECHANICAL breakdowns!

**FACT:** over 77 million VCRs in use today nationwide! Average VCR needs service or repair every 12 to 18 months!

Viejo's **400 PAGE TRAINING MANUAL** (over 500 photos and illustrations) and **AWARD-WINNING VIDEO TRAINING TAPE** reveals the **SECRETS** of VCR maintenance and repair—"real world" information that is **NOT** available elsewhere!

Also includes all the info you'll need regarding the **BUSINESS-SIDE** of running a successful service operation!

**FREE INFORMATION**  
CALL TOLL-FREE 1-800-537-0589

Or write to: Viejo Publications Inc.  
4470-107 Sunset Blvd., #600  
Los Angeles, CA 90027, Dept. RE

CIRCLE 181 ON FREE INFORMATION CARD

Try the

# Radio Electronics®

bulletin board system

(RE-BBS)  
516-293-2283

The more you use it the more useful it becomes.

We support 1200 and 2400 baud operation.

Parameters: 8N1 (8 data bits, no parity, 1 stop bit) or 7E1 (7 data bits, even parity, 1 stop bit).

Add yourself to our user files to increase your access.

Communicate with other R-E readers.

Leave your comments on R-E with the SYSOP.

RE-BBS  
516-293-2283

## PHONE-LINE MONITOR

continued from page 58

high-frequency tone groups, which are then decoded into one four-bit code per key, as shown in Table 3.

The DTMF decoder informs the microprocessor when a tone has been detected by asserting  $\overline{TSTB}$ , which drives bit 6 of port 1 of the 8031, shown back in Fig. 2. The 8031 then reads the 4-bit code by asserting  $\tau\text{-OE}$  through port C0 of the PIO, and reading bits PB0-PB3 of the PIO. In addition to reading DTMF codes, the PIO also reads the status of configuration switch S1 and off/standby switch S2, and can assist RS-232 data flow via the DTR output and the CTS input.

### Audible signalling

The speaker driver is shown in Fig. 4-e. Digi-Call can generate several different sounds, as follows.

- Digi-Call produces a warble sound when the unit is turned on; it emits a beep when the user selects standby mode. Cannot be disabled.
- Digi-Call produces a ringing sound when the unit is on and the phone rings. Can be disabled.
- The turn-on reminder warble sound will chime every ¼ hour when the unit is in standby mode. Can be disabled.
- Power loss causes a short beep to be produced every minute. Cannot be disabled.
- A RAM-full condition causes an alarm to sound every minute until data is erased using the PC-based utility program. Cannot be disabled.
- Illegal configurations of S1 cause a continuous slow-going high-low beep. Cancel by choosing legal switch positions. We'll discuss S1 further next time.

The microprocessor has an internal serial interface that Digi-Call uses to transfer stored telephone data to the PC. However, the microprocessor's TTL levels are not compatible with standard RS-232 levels, so we use a MAX-232, shown in Fig. 4-

TABLE 3—  
DECODED DTMF OUTPUTS

DIGIT	D3	D2	D1	D0
1	0	0	0	1
2	0	0	1	0
3	0	0	1	1
4	0	1	0	0
5	0	1	0	1
6	0	1	1	0
7	0	1	1	1
8	1	0	0	0
9	1	0	0	1
0	1	0	1	0
*	1	0	1	1
#	1	1	0	0

e, both to drive the RS-2 lines, and to generate the ± volt signalling voltages. We a "steal" the -9-volt DC output power op-amp IC1.

### Status indicators

Three status LED's indicate Digi-Call's operational status.

The green "On" indicator (LED4) lights steadily when the unit is on and the phone is on-hook; it blinks when the phone line is off-hook or ringing.

The red "Full" indicator (LED3) indicates that the data RAM is full and no further logging is possible. The "Full" LED also lights during the Power On Self Test (POST), and during the diagnostics accessible through the host PC software. Last, LED3 blinks slowly if configuration switch S1 is in an illegal combination.

The Watch Dog indicator (LED5) blinks slowly under normal circumstances, and rapidly if powered by the batteries.

The power supply, shown in Fig. 5, is designed to operate even in the absence of AC power. Blocking diode D9 isolates back-up cells B1-B6 while power is present; resistor R1 determines charge current to the batteries. Digi-Call's function with nonrechargeable batteries, in which case it should not be installed.

Next time we'll build the phone and get it up and running.

**48 HOUR SHIPPING**

# ELENCO & HITACHI PRODUCTS AT DISCOUNT PRICES

**TO ORDER CALL TOLL FREE 1-800-292-7711**

## Hitachi RSO Series

Portable Real-time Digital Storage Oscilloscopes)  
 /C-6023 - 20MHz, 20MS/s \_\_\_\_\_ \$1,695  
 /C-6024 - 50MHz, 20MS/s \_\_\_\_\_ \$1,995  
 /C-6025 - 50MHz, 20MS/s \_\_\_\_\_ \$2,195  
 /C-6045 - 100MHz, 40MS/s \_\_\_\_\_ \$2,995  
 /C-6145 - 100MHz, 100MS/s \_\_\_\_\_ \$4,495

SO's from Hitachi feature roll mode, averaging, save memory, smoothing, interpolation, pretriggering, cursor measurements. These scopes enable more accurate, multiplier observation of complex waveforms, in addition to such functions as hardcopy via a plotter interface and waveform transfer via the RS-232C interface. Enjoy the comfort of analog and the power to digital.

## 15MHz Elenco Oscilloscope



**\$349**  
S-1325

- Dual Trace
- 1mV Sensitivity
- 6" CRT
- X-Y Operation
- TV Sync
- (2) 1x, 10x Probes included

scopes include probes, schematics, operators manual and 3 year (2 yrs for Elenco scopes) world wide warranty on parts & labor. Many accessories available for all Hitachi scopes. Call or write for complete specifications on these and many other fine oscilloscopes.

## SPECIAL BUY

**V-212 - 20MHz Scope \$425**

## Hitachi Portable Scopes

DC to 50MHz, 2-Channel, DC offset function, Alternate magnifier function

V-525 - CRT Readout, Cursor Meas. \$995  
 V-523 - Delayed Sweep \_\_\_\_\_ \$975  
 V-522 - Basic Model \_\_\_\_\_ \$875  
 V-422 - 40MHz \_\_\_\_\_ \$775  
 V-223 - 20MHz delayed sweep \_\_\_\_\_ \$695  
 V-222 - 20MHz deluxe \_\_\_\_\_ \$625

## PRICE BREAKTHRU

**20MHz Digital Storage Oscilloscope**

- Analog/Digital Scope
  - 2K word per channel memory
  - 10MS/s sampling rate
  - State-of-art technology
  - Includes probes
- DS203 \$795**

## HITACHI COMPACT SERIES SCOPES

This series provides many new functions such as CRT Readout, Cursor measurements (V-1085/1065A/665A), Frequency Ctr. (V-1085), Sweeptime Autotranging, Delayed sweep and Tripper Lock using a 6-inch CRT. You don't feel the compactness in terms of performance and operation.

V-660 - 60MHz, Dual Trace \_\_\_\_\_ \$1,149  
 V-665A - 60MHz, DT, w/cursor \_\_\_\_\_ \$1,345  
 V-1060 - 100MHz, Dual Trace \_\_\_\_\_ \$1,395  
 V-1065A - 100MHz, DT, w/cursor \_\_\_\_\_ \$1,649  
 V-1085 - 100MHz, QT, w/cursor \_\_\_\_\_ \$1,995  
 V-1100A - 100MHz, Quad Trace \_\_\_\_\_ \$2,195  
 V-1150 - 150MHz, Quad Trace \_\_\_\_\_ \$2,695

## Elenco 40MHz Dual Trace



**\$495**  
Good to 50MHz  
S-1340

- High luminance 6" CRT
- 1mV Sensitivity
- 10KV Acceleration Voltage
- 17ns Rise Time
- X-Y Operation
- Includes (2) 1x, 10x Probes

## B + K TEST EQUIPMENT

Call for special price

## Digital Capacitance Meter



CM-1550B  
**\$58.95**  
 9 Ranges  
 .1pf-20,000ufd  
 .5% basic accy.  
 Zero control w/ Case  
 Big 1" Display

## Digital LCR Meter



LC-1801  
**\$125**  
 Measures:  
 Coils 1uH-200H  
 Caps .1pf-200uf  
 Res .01-20M

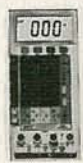

## Multimeter with Capacitance & Transistor Tester

**\$55** CM-1500B  
 Reads Volts, Ohms  
 Current, Capacitors,  
 Transistors and  
 Diodes / with case

## FLUKE

### MULTIMETERS

All Models Available  
 Fluke 70-II \_\_\_\_\_ \$65  
 Fluke 77-II \_\_\_\_\_ \$145  
 Fluke 79-II \_\_\_\_\_ \$169  
 Fluke 87 \_\_\_\_\_ \$289  
 Call for special price

## Quad Power Supply XP-580



**\$59.95**  
 2-20V @ 2A  
 12V @ 1A  
 5V @ 3A  
 -5V @ .5A

Fully regulated and short circuit protected

## Digital Triple Power Supply XP-765



**\$269**  
 0-20V @ 1A  
 0-20V @ 1A  
 5V @ 5A

Fully regulated, Short circuit protected with 2 limit control, 3 separate supplies  
**XP-660 with Analog Meters \$195**

## AM/FM Transistor Radio Kit with Training Course

Model AM/FM 108  
**\$26.95**

14 Transistors • 5 Diodes  
 Makes a great school project



True RMS 4 1/2 Digit Multimeter  
**M-7000**

**\$135**

.05% DC Accuracy  
 .1% Resistance  
 with Freq. Counter and Deluxe Case

## GF-8016 Function Generator with Freq. Counter



**\$249**

Sine, Square, Triangle Pulse, Ramp, .2 to 2MHz  
 Freq Counter .1 - 10MHz  
 Int/Ext operation

GF-8015 without Freq. Meter \$179

## Function Generator Blox #9600



**\$28.95**

Provides sine, triangle, square wave from 1Hz to 1MHz  
 AM or FM capability

## Color Convergence Generator



SG-250

**\$79.95**

Kit \$59.95

Finest in the industry  
 10 rock steady patterns  
 RF & Video output

## STANDARD AMATEUR RADIOS

Now available - The worlds finest amateur radios. Unsurpassed quality and features make STANDARD the worlds most popular line of amateur radios.

### Mini Deluxe HTs:

C168A 2 meter \_\_\_\_\_ CALL  
 C468A 450MHz \_\_\_\_\_

### Twin Band HTs

C228A 2M/220MHz \_\_\_\_\_ CALL  
 C528A 2M/440MHz \_\_\_\_\_

### Twin Band Mobile

C5608DA 2M/440MHz \_\_\_\_\_ CALL

We also have many accessories for these radios and most heath radios. Call for details.

## Learn to Build and Program Computers with this Kit

Includes: All Parts, Assembly and Lesson Manual



Model MM-8000

**\$129.00**

Starting from scratch you build a complete system. Our Micro-Master trainer teaches you to write into RAMs, ROMs and run a 8085 microprocessor, which uses similar machine language as IBM PC.

## Wide Band Signal Generators



SG-9000 \$129

RF Freq 100K-450MHz AM Modulation of 1KHz Variable RF output  
**SG-9500 w/ Digital Display & 150 MHz built-in Counter \$249**

## High Current Power Supply



XP-800

**\$295**

Digital Volt/Amp Meters  
 Fully regulated, 0-122VAC @ 2A, 0-40VAC @ 10A or 0-30VDC @ 10A. Fully variable, Short circuit protected.

**WE WILL NOT BE UNDERSOLD!**

PS Shipping: 48 States 5%

\$3 Min \$10 Max) Shipping

L Res., 7.5% Tax FAX: 708-520-0085

**C & S SALES INC.**

1245 Rosewood, Deerfield, IL 60015  
 (800) 292-7711 (708) 541-0710



**15 Day Money Back Guarantee**

**2 Year Warranty** Prices Subject to Change

**WRITE FOR FREE CATALOG**

CIRCLE 109 ON FREE INFORMATION CARD

## Industry evolution

JEFF HOLTZMAN

IBM dominates the news this month. Since last time, Big Blue signed an historic accord with Intel, formed a trade group with Apple and Motorola, and commenced internal restructuring that, if successful, could point the way to survival for several major U.S. industries (not just the computer industry). If, however, that restructuring is unsuccessful, it may be a harbinger of how the computer industry will follow the automotive and steel industries down the tubes.

### IBM + Intel

With the new-found friendship among IBM, Apple, and Motorola reached last summer, you may have wondered about IBM's commitment to the Intel platform. Well, wonder no longer. IBM and Intel signed a ten-year agreement under which they will collaborate on the design of new 80x86 IC's. About the significance of this deal, Intel's CEO Andrew Grove has said, "This is probably the biggest deal I have signed in my professional career."

The two companies will establish a 100-person development center composed of scientists and engineers from both IBM and Intel. Intel will contribute CPU designs; IBM will contribute systems-level expertise and semiconductor manufacturing technology. (It's not well known that IBM is one of the largest semiconductor manufacturers in the world.) It will take about two years to produce results, including highly integrated modules that incorporate CPU, cache memory, memory management, bus interface logic, disk controller, and graphics. The companies will develop these products jointly; IBM will have a four-month lead in commercializing systems, after which time Intel can sell IC's on the open market. IBM has had the right to build and enhance its own

386 CPU's since 1987. (An enhanced CPU would include the 386SLC, the "weird" CPU mentioned here last time as part of IBM's Ultimedia PC.) However, the new agreement precludes IBM from enhancing future 486-based CPU's.

IBM's four-month lead, as well the changing business climate, has competitors like Compaq deeply worried. For years Compaq was one of Intel's most loyal customers. Recently, however, the company has been warming up to AMD, which is expected to release a line of 486 clones sometime in 1992. Because AMD and Chips & Technologies have already successfully cloned the 386, Intel's marketing effort is focusing more and more on the 486 line. AMD is achieving great success with its 386 line by exceeding its own sales forecasts of 386 clones by 400% through 1991, for a total of about 20% of the 386 market. Intel also suffered a setback in the math coprocessor clone department; a judge in Texas has ruled that Cyrix may continue selling its FasMath clones until a combined antitrust/patent infringement case reaches trial in late summer 1992.

The good thing about all of this is that Intel is not content with trying to protect its prior accomplishments, and in the process leaving the fate of the company (not to mention the industry that depends on x86 chips) up to its lawyers. Rather, it is moving ahead and designing innovative new products, thereby staying a step or two ahead of the cloners. If the software industry followed this kind of model, we'd probably be much further along in the move toward graphical operating environments.

### IBM + Apple + Motorola

Those three companies are forming a trade association, PowerOpen, dedicated to defining and

promulgating software standards for the RISC-based PowerPC architecture announced as part of last summer's historic Apple/IBM accord. These standards involve defining the instruction set of PowerPC, a cross-platform binary compatibility layer called the Application Binary Interface (ABI), and a high-level programming interface. The intent of these technologies is to provide a "universal" software environment that will support future Macintosh and OSF/Motif applications, as well as current Macintosh DOS applications (through emulators), and AIX applications. (All IBM's version of UNIX.) IBM and Apple are also talking about merging AIX and AU/X (Apple's version) over the next few years.

With both Motorola and Intel in their hip pocket, IBM now stands poised to build an incredible machine, one that provides hardware-level support for the major operating systems of the 90's: Macintosh, DOS, Windows, and standards-based UNIX. 1993 will be an interesting year for PC system architecture.

### IBM restructuring

IBM's restructuring may seem to be one of those ho-hum things that the company seems to go through with increasing frequency in recent years. Don't bet on it. IBM is in trouble. Not only IBM the company, but America's whole way of doing business. If IBM fails, we're all going to be liable to significantly increased risk of domination by unfriendly vendors. There are people who believe that this risk represents a greater threat to our society than the political and military risks usually harped on by the press, in Washington, and in state and local governments. You may not like IBM, but you'd probably hope that it finds a way of respo-

g competitively to the changes going on in the world at large.

The most visible but probably most strategically important change is the "reduction" of 20,000 jobs,

at a one-time cost of \$3 billion. More significant is the decision to reduce control over and grant increased autonomy to IBM's major divisions (mainframe, AS/400, S/6000, PC's, core technologies, etc.). Under this new scheme, each division will exert greater control over its fate, thereby allowing faster response time to rapidly changing market conditions. In recent years, IBM has suffered increasingly at the hands of smaller, more efficient, more integrated companies that could detect and rapidly respond to some market need, be it portable PCs, engineering workstations, operating systems, or what have you. IBM suffered again and again because its bureaucracy got in the way of responding to rapidly changing customer needs. In addition, the company suffered from internal bickering over product features and marketing. In some cases, competitors were able to commercialize products before IBM could get out of the planning stage. Meanwhile, the company's market share and credibility dropped on a yearly basis, achieving crisis level in the early part of this decade.

It's still too early to tell whether these changes will provide the needed benefits. There are plenty of skeptics who say that A) the changes do not go far enough, and B) even if they did, they cannot be implemented in time.

I hope the nay-sayers are wrong. The U.S. needs new models of doing business on a very large scale; IBM is poised to lead the way. If IBM fails, who, if anyone, will be able to show us how?

### Jews bits

Intel has leaked more details of the **586**, which will contain 256K of cache memory, a 64-bit data bus, and a 36-bit address bus. It will run at speeds of 33-, 50-, 66-, and 100-MHz, and it will execute common instructions at a rate of two per clock cycle. By contrast, the 486 runs at a maximum of one instruction per cycle, and the 386 at two.

Phoenix Technologies (of clone BIOS fame) has created a reference design for a new class of device called a Companion PC. It will have a 6" x 10" footprint, a full keyboard, CGA graphics, long battery life, and software support (including DOS 5.0 in ROM) by Microsoft and Lotus. Sony, meanwhile, has shown a hand-held pen-based input device, currently sold only in Japan for about \$500. The PTC-300 measures about 2.5" x 6" x 1", and has a large LCD used for both input and output. The device performs sched-

uling, database, and note-taking functions, appears to have a calculator-style keypad, and communicates with a docking station via infrared link. Apple is known to be working with Sony on some sort of miniaturized hand-held device, possibly CD-ROM based.

### Product watch

About twice a year or so I feel obligated to report on the software I'm currently using. Things have actually settled down in the past year and a half or so; I haven't switched a single major application in that time. Best Windows word processor: still Word for Windows, recently upgraded to version 2.0. It is unquestionably the most powerful and best integrated product for the Windows environment. Its desktop publishing features are still weaker than I'd like, but otherwise, I have few complaints. WW2 now has built-in drawing and charting packages, and a much more logical user interface. (If you install all the extras, you'll need about 15MB of disk space. I know it hurts, but this is a trend that seems likely to continue.) The program lists for \$495, but just about anyone can obtain an "upgrade" for \$129 by calling (800) 323-3577, Ext. W87. Drawing/illustration package: Designer 3.1, which boasts much increased speed compared with the previous version, text along a curve, batch printing, and more. Best Windows utility: Adobe Type Manager (ATM), version 2.0. Print any font on any Windows-supported printer, and see it accurately displayed on-screen. Best telecommunications program: Crosstalk for Windows, version 1.2. This version adds support for networked modems, icon-based session launching, dialing queues, and numerous small enhancements. I regularly transfer huge files in the background at 9600 bps with total reliability.

Best small-office network: LANtastic 4.0 The latest version adds speed and support for operating both servers and workstations under the 386-enhanced mode of Windows 3.0 (see Fig. 1). A new utility allows a dedicated server to devote all its resources to the network, greatly improving performance. LANtastic for Windows provides full

### PRODUCTS AND VENDORS

- Adobe Type Manager (\$99), Adobe Systems Incorporated, 1585 Charleston Road, P.O. Box 7900, Mountain View, CA 94039-7900. (800) 833-6687, (415) 961-4400.  
CIRCLE 41 ON FREE INFORMATION CARD

- CrossTalk for Windows 1.2 (\$195), DCA, 1000 Alderman Drive, Alpharetta, GA 30201-4199. (404) 442-4000.  
CIRCLE 42 ON FREE INFORMATION CARD

- Designer 3.1 (\$695), Micrografx, 1301 Arapaho, Richardson, TX 75081. (800) 733-3729, (214) 234-1769.  
CIRCLE 43 ON FREE INFORMATION CARD

- Word for Windows 2.0 (\$495), Microsoft Corp., One Microsoft Way, Redmond, WA 98052-6399. (206) 882-8080.  
CIRCLE 44 ON FREE INFORMATION CARD

- *Multimedia Programmer's Reference* (\$27.95), *Multimedia Authoring and Tools Guide* (\$24.95), and *Multimedia Programmer's Reference* (\$22.95), Microsoft Corp.  
CIRCLE 45 ON FREE INFORMATION CARD

- *The Programmer's PC Sourcebook* (\$39.95), Microsoft Corp.  
CIRCLE 46 ON FREE INFORMATION CARD

- Lantastic 4.0 (\$99/\$50 upgrade), Lantastic for Windows (\$299), Artisoft, Artisoft Plaza, 575 E. River Road, Tucson, AZ 85704. (602) 293-6363.  
CIRCLE 47 ON FREE INFORMATION CARD

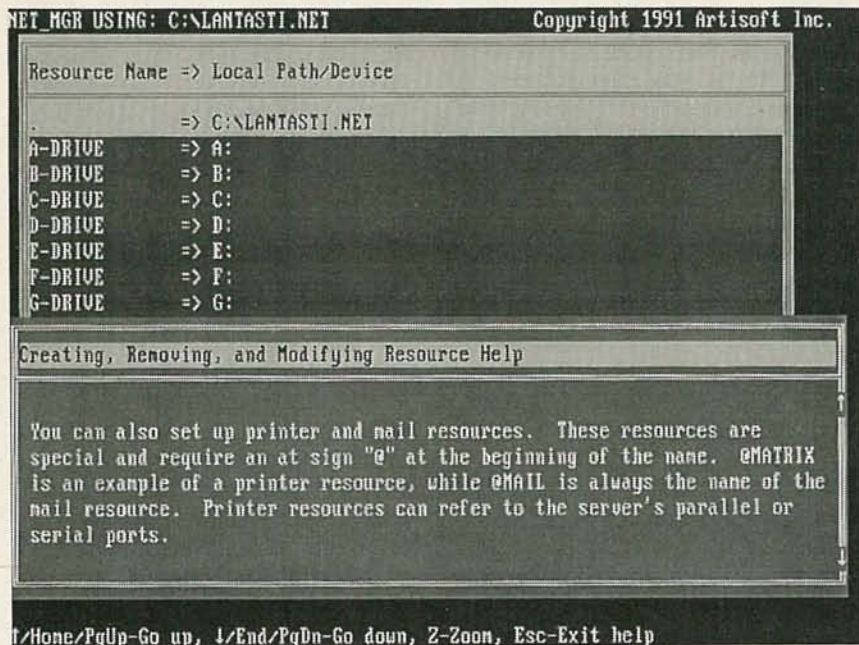

FIG. 1—LANTASTIC 4.0 provides greater speed and security, and full support for Windows 3.0. A separate Windows utility allows full access to all network and management functions.

Windows-based versions of the NET and NET—MGR programs which allow you to log on and off the network, administer network resources, etc. If you're in the market for a fully Windows-integrated, low-cost, DOS-based local area network, there's really no other choice.

### Book nook

If you're interested in getting started with multimedia development under Windows, but don't have a clue about how to get started, check out these three volumes: *Multimedia Programmer's Reference*, *Multimedia Authoring and Tools Guide*, and *Multimedia Pro-*

*grammer's Reference*. All three published by Microsoft; they are also included as part of Microsoft Multimedia Development Kit. *The Reference* details Windows system calls, file formats, and data structures; the *Workbook* describes sample applications; the *Guide* shows how to build multimedia applications. Another impressive Microsoft volume is the second edition of the *The Programmer's Sourcebook*, which contains about 800 pages of tables covering just about everything you could possibly want to know about the PC architecture, both hardware and software. Want to know how to create a 9- to 25-pin RS-232 adapter? No problem. How about the structure of the boot sector of a floppy disk? Easy. Maybe a listing of BIOS, DOS, and Windows function calls? Simple. May I ask: 8088/86/286/386/486 instruction sets? Piece of cake. Not to mention: physical sizes and shapes: XT/AT/EISA/MicroChannel expansion cards, expansion bus pinouts, IC pinouts, etc., etc., etc. If you need just one technical reference on PC architecture, this should be it.

**Next time:** An in-depth look at CompuAdd's Multimedia upgrade components.

## MESSAGING SYSTEM

*continued from page 64*

whenever A6 or A7, or both, are low at the time  $\overline{CE}$  goes low. The ISD 1016's storage array is arranged in 160 segments of 0.1 second each. The segments are numbered 0–9Fh. They may be accessed randomly, however play and record operations will access them sequentially beginning with the address supplied by DIP switch S4 at A0–A7, until an EOM marker is encountered, or the operation is terminated by bringing  $\overline{CE}$  high.

To determine the address to use to select a particular message, or to record a message at a specific point in memory, we will use a simple example. Suppose we want to hear a message we know starts at the 5-second point in memory. Each memory

segment is 0.1-second long, so our message starts at segment 50 ( $5/0.1 = 50$ ). Now we simply convert the decimal segment number into hex (50 decimal = 32 hex). Thus S4 switches 1–4 must be a binary "3" and switches 5–8 must be a binary "2," so switches 2, 5, and 6 would be open (bits 1, 4, and 5 high).

### Configuration mode

If address bits 6 and 7 are both high (S4 switches 7 and 8 both open) at the time  $\overline{CE}$  goes low, the ISD 1016 enters the "Configuration Mode," in which address bits A0–A5 (S4 switches 1–6) take on a different meaning. In this mode, those address bits no longer specify addresses. Instead, they select among the various options available as shown in Table 2.

To illustrate the use of Config-

uration mode, let's assume we've recorded a message using the instructions given earlier, and we would like to have it replayed continuously. (Make sure the message is less than 16 seconds long so the "overflow" condition won't disable the chip after the first replay. Also, the Address mode and Configuration mode are mutually exclusive, so you can have only one message in Configuration mode.) To replay the message back continuously, we want to be in the Configuration mode; A3, A6, and A7 low (open), and the rest of the address switches closed. Now we Power down/Up to the "up" position, and set Disable/Enable to the "enable" position. The message that you recorded will replay continuously until you set to the "disable" position, of course, until your battery power gets used up).



# BUYER'S MART

## FOR SALE

**STRICTED** technical information: Electronic surveillance, schematics, locksmithing, covert phones, hacking, etc. **Huge selection. Free brochures. MENTOR-Z**, Drawer 1549, Asbury Park, NJ 07712.

**FIBER optics** kits, Experimenters \$24.50, Datalink w/PCB \$36.25, **HILL ELECTRONICS**, Box 47103, Phoenix, AZ 85068-7103.

**CABLEBOX**: Fully activate your Zenith ST5612, with no parts! Illustrated instruction manual \$9.99. **JIM CHASE**, Box 148332, Nashville, TN 37214.

**CABLE TV** converters: Jerrold, Oak, Scientific Atlantic, Zenith & many others. "New MTS" stereo add-on: mute & volume. Ideal for 400 and 450 owners! 1 (800) 826-7623, Amex, Visa, M/C accepted. **B & B INC.**, 4030 Beau-D-Rue Drive, Eagan, MN 55122.

**TUBES**, new, up to 90% off, SASE, **KIRBY**, 298 West Carmel Drive, Carmel, IN 46032.

**T.V. notch filters**, phone recording equipment, brochure \$1.00. **MICRO THinc**, Box 63/6025, Margate, FL 33063. (305) 752-9202.

## CLASSIFIED AD ORDER FORM

To run your own classified ad, put one word on each of the lines below and send this form along with your check to:

**Radio-Electronics Classified Ads**, 500-B Bi-County Boulevard, Farmingdale, NY 11735

**PLEASE INDICATE** in which category of classified advertising you wish your ad to appear. For special headings, there is a surcharge of **\$25.00**.

Plans/Kits  Business Opportunities  For Sale  
 Education/Instruction  Wanted  Satellite Television

Special Category: \$25.00

### PLEASE PRINT EACH WORD SEPARATELY, IN BLOCK LETTERS.

(No refunds or credits for typesetting errors can be made unless you clearly print or type your copy.) Rates indicated are for standard style classified ads only. See below for additional charges for special ads. **Minimum: 15 words.**

1	2	3	4	5
6	7	8	9	10
11	12	13	14	15 (\$46.50)
16 (\$49.60)	17 (\$52.70)	18 (\$55.80)	19 (\$58.90)	20 (\$62.00)
21 (\$65.10)	22 (\$68.20)	23 (\$71.30)	24 (\$74.40)	25 (\$77.50)
26 (\$80.60)	27 (\$83.70)	28 (\$86.80)	29 (\$89.90)	30 (\$93.00)
31 (\$96.10)	32 (\$99.20)	33 (\$102.30)	34 (\$105.40)	35 (\$108.50)

We accept MasterCard and Visa for payment of orders. If you wish to use your credit card to pay for your ad fill in the following additional information (Sorry, no telephone orders can be accepted.):

Card Number \_\_\_\_\_ Expiration Date \_\_\_\_\_

Please Print Name \_\_\_\_\_ Signature \_\_\_\_\_

**IF YOU USE A BOX NUMBER YOU MUST INCLUDE YOUR PERMANENT ADDRESS AND PHONE NUMBER FOR OUR FILES. ADS SUBMITTED WITHOUT THIS INFORMATION WILL NOT BE ACCEPTED.**

**CLASSIFIED COMMERCIAL RATE:** (for firms or individuals offering commercial products or services) \$3.10 per word prepaid (no charge for zip code)...**MINIMUM 15 WORDS.** 5% discount for same ad in 6 issues; 10% discount for same ad in 12 issues within one year; if prepaid. **NON-COMMERCIAL RATE:** (for individuals who want to buy or sell a personal item) \$2.50 per word, prepaid...no minimum. **ONLY FIRST WORD AND NAME** set in bold caps at no extra charge. Additional bold face (not available as all caps) \$5¢ per word additional. Entire ad in boldface, \$3.70 per word. **TINT SCREEN BEHIND ENTIRE AD: \$3.85 per word. TINT SCREEN BEHIND ENTIRE AD PLUS ALL BOLD FACE AD: \$4.50 per word. EXPANDED TYPE AD: \$4.70 per word prepaid.** Entire ad in boldface, \$5.60 per word. **TINT SCREEN BEHIND ENTIRE EXPANDED TYPE AD: \$5.90 per word. TINT SCREEN BEHIND ENTIRE EXPANDED TYPE AD PLUS ALL BOLD FACE AD: \$6.80 per word. DISPLAY ADS:** 1" x 2 1/4"—\$410.00; 2" x 2 1/4"—\$820.00; 3" x 2 1/4"—\$1230.00. **General Information:** Frequency rates and prepayment discounts are available. **ALL COPY SUBJECT TO PUBLISHERS APPROVAL. ADVERTISEMENTS USING P.O. BOX ADDRESS WILL NOT BE ACCEPTED UNTIL ADVERTISER SUPPLIES PUBLISHER WITH PERMANENT ADDRESS AND PHONE NUMBER.** Copy to be in our hands on the 5th of the third month preceding the date of the issue. (i.e., Aug. issue copy must be received by May 5th). When normal closing date falls on Saturday, Sunday or Holiday, issue closes on preceding working day. Send for the classified brochure. Circle Number 49 on the Free Information Card.

## WIRELESS CABLE RECEIVERS 1.9 TO 2.7 GHz



30 CH PARABOLIC DISH SYSTEM \$173.90  
 30 CH ROD ANTENNA SYSTEM \$193.90  
 30 CH CRYSTAL CONTROLLED SYSTEM \$294.95

**SUN MICROWAVE INT'L. INC.** SEND \$1.00 FOR P.O. BOX #34522 CATALOG ON THESE PHOENIX, AZ 85067 AND OTHER FINE (602) 230-1245 VIDEO PRODUCTS QUANTITY DISCOUNTS

VISA/MC/AMEX

ORDERS ONLY 1-800-484-4190 CODE 9793

**CIRCUIT Boards** — Complete printed circuit fabrication from single sided to production multi-layers. Twenty-four hour turnaround available. **CIRCUIT CENTER**, PO Box 128, Addison, IL 60101. (708) 543-0671.

**JERROLD, Tocom and Zenith "test" chips.** Fully activates unit. **\$50.00. Cable descramblers from \$40.00. Orders 1 (800) 452-7090. Information (310) 867-0081.**

**TEST equipment** pre-owned now at affordable prices. Signal generators from \$50.00, oscilloscopes from \$50.00, other equipment, including manuals available. Send \$2.00 U.S. for catalog, refunded on 1st order. **J.B. ELECTRONICS**, 3446 Dempster, Skokie, IL 60076. (708) 982-1973.

**DESCRAMBLERS:** Oak Sigma, Varisync, Hamlin, Scientific Atlanta, Jerrold, Pioneer, Sylvia. Catalog \$5.00 moneyorder (credited first order), service manuals, schematics. **SURPLUS ELECTRONICS**, PO Box 10009, Colorado Springs, CO 80932.

## CB RADIO OWNERS!

We specialize in a wide variety of technical information, parts and services for CB radios. 10-Meter and FM conversion kits, repair books, plans, high-performance accessories. Thousands of satisfied customers since 1976! Catalog \$2.

### CBC INTERNATIONAL

P.O. BOX 31500RE, PHOENIX, AZ 85046

**SPEAKER** repair. All makes — models. Stereo & professional. Kits available. Refoaming \$18.00. **ATLANTA AUDIO LABS**, 1 (800) 568-6971.

**ENGINEERING** software and hardware, PC/MSDOS. Circuit design and drawing, PCB layout, FFT analysis, Mathematics, Circuit analysis, etc. Data acquisition, generation, I/O PCB's, etc. Call or write for free catalog. (614) 491-0832, **BSOFT SOFTWARE, INC.**, 444 Colton Rd., Columbus, OH 43207.

**OSCILLOSCOPE** 50 MHz, Hewlett-Packard, solid state calibrated, manual \$290.00 1 (800) 835-8335 X-159.

**CABLE TV Equipment.** Most type available. Special: Oak M35B \$39.95. No catalog. COD orders only. 1 (800) 822-9955.

# CABLE DESCRAMBLERS

Converters, Remote Controls, Descramblers, more



#EX192

All major brands carried

\*JERROLD, \*TOCOM, \*ZENITH  
\*GENERAL INSTRUMENTS  
\*SCIENTIFIC ATLANTA, \*OAK  
\*HAMLIN, \*EAGLE, \*PIONEER

7th Year in business. Thank You  
Member of Omaha Chamber of Commerce  
1 Year warranty on new equipment  
30 Day money back guarantee

Orders shipped from stock within 24 hours

CALL TODAY FOR A FREE CATALOG  
**1-800-624-1150**



C.O.D.



CIRCLE 53 ON FREE INFORMATION CARD

## THE ELECTRONIC GOLDMINE



The Electronic Goldmine has one of the greatest selections of unique electronic kits available in the world! We have over 65 kits and over 1,400 unique, bargain priced, components in our catalog!

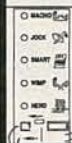

### MACHO METER KIT

Five bright LEDs flash at random. When reveal your rating. 9V battery not included.  
**C6362 \$10.95**



### ROLLING DICE KIT

This kit will replace your ordinary dice and will "roll" your number for you. 9V battery not included.  
**C6412 \$14.95**



### JUNGLE BIRD KIT

This kit produces the sounds of exotic jungle birds with 2 controls to adjust sound. 9V battery not included.  
**C6374 \$6.25**



### FISH CALLER KIT

The clicking sound produced by this kit is said to attract fish! Give it a try! 9V battery not included.  
**C4566 \$4.50**



### INSANITY ALARM KIT

In light it's silent, but when the lights go out, the alarm goes on! Lots of fun to use. 9V battery not included.  
**C6240 \$6.99**



### FLASHING STOP SIGN KIT

Bright red and white stop sign with 22 ultra-bright red LEDs that flash. 9V battery not included.  
**C6458 \$10.95**



### INEXPENSIVE GEIGER

Detects both Beta and Gamma Rays. 9V battery not included.  
**C6447 \$39.95**



### INFRARED DETECTOR

Great for testing and verification of infrared output. 9V battery not included.  
**C6441 \$5.95**

MINIMUM ORDER: \$10.00 plus \$3.50 shipping and handling. We accept MC, Visa and Money Orders.  
SEND ORDERS TO: The Electronic Goldmine  
P.O. Box 5408 Scottsdale, AZ 85261  
PHONE ORDERS (602) 451-7454 FAX ORDERS (602) 451-9495

CIRCLE 177 ON FREE INFORMATION CARD

**SUBWOOFER** design software. Design: port sealed, isobaric enclosures. Calculates optimum box size, graphs performance any subwoofer. 5.25 disk: \$19.95. **SUB-ENGINEERING**, 1236-R, Corvallis, OR 97330.

**PAY TV AND SATELLITE DESCRAMBLING ALL NEW 1992 EDITION ALL NEW**  
It's up to the minute. All new update on cable, wireless and satellite. Turn bypasses, circuits, chipping, bullets, bags, Dectec, Liberty One, ECM's Readers, programming and lots more. Our best yet. Only \$15.95. Other (ferent) editions 1991, 1989, Volume One (Basics) \$15.95 each. MDS Han \$9.95. Satellite systems under \$600 \$12.95. Any 3/\$29.95 or 6/\$49.95. \$29.95. Scrambling News Monthly \$24.95/yr. Sample \$3. All new catalog Shipping costs included.

Scrambling News, 1552 Hertel Ave., Buffalo, NY, 14216. Voice/Fax (716) 874-2088. CDD'S ARE OK. ADD \$5

**DESCRAMBLERS**, M-35-B \$19.00, RTC \$69.00, Z-Tac \$199.00, 5503 \$199.00, S/\$59.00, FTB \$59.00, all brands in stock. **MO HOOD ELECTRONICS**, (206) 260-0107.

**CABLE** boxes. All brands and models. Full ranty, same day shipping, examples RTC \$69.00, 5503-VIP turn on chip \$29.00, M-35-@ \$14.00 ea. **S.A.C.**, 1 (800) 622-3799.

**CABLE test chips**. S-A 8550, S-A 8500 — 311, 320, 321 (specify) — \$33.95. S-A 858C — \$69.95. Tocom 5503/07 VIP — \$33.95. **TI CODE**, PO Box 6426-RE, Yuma, AZ 85366-6

## CABLE TV DESCRAMBLER LIQUIDATION

**FREE CATALOG!**  
Hamlin Combos \$44, Oak M35B \$60 (min. 5  
**WEST COAST ELECTRONIC**  
For Information: 818-709-1758  
Catalogs & Orders: 800-628-965

**LAND/General** mobile radios, CB's, scan radar detectors, auto alarms, marine receivers catalog \$2.00, **RAYS**, Box 14862R Worth, TX 76117-0862.

**TURN-ON** kits for Starcom VII, \$40.00; Star VI, \$30.00; Starcom DPBB, \$50.00; Pic \$75.00; Tocom VIP 5503/5507, \$25.00, \$30.00; Zenith, \$25.00; Cali **N.E. ENGINEERING**, (617) 770-3830.

**TUBES**: "oldest", "latest". Parts and schem SASE for lists. **STEINMETZ**, 7519 Maple Ave., R.E., Hammond, IN 46324.

## PLANS AND KITS

**FASCINATING** electronic devices! Da Lasers! FM/AM/phone transmitters! Detector Kits/assembled! Catalog \$2.00. **QUANTUM SEARCH**, 16645-113 Avenue, Edmonton T5M 2X2.

**HOBBY/broadcasting/HAM/CB/surveillance** transmitters, amplifiers, cable TV, science, other great projects! Catalog \$1.00. **PAN** Box 130-F3, Paradise, CA 95967.

**PROJECTION TV**... Convert your TV to pro 7-foot picture... Easy!... Results compare \$2,500.00 projectors... **Plans and lens \$2!** Professional systems available... Illustratec log free... **MACROCOMA**, 15GG Main St Washington Crossing, PA 18977... Credit cards 24hrs. 1 (800) 955-3979.

## REMOTE CONTROL KEYCH

Complete w/mini-trans and +5 vdc RF re Fully assembled including to build your own auto Quantity discounts av  
**\$24.95** Check, Visa, Add \$3 sh  
**VISITECT INC.** Box 14158, Fremont, Ca (510) 651-1425 Fax (510) 651-

**Quality Microwave TV Antennas**  
WIRELESS CABLE - IFTS - MMDS - Amateur TV Ultra High Gain 50db(+) • Tuneable 1.9 to 2.7 Ghz.  
• 36-Channel System Complete \$149.95  
• 12-Channel System Complete \$114.95  
• Call or write (SASE) for "FREE" Catalog  
**PHILLIPS-TECH ELECTRONICS**  
P.O. Box 8533 • Scottsdale, AZ 85252  
(602) 947-7700 (\$3.00 Credit all phone orders)  
MasterCard • Visa • CDD's • Quantity Pricing

**ELECTRONIC** supermarket surplus prices! Transformer specials, railroaders, builders, engineers, experimenters, LSASE, **FERTIK'S**, 5400 Ella, Phila., PA 19120.

**OUR** monthly picture flyer lists quality surplus parts at low prices. Send today for yours. **STARTRONICS**, Box 683, McMinnville, OR 97128.

**PHOTOFACT** folders under #1400 \$5.00. Others \$7.00. Postpaid. **LOEB**, 414 Chestnut Lane, East Meadow, NY 11554. (516) 481-4380.

**FREE CATALOG**  
**FAMOUS "FIRESTIK" BRAND CB ANTENNAS AND ACCESSORIES. QUALITY PRODUCTS FOR THE SERIOUS CB'er. SINCE 1962**  
**FIRESTIK ANTENNA COMPANY**  
2614 EAST ADAMS  
PHOENIX, ARIZONA 85034

**REMOTE** telephone recorder, \$379.00, with room monitor, \$479.00. Room monitor \$175.00, Room & telephone \$275.00. Catalog, \$3.00. **LISTEN ELECTRONICS**, 603 Elgin, Muskogee, OK 74401. (918) 683-9589.

**FINALLY** — A cross part database program for industry standard part numbers. Crosses industry standard part numbers to two manufacturers of replacement components. Gives the user technical information and allows the user to create a database of electronic components. (3) — 3 1/2 disks. IBM PC/compatible. Send \$38.00 to **CPS SOFTWARE**, PO Box 28, Blackwell, OK 74631.

**IMPOSSIBLE** cable systems. New user programmable units authorize any or all features of Pioneer or Jerrold descramblers. **TAKE CONTROL**, 1 (800) 968-4041.

**80C52**-Basic microcontroller board. Basic interpreter, 32K RAM, 16K Eprom, Eprom programmer, RS232, expansion connector. Bare board with manual, schematics \$22.95. **80C52**-Basic microprocessor chip \$25.95. Assembled and tested \$124.95. **PROLOGIC DESIGNS**, PO Box 19026, Baltimore, MD 21204.

**Advanced solid-state LASER**  
This incredible unit weighs less than 1/2 ounce. Only 1.125" long and 0.580" wide. With a range of more than 1000 yards, you are limited only by your imagination!  
**3mW only \$149.00**  
**5mW only \$175.00**  
Low power, self-contained unit which will produce a visible red beam from a 5 - 10 volt power supply.  
**POLARIS Industries**  
141 W. Wiecua Rd., Suite 300-B Atlanta, GA. 30342  
Call Our Toll Free 24-Hour Order Line  
**1-800-222-5620**

DB and schematic CAD. \$195.00 IBM EGA CGA Jitlayer, rubberband, autovia, NC drill, laser, dot matrix, plotter, library, Gerber, **AUTOSCENE**, 565 Bluebird St., Minneapolis, MN 55433. (612) 7-8584 free demo disk.

**DEOCIPHER II**/scanner/cable/satellite modifications books. Catalog — \$3.00. **TELECODE**, ) Box 6426-HE, Yuma, AZ 85366-6426.

**ESCRAMBLER** kits. Complete cable kit \$44.95. Complete satellite kit \$49.95. Add \$5.00 shipping. See brochure. No New York sales. **SUMMIT RE**, ) Box 489, Bronx, NY 10465.

**JRVILLANCE transmitter kits** tune from 65 to 305 MHz. Mains powered duplex, telephone, com, combination telephone/room. Catalog with **Popular Communications, Popular Electronics and Radio-Electronics** book reviews of **Electronic Eavesdropping Equipment Design**. \$2.00. **SHEFFIELD ELECTRONICS**, 223 Stony Island Ave., Chicago, IL 60649-2806.

**REDIT** card encoding, standard explained in plain English. Illustrative examples included, send \$5.00 **BSC**, Box 1841, Alexandria, VA 22314.

**RED** of breathing smoke from soldering? Plans to build a smoke removal system, simple parts readily available, send S.A.S.E. and \$3.95 to **ELECTRONIC SERVICES**, PO Box 1733, Southgate, MI 48195.

## REMOVE LEAD VOCALS

From Records & CD's

Build this kit for under \$60 which removes lead vocals from standard stereo records, CD's, tapes or FM broadcasts. Easily connects to any home component stereo. Perform live with the backgrounds. You can be the lead singer of your favorite band. Detailed Plans. \$4.95

**Weeder Technologies**  
147/3 Lindsey Rd.  
Mt. Orab, Ohio 45154

**NOW build your own regulated 12VDC to 120VAC, 300W to 500W inverter, a must for campers or emergencies. Includes complete schematics, parts and manufacturers lists and more!** Send \$19.95 to **INVERTER SCIENTIFIC**, Box 778, Suffern, NY 10901.

**DESCRAMBLING.** New secret manual. Build your own descramblers for **cable and subscription TV.** Instructions, schematics for SSAVI, gated sync, Sinewave, (HBO, Cinemax, Showtime, UHF, Adult) \$12.95, \$2.00 postage. **CABLE-TRONICS**, Box 30502R, Bethesda, MD 20824.

**VHF amplifier plans 75-110 MHz, 15-25 watts. \$8.95: PROGRESSIVE CONCEPTS**, 1313 North Grand Ave., #291, Walnut, CA 91789.

## CABLE TV DESCRAMBLERS!

CABLE KINGDOM!

\*JEROLD\* \*OAK\* \*HAMLIN\*  
\*ZENITH\* \*PIONEER\*  
\*SCIENTIFIC ATLANTA\*

IN STOCK

6 MONTH WARRANTY! WE SHIP COD!

ABSOLUTELY LOWEST

WHOLESALE/RETAIL PRICES!

\*\*\*\*\*FREE CATALOG\*\*\*\*\*

J.P. VIDEO

1470 OLD COUNTRY RD

SUITE 315

PLAINVIEW, NY 11803

NO N.Y. SALES

CALL NOW! 1 (800) 950-9145

**PRINTED** circuit boards for .70 square inch. Send artwork to **JM ELECTRONICS**, Box 150454, Altamonte Springs, FL 32715-0454. (407) 767-8196.

**SATELLITE TV descrambler.** Build your own. Easy to follow instructions, parts list, circuit board, wiring diagram, \$9.95. **ABG ENTERPRISES**, 27081A, Halifax, NS, B3H-4M8.

## PATENTS & INVENTIONS

**INVENTORS!** Your first step is important. For free advice, call **ADVANCED PATENT SERVICES**, Washington, DC, 1 (800) 458-0352.

## ANTIQUA RADIO CLASSIFIED

Free Sample!

Antique Radio's  
Largest Circulation Monthly.  
Articles, Ads & Classifieds.



3-Month Trial: \$15. 1-Yr: \$27 (\$40-1st Class).  
S.R.C., P.O. Box 802-L9, Carlisle, MA 01741

## FREE CATALOG

- CABLE T.V. BOXES - ALL TYPES •
- LOW PRICES - DEALER PRICES •

**ACE PRODUCTS**  
1-800-234-0726

### Triplet DMM

Large, easy to read 3-1/2 digit LCD display. Tests voltage in 5 ranges to 750VAC, resistance in 6 ranges to 20M plus diode test with audible continuity. 6 current ranges to 10A. Built-in battery test and LFE test for NPN and PNP transistors. Test leads, instructions and carrying case included.

#RD-390-140 \$47<sup>00</sup> Each

### Infrared Detector Pen

The world's first handheld, Battery powered, InfraRed Detector pen. Instantly recognizes infrared light from television, VCR, and stereo remote controls, VCR tape stop circuits, alarm perimeter detectors, and thousands of other IR controlled products. Allows you to confirm the presence of infrared in normal room lighting. Slim one hand operation makes it easy to reach IR emitters on crowded VCR tape mechanisms. A carrying case to protect and transport your B.I.R.D. is available for \$3.95, order #390-201.

#RD-390-200 \$34<sup>95</sup> Each

### IC Protector Kit

Convenient assortment of 60 IC protectors for camcorders and VCRs. 5 each of 12 different protectors: ICP-F10, ICP-F15, ICP-F20, ICP-F25, ICP-F38, ICP-F50, ICP-F75, ICP-N5, ICP-N10, ICP-N15, ICP-N20 and ICP-N25. A \$45.00 value.

#RD-070-545 \$29<sup>95</sup> Kit

### Audio/Video Cable Checker

Convenient tester checks cable for center conductor and shield continuity. Tests all BNC, "F", RCA, 3.5mm mini, N, UHF, and 1/4" phone cables. Operates on two AA batteries. Built-in battery test function.

#RD-390-250 \$21<sup>50</sup> Each

### 3.5 Amp DC Power Supply

A quality, compact 12VDC power supply. Perfect for testing car stereos, CB equipment, radar detectors and other 12VDC items. Regulated 13.8VDC, 3.5 amp continuous, 6 amp surge. LED power indicator. Binding post outputs. Net weight: 4 lbs.

#RD-120-500 \$23<sup>90</sup> Each

### 3-Way Bookshelf System

High quality, high power bookshelf speaker system. Black matte, diecast aluminum construction. Heavy duty wire mesh grille. 30 watts RMS, 50 watts max. 7" x 5" x 4". Sold in pairs with mounting hardware. Net weight: 8 lbs. per pair.

#RD-310-010 \$37<sup>90</sup> Pair

### Pressfit Speaker Terminal

Spring loaded, pushbutton speaker terminal in a round housing. No screws required to fasten; simply drill a hole, apply glue, and press into place.

#RD-260-295 95¢ Each

### Norelco Type Boxes

Standard replacement plastic box for cassettes. Black base with clear lid. Made in the U.S.A.

#RD-200-060 24¢ Each

### Pioneer 4-1/2" Full Range

This very popular woofer is perfect for making bookshelf speakers or for car stereo installations. Response: 70-15 KHz. fs= 70 Hz. 20 watts RMS, 35 watts max. SPL= 90 dB 1W/1M. 10 oz. magnet. 8 ohm impedance. Pioneer #A11EC80-02F. Net weight: 2 lbs.

#RD-290-010 \$9<sup>90</sup> Each

### 18" Eminence Woofer

Bass reflex woofer with ribbed paper cone and treated cloth accordion surround. Giant 100 oz. magnet. 200 watts RMS, 300 watts max. 3", 2 layer voice coil. 8 ohm impedance (7.5 ohm DCR). Frequency response: 27-3,000 Hz. fs= 28.01 Hz.

#RD-290-200 \$99<sup>80</sup> Each

### 12" Pioneer Subwoofer

12" super duty, dual voice coil subwoofer. 30 oz. magnet, 2" voice coil. 100 watts RMS, 145 watts max. 25 Hz resonant frequency. 6 ohm impedance (4 and 8 ohm compatible). Sensitivity: 94 dB 1W/1M., Response: 25-1,500 Hz. Pioneer #A30GU30-55D.

#RD-290-145 \$39<sup>80</sup> Each



340 E. First St., Dayton, Ohio 45402  
Local: 1-513-222-0173  
FAX: 513-222-4644

• 30 day money back guarantee • \$20.00 minimum order • We accept Mastercard, Visa, Discover, and C. O. D. orders. • 24 hour shipping • Shipping charge = UPS chart rate + \$1.00 (\$3.50 minimum charge) • Hours 8:30 am - 7:00 pm EST, Monday - Friday • 9:00 am - 2:00 pm Saturday. Mail order customers, please call for shipping estimate on orders exceeding 5 lbs. • Foreign destination customers please send \$5.00 U.S. funds for catalog postage •

CALL TOLL FREE

1-800-338-0531

FREE CATALOG



Courteous Service • Discount Prices • Fast Shipping

# ALL ELECTRONICS

P.O. Box 567 • Van Nuys, CA 91408

## Electroluminescent BACKLIGHTS

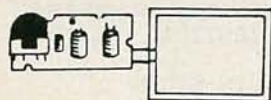

At last! A low cost electroluminescent glow strip and inverter. These brand-new units were designed to backlight small LCD TVs made by the Citizen Watch company. The inverter circuit changes 3 or 6 Vdc to approximately 100 Vac, the voltage required to light the glowstrip. Luminescent surface area is 1.7" X 2.25". The strip is a salmon color in its off state, and glows white when energized. The circuit board is 2.2" X 1". Glow strip and circuitry can be removed easily from plastic housing. Ideal for special lighting effects and backlighting. Two models available:

Citizen# 91TA operates on 3 Vdc CAT# BLU-91

Citizen# 92TA operates on 3-6 Vdc CAT# BLU-92

**\$350**  
each

10 for \$32.00 • 100 for \$275.00

LARGE QUANTITY AVAILABLE

## Special Deal 12 VDC COOLING FANS

Toyo Fan# TFD8012RXAL  
12 VDC, 0.11A cooling fan.  
3.175" square X  
0.92" thick.

7 blade impeller.  
11" long pigtail leads.  
CAT# CF-124  
10 for \$50.00

**\$6**  
each

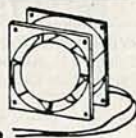

## SUPER SMALL Surface Mount Green LED

Surface mount LED chip.  
Clear when off, green when lit.  
Very tiny - whole unit is 0.115" X 0.055" X 0.05" thick. 1mm (0.04") lens diameter.  
Gold-plated mounting surfaces for superior conductivity.  
CAT# SMLED-2  
100 for \$18.00  
1000 for \$140.00



**10 for \$2**

## S.P.S.T. Pushbutton

SMK Manufacturing  
0.47" square black pushbutton.  
SPST normally open. 4 p.c. pins for mounting. Ideal for low current switching applications.  
CAT# PB-29  
100 for \$15.00



**5 for \$1**

## PHOTORESISTOR

1K ohms bright light. 16K ohms dark.  
0.182" dia. X .08" high. 0.18" long leads.  
CAT# PRE-7  
100 for \$45.00  
1000 for \$400.00



**2 for \$1**

## TOLL FREE ORDER LINES

**1-800-826-5432**

CHARGE ORDERS to Visa, MasterCard or Discover

TERMS: Minimum order \$10.00. Shipping and handling for the 48 continental U.S.A. \$3.50 per order. All others including AK, HI, PR or Canada must pay full shipping. All orders delivered in CALIFORNIA must include state sales tax (7.14%, 7.12%, 7.34%, 8.14%). Quantities Limited. NO C.O.D. Prices subject to change w/out notice.

Call or Write For Our

FREE 64 Page Catalog

(Outside The U.S.A. Send \$2.00 Postage)

**ALL ELECTRONICS CORP.**

P.O. Box 567 • Van Nuys, CA • 91408

CIRCLE 107 ON FREE INFORMATION CARD

\*\*\*PRESENTING\*\*\*  
**CABLE TV  
DESCRAMBLERS**  
\*\*\*\*\*STARRING\*\*\*\*\*  
**JERROLD, HAMLIN, OAK**  
AND OTHER FAMOUS MANUFACTURERS  
• FINEST WARRANTY PROGRAM AVAILABLE  
• LOWEST RETAIL/WHOLESALE PRICES IN U.S.  
• ORDERS SHIPPED FROM STOCK WITHIN 24 HRS.  
• ALL MAJOR CREDIT CARDS ACCEPTED  
FOR FREE CATALOG ONLY **1-800-345-8927**  
FOR ALL INFORMATION **1-818-709-9937**

**PACIFIC CABLE CO., INC.**  
7325 1/2 Reseda Blvd., Dept. 2112  
Reseda, CA 91335

## SATELLITE TV

FREE catalog — Lowest prices worldwide. Satisfaction guarantee on everything sold — systems, upgrades, parts, all major brands factory fresh and warranted. **SKYVISION**, 1012 Frontier, Ferguson Falls, MN 56537. 1 (800) 334-6455. Outside US (218) 739-5231.

**SATELLITE TV** — Do it yourself — systems. Upgrades. Parts. Major brands discounted 40% — 60%. We'll beat everyone's price. **L.J.H. INC.**, call Larry (609) 596-0656.

**VIDEOCIPHER II, descrambling manual.** Schematics, video, and audio. Explains DES, Eprom, CloneMaster, 3Musketeeer, Pay-per-view (HBO, Cinemax, Showtime, Adult, etc.) \$16.95, \$2.00 postage. Schematics for Videocypher Plus, \$20.00. Schematics for Videocypher 032, \$15.00. Collection of software to copy and alter Eprom codes, \$25.00. **CABLETRONICS**, Box 30502R, Bethesda, MD 20824.

## ELECTECH

### CABLE T.V. DESCRAMBLERS

• All quality brand names •  
• All fully guaranteed • All the time •  
Knowledgeable Sales Service Department  
FOR FREE CATALOG 800-253-0099

## EDUCATION & INSTRUCTION

F.C.C. Commercial General Radiotelephone license. Electronics home study. Fast, inexpensive! "Free" details. **COMMAND**, D-176, Box 2824, San Francisco, CA 94126.

## Be a TV/VCR Repair Specialist

Now you can train at home in spare time for a money-making career as a TV/VCR Repair Specialist. No previous experience necessary. No need to quit your job or school. Everything is explained in easy-to-understand language with plenty of drawings, diagrams and photos. We show you how to troubleshoot and repair video-cassette recorders and TV sets, how to handle house calls and shop repairs for almost any make of television or VCR. Tools are included with your course so you can get "hands-on" practice as you follow your lessons step by step. Send for free facts about the exciting opportunities in TV/VCR Repair and find out how you can start making money in this great career. **MAIL COUPON TODAY**

**ICS SCHOOL OF TV/VCR REPAIR**, Dept. ADE022S  
(SINCE 1990) 925 Oak Street, Scranton, PA 18515

Please send me full information and color brochure on how I can learn TV/VCR Repair at home in my spare time. I understand there is no obligation and no salesman will visit me.

Name \_\_\_\_\_ Age \_\_\_\_\_  
Address \_\_\_\_\_ Apt. # \_\_\_\_\_  
City/State \_\_\_\_\_ Zip \_\_\_\_\_  
Phone ( ) \_\_\_\_\_

**ELECTRONIC** engineering. 8 volumes complete \$109.95. No prior knowledge required. Free brochure. **BANNER TECHNICAL BOOKS**, 120 Grant Avenue, Rockford, IL 61103.

VCR tapes by college instructor covering electronic topics. Send for free demo \$3.50 P&H. **O.C.S.**, PO 292, Fort Mill, SC 29715.

**NEW** book, *Getting Started in Nuclear Physics* Easy to follow with illustrative footnotes and advanced practical procedures. \$19.95. **FARAH FARAH**, PO Box 2464, Sarnia, Ontario, N7T 7 Canada.

## CABLE TV DESCRAMBLERS

ALL TYPES **800-582-1114**

FREE CATALOG

**M.K. ELECTRONICS** • 7958 Pines Blvd Suite 276 • Pembroke Pines, FL 3302

## BUSINESS OPPORTUNITIES

**YOUR** own radio station! Licensed/unlicensed AM, FM, TV, cable. Information \$1.00. **BROADCASTING**, Box 130-F3, Paradise, CA 95967.

**LET** the government finance your small business! Grants/loans to \$500,000. Free recorded message: (707) 449-8600. (KS1).

**EASY** work! Excellent pay! Assemble products home. Call toll free **1 (800) 467-5566** Ext. 519

**MAKE \$\$\$!** Become an American electronics dealer! Profit opportunities since 1965. **SCOTT PRUETT**, 1 (800) 872-1373.

**HOME** assembly work available! Guarantee easy money! Free details! **HOMEWORK-R**, E 520, Danville, NH 03819.

**MONEYMAKERS!** Easy! One man CRT rebuilding machinery. \$6,900.00 rebuilt. \$15,900.00 new CRT, 1909 Louise, Crystal Lake, IL 60014. (845) 459-0666. Fax (815) 477-7013.

## CABLE TV DESCRAMBLERS

BEST BUYS BEST SERVICE

BULLET PROOF TV TESTED

WANT TO BUY:

TOCOM, SA 8590, DPV7212

Must be reasonable price.

Call For Your Wholesale

Catalog or Send \$1.00 TO:

Multi-Vision (402)331-3228

Electronica™ 2730 SO.123rd Ct.#126 Omaha, NE 68138



Dealers Wanted

## WANTED

**INVENTIONS/** new products/ideas wanted: TLCI for free information/inventors newsletters (800) 468-7200 24 hours/day — USA/Canada

**INVENTORS:** We submit ideas to industry. I'll tell you what we can do for you. **1 (800) 288-1010**

**INVENTORS!** Confused? Need help? Call **IMI** for free information kit. USA/CANADA: 1 (800) 225-5800 (24 hours!).

**MASTERCARD AND VISA** are now accepted for payment of your advertising. Simply complete the form on the first page of Market Center and we will bill.

THIS IS AN EXPANDED TYPE AD. Notice how it stands out on this page. To get you set in this type style mark your classified order, "Expanded-type ad," and calculate your cost at \$4.70 per word.

**LASER DIODES**

CK #	MFG.	WAVE-LENGTH	OUTPUT POWER	OPER. CURR.	OPER. VOLT.	1-24	25-99	100+
220	TOSHIBA	660nm	3 mW	85 mA	2.5 V	129.99	123.49	111.14
200	TOSHIBA	670nm	3 mW	85 mA	2.3 V	49.99	47.99	43.19
201	TOSHIBA	670nm	5 mW	80 mA	2.4 V	59.99	56.99	51.29
211	TOSHIBA	670nm	5 mW	50 mA	2.3 V	69.99	66.49	59.84
215	TOSHIBA	670nm	10 mW	45 mA	2.4 V	109.99	104.49	94.04
200	NEC	670nm	3 mW	85 mA	2.2 V	59.99	56.99	51.29
22	SHARP	780nm	5 mW	65 mA	1.75 V	19.99	18.99	17.09
053	PHILLIPS	820nm	10 mW	90 mA	2.2 V	10.99	10.44	9.40

**WAO II PROGRAMMABLE ROBOTIC KIT**



The pen mechanism included with the robot allows it to draw. In addition to drawing straight lines, it can also accurately draw circles, and even draw out words and short phrases. WAO II comes with 128 x 4 bits RAM and 2K ROM, and is programmed directly via the keypad attached to it. With its built-in connector port, WAO II is ready to communicate with your computer. With the optional interface kit, you can connect WAO II to an Apple II, IIE, or II+ computer. Editing and transferring of any movement program, as well as saving and loading a program can be performed by the interface kit. The kit includes software, cable, card, and instructions. The programming language is BASIC.

Power Source - 3 AA batteries (not included)

CK #	DESCRIPTION	1-9	10-24	25+
1961	WAO II Programmable Robotic Kit	79.99	75.99	68.39
IAP	Interface Kit For Apple II, IIE, II+	39.99	37.99	34.19

**PROTOBOARD DESIGN STATION**

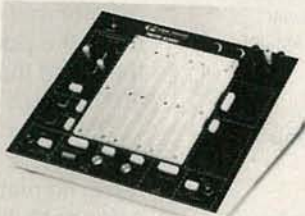

- The total design workstation - including expanded instrumentation, breadboard and power supply.
- Ideal for analog, digital and micro-processor circuits
- 8 logic probe circuits
- Function generator with continuously variable size, square, triangle wave forms, plus TTL pulses
- Triple power supply offers fixed 5 VDC supply plus 2 variable outputs - +5 - 15 VDC and -5 - 15 VDC
- 8 TTL compatible LED indicators, switches
- Pulsers
- Potentiometers
- Audio experimentation speaker
- Multiple features in one complete test instrument saves hundreds of dollars needed for individual units
- Unlimited lifetime guarantee on bread-board sockets
- Fixed DC output +5 VDC @ 1.0 amp, ripple - 5 mV
- Variable DC output +5 - to +15 VDC @ 0.5 amp, ripple - 5 mV

- Variable DC output -5 - to -15 VDC @ 0.5 amp, ripple - 5 mV
- Frequency generator frequency range: 0.1 Hz to 100 KHz in 6 ranges output voltage: 0 to ±10V (20 Vp-p) output impedance: 600 (except TTL) output current: 10mA max., short circuit protected output waveforms: sine, square, triangle, TTL sine wave: distortion 3% (10 Hz to 100 KHz) TTL pulse: rise and fall time 25ns drive 20 TTL loads Square wave: rise and fall time ±1.5 s
- Logic indicators 8 LED's, active high, 1.4 volt (nominal) threshold, inputs protected to ±20 volts
- Debounced pushbuttons (pulsers) 2 push-button operated, open-collector output pulsers, each with 1 normally-open, 1 normally-closed output. Each output can sink up to 250 mA
- Potentiometers 1 - 1K, 1 10K, all leads available and uncommitted
- BNC connectors 2 BNC connectors pin available and uncommitted shell connected to ground
- Speaker 0.25 W, 8 Ω
- Breadboarding area 2520 uncommitted tie points
- Dimensions 11.5" long x 16" wide x 6.5" high
- Input 3 wire AC line input (117 V, 60 Hz typical)
- Weight 7 lbs.

STOCK #	DESCRIPTION	1-9	10-24	25+
PB503	Protoboard Design Station	299.99	284.99	256.49

**IDC BENCH ASSEMBLY PRESS**



The Panavise PV505 1/4 ton manual IDC bench assembly press is a rugged, practical installation tool designed for low volume, mass termination of various IDC connectors on flat ribbon cable.

- Assembly base & standard platen included
- Base plate & platen may be rotated 90° for maximum versatility
- Base plates & cutting accessories are quickly changed without any tools required
- Additional accessories below
- Size - 10" W x 8.75" D x 9" H
- Weight - 5.5 lbs.

CK #	DESCRIPTION	1-9	10-24	25+
105	Panavise Bench Assembly Press	149.99	142.49	128.24

**COLLIMATING PEN**



A low power collimator pen containing a MOVPE grown gain GaAlAs laser. This collimator pen delivers a maximum CW output power of 2.5 mW at 820 nm. The operating voltage of 2.2-2.5v @ 90-150mA is designed for lower power applications such as data retrieval, telemetry, alignment, etc.

The non-hermetic stainless steel case is specifically designed for easy alignment in an optical read or write system, and consists of a lens and a laser diode. The lens system collimates the diverging laser light, 18 mrad. The wavefront quality is diffraction limited.

The housing is circular and precision manufactured measuring 11.0 mm in diameter and 27.0 mm long. Data sheet included. As with all special buy items, quantity is limited to stock on hand.

STOCK #	DESCRIPTION	1-9	10-24	25+
SB1052	Infra-Red Collimator Pen	49.99	47.49	42.74

**LASER DIODE MODULE**



The LDM 135 integrated assembly consisting of a laser diode, collimating optics and drive electronics within a single compact housing. Produces a bright red dot at 650-685 nm. It is supplied complete with leads for connection to a DC power supply from 3 to 5.25 V.

Though pre-set to produce a parallel beam, the focal length can readily be adjusted to focus the beam to a spot.

Sturdy, small and self-contained, the LDM135 is a precision device designed for a wide range of applications. 0.64" diam. x 2" long.

STOCK #	DESCRIPTION	1-9	10-24	25+
LDM135-5	.5 mW Laser Diode Module	179.99	170.99	153.89
LDM135-1	1 mW Laser Diode Module	189.99	180.49	162.44
LDM135-2	2 mW Laser Diode Module	199.99	189.99	170.99
LDM135-3	3 mW Laser Diode Module	209.99	199.49	179.54

**COLLIMATING LENS**



This economical collimating lens assembly consists of a black anodized aluminum barrel that acts as a heat sink, and a glass lens with a focal point of 7.5 mm. Designed to fit standard 9mm laser diodes, this assembly will fit all the above laser diodes. Simply place diode in the lens assembly, adjust beam to desired focus, then set with adhesive.

CK #	DESCRIPTION	1-9	10-24	25+
ENS	Collimating Lens Assembly	24.99	23.74	21.37

**DUAL MODE LASER POINTER**



New slimline laser pointer is only 1/2" in diameter x 6 1/2" long and weighs under 2 oz. CW 70 nm @ less than 1 mW produces a 5 mm beam. 2 switches, one for continuous mode, and one for pulse mode (red dot flashes rapidly). 2 AAA batteries provide 8+ hours of use. 1 year warranty.

STOCK #	DESCRIPTION	1-9	10-24	25+
LP35	Dual Mode Laser Pointer	199.99	189.99	170.99

**ROBOTIC ARM KIT**



Robots were once confined to science fiction movies. Today, whether they're performing dangerous tasks or putting together complex products, robotics are finding their way into more and more industries. The Robotic Arm Kit is an educational kit that teaches basic robotic arm fundamentals as well as testing your own motor skills. Command it to perform simple tasks.

STOCK #	PRICE
YO1	\$43.99

**He-Ne TUBES**



New, tested 632nm He-Ne laser tubes ranging from .5mW to 3mW (our choice). Perfect for hobbyists for home projects. Because of the variety we purchase, we cannot guarantee specific outputs will be available at time of order. All units are new, tested, and guaranteed to function at manufacturers specifications.

STOCK #	DESCRIPTION	1-9	10-24	25+
LT1001	He-He Laser Tube	69.99	66.49	59.84

**AVOIDER ROBOT KIT**



An intelligent robot that knows how to avoid hitting walls. This robot emits an infra-red beam which detects an obstacle in front and then automatically turns left and continues on.

STOCK #	PRICE
MV912	\$43.99

**ORDER LINE — (800) 824-3432 • INTERNATIONAL ORDERS — (818) 341-8833**  
**FAX ORDERS — (818) 998-7975 • TECHNICAL SUPPORT — (818) 341-8833**

• 15.00 MINIMUM ORDER • UPS BLUE, RED & FEDERAL EXPRESS SHIPPING AVAILABLE • OPEN MON-FRI 9:00 AM - 6:00 PM, SAT 10:00 AM - 3:00 PM PDT  
• CA RESIDENTS ADD 8 1/4% SALES TAX • CALL FOR QUANTITY DISCOUNTS • CALL FOR FREE CATALOG (FOR 1ST CLASS DELIVERY OR CATALOGS DELIVERED OUTSIDE THE U.S. — SEND \$2.00) • WE CARRY A COMPLETE LINE OF ELECTRONIC COMPONENTS  
\*NO SHIPPING CHARGES ON PRE-PAID ORDERS DELIVERED IN THE CONTINENTAL U.S.

## Shortwave Listening Guidebook

by Harry Helms

The world is talking on shortwave radio, and here's the book that tells you how to listen in! In direct, nontechnical language, Harry explains how to get the most from your shortwave radio. Its 320 heavily illustrated pages are filled with practical advice on:

- antennas
- when and where to tune
- selecting the right radio for you
- accessories
- reception techniques



Learn how to hear the BBC, Radio Moscow, ham radio operators, ships at sea, even Air Force One! Includes hundreds of frequencies for stations around the world and the times you can hear them.

Only \$16.95 plus \$3.00 shipping (CA residents please include sales tax).

**HighText**  
Publications, Inc.  
7128 Miramar Road  
Suite 15L, San Diego, CA 92121

## DRAWING BOARD

continued from page 83

the last output being used on the last 4017 in the circuit. The only other things on the reset line are the resistor and capacitor pair that generate the power-up reset pulse and the diode that isolates the last used 4017 output from that pulse.

The reset pulse at power-up, by the way, is needed because the 4017, no matter which logic family it belongs to, has a nasty habit of waking up stupid and putting a completely illegal state at its outputs. That can be either no outputs active or, worse than that, more than one active.

By having the reset lines configured as shown in Fig. 2, the circuit is essentially free running. Each successive horizontal sweep will immediately follow the previous one and, since we can control the sweep speed only in discreet steps, most waveforms will creep horizontally across the display. That can be cut to a minimum if you have a variable clock available as an alternative to drive the horizontal section (another good idea to look at later), but using one makes it difficult to estimate frequencies on the display since you never know exactly what the sweep speed is.

A much better way to steady the displayed waveform is to have a circuit that starts each horizontal sweep at the same reference point on the test signal. That's known as "triggered sweep" and it's one of the most powerful features we can add to the design we're working on. Since the trigger signal has to come from the test signal being sent to the vertical section of the scope, we have to wait until we work on that section before we can get into the details of the design. But we can make allowances for it now.

Adding triggered sweep to the circuit means we want the ability to control the situation that makes the horizontal section reset the display to the first column. You might think that all we have to do is pick off some voltage level on the test signal and have that make the display return to the first LED column. If you think that, you should think again.

Under that sort of arrangement things would get really strange if the trigger occurred more often than the time it took to sweep the display across all twenty LED columns. If, for example, the sweep speed was set to 2 milliconds, it would take 40 milliseconds for each complete horizontal sweep. And if the trigger level at the input occurred every 10 milliseconds, the display would be on LED columns wide.

That complication doesn't arise on conventional scopes because they have a CRT for the display and the hardware controlling the horizontal action of the electron beam will always let it finish a horizontal sweep before zipping it back to the left hand side of the screen for start of the next sweep. Since we're dealing with discrete LED columns we have to add circuitry that does the same thing.

In our scope, when we want to trigger a sweep, we have to use the trigger signal with an indicator that the old sweep is finished and the circuit is ready to start the new one. The way to accomplish this is shown in Fig. 3, the schematic for the scope so far. The NAND gate is switched into the circuit and we set the scope to trigger on the sweep. When the last LED column has been displayed, the Q4 output of IC6 will go high, but the circuit won't reset and begin a new sweep until the trigger signal puts a high on the second leg of the NAND gate. If we want the scope to be free running, all we have to do is switch the trigger leg of the gate to +V. The 4017-based horizontal section will reset as soon as the old sweep has been finished.

Get the circuit shown in Fig. 4 working so we can get to work on the vertical section next month. Keep a list of any ideas you come up with to add goodies to your final scope design. One thing you might consider is that, since we're dealing with an LED display, it shouldn't take much to be able to freeze the display and make it hold itself an LED storage scope.

But that's my idea, so expect those gray cells, come up with your own, and let me know what they are.

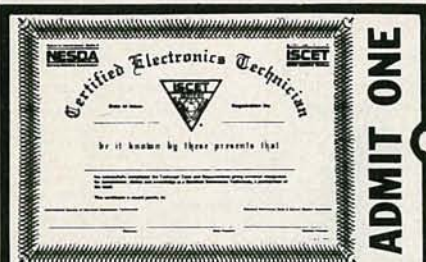

## Your Ticket To SUCCESS

Over 28,000 technicians have gained admittance worldwide as certified professionals. Let your ticket start opening doors for you.

ISCET offers Journeyman certification in Consumer Electronics, Industrial, Medical, Communications, Radar, Computer and Video. For more information, contact the International Society of Certified Electronics Technicians, 2708 West Berry Street, Fort Worth, TX 76109; (817) 921-9101.

Name \_\_\_\_\_  
Address \_\_\_\_\_  
City \_\_\_\_\_  
State \_\_\_\_\_ Zip \_\_\_\_\_

Send material about ISCET and becoming certified.

Send one "Study Guide for the Associate Level CET Test." Enclosed is \$10 (inc. postage).

# CABLE TV "BOXES"

Converters-Descramblers  
Remote Controls-Accessories

- ★ Guaranteed Best Prices ★
- ★ 1 Year Warranty - C.O.D.'s ★
- ★ Immediate Shipping ★
- ★ FREE CATALOG ★

Call or Write  
**NAS/TRANS-WORLD CABLE CO.**  
3958 North Lake Blvd. • Suite 255  
Lake Park, Florida 33403  
1-800-442-9333  
1-800-848-3997

# CABLE TV DESCRAMBLERS ★ CONVERTERS ★ and ACCESSORIES.

## SAVE MONEY. DON'T RENT!

PANASONIC, JERROLD, OAK,  
PIONEER, SCIENTIFIC ATLANTA  
AND MORE. LOWEST PRICES. FREE CATALOG.  
**CABLE READY COMPANY (800) 234-1006**

# DESCRAMBLERS CABLE TV EQUIPMENT



CALL TOLL FREE  
**1-800-228-7404**

FREE CATALOG

30 DAY MONEY BACK GUARANTEE  
OUR PRODUCTS ARE BULLET PROOF  
C.O.D.

YOU WON'T FIND ANY HOLES IN OUR WARRANTIES  
WE CARRY ALL MAJOR BRANDS  
BEST PRICE BEST SERVICE

MAKE THE CONNECTION  
**NU-TEK ELECTRONICS**  
FOR MORE INFORMATION  
CALL OR WRITE  
**1-512-250-5031**  
NU-TEK ELECTRONICS  
8114 BALCONES WOOD DR.  
#307 DEP. 296 AUSTIN TEXAS 78759

## INVENTORS

INVENTORS! Can you patent and profit from your idea? Call **AMERICAN INVENTORS CORP.** for information. Serving inventors since 1975. 1 (800) 338-5656.

## SURFACE MOUNT PARTS

Fast! Small quantities of common SMT capacitors and resistors delivered fast. Call for information. **TECHNICAL SOLUTIONS**, 1 (800) 22-1019.

THIS IS AN EXPANDED-TYPE AD WITH A TINT SCREEN. See how it jumps out on the page. To order your ad in this format calculate the cost at \$5.90 per word for the expanded-type and the tint background.

# FREE CATALOG! 1-800-648-7938 JERROLD HAMLIN OAK ETC CABLE TV DESCRAMBLERS

- Special Dealer Prices!
- Compare our Low Retail Prices!
- Guaranteed Prices & Warranties!
- Orders Shipped Immediately!

**REPUBLIC CABLE PRODUCTS, INC.**

4080 Paradise Rd. #15, Dept RE392  
Las Vegas, NV 89109  
For all other information (702) 362-9026

# TODAY'S THE DAY

Stop Smoking.

American Heart Association

# MARK V ELECTRONICS, INC.

Competitive Pricing \* Fast Shipping Since 1985

IN CA 1-800-521-MARK (orders only)  
OUTSIDE CA 1-800-423-FIVE (orders only)  
ORDER BY FAX (213) 888-6868  
CATALOG & INFORMATION (213) 888-8988

▲ indicates the level of difficulty in the assembling of our Products. ▲ Beginner ▲▲ intermediate ▲▲▲ Advanced ★ Fully Assembled



Special offer will be given to the purchase of Amplifier + Metal Cabinet + Power Transformer: TA-3600, SM-720

AMPLIFIERS		KIT ASSEMB.		MISCELLANEOUS		KIT ASSEMB.	
MODEL	DESCRIPTION			MODEL	DESCRIPTION		
TA 28MK2	Digital Voice Memo Generator	\$ 30.00		TY-238	3 Channel Color Light Controller ★	\$	\$ 65.00
TA 50A B	Multi-Purpose Melody Generator ▲	12.84	17.20	TY-25	Stereo Loudspeaker Protector ▲	14.85	20.85
TA 50C	Multi-Purpose Melody (Happy Birthday, Wedding March, etc.) Generator ▲	13.65	18.71	TY-35	FM Wireless Microphone ▲	11.25	
TA-120MK2	35W Class 'A' Main Power Mono Amp ▲▲	31.50	42.80	TY-36	AC/DC Quartz Digital Clock ▲	19.00	26.20
TA-300	30W Multi-Purpose Single Channel Amp.	20.00	29.00	TY-38	Sound / Touch Control Switch ▲	12.00	
SM-302	60W - 60W Stereo Power Amplifier (with Mic. input)▲▲	73.00	85.00	TY-41MK V	Infrared Remote Control Unit (w/Case) ▲▲▲	22.00	35.00
TA 323A	30W X 2 Stereo Pre-main Amp. ▲	31.50	42.80	TY-42	Bar / Dot Level Meter ▲▲	24.15	33.81
TA 377A	State of the Art Fully Complementary Symmetrical FET Pre-Amp. ▲▲▲	59.95	75.00	TY-43	3 1/2" Digital Panel Meter ▲	29.00	38.00
TA 400	40W Solid State Mono Amp. ▲	28.00	34.93	TY-45	20 Steps Bar / Dot Audio Level Display ▲▲	38.45	46.14
TA 477	120W Mosfet Power Mono Amp. ▲▲	68.00	85.00	TY-47	Superior Electronic Roulette ▲	27.24	27.24
SM-720	120W + 120W AC/DC Stereo Hi-Fi & Pre-Main Amp. ▲▲	75.00	89.00	016	10,000 uf 80V DC Capacitor (TA-3600, TA-477, TA-1000A, TA-802)		23.00
TA-800MK2	120W + 120W Low Tim Pre-Main Stereo Power Amp. ▲▲	63.92		017	8,200 uf 50V DC Capacitor (TA-802, TA-3600, TA-477, TA-1000A, TA-120MK2)		13.00
TA-802	80W + 80W Pure DC Stereo Main Power Amp. ▲	45.94	59.72	021	Nobel Resistor-Single Vol. Control (TA-3600, TA-477, TA-1000A, TA-120MK2)		12.00
TA-1000A	100W Dynamic Class 'A' Main Power Mono Amp. ▲▲	50.00	65.00	022	Alps Resistor - Dual Vol. Control (TA-377A, TA-802, TA-2200)		22.00
TA-1500	100W X 2 Class 'A' DC Stereo Pre-Main Amp. ▲▲	73.70	95.81	<b>REGULATORS</b>			
TA-2200	DC Fet Super Class 'A' DC Pre-Amp. ▲▲▲	47.70	58.24	TR-355A	0-15V 5A Regulated DC Power Supply (no case & x former) ▲	\$15.65	\$ 21.76
TA-2500	HD Pre-Amp w/10 band graphic equalizer ★		78.00	TR-355B	0-30V 3A Regulated DC Power Supply (no case & x former) ▲	15.65	21.76
TA 2800	BI-FET IC Pre-Amp w/3 way tone control ▲	48.90	63.57	TR-503	0-50V 3A Regulated DC Power Supply (no case & x former) ▲	16.75	23.65
TA 3000	Stereo Simulator (For Mono TV or Any Mono Source) ▲	27.00	38.50	<b>METAL CABINETS WITH ALUMINUM PANEL</b>			
TA 3600	300W HD Hi-Fi Power Mono Amp. ▲▲	85.00	110.00	MODEL	H" x W" x D" MATCHING		PRICE
SM-222	7 Band Hi-Fi Graphic Equalizer ▲▲	26.80	38.80	LG-1273	3" 12" 7"	TA-2800, TA-377A, TA-2200	\$ 23.85
SM-333	Audio/Video Surround Sound Processor ▲▲▲	65.00	75.00	LG-1684	4" 16" 8"	TA-323A, TA-377A, TA-2200	28.50
SM-666	Dynamic Noise Reduction ▲	26.00	34.00	LG-1924	4" 19" 11 1/2"	TA-802, TA-1500, TA-120MK2, TA-800 MK2, TA-1000A	34.50
SM-888	Universal Audio/Video KARAOKE Mixer Pre-Amp. ★		155.00	LG-1925	5" 19" 11 1/2"	TA-477, TA-800 MK2, TA-1500, TA-1000A, TA-3600	38.00
				LG-1983	2 1/2" 19" 8"	TA-377A, TA-2800, TA-2200, TA-120MK2	30.50
				<b>POWER TRANSFORMERS</b>			
				MODEL	DESCRIPTION	MATCHING	PRICE
SM-43	3 1/2" Multi-Functional Led D.P.M. (w/ABS plastic case)▲	\$ 34.50	\$ 43.00	001	28V x 2 6A to 30V x 2 6A	TA-800 MK2, TA-802, TA-1000A, TA-1500	\$ 28.00
SM-48	4 1/4" Hi-Precision D.P.M.▲	38.00	48.00	002	36V x 2 3A	TR-503, TA-323A, TA-400, TA-300, TA-377A	23.00
SM-48A	4 1/4" Hi-Precision D.P.M. (w/ABS plastic case)▲	41.20	52.00	003	40V x 2 6A	TA-477	30.00
SM-49	3 1/2" Multi-Functional LCD D.M.P. (w/hold Function)▲	36.00	44.50	004	24V x 2 6A	TA-120 MK2	23.00
SM-100	150MC Digital Frequency Counter▲	79.00	90.00	005	26V x 2 3A	TR-355B	17.00
				006	18V x 2 5A	TR-355A	17.00
				007	53V x 2 8A	TA-3600	45.00

We accept major Credit Cards, Money Orders, Checks and C.O.D. Orders. C.O.D. fee is \$6.50. Minimum order is \$20.00. We ship by UPS ground inside US (min. \$4.00) and ship by US mail. Business & Showroom hours: (Pacific Time) Mon. thru Fri. 9-30 am to 5:00 pm Sat. 10:00 am to 5:00 pm

**MARK V ELECTRONICS, INC. - 8019 E. Slauson Ave, Montebello, CA 90640**

CIRCLE 93 ON FREE INFORMATION CARD

March 1992, Radio-Electronics

# Your Natural Resource for Wide

## Test/Measurement and Prototype Equipment

### Jameco Solderless Breadboards

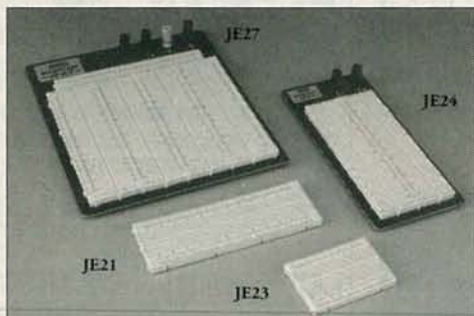

Jameco's long-lasting breadboards feature screen-printed color coordinates and are suitable for many kinds of prototyping and circuit design. Larger models feature a heavy-duty aluminum backing with voltage and grounding posts.

Part No.	Dim. L" x W"	Contact Points	Binding Posts	Price	Part No.	Dim. L" x W"	Contact Points	Binding Posts	Price
JE21	3.25 x 2.125	400	0	\$4.95	JE25	6.500 x 4.25	1,660	3	\$17.95
JE23	6.50 x 2.125	830	0	6.95	JE26	6.875 x 5.75	2,390	4	22.95
JE24	6.50 x 3.125	1,360	2	12.95	JE27	7.250 x 7.50	3,220	4	31.95

### GoldStar 20MHz Dual Trace Oscilloscope



The perfect unit for today's testing and measurement needs! Features include a 6" CRT display, and bandwidth from DC to 20 MHz. The GoldStar Oscilloscope comes with two 40MHz probes, two fuses, power cord, operation manual, schematics and block and wiring diagram. It's lightweight and portable with a two-year warranty.

GS7020.....\$399.95

### BNC Cable Assemblies for GS7020

BNC1	BNC(M) to BNC(M) RG58 A/U (39"L).....	\$3.95
BNC2	BNC(M) to Micro Hook RG174 (39"L).....	3.95
BNC3	BNC(M) to Macro Hook RG174 (39"L).....	3.95

### Miniature RS232 Breakout Box

Design new interfaces or modify old ones quickly and easily. Completely self-contained, these boxes include (25) 22AWG wire jumpers and machine tool sockets so you are sure to have a good connection.



BBMF.....\$9.95

### RS232 Interface Check Tester

Helps avoid expensive repair calls by showing you simple interface problems. In seconds the CT232 will target the status of line 2, 3, 4, 5, 6, 8, 11, 19 and 20. The CT232 includes male to female DB25 connectors.



CT232.....\$14.95

### Metex Digital Multimeters

- Handheld, high accuracy • AC/DC voltage, AC/DC current, resistance, diodes, continuity, transistor hFE (except M3900)
- Manual ranging w/overload protection
- Comes with probes, batteries, case and manual

M3650 & M4650 only:

• Also measures frequency and capacitance

M3800 3.5 Digit Multimeter .....\$39.95

M3610 3.5 Digit Multimeter .....\$59.95

M3900 3.5 Digit Multimeter with Tach/Dwell .....\$59.95

M3650 3.5 Digit Multimeter w/Frequency & Capacitance .....\$74.95

M4650 4.5 Digit w/Frequency & Capacitance & Data Hold Switch.....\$99.95



24 Hour Toll-Free Order Hotline!  
1-800-831-4242

### Jameco Logic Pulser



- Compatible with TTL, DTL, RTL, HTL, HNHL, MOS and CMOS ICs
- 1MΩ Sync input impedance • Pulser mode output current: 10mA • Square wave current output: 5mA • Audible tone

LP540.....\$16.95

### Jameco Logic Probe



- Max Frequency 80MHz • Minimum detectable pulse: 10ns • 120KΩ input impedance • Max. supply voltage: ±25V
- TTL threshold: (Lo) -0.8V ±0.1V, (Hi) +2.3V ±0.2V • CMOS threshold: (Lo) VCC ±10%, (Hi) 70%VCC ±10%

MS104.....\$2

### (E)PROM Programmer 1 Socket 16K-1Meg

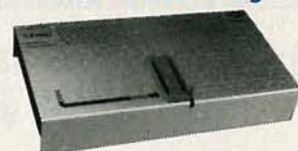

- Built-in Normal, Intelligent I&II, and Quick-pulse algorithms • XP6000A needed for operation • Software included

XP6001 .....\$119.95

XP6000A Adapter Card .....\$29.95

### UVP EPROM Eraser



- Erases all EPROM's • Erases 1 chip 15 minutes and 8 chips in 21 min
- UV intensity: 6800 UW/CM<sup>2</sup>

DE4.....\$

### EPROMs - for your programming needs

Part No.	Price	Part No.	Price	Part No.
TMS2516	\$4.25	2764-20	\$3.95	27256OTP
TMS2532A	6.95	2764-25	3.75	27256-15
TMS2564	5.95	2764A-20	3.75	27256-20
TMS2716	5.95	2764A-25	3.19	27256-25
1702A	3.95	27C64-15	3.95	27C256-15
2708	4.75	27C64-25	3.25	27C256-20
2716	3.39	27128OTP	2.49	27C256-25
2716-1	3.75	27128-20	7.95	27512OTP
27C16	4.25	27128-25	7.75	27512-20
2732	4.95	27128A-15	4.95	27512-25
2732A-20	4.49	27128A-20	4.49	27C512-15
2732A-25	3.49	27128A-25	3.75	27C512-20
2732A-45	2.95	27C128-15	5.75	27C512-25
27C32	4.75	27C128-25	7.95	27C010-15
				68766-35

• Partial Listing • Over 4000 Electronic and Computer Components in Stock!

**JAMECO**  
ELECTRONIC COMPONENTS  
COMPUTER PRODUCTS

24 Hour Toll-Free Order Hotline  
**1-800-831-4242**



Please refer to  
Mail Key 2  
when  
ordering



# Selection & Competitive Prices

## Computer Upgrade Products and Electronic Components

Upgrade your existing computer system! Jameco will help you upgrade easily and economically.

### Jameco 80386SX Motherboard

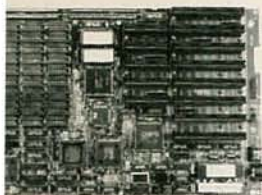

- 16MHz processing speed
- Baby motherboard (8.5"x13")
- Zero or one wait state operation
- Supports up to 8MB of RAM
- Intel 80387SX/compatible math coprocessor socket
- AMI BIOS
- Six 16-bit and two 8-bit expansion bus slots
- One-year Warranty

JE3516SN.....\$299.95

### Fujitsu 101-Key Enhanced Keyboard

This keyboard features 12 function keys, separate cursor and numeric keys.

- IBM PC/XT/AT and compatible computers
- Automatically switches between XT or AT
- LED Indicators for Num Lock, Caps Lock, and Scroll Lock
- Tactile Feedback
- Manual included • One-year Warranty



FKB4700.....\$79.95

### Conner IDE Hard Drives

This series of high-performance Conner disk drives is designed for large storage capacity.

- 33000 40MB 3.5" Low Profile.....\$249.95
- 330084 80MB 3.5" Low Profile.....\$399.95
- 330104 120MB 3.5" Low Profile.....\$479.95
- 33204 200MB 3.5" HH.....\$699.95
- DP20 16-bit Host Adapter.....\$29.95

Additional host adapters available!



Many more Upgrade Products available!

### Toshiba 1.44MB 3.5" Internal Floppy Disk Drive

- IBM PC/XT/AT and compatibles
- Compatible with DOS versions 3.3 or higher
- Includes all necessary installation hardware
- 1.44MB formatted high density mode
- 720KB formatted low density mode
- Size: 1"H x 4"W x 5.9"D (actual drive size)
- One-year Manufacturer's Warranty

356KU.....\$99.95

### Integrated Circuits\*

Part No.	1-9	10+
00.....	\$.29	\$.19
02.....	.29	.19
04.....	.29	.19
06.....	.35	.25
07.....	.35	.25
08.....	.35	.25
10.....	.29	.19
17.....	.35	.25
20.....	.29	.19
32.....	.35	.25
47.....	.89	.79
74.....	.39	.29
76.....	.45	.35
86.....	.45	.35
89.....	2.95	2.75
90.....	.59	.49
121.....	.49	.39
192.....	.79	.69
193.....	.79	.69

### Linear ICs\*

Part No.	1-9	10+
082CP.....	\$.59	\$.49
4317T.....	.65	.55
4324N.....	.35	.29
4336Z.....	1.05	.95
4339N.....	.39	.35
E555V.....	.29	.25
M556N.....	.49	.39
M723CN.....	.49	.39
M741CN.....	.29	.25
M1458N.....	.35	.29
M1488N.....	.45	.39
M1489N.....	.45	.39
LN2003A.....	.69	.59
M3914N.....	1.95	1.75
E5532.....	1.19	1.09
305T.....	.45	.41
312T.....	.45	.41

### Memory

Part No.	Function	Price
41256-120	256K DIP 120ns	\$.179
41256-150	256K DIP 150ns	\$.169
511000P-80	1MB DIP 80ns	\$.599
511000P-10	1MB DIP 100ns	\$.549
41256A9A-10	256K SIPP 100ns	\$.1895
41256A9B-80	256K SIMM 80ns	\$.2095
421000A9A-80	1MB SIPP 80ns	\$.5995
421000A9B-80	1MB SIMM 80ns	\$.6495

### Miscellaneous Components\*

#### Potentiometers

Values available (insert ohms into space marked "XX"):  
 500Ω, 1K, 5K, 10K, 20K, 50K, 100K, 1MEG  
 43PXX 3/4 Watt, 15 Turn ..... \$.99  
 63PXX 1/2 Watt, 1 Turn ..... .89

#### Transistors And Diodes

PN2222	\$.12	1N751	\$.15
PN2907	.12	C106B1	.65
1N4004	.10	2N4401	.15
2N2222A	.25	1N4148	.07
1N4735	.25	2N3055	.69
2N3904	.12	1N270	.25

#### Switches

JMT123	SPDT, On-On (Toggle)	\$.15
206-8	SPST, 16-pin (DIP)	1.09
MPC121	SPDT, On-Off-On (Toggle)	1.19
MS102	SPST, Momentary (Push-Button)	.39

\*Additional components available

### Connectors

Part No.	Description	Price
DB25P	Male, 25-pin	\$.65
DB25S	Female, 25-pin	.75
DB25H	Hood	.39
DB25MH	Metal Hood	1.35
<b>LEDs</b>		
XC209R	T1, (Red)	\$.14
XC556G	T1 3/4, (Green)	.16
XC556R	T1 3/4, (Red)	.12
XC556Y	T1 3/4, (Yellow)	.16

### IC Sockets

	Low Profile	Wire Wrap(Gold)	Level #2
8LP	\$.10	8WW	\$.49
14LP	.11	14WW	.69
16LP	.12	16WW	.79
24LP	.19	24WW	1.15
28LP	.22	28WW	1.39
40LP	.28	40WW	1.89

Soldertail Standard and Header Plug Sockets Also Available

24-Hour Toll-Free Order Hotline:

# 1-800-831-4242

Call or Write for a

## FREE 90-Page 1992 Catalog!

\$30.00 Minimum Order • Data Sheets - 50¢ each

**JAMECO**<sup>®</sup>  
 ELECTRONIC COMPONENTS  
 COMPUTER PRODUCTS

1355 Shoreway Road  
 Belmont, CA 94002  
 FAX: 1-800-237-6948  
 BBS Support: 415-637-9025

International Sales • Customer Service • Technical Assistance  
 • Credit Department • All Other Inquiries: 415-592-8097 • 7AM - 5PM P.S.T.

© 1992 Jameco 3/92

CA Residents Add 7.25%, 7.75%, 8.25% or 8.5% Sales Tax



Shipping, handling and insurance are additional.

Terms: Prices subject to change without notice  
 Items subject to availability and prior sale.  
 Complete list of terms/warranties is available upon request.

# Cable TV Descrambler Kits

**Universal Kit.....\$55.00**

Includes all parts and PC Board. Not included is the ac adaptor or enclosure.

**Tri-Mode Kit.....\$39.00**

Includes all parts, PC Board and AC Adaptor. Not included is the enclosure.

**SB-3 Kit.....\$29.00**

Includes all parts, PC Board and AC Adaptor. Not included is the enclosure.

**Universal Tutorial.....\$9.95**

Includes an in depth study of the technology used and has troubleshooting hints.

**Tri-Mode Tutorial.....\$9.95**

Includes a gate by gate study of the circuit and has troubleshooting hints.

**Snooper Stopper.....\$39.00**

Protect yourself from descrambler detection and stop the "bullet".

Call Toll Free 1-800-258-1134

Visa, MasterCard & COD

**M & G Electronics, Inc.**  
301 Westminister Street  
Providence, RI. 02903

CIRCLE 190 ON FREE INFORMATION CARD



## CABLE TV DESCRAMBLERS

THE MOST ADVANCED TECHNOLOGY IN CABLE EQUIPMENT:

- BASE BAND
- PIONEER
- HAMLIN
- SCIENTIFIC ATLANTA
- JERROLD
- TOCOM
- ZENITH
- OAK

For out of this world prices call

**WORLDWIDE CABLE**  
**1 800-772-3233**

FREE CATALOG AVAILABLE

7491 C-5 N. FEDERAL HWY., SUITE 142  
BOCA RATON, FL 33487

MC / COD / VISA NO FLORIDA SALES

CIRCLE 189 ON FREE INFORMATION CARD

# ADVERTISING INDEX

RADIO-ELECTRONICS does not assume any responsibility for errors that may appear in the index below.

Free Information Number	Page	Free Information Number	Page
108	AMC Sales .....	78	— Science Probe .....
75	Ace Products .....	97	92,179 Tektronix .....
107	All Electronics .....	96	123 Test Probes .....
185	American Reliance Inc. ....	79	— The School of VCR Repair...
84	Appliance Service .....	79	191 Unicorn .....
77	B&K Precision .....	15	188 U.S. Cable .....
109	C & S Sales .....	89	181,182 Viejo Publications .....
—	CIE .....	8, 40	189 Worldwide Cable .....
184	Cable Warehouse .....	78	
—	Command Productions .....	77	
127	Deco Industries .....	79	
177	Electronic Goldmine .....	94	
—	Electronics Book Club .....	23, 84	
121	Fluke Manufacturing .....	CV2	
186	Global Specialties .....	25	
—	Grantham College .....	45	
86	Heathkit .....	13	
192	Hewlett Packard .....	7	
—	ICS Computer Training .....	81	
114	Jameco .....	100, 101	
115	Jensen Tools .....	79	
190	M&G Electronics .....	102	
89	MAT Electronics .....	77	
53	MD Electronics .....	94	
178	MJS Design .....	79	
93	Mark V. Electronics .....	99	
—	NRI Schools .....	21, 32	
180	Optoelectronics .....	29	
56	Parts Express .....	95	
183	People's College .....	27	
78	Radio Shack .....	3	
187	SCO Electronics .....	52	

### ADVERTISING SALES OFFICE

**Gernsback Publications, Inc.**  
500-B Bi-County Blvd.  
Farmingdale, NY 11735  
1-(516) 293-3000  
President: Larry Steckler

**For Advertising ONLY**  
516-293-3000  
Fax 1-516-293-3115  
Larry Steckler  
publisher

**Christina Estrada**  
assistant to the President

**Arline Fishman**  
advertising director

**Denise Haven**  
advertising assistant

**Kelly McQuade**  
credit manager

**Subscriber Customer Service**  
1-800-288-0652

**Order Entry for New Subscribers**  
1-800-999-7139  
7:00 AM - 6:00 PM M-F MST

### SALES OFFICES

**EAST/SOUTHEAST**  
**Stanley Levitan**, Eastern Sales Manager  
Radio-Electronics  
1 Overlook Ave.  
Great Neck, NY 11021  
1-516-487-9357, 1-516-293-3000  
Fax 1-516-487-8402

**MIDWEST/Texas/Arkansas/Oklahoma**  
**Ralph Bergen**, Midwest Sales Manager  
Radio-Electronics

One Northfield Plaza, Suite 300  
Northfield, IL 60093-1214  
1-708-446-1444  
Fax 1-708-559-0562

**PACIFIC COAST/Mountain States**  
**Marvin Green**, Pacific Sales Manager  
Radio-Electronics

5430 Van Nuys Blvd. Suite 316  
Sherman Oaks, CA 91401  
1-818-986-2001  
Fax 1-818-986-2009

### RE Shopper

**Joe Shere**, National Representative  
P.O. Box 169  
Idyllwild, CA 92549  
1-714-659-9743  
Fax 1-714-659-2469

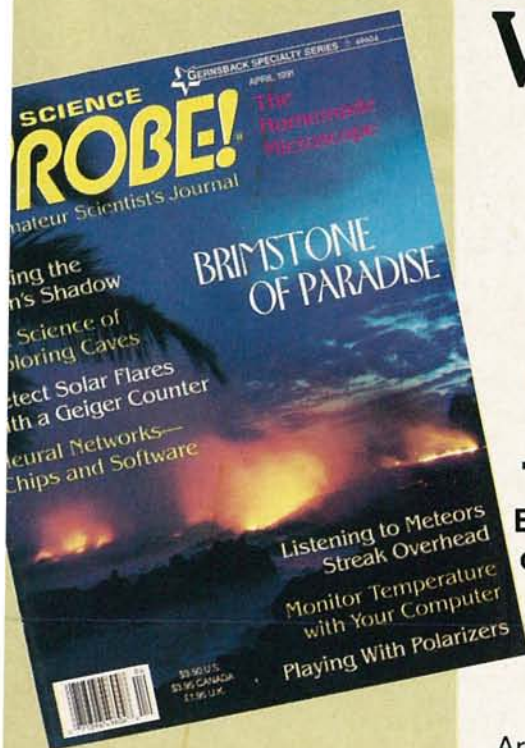

# Welcome to. . .

# SCIENCE PROBE!®

## The Amateur Scientist's Journal

Embark on an irresistible new journey into the realm of mystery, challenge, and exploration! The perfect magazine for the budding scientist, the serious amateur, the professional who would like to relax, and those who simply want to gaze at the stars.

Science PROBE! — the *only* magazine devoted entirely to Amateur Scientists! If you are fascinated by science in all its many forms . . . if you can't stay away from a microscope, telescope, calipers, or test tube — we invite you to share the wonders in every issue of **Science PROBE!** You will join a community of Amateur and Student Scientists who enthusiastically seek scientific knowledge or follow scientific pursuits for their own sakes and not merely as a profession.

Obtain your next issue of **Science PROBE!** by visiting a quality Newsstand, Convenience Store, or Supermarket or by reserving your personal copy through the mail by completing the coupon below.

From your very first issue of **Science PROBE!** you will be involved in a world of scientific facts, experiments, and studies pursued by amateur scientists who are university students, investors, academicians, engineers, or office workers, salesmen, farmers—whose quest is to probe into the mysteries of science and reveal them to all.

Plan to become a **Science PROBE!** reader!

Articles to appear in upcoming issues of **Science PROBE!** are:

**How an Amateur Mapped the Milky Way**  
**Make your own Seismometer**  
**Operate a Solar-powered Weather Station**  
**Grow Crystals Automatically**  
**Experiment with a Saltwater Aquarium**  
**How to Keep a Science Notebook**

If you're fascinated by science in all its many forms, if you are compelled to experiment and explore, then **Science PROBE!** is your kind of magazine!

**Science PROBE!**  
 500-B Bi-County Boulevard  
 Farmingdale, NY 11735

7RC27

Please forward my copy of **Science PROBE!** as soon as it comes off the press. I am enclosing \$3.50-U.S.A. (\$4.23-Canada-includes G.S.T.) plus \$1.00 for shipping and handling. Better still, please enroll me as a subscriber and send the next four (4) quarterly issues of Science Probe. I am enclosing \$9.95-U.S.A. (Canada: \$16.00—includes G.S.T.)

Next Issue Only       Next Four Issues (1 Year)

Offers valid in the U.S.A. and Canada only. No foreign orders.

Name \_\_\_\_\_

Address \_\_\_\_\_

City \_\_\_\_\_ State \_\_\_\_\_ ZIP \_\_\_\_\_

All Orders payable in U.S.A. Funds only.

**ON SALE AT QUALITY NEWSSTANDS, CONVENIENCE STORES AND SUPERMARKETS**  
**GET YOUR COPY TODAY—\$3.50-U.S.A.—\$3.95-Canada**

# YOU CAN ALWAYS SPOT THE TECHNICIAN WHO DOESN'T USE TEKTRONIX.

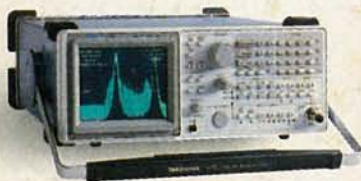

If you're sending technicians and FSEs into the field with equipment other than Tektronix, you don't be surprised to discover some unusual tools in their service kits.



Signal flares, for instance. On the other hand, portable test gear from Tek gets technicians to the root of the problem long before the problem gets to them. Everything from oscilloscopes and spectrum analyzers to handheld DMMs.

As a result, your customers will be back on their feet in what'll seem like no time at all. They'll be happy for that. Not to mention a whole lot nicer to work with. For your employees' sake, get



touch with a Tektronix representative today. Or keep an eye peeled for signs of distress. **TALK TO TEK/1-800-426-2277**

**Tektronix**

Test and Measurement