

TUNE IN TO THE 800-MHz SCANNER BAND!

# Radio Electronics

FEBRUARY 1992

TECHNOLOGY - VIDEO - STEREO - COMPUTERS - SERVICE

## BUILD THIS SCANNER CONVERTER

Gives your scanner  
unrestricted coverage  
of the  
800-MHz  
band

## BUILD R-E's HYPER CLOCK

You've  
never seen  
a clock project  
like this before!

## BUILD A SWEEP/FUNCTION GENERATOR AND FREQUENCY COUNTER

Upgrade your test bench  
today!

## NEW LIFE FOR AM RADIO?

New standards for AM might help  
revive our broadcast band



## DIGITAL-TO-ANALOG CONVERSION

Experimenting with  
the IBM PC



\$2.95 U.S.  
\$3.75 CAN

A  
GERNSBACK  
PUBLICATION

XXXXXXXX CAR-RT SORT \*\* CR03  
750456HRR5165MD93

02 55  
NOV 93  
RE



**FLUKE**®



**PHILIPS**

# Introducing SCOPEMETER™

There's More Than One Reason to Reach for It.

In fact, there's *every* reason to reach for ScopeMeter.™ Because only ScopeMeter combines the expertise of Fluke and Philips to bring you a dual-channel digital scope along with everything you've come to expect from Fluke digital multimeters.

The result: an integrated scope-and-multimeter that lets you see a waveform and digital meter display at the same time from the same input. Or switch between dedicated high-performance Scope and Meter functions with the touch of a key. That makes it faster and easier than ever to capture, store and analyze precisely what you're looking for. At a price that looks good, too.

To get your hands on a ScopeMeter, contact your Fluke sales office or your nearest Fluke distributor. For more product information, call **1-800-44-FLUKE**.



**Built to Take It.**

- Completely sealed against water, dust and contaminants.
- EMI protected and measures up to 600 volts rms.
- Rugged construction with shock-resistant holster.
- Three-year warranty from Fluke.

**SCOPEMETER.** Now there's only one to reach for.

**Simply Easy.**

- Intuitive front panel layout for simple, straightforward operation.
- Pop-up menus and five function keys for easy control.
- Autoset automatically sets voltage, time and trigger functions.
- Safety-designed BNC connectors and probes simplify floating measurements.

**Double Duty.**

- 50 MHz digital storage scope and 3000-count digital multimeter in one handheld package.
- Precision Min Max Record and 40 ns Glitch Capture make it easy to troubleshoot intermittent failures.
- Simultaneous waveform and digital display on a backlit screen you can read across the room.

FLUKE 90 SERIES SCOPEMETER SELECTION GUIDE			
	FLUKE 97	FLUKE 95	FLUKE 93
Suggested List Price	\$1795	\$1495	\$1195
Bandwidth	50 MHz Dual Channel		
Sample Rate	25 Megasamples/second		
Autoset	Automatically sets Voltage, Time and Trigger		
Multimeter Display	3 <sup>2</sup> / <sub>3</sub> digits (>3000 Counts)		
True RMS Volts	AC or AC+DC up to 600V (1700V Pk-Pk)		
Diode Test	Up to 2.8V		
Continuity Beeper	Yes		
Time/Division	10 ns/div to 60 sec/div		
Volts/Division	1 mV/div to 100V/div	5 mV/div to 100V/div	
Digital Delay or Pre-Trigger	By Number of Cycles, Events, Time, or Zoom Mode		By Time
Special Multimeter Modes	Min Max Average Record, Relative (zero), dBm, dBV, dBW, Audio Watts, % Scale, Frequency, Smoothing™ Change Alert™		Frequency, Smoothing™ Change Alert™
Oscilloscope Cursors	12 Measurements, Display 5 Simultaneously		
Glitch Capture	≥40 ns		
Waveform Processing	Average, Variable Persistence, Min Max Record		
Waveform Memory	Store and Recall 8 Waveforms		
Set-Up Memory	Store and Recall 10 Front Panel Set-Ups		
Waveform Mathematics	Add, Subtract, Multiply, Invert, Filter or Integrate Waveforms		
Signal Generator Output	Sinewave or Squarewave		
Component Tester Output	Voltage or Current Ramp		
Optically Isolated RS-232-C Interface	Full Operation by Remote Control		
Printer Output	Serial		
Backlit Display	Electroluminescent		

**Goes Wherever You Go.**

- Runs on rechargeable NiCad Batteries, standard C-cells or the included line voltage adapter/battery charger.
- Adjustable tilt-stand comes in handy as a hanger, too.
- Compatible with a wide range of Fluke multimeter accessories.

©1991 John Fluke Mfg. Co., Inc. Ad No. 00075.

**FLUKE**®

CIRCLE 121 ON FREE INFORMATION CARD

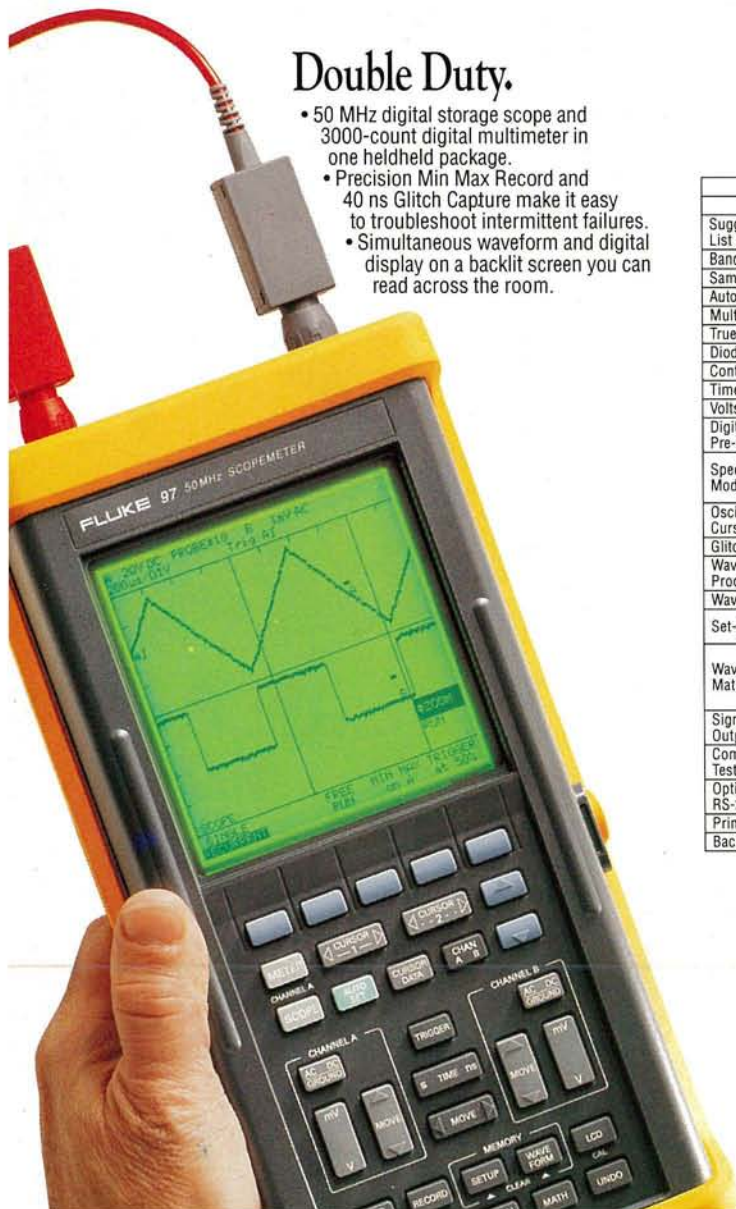

## BUILD THIS

### 33 BUILD THE HYPERCLOCK

Display the time in eight eye-catching modes!

**Leon W. Schmidt**

### 42 SCANNER CONVERTER

It allows unrestricted coverage of the 800-MHz band!

**William Sheets and Rudolf F. Graf**

### 53 SWEEP/FUNCTION GENERATOR

Measure square, triangle, and sine waves with this inexpensive benchtop instrument.

**Michael A. Lashansky**

### 65 EXPERIMENTING WITH ADC FOR YOUR PC

Add analog inputs to the PC-based analog-to-digital converter.

**James J. Barbarello**

## TECHNOLOGY

### 48 AM TRIES FOR A COMEBACK

Will the new AMAX receivers breathe new life into the AM band?

**Len Feldman**

### 69 WORKING WITH LED'S

Our in-depth survey of LED's continues with practical chaser and bargraph circuits.

**Ray Marston**

## DEPARTMENTS

### 6 VIDEO NEWS

What's new in this fast-changing field.

**David Lachenbruch**

### 16 EQUIPMENT REPORTS

Kelvin 100K DMM kit.

### 77 HARDWARE HACKER

Caller ID update, and more.

**Don Lancaster**

### 86 AUDIO UPDATE

More reader questions.

**Larry Klein**

### 89 DRAWING BOARD

Getting back to our oscilloscope.

**Robert Grossblatt**

### 92 COMPUTER

CONNECTIONS

Pen-based computing.

**Jeff Holtzman**

## AND MORE

106 Advertising and Sales Offices

106 Advertising Index

12 Ask R-E

14 Letters

97 Market Center

27 New Lit

22 New Products

4 What's News



PAGE 33



PAGE 42

## ON THE COVER



The 800-1000 MHz band of UHF frequencies contains many signals of interest to the shortwave and scanner enthusiast. However, many scanner can't receive those frequencies. Our scanner converter receives signals from 800-1000 MHz, and outputs them at 400-500 MHz. That allows you to monitor frequencies in the 800-1000 MHz range using your 400-500 MHz scanner. You can also use it to measure frequencies as high as 1000 MHz with a 500-MHz counter. To find out more about our converter, turn to page 42.

## COMING NEXT MONTH

### THE MARCH ISSUE GOES ON SALE FEBRUARY 4.

#### MIDI INTERFACE FOR YOUR PC

Your passport to the world of computer-controlled music.

#### BUILD DIGI-CALL

Keep tabs on phone bills and client billing with this intelligent telephone-line monitor.

#### SCANNER CONVERTER: PART II

Easy-to-build downconverter gives unrestricted coverage of the 800-MHz band.

#### ELECTRONIC TEMPERATURE MEASUREMENT

An overview of the components and circuits used to measure temperature electronically.

As a service to readers, RADIO-ELECTRONICS publishes available plans or information relating to newsworthy products, techniques and scientific and technological developments. Because of possible variances in the quality and condition of materials and workmanship used by readers, RADIO-ELECTRONICS disclaims any responsibility for the safe and proper functioning of reader-built projects based upon or from plans or information published in this magazine.

Since some of the equipment and circuitry described in RADIO-ELECTRONICS may relate to or be covered by U.S. patents, RADIO-ELECTRONICS disclaims any liability for the infringement of such patents by the making, using, or selling of any such equipment or circuitry, and suggests that anyone interested in such projects consult a patent attorney.

RADIO-ELECTRONICS, (ISSN 0033-7862) February 1992. Published monthly by Gernsback Publications, Inc., 500-B Bi-County Boulevard, Farmingdale, NY 11735 Second-Class Postage paid at Farmingdale, NY and additional mailing offices. Second-Class mail registration No. R125166280, authorized at Toronto, Canada. One-year subscription rate U.S.A. and possessions \$17.97, Canada \$25.65 (includes G.S.T. Canadian Goods and Services Tax Registration No. R125166280), all other countries \$26.97. All subscription orders payable in U.S.A. funds only, via international postal money order or check drawn on a U.S.A. bank. Single copies \$2.95. © 1992 by Gernsback Publications, Inc. All rights reserved. Printed in U.S.A.

**POSTMASTER:** Please send address changes to RADIO-ELECTRONICS, Subscription Dept., Box 55115, Boulder, CO 80321-5115.

A stamped self-addressed envelope must accompany all submitted manuscripts and/or artwork or photographs if their return is desired should they be rejected. We disclaim any responsibility for the loss or damage of manuscripts and/or artwork or photographs while in our possession or otherwise.

# Radio Electronics

Hugo Gernsback (1884-1967) founder

Larry Steckler, EHF, CET,  
editor-in-chief and publisher

#### EDITORIAL DEPARTMENT

Brian C. Fenton, editor  
Marc Spiwak, associate editor  
Kim Dunleavy,  
assistant technical editor  
Teri Scaduto, assistant editor  
Jeffrey K. Holtzman  
computer editor  
Robert Grossblatt, circuits editor  
Larry Klein, audio editor  
David Lachenbruch  
contributing editor  
Don Lancaster  
contributing editor  
Kathy Terenzi, editorial assistant

#### ART DEPARTMENT

Andre Duzant, art director  
Injae Lee, illustrator  
Russell C. Truelson, illustrator

#### PRODUCTION DEPARTMENT

Ruby M. Yee, production director  
Janice Box,  
editorial production  
Karen S. Brown  
advertising production  
Marcella Amoroso  
production assistant

#### CIRCULATION DEPARTMENT

Jacqueline P. Cheeseboro  
circulation director  
Wendy Alanko  
circulation analyst  
Theresa Lombardo  
circulation assistant  
Michele Torriolo, reprint books

Typography by Mates Graphics  
Cover photo by Diversified Photo  
Services

Radio-Electronics is indexed  
Applied Science & Technology In  
and Readers Guide to Periodical Literature.

Microfilm & Microfiche editions  
available. Contact circulation department for details.

Advertising Sales Offices list  
on page 106.

Radio-Electronics Executive and  
Administrative Offices  
1-516-293-3000.

Subscriber Customer Service:  
1-800-283-0652.

Order Entry for New Subscribers:  
1-800-999-7139.

The  
Audit  
Bureau  
of Circulation



# A Shocking Offer!

Now for the first time in CIE's 56 year history you do not have to be enrolled at CIE to receive our Electronics and Electricity Lesson Modules. Available for a limited time to non-students for the shockingly low introductory price of only \$99.50.

With CIE's patented AUTO-PROGRAMMED method of learning you'll quickly learn and then master the basics of electronics and electricity and then move on to ... soldering techniques, applications of Kirchhoff's law, voltage and power, printed circuit boards ... and much, much, more.

Your commitment to CIE ends with your payment, but CIE's commitment to your success just begins when you receive your lessons, exams, binder and equipment. This special price includes the benefits CIE normally extends to its students and graduates.

You'll receive CIE Bookstore privileges, a patented learning method, access to CIE's student, faculty and alumni electronic bulletin board and a free issue of CIE's school newspaper "The Electron". 24-Hour grading and unlimited access to CIE's faculty is available on an optional basis.

And best of all, when you decide to continue your electronics education in any of CIE's programs, you'll receive a \$100.00 CIE tuition credit certificate.

All this knowledge and support will put you on the road to understanding digital electronics, microprocessing principles, computer systems, telecommunications, and much, much, more.



All This For Only!

# \$99.50

- Free Issue of "The Electron"
- Build your personal burglar alarm
- Theory and hands-on training lessons and exams covering "current and voltage" through "printed circuit boards"
- CIE Bookstore privileges
- Patent learning method
- Electronic Bulletin Board privileges

• A \$100.00 CIE TUITION CREDIT CERTIFICATE

Yes, send me CIE's Introductory Electronic and Electricity Lessons and Equipment.

A7302

Name: \_\_\_\_\_

Street: \_\_\_\_\_ Apt. #: \_\_\_\_\_

City: \_\_\_\_\_

State: \_\_\_\_\_ Zip: \_\_\_\_\_

Age: \_\_\_\_\_ Phone (\_\_\_\_) \_\_\_\_\_



**BOOKSTORE**  
1776 East 17th Street  
Cleveland, Ohio 44114

Total Merchandise: \_\_\_\_\_ \$99.50

Ohio Residents add 7% Sales Tax: \_\_\_\_\_

California Residents add 6 1/2% Sales Tax: \_\_\_\_\_

Total this order: \_\_\_\_\_

Shipping and Handling Charges: \_\_\_\_\_ \$5.00

Method of Payment: Amount Enclosed: \$ \_\_\_\_\_

Personal Check or Money Order

Master Card  Visa

Card Expiration Date: \_\_\_\_\_

Signature: \_\_\_\_\_



**CHARGE BY PHONE!**



9 AM to 4:30 PM Eastern Time;

1-800-321-2155 ext. 7302; In Ohio 1-800-523-9109 ext. 7302

# WHAT'S NEWS

*A review of the latest happenings in electronics.*

## Device for multiple automobile air bags

Researchers at Sandia National Laboratories (Albuquerque, NM) have invented a low-energy explosive igniter that could make it easier for automobile manufacturers to install multiple air bags in their vehicles. The device, called a semiconductor bridge or SCB, requires much less energy than the hot-wire igniters that are traditionally used in air-bag systems.

During the rapid deceleration caused by a crash, air bags are electrically ignited by a hot-wire device in an explosive cartridge. As the device heats, the sensitive explosive material burns. A hot gas is produced that enters the stowed air bag and ignites a gas-generating propellant, which then releases a burst of nitrogen gas that quickly inflates the bag. That entire process takes place in just thousandths of a second.

When designing air-bag systems, a worst-case scenario of an almost

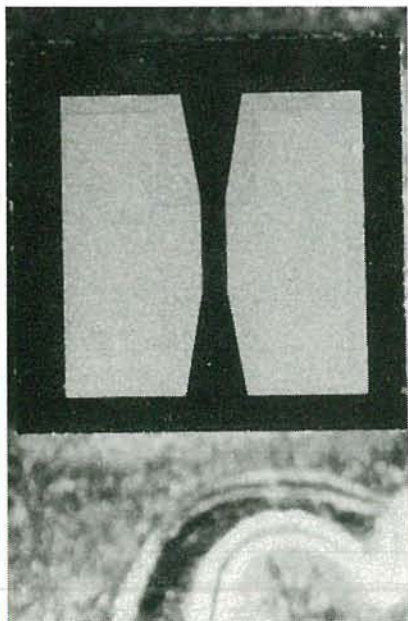

**SANDIA'S SEMICONDUCTOR BRIDGE**, which could be used in multiple air-bag systems, is shown resting on a penny. The penny's "C" letter give an indication of the device's size.

depleted battery is used. In such a case, one hot-wire igniter would consume nearly all of the battery's remaining voltage output—which means trouble for systems incorporating several air bags and explosively activated seat belts.

The semiconductor bridge is about one one-hundredth the volume of a conventional hot wire, and can be heated much faster and with much less energy. Because SCB's are processed on a silicon wafer, the chip can incorporate extra circuitry for logic, timing, and safety.

## Multimillion dollar interactive TV/satellite contract

The introduction of nationwide interactive television is a step closer with the signing of a multimillion contract between TV Answer, a pioneer in real-time wireless Interactive Video Data Service (IVDS) technology, and Hughes Network Systems, Inc. (HNS), manufacturer of interactive Very Small Aperture Terminals (VSAT's). Pending FCC approval, the TV Answer system would allow television viewer to use their TV's as communication devices to pay bills, order take-out food, shop for groceries, do banking transactions, and respond in real time to game shows, TV shopping shows, advertisements, polls, and interactive news and educational programs. In addition, it would serve as a universal remote control, and would provide on-screen TV schedules and VCR programming. The system would work with cable, satellite, and roof-top antenna systems and is expected to cost about \$12.95 a month.

Similar in structure to a cellular phone network, the TV Answer network relies on individual cell sites to provide service to a market area consisting of a maximum of 10,000 households. Each cell site includes a VSAT two-way satellite dish earth-station that communicates with TV

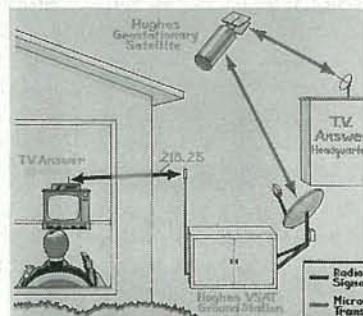

**TV ANSWER'S INTERACTIVE VIDEO DATA SERVICE** would use Hughes work Systems' satellite personal e stations to provide direct transmission paths between remote cell sites and hub station.

Answer Headquarters via a Hughes satellite, and a TV Answer receiver/transmitter that communicates with TV Answer home units. The data received via satellite is transformed at the cell site into a radio signal that is transmitted to each home unit. Viewer responses are relayed to the cell site and back to headquarters in the same way. There the responses are processed and appropriate collection, billing, and ordering activities performed.

The January 10, 1991 FCC Notice of Proposed Rulemaking proposes the allocation of 1/2-MHz of the radio spectrum—between 218.00 and 219.00 MHz, which is the frequency on which TV Answer's system operates—for an Interactive Video Data Service. The action is expected to be finalized, and technical standards and licensing procedures issued, by mid-1992.

Under the initial phase of the contract between HNS and TV Answer, HNS will build and install 10,000 VSAT units for use in cell sites enough to meet the projected 1991 year requirement. The initial phase includes a \$2.1 million hub and network control system at TV Answer headquarters in Reston, VA. TV Answer estimates that a minimum of 10,000 VSAT units will be needed to provide nationwide coverage for the technology.

# YOU CAN ALWAYS SPOT THE TECHNICIAN WHO DOESN'T USE TEKTRONIX.



If you're sending technicians and FSEs into the field with equipment other than Tektronix don't be surprised to discover some unusual tools in their service kits.

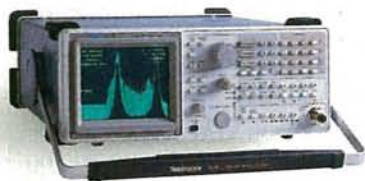

Signal flares, for instance. On the other hand, portable test gear from Tek gets technicians to the root of the problem long before the problem gets to them. Everything from oscilloscopes and spectrum analyzers to handheld DMM



As a result, your customers will be back on their feet in what'll seem like no time at all. They'll be happy for that. Not to mention a whole lot nicer to work with. For your employees' sake, get



touch with a Tektronix representative today. Or keep an eye peeled for signs of distress. **TALK TO TEK/1-800-426-220**

**Tektronix**

Test and Measurement

# VIDEO NEWS

What's new in the fast-changing video industry.

DAVID LACHENBRUCH

## • Compact Disc-Interactive.

Philips has launched its CD-I interactive audio-video multimedia system through 5000 stores, and first reports indicated that the players and discs were selling well. Philips changed its mind about brand name, and its first products were issued under the "Philips" instead of the "Magnavox" brand. The list price of the player was dropped to \$1000 from \$1400, but for all practical purposes, players are selling at about \$800, and discs from \$20 to \$40. Using the theme, "the Imagination Machine," Philips plans major advertising campaigns for the system throughout 1992. This is the second multimedia CD system aimed at the general public via attachments to TV sets, the first being Commodore's CDTV (which stands for Commodore Dynamic Total Vision). Other manufacturers are competing with video and audio CD-ROM systems designed as computer peripherals.

• **Zenith moves TV.** The last major American-owned TV manufacturer will end color-TV manufacture in the United States sometime this year. Zenith Electronics announced that it will start phasing out final assembly of sets in its Springfield, MO plant when its union contract expires on March 22. The company, which has been losing money, explained that price erosion has continued in the TV industry and cost-cutting efforts haven't been sufficient, despite wage concessions by its union in Springfield.

Zenith will move final assembly of large-screen TV sets to its cabinet plant in Juarez, Mexico. Its 19- and 20-inch sets are already being assembled in Reynosa, Mexico. Some plastic molding and distribution operations will continue in Springfield. Zenith will continue to operate its large-picture-tube plant and headquarters in the Chicago. The only other American-owned TV assembler, Curtis Mathis Corpora-

tion, has a final assembly plant in Athens, TX. Although the remainder of TV manufacturers are foreign-owned, many of them continue to assemble their large-screen color TV's in the United States. The leaders are Thomson Consumer Electronics (French-owned), which assembles RCA and GE sets in Bloomington, IN, and Philips (Dutch), which produces Magnavox, Sylvania, and Philips sets in Greeneville, TN. Other final TV assembly is done in Huntsville, AL, by Goldstar (Korean); by Japanese manufacturers in Anaheim, CA; JVC in Elmwood Park, NJ; Mitsubishi in Santa Ana, CA and Braselton, GA; Orion in Princeton, IN; Sanyo in Forrest City, AR; Sharp in Memphis; Toshiba in Lebanon, TN; and Sony in San Diego and soon in New Stanton, PA.

• **"Stereo" TV debate.** As it promised more than a year ago (**Radio-Electronics**, March 1991), a company called dbx Technology Licensing has started a public-relations campaign to inform the public that if a television set doesn't conform with the FCC-backed stereo-TV system, it shouldn't be called "stereo TV." However, Thomson Consumer Electronics, manufacturer of RCA and GE brand sets, has challenged dbx, saying that some of its sets contain a new system called "XS" and qualify as stereo even though they don't use the dbx noise-reduction decoding technology that is officially part of the Multichannel TV System (MTS) stereo standard.

Although Thomson's higher-priced sets do use dbx decoding, Thomson says that the XS sound system, which uses phase shift to process the sound, qualifies as "stereo" even though little separation between left and right channels shows up in tests. dbx demonstrated test results that it says shows that some RCA and GE sets don't reconstruct the true sound

transmitted by the TV station. Thomson retorts that its XS system sounds better than dbx in lower-priced sets. In addition to Thomson, dbx Technology found that some Philips and some Sharp sets can use dbx decoding in their stereo systems. Both of those companies, which use dbx in some of their sets, say they plan to add dbx across the board to all of their sets later this year. Since there is no official definition of "stereo," the dispute is expected to continue for some time. Stereo systems using various types of phase-shift techniques to enhance the "presence" effect include Q sound and SRS, the latter developed by Hughes Aircraft and being used in some high-end sets by Sony and Thomson as an adjunct to MTS stereo. dbx says that's not what some people may prefer: processed sound, but officially MTS sound includes dbx encoding and decoding, therefore, saying that a set including "broadcast TV stereo" or "TV stereo" is misleading.

• **TV for computers.** For years we've heard about the upcoming merger of TV and the computer. A CD-I system is one aspect of adding computer functions to a TV set. Moving in the opposite direction, IBM and others are adding TV functions to the computer. In March, IBM will offer a TV adaptor for its PS/2 computers. That adaptor that permits the computer keyboard to be used to select among 70 TV channels as well as the other normal TV functions. Of course, other video devices may be input as well, including laser disc players or VCR's. The TV picture may be viewed full-screen or fitted in a window—there's no need to watch MTV while working a spreadsheet! The IBM adaptor will carry a list price of \$495, but may be cheap for a computer. But in TV-land, the same adaptor will be a 25-inch color TV set with remote control.



# Some Breadboards Cost Less Than PROTO-BOARD® brand . . . . They Should.

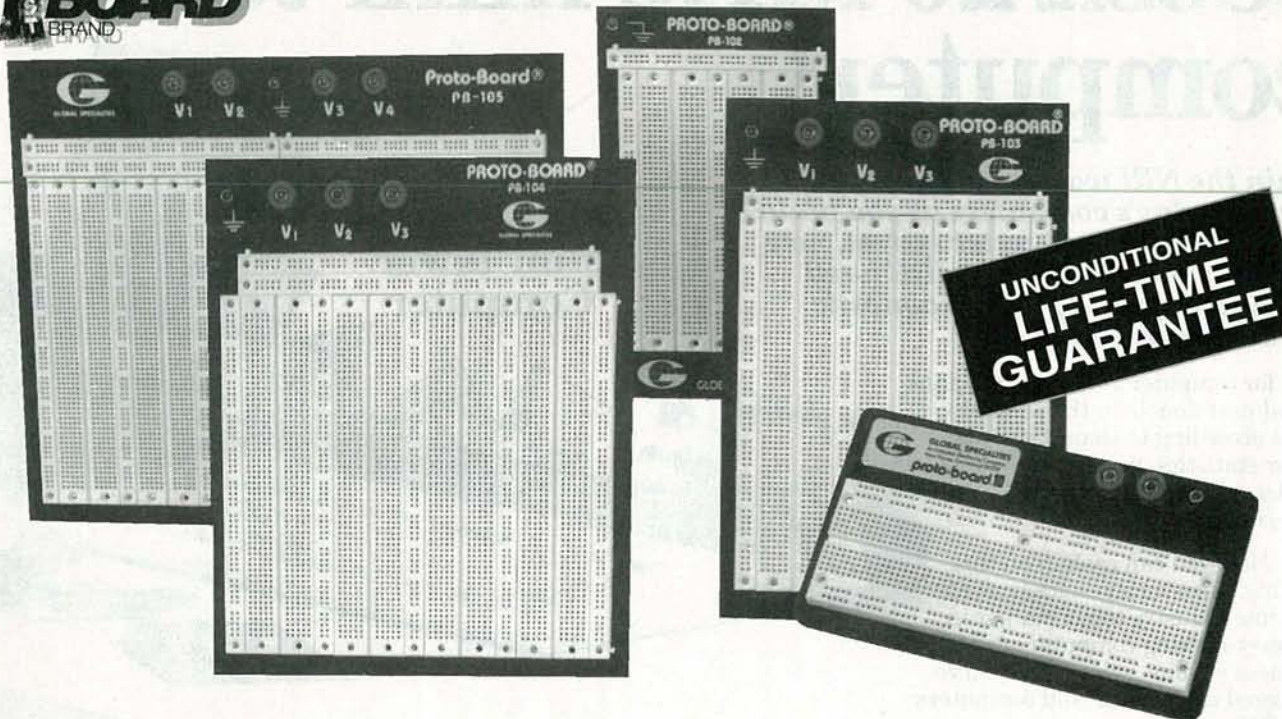

At Global Specialties® we make only one kind of breadboard, the very best, PROTO-BOARD® brand. American made and guaranteed for life.

Sure, save a few dollars today...buy cheap...but remember, you only get what you pay for! Is it really worth it??? Ask yourself...Do they perform like PROTO-BOARD® brand? Are they as reliable? Will they last like a PROTO-BOARD® brand?

How can we guarantee PROTO-BOARD® brand breadboard for life unconditionally? Because we control every step right in our New Haven factory, and because we are obsessed with quality.

That's why we mold our own plastic and stamp our own precision contacts. We even designed our own machine to assemble each breadboard to exacting standards. Assuring every PROTO-BOARD® brand is built to perfection when it leaves our USA factory.....backed by our unconditional "Life-Time" guarantee.

The others, they arrive from Taiwan. With good reason, they are made cheaper!

So next time you consider a cheaper breadboard think twice. You'll need too, because even after you have worn out your second imported breadboard our PROTO-BOARD® brand would have still been going strong.

PROTO-BOARD® brand. *The breadboard you only buy once.* Now which one really cost less?

PROTO-BOARD® brand breadboards and the complete Global® line of test instruments are in stock at fine electronic distributors everywhere.

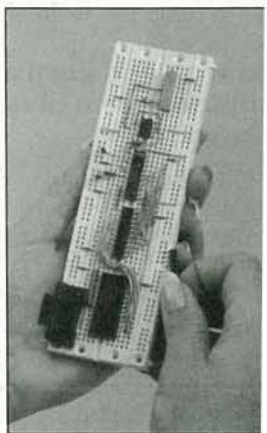

**Can't Wait!**  
Call Toll-Free  
**1-800-572-1028**

**GLOBAL SPECIALTIES®**

GLOBAL SPECIALTIES®  
70 Fulton Terrace, New Haven, CT 06512  
© 1991 Interplex Electronics  
All Global Specialties® breadboarding products are made in New Haven Ct.

A031

**Inte  
Indu  
com**

# Learn to troubleshoot an service today's computer systems as you build a 386sx/20 MHz mini tower computer!

*Train the NRI way—and learn to service today's computers as you build your own 386sx computer system, now with 1 meg RAM, 40 meg IDE hard drive, and exciting new diagnostic hardware and software!*

Jobs for computer service technicians will almost double in the next 10 years according to Department of Labor statistics, making computer service one of the top growth fields in the nation.

Now you can cash in on this exciting opportunity—either as a full-time industry technician or in a money-making computer service business of your own—once you've mastered electronics and computers the NRI way.

NRI's practical combination of "reason-why" theory and hands-on building skills starts you with the fundamentals of electronics, then guides you through more sophisticated circuitry all the way up to the latest advances in computer technology.

## **Train with and keep a powerful 386sx/20 MHz computer system plus popular Microsoft® Works software!**

Only NRI gives you hands-on training with the finest example of state-of-the-art technology: the powerful new West Coast 386sx/20 MHz mini tower computer. As you assemble this 1 meg RAM, 32-bit CPU computer from the keyboard up, you actually see for yourself how each section of your computer works.

You assemble and test your computer's "intelligent" keyboard, install the power supply and 1.2 meg, high-density floppy disk drive, then interface the high-resolution monitor.

Your hands-on training continues as you install a powerful new 40 meg IDE hard disk drive—now included in your course to dramatically increase the data storage capacity of your computer while giving you lightning-quick data access.

**NEW!**  
**386sx/20 MHz**  
**Mini Tower**  
**Computer**



Plus you now go on to work with today's most popular integrated software package, Microsoft Works learning to use its word processing, spreadsheet, database, and communications utilities for your own personal and professional applications. But that's not all.



*Only NRI gives you hands-on training with the remarkable R.A.C.E.R. in diagnostic card and QuickTech diagnostic software for Ultra-X—professional state-of-the-art diagnostic software that makes computer troubleshooting fast and accurate.*

Your NRI computer training includes all this: • NRI's unique Discovery Lab® for circuit design and testing • Hand-held digital multimeter with "talk-you-through" instructions on audio cassette • Dig logic probe that lets you visually examine computer circuits • The new West Coast 386sx/20 MHz computer system, featuring a high-speed 80386sx CPU, 1 meg R 101-key "intelligent" keyboard, 1.2 meg high-density floppy drive, and high-resolution monitor • 40 meg IDE hard driv MS-DOS, GW-BASIC, and Microsoft Works software • R.A.C.E.R. plug-in diagnostic card and QuickTech menu-driven diagnostic software • Reference manuals with guidelines and schematics

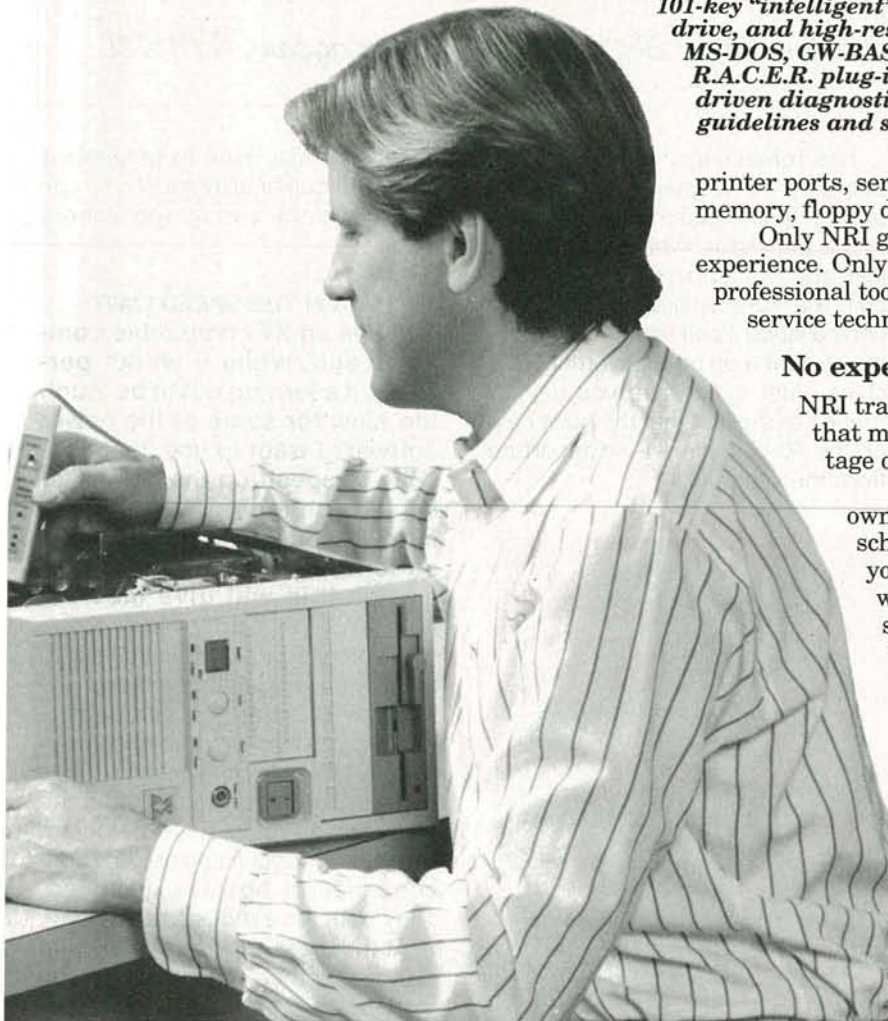

printer ports, serial communications ports, video display memory, floppy drives, and hard disk drives.

Only NRI gives you such confidence-building, real-world experience. Only NRI gives you both the knowledge and the professional tools to succeed as today's in-demand computer service technician.

### No experience needed ... NRI builds it in

NRI training gives you practical, hands-on experience that makes you uniquely prepared to take advantage of today's opportunities in computer service.

You learn at your own convenience in your own home. No classroom pressures, no night school, no need to quit your present job until you're ready to make your move. NRI starts with the basics, building on that foundation step by step until you have the knowledge and skills you need for success.

And all throughout your training you get the full support of your personal NRI instructor and the entire NRI technical staff, always ready to answer your questions and help you achieve your training goals.

### FREE catalog tells more. Send to

Send today for NRI's big, free catalog that describes every aspect of NRI's innovative computer training, as well as hands-on training in other growing high-tech career fields.

If the coupon is missing, write to: NRI School of Electronics, McGraw-Hill Continuing Education Center, 4401 Connecticut Avenue NW, Washington, DC 20008.

### NOW! Training now includes Ultra-X diagnostic hardware and software for quick, accurate troubleshooting!

Now you train with and keep the latest in diagnostic hardware and software: the extraordinary R.A.C.E.R. plug-in diagnostic card and QuickTech diagnostic software, both from Ultra-X. Using these state-of-the-art tools, you learn to quickly identify and service virtually any computer problem on XT, AT 80286/80386, and compatible machines.

You discover how to use the R.A.C.E.R. diagnostic card to identify individual defective RAM chips, locate interfacing problems, and pinpoint defective support chips. Plus you learn to use your QuickTech diagnostic software to test the system RAM and such peripheral adapters as parallel

**NEW!**  
**386sx**



IBM is a registered trademark of International Business Machines Corp. R.A.C.E.R. and QuickTech are registered trademarks of Ultra-X, Inc.

## SEND TODAY FOR FREE CATALOG

**NRI** Schools

McGraw-Hill Continuing Education Center  
4401 Connecticut Avenue, NW  
Washington, DC 20008

#### Check one FREE catalog only

- MICROCOMPUTER SERVICING
- TV/Video/Audio Servicing
- Telecommunications
- Industrial Electronics
- Security Electronics
- Electronic Music Technology
- Basic Electronics
- Automotive Servicing

For career courses approved under GI Bill  
 check for details.

- Computer Programming
- PC Software Engineering
- Desktop Publishing
- Word Processing Home Business
- Paralegal
- Building Construction
- Bookkeeping & Accounting

Name \_\_\_\_\_ (please print) \_\_\_\_\_ Age \_\_\_\_\_

Address \_\_\_\_\_

City/State/Zip \_\_\_\_\_ Accredited Member, National Home Study Council \_\_\_\_\_ 3-1

# ASK R-E

Write to Ask R-E, Radio-Electronics, 500-B Bi-County Blvd., Farmingdale, NY 11735

## MOTOR SPEED CONTROLLER

I have a electric model boat and I'd like to be able to control the speed of the motor. The circuit should be able to make the motor go from very slow to very fast without stalling. I've tried all sorts of things but haven't had any luck—particularly at low speed. The motor is powered by a 7.2-volt battery pack. Do you have any circuits that can help me?—A. Balsys, Howell, NJ

Electric boats aren't my thing but I would have imagined that they all had some way to vary the speed of the motors. Oh well, you live and learn.

Controlling the speed of a small DC motor is something I've talked about several times before but, judging from the number of times I get asked about it in letters and on the phone, it seems a lot of people are interested in the subject. There are several ways to get the job done and even some fairly inexpensive commercial products that will do it for you. In this case, particularly with such a low-voltage motor, there's an easy circuit you can build that will do the job and operate reliably for the life of the motor.

The circuit I'm referring to is shown in Fig. 1. Despite its apparent simplicity, the circuit will drive the motor over a range of speeds from dead slow to full ahead (that's boat talk, I think), without any stalling at even the lowest speeds. The reason it can do this is that the circuit works by controlling the duty cycle of the motor rather than, as in other controllers, the supply voltage.

Two of the inverters in the 4049 are set up as an oscillator whose frequency is roughly determined by:

$$F = 1/1.4RC$$

where R is the total value of the potentiometer. The two diodes isolate both the positive and negative halves of the output frequency and make the output waveform stick close to a 50-50 duty cycle all through its entire operating range.

The remaining inverters in the package are all ganged together in parallel to increase the output drive to the transistor. While you can use just about any inverter for the circuit, the 4049 is probably the best choice since it can handle more output current than other inverting gate chips. Just make sure you pay attention to the fact that the power pin on the 4049 is pin #1—a departure from the other IC's.

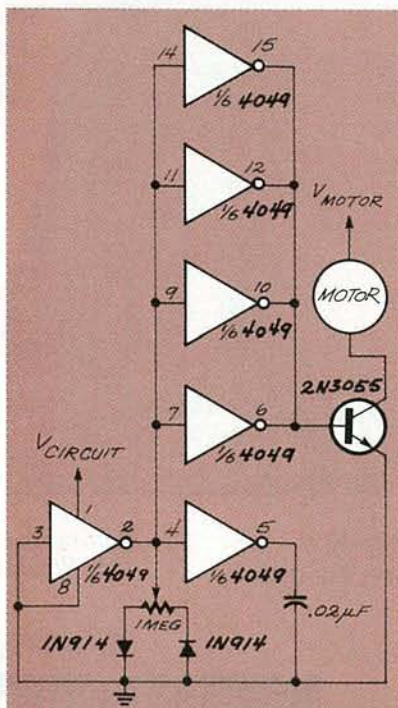

FIG. 1—THIS CIRCUIT WILL DRIVE a small DC motor over a wide range of speeds without stalling by controlling the duty cycle of the motor rather than the supply voltage.

Even though the schematic shows the supply voltage to the motor and the circuit on two separate lines, there's no reason why you can't use the 7.2-volt battery for both of them. The battery is supplying a perfect voltage for CMOS stuff like the 4049.

There's nothing critical about the layout of the circuit and you can build it using any technique you want. In actual fact, it's such a handy

circuit you may want to generate a printed circuit board for it so you can easily use the circuit somewhere else.

## WATCH THE SPEED LIMIT

I have an XT-compatible computer and, while it works perfectly, it's turning out to be much too slow for some of the new software I want to use. Is it possible to speed up the computer by just changing the 14.13 MHz crystal and are there limits as to how much of a speed increase this will give me?—Geeben, Hunter, IN

Before we get into this, I want to make sure you understand that an increase in speed you can get from this is going to be far outweighed by the amount of brain damage it takes to do it. The theory is great but the maximum speed of a motherboard like an automotive engine, is a sequence of how it's designed. They both have red-line numbers.

At the most basic level, the components on your motherboard were chosen to match the computer's original design specifications. The memory controller, interrupt controller, DMA (Direct Memory Access) controller have maximum speed ratings and the ones in your computer were picked to match the speed of the board. The faster any chip's speed rating, the more expensive it is. I don't know who made your motherboard but it's a safe bet that parts on it are only as fast as they have to be.

Changing the crystal changes the board's master clock and the more you step on the electronic accelerator, the closer you're going to get to the point where these chips get flaky and finally fail completely. The point where that happens is determined by the speed ratings stamped on the chips and the tails of the design of your motherboard.

Memory chips have a maximum speed rating as well and it's us-

stamped on the top of the IC right after the chip number. A suffix of 20 means 200 nanoseconds, 15 means 150 nanoseconds, and so on. If the only crystal on your motherboard is a 14.31818-MHz one, it's more than likely that your computer is running, like the original IBM PC, at a speed of 4.77 MHz. This means that your motherboard can operate with memory as slow as 200 nanoseconds. If that's what you have in your machine, you don't have much of a chance of upping the system speed and still maintain much in the way of reliability.

It's possible you can overcome these problems if the design of your motherboard incorporates enough wait states to do things like memory refresh and other housekeeping chores at an increased speed. But there's still another problem that has to be considered.

There are two clock frequencies at the expansion slots and most of the cards you plug into the motherboard are designed to expect the two clocks to be in a particular frequency range. Pin #B20 is known as the CLK and on your motherboard it's probably a buffered version of the 8088's clock frequency—4.77 MHz. That frequency can be higher, and you'll frequently find that it's as high up as 8 MHz.

The second frequency is the one that can cause you a problem. In the original PC (of which yours is a clone), pin #B30 was a buffered version of the crystal frequency—14.31818 MHz. That has remained a standard, even up to this day. Measure the frequency at that pin on the latest 33-MHz 486 motherboard and you'll find 14.31818 MHz. When you change the crystal on the board, you'll also be changing both frequencies at the expansion slots which can cause a problem with some cards that use the two clocks.

The biggest problem will come with floppy-disk controllers since they use those clocks for writing to the disk. Even if you somehow avoid the problem, it's a guaranteed fact that you'll have problems formatting disks.

Keeping all this stuff in mind, you can start experimenting with higher-frequency crystals to see how far you can go before you have major

problems. My guess is that the most you'll be able to get is a 50% increase in speed. If you want to be able to format disks, you have to supply the computer with the original frequencies so don't get rid of the original crystal. Probably the easiest way to do that is to have both the crystals on the motherboard and use a switch to select one or the other.

We're talking about doing a good deal of work here and the possible rewards are really minimal. A 50% increase in speed may sound like a lot but you'll find that the practical effects are just not all that noticeable. A much better solution to the whole problem is to buy a new motherboard that's been designed from the ground up to run faster than the one you have now. **R-E**



"Plant a tree today  
for all the world to share"

You can make life better for your children and for the future. Join me and plant a tree today for all the world to share.

For your free brochure, write:  
Trees for America, The National  
Arbor Day Foundation,  
Nebraska City, NE 68410.



John Denver for  
**The National  
Arbor Day Foundation**

## Be an FCC LICENSED ELECTRONIC TECHNICIAN!



No costly school. No commuting to class. The Original Home-Study course prepares you for the "FCC Commercial Radiotelephone License." This valuable license is your professional "ticket" to thousands of exciting jobs in Communications, Radio-TV, Microwave, Maritime, Radar, Avionics and more...even start your own business! You don't need a college degree to qualify, but you do need an FCC License.

**No Need to Quit Your Job or Go To School**  
This proven course is easy, fast and low cost! **GUARANTEED PASS**—You get your FCC License or money refunded. **Send for FREE facts now. MAIL COUPON TODAY!**

### COMMAND PRODUCTIONS

FCC LICENSE TRAINING, Dept. 90  
P.O. Box 2824, San Francisco, CA 94126  
Please rush FREE details immediately!

NAME \_\_\_\_\_  
ADDRESS \_\_\_\_\_  
CITY \_\_\_\_\_ STATE \_\_\_\_\_ ZIP \_\_\_\_\_

## LEARN to CLEAN/ MAINTAIN/ REPAIR CAMCORDERS



### HUGE EXPANDING MARKET!

Work from your home — part-time or full-time  
No prior experience needed — Average mechanic ability only requirement for your success! Over 1 million camcorders in use — Over 5 million expected to be sold in 1991 alone!

It is a fact that the vast majority of camcorder malfunctions (just like VCRs!) are due to simple mechanical failure... We can show you how to easily fix those breakdowns and earn an average of \$85.00/h while working at home!

**Get In Now** — Soon camcorders will be like VCR i.e., one in almost every home.

For a camcorder cleaning job you can earn \$65.00 or less than 30 minutes work.

For a camcorder repair job you can earn over \$100.00

**FREE INFORMATION PACKAGE** call or write:  
Toll-Free 1-800-537-0589  
Viejo Publications, Inc.  
4470-107 Sunset Blvd. #600  
Los Angeles, CA 90027, Dept. REC

CIRCLE 193 ON FREE INFORMATION CARD

# LETTERS

Write to Letters, Radio-Electronics, 500-B Bi-County Blvd., Farmingdale, NY 11735

## VEHICLE GENERATORS AND REGULATORS

**Radio-Electronics** and its predecessor, *Radio-Craft*, have given me much pleasure for 50 years. Robert Grossblatt's articles have been favorites, but he fell off the track with his comment, "... (vehicle) generators and the regulators that control the current they produce are a really stupid charging system ..." (*Drawing Board, Radio-Electronics*, December 1991).

Low-cost, high-current silicon rectifiers that made the superior alternator available were not developed until after the transistor was invented in 1947. There happened to be a lot of high technology before that. Radio, TV, computers, and automobiles all pre-date the benefits brought by advanced solid-state devices. As I recall, submarines, Rolls Royce automobiles, and high-speed aircraft all used generators, and the electromechanical voltage regulators they required. I don't believe the word "stupid" characterizes that use.

I suspect the author was just trying to interject some lightness—which is all right with me—but his description of the operation of the older voltage regulator is incorrect.

The generator's field current was modulated by a voltage-sensing relay that inserted various values of resistance in the field circuit, not the output lead. The varying field current would then cause the output voltage to remain at the desired value. The relay was also designed to sense the ambient temperature and change the generator-charging voltage accordingly. The voltage regulator case usually contained a current-limiting relay to protect the generator from over-load, and a reverse-current relay to prevent the battery from discharging through the generator windings when the engine was not running.

These latter two functions were

not needed in the alternator, but when they were first installed in new cars, there were no low-cost, high-current transistors developed that could operate at the high-temperatures in the engine compartment. So the same old electromechanical voltage regulator that had been used for 40 years was used again with the new alternator!

The rest of Mr. Grossblatt's article was well done and informative, as usual. I just didn't want to read your fine magazine for the next 50 years without contributing to its technical excellence!

GEORGE W. HAILS  
Arlington Heights, IL

## TESLA COIL IMPOSTORS

I have been tempted several times in the past to write to various magazines after the appearance of certain articles on the construction of Tesla coils. Don Lancaster's comments on the Tesla coil (*Hardware Hacker, Radio-Electronics*, October 1991) finally pushed me to fire up the word processor.

I agree that many "Tesla" coils are essentially nothing more than glorified step-up transformers. The Tesla coil, however, is *meant* to generate its high-frequency high voltage by taking advantage of the special properties of the resonant (quarter wavelength) transmission line (also known, somewhat esoterically, as the Ferranti effect). It can be shown that the voltage amplitude  $V$ , at the unloaded end of an ideal (i.e., lossless, uniform, etc.) quarter wavelength transmission line driven by a source of resonant voltage of amplitude  $V_S$ , and of impedance  $Z_S$  at the resonant frequency (assumed real for notational simplicity) is  $V = (Z_0/Z_S)V_S$ , where  $Z_0$  is the characteristic impedance of the line. This is different in numerous ways from the standard voltage multiplication of a transformer, as it should be; these are quite distinct physical phenomena.

Although the physics of the former is pretty amazing, what is more impressive is that a wire more properly, a transmission line may itself act as a "transformer." A great experiment that shows the construction of a mock transmission line using discrete components to model (mock) distributed parameters of a transmission line.

In reality, a Tesla coil impostor is pretty easy to spot. It will suffer a variety of maladies, some of which include improper magnetic coupling (making it a transformer instead of a propagating transmission line); marked insensitivity to resonant frequency tuning. Generally, even most heinously constructed "Tesla coils" will generate hefty arcing and grabbing sparks, but they are missing the "magic and mystery" of the physics of the resonant line makes it a true Tesla coil.  
MATTHEW KLEJWA  
Schaumburg, IL

## HERE'S TO HOW-TO ARTICLES

I'm writing in response to Funk's letter (*Radio-Electronics*, April 1991) titled "Hack Attack." It might be true that you add up all the component costs required for a home-built computer system, the final price tag will be close to a dealer-bought system. However, there are quite a few people in this world who cannot afford to shell out over \$1000 at once but who can afford to do it piecemeal. It's a lot easier to spend or \$50 at a time than it is to spend \$1000.

And how can you put a price on your time when you are learning to build something as useful as a computer system? How much is your time worth when you sit and watch television?

Please keep publishing the how-to articles!  
JOHN CULLIVAN  
Niles, OH

The world's smallest 12-band receiver.

Includes digital clock, travel alarm, headphones, deluxe travel pouch, and Grundig guide book. Measures approximately 3 1/2" x 5 5/8" x 1 1/4" and weighs a mere 14 ounces!



The world is at your fingertips with...

# The Grundig World Band Receiver

Announcing a revolutionary breakthrough in world-band radios...from Grundig, the leader in German short-wave electronics. This miracle of miniaturization is not sold in U.S. stores or catalogs—only Willabee & Ward has it!

**Tune in to events around the globe.** The RK-709 is the world's smallest 12-band receiver—AM, FM, FM Stereo (with headphones, included), and all 9 major shortwave bands. Small enough to fit into a pocket, briefcase, or purse, yet big on features. Telescoping antenna pulls signals from anywhere in the world. Listen to legendary BBC newscasts—the best in the world. Hear what Radio Moscow is saying about Gorbachev, Yeltsin, and President Bush. Listen to the Voice of America when you travel abroad. Follow a crisis or breaking story wherever you are and no matter where it's happening: Baghdad, Panama, Beijing or Tokyo.

You don't have to pack a travel alarm, either.

You won't need it—this is better. The RK-709 wakes you with the radio or its ingenious "Humane Wake System"—the tone begins softly and gathers volume until you wake up! The digital alarm clock features a sleep timer that turns off the radio 10 to 60 minutes after you turn in!

**Only \$159!**

**Payable in monthly installments.**

The Grundig RK-709 is only \$159 (plus \$7.50 shipping/handling), payable in convenient monthly credit card installments. Includes deluxe carrying pouch and stereo headphones. One year warranty, 30 day money back guarantee. Order today.

Don't be confused by other 4, 5, 7, or 9 band radios. Grundig's RK-709 is today's best buy on a real 12 band receiver.

Willabee & Ward  
47 Richards Avenue  
Norwalk, Conn. 06857



Satisfaction guaranteed.

**CALL TOLL-FREE: 1-800-367-4534**  
Ext. 623-165

Please send me \_\_\_\_\_ Grundig RK-709 World Band Receiver(s). For each receiver, charge 4 installments of \$41.63\* to my credit card:

- MasterCard     VISA  
 Discover         Am. Ex.

Credit Card # \_\_\_\_\_ Exp. Date \_\_\_\_\_

Name \_\_\_\_\_  
PLEASE PRINT CLEARLY

Address \_\_\_\_\_

City/State/Zip \_\_\_\_\_

Signature \_\_\_\_\_  
(All orders subject to acceptance.)

I prefer not to pay by credit card and will pay by check. Enclosed is my check for \$159\* plus \$7.50 shipping/handling, a total of \$166.50 for each receiver.

\*Any applicable sales tax will be billed with shipment.

Phone orders normally shipped next business day.

**CALL TOLL-FREE: 1-800-367-4534 Ext. 623-165**

# EQUIPMENT REPORTS

## The Kelvin 100K Digital Multimeter

*Most multimeters are ready to use right out of the box—but not the Kelvin 100K.*



CIRCLE 10 ON FREE INFORMATION CARD

If we were to tell you that this review is about an inexpensive multimeter, you'd probably be inclined to turn to the next page. After all, multimeters are as common today as silicon chips, and the features found on inexpensive ones have been around for years. So what can we tell you about the *Kelvin 100K* digital multimeter that you couldn't already guess? The answer is that it's available as a kit.

The *Kelvin 100K* (Kelvin Electronics, 7 Fairchild Ave., Plainview, NY 11803) comes with a PC board and all parts that mount on it, a case with a backstand (that's always handy), a pair of test leads, an owner's manual, an assembly manual, an extra fuse, and even a 9-volt battery, all for \$29.95. The *100K*'s features include a 3½-digit LCD; DC ranges of 2, 20, 200, and 1000 volts; AC ranges of 200 and 500 volts; resistance ranges of 200 ohms, 2K, 20K, 200K, and 2 megohms; and DC current ranges of 2 mA, 20 mA, 200 mA, and 10 amps. There's no provision for measuring AC current.

The *100K* also hosts a diode test, a low-battery indicator, and a battery test—a handy feature for a general-purpose multimeter. In the "battery test" mode, the meter will display the voltage of any 1.5-volt battery under a 100-mA load or the voltage of any 9-volt battery under a 6-mA load.

It's likely that not too many experi-

enced kit builders will be interested in building the *100K*, mainly because they almost certainly already own a multimeter. However, the *100K* kit is perfect for any beginner in electronics or a child who's old enough to attempt soldering—especially a kid who's always playing with his dad's multimeter!

The assembly manual is particularly well-suited for a classroom environment, as it reads like an electronics lab manual; parts are installed a small group at a time, alternating with precautionary circuit checks, explanations of how each section of the circuit works, troubleshooting tips, and various quizzes on what has been covered so far.

Experienced kit builders may actually find the assembly manual somewhat irritating, because the sections in which components are installed are scattered throughout a lot of other explanatory paperwork. Remember though, that the kit is aimed at beginners. But this is where the kit's one flaw emerges: the assembly manual contains more than just a few typographical errors. A seasoned kit builder should be able to overcome these problems but they may be very confusing to the beginner. Let's go over the assembly manual and point out any problems we encountered.

The manual starts out with an introduction to the meter and a table listing all of its specifications. A

schematic of the meter's circuit and a parts list follows. Diagrams of all of the parts are provided to you quickly identify everything. A parts-placement diagram is neat, though the PC board is silkscreened with all of the component designations as well. Also included are charts to help identify resistor values by their codes and capacitor values by numbering. Pinout diagrams are provided, of the 3½-digit LCD 7106 A/D converter, and the CMOS XOR gate used in the meter. The brief discussion on proper soldering techniques and the proper handling of IC's. A list of all tools needed to build the meter is also given. Circuit theory is the last thing to be covered before the actual assembly of the board begins.

In the first assembly procedure, certain resistors and capacitors must be soldered to the PC board and some might find this step confusing. You are instructed to install C14, 10 nF, and C16, 0.01 μF—the two capacitors are actually the same value. And the fact that the parts list shows capacitors C14 and C16 to be "0.0 μF" only adds to the confusion.

Next you have to install the 7106 IC so that the A/D circuit can be tested out, which also requires the temporary installation of the battery clip, the LCD, and the rotary knob. The LCD and knob require a bit of sub-assembly before attaching them to the meter, and for some reason the sub-assembly instructions are found much farther on in the manual. The assembly diagram shows the back of the knob as having six plastic tabs which you are to snap on six contact clips—but the knob that came with our kit had seven. After putting the clips on the outermost tabs, the A/D section seemed to work just fine.

For the voltage-reference circuit

*continued on page*



# HASTA LA VISTA BABY!

Terminate your Search for a Handi-Counter™. We're going to blow you away with this offer! \*\$100. off our full range Model 2810.

\*Limited time only, no discounts and no trade ins. Made in the U.S.A.

# \$159

**Don't Wait  
This Offer Can't Last!  
Reg. Price, \$25**



- Full range -10Hz to 3GHz.
- LCD display (daylight visibility).
- True state-of-the-art technology with the high speed ASIC.
- NiCads & Charger included.
- Ultra-high sensitivity.
- 4 gate times.
- Extruded metal case.
- Compatible with MFJ207.

### Suggested options

- TA100S: Telescoping Whip Antenna.....\$ 12.
- CC30 Vinyl Carry Case.....\$ 14.
- BL10: LED Backlight.....\$ 15.
- BL28: EI Backlight for use in roomlight and low light.....\$ 45.
- BG28: Bargraph Signal Level Indicator.....\$100.
- TCXO 30: Precision  $\pm 0.2$ ppm 20 to 40°C temp. compensated time base.....\$100.

Universal Handi-Counter™ Model 3000, \$375. and Bench Model 8030, \$579. Both offer frequency, period, ratio and time interval.



## OPTOELECTRONICS

Call for free catalog - Factory Direct Order Line:

# 1-800-327-5912

FL (305)771-2050 • FAX (305)771-2052

5821 NE 14th Ave. • Ft. Lauderdale, FL 33334  
5% Ship/Handling (Max. \$10) U.S. & Canada.  
15% outside continental U.S.A.  
Visa and Master Card accepted.

CIRCLE 195 ON FREE INFORMATION CARD

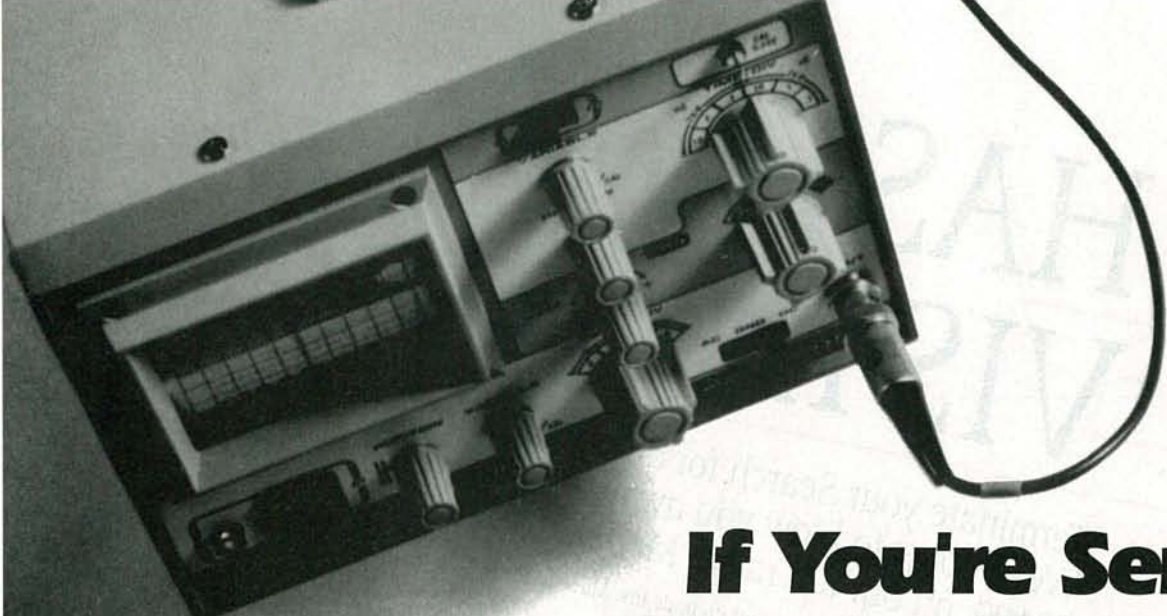

# If You're Serious About a Future in Electronics, Ensure that Your Future with the Best Educational Training Available

## FREE!

SEND FOR YOUR CIE HOME  
STUDY COURSE CATALOG AND  
RECEIVE A FREE 24 PAGE CIE  
ELECTRONICS SYMBOL HANDBOOK!

Includes hundreds of the most frequently  
used electronic symbols. Published by  
CIE exclusively for our students and  
alumni. Yours free when you  
request a CIE Course Catalog.



electronics

ELECTRONICS SYMBOL HANDBOOK

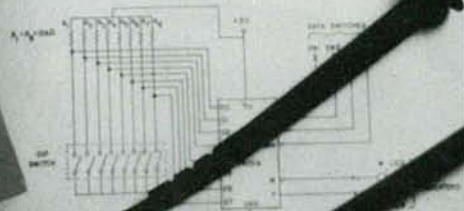

Fig. 16 Circuit for Experiment 2



Fig. 17 Pin diagram for 74151A

### Procedure

Figure 16 shows the circuit diagram for this experiment. You'll also find the numbers for the IC aren't included on the diagram. For those, you'll have to refer to Fig. 17, which shows pertinent 74151A data. For the data switches, you'll use an eight-pole DIP switch in conjunction with 10 k $\Omega$  pull-up resistors. For the Select and Strobe lines, finally, you'll use the trainer data switch.

1. With the power off, mount the 74151A IC and the DIP switch on the breadboard.
2. Connect the eight 10 k $\Omega$  resistors to the DIP switch as shown in Fig. 16. Connect the opposite end of each of these resistors to the +5V supply. The second terminal of each switch is to be connected to trainer ground.
3. Connect the IC's V<sub>CC</sub> pin to +5V, connect the GND to trainer ground.
4. Next, connect the trainer data switches to the Select and Strobe inputs on the IC, using Fig. 17 as a guide. Initially, set SW1 through SW4 to 0.
5. Connect the trainer Y LED to the Y output, and connect trainer X1 to the W output.

7. Turn the power on. The Y LED on your trainer should be off, and the W LED should be on. If you don't observe these conditions, turn off the power and check your connections.
8. From the present input conditions on the inputs, you can see that the input will be enabled.
9. Set the appropriate DIP switch H1 (open), and verify your predictions. Record your results in terms of the selected input D<sub>i</sub> (where  $i$  is the number of the selected data line) in the appropriate space in the table in Fig. 18.

If you want to learn about electronics, and earn a good income with that knowledge then CIE is your best educational value.

CIE's reputation as the world leader in home study electronics is based solely on the success of our graduates. And we've earned that reputation with an unconditional commitment to provide our students with the very best electronics training.

Just ask any of the 50,000-plus graduates of the Cleveland Institute of Electronics who are working in high-paying positions with aerospace, computer, medical, automotive and communication firms throughout the world.



They'll tell you success didn't come easy...but, it did come....thanks to CIE. And today, a career in electronics offers more opportunities and greater rewards than ever before.

### CIE's COMMITTED TO BEING THE BEST....IN ONE AREA....ELECTRONICS.

CIE isn't another be-everything-to-everybody school. We teach only one subject and we believe we're the best at what we do. Also, CIE is accredited by the National Home Study Council. And with more than a 1,000 graduates each year, we're the largest home study school specializing exclusively in electronics. CIE has been training career-minded students like yourself for nearly 60 years and we're the best at our subject ..... **ELECTRONICS ... BECAUSE IT'S THE ONLY SUBJECT WE TEACH!**

### CIE PROVIDES YOU WITH A LEARNING METHOD SO GOOD, IT'S PATENTED.

CIE's Auto-programmed lessons are a proven learning method for building valuable electronics career skills. Each lesson is designed to take you step-by-step and principle-by-principle. And while all CIE lessons are designed for independent study, CIE's instructors are personally available to assist you with just a toll-free call. The result is practical training... the kind of experience you can put to work in today's marketplace.

### LEARN BY DOING...WITH STATE-OF-THE-ART FACILITIES AND EQUIPMENT.

In 1969, CIE pioneered the first Electronics Laboratory course and in 1984, the first Microprocessor Laboratory course. Today, no other home study school can match CIE's state-of-the-art equipment and training. And all your laboratory equipment, books, and lessons are included in your tuition. It's all yours to use while you study at home and for on-the-job after graduation.

### PERSONALIZED TRAINING....TO MATCH YOUR BACKGROUND.

While some of our students have a working knowledge of electronics others are just starting out. That's why we've developed twelve career courses and an A.A.S. Degree program to choose from. So, even if your not sure which electronics career is best for you, CIE can get you started with

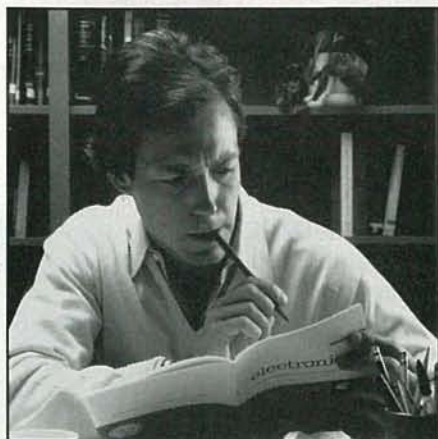

core lessons applicable to all areas of electronics. And every CIE course you take earns you credit towards completion of your Associate in Applied Science Degree. So you can work toward your degree in stages or as fast as you wish. In fact, CIE is the only school that actually rewards you for fast study, which can save you thousands of dollars.

**SEND TODAY FOR YOUR CIE COURSE CATALOG AND WE'LL SEND YOU A FREE 24 PAGE CIE ELECTRONICS SYMBOL HANDBOOK!**

**FINANCIAL AID AVAILABLE TO QUALIFIED INDIVIDUALS.**

#### WHY CHOOSE CIE FOR YOUR TRAINING?

- 150,000 successful graduates from every country around the world.
- Only CIE rewards you for fast study. CIE offers an Associate Degree program based on actual study time used. The faster you complete your degree the less your overall tuition.
- State-of-the-art laboratory equipment is yours to keep and it comes assembled, ready for hands-on experiments.
- Approved for educational benefits under the G.I. Bill for veterans and other eligible persons.
- Upon graduation, CIE offers free preparation to pass the Certified Electronics Technician Exams.

**YES!** I want to get started.

Send me my CIE school catalog including details about the Associate Degree Program. (For your convenience, CIE will have a representative contact you - there is no obligation.)

A E 32

Name: \_\_\_\_\_

Address: \_\_\_\_\_

City: \_\_\_\_\_ State: \_\_\_\_\_

Zip: \_\_\_\_\_ Age: \_\_\_\_\_

Phone No. ( \_\_\_\_\_ ) \_\_\_\_\_

Check box for G.I. Bulletin Benefits

Veteran  Active Duty



**CLEVELAND INSTITUTE OF ELECTRONICS**

1776 East 17th Street  
Cleveland, Ohio 44114  
(216) 781-9400



A school of thousands  
A class of one.  
Since 1934.

# NEW PRODUCTS

Use the Free Information Card for more details on these products.

**DIGITAL MULTIMETER.** The latest edition to Hewlett-Packard's line of digital multimeters is capable of measuring up to 1000 volts with 6½ digits of resolution and 1000 readings per second. By providing the capacity to go through 50-range/function changes per second, the *HP 34401A* has ten times the throughput of other digital multimeters in its class. The instrument offers basic 24-hour DC accuracy of 0.0015 percent, and the best AC accuracy and widest AC bandwidth in its class, according to Hewlett-Packard.

Designed for system and bench applications, the *HP34401A* can be incorporated into existing systems with no changes in software, and includes such system DMM features as dB, null, diode test, and continuity. HP-IB and RS-232C interfaces are standard. In addition, it provides limit test, minimum/



CIRCLE 16 ON FREE INFORMATION CARD

maximum testing results, storage of 512 readings, automatic-reading hold, auto-ranging, display updating, and almost instantaneous continuity readings.

The easy-to-use front panel was designed in response to extensive user testing, and a menu feature allows the user to easily modify secondary functions. An optional strap-on pouch can carry the power

cord, interface cables, test probes, user and service manuals, and other accessories. The carrying handle and bumpers can be removed for rack installation.

The *HP 34401A* digital multimeter has a U.S. list price of \$995.—**Hewlett-Packard Company**, Loveland Instrument Division, P.O. Box 301, Loveland, CO 80539; Phone: 1-800-538-8787.

\$1695.—**Leader Instruments Corporation**, 3 Oser Avenue, Hauppau NY 11788; Phone: 1-800-645-5104 (in NY 516-231-69000).

**SCHEMATIC DRAWING SOFTWARE.** Developed to help engineers, technicians, and hobbyists design and draw electronic circuits on-screen, *AutoSkem CAD Vers 1.4* produces a high-quality printout, eliminating the rough hand-drawn sket



SYMBOLS

CIRCLE 18 ON FREE INFORMATION CARD

**CABLE/TV SIGNAL LEVEL METER.** Designed for measuring performance levels during system construction, installation, and maintenance, Leader Instruments' *Model 951* CATV signal-level meter can be used by the broadcast-TV, FM, MATV, and CATV industries. It has an auto-scanning feature that selects 32 channels encountered and displays measurement results that are auto-ranged and auto-scaled for storage to (or recall from) four groups of eight channel-bargraph

data registers. Users can also select and store four memory-scans of picture and/or sound carriers, and measured results. Single- or multi-channel displays can be selected, using digital readouts and analog bargraph indications on a large, backlit, supertwisted



CIRCLE 17 ON FREE INFORMATION CARD

LCD readout. The *Model 951* provides continuous frequency coverage from 48 to 870 MHz. It features EEPROM look-up tables for picture and sound carriers in broadcast VHF, UHF, and CATV standards of 16 countries. The battery-powered (8 "D"-size cells) unit measures 8.4 x 4.75 x 7.9 inches and weighs just 10.5 pounds. An optional RS-232 interface allows data to be downloaded to a printer or computer.

The *Model 951* Cable/TV signal-level meter costs

Drawings can be constructed using lines, text, and symbols. A software library of more than 50 predefined electronic symbols, logic gates, op-amp transistors, diodes, capacitors, etc., is included. Users can create their own symbols and organize them into unlimited number of libraries of up to 100 symbols each. Text can be rotated and scaled to five sizes before being placed in a drawing. Version 1.4 features improved graphics and drawing features for EGA and VGA systems; "raster banding" for drawing

48 HOUR  
SHIPPING

# ELENCO & HITACHI PRODUCTS AT DISCOUNT PRICES

TO ORDER  
CALL TOLL FREE  
1-800-292-7711

## Hitachi RSO Series

(Portable Real-time Digital Storage Oscilloscopes)

VC-6023 - 20MHz, 20MS/s	\$1,695
VC-6024 - 50MHz, 20MS/s	\$1,995
VC-6025 - 50MHz, 20MS/s	\$2,195
VC-6045 - 100MHz, 40MS/s	\$2,995
VC-6145 - 100MHz, 100MS/s	\$4,495

RSO's from Hitachi feature roll mode, averaging, save memory, smoothing, interpolation, pretriggering, cursor measurements. These scopes enable more accurate, simpler observation of complex waveforms, in addition to such functions as hardcopy via a plotter interface and waveform transfer via the RS-232C interface. Enjoy the comfort of analog and the power to digital.

## 25MHz Elenco Oscilloscope

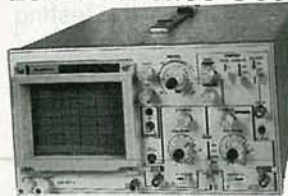

**\$349**

S-1325

- Dual Trace
- 1mV Sensitivity
- 6" CRT
- X-Y Operation
- TV Sync
- (2) 1x, 10x Probes included

All scopes include probes, schematics, operators manual and 3 year (2 yrs for Elenco scopes) world wide warranty on parts & labor. Many accessories available for all Hitachi scopes. Call or write for complete specifications on these and many other fine oscilloscopes.

## SPECIAL BUY

V-212 - 20MHz Scope \$425

## Hitachi Portable Scopes

DC to 50MHz, 2-Channel, DC offset function, Alternate magnifier function

V-525 - CRT Readout, Cursor Meas.	\$995
V-523 - Delayed Sweep	\$975
V-522 - Basic Model	\$875
V-422 - 40MHz	\$775
V-223 - 20MHz delayed sweep	\$695
V-222 - 20MHz deluxe	\$625

## PRICE BREAKTHRU

20MHz Digital Storage Oscilloscope

- Analog/Digital Scope
- 2K word per channel memory
- 10MS/s sampling rate
- State-of-art technology
- Includes probes

DS203

**\$795**

## HITACHI COMPACT SERIES SCOPES

This series provides many new functions such as CRT Readout, Cursor measurements (V-1085/1065A/665A), Frequency Ctr. (V-1085), Sweeptime Autoranging, Delayed sweep and Tripper Lock using a 6-inch CRT. You don't feel the compactness in terms of performance and operation.

V-660 - 60MHz, Dual Trace	\$1,149
V-665A - 60MHz, DT, w/cursor	\$1,345
V-1060 - 100MHz, Dual Trace	\$1,395
V-1065A - 100MHz, DT, w/cursor	\$1,649
V-1085 - 100MHz, QT, w/cursor	\$1,995
V-1100A - 100MHz, Quad Trace	\$2,195
V-1150 - 150MHz, Quad Trace	\$2,695

## Elenco 40MHz Dual Trace



Good to 50MHz **\$495**  
S-1340

- High luminance 6" CRT
- 1mV Sensitivity
- 10KV Acceleration Voltage
- 17ns Rise Time
- X-Y Operation
- Includes (2) 1x, 10x Probes

## B + K TEST EQUIPMENT

All Models Available

Call for special price

## Digital Capacitance Meter



CM-1550B

**\$58.95**

- 9 Ranges
- .1pf-20,000ufd
- .5% basic accy.
- Zero control w/ Case
- Big 1" Display

## Digital LCR Meter



LC-1801

**\$125**

- Measures:
- Coils 1uH-200H
- Caps .1pf-200uf
- Res .01-20M

## Multimeter with Capacitance & Transistor Tester



**\$55**

CM-1500B  
Reads Volts, Ohms  
Current, Capacitors,  
Transistors and  
Diodes / with case

Big 1" Display

## FLUKE

### MULTIMETERS

- All Models Available
  - Fluke 70-II \$65
  - Fluke 77-II \$145
  - Fluke 79-II \$169
  - Fluke 87 \$289
- Call for special price

## Quad Power Supply XP-580



**\$59.95**

- 2-20V @ 2A
- 12V @ 1A
- 5V @ 3A
- 5V @ .5A

Fully regulated and short circuit protected

## Triple Power Supply XP-620



**\$45**

- Assembled \$69
- Kit \$45
- 2 to 15V @ 1A,
- 2 to -15V @ 1A
- (or 4 to 30V @ 1A)
- and 5V @ 3A

All the desired features for doing experiments. Features short circuit protection, all supplies

## AM/FM Transistor Radio Kit with Training Course

Model AM/FM 108

**\$26.95**

14 Transistors • 5 Diodes  
Makes a great school project



## True RMS 4 1/2 Digit Multimeter

M-7000

**\$135**

.05% DC Accuracy  
.1% Resistance  
with Freq. Counter  
and Deluxe Case

## GF-8016 Function Generator

with Freq. Counter

**\$249**

- Sine, Square, Triangle
- Pulse, Ramp, .2 to 2MHz
- Freq Counter: .1 - 10MHz
- Int/Ext operation

GF-8015 without Freq. Meter \$179

## Function Generator



Box

**\$28.95**

Provides sine, triangle, square wave from 1Hz to 1MHz AM or FM capability

## Learn to Build and Program Computers with this Kit

Includes: All Parts, Assembly and Lesson Manual

Model

MM-8000

**\$129.00**



Starting from scratch you build a complete system. Our Micro-Master trainer teaches you to write into RAMs, ROMs and run a 8085 microprocessor, which uses similar machine language as IBM PC.

## Wide Band Signal Generators



SG-9000 \$129

RF Freq 100K-450MHz AM Modulation of 1KHz Variable RF output  
SG-9500 w/ Digital Display & 150 MHz built-in Counter \$249

## XK-500 Digital / Analog Trainer

A complete mini-lab for building, testing, prototyping analog and digital circuits Elenco's Digital / Analog Trainer is specially designed for school projects, with 5 built-in power supplies. Includes a function generator with continuously variable, sine, triangular, square wave forms. All power supplies are regulated and protected against shorts.

### Power Supplies

- Variable Power Supply
- +1.25 to 20VDC @ .5 Amp
- (+1.25 to 15VDC @ 1 Amp)
- -1.25 to -20VDC @ .5 Amp
- (-1.25 to -15VDC @ 1 Amp)
- +12VDC @ 1 Amp
- -12VDC @ 1 Amp
- +5VDC @ 1 Amp
- 30VAC Center tapped @ 15VAC @ 1 Amp

### Analog - Section

- Function Generator Sine, Triangular, Square wave forms
- Frequency adjustable in five ranges from 1 to 100kHz
- Fine frequency adjust
- Amplitude adjust
- DC offset
- Modulation FM-AM

### Digital - Section

- Eight data switches
- Two no bounce logic switches
- Eight LED readouts TTL buffered
- Clock frequency 1 to 100KHz
- Clock amplitude 5VPP square wave

### Breadboards

- 2 breadboards, each contain:
- 840 tie points (total 1,680)

**\$149.95 Assembled**  
**\$119.95 Kit**



WE WILL NOT BE UNDERSOLD!

UPS Shipping: 48 States 5%  
(\$3 Min \$10 Max) Shipping  
IL Res., 7.5% Tax FAX: 708-520-0085

## C & S SALES INC.

1245 Rosewood, Deerfield, IL 60015  
(800) 292-7711 (708) 541-0710



15 Day Money Back Guarantee

2 Year Warranty Prices Subject to Change

WRITE FOR FREE CATALOG

straight or diagonal lines; the ability to save the drawing configuration file with all current program drawing configurations; improved mouse support; and internal high-resolution printer drivers for 9- and 24-pin dot matrix and HP LaserJet printers, and HP Pen Plotters. Parallel as well as serial interfaces are supported. The program requires an IBM PC, XT, AT, PS/2, or compatible computer running DOS 2.1 or higher; 384K RAM; and CGA, EGA, VGA, or Hercules graphics.

*AutoSkem CAD Version 1.4* costs \$49.—**BSOFT Software, Inc.**, 444 Colton Road, Columbus, OH 43207; Phone: 1-800-728-3805.

#### CARTOON-A-DAY PROGRAM.

A PC-calendar pro-

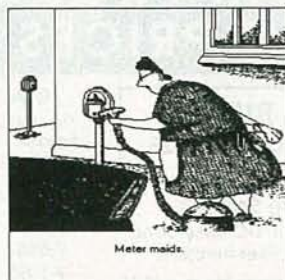

CIRCLE 19 ON FREE INFORMATION CARD

gram with a twist, the *Cartoon-A-Day Calendar Plus* from Individual Software offers DOS and Windows users a daily dose of whimsical humor in the form of the farcical drawing of nationally syndicated "Inside Out" cartoonist Kevin Pope. The daily cartoon can be added to personal calendars, printed correspondence, daily to-do lists, or schedules. The program displays (and

prints) personal schedule information by the day, week, month, or year, and even keeps track of vacation time, personal plans, travel time, and holidays. It can also be used to create or update to-do lists. Both versions feature digital and analog clocks; the Windows version also features time-saving "Quick Memo" and "Quick Fax" functions that generate a memo or fax cover sheet that incorporates the daily computer right from their computer. The DOS version runs on any IBM-compatible PC with DOS 3.3 or higher and 512K of memory. The Windows version requires Windows 3.0 software.

The *Cartoon-A-Day Calendar Plus* program (for DOS or Windows) costs \$29.95.—**Individual Soft-**

**ware**, 5870 Stoneric Drive, #1, Pleasanton, 94588; Phone: 1-800-822-3522.

**ROBOTIC PROBE.** Aimer the electronic service industry, where low-voltage boards, varying dev technologies, and a wide range of repair probe exist, the *Prober RP38* a computer-controlled electro-mechanical probe that automates the test process for component various sizes and packaging, including surfa



CIRCLE 20 ON FREE INFORMATION CARD

## Discover the Pattern for Success.

Work Smarter for Less with a B+K PRECISION Video Generator.



#### Portable IC Color Pattern Generator

- Battery operated, compact portable unit
  - 13 patterns including gated rainbow
  - CH 3/CH 4 output crystal controlled
  - Composite video output to 1 Vp-p
  - Progressive scan
- Model 1211C \$229

#### NTSC Signal Generator

- NTSC color bars, with or without IWQ
  - Linear staircase with high or low chroma
  - Multiburst
  - External video, external audio
  - Interlaced scan
- Model 1251 \$1,195

#### NTSC Generator with RGB

- NTSC color bar pattern
  - 1 Vp-p or variable composite video output
  - RGB outputs on BNC or 9-pin D-type subminiature connector
  - Composite sync, vertical sync, and horizontal sync outputs
  - Interlaced or progressive scan
- Model 1249A \$558

#### Deluxe NTSC Video Signal Generator

- High accuracy NTSC color bars
  - TCXO master oscillator
  - RGB, Gen Lock, Circle, and Black Burst
  - Multiburst to 8 MHz, 100%/50% level
  - Interlaced or progressive scan
- Model 1260 \$1,995

Start working smarter! For details on the complete line of B+K PRECISION video generators or for immediate delivery, contact your local distributor or:



Domestic and International Sales  
6470 W. Cortland St., Chicago, IL 60635  
312-889-1448 • FAX: 312-794-9740

## Shortwave Listening Guidebook

by Harry Helms

The world is talking on shortwave radio and here's the book that tells you how to listen in! In direct, nontechnical language Harry explains how to get the most from your shortwave radio. Its 320 heavily illustrated pages are filled with practical advice on:

- antennas
- when and where to tune
- selecting the right radio for you
- accessories
- reception techniques



Learn how to hear the BBC, Radio Moscow, ham radio operators, ships at sea, even Air Force One! Includes hundreds of frequencies for stations around the world and the time you can hear the

Only \$16.95 plus \$3.00 shipping (CA residents please include sales tax).

**HighTe**  
Publicatio  
7128 Mirama  
Suite 15L, San Diego, CA

For information only circle 77 on free information card.

For sales assistance circle 210 on free information card.

mount devices. According to Huntron Instruments, the robotic probe can set up and test any kind of component on a printed-circuit board faster than using a conventional "bed-of-nails" test system.

The *Prober RP388*, which requires the *5100DS* troubleshooting system for operation, consists of a precision electro-mechanical probe and a software-controlled video-imaging system. The probe can be driven to the test point with approximately  $\pm 4$ -mils accuracy, and the imaging system shows a detailed, real-time image of the board on the PC monitor. Establishing a test routine and troubleshooting is a three-step process using the combination of the *5100DS* and the *Prober RP388*: Teach the Prober

the test-point locations; learn and store signatures of good components; and find faulty components by automatically comparing their signatures to the signatures stored on the PC hard drive. On average, a PCB with 39 surface-mount devices (14 to 20 pins per component) can be tested in less than 10 minutes.

The *Prober RP388* costs \$23,000; the *5100DS* system required to operate it starts at \$10,000.—**Huntron Instruments Inc.**, 15720 Mill Creek Blvd., Mill Creek, WA 98012; Phone: 800-426-2965 or 206-743-3171; Fax: 206-743-1360.

**DIGITAL VOICE CHIP SET.** Electech Electronics' *VCS-1870* allows circuit designers to easily add dig-

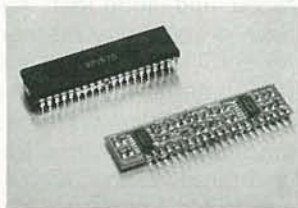

**CIRCLE 21 ON FREE INFORMATION CARD**

itized voice to their designs. The set consists of the 40-pin DIP *VP-1870* voice-processing chip and the 21-pin *SF-700* filter module board. The chip features CVSD encoding at variable sampling rates for natural-sounding voice digitization. Its 8-bit bi-directional interfaces is compatible with most microprocessors. Digitized voice data is stored in external RAM or ROM. The *SF-700* is an active band-pass (300-Hz to 3.4-kHz) filter module with pre-amp for

microphone or line input signals. Specially designed to work with the *VP-1870*, it provides good voice quality and high reliability with greatly reduced components count, board space, and power consumption. Operation requires a single 3- to 6-volt DC power supply.

The *VCS-1870* digital voice chip set costs \$16 in quantities of 1000.—**Electech Electronics**, 1262 East Katella Avenue, Anaheim, CA 92805; Phone: 714-385-1707; Fax: 714-385-1708.

**DIGITAL MULTIMETERS.** An enhanced line of low-cost, pocket-sized digital multimeters from Beckman Industrial include features ordinarily found only in more expensive units. For instance, *Models DM5XL*,

## Train at HOME to be an Electronics Technician!

As the demand for computers and microprocessors in business, manufacturing and communications continues to grow, so does the need for qualified technicians. It's not unusual for experienced technicians to earn from \$30,000 to more than \$40,000 a year.\* Now through Peoples College of Independent Studies you can train for this exciting field without interrupting your job or home life.

### Choose From Five Programs of Study

- Electronics & Microprocessor Technology
- Industrial Electronics & Microprocessor Technology
- Communications Electronics with Microprocessor Technology
- Computer Servicing & Electronics Technology
- Specialized Associate Degree In Electronics Technology

### Professional Equipment Is Included

Depending on the program you select, you'll perfect your skills using this advanced equipment, included in the price of tuition:

- IBM-Compatible Personal Computer
- Digital Multimeter
- Digital Logic Probe
- Elenco Oscilloscope
- Portable Cellular Telephone

(\* Source: U.S. Bureau of Labor Statistics)



### Exclusive Extras That Enhance Your Training

Peoples College introduces some training firsts to make your learning experience more complete:

- Accelerated Learning System — a scientifically proven study system that helps you learn faster and easier than ever before.
- Video Tutor Training Tapes — give you a permanent, visual record of informative lectures and close-up demonstrations.
- Experience Labs — professionally designed experiments that give you hands-on "bench" experience.
- Industry Certification Training Guide — provided with four of our programs. Prepares you for examinations you may take for your professional license or certification.

### Easy Payment Plans — No Finance Charges

To help you get started on your education, Peoples College has reduced tuition rates and offers low monthly payment plans with no finance fees. So don't delay, call or write for more information today!

### For COLOR CATALOG Mail Coupon or Call TOLL FREE 1-800-765-7247

Programs offered only in United States, Canada, Puerto Rico and Virgin Islands. No Obligation. No sales person will call.

Our programs are accredited by the Accrediting Commission of the National Home Study Council

YES! I would like to know more about your training programs. Send a catalog to:

Name \_\_\_\_\_  
 Address \_\_\_\_\_  
 City \_\_\_\_\_  
 State \_\_\_\_\_ Zip \_\_\_\_\_

Phone # \_\_\_\_\_  
**PEOPLES COLLEGE**  
 OF INDEPENDENT STUDIES  
 233 Academy Drive • P.O. Box 421768  
 Kissimmee, FL 34742-1768  
 Member, D.L. Peoples Group R0292



CIRCLE 22 ON FREE INFORMATION CARD

DM10XL and DM15XL each offer 10-amp current fusing to protect both the user and the meter, safety test leads with shrouded input plugs and text points, a warning beeper when the test leads are placed in the wrong input jacks, large LCD numerals, and increased battery life. All three meters measure DC voltage to 1000 volts, AC voltage (to 500 volts for the DM5XL and to 750 volts for the other two), resis-

tance, and diode test, and have a continuity beeper. Model DM10XL adds a feature called the "Safety Tester," which detects and displays commonly encountered AC and DC voltage levels from 6 to 220 volts. This feature works even when the DMM battery is dead, ensuring that the user can always safely detect the presence of live voltage levels. Model DM15XL also adds a logic-measurement function that indicates the presence and polarity of TTL pulses up to 20 MHz.

Models DM5XL, DM10XL, and DM15XL digital multimeters cost \$34.95, \$44.95, and \$59.95, respectively.—Beckman Industrial Corporation, 3883 Ruffin Road, San Diego, CA 92123-1898; Phone: 619-495-3218.

**SEMIANALYZER SIGNAL TRACER.** The EDS-59C Semianalyzer II from Electronic Design Specialists allows the technician to trace audio, video, digital, or FG signals to the problem area, while simultaneously monitoring DC voltages along the way on its 3½-digit voltmeter. Once the technician is in the suspected area, the instrument will check semiconductor devices in circuit and display the type, polarity, and condition of the device in plain English. Different tones beep to

indicate various problems. The Semianalyzer II also checks Zener diodes for their proper voltages, as well as neons, LED's, and capacitors for leakage, noise, and voltage breakdown up to 175 volts using a built-in "Hi-Pot" tester. For repairing remote controls, an optional infrared detector probe is available. The Semianalyzer II comes with a three-year limited warranty and a 60-day money-back trial period. It is also available in kit form, with the 60-day trial period.

The Semianalyzer II costs \$399 fully assembled, and \$299 in kit form, with cabinet.—Electronic Design Specialists Inc., 275 Rock Island Road, North Lauderdale, FL 33068; Phone or Fax: 305-720-4497.



CIRCLE 23 ON FREE INFORMATION CARD

# ProGold™<sub>100</sub>

GOLD CONDITIONER & PRESERVATIVE

## Solid Gold Protection for Audio, Video & Computer Equipment

- Protects Gold Surfaces & Base Metals!
- Improves Conductivity!
- Reduces Intermittent Connection Failures!
- Forms Protective Coating!
- Reduces Wear & Abrasion!
- Reduces Arcing & RFI!



Precision Metered Spray



16744 West Bernardo Dr.  
Rancho Bernardo, CA  
92127-1904  
(619) 451-1799  
FAX: (619) 451-2799

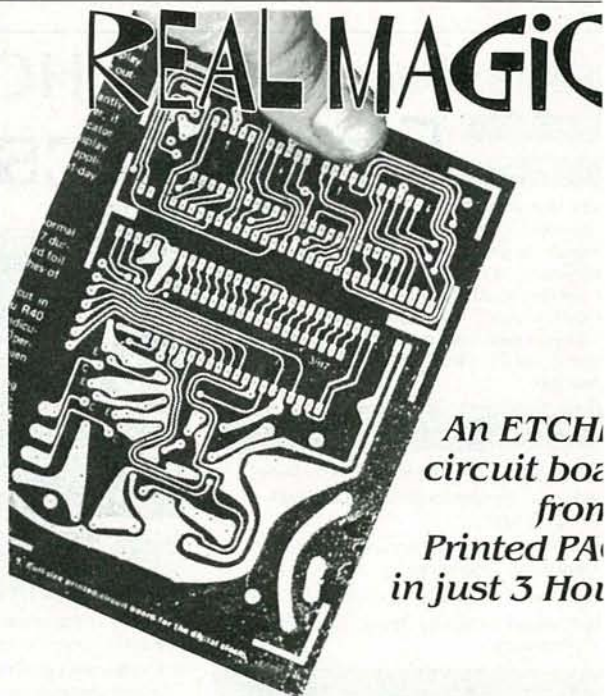

The ER-4 PHOTO ETCH™ KIT gives you the tools, materials and chemicals to make your own circuit boards from the artwork printed in this magazine. You can also do original 1X art using the enclosed patterns and drafting film. Or try the DIRECT ETCH™ system (also included) to make single circuit boards without artwork.

You'll need a reflector photoflood and a UV light source (or sunlight) to search? Get an ER-19 bulb set with your ER-4. Bulbs use an ordinary socket. The ER-4 and ER-19 are stocked by electronic parts distributors. Add \$4.50 for shipping. NV and CA residents must add sales tax. ER-4 PHOTO ETCH SET ..... ER-19 LIGHT BULB SET .....

DATAK Corporation • 55 Freeport Blvd. • Sparks, NV 89434

CIRCLE 187 ON FREE INFORMATION CARD

CIRCLE 50 ON FREE INFORMATION CARD



# NEW LIT

Use The Free Information Card for fast response.

**YOUR NATURAL RESOURCE: 1992 ANNUAL CATALOG; from Jameco Electronic Components and Computer Products, 1355 Shoreway Road, Belmont, CA 94002; Phone: 800-831-4242; Fax: 800-237-6948; free.**

This year's catalog from Jameco, printed on recycled paper, carries the theme "Your Natural Resource." Intended as a complete source book for electronics hobbyists and computer enthusiasts, the 90-page, full-color catalog includes descriptions of more than 3000 products,

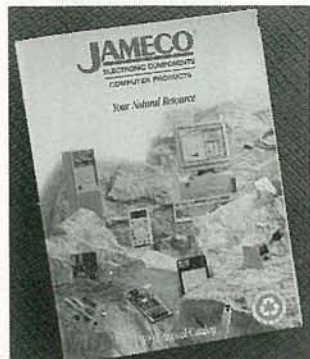

**CIRCLE 40 ON FREE INFORMATION CARD**

from electronic components to test and measurement equipment, from cables to complete computer systems. Other features of the catalog include educational information and a RAM cross-reference guide. To further assist customers in making purchasing decisions, Jameco offers 24-hour toll-free order placement and toll-free fax and BBS service.

**TECHNI-TOOL CATALOG 41; from Techni-Tool Inc., 5 Apollo Road, P.O. Box 368,**

**Plymouth Meeting, PA 19462; Phone: 215-941-2400; Fax: 215-828-5623; free.**

The 240 pages of this catalog are filled with an assortment of tools, tool kits, and test equipment that includes more than 18,000 items from 850 manufacturers. Electronics professionals and hobbyists will find items ranging from electro-mechanical and assembly devices to electronic, telecommunication, and field-service tool kits. Also featured are full lines of tools, equipment, and accessories for computer maintenance and for the fast-growing field of surface-mount technology. Static control and clean-room items are included. Several new items are highlighted, including 100-MHz monolithic oscilloscope



**CIRCLE 39 ON FREE INFORMATION CARD**

probes, the ESD heat gun, the Fluke 88 Automotive Meter, and the kit bag with conductive plastic cabinets for easy carrying of small electronic parts.

**TEST INSTRUMENTS ANALOG & DIGITAL; from Simpson Electric Company, 853 Dundee Avenue, Elgin, IL 60120-3090; Phone: 708-697-2260; Fax:**

**708-697-2272; free.**

This 44-page, four-color catalog features Simpson's lines of hand-held and benchtop multimeters,

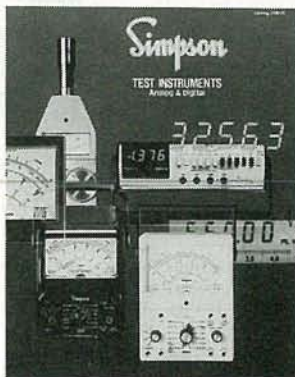

**CIRCLE 38 ON FREE INFORMATION CARD**

special function meters, clamp-on testers, and other specialized testers for electrical, electronic, and environmental applications. In addition to that equipment, the catalog covers special-function ohmmeters, voltmeters, and ammeters; insulation and temperature testers; testers for microwave and AC current leakage; and sound- and noise-measurement instruments and telephone-industry test sets. Capsule descriptions of each item, along with lists of features, ordering information

*continued on page 87*

## GET YOUR AMATEUR HAM RADIO LICENSE!

**The New Code-Free Technician License Is Here!**

**When you pass a 55 question multiple-choice test you can:**

- ★ Transmit over hundreds of miles with handheld two-way radios. Why pay cellular charges for your personal or emergency communications.
- ★ Enjoy all Amateur privileges above 30 MHz all the way up to the uncharted frontiers of microwave and amateur television!
- ★ Access satellite communication—talk to astronauts in orbit... make friends through a fleet of amateur satellites.
- ★ Talk to friends nearby and in faraway places using FM voice repeaters.
- ★ Use your personal computer and radio modem to talk to other hams or exchange computer data and much more!

Send for FREE details on how you can pass the Amateur Radio exam... fast!

**Write for FREE information today.**

### Amateur Radio License Training

PO Box 26348  
San Francisco  
CA 94126

NAME \_\_\_\_\_  
ADDRESS \_\_\_\_\_  
CITY \_\_\_\_\_  
STATE \_\_\_\_\_ ZIP \_\_\_\_\_

# Take any 3 PROFESSIONAL BOOKS for \$9<sup>95</sup>

when you join the **ELECTRONICS ENGINEERS' BOOK CLUB**

Values to \$116.40



**3258**      **\$28.95**  
This book offers up-to-date instructions for troubleshooting and repairing all major brands of equipment, with hundreds of diagrams, specs, and schematics. Covers TVs, VCRs, CD players, and much more. 310 pp.



**3313**      **\$22.95**  
With this guide in hand, readers can produce crisp, concise papers that will leave their intended mark on committees, panels, boards of directors, and customers. Instructions on reports, proposals, books, and oral presentations. 144 pp., 37 illus.



**9255**      **\$97.50**  
"Outstanding, extensive reference to current technology of electronics. Covers everything from principles to applications."  
—Computer Book Review  
2,528 pp., 1,800 illus.  
Counts as 3



**10016**      **\$39.95**  
Design tighter, more complex circuits, on time and on budget with this book, one of the first to provide a thorough coverage of all aspects of PCB design, including CAD.  
320 pp. Counts as 2



**585885-1**      **\$29.95**  
Shows how to reposition yourself as a key player in today's competitive job market. Communications and interpersonal skills, technology evaluation, career positioning interviewing strategies are just few of the areas reviewed. 350 pp., Illus.

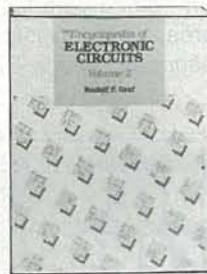

**3138**      **\$60.00**  
A GIANT "Circuit Book" of over 700 of the most widely-used, state-of-the-art electronic and integrated circuits ever compiled in a single source! The perfect sourcebook for all levels of electronics practitioners. 738 pp. Counts as 2



**3147**      **\$38.95**  
Provides a ready source of basic information on using programmable controllers to achieve a wide variety of manufacturing goals. You'll find flowcharts and step-by-step explanations to develop, improve, and monitor process control. 304 pp., 187 illus. Counts as 2



**3557**      **\$29.95**  
A detailed study of signal analysis as it applies to the operation and signal-generating capabilities of today's devices. Explains the composition and use of test instruments, transmission media, satellite systems, broadcast and reception facilities, and more. 272 pp.



**3837**      **\$27.95**  
Focuses on the specific digital circuits used in electronic power applications. Presents state-of-the-art approaches to analysis, troubleshooting, and implementation of new solid-state devices. An excellent sourcebook and a valuable edition to an engineer's library. 272 pp.



**2672**      **\$49.95**  
This one-stop sourcebook bridges the gap between data books and the designer's search for the right component. Covers how linear ICs are fabricated, how they work, what types are available, and techniques for designing. 624 pp.



**020975-8**      **\$99.50**  
The essential reference for all electrical engineers. Completely revised and updated, this classic handbook covers the generation, transmission, distribution, control, conservation, and application of electrical power. 2,416 pp., 1,388 illus., 430 tables. Counts as 3



**3540**      **\$26.95**  
This guide brings you up-to-date on today's most advanced power supply circuits, components, and measurement procedures. Covers switching rates up to 3-MHz and higher as well as the 20-kHz standard. 176 pp.

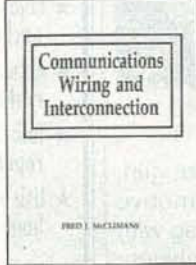

**044847-7**      **\$39.95**  
Learn about the function and design of wiring systems in a clear, structured fashion as you understand wiring components, vendor wiring diagrams, design principles, cable management, systems integration, and standards. 250 pp., 40 illus. Counts as 2

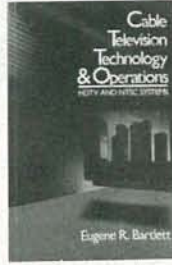

**003957-7**      **\$49.95**  
Written for technical personnel, engineers, managers, and operators, this is a practical guide to design, implementation, and maintenance of cable TV systems, includes an overall introduction to standard NTSC and HDTV systems. 400 pp. Counts as 2



**3589**      **\$27.95**  
A practical toolbox reference for anyone in the electronics field. Phagan guides you through practical calculations needed design and troubleshoot circuits and components. 352 pp., 270 illus.



**053570-1 \$64.95**  
This is a "one-stop" guide to the theory and design of communications receivers: short-wave, broadcast, military, broadcast (AM-FM), radar, aeronautical, marine, and direction finding. 608 pp., 402 illus. *Counts as 2*



**584556-3 \$12.95**  
The best resumes have a tone and vocabulary all their own. Adele Lewis shares her vast experience to help you succeed from cover letter to interview. Provides over 75 sample resumes from all branches of engineering. 346 pp.



**2962P \$17.95**  
This complete EPROM instruction manual provides a detailed explanation of underlying theory, plus 15 different projects, including programmers, erasers, and EPROM-based circuits. 240 pp.



**3787 \$29.95**  
The most current information available on the properties of conductors and insulation, system design and assembly techniques, and guidelines on using the latest equipment. 256 pp.



**050806-2 \$49.95**  
This book emphasizes circuit, transformer, and magnetics design. Provides worked-out examples of transformers, currents, power levels, and more. 550 pp., 250 illus. *Counts as 2*



**3279 \$36.95**  
Perform routine maintenance, and diagnose and repair any kind of computerized device. This popular reference covers large dynamic RAMs, 32-Bit processors, 80286, 80386, and Z8001-Z8002 processors. 570 pp.



**9151 \$69.95**  
One of the most authoritative sources, this edition gives you information on the radio, electronics, computer, and communications fields. Indexed for quick answers, it provides tables, unit conversions, voltages, formulas, and more. 1,363 pp., Illus. *Counts as 3*



**043295-3 \$29.95**  
From the simplest elements of electricity and magnetism to the more advanced topics of polyphase circuits and power electronics, this well-structured book can be used to review the basic principles of electrical engineering and go well beyond. 350 pp., 100 illus.

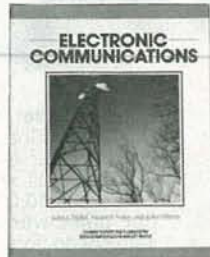

**3365P \$24.95**  
Both a professional reference and a study guide for the aspiring technician, this is a well-illustrated introduction to modern communications. Use it to prepare for your FCC General Radiotelephone Operator License or CET exam. 704 pp.



**033559-1 \$29.95**  
Gives technicians, engineers, scientists, and students the precise data they need to solve day-to-day problems. This guide provides instant access to specifics on components, circuits, power supplies, op amps, and much more. 608 pp. *Counts as 2*

## How the Club Works:

The Electronics Engineers and Designers Book Club and the Electronics and Control Engineers' Book Club have joined forces to bring you *all* the best titles from the most prominent electronics publishers.

**YOUR BENEFITS:** You get 3 books for \$9.95 plus shipping and handling when you join. You keep on saving with discounts of up to 50% off as a member.

**YOUR PROFESSIONAL BOOKSTORE BY MAIL:** Every 3-4 weeks, you will receive the ELECTRONICS ENGINEERS' BOOK CLUB News describing the Main Selection and Alternates, as well as bonus offers and special sales, with scores of titles to choose from.

**CLUB CONVENIENCE & EASY RISK-FREE TERMS:** If you want the Main Selection, do nothing and it will be sent to you automatically. If you prefer another selection, or no selection at all, simply indicate your choice on the reply form provided. You will have at least 10 days to decide. As a member, you agree to purchase at least 3 books within the next 2 years and may resign at any time thereafter. If not satisfied with your books, return them within 10 days without obligation.

**BONUS BOOKS:** Starting immediately, you will be eligible for our *Bonus Book Plan*, with savings of up to 80% off publishers' prices.

**EXCEPTIONAL QUALITY:** All books are quality publishers' editions from ALL the publishers in the field especially selected by our Editorial Board to ensure the information is reliable and specific enough to meet your needs.

All books are hardcover unless number is followed by a "P" for paperback. (Publishers' Prices Shown) ©1992 EEBC, Blue Ridge Summit, PA 17294-0860

Your source for quality, affordable and timely authoritative engineering books.

## ELECTRONICS ENGINEERS' BOOK CLUB

Blue Ridge Summit, PA 17294-0860

**YES** Please accept my membership in the ELECTRONICS ENGINEERS' BOOK CLUB and send my 3 volumes listed below billing me \$9.95. If not satisfied, I may return the books within 10 days and have my membership cancelled. I agree to purchase 3 or more books at regular Club Prices during the next 2 years, and may resign any time thereafter. A shipping/handling charge and sales tax will be added to all orders.

--	--	--

Name \_\_\_\_\_

Address \_\_\_\_\_

City \_\_\_\_\_

State \_\_\_\_\_ Zip \_\_\_\_\_ Phone \_\_\_\_\_

Valid for new members only. Foreign applicants will receive special ordering instructions. Canada must remit in U.S. currency. This order subject to acceptance by the EEBC. DRE292

## THE PARTS PLACE



**NEW! Now You're Talking!** This book will help you earn your first Amateur Radio license and get on the air. It includes all the questions on the new codeless Technician class exam and the Novice written exam. The book also provides helpful tips on equipment and antennas. Illustrated. Over 300 pages. #62-2414 . . . 16.95

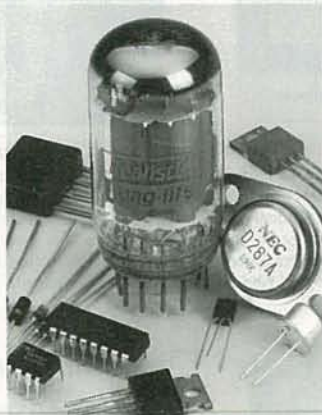

**Special-Order Hotline.** Your local Radio Shack stocks over 1000 popular electronic components. Plus, we can special-order over 10,000 items from our main warehouse—ICs, semiconductors, tubes, crystals, even SAMS® manuals. No postage charges or minimum requirements for this service. Come in for details!

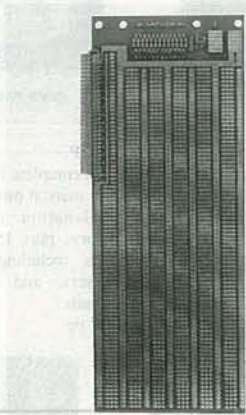

**NEW! PC/XT Experimenter's Circuit Card.** This premium-quality prototyping board fits a computer's XT expansion bus connector. Features durable epoxy glass construction and plated-through holes on standard 0.100" centers. Accepts D-sub connector shown at right. 37/8 x 10 1/16 x 1/16". #276-1598 . . . . . 29.95

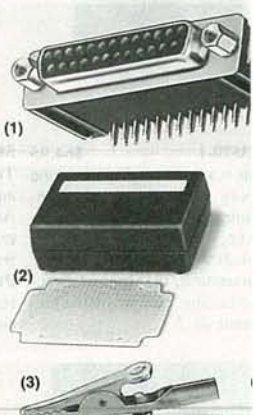

- (1) **NEW! Right-Angle Sub 25 Female Connector.** Ideal for use with PC/XT circuit card at left. #276-1504.
- (2) **Box/Board Combination.** Molded box and 2 x 3 1/8" circuit board. #270-291 . . . . .
- (3) **2" Slim Alligator Clip.** #270-346 . . . Pkg. of 8/
- (4) **Cordless Phone Handset Antenna.** #270-1411 . . . . .

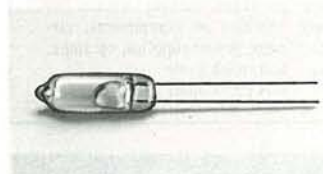

**Mercury Bulb Switch.** Just the thing for motion detectors, alarms, experiments and school science projects. Rated 2 amps at 12VDC. Compact T-1 1/2 size envelope. #275-040 . . . . . 1.29

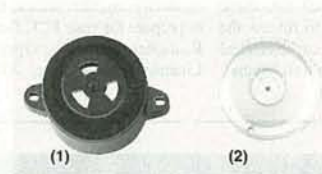

- (1) **Two-Tone Piezo Buzzer.** Extra-loud. Operates from 8 to 16VDC. #273-070 . . . . . 10.95
- (2) **Electromechanical Buzzer.** Loud 12VDC buzzer in a sturdy metal case is great for alarms. #273-051 . . . . . 2.49

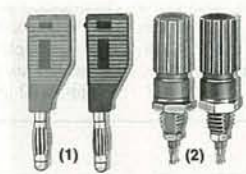

- (1) **Stackable Banana Plugs.** Jack permits "chain" hook-ups. #274-734, Set of 2/1.59
- (2) **Nylon Binding Posts.** #274-662 . . . . . Set of 2/1.59
- (3) **Micro-Clip Jumpers.** 20" long. #278-017 . . . Pair/3.49

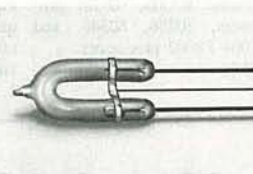

**Super-Bright Strobe Tube.** Perfect for photo replacement hobby projects and experiments. Trigger: 4 kV. And 200V min. Bulb is about 1" long and has 1 3/4" leads. #272-1145 . . . . . 3.95



- (1) **High-Speed 12VDC Motor.** Up to 15,200 RPM! About 2" long. #273-255 . . . . . 2.99
- (2) **Low-Voltage Motor.** For science projects and solar power demos. Requires 1 1/2 to 3VDC. #273-223 . . . . . 99¢



- (1) **Lead-Free Solder.** 96% tin, 4% silver. 0.032" size. 0.25 oz. #64-025 . . . . . 1.99
  - (2) **Rosin Soldering Paste Flux.** 1 oz. #64-021 . . . . . 1.79
- Over 100 soldering items and tools for electronics are in stock now at Radio Shack!

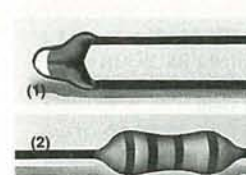

- (1) **Hi-Precision Thermistor.** Resistance changes in proportion to temperature. #271-110 . . . . . 1.99
- (2) **500-Piece Resistor Set.** 1/4-watt, 5% tolerance. Includes 54 popular values. #271-312 . . . . . Set 7.95



**Car Electrical System Test Kit.** Spot problems before you're stranded! Plug this analyzer into your vehicle's light socket. Color-coded LEDs point out problems in your battery, alternator and regulator. #22-1635 . . . . . 5.95

Since 1921 Radio Shack has been the place to obtain up-to-date electronic parts as well as quality tools, test equipment and accessories at low prices. Our nearly 7000 locations are ready to serve you—NOBODY COMPARES

Prices apply at participating Radio Shack stores and dealers. Radio Shack is a division of Tandy Corporation

**Radio Shack** SINCE 1921  
AMERICA'S TECHNOLOGY STORE

THE TECHNOLOGY TO PRODUCE low-cost digital clocks has existed for years. Unfortunately, the style in which these clocks have displayed the time has been mostly limited to four digits (representing hours and minutes). Few digital clocks, if any, have taken full advantage of the great capabilities of today's microprocessors to provide a more novel display . . . that is until the HyperClock.

The HyperClock has a custom-programmed microcontroller that generates all the signals necessary to display time in eight eye-catching (yet easily readable) modes. Among its features are the ability to simulate a sweep second hand with a ring of 60 LED's; it can graphically display the level of ocean tides; it has a "fading" display mode that causes the LED's to gradually change when updated; it has a hourly chime/ alarm output; supports 50- or 60-Hz powerline operation; it has a battery backup; and an intelligent date display that knows the last day of each month. Let's take a look at those features in greater depth.

#### The digital display

In four of the HyperClock's eight modes it can display time with a clever twist that those of you that grew up before the "digital-clock revolution" will appreciate. You may recall that it was fairly common for folks to speak of how many minutes it was till the next hour. For example, people would say "it's ten before five" rather than "it's four-fifty." Well, the HyperClock can actually "display" the time in that manner.

To help explain how that is done, take a look at Fig. 1-a; it shows the six seven-segment LED displays that are used to form the clock's digital display. During the first 30 minutes of each hour, the two middle digits signify the hour and the right-most digits indicate minutes past the hour (like most digital clocks), and the two digits on the left are blank. Figure 1-b shows how eleven fourteen (or literally "fourteen after eleven") would look in this mode.

## BUILD THE



## HYPHER CLOCK

**Build a digital clock  
that's way ahead of its time!**

LEON W. SCHMIDT

However, once the clock advances to beyond half-past the hour, the right digits go blank, the middle display would increment to display the next hour, and the left two digits would indicate how many minutes are left until that hour. For example, if it was thirteen minutes to twelve (or 11:47), the display would look like Fig. 1-c. You could read that literally as "thirteen before twelve."

On the hour, the clock just

displays the hour, so the left and right minute displays remain blank (see the display for 12 o'clock shown in Fig. 1-d).

As mentioned earlier, there are 60 LED's arranged in a circle to display seconds or an approximation of the current tide level in your locale. The LED's act as a light chaser sweeping through the seconds of a minute. They can also show the relative tide level by moving from the 12 o'clock position at high tide to

the 6 o'clock position at low tide. The timing of the tide-indicator mode is set to display two complete tide cycles in 24.51 hours just as it should. (For more on this subject see the sidebar entitled "A Bit About Tides.")

### Fading-out the digits

The HyperClock also differs from other clocks in how it updates its display. In typical clocks, the display digits abruptly change as time passes. However, in four of HyperClock's eight modes when a digit must be updated, the LED segments representing its old value are dimmed as the segments for the new value become brighter. Likewise, each LED in the light chaser fades off rather than turns off. This animation is rather relaxing to watch.

These display effects are accomplished by a mixture of multiplexing and duty-cycle modulation. The seven-segment displays are all common-anode types, so each digit has its own anode-driver transistor. In typical multiplexed-display fashion, the cathodes of corresponding segments of each digit are connected together and share a common driver.

Like any other multiplexed display when the segment data for a digit is placed on the segment data lines, the anode driver for that digit is activated, and the seven-segment display lights to exhibit the appropriate digit. All the other digits are off at this time. After a short period of time (1.83 ms) the segments are turned off via the segment lines and the anode driver is deactivated. The anode driver for the next digit is then activated, the segment data for that digit is placed on the segment lines, and the process continues until all the digits have been lit. Since the human eye is too slow to see the digits turn on and off, it appears as though they are all on simultaneously. Multiplexing the digits in this fashion reduces the number of pins on the microcontroller needed to control the LED displays.

HyperClock's fading effect is created by modulating the duty

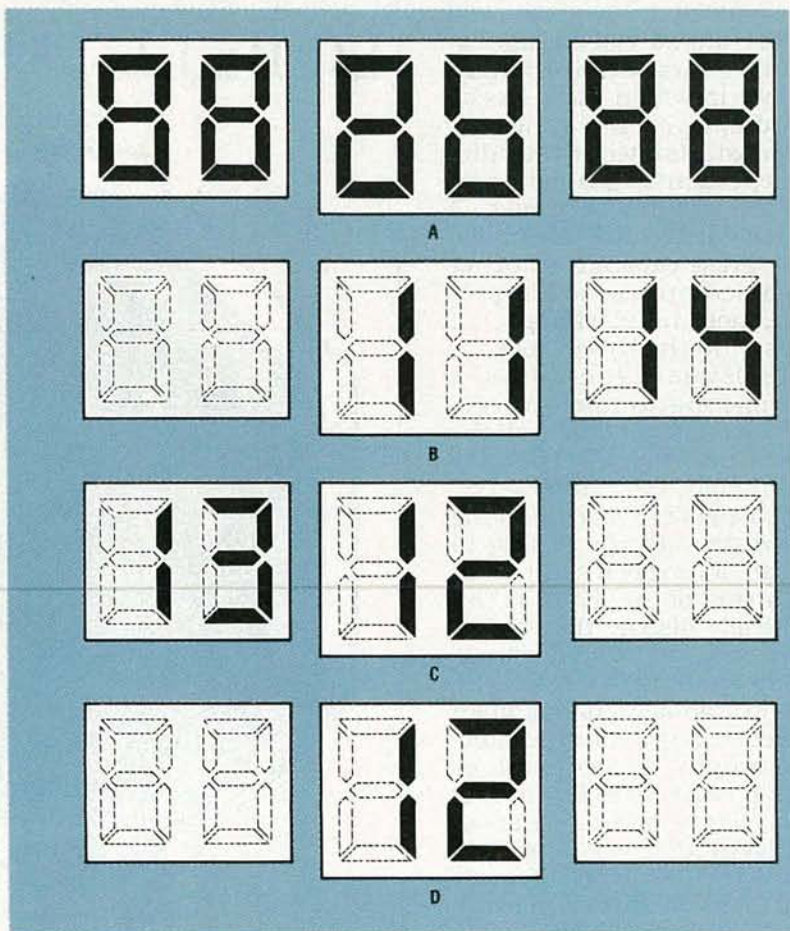

FIG. 1—HYPERCLOCK'S TIME DISPLAY (a) is unique in that it not only displays normally (b), but it can indicate minutes left to the next hour (c), and blanks the m displays on the hour (d).

cycle of the segment enable signals. When a seven-segment display is enabled, the segment data lines spend part of the time in states corresponding to the current digit to be displayed, and the rest of the time in states corresponding to the next or "future" digit that will be displayed. Each time the digit is enabled, the duty cycle will favor the future-digit data more and more, until only the new digit is displayed, and the process repeats each time the display must be updated.

### The microcontroller

At the heart of the HyperClock is an Intel 8749 microcontroller. It is programmed to perform a variety of functions, namely: display multiplexing, time-keeping, receiving switch input, coordinating the hour and alarm chime, and initiating a power-fail mode that permits the time-keeping functions to

continue while blanking display to conserve backup-tory power.

The 8749 has 2K of EPROM, 128 bytes of RAM, 24 I/O pins, a programmable 8-bit timer, an interrupt-control structure. The custom-program places the processor to create HyperClock's special effects exclusively exercises all of the clock's features; Fig. 2 contains a simplified flow chart for the HyperClock program. The program is shown divided into two sections: an interrupt routine and a main loop.

The interrupt routine is mainly responsible for taking the segment data from the microcontroller and placing it on the display-control lines in a multiplexed fashion. The interrupt routine that initiates the routine comes from the 8749's internal timer which has been programmed to execute the interrupt every

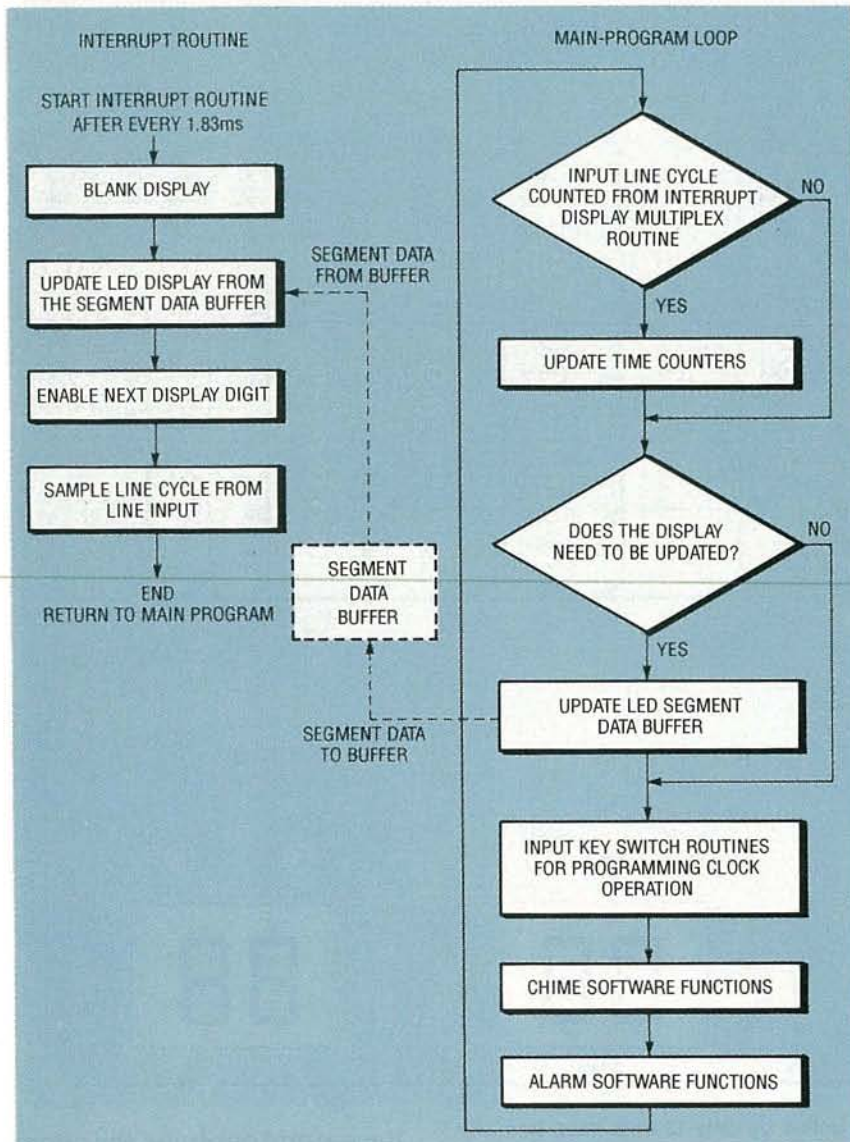

FIG. 2—HYPERCLOCK'S SOFTWARE can be broken down into two distinct code segments: a clock-scheduled interrupt routine, and a main-program loop.

ms. Using an interrupt-program segment in this way allows the display's fading effect to appear gradual because the process of updating the display occurs at regular intervals. This routine is also responsible for checking a powerline-frequency input on the microcontroller to determine if a powerline cycle has passed. If so, it informs the main loop of the program.

The main loop keeps track of the number of cycles that pass so it knows when to update the segment-data buffer or initiate the alarm or chime. If no powerline cycles are detected, the main loop assumes AC power has been terminated and puts the clock in power-fail

mode. In that mode it shuts off the display and allows the microcontroller to "invisibly" keep track of time via a 6-MHz crystal. The main loop also processes input from the clock's switches (we'll talk more about that later).

For all that goes on inside the microcontroller, the functions assigned to its pins by the HyperClock program (see Fig. 3) are relatively easy to understand. Let's take them one group at a time.

The pins labeled A through G and DP (pins 12–19) in Fig. 3 are the outputs for the display-segment data. They indirectly control the cathode drivers for the multiplexed display. Similarly,

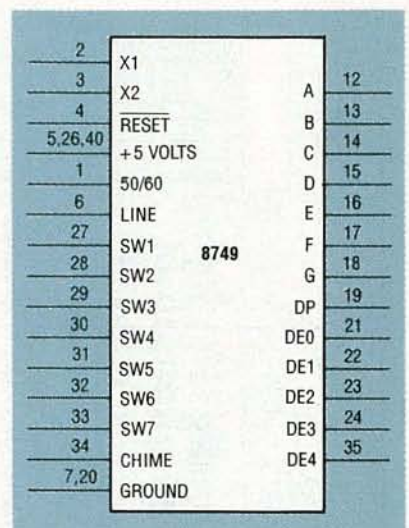

FIG. 3—THE PINS ON THE 8749 microcontroller are assigned various functions by the HyperClock program.

the outputs labeled DE0–DE4 (pins 21–24 and 35) control the anode drivers for the display via demultiplexer chips, which we'll discuss later.

The pins labeled S1–S7 (pins 27–34) are used as function-switch inputs. The switches connected to those inputs (DISPLAY MODE, DISPLAY DATE, DISPLAY ALARM, INCREMENT HOUR/MONTH/MODE, INCREMENT MINUTE/DAY, SNOOZE/TIDE ADVANCE, and ALARM TOGGLE, respectively) activate various chip functions by grounding those pins. A complete explanation of the switches' functions will be presented later.

Low-going pulses from the pin labeled CHIME (pin 34) activate the chime circuit, which is composed of discrete components. The microcontroller triggers the chime circuit with a 12.8-ms wide low-going pulse at one-second intervals. When not in alarm mode, the chime signals the hour by chiming an appropriate number of times, and signals each half-hour by chiming once.

When the microcontroller is in the "alarm" mode, the chime circuitry is used as an alarm annunciator. In this mode the clock does not chime on the hour and half hour. That permits you to use the HyperClock as an alarm clock without the chimes disturbing you until the appointed time.

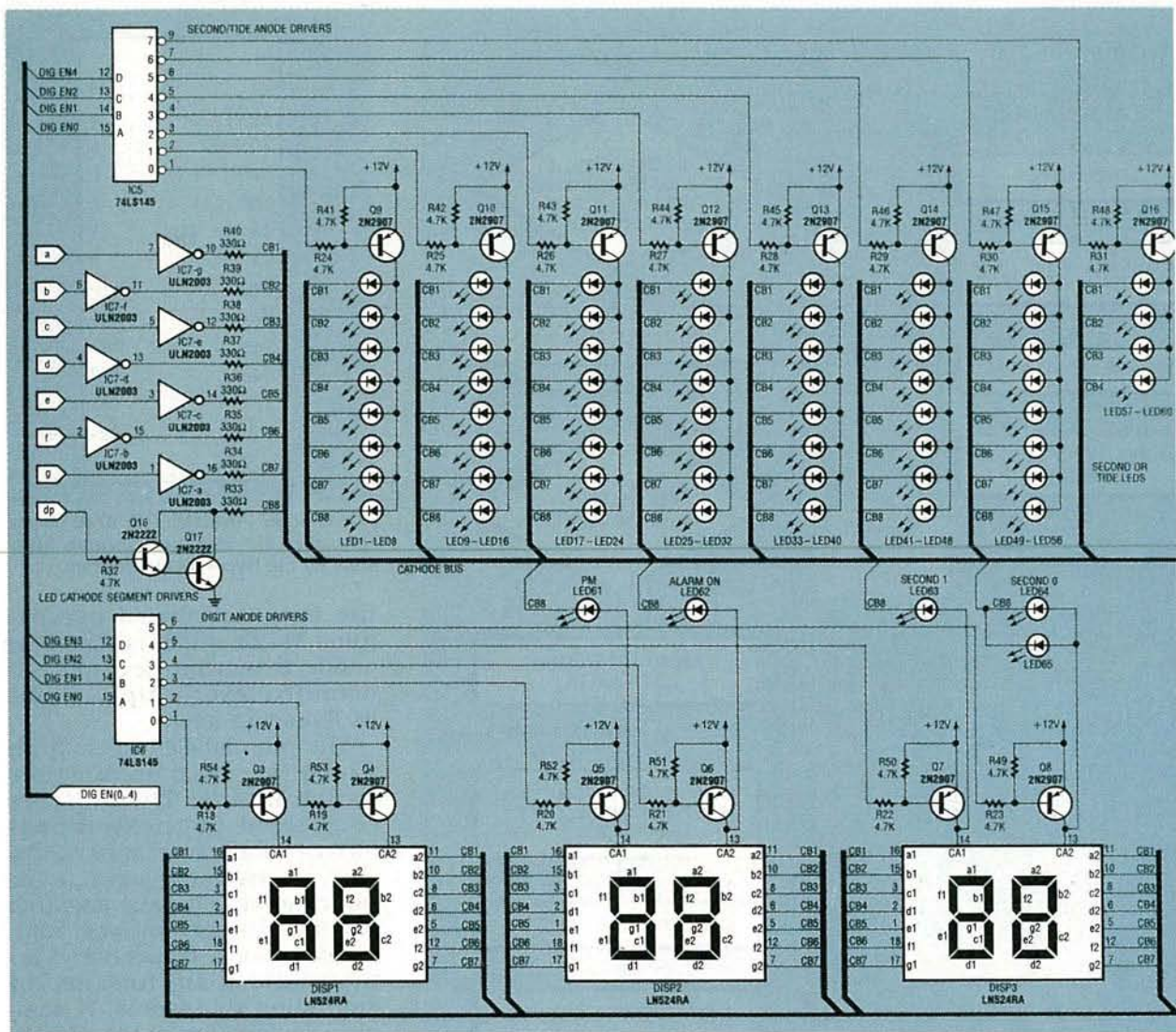

FIG. 4—THE HYPERCLOCK DISPLAY is controlled by only 13 data lines from the microcontroller.

The LINE input (pin 6) is used by the IC to accept a 50- or 60-Hz square wave. The square wave is used for time keeping and to detect AC-power failure as mentioned earlier. The 50Hz/60Hz input (pin 1), tells the 8749 what frequency to expect at the line input. If pin 6 is low, the 8749 assumes the line signal is at 60 Hz, but if that pin is high the 8749 prepares for 50-Hz operation.

As its name implies, the RESET input (pin 4) initializes the microcontroller. A low at that input will erase all modes and settings previously entered.

The x1 and x2 inputs (pins 2 and 3) need to be connected to the 6-MHz crystal, XTAL1, mentioned previously. Last, but cer-

tainly not least, are the 5-volt power inputs (pins 5, 26, and 40) and the grounds (pins 7 and 20). Those inputs of course, are self explanatory.

### The display circuit

While the microcontroller does a great deal, the HyperClock requires some additional circuitry to make it a complete timepiece. For example, the microcontroller cannot provide nearly enough current to drive the LED display. For that reason additional anode and cathode drivers were included in the design. They are shown along with the other display components in Fig. 4.

The control signals for the LED cathodes originate from

the A-G and DP pins of the microcontroller. The A-G signals sent to a ULN2003 buffer/driver (IC7) which contains seven high-current drivers. Each output is capable of providing 100 mA of peak drive current. Since the ULN2003 contains only seven of the eight cathode drivers required, a Darlington driver was made out of two 2N2907 transistors to drive the DP line.

The DE0 through DE4 outputs generated by the microcontroller are decoded by the 74LS145 decoder/driver 1 (IC5 and IC6). Only one decoder output is driven low at any time. Each 74LS145 output supplies current to a 2N2907 driver transistor that sources current to the anodes of a group of LEDs or a display digit.

Note that there are additional LEDs to provide an AM/PM



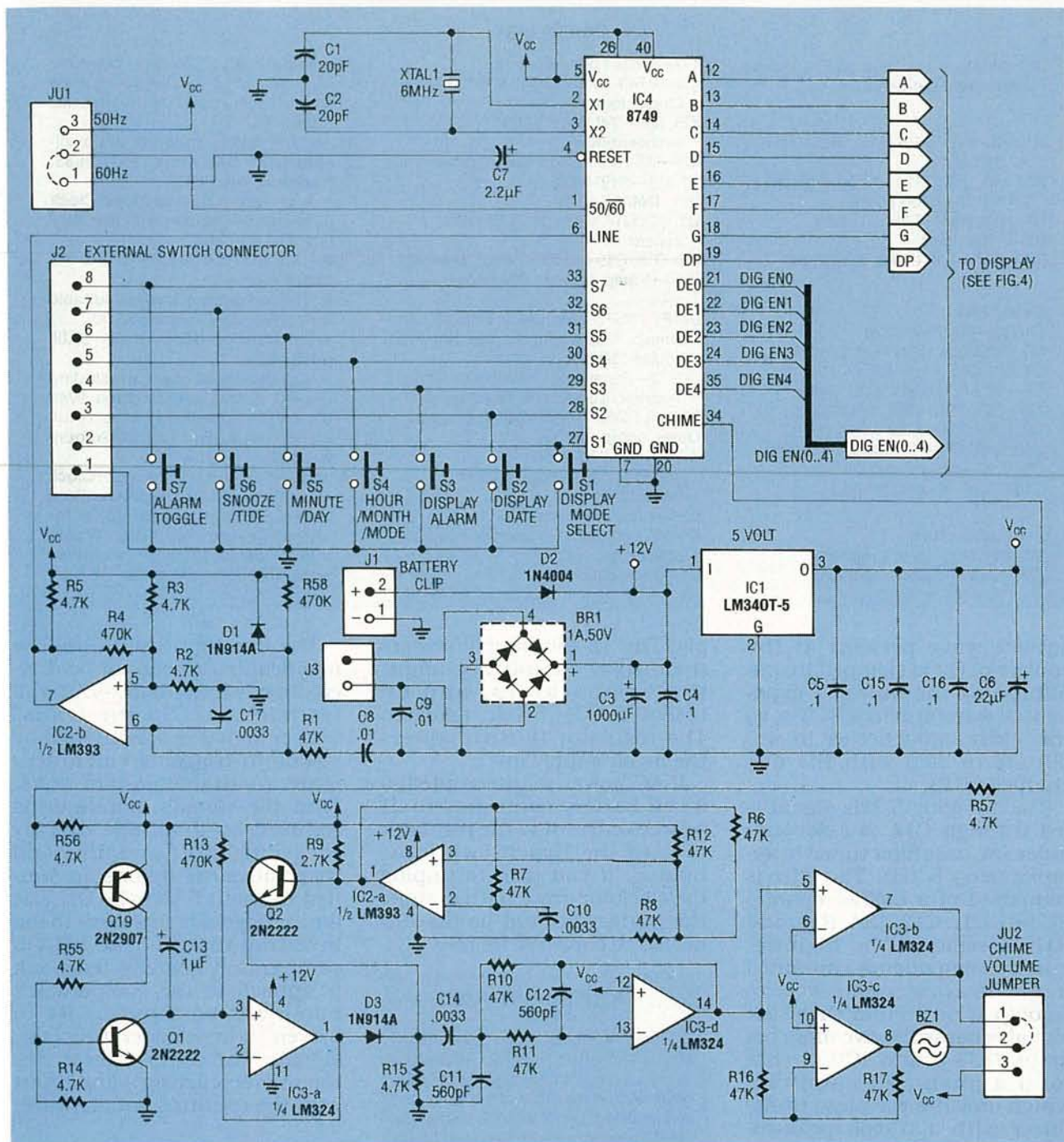

FIG. 5—THIS SCHEMATIC DIAGRAM FOR THE HYPERCLOCK circuit (less the display components) shows the support circuitry required by the microcontroller.

dication (LED61), tell you if the alarm-mode is active (LED62), and provide a winking second display (LED63 to LED65). That's all there is to the display circuit.

#### The remainder

The most noteworthy of the clock's remaining circuitry (shown in Fig. 5) is the chime circuit. When the micro-

controller generates a low-going pulse on pin 34, it activates Q19. That transistor then provides sufficient current to drive Q1 into saturation.

With Q1 on, the negative side of C13 is effectively grounded, which causes it to charge. When Q1 is turned off, C13 discharges through a 470K resistor (R13). The resistor/capacitor combination has a time constant of

0.47 seconds. The exponentially decaying signal produced by the discharge is buffered through a unity-gain amplifier (IC3-a) to a 1N914 diode (D3).

The cathode of D3 is connected to the output of a 50% duty cycle 5-kHz square-wave oscillator consisting of IC2-a, R7, C10, and Q2. Transistor Q2 serves to provide a dynamic pull-up for that oscillator since the LM393 is an open-collector type comparator. The 5-kHz

## PARTS LIST

All resistors are 1/4-watt, 5%, unless otherwise indicated.

R1, R6-R8, R10-R12, R16, R17—47,000 ohms  
R2, R3, R5, R14, R15, R18-R32, R41-R57—4700 ohms  
R4, R13, R58—470,000 ohms  
R9—2700 ohms  
R33-R40—330 ohms, 1/2-watt, 5%

### Capacitors

C1, C2—20 pF ceramic  
C3—1000  $\mu$ F, 16 volts, electrolytic  
C4, C5, C15, C16—0.1  $\mu$ F, ceramic  
C6—22  $\mu$ F, 16 volts, electrolytic  
C7—2.2  $\mu$ F, 16 volts, electrolytic  
C8, C9—0.01  $\mu$ F, ceramic  
C10, C14, C17—0.0033  $\mu$ F, ceramic  
C11, C12—560 pF, ceramic  
C13—1  $\mu$ F, 16 volts, tantalum

### Semiconductors

IC1—LM340T-5 5-volt regulator  
IC2—LM393 dual-comparator

IC3—LM324 quad-op-amp  
IC4—8749 microcontroller with HyperClock program  
IC5, IC6—74LS145 1-of-8 decoder/driver  
IC7—ICLN2003 high-current driver  
D1, D3—1N914A diode  
D2—1N4001 diode  
Q1, Q2, Q17, Q18—2N2222 NPN transistor  
Q3-Q16, Q19—2N2907 PNP transistor  
BR1—1-amp, 50 volts PIV bridge rectifier  
DISP1, DISP3—Panasonic LN524RA or similar 7-segment display (for the smaller digits)  
DISP2—Panasonic LN526RA or similar 7-segment display (for the larger digit)  
LED1-LED65—light-emitting diodes  
**Other components**  
XTAL1—6-MHz crystal  
T1—9-VAC 500-mA wall-mount transformer  
BZ1—piezo transducer  
S1-S7—miniature momentary-contact pushbutton switch  
B1—9-volt battery

**Miscellaneous:** T-220 style heatsink, PC board or perforated construction board, battery clip, shorting blocks, solder, etc.

**Note:** The following items are available from SkiTronix, P.O. 9685, Spokane, WA 99209:

- A pre-programmed HyperClock 8749 microcontroller with firmware license—\$10.00.
- An etched and drilled PC board—\$25.00.
- The foil pattern artwork suitable for conversion to film—\$3.00.
- Software on floppy disk—\$5.00 postpaid
- A complete kit of parts including the PC board, programmed 8749 IC, LED's, displays, electronic components, and the wall-mount transformer—\$70.00.

A detailed drawing of the HyperClock wood case, will be supplied with all orders. Please include \$3.00 for shipping and handling. Washington residents must include an additional 7.9% sales tax.

square wave present at the emitter of Q2 is clamped in amplitude by the buffered exponential waveform from IC3-a, so the 5-kHz signal decays in amplitude in step with the discharge of C13.

The decaying 5-kHz signal is fed through C14 to a second-order low-pass filter tuned to approximately 5 kHz. The filter is composed of a LM324 op-amp (IC3-d), C11, C12, C14, R10, and R11. It removes the high-frequency components contained in the decaying square wave to smooth it out. From there the signal is passed to two more op-amps (IC3-b and IC3-c) that form a push-pull amplifier, which provides the piezo transducer with a 10-volt peak-to-peak drive signal.

While the output signal is not exactly a pure sine wave, the audible result sounds pretty much like a small bell. If you feel the chime is too loud, you can eliminate half of the push-pull amplifier by jumpering one side of the transducer to the 5-volt supply, which is available via JU2.

The entire circuit receives power from a 9-VAC wall-mount transformer. The 9-VAC supply is fed to a full-wave bridge rectifier and filtered by C3 to act as an unregulated 12-volt DC sup-

ply. The 12-volt supply powers the display circuitry, op-amps, the comparators, and an LM340-5 (IC1) 5-volt regulator. The regulator in turn powers the 5-volt supply line.

If AC power is interrupted, a 9-volt battery connected to J1 sources current to the regulator to keep the HyperClock functioning. If you plan to unplug the clock for any length of time, the battery should be disconnected to conserve its life.

## A BIT ABOUT TIDES

Predicting the tides in any given locale is not a simple job. Tides are affected by many cyclic astronomical forces: the declination in the orbits of the moon and sun relative to a point on the Earth, and the local geography of the coast line in the area in which you live, to name a few. HyperClock predicts the tidal levels from the most predominate of these forces, the moon. The moon requires 29.53 days to orbit Earth, and that combined with the 24-hour solar day causes a high and low tide in every 12 hour and 25.5 minute interval. HyperClock tracks the moon's primary affect on the tide. You can find out about the level of local tides in your area from your newspaper or library. The information can be used to initially set the tide indication on your HyperClock to a low or high point. From then on the graphic display will be an aid in the determination of the relative level of the tides in your locality.

The line input (pin 6) of the microcontroller cannot be driven directly from the 12-VAC wall transformer. So the transformer signal is conditioned a Schmitt-trigger circuit to generate a suitable square wave. First the signal's amplitude is reduced by a voltage divider consisting of R1 and R58, and its positive excursions are limited to about 5 volts by D1. The limited signal is then sent to the inverting input of the LM393 comparator. Positive feedback is applied to the comparator non-inverting input by R4 to prevent it from generating false signals. The comparator drives the microcontroller's line input with the resulting square wave.

## Construction

In order to build a HyperClock, you'll need a pre-programmed 8749 microcontroller. A preprogrammed and tested microcontroller is available from the supplier mentioned in the parts list. The execution code to program an 8749 is available from the RE-B (516-293-2283, 1200/2400 8N1), as a file call HYPER.HEX. The file is supplied in Intel's Hex form which is directly compatible with most EPROM programs.

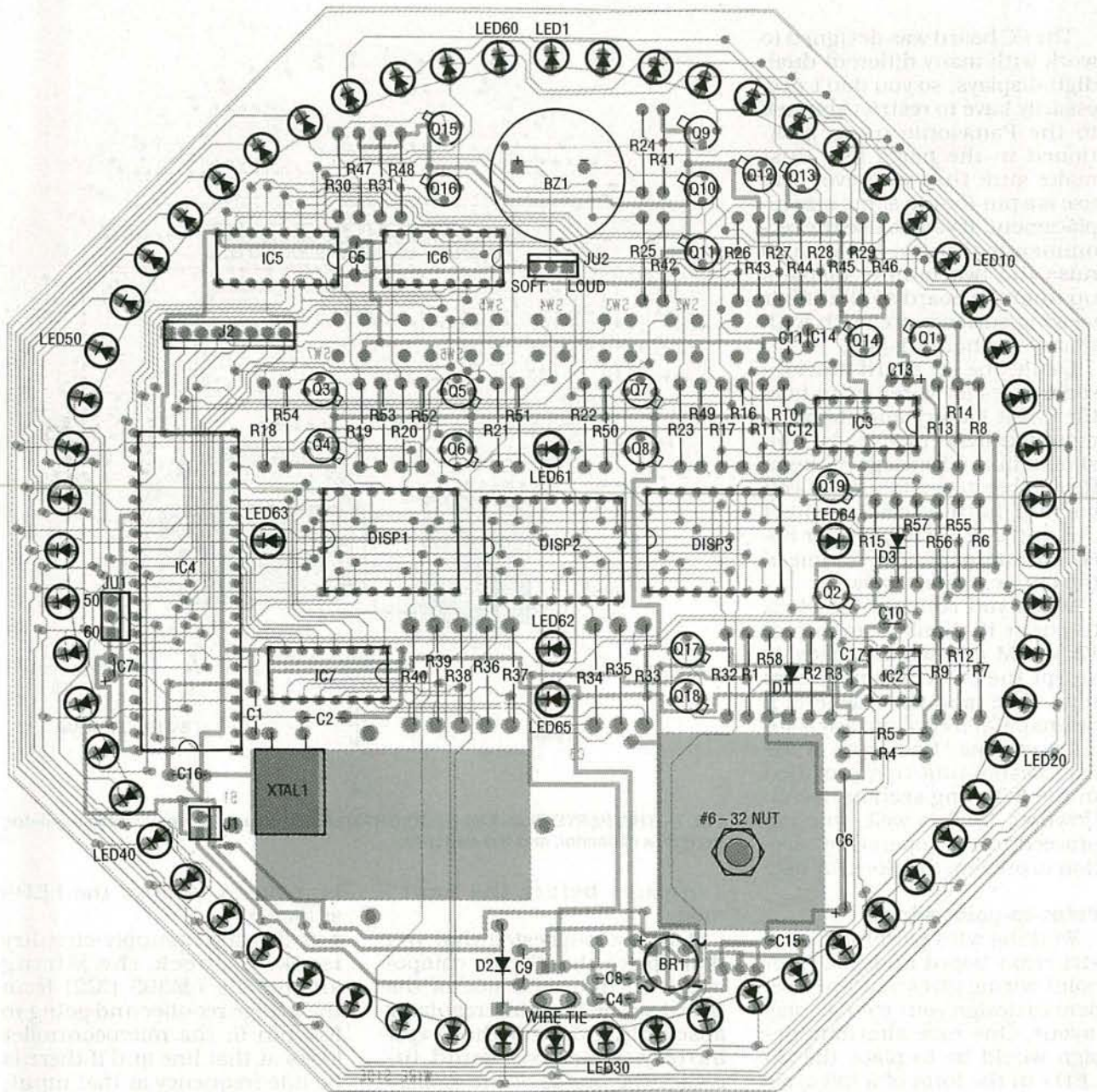

FIG. 6—DISPLAY-SIDE PARTS-PLACEMENT diagram can be used to locate most of the HyperClock's components.

mers. The software is also available on floppy disk from the source mentioned in the parts list.

A 6.5- × 6.5-inch octagon-shaped PC board is also available from that supplier to help you assemble a HyperClock of your own. If you wish, you can make your own double-sided printed-circuit board from the foil patterns included in this article or using artwork from the supplier listed in the parts list. Of course, you could even use a point-to-point wiring tech-

nique, so we'll discuss that briefly later on.

Figures 6 and 7 show the parts-placement diagrams for the HyperClock (6 shows the display side and 7 shows the solder side) for those of you that will use a PC board. All components, except for the wall-mount transformer, are shown mounted on the circuit board. Note that the switches can be placed on either side of the board, depending on the cabinet you wish to place the clock in. There are some additional

connector pads on the board so you can run wires to the switches should your cabinet design require that they be located off the PC board. Figure 8 shows a completed HyperClock board.

The design readily lends itself to many different project cases. However, make sure that the cabinet you choose has some openings in the back to allow a little cool air to flow around the clock's 5-volt regulator and heat sink. If you like the case used for the prototype, you can build one out of a length of wood molding as the author did.

The PC board was designed to work with many different dual-digit displays, so you don't necessarily have to restrict yourself to the Panasonic units mentioned in the parts list. Just make sure that whatever you use is a pin-for-pin same-size replacement. If you do use the recommended units, be sure to raise the two minute displays up from the board so that their viewing surfaces are flush with that of the hour display.

Lastly, the PC board provides some holes for wire ties to hold the 9-volt battery and the wall-mount transformer leads. You should take advantage of them. Remember to install the 9-volt backup battery and connect JU1 and JU2 to select 50- or 60-Hz operation and the volume of the chime, respectively.

When you connect the clock to power it should come up at 12:30 AM and will be ready to accept the current time, alarm time, date, and the tide level if desired. If you run into any difficulty, you may find some of the troubleshooting tips provided in the following section useful. However, if all is well, you can proceed to the "operating" section to prepare the clock for use.

### Point-to-point wiring

Working with perforated construction board and point-to-point wiring gives you the freedom to design your own display layout. One nice alternate design would be to place the 60 LED's in the form of a full cycle of a sine wave, especially if you set the clock to display the tide level.

An early prototype of the clock was built using wire wrap. Regardless of the wiring technique, you should invest in a large enough piece of perforated construction board (at least 6 × 6 inches) so that you can make your custom display with plenty of room to spare for all the support electronics.

Furthermore, when you are shopping for the hour and minute displays, select minute displays that are somehow distinctly different than the hour display. That will make the display more easily readable in the

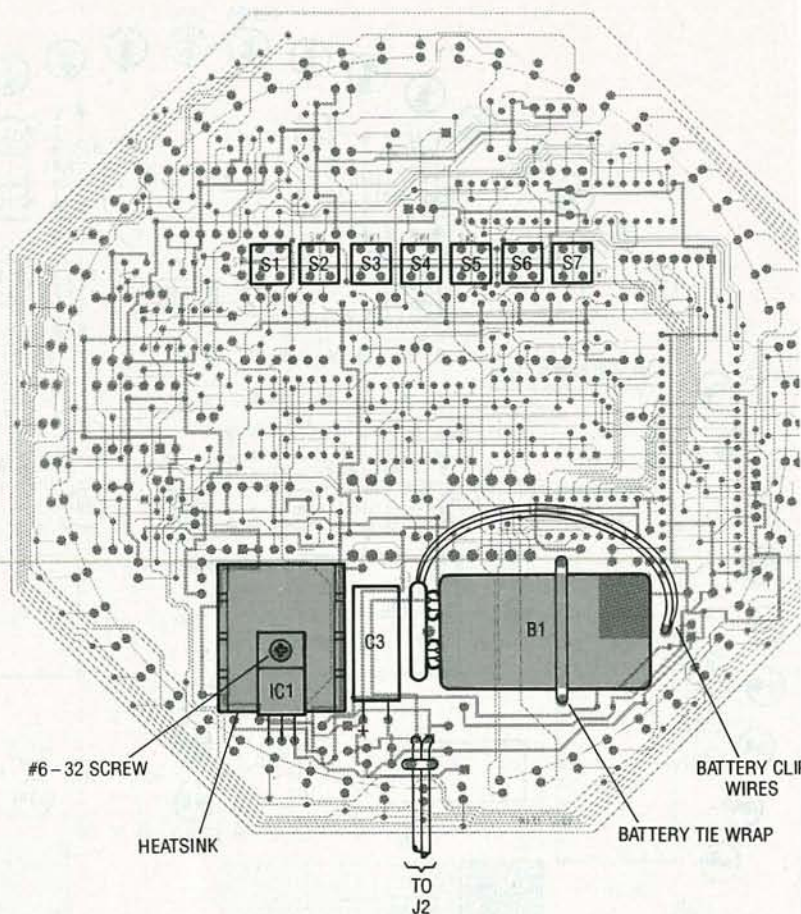

FIG. 7—THIS PARTS-PLACEMENT DIAGRAM should be used to position the regula battery, a capacitor, and the switches.

"minutes before the hour" mode.

It is also suggested that you don't place the display components on the same side of the board as the heatsink/regulator assembly, C3, and the 9-volt battery. Doing so would increase the profile of the display side of the board, forcing you to place the LED lens at an undesirable distance from the display components.

Aside from those suggestions, layout is not critical, so if you observe good construction and wiring techniques you should not have any problem getting the clock to function. However, if you should encounter some difficulty, the following hints ought to help:

- If no LED's are illuminated when you apply power, first check the unregulated supply for a minimum of 10 volts DC. While only 2 to 3 volts of overhead are required to operate the 5-volt regulator, at least 10 volts

is required to drive the LE sufficiently.

- If the power-supply circuit is okay, check the wiring around the LM393 (IC2) from the bridge rectifier and going to IC4 pin 6; the microcontroller looks at that line and if there is no line frequency at that input the clock will shut down the LED drivers (as we explained earlier).

Since most of the wiring for the clock runs between the LED drivers and the LED's, it is likely that you could have made an error in one or more of those connections. If you observe that some active LED segments do not form numbers, then you should check the connections from IC1 to IC7 and the corresponding connections to the cathodes of the LED displays. A mistake between IC4 to IC5 and IC6 will make the displayed digits appear or seconds appear out of order. An error in wiring from the outputs of the 74LS145's to the

TABLE 1—MODES AND THEIR FEATURES

Feature	Mode							
	0	1	2	3	4	5	6	7
Fading Updates		•		•		•		•
Plain Updates	•		•		•		•	
Before-The-Hour Display			•	•			•	•
Plain Display	•	•			•	•		
Tide Light Chaser					•	•	•	•
Seconds Light Chaser	•	•	•	•				

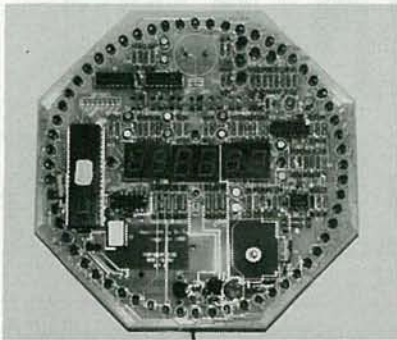
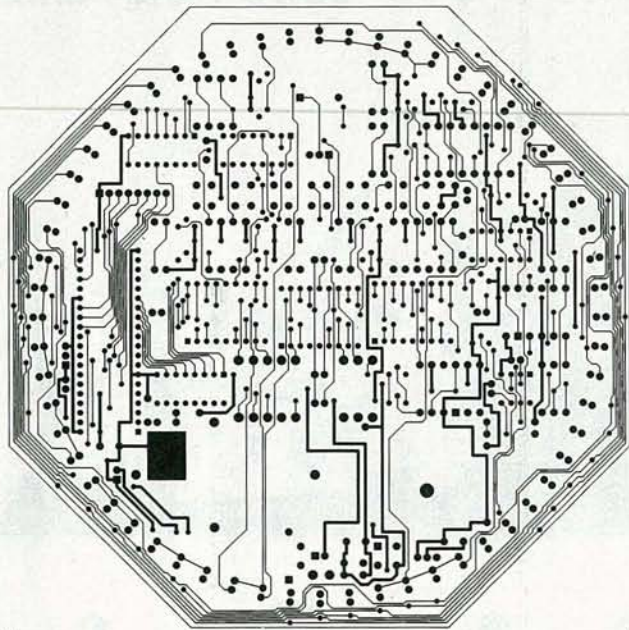
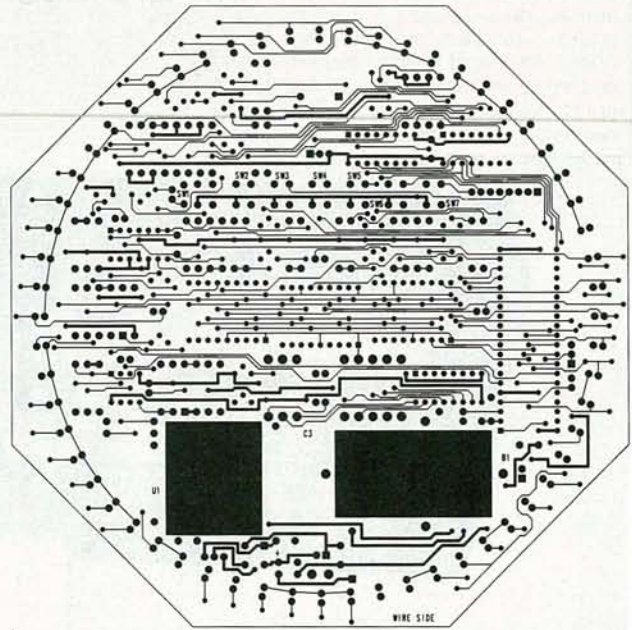

FIG. 8—A FINISHED HYPERCLOCK. The PC board makes assembly neat and straightforward.



THE DISPLAY-SIDE FOIL PATTERN can be used to generate one side of the clock's PC board.



THIS FOIL PATTERN can be used to generate the solder side of the clock's PC board.

driver transistors, which connect to the LED anodes, will cause the same effect.

### Operation

The functions performed by S4 and S5 in the HyperClock depend on the state of the three display switches (S1 through S3). If none of the display switches are depressed, pressing S4 advances the current hour displayed and pressing S5 advances the minute display. That is how you set the time.

Pressing and holding down S1 (the Display-Mode button) causes the clock to display the number of the current operating mode, which can be altered by pressing S4 (S5 will do nothing). The various operating

modes and the features they support are listed in Table 1.

If you depress and hold switch S2 (the Display-Date button) the current month and day are displayed. With that switch depressed, the month and day can be advanced by pressing S4 and S5, respectively.

Activating switch S3 will cause the clock to display the time the alarm is set for. By pressing S3 along with S4 you can alter the hour setting, and by pressing S3 and S5 simultaneously you can change the minute setting.

Moving on to the last two switches, the Alarm Toggle switch (S7) determines the state of the alarm and the hour chime of the clock. For example,

on power-up the hour chime is enabled and the alarm is disabled. If S7 is pressed once, the alarm is turned on and the hour chime is disabled. Depressing the switch again will turn off both the alarm and the hourly chime.

The Snooze/Tide Switch (S6) has a dual purpose. If the HyperClock's alarm was armed and goes off, that button will silence the alarm for an additional ten minutes. You can forestall the alarm in this way as many times as you like. If the alarm is disabled, and the clock is in a mode that supports the tide-level display (modes 4 through 7), pressing S6 will advance the tide indication on the 60-LED display to set its position. R-F

### WARNING!

Please note that unauthorized wire and electronic communications interception and interception of oral communications is illegal under Federal and State Law. In addition Federal Law renders illegal the intentional manufacturing, assembling, possessing, or selling any electronic, mechanical, or other device, knowing or having reason to know that the design of such device renders it primarily useful for the purpose of surreptitious interception or wire, oral, or electronic communications. Federal law imposes both civil and criminal penalties for violations of the applicable statutes. Thus, the use of the Scanner Converter described in this article is intended for and should be restricted to educational, scientific, and/or informational purposes. This is not intended to constitute legal advice and readers are advised to obtain independent advice as to the propriety of their use thereof based upon their individual circumstances and jurisdictions.

# SCANNER CONVERTER

**Upgrade your scanner to receive signals in the 800-900 or 900-1000 MHz band**

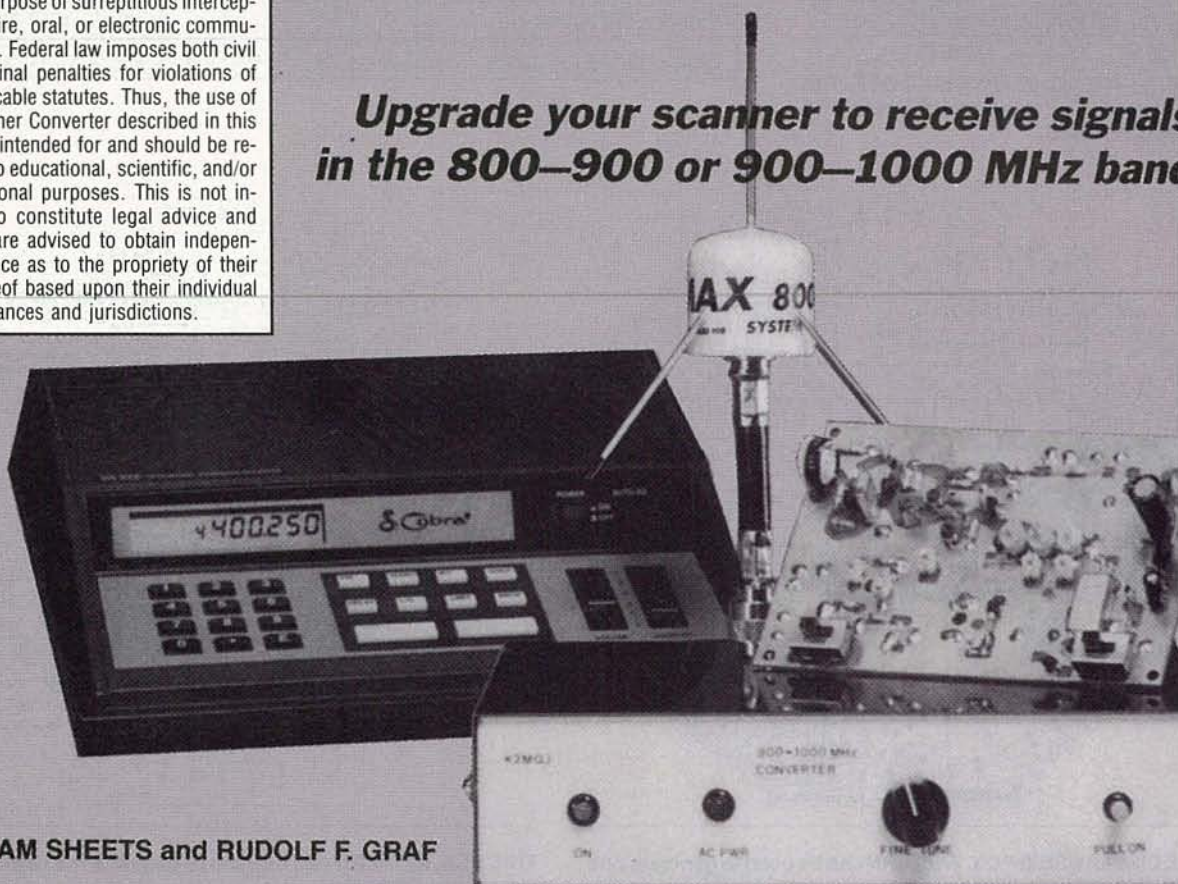

**WILLIAM SHEETS and RUDOLF F. GRAF**

THE 800-1000 MHz BAND OF FREQUENCIES, lying in the portion of the radio spectrum known as the UHF band, has recently become populated with many signals of interest to the shortwave listener (SWL) and scanner hobbyist. Originally, the 800-890 MHz portion was allocated to UHF TV broadcasting. Lack of interest in these frequencies (formerly TV channels 70-83) and a pressing need for spectrum space was largely responsible for re-allocation. The portion of spectrum now includes business radio, public safety (police, fire, etc.) and general-purpose two-way radio. The lower portion is largely used by cellular mobile radio telephone services. The upper

portion (above 900 MHz) is used for two-way radio, industrial radio, amateur radio, and miscellaneous purposes, such as wireless video and audio links, studio to transmitter (STL) links, and various Part 15 applications (low-power license-free uses), and even more! Figure 1 summarizes the current frequency allocations.

The frequencies are almost in the microwave region. Until recently, receivers for this band were scarce and usually special-purpose types. In the past few years, a number of communications receivers have been made available, covering from around 25 MHz or so up to over 1000 MHz. Some of the more expensive scanners cover portions of

the 800-1000 MHz range, while others block out the bands.

Now you can build a converter that will allow the reception of signals from 800-1000 MHz on any scanner that covers frequencies in the 400-500 MHz range. The availability of high performance transistors and Monolithic Microwave Integrated Circuits (MMIC's), together with very small components such as chip capacitors and prepackaged mixer assemblies, have made this feasible.

The antenna shown in the opening photograph is cut specifically for the 800-MHz band. It's available from the Cellular Security Group, 4 Gerri Road, Gloucester, MA 01930. Contact them directly for information.

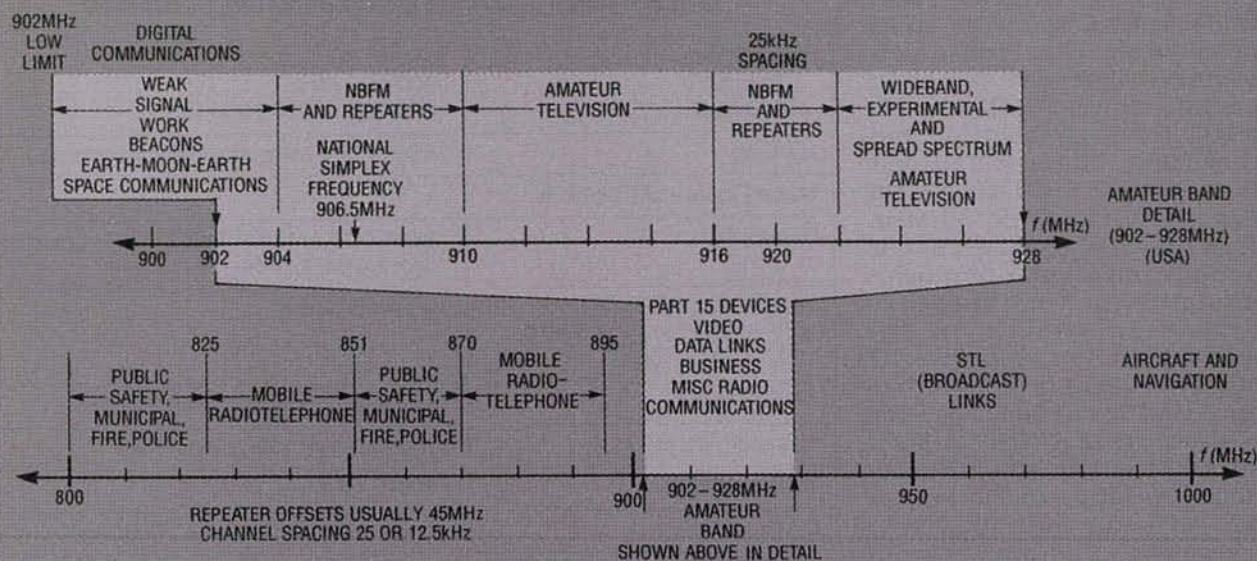

FIG. 1—THE 800–1000 MHz UHF BAND has many signals of interest to the shortwave listener. Here is a summary of the current frequency allocations.

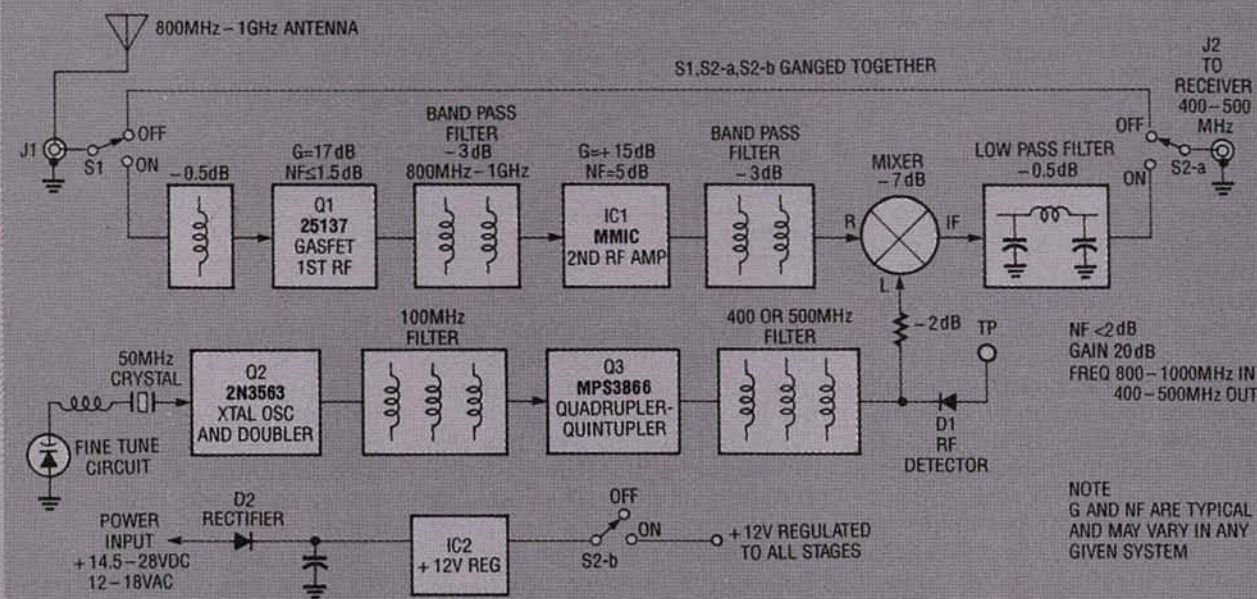

FIG. 2—BLOCK DIAGRAM. A GaAsFET feeds a double-tuned filter and a MMIC RF amplifier that feeds a second double-tuned filter. That feeds a double balanced mixer, or DBM. The DBM is also fed with a local oscillator signal of either 400-MHz or 500-MHz.

mation on that and other various UHF antennas.

The converter described in this article offers excellent performance (about 0.15  $\mu$ V/12dB SINAD—signal-to-noise-and-distortion-ratio—sensitivity for standard 5-kHz FM), having an NF (noise figure) of about 2 dB, a gain of 20–25 dB, and an output frequency of 400–500 MHz. By simple tuning adjustment it

can be set up for 800–900 or 900–1000 MHz ranges and optimized for any 30–40 MHz segment in the range. It will work well over the entire 100-MHz range if circuits are stagger-tuned, with only slightly reduced sensitivity. Applications of the converter are as follows:

1. Monitoring 800–900 or 900–1000 MHz ranges.

2. Amateur use for reception of 902–928 MHz band, downconverting to the 420–450 MHz range.

3. Reception of 902–928 MHz Amateur TV, using a standard TV receiver that covers UHF channels 20–23, and reception of wireless TV links operating in the 900-MHz range.

4. In conjunction with a 500-MHz counter, the measurement of frequencies in the 800–1000 MHz range.

Referring to the block diagram (Fig. 2), the converter uses a low-noise dual-gate

GaAsFET (gallium-arsenide field-effect transistor) as an RF preamplifier. That feeds a double-tuned filter and a second RF amplifier using a MMIC. The MMIC feeds a second double-tuned filter. The overall RF gain is about +27 to 30 dB and the bandwidth is around 30 MHz. That provides good rejection of out-of-band signals and helps minimize the feedthrough of unwanted signals in the 400–500 MHz range. The RF amplifier feeds a double balanced mixer, or DBM. The DBM is also fed with a local-oscillator signal of either 400-MHz (for 800–900 MHz conversion) or 500-MHz (for 900–1000 MHz conversion). The mixer output is therefore kept in the 400–500 MHz range covered by most scanners. The receiver should be suitable for the type of transmission to be received. A scanner is generally set to receive narrowband frequency modulation (NBFM) signals commonly used in this range in steps of 12.5 kHz, 25 kHz, etc. A TV receiver tuned to the lower UHF channels (14–23) can be used to receive TV signals in the 900-MHz range, such as amateur TV (ATV) and the new 900-MHz wireless video links. Converter output is at 50–75 ohms.

The local oscillator (LO) is a 50-MHz crystal-based overtone oscillator. The second harmonic of the oscillator circuit (at 100 MHz) is used. A fine-tuning control is provided to compensate for any 800–1000 MHz signals not fitting the popular 12.5-kHz channel spacing used by many scanners. The LO can be shifted at least  $\pm 6$  kHz to act as a fine-tuning control, if needed. Normally, the fine tuning is left set to center position.

The 100-MHz oscillator signal is fed to a multiplier stage using a UHF large-signal transistor as a quadrupler ( $\times 4$ ) or a quintupler ( $\times 5$ ) stage. The appropriate harmonic (4th or 5th) is selected by a triple tuned filter and the signal at 400 or 500 MHz is delivered to the mixer. The filter can select either signal depending on the setting of three variable capacitors. A diode detector samples the output

TABLE 1—800 TO 100-MHz CONVERTER SPECIFICATION

Freq Range RF Input IF Output	400-500 MHz 800-900 or 900-1000 MHz
LO Freq	400 or 500 MHz, internally selectable
Noise Figure <2dB typical	
Sensitivity	gives 0.15 $\mu$ /12dB SINAD, 5 kHz deviation with typical scanner
Power Gain, RF to IF $f_{in} = 900$ $f_{out} = 500$ MHz $R_s = R_L = 50 \Omega$	+22 dB typical
RF Bandwidth	40 MHz @ 3dB typical @ 900 MHz
Maximum Input Level	-40 dbm @ 1dB compression
Tuning Range	800-1000 MHz
Dynamic Range	Approx 90 dB (0.1 $\mu$ c to 3000 $\mu$ v)
Voltage and Current	+15-25 VDC @ 100mA, Neg ground ok 12-16 VAC @ 300 mA peak, can be modified for +12 VDC regulated
Freq Control of L O	XTAL controlled .005%
Fine Tuning Range	$\pm 7$ kHz typical
PC Board (finished) size	3½" $\times$ 5" $\times$ 1" high
RF to IF Feedthrough Isolation (IN-OUT) DB	>60 dB @ 400 MHz
Insertion Loss in dB with converter off	-1 dB typical @ 400 MHz -0.3 dB typical @ 30 MHz
Switching	Built-in

of the filter so that a VOM can be used to align the filter simply by "peaking" the trimmer capacitors for maximum output.

It is possible to just use the 400-MHz signal. However, for reception of 900–1000 MHz, a receiver capable of tuning 500–600 MHz would be needed. Most scanners cover only up to 512 MHz or thereabouts. Therefore, the 500-MHz signal is necessary with these scanners for reception of frequencies over 912 MHz.

The converter board contains a switching network for switching the converter in or out. In the "out" position, the input jack, J1, simply connects to the output jack, J2, and all frequencies from DC to 550 MHz are passed. In this position, the DC line to the converter circuitry is also opened, thus disabling the converter.

The converter board also contains a rectifier and a regulator

that delivers +12 volts DC to converter circuitry. Either +14.5- to +24-volt DC, or volt AC supply can be used. Suitable supplies are either wall transformer or one that mounts inside the converter case.

Referring to Fig. 3, let's cover a detailed description of the circuit. Signals enter from the antenna and are routed to S1, a DPDT switch with only one side used. With in the "off" position (converter off), signals from S1 are routed to S2-a, another DPDT switch (Slide switches S1 and S2, though mounted at different locations on the PC board, mechanically linked by an actuator rod assembly, so that correct switching is maintained). Next, signals are routed through S2-a to low-pass filter L16-C15, and then to J2. The low-pass filter rejects signals above 600 MHz. A 50-ohm



## PARTS LIST

All resistors are 1/4-watt, 5%, unless otherwise noted.

- R1—100,000 ohms, 1/8-watt
- R2—470,000 ohms, 1/8-watt
- R3—180 ohms, 1/8-watt
- R4—180 ohms
- R5—390 ohms, 1/8-watt
- R6—1000 ohms
- R7—10,000 ohms, trimmer potentiometer with shaft
- R8—10,000 ohms
- R9—15,000 ohms
- R10—3900 ohms
- R11—330 ohms
- R12—100 ohms
- R13—15,000 ohms
- R14—2200 ohms
- R15—10 ohms, 1/8-watt
- R16—47 ohms
- R17—1 megohm
- R18—15 ohms, 1/8-watt
- R19—390 ohms, 1/8-watt
- R20—10 ohms

### Capacitors

- C1, C8, C9, C13, C14—1–5 pF trimmer
- C2—C7, C10—C12, C16, C28, C31—100 pF, 50 volts, chip
- C15—5.6 pF NPO  $\pm 0.25$  pF
- C17—100 pF NPO, 5%
- C18—39 pF NPO, 5%
- C19—22 pF NPO, 5%
- C20—2.2 pF NPO,  $\pm 0.25$  pF
- C21, C29—470 pF  $\pm 20\%$ , disc
- C22, C30, C32, C35, C36—0.01  $\mu$ F, 50 volts, GMV disc
- C23—33 pF NPO  $\pm 5\%$
- C24—56 pF NPO  $\pm 5\%$
- C25—C27—2–10 pF trimmer
- C33—10  $\mu$ F/16 volts, electrolytic
- C34—470  $\mu$ F/25 volts, electrolytic

### Semiconductors

- IC1—MAR-1 UHF amplifier
- IC2—7812 +12-volt regulator
- D1—MV2107 varactor diode
- D2—HP5082-2800 hot carrier diode
- D3—1N4007 rectifier diode
- Q1—25137 dual-gate GaAsFET
- Q2—2N3563 VHF NPN transistor

- Q3—MPS3866 VHF NPN transistor
- LED1—green light-emitting diode (optional)
- LED2—red light-emitting diode (optional)

### Inductors

- L1—L5, L10—L12—part of PC-board etching
- L6, L15—ferrite bead
- L7—0.2–0.32  $\mu$ H (9 1/2 turns #22 enameled wire)
- L8—0.05–0.1  $\mu$ H (3 1/2 turns #22 enameled wire)
- L9—0.05–0.1  $\mu$ H (3 1/2 turns #22 enameled wire)
- L13—1.0  $\mu$ H RF choke
- L14—ferrite bead on R20
- L16—1/2-turn #22 enameled wire, 1/4-inch diameter (see text)

### Other components

- J1, J2—female BNC connector
- MOD1—MCL SBL-IX mixer module
- S1, S2—DPDT PC-mount slide switch
- XTAL1—50-MHz 3rd overtone crystal

**Miscellaneous:** PC board, small-diameter 50-ohm coaxial cable, project case, 14.5–24-volt DC or 12-volt AC 350-mA transformer (see text), hardware as required, brass rod or wire, 2 1/4-inch rubber grommets, line cord if required, solder, etc.

**Note:** The following items are available from North Country Radio, PO Box 53, Wykagyl Station, New Rochelle, NY 10804:

- Converter kit including all parts except case and transformer —\$67.50 + \$3.50 S&H
- PC board only —\$13.50 + \$3.50 S&H
- Transformer —\$9.50 + \$3.50 S&H

New York State residents must add appropriate sales tax.

pedance level is maintained through the converter in the "off" position to reduce VSWR (voltage standing-wave ratio) and line losses, so that a scanner connected to J2 has normal reception when the converter is switched off. Switch S2-b breaks the 12-volt supply line in this position to disable the converter circuitry.

In the converter "on" posi-

tion, signals from J1 in the 800–1000 MHz range are fed through S1 to L1 (an inductor that is incorporated in the PC board etching and acts as a short circuit to lower-frequency signals) and C1, which are resonant at 900 MHz.

For matching purposes, at 900 MHz, C1 and L1 must form a resonant circuit as well as an impedance transformer to step

up the 50-ohm impedance to somewhere between 800 and 1000 ohms. The input impedance of the gate of RF amplifier Q1 is about 1 to 2K or higher, and shunted by about 1 pF capacitance. The output impedance of Q1 is between 1000 and 2000 ohms with 0.5–1 pF shunt capacitance. The voltage gain of Q1 is about 7.5 from gate 1 to drain, or about 17.5 dB.

There is about 1.5 dB loss in the output-coupling network and about 0.5 dB loss in L1, so that a total of about 15 dB gain is observed. The device is rated at 1.1 dB noise figure, but allowing 1 dB (approximate) loss in L1 and S1, an actual NF of about 2 dB will be obtained. That is adequate since cable losses in the typical antenna system will be around 6 dB anyway.

Transistor Q1 is a dual-gate gallium arsenide field effect transistor (GaAsFET) biased to about 5–10 mA drain current; R3 provides a self bias for Q1. Chip capacitors C4 and C5 are RF-bypass capacitors soldered directly to the solder side of the PC board for low inductance. They are the only type of capacitor that provides reliable bypassing at 900 MHz. Resistors R1 and R2 bias gate 2 of Q1.

The drain of Q1 feeds double-tuned filter C8-L2 and C9-L3, and R4 feeds bias to the drain of Q1. Typically, the tuned circuits in this RF amplifier are tuned to 900 MHz with about 2.5 pF capacitance, and L1–L5 have an equivalent inductance of 0.012 microhenry, although these values are typical and cannot really be isolated or measured. Inductors L2 and L3 are printed on the PC board and are proportioned to give the desired coupling and inductance. Their layout is critical and cannot be changed.

The signal from L3 is coupled through chip-capacitor C10 to IC1, a monolithic microwave IC (MMIC) amplifier with 50-ohm input and output. Resistor R5 provides about 17 mA operating bias for IC1, which gives about 13 to 15 dB gain at 900 MHz. The output of IC1 is coupled via C12 to filter L4-C13 and L5-C14. The five tuned circuits in this

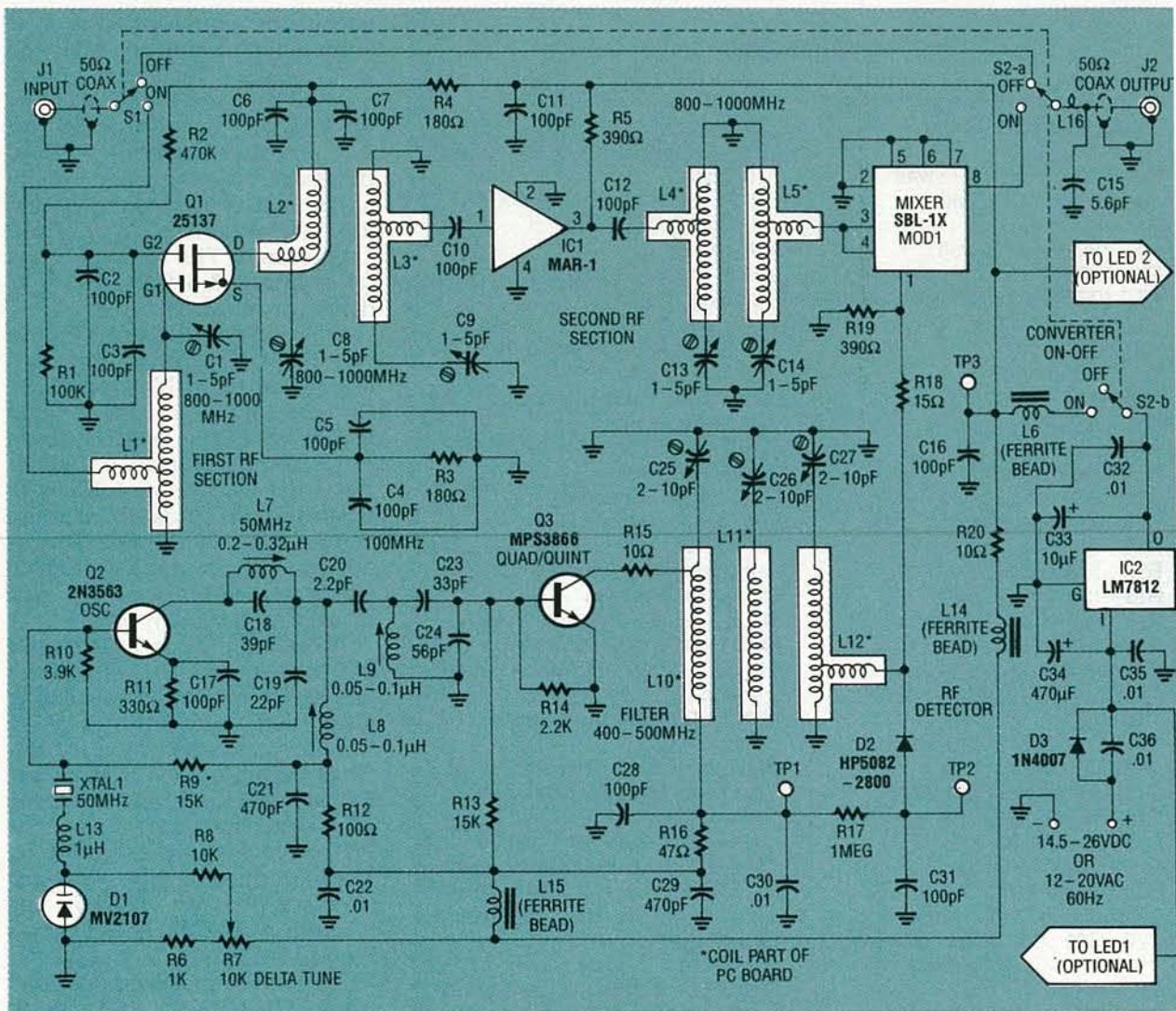

FIG. 3—CONVERTER SCHEMATIC. A 50-ohm impedance level is maintained through the converter with S1 in the "off" position so that a scanner connected to J2 still has normal reception. Switch S2-b breaks the 12-volt supply line in this position to disable the converter circuitry.

converter yield an overall RF bandwidth of 40 MHz at the 3 dB points. The signal from L5, about 28 to 30 dB stronger than the signal at J1, is applied to a mixer module (MOD1), an MCL SBL-IX, where it is mixed with the LO signal at 400–500 MHz. The IF output is then fed to S2-a, where it is connected to J2 via low-pass filter L16-C15.

An LO signal of either 400 or 500 MHz is required by mixer MOD1. It is generated as follows: Q2, a 2N3563, is configured as an overtone crystal oscillator. Emitter stabilization is provided by R11, and R9-R10 provide base bias. Resistor R12 supplies the collector voltage for

Q2 through L7 and L8. Components L7 and C18 are nominally tuned to 50 MHz, the frequency of XTAL1. Components C19 and L8 form a resonant circuit at 100 MHz and therefore have a low impedance to 50-MHz signals. Bypass capacitor C21 RF grounds the bottom (cold end) of L8.

There exists a feedback capacitance (about 3 pF) between the collector and emitter of Q2. That, in conjunction with C17, forms an oscillator; the oscillation of Q2 would tend to take place at the resonant frequency of C18 (plus strays) and L7 (L7 is variable by means of a ferrite slug). The base of Q2 must be

RF grounded, which can or occur at the series-resonant frequency of XTAL1, L13, a varactor-diode D1; D1 acts as capacitor whose value can vary via the applied DC voltage from potentiometer R7. Resistor R6 limits the low voltage to about 1 volt, and L1 provides RF isolation for L7. Varying R7 has the effect of varying the effective frequency of the crystal plus and minus 1000 Hz. When L7 is nominally tuned to 50 MHz, the crystal oscillator circuit produces a signal of 50,000 MHz. However, it need 100 MHz.

Since Q2 operates as class C and produces harmonics, filter L8-C19 is tuned to 100 MHz. That transfers 2nd harmonic energy (6–10 dB below the fundamental 50 MHz) via coupling capacitor C20 to a second 10

MHz tuned circuit (C23, C24, and L9). Capacitors C23 and C24 are chosen so as to match the oscillator to the base of frequency multiplier Q3, an MPS3866. That generates harmonics of 100 MHz in the base circuit of Q3. Capacitor C24 is chosen to have a low impedance at higher frequencies to encourage the flow of harmonic currents in the base circuit of Q3.

Inductors L10, L11, and L12 form a filter tuned to either 400 or 500 MHz by adjustment of C25, C26, and C27. There is sufficient tuning range to cover either 400 or 500 MHz. The filter is triple-tuned and L10, L11, L12, and their coupling coefficients are determined by the PC board layout which they are part of. RF energy at 400 (or 500) MHz is taken from a tap on L12 and fed to mixer MOD1.

Without the right test equipment, it would be difficult to align C25, C26 and C27. However, the problem is solved by diode detector D2, C31, and R17. Resistor R17 slightly forward biases D2 to produce about +0.2V at test point TP2.

When RF drive is applied from L12, a negative voltage is produced at TP2. When the triple-tuned filter is correctly-tuned and Q3 is operating properly, about -0.3 volts is produced by D2, since about 300 millivolts of RF is present from L12. This, when added to the +0.2V bias on D2, produces -0.1V at TP2. Diode D2 is forward-biased to improve its sensitivity at low RF levels. Tuning of C25, C26, and C27 simply consists of monitoring the DC voltage at TP2, and obtaining the most negative voltage possible by peaking C25, C26, and C27.

Regulator IC2, a 7812, provides 12-volts DC power to the circuit; C32 and C33 and C34, C35 help stabilize IC2. Rectifier D3 acts as a protection device in case a negative DC voltage is applied to the circuit, and C36 reduces 60-Hz buzz caused by switching transients in D3. At least 14-volts DC is required across C34 for IC2 to function.

When we continue next time, we'll build the converter and show you how to align it. R-E

## NEXT MONTH IN Popular Electronics

### *Exciting Features, Projects, Reports, & Columns*

- **THE CLASSIC INDUCTION COIL**

Make a spark ring and more when you experiment with this powerful high-voltage generator

- **BUILD THE PRINTER SENTRY**

Use it to keep tabs on all of your printer's functions

- **BUILD A SPEAKER PROTECTOR**

It saves your expensive loudspeakers from amplifier shorts, excessive drive, and turn-on thumps

- **ELECTRONIC TRACKING FOILS CAR THIEVES**

Get the facts on the new high-tech crime-stopping systems

## Popular Electronics MARCH 1992

**ON SALE JANUARY 28, 1992**



### *And there is more!*

**PRODUCT REVIEWS**—Bang & Olufsen Compact Music System, Memorex Subwoofer/Satellite Speaker System, and many more

**DX LISTENING**—The changing face of Russian shortwave

**COMPUTER BITS**—Low priced, high speed modems

**THINK TANK**—A potpourri of automotive circuits

**HAM RADIO**—Design and build loaded-dipole antennas

**SCANNER SCENE**—Monitoring movie-set communications

**CIRCUIT CIRCUS**—Some unusual uses for common regulator IC's

PICK UP Popular Electronics AT YOUR FAVORITE NEWSSTAND, CONVENIENCE STORE, OR SUPERMARKET

Will new standards be  
of AM radio

LEN FELDMAN

# AM TRIES FO

IT MAY COME AS SOMETHING OF A SURPRISE TO THOSE of us who pay little attention to AM radio that the oldest of all broadcast services is due for some upgrading. After all, the FM radio service has been the preferred form of radio broadcasting in this country for at least two decades, now, and even FM radio may some day be obsoleted by digital audio broadcasting, or DAB. In fact, more than a dozen proposals for DAB are currently either on the drawing boards or have been demonstrated in prototype. So why bother with AM radio at this late date?

## The AM stereo debacle

Back in the mid-1980's, the Federal Communications Commission considered several systems for AM stereo broadcasting. Many AM broadcasters felt then that the reason for the decline of AM radio audience was the fact that FM could offer stereo, whereas AM could not. Initially, the FCC selected one of some six systems, the Magnavox proposal, a "standard." Faced with all sorts of threats of litigation by other proponents, the FCC reversed its choice shortly thereafter and in effect, said, "let the marketplace decide." Since then, the field of proponents has narrowed down to two—the Motorola/Quam system (by far the most popular) and the Kahn-Hazeltine system. Many experts maintain that by not coming down in favor of a specific system, the FCC has discouraged both manufacturers of receivers and AM radio broadcasters from moving to stereo.

With AM broadcasting audience on the decline for many years, manufacturers of high quality AM/FM tuners and receivers have paid little attention to the AM circuitry that they incorporate in their products. Figure 1 shows the actual frequency response measured for the AM section of a highly reputed AM/FM stereo receiver. No wonder listeners accustomed to playing digital compact discs and FM radios are "turned off" by this kind of AM reception! This "afterthought" approach by receiver manufacturers further exacerbated the problem. Another problem of AM has been adjacent channel interference—a problem that is particularly intense during evening listening. Many professionals blame the FCC for that problem, as well, maintaining that the granting of broadcast licenses by the FCC has been a poorly administered "pork barrel" affair with lit



ack the good ol' days

# A COMEBACK

attention paid to the technical problems that have inevitably resulted from an overcrowding of the broadcast band.

## NRSC to the rescue!

As the AM broadcasters situation became worse and worse, the National Association of Broadcasters (NAB) and the Electronic Industries Association (EIA) finally decided to address some of the problems in what amounted to a major cooperative effort between organizations that, up until that time, had pretty well ignored each other. The two organizations formed a separate committee known as the National Radio Systems Committee, or NRSC. In a series of meetings, the NRSC came up with two standards recommendations, known as NRSC-1 and NRSC-2. A proposal to make NRSC-1 a national voluntary standard was issued in January 1990, and in March 1991, the EIA published the contents of NRSC-1 as an interim standard (EIA/IS-80) entitled "Audio Bandwidth and Distortion Recommendations for AM Broadcast Receivers." On a parallel track, the FCC issued a report and order on April 27, 1989 in which compliance with NRSC-1 was made mandatory as of June 30, 1990, while measurement of compliance with NRSC-2 was postponed until June 30, 1994. Both NRSC-1 and NRSC-2 were designed to address the problems of audio fidelity and interference mentioned above.

## NRSC-1 and EIA/IS80

Let's take a look at the EIA Standard developed for receiver manufacturers first. Radio receivers that satisfy the technical requirements of this specification must have a frequency response of not less than 50 Hz to 7500 Hz, with limits of +1.5 dB and -3.0 dB, referred to 0 dB at 400 Hz. Since "opening up" the bandwidth to this extent might well increase interference from adjacent channels—especially in crowded metropolitan areas and during nighttime listening—receiver manufacturers may choose to offer a switch on their products that would, at the user's option, reduce bandwidth. As long as at least one of those switch positions results in the frequency response just stated, the receiver will be considered to com-

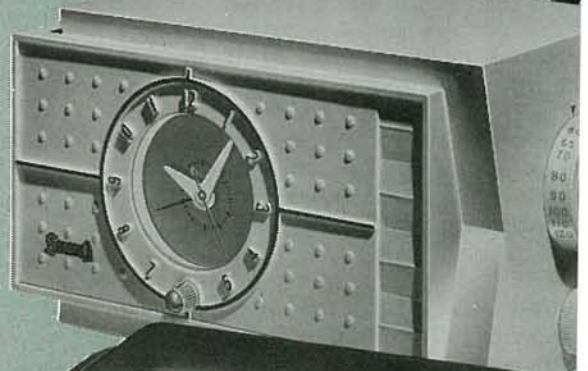
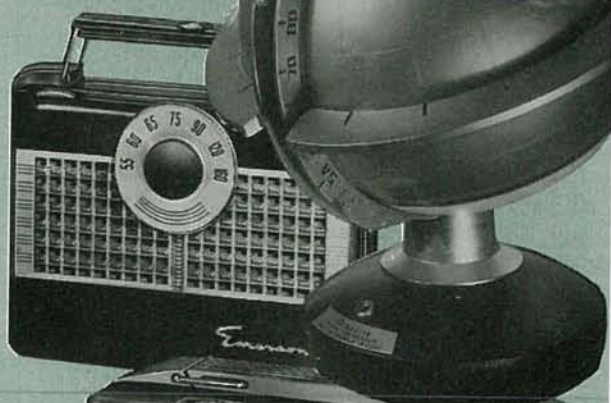
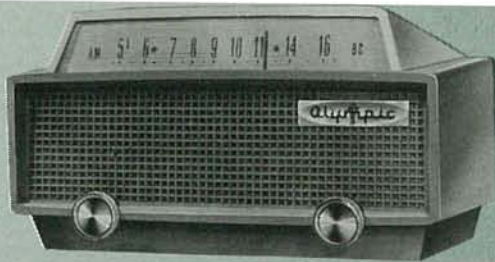

ply with the new standard.

The second part of the NRSC standard deals with harmonic distortion. It states that receivers designed to satisfy the standard shall not exhibit more than two percent (2.0%) total harmonic distortion plus noise (THD + N) at all measured frequencies between 50 Hz and 7500 Hz. Two percent distortion may sound like a high number to those of us accustomed to the distortion levels of modern audio amplifiers and FM tuners, but, in fact, many current non-conforming AM tuners exhibit far higher distortion levels than that!—particularly at higher audio frequencies.

A third recommendation of the standard involves the incorporation of circuitry into AM receivers that attenuates 10.0-kHz adjacent-channel carrier frequencies by 30 dB, or 20 dB when the measurements are made with preemphasis characteristics inserted at the AM input of the RF test signal generator. To clarify that last point, we should note that in recent times, recognizing that AM radios had very poor high-frequency response, broadcasters began boosting the audio treble response of their transmission chains in an attempt to overcome the high frequency attenuation present in nearly all AM radios and tuners. Unfortunately, no two stations used the same boost of preemphasis characteristic. Furthermore, an overly extreme use of high-frequency preemphasis made the problems of interference between adjacent channels even worse. So, included in the NRSC-1 recommendation is a fixed preemphasis characteristic that AM radio broadcasters are required to use. The preemphasis characteristic, not unlike the one used by FM broadcasters in the U.S., is shown in Fig. 2.

Assuming that broadcasters conform (and as of this writing, well over half the AM broadcasters in the United States have embraced NRSC-1 standards), manufacturers of AM radios are expected to voluntarily incorporate standard, fixed

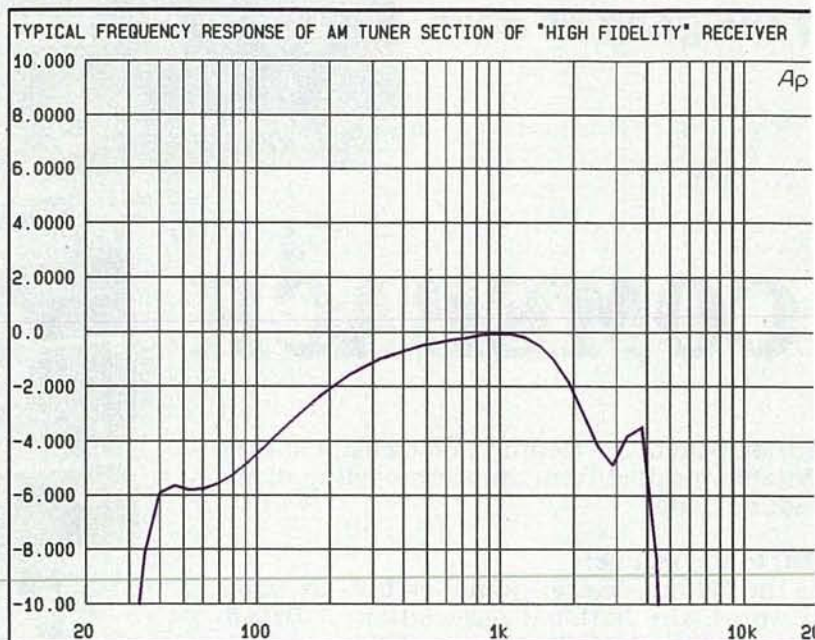

FIG. 1—AMPLITUDE VERSUS FREQUENCY. This is the response of the AM tuner section of a "hi-fi" AM/FM stereo receiver!

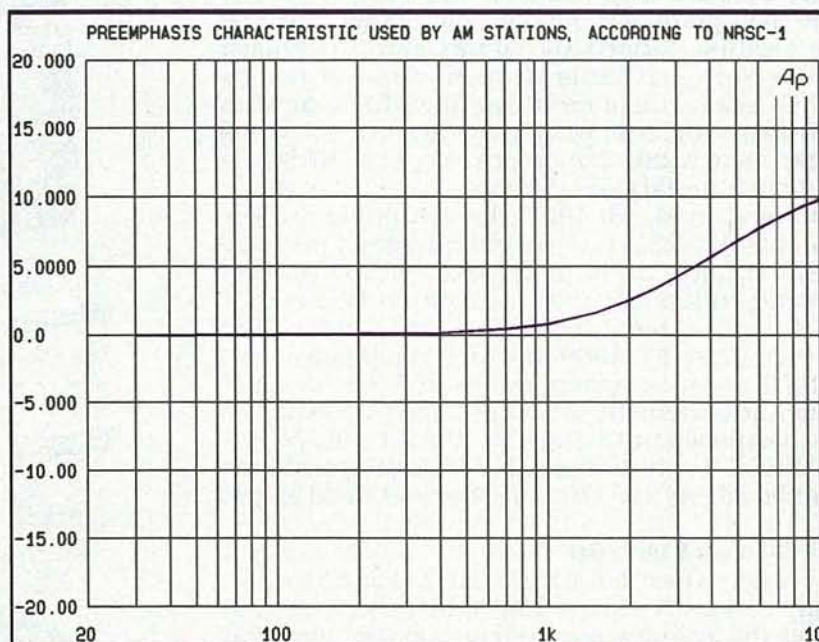

FIG. 2—BY STANDARDIZING THE PREEMphasis CHARACTERISTIC used by broadcasters, AM receiver manufacturers are able to incorporate standard deemphasis networks in their products to achieve the desired flat response to 7.5 kHz better.

deemphasis networks. In measuring the frequency response of an AM radio conforming to the new standards, a laboratory would expect to obtain a frequency response such as that shown by the dashed line in Fig. 3. The solid lines represent the allowable deviation or tolerance over the range from 50 Hz to 7.5

kHz. Results shown in Fig. 4 presuppose that the appropriate preemphasis network is stalled between the audio generator and the amplitude modulation input terminals of the signal generator. If such a preemphasis network is not used in the test, results should be shown in Fig. 4.

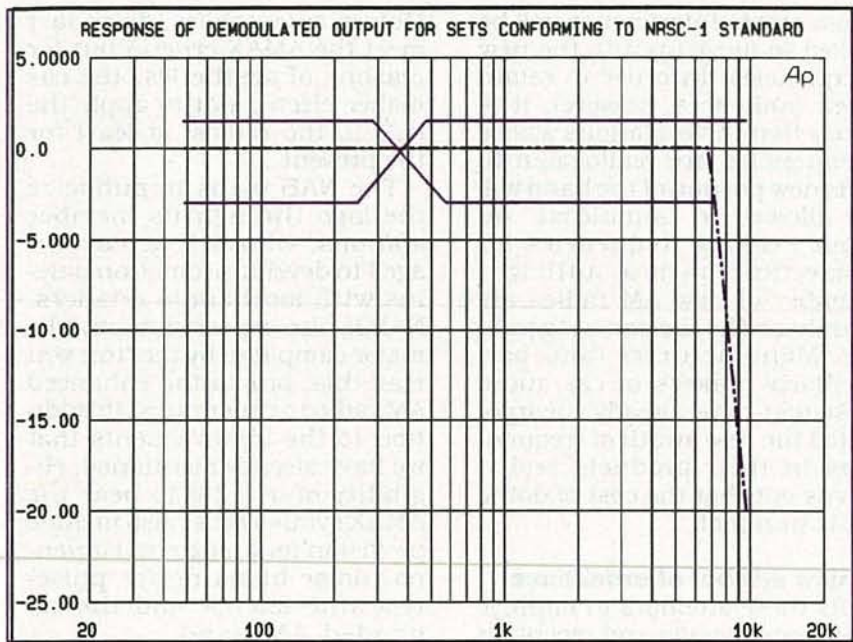

FIG. 3—FREQUENCY RESPONSE of AM circuitry that is required to conform to the NRSC-1 standard. The dashed line represents an ideal response, with the solid lines representing the tolerance limits. (Presumes preemphasis in the RF test generator.)

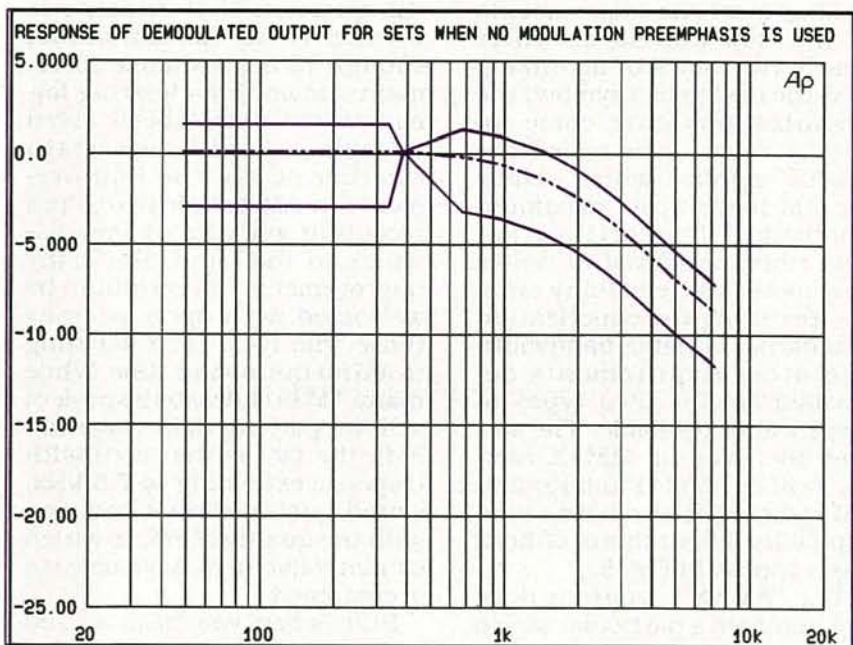

FIG. 4—FREQUENCY RESPONSE of AM circuitry that is required to conform to NRSC-1, with no preemphasis in the RF test generator.

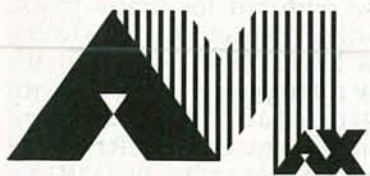

FIG. 5—AMAX LOGOS will identify AM radios that meet the NRSC requirements.

## NRSC-2 by 1994

During the interim period from June 1990 to June 1994, the FCC is going to presume that if a station conforms to NRSC-1, it is also in compliance with NRSC-2. The chief reason for the delay is the lack of appropriate, inexpensive test equipment needed to confirm compliance with all the provisions of NRSC-2. Those provisions mandate that NRSC-2 deals primarily with attenuation of carrier emissions rather than indirectly with audio response and performance. According to the NRSC-2 rules, emissions between 10.2 kHz and 20 kHz removed from the carrier's fundamental RF frequency must be attenuated at least 25 dB below the unmodulated carrier level. Emissions between 20 kHz and 30 kHz away from the carrier frequency must be attenuated by at least 35 dB below the unmodulated carrier level. Emissions that are between 30 kHz and 60 kHz away from the carrier frequency must be attenuated by at least  $5 + 1\text{dB/kHz}$  below the unmodulated carrier level. (For example, emissions that are 50 kHz away from the carrier frequency would have to be attenuated by  $5 + 50$ , or 55 dB relative to the level of the unmodulated carrier). Finally, emissions between 60 kHz and 75 kHz must be attenuated by at least 65 dB.

## More breathing room

While the NRSC-1 and NRSC-2 provisions will certainly help alleviate some of the problems of interference between stations, it cannot do the whole job in view of the congestion of the AM band that now exists in some geographical areas. Accordingly, as of July 1, 1991, the FCC officially expanded the AM band by an additional 100 kHz. The band now extends from 535 kHz to 1705 kHz.

This additional spectrum space is expected to accommodate at least 200 AM stations, nationally. Rather than increase the number of licenses to broadcasters, however, it is expected that those stations causing the

# Want To Be A Partner In A Group That Has A Multi- Billion Dollar Surplus Each Year?

## You Are.

If you're one of the 133 million working Americans and 6 million employers who contribute to Social Security each year, you're already a partner in a group with a multi-billion dollar surplus. Social Security was designed to provide every working member of society with a foundation for retirement. In addition, you get disability insurance and survivor benefits for your family. It's a partnership you can rely on. Learn more about *your* benefits. Write: Dept. 37, Pueblo, Colorado 81009.



Department of Health and Human Services

most severe interference will be asked to move up into the new frequencies. In order to retain their audiences, however, it is likely that those stations whose frequencies are reallocated to this new portion of the band will be allowed to "simulcast" on their existing frequencies for some time until a sufficient number of new AM radios are purchased by the listening public. Manufacturers (and particularly makers of car audio systems) have already incorporated the new swath of frequencies in their products and it turns out that the cost of doing so is minimal.

### A new symbol of excellence

As these attempts to improve AM transmission and reception were being formulated, the NAB and the EIA came up with the idea that it would be nice to have some visible means of identification displayed on radios that meet the requirements of the new standards. After nearly two years of agonizing over the design of a symbol, the organizations have come up with a decal to be called the "AMAX" symbol, which stands for "AM Radio at its maximum potential." The certification logo could be affixed to radios that meet basic eligibility criteria including the equalization standards, variable bandwidth and other requirements described earlier. Two types of logos will be available. The second one, reading "AMAX Stereo," will be applied to improved AM radios that also have stereo capability. Illustrations of both logos appear in Fig. 5.

The "AMAX" program does not mandate a particular stereo AM format—only that the radio be capable of receiving and decoding *some* kind of AM stereo transmission. Of course, the decision to market AMAX certified radios is at the discretion of individual manufacturers, as is the decision to apply the "AMAX" or "AMAX Stereo" logo to the sets themselves. Interestingly, we recently learned that the latest Delco/Bose car audio radios, as installed in some 1992 model General

Motors automobiles, do in fact meet the AMAX criteria but for reasons of aesthetics, the car maker elected not to apply the logo to the radios, at least for the present.

The NAB plans to publicize the logo through its member stations, who will be encouraged to develop promotional ties with local audio retailers. NAB is also expected to unveil a major campaign by the time you read this, promoting enhanced AM radio to consumers. In addition to the improvements that we have already mentioned, the capability of a radio to bear the AMAX symbol must also include provision for an external antenna, noise blanking for pulse type interference and the expanded AM band.

### Will improvements help?

While both the EIA and the NAB are enthusiastic about these attempts to improve AM, the question that remains is whether or not AM can attract enough of an audience to remain a major broadcasting format in the years ahead. Even though it is still uncertain whether or not the improvements in AM broadcasting and reception will attract new listeners to the band, the major improvements are certain to be welcomed with open arms by those who have been listening to AM for quite some time. While many AM broadcasters speak of a "level playing field" (again, FM), the fact is that even with response extending to 7.5 kHz sound quality cannot compare with the quality of FM, to which so many listeners have become accustomed.

Still, when you hear an AM broadcast that has extended frequency response of this kind, it's amazing how good it does sound when compared with the "typical" AM radio sound you have endured for many years. Perhaps AM radio can be given a new lease on life—even if it's only a temporary reprieve until digital audio broadcasting (which some now prefer to call digital audio radio, or DAR) replaces both of our current modes of radio. **R**



MICHAEL A. LASHANSKY

LAST MONTH WE INTRODUCED YOU to our professional-quality 2.5-MHz function generator and frequency counter that can read up to 150 MHz. This month we'll show you how to build, test, and properly use this essential test instrument.

### Construction

The function generator circuitry is mounted on three PC boards; the mother board, daughter board, and LED display board. The PC boards are available from the source mentioned in the parts list. Foil patterns are provided here if you wish to make your own boards, however the artwork was designed for nonplated holes. In places where it is impossible to solder both sides of a component, such as in the switch arrays, vias are provided for wire connections from one side of the board to the other. If you do make your own board, you'll have to solder some wires from the top of the switch arrays to points on the board. That is not necessary if you use the boards supplied with the kit.

Figures 6 and 7 show internal photographs of the author's prototype. Solder all diodes and resistors first, followed by the capacitors and then the IC's. IC sockets are not required, but they may make life a lot easier in the event of trouble.

It's best to build and test functional blocks as you go rather than building the whole unit all at once. First, start by constructing all the cable assemblies as indicated in Fig. 8. Start with the power-supply section, and verify that the output voltages are correct. The AC power cord routes through a strain relief in the back panel, and one side is soldered to the top of switch S15 (pole a). The other AC lead is soldered to the pad connected to fuse F1.

Next, build the triangle and square-wave generator sections. Those sections consist of components with the 1XX and 2XX component numbering scheme. A parts placement diagram of those sections, located

# SWEEP/FUNCTION GENERATOR

*Let's build our benchtop  
function generator  
and frequency counter!*

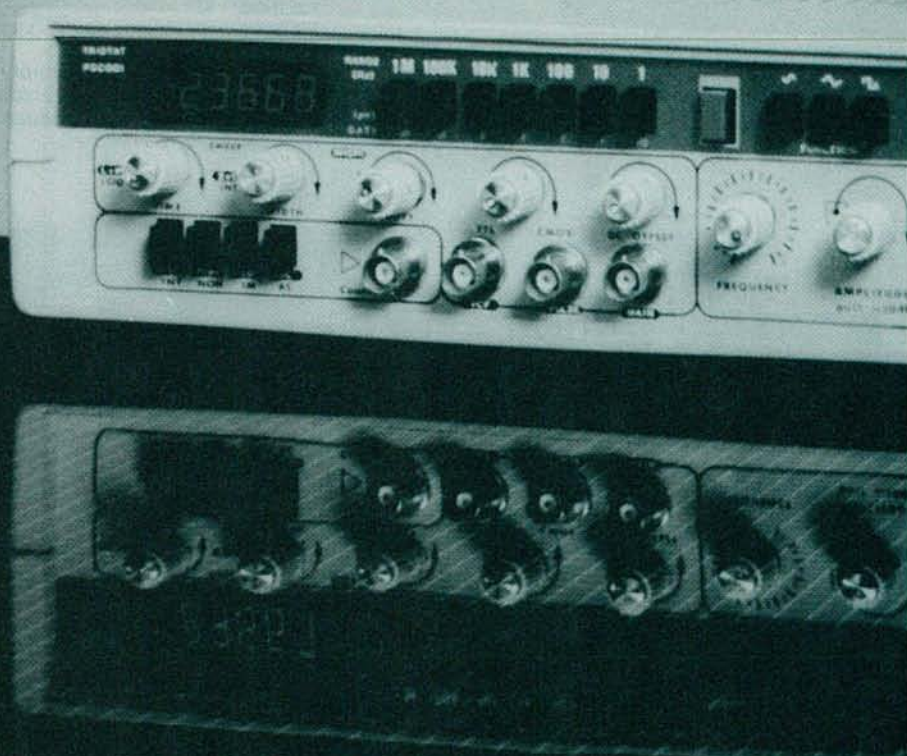

on the main board, is shown in Fig. 9. You will need an oscilloscope to verify that a triangle wave of about two volts peak-to-peak is present at the gate of Q5, and a one-volt peak-to-peak square wave is present at the collector of Q6. If those two waveforms are not present, go back and check your solder joints and component orientations.

Potentiometers R125 and R126 set the symmetry of the waveform and should be adjusted to give a triangle wave with equal slopes. R129 sets the upper frequency limit and

should be adjusted to give your desired high frequency for a given range. That is done with the course frequency-adjust potentiometer S101 in its maximum position. As a general guide, set R129 for a maximum frequency of 2.5 MHz, with the 1-MHz range switch engaged. Potentiometer R223 sets the zero balance of the triangle wave and is adjusted to give a centered signal. Square-wave balance is achieved through potentiometers R224 and R225. You can now check the pulse output for TTL levels and a variable CMOS level. With the basic gen-

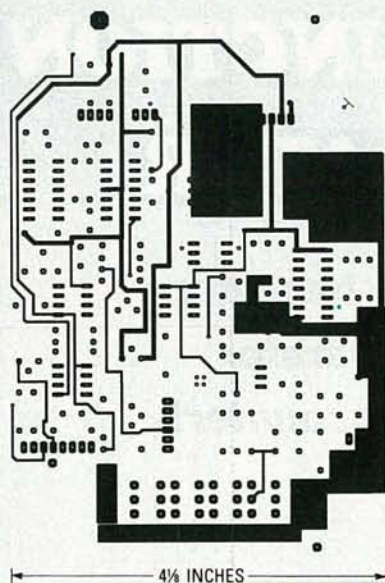

COMPONENT SIDE DAUGHTER BOARD foil pattern.

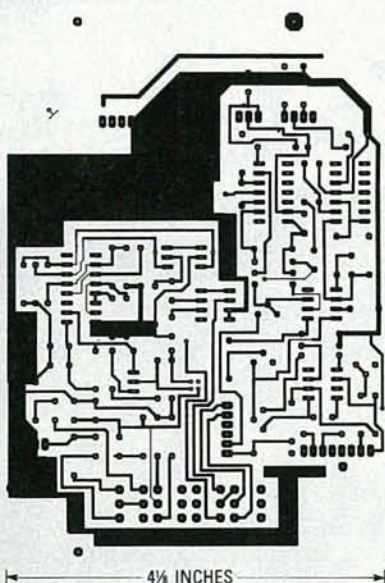

SOLDER SIDE DAUGHTER BOARD foil pattern.

erator now functioning, build the sine-shaper circuit (component numbers 3XX) and verify a sine wave at the output of IC9.

Adjust R323 for a two-volt peak-to-peak sine-wave output at IC9 pin 12. The amplitude of the square wave is controlled by R324, which should be set to give a clean square wave without any overshoot or rounding on the edges.

The output amplifier should be built next. That section uses the 4XX numbering scheme. Set to R423 to its center posi-

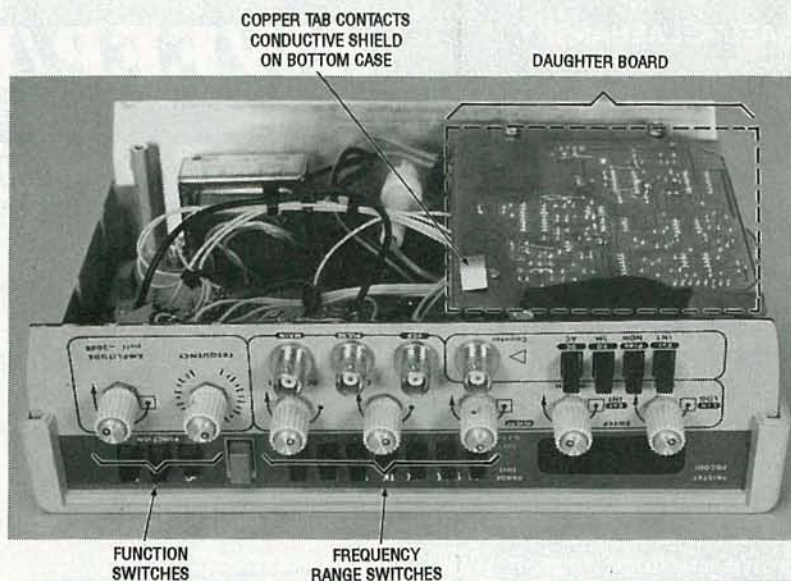

FIG. 6—INSIDE VIEW OF the author's prototype. A transparent red acrylic sheet was used for the front panel. A copper tab is soldered to the ground plane of the daughter board and contacts a 9/16 by 3/16-inch conductive shield, which is glued to the inside the bottom case (not shown).

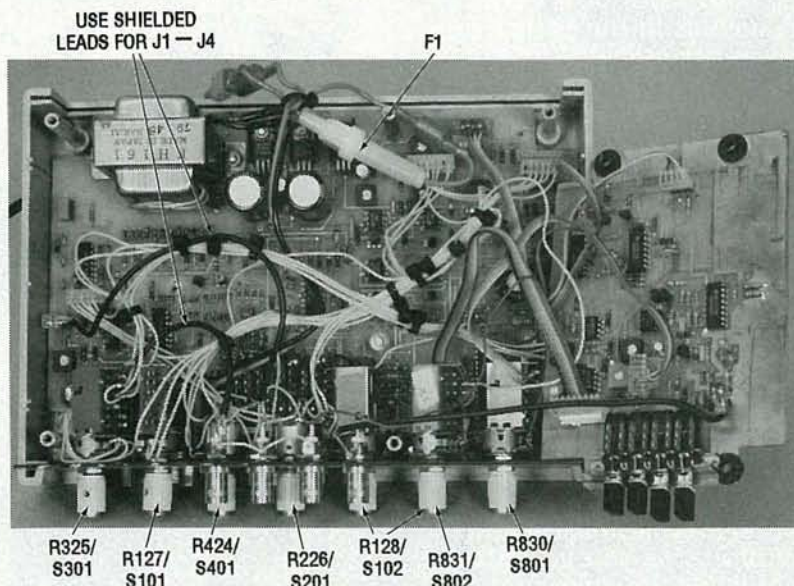

FIG. 7—INTERNAL PHOTO OF the author's prototype. Start construction by connecting all cable assemblies to switch-potentiometers mounted on the front panel.

tion and adjust it only if there is no output. Next, put your oscilloscope on DC coupling and observe the DC level of the output, adjust R422 until the output waveform is centered around zero. Verify the open-circuit signal swing of 20 volts peak-to-peak and the -20-dB attenuator switch.

The last work on the motherboard is to build the frequency-counting section and to mount the display board. The six display LED's are soldered to the display board, which is con-

nected to the motherboard by 90-degree, 14-pin strip header. With the display and components in place, observe the display. Select the MHz range and make sure that all the digits are functioning. If not, go back and double check the circuit. Use frequency counter or scope to calibrate the counter by adjusting C504 so that the display reading is the correct frequency selected.

The daughter board, which holds the counter input amplifier and sweep generator is

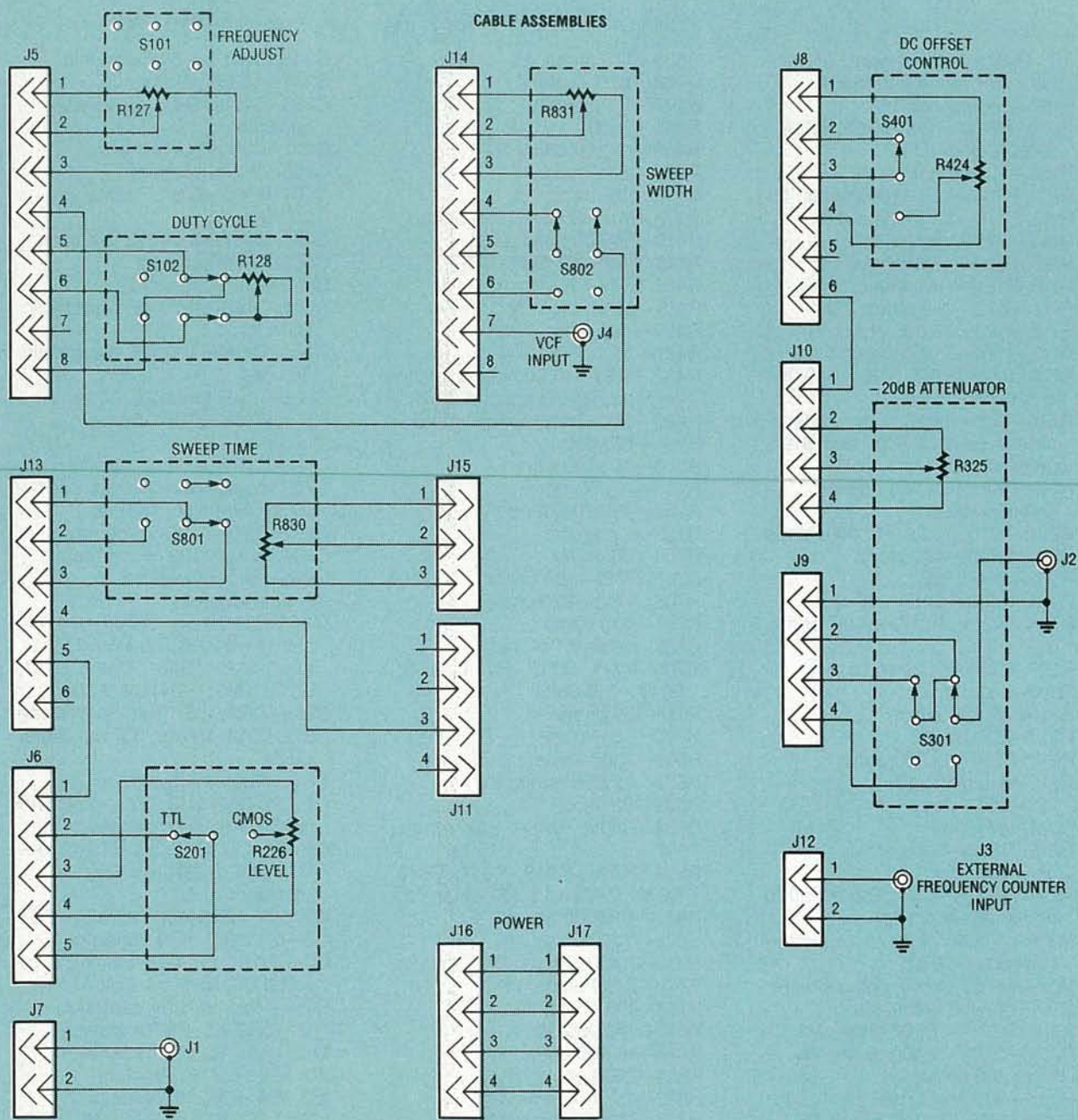

FIG. 8—CABLE ASSEMBLIES show the potentiometers that are connected to each of the function switches.

sembled next. That parts-placement diagram is shown in Fig. 10. The frequency-counter input circuit must be tested with an external signal or by selecting the external-signal source function and jumping the generator output to the counter input. Testing consists of verifying the operation of the switches, S11-S14 and the input amplifier.

The input amplifier can be tested by varying the amplitude

of an input signal from about 25 millivolts to 50 volts peak-to-peak (if no test signal is available, use the generator itself) and observing the frequency reading on the display. The frequency should remain the same for all amplitude conditions. When selecting the prescale function, the display should shift two decimal places to the right if working correctly.

All the boards were designed to use transistors with an emit-

ter-collector-base pin arrangement, and the rectangular pads are configured to accept that. If you choose to use the alternate transistors indicated in the parts list, they are American made, and use an emitter-base-collector pin arrangement. When the substitutes are used, a small circular pad is placed between the emitter and collector of the rectangular pads. This circular pad is used for the base pin and the collectors and emitters remain connected to the rectangular pads.

## PARTS LIST

**All resistors are 1/4-watt, 5% unless otherwise indicated.**

- R101—2700 ohms, 1%  
 R102, R104, R105, R109, R111—100,000 ohms, 1%  
 R106—33,200 ohms, 1%  
 R107, R108, R110—1000 ohms, 1%  
 R112, R114—3010 ohms, 1%  
 R113—49,900 ohms, 1%  
 R115, R120—4990 ohms, 1%  
 R116, R121—7150 ohms, 1%  
 R117, R122—348 ohms, 1%  
 R118, R123—75,000 ohms, 1%  
 R119, R124—750,000 ohms, 1%  
 R125, R126, R826, R827—10,000 ohms, potentiometer  
 R127, R128—5000 ohms, potentiometer (part of S101 and S102, respectively)  
 R129, R825—20,000 ohms, potentiometer  
 R201, R210, R220—10,000 ohms  
 R202, R222—470 ohms  
 R203—390 ohms  
 R204, R206, R219—1000 ohms  
 R205, R216, R217—2700 ohms, 1%  
 R207, R208—4020 ohms, 1%  
 R209—511 ohms  
 R211—30,000 ohms  
 R212—2000 ohms  
 R213, R214—13,000 ohms  
 R215—910 ohms, 1%  
 R218—7500 ohms  
 R221—47 ohms  
 R223, R828—5000 ohms, potentiometer  
 R224, R225, R228, R229—2000 ohms, potentiometer  
 R226—10,000 ohms, potentiometer (part of S201)  
 R227—4700 ohms, potentiometer  
 R301—49,900 ohms, 1%  
 R302, R303—11,300 ohms, 1%  
 R304, R306—12,100 ohms, 1%  
 R305—309 ohms, 1%  
 R307—200 ohms, 1%  
 R308, R309—24,900 ohms, 1%  
 R310—127 ohms, 1%  
 R311—63.4 ohms, 1%  
 R312, R313, R320—1000 ohms  
 R314—5100 ohms  
 R315—680 ohms  
 R316—150 ohms  
 R317—6800 ohms  
 R318, R319—10,500 ohms, 1%  
 R321—2000 ohms  
 R322—12 ohms  
 R323, R324—1000 ohms, potentiometer  
 R325—5000 ohms, potentiometer (part of S301)  
 R401, R402, R503, R504—10,000 ohms  
 R403, R404—22,000 ohms  
 R405—170 ohms, 1%  
 R406—12,000 ohms  
 R407—1200 ohms  
 R408—2000  
 R409—18,200 ohms 1%  
 R410—270 ohms, 1%  
 R411—100 ohms, 1%  
 R412, R414, R502—3000 ohms  
 R413—24,3000 ohms, 1%  
 R415, R418—47 ohms, 1W  
 R416, R417—7.5 ohms  
 R419—50 ohms, 1/2W  
 R420—499 ohms, 1/2W  
 R421—56.2 ohms, 1%  
 R422, R424—10,000 ohms, potentiometer (R424 is part of S401)  
 R423—200 ohms, potentiometer  
 R501—100,000  
 R505—10 megohms  
 R701—10,000 ohms  
 R702—100,000 ohms  
 R703—1 megohm  
 R704—50 ohms  
 R705, R718—150 ohms  
 R706, R712—220 ohms  
 R707—470 ohms  
 R708, R715—51 ohms  
 R709—R711, R713, R714, R716, R717—510 ohms  
 R719—36 ohms  
 R720—1000 ohms  
 R801—7500 ohms, 1%  
 R802—33,000 ohms, 1%  
 R803—33 ohms, 1%  
 R804, R805, R807—5100 ohms, 1%  
 R806, R810, R816, R817, R819, R820, R822—10,000 ohms, 1%  
 R808—510,000 ohms, 1%  
 R809—2200 ohms, 1%  
 R811—22,000 ohms, 1%  
 R812—2400 ohms, 1%  
 R813—100 ohms, 1%  
 R815—150,000 ohms, 1%  
 R818—15,500 ohms, 1%  
 R821—2000 ohms, 1%  
 R823—15,000 ohms, 1%  
 R824—18,000 ohms, 1%  
 R830, R831—5000 ohms, potentiometer (part of S801 and S802, respectively)
- Capacitors**  
 C101, C102, C204, C205—0.1  $\mu$ F ceramic  
 C103, C203—100 pF, ceramic  
 C104—0.001  $\mu$ F, Mylar  
 C105—0.01  $\mu$ F, Mylar  
 C106—0.1  $\mu$ F, Mylar  
 C107—1  $\mu$ F, Mylar  
 C108, C504—15–60 pF, variable capacitor  
 C201—68 pF, ceramic  
 C202—0.047  $\mu$ F, ceramic  
 C301, C303—0.1  $\mu$ F, ceramic  
 C302, C304, C502—39 pF, ceramic  
 C305, C401—4.7 pF, ceramic  
 C307—15 pF, ceramic  
 C308, C408—5–35 pF, variable capacitor  
 C402—120 pF, ceramic  
 C403—2.2 pF, ceramic  
 C404, C406—6.8  $\mu$ F, tantalum, 20 volts  
 C405, C407—0.047  $\mu$ F, ceramic  
 C501—33 pF, ceramic  
 C503—10 pF, ceramic  
 C601, C602—1000  $\mu$ F, electrolytic 50 volts  
 C603, C604—100  $\mu$ F, electrolytic 50 volts  
 C605—1  $\mu$ F, tantalum, 20 volts  
 C701, C704—C706—0.1  $\mu$ F, ceramic  
 C702, C707—100 pF, ceramic  
 C703 10u tantalum 16 volts C801—22  $\mu$ F, tantalum, 16 volts  
 C802, C803—220 pF, ceramic  
 C804, C805—100 pF, ceramic  
 C806—500 pF, ceramic
- Semiconductors**  
 D101—D108, D201—D204, D206—D226, D301—D312, D315—D318, D401, D402, D701, D702, D801—1N4148 diode  
 D205—1N751, 5.1-volt Zener diode  
 D313, D314—1N746, 3.3-volt Zener diode  
 BR1—W02M bridge diode  
 Q1, Q4, Q12, Q13, Q21—2SC1815 or MPSA05 NPN transistor  
 Q2, Q3, Q6, Q7, Q11, Q19, Q20—2SA1015 or 2N4403 PNP transistor  
 Q5, Q17—2N4416, N-channel FET  
 Q8—2N3904, NPN transistor  
 Q9, Q10, Q14—2SC1923 or MPSH34, NPN transistor  
 Q15—2N2219, NPN transistor  
 Q16—2N2905, PNP transistor  
 Q18—PN5139, PNP transistor  
 IC1, IC2—LM741, op-amp  
 IC3, IC4—LM308, op-amp  
 IC5, IC6, IC20—CA3086, NPN transistor IC (Harris)  
 IC7—7420, dual 4-input AND gate  
 IC8—4011, quad NAND gate  
 IC9—CA3030, op-amp  
 IC10—4066, CMOS quad bilateral switch  
 IC11—7216B, frequency counter and LED driver (Intersil)  
 IC12—7815, +15-volt voltage regulator  
 IC13—7805, +5-volt voltage regulator  
 IC14—7915, -15-volt voltage regulator  
 IC15—MC10116, ECL triple-line receiver with Schmitt trigger (Motorola)

IC16—SP8629, prescaler (Plessey)  
 IC17—LM324, quad op-amp  
 IC18—MC1458, dual op-amp  
 IC19—CA3140, op-amp (Harris)  
 SR801—1000 ohms, thermistor  
 DISP1—DISP6—common-cathode  
 LED (FND357)

**Other components**

S1—S7—4PDT-D switch  
 S8—DPDT switch  
 S9—S11—DPDT-D switch  
 S12—S14—DPDT-I switch  
 S15—DPDT on/off switch  
 S101—DTDP switch used with  
 R127 (5K potentiometer)  
 S102—DTDP switch used with  
 R128 (5K potentiometer)  
 S201—SPDT switch used with  
 R226 (10K potentiometer)  
 S301—DPDT switch used with  
 R325 (5K potentiometer)  
 S401—SPDT switch used with  
 R424 (10K potentiometer)  
 S801—DPDT switch used with  
 R830 (5K potentiometer)  
 S802—DPDT switch used with  
 R831 (5K potentiometer)  
 J1—J4—BNC connector  
 J5, J14—8-position female/male,  
 0.1-inch centers  
 J6—5-position female/male, 0.1-  
 inch centers  
 J7, J12—2-position female/male  
 J8, J13—6-position female/male  
 J9—J11, J15, J16—4-position  
 female/male, 0.1-inch centers  
 XTAL1—10-MHz AT/CUT crystal  
 T1—115/40 volts AC, 0.5-amp  
 transformer  
 F1—0.5-amp fuse

**Miscellaneous:** Case (CTP-1 by  
 Global Specialties), three 1.75-  
 inch standoffs, four 2-inch stand-  
 offs, two T0-5 heatsinks, three  
 T0-220 heatsinks, three PC  
 boards, internal wiring,  
 fuseholder, 3-conductor 18-  
 gauge power-supply cord, and  
 strain relief.

**Note:** The following items are  
 available from Tristat Elec-  
 tronics, Inc., 66A Brockington  
 Cres., Nepean, Ontario, Cana-  
 da, K2G 5L1, (613) 228-7223:

- A set of three etched and drilled PC boards—\$76.
- All components without the PC board and case—\$250.
- Complete kit of all parts (un-  
 finished front panel)—\$300.
- Cut and silk-screened front  
 panel—\$10.

Add \$17 for shipping and han-  
 dling. Send check or money  
 order only.

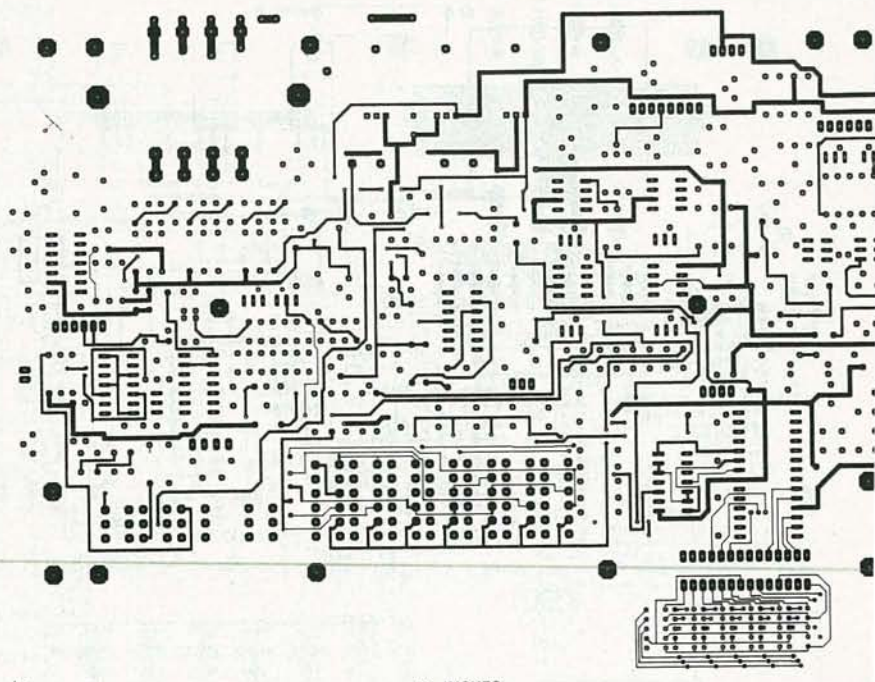

COMPONENT SIDE FOIL pattern of the mother board.

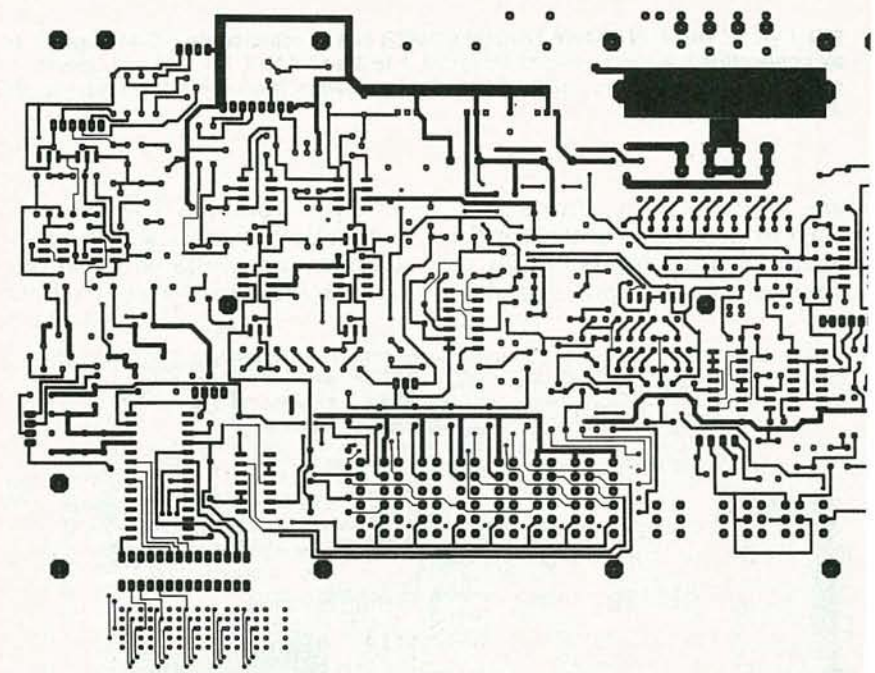

SOLDER SIDE FOIL PATTERN of the mother board.

The sweep generator is built  
 next. If you're using the boards  
 supplied with the kit, mount  
 potentiometers R825—R828 to  
 the solder side of the board.  
 That will make adjustments  
 easier when the unit is as-  
 sembled. If you're making your

own boards, place the potenti-  
 ometers on the component side  
 and make your adjustments be-  
 fore the board is connected to  
 the mother board.

Once again you'll need an os-  
 cilloscope to verify proper align-  
 ment. Set R828 to its midpoint,

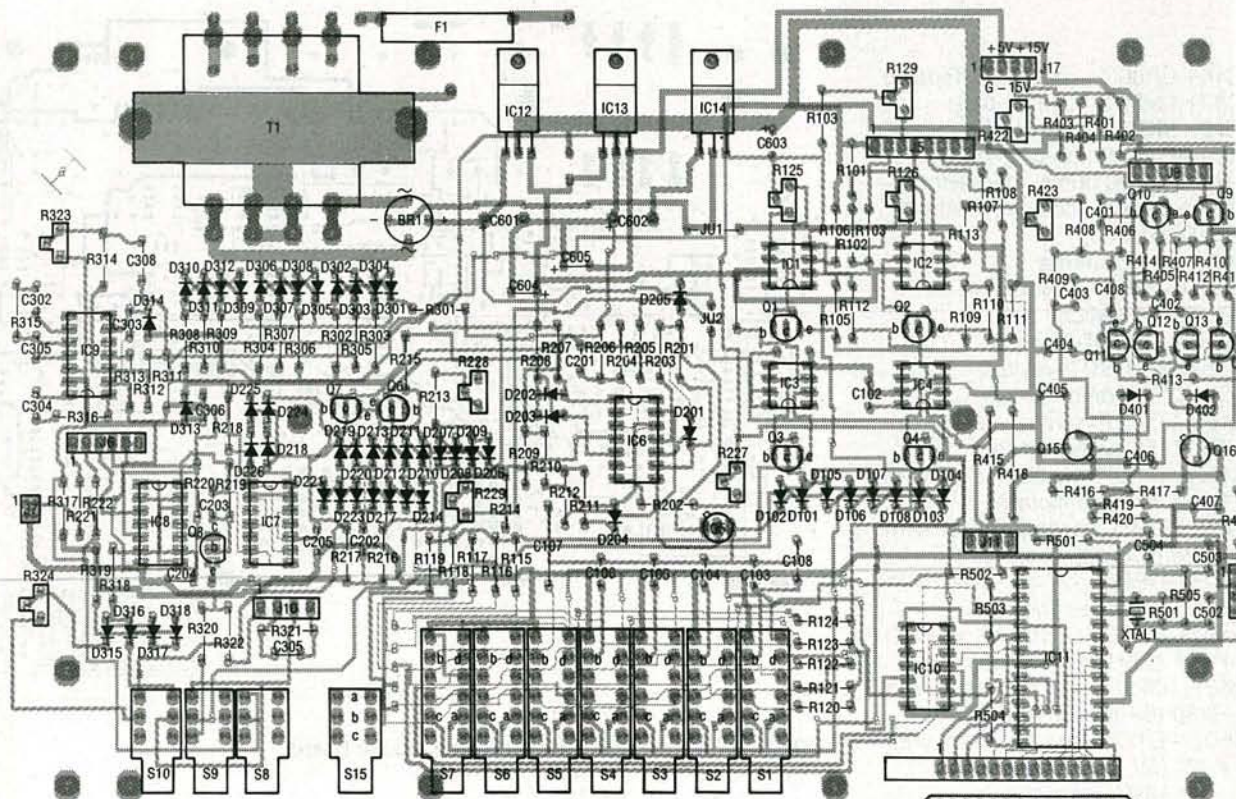

**FIG. 9—THE DUAL-PRIMARY TRANSFORMER** can accommodate 115-volt operation by connecting the two primaries in series: 1 to 3 and 2 to 4. For 220-volt operation, connect pins 2 and 3 in series. Also, the transistors have an extra base pad for different packages.

and adjust R825 to give a good log output (when selected) and a linear output. Adjust R826 to achieve a good input signal to

IC19 pin 2 and R827 will set the maximum sweep width. If a scope is not available, most potentiometers can be set to their

center position and adjustments can be made by observing the LED display with the counter set to the internal count mode.

If everything is working properly, you can install the completed boards into the case. The top of the case uses four 2-in standoffs. The front and back panels supplied with the case are of 0.065-inch aluminum and are not recommended for use as a front panel. A complete cut and silk-screened panel is available from the source mentioned in the parts list, or you can make your own using transparent red acrylic. Secure the mother board in place (top half of case) and finally install the daughter board using three 1-inch standoffs. You're now ready to power up and use your combination function generator and frequency counter.

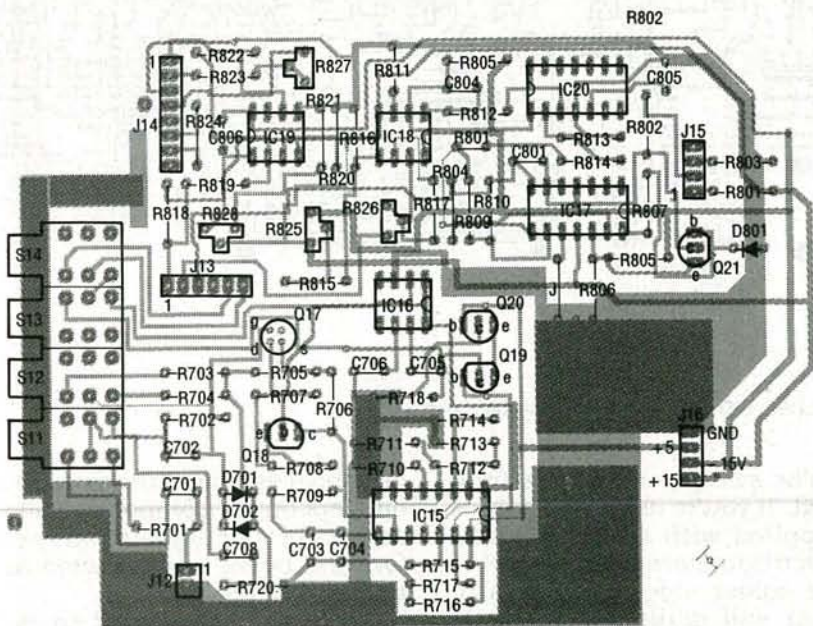

**FIG. 10—PARTS PLACEMENT OF DAUGHTER BOARD** holds the input amplifier and sweep generator circuit.

### Using your unit

Table 1 shows a complete l

TABLE 1—FUNCTION GENERATOR SPECIFICATIONS

FUNCTION	MIN	MAX	UNITS
Sine Wave	0.1	2.5 Mega	Hz
Triangle Wave	0.1	2.5 Mega	Hz
Square Wave	0.1	2.5 Mega	Hz
Pulse	0.1	2.5 Mega	Hz
<b>Amplitude</b>			
Main Output	3.0	20	Vp-p
-20dB	0.5	6	Vp-p
TTL Pulse	50	5	Vp
CMOS Pulse	0.5	15	Vp
Duty Cycle	10	90	%
DC Offset	-10	+10	VDC
<b>Sweep Generator</b>			
Sweep Width	1	1000	X Initial Freq.
Sweep Time	1	20	Seconds
<b>Frequency Counter</b>			
Input Sensitivity	20	100	Vp-p
Input Range	0.1	150 Mega	Hz
Input Impedance	50	1 Mega	Ohms
Gates Times	.01	10	Seconds
Error	± LSD		
Stability	50ppm/°C		

of functions and specifications of the unit.

The square wave output is in phase with the sine wave and the triangle wave, but is 180 degrees out phase with the TTL and CMOS pulse outputs. That feature is useful for creating a two-phase clocking system if you happen to be working with digital equipment. The unit is calibrated to give a frequency range of 0.1 Hz to 2.5 MHz. The upper frequency limit can be extended by adjusting variable capacitor C108 and/or R129. With the component values that we have given, the upper frequency limit can reach as high as 4 MHz.

Changing the values of the timing resistors R115-R119 and R120-R124 will produce output frequencies as determined by the formula  $1/RC$ . That method will achieve a maximum sine-wave output of 10 MHz with an amplitude of 1 volt peak-to-peak above 2 MHz. **R-E**

## GET THE LATEST ADVANCES IN ELECTRONICS

WITH A SUBSCRIPTION TO

# Radio Electronics®

ENJOY THE WORLD OF ELECTRONICS EACH MONTH!

Now you can subscribe to the best electronics magazine. The only one that brings you articles on—electronics projects, technology, circuit design, communications, new products and much more.

Radio-Electronics looks to the future and shows you what new video, audio and computer products are on the horizon. What's more you'll find helpful, monthly departments such as Video News, Equipment

Reports, Hardware Hacker, Audio Update, Drawing Board, Communications Corner. All designed to give you instruction, tips, and fun.



Radio-Electronics gives you exciting articles like:

- ┌ ISDN: The Telephone Network of Tomorrow
- ┌ The Facts on FAX
- ┌ A Digital Phone Lock
- ┌ How To Design Switching Circuits
- ┌ EIA-232 A real standard for serial interfacing?
- ┌ Build a synergy card for your PC
- ┌ '386 Power at a '286 price
- ┌ Build a biofeedback monitor
- ┌ More on Multiplexing



FOR FASTER SERVICE CALL TODAY  
**1-800-999-7139**

**SUBSCRIBE TODAY**

Just fill out the order card in this magazine and mail it in today.

# Countersurveillance

**Never before has so much professional information on the art of detecting and eliminating electronic snooping devices—and how to defend against experienced information thieves—been placed in one VHS video. If you are a Fortune 500 CEO, an executive in any hi-tech industry, or a novice seeking entry into an honorable, rewarding field of work in countersurveillance, you must view this video presentation again and again.**

*Wake up!* You may be the victim of stolen words—precious ideas that would have made you very wealthy! Yes, professionals, even rank amateurs, may be listening to your most private conversations.

*Wake up!* If you are not the victim, then you are surrounded by countless victims who need your help if you know how to discover telephone taps, locate bugs, or “sweep” a room clean.

There is a thriving professional service steeped in high-tech techniques that you can become a part of! But first, you must know and understand Countersurveillance Technology. Your very first insight into this highly rewarding field is made possible by a video VHS presentation that you cannot view on broadcast television, satellite, or cable. It presents an informative program prepared by professionals in the field who know their industry, its techniques, kinks and loopholes. Men who can tell you more in 45 minutes in a straightforward, exclusive talk than was ever attempted before.

## Foiling Information Thieves

Discover the targets professional snoopers seek out! The prey are stock brokers, arbitrage firms, manufacturers, high-tech companies, any competitive industry, or even small businesses in the same community. The valuable information they filch may be marketing strategies, customer lists, product formulas, manufacturing techniques, even advertising plans. Information thieves eavesdrop on court decisions, bidding information, financial data. The list is unlimited in the mind of man—especially if he is a thief!

You know that the Russians secretly installed countless microphones in the concrete work of the American Embassy building in Moscow. They converted



**CALL  
TODAY  
TOLL  
FREE**

**1-800-522-6260**

**HAVE YOUR  
VISA or MC CARD  
AVAILABLE**

what was to be an embassy and private residence into the most sophisticated recording studio the world had ever known. The building had to be torn down in order to remove all the bugs.

## Stolen Information

The open taps from where the information pours out may be from FAX's, computer communications, telephone calls, and everyday business meetings and lunchtime encounters. Businessmen need counselling on how to eliminate this information drain. Basic telephone use coupled with the user's understanding that someone may be listening or recording vital data and information greatly reduces the opportunity for others to purloin meaningful information.

The professional discussions seen on the TV screen in your home reveals how to detect and disable wiretaps, m radio-frequency transmitters, and bugs, plus when to use disinformation to confuse the unwanted listener, and the technique of voice scrambling telephonic communications. In fact, do you know how to look for a bug, where to look for a bug, and what to do when you find one?

Bugs of a very small size are easy to build and they can be placed quickly in a matter of seconds, in any object or room. Today you may have used a telephone handset that was bugged. It probably contained three bugs. One was a pre-recorded message to fool you into believing you found a bug and secured the telephone. The second bug placates the investigator when he finds the real thing! And the third is found only by the professional, and is continued to search just in case there are more bugs.

The professional is not without special tools. Special equipment has been designed so that the professional can sweep a room so that he can detect voice-activated (VOX) and remote-activated bugs. Some of this equipment can be operated by novices, others require a trained countersurveillance professional.

The professionals viewed on your television screen reveal information on the latest technological advances like laser beam snoopers that are installed hundreds of feet away from the room you snoop on. The professionals disclose how computers yield information too easily.

This advertisement was not written by a countersurveillance professional, but by a beginner whose only experience is from viewing the video tape in the privacy of his home. After you review the video carefully and understand its contents, you have taken the first important step in either acquiring professional help with your surveillance problems, or you may very well consider a career as a countersurveillance professional.

## The Dollars You Save

To obtain the information contained on the video VHS cassette, you would attend a professional seminar costing \$350 and possibly pay hundreds of dollars if you had to travel to a distant city to attend. Now, for only \$49.95 (\$4.00 P&H) you can view *Countersurveillance Techniques* at home and refresh your views often. To obtain your copy, complete the coupon below or call toll free.

### RADIO-ELECTRONICS VIDEO OFFER **RE**

500-B Bi-County Blvd.  
Farmingdale, NY 11735

Please rush my copy of the Countersurveillance Techniques Video VHS Cassette for \$49.95 plus \$4.00 for postage and handling.

No. of Cassettes ordered \_\_\_\_\_

Amount of payment \$ \_\_\_\_\_

Bill my  VISA  MasterCard

Card No. \_\_\_\_\_

Expire Date \_\_\_\_/\_\_\_\_/\_\_\_\_

Signature \_\_\_\_\_

Name \_\_\_\_\_

Address \_\_\_\_\_

City \_\_\_\_\_ State \_\_\_\_\_ ZIP \_\_\_\_\_

All payments in U.S.A. funds. Canadians add \$4.00 per VHS cassette. No foreign orders. New York State residents add applicable sales tax.



# EXPERIMENTING WITH ADC FOR YOUR PC

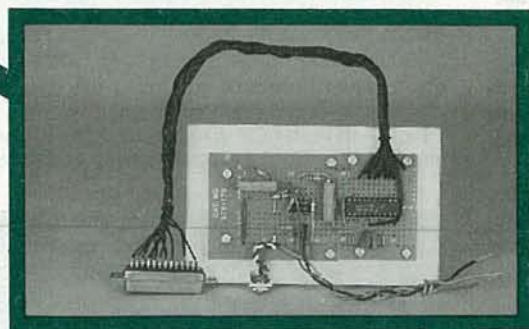
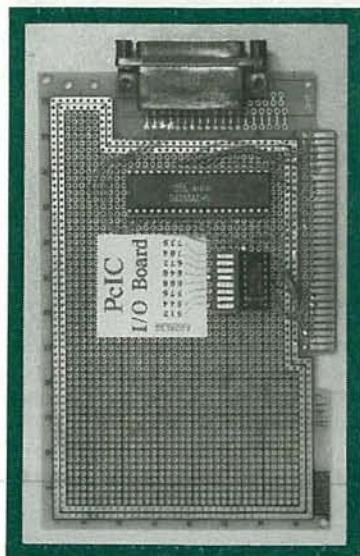

JAMES J. BARBARELLO

## **Add a variety of analog inputs to the PC-based analog-to-digital convertor.**

PC-BASED TEST INSTRUMENTATION has turned out to be a popular topic among readers. We continue this ongoing series by interfacing new sensing devices (a linear displacement transducer, a piezoelectric transducer, and a microphone) to the analog-to-digital converter (ADC) discussed in the January 1992 issue. If you're just getting started with this series, here's a brief review of progress thus far.

### **Quick review**

The heart of the system is a PC I/O expander called the PC IO that adds 24 lines of digital I/O by means of an 8255 Parallel Input/Output (PIO), all on a single 8-bit expansion card. In the January 1992 installment, we added an outboard analog-to-digital converter (ADC), based on an ADC0804. The ADC allows you to measure and capture any 0-5 volt analog signal (e.g., temperature, displacement, and audio). The circuit includes a variable-gain amplifier for low-level inputs, and a DC-offset adjustment for inputs with unwanted DC components. A temperature probe

shown in that article was built around the base-collector junction of a silicon transistor. With the proper settings for amplification and DC offset, a several-hundred millivolt change over a 100°reeC temperature range produced a digital output spread over the full input range of the ADC0804.

In general, an A/D converter and a PC can provide very low-cost solutions to measurement problems that would ordinarily require costly test equipment. Following are some ideas, practical circuits, and software for interfacing other types of devices. These ideas cover the three most common types of sensing: mechanical, electrical, and acoustic.

### **Mechanical sensing**

As an example of mechanical sensing, the author and a friend were contracted to measure the displacement, impact force, and velocity of electromechanical rappers used in the pollution-control industry. Factory smokestacks have environmental controls that contain huge, electrostatically

charged metal plates. As the smoke goes up the smokestack, it passes by those plates; the plates "pull" the suspended particles to them, removing pollution that would otherwise be released to the outside air. Particles accumulate on the plates, and eventually have to be removed. To "clean" the plates, rappers (like giant solenoids) provide quick, hard jolts to the plates, breaking trapped particles free in huge sheets that fall to the bottom of the smokestack. Our task was to determine the characteristics of existing commercial rappers, and then determine whether our customer's rapper could be made better than the competition's.

Our test instrumentation consisted of an 8-bit A/D converter hooked up to a computer, and fed by a rectilinear potenti-



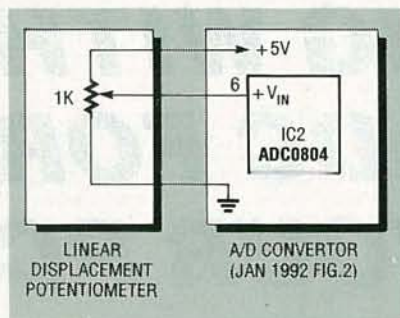

**FIG. 1—INTERFACE A LINEAR displacement transducer to the PC IO as shown here. The wiper of the LDT drives the ADC0804 directly, so remember to disconnect the op-amp output (pin 7) from the ADC's input. (The original circuit was shown in Fig. 2 in the January 1992 installment.)**

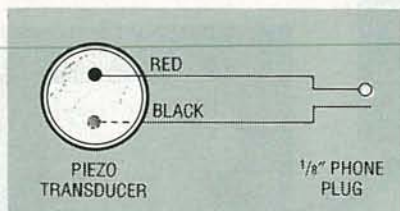

**FIG. 2—INTERFACE A PIEZOELECTRIC transducer as shown here. Make sure the red lead goes to the tip and the black lead to the ring of the plug. Also, to avoid feeding DC voltage into the transducer, disconnect the J1 end of R1.**

ometer (also called a linear displacement transducer, or LDT). LDT's are precision potentiometers that move linearly, rather than circularly. Even at surplus prices, LDT's aren't cheap (\$20-\$50), but they do a great job. Figure 2 in the January 1992 issue shows the complete ADC circuit; we simply supplied it with the input shown here in Fig. 1. Note that we power the LDT directly with a 5-volt DC supply, so neither amplification nor DC offset were required. Instead, we drive the ADC0804 (IC2) directly, as shown in the figure.

If you use this type of arrangement, be sure to disconnect the op-amp's output (pin 7) from the ADC's input (pin 6). In addition, make sure the potentiometer has a resistance of at least 1K, so as not to draw too much current from your PC's power supply. Also, the mechanical linkage between the LDT and the rapper must be firm so there is little or no slippage at the speeds encountered. Otherwise, the potentiometer will not

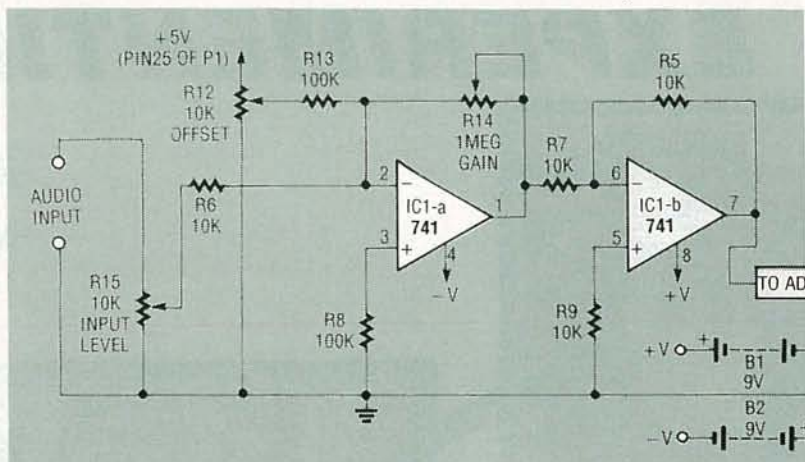

**FIG. 3—INTERFACE AN AUDIO SOURCE as shown here. The nonsequential numbers occur to keep numbering consistent with the original circuit.**

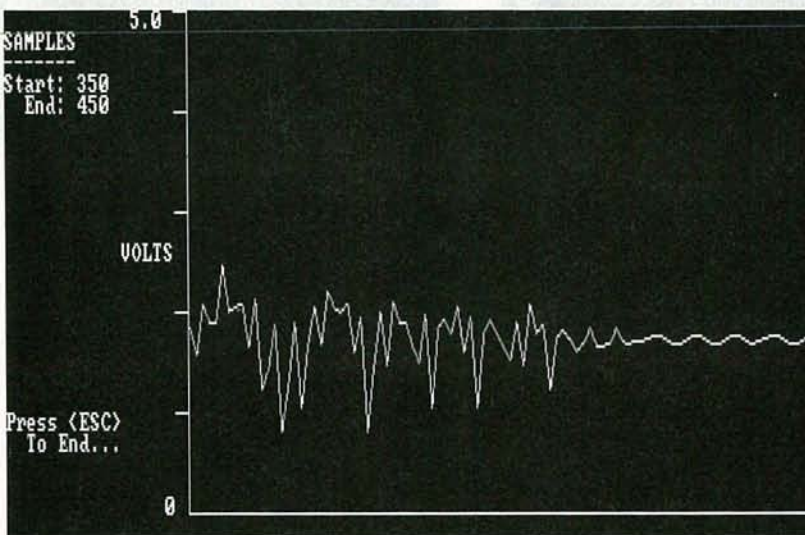

**FIG. 4—GRAPHICAL OUTPUT from GRAFDATA.BAS (Listing 2), which allows you display as many as 1000 data points captured by ADC.BAS (Listing 1).**

give a true indication of displacement. This type of setup would also be useful for measuring the movement of solenoids, pistons, cams, and similar devices.

Using that circuit, we obtained a series of outputs that showed exactly how the rapper's plunger moved a quarter of a second after it triggered. Eight bits of digital data made it easy to calculate the rate of change of displacement (velocity), as well as the maximum displacement. We determined impact force using strain gages.

The only problem we had was in determining just when to read the LDT's resistance. The solution turned out to be straightforward, as we'll see momentarily.

### Electrical sensing

The temperature probe developed last time is one example of electrical sensing. Another good sensing device is piezoelectric material, available both film and crystal form. An inexpensive source of piezoelectric crystal is Radio Shack Piezo Transducer (273-07). Simply break open the plastic case, and you have a circular piezoelectric transducer with red and black leads. When flexed in any way, the transducer produces a voltage that varies proportionally to the amount of flexing.

A piezo transducer can be used to measure force of impact, or the amount of bend and flexing. Figure 2 shows how to connect a piezo transducer

## LISTING 1

```

1 REM*****
2 REM** ADC.BAS - V910803 - JJ Barbarello *
3 REM** Capture/Store Analog Data with Pca/D-MATE *
4 REM*****
10 CLS : DEFINT A, X: DIM A(1000): GOSUB 370: LOCATE 1, 23
20 PRINT "Pca/D DATA COLLECTION SYSTEM": LOCATE 2, 1: PRINT
STRINGS(79, 220)
30 LOCATE 5, 1: PRINT SPACES(79); : LOCATE 5, 10
40 LINE INPUT "Enter Time (0-3600 seconds) between samples...";
interval$
50 interval = VAL(interval$)
60 IF interval < 0 OR interval > 3600 THEN BEEP: GOTO 30
70 LOCATE 7, 10: PRINT "Press <Enter> to begin, or <Esc> to
abort...";
80 GOSUB 350: IF AS$ = CHR$(27) THEN CLOSE : END
90 LOCATE 5, 10: PRINT SPACES(60): LOCATE 7, 10: PRINT SPACES(60)
100 LOCATE 10, 22: PRINT "DIGITAL DATA (0-255)": LOCATE 12, 19
110 IF interval > 0 THEN PRINT "SECONDS BETWEEN SAMPLES: "; interval
120 LOCATE 13, 29: PRINT "SAMPLE NUMBER: "
130 LOCATE 16, 20: PRINT "Press <Esc> to End Sampling...";
140 account = 1: xsample = 1
150 told = VAL(MID$(TIMES$, 4, 2)) * 60 + VAL(RIGHT$(TIMES$, 2))
160 IF interval = 0 THEN GOTO 210
170 T = VAL(MID$(TIMES$, 4, 2)) * 60 + VAL(RIGHT$(TIMES$, 2))
180 IF T = 0 AND (told - T > interval) THEN told = told - 3600
190 IF INKEY$ = CHR$(27) THEN GOTO 260
200 IF T - told > 0 THEN told = told + interval ELSE GOTO 170
210 OUT ADD + 2, 0: OUT ADD + 2, 1
220 x = INP(ADD): LOCATE 10, 44: PRINT USING "###"; x
230 LOCATE 13, 44: PRINT xsample; : xsample = xsample + 1
240 IF account < 1001 THEN A(account) = x: account = account + 1
250 IF INKEY$ <> CHR$(27) THEN GOTO 160
260 BEEP: LOCATE 16, 15
270 PRINT "Press <Enter> to save data, <Esc> for no save...";
280 GOSUB 350: IF ASC(AS) = 27 THEN CLS : END
290 LOCATE 16, 15
300 LINE INPUT "Enter File Name To Save Data (ex: TEST01.ADD)...": f$
310 OPEN "r", 1, f$, 2: FIELD 1, 2 AS d$
320 LOCATE 18, 20: PRINT "Saving Data...";
330 FOR i = 1 TO account: LSET d$ = MKI$(A(i)): PUT 1, LOF(1) / 2 +
1: NEXT
340 PRINT "Done. Press ANY key.": : AS$ = INPUT$(1): CLOSE : CLS :
END
350 AS$ = INKEY$: IF AS$ = "" THEN GOTO 350
360 IF ASC(AS) = 13 OR ASC(AS) = 27 THEN RETURN ELSE BEEP: GOTO 350
370 OPEN "r", 1, "HWADDRES.DAT", 4: FIELD 1, 4 AS AS
380 GET 1, 1: ADD = VAL(AS): CLOSE : DEF SEG = 64: OUT ADD + 3, 146:
RETURN
1 REM** GRAFDATA.BAS
2 REM** Graph Pca/D-Mate .ADD File Data (Requires Graphics Monitor)
3 REM** V910802 - JJ Barbarello
4 REM**
10 CLEAR : DEFINT I-J, Y: KEY OFF: CLS
20 COLOR 0, 7: LOCATE 3, 27: PRINT " GRAPH Pca/D-MATE DATA "; : COLOR
7, 0
30 LOCATE 10, 20: INPUT "Enter File Name (ex: TEST1.ADD)..."; DFNS
40 OPEN "R", 1, DFNS, 2: FIELD 1, 2 AS D$: IF LOF(1) > 0 THEN GOTO 80
50 CLOSE : KILL DFNS: BEEP: LOCATE 25, 13
60 PRINT "That File Doesn't exist. Press ANY key to try again...";
70 AS$ = INPUT$(1): CLS : GOTO 20
80 LOCATE 21, 34: COLOR 16, 7: PRINT " Reading data "; : COLOR 7, 0
90 DIM I((LOF(1) / 2) + 3)
100 FOR I = 1 TO LOF(1) / 2: GET 1, I: I(I) = 190 - CVI(D$): NEXT
110 LOCATE 21, 34: PRINT SPACES(20)
120 LOCATE 12, 20: PRINT "File Has"; LOF(1) / 2: "Samples."
130 LOCATE 14, 20: INPUT "Enter Start Sample To View..."; ISTART
140 LOCATE 15, 20: INPUT "Enter End Sample To View"; IFIN
150 IF IFIN - ISTART > 1000 THEN IFIN = ISTART + 999
160 I(I) = I(I - 1): I(I + 1) = I(I): I(I + 2) = I(I + 1)
170 YINC = 500 / (IFIN - ISTART)
180 IF (IFIN - ISTART) > 499 THEN istp = 2 ELSE istp = 1
190 SCREEN 2: LOCATE 2, 1: PRINT "SAMPLES": LOCATE 3, 1: PRINT "-----
--"
200 LOCATE 4, 1: PRINT "Start: "; ISTART: LOCATE 5, 3: PRINT "End: ";
IFIN
210 LOCATE 20, 1: PRINT "Press <ESC>": LOCATE 21, 3: PRINT "To
End..."
220 LINE (138, 0)-(138, 190): LINE (138, 190)-(639, 190): J = 139
230 FOR I = 0 TO 152 STEP 38: LINE (128, I)-(137, I): NEXT
240 LOCATE 1, 13: PRINT "5.0": LOCATE 24, 16: PRINT "0";
250 LOCATE 12, 12: PRINT "VOLTS";
260 FOR I = ISTART TO IFIN STEP istp
270 LINE (J, I(I))-(J + YINC, I(I + istp)): J = J + YINC: NEXT I
280 AS$ = INKEY$: IF AS$ = "" THEN 280
290 IF ASC(AS) = 27 THEN SCREEN 0: END ELSE BEEP: GOTO 280

```

our circuit. We want only the voltage generated by the piezo sensor, so disconnect the J1 end

of R1, shown in Fig. 2 last time (R1 provided +5-volts DC to the temperature probe). With no in-

put signal, adjust R11 for maximum gain, and R12 so output is about 2.5-volts DC. (The latter setting allows the piezo voltage to vary from that quiescent level.) You might also want to adjust the value of R3 so that the piezo sensor produces maximum indication at its maximum output.

To test the circuit, use a piece of masking tape to secure the piezo sensor to a flat surface, making sure you aren't flexing it. Tap the surface firmly and note the response. In actual use, you would mount the sensor using a clamping device or flexible adhesive. This type of device is useful for measuring applied impact, oscillation after impact, or amount of flex or bend.

## Acoustic sensing

You've probably seen audio signals displayed on an oscilloscope. Now imagine "freezing" those signals—i.e., storing them in digital form. Scientists capture digitized audio in this way to study the sounds that whales, birds, and other animals make. In digitized form, it's easy to compare and contrast different sounds to determine which have similar characteristics, or to look at other factors that wouldn't otherwise be obvious.

To accommodate a microphone input, we modified the ADC circuit as shown in Fig. 3. The changes allow us to increase the gain of IC1-a to a maximum of 100, and to attenuate high-level inputs. Gain is determined by the ratio  $R14/R6 = 10^6/10^4 = 10^2 = 100$ . If the part numbering in Fig. 3 seems strange, it's because we tried to stay consistent with the main circuit shown in Fig. 2 in January. Note that in the January version, R6 was 100K; here we decreased its value to 10K. Also, we no longer use R1-R4.

In operation, first set R12 to mid-value. Then adjust R14 for maximum range, as described last time. Last, readjust R12 as necessary to set the quiescent level to about 2.5-volts DC. For example, a microphone might provide a maximum output

## LISTING 2

```

1 REM** GRAFDATA.BAS
2 REM** Graph Pca/D-Mate .ADD File Data (Requires Graphics Monitor)
3 REM** V910802 - JJ Barbarello
4 REM**
10 CLEAR : DEFINT I-J, Y: KEY OFF: CLS
20 COLOR 0, 7: LOCATE 3, 27: PRINT " GRAPH Pca/D-MATE DATA "; : COLOR
7, 0
30 LOCATE 10, 20: INPUT "Enter File Name (ex: TEST1.ADD)..."; DFNS
40 OPEN "R", 1, DFNS, 2: FIELD 1, 2 AS DS: IF LOF(1) > 0 THEN GOTO 80
50 CLOSE : KILL DFNS: BEEP: LOCATE 25, 13
60 PRINT "That File Doesn't exist. Press ANY key to try again...";
70 AS = INPUT$(1): CLS : GOTO 20
80 LOCATE 21, 34: COLOR 16, 7: PRINT " Reading data "; : COLOR 7, 0
90 DIM I((LOF(1) / 2) + 3)
100 FOR I = 1 TO LOF(1) / 2: GET 1, I: I(I) = 190 - CVI(DS): NEXT
110 LOCATE 21, 34: PRINT SPACE$(20)
120 LOCATE 12, 20: PRINT "File Has"; LOF(1) / 2; "Samples."
130 LOCATE 14, 20: INPUT "Enter Start Sample To View..."; ISTART
140 LOCATE 15, 20: INPUT "Enter End Sample To View"; IFIN
150 IF IFIN - ISTART > 1000 THEN IFIN = ISTART + 999
160 I(I) = I(I - 1): I(I + 1) = I(I): I(I + 2) = I(I + 1)
170 YINC = 500 / (IFIN - ISTART)
180 IF (IFIN - ISTART) > 499 THEN ISTEP = 2 ELSE ISTEP = 1
190 SCREEN 2: LOCATE 2, 1: PRINT "SAMPLES": LOCATE 3, 1: PRINT "-----"
200 LOCATE 4, 1: PRINT "Start:"; ISTART: LOCATE 5, 3: PRINT "End:";
IFIN
210 LOCATE 20, 1: PRINT "Press <ESC>"; LOCATE 21, 3: PRINT "To
End..."
220 LINE (138, 0)-(138, 190): LINE (138, 190)-(639, 190): J = 139
230 FOR I = 0 TO 152 STEP 38: LINE (128, I)-(137, I): NEXT
240 LOCATE 1, 13: PRINT "5.0"; LOCATE 24, 16: PRINT "0";
250 LOCATE 12, 12: PRINT "VOLTS";
260 FOR I = ISTART TO IFIN STEP ISTEP
270 LINE (J, I(I))-(J + YINC, I(I + ISTEP)): J = J + YINC: NEXT I
280 AS = INKEY$: IF AS = "" THEN 280
290 IF ASC(AS) = 27 THEN SCREEN 0: END ELSE BEEP: GOTO 280

```

voltage of 0.5. Adjust R14 so the maximum is about 4.0 volts. Then readjust R12 so the no-signal (quiescent) value is about 2.5-volts DC. Now you'll get the best resolution from the circuit.

### Software

We wrote two programs for data capture and display. Listing 1 shows the capture program (ADC.BAS), and Listing 2 the display program (GRAFDATA.BAS)—both are available on the RE-BBS (516-293-3000, 1200/2400, 8N1) as a file called PCADMAT2.LST. Figure 4 shows sample output from GRAFDATA. Enhanced versions of both programs are available on disk from the author for a nominal fee; see the sidebar for details.

ADC.BAS is a general-purpose data capture and storage utility. To use it, you must create a data file called HWADRES.DAT in the same directory as the program. The file contains the decimal address of the PC IO card. You can create the file with any text editor or word processor capable of storing text in ASCII format. Assuming your card is set to the default

address (640), create a one-line file that contains "640D" (without the quotes) followed by a carriage return.

Connect the ADC circuit to your PC and run ADC.BAS. It initializes the PC IO card, then asks you for the interval (in seconds) to wait between samples. If you want continuous samples (with no delay), enter 0. Otherwise, you can enter any number between 1 and 3600 (one hour). When you press Enter, sampling begins.

The program displays three pieces of information: current data (line 100), time between samples (line 110), and current sample number (line 120). Press Esc at any time to end sampling (line 130).

Lines 150–200 take care of interval timing. The sampling program showed last time used a timing loop that was system-dependent; the current version reads the system clock, hence is system-independent. Sampling takes place in lines 210–250; as many as 1000 samples are saved in array A.

When you press Esc to end sampling, execution continues at line 270. If you press Esc

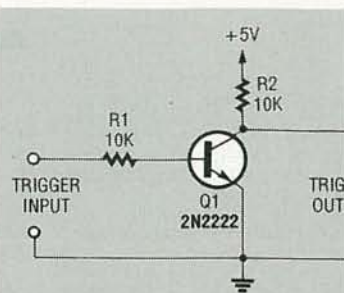

FIG. 5—DIGITAL TRIGGER CIRCUIT allows the PC IO to start reading based on the appearance of a predetermined signal. Connect this circuit between that signal and an unused P input, and modify the software accordingly.

### ORDERING INFORMATION

The following items are available from JJ Barbarello, 817 Tenney Road, Manalapan, NJ 07726.

- Complete PC IO Board with P board and all components (part #PCIO)—\$39.95

- An ADC0804 and a calibrate PN222A temperature sensor transistor (part #ADC)—\$8.00

- PC IO software, including compiled and source code version with continuous and interval sampling and data logging/listing. Specify disk size, 3.5" or 5.25" (part #ADC-S)—\$8.00.

- Software from this installer including a menu-driven, compile program (with source code), expanding on the identified function and adding discrete data listing graphed data sample selection value display, and other features (part #ADM-S)—\$10

Specify part number(s) and send check or Money Order.

The author will be glad to answer all questions, but they must be accompanied by a self-addressed stamped return envelope.

again, data is abandoned and program ends. If you press Enter the program requests a file name for storing the data. Specify complete file name, including any path and extension (e.g., C:\SUB1\TEST01.ADD.) If you don't specify a complete path, file will be stored in the current directory. If the file already exists current data will be appended to the end of the file.

GRAFDATA.BAS allows you to plot your data on-screen. When you run the program, it asks you to specify a data file. As with ADC.BAS, specify the full path if the file is not in the current

(Continued on page

# WORKING WITH LED'S

*We continue our survey of optoelectronic principles and systems, with an in-depth look at practical LED chaser and bar-graph displays.*

RAY MARSTON

LAST MONTH, WE BEGAN INTRODUCING the general subject of optoelectronics, and we examined light-emitting diodes (LED's) and several practical LED flashers in detail. In this article, we'll examine several practical LED chaser (or sequencer), dot, and bar-graph displays.

## Chaser principles

One of the most popular LED displays is known as a chaser, also called a sequencer. That's when an IC drives an LED array, so that each LED (or small groups thereof) turns on and off in a fixed, periodic sequence, that appears as a ripple of light running along a chain. The LED's don't necessarily have to be arranged linearly, and can be placed in any desired geometric pattern, to alter the visual effect.

The most popular CMOS IC which is used for that purpose is the CD4017B, which is a decade counter/divider IC with 10 decoded outputs, each capable of directly driving an LED display. If desired, the outputs can be coupled back to the IC control terminals to make the device count to (or divide by) any number from 2-9, and either stop or recycle.

The CD4017B is easily cascaded for use in multi-decade frequency division, or for use in counters with any number of decoded outputs. It's extremely versatile, and it can easily be

used in a chaser or sequencer LED display of any desired length.

Figure 1 shows the pinouts of a CD4017B, with decoded outputs in arithmetic order. Figure 2 is its timing diagram; the CD4017B is a 5-stage Johnson counter with CLOCK, RESET, and CLOCK INHIBIT inputs. The counters are advanced with each positive-going clock pulse, when the CLOCK INHIBIT and RESET inputs are low. At any time, nine of the 10 decoded outputs are low, while the remaining one is high.

The 10 outputs go high sequentially in step with the clock, with the selected output

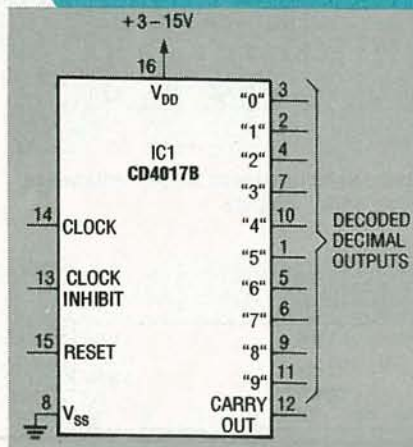

FIG. 1—PINOUTS OF THE CD4017B decade counter/divider, with its decoded outputs shown in ascending arithmetic order. The clock is inhibited by a high on pin 13, and the counter is reset by a high on pin 15 and advances on a positive-going clock transition.

staying high for one full clock cycle. The CARRY OUT goes high for one clock cycle out of every 10 clock cycles, and it can be used to ripple-count more CD4017B's in a multi-decade counting application. The counting cycle is inhibited by setting CLOCK INHIBIT high. A high on the RESET input clears the counter, and sets the "0"-output high.

## CD4017B chaser circuits

Figure 3 shows a practical CD4017B 10-LED chaser, with IC1, a 555 astable multivibrator, which is used as a variable-speed clock generator. The CD4017B becomes a decade counter by grounding pins 13 (CLOCK INHIBIT) and 15 (RESET). The visual display will appear as a moving dot sweeping from left to right (or from LED's "0"- "9") in 10 steps, as the outputs go high and turn the LED's on sequentially. They can either be arranged in a straight line, or configured circularly, so that the dot appears to rotate.

The LED's shown in Fig. 3 aren't current-limited. Manufacturers don't give a maximum short-circuit current for the CD4017B, but practical experience dictates a value somewhere between 10-15 milliamps. The maximum dissipation per output on some data sheets is 100 milliwatts, so up to 7 volts DC can be developed safely across a CD4017B output stage at maximum current.

Each LED is connected between output and ground, and can have a maximum supply of 9 volts DC, for a 2-volt DC drop across each LED that's lit. Above 9 volts DC, use the version shown in Fig. 4, which contains a current-limiting resistor, and is capable of being used with supplies up to 12 volts DC.

Figure 5 shows a possible equivalent of the circuit in Fig. 4, that uses a 15-volt DC supply, that also illustrates a major design flaw. When one LED is on, the anodes of the others are grounded, so R1 reverse-biases them. Due to low LED reverse-voltage ratings, you'll often find that an LED that's off will act like a Zener diode at about 5

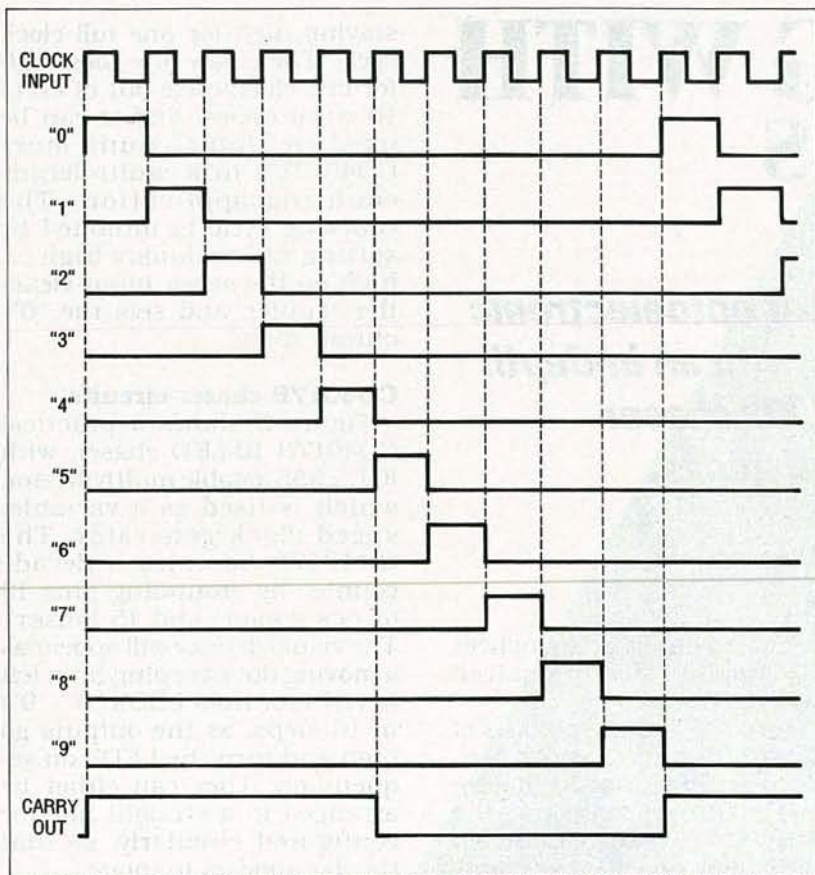

FIG. 2—WAVEFORM TIMING DIAGRAM OF THE CD4017B, with its RESET and CLOCK INHIBIT terminals (pins 13 and 15) grounded.

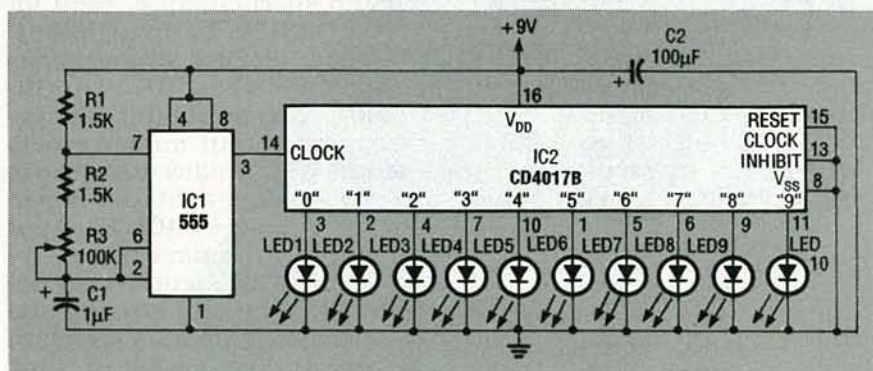

FIG. 3—A 10-LED CHASER OR SEQUENCER that can be used with supply voltages up to only 9 volts DC, and which produces a "moving-dot" display.

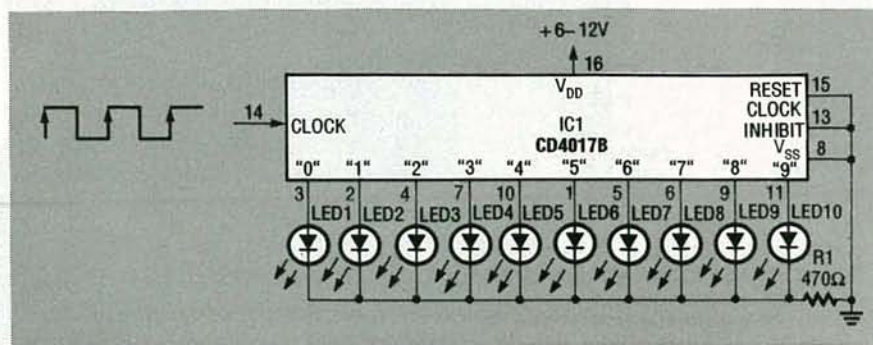

FIG. 4—A 10-LED CHASER, WHICH USES up to a 12-volt DC supply.

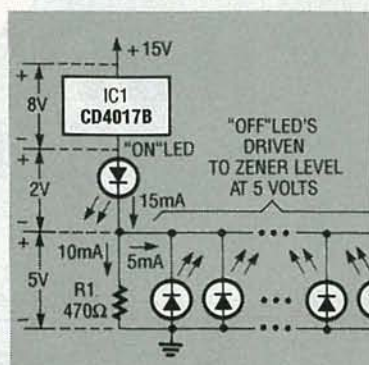

FIG. 5—A POSSIBLE EQUIVALENT Fig. 4, which uses up to a 15-volt supply.

volts DC, and possibly destroying a CD4017B output stage.

When a CD4017B drives LED's in moving-dot mode, they can be connected directly to the IC outputs if supply values are no more than 9 volts DC. For higher supplies, you'll need current-limiting resistors. Several such display circuits are shown in Figs. 6–12.

### Alternative LED displays

The output stages of the CD4017B can either source or sink currents equally well. Figure 3 shows IC2 used in sink-mode to drive a moving-hole LED display in which only one of the 10 LED's are on at any given time, while one turns off sequentially. If the LED's are arranged circularly, they seem to rotate. Since all LED's except one are on at a time, they need current-limiting resistors.

Moving-dot displays are much more popular than the moving-hole variety. The type shown in Fig. 3 can be designed to use fewer LED's just by omitting the unwanted ones, but then the dot moves intermittently or scans, since IC2 takes 10 clock steps per sequence and all the LED's will be off during the unwanted steps.

If a continuously-moving display with fewer than 10 LED's is needed, connect the first unused CD4017B output to pin 15 (RESET), as indicated in the LED version shown in Fig. 7. To achieve an intermittent display using a controlled number of steps, just connect the desired unwanted output to pin 15 (RESET). Or, in other words, modify the connection going to pin

of IC2 to pin 9. In that type of an intermittent display, the LED's will light for four cycles, go blank for four cycles, and the sequence then repeats.

Figure 8 shows a visually attractive 4-LED, 5-step sequencer. Initially, all four LED's are on, and then turn off sequentially until they're all off in the fifth step, as shown in the accompanying table. The LED's are effectively in series, and the basic circuit can't drive over four LED's.

Figure 9 shows another version; here, the CD4017B does a 10-step sequence, with LED 1 on from steps "0"–"3," LED 2 on for "4"–"6," LED 3 on for "7" and "8," and LED 4 on for step "9." The display will accelerate from LED 1–LED 4, not just sweeping smoothly from one LED to the next, and the cycle then repeats ad infinitum.

Figure 10 shows such a circuit modified to produce an intermittent display, where the visual acceleration occurs for 10 clock cycles, the LED's all blank for 20 cycles, and then the counting cycle repeats. When IC2 is in a ÷10 mode as shown in Figs. 9 and 10, pin 12 (CARRY OUT) produces an output each time IC2 does a decade count, which is used to clock IC3 (which is connected in ÷3 mode), with its "0" output fed to Q1.

For the first 10 cycles of a sequence, the "0" output of IC3 is high, and Q1 is biased on, so IC2 acts as shown in Fig. 9, with the LED's turning on sequentially through Q1. After the 10th clock pulse, the "0" output of IC3 goes low, turning Q1 off; the LED's can no longer light, but IC2 keeps counting. After the 30th clock pulse, the "0" output of IC3 again goes high and turns Q1 on, reenabling the display.

Figure 11 is a simple multiplexed display, where IC3 and Q3 enable or disable a bank of LED's. Figure 11 is yet another example of a multiplexed display, which uses three lines of six intermittently-sequenced LED's. They're each sequentially enabled via IC3 and individual gating transistors, only

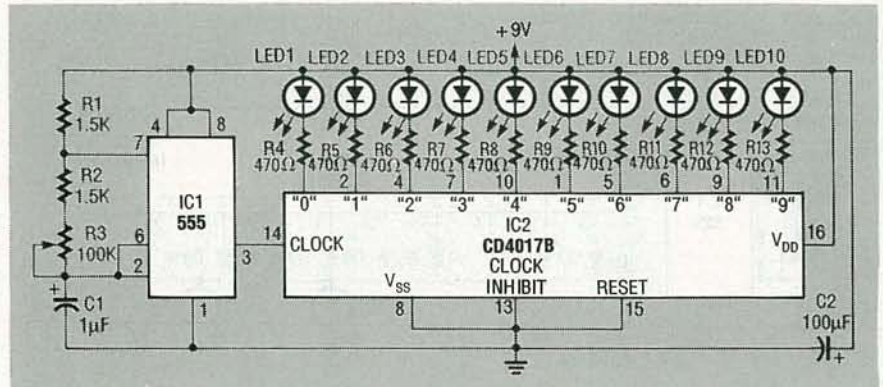

FIG. 6—A 10-LED "MOVING-HOLE" DISPLAY.

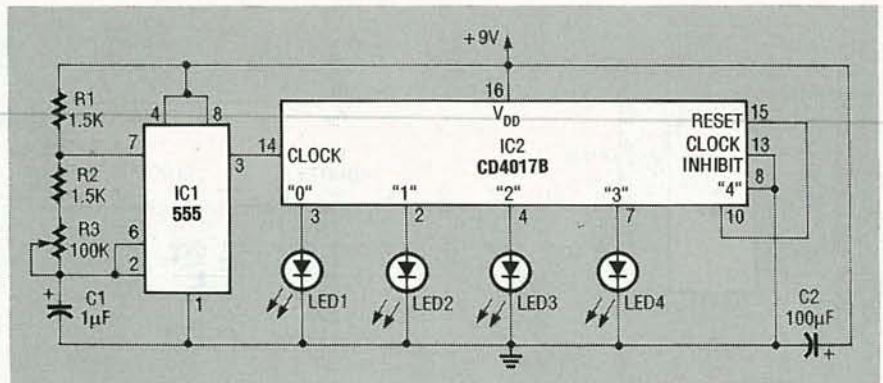
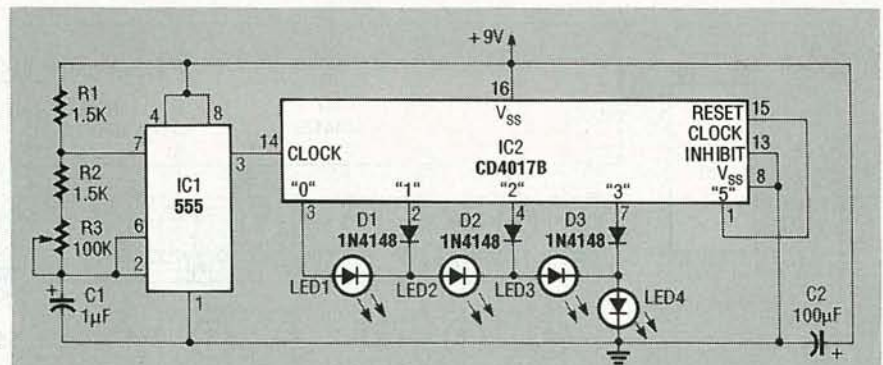

FIG. 7—A 4-LED CONTINUOUS "MOVING-DOT" DISPLAY. To get an intermittent "moving-dot" display using a 50% "blanking" period, just change pin 10 (or output "4") to pin 9 (or output "8").



STEP NUMBER	1	2	3	4	5	6
LED1	ON	OFF	OFF	OFF	OFF	ON
LED2	ON	ON	OFF	OFF	OFF	ON
LED3	ON	ON	ON	OFF	OFF	ON
LED4	ON	ON	ON	ON	OFF	ON

FIG. 8—A 4-LED, 5-STEP SEQUENTIAL TURN-OFF DISPLAY.

one line at a time; if you want, you can expand this version still further to control a 10-line, 100-LED, matrix display.

Figure 12 shows a 4-bank, 5-

step, 20-LED chaser; the four LED's are in series in each of the five CD4017B outputs, so four LED's are lit at any one time. Each lit LED drops about 2 volts

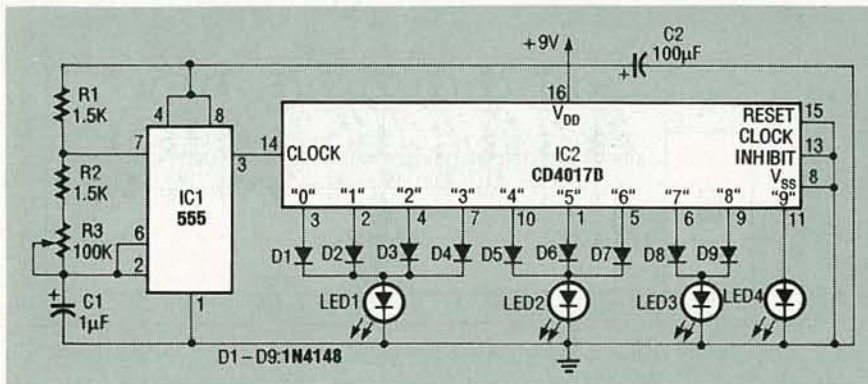

FIG. 9—A 4-LED CONTINUOUS "ACCELERATOR" DISPLAY, where the pattern of the dots appears to accelerate from left to right.

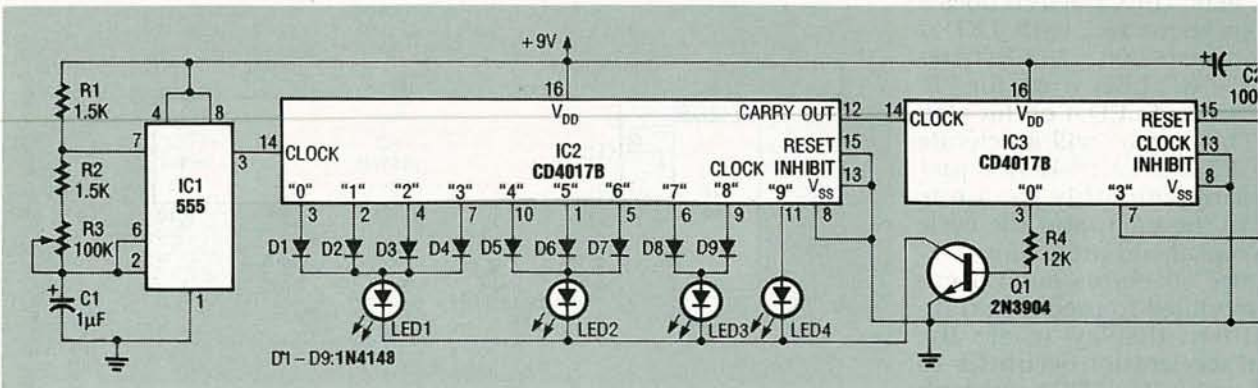

FIG. 10—A 4-LED INTERMITTENT "ACCELERATOR" DISPLAY, where the "acceleration" occurs for 10 out of every 30 clock steps.

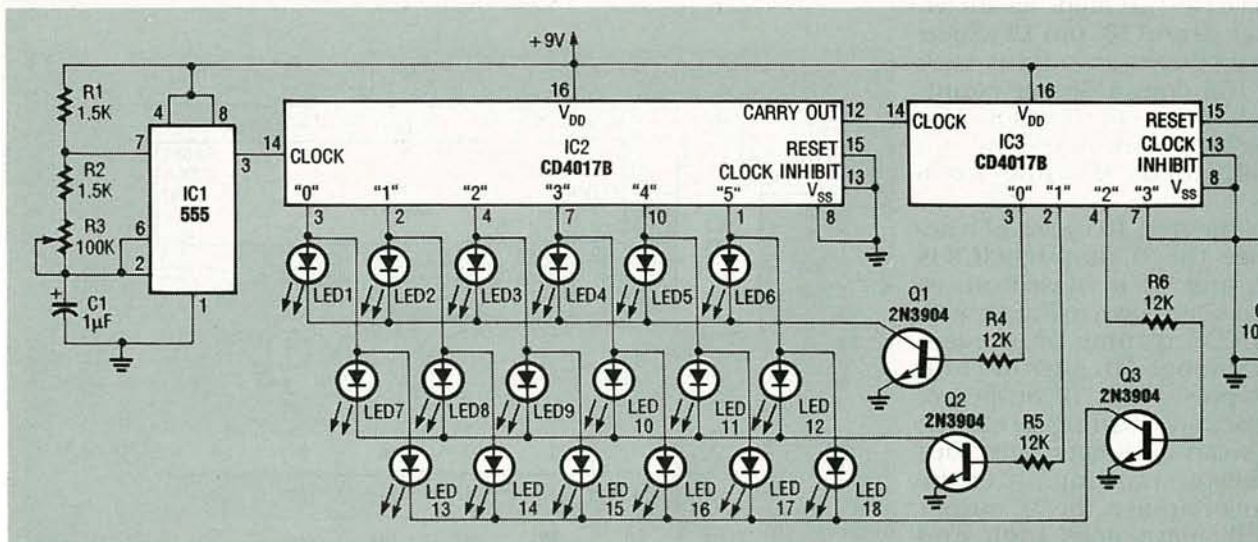

FIG. 11—A MULTIPLEXED 6-LED x 3-LINE MOVING-DOT DISPLAY, in which the dot moves intermittently along the lines.

DC; that's 8 volts DC for each LED bank that's on, so the supply voltage must be greater than that for the circuit to work. A greater number of LED's can be used in each LED bank if the supply voltage is correspondingly increased to handle the added load.

### Bar-graph displays

Another multi-LED indicator circuit is the analog version, which drives a chain of linearly-spaced LED's. The number of LED's that are lit is proportional to the voltage applied to the LED-driver, so the circuit acts like an analog voltmeter. You

can use the LED's as either bar- or dot-graph display. In bar-graph display, the input value is indicated by the total number of LED's that are lit. In the dot display, the input value is indicated by the relative position of just one lit LED.

Special IC's are available for building LED analog displays. The most useful examples are the U2X7B family from Analog Devices and the LM3914 family from National Semiconductors. The U2X7B family consists of several dedicated devices, which

can be usefully cascaded to drive up to 10 LED's in bar-graph mode only, the members being the U237B, U247B, U257B, and U267B. The LM3914 family is more complex and versatile by comparison and are easily cascaded to drive up to 100 LED's in either bar-graph or dot-graph mode. Both varieties of IC's are considered to be bar-graph drivers.



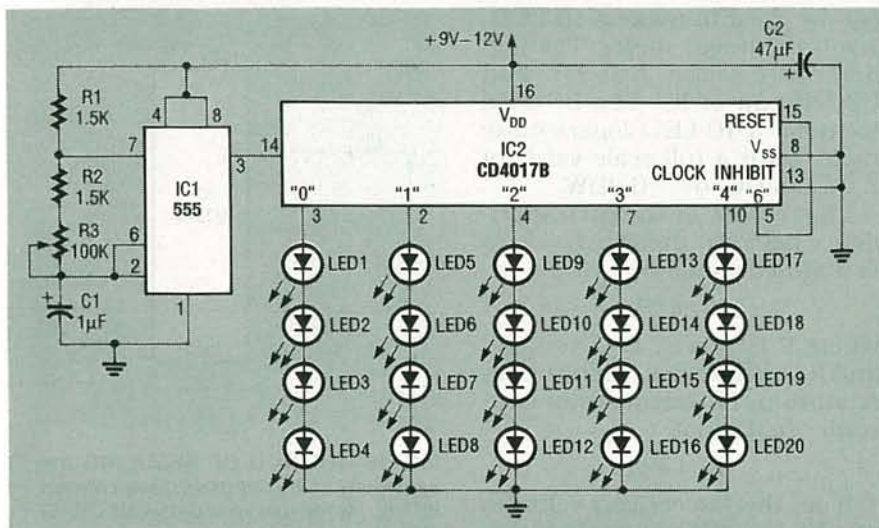

FIG. 12—A 4-BLANK 5-STEP 20-LED CHASER, for use with a supply above 9 volts DC.

TABLE 1—U2X7B INTERNAL TRANSISTOR STATES AT VARIOUS INPUT VOLTAGES

V <sub>IN</sub> V	Q1	Q2	Q3	Q4	Q5
1.0	Off	Off	Off	Off	Off
0.8	Off	Off	Off	Off	On
0.6	Off	Off	Off	On	On
0.4	Off	Off	On	On	On
0.2	Off	On	On	On	On
0.0	On	On	On	On	On

IC-driven bar-graph displays are inexpensive, superior alternatives to analog meters. They don't stick, they're fast, and they're unaffected by both vibration and attitude. Their scales can have any desired shape, they can have mixed LED colors to highlight special sections, and they can be equipped with over-range detectors that are activated by the

drivers to either sound an alarm, flash the display, or both.

The linearity of such a bar- or dot-graph meter is considerably better than that of most analog meters, and is generally about 0.5%. The resolution depends on the number of LED's that are used; a 10-LED version has adequate resolution for most hobbyist purposes.

#### Basics of the U2X7B IC family

The AEG U2X7B IC family is composed of four different 8-pin DIP's, each capable of driving five LED's. The U237B and U247B pair produce a linear display, and are used together when driving 10 LED's. The U257B and U267B pair produce a logarithmic display, and are also used together when driving 10 LED's. All four IC's in the family use the same internal circuitry, in block diagram form, as shown in Fig. 13.

All four IC's contain five Schmitt voltage comparators with unique thresholds feeding

TABLE 2—U237B INTERNAL STEP VOLTAGES

Device	Step 1	Step 2	Step 3	Step 4	Step 5
U237B	200 mV	400 mV	600 mV	800 mV	1.00 V
U247B	100 mV	300 mV	500 mV	700 mV	900 mV
U257B	0.18V/ -15 dBW	0.53V/ -6 dBW	0.84V/ -1.5 dBW	1.19V/ +1.5 dBW	2.0V/ +6 dBW
U267B	0.1V/ -20 dBW	0.32V/ -10 dBW	0.71V/ -3 dBW	1.0V/ 0 dBW	1.41V/ +3 dBW

TABLE 3—U237 IC FAMILY MAJOR SPECIFICATIONS

Parameter	Minimum	Typical	Maximum
Supply voltage	8V	12V	25V
Input voltage	—	—	5V
Input current	—	—	0.5 mA
Max supply current	—	25 mA	30 mA
Power dissipation (at 60°C)	—	—	690 mW
Step tolerance	-30 mV	—	30 mV
Step hysteresis	—	5 mV	10 mV
Input resistance	—	100 K	—
Output saturation voltage	—	—	1V

into transistor switches. The thresholds are fixed by the tapping points on voltage divider R1-R6, which is powered using a built-in voltage regulator: each comparator input is connected to pin 7.

All four IC's also contain an internal 20-milliamp constant-current source, and the five external LED's go in series between it and ground (pin 1), as shown. Groups of LED's are turned on or off using the individual switching transistors. If Q3 is turned on, it sinks 20 milliamps via LED's 1 and 2, so they turn on, and LED's 3-5 turn off.

The U2X7B family has step voltages spaced at 200-millivolt DC intervals, and Table 1 lists the states of its five internal transistors at various input voltages. At 0 volts DC input, all five transistors are switched on, so Q1 sinks the full 20 milliamps, and all five LED's are off. At 200 millivolts DC, Q1 turns off but all other transistors are on, so Q2 sinks the 20 milliamps via LED 1, driving LED 1 on and turning all others off.

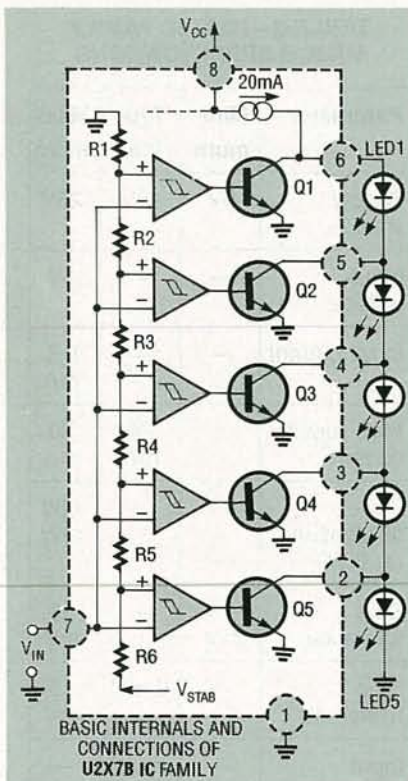

FIG. 13—BLOCK DIAGRAM OF a U2X7B bar-graph driver, showing the basic external connections.

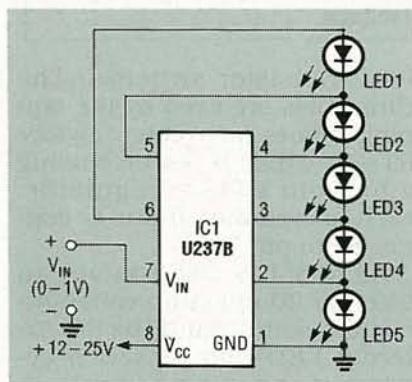

FIG. 14—A 0-1-VOLT DC, 5-LED, linear-scale bar-graph meter using a U237B.

With an input of 1 volt DC, all transistors are off, the 20 milliamps go to ground via the LED's, so all five LED's are on. The IC current is independent of the number of LED's turned on, so minimal RF interference (RFI) is produced as it switches transistors and LED's.

The four IC's in the U2X7B family differ only with regard to their step voltages, which are fixed by R1-R6 as shown in Table 2, and the values for which are also given in dBW (or dB relative to a watt). The linear-scale U237B and U247B pair of IC's

can be used to make a 10-LED, 1-volt DC linear meter. The logarithmic-scale U257B and U267B pair of IC's can be used to make a 10-LED logarithmic meter with a full-scale value of 2.0 volts DC, or +6 dBW.

The reason for the correspondence between those two values is justified as follows. Since

$$P = E^2/R,$$

where P is power, E is voltage, and R is resistance, then the assumption, for purposes of convenience, is that:

$$R = 1 \text{ ohm.}$$

If so, then to convert voltages on the logarithmic-scale meter into a quantity *proportional* to power (and *not* into power itself), just square the voltage indicated, take the  $\log_{10}$  of the result, and multiply by 10. If E has the unit of volts (as opposed to some fractional or multiple unit, like millivolts, for exam-

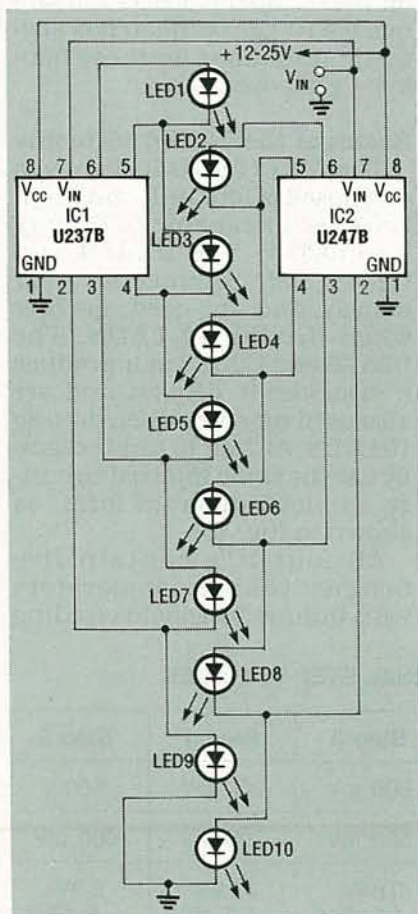

FIG. 15—A 0-1-VOLT DC, 10-LED, linear-scale bar-graph meter using a U237B and a U247B connected as a pair.

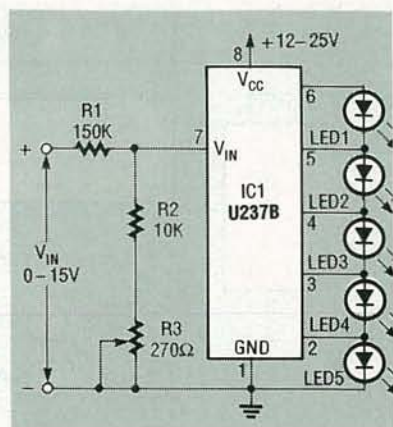

FIG. 16—METHOD OF REDUCING the sensitivity of the bar-graph meter shown in Fig. 14, for use in a 0-15-volt DC, LED, linear-scale, bar-graph meter using a U237B.

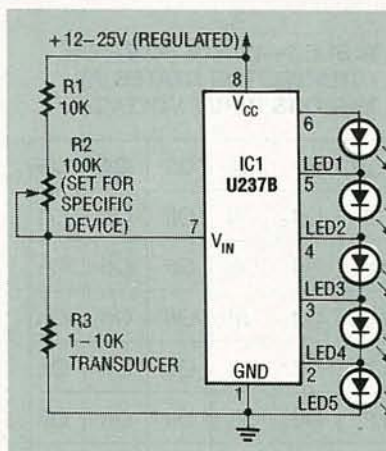

FIG. 17—SIMPLE USE OF A transducer to show the value of a physical quantity.

ple), then P has the units of watts, and the units in dB are called dBV, since they're expressed relative to a fixed value of potential.

Likewise, if you wanted to express dB in terms of power, the proper terminology would be dBW, or a similar unit for an fractional unit of power. The number of dBV is always double the number of dBW, since taking the  $\log_{10}$  of both sides of the power relation gives

$$\begin{aligned} \log(P) &= \log(E^2/R), \\ &= 2 \times \log(E) + \log(R), \\ &= 2 \times \log(E) + \log(1), \\ &= 2 \times \log(E). \end{aligned}$$

For that reason,

$$1 \text{ dBW} = 2 \text{ dBV.}$$

For example, in Table 2, for the U267B and step 5, the entry given is 1.41 volts DC, or +6 dBW. On squaring that, you get

2 volts<sup>2</sup>, so 10 times its log<sub>10</sub> is +3 dBW, and doubling that gives +6 dBW. Of course, when ever you take the logarithm of a quantity like voltage or power, you always operate on the numerical part alone, and ignore the units. If you ever hear of an audio or noise level that's expressed in dB alone, with no unit appended to indicate "dB with comparison to what," such a specification is nonsense.

To express an amplitude in dB relative to a unit of potential or power with a multi-letter abbreviation, just append the whole unit, like dBmV for dB relative to a millivolt. Sometimes, the term dBm is used as an abbreviation for dBmW, or dB relative to a milliwatt.

Table 3 lists the specifications of the U2X7B family. When driving five red LED's, each with a 2-volt DC forward drop, the minimum supply value required must be 12 volts DC. Different-colored LED's with different forward drops can be used together, if the supply voltage is adequate.

Although the IC input impedance is typically 100K, the IC becomes unstable if the source impedance is above 20K. It should ideally be kept under 10K; if it's not, place a 0.01- $\mu$ F capacitor between pins 1 and 7 for added stability.

### Practical U2X7B circuits

Figures 14-19 show practical U2X7B-family circuits; in all of them, the supply is 12-25 volts

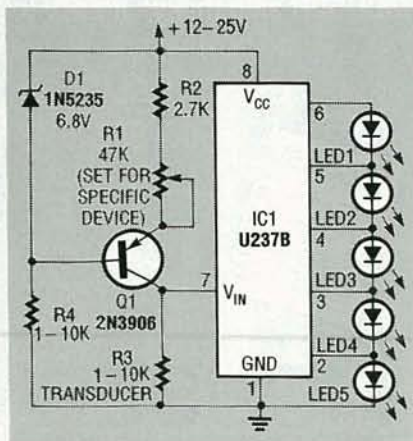

FIG. 18—AN ALTERNATIVE USE of a transducer to show the value of a physical quantity.

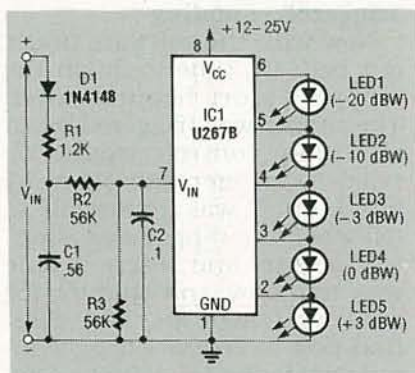

FIG. 19—A 5-LED LOG-SCALE audio-level meter; a 10-LED version is made using a U257B and U267B pair, in a fashion similar to the version shown in Fig. 15.

DC, but you'll have to remember the constraints previously mentioned. Figure 14 shows a 0-1-volt DC, 5-LED, linear-scale meter using a U2X7B, and Fig. 15 shows a U237B and U247B pair used in a 0-1-volt DC, 10-LED, linear-scale meter. The latter circuit operates each IC as shown in Fig. 14, with supply voltages that are appropriate to five LED's, but their input terminals are tied together, and the LED's are alternated, to achieve a 10-LED display.

Figure 16 shows how the full-scale sensitivity of the meter is reduced by feeding the input to IC1 via R1-R2-R3, using a ratio of 15:1, and giving full-scale sensitivity of 15 volts DC. Figures 17 and 18 show how the circuit shown in Fig. 14 can be used to display a physical quantity like light intensity or heat, as represented by the analog resistance R3 of a transducer. In both, the transducer is fed by a constant-current source, so the input voltage to IC1 is directly proportional to the transducer resistance.

As shown in Fig. 17, constant transducer current is derived from regulated supply via R1-R2, since regulated supply voltage is large relative to the 1-volt DC full-scale meter sensitivity. By contrast, as shown in Fig. 18, constant current is ensured via D1-Q1. Finally, Fig. 19 shows the U267B used in a 5-LED logarithmic audio-level meter. A 10-LED meter can be made using a U257B and U267B pair as shown in Fig. 15.

R-E

## Which symbol represents a variable inductor?

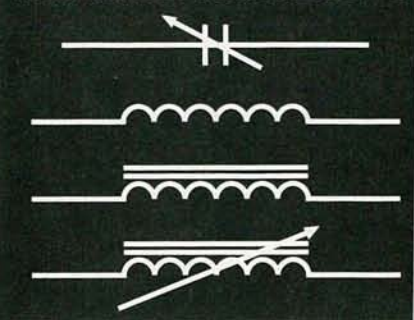

What is the principal disadvantage of neon lights?

What are out-of-phase signals?

### Heath Video Courses speed your learning curve

Learn basic electronics at home at your own pace with four, 60-minute video tapes. Know the variable inductor symbol. Recognize a P1 junction. Understand oscillator fundamentals. Clearly SEE what most basic electronic book can only describe.

**DC ELECTRONICS.** Covers electron movement to troubleshooting and repairing a simple electronic circuit. **EV-3101-A.**

**AC ELECTRONICS.** Follow-up to DC Electronics. Covers the principles of AC, voltage and electrical measurement. Includes motors, generators and test instrument meter movements. **EV-3102-A.**

**SEMICONDUCTORS.** Complete the DC/AC videos and you're ready to learn how semiconductor devices are made, plus the principles of discrete devices, integrated circuits & optoelectronic devices. **EV-3103**

**ELECTRONIC CIRCUITS.** Complete the basic course with amplifier configurations, biasing coupling, audio amplifiers, closed-loop vs. open-loop operation and more. **EV-3104-A**

An activity-filled workbook and explanation of how to solve each problem comes with each tape so you learn three ways — video workbook and hands-on!

Order today!  
Call Toll free,  
24-hours a day.  
1-800-253-0570.

VIDEO TAPES!  
\$44.95 EACH

We accept VISA, MasterCard, American Express and Heath Revolving Charge card. Use Order Code 601-06

# Heath®

Benton Harbor, MI

Call for a FREE catalog 1-800-44HEAT

Price does not include ©1992 Heath Comp. shipping and handling ED-238-R3 or applicable sales tax.

CIRCLE 86 ON FREE INFORMATION CARD

## ADC FOR YOUR PC

continued from page 68

rent directory. If the file exists, the program then tells you how many samples it contains, and asks start and stop points for the plot; the maximum number is 1000.

The program (line 170) scales the graph to produce the widest possible graph; lines 220-270 graph the data. Press Esc to terminate the program. To "magnify" a limited portion of the data set, run the program again, and enter appropriate start and end values (e.g., 350 and 450). You can print your graphs by running the DOS program GRAPHICS.COM before GRAFDATA.BAS. When the desired graph appears on the screen, press PrintScrn. (You must have a compatible printer in order to print out any of the graphs.)

## Triggered sampling

Now with the software under our belt, it's time to finish the "rapper" story begun earlier. The rapper was triggered by an electronic control circuit. We tried to trigger sampling by hand, but it was impossible to tell when the rapper was about to energize, and reaction time was too slow and unsure for accurate triggering. Our solution was to create a trigger input. We tapped a digital signal from the control circuit that changed just before the rapper triggered.

The ADC circuit uses only 8 of the 24 input lines on the PC IO. What we did is use bit 0 of port B as a trigger input. Then by adding a single line of code, we could trip on either a low-to-high signal:

```
145 IF (INP(ADD + 1) AND 1) = 0 THEN  
GOTO 145
```

or a high-to-low signal:

```
145 IF (INP(ADD + 1) AND 1) = 1 THEN  
GOTO 145
```

If you want to add a slight delay between the trigger and start of sampling:

```
146 FOR I = 1 TO DELAYTIME : NEXT I
```

However, the delay time in this case would vary with the speed of your PC. In addition, to ensure the trigger signal is TTL compatible (logic low = 0V, logic high = 5V). If it isn't, you want to buffer the trigger signal from your system. You can use the circuit of Figure 1. Remember, this circuit inverts the incoming trigger signal: a positive-going trigger will be negative-going when it exits the buffer circuit. Adjust added delay accordingly.

## Conclusions

The analog world of nature is not so distant from the digital world of computers. Simple circuitry can allow your PC to function as a digital eye, ear, or hand on the external world. The circuits and software shown here are only the beginning.

## LEARN VCR

**CLEANING/MAINTENANCE/REPAIR**  
EARN UP TO \$1000 A WEEK, WORKING  
PART TIME FROM YOUR OWN HOME!



Secrets  
Revealed!

NO Special  
Tools or  
Equipment  
Needed.

EARN UP TO \$60  
AN HOUR AND  
MORE!

### THE MONEY MAKING OPPORTUNITY OF THE 1990'S

If you are able to work with common small hand tools, and are familiar with basic electronics (i.e. able to use voltmeter, understand DC electronics) . . . IF you possess average mechanical ability, and have a VCR on which to practice and learn. . . then we can teach YOU VCR maintenance and repair!

**FACT:** up to 90% of ALL VCR malfunctions are due to simple MECHANICAL or ELECTRO-MECHANICAL breakdowns!

**FACT:** over 77 million VCRs in use today nationwide! Average VCR needs service or repair every 12 to 18 months!

Viejo's 400 PAGE TRAINING MANUAL (over 500 photos and illustrations) and AWARD-WINNING VIDEO TRAINING TAPE reveals the SECRETS of VCR maintenance and repair—"real world" information that is NOT available elsewhere!

Also includes all the info you'll need regarding the BUSINESS-SIDE of running a successful service operation!

FREE INFORMATION  
CALL TOLL-FREE 1-800-537-0589

Or write to: Viejo Publications Inc.  
4470-107 Sunset Blvd., #600  
Los Angeles, CA 90027, Dept. RE

CIRCLE 192 ON FREE INFORMATION CARD

Save on cable rental fees!

## CABLE TV DESCRAMBLERS WE'LL BEAT ANY PRICE!

JERROLD-TOCOM-ZENITH  
HAMLIN-OAK-PIONEER  
SCIENTIFIC ATLANTA

- 24 HOUR SHIPMENTS!
- MONEY BACK GUARANTEE!
- QUANTITY DISCOUNTS!

MASTER CARD / AMEX / VISA / C.O.D.



Have make and model number of  
equipment used in your area ready

CALL TOLL-FREE  
1-800-284-8432

CABLE WAREHOUSE

10117 West Oakland Park Blvd., Suite  
515, Sunrise, FL 33351  
NO FLORIDA SALES

CIRCLE 198 ON FREE INFORMATION CARD

# 36.284

## ELECTRONIC COMPONENTS

Whether you order 1 part or  
all 36,284...MOUSER stocks  
and...can ship today!!  
MOUSER also makes it easy  
to do business.

CALL...

(800) 992-9944

for your  
FREE

CATALOG

2481 Hwy 287

Mansfield, TX 76063

# MOUSER ELECTRONICS

Sales & Stocking Locations Nationwide

CIRCLE 117 ON FREE INFORMATION CARD

# HARDWARE HACKER

Caller ID update, new wavelet shareware, perpetual motion again, common lab test pitfalls, and Lumeloid and Lepcon films.

DON LANCASTER

**W**avelets. We have got lots of wavelets. You getcher wavelets here. As we've discovered a number of times before, wavelets are a stunning new math concept that is profoundly changing virtually all the advanced electronic topics. A failure to learn wavelets *now* is the same as volunteering for early retirement.

We've already seen that *Jones and Bartlett* has published THE great new wavelets book, and that the *Ultrawave Explorer* from the *Aware* folks is definitely one fine commercial wavelet study and development program.

But the big news is that I've just posted full working PC shareware copies of the *Wavelet Packet Library* from *Digital Diagnostics* on *GENie* PSRT as #365 WAVELET.PS.

Those of you into satellite dishes and microwave electronics are now probably familiar with *Smith Charts*, a handy graphical method of doing things like impedance matching and tuning. I have written a PostScript Smith Chart generator that lets you instantly create all your own Smith charts in any quantity, any size, any resolution, and any where in your publication. Check *GENie* PSRT #367 SMITHCHT.PS for several freeware samples. Your downloading cost on this is around twenty one cents.

## Perpetual motion again

I get an average of three to five helpline calls a week on "free energy" and other perpetual-motion topics. As we have seen in the past, perpetual motion is definitely real as a historic and ongoing societal phenomenon. We have also seen that two ongoing sources of perpetual-motion books, videos, and papers are *High Energy Research* and *Lindsay Publications*.

Now, I personally feel that looking for any free-energy systems is rather dumb. First, because the desirability of any free energy ranks somewhere between Herpes and AIDS. Why? Because this would obviously hasten the already ongoing entropic heat death of the planet. If someone does in fact find a free-energy system, they should be spanked and sent to bed without any supper. Or, better yet, chopped up and fed to the cows.

Second, because the odds of your accomplishing anything that's even remotely useful involving free energy are stupendously low. Third, because your credibility starts out as less than zero and quickly plummets. Owing to previous scams, the "not even wrong" research, and the "few-chips-shy-of-a-full-board" guilt by association.

And, finally, because there's so much better to be doing. We're sitting on the greatest mountain of new hardware hacking chips, tools, info, and concepts anywhere ever. Stuff that's crying for hacker use, and stuff that is nearly certain to result in lots of interesting and profitable things. Why should you ignore the obvious?

Several of the recent callers were making measurements that were just plain wrong. Since I am one of the world's foremost experts in gathering incorrect, misleading, or meaningless lab data, I thought we might briefly focus on a few of the

ways that casual measurements may not end up what they appear to be.

In general, you'll *always* want to assume that *all* meter pointers and, especially, *all* of your digital numeric displays are lying through their teeth. Or, if they are giving you a correct reading, the odds are overwhelming that the *meaning* and the underlying *reasons* for that reading are not at all what you had in mind.

Oscilloscopes do a far better job than the meters or digital displays at showing you what is really coming down. Even here, an uncompensated probe, the wrong setting, improper sync, an invisible glitch, any outband signals, or just a ground clip that is slightly too long can cause you wildly incorrect results.

It is only when the same tests are run over and over again by different people under different circumstances that you can even remotely begin to trust your instruments. Even when repeated, that trust should only apply to the *exact* measuring conditions.

A ferinstance: Figure 1 shows you a seemingly simple method to measure AC power. You connect your new motors-and-magnets perpetual motion machine load to the AC power line through an ammeter and then separately measure the line voltage. Since power equals volts times amps, you just multiply your two readings together and you'll have the input power. Right?

Wrong. Dead wrong.

Let's temporarily forget about any noise, spikes, back-EMF effects, harmonics, and nonlinearities that are certain to be present with your new motors-and-magnets load. Assume a pure sine-wave voltage and a similar current waveform. You have to take the *phase* of the current into account. You would get a zero phase shift

## NEED HELP?

Phone or write your **Hardware Hacker** questions directly to:  
Don Lancaster  
**Synergetics**  
Box 809  
Thatcher, AZ 85552  
(602) 428-4073

with a purely resistive load. In a purely inductive load the voltage would *lead* the current by 90 degrees. In a purely capacitive load, the voltage will *lag* the current by 90 degrees.

Good old *ELI THE ICE MAN*. The voltage is ahead of the current in the eLi's L inductor; the current is ahead of the voltage in his iCe capacitor.

And if you have any purely active load such as another generator, your current could end up phased by 180 degrees. Sourcing, not sinking.

Your actual power will end up as the voltage times the current times the cosine of the phase angle between the two. If your voltmeter reads 110 and your ammeter reads 4, your actual circuit power will be 440 watts to a purely resistive load, ZERO to any purely inductive or capacitive load, and MINUS 440 watts to any purely active load. Or anything between, depending upon your phase angle.

Why is the power zero to a purely inductive load? Because of the

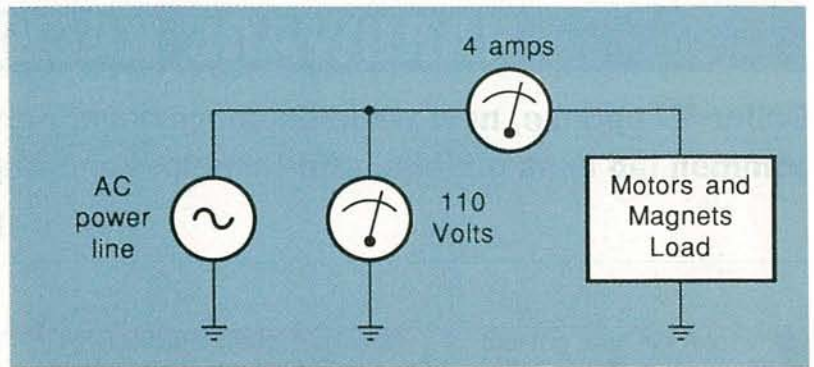

FIG. 1—WHAT IS THE REAL POWER being consumed in this test circuit? There's way to tell with the setup shown. But you can safely bet that it is probably anywhere near 440 watts

phase angle. A math freak will tell you the full cycle cross product of a sine and its cosine is zero. Intuitively, on the first quarter cycle, you have positive voltage and current. On your next quarter cycle, you will have positive voltage and negative current. On the next, negative voltage and negative current. And finally, negative voltage and positive current. Add them all up and average them all out and you end up with zero real power.

Yes, you will get lots of back-and-forth reactive power that can give you real fits. And hack off your electric utility. But your net real power into a pure inductive or capacitive load is precisely zero.

Thus, as far as power goes, all the voltmeter and ammeter readings are *totally meaningless*. And they are even less so in the presence of noise, back EMF's, sparking, or harmonics.

### Measuring real power

So how do you measure real and reactive power? The trick is that you have to multiply the *instantaneous* voltage and current together. Then you sum to find the total power.

The power of any arbitrary waveform is equal to the DC continuous power that would give you exactly the same amount of total heating in a purely resistive load.

You can do this measurement with a real *wattmeter*, or by measuring the rotational speed and direction of a *watthour meter*. The wattmeters and watthour meters are often available through *Fair Radio Sales* or *Herbach and Rademan*.

Electronically, you can use a multi-

plier chip or a special RMS power calculating circuit. *Analog Devices* is one leader in low-cost power chips of this type.

Or graphically, you can take plots of all the exact voltage and current waveforms, split them up into time slices so narrow that the voltage and current does not change much, multiply the results of those slices, then sum the results.

Note that you *must* multiply and then add. Never vice versa.

But you still do have to be careful. Nonlinearities, pulses, harmonic motor back-EMF effects, and noise require special treatment. And most power measurement schemes have a *crest factor* limit which ruins their accuracy on strong but narrow pulses. Especially things like spikes and glitches.

For these reasons, it is extremely difficult to accurately measure your input power to a motors-and-r

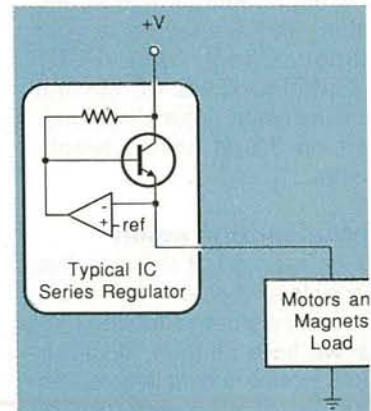

FIG. 2—WHEN IS A REGULATOR not a regulator? Any time that your load is a source (rather than sink) power, a typical IC voltage regulator will shut down or else become unstable. There is no current path to ground.

## NEW FROM DON LANCASTER

### HARDWARE HACKER STUFF

Hardware Hacker Reprints II or III	24.50
Midnight Engineering Reprints	16.50
Incredible Secret Money Machine	18.50
CMOS Cookbook	24.50
TTL Cookbook	24.50
Active Filter Cookbook	19.50
Micro Cookbook vol I or II	19.50
Lancaster Classics Library	109.50
AppleWriter Cookbook	19.50

### POSTSCRIPT STUFF

Ask The Guru Reprints I, II or III	24.50
LaserWriter Secrets (Ile/Mac/PC)	29.50
PostScript Show & Tell	39.50
Intro to PostScript VHS Video	39.50
PostScript Beginner Stuff	39.50
PostScript Cookbook (Adobe)	16.50
PostScript Ref. Manual II (Adobe)	28.50
PostScript Program Design (Adobe)	22.50
Type I Font Format (Adobe)	15.50
LaserWriter Reference (Apple)	19.50
Real World Postscript (Roth)	22.50
PostScript Visual Approach (Smith)	22.50
Thinking in PostScript (Reid)	22.50
Undst PS Pgrmmg (Holtzgang)	26.50
The Whole Works (all PostScript)	349.50

### BOOK-ON-DEMAND STUFF

Book-on-demand resource kit	39.50
GEnie PSRT sampler (Ile/Mac/PC)	39.50

FREE VOICE HELPLINE VISA/MC

## SYNERGETICS

Box 809-RE  
Thatcher, AZ 85552  
(602) 428-4073

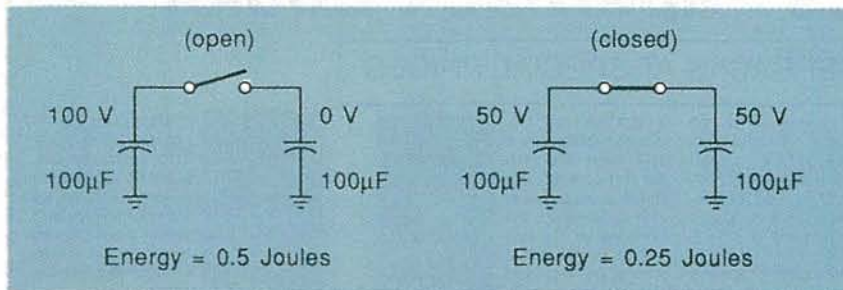

FIG. 3—QUICKLY CLOSE THE PERFECT AND LOSSLESS SWITCH. And half of your circuit energy will vanish without a trace. Where did the energy go?

nets perpetual motion machine. If you do not know *exactly* what you are doing, all your results are *guaranteed* to be wildly wrong. And so, of course, will be all of your conclusions.

Figure 2 shows you a second measurement pitfall that the recent callers have all decided to ignore. A voltage regulator is always a voltage regulator, right?

Wrong. Dead wrong.

Most popular voltage regulators are only capable of *sourcing* current. If the *load* starts *sourcing* any power even briefly, there is no place for the current to go, and the regulator either shuts down or starts oscillating.

Thus, if you have a motors-and-magnets load, there could be times when the back-EMF effects, spikes, commutator noise, or whatever, will try to *source* power back *into* your supposed power source.

Put in another way, typical power supplies and most regulators have wildly different impedances between when they source and sink power.

Note that any normally connected Zener diode will behave precisely the opposite—they are great power sinks but poor sources.

An output filter capacitor on your regulator is essential for grabbing and smoothing out high-frequency load sourcing variations.

Beyond proper output filtering, two ways around load sourcing effects are to hang enough of a resistive load on your regulator that the regulator will always output a net sourcing current. Most batteries are usually capable of sourcing and sinking any reasonable amount of current.

Figure 3 shows you yet another way to go astray. All bets are off if

there is any sparking or arcing. It is physically impossible to instantly change the voltage across a circuit capacitor or the current through an inductor. The usual result when you try this is sparking or arcing.

Take a 100-microfarad capacitor and charge it up to 100 volts. Your energy in any capacitor is...

$$E = 0.5CV^2$$

or, in this case, 0.5 Joules of stored energy. Now, you close your lossless switch so you have two capacitors in parallel. The voltage must, of course, drop in half, since the same charge is now spread across twice your plate area. And by the same formula, you now have only 0.25 Joules of stored energy.

Question: Where did the rest of your energy go? If you have a non-lossless switch of resistance  $R$ , the answer is easy. In the process of charging the second capacitor, the extra energy got burned up in your resistor as heat during charging. But go through the charging math, and you'll find that the loss of half the stored energy is a constant which is *totally independent* of the value of  $R$ !

If  $R$  equals zero, then you have to get a spark and radiated energy. But you still lose half of it, regardless of how good the switch is.

Thus, if there is any sparking or arcing whatsoever in your machine, your readings are once again *absolutely certain* to be wrong.

Always think carefully about your measurements and how they could be wrong or misleading.

#### Lumeloid and Lepcon films

We sure had a bunch of helpline calls over the new materials stuff I announced a column or two back and in our *Hardware Hacker III* reprints. I've picked up some more

## Earn Your B.S. Degree in ELECTRONICS or COMPUTERS



### By Studying at Home

Grantham College of Engineering now in our 41st year, is highly experienced in "distance education" teaching by correspondence—through printed materials, computer material, fax, and phone.

No commuting to class. Study your own pace, while continuing your present job. Learn from easy to understand but complete and thorough lesson materials, with additional help from our instructors.

Our Computer B.S. Degree program includes courses in BASIC, PASCAL and C languages — as well as Assembly Language, MS DOS, C++, Robotics, and much more.

Our Electronics B.S. Degree program includes courses in Solid-State Circuit Analysis and Design, Control Systems, Analog/Digital Communications, Microwave Engr, and much more.

An important part of being prepared to *move up* is holding the college degree, and the absolutely necessary part is knowing your field. Grantham can help you both ways: to learn more and to earn your degree in the process.

Write or phone for our catalog. Toll free, 1-800-955-252. See mailing address below.

Accredited by  
the Accrediting Commission of the  
National Home Study Council

**GRANTHAM**  
**College of Engineering**  
Grantham College Road  
Slidell, LA 70460

# Electronics Paperback Books

GREAT PAPERBACKS AT SPECIAL PRICES

**BP248—TEST EQUIPMENT CONSTRUCTION** ..... \$5.95. Details construction of simple, inexpensive, but extremely useful test equipment. AF Gen, Test Bench Ampl, Audio Millivoltmeter, Transistor Tester and six more.



**BP267—HOW TO USE OSCILLOSCOPES AND OTHER TEST EQUIPMENT** ..... \$6.95. Mastering the oscilloscope is not really too difficult. This book explains all the standard controls and functions. Other equipment is also described.

**BP265—MORE ADVANCED USES OF THE MULTIMETER** ..... \$5.95. Use these techniques to test and analyze the performance of a variety of components. Also see how to build add-ons to extend multi-meter capabilities.



**BP256—INTRO LOUDSPEAKER AND ENCLOSURE DESIGN** ..... \$5.05. Explore the variety enclosure and speaker designs in use today. The reader can understand the principles involved.

**BP263—A CONCISE INTRO TO dBASE** ..... \$6.95. The dBASE series of programs are probably the best known database programs for micro-computers. This book is designed to help you get started working with them.



**BP260—CONCISE INTRO TO OS/2** ..... \$5.95. If you are a multitasking PC user and want to get the most out of your computer, then you must learn its OS/2 operating system. This book shows you just how to do that, quickly and easily.



**BP249—MORE ADVANCED TEST EQUIPMENT CONSTRUCTION** ..... \$6.95. Eleven more test equipment construction projects. They include a digital voltmeter, capacitance meter, current tracer and more.



Digital Audio Projects



**BP245—DIGITAL AUDIO PROJECTS** ..... \$5.95. Practical circuits to build and experiment with. Includes A/D converter, input amplifier, digital delay line, compander, echo effect and more.

**BP247—MORE ADVANCED MIDI PROJECTS** ..... \$5.95. Circuits included are a MIDI indicator, THRU box, merge unit, code generator, pedal, programmer, channelizer, and analyzer.



**BP257—INTRO TO AMATEUR RADIO** ..... \$6.95. Amateur radio is a unique and fascinating hobby. This book gives the newcomer a comprehensive and easy to understand guide to the subject.



**PCP102—INTRODUCING DIGITAL AUDIO** ..... \$9.95. Cover all kinds of digital coding methods CD, DAT and Sampling. Bridges the gap between the technic and the enthusiast. Principles and methods are explained.



**PCP107—DIGITAL LOGIC GATES AND FLIP-FLOPS** ..... \$10.00. Thorough treatment of gates and flip-flops for enthusiasts, student and technicians. Only a basic knowledge of electronics is needed.

**BP251—COMPUTER HOBBYISTS HANDBOOK** ..... \$8.95. A wrap-up of everything the computer hobbyist needs to know in one easy to use volume. Provides a range of useful reference material in a single source.



**PCP108—COMPUTERS AND MUSIC** ..... \$9.95. Explains the basics of computers and music with no previous knowledge of computers needed. Covers types of music software and explains how to set up your own computer music studio.

- BP195—INTRODUCTION TO SATELLITE TV**..... \$9.95. A definitive introduction to the subject written for the professional engineer, electronics enthusiast, or others who want to know more before they buy. 8 x 10 in.
- BP190—ADVANCED ELECTRONIC SECURITY PROJECTS**.....\$5.95. Includes a passive infra-red detector, a fiber-optic loop alarm, computer-based alarms and an unusual form of ultrasonic intruder detector.
- BP235—POWER SELECTOR GUIDE**.....\$10.00. Complete guide to semiconductor power devices. More than 1000 power handling devices are included. They are tabulated in alpha-numeric sequence, by technical specs. Includes power diodes, Thyristors, Triacs, Power Transistors and FET's.
- BP234—TRANSISTOR SELECTOR GUIDE**.....\$10.00. Companion volume to BP235. Book covers more than 1400 JEDEC, JIS, and brand-specific devices. Also contains listing by case type, and electronic parameters. Includes Darlingtons transistors, high-voltage devices, high-current devices, high power devices.
- BP99—MINI-MATRIX BOARD PROJECTS**.....\$5.50. Here are 20 useful circuits that can be built on a mini-matrix board that is just 24 holes by ten copper-foil strips.
- BP117—PRACTICAL ELECTRONIC BUILDING BLOCKS—Book 1**.....\$5.75. Oscillators, Timers, Noise Generators, Rectifiers, Comparators, Triggers and more.
- BP184—INTRO TO 68000 ASSEMBLY LANGUAGE**.....\$6.95. The 68000 is a great new breed of microprocessor. Programming in assembly language increases the running speed of your programs. Here's what you need to know.

**BP179—ELECTRONIC CIRCUITS FOR THE COMPUTER CONTROL OF ROBOTS** ..... \$7.50. Data and circuits for interfacing the computer to the robot's motors and sensors.

- BP239—GETTING THE MOST FROM YOUR MULTIMETER**..... \$5.95. Cover basics of analog and digital meters. Methods of component testing includes transistors, thyristors, resistors, capacitors and other active and passive device
- BP97—IC PROJECTS FOR BEGINNERS**.....\$5.50. Power supplies, radio ar audio circuits, oscillators, timers, switches, and more. If you can use a soldering iron you can build these devices.
- BP37—50 PROJECTS USING RELAYS, SCR'S & TRIACS**.....\$5.50. Build priority indicators, light modulators, warning devices, light dimmers and more.
- RADIO—100 RADIO HOOKUPS**.....\$3.00. Reprint of 1924 booklet presents rare circuits of the era including regenerative, neutrodyne, reflex & more.
- BP42—SIMPLE LED CIRCUITS**.....\$5.50. A large selection of simple applications for this simple electronic component.
- BP127—HOW TO DESIGN ELECTRONIC PROJECTS**.....\$5.75. Helps the reader to put projects together from standard circuit blocks with a minimum of trial and error.
- BP122—AUDIO AMPLIFIER CONSTRUCTION**.....\$5.75. Construction details for preamps and power amplifiers up through a 100-watt DC-coupled FED amplifier
- BP92—CRYSTAL SET CONSTRUCTION**.....\$5.50. Everything you need to know about building crystal radio receivers.
- BP45—PROJECTS IN OPTOELECTRONICS**.....\$5.50. Includes infra-red detectors, transmitters, modulated light transmission and photographic applications.

**BP185—ELECTRONIC SYNTHESIZER CONSTRUCTION** ..... \$5.95. Use this book to learn how to build reasonably low cost yet worthwhile monophonic synthesizer. Learn a lot about electronic music synthesis in the process.

CHECK OFF THE BOOKS YOU WANT

**ELECTRONIC TECHNOLOGY TODAY INC.**  
P.O. Box 240, Massapequa Park, NY 11762-0240

SHIPPING CHARGES IN USA AND CANADA

**SORRY** No orders accepted outside of USA & Canada

Number of books ordered

Name \_\_\_\_\_  
Address \_\_\_\_\_  
City \_\_\_\_\_ State \_\_\_\_\_ Zip \_\_\_\_\_

\$0.01 to \$5.00	.....	\$1.50
\$5.01 to \$10.00	.....	\$2.50
\$10.01 to \$20.00	.....	\$3.50
\$20.01 to \$30.00	.....	\$4.50
\$30.01 to \$40.00	.....	\$5.50
\$40.01 to \$50.00	.....	\$6.50
\$50.01 and above	.....	\$8.00

Total price of merchandise ..... \$ \_\_\_\_\_  
Sales Tax (New York State Residents only) ..... \$ \_\_\_\_\_  
Shipping (see chart) ..... \$ \_\_\_\_\_

All payments must be in U.S. funds

Total Enclosed .. \$ \_\_\_\_\_

R292



The transformer is 1:1  
600 Ohms, with a 1500  
volt breakdown rating.

The zener diodes are  
3.9 volt devices, such  
as a type 1N5228.

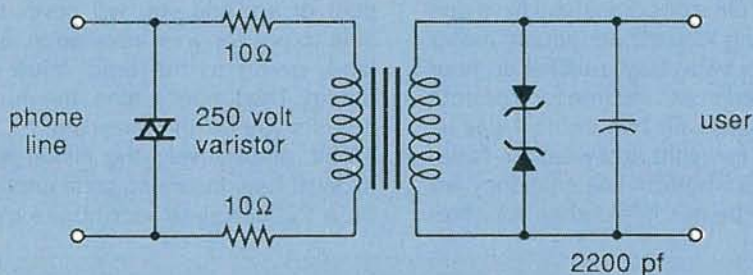

FIG. 4—A FCC PART 68 INTERFACE is required any time you connect any circuit of your own to the phone line. While this interface can be both simple and cheap, the required submission and approval process is not.

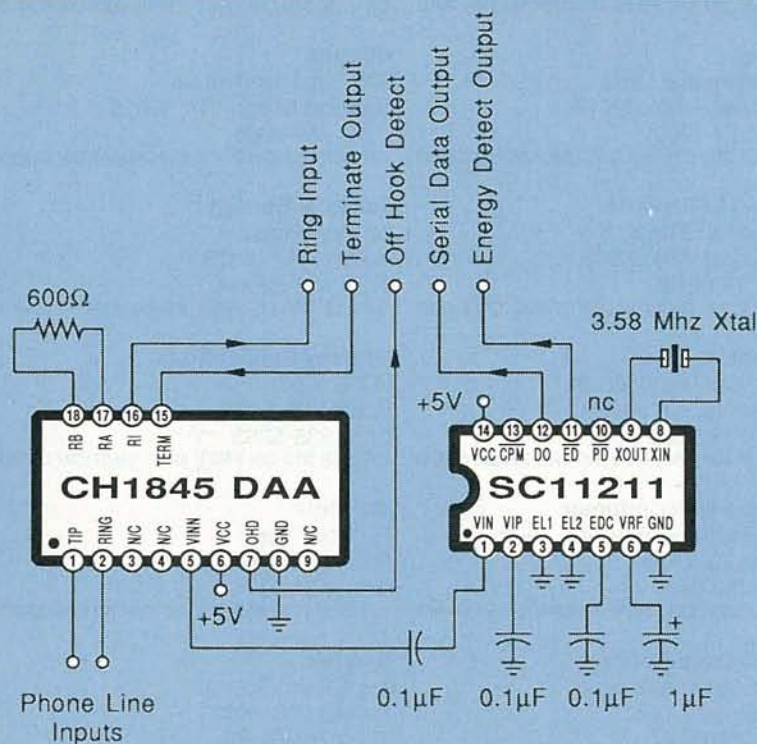

FIG. 5—PRE-APPROVED PART 68 INTERFACE HYBRIDS are available, but they are rather expensive. Here is a caller-ID circuit that uses the Cermetek CH1845 DAA interface and the Sierra SC11211 caller ID chip.

info, and have summarized where to go for more in our *Lumeloid and Lepcon Solar Resources* sidebar.

Let's start off with the bottom line: Yes, this looks like it someday could be real. Maybe. At least in the lab. No, you cannot yet buy the stuff by the yard through your local *K-Mart* fabric department and staple it to your roof. Yes, this is a great topic for a school paper or a science fair. And an incredible emerging re-

search area.

On the other hand, *working prototypes do not yet exist*. And there are just enough "penny stock" and "media hype" aspects to all this that I have lowered my rating from "solar breakthrough" to "an interesting potential solar development." But you could judge for yourself, just by picking up on the resources in our sidebar.

The key individual behind all this

## DIGITAL VIDEO STABILIZER ELIMINATES ALL VIDEO COPYGUARDS



While watching rental movies, you will notice annoying periodic color darkening, color shift, unwanted lines, flashing or jagged edges. This is caused by the copy protection jamming signals embedded in the video tape, such as Macrovision copy protection. THE DIGITAL VIDEO STABILIZER: RXII COMPLETELY ELIMINATES ALL COPY PROTECTIONS AND JAMMING SIGNALS AND BRINGS YOU CRYSTAL CLEAR PICTURES.

### FEATURES

- Easy to use and a snap to install
- State-of-the-art Microchip technology
- 100% automatic
- Compatible to all types of VCRs and TVs
- The best and most exciting Video Stabilizer in the market
- Light weight (8 ounces) and compact (1x3.5x5")
- Uses a standard 9 Volt battery (last 1-2 years)
- Fast UPS delivery
- Air shipping available
- UNCONDITIONAL 30 day money back guarantee
- 1 year warranty

### WARNING

THE DIGITAL VIDEO STABILIZER IS INTENDED FOR PRIVATE HOME USE ONLY. IT IS NOT INTENDED TO COPY RENTAL MOVIES OR COPYRIGHTED VIDEO TAPES THAT MAY CONSTITUTE COPYRIGHT INFRINGEMENT.

(Dealers Welcome)  
**FREE 20P Catalog**

To Order: \$59.95 ea +\$4 for p & h  
Visa, M/C, COD Mon-Fri: 9-6 EST

**1-800-445-9285 ext. 63802**  
SCO Electronics Inc. Dept. 63802  
581 W. MERRICK RD. VALLEY STREAM, NY 11580

CIRCLE 177 ON FREE INFORMATION CARD

## CABLE TV DESCRAMBLERS How You Can Save Money on Cable Rental Fees

### Bullet Proof



1 Unit 5+

BEST Super Tri-Bi Auto/  
Var. Gain Adjustment \$119.95...\$85  
Jerrold Super Tri-Bi ... \$109.95...\$79  
Scientific Atlanta ..... \$109.....\$79  
Pioneer ..... \$109.....\$79  
Panasonic TZPC145.... \$99.95...\$79  
Stargate Converter..... \$95.....\$69  
Digital Video Stabilizer. \$59.95...\$29  
Wireless Video Sender...\$59.95...\$49.95

US Cable'll Be  
Anyone's Price  
Advertised in  
this Magazine!

**30 Day Money Back Guarantee**  
FREE 20 page Catalog

Visa, M/C, COD or send money order to:

**U.S. Cable TV Inc.** Dept. 53802  
4100 N. Powerline Rd., Bldg. F-4  
Pompano Beach, FL 33073

**1-800-772-6244 ext. 53802**

### For Our Record

I, the undersigned, do hereby declare under penalty of perjury that all products purchased, now and in the future, will only be used on Cable TV systems with proper authorization from local officials or cable company officials in accordance with all applicable federal and state laws. FEDERAL AND VARIOUS STATE LAWS PROVIDE FOR SUBSTANTIAL CRIMINAL AND CIVIL PENALTIES FOR UNAUTHORIZED USE.

Date: \_\_\_\_\_

Signed: \_\_\_\_\_

**No Florida Sales!**

CIRCLE 178 ON FREE INFORMATION CARD

is one Alvin Marks and his company of *Advanced Research Development*. Their OTC pink sheet stock is traded under the name *Phototherm*. This is strictly an unregistered blue sky security, and trading remains illegal in Massachusetts, the issuing state.

Marks is a credible, experienced, and independent researcher with a long history of successful energy, optical-film, and pollution-control developments. Among other things, he developed the cheap glasses once used for 3-D movies.

And EPRI, that ultra-conservative *Electric Power Research Institute* electric utility consortium has seen fit to fund Marks with a modest research grant. Albeit a paltry one by EPRI standards. Coffee money.

The two key patents that are involved in this are #4,445,050 *Device for Conversion of Light Power into Electric Power*, and #4,574,161 *An Ordered Dipolar Light-Electric Power Converter*.

There is very little published to date. And *all* of it is single sourced. None appears to be peer reviewed or critiqued. A collection of reprints is now available free on request from *Advanced Research Development*. One original paper has shown up as *Lumeloid Solar Plastic Films and Lepcon Submicron Dipolar Antennae on Glass*, from the 1990 *International New Energy Technology* symposium published by the *Planetary Association for Clean Energy*, located in Ottawa, Canada.

As we've seen a number of times in the past, you can quickly research any technical topic by using the *Dialog Information Service* at your local library, and then can get any reprint by using either interlibrary loan or the *UMI* reprint service.

So what is the big deal here and how does it work? Your traditional methods of generating electricity from the sun are seriously flawed. The old mirrors-and-boilers method involves a thermodynamic cycle with a *Carnot* thermodynamic efficiency limit around 35 percent. Besides not downsizing very well. Silicon solar cells at a theoretical 26 percent are even less efficient. It seems that they can only accept "whole lumps" of quantum energy, and have to throw the rest away as

heat. And, before Marks, any photosynthesis scheme was well under six percent efficient.

Efficiency is everything in solar power. On a good day, you have one incoming kilowatt per square meter to work with. Say a nickel an hour "avoided cost" income for a perfect conversion. Or two cents a day allowing for night and weather. Naturally, your bottom-line efficiency will usually be much less than your the-

oretical. Let your efficiency drop to low and there's no way that so can be competitive. Get under the bottom-line efficiency of seven percent or so, and you will *never* be able to pay for your installation a land, owing to the time value money. The longer it runs, the more it costs you for the financing.

But, alternatively, the nickel-per kilowatt-hour incoming solar energy on a 2200 square foot house re-

## NAMES AND NUMBERS

### Analog Devices

One Technology Way  
Norwood, MA 02062  
(617) 329-4700  
CIRCLE 301 ON FREE INFORMATION CARD

### Aware

One Memorial Drive  
Cambridge, MA 02142  
(617) 577-1700  
CIRCLE 302 ON FREE INFORMATION CARD

### Bennet LaserBrite

720 Fourth Street, SW  
Rochester, MN 55902  
(507) 280-9101  
CIRCLE 303 ON FREE INFORMATION CARD

### Cermetek

1308 Borregas Avenue  
Sunnyvale, CA 94089  
(408) 752-5000  
CIRCLE 304 ON FREE INFORMATION CARD

### Dallas Semiconductor

4401 Beltwood Parkway South  
Dallas, TX 75244  
(214) 450-0400  
CIRCLE 305 ON FREE INFORMATION CARD

### Digital Diagnostics

1025 Sherman Avenue  
Hamden, CT 06514  
(203) 288-9444  
CIRCLE 306 ON FREE INFORMATION CARD

### Direct Imaging

2 Technology Drive  
West Lebanon, NH 03784  
(603) 298-8383  
CIRCLE 307 ON FREE INFORMATION CARD

### Genie

401 North Washington Street  
Rockville, MD 20850  
(800) 638-9636  
CIRCLE 308 ON FREE INFORMATION CARD

### Hello Direct

140 Great Oaks Blvd  
San Jose, CA 95119  
(800) 444-3556  
CIRCLE 309 ON FREE INFORMATION CARD

### High Energy Enterprises

PO Box 5636  
Security, CO 80931  
(719) 475-0918  
CIRCLE 310 ON FREE INFORMATION CARD

### Hughes

500 Superior Avenue  
Newport Beach, CA 92658  
(714) 759-2665  
CIRCLE 311 ON FREE INFORMATION CARD

### Jones & Bartlett

20 Park Plaza  
Boston, MA 02116  
(617) 482-3900  
CIRCLE 312 ON FREE INFORMATION CARD

### Lindsay Publications

PO Box 538  
Bradley, IL 60915  
(815) 935-5353  
CIRCLE 313 ON FREE INFORMATION CARD

### Motorola

PO Box 1466  
Austin, TX 78767  
(800) 521-6274  
CIRCLE 314 ON FREE INFORMATION CARD

### NewTek

215 SE 8th Avenue  
Topeka, KS 66603  
(800) 765-3406  
CIRCLE 315 ON FREE INFORMATION CARD

### Serpac

612 Commercial Avenue  
Covina, CA 91723  
(818) 331-0517  
CIRCLE 316 ON FREE INFORMATION CARD

### Sierra Semiconductor

2075 North Capitol Avenue  
San Jose, CA 95132  
(408) 263-9300  
CIRCLE 317 ON FREE INFORMATION CARD

### Sony

10833 Valley View Street  
Cypress, CA 90630  
(714) 229-4175  
CIRCLE 318 ON FREE INFORMATION CARD

adds up to over \$3000 a year. Which is lots more than usually gets used underneath as electricity. So efficient solar electric conversion could completely blow away coal, nuclear, and even most hydro.

Marks has developed two different solar-to-electric systems that seem to have rather high theoretical efficiencies.

Radio waves are electromagnetic. Solar energy is electromagnetic. The main difference between orange light (at 600 nanometers) and television channel two (6 meters) is a 10,000:1 size factor. Those light wavelengths may seem tiny, but we are starting to routinely handle *submicron* distances in integrated-circuit manufacturing.

There's this thing called a *crystal set* that you might have heard of. Just shove some electromagnetic energy into an antenna, rectify it somehow, and out comes DC power. These days, we call the same thing a *rectenna*. So why not use light waves instead of radio waves?

An antenna is any subsystem for converting radiated electromagnetic energy into conducted wire electromagnetic energy. Or vice versa. As a transmitter, if your antenna is now properly *matched* to the rest of your circuit, nearly all of your input energy will get radiated. And, since most antennas are linear and reciprocal devices, if you input any electromagnetic energy well inside of the antenna's *effective area*, nearly all of it will get converted into conducted electricity. So, a properly matched antenna can be 100 percent efficient. And a rectifier nearly so.

Now, an optical antenna is trivial. Just make it any old color so long as it is black. Even a black felt tip pen will do. The trick lies in rectifying and gathering all the received solar electromagnetic electricity, rather than burning it up as heat.

The *Lepcon* panel is the older of Marks' two new developments. In a *Lepcon* panel, tiny *rectenna* elements are created on glass using more or less conventional but very advanced microlithography. These are basically a conductive channel ending with a metal barrier diode. The photons in the incoming solar

## LUMELOID & LEPCON SOLAR RESOURCES

### Key Patents:

#4,445,050—Device for Conversion of Light Power into Electric Power.

#4,574,161—An ordered Dipolar Light-Electric Power Converter.

### Key Paper:

Lumeloid Solar Plastic Film and Lepcon Submicron Dipolar Antennae on Glass. 1990 International New Energy Technology Symposium, pages 201-210. From Planetary Association for Clean Energy below.

### Key Info Packet:

From Advanced Research Development below.

### Key Players:

#### Advanced Research Development

359R Main Street  
Athol, MA 01331  
(508) 249-4696  
CIRCLE 319 ON FREE INFORMATION CARD

### Dialog

3460 Hillview Avenue  
Palo Alto, CA 94304  
(415) 858-2700  
CIRCLE 320 ON FREE INFORMATION CARD

### Electric Power Research Inst.

PO Box 10412  
Palo Alto, CA 94303  
(415) 855-2000  
CIRCLE 321 ON FREE INFORMATION CARD

### Home Power

PO Box 130  
Hornbrook, CA 96044  
(916) 475-3179  
CIRCLE 322 ON FREE INFORMATION CARD

### Planetary Assoc Clean Energy

191 Promenade du portage, #600  
Hull PQ, CANADA J8X 2K6  
(819) 777-9696  
CIRCLE 323 ON FREE INFORMATION CARD

### UMI

300 North Zeeb Road  
Ann Arbor, MI 48106  
(800) 521-3044  
CIRCLE 324 ON FREE INFORMATION CARD

NO COMPLICATED ELECTRONICS, NO EXPENSIVE INSTRUMENTS:

## Home study course shows you how to make good money in VCR repair.

An amazing fact: you can do more than four out of five VCR repairs with ordinary tools and basic fix-it procedures. Our home study program shows you how.

Learn all of the systems, mechanisms, and parts of almost all brands of VCRs. With *no* expensive instruments. *No* complicated electronics. *No* fancy workshop. The step-by-step texts and close personal attention from your instructor make learning easy.



Texts, course materials, and tool kit are sent to your home. Graduate ready to make up to \$50.00 or more per hour in your own spare-time or full-time business.

**Send today for your free career booklet. Or call 800-223-4542**

Name \_\_\_\_\_  
Address \_\_\_\_\_  
City \_\_\_\_\_ State \_\_\_\_\_ Zip \_\_\_\_\_

## The School of VCR Repair

2245 Perimeter Park, Dept. V B 342, Atlanta, Georgia 30341



energy are used to accelerate electrons, which jump the barrier diode to become a DC current. Unlike a traditional solar cell, there are no "whole lumps only" quantum effects involved, and nearly all of the available energy gets converted.

The antenna/rectifier combination only works with one polarization of light. It converts the one polarization with up to a theoretical 80 percent efficiency, and passes the remainder on through. You could put a second Lumeloid panel underneath that is oriented 90 degrees from the first to convert the other polarization.

Or, you could use a sneaky trick consisting of a *quarter wave plate* and a mirror to rotate your rejected polarization by 90 degrees and shove it back up through the original film. Your combined efficiency ends up around a theoretical 72 percent.

The projected costs of the Lepcon process is around \$250 per panel, and the panels should last 25 years.

The *Lumeloid* film process uses chemicals instead of very expensive microlithography. The chemical techniques in theory lend themselves to low-cost and high-volume production. The chemicals attempt to mimic the first half of the long photosynthesis process. A rather long chain carbon molecule, such as polyacetylene, is attached to some electron donor acceptor complex, such as porphyrin and quinone.

The long chain molecule acts as a conductive antenna, changing the input optical energy into electron energy. The tunneling gap effect between the large donor and small acceptor rings acts as a rectifying diode for DC conversion.

For all this to work, the molecules have to be carefully oriented while the sheet is being created. Mark's work has centered on suitable bulk processes to do the orientation in a low-cost and high-volume process. Projected costs are five dollars per meter and three cents per watt.

At present, the Lumeloid films are only expected to last a year in strong sunlight. Once again, Lepcon panels use conventional microlithography on glass, while Lumeloid use oriented films that mimic photosynthesis.

Interestingly, the Lumeloid process is totally reversible. You can input electricity and get light out as well. Which could lead to new lighting and display technologies.

For any of this to become real, we will need working prototype panels, credible third party research, and the proper peer review. My "usual suspects" of *Science*, *Nature*, *Science News*, and the technology page of the *Wall Street Journal* have been suspiciously silent to date.

My own feelings are that short and open circuits in production panels are going to lead to the very same type of yield problems that have held back and restricted development of large area flat-panel TV displays.

Because of the lack of even lab prototypes, their efficiency and cost projections at this time would appear totally meaningless.

### Caller ID update

Time sure does fly when you are having fun. As a result, I've gotten hopelessly far behind on a bunch of potentially great projects here. So my caller-ID project may take a while.

Caller ID should be available in most parts of the country very soon. The controversy is dying down, since the benefits so totally and ludicrously outweigh any potential problems. To see what dozens of others are now thinking about caller ID, you might want to check #2239 CALLERID.CAP on the *GENIE* RADIO RoundTable.

If for no other use, the convenience of having a no-charge, no-hassle list of everyone that called you while you were out is just flat out wonderful.

*Motorola* has just announced a brand new MC145447 caller ID chip. Free sample kits are available. This one is supposed to include internal ring detection. But, as near as I can tell so far, the chip of choice remains the *Sierra* SC11211.

An FCC Part 68 interface is shown in Fig. 4. Which is what normally has to go between you and the phone company. Key points include an exceptionally well-balanced transformer with a 1500-volt isolation capability. While such an interface is fairly cheap and simple,

getting the needed approval is

Several companies now (some ready-to-go Part 68 interfaces). These are priced well at what you could build your own. But they come pre-approved, eliminating most legal hassles. *D Semiconductor* and *Cermetek* are two typical sources. An interface between the new Cermetek CH1845 and the *Sierra* SC11211 caller ID chip is shown in Fig. 5.

Both *Cermetek* and *Sierra* have free caller-ID ap notes available.

As we've seen before, a number of ready-to-use caller-ID products are available from *Hello Direct*.

### New tech lit

From *Sony*, a new *Laser Disc Guidebook*. And from *Hughes* a free brochure on their *Nonvo. Serial Programmable Devices*.

*The Best of Analog Dialogue* is a three decade compilation of very best in analog linear integrated circuit design info. From the corny *Analog Devices*.

In a startling development, *thermography* is now available on a toner-based desktop publisher. One new source is *Berkeley LaserBrite*. You spray on chemical to soften your toner, dust powder B, and then apply heat with a desk lamp C. Presto. Instant rainbow letters. Even Braille.

Free stuff this month: A video on a high-end printed circuit prototyping system from *Direct Imaging*. A free video on the *Toaster*, the cost broadcast-quality video production system from *NewTek*. A great new sample A-42 plastic electronic case from *Serpac*.

A reminder that I do have a collection of reprints available. These include *Hardware Hacker III*, my *Ask the Guru I & II & III*, *Blatant Opportunist I*, *LaserWare Secrets*, and our brand new *Be On-Demand Resource Kit*. Just me a call on our no-charge telephone helpline (per the box) for more tails. Or call me at my *Synergetic*.

You can also reach me via GPRS (800) 638-9636. Besides wavelet freeware and the *Sierra* Chart package, you'll find lots of *Hardware Hacker* and *Midnight Engineering* hard-to-find resolution stuff.

## More from the mail bag

LARRY KLEIN

Last month, I answered several hi-fi questions from readers, but ran out of room before getting to them all. This month, we'll get to the bottom of the mail bag.

### Overpriced signals?

*I'm appalled by the proliferation of signal processors—particularly equalizers—in the audio market place. What ever happened to the notion that a hi-fi system should be a "straight wire with gain"?*

A.T.

McAlester, OK

The idea is alive and well, but beset by philosophical confusions. While the concept has validity for, say, power amplifiers, it really can't be applied to the entire recording-reproduction chain. Straight-wire-with-gain audiophiles—for whom tone controls of any kind are anathema—appear to assume that whatever signal comes out of their carefully chosen disc player or tape machine somehow perfectly embodies an original performance. Anyone naive enough to harbor such a belief has, at best, a very unclear notion as to how sound is recorded and reproduced.

Assuming that you had a perfect stereo recording of the sound field (at a specific location) of a live musical event—and all the electromechanical and electronic elements in your playback system were perfect—your speakers would still have the task of replicating the acoustics of a concert hall within the comparatively cramped space of a conventional listening room. In short, the chances of exactly duplicating an original live sound field in your listening room are about zero.

Given the aberrations in frequency balance, noise level, and dynamic range likely to be introduced, plus the loss of rear ambience and reflec-

tions, I see nothing wrong with using signal processors to help minimize, ameliorate, or eliminate the various ill effects. I've long since given up any hope of reproducing the precise sound of any original musical performance in my home. But when I achieve plausible reproduction, then I'm satisfied that I've achieved high, if not absolute, fidelity.

### System imbalance

*After a long struggle to find the reason for my having to operate the balance control on my preamplifier at the 3-o'clock position, I traced the difficulty to my speakers. What would account for the fact that a readjustment of the midrange control on one of my speakers cured the problem?*

J.W.

Freeport, TX

The frequencies that contribute to the perception of "loudness" are mostly in the midrange. (You can confirm this for yourself by noting the small effect on the overall loudness of music produced by the outermost controls of a ten-band equalizer.) Hence, any control that boosts or cuts the mid-frequencies in a speaker system will also necessarily influence its relative "efficiency" or loudness.

### Alcoholic anxiety

*Some tape-cleaner ads seem to say that alcohol may be injurious to the insides of recorders. But magazines seem to recommend alcohol as a cleanser. Which information is correct?*

N.W.

Covington, LA

You should avoid solutions sold as "rubbing alcohols" because they are likely to include a skin lubricant (usually glycerin) that could be transferred to the tape and the pinch roller. Ask your pharmacy for

isopropyl alcohol in "NF" purity; that will work fine for heads, pinch rollers, and for general internal cleaning of your machine.

### Costly repairs

*My receiver recently went dead in one channel, and I brought it to a local authorized service center. They charged me \$75 to repair a unit that cost \$300 when new. My friends have had similar experiences. Are the repair-shop owners trying to get rich at our expense—and why don't the manufacturers do something about it?*

K.U.

Boston, MA

We live in a time when very complex electronic devices are manufactured by automated machinery controlled by computers. That is the reason why you can buy a digital watch or a pocket AM/FM radio for well under \$10. But the elimination or reduction of the expensive hand-labor element in many of today's electronic devices is of no help when the device needs repair. The repair process continues to be labor intensive, and it involves skilled, expensive labor at that. In short, although electronic products are built by the most sophisticated automated techniques available to the 20th century, they are repaired one at a time by the equivalent of an 18th-century handicraft approach. As you have found, that's not cheap!

### Slam damage

*I've noticed that when I close the trunk lid the cones of the woofers installed in my car's rear deck seem to jump forward. Can the woofers be damaged by my slamming the trunk shut?*

E.C.

Chicago, IL

Possibly, but not probably. The variables in the situation are the rug-



**FREE CATALOG OF TEST INSTRUMENTS & TOOLS** is packed with thousands of products for testing, repairing, and assembling electronic equipment. Featured are brand name instruments such as Fluke, Tektronix, Leader, Weller, 3M plus many more. Also included are DMM's, hand tools, power supplies, tool kits, test equipment, static supplies plus many other new products. Orders placed by 4 PM are shipped before we go home! **CONTACT EAST, 335 Willow St., No. Andover, MA 01845. (508) 682-2000, Fax: (508) 688-7829.**

CIRCLE 55 ON FREE INFORMATION CARD



**TWO FOR THE PRICE OF ONE! 5 MINUTE ASSEMBLY! MONEYBACK GUARANTEE!** Attach any 3V-12V battery and have the most stable, sensitive, powerful room transmitter you can buy. Or attach to telephone line. Hear all telephone conversations—crystal clear—over 1 mile away without batteries! Use any FM radio or wideband scanner. 80-130 MHz. 100mW output! VT-75 microtransmitter chip **\$49.94 + 1.50 S&H. VISA, MC, MO. COD's add \$4.00. DECO INDUSTRIESG, Box 607, Bedford Hills, NY 10507. 1-800-759-5553.**

CIRCLE 127 ON FREE INFORMATION CARD



**GET YOUR RECHARGE CATALOG FREE...EARN BIG \$\$ IN YOUR SPARE TIME**—All supplies and Do-It-Yourself kits with complete instructions available. Supplies cost from **\$9.95** in qty and you can sell recharged toner cartridges for **\$40.00** to **\$55.00** each. Printers include HP LaserJet and Series II, Apple LaserWriter, QMS, etc. Canon PC-25 Copier also. **CHENESKO PRODUCTS, 2221 Fifth Ave., Suite #4, Ronkonkoma, NY 11779, 516-467-3205. FAX 516-467-3223, 1-800-221-3516**

CIRCLE 179 ON FREE INFORMATION CARD



**CABLE TV CONVERTERS AND DE-SCRAMBLERS SB-3 \$79.00 TRI-BI \$95.00 MLD-\$79.00 M35B \$69.00 DRZ-DIC \$149.00.** Special combos available. We ship COD. Quantity discounts. Call for pricing on other products. Dealers wanted. **FREE CATALOG.** We stand behind our products where others fail. One year warranty. **ACE PRODUCTS. P.O. Box 582, Saco, ME 04072 1 (800) 234-0726.**

CIRCLE 75 ON FREE INFORMATION CARD

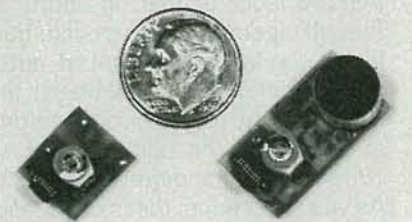

**WORLD'S SMALLEST FM TRANSMITTERS!** New Surface Mount Technology (SMT) makes all others obsolete! XST500 Transmitter—powerful 3 transistor audio amplifier, transmits whispers up to 1 mile. XSP250 Telephone Transmitter—line powered, transmits conversations up to ¼ mile. Both tune 88-108 MHz. Easy to assemble **E-Z KITS** (SMT components pre-assembled to circuit board)! XST500—**\$39.95, XSP250—\$29.95, VISA/MC. COD add \$5. XANDI ELECTRONICS, 201 E. Southern Ave., Suite 111, Tempe, AZ 85282. 1-800-336-7389.**

CIRCLE 186 ON FREE INFORMATION CARD

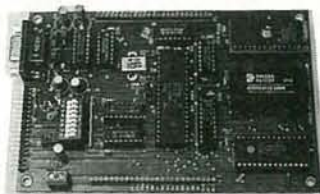

**CREATE INTELLIGENT PROJECTS WITH THE VERSATILE Z8 PROGRAMMABLE MICROCOMPUTER.** This powerful computer was designed for flexibility and can be used for various electronic projects. I/O Intensive. Up to 20MHz operation. Download programs or run EPROM code. Special hardware features included. Prices from **\$125.00.** Battery-backed RAM, X-assembler, and other options available. **CALL FOR FREE BROCHURE. MJS DESIGNS, INC., 1438 W. Broadway Rd., Suite B185. Tempe, AZ 85282. (602) 966-8618.**

CIRCLE 184 ON FREE INFORMATION CARD

gedness of the woofer-cone suspensions, the size and air leak the trunk, and the velocity c slam. To determine whether th a potential problem, watch woofer cone (with its prote grille removed, if possible) du typical slam. If the forced ou excursion exceeds a quarter ir so, it might be best to close trunk a bit more gently in the fu However, I expect that the l manufacturers of the larger car eo speakers, who knew where would be mounted, have des their cone suspensions to stand large pneumatic shocks

## FM bandwidth

*What is the purpose of a narrow band bandwidth switch on a tuner?*

R.A.  
Bay Shore, NY

As far as I know, the only justification for a narrow-band switch is in a rare case when a listener is located between two transmitters of comparable strength that are adjacent to each other on the FM dial. In that case, a rotatable directional antenna will probably be of more help in separating the two stations than a tuner's ability to narrow its IF bandwidth. The narrow bandwidth filtering may be helpful if the conflicting stations are in approximately the same direction, or possibly if there are severe noise conditions.

## Off-frequency FM

*Many of the rock stations in my area advertise themselves as "100% FM dial." But my digital tuner tunes to even numbers; it sets for 99.9 or 100.1. Does some need adjustment?*

R.P.  
San Diego, CA

Yes—the thinking of those who like to reduce all communications to the short, punchy, and simple is widespread. In the U.S., all broadcast stations are assigned odd-numbered operating frequencies, 2-megahertz apart. Even if you could tune to 100 MHz, you wouldn't find any stations there but a lot of noise and interference. But, come to think of it, maybe you're pretty close to what's really broadcasting.

# R-E Engineering Admart

Rates: Ads are 2 1/4" x 2 7/8". One insertion \$995 each. Six insertions \$950 each. Twelve insertions \$925 each. Closing date same as regular rate card. Send order with remittance to Engineering Admart, Radio-Electronics Magazine, 500-B Bi-County Blvd., Farmingdale, NY 11735. Direct telephone inquiries to Arline Fishman, area code-1-516-293-3000. FAX 1-516-293-3115. Only 100% Engineering ads are accepted for this Admart.

**Big Plans . . .  
Small Budget??**



**6805 Microcomputer Development System**

TECI's MCPM-1 system allows your IBM PC and Compatibles to be used as a complete development system for the Motorola 6805 family of single chip microcomputers. Many time saving features at an affordable price.

**MCPM-1 Programmer for Motorola MC68705P3, P5, U3, U5, R3, R5**

MCPM-1 w/driver, assembler, simulator/debugger . . . \$449  
MCPM-1 w/driver program only . . . . . \$349

Also available—Programmer for 68HC05, in-circuit emulators and many software tools to help you. Call for a complete catalog and let us help you select your tools.



The Engineers Collaborative, Inc.  
Rt #3, Box 8C Barton, VT 05822 USA  
TEL: (802) 525-3458 FAX: (802) 525-3451 Call Toll Free (800) 336-8321

**CIRCLE 196 ON FREE INFORMATION CARD**

**Surface Mount Chip Component Prototyping Kits—  
Only \$49.95**



**CC-1 Capacitor Kit** contains 365 pieces, 5 ea. of every 10% value from 1pf to .33µf. **CR-1 Resistor Kit** contains 1540 pieces; 10 ea. of every 5% value from 10Ω to 10 megΩ. Sizes are 0805 and 1206. Each kit is ONLY \$49.95 and available for Immediate One Day Delivery!

Order by toll-free phone, FAX, or mail. We accept VISA, MC, COD, or Pre-paid orders. Company PO's accepted with approved credit. Call for free detailed brochure.



**COMMUNICATIONS SPECIALISTS, INC.**  
426 West Taft Ave. • Orange, CA 92665-4296  
Local (714) 998-3021 • FAX (714) 974-3420

**Entire USA 1-800-854-0547**

**CIRCLE 181 ON FREE INFORMATION CARD**

## FCC LICENSE PREPARATION

The FCC has revised and updated the commercial license exam. The **NEW EXAM** covers updated marine and aviation rules and regulations, transistor and digital circuitry. **THE GENERAL RADIOTELEPHONE OPERATOR LICENSE - STUDY GUIDE** contains vital information. **VIDEO SEMINAR KITS ARE NOW AVAILABLE.**

**WPT PUBLICATIONS**  
7015 N.E. 61st Ave.  
Vancouver, WA 98661  
Phone (206) 750-9933 Dept. 50

**CIRCLE 185 ON FREE INFORMATION CARD**

### NEW LITERATURE

*continued from page 27*

mation, complete specifications, and operating range data, are provided for more than 50 models. A five page summary of specifications and ranges is organized by instrument type to help the reader make model-by-model comparisons. Besides being chock full of test instruments, the catalog describes protective cases that are tailored for individual models, and a complete line of accessory test probes, cables, and test lead kits.

**THE HIDDEN SIGNALS ON SATELLITE TV: THIRD EDITION;** by Thomas P. Harrington. Universal Electronics, Inc., 4555 Groves Road, Suite 13, Columbus, OH 43232; Phone: 614-866-4605; \$19.95, plus \$3.00 shipping and handling.

Everyone knows that you can pick up video signals with a satellite dish, and most satellite owners know

**The Hidden Signals on Satellite TV**  
Third Edition  
Thomas P. Harrington



- Broad Bandwidth
- Satellite Channels
- Wide Area Services
- Audio Subcarrier
- Stereo Subcarriers
- Multiple Channels
- Local Broadcast
- Teletext
- Single Channel Per Carrier
- Multiple Use Channels
- Pay-Per-View
- Other Services

*The Secret Signals On The Satellite*

**CIRCLE 37 ON FREE INFORMATION CARD**

that they can also receive audio channels on receivers equipped with tunable audio subcarrier sections. However, not many people are aware of the variety of non-video and data services that are also carried on satellites. Those services include audio news, stereo subcarriers, telephone systems, world news and press services, teletext, single-channel-per-carrier (SCPC) systems, stock market reports, financial news services, and business data channels. This book covers all phases of

this expanding side of the satellite business. Beginning with an explanation of the transmission and reception of satellite signals, the book goes on to provide details about each of the systems transmitting hidden signals. It describes each system and how it works, explaining who uses it and how the reader can receive it. The book also includes glossaries of data-communications and satellite-system terms.

**THE ARRL HANDBOOK FOR RADIO AMATEURS 1992;** Edited by Charles L. Hutchinson, K8CH and Joel P. Kleinman, N1BKE. American Radio Relay League, 225 Main Street, Newington, CT 06111; \$25.00.

Everything you ever wanted to know about amateur radio—and then some—can be found in the more than 1100 pages of this book. Aimed at hams, technicians, and engineers, the book provides a thorough introduction to the basics of amateur radio, including electrical fun-

**THE ARRL HANDBOOK**  
FOR RADIO AMATEURS  
1992



**CIRCLE 36 ON FREE INFORMATION CARD**

damentals, the techniques and terminology of radio design, and the basics of solid-state and vacuum-tube sets. A comprehensive section on radio principles covers power supplies, audio and video communications, digital basics, modulation and demodulation, RF oscillators and synthesizers, principles of radio transmitting and receiving, transceivers, repeaters, amplifiers, antennas, and transmission lines. Modulation methods for voice, digital, and image communication

*continued on page 102*

# DRAWING BOARD

## Our long-lost discussion on digital scopes.

ROBERT GROSSBLATT

**W**ell, it's been a while coming but, at long last, we're finally back to talking about digital scopes. There have been some interruptions in the meantime but that's the way life is—it sometimes interferes with living. This subject got put on hold for a bit because of the business of voltage regulators. Sorry about that but, even if you don't have any particular interest in cars or motorcycles, all that information should be put away for future reference. You never know.

Just to refresh all our memories, we had been talking about the things to be considered in designing a circuit that would serve as the beginnings of a digital scope. All scopes, even the one we're going to design, have certain basic things in common and any project you have in mind that involves scope design has to start out life around these fundamentals. Your ultimate goal may be to construct something that's bigger, faster, or (to use my favorite phrase), "feature rich," but no matter what you have in mind, when you're just getting started it makes sense to approach things from the beginning.

The design criteria for the scope we are going to be putting together are the following:

1. The scope will have a maximum bandwidth of at least 1 MHz.
2. There will be eight selectable sweep speeds.
3. There will be eight selectable gain levels.
4. There will also be a variable gain control.
5. The display will be in a twenty-by-twenty matrix.

The block diagram of the scope we're talking about is shown in Fig. 1. While you're looking at it keep in mind that, even though we're only talking about a demonstration cir-

cuit, the basic structure is the same for every scope there is. Once you go through the design of a simple scope, it'll be much easier to understand the workings of more complex ones.

There are all sorts of interesting things that can be done with the scope we're building and there's no reason whatsoever why you can't take the basic circuit and add anything you want to it. But we're getting ahead of ourselves.

One of the major players in the accuracy of a digital scope is the timebase. Ordinarily, in a simple scope such as ours, the timebase is an RC-type circuit that gives you... well, RC-type accuracy. But just because we're not building the world's most complex scope, there's no reason why we have to settle for so-so accuracy. Whenever you want accurate timekeeping, the answer is a crystal-based circuit, and that's what we'll use here.

There's no shortage of circuit when it comes to building a crystal oscillator, and the schematic shown in Fig. 2 is as good as any. If you need frequencies up in the megahertz or even the gigahertz range, you'd have to devote a lot of time to this part of the scope, but since we're keeping everything under one measly megahertz, the schematic is a simple answer to the problem.

I've picked one megahertz for the basic crystal frequency because it's a nice even number to work with and 1-MHz crystals are readily available. You shouldn't have any trouble getting the 4049's to work at 1 MHz even if you're only operating the circuit at 5 volts. If you have any problems, up the voltage to 9 volts or more (working with CMOS stuff is great!), and that should take care of the problem.

Should you want or need to start down at 5 volts and you find that t

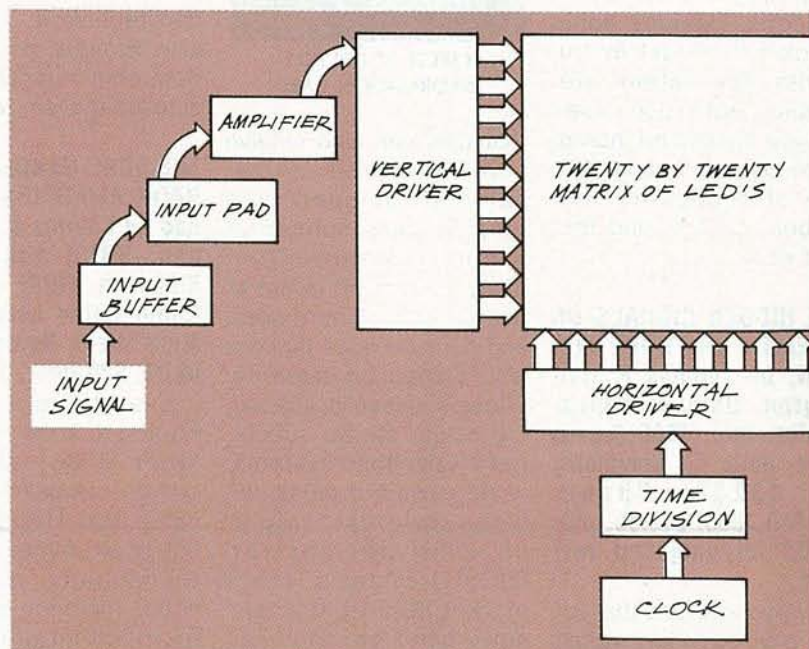

FIG. 1—BLOCK DIAGRAM of our oscilloscope. The basic structure is the same every scope there is.



oscillator isn't self-starting at that voltage, use an equivalent high-speed CMOS part like the 74HCT4049. Most of the mail-order houses carry the 74HCT family and you'll find that they're all faster than the 4000 series and just as reliable. Just about the only restriction you'll have is that 74HCT parts have the same voltage restrictions as TTL. They want a supply voltage of 5 volts and going any higher than that is a sure way to cook the chip.

Once we have the timebase circuit working properly, the next step is to do some straightforward frequency division to generate all the sweep speeds we need. First, however, we should decide what those sweep speeds are going to be and, even before that, we have to work out how the horizontal part of the display is going to be conceptually organized.

Our display is going to be, as we specified, a twenty-by-twenty LED matrix. There are twenty columns of LED's and each column is going to be enabled in turn for a particular length of time. When we refer to the sweep speed, we have to distinguish whether we're talking about how long it takes to sweep across the entire twenty columns or how long each of the twenty columns is enabled.

If you look at the sweep-speed settings on a standard oscilloscope, you'll see that it's marked in seconds/division. Since our display is made up of separate

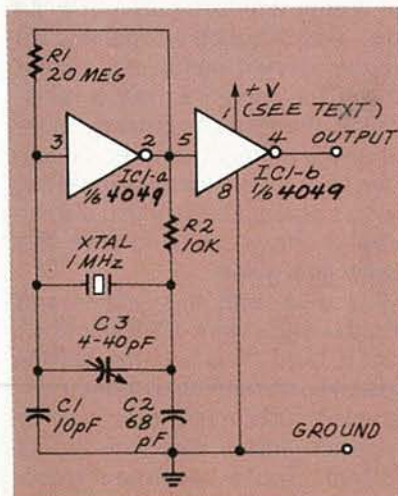

FIG. 2—A CRYSTAL OSCILLATOR for our scope. For frequencies below 1 MHz, this schematic is a simple solution.

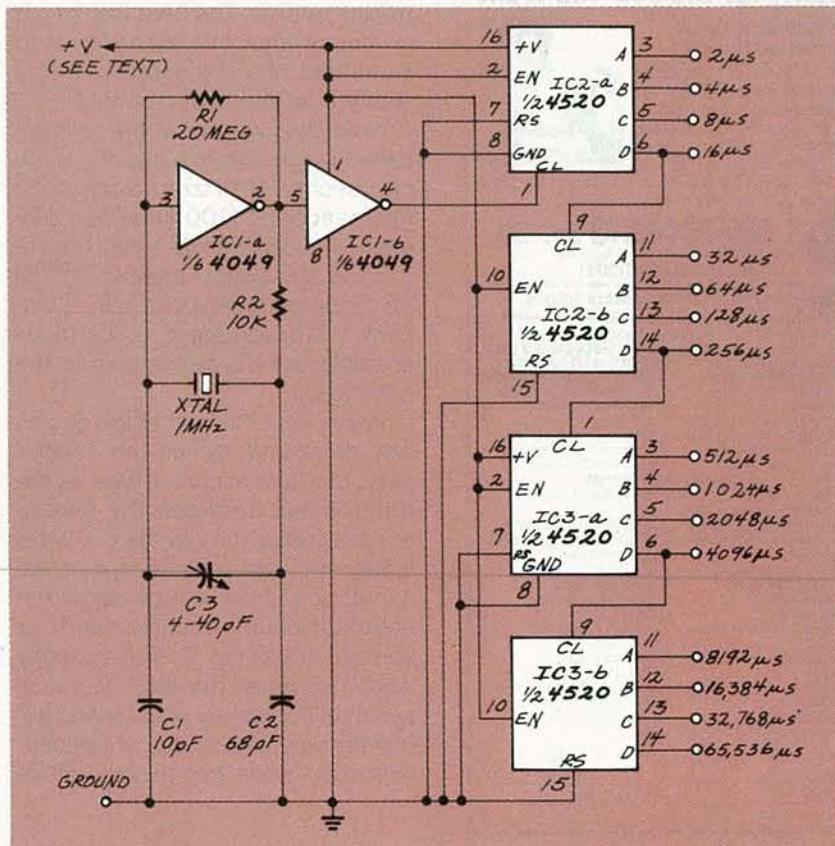

FIG. 3—THE 4520 DUAL SYNCHRONOUS BINARY COUNTER will provide us with a series of frequencies that are accurate enough for the kind of circuit we're designing.

columns, we can translate that into seconds per column. Therefore, we'll arrange our sweep speeds around the time each column is enabled, and not how long it takes to cycle through all the columns. That is important to keep in mind because we want to be able to get a rough idea of frequency when we're viewing a waveform on the scope, and the standard way of doing that is to count the number of divisions covered by a complete cycle. Since each division relates to a particular amount of time, you can estimate the period and calculate the frequency of whatever waveform is being displayed.

Standard oscilloscopes use a 5-2-1 counting sequence for dividing the sweep frequency. That means, at a basic level, that it takes the trace five, two, or one second (or some fraction of a second) to cover each division. The maximum sweep speed we can reasonably expect to have is about 10 microseconds since there are certain limitations to LED intensity, construction methods, and so on. It's

possible to do a lot better, but the stuff you have to worry about has nothing to do with the basic design of the scope itself.

The lowest sweep speed that makes sense for the scope we're working on is about a tenth of a second per column. The major factor here is that when you get much slower than this, it gets increasingly hard to visualize the waveform on LED's. Remember that the scope will be enabling one column at a time and only one LED in each column will be lit. If the sweep speed is too slow, the eye won't be fooled into seeing several of the columns lit at the same time.

Once we get the circuit working, you can experiment with the range of sweep speeds and see what the outside limits are. The top limit is a function of electronics but the bottom is determined by considering the persistence of the retina and other biological factors. If you want to drop the sweep speed to one second per division because you have a particular need to do that it's relatively simple to set the elec-

## 45 Ways to Help You Qualify for the Job You Want

### Free Facts about Career Diplomas and Degrees

Now at home in your spare time, without any previous experience, you can train for a money-making career...even get a Specialized Associate Degree. Call or send for free information on the career field that interests you most and how to train for it.



**CALL TOLL FREE 1-800-234-9070 Ext. 488**  
CALL ANYTIME—24 hours a day, 7 days a week.  
OR MAIL COUPON TODAY!

**ICS** International Correspondence Schools  
SINCE 1890 Dept. ADES12S, 925 Oak Street, Scranton, PA 18515

Send free facts on how I can study at home for the career I have chosen. No obligation. No salesman will visit. **CHECK ONE BOX ONLY!**

**ASSOCIATE IN SPECIALIZED BUSINESS DEGREE PROGRAMS**

- Business Management
- Accounting
- Bus. Mgmt.—Finance Option
- Bus. Mgmt.—Marketing Option
- Applied Computer Science
- Hospitality Management

**ASSOCIATE IN SPECIALIZED TECHNOLOGY DEGREE PROGRAMS**

- Civil Engineering Technology
- Mechanical Engineering Technology
- Electrical Engineering Tech.
- Industrial Engineering Tech.
- Electronics Technology

**CAREER DIPLOMA PROGRAMS**

- Computer Programming
- Computer Programming/COBOL
- Personal Computer Specialist
- Computer-Assisted Bookkeeping
- High School
- Catering/Gourmet Cooking
- Microcomputer Repair
- Auto Mechanics
- Bookkeeping
- Hotel/Restaurant Management
- Drafting
- Air Conditioning & Refrigeration
- Electronics
- Electrician
- Child Day Care
- Legal Assistant
- Police Sciences
- Private Security Officer
- Art
- Small Business Management
- Wildlife/Forestry Conservation
- Diesel Mechanics
- Gun Repair
- Motorcycle Repair
- Surveying & Mapping
- TV/VCR Repair
- Animal Care Specialist
- Travel Agent
- Fitness and Nutrition
- Photography
- Journalism/Short Story Writing
- Dressmaking & Design
- Interior Decorating
- Florist

Name \_\_\_\_\_ Age \_\_\_\_\_  
Address \_\_\_\_\_ Apt. # \_\_\_\_\_  
City/State \_\_\_\_\_ Zip \_\_\_\_\_  
Phone ( ) \_\_\_\_\_

tronics to do it. The best way to get an idea of what it would be like is to sit in front of a real scope and play with the sweep-speed control.

Now that we know the sweep-speed range—from a low of a tenth of a second (10 Hz) to a top of 10 microseconds (100 kHz) per division—we can decide what the remaining six sweep speeds should be. Generating divisions in the standard 1-2-5 sequence is certainly possible but it's also a pain in the neck to do.

We can cut this part of the design way down and reduce the needed parts to a bare minimum if we let the relationship between the sweep speeds follow the standard 1-2-4-8 binary sequence. By doing that, we can choose from a wide variety of standard binary counters and, as you can see in Fig. 3, that's exactly what I've done. The 4520 is a dual synchronous binary counter and will provide us with a series of frequencies that, while not exactly whole

numbers, are close enough for the kind of circuit we're designing.

Remember that the resolution of the scope we're building isn't all that great in the first place.

Feeding a standard CMOS package like the 4520 with a clock as high as 1-MHz is an iffy business—especially, as we discussed a while ago, if you're running off a supply that's down in the range of only a few volts or so. If you have such a problem, the ways to get around it are the same as the ones we talked about earlier; you can either raise the supply voltage or use the 74HCT4520's instead of the standard 4520.

The two 4520's in the circuit give you a choice of sixteen clock frequencies (seventeen if you count the basic crystal frequency), so you have lots of sweep-speed choice. When we get together next time we'll finish the horizontal circuit and go through the design of the vertical amps and driver circuit as well. ■

## SUPER LONG PLAY TAPE RECORDERS

12 Hour Model —  
USES 120 TAPE  
\$119.00\*



Modified Panasonic Slimline, high quality AC-DC provide 6 continuous hours of quality recording & playback on each side of cassette for 12 hours total. Includes • Voice level control • Digital counter, etc. TDK - 120 Cassette Furnished.

### PHONE RECORDING ADAPTER

Records calls automatically. All Solid state connects to your telephone jack and tape recorder. Starts recording when phone is lifted. Stops when you hang up. **\$28.50\*** FCC APPROVED

**VOX VOICE ACTIVATED CONTROL SWITCH**  
Solid state. Self contained. Adjustable sensitivity. Voices or other sounds automatically activate and control recorder. Uses either recorder or remote mike. **\$28.50\***

\* Add for ship. & handling. Phone Adapter & Vox \$2.00 each. Recordings \$5.00 each. Calif. Res. add tax. Mail order, VISA, M/C, COD's OK. Money Back Guarantee. Free data available. Dealer Inquiries invited. Free data.  
**AMC SALES INC.** Dept A 9335 Lubec Street  
Box 928, Downey, CA 90241  
Phones (213) 868-8519 1-800-926-2488  
FAX (213) 923-1478  
Mon-Fri 8-5 PAC TIME

## EQUIPMENT REPORT

continued from page 16

the manual says to install C40, a 22 pF, 16-volt electrolytic, but the actual part, as shown in the parts list, is 22  $\mu$ F. Also, a spring must be installed to the left of the 7106 IC to ground a metallic shield in the back of the meter housing; the instruction manual does not clearly show where the spring goes.

Other problems included R43, one of four 1-megohm resistors to be installed, but the parts list shows only three 1-megohm resistors and R43 as 100K—also, the 100K resistor was missing from our kit. Resistor R7 is said to be installed as 900K but the parts list shows it to be 898 ohms and that's what was included in our kit. Likewise with R8; it's installed as 100K but listed and included as 100 ohms. Another 100-ohm resistor, RX, was not among the parts included in our kit, but they did include an unnecessary 75K resistor—perhaps it was intended to be close enough in value to R43. Resistors R09 and R17 are to be installed as 19 ohms each but listed

as 8.98 ohms. Neither of the two remaining resistors were color-coded for 8.98 ohms, but they measured about 12 ohms. Close enough we decided, and the meter seems to work just fine.

You never know exactly what's inside something until you take it apart, so you can't help but be familiar with the basic insides of any multimeter once you build the 100K. The finished 100K is a sturdy, capable meter, and certainly worth its price. And although we feel that it's a pretty decent meter and a great project for someone new to electronics, the help of someone more experienced might be necessary. However, we've already pointed out the kit's sore spots so if you plan to build one you should save this review as a guide.

If you've read this review and would like to own a 100K but don't want to build it yourself, the 100K is available preassembled. And the assembled 100K multimeter actually costs ten dollars less than the kit (\$19.95). That's because it costs more to package the unit in pieces and the kit includes a 47-page assembly manual. ■

CIRCLE 108 ON FREE INFORMATION CARD

# COMPUTER CONNECTIONS

## Pen-Based Computing

JEFF HOLTZMAN

**P**en-based computing is one of this year's hot topics. At first glance, this new class of device seems to be more gadget than computer. On closer examination, however, it looks more like a glimpse of the future.

As with many hot topics in today's computer world, pen-based computing got its start at Xerox PARC (Palo Alto Research Center), a research division of the corporation mostly famous for photocopying, but whose basic research has fueled much of the personal computer revolution—but that's another story.

In 1968, a fellow by the name of Alan Kay, now a researcher at Apple, put together a cardboard model of something he called the Dynabook. Kay didn't call it a computer; he intended to suggest something far larger, more grandiose, more connected, and more accessible than any mere data-processing machine. The original design called for a notebook with a megapixel screen, multiple CPU's, and wired and wireless networking. Since then Kay realized that the hardware alone was not enough; a user-friendly (Macintosh-like) user interface would also be required. Even more important, a cooperating system of software "agents" would assist the user in gathering information and performing routine tasks. Agents are not yet ready for prime-time. User interfaces have evolved considerably since 1968, but still have a long way to go. Perhaps not surprisingly, as in most areas of the computer business, the greatest strides have been made in hardware.

Since portable computers, laptop computers, and notebook computers first started to appear, several companies have released suboptimal designs bearing the title Dynabook; however, it is only the very

latest generation of pen-based machines that even dignify the concept. NCR released the first of this new breed in the spring of 1991; fall COMDEX in Las Vegas saw the release of a spate of new machines by other vendors. This first generation of commercial machines illustrates several points: (1) The Dynabook concept is valid, but (2) current hardware and software have not fully achieved the vision; even so (3) there is a light at the end of the tunnel.

### Hardware and software

The typical pen-based machine is about the same size as a notebook PC (8.5" × 11" × 2", less than five pounds). The current generation typically has a 286 or 386SX processor, a few megabytes of memory, a floppy drive, possibly a hard drive, and a slot or two for special credit-card sized memory cards (these cards have now been standardized; more in a future installment). Usually there's no keyboard,

although there are "convertible" units that allow both keyboard and pen input. Some units, such as Grid's GridPad RF (shown in Fig. 1), allow wireless connection to standard networks. Overall, the most interesting thing about pen-based machines is that the screen is used for both input and output. Using a special stylus, you draw, write, and edit directly on the display surface—it's like an intelligent Etch-A-Sketch, one that allows you to store and recall text and graphics. It's what some call a *direct-manipulation environment* (DME).

If there's no keyboard, how do you use the thing? There are three basic approaches. The first simply glues a pen-input interface on familiar operating environments (DOS or Windows). The second creates a rich new environment (GO's Pen-Point operating system). The third creates a limited new environment, one that restrains cost and power in service of specialized applications.

Microsoft, as might be expected,

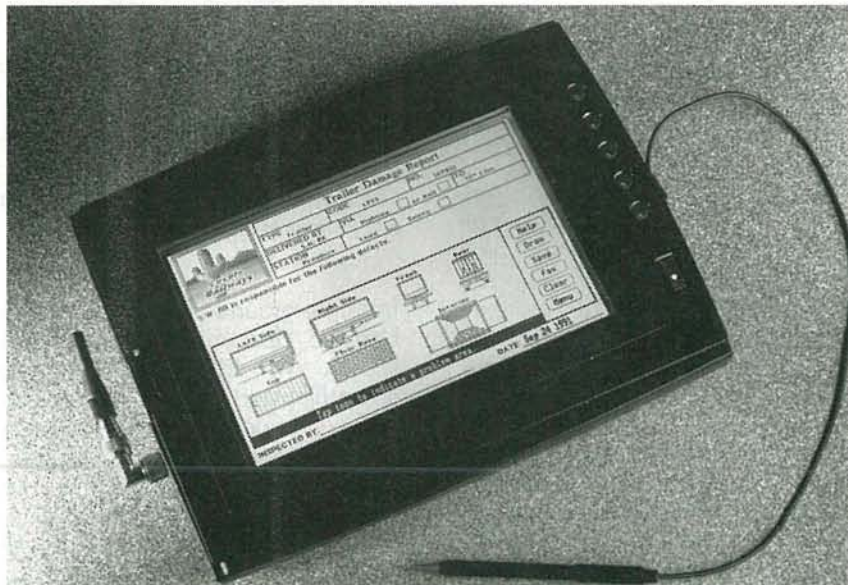

FIG. 1—THIS PEN-BASED PC FROM GRID features wireless RF connectivity to Novell networks.

has adopted the first course. The company has defined a set of pen-oriented extensions to the Windows environment, called Windows for Pen Computing (WPC). This environment is scheduled to be released in the first quarter of 1992, right after Windows 3.1. WPC has already garnered support from some three dozen hardware vendors, including AST, Dell, Grid/Tandy, NCR, Zenith, Sharp, Sony, Toshiba, Tusk, Momenta, NEC, Samsung, Sanyo, and many more. Currently Grid owns more than 50% of the market, but in five years that's expected to drop to about 10% of the current level, with Sony, Toshiba, and Sharp accounting for about 36%, and IBM and Apple together for about 30%. Hundreds of software developers have also shown support for WPC.

A company called GO Corporation has pursued the second option with a product called PenPoint, the chief competitor to WPC. PenPoint has not achieved as much support as WPC (yet), but the support it has achieved is quite meaningful. IBM, for instance, has licensed PenPoint, and has shown it running on a to-be-released pen machine. Apple is evaluating use of PenPoint versus its own internally developed pen-based operating system for a soon-to-be-released pen machine.

Although extending an already popular environment has some advantages, some feel that a whole new way of looking at things is required. This new paradigm returns to square one in the process of thinking about how people can best interact with a computer. For example, the select-do paradigm (e.g., select text, press Delete) of Windows may not make sense in a direct-manipulation environment. In a DME you might simply draw a line through unwanted text. It's more direct, more natural, more efficient, more comprehensible by computer novices. This is the tack taken by PenPoint.

A related area is compound documents, documents that include text, graphics, possibly other media. Windows is just about to the point where building compound documents is reliable and efficient. By contrast, PenPoint has been built

**Gesture Meaning**

•	Places the insertion point or selects where you tap the pen.
—	Selects all characters under the line.
	Extends the selection to the location where you draw the gesture.
↶	Deletes the current selection or the character to the right of the insertion point.
⇐	Deletes words or objects underneath the gesture.
↶	Backspaces and deletes the character to the left of the insertion point. (Optional)
␣	Inserts space at the insertion point. (Optional; can also be positional)
↵	Inserts a new line (Return) at the insertion point. (Optional; can also be positional)
⇥	Inserts a Tab at the insertion point. (Optional; can also be positional)
✓	Places the checked word or selection in the Edit Text dialog box.
✂	Cuts the selection and places it on the Clipboard.
⌘	Copies the selection and places it on the Clipboard.
^	Pastes the contents of the Clipboard at the insertion point. (Optional; can also be positional)
↶	Reverses the previous action.

a

**Gesture**

**Meaning**

Tap	▪	Select/Invoke
Press-hold	⊙	Initiate drag (move, wipe-through)
Tap-hold	▪⊙	Initiate drag (copy)
Flick (four directions)		Scroll/Browse
Cross out	✕	Delete
Scratch out	≡	Delete
Circle	○	Edit
Check	✓	Options
Caret	^	Insert
Brackets	[ ]	Select object, adjust selection
Pigtail (vertical)	↶	Delete character
Down-right	└	Insert space

b

**FIG. 2—PEN-BASED GESTURES differ between Microsoft's Windows for Pen Computing (a) and GO Corp.'s PenPoint (b).**

from the ground up to support Embedded Document Architecture (EDA). With EDA, you just grab something and start working on it. If it's text, a text-editing window pops up; if it's graphics, sizing/shaping handles appear. This focus on the document, rather than the applications used to produce it, is what will make pen PC's attractive to novices, and to the those of us tired of fighting the battle for integration.

Deferred I/O is another interesting capability of PenPoint. It allows you to "send" documents to other people, regardless whether you are plugged into the company network or riding a camel in Riyadh. If the hardware can't physically send the file when you make your request, it adds it to a queue and sends it when the required resources become available. Likewise with modem output, fax output, and printer output.

## Gestures

Both PenPoint and WPC make use of *gestures*, pen motions that signal an intent to do something, and depending on the operation, the data to which it is done (e.g., striking a line of text). Gestures come in several sizes and shapes, depending on the system; and specific gestures tend to be inconsistent from system to system, as shown in Fig. 2-a (WPC) and Fig. 2-b (PenPoint). (This is equivalent to the once-heated argument about whether the Delete key should work on characters to the right or left of the cursor. The vast majority of users simply didn't care, as long as usage was consistent from program to program.)

PenPoint demonstrations are extremely compelling. But Microsoft is Microsoft, and Windows is Windows. Does PenPoint have a chance? It's simply too soon to tell. The Windows juggernaut is rapidly crushing everything in its path; GO is working hard on data portability, so there's a good chance it will at least survive. In any case, most hardware vendors are playing it safe and supporting both operating systems. Phoenix has even released a dual-mode BIOS that provides low-level support for both.

Theoretically, anything that runs under Windows should run under WPC. PenPoint is in a more precarious position regarding applications; however, WordPerfect and Lotus are converting and developing applications, and several other companies are developing new applications, including telecommunication, word processor, spreadsheet, network interface, outliner, PIM, and more.

Some developers are targeting applications for both environments. Slate is one interesting example. The company has introduced a product called PenBook that allows you to take any file in PostScript format and convert it for use in a pen environment. The software allows you to build a table of contents and link specific pages to it. It also indexes the text. Rather than 45 pounds of manuals, imagine being able to take a notebook with all relevant service information on a house call, and instantly locate the desired

information with a few taps and flicks of the pen. There's potential here.

## Who cares?

Companies marketing pen products see two initial foci: highly mobile personnel (e.g., doctors and nurses, delivery people, sales people, insurance sales people and adjusters, etc.) and professionals who travel a lot.

Mobile usage is already happening. For example, a major pharmaceutical company recently purchased 1000 pen units from Grid for on-site sales; the San Jose Police Department is evaluating use of Grid machines to reduce paperwork.

Some industry veterans feel that pen computing is just another overhyped technology, with little mainstream application. More informed sources, those with a little historical perspective, see the potential. It will take a few years, but by the end of the decade, most of us will be carrying "pentops" and wondering how we ever got along without them.

## News bits

Last time I talked about the significant effect that multimedia will be having on the computer industry, the publishing industry, and society in general. At the time, I wondered how IBM planned to get involved. Shortly after my deadline, Big Blue announced a wide variety of products and services under the banner "**Ultimedia.**" The software (discussed last time) is in some ways the most interesting part of the announcement; however, there are some interesting hardware goodies as well, including a device that lets you broadcast and receive television signals across a token-ring network simultaneously with normal network traffic, thereby setting the stage for real-time video-conferencing. IBM also co-released with Intel a \$2000 NTSC video board, called the ActionMedia II, that allows playback of digitally recorded video. (A \$900 add-on allows digital recording.) The basic technology is Intel's DVI (Digital Video Interactive); the board, though it may sound expensive, is about half the cost of the previous version, occupies half as much space, and reportedly pro-

vides about twice the performance. In addition, the company released a rather weird multimedia PC (the M57SLC) that includes a high-performance CD-ROM drive, XGA graphics, 16-bit audio capture/playback, and a souped-up 386SX processor that sounds like a 486SX crammed into a 16-bit package.

After years of promises, Philips finally unleashed its **CD-I** (Compact Disc Interactive) technology on the consumer market under the name Imagination Machine. It costs in the neighborhood of \$800, but does only one thing. Conversely, you can upgrade your PC with a CD-ROM drive and a slew of useful software for that amount of money, have change in your pocket, and have a general-purpose tool that's truly only limited by your imagination. I think Philips' marketeers inadvertently hit on the right name, but for the wrong reason. The only imagination is in the amount of sales CD-I will generate.

On the software front, IBM has delayed release of a fully functional (i.e., Windows compatible) version of **OS/2 2.0** until the end of the first quarter of 1992. In the meantime, Microsoft will sell another couple million copies of Windows. However, Microsoft also slipped its ship date for Windows 3.1 until the first quarter of 1992, but has publicly shown a fairly robust version of **Windows NT** (New Technology), betas of which will be shipping to developers by the time you read this. Digital Research released **DR-DOS 6.0**, the major addition to which is RAM-based task switching and some utilities. It seems like a good product, and three or four years ago would have been a great competitor to DESQview. **R-E**

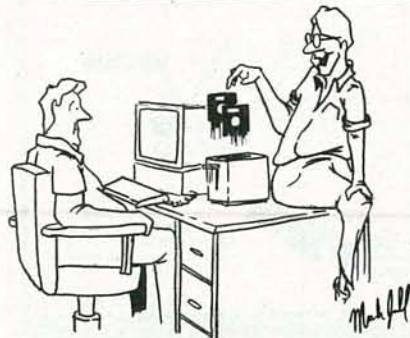

*Nifty, huh? . . . I built this new drive out of a toaster.*

# BUYER'S MART

## FOR SALE

**TUBES:** "oldest," "latest." Parts and schematics. SASE for lists. **STEINMETZ**, 7519 Maplewood Ave., R.E., Hammond, IN 46324.

**RESTRICTED** technical information: Electronic surveillance, schematics, locksmithing, covert sciences, hacking, etc. **Huge selection. Free brochures.** **MENTOR-Z**, Drawer 1549, Asbury Park, NJ 07712.

**Quality Microwave TV Antennas**

**WIRELESS CABLE - IFTS - MMDS - Amateur TV**  
Ultra High Gain 50db(+) • Tuneable 1.9 to 2.7 Ghz.

- 36-Channel System Complete \$149.95
- 12-Channel System Complete \$114.95
- Call or write (SASE) for "FREE" Catalog

**PHILLIPS-TECH ELECTRONICS**  
P.O. Box 8533 • Scottsdale, AZ 85252  
(602) 947-7700 (\$3.00 Credit all phone orders)  
MasterCard • Visa • COD's • Quantity Pricing

**LIFETIME WARRANTY**

**CABLE TV converters:** Jerrold, Oak, Scientific Atlantic, Zenith & many others. "New MTS" stereo add-on: mute & volume. Ideal for 400 and 450 owners! 1 (800) 826-7623, Amex, Visa, M/C accepted. **B & B INC.**, 4030 Beau-D-Rue Drive, Eagan, MN 55122.

**T.V. notch filters, phone recording equipment, brochure \$1.00.** **MICRO Thinc.** Box 63/6025, Margate, FL 33063. (305) 752-9202.

**CIRCUIT Boards** — Complete printed circuit fabrication from single sided to production multilayers. Twenty-four hour turnaround available. **CIRCUIT CENTER**, PO Box 128, Addison, IL 60101. (708) 543-0671.

**THE ELECTRONIC GOLDMINE**

The Electronic Goldmine has one of the greatest selections of unique electronic kits available in the world! We have over 65 kits and over 1,400 unique, bargain priced, components in our catalog!

**FREE CATALOG**  
With OVER 1400 DIFFERENT ITEMS INCLUDING 50 KITS! REQUEST YOUR COPY TODAY!

**SURFACE MOUNT TECHNOLOGY KIT**  
This kit contains 2 bright tiny LED's (one red and one green) that alternate flash. The two transistor multivibrator circuit uses the same tiny surface mount devices (SMD) as used in almost all late model sophisticated electronic products. Size only 1.5" x 3/4". Complete with all parts, PC board and instructions.  
**C6465 \$5.00**

**INFRARED DETECTOR KIT**  
Great for testing and verification of infrared output. Uses sensitive sensor and electronic circuitry to respond to all types of infrared TV, VCR, etc. remote controllers and LEDs producing sound and lighting a bright red LED. 9V battery (not included). Size of board: 2.5" x 1.4". Complete with all parts, PC board and instructions.  
**C6441 \$5.95**

**INEXPENSIVE GEIGER COUNTER**  
Probably the lowest priced Geiger Counter kit available in the world today! Features sensitive thin windowed Geiger Mueller tube and speaker that emits clicks in proportion to the radiation level. Detects Beta and Gamma rays. Operates from one 9V battery (not included). Only 3" x 1.88".  
**C6447 \$39.95**

**BATTERY POWERED ULTRAVIOLET MINERALIGHT LAMP**  
UVG-4 SHORT WAVE TYPE  
Useful for detecting fluorescent minerals.  
4 watt uses 4 "AA" (not included).  
Size 6.5" x 1.25" x 1.75".  
**G812 \$31.95**

**MINIMUM ORDER: \$10.00** plus \$3.50 shipping and handling  
We accept MC, Visa and Money Orders.  
**SEND ORDERS TO: The Electronic Goldmine**  
P.O. Box 5409 Scottsdale, AZ 85261  
**PHONE ORDERS (602) 451-7454 FAX ORDERS (602) 451-9495**

## FREE CATALOG

- CABLE T.V. BOXES - ALL TYPES •
- LOW PRICES - DEALER PRICES •

**ACE PRODUCTS**  
1-800-234-0726

**FREE catalog.** Books, periodicals on techn in, out of print. **BRIAN MCMILLAN, BC** (319) 478-2360.

**ELECTRONIC** supermarket surplus p Transformer specials, railroaders, builders neers, experimenters, LSASE, **FERTIK'S**, Ella, Phila., PA 19120.

**TUBES**, new, up to 90% off, SASE, **KIRB** West Carmel Drive, Carmel, IN 46032.

## CLASSIFIED AD ORDER FORM

To run your own classified ad, put one word on each of the lines below and send this form along with your check.

**Radio-Electronics Classified Ads**, 500-B Bi-County Boulevard, Farmingdale, NY 11735

**PLEASE INDICATE** in which category of classified advertising you wish your ad to appear. special headings, there is a surcharge of **\$25.00**.

- ( ) Plans/Kits ( ) Business Opportunities ( ) For Sale  
( ) Education/Instruction ( ) Wanted ( ) Satellite Television

Special Category: \$25.00

**PLEASE PRINT EACH WORD SEPARATELY, IN BLOCK LETTERS.** (No refunds or credits for typesetting errors can be made unless you clearly print or type y copy.) Rates indicated are for standard style classified ads only. See below for additio charges for special ads. **Minimum: 15 words.**

1	2	3	4	5
6	7	8	9	10
11	12	13	14	15 (\$46.50)
16 (\$49.60)	17 (\$52.70)	18 (\$55.80)	19 (\$58.90)	20 (\$62.00)
21 (\$65.10)	22 (\$68.20)	23 (\$71.30)	24 (\$74.40)	25 (\$77.50)
26 (\$80.60)	27 (\$83.70)	28 (\$86.80)	29 (\$89.90)	30 (\$93.00)
31 (\$96.10)	32 (\$99.20)	33 (\$102.30)	34 (\$105.40)	35 (\$108.50)

We accept MasterCard and Visa for payment of orders. If you wish to use your credit card to pay for your ad in the following additional information (Sorry, no telephone orders can be accepted):

Card Number

Expiration D

Please Print Name

Signature

**IF YOU USE A BOX NUMBER YOU MUST INCLUDE YOUR PERMANENT ADDRESS AND PHO NUMBER FOR OUR FILES. ADS SUBMITTED WITHOUT THIS INFORMATION WILL NOT BE ACCEPTED.**

**CLASSIFIED COMMERCIAL RATE:** (for firms or individuals offering commercial products or services) \$3.10 per word prepaid (no charge for zip code). **MINIMUM 15 WORDS.** 5% discount for same ad issues; 10% discount for same ad in 12 issues within one year; if prepaid. **NON-COMMERCIAL RATE:** individuals who want to buy or sell a personal item) \$2.50 per word, prepaid...no minimum. **ONLY FIRST WORD AND NAME** set in bold caps ad no extra charge. Additional bold face (not available as all caps) 1 per word additional. Entire ad in boldface, \$3.70 per word. **TINT SCREEN BEHIND ENTIRE AD: \$3.85** word. **TINT SCREEN BEHIND ENTIRE AD PLUS ALL BOLD FACE AD: \$4.50** per word. **EXPAND TYPE AD: \$4.70** per word prepaid. Entire ad in boldface, \$5.60 per word. **TINT SCREEN BEHIND ENTIRE AD PLUS ALL BOLD FACE AD: \$6.80** per word. **DISPLAY ADS:** 1" x 2 1/4"—\$410.00; 2" x 2 1/4"—\$820.00; 3" x 2 1/4"—\$1230.00. **General Information:** Frequency rates and prepayment discounts are available. **A COPY SUBJECT TO PUBLISHERS APPROVAL. ADVERTISEMENTS USING P.O. BOX ADDRESS WILL NOT BE ACCEPTED UNTIL ADVERTISER SUPPLIES PUBLISHER WITH PERMANENT ADDRESS AND PHONE NUMBER.** Copy to be in our hands on the 5th of the third month preceding the date of issue. (i.e., Aug. issue copy must be received by May 5th). When normal closing date falls on Saturday or Holiday, issue closes on preceding working day. Send for the classified brochure. Circle Number 49 on the Free Information Card.

## FREE CATALOG

FAMOUS "FIRESTIK" BRAND CB ANTENNAS AND ACCESSORIES. QUALITY PRODUCTS FOR THE SERIOUS CB'er. SINCE 1962  
**FIRESTIK ANTENNA COMPANY**  
 2614 EAST ADAMS  
 PHOENIX, ARIZONA 85034

OUR monthly picture flyer lists quality surplus parts at low prices. Swap meet every month. **STAR-TRONICS**, Box 683, McMinnville, OR 97128.

**PHOTOFACT** folders under #1400 \$5.00. Others \$7.00. Postpaid. **LOEB**, 414 Chestnut Lane, East Meadow, NY 11554. (516) 481-4380.

**SPEAKER** repair. All makes — models. Stereo & professional. Kits available. Refoaming \$18.00. **ATLANTA AUDIO LABS**, 1 (800) 568-6971.

**ENGINEERING** software and hardware, PC/MSDOS. Circuit design and drawing, PCB layout, FFT analysis, Mathematics, Circuit analysis, etc. Data acquisition, generation, I/O PCB's, etc. Call or write for free catalog. 1 (614) 491-0832, **BSOFT SOFTWARE, INC.**, 444 Colton Rd., Columbus, OH 43207

**PREVENT** descrambler detection & damage! Order Tech-Block today! Simple in-line connection. Only \$19.95 P.P.D. **THE STAGE DOOR VIDEO**, PO Box 518, Belleview, FL 32620. For C.O.D.'s 1 (800) 395-4557.

**DESCRAMBLERS** cable TV converters, lowest prices, guaranteed, best quality, all types available, **CNC CONCEPTS, INC.**, Box 34503, Minneapolis, MN 55434. 1 (800) 535-1843.

**JERROLD**, Tocom and Zenith "test" chips. Fully activates unit. \$50.00. Cable descramblers from \$40.00. Orders 1 (800) 452-7090. Information (213) 867-0081.

**TEST** equipment pre-owned now at affordable prices. Signal generators from \$50.00, oscilloscopes from \$50.00, other equipment, including manuals available. Send \$2.00 U.S. for catalog, refunded on 1st order. **J.B. ELECTRONICS**, 3446 Dempster, Skokie, IL 60076. (708) 982-1973.

## CB RADIO OWNERS!

We specialize in a wide variety of technical information, parts and services for CB radios. 10-Meter and FM conversion kits, repair books, plans, high-performance accessories. Thousands of satisfied customers since 1976! Catalog \$2.

**CBC INTERNATIONAL**  
 P.O. BOX 31500RE, PHOENIX, AZ 85046

**DESCRAMBLERS:** Oak Sigma, Varisync, Hamlin, Scientific Atlanta, Jerrold, Pioneer, Sylvania. Catalog \$5.00 moneyorder (credited first order), service manuals, schematics, **SURPLUS ELECTRONICS**, PO Box 10009, Colorado Springs, CO 80932.

## WIRELESS CABLE RECEIVERS 1.9 TO 2.7 GHz



VISA/MC/AMEX

30 CH PARABOLIC DISH SYSTEM	\$173.90
30 CH ROD ANTENNA SYSTEM	\$193.90
30 CH CRYSTAL CONTROLLED SYSTEM	\$294.95
<b>SUN MICROWAVE INT'L. INC.</b> SEND \$1.00 FOR P.O. BOX #34522 CATALOG ON THESE PHOENIX, AZ. 85067 AND OTHER FINE VIDEO PRODUCTS (602) 230-1245 QUANTITY DISCOUNTS	
<b>ORDERS ONLY 1-800-484-4190 CODE 9753</b>	

★★★★ PRESENTING ★★★★★  
**CABLE TV  
 DESCRAMBLERS**  
 ★★★★★ STARRING ★★★★★  
**JERROLD, HAMLIN, OAK**  
 AND OTHER FAMOUS MANUFACTURERS

- FINEST WARRANTY PROGRAM AVAILABLE
- LOWEST RETAIL/WHOLESALE PRICES IN U.S.
- ORDERS SHIPPED FROM STOCK WITHIN 24 HRS.
- ALL MAJOR CREDIT CARDS ACCEPTED

FOR FREE CATALOG ONLY **1-800-345-8927**  
 FOR ALL INFORMATION **1-818-709-9937**

**PACIFIC CABLE CO., INC.**  
 7325½ Reseda Blvd., Dept. 2111  
 Reseda, CA 91335

**CABLE TV Equipment.** Most type available. Special: Oak M35B \$39.95. No catalog. COD orders only. **1 (800) 822-9955.**

**PHOTOVOLTAIC** solar panels affordably priced. Catalog \$2.00. **SOLAR DEPOT**, 99R Washington St., Melrose, MA 02176.

**OSCILLOSCOPE** 50 MHz, Hewlett-Packard, solid state calibrated, manual \$290.00 1 (800) 835-8335 X-159.

**CABLE TV** descramblers, converters. Oak RTC-56 \$99.00, 5503 Tocom \$225.00, Sylvania 4040-DIC replaces Jerrold 400-DIC \$49.00, Oak M-35-B \$25.00. All brands in stock. **MOUNT HOOD ELECTRONICS**, (206) 260-0107.

**CABLE** equipment. Oak — Tocom — Zenith — Jerrold S.A. wholesale to all. Example Oak RTC-56 \$89.00, M-35-B \$25.00. **S.A.C.**, 1 (800) 622-3799.

# ALL THE PARTS YOU'LL EVER NEED...



Call Today For Your  
**FREE Catalog  
 Subscription!**  
**1-800-543-4330**  
**FAX 1-513-434-6959**



**MCM ELECTRONICS**

A PREMIER Company

# AT MCM ELECTRONICS

SOURCE NO. RE-74

**Advanced solid-state LASER**

This incredible unit weighs less than 1/2 ounce. Only 1.125" long and 0.590" wide. With a range of more than 1000 yards, you are limited only by your imagination!

This is not a breakable glass tube but a state-of-the-art advanced solid-state laser with literally hundreds of applications!!

**3mW only \$149.00**

**5mW only \$175.00**

**SPECIAL DEAL** save 10% on two or more!

Low power, self-contained unit which will produce a visible red beam from a 9 - 10 volt power supply.

**POLARIS Industries**  
141 W. Wieuca Rd., Suite 300-B  
Atlanta, GA. 30342  
Call Our Toll Free 24-Hour Order Line  
**1-800-222-5620**

MC VISA  
Discover COD

**PIONEER for Warner system.** Digital insert for your SA-3. Changes with their signal. \$150.00 with simple instructions and guarantee. **NEEDY'S ELECTRONICS**, US Hwy 23 South, Weber City, VA 24290. (703) 225-3334/fax (703) 225-3296.

**LONG play cassette recorder** — Records 12 hours on a single standard cassette. Voice-activated. Also miniature long play recorders, mini microphones, telephone record controllers, stun guns, surveillance/countermeasures devices. Catalog \$2.00. **PRODUCTIVE ELECTRONICS**, Box 930024-R, Norcross, GA 30093.

### PLANS AND KITS

**FASCINATING** electronic devices! Dazers! Lasers! FM/AM/phone transmitters! Detectors! Kits/assembled! Catalog \$2.00. **QUANTUM RESEARCH**, 16645-113 Avenue, Edmonton, AB. T5M 2X2.

**HOBBY/broadcasting/HAM/CB/surveillance transmitters, amplifiers, cable TV, science, bugs, other great projects!** Catalog \$1.00. **PANAXIS**, Box 130-F2, Paradise, CA 95967.

**PCB and schematic CAD.** \$195.00 IBM EGA CGA Multilayer, rubberband, autovia, NC drill, laser, dot matrix, plotter, library, Gerber, **AUTOSCENE**, 10565 Bluebird St., Minneapolis, MN 55433. (612) 757-8584 free demo disk.

**DIGITAL recorder.** Digitally record any audio source with special effects. Microprocessor controlled device. Detailed plans, \$9.75: **T. ZURAW**, Box 341, Dearborn Hts, MI 48127.

**PRINTED** circuit art work. Low cost, for free information write **NEGRON ENGINEERING**, 159 Garfield Place, Brooklyn, NY 11215. Fax or call (718) 768-4028.

**VIDEOCIPHER II/scanner/cable/satellite modifications books.** Catalog — \$3.00. **TELECODE**, PO Box 6426-RE, Yuma, AZ 85366-6426.

### REMOTE CONTROL KEYCHAIN



Complete w/minit-transmitter and +5 vdc RF receiver. Fully assembled including plans to build your own auto alarm. Quantity discounts available.

**\$24.95** Check, Visa or M/C Add \$ 3 shipping

**VISITECT INC.** Box 14198, Fremont, Ca. 94539  
(510) 651-1425 Fax (510) 651-8454

**NOW build your own Regulated 12VDC to 120VAC, 300W to 500W inverter, a must for campers or emergencies.** Includes complete schematics, parts and manufacturers lists and more! Send \$19.95 to **INVERTER SCIENTIFIC**, Box 778, Suffern, NY 10901.

## REMOVE LEAD VOCALS

From Records & CD's

Build this kit for under \$! removes lead vocals from stereo records, CD's, tape broadcasts. Easily come home component stereo live with the backgrounds be the lead singer of your band. Detailed Plans. \$4. **Weeder Technol** 14773 Lindsey | Mt. Crab, Ohio 4

**DESCRAMBLER kits.** Complete cable kit \$! Complete satellite kit \$49.95. Add \$5.00 shipping. Free brochure. No New York sales. **SUMMI** Box 489, Bronx, NY 10465.

**SURVEILLANCE transmitter kits** tune fr to 305 MHz. Mains powered duplex, teleg room, combination telephone/room. Catalog **Popular Communications, Popular Electronics and Radio-Electronics** book review "Electronic Eavesdropping Equipment sign," \$2.00. **SHEFFIELD ELECTRO** 7223 Stony Island Ave., Chicago, IL 60649-

**ROOM surveillance telephone \$175.00.** and telephone monitor \$275.00. Remote phone recorder \$479.00. \$3.00 catalog. **LI ELECTRONICS**, 603 Elgin, Muskogee 74401. (918) 683-9589.

**SATELLITE TV descrambler.** Build your Easy to follow instructions, parts list, circuit wiring diagram, \$9.95. **4BG ENTERPR** 27081A, Halifax, NS, B3H-4M8.

**REMOVE VCR copy protection PCB PAL in tions \$16.50 w/P&H NORM HOGARTH**, 95 Ogden, Bend, OR 97701.

**TOUCH tone decoder** displays dialed nu Store and retrieve up to 256 numbers. Input phone, scanner, tape. SASE for brochure. **VESIGNS**, Box 200091R, Denver, CO 80220-

### Ferro Fluid

Pro-Tech ferro fluid is commonly used on voice coils to substantially improve frequency response, increase transient and continuous power handling capabilities and reduce second and third order harmonic distortion. It reduces the Q and lowers the impedance peak at resonance without a significant reduction in SPL. General purpose fluid for tweeters and midranges only. 5cc bottle.



#RC-340-431

**\$10<sup>95</sup>** Each

### Light Oak Speaker Cabinet



Premium ported speaker cabinet made of acoustical grade particle board and covered with a light oak vinyl laminate. Precut with an 11-1/4" hole for use with most 12" woofers. The baffle board has no tweeter or midrange holes for design flexibility. The 3/4" thick particle board ensures low panel resonance. Dimensions: 11" x 15" x 27". Volume: 2.5 cu ft. Grill and terminal included. Sold individually.

#RC-262-100

**\$49<sup>00</sup>** Each

**\$39<sup>90</sup>** (2-up)

### 12 Gauge Neon Wire

The competition in today's auto sound contests is so fierce that good sound alone is not enough to win. More and more installers are striving to make their installation more pleasing to the eye. Parts Express now stocks



12 gauge speaker wire in vibrant neon colors. This wire is the same high quality, made in the U.S. wire you have used before, but now it has flashy, neon colored insulating jackets. Available in neon pink, neon green, and neon orange. Sold by the foot on or 50 ft. spools.

#RC-100-162 (Neon pink)

#RC-100-166 (Neon orange) **49¢/Ft.**

#RC-100-170 (Neon green)

### Tuned Port Tubes

These attractive, preformed tuned ports allow the back pressure radiated from the rear of the woofer to reinforce the sound level in front. Made of black plastic.



Part #	Length	Diameter	(1-9)	Price (10-up)
#RC-260-320	2 3/8"	1-3/4"	.40	.37
#RC-260-321	4"	1-7/8"	.60	.55
#RC-260-322	5"	2"	.65	.59
#RC-260-323	1"	2-7/8"	.40	.37
#RC-260-324	5"	2-7/8"	.60	.55
#RC-260-326	3"	2-7/8"	.52	.48
#RC-260-327	2-1/2"	3-7/8"	.58	.53
#RC-260-328	5"	3-7/8"	.64	.59

No mixing for quantity pricing.

### Famous Maker 3-1/2" Speaker F

Dual cone 3-1/2" speaker pair for upgrading stock dash speakers. Graphite fiber composite woofer cone provides a smooth extended response at all power levels. The high frequency radiator (whizzer) takes over from the woofer at 6,000 Hz & greatly extends the response past 20 KHz. Strontium ferrite magnet. 3/4" high temperature voice coil. Impedance: 4 ohm. Power handling capability: 2 continuous, 70 watts peak. Frequency response: 21,000 Hz. Equipped with dust screen. Made in t by a company with over 40 years experience in the sound market.



#RC-265-275

**\$19<sup>95</sup>** Pa

### Subwoofer Input/Output Termi

This recessed terminal panel has inputs for right and left channels as well as outputs for right and left channels to route to your satellite speakers. Greatly simplifies subwoofer hook-up. Outside dimensions: 3-7/8" x 5-3/8".

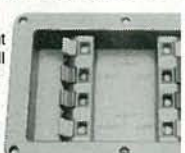

#RC-260-308

**\$3<sup>95</sup>** (1-9)

**\$3<sup>50</sup>** (10-up)



340 E. First St., Dayton, Ohio 45402  
Local: 1-513-222-0173  
FAX: 513-222-4644

• 30 day money back guarantee • \$20.00 minimum order • We accept Mastercard, Visa, Discover, and C. O. D. orders. • 24 hour shipping • Shipping charge = UPS chart rate + \$1.00 (\$3.50 minimum charge) • Hours 8:30 am - 7:00 pm EST, Monday - Friday • 9:00 am - 2:00 pm Saturday. Mail order customers, please call for shipping estimate on orders exceeding 5 lbs. • Foreign destination customers please send \$5.00 U.S. funds for catalog postage •

CALL TOLL FREE

**1-800-338-0531**

FREE CATALOG





## RECEIVING TUBES

**OVER 3000 TYPES IN STOCK!**

Also hard-to-find transformers, capacitors and parts for tube equipment.

Send \$2.00 for our 32 page catalog.

## ANTIQUE ELECTRONIC SUPPLY

5221 S. Maple Ave. • Tempe, AZ 85283 • 602-820-5411

**GAMBLING:** build miniature computer-clock roulette wheels, play perfect blackjack — Z-80 based; software available. For detailed plans and info send \$15.00 to **G.R. ENTERPRISES**, PO box 424, Portland, OR 97207.

**ZAPPER!** electronic fun, simple and inexpensive, battery powered. Plans \$2.00 to: **PAR**, 417 Associated, Suite A-313, Brea, CA 92621.

**PROJECTION TV...** Convert your TV to project a 7-foot picture... Easy!... Results comparable to \$2,500.00 projectors... **Plans and lens \$29.95...** Professional systems available... Illustrated catalog **free...** **MACROCOMA**, 15GF Main Street, Washington Crossing, PA 18977... Creditcard orders 24hrs. 1 (800) 955-3979.

## CABLE TV

**CONVERTERS** with 2 year warranties. Scientific Atlanta — Tocom — Jerrold 8580 & 8590's. Test modules for Star Comm 6 & 7's. All Tocoms and Scientific Atlanta. (712) 323-9445.

## SATELLITE TV

**FREE** catalog — Lowest prices worldwide. Save 40 — 60%. Systems, upgrades, parts, all major brands factory fresh and warranted. **SKYVISION**, 1012 Frontier, Fergus Falls, MN 56537. 1 (800) 334-6455.

# CABLE TV "BOXES"

## Converters-Descramblers Remote Controls-Accessories

- ★ Guaranteed Best Prices ★
- ★ 1 Year Warranty - C.O.D.'s ★
- ★ Immediate Shipping ★
- ★ FREE CATALOG ★

Call or Write

## NAS/TRANS-WORLD CABLE CO.

3958 North Lake Blvd. • Suite 255

Lake Park, Florida 33403

1-800-442-9333

1-800-848-3997

**SATELLITE TV** — Do it yourself — systems. Upgrades. Parts. Major brands discounted 40% — 60%. We'll beat everyone's price. **L.J.H. INC.**, call Larry (609) 596-0656.

**CABLE TV Secrets** — the outlaw publication the cable companies tried to ban. HBO, Movie Channel, Showtime, descramblers, converters, etc. Suppliers list included. \$9.95. **CABLE FACTS**, Box 711-R, Pataskala, OH 43062.

## Ω DESCRAMBLERS CABLE T.V. EQUIPMENT

Whole Sale Pricing For: Jerrold, Scientific Atlanta, Pioneer, Tocom, Zenith, Oak, Base Band, Etc.

✓ Lowest Prices Guaranteed ✓ Free Catalog

ORDERS CALL 1-800-835-2330/402-331-3228

Or Write **MULTI-VISION ELECTRONICS** at:

2730 South 123rd Ct. #126 Omaha, NE. 68144

## DESCRAMBLERS CABLE TV EQUIPMENT



CALL TOLL FREE  
**1-800-228-7404**



**30 DAY MONEY BACK GUARANTY** **OUR PRODUCTS ARE BULLET PROOF**

**YOU WON'T FIND ANY HOLES IN OUR WARRANTIES**

**WE CARRY ALL MAJOR BRANDS BEST PRICE BEST SERVICE**

**MAKE THE CONNECTION**

**NU-TEK ELECTRONICS**

FOR MORE INFORMATION CALL OR WRITE

**1-512-250-5031**

**NU-TEK ELECTRONICS**  
#114 BALCONES WOOD DR.  
#507 DEP. 296 AUSTIN TEXAS 78769

## ANTIQUE RADIO CLASSIFIED

**Free Sample!** Antique Radio's

Largest Circulation Monthly. Articles, Ads & Classifieds.

6-Month Trial: \$15. 1-Yr: \$27 (\$40-1st Class).

A.R.C., P.O. Box 802-L9, Carlisle, MA 01741

# MARK V ELECTRONICS, INC.

**Competitive Pricing \* Fast Shipping Since 1985**

▲ indicates the level of difficulty in the assembling of our Products. ▲ Beginner ▲▲ intermediate ▲▲▲ Advanced ★ Fully Assembled

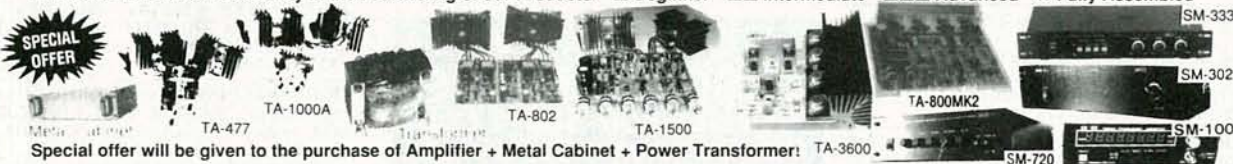

Special offer will be given to the purchase of Amplifier + Metal Cabinet + Power Transformer: TA-3600.

AMPLIFIERS		KIT ASSEMB.		MISCELLANEOUS		KIT ASSEMB.	
MODEL	DESCRIPTION			MODEL	DESCRIPTION		
TA-28MK2	Digital Voice Memo ▲▲	\$ 30.00		TY-23B	3 Channel Color Light Controller ★	\$	\$ 65.00
TA-50A/B	Multi-Purpose Melody Generator ▲	12.84	17.20	TY-25	Stereo Loudspeaker Protector ▲	14.85	20.85
TA-50C	Multi-Purpose Melody (Happy Birthday, Wedding March, etc.) Generator ▲	13.65	18.71	TY-35	FM Wireless Microphone ▲	11.25	
TA-120MK2	35W Class 'A' Main Power Mono Amp ▲▲	31.50	42.80	AC/DC Quartz Digital Clock ▲		19.00	26.20
TA-300	30W Multi-Purpose Single Channel Amp ▲	20.00	29.00	TY-38	Sound / Touch Control Switch ▲	12.00	
SM-302	60W + 60W Stereo Power Amplifier (with Mic. input) ▲▲	73.00	85.00	TY-41MK V	Infrared Remote Control Unit (w/Case) ▲▲▲	22.00	35.00
TA-323A	30W X 2 Stereo Pre-main Amp ▲	31.50	42.80	TY-42	Bar / Dot Level Meter ▲	24.15	33.81
TA-377A	State of the Art Fully Complementary Symmetrical FET Pre-Amp. ▲▲▲	59.95	75.00	TY-43	3 1/2" Digital Panel Meter ▲	29.00	38.00
TA-400	40W Solid State Mono Amp ▲	28.00	34.93	TY-45	20 Steps Bar / Dot Audio Level Display ▲▲	38.45	45.14
TA-477	120W Mosfet Power Mono Amp ▲▲	68.00	85.00	016	10,000 of 80V DC Capacitor (TA-3600, TA-477, TA-1000A, TA-802)		23.00
SM-720	120W + 120W AC/DC Stereo Hi-Fi & Pre-Main Amp ▲	75.00	89.00	017	8,200 of 50V DC Capacitor (TA-802, TA-120MK2)		13.00
TA-800MK2	120W + 120W Low Tim Pre-Main Stereo Power Amp ▲▲	63.92		021	Nozel Resistor - Single Vol. Control (TA-3600, TA-477, TA-1000A, TA-120MK2)		12.00
TA-802	80W + 80W Pure DC Stereo Main Power Amp ▲	45.94	59.72	022	Alps Resistor - Dual Vol. Control (TA-377A, TA-802, TA-2200)		22.00
TA-1000A	100W Dynamic Class 'A' Main Power Mono Amp ▲▲	50.00	65.00	<b>REGULATORS</b>			
TA-1500	100W X 2 Class 'A' DC Stereo Pre-Main Amp ▲	73.70	95.81	TR-355A	0-15V 5A Regulated DC Power Supply (no case & x former) ▲	\$15.65	\$ 21.76
TA-2200	DC Fet Super Class 'A' DC Pre-Amp ▲▲	47.70	58.24	TR-355B	0-30V 3A Regulated DC Power Supply (no case & x former) ▲	15.65	21.76
TA-2500	HQ Pre-Amp w/10 band graphic equalizer ★		78.00	TR-503	0-50V 3A Regulated DC Power Supply (no case & x former) ▲	16.75	23.65
TA-2800	BI-FET IC Pre-Amp w/3 way tone control ▲	48.90	63.57	<b>METAL CABINETS WITH ALUMINUM PANEL</b>			
TA-3000	Stereo Simulator (For Mono TV or Any Mono Source) ▲▲	27.00	38.50	MODEL	H" x W" x D" MATCHING		PRICE
TA-3600	300W HQ Hi-Fi Power Mono Amp ▲▲	85.00	110.00	LG-1273	3" x 12" x 7"	TA-2800, TA-377A, TA-2200	\$ 23.85
SM-222	7 Band Hi-Fi Graphic Equalizer ▲▲	26.80	38.80	LG-1684	4" x 16" x 8"	TA-323A, TA-377A, TA-2200	28.50
SM-333	Audio/Video Surround Sound Processor ▲▲▲	65.00	78.00	LG-1924	4" x 19" x 11 1/2"	TA-802, TA-1500, TA-120MK 2, TA-800 MK2, TA-1000A	34.50
SM-666	Dynamic Noise Reduction ▲	26.00	34.00	LG-1925	5" x 19" x 11 1/2"	TA-477, TA-800 MK2, TA-1500, TA-1000A, TA-3600	38.00
SM-888	Universal Audio/Video KARAOKE Mixer, Pre-Amp. ★		155.00	LG-1983	2 1/2" x 19" x 8"	TA-377A, TA-3600, TA-2200, TA-120MK 2	30.50
<b>DIGITAL METERS AND COUNTER</b>				<b>POWER TRANSFORMERS</b>			
MODEL	DESCRIPTION			MODEL	DESCRIPTION	MATCHING	PRICE
SM-43	3 1/2" Multi-Functional Led D.P.M. (w/ABS plastic case) ▲▲	\$ 34.50	\$ 43.00	001	28V x 2.6A to 30V x 2.6A	TA-800 MK2, TA-802, TA-1000A, TA-1500	\$ 28.00
SM-48	4 1/2" Hi-Precision D.P.M. ▲	38.00	48.00	002	36V x 2.3A	TR-503, TA-323A, TA-400, TA-300, TA-377A	23.00
SM-48A	4 1/2" Hi-Precision D.P.M. (w/ABS plastic case) ▲▲	41.20	52.00	003	40V x 2.6A	TA-477	30.00
SM-49	3 1/2" Multi-Functional LCD D.P.M. (w/Hold Function) ▲	36.00	44.50	004	24V x 2.6A	TA-120 MK 2	23.00
SM-100	150MC Digital Frequency Counter ▲▲	79.00	90.00	005	28V x 2.3A	TR-355B	17.00
				006	18V x 2.5A	TR-355A	17.00
				007	53V x 2.8A	TA-3600	45.00

We accept major Credit Cards, Money Orders, Checks and C.O.D. Orders. C.O.D. fee is \$6.50. Minimum order is \$20.00. \* We ship by UPS ground inside US (min. \$4.00) and ship by US Mail Business & Showroom hours: (Pacific Time) outside US. Please call our sales department for orders over 2 lbs. or foreign orders. \* All assembled units have a 30 days warranty. \* Quality or Volume discount available upon request. \* Residents Mon. thru Fri. 9:30 am to 5:00 pm of CA please add sales tax @ 25%. \* Prepaid Order for faster shipment. Prices are subject to change without prior notice. We are not responsible for typographical errors. Sat. 10:00 am to 5:00 pm

**MARK V ELECTRONICS, INC. - 8019 E. Slauson Ave, Montebello, CA 90640**

CIRCLE 93 ON FREE INFORMATION CARD

# Worldwide Cable

## CABLE TV DESCRAMBLERS

THE MOST ADVANCED  
TECHNOLOGY IN CABLE EQUIPMENT:

- BASE BAND
- PIONEER
- HAMLIN
- SCIENTIFIC ATLANTA
- JERROLD
- TOCOM
- ZENITH
- OAK

For out of this world prices call  
**WORLDWIDE CABLE**  
**1 800-772-3233**  
FREE CATALOG AVAILABLE

7491 C-5 N. FEDERAL HWY., SUITE 142  
BOCA RATON, FL 33487

MC / COD / VISA NO FLORIDA SALES

CIRCLE 191 ON FREE INFORMATION CARD

## Cable TV Descrambler Kits

Universal Kit.....\$55.00

Includes all parts and PC Board. Not included is the ac adaptor or enclosure.

Tri-Mode Kit.....\$39.00

Includes all parts, PC Board and AC Adaptor. Not included is the enclosure.

SB-3 Kit.....\$29.00

Includes all parts, PC Board and AC Adaptor. Not included is the enclosure.

Universal Tutorial.....\$9.95

Includes an in depth study of the technology used and has troubleshooting hints.

Tri-Mode Tutorial.....\$9.95

Includes a gate by gate study of the circuit and has troubleshooting hints.

Call Toll Free 1-800-258-1134

COD Only

M & G Electronics, Inc.  
72 Orange St., Suite 216  
Providence, RI. 02903

CIRCLE 200 ON FREE INFORMATION CARD

VCR tapes by college instructor covering tonic topics. Send for free demo \$3.50 O.C.S., PO 292, Fort Mill, SC 29715.

NEW book, Getting Started in Nuclear Physics Easy to follow with illustrative footnotes at advanced practical procedures. \$19.95. F. FARAH, PO Box 2464, Sarnia, Ontario, N7 Canada.

## FREE CATALOG! 1-800-648-7938 JERROLD HAMLIN OAK CABLE TV DESCRAMBLERS

- Special Dealer Prices!
- Compare our Low Retail Prices!
- Guaranteed Prices & Warranties!
- Orders Shipped Immediately!

REPUBLIC CABLE PRODUCTS, INC.  
4080 Paradise Rd. #15, Dept RE29  
Las Vegas, NV 89109  
For all other information (702) 362-90

## BUSINESS OPPORTUNITIES

YOUR own radio station! Licensed/unlicensed AM, FM, TV, cable. Information \$1.00. **BF CASTING**, Box 130-F2, Paradise, CA 9599

LET the government finance your small business Grants/loans to \$500,000. Free recorded message: (707) 449-8600. (KS1).

EASY work! Excellent pay! Assemble products at home. Call toll free 1 (800) 467-5566 Ext.

MAKE \$\$\$! Become an American electrical dealer! Profit opportunities since 1965. **SCOTT PRUETT**, 1 (800) 872-1373.

HOME assembly work available! Guaranteed easy money! Free details! **HOMEWORK-1** 520, Danville, NH 03819.

SNOW? Thriving, fully equipped, audio-visual pair shop. \$130K + this year! Proven 40% + last three years. \$70,000.00 cash. **AUDIO** 256-B North Highway 101, Encinitas, CA 9 FAX (619) 944-0345, Phone (619) 944-904

MONEYMAKERS! Easy! One man CRT reworking machinery. \$6,900.00 rebuilt. \$15,900.00 CRT, 1909 Louise, Crystal Lake, IL 60014 459-0666. Fax (815) 477-7013.

LEGITIMATE \$\$\$ opportunity \$\$\$ weekly complete report \$19.00. **DME**, 1317 N. San Fernando #325, Dept. 02W4, Burbank, CA 91504.

## EDUCATION & INSTRUCTION

F.C.C. Commercial General Radiotelephone license. Electronics home study. Fast, inexpensive! "Free" details. **COMMAND**, D-176, Box 2824, San Francisco, CA 94126.

BE a recording engineer; Train at home for high paying — exciting careers. Free information. **AUDIO INSTITUTE**, 2258-A Union St., Suite K, San Francisco, CA 94123.

COMPLETE course in electronic engineering. Eight volumes. Includes all necessary math and physics. Free brochure. **BANNER TECHNICAL BOOKS**, 1203 Grant Avenue, Rockford, IL 61103.

## CABLE TV DESCRAMBLERS ALL TYPES 800-582-1114 FREE CATALOG M.K. ELECTRONICS • 7958 Pines Blvd Suite 276 • Pembroke Pines, FL 33024

MAKE a thing... make a living... Study **Industrial Design Technology** and bring your ideas to life. Learn to problem-solve, sketch, render and design. Develop models, create prosthetic appliances. Build your future in movie and theater special effects, toy and product, exhibit, transportation, furniture/fixtures, architectural and amusement environmental design at **The Art Institutes of Pittsburgh, Fort Lauderdale, Seattle or The Colorado Institute of Art**. For information write 526 Penn Avenue, Dept. 61, Pittsburgh, PA 15222. Or call 1 (800) 525-1000.

**BIOMEDICAL** letter covers medical electronics, anatomy, equipment function, electrical safety, troubleshooting. **PNP PUBLISHING**, Box 333, Brooklyn, NY 11204. (718) 837-9349 Extension 55.

PAY TV AND SATELLITE DESCRAMBLING  
ALL NEW 1992 EDITION ALL NEW  
It's up to the minute. All new updates on cable, wireless and satellite. Turn-ons, bypasses, circuits, chipping, bullets, bags, Dectac, Liberty One, ECM's, Data Readers, programming, and lots more. Our best yet only \$15.95. Other (all different) editions 1991, 1989, Volume One (Basics) \$15.95 each. MDS Handbook \$9.95. Satellite systems under \$600 \$12.95. Any 3/\$29.95 or 6/\$49.95. Video \$29.95. Scrambling News Monthly \$24.95/yr. Sample \$3. All new catalog \$1. Shipping costs included.  
Scrambling News, 1552 Hertel Ave.,  
Buffalo, NY, 14216. Voice/Fax (716) 874-2088  
COD'S ARE OK. ADD \$6

## Be a TV/VCR Repair Specialist

Now you can train at home in spare time for a money-making career as a TV/VCR Repair Specialist. No previous experience necessary. No need to quit your job or school. Everything is explained in easy-to-understand language with plenty of drawings, diagrams and photos. We show you how to troubleshoot and repair video-cassette recorders and TV sets, how to handle house calls and shop repairs for almost any make of television or VCR. Tools are included with your course so you can get "hands-on" practice as you follow your lessons step by step. Send for free facts about the exciting opportunities in TV/VCR Repair and find out how you can start making money in this great career. **MAIL COUPON TODAY** K03C

**SCHOOL OF TV/VCR REPAIR**, Dept. ADE012S  
925 Oak Street, Scranton, PA 18515  
Please send me full information and color brochure on how I can learn TV/VCR Repair at home in my spare time. I understand there is no obligation and no salesman will visit me.

Name \_\_\_\_\_ Age \_\_\_\_\_  
Address \_\_\_\_\_ Apt. # \_\_\_\_\_  
City/State \_\_\_\_\_ Zip \_\_\_\_\_  
Phone (\_\_\_\_) \_\_\_\_\_

## CABLE TV DESCRAMBLERS!

CABLE KINGDOM!

\*JERROLD\* \*OAK\* \*HAMLIN\*  
\*ZENITH\* \*PIONEER\*  
\*SCIENTIFIC ATLANTA\*

IN STOCK

6 MONTH WARRANTY! WE SHIP  
ABSOLUTELY LOWEST  
WHOLESALE/RETAIL PRICES  
\*\*\*\*\*FREE CATALOG\*\*\*\*\*  
J.P. VIDEO  
1470 OLD COUNTRY ROAD  
SUITE 315  
PLAINVIEW, NY 11803  
NO N.Y. SALES  
CALL NOW! 1 (800) 950-

**EASY ORDER**  
1-800-582-4044



**EASY FAX**  
1-800-582-1255

**TRIPP LITE — PRECISION REGULATED DC POWER SUPPLIES**

Complete Line of DC Power Supplies to Convert 120VAc to 13.8Vdc ±0.5Vdc.

**Standard Features Include:**

- Solid state integrated circuit provides excellent regulation
- Output voltage maintained up to 95% of no load value
- High quality filtering for low noise operation
- Heavy duty power transformer for complete line isolation
- On/Off indicator light and rugged on/off switch on faceplate
- Grounding conductor grounded cord on 10 Amp and larger models
- Current limiting electronic foldback for auto overcurrent protection



PR4.5



PR25

Tripp Lite DC Power Supplies Are Designed For Reliability and Superior Performance.

Order #	Price	ICS* (amps)	Continuous Duty (amps)	Fusing	Ripple Voltage	HxWxD (Inches)	Weight
PR4.5	32.95	4.5	3	Internal	0.1 Volt Max.	3.125 x 4.75 x 8.25	5 lbs.
PR7	44.95	7	5	Chassis Mount	0.15 Volt Max.	3.75 x 6.5 x 7.5	7 lbs.
PR10	64.95	10	7.5	Chassis Mount	0.15 Volt Max.	4.5 x 6.625 x 7.625	10 lbs.
PR15	89.95	15	12	Chassis Mount	0.15 Volt Max.	4.75 x 7.5 x 8.25	13 lbs.
PR25	126.95	25	20	Chassis Mount	0.15 Volt Max.	5.125 x 12.5 x 10.5	20 lbs.
PR40	179.95	40	32	Chassis Mount	0.15 Volt Max.	7.25 x 12.5 x 10	26 lbs.
PR60	249.95	60	48	Chassis Mount	0.15 Volt Max.	8.5 x 12.5 x 10	29 lbs.

Intermittent Communications Duty (50% Duty Cycle)

**ACTIVE COMPONENTS**

MICROS		DRAMS		
Order #	Price	Order #	Price	Des
6242	8.95	MK4027N2	.75	4
6502	2.95	4116-20	.85	16
6522A	3.75	4416-12	2.95	16
6821	1.75	4164-10	1.95	64
6845	2.45	4164-15	1.55	64
8080A	2.75	4164-20	1.25	64
8085A	2.95	4164-12	2.75	64
8086	4.45	41256-80	2.75	256
8088	4.25	41256-12	2.15	256
8237A5	4.15	51258-80	4.95	256
8250	5.75	514256-10	6.95	256
8251A	2.25	514258-80	9.95	256
8253-5	2.25	511000-80	7.25	1M
8255A5	2.75	511000-10	6.95	1M
8275	18.95	511001-80	8.25	1M

STATIC RAMS		EPROMS		
Order #	Price	Order #	Price	Prc
2101	1.65	2708	4.75	2
2114L25	1.39	2716	3.45	2
2147-3	3.75	2732	3.95	2
6116LP3	2.75	2732A25	3.45	2
6116-3	2.25	2732B45	4.25	12
6264LP10	4.95	2764-25	3.75	2
6264LP15	3.95	2764A25	3.25	12
6264-10	4.75	27C64A15	3.95	12
6264-15	3.75	27128A25	3.95	12
62256LP10	6.75	27256-25	4.75	12
62256LP15	6.25	27C512-15	6.95	12
628128LP8	34.95	27C010-15	9.95	12
628128LP10	32.95	27C020-15	24.95	12

LINEAR		LINEAR		
Order #	Price	Order #	Price	Descripti
MAX232CPE	4.55	CA3161E	1.95	Decoder Dri
LM311N	.49	CA3162E	6.25	Converter
LM324N	.35	78L05	.35	5V Pos. Reg. TO
LM339N	.39	7805K	1.25	5V Pos. Reg. TO
LM555CN	.29	7805T	.45	5V Pos. Reg. TO
LM741CN	.29	7812T	.45	5V Pos. Reg. TO
LM1488N	.45	79L05	.29	5V Neg. Reg. TO
LM1489N	.45	7905T	.49	5V Neg. Reg. TO

**MEMORY MODULES—SIMM**

Order #	Price	Organization	Spe
256x9-80	19.95	262,144x9	80
1x9-80	57.00	1,048,576x9	80
4x9-80	210.00	4,194,304x9	80

**SOLDERLESS PROTOTYPING BOARDS**

**Features**

- Color coordinates for easy recognition
- Insertion wire: 20-29 AWG (0.3 – 0.8 mm)
- Over 10,000 insertion cycles
- Accepts all standard components



Order #	Price 1-9	Price 10+	Dimensions (in.) L x W x H	Dist. Strips	Dist. Points	Terminal Strips	Terminal Points	Binding Posts
B200	2.99	2.49	6.5 x 0.37 x 0.4	2	100 x 2	0	0	0
B400	4.89	4.39	3.3 x 2.2 x 0.4	2	100	1	300	0
B630	5.45	4.95	6.5 x 1.4 x 0.4	0	0	1	630	0
B830	6.49	5.99	6.5 x 2.2 x 0.4	2	200	1	630	0
B1360	12.49	11.99	8.5 x 3.9 x 1.2	1	100	2	1,260	2
B1660	17.45	16.95	8.5 x 5.1 x 1.2	4	400	2	1,260	3
B2390	22.49	21.49	9.1 x 6.9 x 1.2	5	500	3	1,890	4
B3220	31.49	30.49	9.5 x 8.3 x 1.2	7	700	4	2,520	4

**ZILOG DATABOOKS\***

**Z80 CPU Technical Manual**

This 338 page manual contains the architecture, pin description, timing, instruction set, instruction description, interrupt response and hardware/software implementation examples of the Z80 CPU.

Order # Z29 9.95 Z80 CPU Technical Manual .....Weight: 1 lb.

**Intelligent Peripheral Controllers**

Over 700 pages of data sheets, application notes and technical information on Zilog's intelligent peripheral controllers. The part numbers contained in this book are Z8400, Z84C00, Z84C01, Z84C010, Z84C020, Z84C030, Z84C01/2/4, Z84C40/1/2/3/4, Z84C50, Z8470, Z84C90, Z84011/C11, Z84013/15, Z84C13/C15, Z80180, Z80181 and Z880.

Order # Z2480 13.95 Intelligent Peripheral Controllers .....Weight: 2 lbs.

**Datacom ICs**

Over 700 pages of data sheets and other technical information on Zilog's Data Communications ICs. Part numbers contained in this book are the Z16C30/31/33/35/50, Z5380, Z85230, Z80C30, Z85C30, Z030, Z8530, Z80181, Z84013, Z84015, Z84C13, Z84C15, Z8440, Z84C40 and Z85C80. Also included are application notes.

Order # Z2503 13.95 Datacom ICs .....Weight: 2 lbs.

**Microcontrollers**

Over 1300 pages of data sheets, application notes and technical information on Zilog's microcontrollers. The part numbers contained in this book are Z8600/01/02/03/04/11/12/13/71/81/82/91, Z800/01/20/22, Z86C00/C06/C08/C09/C10/C12/C19/C20/C21/C27/C30/C40/C50/C61/C62/C89/C90/91/C93/C94/C96/C97, Z86E08/E19/E21/E30/E40, Z88C00, Z86127, Z86128, Z765A, Z5380 and Z5380.

Order # Z8275 16.95 Microcontrollers .....Weight: 3 lbs.

Books are not returnable. We carry the newest versions available.



2917 Bayview Drive  
Fremont, CA 94538



**Easy Order: 1-800-582-4044**

**Easy Fax: 1-800-582-1255**

**International Fax: 1-510-770-2346**

**Customer Service: 1-510-770-2345**

Monday-Friday, 7am - 5pm (PST)/10am-8pm (EST)

- COD-No personal checks, US funds (\$5.00 Surcharge)
- USPS
- UPS
- Federal Express
- Airbon

Add 5% of total for shipping UPS Ground (\$3.00 min.).

Actual shipping charges based on weight.

Call or write today for your free copy of our catalog.

California residents, add appropriate sales tax.  
12 month warranty on all EasyTech products.  
30 day money back guarantee.  
We reserve the right to substitute manufacturers.  
Prices subject to change without notice.

# Your Natural Resource for Wire

## Test/Measurement and Prototype Equipment

### Jameco Solderless Breadboards

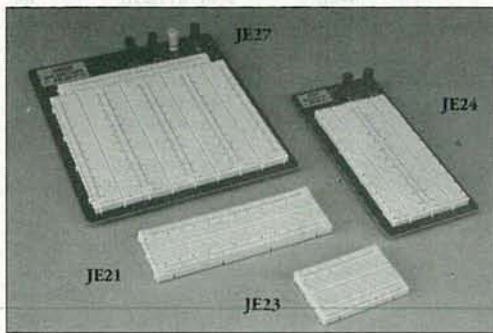

Jameco's long-lasting breadboards feature screen-printed color coordinates and are suitable for many kinds of prototyping and circuit design. Larger models feature a heavy-duty aluminum backing with voltage and grounding posts.

Part No.	Dim. L" x W"	Contact Points	Binding Posts	Price	Part No.	Dim. L" x W"	Contact Points	Binding Posts	Price
JE21	3.25 x 2.125	400	0	\$4.95	JE25	6.500 x 4.25	1,660	3	17.95
JE23	6.50 x 2.125	830	0	6.95	JE26	6.875 x 5.75	2,390	4	22.95
JE24	6.50 x 3.125	1,360	2	12.95	JE27	7.250 x 7.50	3,220	4	31.95

### GoldStar 20MHz Dual Trace Oscilloscope



The perfect unit for today's testing and measurement needs! Features include a 6" CRT display, and bandwidth from DC to 20 MHz. The GoldStar Oscilloscope comes with two 40MHz probes, two fuses, power cord, operation manual, schematics and block and wiring diagram. It's lightweight and portable with a two-year warranty.

GS7020.....\$399.95

### BNC Cable Assemblies for GS7020

BNC1	BNC(M) to BNC(M) RG58 A/U (39"L) .....	\$3.95
BNC2	BNC(M) to Micro Hook RG174 39"L).....	3.95
BNC3	BNC(M) to Macro Hook RG174 (39"L).....	3.95

**JAMECO**  
ELECTRONIC COMPONENTS  
COMPUTER PRODUCTS

24 Hour Toll-Free Order Hotline  
**1-800-831-4242**



Please refer to  
Mail Key 2  
when  
ordering

### Weller Soldering and Desoldering Stations



- Temperature adjustable from 350° to 850°F
- Zero voltage circuit protects sensitive components from damage
- Lighted on/off switch

WCC100 Soldering Station.....\$89.95

- 50 Watt Temperature Controlled Desoldering Station
- Desoldering head is temperature controlled to 800°F
- Low maintenance vacuum system

DS600 Desoldering Station...\$549.95

### Metex Digital Multimeters

- Handheld, high accuracy • AC/DC voltage, AC/DC current, resistance, diodes, continuity, transistor hFE (except M3900)
- Manual ranging w/ overload protection
- Comes with probes, batteries, case and manual

M3650 & M4650 only:

- Also measures frequency and capacitance

M3800 3.5 Digit Multimeter .....\$39.95

M3610 3.5 Digit Multimeter .....\$59.95

M3900 3.5 Digit Multimeter with Tach/Dwell .....\$59.95

M3650 3.5 Digit Multimeter w/Frequency & Capacitance .....\$74.95

M4650 4.5 Digit w/Frequency & Capacitance & Data Hold Switch.....\$99.95

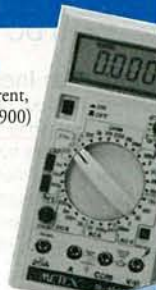

24 Hour Toll-Free  
Order Hotline  
1-800-831-4242

### Jameco Logic Pulser



- Compatible with TTL, DTL, RTL, HTL, HNIL, MOS and CMOS ICs
- 1MΩ Sync input impedance • Pulsar mode output current: 10mA • Square wave current output: 5mA • Audible tone

LP540.....\$16.95

### Jameco Logic P



- Max Frequency 80MHz • Min detectable pulse: 10ns • 120KΩ impedance • Max. supply voltage
- TTL threshold: (Lo)+0.8V ±0.1V • +2.3V ±0.2V • CMOS threshold VCC ±10%, (Hi) 70%VCC±10%

MS104.....\$16.95

### A.R.T. EPROM Programmer



- Programs all current EPROMs in the 2716 to 27512 range plus the X2864 EEPROM
- RS232 port • Software included

EPP.....\$199.95

### UVP EPROM Eraser



- Erases all EPROM's • Erases 15 minutes and 8 chips in 21 min
- UV intensity: 6800 UW/CM<sup>2</sup>

DE4.....\$199.95

### EPROMs - for your programming need

Part No.	Price	Part No.	Price	Part No.
TMS2516.....	\$4.25	2764-20.....	\$3.95	27256OTP..
TMS2532A.....	6.95	2764-25.....	3.75	27256-15....
TMS2564.....	5.95	2764A-20.....	3.75	27256-20....
TMS2716.....	5.95	2764A-25.....	3.19	27256-25....
1702A.....	3.95	27C64-15.....	3.95	27C256-15..
2708.....	4.75	27C64-25.....	3.25	27C256-20..
2716.....	3.39	27128OTP.....	2.49	27C256-25..
2716-1.....	3.75	27128-20.....	7.95	27512OTP..
27C16.....	4.25	27128-25.....	7.75	27512-20....
2732.....	4.95	27128A-15.....	4.95	27512-25....
2732A-20.....	4.49	27128A-20.....	4.49	27C512-15..
2732A-25.....	3.49	27128A-25.....	3.75	27C512-20..
2732A-45.....	2.95	27C128-15.....	5.75	27C512-25..
27C32.....	4.75	27C128-25.....	7.95	27C010-15..
				68766-35....

• Partial Listing • Over 4000 Electronic and Computer Components in Stock!

# Selection & Competitive Price

## Computer Upgrade Products and Electronic Components

Upgrade your existing computer system! Jameco will help you upgrade easily and economically.

### Jameco 80386SX Motherboard

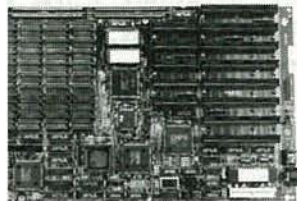

- 16MHz processing speed
- Baby motherboard (8.5"x13")
- Zero or one wait state operation
- Supports up to 8MB of RAM
- Intel 80387SX/compatible math coprocessor socket
- AMI BIOS
- Six 16-bit and two 8-bit expansion bus slots
- One-year Warranty

JE3516SN.....\$299.95

### Fujitsu 101-Key Enhanced Keyboard

This keyboard features 12 function keys, separate cursor and numeric keys.

- IBM PC/XT/AT and compatible computers
- Automatically switches between XT or AT
- LED Indicators for Num Lock, Caps Lock, and Scroll Lock
- Tactile Feedback.
- Manual included • One-year Warranty



FKB4700.....\$79.95

### Conner IDE Hard Drives

This series of high-performance Conner disk drives is designed for large storage capacity.

- CP3000 40MB 3.5" Low Profile.....\$249.95
- CP30084 80MB 3.5" Low Profile.....\$399.95
- CP30104 120MB 3.5" Low Profile...\$479.95
- CP3204 200MB 3.5" HH.....\$699.95
- ADP20 16-bit Host Adapter .....\$29.95

Additional host adapters available!

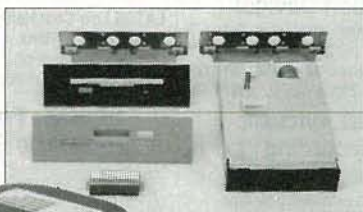

Many more Upgrade Products available!

### Toshiba 1.44MB 3.5" Internal Floppy Disk Drive

- IBM PC/XT/AT and compatibles
- Compatible with DOS versions 3.3 or higher
- Includes all necessary installation hardware
- 1.44MB formatted high density mode
- 720KB formatted low density mode
- Size: 1"H x 4"W x 5.9"D (actual drive size)
- One-year Manufacturer's Warranty

356KU.....\$99.95

### Integrated Circuits\*

Part No.	1-9	10+
7400	\$.29	\$.19
7402	.29	.19
7404	.29	.19
7406	.35	.25
7407	.35	.25
7408	.35	.25
7410	.29	.19
7417	.35	.25
7420	.29	.19
7432	.35	.25
7447	.89	.79
7474	.39	.29
7476	.45	.35
7486	.45	.35
7489	2.95	2.75
7490	.59	.49
74121	.49	.39
74192	.79	.69
74193	.79	.69

### Linear ICs\*

Part No.	1-9	10+
TL082CP	\$.59	\$.49
LM317T	.65	.55
LM324N	.35	.29
LM336Z	1.05	.95
LM339N	.39	.35
NE555V	.29	.25
LM556N	.49	.39
LM723CN	.49	.39
LM741CN	.29	.25
LM1458N	.35	.29
LM1488N	.45	.39
LM1489N	.45	.39
ULN2003A	.69	.59
LM3914N	1.95	1.75
NE5532	1.19	1.09
7805T	.45	.41
7812T	.45	.41

\* Call for a complete listing of ICs

### Dynamic RAMs

Part No.	Description	Price
4164-100	100ns, 64K x 1	\$1.89
4164-120	120ns, 64K x 1	1.69
4164-150	150ns, 64K x 1	1.49
41256-60	60ns, 256K x 1	2.49
41256-80	80ns, 256K x 1	2.19
41256-100	100ns, 256K x 1	1.95
41256-120	120ns, 256K x 1	1.79
41256-150	150ns, 256K x 1	1.69
511000P-80	80ns, 1MB x 1	5.99
511000P-10	100ns, 1MB x 1	5.49

### Miscellaneous Components\*

#### Potentiometers

Values available (insert ohms into space marked "XX"):

500Ω, 1K, 5K, 10K, 20K, 50K, 100K, 1MEG
43PXX 3/4 Watt, 15 Turn ..... \$ .99
63PXX 1/2 Watt, 1 Turn ..... \$ .89

#### Transistors And Diodes

PN2222 \$ .12	1N751 \$ .15
PN2907 .12	C106B1 .65
1N4004 .10	2N4401 .15
2N2222A .25	1N4148 .07
1N4735 .25	2N3055 .69
2N3904 .12	1N270 .25

#### Switches

JMT123 SPDT, On-On (Toggle) \$1.15
206-8 SPST, 16-pin (DIP) .....1.09
MPC121 SPDT,
On-Off-On (Toggle) .....1.19
MS102 SPST, Momentary
(Push-Button) ..... \$ .39

\*Additional components available

### Connectors

Part No.	Description	Price
DB25P Male, 25-pin	\$.65	
DB25S Female, 25-pin	.75	
DB25H Hood	.39	
DB25MH Metal Hood	1.35	

#### LEDs

XC209R T1, (Red)	\$.14
XC556G T1 3/4, (Green)	.16
XC556R T1 3/4, (Red)	.12
XC556Y T1 3/4, (Yellow)	.16

### IC Sockets

Low Profile	Wire Wrap(Gold)	Leve
8LP \$ .10	8WW	\$. .
14LP .11	14WW	. .
16LP .12	16WW	. .
24LP .19	24WW	1. .
28LP .22	28WW	1. .
40LP .28	40WW	1. .

Soldertail Standard and Header Plug Sockets Also Available

24-Hour Toll-Free Order Hotline:

# 1-800-831-4242

Call or Write for a

## FREE 90-Page 1992 Catalog!

\$30.00 Minimum Order • Data Sheets - 50¢ each

**JAMECO**<sup>®</sup>  
ELECTRONIC COMPONENTS  
COMPUTER PRODUCTS

1355 Shoreway Road  
Belmont, CA 94002  
FAX: 1-800-237-6948  
BBS Support: 415-637-90.

International Sales • Customer Service • Technical Assistance  
• Credit Department • All Other Inquiries: 415-592-8097 • 7AM - 5PM P.M.

© 1992 Jameco 2/92

CA Residents Add 7.25%, 7.75% or 8.25% Sales Tax

Shipping, handling and insurance are additional.

Terms: Prices subject to change without notice

Items subject to availability and prior sale. Complete list of terms/warranties is available upon request.

# AMAZING \* ELECTRONIC PRODUCTS and KITS

Remember those Martian Space Ships in HG Wells War of the Worlds?

## MYSTERY Levitating Device

Objects float on air and move to the touch. Defies gravity! Amazing gift, conversation piece, magic trick or great scientific project.

ANT1K Easy-Ass'y Kit/Plans \$19.50



## 3 MILE FM Wireless Microphone!

Crystal clear, ultra-sensitive pickup transmits voices, sounds to any FM radio. For security, monitoring children, invalids. Be the local DJ!

MVP1 Plans ..... \$7.00

MVP1K Kit/Plans ..... \$39.50

## 3 MILE Telephone Transmitter!



Automatically transmits 2 sides of phone conversation to any FM radio. Tunable, easy-assembly PC board. Operates only when phone is in use.

VWPM7 Plans ..... \$7.00

VWPMK7 Kit/Plans ..... \$39.50



## TV & FM Joker/Jammer

Pocket size device lets you remotely disrupt TV or radio reception. Great gag! Discretion required. Easy-build electronic kit. EJK1KM .... \$19.50

## 100,000 V - 20' Range Intimidation Device!

Electronic module, may be enclosed for handheld, portable, or fixed uses. ITM2 Plans (creditable to kit) \$10.00 ITM2K Kit & Plans ..... \$49.50

## READY-TO-USE, AUTOMATIC Phone Recording System

Complete with extended play tape recorder & line interface switch. Automatically records both sides of conversation. Check Local Laws on Proper Use! Ready-to-Use System. TAP20X System ..... \$149.50

## Laser Pen

Pen sized laser, great for movies, drive-ins, pointer. Ready to use, with batt's. LAPN1 Laser Pen . \$149.50

## Pocket Laser Kit

3mw or 5mw kits, with solid state 670nm diode. Caution, Class IIIa item. VRL3KM 3mw Laser Kit . . . \$99.50 VRL5KM 5mw Laser Kit . . \$119.50

## MORE Laser Kits!

LAS1KM 1mw Laser, 632nm, HeNe Easy to Build Kit . . . . . \$69.50 LAS4KM 3mw Version, Kit \$99.50

LAT05 Low Cost HeNe Laser Tube! .5mw Tube & Plans . . only \$24.50

Other parts available separately. Great Low Budget Science Project!

## Shocker Force Field Vehicle Electrifier

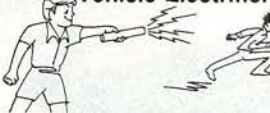

Make hand shock balls, shock wands electrify objects, charge capacitors. Great pay back for those wise guys! SHK1KM Easy-Assembly Kit \$24.50

## CATALOG!

with many more items!  
FREE with order, or send \$1 P&H

## INFORMATION UNLIMITED

Dept RE-4 Box 716, Amherst NH 03031  
Phone 603-673-4730 FAX 603-672-5406  
MC, VISA, COD, Check Accepted. ADD \$5 S&H.

Order by Mail, or by  
24 Hr Order Phone:  
800-221-1705

## CABLE TV DESCRAMBLE \* CONVERTERS and ACCESSORIES.

## SAVE MONEY DON'T RENT

PANASONIC, JERROLD, C PIONEER, SCIENTIFIC ATLA AND MORE. LOWEST PRICES. FREE CATALOG  
CABLE READY (800) 234-10 COMPANY

## FREE CATALOG

- CABLE T.V. BOXES - ALL TYPE
- LOW PRICES - DEALER PRICE

## ACE PRODUCTS 1-800-234-0726

INVENTORS! Confused? Need help? Call I for free information kit. USA/CANADA: 1 225-5800 (24 hours!).

## INVENTORS

INVENTORS! Can you patent and profit from idea? Call AMERICAN INVENTORS COI for free information. Serving inventors since 1 (800) 338-5656.

## PATENTS & INVENTIONS

INVENTORS! Your first step is important. For advice, call ADVANCED PATENT SERV Washington, DC, 1 (800) 458-0352.

## MILITARY SURPLUS

TELEVISION, radio, radar, fax, antenna, navigation and scope surplus equipment. Full catalogs. Send \$6.00 VLSI, 4960 Jasper Ave North, Lake Elmo, MN 55042.

## PRINTED CIRCUIT BOARDS

HAVE a requirement for your project or profession? Small runs O.K. Call or write to: SHORE PRINTED CIRCUITS, 36 Fairview Avenue, Little Silver, NJ 07739-1594. 1 (800) 752-1574 Fax — (908) 747-6301 In NJ (908) 747-6300.

## WANTED

INVENTIONS/ new products/ideas wanted: call TLCI for free information/inventors newsletter. 1 (800) 468-7200 24 hours/day — USA/Canada.

INVENTORS: We submit ideas to industry. Find out what we can do for you. 1 (800) 288-IDEA.

## NEW LITERATURE

continued from page 87

tions are described, along with some special modulation techniques. Radio frequencies, propagation, and space communications are covered.

Almost half of the book focuses on construction and maintenance of ham equipment, and getting on the air. It provides practical advice about construction techniques, test equipment, measurements, troubleshooting and repair. Instructions are provided for building your own power supplies; audio and video

equipment; modems; HF, VHF, UHF, and microwave equipment; antennas; and accessories. PC board patterns are included, as are parts lists. Tips are provided about how to assemble a station, monitoring and direction finding, and coping with interference.

EQUIPMENT, TOOLS & SUPPLIES FOR ELECTRONIC MAINTENANCE & SERVICE 1991-1992; from Print Products International, 8931 Brookville Road, Silver Spring, MD 20910; Phone: 800-638-2020; Fax: 800-545-0058; \$2.00.

The 64 pages of this catalog are filled with products



CIRCLE 35 ON FREE INFORMATION CARD

from major manufacturers, including power-protection gear from Triplet; test equipment from Beckman, Leader, B&K, Soar, Global Specialties, Hitachi, Ken-

wood, Simpson, and Victor Viz; Pace soldering desoldering and surface mount rework and rework equipment; programmable logic from Logical, C.S.T., American Reliance; Print's own custom tool and cases. New to this catalog are service monitoring and radio test equipment from Helper; Landmark PC-troubleshooting gear; AEMC test equipment; power-demand analyzer; Ungar soldering iron; Fieldpiece field-service equipment; static-detonation meters from Static and spectrum analyzer from Avcom, Pennetek, B&K.

## LASER DIODES

STOCK #	MFG.	WAVE-LENGTH	OUTPUT POWER	OPER. CURR.	OPER. VOLT.	1-24	25-99	100+
LS9220	TOSHIBA	660nm	3 mW	85 mA	2.5 V	129.99	123.49	111.14
LS9200	TOSHIBA	670nm	3 mW	85 mA	2.3 V	49.99	47.99	43.19
LS9201	TOSHIBA	670nm	5 mW	80 mA	2.4 V	59.99	56.99	51.29
LS9211	TOSHIBA	670nm	5 mW	50 mA	2.3 V	69.99	66.49	59.84
LS9215	TOSHIBA	670nm	10 mW	45 mA	2.4 V	109.99	104.49	94.04
LS3200	NEC	670nm	3 mW	85 mA	2.2 V	59.99	56.99	51.29
LS022	SHARP	780nm	5 mW	65 mA	1.75 V	19.99	18.99	17.09
SB1053	PHILLIPS	820nm	10 mW	90 mA	2.2 V	10.99	10.44	9.40

## WAO II PROGRAMMABLE ROBOTIC KIT

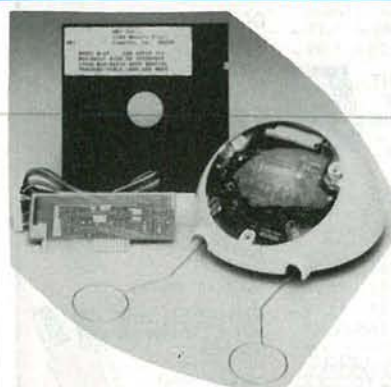

The pen mechanism included with the robot allows it to draw. In addition to drawing straight lines, it can also accurately draw circles, and even draw out words and short phrases. WAO II comes with 128 x 4 bits RAM and 2K ROM, and is programmed directly via the keypad attached to it. With its built-in connector port, WAO II is ready to communicate with your computer. With the optional interface kit, you can connect WAO II to an Apple II, IIe, or II+ computer. Editing and transferring of any movement program, as well as saving and loading a program can be performed by the interface kit. The kit includes software, cable, card, and instructions. The programming language is BASIC.

• Power Source - 3 AA batteries (not included)

STOCK #	DESCRIPTION	1-9	10-24	25+
MV961	WAO II Programmable Robotic Kit	79.99	75.99	68.39
WIAP	Interface Kit For Apple II, IIe, II+	39.99	37.99	34.19

## PROTOBOARD DESIGN STATION

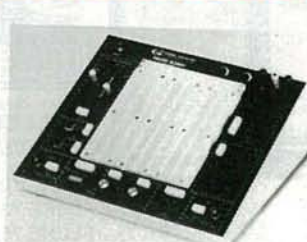

- The total design workstation - including expanded instrumentation, breadboard and power supply.
- Ideal for analog, digital and micro-processor circuits
- 8 logic probe circuits
- Function generator with continuously variable size, square, triangle wave forms, plus TTL pulses
- Triple power supply offers fixed 5 VDC supply plus 2 variable outputs - +5 - 15 VDC and -5 - 15 VDC
- 8 TTL compatible LED indicators, switches
- Pulsers
- Potentiometers
- Audio experimentation speaker
- Multiple features in one complete test instrument saves hundreds of dollars needed for individual units
- Unlimited lifetime guarantee on bread-board sockets
- Fixed DC output  
+5 VDC @ 1.0 amp, ripple - 5 mV
- Variable DC output  
+5 - to +15 VDC @ 0.5 amp, ripple - 5 mV

- Variable DC output  
-5 - to -15 VDC @ 0.5 amp, ripple - 5 mV
- Frequency generator  
frequency range: 0.1 Hz to 100 KHz in 6 ranges  
output voltage: 0 to ±10V (20 Vp-p)  
output impedance: 600 (except TTL)  
output current: 10mA max., short circuit protected  
output waveforms: sine, square, triangle, TTL  
sine wave: distortion 3% (10 Hz to 100 KHz)  
TTL pulse: rise and fall time 25ns  
drive 20 TTL loads  
Square wave: rise and fall time ± 1.5 μs
- Logic indicators  
8 LEDs, active high, 1.4 volt (nominal) threshold, inputs protected to ± 20 volts
- Debounced pushbuttons (pulsers)  
2 push-button operated, open-collector output pulsers, each with 1 normally-open, 1 normally-closed output. Each output can sink up to 250 mA
- Potentiometers  
1 - 1K, 1 10K, all leads available and uncommitted
- BNC connectors  
2 BNC connectors pin available and uncommitted shell connected to ground
- Speaker  
0.25 W, 8 Ω
- Breadboarding area  
2520 uncommitted tie points
- Dimensions  
11.5" long x 16" wide x 6.5" high
- Input  
3 wire AC line input (117 V, 60 Hz typical)
- Weight  
7 lbs.

STOCK #	DESCRIPTION	1-9	10-24	25+
PB503	ProtoBoard Design Station	299.99	284.99	256.49

## IDC BENCH ASSEMBLY PRESS



The Panavise PV505 1/4 ton manual IDC bench assembly press is a rugged, practical installation tool designed for low volume, mass termination of various IDC connectors on flat ribbon cable.

- Assembly base & standard platen included
- Base plate & platen may be rotated 90° for maximum versatility
- Base plates & cutting accessories are quickly changed without any tools required
- Additional accessories below
- Size - 10" W x 8.75" D x 9" H
- Weight - 5.5 lbs.

STOCK #	DESCRIPTION	1-9	10-24	25+
PV505	Panavise Bench Assembly Press	149.99	142.49	128.24

## COLLIMATING PEN



A low power collimator pen containing a MOVPE grown gain GaAlAs laser. This collimator pen delivers a maximum CW output power of 2.5 mW at 820 nm. The operating voltage of 2.2-2.5V @ 90-150mA is designed for lower power applications such as data retrieval, telemetry, alignment, etc.

The non-hermetic stainless steel case is specifically designed for easy alignment in an optical read or write system, and consists of a lens and a laser diode. The lens system collimates the diverging laser light .18 mrad. The wavefront quality is diffraction limited.

The housing is circular and precision manufactured measuring 11.0 mm in diameter and 27.0 mm long. Data sheet included.

As with all special buy items, quantity is limited to stock on hand.

STOCK #	DESCRIPTION	1-9	10-24	25+
SB1052	Infra-Red Collimator Pen	49.99	47.49	42.74

## LASER DIODE MODULE



The LDM 135 integrated assembly consisting of a laser diode, collimating optics and drive electronics within a single compact housing. Produces a bright red dot at 660-685 nm. It is supplied complete with leads for connection to a DC power supply from 3 to 5.25 V.

Though pre-set to produce a parallel beam, the focal length can readily be adjusted to focus the beam to a spot.

Sturdy, small and self-contained, the LDM135 is a precision device designed for a wide range of applications. 0.64" diam. x 2" long.

STOCK #	DESCRIPTION	1-9	10-24	25+
LDM135-5	5 mW Laser Diode Module	179.99	170.99	153.89
LDM135-1	1 mW Laser Diode Module	189.99	180.49	162.44
LDM135-2	2 mW Laser Diode Module	199.99	189.99	170.99
LDM135-3	3 mW Laser Diode Module	209.99	199.49	179.54

## COLLIMATING LENS



This economical collimating lens assembly consists of a black anodized aluminum barrel that acts as a heat sink, and a glass lens with a focal point of 7.5 mm. Designed to fit standard 9mm laser diodes, this assembly will fit all the above laser diodes. Simply place diode in the lens assembly, adjust beam to desired focus, then set with adhesive.

STOCK #	DESCRIPTION	1-9	10-24	25+
LSLENS	Collimating Lens Assembly	24.99	23.74	21.37

## POWER SUPPLY



- Input: 115/230V
- Output: +5V @ 3.75A  
+12V @ 1.5A  
-12V @ .4A
- Size: 7" L x 5 1/2" W x 2 1/2" H

STOCK #	PRICE
PS1003	\$19.99

## DUAL MODE LASER POINTER



New slimline laser pointer is only 1/2" in diameter x 6 1/4" long and weighs under 2 oz. 670 nm @ less than 1 mW produces a 6 mm beam. 2 switches, one for continuous mode, and one for pulse mode (red dot flashes rapidly). 2 AAA batteries provide 8+ hours of use. 1 year warranty.

STOCK #	DESCRIPTION	1-9	10-24	25+
LP35	Dual Mode Laser Pointer	199.99	189.99	170.99

## ROBOTIC ARM KIT



Robots were once confined to science fiction movies. Today, whether they're performing dangerous tasks or putting together complex products, robotics are finding their way into more and more industries. The Robotic Arm Kit is an educational kit that teaches basic robotic arm fundamentals as well as testing your own motor skills. Command it to perform simple tasks.

STOCK #	PRICE
YO1	\$43.99

## He-Ne TUBES



New, tested 632nm He-Ne laser tubes ranging from 5mW to 3mW (our choice). Perfect for hobbyists for home projects. Because of the variety we purchase, we cannot guarantee specific outputs will be available at time of order. All units are new, tested, and guaranteed to function at manufacturers specifications.

STOCK #	DESCRIPTION	1-9	10-24	25+
LT1001	He-He Laser Tube	69.99	66.49	59.84

## AVOIDER ROBOT KIT



An intelligent robot that knows how to avoid hitting walls. This robot emits an infra-red beam which detects an obstacle in front and then automatically turns left and continues on.

STOCK #	PRICE
MV912	\$43.99

**ORDER LINE — (800) 824-3432 • INTERNATIONAL ORDERS — (818) 341-8833**  
**FAX ORDERS — (818) 998-7975 • TECHNICAL SUPPORT — (818) 341-8833**

• 15.00 MINIMUM ORDER • UPS BLUE, RED & FEDERAL EXPRESS SHIPPING AVAILABLE • OPEN MON-FRI 9:00 AM - 6:00 PM, SAT 10:00 AM - 3:00 PM PDT  
• CA RESIDENTS ADD 8 1/2% SALES TAX • CALL FOR QUANTITY DISCOUNTS • CALL FOR FREE CATALOG (FOR 1ST CLASS DELIVERY OR CATALOGS DELIVERED OUTSIDE THE U.S. — SEND \$2.00) • WE CARRY A COMPLETE LINE OF ELECTRONIC COMPONENTS  
\*NO SHIPPING CHARGES ON PRE-PAID ORDERS DELIVERED IN THE CONTINENTAL U.S.

Kelvin Meters backed by a 2 Yr Warranty - Parts & Labor

**KELVIN DIGITAL MULTIMETERS**



100 Basic	150 Basic+	200 Advanced	PRO 400 with 20MHz Freq Counter
DC VOLTAGE AC VOLTAGE DC CURRENT RESISTANCE CONTINUITY - Test - Buzzer DIODE TEST BATTERY TEST 3 1/2 Digit LCD LOW BATTERY ACCURACY - ±0.5% RDG	DC VOLTAGE AC VOLTAGE DC CURRENT RESISTANCE CONTINUITY - Test - Buzzer DIODE TEST TRANSISTOR hFE BATTERY TEST 3 1/2 Digit LCD LOW BATTERY ACCURACY - ±0.5% RDG	DC VOLTAGE AC VOLTAGE DC CURRENT RESISTANCE CONTINUITY - Test - Buzzer DIODE TEST TRANSISTOR hFE 3 1/2 Digit LCD LOW BATTERY ACCURACY - ±0.5% RDG	FREQUENCY COUNTER TO 20MHz IDEAL FOR TROUBLE SHOOTING AC/DC VOLTAGE RANGES AC/DC CURRENT RANGES 5 FREQUENCY RANGES 5 CAPACITANCE RANGES LOGIC TEST CONTINUITY TESTER/Buzzer DIODE CHECK TRANSISTOR hFE TEST LED TEST VERIFY GOOD/BAD DISPLAY - 3 1/2 DIGIT LCD ACCURACY - 0.5% IMPEDANCE - 10 Mega Ohm
<b>KELVIN 100 Basic</b> \$19.95	<b>KELVIN 150 Basic+</b> \$29.95	<b>KELVIN 200 Advanced</b> \$39.95	<b>KELVIN PRO 400</b> \$69.95

Protective Cases For Models 100, 150, 200 ..... \$4.95 Case For Model Pro 400 ..... \$9.95

**DIGITAL TRAINER**



Trainer Manual (100 Pgs) gives detailed instructions. An excellent training tool covering topics for High School (Beginner - Advanced), Trade School (Beginner Intermediate) & College.

A PERFECT FIT WITHIN ANY DIGITAL CURRICULUM & YOUR CLASSROOM TEXTBOOK

**FEATURES**  
 ■ ONE DIGIT TRUE HEXADECIMAL DISPLAY WITH BUILT IN LOGIC (MEMORY, DECODER, DRIVERS) FULL ALPHA CHARACTERS  
 ■ TWO INDEPENDENT CLOCKS - USER ADJUSTABLE FREQUENCY & DUTY CYCLES  
 ■ BREADBOARD-500 PT. PROTO-TYPE AREA TWO POWER DISTRIBUTION BUSES (GND, VCC)  
 ■ 4 DATA BIT SWITCHES  
 ■ MOMENTARY PUSH BUTTON SWITCH (SPDT)  
 ■ 4 LED DISPLAYS W/IC DRIVERS  
 ■ POWER SUPPLY: WALL PLUG-IN TYPE, U.L. LISTED  
 ■ VOLTAGE REG: +5 VOLTS, SHORT CIR, OVERLOAD PROTECT  
 ■ HOOK-UP WIRES  
 ■ COMPACT CARRYING CASE  
 ■ INSTRUCTION MANUAL FOR BEGINNER TO ADVANCED USERS

FREE WITH PRIDE IN THE USA  
 FREE COMPREHENSIVE TEACHER/STUDENT LAB MANUAL

**THE KELVIN LDT™ Laptop Digital Trainer**

ONLY **\$99.95**

Stock No. 840460

**WALL TRANSFORMERS**

**WALL TRANSFORMER**

STOCK NO. TYPE - Female  
 220069 9V DC/500 mA ..... \$3.95 ea  
 220068 12V DC/500 mA ..... \$4.25 ea

**MALE JACK**

STOCK NO. TYPE  
 370048 2.1 mm Male  
 \$ .49 ea ..... \$ .39 /10+

**COMPONENTS**

Stock No.	TYPE	YOUR COST
600021	555 TIMER	\$ .20 ea
600029	556 DUAL TIMER	\$ .40 ea
600039	LM566 PLL FUNCTION GENERATOR	\$ .60 ea
600018	741C OP-AMP INTERNALLY COMPENSATED	\$ .30 ea
600026	1458 OP-AMP DUAL 741C OP-AMP DIP	\$ .35 ea
630041	2N2222	\$ .18 ea
630383	PN2222	\$ .08 ea
600023	7805 VOLTAGE REG	\$ .36 ea
SILICON CONTROLLED RECTIFIER (Similar to GE C106C1) 4.0 AMP, 100 PIV		
600014		\$ .89 ea \$ .79 ea/50+

**BREADBOARDS**

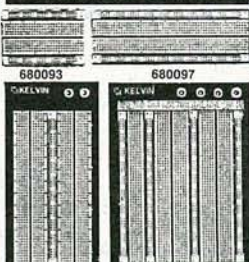

Stock No.	Post	Contacts	YOUR COST
680093	0	500	\$ 4.25
680097	0	840	\$ 5.95
680098	2	1380	\$ 11.75
680100	4	2390	\$ 22.95

**WIRE JUMPER KIT**  
 Pre-cut, Pre-Stripped  
 330289 140 Piece Set ... \$ 4.75  
 330290 350 Piece Set ... \$ 7.75

**LED CENTER**

**RED LED As Low As 5¢ ea/1000+ Qty**

**JUMBO LED**  
 TYPE - T 1 3/4, 5mm  
 STOCK NO. YOUR COST 1000+ Qty  
 260020 Red \$.06 ea/100+ \$.05 ea  
 260027 Green \$.08 ea/100+ \$.07 ea  
 260026 Yellow \$.08 ea/100+ \$.07 ea

**LED HOLDER**  
 for T 1 3/4 SIZE, BLACK  
 Stock No. 250019  
 \$.10 ea/100+ Qty  
 \$.06 ea/1000+ Qty

**DISCOUNTED PRICES!**

BEST BUY ..... NEW Series II

FLUKE 70 Series II	\$ 63
FLUKE 73 Series II	\$ 89
FLUKE 75 Series II	\$ 127
FLUKE 77 Series II	\$ 149
FLUKE 79 Series II	\$ 169
FLUKE 83	\$ 199
FLUKE 85	\$ 229
FLUKE 87 TRUE RMS	\$ 269
FLUKE 86 AUTOMOTIVE	\$ 367
FLUKE 88 AUTOMOTIVE	\$ 423
FLUKE 45	\$ 579



**NEW! SCOPEMETER™ SERIES**  
 HAND HELD, 50 MHz, DUAL CHANNEL

FLUKE 93	\$ 1095
FLUKE 95	\$ 1395
FLUKE 97 FULLY LOADED	\$ 1695

**SCOPES**

**20 MHz SCOPE** ..... \$345  
 Dual Trace 2 Yr Warranty-Parts & Labor  
 Stock No. 740085



**SCOPE PROBES**  
 60 MHz, X1 & X10 SPECIAL  
 700072 ..... \$18.95  
 150 MHz, X10  
 700073 ..... \$39.95

**BATTERIES**

Duracell / Eveready  
**9V Alkaline Battery**  
 \$ 1.95 ea  
 \$ 1.75 ea/10+

**9V Battery SNAP & HOLDER**  
 Snap \$ .15 ea \$ .10 ea/100+  
 Holder \$ .20 ea \$ .10 ea/100+

**PROJECT PART**

**Soldering IRON**  
 with STAND, BLUE LONG LIFE TIP  
 Stock No. 990098  
 \$4.50 ea

**Project Speaker**  
 2", 8 Ohm, 1 Watt  
 Stock No. 350009  
 59 ¢

**Project BUZZER**  
 3 - 9 Volt DC, 80 db  
 Stock No. 680089  
 \$1.59 ea

**HORN ALARM**  
 Loud Penetrating Sound  
 Stock No. 640001  
 \$.75 ea 9V DC  
 \$.69 ea/10+ Qty

**DC MOTOR for SOLAR/ROBOTIC**  
 Stock No. 852211  
 \$.50 ea 1.5 to 6VDC  
 \$.45 ea/20+ Qty

**XENON STROBE TUBE**  
 Stock No. 260050  
 \$2.95 ea  
 \$2.50 ea/20+ Qty

**TRIGGER COIL for XenonStrobe Tube**  
 Stock No. 320037  
 \$1.25 ea  
 \$.89 ea/20+ Qty

**INFRARED LED IR Pair, LED infrared transmitter and receiver**  
 Stock No. 260061  
 \$2.79 ea

**NEON LAMP**  
 NE2, Long Leads  
 Stock No. 260003  
 \$1.15 ea  
 \$.12 ea/100+ Qty

**PHOTO CELL**  
 CADMIUM SELENIDE  
 Stock No. 260017  
 \$.99 ea

**PHOTO CELL**  
 SULPHIDE  
 Stock No. 260018  
 \$.99 ea

**PUSH-BUTTON SWITCH**  
 PUSH-ON, PUSH-OFF  
 Stock No. 270021  
 \$.55 ea  
 \$.49 ea/100+ Qty

**SUB-MINIATURE MOMENTARY SWITCH**  
 Stock No. 990002  
 \$.35 ea  
 \$.28 ea/100+ Qty

**MINIATURE TOGGLE SWITCH**  
 Stock No. 270034  
 \$.90 ea Type - SPST  
 \$.79 ea/50+ Qty

**DOUBLE BANANA JACK**

Stock No. YOUR COST 3+ Qty  
 600056 \$2.30 ea \$2.07 ea

**FEMALE BNC TO DUAL BANANA PLUG**

Stock No. YOUR COST 3+ Qty  
 990103 \$2.95 ea \$2.75 ea

**DUAL BANANA BINDING POST TO MALE BNC PLUG**

Stock No. YOUR COST 3+ Qty  
 600058 \$5.95 ea \$4.95 ea

**BNC TEST CABLES 3 FT.**

Stock No. YOUR COST 3+ Qty  
 990101 \$3.45 ea \$2.95 ea

**KELVIN ELECTRONICS**

CIRCLE RESPONSE CARD WRITE for our CATALOG full WHOLESALE PRICED ITEM

OVER 10,000 ITEMS IN STOCK

ELECTRONIC COMPONENTS & TECHNOLOGY ACTIVITIES

VISA & MASTERCARD ACCEPT \$20 MINIMUM ORDER MINIMUM FREIGHT-\$5



COURTEOUS SERVICE • QUALITY PARTS • DISCOUNT PRICES • FAST SHIPPING

# ALL ELECTRONICS CORP.

## "MAX" The Remote VCR Controller

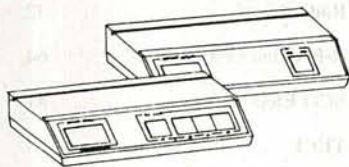

"MAX" allows you to watch and control a single VCR from other locations in the house. Transmits audio, video and IR signals up to 100 feet through mini-cable. Works on up to 4 televisions at a time, but a separate "MAX" receiver is required for each TV. Can also be used with other infrared controller devices such as CD players or stereos. Because it is hardwired, signal transmission is clearer than more expensive non-hardwired

units. Includes transmitter, receiver, 100' cable, hook-up cables and wall transformer. These new units originally sold for over \$100.00.  
**CAT# MAX \$40.00 each 4 or more \$35.00 each**

## WIRELESS REMOTE CONTROL FOR NINTENDO™

**ATTENTION NINTENDO™ USERS!!!**



CAMERICA "Freedom Connection"™

Turns your wired Nintendo™ control paddle into a remote control unit. Infrared remote like those used on TV's and VCR's eliminates messy wires. Allows players more mobility. Two players can use one remote unit except on games where they play simultaneously. In those games two "Freedom Connections" units are required. A well-known national discount toy chain sells these for more than twice our price. Operates on 4 AAA batteries (not included).

**CAT# IR-1 \$9.95 each**  
 Set of 4 AAA batteries **CAT# BAT-4AAA \$2.40 per set**

### TOUCH DIMMER

The "brain" part of the "LITE TOUCH" touch dimmer, when connected to any lamp, will turn it on and off and change the brightness level when any metal part is touched. We don't have the wiring harness that originally connected this to the lamp, but we can provide a simple hook-up diagram and instruction sheet. The solid-state circuitry is contained in a thermo-plastic box 1.91" X 3.11" X 0.835".  
**CAT# DMR-1 \$3.50 each**



### L.E.D.'s

**Standard JUMBO**  
 Diffused T-1-3/4 size (5 mm)

**RED CAT# LED-1**  
 10 for \$1.50 • 100 for \$13.00  
**GREEN CAT# LED-2**  
 10 for \$2.00 • 100 for \$17.00  
**YELLOW CAT# LED-3**  
 10 for \$2.00 • 100 for \$17.00

### FLASHING LED

W/ built in flashing circuit  
 5 volt operation. T-1-3/4 (5mm)

**RED \$1.00 each**  
**CAT# LED-4 10 for \$9.50**  
**GREEN \$1.00 each**  
**CAT# LED-4G 10 for \$9.50**  
**YELLOW \$1.00 each**  
**CAT# LED-4Y 10 for \$9.50**

### LED HOLDER

Two piece holder.  
**CAT# HLED 10 for 65¢**

### RECHARGEABLE BATTERIES

#### Nickel-Cad



**AAA SIZE \$1.50 each**  
 1.2 volts 180 mAh  
**CAT# NCB-AAA**

**AA SIZE \$2.00 each**  
 1.25 volts 500 mAh  
**CAT# NCB-AA**

**AA SIZE \$2.20 each**  
 WITH SOLDER TABS  
**CAT# NCB-SAA**

**C SIZE \$4.25 each**  
 1.2 volts 1200 mAh  
**CAT# NCB-C**

**D SIZE \$4.50 each**  
 1.2 volts 1200 mAh  
**CAT# NCB-D**

### 14/3 LINE CORD

#### 8' BLACK SJT 14/3



Heavy duty A.C. power cord. Standard 3 prong grounded plug one end, bare wire the opposite end. Blue, brown, green w/stripes wire color code. 0.37" nom. o.d.  
**CAT# RDAC-HDB \$4.50 each**

### WALL TRANSFORMERS

#### 12 Vdc 500 ma.

2.1mm D.C. power plug with center negative. White case.  
**CAT# DCTX-125W \$4.50 each**

#### 12 Vdc 200 ma.

2.1 mm D.C. power plug with center negative. **CAT# DCTX-122 \$3.00 each**

### HEAT SINK COMPOUND

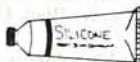

G C Electronics # 10-8109 - For effective transfer of heat between components and heat sinks. Z9 silicone heat sink compound.  
**CAT# HSC-1 \$2.00 per 1 oz tube**

### PHOTORESISTOR

1,000 ohms bright light.  
 16K ohms dark.  
 0.182" dia. X .08" high. 0.18" long leads.  
**CAT# PRE-7 2 for \$1.00**  
 100 for \$45.00 • 1000 for \$400.00

### Highest Quality METAL CASSETTES

Premium quality metal tape in C-60 style cassettes (30 or more per side). One of the finest "brand-name" tapes on the market, in durable, clear plastic transport mechanisms. Recorded and bulk erased, the record-protect tabs have been removed and therefore, need to be taped over to re-record. Audiophiles will appreciate the wide dynamic range of this tape. If your cassette deck has a "metal" setting you will hear the difference. A real bargain!  
 60 min. tape - **CAT# C-600M \$1.25 each • 10 for \$10.00**

### CASSETTE STORAGE CASE

Black, unbreakable plastic audio cassette storage case.  
**CAT# CBOX 5 for \$1.00 • 100 for \$15.00**

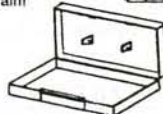
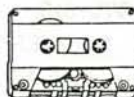

### DIP RELAYS

Miniature Relays With Pin Configuration To Fit 14 DIP.



#### 5 Vdc - S.P.S.T.

GI Clare # PRMA-1A05B. Normally open reed relay. 500 ohm coil. U.L. listed. Diode protected.  
**CAT# DRLY-57 \$1.50 each**

#### 12 Vdc - S.P.S.T.

Gordos# 846A-412 575 ohm coil. Sealed. Internal clamping diode.  
**CAT# DRLY-12 \$1.25 each**

#### 24 Vdc - S.P.D.T.

GI Clare # PRMA 1C24 2,150 ohm coil. 10 vA switching power.  
**CAT# DRLY-1C24 \$1.00 ea.**

#### 48Vdc - S.P.D.T.

Aromat # DS1E-A-DC48V 5,750 ohm coil. 2 amp contacts.  
**CAT# RLY-788 \$1.00 each**

### SWITCHES

#### Pushbutton Switch

SMK Manufacturing 0.47" square black pushbutton. SPST normally open. 4 p.c. pins for mounting. Ideal for low current switching applications.  
**CAT# PB-29 5 for \$1.00 • 100 for \$15.00**



### OPTO-SENSORS

GE H1381 U-shaped opto with 0.125" gap between emitter and sensor. 0.75" mounting centers.  
**CAT# OSU-11 2 for \$1.00**



TRW/Optron # OPB5447-2 IR emitter/sensor pair in rectangular package with 28" color coded leads.  
**CAT# OSR-4 2 for \$1.00**



### 4 AMP Full Wave BRIDGE

#RS405L 4 Amp 500 pV Epoxy package. In-Line leads  
**CAT# FWB-405 85¢ each**



### Rechargeable Batteries SUB-C 2 PACK

2 Sub-C nickel-cadmium batteries with solder tabs. Connected in series. This size battery is typically found in power tools, remote control models, electric shavers and other home appliances. Each battery measures 0.87" diameter X 1.66" long.  
**CAT# NCB-2C \$3.50 per pack**



# ORDER TOLL FREE 1-800-826-5432

FAX (818) 781-2653 • INFORMATION (818) 904-0524

Call Or Write For Our Free 64 Page Catalog  
 Outside the U.S.A. send \$2.00 postage for a catalog.

Minimum Order \$10.00 • All Orders Can Be Charged To Visa, Mastercard Or Discovercard • Checks and Money Orders Accepted By Mail • California, Add Sales Tax • Shipping And Handling \$3.50 for the 48 Continental United States - All Others Including Alaska, Hawaii, P.R. And Canada Must Pay Full Shipping • Quantities Limited • No C.O.D. • Prices Subject to change without notice.

DISCOVER

VISA

MasterCard

MAIL ORDERS TO: ALL ELECTRONICS CORP • P.O. BOX 567 • VAN NUYS, CA 91408

CIRCLE 107 ON FREE INFORMATION CARD

# CABLE DESCRAMBLERS

Converters, Remote Controls, Descramblers, more



#EX192

All major brands carried

\*JERROLD, \*TOCOM, \*ZENITH  
\*GENERAL INSTRUMENTS  
\*SCIENTIFIC ATLANTA, \*OAK  
\*HAMLIN, \*EAGLE, \*PIONEER

7th Year in business. Thank You  
Member of Omaha Chamber of Commerce  
1 Year warranty on new equipment  
30 Day money back guarantee  
Orders shipped from stock within 24 hours

CALL TODAY FOR A FREE CATALOG  
**1-800-624-1150**



C.O.D.



875 SO. 72nd St.  
Omaha, NE 68114

CIRCLE 188 ON FREE INFORMATION CARD

## CABLE BOXES BELOW WHOLESALE GUARANTEED STOCK - COD'S

### - DESCRAMBLERS -

(QTY)	(10)	(20)	(50)	(100)
TB 2-3	45	40	36	33
SA3-B	45	40	36	33
XN12 +	43	38	34	29
SB 2-3	43	38	34	30

### 60 CH REMOTE CONV/DECODER

DRX-DIC	90	75	70	65
SYL DIC	75	60	50	45

### - CONVERTERS W/REMOTES -

#### PANASONIC TZPC145

5 YR. WAR. + PARENTAL + 86 CH

TIMER + MEMORY + CH 2 OR 3 +

NEW	70	65	61	57
-----	----	----	----	----

#### REFURB 60 CH W/REMOTE

S-4040	38	36	34	31
--------	----	----	----	----

#### HAMLIN-ZENITH-TOCOM-CALL

IT IS NOT THE INTENT OF LAKE SYLVAN SALES TO DEFAUD ANY CABLE TELEVISION OPERATOR. FEDERAL AND STATE LAWS PROVIDE SUBSTANTIAL PENALTIES FOR THEFT OF CABLE TELEVISION SERVICES.

#### LAKE SYLVAN SALES, INC.

SORRY, NO MINNESOTA SALES

**800-800-4582**  
**DESCRAMBLERS PLUS!**

CIRCLE 199 ON FREE INFORMATION CARD

## ADVERTISING INDEX

RADIO-ELECTRONICS does not assume any responsibility for errors that may appear in the index below.

Free Information Number	Page	56	Parts Express
108	AMC Sales	90	197
75	Ace Products	86, 102	78
107	All Electronics	105	—
—	Amazing Concepts	102	177
77	B&K Precision	24	196
109	C & S Sales	23	92,190
—	CIE	3, 18	—
198	Cable Warehouse	76	194
50	Caig Laboratories	26	178
179	Cheneko Products	86	192,193
—	Command Productions	13, 27	185
181	Communications Specialists	87	—
55	Contact East	86	191
187	Datak Corporation	26	186
127	Deco Industries	86	
182	EasyTech	99	
183	Electronic Goldmine	94	
—	Electronic Tech. Today	80	
—	Electronics Book Club	28	
121	Fluke Manufacturing	CV2	
176	Global Specialties	7	
—	Grantham College	79	
86	Heathkit	75	
—	HighText Publications, Inc.	24	
—	ICS Computer Training	90	
114	Jameco	100	
180	Kelvin	104	
199	Lake Sylvan Sales, Inc.	106	
200	M&G Electronics	98	
87	MCM Electronics	95	
188	MD Electronics	106	
184	MJS Design	86	
93	Mark V. Electronics	97	
117	Mouser	76	
—	NRI Schools	8	
71	NTE Electronics	CV3	
195	Optoelectronics	17	
			People's College
			Radio Shack
			R-E Video Offer
			SCO Electronics
			TECI
			Tektronix
			The School of VCR Repair
			Unicorn
			U.S. Cable
			Viejo Publications
			WPT Publications
			Willabee & Ward
			Worldwide Cable
			Xandi Electronics

### ADVERTISING SALES OFFICE

**Gernsback Publications, Inc.**  
500-B Bi-County Blvd.  
Farmingdale, NY 11735  
1-(516) 293-3000  
President: Larry Steckler

For Advertising ONLY  
516-293-3000  
Fax 1-516-293-3115  
Larry Steckler  
publisher

Christina Estrada  
assistant to the President  
Arline Fishman  
advertising director  
Denise Haven  
advertising assistant  
Kelly McQuade  
credit manager

Subscriber Customer Service  
1-800-288-0652

Order Entry for New Subscribers  
1-800-999-7139  
7:00 AM - 6:00 PM M-F MST

### SALES OFFICES

#### EAST/SOUTHEAST

Stanley Levitan, Eastern Sales Manager  
Radio-Electronics  
1 Overlook Ave.  
Great Neck, NY 11021  
1-516-487-9357, 1-516-293-3000  
Fax 1-516-487-8402

MIDWEST/Texas/Arkansas/Okla.  
Ralph Bergen, Midwest Sales Manager  
Radio-Electronics  
One Northfield Plaza, Suite 300  
Northfield, IL 60093-1214  
1-708-446-1444  
Fax 1-708-559-0562

PACIFIC COAST/Mountain States  
Marvin Green, Pacific Sales Manager  
Radio-Electronics  
5430 Van Nuys Blvd. Suite 316  
Sherman Oaks, CA 91401  
1-818-986-2001  
Fax 1-818-986-2009

RE Shopper  
Joe Shere, National Representative  
P.O. Box 169  
Idyllwild, CA 92549  
1-714-659-9743  
Fax 1-714-659-2469

**WHOOSH!!!**  
**THE FASTEST, EASIEST CROSS-REFERENCING**  
**OF ORIGINAL DEVICES TO NTE**  
**REPLACEMENT PARTS!**



**NTE'S NEW SOFTWARE**  
**QUICK Cross™**

"QUICK Cross" is the industry's first PC-based software cross-reference to NTE's highly successful line of semiconductors and relays! Just type in any of a quarter of a million industry device numbers — U.S., Japanese, and European — and you'll get the ideal replacement from over 4,750 NTE devices *in about one second!*

All NTE parts carry a two-year warranty and most are available off the shelf. "QUICK Cross" 5 1/4" and 3 1/2" floppy diskette MS-DOS versions are available direct from NTE or through your local NTE distributor. For your nearest one, call NTE toll-free 1-800-631-1250 (including Canada) or (201) 748-5089. FAX: (201) 748-6224.



**NTE ELECTRONICS, INC.**

A WORLDWIDE REPUTATION FOR QUALITY, SERVICE AND VALUE

- YES, PLEASE SEND ME THE FOLLOWING NUMBER OF COPIES OF "QUICK Cross" SOFTWARE ON FLOPPY DISKETTES
- \_\_\_ 5 1/4" (1.2M) \*5.00 ea.      \_\_\_ 3 1/2" (720K) \*6.00 ea.
  - \_\_\_ 5 1/4" (360K) \*7.50 ea.

Enclosed please find my check or money order for \$ \_\_\_\_\_ (U.S. funds only.)

Name \_\_\_\_\_  
 Company \_\_\_\_\_  
 Address \_\_\_\_\_  
 City \_\_\_\_\_ State \_\_\_\_\_ Zip \_\_\_\_\_

Attach this coupon to your letterhead and mail to:  
 NTE, 44 Farrant St., Bloomfield, NJ 07003

RE292

"QUICK Cross" software runs in MS-DOS on any IBM PC or compatible with 640K of RAM, a small hard drive, and a 5 1/4" or a 3 1/2" floppy drive. NTE's database occupies only 2.1 Mbytes of hard disk space when loaded. It is a public domain release. MS-DOS is a registered trademark of Microsoft Corporation. IBM is a registered trademark of International Business Machines.



# WHAT YOUR TOOLS SAY ABOUT YOU.

## “ULTIMATE PROFESSIONAL”

Here's the newest family member: the 60 MHz Tek 224. It's as rugged, reliable and easy to use as the rest of the 220 Series—and extended bandwidth makes it the logical choice for computer service professionals.



## “ACE TROUBLESHOOTER”

The Tek 222 is everything a service scope ought to be. Lightweight. Rugged. Fully programmable. Floatable to  $\pm 400$  V. Two channels, 10 MHz, Auto Setup and Auto Trigger make it easy finding trouble—fast.



## “RUGGED SURVIVALIST”

Tek's 222PS Power Scout™ offers the field-proven performance of the 222, *plus* it's rated 600 VAC, 850 VDC and 6 kV peak surge. Perfect for circuit measurements requiring extra protection—and a few added guts.



They're just 4½ pounds. U.L. certified. And start at \$2450. 220 Series handheld oscilloscopes—all with Tek's exclusive IsolatedChannel™ architecture—are the service tools the professionals use. There's one with you written all over it. To order, contact your Tek representative or distributor. Or just call Tek direct: 1-800-426-2200

**Tektronix**

Test and Measurement