

# Radio **Electronics**

JANUARY 1992

TECHNOLOGY - VIDEO - STEREO - COMPUTERS - SERVICE

## BUILD THIS SWEEP/FUNCTION GENERATOR AND FREQUENCY COUNTER

Square, triangle and sine waves to 2.5 MHz, and a 150-MHz frequency counter!



## CABLE TV's MAGIC BULLET

Find out how it works

## BUILD A MONITOR EXERCISER

A convenient troubleshooting tool for computer monitors



## TURN ANY PHONE INTO A HIGH-QUALITY SPEAKERPHONE

Build R-E's Speaker Mate!

## ANALOG-TO-DIGITAL CONVERSION

Experimenting with the IBM PC

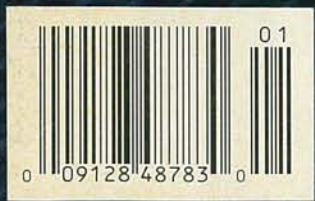

\$2.95 U.S.  
\$3.75 CAN

A GERNSBACK PUBLICATION

\*\*\*\*\* CAR-RT SORT \*\* CR03  
750456HRR5165MD93 01 12  
NOV 93  
RB



**FLUKE**®



**PHILIPS**

# Introducing SCOPEMETER

There's More Than One Reason to Reach for It.

In fact, there's *every* reason to reach for ScopeMeter.™ Because only ScopeMeter combines the expertise of Fluke and Philips to bring you a dual-channel digital scope along with everything you've come to expect from Fluke digital multimeters.

The result: an integrated scope-and-multimeter that lets you see a waveform and digital meter display at the same time from the same input. Or switch between dedicated high-performance Scope and Meter functions with the touch of a key. That makes it faster and easier than ever to capture, store and analyze precisely what you're looking for. At a price that looks good, too.

To get your hands on a ScopeMeter, contact your Fluke sales office or your nearest Fluke distributor. For more product information, call **1-800-44-FLUKE**.

SCOPEMETER. Now there's only one to reach for.

**Built to Take It.**

- Completely sealed against water, dust and contaminants.
- EMI protected and measures up to 600 volts rms.
- Rugged construction with shock-resistant holster.
- Three-year warranty from Fluke.



**Simply Easy.**

- Intuitive front panel layout for simple, straightforward operation.
- Pop-up menus and five function keys for easy control.
- Autoset automatically sets voltage, time and trigger functions.
- Safety-designed BNC connectors and probes simplify floating measurements.

**Double Duty.**

- 50 MHz digital storage scope and 3000-count digital multimeter in one handheld package.
- Precision Min Max Record and 40 ns Glitch Capture make it easy to troubleshoot intermittent failures.
- Simultaneous waveform and digital display on a backlit screen you can read across the room.

FLUKE 90 SERIES SCOPEMETER SELECTION GUIDE			
	FLUKE 97	FLUKE 95	FLUKE 93
Suggested List Price	\$1795	\$1495	\$1195
Bandwidth	50 MHz Dual Channel		
Sample Rate	25 Megasamples/second		
Autoset	Automatically sets Voltage, Time and Trigger		
Multimeter Display	3 2/3 digits (>3000 Counts)		
True RMS Volts	AC or AC+DC up to 600V (1700V Pk-Pk)		
Diode Test	Up to 2.8V		
Continuity Beeper	Yes		
Time/Division	10 ns/div to 60 sec/div		
Volts/Division	1 mV/div to 100V/div		5 mV/div to 100V/div
Digital Delay or Pre-Trigger	By Number of Cycles, Events, Time, or Zoom Mode		By Time
Special Multimeter Modes	Min Max Average Record, Relative (zero), dBm, dBV, Audio Watts, % Scale, Frequency, Smoothing™ Change Alert™		Frequency, Smoothing™ Change Alert™
Oscilloscope Cursors	12 Measurements, Display 5 Simultaneously		
Glitch Capture	≥40 ns		
Waveform Processing	Average, Variable Persistence, Min Max Record		
Waveform Memory	Store and Recall 8 Waveforms		
Set-Up Memory	Store and Recall 10 Front Panel Set-Ups		
Waveform Mathematics	Add, Subtract, Multiply, Invert, Filter or Integrate Waveforms		
Signal Generator Output	Sinewave or Squarewave		
Component Tester Output	Voltage or Current Ramp		
Optically Isolated RS-232-C Interface	Full Operation by Remote Control		
Printer Output	Serial		
Backlit Display	Electroluminescent		

**Goes Wherever You Go.**

- Runs on rechargeable NiCad Batteries, standard C-cells or the included line voltage adapter/battery charger.
- Adjustable tilt-stand comes in handy as a hanger, too.
- Compatible with a wide range of Fluke multimeter accessories.

©1991 John Fluke Mfg. Co., Inc. Ad No. 00075.

**FLUKE**®

CIRCLE 11 ON FREE INFORMATION CARD

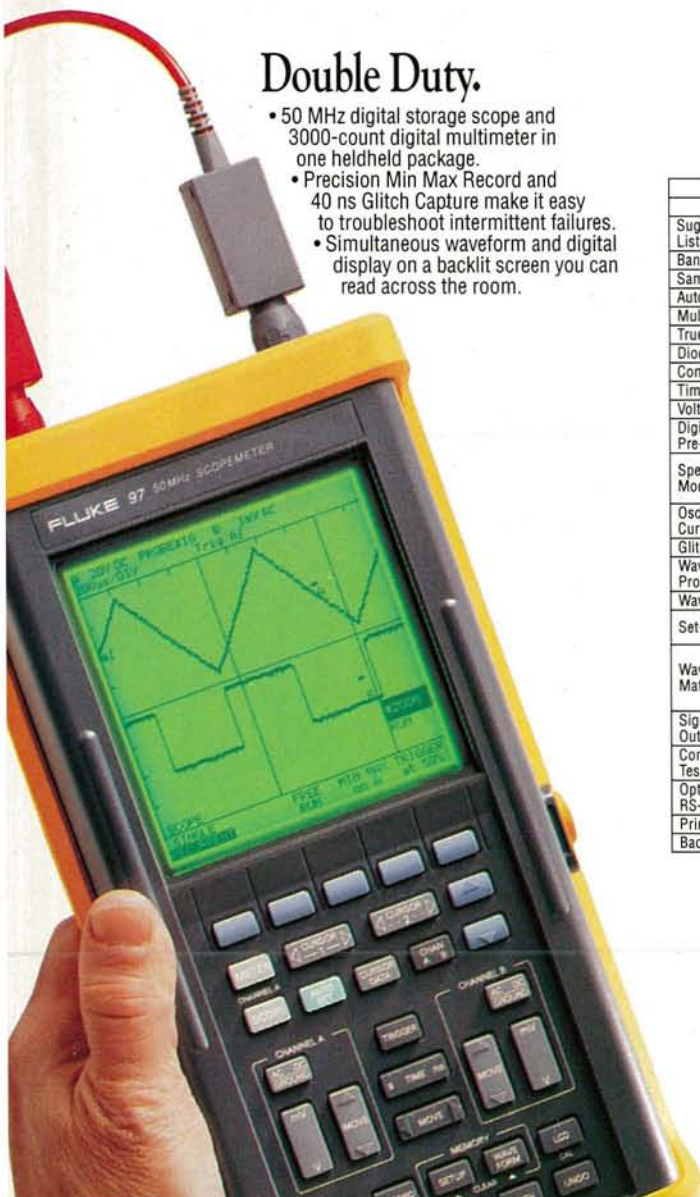

# January 1992 *Radio Electronics*<sup>®</sup>

Vol. 63 No.

## BUILD THIS

### 35 SWEEP/FUNCTION GENERATOR

Generate square, triangle, and sine waves with this inexpensive benchtop instrument.

**Michael A. Lashansky**

### 43 SPEAKER MATE

Turn any regular telephone into a high-quality speakerphone!

**David Plant**

### 47 MONITOR TESTER

Troubleshoot computer monitors without hooking them up to a computer.

**Garth Price**

### 59 EXPERIMENTING WITH ADC FOR YOUR PC

Build a low-cost automatic data-capture system.

**James J. Barbarello**

## TECHNOLOGY

### 33 CABLE TV'S INFAMOUS BULLET

How a New York cable company zapped signal pirates.

**Ken Foley**

### 50 WORKING WITH LED'S

A close look at a variety of LED circuits.

**Ray Marston**

## DEPARTMENTS

### 6 VIDEO NEWS

What's new in this fast-changing field.

**David Lachenbruch**

### 22 EQUIPMENT REPORTS

McGraw-Hill Science & Technical CD-ROM.

### 69 HARDWARE HACKER

VGA adapter for the Mac LC, computer monitors, and more.

**Don Lancaster**

### 73 AUDIO UPDATE

Reader questions.

**Larry Klein**

### 75 DRAWING BOARD

More on automotive voltage regulators.

**Robert Grossblatt**

### 84 COMPUTER CONNECTIONS

The future of multimedia mayhem.

**Jeff Holtzman**



**PAGE 63**



**PAGE 33**

## AND MORE

**96 Advertising and Sale Offices**

**96 Advertising Index**

**12 Ask R-E**

**14 Letters**

**86 Market Center**

**30 New Lit**

**24 New Products**

**63 1991 Annual Index**

**4 What's News**

## ON THE COVER



Even though a dependable function generator and frequency counter are invaluable pieces of test equipment—ones that are a necessity on a professional test bench—they're often simply beyond the means of the hobbyist. Until now, that is. Our sweep/function generator and frequency counter produces up to a 2.5-MHz square, triangle, or sine-wave output with a 1- to 20-volt peak-to-peak amplitude, and it costs just \$300 to build. In addition, the instrument features a TTL or CMOS 0.5- to 15-volt peak output, and can be used as a 150 MHz frequency counter. For all the details, turn to page 35.

## COMING NEXT MONTH

### THE FEBRUARY ISSUE GOES ON SALE JANUARY 7.

#### BUILD THIS SCANNER CONVERTER

It allows unrestricted coverage of the 800-MHz band.

#### CIRCUIT COOKBOOK

Our in-depth survey of LED's continues with practical chaser and bargraph circuits.

#### SWEEP/FUNCTION GENERATOR AND FREQUENCY COUNTER

Part II provides all the construction details.

#### NEW LIFE FOR AM RADIO?

Will AMAX receivers breathe new life into the AM band?

As a service to readers, RADIO-ELECTRONICS publishes available plans or information relating to newsworthy products, techniques and scientific and technological developments. Because of possible variances in the quality and condition of materials and workmanship used by readers, RADIO-ELECTRONICS disclaims any responsibility for the safe and proper functioning of reader-built projects based upon or from plans or information published in this magazine.

Since some of the equipment and circuitry described in RADIO-ELECTRONICS may relate to or be covered by U.S. patents, RADIO-ELECTRONICS disclaims any liability for the infringement of such patents by the making, using, or selling of any such equipment or circuitry, and suggests that anyone interested in such projects consult a patent attorney.

RADIO-ELECTRONICS, (ISSN 0033-7862) January 1992. Published monthly by Gernsback Publications, Inc., 500-B Bi-County Boulevard, Farmingdale, NY 11735 Second-Class Postage paid at Farmingdale, NY and additional mailing offices. Second-Class mail registration No. R125166280, authorized at Toronto, Canada. One-year subscription rate U.S.A. and possessions \$17.97, Canada \$25.65 (includes G.S.T. Canadian Goods and Services Tax Registration No. R125166280), all other countries \$26.97. All subscription orders payable in U.S.A. funds only, via international postal money order or check drawn on a U.S.A. bank. Single copies \$2.95. © 1992 by Gernsback Publications, Inc. All rights reserved. Printed in U.S.A.

**POSTMASTER:** Please send address changes to RADIO-ELECTRONICS, Subscription Dept., Box 55115, Boulder, CO 80321-5115.

A stamped self-addressed envelope must accompany all submitted manuscripts and/or artwork or photographs if their return is desired should they be rejected. We disclaim any responsibility for the loss or damage of manuscripts and/or artwork or photographs while in our possession or otherwise.

# Radio Electronics®

Hugo Gernsback (1884-1967) founder

Larry Steckler, EHF, CET,  
editor-in-chief and publisher

#### EDITORIAL DEPARTMENT

Brian C. Fenton, editor  
Marc Spiwak, associate editor  
Kim Dunleavy,  
assistant technical editor  
Teri Scaduto, assistant editor  
Jeffrey K. Holtzman  
computer editor  
Robert Grossblatt, circuits editor  
Larry Klein, audio editor  
David Lachenbruch  
contributing editor  
Don Lancaster  
contributing editor  
Kathy Terenzi, editorial assistant

#### ART DEPARTMENT

Andre Duzant, art director  
Injae Lee, illustrator  
Russell C. Truelson, illustrator

#### PRODUCTION DEPARTMENT

Ruby M. Yee, production director  
Janice Box,  
editorial production  
Karen S. Brown  
advertising production  
Marcella Amoroso  
production assistant

#### CIRCULATION DEPARTMENT

Jacqueline P. Cheeseboro  
circulation director  
Wendy Alanko  
circulation analyst  
Theresa Lombardo  
circulation assistant  
Michele Torriolo, reprint bookstore

Typography by Mates Graphics  
Cover photo by Diversified Photo  
Services

Radio-Electronics is indexed in  
*Applied Science & Technology Index*  
and *Readers Guide to Periodical Literature*.

Microfilm & Microfiche editions are  
available. Contact circulation department  
for details.

Advertising Sales Offices listed  
on page 96.

Radio-Electronics Executive and  
Administrative Offices  
1-516-293-3000.  
Subscriber Customer Service:  
1-800-288-0652.  
Order Entry for New Subscribers:  
1-800-999-7139.

 The  
Audit  
Bureau  
of Circulation



# HASTA LA VISTA BABY!

Terminate your Search for a Handi-Counter™. We're going to blow you away with this offer! \*\$100. off our full range Model 2810.

\*Limited time only, no discounts and no trade ins. Made in the U.S.A.

# \$159

**Don't Wait  
This Offer Can't Last  
Reg. Price, \$259**



- Full range -10Hz to 3GHz.
- LCD display (daylight visibility).
- True state-of-the-art technology with the high speed ASIC.
- NiCads & Charger included.
- Ultra-high sensitivity. • 4 gate times.
- Extruded metal case. • Compatible with MFJ207.

### Suggested options

- |                 |   |        |
|-----------------|---|--------|
| <b>TA100S:</b>  | Telescoping Whip Antenna.....                                       | \$ 12. |
| <b>CC30</b>     | Vinyl Carry Case.....   | \$ 14. |
| <b>BL10:</b>    | LED Backlight.....  | \$ 15. |
| <b>BL28:</b>    | EI Backlight for use in roomlight and low light.....                | \$ 45. |
| <b>BG28:</b>    | Bargraph Signal Level Indicator.....                                | \$100. |
| <b>TCXO 30:</b> | Precision $\pm 0.2$ ppm 20 to 40°C temp. compensated time base..... | \$100. |

Universal Handi-Counter™ Model 3000, \$375. and Bench Model 8030, \$579. Both offer frequency, period, ratio and time interval.



## OPTOELECTRONICS

Call for free catalog - Factory Direct Order Line:

# 1-800-327-5912

FL (305)771-2050 • FAX (305)771-2052

CIRCLE 189 ON FREE INFORMATION CARD

5821 NE 14th Ave. • Ft. Lauderdale, FL 33334  
5% Ship/Handling (Max. \$10) U.S. & Canada.  
15% outside continental U.S.A.  
Visa and Master Card accepted.

# WHAT'S NEWS

*A review of the latest happenings in electronics.*

## Wireless data communication for mobile workers

Incorporating Motorola's RPM400i radio packet modem, a notebook-size, battery-operated computer from IBM (White Plains, NY) will allow users to access and input information to a mainframe computer from remote locations. Service technicians, for instance, could use the 9075 PCradio Model 002 to obtain technical information or order emergency parts without leaving the job site. The modem incorporates the smallest and lightest data radio currently available, according to Motorola. The PCradio operates over the ARDIS network, a partnership of IBM and Motorola that was formed last year to provide nationwide wireless communications to Fortune 1000 companies, and the Mobidata network in Canada. The unit uses an 80C186 microprocessor and operates at either 5 or 10 MHz. The model 002, whose wireless modem operates at up to 4800 bps, can also be used with telephone communications networks (at 2400 bps). PCradio can send or receive fax copies over cellular networks at up to 9600 bps and over



**INCORPORATING MOTOROLA'S** radio packet modem, IBM'S PCradio can provide a wireless link to larger IBM computers via radio or cellular-based communications—ideal for police officers checking license-plate numbers, sales reps requiring immediate information on product inventories, or service technicians ordering emergency parts.

landlines at 2400 bps. On cellular networks, with an optional handset, PCradio can be used as a telephone. Two other PCradio models will also be available: The model 001 is a basic unit for conventional telephone communications; the model 003 is designed for cellular-based communications, includes a cellular modem, and can also be used with standard telephone networks. As we go to press, FCC approval has just been granted.

## Highly sensitive moisture sensors

Researchers at Sandia National Laboratories (Albuquerque, NM) have fabricated from silicon extremely sensitive moisture sensors capable of making accurate humidity measurement inside IC's.

Besides their excellent sensitivity and quick response time, the sensors offer several other advantages, including consistent performance at temperatures higher than 100°C. But their primary advantage lies in the fact that because they are made of silicon—the same basic material used to manufacture IC's—the sensors can be made by manufacturing methods that are compatible with the standard techniques used to make IC's. That "complete compatibility" of equipment and procedures holds the promise of the future manufacture of so-called "smart sensors" that combine the sensor and micro-electronic logic elements on the IC chip. That opens the door to such applications as environmental control in buildings by integrating a smart humidity sensor within heating, ventilation, and air-conditioning (HVAC) systems.

The capacitor-type sensors use a material known as oxidized porous silicon (OPS) as the moisture-adsorbing dielectric between the two electrodes in the capacitor. When water vapor contacts the sensor, it permeates through the porous volume between the electrodes, causing a net change in the dielectric

constant of the porous volume, which is then monitored by measuring the capacitance of the device.

## Law-enforcement aircraft

A light utility aircraft has been specially modified by the British company Pilatus Britten Norman to accommodate state-of-the-art surveillance and anti-narcotic detection equipment manufactured by Westinghouse Electronic Systems Group (Baltimore, MD). The modified plane is known as the Multi-Sensor Surveillance Aircraft, or MSSA, featuring



**THE WESTINGHOUSE Multi-System Surveillance Aircraft (MSSA), a specially modified light plane fitted with advanced detection and interdiction technology, is designed for law-enforcement and anti-narcotic surveillance missions.**

a unique, bulbous nose that provides enough room for the installation of sensors and avionics systems, including the radar and infrared imaging system that form the heart of the MSSA's ability to detect and track unusual activity on the ground or in the air, night or day.

In addition to the radar (a version of the one supplied by Westinghouse for the USAF's F-16 fighter) and the infrared system (similar to that used by the U.S. Coast Guard), the MSSA has a high-tech operations console and an advanced communications system that put the plane's capabilities at the fingertips of a cockpit operator and link them to support personnel in the air or on the ground. The aircraft, which is intended for use in drug interdiction, law enforcement surveillance, border fisheries patrol, airspace control, etc., was scheduled to be available by the end of 1991.

# TEST FOR LESS WITH FORDHAM

**Model DVM-636**

**Now Only \$59<sup>95</sup>**

- Rugged & Reliable
- 8 Functions
- 57 Ranges

**SCOPE Hand Held Digital Multimeters**



**Model DVM-638**

**Now Only \$69<sup>95</sup>**

- 11 Functions
- 38 Ranges
- Continuity Beeper
- Overload Protection

*Optional Carrying Case CA-92 \$9.95*



**NEW! GLOBAL<sup>®</sup> SPECIALTIES Digital Multimeter**

- 3½ Digit LCD
- Full Overload protection
- Diode & Continuity Checks With Audible Alarm
- 10MΩ Input Impedance
- Auto Ranging: AC/DC Voltage AC/DC Current Resistance
- Accuracy 0.5%

**Model 735 Our Price \$49<sup>95</sup>** *Optional Carrying Case CA-92 \$9.95*



**SCOPE 3½ Digit LCR Meter**

- Ideal for field applications!*
- Light weight • Portable • Hand Held
  - Overload Protection • Test Leads

**Model LCR-680 SALE \$119<sup>95</sup>**

*Optional Carrying Case CA-92 \$9.95*

**SCOPE 3½ Digit LCD Meter**

- 0.5% Accuracy • DC/AC Voltage, DC Current
- Diode & Battery Test • Overload Protection

**Model DVM-630 SALE \$32<sup>50</sup>**

*Reg. \$50.00 Optional Deluxe Carrying Case CC-30 \$4.50*



**Sweep Function Generator Sale! Now \$198<sup>00</sup>**

*Reg. \$319.95*

**Model FG-801**

- Selectable Wave & TTL Pulse
- 7 Freq. Ranges (0.2 Hz to 2MHz)
- Sweep Ratio 100:1



**SCOPE Analog Lab**

**Sale! Now \$198<sup>00</sup>**

*Reg. \$225.00*

**Model SC-6000**

- 5 Freq. Ranges
- Variable Positive Power
- Potentiometer



**Proto-Board Station Special! \$298<sup>00</sup>**

**Model SC-9000A**

- 3 Wire AC Line Input
- Function Generator
- Triple Power Supply
- 8 Logic LED's



**Feature Packed! HITACHI Oscilloscope**

**Now \$425<sup>00</sup> Save \$190<sup>00</sup>**

*Reg. \$615.00*

**Model V-212 Dual Trace**

- DC to 20 MHz, 1mV/div
  - 6" Rectangular Screen
- PROBES INCLUDED!**



**HITACHI Dual Trace Oscilloscope**

**Now \$598<sup>00</sup>**

**Model V-355**

- 19 Calibrated Sweeps
  - 6" CRT • Auto Focus
- PROBES INCLUDED!**



**Best Value**

**Fordham**  
260 Motor Parkway, Hauppauge, New York 11788

ASK FOR YOUR FREE CATALOG

**TOLL FREE 800-695-4848**

Service & Shipping Charge Schedule  
Continental U.S.A.

FOR ORDERS	ADD	FOR ORDERS	ADD
\$0-25	\$4.50	\$501-750	\$14.00
\$26-50	\$6.00	\$751-1,000	\$18.00
\$51-100	\$7.50	\$1,001-1,250	\$22.00
\$101-200	\$9.00	\$1,251-1,500	\$26.00
\$201-300	\$10.00	\$1,501-2,000	\$30.00
\$301-400	\$12.00	\$2,001 and up	\$34.00
\$401-500	\$14.00		



Money orders, checks accepted  
C.O.D.'s require 25% deposit

# VIDEO NEWS

What's new in the fast-changing video industry.

DAVID LACHENBRUCH

● **"Flat" tubes.** The catch-phrase for next year's color TV sets will be "flat tubes." Panasonic was the first in this latest flat-tube wave, introducing the "SuperFlat" under its premium Prism brand name. The SuperFlat scored a big success in Japan under the name "Gao," which means "king of pictures." The tube has a computer-designed faceplate which isn't really flat but has considerably less curvature than a conventional tube. In addition, the faceplate is extremely dark, providing more contrast, and new electronics supply the power and focus to realize the contrast without a loss of brightness and detail.

Not to be outdone, most other Japanese companies are now preparing their flatter tube versions. Sony will field a "Super Trinitron" in the United States in 1992, and Hitachi, Mitsubishi, and Toshiba are also flattening out their faceplates in Japan. All of this raises the question: What is "flat"? In a previous go-round, Toshiba developed the "FST," which originally stood for the "flat square tube." However, the tube wasn't either flat or square, so Toshiba changed the phrase to "flatter square tube," still preserving the acronym "FST."

Thomson Consumer Electronics, whose European tube operation has been selling a tube with a computer-designed faceplate—not quite flat, but with a flat appearance—took a poke at Panasonic's SuperFlat at a recent trade show with the slogan, "Super Planar, world's first super flat tube—4 million sold to date." Then along came Zenith, which is developing a truly flat-faced tube, the FTM (for "flat tension mask") tube that uses a piece of plate glass for a face. Zenith filed a complaint with the Better Business Bureau's National Advertising Division urging it to stop manufacturers from advertising "reduced curvature" tubes as "flat." But, somehow, "SuperReducedCurvature" doesn't have that special ring

to it. How about going back to "Gao?"

● **Digital sound for VHS.** First there was a longitudinal monophonic audio track on VHS, then longitudinal stereo, then hi-fi helical stereo. Now, finally, digital stereo is here. In Japan, JVC, Panasonic, Mitsubishi, Hitachi, and Sharp have introduced Super VHS recorders with digital audio tracks. The digital sound will be available only with S-VHS because the layout of the standard VHS signal doesn't have enough space for digital audio. The digital-sound recorders, having analog longitudinal and helical tracks as well, are compatible with previous recorders. The digital-audio system can record two channels at 48-kHz sampling frequency, 16 bits, or four channels at 32 kHz, 12 bits. Principal use of the recorders in Japan will be the tape satellite broadcasts that have digital audio. There's no word on whether the digital-sound recorders will be exported.

● **Public electronics show.** The latest advances in TV's, VCR's, camcorders, and home multimedia products will be on display to the public as the Consumer Electronics Show (CES) in Chicago opens its doors to actual "consumers" for the first time in its 25-year history. It's expected to attract as many as 100,000 visitors from the Chicago area and beyond. In the past, CES has been for the trade only, but this year's show, which will run from May 28 through May 31, will have two public days. May 28 and 29 will be trade-only days, as will the morning of Saturday, May 30, but the show will be open to all visitors from noon Saturday through 6 PM Sunday at the McCormick Convention Center and the Hilton Hotel. The nominal admission price will be \$10, but it's expected that dealers and exhibitors will distribute cut-rate tickets. The show's sponsor is the Electronic Industries Association's Consumer Electronics Group (EIA/CEG).

● **Camcorder format war.** The 8mm format was the clear winner in 1991 in the battle of the camcorder formats, with the VHS-C (compact and full-size VHS models trailing with about equal shares. The EIA tallies sales of "compact" VCR's and full-size VHS. The "compact" category includes both 8mm and VHS-C. For the six months from April through September 1991, compacts outsold full-size units by 70% to 30% (but for the nine months through September full-size models represented 33.2% of the total). The EIA doesn't break down compacts between VHS-C and 8mm, but the U.S. Commerce Department keeps track of imports of 8mm as a separate category, without breaking down between VHS and VHS-C model imports. In the late available figures, for 1991's first seven months, 8mm constituted 42% of imported camcorders. Applying these figures to the EIA's data, this indicates that the ratio in 1991 worked out to roughly 40% 8mm and 30% each VHS-C and full-size VHS.

But don't count VHS-C out. The VHS-C proponents, led by Panasonic and JVC, are mounting a major campaign stressing compatibility of VHS-C with VHS home VCR decks. It means of the VHS adaptor that comes with all VHS-C camcorders—not to mention a forthcoming generation of VCR's that can accept both VHS and VHS-C cassettes without adaptors.

The latest trends in camcorders include "digital zoom," an electronic extension of optical zoom to provide as much as 100:1 zoom ratio, at least theoretically. At that magnification however, so much detail is lost that the picture isn't very viewable. Other trends are color LCD viewfinders; internal titles, including pre-selected on-screen messages such as "Birthday Party," "Wedding," "Our Vacation," etc.; and remote controls that permit the user to operate the tripod-mounted camcorder while he or she is in the picture. **R**



48 HOUR  
SHIPPING

# ELENCO & HITACHI PRODUCTS AT DISCOUNT PRICES

TO ORDER  
CALL TOLL FREE  
1-800-292-7711

## Hitachi RSO Series

(Portable Real-time Digital Storage Oscilloscopes)

VC-6023 - 20MHz, 20MS/s	\$1,695
VC-6024 - 50MHz, 20MS/s	\$1,995
VC-6025 - 50MHz, 20MS/s	\$2,195
VC-6045 - 100MHz, 40MS/s	\$2,995
VC-6145 - 100MHz, 100MS/s	\$4,495

RSO's from Hitachi feature roll mode, averaging, save memory, smoothing, interpolation, pretriggering, cursor measurements. These scopes enable more accurate, simpler observation of complex waveforms, in addition to such functions as hardcopy via a plotter interface and waveform transfer via the RS-232C interface. Enjoy the comfort of analog and the power to digital.

## 25MHz Elenco Oscilloscope



**\$349**  
S-1325

- Dual Trace
- 1mV Sensitivity
- 6" CRT
- X-Y Operation
- TV Sync
- (2) 1x, 10x Probes included

## SPECIAL BUY

V-212 - 20MHz Scope \$425

## Hitachi Portable Scopes

DC to 50MHz, 2-Channel, DC offset function, Alternate magnifier function

V-525 - CRT Readout, Cursor Meas.	\$995
V-523 - Delayed Sweep	\$975
V-522 - Basic Model	\$875
V-422 - 40MHz	\$775
V-223 - 20MHz delayed sweep	\$695
V-222 - 20MHz deluxe	\$625

## PRICE BREAKTHRU

20MHz Digital Storage Oscilloscope

- Analog/Digital Scope
- 2K word per channel memory
- 10MS/s sampling rate
- State-of-art technology
- Includes probes

DS203  
**\$795**

## HITACHI COMPACT SERIES SCOPES

This series provides many new functions such as CRT Readout, Cursor measurements (V-1085/1065A/665A), Frequency Ctr. (V-1085), Sweeptime Autoranging, Delayed sweep and Tripper Lock using a 6-inch CRT. You don't feel the compactness in terms of performance and operation.

V-660 - 60MHz, Dual Trace	\$1,149
V-665A - 60MHz, DT, w/cursor	\$1,345
V-1060 - 100MHz, Dual Trace	\$1,395
V-1065A - 100MHz, DT, w/cursor	\$1,649
V-1085 - 100MHz, QT, w/cursor	\$1,995
V-1100A - 100MHz, Quad Trace	\$2,195
V-1150 - 150MHz, Quad Trace	\$2,695

## Elenco 40MHz Dual Trace



Good to 50MHz  
**\$495**  
S-1340

- High luminance 6" CRT
- 1mV Sensitivity
- 10KV Acceleration Voltage
- 17ns Rise Time
- X-Y Operation
- Includes (2) 1x, 10x Probes

All scopes include probes, schematics, operators manual and 3 year (2 yrs for Elenco scopes) world wide warranty on parts & labor. Many accessories available for all Hitachi scopes. Call or write for complete specifications on these and many other fine oscilloscopes. 1x, 10x Scope Probes: P-1 65MHz \$19.95, P-2 100MHz \$26.95

## B + K TEST EQUIPMENT All Models Available

Call for special price

## Digital Capacitance Meter



CM-1550B

**\$58.95**

- 9 Ranges
- .1pf-20,000ufd
- .5% basic acy.
- Zero control w/ Case
- Big 1" Display

## Digital LCR Meter



LC-1801

**\$125**

- Measures:
- Coils 1uH-200H
- Caps .1pf-200uf
- Res .01-20M



## Multimeter with Capacitance & Transistor Tester

**\$55** CM-1500B

- Reads Volts, Ohms
- Current, Capacitors,
- Transistors and
- Diodes / with case

Big 1" Display

## FLUKE

### MULTIMETERS

- All Models Available
- Fluke 70-II \$65
- Fluke 77-II \$145
- Fluke 79-II \$169
- Fluke 87 \$269
- Call for special price

## Quad Power Supply XP-580

**\$59.95**

- 2-20V @ 2A
- 12V @ 1A
- 5V @ 3A
- 5V @ .5A

Fully regulated and short circuit protected

## Digital Triple Power Supply

XP-765

**\$269**

- 0-20V @ 1A
- 0-20V @ 1A
- 5V @ 5A
- Fully regulated, Short circuit protected
- with 2 limit control, 3 separate supplies
- XP-660 with Analog Meters \$195

## AM/FM Transistor Radio Kit with Training Course

Model AM/FM 108

**\$26.95**

- 14 Transistors + 5 Diodes
- Makes a great school project



True RMS 4 1/2  
Digit Multimeter  
M-7000

**\$135**

- .05% DC Accuracy
- .1% Resistance
- with Freq. Counter
- and Deluxe Case

## GF-8016 Function Generator with Freq. Counter

**\$249**

- Sine, Square, Triangle
- Pulse, Ramp, .2 to 2MHz
- Freq Counter .1 - 10MHz
- Int/Ext operation

GF-8015 without Freq. Meter \$179

## Function Generator Blox

#9600

**\$28.95**

- Provides sine, triangle, square
- wave from 1Hz to 1MHz
- AM or FM capability

## Color Convergence Generator



SG-250

**\$79.95**

Kit \$59.95

- Finest in the industry
- 10 rock steady patterns
- RF & Video output

## Learn to Build and Program Computers with this Kit

Includes: All Parts, Assembly and Lesson Manual

Model

MM-8000

**\$129.00**



Starting from scratch you build a complete system. Our Micro-Master trainer teaches you to write into RAMs, ROMs and run a 8085 microprocessor, which uses similar machine language as IBM PC.

## Wide Band Signal Generators



SG-9000 \$129

- RF Freq 100K-450MHz AM Modulation
- of 1KHz Variable RF output
- SG-9500 w/ Digital Display &
- 150 MHz built-in Counter \$249

## High Current Power Supply



XP-800

**\$295**

Digital

Volt/Amp Meters

- Fully regulated, 0-122VAC @ 2A, 0-40VAC @ 10A or 0-30VDC @ 10A. Fully variable, Short circuit protected.

## STANDARD AMATEUR RADIOS

Now available - The worlds finest amateur radios. Unsurpassed quality and features make STANDARD the worlds most popular line of amateur radios.

### Mini Deluxe HTs:

- C168A 2 meter CALL
- C468A 450MHz

### Twin Band HTs

- C228A 2M/220MHz CALL
- C528A 2M/440MHz

### Twin Band Mobile

- C5608DA 2M/440MHz CALL

We also have many accessories for these radios and most heath radios. Call for details.

WE WILL NOT BE UNDERSOLD!

UPS Shipping: 48 States 5%  
(\$3 Min \$10 Max) Shipping  
IL Res., 7.5% Tax FAX: 708-520-0085

## C & S SALES INC.

1245 Rosewood, Deerfield, IL 60015  
(800) 292-7711 (708) 541-0710



15 Day Money Back Guarantee  
2 Year Warranty Prices Subject to Change

WRITE FOR FREE CATALOG

CIRCLE 109 ON FREE INFORMATION CARD

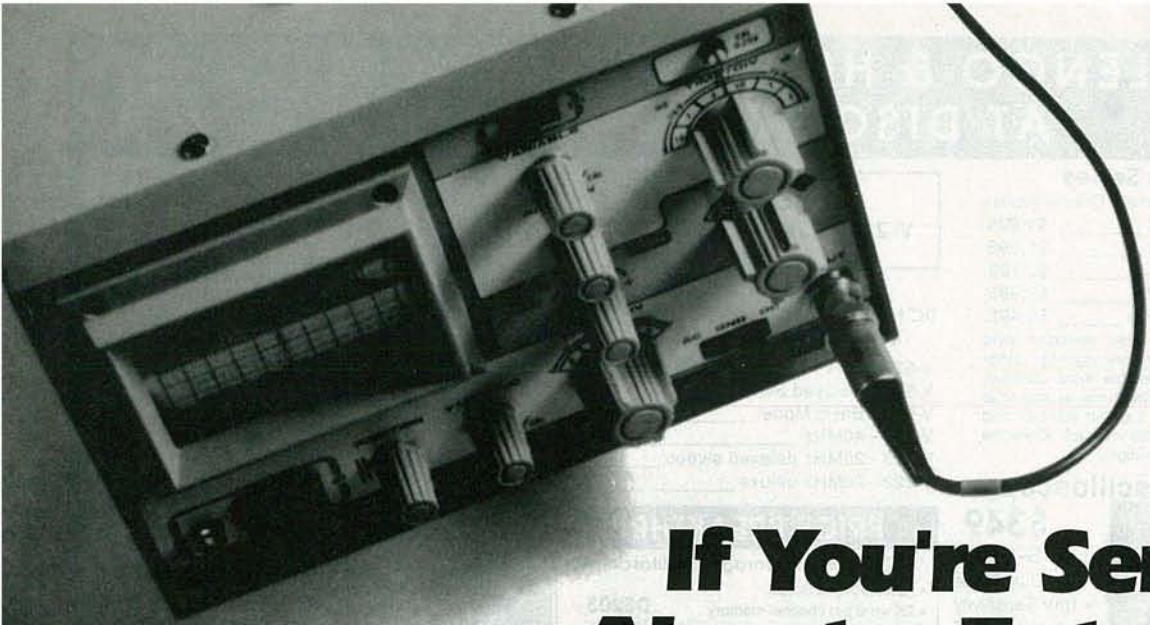

# If You're Serious About a Future in Electronics, Ensure that Future with the Best Educational Training Available.

**FREE!**

SEND FOR YOUR CIE HOME  
STUDY COURSE CATALOG AND  
RECEIVE A FREE 24 PAGE CIE  
ELECTRONICS SYMBOL HANDBOOK!

Includes hundreds of the most frequently  
used electronic symbols. Published by  
CIE exclusively for our students and  
alumni. Yours free when you  
request a CIE Course Catalog.



electronics

## Procedure

Figure 16 shows the circuit diagram for this experiment. You'll note that the numbers for the IC aren't included on the diagram. For those, you'll have to refer to Fig. 17, which shows pertinent 74151A data. For the data inputs, you'll use an eight-pole DIP switch in conjunction with 10 k $\Omega$  pull-up resistors. For the Select and Strobe lines, finally, you'll use the trainer data switches.

1. With the power off, mount the 74151A IC and the DIP switch on the breadboard.
2. Connect the eight 10 k $\Omega$  resistors to the DIP switch as shown in Fig. 16. Connect the opposite end of each of these resistors to the +5V supply. The second terminal of each switch is to be connected to trainer ground.
3. Connect the IC V<sub>CC</sub> pin to +5V; connect the GND to trainer ground.
4. Next, connect the trainer data switches to the Select and Strobe inputs on the IC, using Fig. 17 as a guide. Initially, set SW1 through SW4 to 0.
5. Connect the trainer Y LED to the F output, and connect the R LED to the B output.

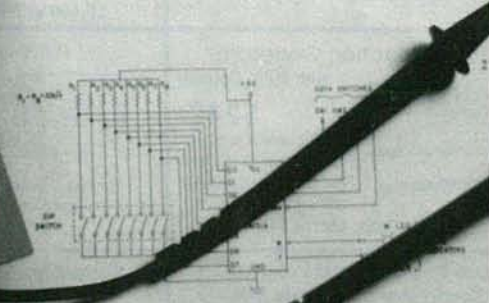

Fig. 16. Circuit for Experiment 2.



Fig. 17. Pin diagram for 74151A.

7. Turn the power on. The F LED on your trainer should be off, and the W LED should be on. If you don't observe these conditions, turn off the power and check your connections.
8. From the present input conditions on the inputs, you can see that the input will be enabled.
9. Set the appropriate DIP switch B1 (open), and verify your prediction. Record your results in terms of the selected input D, where X is the number of the selected data line (in the appropriate space in the truth table in Fig. 18).

If you want to learn about electronics, and earn a good income with that knowledge then CIE is your best educational value.

CIE's reputation as the world leader in home study electronics is based solely on the success of our graduates. And we've earned that reputation with an unconditional commitment to provide our students with the very best electronics training.

Just ask any of the 50,000-plus graduates of the Cleveland Institute of Electronics who are working in high-paying positions with aerospace, computer, medical, automotive and communication firms throughout the world.



They'll tell you success didn't come easy...but, it did come....thanks to CIE. And today, a career in electronics offers more opportunities and greater rewards than ever before.

## CIE'S COMMITTED TO BEING THE BEST....IN ONE AREA....ELECTRONICS.

CIE isn't another be-everything-to-everybody school. We teach only one subject and we believe we're the best at what we do. Also, CIE is accredited by the National Home Study Council. And with more than a 1,000 graduates each year, we're the largest home study school specializing exclusively in electronics. CIE has been training career-minded students like yourself for nearly 60 years and we're the best at our subject .....  
**ELECTRONICS ... BECAUSE IT'S THE ONLY SUBJECT WE TEACH!**

## CIE PROVIDES YOU WITH A LEARNING METHOD SO GOOD, IT'S PATENTED.

CIE's Auto-programmed lessons are a proven learning method for building valuable electronics career skills. Each lesson is designed to take you step-by-step and principle-by-principle. And while all CIE lessons are designed for independent study, CIE's instructors are personally available to assist you with just a toll-free call. The result is practical training... the kind of experience you can put to work in today's marketplace.

## LEARN BY DOING...WITH STATE-OF-THE-ART FACILITIES AND EQUIPMENT.

In 1969, CIE pioneered the first Electronics Laboratory course and in 1984, the first Microprocessor Laboratory course. Today, no other home study school can match CIE's state-of-the-art equipment and training. And all your laboratory equipment, books, and lessons are included in your tuition. It's all yours to use while you study at home and for on-the-job after graduation.

## PERSONALIZED TRAINING....TO MATCH YOUR BACKGROUND.

While some of our students have a working knowledge of electronics others are just starting out. That's why we've developed twelve career courses and an A.A.S. Degree program to choose from. So, even if your not sure which electronics career is best for you, CIE can get you started with

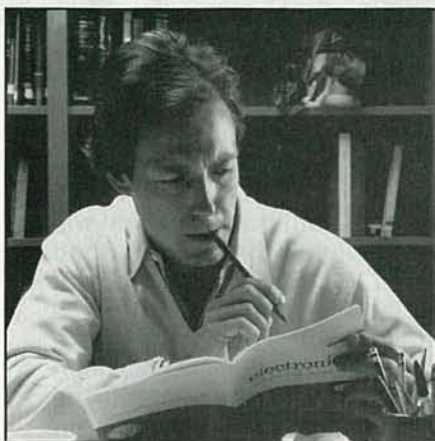

core lessons applicable to all areas of electronics. And every CIE course you take earns you credit towards completion of your Associate in Applied Science Degree. So you can work toward your degree in stages or as fast as you wish. In fact, CIE is the only school that actually rewards you for fast study, which can save you thousands of dollars.

**SEND TODAY FOR YOUR CIE COURSE CATALOG AND WE'LL SEND YOU A FREE 24 PAGE CIE ELECTRONICS SYMBOL HANDBOOK!**

**FINANCIAL AID AVAILABLE TO QUALIFIED INDIVIDUALS.**

### WHY CHOOSE CIE FOR YOUR TRAINING?

- 150,000 successful graduates from every country around the world.
- Only CIE rewards you for fast study. CIE offers an Associate Degree program based on actual study time used. The faster you complete your degree the less your overall tuition.
- State-of-the-art laboratory equipment is yours to keep and it comes assembled, ready for hands-on experiments.
- Approved for educational benefits under the G.I. Bill for veterans and other eligible persons.
- Upon graduation, CIE offers free preparation to pass the Certified Electronics Technician Exams.

**YES!** I want to get started.  
 Send me my CIE school catalog including details about the Associate Degree Program. (For your convenience, CIE will have a representative contact you - there is no obligation.)

AE34

Name: \_\_\_\_\_

Address: \_\_\_\_\_

City: \_\_\_\_\_ State: \_\_\_\_\_

Zip: \_\_\_\_\_ Age: \_\_\_\_\_

Phone No. ( \_\_\_\_\_ ) \_\_\_\_\_

Check box for G.I. Bulletin Benefits

Veteran  Active Duty

**CIE**

**CLEVELAND INSTITUTE OF ELECTRONICS**

1776 East 17th Street  
 Cleveland, Ohio 44114  
 (216) 781-9400



A school of thousands.  
 A class of one.  
 Since 1934.

# ASK R-E

Write to Ask R-E, Radio-Electronics, 500-B Bi-County Blvd., Farmingdale, NY 11735

## AUDIO LIGHT

I'd like to build a device that will turn on a light if the decibel sound level of a band exceeds a preset level at a distance of 75 to 100 feet. I'd like the device to be adjustable between 60 and 120 decibels, and when the sound hits the preset level a light will come on and stay on until the sound drops again. Do you have something that can help me?—C. Jones, Broken Arrow, OK

Every time I go to a wedding or other large family affair I think about building something like that. It seems that I always wind up sitting right in front of the band's speakers.

Seriously though, this isn't a difficult thing to design but you can get yourself terribly confused by thinking about things like the distance in feet or the sound level in decibels. What you're really talking about is building yourself an amp to drive a simple VU meter that can be scaled for really high sound levels. Calibrating it to detect a particular sound level at a particular distance should be just a matter of tweaking a potentiometer.

The easiest way to put together a circuit like this is to build it around one of National Semiconductor's LM3915's. That chip will take an analog signal, do all the voltage scaling for you, and give you ten logarithmic outputs that are just what you want for a VU meter. While it's a really simple chip to use, I would suggest very strongly that you get a data sheet for it before you start using it.

The circuit in Fig. 1 is a good beginning for the project you have in mind. It will take four mike inputs, amplify them, and use the outputs to drive an LM3915 set up as a VU meter. One of the nice things about the LM3915 is that simply switching one connection will give you either a bar or dot output. The schematic has the chip arranged for a dot output since you're interested in having a light trigger from only one of the outputs. When you build the circuit, you can hang up to four mikes around the room and use

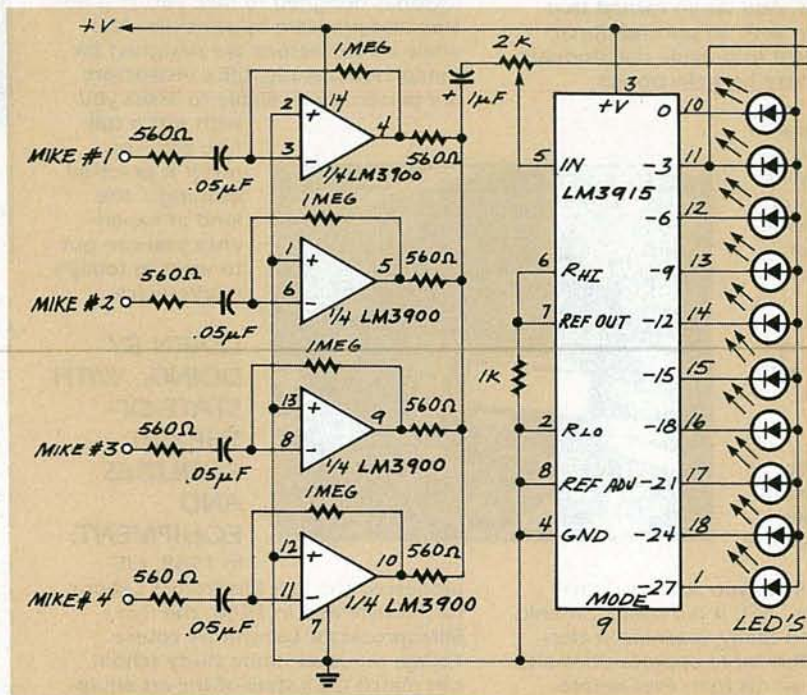

FIG. 1—TO TURN ON A LIGHT whenever the sound level in a room exceeds a preset level, you can use one of National Semiconductor's LM3915's (see text).

the potentiometer shown in the schematic to calibrate the LM3915 outputs any way you want.

Even though I've shown the LED's connected to the chip's outputs, you'll probably want to use one of the outputs to trigger the light you referred to in your letter. I have no idea how bright a light you want to use, but it's a safe bet that you won't be able to connect the bulb directly to any of the outputs of the LM3915. You just won't be able to get the drive current you need.

You can, however, use any of the

LM3915 outputs to drive a transistor as shown in Fig. 2, without having to disconnect the LED. Even a signal transistor such as a 2N2222 is chunky enough to light a bright 100-watt bulb as shown. If you want a larger bulb—something like an incandescent 100-watt bulb—use a power transistor's output to power a relay whose contacts can handle the current required by the bulb. A relay with contacts rated at two amps would certainly be more than adequate.

## COMMERCIAL LIMITER

I've reached my limit as far as television commercials are concerned since some of them are so loud I'm afraid they're going to destroy the speaker in my television set. I've been looking for a circuit that would detect a rise in volume and reduce the level going to the speaker. I found a circuit called the "Commercial Zapper" in an old issue of Radio Electronics (Feb., 1983), but it blanks out the audio and all I want

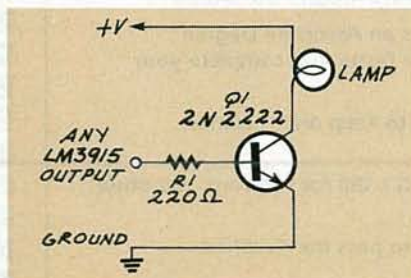

FIG. 2—TO DRIVE HEAVY current loads with an LM3915 output, you must add a transistor as shown here.

to do is reduce it. Do you have anything that will help solve my problem or at least point me in the right direction?—D. Alford Jr., Libuse, LA

I'm fully aware of the problem you're talking about. I don't know how it's possible for people to fall asleep in front of the TV any more since every time I try it, the commercials keep waking me up. Nothing is more annoying than just being on the verge of flaking out during some mindless pap on the tube and being jolted awake by some voice screaming out the virtues of four wheel drive, gourmet dog food or the dirt-eating power of an old detergent in a new box. Maybe we should all stick to public television, pledge drives and all.

The FCC sets strict limits on the audio level that can be sent over the publicly owned (that includes you and me) airwaves and, believe it or not, the people whose grand mission in life is to say as little as they can in as many words as possible always manage to stay within the FCC limits. I've read studies about this and even did some of my own spot measurements to verify it. I'm sorry to report that we can't get them for a violation of the FCC guidelines.

Most of the program audio on the tube has a dynamic range that goes from dead silence to the maximum allowed. The people responsible for the commercials you're complaining about keep the audio level up near the top most of the time and, as far as silence goes, hey, they're paying for thirty seconds and unfortunately they can do anything they want with that time—however obnoxious it might be.

The "Commercial Zapper" you saw in **Radio-Electronics** was designed to put VCR's in pause during commercials so you could automatically eliminate them while you were taping black-and-white movies. The theory behind it was that the colorburst reference signal would be absent during the movie and present only during the commercials. By detecting burst, you could tell when a commercial was coming on and output a signal that would put your VCR in pause.

Most broadcasters leave the burst signal active all the time now, even during black-and-white transmis-

sions, so the Commercial Zapper, while great back then, wouldn't do a lot for you now. And, since you want to reduce only the level of the sound, there are much better ways to get the job done.

Before we start talking about schematics and circuits, there's one big thing you should keep in mind. Modifying any of the stuff inside your TV, even just the audio circuits, can be an extremely dangerous undertaking. Owning a TV set is kind of like being married—it can give you a lot of pleasure if you sit back and enjoy it but you can be in for a lot of trouble if you open it up and fool around with the way it works. There are lots of hazardous components in a TV and they're operating at voltages that can kill you if you're not careful about what you're doing.

If you don't have a good deal of electronic experience under your belt, you should stop reading this right now and switch most of your viewing to public television. Be warned about the hazards involved.

In order to automatically cut the level of the audio from your TV when it reaches a preset level, you're going to have to modify the audio circuitry in the TV—or at least be able to identify it so you can add to it. You shouldn't do anything to your TV unless you have the paperwork and service manuals so you can locate and identify the circuitry that deals with the audio.

If you don't have or can't get the paperwork but are still determined to modify it, the safest places to get the audio are either at the volume control or the speaker. Unplug the TV from the wall and VERY CAREFULLY discharge the second anode and high-voltage capacitors to avoid a possible shock hazard. Modern TV's use very low leak components and they can hold a charge for a long time.

The circuit you're looking for is an audio limiter—one that will turn the volume down for you whenever the sound gets too loud. Since it's difficult to modify the TV's existing audio circuitry, the best way to do it is to run the audio through a small add-on board. There are lots of limiter circuits but I've been using the limiter circuit shown in Fig. 3 for several years in several applications.

All the current that is drawn by the  
*continued on page 82*

# Safety, Security, Convenience, Entertainment and Energy Management

## Home Automation from Heath, the catalog that has it all...

Enter the world of Home Automation. Remote lighting and appliance controls. Security alarms and lighting. Automated thermostats. Video monitoring systems. Whole-house security systems. They're all yours in the Heath Home Automation Catalog. To receive your FREE copy, call today toll-free.

**1-800-44-HEATH**  
(1-800-444-3284)

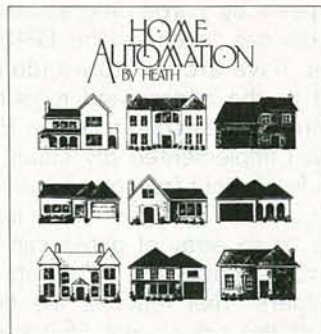

## Heath Company

Marketing Dept. 020-130  
Benton Harbor, MI 49022

CL-807R1

CIRCLE 86 ON FREE INFORMATION CARD

# LETTERS

Write to Letters, Radio-Electronics, 500-B Bi-County Blvd., Farmingdale, NY 11735

## DIGITAL SINEWAVE GENERATOR

I enjoyed the article "Digital Sinewave Synthesizer" by Steven D. Swift (**Radio-Electronics**, October 1991). About three years ago, I designed an almost identical circuit for work. I needed a precisely controlled sinewave generator that produced six specific frequencies. Based on my experience, I have some comments for the more advanced and creative hobbyists who are building this project.

I have not looked at the contents of the author's EPROM, but Fig. 2-c on page 44 led me to believe that his sine-lookup table contains the zero-crossing values of 80 H at 0° and 180° on the waveform. Harmonic distortion can be slightly reduced if the table is offset slightly from these values (by adding 0.5 degrees to the calculation, for example). I can prove this mathematically, but the reasoning might be clearer if you think of the zero crossings as crossover notch distortion. The rate of change of amplitude of the sinewave should be maximum at the zero crossings. It should not dwell there. The theoretical limit of the THD is 0.7% (for 256 steps in an 8-bit EPROM) if this suggestion is followed.

The author's circuit shows a discrete implementation that should work perfectly. Large programmable logic devices, such as the EP1800 series, have architectures ideally suited to the adders and registers that form the heart of the circuit. That is how I implemented my circuit. If only a few output frequencies are required, a second programmable logic device or an array of gates can be used to generate the "A" inputs to the adders. That reduces the flexibility of the circuit, but also eliminates the hassle of looking up binary codes.

If dual outputs are required, two circuits that are clocked by the same clock generator can be constructed. Those outputs can be locked together in phase, or varied in phase if

an offset generator is placed between the "S" outputs and the second sine-lookup table EPROM. That then makes possible 26 discrete phases.

The author's circuit has no adjustment for amplitude or phase. Those can easily be added in one more op-amp stage. When I constructed my circuit, I had to back off from 8 bits of resolution at higher frequencies. That caused no problems because higher frequencies were nearer the corner frequency of the low-pass filter, and, therefore, harmonics caused by larger steps were attenuated anyway.  
BRUCE CARTER  
Port Orange, FL

## AUDIO SWEEP/MARKER GENERATOR UPDATE

Anyone building my "Audio Sweep/Marker Generator" (**Radio-Electronics**, February and March 1991) might encounter a problem that we cannot explain. It concerns IC11, an 8-input NAND gate. Two sources of information on the pinout arrangement show that there is no internal connection to pin 1. In the PC layout, pin 1 is connected to pin 2 to make the foil pattern layout a little simpler. That arrangement worked well with my prototype. However, I am indebted to Mr. Gordon La Grange of Baytown, TX, for pointing out that he had to snip off pin 1 before he could get a proper output from the NAND gate. That output is not shown properly in Fig. 13-e on page 59 in the March issue. The correct output is properly described in the paragraph almost directly below Fig. 13-k. If you invert the pulses in Fig. 13-e and make them no wider than a single line width, you'll have a correct picture.  
JOHN WANNAMAKER

## TRUE TESLA COIL?

In the article entitled "Solid-State Tesla Coil" (**Radio-Electronics**, September 1991), the circuit is described as an end-fed Tesla coil.

I would like to point out that, in

actuality, this is not a true Tesla coil that Tesla dealt with separately tunable circuits (the primary and the secondary). While it is true that Tesla did use an end-fed resonator in his Colorado Springs "Magnifying Transmitter," actual RF-coupled coil was used the signal generator.

The basic idea for an end-fed resonator was devised by a French inventor named Dr. Paul Oudin, who based his work on the experiments of another Frenchman, D'Arsonval. D'Arsonval's work centered around what is known as the D'Arsonval Solenoid. Its purpose was to create, via an inductive/capacitive tank circuit, the periodic RF currents to treat various bodily dysfunctions. Oudin reasoned that high voltages could be produced if one were to attach a second coil D'Arsonval's tank circuit.

If one examines Tesla's patents related to his work in early radio, it becomes quite evident that the true definition of the Tesla coil must include separate circuits.

I would also like to comment on the size of the secondary coil in the project. In the case of Tesla's Magnifying Transmitter, the extra (or free-resonant) coil's inductance was actually very low in comparison to the secondary winding that was driving it. The main problem is one of adjusting the frequencies so that the resonant coil runs in the current-fed mode rather than becoming a simple extension of the driving primary. In the case of the **Radio-Electronics** project that would imply that the external secondary winding could behave simply as additional windings of the high frequency ferrite transformer, T2.

If any readers wish further clarification on this, I would suggest the manuscript entitled "Tesla Coils—An Power Processing Tutorial for Engineers," by Kenneth & James Corum, Ph.D's. It's available from Corum Associates, 8551 State Route 5; Windsor, OH 44099.  
BRENT C. TURNER  
Villa Park, CA

## TUBE AMPLIFIERS REVISITED

At this late date, I would like to add my two cents' worth to the ongoing discussion on tube audio amplifiers. I must first admit that I like tube amplifiers and have built several of them myself.

I believe that correctly designed tube and solid-state amplifiers probably do sound the same, as long as you don't drive either one into clipping. However, to never drive an amplifier into clipping at any point in its circuit requires that sufficient voltage and current be available from each stage, so as to always meet the demands made by the next device. In most tube audio amps, everything up to the final stage is run in Class A1, where the tube is a pure transconductance device, whereas a transistor requires current.

Another advantage to tube amps is the fact that they operate at low currents and high voltages. It is much easier to make such a supply smoother and "stiffer." Modern high-end amplifiers and home-built ones made by knowledgeable "audio amateurs" use very large values of filter capacitance in their power supplies to provide a high level of reserve input voltage.

Finally, tube amps are simpler and use fewer active devices. The classic Dynaco uses one voltage-amplifier tube and one phase-inverter triode—both in one envelope as a 7199—to drive its output tubes; the notorious Carver Silver Seven uses essentially the same basic circuit. A solid-state amplifier comparable to the Dynaco, using only discrete parts, would use two dozen transistors.

So, while I must admit that there are some great solid-state amplifiers, I am going to stick with the tube ones. The tubes are still available, the transformers can be found, and the electrical power to run the heaters doesn't cost much. The added benefit to my home-built tube gear is that I had a lot of fun building it and spent very little money.

CHRIS L. DONALDSON  
Blue Springs, MO

## COMPUTER CLASHES CONTINUED

I really do think that Mr. Cheng's comments in the April "Letters" column went a bit far—and so did Mr.

Holtzman's reply. The entire exchange brings to mind the old tale about the blind man and the elephant; it really is tough to discern the big picture through all the fog. As one who has programmed extensively for 80X86 PC's, Amigas, and other computers, I have more comments than I can fit in a reasonably sized letter. A few will have to do.

First, on standardization: As Mr. Holtzman pointed out, the desirable part about standardization is that it facilitates communication. There are two flip sides. One is that many software (as well as hardware) suppliers don't want communication. Suppliers of programs for CAD and music scoring are especially notorious—they want you locked in tight. The second is that standards are often ages out of date—witness the NTSC television standard—to the point of stifling innovation.

The niche machines are a paradox. They owe their existence to the fact that in one important sense they are *more* standardized than PC's. No two PC's are alike, even in such fundamentals as memory organization, video graphics layout, and interrupt organization. As we all know, that causes no end of problems. Within the CPU itself, the instruction set is an unstandardized chaos, having on the order of a thousand individual quirks. Even the largest, best-capitalized organizations have been able to cope with that, so that compiled code tends to be a wretchedly sub-optimal joke. The lessons of the old mainframes have yet to be learned.

The upshot is that things that aren't done often enough to support multi-billion-dollar software companies are often best done on niche machines, especially if speed, large memory, or a GUI is desired, or interrupts are needed. Sure, a Lotus or a Microsoft can handle the problems caused by dozens of graphics drivers, dozens of extended memory drivers, more than 500 printer drivers, dozens of slightly different serial and parallel ports, hundreds of quirky BIOS variants, and hundreds or maybe thousands of hard-disk variants. The person who writes a specialized program for filter analysis and sells a few hundred copies probably can't make it multi-compatible, except by resorting to lowest-common-denominator user

## Earn Your B.S. Degree in ELECTRONICS or COMPUTERS



## By Studying at Home

Grantham College of Engineering now in our 41st year, is highly experienced in "distance education" teaching by correspondence—through printed materials, computer materials, fax, and phone.

No commuting to class. Study your own pace, while continuing your present job. Learn from easy-to-understand but complete and thorough lesson materials, with additional help from our instructors.

Our Computer B.S. Degree Program includes courses in BASIC, PASCAL and C languages—as well as Assembly Language, MS DOS, CAD, Robotics, and much more.

Our Electronics B.S. Degree Program includes courses in Solid-State Circuit Analysis and Design, Control Systems, Analog/Digital Communications, Microwave Engr, and much more.

An important part of being prepared to *move up* is holding the right college degree, and the absolutely necessary part is knowing your field. Grantham can help you both ways to learn more and to earn your degree in the process.

Write or phone for our free catalog. Toll free, 1-800-955-2527, see mailing address below.

Accredited by  
the Accrediting Commission of the  
National Home Study Council

**GRANTHAM**  
**College of Engineering**  
Grantham College Road  
Slidell, LA 70460

# Electronics Paperback Books

GREAT PAPERBACKS AT SPECIAL PRICES

**BP248—TEST EQUIPMENT CONSTRUCTION** ..... \$5.95. Details construction of simple, inexpensive, but extremely useful test equipment. AF Gen, Test Bench Ampl, Audio Millivoltmeter, Transistor Tester and six more.



**BP267—HOW TO USE OSCILLOSCOPES AND OTHER TEST EQUIPMENT** ..... \$6.95. Mastering the oscilloscope is not really too difficult. This book explains all the standard controls and functions. Other equipment is also described.

**BP265—MORE ADVANCED USES OF THE MULTIMETER** ..... \$5.95. Use these techniques to test and analyze the performance of a variety of components. Also see how to build add-ons to extend multi-meter capabilities.

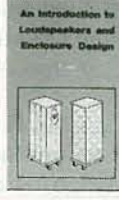

**BP256—INTRO LOUDSPEAKERS AND ENCLOSURE DESIGN** ..... \$5.95. explore the variety enclosure and speaker designs in use today the reader can understand the principles involved.

**BP263—A CONCISE INTRO TO dBASE** ..... \$6.95. The dBASE series of programs are probably the best known database programs for micro-computers. This book is designed to help you get started working with them.



**BP260—CONCISE INTRO TO OS/2** ..... \$5.95. If you are a multitasking PC user and want to get the most out of your computer, then you must learn its OS/2 operating system. This book shows you just how to do that, quickly and easily.



**BP249—MORE ADVANCED TEST EQUIPMENT CONSTRUCTION** ..... \$6.95. Eleven more test equipment construction projects. They include a digital voltmeter, capacitance meter, current tracer and more.



Digital Audio Projects



**BP245—DIGITAL AUDIO PROJECTS** ..... \$5.95. Practical circuits to build and experiment with. Includes A/D converter, input amplifier, digital delay line, compander, echo effect and more.

**BP247—MORE ADVANCED MIDI PROJECTS** ..... \$5.95. Circuits included are a MIDI indicator, THRU box, merge unit, code generator, pedal, programmer, channelizer, and analyzer.



**BP257—INTRO TO AMATEUR RADIO** ..... \$6.95. Amateur is a unique and fascinating hobby. This book gives the newcomer a comprehensive and easy to understand guide to the subject.



**PCP102—INTRODUCING DIGITAL AUDIO** ..... \$9.95. Covers all kinds of digital coding methods CD, DAT and Sampling. Bridges the gap between the technician and the enthusiast. Principles and methods are explained.

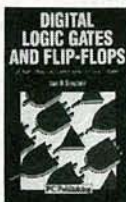

**PCP107—DIGITAL LOGIC GATES AND FLIP FLOPS** ..... \$10.00. Thorough treatment of gates and flip-flops for enthusiasts, student and technicians. Only a basic knowledge of electronics is needed.

**BP251—COMPUTER HOBBYISTS HANDBOOK** ..... \$8.95. A wrapup of everything the computer hobbyist needs to know in one easy to use volume. Provides a range of useful reference material in a single source.

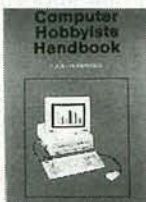

**PCP108—COMPUTERS AND MUSIC** ..... \$9.95. Explains the basics of computers and music with no previous knowledge of computers needed. Covers types of music software and explains how to set up your own computer music studio.

**BP195—INTRODUCTION TO SATELLITE TV** ..... \$9.95. A definitive introduction to the subject written for the professional engineer, electronics enthusiast, or others who want to know more before they buy. 8 x 10 in.

**BP190—ADVANCED ELECTRONIC SECURITY PROJECTS** ..... \$5.95. Includes a passive infra-red detector, a fiber-optic loop alarm, computer-based alarms and an unusual form of ultrasonic intruder detector.

**BP235—POWER SELECTOR GUIDE** ..... \$10.00. Complete guide to semiconductor power devices. More than 1000 power handling devices are included. They are tabulated in alpha-numeric sequence, by technical specs. Includes power diodes, Thyristors, Triacs, Power Transistors and FET's.

**BP234—TRANSISTOR SELECTOR GUIDE** ..... \$10.00. Companion volume to BP235. Book covers more than 1400 JEDEC, JIS, and brand-specific devices. Also contains listing by case type, and electronic parameters. Includes Darlingtons transistors, high-voltage devices, high-current devices, high power devices.

**BP99—MINI-MATRIX BOARD PROJECTS** ..... \$5.50. Here are 20 useful circuits that can be built on a mini-matrix board that is just 24 holes by ten copper-foil strips.

**BP117—PRACTICAL ELECTRONIC BUILDING BLOCKS—Book 1** ..... \$5.75. Oscillators, Timers, Noise Generators, Rectifiers, Comparators, Triggers and more.

**BP184—INTRO TO 68000 ASSEMBLY LANGUAGE** ..... \$6.95. The 68000 is a great new breed of microprocessor. Programming in assembly language increases the running speed of your programs. Here's what you need to know.

**BP179—ELECTRONIC CIRCUITS FOR THE COMPUTER CONTROL OF ROBOTS** ..... \$7.50. Data and circuits for interfacing the computer to the robot's motors and sensors.

**BP239—GETTING THE MOST FROM YOUR MULTIMETER** ..... \$5.95. Covers basics of analog and digital meters. Methods of component testing includes transistors, thyristors, resistors, capacitors and other active and passive devices.

**BP97—IC PROJECTS FOR BEGINNERS** ..... \$5.50. Power supplies, radio & audio circuits, oscillators, timers, switches, and more. If you can use a soldering iron you can build these devices.

**BP37—50 PROJECTS USING RELAYS, SCR'S & TRIACS** ..... \$5.50. Build variety indicators, light modulators, warning devices, light dimmers and more.

**RADIO—100 RADIO HOOKUPS** ..... \$3.00. Reprint of 1924 booklet presents radio circuits of the era including regenerative, neutrodyne, reflex & more.

**BP42—SIMPLE LED CIRCUITS** ..... \$5.50. A large selection of simple applications for this simple electronic component.

**BP127—HOW TO DESIGN ELECTRONIC PROJECTS** ..... \$5.75. Helps the reader to put projects together from standard circuit blocks with a minimum of trial & error.

**BP122—AUDIO AMPLIFIER CONSTRUCTION** ..... \$5.75. Construction details preamps and power amplifiers up through a 100-watt DC-coupled FED amplifier.

**BP92—CRYSTAL SET CONSTRUCTION** ..... \$5.50. Everything you need to know about building crystal radio receivers.

**BP45—PROJECTS IN OPTOELECTRONICS** ..... \$5.50. Includes infra-red detectors, transmitters, modulated light transmission and photographic applications.

**BP185—ELECTRONIC SYNTHESIZER CONSTRUCTION** ..... \$5. Use this book to learn how to build reasonably low cost yet worthwhile monophonic synthesizers. Learn a lot about electronic music synthesis in process.

## CHECK OFF THE BOOKS YOU WANT

**ELECTRONIC TECHNOLOGY TODAY INC.**  
P.O. Box 240, Massapequa Park, NY 11762-0240

SHIPPING CHARGES IN USA AND CANADA

**SORRY** No orders accepted outside of USA & Canada

Number of books ordered

Name \_\_\_\_\_  
Address \_\_\_\_\_  
City \_\_\_\_\_ State \_\_\_\_\_ Zip \_\_\_\_\_

\$0.01 to \$5.00 ..... \$1.50  
\$5.01 to \$10.00 ..... \$2.50  
\$10.01 to 20.00 ..... \$3.50  
\$20.01 to 30.00 ..... \$4.50  
\$30.01 to 40.00 ..... \$5.50  
\$40.01 to 50.00 ..... \$6.50  
\$50.01 and above ..... \$8.00

Total price of merchandise ..... \$ \_\_\_\_\_  
Sales Tax (New York State Residents only) ..... \$ \_\_\_\_\_  
Shipping (see chart) ..... \$ \_\_\_\_\_

All payments must be in U.S. funds

Total Enclosed .. \$ \_\_\_\_\_

R-192



interfaces and sticking by a 640K memory model. Even then, it's never really certain that the program that runs on my PC will run on the PC next door—and getting it to print properly on the system next door is well nigh out of the question.

So, what will become of those 60 million PC's, plus the Macs, Amigas, Ataris, and so on? It's sad, but humanity has been down this road before, and we find that horse carts, though they were once as abundant proportionally, simply aren't permitted on the freeway. Those computers aren't going to make it either, though some, notably the DOS PC, may well hang on for a long while as windows in some POSIX-OS/2-Windows-DOS-Sparc-Mac-PC-Amiga-machine of the future. (After all, if it were worth the trouble, it wouldn't be all that hard to *simulate* an Apple or Commodore 64 of seven years ago on a 486 PC, high-end Mac, or high-end Amiga—*faster than real time!*)

And that raises what should be the hottest issue of all, something far more important than ranting and rav-

ing over doomed PC's versus doomed Macs versus doomed Amigas. The issue is our own data, which we must somehow get out of that DOS window and onto that machine of the future—to say nothing of moving it from one application to another or to a supercomputer. We have allowed much of our data, entered laboriously and at tremendous expense, to become embodied in files that are formatted in obtuse, secret, and unstandardized ways.

It is high time that the software manufacturers who practice this are forced to change. They are in effect thieves who have stolen from us what is rightfully our property. It is time to insist that all software that we buy have the capability to disgorge our data in full, including such things as the coordinates of graphical objects, in an open, published-data-interchange format. As a symbolic discouragement to theft and extortion by software manufacturers, and to allow third parties to assist in retrieving the stolen property without fear of litigation, it is time to amend the

copyright law to explicitly permit reverse engineering in any program that stores output but won't provide it in an open format, irrespective of any and all language to the contrary in the licensing "agreement."

We have been down this road before. Compiler suppliers once swore that royalty-free function libraries would end the world. Much the same was said of ANSI-standard C, and of spreadsheet DIF files, and so on. Oddly enough, the world is still here. So to any manufacturer who feels this proposal is unreasonable, I say this: Maybe your problem is that you are making money by holding your customers up for ransom, rather than by providing a good product. If so, the sooner you are out of business, the better—preferably on terms that are as punitive as possible to you, your investors, and your bankers. You are not indispensable, regardless of who you think you are or how big you are. There are hungry hordes waiting in the wings to replace you.

PAUL SCHICK  
Madison, WI

R-E

## LEARN to CLEAN/ MAINTAIN/ REPAIR CAMCORDERS



EARN \$85  
AN HOUR!

### HUGE EXPANDING MARKET!

Work from your home - part-time or full-time!  
No prior experience needed - Average mechanical ability only requirement for your success! Over 15 million camcorders in use - Over 5 million expected to be sold in 1991 alone!

It is a fact that the vast majority of camcorder malfunctions (just like VCRs!) are due to simple mechanical failure... We can show you how to easily fix those breakdowns and earn an average of \$85.00/Hr. while working at home!

**Get In Now** - Soon camcorders will be like VCRs, i.e., one in almost every home.

For a camcorder cleaning job you can earn \$65.00 for less than 30 minutes work.

For a camcorder repair job you can earn over \$100.00.

**FREE INFORMATION PACKAGE** call or write:  
Toll-Free 1-800-537-0589  
Viejo Publications, Inc.  
5329 Fountain Ave., Dept. REC  
Los Angeles, CA 90029

CIRCLE 188 ON FREE INFORMATION CARD

## Discover the Pattern for Success.

Work Smarter for Less  
with a B+K PRECISION  
Video Generator.

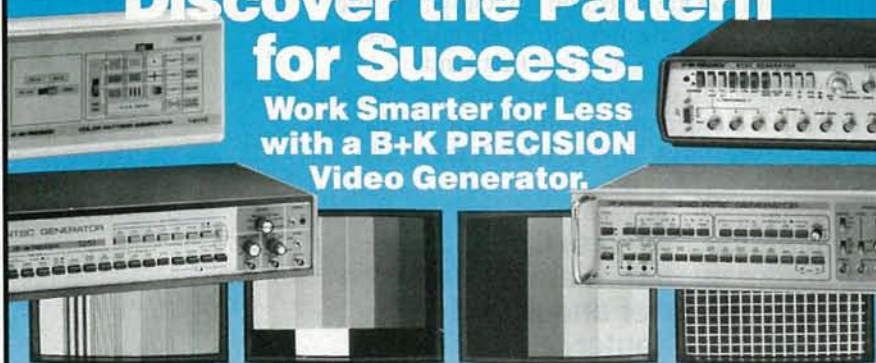

### Portable IC Color Pattern Generator

- Battery operated, compact portable unit
- 13 patterns including gated rainbow
- CH 3/CH 4 output crystal controlled
- Composite video output to 1 Vp-p
- Progressive scan

Model 1211C \$229

### NTSC Signal Generator

- NTSC color bars, with or without IWQ
- Linear staircase with high or low chroma
- Multiburst
- External video, external audio
- Interlaced scan

Model 1251 \$1,195

### NTSC Generator with RGB

- NTSC color bar pattern
- 1 Vp-p or variable composite video output
- RGB outputs on BNC or 9-pin D-type subminiature connector
- Composite sync, vertical sync, and horizontal sync outputs
- Interlaced or progressive scan

Model 1249A \$558

### Deluxe NTSC Video Signal Generator

- High accuracy NTSC color bars
- TCXO master oscillator
- RGB, Gen Lock, Circle, and Black Burst
- Multiburst to 8 MHz, 100%/50% level
- Interlaced or progressive scan

Model 1260 \$1,995

Start working smarter! For details on the complete line of B+K PRECISION video generators or for immediate delivery, contact your local distributor or:



Domestic and International Sales  
6470 W. Cortland St., Chicago, IL 60635  
312-889-1448 • FAX: 312-794-9740

For information only

circle 187 on free information card

For sales assistance

circle 188 on free information card

# No other training to troubleshoot computer

Only NRI walks you through the step-by-step assembly of a powerful 386sx computer system you train with and keep—giving you the hands-on experience you need to work with, troubleshoot, and service today's most widely used computer systems. Only NRI gives you everything you need to start a money-making career, even a business of your own, in computer service.

No doubt about it: The best way to learn to service computers is to actually build a state-of-the-art computer from the keyboard on up. Only NRI, the leader in career-building at-home electronics training for more than 75 years, gives you that kind of practical, real-world computer servicing experience.

Indeed, no other training—in school, on the job, *anywhere*—shows you how to troubleshoot and service computers like NRI.

**Get inside the West Coast 386sx computer system... and experience all the power and speed of today's computer technology!**

With NRI's exclusive hands-on training, you actually build and keep the powerful new West Coast 386sx/20 MHz mini tower computer system.

You start by assembling and testing your computer's 101-key "intelligent" keyboard, move on to test the circuitry of the main logic board, install the power supply and 1.2 meg high-density floppy disk drive, then interface your high-resolution monitor.

What's more, you now go on to install and test a powerful 40 meg IDE hard disk drive—today's most-wanted computer peripheral—included in your course to

**NEW!**  
386sx/20 MHz  
Mini Tower  
Computer!

#### DIAGNOSTIC HARDWARE AND SOFTWARE

R.A.C.E.R. plug-in diagnostic card and QuickTech menu-driven software, both from Ultra-X, give you hands-on experience with today's professional diagnostic tools

#### DISCOVERY LAB

Complete breadboarding lets you design and modify circuits, diagnose and repair

#### LESSONS

Clear, illustrated text build your understanding of computers step

#### MONITOR

High-resolution, nonglare, 14" TTL monochrome monitor with tilt and swivel base

#### DIGITAL LOGIC PROBE

Simplifies analyzing digital circuit operation

#### DIGITAL MULTIMETER

Professional test instrument for quick and easy measurements

#### SOFTWARE

Train with MS-DOS, GW-BASIC, and popular Microsoft Works applications software

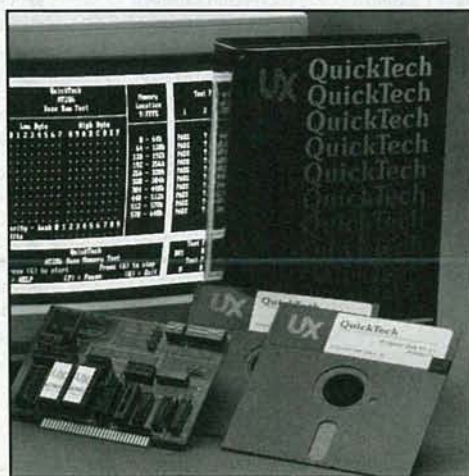

dramatically increase your computer's data storage capacity while giving you lightning-quick data access. But that's not all!

**Professional diagnostic hardware and software makes troubleshooting fast and accurate**

Your NRI training now includes a remarkable diagnostic package that allows you to quickly locate and correct defects in IBM XT, AT 80286/80386, and

# shows you how and service like NRI!

**NEW! 40 MEG HARD  
K DRIVE!**  
Install this 40 meg IDE  
1 disk drive internally, for  
greater data storage capacity  
and faster data access speed

**NEW! 386sx/20 MHz  
MINI TOWER COMPUTER!**  
Features 32-bit 80386sx CPU, 1  
meg RAM, 64K ROM, 1.2 meg  
high-density floppy disk drive

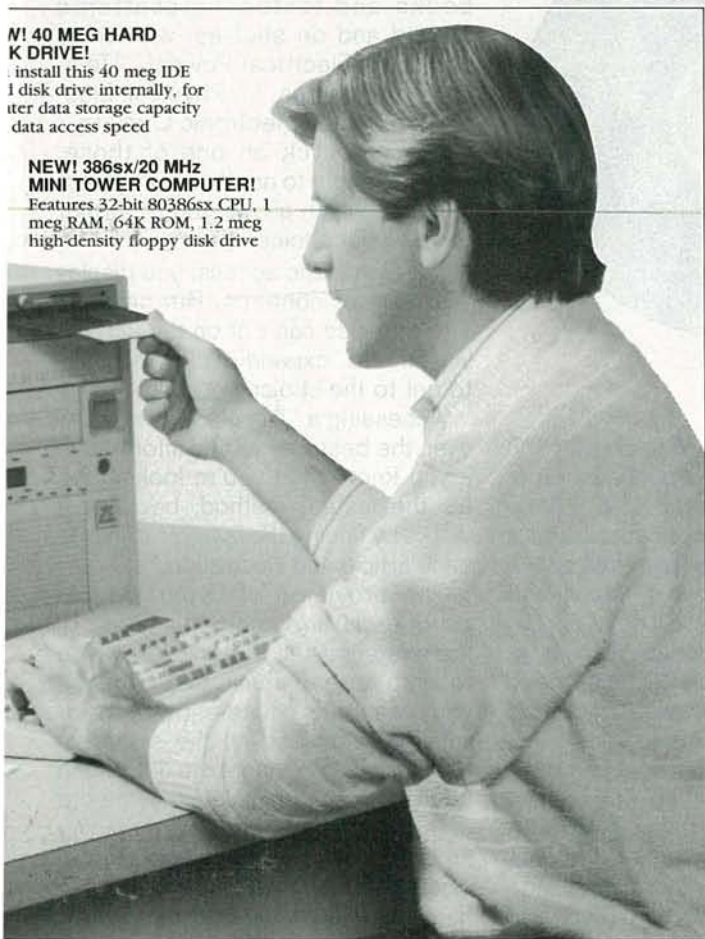

NRI gives you the confidence and the know-how  
step into a full-time, money-making career as an  
industry technician, even start a computer service  
business of your own!

**No experience necessary...  
NRI builds it in**

With NRI, you learn at your own pace in your own  
home. No classroom pressures, no night school, no  
need to quit your present job until you're ready to  
make your move. And all throughout your training  
you have the full support of your personal NRI  
instructor and the NRI technical staff, always ready  
to answer your questions and give you help whenever  
you need it.

**FREE catalog tells more. Send today!**

Send today for NRI's big, free catalog that describes  
every aspect of NRI's innovative computer training  
as well as hands-on training in TV/video/audio  
servicing, telecommunications, industrial electro-  
nics, and other high-growth, high-tech career fields.

If the coupon is missing, write to NRI School  
Electronics, McGraw-Hill Continuing Education  
Center, 4401 Connecticut Avenue, NW, Washing-  
ton, DC 20008.

IBM is a registered trademark of International Business Machines Corp.  
QuickTech and R.A.C.E.R. are registered trademarks of Ultra-X, Inc.  
West Coast is a member of the Syntax Group.

compatible computers.

You'll use your Ultra-X  
QuickTech diagnostic software  
to test the system RAM and  
such peripheral adapters as  
parallel printer ports, serial  
communications ports, video  
adapters, and floppy and hard  
disk drives. You'll go on to use  
your R.A.C.E.R. diagnostic card,  
also from Ultra-X, to identify  
individual defective RAM chips,  
locate interfacing problems, and  
pinpoint defective support chips.

This ingenious diagnostic  
package is just one more way

**NRI** School of  
Electronics

McGraw-Hill Continuing Education Center  
4401 Connecticut Avenue, NW  
Washington, DC 20008



For career courses approved  
under GI Bill  
 check for details

Check one FREE catalog only

- MICROCOMPUTER SERVICING
- TV/Video/Audio Servicing
- Industrial Electronics & Robotics
- Telecommunications
- Basic Electronics

- Computer Programming
- Security Electronics
- Electronic Music Technology
- Desktop Publishing
- PC Software Engineering Using C

Name \_\_\_\_\_ (Please print) \_\_\_\_\_ Age \_\_\_\_\_

Address \_\_\_\_\_

City/State/Zip \_\_\_\_\_ Accredited Member, National Home Study Council 307

# EQUIPMENT REPORTS

## McGraw-Hill CD-ROM Science and Technical Reference Set

Everything you ever  
wanted to know  
... on a disc.



CIRCLE 10 ON FREE INFORMATION CARD

What would you say if we told you that you could have easy access to all of the McGraw-Hill *Concise Encyclopedia of Science and Technology* and the McGraw-Hill *Dictionary of Scientific and Technical Terms* without having to give up any room on your already crowded bookshelf of reference and data books? Thanks to the CD-ROM format, all of that fits on a disc that looks just like a standard audio CD.

The *Concise Encyclopedia*, which contains some 7700 articles and 1700 photos and line drawings, is a condensed version of McGraw-Hill's 20-volume encyclopedia. It has been one of our favorite desk references for the past several years because of its broad coverage of more than 75 major science and engineering disciplines. Unfortunately, the book is a bit unwieldy—it has more than 2000 pages, is 3½ inches thick, and weighs several pounds. The *Dictionary of Scientific and Technical Terms* is another impressive reference, with 117,000 terms and definitions.

Unlike a book, you need the right computer equipment to read a CD-ROM. First, of course, you need a CD-ROM drive with the Microsoft CD-ROM extensions that allow DOS to access it. (The extensions are supplied when you purchase a drive.) You

also need an IBM AT or better PC with 1 megabyte of expanded memory compatible with the LIM (Lotus-Intel-Microsoft) specification, and a minimum of 1 megabyte of free space on your hard disk drive. If you want to view the graphics, you'll need a VGA graphics card and monitor. If you want to output text to a printer, you'll need a LaserJet or compatible. A mouse is supported, but not required.

As long as you have enough space on your hard disk, you'll run into little problem installing the software. A setup program on the CD-ROM copies files onto your hard disk, and modifies your CONFIG.SYS and AUTOEXEC.BAT files.

### Using the database

Once the installation is finished, you're ready to jump into the database. The retrieval software, Discover, is your interface to the reference set. There are several ways to get to the information you want: graphic access, alphabetical access, link-phrases/terms, and complete text search.

Graphic access is the way to go if you don't know the precise term or phrase you want to find information on. A color graphic, "Mirror of the Cosmos" appears on the screen, reflecting the major disciplines of the

encyclopedia. You could click on "Engineering," for example, and then presented with another graphic—this time it's a laboratory bench with not books and textbooks scattered around and on shelves, with titles such as "Electrical Power," "Telecommunications," "Physical Electronics," and "Electronic Circuits." When you click on one of those you're brought to another, non-graphic menu, which allows you to further narrow your choice.

For alphabetic access, you display the table of contents. But since 7700 articles can't fit on the screen you have to "expand" it alphabetically to get to the choice you want.

Accessing a "link phrase" is, however, the best way to find information if you know what you're looking for. It's the fastest method, because it works by finding the *hypertext* links each article and illustration.

The provision of hypertext capabilities is an important feature of the reference set. The links allow you to jump from one article to another you pass terms of interest. Any major links are indicated on the screen color. You can navigate the data in the reference via the "links" that tie the data together. So if you were reading an article on electronic listening devices, you might see links to "Amplifiers" or "Radio Transmitter."

It is also possible to do a wide search on the entire database, but that inefficient searching takes a awful long time.

We found the database to be relatively easy to use, although we would have preferred to have an on-disc tutorial. After all, there's certainly enough room on the disc for a megabyte tutorial.

We think that the McGraw-Hill CD-ROM Science and Technical Reference Set is a very strong product. Before you buy, however, consider that the paper versions are available for a total of just over \$200. The CD-ROM, which has much lower production costs, sells for \$495. **R**



**CABLE TV CONVERTERS AND DE-SCRAMBLERS** SB-3 \$79.00 TRI-BI \$95.00 MLD-\$79.00 M35B \$69.00 DRZ-DIC \$149.00. Special combos available. We ship COD. Quantity discounts. Call for pricing on other products. Dealers wanted. FREE CATALOG. We stand behind our products where others fail. One year warranty. **ACE PRODUCTS**. P.O. Box 582, Saco, ME 04072 1 (800) 234-0726.

CIRCLE 75 ON FREE INFORMATION CARD



**APPLIANCE REPAIR HANDBOOKS**—13 volumes by service experts; easy-to-understand diagrams, illustrations. For major appliances (air conditioners, refrigerators, washers, dryers, microwaves, etc.), elec. housewares, personal-care appliances. Basics of solid state, setting up shop, test instruments. **\$2.65 to \$5.90 each**. Free brochure. **APPLIANCE SERVICE**, PO Box 789, Lombard, IL 60148. 1-(312) 932-9550.

CIRCLE 84 ON FREE INFORMATION CARD



**THE MODEL WTT-20 IS ONLY THE SIZE OF A DIME**, yet transmits both sides of a telephone conversation to any FM radio with crystal clarity. Telephone line powered - never needs a battery! Up to 1/4 mile range. Adjustable from 70-130 MHz. Complete kit **\$29.95 + \$1.50 S+H**. Free Shipping on 2 or more! COD add \$4. Call or send VISA, MC, MO. **DECO INDUSTRIES**, Box 607, Bedford Hills, NY 10507. (914) 232-3878.

CIRCLE 127 ON FREE INFORMATION CARD



**COMPUTER CRACKING, INFORMATION TRACKING**, cutting edge audio/video surveillance, electronic trailing, night vision, surveillance photography, intelligence kits, cellular, pager, fax interception, recorders, scrambling and sources. ALL NEW—BOOK II HOW TO GET ANYTHING ON ANYBODY—Lee Lapin. "Really scary stuff"—Charles Jaco, CNN. **\$38.50**. ISECO, 2228 El Camino, No. 349-R, San Mateo, CA 94103.

CIRCLE 194 ON FREE INFORMATION CARD



**FUNCTION GENERATORS WITH INTELLIGENT 100MHz FREQUENCY COUNTER**. Sine, square, triangle, ramp, DC & Sync. TTL outputs. Seven frequency ranges: 2Hz to 6MHz (FG-506), 2Hz to 13MHz (FG-513). Intelligent 100MHz frequency counter with period mode. Continuous, trigger, gate, clock, sweep and external frequency modes. Lin/Log sweep. Adjustable duty cycle/symmetry. Voltage controlled frequency functions. TCXO with 1ppm/yr. aging rate (optional). FG-506 **\$695.00**; FG-513 **\$1295.00**. Call: 800-664-9838. **AMERICAN RELIANCE INC.**, 9952 E. Baldwin Pl., El Monte, CA 91731.

CIRCLE 176 ON FREE INFORMATION CARD

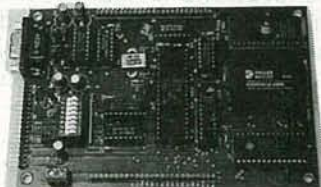

**CREATE INTELLIGENT PROJECTS WITH THE VERSATILE Z8 PROGRAMMABLE MICROCOMPUTER**. This powerful computer was designed for flexibility and can be used for various electronic projects. I/O Intensive. Up to 20MHz operation. Download programs or run EPROM code. Special hardware features included. Prices from **\$125.00**. Battery-backed RAM, X-assembler, and other options available. CALL FOR FREE BROCHURE. **MJS DESIGNS, INC.**, 1438 W. Broadway Rd., Suite B185. Tempe, AZ 85282. (602) 966-8618.

CIRCLE 179 ON FREE INFORMATION CARD

## CALL NOW AND RESERVE YOUR SPACE

- 6 x rate \$940.00 per each insertion.
- Fast reader service cycle.
- Short lead time for the placement of ads.
- We typeset and layout the ad at no additional charge.

Call **516-293-3000** to reserve space. Ask for Arline Fishman. Limited number of pages available. Mail materials to: mini-ADS, RADIO-ELECTRONICS, 500-B Bi-County Blvd., Farmingdale, NY 11735.

FAX: 516-293-3315

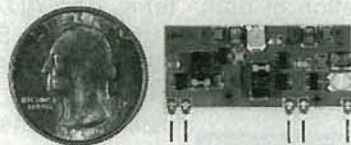

**5 MINUTE ASSEMBLY! MONEYBACK GUARANTEE!** Attach the VT-75 chip to any 3V-12V battery and you have the most powerful miniature transmitter you can buy *anywhere*. Tiny Law Enforcement grade device allows you to hear every sound—even footsteps—over 1 mile away on any FM radio or wideband scanner. 80-130MHz. 100mW output! VT-75 microtransmitter complete **\$49.95 + \$1.50 S & H**. Visa, MC, MO. COD's add \$4.00. **DECO INDUSTRIES**, Box 607, Bedford Hills, NY 10507. 1-800-759-5553.

CIRCLE 127 ON FREE INFORMATION CARD



**FREE CATALOG! ELECTRONIC TOOLS & TEST EQUIPMENT**—Jensen's new Maste Catalog, available free, presents major brand name electronics tools, tool kits, and test instruments, plus unique, hard-to-find products for assembly and repair and custom field service kits available only from Jensen. All full! described and illustrated. Enjoy free technical support and rapid, post-paid delivery any where in the Continental USA. **JENSEN TOOLS, INC.**, 7815 S. 46th St., Phoenix, AZ: 85044. Phone: 602-968-6231; FA: 1-800-366-9662.

CIRCLE 115 ON FREE INFORMATION CARD

# NEW PRODUCTS

Use the Free Information Card for more details on these products.

## MULTIFUNCTION COUNTER.

Especially well-suited for the communications industry, *B&K Precision's 1856 multifunction counter* can be used to make highly accurate and repeatable measurements of radio transmitter frequency right up to the microwave range. It exceeds the requirements for adjusting transmitter frequency to FCC standards, as required for radio stations or land mobile, radio telephone receivers. Because the 1856 extends to 1.3 GHz, it even covers cellular channels.

The counter has a 5-Hz to 1.3-GHz bandwidth and a TCXO (temperature-compensated crystal oscillator) timebase with 0.5-ppm stability at  $23 \pm 5^\circ\text{C}$  and 1-ppm stability from 0 to  $50^\circ\text{C}$ . The model 1856's functions include frequency, period, period average, and totalize. The period-measurement function, used for very low-frequency measurements, makes



CIRCLE 16 ON FREE INFORMATION CARD

it easy to measure tone-encoding functions used in many types of communications systems. In the totalize mode, useful in counting the number of operations performed by production machines or in quality-control tests, pulses from 5 Hz to 10 MHz are counted up to 99,999,999. Reset and hold can be performed using a switch, or using a remote start/stop input.

The compact model 1856 measures  $2.5 \times 9.4 \times 7.5$  inches and weighs 3.3 pounds. Its large, high-intensity, 8-digit

LED readout provides kHz/ $\mu\text{s}$ , MHz/ms, gate, and overflow indicators. A detachable power cord, a schematic, parts list, spare fuses, and an instruction manual are included. Optional accessories include an antenna for conveniently checking transmitter frequency and a 10:1/direct probe.

The model 1856 multifunction counter has a suggested list price of \$495.—**B&K Precision**, 6470 West Cortland Street, Chicago, IL 60635; Phone: 312-889-1448.

sor, which produces a force exactly opposite to that caused under acceleration. The sensor therefore remains at rest at all times and the nonlinear mechanical properties of the silicon structure can be effectively ignored. Signal-conditioning circuitry provides excitation signals for the sensor, then amplifies and linearizes the analog output signal to 0.25 to 4.7 volts.

The ADXL-50 accelerometer costs \$23.00 (100's) and \$5.00 in automotive OEM quantities.

**Analog Devices**, Literature Center, 70 Shawmut Road, Canton, MA 02020

**DMM ACCESSORIES.** A new line of modular test accessories from *Fieldpiece* is designed to solve such on-site servicing problems as not having the right tool lead for the job, alligator clips that pop off of test points, and too-short probe tips. The solution is simple but innovative: All the accessories connectors, including the connections between the probe tip and the probe handle, are standard banana plugs or jack. A female banana jack, built into the "handle" of the deluxe test lead, fits a sleeve male banana plug. The line includes a variety of probe tips, alligator clips with pig tails, and a current clamp head, all of which plug on the end of the deluxe test lead. One test lead end can be plugged into another to double the length of the test lead; with the addition of an alligator clip, it's possible to build an 8-foot

## ACCELERATION SENSOR.

According to *Analog Devices*, their *ADXL-50* is the industry's first surface-micromachined acceleration sensor (accelerometer) and the only one to offer complete signal-conditioning and self-test circuitry on-chip. Designed primarily for automotive applications such as collision detection, active suspension, and anti-skid braking systems, the device measures acceleration in a single plane of sensitivity over the  $\pm 50\text{-g}$  range to an accuracy of 5%. Self-test cir-

cuitry is activated by a digital command and guarantees operation of both the sensor and associated signal conditioning to stated specifications. That

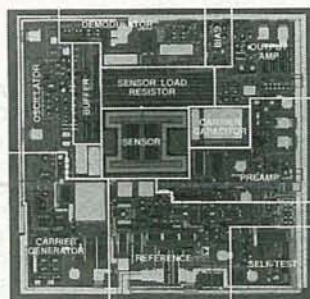

CIRCLE 17 ON FREE INFORMATION CARD

is a vital feature in applications such as air-bag systems. The ADXL-50 measures only  $500\mu\text{m} \times 625\mu\text{m}$ , much smaller than other types of micro-machined sensors. Unlike other accelerometers that monitor the resistance change of stressed piezoresistors to detect acceleration, the ADXL-50 measures the changes in capacitance, and is therefore insensitive to temperature changes.

The sensor operates in a force/balance mode. Voltage is applied to the sen-



**CIRCLE 18 ON FREE INFORMATION CARD**

ground lead that is unlikely to come apart. The accessory kit, model *ADK10* includes a pair (red and black) of each of the following: 42-inch test leads, small and large alligator clips, and short (1/2-inch) and long (3-inch) probe tips, packed in a plastic box.

The box has room for the model *ACH current clamp head*, which can be used with Fieldpiece "Stick"-style DMM's as well as any multimeter with 1mVDC resolution (most meters).

The small-head clamp fits into tight spaces and measures current up to 300 amps. Also available is the *ALC1 leather case*, which holds a DMM and accessories. It has a belt loop on the back and leather loops on the front hold two extra probe tips or the *ACH current clamp head*. The leather case can accommodate a "Stick," Fluke 70 Series (without the boot), or Beckman 220/150 Series (without the tilt stand) multimeter. It is available with the accessories and current clamp head as model *ALCK8*.

The *ADK10* accessory kit, *ACH current clamp head*, *ALC1 leather case*, and *ALC8 leather case* with accessories and current clamp head cost \$26.95, \$24.95, \$24.95, and \$59.95, respectively.—**Fieldpiece Instru-**

**ments, Inc.**, 8322B Artesia Blvd., Buena Park, CA 90621; Phone: 714-992-1239; Fax: 714-992-1239.

**UV-LIGHT-BLOCKING EPROM LABEL.** When used on EPROM packages, a UV-opaque write-on label



**CIRCLE 19 ON FREE INFORMATION CARD**

from *DATAK (Cat# EP-1)* gives added assurance that the burned program will not be accidentally erased by stray light from fluorescent lamps or other ultra-violet sources. The label consists of a white polyurethane layer for writing, a black opaque-vinyl layer, and a layer of pressure-sensitive adhesive. The flexible film construction conforms to EPROM packages having raised windows. The label can be removed without leaving an adhesive residue on the EPROM package. Sized to fit on top of a 24-pin wide DIP, the 1.1x0.46-inch label will accommodate three lines of standard type. It can be written on with a typewriter, ball-point pen, soft pencil, or any platen feed computer printer.

Cat# EP-1, containing

## Train at HOME to be an Electronics Technician!

As the demand for computers and microprocessors in business, manufacturing and communications continues to grow, so does the need for qualified technicians. It's not unusual for experienced technicians to earn from \$30,000 to more than \$40,000 a year.\* Now through Peoples College of Independent Studies you can train for this exciting field without interrupting your job or home life.

### Choose From Five Programs of Study

- Electronics & Microprocessor Technology
- Industrial Electronics & Microprocessor Technology
- Communications Electronics with Microprocessor Technology
- Computer Servicing & Electronics Technology
- Specialized Associate Degree In Electronics Technology

### Professional Equipment Is Included

Depending on the program you select, you'll perfect your skills using this advanced equipment, included in the price of tuition:

- IBM-Compatible Personal Computer
- Digital Multimeter
- Digital Logic Probe
- Elenco Oscilloscope
- Portable Cellular Telephone

(\* Source: U.S. Bureau of Labor Statistics)



### Exclusive Extras That Enhance Your Training

Peoples College introduces some training firsts to make your learning experience more complete:

- Accelerated Learning System — a scientifically proven study system that helps you learn faster and easier than ever before.
- Video Tutor Training Tapes — give you a permanent, visual record of informative lectures and close-up demonstrations.
- Experience Labs — professionally designed experiments that give you hands-on "bench" experience.
- Industry Certification Training Guide — provided with four of our programs. Prepares you for examinations you may take for your professional license or certification.

### Easy Payment Plans — No Finance Charges

To help you get started on your education, Peoples College has reduced tuition rates and offers low monthly payment plans with no finance fees. So don't delay, call or write for more information today!

For COLOR CATALOG Mail Coupon or Call TOLL FREE 1-800-765-7247

Programs offered only in United States, Canada, Puerto Rico and Virgin Islands. No Obligation. No sales person will call.

Our programs are accredited by the Accrediting Commission of the National Home Study Council

YES! I would like to know more about your training programs. Send a catalog to:

Name \_\_\_\_\_

Address \_\_\_\_\_

City \_\_\_\_\_

State \_\_\_\_\_ Zip \_\_\_\_\_

Phone # \_\_\_\_\_

**PEOPLES COLLEGE**  
OF INDEPENDENT STUDIES

233 Academy Drive • P.O. Box 421768  
Kissimmee, FL 34742-1768

Member, D.L. Peoples Group RO192

CIRCLE 190 ON FREE INFORMATION CARD

147 UV-opaque EPROM labels on three sheets, costs \$4.00.—**DATAK Corporation**, 55 Freeport Blvd., #23, Sparks, NV 89431; Phone: 702-359-7474; Fax: 702-359-7494.



CIRCLE 20 ON FREE INFORMATION CARD

**SERIAL LINE MONITOR/PROTOCOL ANALYZER SOFTWARE.**

**DataScope Version 2.0** transforms a PC into a passive or active RS-232 data and signal-line monitor that can eliminate guesswork while dealing with serial transmissions. The upgraded version of **Paladin Software's** program is still capable of collecting 8 megabytes of data and signal information with microsecond time-stamp resolution, but has been enhanced with tiled concurrent window displays and a pull-down menu interface. Up to four unique

and simultaneous displays can be active at the same time, providing passive, interactive, and historic monitoring in any user-selected combination. Display tiles can be combined to create larger windows, and one of four presentation filters (mixed, alternating, COM1, or COM2) can be applied to every window. DataScope can operate at all possible rates up to 115,200 baud, while matching user-specified trigger strings against incoming

data. It offers full archive-parameter control combined with pre-, center-, and post-trigger positioning. Character translation sets can be replaced or altered by the user to modify the translation strings and/or attributes for each source separately. Version 2.0 runs on all IBM-PC-compatible machines with MS-DOS 2.1 or above, 256K of available RAM, and at least one serial port.

DataScope Version 2.0, with connector shells, cables, and a comprehensive manual, costs \$249.—**Paladin Software, Inc.**, 3945 Kenosha Avenue, San Diego, CA 92117; Phone: 619-490-0368.

**CEBUS-NETWORK DEVELOPMENT PRODUCTS.**

An integrated circuit, a modem subsystem, and an evaluation system from

**Intellon Corporation** enable manufacturers and application developers implement carrier sense multiple access (CSMA) networks over standard AC electrical wiring. The products are based on Intellon's patented "Spread Spectrum Carrier" technology, which is being considered by the Electronics Industries Association as the power-line signalling standard for its Consumer Electronics Bus (CEBus). The CEBus power line standard offers more than 100 times the speed of traditional power line signalling methods most widely used today and will enable communication and control among electrical devices, sensors, and control systems in homes and commercial buildings.

The *Spread Spectrum Power Line Mode*

**PUSH BUTTON TECHNOLOGY**

**AT PRICES THAT WON'T PUSH YOU OVER THE EDGE**

- Environmentally Engineered Formulations
- Chemicals For All Your Repair/Production Needs
- Quality Products Since 1965

Call Today For More Information  
Manufacturers Reps Wanted

WE DARE YOU TO COMPARE!

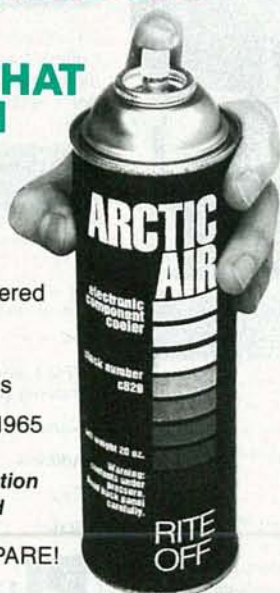

**RITE OFF**  
1545 5TH INDUSTRIAL COURT  
BAY SHORE, NEW YORK 11706  
(800) 645-5853  
IN NY (516) 665-6868

Yesterday's Values, Tomorrow's Technology

CIRCLE 195 ON FREE INFORMATION CARD

**CABLE - TV**

**TUNABLE NOTCH FILTERS**

- FOR ELIMINATION OF SEVERE INTERFERENCE
- FOR "CENSORING" OF ADULT BROADCASTS

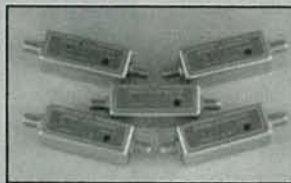

- 45 dB AT CENTER FREQUENCY
- 5 dB AT 2 MHZ FROM CENTER
- 2 dB INSERTION LOSS

MODEL	TUNES TO CHANNEL	PRICE	SHIPPING
23H	2 or 3 (or 6 meter ham)	\$30	NO
46FM	4, 5, or 6 (or any FM station)	\$30	SHIPPING
713	7, 8, 9, 10, 11, 12, or 13	\$30	OR
1417	14(A), 15(B), 16(C), or 17 (D)	\$30	C.O.D.
1822	18(E), 19(F), 20(G), 21(H), or 22(I)	\$30	CHARGES

**3 for \$75 - 10 for \$200 - Mix or Match**  
30 DAY MONEY BACK GUARANTEE (3 FILTER LIMIT)

**FAST DELIVERY**  
CALL TOLL FREE FOR C.O.D. OR SEND CHECK TO ORDER

**STAR CIRCUITS**

P.O. BOX 94917  
LAS VEGAS, NV 89193  
**1-800-535-7827**



(SSPM), built around the SSPM IC, is said by Intel to be the first integrated circuit to implement the EIA's proposed CEBus power line physical layer standard. The 28-pin chip operates at the CEBus standard rate of 10,000 "1" bits per second. It generates and receives all the required signalling information, handles the CEBus physical layer protocol, and assists the higher-layer protocols. The modem board, which can be attached to a power supply and a host microprocessor that supports CEBus protocols, helps speed application development by freeing engineers from developing and testing the power line network hardware.

The evaluation system allows developers to evaluate CEBus and Spread

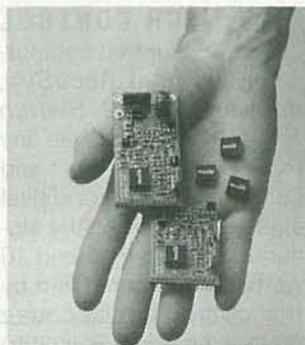

CIRCLE 21 ON FREE INFORMATION CARD

Spectrum Carrier technology and to implement a demonstration CEBus CSMA network that communicates over AC power wiring, which can be used to model and analyze network characteristics by creating and running various traffic-loading scenarios. The system includes software that runs on any IBM or compatible PC and three complete CEBus network nodes. It

features an electronic mail system to demonstrate the network and its capabilities.

The evaluation system costs \$3,495; the SSPM chip and the modem board (pictured) cost less than \$5 plus a one-time, \$2500 license fee in OEM quantities and \$105 in quantities of ten, respectively.—**Intellon Corporation**, 5150 West Highway 40, Ocala, FL 32675; Phone: 914-237-7416; Fax: 914-237-7616.

**BEZEL SELECTION.** Designed for use in the electronics industry as a frame for LCD displays, *Ill's Bezel*

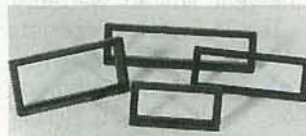

CIRCLE 22 ON FREE INFORMATION CARD

*Beautiful* comes in four popular sizes that fit most LCD small-character displays. Available in colors (red, yellow, and blue) as well as black and white, Bezel Beautiful is molded in UL-listed, machinable, engineering-grade plastic. Molded with a slightly concave, outward curve from mounting edge to mounting edge, the bezel automatically adjusts itself to the product to which it has been bonded for the life of the unit. It can be attached using the heat-seal method, sheet-metal screws, or a glue gun. The bezels come in four sizes, with measurements in inches for the viewing area of 1 x 2.5, 0.7 x 1.8, 0.7 x 2.5, and 0.7 x 3.5.

NO COMPLICATED ELECTRONICS, NO EXPENSIVE INSTRUMENTS:

## Home study course shows you how to make good money in VCR repair.

An amazing fact: you can do more than four out of five VCR repairs with ordinary tools and basic fix-it procedures. Our home study program shows you how.

Learn all of the systems, mechanisms, and parts of almost all brands of VCRs. With *no* expensive instruments. *No* fancy workshop. The step-by-step texts and close personal attention from your instructor make learning easy.

Texts, course materials, and tool kit are sent to your home. Graduate ready to make up to \$50.00 or more per hour in your own spare-time or full-time business.

**Send today for your free career booklet. Or call 800-223-4542**



Name \_\_\_\_\_  
 Address \_\_\_\_\_  
 City \_\_\_\_\_ State \_\_\_\_\_ Zip \_\_\_\_\_

**The School of VCR Repair**

2245 Perimeter Park, Dept. VA342, Atlanta, Georgia 30341

**CHRISTMAS SALE!**

Save on cable rental fees!  
**CABLE TV  
 DESCRAMBLERS  
 WE'LL BEAT  
 ANY PRICE**

**JERROLD—TOCOM—ZENITH  
 HAMLIN—OAK—PIONEER  
 SCIENTIFIC ATLANTA**

- 24 HOUR SHIPMENTS!
- MONEY BACK GUARANTEE!
- QUANTITY DISCOUNTS!

MASTER CARD / AMEX / VISA / C.O.D.



Have make and model number of equipment used in you area ready.

**CALL TOLL-FREE  
 1-800-284-8432**

**CABLE WAREHOUSE**  
 10117 West Oakland Park Blvd.,  
 Suite 515, Sunrise, FL 33351  
 NO FLORIDA SALES

CIRCLE 186 ON FREE INFORMATION CARD

Bezel Beautiful is priced at less than a dollar each in OEM quantities.—**International Instrumentation Incorporated (I<sup>2</sup>I)**, Box 3751, Thousand Oaks, CA 91359; Phone: 805-495-7673.

**TRI-FIELD METER.** The *Tri-Field Meter* from *AlphaLab* independently reads AC electric fields, AC magnetic fields, and radio/microwaves with multi-directional sensors that read field strengths in all directions simultaneously. It reads all three types of fields numerically and with a safe/borderline/high scale, weighted proportionally to the fields' effect on the body. Thresholds are based on epidemiological and laboratory studies. Although no absolute hazard thresholds have been established, re-



CIRCLE 23 ON FREE INFORMATION CARD

duction of relative exposure is advised. The meter comes with batteries, instructions, and a one-year limited warranty. The Tri-Field Meter costs \$100 postpaid.—**AlphaLab**, 1272 East Alameda Ave., Salt Lake City, UT 84102; Phone: 503-621-9701.

**32-SWITCH CONTROL CARD.** An eight-bit computer board from *AccuSys*, dubbed the *32 Switch Reed Relay Card* gives any PC the ability to select and control 32 analog or digital signals with ease. Any signal up to 100 volts and 10 watts can be controlled by the computer. Because there is no address limit to the number of boards that can co-reside in a single PC, one computer can control the connection of hundreds of signals by plugging in as many switch cards as there are available slots. The *32 Switch*

*Card's* ability to route multiple analog signals through a single interface eliminates the need for redundant modems. When combined with higher capacity external relays, the card is capable of more applications. For instance, when combined with an application that senses energies, it can switch off water heaters and household appliances when they are needed and automatically close ventilation systems or call the police or fire department when sensing fire or break-in.

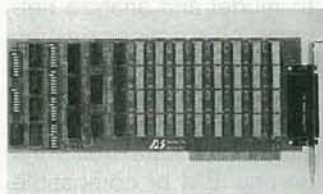

CIRCLE 24 ON FREE INFORMATION CARD

The *32 Switch Reed Relay Card*, including software interface examples with source code in Assembler, BASIC, C, Fortran, Cobol, and dBAS costs \$395.—**AccuSys Inc.**, 3695 Kings Road, Reno, NV 89503; Phone: 702-746-1111. **F**

## The World's Most Popular Probe



Model SP100  
100 MHz Switchable 1x-10x ... **\$45**



Free probe guide shows economical replacements for Tektronix, H-P, Philips and all others

**More SP100 Probes Have Been Sold Worldwide Than Any Other Probe Ever Made**

- **Universal**  
For Tektronix, Hewlett Packard, Philips, Leader, B&K, Kikusui, Hitachi, Beckman and other oscilloscopes
- **Economical**  
Substantial savings compared to OEM probes
- **10 day return policy**  
Guaranteed performance and quality

**TEST  
PROBES, INC.**



9178 Brown Deer Road, San Diego, CA 92121  
Toll Free 1-800-368-5719

CIRCLE 123 ON FREE INFORMATION CARD

Try the

**Radio  
Electronics®**

bulletin board  
system

(RE-BBS)  
516-293-2283

The more you use it the more useful it becomes.

We support 1200 and 2400 baud operation.

Parameters: 8N1 (8 data bits, no parity, 1 stop bit) or 7E1 (7 data bits, even parity, 1 stop bit).

Add yourself to our user files to increase your access.

Communicate with other R-E readers.

Leave your comments on R-E with the SYSOP.

RE-BBS  
516-293-2283

# GET THE LATEST ADVANCES IN ELECTRONICS

WITH A SUBSCRIPTION TO

# Radio Electronics®



ENJOY THE WORLD OF ELECTRONICS EACH MONTH!

Now you can subscribe to the best electronics magazine. The only one that brings you articles on—electronics projects, technology, circuit design, communications, new products and much more.

Radio-Electronics looks to the future and shows you what new video, audio and computer products are on the horizon. What's more you'll find helpful, monthly departments such as Video News, Equipment Reports, Hardware Hacker, Audio Update, Drawing Board, Communications Corner. All designed to give you instruction, tips, and fun.

## Radio-Electronics gives you exciting articles like:

- ISDN: The Telephone Network of Tomorrow
- The Facts on FAX
- A Digital Phone Lock
- How To Design Switching Circuits
- EIA-232 A real standard for serial interfacing?
- Build a synergy card for your PC
- '386 Power at a '286 price
- Build a biofeedback monitor
- More on Multiplexing



FOR FASTER SERVICE CALL TODAY  
1-800-999-7139

# DON'T DELAY SUBSCRIBE TODAY!

Just fill out the order card in this magazine and mail it in today.

# NEW LIT

Use The Free Information Card for fast response.

## HOW TO SERVICE YOUR OWN TUBE AMP; by Tom Mitchell. Media Concepts, P.O. Box 1408, Norwalk, CT 90651-1408; 213-594-4717; \$69.95.

This "how-to" course is a complete multi-media package that consists of a 247-page guidebook and a 68-minute videotape, stored in a plastic binder. Designed to save musicians money, the program instructs guitarists on the care, service, and modification of their tube-based guitar amplifiers. The author claims that, by following the instructions in the course, users can diagnose and repair more than 95% of all tube amplifier breakdowns and problems.



CIRCLE 28 ON FREE INFORMATION CARD

In a nontechnical, informal, and entertaining style, the program introduces guitarists to electronics, explaining how to recognize components, exploring basic amplifier circuits, describing tools and test equipment, and providing in-depth coverage of tubes, transformers, speakers, and enclosures. It discusses how to read schematic diagrams, how to troubleshoot with voltage charts, biasing, and the correct ways to use an amplifier. Included are voltage charts for most common amplifiers, ten troubleshooting flowcharts, a maintenance checklist, and

useful reference information. Several do-it-yourself amplifier modifications are also described.

## HMC FULL LINE CATALOG; from Hub Material Company, 33 Springfield Avenue, Canton, MA 02021; Phone: 617-821-1870; Fax: 617-821-4133; free.

Containing a broad selection of products for electronics professionals and hobbyists, this 142-page catalog features a full index, a table of contents, and color-coded pages to help readers find specific items. The fully-illustrated guide to electronic tools, test equipment, and supplies for the manufacture, assembly, and repair of electronics contains a variety of brand-name, competitively priced products.



CIRCLE 25 ON FREE INFORMATION CARD

Included are test instruments (DMM's, oscilloscopes, and datacommunications test sets), tool kits and precision hand tools, soldering and desoldering systems and supplies (fluxes, solder, tips, wick, and sponges), lamps and magnifiers, and anti-static devices (bags, wrist straps, mats, runners, meters, and ionizers. Prod-

uct descriptions are accompanied by photographs and prices, as well as "Tech Tips" and comparison tables to make selection easier.

## HOLIDAY 1991 HOME AUTOMATION BY HEATH; from Heath Company, Dept. 350-058, Benton Harbor, MI 49022; Phone: 1-800-44-HEATH; free.

Consumer products designed for safety, security, convenience, entertainment, and energy management are featured in this 40-page, full-color catalog.



CIRCLE 26 ON FREE INFORMATION CARD

Aimed at do-it-yourselfers and electronics hobbyists, the catalog introduces several new products, including an electronic drape controller that allows drapes to be controlled by a handheld remote or be programmed to open or close at set times throughout the day, three air cleaners that electronically deep-clean the air, a gas detector that sounds a loud alarm in the event of a poisonous or explosive gas leak, and a wireless add-on light switch for installation in staircases or long hallways that need a light switch at each end. Also featured in the catalog are whole-house automation and se-

curity systems, motion sensing indoor and outdoor lighting controls, security cameras, wireless video broadcasters, an energy-saving thermostat. The catalog provides technical information on the products, and explains how the product works. Such topics as passive-infrared technology, X-10 technology, and how time is measured are also discussed.

## AUDIO FLYER; from Par Express, 340 East First Street, Dayton, OH 45402-125; Phone: 513-222-0173; Fax: 513-222-4644; free.

Audiophiles and electronics enthusiasts alike will appreciate the selection of goods offered in this 44-page, full-color catalog.



CIRCLE 27 ON FREE INFORMATION CARD

The catalog is filled with audio sound components and accessories; cables and wires; audio accessories; speaker enclosures, woofers, midranges, tweeters, and speaker systems; P.E. equipment; and crossovers. Highlights of this issue include decorative wall plates and accessories; in-wall installed audio systems; 12-gauge neon wire; in-wall speakers; seven woofers; and an isobutane soldering iron. F

# A Shocking Offer!

Now for the first time in CIE's 56 year history you do not have to be enrolled at CIE to receive our Electronics and Electricity Lesson Modules. Available for a limited time to non-students for the shockingly low introductory price of only \$99.50.

With CIE's patented AUTO-PROGRAMMED method of learning you'll quickly learn and then master the basics of electronics and electricity and then move on to ... soldering techniques, applications of Kirchhoff's law, voltage and power, printed circuit boards ... and much, much, more.

Your commitment to CIE ends with your payment, but CIE's commitment to your success just begins when you receive your lessons, exams, binder and equipment. This special price includes the benefits CIE normally extends to its students and graduates.

You'll receive CIE Bookstore privileges, a patented learning method, access to CIE's student, faculty and alumni electronic bulletin board and a free issue of CIE's school newspaper "The Electron". 24-Hour grading and unlimited access to CIE's faculty is available on an optional basis.

And best of all, when you decide to continue your electronics education in any of CIE's programs, you'll receive a \$100.00 CIE tuition credit certificate.

All this knowledge and support will put you on the road to understanding digital electronics, microprocessing principles, computer systems, telecommunications, and much, much, more.



All This For Only!

**\$99<sup>50</sup>**

**• A \$100.00 CIE TUITION CREDIT CERTIFICATE**

- Free Issue of "The Electron"
- Build your personal burglar alarm
- Theory and hands-on training lessons and exams covering "current and voltage" through "printed circuit boards"
- CIE Bookstore privileges
- Patent learning method
- Electronic Bulletin Board privileges

Yes, send me CIE's Introductory Electronic and Electricity Lessons and Equipment.

A7301

Name: \_\_\_\_\_

Street: \_\_\_\_\_ Apt. #: \_\_\_\_\_

City: \_\_\_\_\_

State: \_\_\_\_\_ Zip: \_\_\_\_\_

Age: \_\_\_\_\_ Phone (\_\_\_\_) \_\_\_\_\_

Total Merchandise: \_\_\_\_\_ \$99.50

Ohio Residents add 7% Sales Tax: \_\_\_\_\_

California Residents add 6 1/2% Sales Tax: \_\_\_\_\_

Total this order: \_\_\_\_\_

Shipping and Handling Charges: \_\_\_\_\_ \$5.00

Method of Payment: Amount Enclosed: \_\_\_\_\_ \$

Personal Check or Money Order

Master Card  Visa

Card Expiration Date: \_\_\_\_\_

Signature: \_\_\_\_\_



**BOOKSTORE**

1776 East 17th Street  
Cleveland, Ohio 44114



**CHARGE BY PHONE!**

9 AM to 4:30 PM Eastern Time;

1-800-321-2155 ext. 7301; In Ohio 1-800-523-9109 ext. 7301



## THE PARTS PLACE



**NEW! Now You're Talking!**  
This book will help you earn your first Amateur Radio license and get on the air. It includes all the questions on the new codeless Technician class exam and the Novice written exam. The book also provides helpful tips on equipment and antennas. Illustrated. Over 300 pages. #62-2414 . . . 16.95



**Special-Order Hotline.** Your local Radio Shack stocks over 1000 popular electronic components. Plus, we can special-order over 10,000 items from our main warehouse—ICs, semiconductors, tubes, crystals, even SAMS® manuals. No postage charges or minimum requirements for this service. Come in for details!

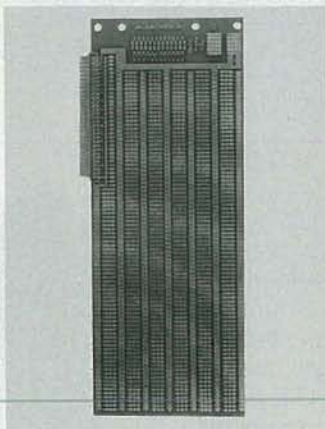

**NEW! PC/XT Experimenter's Circuit Card.** This premium-quality prototyping board fits a computer's XT expansion bus connector. Features durable epoxy glass construction and plated-through holes on standard 0.100" centers. Accepts D-sub connector shown at right. 37/8 x 10 1/16 x 1/16". #276-1598 . . . . . 29.95

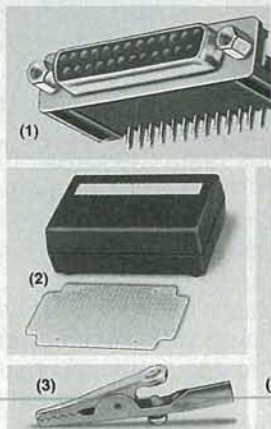

(1) **NEW! Right-Angle Sub 25 Female Connector.** Ideal for use with PC/XT circuit card at left. #276-1504, 29.95  
(2) **Box/Board Combinator.** Molded box and 2 x 3 1/8" circuit board. #270-291 . . . 4.95  
(3) **2" Slim Alligator Clip.** #270-346 . . . Pkg. of 8/.95  
(4) **Cordless Phone Hand Antenna.** #270-1411 . . . 2.95

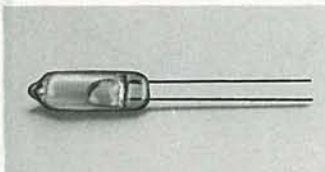

**Mercury Bulb Switch.** Just the thing for motion detectors, alarms, experiments and school science projects. Rated 2 amps at 12VDC. Compact T-1 1/2 size envelope. #275-040 . . . . . 1.29

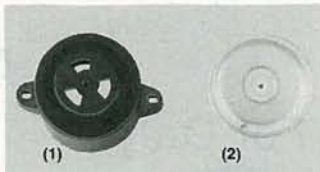

(1) **Two-Tone Piezo Buzzer.** Extra-loud. Operates from 8 to 16VDC. #273-070 . . . . . 10.95  
(2) **Electromechanical Buzzer.** Loud 12VDC buzzer in a sturdy metal case is great for alarms. #273-051 . . . . . 2.49



(1) **Stackable Banana Plugs.** Jack permits "chain" hook-ups. #274-734, Set of 2/1.59  
(2) **Nylon Binding Posts.** #274-662 . . . . . Set of 2/1.59  
(3) **Micro-Clip Jumpers.** 20" long. #278-017 . . . Pair/3.49

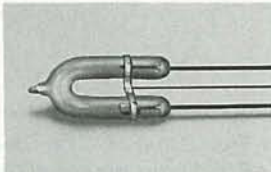

**Super-Bright Strobe Tube.** Perfect for photo replacement hobby projects and experiments. Trigger: 4 kV. And 200V min. Bulb is about 1" long and has 1 3/4" leads. #272-1145 . . . . . 3.95



(1) **High-Speed 12VDC Motor.** Up to 15,200 RPM! About 2" long. #273-255 . . . . . 2.99  
(2) **Low-Voltage Motor.** For science projects and solar power demos. Requires 1 1/2 to 3VDC. #273-223 . . . . . 99¢



(1) **Lead-Free Solder.** 96% tin, 4% silver. 0.032" size. 0.25 oz. #64-025 . . . . . 1.99  
(2) **Rosin Soldering Paste Flux.** 1 oz. #64-021 . . . 1.79  
Over 100 soldering items and tools for electronics are in stock now at Radio Shack!

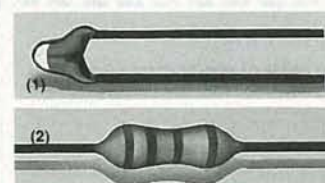

(1) **Hi-Precision Thermistor.** Resistance changes in proportion to temperature. #271-110 . . . . . 1.99  
(2) **500-Piece Resistor Set.** 1/4-watt, 5% tolerance. Includes 54 popular values. #271-312 . . . . . Set 7.95



**Car Electrical System Tester.** Spot problems before you're stranded! Plug this analyzer into your vehicle's light socket. Color-coded LEDs pinpoint problems in your battery, alternator and regulator. #22-1635 . . . . . 5.95

Since 1921 Radio Shack has been the place to obtain up-to-date electronic parts as well as quality tools, test equipment and accessories at low prices. Our nearly 7000 locations are ready to serve you—NOBODY COMPARES

**Radio Shack** SINCE 1921  
AMERICA'S TECHNOLOGY STORE

Prices apply at participating Radio Shack stores and dealers. Radio Shack is a division of Tandy Corporation

# CABLE TV'S INFAMOUS BULLET



**How American Cablevision's "bullet" zapped signal pirates.**

**KEN FOLEY**

ON WEDNESDAY, MARCH 13, 1991, American Cablevision of Queens fired their first infamous electronic "bullet." According to American Cablevision, they fired a direct hit. Within minutes their switchboard was overloaded with calls from subscribers whose television sets had gone black. American Cablevision was elated—the victims had unsuspectingly taken the bait.

The next morning, American Cablevision sent armies of technicians to service the homes of the complaining customers. They replaced the cable converter

boxes, and took the dead boxes back to the electronic coroner's laboratory, performing hundreds of autopsies. According to official American Cablevision records of the mass epidemic, the "Certificates of Death" were identical—illegal chip "zaps".

On Wednesday April 24, 1991, American Cablevision filed a civil suit in New York City federal court against three hundred and seventeen alleged cable pirates. That was the first time such a large number of cable crooks had been arraigned together. American Cablevision offered the de-

fendants a deal: Pay five hundred dollars within twenty days, or face prosecution and fines from one thousand, to one hundred and ten thousand dollars.

"I think this is something that everybody's going to have to start doing," said American Cablevision President Barry Rosenblum. American Cablevision has approximately three hundred and thirty thousand paid subscribers in Queens and Brooklyn, and estimates it forfeits hundreds of thousands of dollars each year to video marauders, and plans to fire more bullets. The electron-

bullet is the brainchild of Jerrold Communications of Hatboro, Pennsylvania. It was first fired in 1990, by Greater Media Cable of Philadelphia.

In three separate assaults, Greater Media Cable blasted away, netting three hundred and sixty eight illegal converters, which garnered a bounty close to twenty thousand dollars.

We spoke to Jim Bathold, spokesman for Jerrold Communications, to confirm American Cablevision's story that the electronic bullet is a signal fired from a cable company's headquarters directly into a customer's cable converter. If the box is legitimate, the customer never knows he was just zapped. But if black-market chips were installed in a basic converter to circumvent paying the monthly service charge, the bullet uses the chips' own programs to neutralize the decoder and halt the cable service immediately.

Mr. Bathold then elaborated "Yes, that is basically how the bullet works," he confirmed. "But it would not be in our best interest to elaborate, or explain the operational procedure in detail. Otherwise it tells subscribers, 'Here we come.' We have not put one word out there in writing of how it works—no press packages or news releases. We especially wouldn't go into detail with electronic hobbyists," he choked out laughing.

Hoping to fare better in Jerrold's engineering division, we were fortunate to reach an engineer that was also a reader of **Radio-Electronics**. His boss' boss, technical engineering supervisor, Stan Dori, said: One of the approaches pirates have been taking for years to defeat scrambling is to physically use a decoder box to unscramble the scrambling method. That is, to reverse engineer the legitimate descrambler's software.

The bullet came into being because one of Jerrold's customers (a cable company) told them of rumors that pirates were defeating Jerrold's scrambling technology. And the cable company wanted to aggressively pursue them. So Jerrold acquired a number of the pirate devices

through various methodologies, and reverse engineered them so that a counter measure could be developed. That counter measure was the bullet, an offensive signal that Jerrold can send down the data stream to neutralize what the pirates reverse engineered. That's the bullet—double-reverse engineering.

Dori continued, "So by understanding what the pirates are doing and not doing to defeat current technology, we're able to launch a counter-offensive signal, the bullet, to defeat them."

In the hopes of discouraging customers from buying illegitimate descramblers, information regarding the bullet is being leaked from the cable industry, which claims they are losing up to three billion annually from piracy.

According to Jodi Hooper of the National Cable Television Association, "People think cheating on cable services is like a school prank. They don't really think they are committing a crime and stealing. They just don't take it seriously." Hooper also indicated that some cable companies are offering complete amnesty to people who come forward before their systems are audited and the bullet is released. She says if the culprits wait until they are discovered, they will chance the possibility of criminal prosecution and heavy fines.

Richard Aurelio, president of Time Warner's New York City Cable Group, compares cable piracy to shoplifting. "Now that we have the technology, we're going to use it to rope them in." But it's a migraine for the cable industry. Most of the cable companies began scrambling their satellites in 1986, and are now concentrating on detecting people with decoders and illegal hookups.

The National Cable Television Association says about eight million homes nationwide are linked illegally to basic cable signals. And an additional three million homes illegally tap into pay services such as Cinemax and HBO.

But from 1975 through last year, the number of basic service subscribers nationwide grew from nine million to fifty-five million. The U.S. Telephone Association reports that the average

basic cable rate nationwide jumped sixty-eight percent between 1986 and 1989.

So even though the cable companies are reporting that losses from theft have tripled during the same period, cable industry revenue has jumped about seventy percent from over ten billion in 1986 to almost eighteen billion last year.

Such large revenues have caused some consumer groups to become skeptical of the cable companies' claims of being financially wounded by theft. "There is no justification for using speculative high-theft figures to justify outrageous rate increases," says Ken McEldowney, head of the San Francisco-based Consumer Action.

Another method the cable companies are using to detect rates, is the "closed circuit reflectometer," or time-domain reflectometer. The major drawback with the reflectometer is that it has to be physically attached to the cable entering each home to detect unauthorized connections or decoders. Other than this sleuthing is still done primarily by inspectors who spend thousands of days eyeballing exterior cables for tampering.

So naturally if the cable industry succeeds in scaring thousands into confessing, it will score a two-headed victory. Finally recovering millions in lost revenue having people sign up—was the case for Utah's Time Warner Cablevision in 1989 where they ran a blitz advertising campaign showing guilt-ridden signal rates imprisoned—and secured the bullet in reserve as a secret weapon and not necessarily hoping to pay the hefty zapper fees Jerrold Communications.

Now Time Warner, the second largest cable company with over six million subscribers in thirty-six states, is threatening to start firing bullets nationwide. Are they bluffing?

If they are not bluffing, they will undoubtedly catch more cable thieves who are foolish enough to run to their cable company to complain that their rented cable box is not working properly.



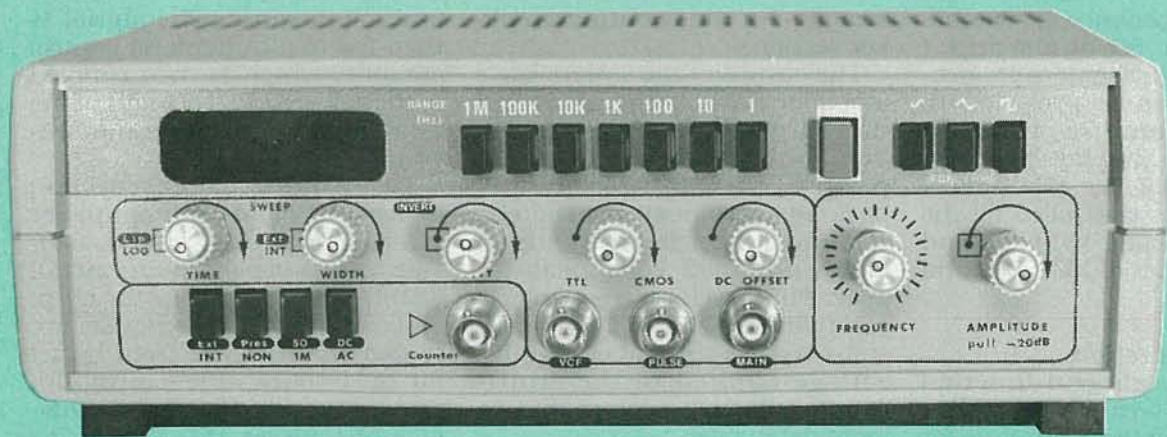

**Build this sweep/function generator and frequency counter and add to your bench-top instrument collection.**

**MICHAEL A. LASHANSKY**

IF YOU'RE AN ELECTRONIC PROFESSIONAL or advanced hobbyist, you know the value of a well-equipped workbench. An important piece of basic equipment is a function generator and frequency counter. Although few professionals are missing one from their bench, many hobbyists can't justify the expense of quality commercial units. If you're one of those who has put off buying such an instrument, we can show you how to build one that produces up to a 2.5-MHz square, triangle, or sine-wave output with a 1 to 20-volt peak-to-peak amplitude and a 20-dB attenuator. This instrument also has a TTL or CMOS 0.5- to 15-volt peak output as well as a sweep generator and frequency counter that can read up to 150 MHz. All of these features are combined in a single bench-top unit, for a price of \$300.

#### **Overview**

Our function generator and counter produces a square, triangle, or sine-wave output with a continuously variable amplitude of one volt to 20 volts peak-to-peak. A 20-dB attenuator allows smaller amplitude signals to be generated. A variable 0.5 to 15-volt peak TTL or CMOS pulse out-

put is also available. You can vary the DC-level content, duty cycle, or invert any of those signals.

The output frequency covers seven decades, ranging from 0.1 Hz up to 2.5 MHz. (A higher frequency limit can be attained by making some potentiometer adjustments, but at the expense of a degraded amplitude and waveform shape, which we will discuss in our next article.) Fine adjusting is achieved through a linear dial. A six-digit LED indicates the output frequency of the generator, or it can be used to display the frequencies of external signals.

Using the sweep generator, any of the output waveforms can be swept linearly or logarithmically by selecting the sweep width and/or speed with the front panel controls. You can also sweep the selected waveform under the control of an external voltage, which is useful for frequency modulation generation techniques.

The frequency-counter section can either give a readout of the frequency being generated or it can measure external signals. The counter's range is from DC to 150 MHz with an input sensitivity of 20 millivolts. Input signals can be DC or AC coupled and

**SWEEP/FUNCTION GENERATOR**

the input impedance is switchable between 50 ohms and 1 megohm. A prescale/non-prescale function is provided to make maximum use of the six-digit LED to display high-frequency counts. The gate time of the counter is controlled by the frequency decade switches and offers gate times of 10, 1, 0.1, and 0.01 seconds.

### Theory of operation

All low- to mid-end function generators—including this one—use a similar technique for generating a waveform. A basic triangle wave is first generated, then massaged into a sine wave and a square wave. The block diagram of Fig. 1 shows the basic workings of the main board. A frequency-controlled multivibrator drives two current switches, which alternately charge and discharge a capacitor through a resistor. The resulting triangle wave is fed either through a sine-shaper circuit, a square-wave amplifier, or

straight out to the output amplifier section.

The output of the square-wave amplifier controls the polarity of the charging voltage of the capacitor. The capacitor will charge to positive, then to negative and back again to positive, thereby creating a triangle wave with an amplitude of 2 volts peak-to-peak. The waveform frequency is controlled by the RC time constant and the amount of negative voltage applied to the multivibrator. We will explore that in more detail later.

The output of the square-wave amplifier is also used to drive a TTL gate and CMOS level-shifter gate combination, which allows both TTL- and CMOS-level pulse outputs.

The sweep-generator section is made up of a voltage controlled multivibrator with a long time constant. That produces a DC voltage that varies according to the voltage applied. The output can be routed to a logarithmic amplifier to create both linear

and log outputs. The signal then fed to a buffer/level control amplifier which is then coupled to the voltage-control input of the function generator's main multivibrator.

The frequency-counter section is made up of an input-amplifier signal-conditioning circuit, a cascade-by-100 prescaler, an Intersil 7216B frequency-counter chip, and a six-digit LED. Signals are routed through the front panel for measuring. Prescaling decreases the resolution of the display but allows 150 MHz to be displayed with six digits. The decimal point on the LED indicates that the display is read in kHz.

### Triangle-wave generation

Figure 2 shows the schematic of the current switch and the triangle/square-wave generator. The combination of IC1-IC4 and Q1-Q4 makes up the main voltage-controlled multivibrator. Negative voltage is applied to the inverting input of IC1, which

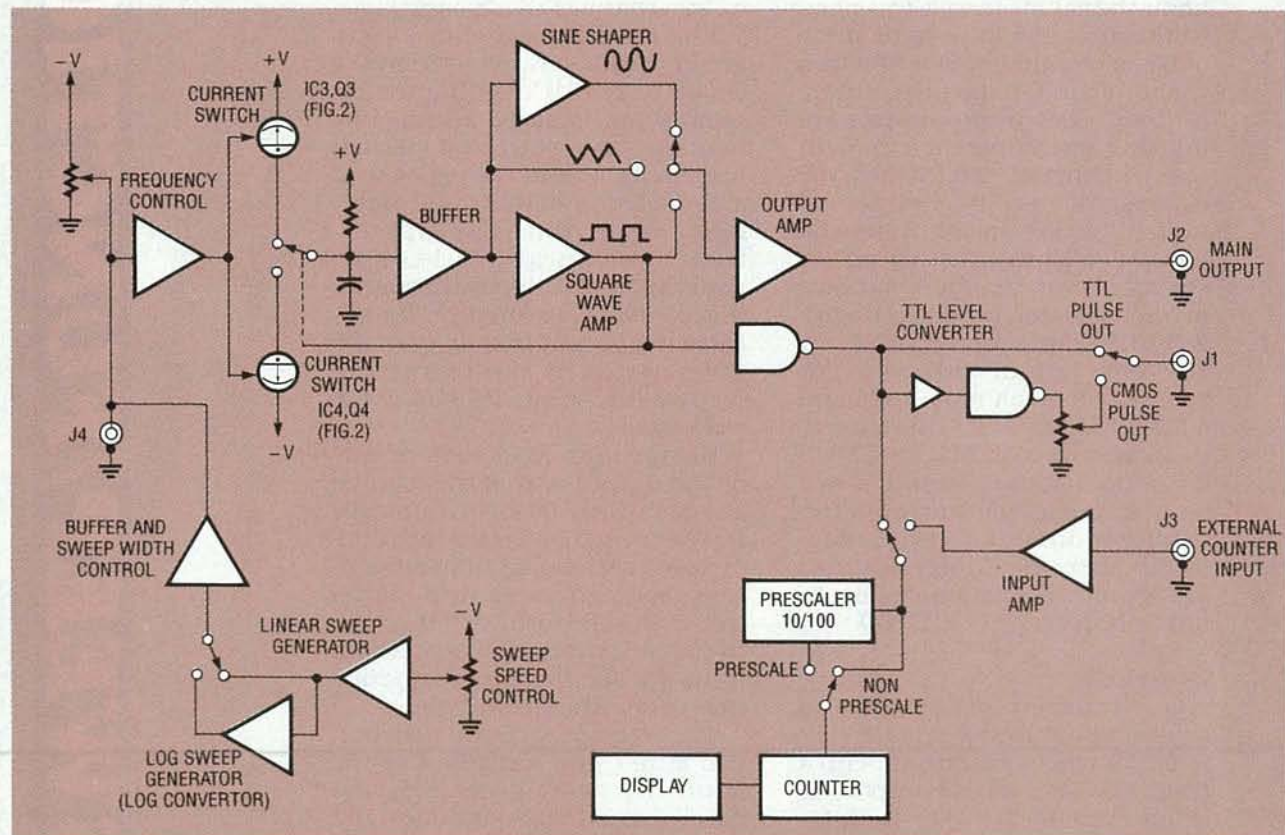

FIG. 1—BLOCK DIAGRAM OF THE FUNCTION GENERATOR. Note how the square-wave output is continuously fed back into the current-switch input. That is done to precisely align the triangle and square wave output through the hysteresis loop to prevent crossover distortion.

1MEG	100K	10K	1K	100	10	1
------	------	-----	----	-----	----	---

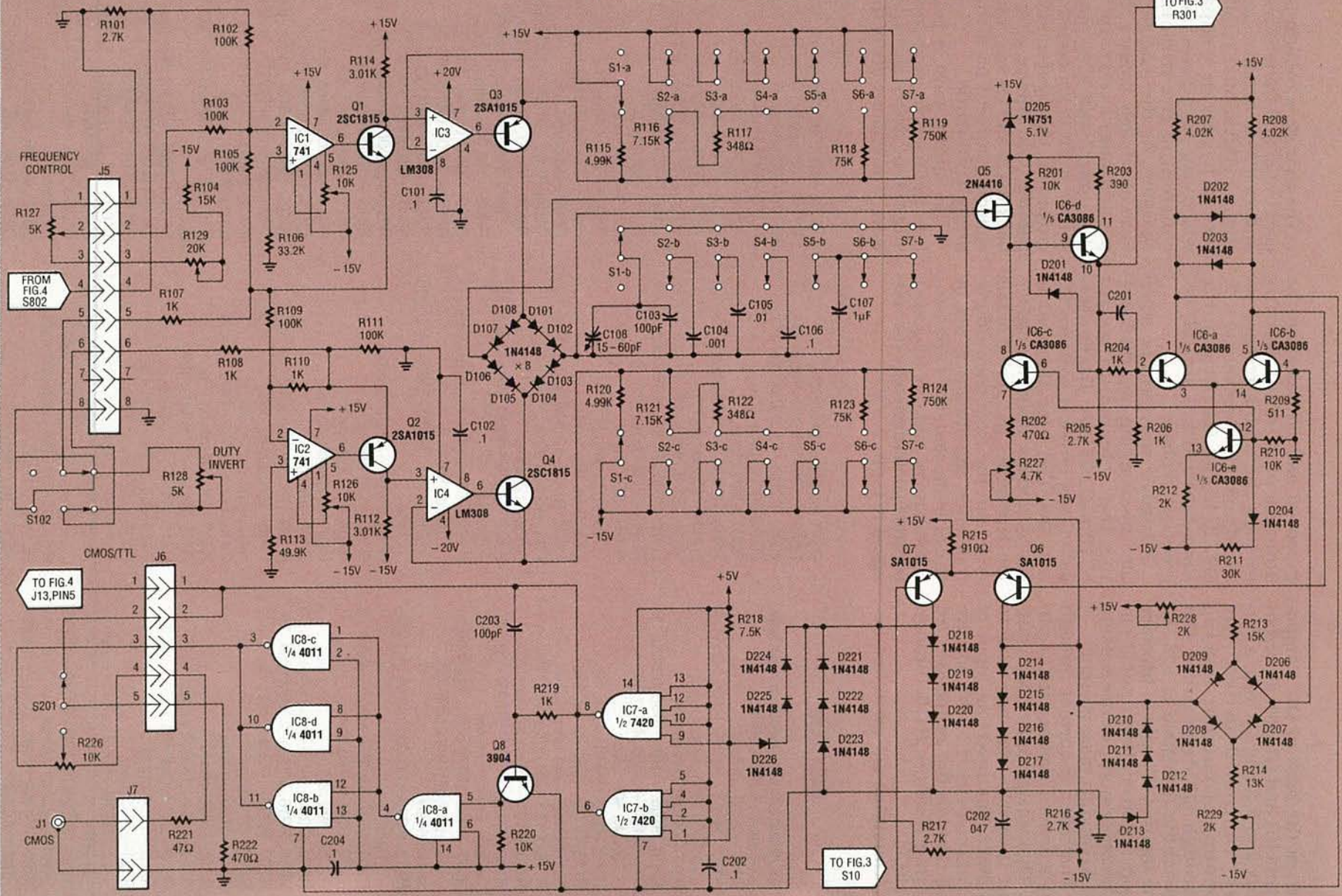

FIG. 2—CURRENT SWITCH, TRIANGLE/SQUARE-WAVE GENERATOR schematic. The triangle waveform is generated by alternately switching current sources Q3 and Q4, thereby charging and discharging C103-C107. As the triangle wave crosses the upper and lower levels of IC3's input, a square wave is generated at the output of hysteresis comparator IC6.

TO FIG. 3  
R301

TO FIG. 3  
S10

drives the base of Q1. Components IC1 and Q1 form a current sink and IC3 and Q3 form a current-controlled switch. The amount of current flowing through Q1 determines the switching threshold of IC3. As the input of IC1 (pin 2) becomes more negative, the output at pin 6 becomes more positive causing Q1 to conduct more current.

The collector current through Q1 generates a voltage at IC3, pin 3. That voltage causes IC3's output to switch from one state to another. The inverting input of IC3 is connected to the positive rail through the switch-selected timing resistors R115 through R119.

Transistor Q3 switches be-

tween on and off based on the amount of current flowing through the timing resistor selected and Q1. Components IC2, Q2, IC4, and Q4 perform the same function but are 180 degrees out of phase.

A triangle waveform is generated by charging and discharging the selected capacitor (C103-C107) by alternately switching current sources Q3 and Q4. The time required to charge and discharge the capacitor determines the period of one cycle and the frequency. Course frequency adjustment is set by the chosen resistor-capacitor combination, and fine frequency control is determined by the voltage at IC1, pin 2.

The triangle waveform is buffered by Q5 and transistors IC and -d. IC6-a, -b, and -e acts as a balanced differential amplifier which forms a hysteresis comparator which acts as a two-state latch controlling the direction of charging. As the triangle waveform alternately crosses the upper and lower levels of the input (IC3, pin 2 and IC4, pin 2) a square wave is generated at the output of the hysteresis comparator. That square wave is fed back to Q3 and Q4 to control charging current path through bridge D101-D108.

The square wave is fed back into the triangle wave input alignment with the triangle wave. The importance of the h

## PARTS LIST

**All resistors are 1/4-watt, 5% unless otherwise indicated.**

R101—2700 ohms, 1%	R301—49,900 ohms, 1%	R702—100,000 ohms
R102, R104, R105, R109, R111—100,000 ohms, 1%	R302, R303—11,300 ohms, 1%	R703—1 megohm
R106—33,200 ohms, 1%	R304, R306—12,100 ohms, 1%	R704—50 ohms
R107, R108, R110—1000 ohms, 1%	R305—309 ohms, 1%	R705, R718—150 ohms
R112, R114—3010 ohms, 1%	R307—200 ohms, 1%	R706, R712—220 ohms
R113—49,900 ohms, 1%	R308, R309—24,900 ohms, 1%	R707—470 ohms
R115, R120—4990 ohms, 1%	R310—127 ohms, 1%	R708, R715—51 ohms
R116, R121—7150 ohms, 1%	R311—63.4 ohms, 1%	R709—R711, R713, R714, R717—510 ohms
R117, R122—348 ohms, 1%	R312, R313, R320—1000 ohms	R719—36 ohms
R118, R123—75,000 ohms, 1%	R314—5100 ohms	R720—1000 ohms
R119, R124—750,000 ohms, 1%	R315—680 ohms	R801—7500 ohms, 1%
R125, R126, R826, R827—10,000 ohms, potentiometer	R316—150 ohms	R802—33,000 ohms, 1%
R127, R128—5000 ohms, potentiometer (part of S101 and S102, respectively)	R317—6800 ohms	R803—33 ohms, 1%
R129, R825—20,000 ohms, potentiometer	R318, R319—10,500 ohms, 1%	R804, R805, R807—5100 ohms, 1%
R201, R210, R220—10,000 ohms	R321—2000 ohms	R806, R810, R816, R817, R820, R822—10,000 ohms, 1%
R202, R222—470 ohms	R322—12 ohms	R808—510,000 ohms, 1%
R203—390 ohms	R323, R324—1000 ohms, potentiometer	R809—2200 ohms, 1%
R204, R206, R219—1000 ohms	R325—5000 ohms, potentiometer (part of S301)	R811—22,000 ohms, 1%
R205, R216, R217—2700 ohms, 1%	R401, R402, R503, R504—10,000 ohms	R812—2400 ohms, 1%
R207, R208—4020 ohms, 1%	R403, R404—22,000 ohms	R813—100 ohms, 1%
R209—511 ohms	R405—170 ohms, 1%	R815—150,000 ohms, 1%
R211—30,000 ohms	R406—12,000 ohms	R818—15,500 ohms, 1%
R212—2000 ohms	R407—1200 ohms	R821—2000 ohms, 1%
R213, R214—13,000 ohms	R408—2000	R823—15,000 ohms, 1%
R215—910 ohms, 1%	R409—18,200 ohms, 1%	R824—18,000 ohms, 1%
R218—7500 ohms	R410—270 ohms, 1%	R830, R831—5000 ohms, potentiometer (part of S801 and S802, respectively)
R221—47 ohms	R411—100 ohms, 1%	
R223, R828—5000 ohms, potentiometer	R412, R414, R502—3000 ohms	<b>Capacitors</b>
R224, R225, R228, R229—2000 ohms, potentiometer	R413—24,300 ohms, 1%	C101, C102, C204, C205—0.1 $\mu$ F ceramic
R226—10,000 ohms, potentiometer (part of S201)	R415, R418—47 ohms, 1W	C103, C203—100 pF, ceramic
R227—4700 ohms, potentiometer	R416, R417—7.5 ohms	C104—0.001 $\mu$ F, Mylar
	R419—50 ohms, 1/2W	C105—0.01 $\mu$ F, Mylar
	R420—499 ohms, 1/2W	C106—0.1 $\mu$ F, Mylar
	R421—56.2 ohms, 1%	C107—1 $\mu$ F, Mylar
	R422, R424—10,000 ohms, potentiometer (R424 is part of S401)	C108, C504—15–60 pF, variable capacitor
	R423—200 ohms, potentiometer	C201—68 pF, ceramic
	R501—100,000	C202—0.047 $\mu$ F, ceramic
	R505—10 megohms	C301, C303—0.1 $\mu$ F, ceramic
	R701—10,000 ohms	

teresis loop (IC6 pin 4) is to ensure that the triangle and square wave are perfectly timed to avoid any crossover distortion.

The collector of Q7 is clipped to approximately 3 volts by D218-D226 and fed to IC7, pins 1 and 9. IC7 is a dual four-input AND gate, which logically AND's the input square wave with a logic high to produce a TTL-level square wave output. The outputs of the two gates are tied together for increased current drive, and fed to the pulse-output control circuitry. The TTL square wave is level shifted by Q8 to 15-volt CMOS levels, where it is NANDed with 15 volts in IC8-a. The output of the gate is fed in parallel to IC8-b, -c, and -d, where they are also

NANDed with 15 volts.

The outputs of IC8-b, -c, and -d are connected in parallel for greater drive capability and routed through S201, a 10K potentiometer with a SPDT switch, which controls the pulse output mode. With the potentiometer in the OFF position, a TTL-level output is available. Turning the potentiometer throws the switch, which routes the CMOS output to the BNC connector J1. The 10K potentiometer controls the amount of signal available to J1 and will vary the amplitude of the signal from 0.5 volts to 15 volts.

Figure 3 shows the schematic of the sine shaper and output amplifier. Sine-wave generation is accomplished by taking the tri-

angle wave from IC6-d and feeding it through the nonlinear network made up of D301-D312 and resistors R301-R310. The circuit attenuates the input triangle wave according to its level, producing a sine-wave equivalent. The output of the sine shaper is fed through a high-pass filter to the input of IC9, a CA3030 op-amp. Zener diodes D313 and D314 drop the 15-volt supply voltage to  $\pm 11.3$  volts to accommodate the  $\pm 12$ -volt requirements of the IC. The gain of IC9 is about 10, and can be adjusted by potentiometer R323. The CA3030 is an inexpensive wide-band op-amp but requires some frequency compensation to work over its entire bandwidth.

C302, C304, C502—39 pF, ceramic  
C305, C401—4.7 pF, ceramic  
C307—15 pF, ceramic  
C308, C408—5–35 pF, variable capacitor  
C402—120 pF, ceramic  
C403—2.2 pF, ceramic  
C404, C406—6.8  $\mu$ F, tantalum, 20 volts  
C405, C407—0.047  $\mu$ F, ceramic  
C501—33 pF, ceramic  
C503—10 pF, ceramic  
C601, C602—1000  $\mu$ F, electrolytic, 50 volts  
C603, C604—100  $\mu$ F, electrolytic, 50 volts  
C605—1  $\mu$ F, tantalum, 20 volts  
C701, C704–C706—0.1  $\mu$ F, ceramic  
C702, C707—100 pF, ceramic  
C703 10 $\mu$  tantalum 16 volts C801—22  $\mu$ F, tantalum, 16 volts  
C802, C803—220 pF, ceramic  
C804, C805—100 pF, ceramic  
C806—500 pF, ceramic

#### Semiconductors

D101–D108, D201–D204, D206–D226, D301–D312, D315–D318, D401, D402, D701, D702, D801—1N4148 diode  
D205—1N751, 5.1-volt Zener diode  
D313, D314—1N746, 3.3-volt Zener diode  
BR1—W02M bridge diode  
Q1, Q4, Q12, Q13, Q21—2SC1815 or MPSA05 NPN transistor  
Q2, Q3, Q6, Q7, Q11, Q19, Q20—2SA1015 or 2N4403 PNP transistor  
Q5, Q17—2N4416, N-channel FET  
Q8—2N3904, NPN transistor  
Q9, Q10, Q14—2SC1923 or MPSH34, NPN transistor  
Q15—2N2219, NPN transistor  
Q16—2N2905, PNP transistor

Q18—PN5139, PNP transistor  
IC1, IC2—LM741, op-amp  
IC3, IC4—LM308, op-amp  
IC5, IC6, IC20—CA3086, NPN five-transistor IC (Harris)  
IC7—7420, dual 4-input AND gate  
IC8—4011, quad NAND gate  
IC9—CA3030, op-amp  
IC10—4066, CMOS quad bilateral switch  
IC11—7216B, frequency counter and LED driver (Intersil)  
IC12—7815, +15-volt voltage regulator  
IC13—7805, +5-volt voltage regulator  
IC14—7915, -15-volt voltage regulator  
IC15—MC10116, ECL triple-line receiver with Schmitt trigger (Motorola)  
IC16—SP8629, prescaler (Plessey)  
IC17—LM324, quad op-amp  
IC18—MC1458, dual op-amp  
IC19—CA3140, op-amp (Harris)  
SR801—1000 ohms, thermistor  
DISP1–DISP6—common-cathode LED (FND357)

#### Other components

S1–S7—4PDT-D switch  
S8—DPDT switch  
S9–S11—DPDT-D switch  
S12–S14—DPDT-I switch  
S15—DPDT on/off switch  
S101—DTDP switch used with R127 (5K potentiometer)  
S102—DTDP switch used with R128 (5K potentiometer)  
S201—SPDT switch used with R226 (10K potentiometer)  
S301—DPDT switch used with R325 (5K potentiometer)  
S401—SPDT switch used with R424

(10K potentiometer)  
S801—DPDT switch used with R830 (5K potentiometer)  
S802—DPDT switch used with R831 (5K potentiometer)  
J1–J4—BNC panel mount connector  
J5, J14—8-position female/male, 0.1-inch centers  
J6—5-position female/male, 0.1-inch centers  
J7, J12—2-position female/male, 0.1-inch centers  
J8, J13—6-position female/male, 0.1-inch centers  
J9–J11, J15, J16—4-position female/male, 0.1-inch centers  
XTAL1—10-MHz AT/CUT crystal  
T1—115/40 volts AC, 0.5-amp transformer  
F1—0.5-amp fuse

**Miscellaneous:** Case (CTP-1 by Global Specialties), three 1.75-inch standoffs, two T0-5 heatsinks, three T0-220 heatsinks, three PC boards, internal wiring, fuseholder, 3-conductor 18-gauge power-supply cord and strain relief.

**Note:** The following items are available from Tristat Electronics, Inc., 66A Brockington Cres., Nepean, Ontario, Canada, K2G 5L1, (613) 228-7223:

- A set of three etched, drilled and plated-through PC boards—\$76.
- All components without the PC board and case—\$250.
- Complete kit of all parts (unfinished front panel)—\$300.
- Cut and silk-screened front panel—\$10.

Add \$17 for shipping and handling. Send check or M.O.

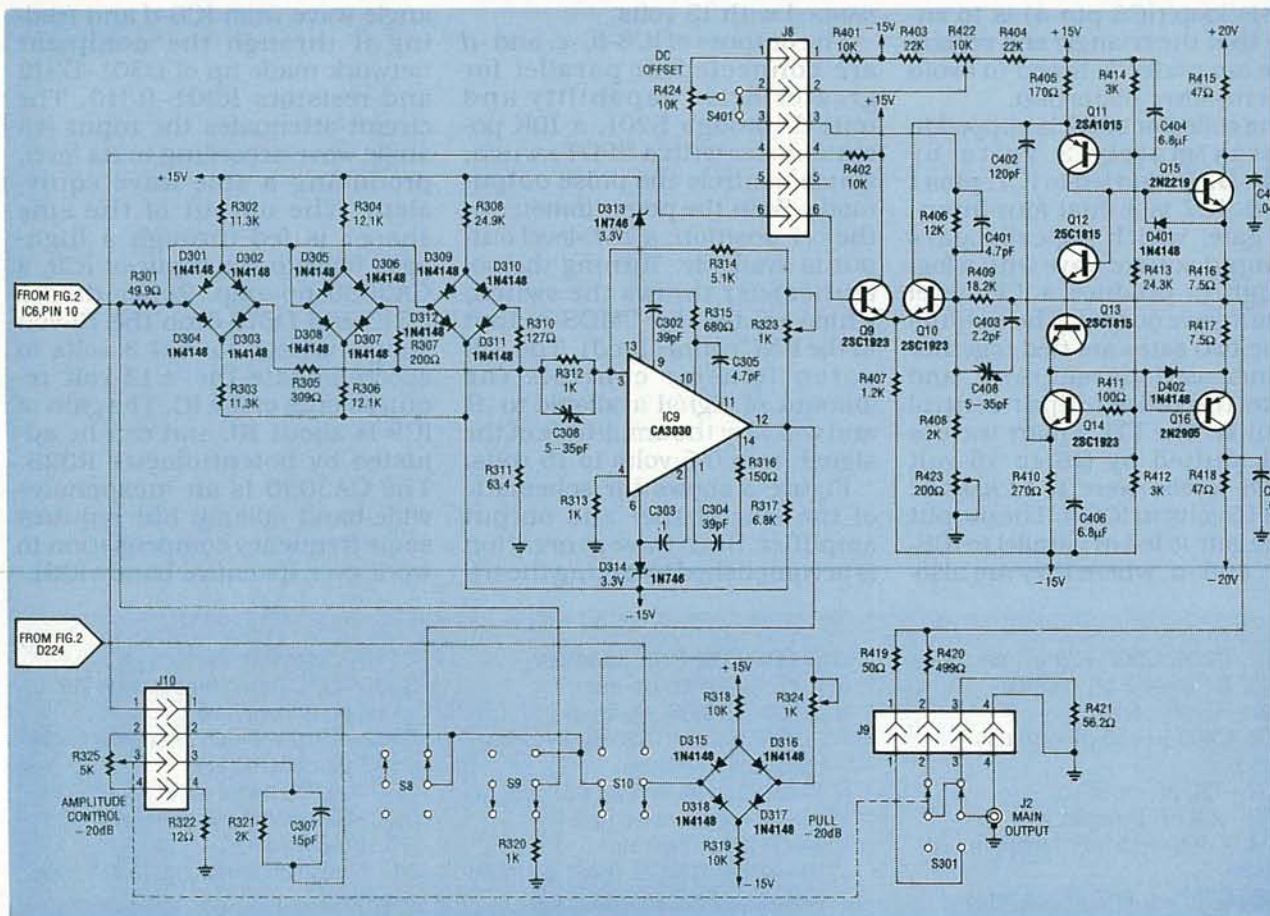

**FIG. 3—SINE SHAPER AND OUTPUT AMPLIFIER schematic.** The triangle wave from IC6-d is fed to a nonlinear network made up of D301–D312 and R301–R310. The triangle wave is attenuated according to its level, producing a sine-wave equivalent.

The main output amplifier consists of Q9 and Q10 configured as an unbalanced differential pair and transistors Q11–Q16 configured as a complementary symmetry push-pull amplifier. A differential amplifier amplifies the difference between the signals present at the base of each transistor. The input signal is fed into the base of Q9 and the output of the push-pull amplifier is fed back through the attenuating circuit of R409, C403, and C408 and coupled to the base of Q10. The output of the differential pair, Q9 and Q10, is taken from the collector of Q10 with the gain of that signal controlled by R408 and R423, which shunts the input signal to ground.

The DC content of the output signal is determined by the DC bias voltage at the base of Q10 (that value is set by potentiometer R422 and should be adjusted to give a 0-volt DC level). Panel-mounted switch/potentiometer

S401 allows the user to adjust the DC base bias of Q10, which causes the output signal to ride on a DC voltage from -10 volts to +10 volts depending on the potentiometer setting.

The output of Q10 is connected to the emitters of Q11 and Q14 through DC blocking capacitor C402. Transistors Q11 and Q14 are used in the common-base mode with the input signal fed into the emitters and the outputs taken from the collectors. Transistors Q12 and Q13 are used as diodes to connect the collectors of Q11 and Q14. The output of Q11 is fed to the base of Q15, which amplifies the positive half of the signal. The output of Q14 is fed into the base of Q16 which amplifies the negative excursion of the signal. Switch S301 controls the amount of signal entering the amplifier section through the use of a potentiometer. When the ganged DPDT switch is left in its normal IN position, the output

will swing 20 volts peak-to-peak (open circuit). Pulling the switch attenuates the signal by 20 dB. Output impedance is approximately 600 ohms in the normal switch position and 50 ohms the 20-dB position.

The frequency-counter and sweep-generator circuits are shown in Fig. 4. The sweep generator consists of IC7–IC9. The potentiometer section of the circuit is controlled by switch S801 which applies a negative voltage to the inverting input of integrator IC7-a. The input signal is inverted and charges C801 until it reaches the switching threshold of comparator IC7-b. When the switching threshold is reached the output will go high, forward-biasing Q21 which discharges C801 to ground through R801. The output at IC7-a pin 7 is a positive-going ramp and is routed through the linear/logarithmic switch S801 to either the output buffer amp or the linear arithmetic ramp generator.

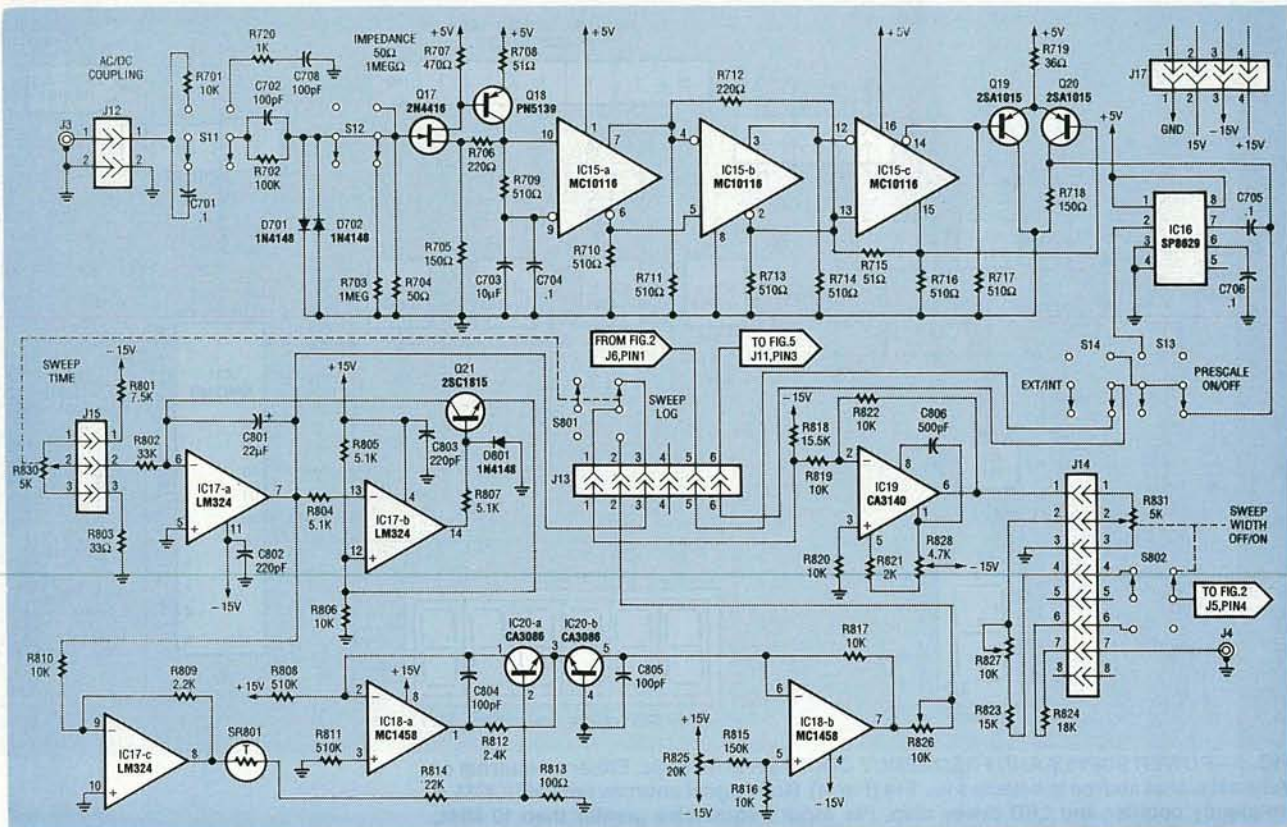

**FIG. 4—SWEEP GENERATOR AND SIGNAL ROUTING.** Potentiometer R830 applies a negative voltage to IC17-a; C801 charges until it reaches the switching threshold of IC17-b, which then forward biases Q1. The output at IC17, pin 7 is a positive-going ramp which is routed through the linear/log selection switch S801 to the output buffer amp or log ramp generator. IC16 is a prescaler chip used to downscale frequencies greater than 10 MHz.

An anti-log generator circuit is made up of IC17-c, IC18-a, -b, IC20-a, and -b, which performs an  $X^2$  function. IC17-c acts as an input buffer and attenuator. IC18-a and IC20-a drives the emitter of IC20-b in proportion to the input voltage at the base of IC20-a. The collector current of IC20-b varies exponentially with the emitter-base voltage. The current is then converted to a voltage by amplifier IC18-b. Potentiometer R825 sets the balance of IC18-b's output between a linear and exponential function while potentiometer R826 controls the output signal level. Thermistor SR801 is necessary to compensate for temperature drift because the output of the circuit is directly proportional to the anti-log of the input voltage, and the coefficient of the log term is directly proportional to absolute temperature. Without compensation, the scale factor would also vary directly with temperature. Constant gain is achieved by making the voltage at the base of

IC20-a directly proportional to temperature.

The linear and logarithmic positive-going ramps are buffered by IC19, a CA3140 op-amp, and are converted to a negative-going ramp. That signal is then fed into IC1 pin 2 through R102. Switch-potentiometer S802-R831 controls the negative voltage that is coupled to IC1 pin 2 when it is in the normal position. IC1 is controlled by the main frequency-adjust potentiometer S101, which consists of R127 unconnected to S101.

With S802 in the out position, the output of IC19 will be present at IC1. Potentiometer S802 sets the level of the ramp and controls the sweep width. It should be noted that IC1 pin 2 is a summing point and the voltage present from the main frequency control and the sweep generator adds together. The sweep generator starts its sweep at the point determined by the initial voltage at pin 2. For maximum sweep control, the main frequency ad-

just potentiometer should be turned to its minimum level.

### Frequency counter

The power supply and frequency counter circuit is shown in Fig. 5. The frequency counter can count either signals generated internally or measure external signals. The external signal is directly coupled through S11, or capacitively coupled through C701, as shown in Fig. 4. When the input signal is directly coupled, the low-pass filter of C708 and R72 is present. Capacitively-coupled signals by-pass the low-pass filter and pass through a high-pass filter. Diodes D701 and D702 clamper the input to protect Q17. Switch S12 selects the gate resistor and sets the input impedance of the circuit. Transistors Q17 and Q19 provide amplification and impedance matching for IC15, a MC10116 ECL triple-line receiver with Schmitt trigger. Differential amplifier Q19 and Q20 provide single-ended output from the di-

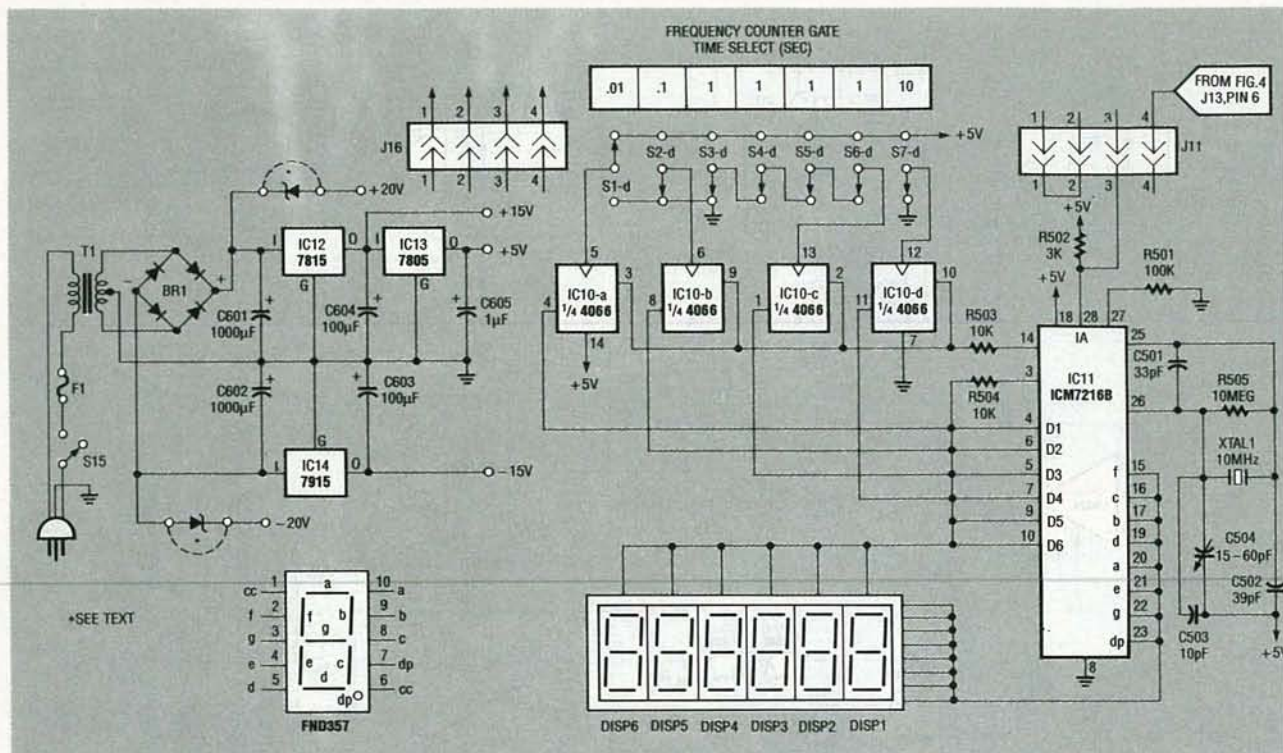

**FIG. 5—POWER SUPPLY AND FREQUENCY COUNTER schematic.** Either an internal or external signal source is selected via S14 (Fig. 4). Both signal sources are fed to IC11, a frequency counter and LED driver chip. For input frequencies greater than 10 MHz, prescaling is needed.

ferential outputs of IC15. Switch S13 controls whether the input signal is fed directly from the input amplifier or from the divide-by-100 prescaler to the counter section.

The counter section can take its input from the internal source or from an external source via S14. The internal signal represents the output frequency of the frequency generator and is taken from the junction of D221 and D224. Both signal sources are pulled up to CMOS levels by R502 and fed into IC11, an Intersil frequency counter and LED driver chip. The chip combines a high-frequency oscillator, decade time-base counter, an 8-decade data counter and latches, 7-segment decoder, digit multiplexes, and 8-segment and 8-digit drivers, which directly drive multiplexed LED's. The input frequency of the chip is limited to 10 MHz, so prescaling of the input is required to measure higher frequency signals. The 7216B is a multifunctional chip, performing many useful measuring tasks.

A 10-MHz crystal, XTAL1 with components C501–C504 and R505 set the internal timebase to

10 MHz. That configuration works well with our divide-by-100 prescaler because the timebase can remain the same, only the decimal point takes on a different meaning. In non-prescaled operation, the decimal point on the LED indicates the reading is in kHz, when the input is prescaled, the decimal point indicates the display is read as  $\times 10$  kHz. We'll discuss more about that later.

Gate-time selection is controlled by the main frequency selection switches S1-d through S7-d. They are configured to give gate times of 0.01 seconds in the 1-MHz range, 0.1 seconds in the 100-kHz range, 1 second in the 10-kHz through 10-Hz ranges, and 10 seconds in the 0.1-Hz range. The gate time select (IC11 pin 14) must be connected to the appropriate digit driver to select the required time.

Gate-time selection is achieved by applying 5 volts DC from one of the switches S1-d through S7-d to the control input of one of the quad-bilateral switches of IC10. Each of the bilateral switches of IC10 controls the digit driver that is connected to the gate-select in-

put. Because switches S1 through S7-d are dependent (only one can be engaged at a one time) only one of the bilateral switches will have 5 volts on its control input, all the others will be at ground. Resistor R503 hardwires the function select input to implement the frequency measuring mode only. Both R504 and R503 are required to reduce ringing at the input, which could result in false selections.

The power supply is fairly straightforward. AC line current is switch-connected through S15 to fuse F1 to the primary of T1. The transformer is center tapped with a secondary voltage of 40 volts and full load current of 0.1 amps. Diode bridge BR1 rectifies the AC secondary voltage and it is filtered by capacitors C601 and C602. Voltage regulator IC12–IC14, provide +15, +5, and –15 volts DC. The  $\pm 20$  volt DC is taken right from the bridge circuit. If a 40-volt AC secondary transformer cannot be found, two Zener diodes can be used to drop a high secondary voltage down to the  $\pm 20$ -volt range. Next time we'll discuss how to build a test the function generator. **F**



# SPEAKER MATE

*This easy-to-build project will turn any regular telephone into a high-quality speakerphone!*



DAVID PLANT

SPEAKERPHONES HAVE COME A LONG way since the two-piece units we used to see on the 1958 TV series, *The FBI*. There, an agent, played by Ephrim Zimbalist Jr., sat on his chief's desk as they "conferenced" around the country, planning the capture of the villain. In those days the units were available only by a rather expensive lease from Ma Bell, and the talk unit and receive section had to be located on opposite sides of the desk to avoid acoustic feedback—the same sort of sound that a public address system generates when the speakers are located too close to the microphone.

Today, thanks to some sophisticated electronics, the speaker and the microphone can now be used in a single enclosure. However, as we will discuss later, there are still acoustic considerations

to contend with. We've all heard what the typical speakerphone sounds like, and that's probably why most of us don't already own one. Speakerphones have also had a history of being expensive—until now.

The Speaker-Mate speakerphone is inexpensive, compact, easy to build, and powered from the phone line. You'll still need a regular phone because you can't dial out on the Speaker-Mate, and it doesn't have a ringer. But its sound quality is excellent.

A quality speakerphone relies on a balanced combination of electronic design and acoustic physics. With the Speaker-Mate, once an enclosure was chosen, the microphone and speaker were moved to different positions to achieve the best possible sound before making the final design.

## Operation

Modern speakerphones work on a switching principle to minimize audio feedback. Neither the talk path nor the receive path are totally off, but each are attenuated by a factor of 52 dB, and both sit in an idling mode until one person talks. It's similar to voice-controlled transmission (VOX) used by ham operators where both station transmitter are off until one operator talks when they are through the other station can talk. The comparison ends here because with a speakerphone, the receiving station can interrupt simply by talking louder.

Figure 1 is a block diagram of the Speaker-Mate. The talk path goes left to right on the upper half of the drawing, and the receive path goes from right to left. Both paths go through their respective

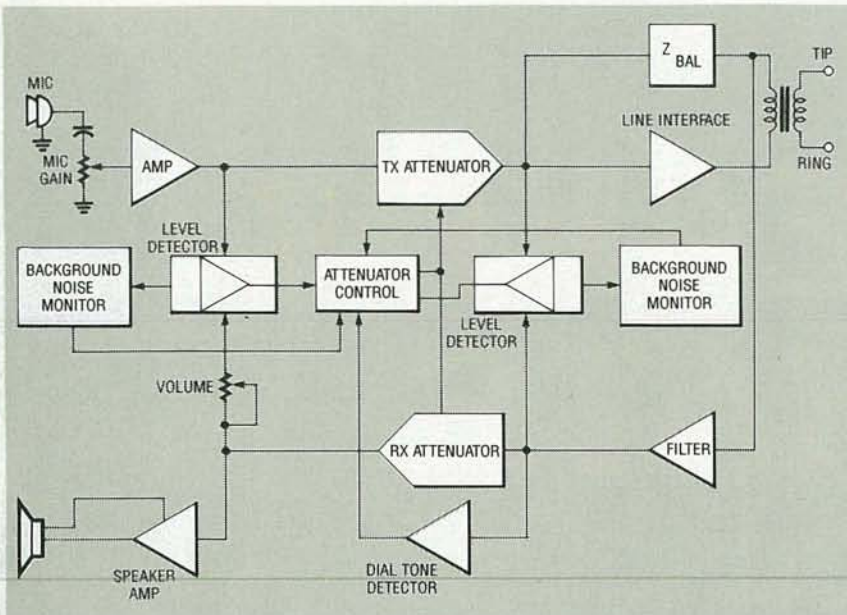

**FIG. 1—BLOCK DIAGRAM OF THE SPEAKER-MATE.** The talk path goes left to right on the upper half of the drawing, and the receive path goes from right to left.

attenuators which are controlled by the attenuator control block. That section gets its data from level detectors on both circuit paths. The detectors are interconnected with background noise monitors.

One of the requirements of a speaker-phone design is to differentiate between speech, which constantly varies in amplitude, and constant background noise. When constant and unvarying noise is heard, the attenuator control mutes both paths until speech is read. A separate detector is provided to attenuate the dial tone; it is not a single tone and does not qualify as noise. The Z balance network matches both paths to the phone line.

### Circuitry

Referring to the schematic in Fig. 2, the 600-ohm balanced telephone line is coupled to the

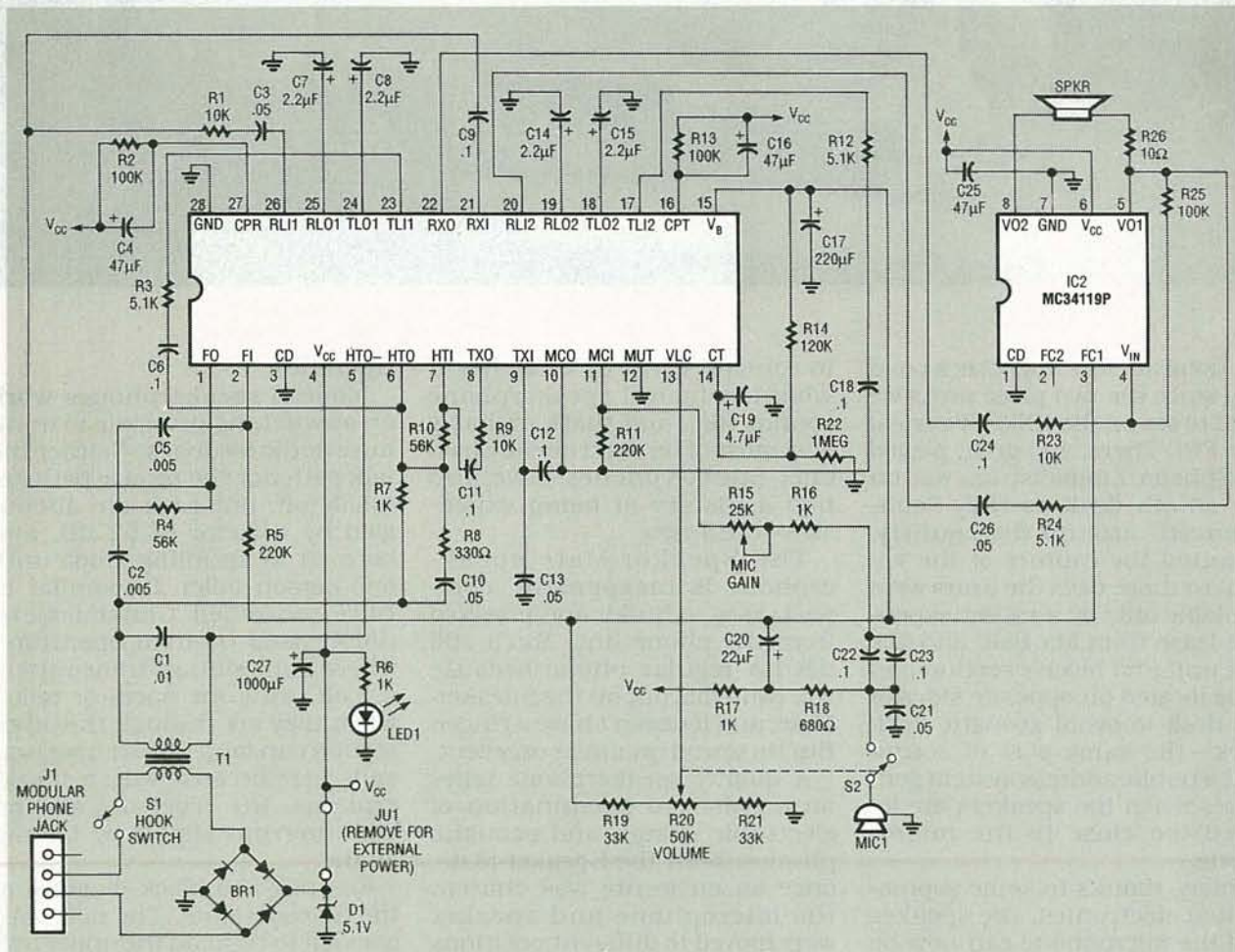

**FIG. 2—SPEAKER-MATE SCHEMATIC.** The 600-ohm balanced telephone line is coupled to the device through T1, a 600-to-600 ohm transformer. A Zener diode limits transient spikes and regulates the supply to 5.1 volts.

## PARTS LIST

### All resistors are 1/4-watt, 5%

R1, R9, R23—10,000 ohms  
 R2, R13, R25—100,000 ohms  
 R3, R12, R24—5100 ohms  
 R4, R10—56,000 ohms  
 R5, R11—220,000 ohms  
 R6, R7, R16, R17—1000 ohms  
 R8—330 ohms  
 R14—120,000 ohms  
 R15—25,000 ohms, PC-mount vertical potentiometer  
 R18—680 ohms  
 R19, R21—33,000 ohms  
 R20—50,000 ohms, potentiometer with switch (S2)  
 R22—1 megohm  
 R26—10 ohms

### Capacitors

C1—0.01  $\mu$ F, ceramic disk  
 C2, C5—0.005  $\mu$ F, ceramic disk  
 C3, C10, C13, C21, C26—0.05  $\mu$ F ceramic disk  
 C4, C16, C25—47  $\mu$ F, 16 volts, radial electrolytic  
 C6, C9, C11, C12, C18, C22, C23, C24—0.1  $\mu$ F, ceramic disk

C7, C8, C14, C15, C19—2.2  $\mu$ F, 16 volts, radial electrolytic  
 C17—220  $\mu$ F, 16 volts, radial electrolytic  
 C20—22  $\mu$ F, 16 volts, radial electrolytic  
 C27—1000  $\mu$ F, 16 volts, radial electrolytic

### Semiconductors

IC1—MC34118P voice-switched speakerphone, Motorola  
 IC2—MC34119P low-power audio amplifier, Motorola  
 D1—1N4733 5.1-volt Zener diode, or equivalent  
 LED1—high efficiency red light-emitting diode, GI MV5774 or equivalent  
 BR1—50-volt bridge rectifier, RB115 or equivalent

### Other components

MIC1—electret microphone element  
 T1—600-to-600 ohm PC-mount transformer, 0.75-inch mounting center  
 J1—modular PC-mount phone jack  
 S1—SPST toggle switch

S2—SPST switch (mounted on potentiometer R20)

**Miscellaneous:** Cabinet, PC board, 3/8-inch I.D. rubber grommet, 3-inch 8-ohm speaker, knob, modular phone cord, wire, solder, RTV silicon glue, etc.

**Note:** The following items are available from Project-Mate, 2727 W. Manor Pl., Seattle, WA 98199 (206) 283-4700:

- A kit containing a PC board and all listed parts except the cabinet, speaker, and modular phone cord—\$46.00.

- Pac-Tec cabinet with silk-screened front panel—\$18.50

- 3-inch speaker—\$3.75.

- Drilled and plated PC board—\$11.50

- IC1 and IC2—\$18.50

- Ring detector kit including piezo transducer—\$9.50

Include \$3.50 shipping and handling and allow 2 weeks for delivery. 15% discount on orders of 2 or more similar items.

Speaker-Mate through T1, a 600-to-600 ohm transformer. Switch S1 in series with T1 provides the answer function, and when the circuit is closed (off-hook), current flows through BR1 which produces a DC voltage of 6–8 volts. A Zener diode across the output limits transient spikes and regulates the supply to 5.1 volts which powers the circuit and optional LED1. The LED, if used, should be of the high-efficiency variety, because R6 limits its current to 2 mA to minimize telephone-loop current drain. The secondary of T1 is fed to IC1, a Motorola MC34118P voice-switched speakerphone chip, which controls all functions except driving the speaker. That is

done by IC2, a Motorola MC34119P low-power audio amplifier IC. Both IC's can operate from less than 3 volts.

Potentiometer R20 controls the volume and is limited in range by R19 which sets the high level, and R21 which sets the low

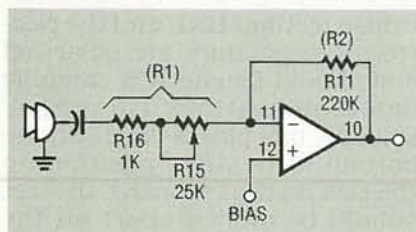

**FIG. 3—YOU CAN ADD** a microphone gain adjustment to allow for different environments and applications. The gain is the ratio of R2/R1. With R1 at 1K, the gain is 220, and with R1 at 26K, the gain is 8.5.

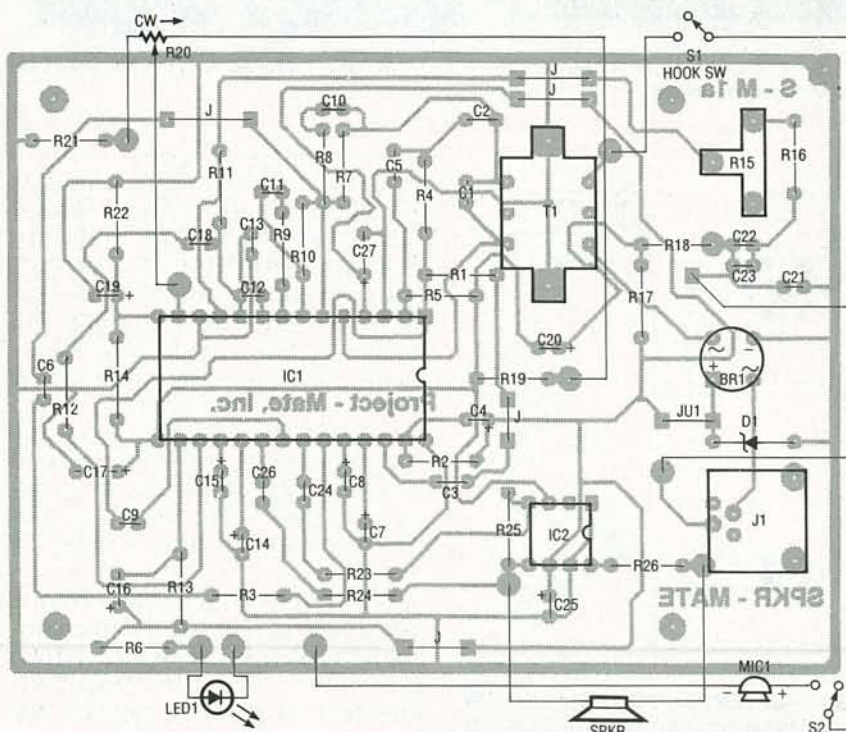

**FIG. 4—PARTS-PLACEMENT DIAGRAM.** Mount the two IC's first to provide a go-reference for the rest of the components. Use sockets for both IC's, especially for the 2 pin chip.

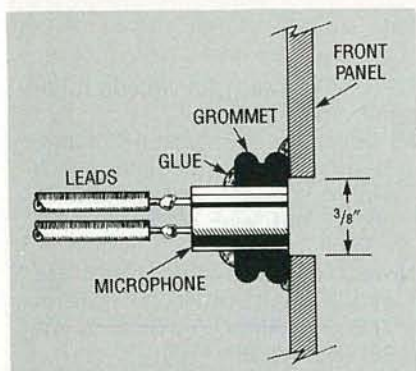

**FIG. 5—MICROPHONE MOUNTING** scheme. A rubber grommet is glued to the inside of the front panel behind the microphone opening. The microphone should not touch the front panel, but if it's too far recessed it will give an echo sound.

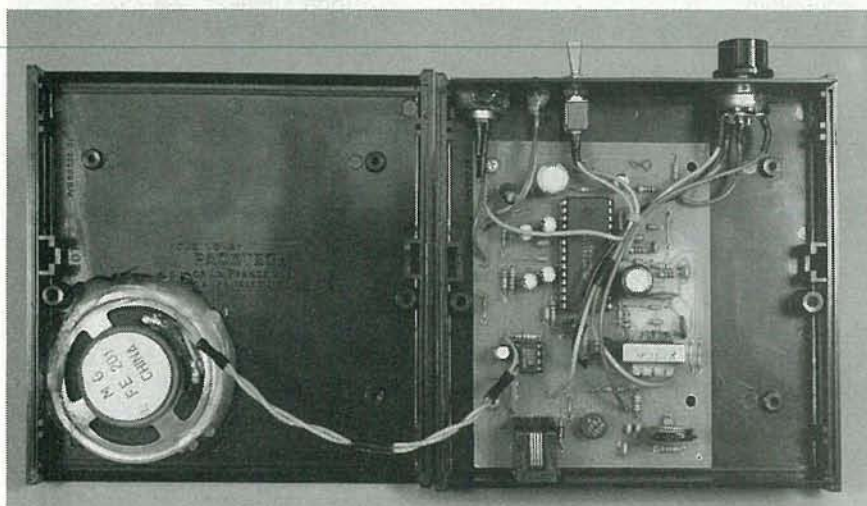

**FIG. 6—THE COMPLETED PROTOTYPE.** The front panel included with the kit makes for a nice finishing touch.

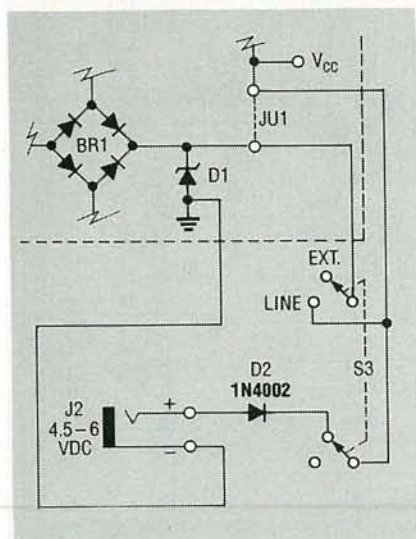

**FIG. 7—EXTERNAL POWER ADDITION.** The parts can be mounted on the rear panel and wired into the board. S3 will switch the unit between being line-powered and powered from an external source.

level. The low end is set to not completely turn off the audio and the high end limits the current required by the power amplifier to within the parameters allowed by the telephone loop current. Excessive audio would create a pumping sound due to the voltage dropping on audio peaks. Potentiometer R20 can be either linear or audio taper with very little effect on the sound, due to the limiting resistors.

We found it desirable to add a microphone gain adjustment to allow for different environments and applications. That was done by adding a 25K potentiometer (R15) in series with a 1K limiting

With R20 connected to  $V_{CC}$ , the calling station will have the slight capture advantage, and of the three options, we found that R2 to ground worked best.

### Construction

Because the Speaker-Mate is designed with some tight timing constants, it is highly recommended that suggested part values be followed for optimum performance. And, although a variety of project cases can be used, the electronics and the physical layout were tuned for the enclosure used with the prototype; it is available from many different distributors as well as from the source mentioned in the parts list. The project case comes with a professionally screened front panel when purchased from that source.

With the exception of the front panel mounted components and the speaker, all parts fit on the PCB; a foil pattern is provided if you want to etch your own board. A pre-etched board is available separately, as is a kit that includes the PCB and all other parts to completely build the Speaker-Mate project.

A parts-placement diagram is shown in Fig. 4. Mounting the two IC's first gives a good reference for the rest of the component mounting. Double check the polarity of each IC before soldering, and note that pin 1 goes on the square pad on the PCB board. (Incidentally, the other square pads indicate jumpers (J) external leads.) It is suggested that you use IC sockets for both IC's, especially for the 28-pin chip.

The resistors can be mounted next, their clipped leads can be used as jumpers (J) where necessary. However, don't install the jumpers at this time. Diode D1, bridge rectifier BR1, and the electrolytic capacitors are polarized and should be checked carefully before mounting. The phone jack, J1, has plastic "feet" on the bottom of it. After positioning the jack on the PCB board, the feet should be melted apart on the underside of the board with the tip of your soldering iron to provide mechanical strength. I

resistor (R16). Figure 3 shows how the circuit works; the gain is calculated by the ratio of R2/R1. Using the actual values in the circuit, and with R1 at 1K, the voltage gain should be 220, and with R1 increased to 26K, the gain will reduce to 8.5. In actuality, these figures will be approximately 10 percent less because of other factors. Ideal AC coupling from the microphone (0.2  $\mu$ F) is provided by two 0.1  $\mu$ F capacitors in parallel (C22 and C23); the 0.1  $\mu$ F capacitors are much easier to obtain.

The other components provide filtering and talk/listen time constants. Resistor R22, when grounded, provides approximately a 20 percent capture advantage to the speakerphone user; without it, the unit will idle halfway between listen and talk.

*continued on page 6*

# MONITOR TESTER

***Our sync generator lets you test computer monitors without having to connect them to a computer.***

SERVICING COMPUTER monitors isn't all too different from servicing composite-video monitors and television sets. There are some very important differences, however, the most obvious of which is that most computer monitors don't operate on the NTSC horizontal frequency of 15.734 kHz and vertical frequency of 59.94 Hz. Since your standard video test gear can't be used, you need a new troubleshooting tool—a computer-video sync generator.

We'll show you how to build a "sync generator" that provides horizontal sync, vertical sync, and RGB video for three popular styles of monitors: CGA, EGA, and VGA. Without connecting the monitor to a computer, you'll be able to verify video, deflection, and DC supply generation. Once repairs are made, fine tuning adjustments can be done with the monitor connected to a computer using appropriate software. However, using the sync generator first prevents tying up a computer that could be used more productively elsewhere.

## Circuit description

The sync generator is a complex frequency-divider circuit. The starting point is two TTL clock oscillators—one is 5.0688-MHz (OSC1) and the other is 4.9152-MHz (OSC2). Depending upon two switch settings, one of the clock signals gets routed to various divider stages, ultimately leading to the final stage, a 4-bit binary counter.

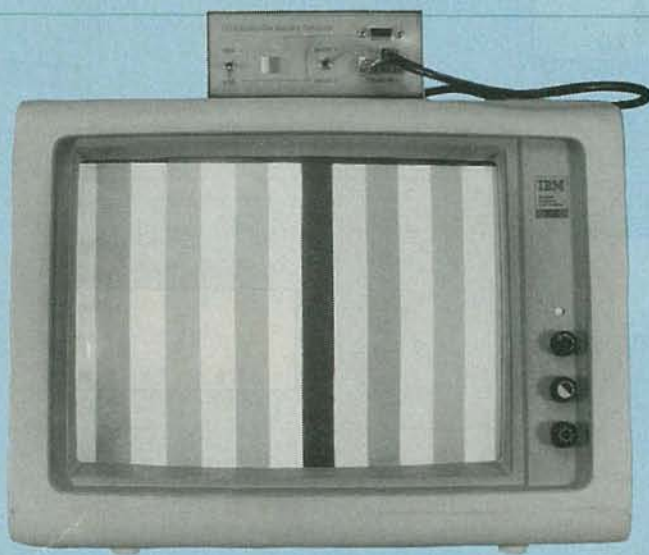

GARTH PRICE, CET

## VGA operation

Referring to the schematic in Fig. 1, switch S2, when closed, places a logic "0" (a low) on pin 1 of IC6, a 74HC158 quad 2-line to 1-line selector, so all "A" inputs will be passed to the "Y" outputs. The output of OSC1, a TTL clock oscillator, is then passed from pin 14 of IC6 (A4) to pin 12 (Y4) and then to the CLK input (pin 8) of IC3, a 74LS164 shift register. (NOTE: It is important that the EGA/VGA switch S2 is in the proper position for the type of monitor in use. An improper horizontal sync frequency can easily cause damage to deflection circuits!)

At the same time, the OE output of IC3 (pin 10) is fed

through a 74HC14 Schmitt inverter (IC2-d) into the A3 input of IC6 (pin 11). That signal is then passed to the Y3 output (pin 9), through R10, to the base of Q1, and to IC3's CLR input (pin 9). As a result, the clock signal is divided by five and used as a reset, so every fifth clock pulse causes a clear to occur.

As just mentioned, shift register IC3 divides its CLK input (OSC1's output) by five ( $5.0688/5 = 1.01376$ ). In other words, all of the "Q" outputs have a frequency of  $\frac{1}{5}$  the clock input, but only when the chip is reset by its own OE output. The QC output (which is also  $\frac{1}{5}$  the clock input when the chip is reset by OE) of IC3 (pin 5) sends the 1.01376-MHz signal to IC4-a's (a 74LS74 D-type flip-flop) CLK input (pin 3) where it is further divided by 2, so the net division is ten.

With that division by ten, a 506.88-kHz signal is sent to pin 2 of IC6 (A1), passed through to pin 4 (Y1), and on to binary counter IC5's (a 74LS163) CLK input (pin 2). Counter IC5 divides the signal by 16 to produce a horizontal sync of 31.68 kHz with a pulse width of 2 microseconds. Counter IC5 also divides the CLK input by two for generating blue (QA, pin 14), by four for red (QB, pin 13), and by eight for green (QC, pin 12). In other words, blue video is gated eight times the horizontal sync, red video four times, and green twice. The monitor thus lights up with yellow, cyan, green, magenta, red, blue, black, and white bars, and then repeats. (Note that the CGA/EGA

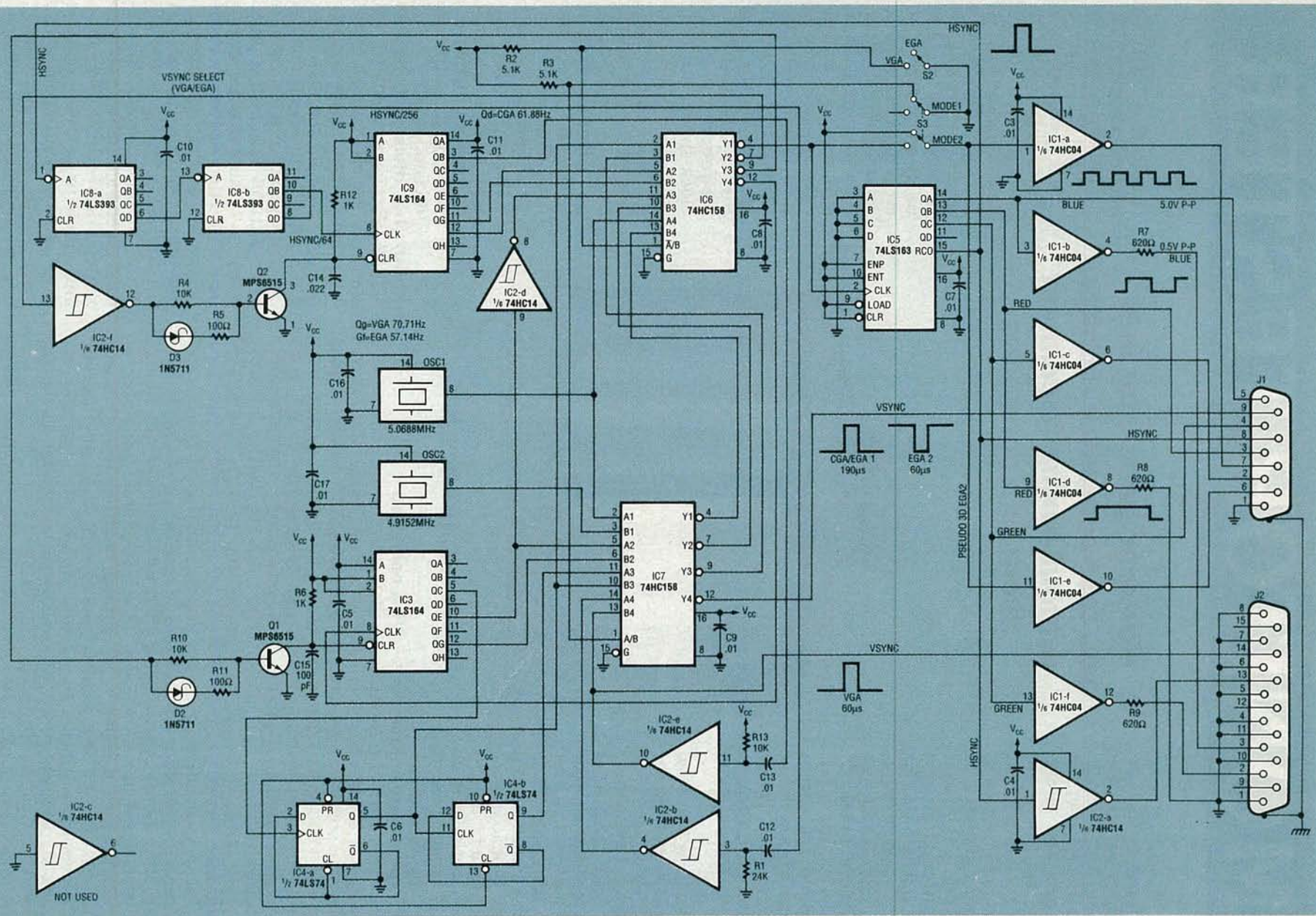

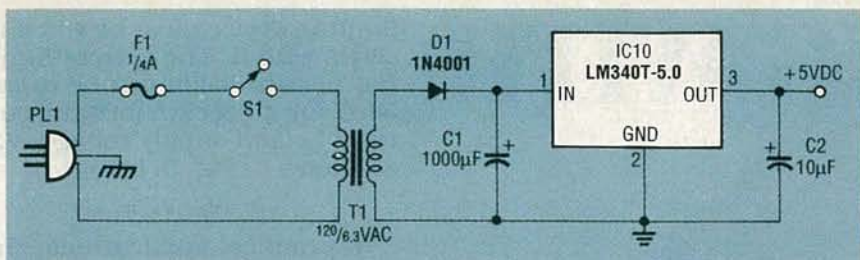

**FIG. 2—POWER SUPPLY.** If you don't have a suitable 5-volt DC power supply available, you can build this one.

color sequence is the reverse of VGA.)

Vertical sync is generated by sending horizontal sync to pin 1 of IC8-a, a 74LS393 binary coun-

#### PARTS LIST

##### All resistors are 1/4-watt, 5%.

R1—24,000 ohms  
R2, R3—5100 ohms  
R4, R10, R13—10,000 ohms  
R5, R11—100 ohms  
R6, R12—1000 ohms  
R7—R9—620 ohms  
R14—56 ohms

##### Capacitors

C1—1000 µF, 50 volts, electrolytic  
C2—10 µF, 10 volts, electrolytic  
C3—C13, C16, C17—0.01 µF, 50 volts, ceramic  
C14—0.022 µF, 50 volts, ceramic  
C15—100 pF, 50 volts, ceramic

##### Semiconductors

IC1—74HC04 hex inverter  
IC2—74HC14 hex Schmitt trigger inverter  
IC3, IC9—74LS164 shift register  
IC4—74LS74 D flip-flop  
IC5—74LS163 4-bit binary counter  
IC6, IC7—74HC158 2-line to 1-line selector  
IC8—74LS393 dual 4-bit binary counter

IC10—LM340T-5.0 5-volt regulator

OSC1—5.0688-MHz TTL clock oscillator

OSC2—4.9152-MHz TTL clock oscillator

D1—1N4001 diode

D2, D3—1N5711 Schottky diode

Q1, Q2—MPS6515 NPN transistor

##### Other components

F1—0.25-amp AGC fast-blow fuse

J1—DE9S 9-pin female connector

J2—HD DB15S 15-pin high-density female connector

S1, S2—SPST switch

S3—DPDT switch

T1—120/6.3VAC transformer

**Miscellaneous:** AC linecord, wire-wrap IC sockets, metal enclosure, wire, solder, etc.

ter, where it ends up divided by 64 at pin 10 of IC8-b and fed into the CLK input (pin 8) of IC9, another 74LS164 shift register. The CLR input to IC9 (pin 9) ultimately comes from its own QG output via IC6's A2 input (pin 5), its Y2 output (pin 7), Schmitt inverter IC2-f, and transistor Q2. Using IC9's QG output to reset itself causes a division of its clock input by 7. Therefore, the horizontal sync is first divided by 64 by IC8, then divided by seven by IC9, making a total division of 448. Therefore, a 70.71-Hz signal (31.68 kHz divided by 448) with a 60-µs pulse width is sent from IC9 pin 3 to pin 14 of J2, a 15-pin high-density VGA connector, via C13, R13, and Schmitt inverter IC2-e.

#### CGA/EGA1 operation

When switch S2 is set to "EGA," it places a logic "1" (a high) on pin 1 of IC6, which then connects its "B" inputs to the "Y" outputs. When S3 is set to "Mode 1," it places a logic "0" (a low) on pin 1 of IC7, another 74HC158 selector, which connects its "A" inputs to the "Y" outputs. Now

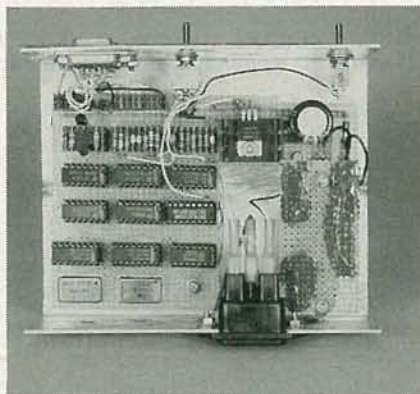

**FIG. 3—THE AUTHOR'S PROTOTYPE.** Perforated construction board and wire-wrap techniques were used to assemble the project.

IC7 uses OSC1 as its timing source which is input at pin 2 and output at pin 4. That, in turn, is input to pin 13 of IC6 and output at pin 12. From pin 12 of IC6, OSC1 is to IC3's CLK input (pin 8). Because IC3's QG output (pin 10) is tied back to its CLR input (pin 9) via IC7 pins 5 and 7, IC6 pins 10 and 9, R1, and Q1, IC3 divides OSC1 by five.

Output QG of IC3, which is also OSC1/5 because QG is used as the clear signal, routes 1.014 MHz (5.0688/5) to pin 3 of IC4-a, causing further division by four at pin 9 of IC4-b for a total division of 20 (253.44 kHz). The 253.44-kHz output from IC4 pin 9 is connected to pin 3 of IC6 via IC7 pins 11 and 9. The input to pin 3 of IC6 is output at pin 4, and from there it goes to S3 and the CLK input of IC5 (pin 2). After IC5 divides the 253.44 kHz by sixteen, the horizontal sync measures 15.84 kHz.

Vertical sync is generated by dividing horizontal sync (15.84 kHz) by 256 at pin 8 of IC8. That output connects to C12, R1, IC2-b, and pin 14 of IC7. The 61.88 Hz vertical sync signal with a 190 µs positive pulse width is then sent to pin 9 of output jack J1 via IC7 pin 12.

#### EGA2 operation

When S2 is set to "EGA," it places a high on pin 1 of IC6, which then selects its "B" inputs. With S3 set to "Mode 2," it places a high on pin 1 of IC7 so it also selects "B" inputs. With the "B" inputs selected, IC7 uses OSC2 as its timing source and 4.9152 MHz passes from pin 4 of IC7 to pin 13 of IC6. The signal then connects to IC3's CLK input (pin 8) from pin 12 of IC6. The QG output from IC3 is connected to IC6 pin 10 via IC7 pins 6 and 7. The signal is then output at pin 9 of IC6, and connects back to the CLR input (pin 8) of IC3. The OSC2 signal is divided by seven by IC3 producing 702.17 kHz at IC3's QG output. The QG output from IC3 ties to IC4-a, which causes an additional division by 2, for a net of 14. The 351.08 kHz from IC4-a pin 5 is connected to IC5's CLK input (pin 2) via IC7 pins 10 and 9, and IC6 pins 3 and 4. The signal is further divided by

*continued on page 94*

# WORKING WITH LED'S

**We begin our in-depth survey of optoelectronic systems by taking a close look at a wide variety of LED circuits.**

RAY MARSTON

OPTICAL ELECTRONIC DEVICES ARE so widely used in today's consumer-electronics that it's hard to come across a product that doesn't use light-emitting diodes (LED's) in one way or another. If you've ever had a need to use LED's or specialized flashing devices in your circuit design, we might be of some help to you. We'll start by presenting some basic information on LED's, then we'll take a look at some multi-LED packages. Finally, we'll round-off with a discussion of different types of flasher circuits used for controlling LED's.

## LED basics

LED's are commonly used as visual indicators because of their fast response time and high efficiency. When compared to tungsten-filament lamps, their typical energy conversion efficiency is ten to fifty times greater and their response time is one hundred to one thousand times faster. LED's are widely available in red, orange, yellow and green colors.

Figure 1 shows the standard LED symbol and typical forward voltages of different colored LED's. The device is a genuine diode, and a voltage of approximately 2 volts is produced across it when it is passing a forward current of 20 milliamps. If an LED is reverse biased, it will avalanche or "Zener" at a fairly low voltage value, as shown in Fig. 2. Most LED's have maximum reverse voltage ratings in the range of 3 to 5 volts.

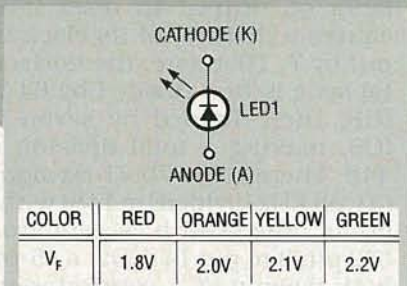

FIG. 1—LED SYMBOL AND TYPICAL forward voltages of standard LED's at  $I_F = 20$  milliamps.

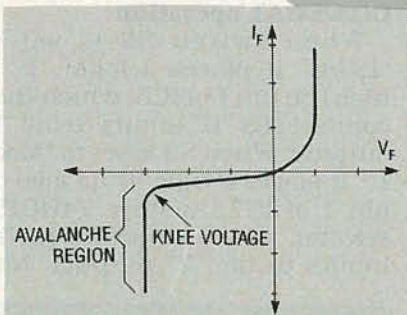

FIG. 2—GRAPH SHOWING REVERSE biased LED responding as a Zener diode.

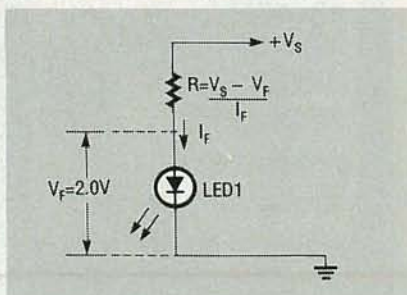

FIG. 3—METHOD OF FINDING the current-limiting resistance value for a given  $V_S$  and  $I_F$ .

When an LED is used, a resistor or other suitable current-

limiting device must be wired in series with it. The current-limiting resistor value can be calculated for a specific forward current,  $I_F$ , and supply voltage, as shown in Fig. 3, being,

$$R = (V_S - V_F) / I_F$$

In practical applications, a series resistor can be connected to either the anode or the cathode of the LED. The LED brightness is proportional to the LED current; most LED's will operate safely up to absolute maximum currents of 30 to 40 milliamps. With a DC supply voltage and a suitable line dropping resistor, the current through the LED should be maintained at a constant value of approximately 20 milliamps.

An LED can be used as an indicator in an AC circuit by wiring a diode in inverse parallel with it, as shown in Fig. 4. The diode prevents the LED from becoming reverse biased on the negative half of the sine wave cycle. For a given brightness, the line dropping resistance value in an AC circuit should be one half that used in a DC circuit. When an LED is used in an AC circuit, the forward current conducted through the LED only during the positive half of the sine wave cycle, after the LED has reached its threshold voltage of about 2 volts. Therefore, the LED conducts current less than one half the time in an AC circuit as it does in a DC circuit. In order to achieve the same average current through the LED with an AC supply, approximately twice as much current must flow so the resistance value must be reduced one half.

One of the first problems you will encounter when using an LED is identifying its polarity. The cathode on most LED's is identified by a notch or flat surface on the component, or by a shorter lead. That practice is universal, however, so the most accurate way to identify the polarity of an LED is to test it in the basic circuit of Fig 3; try the LED in both positions, when it glows the cathode is the most negative of the two terminals. It is always good practice to test an LED before soldering it onto the board.



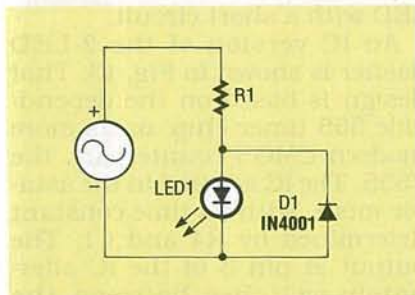

FIG. 4—AN LED USED IN AN AC circuit; D1 is wired in inverse parallel to prevent the LED from being reverse biased.

Special mounting kits are available for securing LED's onto PC boards and front panels. Those kits consist of a special mounting grommet and grooved ring shown in Fig. 5-a. If mounting hardware is not available, you can drill panel holes and either epoxy the LED into place or solder its leads into a PC board, which can support the LED. That method is shown in Fig. 5-b.

### LED packages

LED's can be purchased as single components, as shown in Fig. 1, or in a multi-LED package. The most common type of multi-LED package is the 7-segment display, comprising seven or eight LED's packaged for displaying alphanumeric characters. Another

well-known type of multi-LED package is the bar-graph display, which is made up of ten to thirty linearly-mounted LED's. An example of a ten-element LED package is shown in Fig. 6-a.

Most LED's provide only a single output color. There are, however, a few specialized LED packages that provide multi-color outputs. Those devices actually consist of two LED's contained in one package. Figure 6-b shows a bi-color LED which is comprised of a pair of LED's connected in inverse parallel. The color green is emitted when the device is biased in one direction,

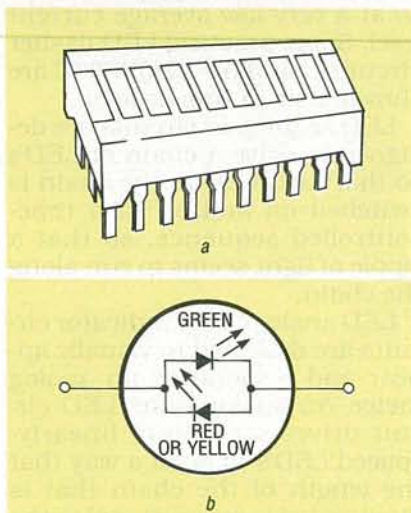

FIG. 6—MULTI-LED PACKAGES; (a) is a 10-element LED, and (b) is a 2-color LED which contains two LED's connected in inverse parallel.

and red or yellow is emitted when it is biased in the reverse direction. The bi-color LED is useful for giving polarity indication and null detection.

Another type of multi-color LED is shown in Fig. 7. This four color LED is made by mounting a green and red LED in a 3-pin common-cathode package. That device can generate green or red colors by turning on only one LED at a time, or it can generate orange and yellow by turning on the two LED's in the current ratios shown in the table.

A very important practical point concerns the use of "second-grade" or "out-of-spec" devices advertised as bargain packages. Those devices often have forward voltage drops in the range of three to ten volts. Al-

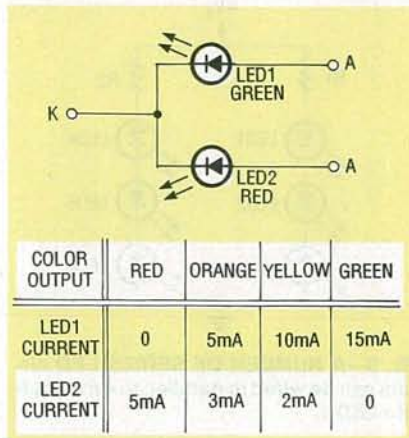

FIG. 7—MULTI-COLOR LED; this LED gives four colors from two junctions as shown in the current ratios given in the table.

though "second grade" LED's may be suitable for many applications, it's always a good idea to test those devices before using them in your circuit, as we said earlier.

### Multi-LED circuits

A number of LED's can be driven from a single source by wiring all LED's in series as shown in Fig. 8. The supply voltage used in that circuit is equal to the sum of the individual LED forward voltages and the voltage drop across the line-dropping resistor. The line-dropping resistance value can be calculated by using the equation

$$R = (V_S - V_{FT}) / I_F$$

The total forward voltage,  $V_{FT}$ , is the sum of the forward voltage drop of each LED.

The circuit shown in Fig. 8 draws minimal total current, but is limited in the number of LED's that it can drive. A number of those series LED circuits can,

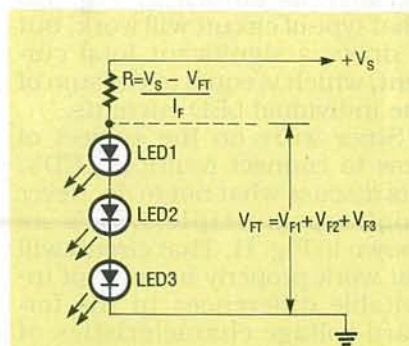

FIG. 8—LED'S WIRED IN SERIES and driven by a single current-limiting resistor.

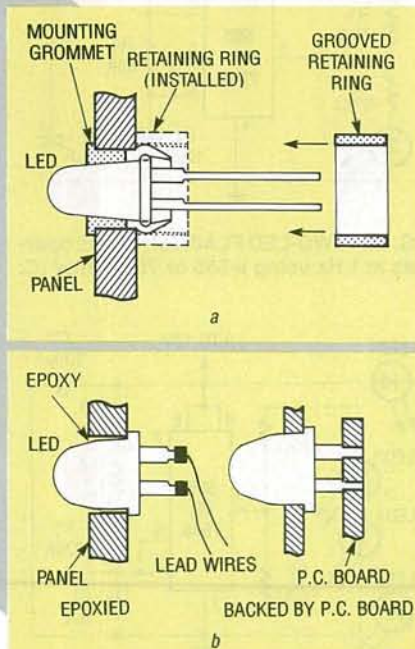

FIG. 5—LED MOUNTING METHODS; (a) shows an LED mounting kit consisting of a grommet and retaining ring, and (b) shows an LED mounted in a drilled hole with epoxy or soldered leads.

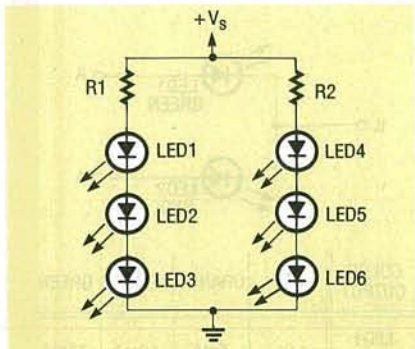

FIG. 9—A NUMBER OF SERIES LED circuits can be wired in parallel, to drive multiple LED's.

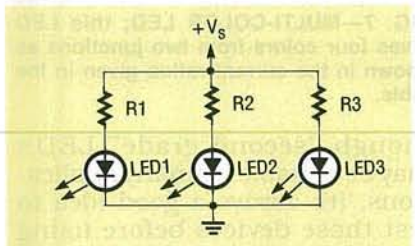

FIG. 10—THIS CIRCUIT CAN DRIVE a large number of LED's, but at the expense of high current.

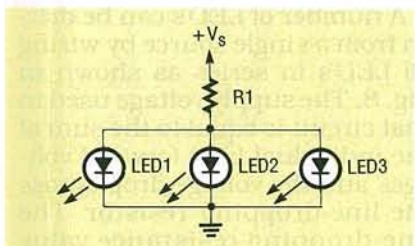

FIG. 11—NEVER USE THIS LED driving circuit. One LED will draw all of the current.

however, be wired in parallel, so that almost any number of LED's can be driven from a single source, as shown in the 6-LED circuit of Fig. 9.

An alternate but less efficient method of driving multiple LED's is to simply wire a number of dropping resistors and LED's in parallel, as shown in Fig. 10. That type of circuit will work, but it draws a significant total current, which is equal to the sum of the individual LED currents.

Since we're on the subject of how to connect multiple LED's, let's discuss what *not* to do. Never hook-up multiple LED's as shown in Fig. 11. That circuit will not work properly because of inevitable differences in the forward-voltage characteristics of the LED's, one LED will usually draw most of the available cur-

rent, leaving little or none left for the remaining LED's.

Three widely used types of visible-output LED-control circuits are those used for LED flashing, LED sequencing, and LED dot or bar analog-value indication. LED flasher circuits are designed to turn an LED alternately on and off, to give an eye-catching display action. Those circuits may control a single LED, or they may be designed to control two LED's in such a way that one turns on as the other turns off.

A special LED-flasher IC is available, the LM3909, which can be used to flash an LED from a low voltage DC supply, and does so at a very low average current level. Some practical LED flasher circuits using the LM3909 IC are shown later in this article.

LED sequencer circuits are designed to drive a chain of LED's so that each LED in the chain is switched on and off in a time-controlled sequence, so that a ripple of light seems to run along the chain.

LED analog-value indicator circuits are designed to visually appear and respond as an analog meter. An analog-value LED circuit drives a chain of linearly-spaced LED's in such a way that the length of the chain that is illuminated is proportional to the analog value of a voltage applied to the input of the driver circuit.

### LED-flasher circuits

One of the simplest types of LED display circuits is the LED flasher, in which a single LED repeatedly switches alternately on and off, usually at a rate of one or two flashes per second. A 2-LED flasher is a simple modification of this circuit, but is arranged so that one LED switches on when the other switches off. A 2-LED transistor flashing circuit is shown in Fig. 12.

In the flashing circuit shown in Fig. 12, Q1 and Q2 are wired as astable multivibrators, with their switching speeds determined by time constants  $R3 \times C1$  and  $R4 \times C2$ . The circuit operates at about 1 flash per second using the component values shown. The 2-LED flashing circuit can be converted to single-LED operation by replacing the unwanted

LED with a short circuit.

An IC version of the 2-LED flasher is shown in Fig. 13. This design is based on the dependable 555 timer chip, or its more modern CMOS counterpart, the 7555. The IC is wired in the astable mode, with its time constant determined by R4 and C1. The output at pin 3 of the IC alternately switches between the ground and the positive supply voltage, alternately shorting out

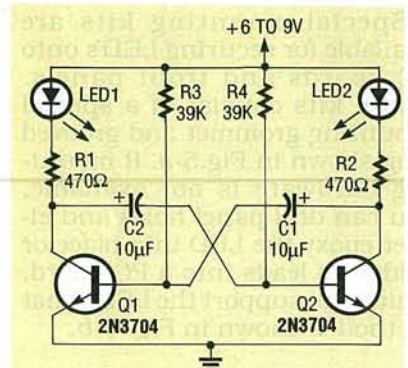

FIG. 12—TWO-LED FLASHER circuit operates at 1 Hz; Q1 and Q2 respond as astable multivibrators while LED1 and LED2 alternately flash on and off.

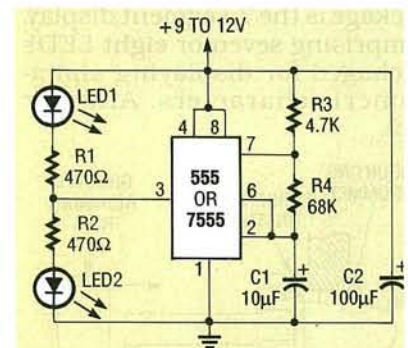

FIG. 13—TWO-LED FLASHER circuit operates at 1 Hz using a 555 or 7555 timer IC.

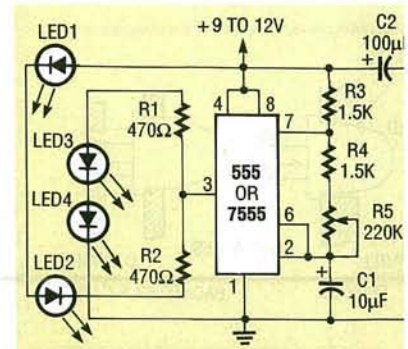

FIG. 14—FOUR-LED DOUBLE-BAR flasher in a "cross" configuration; the flash rate is variable from 15 to 2000 flashes per minute.

and disabling LED1 or LED2. The flashing circuit can be converted to single-LED operation by shorting out the unwanted LED and its associated current-limiting resistor.

A visually interesting display can be produced with a useful modification of the above circuit, shown in Fig. 14. Two pairs of series-connected LED's are connected in the form of a cross so that the visual display alternately switches between a horizontal bar (LED1 and LED2 on) and a vertical bar (LED3 and LED4 on). The flash rate is made variable via potentiometer R5 and can range between 15 and 2000 flashes per second.

### Flasher IC LM3909

A seemingly trivial task that sometimes faces the design engineer is that of providing illuminated power indication of the ON state of an electronic unit or the location of a passive device such as a fire extinguisher or emergency switch in a darkened room. LED's operate reliably when main power is available, but a serious problem arises when battery-powered equipment is involved.

LED indicators typically draw about 12 milliamps when illuminated and can therefore place a fairly heavy strain on small supply batteries. Since LED's drop two or more volts under the ON condition, they can not readily be powered from battery voltages below about 3 volts.

National Semiconductor provides an ingenious solution to the problem of LED power drain and operation from weak batteries with the 8-pin LM3909 LED flasher/oscillator IC. The LM3909 IC is a low-duty-cycle (brief ON period, long OFF period) oscillator that provides a voltage-doubled, high-current pulse to an external LED. High pulse currents of up to 100 milliamps are produced from the IC, while still drawing very low average currents of about 0.3 to 1.5 milliamps. Because of the voltage-doubling capability, the LM3909 can flash an LED even when powered from battery voltages as low as 1.1 volts, and can provide months, or even years, of continuous flashing operation from a

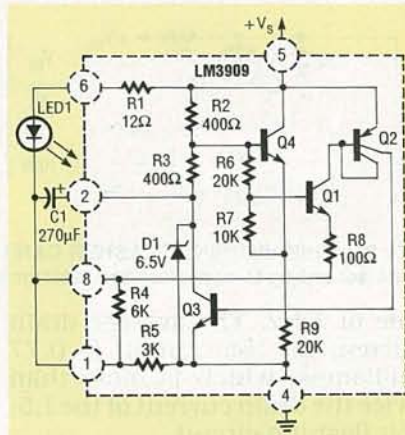

FIG. 15—INTERNAL CIRCUIT AND external connections of the LM3909 low-voltage LED flasher IC.

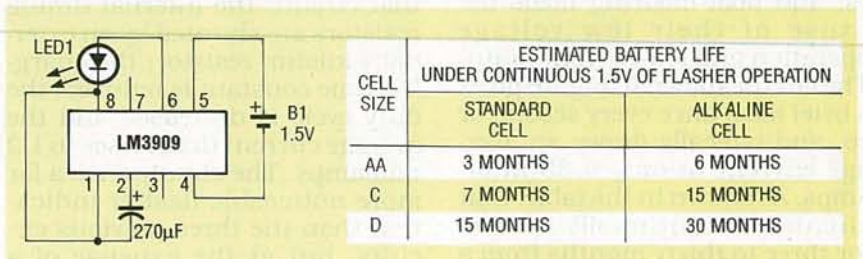

FIG. 16—LED FLASHER USING 1.5 VOLT SUPPLY. TABLE shows estimated battery life under continuous 1.5-volt LED flashing operation.

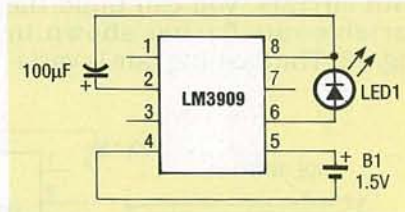

FIG. 17—MINIMUM POWER, longer life, 1.1-Hz flasher. Average drain current is 0.32 milliamps.

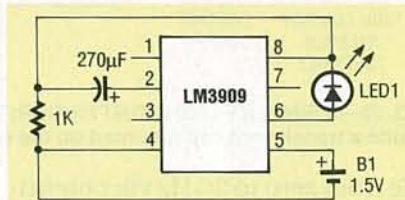

FIG. 18—FAST 1.5-VOLT BLINKER; flash rate is 2.6 Hz and drain current is 1.2 milliamps.

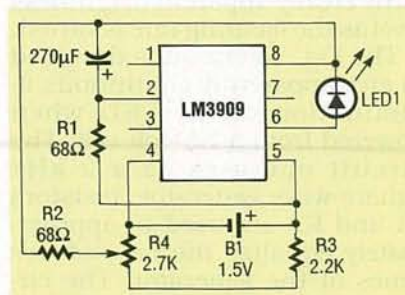

FIG. 19—VARIABLE-RATE FLASHER.

single 1.5-volt cell.

The LM3909 requires the addition of only a battery and a timing capacitor to function as an LED flasher. The internal circuit of this IC, together with typical external connections for 1.5-volt flasher operation, are shown in Fig. 15. In that particular application, the LED receives current via the 270- $\mu$ F timing capacitor C1, R1, and Q3 for only about 1% of the time. All transistors except Q4 are off for the remaining part of each operating cycle. Resistor R9 draws only about 50  $\mu$ A. The timing capacitor C1 is charged through R2 and

R3 and through R5 connected between pins 1 and 4 of the IC.

Transistors Q1 through Q3 remain off until C1 becomes charged to about 1 volt. That voltage is determined by the junction drop of Q4, its base-emitter voltage divider, consisting of R6-R7, and the junction drop of Q1. When the voltage at pin 1 becomes a volt more negative than that at pin 5 (+V<sub>S</sub>), Q1 begins to conduct and turns Q2 and Q3 on. The IC then supplies a pulse of high current to the LED. The current gain of Q2-Q3 is approximately 500. Transistor Q3 can handle over 100 milliamps of collector current, and rapidly pulls pin 2 close to ground, pin 4. Since C1 is charged at that time, it forces the pin 1 terminal below the ground potential value. As a result of the pin 1 terminal being less than the ground potential, the one-volt drop across the LED is greater than the supply voltage value—R1 then limits the LED current to a safe value.

Capacitor C1 alternately charges via the timing resistor R5 and discharges via the LED and R1 in this application. In some other applications, the

short between pins 1 and 8 can be removed, enabling the capacitor to charge through a total of 9 kilohms, increasing the duty cycle and reducing the average current drawn. If voltage boosting is not needed, loads can be wired directly between pins 2 and 6 or pins 2 and 5 of the IC.

The LM3909 IC is thus a fairly versatile device. A variety of useful applications are shown in the remaining part of this article.

### Practical LM3909 circuits

The LM3909 circuits shown in Figs. 16 and 17 can be used as locator beacons for fire extinguishers, emergency switches, and boat-mooring floats because of their low voltage operation and low current drain. The circuit shown in Fig. 16 gives a brief flash once every second or so, and typically draws an average current of only 0.63 milliamps. As shown in the table, that circuit will continually operate for three to thirty months from a battery, depending on the size and type of cell that is used.

An even longer life can be obtained from the minimum-power flasher circuit shown in Fig. 17. That circuit is similar to the one described above, except that the short is removed from between pins 1 and 8, causing the capacitor to charge via 9 kilohms of internal IC resistance ( $R4 + R5$ ). The IC then operates with an increased duty cycle, and reduced average current is drawn. That circuit has a typical current drain of 0.32 milliamps.

A circuit similar to that of Fig. 17 can be designed for use with a 3-volt power supply. For 3-volt operation, the timing capacitor value should be increased to 270  $\mu\text{F}$  for approximately the same flash

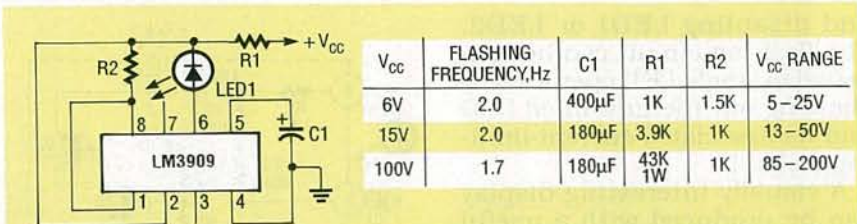

FIG. 21—THIS WARNING FLASHER CAN OPERATE within a voltage range of 5 to 200 volts according to capacitor and resistor values specified in the table.

rate of 1 Hz. The average drain current for that circuit is 0.77 milliamps, which is more than twice the drain current of the 1.5-volt flashing circuit.

Another variation of the 1.5-volt flasher shown in Fig. 18 operates at a frequency of 2.6 Hz. In that circuit, the internal timing resistors are shunted by an external 1-kilohm resistor; the charging time constant is reduced, the duty cycle is decreased and the average current drain rises to 1.2 milliamps. The circuit gives a far more noticeable flasher indication than the three previous circuits, but at the expense of a much higher current drain.

If you enjoy experimenting with circuits, you can build the variable-rate flasher shown in Fig. 19. The flashing rate is varia-

lumination and has a rather modest battery drain of about 4 milliamps.

All of the LED flasher circuits we have discussed in Figures 16 through 20 are intended for operation from 1.5- or 3-volt supplies. The LM3909 can also be used with much higher supply voltages, ranging from 5-200 volts DC. The internal 6.5-volt Zener diode, wired between pins 2 and 4 of the IC, regulates the voltage between the LED cathode and ground. Those circuit configurations can be made with a minimum number of external components, as shown in the schematic of Fig. 21.

As a final circuit suggestion, you can build a useful flashlight-finder shown in Fig. 22. The LM3909, 200- $\mu\text{F}$  timing capaci-

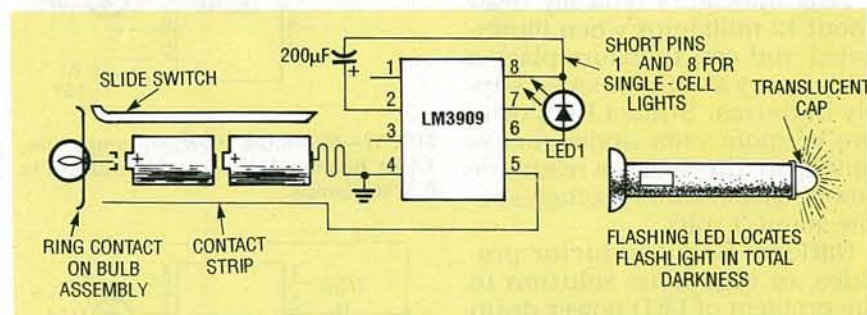

FIG. 22—A SIMPLE FLASHLIGHT FINDER; THE LM3909, capacitor and LED are installed inside a translucent cap mounted on the end of the battery.

ble from zero to 20 Hz via potentiometer R4. Resistors R1 and R2 are used to stabilize the duty cycle of the circuit and maintain a fairly steady apparent brightness level as the flashing rate is varied.

The Fig. 20 circuit is designed to give apparently continuous illumination of the LED when powered from a 1.5-volt cell. The circuit operates as a 2-kHz square-wave generator; resistors R1 and R2 are used to approximately equalize the ON and OFF times of the generator. The circuit gives a fairly dim LED il-

luminance and the LED are installed inside a translucent cap mounted on the end of the flashlight. An insulated contact strip connects to the positive terminal of the battery and passes through the case for connection to pin 5 of the IC. The negative terminal of the battery connects to pin 4 (ground) of the IC. If a single-cell light is used, short pins 1 and 8. Drawing current through the lamp filament simplifies wiring and causes negligible power loss since the resistance of a cold bulb is less than 2 ohms.

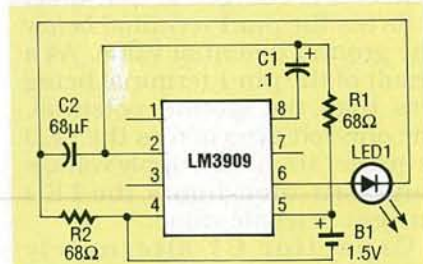

FIG. 20—HIGH EFFICIENCY LED indicator gives seemingly "continuous" operation from 1.5 volts. The current drain is 4 milliamps.



# Plug a Friend into **Radio Electronics**<sup>®</sup> this Christmas ... and Save \$19.43!

*This Christmas give an electrifying gift ... plug a friend into Radio-Electronics and brighten his whole new year! Whether electronics is his livelihood or his hobby, your gift will sharpen his focus and illuminate the whole spectrum of electronics throughout the coming year.*

Radio-Electronics will keep him informed and up-to-date with new ideas and innovations in all areas of electronic technology ... computers, video, radio, stereo, solid state technology, satellite TV, industrial and medical electronics, communications, robotics, and much, much more.

He'll get great plans and printed circuit patterns for great electronic projects. In just the last year, Radio-Electronics has presented voice scramblers, video switchers, frequency standards, wireless audio links, radiation monitors, function generators, and much more.

In coming issues, Radio-Electronics will present practical, educational, and money-saving projects like: a helium-neon laser ... a lighting controller ... a video timebase corrector ... a video noise processor ... a light-beam communicator ... an antenna amplifier ... and many others!

PLUS ... equipment troubleshooting techniques ... circuit design ... reports on new technology and new products ... equipment test reports ... in-depth coverage on computers, video, audio, shortwave radio ... and lots more exciting features and articles.

SAVE \$19.43\* ... OR EVEN \$38.86\* ... For each gift of Radio-Electronics you give this Christmas, you save a full \$19.43\* off the newsstand price. And as an R-E gift donor, you're entitled to start or extend your own subscription at the same Special Holiday Gift Rate —you save an additional \$19.43\*!

No need to send money ... if you prefer, we'll hold the bill till January, 1992. But you must rush the attached Gift Certificate to us to allow time to process your order and send a handsome gift announcement card, signed with your name, in time for Christmas.

So do it now ... take just a moment to fill in the names of a friend or two and mail the Gift Certificate to us in its attached, postage-paid reply envelope. That's all it takes to plug your friends into a whole year of exciting projects and new ideas in Radio-Electronics!

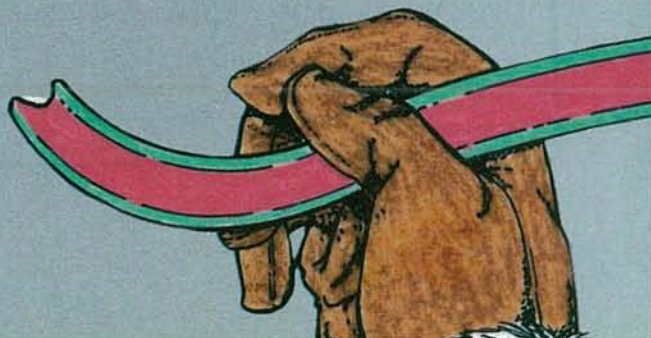

\*Basic sub rate — 1 yr/\$17.97 2 yrs/\$34.97

# Enter A World Of Excitement with a Subscription to Popular Electronics®

## Get the latest electronic technology and information monthly!

Now you can subscribe to the magazine that plugs you into the exciting world of electronics. With every issue of Popular Electronics you'll find a wide variety of electronics projects you can build and enjoy.

Popular Electronics brings you informative new product and literature listings, feature articles on test equipment and tools—all designed to keep you tuned in to the latest developments in electronics. So if you love to build fascinating electronics, just fill out the subscription form below to subscribe to Popular Electronics... It's a power-house of fun for the electronics enthusiast.

### EXCITING MONTHLY FEATURES LIKE:

- CONSTRUCTION**—Building projects from crystal sets to electronic roulette
- FEATURES**—Educational training on digital electronics, Ohm's Law, Antennas, Communications, Antique Radio, Simplified Theory
- HANDS-ON-REPORTS**—User test comments on new and unusual consumer products
- SPECIAL COLUMNS**—Think Tank, Circuit Circus, Computer Bits, DX Listening, Antique Radio, Amateur, Scanner Scene

### PLUS: ALL OUR GREAT DEPARTMENTS!

You'll get 12 exciting and informative issues of Popular Electronics for only \$18.95. That's a savings of \$16.45 off the regular single copy price. Subscribe to Popular Electronics today! Just fill out the subscription order form below.

**HOW RADIO GOT ITS VOICE**  
**Popular Electronics**  
 OCTOBER 1991  
**A Buyer's Guide to DMM's**  
 Explore the digital-multimeter marketplace at a glance in our handy round up  
**Does Your Meter Lie To You?**  
 Even the best meter can lead you astray if you don't fully understand what you are measuring  
**Build a Precision Dual-Output Power Supply**  
 An inexpensive, adjustable, dual-output supply that's packed with features  
**The Light-Beam Communicator**  
 Talk on a beam of light with this just-for-fun project  
**Product Reviews**  
 Canon L1 Camcorder, Yamaha AM/FM Stereo Tuner, Heath Analyzer, Neo-Geo Video System, and more  
**Save 46% Off The Regular NEWSSTAND Rate**  
 \$2.95 U.S. / \$3.75 CANADA  
 3 NEW Fact Cards IN THIS ISSUE  
 Also: • Think Tank • Ham Radio • Antique Radio • Scanner Scene

FOR FASTER SERVICE CALL TODAY

**1-800-827-0383**

(7:30AM-8:30PM)

EASTERN STANDARD TIME

## Popular Electronics® SUBSCRIPTION ORDER FORM

P.O. Box 338, Mt. Morris IL. 61054

AREA2

**YES!** I want to subscribe to Popular Electronics for 1 Full year (12 Issues) for only \$18.95. That's a savings of \$16.45 off the newsstand price.

- Payment Enclosed     Bill me later  
 Please charge my:     Visa     Mastercard

Acct. #

Signature

Exp. Date

PLEASE PRINT BELOW:

NAME

ADDRESS

CITY  STATE  ZIP

Allow 6 to 8 weeks for delivery of first issue. U.S. Funds only.  
 In Canada add \$6.68 Postage (Includes G.S.T.). All Other Foreign add \$7.50 Postage.

# EXPERIMENTING WITH ADC FOR YOUR PC

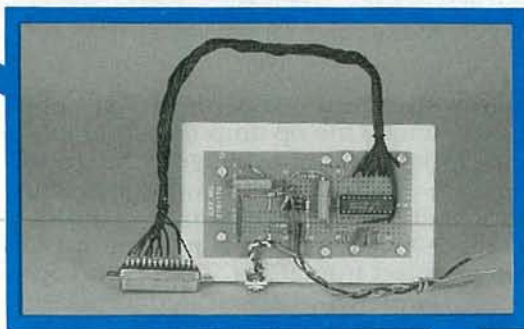
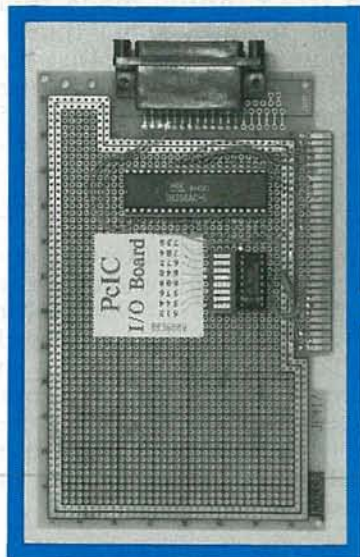

JAMES J. BARBARELLO

**Build our low-cost data-capture system and let your PC measure temperature, displacement, and other quantities.**

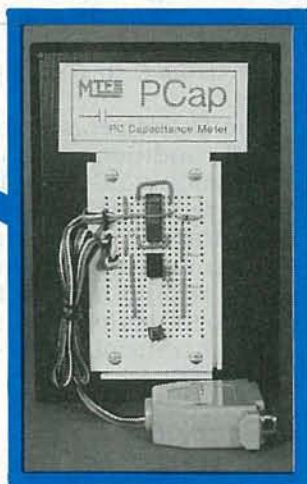

IN PREVIOUS ARTICLES, WE INTRODUCED several general-purpose analog and digital I/O systems for the PC. (See "Experimenting With PC-Based Test Equipment" in May, June, and July of 1991.) The first installment described a test instrument for measuring capacitance; the second described a digital R/C meter. Both devices interfaced to the PC via a standard parallel port. The third installment described a simple PC expansion card, the PC IO, that adds 24 digital I/O lines by means of an 8255 Parallel Input/Output (PIO) device, the standard in the PC architecture.

In this article, we'll build a very low cost analog-to-digital converter (ADC) interface that allows you to measure temperature, displacement, audio signals, and any other 0–5 volt analog signal. Our ADC builds off the PC IO: By adding an amplifier and ADC circuit, and some simple BASIC software, you can capture and display data and log it to your PC at a rate of 1000 (or more, de-

pending on the speed of your PC) data points per second.

This article shows you how to use the ADC to build an accurate temperature sensor, but it's easy to modify the circuit to accept other types of analog input devices.

## Circuit theory

As shown in the block diagram of Fig. 1, the circuit consists of two functional blocks: a signal conditioner and an A/D converter. The signal conditioner is a variable-gain amplifier with an adjustable DC offset that allows you to calibrate the circuit for a variety of sensors. To understand why calibration is necessary, let's look at the IC that does the actual analog-to-digital conversion, a standard eight-bit device called the ADC0804. Unlike a traditional voltmeter, the ADC0804 responds to AC voltage changes very quickly, in fact at a rate greater than 1000 per second. The ADC0804 converts each sample to digital form, after

which a computer may read the digital outputs for display or subsequent analysis.

The ADC0804 accepts an analog input of 0–5 volts DC and converts it to a binary number between 0 and 255. With a maximum range of 5 volts, and 256 steps between 0 and 5, resolution is  $5/256 = 0.0195$  volts, or almost 20 millivolts. So for any analog input voltage between 0.0000 and 0.0195, the ADC0804 will produce a binary 0 (00000000); for any voltage between 0.0195 and 0.0390, a binary 1 (00000001), and so on.

Twenty millivolts may seem like more than enough resolution, but what if you wanted to measure a signal with a maximum value of 40 millivolts? You'd only be able to distinguish two values in the given range. That's where the signal-conditioning portion

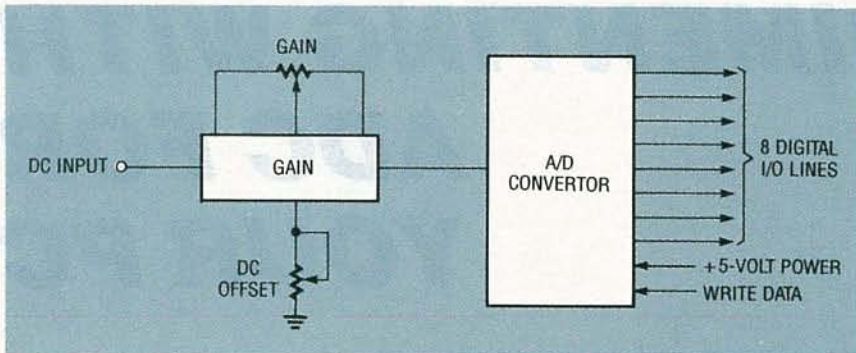

FIG. 1—BLOCK DIAGRAM shows the two major sections of the circuit, an amplifier and the ADC proper.

of the circuit comes in. By amplifying the signal so that it has an effective range close to the maximum range of the IC, we can break it down into much finer increments, and then let software scale it back to the appropriate value.

The DC offset portion of the signal conditioner lets us cancel any steady-state DC voltage and measure only the change in the DC voltage. That's required for the temperature sensor probe, which is built around the base-collector junction of a standard 2N2222 transistor. More on that in a moment.

### The circuit

Referring to the schematic diagram shown in Fig. 2, IC1 is a

standard 1458 (dual 741) op-amp. One op-amp (IC1-a) amplifies the input voltage by the ratio  $-R3/R6$ . With the values shown, that's a voltage gain of  $-10$ . Resistor R8 ensures minimum DC offset from IC1-a. The second op-amp (IC1-b) also functions as an amplifier, but in this case, voltage gain is  $-(R5 + R11)/R7$ , where R11 is a 15-turn, 10K potentiometer that allows the gain to be adjusted between values of  $-1$  and  $-2$ . Like R8, R9 ensures minimum DC offset from IC1-b. The two inversions in the op-amps result in a non-inverted output signal.

The voltage divider consisting of R2 and R12 allows insertion of a DC offset voltage of  $0$ – $+2.5$  volts DC. This can offset any

positive quiescent DC voltage from an input device.

The ADC is IC2; it is configured for a free-running mode that samples the input signal (pin 6) continuously. To ensure that the A/D is initialized properly, the software drives pins 3 ( $\overline{WR}$ ) and 5 ( $\overline{INTR}$ ) low momentarily on startup. The eight digital outputs (IC2 pins 12–18) drive the PIO directly, by way of P1.

A pair of 9-volt batteries supplies power for the op-amps; the host PC supplies +5-volt power for the voltage-divider circuit and IC2 via pin 25 of P1. Doing so ensures a more stable reference voltage than if the batteries were used. Of course, you're free to use a dual-polarity power supply in place of the batteries.

### Temperature sensing

A standard 2N2222 transistor can readily serve as a \$0.20 temperature sensor. Referring to Fig. 3-a, note that the emitter and base of Q1 are shorted together. That connection provides a diode—the base/collector junction. When power is applied across the junction, we would expect a constant drop of about 0.7 volts across it. The term *about* is important here, because the actual drop depends on the temperature of the junction.

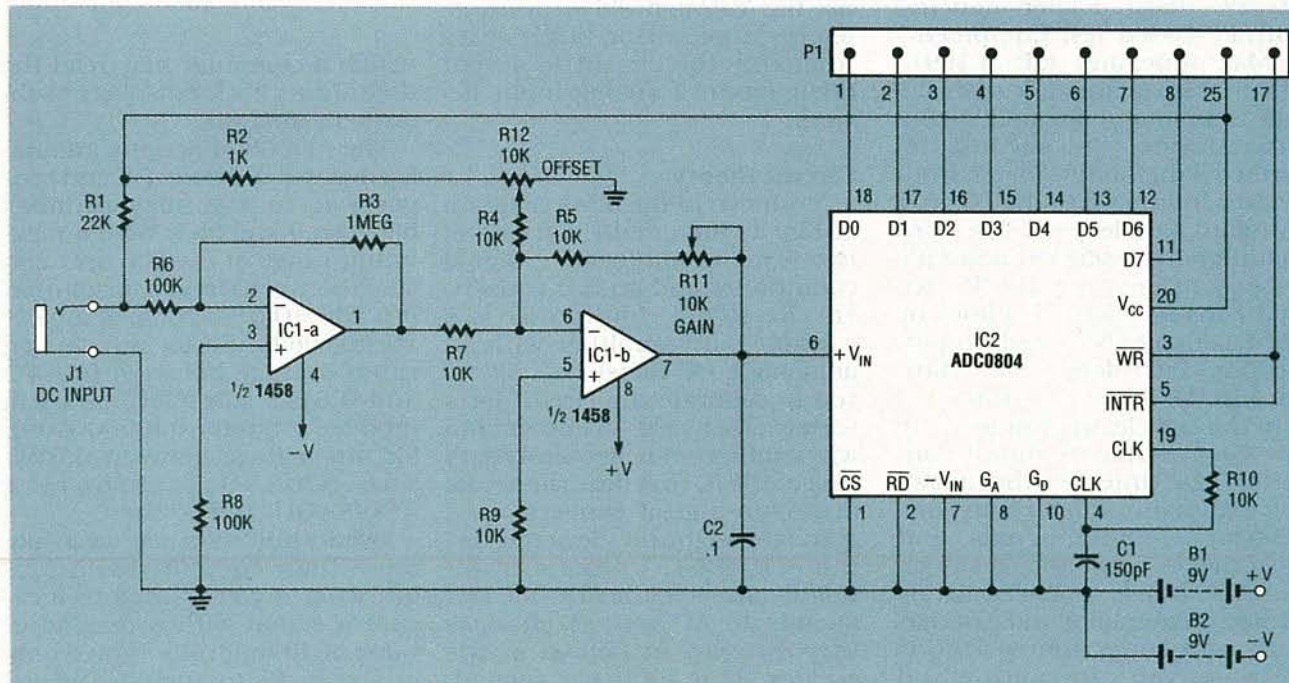

FIG. 2—COMPLETE SCHEMATIC shows the two gain stages (IC1-a, IC1-b) and the A/D converter (IC2).



## PARTS LIST

All resistors are 1/4-watt, 5%, unless otherwise noted.

R1—22,000 ohms

R2—1000 ohms

R3—1 megohm

R4, R5, R7, R9, R10—10,000 ohms

R6, R8—100,000 ohms

R11—R13—10,000 ohms, 15-turn potentiometer

### Capacitors

C1—150 pF, ceramic disk (any value between 150–330 pF OK)

C2—0.1  $\mu$ F, ceramic disk

### Semiconductors

IC1—5558 or 1458 dual op-amp, 8-pin DIP

IC2—ADC0804 or ADC0803 8-bit

A/D converter

Q1—2N2222 or PN2222 general purpose transistor

### Other components

B1, B2—9-volt battery

J1—miniature (1/8-inch) phono jack

P1—DB-25 male connector

**Miscellaneous:** 24-gauge stranded wire, perforated construction board, 9-volt battery clips, housing for probe, shielded cable.

**Note:** The complete PC IO Board (with PC board, and all components) is available for \$39.95 (part #PCIO). The ADC0804 and a calibrated PN2222A temperature sensor transistor are available for \$8.00 (part #ADC). Software, including compiled and source code versions with continuous and interval sampling and data logging/listing is available for \$8.00 (part #ADC-S). Specify part numbers and send check or Money Order to JJ Barbarello, 817 Tennent Road, Manalapan, NJ 07726. The author will be glad to answer any questions, but they must be accompanied by a self-addressed stamped return envelope.

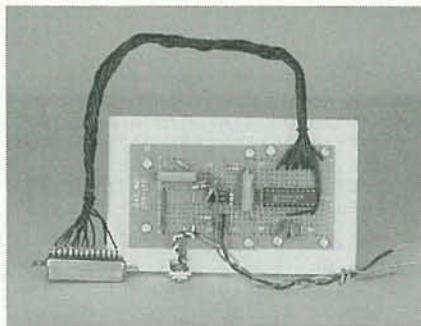

FIG. 4—THE AUTHOR'S PROTOTYPE was built on several pieces of scrap perforated construction board.

Silicon transistors used in this way have a temperature coefficient of about  $-2\text{mV}/^\circ\text{C}$ . That is, at  $0^\circ\text{C}$ , the drop would be about 0.6 volt. As the temperature increases, the drop decreases. At  $100^\circ\text{C}$  the drop will be about 0.4 volt. Although every transistor has a slightly different temperature coefficient, all transistors vary linearly with temperature. So by calibrating for the particular transistor used, it's possible to obtain an accurate yet low-cost temperature sensor.

## Construction

Assembly is not critical; you can build the circuit on perforated construction board as shown in Fig. 4. We recommend using sockets for the IC's.

To connect to the PC IO board, connect eleven one-foot lengths of wire to the appropriate points on IC2, and the other ends to the corresponding pins of P1, a standard DB-25 male connector.

Next, build the temperature probe. Use either a 2N2222A (metal case) or PN2222A (plastic case) and a length of shielded cable. Twist the base and emitter leads together, and solder them to the center conductor of the cable. To avoid shorts, cover the leads near the transistor with heat-shrink tubing. Mount the transistor in a cylindrical case (a hollowed-out ballpoint pen body, for example), making sure the case can withstand the temperature range you will be measuring. Fill the probe with silicone or epoxy. Then attach a miniature phono plug to the free end of the cable, making sure that the center conductor goes to the tip and the shield to the ring.

## The software

The QuickBASIC program that reads the voltage output of the circuit and converts it to a temperature is shown in Listing 1; note that line numbers are included for reference only. (The software is also available on the RE-BBS, 516-293-2283, 1200/2400, 8N1, as a file called PCADMATE.LST.) The program requires several constants to work. Rather than store that information in the QB file, which would require recompiling every time we recalibrate, we store it in a sequential data file, TEMP.DAT, which contains the values we need, each separated by a comma. First comes the decimal I/O port address of the PC I/O card (described in July), followed by the voltage at the low temperature, the low temperature, the voltage at the high temperature, and the high temperature. (Voltages should be specified in volts and temperatures in  $^\circ\text{C}$ .)

For example, if those values were 640, 4.1, 0, 0, and 100, TEST.DAT would contain

```
640, 4.1, 0, 0, 100
```

followed by a carriage return and line feed. The file can be created with any word processor; just remember to save it in ASCII or text format, not the word processor's native format.

Lines 2–4 of the program open TEMP.DAT, read the values, close the file, and then set up the 8255 on the PC IO card so that lines 1–16 are inputs, and 17–22 are outputs.

Lines 5–8 format the screen for a pleasing look.

Lines 9–17 are the real meat of the program, the measuring and display loop. Line 10 pulses the WRITE line low to obtain a reading. Line 11 then retrieves that reading into variable X. The program converts that number into a voltage (V) between 0 and 5.0. Next, line 12 calculates the Centigrade (cent) and Fahrenheit (faren) temperature values. Then lines 13–15 format and display the values. Line 16 pauses before the next sample is taken, and line 17 checks whether the Escape key has been pressed. If so, the program ends; otherwise, execution loops back to line 10.

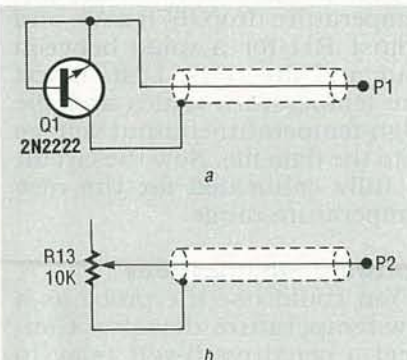

FIG. 3—DRIVE THE ADC with a temperature-sensing transistor (a) or a calibration potentiometer (b).

## Calibration

First create the data file (TEMP.DAT) with nominal values for port address, voltages, and temperatures (640, 4.1, 0, 0, 100); we'll fine-tune those values momentarily. Then run the program to initialize the PC IO card.

Next, connect the ADC circuit to the PC IO card, plug the probe into J1, and place the tip of the probe against a piece of ice. Using a digital voltmeter on a low range, measure the voltage across the tip and ring of the plug. Record the temperature (0°C) and the resultant voltage.

Pour some boiling water in a styrofoam cup, place the probe in the water, and repeat the process, recording both temperature (100°C) and voltage. Use the two voltage values to determine the temperature coefficient of your probe. For instance, if the 0°C reading were 552 mV and the 100°C reading were 342 mV, the temperature coefficient would be  $(0.342 - 0.552)/(100) = -2.1\text{mV}/^\circ\text{C}$ .

Prepare a 10K potentiometer as shown in Fig. 3-b. At this point, the ADC board should be connected to the PC IO, the 9-volt batteries (or other power source) should be connected, and the BASIC program should be running. Connect a DVM across J1, set the calibration potentiometer so the value on the DVM equals the high value taken earlier, and adjust R12 for 0.000 volts, as shown on the PC's screen. Then set the calibration potentiometer so the value on the DVM equals the low value, and adjust R11 for a value (as shown on the screen) between 4.0 and 4.5 volts. The actual value doesn't matter, just the difference between the high and low values.

Check the high reading setting again to make sure it is still 0.0 volts, and recalibrate if necessary. Go back and forth between the two readings several times.

Now enter the correct values into TEMP.DAT. Make sure the file is stored in the same sub-directory as the program.

Now you're ready to use the probe. Just place it against the item to be measured, and hold it there until you get a steady temperature reading.

## LISTING 1

```
REM*****
REM** ADCTEMP.BAS - V910629 *
REM** ADC0804 A/D IC & 2N2222 Temp Probe *
REM*****
1 CLS : DEFINT A, X: DEF SEG = 64
2 OPEN "TEMP.DAT" FOR INPUT AS 1
3 INPUT #1, add, lowvolt, lowval, hivalent, hival
4 CLOSE #1: OUT ADD + 3, 146
REM***** SET UP SCREEN *****
5 LOCATE 1, 23: PRINT "PCTEMP TEMPERATURE MEASURING SYSTEM"
6 LOCATE 2, 1: PRINT STRINGS(79, 220): LOCATE 8, 32: PRINT
STRINGS(16, 220)
7 FOR i = 9 TO 16: LOCATE i, 32: PRINT CHR$(219); SPACES(14);
CHR$(219): NEXT
8 LOCATE 12, 33: PRINT STRINGS(14, 220): LOCATE 16, 33: PRINT
STRINGS(14, 220)
REM***** SAMPLING LOOP *****
9 again:
10 OUT add + 2, 0: OUT add + 2, 1: REM: Take A Sample
11 x = INP(add): v = x * 5 / 255
12 cent=hival - (v * (hival - lowval) / lowvolt):faren = 1.8 *
INT(cent) + 32
13 LOCATE 4, 33: PRINT USING "Output = ### v"; v
14 LOCATE 10, 37: PRINT USING "###"; cent: PRINT CHR$(248); "C
15 LOCATE 14, 37: PRINT USING "###.##"; faren; : PRINT CHR$(248);
"F"
16 FOR i = 1 TO 500: NEXT
17 IF INKEY$ = CHR$(27) THEN END ELSE GOTO again
```

## LISTING 2

```
IF CENT < 10.5 THEN OUT ADD+1, 1
IF CENT > 10.5 THEN OUT ADD+1, 0
```

where  $V_Z$  is the voltage drop at 0°C, T is the temperature in °C and TC is the temperature coefficient.

## LISTING 3

```
4 CLOSE #1: OUT ADD + 3, 146: OPEN "READING.DAT" FOR OUTPUT AS 1
16 FOR i = 1 TO 500: NEXT: OUTPUT #1, v
17 IF INKEY$ = CHR$(27) THEN CLOSE: END ELSE GOTO again
```

## LISTING 4

```
OPEN "READING.DAT" FOR INPUT AS 1
DO WHILE NOT EOF(1)
INPUT #1, v: PRINT v
LOOP
CLOSE: END
```

## Alternate ranging

It is possible to adjust the circuitry and the computer program to any temperature range you desire. Just recalibrate the circuit and adjust the constants in TEMP.DAT. For example, assume you want to measure temperatures between -35°F and +104°F.

First, determine the temperature coefficient as described above. Next, convert the desired temperature range from °F to °C using the formula  $C = 5/9 \times (F - 32)$ . In our example, +104°F is 40°C, and -35°F is -37.2°C. Then calculate the drop at those two temperatures using the following formula.

$$V_D = V_Z + (T \times TC)$$

At 40°C,  $V_D = 600\text{ mV} + (40^\circ\text{C} \times -2.1\text{ mV}/^\circ\text{C}) = 600\text{ mV} - 84\text{ mV} = 516\text{ mV}$ .

At -37.2°C,  $V_D = 600\text{ mV} + (-35^\circ\text{C} \times -2.1\text{ mV}/^\circ\text{C}) = 600\text{ mV} + 78.17\text{ mV} = 678.17\text{ mV}$ .

Now plug in the calibration potentiometer (shown in Fig. 3-b) set it to the high-temperature drop (516 mV), and adjust R12 until the output is 0.000. Then set the potentiometer to the low temperature drop (678 mV), and adjust R11 for a value between four and five volts. Last, insert the temperature values and the high-temperature output voltage into the data file. Now the circuit is fully calibrated for the new temperature range.

## Software modifications

You could use the probe as a low-temperature detector. Connect a sensitive 5-volt relay to pins 9 (+) and 23 (gnd) of P1. The temperature goes below:

*continued on page 8.*



Corel Draw (Holtzman)(CC)	Feb 78	Ferroelectric IC's: Chips That Remember (Byers)	Mar 63	Laser Printer, Poor Man's (Renton)(C)	Apr
Current-Transformer Ideas (Lancaster)(HH)	Dec 69	FirstApps, hDC Computer Corp. (Holtzman)(CC)	Feb 78	LED Troubles (ARE)	Sep
Curve Fitting Fuzzy Data (Lancaster)(HH)	Oct 72	Flashlight Battery Supplies (Lancaster)(HH)	Oct 72	<b>Let's</b> Add an Audible Indicator to Our Logic Probe (Grossblatt)(DB)	Jun
<b>D</b>					
Data Controls' Analyst 2 Data Line Monitor (ER)	Feb 20	<b>Fluke</b> Model 12 Digital Multimeter (ER)	Dec 22	Build an Oscilloscope! (Grossblatt)(DB)	Oct
DC-to-AC Inverter Line Power From 12 Volts (Cuthbert)(C)	Apr 43	Model 45 Dual Display Multimeter (ER)	Mar 22	Look at Electronic Tuning Diodes (Lancaster)(HH)	Jun
<b>Digital Multimeter</b> <b>Fluke</b> Model 12	Dec 22	Model 79 DMM (ER)	Jul 20	<b>LETTERS (D)</b>	Jan 9, Feb 17, Mar
Model 45 Dual Display Multimeter	Mar 22	Flyback Squeal (ARE)	Apr 12	Line Power From 12 Volts (Cuthbert)(C)	Apr 13, May 14, Jun
Model 79	Jul 20	<b>FM</b> Stereo Standards (Lancaster)(HH)	Dec 69	Logic Analyzer (Robidoux & Dmitrova)(C)	Jun 31, Jul
Global Specialties PCI-DMM PC-Based Multimeter	Nov 22	Transmitter, Simple (Melton)(C)	Nov 84	The Micro Monitor (Cooke)(C)	Oct 67, Nov
<b>Digital</b> Signal Processing New World of DSP, The (Bernard)	Jun 43	Focused X-Ray Breakthrough, and More (Lancaster)(HH)	Aug 69	<b>Logic Probe</b> A Simple, Inexpensive (Grossblatt)(HH)	May
Sinewave Synthesizer (Swift)(C)	Oct 43	Fractals and Chaos Update (Lancaster)(HH)	Dec 69	Audible PC Board For Our (Grossblatt)(DB)	Aug
Storage Oscilloscopes, A Buyer's Guide to (Prentiss)	Nov 31	Frequency Counter, Universal, Turn Your PC Into a (Grasty & Schulz)(C)	Feb 37	Let's Add an Audible Indicator to (Grossblatt)(DB)	Jun
Tachometer (ARE)	Jun 8	Friendly Amiga, The (Holtzman)(CC)	Aug 81	Long-Playing Recorder, A (ARE)	Mar
-to-Analog and Analog-to-Digital Converters (Bigelow)	Jul 58	Frugalvision Image Capture Board Video Capture on the Cheap! (Toner)(C)	Dec 37		
Distortion Primer, A: Part I (Klein)(AUD)	Jun 72	Fuel Cells (Hubscher)	Jun 61, (LET)		
Part II (Klein)(AUD)	Jul 74	Future Products (Klein)(AUD)	Sep 74		
Doppler-Ultrasound Heart Monitor (Jaffe)(C)	Nov 49	<b>G</b>			
DRAM Tester (Huff)(C)	May 33	<b>Global Specialties</b> PCI-DMM PC-Based Multimeter (ER)	Nov 22	Machine-Shop Resources (Lancaster)(HH)	Apr
<b>DRAWING BOARD (Grossblatt)(D)</b>	Mar 77, Apr 78	Protolab (ER)	Jan 12	Macintosh-Compatible Computer, Build Your Own (Colby)(C)	Jan 31, (LET) May
Automotive Charging Systems Every Test Bench Needs a Good Power Supply	Dec 75				
Let's Add an Audible Indicator to Our Logic Probe	Jun 74				
Let's Build an Oscilloscope!	Oct 85				
PC Board For Our Audible Logic Probe	Aug 77				
Simple but Effective Test Equipment	Apr 78				
Driving Inductive Loads, and More (Lancaster)(HH)	Sep 67				
DSP, The New World of (Bernard)	Jun 43				
Dual-Digital Potentiometer (Lancaster)(HH)	Feb 71				
Dual Display Multimeter, Fluke Model 45 (ER)	Mar 22				
<b>E</b>					
E-Field Machines (Lancaster)(HH)	Oct 72				
Efficiency and Amplifier Design (Klein)(AUD)	Dec 78				
<b>Electric</b> Dog Tag Contest, and More (Lancaster)(HH)	Nov 78				
Motor Resources (Lancaster)(HH)	Feb 71				
Electrical Quantities One Volt = ?	Feb 63				
Electrocardiograph, Build Your Own (Roberts)(C)	Jul 31, Aug 44				
Electromagnetic Theory, An Intuitive Look at (Rice)	Aug 65, Sep 57				
	Oct 53, Nov 64, Dec 60				
<b>Electronic</b> Compass (Caristi)(C)	Jun 39, (LET) Sep 16				
Fuse (Petruzzellis)(C)	Dec 63				
Tuning Diodes, Let's Look at (Lancaster)(HH)	Jun 65				
Electronics Workbench, Interactive Image Technologies' (Holtzman)(CC)	Jul 77				
ELF Gaussmeter Magnetic Field Meter (Metz)(C)	Apr 33				
Energy Consumption Monitor (Brule)(C)	Dec 31				
<b>EQUIPMENT REPORTS (D)</b>	Jan 12, Feb 20, Mar 22				
	Apr 18, Jun 22, Jul 20				
	Aug 22, Sep 18, Oct 22				
	Nov 22, Dec 22				
Data Controls' Analyst 2 Data Line Monitor	Feb 20				
<b>Fluke</b> Model 12 Digital Multimeter	Dec 22				
Model 45 Dual Display Multimeter	Mar 22				
Model 79 DMM	Jul 20				
Global Specialties PCI-DMM PC-Based Multimeter	Nov 22				
Protolab	Jan 12				
Hewlett Packard 54601A Portable Digital Oscilloscope	Apr 18				
HS25 Heavy Duty "Stick" Style Multimeter	Jun 22				
R.L. Drake R-8 World Band Shortwave Receiver	Sep 18				
Sharp Model PC-E500 Pocket Computer	Aug 22				
Units + Conversion Factors Unit Conversion Software	Oct 22				
Every Test Bench Needs a Good Power Supply (Grossblatt)(DB)	Mar 77				
Evolution of Standards, The (Holtzman)(CC)	Apr 85				
Experimenting With PC-Based Test Equipment (Barbarelli)(C)	May 57, Jun 48, Jul 53				
Experiments in Voice Recognition (Cooper)(C)	Apr 49				
<b>F</b>					
<b>FCC</b> Approves No-Code (Stone)	Apr 27				
Regulations (Lancaster)(HH)	Oct 72				
<b>H</b>					
Ham Radio Call-Alert, Build R-E's (Kreuter & Plant)(C)	Oct 60				
<b>HARDWARE HACKER (Lancaster)(D)</b>	Jan 68, Feb 71				
	Apr 71, May 65, Jun 65				
	Jul 68, Aug 69, Sep 67				
	Oct 72, Nov 78, Dec 69				
Cheap Visible Lasers, and More Cold Fusion Update, and More Curve Fitting Fuzzy Data	Feb 71 Jan 68 Oct 72				
Driving Inductive Loads, and More Electric Dog Tag Contest, and More Focused X-Ray Breakthrough, and More Let's Look at Electronic Tuning Diodes New Hackable Project Ideas, and More	Nov 78 Aug 69 Jun 65 Apr 71, (LET) Jul 8				
Standards Resource Information, and More Toner Cartridge Reloading, More On	Dec 69 May 65, (LET) Aug 14 Jul 68				
Understanding Transforms, and More	Jul 68				
Heart Monitor, Doppler-Ultrasound (Jaffe)(C)	Nov 49				
Hercules Graphics Station Card (Holtzman)(CC)	May 77				
Hewlett Packard 54601A Portable Digital Oscilloscope (ER)	Apr 18				
High-Energy Resources (Lancaster)(HH)	Oct 72				
History in the Making (Holtzman)(CC)	Oct 94				
Home Intercom System, Use Your Telephones as a (Polimene)(C)	May 44				
Home-Energy Monitoring (Lancaster)(HH)	Dec 69				
Hot Troubleshooting Tips (Phelps)	Feb 61				
Houghton Mifflin's American Heritage Dictionary (Holtzman)(CC)	Jul 77				
HS25 Heavy Duty "Stick" Style Multimeter (ER)	Jun 22				
<b>I</b>					
<b>IBM</b> Compatibility (ARE)	Dec 12				
XGA Adapter (Holtzman)(CC)	Jun 80				
Induction Motor Speed Controls (Lancaster)(HH)	Feb 71				
Infrared People Detectors (Lancaster)(HH)	Apr 71				
"In-Package" Battery Testers (Lancaster)(HH)	Apr 71				
<b>Inside</b> Marketing Information for the Audio Consumer (Klein)(AUD)	Nov 86				
Switching Power Supplies (Triefley)	Apr 57, May 49				
Intel 8052 (ARE)	Oct 8				
Interactive Image Technologies' Electronics Workbench (Holtzman)(CC)	Jul 77				
Intercom, Home System Use Your Telephones as a (Polimene)(C)	May 44				
Intuitive Look At Electromagnetic Theory, An (Rice)	Aug 65, Sep 57, Oct 53, Nov 64, Dec 60				
<b>J</b>					
Japan: The Evolution of an Audio Colossus (Klein)(AUD)	May 72				
<b>K</b>					
Keyboard Tracer (ARE)	May 12				
<b>L</b>					
LANtastic Two-Station AE-2 Ethernet Starter Kit, Artisoft's (Holtzman)(CC)	Mar 84				
<b>M</b>					
Machine-Shop Resources (Lancaster)(HH)	Apr				
Macintosh-Compatible Computer, Build Your Own (Colby)(C)	Jan 31, (LET) May				
	(LET) Apr 13, (LET) Aug				
Magnetic Field Meter (Metz)(C)	Apr 33, (LET) Jul 8, (LET) Sep				
Making Connections (Holtzman)(CC)	Mar				
Micro Monitor (Cooke)(C)	Oct 67, Nov				
Microanalyzer, Build the (Miga)(C)	Sep				
Micrografx Designer 2.0 (Holtzman)(CC)	Jul				
<b>Microsoft</b> MS-DOS 5.0 (Holtzman)(CC)	Sep				
Windows 3.0 (Holtzman)(CC)	Jan 84, Feb				
Windows 3.1 (Holtzman)(CC)	Jun				
Microwave-Oven Tester Build the Microanalyzer (Miga)(C)	Sep				
Microwave Resources (Lancaster)(HH)	May				
More On AM Radio (Dec 1990)	(LET) Feb				
More Fonts, MicroLogic (Holtzman)(CC)	Feb				
Motorcycle Rebuild (ARE)	Aug				
MS-DOS 5.0 (Holtzman)(CC)	Sep				
Multilayer Keyboard (ARE)	Jun 8, (LET) Sep				
Multimeter, Fieldpiece HS25 "Stick" Style (ER)	Jun				
Music on Hold (Hausman)(C)	Nov				
<b>N</b>					
Negative Ion Generator, Build a (Caristi)(C)	Jan 41, Feb				
New Beginning for this Column, A (Holtzman)(CC)	Jul				
New Hackable Project Ideas, and More (Lancaster)(HH)	Apr				
<b>NEW LIT (D)</b>	Jan 28, Feb 31, Apr				
	May 28, Jun 28, Jul 29, Aug				
	Sep 28, Oct 27, Nov 28, Dec				
<b>NEW PRODUCTS (D)</b>	Jan 18, Feb 22, Mar				
	Apr 22, May 22, Jun				
	Jul 22, Aug 24, Sep				
	Oct 24, Nov 24, Dec				
New Wave in the Computer Industry, A (Holtzman)(CC)	Nov				
New World of DSP, The (Bernard)	Jun				
No Color Titles (ARE)	Mar				
NTSC-To-RGB Converter (Oct 1990)	(LET) Feb				
<b>O</b>					
OEM, Custom Models, and Private Labels (Klein)(AUD)	Nov				
One Volt = ? (Nasser)	Feb				
<b>Oscilloscope</b> Hewlett Packard 54601A Portable Digital (ER)	Apr				
Let's Build an (Grossblatt)(DB)	Oct				
<b>Oscilloscopes</b> Analog (O'Neal)	Nov				
Putting a New Scope to Work (Ramirez)	Jan				
<b>P</b>					
Parametric Amplification (Lancaster)(HH)	Jun				
Past, Present, and Future of Tape Cartridges, The (Klein)(AUD)	Aug				
Patent Alternatives (Lancaster)(HH)	Jan				
PC Board For Our Audible Logic Probe (Grossblatt)(DB)	Aug				
<b>PC-Based</b> Multimeter, Global Specialties' PCI-DMM (ER)	Nov				
Test Equipment, Experimenting With (Barbarelli)(C)	May 57, Jun 48, Ju				
PC-to-TV Converter (Stevens)(C)	Oct				
Personal Communications Networks (Newell)	Ma				
Photovoltaic Panel Bargains (Lancaster)(HH)	No				

ne (See also TELEPHONE)  
 Caller ID (Lancaster)(HH) Sep 67  
 Entry, The (Cooper)(C) Sep 60  
 Pizzazz Plus, Application Techniques (Holtzman)(CC) Feb 78  
 Pocket Computer, Sharp Model PC-E500 (ER) Aug 22  
 Printer Man's Laser Printer (Renton)(C) Apr 17, (LET) Jun 74, Jul 8  
 Power Electronic Resources (Lancaster)(HH) Jul 68  
 Converter, DC-to-AC Line Power From 12 Volts (Cuthbert)(C) Apr 43  
 Supply, Every Test Bench Needs a Good (Grossblatt)(DB) Mar 77  
 Venting Modem Dropouts (Lancaster)(HH) Jun 65  
 Full-Screen Indicator (ARE) May 12, Sep 12, (LET) Dec 14  
 Programmable Logic Resources (Lancaster)(HH) Sep 67  
 Programmer, 874X (Eady)(C) Nov 71  
 Protolab, Global Specialties' (ER) Jan 12  
 Pulse Mate (Plant)(C) May 41  
 Putting a New Scope to Work (Ramirez) Jan 50

## R

Radio All-Alert, Build R-Es (Kreuter & Plant)(C) Oct 60  
 R.L. Drake R-8 World Band Shortwave Receiver (ER) Sep 18  
 R-Es EZ Shortwave Receiver, Tune in the World With (Kreuter)(C) Jan 56  
 R-8 Drake R-8 World Band Shortwave Receiver (ER) Sep 18  
 Reader Letters: Some Bouquets and Brickbats (Klein)(AUD) Oct 82  
 Robot, Stepper-Motor (Eady)(C) Apr 63  
 RS-232 Terminal/Monitor (Avritch)(C) Aug 50

## S

Secondary Charging (ARE) Jun 8, Oct 14  
 Santa Claus Machines (Lancaster)(HH) May 65  
 Scope, Putting a New One to Work (Ramirez) Jan 50  
 Semiconductor Memories (Bigelow) Mar 68  
 Serial-Bus Analyzer RS-232 Terminal/Monitor (Avritch)(C) Aug 50  
 Servicing Hot Troubleshooting Tips (Phelps) Feb 61  
 Putting a New Scope to Work (Ramirez) Jan 50  
 Sharp Model PC-E500 Pocket Computer (ER) Aug 22  
 Shortwave Receiver R-Es EZ, Tune in the World With (Kreuter)(C) Jan 56  
 R.L. Drake R-8 World Band (ER) Sep 18  
 Simple but Effective Test Equipment (Grossblatt)(DB) Apr 78  
 FM Transmitter (Melton)(C) Nov 84  
 Sensitive Logic Probe, A (Grossblatt)(HH) May 75  
 Software Generator (ARE) Oct 8  
 Synthesizer, Digital (Swift)(C) Oct 43  
 Single-Channel Filter (ARE) Aug 8  
 Power Recording (ARE) Oct 8  
 NIST Time Code Standards (Lancaster)(HH) Nov 78  
 SOFTWARE 874X Programmer (Eady)(C) Nov 71  
 Adobe PostScript Cartridge (Holtzman)(CC) Mar 84  
 Type Manager (Holtzman)(CC) Feb 78  
 American Heritage Electronic Dictionary, Houghton Mifflin's (Holtzman)(CC) Jul 77  
 CrossTalk for Windows, DCA (Holtzman)(CC) Feb 78  
 Corel Draw (Holtzman)(CC) Feb 78  
 Electronics Workbench, Interactive Image Technologies' (Holtzman)(CC) Jul 77  
 FirstApps, hDC Computer Corp. (Holtzman)(CC) Feb 78  
 Micrografx Designer 2.0 (Holtzman)(CC) Jul 77  
 Microsoft MS-DOS 5.0 (Holtzman)(CC) Sep 75  
 Windows 3.0 (Holtzman)(CC) Jan 84, Feb 78  
 Windows 3.1 (Holtzman)(CC) Jun 80

MoreFonts, MicroLogic (Holtzman)(CC) Feb 78  
 Pizzazz Plus, Application Techniques (Holtzman)(CC) Feb 78  
 Software Solution (ARE) Sep 12  
 ToolBook 1.0, Asymetrix Corp.'s (Holtzman)(CC) Feb 78  
 Ventura Publisher Windows Edition (Holtzman)(CC) Feb 78  
 Windows, Microsoft Pains (and Pleasures) (Holtzman)(CC) Feb 78  
 3.0, Microsoft (Holtzman)(CC) Jan 84, Feb 78  
 3.1 (Holtzman)(CC) Jun 80  
 Watch (Holtzman)(CC) Jun 80  
 Units + Conversion Factors Unit Conversion Software (ER) Oct 22  
 Solar Energy Breakthrough (Lancaster)(HH) Nov 78  
 Solid State Tesla Coil (Bylund)(C) Sep 33  
 Some Predictions for PC's to Come During the Next Decade (Holtzman)(CC) Jan 84  
 Speaker Cables, Will "Beastie" Improve Your Audio? (Honeycutt) Feb 50  
 Speaker Protector (Vaught)(C) Aug 55, (LET) Dec 14  
 Spectrum Analyzer (Doberstein & Cardone)(C) Aug 33, Sep 40  
 Standards Resource Information, and More (Lancaster)(HH) Dec 69  
 The Evolution of (Holtzman)(CC) Apr 85  
 Video (Holtzman)(CC) May 77  
 Stepper-Motor Robot (Eady)(C) Apr 63  
 Switching Power Supplies, Inside (Trietley) May 49, Apr 57

## T

Tape Cartridges, The Past, Present, and Future of (Klein)(AUD) Aug 80  
 Technical Literature (Lancaster)(HH) Jan 68, Feb 71  
 Apr 71, Aug 69, Oct 71  
 Telecommunications Personal Communications Networks (Newell) May 61  
 TELEPHONE Build R-Es Call-Alert (Kreuter & Plant)(C) Oct 60  
 Caller ID (Lancaster)(HH) Aug 69  
 Music on Hold (Hausman)(C) Nov 58  
 Phone Sentry, The (Cooper)(C) Sep 60  
 Telephone Information (Lancaster)(HH) Aug 69  
 Use Your Telephones as a Home Intercom System (Polimene)(C) May 44  
 Video Telephone (Colby)(C) Mar 33, Apr 45  
 Terminal/Monitor, RS-232 (Avritch)(C) Aug 50  
 Tesla Coil, Solid State (Bylund)(C) Sep 33  
 Coils (Lancaster)(HH) Oct 72  
 TEST EQUIPMENT Analog Scopes (O'Neal) Nov 43  
 Audio Sweep/Marker Generator (Wannamaker)(C) Feb 43, Mar 55  
 Build the Microanalyzer (Miga)(C) Sep 47  
 Color Bar Generator (Gould)(C) Jul 41  
 Data Controls' Analyst 2 Data Line Monitor (ER) Feb 20  
 Digital Sinewave Synthesizer (Swift)(C) Oct 43  
 Digital Storage Oscilloscopes, A Buyer's Guide to (Prentiss) Nov 31  
 DRAM Tester (Huff)(C) May 33  
 Electronic Fuse (Petruzzellis)(C) Dec 63  
 Experimenting With PC-Based Test Equipment (Barbarelli)(C) May 57, Jun 48, Jul 53  
 Fluke Model 12 Digital Multimeter (ER) Dec 22  
 Model 45 Dual Display Multimeter (ER) Mar 22  
 Model 79 DMM (ER) Jul 20  
 Global Specialties PCI-DMM PC-Based Multimeter (ER) Nov 22  
 Protolab (ER) Jan 12  
 Hewlett Packard 54801A Portable Digital Oscilloscope (ER) Apr 18  
 Hot Troubleshooting Tips (Phelps) Feb 61  
 Let's Build an Oscilloscope! (Grossblatt)(DB) Oct 85  
 Logic Analyzer (Robidoux & Dmitrova)(C) Jun 31, Jul 47  
 Micro Monitor (Cooke)(C) Oct 67, Nov 67  
 Pulse Mate (Plant)(C) May 41  
 Putting a New Scope to Work (Ramirez) Jan 50

Simple but Effective Test Equipment (Grossblatt)(DB) Apr 78  
 Spectrum Analyzer (Doberstein & Cardone)(C) Aug 33, Sep 40  
 THD Analyzer (Keidel)(C) Dec 47  
 Turn Your PC Into a Universal Frequency Counter (Grasty & Schulz)(C) Feb 37, Mar 43  
 THD Analyzer (Keidel)(C) Dec 47  
 Toner Cartridge Reloading, More On (Lancaster)(HH) May 65  
 ToolBook 1.0, Asymetrix Corp.'s (Holtzman)(CC) Feb 78  
 Total Harmonic Distortion (ARE) Dec 12  
 Transfer Functions Part II: Answering a Letter of Protest (Klein)(AUD) Mar 74  
 Transmitter, Simple FM (Melton)(C) Nov 84  
 Troubleshooting Tips, Hot (Phelps) Feb 61  
 Tune In the World With R-Es EZ Shortwave Receiver (Kreuter)(C) Jan 56, (LET) Oct 14  
 Turn Your PC Into a Universal Frequency Counter (Grasty & Schulz)(C) Feb 37, Mar 43

## U

Understanding Decibels (Lancaster)(HH) Jan 68  
 Transforms, and More (Lancaster)(HH) Jul 68  
 Units + Conversion Factors Unit Conversion Software (ER) Oct 22  
 Universal Frequency Counter, Turn Your PC Into a (Grasty & Schulz)(C) Feb 37, Mar 43  
 Unusual Newsletters (Lancaster)(HH) Jun 65  
 Use Your Telephones as a Home Intercom System (Polimene)(C) May 44, (LET) Nov 16

## V

V/F Converters (Trietley) Jun 54  
 Ventura Publisher Windows Edition (Holtzman)(CC) Feb 78  
 VHF Resources (Lancaster)(HH) May 65  
 VIDEO (See also VIDEO NEWS) Color Bar Generator (Gould)(C) Jul 41  
 PC-to-TV Converter (Stevens)(C) Oct 33  
 Capture on the Cheap! (Toner)(C) Dec 37  
 Compression Secrets (Lancaster)(HH) Jul 68  
 Crosshatch Generator (Lancaster)(HH) Jul 68  
 Standards (Holtzman)(CC) May 77  
 Sync (ARE) Mar 33, Apr 45  
 Telephone (Colby)(C) Dec 69  
 Time Codes (Lancaster)(HH) Dec 69  
 VIDEO NEWS (Lachenbruch)(D) Jan 8, Feb 6, Mar 6  
 Apr 6, May 6, Jun 6  
 Jul 6, Aug 6, Sep 6  
 Oct 6, Nov 6, Dec 6  
 Vocal Effects/Mixer (Weeder)(C) Oct 39  
 Voice Recognition, Experiments in (Cooper)(C) Apr 49  
 Voltage Doubler (Hubscher)(C) Aug 61  
 -to-Frequency Converters (Trietley) Jun 54

## W

WHAT'S NEWS (D) Jan 4, Feb 4, Mar 4  
 Apr 4, May 4, Jun 4  
 Jul 4, Aug 4, Sep 4  
 Oct 4, Nov 4, Dec 4  
 Wavelet Breakthroughs (Lancaster)(HH) Jul 68  
 Wholesale Surplus Sources (Lancaster)(HH) Jan 68  
 Wig-Wag Circuit? (ARE) Nov 12  
 Will "Beastie" Speaker Cables Improve Your Audio? (Honeycutt) Feb 50  
 Wind-Speed Read (ARE) Apr 12 (ARE) Apr 12  
 Windows Pains (and Pleasures) (Holtzman)(CC) Feb 78  
 3.0, Microsoft (Holtzman)(CC) Jan 84, Feb 78  
 3.1 (Holtzman)(CC) Jun 80  
 Watch (Holtzman)(CC) Jun 80



He's listening to a radio station in China.



It's a microphone.



64K! And you call yourself a man...

## SPEAKER MATE

continued from page 46

sure to wipe off the tip of your iron on a wet sponge immediately after melting the plastic. Transformer T1 should be mounted with its marker, if any, toward the input jack side.

The last step is installing all jumpers (J) and JU1; the JU1 jumper is installed for phone-line powered applications, and left out for use with an external power source. So install JU1 for now, and we'll go into greater detail on it later. If a jumper runs close to existing circuitry, you might place some shrink tubing on the bare lead. The kit mentioned in the parts list includes some shrink tubing.

There are some options for the front-panel configuration. In the prototype, SPST toggle switch S1 is used as the ANSWER switch and is mounted next to LED1, the "power on" indicator. Cut the leads long enough to reach the front panel without too much excess. Volume control R20 has its attached switch, S2, wired in series with the microphone element to provide a "mute" function. The mute setup works well because the low-impedance microphone circuit doesn't pick up interference when open. If the mute function is not needed, R20's switch can become the ANSWER switch and you can eliminate toggle switch S1. However, the complete kit does include the toggle switch.

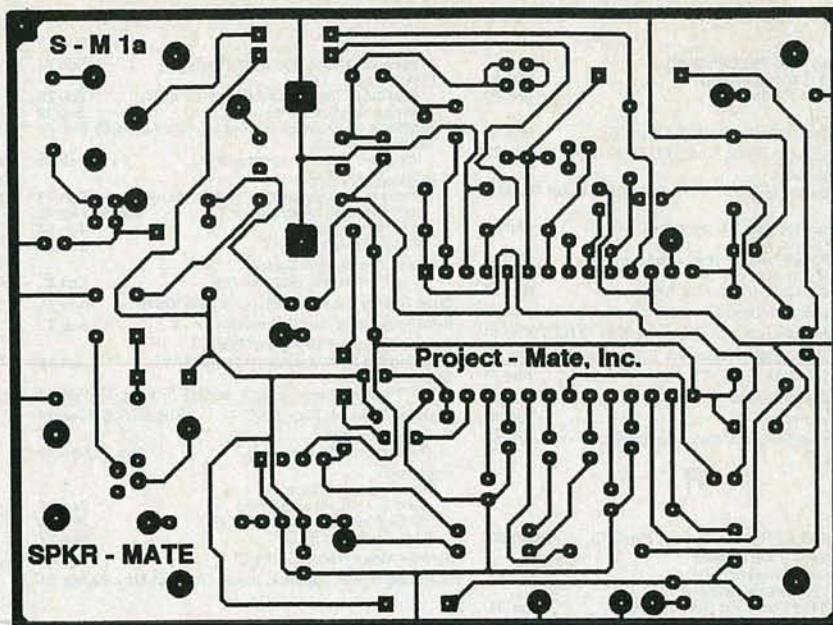

FOIL PATTERN for the Speaker-Mate.

In preparing the circuit board for the cabinet, leave the speaker leads long enough to attach the speaker on the top half of cabinet. We have found that a spare piece of perforated construction board makes an excellent drilling guide for making a neat speaker grille on top of the cabinet. Cutting out a notch on the cabinet rear for the modular telephone jack (J1) and drilling a 1/2-inch hole for access to the microphone gain potentiometer completes the cabinet back.

Completion of the front panel is next. Figure 5 shows how we mounted the microphone. A 3/8-inch inside-diameter rubber grommet was glued to the inside of the front panel behind the 3/8-inch microphone opening. You can use either hot-melt glue or

RTV silicone. Insert the microphone element (with leads attached) into the grommet so that it sits back just enough to not touch the front panel, but not more; a recessed element will give an echo sound we want to avoid. This step acoustically and mechanically decouples the microphone from the speaker output yet gives some directional effect. It will be glued in such a position in the grommet in just a minute. Note that an electret microphone is polarity-sensitive; the pin that connects to the case of the microphone is ground.

Finish up by wiring R20 and its switch S2, LED1, and S1. We found that prewiring these components first makes assembly easier. The final step is to fit the panel into the enclosure and glue LED1, the microphone, and the speaker in place with RTV silicone, making sure that the electret element is positioned as mentioned before. Set the microphone gain potentiometer, R1, to about half way. Figure 6 shows the completed Speaker-Mate prototype.

### Testing and use

For acoustical reasons, the proven approach to testing the unit is with the board mounted in a closed case. At an extreme setting of microphone gain, the microphone may pick up the speaker output. This extreme

continued on page 48

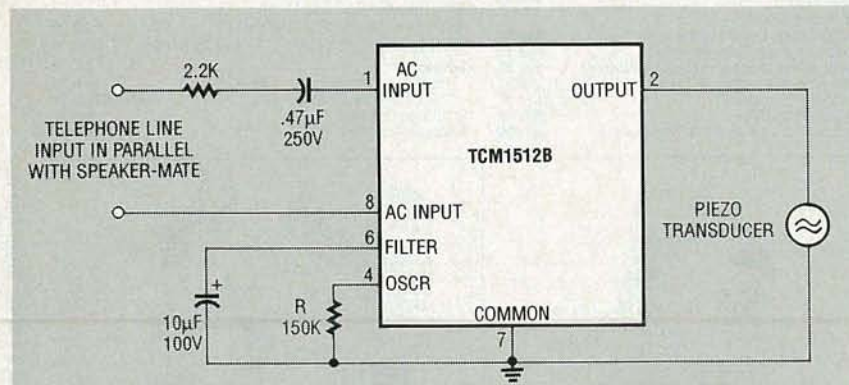

FIG. 8—YOU MAY WANT TO ADD a ringer to the Speaker-Mate. The tone ringer chip (IC3) monitors the telephone line for a ring signal of 15 to 68 Hz, 40 to 150 volts AC. Resistor R sets the warble and center frequency; with R at 150K, the warble is approximately 10 Hz and the center frequency is 1250 Hz.

# HARDWARE HACKER

VGA adapter for the Mac LC, computer monitors, flyback, shielding, and GPS navigation resources.

DON LANCASTER

It seems I did miss an obvious source in our recent *Tesla and High Energy Resources* sidebar. This is the *Tesla Society* up in Colorado, who runs a great museum and now offers annual Tesla and nontraditional energy conferences. Their *High Energy Enterprises* division has lots of books and videotapes.

These range the gamut from hard-to-find and genuinely useful research materials on down (way on down) through bunches of "Boy-a-whole-flock-of-them-flew-over-that-time!" pseudoscience titles.

On the other hand, if you are into antigravity, the 1000 miles per gallon carburetors, Russian weather control conspiracies, *Reed* motors, all those pangalactic happy faces on Mars, or zero point scalar energy, these books and videos are definitely for you. This is *most* fascinating reading and watching, either way.

Actually, I'll freely admit that I firmly now believe in one trilateral conspiracy. That's the one involving the first, second, and third laws of thermodynamics. But that's just me. And if you want to prove me wrong, just show to me any simple and independently verifiable experiment that anyone can reliably duplicate.

Some more info on wavelets: The *Wavelets* book offered by *Jones and Bartlett* is at long last in print. And a major new tutorial just came out in the October 1991 *IEEE-SP Signal Processing* magazine on pages 14-38.

## Shields and shielding

These have been popular topics lately on our helpline, so perhaps it is time to go over some fundamentals. You can *shield* something electronic either to keep objectionable signals from getting out or getting in. For instance, on any light dimmer, you might want to suppress the horrible AM radio interference caused by a triac suddenly turning on. On a low-

level audio circuit, you might want to prevent power-line hum and noise from getting to you.

If you do know ahead of time that you're going to have interfering noise or signals present, one very powerful technique is to change over to fully *balanced* circuits. They sense only the *differences* between their inputs, rather than any absolute values with respect to ground. Thus, any *common mode* interfering signals that bounce both inputs up and down together will automatically be rejected. Or at least suppressed. Several fancy audio studios have even gone to totally balanced power lines to dramatically reduce their hum and noise problems.

There are usually two paths that interference can travel. One is with *radiated* energy, which can propagate directly through space to emit from or interact with your circuit. The other is *conducted* energy, which enters along your power connectors and input or output cables.

Since separate tricks are needed to deal with any radiated or conducted energy, step one is finding out *which* path is the one you will want to deal with first.

The radiated energy interference will usually have two components. They are that "E" or *electric* field, which largely concerns itself with induced *voltages* and that "H" or *magnetic* field, which creates induced *currents*. Once again, you have to

know *which* field component you are going to suppress before you pick a proper method.

Any old conductor should usually block an E field. One obvious hacker choice that works well are boxes built up out of double-sided printed-circuit board. See Fig. 1.

But there are gotchas. At lower frequencies, there is the lack of a well-developed *skin effect*, which causes an E field to penetrate *deeper* into a conductor. Thus, *thicker* shields are needed to suppress *lower* frequencies. Say 20 mils for an AM broadcast band use or 80 mils for the high ultrasonic frequencies.

A shield can also act as a shorted turn to any nearby inductor, possibly lowering the Q and detuning. A slot or other continuity break can sometimes help this problem.

While some small shield holes are often tolerable, any poor contacts are definitely not. A continuous solder bead or else lots and lots of individual screws may be needed for really high shielding effectiveness.

It's very important that unintended currents don't ever run through any shields. Unwanted signal drops can often end up in *series* with your input signals, making things much worse rather than better. Which is also why you should keep all your digital and analog grounds separate.

The H fields can be blocked by use of any strongly magnetic materials. These materials are said to have a very high *permeability*. The simplest magnetic shield is a piece of scrap sheet steel from the air conditioning shop or trailer hitch works. But things get messy in a hurry if you need lots of magnetic attenuation.

Those special and fancy shielding materials are optimum only in certain thicknesses and over a specific frequency range. Worse yet, some of these cannot be cut or drilled without a complex reannealing process. An

## NEED HELP?

Phone or write your **Hardware Hacker** questions directly to:  
Don Lancaster  
**Synergetics**  
Box 809  
Thatcher, AZ 85552  
(602) 428-4073

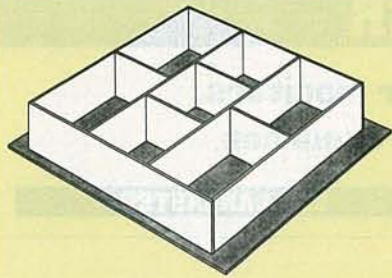

**FIG. 1—SIMPLE E-FIELD SHIELDS** for radio-frequency hacker projects are easily built up from pieces of double-sided printed circuit board stock.

too strong of a magnetic field could saturate a shield, making it useless.

To be effective, a magnetic shield should completely surround the volume it is protecting.

A good free booklet on all of the fundamentals of magnetic shielding is available from *Amuneal*, while other sources of custom shield materials now include *Advance Magnetics* and *Magnetic Shield Corp.*

Conducted interference can be best eliminated by some blocking filter. These filters should freely pass

## GPS RESOURCES

**Ashtech**  
390 Potrero Avenue  
Sunnyvale, CA 94086  
(800) 229-2400  
CIRCLE 301 ON FREE INFORMATION CARD

**Bancomm**  
6541 Via del Oro  
San Jose, CA 95119  
(408) 578-4161  
CIRCLE 302 ON FREE INFORMATION CARD

**GPS World**  
P.O. Box 10460  
Eugene, OR 97440  
(503) 343-1200  
CIRCLE 303 ON FREE INFORMATION CARD

**Magellan Systems Corp.**  
960 Overland Court  
San Dimas, CA 91773  
(818) 358-2363  
CIRCLE 304 ON FREE INFORMATION CARD

**Magnavox**  
2829 Maricopa Street  
Torrance, CA 90503  
(800) 421-5864  
CIRCLE 305 ON FREE INFORMATION CARD

**NASA Tech Briefs**  
41 East 42nd Street Ste. 921  
New York, NY 10017  
(212) 490-3999  
CIRCLE 306 ON FREE INFORMATION CARD

**Rockwell Commercial GPS**  
P.O. Box 568842  
Dallas, TX 75356  
(214) 996-5863  
CIRCLE 307 ON FREE INFORMATION CARD

**Speleonics**  
P.O. Box 5283  
Bloomington, IN 47407  
(812) 339-7305  
CIRCLE 308 ON FREE INFORMATION CARD

**TI/GPS Products**  
P.O. Box 869305, M/S 8449  
Plano, TX 75086  
(214) 575-4057  
CIRCLE 309 ON FREE INFORMATION CARD

**Trimble Navigation**  
585 North Mary Avenue  
Sunnyvale, CA 94086  
(800) TRI-MBLE  
CIRCLE 310 ON FREE INFORMATION CARD

the signals of interest, but present a high series impedance and a low shunt impedance to all others. *Murata-Erie* is one good source.

The *ferrite bead* is a remarkably cheap and super effective inter-

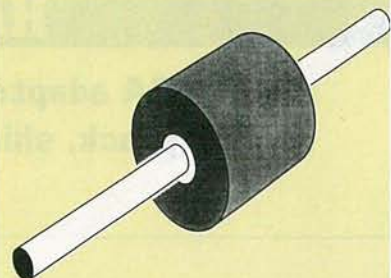

**FIG. 2—FERRITE BEAD** interference suppressors are simply slipped onto any conductor. The ferrite beads behave as lossy and broadband high-frequency transformers. Multiple turns can also be used.

ference suppressor. As Fig. 2 shows, you simply hang them on a wire, or else run a turn or two through them. Ferrite beads act as a broadband high-frequency lossy transformer. There are various materials and sizes again depending on frequency. Sources of ferrite beads include *Fa Rite*, *FerriShield*, *Ferroxcube*, *Intermark*, and *Siemens*.

One very little known ferrite bead gotcha: Do *not* ever cast a ferrite bead in epoxy or otherwise constrain it so it cannot move. The beads *must* be able to physically change their size slightly, or else the performance will sharply degrade.

Two trade journals that involve themselves with shields and shielding are *Electronics Test and Compliance Engineering*.

## Monitor fundamentals

We sure do get a lot of computer monitor and TV compatibility calls. Let's start off with the obvious: The performance and bandwidth of an ordinary TV or VCR using composite NTSC video is severely limited. That is why all the computer folks went for special RGB monitors in the first place. And that is why nearly all the computers are *totally incompatible* with ordinary television gear.

Yes, there now are all sorts of ways you can use your computer for video editing or to record computer screens on a VCR. But note that there is *no way* I know of that you can record plain old 80-column text as composite video on your VCR.

How does a monitor work? Inside is a cathode ray "picture tube" with one or more guns that squirt lots of electrons at a phosphor screen.

## NEW FROM DON LANCASTER

### HARDWARE HACKER STUFF

Hardware Hacker Reprints II or III	24.50
Midnight Engineering Reprints	16.50
Incredible Secret Money Machine	16.50
CMOS Cookbook	24.50
TTL Cookbook	24.50
Active Filter Cookbook	19.50
Micro Cookbook vol I or II	19.50
Lancaster Classics Library	109.50
AppleWriter Cookbook	19.50

### POSTSCRIPT STUFF

Ask The Guru Reprints I, II or III	24.50
LaserWriter Secrets (Ile/Mac/PC)	29.50
PostScript Show & Tell	39.50
Intro to PostScript VHS Video	39.50
PostScript Beginner Stuff	39.50
PostScript Cookbook (Adobe)	16.50
PostScript Ref. Manual II (Adobe)	28.50
PostScript Program Design (Adobe)	22.50
Type I Font Format (Adobe)	15.50
LaserWriter Reference (Apple)	19.50
Real World Postscript (Roth)	22.50
PostScript Visual Approach (Smith)	22.50
Thinking in PostScript (Reid)	22.50
Undst PS Pgrmmg (Holtzgang)	26.50
The Whole Works (all PostScript)	299.50

### BOOK-ON-DEMAND STUFF

Book-on-demand resource kit	39.50
Bakerizing film package	16.50

FREE VOICE HELPLINE VISA/MC

## SYNERGETICS

Box 809-RE  
Thatcher, AZ 85552,  
(602) 428-4073



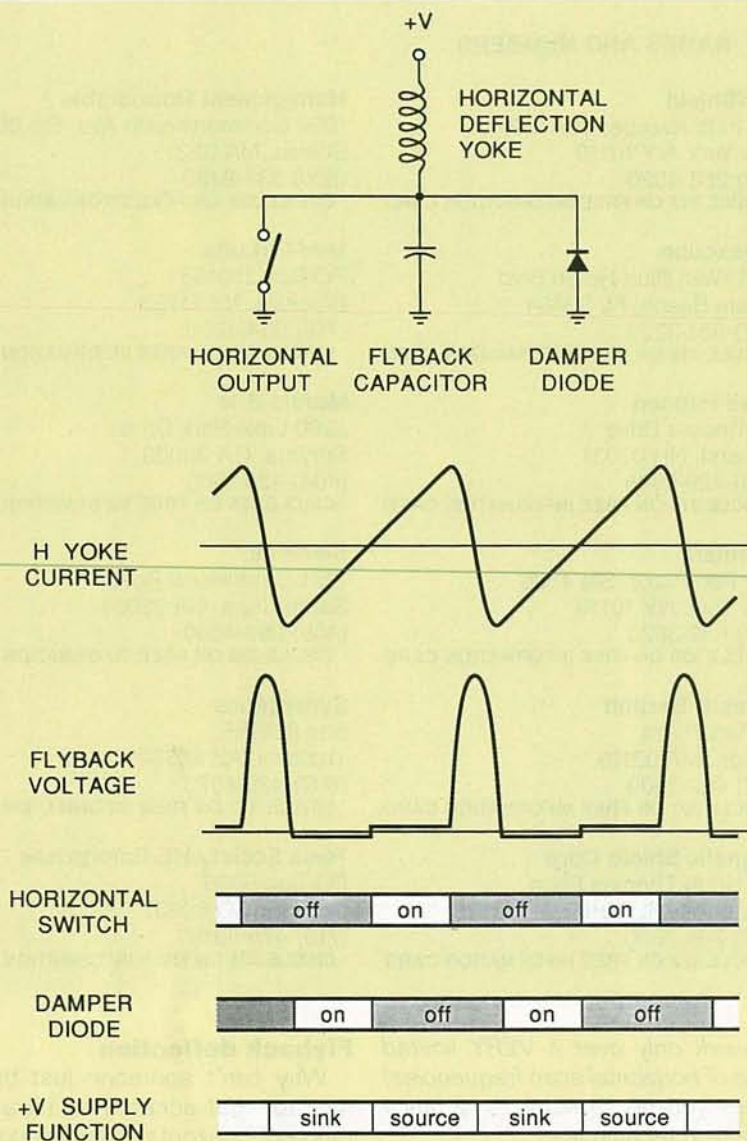

**FIG. 3—THE RECURRENT FLYBACK SWEEP** on television sets and computer monitor displays is extremely energy efficient, but will only work over a VERY limited range of horizontal scan rates.

any instant, *only one single dot* appears on the screen. That dot gets moved around by the scanning process, and will get brightened and dimmed by rapidly setting its intensity at a video modulation rate.

To build up the *illusion* of a full picture, that scanned dot is moved rapidly and *horizontally* from left to right and more slowly *vertically* from the top to bottom. The decay characteristics of the phosphors selected and your human persistence of vision combine to create the *illusion* of a total picture.

Television uses what is known as an *interlaced* scan. To build up a TV frame, the dot starts at the upper left

and rapidly scans to the right and slowly on downward, painting every *second* scan line. When it gets to the bottom of this *field*, it goes back to the top and picks up what it missed, painting a second field. The normal field rate is usually 60 hertz for black and white or 59.94 hertz for color.

The NTSC (National Television Standards Committee) standard uses 512 lines per frame, or 262.5 lines per field. That leads to standard horizontal scan rates of 15750 Hertz for black and white or 15735 Hertz for color. The two numbers end up slightly different to get all the rest of those color magic numbers to properly drop in place.

## DIGITAL VIDEO STABILIZER ELIMINATES ALL VIDEO COPYGUARDS



While watching rental movies, you will notice annoying periodic color darkening, color shift, unwanted lines, flashing or jagged edges. This is caused by the copy protection jamming signals embedded in the video tape, such as Macrovision copy protection. THE DIGITAL VIDEO STABILIZER: COMPLETELY ELIMINATES ALL COPY PROTECTIONS AND JAMMING SIGNALS AND BRINGS YOU CRYSTAL CLEAR PICTURES.

### FEATURES

- Easy to use and a snap to install
- State-of-the-art Microchip technology
- 100% automatic
- Compatible to all types of VCRs and TVs
- The best and most exciting Video Stabilizer in the market
- Light weight (8 ounces) and compact (1x3.5x5")
- Uses a standard 9 Volt battery (last 1-2 years)
- Fast UPS delivery
- Air shipping available
- UNCONDITIONAL 30 day money back guarantee
- 1 year warranty

### WARNING

THE DIGITAL VIDEO STABILIZER IS INTENDED FOR PRIVATE HOME USE ONLY. IT IS NOT INTENDED TO COPY RENTAL MOVIES OR COPYRIGHTED VIDEO TAPES THAT MAY CONSTITUTE COPYRIGHT INFRINGEMENT.

(Dealers Welcome)  
**FREE 20P Catalog**

To Order: \$59.95 ea +\$4 for p & h  
Visa, M/C, COD Mon-Fri: 9-6 EST

**1-800-445-9285 ext. 63801**  
SCO Electronics Inc. Dept. 63801  
581 W. MERRICK RD. VALLEY STREAM, NY 11580

CIRCLE 191 ON FREE INFORMATION CARD

## CABLE TV DESCRAMBLERS How You Can Save Money on Cable Rental Fees

### Bullet Proof

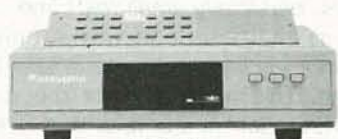

1 Unit 5+

BEST Super Tri-Bi Auto/  
Var. Gain Adjustment \$119.95...\$85  
Jerrold Super Tri-Bi... \$109.95...\$79  
Scientific Atlanta... \$109.95...\$79  
Pioneer... \$109.95...\$79  
Panasonic TZPC145... \$99.95...\$79  
Stargate Converter... \$95...\$69  
Digital Video Stabilizer...\$59.95...\$29  
Wireless Video Sender...\$59.95...\$49.95

**US Cable'll Beat  
Anyone's Price  
Advertised in  
this Magazine!**

**30 Day Money Back Guarantee  
FREE 20 page Catalog**

Visa, M/C, COD or send money order to:

**U.S. Cable TV Inc.** Dept. 53801  
4100 N. Powerline Rd., Bldg. F-4  
Pompano Beach, FL 33073

**1-800-772-6244 ext. 53801**

### For Our Record

I, the undersigned, do hereby declare under penalty of perjury that all products purchased, now and in the future, will only be used on Cable TV systems with proper authorization from local officials or cable company officials in accordance with all applicable federal and state laws. FEDERAL AND VARIOUS STATE LAWS PROVIDE FOR SUBSTANTIAL CRIMINAL AND CIVIL PENALTIES FOR UNAUTHORIZED USE.

Date: \_\_\_\_\_

Signed: \_\_\_\_\_

**No Florida Sales!**

CIRCLE 192 ON FREE INFORMATION CARD

## NAMES AND NUMBERS

### Actel

955 East Arques Avenue  
Sunnyvale, CA 94086  
(408) 739-1010  
CIRCLE 311 ON FREE INFORMATION CARD

### AD-Vance Magnetics

625 Monroe Street  
Rochester, IN 46975  
(219) 223-3158  
CIRCLE 312 ON FREE INFORMATION CARD

### American Colloid Co

1500 West Shore Drive  
Arlington Heights, IL 60004  
(708) 392-4600  
CIRCLE 313 ON FREE INFORMATION CARD

### Amuneal

4737 Darrah Street  
Philadelphia, PA 19124  
(215) 535-3000  
CIRCLE 314 ON FREE INFORMATION CARD

### Aremco

PO Box 429  
Ossining, NY 10562  
(914) 762-0685  
CIRCLE 315 ON FREE INFORMATION CARD

### Fair-Rite

PO Box J  
Wallkill, NY 12589  
(914) 895-2055  
CIRCLE 316 ON FREE INFORMATION CARD

### FerriShield

350 Fifth Avenue, Ste 7505  
New York, NY 10118  
(212) 268-4020  
CIRCLE 317 ON FREE INFORMATION CARD

### Ferroxcube

2001 West Blue Heron Blvd  
Riviera Beach, FL 33404  
(407) 881-3200  
CIRCLE 318 ON FREE INFORMATION CARD

### Steve Hansen

35 Windsor Drive  
Amherst, NH 03031  
(603) 429-0948  
CIRCLE 319 ON FREE INFORMATION CARD

### Intermark

One Pen Plaza, Ste 4526  
New York, NY 10119  
(212) 629-3620  
CIRCLE 320 ON FREE INFORMATION CARD

### Jones & Bartlett

20 Park Plaza  
Boston, MA 02116  
(617) 482-3900  
CIRCLE 321 ON FREE INFORMATION CARD

### Magnetic Shield Corp

740 North Thomas Drive  
Bensenville, IL 60106  
(708) 766-7800  
CIRCLE 322 ON FREE INFORMATION CARD

### Management Roundtable

1050 Commonwealth Ave, Ste 301  
Boston, MA 02215  
(800) 338-2223  
CIRCLE 323 ON FREE INFORMATION CARD

### Mini-Circuits

PO Box 350166  
Brooklyn, NY 11235  
(718) 934-4500  
CIRCLE 324 ON FREE INFORMATION CARD

### Murata-Erie

2200 Lake Park Drive  
Smyrna, GA 30080  
(404) 436-1300  
CIRCLE 325 ON FREE INFORMATION CARD

### Siemens

2191 Laurelwood Road  
Santa Clara, CA 95054  
(408) 980-4500  
CIRCLE 326 ON FREE INFORMATION CARD

### Synergetics

Box 809-RE  
Thatcher, AZ 85552  
(602) 428-4073  
CIRCLE 327 ON FREE INFORMATION CARD

### Tesla Society/HE Enterprises

PO Box 5636  
Security, CO 80931  
(719) 475-0918  
CIRCLE 328 ON FREE INFORMATION CARD

Interlaced scan is used by NTSC to minimize flicker. But *interlaced scan is totally unsuitable for data displays, especially small text!* The reason is that interlace works only if successive lines are more or less the same. This is clearly *not* the case between dot lines of finer text. Thus, most computer screens *demand* a *noninterlaced* display where each field is complete and identical.

Most computer monitors also will use a 59.94- or a 60-hertz vertical scan rate. Less than that and you'll end up with too much flicker. If you try to lengthen the phosphor persistence you may end up with "comets" for traveling balls.

The horizontal scan rate is decided by how many horizontal lines you are using per field. As you increase the number of lines in a display, the horizontal scan rate goes up. Scan rates from 22 to 45 kilohertz are typical, with some exotic displays going much higher.

Now for the kicker: *Most monitors*

*will work only over a VERY limited range of horizontal scan frequencies! Unless you go to some very fancy multi-sync techniques.*

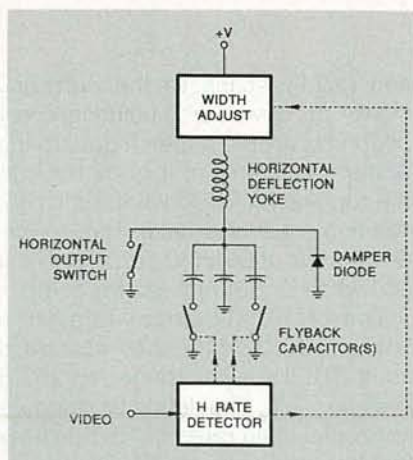

**FIG. 4—MULTI-SYNCING MONITORS change their sweep values to try and match an input horizontal scanning rate. But once selected, they still operate only over a very limited frequency range.**

### Flyback deflection

Why can't someone just build monitor that accepts an ultra-wide range of horizontal scan frequencies and be done with it? The answer that has much to do with both energy conservation and the way things have been done in the past.

A set of coils known as a *deflection yoke* normally goes on the neck of the display tube. These are plain coils that will move your electron beam to wherever you want it to go. Normally, the horizontal yoke is where all the action is, since it does things several hundred times faster than the vertical one.

Since several kilowatts or more of deflection power are involved in the horizontal deflection of a large computer display, sneaky tricks will have to be played to reuse and recycle all of the energy involved. These sneaky tricks go by the name of *recurrent flyback deflection*, and are shown to you in Fig. 3.

The basic rule of any inductor

that...

$$e = L \Delta i / \Delta t$$

Let's rearrange things a tad...

$$\Delta i / \Delta t = e / L$$

Now  $\Delta i$  is the change in current and  $\Delta t$  is the change in time, so  $\Delta i / \Delta t$  will be a *linear current ramp* whose rate of change should equal your supply voltage divided by the inductance of your horizontal yoke.

Say that the switch in Fig. 3 is now open and has been that way for a long time. There is no current in the yoke, and no deflection. The spot will still be in the middle of the line.

Now, close the switch, but just for around *one-half* of the live scan time. What happens? We now apply a positive voltage to an inductor, and start building a linear current ramp. That current ramp in the deflection yoke creates one linearly increasing magnetic field, and the spot moves to the right. When you get to the right side of the screen, you'll have bunches of energy stored in the horizontal yoke's magnetic field.

What are you going to do with it? If you just burn it up as heat, you'll end up with bad reliability and high power consumption. Besides needing *far* tougher electronics. Instead, let's work smarter instead of harder.

Open your switch. Your equivalent circuit now consists of a yoke coil in series with the *flyback* capacitor. A standard and high-Q series-resonant circuit. But one that started out with zero volts on your capacitor and a strong current through the coil.

At this time, all of the energy is in the coil and none is in the capacitor. Let the circuit resonate for a while, exactly like any other series-resonant circuit. In one quarter of a cycle, the capacitor will be charged up to a large positive voltage, often in the 800-1200 volt range. At the peak, the current will be zero, and the inductor will be "empty" and field-free.

You have now transferred all of the magnetic energy that was in the yoke into electrical energy stored in the flyback capacitor! And done so with very little loss.

Let the circuit continue to resonate. The current will reverse in direction, and energy will start transferring back into the inductor. Note that the current is now going in the *opposite* direction.

Let the circuit resonance continue

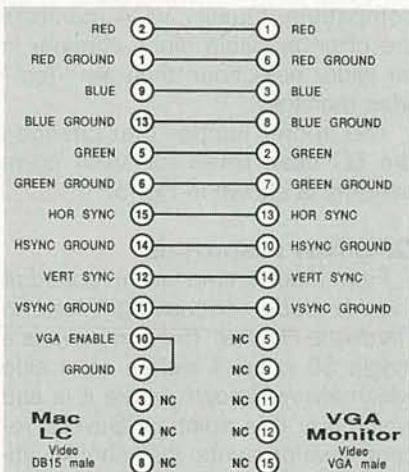

**FIG. 5—THE MACINTOSH LC definitely can NOT be used with a NTSC monitor. But this simple cable and jumpering lets you use it with most VGA color monitors. The configuration jumper from pin 7 to pin 10 selects VGA scan rates and standards.**

until the capacitor gets to zero volts. You will now have placed all of the original magnetic energy right back into the deflection yoke, with one very important difference: Since the current is going in the opposite direction, you're now at the *maximum left*

spot position, compared to the maximum right that you were half a resonance cycle ago. And, again, you have done this with very little loss.

This process is known as a *flyback*, and the retrace interval is called the *flyback time*. The beam is turned off during the flyback time so the retrace is invisible.

Let the circuit resonance try and continue. The flyback capacitor will try and go negative but, at that time, a *dampener diode* will turn itself on. Your circuit now consists once again of a coil connected between a positive voltage and ground. It will once again start generating a positive current ramp. Only this time, it starts from a *negative* initial current. Thus, your sweep starts linearly moving from the left to the center. As you move on towards the center of your scan line, the yoke energy gets sent back into the positive supply.

When you get to the center of the screen, you once again close your switch to repeat everything for the next cycle. The dampener diode shuts down just as soon as you cross cen-

**LEARN VCR**  
CLEANING/MAINTENANCE/REPAIR  
EARN UP TO \$1000 A WEEK, WORKING PART TIME FROM YOUR OWN HOME!

Secrets Revealed!  
NO Special Tools or Equipment Needed.

**EARN UP TO \$60 AN HOUR AND MORE!**

**THE MONEY MAKING OPPORTUNITY OF THE 1990'S**

IF you are able to work with common small hand tools, and are familiar with basic electronics (i.e. able to use voltmeter, understand DC electronics). . . . IF you possess average mechanical ability, and have a VCR on which to practice and learn. . . . then we can teach YOU VCR maintenance and repair!

**FACT:** up to 90% of ALL VCR malfunctions are due to simple MECHANICAL or ELECTRO-MECHANICAL breakdowns!

**FACT:** over 77 million VCRs in use today nationwide! Average VCR needs service or repair every 12 to 18 months!

Viejo's 400 PAGE TRAINING MANUAL (over 500 photos and illustrations) and AWARD-WINNING VIDEO TRAINING TAPE reveals the SECRETS of VCR maintenance and repair—"real world" information that is NOT available elsewhere!

Also includes all the info you'll need regarding the BUSINESS-SIDE of running a successful service operation!

**FREE INFORMATION**  
CALL TOLL-FREE 1-800-537-0589  
Or write to: Viejo Publications Inc.  
5329 Fountain Ave.  
Los Angeles, CA 90029 Dept. RE

CIRCLE 187 ON FREE INFORMATION CARD

**Be an FCC LICENSED ELECTRONIC TECHNICIAN!**

Earn up to \$30 an hour and more!

Learn at home in spare time. No previous experience needed!

No costly school. No commuting to class. The Original Home-Study course prepares you for the "FCC Commercial Radiotelephone License." This valuable license is your professional "ticket" to thousands of exciting jobs in Communications, Radio-TV, Microwave, Maritime, Radar, Avionics and more... even start your own business! You don't need a college degree to qualify, but you do need an FCC License.

**No Need to Quit Your Job or Go To School**  
This proven course is easy, fast and low cost! **GUARANTEED PASS**—You get your FCC License or money refunded. **Send for FREE facts now. MAIL COUPON TODAY!**

**COMMAND PRODUCTIONS**  
FCC LICENSE TRAINING, Dept. 90  
P.O. Box 2824, San Francisco, CA 94126  
Please rush FREE details immediately!

NAME \_\_\_\_\_  
ADDRESS \_\_\_\_\_  
CITY \_\_\_\_\_ STATE \_\_\_\_\_ ZIP \_\_\_\_\_

ter screen. Automatically.

Once again: Close your switch to move from center to right. Transfer the coil energy to a flyback capacitor. Resonate half a cycle and transfer the flyback capacitor energy back to the coil *inverting its sign* and putting you far left. Turn on the damping diode to move from left to center. And repeat the process once each scan line.

Several details I've omitted: That flyback pulse also gets sensed and routed to a current step-up transformer called a *flyback transformer*. The flyback transformer steals a minor part of the energy and uses it to create the high voltage DC supply that is needed by the display tube. Other windings can be used for blanking, horizontal phase comparison, and boosted supply voltages elsewhere in the TV or monitor. And games have to be played to keep any uncenter DC bias out of the horizontal yoke. But regardless of these details, the basic concept of recycling your deflection energy remains.

This very elegant, highly tested, and ultra conservative flyback scheme inherently works best only at *one* horizontal scan frequency. And that is why you can't normally get a monitor that can accept any old horizontal rate.

Yes, there are multi-sync monitors. These usually work by measuring the intended input scan frequency and then switching in one or more flyback capacitors and adjusting the supply voltage accordingly. Figure 4 shows one multisync scheme. Once switched, a multisync monitor is a narrow-band system just like any other flyback-driven circuit.

### VGA for the Mac LC

The Macintosh LC computer was designed for use with the Mac color monitors to the Mac color standards. Since these can be expensive, lots of hackers are often on the lookout for lower-cost substitutes. But note that you definitely can *not* use an NTSC color monitor because of the higher scan rates on the LC.

And also do note that you should *never* buy a substitute monitor without making certain it works and is good enough for your uses.

Happily, there is a hidden "secret" provision on the Mac LC that lets you change your LC output so it is VGA-

compatible. Quality VGA monitors are often available much cheaper in far wider selections than are "real" Mac monitors.

The secret jumper that changes the LC scan rates for VGA compatibility is shown in Fig. 5.

### GPS Nav resources

From time to time we've looked at the *Navicube* concept right here in *Hardware Hacker*. The *Navicube* is a magic \$5 cube 3 inches on a side which always knows where it is and which way it is pointing. Several recent developments that should ultimately make the *Navicube* possible include low-cost accelerometers, advances in fiber-optic gyros, and the ongoing GPS navigation system.

GPS is short for *Global Positioning Satellites*, a military navigation system that has recently seen several dramatic improvements in price, reliability, and availability. I've tried to gather together some GPS info for you as this month's resource sidebar.

The system consists of a flock of roving satellites, any five or six of which should be overhead at any given time. The satellites broadcast a series of low microwave-frequency radio signals. By intercepting and comparing the signals from several overhead satellites, you can extract your current absolute position and do so to around a fifty-foot accuracy. Your speed, acceleration, and current time can also be determined to surprisingly high accuracies. Within two inches per second even.

And by shifting to a *differential* scheme from any one known and fixed point, you can improve your accuracy to a fraction of an inch.

Amazingly, the antennas needed are no big deal. They can easily fit inside a small shoebox. Unlike video satellites, the GPS antennas need a wide beamwidth, a narrow-frequency bandwidth, plus a pseudorandom modulation which works acceptably well with lower signal-to-noise ratios. The antennas do require line-of-sight operation, so they have to be used outdoors, on a rooftop, or on the top of a vehicle or boat.

Since the reception electronics are incredibly complex, it is unlikely that you would want to try and build up your own GPS receivers by using discrete components.

Thankfully, sophisticated chip sets are now becoming readily available from *Rockwell*, *Magellan*, and others. Their initial pricing is in the \$50 range. But it is reasonable to expect Japanese GPS chips within a year or two for under \$35. So now is the time to start on your GPS hacks.

The leading trade journal in the field is called, of all things, *GPS World*. It is free to qualified subscribers. An interesting hacker newsletter that deals with navigation and communication of interest to cavers is Frank Reid's great *Speleonics*. Some other GPS info appears from time to time in *NASA Tech Briefs*. Several other sources of GPS gear include *Ashtech*, *Bancomm*, *Texas Instruments*, and *Trimble Navigation*. Trimble has a nice GPS intro book available. It's called *GPS—A guide to the next utility*.

### New tech lit

From *Actel*, a new databook called *Field Programmable Gate Array*. And from *Mini-Circuits* a new *RF/Signal Processing Guide* on high-frequency mixers, splitters, amplifiers, transformers, and such. The broadband amplifiers cost around a dollar or so each.

A free update on our Santa Clara machine technology is now titled *Insiders Guide to Rapid Prototyping*, and is available from *Management Roundtable*. These folks also put on annual conferences.

A new quarterly hacker newsletter on lower-cost vacuum projects and techniques is now available through *Steve Hansen*. It's called *The Bell Jar*.

Free samples of *Liquisorb*, a low-cost cornstarch colloidal absorber, are available from *American Colloidal Company*. Since these sample packets dramatically swell up in the presence of liquid water, one obvious use is as a low-cost flood alarm.

And through *Aremco*, a *Materials Catalog M12* that includes a wide variety of high-temperature ceramic materials, including machinable and pourable versions.

For the fundamentals of digital integrated circuits, be sure to check out my classic *CMOS Cookbook* and *TTL Cookbook*. You can also reach me via *GENIE* PSRT (800) 638-963 where you'll find lots of resource stuff not available elsewhere. ■

# AUDIO UPDATE

## Reader questions: Real and imagined, serious and silly

LARRY KLEIN

**A**fter several decades of answering readers' hi-fi questions for various electronics and audio publications, one can get a little nostalgic. I look back with fondness to the days when I had all the answers—or at least thought I did—and was pleased to provide them to curious readers. Today I certainly don't have all the answers, and occasionally I don't even understand the questions. In any case, herewith is a selection of updated Q's and A's that, if not my greatest hits, at least reflect some of the interesting concerns of the audio public in the last decade.

### Subliminal Satanism

*I keep hearing that some heavy-metal rock bands put subliminal Satanic messages on their albums. The messages are supposedly in the form of words recorded in reverse at the ends of certain cuts. What effect do these messages have on listeners?*  
L.B.  
Everetts, N.C.

Mostly it causes them to write silly questions to magazine columnists. The term "subliminal" is usually applied to stimuli that are outside the range of conscious perception but are nevertheless said to reach the brain and affect thinking. The purported danger in such a technique is that the messages bypass conscious evaluation and cause their hearers (or viewers) to uncritically buy products, vote for certain candidates... or worship Satan. Since there appears to be no legitimate research indicating any effect at all from subliminal motivational messages, good or bad, I wouldn't worry about it... unless, of course, you experience sudden inexplicable urges to buy large quantities of toothpaste, to vote for Jesse Helms, or join your local coven after a long evening of heavy-metal head banging.

My comments also apply to "subliminal" self-help tapes. A recent study by the National Academy of

Sciences concluded that such tapes "have no proven value." That seems logical, considering that any messages recorded below the threshold of hearing would necessarily be buried in normal tape noise.

### Record and tape wear

*I hope you can settle a bet for me. I maintain that, unlike LP records, cassettes don't wear out. My friend insists that they both wear with use. And what's the situation with CD longevity? I've read some troubling reports lately.*

J.S.

Evanston, IL

They both wear, but the effects are different for tapes and discs. When vinyl discs begin to wear, noise and distortion are *added* to the signal. Worn tapes, on the other hand, tend to suffer signal losses. There are momentary "dropouts" that reflect damage to the tape's oxide coating caused by friction against the player's heads, capstan, and guides. There may also be a partial erasure of the high frequencies brought about by an accumulation of residual magnetism in those same metal parts. Periodic cleaning and demagnetizing of the player help minimize the damage.

Over time, there may be a marked increase in cassette wow and flutter. Assuming that the player is okay, and that the tape or the cassette shell mechanism has not been damaged through overheating on a car's dashboard, the fault is probably caused by an overly tight winding inside the cassette. The tape pack can be restored to its normal looseness by repeatedly, but gently, slapping the cassette face down against a semi-hard surface such as a magazine or book. Squeal can sometimes be helped by a very small amount of silicone lubricant applied in the areas where the tape hubs meet the shell, but most of the time it reflects a problem (sometimes brought about by aging) in the composition of the tape coating.

Recently questions have been raised about CD longevity, with claims that CD's suffer from "laser rot" over time. The reasons given for the self-destructive tendencies of CD's have been varied, but the claim is that today's CD's have, at best, a very limited life span.

I think that such predictions should be taken with a sack of salt, considering their original sources are the same "underground" audio publications that disparaged CD's from the outset.

I spoke to a gentleman in charge of preservation research at the Library of Congress, and he says he knows of no evidence that supports the view that normal, properly manufactured CD's will spontaneously "fail" over time. All of which is not to say that some CD's haven't had playback problems because of mishandling or manufacturing defects.

### Undriven drivers

*There's a hi-fi dealer in my area who features what he calls "Single Speaker Demonstrations." He claims that it was discovered in England that the presence of other non-playing speaker systems in a listening room can affect the sound produced by the playing speakers. Does the removal of non-playing speakers really help a listener evaluate different systems more accurately?*

J.S.

Los Angeles, CA

I don't think so, particularly since it would certainly prevent a fast A/B comparison between systems. It's probable that there is a slight measurable acoustic effect in a show-room produced by stacks of unconnected speaker systems. Theoretically, acoustic-suspension speakers would function as Helmholtz absorbers at the frequency of their system resonances, and vented systems would do the same at their port resonances. In either case, the suck-outs would occur in the same low-frequency areas where

most standing-wave problems occur and conceivably might moderate the effects. But given the very large (10–20 dB) bass-response irregularities found in most rooms—including dealer demo rooms—it seems unlikely that even the most golden of ears could isolate a positive or negative effect produced by the presence of a dozen or so undriven speaker systems.

Incidentally, I understand that some lunatic fringe audiophiles even advocate removing telephones, clocks, and watches from listening rooms in the belief that they somehow resonate destructively with the music. As with so many other superstitious beliefs, this one also has in it a small—very small—grain of truth.

If you were to feed an audio oscillator through your system and sweep it slowly at high volume from, say, 40 to 200 Hz, you would find that small and large objects in the room vibrate slightly at their specific resonant frequencies. But with music there is usually not enough sustained

acoustic energy at any one frequency to produce audible resonances. However, it is not a good idea to place small art objects on top of your speakers as there might be enough coupled vibration to cause them to dance sympathetically to whatever tune is playing.

### Sonic shatter

*I'm curious about the old Memorex wine glass shattering commercials. Exactly what technology was involved? Was it anything like Caruso's vocal trick?*

M.H.  
Mendenhall, MS

Like all good wine glasses, the goblets used in the commercial were both rigid and relatively fragile. To calibrate the goblets, each was placed directly in front of a loudspeaker driven by an audio oscillator. The oscillator was swept slowly through the range of approximately 700 to 850 Hz, which covered the resonant frequencies of the glasses used by Memorex. During the frequency

sweep, a finger resting lightly on the rim of the goblet could easily detect the increase in vibration at the goblet's specific resonant frequency. That was marked on the crystal goblet for future reference.

At glass-breaking time, a tape recording (on a Memorex cassette) was made of the celebrity singer producing a sustained note at the previously determined critical frequency. When the cassette tape was played back very loudly through a speaker the wine glass—which had an approximately 140-dB sound field impinging on it—would react by flexing itself to pieces.

Given the above, it should be clear that shattering a glass by an amplified voice is no easy trick. Not only does the singer have to produce an enormous sound pressure level but also the frequency has to be within a hertz or so of the wine glass specific—and unknown—resonant frequency. Perhaps in Caruso's days voices were stronger and crystals more fragile.

U.S. Postal Service STATEMENT OF OWNERSHIP, MANAGEMENT AND CIRCULATION <small>Required by 39 U.S.C. 3685</small>			
1A. TITLE OF PUBLICATION RADIO-ELECTRONICS		1B. PUBLICATION NO. 0 0 3 3 7 8 6 2	
3. FREQUENCY OF ISSUE MONTHLY		2. DATE OF FILING 10/9/91	
4. COMPLETE MAILING ADDRESS OF KNOWN OFFICE OF PUBLICATION (Street, City, County, State and ZIP+4 Code) (Not printer)		3A. NO. OF ISSUES PUBLISHED ANNUALLY 12	
500-B BI-COUNTY BLVD. FARMINGDALE, NY 11735		3B. ANNUAL SUBSCRIPTION PRICE \$17.97	
5. COMPLETE MAILING ADDRESS OF THE HEADQUARTERS OF GENERAL BUSINESS OFFICES OF THE PUBLISHER (Not printer)			
500-B BI-COUNTY BLVD. FARMINGDALE, NY 11735			
6. FULL NAMES AND COMPLETE MAILING ADDRESS OF PUBLISHER, EDITOR, AND MANAGING EDITOR (This item MUST NOT be blank)			
PUBLISHER (Name and Complete Mailing Address)			
LARRY STECKLER 500-B BI-COUNTY BLVD. FARMINGDALE, NY 11735			
EDITOR (Name and Complete Mailing Address)			
BRIAN FENTON 500-B BI-COUNTY BLVD. FARMINGDALE, NY 11735			
MANAGING EDITOR (Name and Complete Mailing Address)			
7. OWNER (If owned by a corporation, its name and address must be stated and also immediately thereunder the names and addresses of stockholders owning or holding 1 percent or more of total amount of stock. If not owned by a corporation, the names and addresses of the individual owners must be given. If owned by a partnership or other unincorporated firm, its name and address, as well as that of each individual must be given. If the publication is published by a nonprofit organization, its name and address must be stated.) (This must be completed.)			
FULL NAME		COMPLETE MAILING ADDRESS	
GERNSBACK PUBLICATIONS INC.		500-B BI-COUNTY BLVD. FARMINGDALE, NY 11735	
LAWRENCE STECKLER		500-B BI-COUNTY BLVD. FARMINGDALE, NY 11735	
8. KNOWN BONDHOLDERS, MORTGAGEES, AND OTHER SECURITY HOLDERS OWNING OR HOLDING 1 PERCENT OR MORE OF TOTAL AMOUNT OF BONDS, MORTGAGES OR OTHER SECURITIES (If none see none, in year)			
FULL NAME		COMPLETE MAILING ADDRESS	
9. FOR COMPLETION BY NONPROFIT ORGANIZATIONS AUTHORIZED TO MAIL AT SPECIAL RATES (Section 412.12 DMM only) <small>The purpose, function, and nonprofit status of this organization and the exempt status for Federal income tax purposes (Check one)</small>			
<input type="checkbox"/> (1) HAS NOT CHANGED DURING PRECEDING 12 MONTHS			
<input type="checkbox"/> (2) HAS CHANGED DURING PRECEDING 12 MONTHS (If changed, publisher must submit explanation of change with this statement.)			
10. EXTENT AND NATURE OF CIRCULATION (See instructions on reverse side)		AVERAGE NO. COPIES EACH ISSUE DURING PRECEDING 12 MONTHS	
ACTUAL NO. COPIES OF SINGLE ISSUE PUBLISHED NEAREST TO FILING DATE			
A. TOTAL NO. COPIES (Net Press Run)		280,140	
B. PAID AND/OR REQUESTED CIRCULATION 1. Sales through dealers and carriers, street vendors and counter sales		54,898	
2. Mail Subscriptions (Paid and/or requested)		124,791	
C. TOTAL PAID AND/OR REQUESTED CIRCULATION (Sum of B1 and B2)		179,689	
D. FREE DISTRIBUTION BY MAIL, CARRIER OR OTHER MEANS SAMPLES, COMPLIMENTARY, AND OTHER FREE COPIES		7,003	
E. TOTAL DISTRIBUTION (Sum of C and D)		186,692	
F. COPIES NOT DISTRIBUTED 1. Office use, left over, unaccounted, spoiled after printing		8,201	
2. Return from News Agents		85,247	
G. TOTAL (Sum of E, F1 and 2—should equal net press run shown in A)		280,140	
11. I certify that the statements made by me above are correct and complete		SIGNATURE AND TITLE OF EDITOR, PUBLISHER, BUSINESS MANAGER, OR OWNER EDITOR	



One tree can make 3,000,000 matches.



One match can burn 3,000,000 trees.

A Public Service of This Magazine & The Advertising Council

# DRAWING BOARD

## More on automotive voltage regulators.

ROBERT GROSSBLATT

Once again I have to apologize to everyone out there who's waiting for us to get back to the design of a digital scope. We won't be doing that until next time because I need this space to finish going through our discussion of generators, alternators, voltage regulators, and all the rest of the stuff you meet when you take a trip to the always amazing world of charging systems.

As I mentioned last time, I was amazed by the amount of interest in this and, as a certified member in good standing of the old car and bike freak club (with a particular emphasis on British stuff), my duty is clear.

We've already gone through the basics of the charging system and seen that there are really only two ways an alternator can be wired into a bike or car. One side of the field winding is tied to either the hot side of the battery (a pulled-up field), or to ground (a grounded field). Most British cars and bikes use a pulled-up field and you'll find a lot of American cars using a grounded field. I said this last time but it's really important so let me repeat it. Before you can build your own voltage regulator, you **HAVE** to know how your alternator is wired. Using the wrong regulator will destroy the regulator and probably trash the alternator as well.

The easiest way to tell what system is used in your car or bike is to use a multimeter. With the ignition turned on, but the engine not running, measure the voltage from the hot side of the battery to the terminal marked "F" on your existing regulator. If you get a reading between 12 and 13 volts (the battery voltage), your car is using a pulled-up field.

If you get a zero, or near-zero reading, you're probably looking at a grounded field. You can make sure by reading the voltage from the regulator's "F" terminal to ground. You should see the 12- to 13-volt battery

voltage there. If you don't see the battery voltage anywhere you either have a bad connection or you're measuring from the wrong terminals. Check the multimeter leads and, if that doesn't cure the problem, get out a flashlight and trace the wires. You absolutely have to know what you're dealing with before you add a voltage regulator!

Anyone who finds that they have a pulled-up field can stop reading right now and skip ahead a bit because the regulator we designed last month is exactly the one needed. If you've got a grounded-field alternator, there's still some work to do. The regulator we designed has to be modified before you can use it.

The easiest way to see the changes is to compare the original pulled-up field circuit (last month's Fig. 3) to the modified design for a grounded-field regulator shown in Fig. 1. One of the first things you should notice is that R7 and R8 are now in parallel. Electrically, there's no real reason for having those two resistors in parallel. The only reason I left them both there is to help make the similarity between the two circuits more evident. You can leave them wired in parallel or simply do the

arithmetic necessary to come up with an equivalent single-resistor replacement.

The major change to the circuit is that the alternator field connection is now made off the emitter of Q3 rather than the collector. All the changes in the circuit are aimed at varying the voltage at Q3's emitter. The Darlington pair made from Q2 and Q3 is still controlled by the voltage at the collector of Q1 in exactly the same way as it is for the pulled-up field regulator. The positive feedback (supplied by C3 and R8) that speeds up the switching of the circuit from fully on to fully off now comes from Q3's emitter rather than its collector.

The reasons for the changes in the circuit are all based around the idea of being able to vary the output voltage. Since, in the case of a grounded field, the given is that one side of the field is tied to ground, the job of the regulator is to increase the output voltage at the "F" terminal when the control voltage at the base of Q1 falls below the point set by R10. The LED has been moved so it will monitor the field voltage and D1 has been moved so it can soak up any back-voltage generated when the alternator field collapses. You'll also see that the value of R7

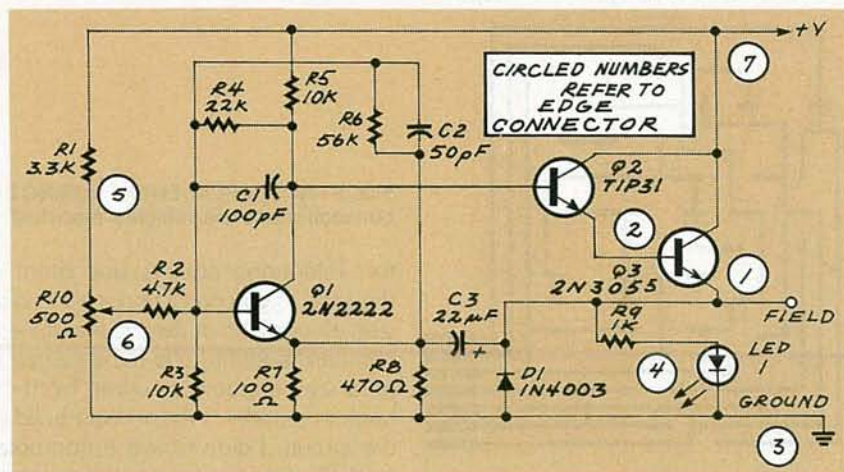

FIG. 1—COMPARE THE ORIGINAL pulled-up field circuit (last month's Fig. 3) to the modified design for a grounded-field regulator shown here.

# R-E Engineering Admart

Rates: Ads are 2 1/4" x 2 7/8". One insertion \$995 each. Six insertions \$950 each. Seven insertions \$925 each. Closing date same as regular rate card. Send order with remittance to: **Engineering Admart**, Radio-Electronics Magazine, 500-B Bi-County Blvd., Farmingdale, NY 11735. Direct telephone inquiries to Arline Fishman, area code-1-516-293-3000 or 1-516-293-3115. *Only 100% Engineering ads are accepted for this Admart.*

## FCC LICENSE PREPARATION

The FCC has revised and updated the commercial license exam. The **NEW EXAM** covers updated marine and aviation rules and regulations, transistor and digital circuitry. **THE GENERAL RADIOTELEPHONE OPERATOR LICENSE - STUDY GUIDE** contains vital information. **VIDEO SEMINAR KITS ARE NOW AVAILABLE.**

**WPT PUBLICATIONS**  
979 Young Street, Suite E  
Woodburn, Oregon 97071  
Phone (503) 981-5159 Dept. 50

CIRCLE 181 ON FREE INFORMATION CARD

## HIGH POWER AUDIO AMPLIFIER CONSTRUCTION



**BP277**—Here's background and practical design information on high power audio amplifiers capable of 300 ± 400 watts r.m.s. You'll find MOSFET and bipolar output transistors in inverting and non-inverting circuits. To order your copy **send \$6.25 plus \$2.50 for shipping** in the U.S. to **Electronic Technology Today Inc., P.O. Box 240, Massapequa Park, NY 11762-0240.**

## MIDI PROJECTS



**BP182**—MIDI interfacing enables any equipped instruments, regardless of the manufacturer, to be easily connected together used as a system with easy computer control of these music systems. Combine a computer and some MIDI instruments and you can have what is virtually a programmable orchestra. To order your copy **send \$6.95 plus \$2.50 shipping** in the U.S. to **Electronic Technology Today Inc., P.O. Box 240, Massapequa Park, NY 11762-0240.**

has been dropped to 100 ohms but, as I said earlier, you can replace it and R8 with a single resistor.

Before we take this any further, a word or two has to be said about C3. When the voltage on the output side of the regulator changes, some voltage is bled off through C3 and used to help speed up the action of the regulator. That is true both when the regulator is supplying current to the alternator field and when it's shutting the field current down as well. So, when the regulator is working, current will flow back and forth through C3.

Whenever you have that situation with an electrolytic, the right component to use is a non-polarized capacitor.

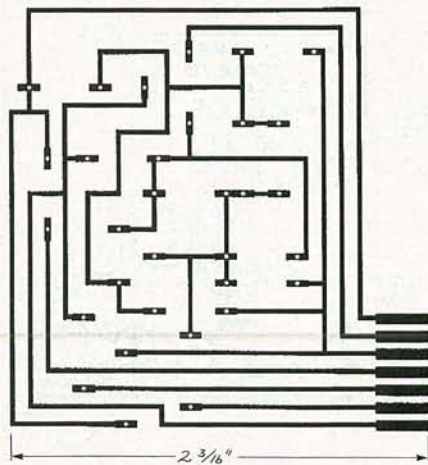

**FIG. 2—FOIL PATTERN** for the grounded-field regulator.

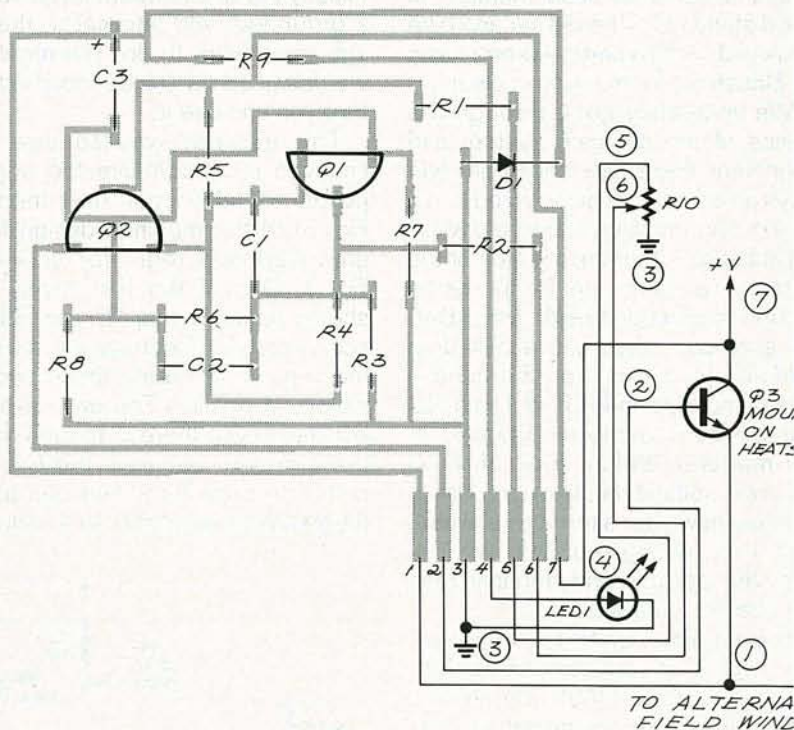

**FIG. 3—PARTS-PLACEMENT/WIRING DIAGRAM.** Use at least 14-gauge wire for the connections to the vehicle's electrical system.

tor. Telephone circuits use them all the time. If you can't find a non-polarized electrolytic of the proper value, a standard substitute is to use a pair of polarized capacitors wired front-to-back in parallel. When I was building the circuit, I didn't have a non-polarized 22 µF capacitor around so, since I was in a hurry to get the circuit in my car, I just used a regular polarized

capacitor instead. Once the car back on the road, I figured I'd be to drive to the parts supplier, get the right component, and make the rect substitution.

That was several years ago even though I've made many trip Capacitors-R-Us since then, I've never replaced the original polarized capacitor. I know it's the right thing to



but I've never gotten around to it. The choice is yours.

The foil pattern for the grounded-field regulator is in Fig. 2, and the parts-placement/wiring diagram is shown in Fig. 3. If you have last month's column around, you'll see that the new pattern is not very different from the pattern for the previous regulator.

Once you have the regulator ready to install in your car, use at least 14-gauge wire for the three connections to the vehicle's electrical system. Remember that the field windings in the alternator have an impedance of only about four ohms so, with a minimum of twelve volts from the battery, the wire has to carry at least four amps. If you have any doubts about the gauge of the wire, use the same stuff that was there originally.

The only other precaution to take when you're using either one of the two regulators is to realize that, since they're designed to be adjustable, they're capable of making the alternator put out a lot of power. While that isn't so bad for short periods of time, having the electrical system run at a constant level of sixteen or seventeen volts is a good way to blow stuff up.

As soon as you have the circuit connected and you're sure that the whole charging system is working, spend a little bit of time with your multimeter to calibrate the potentiometer (R10). Adjusting the potentiometer will change the trip point of the regulator and you should have those voltages marked wherever you have the potentiometer mounted. Red-line the settings at sixteen volts—you never, NEVER want the system voltage to get beyond that point.

If you're one of those unfortunate people who have a generator as your system's electrical engine, none of the circuits we've developed are suitable. As we discussed last month, since the amount of current you get from a generator is solely dependent on how fast it's turning, the only way to control the current being fed to the electrical system is to have a make-and-break type switch between the generator's output and the rest of the electrical system.

You can always use an alternator/regulator combination in place of a

generator. The only problems you'll have are mechanical ones, since you'll more than likely have to fabricate your own mounting brackets and you may be forced to do a bit of surgery to make everything fit in securely. While doing a substitution like this is simple in theory, in practice there are a couple of nasty things that can screw you up if you're not careful.

The two big hassles are the substitute alternator's maximum current output for a given RPM and the size of the alternator pulley. As your starting point, you want the alternator to be able to generate enough current when the engine is idling. I can't give you exact figures since they'll depend on your vehicle. You might be able to get them from the paperwork covering your existing generator.

Once you have a ballpark current figure, you're ready to start the search for a suitable alternator. Most alternator pulleys are about half the diameter of the main one driven by the engine. That means the alternator generally turns twice as fast as the

engine and the alternator you need should have a high enough maximum current output at about twice your engine idle speed. The voltage regulator will take care of determining how much below that maximum current is right for your system. All you'll have to do is put a multimeter across the battery and adjust R10.

What makes everything complicated is the fan belt. You want to be absolutely sure that, once you have the new alternator mounted next to the engine, you can use a standard-size fan belt. This is such a big deal that I'd remake the alternator mounts to change the circumference of the needed fan belt. Nothing is worse than not being able to get replacement fan belts from any auto supplier in the universe.

I wish I had a simpler answer to the problem of generators but all I've ever done is replace them with alternators. I'll admit that it's a lot more work than building a replacement regulator but the ultimate outcome is a lot better.

R-E

# JAN Crystals

*your reliable source for  
a world of crystal clear  
communication*



- Commercial Two-Way
- MicroProcessors
- Amateur/Experimental
- Scanners/Monitors/Pagers
- Satellite-Telemetry
- Plus custom applications

**EXPEDITED ORDER SERVICE!**  
FOR FREE CATALOG,  
CALL OR WRITE:  
**JAN CRYSTALS**  
P.O. Box 06017  
Ft. Myers, FL 33906  
(813) 936-2397

**TOLL FREE 1-800-526-9825**  
**FAX ORDERS: 1-813-936-3750**



CIRCLE 104 ON FREE INFORMATION CARD

# SUPER LONG PLAY TAPE RECORDERS

**12 Hour Model —  
USES 120 TAPE  
\$119.00\***



Modified Panasonic Slimline, high quality AC-DC provide 6 continuous hours of quality recording & playback on each side of cassette for 12 hours total. Includes • Voice level control • Digital counter, etc. TDK - 120 Cassette Furnished.

**PHONE RECORDING ADAPTER**  
Records calls automatically. All Solid state connects to your telephone jack and tape recorder. Starts recording when phone is lifted. Stops when you hang up. **\$28.50\***  
FCC APPROVED

**VOX VOICE ACTIVATED CONTROL SWITCH**  
Solid state. Self contained. Adjustable sensitivity. Voices or other sounds automatically activate and control recorder. Uses either recorder or remote mike. **\$28.50\***

\* Add for ship. & handling. Phone Adapter & Vox \$2.00 each. Recorders \$5.00 each. Calif. Res. add tax. Mail order. VISA, M/C, COD's OK. Money Back Guarantee. Quantity discounts available. Dealer inquiries invited. Free data.

**AMC SALES INC.** Dept. A 9335 Lubec Street  
Box 928, Downey, CA 90241  
Phones (213) 859-8519 1-800-926-2488  
FAX (213) 923-1478  
Mon-Fri 8-5 PAC TIME

CIRCLE 108 ON FREE INFORMATION CARD

# SELECT 5 BOOKS for only \$4<sup>95</sup>

(values to \$152.75)

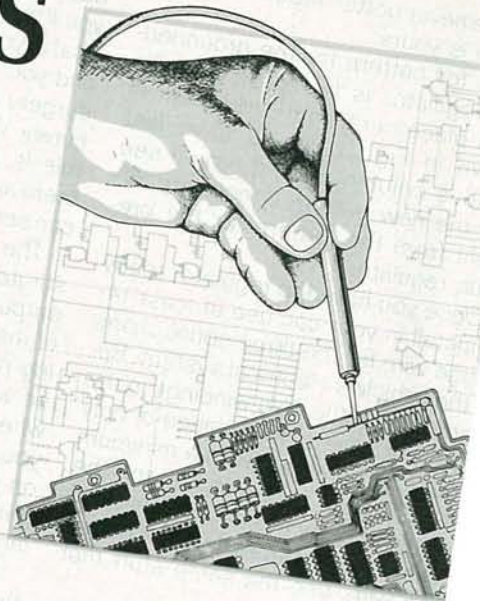

3414 \$39.95  
Counts as 2



2883P \$18.95



585120-2 \$12.95



10024 \$32.95  
Counts as 2



2613P \$17.95



3107P \$18.95



2980P \$19.95

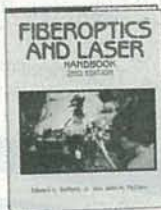

2981P \$18.95



3550 \$34.95  
Counts as 2



1367P \$24.95



3031P \$17.95



3321P \$16.95

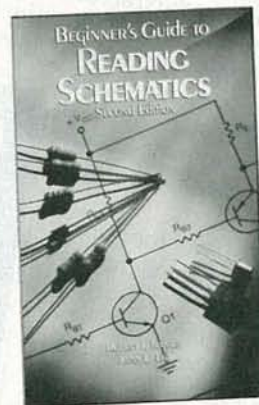

3632 \$18.95



3672 \$28.95



3145P \$12.95



3345 \$39.95

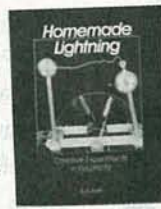

3576P \$14.95



3270 \$32.95  
Counts as 2

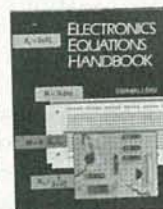

3241P \$16.95



9372P \$21.95



3122P \$21.95

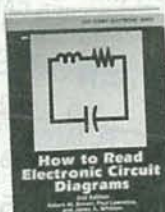

2880P \$14.95



3804P \$19.95



3205 \$24.95



3778 \$26.95

# Your most complete source for electronics books for over 25 years.

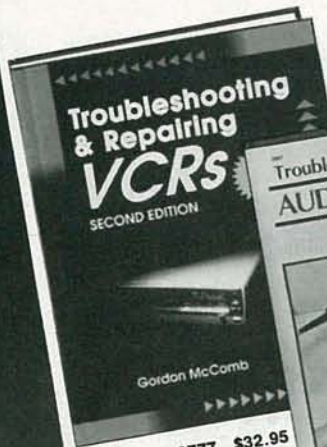

3777 \$32.95  
Counts as 2



2867P \$18.95



1938 \$60.00  
Counts as 3



2925P \$9.95



3557 \$29.95  
Counts as 2

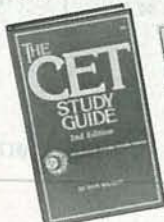

2941P \$16.95



3374P \$16.95



9370 \$38.60  
Counts as 2



3279 \$36.95  
Counts as 2



2995 \$25.95



2996P \$14.95



3660 \$32.95  
Counts as 2



3627 \$29.95  
Counts as 2



033559-1 \$29.95  
Counts as 2



3258 \$28.95



3475 \$27.95

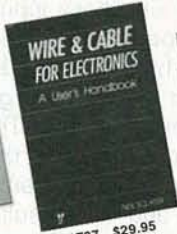

3787 \$29.95  
Counts as 2



1604P \$17.95



3659 \$21.95

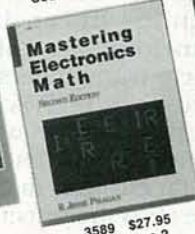

3589 \$27.95  
Counts as 2

**Membership Benefits • Big Savings.** In addition to this introductory offer, you keep saving substantially with members' prices of up to 50% off the publishers' prices. • **Bonus Books.** Starting immediately, you will be eligible for our Bonus Book Plan, with savings of up to 80% off publishers' prices. • **Club News Bulletins.** 15 times per year you will receive the Book Club News, describing all the current selections—mains, alternates, extras—plus bonus offers and special sales, with scores of titles to choose from. • **Automatic Order.** If you want the Main Selection, do nothing and it will be sent to you automatically. If you prefer another selection, or no book at all, simply indicate your choice on the reply form provided. You will have at least 10 days to decide. As a member, you agree to purchase at least 3 books within the next 12 months and may resign at any time thereafter. • **Ironclad No-Risk Guarantee.** If not satisfied with your books, return them within 10 days without obligation! • **Exceptional Quality.** All books are quality publishers' editions especially selected by our Editorial Board. (Publishers' Prices Shown)

All books are hardcover unless number is followed by a "P" for paperback.  
©1992 ELECTRONICS BOOK CLUB, Blue Ridge Summit, PA 17294-0810



## ELECTRONICS BOOK CLUB

Blue Ridge Summit, PA 17294-0810

YES! Please accept my membership in the Electronics Book Club and send the 5 volumes listed below, billing me \$4.95. If not satisfied, I may return the books within ten days without obligation and have my membership cancelled. I agree to purchase at least 3 books at regular Club prices during the next 12 months and may resign any time thereafter. A shipping/handling charge and sales tax will be added to all orders.

--	--	--	--

Name \_\_\_\_\_

Address \_\_\_\_\_

City \_\_\_\_\_

State \_\_\_\_\_ Zip \_\_\_\_\_ Phone \_\_\_\_\_

Signature \_\_\_\_\_

Valid for new members only. Foreign applicants will receive special ordering instructions. Canada must remit in U.S. currency. This order subject to acceptance by the Electronics Book Club.

RE192

## PC-BASED TEST EQUIPMENT

continued from page 62

specified value, the relay will be energized. When the temperature rises again, the relay will be de-energized. For example, to trip at 10.5°C, add the lines shown in Listing 2 between lines 16 and 17 of the original program.

You can also change the value in the FOR-NEXT loop to alter the time between samples. For instance, on the author's system, changing the value to 5000 causes samples to be collected once every 10 seconds. The exact time depends on your PC's speed, so you'll have to experiment.

With a longer time between samples, you can log data samples to disk. To do so, change lines 4, 16 and 17 as shown in Listing 3.

To read and display the resultant data, run the program shown in Listing 4.

### Other inputs

The signal conditioner circuit can accept other input sources, including linear-displacement potentiometers (LDP's), piezoelectric transducers, and microphones. An LDP is a specialized potentiometer whose wiper moves linearly instead of in the normal circular fashion. Usually these extremely accurate devices, which can be purchased from surplus electronics suppliers, are mechanically connected to a moving mechanism. They convert linear motion into a corresponding resistance. If a DC voltage is placed across the LDR, the output at the wiper is a voltage proportional to the amount of displacement of the slider.

Piezoelectric devices can be attached directly to a surface to measure tension and stress. Unlike an LDP, a piezoelectric device produces a voltage directly, hence doesn't need a DC voltage source. A microphone can also be used to measure sound-related phenomenon.

In fact, any device that can provide a voltage that varies between zero and a few hundred millivolts can be connected to the circuit described in this article. **R-E**

## ASK R-E

continued from page 13

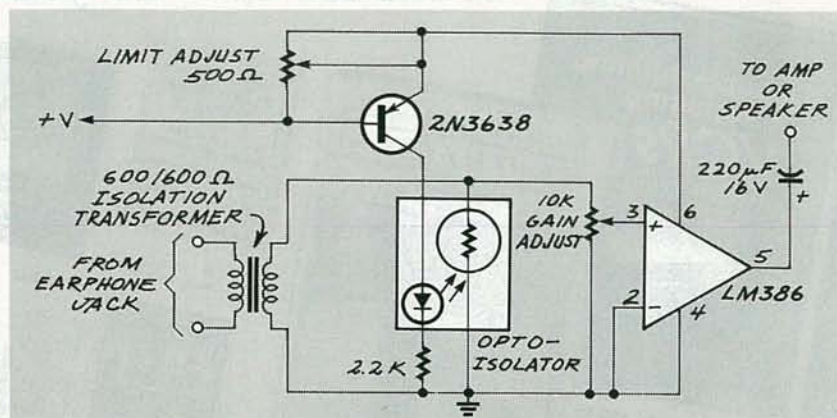

FIG. 3—AN AUDIO LIMITER will turn the volume down for you whenever the sound gets too loud.

amplifier has to pass through the resistor on the +V line. The amount of current drawn by the amp will vary in direct proportion to the amount of work the amplifier has to do. As the input signal increases, so does the amount of current the amplifier needs to handle it.

The voltage created across the resistor is a DC analog of the AC audio voltage at the amplifier's inputs. The DC voltage controls the transistor and, when it's high enough, the transistor will turn on and energize the LED in the optoisolator. That will change the resistance of the photoresistor wired into the amplifier's feedback loop and, as a result, cause a change in the gain of the amplifier. All the parts used in the limiter are easy to find with the possible exception of the optoisolator. That isn't a big deal since you can make one of your own by using a standard LED and photoresistor. Just put them next to each other in a small tube and seal up the tube ends to make it light-tight.

Building the circuit is a lot easier than getting it into your TV set. If you have any doubts at all about doing it, you're much better off forgetting the whole idea. You really don't want to blow up the TV or yourself in the process of modifying the audio.

If your TV has an earphone jack, you can build the circuit in a small box and run the audio from the jack, through a small isolation transformer, through the limiter, and finally connect it to a separate amplifier and speaker.

### POWER-SUPPLY REPAIR

I have an IBM-compatible computer and the power supply died on me. I took it out of the case and, after some investigation, I'm pretty sure that one of the transformers is shorted. It seems like a shame to buy a new supply since all it would take to repair my old one is replacing one component. Do you have any sources of supply for the transformer I need?—**G. Benfisch, New York, NY**

All of the IBM-type power supplies are regulated switchers and they use at least two transformers—one for the AC line voltage and the other for the switcher. You didn't specify which one was shorted but remember that both of them have to be exactly on the printed circuit board. You can probably find a replacement transformer that has the same specification as the one you need but you also have to make sure it fits on the board.

If you are willing to devote a lot of time to catalogs, ads, and the telephone, you might come up with something suitable, but since a replacement supply costs only about forty or fifty bucks from just about every supplier in the universe, I can see any reason to screw around with fixing your old one.

Your time has to be worth something, and even if you found a replacement transformer I wouldn't be surprised if it costs as much as a whole new power supply. But then again, the education just might be worth the expense. **R**

## SPEAKER MATE

continued from page 66

gain is built into the unit to allow for different electret microphones, but it can be set very high before any feedback occurs. You can actually set the gain to the point where you can be heard on the speakerphone in an adjacent room.

With the unit plugged into your phone line, turn the ANSWER switch on and you should hear a dial tone. (You may need a "Y" adaptor to put the Speaker-Mate in parallel with an existing telephone.) The dial tone will not be very loud because the device is designed to limit the volume of the dial output, but you will hear it. The LEVEL control will respond only a little bit due to the limiting action of the dial-tone detector within IC1.

The next step is to get a friend to help you set up the microphone gain. The mid setting will probably be close, but you may want more gain depending on the environment and if you want to be able to use the device at some distance. Remember, though, that at higher settings background noise will also come through and the speech may have an echo. For desk use, a setting can be found that allows talking in a normal voice with the unit placed about 15 to 20 inches from the user. Remember that the person you are talking to is the judge of the microphone setting, and the VOLUME control affects only your received listening level.

Once set up, you must call someone on a conventional phone, turn on the Speaker-Mate, and then hang up the regular phone. To receive calls, simply answer with the Speaker-Mate and speak in a normal voice. The sound quality is so good that the calling party will probably not even know you are using a speakerphone.

### User add-ons

In a rural installation, the added distance from the central phone office can cause a reduction in loop current to the point

where line-powered operation of the project may become marginal. Performance in the talk path is normal, but the received audio may have a pumping sound due to the lack of available current to reproduce the audio peaks.

While the project would still be usable, Fig. 7 shows a simple external power addition which consists of adding a 1/8-inch miniature jack (J2), a DPDT slide switch (S3), and a diode (D2). The parts can be mounted on the rear panel of the project case and wired into the printed-circuit board. The PC board is prepared by removing jumper JU1 and connecting the two wires from S3 in place of JU1; the ground connection can be made to a spare hole in the board provided for this purpose.

As shown in Fig. 7, S3 will switch the unit between being line-powered and powered from an external source. If you're using the external-power modification, a 4.5- or 6-volt DC wall adaptor is perfect. Do not exceed 6 volts, as the Zener diode is not in the circuit when using external power.

The Speaker-Mate is not a stand alone telephone because a ringer is needed to hear incoming calls and a dialer is required to make outgoing calls. You may want to add the ringer to the Speaker-Mate, as shown in Fig. 8. The tone ringer chip (IC3), manufactured by Texas Instruments, monitors the telephone line for a ring signal of 15 to 68 Hz, 40 to 150 volts AC. The ring signal powers a two-tone warble signal generated by IC3. The output of the device drives a solid-state piezoelectric transducer. The circuit can be installed within the Speaker-Mate's enclosure and the transducer can be mounted on the front or rear panel, with a small hole drilled as an audio port.

There is also a dialer circuit you can build using Motorola's MC145412 IC and a handful of other miscellaneous parts. The schematic for the dialer circuit is available from Project-Mate (see the parts list) if you send a self-addressed stamped envelope (SASE). R-E

## ELECTRONICS PAPERBACKS



◀ **BP282—UNDERSTANDING PC SPECIFICATIONS...\$7.25.** Explains difference between types (XT, AT, 80386, etc.), math co-processors, input devices, memory, RAM discs, floppy drives, hard discs, displays and more. Everything you need to know if you can't tell your E.M.S. from your E.G.A.!

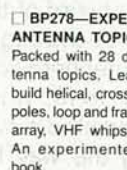

▶ **BP278—EXPERIMENTAL ANTENNA TOPICS...\$5.95.** Packed with 28 different antenna topics. Learn how to build helical, crossed field, dipoles, loop and frame, phased array, VHF whips and more. An experimenter's dream book.



▶ **BP276—SHORT WAVE SUPERHET RECEIVER CONSTRUCTION...\$5.95.** Everything you need to know to build your own receiver plus a variety of enhancement you can add later—input filter, rf amplifier, product detector, S meter, and more.

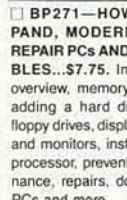

▶ **BP271—HOW TO EXPAND, MODERNIZE AND REPAIR PCs AND COMPATIBLES...\$7.75.** Includes PC overview, memory upgrades, adding a hard disc, adding floppy drives, display adapters and monitors, installing a co-processor, preventive maintenance, repairs, do it yourself PCs and more.



▶ **BP266—ELECTRONIC MODULES AND SYSTEMS FOR BEGINNERS...\$7.25.** Describes more than 60 modular electronics circuits—how they work, how to build them, and how to use them. A wonderful book for the experimenter.

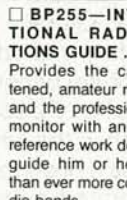

▶ **BP255—INTERNATIONAL RADIO STATIONS GUIDE...\$7.95.** Provides the casual listener, amateur radio DXer and the professional radio monitor with an essential reference work designed to guide him or her around than ever more complex radio bands.

MAIL TO: Electronic Technology Today, Inc.  
P.O. Box 240  
Massapequa Park, NY 11762-0240

### SHIPPING CHARGES IN USA AND CANADA

\$0.01 to \$5.00	.. \$1.50	\$30.01 to 40.00	.. \$5.50
\$5.01 to \$10.00	.. \$2.50	\$40.01 to 50.00	.. \$6.50
\$10.01 to 20.00	.. \$3.50	\$50.01 and above	.. \$8.00
\$20.01 to 30.00	.. \$4.50		

**SORRY, No orders accepted outside of USA and Canada**

Total price of merchandise	..... \$	_____
Shipping (see chart)	..... \$	_____
Subtotal	..... \$	_____
Sales Tax (NYS only)	..... \$	_____
Total Enclosed	..... \$	_____

Name \_\_\_\_\_  
Address \_\_\_\_\_  
City \_\_\_\_\_ State \_\_\_\_\_ Zip \_\_\_\_\_

## Multimedia mayhem

JEFF HOLTZMAN

**M**ultimedia. It may be the first overhyped buzzword of the 90's. Or it may be the beginning of Gutenberg II. Gutenberg I occurred around the year 1440, when Johannes Gutenberg invented movable type, thus clearing the way for high-volume printing. High-volume printing did two things: it vastly increased the variety of literature available, and it vastly increased the audience for that literature. Sixty years later, millions of books had been printed, and Europe was home to thousands of what we today might call "QwikPrint" shops. Five hundred and fifty one years later, we're on the threshold of another revolution in publication technology. Gutenberg I brought to the masses media for the efficient transmission of language; Gutenberg II will bring to the masses media for the efficient transmission of all aural and visual information.

That's a grandiose claim. However, the confluence of several social and technological factors makes it a likely one.

Socially, traditional forms are losing out to other media. Literacy is dropping; mixed-media forms of education and entertainment are becoming increasingly popular. People depend more on CNN than the New York Times to keep abreast of current events. Computer-generated graphics receive frequent showings in major art centers. Electronic music has received the attention of serious composers. Live drama is now minuscule compared to film. Traditional print publishers are dabbling in new forms—books on tape, encyclopedias on CD-ROM. And video games are preparing an entire generation for a lifetime of interaction with electronic media. High schools are graduating illiterate, innumerate people; to compensate, corporations are spending billions educating, re-educating, and preeducating this increasingly unqualified work force.

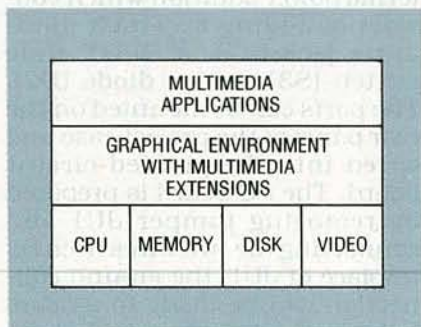

**FIG. 1—MULTIMEDIA ARCHITECTURE provides a standard interface for multimedia applications to build on.**

You may bemoan the loss of traditional modes of communication—and I would join you. Nonetheless, it's happening. So you can either throw up your hands or find a way of preserving the old while embracing the new. And that's where multimedia fits in.

### Gutenberg II

In addition to those social factors, there's a whole lot of technology coming together to set the stage for Gutenberg II. The basic architecture is shown in Fig. 1.

Multimedia demands computing power, including a fast CPU, lots of memory (RAM) and permanent storage (disk), and high resolution video. Now this base technology level is here, at affordable prices.

On top of the base technology layer is a user-friendly graphical environment, with special extensions to

handle new media (sound cards, CD-ROM drives, MIDI interfaces, las disc and other motion video source etc.). The graphical environment is highly contentious area right now, but recent events lead me to the conclusion that when all the smoke clears, there's going to be much less difference among the competing systems than there is in common. Windows, OS/2, and the Mac environment are all headed toward standards. Architectural layering will hide underlying technologies, so it won't matter whether you're running the Mac Finder, Windows' Program Manager, or the OS/2 Desktop. It'll matter even less whether it's an Intel or Motorola CPU under the hood. When you plug in the latest multimedia extravaganza, it'll just run.

At the highest level are the applications. There are some 2500 CD-ROM titles in "print" right now. Few of these are multimedia based; the vast majority consist of pretty boring text/numeric databases. However, several dozen full multimedia titles will be released between the time it is written and the time you read this. 1992 promises the release of hundreds of new titles. Such as? How about: Compton's Multimedia Encyclopedia, the Guinness Multimedia Disk of Records, Just Grandma & Me: A Broderbund Living Book, Countries of the World, Compton Quest, The Electronic Library of Berlitz language lessons (Spanish, French, German, Italian), Great Cities of the World, Battle Chess, SimCity, The Macmillan Dictionary for Children, Multimedia Beethoven, Introductory Games in French & Spanish, World Atlas, Desert Storm.

There are other factors contributing to this revolution in publishing. Hypertext research initiated by Nelson in the early 60's plays a prominent role. Advances in cognitive and instructional psychology also contribute significantly.

### VENDOR INFORMATION

SideBar (\$99.99), Paper Software, P.O. Box 567, New Paltz, NY 12561. (800) 551-5187, (914) 255-0056.

CIRCLE 41 ON FREE INFORMATION CARD

*High-Tech Ventures, The Guide for Entrepreneurial Success, (\$29.25) C. Gordon Bell and John E. McNamara, by Addison-Wesley, April 1991.*

CIRCLE 42 ON FREE INFORMATION CARD

**TABLE 1—MULTIMEDIA HARDWARE LEVELS**

Component	Base Level	Power User	Developer
CPU	80286/10 MHz	80386/25 MHz	80486/33 MHz
RAM	2 MB	4 MB	16 MB
Hard disk	30 MB	80 MB	0.5–1.0 GB
Video	VGA (16 color)	VGA (256 color)	1024 × 768 × 256 color, non-interlaced, video overlay
Optical storage*	CD-ROM with audio output		
Audio*	8-bit DAC, 8-bit ADC, 11 and 22 kHz sampling rates. 16-bit DAC and ADC preferred. Multi-voice synthesizer. MIDI		
*Note: Required for upgrade kit			

### Getting in step

Chances are you don't own a multimedia-compatible PC right now. But as those titles are released, you're going to start thinking strongly about buying one, or about buying an upgrade kit for your existing PC (or buying separate components for an upgrade.)

Microsoft has defined a basic multimedia PC as shown in Column 2 of Table 1; performance-conscious users will want a system like that in Column 3; developers will opt for something like Column 4. An upgrade kit consists of a CD-ROM drive, along with an audio board that provides ADC, DAC, and MIDI support.

NCR, CompuAdd, Tandy, NEC, Olivetti, Zenith, Fujitsu, and Philips have all announced or begun shipping multimedia PC's; prices start around \$2500. Upgrade kits starting around \$700 are available from CompuAdd, Creative Labs, Headland, Media Vision, and Tandy.

It's only a matter of time before all major hardware vendors provide similar offerings.

### Standards and competition

Microsoft initiated formation of a trade group, the Multimedia PC Marketing Council (MPMC). Since its formation, however, the MPMC has attached itself to the Software Publishers Association, thereby guaranteeing that no one vendor's interests will be served at the expense of others—or the consumer's.

Nonetheless, there is IBM, which has been strangely silent about the

MPMC. The IBM/Microsoft battle is one thing, but bear in mind that IBM is heavily involved in multimedia technologies. A few years ago Big Blue introduced a touch-screen system that is widely used in training applications. The company has an entire division dedicated to educational systems; it has funded or sponsored projects that we'll soon be hearing lots about, including one on the voyage of Columbus. Other IBM titles include Ulysses, the Declaration of Independence, and Hamlet. Expect a strong showing—when IBM is ready.

There are some other technologies that have been hanging around for years, waiting to become economical and adopted by large numbers of users. DVI (Digital Video Interactive) is one; CD-I (Compact Disc Interactive) is another. It's too soon to tell whether the Microsoft/MPMC standards will really take hold. It's likely that they will, however. These standards are comprehensive, are built on general-purpose computing platforms, and are supported by a fairly broad spectrum of vendors. Why would the average consumer buy a CD-I player when he or she can get the same effect on a PC that also allows word processing, checkbook balancing, etc? DVI, CDI, and similar technologies will either become compliant with emerging standards, remain as they are and carve out niche markets, or simply die.

### Conclusions

Above I said that Gutenberg II would support all sound and visual information. Want to guess what

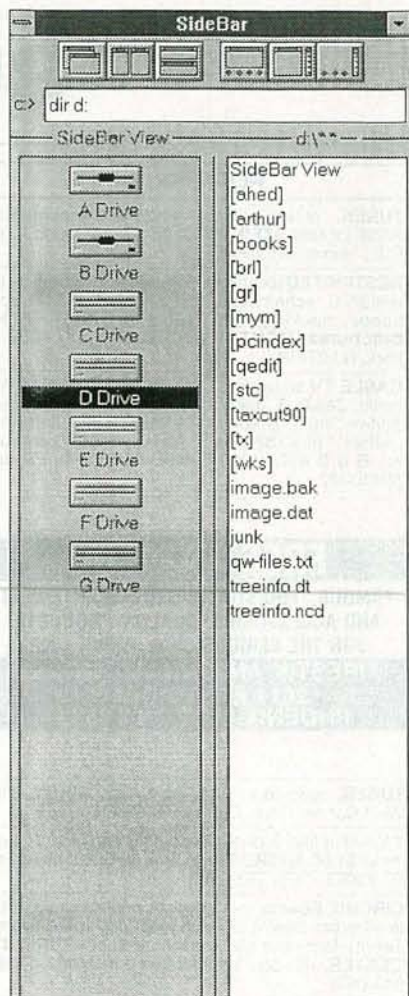

**FIG. 2—SIDEBAR is the most elegant Windows shell on the market. It won't overload you with features; rather it adheres to a small-is-beautiful philosophy. Nice work.**

Gutenberg III will support? Even better, when it'll happen?

### News bits

Intel's microprocessor line is coming under increasing pressure. **Chips & Technologies**, which has suffered financial hardships in recent years, has bet the farm on two new chip lines that the company hopes will restore it to the glory of former days. One line comprises a set of 386DX and 386SX CPU's; the other is a complete PC-on-a-chip. The latter combines fully compatible versions of the major system components (8086 CPU, 8254 timer, 8259 interrupt controller, DMA emulator, XT bus controller, CGA graphics controller, and 16C450 UART) in a single package called the F8680. Building a system with the F8680 amounts to

*continued on page 92*

# BUYER'S MART

## FOR SALE

**TUBES:** "oldest," "latest." Parts and schematics. SASE for lists. **STEINMETZ**, 7519 Maplewood Ave., R.E., Hammond, IN 46324.

**RESTRICTED** technical information: Electronic surveillance, schematics, locksmithing, covert sciences, hacking, etc. **Huge selection. Free brochures.** **MENTOR-Z**, Drawer 1549, Asbury Park, NJ 07712.

**CABLE TV** converters: Jerrold, Oak, Scientific Atlantic, Zenith & many others. "New MTS" stereo add-on: mute & volume. Ideal for 400 and 450 owners! 1 (800) 826-7623, Amex, Visa, M/C accepted. **B & B INC.**, 4030 Beau-D-Rue Drive, Eagan, MN 55122.

## FREE CATALOG

**FAMOUS "FIRESTIK" BRAND CB ANTENNAS AND ACCESSORIES. QUALITY PRODUCTS FOR THE SERIOUS CB'er. SINCE 1962**  
**FIRESTIK ANTENNA COMPANY**  
 2614 EAST ADAMS  
 PHOENIX, ARIZONA 85034

**TUBES**, new, up to 90% off, SASE, **KIRBY**, 298 West Carmel Drive, Carmel, IN 46032.

**T.V. notch filters**, phone recording equipment, brochure \$1.00. **MICRO THinc**, Box 63/6025, Margate, FL 33063. (305) 752-9202.

**CIRCUIT Boards** — Complete printed circuit fabrication from single sided to production multilayers. Twenty-four hour turnaround available. **CIRCUIT CENTER**, PO Box 128, Addison, IL 60101. (708) 543-0671.

**PREVENT** descrambler detection & damage! Order Tech-Block today! Simple in-line connection. Only \$19.95 P.P.D. **THE STAGE DOOR VIDEO**, PO Box 518, Belleview, FL 32620. For C.O.D.'s 1 (800) 395-4557.



### Quality Microwave TV Antennas

**WIRELESS CABLE - IFTS - MMDS - Amateur TV Ultra High Gain 50db(+)** • Tuneable 1.9 to 2.7 Ghz.  
 • 36-Channel System Complete \$149.95  
 • 12-Channel System Complete \$114.95  
 • Call or write (SASE) for "FREE" Catalog

**PHILLIPS-TECH ELECTRONICS**  
 P.O. Box 8533 • Scottsdale, AZ 85252  
 (602) 947-7700 (\$3.00 Credit all phone orders)  
 MasterCard • Visa • COD's • Quantity Pricing

LIFETIME WARRANTY

**ELECTRONIC** supermarket surplus prices! Transformer specials, railroaders, builders, engineers, experimenters, LSASE, **FERTIK'S**, 5400 Ella, Phila., PA 19120.

**OUR** monthly picture flyer lists quality surplus parts at low prices. Single and quantity prices. **STARTRONICS**, Box 683, McMinnville, OR 97128.

**PHOTOFACT** folders under #1400 \$5.00. Others \$7.00. Postpaid. **LOEB**, 414 Chestnut Lane, East Meadow, NY 11554. (516) 481-4380.

## CB RADIO OWNERS!

We specialize in a wide variety of technical information, parts and services for CB radios. 10-Meter and FM conversion kits, repair books, plans, high-performance accessories. Thousands of satisfied customers since 1976! Catalog \$2.

### CBC INTERNATIONAL

P.O. BOX 31500RE, PHOENIX, AZ 85046

**DESCRAMBLERS** cable TV converters, lowest prices, guaranteed, best quality, all types available, **CNC CONCEPTS, INC.**, Box 34503, Minneapolis, MN 55434. 1 (800) 535-1843.

**TOCOM and Zenith "test" chips. Fully activates unit. \$50.00. Cable descramblers from \$40.00. Orders 1 (800) 452-7090. Information (213) 867-0081.**

**SPEAKER** repair. All makes — models. Stereo professional. Kits available. Refoaming \$18.00. **LANTA AUDIO LABS**, 1 (800) 568-6971.

**REMOVE** tamper resistant torx screws. Set includes seven 1/4" bits. \$29.95 plus \$3.50 S&H. **SET ELECTRONICS**, 12145 Alta Carmel Co Suite 250-139, San Diego, CA 92128.

## CLASSIFIED AD ORDER FORM

To run your own classified ad, put one word on each of the lines below and send this form along with your check to

**Radio-Electronics Classified Ads**, 500-B Bi-County Boulevard, Farmingdale, NY 11735

**PLEASE INDICATE** in which category of classified advertising you wish your ad to appear. For special headings, there is a surcharge of \$25.00.

( ) Plans/Kits ( ) Business Opportunities ( ) For Sale  
 ( ) Education/Instruction ( ) Wanted ( ) Satellite Television

Special Category: \$25.00

### PLEASE PRINT EACH WORD SEPARATELY, IN BLOCK LETTERS.

(No refunds or credits for typesetting errors can be made unless you clearly print or type your copy.) Rates indicated are for standard style classified ads only. See below for additional charges for special ads. **Minimum: 15 words.**

1	2	3	4	5
6	7	8	9	10
11	12	13	14	15 (\$46.50)
16 (\$49.60)	17 (\$52.70)	18 (\$55.80)	19 (\$58.90)	20 (\$62.00)
21 (\$65.10)	22 (\$68.20)	23 (\$71.30)	24 (\$74.40)	25 (\$77.50)
26 (\$80.60)	27 (\$83.70)	28 (\$86.80)	29 (\$89.90)	30 (\$93.00)
31 (\$96.10)	32 (\$99.20)	33 (\$102.30)	34 (\$105.40)	35 (\$108.50)

We accept MasterCard and Visa for payment of orders. If you wish to use your credit card to pay for your ad in the following additional information (Sorry, no telephone orders can be accepted.):

Card Number

Expiration Date

Please Print Name

Signature

**IF YOU USE A BOX NUMBER YOU MUST INCLUDE YOUR PERMANENT ADDRESS AND PHONE NUMBER FOR OUR FILES. ADS SUBMITTED WITHOUT THIS INFORMATION WILL NOT BE ACCEPTED!**

**CLASSIFIED COMMERCIAL RATE:** (for firms or individuals offering commercial products or service \$3.10 per word prepaid (no charge for zip code)...**MINIMUM 15 WORDS.** 5% discount for same ad in issues; 10% discount for same ad in 12 issues within one year; if prepaid. **NON-COMMERCIAL RATE:** (for individuals who want to buy or sell a personal item) \$2.50 per word, prepaid...no minimum. **ONLY FIRST WORD AND NAME** set in bold caps at no extra charge. Additional bold face (not available as all caps) 5¢ per word additional. Entire ad in boldface, \$3.70 per word. **TINT SCREEN BEHIND ENTIRE AD: \$3.85 per word. TINT SCREEN BEHIND ENTIRE AD PLUS ALL BOLD FACE AD: \$4.50 per word. EXPANDED TYPE AD: \$4.70 per word prepaid.** Entire ad in boldface, \$5.60 per word. **TINT SCREEN BEHIND ENTIRE AD PLUS ALL BOLD FACE AD: \$6.80 per word. DISPLAY ADS:** 1" x 2 1/4"—\$410.00; 2" x 2 1/4"—\$820.00; 3" x 2 1/4"—\$1230.00. **General Information:** Frequency rates and prepayment discounts are available. **ALL COPY SUBJECT TO PUBLISHERS APPROVAL. ADVERTISEMENTS USING P.O. BOX ADDRESS WILL NOT BE ACCEPTED UNTIL ADVERTISER SUPPLIES PUBLISHER WITH PERMANENT ADDRESS AND PHONE NUMBER.** Copy to be in our hands on the 5th of the third month preceding the date of issue. (i.e., Aug. issue copy must be received by May 5th). When normal closing date falls on Saturday or Holiday, issue closes on preceding working day. Send for the classified brochure. Circle Number 49 on the Free Information Card.



**EST equipment** pre-owned now at affordable prices. Signal generators from \$50.00, oscilloscopes from \$50.00, other equipment, including manuals available. Send \$2.00 U.S. for catalog, refunded on 1st order. **J.B. ELECTRONICS**, 3446 Dempster, Skokie, IL 60076. (708) 982-1973.

**DESCRAMBLERS:** Oak Sigma, Varisync, Hamlin, Scientific Atlanta, Jerrold, Pioneer, Sylvania. Catalog \$5.00 money order (credited first order), service manuals, schematics, **SURPLUS ELECTRONICS**, P.O. Box 10009, Colorado Springs, CO 80932.

**WIRELESS CABLE RECEIVERS 1.9 TO 2.7 GHz**



30 CH PARABOLIC DISH SYSTEM \$173.90  
 30 CH ROD ANTENNA SYSTEM \$193.90  
 30 CH CRYSTAL CONTROLLED SYSTEM \$294.95  
**SUN MICROWAVE INT'L. INC.** SEND \$1.00 FOR P.O. BOX #34522 CATALOG ON THESE PHOENIX, AZ. 85067 AND OTHER FINE VIDEO PRODUCTS QUANTITY DISCOUNTS  
**ORDERS ONLY 1-800-484-4190 CODE 9783**

VISA/MC/AMEX

**YO! Like to go exploring?** New computer maze game — Dungeon Thief. Simple, fun, for all ages/abilities. Full game \$15.00, demo \$3.00. PC's/compatibles, color or mono. Specify disk (5.25", 3.5") Check/m.o. to: **SENTE SYSTEMS, INC.**, Dept. 67, Box 9439, Anaheim, CA 92812.

**MASTERCARD AND VISA** are now accepted for payment of your advertising. Simply complete the form on the first page of the Market Center and we will bill.

**ELECTRONIC** test equipment and parts. Free catalog. **EF ELECTRONICS**, Box 326, Aurora, IL 60506.

**DESCRAMBLERS**, all brands, examples Tocom VIP w/r \$275.00, Oak RTC-56 w/r 10 @ \$89.00, M-3 5-B \$35.00 — 10 @ \$29.00, F.T.B. 10 @ \$59.00, SA3-B 10 @ \$59.00, Hamlin CRX-6600 w/r 10 @ \$79.00, Sylvania 4040 DIC replaces Jerrold 400 DIC w/r 10 @ \$69.00, full warranty C.O.D. orders OK **MOUNT HOOD ELECTRONICS**, (206) 260-0107.

**Advanced solid-state LASER**

This incredible unit weighs less than 1/2 ounce. Only 1.125" long and 0.980" wide. With a range of more than 1000 yards, you are limited only by your imagination!

This is not a breakable glass tube but a state-of-the-art advanced solid-state laser with literally hundreds of applications!

**3mW only \$149.00**

**5mW only \$175.00**

**SPECIAL DEAL** save 10% on two or more!

Low power, self-contained unit which will produce a visible red beam from a 5 - 10 volt power supply.

**POLARIS Industries**  
 141 W. Wieuca Rd. Suite 300-B  
 Atlanta, GA 30342  
 Call Our Toll Free 24-hour Order Line  
**1-800-222-5620**

MC VISA  
 DISCOVER COD

**TEST TURN-ONS** SA 8580 SA 8550 SA 8500 SA 8570/90 Zenith all Jerrold Starcom 6/7 Tocom-VIP \$44.95 each 1 pc boxes SA 8580 Starcom 7B/B Pioneer 6110 Tocom VIP \$279.95 each. 1 (800) 74-CABLE.

**CB TV Jerrold 450-DIC \$45.00, JSX-DIC M35B or SB-3 \$19.00, RTC-56 \$79.00.** Other brands in stock. For dealers only (405) 685-2048.

**TUBES.** Thousands. \$.85. None higher. SASE for list. **CHUCK ADAMSON**, 3410 Sands, El Paso, TX 79904. (915) 757-8609.

**DESCRAMBLERS**  
**CABLE TV EQUIPMENT**

CALL TOLL FREE  
**1-800-228-7404**

FREE CATALOG

30 DAY MONEY BACK GUARANTY

OUR PRODUCTS ARE BULLET PROOF

YOU WON'T FIND ANY HOLES IN OUR WARRANTIES

WE CARRY ALL MAJOR BRANDS  
 BEST PRICE BEST SERVICE

MAKE THE CONNECTION

**NU-TEK ELECTRONICS**

FOR MORE INFORMATION CALL OR WRITE

**1-512-250-5031**

NU-TEK ELECTRONICS  
 8114 BALCONES WOOD DR.  
 #507 DEP. 296 AUSTIN TEXAS 78769

**CABLE TV**  
**DESCRAMBLER LIQUIDATION!**

**FREE CATALOG!**

Hamlin Combos \$44, Oak M35B \$60 (min. 5), etc.

**WEST COAST ELECTRONICS**

For Information: 818-709-1758  
 Catalogs & Orders: 800-628-9656

**Ferro Fluid**

Pro-Tech ferro fluid is commonly used on voice coils to substantially improve frequency response, increase transient and continuous power handling capabilities and reduce second and third order harmonic distortion. It reduces the Q and lowers the impedance peak at resonance without a significant reduction in SPL. Ferro fluid can effectively increase power handling capability of a driver by 200-300%. General purpose fluid for tweeters and midranges only. 10cc bottle (enough for 75-100 tweeters).



**#RM-340-430 \$19.95 Each**

**Light Oak Speaker Cabinet**

Premium ported speaker cabinet made of acoustical grade particle board and covered with a light oak vinyl laminate. Precut with an 11-1/4" hole for use with most 12" woofers. The baffle board has no tweeter or midrange holes for design flexibility. The 3/4" thick particle board ensures low panel resonance. Dimensions: 11" x 15" x 27". Volume: 2.5 cu ft. Grill and terminal included. Sold individually.

**#RM-262-100 \$49.00 Each \$45.50 (2-up)**



**Parts Express International Inc.**  
 340 E. First St., Dayton, Ohio 45402  
 Local: 1-513-222-0173  
 FAX: 513-222-4644

**12 Gauge Neon Wire**

The competition in today's auto sound contests is so fierce that good sound alone is not enough to win. More and more installers are striving to make their installation more pleasing to the eye. Parts Express now stocks 12 gauge speaker wire in vibrant neon colors. This wire is the same high quality, made in the U.S. wire you have used before, but now it has flashy, neon colored insulating jackets. Available in neon pink, neon green, and neon orange. Sold by the foot on or 50 ft. spools.



**#RM-100-162 (Neon pink)**  
**#RM-100-166 (Neon orange) 49¢/Ft.**  
**#RM-100-170 (Neon green)**

**Tuned Port Tubes**

These attractive, preformed tuned ports allow the back pressure radiated from the rear of the woofer to reinforce the sound level in front. Made of black plastic.



Part #	Length	Dia.	(1-9)	(10-up)
#RM-260-320	2"	1-7/8"	1.40	.95
#RM-260-321	4"	1-7/8"	1.60	1.20
#RM-260-322	5"	2"	1.65	1.30
#RM-260-323	1"	2-7/8"	1.40	.95
#RM-260-324	5"	2-7/8"	1.85	1.50
#RM-260-326	3"	2-7/8"	1.65	1.30
#RM-260-327	2-1/2"	3-7/8"	1.85	1.50
#RM-260-328	5"	3-7/8"	1.95	1.60

No mixing for quantity pricing.

• 15 day money back guarantee • \$15.00 minimum order •  
 We accept Mastercard, Visa, Discover, and C.O.D. orders. •  
 24 hour shipping • Shipping charge = UPS chart rate + \$1.00  
 (\$3.00 minimum charge) • Hours 8:30 am - 7:00 pm EST,  
 Monday - Friday • 9:00 am - 2:00 pm Saturday. Mail order customers,  
 please call for shipping estimate on orders exceeding 5 lbs. Foreign  
 destination customers please send \$5.00 U.S. funds for catalog postage.

**Famous Maker 3-1/2" Speaker Pair**

Dual cone 3-1/2" speaker pair for upgrading stock dash speakers. Graphite fiber composite woofer cone provides a smooth extended response at all power levels. The high frequency radiator (whizzer) takes over from the woofer at 6,000 Hz and greatly extends the response past 20 KHz. Strontium ferrite magnet. 3/4" high temperature voice coil. Impedance: 4 ohm. Power handling capability: 25 watts continuous, 70 watts peak. Frequency response: 120-21,000 Hz. Equipped with dust screen. Made in the U.S. by a company with over 40 years experience in the auto sound market.



**#RM-265-275 \$29.95 Pair**

**Subwoofer Input/Output Terminal**

This recessed terminal panel has inputs for right and left channels as well as outputs for right and left channels to route to your satellite speakers. Greatly simplifies subwoofer hook-up. Outside dimensions: 3-7/8" x 5-3/8".

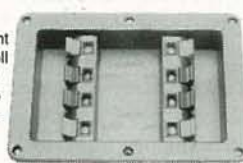

**#RM-260-308 \$3.95 (1-9) \$3.50 (10-up)**



CALL TOLL FREE  
**1-800-338-0531**

**FREE CATALOG**

\*\*\*\*\*PRESENTING\*\*\*\*\*  
**CABLE TV  
 DESCRAMBLERS**  
 \*\*\*\*\*STARRING\*\*\*\*\*  
**JERROLD, HAMLIN, OAK**  
 AND OTHER FAMOUS MANUFACTURERS

- FINEST WARRANTY PROGRAM AVAILABLE
- LOWEST RETAIL / WHOLESALER PRICES IN U.S.
- ORDERS SHIPPED FROM STOCK WITHIN 24 HRS.
- ALL MAJOR CREDIT CARDS ACCEPTED

FOR FREE CATALOG ONLY **1-800-345-8927**  
 FOR ALL INFORMATION **1-818-709-9937**

**PACIFIC CABLE CO., INC.**  
 7325 1/2 Reseda Blvd., Dept. 2110  
 Reseda, CA 91335

EDITOR with source \$49.00 modify and sell all you like. No royalties. Written in QuickBasic version 4.5. Manual on disk included. **TARBELL ELECTRONICS**, 5881 John Avenue., Long Beach, CA 90805. (213) 423-2792.

### PLANS AND KITS

**FASCINATING** electronic devices! Dazers! Lasers! FM/AM/phone transmitters! Detectors! Kits/assembled! Catalog \$2.00. **QUANTUM RESEARCH**, 16645-113 Avenue, Edmonton, AB. T5M 2X2.

**HOBBY/broadcasting/HAM/CB/surveillance** transmitters, amplifiers, cable TV, science, bugs, other great projects! Catalog \$1.00. **PANAXIS**, Box 130-F1, Paradise, CA 95967.

**DIGITAL recorder.** Digitally record any audio source with special effects. Microprocessor controlled device. Detailed plans, \$9.75: **T. ZURAW**, Box 341, Dearborn Hts, MI 48127.

**BUILD** our picture only, satellite TV descrambler for most channels. Uses 6 transistors and 4 chips. Most parts from Radio Shack. For educational purposes only, not to be used illegally. Circuit board and plans \$30.00 U.S. funds. Circuit board, plans, and parts kit \$89.00 U.S. funds. Build a super high economy carburetor, to make eight cylinder engines run on less than one gallon of gasoline per hour. Plans for 5 types \$20.00 U.S. funds. Cheque, money order or Visa welcome. Order from **VALLEY MICROWAVE**, Bear River, Nova Scotia, Canada B0S 1B0. Tel. (902) 467-3577 8 to 4 eastern time. Fax: (902) 467-3937 anytime.

**INVESTIGATORS**, experimenters — Quality new plans. Micro and restricted devices. Free catalog. Self addressed stamped envelope required. **KELLEY SECURITY, INC.** Suite 90, 2531 Sawtelle Blvd., Los Angeles, CA 90064.

### REMOTE CONTROL KEYCHAIN



Complete w/mini-transmitter and +5 vdc RF receiver Fully assembled including plans to build your own auto alarm. Quantity discounts available.

**\$24.95** Check, Visa or M/C Add \$3 shipping

**VISITECT INC.** Box 14156, Fremont, Ca. 94539  
 (510) 531-8425 Fax (510) 531-8442

**PCB and schematic CAD.** \$195.00 IBM EGA CGA Multilayer, rubberband, autovia, NC drill, laser, dot matrix, plotter, library, Gerber, **AUTOSCENE**, 10565 Bluebird St., Minneapolis, MN 55433. (612) 757-8584 free demo disk.

**GREAT** value. **Precision** fully-regulated supply (2 +x0-50V +/-0.01%5A0.5%) and (1 +x5V-3A). Tested parts as specified Radio El. Mar/90. No case U.S. \$560.00 +\$20.00 shipping (U.S./Can) 299 or M.O. to: **BCH**, 150 Clark Blvd., Dept. 299, Bramalea, Ontario Canada L6T-4Y8.

## REMOVE LEAD VOCALS

Build this kit for under \$60 which removes lead vocals from standard stereo records, CDs, tapes or F broadcasts. Easily connects to any home component stereo. Perform live with the backgrounds. You can be the lead singer of your favorite band. Detailed Plans. \$4.95  
**Weeder Technologies**  
 14773 Lindsey Rd.  
 Mt. Orab, Ohio 45154

**REMOVE VCR copy protection.** PCB PAL instructions \$16.50 w/P&H, **LOGICAL CHOICE**, 955 N Ogden, Bend OR 97701.

**BUG, telephone, FM, plans.** Convert RadioShack device, easy. \$12.95 **ALLAN LABS**, PO Box 143, 101 Allan Lane, Research Triangle Park, NC 2770

**PRINTED** circuit art work. Low cost, for free information write **NEGRON ENGINEERING**, 159 G field Place, Brooklyn, NY 11215. Fax or call (776-84028).

**VIDEOCIPHER II/scanner/cable/satellite** modifications books. Catalog — \$3.00. **TELECODE**, 1 Box 6426-RE, Yuma, AZ 85366-6426.

**DESCRAMBLER** kits. Complete cable kit \$44. Complete satellite kit \$49.95. Add \$5.00 shipping. Free brochure. No New York sales. **SUMMIT F** Box 489, Bronx, NY 10465.

### CABLE T.V. EQUIPMENT

**OAK RTC-56 99.00 M35-B 29.00**  
**TOCOM BULLET PROOF TEST CHIP 59.00 EA.**  
**TOCOM 5503-VIP 250.00 5503-A 200.00**  
**HAMLIN, JERROLD, ZENITH, S.A. LOW AS 19.00**  
**M-F 6A-3P PST. 1-800-622-3799**  
**SAME DAY SHIPPING. FULL WARRANT**

**SECURITY system** plans for eight zone, entry, delay, prealarm controller with independent tam fire zones. Build it yourself for under \$50.00! In ductory offer also includes plans to modify a real available product into an inexpensive alarm system motion detector. \$15.00 ppd. **V-TRONICS**, PO 177, Ruby, NY 12475.

**PLANS:** New 150 watts audio amplifier SC completed with power supply. Send SASE and \$10. **COVATION**, 21 Tennyson, Dover, NH 03820.

**ELECTRONIC projects** — Complete plans/p list. Audio/automotive/infrared/magnetic/photographic/custom designs/computer programs. Catalog \$3.00 credit 1st order. **ULRICH ELECTRONICS**, 11625 Jefferson St. NE, Blaine, 55434.

**BUILD** 6 simple low cost circuits to extend the functions and ranges of your meters and scope. Easy build, useful! Send now for complete instructions \$5.00 **BLUE BELL DESIGN, INC.**, Dept REM, White Oak Rd., Blue Bell, PA 19422.

### INVENTORS

**INVENTORS!** Can you patent and profit from idea? Call **AMERICAN INVENTORS CORP.** for information. Serving inventors since 1975. 1 (338-5656).

### SPECIALIZED SECURITY

**SURVEILLANCE** — Audio/vidoe/infra-red, personal protection equipment. Public, private, corp uses. Extensive book; \$9.00. Was "Security terms" catalog. **TRI-TRON OF ATLANTA**, 18 Fox Hollow, Lilburn, GA 30247-3363.

### SATELLITE TV

**FREE** catalog — Lowest prices worldwide. **SK SION**, 1012 Frontier, Fergus Falls, MN 5653 (800) 334-6455. (See full page ad the Shopper tion)

**SATELLITE TV** — Do it yourself — systems, grades. Parts. Major brands discounted 40% 60%. We'll beat everyone's price. **L.J.H. INC.** Larry (609) 596-0656.

## CABLE DESCRAMBLERS

Converters, Remote Controls, Descramblers, more



#EX192

All major brands carried

- \*JERROLD, \*TOCOM, \*ZENITH
- \*GENERAL INSTRUMENTS
- \*SCIENTIFIC ATLANTA, \*OAK
- \*HAMLIN, \*EAGLE, \*PIONEER

7th Year in business. Thank You  
 Member of Omaha Chamber of Commerce  
 1 Year warranty on new equipment  
 30 Day money back guarantee  
 Orders shipped from stock within 24 hours

CALL TODAY FOR A FREE CATALOG  
**1-800-624-1150**

VISA MasterCard AMERICAN EXPRESS C.O.D.

**M&G ELECTRONICS**  
 875 SO. 72nd St.  
 Omaha, NE 68114

## Cable TV Descrambler Kits

**Universal Kit.....\$55.00**  
 Includes all parts and PC Board. Not included is the ac adaptor or enclosure.

**Tri-Mode Kit.....\$39.00**  
 Includes all parts, PC Board and AC Adaptor. Not included is the enclosure.

**SB-3 Kit.....\$29.00**  
 Includes all parts, PC Board and AC Adaptor. Not included is the enclosure.

**Universal Tutorial.....\$9.95**  
 Includes an in depth study of the technology used and has troubleshooting hints.

**Tri-Mode Tutorial.....\$9.95**  
 Includes a gate by gate study of the circuit and has troubleshooting hints.

Call Toll Free 1-800-258-1134

COD Only

**M & G Electronics, Inc.**  
 72 Orange St., Suite 216  
 Providence, RI. 02903

CIRCLE 197 ON FREE INFORMATION CARD

# FREE CATALOG!

## 1-800-648-7938

ERROLD HAMLIN OAK ETC

# CABLE TV DESCRAMBLERS

- Special Dealer Prices!
- Compare our Low Retail Prices!
- Guaranteed Prices & Warranties!
- Orders Shipped Immediately!

**REPUBLIC CABLE PRODUCTS, INC.**  
4080 Paradise Rd. #15, Dept RE192  
Las Vegas, NV 89109

For all other information (702) 362-9026

**CABLE TV Secrets** — the outlaw publication the cable companies tried to ban. HBO, Movie Channel, Showtime, descramblers, converters, etc. Suppliers list included. \$9.95. **CABLE FACTS**, Box 711-Pataskala, OH 43062.

**SECRET cable descrambler.** Build your own descrambler for less than \$11.00, in seven easy steps. Radio Shack parts list included. Also free descrambling methods that cost nothing to try! Send \$10.00 to: **LOUIE WHITE**, 2 Marlin, Baytown, TX 77520.

## CABLE DESCRAMBLERS OAK M35B COMBO \$39.95

Jerrod, Zenith, Hamlin, Sci. Atlanta, Pioneer  
MORE! OUR PRICES ARE BELOW WHOLESALE!

### CABLE+PLUS

14417 Chase St. #481-A Panorama City, CA 91402  
1-800-822-9955 • Other Info. 1-818-785-4500  
NO CALIF. SALES — DEALERS WANTED

## BUSINESS OPPORTUNITIES

**YOUR** own radio station! Licensed/unlicensed AM, FM, TV, cable. Information \$1.00. **BROADCASTING**, Box 130-F1, Paradise, CA 95967.

**LET** the government finance your small business. Grants/loans to \$500,000. Free recorded message: (707) 449-8600. (KS1).

**EASY** work! Excellent pay! Assemble products at home. Call toll free 1 (800) 467-5566 Ext. 5192.

## FREE CATALOG

- CABLE T.V. BOXES - ALL TYPES •
- LOW PRICES - DEALER PRICES •

## ACE PRODUCTS

1-800-234-0726

**HOME** assembly work available! Guaranteed easy money! Free details! **HOMEWORK-R**, Box 520, Danville, NH 03819.

**WHAT** snow? For sale: thriving, fully equipped, audio-video repair shop. Proven 40%+ increase in net last three years. \$70,000.00 cash. **AUDIOTECH**, 256-B North Highway 101, Encinitas, CA 92024. FAX (619) 944-0345, Phone (619) 944-9048.

## BIG PROFITS ELECTRONIC ASSEMBLY BUSINESS

Start home, spare time. Investment knowledge or experience unnecessary. **BIG DEMAND** assembling electronic devices. Sales handled by professionals. Unusual business opportunity.

**FREE:** Complete illustrated literature  
BARTA RE-00 Box 248  
Walnut Creek, Calif. 94597

# CABLE TV "BOXES"

## Converters-Descramblers Remote Controls-Accessories

- ★ Guaranteed Best Prices ★
- ★ 1 Year Warranty - C.O.D.'s ★
- ★ Immediate Shipping ★
- ★ FREE CATALOG ★

Call or Write  
**NAS/TRANS-WORLD CABLE CO.**  
3958 North Lake Blvd. • Suite 255  
Lake Park, Florida 33403  
1-800-442-9333  
1-800-848-3997

**MAKE \$\$\$!** Become an American electronics dealer! Profit opportunities since 1965. Call **SCOTT PRUETT**, 1 (800) 872-1373.

**MONEYMAKERS!** Easy! One man CRT rebuilding machinery. \$6,900.00 rebuilt. \$15,900.00 new. **CRT**, 1909 Louise, Crystalake, IL 60014. (815) 459-0666. Fax (815) 477-7013.

## ANTIQUE RADIO CLASSIFIED

Free Sample!  
Antique Radio's  
Largest Circulation Monthly.  
Articles, Ads & Classifieds.

6-Month Trial: \$15. 1-Yr: \$27 (\$40-1st Class).  
A.R.C., P.O. Box 802-L9, Carlisle, MA 01741

# MARK V ELECTRONICS, INC.

Competitive Pricing \* Fast Shipping Since 1985

▲ indicates the level of difficulty in the assembling of our Products. ▲ Beginner ▲▲ intermediate ▲▲▲ Advanced ★ Fully Assembled

**SPECIAL OFFER**

Special offer will be given to the purchase of Amplifier + Metal Cabinet + Power Transformer: TA-3600.

AMPLIFIERS		KIT ASSEMB.	MISCELLANEOUS		KIT ASSEMB.
MODEL	DESCRIPTION		MODEL	DESCRIPTION	
TA-28MK2	Digital Voice Memo ▲▲	\$ 30.00	TY-23B	3 Channel Color Light Controller ★	\$ 85.00
TA-50A/B	Multi-Purpose Melody Generator ▲	12.84 17.20	TY-25	Stereo Loudspeaker Protector ▲	14.85 20.85
TA-50C	Multi-Purpose Melody (Happy Birthday, Wedding March, etc.) Generator ▲	13.65 18.71	TY-35	FM Wireless Microphone ▲	11.25
TA-120MK2	35W Class 'A' Main Power Mono Amp ▲	31.50 42.80	TY-36	AC/DC Quartz Digital Clock ▲	19.00 26.20
TA-300	30W Multi-Purpose Single Channel Amp ▲	20.00 29.00	TY-38	Sound / Touch Control Switch ▲	12.00
SM-302	60W + 60W Stereo Power Amplifier (with Mic input)▲▲	73.00 85.00	TY-41MK V	Infrared Remote Control Unit (w/Case) ▲▲▲	22.00 35.00
TA-323A	30W X 2 Stereo Pre-main Amp ▲	31.50 42.80	TY-42	Bar / Dot Level Meter ▲▲	24.15 33.81
TA-377A	State of the Art Fully Complementary Symmetrical FET Pre-Amp ▲▲▲	59.95 75.00	TY-43	3 1/2 Digital Panel Meter ▲	29.00 38.00
TA-400	40W Solid State Mono Amp ▲	28.00 34.93	TY-45	20 Steps Bar / Dot Audio Level Display ▲▲	38.45 46.14
TA-477	120W Mostel Power Mono Amp ▲▲	68.00 85.00	TY-47	Superior Electronic Roulette ▲▲	19.46 27.24
SM-720	120W + 120W AC/DC Stereo Hi-Fi & Pre-Main Amp ▲▲	75.00 89.00	016	10,000 uf 80V DC Capacitor (TA-3600, TA-477, TA-1000A, TA-802)	23.00
TA-802	120W + 120W Low Tim Pre-Main Stereo Power Amp ▲▲	63.92	017	8,200 uf 50V DC Capacitor (TA-802, TA-120MK2)	13.00
TA-800MK2	80W + 80W Pure DC Stereo Main Power Amp ▲▲	45.94 59.72	021	Nobel Resistor-Single Vol. Control (TA-3600, TA-477, TA-1000A, TA-120MK2)	12.00
TA-1000A	100W Dynamic Class 'A' Main Power Mono Amp ▲▲	50.00 65.00	022	Alps Resistor - Dual Vol. Control (TA-377A, TA-802, TA-2200)	22.00
TA-1500	100W X 2 Class 'A' DC Stereo Pre-Main Amp ▲▲▲	73.70 95.81	TR-355A	0-15V 5A Regulated DC Power Supply (no case & x former) ▲	\$15.65 \$ 21.76
TA-2200	DC Fet Super Class 'A' DC Pre-Amp ▲▲▲	47.70 58.24	TR-355B	0-30V 3A Regulated DC Power Supply (no case & x former) ▲	15.65 21.76
TA-2500	HD Pre-Amp w/10 band graphic equalizer ★	78.00	TR-503	0-50V 3A Regulated DC Power Supply (no case & x former) ▲▲	16.75 23.65
TA-2800	BI-FET IC Pre-Amp w/3 way tone control ▲▲	48.90 63.57	<b>REGULATORS</b>		
TA-3000	Stereo Simulator (For Mono TV or Any Mono Source) ▲▲	27.00 38.50	<b>METAL CABINETS WITH ALUMINUM PANEL</b>		
TA-3600	300W HD Hi-Fi Power Mono Amp ▲▲	85.00 110.00	MODEL	H" x W" x D" MATCHING	PRICE
SM-222	7 Band Hi-Fi Graphic Equalizer ▲▲	26.80 38.80	LG-1273	3" x 12" x 7" TA-2800, TA-377A, TA-2200	\$ 23.85
SM-333	Audio/Video Surround Sound Processor ▲▲▲	65.00 75.00	LG-1684	4" x 16" x 8" TA-323A, TA-377A, TA-2200	28.50
SM-666	Dynamic Noise Reduction ▲	26.00 34.00	LG-1924	4" x 19" x 11 1/2" TA-802, TA-1500, TA-120MK2, TA-800 MK2, TA-1000A	34.50
SM-888	Universal Audio/Video KARAOKE Mixer, Pre-Amp ★	155.00	LG-1925	5" x 19" x 11 1/2" TA-477, TA-800 MK2, TA-1500, TA-1000A, TA-3600	38.00
			LG-1983	2 1/2" x 19" x 8" TA-377A, TA-2800, TA-2200, TA-120MK2	30.50
<b>DIGITAL METERS AND COUNTER</b>			<b>POWER TRANSFORMERS</b>		
MODEL	DESCRIPTION		MODEL	DESCRIPTION	
SM-43	3 1/2 Multi-Functional Led D.P.M. (w/ABS plastic case)▲▲	\$ 34.50 \$ 43.00	001	28V x 2.6A to 30V x 2.6A	\$ 28.00
SM-48	4 1/2 Hi-Precision D.P.M.▲▲	38.00 48.00	002	36V x 2.3A	23.00
SM-48A	4 1/2 Hi-Precision D.P.M. (w/ABS plastic case)▲▲▲	41.20 52.00	003	40V x 2.6A	30.00
SM-49	3 1/2 Multi-Functional LCD D.M.P. (w/Hold Function)▲▲	36.00 44.50	004	24V x 2.6A	23.00
SM-100	150MC Digital Frequency Counter▲▲▲	79.00 90.00	005	28V x 2.3A	17.00
			006	18V x 2.5A	17.00
			007	53V x 2.8A	45.00

We accept major Credit Cards, Money Orders, Checks and C.O.D. Orders. C.O.D. fee is \$6.50. Minimum order is \$20.00. We ship by UPS ground inside US (min. \$4.00) and ship by US mail. Business & Showroom hours: (Pacific Time) Mon. thru Fri. 9:30 am to 5:00 pm Sat. 10:00 am to 5:00 pm

**MARK V ELECTRONICS, INC. - 8019 E. Slauson Ave, Montebello, CA 90640**

CIRCLE 93 ON FREE INFORMATION CARD

January 1984, Radio-Television

# Your Natural Resource for Wide

## Test/Measurement and Prototype Equipment

### Jameco Solderless Breadboards

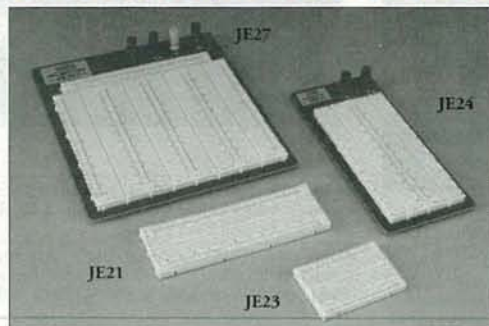

Jameco's long-lasting breadboards feature screen-printed color coordinates and are suitable for many kinds of prototyping and circuit design. Larger models feature a heavy-duty aluminum backing with voltage and grounding posts.

Part No.	Dim. L" x W"	Contact Points	Binding Posts	Price	Part No.	Dim. L" x W"	Contact Points	Binding Posts	Price
JE21	3.25 x 2.125	400	0	\$4.95	JE25	6.500 x 4.25	1,660	3	17.95
JE23	6.50 x 2.125	830	0	6.95	JE26	6.875 x 5.75	2,390	4	22.95
JE24	6.50 x 3.125	1,360	2	12.95	JE27	7.250 x 7.50	3,220	4	31.95

### GoldStar 20MHz Dual Trace Oscilloscope



The perfect unit for today's testing and measurement needs! Features include a 6" CRT display, and bandwidth from DC to 20 MHz. The GoldStar Oscilloscope comes with two 40MHz probes, two fuses, power cord, operation manual, schematics and block and wiring diagram. It's lightweight and portable with a two-year warranty.

GS7020.....\$399.95

### BNC Cable Assemblies for GS7020

BNC1	BNC(M) to BNC(M) RG58 A/U (39"L).....	\$3.95
BNC2	BNC(M) to Micro Hook RG174 39"L).....	3.95
BNC3	BNC(M) to Macro Hook RG174 (39"L).....	3.95



24 Hour Toll-Free Order Hotline  
1-800-831-4242



Please refer to Mail Key 2 when ordering



### Weller Soldering and Desoldering Stations



- Temperature adjustable from 350° to 850°F
- Zero voltage circuit protects sensitive components from damage
- Lighted on/off switch

WCC100 Soldering Station....\$89.95

- 50 Watt Temperature Controlled Desoldering Station
- Desoldering head is temperature controlled to 800°F
- Low maintenance vacuum system

DS600 Desoldering Station..\$549.95

### Metex Digital Multimeters

- Handheld, high accuracy • AC/DC voltage, AC/DC current, resistance, diodes, continuity, transistor hFE
  - Manual ranging w/ overload protection
  - Comes with probes, batteries, case and manual
- M3650 & M4650 only:  
• Also measures frequency and capacitance

M3800 3.5 Digit Multimeter .....\$39.95

M3610 3.5 Digit Multimeter .....\$59.95

M3650 3.5 Digit Multimeter w/Frequency & Capacitance .....\$74.95

M4650 4.5 Digit w/Frequency & Capacitance & Data Hold Switch.....\$99.95



24 Hour Toll-Free Order Hotline  
1-800-831-4242

### Jameco Logic Pulser



- Compatible with TTL, DTL, RTL, HTL, HNLL, MOS and CMOS ICs
- 1MΩ Sync input impedance • Pulser mode output current: 10mA • Square wave current output: 5mA • Audible tone

LP540.....\$16.95

### A.R.T. EPROM Programmer



- Programs all current EPROMs in the 2716 to 27512 range plus the X2864 EEPROM
- RS232 port • Software included

EPP.....\$199.95

### Jameco Logic P



- Max Frequency 80MHz • Mini detectable pulse: 10ns • 120KΩ impedance • Max. supply voltage
- TTL threshold: (Lo)+0.8V ±0.1 +2.3V ±0.2V • CMOS threshold: VCC ±10%, (Hi) 70%VCC ±10%

MS104.....

### UVP EPROM Er



- Erases all EPROM's • Erases 15 minutes and 8 chips in 21 r
- UV intensity: 6800 UW/CM<sup>2</sup>

DE4.....

### EPROMs - for your programming need

Part No.	Price	Part No.	Price	Part No.
TMS2516.....	\$4.25	2764-20.....	\$3.95	27256OTP...
TMS2532-35.....	8.95	2764-25.....	3.75	27256-15.....
TMS2532A.....	6.95	2764A-20.....	3.75	27256-20.....
TMS2564.....	5.95	2764A-25.....	3.19	27256-25.....
TMS2716.....	5.95	27C64-15.....	3.95	27C256-15...
1702A.....	3.95	27C64-25.....	3.25	27C256-20...
2708.....	4.75	27128OTP.....	3.49	27C256-25...
2716.....	3.39	27128-20.....	7.95	27512OTP...
2716-1.....	3.75	27128-25.....	7.75	27512-20.....
27C16.....	4.25	27128A-15.....	4.95	27512-25.....
2732.....	4.95	27128A-20.....	4.49	27C512-15..
2732A-20.....	4.49	27128A-25.....	3.75	27C512-20..
2732A-25.....	3.49	27C128-15.....	5.75	27C512-25..
2732A-45.....	2.95	27C128-25.....	7.95	27C010-15..
27C32.....	4.75			68766-35.....

• Partial Listing • Over 4000 Electronic and Computer Components in Stock!

# Selection & Competitive Prices

## Computer Products and Electronic Components

### Assemble Your Own Computer Kit!

#### Jameco 16MHz 80286 Computer Kit

Assembling your own computer provides you with a better understanding of components and their functions. Step-by-step assembly instructions included with your new computer assembled and ready to go in an evening, using common tools are included. These computer kits configured by you or design your own.

- 6-16 Motherboard with 1MB RAM (expandable to 8MB)
- Key enhanced keyboard
- I/O Card w/ controller
- Hard disk drive
- 15" sized desktop case
- 50 Watt power supply
- DOS 5.0
- Diagnostic software

16.....\$599.95

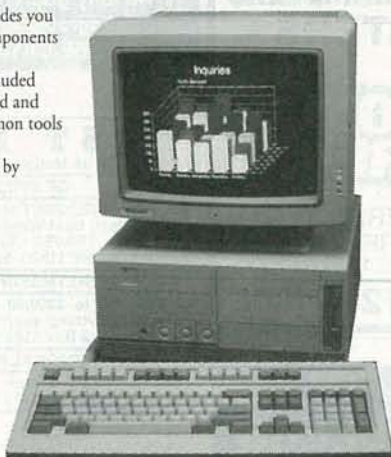

monitor and adapter extra

#### Jameco 4-Channel Switching Power Supply

- +5VDC @ 5.0A
- 5VDC @ 1.0A
- +12VDC @ 1.0A
- 12VDC @ 1.0A

- Microprocessor, mini-computer, terminal and process control applications
- Input: 90-130VAC @ 47-440Hz
- Size: 6.25"L x 3.88"W x 1.5"H
- Weight: 1.25 lbs.
- Data included

FCS604A.....\$44.95 Additional Power Supplies available!

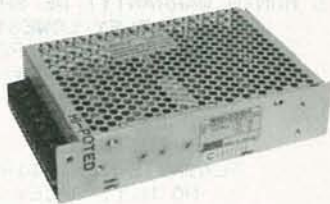

#### Zaison 56 Watt Switching Power Supply

- +5VDC @ 4.5A
- +12VDC @ 1.4A
- 12VDC @ 0.3A
- +12VDC @ 1.2A

Limited Quantity

- Input: 115VAC @ 47-440Hz
- Two 4 pin molex style connectors for voltage output
- Size: 6"L x 4.5"W x 2"H
- Weight 1.5 lbs.

PS6141.....\$24.95



#### Integrated Circuits\*

No.	1-9	10+
.....	\$.29	\$.19
.....	.29	.19
.....	.29	.19
.....	.35	.25
.....	.35	.25
.....	.35	.25
.....	.29	.19
.....	.35	.25
.....	.29	.19
.....	.35	.25
.....	.89	.79
.....	.39	.29
.....	.45	.35
.....	.45	.35
.....	2.95	2.75
.....	.59	.49
.....	.49	.39
.....	.79	.69
.....	.79	.69

#### Dynamic RAMs

Part No.	Description	Price
4164-100.....	100ns, 64K x 1	\$1.89
4164-120.....	120ns, 64K x 1	1.69
4164-150.....	150ns, 64K x 1	1.49
41256-60.....	60ns, 256K x 1	2.49
41256-80.....	80ns, 256K x 1	2.19
41256-100.....	100ns, 256K x 1	1.95
41256-120.....	120ns, 256K x 1	1.79
41256-150.....	150ns, 256K x 1	1.69
511000P-80...	80ns, 1MB x 1	7.25
511000P-10...	100ns, 1MB x 1	6.75

#### Miscellaneous Components\*

##### Potentiometers

Values available (insert ohms into space marked "XX"):

500Ω, 1K, 5K, 10K, 20K, 50K, 100K, 1MEG
43PXX 3/4 Watt, 15 Turn ..... \$ .99
63PXX 1/2 Watt, 1 Turn ..... \$ .89

#### Transistors And Diodes

PN2222 \$ .12	1N751 \$ .15
PN2907 .12	C106B1 .65
1N4004 .10	2N4401 .15
2N2222A .25	1N4148 .07
1N4735 .25	2N3055 .69
2N3904 .12	1N270 .25

#### Switches

JMT123 SPDT, On-On (Toggle) ..... \$1.15
206-8 SPST, 16-pin (DIP) ..... \$1.09
MPC121 SPDT, On-Off-On (Toggle) ..... \$1.19
MS102 SPST, Momentary (Push-Button) ..... \$ .39

\*Additional components available

#### Connectors

Part No.	Description	Price
DB25P Male, 25-pin		\$.65
DB25S Female, 25-pin		.75
DB25H Hood		.39
DB25MH Metal Hood		1.35
<b>LEDs</b>		
XC209R T1, (Red)		\$.14
XC556G T1 3/4, (Green)		.16
XC556R T1 3/4, (Red)		.12
XC556Y T1 3/4, (Yellow)		.16

#### IC Sockets

	Low Profile	Wire Wrap (Gold)	Level #2
8LP	\$.10	8WW	\$.49
14LP	.11	14WW	.69
16LP	.12	16WW	.79
24LP	.19	24WW	1.15
28LP	.22	28WW	1.39
40LP	.28	40WW	1.89

Soldertail Standard and Header Plug Sockets Also Available

24-Hour Toll-Free Order Hotline:

# 1-800-831-4242

Call or Write for a

## FREE 90-Page 1992 Catalog!

\$30.00 Minimum Order • Data Sheets - 50¢ each

**JAMECO**<sup>®</sup>  
ELECTRONIC COMPONENTS  
COMPUTER PRODUCTS

1355 Shoreway Road  
Belmont, CA 94002  
FAX: 1-800-237-6948  
BBS Support: 415-637-9025

International Sales • Customer Service • Technical Assistance  
• Credit Department • All Other Inquiries: 415-592-8097 • 7AM - 5PM P.S.T.

© 1992 Jameco 1/92  
CA Residents Add 7.25%, 7.75% or 8.25% Sales Tax  
Shipping, handling and insurance are additional.

Terms: Prices subject to change without notice.  
Items subject to availability and prior sale.  
Complete list of terms/warranties is available upon request.

\* Call for a complete listing of ICs

## CABLE TV DESCRAMBLERS!

### CABLE KINGDOM!

\*JEROLD\* \*OAK\* \*HAMLIN\*  
\*ZENITH\* \*PIONEER\*  
\*SCIENTIFIC ATLANTA\*

IN STOCK

6 MONTH WARRANTY! WE SHIP COD!  
ABSOLUTELY LOWEST  
WHOLESALE/RETAIL PRICES!  
\*\*\*\*\*FREE CATALOG\*\*\*\*\*

J.P. VIDEO  
1470 OLD COUNTRY RD  
SUITE 315  
PLAINVIEW, NY 11803  
NO N.Y. SALES  
CALL NOW! 1 (800) 950-9145

## WANTED

**INVENTIONS/** new products/ideas wanted: call TLCI for free information/inventors newsletter. 1 (800) 468-7200 24 hours/day - USA/Canada.

**INVENTORS:** We submit ideas to industry. Find out what we can do for you. 1 (800) 288-IDEA.

**INVENTORS!** Your first step is important. For free advice, call **ADVANCED PATENT SERVICES**, Washington, DC, 1 (800) 458-0352.

**INVENTORS!** Confused? Need help? Call **IMPAC** for free information kit. USA/CANADA: 1 (800) 225-5800 (24 hours!).

## EDUCATION & INSTRUCTION

**F.C.C. Commercial General Radiotelephone License.** Electronics home study. Fast, inexpensive! "Free" details. **COMMAND**, D-176, Box 2824, San Francisco, CA 94126.

**COMPLETE** course in electronic engineering. Eight volumes. Includes all necessary math and physics. Free brochure. **BANNER TECHNICAL BOOKS**, 1203 Grant Avenue, Rockford, IL 61103.

## CABLE TV DESCRAMBLERS ★ CONVERTERS ★ and ACCESSORIES.

## SAVE MONEY. DON'T RENT!

PANASONIC, JERROLD, OAK,  
PIONEER, SCIENTIFIC ATLANTA  
AND MORE. LOWEST PRICES. FREE CATALOG.  
**CABLE READY (800) 234-1006  
COMPANY**

## CABLE TV DESCRAMBLERS ALL TYPES 800-582-1114 FREE CATALOG M.K. ELECTRONICS • 7958 Pines Blvd Suite 276 • Pembroke Pines, FL 33024

**BE a recording engineer;** Train at home for paying — exciting careers. Free information **DIO INSTITUTE**, 2258-A Union St., Suite K Francisco, CA 94123.

**VCR** tapes by college instructor covering elec topics. Send for free demo \$3.50 P&H O.C.S 292, Fort Mill, SC 29715.

**ELECTECH**  
**CABLE T.V. DESCRAMBLE**  
• All quality brand names •  
• All fully guaranteed • All the time  
Knowledgeable Sales Service Department  
**FOR FREE CATALOG 800-253-00**

## BEST BY MAIL

Rates: Write National, Box 5, Sarasota, FL 3

OF INTEREST TO ALL

**50% CASH DISCOUNT** at over 1,000 select Holiday Hilton Hotels, Best Western & More! Information **DISCOUNT TRAVEL SERVICE**, 662 Franklin Garden City, NY 11530, Suite 421.

### MONEYMAKING OPPORTUNITIES

**WE PAY UP TO \$300.00 weekly** Woodburning Frames. Everything supplied. No experience or Bay Frame, PO Box 1588-(RE), Jackson, TN 3830

### PERSONAL-MISCELLANEOUS

**SINGLES! MEET OTHER** Fun Exciting People! **TRODUCTIONS** 1-900-776-4225. \$2/Min.

### PAY TV AND SATELLITE DESCRAMBLING

ALL NEW 1992 EDITION ALL NEW

It's up to the minute. All new update on cable, wireless and satellite. TV bypasses, circuits, chipping, bullets, bags, Dectec, Liberty One, ECV Readers, programming, and lots more. Our best yet. Only \$15.95. Other (rent) editions 1991, 1989, Volume One (Basics) \$15.95 each. MODS \$39.95. Satellite systems under \$600 \$12.95. Any 3/\$29.95 or 6/\$49.9 \$29.95. Scrambling News Monthly \$24.95/yr. Sample \$3. All new cat Shipping costs included.

Scrambling News, 1552 Hertel Ave.,  
Buffalo, NY, 14216. Voice/Fax (716) 874-2088  
COD'S ARE OK. ADD \$6

## COMPUTER CONNECTIC

continued from page 85

adding some SRAM or DRAM that's it. Who wants it? In the \$2000 386 boxes and \$3000 boxes, who cares about a CGA 8086? Makers of laptop and handheld devices like HP's 95LX. The theory, anyway. It may be we're about to witness an explosion of PC Gadgets, miniature DOS devices that surpass calculator: the Sharp Wizard type of device other line consists of 386 clones provide 10-15% better performance. Both lines incorporate a new technology called SuperState that provides an interrupt level higher than normal IRQ's and the NMI, and when entered gives a totally new address space for executing code. SuperState could be used to implement power management functions. It updates missing instructions (e.g. continued on page

## THE ELECTRONIC GOLDMINE

The **Electronic Goldmine** has one of the greatest selections of unique electronic kits available in the world! We have over 65 kits and over 1,400 unique, bargain priced, components in our catalog!

**FREE CATALOG**  
with OVER 1400 DIFFERENT ITEMS INCLUDING 65 KITS! REQUEST YOUR COPY TODAY!

### SURFACE MOUNT TECHNOLOGY KIT

This kit contains 2 bright tiny LED's (one red and one green) that alternately flash. The two transistor multivibrator circuit uses the same tiny surface mount devices (SMD) as used in almost all late model sophisticated electronic products. Size only 1.58" x .34". Complete with all parts, PC board and instructions.

**C6465 \$5.00**

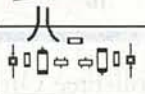

### INFRARED DETECTOR KIT

Great for testing and verification of infrared output! Uses sensitive sensor and electronic circuitry to respond to all types of infrared TV, VCR, etc. remote controllers and LEDs producing sound and lighting a bright red LED. 9V battery (not included). Size of board: 2.5" x 1.4". Complete with all parts, PC board and instructions.

**C6441 \$5.95**



### INEXPENSIVE GEIGER COUNTER

Probably the lowest priced Geiger Counter kit available in the world today! Features sensitive thin window Geiger Mueller tube and speaker that emits clicks in proportion to the radiation level. Detects Beta and Gamma rays. Operates from one 9V battery (not included). Only 3" x 1.8"

**C6447 \$39.95**

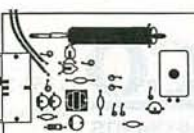

### BATTERY POWERED ULTRAVIOLET MINERALIGHT LAMP

UVG-4 SHORT WAVE TYPE  
Useful for detecting fluorescent minerals. 4 watt uses 4 "AA" (not included). Size 6.5" x 1.25" x 1.75"

**G812 \$31.95**



MINIMUM ORDER: \$10.00 plus \$3.50 shipping and handling. We accept MC, Visa and Money Orders.

SEND ORDERS TO: The Electronic Goldmine

P.O. Box 5408 Scottsdale, AZ 85261

PHONE ORDERS (602) 451-7454 FAX ORDERS (602) 451-9495

CIRCLE 178 ON FREE INFORMATION CARD

## Worldwide Cable

## CABLE TV DESCRAMBLERS

THE MOST ADVANCED TECHNOLOGY IN CABLE EQUIPMENT:

- BASE BAND
- PIONEER
- HAMLIN
- SCIENTIFIC ATLANTA • OAK
- JERROLD
- TOCOM
- ZENITH

For out of this world prices call  
**WORLDWIDE CABLE**  
**1 800-772-3233**  
**FREE CATALOG AVAILABLE**

7491 C-5 N. FEDERAL HWY., SUITE 142  
BOCA RATON, FL 33487

MC / COD / VISA NO FLORIDA SALES

CIRCLE 193 ON FREE INFORMATION CARD

**EASY ORDER**  
800-582-4044

# EASYTECH

THE ELECTRONICS SOURCE

**EASY FAX**  
1-800-582-1255

## TRIPP LITE — PRECISION REGULATED DC POWER SUPPLIES

Complete Line of DC Power Supplies to Convert 120VAC to 13.8VDC ±0.5VDC.

### Standard Features Include:

- State integrated circuit provides excellent regulation
- Output voltage maintained up to 95% of no load value
- Quality filtering for low noise operation
- Heavy duty power transformer for complete line isolation
- Power off indicator light and rugged on/off switch on faceplate
- Inductor grounded cord on 10 Amp and larger models
- Output limiting electronic foldback for auto overcurrent protection



PR4.5



PR25

Lite DC Power Supplies Are Designed For Reliability and Superior Performance.

Part #	Price	ICS* (amps)	Continuous Duty (amps)	Fusing	Ripple Voltage	HxWxD (Inches)	Weight
32.95	4.5	3	Internal	0.1 Volt Max	3.125 x 4.75 x 8.25	5 lbs.	
44.95	7	5	Chassis Mount	0.15 Volt Max	3.75 x 6.5 x 7.5	7 lbs.	
64.95	10	7.5	Chassis Mount	0.15 Volt Max	4.5 x 6.625 x 7.625	10 lbs.	
89.95	15	12	Chassis Mount	0.15 Volt Max	4.75 x 7.5 x 8.25	13 lbs.	
126.95	25	20	Chassis Mount	0.15 Volt Max	5.125 x 12.5 x 10.5	20 lbs.	
179.95	40	32	Chassis Mount	0.15 Volt Max	7.25 x 12.5 x 10	26 lbs.	
249.95	60	48	Chassis Mount	0.15 Volt Max	8.5 x 12.5 x 10	29 lbs.	

Intermittent Communications Duty (50% Duty Cycle)

## SOLDERLESS PROTOTYPING BOARDS



SB830



SB1660



SB2390



SB3220

- Features
- Coordinates for easy recognition
- Striation wire: 20-29 AWG (0.3 - 0.8 mm)
- Supports up to 10,000 insertion cycles
- Supports all standard components

Part #	Price 1-9	Price 10+	Dimensions (in.) L x W x H	Dist. Strips	Dist. Points	Terminal Strips	Terminal Points	Binding Posts
100	2.99	2.49	6.5 x 0.37 x 0.4	2	100 x 2	0	0	0
100	4.89	4.39	3.3 x 2.2 x 0.4	2	100	1	300	0
130	5.45	4.95	6.5 x 1.4 x 0.4	0	0	1	630	0
130	6.49	5.99	6.5 x 2.2 x 0.4	2	200	1	630	0
1360	12.49	11.99	8.5 x 3.9 x 1.2	1	100	2	1,260	2
1660	17.45	16.95	8.5 x 5.1 x 1.2	4	400	2	1,260	3
2390	22.49	21.49	9.1 x 6.9 x 1.2	5	500	3	1,890	4
3220	31.49	30.49	9.5 x 8.3 x 1.2	7	700	4	2,520	4

## ZILOG DATABOOKS\*

### Z80 CPU Technical Manual

338 page manual contains the architecture, pin description, timing, instruction set, instruction operation, interrupt response and hardware/software implementation examples of the Z80 CPU.

Part # Z29 9.95 Z80 CPU Technical Manual .....Weight: 1 lb.

### Intelligent Peripheral Controllers

700 pages of data sheets, application notes and technical information on Zilog's intelligent peripheral controllers. The part numbers contained in this book are Z8400, Z84C00, Z84C01, 10/C10, Z8420/C20, Z8430/C30, Z8440/1/2/4, Z84C40/1/2/3/4, Z84C50, Z8470, Z84C90, 11/C11, Z84013/15, Z84C13/C15, Z80180, Z80181 and Z280.

Part # Z2480 13.95 Intelligent Peripheral Controllers .....Weight: 2 lbs.

### Datacom ICs

700 pages of data sheets and other technical information on Zilog's Data Communications ICs. Numbers contained in this book are the Z16C30/31/33/35/50, Z5380, Z85230, Z80C30, Z85C30, 30, Z8530, Z80181, Z84013, Z84015, Z84C13, Z84C15, Z8440, Z84C40 and Z85C80. Also included are application notes.

Part # Z2503 13.95 Datacom ICs .....Weight: 2 lbs.

### Microcontrollers

1300 pages of data sheets, application notes and technical information on Zilog's microcontrollers. Part numbers contained in this book are Z8600/01/02/03/04/11/12/13/71/81/82/91, 00/01/20/22, Z86C00/C06/C08/C09/C10/C12/C19/C20/C21/C27/C30/C40/C50/C61/C62/C89/C90/C93/C94/C96/C97, Z86E08/E19/E21/E30/E40, Z88C00, Z86127, Z86128, Z765A, Z5380 and C80.

Part # Z8275 16.95 Microcontrollers .....Weight: 3 lbs.

Databooks are not returnable. We carry the newest versions available.

## ACTIVE COMPONENTS

MICROS		DRAMS	
Order #	Price	Order #	Price Desc.
6242	8.95	MK4027N2	.75 .....4x1
6502	2.95	4116-20	.85 .....16x1
6522A	3.75	4416-12	2.95 .....16x4
6821	1.75	4164-10	1.95 .....64x1
6845	2.45	4164-15	1.55 .....64x1
8080A	2.75	4164-20	1.25 .....64x1
8085A	2.95	41464-12	2.75 .....64x4
8086	4.45	41256-80	2.75 .....256x1
8088	4.25	41256-12	2.15 .....256x1
8237A5	4.15	51258-80	4.95 .....256x1
8250	5.75	514256-10	6.95 .....256x4
8251A	2.25	514258-80	9.95 .....256x4
8253-5	2.25	511000-80	7.25 .....1Mx1
8255A5	2.75	511000-10	6.95 .....1Mx1
8275	18.95	511001-80	8.25 .....1Mx1

STATIC RAMS		EPROMS	
Order #	Price	Order #	Price Prog.
2101	1.65	2708	4.75 .....25V
2114L25	1.39	2716	3.45 .....25V
2147-3	3.75	2732	3.95 .....25V
6116LP3	2.75	2732A25	3.45 .....21V
6116-3	2.25	2732B45	4.25 .....12.5V
6264LP10	4.95	2764-25	3.75 .....21V
6264LP15	3.95	2764A25	3.25 .....12.5V
6264-10	4.75	27C64A15	3.95 .....12.5V
6264-15	3.75	27128A25	3.95 .....12.5V
62256LP10	6.75	27256-25	4.75 .....12.5V
62256LP15	6.25	27C512-15	6.95 .....12.5V
628128LP8	34.95	27C010-15	9.95 .....12.5V
628128LP10	32.95	27C020-15	24.95 .....12.5V

LINEAR		LINEAR	
Order #	Price	Order #	Price Description
MAX232CPE	4.55	CA3161E	1.95 .....Decoder Driver
LM311N	.49	CA3162E	6.25 .....Converter
LM324N	.35	78L05	.35 .....5V Pos. Reg. TO-92
LM339N	.39	7805K	1.25 .....5V Pos. Reg. TO-3
LM555CN	.29	7805T	.45 .....5V Pos. Reg. TO-220
LM741CN	.29	7812T	.45 .....5V Pos. Reg. TO-220
LM1488N	.45	79L05	.29 .....5V Neg. Reg. TO-92
LM1489N	.45	7905T	.49 .....5V Neg. Reg. TO-220

## MEMORY MODULES—SIMMS

Order #	Price	Organization	Speed
256x9-80	19.95	262,144x9	80ns
1x9-80	57.00	1,048,576x9	80ns
4x9-80	210.00	4,194,304x9	80ns

# EASYTECH

THE ELECTRONICS SOURCE



2917 Bayview Drive  
Fremont, CA 94538



**Easy Order: 1-800-582-4044**  
**Easy Fax: 1-800-582-1255**

**International Fax: 1-510-770-2346**  
**Customer Service: 1-510-770-2345**

Monday-Friday, 7am - 5pm (PST) / 10am-8pm (EST)

- COD-No personal checks, US funds (\$5.00 Surcharge)
- USPS
- UPS
- Federal Express
- Airborne

Add 5% of total for shipping UPS Ground (\$3.00 min.).  
Actual shipping charges based on weight.

Call or write today for your free copy of our catalog.

California residents, add appropriate sales tax.  
12 month warranty on all EasyTech products.  
30 day money back guarantee.  
We reserve the right to substitute manufacturers.  
Prices subject to change without notice.

# ALL ELECTRONICS

P.O. Box 567 • Van Nuys, CA 91408

## 20 AMP RFI/EMI FILTER

Corcom# 20B6  
20 amp RFI/EMI general purpose common-mode filter. Controls line-to-ground noise. Small size, low leakage. 3.46" X 1.16" X 2.81". UL and CSA listed. CAT# RFI-201 \$8.50 each



## 4PDT - 24 Vdc RELAY

24 Vdc, 650 ohm coil - 3 amp contacts Standard 14 pin (ICE CUBE) style. Plastic dust cover. Size: 1 1/4" X 1 3/4" X 7/8" CAT# 4PRLY-24N \$4.00 each



## HIGHEST QUALITY METAL CASSETTES (ERASED)

Premium quality metal tape in C-60 cassettes (30 min. or more per side). One of the finest "brand-name" tapes on the market, in durable, clear plastic transport mechanisms. Recorded and bulk erased, the record-protect tabs have been removed and therefore, need to be taped over to re-record. Audiophiles will appreciate the wide dynamic range of this tape. If your cassette deck has a "metal" setting you will hear the difference. A real bargain! 60 min. tape - CAT# C-600M \$1.25 each \*10 for \$10.00

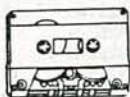

## CASSETTE STORAGE CASE

Black, unbreakable plastic audio cassette storage case. CAT# CBOX 5 for \$1.00 100 for \$15.00



## HEAT SINK COMPOUND

G C Electronics # 10-8109 For effective transfer of heat between components and heat sinks. Z9 silicone heat sink compound.



CAT# HSC-1 \$2.00 per 1 oz tube

## OPTO SENSOR

TRW/Optron # OPB5447-2 IR emitter/sensor pair in Rectangular package with 28" color coded leads. CAT# OSR-4 2 for \$1.00



## WALL TRANSFORMER

12 Vdc 500 ma.

2.1mm D.C. power plug with center negative. White case. CAT# DCTX-125W \$4.50 each

12 Vdc, 200 ma.

2.1 mm D.C. power plug with center negative. CAT# DCTX-122 \$3.00 each



## PHOTORESISTOR

1,000 ohms bright light, 16K ohms dark. 0.182" dia. X .08" high. 0.18" long leads.

CAT# PRE-7 2 for \$1.00 100 for \$45.00 • 1000 for \$400.00



## TOLL FREE ORDER LINES

1-800-826-5432

CHARGE ORDERS to Visa, MasterCard or Discover

TERMS: Minimum order \$10.00. Shipping and handling for the 48 continental U.S.A. \$3.50 per order. All others including AK, HI, PR or Canada must pay full shipping. All orders delivered in CALIFORNIA must include state sales tax (7 1/4%, 7 1/2%, 7 3/4%, 8 1/4 %). Quantities Limited. NO C.O.D. Prices subject to change w/out notice.

Call or Write For Our

FREE 64 Page Catalog

(Outside The U.S.A. Send \$2.00 Postage)

ALL ELECTRONICS CORP.

P.O. Box 567 • Van Nuys, CA • 91408

# Shortwave Listening Guidebook

by Harry Helms

The world is talking on shortwave radio, and here's the book that tells you how to listen in! In direct, nontechnical language, Harry explains how to get the most from your shortwave radio. Its 320 heavily illustrated pages are filled with practical advice on:

- antennas
- when and where to tune
- selecting the right radio for you
- accessories
- reception techniques



Learn how to hear the BBC, Radio Moscow, ham radio operators, ships at sea, even Air Force One! Includes hundreds of frequencies for stations around the world and the times you can hear them.

Only \$16.95 plus \$3.00 shipping (CA residents please include sales tax).

HighText

Publications, Inc.  
7128 Miramar Road  
Suite 15L, San Diego, CA 92121



**ANNOUNCING:**  
AN END  
TO  
HIGH MONTHLY  
CABLE FEES!

All Jerrold, Oak, Hamlin, Zenith, Scientific Atlanta, Magnavox and all specialized cable equipment available for shipment within 24 hours. For fast service MC/VISA or C.O.D. telephone orders accepted. 60 Day Guarantee (Quantity Discounts). Send self-addressed Stamped envelope.

1-800-232-5017



C.O.D. ORDERS  
ACCEPTED



**CABLE-TRONICS, INC.**

1304 E. Algonquin Road Suite 501  
Algonquin, Illinois 60102

## MONITOR TESTER

continued from page 49

16 by IC5 to produce a horizontal sync of 21.94 kHz.

Vertical sync is generated by dividing the horizontal sync by 6 at IC8's QB output (pin 10). The output of IC9 connects back to its own CLR input via IC6 pins 6 and 7 causing IC9 to divide by 6, a net division of 384. That gives a vertical sync of 57.14 Hz at IC9's QA output. That QA output is connected to IC2-e pin 11, which is configured as a one-shot, and outputs a 60-microsecond positive pulse to IC7 pin 13. The output of IC7 is output at pin 12 of IC7 which is connected to pin 9 of connector J1. Switch S3 routes 351.08 Hz to the low-byte RGB inputs of the EGA monitor. That causes the monitor to display a positive three-dimensional pattern on the monitor.

As a few final notes, VGA inputs are 75-ohm impedance. Resistors R7-R9 reduce the amplitude of the color signals to about 1 volt p-p. 400-line operation is produced by making horizontal sync negative polarity and vertical sync positive. EGA monitor switch from Mode 2 (enhanced) to Mode 1 by changing the polarity of vertical sync; in Mode 2, it's negative.

## Construction

The use of perforated construction board and wire-wrap is recommended for this project. Try to keep the TTL clock oscillators (OSC1 and OSC2) close to IC6 and IC7 as possible. Also, decouple all IC's and oscillators with the 0.01 µF ceramic disc capacitors as shown in the schematic in Fig. 1. (You can order them directly to the Vcc ground wire-wrap pins).

This project requires +5V to operate. If you've already got a suitable power supply you can use it. Otherwise, Fig. 2 shows a suitable one for the project.

Once the circuitry is completed, you should put the assembled boards in a metal project box and tie earth ground to case. Figure 3 shows the completed prototype.

# EXERCISE

Does Your Heart Good.



American Heart Association





# UNICORN ELECTRONICS

10010 Canoga Ave., Unit B-8  
Chatsworth, CA 91311

SINCE 1983 — YOUR I.C. SOURCE — AND MUCH MORE!!  
NO SHIPPING CHARGES ON PRE-PAID ORDERS!\*

NO CREDIT CARD SURCHARGE!

SCHOOL P.O.'s WELCOME!

## LASER DIODES

STOCK #	MFG.	WAVE-LENGTH	OUTPUT POWER	OPER. CURR.	OPER. VOLT.	PRICE
19220	TOSHIBA	660 nm	3 mW	85 mA	2.5v	129.99
19200	TOSHIBA	670 nm	3 mW	85 mA	2.3v	49.99
19201	TOSHIBA	670 nm	5 mW	80 mA	2.4v	59.99
19211	TOSHIBA	670 nm	5 mW	50 mA	2.3v	69.99
19215	TOSHIBA	670 nm	10 mW	45 mA	2.4v	109.99
13200	NEC	670 nm	3 mW	85 mA	2.2v	79.99
1022	SHARP	780 nm	5 mW	65 mA	1.75v	19.99

## LASER TUBES

STOCK #	WAVELENGTH	OUTPUT POWER (MIN.)	OUTPUT POWER (MAX.)	BEAM DIAM.	BEAM DIVERG.	POLARIZATION	OPERATING VOLTAGE	OPER. CURR.	FIRING VOLT.	MIN. SERIES RES.	SIZE D X L (IN MM)	WT. (GM.)	BRH CL.	PRICE 1-9	10+
7770	543nm (Green)	0.5mW	1.0mW	0.71mm	≤ 1.2 mrad	random	1750v ± 110v	6.5 mA	≤ 8 kV	81k Ω	37 x 350	200	II	799.99	749.99
7650	632.8nm (Red)	0.5mW	2.0mW	0.49mm	≤ 1.7 mrad	>100:1	1000v ± 100v	3.5 mA	≤ 7 kV	68k Ω	25 x 146	70	IIIa	529.99	479.99
7656	632.8nm (Red)	0.5mW	2.0mW	0.34mm	≤ 2.4 mrad	random	1050v ± 100v	2.8 mA	≤ 8 kV	82k Ω	22.5 x 118	60	IIIa	134.99	124.99
7655	632.8nm (Red)	0.5mW	2.0mW	0.49mm	≤ 1.7 mrad	random	1000v ± 100v	3.5 mA	≤ 7 kV	68k Ω	25 x 150	70	IIIa	144.99	134.99
7655S	632.8nm (Red)	1.0mW	2.0mW	0.49mm	≤ 1.7 mrad	random	1000v ± 100v	3.5 mA	≤ 7 kV	68k Ω	25 x 150	70	IIIa	159.99	144.99
7632	632.8nm (Red)	1.2mW	3.0mW	0.61mm	≤ 3.0 mrad	random	1300v ± 100v	3.5 mA	≤ 7 kV	81k Ω	20 x 210	70	IIIa	249.99	229.99
7621S	632.8nm (Red)	2.0mW	5.0mW	0.75mm	≤ 1.2 mrad	random	1300v ± 100v	5.0 mA	≤ 7 kV	68k Ω	30 x 255	140	IIIa	204.99	191.99
7634	632.8nm (Red)	2.0mW	5.0mW	0.75mm	≤ 1.2 mrad	>500:1	1300v ± 100v	5.0 mA	≤ 7 kV	68k Ω	30 x 255	140	IIIa	209.99	194.99
7621MM	632.8nm (Red)	5.0mW	15mW	1.0mm	≤ 2.5 mrad	random	1250v ± 100v	6.5 mA	≤ 7 kV	68k Ω	30 x 255	140	IIIb	359.99	334.99
7627	632.8nm (Red)	5.0mW	15mW	0.80mm	≤ 1.1 mrad	random	1900v ± 100v	6.5 mA	≤ 8 kV	81k Ω	37 x 350	200	IIIb	369.99	344.99
7628	632.8nm (Red)	5.0mW	15mW	0.80mm	≤ 1.1 mrad	>500:1	1900v ± 100v	6.5 mA	≤ 8 kV	81k Ω	37 x 350	200	IIIb	389.99	364.99
7627MM	632.8nm (Red)	10mW	30mW	1.2mm	≤ 4.0 mrad	random	1750v ± 100v	6.5 mA	≤ 8 kV	81k Ω	37 x 350	200	IIIb	479.99	444.99

## Dynamic RAMS

STOCK #	DESC.	SPEED	1-24	25-99	100+	STOCK #	SPEED	1-24	25-99	100+
41256-60	256K x 1	60 ns	2.59	2.46	2.21	2716	450 ns	3.29	3.13	2.82
41256-80	256K x 1	80 ns	2.19	2.08	1.87	2732	450 ns	4.19	3.98	3.58
41256-100	256K x 1	100 ns	1.99	1.89	1.70	2732A	250 ns	3.29	3.13	2.82
41256-120	256K x 1	120 ns	1.89	1.80	1.62	2764	250 ns	3.49	3.32	2.99
41256-150	256K x 1	150 ns	1.79	1.70	1.53	2764A	250 ns	3.09	2.94	2.65
511000-70	1 meg x 1	70 ns	5.49	5.22	4.70	27128	250 ns	4.79	4.55	4.10
511000-80	1 meg x 1	80 ns	5.29	5.03	4.53	27C128	250 ns	4.79	4.55	4.10
511000-10	1 meg x 1	100 ns	5.09	4.84	4.36	27256	250 ns	4.59	4.36	3.92
514256-70	256K x 4	70 ns	6.49	6.17	5.55	27C256	250 ns	4.29	4.08	3.67
514256-80	256K x 4	80 ns	6.09	5.79	5.21	27512	250 ns	5.49	5.22	4.70
514256-10	256K x 4	100 ns	5.69	5.41	4.87	27C512	250 ns	5.49	5.22	4.70
541000-80	4 meg x 1	80 ns	26.99	25.64	23.08	27C1024	200 ns	10.99	10.44	9.40
544256-80	1 meg x 4	80 ns	31.99	30.39	27.35	27C2048	200 ns	21.99	20.89	18.80

## EPROMS

### Laser Pointer



Output: 3.5 mW  
Wavelength: 670NM  
Power Supply: 2xAAA Batteries (included)  
Beam: Approx. 3" @ 100 yards  
Quantity Discounts Available

STOCK #	PRICE
LSPOINT	\$199.99

### Power Supply



- Input: 115/230V
- Output: +5v @ 3.75A  
+12v @ 1.5A  
-12v @ .4A
- Size: 7" L x 5 1/4" W x 2 1/2" H

STOCK #	PRICE
PS1003	\$19.99

### Collimator Pen



- Output: 2.5 mW (max.)
- Current: 90-150 mA
- Op. Volt.: 2.2-2.5V
- Wavelength: 820NM
- Data Sheet inc.

STOCK #	PRICE
SB1052	\$39.99

### Disc Drive & Computer Cleaning Kit



Not just a drive cleaner-but a complete computer cleaning kit. Includes swabs, head cleaning fluid, anti-static cleaner, screen wipes and cleaning diskette.

STOCK #	PRICE
SB1099 3 1/2" Kit	\$6.99
SB1100 5 1/4" Kit	\$6.99

### Disc Drive Head-Cleaning Kit



Includes cleaning fluid and head-cleaning diskette

STOCK #	PRICE
SB1105 3 1/2" Drive Kit	\$1.99
SB1106 5 1/4" Drive Kit	\$1.99

### Anti-Static Screen Wipes



For static-sensitive applications. Dispenser packs, individually wrapped.

STOCK #	PRICE
SB1104 Dispenser pack of 25 wipes	\$1.99
SB1107 Dispenser pack of 100 wipes	\$4.99

### Robotic Arm Kit



Robots were once confined to science fiction movies. Today, whether they're performing dangerous tasks or putting together complex products, robotics are finding their way into more and more industries. The Robotic Arm Kit is an educational kit that teaches basic robotic arm fundamentals as well as testing your own motor skills. Command it to perform simple tasks.

STOCK #	PRICE
YO1	\$49.99

### Avoider Robot Kit



An intelligent robot that knows how to avoid hitting walls. This robot emits an infra-red beam which detects an obstacle in front and then automatically turns left and continues on.

STOCK #	PRICE
MV912	\$49.99

ORDER LINE — (800) 824-3432



- 15.00 MINIMUM ORDER
- UPS BLUE, RED & FEDERAL EXPRESS SHIPPING AVAILABLE



INTERNATIONAL ORDERS — (818) 341-8833

TEXAS ORDERS — (818) 998-7975

TECHNICAL SUPPORT — (818) 341-8833

- CA RESIDENTS ADD 7% SALES TAX
- CALL FOR QUANTITY DISCOUNTS
- CALL FOR FREE CATALOG (FOR 1ST CLASS DELIVERY OR CATALOGS DELIVERED OUTSIDE THE U.S. — SEND \$2.00)
- WE CARRY A COMPLETE LINE OF ELECTRONIC COMPONENTS

\*NO SHIPPING CHARGES ON PRE-PAID ORDERS DELIVERED IN THE CONTINENTAL U.S.

# COMPUTER CONNECTIONS

continued from page 92

or even 386 op codes), to perform multitasking, and all sorts of other things creative designers will enjoy thinking up.

## Product Watch

If you've bitten the Windows bug, you've probably heard about Norton's Desktop for Windows (NDW), an everything-including-the-kitchen-sink collection of Win3 utilities. If that sort of overblown approach turns you off, check out SideBar (Fig. 2). This is quite simply the most elegant Windows program I've seen in four or five years of Windows watching. As the name suggests, SideBar places a bar along the side of your screen; this bar gives you the best of both DOS and Windows. At the top, the bar contains several pushbuttons for arranging icons on your desktop. Beneath the buttons is a text box for entering DOS commands (dir, cd, md, etc.). SideBar interprets your commands itself; it does not run a copy of COM-MAND.COM. The remainder of the space is occupied by a set of drive icons, file/directory listings, or both. The dual display can locate two file windows horizontally or vertically. You can select one or more files from one window and drag them to the other. The same approach works for copying, moving, deleting, renaming, changing attributes, associating (documents to applications), and placing icons on SideBar to execute directly.

SideBar can replace Windows' Program Manager, File Manager, or both. It provides a text-menu approach to launching applications, that while not as visual as NDW, is really elegant and easy to use.

SideBar is extremely resource aware and efficient. You can force it to unload itself and thereby save memory when running applications; just double-click on the background to bring SideBar back. The documentation is quite well done; all product packaging is made from recycled materials.

I really like some of NDW's utilities. But for the time being, I'm going to use SideBar as my main Windows interface.

R-E

# ADVERTISING INDEX

RADIO-ELECTRONICS does not assume any responsibility for errors that may appear in the index below.

Free Information Number	Page	191	SCO Electronics .....	
108	AMC Sales .....	77	—	Science Probe .....
75	Ace Products .....	23, 89	—	Scope Electronics .....
107	All Electronics .....	94	—	Star Circuits .....
176	American Reliance Inc. ....	23	92	Tektronix .....
84	Appliance Service .....	23	123	Test Probes .....
77,182	B&K Precision .....	17	—	The School Of VCR Repair .....
109	C & S Sales .....	7	196	Unicorn .....
—	CIE .....	8, 31	192	U.S. Cable .....
186	Cable Warehouse .....	27	187,188	Viejo Publications .....
—	Command Productions .....	71	181	WPT Publications .....
127	Deco Industries .....	23	193	Worldwide Cable .....
177	EasyTech .....	93		
178	Electronic Goldmine .....	92		
—	Electronic Tech. Today ...	16, 82, 83		
—	Electronics Book Club .....	79		
121	Fluke Manufacturing .....	CV2		
—	Grantham College .....	15		
86	Heathkit .....	13		
—	HighText Publications, Inc. ....	94		
—	ISCET .....	28		
194	ISECO, Inc. ....	23		
114	Jameco .....	90, 91		
104	Jan Crystals .....	77		
115	Jensen Tools .....	23		
197	M&G Electronics .....	88		
53	MD Electronics .....	88		
179	MJS Design .....	23		
93	Mark V. Electronics .....	89		
—	NRI Schools .....	18		
189	Optoelectronics .....	3		
56	Parts Express .....	87		
190	People's College .....	25		
78	Radio Shack .....	32		
195	Rite-Off .....	26		

## ADVERTISING SALES OFFICE

**Gernsback Publications, Inc.**  
500-B Bi-County Blvd.  
Farmingdale, NY 11735  
1-(516) 293-3000  
President: Larry Steckler

**For Advertising ONLY**  
516-293-3000  
Fax 1-516-293-3115  
Larry Steckler  
publisher

**Christina Estrada**  
assistant to the President

**Arline Fishman**  
advertising director

**Denise Haven**  
advertising assistant

**Kelly McQuade**  
credit manager

**Subscriber Customer Service**  
1-800-288-0652

**Order Entry for New Subscribers**  
1-800-999-7139

7:00 AM - 6:00 PM M-F MST

## SALES OFFICES

### EAST/SOUTHEAST

**Stanley Levitan**, Eastern Sales Manager

Radio-Electronics

1 Overlook Ave.

Great Neck, NY 11021

1-516-487-9357, 1-516-293-3000

Fax 1-516-487-8402

### MIDWEST/Texas/Arkansas/Okla.

**Ralph Bergen**, Midwest Sales Manager

Radio-Electronics

One Northfield Plaza, Suite 300

Northfield, IL 60093-1214

1-708-446-1444

Fax 1-708-559-0562

### PACIFIC COAST/Mountain States

**Marvin Green**, Pacific Sales Manager

Radio-Electronics

5430 Van Nuys Blvd. Suite 316

Sherman Oaks, CA 91401

1-818-986-2001

Fax 1-818-986-2009

### RE Shopper

**Joe Shere**, National Representative

P.O. Box 169

Idyllwild, CA 92549

1-714-659-9743

Fax 1-714-659-2469

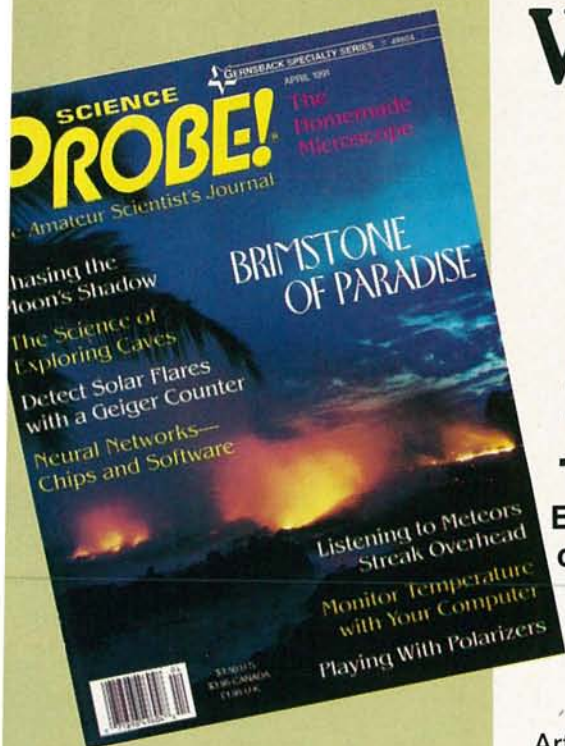

# Welcome to . . .

# SCIENCE PROBE!®

The Amateur Scientist's Journal

**Science PROBE!** — the *only* magazine devoted entirely to Amateur Scientists! If you are fascinated by science in all its many forms . . . if you can't stay away from a microscope, telescope, calipers, or test tube — we invite you to share the wonders in every issue of **Science PROBE!** You will join a community of Amateur and Student Scientists who enthusiastically seek scientific knowledge or follow scientific pursuits for their own sakes and not merely as a profession.

Obtain your next issue of **Science PROBE!** by visiting a quality Newsstand, Convenience Store, or Supermarket or by reserving your personal copy through the mail by completing the coupon below.

From your very first issue of **Science PROBE!** you will be involved in a world of scientific facts, experiments, and studies pursued by amateur scientists who are university students, investors, academicians, engineers, or office workers, salesmen, farmers—whose *quest* is to probe into the mysteries of science and reveal them to all.

Plan to become a **Science PROBE!** reader!

Embark on an irresistible new journey into the realm of mystery, challenge, and exploration! The perfect magazine for the budding scientist, the serious amateur, the professional who would like to relax, and those who simply want to gaze at the stars.

Articles to appear in upcoming issues of **Science PROBE!** are:

**How an Amateur Mapped the Milky Way**  
**Make your own Seismometer**  
**Operate a Solar-powered Weather Station**  
**Grow Crystals Automatically**  
**Experiment with a Saltwater Aquarium**  
**How to Keep a Science Notebook**

If you're fascinated by science in all its many forms, if you are compelled to experiment and explore, then **Science PROBE!** is your kind of magazine!

**Science PROBE!**  
500-B Bi-County Boulevard  
Farmingdale, NY 11735

7RA29

Please forward my copy of **Science PROBE!** as soon as it comes off the press. I am enclosing \$3.50-U.S.A. (\$4.23-Canada-includes G.S.T.) plus \$1.00 for shipping and handling. Better still, please enroll me as a subscriber and send the next four (4) quarterly issues of **Science Probe**. I am enclosing \$9.95-U.S.A. (Canada: \$16.00—includes G.S.T.)

Next Issue Only       Next Four Issues (1 Year)

Offers valid in the U.S.A. and Canada only. No foreign orders.

Name \_\_\_\_\_

Address \_\_\_\_\_

City \_\_\_\_\_ State \_\_\_\_\_ ZIP \_\_\_\_\_

All Orders payable in U.S.A. Funds only.

**ON SALE AT QUALITY NEWSSTANDS, CONVENIENCE STORES AND SUPERMARKETS**  
**GET YOUR COPY TODAY—\$3.50-U.S.A.—\$3.95-Canada**

# WHAT YOUR TOOLS SAY ABOUT YOU.

## "ULTIMATE PROFESSIONAL"

Here's the newest family member: the 60 MHz Tek 224. It's as rugged, reliable and easy to use as the rest of the 220 Series—and extended bandwidth makes it the logical choice for computer service professionals.

## "ACE TROUBLESHOOTER"

The Tek 222 is everything a service scope ought to be. Lightweight. Rugged. Fully programmable. Floatable to  $\pm 400$  V. Two channels, 10 MHz, Auto Setup and Auto Trigger make it easy finding trouble—fast.



## "RUGGED SURVIVALIST"

Tek's 222PS Power Scout™ offers the field-proven performance of the 222, *plus* it's rated 600 VAC, 850 VDC and 6 kV peak surge. Perfect for circuit measurements requiring extra protection—and a few added guts.

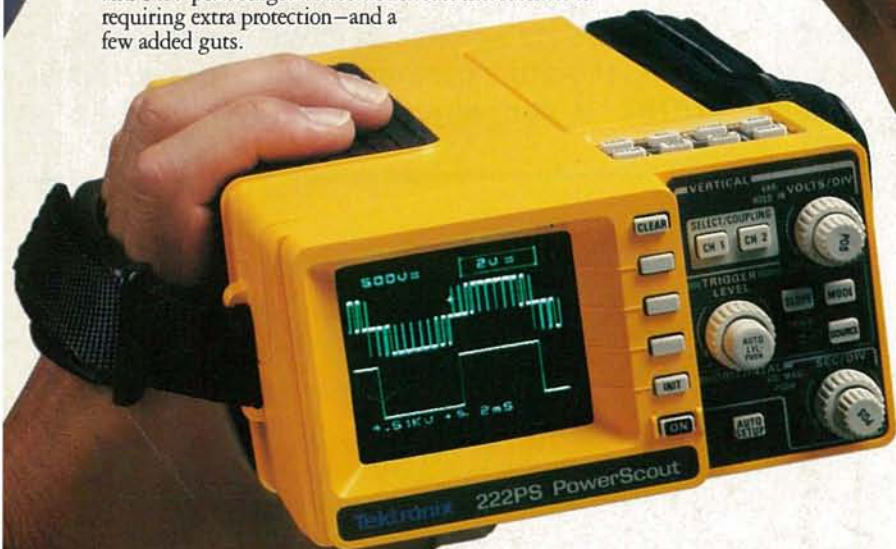

They're just 4½ pounds. U.L. certified. And start at \$2450. 220 Series handheld oscilloscopes—all with Tek's exclusive Isolated Channel™ architecture—are the service tools the professionals use. There's one with you written all over it. To order, contact your Tek representative or distributor. Or just call Tek direct: 1-800-426-2200

**Tektronix**  
COMMITTED TO EXCELLENCE