

Radio - BUILD A TV TRANSMITTER

JUNE 1989

# Electronics

TECHNOLOGY - VIDEO - STEREO - COMPUTERS - SERVICE

## BUILD THIS BUG DETECTOR

Sensitive detector helps you find RF bugs!

### DEBUGGING FOR BUCKS

Super sleuth shows how to use a spectrum analyzer to track down bugging devices

### SHORTWAVE RADIO

The end of the jamming era?

### SDN

Build a prototyping telephone and put it to work

### RADIATION MONITORING

Let your computer track radiation levels in your home or neighborhood

### COMPUTER DIGEST

In depth look at a 386SX motherboard

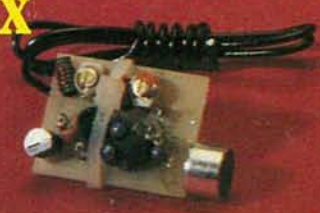
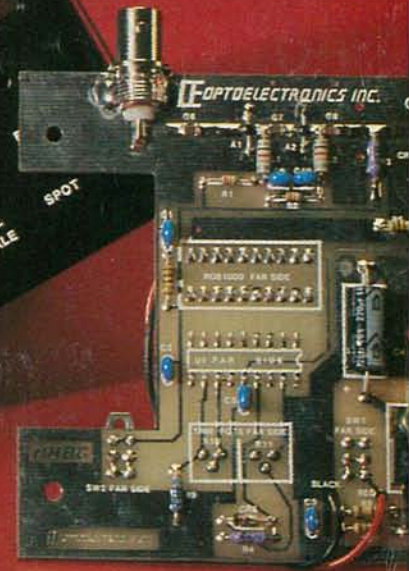

\$2.25 U.S.  
\$2.75 CAN



A  
**GERNSBACK**  
PUBLICATION





**FLUKE**



**PHILIPS**

# Other meters show half the picture

## The new Fluke 45 has dual display versatility.

**With 2 multifunction displays and 16 different measurement capabilities, the new Fluke 45 does virtually everything you want a meter to do. And for a surprisingly affordable price.**



**Get everything you've ever wanted.**

Dual displays. 16 functions. Even the security of an optional two-year warranty extension for only \$35. For all the information on the new Fluke 45, contact your local distributor. Or call toll-free 1-800-44-FLUKE, ext. 33.

The 5-digit, 100,000 count dual displays give you more information in less time — and with less effort. For example, measure the VDC output of a power supply while measuring the VAC ripple. Or check the amplitude and frequency of an AC signal. From a single test connection!

And the Fluke 45 is designed to make complex measurements easier, with standard features like a 1 MHz frequency counter, Min Max, limits testing (Hi/Lo/Pass), Touch Hold® and Relative modes. There are 21 different reference impedances for dB measurements; in the 2 Ω to 16 Ω ranges, audio power can be automatically displayed in watts.

### Accuracy to get the job done right.

The Fluke 45 is a true-rms meter, with 0.02% basic dc voltage accuracy and 100,000 count resolution on both displays. Basic dc current accuracy is 0.05%, making the 45 ideal for servicing 4-20 mA current loops. Closed-case calibration simplifies the calibration process and increases uptime.

### Even an RS-232 interface is standard.

Connecting the Fluke 45 to PCs, RS-232 printers and modems is as easy as attaching the cable. An IEEE-488.2 interface and rechargeable batteries are available as options.

### FLUKE 45 DUAL DISPLAY MULTIMETER

\$595*	Compare and Relative functions
Dual Display	Min Max and Touch Hold® functions
True-rms voltage and current, including ac + dc	Optional PC software for RS-232 applications
0.02% basic dc voltage accuracy	Optional IEEE-488.2 interface, battery pack
0.05% basic dc current accuracy	One year warranty
1 MHz frequency counter	Optional two year warranty extension \$35*
RS-232 interface standard	
dB, with 21 reference impedances, and audio power calculations.	
*Suggested U.S. List Price	

John Fluke Mfg. Co., Inc. P.O. Box C9090 M/S 250C Everett, WA 98206  
U.S.: 206-356-5400 Canada: 416-890-7600 Other Countries: 206-356-5500

© Copyright 1989 John Fluke Mfg. Co., Inc. All rights reserved. IBM PC is a registered trademark of International Business Machines Corporation. Ad No. 1181-F45.

**FLUKE**







## ON THE COVER



Maybe you feel like you've been bugged, but lack the skills to know for sure. Here's how to set your mind at ease! Build our bug detector to sweep your home or office for any covert RF-transmitters, no matter how small, or inconspicuous.

Couched in a euphemism, bugs are tiny transmitters that (like a fly on the wall) will eavesdrop on your every word. A few examples of bugging devices from Deco Industries are shown on the cover. They can be planted in your telephone, behind a pillow, or in a kitchen cabinet solely to hear your most intimate conversations.

Fight back by turning to page 42 for our top-secret de-bugger plans.

## COMING NEXT MONTH

### THE JULY ISSUE IS ON SALE JUNE 1.

#### TALK ON A LIGHT BEAM

Get up to 1/2-mile range using an LED and simple optics.

#### BUILD A CAPACITOR TESTER

Identify and check the values of all your capacitors with this inexpensive tester.

#### AMATEUR TV TRANSMITTER

Part 2 explains how to get on the air with our transmitter and a video camera.

#### SELECTING THE RIGHT SHORTWAVE ANTENNA

A little know-how can give your reception a big boost.

#### SERVICING DIGITALLY TUNED RADIOS

Professional tips for getting electronically tuned radios back in working order.

As a service to readers, RADIO-ELECTRONICS publishes available plans or information relating to newsworthy products, techniques and scientific and technological developments. Because of possible variances in the quality and condition of materials and workmanship used by readers, RADIO-ELECTRONICS disclaims any responsibility for the safe and proper functioning of reader-built projects based upon or from plans or information published in this magazine.

Since some of the equipment and circuitry described in RADIO-ELECTRONICS may relate to or be covered by U.S. patents, RADIO-ELECTRONICS disclaims any liability for the infringement of such patents by the making, using, or selling of any such equipment or circuitry, and suggests that anyone interested in such projects consult a patent attorney.

RADIO-ELECTRONICS, (ISSN 0033-7862) June 1989. Published monthly by Gernsback Publications, Inc., 500-B Bi-County Boulevard, Farmingdale, NY 11735 Second-Class Postage paid at Farmingdale, NY and additional mailing offices. Second-Class mail registration No. 9242 authorized at Toronto, Canada. One-year subscription rate U.S.A. and possessions \$17.97, Canada \$23.97, all other countries \$26.97. All subscription orders payable in U.S.A. funds only, via international postal money order or check drawn on a U.S.A. bank. Single copies \$2.25. © 1989 by Gernsback Publications, Inc. All rights reserved. Printed in U.S.A.

**POSTMASTER:** Please send address changes to RADIO-ELECTRONICS, Subscription Dept., Box 55115, Boulder, CO 80321-5115.

A stamped self-addressed envelope must accompany all submitted manuscripts and/or artwork or photographs if their return is desired should they be rejected. We disclaim any responsibility for the loss or damage of manuscripts and/or artwork or photographs while in our possession or otherwise.

## Radio Electronics

Hugo Gernsback (1884-1967) founder  
M. Harvey Gernsback,  
editor-in-chief, emeritus

Larry Steckler, EHF, CET,  
editor-in-chief and publisher

#### EDITORIAL DEPARTMENT

Art Kleiman, editorial director  
Brian C. Fenton, editor  
Marc Spiwak, associate editor  
Daniel Goodman, technical editor  
Jonathan A. Gordon,  
assistant technical editor  
Teri Scaduto, assistant editor  
Jeffrey K. Holtzman,  
computer editor  
Robert A. Young, assistant editor  
Byron G. Wels, editorial associate  
Jack Darr, CET, service editor  
Robert Grossblatt, circuits editor  
Larry Klein, audio editor  
David Lachenbruch,  
contributing editor  
Don Lancaster,  
contributing editor  
Richard D. Fitch,  
contributing editor  
Kathy Campbell, editorial assistant  
Andre Duzant, technical illustrator  
Injae Lee, assistant illustrator

#### PRODUCTION DEPARTMENT

Ruby M. Yee, production director  
Robert A. W. Lowndes,  
editorial production  
Karen Tucker, advertising production  
Marcella Amoroso, production traffic

#### CIRCULATION DEPARTMENT

Jacqueline P. Cheeseboro,  
circulation director  
Wendy Alanko,  
circulation analyst  
Theresa Lombardo,  
circulation assistant

Typography by Mates Graphics  
Cover photo by John D. McManus

Radio-Electronics is indexed in  
*Applied Science & Technology Index*  
and *Readers Guide to Periodical Literature*.

Microfilm & microfiche editions are  
available. Contact circulation department  
for details.

Advertising Sales Offices listed  
on page 106.





# HITACHI SCOPES AT DISCOUNT PRICES



**V-212**  
**\$419**

List \$560  
Save \$141

## 20MHz Dual Trace Oscilloscope

All Hitachi scopes include probes, schematics and Hitachi's 3 year warranty on parts and labor. Many accessories available for all scopes.



**V-425**  
List \$995 **\$835**

- DC to 40MHz
- Dual Channel
- CRT Readout
- Cursor Meas
- DC Offset
- Alt Magnifier
- Compact Size



**V-1060**  
List \$1595 **\$1,325**

- DC to 100MHz
- Dual Channel
- Delayed Sweep
- CRT Readout
- Sweep Time
- Autoranging
- Trigger Lock
- 2mV Sensitivity

	LIST	PRICE	SAVE
V-223 20MHz	\$770	\$695	\$75
V-422 40MHz	\$875	\$725	\$150
V-423 40MHz	\$955	\$825	\$130
V-660 60MHz	\$1,195	\$1,025	\$170
V-1065 100MHz	\$1,895	\$1,670	\$225
V-1100A 100MHz	\$2,295	\$2,045	\$250
V-1150 150MHz	\$3,100	\$2,565	\$535

# ELENCO PRODUCTS AT DISCOUNT PRICES

## 20MHz Dual Trace Oscilloscope



**\$359**  
**MO-1251**

- 6" CRT
- Built in component tester
- TV Sync
- X-Y Operation

Top quality scopes at a very reasonable price. Contains all desired features. Two 1x, 10x probes, diagrams and manual. Two year guarantee.

## SCOPE PROBES

P-1 65MHz, 1x, 10x **\$19.95**  
P-2 100MHz, 1x, 10x **\$23.95**  
Fits all scopes with BNC connector

## 35MHz Dual Trace Good to 50MHz



**\$495**  
**MO-1252**

- High luminance 6" CRT
- 1mV Sensitivity
- 6KV Acceleration Voltage
- 10ns Rise Time
- X-Y Operation • Z Axis
- Delayed Triggering Sweep

## Autoranging DMM



**M-5000**

**\$45**

- 9 Functions
- Memory and Data hold
- 1/2 % basic acc
- 3 1/2 digit LCD



## True RMS 4 1/2 Digit Multimeter

**M-7000**

**\$135**

- .05% DC Accuracy
- .1% Resistance with Freq. Counter and deluxe case



## Multimeter with Capacitance and Transistor Tester

**CM-1500**

**\$55**

- Reads Volts, Ohms, Current, Capacitors, Transistors and Diodes with case

## Digital Capacitance Meter



**CM-1550**

**\$58.95**

- 9 Ranges
- .1pf-20,000ufd
- .5% basic accy
- Zero control with case

## Digital LCR Meter



**LC-1801**

**\$125**

- Measures Coils 1uH-200H
- Caps .1pf-200uf
- Res .01-20M

## AC Clamp-On Current Adapter



**ST-265**

**\$22**

- 0-1000A AC
- Works with most DMM



## Bench DMMS

**M-3500**

**\$125**

- 3 1/2 digit .1% accy

**M-4500**

**\$175**

- 4 1/2 digit .05% accy

## SOLDERING STATION TEMPERATURE CONTROLLED



**SL-30**

**\$135**

- Digital display
- Temp range: 300F-900F
- Grounded tip
- Overheat prot

## Solderless Breadboards

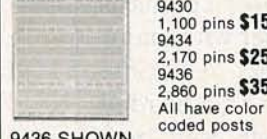

**9430**

1,100 pins **\$15**

**9434**

2,170 pins **\$25**

**9436**

2,860 pins **\$35**

All have color coded posts

## Low Cost Multimeter



**M-1600**

**\$25**

- 3 1/2 digit LCD
- 1% DC Accy
- 10A Scale
- Auto zero /polarity

## Wide Band Signal Generators



**SG-9000**

**\$129**

- RF Freq 100K-450MHz
- AM Modulation of 1KHz
- Variable RF output

**SG-9500 with Digital Display and 150MHz built-in Freq Ctr \$249**

## 3 1/2 Digit Probe Type DMM

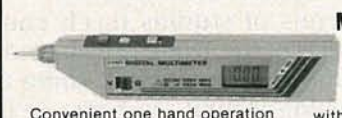

**M-1900**

**\$39**

- Convenient one hand operation with batteries and case
- Measures DCV, ACV, Ohms
- Audible continuity check, Data hold

## Function Generator



**#9600**

**\$28.95**

- Provides sine, tri, squ wave
- From 1Hz to 1MHz
- AM or FM capability

## Decade Blox



**9610 or 9620**

**\$18.95**

- #9610 Resistor Blox 47 ohm to 1M & 100K pot
- #9620 Capacitor Blox 47pf to 10MFD

## Digital Triple Power Supply



**XP-765**

**\$249**

- 0-20V at 1A
- 0-20V at 1A
- 5V at 5A

Fully Regulated, Short circuit protected with 2 Limit Cont., 3 Separate supplies  
**XP-660 with Analog Meters \$175**

## Quad Power Supply



**XP-580**

**\$59.95**

- 2-20V at 2A
- 12V at 1A
- 5V at 3A
- 5V at 5A

Fully regulated and short circuit protected  
**XP-575 without meters \$39.95**

## 10MHz XT 100% IBM® Compatible



**5 Year Warranty**

**\$595**  
**MODEL PC-1000**

- 5/10MHz Motherboard
- 8 Expansion Slots
- Math Compressor Slots
- 360K Floppy Drive
- AT Style Keyboard
- 150W Power Supply
- 256K RAM
- Expandable to 640K
- Monochrome Monitor
- Monographic Video Card
- Parallel Printer Port

**FREE spreadsheet and word processor**  
3.XXMS DOS and GW Basic add \$75

## Four-Function Frequency Counters



**F-1000 1.2GH**

**\$259**

**F-100 120MH**

**\$179**

- Frequency, Period, Totalize, Self Check with High Stabilized Crystal Oven Oscillator, 8 digit LED display

## GF-8016 Function Generator with Freq. Counter



**\$239**

- Sine, Square, Triangle Pulse, Ramp, .2 to 2MHz
- Freq Counter .1 - 10MHz

**GF-8015 without Freq. Meter \$179**

**WE WILL NOT BE UNDERSOLD!**  
UPS Shipping: US 5%  
(\$10 Max) IL Res., 7% Tax



**C & S SALES INC.**  
1245 Rosewood, Deerfield, IL 60015  
(800) 292-7711 (312) 541-0710

**15 Day Money Back Guarantee**  
**2 Year Warranty**  
**WRITE FOR FREE CATALOG**



Put Professional Knowledge and a  
**COLLEGE DEGREE**  
in your Technical Career through  
**HOME  
STUDY**

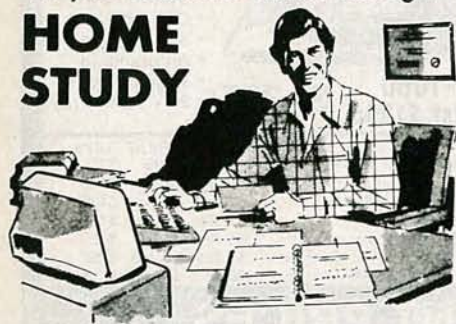

Add prestige and earning power to your technical career by earning your Associate or Bachelor degree through directed home study.

Grantham College of Engineering awards accredited degrees in  
**electronics and computers.**

An important part of being prepared to *move up* is holding the right college degree, and the absolutely necessary part is knowing your field. Grantham can help you both ways—to learn more and to earn your degree in the process.

Grantham offers two degree programs—one with major emphasis in **electronics**, the other with major emphasis in **computers**. Associate and bachelor degrees are awarded in each program, and both programs are available completely by correspondence.

No commuting to class. Study at your own pace, while continuing on your present job. Learn from easy-to-understand lessons, with help from your Grantham instructors when you need it.

*Write for our free catalog* (see address below) or telephone us at (213) 493-4421 (no collect calls) and ask for our "degree catalog."

Accredited by  
the Accrediting Commission of the  
National Home Study Council

**GRANTHAM**  
*College of Engineering*  
10570 Humbolt Street  
Los Alamitos, CA 90720

# EDITORIAL



## Radiation awareness

Last June, we presented a construction story that showed how to build International Medcom's Radalert Radiation Monitor. The article generated significant response and even some controversy, as any article that discusses radiation and safety does.

Some of you readers criticized us for irresponsibility for presenting articles on radiation—a subject on which we are not authorities. Others thanked us for a useful, and educational construction article, in the tradition of **Radio-Electronics**.

As an editor, I'm always pleased when an article generates passionate responses. But I'm even happier when an article generates something more tangible. Hundreds of readers built units and put them to use.

Since the article appeared, the need for some type of radiation monitoring device has become very apparent. Government reports released late last year admitted that several nuclear-weapons plants exposed nearby communities to excessive radiation over a period of decades. The EPA has warned homeowners about the hazardous potential of radioactive radon gas buildup.

Dozens of studies reach conflicting conclusions about the effects of the Three Mile Island accident. Of course, if members of the community had some way of monitoring radiation and keeping accurate records, we might have less conflict and more conclusions on the real effect of the accident.

That brings us to this month's "Radiation Monitor Followup." The article, which begins on page 51 shows how the Radalert radiation monitor can be connected to a computer for automated logging of radiation levels. By joining together and uploading your readings to a central computer bulletin board, you readers have a opportunity to contribute to our knowledge of radiation. We hope you take the opportunity.

Brian C. Fenton  
Editor



# Cable Checklist

## ENJOY CABLE TV MORE THAN EVER



### SNOOPER STOPPER/DATA BLOCKER ..... \$39<sup>95</sup>



- Prevent cable companies from spying on you to see how many cable converters you have
  - Removes beeping sound from your FM when radio is connected to cable TV
  - Cable TV descramblers are being sold by the thousands, but few people know descramblers can be detected on most addressable systems
- Maintain your privacy with a Snooper Stopper. For more detailed information, send \$2.00 for our "Cable TV Snooper Stopper" article.



### MACROVISION... NOW YOU SEE IT, NOW YOU DON'T

#### MS1-KIT ..... \$29<sup>95</sup>

Includes all the parts, pc board, AC adaptor, and instructions from a published construction article in *Radio Electronics* magazine.



- Remove copy-protection from video cassettes
- Digital filter type; removes only Macrovision pulses

#### JMAK-4 BLACK BOX ..... \$14<sup>95</sup>

Original box as shown in ad with two feet and four holes to mount pc board.

- No adjustments; crystal controlled
- Compatible with all VCRs
- Uses automatic vertical blanking level
- Assembles in less than three hours



### SIGNAL ELIMINATOR ..... \$29<sup>95</sup>

- Works on cable or broadcast TV
- External adjustments allow precise tuning to any frequency

- #23H-Tuneable to ch. 2 & 3 (50-66 Mhz) also 6 meter HAM TVI interference filter
- #46FM-Tuneable to ch. 4-6 (66-108 Mhz & FM Band)
- #713-Tuneable to ch. 7-13 (174-216 Mhz)
- #1417-Tuneable to ch. 14-17 (A-D) (120-144 Mhz)
- #1822-Tuneable to ch. 18-22 (E-J) (144-174 Mhz)



#### ELIMINATE a Channel

that you find unsuitable for family viewing, but is poorly scrambled by your cable company. **OR**

**CLEAR UP a Channel** that presently contains severe interference by **ELIMINATING** whatever signal is causing this.

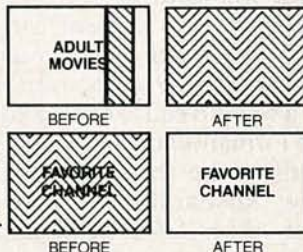

Note: If picture and sound are equally affected, this IS interference and CAN be removed by our product. If only picture is affected, this usually IS NOT interference and CANNOT be removed by our product.



### 72 Channel CABLE CONVERTER with Infra-Red Remote ..... MC-702 Converter \$79<sup>95</sup>



- Microprocessor controlled PLL operation
- Skip channel memory eliminates unused channels
- Parental control for all channels
- Compatible with all external descramblers
- Last channel recall
- Fine tune memory
- UL listed/FCC approved
- Simple installation with any TV
- Includes battery and 3 foot coax
- Channel output 2 or 3 switchable

Add \$3.50 shipping & handling  
\$9.50 Canadian orders

**ORDER TOLL FREE ANYTIME**  
**1-800-227-8529**

Inside MA: 508-695-8699 Fax: 508-695-9694  
Ask for additional free information  
Add \$3.00 shipping & handling on all orders unless otherwise noted. \$6.00 Canadian orders.  
Visa, MasterCard, or C.O.D.



**J & W**  
**ELECTRONICS, INC.**

P.O. BOX 800 • MANSFIELD, MA 02048



# WHAT'S NEWS

## Predicting IC defects

Metallurgic researchers at Sandia National Laboratories have developed a model that explains and predicts a type of defect that seriously affects the reliability of integrated circuits with 4-micron aluminum metallization lines. (The problem is seemingly caused by miniaturization, as the defect is rarely found in circuits with 6-micron metallizations.) Metallizations are the thin conductors, made of aluminum, aluminum-copper, or other alloys, that link circuits on an IC. The defects, which are manifested as cracks or wedge-shaped voids in the aluminum, appear after months of storage for no apparent reason in previously acceptable IC's. Using Sandia's quantitative model, researchers can predict under what conditions and at what rates the voids will form.

While high current can cause voiding (called electromigration), Sandia's research focused instead on a second cause of breakdown—the formation of cracks and wedge voids in the absence of a current flow. Researchers Frederick G. Yost, Alton D. Romig Jr., and Roy J. Bourcier investigated the stresses that develop after the metallizations are made and then covered by and bonded to a deposit of glass (a "passivation layer") at temperatures of 400° to 450°C, and then cooled. They discovered that as a result of aluminum's much larger coefficient of expansion, the tightly bonded passivation layer resists the tendency of the aluminum grains to move differentially while cooling. That causes extremely high stresses—high

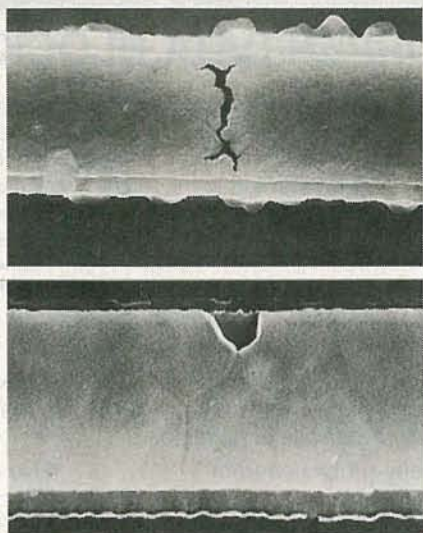

DEFECTS IN AN IC'S 4-MICRON-WIDE aluminum conductor lines are visible in scanning electron micrographs. The top photo depicts a crack; the bottom shows a wedge-like void.

enough to transport sufficient mass to create voids.

With Sandia's model, which uses numerical stress analysis to calculate the stress gradients in conductor lines, researchers determined the time to failure for various widths of conductor lines when subjected to different temperatures. The results, as they expected, showed that time to failure decreases as the lines get narrower and as the temperature increases. In 3-micron conductor lines, the minimum time for the development of cracks is 1.5 years, and 2.3 years for wedges to form.

Those results, which are consistent with the experience of the microelectronics community, suggest that mass movement and the resulting void formation could be reduced by alloying the aluminum with copper.

distributed to over 2,000 American engineers of all disciplines, asked the respondents to describe in detail the technological advances that would be achieved by the 22nd century.

While some of the results came as no surprise—we will live to an average age of 80 to 100, and critical environmental problems will include lack of clean air and water and hazardous-waste disposal—others were more innovative. More than one-third of those surveyed believe that we will communicate with extraterrestrials; that we will inhabit the Moon and man-made planets, but not Mars or other planets; and that artificial body parts will be so commonplace that they will be sold as "off-the-shelf" items to be purchased as needed.

Although we will not control the earth's weather, and despite the lack of natural resources and longer lifespans, the engineers think there will be enough organic food sources to feed the world. The likelihood of an adequate food supply is due, in part, to our becoming less "earth-dependent" as we expand our frontiers to work in space.

Respondents also predicted that nuclear power and solar power captured with proactive satellites would be our main energy sources; railroads will travel at 200–400 MPH, air travel could increase to as much as 3 to 4 times the speed of sound, and computer-driven cars made of composite parts would navigate the highways, equipped with collision-avoidance systems; newspapers will be replaced by new communications techniques; and buildings as high as 300-stories tall will be constructed.

National Engineers Week is dedicated to honoring the achievements and contributions of the nation's engineers. **R-E**

## Engineers predictions for life in the 22nd century

The results of a survey entitled "Engineers Preview Highlights of the 22nd Century City" were pre-

sented by Robert E. Hogan, president of the American Consulting Engineers Council, during National Engineers Week (February 19–25, 1989). The survey, which was



# No other training—in school, on the job, anywhere—shows you how to troubleshoot and service computers like NRI

## HARD DISK

20 megabyte hard disk drive you install internally for greater data storage capacity and data access speed.

## PACKARD BELL COMPUTER

NEC V40 dual speed (4.77 MHz/8 MHz) CPU, 512K RAM, 360K double-sided disk drive.

## MONITOR

High-resolution, non-glare, 12" TTL monochrome monitor with tilt and swivel base.

## DIGITAL MULTIMETER

Professional test instrument for quick and easy measurements.

## LESSONS

Clearcut, illustrated texts build your understanding of computers step by step.

## SOFTWARE

Including MS-DOS, GW BASIC, word processing, database and spreadsheet programs.

## TECHNICAL MANUALS

With professional programs and complete specs on Packard Bell computer.

## DISCOVERY LAB

Complete breadboarding system to let you design and modify circuits, diagnose and repair faults.

## DIGITAL LOGIC PROBE

Simplifies analyzing digital circuit operation.

Only NRI walks you through the step-by-step assembly of a powerful XT-compatible computer system you keep—giving you the hands-on experience you need to work with, troubleshoot, and service all of today's most widely used computer systems. You get all it takes to start a money-making career, even a business of your own in computer service.

No doubt about it. The best way to learn to service computers is to actually build a state-of-the-art computer from the keyboard on up. As you put the machine together, performing key tests and demonstrations at each stage of assembly, you see for yourself how each part of it works, what can go wrong, and how you can fix it.

Only NRI—the leader in career-building, at-home electronics training for 75 years—gives you such practical, real-world computer servicing experience. Indeed, no other training—in school, on the job, *anywhere*—shows you how to troubleshoot and service computers like NRI.

**You get in-demand computer servicing skills as you train with your own XT-compatible system—now with 20 meg hard drive**

With NRI's exclusive hands-on training, you actually build and keep the powerful new Packard Bell VX88 PC/XT compatible computer, complete with 512K RAM and 20 meg hard disk drive.

You start by assembling and testing the "intelligent" keyboard, move on to test the circuitry on the main logic board, install the power supply and 5 1/4" disk drive, then interface your high-resolution monitor. But that's not all.

**Only NRI gives you a top-rated micro with complete training built into the assembly process**

Your NRI hands-on training continues as you install the powerful 20 megabyte hard disk drive—today's most wanted computer peripheral—included in your course to dramatically increase your computer's storage capacity while giving you lightning-quick data access.

Having fully assembled your Packard Bell VX88, you take it through a complete series of diagnostic tests, mastering professional computer servicing techniques as you take command of the full power of the VX88's high-speed V40 microprocessor.

In no time at all, you have the confidence and the know-how to work with, troubleshoot, and service every computer on the market today. Indeed you have what it takes to step into a full-time, money-making career as an industry technician, even start a computer service business of your own.

**No experience needed, NRI builds it in**

You need no previous experience in computers or electronics to succeed with NRI. You start with the basics, following easy-to-read instructions and diagrams, quickly

moving from the fundamentals to sophisticated computer servicing techniques. Step by easy step, you get the kind of practical hands-on experience that makes you uniquely prepared to take advantage of every opportunity in today's top-growth field of computer service.

What's more—you learn at your own pace in your own home. No classroom pressures, no night school, no need to quit your present job until you're ready to make your move. And all throughout

your training, you have the full support of your personal NRI instructor and the NRI technical staff always ready to answer your questions and give you help whenever you need it.

## Your FREE NRI catalog tells more

Send today for your free full-color catalog describing every aspect of NRI's innovative computer training, as well as hands-on training in robotics, video/ audio servicing, electronic music technology, security electronics, data communications, and other growing high-tech career fields.

If the coupon is missing, write to NRI School of Electronics, McGraw-Hill Continuing Education Center, 4401 Connecticut Avenue, Washington, DC 20008.

PC/XT and XT are registered trademarks of International Business Machines Corporation

## NRI School of Electronics

McGraw-Hill Continuing Education Center  
4401 Connecticut Avenue, Washington, DC 20008

For career courses approved under GI bill  
 check for details

**Check one FREE catalog only**

<p><input type="checkbox"/> Computers and Microprocessors</p> <p><input type="checkbox"/> Robotics</p> <p><input type="checkbox"/> TV/Video/Audio Servicing</p> <p><input type="checkbox"/> Computer Programming</p>	<p><input type="checkbox"/> Security Electronics</p> <p><input type="checkbox"/> Electronic Music Technology</p> <p><input type="checkbox"/> Basic Electronics</p> <p><input type="checkbox"/> Data Communications</p>
--	--

Name (please print) Age

Address

City/State/Zip

Accredited by the National Home Study Council

10-069



# VIDEO NEWS



● **Digital HDTV.** Is the United States being stampeded into high-definition TV by the Europeans and Japanese—and by congressmen looking for a glamorous issue? Recently, three different experts have at least hinted that they think it would be a mistake to adopt an analog HDTV-broadcasting system in this digital age. Former FCC Chairman Mark Fowler, in a New York speech, said that a broadband digital fiber-optic network could leapfrog Japan's "inferior" analog HDTV technology. He branded "analog technology in a world increasingly moving to digital" a "fallacy" and added, "We should consider television as part of the computer industry rather than the radio industry."

Speaking at a Society of Motion Picture and Television Engineers seminar, Julius Barnathan, president of ABC Network Broadcasting and Engineering, said that any analog-based HDTV would have the same problems that plague NTSC. "We need better TV sets—smart digital sets that can minimize noise and interference" before HDTV should be considered. John Sie, senior vice president of Telecommunications Inc. (TCI), a major cable-TV operator, proposed the use of a digital signal for all video—including broadcast, cable, and satellite. He urged that a compatible, improved, analog HDTV system be adopted as an interim measure, with the industry switching to a process digital system when the technology is ready.

● **Introducing Hi8.** The 8mm group has answered Super VHS with the "8mm Hi-Band" system, or "Hi8," as it will be known. The specs of Hi8 are very similar to those of S-VHS: white peak 7.7 MHz, sync peak 6.7 MHz, frequency deviation 2 MHz, white clip 220%. Like S-VHS, Hi8 is claimed to provide a picture with more than 400 lines of horizontal resolution, and has separate luminance and chrominance outputs for sets with Y/C inputs; Hi8 VCR's will be capable of recording and playing back in the standard 8mm mode, but standard 8mm recorders won't be able to play back Hi8 tapes. Two improved types of videotape are being introduced for Hi8—a higher

coercivity metal-particle tape and the first metal-evaporated tape to be mass-produced.

As the first major manufacturer to introduce Hi8, Sony was careful to explain that it views the new product somewhat differently from the VHS group's view of S-VHS. It's described as "a new option, not a replacement" for standard 8mm, with "premium performance for those willing to pay a premium price." JVC and other members of the VHS group have forecast that S-VHS eventually will replace standard VHS. The first Sony Hi8 products are indeed premium priced—\$2,200 for an editing camcorder and \$2,000 for a deck loaded with editing features. They should be on the market by the time you read this.

● **"SmarTV."** That's the name of a new television system, based on artificial intelligence, being tested in a few homes in southern California. SmarTV is connected to the home telephone. Once a week it dials an 800 number, linking it to a central computer that contains the week's TV schedule and a profile of the specific viewer's personal tastes in programming. Any time something that the set owner might want to see is on the air, it's recorded. An on-screen listing tells the viewer what the options are. Thus, SmarTV lets viewers watch what they want when they want without the bother of having to tune the TV or set the VCR. The first model, which can store 32 cassettes, costs about \$6,000. The company promises that it also will have cheaper models with less memory.

● **Stereo TV heats up.** One out of four color-TV sets sold last year had built-in multichannel TV sound (MTS), according to EIA figures, which showed that the total of MTS sets sold exceeded 5 million, or 25.2% of the 20 million color sets sold. It's estimated that some 14.8 million U.S. households now have MTS sets, representing 16.4% of the nation's homes. In addition, more than 6 million MTS-stereo VCR's have been sold. If there was no duplication—stereo VCR's in homes with stereo TV's—as many as 23.5% of all U.S. homes could be equipped to receive MTS. **R-E**



# EXPAND YOUR CAREER HORIZONS...

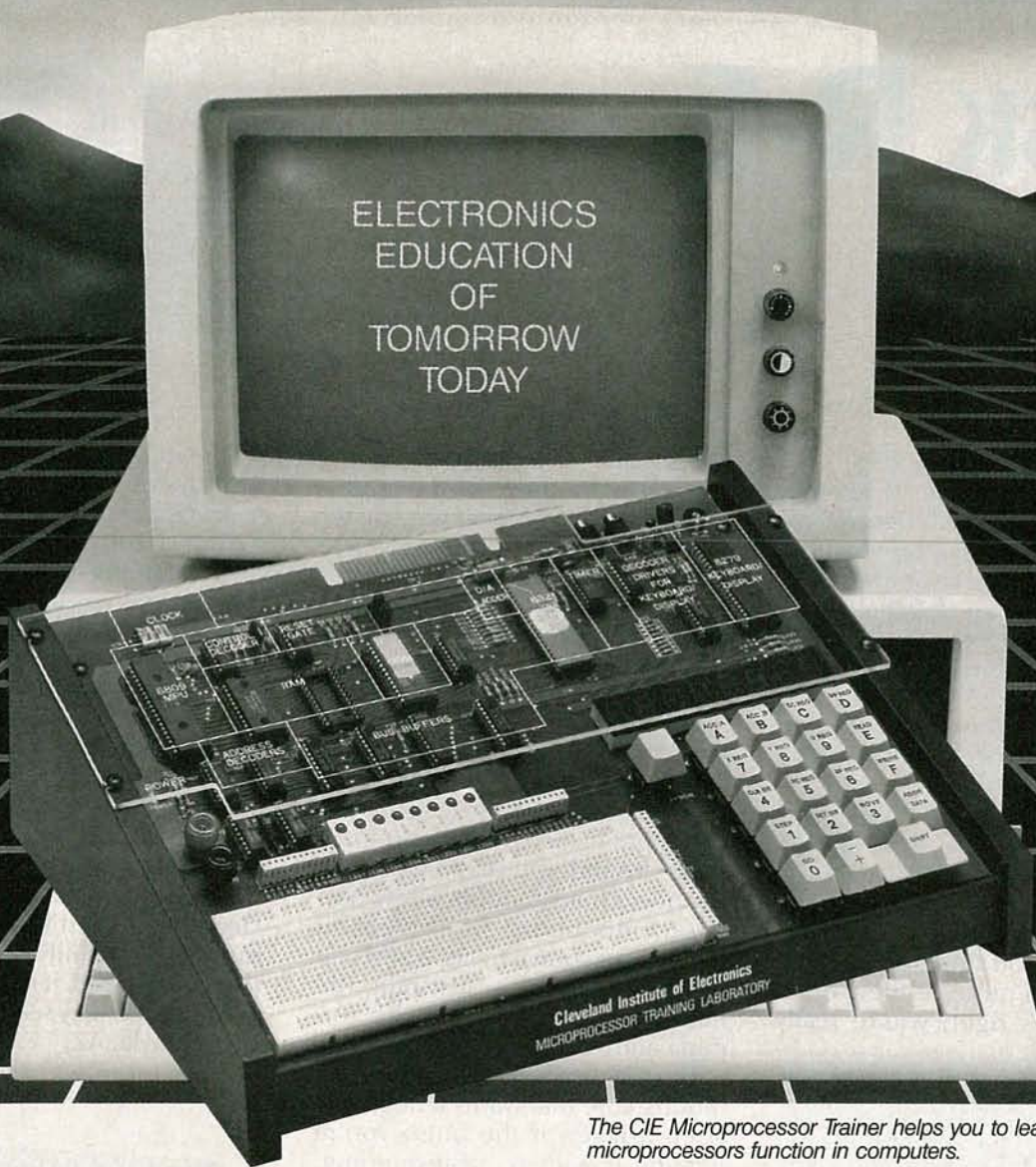

*The CIE Microprocessor Trainer helps you to learn how circuits with microprocessors function in computers.*

## START WITH CIE.

Microprocessor Technology. Satellite Communications. Robotics. Wherever you want to go in electronics... start first with CIE.

Why CIE? Because we're the leader in teaching electronics through independent study. Consider this. We teach over 25,000 students from all over the United States and in over 70 foreign countries. And we've been doing it for over 50 years, helping thousands of men and women get started in electronics careers.

We offer flexible training to meet your needs. You can start at the beginner level or, if you already know something about electronics, you may want to start at a higher level. But wherever you start, you can go as far as you like. You can even earn your Associate in Applied Science Degree in Electronics.

Let us get you started today. Just call toll-free **1-800-321-2155** (in Ohio, 1-800-362-2105) or mail in

**CIRCLE 60 ON FREE INFORMATION CARD**

the handy reply coupon or card below to:  
Cleveland Institute of Electronics,  
1776 East 17th Street, Cleveland, Ohio 44114.

**CIE** World Headquarters

ARE-128

**Cleveland Institute of Electronics, Inc.**  
1776 East 17th Street • Cleveland, Ohio 44114

Please send your independent study catalog.  
For your convenience, CIE will try to have a representative contact you — there is no obligation.

Print Name \_\_\_\_\_

Address \_\_\_\_\_ Apt. \_\_\_\_\_

City \_\_\_\_\_ State \_\_\_\_\_ Zip \_\_\_\_\_

Age \_\_\_\_\_ Area Code/Phone No. \_\_\_\_\_

Check box for G.I. Bill bulletin on Educational Benefits

Veteran  Active Duty **MAIL TODAY!**

Just call toll-free **1-800-321-2155** (in Ohio, 1-800-362-2105)



# ASK R-E

## PULSE SHORTENER

I'm building a circuit that's triggered on by a high and triggered off by a low. I'm having a problem because the pulses are lasting too long. I know about pulse stretchers but I need a pulse shortener. Any ideas?—G. Fischer, New York, NY.

I have to agree with you. I've heard about pulse stretchers and I've never heard about pulse shorteners. The details in your letter are sketchy but I think your problem is that you're looking at the problem incorrectly.

Rather than trying to shorten the trigger pulse that is being sent to your circuit, you should be using it to generate a pulse of the correct length. That's right, you're really

looking for an edge detector that will put out a pulse of the appropriate width whenever the trigger line changes state. Admittedly you won't be triggering your final circuit with your original trigger pulse but, as they say, a pulse is a pulse.

Now that we know what we're looking for, the problem is to design an edge detector—and that's a piece of cake. You can add circuitry to the board to get the job done, but if you've got some spare gates around you may be able to get by with just adding a few passive components. Both types of circuits are shown in Fig. 1 and you can take your pick. Just plug the numbers you need into the formula and your problem is solved.

The 555 in Fig. 1-a is set up as a monostable that wants a negative-going trigger. If the pulse you're feeding it with is positive-going, you can run it through an inverter made up of either an inverting gate or, if you're tight on space, a single transistor. Both ways are shown in the drawing. A monostable built around a 555 is a reliable circuit that isn't at all picky about the shape of an incoming trigger pulse. If you need two of those circuits, you get a 556 dual timer and build both of them with that.

If you're lucky enough to have some spare gates around, you can use the circuits shown in Fig. 1-b. They are edge detectors as well, and are usually referred to as half monostables since they can't be used in every application. As you can see, the width of the output pulse is determined by the RC value, but there are a few rules governing their use.

## WRITE TO:

ASK R-E  
Radio-Electronics  
500-B Bi-County Blvd.  
Farmingdale, NY 11735

- The input pulse has to be wider than the output pulse.
- The input pulse can't be glitchy.
- The circuit can't be retriggered faster than the RC time.

Since you're looking for a pulse shortener, the first rule's not much of a problem. The second one can be handled by debouncing the input. The third one, however, may cause some grief since you didn't indicate the rate at which you want the circuit triggered.

## VIDEOS IN GERMANY

I have some friends living in West Germany, and I'd like to send them some of my family video tapes. Is that possible and, if not, what kind of an image will they see?—R. Doering, Camp Verde, AZ.



FIG. 2

The easiest thing to do is to go out and buy a VCR that can play PAL and SECAM video formats, as well as NTSC. Figure 2 shows one such VCR. It is the *Multiplay TL-1000*, manufactured by Ten-Lab Multisystem Video Products, 11064 Mississippi Ave., Los Angeles, CA 90025 (213) 473-6551. The unit lists for \$795. Other than buying one of those VCR's, there's not much you can do. A video signal is extremely complex and, consequently, the

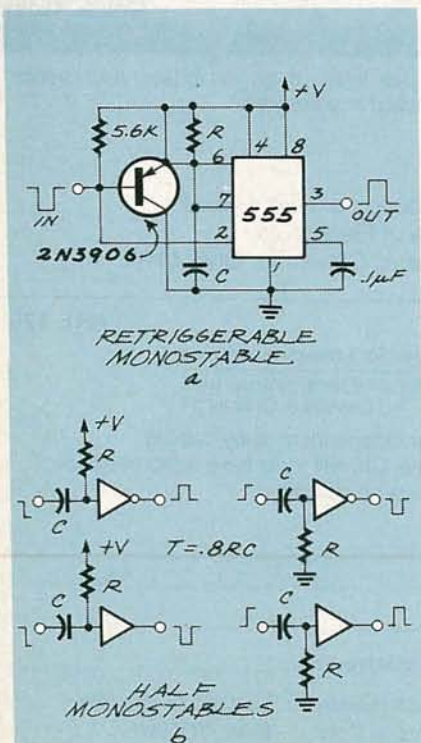

FIG. 1



timing parameters are really tight. The picture and control signals have to be in the right place at the right time, or all you'll be looking at on the screen is modern art.

There are three basic video standards—NTSC, SECAM, and PAL—and just about the only thing they have in common is that they live in the electromagnetic spectrum. The first is used both here and Japan, the second is used in France, and the third is used pretty much everywhere else.

You don't have to understand the difference between them to know that circuitry designed to make sense out of one is going to have a hard time making sense out of the others. That is particularly true with VCR's because they're dealing with signals recorded on tape rather than pulling them from the air. A VCR designed to handle NTSC is going to assume that there are certain control signals recorded on a particular part of the tape and, if they're not there or not just right, it won't be able to properly process the video-image signals. The result won't exactly be something you'd want to watch on a rainy afternoon.

If you really want your friends to be able to see the tapes you have, you'll have to get them converted to the correct video format. A brief trip through the yellow pages should yield a service that does that. If you can't find anything there, check with your local videotape rental store. They usually know where to get it done.

### GUITAR EQUALIZER

I'm a guitarist and I like to use somewhat non-standard audio equipment rather than the ones made specifically for an electric guitar. That usually works well but the output of the graphic equalizer that I'm using is not enough to drive my power amp. Is there some small amplifier I could build that runs off a nine-volt battery that also has a volume control?—K. LaDow, Milwaukee, WI.

There used to be no such thing as a small amplifier. You might have had small amplification, but there were no small amplifiers. Fortunately for you, there's a whole slew of circuits you can use

and two basic ones are shown in Fig. 3. Both of those amps have all the good things you'd expect from IC's. They are easy to assemble, very tolerant of component values, they require simple layouts, and while you can't feed them every frequency from DC to daylight, they're flat all across the audio spectrum. Each, however, has its own pluses and minuses.

The 741 circuit (3-a) is nice because it's truly a one-chip line amp. It uses very little current so your

nine-volt batteries will last a long time. The disadvantage is that it needs a bipolar supply. That can easily be handled by using two nine-volt batteries but if you've got a space problem, that could be a pain in the neck. It's possible to run the circuit off a single supply but the op-amp won't perform as well. In general, when an IC wants a bipolar supply, you should give it one.

You can use other op-amps that  
*continued on page 77*



## Triplett Corporation

### Instrument Sale!

85th Anniversary of Manufacturing Test Equipment

SAVE SAVE SAVE

#### analog

**Model 310** Hand size VOM. Drop resistant, high impact case. List 72.00



**64.79**  
Sale Price

**Model 630** 25 range VOM. Thermoset plastic case, Diode overload protection, fuse arrangement, Mirror scale. List 130.00



**117.00**  
Sale Price

**Model 60** X'TRA rugged VOM. Guaranteed to withstand drop up to five foot. Safety designed, Mirror scale. List 160.00



**144.00**  
Sale Price

#### NEW! Model 2200

3 1/2 digit high contrast LCD, 18 ranges, protected to 450 VAC/VDC on ohmmeter, DMM. List 45.00



**39.99**  
Sale Price

**Model 3525-B** Digi-probe. Auto-ranging, easy to use, pocket-sized DMM. List 55.00



**49.50**  
Sale Price

**Model 44** Hand size Clamp-on. 3 1/2 Digit LCD Display Peak Hold and Data Hold. List 97.50



**87.75**  
Sale Price

#### digital

**Model 2030** DMM. Multi-use, pocket size, auto-ranging, portable and economical. List 33.00



**29.70**  
Sale Price

**Model 3360** 21 range DMM. Data Hold, auto/manual ranging with range hold. List 89.50



**79.99**  
Sale Price

**Model 4750** 4.5 digit DMM. Extended range accuracy, 14 functions, true RMS. List 399.00



**359.10**  
Sale Price

**Model 4800** 4.5 digit bench DMM. 17 functions, auto or manual ranging, true RMS. List 600.00



**540.00**  
Sale Price

ORDER TOLL FREE  
**1-800-262-3600**  
IN OHIO  
**1-800-362-9127**  
FAX: 216-663-1004



#### Pioneer Standard Electronics Inc.

4800 East 131st Street  
Cleveland, Ohio 44105

VISA  MASTERCARD  CHECK  MONEY ORDER

Card No. \_\_\_\_\_ Exp. Date \_\_\_\_\_

Name \_\_\_\_\_

Company \_\_\_\_\_

Street Address \_\_\_\_\_

City/State/Zip \_\_\_\_\_



# LETTERS

2000P 11/10/78  
3000P 11/10/78  
4000P 11/10/78  
5000P 11/10/78

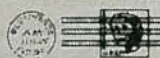

**LETTERS**  
RADIO-ELECTRONICS  
500-B BI-COUNTY BOULEVARD  
FARMINGDALE, NY 11735

## CAUTION

It has come to our attention that the advice given in "Ask R-E" (*Radio-Electronics*, April 1989, page 89) concerning adding an earphone jack to a TV set is potentially dangerous. It is a fact that, in many modern TV sets, the chassis is actually at 60- to 80-volts AC with respect to ground. A 1:1 audio transformer, installed between the chassis and the speaker/earphone jack, as shown in Fig. 1, will provide enough isolation to be safe. We apologize for the error.—  
Editor

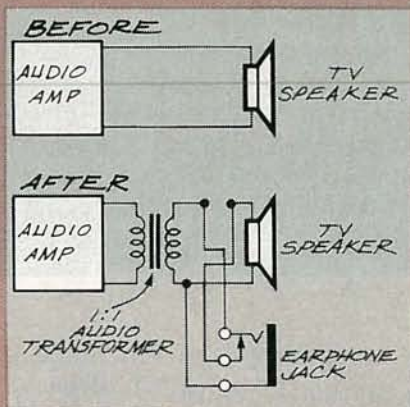

## DESK-TOP VIDEO PRODUCTION

As the manufacturers of what we feel is the premier "genlock" for the Amiga 2000, we were pleased to see the attention given to the many video applications of the Amiga in the article "Computer Aided Video" (*Radio-Electronics*, March 1989, page 93). However, we'd like to comment on some common misconceptions—reinforced, we fear, by that piece—on what a genlock is and does.

The process of "genlocking"—interconnecting various pieces of video equipment so as to ensure that they are running in agreement with one another—does not, in and of itself, guarantee a video output that meets broadcast standards. Signal components like correct sync, blanking, and SC-H phasing are critical for an accurate NTSC signal to be produced. Most Amiga genlocks rely on that information to be provided by whatever equipment the computer is "genlocked" to. If the adjustment of that equipment does not meet cor-

rect broadcast standards, your Amiga-produced signals won't meet them either, genlock or not.

That dependence of genlocks like Supergen on external sources also explains the "snow and other garbage" appearing on the screen, solved by the authors with a video feed demodulated from the source VCR. With the source VCR not operating, the information has to be provided for the Amiga from somewhere, or the external-reliant genlock becomes useless.

The 4004 Genlockable Video Graphics Encoder does not depend on external sources. Correct sync, burst, and blanking are provided as on-board elements of the encoder card, which is installed in the Amiga, so the computer effectively becomes a free-running broadcast-video source. Complete features for keying and fading are also included. EILEEN TUURI, Marketing Communications Manager  
MAGNI SYSTEMS, INC.  
Beaverton, OR 97005

## ACTIVE ANTENNA

I have two minor comments on Rodney Kreuter's "Active Antenna" article (*Radio-Electronics*, February 1989, page 51). It's a good article, and I'm sure the antenna works fine. However, if memory serves me right, the MPF102 is a junction field-effect device (JFET), rather than a metal-oxide-semiconductor FED (MOSFET). I don't think JFET's require any more electrostatic protection than MOSFET's 2N3904's, although JFET's do have another failure mode that requires a little caution. They will not tolerate much current flow through a forward-biased gate. Fortunately, Mr. Kreuter's design puts a 1 megohm "grid-leak" resistor (R1) in series with the gate, and the antenna is isolated with a capacitor. Similar designs that don't isolate the antenna, or that provide a DC path to ground (through the inductor in a tuned circuit, for example), are likely to quit working if the battery is hooked up backwards or if the antenna is inadvertently shorted to a circuit component at a voltage around 2 volts.

The second point—and I'm going from memory again—is that the MPF102 and similar devices have rather broad specifications. Because a short antenna can deliver surprisingly high signal voltages (at minute currents), and because the untuned input allows strong local signals to get into the active circuitry even though the receiver isn't tuned to them, the critical parameter in that application is the voltage range over which the device will respond linearly. If that range is exceeded, the input amplifier becomes a just-dandy mixer. Note that here the MPF102 has



no voltage gain, but actually alternates, due to the low  $R_2 = 22 \Omega$ . If spurious signals are encountered in the output, it may be a good idea to substitute another MPF102 (or whatever), for a wider linear range. Of course, the culprit could be Q3, which can also act as a mixer if it's overdriven into its non-linear operating range.

DONALD KENNEY  
San Diego, CA

### CABLE CAPER

The subject of *Monster Cable* provides a lot of "yuks" here at the plant. Usually we just grin and move on, because the testimonials normally skip over the facts and concentrate on faith.

However, in the "Letters" column of the March 1989 issue of *Radio-Electronics*, Leland Faber describes the testing of equal lengths (50 feet) of *Monster Cable* and a variety of other wires including zip cord and house wiring. He says that with a matched 8-ohm source and load, and a frequency range of 20 Hz to 20 kHz, *Monster Cable* was "within  $\pm 3\text{dB}$ ," whereas all other wire was not "within 9 to 10 dB's at the upper end."

Any audio professional can tell you that under those conditions, *Monster Cable*, zip cord, house wire, or just about anything you might find lying around, will have a virtually flat response from 20 Hz to 20 kHz. If Mr. Faber really got the results he said he did, there was something wrong with his test setup.

JOHN WILSON  
CAPITAL CITIES/ABC, INC.  
Hollywood, CA

### ENGINEERING REWARDS

Anyone who agrees with Mr. Lancaster's hang-up ("Hardware Hacker," *Radio-Electronics*, March 1989) with the fact that "...[technicians] often do all the work and engineers get all the credit, all of the pay, and all of the promotions..." should realize that anyone who can survive 3 years of Engineering Calculus *should* be placed on a pedestal.

JOHN SAWKA  
*Engineering Student*  
Milwaukee, WI

R-E

When performance & price really count...



# CRYSTEK

## CRYSTALS

The pulse of dependable communications

### QUARTZ CRYSTALS FOR Industrial Equipment/Instrumentation

- Micro-processor control
- Computers/Modems
- Test/Measurement
- Medical

### General Communications

- Channel element Service (VHF/UHF)
- Land Mobile 2-way
- Marine
- Aircraft
- Telemetry
- Monitors/Scanners/Pagers

### Amateurs/2-Meter/General Coverage CB/Hobbyist/Experimenter

**NEW**

**For Optimum Stability and Reliability in Frequency Management**



Custom Made Crystals Catalog



Replacement Crystals Catalog

**The Pulse of Dependable Communications...**

Crystek Crystals offers their new 16 page FREE catalog of crystals and oscillators. Offering state of the art crystal components manufactured by the latest automated technology. Custom designed or "off the shelf," Crystek meets the need, worldwide. Write or call today!

### CRYSTEK CORPORATION

DIVISION OF WHITEHALL CORPORATION



2351/2371 Crystal Drive • Ft. Myers, FL 33907  
P.O. Box 06135 • Ft. Myers, FL 33906-6135  
**TOLL FREE 1-800-237-3061**  
PH 813-936-2109/TWX 510-951-7448/FAX 813-939-4226  
**TOLL FREE IN THE U.S.A. EXCEPT FLORIDA, ALASKA, HAWAII**

CIRCLE 69 ON FREE INFORMATION CARD

### DIGITAL VIDEO STABILIZER ELIMINATES ALL VIDEO COPY PROTECTIONS



While watching rental movies, you will notice annoying periodic color darkening, color shift, unwanted lines, flashing or jagged edges. This is caused by the copy protection jamming signals embedded in the video tape, such as Macrovision copy protection. Digital Video Stabilizer: RXII completely eliminates all copy protections and jamming signals and brings you crystal clear pictures.

- FEATURES:**
- Easy to use and a snap to install
  - State-of-the-art integrated circuit technology
  - 100% automatic - no need for any troublesome adjustments
  - Compatible to all types of VCRs and TVs
  - The best and most exciting Video Stabilizer in the market
  - Light weight (8 ounces) and Compact (1x3.5x5")
  - Beautiful deluxe gift box
  - Uses a standard 9 Volt battery which will last 1-2 years.

**WARNING :**  
SCO Electronics and RXII dealers do not encourage people to use the Digital Video Stabilizer to duplicate rental movies or copyrighted video tapes. RXII is intended to stabilize and restore crystal clear picture quality for private home use only.

(Dealers Welcome)

To Order: \$49 ea + \$3 for FAST UPS SHIPPING  
**1-800-445-9285 or 516-694-1240**  
Visa, M/C, COD M-F: 9-6 (battery not included)  
SCO ELECTRONICS INC.  
Dept. CJ5 581 W. Merrick Rd. Valley Stream NY 11580  
Unconditional 30 days Money Back Guarantee

CIRCLE 186 ON FREE INFORMATION CARD

## Be an FCC LICENSED ELECTRONIC TECHNICIAN!



No costly School. No commuting to class. The Original Home-Study course prepares you for the "FCC Commercial Radio-telephone License". This valuable license is your "ticket" to thousands of exciting jobs in Communications, Radio-TV, Microwave, Computers, Radar, Avionics and more! You don't need a college degree to qualify, but you do need an FCC License. **No Need to Quit Your Job or Go To School** This proven course is easy, fast and low cost! **GUARANTEED PASS** — You get your FCC License or money refunded. **Send for FREE facts now. MAIL COUPON TODAY!**

### COMMAND PRODUCTIONS

FCC LICENSE TRAINING, Dept. 90  
P.O. Box 2824, San Francisco, CA 94126  
Please rush FREE details immediately!

NAME \_\_\_\_\_  
ADDRESS \_\_\_\_\_  
CITY \_\_\_\_\_ STATE \_\_\_\_\_ ZIP \_\_\_\_\_

JUNE 1989



# EQUIPMENT REPORTS

## Jameco Electronics JE680 Universal IC Programmer

Program virtually any  
programmable logic  
or memory device.

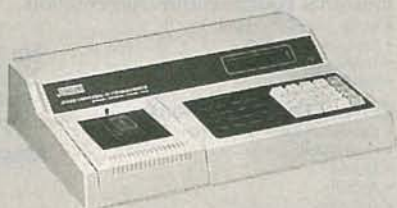

CIRCLE 28 ON FREE INFORMATION CARD

CAN YOU IMAGINE THE WORLD OF electronics without EPROM's, PAL's and other programmable memory and logic? Of course not! But if you don't have access to a programmer, you are effectively isolated from using those versatile devices in your designs.

We recently got a chance to examine a sophisticated programmer, the *JE680 Universal IC Programmer* from Jameco Electronics (1355 Shoreway Road, Belmont, CA 94002). The *JE680* can handle PAL, GAL, RAL, PLD, EPLD, EEPLD, and FPLD logic devices. It can also process PROM, Bipolar PROM, MOS/CMOS EPROM and EEPROM memory devices from 16K to 512K. The programmer can act as a stand-alone device or it can be controlled from the serial port of a personal computer.

The *JE680* is packaged in a sturdy metal and plastic case that measures about 15 x 12 x 3½ inches. The top panel features a 2-line by 20-character LCD readout, a ZIF (Zero Insertion Force) socket, 16 LED function indicators, and a 20-key keypad. Rear-panel connectors include a Centronics-type printer port and a DB-25 connector for serial communications.

The programmer has three operating modes. First is the Local mode, where all operations are controlled by keypad entries, and all outputs are displayed on the LCD. Second is the Computer

mode, where an IBM PC or compatible computer takes control of all but the editing functions of the programmer. (The control software is provided with the programmer.) Third is the Terminal mode, where any dumb terminal (or a computer running communications software) can control the programmer.

We preferred the Computer mode because of the online help provided by the software. However, in production environments, we can see the Local mode being favored. An especially useful feature in such environments is *Auto-Sense*, in which IC insertions and removals are automatically detected.

### Putting it to work

The *JE680* offers numerous functions. A **BLANK** function performs a check to ensure that EPROM's are fully erased, or that logic devices are unprogrammed. Using *Auto-Sense*, it becomes as easy as setting up the function, and inserting devices one after the other. The programmer senses when the IC is in place and performs the test. If your IC is inserted backward, or is not recognized, the *JE680* immediately reports it—without damaging the chip—and even suggests a solution.

All communication with the programmer takes place via the

programmer's RAM buffer. If a device is to be programmed, the buffer must first be loaded with the proper programming data. Then the **PROG** function programs the data from the RAM buffer into the IC. If a programmable device is to be read, the data of an IC is first loaded into the RAM buffer, where it can be accessed via the **READ** function.

A **COPY** function allows a master IC to be read into the programmer's RAM buffer so that the contents can be rapidly programmed into other devices. If changes need to be made, the **EDIT** function can be used. Along with normal editing functions, it is possible to split code into more than one device, or to reconstruct code from multiple chips.

A **CHECKSUM** function calculates and displays the checksum of the RAM buffer. For logic devices, the programmer reports the number of blown fuses along with the hex JEDEC (Joint Electronic Device Engineering Council) checksum.

Once a function has been executed, it can be re-executed by using the **REPEAT** function. That can help speed some operations considerably.

Other functions include **IN** and **OUT** for downloading and uploading files to and from the programmer's RAM buffer; **VERIFY**, which is used to double check that the data in a programmed device matches the RAM buffer; and **PRINT**, which outputs data to the Centronics port.

### Software option

A \$30 software option package, the *JE680AP*, is available for logic-design applications. It runs on an IBM PC or a close compatible and offers Boolean conversion, auto compilation, and fuse-map generation.



The software includes four independent modules. A parser module analyzes the syntax of Boolean equations. A fusemap module creates the JEDEC format file for downloading to the programmer. A Document module generates report records (such as IC pinouts, symbol tables, PLD fuse maps, and test vector tables), and a SGUP module downloads and burns in the JEDEC file created by the fusemap module. SGUP can also read the IC pattern from the programmer.

While the *JE680* is sophisticated enough to handle any programming task you're likely to come up with, it's also easy to use—despite a somewhat frustrating operating manual.

The programmer's multiple operating modes mean that it will be at home in either an engineering laboratory or in a production environment. Such features don't come cheap—the *JE680* is priced at \$1799.95. But if you're serious about programmable devices, it's certainly worth a serious look. **R-E**

## Global Specialties BOA Microcomputer Applications Workstation

A "box of applications" for  
your PC



CIRCLE 29 ON FREE INFORMATION CARD

COMPUTERS HAVE BECOME UBIQUITOUS. You'll find them in electronics labs, in schools, even in many homes. Unfortunately computers have, for most people, become nothing more than appliances. Even young hobbyists don't have much opportunity to "get their hands dirty" with computer hardware. We recently discovered a device that could change that by turning any PC into a microcomputer applications workstation. It's called the *BOA*

(an acronym for *Box Of Applications*) and is sold by a division of Interplex Electronics, Global Specialties (70 Fulton Terrace, P.O. Box 1942, New Haven, CT 06509).

The *BOA* is housed in a metal slope-front cabinet that measures roughly 13×11×4 inches. It connects to the computer's bus through a buffer card and cables, and offers access to the computer's bus through a solderless connector block which, along with a

**With Just One Probe Connection, You Can Confidently Analyze Any  
Waveform To 100 MHz, 10 Times Faster, 10 Times More Accurately,  
Absolutely Error Free, Guaranteed — Or Your Money Back!**

**SC61 Waveform Analyzer™**  
Patented  
**\$3295**

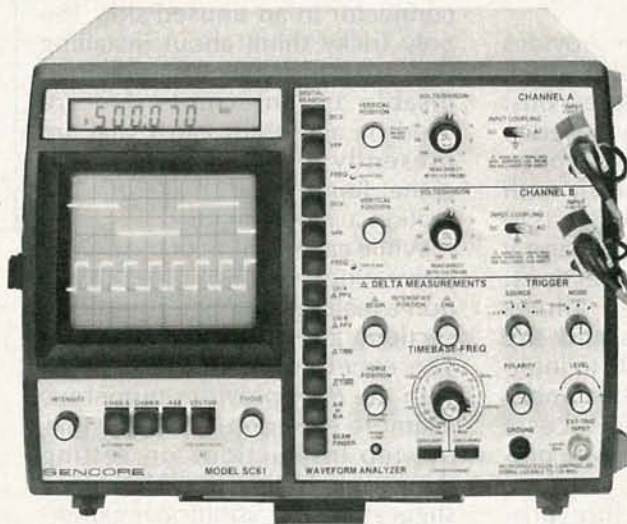

There are other digital readout oscilloscopes, but none of them completely eliminate graticule counting and calculations like the SC61 Waveform Analyzer. The innovative, time-saving AUTO-TRACKING™ digital readout automatically gives you every waveform parameter you need for fast troubleshooting.

The SC61 Waveform Analyzer is a triple patented high performance scope that provides you with a digital LCD read-out of all key waveform parameters (DC volts, peak-to-peak volts, and frequency) at the push of a button, and all with one probe connection.

Other time-saving features include exclusive ECL sync circuits that allow you to lock quickly onto waveforms up to 100 MHz. Plus, with 3000 volts of input protection, you never have to worry about an expensive front end repair job.

Call **1-800-843-3338** to find out more about what the SC61 can do for your service business. In Canada call **1-800-851-8866**.

**SENCORE**

3200 Sencore Drive, Sioux Falls, SD 57107

100% American Made

CIRCLE 180 ON FREE INFORMATION CARD



solderless breadboard, dominates the unit's top panel.

More than two dozen solderless connector blocks encircle the breadboard and bus-access block. They offer tie points to such things as output ports, input ports, DMA latches, A/D and D/A converters, a digitally programmable amplifier, a function generator, an audio amplifier, and so on. A brief description of each section follows

### Circuit sections

Two output ports use two 74LS75 4-bit bistable latches to capture buffered data-bus signals. Each port has LED logic indicators and TTL-level interface outputs. As with all sections, all signals are accessible via tie points on solderless connectors.

Two 8-bit input ports provide the means to input data to the PC's bus. Top-panel DIP switches can be used to input data. Alternately, TTL-level signals can be sent through tie points. Data latching is available on both input ports.

A MEMORY section provides two 28-pin sockets to accept up to 16K of EPROM or RAM memory. (EPROM and static RAM can be mixed). A SEGMENT SELECT DIP switch is used to set the position of the memory in the computer's memory map.

An I/O DECODE section provides I/O device-select signals, which are decoded from the address bus. An 8-position DIP switch is used to set the address of the I/O decoder. It is used in combination with READ, WRITE, and SELECT tie points to provide I/O write, I/O read, and I/O select signals for other sections.

A DMA LATCH section allows breadboarded circuits and the other sections of the BOA to interface to the computer's bus under DMA (Direct Memory Access) control. Two DMA latches are provided for you.

A D/A CONVERTER section provides two digital-to-analog converters, an op-amp circuit, and a precision voltage source. Two A/D CONVERTER sections are provided as well.

An EXTERNAL INTERFACE section provides a convenient method of attaching peripheral modules to the side of the BOA. A DB-25 connector is connected in parallel

with solderless tie points, which can then be connected to the various other sections of the BOA.

A PULSER section provides D-type latches and push-button switches to provide pulses to other circuits. Pulses can either be provided under circuit control, or by physically pushing the pushbuttons.

A FUNCTION GENERATOR section provides sine-wave and TTL-level pulse outputs. The amplitude and frequency of the function generator are controlled via AM and FM inputs.

A DIGITAL GAIN section can control the amplitude of an analog input signal under computer control, while an AUDIO AMPLIFIER section with a speaker provides a convenient way to hear an analog output signal. A MICROPHONE AMPLIFIER section is provided to amplify low-level inputs for use by other sections.

Hooking the BOA to the computer consists of inserting a card into a slot, and plugging a 50-conductor cable into the card's output and into the BOA's top panel. The card "steals" power from the bus and outputs +5-, +12-, and -12-volt power on a 9-pin connector. If your computer doesn't have a 9-pin knockout, you can use an adapter plate to mount the power connector in an unused slot. The only tricky thing about installing the card is that you must be sure to disable any interrupts that are used by any other cards that are presently installed in your machine. Jumper pads make that operation a simple matter.

While each section of the BOA is interesting in its own right, things don't really get exciting until the sections are connected together. The excellent manual supplied with the BOA provides numerous example experiments, and step-by-step instructions on setting things up. It also provides many suggestions for additional experiments you can do.

Among the suggested projects is a DC volt meter, which can be assembled using the I/O DECODE, BUS INTERFACE, and A/D CONVERTER sections along with a top-panel potentiometer and some supplied BASIC software. Another experiment suggests how to build a frequency counter using interrupts.

## READER HELP READER

We often receive letters from readers who have searched, in vain, for schematic drawings and other documentation, or for discontinued parts. Unfortunately, we don't usually have this information at our fingertips, and don't have the time to mount our own searches for it. However, there is one invaluable source that we can easily tap—Radio-Electronics' readers! Here's your chance to get some assistance, or to help out a fellow electronics enthusiast.

● If you have service literature for a Garrard "Music Recovery Module" model MRM 101, MARK DESZCZ will gladly cover the shipping costs to send it to P. O. Box 1168, Williamsville, NY 14221.

● MICHAEL CARTER is trying to find a transformer for a Zenith radio, model 7S363, that dates back to the late 1930's or early 1940's. The transformer number is C95-526N. He can be reached at M.A.C. Electronics, RR4, Box 110, Hutchinson, MN 55350.

● Can you help DONALD A. NEWELL JR. obtain an RCA Data Manual SSD-245? He's also seeking a source for RCA Bulletin Files and Application Notes. Write to him at P. O. Box 181, Bruce, WI 54819.

Experiments in digital audio recording and playback—even an experimental echo machine—are also suggested.

The BOA is a great tool, and would be at home in an engineering lab or a microprocessor lab course. Because it encourages experimentation, it also makes an excellent self-teaching tool for anyone who wants to learn about computer interfacing. We'd be hard pressed to think of a better way to breadboard prototypes for computer add-on cards. The BOA is priced at \$1088. We recommend it to anyone who believes that computers are meant to do more than just run software. **R-E**



# Get hands-on training for a high-paying career in today's booming electronic information industry as you build your own complete data communications system

Includes  
XT-compatible  
computer you  
keep!

NRI's new Data Communications training gives you the high-tech, hands-on skills in demand in today's explosive new electronic information industry. Now with NRI, you actually build and go on-line with your own powerful data communications system, complete with IBM PC/XT-compatible computer, 2400 baud modem, communications software, breakout panel, test instruments, and more!

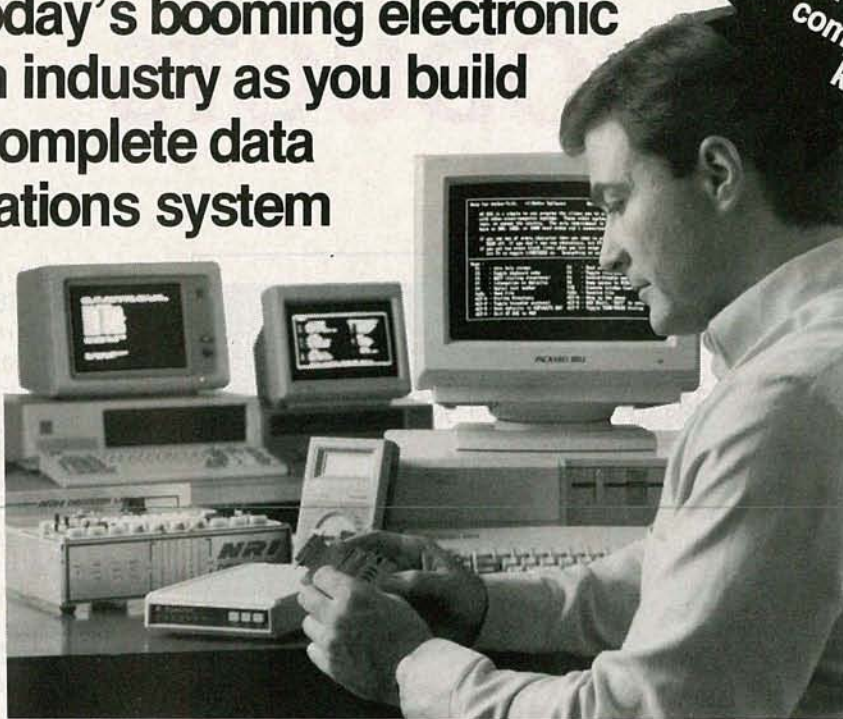

your modem, and you're ready to put your system on-line with a world of electronic information.

Go on-line with the exclusive NRI network

Your NRI training continues by giving you exciting real-world experience in data communications.

It's a fact: The hot jobs in electronics today are in the electronic information industry. An explosion in new technologies is turning desktop computers into high-powered, high-speed data communications systems—making it possible for computers to talk to computers the world over.

Already, electronics technicians trained to install and service the new data communications equipment demand and get \$25,000, \$30,000, \$35,000 a year and more.

Now with NRI, you get hands-on data communications know-how, so you too can cash in on today's multibillion-dollar electronic information industry. NRI's ready to help you succeed now with new at-home training featuring a powerful data communications system you build, program, operate, and keep!

**NRI trains you from the basics on up—giving you everything you need to get a fast start in data communications**

Your NRI training starts with the electronics fundamentals you need to understand and service all data communications equipment. As you assemble your NRI Discovery Lab®, a complete breadboarding system included in your course, you perform experiments and demonstrations that show you electronics principles at work firsthand.

Quickly moving on, you use NRI's professional digital multimeter to take voltage, current, and resistance measurements, testing a variety of circuits you build on your

Discovery Lab—circuits just like those in today's data communications equipment.

And that's just the beginning. With a solid foundation in electronics behind you, you're ready to build your own powerful data communications system.

**Breakthrough training includes 512K computer, 2400 baud modem, communications software, breakout panel, much more**

At this point in your training, you're sent the new IBM PC/XT compatible Packard Bell VX88 computer. Following NRI's clearcut instructions, you easily master your computer's powerful operating functions, then move on to build your own complete data communications system.

You begin by programming the RS-232C communications interface built into your computer, giving the Packard Bell the power to transmit data over serial lines. Next you construct a high-quality breakout panel, an indispensable diagnostic tool you use to examine and test the internal workings of your interface.

Then, completing your state-of-the-art system, you power up the 2400 baud modem included in your course and take it through a series of comprehensive tests and demonstrations. In no time, you have a firm understanding of the data conversion system built into

Having completed your data communications system, you actually take it on-line to "talk" to your instructor and other NRI students, complete a final project by computer link, and leave messages on the NRI Bulletin Board.

Step by step, NRI gives you a complete hands-on understanding of the technology that's powering today's booming electronic information industry. Step by step, you get what it takes to start a high-paying career as today's in-demand data communications technician!

**FREE 100-page catalog tells more**

Send today for NRI's big, 100-page, full-color catalog describing every aspect of NRI's hands-on training in data communications, as well as at-home training in other fast-growing, high-tech career fields.

If the coupon is missing, write to NRI School of Electronics, McGraw-Hill Continuing Education Center, 4401 Connecticut Avenue, NW, Washington, DC 20008.

**NRI** School of Electronics

McGraw-Hill Continuing Education Center  
4401 Connecticut Avenue, NW  
Washington, DC 20008

For career courses approved under GI bill  
 check for details

Check one catalog only

- Data Communications
- Computers and Microprocessors
- Robotics
- TV/Video/Audio Servicing

- Computer Programming
- Electronic Music Technology
- Cellular Telephone Servicing
- Security Electronics
- Digital Electronics Servicing
- Basic Electronics

Name \_\_\_\_\_ (please print) Age \_\_\_\_\_

Address \_\_\_\_\_

City/State/Zip \_\_\_\_\_ Accredited by the National Home Study Council 3-069



# NEW PRODUCTS



CIRCLE 10 ON FREE INFORMATION CARD

**POINTING DEVICE.** *Fulcrum's Trackball Plus*, featuring trackball-pointing technology, is a versatile and easy-to-use alternative to—and requires less desk space and less frequent cleaning than—the mouse. Ball motion is detected optically and transformed to one of many formats by a local micro-processor before being sent to the host. The pointing device is easily interfaced to IBM compatibles with a standard RS-232 serial port, and offers an ALTERNATE CURSOR switch for CAD/CAM applications.

*Trackball Plus* emulates Microsoft Mouse and Mouse Systems Mouse, and comes with software drivers for both. It also emulates 8

popular pointing devices, and several digitizers. It supports a dozen commonly used programs—including Lotus 1-2-3, dBASE III Plus, MS-DOS, and WordPerfect—and offers "Point-n-Shoot Pop-Up" menus, which make it unnecessary for users to memorize the extensive codes that accompany software. The pointing device's MENUKEY provides arrow-key emulation for programs that don't normally accept pointing devices.

The *Trackball Plus*, complete with a comprehensive user's manual and an extended 6-month warranty, has a retail price of \$99.00.—**Fulcrum Computer Products**, 459 Allan Court, Healdsburg, CA 95448.

**MULTI-SPEED TURNTABLE.** For collectors of "antique" phonograph records, *Esoteric Sound's*

*Vintage* phonographic-disc player features a variety of speeds, providing convenient listening at

the correct pitch. Because many so-called "78's" were actually recorded at other speeds, the 6-speed turntable plays at 71.29 rpm (the speed of the original *Berliner Gramophone* record), 76.59 rpm (many acoustic *Victors*), 78.26 rpm (modern 78's), and 80 rpm (*Edison*, vertical *Pathe*, and acoustic *Columbia* and *Okeh*, most vertical). The modern, high-fidelity turntable also offers 33 and 45 rpm for today's recordings. An optional accessory adapts the unit for vertical play, and Stanton pickup features 2 separate styli, one for LP's and one for 78's.



CIRCLE 11 ON FREE INFORMATION CARD

The *Vintage* 6-speed turntable is now available at a special introductory price is \$225.00 (including the Stanton pickup and both styli) plus \$4.00 shipping east of the Mississippi or \$6.00 shipping west of the Mississippi. (C.O.D. orders add \$2.25.) The optional vertical/lateral switch costs \$22.50.—**Esoteric Sound**, 4813 Wallbank Ave., Downers Grove, IL 60515.

**TEST LEAD ADAPTER KIT.** *Pomona Electronics' Multimeter Test-Lead Adapter Kit* is offered in four models: 5592 to fits almost all Beckman and Amprobe; 5593, Simpson; 5594, Triplet; and 5543, B&K and Fluke multimeters. The kit's modu-





CIRCLE 12 ON FREE INFORMATION CARD

lar construction allows the use of a conventional test probe, a spade lug, a Minigrabber test clip, or an alligator clip, through interconnects of sheathed banana plugs. The test-lead wire used in the kit is made with heat- and chemical-resistant silicone insulation.

The user simply connects the test lead to the multimeter with the right-angled sheath plug, and then fits his choice of test-contact device to the sheathed banana plug on the other end. The banana-plug interconnects can withstand over 5 pounds of separation force.

The Multimeter Test Lead Adapter Kits each have a suggested retail price of \$27.50.—**Pomona Electronics Division**, ITT Corporation, 1500 East Ninth St., P.O. Box 2767, Pomona, CA 91769-2767.

**3-PIN POWER RECEPTACLE.** The *NE20B* from *ITT Schadow* combines an IEC 3-pin receptacle, a power switch, and a remote actuator in one user-friendly package. It allows equipment manufac-

turers to put the ON/OFF switch on the front panel, where the status is clearly apparent, while leaving the power circuit at the back panel. A flexible cable connects the power module and the actuator, eliminating the need for more costly wiring. Switching power at the back panel increases safety and decreases EMI/RFI. The *NE20B* is easily mounted with a clip. Cable length is made to order.

The *NE20B* 3-pin power receptacle costs between \$5.00 and

\$10.00, depending on options and quantity ordered.—**ITT Schadow, Inc.**, 8081 Wallace Road, Eden Prairie, MN 55344.

**BENCH MULTIMETER.** The *Fluke 45* has a multi-function dual display that allows more measurements to be taken from a single connection and a single instrument setup. The 5-digit, 100,000-counts digital multimeter has additional selectable resolutions of 30,000 and 3,000 counts, and includes a built-in

# BK

## Special INSTRUMENT SALE!

Joseph Electronics' 40th Anniversary Specials!



**Model 2120 Oscilloscope**  
DC to 20 MHz. Dual Trace, 6" CRT, 1mv Sensitivity.  
Reg. \$520 **\$379.40**  
40TH ANNIVERSARY PRICE

**Model 2125 Oscilloscope**  
Same great features as 2120, except with delayed sweep  
Reg. \$620 **\$519.40**  
40TH ANNIVERSARY PRICE

**Model 1541A Oscilloscope** DC to 40 MHz, Dual Trace, 6" CRT 1mv Sensitivity  
Reg. \$845 **\$739.40**  
40TH ANNIVERSARY PRICE

**Model 2160 Oscilloscope** DC-60MHz, dual trace, delay sweep, 6" CRT, 1mv sensitivity  
Reg. \$995 **\$839.40**  
40TH ANNIVERSARY PRICE

**Model 2520 Digital Storage** 20MHz, Dual Trace, 2mv Sens.  
Reg. \$1990 **\$1795.40**  
40TH ANNIVERSARY PRICE

**Model 2521 Digital Storage** 20MHz, Dual Trace CRT Readout, Cursors, RS232 Interface  
Reg. \$3050 **\$2745.40**  
40TH ANNIVERSARY PRICE

**Model 1249 NTSC/RGB Color Bar Generator.** Composite Video Output, RF Output  
Reg. \$499 **\$419.40**  
40TH ANNIVERSARY PRICE

**Model 2009 MTS TV Stereo Generator** ideal for Stereo TV, Receivers, VCR's and Stereo Adapter Service  
Reg. \$499 **\$419.40**  
40TH ANNIVERSARY PRICE

**Model 2830 3 1/2 DIGIT LED BENCH Multimeter.** 5 DCV Accuracy, ALL 33 Ranges and Functions are Push Button Selectable  
Reg. \$243 **\$209.40**  
40TH ANNIVERSARY PRICE

**Model 1045 Telephone Product Tester** Provides Basic Operation Tests for Corded and Cordless Telephones, Answering Machines and Automatic Dialers  
Reg. \$495 **\$415.40**  
40TH ANNIVERSARY PRICE

**Model 1803 Frequency Counter** 100 MHz, 8 digit display, zero blanking AC or Battery  
Reg. \$199 **\$169.40**  
40TH ANNIVERSARY PRICE

**Model 2005 RF Signal Generator** 100 KHz to 150 MHz, in 6 fundamental bands and 450 MHz in harmonics  
Reg. \$195 **\$165.40**  
40TH ANNIVERSARY PRICE

**Model 3011 Function Generator** 2 MHz, 4 digit display, TTL & CMOS pulse outputs  
Reg. \$239 **\$199.40**  
40TH ANNIVERSARY PRICE

**Model 1630 DC Power Supply** 0-30V, 0-3A, high-low current range, Low ripple  
Reg. \$251 **\$209.40**  
40TH ANNIVERSARY PRICE

**Model 1601 DC Power Supply** isolated 0-50V, 0-2A in ranges, fully automatic shutdown, Adj. current limit  
Reg. \$463 **\$389.40**  
40TH ANNIVERSARY PRICE

**Model 1650 Triple Output Power Supply** two 0-25 VDC @ .5A and 5VDC @ 5A, fully automatic shutdown  
Reg. \$489 **\$409.40**  
40TH ANNIVERSARY PRICE

**Model 1653 AC Power Supply** variable isolated 0-150 VAC @ 2A, built-in isolation transformer  
Reg. \$200 **\$169.40**  
40TH ANNIVERSARY PRICE

**NEW! Model 388-HD Hand-held 3 1/2 Digit LCD TEST BENCH**

41 voltage ranges, frequency counter, capacitance meter, logic probe, transistor and diode tester. All packed into a drop-resistant case. **SPECIAL PRICE!**  
Reg. \$139 **\$119.40**



We are celebrating our 40th Anniversary by offering you huge savings on B&K Test Equipment.

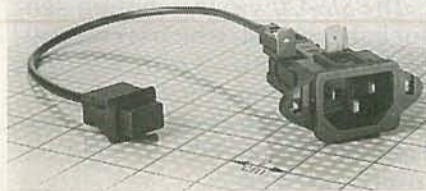

CIRCLE 13 ON FREE INFORMATION CARD

Send for FREE 528 page "Industrial Products Catalog." I understand it is FREE with any order or if requested on company letterhead. (Otherwise, \$4.95 to cover catalog and shipping costs.)

ORDER TOLL FREE  
**1-800-323-5925**  
IN CHICAGOLAND  
**312-297-4200**  
FAX: 312-297-6923

**Joseph ELECTRONICS**



**JOSEPH ELECTRONICS, INC.** Dept. R  
8830 N. Milwaukee Ave., Niles, IL 60648

Rush merchandise per attached order. I understand rated accounts are shipped open account; otherwise send per credit card.

Include \$5.00 per item for shipping and handling.

Visa  Master Card  Discover  
 Check  Money Order  Rush Catalog

Card No. \_\_\_\_\_ Exp. Date \_\_\_\_\_

Name \_\_\_\_\_

Company \_\_\_\_\_

Street Address \_\_\_\_\_

City \_\_\_\_\_ State \_\_\_\_\_ Zip \_\_\_\_\_

IL Res. 7% Tax

JUNE 1989



RS-232 interface for PC instrument applications. An optional IEEE-488 interface and QuickStart 45 software are available separately.

Using the bright, vacuum-fluorescent primary and secondary displays, a wide variety of different measurement combinations can be viewed. Other features include true RMS AC and DC measurement for voltage or current, MIN MAX, relative reference, and auto-ranging. The unit also has a compare function for easy in-tolerance



CIRCLE 14 ON FREE INFORMATION CARD

testing, a frequency-counter function to 1 MHz, a dB-function with 25 reference impedances, audio power, diode test, and continuity.

The *Fluke 45* bench multimeter has a suggested list price of \$595.00.—**John Fluke Mfg. Co., Inc.**, P.O. Box C9090, Everett, WA 98206; 800-443-5853, ext. 33.

#### SECURITY LIGHT CONTROL.

*Heath Zenith's Model SL5420* wireless motion-sensor light control is designed to deter burglars by combining illumination with an element of surprise, as the light flashes on as soon as a person enters the detection field.

The wireless control consists of a battery-operated motion sensor and a receiver, which replaces any existing wall switch to control the light. The fully-adjustable motion sensor can be placed up to 150 feet from the receiver; by adding extra receivers, multiple lights can be controlled. The *SL5420* uses pulse-count technology, which reduces the chance of false alarms.



CIRCLE 15 ON FREE INFORMATION CARD

The control can be easily mounted indoors or outdoors on any surface, including lamp posts, walls, and fences. Packaged in a dark, weather-resistant case, it is difficult for an intruder to detect at night. The user can set the duration that lights remain on, or an adjustable photo cell can change the times the lights turn on at night.

The *SL5420* wireless motion-sensor light control, which is compatible with Heath Zenith wireless security systems, retails for under \$100.00.—**Heath Zenith**, Consumer Products Group, Hilltop Road, St. Joseph, MI 49085.

*continued on page 26*

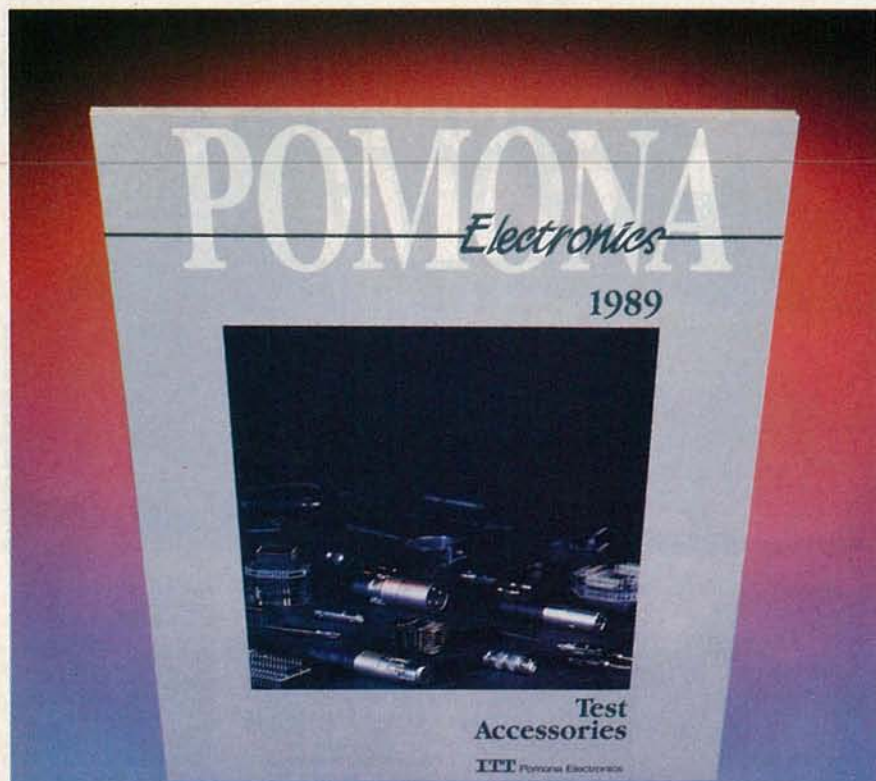

## Problem Solving Manual

**1989 Edition** As all engineers and technicians know, assembling a test setup can become quite a problem if the proper interconnecting test accessories are not readily at hand.

That's why it's smart to review the products featured in our new 1989 'Problem Solving' General Catalog, and have the solution handy before assembly.

Our 1989 edition features 900 of the highest quality and most accurate test products you will find anywhere. Rest assured, Pomona delivers—on time—the broadest and most varied selection of precision test accessories in the industry.

For your FREE 1989 General Catalog, circle reader service number printed below.

**ITT Pomona Electronics**  
An ITT ElectroMechanical Components Worldwide Company

CIRCLE 101 ON FREE INFORMATION CARD







# LEARN VCR

## CLEANING/MAINTENANCE/REPAIR

EARN UP TO \$1000 A WEEK, WORKING PART TIME FROM YOUR OWN HOME!



Secrets Revealed!  
NO Special Tools or Equipment Needed.

EARN UP TO \$60 AN HOUR AND MORE!

### THE MONEY MAKING OPPORTUNITY OF THE 1990'S

IF you are able to work with common small hand tools, and are familiar with basic electronics (i.e. able to use voltmeter, understand DC electronics) . . . IF you possess average mechanical ability, and have a VCR on which to practice and learn . . . then we can teach YOU VCR maintenance and repair!

**FACT:** up to 90% of ALL VCR malfunctions are due to simple MECHANICAL or ELECTRO-MECHANICAL breakdowns!

**FACT:** over 77 million VCRs in use today nationwide! Average VCR needs service or repair every 12 to 18 months!

Viejo's 400 PAGE TRAINING MANUAL (over 500 photos and illustrations) and AWARD-WINNING VIDEO TRAINING TAPE reveals the SECRETS of VCR maintenance and repair—"real world" information that is NOT available elsewhere!

Also includes all the info you'll need regarding the BUSINESS-SIDE of running a successful service operation!

FREE INFORMATION  
CALL TOLL-FREE 1-800-537-0589  
Or write to: Viejo Publications  
3540 Wilshire BL. STE 310  
Los Angeles, CA 90010 Dept RE

CIRCLE 185 ON FREE INFORMATION CARD

### TELEPHONE DIALER/DIRECTORY.

Texas Instrument's TI-3100 Pocket Dialer also acts as a telephone directory, an appointment schedule, a calculator, and a clock with alarm. The compact unit weighs only 5 ounces (included), runs on one lithium battery (included), and comes with a protective slide case that doesn't interfere with the dial function. It offers the convenience of completely portable, one-handed, one-button telephone dialing, with keyboard graphics that are color-coded by function.

As a dialer, users hold the unit against a phone with one hand, leaving the other hand free for writing. It has one-button redial, pause, slow-dialing, and local-dialing features. The TI-3100's directory function provides storage of up to 125 two-line entries, which are stored alphabetically and can be retrieved by scrolling or, more quickly, by typing the first word or letter and then scrolling. A secret password can be used to protect sensitive entries. Information about appointments is stored by



CIRCLE 16 ON FREE INFORMATION CARD

date, in chronological order; the alarm can be used as a reminder.

The TI-3100 Pocket Dialer has a suggested retail price of \$65.00.—Texas Instruments, Consumer Relations, P.O. Box 53, Lubbock, TX 79408; 806-747-1882.

**TOOL CASE.** Vaco's Tool Bux #70470 is a rugged Cordura nylon case that contains a convenient assortment of 20 popular tools, including screwdrivers, nutdrivers, electrical tools, and specialty tools. Strong elastic holders keep each tool in place, for well-organized ease of selection. The water-resistant case has sturdy webbed handles and three expandable pockets. It measures 15 x 11 x 2 1/4 inches.



CIRCLE 17 ON FREE INFORMATION CARD

The Tool Bux #70470 tool case costs \$222.04.—Vaco Products., 7200 McCormick Blvd., Chicago, IL 60645. R-E

## Choose from 31 Career Opportunities

Get Your Specialized Associate Degree or Career Diploma at Home in Spare Time

Without attending college and with no previous experience, you can train for a money-making career. Send for free facts and color brochure on employment opportunities in the field that interests you most. See how easy it is to train at home for a great new career or advancement on your present job.



CALL TOLL FREE 1-800-228-5300 Dept. DES59  
CALL ANYTIME—Operators to take your call 24 hours a day, 7 days a week. No cost. No obligation. No salesman will visit you.

OR MAIL COUPON TODAY! 495ZB

### IGS International Correspondence Schools

Dept. DES59, Scranton, PA 18515

Please send me free facts, color brochure and full information on how I can study at home for the career I have chosen.

CHECK ONE BOX ONLY!

- |   |  |
|---|--|
| <b>ASSOCIATE IN SPECIALIZED BUSINESS DEGREE PROGRAMS</b><br><input type="checkbox"/> Business Management<br><input type="checkbox"/> Accounting<br><input type="checkbox"/> Business Management with option in Finance<br><input type="checkbox"/> Business Management with option in Marketing | <b>ASSOCIATE IN SPECIALIZED TECHNOLOGY DEGREE PROGRAMS</b><br><input type="checkbox"/> Civil Engineering Technology<br><input type="checkbox"/> Mechanical Engineering Tech.<br><input type="checkbox"/> Electrical Engineering Tech.<br><input type="checkbox"/> Electronics Technology |
|---|--|

#### CAREER DIPLOMA PROGRAMS

- |  |   |
|--|---|
| <input type="checkbox"/> High School<br><input type="checkbox"/> Auto Mechanics<br><input type="checkbox"/> Surveying & Mapping<br><input type="checkbox"/> Drafting<br><input type="checkbox"/> Air Conditioning & Refrigeration<br><input type="checkbox"/> Wildlife/Forestry Conservation<br><input type="checkbox"/> Police Sciences<br><input type="checkbox"/> Diesel Mechanics<br><input type="checkbox"/> Electrician<br><input type="checkbox"/> Small Business Management<br><input type="checkbox"/> Gun Repair<br><input type="checkbox"/> Electronics | <input type="checkbox"/> Microcomputer Repair<br><input type="checkbox"/> Bookkeeping<br><input type="checkbox"/> Art<br><input type="checkbox"/> Motorcycle Repair<br><input type="checkbox"/> Catering/Gourmet Cooking<br><input type="checkbox"/> Computer Programming<br><input type="checkbox"/> Fitness & Nutrition<br><input type="checkbox"/> TV/VCR Repair<br><input type="checkbox"/> Photography<br><input type="checkbox"/> Journalism/Short Story Writing<br><input type="checkbox"/> Commercial Art |
|--|---|

Name \_\_\_\_\_ Age \_\_\_\_\_  
 Address \_\_\_\_\_ Apt. # \_\_\_\_\_  
 City/State \_\_\_\_\_ Zip \_\_\_\_\_  
 Phone ( ) \_\_\_\_\_

© A Subsidiary of National Education Corporation

CIRCLE 182 ON FREE INFORMATION CARD

## NEW SUPER LONG PLAY TAPE RECORDERS

12 Hour Model — \$119.00\*  
 Modified Panasonic Slimline, high quality, AC-DC Recorders provide 6 continuous hours of quality recording & playback on each side of cassette for a total of 12 hours.  
 Built-in features include:  
 • Voice level control • Digital counter, etc. TDK DC 120 Cassette Furnished.



### PHONE RECORDING ADAPTER

Records calls automatically. All Solid state connects to your telephone jack and tape recorder. Starts recording when phone is lifted. Stops when you hang up. \$24.95\*  
 FCC APPROVED



### VOX VOICE ACTIVATED CONTROL SWITCH

Solid state. Self contained. Adjustable sensitivity. Voices or other sounds automatically activate and control recorder. Uses either recorder or remote mike. \$28.50\*  
 \* Add for ship & hdg. Phone Adapter & Vox \$1.50 ea. Recorders \$4.00 ea. Cal. Res. add tax. Mail order, VISA, M/C, COD's OK. Money Back Guarantee. Qty. disc. avail., Dealer inquiries invited, Free data. ©



AMC SALES INC. Dept. A9335 Lubec St., Box 928, Downey, CA 90241 Phone (213) 869-8519

CIRCLE 108 ON FREE INFORMATION CARD





# Now Testing Is Seven Times Easier.

## 1. End Blown Fuses.

The new 200 Series multimeter is protected from excess voltage or surges with a self-resetting fuse.

## 2. Keep Your Eyes On Your Work.

Quickly probe a circuit board listening for audible tone changes that pinpoint the problem without glancing at the LCD.

## 3. Detect Intermittents.

Hear a distinctive crackling sound when an intermittent occurs.

## 4. Find Dead Capacitors.

Capacitor voltage build-up or

bleed-off is heard loud and clear with the 200 Series' Audible Readout.

## 5. Find Logic Stuck-Ats.

Using standard leads, a fast Logic Pulse Detector lets you easily detect pulses down to 50ns.

## 6. Adjust Voltage Levels.

When adjusting audio or video response, an audible tone that changes pitch as measured signals increase or decrease permits faster and easier adjustments.

## 7. Stop Third Hand Problem.

Tilt stand and Skyhook™ auto-ranging,

and Audible Readout allow you to spend less time fiddling with your meter.

FEATURES	222	223
Audible Readout		•
Logic Pulse Detector		•
Fast Auto-Ranging	•	•
Self-Resetting Fuse	•	•
Auto-off Battery Saver	•	•
DC Voltage Accuracy	0.5%	0.25%
Warranty	2 years	2 years
Price	\$129.00	\$149.00

The 200 Series. Multimeters that take the work out of work. Call or write for complete information. 1-800-227-9781 Inside California. 1-800-854-2708 Outside California.

**30 DAY  
MONEY BACK  
GUARANTEE**

## Beckman Industrial™

3883 Ruffin Road, San Diego, CA 92123-1898

Beckman Industrial Corporation Instrumentation Products Division A Subsidiary of Emerson Electric Company  
© 1989 Beckman Industrial Corporation Specifications Subject To Change Without Notice.

CIRCLE 98 ON FREE INFORMATION CARD



# An affordable portable

## Price/Bandwidth

**\$4995** 100 MHz 2230 DSO\*, 20 MS/s, 4K Record Length, 100 ns Glitch Capture, Cursors, CRT Readout, GPIB or RS-232-C Option

**\$3995** 60 MHz 2221 DSO, 20 MS/s, 4K Record Length, 100 ns Glitch Capture, Cursors, CRT Readout, GPIB or RS-232-C Option

**\$2995** 60 MHz 2220 DSO, 20 MS/s, 4K Record Length, 100 ns Glitch Capture, GPIB or RS-232-C Option

**\$2995** 100 MHz 2236 Two Channel, Counter/Timer/DMM, Dual Time Base

**NEW** **\$2795** 100 MHz 2247A Four Channel, Counter/Timer, Store/Recall of 20 Front Panel Setups, Auto Setup, Smart Cursors™

**\$2495** 100 MHz 2246A Four Channel, Store/Recall of 20 Front Panel Setups, Auto Setup, Smart Cursors™, Dual Time Base

**\$2395** 50 MHz 2210 DSO, 20 MS/s Sample Rate, 4K Record Length

**NEW** **\$1495** 20 MHz 2201 DSO, 10 MS/s Sample Rate, 2K Record Length, Hard Copy (RS-232-C) Option

**\$1895** 100 MHz 2245A Four Channel, Auto Setup, Cursors, Dual Time Base

**\$1695** 100 MHz 2235 Two Channel, Dual Time Base

**\$1095** 50 MHz 2225 Two Channel, Horizontal Magnification (x5, x10, x50)

**\$695** 20 MHz 2205 Two Channel

\*Digital Storage Oscilloscope

**\$695.**

**Check the prices and performance.** You'll find the best measure of both in Tek 2200 Series Oscilloscopes. Twelve scopes with bandwidths ranging from 20 to 100 MHz. Two and four channels. Analog and digital. And prices starting at just \$695.

Select for such features as automatic setup, time and voltage cursors, built-in DMM functions, Counter/Timer and dual analog/digital capabilities at the push of a button.

These are scopes you'll appreciate for their well-proven reliability, achieved through simplified, practical internal design. They come

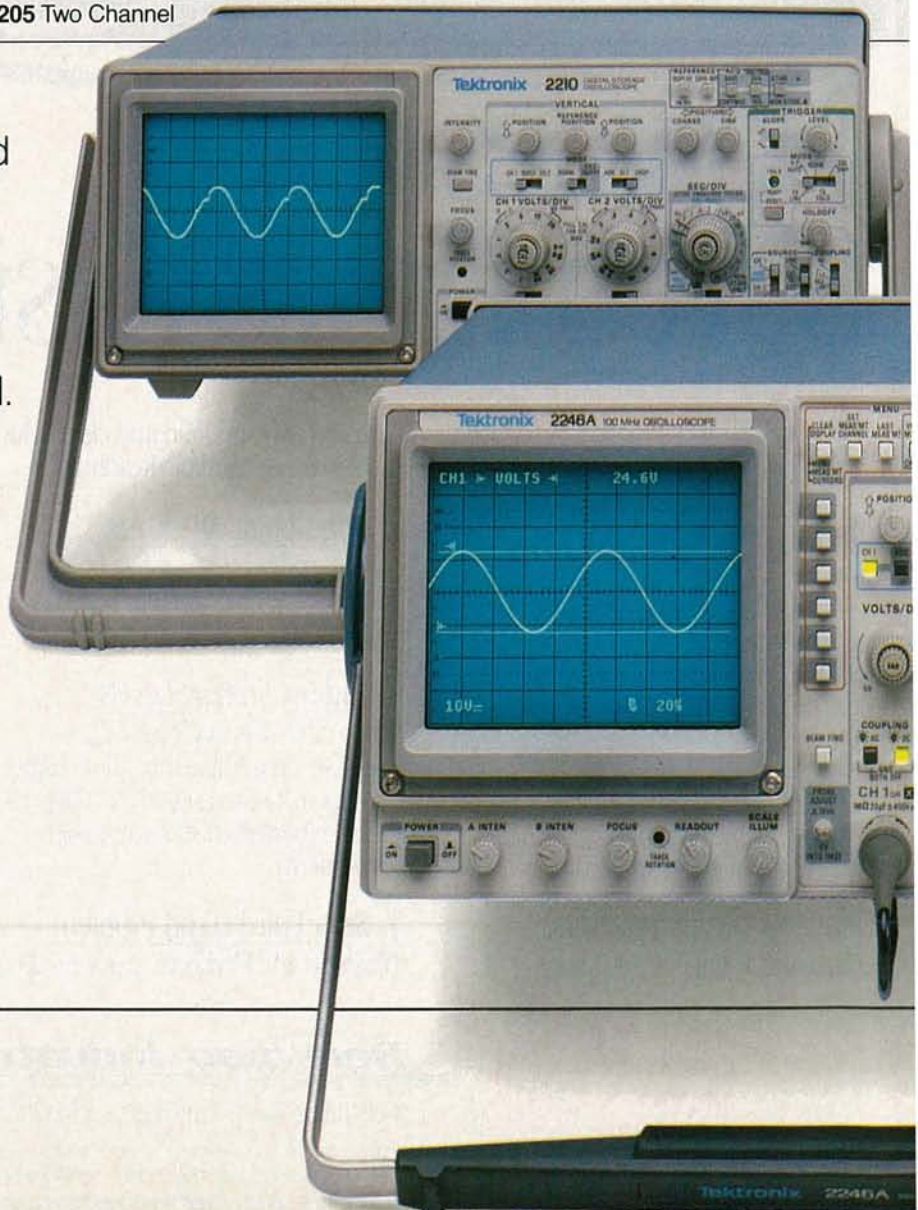



# right within your range.

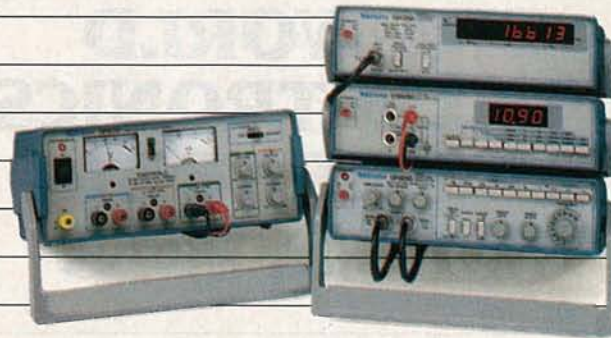

Industrial-quality test instrumentation starting at \$295.

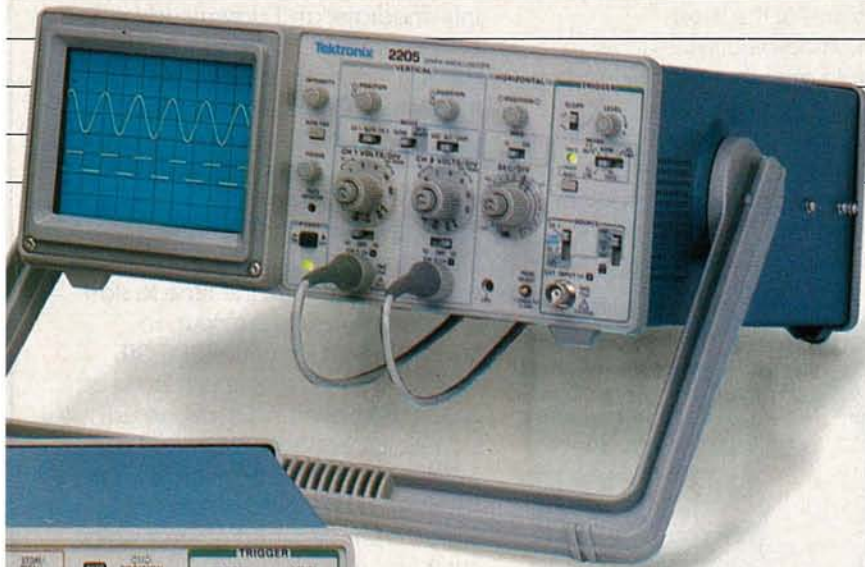

complete with probes and comprehensive Tek warranty that includes the CRT.

Ask those who own, use and rely on one—on the bench or in the field. There's just no substitute for genuine Tek quality. At any price. And at these prices, all the better.

**Order one to go.** Ask your Tek representative to set up a demo. Or call Tek direct. No need to settle for less when there's a top quality Tek portable with performance and price right within your range.

LISTED



For easy ordering or more information, call Tek direct:

## 1-800-426-2200



**Tektronix**  
COMMITTED TO EXCELLENCE

CIRCLE 92 ON FREE INFORMATION CARD





# WITH CIE, THE WORLD OF ELECTRONICS CAN BE YOUR WORLD, TOO.

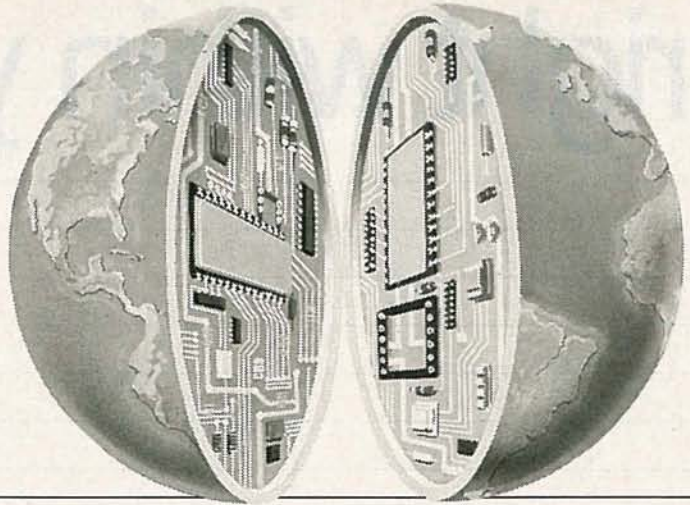

**L**ook at the world as it was 20 years ago and as it is today. Now, try to name another field that's grown faster in those 20 years than electronics. Everywhere you look, you'll find electronics in action. In industry, aerospace, business, medicine, science, government, communications—you name it. And as high technology grows, electronics will grow. Which means few other fields, if any, offer more career opportunities, more job security, more room for advancement—if you have the right skills.

## SPECIALISTS NEED SPECIALIZED TRAINING.

It stands to reason that you learn anything best from a specialist, and CIE is the largest independent home study school specializing exclusively in electronics, with a record that speaks for itself. According to a recent survey, 92% of CIE graduates are employed in electronics or a closely related field. When you're investing your time and money, you deserve results like that.

## INDEPENDENT STUDY BACKED BY PERSONAL ATTENTION.

We believe in independent study because it puts you in a classroom of one. So you can study where and when you want. At your pace, no somebody else's. And with over 50 years of experience, we've developed proven programs to give you the support

such study demands. Programs that give you the theory you need backed with practical experience using some of the most sophisticated electronics tools available anywhere, including our Microprocessor Training Laboratory with 4K of random access memory. Of course, if you ever have a question or problem, our instructors are only a phone call away.



## START WHERE YOU WANT, GO AS FAR AS YOU WANT.

CIE's broad range of entry, intermediate, and advanced level courses in a variety of career areas gives you many options. Start with the Career Course that best suits your talents and interests and go as far as you want—all the way, if you wish, to your Associate in Applied Science Degree in Electronics Engineering Technology. But wherever you start, the time to start is **now**. Simply use the coupon below to send for your FREE CIE catalog and complete package of career information. Or phone us, toll-free, at **1-800-321-2155** (in Ohio, 1-800-523-9109). Don't wait, ask for your free catalog now. After all, there's a whole world of electronics out there waiting for you.

# CIE

**Cleveland Institute of Electronics, Inc.**  
1776 East 17th Street, Cleveland, Ohio 44114

Member NHSC  
Accredited Member National Home Study Council

**CIE Cleveland Institute of Electronics, Inc.**  
1776 East 17th Street, Cleveland, Ohio 44114

ARE-129

**YES...** I want to learn from the specialists in electronics—CIE. Please send me my FREE CIE school catalog, including details about CIE's Associate Degree program, plus my FREE package of home study information.

Name (print): \_\_\_\_\_

Address: \_\_\_\_\_

City: \_\_\_\_\_ State: \_\_\_\_\_ Zip: \_\_\_\_\_

Age: \_\_\_\_\_ Area Code/Phone No.: \_\_\_\_\_ / \_\_\_\_\_

Check box for G.I. Bill bulletin on educational benefits:

Veteran  Active Duty

**MAIL  
TODAY!**



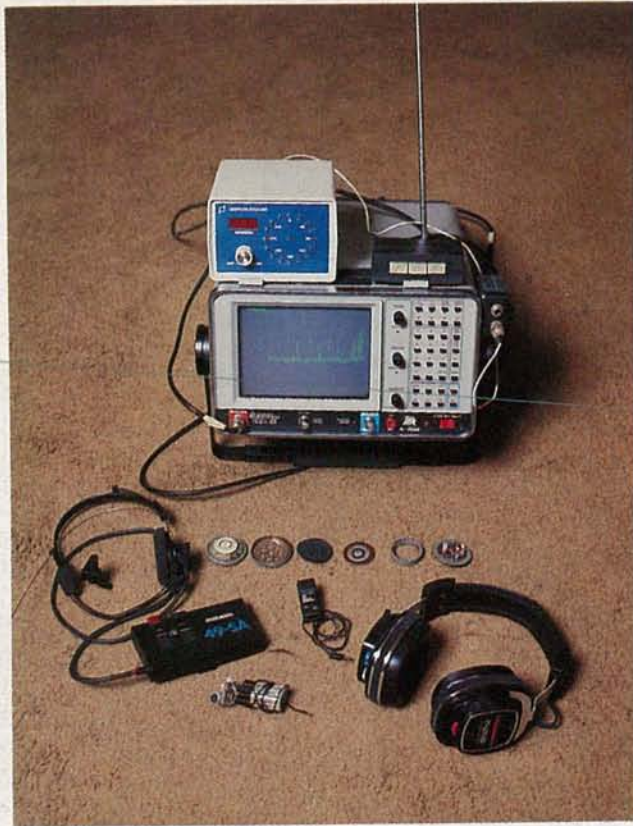

## TRACKING DOWN BUGS USING A SPECTRUM ANALYZER

*Are you being bugged?  
Here's how to find RF  
bugging devices that  
are invading your privacy.*

**RICHARD A. BOWEN**

BEING WIRETAPPED IS NO JOKE. TODAY'S micro-miniaturized electronics have made it easy for anyone with a little know-how and willful attitude to tap your phone and invade your privacy. Whether you call it eavesdropping, phone tapping, radio interception, or covert operations, we'll show you how to hunt down those tiny bugs.

Although there are many advertised gadgets that claim to locate clandestine transmitters, licensed private investigators, with few exceptions, have neither the technical expertise nor background to properly use them. Consequently, more and more investigators are turning to radio technicians who are knowledgeable in counter-surveillance technology.

That's why a competent radio technician with an inquisitive mind and the proper equipment can make a supplemental income (perhaps \$100+ per hour) by availing himself, his

equipment, and his expertise to investigators who are trying to locate clandestine transmitters.

### Tools of the trade

The first order of business is to have the right tools. But what are the right tools for detecting bugs that are positioned by persons good at hiding them? Bar none, the most invaluable tool is a *spectrum analyzer* (spec-an). The one used by the author is an IFR model A7550, which becomes portable when using its built-in Nickel Cadmium (Ni-Cd) battery—an essential convenience.

You'll also need a good receiver to scan the RF spectrum looking for the bug's frequency. Many spec-ans have radio-scanner options (receivers) that are designed to be hooked up without modification. Now admittedly, \$500 dollars for that option might sound like a lot of money; but when you're

talking about a \$10,000 investment, if it's not really that much. After all, you're trying to discern what type of intelligence is contained in a detected signal, you need a good receiver. Of tremendous benefit would be some kind of mixer, down converter, or pre-scaler to extend the receiver's frequency range.

For obvious reasons, it's paramount to tape-record the bugged audio; also, a first-rate direction-finder is necessary so you can track down and locate clandestine, or spurious emissions.

Another option that is extremely useful is a *General Purpose Interface Bus* (GPIB) interface with a plotter, which will allow you to make hard-copy two-color printouts of the suspect frequencies that you have discovered, or wish to document. The GPIB will interface the spec-an's output to the plotter.



There are a lot of gizmos that are advertised on the market as so-called "counter-intelligence devices." The author is compelled to warn you that most of the equipment will not perform as advertised, and the equipment that *will* perform is often unethically sold for 3 to 5 times the list price—*caveat emptor!*

If you think that you're being bugged, you may be desperate for anything that advertises to solve your problem quickly. The false promise of those gizmos seems like a good risk. But wait a minute: That's exactly what those unethical companies are depending on to motivate a sale! Don't fall into their trap. There's no shortcut gizmo that can replace the proper test equipment in the hands of a qualified radio technician.

### Sleuthing

Technicians make some of the best detectives in the world—no kidding! They have to investigate why something doesn't work and trace down the fault; that takes an inquisitive mind. And if one has a good sense of business, there's plenty of work in counter-surveillance. That's because private citizens are being illegally bugged every day; not to mention all the industrial and foreign espionage that seems so prevalent in today's world. Yes, indeed, when word gets around that a technician knows how to ferret out phone-taps, that person's skills will be in demand.

Most people just aren't aware of all the inexpensive devices that can be legally purchased to invade their privacy. Figure 1 shows three tiny bugs that can hear everything you say. Although clandestine bugs can come in small packages, a willful intruder will use what's handy and what works. Bugs range from sugar-cube sized "wireless microphones" for \$20, to candy-box sized "wireless intercoms," and handhelds, that will allow anyone within a half-mile radius to listen to every spoken word in your home. And you can bet that there are many more sophisticated and much more expensive devices, too! Let's face it; not just anyone can find one of those cleverly hidden bugs in your home or office. It takes someone like a technician with expert knowledge of radio transmissions, having the skills and equipment needed to track down tiny radio bugs.

Did you know that a perfectly legal



**FIG. 1—THESE ARE CLANDESTINE radio bugs.** In (a), a parasitic phone-tap is shown disassembled. In (b), a Radio Shack FM-transmitter (part No. 33-1076) can be conveniently dropped behind the cushion of a chair. In (c), this tiny FM transmitter can be hidden in a kitchen cabinet.

(FCC registered) phone tap is available from many companies for only \$25? That's because there's a big market for bugging *your own* phone. Just think for a moment: At one time or another haven't you called some big-time attorney, or doctor, or insurance company, only to hear strange beep-tones or clicks. That's right, you're being recorded—and it's all legal!

Most people are under the impression that intercepting *your own* telephone conversation, or recording the conversion without beep tones, is illegal. That simply isn't true! You don't have to notify anyone that you're tapping *your own* phone. How about that! And if you can buy a simple phone-tap, so can a criminal out to victimize the average Joe.

### Bug frequency

Let's suppose a client suspects a

radio bug has been planted in his telephone. However, the client might lack the know-how to either disassemble the phone, or even tell the difference between a wiretap and the normal telephone's circuitry. It's possible that the client has found a wiretap, but doesn't know what to do. A common wiretap is shown in Fig 1-a. It's a "parasitic telephone transmitter" (not to be confused with parasitic or spurious emissions from a legal RF transmitter).

The nomenclature "parasitic" was derived from the fact that the bug steals power (as a parasite feeds on others) from the telephone company and, consequently, needs no external battery or antenna. Those devices use the telephone's own headset coil-cord and associated wiring as the antenna, and the 48-volt central-station battery for power (which drops to about 10 volts when the handset is off hook).

Depending upon how the tiny phone-bug is designed and where it's located, it can be received on an FM radio, or other receiver, up to one-half mile away. The beauty of that bug is that it can't be detected unless it's actually operating, which means the phone must be off-hook. And although able to operate on virtually any frequency, it's common to sandwich the transmissions between high-powered FM-broadcast stations; that's so they won't create radio interference that would tip off the authorities. Besides, an FM transmission can be received by any inexpensive FM car radio—usually sitting in front of, or nearby, the victim's house or business.

Here's a step-by-step procedure using a spec-an to make any bug stand out like a sore thumb:

**Step 1:** Set scan-width for the 88 MHz to 108 MHz FM broadcast spectrum.

**Step 2:** Set bandwidth resolution to 3 kHz. You will now have a factual display of all electromagnetic radiations occurring in the 88 MHz to 108 MHz frequency range.

**Step 3:** Set the "peak hold" to capture and store all legitimate signals that are on the air (see Fig. 2-a).

**Step 4:** Digitally invert all stored information (see Fig. 2-b).

**Step 5:** Pick up the suspected telephone (off hook) and you'll notice that the signal previously not present is now displayed (see Fig. 2-c).

What we have accomplished is a digital cancellation of everything that



should be on the air against a brand new signal that was not there prior to our picking up the phone, but which now sticks out like a *sore thumb*.

Incidentally, for evidence in court (and customer records) the plots that are reproduced can be made at the actual scene of the crime with the GPIB option (also known as IEEE-488). One GPIB is available from IFR to connect their spec-an to a Hewlett Packard 7470A Plotter. Whatever spectrum analyzer and plotter you're using, contact the manufacturer's representative for interfacing suggestions.

### Bug locating

If you are sharp enough to find a bug, the last thing in the world that you want is the bug to hear itself! (If the bug is active, it is logical to assume that someone is listening.) If you have a receiver tuned to the bug with speaker audio, and you get too close, you'll get audio feedback, which will immediately tip off the spy that you're on to him! No good! Here's what to do.

Once the bug's frequency is found, use headphones with a long, long, extension cord (maybe 50-100 feet or so) to listen to the audio. Now walk around the house tapping the walls, rattling objects, or talking in a normal voice, while listening for an increase in volume level. Make your rattling sounds appear as natural as possible, so that the "bad guys" don't become suspicious. If the bug is in the kitchen, then as you move from the living room into the kitchen, the bug will pick up more audio thereby transmitting a higher-amplitude signal. You'll hear that over your headphones.

The receiver option of your spec-an will undoubtedly have a speaker output. Figure 3 shows how to convert the speaker output to a headphone output only. Although by no means any engineering marvel, the modification is extremely effective and retains the integrity of the receiver! The audio is re-directed (using shielded coaxial-cable) from the speaker to a set of headphones. Figure 4 shows the author's home-built adaptor box. Alternatively, a set of cordless infrared headphones, such as Maxon's model 49-SA can be used, which would not only eliminate the possibility of tripping over a long headphone cord; but they are also useful in detecting infrared bugs—yes, those exist, too!

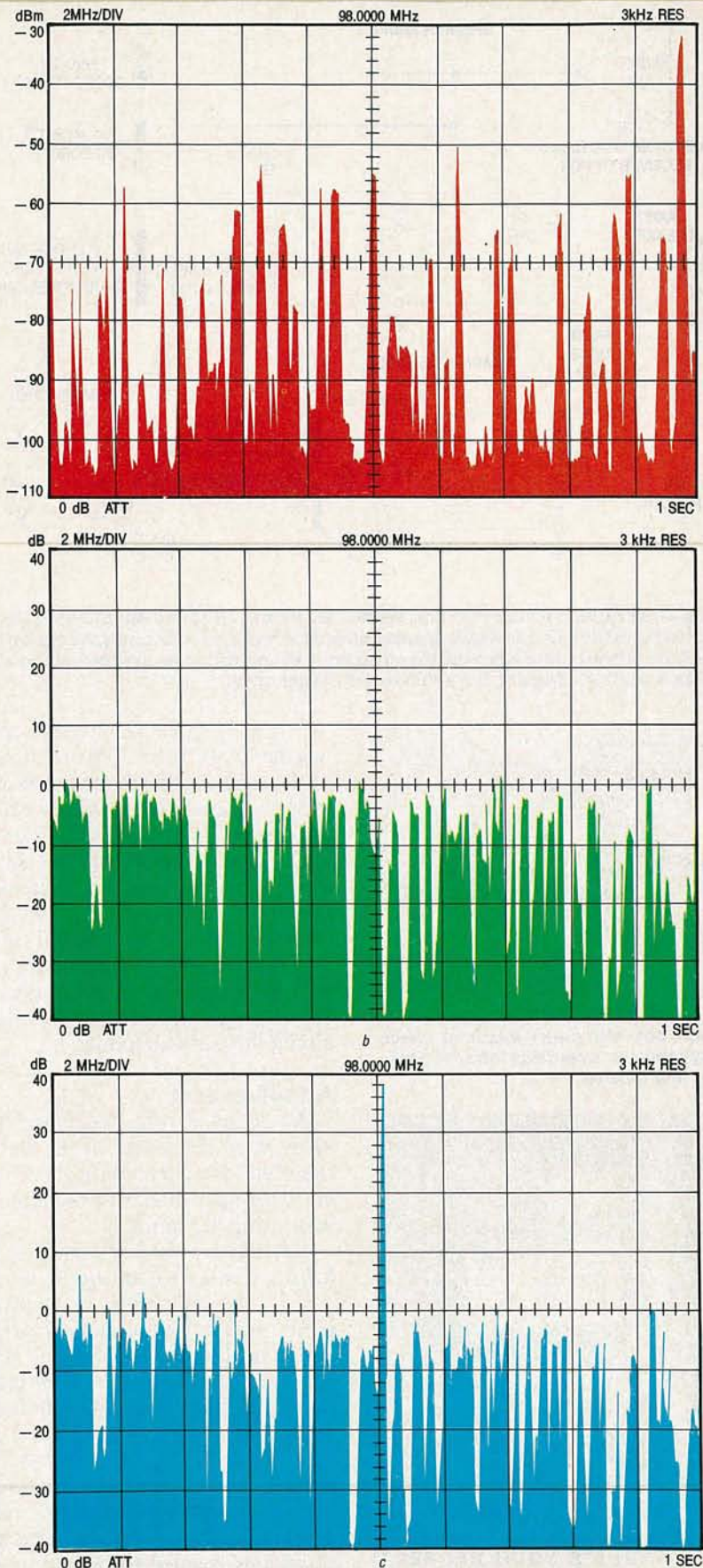
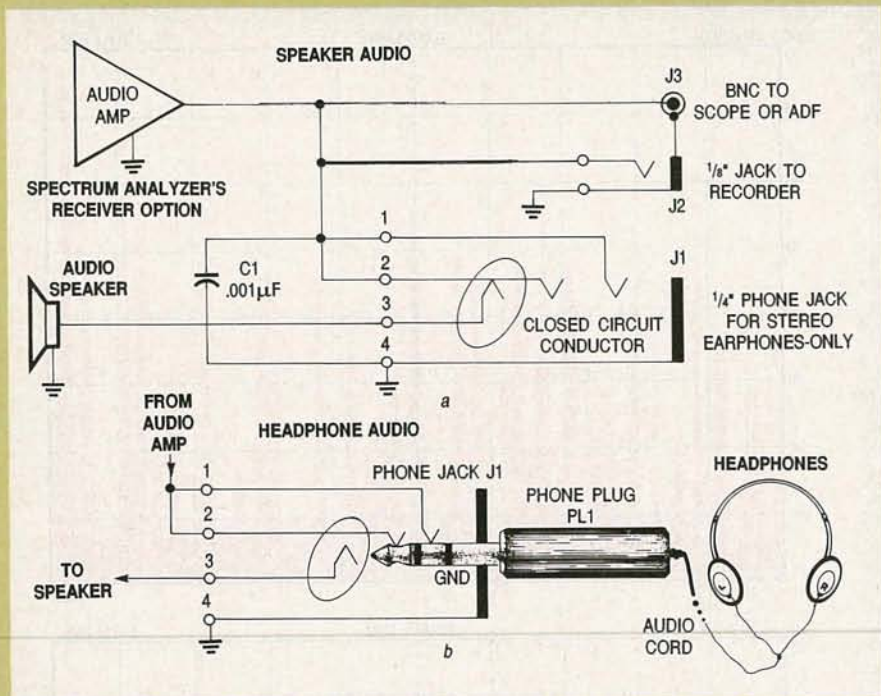

FIG. 2—A SPECTRUM ANALYZER WILL INTERCEPT THE BUGS FREQUENCY. In (a), the broadcast (88-108MHz) FM spectrum is scanned and stored. In (b), the stored spectrum is digitally inverted. In (c), the bugs frequency sticks out like a sore thumb when the phone-tap begins transmitting.





**FIG. 3—USE HEADPHONES FOR LISTENING TO THE BUG'S TRANSMISSIONS.** In (a), this circuit will modify your receiver's speaker output for headphone use only. As shown in (b), when the phone plug is inserted, the closed-circuit spring opens, thereby cutting off the speakers while re-directing the audio to the headphones.



**FIG. 4—USE THE AUTHOR'S home-built adaptor box with either a pair of stereo headphones, or a cordless infrared transmitter and receiver.**



**FIG. 5—HERE'S YOUR PERFECT sleuthing setup: a spectrum analyzer, automatic direction-finder, antenna switching box, and headphone audio-adaptor to listen privately to clandestine transmissions.**

The headphone adaptor box can be attached with *Velcro* tape to the side of the spec-an. In addition to providing headphone-only audio, J2 can input to a Voice Operated Transmit (VOX) actuated tape-recorder, J3 can input to an oscilloscope, Automatic Direction Finder (ADF), or whatever else is required. Note: Use only a 1/4" stereo phone-plug for audio-jack J1; that's because if a monophonic phone-plug is inserted, it will short-circuit the audio amplifier.

### An actual bust

As a case in point, the author's services were requested by an out-of-state detective agency. They had a client who quite honestly thought she was losing her mind.

Separated from her husband and having their two children in her custody, the children stood to inherit close to three million dollars, which would be administered by their legal guardian as a trustee. (Not a bad situation for the legal guardian.) To her, it seemed that every single word she said inside her home, or over the phone, was somehow being overheard. No one could find any clandestine listening device, and her suspicions seemed to be getting the best of her. She thought, "Is my ex-husband trying to collect evidence to prove that I'm an unfit mother, and then use that as a tactic in court to

remove my guardianship?" The husband would then stand to become the trustee to three-million smackers.

The author and out-of-state detective set up a spectrum analyzer, and proceeded to search for a radio signal that shouldn't be there. After an hour or so, an intermittent signal kept popping up in the middle of the FM-broadcast band that didn't correlate with any known or published local radio-stations in the area. Without going into detail, it was established that a *frequency-hopping transmitter* was operating, and was remotely controlled by an AC line-current carrier transmitter.

In other words, that was a bug that selectively transmitted information on numerous frequencies. The purpose was to make it much more difficult for someone, to locate the bug because it would continually "hop" to a new frequency. If such a signal is monitored on a single frequency, all that is heard is gibberish.

The control of that device was discovered to be an AC line-current carrier transmitter that could activate or disable the bug from a convenient location in the neighborhood. Now that you have found something as insidious as that, what do you do? Psychology is always the best weapon. If we were to rip the bug out, the "bad guys" would instantly know that it was found.

The author made a hand-written note, showed it to the parties involved, and instructed them to walk outside onto the patio where their conversation could not be overheard. There he informed the victim that she was neither paranoid nor insane, and she immediately fell into the author's arms, crying in relief. The author advised that if they tore apart the kitchen cabinets, (where the bug was located) that the perpetrator would be aware that the bug had been discovered.

So "what now?" The author suggested that she make a tape recording (at another residence) of the kids screaming and carrying on, as if something terrible was happening. The next step of the plan was to take the children and place them in someone else's custody, whose testimony and verification could not be disputed in a court of law.

Having done that, she should stay in her house alone, play back the tape as loud as possible, grab a few pots and pans and make as much noise as



possible (portraying a scene of total chaos and child abuse). The whole purpose of that action was to find out who would show up.

Well, it worked! It was the in-laws (outlaws) that showed up, and not the husband, much to the surprise of everyone. I can only presume that they cared more about the three-million dollar inheritance than they did about the welfare of their grandchildren.

### Spec-an modifications

Unfortunately, the IFR A7550, along with other spectrum analyzers, has one fault in common: There is an unacceptable amount of leakage from the internal oscillators that cause alarming and inaccurate readings with an antenna placed as far as 20 to 30 feet away. The problem is caused by RF case leakage that can easily be corrected. But if you don't correct it, that leakage will ruin your day!

Spectrum analyzer RF leakage can be cured by making sure that the front and rear mounting bezels make good contact with the case. Dissimilar metals should not be used, because oxides caused by the bi-metallic contact will form a resistive film that isolates the bezel from the chassis. That turns the bezel and aluminum case into an antenna which, in turn, radiates all of the internal RF of the spec-an's circuitry. Also make sure that your plotter is line-filtered so that RF energy emitted by its microprocessor circuitry is not radiated into the power line.

### RF direction-finding

Sometimes clandestine, spurious or overbearing emissions can be so powerful that they cause problems many miles from their source. Enter the *automatic direction-finding system* manufactured by Doppler Systems Inc., PO Box 31819, Phoenix, AZ. 85046, (602) 488-9755. Figure 5 shows the Doppler direction-finder attached by *Velcro* to the right top of the spec-an. The circle of LEDs indicates the bearing to the RF source, while a 7-segment LED-display indicates the bearing in large numerals. The Doppler system has a frequency range of 27 MHz to 500 MHz, and can be connected to any standard VHF or UHF FM-receiver. No receiver modifications are required—simply plug the Doppler electronics into the receiver's antenna and external speaker jacks.

As shown in Fig. 6, four 1/4-wave



FIG. 6—DIRECTION FINDING using Doppler System's four matched quarter-wave whips, shown in (a), are supported on magnetically mounted bases for mobile operation. In (b), four collapsible antennas are mounted on a sturdy platform, on top of the author's roof.

whip antennas can be mounted on a car's roof for mobile operation, or on the roof of a house. The antennas can electronically simulate a rotating directional-antenna. As the antenna moves toward the RF source, the apparent signal frequency increases; as the antenna moves away from the source, the apparent signal frequency decreases. That up-down (Doppler) frequency shift is detected by the FM receiver as a 300-Hz audio tone. The phase of the tone is related to the bearing angle and is used by the direction-finder electronics to compute and display the bearing.

The purpose of the direction-finding platform is to get an initial bearing to the desired signal, and the relative signal strength. The 1/4-wave whip antennas must be tuned to the exact frequency of the clandestine transmissions. You know the exact frequency by using the spectrum analyzer. The antennas are collapsible and will allow tuning by extension-retraction, and spacing the bases by sliding them along the platform. To work properly, the antennas must be spaced approximately 1/4-wavelength apart.

One of the capabilities of a spectrum analyzer is the ability to identify the frequency of the offending radio-emission. That includes spurious emissions that are common in areas where multiple transmitters are placed in close proximity with each other. Besides the non-linear mixing that occurs in a transmitter's final-amplifier (called intermodulation) that create strong spurious signals, other far more exotic kinds of heterodyning also occur.

One time the author found a "difference" frequency coming from an oxidized dome of a town hall. There

were two AM-broadcast stations less than a mile away; one was on 1590 kHz and the other on 900 kHz. Within a half mile of the town hall, everyone in town could hear one of the stations at 690 kHz! That was caused by rectification from the dome's copper-oxide layer.

When "DF-ing" a spurious signal in a moving vehicle, it is absolutely imperative that you have an assistant, or navigator to read a road map and give directions, or more important—to prevent you from kissing a telephone pole. Using Doppler System's Automatic Direction Finder (ADF), the author has been able to track down signals to a specific section of a house—from the road out front!

### Proximity signals

If you narrow down a suspected transmitter to within a given area, here's one method of determining its proximity. Place three identical antennas having identical lengths (and types) of coaxial cable connected to a coaxial-switch box. Use the best coax, like RG 223-U coaxial cable, which is double-shielded (98% each) silver-plated (both shields and center-conductor) cable to ensure total integrity of the received signal. That may sound like overkill, but if you're going to do something, why not do it right?

Separate the three antennas by about 30 feet. A low-powered bug will show a marked change in signal strength on the spec-an, when antennas are independently selected. The stronger signal will indicate the relative bearing of the transmitter's location. Transmissions from far away will indicate almost identical signal strength.

R-E



# Join the Electronics and Control Engineers' Book Club®

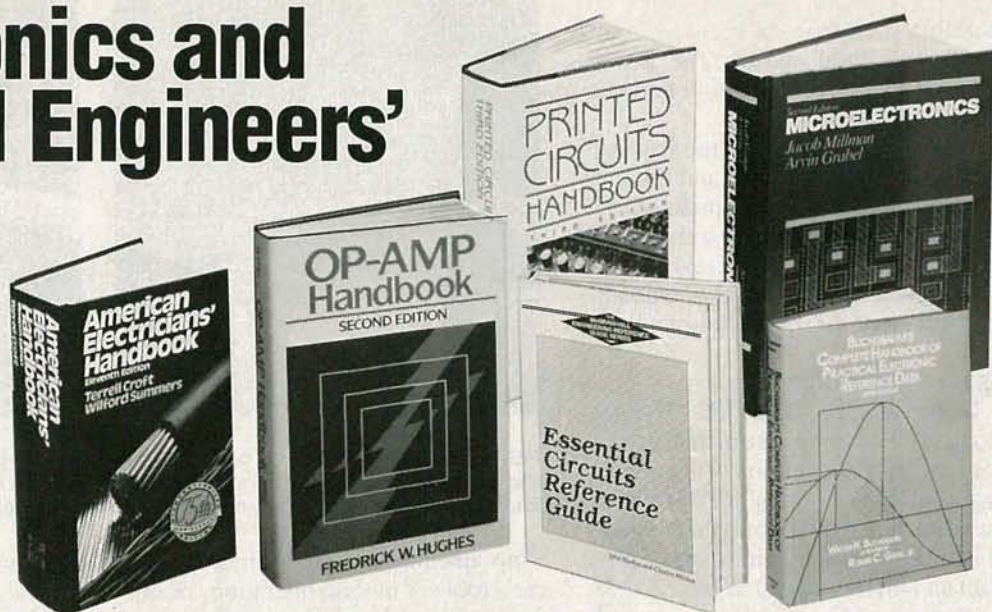

**BUCHSBAUM'S COMPLETE HANDBOOK OF PRACTICAL ELECTRONIC REFERENCE DATA, Third Ed.** By W.H. Buchsbaum, revised by R.C. Genn, Jr. 635 pp., 357 illus. & tables. This best-selling reference is invaluable for engineers whose work involves going outside their own area of expertise. Coverage includes digital logic; optoelectronics; antennas and transmission lines; RF and microwave fundamentals; communications systems; television systems; computers; radio; recording; and more. 583880-X Pub. Pr., \$34.95 Club Pr. \$26.50

**PRINTED CIRCUITS HANDBOOK, Third Edition.** By C.F. Coombs, Jr. 960 pp., 556 illus. Here in one handy volume is all the information you need to design, manufacture, test, and repair printed wiring boards and assemblies. This new edition features ten all-new chapters, including three on SMT. 126/097 Pub. Pr., \$59.50 Club Pr., \$45.50

**32-BIT MICROPROCESSORS.** Edited by H. J. Mitchell, 248 pp., 104 illus. and tables. A complete survey of the architecture, operation, and applications of today's most important new devices from AT&T, Immos, Intel, and Motorola. 425/85X Pub. Pr., \$45.00 Club Pr., \$35.00

**MICROWAVE AMPLIFIERS AND OSCILLATORS.** By C. Gentili. 150 pp., 79 illus. A thorough, practical introduction to the theory and design of microwave amplifiers and oscillators, with coverage of the scattering matrix, the gallium arsenide field-effect transistor, and microstrip technology. 229/953 Pub. Pr., \$34.95 Club Pr., \$27.95

**COMMUNICATIONS RECEIVERS: Principles and Design.** By Ulrich L. Rohde and T.T.N. Bucher, 608 pp., 402 illus. Everything you need to know if you design or work with communications receivers, from theory to practical design approaches. Coverage includes all types of receivers: shortwave, broadcast, radar, military, marine, aeronautical, and more. 535/701 Pub. Pr., \$59.50 Club Pr., \$44.50

- your one source for engineering books from over 100 different publishers
- the latest and best information in your field
- discounts of up to 40% off publishers' list prices

New Members!  
Take any one of these great professional books for only **\$289** as a premium with your first selection!

Spectacular values up to **\$99.90**

**ESSENTIAL CIRCUITS REFERENCE GUIDE.** By J. Markus & C. Weston. 528 pp., illus. Collects into one convenient volume more than 1,000 ready-to-use circuit diagrams for today's electronics applications. Now you can have the circuit you need in a matter of seconds — without having to reinvent the wheel. 404/623 Pub. Pr., \$59.50 Club Pr., \$47.50

**CIRCUIT DESIGN FOR ELECTRONIC INSTRUMENTATION: Analog and Digital Devices from Sensor to Display, Second Ed.** By D. Wobschall. 400 pp., 365 illus. Brings you the entire process of circuit design in a comprehensive, easy-to-follow format. This new edition reflects the latest in IC technology, including CMOS and ECL devices. 712/31X Pub. Pr., \$49.50 Club Pr., \$36.95

**AMERICAN ELECTRICIANS' HANDBOOK, Eleventh Ed.** By T. Croft and W. Summers. 1,824 pp., 1,560 illus. This newly updated handbook shows you how to select, install, maintain, and operate all the latest electrical equipment and wiring. It includes the most recent code requirements, basic formulas, and a wealth of circuit diagrams and illustrations. 139/326 Pub. Pr., \$64.50 Club Pr., \$49.50

**ENGINEERING FUNDAMENTALS FOR THE PROFESSIONAL ENGINEERS' EXAM, Third Ed.** By L. M. Polentz. 432 pp., 170 illus. Features worked-out solutions and full explanations for all sample problems so you can learn how to solve them. It's a dependable way to prepare for the exam or a perfect on-the-job reference. 503/931 Pub. Pr., \$36.50 Club Pr., \$27.95

**AUTOMATIC CONTROL SYSTEMS, Fifth Ed.** By B. C. Kuo. 736 pp., illus. Provides an overview of automatic control systems, including in-depth coverage of classical control techniques, optimal control theory, and analog and digital control system design. This up-dated edition discusses the latest ideas on the use of computers to design control systems and as components of such systems. 583706-4 Pub. Pr., \$51.00 Club Pr., \$36.95

**OP-AMP HANDBOOK, Second Ed.** By F. W. Hughes. 320 pp., 231 illus. Organized for on-the-job reference, this handbook covers all facets of op-amps, from stability and protection to signal processing using op-amps. Includes a collection of over 60 practical circuits for a variety of applications, procedures, and experiments. 583651-3 Pub. Pr., \$39.00 Club Pr., \$27.50

**MICROELECTRONICS, Second Ed.** By J. Millman and A. Grabel. 1,001 pp., 646 illus. Takes you from the basics of semiconductor properties to an understanding of the operation of solid-state devices, and then to more advanced topics. Its up-to-date coverage, real-life examples, and practical data make this an ideal reference for the working engineer. 423/30X Pub. Pr., \$51.95 Club Pr., \$41.50

**HANDBOOK FOR SOUND ENGINEERS: The New Audio Cyclopedea.** Edited by G. Ballou. 1,247 pp., over 1,200 illus. This giant handbook gives you truly comprehensive coverage of sound — and the methods of producing, reproducing, controlling, changing, reinforcing, and measuring it. 583913-X Pub. Pr., \$79.95 Club Pr., \$55.95

**ENGINEERING MATHEMATICS HANDBOOK, Third Ed.** By J. J. Tuma. 512 pp., illus. This best-selling handbook gives you the essential mathematical tools—formulas, definitions, theorems, tables, and models for computer programming — that you need for your day-to-day engineering calculations. 654/433 Pub. Pr., \$46.50 Club Pr., \$34.50

## ELECTRONICS SOURCEBOOK FOR TECHNICIANS AND ENGINEERS

592 pp., 800 illus., softbound 335/591

This condensed, paperback version of the **Handbook for Electronics Engineering Technicians** is the perfect on-the-job reference for all electronics professionals. From fully worked-out examples, explanations, tables, and graphs... through up-to-date coverage of active filters, microwaves, and fiber optics... to using the full spectrum of technical equipment, the **Sourcebook** is the single most convenient professional electronics reference available.



A \$22.95 Value — Yours ABSOLUTELY FREE when you join!



**BASIC TELEVISION AND VIDEO SYSTEMS, Fifth Ed.** By B. Grob. 592 pp., illus. Provides the clearest picture of how television and video systems work, and what to do when they don't. Covers television receivers, VCR's, video cameras, and cable systems — all in readable, practical detail.  
249/334 Pub. Pr., \$34.95 Club Pr., \$24.95

**ANALOG ELECTRONIC CIRCUITS.** By G. M. Glasford. 480 pp., 350 illus. Gives you the detailed information and equations you need to create and analyze top quality circuit designs or effectively utilize the designs of others.  
583768-4 Pub. Pr., \$55.00 Club Pr., \$39.50

**HANDBOOK OF ELECTRONIC NOISE MEASUREMENT AND TECHNOLOGY, Second Ed.** By C. A. Vergers. 440 pp., 213 illus. Provides answers to all your questions about noise origins, causes, effects. Also shows you how to predict and measure noise, and how to design low-noise circuits.  
583947-4 Pub. Pr., \$39.95 Club Pr., \$29.95

**SWITCHGEAR AND CONTROL HANDBOOK, Second Ed.** Edited by R. W. Smeaton. 1,056 pp., 789 illus. The only handbook that treats all aspects of switchgear control, including design, applications, safety, and maintenance. Updated to reflect the changes brought about by the use of computers, solid-state devices, and programmable controls.  
584/494 Pub. Pr., \$75.00 Club Pr., \$56.95

**ANTENNA APPLICATIONS REFERENCE GUIDE.** Edited by R. C. Johnson and H. Jaski. 496 pp., 368 illus. and tables. Covers the major applications of antenna technology in all areas of communications and their design methods. Emphasizes important new applications such as earth station, satellite, seeker, aircraft, and microwave-relay antennas.  
322/848 Pub. Pr., \$53.95 Club Pr., \$42.50

**MICROCOMPUTER DESIGN.** By M. Hordeski. 406 pp., illus. Emphasizes the most current, cost effective methods for developing, debugging and testing all types of microprocessor products, including software and hardware.  
583683-1 Pub. Pr., \$43.00 Club Pr., \$29.95

**BOB MIDDLETON'S HANDBOOK OF ELECTRONIC TIME-SAVERS AND SHORTCUTS.** By R.G. Middleton. 378 pp., illus., softbound. Packed with little-known tricks of the trade and brand-new techniques, this popular handbook makes it easier than ever to troubleshoot radio, TV, audio equipment, CCTV, and more.  
583865-6 Pub. Pr., \$29.95 Club Pr., \$22.50

**Be sure to consider these important titles as well!**

**INTRODUCTION TO RADAR SYSTEMS, Second Ed.** By M. I. Skolnik.  
579/891 Pub. Pr., \$52.95 Club Pr., \$42.50

**ELECTRONIC TEST EQUIPMENT: Principles and Applications.** By T.J. Byers.  
095/221 Pub. Pr., \$39.95 Club Pr., \$29.95

**OPERATIONAL AMPLIFIERS AND LINEAR INTEGRATED CIRCUITS, Third Ed.** By R. F. Coughlin and F. F. Driscoll.  
583754-4 Pub. Pr., \$40.00 Club Pr., \$25.95

**McGRAW-HILL'S NATIONAL ELECTRICAL CODE HANDBOOK, 19th Ed.** By J. F. McPartland.  
457/077 Pub. Pr., \$42.50 Club Pr., \$31.95

**HANDBOOK OF ELECTRONICS CALCULATIONS FOR ENGINEERS AND TECHNICIANS, Second Ed.** Edited by M. Kaufman & A. H. Seidman.  
335/281 Pub. Pr., \$49.50 Club Pr., \$37.50

**PROBABILITY, SIGNALS, NOISE.** By J. Dupraz.  
183/389 Pub. Pr., \$43.95 Club Pr., \$34.95

**POWER GENERATION CALCULATIONS REFERENCE GUIDE.** By T. G. Hicks.  
288/283 Pub. Pr., \$36.50 Club Pr., \$27.50

**HUMAN FACTORS REFERENCE GUIDE FOR ELECTRONICS AND COMPUTER PROFESSIONALS.** By W. E. Woodson.  
717/684 Pub. Pr., \$35.95 Club Pr., \$29.50

**REFERENCE DATA FOR ENGINEERS: Radio, Electronics, Computer, and Communications, Seventh Ed.** Edited by E. C. Jordan.  
583619-X Pub. Pr., \$39.95 Club Pr., \$49.95

**THE LASER GUIDEBOOK.** By J. Hecht.  
277/338 Pub. Pr., \$52.95 Club Pr., \$41.50

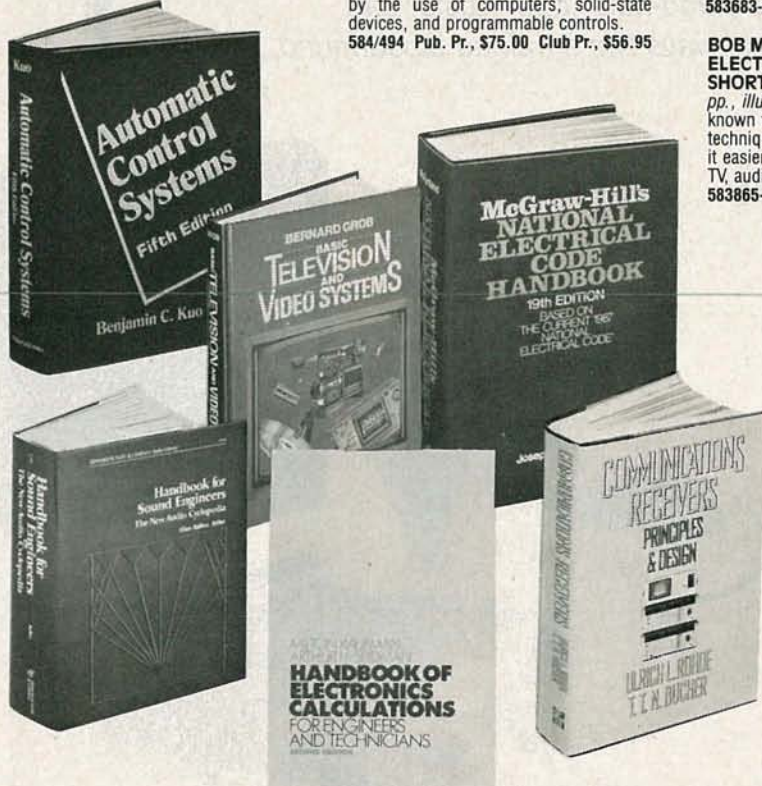

## Here's how the Club works to serve YOU:

### ■ IMPORTANT INFORMATION... WE MAKE IT EASY TO GET!

In our rapidly changing world, those who perform best are those who are best informed. Designed exclusively for the practicing engineer, the Electronics and Control Engineers' Book Club provides you with information that is relevant, reliable, and specific enough to meet your needs. Each Club bulletin comes your way 14-16 times a year and offers you more than 30 books to choose from — the best and newest books from all publishers!

### ■ DEPENDABLE SERVICE... WE'RE HERE TO HELP!

Whether you want information about a book or have a question about your membership, our qualified staff is here to help. Just call us toll-free or write to our Customer Service. We also make sure you get only the books you want. All you do is simply tell us your choice on the Reply Card and return it to us by the specified date. If you want the Main Selection, do nothing — it will be sent to you automatically. (A small shipping and handling charge is added to each shipment.)

### ■ CLUB CONVENIENCE... WE DO THE WORK!

Beyond the benefit of timely information, Club membership offers many other benefits. For example, you get a wide choice of books that cannot be matched by any bookstore — anywhere. And all your books are conveniently delivered right to your door. You also get the luxury of 10 full days to decide whether you want the Main Selection. If you should ever receive a Main Selection you don't want because the Club bulletin came late, just return it for credit at our expense.

### ■ SUBSTANTIAL SAVINGS... AND A BONUS PROGRAM TOO!

In keeping with our goal to provide you with the best information at the greatest possible savings, you will enjoy substantial discounts — up to 40%! — on every book you buy. Plus, you're automatically eligible for our Bonus Book Plan which allows you savings up to 70% on a wide selection of books.

### ■ EASY MEMBERSHIP TERMS... IT'S WORTHWHILE TO BELONG!

Your only obligation is to purchase one more book — at a handsome discount — during the next 12 months, after which you enjoy the benefits of membership with no further obligation. Either you or the Club may cancel membership anytime thereafter.

**FOR FASTER SERVICE IN ENROLLING  
CALL TOLL-FREE 1-800-2-MCGRAW**

**MAIL THIS COUPON TODAY**

### McGraw-Hill Book Clubs Electronics and Control Engineers' Book Club®

P.O. Box 582, Hightstown, NJ 08520-9959

Please enroll me as a member and send me the two books indicated, plus the ELECTRONICS SOURCEBOOK FOR TECHNICIANS AND ENGINEERS. I am to receive one book for just \$2.89, the other at the discounted member's price, plus local tax, shipping and handling charges. I agree to purchase a minimum of one additional book during my first year of membership as outlined under the Club plan described in this ad. I understand that a shipping and handling charge is added to all shipments.

Your FREE Sourcebook

335/591

Write Code No. of the  
\$2.89 selection here

Write Code No. for the  
First selection here

Signature \_\_\_\_\_

Name \_\_\_\_\_

Address/Apt. # \_\_\_\_\_

City \_\_\_\_\_

State \_\_\_\_\_ Zip \_\_\_\_\_

This order subject to acceptance by McGraw-Hill. All prices subject to change without notice. Offer good only to new members. Foreign member acceptance subject to special conditions.

E34053



# BUILD THIS

IF YOU'VE EVER HAD THE FEELING THAT someone was illegally bugging your conversations, you were probably at a loss at how to find out for sure. Signal-detection equipment is expensive, and paying a professional to sniff out bugs is even more so. Here we show you how to build an RF detector that can locate low-power transmitters (bugs) that are hidden from sight. It can sense the presence of a 1-mW transmitter at 20 feet, which is sensitive enough to detect the tiniest bug.

As you bring the RF detector closer to the bug, more and more segments of its LED bargraph display light, which aids in direction finding. Furthermore, our bug buster costs less than \$60 to construct, and is more effective than most high-priced gadgets to be found in flashy mail-order catalogs.

## Little-known ability

Enter the cloak and dagger world of counter-surveillance electronics. Frequency counters have been used for years by the federal government, and police agencies for security work. You see, counters have the little-known ability to pick up and display the frequency of a hidden transmitter.

Our bug buster was developed to solve a problem that law-enforcement personnel were having when using frequency counters to locate bugs. A sensitive frequency-counter with an antenna input will continuously display random numbers caused by the counter's own oscillating circuitry. Nontechnical users tend to stare into the meaningless display, attempting to interpret the constantly changing numbers. Of course, the counter locks in solid when a real signal is present.

The bug buster is a frequency counter that doesn't self-oscillate, and is useful when knowing the bug's transmitter frequency is unimportant. As a field-strength meter, it will respond as the distance to the RF transmitter changes, allowing any bug to be precisely located.

## Circuit theory

As shown in Fig. 1, the front end has a two-stage wideband RF amplifier, and a forward-biased hot-carrier

# BUG DETECTOR

*Our hand-held "bug" buster can sniff-the-airways like a trained bloodhound.*

L. K. ROSS



diode for a detector. After detection, the signal is filtered and fed to IC1, a LM3915N bar-graph driver having a logarithmic (log) output; that means each successive LED segment represents a 3-dB step, which helps display the wide dynamic-range signals that the bug buster will encounter.

The front-end RF amplifiers are wideband Monolithic Microwave Integrated Circuit (MMIC) devices from Mini-Circuits, PO Box 350166, Brooklyn, NY 11235-0003: (718) 934-4500. They have 50-ohm input and output impedances from DC to 2000 MHz. The gain is 20 dB through 500 MHz, dropping to 11 dB at 2000 MHz. The amplifiers are surface mounted on a .1" wide microstrip lead. Surrounding the amplifiers are surface-mounted coupling capacitors, standard (current limiting) resistors, decoupling capacitors, and chokes. Chip components were selected based on information supplied in the Mini-

Circuits Publication entitled, *A handy "how-to-use" guide for MAR monolithic drop-in amplifiers*. The amplifiers perform exactly as described by the manufacturer; the agreement with specifications is really quite good.

The input-sensitivity plot is shown in Fig. 2. Up to five amplifiers were connected in series in an attempt to increase the front-end sensitivity down to the level of a few microvolts. Although using more amplifiers does, in fact, increase apparent sensitivity when tested by a signal generator, the effective transmitter detection range does not increase. That's because the amplifiers are wideband, and have no tuning; therefore, increased amplification is applied across the entire RF spectrum. The signal being measured in the real world must appear larger than the RF noise background in order to be detected. In conclusion, a gain of about 40 dB was found to work best for detecting hidden transmitters.



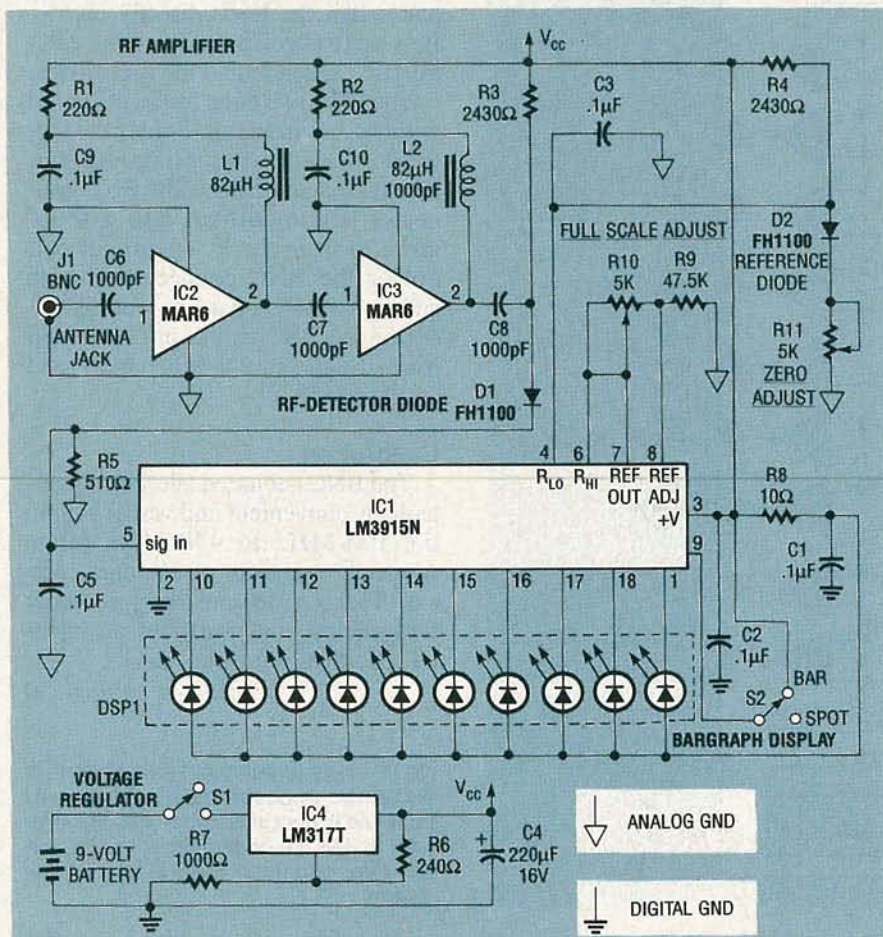

FIG. 1—THE RF FRONT-END USES MMIC wide-band amplifiers, and a hot-carrier diode detector.

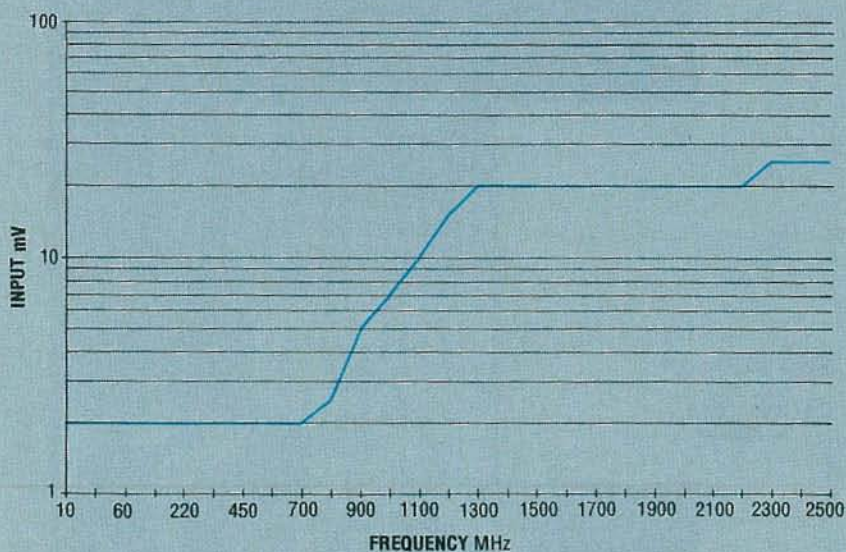

FIG. 2—THE INPUT RF-SENSITIVITY is greatest between 10 and 700 MHz. It then rolls off between 700 MHz and 1300 MHz, and remains almost constant out to 2500 MHz.

To ensure stable operation without scale or zero-adjust potentiometers, having to constantly re-adjust the full-

scale or zero-adjust potentiometers, voltage regulator IC4, an LM317T, is

programmed for approximately 6 volts by R6 and R7. A 9-volt alkaline battery supplies the regulator.

Figure 3 shows the block diagram of the LM3915, consisting of a resistor-divider network and a chain of op-amp comparators. The output of each comparator is open (no current in or out) when the noninverting input is higher than the inverting input; the output goes low (sinking current) when the inverting input is higher. Each comparator controls a single LED segment, which lights when the comparator's output is low.

The noninverting inputs can be considered as reference inputs. The resistor string has log-weighted values, so that the current flowing from pin 6 to pin 4 generates the appropriate reference voltages at each of the ten comparator inputs. Those ten voltages always maintain the same relative relationship even when the reference voltage changes. The signal input is buffered (amplified with a voltage gain of 1) to prevent loading the source. As the signal input increases between the reference low and reference high voltages, each comparator will change state as its noninverting voltage is exceeded.

The LM3915 has an internal 1.25-volt reference source. Trimmer R10 will adjust the reference voltage according to this formula:

$$V_{REF HI} = 1.25 (1 + R^9/R_{10}) + R2 I_{ADJ}$$

The  $I_{ADJ}$  current is internally set to be less than 120  $\mu$ A, while the LED brightness is controlled by the reference current out of pin 7. The current through each LED segment is equal to ten times the current through R9 and R10; therefore, changing R9 and R10 will change the LED brightness.

Switch S2 programs the LM3915 for either a bar or a spot display. The spot display conserves battery life because only one segment is on at any given time; however, the bar display is more pleasing visually.

The SIG IN voltage is the sum of the bias voltage on detector diode D1, plus any rectified and filtered RF from the input amplifiers IC2 and IC3. To offset the bias voltage, a low-voltage reference is generated by R4, D2, and R11; it should track the bias voltage



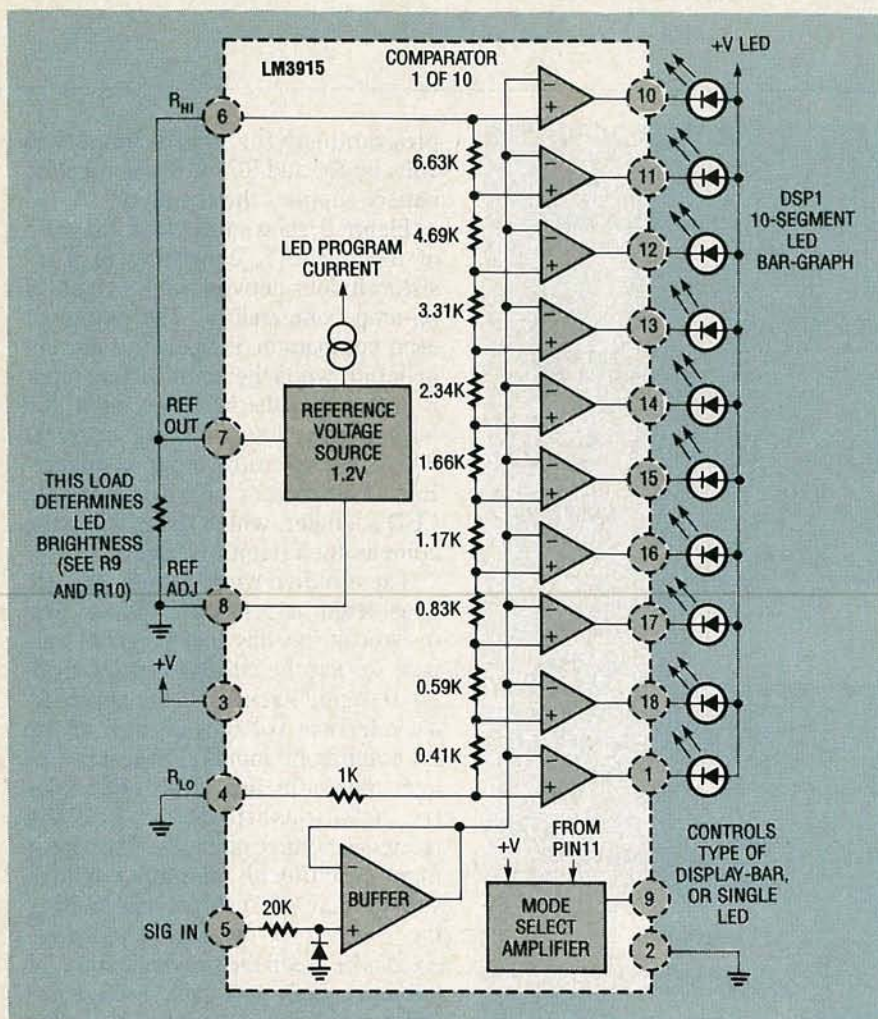

FIG. 3—INSIDE THE BARGRAPH DRIVER is a series of op-amp comparators driving a LED bargraph.

despite temperature changes, while capacitor C3 bypasses any RF to ground.

### Construction

Figure 4 shows the parts placement for the bug buster's double-sided PC board. A plated-through silk-screened G10 glass-epoxy board is available from the source listed in the parts list, or you can etch your own using the artwork provided in "PC Service."

In Fig. 5, the MMIC surface-mounted amplifiers and chip capacitors require a little extra care during installation. They can be hand-soldered with a small-tipped iron, but must not be overheated—and watch out for solder bridges. The LM3915 bargraph-driver IC (IC1), the two trimmer potentiometers (R10, R11), and the two slide switches (S1, S2), all install on the solder side (also referred to as the far side) of the PC

board. All remaining components install on the silk-screen printed side of the PC board. Holes are not provided in the microstrip for component leads; just solder the leads directly on top. Be sure to check polarity on the electrolytic capacitor, and the two diodes.

The LM317T bolts to the PC board without any insulator. Solder the battery leads to the appropriate locations labeled red and black. The BNC connector was modified with a 0.06" groove to fit in the PC-board cut out. Solder the BNC connector to both sides of the PC board as well as soldering the BNC center-pin to the foil trace. Snap on a 9-volt battery and you're ready.

### Calibration

The BNC-mounted telescoping-antenna is convenient and works well in the 100-MHz to 470-MHz range where the majority of all bugs operate. To increase sensitivity to other frequencies, you have to use an antenna specifically for that service.

*continued on page 50*

FIG. 4—THIS IS THE PARTS-PLACEMENT DIAGRAM. Opposite the side that's silk screened is the solder side—called the far side. Install the components on the correct side, with the polarity in the right direction.

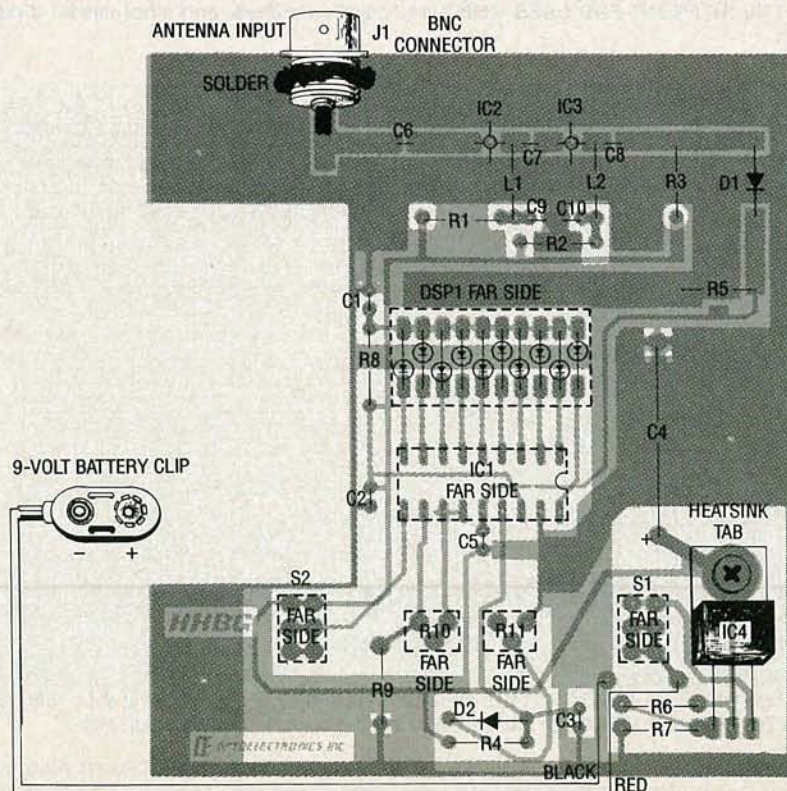



# BUILD THIS

## AMATEUR TV TRANSMITTER

*Add TV transmission to your radio shack.*

**RUDOLF F. GRAF and  
WILLIAM SHEETS**

HOW WOULD YOU LIKE TO TRANSMIT COMPLETE VIDEO, EITHER COLOR OR BLACK-AND-WHITE, with accompanying audio, either through coaxial cable, or to a remote receiver? Hold your breath, because it's all possible with our video-link transmitter, an inexpensive way to get involved in all the following applications:

1. Amateur TV transmission.
2. Video installations where cable hookups are not possible, like robotics.
3. Security and industrial work.
4. Simultaneous viewing of several remote TV receivers.
5. Remote sensing application, like wildlife viewing.
6. Cable transmission.
7. Wireless camera/TV receiver, or VCR link.

Our video-link transmitter is available in two levels of RF power. For low-power wireless video like in a house or office, where simultaneous monitoring of program material is desirable without cumbersome hookups, 1-30 mW is available. For longer ranges up to several miles, as in amateur (ham) TV, security, and surveillance purposes, 2 watts into a 50-ohm load is available.

The video-link transmitter will accept color and B/W video, and audio inputs from VCR's, camcorders, small TV cameras, and microphones. The unit runs on a nominal 12-volts DC and draws 100 mA in the low-power version, or 500 mA in the 2-watt version.

The PC board is quite small (2¼ inches × 4 inches), and contains everything needed except a power supply and connectors. We used both

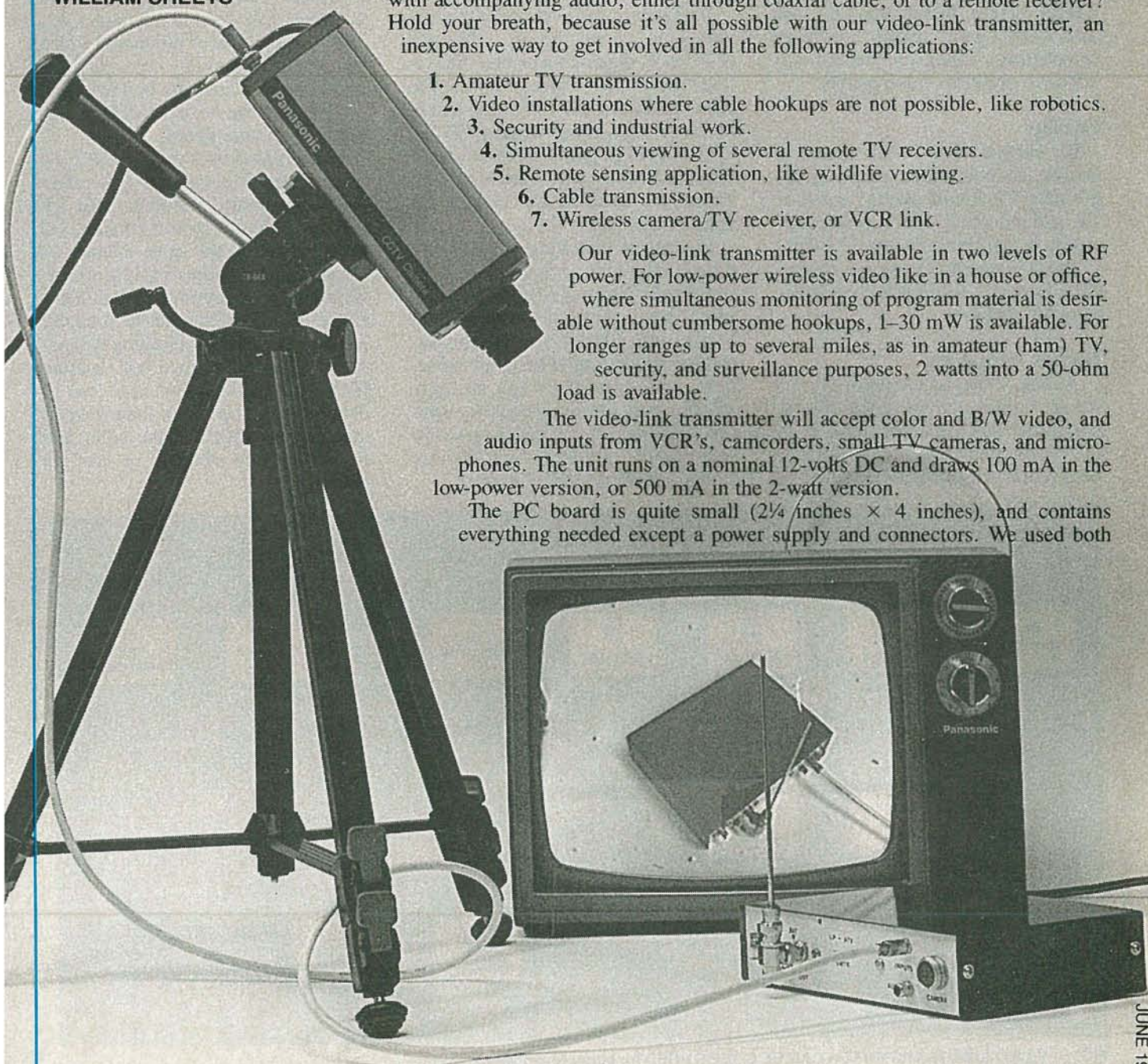



subminiature and surface-mount components because they perform well at RF, requiring simple tuneup without complex test equipment. In fact, a good tuneup can be achieved with only a VOM and a TV receiver.

Readers may be familiar with the author's previous article on an RF video-link (February, 1986, **Radio-Electronics**). Since then, many improvements have been made. The new transmitter is easier to tune, uses three slug-tuned coils instead of air-wound, and has a double-sided PC board for better shielding and grounding. Additionally, better transistors were substituted in the new design, which also has an integral power amplifier, and audio/video gain controls for easier interfacing. Linearity control was added to optimize video quality.

### Liability

**Be warned:** The 2-watt version is intended for educational purposes, legitimate TV broadcasting, amateur TV, and industrial, and scientific purposes. It can transmit several miles, so those intending to use our design must have a Technician-class amateur-radio license.

### Carrier frequency

As Fig. 1 shows, transistor Q1 and the surrounding circuitry is a crystal-controlled oscillator operating at  $\frac{1}{8}$  the video frequency, from 52.5 to 62.5 MHz. After being multiplied by

four through frequency-doublers Q2 and Q3, the output covers 420–500 MHz, overlapping the 430-MHz ham TV band and the lower UHF (300 MHz–3 GHz) TV channels.

First, the frequency is doubled to 105–125 MHz by Q2, and then to 210–240 MHz by Q3. With some modifications, higher or lower frequencies are possible, but with lower power above 500 MHz, and higher power below 420 MHz. Double-tuned interstage networks suppress unwanted harmonics. Then, Q4 doubles Q3's output to the final carrier frequency, which is injected into transistor Q5.

In the low-power version, Q5 modulates the carrier by  $V_{cc}$ . The RF (1–30 mW, depending on coupling) is taken from Q5's collector and fed to either a cable or a 6-inch whip antenna. In the high-power version, Q6 and Q7 form a high-gain RF power amplifier, and adjustable matching networks are used in the circuit for optimum tuneup.

Instead of matching networks, a tuned strip-line design was contemplated, but at 420–500 MHz, it would have occupied too much PC-board area. Broadband RF chokes, surface-mount (tantalum chip) capacitors, and careful design strategy avoided possible low-frequency spurious oscillations. We ended up with a very stable, efficient, reproducible circuit having no UHF "horrors."

### Modulator

The audio input at J1 will accept a wide range of voltage levels; 10 mV (typical microphone output) to 1 V (line input) is fed to audio-amplifier Q8. The audio-gain control adjusts for optimum modulation of Q9, a Colpitts Variable Control Oscillator (VCO) producing 4.5-MHz FM audio subcarrier, which is fed to video amplifier Q10, where it is then combined with the video from J3.

The video input at J3 may be 0.5– to 1.5-volts peak-to-peak, negative sync, while the video-gain control prevents Q10 and Q11 from video overload. Current-source Q10 and amplifier Q11 feed modulator Q12, which is capable of producing video having a 12-volt swing, and can drive a load up to 1 amp. Its bandwidth at –3 dB is in excess of 10 MHz, assuring crisp picture detail.

In the high-power version, Q12 is a power supply to Q6 and Q7, effectively amplitude modulating the RF carrier. In the low-power version, Q5 is modulated in the same manner. A linearity control adjusts Q12's operating point for optimum modulation linearity. The Q-point must be properly set; otherwise, video clipping will occur, producing "burned-out" picture highlights (white areas) and loss of detail. Other Q-point problems could include sync "buzz" in the audio, and loss of picture stability in extreme cases.

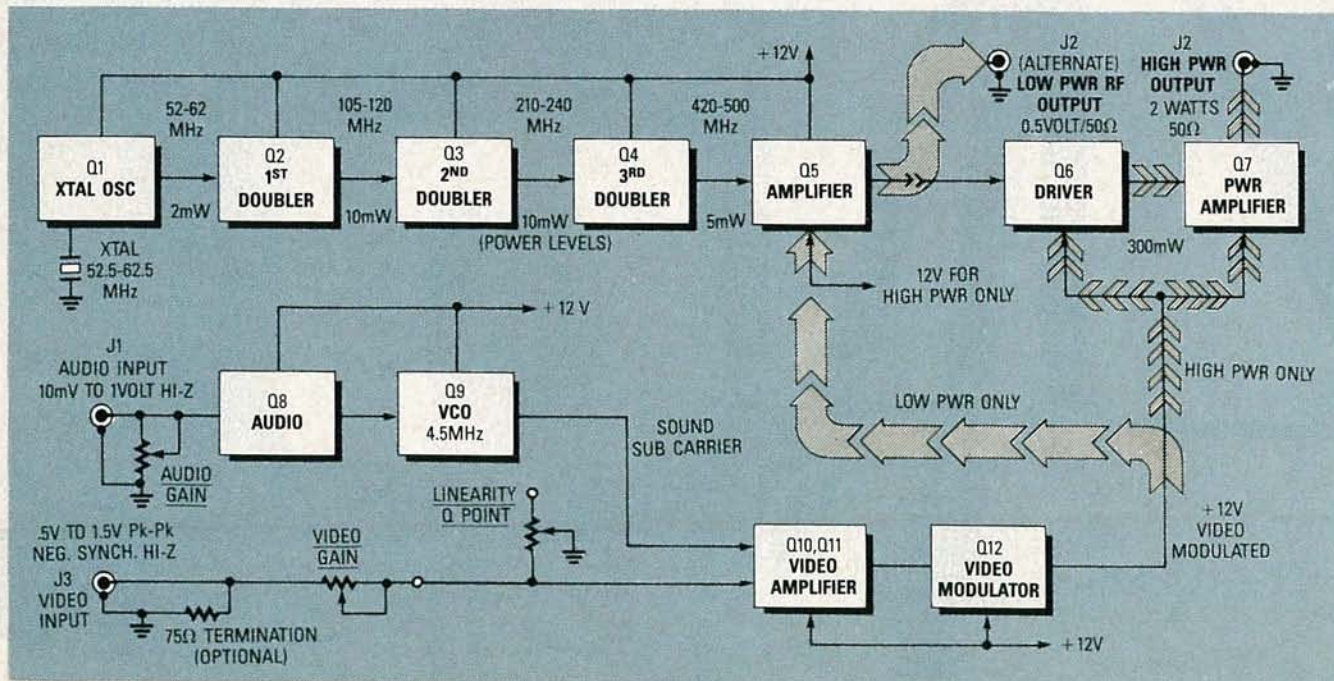
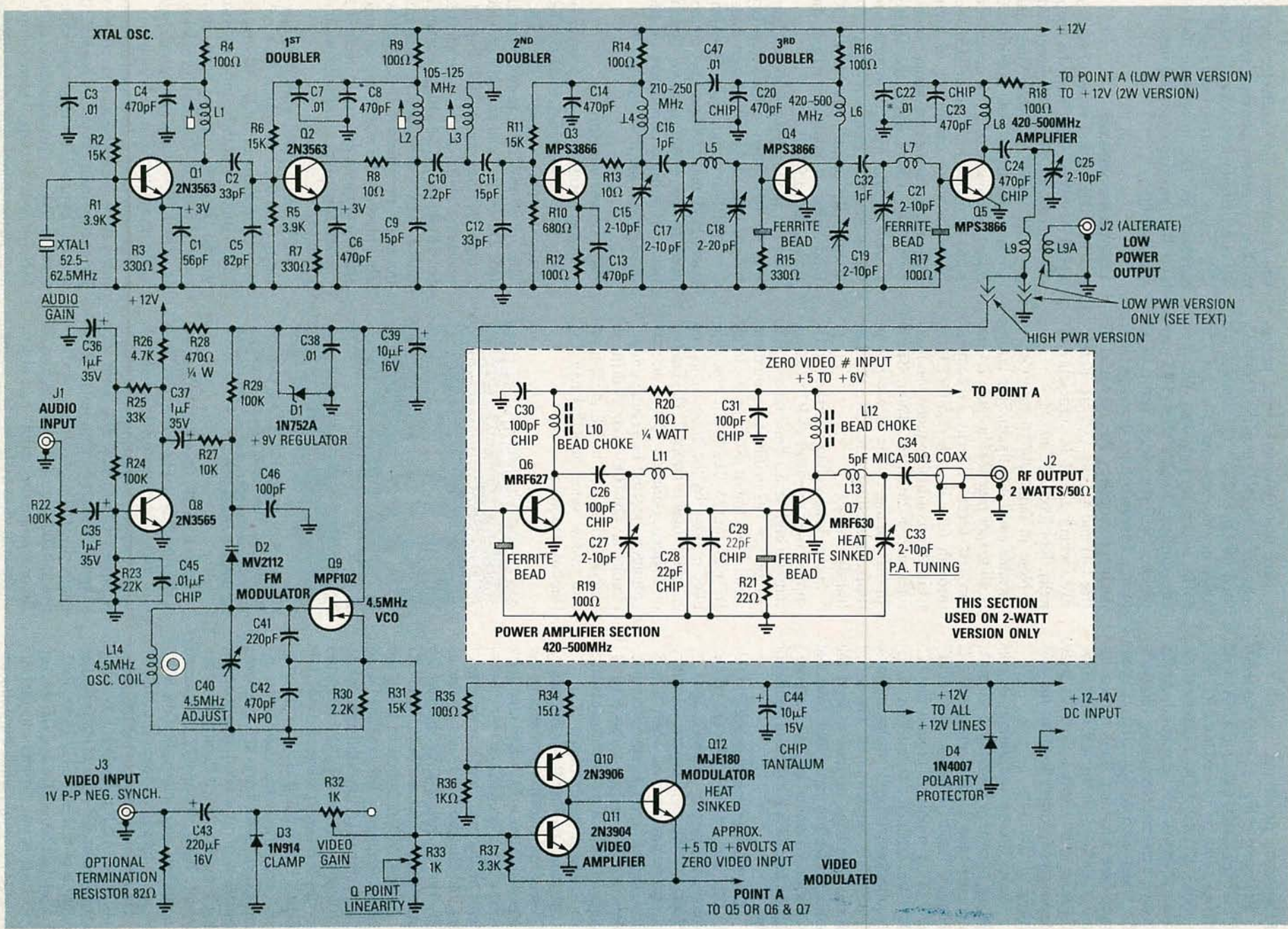

FIG. 1—VIDEO-LINK TRANSMITTER CAN BE CONFIGURED for either low-power, or high-power operation.



FIG. 2—HIGH POWER, 2-WATT Video-link Transmitter.





## Frequency doublers

Referring to Fig. 2, VHF transistor Q1 is biased at 10 volts and 5 mA, with the Q-point set by resistors R1, R2, and R3. Crystal XTAL1 is series-resonant, "bypassed" to ground. At the crystal's resonant frequency (between 52.5 and 62.5 MHz), Q1 is a common-base amplifier. Tank (tuned circuit) L1/C2, in series with C5, together with about 1–2 pF of stray capacitance, form a load for the collector of Q1.

Once Q1 starts oscillating, its collector current is typically 5–10 mA, and depends on the tuning of L1. Here, C3 and C4 bypass the "cold" end of L1 solidly to ground for AC. Internal collector-to-emitter (C-E) feedback occurs in Q1 via the intrinsic 2-pF C-E capacitance. Here, C1 forms a voltage divider to feed the collector back to the emitter. Note that C1 is not for emitter bypass, but is part of the feedback network of oscillator Q1.

A portion of the voltage across tank L1/C2, and C5, is fed to Q2 by the voltage division between C2 and C5. Next, Q2 and its associated circuitry is a frequency doubler, where a large drive signal from Q1 causes rectification in Q2's emitter-to-base (E-B) junction, which produces considerable harmonic generation.

At twice the oscillator frequency, C5 has low impedance; keeping the impedance low in Q2's E-B circuit by using a large value (82 pF) for C5 also helps produce efficient harmonic generation. Biasing for Q2 is the same as Q1, via R5, R6, and R7. Bypass C6 adds stabilization, as does C7 and C8.

Tank L2/C9 is tuned to twice the crystal frequency. R9 supplies DC to Q2. A slug in L2 tunes the tank, while C10 couples RF energy at 2 times the crystal frequency to a second tank L3/C11/C12, also tuned to twice the crystal frequency. Using dual tanks assures good selectivity, and improved rejection of unwanted frequencies; that's important for a clean transmitter signal. Next, R8 in Q2's collector suppresses any self-oscillation tendencies at unwanted, parasitic UHF.

Frequency doubler Q3 (MPS3866, 400-MHz, medium power, 1-W, plastic) is fed at 105–125 MHz from the junction of C11 and C12. Here, R10, R11, and R12 bias Q3. The RF level at Q3's base is quite high, and that affects Q3's biasing, while the collector current runs at 10–15 mA.

Note that Q3 offers better performance at 250 MHz than the 2N3563's used for Q1 and Q2; Q3 doubles the frequency to between 210 and 250 MHz. Except for frequency, Q3 operates similarly to Q2. Then, R13 suppresses UHF parasitics, and L4/C15 form a bandpass filter tuned to twice the input frequency. At 250 MHz, C1 (for Q1) and C3 (for Q2) are ineffective, whereas C14 is sufficient. Finally, R14 feeds DC to Q3.

Note in tank L4/C15 that C15 is variable and L4 is fixed. Slug tuning is no longer practical because L4 has too few turns. Energy is coupled through C16 to tank L5/C17/C18, which forms a double-tuned bandpass filter at 210–250 MHz. Then, C17 is for RF tuning, while C18 will optimize matching into Q4, the last (third) doubler.

Figure 3 shows how a ferrite bead is slipped over one lead of R15, which causes a high series-impedance at RF, yet passes DC without attenuation, thereby completing the base circuit DC path for Q4. The bias is now supplied entirely by the drive signal; no extra DC bias is applied. The emitter of frequency-doubler Q4 is directly grounded, because bypassing emitter circuits at 420–500 MHz is difficult without some loss of RF gain; however, a low value of R15 keeps DC stability adequate.

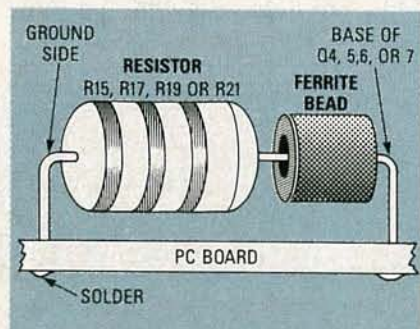

**FIG. 3—SLIP RESISTOR LEAD through ferrite bead. The bead inductor causes a high series impedance at RF, yet passes DC without attenuation.**

Tank L6/C19 (a short length of wire) operates at 420–500 MHz. Both C19 and C20 provide low-frequency video and RF bypassing, while C29 bypasses UHF; they also stop any stray low-frequency gain in Q4. Tantalum-chip C20 is the only type effective at 420 MHz, and provides a solid RF ground for the "cold" end of L6.

The 420–500-MHz at Q4's collector is fed to tank L7/C21, via C32,

which matches Q4's collector circuit to Q5's low base impedance; together with L6/C19 they form a double-tuned UHF circuit. The ferrite bead and R17 provide a low DC impedance, but a high RF impedance to the base of amplifier Q5.

## Low-power version

The UHF signal is amplified to about 30 mW by Q5. Choke L8 keeps RF energy out of the DC power supply. C22 and C23 bypass video and UHF, respectively. Note that if Q5 is video modulated (the low-power version) then C22 must be deleted, because it would cause loss of high-frequency video components; moreover, R18, which limits the supply current to Q5, must be returned to Q12's emitter. Tantalum-chip C24 couples RF output, yet blocks DC (and video, if applicable) from the tank circuit L9/C25.

In the 1–30-mW version, L9 couples the RF output to the secondary link of wire L9A, which then transfers the RF to output jack J2A (Alternate). Note that J2A and L9A are not used in the 2-watt version. Output power is limited depending on the proximity of the link L9A to L9.

## High-power version

In the 2-watt version, L9 matches to the base of driver Q6, and Q5 is fed straight, unmodulated +12-V DC. The full 30-mW drive from Q5 drives Q6. The ferrite bead and R19 provide a high RF impedance, and low DC resistance at Q6's base. Since a ferrite bead looks more like a high resistance rather than a reactance at high frequencies, the effective Q is very low. That prevents the possibility of parasitic oscillations that could occur if a conventional-type solenoid-wound RF choke were used.

Here, C27, L11, and tantalum-chips C28 and C29 match Q6's collector impedance to Q7. RF-choke L10 is made with three turns of wire wound through a ferrite bead, in a toroidal fashion. That results in a low Q, about 1000 ohms resistance, and again avoids possible parasitics.

Tantalum-chip C26 is used to minimize stray inductance, and couples RF energy from Q6 to Q7. Now, C30 and C31 bypass UHF to ground while looking like a high impedance at 20 MHz or lower, so the video component of the modulating power supply voltage is relatively unaffected. Note



## PARTS LIST

### Resistors; all are 1/8 or 1/10-W, 5%

R1, R5—3900 ohms  
R2, R6, R11, R31—15,000 ohms  
R3, R7, R15—330 ohms  
R4, R9, R12, R14, R16—R19, R35—100 ohms  
R8, R13—10 ohms  
R10—680 ohms  
R20—10 ohms, 1/4-W  
R21—22 ohms  
R22—100K-ohms potentiometer  
R23—22,000 ohms  
R24, R29—100K ohms  
R25—33,000 ohms  
R26—4700 ohms  
R28—470 ohms, 1/4-W  
R30—2200 ohms  
R32, R33—1000-ohm potentiometer  
R34—15 ohm  
R36—1000 ohms  
R37—3300 ohms

### Capacitors

C1—56 pF, NPO, ceramic disc  
C2, C12—33 pF, NPO, ceramic disc  
C3, C7, C19, C22, C38, C47—0.01 $\mu$ F, ceramic disc  
C4, C6, C8, C13, C14—470 pF, NPO, ceramic disc  
C5—82 pF, NPO, ceramic disc  
C9, C11—15 pF, NPO, ceramic disc  
C10—2.2 pF, NPO, ceramic disc  
C15, C17, C19, C21, C25, C27, C33—2-10-pF, trimmer  
C16, C32—1 pF, NPO, ceramic disc  
C18—2-18 pF, or 2-20-pF-trimmer  
C20, C23, C24, C45—470 pF, ceramic chip  
C26, C30, C31—100 pF, ceramic chip  
C28, C29—22 pF, ceramic chip  
C34—5 pF, silver mica  
C35—C37—1  $\mu$ F, 50 V, electrolytic  
C39—10  $\mu$ F, 16 V, electrolytic  
C40—3-40 pF, trimmer  
C41—220 pF, NPO, ceramic disc  
C42—470 pF, NPO, ceramic disc  
C43—220  $\mu$ F, 16 V, electrolytic  
C44—10  $\mu$ F, 16 V, tantalum chip  
C45—0.01  $\mu$ F, ceramic chip  
C46—100 pF, NPO, ceramic disc

### Semiconductors

Q1, Q2—2N3563, transistor  
Q3—Q5—MPS3866, transistor  
Q6—MRF559, or MRF627 transistor  
Q7—MRF630, transistor

Q8—2N3565, transistor  
Q9—MPF102, transistor  
Q10—2N3906, transistor  
Q11—2N3904, transistor  
Q12—MJE180, transistor  
D1—1N757A, diode  
D2—MV2112, varactor diode  
D3—1N914, diode  
D4—1N4007, diode

### Inductors

L1—L14—See table 1.

### Other components

XTAL1—52.5-62.5 MHz

**Note: Kits for this project are available from North Country Radio, PO Box 53, Wykagyl Station, New Rochelle, NY 10804. Two different kits are available; one is a low-power, the other is a high-power version. Those kits include the PC board and everything on it, except jacks, connectors, batteries, power-supply components, and case. Those are not included, because individual hobbyists may have their own preferences and interface requirements. The author recommends that those components be obtained at another supplier.**

**The Low-Power Kit w/ATV crystal for operation on 439.25 MHz costs \$79.95, plus \$2.50 for shipping and handling; the 2-W Kit w/ATV crystal for operation on 439.25 MHz costs \$104.95, plus \$2.50 for shipping and handling. Extra crystals for CH14/CH15 operation are \$6.50, plus \$1.50 for shipping and handling. The PC board only, plus cores, chip capacitors, and D2 (a partial kit) cost \$49.95, plus \$2.50 shipping and handling. The Video-Link transmitter, Radio-Electronics, February, 1986, plus a reprint of the article, costs \$69.95, plus \$2.50 shipping and handling. Crystals can be purchased separately from Crystek Corporation, PO Box 06135, Fort Myers, FL 33906.**

that Q6 draws about 130 mA at modulation peaks (sync tips).

Also, Q6 supplies between 300- and 500-mW drive to Q7, an MRF630 (Q6 and Q7 are similar in their operation). RF-choke L12 functions exactly the same as L10. Collector matching-network L13/C33, together with mica C34 match the 50-ohm load impedance to the optimum collector load-impedance needed by Q7. Note that a 50-ohm load must always be present at J2, otherwise Q7

may be damaged. A tolerance of  $\pm 50\%$  (25–100 ohms) is permissible here; however, optimum performance is obtained with a 50-ohm load.

Suitable 50-ohm coax must be connected from C34 (on the PC board) and J2, with short connections (a 1/4-inch or so). Any length of coax can be used, but for the best results, keep it short. We used RG174/V PVC type, but teflon coax (RG188/U) would be better. From J2, a standard coax (RG8U, RG58/U, etc.) will do. Re-

member, feedline loss must be avoided as it can be very high at 420 MHz and up.

### Video feed

Input video from J3 (standard 1-V p-p negative sync.) is fed through C43 to clamp-diode D3. Note that C43 is apparently incorrectly polarized; that is to allow for video equipment that may have a DC component of up to 16 volts at the video output. If you do not expect to encounter that, you can reverse the polarity of C43—if you wish. When turned around, the low reverse voltage (0.6 V) appearing across it doesn't seem to do any harm. Diode D3 clamps the maximum negative input level to  $-0.7$  V, and avoids serious over-modulation at the sync tip levels. If you wish, you can DC couple from J3 directly into R32, the video-gain control, if your equipment interface permits. Also, note the optional 82-ohm termination (R32A) is not on the PC board, but is soldered across J2. Use it unless you're in a situation where loop-through (several other video loads in parallel) is required. It was not placed on the PC board so that possibility would not be compromised.

Video-gain control R32 feeds the base of video-amplifier Q11. Video-amplifier Q11's collector is fed by current-source Q10, which is biased by R34, R35, and R36 to about 50-mA of collector current. That permits Q11's collector to supply plenty of drive to modulator Q12, and eliminates the need for a low-value decoupling resistor from Q11's collector to the power-supply rail (+12V); therefore, Q12's base can approach  $V_{cc}$ , and allows a higher positive swing of Q12's emitter than a resistor from Q11 to +12V would permit, due to Q12's base-drive needs.

Modulator Q12, an MJE180, is configured as an emitter follower. It must supply all the current to Q6, Q7 (or Q5), have a low supply impedance, and high slew rate. The low impedance is necessary for both full RF power output, and to control the parasitic-oscillation tendencies in power amplifiers Q6 and Q7. The load tends to be capacitive due to the bypassing from C26 (somewhat), C30, and C31.

In tests; Q12 can supply nearly 12 volts of video into a 10-ohm load, at 1.2 amps; therefore, Q12 must be heat sunk. To establish both Q-point,



video gain, and bandwidth, R37 provides feedback around the modulator; however, R33 sets the exact Q-point (voltage seen at point A, Q12's emitter), under zero-drive conditions at about 5- to 6-volts DC, to Q6 and Q7. R33 is adjusted for maximum undistorted symmetrical video at point A, while R32 controls video drive to Q11. Supply bypassing must be effective at Q12's collector due to the high current and fast waveforms handled. The main supply bypass, C44, a 10- $\mu$ F, 15-volt, tantalum chip was used because standard electrolytics are somewhat less effective.

### Power feed

DC power is fed to the transmitter at J4. Diode D4, a 1N4007, is provided to serve as reverse-polarity protection. It's cheap insurance against inadvertent damage to Q6, Q7, Q10, Q11, and Q12, should the negative and positive leads of the power supply be reversed by accident. Diode D1 is connected directly across J4. The 12-volt supply (11-14 V is OK) may come from Nickel-Cadmium batteries, an auto's electrical system, or any kind of AC-operated power supply.

### Audio feed

Audio is fed to gain control R22 from jack J3. Input level should be between 10 mV and 1 volt at high impedance, allowing direct interfacing with most microphones, or other audio sources. From R22 the audio is coupled through C35 to Q8, which is biased from R23, R24, and R25. Bypass C36 will prevent audio degenerative feedback, and loss of gain. Collector-load R26 supplies DC to Q8, while C37 blocks DC and couples audio through R27 to the frequency modulator.

Note that no pre-emphasis (high-frequency boost) has been used. If you want to use it, for better high-frequency audio response, change C37 to 0.001  $\mu$ F, and set the gain-control R22 up higher to compensate for loss. The author found that pre-emphasis was unnecessary for most applications.

Audio is coupled to the varactor diode D2, an MV2112, where R29 biases D2 at 9 V. The varactor diode varies its capacitance at an audio rate from 56 pF at 4 V, to about 33 pF at 9 V. The capacitance of D2 appears across 4.5-MHz oscillator coil L14.

Then, Q9, an MPF102 FET, together with C41, C42, C40, and L14 form a Colpitts RF oscillator operating at 4.5 MHz. Trimmer C40 is used to set the frequency to exactly 4.5 MHz, while toroidal coil L14 is used to minimize stray magnetic field generation.

The audio voltage on the DC bias causes D2 to change capacitance, which shifts the oscillator frequency causing frequency modulation (FM) of the 4.5-MHz generated in Q9, the Colpitts oscillator. Bias for Q9 is provided by R30, while R31 couples the audio subcarrier (4.5-MHz FM) into the video amplifier, which modulates it and the video onto the RF.

Zener-diode D1, R28, and C38 and C39 (which provide bypass) supply a regulated 9-V DC voltage to Q9, and varactor D2. The regulation prevents oscillator drift if the supply voltage were to vary. A frequency counter can be connected to point A to set C40 to exactly the value needed for 4.5-MHz audio subcarrier.

Looks like we've run out of space. Next month we'll focus on construction techniques, like how to wind coils, how to solder tantalum-chip capacitors, and circuit modifications. **R-E**

## BUG DETECTOR

*continued from page 44*

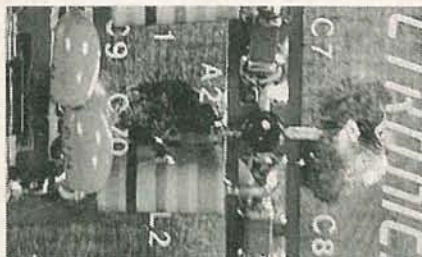

**FIG. 5—THE Monolithic Microwave Integrated Circuit (MMIC) looks like a tiny dot with microstrip leads.**

Put the PC board into its cabinet, and install the antenna before making any adjustments. Start with the zero-adjust set counter-clockwise, and the full-scale adjust set clockwise.

To properly calibrate our bug buster, a low-power transmitter is needed. A cordless-telephone handset is ideal. (Cordless phones are in the 40-MHz to 60-MHz region, and radiate less than most bugs!) Set the zero adjust until the left-most segment is about to come on. Set the full-scale adjust until all segments are lit when placed next to the cordless phone.

### PARTS LIST

All resistors are 1/4-watt, 5%, unless otherwise noted

R1, R2—220 ohms, 1/8-watt  
R3, R4—2430 ohms, 1%  
R5—510 ohms  
R6—240 ohms  
R7—1000 ohms  
R8—10 ohms  
R9—47,500 ohms, 1%  
R10, R11—5000-ohm trimmer potentiometer

#### Capacitors

C1—C3, C5, C9, C10—0.1  $\mu$ F, 50 volt, monolithic ceramic  
C6—C8—1000 pF, ceramic chip  
C4—220  $\mu$ F, 16 volt, electrolytic

#### Semiconductors

IC1—LM3915N, log-bargraph display driver  
IC2, IC3—Mini-Circuits, Inc., MAR6, MMIC  
IC4—LM317T, voltage regulator  
D1, D2—FH1100, hot-carrier diode

#### Inductors

L1, L2—82  $\mu$ H RF choke

#### Other components

DSP1—RGB 1000, 10-segment bargraph display  
J1—CP1094 modified, BNC connector

#### Miscellaneous

Cabinet assembly, cable, and battery clip.

**Notes: A complete set of all parts except cabinet for \$59.95; cabinet is \$20; telescoping BNC antenna \$12; lined zipper carrying-case \$10; PC board only \$25; all IC's and bargraph \$30. Order from Optoelectronics, Inc. 5821 N.W. 14th Avenue, Fort Lauderdale, FL 33334; phone (800) 327-5912, in FL (305) 771-2050. Add \$3.50 for shipping; FL address include 6% state sales tax. Master card and Visa orders must be over \$20.**

### Some hints

You are now ready to put your bug buster to work. To effectively sweep a room, you need to get familiar with

your bug buster's operating characteristics in as many situations as possible. Be sure to leave the power switch off when not in use. **R-E**



TECHNOLOGY



# RADIATION MONITOR UPDATE



*The RadaAlert and your PC: a great combination!*

IT'S BEEN A YEAR SINCE WE PUBLISHED our article (with Steve Weiss) on building the RadaAlert radiation monitor. Since then we've heard from over a thousand **Radio-Electronics** readers who are interested in radiation detection. Hundreds have built the RadaAlert kit, and many breadboarded their own adaptations of the circuit. Hundreds more purchased an assembled version of the RadaAlert.

Those of you with whom we have spoken are interested in radiation detection for a variety of reasons. A nuclear-medicine class at a large midwestern university had each student build a RadaAlert as part of the course material. Many kits were also assembled by college, high-school, and vocational-school students. Some people built the RadaAlert because they work around radioactive

materials; others built it for fun.

We heard from doctors and welders, students and scientists—it's surprising to see the wide variety of people who read **Radio-Electronics**. NASA is using RadaAlerts, as well as nuclear power-plant designers, operators, and employees, and environmental groups are monitoring plant perimeters to make sure they are safe.

The use of the RadaAlert to collect and disseminate radiation data over the past year has contributed to a better understanding of radiation, as events of the past year have indicated. One such event was the disclosure last September by the Department of Energy that thousands of residents near nuclear-weapons plants in Ohio, South Carolina, Colorado, and Washington have been exposed for decades to excessive radiation as a result of

**JOE JAFFE and DAN SYTHE**

emissions from those facilities. One RadaAlert user living near the Fernald, Ohio plant noted a doubling of background radiation at certain times when the wind blew from the plant. Documenting such readings can be an important way to encourage plant operators to improve their safety measures and precautions.

## **A computer interface**

This is the first of a series of articles on radiation monitoring, in which we will present samples of interesting experiments that **Radio-Electronics** readers have performed, and the results they have obtained. We will also describe a few simple interface circuits that can be built to increase the usefulness of the RadaAlert.

With the help of a computer, interested individuals and groups can now



## RADIATION MONITORING—A CASE STUDY

This story began last Spring when I built the radiation monitor described in the June 1988 **Radio-Electronics** article by Joe Jaffe, Dan Sythe, and Steve Weiss. I have always had a natural curiosity about radiation. I'm interested in knowing the levels of radiation in the environment, and what the radon level is in my home.

Some of my interest relates to my experiences when I lived in Southern Utah in the Sixties. Radioactive fallout from the bomb tests in Nevada used to blow across the small desert communities there. People there are still very concerned about their exposure and the health effects from it.

When I built the kit version of the Radalert, I had a small problem with it. Several telephone conversations with Dan Sythe isolated the problem, and everything worked fine. During our conversations, I became friends with Dan and Joe Jaffe. We had several discussions about the need for a low-cost way to record and store radiation-level data, and to process the data into a useful form.

As an Electronics Engineer I do a lot of microprocessor programming, and I enjoy doing it—so I decided to create a program and interface that allows the Radalert to send information to an IBM-compatible personal computer through the RS-232 port. The program can collect, process, and plot data. With a modem, it enables a network of monitoring stations to communicate and share data. A monitoring station can be configured to automatically notify a central computer if a preset radiation level is exceeded.

I chose PC compatibles for this project because they are so inexpensive now. A recent browse through a computer publication shows a computer with all the necessary hardware selling for as little as \$359 (without the printer, modem or monitor). Another ad offers, for less than \$700, a portable computer that can run on battery power and has two disk drives and an internal modem.

The designers of the Radalert provided an output jack which furnishes a positive-going 5-volt signal, approximately 120 microseconds long, for each ionizing radiation event in the Geiger tube. The output signal can be coupled to a computer using the cable described here.

The software performs the following functions:

(1) It collects radiation data for a user-selectable number of samples. The

computer can calculate the standard deviation for that data. (This mode is called the "survey" mode.)

(2) It collects and records radiation data, sounds an alert if a pre-set alert level is exceeded, and automatically dials another computer if a pre-set emergency-alert level is exceeded. (This mode is called the "monitor mode".)

(3) It saves the data collected (in either the survey or monitor mode) to a disk file.

(4) It prints or graphs the data stored in the alert mode on the disk.

(5) It sets up an automatic data-collection station, which can be used to manually poll a number of monitoring computers each hour and collect their data. The data-collection station can receive emergency-alert messages from the monitoring stations. It can also reset the monitoring computer's alert levels and other settings remotely from the collection station.

The hardware requirements for this system are a Radalert, an interface cable, and an IBM or compatible PC, XT, or AT computer with an RS-232 serial input, clock/calendar, at least 256K memory, and MS DOS 2.1 or later. A printer is needed to print or plot the radiation data, and a modem is needed to send data or alert messages to a remote radiation-data collection station. (The hardware requirements for the data-collection station are the same as for the monitoring station.)

The two programs I wrote demonstrate the capabilities of a computer for data collection, display, and auto-

matic transmission, using the Radalert as the source of data. The first is written in GW BASIC, and the code for it is shown in Listing 1. You can enter it from the keyboard, or download it from the **Radio-Electronics BBS Radalert** conference. The program has the two modes mentioned, monitor and survey. In the survey mode, it collects, stores, and prints data for the statistical survey, but does not do any data analysis. In the monitor mode, it collects, stores, and plots data, and sounds an alert if the pre-set alert level is exceeded, but does not communicate with another computer.

The second program, a compiled version of the first program, written in Microsoft Quick Basic 4.5, is available from the author. In addition to what the first program does, it does standard-deviation analysis in the survey mode, and uses the modem for automatic data transmission in the monitor mode. It can participate in a data-collection network via modem and can automatically dial a data-collection station if the emergency-alert level is exceeded.

### CABLE INTERFACE

To construct the cable interface, note whether your RS-232 serial-input connector has 25 or 9 pins, and obtain the corresponding female connector for one end of the cable. For the other end of the cable, use a miniature stereo plug to mate with the jack on the Radalert. Use a convenient length of coaxial cable or shielded microphone cable (it is important to

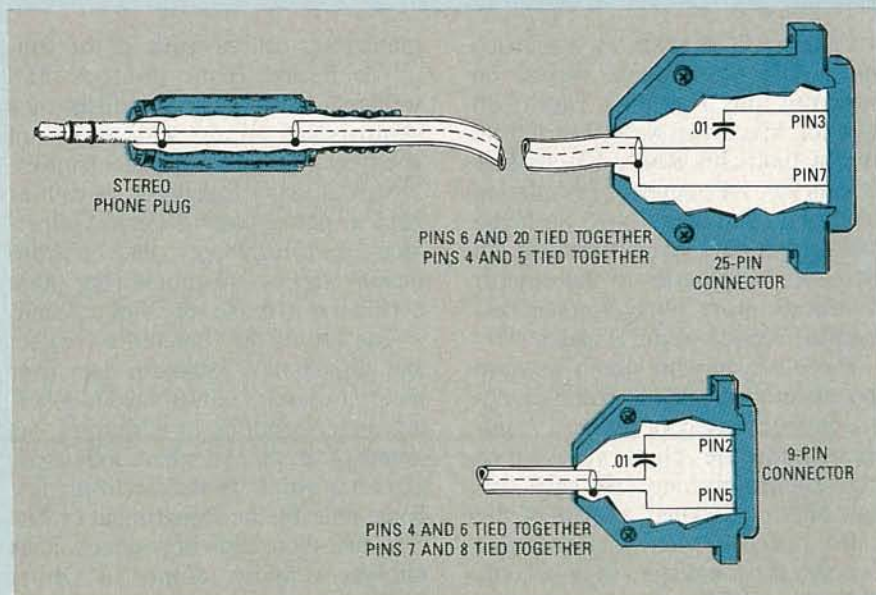

FIG. 1







store and chart their radiation readings. Bud Cole, an Electronic Engineer from Albuquerque, NM, wrote a very useful program that collects data from the Radalert output jack (J2) and processes it using an IBM-compatible personal computer (see sidebar).

Figure 1 is an 8-hour graph of radiation levels, taken in Bud Cole's home using his computer program. The average level for that period was over 50 counts per minute, about four times normal. The previously unknown radiation source turned out to be an optical lens in Bud's desk drawer, intended for a future telescope project. The radiation level at the surface of the lens was over 2000 counts per minute. Fortunately, that discovery prevented the use of the lens in a telescope, where it could have caused serious eye damage. According to an International Atomic Energy Agency publication in 1974, some optical lenses contain up to 30%, by weight, of uranium or thorium. Those materials are selected for lens coatings in some applications because of their optical properties.

One interesting experiment involved a computer that used the Radalert to monitor its own monitor's

radiation levels. The computer was used to plot about 10 hours of data collected while monitoring the radiation levels at the surface of the monitor's screen. The average counts-per-minute was 14.41, with a high reading of 18. When the same test was performed with the Radalert about 12 inches away from the monitor, the average reading was 10.26 cpm, with a high of 13 cpm. At 18 inches away from the CRT, the average reading was 9.8 cpm, with a high reading of 12 cpm.

### Radon

Last September the EPA and Public Health Service announced that "Radon-induced lung cancer is one of today's most serious public health issues." We stated in the July, 1988 article that the Radalert does not specifically measure radon gas, but our experiments indicated that the average counts per minute did rise and fall with radon concentration.

Robert Vivian, a **Radio-Electronics** reader and Radalert kitbuilder from Provo, Utah, did some experiments. Robert operates a small radon-testing company called Radon Testing Services. His radon-test results

### ORDERING INFORMATION

A kit to build the Radalert is available from International Medcom, 7497 Kennedy Road, Sebastopol, CA 95472, for \$185. An assembled Radalert, ready to use, is \$275. To order a kit, or an assembled Radalert, and charge to your VISA or MasterCard, call toll free 1-800-257-3825 Nationwide, 1-800-255-3825 in California. To order from outside the U.S., call (707) 823-0336, or you can FAX International Medcom at (707) 823-7207. Add \$4.00 for shipping/handling (in U.S.) for each unit. California residents please add 6% sales tax.

For EPA-approved Radon test kits contact: Robert Vivian at Radon Testing Services, 4096 Scenic Drive, Provo, Utah 84604, 1-800-777-2320.

Back issues of the June and July 1988 **Radio-Electronics** are available from the RE Reprint Bookstore for \$3.75 each plus shipping and handling (\$1.25 for one issue or \$2.00 for two). Send check or money order, payable to Gernsback Publications, to: **Radio-Electronics** Reprint Bookstore, P.O. Box 4079, Farmingdale, NY 11735. Indicate the issue(s) you want, and allow 4-5 weeks for delivery.

The following items are available from Harold (Bud) Cole, 614 Cedar Hill Road North East, Albuquerque, NM 87122 (505) 296-2632. A kit for the interface cable containing the connectors and 10 feet of cable is \$11, and an assembled 10-foot interface cable is \$20. Specify 9-pin or 25-pin for the RS-232 connector. The compiled version of the software, with documentation on disk, is available for \$49. All prices include postage. New Mexico residents add 5¼% sales tax.

were within 2% of the EPA's in the EPA Radon Measurement Proficiency program. That is unusually good, with 20% accuracy considered acceptable. He put his Radalert in his basement, side by side with the standard charcoal canister radon-detection package, with the Radalert in the "total count" mode.

To get accurate results with the carbon canister he had to run the test for a 48-hour period. To prevent the Radalert counter from overflowing during that period he recorded his count every 12 hours, and then reset the Radalert to count for another 12-hour period. He converted his counts

Buds bedroom desk.  
High levels due to radioactive lens in drawer.  
Source was unknown at time of plot.

Plotting:\turbocom\charhod2.msg  
(An \* means the Emergency radiation level was exceeded)

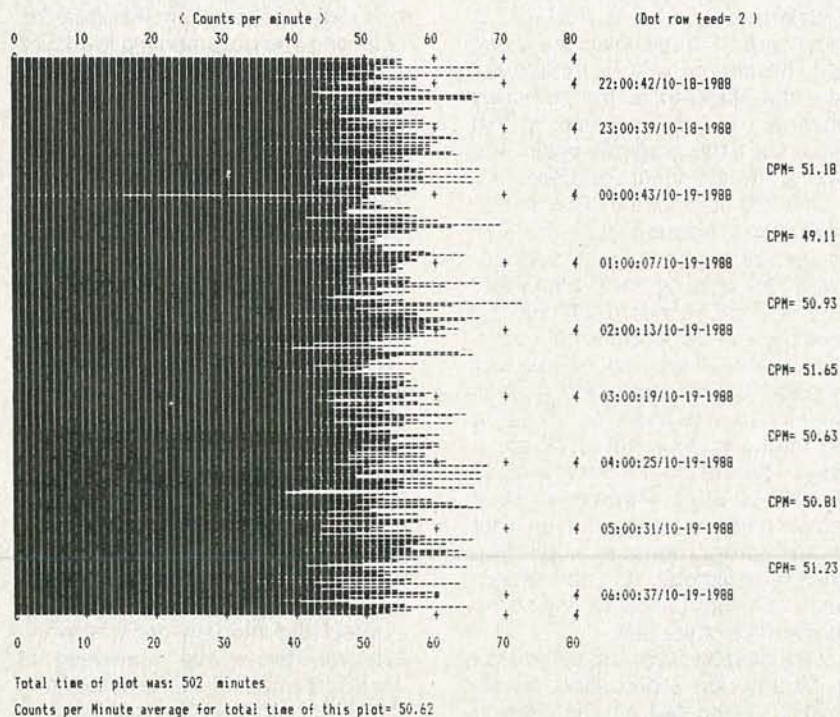

FIG. 1—AN 8-HOUR COMPUTER-GENERATED GRAPH of the radiation levels that were measured in Bud Cole's home.



for the 48 hour period into average counts per minute and obtained 18.11 for the average. (By using Bud Cole's computer program, he could have recorded the counts per minute for as long as a week and let computer calculate the average cpm for the period).

The average radon concentration as measured by the carbon canister was 8 picoCuries per liter of air. He also did a 48-hour count outdoors and determined that his outdoor radiation level was 14.75 counts per minute. That count was subtracted from his indoor count, as outlined in the July article. (Outdoor air is considered to average about 0.2 picoCuries of radon per liter).

The difference between his average indoor and outdoor counts, 3.36 counts per minute for a radon concentration of 8 pCi/l, shows a sensitivity of 0.42 cpm for 1 pCi/l, assuming there was no other source of radioactivity in the basement. The EPA considers the risk of radon concentration of 4 pCi/l to be equivalent to the risk of 200 chest X-rays per year. At that level or higher, they recommend follow-up testing to determine if remedial action is necessary.

One Radalert kitbuilder, from Harrisburg, Pennsylvania, has a radon level of 55 picoCuries per liter (pCi/l) in his home. He also has an electrostatic air cleaner. Using the Radalert, he discovered that the dust collected by the filter is quite radioactive due to the radon daughter elements; he has gotten readings of over 400 counts per minute next to the filter.

Those experiments and others indicate that the Radalert can be useful in screening for radon levels of about 4 pCi/l or higher. Levels below 4 pCi/l may be difficult to detect reliably.

Use of the Radalert for radon testing should be considered experimental, as the EPA has not approved Geiger counters for that purpose, and your results should be confirmed by EPA-approved test methods. For example, you can use the Radalert to locate the area in a basement or other part of the building with the highest radiation level. Then you can place a testing device that is specific for radon, such as a carbon canister, in that location to confirm whether or not the increased radiation is due to radon. In the case of Bud Cole's house, the carbon canister test showed the high radiation level was

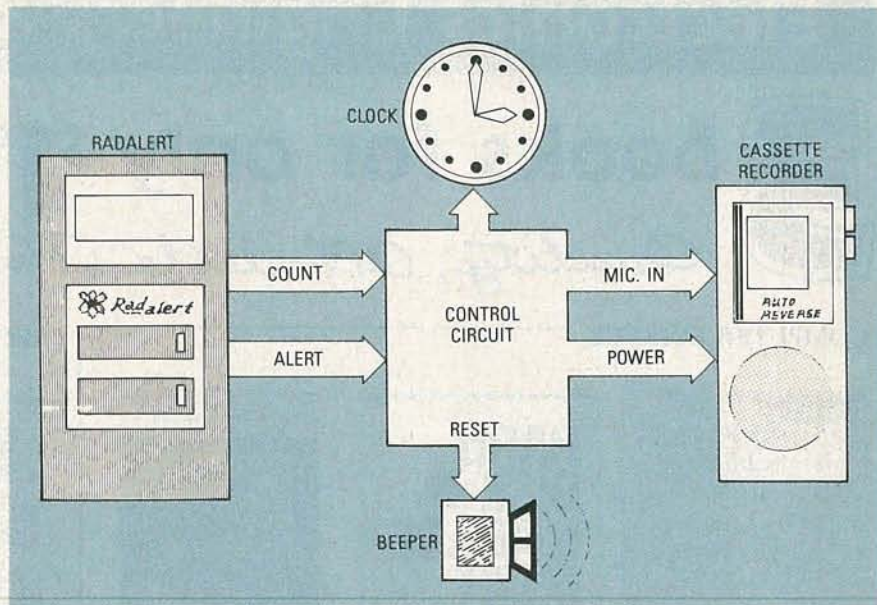

FIG 2—THE CONTROL CIRCUIT stops the clock and starts the recorder.

not due to radon, and continued investigation located the radioactive optical lens.

#### Radioactive sources

Radalert users have added to our list of radioactive materials that people work and live with. In addition to the optical lens described earlier in this article, we have reports on the following items: an optical prism which measured over 11,000 counts per minute, a thoriated filament on a 4-1000A power transmitting tube, some welding rods, and wood ash (where soil was contaminated with radioactive isotopes). If you have found any interesting and/or previously unknown radioactive sources, contact **Radio-Electronics** and share your story.

#### Networking/BBS

Radalert users are starting to network regionally to compare their readings, share information, and exchange application ideas. The RE BBS, (516) 293-2283, is available for readers who wish to contribute information on their experiences or learn more about radiation. Other national and international forums and on-line conferences seem to be developing, so check in on the bulletin board to stay up to date.

#### Monitoring nuclear plants

Dr. Donald Muirhead, a pediatrician, and David Quaid, an independent film maker, of Duxbury, Massachusetts, have put together a

radiation-monitoring network of 23 Radalerts, around the Pilgrim nuclear plant. Dr. Muirhead was concerned about safety problems at the plant, and about a Massachusetts Department of Public Health allegation of increased leukemia and other cancers downwind from the plant. By collecting radiation data and sharing the information, their group hopes to increase the community's peace of mind, and encourage safe operation at the facility. Keep watching **Radio-Electronics** for an update on that monitoring network and the data they are collecting.

#### Budget monitoring

In 1978 a group of people living near the Maine Yankee nuclear power plant decided they would like to monitor emissions from the plant, so they would be aware of releases. An engineer in the group, Will Byers, developed an inexpensive build-it-yourself Geiger counter with an alarm. The counter was connected to a clock, so that when a pre-set radiation level was reached the clock would be stopped. That let the user know when the radiation increase was recorded. Will also built the Radalert kit, and has added it to their Citizen's Monitoring Network.

Bud Cole's program (with its real-time clock signature on radiation plots) is perfect for that type of application. Bud's program can also dial a telephone number to report high radiation levels to other computers in the network. But what if you want to



# Electronics Engineers & Designers!

# 3 books for only \$195 (values to \$186.40)

*Quality, Affordable Professional Books*

## COMPUTER SCIENCE



**3028** **\$27.95**  
Hands-on guide to explore the power of batch file programming under PC-DOS, MS-DOS, and OS/2. 320 pp.



**2897** **\$27.95**  
Simple and straightforward, terrific for the power user. 324 pp.



**2888** **\$32.95**  
How computer networks work, how to make them work for you. 340 pp.

## ELECTRONIC CIRCUITS

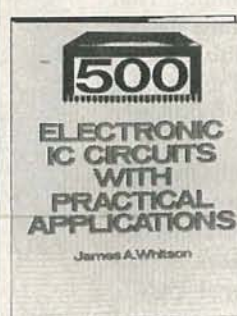

**2920** **\$29.95**  
600 diagrams, schematics, and tables showing IC circuits. 352 pp.



**1938** **\$60.00**  
Over 1,300 useful and versatile electronic circuit designs. 768 pp. *Counts as three.*



**3131** **\$24.95**  
Assemble your own powerful microcomputer system . . . it's easy and inexpensive. 224 pp.

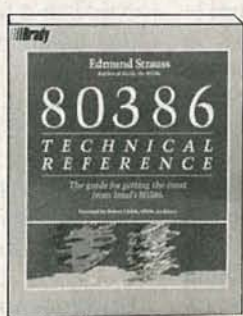

**9759** **\$22.95**  
80386 architecture, assembly language programming as well as multitasking and processing. 150 illus., 515 pp.

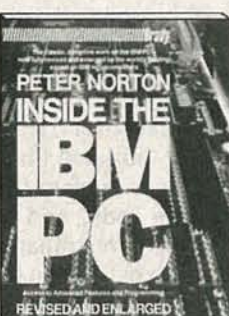

**9762P** **\$21.95**  
The classic definitive work on the IBM PC—fully revised and enlarged. 387 pp.



**9825** **\$49.95**  
A comprehensive manual for soldering and cleaning printed circuit boards. 430 pp.



**3212** **\$34.95**  
A no-nonsense guide on design, building, and applications of small iron-core transformers. 350 pp. *Counts as 2.*

## ENGINEERING MATH

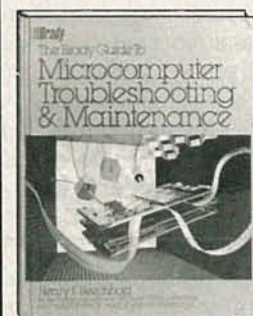

**9760** **\$17.95**  
Instant access to pinpoint ailments and suggest possible cures. 324 pp.



**9778** **\$44.95**  
Successfully select, design, and implement microprocessor-based systems. 287 pp.

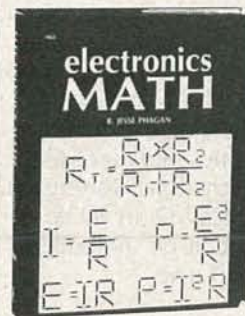

**1962** **\$22.95**  
A practical reference to basic electronics math usage. 247 illus., 256 pp.



**2612** **\$25.95**  
Step-by-step methods for solving real-world partial and differential equations. 102 illus., 560 pp.



**2988** **\$39.50**  
Keep up with current strategies—learn to use CIM systems to tie your manufacturing operation together. 470 pp. *Counts as 2.*



## STATE-OF-THE-ART



**9773** **\$44.95**  
Examines the significant advances in communications technology. 406 pp.



**3035P** **\$14.95**  
How to write and file a successful patent application in four simple steps. 176 pp.



**3115** **\$21.95**  
Background information on the theory and history of lasers, as well as practical experiments. 176 pp.



**2720** **\$32.50**  
State-of-the-art design techniques and manufacturing methods. 250 illustrations. 304 pp.



**3089** **\$26.95**  
A nonmathematical introduction to the design, fabrications, and application. 272 pp.

## ELECTRONIC COMPONENTS

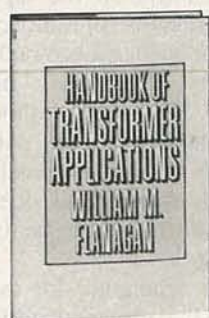

**9788** **\$49.50**

**9788** Comprehensive, up-to-the-minute information and data not previously available in a single source. 432 pp., 175 illus.

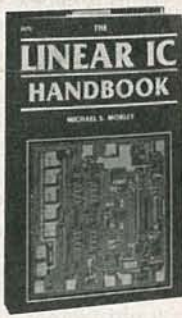

**2672** **\$49.50**

**2672** Linear integrated circuits—specifications, prices & data. 614 pp. *Counts as two.*



**3002** **\$49.50**

**3002** Fast, accurate information guaranteed to simplify your search for the right IC. 624 pp. *Counts as two.*

## REFERENCE

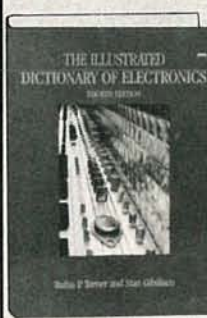

**2900** **\$36.95**

**2900** "An excellent dictionary for all levels of users, from the hobbyist to the researcher." *Libraries Unlimited*, 584 illus., 656 pp. *Counts as two.*



**9785** **\$86.95**

**9785** This professional sourcebook delivers the essentials you need in hardware and software areas. 874 pp.

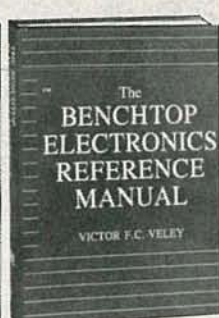

**2785** **\$39.95**

**2785** Easy-to-use reference to 160 electronic principles: ac/dc, solid-state, oscillators, amplifiers and radio communications. 620 pp. *Counts as two.*

## How the Club Works

**YOUR BENEFITS:** You get 3 books for \$1.95 plus shipping & handling when you join. You keep on saving with discounts up to 50% as a member.

**YOUR PROFESSIONAL BOOKSTORE BY MAIL:** Every 3-4 weeks, you will receive the EE&D Book Club News describing the Main Selection and Alternates, as well as bonus offers and special sales, with scores of titles to choose from.

**AUTOMATIC ORDER:** If you want the Main selection, do nothing and it will be sent to you automatically. If you prefer another selection, or no selection at all, simply indicate your choice on the reply form provided. As a member, you agree to purchase at least 3 books within the next 2 years and may resign at any time thereafter.

**BONUS BOOKS:** Starting immediately you will be eligible for our *Bonus Book Plan* with savings of up to 80% off publishers' prices.

**IRONCLAD NO-RISK GUARANTEE:** If not satisfied with your books, return them within 10 days without obligation!

**EXCEPTIONAL QUALITY:** All books are quality publishers' editions especially selected by our Editorial Board.

All books are hardcover unless number is followed by a "P" for paperback. (Publishers' Prices shown)  
©1989 EEDBC, Blue Ridge Summit, PA 17294-0860



### ELECTRONICS ENGINEERS & DESIGNERS BOOK CLUB®

Blue Ridge Summit, PA 17294-0860

YES! Please accept my membership in the *Electronics Engineers & Designers Book Club®* and send me the volumes I have listed below, billing me only \$1.95 plus shipping and handling charges. I understand that the books are sent on a 10-Day Free Examination basis. If dissatisfied in any way, I may return the books within 10 days and incur no further obligation. Otherwise, I agree to pay the enclosed invoice promptly and to receive regular club bulletins as described in "How the Club Works." To complete my membership obligation I need only purchase 3 additional books at regular members' prices during the next 2 years, and may resign at any time thereafter.

--	--	--

NAME \_\_\_\_\_

ADDRESS \_\_\_\_\_

CITY \_\_\_\_\_

STATE \_\_\_\_\_ ZIP \_\_\_\_\_ PHONE \_\_\_\_\_

SIGNATURE \_\_\_\_\_

Valid for new members only. Foreign applicants will receive special ordering instructions. Canada must remit in U.S. funds. This order is subject to acceptance by the *Electronics Engineers & Designers Book Club®*. DRE689



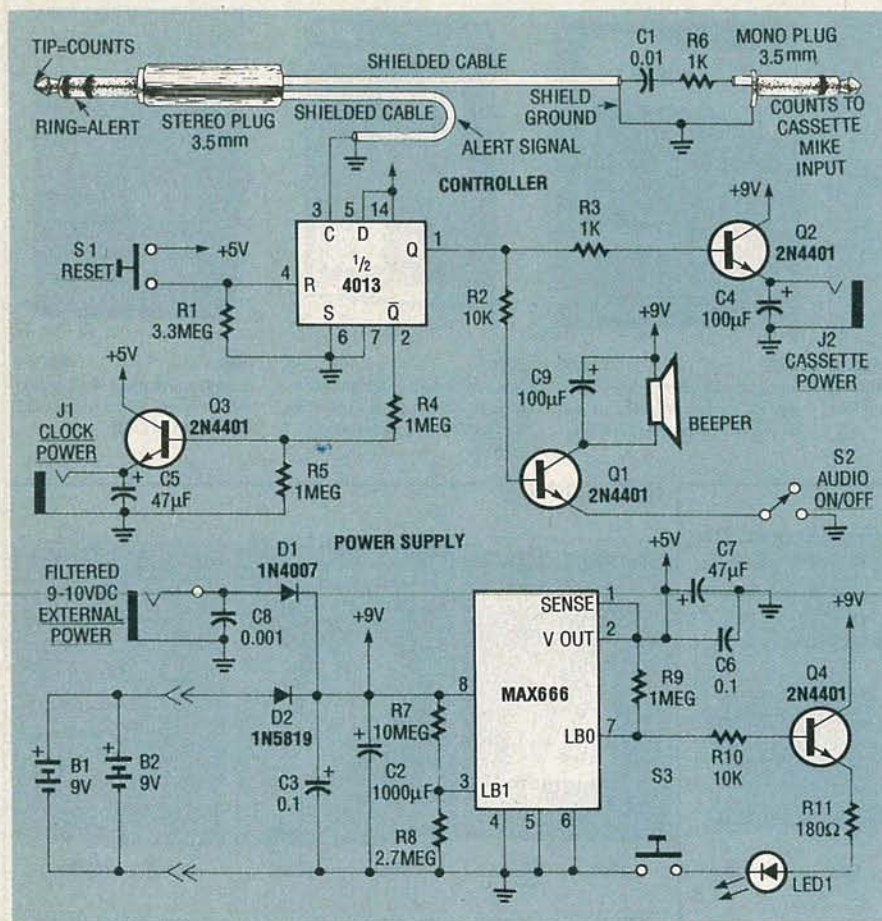

FIG. 3—CONTROL-CIRCUIT SCHEMATIC. The clock must run on 1.5-volts.

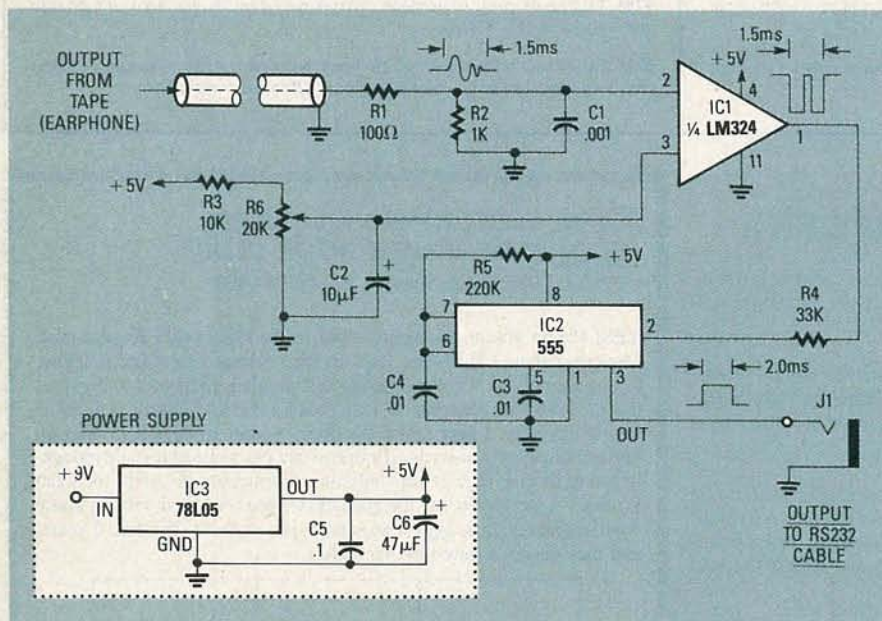

FIG. 4—DEMODULATOR CIRCUIT extracts the recorded data from the tape.

use your computer to do something else? Or what if every station in your monitoring network cannot afford to dedicate a computer for the task?

A simple and inexpensive data logger can be built to use with the Radalert. It takes Will Byers' "clock

stopper" one step further by recording radiation levels on magnetic media, when an alert signal is generated. The technique is similar to those used in medicine, especially cardiology, to record information only when something abnormal happens. The

"event" recorder stores radiation data on a standard microcassette recorder for a 60-minute period when "abnormal" radiation levels are detected. The data can be stored and processed on a computer by playing it back through the tape recorder's earphone jack into a demodulator which feeds the data into Bud Cole's interface cable. Then Bud's software can recreate the event and plot the results.

The block diagram for the device is shown in Fig. 2. When the radiation level exceeds the alert setting on the Radalert, the control circuit stops the clock, documenting the time that the incident occurred. At the same instant, the circuit turns on the tape recorder to record the level of radioactivity, and sounds a beeper. Each radiation event is detected as a "click" on the magnetic tape. While this method of storing data has limitations, particularly at high radiation levels where accuracy is reduced, it does allow important information to be recorded at low cost.

Figure 3 is the schematic for the control circuit. All parts are readily available. The clock cost \$7.50 at a discount hardware store—just make sure that the clock you get can run on a 1.5-volt battery. That way, it can be turned on and off via J1, the clock-power output.

Here's how the circuit in Fig. 3 works: A 3.5-mm stereo phone plug is inserted into the Radalert's COUNT output jack. The tip of the plug picks up the Radalert's count pulses whenever a radioactive particle or photon is detected by the Geiger tube (see **Radio-Electronics**, June 1988, for a more detailed explanation). The ring of the plug (the middle conductor of the plug) is connected to the Radalert's ALERT output, which goes high when the alert level has been exceeded. Use a shielded two-conductor cable to connect the plug to the control-circuit board (one that has two conductors in addition to the shield). Remember never to put a mono plug into the Radalert's COUNT output jack, or else its alert output buffer could be damaged.

When the Radalert's ALERT output goes high, the flip-flop IC1 (½ of a 4013) is toggled, turning on the beeper switch, Q1, and the cassette-power switch, Q2. (Just make sure that the cassette recorder you use can run on the voltage provided by J2.

*continued on page 66*



# BUILD THIS

## ISDN PROTOTYPING TELEPHONE

DOUG TOUSIGNANT and KEN SLIGER

WHEN WE LEFT OFF LAST TIME, WE had just finished preliminary testing of the tip-and-ring section. As we continue, you'll want to refer to Fig. 1 in last month's issue, and Fig. 7, the parts-placement diagram.

Install the socket for IC6, C9, C16, C17, R1, R11, JD, JE, J5, D3, and D5; then press IC6 into its socket. Connect a conventional handset to J5 and listen for a dial tone while powering the prototyping telephone from a 9-volt DC source, and having it plugged into the phone-line "T" adapter; you should *not* hear one. Take the regular phone off hook, listen for a dial tone, and then dial your local time number. While listening to the local-time recording, activate RY1 by connecting a test lead between pins 32 and 34 of IC1. If there are no problems, install RES1, C6, and J10.

Solder in the sockets for IC8 and IC4, XTAL2, R12, and C7, and then press IC8 and IC4 into the sockets. Next, install the socket for IC3, C1-C4, and the right-angle header for J2. Do *not* put IC3 in its socket just yet.

The next step is to wire up a serial cable for connection between J2 and your terminal or a PC running terminal-emulation software. Basically, we'll be using a three-wire cable between the TXD, RXD, and GND on J2 and your terminal. (Don't forget that your terminal's TXD must be connected to J2's RXD.)

Some terminals or computers will require that the DATA TERMINAL READY, DATA SET READY and CARRIER DETECT be wired together. (If your computer uses a DB-9 connector, those are pins 1, 4, and 6; for a DB-25 connector, those are pins 20, 6, and 4.) Some terminals will also require that the REQUEST TO SEND and CLEAR TO SEND be jumpered together. (Pins 7 and 8 on a DB-9 connector; pins 4 and 5 on a DB-25.)

The transmission parameters of your terminal or PC are unimportant at this time, but, if you wish, you can set them as follows:

- 9600 baud
- no parity
- 8 data bits
- 1 stop bit
- echo disabled
- XON/XOFF enabled

Hook the serial cable to your PC but don't hook the other end to J2. Strip both ends of a 1-inch piece of bell wire, and use it to jump TXD AND RXD on your serial cable. Type some characters on the terminal keyboard; they should appear on the screen because the jumper creates a loopback between the transmit and receive pins of the connector. Remove the jumper;

there should be no characters on the screen. If you still have characters echoing, or a double set of them, make sure that echo is set to off (ATEO for Hayes-type modems). Now connect the adapter cable to J2, and jump pins 13 and 14 of the IC3 socket, and repeat the echo test. Using a logic probe (or an LED/10K resistor combination), make sure that pin 13 is receiving data from your terminal. Remove the jumper and disconnect the cable from the terminal or PC.

Now, insert IC3 in its socket, making sure that the power to the prototyping telephone is off *before* doing so. Apply power, and check for the following voltages on IC3; pin 1, +7.17; pin 2, +9.00; pin 3, +2.36; pin 4, 4.80; pin 5, -4.27; pins 6 and 7, -8.93; pins 8 and 15, ground; pins 9-13 and 16, +5.00; pin 14, ± 12.00.





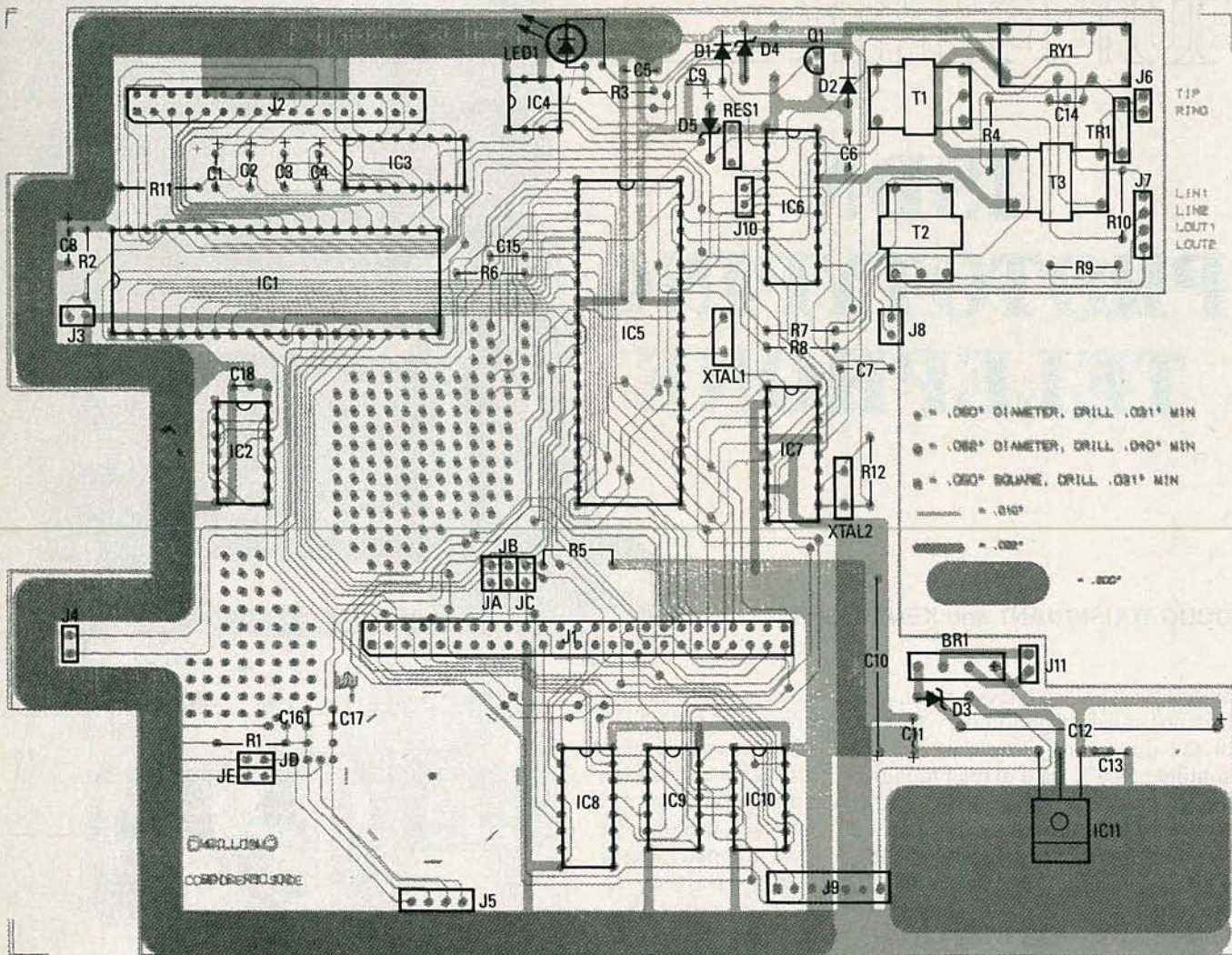

FIG. 7—PARTS-PLACEMENT DIAGRAM. The foil patterns for the double-sided PC board are provided in PC Service.

Jump pins 19 and 23 of IC1, and repeat the character echo test. Then go on and install any remaining parts on the PC board.

### The ISDN alphabet soup

The ISDN is a service that is supplied by the telephone company that you subscribe to, in the same way that supplying a dial tone and completing telephone calls for you is a service. It is a digital data network. Voice data is digitized and sent as so many data bits, just like text, images, or video.

Figure 8 shows a typical ISDN configuration. The terms used are defined as follows:

**NT 1** (Network Terminator 1)—Box containing 2-wire “U” loop to 4-wire “S”/“T” loop.

**NT 2** (Network Terminator 2)—Intelligent box for data concentration, maintenance, or switching. Can be PBX.

“**R**”—Reference point between terminal equipment which is not compatible with ISDN (TE2) and a Terminal Adapter (TA).

“**S**”—Reference point between ISDN terminal equipment (TE1) and ISDN line.

**TE1**—ISDN-compatible terminal equipment.

**TE2**—Non-ISDN-compatible terminal equipment. Requires a terminal adapter.

“**U**”—Reference point between PSTN exchange and NT 1 on the customer’s side.

From our perspective, we’re interested in the “S” interface, which will be a modular RJ11-C wall socket; the class of device used on the “S” reference is a TE1. Non-ISDN equipment (TE2) such as PC’s are used on the “R” reference point with a terminal adapter. The NT (Network Termination) may be an existing PBX or on-

premise switch, or it may reside at the central office. The telephone company takes care of the rest.

ISDN provides two types of service. 2B + D, or Basic Access Rate, which supplies two simultaneous, independent 64-kbit/s B-channels for transmitting and receiving data, and a 16-kbit/s D-channel for limited packet-data transfer and control functions.

The second service is 23B + D, the Primary Access Rate. 23B + D provides 23 B-channels multiplexed on a T1 (1.54 mbit/s) PCM (Pulse Code Modulation) transmission highway and a D-channel for control.

Basic Access Rate is for individual devices, and the Primary Access Rate collects the Basic Rate B-channels and sends them outside.

Basically, here’s how it works. Somebody picks up the handset of an ISDN TE1 that happens to be a telephone. On the D-channel, a packet is prepared and sent from the TE1 to the switching equipment, which might be



## ISDN

Take the completed prototyping telephone configured for ISDN, plug it into an ISDN "S" reference and pick up the handset. There is no dial tone and you can't make a simple phone call. Why is it that a high-tech ISDN-technology telephone won't even do what a \$15 telephone can do?

The fundamental difference between the analog, tip-and-ring telephone and an ISDN TE1 is that tip-and-ring telephones work on a specific analog network designed and engineered to transmit and receive voice via a simple base-band transport. ISDN is a complete digital network designed and engineered as a data network, whether the data is text, FAX, music, CATV, or voice. ISDN has protocols, or rules, for using the network. Before a TE1 can use ISDN, those rules must be implemented with software.

Figure 1 shows the relationship between the CCITT (International Telegraph and Telephone Consultative Committee—a United Nations organization headquartered in Geneva, Switzerland) recommendations for ISDN and how they fit with the ISO (International Standards Organization) seven-layer model for OSI (Open Systems Interconnect) architecture. It is a hierarchical design, with the layer above providing control functions for the one below. That sounds like a mouthful, but it is an international agreement about how networks should be engineered.

Though it looks complex, the ISO seven-layer model is designed to make data communications between disparate equipment and different countries easier. By following those recommendations, you should be able to communicate with any device, in any country.

The good stuff comes in at the bottom (layer 1), rises through the other layers as far as the application requires, and then goes back down and out. ISDN is an international standard for a digital network, and it is defined for the first three layers of the seven-layer model.

In layer 1, the physical layer, analog-to-digital conversion takes place, and some time-division multiplexing to break out B-channel and D-channel information is done. In addition, CSMA/CD (Carrier-Sense Multiple Access with Collision Rejection) is used if the D-channel is accessed by multiple terminals—almost like a LAN (Local Area Network) so far. The control functions are handled by the line-interface and the data-link controller sections of the AM79C30A dig-

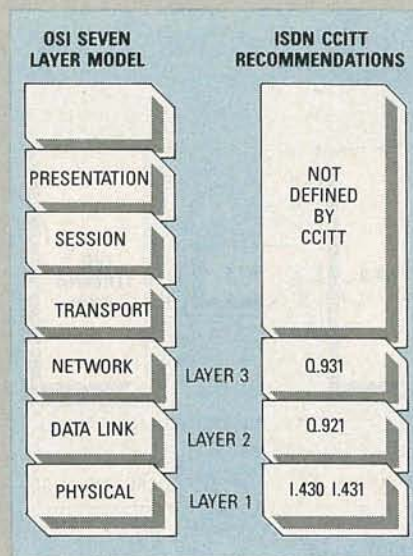

FIG. 1

ital subscriber controller. Those are the I.430 and I.431 CCITT ISDN recommendations.

Layer 2 of the ISO model, the data-link layer, connects the D-channel and B-channels to actual devices in layer 3. Layer 2 uses statistical multiplexing to send D-channel information up to layer 3, and also imposes further error controls on the data coming from the layer 1. Some of those functions are implemented for D-channel information in the data-link control section of the AM79C30A. The rest of layer 2 is done with software called LAPD (Link Access Protocol for the D-channel) and LAPB (Link-Access Protocol for the B-channels). This is the CCITT Q.921 ISDN recommendation.

Layer 1 can be considered the electron level, because it processes voltages, timing, and pin configurations. Any A/D conversion is done and the D-channel information and B-channel information has been identified, multiplexed, and checked. Layer 2 might be defined as the bit level, because bit patterns are recognized. In layer 2, D-channel data is processed (what is to be done, who is it for) and the data from layer 1 is checked again for errors. With the LAPD and LAPB software in place, the TE1 is doing everything the ISDN network requires for layer 1 and layer 2. But there's still one more layer between you and the simple phone call.

Layer 3 of the ISO model, the network layer, is where the devices reside. It might be called the byte level. Now we process characters and numbers. From layer 2, the devices are informed of what action to take by D-channel data which has been formed into packets, and those devices are allowed to use the network

to transmit and receive packet data on one or more B-channels. Those devices are the ISDN telephones (TE1's) and other terminal equipment, as well as the digital switching equipment at the telephone company's central office.

In layer 3, meaningful packets of D-channel information are sent and received to and from the digital switch. A TE1 that happens to be a telephone is identified to the ISDN switching equipment by the SAPI (Service Access Point Identifier) and TEI (Terminal Endpoint Identifier), sent via the D-channel. Once the TE1 tells the switching equipment its SAPI and TEI, the equipment can allocate a B-channel and connects you to the outside world. It is the use of the CCITT Q.931 recommendation that makes the D-channel packets mean something to another layer-3 device. Q.931 is generally software implemented.

A TE1 that works on an AT&T 5ESS ISDN digital switch probably won't work when connected to a Northern Telecom DMS-100 ISDN digital switch. Each company implements Q.931 differently, so a TE1 must have different Q.931 software for each vendor's switch.

Before you throw your hands up in disgust and roundly curse the manufacturers for their duplicity, and before you lose hope of ever making a phone call with your ISDN-compatible, prototyping telephone, remember that a station set designed to work on a Northern Telecom DL-1 digital switch won't work on an AT&T S-75 digital switch. Vendor-specific equipment isn't new with ISDN.

To see what a Q.931 interface looks like, you may want to examine the *DMS-100 Family ISDN Basic Rate Access User-Network Interface Specifications*, published by Northern Telecom for their DMS-100 digital switching equipment.

A copy can be ordered by calling 1 800 422-6373, and ordering publication number BRA-NIS-S208-3. It explains in detail how the Q.931 recommendation is implemented on the Northern Telecom DMS-100.

The Q.931 interface that you use depends on which big digital switch your local telephone company is using for ISDN. The Northern Telecom DMS-100 and the AT&T 5ESS seem to be widely used.

If you are a programmer who likes to really grovel in the bits, writing a Q.931 interface is a very elegant project. If not, you should contact the switch manufacturer or the IC manufacturer and see if they offer the LAPB, LAPD, and Q.931 software for your particular configuration. R-E



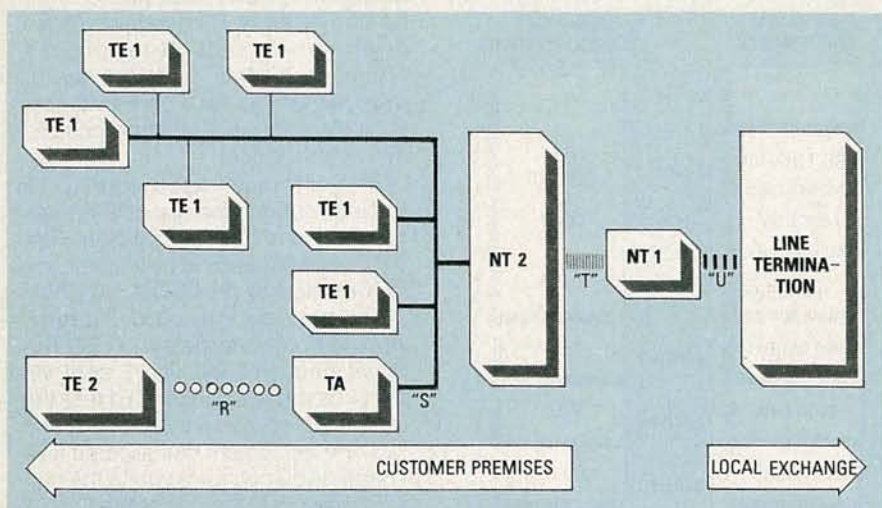

FIG. 8—SHOWN HERE IS A TYPICAL ISDN configuration.

an NT2. The switch will supply the dial tone, identify the device, and signal back. The user types in *Touch Tone* digits to make a phone call. Those are decoded and put into another D-channel data packet and sent to the switch. The switch then allocates Basic Access B-channel and switches the call.

Now the TE1 has been allocated a B-channel back to the switch. The switch takes the B-channel information and puts it on the 23B + D PCM data highway to wherever the data is going. You might think of the 23B channels as 23 trunks or central-office lines. As always, the D-channel lurks in the background.

Your call has been switched (you're talking to someone), but let's assume the ISDN TE1 is both a telephone and

a video monitor/camera. Your voice uses one B-channel, and the video uses the other. The D-channel can be used to tell you that you have another incoming call or, if you have an ISDN security system in your house, the D-channel can inform you of a break-in.

And you thought a telephone was a bunch of wire and a big bell. In the contemporary office, a handwritten letter has become an E-mail packet or a fax. A photograph is a digitized image stored on a laser disk. Typewriters are hard to find. Telephone communication is part of the information age, and the prototyping telephone, like the personal computer, is a development tool. With high-speed

digital networks like ISDN handling text, video, imaging, and voice, the telephone has become a computer.

### Scratching the surface

While the concepts of ISDN are exciting, things don't really start cooking until you actually start *applying* ISDN capability to the Millcom ISDN prototyping telephone.

By 1992 enough ISDN technology will be in use that it should be easy to market applications programs and products that are TE1-compatible. Such software might provide a TE1 with capabilities such as accepting, rejecting, rerouting, recording, calling back, or ignoring any incoming call based on its D-channel packet.

What can you do before 1992? Lots. You have ISDN users to share your applications ideas with. Your government will be one of ISDN's biggest users and is helping them voice their application ideas and needs. Congress appropriated funds to the National Institute of Standards and Technology (formerly the National Bureau of Standards) to establish the North American ISDN Users Forum (NIU). NIU is a users group with quarterly meetings and an electronic bulletin board (301 869-7281) to support and promote ISDN-related application profiles and ideas. The bulletin board is for NIU members only, but it's easy to join. They want and need application ideas. This new

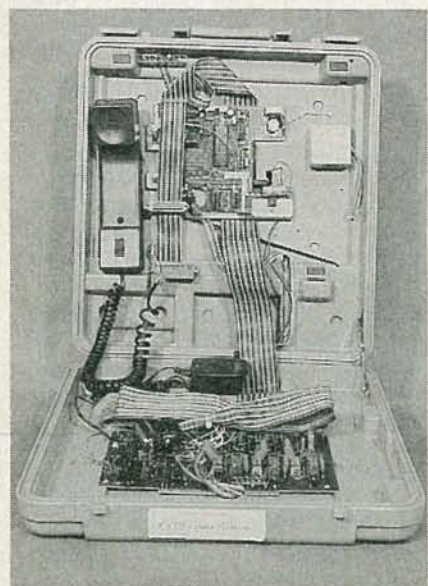

FIG. 9—THE MILLCOM BOARD is installed in the case along with a multi-purpose single-board computer.

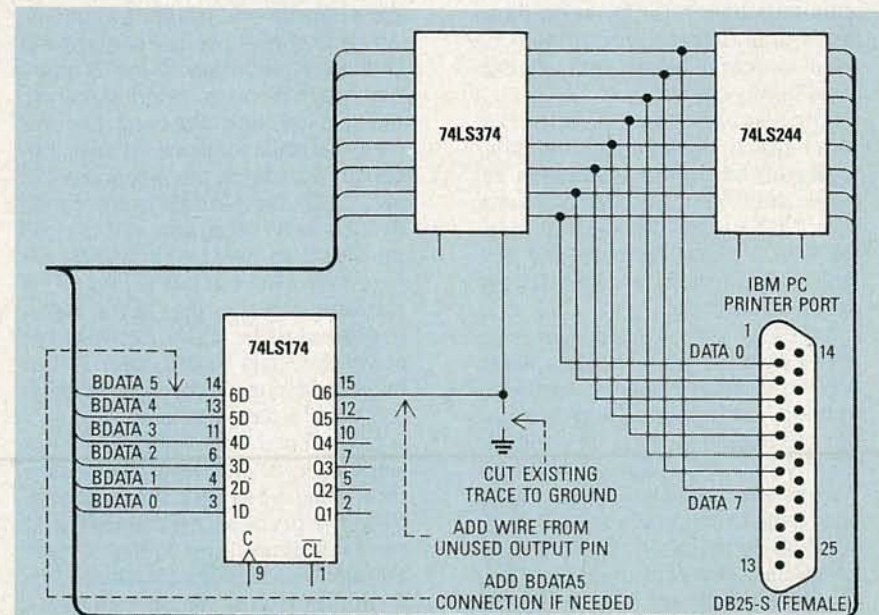

FIG. 10—THE MODIFICATION requires a single trace to be cut, and one or two jumpers to be installed.



industry needs ISDN-knowledgeable programmers and hardware designers. Therefore, the knowledge you gain from building the Millcom kit may benefit your career.

You may not be able to order ISDN BRI service yet, but you can get on a waiting list for future subscribers. You can build the Millcom ISDN Kit and experiment with ISDN's D-channel applications, and begin to study ISDN protocols with simulators and protocol analyzers. Teleos, Progressive Computing, Hard Engineering, Intel, AMD, Mitel, Hayes, and others have developed ISDN PC boards and development software.

Sometimes unwanted calls can result in missing an important call. And with an analog telephone system, there is no effective way to filter out unwanted calls, or to have the system interrupt an unimportant one for one that is important.

The prototyping telephone lets you simulate *Calling Party Identification* (CPID). Of course, since there's no D-channel to detect, the caller has to be prompted by an answering machine to enter his phone number, while the prototyping telephone, which is connected to the same phone line, listens to the caller's number (the DTMF data) and determines whether or not the call should be put through. If the caller's number matches one that has been programmed into memory as one that should be put through, the prototyping telephone will then ring to alert you.

Incoming callers will hear: "You have reached the offices of so and so. I'm sorry but no human is available to take your call right now. If you are calling from a *touch tone* phone please enter your area code now (pause 3 seconds)...Please enter the remaining seven digits of your phone

## SOURCES

Note: The following are available from Millcom, 3014 Pershall, Saint Louis, MO 63136 (314-524-0804): Prototyping Telephone Kit board and all parts, \$239. Refurbished Telenova station set with Millcom PROM BIOS monitor, \$260. PC board, \$39. Flat-rate repair, \$100. The monitor ROM and the source code are \$35 apiece.

TABLE 1

(1) 2000h - 3FFFh	8K unused and unreferenced for user expansion.
(2) 4000h - 40FFh	256 bytes for monitor variables
(3) 4100h - 41FFh	Interrupt and utility vectors. User access and interception of ROM-based functions can be achieved via the defined vectors in this block of ram.
(4) 4200h - 43FFh	Command function pointers. This block contains the jump table for all serial commands. User additions to, and interception of the basic monitor commands can be accessed here.
(5) 4400h - 46FFh	700-byte free area. Can be used by applications code for variables or as an image of 4100h - 43FFh.
(6) 4700h - 5FFFh	6K Free area. Applications code should be originated here. The "g/G" command calls address 4730 for execution. The stack pointer is initialized to 5FFFh.

```

CONNECTED TO MILLCOM PHONE
h
Millcom ISDN Experimenters Kit BIOS Monitor ver1.8
Help Menu
t = test and clear all memory
d = dump memory
? = dump 79c38 registers
8 = dump 8256 registers
i = read io address
o = write io address
; = intel hex downloader
g = jump to 2380h
a = send addresses
h = display this help menu
m = modify memory
j = call address

command:

Ctrl Z to exit
Millcom ISDN Experimenter's Toolkit v1.8

```

FIG. 11—THE MONITOR'S HELP SCREEN displays the monitor's basic commands.

number now (pause 7 seconds)...You may now leave a voice or fax message after the beep.

The prototyping telephone can collect the area code and, if it is different, closes the contact on the beeper which immediately informs you that you have a long-distance call. If you pick up an extension phone you can intercept the call.

On local calls the prototyping telephone collects and compares the seven-digit phone number to the allowed-calls list downloaded from the PC. If it finds a match it beeps twice. That lets you know that you are receiving an expected call; you can intercept it or let the machine get it.

Another experiment would be to

design an *Intelligent Proximity Detector*, or IPD. Such a device would be able to detect whether or not you are within a certain distance from your telephone. And, depending upon where you are, it could put the caller on hold, transfer the call to another extension, take a message, or whatever. The action would be up to you.

## Phoneless ISDN

We have mentioned that the Millcom experimenter's kit can be used without the Telenova station set. All that you need is a PC, or some other kind of computer that can communicate with the kit board through its parallel port. Figure 9 shows the board installed in a case, along with a



multi-purpose single-board computer that can be used to control the Millcom board.

In order to communicate with the Millcom board, you do need a bi-directional parallel port. Unfortunately the parallel printer port on IBM PC's is capable of outputting data only. (Most—but not all—clones and compatibles have a bi-directional port, though.)

As discussed by Steve Ciarcia in the September 1988 Byte magazine, the following printer-port modification will provide bi-directional communication to PC's that don't already have it. It seems that all of the hardware that was needed to read or write 8 bits of data is already on board. The modification, as shown in Fig. 10, requires a single trace to be cut, and one or two jumpers to be installed. Be warned, though, that not all boards have the same traces, IC numbers, or bit assignments. So be sure that you have the correct documentation for your card, and that you know what you are doing *before* you begin to cut traces. (You can always buy a bi-directional clone printer-port card for

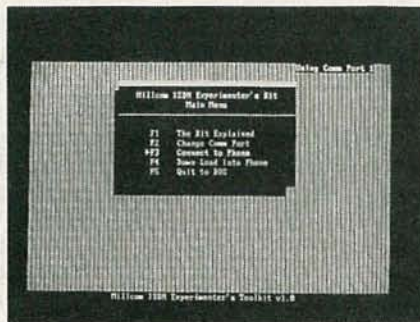

FIG. 12—THE MENU SCREEN from MILLCOM.EXE.

around \$50.)

Now that you have the board communicating through a parallel port, the board has to know *how* to communicate through the port. And that's where the Millcom Monitor ROM comes in. Basically, the monitor ROM is the "bios" of the kit board. Without it, the board knows nothing. The ROM contains the basic set of commands that are used to control the phone's operations. Figure 11 shows a menu of basic commands that are available to a user when connected to the phone thru the serial port. The Monitor allows the user to access and

program the Millcom board from a variety of terminals and computers.

The monitor occupies about 4K of code space. That allows the user to access the upper 4K for special applications. Also, the first 8K is not used by the Monitor to provide an additional 8K of user ROM. 16K of RAM is divided into 2 contiguous blocks which are allocated as shown in Table 1.

On the free side, a "tool kit" containing an executable program called MILLCOM.EXE, hex files, and communications software, is available on the R-E BBS (516) 293-2283; the tool kit is called MILLCOM.ARC. The hex files can be downloaded into the Millcom board, using the executable file. The main menu screen from MILLCOM.EXE is shown in Fig. 12.

We've only scratched the surface of ISDN and how it will change the way we use telephones. The prototyping telephone we've described is not the end—it's the beginning. We hope that the readers of **Radio-Electronics** become the developers of the best ISDN applications. Let us know about your successes. **R-E**

## RADALERT

*continued from page 60*

Otherwise you may have to slightly alter the circuit so that it can turn the cassette recorder on and off via its "remote" jack, if it has one.) At the same time, Q3 is turned off, stopping the clock by cutting the power to the clock-power jack, J1. The beeper sounds a pulsating beep until S1 is depressed, resetting the system. The count pulses from the Radalert are fed to the microphone input of the cassette player, through C1, which provides DC isolation.

To begin operation, set the clock to the correct time, and put the cassette recorder in its record mode with a tape installed. You'll have to make sure that nobody disturbs any of the equipment, so it is advisable to choose an out-of-the-way location for the setup. Also remember that if your setup is outdoors, the equipment must be shielded from nature's elements. Test the system and check the batteries periodically. Use good-quality tapes

and record at the normal speed for best results.

Figure 4 shows the demodulator circuit for extracting the data from the tape. Use a 3.5-mm *mono* phono plug and shielded cable to connect to the earphone jack of the tape recorder. The pulses that were recorded before are easily detected by IC1, an op-amp (1/4 of an LM324) configured as a comparator. R6 must be adjusted so that the output of IC1 does not trigger on noise. Remember not to change the volume level on the cassette player once R6 has been set. The output pulse, which may have some ringing, should not be longer than 1.5 ms. That pulse is fed into IC2, a 555 timer configured as a one-shot with a 2-ms output pulse. The 2-ms pulse width decreases the resolution at high radiation levels, but it is necessary so that the ringing is not detected as more than one pulse.

The output is coupled to the tip connector of J1, a 3.5-mm stereo jack, which can be connected to the mini-plug end of the RS232 cable described in the sidebar. If you connect the other end of that cable to the

RS232 port on a computer running the Radalert program, you can process and plot the data on the data logger. Using Bud Cole's software, you can recreate and plot the "event" previously recorded.

The control circuit we have described can also be used for doing long-time-period counting (described in detail in the July 1988 article). Set the alert level on the Radalert to 9990 counts, reset the control circuit, and log the time on the clock. Put the Radalert in the total-count mode and begin counting. When the count reaches 9990 the clock will stop and the beeper will let you know. Then you can calculate the counts per minute for that time period.

The Radalert, and other similar devices, are making radiation information more available to more people. Now, people living near nuclear plants can independently monitor radiation levels and gain peace of mind—or alert themselves to danger. We cannot eliminate radiation from our lives, but if we can detect and measure its level, we can take appropriate action. **R-E**



# HARDWARE HACKER

## Soup cans full of chips

THERE SURE WAS A LOT OF READER RESPONSE to our big HDTV contest we ran a few issues back. As expected, most of you strongly supported the flushing of NTSC compatibility at the earliest possible opportunity.

Fortunately, there is a new HDTV consortium starting up that includes such outfits as *IBM, Apple, Hewlett Packard, Compac, Tektronix*, and a few others. Together that crew should have enough clout to spank both the FCC and the networks and send them all off to bed without any supper, if they continue to insist on all of their pathetically limiting and mindlessly short-sighted substitutes for genuine digital HDTV.

Here, more or less at random, are several of the more interesting HDTV points that many of you made:

"The concept that HDTV will only be good for the 40-inch and higher screens is not only totally absurd but completely misses the point. The key to the future of HDTV lies in closing the gap between computing and home-video displays. Any time that HDTV text is involved, all of the differences will be obvious on a two-inch screen, let alone a larger one..."

"Twelve years ago, a video-display device in the home was used only to watch network TV. Today it can do a dozen major functions, the most important of which include personal computing, video games, those cable services, and for watching videotape rentals. And, twelve years from now, there will likely be hundreds of possible

uses, the most significant of which will probably be a fax-mail delivery service..."

"The phone company should be a big player here. They recently got approval for a total fiber-optic phone network, which ultimately just might make them the primary broker for home-HDTV material. The obvious advantage here is that you have a full-bandwidth, two-way comm setup in which each customer's needs can be individually provided for..."

"There *already* are several million HDTV display devices in consumer's homes today. They are called *NEC Multi-Sync Monitors*, and there will probably be ten or fifteen million of them around by the time the first of the real HDTV receivers roll off the production line. To simply ignore them is sheer lunacy..."

Once again, many thanks for your input. One interesting way of getting a good handle on any major technological change is to look into another from long ago and far away. To that end, you might find *The Electric Interurban Railways In America*, by George Hilton and John Due, to have an awful lot

### NEED HELP?

Phone or write your **Hardware Hacker** questions directly to:  
Don Lancaster  
**Synergetics**  
Box 809  
Thatcher, AZ 85552  
(602) 428-4073

Soup cans full of chips  
Digital audio front ends  
Sensors and transducers  
Starting your tech venture  
Delta-Sigma A/D conversion

DON LANCASTER

more to say about HDTV than you'd first expect. Stanford University Press, 1964.

Once again, this is your column and you can get technical help and off-the-wall networking per the *Need Help?* sidebar.

Our real biggies this month include some ready-to-use, sanely priced, and rather hacker-friendly digital audio front ends. But first...

### Starting a tech business

Step number one of any serious hardware hacking is to create your own tech venture having all its own letterheads, business cards, mailing address, answering machine, and a bank account. There are simply too many doors that get slammed in your face if you omit that essential step.

Among zillions of other benefits, it is far easier and ridiculously cheaper to get the free trade-journal subscriptions, samples, data books, and application notes if you appear to be professionally competent.

These days, it can be very fast and cheap to form your own tech venture. What you do is to set up a new business entity called a *simple proprietorship*.

To start, pick a name and register it with your state's Secretary of State as a trade name. The name must not be in use, must not be deceptive, and must not be obscene. Beyond that, anything usually goes. Stay a tad on the "vague-but-unusual" side, so that you can use the same name for different purposes and are unlikely to become confused with



anyone else. The cost of trade-name registration out here in Arizona is around \$15 for five years. The price varies with the state, but usually it is no big deal.

Next, rent yourself a post-office box and on the "Who uses this box?" form, put in your name and the name or names of your venture. Open up a new bank account and fill out the bank's alias card the same way. Get a *for deposit only* rubber stamp with both your own name and the company name.

For stationary, simply use a PostScript speaking laser printer to work up all your own letterheads, business cards, logos, invoices, and shipping labels. It's fast and cheap. You'll find more details on all this in my other column that's over in *Computer Shopper* magazine, as well as in my *Ask the Guru* reprints.

With a proprietorship, many of your hardware-hacking expenses can easily become fully tax deductible, provided that a few common-sense rules are followed.

## NEW FROM DON LANCASTER

### HANDS-ON BOOKS

Hardware Hacker Reprints II	24.50
Ask The Guru Reprints I or II	24.50
CMOS Cookbook	18.50
TTL Cookbook	16.50
Active Filter Cookbook	15.50
Micro Cookbook vol I or II	16.50
Enhancing your Apple I or II	17.50
AppleWriter Cookbook	19.50
Apple Assembly Cookbook	21.50
Incredible Secret Money Machine	10.50
LaserWriter Reference (Apple)	19.50
PostScript Cookbook (Adobe)	16.50
PostScript Ref. Man. (Adobe)	22.50
PostScript Prog. Design (Adobe)	22.50
Real World PostScript (Roth)	22.50

### UNLOCKED SOFTWARE

PostScript Show & Tell (Ile/Mac/PC)	39.50
PostScript Beginner Stuff	39.50
PostScript Perspective Draw	39.50
PostScript Printed Circuits	39.50
PostScript Technical Illustrations	39.50
PostScript Work in Progress	39.50
PostScript BBS stuff	19.50
Absolute Reset Ile & Ilc	19.50
AppleWriter/Laserwriter Utilities	49.50
Enhance I or II Companion Disk	19.50
AppleWriter CB or Assy CB Disk	24.50
Intro to PostScript VHS Video	39.50

FREE VOICE HELPLINE

VISA/MC

## SYNERGETICS

Box 809-RE  
Thatcher, AZ 85552  
(602) 428-4073

## SENSOR AND TRANSDUCER RESOURCES

### Amperex

230 Duffy Avenue  
Hicksville, NY 11802  
(516) 931-6200

### General Eastern

50 Hunt Street  
Watertown, MA 02172  
(617) 923-2386

### Hewlett-Packard

PO Box 10301  
Palo Alto, CA 94304  
(415) 857-1501

### IC Sensors

1701 McCarthy Blvd  
Milpitas, CA 95035  
(408) 432-1800

### Intech

57 Alexander Drive  
Research Triangle, NC 27709  
(919) 549-8411

### Measurement & Control

2994 West Liberty Avenue  
Pittsburgh, PA 15216  
(412) 343-9666

### Micro Switch

11 West Spring Street  
Freeport, IL 61032  
(815) 235-6600

### Motion Magazine

2 Box 6430  
Orange, CA 92613  
(714) 974-0200

### Motorola

5005 E McDowell Road  
Phoenix, AZ 85008  
(602) 244-6900

### Nova Sensor

1055 Mission Court  
Fremont, CA 94539  
(415) 490-9100

### Omega Engineering

Box 4047  
Stamford, CT 06907  
(203) 359-1660

### Pollution Equipment News

8650 Babcock Blvd  
Pittsburgh, PA 15237  
(412) 364-5366

### Sensors

174 Concord Street  
Peterborough, NH 03458  
(603) 924-9631

### SenSym

1255 Reamwood Avenue  
Sunnyvale, CA 94089  
(408) 744-1500

### Weathertronix

1165 National Drive  
Sacramento, CA 95834  
(800) 824-5873

### Yellow Springs Instrument

Box 279  
Yellow Springs, OH 45387  
(513) 767-7241

Your business is expected to show a profit two years out of five. It is expected to be conducted as a business as opposed to a hobby. Any home office or lab space must be clearly and exclusively dedicated totally and absolutely to the goals of your intended venture.

All of the deduction rules on home office space have been tightened up considerably, owing to previous abuses. But if your home space is the *exclusive* and *primary* place where all business activities take place, and is in no way for the convenience of you or your employer, you should rightfully claim a tax deduction.

The primary goals of your venture also have to be legal and must *not* be centered on the management of your investments. Above all, accurate and professional records must be kept, consistent in detail with what others would do in a similar enterprise.

With careful records, you can also tap other major tax benefits such as depreciation, investment tax credit, minority and female business credits, and even research and development tax credits. The obvious way to start is with one each of every free tax booklet from the IRS.

Lots more info on that sort of thing appears in my *Incredible Secret Money Machine* book.

### Digital audio A/D front ends

There is a spunky little integrated-circuit house way down in Texas by the name of *Crystal Semiconductor*, and they are totally upsetting the entire A/D-converter industry. What they produce are some totally revolutionary and yet moderately priced single-chip A/D conversion systems and "plug and go" evaluation boards. What that means is that at long last there are some instant and professional-quality digital stereo audio front ends that are hacker-friendly and sanely priced.

As we've seen in previous issues, it is real hard for your typical hacker lashup to yield even 9 bits of A/D resolution, let alone 16. The new evaluation boards eliminate all of that black magic involved in proper shielding, grounding, and guarding. While by no means a beginner project, those boards will



## NAMES AND NUMBERS

### All Electronics

PO Box 5167  
Van Nuys, CA 91408 (800) 826-5432

### BCD Electro

PO Box 830119  
Richardson, TX 75083  
(800) 456-2233

### Computer Shopper

Box F  
Titusville, FL 32781  
(407) 269-3211

### Crystal Semiconductor

4210 S. Industrial Drive  
Austin, TX 78744  
(512) 445-7222

### Fiberoptic Product News

301 Gibraltar Drive  
Morris Plains, NJ 07950  
(201) 292-5100

### Linear Technology

1630 McCarthy Blvd  
Milpitas, CA 95035  
(408) 432-1900

### National Semiconductor

2900 Semiconductor Drive  
Santa Clara, CA 95051  
(408) 721-5000

### NEC Electronics

401 Elis Street  
Mountain View, CA 94039  
(800) 632-3531

### Newark Electronics

228 East Lake Street  
Addison, IL 60101  
(312) 941-7200

### Precision Decisions/PMI

1500 Space Park Drive  
Santa Clara, CA 95052  
(408) 727-9222

### SGS-Thompson

1000 East Bell Road  
Phoenix, AZ 85022  
(602) 867-6259

### Solid State Music/PMI

2076-B Walsh Avenue  
Santa Clara, CA 95050  
(408) 727-0917

### Stanford University Press

Stanford University  
Stanford, CA 94305  
(415) 723-9434

### Stick II Products

Box 670  
Easthampton, MA 01027  
(800) 356-3572

### Texas Instruments

PO Box 809066  
Dallas, TX 75380  
(800) 232-3200

### Time Line

1490 W Artesia Blvd  
Gardena, CA 90248  
(800) 872-8878

### Ultimate Technology

5955 Jimmy Carter Blvd #20  
Norcross, GA 30071  
(404) 242-0125

### Unette

26 Eastmans Road  
Parsippany, NJ 07054  
(201) 884-0010

let an advanced hacker quickly digitize first-quality stereo audio to 16 bits and beyond. For just about any use at all.

Figure 1 summarizes three of

their more interesting chips and their supporting evaluation boards. The chips are typically priced in the \$16 to \$50 range, while their ready-to-use evalua-

tion boards run around \$150 or so, including the needed A/D chip.

The oldest of the three chips is called the CSZ5126, and is included in the CDB5126 evaluation board. A simplified block diagram of the board is shown in Fig. 2, and a simplified pictorial appears in Fig. 3.

What you have is basically a 16-bit and 100-kHz Analog-to-Digital converter. It uses the traditional successive-approximation method, but uses capacitors, rather than resistors, in a *charge rebalancing* scheme. The circuit provides for its own internal sample-and-hold. On any reset, it automatically self-recalibrates itself. You can also force a recalibration at any time you care to.

For stereo-audio operation, a left-channel sample and a right-channel sample are alternated, using an input multiplexer. Each channel is sampled at 44 kilohertz for CD digital audio, or any sample rate from DC up to 50 kHz for special uses. The channel separation and signal-to-noise ratio are both a respectable 92 decibels. Distortion is around 0.001 percent.

Your usual output is a serial data stream consisting of alternating 16-bit words of left- and right-channel data. While that is ideal for recording, it is rather fast and awkward

The **CSZ5126** is an older 16-bit and 50 kHz two-channel successive approximation A/D conversion chip. It is self-calibrating and needs no sample-and-hold, but still requires an input anti-aliasing filter.

The companion evaluation board is model **CDB5126/5101**, and can be used as a nearly complete stereo audio front end. Both serial and parallel digital outputs are available, with a choice of internal or external clocking easily selected.

The **CS5501** is a 16-bit and 10 Hertz single channel Delta-Sigma A/D conversion chip intended for precision DC measurements. It is a total conversion subsystem that includes a powerful internal anti-aliasing filter, sample and hold, and auto calibration.

The companion evaluation board is model **CDB5501**, and can be used as a complete precision instrumentation front end. The output serial data is easy to interface to most any modem or computer.

The **CSZ5326** is a new 16-bit and 50 kHz two-channel Delta-Sigma A/D conversion chip. It is a total conversion subsystem that includes a powerful internal anti-aliasing filter, sample and hold, and features auto calibration. The impressive specs include a dynamic range of 95 decibels, signal-to-noise of 106 decibels, 0.001 decibels of passband ripple, and 0.0015 percent of total harmonic distortion.

The companion evaluation board is model **CDB5326**, and can be used as a complete high performance stereo audio front end. Both serial and parallel digital outputs are available, with a choice of internal or external clocking.

**FIG. 1—CRYSTAL SEMICONDUCTOR has all of these very impressive new A/D converter chips and evaluation boards out. They can be used as stereo digital-audio or precision instrumentation and measurement front ends.**



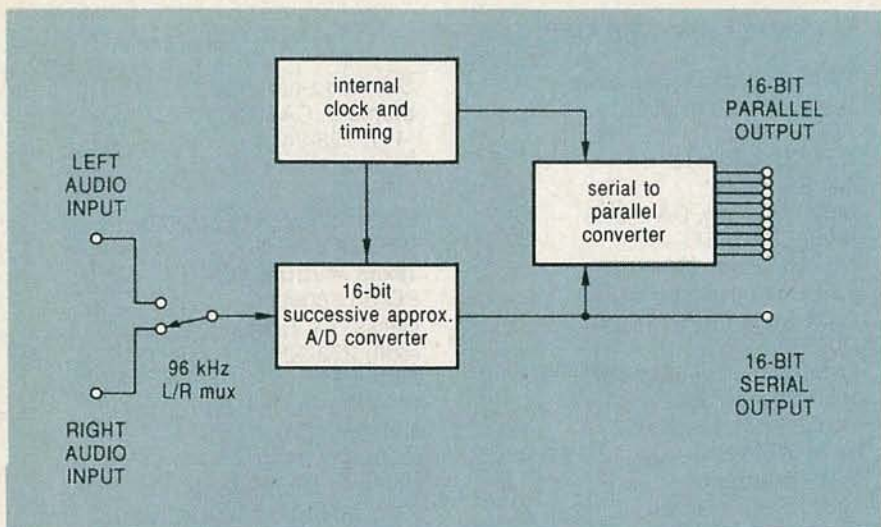

FIG. 2—A SIMPLIFIED BLOCK DIAGRAM of the CDB5126 stereo-audio A/D front-end board. Because of a factory-tested layout, nearly all of the usual black magic involving ground noise, shielding, and guarding has been done for you.

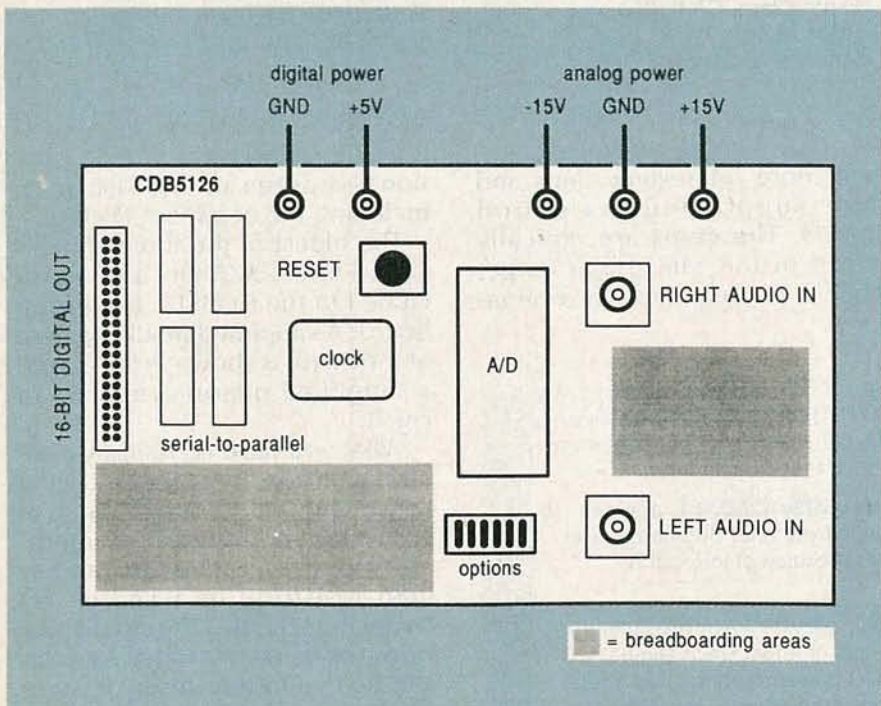

FIG. 3—THE LAYOUT OF THE CDB5126 stereo-audio front end. You literally squirt your stereo audio into the right side connectors, and 16-bit digital bits and bytes pour out the left. Note that the digital +5-volt supply power must be applied AFTER the analog power or serious damage can result.

for personal-computer use. What's also nice is a serial-to-parallel converter that is included; it directly gives you the separate left- and right-channel parallel 16-bit digital words at speeds that most personal computers can accept and use.

What you do is simply squirt in the left- and right-channel hi-fi audio, and the 16-bit digital words will fall off the other end of the board. It is that fast and simple.

Since it's more or less a traditional converter circuit, you still need analog anti-alias filtering on your input. Figure 4 shows you a simple input driver and filter that should be good for test purposes. For your final circuit, though, a rather high-quality anti-aliasing filter must be provided at each input. *Linear Technology* is the unique source for single-chip stereo CD audio anti-aliasing filters.

As a review, any A/D conversion

scheme must limit its input frequencies to less than *one-half* of the clock frequency or quite serious aliasing will result. For a 44-kHz CD audio, a very high-quality 22-kHz low-pass filter is needed.

There are all sorts of jumper and dip-switch options on the CDB5126 board for clocking sources, selecting the output codes, and such. Do be sure to read *all* the ap-notes and data sheets carefully before you use any of the evaluation boards. Although they're essentially plug-and-go systems, a 25-MHz oscilloscope is absolutely essential for most of your initial testing and debugging. Do not even think of hacking those boards without having such a scope on hand.

One major gotcha on the CDB5126 evaluation board: Always apply your analog power *before* you apply your +5-volt digital power. Should digital power be applied without analog power, the chip can be destroyed. The simplest way to handle everything is to derive your digital +5 volts off the analog +5-volt source. By the way, the A/D chip draws only a quarter of a watt, so it is usable for portable applications. There's also a standby mode.

Naturally, there is no reason why you have to run the 5126 at full tilt. Drop down to a 7-kHz sample rate, and you can handle voice-grade audio, with far less memory-storage needed inside your personal computer.

Exciting as the chip-and-board combo sounds, the other two are even more impressive. Before we can understand them, though, we have to take a look at...

### Oversampling

It sure would be nice to do everything on a single chip. The CSZ5126 comes close, but it still needs a high-performance anti-aliasing filter at its input for serious applications. And its specs are useful but not outstanding. Can we either eliminate the need for the filter or substitute a simpler one?

Crystal reasoned that an entirely new approach to A/D conversion was needed. So, they went back to the drawing board.

Well, the simplest A/D converter



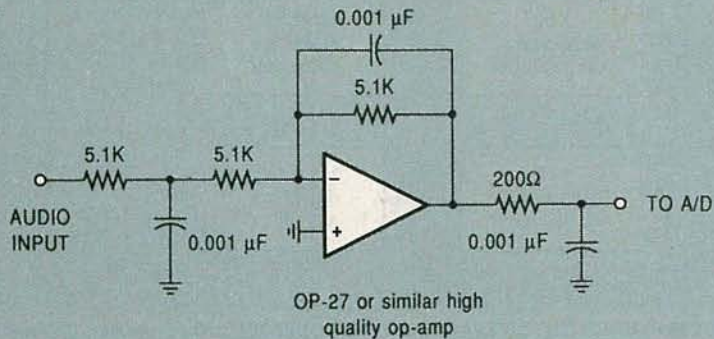

FIG. 4—A RECOMMENDED INPUT DRIVER CIRCUIT. Additional anti-alias filtering is likely to be needed for your final CSZ5126 application.

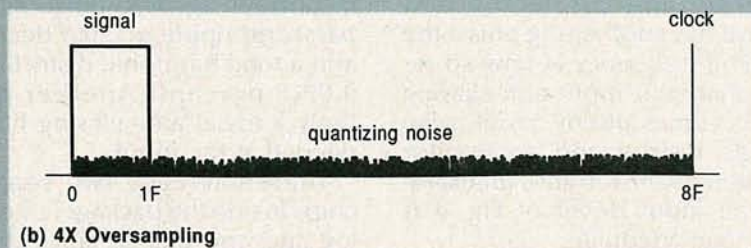
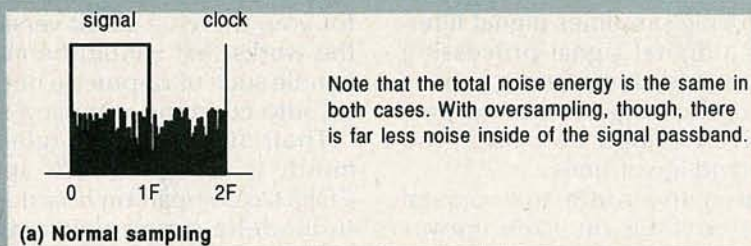

FIG. 5—THE QUANTIZATION NOISE of an A/D converter is often distributed from DC on up to the sampling frequency. By oversampling and then digital low-pass filtering, a 1-bit A/D converter can actually end up with far less noise than a 16-bit one! That is one of the key secrets to Crystal's Delta-Sigma conversion and post decimation digital filtering scheme.

is a one-bit converter. You can build one of those by using nothing but a comparator or even an op-amp. And it turns out that there is only one tiny thing wrong with a one-bit A/D converter: The signal-to-quantizing-noise ratio is a miserable seven decibels. Most people would instantly flush a one-bit converter as being uselessly noisy, especially for high-quality services.

But wait. Crystal decided to ask just where all the quantization noise came from and just how all the noise was distributed. Well, it turns out that the quantization

noise is pretty near uniformly distributed from DC clear on up to your actual sampling frequency.

So what happens if we dramatically raise that sampling frequency? As Fig. 5 shows us, most of the noise ends up *outside* the passband of your intended input frequencies. If you now *digitally* filter your output, you can literally throw away most of your quantization noise, and might ultimately get as much as 16 or even 20 bits of signal-to-noise ratio out of a one-bit converter!

That newer process is known as *oversampling*, and one way of

## ORDER FROM JAN FOR CRYSTAL CLEAR COMMUNICATION



- YOUR RELIABLE SOURCE SINCE 1965
- QUICK DELIVERY
- PRICED RIGHT
- EMERGENCY ORDER SERVICE AVAILABLE

FOR FREE CATALOG, CALL OR WRITE:

### JAN CRYSTALS

P.O. BOX 06017  
FORT MYERS, FL 33906



(813) 936-2397



TOLL-FREE: 1-800-237-3063

IN FLORIDA: 1-800-226-XTAL  
FAX ORDERS: 1-813-936-3750

CIRCLE 104 ON FREE INFORMATION CARD

## ATTENTION! ELECTRONICS TECHNICIANS

EARN YOUR B.S.E.E. DEGREE



THROUGH HOME STUDY

Our New and Highly Effective Advanced-Placement Program for experienced Electronic Technicians grants credit for previous Schooling and Professional Experience, and can greatly reduce the time required to complete Program and reach graduation. No residence schooling required for qualified Electronic Technicians. Through this Special Program you can pull all of the loose ends of your electronics background together and earn your B.S.E.E. Degree. Upgrade your status and pay to the Engineering Level. Advance Rapidly! Many finish in 12 months or less. Students and graduates in all 50 States and throughout the World. Established Over 40 Years! Write for free Descriptive Literature.

COOK'S INSTITUTE OF ELECTRONICS ENGINEERING



4251 CYPRESS DRIVE  
JACKSON, MISSISSIPPI 39212

CIRCLE 58 ON FREE INFORMATION CARD

JUNE 1989

71



Get A Complete Course In

## ELECTRONIC ENGINEERING

8 volumes, over 2000 pages, including all necessary math and physics. 29 examinations to help you gauge your personal progress. A truly great learning experience.

Prepare now to take advantage of the growing demand for people able to work at the engineering level.

Ask for our brochure giving complete details of content. Use your free information card number, or write us directly. \$99.95, Postage Included. Satisfaction guaranteed or money refunded.



**Banner  
Technical  
Books, Inc.**

1203 Grant Ave.  
Rockford, IL 61103

CIRCLE 67 ON FREE INFORMATION CARD

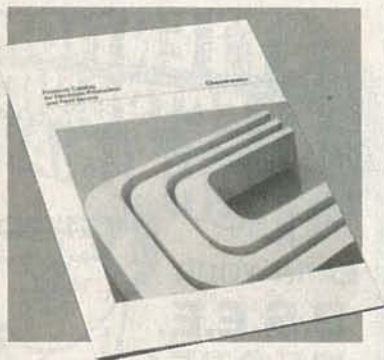

## CHEMICAL SOLUTIONS

### FREE CHEMTRONICS CATALOG!

Comprehensive new source for over 200 products used in electronic manufacturing and field service. Precision cleaning agents, flux removers, bulk solvents, circuit refrigerants, precision dusters, non-residual wipers, foam swabs, premoistened pads/swabs, antistatic compounds, conformal coatings, lubricants, adhesives, desoldering braids, rosin core solder and solder masking agents. Complete with technical specifications and application guide.



**Chemtronics Inc.**  
681 Old Willets Path  
Hauppauge, N.Y. 11788  
516-582-3322

CIRCLE 54 ON FREE INFORMATION CARD

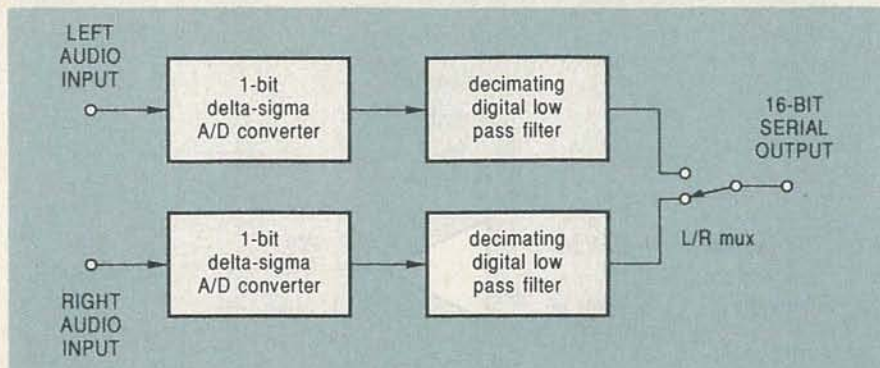

**FIG. 6—A SIMPLIFIED BLOCK DIAGRAM of the CSZ5326 A/D converter. The mind-blowing specs include a 95-decibel dynamic range, 106 decibels of signal/noise ratio, 0.001 decibels of passband ripple, and 0.0015 percent harmonic distortion for both 44-kHz stereo channels. The input anti-alias filtering is also trivial.**

doing the one-bit A/D conversion is called *Delta-Sigma* conversion. One hairy but easily done process that greatly simplifies digital filtering is a digital signal-processing scam called *decimation*, where high clock frequencies are progressively *folded over* back into lower and lower ones.

That is the route that Crystal chose to take on their newer chips. Besides being elegant, powerful, and cheap, the new method has another big plus—the sampling frequency is now so remote that your input anti-aliasing filter becomes utterly trivial. Even a single resistor and a capacitor can often do the job and, for example, the input driver of Fig. 4 is more than adequate.

Crystal chose two different routes for their first delta-sigma A/D products. The first is the CS5501 and its companion CDB5501 evaluation board. That chip is optimized for precision instrumentation-measurement at sampling rates of 10 Hz or less. Totally useless for audio, of course, but it's just what you need for precision electronic measurements. There's no point in updating digital displays faster than you can read them. And locking to a submultiple of the power-line frequency might dramatically reduce hum, noise, and digit bobbles.

A high-performance anti-aliasing filter is included internally; that filter lets you preselect your system bandwidth. The output is optimized for serial communications to a personal computer or over a modem. The linearity error is an absurdly low 0.0015 percent

of full scale, or a little over one part in ten thousand.

And if that's not good enough for you, there's a 20-bit version in the works that should be able to handle such ultra-precise needs as an auto-counting weighing scale.

Their final chip boggles the mind. It is the CS5326 and its CDB5326 companion board. A full 16-bit delta-sigma oversampling stereo audio A/D processor with a 96-decibel signal-to-noise ratio, a passband ripple of 0.001 decibels, and a total harmonic distortion of 0.0015 percent. Another plus: Only a trivial anti-aliasing filter is needed at the input.

There's actually two separate chips inside the package, one analog and one digital, since there's no way to get enough noise isolation on a single chip. The analog half still uses loose design rules and is continually being improved. Figure 6 shows you a simplified block diagram.

For our first contest this month, just tell me what you would do with a stereo audio front end or a precision analog instrumentation input circuit. There will be all the usual *Incredible Secret Money Machine* book prizes for the best dozen or so entries, with an all-expense-paid (FOB Thatcher, AZ) *tinaja quest* for two going to the very best of all.

As usual, send your entries directly to me per the *Need Help* box, and not to the **Radio-Electronics** editorial offices.

### Sensors and transducers

I sure do get a lot of helpline calls from **Radio-Electronics** read-



# Radio-Electronics mini-ADS

ers after humidity sensors, strain gauges, pressure transducers, shaft encoders, and such. As with any other field, you start off with the trade journals and major-supplier catalogs, and build up your personal data base from there. The *Sensor and Transducer Resources* sidebar shows you a few of my favorite information sources.

I guess I do like the free *Measurements and Control* trade journal best, with Carl Helmer's *Sensors* coming in a close second.

While it sounds a tad off-the-wall, *Pollution Equipment News* does have plenty of useful transducer and sensor info in it. I happened into that trade journal after I got rather tired of paying \$2 per ounce for the hot-tub clarifier that the sewage-plant people were paying \$2 a gallon for.

*Omega Engineering* probably has the widest selection of the sensors for pressure, temperature, humidity, pH, conductivity, strain, and whatever else is available, along with lots of fine technical books, excellent application notes, and ready-to-use instruments. Unfortunately, those folks are often very expensive.

Some very low-cost temperature and pyroelectric people-detector sensors are now available from *Amperex*, while the traditional source of very linear thermistor temperature sensors has been *Yellow Springs Instrument*.

While there still is no stable and wide-ranging \$5 humidity sensor yet available, two useful supply sources include *Omega* and *General Eastern*.

For pressure transducers, *Motorola* and *MicroSwitch* were the traditional biggies, but they have now gotten totally eclipsed by the "gang of three," that includes *SenSym*, *IC Sensors*, and *NovaSensor*. Start with *SenSyms* outstanding data book, slide rule, and ap-note package.

Shaft encoders and their low-cost encoder-conditioning integrated circuits are now readily available from *Hewlett-Packard*, while some other competing sources will often run ads in *Motion* magazine. Be sure and let me know if you have any other favorites that belong in our list.



**CABLE TV CONVERTERS AND DE-SCRAMBLERS** SB-3 \$79.00 TRI-BI \$95.00 MLD-\$85.00 M35B \$89.00 JRX-DIC \$129.00 Special combos available. We ship COD. Quantity discounts. Call for pricing on other products. Dealers wanted. FREE CATALOG. We stand behind our products where others fail. One year warranty. **ACE PRODUCTS, P.O. Box 582, Saco, ME 04072 (207) 967-0726.**

CIRCLE 75 ON FREE INFORMATION CARD



**THE MODEL WTT-20 IS ONLY THE SIZE OF A DIME**, yet transmits both sides of a telephone conversation to any FM radio with crystal clarity. Telephone line powered - never needs a battery! Up to 1/4 mile range. Adjustable from 70-130 MHZ. Complete kit **\$29.95 + \$1.50 S+H**. Free Shipping on 2 or more! COD add \$4. Call or send VISA, MC, MO. **DECO INDUSTRIES, Box 607, Bedford Hills, NY 10507. (914) 232-3878.**

CIRCLE 127 ON FREE INFORMATION CARD

## CALL NOW AND RESERVE YOUR SPACE

- 6 x rate \$890.00 per each insertion.
- Fast reader service cycle.
- Short lead time for the placement of ads.
- We typeset and layout the ad at no additional charge.

Call **516-293-3000** to reserve space. Ask for Arline Fishman. Limited number of pages available. Mail materials to: mini-ADS, RADIO-ELECTRONICS, 500-B Bi-County Blvd., Farmingdale, NY 11735. FAX: 516-293-3115.



**SM-333 Surround Sound Processor** for ultimate realism. Features VCR, Video Disc and CD selectable inputs. Can be used with tuners, tape desks and LP discs. Has front panel controlled DYNAMIC NOISE REDUCTION, level, effect and delay. Outputs for front and rear stereo speaker amplifiers. COMPLETE KIT **\$62.00** Assembled & Tested **\$83.00 + 10% S+H**. Call or send VISA, MC, AMEX, MO, CK. **MARK V ELECTRONICS, NC, 8019 E. Slauson Ave., Montebello, CA 90640. (213) 888-8988 FAX (213) 888-6868.**

CIRCLE 93 ON FREE INFORMATION CARD

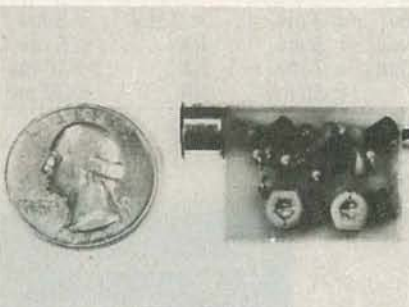

**SIMPLY SNAP THE WAT-50 MINIATURE FM TRANSMITTER** on top of a 9v battery and hear every sound in an entire house up to 1 mile away! Adjustable from 70-130 MHZ. Use with any FM radio. Complete kit **\$29.95 + \$1.50 S+H**. Free shipping on 2 or more! COD add \$4. Call or send VISA, MC, MO. **DECO INDUSTRIES, Box 607, Bedford Hills, NY 10507. (914) 232-3878.**

CIRCLE 127 ON FREE INFORMATION CARD

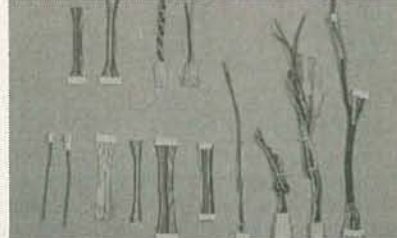

**WIRE HARNESS ASSEMBLY FROM KOREA.** Expand your interests with high quality and low production costs!!! We produce wire harness connector assembly, flat wire rework, flat cable connector and molding for most electronics and communication products. Send your schematic or sample for quick quotation and cheapest price. Free sample and estimate. Fast shipping! Low production cost! Best Quality! Distributors welcome! Mail to: **DAESHIN ELECTRONICS COMPANY, 630-18, Banghak 2-dong, Dobong-ku, Seoul, Korea (TEL) 82-2-904-1977, 908-0523 (FAX) 82-2-702-3577.**

CIRCLE 178 ON FREE INFORMATION CARD



## Discrete soup cans

All of the good folks at SGS have recently run a free "soup can" promotion. On your letterhead request, they will send you a can full of a dozen mainstream discrete semiconductors. And nearly every one of them is an outstanding hacker component.

There's a Zener diode, an AC power-line controlling triac, a fast-recovery diode, and a transient zapper. Fancier chips here include a medium-power bipolar power

transistor and a high-power MOS transistor, a 5-volt regulator, and the obligatory 555 timer. From various logic families, you will find an actual latch, a hex inverter, a quad AND gate, and a dual AND-OR-INVERT gate. That is an all around "must have" good deal. Let's start with the soup can and go a step further.

What are the *real* top forty hacker components? As a second contest this month, send me a list of a dozen or so of all of your favorite electronics parts, tell me why

you like them, and why they belong in the top forty. Later on, we'll work up a master list of all the good stuff.

## New tech literature

*Newark Electronics* has just come out with their free, monster 1106 page Catalog #110. Although *Newark* was among the oldest of those "old line" distributors, they do stock everything in depth, have a tolerable minimum order, and are not nearly as hacker vicious as most of their competitors.

Some of the more interesting new surplus flyers this month include *BCD Electro*, *All Electronics*, and *Time Line*. The latter has 256-element CCD line-image video scanners for an unbelievable \$5 each.

The old *Solid State Music* analog integrated circuits has been taken over by PMI. Ask for their *SSM Audio Products Catalog*.

You'll find a brand-new free trade journal known as *Fiberoptic Product News*. It's chock full of infrared lasers and similar goodies. The free demo disks this month include *Precision Decisions* from PMI, and *UltiBoard PCB Design* from all of the people at *Ultimate Technology*.

Switching to the mechanical stuff, *Stick II Products* has a free sample flyer on many of their pressure-sensitive foam tapes, while *Unette* has a free sample packet of their miniature liquid-dispensing packages.

There's a rash of free samples on all of those new fifth-generation op-amps floating around. Check out *Texas Instruments* for a freebie on their *Enhanced JFET* technology, or *National Semiconductor* for their *VIP Process* high-speed op-amps and video buffer circuits.

Turning to my own products, yes, we are now shipping the *Hardware Hacker II* reprints of everything you have seen here in *Radio-Electronics*, along with my *Ask the Guru*, volumes I and II from the sister column to this one over in *Computer Shopper* magazine. And, yes, I do stock autographed copies of five of my classics—*TTL Cookbook*, *CMOS Cookbook*, *Active Filter Cookbook*, and *Micro Cookbook*, volumes I and II. R-E

# OPTOELECTRONICS

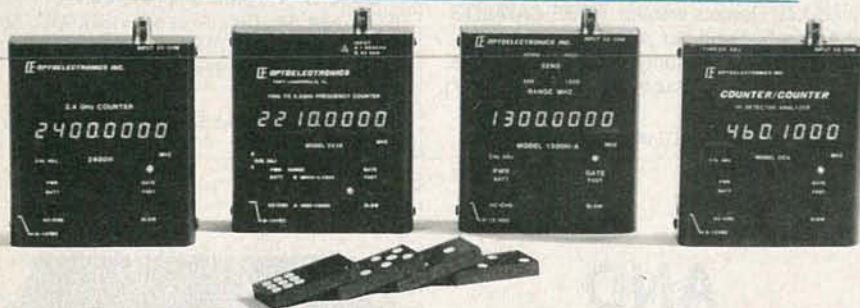

## COUNTER THEORY

Affordable, compact, and ultra-sensitive. More and more people are discovering new applications for our counters than ever before. Now used by technicians, engineers, law enforcement officers, private investigators, two-way radio operators, scanner hobbyists, and amateur radio operators, just to name a few.

Over 15 years of service, quality, experience and dedication has proven you can count on us.

### Hand Held Series Frequency Counters and Instruments

MODEL	2210 <i>New</i>	1300H/A	2400H	CCA	CCB <i>New</i>
RANGE: FROM	10 Hz	1 MHz	10 MHz	10 MHz	10 MHz
TO	2.2 GHz	1.3 GHz	2.4 GHz	550 MHz	1.8 GHz
APPLICATIONS	GENERAL PURPOSE AUDIO-MICROWAVE	RF	MICROWAVE	SECURITY	SECURITY
PRICE	\$199	\$169	\$249	\$299	\$99
SENSITIVITY					
1 KHz	< 5 mv	NA	NA	NA	NA
100 MHz	< 3 mv	< 1 mv	< 3 mv	< .5 mv	< 5 mv
450 MHz	< 3 mv	< 5 mv	< 3 mv	< 1 mv	< 5 mv
850 MHz	< 3 mv	< 20 mv	< 5 mv	NA	< 5 mv
1.3 GHz	< 7 mv	< 100 mv	< 7 mv	NA	< 10 mv
2.2 GHz	< 30 mv	NA	< 30 mv	NA	< 30 mv

ACCURACY ALL HAVE +/- 1 PPM TCXO TIME BASE.

All counters have 8 digit red .28" LED displays. Aluminum cabinet is 3.9" H x 3.5" W x 1.1" D. Internal Ni-Cad batteries provide 2-5 hour portable operation with continuous operation from AC line charger/power supply supplied. Model CCB uses a 9 volt alkaline battery. One year parts and labor guarantee. A full line of probes, antennas, and accessories is available.

**OPTOELECTRONICS INC.**  
5821 N.E. 14th Avenue  
Fort Lauderdale, FL 33334  
(800) 327-5912  
IN FL (305) 771-2050



CIRCLE 183 ON FREE INFORMATION CARD



# SHORTWAVE RADIO



STANLEY LEINWOLL

## Jamming: the end of an era?

ONE OF THE MOST MOMENTOUS events in the history of shortwave broadcasting took place at 2100 UTC on November 29, 1988, when the Soviet Union abruptly stopped jamming the broadcasts of Radio Liberty after thirty six years of un-interrupted, intentional, harmful interference.

In all, twelve Radio-Liberty languages to the USSR, including Russian, are no longer jammed. In addition, the Soviets also stopped jamming Radio Free Europe (RFE) broadcasts in Latvian, Lithuanian and Estonian, Deutsche Welle broadcasts in Russian, and Israeli broadcasts in Yiddish, Hebrew, Russian, Georgian, and Bukharic. In addition, the Dari and Pashto broadcasts of Radio Free Afghanistan were also cleared of jamming on November 29.

On December 16, jamming of RFE Czechoslovak broadcasts, which had continued uninterrupted since 1951, was terminated, and on December 23, RFE Bulgarian jamming ceased.

It is estimated that during this truly historic period the Soviet Union took about 2,500 jamming transmitters off the air.

Because of the importance of that event to shortwave broadcasting, we will devote our next several columns to jamming, in order to properly assess the event's impact on the high-frequency spectrum. The assessment will include a brief history of jamming, as well as a detailed look at the Soviet jamming system. Some of the technical consequences of the cessation of most jamming will be

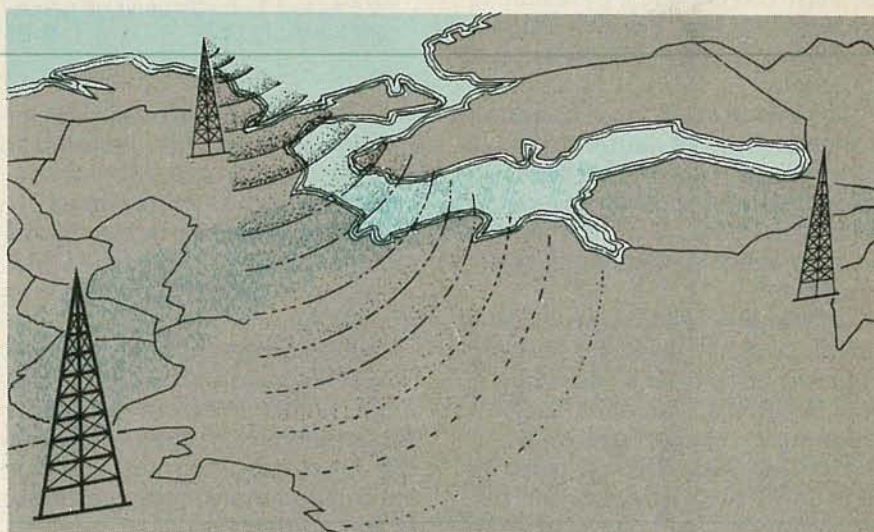

FIG. 1

discussed. We will also try to analyze the motives behind such an important event, and conclude with a look at the future. Some of the material has not been published before in the West.

Never before has an event of such broad impact occurred in shortwave broadcasting. Although the Soviets had periodically stopped jamming some broadcasters, only to resume at a later date, it has never involved virtually the entire USSR jamming system.

Jamming is well known to all shortwave listeners. It is the transmission of deliberate interference, in the form of white noise or other disruptive material, in order to make reception of a broadcast impossible. Jamming is intended not only to prevent reception, but to make listening so annoying that even repeated *attempts* to listen will be discouraged.

One of the more serious side

effects of jamming is that, because of its broadband nature, it not only affects the program being jammed, it also affects reception on adjacent channels, as well. Thus, innocent bystanders have also suffered from the deleterious effects of jamming.

### A history of jamming

Radio historians generally credit the Germans with the first use of jamming techniques. During World War I they transmitted random characters to disrupt radioteletype communication between Paris and St. Petersburg (now Leningrad) in Russia.

In the 1920's, before broadcasting in the United States was regulated, radio programs were often deliberately disrupted by competing broadcasters in attempts to drown out the competition.

Jamming became a political weapon in the 1930's. The first re-



corded instances of such jamming occurred in 1934, when Austria jammed Nazi German broadcasts, and in 1935, when the Nazis began jamming Radio Moscow.

World War II saw the continued development of jamming. Both sides used it extensively. The Germans used it as a means of censorship, jamming the broadcasts of the BBC regularly. It was also used as a military weapon. Perhaps the most notable example was the German naval coup which enabled the warships *Prinz Eugen*, *Scharnhorst*, and *Gneisenau* to race through the English Channel under the noses of British artillery because the Germans were able to successfully jam British radar installations overlooking the English channel.

The end of World War II saw the continuation of jamming on a much more massive scale than had been dreamed of during the war. A new type of war, a Cold War, was being waged, and jamming really flourished.

In February 1948, Stalin made a major decision. In order to keep censorship as total as possible, it was decided to launch a massive jamming campaign against Western broadcasts. The purpose of that effort was two-fold. The obvious one was to keep control of the information monopoly that the Soviets enjoyed; the second, more subtle, but equally important, involved the military. It had been demonstrated in World War II that an effective jamming network, operating against military circuits, was a potent wartime weapon. Establishing an active network to jam radio broadcasts would also serve to keep the military jamming machine well-oiled.

The commitment was made with a dozen or so jammers commencing operations against the Russian-language broadcasts of the Voice of America. Within two years, over 450 jamming transmitters were in operation, during which time BBC Russian-language broadcasts joined the list of jammed services.

By the end of 1951, all languages beamed to East Europe from the West were jammed, and a total of over 1,000 jammers were in operation. In 1951, Radio Free Europe

#### CONDITIONS, MAY AND JUNE 1989

A combination of lengthening hours of daylight and continued increases in sunspot activity will result in a trend toward higher usable frequencies during this period. Around-the-clock DX in the 19-meter band will be possible, and during the daylight hours 13, 16, and 19 meters will be open for DX. During the evening and nighttime periods all bands between 49 and 19 meters will be open, with some 16-meter openings probable as well.

During the period from about noontime to early evening, local time, openings in the Citizens' band and the Amateur 10-meter band will occur fairly regularly. **R-E**

commenced operations from Germany with programs beamed to the East European block; they were immediately jammed. In 1953, Radio Liberty began broadcasts in the languages of the USSR. It, too, was severely jammed from the outset.

By 1956 between 2,500 and 3,000 Soviet bloc jammers were in operation against Western shortwave broadcasts. Then, the first break in the Electronic Curtain that had sprung up around the Communist bloc occurred.

Coincident with a series of riots in the city of Poznan, and the coming into power of a new Polish Communist Government, jamming of RFE Polish language programs was ended. The official date was November 24, 1956. There had been mounting outcries from the press about the jamming of foreign broadcasts, and at the onset of the Poznan rioting the local jamming station was destroyed.

RFE Polish-language programs continued unjammed for fourteen years, when food riots in Polish coastal cities broke out. In an apparent panic, Polish authorities deployed transmitters that had been used by Radio Warsaw's external service to jam the Polish transmissions of Radio Free Europe. The hierarchy had been caught off guard, with no spare jamming transmitters. Until they were available, Radio Warsaw international broadcasts were severely cut back. As jamming

transmitters became available, Polish broadcast transmitters were put back into service.

The use of broadcast transmitters for jamming purposes was an indication of the high priority placed by bloc countries on obliterating news from the outside world. One of the counter-measures that have been attempted by Western nations over the years involves scheduling frequencies that are used by Soviet-bloc countries for their own international broadcasting efforts. Without exception, the frequencies have been jammed relentlessly within minutes, a sure sign that even if they had to jam themselves, they would do so to keep unwanted programs out.

Another major break in the jamming pattern occurred in June of 1963. Following an atomic-test ban treaty, BBC and Voice of America programs in the languages of the USSR were unjammed for the first time in almost 15 years. The following month, Rumania stopped jamming the broadcasts of Radio Free Europe, the Voice of America, and the BBC. In February 1964, Hungary followed suit. In April of 1964, Czechoslovakia stopped jamming VOA and BBC but continued its efforts against RFE.

But if anyone thought the situation was permanent, such persons were mistaken. Jamming can be turned on and off like a faucet, at the discretion of those doing the jamming. That became clear in 1968, with the invasion of Czechoslovakia on August 21, 1968 by 200,000 Warsaw-Pact troops. With the invasion, massive jamming of VOA, BBC, and Deutsche Welle resumed. Languages of the USSR were affected, as were Czechoslovak transmissions. The wheel of jamming had come full circle.

The situation did not change until 1973, when once again, Soviet jamming of the VOA, BBC, and Deutsche Welle Russian and minority languages of the USSR ended during a thaw in the cold war.

Those of us who are a little more cynical are of the opinion that the Russian jamming of some of the western broadcasts ceased because many of the jammers were needed for use against Peking transmissions to the USSR. Fur-



# R-E Engineering Admart

Rates: Ads are 2 1/4" x 2 7/8". One insertion \$900. Six insertions \$875. each. Twelve insertions \$845. each. Closing date same as regular rate card. Send order with remittance to Engineering Admart, Radio Electronics Magazine, 500-B Bi-County Blvd., Farmingdale, NY 11735. Direct telephone inquiries to Arline Fishman, area code-516-293-3000. Only 100% Engineering ads are accepted for this Admart.

## Surface Mount Chip Component Prototyping Kits—

Only \$49.95



CC-1 Capacitor Kit contains 365 pieces, 5 ea. of every 10% value from 1p to .33μf. CR-1 Resistor Kit contains 1540 pieces; 10 ea. of every 5% value from 10Ω to 10 megΩ. Sizes are 0805 and 1206. Each kit is ONLY \$49.95 and available for immediate One Day Delivery!

Order by toll-free phone, FAX, or mail. We accept VISA, MC, AMEX, COD, or Pre-paid orders. Company P.O.'s accepted with approved credit. Call for free detailed brochure.

**COMMUNICATIONS SPECIALISTS, INC.**  
426 West Taft Ave. • Orange, CA 92665-4296  
Local (714) 998-3021 • FAX (714) 974-3420

Entire USA 1-800-854-0547

CIRCLE 176 ON FREE INFORMATION CARD

## FCC LICENSE PREPARATION

The FCC has revised and updated the commercial license exam. The NEW EXAM covers updated marine and aviation rules and regulations, transistor and digital circuitry. THE GENERAL RADIOTELEPHONE OPERATOR LICENSE - STUDY GUIDE contains vital information. VIDEO SEMINAR KITS ARE NOW AVAILABLE.

WPT PUBLICATION  
979 Young Street, Suite A  
Woodburn, Oregon 97071  
Phone (503) 981-5159

CIRCLE 177 ON FREE INFORMATION CARD

## MIDI PROJECTS



BP182—MIDI interfacing enables any so equipped instruments, regardless of the manufacturer, to be easily connected together and used as a system with easy computer control of these music systems. Combine a computer and some MIDI instruments and you can have what is virtually a programmable orchestra. To get your copy send \$6.95 plus \$1.25 for shipping in the U.S. to Electronic Technology Today Inc., P.O. Box 240, Massapequa Park, NY 11762-0240.

thermore, the Soviets were launching a massive jamming effort against the Voice of Israel, whose pleas for a more liberal emigre policy were not enthusiastically received in the Soviet Union.

The on-again, off-again nature of the Soviet jamming turned on-again in 1980, with the emergence of the Solidarity trade-union movement in Poland, as well as the growing world disenchantment with the Soviet invasion of Afghanistan. On August 20, 1980,

the USSR resumed jamming VOA, BBC, and Deutsche Welle broadcasts to the Soviet Union. Inasmuch as that effort had no effect on the continuing jamming against RFE, RL and Radio Israel, it is clear that the 1970 cessation did not result in the dismantling of the Soviet jamming system. Evidently, great numbers of transmitters had been mothballed in 1970, in the event of future need. That need arose in 1980.

The situation remained essentially unchanged until 1987, when,

as part of the Gorbachev thaw, jamming of the BBC broadcasts to the USSR ended in January, with VOA jamming ending in May of the same year.

Next time we will discuss the Soviet jamming system, how it works, how much it costs, and the countermeasures that have been taken against jamming and the success of those countermeasures. We'll also assess the impact of the cessation of jamming, who is still jammed, and what the outlook is for the future. R-E

## ASK R-E

continued from page 13

are designed to work off a single supply but the IC might not be as easy to find locally.

If you can use other amps—for stereo, or as the basis of a small distribution system—check out the LM324. It's a quad op-amp (four separate op-amps in one package) and you can use the same circuit that is shown for the 741 by tying  $-V$  and ground together. The LM324 was designed to work on a single-ended supply so you won't be making any compromises if you use it like that.

The circuit using the LM386 (3-B) runs off a single supply and has the

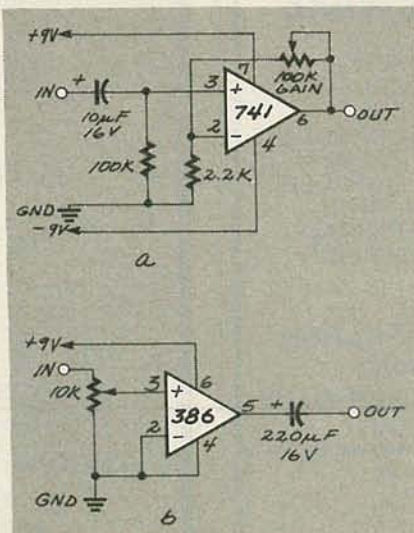

FIG. 3

advantage of being able to directly drive an 8-ohm speaker. Since you

never get something for nothing (unless that's what it's worth), you have to pay a price to drive a speaker and the currency is milliamps. Your battery won't last very long. Power consumption, however, is directly related to output load, so if you're feeding the amp into a 50K line input, you won't have a battery problem.

The frequency response of the 386 is pretty flat but the specs just aren't as good as the 741 circuit. That is particularly true with harmonic distortion, since the 386 has over 1% THD when you get above 12 kHz or so. However, the 386 amp is easy to assemble and will give you a maximum gain of 200, so it's a handy circuit to keep in the back of your brain. R-E



# PC SERVICE

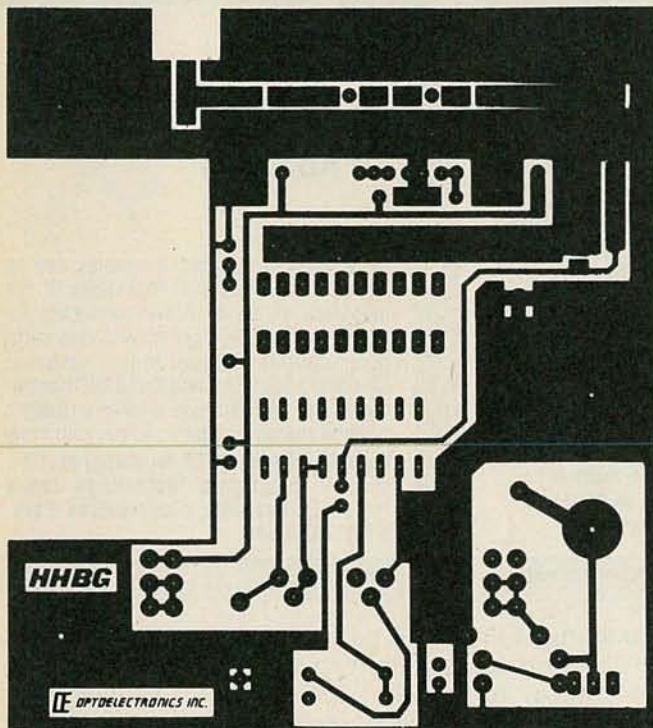

3 11/32 INCHES  
"SILKSCREENED" side of the bug detector.

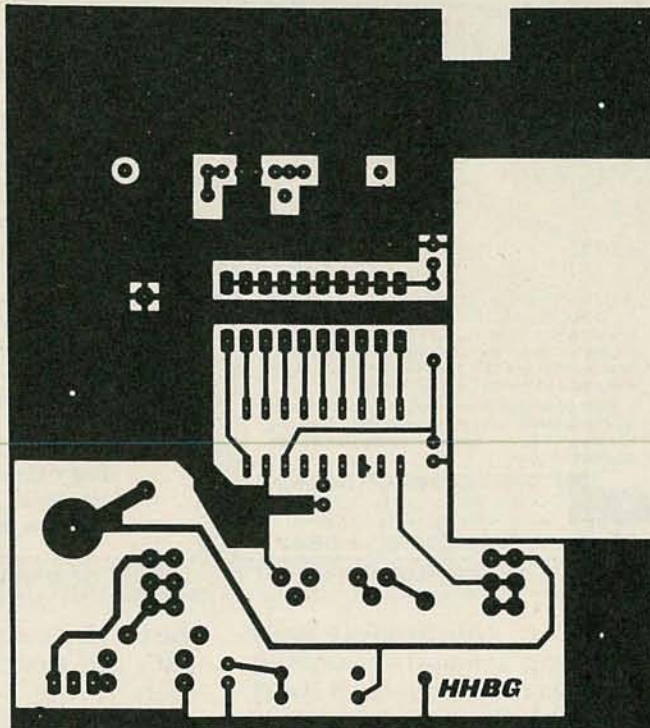

3 11/32 INCHES  
THE "FAR" SIDE of the bug detector.

**FREE CONCORD<sup>®</sup> TEST ACCESSORIES**  
**'89 CATALOG ELECTRONIC COMPONENTS & HARDWARE**



INCLUDING  
PATCH CORDS & JUMPERS  
RF COAXIAL CONNECTORS  
JACKS • PLUGS  
STANDOFFS & SPACERS  
TEFLON\* AND  
SOLDER TERMINALS  
P.C. JACKS & PINS

**MANY NEW PRODUCTS**

**CONCORD ELECTRONICS CORPORATION**  
30 GREAT JONES ST., NY, NY 10012

**1-800-847-4162 • Fax: 212-995-0161**

THIS IS YOUR LABEL—PLEASE PRINT CLEARLY

Please send me your new FREE '89 Catalog.  
NAME \_\_\_\_\_  
FIRM \_\_\_\_\_  
TITLE \_\_\_\_\_ DIV. \_\_\_\_\_  
ADDRESS \_\_\_\_\_  
CITY \_\_\_\_\_ STATE/ZIP \_\_\_\_\_

\*Teflon is Du Pont's registered trademark.

CIRCLE 187 ON FREE INFORMATION CARD

## CABLE - TV band - stop filters

- FOR ELIMINATION OF SEVERE INTERFERENCE
- FOR "CENSORING" OF ADULT BROADCASTS



- ATTENUATION - 45 dB TYPICAL
- BANDWIDTH - 4 MHz AT 5 dB POINTS
- INSERTION LOSS - 2 dB

MODEL	TUNING RANGE	FOR CHANNELS	PASSBAND	PRICE	SHIPPING/HANDLING
23H	50-66 MHz	2,3 (for 6 meter ham)	50-300 MHz	\$30	FREE
46FM	66-108 MHz	4,5,6 (or any FM)	50-300 MHz	\$30	FREE
1417	120-144 MHz	14(A) 15(B) 16(C) 17(D)	50-400 MHz	\$30	FREE
1822	144-174 MHz	18(E) 19(F) 20(G) 21(H) 22(I)	50-400 MHz	\$30	FREE
713	174-216 MHz	7,8,9,10,11,12,13	50-400 MHz	\$30	FREE

**3 for \$72 - 10 for \$180 - mix & match**

Call Toll Free For C.O.D. or Send Check To Order

**No Shipping Charges**

- Shipped Within 3 Days
- 30 Day Money Back Guarantee

**FACTORY DIRECT FROM**

**Star Circuits**

P.O. Box 8067

Pembroke Pines, FL 33084

**1-800-433-6319**



# COMPUTER DIGEST

## PUT A 386SX TIGER IN YOUR TANK!

BERNARD A. McILHANY

You think that you don't need a 386. And maybe you're right—today. You'll be dead wrong tomorrow; but even today you can use 386<sup>MAX</sup> and OMNIVIEW (which we'll examine in detail next month) to make your computing under DOS much more efficient and much more fun. If a graphic environment is your bag, Windows/386 is light-years ahead of Windows/286. Tomorrow, of course, OS/2 (or OS/3 or OS/386 or whatever it will be called) will offer applications as far beyond what we use now as present applications are beyond CP/M.

But you feel like the kid with empty pockets staring into a candy shop? Not to worry—we've got the solution. For less than \$700 (without memory) you can build a 386SX motherboard to upgrade your present AT clone or serve as the basis of a new sys-

tem. Our board features up to five megabytes of memory, one parallel and two serial ports, and an on-board floppy-disk controller.

Actually, the 16-MHz motherboard is built around an 80286 CPU and a special VLSI chip set. What we've done is design an 80386SX daughtercard that plugs cleanly and neatly into the 80286 socket to make 386 power affordable to everyone. There are no traces to cut or jumpers to run; just plug in the card and go! If your budget is extremely limited, you can build the motherboard with an 80286 (for \$465); later, when you're ready, you can add the 386SX daughterboard.

The prices quoted don't include RAM. For absolute top performance (zero wait states), you can populate the board with fast (70-ns) RAM's; if your budget is restricted, 100-, 120-, and 150-ns IC's also work, at varying performance penalties. A good balance between price and performance is provided by 100-ns IC's, which run at about 0.7 wait states.

The secret is a special chip set designed by Chips & Technologies. The NEAT (New Enhanced AT) set consists of four VLSI components that reduce the number of parts required in a standard AT design by about one third (from 100 to 29). The NEAT chip set uses CMOS technology, so it consumes about 60 percent less power than conventional-design components. In addition, it comes in 12-, 16-, and 20-MHz versions. Our motherboard uses components rated for 20-MHz operation, so to upgrade from 16 to 20 MHz, you'd only have to change a few components (CPU, clock oscillator, and NEAT IC's).

*continued on page 82*

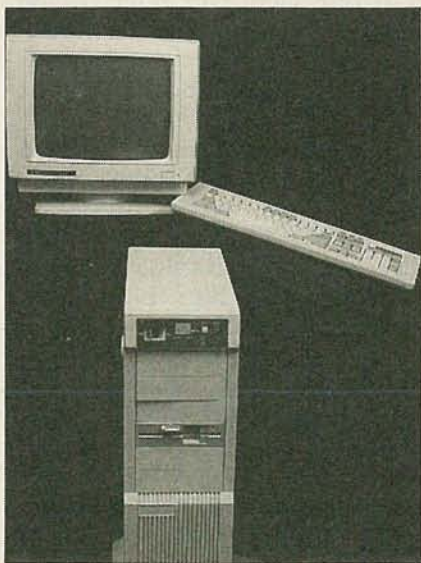

WE INSTALLED THE 386SX motherboard in a roomy tower case.

## EDITOR'S WORK- BENCH



JEFF HOLTZMAN

### Teletek X-Bandit EMS 4.0 Memory Board

One of the biggest advantages of the 80386 is, with the proper software, its ability to emulate EMS 4.0 memory. Conversely, EMS 4.0 memory can bring a bit of 80386 power to users of 8088 and 80286 machines. Because of the high cost of RAM IC's, memory boards are not the most popular upgrade items these days. However, memory prices are dropping, and a memory-board upgrade may be a better solution for many users than scrapping a perfectly good system for a new 80386. Further, a memory-board upgrade may be more affordable (in the short run, anyway) than a motherboard upgrade, which requires memory of its own.

Several vendors offer boards claiming compatibility with the EMS 4.0 standard, but many are limited in that they emulate the hardware page-mapping registers in software, and that software emulation can cripple the effectiveness of multi-tasking software.

Other vendors offer extremely flexible memory-allocation schemes that let you perform 386-like tricks, such as back-filling system memory to the 640K limit, and "overflowing" system memory to B000:0000 (Hercules) or even B800:0000 (CGA), thus providing 64K or 96K more contiguous memory for DOS.

Teletek, a company that got its



start selling S-100 bus peripherals for CP/M machines, sells several memory boards for 8- and 16-bit PC systems; I looked at the 8-bit X-Bandit. The board can hold as much as two megabytes of RAM (in 41256 IC's); you can install as many as four boards in a single system, for a total of eight megabytes of RAM. The 8-bit board has one set of hardware memory-mapping registers, and an extremely versatile ability to re-map memory. It's also cheaper (\$229) than any other true EMS 4.0 board on the market. The 16-bit version has 7 sets of hardware registers, which makes for even more efficient task swapping; it lists for \$259.

I installed the board in a generic XT clone with a Hercules monochrome Graphics Card Plus video adapter. Originally, the machine had 640K on the motherboard, along with a Microsoft Mach 20 accelerator card with 1.5MB of EMS 4.0 memory. I was unsuccessful in getting the X-Bandit to run with the Mach 20; I suspect the Mach 20's memory-caching driver to be the culprit.

After determining that the X-Bandit wouldn't get along with the Mach 20, I removed the latter and stripped system-board memory to 256K. Then I let the X-Bandit fill in the gap all the way to B000:0000, which gave me a 704K DOS partition, of which a memory utility told me that 637,952 bytes were available after booting and loading the X-Bandit EMS driver. An XT with an EGA or VGA video system would have about 570K of memory after booting.

Why did I remove the system-board memory? Because the larger the chunk of memory that a multitasking environment (OMNIVIEW, for example) can control, the more efficiently it can operate. True, I lost 384K of memory, but I found the compromise worth it. In fact, I found it more efficient to use the XT with back filling and overfilling than with the Mach 20 and 640K installed on the motherboard. CPU-intensive tasks (like decompressing ARC files) ran slower, but task swapping under OMNIVIEW was faster and smoother.

Over the course of several months, I received several versions of the EMS software driver; all versions had trouble dealing with my 101-key enhanced keyboard under DESQview; however, I experienced no problems under OMNIVIEW.

The X-Bandit doesn't come with fancy packaging or documentation, but it does come with a RAM disk and a print spooler. If you're looking for a way to upgrade an XT, and have some spare 41256's, the X-Bandit's versatility and low price make it an extremely good buy. **CD**



### Get Organized With ViewLink

**H**ard disks fill up and files get lost; it's a fact of life with PC's. Of course, numerous utilities exist for locating files by name and by contents; but those types of utilities do nothing to solve the real problem: the fact that even DOS's two-dimensional directory structure does not allow proper organization.

You might, for example, organize your hard disk with separate subdirectories for each main program you use (Q&A Write, VP Planner, and PC-File, for example), one for all the little utility programs, and several data directories, say, for letters, spreadsheets, and databases.

But suppose you're working on a big project (possibly with several other people over a network), with several related files. It's a pain to keep track of all those files in the scheme previously outlined, so you create a special project subdirectory where all the letters, spreadsheets, graphics files, and whatever else has to do with that project are stored.

Six months down the road someone comes asking for a copy of the letter to Mr. Trimble. With

System	Views	Items	Tagging
APPLICATIONS	385X.WKS	4020	Feb 15 16:43:02 1989
CP	BENCH.WKS	19588	Nov 02 11:36:24 1988
LDOS	TEST1.WKS	1361	Jan 04 21:28:26 1989
PC	LIST.WKS	13714	Feb 20 17:59:10 1989
PCPLUS	MIPS.WKS	3133	Mar 13 13:44:54 1988
QUIT	PHONES.WKS	3535	Feb 10 15:54:10 1988
VP	FORTRAN.WKS	7561	Nov 02 15:45:08 1988
SEARCH	HANSHI.WKS	38294	Nov 12 12:44:34 1987
VIEWS	TEST.WKS	186467	Feb 10 13:10:30 1989
VP	TURBOC.WKS	13471	Dec 11 12:00:02 1987
	VGA16.WKS	13076	Dec 01 14:23:20 1988

FIG. 1

pride in your well-maintained directory structure, you immediately change to LETTERS—but can't find anything to Trimble. It takes a few minutes, but eventually you remember that that's one of the files you stored in the special project directory.

ViewLink is Traveling Software's attempt to provide a tool that solves what is really a three- or four-dimensional organizational problem. The current version runs under DOS 2.0 or higher, and requires 384K of RAM, the company states that a version for the OS/2 Presentation Manager will be released by the end of the year. I examined version 1.0; version 1.1, which should be out by the time you read this, has support promised for EMS memory, a mouse, and more (see Fig. 1). Purchasers of 1.0 get a free upgrade to 1.1.

With ViewLink you create *views*, each of which is a list of items or other views; each *item* is a pointer to a file (either a data file or an application program). More than one view can refer to the same items. Thus, in the example above, one view might contain *all* letters; another might contain *all* files related to a particular project. Thus, letters to Trimble that are really part of the special project may be stored either in LETTERS or the special directory; to ViewLink, the actual locations of the files in question are basically irrelevant.

ViewLink works by letting you get into an application program from an item. For example, you can bring up a spreadsheet view, scroll through the list of spreadsheet items (i.e., worksheets, each of which may have a descriptive annotation), and then run the spreadsheet pro-



# HOW TO INSTALL A TAPE BACKUP UNIT



HEATHKIT's HBT-40-AT Streaming Tape Drive, shown with external mounting hardware, offers peace of mind for hard disk users.

*Your hard disk is inevitably going to crash. A good backup system makes it an inconvenience instead of a disaster.*

**BRIAN FENTON**

**J**ust as most home-security systems aren't installed until after a house has been burglarized, most hard-disk backup systems aren't installed until after a disk crash has caused a disaster. In either case, the lesson is a painful one.

If you have important data on your hard disk, you're inviting catastrophe if you don't back it up regularly. If the inconvenience of floppy disks stops you from backing up your data as often as you should, it's time to install a tape-backup unit. We recently chose Heathkit's HBT-40 streaming tape-drive kit to back up a 40-megabyte hard-disk drive in an AT clone to show how easy it can be. We got everything up and running in less time than we normally spend backing up to floppy.

## Why tape backup?

Streaming tape drives aren't the only way to back up your hard disk. We all know that backups can be done with a floppy disk drive and DOS's BACKUP and RESTORE commands—if you're willing to spend an entire afternoon doing it. If you have about 30 megabytes worth of files on your hard disk, you're going to need about 90 360K floppy disks to complete a backup! While that inconvenience is bad enough,

the result is even worse. Human nature being what it is, the prospect of swapping and labeling 90 floppies usually means that the task is put off—until it's too late.

Many software manufacturers have produced new programs that are miles ahead of DOS's BACKUP and RESTORE. Menu-driven programs make it easy to choose which files to backup, and they can be configured to operate almost automatically. But they are still no match for a streaming tape drive and tape cartridge.

The most popular tape-backup systems today use DC-2000 tape cartridges. The most popular tape format for PC's follows the QIC-40 standard (developed by the Quarter Inch Compatibility committee), which arranges 20 tracks across the width of the tape, each track holding about 2 MB. The result is that those smaller-than-shirt-pocket-sized cartridges can hold up to 40 megabytes of data.

Heathkit's drive closely follows the standard. We should point out, however, that even with the QIC-40 standard, you may not be able to transfer tapes between QIC-40 drives from different manufacturers. The tape file structure is not specified by the standard, resulting in unpredictable transfers.

Heath offers two streaming tape drives: the HBT-40-XT and the HBT-40-AT for XT and AT computers, respectively. The difference between the two models is speed, and is brought about because QIC drives use the PC's standard floppy-disk controller for data transfer. AT-type control-

lers can transfer data at 500 kilobits per second (as opposed to the XT's rate of 250 kb/s), thus making the two versions necessary. Of course, it is possible to use the XT version in an AT, but it will run at half the speed. The converse is not true. Tapes produced by either of Heath's drive—regardless of which machine they're made in—are compatible with the other.

The heart of the Heathkit backup system is an XL5540 tape drive manufactured by Archive Corp. That rugged drive can mount in both 3½ or 5¼-inch drive bays, or, as we chose, an external case—a decided advantage if your drive slots are already full! Speaking of full drive bays, you may be wondering how a standard AT drive controller can support two floppies along with a third device. The answer is an adapter card that intercepts signals from the disk controller. For external systems, the card provides a rear connector for signals and power.

Although Heathkit's system is technically a kit, it's simple enough for anyone to build. Most of the work involves simply installing the drive in an external shielded case. Mounting the drive internally—if your computer can support it—is about as complicated as installing a new floppy-disk drive. As we'd expect from Heath, the manuals detail everything step-by-step, leaving no questions unanswered. The only problems we ran into were caused by an incompatible disk controller card in our AT clone.

*continued on page 86*



## 386SX MOTHERBOARD

continued from page 79

### Neato!

The NEAT set has a plethora of features that are worth describing; one of the best is its extremely versatile ability to handle memory, including types of IC's and speed, how memory is allocated (conventional, extended, and EMS 4.0 are all supported), and whether RAM is used to "shadow" the ROM BIOS. (Shadowing involves copying the contents of a slow ROM or EPROM into RAM and then physically mapping the ROM out of its normal address space, and mapping the RAM in). All of that is under software control, as are all NEAT features, so system setup and maintenance is simple.

To get started, you can populate the PT-386-PLUS motherboard with 512K, 640K, or 1M of DRAM in standard DIP packages. In addition, the motherboard has four SIMM (Single Inline Memory Module) sockets on the motherboard, into which you can install either two or four SIMM's. That means that you can install 512K, 640K, 1M, 3M, or 5M of memory directly on the motherboard; through the standard bus, you can expand the system to a full 16 megabytes of memory.

### Paged/interleaved memory

For best performance, the PT-386-PLUS uses two of today's leading memory-design techniques; most systems use one or the other. First is page-mode memory access. In a computer *without* page-mode architecture, both a RAS strobe and a CAS strobe must be generated for each memory location that is accessed. In a page-mode system, however, first a row address is presented; then

the RAS line is held low. Subsequently, any memory location in the current page may be accessed simply by generating a column address and a CAS strobe. (The page size for 256K DRAMS is 9 bits or 512 bytes; for 1024K DRAMS the page size is 10 bits or 1024 bytes.) Since a RAS strobe is not generated unless the memory request falls outside the current page, data can be accessed in about half the usual time.

However, if the required memory location is not within the current page, a new RAS address must be generated before data can be retrieved. The penalty when a RAS page boundary is crossed is that wait states will be generated. But programs typically access several addresses sequentially, so sustained operation on a single page is fairly common.

The second memory architecture used by the PT-386-PLUS is called interleaved memory, in which memory is divided into two (or sometimes four) banks, each of which is alternately accessed under most circumstances. Most interleaved memory designs require sequential memory accesses for no-wait-state operation, so that the RAS precharge time of one memory bank overlaps the access time of the other bank. That means that an access that is *not* sequential can cause a wait state.

The combination of page-mode and interleaved memory in the PT-386-PLUS results in RAS page boundaries occurring at 1K-byte intervals. That means that any access within the 1K-byte boundary can occur without a RAS cycle, which effectively cuts the memory access time in half. When a memory access crosses a 1K boundary there is a page miss, requiring that a new page be selected; in addition, a wait state will be generated for the first access to the new page.

The typical "hit rate" for standard interleaved memory designs is around 50 percent. Essentially, the higher the hit rate, the lower the average number of wait states. In page/interleaved-mode, a 100% hit rate can, in theory, never be achieved. However,

### Harness that 386

The 80386 and 80386SX microprocessors are more than just fast 80286's. With the right software, you can maximize your DOS memory space, perform multitasking, or both.

386<sup>MAX</sup> is a utility program that taps the microprocessor's ability to physically map memory. With it, you can fill out a 512K motherboard with extended memory; you can load TSR's (SideKick, disk caches, keyboard enhancers, etc.) into memory above the first 640K, leaving 600K or more of contiguous DOS memory; and other tricks.

OMNIVIEW is a multitasking environment that runs on all Intel 80xxx family processors. (Watch for a detailed feature article next month.) With OMNIVIEW you can download information from your favorite BBS while simultaneously typing in your word processor; you can also switch instantly among several tasks.

SunnyHill Software has arranged special 30% discounts off the list prices of OMNIVIEW and 386<sup>MAX</sup> for readers of **Radio-Electronics**. OMNIVIEW normally lists for \$89.95; the discount price is \$62.95. 386<sup>MAX</sup> normally lists for \$74.95; the discount price is \$52.45. Order both from SunnyHill Software, P.O. Box 33711, Seattle, WA 98133-3711. (800) 367-0651; (206) 367-0650. Be sure to mention this article.

when page/interleaving-mode memory access is used, as in the PT-386-PLUS, typical hit rates may exceed 80 percent.

What does page/interleaved memory operation mean in terms of performance and cost? When operating at a 16-MHz clock rate with zero-wait-state memory, 60- or 70-ns DRAM's are required. When page mode is combined with interleaving, near-zero-wait-state operation can be achieved with 100-ns DRAM's.

### Bus synchronization

In the PT-386-PLUS the clock speed of the CPU and the speed of

### Acknowledgements

Peripheral Technology would like to acknowledge the exceptional assistance and cooperation of Chuck Link of Chips and Technologies and Eric Koch of The Novus Group.



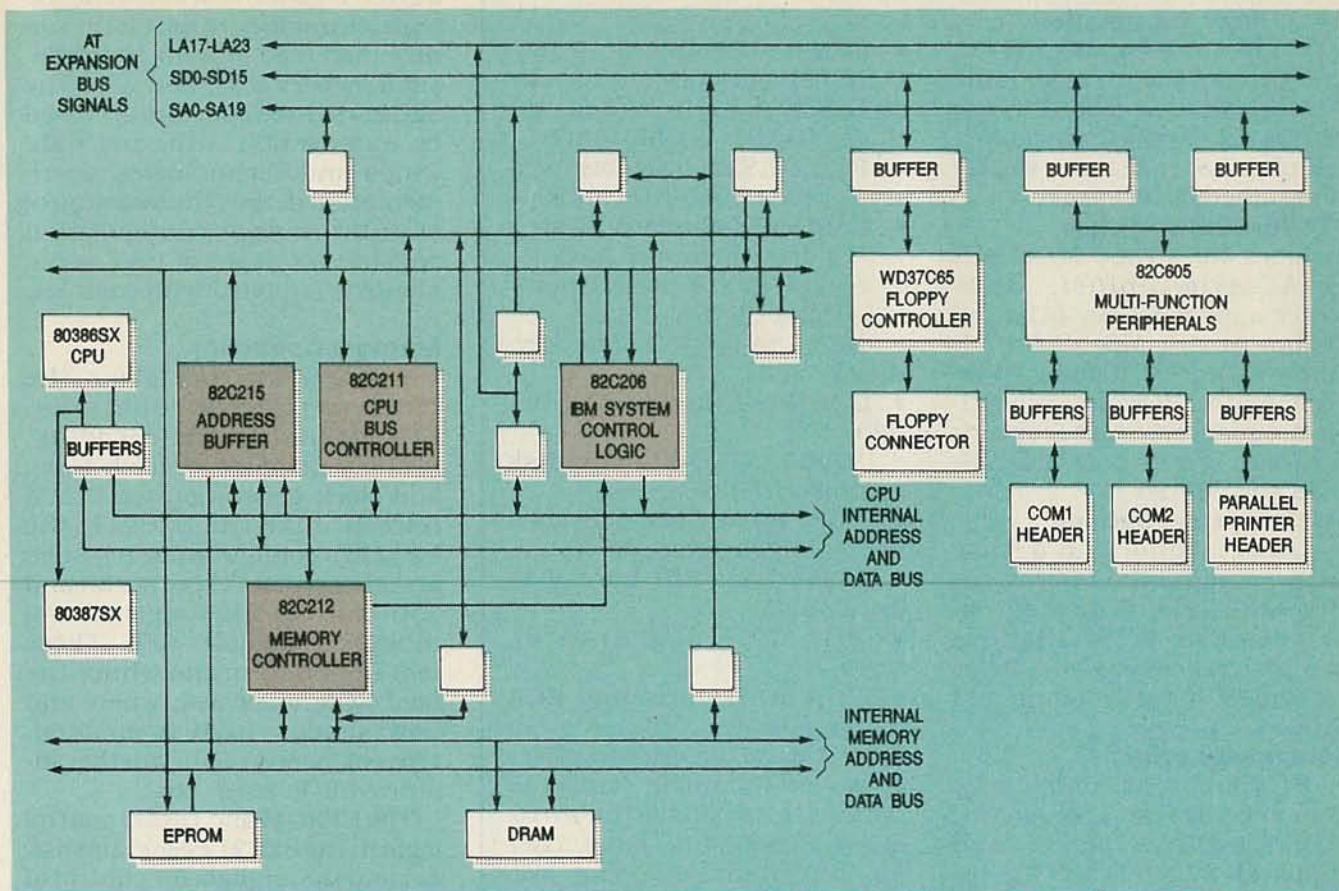

**Fig. 1. PT-386-PLUS BLOCK DIAGRAM.** The system is built around Chips & Technologies' NEAT CHIPset, a single-chip floppy-disk controller, and a peripheral controller with two serial and one parallel ports. The complete 80386SX-based motherboard can be built for less than \$700 (not counting RAM).

the AT bus needn't be the same. If they were the same, and a CPU ran any faster than 8 MHz, then

#### Editor's Note

I tested the 80386SX version of this board extensively and found no incompatibilities whatsoever. Test software included: Windows/386, 386<sup>MAX</sup>, OMNIVIEW 4.12, Lotus 1-2-3, several word processors and database managers, and numerous small utility programs.

The board's performance is approximately equal to that of the Compaq 386s, an 80386SX design that costs about \$5000 with a fast 40-megabyte hard disk and VGA video system. With judicious purchasing, you should be able to put together a comparable system based on the PT-386-PLUS for about 60% of that amount, or even less if you go for a monochrome system and a slower hard disk.—  
*Jeff Holtzman*

there could be problems with slow peripheral devices. (For that reason, it's advantageous to fill out the on-board SIMM memory before adding memory via the bus.) Further, the NEAT set supports fast switching between real and protected modes, which results in as much as 20% better performance under OS/2 than conventional designs. It also increases the performance of RAM disks and other DOS applications that use extended memory.

Not part of the NEAT set, but equally important, are the on-board peripheral controllers, including: a floppy-disk controller (for 5.25-inch drives in both 360K and 1.2M formats, and for 3.5-inch drives in both 720K and 1.44M formats), a standard parallel printer port, two standard RS-232 serial ports, and a real-time clock, all of which are under software control.

As for the basics, the PT-386-PLUS board has the full-size AT format, two 8-bit (XT) slots, six

16-bit (AT) slots, and it accepts a 101-key or AT-style keyboard. It comes with a BIOS ROM with a built-in setup program and extensive diagnostics.

To put things in perspective, those features give you the ability to build a five-megabyte system, with a hard disk and video adapter, and still have six free expansion slots! On the other hand, to get a minimal system up and running, you have to add only a single floppy drive and cable, a video adapter and monitor, a keyboard, and a power supply.

#### System overview

The NEAT set consists of a CPU/bus controller (82C211), a memory controller (82C212), an address/data buffer (82C215), and system control logic (82C206). Figure 1 shows a block diagram of the system; the basic system-control devices are shown on the left and the peripheral devices on the right.

Let's discuss the NEAT devices



### Price Information

Peripheral Technology (1710 Cumberland Point Drive, Suite 8, Marietta, GA 30067 (404) 984-0472) is selling parts kits, complete systems, and a variety of peripherals, as follows.

#### PT386-Starter-system

Includes the PT386-PLUS KIT, an AT-style cabinet, 200W power supply, 84-key (AT-style) keyboard, 1.2-MB 5.25-inch floppy-disk drive, Samsung amber monitor, Hercules-compatible monochrome text/graphics card with printer port, and MS-DOS 4.01: \$1195

#### Starter system options

For EGA monitor and display adapter, add \$400.00; for 20-MB hard-disk drive and controller, add \$349; for 40-MB drive and controller, add \$485.00; for assembled and tested unit, add \$100.

#### Component prices

- PT386-PLUS-KIT (includes system board, daughterboard, BIOS, 16-MHz 80386SX, and support IC's. DRAM and the optional 8037SX math coprocessor not included), \$695
- PT386-PLUS-ASM (assembled version of the PT386-PLUS), \$795

- PT286-KIT (same as PT386-PLUS KIT but does not include 80386SX daughterboard. Includes 16-MHz 80286), \$465
- PT286-ASM (assembled version of the PT286-KIT), \$495
- CABINET (standard AT style with 3 drive openings), \$65
- PS-200 (200W power supply for AT case), \$70
- KEY (84-key AT-style keyboard), \$60
- DOS (MS-DOS version 4.01), \$80
- AT1003 (Hard/floppy disk controller), \$139
- DISK 1.2 (1.2-MB 5.25-inch floppy-disk drive), \$109
- 20MEG (20-MB hard disk drive), \$230
- EGA (EGA display card), \$189
- EGA MON (Samsung EGA monitor), \$360
- DRAM, call for current prices
- Notes: Complete catalog of options is available upon request; PT386-PLUS kits add \$7 for UPS ground shipping, systems add \$22, other items additional. VISA/MC orders accepted without surcharge. Technical assistance and repair service available. Georgia residents add appropriate sales tax.

first. The PT-386-PLUS contains a local CPU bus, a 16-bit system memory bus, and the AT expansion bus. The 82C211 synchronizes and controls all buses; it also provides an independent AT bus clock speed that may be set by the user under software control. In addition, wait states and command delays to the AT bus may be programmed to allow for either fast or slow peripherals. The 82C211 also provides DMA control, refresh logic, numeric coprocessor interface logic, and configuration registers.

The 82C211 has two reset inputs and two reset outputs. RESET1 is the power-good indicator from the power supply. RESET2 is generated from the keyboard controller. The two outputs (RESET3 and RESET4) are activated in various combinations depending on the type of reset desired. For

example, when a cold (power-on) reset is required, RESET3 and RESET4 are both activated. When a warm boot is required (Ctrl-Alt-Del) RESET3 is activated. RESET3 and RESET4 may be activated in other combinations when a shutdown sequence is detected by the processor.

The 82C211 is what sets processor and bus speeds. The IC has two clock inputs, CLK2IN and ATCLK, either of which may be directed to the processor bus and the expansion bus. The processor may be driven by CLK2IN directly, by  $(CLK2IN \div 2)$ , or by ATCLK; the bus can also be driven by any of those signals. The source is determined by a setup program. (Setup and operation will be discussed next time.)

There are three bytes of indexed configuration registers in the 82C211. I/O port 22h is used as an indexing register. To access

a given register, first you write the register number to port 22h. You may then read or write to the desired register at I/O port 23h. The 82C211's three bytes are accessed by indexes 60h, 61h, and 62h. Chips and Technologies' documentation details the meaning of each bit in each configuration register; a full set of C&T documents is supplied with each kit.

#### Memory controller

The 82C212 performs the memory-control functions: EPROM and DRAM decoding, memory mapping, refresh logic, and clock generation for DRAM refresh. Like the 82C211, the 82C212's configuration registers are accessed at I/O ports 22h and 23h, but the 212's registers are indexed from 64h-6Fh. These registers determine where the boot ROM is located, where and how shadow RAM is enabled, types of memory IC's, whether interleaving is used, etc.

The EPROM and DRAM control logic in the 82C212 generates RAS, CAS and MWE signals for control of DRAM. The 212 also generates a ROMCS signal for enabling the BIOS EPROM. In addition, the control logic generates READY for indicating to the CPU when the current memory operation is complete; the appropriate number of wait states are inserted, according to how the 212's wait-state register has been programmed.

The 82C211 and 82C212 chips jointly handle the refresh chores. The timing for the refresh task is generated by an oscillator circuit in the 82C212. (A 14.31818-MHz crystal is connected to the 82C212; its output is divided by 12 to generate a 1.19381-MHz clock.) A separate counter is maintained for each RAM bank; when each counter times out (in about 9 clock cycles or 10  $\mu$ s), a refresh request is generated.

Why is a separate counter maintained for each bank, rather than simply refreshing all banks simultaneously? When a DRAM chip is refreshed it draws hundreds of milliamps, albeit for only a very brief time. However, when refreshing a large number of DRAM's, several amps of current



# R-E Computer Admart

Rates: Ads are 2 1/4" x 2 7/8". One insertion \$900. Six insertions \$875. each. Twelve insertions \$845. each. Closing date same as regular rate card. Send order with remittance to Computer Admart, Radio Electronics Magazine, 500-B Bi-County Blvd., Farmingdale, NY 11735. Direct telephone inquiries to Arline Fishman, area code-516-293-3000. Only 100% Computer ads are accepted for this Admart.

## SECRETS OF THE COMMODORE 64



**BP135**—A beginners guide to the Commodore 64 presents masses of useful data and programming tips, as well as describing how to get the best from the powerful sound and graphics facilities. We look at how the memory is organized, random numbers and ways of generating them, graphics-color-and simple animation, and even a chapter on machine code. Get your copy today. Send **\$5.00 plus \$1.25 for shipping** in the U.S. to **Electronic Technology Today Inc., P.O. Box 240, Massapequa Park, NY 11762-0240.**

## A PRACTICAL INTRODUCTION TO MICROPROCESSORS

A Practical Introduction to Microprocessors

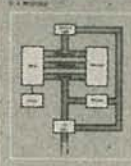

**BP123**—Introduces microprocessors by having the reader construct a very simple microprocessor circuit that he can experiment with and thus hopefully gain a clear insight into this complex subject. The completed unit is only intended as an education aid, but can be built inexpensively and many of the parts can be reused for other applications later. Get your copy for **\$5.00 plus \$1.25 for shipping** in the U.S. from **Electronic Technology Today Inc., P.O. Box 240, Massapequa Park, NY 11762-0240.**

## ICs PROMPT DELIVERY!!!

SAME DAY SHIPPING (USUALLY)  
QUANTITY ONE PRICES SHOWN FOR MARCH 26, 1989

OUTSIDE OKLAHOMA NO SALES TAX

DYNAMIC RAM			
SIMM (1)	256Kx36	80 ns	\$460.00
SIMM	1Mx9	80 ns	295.00
SIMM (2)	1Mx9	85 ns	225.00
SIMM	256Kx1	60 ns	125.00
1Mbit	1Mx1	100 ns	20.95
41256	256Kx1	60 ns	11.25
41256	256Kx1	80 ns	10.85
41256	256Kx1	100 ns	8.95
51258 (3)	256Kx1	100 ns	10.50
41256	256Kx1	120 ns	8.25
41264 (4)	64Kx4	120 ns	14.50
EPROM			
27C1000	128Kx8	200 ns	\$28.50
27C512	64Kx8	200 ns	13.95
27256	32Kx8	150 ns	8.15
27128	16Kx8	250 ns	4.75
STATIC RAM			
62256P-10	32Kx8	100 ns	\$23.50
6264P-12	8Kx8	120 ns	9.50
6116AP-12	2Kx8	120 ns	5.50

OPEN 6 1/2 DAYS, 7:30 AM-10 PM SHIP VIA FED-EX ON SAT.

SAT DELIVERY INCLUDED ON FED-EX ORDERS RECEIVED BY: The 9th Air 363 B Ft Ft 112551 B  
MasterCard/VISA or UPS CASH COD MICROPROCESSORS UNLIMITED, INC. 24,000 S. Peoria Ave. BEGGS, OK, 74421 (918) 267-4961  
No minimum order. Please note: prices subject to change! Shipping, insurance extra, up to \$1 for packing materials.

CIRCLE 61 ON FREE INFORMATION CARD

may be required from the power supply for a few nanoseconds. Most power supplies simply are not able to respond that quickly, and the result is spikes or noise on the power line. Staggering DRAM refresh reduces the noise generated by the power supply during refresh.

### Data/address buffer

The 82C215 provides data and address buffers, bus conversion logic for 16-bit to 8-bit transfers, and parity generation and detection logic. Unlike the NEAT family members discussed so far, the 82C215 has no configuration registers. The IC's buffers isolate the CPU from the local and expansion buses.

### Glue

The 82C206 contains the real-time clock and CMOS RAM that are standard parts of any AT system board. The 206 also handles interrupts and DMA requests, and it provides "glue" logic to tie the system together. The 82C206 requires a battery to power the CMOS RAM and real-time clock when the computer is turned off.

In addition to the four major IC's of the NEAT set, the PT-386-PLUS has two other major VLSI IC's: the WD37C65 and the

82C605, which provide onboard control of key peripheral devices.

### Floppy-disk controller

The WD37C65 is a single-IC floppy-disk controller that contains all circuitry necessary to control two floppy-disk drives. In older systems, a floppy-disk controller might require as many as 20 IC's; with the WD37C65, only three are required, including a data-bus buffer, an I/O port decoding PAL, and the WD37C65 itself.

### Peripheral controller

The 82C605 contains one parallel printer port and two UART's (Universal Asynchronous Receiver/Transmitters) that are compatible with standard 6450 devices. A big advantage of the

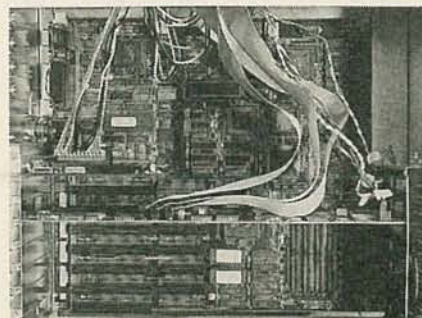

THE 386SX MOTHERBOARD is shown here. We'll talk about building it next time.

82C605 over traditional devices are the configuration registers that allow peripherals to be disabled or re-assigned to other addresses in the event of conflict with some other device. Since these registers are configurable by a software program, the user doesn't have the hassle of opening up the case, hunting for the dip switches, fumbling for the correct page in the hardware manual, and so forth.

We'll present complete construction details next time. **CD**

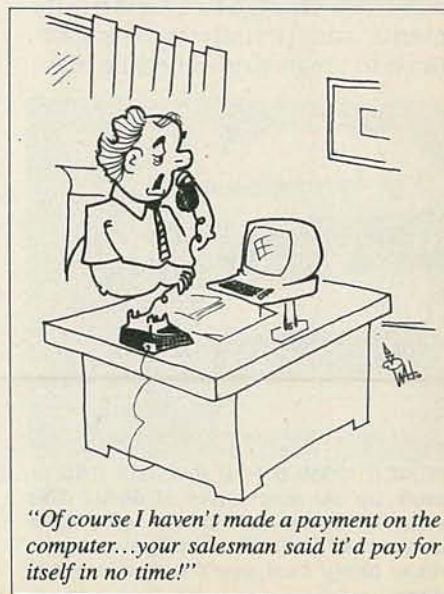

"Of course I haven't made a payment on the computer...your salesman said it'd pay for itself in no time!"

JUNE 1989



## EDITOR'S WORKBENCH

continued from page 80

gram just by pressing the Enter key; up will pop 1-2-3 with the desired file loaded and ready.

Or you could bring up the Special Project view and run either your word processor or your spreadsheet, etc., depending on the type of the file you choose. ViewLink can learn what program to run for a given data file automatically by enabling the "autolink" feature. You can also set up links manually.

One real strong point is the ability to hot-link from one application to another, almost like a multitasking environment. For example, if you're in the middle of WordStar and need some information from a linked spreadsheet file, you can hot-key directly to 1-2-3, which will bring up the desired file automatically. You can then capture data from the screen, hot-link back to WordStar, and transfer the infor-

mation into your document. Unlike a multitasker, however, ViewLink does not keep the switched-from program loaded in RAM (much less running); rather, it must close one and then open another application.

From the factory, the program supports many common applications (AskSam, dBASE, GrandView, Lotus 1-2-3, Microsoft Word and Works, most of the PFS series, Quattro, Sprint, SuperCalc 4, WordStar, XyWrite, among others); provision is made for adding your own.

One problem, as you might suspect, is that to use ViewLink effectively, you must use it religiously. Actually, Traveling Software provides a means of updating View lists after creating files outside the ViewLink domain, so you really needn't be obsessive about it. Even so, greatest efficiency will be gained by using ViewLink as a kind of "control center" for launching all your software applications.

ViewLink is a clever program; if

you pride yourself on organization but have trouble maintaining a suitable structure, it could be a big help. A prime target is a manager responsible for maintaining multiple multi-file projects simultaneously. Just be aware that, like most personal information organizers, proper use of ViewLink will require some serious mental effort, and an ongoing commitment. ViewLink is a great hammer, but it won't drive the nails for you. **CD**

### PRODUCTS REVIEWED

- X-Bandit-8 (\$229), X-Bandit-16 (\$259), Teletek Enterprises, Inc., 4600 Pell Drive, Sacramento, CA 95838, (916) 920-4600.

CIRCLE 50 ON FREE INFORMATION CARD

- ViewLink (\$149.95), Traveling Software, Inc., 18702 North Creek Parkway, Bothell, WA 98011, (206) 483-8088.

CIRCLE 49 ON FREE INFORMATION CARD

## TAPE BACKUP

continued from page 81

### Putting it to work

The HBT-40 is supplied with menu-driven *HeathStream* software (which is evidently a re-named version of Archive's *QICstream* program). The main menu lets you back up to tape, restore from tape, display a tape's directory, change to a tape utility menu, and, perhaps most important, to create and schedule mac-

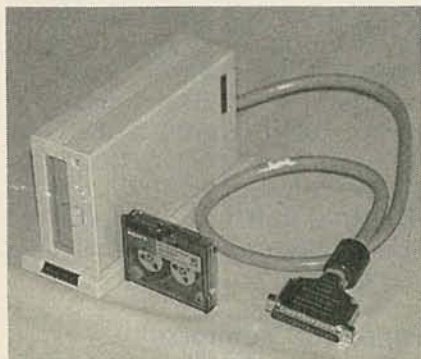

**IF YOUR DRIVE BAYS are already full, you'll want to use an external case.**

ros. The macros let you automatically perform backups, restores, and the like, unattended, at dates and times you schedule in advance. The HBT-40 supports only file backups—support for image backups is not provided.

Backing up 40 megabytes on the HBT-40 isn't fast, but the same is true for any DC-2000 drive. HeathStream software keeps you informed of its progress as the tape winds seemingly endlessly back and forth. It even displays a time-line that reports the approximate length of time remaining for the selected

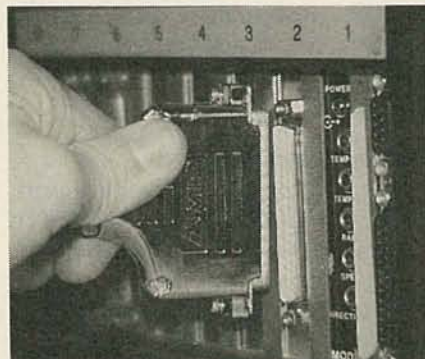

**THE EXTERNAL DRIVE CONNECTS TO an adapter card which provides power, data, and control.**

operation. Since formatting a tape to hold 40 megabytes takes about 45 minutes—and actual backups seem only slightly faster—the time line and progress information, if nothing else, is comforting.

The HBT-40 is available for \$379 and \$389 for the XT and AT versions respectively. For external mounting, the HBT-40-SD and HBT-40-HZ are \$139 and \$199 for XT's and AT's respectively. Are they worth it? When your hard disk suffers that inevitable crash, they're worth their weight in gold! **CD**

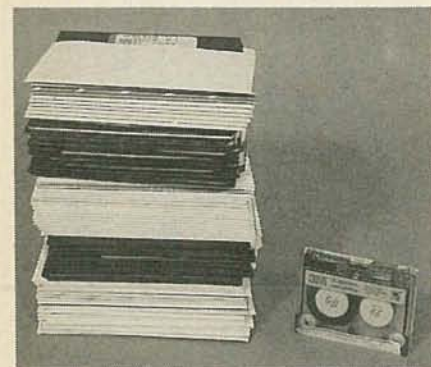

**WHICH WOULD YOU RATHER USE to back up 30 megabytes of data? The stack of ninety disks on the left can do it, but the DC-2000 cartridge makes it more likely that you'll actually get it done.**



# AUDIO UPDATE



LARRY KLEIN,  
AUDIO EDITOR

## How Important is Slew Factor?

IN THE LAST DECADE OR SO, MOST JAPANESE and some U.S. audio-equipment manufacturers have devoted enormous amounts of effort to the discovery of previously unrecognized forms and sources of audible distortion. Their purpose, aside from a desire to advance the state of the audio art, was to promote their latest products that embodied their proprietary cures for the newly discovered diseases. The true seriousness of their concerns can best be judged by the rapidity with which each year's distortion and its cure is abandoned in favor of a new problem and its so-called solution.

One of the most durable of the "nouveau" distortions is *Transient Intermodulation Distortion (TIM)*, which—despite my efforts during my service on the 1975 IHF Standards Committee—made its way into the current amplifier Standard (RS-490). Hailed by some manufacturers as a major source of audible distortion not revealed by conventional testing, the cause and cure of TIM was actually discussed in the early Fifties—although not by that name. Several articles dealing with feedback-induced slewing distortion in tube amplifiers are cited in the Fourth Edition (1952) of the classic *Radiotron Designer's Handbook* under the heading "Overloading of Feedback Amplifiers on Transients."

We seldom see figures for transient intermodulation distortion listed in amplifier spec sheets because there's no general agreement as to the best way of



FIG. 1

measuring it. However, Slew Factor, which relates to TIM, appears frequently. Exactly what is "slewing?" My dictionary of electronics describes slew rate as the rate at which the output of an electronic circuit or device can be driven to the limit of its dynamic range. When it appears in spec sheets, slew rate is given in volts per microsecond. In other words, the "speed" of the circuit's response enables it to go from zero to X volts in one millionth of a second. That sort of response is easily viewed on an oscilloscope. When an amplifier is unable to slew (change) its output rapidly over its full

range, it is reflected by a high-frequency response that falls as the signal output level increases. That is the reason that amplifier spec sheets usually give a very wide frequency response at low power levels, and a somewhat reduced high-frequency response at full output power.

When a transient reaches a high level very quickly—in other words, a fast rise-time—it (theoretically) can exceed the ability of an amplifier using overall negative feedback to "track" it. In such a case, the negative-feedback signal from the output of the amplifier returns to the input too slowly to prevent



the input stages from being driven by the input transient into momentary overload. The overload is the cause of TIM.

On a theoretical level, there are several ways to minimize or eliminate TIM: (1) The response speed of the entire amplifier can be made fast enough (which is to say, its bandwidth wide enough) to prevent the time delay in negative feedback; (2) the amplifier can be designed without the negative feedback that produces the problem; or, (3) the bandwidth at the amplifier input can be limited so that the high-frequency components in the program are never faster than the frequency capabilities of the following stages. All of those techniques are effective, but in my view, option (3) represents the best engineering practice. Not only is it the least expensive way to go, but it also keeps ultrasonic and radio-frequency signals out of the amplifier circuitry where they could only cause trouble.

#### Testing TIM

Many manufacturers have devised complex and non-comparable tests to measure TIM and are pleased to tell you about them in their literature. The simplest and easiest one to interpret is the Slew Factor (SF) measurement found in the EIA amplifier standard mentioned earlier. The amplifier under test is driven to its full rated output with a 1,000-Hz test signal. Then, without changing the test signal's amplitude, its frequency is raised until the total harmonic distortion of the output signal hits 1 percent. The Slew Factor number is derived by dividing the highest frequency achieved before distortion by 20,000 (Hz). An amplifier that is able to deliver say, 40 kHz, before hitting 1 percent distortion, therefore has an SF of 2.

In practice, it's rarely necessary to actually measure THD during the SF test because: (1) the amplifier's output may decrease—not distort—as the frequency is raised; (2) the output waveform viewed on an oscilloscope may distort abruptly as slew limiting occurs; or, (3) the amplifier blows its fuses or output transistors. With an amplifier whose band-

width is properly limited (as in the first case), the signal generator's highest available test frequency usually establishes the amplifier's Slew Factor. For example, if its highest frequency is 500 kHz, the SF is at least 25.

What is the minimum acceptable Slew Factor? Slew Factors commonly seem to range from a low of about 5 to a figure determined, as I said, by the upper frequency limit of the signal generator used. But, more important, it seems evident that no recorded or

broadcast signal will have a fast enough rise-time (a wide enough bandwidth) to cause trouble with any competently designed amp.

To my mind, those designers and audiophiles hyperconcerned about slew rate, Slew Factor, or TIM as an insidious source of distortion are essentially chasing a wild goose up a blind alley. In short, if you hear some unpleasant sonic quality in the sound of any of today's amplifiers, you can be almost positive that TIM is not likely to be its source. **R-E**

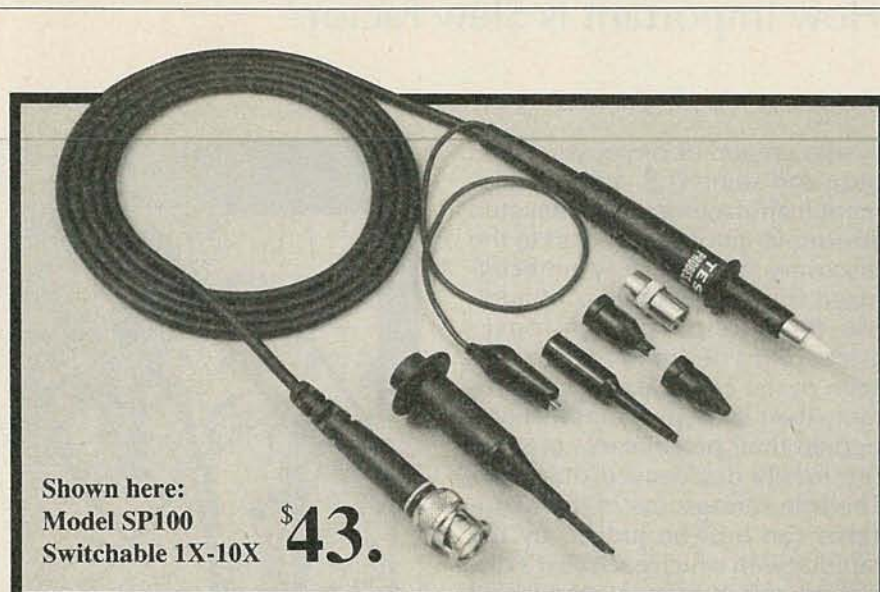

Shown here:  
Model SP100  
Switchable 1X-10X

\$ 43.

## TPI Probes Last Longer, Cost Less

Unique flexible cable and superior strain relief give longer life and easier, more comfortable handling

Order from these distributors:

- ACTIVE
- ALLAN CRAWFORD ASSOC.
- ALLIED ELECTRONICS
- CALCOTRON
- CONTACT EAST
- EIL INSTRUMENTS
- ELECTRA TEST
- ELECTRONIC PARTS CO.
- ELECTROTEX
- JENSEN TOOLS
- JOSEPH ELECTRONICS
- MARSHALL INDUSTRIES
- MC MASTER-CARR
- METERMASTER
- RADAR ELECTRIC CO.
- SOUTHEASTERN ELECTRONICS
- SPECIALIZED PRODUCTS CO.
- TECHNI-TOOL
- WESTCON INC.
- WM. B. ALLEN

**TEST  
PROBES, INC.**



9178 Brown Deer Road, San Diego, CA 92121  
Call Toll Free for information and free catalog:  
1-800-368-5719  
1-800-643-0382 in CA

CIRCLE 123 ON FREE INFORMATION CARD



# MARKET CENTER

## FOR SALE

**PHOTOFAC** folders, under #1400 \$4.00. Others \$6.00. Postpaid. **LOEB**, 414 Chestnut Lane, East Meadow, NY 11554.

**GREAT buys!** Surplus prices, ICs, linears, transformers, PS, stepping motors, vacuum pump, phototransistor, meters, LSASE, **FERTIK'S**, 5400 Ella, Phila., PA 19120.

**COMMUNICATIONS** radio, electronic equipment, sales service, FCC licensed, catalog. **RAYS**, 2025 Moline, Ft. Worth, TX 76117. (817) 831-7717.

**DESCRAMBLERS.** All brands. Special: Jerrold combo 400 and SB3 \$165. Complete cable descrambler kit \$39. Complete satellite descrambler kit \$45.00. Free catalog. **MJM INDUSTRY**, Box 531, Bronx, NY 10461-0531.

**BANDSTOP** Filters — Clear up channels affected by interfering signals. Channels 2, 3, 4, 8, 14, 15, 16, 17, 18, 19, 20, 21 and 22 available. \$20 each — 10 for \$130. **dB ELECTRONICS**, PO Box 8644, Pembroke Pines, FL 33084.

T.V. Tunable notch filters. Free Brochure. **D.K. VIDEO**, Box 63/6025, Margate, FL 33063. (305) 752-9202.

**CABLE descrambler liquidation.** Major makes and models available. Industry pricing! (Example: Hamlin Combo's, \$44 each...minimum 10 orders). **DEALERS ONLY!** Call **WEST COAST ELECTRONICS**, (818) 709-1758.

**Quality Microwave TV Antennas**

Multi-Channel 1.9 to 2.7 GHz. 40dB Gain

- 30-Channel System complete \$149.95
- 12-Channel System complete \$104.95
- 2-Channel System complete \$79.95

**Phillips-Tech Electronics**  
P.O. Box 8533 • Scottsdale, AZ 85262  
(602) 947-7700 (\$3.00 Credit all phone orders!)

LIFETIME WARRANTY  
MasterCard • Visa • COD's • Quantity Pricing

The **DECODER**. VideoCipher II newsletter. News — schematics — modifications — reviews. \$24.00/year. Complementary sample. **TELECODE**, Box 6426, Yuma, AZ 85366-6426.

**SENIOR** Prom — For all your EPROM needs! Duplication, programming, supplies. Great Prices! Write for details. **SENIOR PROM**, 11 Manor Ridge Drive, Princeton Junction, NJ 08550.

**DESCRAMBLERS**, wholesale prices — Oak, Jerrold, SA, SB3, Tri-Bi, Zenith, Pioneer: example — 10 Hamlin at \$45.00 each, full warranty. **G.D. ELECTRONICS**, (602) 829-9441.

**REDUCED 75%** Diehl Mark V-Scanner \$249. Diehl Mark III \$99. **NEW. WEEC** 2805 University Ave., Madison, WI 53705. (608) 233-9741, (608) 238-4629.

## CB RADIO OWNERS!

We specialize in a wide variety of technical information, parts and services for CB radios. 10-Meter and FM conversion kits, repair books, plans, high-performance accessories. Over 12 years of satisfied customers! Catalog \$2.

**CBC INTERNATIONAL**  
P.O. BOX 31500RE, PHOENIX, AZ 85046

**SURPLUS ELECTRONICS.** New giant wholesale catalog. Hundreds of amazing bargains. \$2. Box 840, Champlain, NY 12919.

**SOLAR** electronic systems. Discount prices. **SUN POWER-TEXAS**, PO Box 2788A-R, Freeport, TX 77541. (409) 233-8350.

**DESCRAMBLERS** wholesale, Tocom, Zenith, Jerrold, Hamlin, Oak, SA, SB, Tri-Bi, Pioneer. COD ok. **GD ELECTRONICS**, (602) 829-9441.

**RADIO** amateur (HAM) education. Learn at home or in your car. VHS Video or Audio Cassettes. Easy to obtain license. Free information. **AMATEUR RADIO SCHOOL** 2350 Rosalia Drive, Fullerton, CA 92635.

**ALUMINUM** image transfer process, your artwork to aluminum. Write: **J & E ENTERPRISES**, 2457 N. Marmora, Chicago, IL 60639.

**FAIR** prices SB-3, Z-TAC, SA3, TRI-BI, MLD-1200-3. Pioneer, any notch filters. Small dealer only. No Michigan sales (313) 979-8356.

**TEST** Equipment pre-owned now at affordable prices. Signal generators from \$50. Oscilloscopes from \$50, other equipment, including manuals available. Send for catalog **J.B. ELECTRONICS**, 9518 Grand Ave., Franklin Park, IL 60131. (312) 451-1750.

## FREE CATALOG

**FAMOUS "FIRESTIK" BRAND CB ANTENNAS AND ACCESSORIES. QUALITY PRODUCTS FOR THE SERIOUS CB'er. SINCE 1962**

**FIRESTIK ANTENNA COMPANY**  
2614 EAST ADAMS  
PHOENIX, ARIZONA 85034

**RENTAL** movie stabilizer. Connect between VCRs or to monitor. Satisfaction guaranteed. \$59.95, \$4 handling. 1 (800) 367-7909.

**SPECIALS** — cable, satellite, computer. Stand alone EPROM programmer no computer needed. Prices and data sent on request. **HI-TECH ELECTRONICS**, PO Box 42423, Detroit, MI 48242. Investor wanted, 25 thousand SSAVI boxes. Most are new, never been in service. Encoders, chips, burners, computers, etc. 220 volt transformers can be modified. (313) 722-9381.

**GATED** Pulse descrambler as described in December '88 Radio-Electronics article. Partial kit \$25.00. Works on in-band, out-band, AM or FM reference and pilotless systems. Canadian orders add \$2.00 shipping. Cannot accept ARZ. orders. Allow 4 to 6 weeks for delivery. **CYBERNETWORKS**, Box 41850, Phoenix, AZ 85080.

**ELECTRONIC** fish detector. It brings the ageless pleasure of fishing right into the electronic age. And it's low cost is within the reach of everyone. Send \$5.00 and **SASE** for info to **JAMES TYLER** 107-51 139 St., Jamaica, NY 11435.

## MICROWAVE TV RECEIVERS 1.9 to 2.7 GHz

2 CH Compact Dish System - \$77.95  
5 CH Dish System - \$93.95  
12 CH Yagi (Rod) System - \$123.95  
30 CH Dish System - \$163.90 Yagi - \$183.90

**SUN MICROWAVE INT'L. INC.** Send \$1<sup>00</sup> for catalog on these and other fine video products.  
P.O. BOX 34522  
PHOENIX, AZ 85067  
(602) 230-0640

VISA/MC/COD QUANTITY DISCOUNTS LIFETIME WARRANTY

**CABLE** descramblers, Tocom, Zenith Z-Tac, Oak RTC 56, Jerrold 400-450, SA 8580, all remote controlled, add ons, MLD 1200, SB 3, SA-3, Pioneer, Tri Bi. Special 5 pak price, 5-Oak M35B \$300.00, 5-TC35 \$300.00, 5 MLD 1200 \$245.00. Full Warranty. **S.A.C.** (702) 647-3799.

**AUTO** alarm module. Exit/Entry delay, on-board siren driver, unlimited inputs. Complete with wiring, hook-up diagram. \$14.95. Remote-controlled alarm kit. Info \$25. **CHALKER** 8 Manor House Lane, Uxbridge, MA 01569.

**IS** it true... Jeeps for \$44 through the government? Call for facts! 1 (312) 742-1142 Ext. 4673.

**ELECTRONIC** components. Free 192 page catalog including capacitors, resistors, relays, connectors, soldering equipment and supplies. **BOX 699**, Mansfield, TX 76063. 1 (800) 992-9943.

CABLE-TV AT ITS BEST

**SCIENTIFIC ATLANTA:**  
Models 8500-8550-8580 ... \$275.00  
SA-3 [Add-On Descrambler] ... \$ 99.00

**JERROLD:**  
SB-3 [Inband Gated Sync] ... \$ 74.00  
TRI-BI [Trimode/Bistate] ... \$ 95.00

**OAK:**  
M-35B [Combo W/Vari-sync] ... \$ 99.00  
N-12 [Add-On W/Vari-sync] ... \$ 89.00

**HAMLIN:**  
MLD-1200 [Add-On] ... \$ 89.00  
ZENITH: [Z-TAC Descrambler] \$169.00  
**CONVERTERS:** [80-Channels] \$ 95.00

DEALER DISCOUNT ON <5> UNITS  
DISTRIBUTOR DISCOUNT ON <10> UNITS

N.A.S. INTERNATIONAL  
(213) 631-3552

**CABLE** converters and descramblers. Call or write for free catalog. Includes Jerrold, Oak, Zenith, Hamlin, Scientific Atlanta, many more. **NU-TEK ELECTRONICS**, 305 South Bell Blvd., Suite #583, Cedar Park, TX 78613. (512) 250-5031.

**RARE**, dual element, magnetodiodes with flux concentrator; 3 for \$10 with datasheets. Allow 3-4 weeks for postpaid delivery. **PROCTOR**, 1507 Brooks, Rosenberg, TX 77471.

**WANTED:** Old, Western Electric, McIntosh, Marantz, Dynaco, Altec, JBL, Jensen, RCA; tubes, speakers, amps. (713) 728-4343. **MAURY**, 12325 Ashcroft, Houston, TX 77035.

## THE ELECTRONIC GOLDMINE

Send for your copy of our 1989 catalog featuring hundreds of electronic components and unique electronic project kits. Each of our project kits include all necessary parts and a glass epoxy etched and drilled PC board - you only need to solder in the parts and provide a battery (on battery operated kits)



### Here are two examples of our Unique Kits!

**SIMULATED LASER KIT**  
Kit emits bright pulsating red light from a 500mcd Stanley LED. Stimulate lasers or light your science projects! Kit can project a small (1 ft.) circle about 10 feet in a dark room. Operates from 9v battery (not included).  
G6394 \$8.00



**INSANITY ALARM KIT**  
When light is shining on the kit, the alarm is silent. But turn off the light, and this kit will emit a high pitched sound! Turn the lights back on-silence! Great fun at parties! Operates from 9v battery (not included).  
G6240 \$6.98



### Fabulous Component Values!

<b>MOTOROLA 2N3055</b>  .59	<b>GRAVITY SWITCH</b>  .29 EACH	<b>ALL COLOR LED ASST.</b>  Various shapes, colors and sizes. PKG. of 10 for 2.25
<b>1 3/8" XENON STROBE TUBE &amp; TRIG COIL</b>  1.75 50 sets for 75.00	<b>PIEZO DISC Great experimenter item</b>  .69 EACH	<b>ELECTREC MICROPHONE</b>  .50

MINIMUM ORDER \$10.00 plus 3.00 shipping and handling. We accept M/C, Visa and money orders. COD fee: 2.50 in addition to 3.00 shipping charge.  
SEND ORDERS TO: The Electronic Goldmine  
P.O. Box 5408 Scottsdale, AZ 85261  
PHONE ORDERS: (602) 451-7454

CIRCLE 181 ON FREE INFORMATION CARD



## VCR PARTS

SANYO RF Modulator #4-1164-031600	\$17.95 Ea.
FISHER RF Modulator 191002-143-9-4300	17.95 Ea.
MITSUBISHI RF Modulator #PU57855-01	19.95 Ea.
TOSHIBA RF Modulator #MSU-911	19.95 Ea.
RCA Loading Belt 157061 or 157062	10/For 8.50
FISHER Loading Belt 143-2-7504-01000	10/For 8.50
GOLDSTAR Samsung Photo Interrupter	1.99 Ea.
RCA Idler 164113	3.25 Ea.
FISHER Idler 143-0-4204-00400	3.99 Ea.
SHARP Idler NIDL0005	2.99 Ea.
SHARP Idler NIDL0006	2.99 Ea.

## POPULAR SEMICONDUCTORS

2SD1341P	Original Sanyo	10 For \$19.90
2SD869	Original Toshiba	10 For 19.90
BU206A	Original Toshiba	10 For 19.90
2SD1398	Original Sanyo	10 For 19.90
STR3115	Original Sanken	3.95 Ea.
STR3125	Original Sanken	3.95 Ea.
STR30120	Original Sanken	3.95 Ea.
STK4273	Original Sanken (10 min.)	9.95 Ea.
STK0080	Original Sanken	15.95 Ea.
375 Replacement	(10 min.)	99¢ Ea.

## POPULAR CAPACITORS

100MFD/50 Volts	Radial	20 For \$10.00
4.7MFD/250 Volts	Radial	10 For 5.50
10MFD/350 Volts	Radial	10 For 7.50
1000MFD/200 Volts	Snap-In	5 For 12.50
680MFD/200 Volts	Snap-In	5 For 12.50
100MFD/200 Volts	Radial	10 For 12.50
47MFD/50 Volts	Radial	10 For 4.50
10MFD/25 Volts	Non Polarized	10 For 5.00
825MFD/250 Volts	Snap-In	3.95 Ea.
80MFD/450 Volts	Axial	10 For 19.90

## POPULAR ITEMS

Sharp Flyback	FO009G	\$27.95 Ea.
Sharp Flyback	FO003G	27.95 Ea.
Sanyo Flyback	FO260	14.95 Ea.
Sanyo Flyback	FO192	14.95 Ea.
Tripler	523A/526A	9.95 Ea.
Sanyo Focus Divider	Z0064	11.95 Ea.
Minus-62	Freeze Spray	4.95 Ea.
Freon TF Clnr./Precision Clnr.	Degreaser	4.95 Ea.
Chemtronics Solder—1 Lb. Spool .031 Dia.		7.95 Lb.
Chem-Wick Lite	1/8 Dia. 25' Spool	5.50

ASK FOR OUR FREE CATALOG!

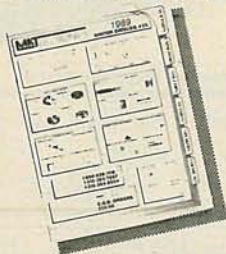

**MAT ELECTRONICS**

975 Jaymor Rd.  
Southampton, PA 18966

CALL TOLL FREE:  
1-800-628-1118

**LASER LISTENER II**, other projects. Surveillance, descrambling, false identification, information. Plans, kits, other strange stuff. Informational package \$3.00 refundable. **DIRIJO/BOND ELECTRONICS**, Box 212, Lowell, NC 28098.

**RESISTOR cabinet** — 5000 quality 1/4w 5% carbon film resistors. 100 per value in 50 labeled drawers. \$79.95 plus \$5.00 shipping (check, MO). **KENTEX INDUSTRIES**, PO Box 1314, St Charles, MO 63302.

**TESTMATE** with **circuit memory** finds intermittent wiring problems fast. Unique product catalog \$1.00 refundable. **B & M ENGINEERING**, Box 823, Simi Valley, CA 93062.

**CABLE TV** descramblers, Oak, Tocom, Zenith, Jerrold, Hamlin, Pioneer, Scientific Atlanta. Full technical support, COD ok. Full warranty. **S.A.C.**, (702) 647-3799.

## REMOTE CONTROL KEYCHAIN



Complete w/mini-transmitter and +5 vdc RF receiver. Fully assembled including plans to build your own auto alarm. Quantity discounts available.

**\$19.95** Check, Visa or M/C Add \$2 shipping

VISITECT INC. (415) 872-0128  
PO BOX 5442, SO. SAN FRAN., CA 94080

**Cable TV converters**, Jerrold, Oak, Scientific Atlantic, Zenith & many others. "New" MTS stereo add-on: mute & volume. Ideal for 400 and 450 owners! 1 (800) 826-7623. Amex, Visa, M/C accepted. **B & B INC.**, 4030 Beau-D-Rue Drive, Eagan, MN 55122.

**TUBES**: "oldest," "latest." Parts and schematics. SASE for lists. **STEINMETZ**, 7519 Maplewood Ave., RE, Hammond, IN 46324.

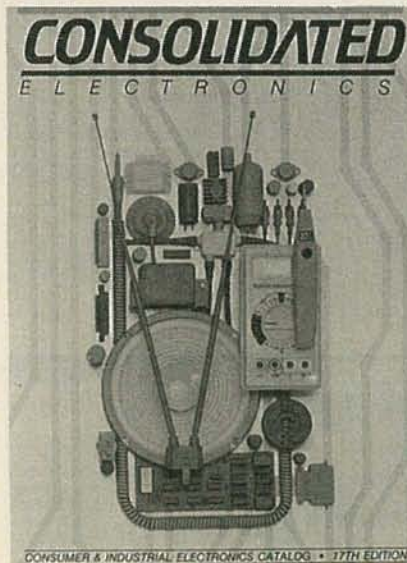

## THE ULTIMATE ELECTRONICS CATALOG.

Order your 260 page catalogue packed with over 10,000 money saving electronic parts and equipment. Send \$3.00 check or money order, or call 1-800-543-3568 today and use your Mastercard or Visa.

Consolidated Electronics, Incorporated  
705 Watervliet Ave., Dayton, Ohio 45420-2599

NAME \_\_\_\_\_  
ADDRESS \_\_\_\_\_  
CITY \_\_\_\_\_  
STATE \_\_\_\_\_ ZIP \_\_\_\_\_

CIRCLE 70 ON FREE INFORMATION CARD

## PLANS AND KITS

**BUILD** this five-digit panel meter and square-wave generator including an ohms, capacitance and frequency meter. Detailed instructions \$2.50. **BAGNALL ELECTRONICS**, 179 May, Fairfield, CT 06430.

**FM transmitter 88 to 108 MHZ** kit \$12.95 **SIERRA ELECTRONICS**, Box 709, Elfers, FL 34680-0709.

## Cable TV Converters Why Pay A High Monthly Fee?

Jerrold Products include "New Jerrold Tri-Mode," SB-3. Hamlin, Oak VN-12, M-35-B, Zenith, Magnavox, Scientific Atlanta, and more. (Quantity discounts) 60 day warranty. For fast service C.O.D. orders accepted. Send SASE (60 cents postage) or call for info 1-800-648-3030. **MIDWEST ELECTRONICS, INC.**, 5143-R W. Diversey, Chicago, IL 60639. MC/Visa orders accepted. No Illinois orders accepted. Mon.-Fri. 8 A.M.-5 P.M. CST

**ELECTRONIC** kits! Transmitters! Recorders! Phone devices! Bug detectors! Surveillance items! More! Catalog \$1.00: **XANDI ELECTRONICS**, Box 25647, 60P, Tempe, AZ 85285-5647.

**INVESTIGATORS**, experimenters. Quality new plans. Hard to find micro and restricted devices. Free catalog. **SASE. KELLEY SECURITY, INC.**, Suite 90, 2531 Sawtelle Blvd., Los Angeles, CA 90064.

**CIRCUIT** boards from this and past issues PC-Service about half price. **KLAY-CORP**, 106 Mark Drive, Syracuse, NY 13209-1808.

**OPENING** special. Super duper kits. Send \$2.00 U.S.\$ for booklet to **3C TECHNOLOGY**, Box 306, S. Lafleche, St. Hubert, Quebec, J4T-3J2.



DETAILED PLANS: \$4.95

## TV-SCOPE

PENN RESEARCH,  
Box 3543  
Williamsport, PA 17701

## FINALLY!

An interesting and worthwhile project. This **EASY-TO-BUILD** circuit lets you use any regular TV set as a simple **OSCILLOSCOPE**. Build for less than \$10. **NO MODIFICATIONS TO TV!** Single or dual trace. Send for **FREE CATALOG** of other plans and kits.

**FM stereo transmitter**. Transmit your VCR/CD/Walkman to any FM stereo radio. One chip does it all! Free schematic and info. Send a self addressed/stamped envelope to: **DJ INC.**, 847A Second Ave., Suite 113, New York, NY 10017.

**DESCRAMBLING**, new secret manual. Build your own descramblers for **Cable and Subscription TV**. Instructions, schematics, for SSAVI, gated sync, sinewave. Jerrold, Hamlin, Oak, Zenith, Sylvania (HBO, Cinemax, Showtime, UHF, Adult) \$8.95, \$2 postage. **CABLETRONICS**, Box 30502R, Bethesda, MD 20814.

**CB tricks** booklet. Modifications, tune-ups, channel expansion, clarifier tricks. Send \$19.95 to **MEDICINE MAN CB**, P.O. Box 37, Clarksville, AR 72830.

**DETECTION** — surveillance, debugging. Plans, kits, assembled devices. Latest high-tech catalog \$5. **DETECTION SYSTEMS**, 2515 E. Thomas, #16-864F, Phoenix, AZ 85016.

**PROJECTION TV**... Convert your TV to project 7 foot picture... Easy!... Results comparable to \$2,500 projectors... **Plans and 8" lens \$24.95... Professional systems available... Illustrated catalog free.** **MACROCOMA**, 15GJ Main Street, Washington Crossing, PA 18977... Credit card orders 24HRS. (215) 736-3979.

**PRINTED** circuit boards etched & drilled. Free delivery. **K & F ELECTRONICS, INC.**, 33041 Groesbeck, Fraser, MI 48026. (313) 294-8720.











## EDUCATION & INSTRUCTION

**MAGIC!** Four illustrated lessons plus inside information shows you how. We provide almost 50 tricks including equipment for four professional effects. You get a binder to keep the materials in, and a one-year membership in the International Performing Magicians with a plastic membership card that has your name gold-embossed. You get a one-year subscription to our quarterly newsletter "IT'S MAGIC!" Order now! \$29.95 for each course + \$3.50 postage and handling. (New York residents add applicable state and local sales tax). **THE MAGIC COURSE**, 500-B BiCounty Boulevard, Farmingdale, NY 11735.

**COMPUTER/satellite video tapes:** Make \$50.00 or more per year! Step by step instructions. How to build IBM PC-XT compatible computers \$69.95. How to repair Videocipher II descramblers \$69.95. **COMPUTER BOARDS UNLIMITED**, 1317 West North Ave., Baltimore, MD 21217. (301) 728-3690.

**IBM PC.** Learn assembly language. Spaceship game. Find princess game. \$5 each. Book \$18. **ZIPFAST**, Box 12238, Lexington, KY 40581-2238.

## DESCRAMBLER MODULE

**LATEST** technology alternative to Jerrold SB-3 or Radio-Electronics Feb. 1984 project. Featuring electronic tuning, AGC, auto-on/off, AC/DC power, mini-size, A&T, and more. For literature — **SOUTHTECH DISTRIBUTING**, (813) 527-2190.

## SCRAMBLE FACTS

718-343-0130

**PHONE TODAY** for 3 minutes of satellite TV industry news, technical tips, and new product information.

**NUTS & VOLTS MAGAZINE** P.O. Box 1111-E, Placentia, CA 92670  
714-632-7721

**GIVE YOURSELF A BREAK — A PRICE BREAK!**  
**NUTS & VOLTS WILL SAVE YOU MONEY ON ELECTRONIC PARTS & EQUIPMENT. PLUS SHOW YOU WHERE TO FIND UNIQUE, UNUSUAL AND HARD-TO-FIND ITEMS.**

**SUBSCRIBE TODAY!**

Subscription Rates	
U.S. (1 Year)	\$12.00
3rd Class Mail - USA	\$12.00
One Year	\$21.00
Two Years	\$21.00
Lifetime	\$60.00
1st Class Mail	
One Year USA	\$30.00
Canada/Mexico	\$32.00
Air Mail	
Foreign 1 Yr.	\$55.00

*A National Publication For The Buying And Selling Of Electronic Equipment*

## WANTED

**WANTED** - Pen R.F. Jammer and electronic stethoscope. **EUGENE DELL**, 1416 E. Market Street, York, PA 17403. (717) 845-9945.

**SEISMOMETER** wanted to measure earthquakes. Pay cash. **D. HUTCHISON**, 4000 Little Timmer, Edmond, OK 73034. (405) 341-9615.

**TUBES - 2000 TYPES DISCOUNT PRICES!**

Early, hard-to-find, and modern tubes. Also transformers, capacitors and parts for tube equipment. *Send \$2.00 for 24 page wholesale catalog.*

**ANTIQUE ELECTRONIC SUPPLY**  
688 W. First St. • Tempe, AZ 85281 • 602/894-9503

## CABLE TV

**CATV converters & descramblers.** Quality products. Professional service. Call 1 (800) 541-5487. Visa-M/C accepted. **MOUNTAINTech, INC.**, Box 5074, Mt. Crested Butte, CO 81225.

## CABLE TV DESCRAMBLERS

JERROLD™ Tri-Bi Mode	\$105.00	10 Lot	\$85.00
JERROLD™ SB-3 OR 2	\$89.00		\$65.00
Hamlin MLD-1200	\$99.95		\$62.00
Oak N-12 W/V.S.	\$99.95		\$62.00
Oak M-35-B W/V.S.	\$99.00		\$78.00
OAK E-13	\$99.95		\$58.00
Zenith SSAVI	\$185.00		\$145.00
Eagle PD-3	\$120.00		\$85.00
Scientific Atlanta	\$129.95		\$105.00
SA-Combo's	CALL		\$CALL
Tocom	\$350.00		\$295.00
Oak N-12 W/ Auto	\$140.00		\$105.00
Jerrold Starcom CSV	\$139.95		Call

**M.D. ELECTRONICS WILL MATCH ANY ADVERTISED PRICE IN THIS MAGAZINE**

## \*NEW STARGATE 2000 CABLE CONVERTER



1-\$89.00 10-\$69.00 100-Call  
Last channel recall-Favorite channel select-75 channel-Channel scan-Manual fine tune-One year warranty-surge protection-HRC & Standard switchable-and much more. **Call Today!**

INFORMATION (402) 554-0417

Orders Call Toll Free  
1-800-624-1150

**M.D. ELECTRONICS**  
115 NEW YORK MALL  
SUITE 133E  
OMAHA, NE. 68114

M.C. VISA C.O.D.

CIRCLE 53 ON FREE INFORMATION CARD

## 300W HQ HI-FI POWER AMPLIFIER (MONO) TA-3600

QUASI-COMPLEMENTARY SYMMETRY WITH PARALLEL HIGH OUTPUT TRANSISTORS. SPECIFICATIONS:  
\*POWER OUTPUT 300W (RMS) INTO 8 OHMS  
2450W (P.M.P.O.) INTO 8 OHMS  
540W (MUSIC POWER) INTO 8 OHMS  
\*LOAD IMPEDANCE 4 OHMS OR 8 OHMS  
\*FREQUENCY RESPONSE: 10Hz-200,000Hz  
\*TOTAL HARMONIC DISTORTION LESS THAN 0.05%  
\*INPUT SENSITIVITY AND IMPEDANCE AT 1KHz: 1V/1.4V 47K OHMS  
\*SUPPLY VOLTAGE DC ±75V OR AC 53V x 2 BA  
KIT/ASSM AND TESTED \$86/110  
\*FORMERLY 10,000 µF 80V E-CAP \$39/20

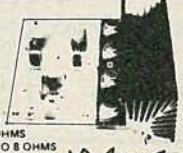

**NEW with 4 pos THOMSON HUGE 250 W POWER TR!**

## PROFESSIONAL COLOR LIGHT CONTROLLER SM-328

FEATURES:  
1. FOUR GROUPS OF INDEPENDENT OUTPUT SYSTEM (1000W/CH MAX) 4600V (100-110V)  
2. PROFESSIONAL COLOR CONTROL SYSTEM (KEY BOARD TYPE) 3. INDEPENDENT INPUT SIGNAL ADJUSTMENT 4. FOUR GROUPS OF INDEPENDENT DIMMER CONTROL 5. SPEED CONTROL CHASER 6. AUTOMATIC CHASING CONTROL SYSTEM 7. FOUR KINDS OF SPECIAL CHASING PROGRAM 8. COMBINATION OF PROGRAM AND MUSIC CHASING EFFECT 9. FORWARD BACKWARD CHASING CONTROL  
SM-328 color light controller is specialized for ballroom, night club disco and advertisement lighting. It consists with several color control characteristics, which employ professional color control system and keyboard program selection. Therefore, it is capable of producing lighting effects by using chasing program and fluctuating music signal. There are two kinds of lightings. The first type is controlled by music signal. In order to adjust the brightness of four groups of lightings, each music signal will be separated into high, medium low A, and low B frequency range. Furthermore, each group of lightings is incorporated with an independent signal adjustment. The second kind is composed of electrical circuits and this is the main part for creating a special lighting effect. It has four chasing programmes.  
Dimensions 14.5" 16" x 8.15" 16" x 3.316"  
Asst. AND tested \$150.00



**ONLY**

## 150MC Digital SM-100 Frequency Counter

Frequency Range 10Hz-150MHz  
Event Counter 0 to 99999999 counts (8 Digit)  
Input sensitivity: KHz range 10Hz-10MHz 50mVrms  
MHz range 1MHz-150MHz 40mVrms  
Response time: 0.2 second  
Hold Function: Hold the last input signal  
Power Supply: DC6V Battery or DC9V Adaptor  
Dimensions 9.78" x 6.11" 16" x 2.34"  
Assembled AND tested \$99.00



**FREE AC ADAPTOR AVAILABLE UNTIL STOCKS LAST!**

## MARK V ELECTRONICS, INC.

8019, E. SLAUSON AVE. MONTEBELLO, CA 90640

CATALOG OR INFORMATION: (213) 888-8988  
TOLL FREE 1-800-423-3483 OR

1-800-521-MARK (IN CAL) FOR ORDERS

PAID BY ONLY

ORDER BY FAX (213) 888-6868

## DC FET SUPER CLASS "A" PRE-AMP TA-2200

The TA-2200 is a discrete transistor stereo pre-amplifier using FETs in the critical stages for ultra low noise, linear operation. All amplifier stages operate in class A.

The circuit is divided of all signal processing circuits such as tone controls, filters, etc., in order to closely approximate a straight wire with gain configuration. The power supply is heavily regulated to provide a low impedance constant voltage source.

TA-2200

Kit \$47.70 ASSM & TESTED \$58.25

## 100W+100W NEW CLASS 'A' DC STEREO PRE-MAIN AMP TA-1500

200W POWERFUL AMP W/MIC MIXER!  
KIT METAL CABINET X FORMER \$73.70 \$33.25

**FREE CATALOG**

TERMS: \$10 min. order. \$20 min. charge card order. Check, money order or phone order accepted. We ship UPS Ground. Add 10% of total order (min \$2.5) for shipping, outside USA add 20% (min \$5.00). Transit insurance add 5% of total (outside USA only). CA residents add sales tax. All merchandise subject to price table. Prices are subject to change without notice. Any goods proved to be defective MUST BE RETURNED IN ORIGINAL FORM WITH A COPY OF YOUR INVOICE WITHIN 30 DAYS FOR REPLACEMENT.

SHOWROOM HOURS: (PACIFIC TIME)  
MON.-FRI. 9:30 to 5:00 SAT. 10:00-5:00

## DIGITAL VOICE MEMO TA-28 MKII



**NEW**

FEATURES:  
• SOLID STATE RECORD/PLAY BACK.  
• POWER/RECORD LED INDICATOR.  
• 4 BIT ADPCM ALGORITHM.  
• 8 BIT AD/DA CONVERTER.  
• 256K MEMORY CAPACITY.  
• 8 SEC OR 16 SEC RECORD TIME.  
• SAMPLING FREQUENCY 8KHz OR 4 KHz.  
• INCLUDED CONDENSOR MIC & SPEAKER.  
• BUILT IN LOW PASS FILTER.  
• MORE REALISTIC & CLEARLY.  
• LOW POWER CONSUMPTION.  
• SUPPLY VOLTAGE: 5.6V DC.  
• DIMENSIONS: 3 1/2" x 2 1/2" x 1 1/2"  
\*\* FREE 256K TOY GRADE DRAM

KIT/ASSM & TESTED \$30/40

## 8 Digit 1GHz Multifunctional Counter FC-1000A

A versatile laboratory bench digital counter with 8 FUNCTIONs and performance FREQUENCY PERIOD UNIT TOTALIZE DATA HOLD & BEEP CHECK. The period function makes the instrument outstanding for time take recorder service as well as time & length LED display, secure any readability of values, high speed and clear display indicators are used to ensure the accuracy of measurement. Durable also calculator in a fully locking panel. Comes complete with test leads and owners manual.

FEATURES:  
Frequency range: 10Hz-1GHz GUARANTEED 5Hz 120Hz (typical)  
Input sensitivity: 10Hz-100MHz 10mV-20mV  
100MHz-1.5GHz 5mV-20mV  
Period range: 0.5-100s  
Input counting capacity: 99999999  
Accuracy: ± 1 count (1 count error accurate)  
Hold function: Hold the last input signal (Max 8 digit)  
Power supply: 1.5V AC 15-20V (RMS)  
Dimensions: 9.8" 10" x 2.7" 10" x 3.1"  
ASSM AND TESTED & CAL. \$192.00

## 0-15V 2A REGULATED DC POWER SUPPLY

TR-100 TR-100A

**SALE**

Kit ~~\$89.50~~ ~~\$59.50~~ ~~\$49~~ ~~\$29.50~~ ~~\$19.50~~ ~~\$63~~

Output voltage is adjustable from 0-15V DC, two current limit range are available for selection: 200mA or 2A.  
An elaborated protection system is specially designed, a BB sound and a sparkling light will appear when the output is overloaded.  
High stability and reliability is resulted by employing high quality voltage regulated IC.  
King size meter makes the reading of voltage and current more clearly and accurately.  
A refined case, meter and all accessory are enclosed for both kit and assembled form. It is most suitable for professional or amateur use.

CIRCLE 93 ON FREE INFORMATION CARD



# AMAZING SCIENTIFIC & ELECTRONIC PRODUCTS

## PLANS

Build Yourself — All Parts Available in Stock

LC7— BURNING CUTTING CO<sub>2</sub> LASER ..... \$20.00  
 RUB4— PORTABLE LASER RAY PISTOL ..... \$20.00  
 TCC1— 3 SEPARATE TESLA COIL PLANS TO 1.5 MEV ..... \$25.00  
 IOG1— ION RAY GUN ..... \$10.00  
 GRA1— GRAVITY GENERATOR ..... \$10.00  
 EML1— ELECTRO MAGNET COIL GUN/LAUNCHER ..... \$8.00

## KITS

With All Necessary Plans

MFT3K— FM VOICE TRANSMITTER 3 MI RANGE ..... \$49.50  
 VWP7K— TELEPHONE TRANSMITTER 3 MI RANGE ..... \$39.50  
 BTC3K— 250,000 VOLT 10-14" SPARK TESLA COIL ..... \$249.50  
 LHC2K— SIMULATED MULTICOLOR LASER ..... \$44.50  
 BLS1K— 100,000 WATT BLASTER DEFENSE DEVICE ..... \$69.50  
 ITM1K— 100,000 VOLT 20" AFFECTIVE RANGE INTIMIDATOR ..... \$69.50  
 PSP4K— TIME VARIANT SHOCK WAVE PISTOL ..... \$59.50  
 STA1K— ALL NEW SPACE AGE ACTIVE PLASMA SABER ..... \$59.50  
 MVP1K— SEE IN DARK KIT ..... \$199.50  
 PTG1K— SPECTACULAR PLASMA TORNADO GENERATOR ..... \$149.50

## ASSEMBLED

With All Necessary Instructions

BTC10— 50,000 VOLT-WORLD'S SMALLEST TESLA COIL ..... \$54.50  
 LGU40— 1MW HeNe VISIBLE RED LASER GUN ..... \$249.50  
 TAT30— AUTO TELEPHONE RECORDING DEVICE ..... \$24.50  
 GVP10— SEE IN TOTAL DARKNESS IR VIEWER ..... \$349.50  
 LIST10— SNOOPER PHONE INFINITY TRANSMITTER ..... \$169.50  
 IPG70— INVISIBLE PAIN FIELD GENERATOR MULTIMODE ..... \$74.50

• CATALOG CONTAINING DESCRIPTIONS OF ABOVE PLUS HUNDREDS MORE AVAILABLE FOR \$1.00 OR USE OUR PHONE FOR "ORDERS ONLY" 603-673-4730.

PLEASE INCLUDE \$3.00 PH ON ALL KITS AND PRODUCTS PLANS ARE POSTAGE PAID. SEND CHECK, MO, VISA, MC IN US FUNDS.

**INFORMATION UNLIMITED**  
 P.O. BOX 716 DEPT. RE, AMHERST, NH 03031

## SINGERS! REMOVE VOCALS FROM RECORDS AND CDs!



### SING WITH THE WORLD'S BEST BANDS!

An Unlimited supply of Backgrounds from standard stereo records! Record with your voice or perform live with the backgrounds. Used in Professional Performance yet connects easily to a home component stereo. This unique product is manufactured and sold Exclusively by LT Sound - Not sold through dealers. Call or write for a Free Brochure and Demo Record.

**LT Sound**, Dept. RL-3, 7980 LT Parkway  
 Lithonia, GA 30058 (404) 482-4724  
 Manufactured and Sold Exclusively by LT Sound  
**24 HOUR PHONE DEMO LINE: 1404/482-2485**

## GLOBAL CABLE NETWORK

**YOUR** converters and descramblers bargain headquarters. All makes, Zenith 140, Hamlin CRX5000 with remote \$140, SB3 \$70. Call today (415) 584-1627.

# BUY BONDS

## ATTENTION CABLE BROKERS

**SURPLUS** CATV equipment at wholesale prices. Unmodified units only, Oak M35B \$30, Tocom 5504 with remote \$55, Jerrold JSX3NIC \$30. (415) 337-8301.

## ENGINEERING SOFTWARE

**MACINTOSH** electronic schematic symbols. Macprint format. Hundreds. \$44.95. **OASIS DESIGNS**, 61159 El Coyote, Joshua Tree, CA 92252. (619) 366-8570.

## INVENTORS

**INVENTORS!** Can you patent and profit from your idea? Call **AMERICAN INVENTORS CORPORATION** for free information. Over a decade of service 1 (800) 338-5656. In Massachusetts or Canada call (413) 568-3753.

## NEW HE NE LASER TUBES \$35

Dealer Inquiries Invited.  
 Free Catalog!

**MEREDITH INSTRUMENTS:** 6403 N. 59th Ave.  
 Glendale, AZ 85301 • (602) 934-9387  
 "The Source for Laser Surplus"

**MASTERCARD AND VISA** are now accepted for payment of your advertising. Simply complete the form on the first page of the Market Center and we will bill.



**EMINENCE**



**MOTOROLA**

**Polydax**

**1-800-338-0531**

**PIONEER**

### 3-WAY 100W CROSSOVER

12 dB/octave rolloff.  
 800Hz, 5000Hz  
 crossover points. 8  
 ohm. 100 watts RMS.



#260-210 **\$12.50** **\$9.95**  
 (1-9) (10-up)

### SPEAKER CONTROL PANEL

Panel with 50 watt L-pads  
 for tweeter and midrange  
 and built-in LED power  
 meter. 5" x 2 1/2" 100  
 watt version available



#260-235 **\$14.50** **\$12.90**  
 (1-5) (6-up)

### 12" POLY WOOFER

Super duty, 40 oz. magnet.  
 100 watts RMS, 145 watts  
 max. 4 and 8 ohm compat-  
 ible (6 ohm). 2" voice coil.  
 fs = 25 Hz. QTS = .166,  
 VAS = 10.8 cu. ft.  
 Response: 25-1500 Hz. Net  
 weight: 9 lbs. Pioneer  
 #A30GU40-51D



#290-125 **\$36.80** **\$34.50**  
 (1-3) (4-up)

### WALNUT SPEAKER CABINET KIT

Super quality,  
 genuine walnut  
 veneer cabinet. Kit  
 includes: routed and  
 mitred top, sides,  
 and bottom in  
 unfinished 3/4"  
 walnut veneer. Cut  
 your own custom  
 holes in the front  
 and rear to match  
 your drivers. 15" x  
 24" x 11". Volume:  
 1.9 cubic feet.

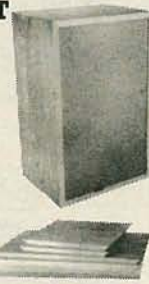

#260-350 **\$22.50** **\$19.95**  
 (1-3) (4-up)

### PIONEER HORN TWEETER

Mylar dome. 2.93 oz.  
 barium ferrite magnet. 8  
 ohm. Response: 1900-  
 20000 Hz. 35W RMS,  
 90W max. fs = 2000 Hz,  
 SPL = 106 dB. Pioneer  
 #AHE60-51F



#270-050 **\$6.50** **\$5.90**  
 (1-9) (10-up)

### 12" SUB WOOFER

Dual voice coil sub woofer.  
 30 oz. magnet, 2" voice  
 coils. 100 watts RMS, 145  
 watts max. fs = 25 Hz. 6 ohm  
 (4 and 8 ohm compatible).  
 SPL = 89 dB 1W/1M.  
 Response: 25-700 Hz.  
 QTS = .31, VAS = 10.3 cu. ft.  
 Pioneer #A30GU30-55D.  
 Net weight: 6 lbs.



#290-145 **\$39.80** **\$36.80**  
 (1-3) (4-up)

### 15" THRUSTER WOOFER

Thruster by Eminence.  
 Made in USA. Poly foam  
 surround, 56 oz. magnet.  
 2-1/2", 2 layer voice coil.  
 150 watts RMS, 210 watts  
 max. 4 ohm. fs = 23.5  
 Hz, QTS = .33, VAS = 17.9  
 cu. ft. SPL = 94.8 dB 1W/  
 1M. Net weight: 15 lbs.



#290-180 **\$43.50** **\$39.80**  
 (1-3) (4-up)

### GRILL FRAME KIT

With this kit you  
 can make speaker  
 grill frames up to  
 30" x 40". Kit  
 includes 4 corner  
 pieces, 2 "T"  
 brackets, and 7  
 frame bars. Grill  
 mounting kit  
 included.

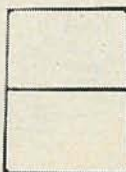

#260-333 **\$8.50** **\$7.80**  
 (1-9) (10-up)

### 18" EMINENCE WOOFER

#### MADE IN USA

100 oz. magnet, 3" voice  
 coil. 250 watts RMS, 350  
 watts max. 8 ohm, 30 Hz  
 resonant frequency. 22-  
 2700 Hz response.  
 Efficiency: 95 dB 1W/1M.  
 Paper cone, treated  
 accordian surround. Net  
 weight: 29 lbs.



#290-200 **\$98.90** **\$89.50**  
 (1-3) (4-up)

### TITANIUM COMPOSITE TWEETER

Titanium is deposited on a polymer  
 dome to combine the advantages of  
 both hard and soft dome  
 technologies. 8 ohm. Ferro fluid  
 cooled voice coil. fs = 1200 Hz,  
 SPL = 90 dB 1W/1M. 50 watts RMS,  
 70 watts max. 4" round. Polydax  
 part #DTW100T125.



#270-047 **\$27.50** **\$24.80**  
 (1-9) (10-up)





# Spring Specials from Heath

## Kit projects...

### Heathkit Flood Alarm

**detects unwanted water** Avert damage from leaking water pipes or basement wall seepage. Three hours to build. Needs 9V battery. 1 3/4" H x 3 5/8" W x 4 7/8" L. Kit GD-1701 (2 lbs.) ... **\$12.95**



### Program your doorbell with a favorite tune

Arrange wire leads on one-octave keyboard inside doorbell to program any tune. Includes songbook with 50+ college, seasonal, Christmas and special occasion songs. Back door button activates a part-tune. Volume, tone, speed and delay adjustable. Two-evening kit. Takes standard 16 VAC, 50/60 Hz bell transformer. Kit TD-1089 (3 lbs.) ... **\$32.95**



### Build your own Heathkit draft detector

Easily detect heat loss areas. Turn it on, adjust for silence, then move sensor in areas where heating or cooling losses occur. Temperature changes set off beeping alarm and flashing LED. Used in temperatures from 59-95F. Takes a 9-volt battery (not included). Kit NE-2112 (2 lbs.) ... **\$14.95**



### Heathkit Furnace Air Cleaner.

Works with heating or A/C system to reduce the effects of pollen, dust and cigarette smoke. Power supply mounts onto a cold air duct, and turns on collecting cell when blower is running. 1" collecting cells below directly replace original furnace filter. 120VAC also works with GD-2196 2" filters. Kit GD-3196 (9 lbs.) **\$79.95**  
**Accessory filters** 4 sizes available, each ... **\$74.95**



### Heathkit Portable Air Cleaner.

Helps solve tough air-cleaning problems, removes dust, smoke, other pollutants from 6,000 cubic feet (25' x 30' x 8' room). One-evening kit includes power supply, 3-speed fan control and assembled filter. 120 VAC, 60 Hz. Dimensions 26 1/2" H x 17 1/4" W x 13 1/2" D. Kit GDS-1297 (59 lbs.) ... **\$199.00**  
Accessory: Replacement Charcoal Filter Assd. GDA-1297-2 (2 lbs.) **\$.95**



### Charging system tester

Diagnose faulty components in your car's charging system with accuracy and ease. A two-wire setup and three quick tests show you if the battery has sufficient charge to reliably start the engine, if the battery is being charged by the alternator, if the voltage regulator is faulty (causing the battery to become overcharged), or if the alternator stator windings and rectifier diodes are functioning properly. No external power or battery required. Dimensions are 5 1/2" H x 2 3/4" W x 3/4" D. Kit CI-2065 (2 lbs.) ... **\$19.95**

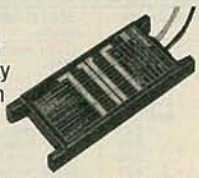

### Noise generator kit

To properly check out any stereo or sound system with a spectrum analyzer, you need a noise source with a nearly constant energy output. This one-evening Pink/White Noise Generator will do just that...and at a fraction of the cost of comparable noise generators. Kit AD-1309 (2 lbs.) ... **\$24.95**



## For the electronic hobbyist...

**Pocket-size digital meter for home and shop** Compact digital meter includes 3 1/2 digit, LCD display for readings up to 1999, audible continuity checker and diode test. Overload protected on all ranges, new transistor hFE test. Assd. SM-2310 (1 lb.) Now only **\$24.95**



### Connector adapter kit

Make 108 different coaxial connector adapters with gold-plated pins and Teflon insulation. Kit contains male and female, N, BNC, UHF, SMA TNC and mini UHF connectors. Special in-between fittings allow you to assemble your own adapters in seconds. Assd. HCA-3000 (2 lbs.) ... **\$69.95**



### Coax adapter cables

Solve frustrating coax connection problems with this convenient adapter cable assortment. Twenty cables in all help you make almost any connection. Two handy

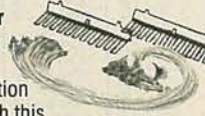

storage racks keep your cables neatly organized. 50 ohm impedance. Assd. TPI-5000 (5 lbs.) . Now **\$49.95**

## Unbeatable Scanner Prices...

**Uniden 10-Channel/10-Band Handheld Scanner. Save \$31.** Superportable, programmable, direct channel access, channel lockout, keyboard lock switch prevents accidental reprogramming. 55 dB @ +25kHz selectivity; audio output 300 milliwatts maximum. Receive 29 to 512 MHz with a 15-channel-per-second scan speed. Requires 5, AA (not included) or rechargeable NiCd batteries. Assd. BC-55X-LT (1 lb.) ... **\$108.88**

**100-Channel/11-Band Uniden Handheld scanner. Reduced \$41.** 100 programmable channels, 10 scanning banks, 11 bands of coverage. Automatic and manual search, weather search, 10 priority channels, squelch, lockout and delay. Selectivity is -55 dB @ +25kHz; audio output is 450mW maximum. Snap-on battery pack gives full-powered portable scanning. Assd. BC-100X-LT (3 lbs.) ... **\$188.88**

**Uniden Tabletop Scanner.** 11 bands of coverage, 5 or 15 channels-per-second scanning speed. Features automatic memory search, backup, priority, programmable lockout, scan speed control and automatic squelch setting. Selectivity -45 dB @ +25 kHz; audio output one watt at 10% THD. Takes 117 VAC, 60 Hz from an external wall outlet. Originally priced at \$169.95. Assd. BC-175X-L (3 lbs.) ... **\$148.88**

**100 Channel/11-Band Uniden Mobile scanner.** Auto search aircraft, police, marine and emergency bands. Fully programmable. Fits neatly under dash, flip-down stand and telescopic antenna included. Audio output is 1.5 watts at 10% THD; require 13.8 VDC (vehicle battery or AC adapter). Save \$61+. Assd. BC-580X-LT (5 lbs.) ... **\$198.88**

**Deluxe Uniden Mobile Scanner. Save \$81+.** 100-channel/12-band mobile scanner. Covers 800 MHz band for full 12-channel coverage. Weather search, priority, squelch, lockout, delay, auto and manual band search. Mount under dash, or AC adapter (included), flip-down stand and telescopic antenna. Takes 13.8 VDC. Assd. BC-760X-LT (5 lbs.) ... **\$248.88**

## Make life easier...

**Full-featured remote control center for your TV, VCR and CATV** Assd. GDZ-143 (1 lb.) ... **\$29.95**  
\*\*Zenith cannot guarantee that the PCC will operate every model TV or VCR.



**Recharge your NiCd batteries** Assd. BP-1234 (4 lbs.) ... **\$17.95**

### Amber screen fish finder

Assd. MI-2020 (6 lbs.) ... **\$244.95**  
**Accessories:** Transom Mount Transducer Assd. MIA-2020-1 (4 lbs.) ... **\$44.95**  
Through-Hull Transducer Assd. MIA-2020-2 (6 lbs.) ... **\$99.95**



### Full color fish finder

Assd. MI-2040 (10 lbs.) ... **\$399.00**



**Portable weather computer travels in your shirt pocket** Save over \$15 on this compact weather instrument that goes with you hiking, biking, boating and camping. Gives time, date and current temperature, plus keeps a record of highest and lowest temperatures. Also acts as a stopwatch. Automatic power-down feature extends battery life. Requires three AAA batteries (not included). Assd. BW-100 (1 lb.) Now only **\$24.95**

## Heathkit®

to order CALL TOLL FREE  
**1-800-253-0570**  
Use order code 216-020



for credit card orders, 24 hours a day.

Some items are closeouts. All items are available in limited quantities. Prices for some items were previously reduced.

For your free Heathkit catalog call 1-800-44-HEATH.



Mail Order Electronics - Worldwide

# ameco ELECTRONICS

# Mail-Order Electronics

24 HOUR ORDER HOTLINE  
415-592-8097

IC Clearance Sale!  
Expires 5/31/89

## NEC V20 & V30 CHIPS

Replace the 8086 or 8088 in Your IBM PC and Increase its Speed by up to 30%!

Part No.	Description	Price
UPD70108-5	(5MHz) V20 Chip	\$ 7.49
UPD70108-8	(8MHz) V20 Chip	\$16.75 \$ 9.49
UPD70110-8	(10MHz) V20 Chip	\$12.95 \$12.25
UPD70116-8	(8MHz) V30 Chip	\$9.95 \$ 7.95
UPD70116-10	(10MHz) V30 Chip	\$16.95 \$15.49

## 7400

Part No.	1-9	10+	Part No.	1-9	10+
7400	SALE	15	7485	SALE	45
7402	SALE	29	7486	SALE	29
7404	SALE	15	7489	1.95	1.85
7405	SALE	35	7490	49	39
7406	SALE	39	7493	45	35
7407	SALE	25	74121	SALE	25
7408	SALE	35	74123	SALE	35
7410	SALE	15	74125	SALE	35
7414	SALE	25	74126	SALE	35
7416	SALE	19	74143	SALE	3.95
7417	SALE	19	74150	SALE	1.10
7420	SALE	29	74154	1.35	1.25
7430	SALE	15	74158	SALE	1.25
7432	SALE	39	74173	SALE	59
7438	SALE	25	74174	SALE	35
7442	SALE	29	74175	SALE	35
7445	SALE	59	74176	SALE	49
7446	SALE	79	74181	SALE	1.49
7447	SALE	89	74189	SALE	1.49
7448	SALE	1.95	74193	79	69
7472	SALE	25	74198	SALE	1.25
7473	SALE	39	74221	SALE	69
7474	SALE	25	74273	SALE	1.49
7475	SALE	39	74365	SALE	35
7476	SALE	45	74367	SALE	35

## 74LS

74LS00	SALE	15	74LS165	75	65
74LS02	SALE	15	74LS166	SALE	69
74LS04	SALE	16	74LS173	SALE	25
74LS05	SALE	16	74LS174	SALE	25
74LS06	SALE	59	74LS175	SALE	25
74LS07	SALE	59	74LS189	SALE	2.95
74LS08	SALE	28	74LS191	SALE	39
74LS10	SALE	15	74LS193	69	59
74LS14	SALE	29	74LS221	SALE	49
74LS27	SALE	19	74LS240	SALE	45
74LS30	SALE	15	74LS243	SALE	45
74LS32	SALE	19	74LS244	SALE	49
74LS42	SALE	49	74LS245	SALE	59
74LS47	SALE	89	74LS259	99	89
74LS73	SALE	25	74LS273	89	79
74LS74	SALE	19	74LS279	49	39
74LS75	SALE	25	74LS322	3.49	3.39
74LS79	SALE	39	74LS365	SALE	35
74LS85	SALE	59	74LS366	SALE	35
74LS86	SALE	29	74LS367	SALE	29
74LS90	SALE	29	74LS368	SALE	35
74LS93	SALE	29	74LS373	SALE	59
74LS123	SALE	35	74LS374	SALE	49
74LS125	SALE	49	74LS395	SALE	35
74LS138	SALE	39	74LS590	5.95	5.85
74LS139	SALE	29	74LS624	1.95	1.85
74LS154	SALE	1.19	74LS629	SALE	1.95
74LS157	SALE	45	74LS640	SALE	89
74LS158	SALE	25	74LS645	SALE	89
74LS163	SALE	35	74LS670	SALE	79
74LS164	SALE	35	74LS688	2.39	2.29

## 74LS/PROMS\*

74S00	SALE	19	74S188*	1.49	
74S04	SALE	19	74S189	1.49	
74S08	SALE	19	74S196	SALE	99
74S10	SALE	19	74S240	1.39	
74S32	SALE	19	74S243	SALE	75
74S74	SALE	19	74S253	SALE	99
74S85	SALE	49	74S287*	1.49	
74S86	SALE	49	74S288*	1.49	
74S124	SALE	1.25	74S373	SALE	99
74S174	SALE	25	74S374	SALE	99
74S175	SALE	25	74S472*	SALE	2.49

## CD - CMOS

CD4001	19	CD4076	59
CD4008	59	CD4081	22
CD4011	19	CD4082	22
CD4013	29	CD4093	35
CD4016	29	CD4094	89
CD4017	49	CD40103	1.49
CD4018	59	CD40107	49
CD4020	59	CD4511	69
CD4024	45	CD4511	69
CD4027	35	CD4520	75
CD4030	35	CD4522	79
CD4040	65	CD4538	79
CD4049	29	CD4541	69
CD4050	29	CD4543	79
CD4051	59	CD4553	3.95
CD4052	59	CD4555	79
CD4053	59	CD4559	7.95
CD4063	1.49	CD4566	1.95
CD4066	29	CD4583	59
CD4067	1.49	CD4584	49
CD4069	19	CD4585	69
CD4070	29	MC14411P	7.95
CD4071	29	MC14490P	4.49
CD4072	22		

## EEPROMS

2816A	2048x8	350ns (9V-15V) 5V Read/Write	5.25
2816A-25	2048x8	250ns (9V-15V) 5V Read/Write	5.49
2817A	2048x8	350ns 5V Read/Write	6.95
2864A	8192x8	250ns 5V Read/Write (Pin 1, No R/B)	13.95
2864A-30	8192x8	300ns 5V Read/Write (Pin 1, No R/B)	12.95
2865A-30	8192x8	300ns 5V Read/Write	12.95
52B13	2048x8	350ns (21V) 5V Read Only	1.49

## MICROPROCESSOR COMPONENTS

MISCELLANEOUS CHIPS		8000 SERIES Continued		8000 SERIES Continued	
Part No.	Price	Part No.	Price	Part No.	Price
D765AC	9.95	8065 (5MHz)	99.95	8748H (HMOS) (21V)	9.95
WD9216	3.95	8087-1 (10MHz)	194.95	8749	9.95
<b>Z80, Z80A, Z80B SERIES</b>					
Z80	1.19	8087-2 (8MHz)	139.95	8751H (3.5-8MHz)	37.95
Z80-CTC	1.29	8088 (5MHz)	4.95	8751H (3.5-12MHz)	39.95
Z80A-CTC	1.29	8088-2 (8MHz)	5.95	8755	12.95
Z80A-DART	4.95	8088-2 (8MHz)	5.95	80286-10 LCC	59.95
Z80A-PIO	1.49	8088-2 (8MHz)	5.95	80287 (8MHz)	159.95
Z80B-SIO/IO	9.95	8088-2 (8MHz)	5.95	80287-8 (8MHz)	229.95
Z80B	2.75	8088-2 (8MHz)	5.95	80287-10 (10MHz)	279.95
Z80B-CTC	9.95	8088-2 (8MHz)	5.95	80386-16 PGA	309.95
Z80B-PIO	3.95	8088-2 (8MHz)	5.95	80387-16 (16MHz)	439.95
Z8515	7.95	8088-2 (8MHz)	5.95	80387-20 (20MHz)	499.95
Z8681B1	8.95	8088-2 (8MHz)	5.95	80387-25 (25MHz)	599.95
<b>8000 SERIES</b>					
8031	9.95	8250A	4.95	80387-SX (16MHz)	399.95
8032	9.95	8250A (For IBM)	5.95	82284 (8MHz)	9.49
8033	1.95	8251A	1.89	82288 (8MHz)	9.95
8052AHBASIC	24.95	8254	3.95	<b>DATA ACQUISITION</b>	
8080A	2.49	8254A-5	2.95	ADC0804LNC	2.79
8085A	2.49	8259	2.95	ADC0808BCN	5.95
8086-2	6.95	8259-5	2.25	ADC0809CN	9.99
		8272	9.95	ADC1205CCJ-1	19.95
		8279-5	2.95	DAC0808LNC	1.49
		8741	9.95	DAC1008LNC	5.95
		8742	10.95	AY-3-1015D	4.95
		8748 (25V)	7.95	AY-5-1013A	1.95

## STATIC RAMS

Part No.	Function	Price
2016-12	2048x8 120ns	4.95 3.75
2018-45	45ns 300MIL	6.95
1024x1	350ns	89
2114N	1024x4 45ns	99 79
2114N-2L	1024x4 200ns Low Power	1.49
21C14	1024x4 200ns CMOS	49
5101	256x4 450ns CMOS	9.95 2.49
6116P-1	2048x8 100ns (16K) CMOS	3.19
6116P-3	2048x8 150ns (16K) CMOS	3.49
6116LP-1	2048x8 100ns (16K) LP CMOS	4.95 3.59
6116LP-3	2048x8 150ns (16K) LP CMOS	5.95 3.09
6264P-10	8192x8 100ns (64K) CMOS	9.95 7.49
6264P-15	8192x8 150ns (64K) CMOS	9.95 7.49
6264P-10	8192x8 100ns (64K) LP CMOS	10.95 7.25
6264P-15	8192x8 150ns (64K) LP CMOS	10.95 7.95
6514	1024x4 350ns CMOS	9.95 3.49
43256-10L	32,768x8 100ns (256K) Low Power	23.95
43256-15L	32,768x8 150ns (256K) Low Power	22.95
62256P-85	65,536x8 85ns (256K) LP CMOS	26.95
62256LP-10	32,768x8 100ns (256K) LP CMOS	24.95
62256LP-12	32,768x8 120ns (256K) LP CMOS	24.25

## DYNAMIC RAMS

THM51000L-10	1,048,576x9	100ns 1Meg x9 SIP	99.95	329.95
THM51000S-10	1,048,576x9	100ns 1Meg x9 SIM	99.95	295.95
THM51000L-80	1,048,576x9	80ns 1Meg x9 SIP	449.95	349.95
THM51000S-80	1,048,576x9	80ns 1Meg x9 SIM	449.95	339.95
TMS4416-12	16,384x4	120ns	3.75	6.75
TMS4416-15	16,384x4	150ns	3.25	6.25
4128-15	131,072x1	150ns (Poggyback)	1.99	1.25
4164-100	65,536x1	100ns	3.49	
4164-120	65,536x1	120ns	2.95	
4164-150	65,536x1	150ns	2.59	
41256-60	262,144x1	60ns	14.99	11.99
41256-80	262,144x1	80ns	16.99	10.15
41256-100	262,144x1	100ns	16.99	9.75
41256-120	262,144x1	120ns	14.95	9.95
41256-150	262,144x1	150ns	14.99	8.49
41264-12	64Kx4	120ns Video RAM	19.95	
41464-10	65,536x4	100ns	14.99	11.95
41464-12	65,536x4	120ns	14.95	9.95
41464-15	65,536x4	150ns	15.95	13.95
51258-10	262,144x1	100ns Static Column	99.95	11.95
85227-10PL	262,144x9	100ns 256Kx9 SIP	149.95	119.95
85227-10PS	262,144x9	100ns 256Kx9 SIM	149.95	119.95
511000P-10	1,048,576x1	100ns (1 Meg)	99.95	25.95
511000P-80	1,048,576x1	80ns (1 Meg)	49.95	35.95
511000S-85	1,048,576x1	85ns (1 Meg)	49.95	35.95
514256P-10	262,144x1	100ns (1 Meg)	34.95	29.95

## EPROMS

TMS2516	2048x8	450ns (25V)	6.95	5.95
TMS2532	4096x8	450ns (25V)	6.95	4.95
TMS2532A	4096x8	450ns (12.5V)	4.49	3.25
TMS25				



# Now Available...Jameco's NEW Winter/Spring Flyer #138 with 48 pages of Computer Peripherals, Components & More!

# 15<sup>th</sup> ANNIVERSARY YEAR 1974 - 1989

## TEST EQUIPMENT

### Metex Digital Multimeters

**Metex General Specs:**  
• Handheld, high accuracy  
• AC/DC Voltage, AC/DC Current, Resistance, Diodes, Continuity, Transistor hFE • Manual ranging w/overload protection  
**M3650/B & M4650 only:**  
• Also measures frequency and capacitance  
**M4650 only:**  
• Data Hold Switch  
• 4.5 Digit



M4650 Pictured

M3610	3.5 Digit Multimeter.....	\$49.95
M3650	3.5 Digit w/Freq. & Capacitance.....	\$69.95
M3650B	Same as M3650 w/Bargraph.....	\$79.95
M4650	4.5 Dig. w/Freq., Capacitance and Data Hold Switch.....	\$99.95

### Metex Autoranging Jumbo Readout DMM

• AC/DC Voltage, AC/DC Current, Resistance, Diodes, Continuity and Frequency  
• 3.75 Digit (.8" High)  
• Ruggedized, Water-resistant case  
• Easy-to-use pushbutton switches

M80.....\$59.95



### Logic Pulser and Logic Monitor

Ideal for inspecting and repair of Logic Circuits

#### Logic Pulser (LP540):

• Generates "one-shot" pulse or continuous 5Hz pulse train  
• Pulse repetition rate: 0.5pps/400pps • Audible tone • Compatible with: TTL, DTL, RTL, HTL, HINIL, MOS and CMOS ICs

#### Logic Monitor (LM20):

• Tests 14 through 20 pin ICs • Detachable, heavy-duty spring clip • LED on or off indicates high or low level

LP540	Logic Pulser.....	\$19.95
LM20	Logic Monitor.....	\$49.95

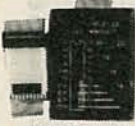

LM20 Pictured

### Oscilloscope Probes

• Attenuation: x1 / x10  
• Capacitance (LF180): 180pF / 22pF; (LF210): 40pF / 17pF



LF180 Pictured

LF180	40MHz Oscilloscope Probe.....	\$19.95
LF210	100MHz Oscilloscope Probe.....	\$29.95

### Digital Logic Probes

• High, low and pulse indication  
• 20MHz and 50MHz versions available  
• Circuit powered w/ over/undervoltage indicators

PRB20	20MHz Logic Probe.....	\$26.95
PRB20A	20MHz Audible Logic Probe.....	\$33.95
PRB50	50MHz Logic Probe.....	\$47.95

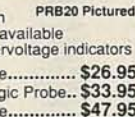

PRB20 Pictured

### RS232 Tester and Breakout Box Make Your Own Custom Cables!

• Complete cable breakout and reconfiguration exists with 24 in-line switches and 54 in-line machine tool sockets • Bi-color LEDs tell you if a line is hi, low or off  
• Male to female DB25 pin connectors • Includes device wiring chart

MLA1.....\$29.95

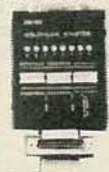

## Jameco IBM PC/XT 8MHz Turbo Compatible Kit With 256K RAM

- Free! QAPLUS Diagnostic Software Included!
- Free! PC Write Word Processing Software Included!
- 256K RAM Included, Expandable to 640K
- AMI BIOS ROMs Included
- 4.77 or 8MHz Operation
- Regular \$628.01 value for only \$499.95!
- Flip-Top Case w/150 Watt Power Supply
- 360K Disk Drive
- Parallel Printer Port
- 84-Key Keyboard
- Monochrome Amber Monitor



JE3002 IBM Compatible PC/XT 8MHz Turbo Kit.....\$499.95  
EZDOS Digital Research MS/PC-DOS Comp. Operating System...\$49.95  
EZDOSP Same as above with TrueBASIC.....\$69.95

## IBM COMPATIBLE DISPLAY MONITORS

AMBER	12" Amber Mono.	\$99.95
CTX2410	14" RGB 640x200	\$279.95
TM5154	EGA 14" 720x350	\$399.95
JE1059	EGA Monitor & Card	\$519.95
TM5155	14" Multiscan 800x560	\$499.95
QC1478	14" VGA 720x480	\$449.95
JE2055	VGA Monitor & Card	\$649.95



QC1478 Pictured

## JAMECO IBM PC/XT/AT COMPATIBLE CARDS

JE1050	Monochrome Graphics Card w/Parallel Printer Port (PC/XT/AT).....	\$59.95
JE1052	Color Graphics Card w/Parallel Printer Port (PC/XT/AT).....	\$49.95
JE1055	EGA Card w/256K Video RAM (PC/XT/AT).....	\$159.95
JE1071	Multi I/O Card w/Controller & Monochrome Graphics (PC/XT).....	\$119.95
JE1060	I/O Card w/Serial, Game, Printer Port & Real Time Clock (PC/XT).....	\$59.95
JE1061	RS232 Serial Half Card (PC/XT).....	\$29.95
JE1062	RS232 Serial Half Card (AT).....	\$34.95
JE1065	I/O Card w/Serial, Game and Parallel Printer Port (AT).....	\$59.95
JE1081	2MB Expanded or Extended Memory Card (zero-K on-board) (AT).....	\$119.95
JE1041	20/40MB Hard Disk Controller Card (PC/XT).....	\$79.95
JE1043	360K/720K/1.2MB/1.44MB Floppy Disk Controller Card (PC/XT/AT).....	\$49.95
JE1044	360K Floppy/Hard Disk Controller Card (PC/XT).....	\$129.95
JE1045	360K/720K/1.2MB/1.44MB Floppy/Hard Disk Controller Card (AT).....	\$149.95

## SEAGATE HALF-HEIGHT HARD DISK DRIVES

ST225	20MB Drive only (PC/XT/AT)	\$224.95
ST225XT	20MB w/Controller (PC/XT)	\$269.95
ST225AT	20MB w/Controller (AT)	\$339.95
ST238	30MB Drive only (PC/XT/AT)	\$249.95
ST238XT	30MB w/Controller (PC/XT)	\$299.95
ST238AT	30MB w/Controller (AT)	\$389.95



ST225XT Pictured

Seagate 40MB and 60MB Hard Disk Drives Also Available!

## IBM PC/XT/AT COMPATIBLE MOTHERBOARDS

JE1001	4.77/8MHz (PC/XT)	\$89.95
JE1002	4.77/10MHz (PC/XT)	\$109.95
JE3005	Baby 8/12MHz (AT)	\$329.95
JE3010	Baby 8/16MHz NEAT (AT)	\$469.95
JE3020	Baby 16MHz 80386 (AT)	\$1199.95
JE3025	Baby 20MHz 80386 (AT)	\$1499.95
JE3026	Full-Size 25MHz 80386 (AT)	\$2299.95



JE3025 Pictured

## IBM PC/XT/AT COMPATIBLE 3.5"/5.25" DISK DRIVES

352KU	3.5" 720KB (PC/XT/AT)	\$109.95
356KU	3.5" 1.44MB (PC/XT/AT)	\$129.95
JE1020	5.25" 360KB (PC/XT/AT) Black	\$89.95
JE1021	5.25" 360KB (PC/XT/AT) Beige	\$89.95
JE1022	5.25" 1.2MB (PC/XT/AT) Beige	\$99.95



JE1022 Pictured

## IBM PC/XT/AT COMPATIBLE INTERNAL MODEMS

1200H	1200/300 Baud Internal Modem w/Max/Mite Comm. Software (PC/XT/AT)	\$69.95
2400H	2400/1200/300 Baud Internal Modem w/Max/Mite Comm. Swr. (PC/XT/AT)	\$129.95

External Modems and Pocket-Size Modem Also Available!

## PROTOTYPING PRODUCTS

### Jameco Solderless Breadboards

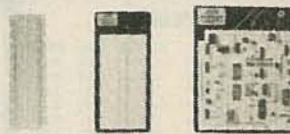

Part No.	Dim. L" x W"	Contact Points	Binding Posts	Price
JE20	6.5x7.5	200	0	\$1.95
JE21	3.25x2.125	400	0	\$4.95
JE22	6.5x1.325	630	0	\$5.95
JE23	6.5x2.125	830	0	\$7.95
JE24	6.5x3.125	1,360	2	\$12.95
JE25	6.5x4.25	1,660	3	\$19.95
JE26	6.875x5.75	2,390	4	\$24.95
JE27	7.25x7.5	3,220	4	\$34.95

### DATAK Photo Etch PCB Kit Make your own circuit boards!

The ER4 photo etch kit contains all the chemicals necessary for any hobbyist, engineer or student to create professional circuit boards. Contains: Print frame, photo copy film, resist developer, etch resist, 2 copper circuit boards, concentrated etchant, film developer and fixer, resist patterns and complete instructions.



ER4 Photo Etch PCB Kit.....\$34.95

### Jameco Prototype PC Boards

Specs: Laminated glass epoxy .062" thick 2 oz. copper clad with solder tin finish. All holes are .042" dia. on .10" x .10" grid pattern.



JE401 Pictured

JE401	4.5"x6.5" 1-sided 3-hole pad pattern	\$9.95
JE403	4.5"x6.5" 1-sided pwr & gnd busses	\$9.95
JE405	4.5"x6.5" 1-sided general purpose	\$9.95
JE407	5"x13.25" 2-sided general purpose	\$19.95
JE417	4.2"x6.5" PC/XT 1/2 card proto board	\$19.95
JE421	4.75"x3.7" IBM PC/XT Card Extender	\$19.95

## ENGINEERING/DATA BOOKS

21035	Sams TTL Cookbook (88)	\$14.95
21398	Sams CMOS Cookbook (88)	\$19.95
22453	Sams Op-Amp Cookbook (88)	\$21.95
270645	Intel 8-bit Controller Hndbk. (89)	\$19.95
270646	Intel 16-bit Controller Hndbk. (89)	\$19.95
270647	Intel 32-bit Controller Hndbk.(89)	\$19.95
400041	NSC Linear Data Book Vol 1 (88)	\$14.95
400042	NSC Linear Data Book Vol 2 (88)	\$9.95
400043	NSC Linear Data Book Vol 3 (88)	\$9.95
ICM89	1989 IC Master (3 Volume Set)	\$129.95

## EDUCATIONAL KITS

JE310/315:	Fiber optics kits demonstrate the principles of fiber optic system design. Complete step-by-step instructions, theory of operation and tutorial info. incl.	
JE2206:	Function generator kit provides three basic waveforms: sine, triangle and square wave. Frequency range: 1Hz to 100kHz	
JE310	Fiber Optics Experimenter Kit.	\$19.95
JE315	Advanced Fiber Optics Kit....	\$29.95
JE2206	Function Generator Kit.....	\$19.95

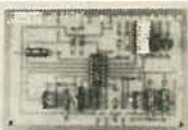

JE2206 Pictured

1355 Shoreway Road  
Belmont, CA 94002  
24 Hour Order Hotline (415) 592-8097  
FAX's (415) 592-2503 or (415) 595-2664  
Telex 176043 - Ans. Back: Jameco Blmt  
Data Sheets - 50¢ each  
Send \$2.00 Postage for a FREE 1989 CATALOG  
© 1989 Jameco Electronics 6/89  
IBM is a registered trademark of International Business Machines



\$20.00 Minimum Order - U.S. Funds Only  
CA Residents Add 6%, 6.5% or 7% Sales Tax  
Shipping - Add 5% plus \$1.50 Insurance  
(May vary according to weight)  
Terms: Prices subject to change without notice.  
We are not responsible for typographical errors.  
We reserve the right to substitute manufacturers.  
Items subject to availability and prior sale.  
Products pictured may only be representative.  
Complete list of terms/warranties is available upon request.

24-Hour Order Hotline (415) 592-8097 • The Following Phone Lines Are Available From 7AM - 5PM P.S.T.:

• Customer Service (415) 592-8121 • Technical Assistance (415) 592-9990 • Credit Department (415) 592-9983 • All Other Inquiries (415) 592-7108







## POWER SUPPLIES



**135 WATT POWER SUPPLY**  
 ■ UL APPROVED  
 ■ +5V @ 15A, +12V @ 4.2A,  
 -5V @ 5A, -12V @ 5A

**PS-135** \$59.95  
**PS-150** 150W SUPPLY \$69.95



**200 WATT POWER SUPPLY**  
 ■ UL APPROVED  
 ■ +5V @ 20A, +12V @ 7A,  
 -5V @ 5A, -12V @ 5A

**PS-200** \$89.95



**APPLE TYPE SUPPLY**  
 ■ WITH APPLE CONNECTOR  
 ■ +5V @ 6A, +12V @ 3A,  
 -5V @ 1A, -12V @ 1A

**PS-A** \$49.95



**36 WATT POWER SUPPLY**  
 ■ +5V @ 2.5A, +12V @ 1.5A  
 ■ 3 PIN INPUT, 6 PIN OUTPUT  
 ■ SELECTABLE 110V-220V

**PS-3045** \$12.95

## SOLDER STATIONS



### SOLDER/DESOLDER STATION

■ OIL-FREE VACUUM PUMP  
 ■ TEMP. ADJUSTS (212 ° F-900° F)  
 & VACUUM (0-60 CM/HG)  
 ■ WITH GUN-REST, COOLING TRAY,  
 WIRE BRUSH & TIP CLEANER ROD

**XY999SD** \$399.95  
**XY999D** DESOLDER ONLY \$349.99



### DELUXE SOLDER STATION

■ ROTARY SWITCH TEMP CONTROL (200 ° F-878 ° F RANGE)  
 ■ LED TEMPERATURE READOUTS  
 ■ INCLUDES COOLING TRAY

**XY9-60L** \$79.95



### SOLDER STATION

■ UL APPROVED  
 ■ HEAT SETTING ADJUSTS  
 ■ TIP TEMPERATURE READOUT  
 ■ REPLACEMENT TIPS @ \$2.95

**168-3C** \$59.95

## WIREWRAP PROTOTYPE CARDS

FR-4 EPOXY GLASS LAMINATE WITH GOLD PLATED  
 EDGECARD FINGERS AND SILK SCREENED LEGENDS



### FOR XT

**JDR-PR1** WITH +5V AND GROUND PLANE \$27.95  
**JDR-PR2** ABOVE WITH I/O DECODING LAYOUT \$29.95

### FOR AT

**JDR-PR10** 16 BIT WITH I/O DECODING LAYOUT \$34.95  
**JDR-PR10PK** PARTS KIT FOR JDR-PR10 ABOVE \$12.95

### FOR PS/2

**JDR-PR32** 32 BIT PROTOTYPE CARD \$69.95  
**JDR-PR16** 16 BIT WITH I/O DECODING LAYOUT \$49.95  
**JDR-PR16PK** PARTS KIT FOR JDR-PR16 ABOVE \$15.95  
**JDR-PR16V** 16 BIT FOR VIDEO APPLICATIONS \$39.95

## JDR INSTRUMENTS—2 YEAR WARRANTY!

### 35 MHZ DUAL TRACE OSCILLOSCOPE

■ WIDE BAND WIDTH ■ VARIABLE HOLDOFF  
**MODEL-3500** (SHOWN) \$499.95

### 20 MHZ DUAL TRACE OSCILLOSCOPE

■ TV SYNC FILTER ■ COMPONENTS TESTER  
**MODEL 2000** \$389.95

### 3.5 DIGIT PROBE TYPE DMM

■ AUTORANGING ■ AC/DC 2V - 500V, RESIS. 2K-2M  
**DPM-1000** (SHOWN) \$54.95

### 3.5 DIGIT POCKET SIZE DMM

■ BASIC DC ACCURACY ±0.5% ■ 14 RANGES  
**DMM-100** \$29.95

### 3.5 DIGIT FULL FUNCTION DMM

■ BASIC DC ACCURACY ±0.25% ■ 22 RANGES  
**DMM-200** \$49.95

### THE ULTIMATE 3.5 DIGIT DMM

■ BASIC DC ACCURACY ±0.25% ■ 34 RANGES  
 ■ TEMP, TRANSISTOR & RESISTANCE FEATURES  
**DMM-300** (SHOWN) \$79.95

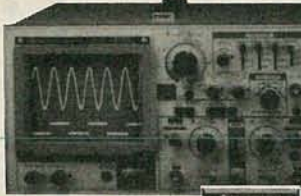

RELIABLE,  
 HIGH QUALITY  
 TEST EQUIPMENT,  
 REASONABLY  
 PRICED



## DATA SWITCH BOXES

TYPE	# OF POS.	PARALL.	SERIAL	PRICE
PUSHBTN.	2-WAY	AB-P	AB-S	39.95
ROTARY	2-WAY	RSP-2	RSS-2	24.95
ROTARY	3-WAY	RSP-3	RSS-3	27.95
ROTARY	4-WAY	RSP-4	RSS-4	29.95

## COMPUTER CABLES

GOLD-PLATED CONTACTS; 100% SHIELDED

CBL-PRINTER	PC PRINTER CABLE	9.95
CBL-PRINTER-25	AS ABOVE-25 FT.	15.95
CBL-PRINTER-RA	RT. ANGL. PRINTER	15.95
CBL-DB25-MM	DB25 MALE-MALE	9.95
CBL-DB25-MF	DB25 MALE-FEMALE	9.95
CBL-9-SERIAL	9 PIN-25 PIN SERIAL	6.95
CBL-KBD-EXT	KEYBOARD EXTN.	7.95
CBL-CNT-MM	36 PIN CENTRON-M/M	14.95
CBL-HD-20	20 PIN HARD DISK	3.95
CBL-HD-34D	34 PIN DUAL HARD DISK	6.95
CBL-FDC-EXT	37 PIN EXT. FLOPPY	9.95
CBL-MNT-9	9 PIN MONITOR EXTN.	6.95
CBL-MODEM	DB25-DB25 FEMALE	7.95

## EXTENDER CARDS

FOR PROTOTYPE DEBUGGING,  
 TESTING AND TROUBLESHOOTING

**EXT-8088** XT COMPATIBLE \$29.95  
**EXT-80286** AT COMPATIBLE \$39.95  
**EXT-16** MICROCHANNEL 16-BIT \$69.95  
**EXT-32** MICROCHANNEL 32-BIT \$99.95



NEW LOW  
 PRICES!

## SOLDERLESS BREADBOARDS

**PDS-100** 1360 TIE PTS \$12.95  
**PDS-200** 1660 TIE PTS \$19.95  
**PDS-300** 2390 TIE PTS \$24.95  
**PDS-400** 3220 TIE PTS \$34.95



## IDC CONNECTORS/RIBBON CABLE

DESCRIPTION	ORDER BY	CONTACTS					
		10	20	26	34	40	50
SOLDER HEADER	IDHxxS	.82	1.29	1.68	2.20	2.56	3.24
RIGHT ANGLE SOLDER HEADER	IDHxxSR	.85	1.35	1.76	2.31	2.72	3.39
WIREWRAP HEADER	IDHxxW	1.86	2.98	3.84	4.50	5.28	6.63
RIGHT ANGLE WIREWRAP HEADER	IDHxxWR	2.05	3.28	4.22	4.45	4.80	7.30
RIBBON HEADER SOCKET	IDSxx	.63	.89	.95	1.29	1.49	1.69
RIBBON HEADER	IDMxx	--	5.50	6.25	7.00	7.50	8.50
RIBBON EDGE CARD	IDExx	.85	1.25	1.35	1.75	2.05	2.45
10' RIBBON CABLE	RCxx	1.60	3.20	4.10	5.40	6.40	7.50

FOR ORDERING INSTRUCTIONS, SEE D-SUBMINIATURE CONNECTORS BELOW

## RS-232 BREAKOUT BOX

FOR TROUBLESHOOTING  
 SERIAL COMMUNICATIONS

■ OPEN/CLOSE INDIVIDUAL  
 CIRCUITS ■ 20 JUMPERS  
 CROSS-CONNECT ANY TWO  
 CIRCUITS ■ 10 CIRCUIT  
 ACTIVITY LEADS  
**GENDER-BO** \$34.95



## SURGE SUPPRESSOR

PROTECTS YOUR EQUIPMENT!

■ SIX 3-PRONG AC OUTLETS  
 ■ 15 AMP CIRCUIT BREAKER  
 ■ 6' HEAVY DUTY CORD  
 ■ 15 AMP MAX LOAD, 1875 WATTS  
 ■ UL APPROVED  
**POWER-SURGE** \$12.95  
**POWER-STRIP** W/O SURGE \$9.95



## LITHIUM BATTERY

■ 6V FOR 286 AND 386 PCS  
 ■ MOTHERBOARD CONNECTOR  
 ■ ADHESIVE VELCRO MOUNTING  
 STRIP  
**LITHIUM 6.8V** \$11.95



**COIN TYPE BATTERY**  
 LONG-LASTING 3V LITHIUM  
**3V-MHW** \$1.95  
**HOLDER** \$1.49



## PC BREADBOARD

■ 62 CLEARLY LABELLED BUS LINES  
 ■ ACCEPTS UP TO 24 14-PIN ICs  
 ■ 1940 TIE POINTS  
 ■ EXT FEMALE DB25 D-SUB CONNECT.  
**PDS-604** \$49.95

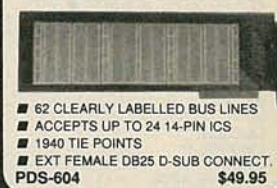

## GENDER CHANGERS

**GENDER-FF** FEMALE-FEMALE \$7.95  
**GENDER-MM** MALE-MALE \$7.95  
**GENDER-MF** MALE-FEMALE \$7.95  
**GENDER-NF** NULL MODEM \$8.95  
**GENDER-JB** JUMPER BOX \$8.95  
**GENDER-MT** MINIFESTER \$14.95  
**GENDER-VGA** DB9-DB15 \$19.95  
**GENDER-9-25** DB9-DB25 \$4.95



## D-SUBMINIATURE CONNECTORS

DESCRIPTION	ORDER BY	CONTACTS						
		9	15	19	25	37	50	
SOLDER CUP	MALE	DBxxP	.45	.59	.69	.69	1.35	1.85
	FEMALE	DBxxS	.49	.69	.75	.75	1.39	2.29
RIGHT ANGLE PC SOLDER	MALE	DBxxPR	.49	.69	--	.79	2.27	--
	FEMALE	DBxxSR	.55	.75	--	.85	2.49	--
WIREWRAP	MALE	DBxxPWW	1.69	2.56	--	3.89	5.60	--
	FEMALE	DBxxSww	2.76	4.27	--	6.84	9.95	--
IDC RIBBON CABLE	MALE	IDBxxP	1.39	1.99	--	2.25	4.25	--
	FEMALE	IDBxxS	1.45	2.05	--	2.35	4.49	--
HOODS	METAL	MHOODxx	1.05	1.15	1.25	1.25	--	--
	PLASTIC	HOODxx	.39	.39	--	.39	.69	.75

ORDERING INSTRUCTIONS: INSERT THE NUMBER OF CONTACTS IN THE POSITION MARKED "xx" OF THE "ORDER BY" PART NUMBER LISTED. EXAMPLE: A 15 PIN RIGHT ANGLE MALE PC SOLDER WOULD BE DB15PR  
 MOUNTING HARDWARE .59

## IC SOCKETS/DIP CONNECTORS

DESCRIPTION	ORDER BY	CONTACTS									
		8	14	16	18	20	22	24	28	40	
SOLDERTAIL SOCKETS	xxST	.11	.11	.12	.15	.18	.15	.20	.22	.30	
WIREWRAP SOCKETS	xxWW	.59	.69	.69	.99	1.09	1.39	1.49	1.69	1.99	
ZIF SOCKETS	ZIFxx	--	4.95	4.95	--	5.95	--	5.95	6.95	9.95	
TOOLED SOCKETS	AUGATxxST	.62	.79	.89	1.09	1.29	1.39	1.49	1.69	2.49	
TOOLED W/ SOCKETS	AUGATxxWW	1.30	1.80	2.10	2.40	2.50	2.90	3.15	3.70	5.40	
COMPONENT CARRIERS	ICCxx	.49	.59	.69	.99	.99	.99	.99	1.09	1.49	
DIP PLUGS (IDC)	IDPxx	.95	.49	.59	1.29	1.49	--	.85	1.49	1.59	

FOR ORDERING INSTRUCTIONS SEE D-SUBMINIATURE CONNECTORS ABOVE

## APPLE-COMPATIBLE PRODUCTS

**FLOPPY DRIVE FOR APPLE II SERIES**  
**AP-150** (W/CABLE, CONNECTOR) \$99.95  
**REPLACEMENT KEYBOARD FOR APPLE II & II+**  
**KEYBOARD-AP** \$59.95  
**EPROM PROGRAMMER. NOT REC. FOR CMOS.**  
**RP-525** (NO POWER SUPPLY REQ.) \$89.95  
**16K RAM CARD BOOSTS 48K APPLE TO 64K**  
**RAM-CARD** (2 YEAR WARRANTY) \$39.95

## "SNAPABLE HEADERS"

SNAP APART TO MAKE ANY SIZE  
 HEADER, WITH .1" CENTERS

**1 x 40** STRAIGHT LEAD .99  
**1 x 40** RIGHT ANGLE LEAD \$1.49  
**2 x 40** STRAIGHT LEAD \$2.49  
**2 x 40** RIGHT ANGLE LEAD \$2.99



JDR MICRODEVICES, 2233 BRANHAM LANE, SAN JOSE, CA 95124  
 LOCAL (408) 866-6200 FAX (408) 559-0250 TELEX 171-110  
 RETAIL STORE: 1256 S. BASCOM AVE., SAN JOSE, CA  
 (408) 947-8881 HOURS: M-F 9-7 SAT. 9-5 SUN. 12-4

NEW  
 ADDRESS!

Terms: Minimum order \$10.00. For shipping & handling include \$3.50 for ground and \$4.50 for air. Orders over 1 lb and foreign orders may require additional shipping charges—contact the sales department for the amount. CA residents must include applicable sales tax. Prices subject to change without notice. We are not responsible for typographical errors. We reserve the right to limit quantities and to substitute manufacturer. All merchandise subject to prior sales. A full copy of our terms is available upon request. Items pictured may only be representative.

# ORDER TOLL FREE 800-538-5000

COPYRIGHT 1989 JDR MICRODEVICES

CONTINENTAL U.S.



## 2400 BAUD MODEM

# \$99.95

PROMETHEUS

- HAYES COMPATIBILITY ■ 1/2-CARD ■ AUTO DIAL/ANSWER
- SELF-TEST ON POWER UP ■ FULL AND HALF DUPLEX
- TOUCHTONE OR PULSE DIALING ■ 2ND PHONE JACK
- CALL PROGRESS MONITORING ■ ADJUSTABLE VOLUME

**PRO-24I**  
INTERNAL MODEMS (MIRROR II SOFTWARE INCLUDED)  
PRO-12I 1200 BAUD 1/2 CARD \$69.95  
PRO-24M 2400 BAUD FOR PS/2 \$249.95

**EXTERNAL MODEMS (REQ. SERIAL PT. CABLE, SOFTWARE)**  
PRO-24E 2400 BAUD \$169.95  
PRO-12E 1200 BAUD \$99.95

## DFI HANDY SCANNER

# 400 DPI \$199.95

- INSTANTLY SCANS UP TO 4.1" WIDE IMAGES ■ 100, 200, 300, 400 DPI BOTH DIRECTIONS ■ B&W & 3 HALF-TONE MODES ■ 32 LEVELS OF GRAY SCALE ■ HERCULES, CGA, EGA AND VGA COMPATIBLE
  - INCLUDES HALO DPE AND IMAGE EDITOR SOFTWARE
- HS-3000  
OCR-SOFT SOFTWARE \$99.95

## UPRIGHT CASE \$299.95

- SPACESAVING DESIGN HOLDS ALL SIZES OF MOTHERBOARDS. INCLUDES:
- 250W POWER SUPPLY ■ MOUNTS FOR 3 FLOPPY & 4 HARD DRIVES
  - TURBO & RESET SWITCH ■ LED SPEED DISPLAY ■ POWER & DISK LED'S
  - ALL HARDWARE, FACEPLATES & SPEAKER
- CASE-100** FOR 8088 BOARDS \$39.95  
**CASE-FLIP** FOR 8088 BOARDS \$39.95  
**CASE-SLIDE** FOR 8088 BOARDS \$39.95  
**CASE-70** FOR 286 BOARDS \$89.95  
**CASE-50** FOR 8088/286 BOARDS \$59.95  
**CASE-JR** MINI-286 W/150W PS \$149.95

## LOGITECH HIREZ MOUSE

# \$89.95

- HIGH RESOLUTION BUS MOUSE, IDEAL FOR CAD WORK ■ 320 DPI ■ WITH DRIVER, TEXT EDITOR & POP-UP MENUS ■ NO PAD, POWER SUPPLY OR PORT REQ.
- LMOUSE-BH**  
LOGITECH 3 BUTTON MOUSE  
PC MAGAZINE EDITORS' CHOICE! ALL MODELS HAVE SERIAL SUPPORT (COM1/COM2), 200 D.P.I., RESOLUTION, LOTUS 1-2-3 SHELL, SELF-INSTALLING SOFTWARE AND "POINT EDITOR"
- LMOUSE** \$74.95  
**LMOUSE-P** SERIAL MOUSE W/LOGIPAIN \$89.95  
**LMOUSE-BP** BUS MOUSE W/LOGIPAIN \$89.95  
**LMOUSE-BPBL** BUS MOUSE W/PUBLISHER PKG \$129.95  
**LMOUSE-BPC** BUS MOUSE W/LOGIPAIN/CAD \$139.95

## MODULAR PROGRAMMING SYSTEM

INTEGRATED MODULAR SYSTEM EASILY EXPANDS! ALL MODULES USE A COMMON HOST ADAPTOR CARD-- USE JUST ONE SLOT TO PROGRAM EPROMS, PROMS, PALS & MORE

### HOST ADAPTOR CARD \$29.95

- UNIVERSAL INTERFACE FOR ALL THE PROGRAMMING MODULES!
  - SELECTABLE ADDRESSES PREVENTS CONFLICTS
  - MOLDED CABLE
- MOD-MAC**

### UNIVERSAL MODULE \$499.95

- PROGRAMS EPROMS, EEPROMS, PALS, BI-POLAR PROMS, 8748 & 8751 SERIES DEVICES; 16V8 AND 20V8 GALS (GENERIC ARRAY LOGIC) FROM LATTICE, NS, SGS ■ TESTS TTL, CMOS, DYNAMIC & STATIC RAMS ■ LOAD DISK, SAVE DISK, EDIT, BLANK CHECK, PROGRAM, AUTO, READ MASTER, VERIFY AND COMPARE
  - TEXTLOO SOCKET FOR .3" TO .6" W. IC'S (8-40 PINS)
- MOD-MUP**

## VGA COMPATIBLE PACKAGE \$549.95

- 800 X 560 MAX. RESOLUTION ■ 640 X 480 IN 16 COLORS
  - 320 X 200 IN 256 COLORS ■ IBM STYLE MONITOR
  - VGA, EGA, CGA, HERCULES, MONOCHROME COMPATIBLE
- VGA-PKG** (INCLUDES ATI CARD AND MONITOR)

**NEC MULTISYNC II MONITOR** \$599.95  
■ AUTO FREQ ADJUSTMENT ■ RESOLUTION TO 800 X 560  
■ IDEAL FOR CAD, CAM, WINDOWS ■ 9-15 PIN ADAPTER

**NEC-MULTI**

**JDR MULTI** \$499.95  
■ FULL FEATURED MULTISCAN MONITOR WITH UNLIMITED COLORS ■ HIGH RESOLUTION, 14" NON-GLARE DISPLAY  
■ AUTO SWITCHING ■ TTL/ANALOG VIDEO INPUT

**JDR-MULTI**  
**JDR-MONO** (12" MONOCHROME MONITOR) \$69.95

**EGA MONITOR** \$399.95  
■ 640 X 200/350 RESOLUTION ■ .31 MM DOT PITCH ■ 14" BLACK MATRIX SCREEN ■ 16 COLOR DISPLAY ■ 9-PIN CABLE

**EGA-MONITOR**

SAVE \$50! EGA CARD & MONITOR--JUST \$499

## KEYBOARDS

**101 KEY ENHANCED, W/SEPARATE CURSOR PAD:**  
BTC-5339 AUTOSENSE FOR XT/AT, AUTOREPEAT \$79.95  
K103-A AUDIBLE "CLICK" STYLE \$84.95  
MAX-5339 MAXI-SWITCH W/TACTILE FEEDBACK \$84.95

**84 KEY STYLES:**  
BTC-5060 AUTOSENSE FOR XT/AT \$59.95  
MAX-5060 MAXI-SWITCH W/TACTILE FEEDBACK \$64.95

## MODULAR CIRCUIT TECHNOLOGY NEW LOW PRICES!

**MOTHERBOARDS:**  
MCT-XMB STANDARD 8088 MOTHERBOARD \$87.95  
MCT-TURBO 4.77/8 MHZ 8088 MOTHERBOARD \$95.95  
MCT-TURBO-10 4.77/10 MHZ SINGLE CHIP 8088 \$99.95  
MCT-M286 6/10 MHZ MINI-286 \$269.95  
MCT-M286-12 6/12 MHZ MINI-286 \$299.95

**DRIVE CONTROLLERS:**  
MCT-FDC FLOPPY DISK CONTROLLER \$29.95  
MCT-FDC-1.2 1.2 MB FLOPPY CONTROLLER \$49.95  
MCT-HDC HARD DISK CONTROLLER \$79.95  
MCT-RLL RLL CONTROLLER \$89.95  
MCT-FH FLOPPY/HARD CONTROLLER \$139.95  
MCT-AFH 286/386 FLOPPY/HARD \$149.95  
MCT-AFH-RLL 286/386 RLL CONTROLLER \$199.95

**DISPLAY ADAPTOR CARDS:**  
MCT-MGP MONOCHROME GRAPHICS \$59.95  
MCT-CG COLOR GRAPHICS ADAPTOR \$49.95  
MCT-EGA ENHANCED GRAPHICS ADAPTOR \$149.95  
MCT-MGMIO MONOGRAPHICS MULTI I/O \$119.75  
MCT-MGAI0 286/386 MONOGRAPHICS I/O \$99.95

**MULTIFUNCTION CARDS:**  
MCT-MIO MULTI I/O FLOPPY CONTROLLER 79.95  
MCT-IO MULTI I/O CARD \$59.95  
MCT-AMF 286/386 MULTIFUNCTION \$139.95  
MCT-AIO 286/386 MULTI I/O CARD \$59.95

**MEMORY CARDS:**  
MCT-RAM 576K RAM CARD \$59.95  
MCT-EMS EXPANDED MEMORY CARD \$129.95  
MCT-AEMS 286/386 EMS CARD \$139.95

## 20 MB \$269 Seagate

## 30 MB \$299

KITS INCLUDE A SEAGATE HARD DISK DRIVE, DRIVE CONTROLLER, CABLES AND INSTRUCTIONS.

**HDKIT20** 20 MB SYSTEM KIT  
**HDKIT30** 30 MB SYSTEM KIT

## FAST, RELIABLE SEAGATE HARD DISKS:

DISK SIZE	MODEL	AVG. SPD.	SIZE	PRICE
20MB	ST-125	65 MS	3-1/2"	\$259
20MB	ST-225	65 MS	5-1/4"	\$225
30MB RLL	ST-238	65 MS	5-1/4"	\$249
40MB	ST-251	40 MS	5-1/4"	\$379
40MB	ST-251-1	28 MS	5-1/4"	\$469
60MB RLL	ST-277	40 MS	5-1/4"	\$449
80MB	ST-4096	28 MS	5-1/4"	\$629

## 1 Mb 3 1/2" DRIVE \$99.95

- ULTRA HIGH DENSITY
  - READ/WRITE 720K DISKS, TOO
- FDD-1.44X** BLACK FACEPLATE  
**FDD-1.44A** BEIGE FACEPLATE  
**FDD-1.44 SOFT** SOFTWARE DRIVER \$19.95

**1/2 HEIGHT FLOPPY DISK DRIVES:**  
FD-55B 5-1/4" TEAC DS/DD 360K \$99.95  
FD-55G 5-1/4" TEAC DS/HD 1.2M \$129.95  
FDD-360 5-1/4" DS/DD 360K \$89.95  
FDD-1.2 5-1/4" DS/HD 1.2M \$95.95  
FDD-3.5X 3-1/2" 720K (BLACK) \$97.95  
FDD-3.5A 3-1/2" 720K (BEIGE) \$97.95

**NASHUA DISKETTES (BOXES OF 10):**  
N-MD2D 360K DS/DD \$6.95  
N-MD2D BULK (MULTIPLES OF 50 DISKS) EACH \$4.95  
N-MD2H 1.2 MB DS/HD \$13.95  
N-3.5HD 1.44 MB 3-1/2" DS/HD \$49.95  
N-3.5DS 720K 3-1/2" DD/DS \$16.95

## BUILD YOUR OWN SYSTEM!

OVER 25,000 JDR SYSTEMS HAVE BEEN BUILT. OUR DETAILED INSTRUCTIONS MAKE IT VERY EASY--ALL YOU NEED IS ABOUT 2 HOURS AND A SCREWDRIVER!

### VIDEO INSTRUCTIONS \$4.95 WITH SYSTEM

OUR 20 MINUTE VIDEO SHOWS YOU STEP-BY-STEP HOW TO BUILD AN XT-COMPATIBLE SYSTEM. SPECIFY VHS OR BETA. VIDEO WITH SYSTEM KIT, \$4.95 VIDEO ALONE, 19.95

### 10 MHz TURBO 8088 SYSTEM \$595.86

- SERIAL/PARALLEL PORTS, CLOCK/CALENDAR & GAME ADAPTOR
- RUNS COLOR GRAPHICS SOFTWARE ON ITS MONOCHROME MONITOR ■ MOTHERBOARD ■ 256K RAM MEMORY ■ 135W POWER SUPPLY ■ FLUPTOP CASE
- 84 KEY KEYBOARD ■ 360K FLOPPY DRIVE
- MONOGRAPHICS I/O CARD

### 12 MHz MINI-286 SYSTEM \$1038.47

- 12 MHZ MINI-286 MOTHERBOARD ■ 512K RAM MEMORY
- MINI-AT CASE W/POWER SUPPLY ■ 84 KEY KEYBOARD
- MONOCHROME MONITOR ■ 1.2 MB FLOPPY DRIVE
- FLOPPY/HARD CONTROL ■ MONOGRAPHICS CARD

### EPROM PROGRAMMER \$129.95

- PROGRAMS 27XX AND 27XXX EPROMS UP TO 27512
  - SUPPORTS VARIOUS PROGRAMMING FORMATS & VOLTAGES ■ SPLIT OR COMBINE CONTENTS OF SEVERAL EPROMS OF DIFFERENT SIZES
  - READ, WRITE, COPY, ERASE, CHECK & VERIFY
  - SOFTWARE FOR HEX AND INTEL HEX FORMATS
- MOD-EPROM**

JDR MICRODEVICES, 2233 BRANHAM LANE, SAN JOSE, CA 95124  
LOCAL (408) 866-6200 FAX (408) 559-0250 TELEX 171-110  
RETAIL STORE: 1256 S. BASCOM AVE., SAN JOSE, CA  
(408) 947-8881 HOURS: M-F, 9-7 SAT. 9-5 SUN. 12-4

NEW ADDRESS!

Terms: Minimum order \$10.00. For shipping & handling include \$3.50 for ground and \$4.50 for air. Orders over 1 lb and foreign orders may require additional shipping charges--please contact the sales department for the amount. CA residents must include applicable sales tax. Prices subject to change without notice. We are not responsible for typographical errors. We reserve the right to limit quantities and to substitute manufacturer. All merchandise subject to prior sales. A full copy of our terms is available upon request. Items pictured may only be representative.

# ORDER TOLL FREE 800-538-5000

COPYRIGHT 1989 JDR MICRODEVICES

CONTINENTAL US



★ **QUALITY PARTS** ★ **DISCOUNT PRICES** ★ **FAST SHIPPING**

# ALL ELECTRONICS CORP.

### 3 to 6 Vdc MOTOR with GEARBOX

Probably designed for child's toy. Lever selects 2 forward and one reverse speed. 1st gear approx. 120 rpm/6vdc, 2nd gear approx. 300 rpm/6vdc, Reverse approx. 120 rpm/6vdc.

3.35" X 1.75" X 3.25"  
CAT# DCM-10 \$6.00

### CASSETTE MECHANISM

Alpine cassette transport mechanism. Includes stereo tape head, Mitsubishi # MET-3RF2B 13.2 Vdc motor, belt, pulleys, capstan, fast forward, rewind and eject actuator. Does not include amplifier section. 6 1/2" X 5 1/4" X 1 3/4".

CAT# CMEC-5 \$7.50 each  
10 for \$65.00

### 6 VOLT D.C. 9.5 AMP/HOUR GEL-CELL

Elpower# 695  
6 volt, 9.5 amp/hour rechargeable gel-cell battery. 4.25" X 2.75" X 5.5". Quick connect terminals.

CAT# GC-695 \$15.00 each

### 0 - 8 AMP DC METER

No shunt required. 2 2/8" square. Black plastic and white face clearly marked "DC Amperes". Ideal for power supplies, battery chargers, etc.

CAT# MET-12 \$3.75 each

### WALL TRANSFORMERS

ALL PLUG DIRECTLY INTO 120 VAC OUTLET

6 Vdc @ 200 ma. CAT# DCTX-620 \$2.25  
6 Vdc @ 750 ma. CAT# DCTX-675 \$3.50  
9 Vdc @ 250 ma. CAT# DCTX-925 \$2.50  
12 Vdc @ 900 ma. CAT# ACTX-1293 \$3.50  
18 Vdc @ 1 amp. CAT# ACTX-1885 \$3.50

### LED'S

STANDARD JUMBO DIFFUSED T-1-3/4 size

RED CAT# LED-1  
10 for \$1.50 - 100 for \$13.00

GREEN CAT# LED-2  
10 for \$2.00 - 100 for \$17.00

YELLOW CAT# LED-3  
10 for \$2.00 - 100 for \$17.00

FLASHING LED with built in flashing circuit operates on 5 volts...

RED \$1.00 each  
CAT# LED-4 10 for \$9.50

GREEN \$1.00 each  
CAT# LED-4G 10 for \$9.50

BI-POLAR LED Lights RED one direction, GREEN the other. Two leads.

CAT# LED-6 2 for \$1.70

LED HOLDER Two piece holder.  
CAT# HLED 10 for 85¢

### MINIATURE BCD THUMBWHEEL SWITCHES

SMK# J-D0001 #01  
Each switch has digits 0-9. Snap together to make up any necessary configuration. Designed to mount directly to P.C. board. Pins on .1" centers. Each switch is .64" high X .59" wide X .235" thick.

CAT# SWTH-5 2 for \$1.00  
10 for \$4.50 - 100 for \$40.00

### PIEZO WARNING DEVICE

Murata Erie # PKB8-440  
High pitched audible alarm. Operates on 3 - 20 Vdc @ 20 ma. 1" high x 7/8" dia. P.C. board mount.

CAT# PBZ-84 \$1.75 each

NICKEL-CAD BATTERIES (RECHARGEABLE)

SPECIAL!! AAA SIZE  
Panasonic P-18AAA  
1.2 volt @ 180 MAh  
CAT# NCB-AAAX \$1.50 each  
10 for \$13.50 - 100 for \$125.00

### WIDE BAND AMPLIFIER

NEC# UPC1651G. 1200 Mhz @ 3 db. Gain: 19db @ 1-500 Hz. 5 volt operation. Small package 4mm dia. X 2.5 mm thick.

CAT# UPC-1651 2 for \$1.00  
10 for \$4.50 - 100 for \$35.00

N-CHANNEL MOSFET  
RF-511 TO-220 case  
CAT# IRF 511 \$1.00 each - 10 for \$9.00  
LARGE QUANTITY AVAILABLE

### SWITCHES

ITT PUSH BUTTON  
ITT MDPL series. 3/4" X 1/2" gray rectangular key cap. S.P.S.T. N.O.

Push to close. RATED: 0.1 amp switching, 0.25 amp carry current. P.C. mount. CAT# PB-8 65¢ each - 10 for \$6.00 - 100 for \$50.00

10 POSITION MINI-ROTARY  
Grayhill 56P36-01-1-10N-C  
Mini rotary switch. Non-shorting. 1 deck, 10 positions. .125" dia. shaft X .375" long. .377" behind the panel depth. P.C. pins.

CAT# MRS-10 WAS \$2.50 NOW \$1.50 each

SPDT PUSHBUTTON  
Marquardt 1843  
Rated 6 amps @ 125/250 Vac.  
Black plastic pushbutton.  
Switch body: .92" X .94" X .65".  
CAT# PB-18 \$1.65 each - 10 for \$15.00 each

S.P.S.T. (ON-OFF)  
All plastic body. Standard size toggle. 7/16" threaded mounting bushing. Copper contacts.  
Rated: 10 amp @ 125 Vac.  
CAT# STS-1 \$1.00 each  
10 for \$8.50 - 100 for \$75.00

### RELAYS

12 VOLT D.C. COIL S.P.D.T.  
Omron G2E-184P 4 Amp contacts 335 ohm coil.  
Sugar cube size. .61" X .42" X .44" high.  
P.C. mount with pins on DIP spacing.  
CAT# RLY-787 \$1.50 each

5 VOLT DC SIP RELAY  
Gould, Allied Control SR-1A-5VDC  
SPST-normally open SIP reed relay. 95 ohm coil. 2 amp contacts. .9" X .29" X .39" high. Housing resists fasteners fluorocarbon and chlorinated commercial solvents. CAT# RLY-SIP6 \$1.00 each - 10 for \$8.50

### SOUND AND VIDEO MODULATOR

TM UM1381-1. Designed for use with T.V. computers. Can be used with video cameras, games or other audio/video source. Built in A/B switch enables user to switch from T.V. antenna without disconnection. Operates on channel 3 or 4. Requires 12 Vdc. Hook up diagram included.

CAT# AVMOD \$5.00 each

### LIGHT ACTIVATED MOTION SENSOR

This device contains a photocell which senses sudden change in ambient light. Could be used as a door annunciator or modified to trigger other devices. 5 1/2" X 4" X 1". Operates on 6 Vdc. Requires 4 AA batteries (not included).

CAT# LSMD \$5.75 per unit

### 1/4 WATT RESISTOR KIT

Ideal for the workshop, this 1/4 watt resistor kit contains 10 pieces each of 42 of the most popular values (420 pieces total). Includes a divided box and a parts locator.

VALUES in this kit are:  
1 ohm, 10 ohm, 39 ohm, 47 ohm, 51 ohm, 68 ohm, 100 ohm, 130 ohm, 150 ohm, 180 ohm, 220 ohm, 330 ohm, 470 ohm, 560 ohm, 680 ohm, 1K, 1.2K, 1.5K, 2K, 2.2K, 2.7K, 3K, 4.7K, 5.1K, 5.6K, 10K, 15K, 22K, 30K, 33K, 39K, 47K, 56K, 68K, 100K, 120K, 150K, 220K, 470K, 1 MEG, 5.1 MEG, 10 MEG

The resistors alone would sell for \$21.00.  
Complete kit - CAT# REKIT-14 \$17.00

### XENON TUBE

1" long flashtube prepped with 3 1/2" red and black leads. Ideal for electronic flash or strobe projects.

CAT# FLT-3 2 for \$1.00

### STROBE KIT

Variable rate strobe kit, flashes between 60 to 120 times per minute. Will operate on either 6 or 12 Vdc depending upon how you wire the circuit. Comes complete with P.C. board and instructions for easy assembly.

CAT# STROBE-1 \$7.50 each

### TELEPHONE COUPLING TRANSFORMER

Multi Products International# A19N-HO-1D1  
Primary 600 ohm  
Secondary: 600/600 ohm  
77" X .61" X .63" high.  
6 p.c. pins on .187" centers.  
Primary inductance:  
300 mH min., at 1kHz, 1 volt.

CAT# TCTX-1 \$1.25 each  
10 for \$11.00 - 100 for \$95.00

### TRANSISTORS

ORDER BY PART #

PN2222 NPN TO-92 5 for 75¢  
PN2907 PNP TO-92 5 for 75¢  
2N 3055 NPN TO-3 \$1.00 each  
MJ2955 PNP TO-3 \$1.50 each  
MJE2955T PNP TO-220 75¢ each  
MJE3055T NPN TO-220 75¢ each  
TIP31 NPN TO-220 75¢ each  
TIP32 PNP TO-220 75¢ each  
TIP121 NPN TO-220 75¢ each  
TIP126 PNP TO-220 75¢ each

### OPTO SENSOR

U shaped package with mounting ears. 1/8" opening. 3/4" mounting holes. CAT# OSU-6 50¢ each  
10 for \$4.50 - 100 for \$40.00

### MOTORS

1 1/2 Vdc TOY MOTOR  
Best Motor Co.# R-20  
Designed to run on 1.5 volt batteries. 0.83" diameter, 1.14" long. 0.08" dia. shaft is 0.32" long. Prepped with red and blue wire leads. Ideal for toys, science projects and low power applications.

CAT# DCM-15 3 for \$1.00  
10 for \$3.00 - 100 for \$25.00

3-6 Vdc MOTOR  
Mabuchi Motor.  
1.08" diameter X 1.42" long. .09" diameter knurled shaft X .3" long. Solder terminals. Threaded mounting holes on .65" centers.

CAT# DCM-16 65¢ each  
10 for \$6.00 - 125 for \$62.50

CALL OR WRITE FOR OUR FREE CATALOG OVER 4000 PARTS!



56 pages!

MAIL ORDERS TO:  
**ALL ELECTRONICS**  
P.O. BOX 567  
VAN NUYS, CA 91408

TWX-5101010163 (ALL ELECTRONIC)

OUTSIDE THE U.S.A. SEND \$2.00 POSTAGE FOR A CATALOG!!

ORDER TOLL FREE  
**800-826-5432**  
INFO: (818)904-0524  
FAX: (818)781-2653  
MINIMUM ORDER \$10.00  
QUANTITIES LIMITED  
CALIF. ADD SALES TAX  
USA: \$3.00 SHIPPING  
FOREIGN ORDERS INCLUDE SUFFICIENT SHIPPING. NO C.O.D.













Buy with

# Confidence



In an effort to make your telephone purchasing a more successful and pleasurable activity, The Microcomputer Marketing Council of the Direct Marketing Association, Inc. offers this advice, "A knowledgeable buyer will be a successful buyer." These are specific facts you should know about the prospective seller before placing an order:

## Ask These Important Questions

- How long has the company been in business?
- Does the company offer technical assistance?
- Is there a service facility?
- Are manufacturer's warranties handled through the company?
- Does the seller have formal return and refund policies?
- Is there an additional charge for use of credit cards?
- Are credit card charges held until time of shipment?
- What are shipping costs for items ordered?

Reputable computer dealers will answer all these questions to your satisfaction. Don't settle for less when buying your computer hardware, software, peripherals and supplies.

## Purchasing Guidelines

- State as completely and accurately as you can what merchandise you want including brand name, model number, catalog number.
- Establish that the item is in stock and confirm shipping date.
- Confirm that the price is as advertised.
- Obtain an order number and identification of the sales representative.
- Make a record of your order, noting exact price including shipping, date of order, promised shipping date and order number.

If you ever have a problem, remember to deal first with the seller. If you cannot resolve the problem, write to MAIL ORDER ACTION LINE, c/o DMA, 6 E. 43rd St., New York, NY 10017.

This message is brought to you by:

the MICROCOMPUTER  
MARKETING COUNCIL  
of the Direct Marketing  
Association, Inc.  
6 E. 43rd St.,  
New York, NY 10017

**MMMC**  
MICROCOMPUTER  
MARKETING COUNCIL  
of the Direct Marketing Association, Inc.

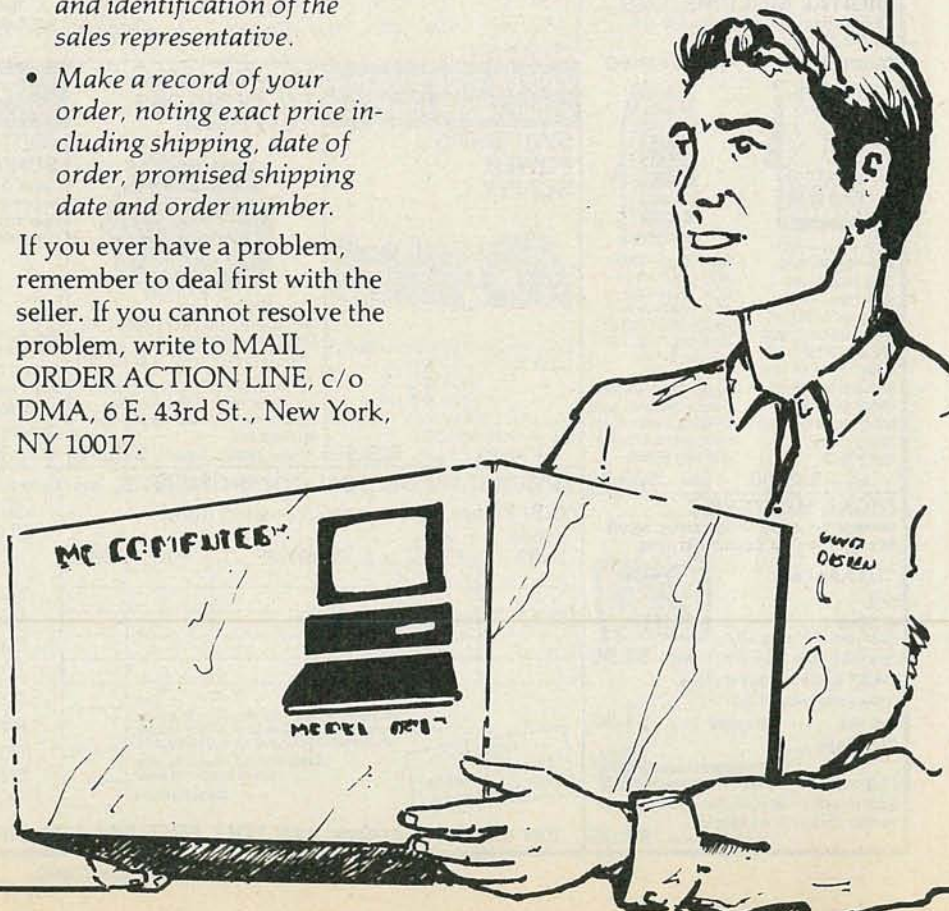



# Radio Shack Parts Place™

## SUPER SELECTION, SUPER VALUES—COME IN TODAY!

### "Hotline" Special-Order Service

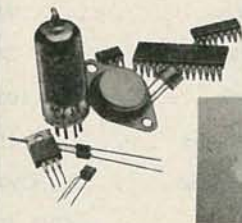

Save Postage! We Deliver to Your Local Radio Shack  
Save Time! Delivery on Most Items in One Week

Your Radio Shack store manager can special-order a wide variety of parts and accessories not shown in our catalog—tubes, ICs, phono cartridges and styli, crystals, SAMS Photofacts®. No minimum or handling charge!

### Get Your Novice Ham License

# 1995

Complete Self-Study Course



Prepared by Gordon West, WB6NOA

Take advantage of the new voice and radio-computing privileges! Includes two self-paced code cassettes, study guide with exam questions and answers, FCC Form 610 and a sturdy molded binder. #62-2402

### Computer Hookups



Fig.	Description	Cat. No.	Price
1	6-Ft. Grounded AC Power Cord	278-1257	3.99
2	"Snap" Toroid Choke Cores (2)	273-104	6.95
3	IDC Installation Tool	276-1596	12.95
4	Male D-Sub 25 Connector	276-1559	3.99
—	Female D-Sub 25	276-1565	3.99
—	36-Position IDC Male	276-1533	4.99
—	36 Position IDC Female	276-1523	4.99

### ICs for Experimenters



995

595

**VCP200 Voice Recognizer.** Easy-to-use LSI device understands seven preset motion and start/stop commands. With data. #276-1308 . . . . . 9.95

**TDA7000 FM Receiver.** RF, mixer, 70 kHz IF and demod stages in one IC. With data. See project in July '88 *Hands On Electronics*. #276-1304 . . . . . 5.95

### Solar Project Kit



995

**Harness The Sun!**



Great for scouts or school science class! Includes mini solar panel, motor, color wheel, propeller, project booklet. #277-1201

### Capacitor Bargains

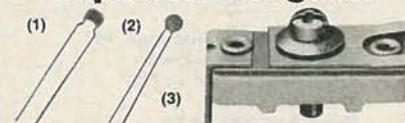

- (1) 0.1  $\mu$ F Monolithics. 50 WVDC. High capacity in a tiny size—ideal for on-board noise cleanup. #272-109 . . . . . Pkg. of 5/1.79
- (2) Low-pF Assortment. 50 ceramic discs, hard-to-find values from 1 to 33 pF. 50 WVDC. #272-806 . . . . . Pkg. of 50/2.99
- (3) 95-420 pF Trimmer. #272-1336 . . . . . 1.69

### Antenna Components

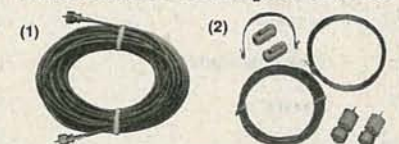

- (1) 50 Feet of RG-58 52-Ohm Cable. Top quality and prewired! PL-259 plug at each end. #278-971 . . . . . 11.95
- (2) Shortwave Antenna Kit. 75 feet of copper antenna wire, 50 feet of lead-in, window feed-through and insulators. #278-758 . . . . . 8.49

### Project Accessories

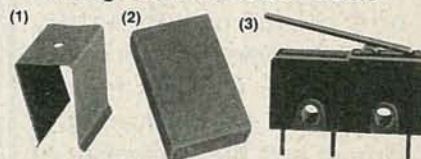

- (1) 9V Battery Holders. #270-326 . . . . . 2/69¢
- (2) Case. For a controller, beeper, small portable device. 3 $\frac{3}{4}$  x 2 $\frac{5}{16}$  x 1". Removable end panel. #270-293 . . . . . 3.99
- (3) SPDT Lever Switch. #275-016 . . . . . 1.69

### Resistor Values

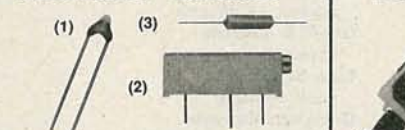

- (1) Precision Thermistor. Range: -50 to +110° C. #271-110 . . . . . 1.99
- (2) 15-Turn Trimmer Pots. Select from 1k, #271-342. 10k, #271-343. 20k, #271-340 . . . . . Each 1.49
- (3) 8-Ohm Non-Inductive Resistor. 20W. #271-120 . . . . . 1.39

### Bench Helpers

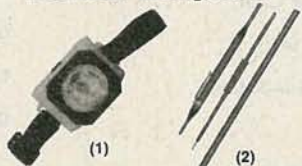

- (1) Head Light. Really handy—puts light where you look! Comfortable band. #61-2510 . . . . . 3.99
- (2) Anti-Static TV/RF Alignment Tool Set. #64-2230 . . . . . 3.99

### Chime and Buzzers



- (1) Electronic Chime. Delivers pleasant "ding-dong" output. #273-071 . . . . . 8.69
- (2) Two-Tone Piezo Alert. For 6 to 18VDC. Extra-loud. #273-070 . . . . . 9.95
- (3) Miniature DC Buzzers

DC Voltage	Cat. No.	Each
1.5 to 3	273-053	1.99
6	273-054	1.99
12	273-055	1.99

### Optoelectronics

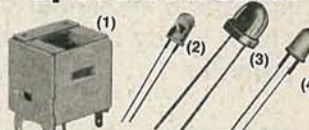

- (1) Infrared Detector Module. Built-in amp. 5VDC. #276-137 . . . . . 3.49
- (2) SEP8703-1 Infrared LED. Low power and high output. #276-143 . . . . . 1.69
- (3) Blinking Red LED. Super indicator! #276-036 . . . . . 1.29
- (4) Blinking Green LED. 1 Hz flash rate. #276-030 . . . . . 1.29

### Handy Tools

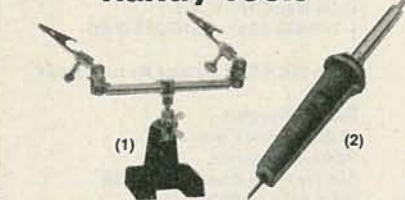

- (1) Adjustable Project Holder. For easier soldering, gluing and assembly. #64-2093 . . . . . 7.99
- (2) Dual-Wattage Soldering Iron. Go from 15 to 30 watts with the flick of a switch. Replaceable tip. 8 $\frac{1}{4}$ " long. #64-2055 . . . . . 8.95

### Logic Probe and Pulsar



- (1) Probe. LEDs and tones reveal logic states in digital circuits. #22-303 . . . . . 16.95
- (2) Pulsar. Teammate for the probe. Produces a single 5  $\mu$ s pulse or a continuous pulse train at the push of a button. #22-304 . . . . . 17.95

### Clamp-On AC Meter



Measures AC current without direct connection to circuit and AC voltage with included test leads. Plug-in inductive pickup/multiplier for testing devices with an AC cord. #22-161

Over 1000 items in stock! Binding Posts, Books, Breadboards, Buzzers, Capacitors, Chokes, Clips, Coax, Connectors, Fuses, Hardware, ICs, Jacks, Knobs, Lamps, Multitesters, PC Boards, Plugs, Rectifiers, Resistors, Switches, Tools, Transformers, Transistors, Wire, Zeners, More!

Prices apply at participating Radio Shack stores and dealers

# Radio Shack®

## The Technology Store™

A DIVISION OF TANDY CORPORATION

CIRCLE 78 ON FREE INFORMATION CARD

JUNE 1988



# Active keeps you active!



Whether you are in an "after-hour emergency" or are a dedicated "do-it-yourselfer", **Active** can help you! Visit one of our conveniently located stores, or refer to our catalogue. Call toll-free to access North America's largest and best selection of electronic components and accessories! **Active**, an affiliate of **Future Electronics** has over 12,000 first grade, industrial items in stock ready for immediate delivery.

## You can count on us!

Locations Nearest You

Westborough, MA 508-366-8899	Chicago, IL 312-593-6655
Woburn, MA 617-932-4616	Seattle, WA 206-881-8191
Long Island, NY 516-471-5400	Santa Clara, CA 408-727-4550
Mt. Laurel, N.J. 609-273-2700	Baltimore, MD 301-536-5400
Detroit, MI 313-689-8000	BY PHONE 1-800-ACTIVE-4



# TOLL-FREE 1-800-ACTIVE-4

CIRCLE 52 ON FREE INFORMATION CARD

## ADVERTISING INDEX

RADIO-ELECTRONICS does not assume any responsibility for errors that may appear in the index below.

Free Information Number	Page		
		183	Opto Electronics..... 74
108	AMC Sales .....	26	— Pacific Cable..... 94, 91
75	Ace Products.....	73	56 Parts Express .....
52	Active Electronics .....	106	101 Pomona Electronics.....
107	All Electronics .....	101	78 Radio Shack .....
—	Amazing Concepts.....	92, 94	186 SCO Electronics.....
106	American Design Components..	103	— Scope Electronics .....
77	B&K Precision .....	25	179,180 Sencore .....
67	Banner Technical Books .....	72	74 Solid State Sales.....
98	Beckman Industrial .....	27	— Star Circuits.....
109	C & S Sales.....	3	— Synergetics .....
70	CEI .....	90	92 Tektronix.....
60	CIE .....	11, 32	123 Test Probes .....
54	Chemtronics .....	72	184 Triplett.....
—	Command Productions .....	15	185 Viejo Publications .....
176	Communications Specialists .....	77	177 WPT Publications .....
187	Concord.....	78	
58	Cook's Institute .....	71	
69	Crystek .....	15	
178	Daeshin .....	73	
127	Deco Industries.....	73	
82	Digi-Key .....	102	
181	Electronic Goldmine .....	89	
—	Electronics Book Club.....	56	
121	Fluke Manufacturing.....	CV2	
—	Grantham College of Eng.....	4	
86	Heathkit .....	95	
182	ICS Computer Training .....	26	
65	J & W .....	5	
113	JDR Microdevices .....	98	
170,171	JDR Microdevices .....	99, 100	
114	Jameco .....	96	
104	Jan Crystals .....	71	
—	Joseph Electronics .....	23	
89	MAT Electronics .....	90	
53	MD Electronics.....	93	
93	Mark V. Electronics .....	93, 73	
—	McGraw Hill Book Club.....	38	
61	Microprocessors Unltd.....	85	
—	Microcomputer Marketing.....	104	
—	NRI .....	7, 21	
—	Nuts & Volts .....		

**Gernsback Publications, Inc.**  
500-B Bi-County Blvd.  
Farmingdale, NY 11735  
1-516-293-3000  
Fax 1-516-293-3115  
President: **Larry Steckler**  
Vice President: **Cathy Steckler**

**For Advertising ONLY**  
1-516-293-3000  
Fax 1-516-293-3115  
**Larry Steckler**  
publisher

**Arline Fishman**  
advertising director  
**Shelli Weinman**  
advertising associate  
**Lisa Strassman**  
credit manager  
**Christina Estrada**  
advertising assistant

### SALES OFFICES

**EAST/SOUTHEAST**  
**Stanley Levitan**  
Eastern Sales Manager  
Radio-Electronics  
259-23 57th Avenue  
Little Neck, NY 11362  
1-718-428-6037, 1-516-293-3000

### MIDWEST/Texas/Arkansas/ Okla.

**Ralph Bergen**  
Midwest Sales Manager  
Radio-Electronics  
540 Frontage Road—Suite 339  
Northfield, IL 60093  
1-312-446-1444  
Fax 1-312-446-8451

### PACIFIC COAST/ Mountain States

**Marvin Green**  
Pacific Sales Manager  
Radio-Electronics  
5430 Van Nuys Blvd. Suite 316  
Van Nuys, CA 91401  
1-818-986-2001  
Fax 1-818-986-2009



# Find The Defective Capacitors, Coils, Resistors, SCRs And Triacs That All Other Testers Miss . . .

Presenting a new, improved, dynamic and mistake proof LC Analyzer that finds defective components all other testers miss.

Dynamically tests capacitors for value from 1 pF to 20F, leakage with up to 1000 volts applied, dielectric absorption and equivalent series resistance (ESR).

Dynamically tests inductors, in-or-out of circuit, from 1 uH to 20 Henrys for opens, shorts, value, and detects even the shorted turn.

- Dynamically tests SCRs, Triacs, High Value Resistors, and locates the distance to within feet of an open or short in a transmission line for an added bonus.

- Automatically makes all of the tests, compares them to EIA (Electronic Industries Association) standards and reads the results as Good or Bad. Enter all information right from the component without look-up charts, calculations, or errors.

- Extends your testing capability to places where an AC cord won't reach, with rechargeable 9 hour battery or AC operations.

- An added feature alerts you that the fuse has opened, and that there may be residual high voltage on the component under test.

**New!**  
And Improved!

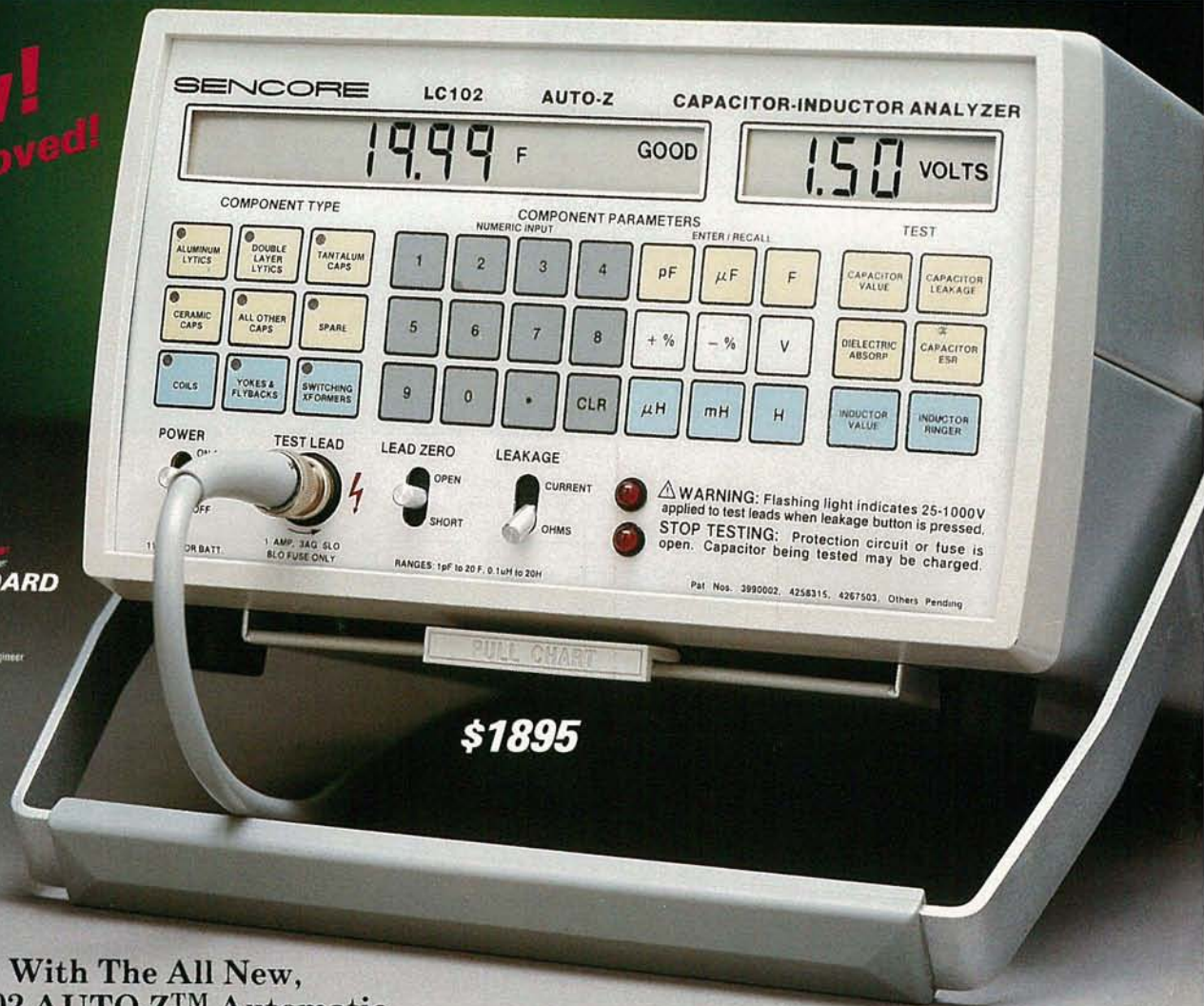

**\$1895**

With The All New,  
LC102 AUTO-Z™ Automatic  
Capacitor-Inductor Analyzer.  
Four Patents

**Call 1-800-843-3338**  
**In Canada Call 1-800-851-8866**



# QUICK FIX

Super values on the tools and instruments you need to identify problems, get to them quickly and make repairs easily!

## PRECISION HAND-HELD INSTRUMENTS

- Lightweight convenience. Easy to read
- Fast, precise results

### B & K Precision Test Bench™

- 41 range voltmeter • Ammeter
- Ohmmeter • Frequency counter
- Capacitance meter
- Logic probe
- Transistor & diode tester
- Extra-large LCD display



**Model 388-HD**  
Reg. \$129.95  
Our Price **\$11900**

### SCOPE Digital Multimeter

- 11 function, 38 ranges including: Logic Level Detector, Audible and Visual Continuity, Capacitance & Conductance measurements.



**Model DVM-638**  
Reg. \$87.50  
Our Price **\$7995**

CA-92 Deluxe Padded Case for DVM meters \$9.95  
TL-216 Transistor and Capacitance Test Leads \$9.90

## ALL-PURPOSE 92-PC. TOOL CASE

- Complete kit for home, workshop and auto
- Includes 52-pc. socket set with extenders • 2 tool pallets with roomy rear storage compartments • Attractive, rugged carry case.

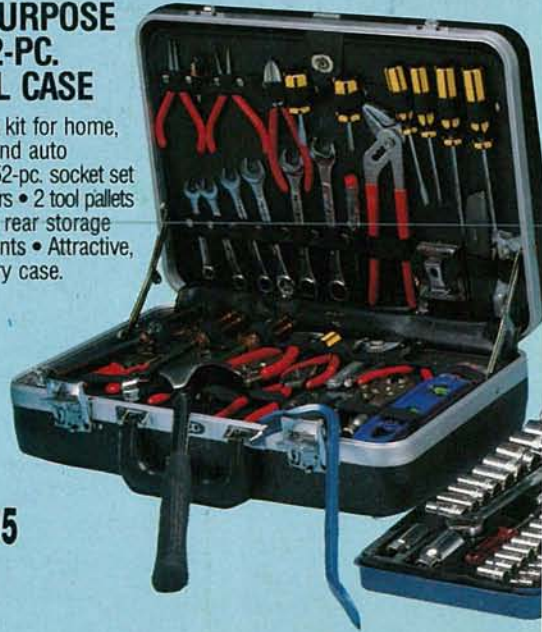

**Model FTK-28**  
Reg. \$169.95  
Our Price **\$12995**

## DUAL TRACE OSCILLOSCOPES

### A.W. SPERRY 20 MHz OSCILLOSCOPE

- Built-in component checker • Z-axis input
- Low power consumption
- TV Video sync filter • High-sensitivity X-Y mode
- Front panel trace rotator • Includes 2 test probes



**Model 620C**  
Our Price **\$34995**  
*Special Price*

### HITACHI 35 MHz OSCILLOSCOPE

- 19 calibrated sweeps
- 6" CRT with internal graticule, scale illumination & photographic bezel
- Auto focus • X-Y operation
- TV sync separation
- Includes 2 probes (10:1 and 1:1)



**Model V-355**  
Reg. \$899.95  
Our Price **\$59800**

ASK FOR YOUR FREE CATALOG

# SCOPE ELECTRONICS

260 Motor Parkway  
Hauppauge, New York 11788

**TOLL FREE 800-648-2626**

(In NY State 800-832-1446 Ext. 242)

TELEPHONE ORDERS NOW!



### Service & Shipping Charge Schedule Continental U.S.A.

FOR ORDERS	ADC
\$25-50	\$4.50
\$51-100	\$5.50
\$101-200	\$7.00
\$201-300	\$8.00
\$301-400	\$9.00
\$401-500	\$10.00
\$501-750	\$12.50
\$751-1000	\$15.00
\$1,001-1,250	\$17.50
\$1,251-1,500	\$20.00
\$1,501-2,000	\$25.00
\$2,001 and Up	\$30.00