

48783

Radio - DESCRAMBLING THE SSAVI SYSTEM

\$1.95 NOV. 86
IN CANADA \$2.50

Electronics

TECHNOLOGY - VIDEO - STEREO - COMPUTERS - SERVICE

GERMSBACK PUBLICATION

BUILD THIS CLOSED-CAPTION DECODER

Get more from your TV

BUILD A LATCHING CONTINUITY TESTER

Find shorts and opens as short as one millisecond!

BURN YOUR OWN EPROMS

With R-E's easy-to-build programmer

OSCILLATORS

Crystal-controlled circuits

THE EARLY DAYS OF RADIO

The birth of the vacuum tube

INSTALL YOUR OWN TELEPHONE

We show you how



PLUS:

- ★ Ask R-E
- ★ Robotics
- ★ PC Service
- ★ COMPUTERDIGEST
- ★ Antique Radios
- ★ Video News



New GPS Series: Tek sets the pace with SmartCursors™ and push-button ease.

Work faster, smarter, with two new general purpose scopes from Tektronix. The four-channel, 100 MHz 2246 and 2245 set the new, fast pace for measurements at the bench or in the field. They're easy to use and afford, by design.

On top: the 2246 with exclusive integrated push-button measurements. Measurements are accessed through easy, pop-up menus and implemented at the touch of a button. Measure peak volts, peak-to-peak, \pm peak, dc volts and gated volts with new hands-off convenience and on-screen readout of values.

SmartCursors™ track voltmeter measurements in the 2246 and visually indicate where ground and trigger levels are located. Or use cursors in the manual mode for immediate, effortless measurement of waveform parameters.

Both scopes build on performance you haven't seen at the bandwidth or prices. Lab grade features include sweep speeds to 2 ns/div. Vertical sensitivity of 2 mV/div at full bandwidth for low-level signal capture. Plus trigger

Features	2246	2245
Bandwidth	100 MHz	100 MHz
No. of Channels	4	4
Scale Factor Readout	Yes	Yes
SmartCursors™	Yes	No
Volts Cursors	Yes	No
Time Cursors	Yes	No
Voltmeter	Yes	No
Vertical Sensitivity	2 mV/div	2 mV/div
Max. Sweep Speed	2 ns/div	2 ns/div
Vert/Hor Accuracy	2%	2%
Trigger Modes	Auto Level, Auto, Norm, TV Field, TV Line, Single Sweep	
Trigger Level Readout	Yes	No
Weight	6.1 kg	6.1 kg
Warranty	3-year on parts and labor including CRT	
Price	\$2400	\$1875

sensitivity to 0.25 div at 50 MHz, to 0.5 div at 150 MHz.

Accuracy is excellent: 2% at vertical, 2% at horizontal. And four-channel capability includes two channels optimized for logic signals.

Best of all, high performance comes with unmatched convenience. You can see it and feel it—in the

responsive controls and simple front-panel design, in extensive on-screen scale factor readouts, and in simplified trigger operation that includes Tek's Auto Level mode for automatic triggering on any signal. Start to finish, the GPS Series saves steps and simplifies tasks.

Get out in front! Call toll-free today to order, to get more details or a videotape demonstration.

1-800-433-2323

In Oregon, call collect 1-627-9000

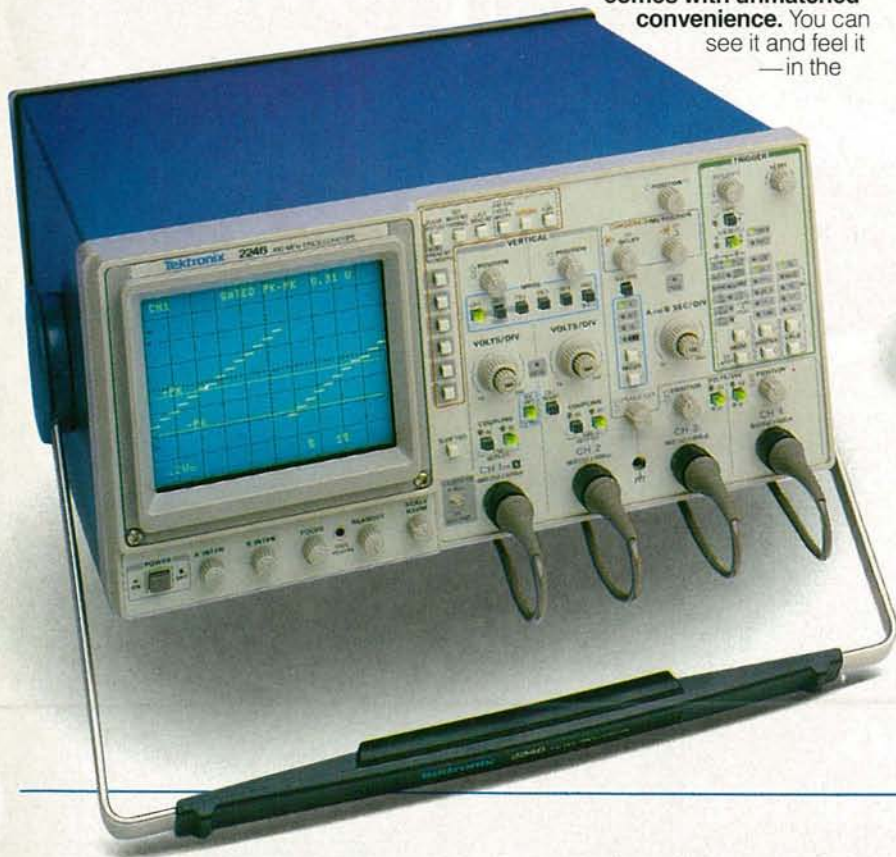

Featuring four channels, flexible triggering, extensive CRT readouts and push-button ease of use, the new Tek 2246 (left) and 2245 (above) bring high-quality, low-cost analysis to diverse applications in digital design, field service and manufacturing.

Tektronix
COMMITTED TO EXCELLENCE

NOVEMBER '86

**Radio-
Electronics**

Electronics publishers since 1908

Vol. 57 No. 11

- BUILD THIS**
- 41 CLOSED-CAPTION DECODER**
This decoder brings the full enjoyment of TV to the hearing-impaired. And it brings Line-21 teletext to everyone.
J. Daniel Gifford
- 49 LATCHING CONTINUITY TESTER**
Now you can find those intermittent shorts and opens easily.
Eldon L. Knight
- 55 EPROM PROGRAMMER**
Part 2. Here's a low-cost programmer that lets you get started with EPROM projects. It programs all popular devices.
Lubomir B. Sawkiw
- 65 PC SERVICE**
Use our exclusive direct-etch foil patterns to make circuit boards for the EPROM programmer and continuity tester.

- TECHNOLOGY**
- 6 VIDEO NEWS**
Inside the fast-changing video scene.
David Lachenbruch
- 51 INSIDE THE TELEPHONE**
Part 2. A look at the technology we often take for granted.
Rudolf Graf and Calvin Graf
- 70 SATELLITE TV**
Ku reception on a budget.
Bob Cooper, Jr.
- 74 ROBOTICS**
Simple vision systems for robots.
Mark J. Robillard

- CIRCUITS AND COMPONENTS**
- 38 NEW IDEAS**
A simple light-seeking robot.
- 46 TV DESCRAMBLING**
Part 5. Descrambling the SSAVI system.
Rudolf and William Sheets
- 63 HOW TO DESIGN OSCILLATOR CIRCUITS**
Part 5. Crystal-controlled oscillator circuits.
Joseph J. Carr

RADIO

- 60 THE EARLY DAYS OF RADIO**
The second in a series of occasional articles that take a nostalgic look back at the early days of radio and electronics.
Martin Clifford.
- 76 ANTIQUE RADIOS**
Restoring AC/DC radios—useful hints.
Richard D. Fitch
- 80 COMMUNICATIONS CORNER**
Privacy for amateur radio? Controlled repeater access
Herb Friedman

COMPUTERS

- Following page 68
- COMPUTER DIGEST**
Tape backup, No-frills modem, Schmitt-trigger design, and more.

EQUIPMENT REPORTS

- 26 Rabbit Systems VCR Rabbit Signal Distribution System**

DEPARTMENTS

- 104 Advertising and Sales Offices**
- 104 Advertising Index**
- 23 Ask R-E**
- 105 Free Information Card**
- 10 Letters**
- 85 Market Center**
- 31 New Products**
- 4 What's News**

RADIO-ELECTRONICS, (ISSN 0033-7862) November 1986. Published monthly by Gernsback Publications, Inc., 500-B Bi-County Boulevard, Farmingdale, NY 11735 Second-Class Postage paid at Farmingdale, NY and additional mailing offices. Second-Class mail registration No. 9242 authorized at Toronto, Canada. One-year subscription rate U.S.A. and possessions \$16.97, Canada \$22.97, all other countries \$25.97. Subscription orders payable in US funds only, international postal money order or check drawn on a U.S.A. bank. Single copies \$1.95. © 1986 by Gernsback Publications, Inc. All rights reserved. Printed in U.S.A.

POSTMASTER: Please send address changes to RADIO-ELECTRONICS, Subscription Dept., Box 55115, Boulder, CO 80321-5115.

A stamped self-addressed envelope must accompany all submitted manuscripts and/or artwork or photographs if their return is desired should they be rejected. We disclaim any responsibility for the loss or damage of manuscripts and/or artwork or photographs while in our possession or otherwise.

COVER 1



If you watch TV, you're undoubtedly familiar with the phrase, "Closed-captioned for the hearing impaired." You may not, however, be familiar with closed-captioning itself, or the technology behind it. So build a decoder yourself and find out what you've been missing and what closed-captioning is all about.

You don't have to be hearing-impaired to use the decoder. Closed captions can be an excellent educational tool. The unit also decodes Line-21 teletext, which offers such information as news updates and sports scores. To find out more about closed-captioning and how to build your own decoder, turn to page 41.

NEXT MONTH

THE DECEMBER ISSUE IS
ON SALE NOVEMBER 1

BUILD THE R-E ROBOT

An exciting project that describes how to design and build a very sophisticated robot.

BUILD A CLOSED-CAPTION DECODER

Part 2. We include complete construction details.

SATELLITE-TV SIGNAL SCRAMBLING

Part 6. Three descrambler circuits you can build for the gated-sync, outband, and sinewave scrambling systems.

TOUCH-TONE ENCODING AND DECODING

How to use DTMF signals for control.

COMPUTERS AS TEST INSTRUMENTS

How the computer is becoming a tool on the workbench.

COMPUTERS AS DESIGN TOOLS

New computer software streamlines electronics design.

As a service to readers, RADIO-ELECTRONICS publishes available plans or information relating to newsworthy products, techniques and scientific and technological developments. Because of possible variances in the quality and condition of materials and workmanship used by readers, RADIO-ELECTRONICS disclaims any responsibility for the safe and proper functioning of reader-built projects based upon or from plans or information published in this magazine.

Since some of the equipment and circuitry described in RADIO-ELECTRONICS may relate to or be covered by U.S. patents, RADIO-ELECTRONICS disclaims any liability for the infringement of such patents by the making, using, or selling of any such equipment or circuitry, and suggests that anyone interested in such projects consult a patent attorney.

Radio Electronics

Hugo Gernsback (1884-1967) founder
M. Harvey Gernsback,
editor-in-chief, emeritus

Larry Steckler, EHF, CET, editor-in-chief
and publisher

EDITORIAL DEPARTMENT

Art Kleiman, editorial director
Brian C. Fenton, managing editor
Carl Larson, WB2SLR, associate editor
Jeffrey K. Holtzman,
assistant technical editor
Robert A. Young, assistant editor
Julian S. Martin, editorial associate
Byron G. Wels, editorial associate
M. Harvey Gernsback,
contributing editor
Jack Darr, CET, service editor
Robert F. Scott,
semiconductor editor
Herb Friedman,
communications editor
Bob Cooper, Jr., satellite-TV editor
Robert Grossblatt, circuits editor
David Lachenbruch,
contributing editor
Richard D. Fitch,
contributing editor
Mark J. Robillard, robotics editor
Teri Scaduto Wilson, editorial assistant

PRODUCTION DEPARTMENT

Ruby M. Yee, production director
Robert A. W. Lowndes,
editorial production
Andre Duzant, technical illustrator
Karen Tucker, advertising production
Geoffrey S. Weil, production traffic

CIRCULATION DEPARTMENT

Jacqueline P. Cheeseboro,
circulation director
Wendy Alanko,
circulation analyst
Theresa Lombardo,
circulation assistant

Cover photo by Dan Muro

Typography by Mates Graphics

Radio-Electronics, Gernsback Publications, Inc., 500-B Bi-County Blvd., Farmingdale, NY 11735. 516-293-3000

Radio-Electronics is indexed in *Applied Science & Technology Index* and *Readers Guide to Periodical Literature*.

Microfilm & Microfiche editions are available. Contact circulation department for details.

Advertising Sales Offices listed on page 104.



NEW! Lower Price Scanners

Communications Electronics™, the world's largest distributor of radio scanners, introduces new lower prices to celebrate our 15th anniversary.

Regency® MX7000-GR

List price \$699.95/CE price \$469.95
10-Band, 20 Channel • Crystalless • AC/DC
Frequency range: 25-550 MHz. continuous coverage and 800 MHz. to 1.3 GHz. continuous coverage. The Regency MX7000 scanner lets you monitor Military, Space Satellites, Government, Railroad, Justice Department, State Department, Fish & Game, Immigration, Marine, Police and Fire Departments, Broadcast Studio Transmitter Links, Aeronautical AM band, Aero Navigation, Paramedics, Amateur Radio, plus thousands of other radio frequencies most scanners can't pick up. The Regency MX7000 is the perfect scanner to receive the exciting 1.2 GHz. amateur radio band.

Regency® Z60-GR

List price \$299.95/CE price \$179.95/SPECIAL
8-Band, 60 Channel • No-crystal scanner
Bands: 30-50, 88-108, 118-136, 144-174, 440-512 MHz. The Regency Z60 covers all the public service bands plus aircraft and FM music for a total of eight bands. The Z60 also features an alarm clock and priority control as well as AC/DC operation. Order today.

Regency® Z45-GR

List price \$259.95/CE price \$199.95/SPECIAL
7-Band, 45 Channel • No-crystal scanner
Bands: 30-50, 118-136, 144-174, 440-512 MHz. The Regency Z45 is very similar to the Z60 model listed above however it does not have the commercial FM broadcast band. The Z45, now at a special price from Communications Electronics.

Regency® RH250B-GR

List price \$659.00/CE price \$329.95/SPECIAL
10 Channel • 25 Watt Transceiver • Priority
The Regency RH250B is a ten-channel VHF land mobile transceiver designed to cover any frequency between 150 to 162 MHz. Since this radio is synthesized, no expensive crystals are needed to store up to ten frequencies without battery backup. All radios come with CTCSS tone and scanning capabilities. A monitor and night/day switch is also standard. This transceiver even has a priority function. The RH250 makes an ideal radio for any police or fire department volunteer because of its low cost and high performance. A 60 Watt VHF 150-162 MHz. version called the RH600B is available for \$454.95. A UHF 15 watt version of this radio called the RU150B is also available and covers 450-482 MHz. but the cost is \$449.95.

NEW! Bearcat® 50XL-GR

List price \$199.95/CE price \$114.95/SPECIAL
10-Band, 10 Channel • Handheld scanner
Bands: 29.7-54, 136-174, 406-512 MHz. The Uniden Bearcat 50XL is an economical, hand-held scanner with 10 channels covering ten frequency bands. It features a keyboard lock switch to prevent accidental entry and more. Also order part # **BP50** which is a rechargeable battery pack for \$14.95, a plug-in wall charger, part # **AD100** for \$14.95, a carrying case part # **VC001** for \$14.95 and also order optional cigarette lighter cable part # **PS001** for \$14.95.

NEW! Scanner Frequency Listings

The new Fox scanner frequency directories will help you find all the action your scanner can listen to. These new listings include police, fire, ambulances & rescue squads, local government, private police agencies, hospitals, emergency medical channels, news media, forestry radio service, railroads, weather stations, radio common carriers, AT&T mobile telephone, utility companies, general mobile radio service, marine radio service, taxi cab companies, tow truck companies, trucking companies, business repeaters, business radio (simplex) federal government, funeral directors, veterinarians, buses, aircraft, space satellites, amateur radio, broadcasters and more. Fox frequency listings feature call letter cross reference as well as alphabetical listing by licensee name, police codes and signals. All Fox directories are \$14.95 each plus \$3.00 shipping. State of Alaska-**RL019-1**; State of Arizona-**RL025-1**; Baltimore, MD/Washington, DC-**RL024-1**; Buffalo, NY/Erie, PA-**RL009-2**; Chicago, IL-**RL014-1**; Cincinnati/Dayton, OH-**RL006-2**; Cleveland, OH-**RL017-1**; Columbus, OH-**RL003-2**; Dallas/Ft. Worth, TX-**RL013-1**; Denver/Colorado Springs, CO-**RL027-1**; Detroit, MI/Windsor, ON-**RL008-3**; Fort Wayne, IN/Lima, OH-**RL001-1**; Hawaii/Guam-**RL015-1**; Houston, TX-**RL023-1**; Indianapolis, IN-**RL022-1**; Kansas City, MO/KS-**RL011-2**; Long Island, NY-**RL026-1**; Los Angeles, CA-**RL016-1**; Louisville/Lexington, KY-**RL007-1**; Milwaukee, WI/Waukegan, IL-**RL021-1**; Minneapolis/St. Paul, MN-**RL010-2**; Nevada/E. Central CA-**RL028-1**; Oklahoma City/Lawton, OK-**RL005-2**; Orlando/Daytona Beach, FL-**RL012-1**; Pittsburgh, PA/Wheeling, WV-**RL029-1**; Rochester/Syracuse, NY-**RL020-1**; San Diego, CA-**RL018-1**; Tampa/St. Petersburg, FL-**RL004-2**; Toledo, OH-**RL002-3**. New editions are being added monthly. For an area not shown above call Fox at 800-543-7892. In Ohio call 800-621-2513.

NEW! Regency® HX1500-GR

List price \$369.95/CE price \$239.95
11-Band, 55 Channel • Handheld/Portable
Search • Lockout • Priority • Bank Select
Sidelit liquid crystal display • EAROM Memory
Direct Channel Access Feature • Scan delay
Bands: 29-54, 118-136, 144-174, 406-420, 440-512 MHz. The new handheld Regency HX1500 scanner is fully keyboard programmable for the ultimate in versatility. You can scan up to 55 channels at the same time including the AM aircraft band. The LCD display is even sidelit for night use. Includes belt clip, flexible antenna and earphone. Operates on 8 1.2 Volt rechargeable Ni-cad batteries (not included). Be sure to order batteries and battery charger from accessory list in this ad.

Bearcat® 100XL-GR

List price \$349.95/CE price \$203.95/SPECIAL
9-Band, 16 Channel • Priority • Scan Delay
Search • Limit • Hold • Lockout • AC/DC
Frequency range: 30-50, 118-174, 406-512 MHz. The world's first no-crystal handheld scanner now has a LCD channel display with backlight for low light use and aircraft band coverage at the same low price. Size is 1 3/4" x 7 1/2" x 2 1/2". The Bearcat 100XL has wide frequency coverage that includes all public service bands (Low, High, UHF and "T" bands), the AM aircraft band, the 2-meter and 70 cm. amateur bands, plus military and federal government frequencies. Wow...what a scanner! Included in our low CE price is a sturdy carrying case, earphone, battery charger/AC adapter, six AA ni-cad batteries and flexible antenna. Order your scanner now.

Bearcat® 210XW-GR

List price \$339.95/CE price \$209.95/SPECIAL
8-Band, 20 Channel • No-crystal scanner
Automatic Weather • Search/Scan • AC/DC
Frequency range: 30-50, 136-174, 406-512 MHz. The new Bearcat 210XW is an advanced third generation scanner with great performance at a low CE price.

NEW! Bearcat® 145XL-GR

List price \$179.95/CE price \$102.95/SPECIAL
10 Band, 16 channel • AC/DC • Instant Weather
Frequency range: 29-54, 136-174, 420-512 MHz. The Bearcat 145XL makes a great first scanner. Its low cost and high performance lets you hear all the action with the touch of a key. Order your scanner from CE today.

TEST ANY SCANNER

Test any scanner purchased from Communications Electronics™ for 31 days before you decide to keep it. If for any reason you are not completely satisfied, return it in original condition with all parts in 31 days, for a prompt refund (less shipping/handling charges and rebate credits).

NEW! Bearcat® 800XL-GR

List price \$499.95/CE price \$317.95
12-Band, 40 Channel • No-crystal scanner
Priority control • Search/Scan • AC/DC
Bands: 29-54, 118-174, 406-512, 806-912 MHz. The Uniden 800XL receives 40 channels in two banks. Scans 15 channels per second. Size 9 1/4" x 4 1/2" x 1 1/2".

OTHER RADIOS AND ACCESSORIES

Panasonic RF-2600-GR Shortwave receiver.....\$179.95
RD95-GR Uniden Remote mount Radar Detector.....\$128.95
RD55-GR Uniden Visor mount Radar Detector.....\$98.95
RD9-GR Uniden "Passport" size Radar Detector.....\$199.95
BC-WA-GR Bearcat Weather Alert.....\$49.95
DX1000-GR Bearcat shortwave receiver SALE.....\$349.95
PC22-GR Uniden remote mount CB transceiver.....\$99.95
PC55-GR Uniden mobile mount CB transceiver.....\$59.95
R1060-GR Regency 10 channel scanner SALE.....\$92.95
MX3000-GR Regency 30 channel scanner.....\$229.95
XL156-GR Regency 10 channel scanner.....\$139.95
UC102-GR Regency VHF 2 ch. 1 Watt transceiver.....\$124.95
P1405-GR Regency 5 amp regulated power supply.....\$69.95
P1412-GR Regency 12 amp reg. power supply.....\$164.95
MA256-GR Drop-in charger for HX1200 & MX5000.....\$84.95
MA518-GR Wall charger for HX1500 scanner.....\$14.95
MA516-GR Carrying case for HX1500 scanner.....\$14.95
MA257-GR Cigarette lighter cord for HX12/1500.....\$19.95
MA917-GR Ni-Cad battery pack for HX1200.....\$34.95
SMMX7000-GR Svc. man. for MX7000 & MX5000.....\$19.95
SMMX3000-GR Service man. for Regency MX3000.....\$19.95
B-4-GR 1.2 V AAA Ni-Cad batteries (set of four).....\$9.95
B-8-GR 1.2 V AA Ni-Cad batteries (set of eight).....\$17.95
FB-E-GR Frequency Directory for Eastern U.S.A.....\$14.95
FB-W-GR Frequency Directory for Western U.S.A.....\$14.95
ASD-GR Air Scan Directory.....\$14.95
SRF-GR Survival Radio Frequency Directory.....\$14.95
TSG-GR "Top Secret" Registry of U.S. Govt. Freq.....\$14.95
TIC-GR Techniques for Intercepting Comm.....\$14.95
RRF-GR Railroad frequency directory.....\$14.95
CIE-GR Covert Intelligenc, Elect. Eavesdropping.....\$14.95
A60-GR Magnet mount mobile scanner antenna.....\$35.95
A70-GR Base station scanner antenna.....\$35.95
USAMM-GR Mag mount VHF/UHF ant. w/ 12' cable.....\$39.95
USAK-GR 3/4" hole mount VHF/UHF ant. w/ 17' cable.....\$35.95
USATLM-GR Trunk lip mount VHF/UHF antenna.....\$35.95
Add \$3.00 shipping for all accessories ordered at the same time.
Add \$12.00 shipping per shortwave receiver.
Add \$7.00 shipping per scanner and \$3.00 per antenna.

BUY WITH CONFIDENCE

To get the fastest delivery from CE of any scanner, send or phone your order directly to our Scanner Distribution Center. Michigan residents please add 4% sales tax or supply your tax I.D. number. Written purchase orders are accepted from approved government agencies and most well rated firms at a 10% surcharge for net 10 billing. All sales are subject to availability, acceptance and verification. All sales on accessories are final. Prices, terms and specifications are subject to change without notice. All prices are in U.S. dollars. Out of stock items will be placed on backorder automatically unless CE is instructed differently. A \$5.00 additional handling fee will be charged for all orders with a merchandise total under \$50.00. Shipments are F.O.B. Ann Arbor, Michigan. No COD's. Most products that we sell have a manufacturer's warranty. Free copies of warranties on these products are available prior to purchase by writing to CE. Non-certified checks require bank clearance. Not responsible for typographical errors.

Mail orders to: Communications Electronics, Box 1045, Ann Arbor, Michigan 48106 U.S.A. Add \$7.00 per scanner for R.P.S./U.P.S. ground shipping and handling in the continental U.S.A. For Canada, Puerto Rico, Hawaii, Alaska, or APO/FPO delivery, shipping charges are three times continental U.S. rates. If you have a Discover, Visa or Master Card, you may call and place a credit card order. Order toll-free in the U.S. Dial 800-USA-SCAN. In Canada, order toll-free by calling 800-221-3475. WUI Telex anytime, dial 671-0155. If you are outside the U.S. or in Michigan dial 313-973-8888. Order today. Scanner Distribution Center™ and CE logos are trademarks of Communications Electronics Inc.

† Bearcat is a registered trademark of Uniden Corporation.
‡ Regency is a registered trademark of Regency Electronics Inc. AD #070286-GR

Copyright © 1986 Communications Electronics Inc.

For credit card orders call
1-800-USA-SCAN

**COMMUNICATIONS
ELECTRONICS INC.**

Consumer Products Division
P.O. Box 1045 □ Ann Arbor, Michigan 48106-1045 U.S.A.
Call 800-USA-SCAN or outside U.S.A. 313-973-8888
CIRCLE 79 ON FREE INFORMATION CARD



WHAT'S NEWS

Kodak claims quantum leap in new imaging sensor

Eastman Kodak Co. scientists report development of a solid-state monochrome imaging sensor capable of imaging 1.4 million individual picture elements (pixels.) The picture element size is only 6.8 microns—about one-tenth the width of a human hair. That makes it possible to put the megapixel sensor on a 6 × 9 millimeter chip, which formerly held only about 250,000 conventional pixels. The breakthrough is due to a revolutionary new design—now in the process of being patented—that uses only half as many transistor gates per imaging cell as do present sensors.

A major challenge facing the research team was to achieve the ultra-clean processing techniques necessary in manufacturing so small a chip. In a memory chip of the same size a few spare cells can be added to substitute for defective ones, but each cell in an imaging chip is "part of the picture," and a microscopic speck of dust shows up like a boulder.

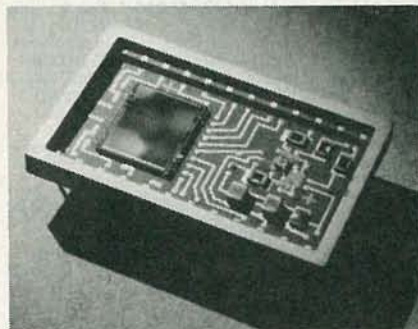

KODAK'S NEW MONOCROME CCD SENSOR, shown at the left of the circuit board, has a resolution of 1.4 million pixels.

The first commercial application of the new chip will be a camera produced by Kodak subsidiary Videk, a company formed to serve the machine vision market. The new camera will be used for both advanced scientific and industrial applications.

While the first application of the sensor technology is for limited, specialized uses, a Kodak spokesman says that "it may well one day find application in professional and consumer products."

U. S. trade organizations join forces in Japan

The American Electronics Association (AEA) and the Electronic Industries Association (EIA), the two largest American electronics trade associations, merged their Tokyo offices into a single U. S. electronics industry facility as of last July 1. The goal of the new entity, now called the U. S. Electronics Industry Japan Office, is to improve the environment for all U. S. electronics companies doing business in or with Japan.

A "galloping negative trade balance" between the United States and Japan was cited as one of the

reasons for the cooperative effort. "In 1980, U.S./Japan trade in electronic products and services resulted in a deficit of \$3.9 billion. In 1985, it was \$17.6 billion," reports AEA president J. Richard Iverson.

Zenith gives top award to stereo TV inventor

The Robert Adler Technical Excellence Award of the Zenith Electronics Corp. was awarded to company scientist Carl G. Eilers at Zenith's annual Inventors' Banquet. He is a co-inventor of two broadcast industry standards—stereo-TV sound and stereo-FM radio broadcasting technology. Eilers, manager of systems re-

search and development for color television, headed the group that developed Zenith's MTS (multi-channel TV Sound) stereo-TV transmission system. More than 250 U.S. TV stations have begun using the Zenith system since stereo-TV broadcasting was approved in March 1984. That number is expected to double by the end of next year.

New heart-rate monitor operates like radar

A device for remotely measuring human heart and respiration rates works by reflecting electronic waves off the subject's chest in a fashion similar to that of radar. The device, just patented by RCA, directs two microwave beams of different frequencies toward the person being examined. Those beams are reflected back and recorded.

Since low-frequency signals penetrate the body to a greater depth than high-frequency ones, signals coming from different depths of the human body can be distinguished. The high-frequency signal is used to measure respiration rate, while the low-frequency one measures heart rate. The strength of the signals is well below the safety limits recommended by the American National Standards Institute.

Since the device is wireless and can operate up to eight feet from the person observed, it requires no attachments to the body. No clothing need be removed and there is no disturbance of the subject's freedom of movement.

The unit is expected to be useful for checking the heart and lung performance of astronauts, pilots, and other military personnel in training. An early version of the instrument is now being tested by the U.S. Army, which sponsored its development. **R-E**



ELECTRONICS, INC.

New and Used Electronic Test Equipment
Sales • Service • Rental • Leasing

HAMEG Oscilloscopes with Component Tester 2-year warranty



HM 203-6 DC to 20MHz **\$489.00**

- Rectangular screen, internal graticule 8x10cm.
- Deflection: 5mV/cm to 20V/cm
- Timebase: 0.5us/cm to 0.2s/cm X-Magnification x 10
- Component Tester
Test voltage: max. 8.5Vrms (open circuit)
Test current: max. 24mA rms (shorted)



HM 204-2 DC to 20MHz **\$629.00**

- Component Tester
- Deflection: 5mV/cm to 20V/cm Y-Magnification x 5
- Timebase: 0.1 us/cm to 0.5s/cm X-Magnification x 10
- Sweep delay: 100 ns to 0.1 s.
- Calibrator: square-wave generator, ≈1 kHz/1MHz switchable, risetime<5ns, for probe compensation, output voltages: 0.2V and 2V ± 1%.

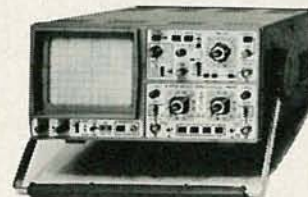

HM 605 DC to 60 MHz **\$899.00**

- Component Tester
- Deflection: 5mV/cm to 20V/cm Y-Magnification x 5
- Y-Output from Ch.I or Ch.II: ≈45 mV/cm into 50Ω.
- Timebase: 50ns/cm to 1 s/cm X-Magnification x 10
- Sweep delay: 100ns to 0.1s.



HM 205 **\$799.00**

Real-time - See 203-6 Specifications

Digital Storage

- Operating modes: Refresh and Single with Reset (incl. LED indication for Ready), Hold Ch.I, Hold Ch.II. 1024x8 bit for each chan. Sample rate: max. 100kHz. Resolution: vertical 28 pts/cm, horiz. 100 pts/cm.
- Option: Interface for plotter.
- Component Tester



Modular System 8000



HM 208 **\$2,380.00**

HM 208-1 **\$2,860.00**

(with IEEE Interface)

Real-time - See 203-6 Specifications

Digital Storage

- Operating modes: XY, Roll, Refresh, Single (LED ind.), Hold Ch.I, Hold Ch.II, Plot I and Plot II with read-out check on screen, backing storage, Dot Joining button. 2 x 1024 x 8bit for each ch. Sample rate: max. 20MHz. Resolution: vert. 28 pts/cm, horiz. 200 or 100 pts/cm.
- Plotter output: vertical 0.1V/cm, horizontal 0.1V/cm. Output imped.: 100Ω each. Penlift: TTL/CMOS compat. Output speed rate: 5-10-20/10-20-40 s/cm.
- Option: Lithium battery for memory backup.

ATTACHES TO ALL HAMEG SCOPES ON THIS PAGE!

HM 8001	2 BAY Mainframe	\$228.00
HM 8002	4 BAY Mainframe	call 800N
HM 8011-2	Digital Multimeter 4½ digits	298.00
HM 8014	Milli Ohm Meter	298.00
HM 8021-2	Counter, 0.1Hz-1GHz	324.00
HM 8027	Distortion Meter	248.00
HM 8030-2	Function Gen. 0.1Hz-1MHz	288.00
HM 8032	Sine Wave Gen. 20Hz-20MHz	288.00
HM 8035	Pulse Generator, 2Hz-20MHz	455.00
HM 8037	Low Dist. Sine Gen. 5Hz-50kHz	248.00
HM 8040	Triple Power Supply	278.00
HM 8045	Oscilloscope Calibrator	378.00

CIRCLE 126 ON FREE INFORMATION CARD
CALL US TOLL FREE

1-800-732-3457
IN CALIFORNIA TOLL FREE
1-800-272-4225

- Master Charge
- VISA ■ COD
- Money Order
- Check



ADD FOR SHIPPING AND INSURANCE

\$0 to \$250.00	\$4.50
\$251.00 to 500.00	\$6.50
\$501.00 to 750.00	\$8.50
\$751.00 to \$1000.	\$12.50
over \$1000.00	\$15.00/1000

Prices subject to change without notice.

RAG ELECTRONICS, INC. / 21418 Parthenia Street / Canoga Park, CA 91304 / 1-818-998-6500

VIDEO NEWS



• **More camcorders.** This year's hottest product is the camera-recorder combination, or camcorder. It's available in three different formats (8mm, VHS, and VHS-C). Manufacturers are choosing up sides, and it's obvious that the VHS group is engaged in a boycott of the upstart 8mm format. Under pressure from JVC, which invented VHS, most of the group has endorsed VHS-C rather than 8mm as their miniaturized format. But some manufacturers are hedging their bets. Matsushita, which owns both Panasonic and Quasar, is making 8mm equipment for Eastman Kodak as well as a very lightweight 8mm camcorder for Olympus. Hitachi is manufacturing 8mm camcorders for Minolta and Pentax. Neither manufacturer sells 8mm equipment under its own brand name.

The photography marketers are also hedging their bets. Some are selling multiple formats. Pentax is fielding both the full-sized VHS and 8mm camcorders; Minolta went whole hog and is marketing units in all three formats.

The little 8mm camcorder that Matsushita makes for Olympus is quite impressive. It weighs only 3.3 pounds and has autofocus, a solid-state CCD pickup, and all the other goodies. The Hitachi-made versions for Minolta and Pentax also look like winners, weighing just 3.08 pounds for the Minolta and 3.2 pounds for the Pentax; both units feature MOS pickup, autofocus, and more.

The Minolta VHS-C compact unit is the first VHS-C machine to be shown that wasn't completely manufactured by JVC. The recorder section is a JVC product, but the camera portion is made by Minolta. Instead of the solid-state pickup used in the completely JVC-made units, the Minolta camcorder has a Saticon tube and weighs a relatively heavy 4.4 pounds; by comparison, a JVC VHS-C camcorder weighs 2.9 pounds.

• **Vidiwall.** That's the name of the show-stealer in London's hit musical, "Chess." While a musical about a chess championship seems unlikely, its "star" is even more unusual. It's a matrix of 64 large-screen television sets,

weighing a total of 3.8 tons. Vidiwall is suspended at center stage, above the actors. In addition, two 32-set banks of televisions are set up at the left and right of the stage. That makes for 128 TV-screens in all. The producers were forced to reduce the number of screens to 128 because the video was upstaging the "other" actors.

Programing is provided by six Laserdisc players as well as by six on-stage cameras. Glass Laserdiscs, rather than the familiar plastic ones, are used as the material is continuously updated during the run of the show.

All of the TV screens are perfectly color-matched. That leads to one of the show's major problems. If one of the sets fails, its replacement must be matched to preserve the color harmony.

Vidiwall was built by Philips. There is no word on when or if the show will open in New York, but if it does, it is likely that PAL equipment will still be used due to that system's better color consistency.

• **VCR prices falling again.** Amid all the talk about the rise in the price of the Yen against the Dollar, have you wondered why VCR and color-TV prices haven't risen noticeably? Many people have, but the explanation is relatively simple. In the case of VCR's, the Japanese are building them faster than they can be sold, even in today's booming market, and this summer nearly 3,000,000 unsold units accumulated in U.S. warehouses.

At the same time, the Japanese improved their efficiency and worked mightily to keep costs down. The result was that while the Yen's value against the Dollar increased by about one-third, the factory costs of VCR's were up only about five percent or so. Competition among the more-than-80 VCR brands here also tended to push prices down.

Generally speaking, the same factors have kept the price of color TV-sets depressed. Additionally, many Japanese manufacturers assemble their sets in other countries, including the U.S. The result is that production costs are not as closely tied to fluctuations in the value of the Yen and therefore remained more stable.

R-E

SAVE 50% ON  DMM'S

WITH PURCHASE OF

**Tektronix® OSCILLOSCOPES
FROM JOSEPH ELECTRONICS**

**FOR A LIMITED TIME YOU CAN SAVE BIG WHEN YOU BUY THE LEADING LINES
OF SCOPES AND DMM'S FROM THE LEADING INSTRUMENT DISTRIBUTOR!**

NEW CRT READOUT 100 MHz FOUR-CHANNEL SCOPES

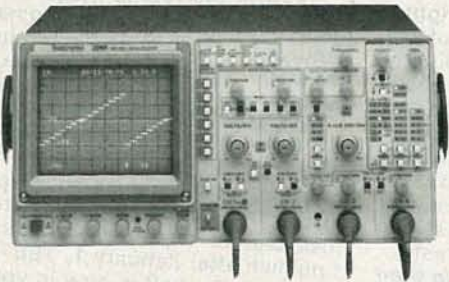

A real price breakthrough in lab-grade scopes from Tektronix. The **2246** and **2245** both feature: ■ Scale factor readout ■ 2mV/division vertical sensitivity ■ 2% vertical and horizontal accuracy ■ Four vertical inputs ■ 3-year warranty.

The **2246** also features: ■ Pop-up menus at the touch of a button ■ On-screen voltage, and time and trigger-level readouts ■ Exclusive Smart Cursors™ track voltage measurements.

Model 2245 **\$1,875** Model 2246 **\$2,400**

FAMOUS TEK 2200 SERIES 60/100MHz DUAL-CHANNEL SCOPES

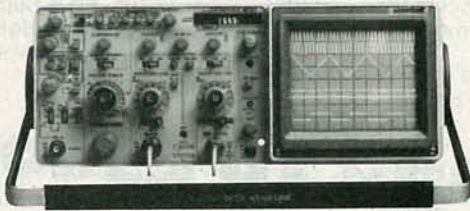

The 60MHz 2213A, 2215A and 100MHz 2235 and 2236 are industry leaders for value and performance ■ 2mV/division vertical sensitivity ■ Advanced triggering for stable displays ■ X-Y operation ■ 3-year warranty ■ Dual-time base delayed-sweep measurements (2t.b. on 2213A) ■ Integrated counter/timer/multimeter on 2236.

60MHz 2213A **\$1,275** *100MHz 2235 **\$1,575**
60MHz 2215A **\$1,525** *100MHz 2236 **\$2,650**

**BUY ANY TEKTRONIX SCOPE ABOVE AND SAVE 50% ON ANY FLUKE DMM BELOW.
LIMIT ONE DMM PER SCOPE. NO LIMIT ON NUMBER OF SCOPE/DMM PACKAGES!**

FLUKE 70 AND 20 SERIES ANALOG/DIGITAL MULTIMETERS



On this limited-time super special, you can buy a Fluke 73, 75, 77, 21 or 23 at below rock-bottom pricing!

All units feature: ■ 3½ digit, 3200 count LCD displays ■ 31 segment analog bar graph ■ Single rotary control ■ Auto ranging and polarity ■ Tough textured case ■ Continuity beeper and diode test (except 73) ■ 2000 hour battery life ■ Range hold (except 73) The **77** and **23** also feature exclusive Touch Hold™ to lock-in your measurement ■ 21 and 23 series DMM's feature protection from high-energy overloads; survives 6kV transients.

Standard Equipment
Safety-designed test leads, manual, battery and spare fuse. The multipurpose C70 holster is included with the 77 and 23.

Basic Accuracy
(% of reading + number of digits)

	73	75, 21	77, 23
DC Voltage	0.7% + 1	0.5% + 1	0.3% + 1
AC Voltage	3% + 2	2% + 2	2% + 2
Ohms	1% + 1	0.7% + 1	0.5% + 1
DC Current	2% + 2	1.5% + 2*	1.5% + 2*
AC Current	3% + 2	3% + 2	3% + 2

*2% + 2 on 21 and 23

Model 73 reg. \$85 **\$42.50** Model 77 reg. \$129 **\$64.50** Model 23 reg. \$145 **\$72.50**
Model 75 reg. \$90 **\$49.50** Model 21 reg. \$99 **\$49.50**

FREE shipping and handling on Tektronix and Fluke to U.S. Shipable Destinations!

- Full 3-year factory warranty
- Authorized distributor for Tektronix, Fluke and 30 other instrument lines
- 40 years of industry service—Buy with confidence

**LIMITED TIME OFFER, PHONE TODAY TOLL-FREE!
1-800-323-5925 (In Illinois 1-312-297-4200)**

VISA-MASTERCARD-DISCOVER
CARDS WELCOMED. OPEN
ACCOUNT ORDERS TO RATED
COMPANIES. Illinois residents add 7% tax.

Free 116 page Joseph Electronics
discount instrument catalog with your
order or on request.

**Joseph
Electronics**

8830 N. Milwaukee Niles, IL 60648

Escort Refuses!

Dear Customer, From: Drew Kaplan

Escort turned down our \$10,000 head to head challenge described below. Escort says that Maxon's Radar Detector is "primitive", "bottom-end" and "an off-shore produced electronics 'gadget' ". I don't know about you, but to me these words conjure up visions of a cheap toy being produced off in the middle of a rice paddy somewhere in the middle of nowhere.

Escort, on the other hand, which is made in the U.S., exudes a high cost, quality image. Don't you just bet that it costs a fortune to build Escort and Passport (the smaller version)?

Well, we are going to challenge Escort AGAIN to a head to head 'duel to the death' on Maxon's electronic merits alone. And, we plan to win. But first there are a few things you should know.

Cincinnati Microwave, the company that makes Escort & Passport, is a public company. And being public, they have to file financial information with the SEC.

The public information they have published appears to show that in the year that ended Dec. 1985, Cincinnati Microwave with "substantially all of its revenues and profits derived from the sale of radar warning receivers" made an operating profit of about \$45,810,000 on sales of about \$112,605,000. Wow!

The \$45 million profit is after all engineering, selling and General & Administrative expenses, but before taxes.

Their cost of sales (goods) was only about \$40,027,000. So, if you divide \$40,027,000 by \$112,605,000 it doesn't take a genius to figure out that cost of goods represents an average of only about 35.5% of selling price. Wow!

I only bring up their profit to illustrate that a high retail price doesn't always

mean a high manufacturing cost.

There's no question in my mind that Maxon can manufacture cheaper in an off-shore 'rice paddy', but if you pay \$245 for Escort or \$295 for Passport, it should be based on a head to head test with Maxon, not on perceived retail price points.

FORGET PRICE COMPLETELY

So, forget that Escort costs \$245, Passport \$295, and Maxon \$99⁹⁰. Let's judge them on their own merits. And, let's look at just what Escort itself has to say about our challenge. (Please read DAK's and Escort's letters to the right.)

Escort says that, "Regardless of the results, such an event lends credibility to the challenger." Well, they are absolutely correct. That's why I put up the \$10,000 in the first place. Fair is fair.

Plus, there are several radar detectors that claim to have won this or that ranking in "Independent Magazine Reviews." So, I'm ignoring any reviews and asking for a one on one, head to head test.

But look at what Escort says in their letter: "Range is the easiest detector quality to measure, but by no means the only important quality." Wow, I thought range was really important?? Escort refers to "goodness" being determined by things not so easily measured.

Well frankly, I don't know how to measure "goodness". Escort, in my opinion,

is a top notch company. They make a superb product I'd be proud to sell. And, they have great customer service.

DAK has great toll free technical and regular customer service. But, I'd be the first to admit that with over \$45 million in profits, Escort can probably run circles around us in advertising, and maybe even in service. But, I don't think they can beat Maxon's Radar Detector.

HOW GOOD IS GOOD?

When Escort was introduced, it was revolutionary. But, you can only go so far. And in my opinion (someone else might object), radar detecting has gone about as far as it can go. So, while Escort has made improvements, it's Maxon who has moved mountains to catch up.

DAK UPS THE ANTE TO \$20,000

Now I realize that next to \$45 million dollars, \$20,000 isn't much, but it's a lot to DAK. And, I'll even go one step farther. I'll print the exact results of the test, win, lose, draw, or no-show in the first catalog I publish after January 1, 1987.

Escort, the ball is now in your court. Below is the "NEW" version of my challenge with the time and amount changed.

I don't know what else DAK or Maxon can do to prove that the RD-1 Superheterodyne Detector should be judged on its head to head performance against Escort, not on its selling price!

WAS \$10,000

A \$20,000 Challenge To Escort

Let's cut through the Radar Detector Glut. We challenge Escort to a one on one Distance and Falsing 'duel to the death' on the highway of their choice. If they win, the \$20,000 (was \$10,000) check pictured below is theirs.

By Drew Kaplan

We've put up our \$20,000 (was 10). We challenge Escort to take on Maxon's new Dual Superheterodyne RD-1 \$99⁹⁰ radar detector on the road of their choice in a one on one conflict.

Even Escort says that everyone compares themselves to Escort, and they're right. They were the first in 1978 to use superheterodyne circuits and they've got a virtual stranglehold on the magazine test reports.

But, the real question today is: 1) How many feet of sensing difference, if any, is there between this top of the line Maxon Detector and Escort's? And 2) Which unit is more accurate at interpreting real radar versus false signals?

So Escort, you pick the road (continental U.S. please). You pick the equipment to create the false signals. And finally, you pick the radar gun.

Maxon and DAK will come to your highway with engineers and equipment to verify the results. And oh yes, we'll have the \$20,000 check (pictured) to hand over if you beat us by more than 10 feet in either X or K band detection.

BOB SAYS MAXON IS BETTER

Here's how it started. Maxon is a mammoth electronics prime manufacturer. They actually make all types of sophisticated electronic products for some of the biggest U.S. Electronics Companies. (No, they don't make Escort's).



Bob Thetford, the president of Maxon Systems Inc., and a friend of mine, was explaining their new RD-1 anti-falsing Dual Superheterodyne Radar detector to me. I said "You know Bob, I think Escort really has the market locked up." He said, "Our new design can beat theirs".

So, since I've never been one to be in second place, I said, "Would you bet

\$20,000 (10) that you can beat Escort?" And, as they say, the rest is history.

By the way, Bob is about 6'9" tall, so if we can't beat Escort, we can sure scare the you know what out of them. But, Bob and his engineers are deadly serious about this 'duel'. And you can bet that our \$20,000 (was \$10,000) is serious.

...Next Page Please

...Challenge Continued
We ask only the following. 1) The public be invited to watch. 2) Maxon's Engineers as well as Escort's check the radar gun and monitor the test and the results. 3) The same car be used in both tests. 4) We'd like an answer from Escort no later than December 31, 1986 and 60 days notice of the time and place of the conflict. And, 5) We'd like them to come with a \$20,000 (was \$10,000) check made out to DAK if we win.

into action in just 1/4 of one second. Just imagine the sophistication of a device that can test a signal 4 times in less than 1/4 of one second. Maxon's technology is mind boggling. **But, using it isn't.** This long range detector has all the bells and whistles. It has separate audible sounds for X and K radar signals because you've only got about 1/3 the time to react with K band. There's a 10 step LED Bar Graph Meter to accurately show the radar signal's

And you'll have a very high level of protection. Maxon's Dual Conversion Scanning Superheterodyne circuitry combined with its ridge guide wideband horn internal antenna, really ferrets out radar signals.



By the way Escort, we'll be happy to have our test around a bend in the road or over a hill. Maxon's detector really picks up 'ambush type' radar signals.

And the key word is 'radar', not trash signals. The 4 test check system that operates in 1/4 second gives you extremely high protection from signals from other detectors, intrusion systems and garage door openers.

So, when the lights and X or K band sounds explode into action, take care, there's very likely police radar nearby. You'll have full volume control, and a City/Highway button reduces the less important X band reception in the city.

Maxon's long range detector comes complete with a visor clip, hook and loop dash board mounting, and the power cord cigarette adaptor.

It's much smaller than Escort at just 3 1/2" wide, 4 3/4" deep and 1 1/2" high. It's backed by Maxon's standard limited warranty. Note from Drew: 1) Use of radar detectors is illegal in some states.

2) Speeding is dangerous. Use this detector to help keep you safe when you forget, not to get away with speeding.

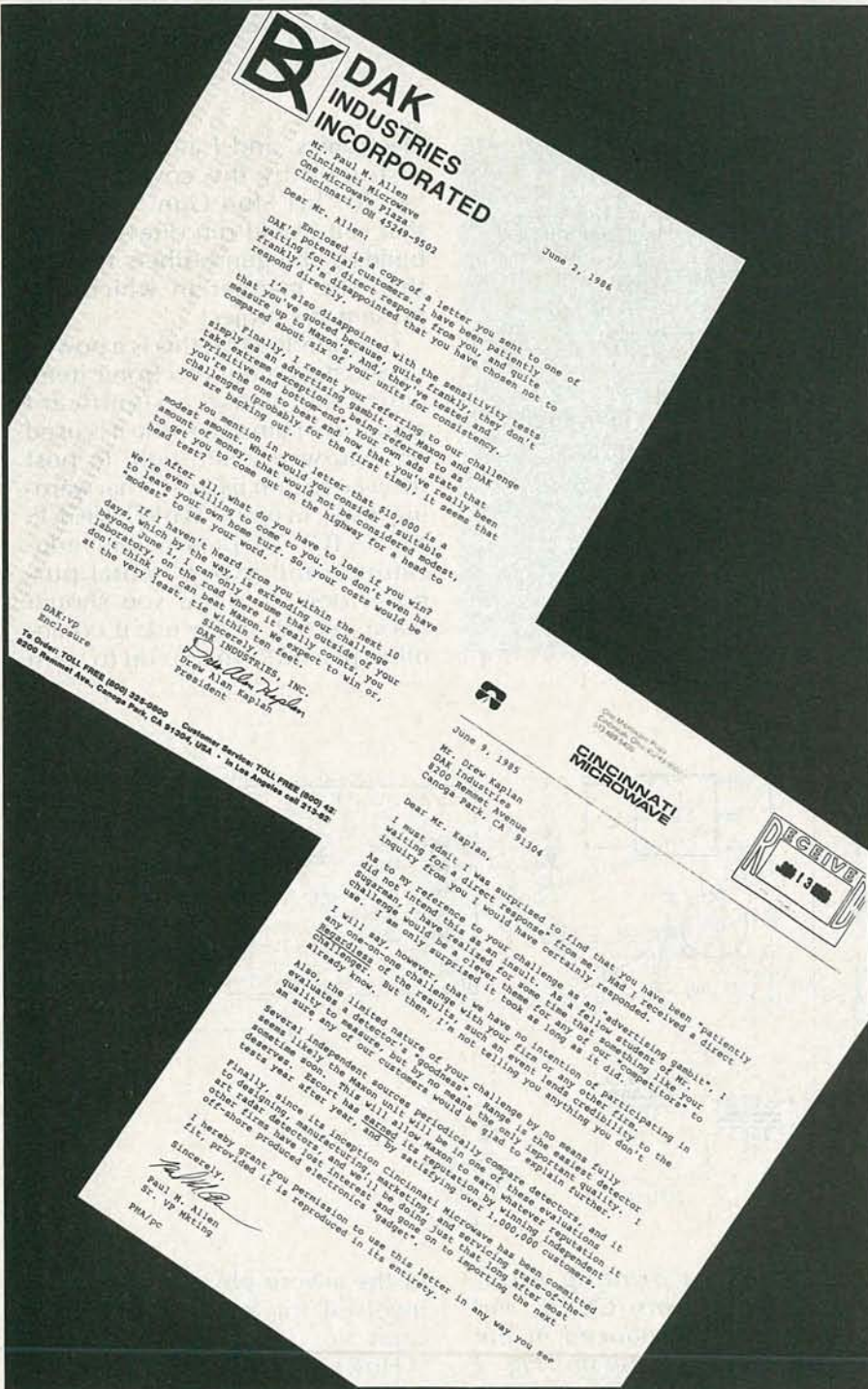

DAK INDUSTRIES INCORPORATED
 Mr. Paul M. Allen
 Cincinnati Microwave
 One Microwave Plaza
 Cincinnati, OH 45248-9502

Dear Mr. Allen:
 Enclosed is a copy of a letter you sent to one of DAK's potential customers. I have been patiently waiting for a direct response from you, and quite frankly, I'm disappointed that you have chosen not to respond directly.
 I'm also disappointed with the sensitivity tests that you've quoted because quite frankly they don't measure up to Maxon's. And, they've tested and compared about six of your units for consistency.
 Finally, I resent your referring to our challenge simply as an "advertising gambit". Maxon and DAK take extreme exception to being referred to as "challenged" and "bottomed" being referred to as "challenged" (probably for the first time). It seems that you are backing out.
 You mention in your letter that \$10,000 is a modest amount. What would you consider a "modest" amount of money that would not be considered "modest" to get you to come out on the highway for a head to head test?
 After all, what do you have to lose if you win? We're even willing to come to you. You don't even have to leave your own home turf. So, your loss would be "modest" to use your word.
 If I haven't heard from you within the next 10 days, which by the way, is extending our challenge beyond June 11, I can only assume that you've decided the laboratory on the road where it's all outside of your don't think you can beat Maxon. We expect counter to win or the very least, tie within ten tenths.
 Sincerely,
 DAK INDUSTRIES, INC.
 Drew Alan Kaplan
 President

June 9, 1986
 Mr. Drew Kaplan
 DAK Industries
 8200 Remmet Ave
 Canoga Park, CA 91304

Dear Mr. Kaplan,
 I must admit I was surprised to find that you have been "tentatively waiting for a direct response" from me. Had I received a direct inquiry from you I would have certainly responded.
 As to my reference to your challenge as an "advertising gambit", I did not intend this as an insult. As a fellow student of Mr. Escort's, I have this as a clever time that something like your challenge would be a clever time for any of our competitors' use. I am only surprised it took as long as it did.
 I will say, however, that we have no intention of participating in an one-on-one challenge with your firm or any other firm. We are interested in the results of an event lends credibility to the challenge. But then, I'm not telling you anything you don't already know.
 Also, the listed nature of your challenge by no means fully qualifies a detector, but "goodness". As to the "advertising gambit" nature of your challenge, I have no objection to your using the name of our customers would be glad to explain further.
 Several independent sources periodically compare detectors, and it seems like the Maxon unit will be in one of these evaluations. I am not a fan of the Maxon unit, but I will be in one of these evaluations. I am not a fan of the Maxon unit, but I will be in one of these evaluations. I am not a fan of the Maxon unit, but I will be in one of these evaluations.
 Finally, since its inception Cincinnati Microwave has been committed to designing, manufacturing, marketing and servicing state-of-the-art radar detectors and will be doing just that. The time after that other firms have lost interest and gone on to importing state-of-the-art off-shore produced electronics "gadgets".
 I hereby grant you permission to use this letter in any way you see fit, provided it is reproduced in its entirety.
 Sincerely,
 Paul M. Allen
 Sr. VP Marketing
 PMA/PC

SO, WHAT'S DUAL SUPERHETERODYNE?
 Ok, so far we've set up the conflict. Now let me tell you about the new dual superheterodyne technology that lets Maxon leap ahead of the pack.
 It's a technology that tests each suspected radar signal 4 separate times before it notifies you, and yet it explodes

strength. And, you won't have to look at a needle in a meter. You can see the Bar Graph Meter with your peripheral vision and keep your eyes on the road and put your foot on the brake.
 So, just turn on the Power/Volume knob, clip it to your visor or put it on your dash. Then plug in its cigarette lighter cord and you're protected.



CHECK OUT RADAR YOURSELF RISK FREE

Put this detector on your visor. When it sounds, look around for the police. There's a good chance you'll be saving money in fines and higher insurance rates. And, if you slow down, you may even save lives.

If you aren't 100% satisfied, simply return it in its original box within 30 days for a courteous refund.

To get your Maxon, Dual Superheterodyne, Anti-Falsing Radar Detector risk free with your credit card, call toll free or send your check for just \$99⁰⁰ (\$4 P&H). Order No. 4407. CA res add tax.

OK Escort, it's up to you. We've got \$20,000 (10) that says you can't beat Maxon on the road. Your answer, please?
 Escort and Passport are registered trademarks of Cincinnati Microwave.

DAK INDUSTRIES INC.
 Call Toll Free For Credit Card Orders Only
 24 Hours A Day 7 Days A Week
1-800-325-0800
 For Toll Free Information, Call 6AM-5PM Monday-Friday PST
Technical Information . . . 1-800-272-3200
Any Other Inquiries . . . 1-800-423-2866
 8200 Remmet Ave., Canoga Park, CA 91304

LETTERS

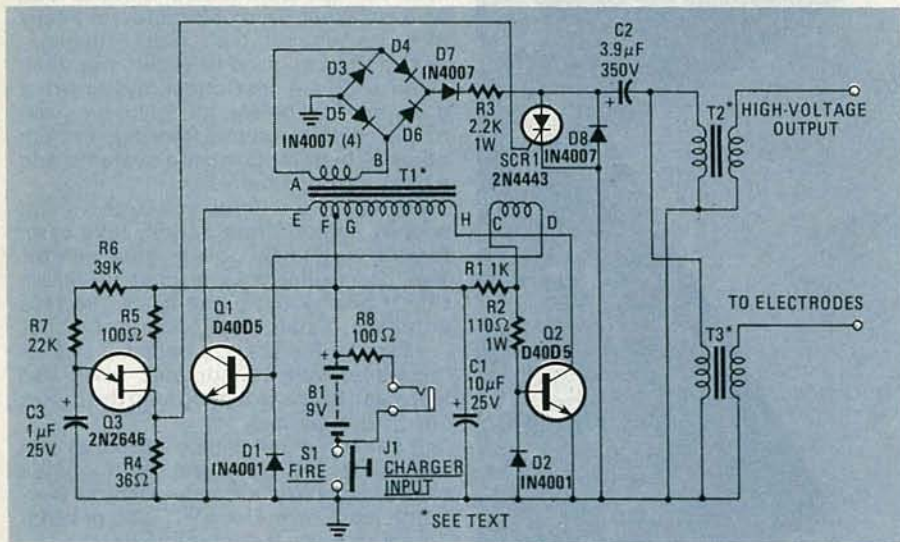

FIG. 1

STUN-GUN ERRORS

As a long-time subscriber, I enjoy **Radio-Electronics** very much, especially the smaller construction articles.

However, I question whether the construction article dealing with the Stun Gun (September 1986) should have been published. It is dangerous to put such equipment in the hands of persons who might misuse it.

Referring to the schematic for that article: In order to recharge the battery, the FIRE button (S1) needs to be closed! I would return the charger input directly to the negative terminal of the battery, rather than to ground.

Keep up the articles—*ComputerDigest* also. I have built the voice synthesizer project using the SPO-156-AL2.

RODNEY B. LEWIS
Seymour, MO

Mr. Lewis is correct; the charger jack's return should connect to the negative terminal of the battery, not to ground. The correct schematic is shown in Fig. 1. In addition,

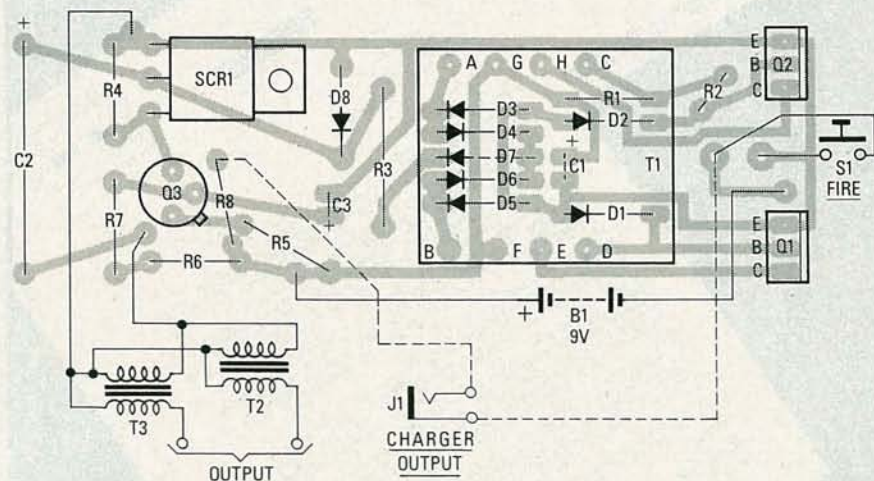

FIG. 2

tion, due to a printing error, several components (C1, D7, and J1) were not reproduced in the parts-placement diagram; Fig. 2 shows how those components should be mounted. We apologize for those errors.—Editor

DISTURBED BY OUR COVER

The library where I work just received the September 1986 **Radio-**

Electronics, and I am very much disturbed by the cover article, "Build This Stun Gun." The fact that you would run directions for building the gun bothers me less than the manner in which you present the project.

Considering that this is a powerful and dangerous electronic item, which can cause a significant amount of pain to anyone it is used on, you were quite right to post the warning on page 41. That warning reads, in part: "THIS DEVICE IS NOT A TOY. We present it for educational and experimental purposes only . . . and you should never, repeat, never use it on another person!" You go on to warn

of the severe physiological risks involved for anyone the gun is used on.

However, the effect of your warning is completely negated by the cover photograph, which is repeated on the first page of the article: It shows a young woman pointing a stun gun in a very aggressive fashion at a person who holds a knife blade aimed at her

INTRODUCING THE REPLACEMENT FOR OUR REPLACEMENT GUIDE.

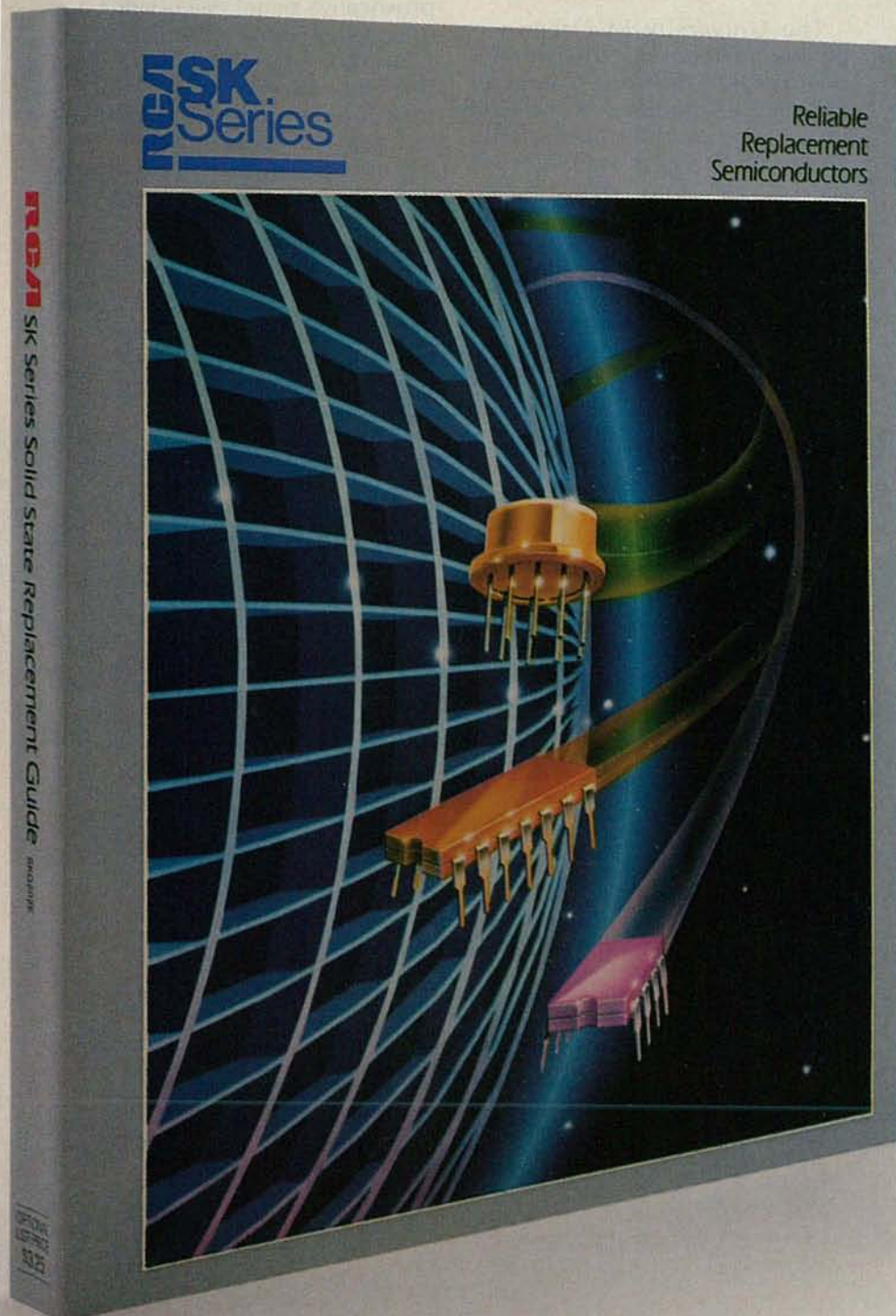

RCA's new SK Guide gives you fast, accurate solid state replacements.

In the world of semiconductor replacements, no one outperforms RCA's engineering excellence. We're in the business of manufacturing semiconductors, so you can depend on our reliability.

Our new, expanded RCA SK Guide to Reliable Replacement Semiconductors lists more than 2,900 SK and KH types that replace over 214,000 industry types. And, for the first time, QMOS logic devices and an extensive line of RF types are included.

The new RCA SK Replacement Guide (SKG202E). It's the only solid state replacement source you need. For a copy, see your RCA SK Distributor. Or mail a check or money order for \$3.25 to RCA Distributor and Special Products Division, Box 597, Woodbury, New Jersey 08096-2088.

RCA SK Replacement
Solid State

face. Effective advertising that may be, but it rather contradicts your warnings.

Please show enough responsibility and consistency in the future to heed your own warnings. If an item is too dangerous to be used on a person, you should not depict it in a way that implies it is being used on someone.

CATHERINE COX
Sunnyvale, CA

COMPONENTS NOT SHOWN

I have been looking over your articles on the FET Stereo Amp presented in the June, July, and August issues, and I plan on building it, little by little. I am no expert in electronics, but it seems to me that you forgot to show where C238, C239, and R220 were supposed to be placed in Fig. 13 of the August installment. I would also like to know whether I should use 25- or 50-volt capacitors for C132 and C232.

TODD AUSMAN
LaCrosse, WI

In the right-channel preamp,

R220 mounts in the unused pads beneath Q200 and Q201. In the right-channel power amp, power-supply bypass capacitors C238 and C239 mount in the unused pads beneath Q209. Viewing the board from the component side, mount C238 to the right of D207, horizontally, with the + side to the right. Mount C239 to the right of C238, vertically, more or less in line with R255. Use 50-volt devices for C132 and C232.—Editor.

COMPUTER GRAPHICS CONFERENCE

The University of Oregon is pleased to announce the Fifth Annual Pacific Northwest Computer Graphics Conference, to be held on Monday and Tuesday, October 27 and 28, in Eugene, Oregon, at the Eugene Conference Center/Hilton Hotel Complex and the Hult Center for the Performing Arts. This year's Conference will once again focus on leading-edge computer-graphics applications in a multi-disciplinary context. Artists, engineers, designers, archi-

tects, scientists, advertisers, and all others interested in the latest in computer-graphics technologies, are invited to participate in what certainly will be an exciting and informative two-day event.

The Conference program features six General-Session presentations, workshops on specific applications to various fields, an extensive Trade Exposition, and the dynamic Monday evening Film and Video Show. Exhibits of computer art and design imagery, a hands-on microcomputer lab, and provocative panel discussions are open to the public without charge. *New this year* will be pre-conference Macintosh workshops providing concentrated, hands-on, personalized instruction, and a Vendor debate on the latest technology in computer-graphics hardware and software.

For more information, contact: Conference Manager, Fifth Annual Pacific Northwest Computer Graphics Conference, University of Oregon Continuation Center, 1533 Moss Street, Eugene, OR

68 Testing Problems



An A P Products™ brand 68 Pin Chip Carrier Test Clip

- Allows safe, convenient testing of Plastic Leaded Chip Carrier (PLCC) style ICs.
- All four sides of test clip open simultaneously for fast and easy attachment to PLCC being tested.
- Stays securely clamped to PLCC until removed.
- Helical compression springs and insulating contact combs ensure contact integrity during testing.

One Solution



- Permits testing of ICs with as little as .200" row to row spacing between devices.
- Probe access points are immediately visible for fast and safe individual lead testing.
- Staggered contact rows on .100" centers facilitate probe attachment and help prevent accidental shorting of adjacent probes.
- Industry standard .025" square contact pins on the .100" centers easily accept single row female socket connectors.
- Available with tin plated leads and gold plated leads.

For information contact a local authorized A P Products Prototype & Test Devices distributor. For immediate response telephone 800-321-9668 or (216) 354-2101 in Ohio.

We Solve Problems.

Associated Electronics/3M

A P Products Prototype & Test Devices
9325 Progress Parkway, P.O. Box 540
Mentor, Ohio 44060

CIRCLE 76 ON FREE INFORMATION CARD

3M

Increase your knowledge about all aspects of electronics

An absolutely no-risk guarantee.

Select 5 Books for only \$2⁹⁵ and get a Free Gift!

values to \$151.70

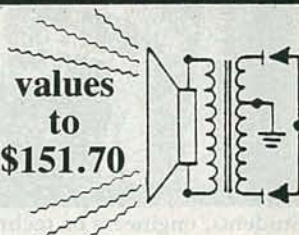

1536 \$14.95



1777P \$13.95



2609 \$26.95



800P \$19.95



1925 \$24.95



1835 \$15.95



1492 \$14.95



1503P \$15.95

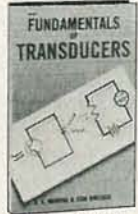

1693 \$21.95



1870 \$19.95



1663 \$24.95

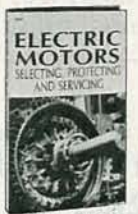

2663 \$19.95



1218P \$13.95



1683 \$21.95



1984P \$9.95



2728 \$15.95



1604P \$15.95



1899 \$24.95



1962 \$22.95



2641 \$19.95



1587P \$13.95



1199P \$16.95

BASIC ELECTRONICS

1531P. Concepts of Digital Electronics Paper \$11.50

1553. Understanding Electronics—2nd Edition \$15.95

TROUBLESHOOTING & REPAIR

1250P. Digital Electronics Troubleshooting Paper \$14.95

1887. Pocket Digital Multimeter Techniques \$22.95

1897P. Beginner's Guide To TV Repair—3rd Edition Paper \$12.95

HIGH TECHNOLOGY

1858. Robotics \$16.95

1167. Electronic Music Synthesizers \$11.95

EXCITING PROJECTS

1586. 25 Silicon-Controlled Rectifier Projects \$17.95

1992. The Transducer Project Book \$14.95

RADIO/TV/STEREO

2653P. How to Be a Ham—3rd Edition Paper \$12.95

1964P. Designing, Building and Testing Your Own Speaker System... with Projects—2nd Edition Paper \$10.95

781P. Handbook of Multichannel Recording Paper \$12.95

1685P. The Complete Guide to Satellite TV Paper \$11.95

(Publisher's Prices Shown)

Membership Benefits • Big Savings. Save up to 75% on books sure to increase your electronics know-how. • **Ironclad No-Risk Guarantee.** If not satisfied with your books, return them within 10 days without obligation! • **Club News Bulletins.** All about current selections—mains, alternates, extras—plus bonus offers and special sales. Comes 14 times a year with hundreds of titles to choose from. • **Automatic Order.** Do nothing, and the Main Selection will be shipped automatically! But... if you want an Alternate Selection, or no books at all, we'll follow the instructions you give on the reply form provided with every News Bulletin. • **Bonus Books.** Immediately get Dividend Certificates with every book purchased and qualify for big discounts of 60% to 80%. • **Exceptional Quality.** All books are quality publisher's editions especially selected by our Editorial Board.



FREE when you join

An All-Purpose Collection of Easy-to-Build Circuits
a \$26.95 value!

532 pps.
923 illus.

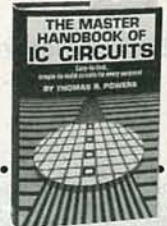

ELECTRONICS BOOK CLUB

P.O. Box 10, Blue Ridge Summit, PA 17214

Please accept my membership in the Electronics Book Club and send the 5 volumes circled below, plus my FREE copy of *The Master Handbook of IC Circuits*, (1370), billing me \$2.95 plus shipping and handling charges. If not satisfied, I may return the books within ten days without obligation and have my membership canceled. I agree to purchase 4 or more books at regular Club prices (plus shipping/handling) during the next 12 months, and may resign any time thereafter.

- 781P 800P 1167 1199P 1218P 1250P 1492 1503P 1531P 1536 1553 1586
- 1587P 1604P 1663 1683 1685P 1693 1777P 1835 1858 1870 1887
- 1897P 1899 1925 1962 1964P 1984P 1992 2609 2641 2653P 2663 2728

Name _____
 Address _____
 City _____
 State/Zip _____ Phone _____

Valid for new members only. Foreign applicants will receive ordering instructions. Canada must remit in U.S. currency. This order subject to acceptance by the Electronics Book Club.

RE-1186

Learn micro-processing with the new
MICRO-PROFESSOR 1P



Students, engineers or technicians—
upgrade your micro-processing skills
with the new Micro-Professor 1P.

The MPF-1P features:

- extensive software support
- more built-in memory
- improved keyboard
- larger display

Three tutorial guides help cover all
capabilities. The ideal training tool!
MPF-1P will deliver you into the growing
world of micro-processing. Invest now!

Plus—FREE GIFT Only **\$199.95**

Check this box for **FREE**
Z-80 Microprocessor
Programming and
Interfacing textbook when
you order within 7 days.
\$16.95 value. (Include
\$7.50 postage &
handling)

ETRONIX

Dept RE-11-86
5326 9th Ave. N.E.
Seattle, WA 98105-3617

For immediate action call TOLL FREE:

1-800-426-1044

Full money back guarantee.
Pictured with optional printer



CIRCLE 111 ON FREE INFORMATION CARD

97403. Telephones: 800-228-6891
(National), 800-824-1714 (Oregon),
503-686-3537 (National).

PAUL KATZ
Eugene, OR

OBJECTION

I believe that it is a bad choice to
run ads unrelated to electronics in
Radio-Electronics. I am referring to
the *Nutri-Wheat* ad on page 14 of
the August 1986 issue. Independent
of the merits of the specific
product, I buy **Radio-Electronics**
for its area of specialization, not
for general-product ads, with
which I'm inundated in all other
publications.

ARTHUR WRIGHT
Address Withheld

NEGATIVE FEEDBACK

I enjoy the articles on the early
days of radio; they bring back
many memories. But I would like
to point out that I have not seen
any mention of negative feedback,
which was introduced by FAD An-
drea. The FADA tuned-radio-fre-

quency receivers used negative
feedback to overcome oscillation.
To adjust the feedback caps, you
had to use a tube with one fila-
ment prong cut off in the stage you
were working on. Then, by using a
modulated signal generator, you
adjusted for minimum output. I
believe that the FADA came out in
1926, and other manufacturers
were licensed to use that feature.

One article mentioned the sev-
eral types of variable capacitors,
but failed to mention the one used
by some early Crosley radios. It
was like two pages in a book. As
you turned the dial, a cam pressed
the two pages together. A piece of
mica supplied the insulation be-
tween the pages. Using that cap,
Crosley was able to produce some
of the cheapest radios at the time.

I remember very well the first
dynamic loudspeaker that I heard,
about 1926. That was a 110-volt AC-
powered set, one of the first. It was
made by GE and housed in a
Brunswick cabinet. The radio was
a superheterodyne with an IF of 90
kHz. There were two tuning dials,

Experience the wonder... of **fischertechnik**® kits

Learn about:



We make a variety
of easy-to-build, educational kits,
from the simple to the complex. For ages
6 and up. For learning that's fun.

Explore other fascinating
concepts like Robotics,
Hydraulics, Statics, and more!



Available at your Heath/
Zenith Computers &
Electronics Center. See
your telephone white pages
for the store nearest you. Or order
from the Heathkit Catalog. To order by phone,
call 1-800-253-0570.



fischertechnik® 

PERFORMANCE

THAT IS OUT OF THIS WORLD...



\$389⁰⁰
MODEL 2000 20MHz
DUAL TRACE

\$549⁰⁰
MODEL 3500 35MHz
DUAL TRACE DELAYED SWEEP

...AT A DOWN TO EARTH PRICE

At last! Truly affordable test equipment with no compromise in design, and features you would expect to find only on oscilloscopes costing hundreds of dollars more! JDR Instruments presents two, new, high-performance models backed by a two year warranty and technical support which is only a phone call away. Perfect for the technician or advanced hobbyist, both models feature Dual Trace capability and a variety of operating and triggering modes, including CH-B Subtract and X-Y operation.

MODEL 2000 has a 20 MHz bandwidth and 20 calibrated sweeps ranging from .2s to .2 μ s. A convenient built-in component tester provides additional diagnostic power.



CIRCLE 59 ON FREE INFORMATION CARD

MODEL 3500 features a 35 MHz bandwidth and exceptional 1mV/DIV sensitivity. Delayed sweep and variable holdoff allow stable viewing of complex waveforms.

ORDER TOLL FREE
800-538-5000
800-662-6279 (CA)

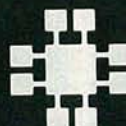

JDR INSTRUMENTS
1224 South Bascom Avenue
San Jose, California 95128 (408) 995-5430

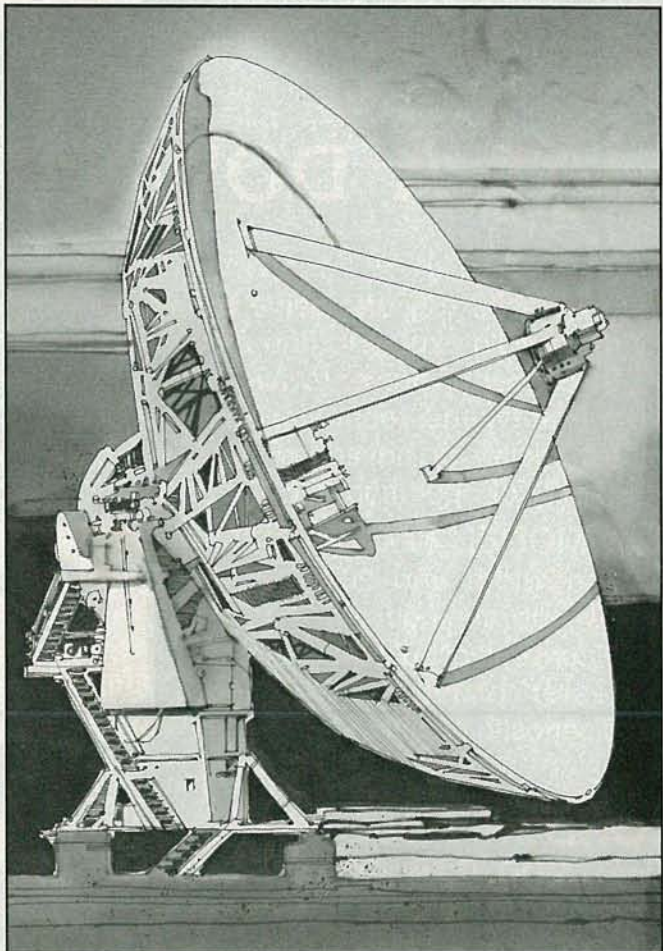
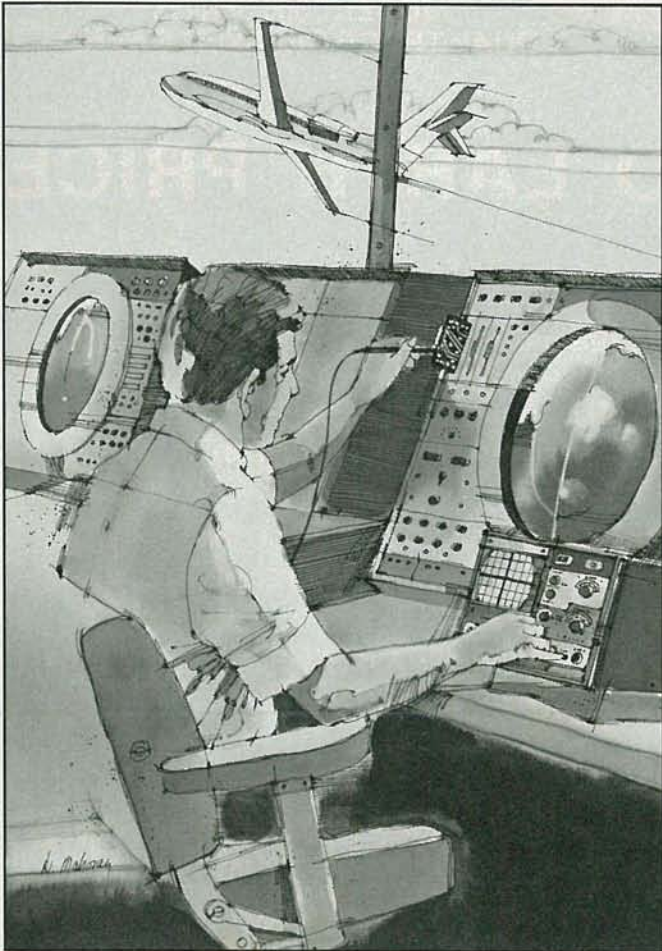
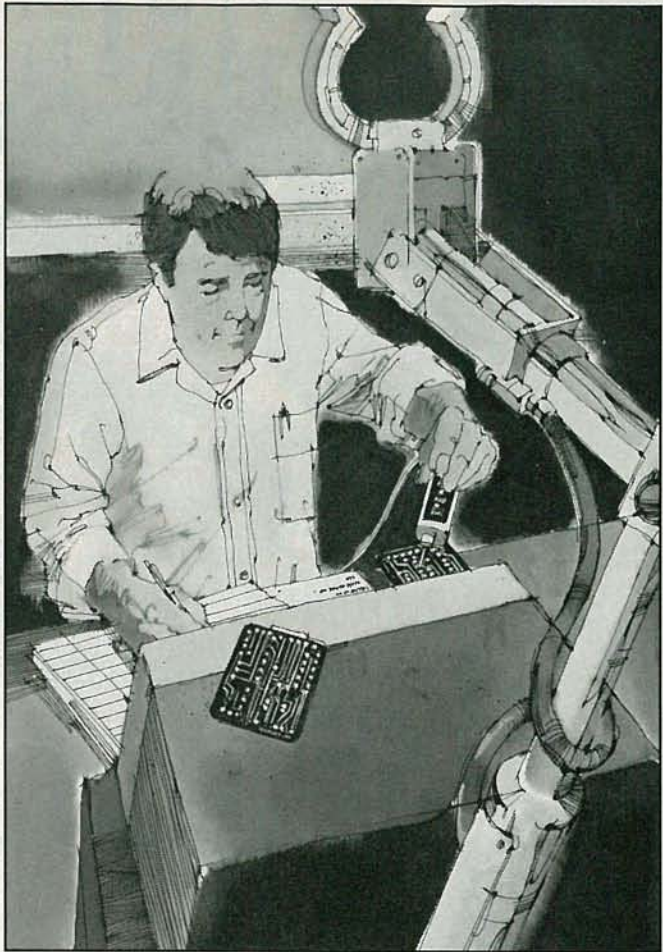

CIE MAKES THE WORLD OF ELECTRONICS YOURS.

Today's world is the world of electronics. To be part of it, you need the right kind of training, the kind you get from Cleveland Institute of Electronics, the kind that can take you to a fast growing career in business, aerospace, medicine, science, government, communications, and more.

Specialized training.

You learn best from a specialist, and that's CIE. We're the leader in teaching electronics through independent study, we teach only electronics and we've been doing it for over 50 years. You can put that experience to work for you just like more than 25,000 CIE students are currently doing all around the world.

Practical training.

You learn best with practical training, so CIE's Auto-Programmed® lessons are designed to take you step-by-step, principle-by-principle. You also get valuable hands-on experience at every stage with sophisticated electronics tools CIE-designed for teaching. Our 4K RAM Microprocessor Training Laboratory, for example, trains you to work with a broad range of computers in a way that working with a single, stock computer simply can't.

Personalized training.

You learn best with flexible training, so we let you choose from a broad range of courses. You start

with what you know, a little or a lot, and you go wherever you want, as far as you want. With CIE, you can even earn your Associate in Applied Science Degree in Electronics Engineering Technology. Of course, you set your own pace, and, if you ever have questions or problems, our instructors are only a toll-free phone call away.

The first step is yours.

To find out more, mail in the coupon below. Or, if you prefer, call toll-free **1-800-321-2155 (in Ohio, 1-800-523-9109)**. We'll send a copy of CIE's school catalog and a complete package of enrollment information. For your convenience, we'll try to have a representative contact you to answer your questions.

CIE Cleveland Institute of Electronics

1776 East 17th St., Cleveland, Ohio 44114

YES! I want to get started. Send me my CIE school catalog including details about the Associate Degree Program. I am most interested in:

- | | |
|--|---|
| <input type="checkbox"/> computer repair | <input type="checkbox"/> television/high fidelity service |
| <input type="checkbox"/> telecommunications | <input type="checkbox"/> medical electronics |
| <input type="checkbox"/> robotics/automation | <input type="checkbox"/> broadcast engineering |
| <input type="checkbox"/> other _____ | |

Print Name _____

Address _____ Apt. _____

City _____ State _____ Zip _____

Age _____ Area Code/Phone No. _____

Check box for G.I. Bulletin on Educational Benefits

Veteran Active Duty **MAIL TODAY!**

OR CALL TOLL FREE
1-800-321-2155
(In Ohio, 1-800-523-9109)

RE-48

with only parts of their edges showing. One tuned the loop antenna and the RF stage; the other was the oscillator. You normally adjusted both dials together, but you could adjust the oscillator to a different spot about 180 kHz away and pick up the same station. That set had several interesting features: It used 8 UV-199 tubes with their 2-volt filaments in series, supplied with DC. The tube sockets and IF transformers were housed in a brass metal can. That

can or trough was potted to keep construction details secret. The troughs were called catacombs.

The loudspeaker had a huge electromagnet, about 4 inches in diameter and 6 inches long. The cone was 10 inches in diameter. That set also contained a record player with a magnetic pickup. It only played one record at a time, but the sound was wonderful. The turntable was driven directly by disk like that in a kilowatt meter. There was a flyball governor to

control speed. That set cost about \$600.00, which was a lot of money at that time.

You may be interested in the following story: Because long-distance reception was the main attraction of radio in the early days, it happened that all of the stations in the US were to be off the air for one hour during the winter of 1926. That was to allow people in the US to try to pick up some signals from Europe. I conceived the idea of helping out by building a small transmitter in my basement. I built an oscillator with three 201A's in parallel; they were excited by all the B batteries that I could borrow from friends. That let them in on the prank, too. For a microphone, we used a carbon telephone mouthpiece. It was connected through 40 feet of twisted pair between oscillator and ground. The telephone mouthpiece was pushed into the horn of a phonograph in our front room to pick up music.

We picked out some call letters of a station in France. I did the announcing and stated that this was a special English broadcast to the USA. When the time came, we started broadcasting music such as "My Old Kentucky Home." We did that very seriously until the hour was up. Of course, we had no idea whether we were being heard or not.

So the next day at high school, we were tickled to find out that a loud station in France had been heard. We kept quiet for about a week, but couldn't keep our secret any longer. The local newspaper ran an article stating that certain young men had violated the law and were liable to go to prison for such pranks—but what a kick we got! All that happened in Lebanon, a small town in Kentucky.

DONALD K. McCAMMON
Louisville, KY

KUDOS FOR MARTIN CLIFFORD

To Martin Clifford for his "The Early Days of Radio," (Radio-Electronics, July 1986) a *Thank You!*

Your article brought back fond memories of the late twenties when I first became interested in radio. The cat whisker that never



3 Amp Regulated Power Supply BM-510
Specification: input voltage: 115 Vac. Output voltage: 13.8 VDC. Current: 3 amp constant. 5 amp surge, short circuit protection.
Special Sale \$14.95
Reg Price \$23.40



VOM Multitester
20,000 Ohms per volt DC
Special Sale **\$15.95** Reg. \$22.70
BM-313



Video Accessories SALE \$4.95
Gold Plated 6 Foot Video Dubbing Cable Set
Gold Video Dubbing Kit for recording from one video recorder to another, includes video/audio cable and adapters for VHS and Beta recorders.



6 Piece
Cushion Grip Screwdriver Set
Reg. Price \$4.50
Super Special \$1.70 EA. SET
MIN. 5 PA-109



21 PC. PRECISION SCREW DRIVER SET
COMPLETE w/5 SIZES PRECISION WRENCHES, 2 CROSSPOINT SCREWDRIVERS 3 HEX KEY WRENCHES, 5 HEX NUT DRIVERS, 6 SLOT SCREWDRIVERS, & TORX KEY
Reg. \$9.38
SALE \$5.95 BM-353



MINI STEREO HEADPHONE
\$4.99
BM-73

TRIPLERS:
T-184 equivalent to ECG-523 1-9 10 up
T-53 equivalent to ECG 526 **\$9.95 \$8.99**
T-45 equivalent to ECG 500A

GE, Magnavox, Sony, Sears
CALL FOR NUMBERS

ALL SAFETY CAPACITORS 10 FOR \$35.00

TRANSISTORS
A-41.....SANYO 1308K.....1-49 **1.79** 50-99 **1.59** 100-up **1.45**
A-15.....TOSHIBA 1172B.....1-25 **2.65** 26-49 **2.25** 50-up **2.00**

COAXIAL CABLE 

Copper Braid Shield Add \$5.00 per roll shipping

RG 59u1000'Reg. \$82.00 **SALE \$44.00**
RG 6u500'Reg. \$55.10**SALE \$35.95**

ESI
Electronic Parts & Accessories
3820 14th Avenue, Brooklyn, NY 11218
a division of **ALPHA-KENCO INC.**
SYSTEMS & ELECTRONICS

ORDER BY PHONE:
800-645-4720
(718)436-9700

call for
our free
104 Page
CATALOG

CIRCLE 199 ON FREE INFORMATION CARD

RADIO-ELECTRONICS

20

stayed put and the peanut tube created a desire that led to a lifetime career. That career covered the early days of commercial radio, when most equipment was home made, to the design and development of computers—and, in retirement, robotics.

Please retain the present format of **Radio-Electronics**. Leave the long-winded computer articles to others. **Radio-Electronics** is, I am sure, the starting point for many of tomorrow's designers and scientists.

ROBERT E. SCHULTZ
Lawrenceville, NJ

SPEECH SYNTHESIS

Ricardo Jiminez and Adrian Valle are to be commended for their article in *ComputerDigest* section the August 1986 **Radio-Electronics** on speech synthesis for the Commodore 64. That is the only such article that I have seen, which is surprising when we consider how easy and interesting it is to give a 64 a voice.

Radio Shack has another neat trick up its sleeve, in addition to the SP0256-AL2. It is called the CTS256A-AL2, and it makes things even better for the speech hobbyist. "CTS" stands for Code-To-Speech, and it is a digital signal-processing IC that "reads" English words as input, and produces the right allophones as output. You hook it up to the SP0256-AL2, and your computer can actually read and speak English text.

Radio Shack provides a data sheet on how to wire up the circuit, which is quite simple. I was not able to get the parallel interface (of the Commodore's expansion port) to work very well, but there is an RS232 interface that worked perfectly for me—first try.

Figure 5 in the article was a fairly laborious encoding of a BASIC program to make the SP0256 say, "I am a talking computer." The cable from the C54 constituted a pretty tedious piece of work, too, using 9 signal wires plus 2 more for power supply and ground. The equivalent using the CTS256, in addition to the SP0256, is a 3-wire RS-232 cable, 2 lines for power supply and ground, and the following program:

```
10 OPEN 2,2,3,CHR$(3+32+128)
```

Free Famous hi-tech catalog



A very special computer & electronics guide that shows you what the exciting world of kitbuilding can do for you.

Challenge. Knowledge. Achievement. Enjoyment. All of these things are yours when you build a Heathkit high-quality product. Our colorful, informative catalog reflects the years of experience and technological expertise that make these things happen for you.



HERO® 2000 Educational Robot and Courseware

IBM-PC Compatible Expandable Computers

Amateur Radio Terminal Node Controller

Precision Test Instruments

Electronic Keyless Doorlock

In our catalog you'll find over 450 interesting and useful items – from computer hardware and software to robots and test instruments, and from home security systems to color tv's and amateur radio equipment.

But what makes Heath Company unique is that we offer you the confi-

dence and pride that you can only get by building a state-of-the-art product yourself. And you're backed by our promise, "We won't let you fail."

The Heathkit Catalog is a simple – and FREE – first step toward this excellent opportunity.

Send NOW for your FREE Heathkit Catalog



Yes! I want to see what kitbuilding can do for me. Please send me the latest Heathkit Catalog Free.

Send to: Heath Company, Dept. 020-472
Benton Harbor, Michigan 49022

Name _____

Address _____

City _____ State _____

Zip _____

Heathkit®

Heath
Company

A subsidiary of Zenith Electronics Corporation

CL-87R1

Be an FCC LICENSED ELECTRONIC TECHNICIAN!



Learn at home in spare time.
No previous experience needed.

No costly school. No commuting to class. The Original Home-Study course prepares you for the "FCC Commercial Radiotelephone License". This valuable license is your "ticket" to thousands of exciting jobs in Communications, Radio-TV, Microwave, Computers, Radar, Avionics and more! You don't need a college degree to qualify, but you do need an FCC License.

No Need to Quit Your Job or Go To School
This proven course is easy, fast and low cost! **GUARANTEED PASS** - You get your FCC License or money refunded. **Send for FREE facts now. MAIL COUPON TODAY!**

COMMAND PRODUCTIONS

FCC LICENSE TRAINING, Dept. 90
P.O. Box 2223, San Francisco, CA 94126

Please rush **FREE** details immediately!

NAME _____
ADDRESS _____
CITY _____ STATE _____ ZIP _____

20 PRINT#2 "I am a talking computer."

The CTS256 figures out the weird allophones required by the SP0256—we don't have to worry about such details. Pronunciation is 85% accurate, according to Radio Shack, and I found it trivial to substitute phonetic spellings in those cases where the CTS256 errs. For example, it pronounces the word "shine" as "sheen," so I just spell in "shyne," which, for some reason, works great. You could build a "pronouncing gazeteer" for your own application if you wanted to do some fancy dictionary software, instead of remembering to fake out the tricky words yourself with phonetic spellings.

In one major respect, I found the SP0256 to be a huge failure—it sounds like a stupid robot speaking in a monotone. There is no way to vary the inflection, or pitch, of the voice. Even TI's *Speak 'n Spell* sounds more natural. You should probably have mentioned that in

your article, to prevent reader disappointment.

JIM CRAIG
Leander, TX

SPEECH SYNTHESIZER

I was very interested in your article "Speech Synthesizer," by Ricardo Jimenez & Adrian Valle, in the *ComputerDigest* section of the August 1986 issue of *Radio-Electronics*.

I'd like to point out that a 2" x 3" circuit board, with the circuit shown in of Fig. 3 of that article is available through Celtic Industries, Inc., 14654 Keswick St., Van Nuys, CA 91405 (818) 787-3615.

The above mentioned circuit board is universally usable on the SPO256-AL2 Voice Synthesizer, and the SPO156 Narrator Speech Processor, and can be an integral part of Radio Shack's Text to Speech Controller CT5256A-AL2. It can also be used with a Commodore VIC-20 or 64 computer.

JACOB LOOSLI
Panama City, CA

R-E

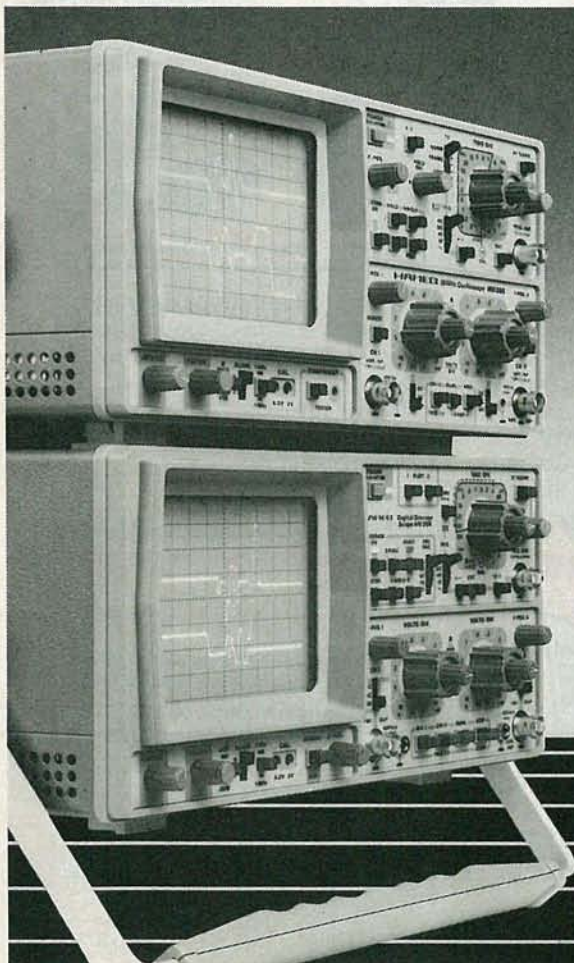

HAMEG Instruments

HM 205 an outstanding Oscilloscope with digital storage

This scope offers all the features of a 20MHz realtime instrument. In addition it provides digital storage capability for signals between 50s and 0.3ms duration, with a max. sampling rate of 100kHz. When working with slow phenomenae, the HM205 can easily replace considerably more expensive digital storage scopes.

HM 208 the high tech Storage Scope with 20MHz sampling rate

The HM208's sampling rate of max. 20MHz facilitates storing of fast single events. Max. memory is 4096x8 bit, conveniently divided into two independent blocks. XY-storage capability enables easy viewing and recording of characteristic curves and Lissajous figures. An XY-recorder output and the optional IEEE-488 Interface allow full integration in automatic measurement systems.

Write or call toll free 800.247.1241

HAMEG, INC.

88-90 Harbor Road · Port Washington N.Y. 11050
Phone (516) 883.3837 · TWX (510) 223.0889

ASK R-E

WRITE TO:

ASK R-E
Radio-Electronics
500-B Bi-County Blvd.
Farmingdale, NY 11735

SORTING ZENER DIODES

I purchased a grab-bag of dozens of unmarked Zener diodes. Is there a circuit that I can use to measure their Zener voltages safely?—C. W. L., Bradenton, FL.

Yes. But let's take a step back and review the basic characteristics of Zener diodes first.

Shown in Fig. 1 is the voltage-current characteristic curve of a Zener diode. When the diode is forward-biased past the 0.6-volt barrier potential, it has a low resistance, so a considerable amount of current can flow.

However, when the applied voltage is reversed, the junction's reverse resistance is very high initially, so current is very low—in

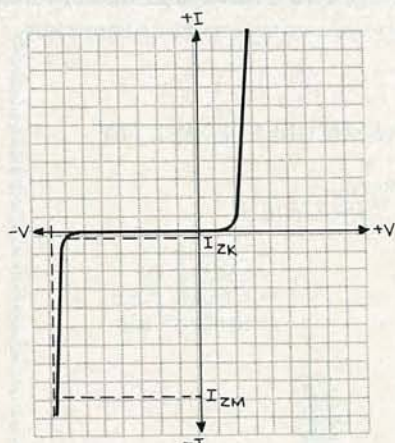

FIG. 1

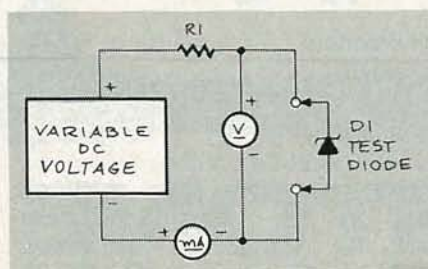

FIG. 2

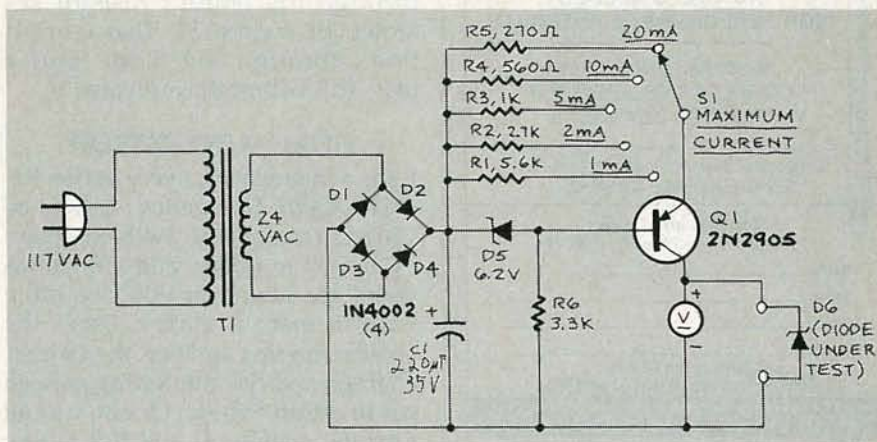

FIG. 3

the microampere range. As the voltage across the diode increases to a specific and critical value, V_Z , the normally high junction resistance drops to a very low value, and diode current increases considerably. The Zener voltage, V_Z , remains constant as the applied voltage increases; it is the latter characteristic that makes the Zener diode useful as a voltage regulator.

The knee in the negative-going portion of the curve is the point where a small current flows just before the onset of avalanche current. That holding current, I_{ZK} , is considered the minimum current that must be maintained when a Zener diode is being used as a voltage regulator. The maximum Zener current, I_{ZM} , is limited by junction temperature and by the maximum power that the device can dissipate. Both I_{ZK} and I_{ZM} are given in manufacturers' data sheets. When current is maintained between those two points, V_Z is constant. The value of I_{ZK} is low; it's typically 0.25 mA for 1-watt diodes, 1.0 mA for 10-watt diodes,

and 5 mA for 50-watt devices.

You can get Zener diodes that are rated from about 2 volts to 200 volts. The power-handling capacity of Zener diodes ranges from $\frac{1}{4}$ watt to 50 watts. With those ideas in mind, let's see how we can measure V_Z of an unknown diode without exceeding I_{ZM} and possibly destroying the diode.

Figure 2 shows the basic scheme for determining V_Z . The test circuit is powered by a variable DC source whose output is equal to or greater than the highest Zener voltage you expect to encounter. Resistor R1 should be selected to limit current to about ten mA at the highest voltage delivered by the power supply. The diode to be tested is connected across the DC source with its cathode connected to the positive terminal. The two meters allow you to monitor both voltage and current.

To find V_Z , start with the output of the power supply at zero volts. Gradually increase the voltage while monitoring the voltmeter. As the test voltage increases, the current meter will show little or no

SEE YOUR DEALER TODAY

FROM

Firestik®
ANTENNAS
ACCESSORIES

HERE'S A TIP
THAT'S PERFECT!

AM/FM AUTO RADIO
AND CB

Firestik® II
GOLDEN SERIES

BARE-HANDS TUNABLE
"NO TOOLS NEEDED"
HIGH PERFORMANCE ANTENNAS

ALSO ANTENNAS FOR
CORDLESS TELEPHONES
MONITOR SCANNERS

Dealer & Distributor Inquiries Invited
SEND FOR FREE CATALOG

Firestik® Antenna Company
2614 East Adams/Phoenix, AZ 85034

Name _____
Street _____
City _____
State _____ Zip _____

Serving the CB and
Communications Market Since 1962.

5-YEAR REPLACEMENT WARRANTY

CIRCLE 100 ON FREE INFORMATION CARD

current flow. But when the voltage approaches the avalanche level, current will increase, and voltage will stabilize. After that point, current will increase drastically, and voltage will remain constant. The constant voltage is V_Z .

A more versatile circuit is shown in Fig. 3. That circuit works only with Zener diodes rated at less than about 25 volts. The circuit works by using a 2N2905 PNP transistor as a constant-current generator whose output impedance is determined by feedback current through the emitter resistor selected by switch S1. That current flows through the diode under test; the voltmeter indicates V_Z .

DUAL AUTO BATTERY

I am a member of a very active REACT (Radio Emergency Associated Citizen Teams) unit. With emergency lights, monitor, and CB radios going for hours on end, we often have to make a choice. Leave the engine running to keep the battery charged and risk not having enough gas to return to base. Or else we can turn the engine off and risk letting

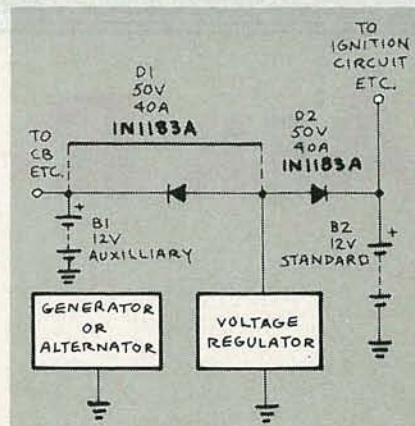

FIG. 4

the battery discharge too low to restart the engine. I've heard that some REACT groups use two batteries in their emergency vans and in their cars. How does that work?—G. McC., Palmetto, SC.

Figure 4 shows how to use one battery for the normal circuits (ignition, horn, heater, etc.), and the other battery for your CB radio, siren, emergency lights, etc.

The diodes (D1 and D2) isolate the two batteries and their loads so that neither can be discharged by the other accidentally. R-E

WE SHIP PRODUCTS...NOT PROMISES

SAFE 'N SURE UNIVERSAL TEST LEAD KIT

• PRACTICAL • ECONOMICAL • HANDY • TIME SAVING • MAXIMUM FLEXIBILITY

This Versatile Modular Kit with 1001 uses allows you to make: **TEST LEADS, PATCH CORDS, CLIP LEADS, JUMPER-CABLES, TEST HOOK LEADS** compatible with instruments manufactured by: **Beckman, Triplett, Simpson, Fluke, B&K, Keithley, Amprobe** and other leading brands.

- Accessories screw on for positive, reliable connection. Supplied in pairs (red & black) with 48" long wire leads.
- Packaged complete in neat and handy vinyl organizer carry pouch.
- Custom Leads on special order.
- Made in the U.S.A.

Kit Includes The Following:
SCREW-ON ACCESSORIES

- * Test Hooks
- * Spade Lugs
- * Alligator Clips
- * Banana Plugs



NEW!

Send For Complete Brochure

On-The-Shelves at your Local Distributor.



KEYSTONE
ELECTRONICS CORP.

49 Bleecker Street, New York, NY 10012-2484 • Tel: (212) 475-4600 • TLX: 35-3700 • FAX: 212-529-5923 • (800) 221-5510

CIRCLE 197 ON FREE INFORMATION CARD

World Series of Savings

INSTANT REBATES ON B&K-PRECISION SCOPES

Limited time offer—expires November 30, 1986

Call
1-800-654-7256

\$100 INSTANT REBATE

BK PRECISION 100 MHz, Quad Input Oscilloscope

Model
1590A

- 1 mV/div sensitivity— Full Bandwidth
- 2% Vertical and Horizontal Sweep Accuracy
- Dual Independent Time Base
- Calibrated Delayed Sweep
- 20 kV Accelerating Voltage
- V Mode— Displays Four Signals Unrelated in Frequency
- And Much More!!!

\$1886 Price /less
\$100.00 Rebate

\$1786
FINAL PRICE

\$90 INSTANT REBATE

BK PRECISION Digital Storage/Analog Oscilloscope

Model
2520

- 20 MHz Real Time Bandwidth 20 MHz Storage Bandwidth
- 2 Megasample/Second Sampling Rate
- 1 K Memory Per Channel
- Equivalent Time Sampling
- Pre-Trigger Capture
- And Much More!!!

\$1895 Price /less
\$90.00 Rebate

\$1805
FINAL PRICE

\$80 INSTANT REBATE

BK PRECISION 80 MHz, Quad Input Oscilloscope

Model
1570A

- 1 mV/div sensitivity— Full Bandwidth
- 2% Vertical and Horizontal Sweep Accuracy
- Dual Time Base/Calibrated Delayed Sweep
- 12 kV Accelerating Voltage
- V Mode— Displays Four Signals Unrelated in Frequency
- And Much More!!!

\$1464 Price /less
\$80.00 Rebate

\$1384
FINAL PRICE

\$60 INSTANT REBATE

BK PRECISION 60 MHz, Triple Input Oscilloscope

Model
1564

- 1 mV/div sensitivity
- ±3% Vertical and Horizontal Sweep Accuracy
- Dual Time Base/Calibrated Delayed Sweep
- 12 kV Accelerating Voltage
- V Mode— Displays Three Signals Unrelated in Frequency
- And Much More!!!

\$1267 Price /less
\$60.00 Rebate

\$1207
FINAL PRICE

\$40 INSTANT REBATE

BK PRECISION 40 MHz, Dual Input Oscilloscope

Model
1541

- 1 mV/div sensitivity
- 3% Vertical and Horizontal Sweep Accuracy
- Single Time Base
- 20 Calibrated Sweeps
- 6 kV Accelerating Voltage
- V Mode— Displays Two Signals Unrelated in Frequency
- And Much More!!!

\$847 Price /less
\$40.00 Rebate

\$807
FINAL PRICE

\$20 INSTANT REBATE

BK PRECISION 25 MHz, Dual Input Oscilloscope

Model
1524

- 1 mV/div sensitivity
- 3% Vertical and Horizontal Sweep Accuracy
- Single Time Base
- 20 Calibrated Sweeps
- 6 kV Accelerating Voltage
- V Mode— Displays Two Signals Unrelated in Frequency
- And Much More!!!

\$767 Price /less
\$20.00 Rebate

\$747
FINAL PRICE

B&K-Precision is offering these instant factory rebates on selected B&K-Precision Oscilloscopes to you through Participating Distributors.

HERE'S HOW IT WORKS!!!

1. Call 1-800-654-7256 for the name of your Participating B&K-PRECISION Distributor
2. Select the B&K-PRECISION Oscilloscope that meets your needs from the Participating Distributor's stock.
3. The Participating Distributor will deduct the "INSTANT REBATE" for that model directly from the invoice price. You save instantly!

PLEASE NOTE: This offer is available *only* at Participating B&K-PRECISION Distributors. Only B&K-PRECISION Models 2520, 1590A, 1570A, 1564, 1541 and 1524 are eligible for INSTANT REBATES. Sorry, no substitutions are allowed. INSTANT REBATES apply to purchases from October 1, 1986 through November 30, 1986 only.

BK PRECISION DYNASCAN CORPORATION

6460 West Cortland Street • Chicago, Illinois 60635 • 312/889-9087

International Sales, 6460 W. Cortland St., Chicago, Illinois 60635

Canadian Sales, Atlas Electronics, Ontario

South and Central American Sales, Empire Exporters, Plainview, NY 11803

CIRCLE 77 ON FREE INFORMATION CARD

EQUIPMENT REPORTS

Rabbit Systems VCR Rabbit Signal Distribution System

Multiply your video signal

CIRCLE 9 ON FREE INFORMATION CARD



multiple-set installation, you'll fall in love with the *VCR Rabbit* (Rabbit Systems, Inc., 233 Wilshire Blvd., Santa Monica, CA 90401).

The *VCR Rabbit*, which consists of a receiver, a transmitter, an infrared transmitter, cabling, and connectors, allows you to input a Channel 3 or 4 TV signal from a VCR, cable-system converter, satellite receiver, computer, videocamera, or other RF-modulated video source and send it to as many as four remotely located TV receivers. The sets may be located up to 150 feet away from the trans-

IF YOU HAVE EVER TANGLED WITH A/B switches, signal splitters, and coax

cables in an effort to route video signals to different TV sets in a

Send Purchase Order
Check, Money Order, or C.O.D.
or Call Toll Free
800-223-0826
in N.Y. State (212) 865-5580

CABLE BOXES JERROLD CORDLESS CABLE TV CONVERTERS

MODEL DRX3-105/400

- 60 channels
- Remote channel changing
- Remote ON/OFF switch
- Remote fine tuning

\$69⁹⁵

EXTRA HAND REMOTES
REM 400 - \$29⁹⁵



JERROLD CORDLESS CABLE TV CONVERTER Model STARCOM CS-V

\$129

- Volume control
- 68 channels
- Mute control
- Instant channel recall
- Automatic fine tuning



JERROLD CORDLESS CABLE TV CONVERTER Model DRZ/450

\$69⁹⁵
/ 10 lot
79⁹⁵ ea.

- 66 CHANNELS
- AUTOMATIC FINE TUNING
- A/B SWITCH OPTION



TEKNICA CORDLESS CABLE TV CONVERTER Model 6510

\$139⁹⁵

- VOLUME CONTROL
- 140 CHANNEL CAPABILITY



JERROLD CORDLESS CABLE TV CONVERTER Model JRX3-105

\$49⁹⁵

- 36 channels



HITACHI SCOPES

V-212-20 MHz-**\$460**
V-222-20 MHz-**\$535**
V-422-40 MHz-**\$689**
V-223-20 MHz-**\$599**
DELAYED SWEEP



PROBES INCLUDED

B&K DUAL TRACE SCOPES

1476-10MHz-**\$375**
1477-15MHz-**\$425**
1479-30MHz-**\$550**
DELAYED SWEEP

■ MASTER CARD ■ VISA

OMNITRON ELECTRONICS

770 Amsterdam Ave., New York, NY 10025

SHIPPING CHARGES

For Orders	Add
\$25-100	\$6.50
\$100-500	\$8.50
\$500-750	\$10.50
\$750 and up	\$20.00

Write for
**FREE
CATALOG**
136 page

CIRCLE 110 ON FREE INFORMATION CARD

Where's Your **ELECTRONICS** Career Headed?

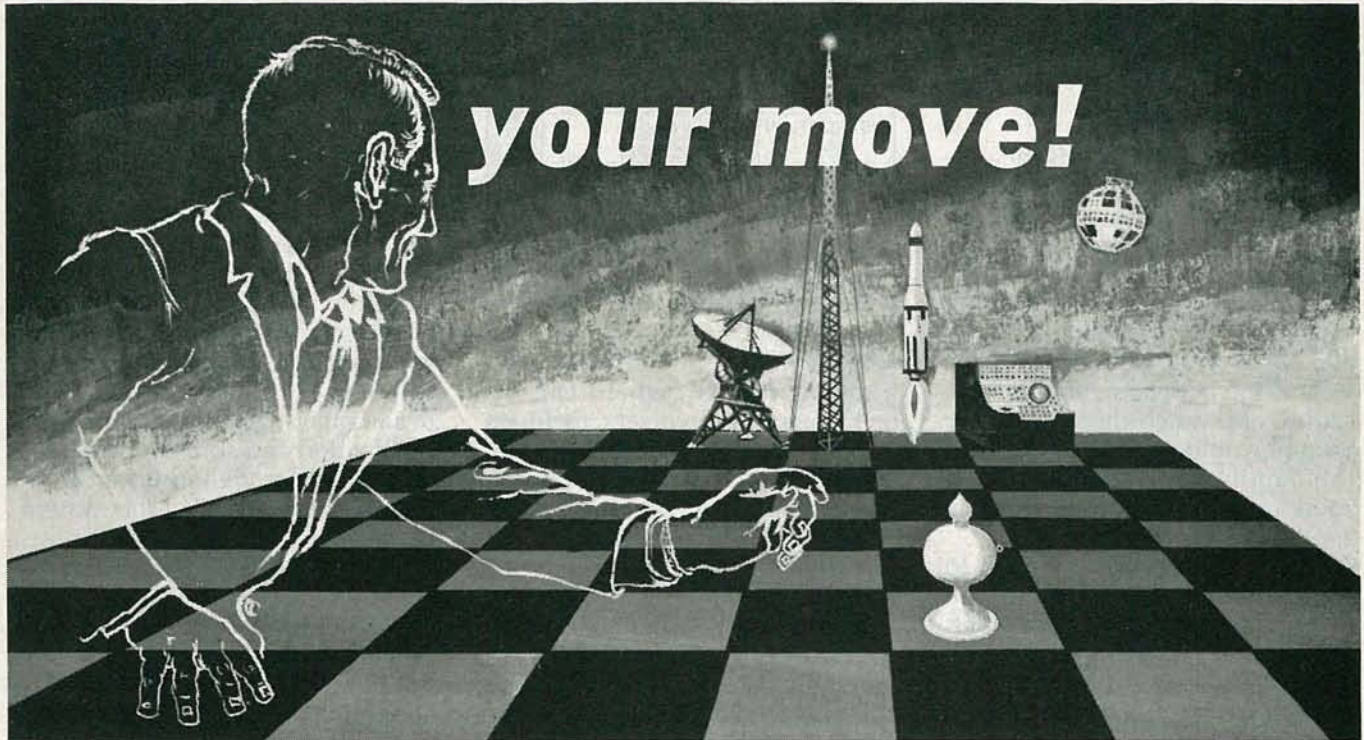

The Move You Make Today Can Shape Your Future

Yes it's your move. Whether on a chess board or in your career, you should plan each move carefully. In **electronics**, you can *move ahead* faster and further with a

B. S. DEGREE

Put professional knowledge and a COLLEGE DEGREE in your electronics career. Earn your degree through independent study at home, with Grantham College of Engineering. No commuting to class. Study at your own pace, while continuing your present job.

The accredited Grantham non-traditional degree program is intended for mature, fully employed workers who want to upgrade their careers . . . and who can successfully study electronics and supporting subjects through

INDEPENDENT STUDY, AT HOME

Free Details Available from:

Grantham College of Engineering
10570 Humbolt Street
Los Alamitos, California 90720

Independent Home Study Can Prepare You

Study materials, carefully written by the Grantham staff for independent study at home, are supplied by the College, and your technical questions related to those materials and the lesson tests are promptly answered by the Grantham teaching staff.

Recognition and Quality Assurance

Grantham College of Engineering is accredited by the Accrediting Commission of the National Home Study Council.

All lessons and other study materials, as well as communications between the college and students, are in the English language. However, we have students in many foreign countries; about 80% of our students live in the United States of America.

Grantham College of Engineering R-11-86
10570 Humbolt Street, Los Alamitos, CA 90720

Please mail me your free catalog which explains your B.S. Degree independent-study program.

Name _____ Age _____

Address _____

City _____ State _____ Zip _____

mitter. If the video source is equipped for infrared remote control, each connected receiver can control that source.

Focus on flexibility

The *VCR Rabbit* affords the user a high degree of flexibility. For instance, suppose you have a remote-control VCR in your family room, but would like to watch video tapes in the master bedroom. You could buy a second VCR, or you could drag your family-room VCR to the bedroom, connect the cables, and watch there. But then no one would be able to watch in the family room. And what if someone wanted to watch TV at another location?

The conventional approach to allow multiple viewing would be to use A/B switches, signal splitters, and coax cable. But each component inserted into the line takes its toll on signal strength and therefore picture quality. They also can generate a rat's nest of wiring and switches.

The *VCR Rabbit* system elimi-

Rabbit Systems VCR Rabbit										
OVERALL PRICE										
EASE OF USE										
INSTRUCTION MANUAL										
PRICE/VALUE										
	1	2	3	4	5	6	7	8	9 10	
	Poor		Fair			Good		Excellent		

nates most of the bother. The transmitter unit, which can directly feed two receivers, includes a power supply, two splitters, an A/B switch, an RF amplifier, and an infrared amplifier, all housed in a 6½ by 4 by 1¾-inch black and silver plastic cabinet. The receiver, which can feed another receiver, contains an A/B switch, an RF amplifier, and an infrared amplifier in the same-size cabinet. Hooking up the receiver to a TV set or a transmitter to a video source is easy using the color-coded three-foot cables supplied.

The *VCR Rabbit* presently being

sold is *not* the wireless TV-transmitter of a couple of years ago. Devices like that, which radiate a Channel 3 or 4 TV signal over a distance of about 200 feet, have been banned by the FCC. Those can easily interfere with your neighbors' TV reception; and sellers or users of such devices could be subject to heavy fines.

Instead, the *VCR Rabbit* uses very thin two-conductor "micro-wire" (only 1/16 in diameter) for the link between the transmitter and the receiver. Those cables are used to carry the amplified Channel-3 or -4 TV video and sound, 12-volt DC power, and amplified infrared remote-control signals. The system is completely legal; it complies with all FCC rules and regulations.

Using the Rabbit

Installation is a snap. Assuming that there is a TV set located at the signal source, the transmitter is installed between the source and the set using the supplied color-coded cable. If there is no set at the source, the source's output is

WM. B. ALLEN has unbelievable prices on LEADER!

LEADER
Instruments Corporation



LBO5825 TWO CHANNEL DIGITAL STORAGE OSCILLOSCOPE
5MHz sampling rate, 35MHz analog bandwidth, A/D converter each channel, 1k word per channel, two channels, Memory protect, X-Y recorder, Roll function, 5MHz storage.
REGULARLY \$2850.00
NOW ONLY \$2565.00

LPS151 TRIPLE OUTPUT POWER SUPPLY
0 to +6V, 0 to +25V
0 to -25V all adjustable,
0 to 6V output-3.0A max.,
+25V-0.5A max.
REGULARLY \$425.00
NOW ONLY \$392.00



LFG1300S FUNCTION/SWEEP GENERATOR
Sine, square, triangle, ramp and pulse output, Adjustable pulse width, Linear or log sweep, 1000:1 range.
REGULARLY \$495.00
NOW ONLY \$426.00

LAG-27 SINE/SQUARE WAVE GENERATOR 1 MHz
10MHz -1MHz range, 600 Ohm output impedance approx., Square wave frequency range 10Hz-100KHz, Output voltage 5V p-p or more (unloaded).
REGULARLY \$225.00
NOW ONLY \$207.00

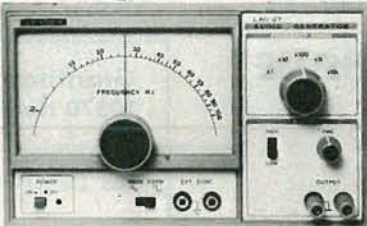

FOR PRICES ON OTHER LEADER PRODUCTS, CALL WM. B. ALLEN TOLL FREE!

WM. B. ALLEN SUPPLY COMPANY, INC.

NATIONWIDE 800-535-9593
NEW ORLEANS 504-525-8222
LOUISIANA 800-462-9520

ALLEN SQUARE
300 BLOCK, N. RAMPART STREET
NEW ORLEANS, LA 70112



Super Disk™ Diskettes

Now...Diskettes you can swear by, not swear at.

Lucky for you, the diskette buyer, there are many diskette brands to choose from. Some brands are good, some not as good, and some you wouldn't think of trusting with even one byte of your valuable data. Sadly, some manufacturers have put their profit motive ahead of creating quality products. This has resulted in an abundance of low quality but rather expensive diskettes in the marketplace.

A NEW COMPANY WAS NEEDED AND STARTED

Fortunately, other people in the diskette industry recognized that making ultra-high quality diskettes required the best and newest manufacturing equipment as well as the best people to operate this equipment. Since most manufacturers seemed satisfied to give you only the everyday quality now available, an assemblage of quality conscious individuals decided to start a new company to give you a new and better diskette. They called this product the *Super Disk* diskette, and you're going to love them. Now you have a product you can swear by, not swear at.

HOW THEY MADE THE BEST DISKETTES EVEN BETTER

The management of *Super Disk* diskettes then hired all the top brains in the diskette industry to make the *Super Disk* product. Then these top bananas (sometimes called floppy freaks) created a new standard of diskette quality and reliability. To learn the "manufacturing secrets" of the top diskette makers, they've also hired the remaining "magnetic media moguls" from competitors around the world. Then all these world class, top-dollar engineers, physicists, research scientists and production experts (if they've missed you, send in your resume to *Super Disk*) were given one directive...to pool all their manufacturing know-how and create a new, better diskette.

HOW SUPER DISK DISKETTES ARE MANUFACTURED

The *Super Disk* crew then assembled the newest, totally quality monitored, automated production line in the industry. Since the manufacturing equipment at *Super Disk* is new, it's easy for *Super Disk* to consistently make better diskettes. You can always be assured of ultra-tight tolerances and superb dependability when you use *Super Disk* diskettes. If all this manufacturing mumbo-jumbo doesn't impress you, we're sure that at least one of these other benefits from using *Super Disk* diskettes will:

- TOTAL SURFACE TESTING** - For maximum reliability, and to lessen the likelihood of disk errors, all diskettes must be totally surface tested. At *Super Disk*, each diskette is 100% surface tested. *Super Disk* is so picky in their testing, they even test the tracks that are in between the regular tracks.
- COMPLETE LINE OF PRODUCTS** - For a diskette to be useful to you and your computer, it must be compatible physically. *Super Disk* has an entire line of 5 1/4-inch and 3 1/2-inch diskettes for your computer.
- SPECIALLY LUBRICATED DISK** - *Super Disk* uses a special oxide lubricant which is added to the base media in the production of their diskettes. This gives you a better disk drive head to media contact and longer head and disk life.
- HIGH TEMPERATURE/LOW-MARRING JACKET** - A unique high temperature and low-marring vinyl jacket allows use of their product where other diskettes won't work. This special jacket is more rigid than other diskettes and helps eliminate dust on the jacket.
- REINFORCED HUB RINGS** - Standard on all 48 TPI *Super Disk* mini-disks, to strengthen the center hub hole. This increases the life of the disk to save you money and increase overall diskette reliability.
- DISK DURABILITY** - *Super Disk* diskettes will beat all industry standards for reliability since they will give you more than 75% of the original signal amplitude remaining even after an average (Weibull B-50) of 30 million passes. They are compatible with all industry specifications as established by ANSI, ECMA, ISO, IBM and JIS.
- CUSTOMER ORIENTED PACKAGING** - All *Super Disk* diskettes are packaged 100 diskettes to a carton and 10 cartons to a case. The economy bulk pack is packaged 100 or 500 disks to a case without envelopes or labels.
- LIFETIME WARRANTY** - If all else fails, remember, all disks made by *Super Disk* Inc., have a lifetime warranty. If any *Super Disk* diskette fails to meet factory specifications, *Super Disk* Inc. will replace them under the terms of the *Super Disk* warranty.
- SUPERB VALUE** - With *Super Disk*'s automated production line, high-quality, error-free disks are yours without the high cost.

Order toll free 800-USA-DISK
CIRCLE 179 ON FREE INFORMATION CARD

SAVE MONEY... QUANTITY DISCOUNTS AVAILABLE

Super Disk diskettes are packed 10 diskettes to a carton and 10 cartons to a case. To save you even more, we also offer *Super Disk* bulk product where 100 or 500 diskettes are packaged in the same box without envelopes or labels. Since we save packaging costs, these savings are passed on to you. For best value, you should order in increments of 100 diskettes. **Quantity discounts** are also available. Order 200 or more disks at the same time and deduct 1%; 300 or more 2%; 400 or more 3%; 500 or more 4%; 1,000 or more 5%; 2,000 or more 6%; 3,000 or more 7% and 5,000 or more disks earns you an 8% discount off our quantity 100 price. *Super Disk* and tear resistant 5 1/4" diskette envelopes are available from us for only \$10.00 per pack of 100. Use order # CV-5 for a 100 pack of 5 1/4" diskette envelopes.

39¢ per disk Quantity One

Almost all diskettes are immediately available from *Super Disk*. With our efficient warehouse facilities, your order is normally shipped in less than a day.

SAVE ON SUPER DISK™ DISKETTES Product Description	Part #	Super Disk price per disc (\$)
5 1/4" SSSD Soft Sector w/Hub Ring Retail 10 pack	6431-HR	0.64
5 1/4" Same as above, but bulk pack w/o envelope	6437-HR	0.39
5 1/4" SSDD Soft Sector w/Hub Ring Retail 10 pack	6481-HR	0.68
5 1/4" Same as above, but bulk pack w/o envelope	6487-HR	0.43
5 1/4" DSDD Soft Sector w/Hub Ring Retail 10 pack	6491-HR	0.74
5 1/4" Same as above, but bulk pack w/o envelope	6497-HR	0.49
5 1/4" DSQD Soft Sector (96 TPI) Retail 10 pack	6501-HR	1.09
5 1/4" Same as above, but bulk pack w/o envelope	6507-HR	0.79
5 1/4" DSHD for IBM PC/AT - bulk pack	6667-HR	1.49
3 1/2" SSHD (135 TPI) - Retail 10 pack	6311-HR	1.50
3 1/2" SSHD (135 TPI) - bulk pack	6317-HR	1.14
3 1/2" DSHD (135 TPI) - Retail 10 pack	6321-HR	1.68
3 1/2" DSHD (135 TPI) - bulk pack	6327-HR	1.49

SSSD = Single Sided Single Density; SSDD = Single Sided Double Density; DSDD = Double Sided Double Density; DSQD = Double Sided Quad Density; SSHD = Single Sided High Density; DSHD = Double Sided High Density.

BUY YOUR DISKETTES FROM CE WITH CONFIDENCE

To get the fastest delivery of your diskettes, phone your order directly to our order desk and charge it to your credit card. Written purchase orders are accepted from approved government agencies and most well rated firms at a 10% surcharge for net 10 billing. For maximum savings, your order should be prepaid. All sales are subject to availability, acceptance and verification. All sales are final. All prices are in U.S. dollars. Prices, terms and specifications are subject to change without notice. Out of stock items may be placed on backorder or substituted for equivalent product unless we are instructed differently. A \$5.00 additional handling fee will be charged for all orders with a merchandise total under \$50.00. All shipments are F.O.B. CE warehouse in Ann Arbor, Michigan. No COD's. Non-certified checks require bank clearance. Michigan residents add 4% sales tax or supply your tax ID number and reason for tax exemption.

For shipping charges add \$6.00 per 100 diskettes and/or any fraction of 100 5 1/4-inch or 3 1/2-inch diskettes for U.P.S./R.P.S. ground shipping and handling in the continental U.S. UPS 2nd day air rates are three times continental U.S. rates. For Canada, Puerto Rico, Hawaii, Alaska, or APO/FPO delivery, shipping is three times the continental U.S. rate.

Mail orders to: Communications Electronics Inc., Box 1045, Ann Arbor, Michigan 48106-1045 U.S.A. If you have a Discover, Visa or Master Card, you may call and place a credit card order. Order toll-free in the U.S. Dial 800-USA-DISK. In Canada, order toll-free by calling 800-CA1-DISK. If you are outside the U.S. or in Michigan dial 313-973-8888. Telex anytime 671-0155 (6710155 CE UW). Order today.

Copyright © 1986 Communications Electronics Inc.

Ad #100186-HR



Now  **39¢**
a disk

NOVEMBER 1986

merely fed to the transmitter. The micro-wire is then connected to the transmitter via spring-loaded terminals and fed along baseboards and door frames to the receiver. Enough micro-wire (150 feet) is supplied with the unit for almost any domestic applications; the cable ends are stripped and tinned for easy connection. The wire is installed by stapling it to the baseboard, etc., and is hardly noticeable. You must be careful, however, not to pierce the wire

with the staples. At the receiver, the micro-wire is connected to the unit via spring-loaded terminals. The receiver is connected to the TV set via the supplied cable. That's all there is to it.

As mentioned, power and infrared signals are sent to the receiver from the transmitter via the micro-wire. That means that the receiver itself is not connected to the house wiring.

More significantly, it means that you can control a signal source

from a remote viewing location by using its infrared remote control as you normally use it. Infrared signals from the control are picked up by the receiver, sent to the transmitter via the wire, and emitted by an infrared source at the transmitter. The signals are then picked up by the signal source's infrared receiver.

The infrared source was originally mounted inside the transmitter, behind a window. However, not all installations allowed for reliable operation using that scheme. Therefore, an external infrared source, or "wand," was added. That wand is connected to the transmitter via a jack and is placed directly in front of the signal source's infrared transmitter.

The owner's manual is excellent as far as it goes, but it only shows the connections for a VCR and a remote TV set. No attempt is made to show other combinations, probably because there are so many possibilities. The unit can be inserted anywhere within the RF signal path.

This reviewer's major complaint with the unit is that it lacks a main power switch. Although the power consumption of the transmitter is only 14 watts, there is little reason for leaving the unit on all the time, even when the signal source and attached TV sets are off. Further, that omission may lead to shorter device life. Adding the switch, as well as an LED power indicator would not add much to the unit's cost, or its power consumption; both additions would be worthwhile enhancements.

At a suggested retail price of \$89.95, the *VCR Rabbit* is far less expensive than adding another cable converter, VCR, or satellite receiver, yet offers you much of the convenience of such an addition. Additional receivers, supplied with 150 feet of wire, are available at a suggested retail price of \$44.95.

Some might feel that the micro-wire link is unsightly or undesirable, but this reviewer found that the wire was nearly unnoticeable. Further, the video signal supplied by the *VCR Rabbit* is superior to that supplied by any RF-link system we've seen, and without the threat of an FCC fine!

R-E

★ **CABLE TV SPECIALS** ★
CONVERTERS

- JERROLD:** DRZ-3DIC105—66 Channel Wireless \$199.⁹⁵
 JRX-3 DIC—36 Channel Corded Remote..... \$149.⁹⁵
 JSX-3 DIC—36 Channel Set Top..... \$129.⁹⁵
 SB-3—'The Real Thing' \$119.⁹⁵

- MAGNAVOX:** 6400—60 Channel Wireless w/Parental Lockout for Jerrold systems..... \$199.⁹⁵

- ZENITH:** Z-TAC Cable Add-On..... \$225.⁰⁰

- VIEW STAR:** EVSC-2000—60 Channel Wireless— with Parental Lockout..... \$ 99.⁹⁵
 EVSC-2000A-B—Same as above with A-B Switch \$109.⁹⁵
 View Star 1000—60 Channel Wireless..... with Volume \$119.⁹⁵

MISCELLANEOUS

- OAK:** N-12 Mini-Code \$ 89.⁹⁵
 N-12 Mini-Code Vari-Sync..... \$109.⁹⁵
 N-12 Mini-Code Vari-Sync Plus Auto On-Off .. \$165.⁰⁰

- JERROLD:** 400 & 450 Handheld Transmitters..... \$ 29.⁹⁵

- HAMLIN:** MLD-1200 \$ 99.⁹⁵

- NEW ITEMS:** Standard Components—66 Channel Wireless— with Parental Lockout \$ 99.⁹⁵

Scientific Atlanta **Call for Price**

- Power Zapper Stun Gun, 46, 000V..... \$ 59.⁹⁵

- K-40 Radar Detector—Dash Model \$199.⁹⁵

- K-40 Radar Detector—Remote..... \$229.⁹⁵

ALL UNITS GUARANTEED. QUANTITY PRICES AVAILABLE.

UNITED ELECTRONIC SUPPLY

P.O. BOX 1206 • ELGIN, ILLINOIS 60121 • 312-697-0600

NEW PRODUCTS

AUTOMATIC IC TEST SYSTEM, the model 560, is designed for testing IC's in and out of circuit. It will test over 90% of the most popular TTL and CMOS IC's.

In-circuit test applications include diagnostic tests on completed circuit boards on a production line, at a quality-control point, in a service depot, or even in a field-service operation. It can be programmed to test all IC's in sequence on a board, or to test large quantities of one IC type. Programming setup time is a minute or less for simple boards.

Tests can be conducted in ran-



CIRCLE 30 ON FREE INFORMATION CARD

dom order or in a pre-determined test sequence. A particular series of IC numbers used on a circuit board can be selected from the model 560's resident library and loaded into RAM, or programmed into EEPROM memory for perma-

nent storage. So rapid is its operation that faulty PC boards that were previously discarded—because of the cost of labor—can now be debugged in minutes by non-technical personnel.

All test results are displayed on a 20-character dot-matrix vacuum fluorescent display. Plain-English user-prompts guide every step of the operation. In addition, front-panel LED indicators display the test mode and device type.

The model 560 is priced at \$3500.00.—**B&K Precision Product Group**, 6640 W. Cortland St., Chicago, IL 60635.

DMM, the Mercer model 9370, offers autoranging and manual selection of voltage and resistance ranges. It measures up to 1000 volts DC (in 5 ranges), 750 volts AC (in 4 ranges), 10 amps AC and DC (in 2 ranges), and 2 megohms (in 5 high- and 4 low-power ranges.)

The memory mode provides up to 99 counts of zero offset. Also included is an audible continuity indication. Basic DC-voltage accuracy is 0.5%. Low and high energy fuses are provided.

The unit is housed in a 5.9" × 2.95" × 1.34" high impact case, and it weighs ¾ pound. A 9-volt battery, color-coded test leads with screw-on alligator clips, and an op-

erator's manual are also furnished. The model 9370 has a suggested list price of \$59.00.—**Mercer Elec-**

tronics, Division of Simpson Electric Company, 853 Dundee Avenue, Elgin, IL 60120.



CIRCLE 31 ON FREE INFORMATION CARD

Card Size Digital Multimeter



puts an ace in your pocket.

TESTON'S CHECKMAN MINI

fits any shirt pocket. Carry it with you at all times to test and measure AC/DC volts, ohms, and even do diode checks. **Self-contained in a vinyl case, with probes attached, this compact 3½ digit multimeter folds to approx. 4.5"H x 3"W x 0.5"D and weighs only 3 oz.** Always ready for action, the high quality CHECKMAN MINI offers built-in autoranging, easy-to-read 0.4" high LCD, continuity/diode testing, and low cost.

To order, for shipment within the USA, send check or money order for \$29.95 (CT residents add 7½% sales tax) plus \$1.50 for handling and shipping or call TOLL FREE: 1-800/221-5749. FULL ONE YEAR WARRANTY.



SIBER HEGNER NORTH AMERICA INC.

5 Landmark Square, Stamford, CT 06901

Call TOLL FREE: 1-800/221-5749

In CT: 203/967-4441 Telex: 279653 SANDH UR

CIRCLE 195 ON FREE INFORMATION CARD

Radio-Electronics mini-ADS

KEYLESS DOOR LOCK KIT, the model *GD-3830*, is a keypad-controlled latch. The 12-button keypad mounts outside the door at doorknob level, while a solenoid-operated latch replaces the conventional strike-plate. The user programs the lock to accept a four-digit sequence.



CIRCLE 32 ON FREE INFORMATION CARD

The user may change the entry code as often as desired, and he may also select an entry-code time range from a group of ranges between 2 and 20 seconds. The door will remain locked if it takes longer than the programmed time range to enter the code. The *Keyless Door Lock* can also be set to remain unlocked for as long as 45 seconds.

The model *GD-3830* operates from a power-cube transformer and has a jack for a 12-volt rechargeable battery backup in case of power failure. It is priced at \$99.55.—**Heath Company**, Benton Harbor, MI 49022.

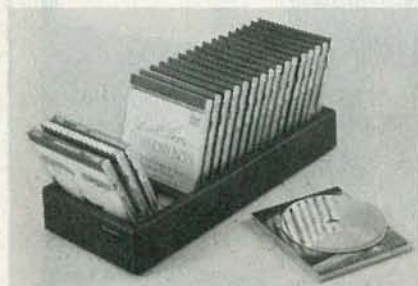

CIRCLE 33 ON FREE INFORMATION CARD

CD STORAGE SYSTEM, measures 6" wide, 15" long, and 2" deep, and can hold up to 20 compact-disc jewel boxes. The storage clip pivots forward, allowing the user to scan the titles and remove selections with ease.

The *CD Storage System* can be either wall-mounted or placed on a flat surface. Because of its light weight, it can also be carried from home to car. The retail price is \$19.95.—**Discwasher**, 4309 Transworld Road, Schiller Park, IL 60176.

continued on page 39



THE MODEL WTT-20 IS ONLY THE SIZE OF A DIME, yet transmits both sides of a telephone conversation to any FM radio with crystal clarity. Telephone line powered - never needs a battery! Up to ¼ mile range. Adjustable from 70-130 MHz. Complete kit \$29.95 + \$1.50 S+H. Free Shipping on 2 or more! COD add \$4. Call or send VISA, MC, MO. **DECO INDUSTRIES**, Box 607, Bedford Hills, NY 10507. (914) 232-3878.

CIRCLE 127 ON FREE INFORMATION CARD



THIS CHRISTMAS GIVE THE GIFT OF MTS Stereo with the Reconton V622 Entertainment Decoder. The V622 adds a new dimension to your TV viewing - cinema-like audio reproduction that was never before possible. Features include • dbx/NDR Noise Reduction • Stereo Synthesizer • MPX input \$109.75 ea. plus \$3.50 shipping (In NY add Tax.) 15 day money back guarantee. **DEL-PHONE INDUSTRIES INC.**, Box 150, Elmont, NY 11003, (718) 468-7367.

CIRCLE 56 ON FREE INFORMATION CARD



CABLE TV CONVERTERS AND DE-SCRAMBLERS. Large selection of top quality merchandise. Low prices. Quantity discounts. We ship COD. Most orders are shipped within 24 hrs. Send \$2.00 for catalog. **CABLETRONICS UNLIMITED**, P.O. Box 266 Dept. R, S. Weymouth, MA 02190 (617) 871-6500

CIRCLE 190 ON FREE INFORMATION CARD



FREE CATALOG OF HARD-TO-FIND TOOLS is packed with more than 2000 quality items. Your single source for precision tools used by electronic technicians, engineers, instrument mechanics, schools, laboratories and government agencies. Also contains Jensen's line of more than 40 tool kits. Send for your free copy today! **JENSEN TOOLS INC.**, 7815 46th St., Phoenix, AZ 85044. (602) 968-6231.

CIRCLE 115 ON FREE INFORMATION CARD



"SODDER" WITH THE NEW BUTANE POWERED PORTASOL. No matter how you spell it Portasol is the handiest soldering iron around. Seven inches long. Variable power: 10 to 60 watts. 60 minutes use per refill. Only \$29.95 + 2.00 P&H. Replacement tips: 1.2, 2.4 (standard), 3.2, 4.8mm, 7.50 + .50. Butane: 3.50 + .50. VA add 4% tax. Quantity discounts/dealers invited. Visa/MC orders: (703) 323-8000. Mail Ck/Money-order to: **PORTASOL**, 4358 Harvester Farm Lane, Fairfax, VA 22032.

CIRCLE 204 ON FREE INFORMATION CARD



A CAREER START FOR THE 21ST CENTURY. Since 1905, National Technical Schools has helped people build successful careers. Enter the 21st Century through home study courses in Robotics, Computer Technology and Servicing, Microprocessors, Video Technology, Basic Electronics, Transportation Technology, Climate Control Technology or TV and Radio Servicing. For a FREE catalog, call 1-800-B-BETTER. Or write **NTS/INDEPENDENT TRAINING GROUP**, 456 West M. L. King Jr. Blvd. L.A., CA 90037.

CIRCLE 200 ON FREE INFORMATION CARD

Radio-Electronics mini-ADS

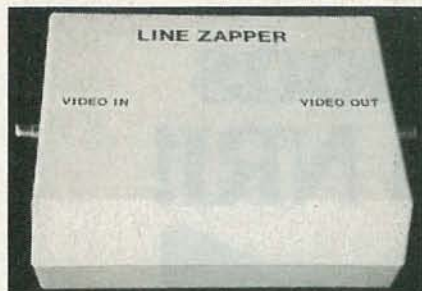

DESCRAMBLE THE NEW VIDEO TAPE COPY PROTECTION SCHEME. When you rent or buy a recent movie release, stop the vertical jumping and jittering in your TV picture with the LINE ZAPPER. This project detects and removes selected lines of video that have been modified and often interfere with normal television operation. Get your kit today only **\$49.95** plus **\$2.00** for shipping and handling. **ELEPHANT ELECTRONICS, Box 41865-L, Phoenix, AZ 85080. (602) 581-1973.** MasterCard and Visa accepted.
CIRCLE 120 ON FREE INFORMATION CARD



60 dB SIGNAL ELIMINATOR—for removal of undesirable TV/FM/VHF signals. Can be tuned precisely to ANY signal within these ranges: *Model 26 - Ch's. 2-6 plus FM (54-108 Mhz) *Model 1422 - Ch's. 14(A) - 22(1) (120-174Mhz) *Model 713 - Ch's. 7-13 (174-216 Mhz). Highly selective notch/adjustable strength. Singles **\$30**. Quantity discounts to 60%. **STAR CIRCUITS - P.O. Box 8332 - Pembroke Pines, FL. 33084**
CIRCLE 94 ON FREE INFORMATION CARD



NEW JERROLD CS 68 CHANNEL CABLE TV CONVERTER with volume control & descrambler loop (Port). Programmable clock turns TV on/off & changes channel. Audio mute kills commercials. Programmable channel scan. Instant channel recall. Automatic fine tuning with manual override. Video & audio outputs. Friendly to all descramblers. Specify output. 1 year warranty. **\$139. \$118 ea./case lot of 10.** Free delivery. Dealers wanted. **514-739-9328. CROSLEY ELECTRONICS, Box 840, Champlain, N.Y. 12919.**
CIRCLE 191 ON FREE INFORMATION CARD



NEW SATELLITE DECODER. Parts, kits, assembled units. BASIC KIT with PC board, all parts, manual—**\$69.95**. COMPLETE KIT, including RF modulator & cabinet—**\$109.95**. COMPLETE UNIT (no RF modulator, but ready to run)—**\$169.95**. COMPLETE UNIT w/ RF MODULATOR—**\$189.95**. PC BOARD & assembly manual—**\$24.95**. TWO BASIC KITS...Get the third free—**\$139.90**. **PILGRAM VIDEO PRODUCTS, P.O. Box 3325, Plymouth Center, MA 02361.**
CIRCLE 198 ON FREE INFORMATION CARD

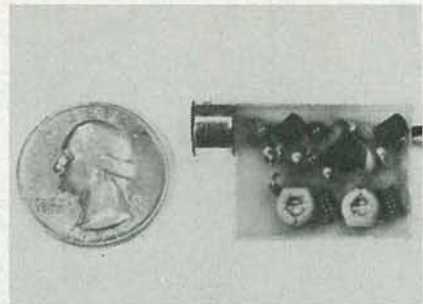

SIMPLY SNAP THE WAT-50 MINIATURE FM TRANSMITTER on top of a 9v battery and hear every sound in an entire house up to 1 mile away! Adjustable from 70-130 MHz. Use with any FM radio. Complete kit **\$29.95 + \$1.50 S + H**. Free shipping on 2 or more! COD add **\$4**. Call or send VISA, MC, MO. **DECO INDUSTRIES, Box 607, Bedford Hills, NY 10507. (914) 232-3878.**
CIRCLE 127 ON FREE INFORMATION CARD



APPLIANCE REPAIR HANDBOOKS—13 volumes by service experts; easy-to-understand diagrams, illustrations. For major appliances (air conditioners, refrigerators, washers, dryers, microwaves, etc.), elec. housewares, personal-care appliances. Basics of solid state, setting up shop, test instruments. **\$2.65 to \$5.90 each**. Free brochure. **APPLIANCE SERVICE, PO Box 789, Lombard, IL 60148. 1-(312) 932-9550.**
CIRCLE 84 ON FREE INFORMATION CARD

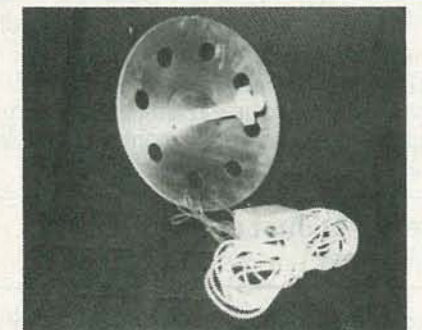

MICROWAVE ANTENNAS \$69.95. Now including shipping and Lifetime warranty. We Repair all types of Downconverters. Cable Converters and equipment available! Jerrold 400 wireless Converter **\$72.95** plus shipping. Coax cable, T.V. parts, accessories, connectors, T.V. amplifiers. Write for free catalog or call for prices. **BLUE STAR IND., Dept. 105-RE11-86, 4712 Ave. N, Brooklyn, N.Y. 11234 (718) 338-8318 Ext. 105.**
CIRCLE 85 ON FREE INFORMATION CARD

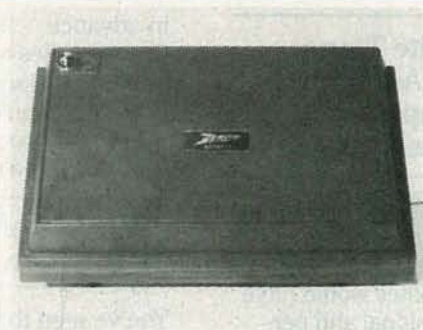

ZENITH SSAVI \$169 EACH, beat the price increase. UHF gated pulse **\$199**. Reconditioned original equipment for UHF chs. 27,48,51,60, etc. Quantity discounts. Satellite equipment. Surplus TV equipment: N-12, SB-3, Hamlin 1200, converters, amplifiers, etc. Catalog **\$1**. SSAVI modification/troubleshooting handbook **\$6.50** ppd. **AIS SATELLITE, INC., P.O. BOX 1226-E Dublin, PA, 18917. 215-249-9411.**
CIRCLE 81 ON FREE INFORMATION CARD



SAFE-LEGAL-EFFECTIVE STUN GUN VIPER II. Instantly immobilizes an attacker up to 15 minutes. Penetrates through leather and thick clothing. Discharges 50,000v from a single 9v NiCad battery. Used by police around the country. 1 Year Guarantee. 1 Viper II **\$39.95**. With NiCad battery and charger **\$49.95**. Free belt clip with every VIPER II. Catalog Free. **UNITED IMPORTS & MFG., 6846 PACIFIC ST. RE1, OMAHA, NE 68106, (402) 554-0383, TLX: 5106016153, MC, VISA, C.O.D.**
CIRCLE 202 ON FREE INFORMATION CARD

NEW!

Satellite Communications Training from NRI!



Move into commercial satellite communications and home satellite TV with NRI's latest training breakthrough!

Explore Every Aspect of Satellite Transmission and Reception As You Assemble, Install, and Train With the Complete TVRO System Included in Your Course

Back in 1964, great excitement surrounded the launching of Syncom 2, the true forerunner of today's satellites. But not even the most hopeful of scientists believed that in less than 25 years, communications satellites would have such a tremendous impact on the professional and personal lives of millions of people around the globe.

Today, thanks to the rapid development of satellite technology, a call to Paris is as clear and as easy to make as a call to your next door neighbor . . . executives from multi-national corporations and even small businesses use video conferencing to "meet" without leaving their offices . . . simultaneously a billion people witness a single event (a soccer game, an inauguration, a benefit rock concert) . . . global weather maps transmitted from satellites allow meteorologists to forecast weather trends weeks

in advance . . . and scientists now explore and investigate the mysteries of outer space without leaving their labs.

And, not surprisingly, these amazing applications of satellite technology have opened up exciting new opportunities for the technician trained to install, maintain, troubleshoot and repair satellite communications equipment.

Home Satellite TV Is Just at the Start of Its Explosive Future

You've seen them in suburban backyards and alongside country farmhouses. Home satellite TV systems are springing up all across the country.

Already there are over a million TVRO (Television Receive-Only) systems in place in the U.S. alone, and experts predict that by 1990, a remarkable 60% of U.S. homes will have a satellite dish. Contributing to the field's phenomenal growth are the support of the FCC and Congress, steady improvement in product quality, the development of smaller dishes, and a growing consumer enthusiasm for satellite TV.

New Jobs, New Careers for the Trained Technician

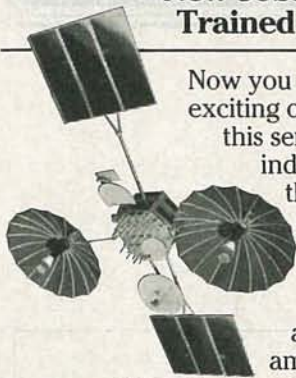

Now you can take advantage of the exciting opportunities opening up in this service- and support-intensive industry. NRI's new breakthrough training prepares you to fill the increasing need for technicians to install, adjust, and repair earth station equipment, such as dishes, antennas, receivers, and amplifiers.

As an NRI-trained technician, you can concentrate your efforts on consumer-oriented TVRO equipment. Or you can use your NRI training to build a career servicing larger commercial or military equipment used both to transmit and receive voice, data, and video signals. You'll also find opportunities in sales and system consulting, a role some expect to increase tenfold within the next five years on both the corporate and consumer levels.

NRI Brings Satellite Technology Down to Earth

Only NRI has the resources and the skills necessary to transform today's most sophisticated technology into understandable, step-by-step training.

NRI's new course in Satellite Communications gets you in on the ground floor of this booming technology. You are thoroughly trained in the necessary basic electronics, fundamental communications principles, and television transmission and operation.

Using the remarkable NRI Discovery Lab®, you demonstrate first-hand many important points covered in your lessons. You perform critical tests and measurements with your digital multimeter. And, using your NRI Antenna Applications and Design Lab, you assemble and test various types of antennas and matching sections.

Then you concentrate on both commercial and consumer satellite earth station equipment, putting theory to practice as you assemble and install the 5' parabolic dish antenna system included in your course.

Your Home Satellite TV System Brings Theory to Life!

The Wilson TVRO system included in your course comes complete with 5' parabolic dish antenna system, low-noise amplifier (LNA), down converter, receiver, low-loss coaxial cable, and even a permanent polar mount.

By training with an actual TVRO system, you'll come to understand the function and operation of a satellite earth station—knowledge that you can apply to both consumer and commercial equipment. And once you have completed your TVRO system, you'll have access to the best television entertainment available—direct from the satellite to your home.

At-Home Training the Uniquely Successful NRI Way

It's hands-on training, at home... designed around the latest state-of-the-art electronic equipment you work with as part of your training. You start from scratch and "discover by doing" all the way up to the level of a fully qualified professional. You conduct key experiments... perform vital tests... install your own system... and you do it at the pace that suits you best.

But, most important to your success, you don't do it alone. Built into your NRI training is the enormous experience of our development specialists and instructors, whose long-proven training skills and personal guidance come to you on a one-to-one basis. They are always available for consultation and help.

Make Your Move Into the Future Today! Send for Your FREE NRI Catalog

Only NRI can train you at home for an exciting and rewarding career as a satellite communications technician. The knowledge and know-how you gain from your NRI training provide you with the soundest possible foundation for further growth with the industry. But now is the time to act. Return the post-paid card to us today. You will receive your 100-page catalog free. It's filled with all the details you'll want to know about our training methods and materials and our more than 70 years of successful

innovation in at-home, hands-on career training—the kind of experience that enables NRI to provide the most effective training possible to prepare you for today's, and tomorrow's, high-tech opportunities. (If the card is missing, write to us at the address below.)



NRI SCHOOL OF ELECTRONICS

McGraw-Hill Continuing Education Center
3939 Wisconsin Avenue, NW
Washington, DC 20016

We'll give you tomorrow.



NEW IDEAS

Light-seeking robot

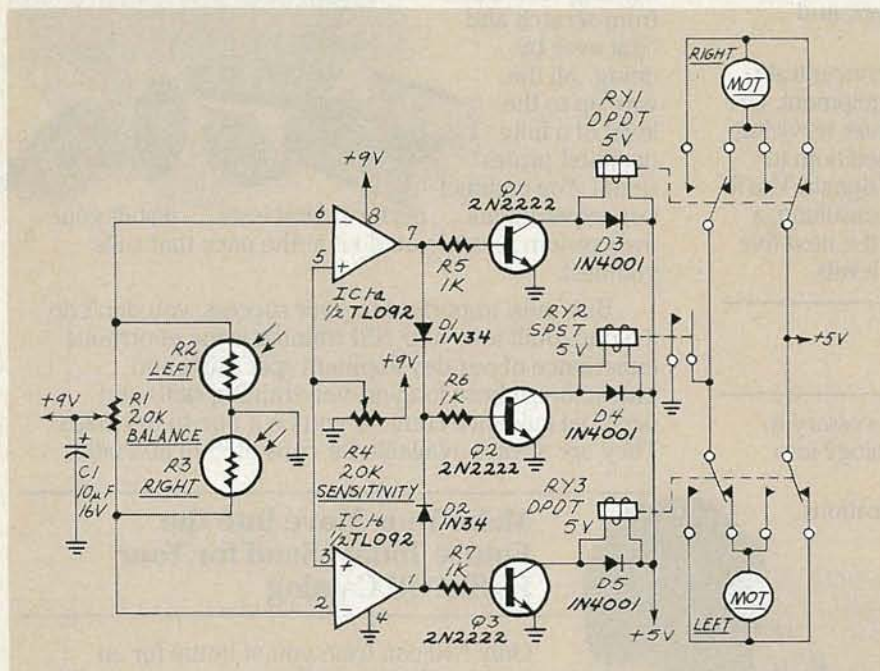

FIG. 1

HERE'S A SIMPLE CIRCUIT FOR DEMONSTRATING some basic principles of robotics. The circuit is light seeking; with careful adjustment it will follow a flashlight around a darkened room. The heart of the circuit is a pair of photocells that determine the direction in which the robot will move. Depending on how light falls on the cells, the robot can be made to move forward, left, or right. Motion is provided by two independent DC motors; a swivel-wheel maintains balance.

How it works

In the circuit shown in Fig. 1, each photocell is connected to an op-amp configured as a comparator. When sufficient light falls on photocell R2, the voltage at the inverting input (pin 6) of IC1-a will fall below the voltage at the non-inverting input (pin 5), so the output of the comparator will go high, and transistors Q1 and Q2 will turn

on. That will enable relays RY1 and RY2, and thereby provide power for the right motor. The robot will then turn left.

Likewise, when light falling on R3 lowers its resistance, Q2 and Q3 will turn on, the left motor will energize, and the robot will turn right.

Notice that diodes D1 and D2 provide an OR function: Q2 turns on when either comparator goes high (or when both do). When Q2 turns on, it energizes relay RY2, which provides a path to ground for either motor coil, or both. When there is not enough light falling on the photocells, neither comparator will go high, so RY2 will be off. That is what prevents the robot from moving when neither photocell is lit.

Also note that the photocells and motors are cross-wired—the left photocell controls the right motor, and the right photocell controls the left motor.

NEW IDEAS

This column is devoted to new ideas, circuits, device applications, construction techniques, helpful hints, etc.

All published entries, upon publication, will earn \$25. In addition, for U.S. residents only, Panavise will donate their *model 333*—The Rapid Assembly Circuit Board Holder, having a retail price of \$39.95. It features an eight-position rotating adjustment, indexing at 45-degree increments, and six positive lock positions in the vertical plane, giving you a full ten-inch height adjustment for comfortable working.

I agree to the above terms, and grant **Radio-Electronics** Magazine the right to publish my idea and to subsequently republish my idea in collections or compilations of reprints of similar articles. I declare that the attached idea is my own original material and that its publication does not violate any other copyright. I also declare that this material has not been previously published.

Title of Idea

Signature

Print Name

Date

Street

City

State

Zip

Mail your idea along with this coupon to: **New Ideas Radio-Electronics, 500-B Bi-County Boulevard Farmingdale, NY 11735**

Construction

Building this circuit requires more mechanical than electronic skills. In addition to a circuit board, you'll have to provide a platform for the motors, the swivel wheel, and the batteries. You could generate the five-volt motor/relay supply from a six-volt battery or gel-cell in series with a power diode. Make sure to use a diode that can handle about four times the maximum current drain of a single motor. To provide noise immunity, the comparators should

be powered from a separate low-current nine-volt supply.

The photocells should be mounted on the front of the platform, several inches apart, with a light barrier between them. You'll have to experiment to find the exact dimensions for your application, but try mounting the photocells two inches apart, and make the light barrier about four inches long. Also, it's a good idea to coat the barrier and whatever the photocells are mounted on with flat black paint.

After wiring the circuit, check it over and correct any errors. Then turn off the lights and adjust R4 so that the robot doesn't move when only ambient light is falling on the photocells. Next adjust R1 so that the photocells are equally responsive to your signal light. Last, try leading the robot around the room. —J. A. Tavares

NEW PRODUCTS

continued from page 32

PROTOTYPING STATION, the model *PB 503 PROTO-BOARD*, has a large, three-socket breadboarding area and support features including a function generator, a variable power supply, and eight LED logic indicators.



CIRCLE 34 ON FREE INFORMATION CARD

Also built in are such frequently used circuit components as de-bounced pushbuttons, eight-position DIP switch, SPDT switch, 1K and 10K potentiometers, a speaker, and two BNC connectors. Everything is connected to the breadboarding area through a PC board, and access is quick and simple.

The model *PB-503 PROTO-BOARD* has a suggested retail price of \$275.00.—**Global Specialties**, 70 Fulton Terrace, P. O. Box 1942, New Haven, CT 06509.

CASSETTE DEMAGNETIZER, the model *SK308*, is powered by a 1.5-volt mercury disc dry cell. The unit's electronic circuit generates a large electronic field at the tape head, then slowly breaks the field down. As the field decays, it dissipates the tape-head magnetism in less than one-third of a second.



CIRCLE 35 ON FREE INFORMATION CARD

The battery has an average life of 500 hours, and is readily replaceable. A recessed LED in the cassette informs the user whether the cell requires replacement.

The model *SK308* is priced at under \$20.00.—**Signet**, 4701 Hudson Drive, Stow, OH 44224.

TUBES and IC's FAST DELIVERY LOWEST PRICES call Toll Free (800) 221-5802

In-depth Inventory - Industrial & Receiving Tubes

3-500Z	\$85.00	8122	\$135.00
572B	75.00	813	45.00
811A	15.00	MRF450	12.95
6146B	8.75	MRF454	18.95
M2057	15.00	MRF455	14.95
8950	12.50	MRF492	19.95
4CX250B	75.00	6LF6	8.26
6883B	9.50	6JS6C	7.46
SG613	10.50	6CA7	6.91

CHEMTRONICS CHEMICALS

TUN-O-WASH 24oz.	\$3.89
TUN-O-POWER	3.39
TUNER RENU 6oz.	1.25
FREEZE IT 22oz.	3.39

Major Manufacturers Factory Boxed and Full line of
Sylvania ECG Replacement Semiconductors



Minimum order \$25.00 Allow \$3 UPS charge

TRANSLETRONIC INC.

Box R, 1365 39th Street, Brooklyn, NY 11218
Tel. 718-633-2800/Watts Line 800-221-5802
FAX # (718) 633-4375

CIRCLE 193 ON FREE INFORMATION CARD

Capacitance, logic and more. For less.

Now, a fully-loaded DMM combines a capacitance meter, logic probe, and an hFE meter, all for the price of a DMM.

TTL Logic Probe: 20 MHz

Hi/lo/off indications

Detects 25nS pulse width

Capacitance: 5 ranges (2nF to 20μF)

hFE (NPN or PNP): 1 range (1000)

DMM: DCV-5 ranges (.2V to 1kV)

ACV-5 ranges (.2V to 750V)

DCA-4 ranges (200μA to 10A)

ACA-3 ranges (20mA to 10A)

Ohms-7 ranges (200 Ohms

to 2000 Megohms)

Continuity beeper

Diode check

Built-in bail

Anti-skid pads

See one now at your local Beckman Industrial distributor.

DM25L... \$89⁹⁵*



*Suggested list price (\$US) with battery, test leads and manual.

Beckman Industrial™

Beckman Industrial Corporation
A Subsidiary of Emerson Electric Company
630 Puente Street, Brea, CA 92621
(714) 671-4800

© Copyright 1985 Beckman Industrial Corporation

CIRCLE 98 ON FREE INFORMATION CARD

ELENCO PRODUCTS AT DISCOUNT PRICES!



20 MHz DUAL TRACE OSCILLOSCOPE

\$369 MO-1251

FREE
DIGITAL
METER
WITH
SCOPE
PURCHASE

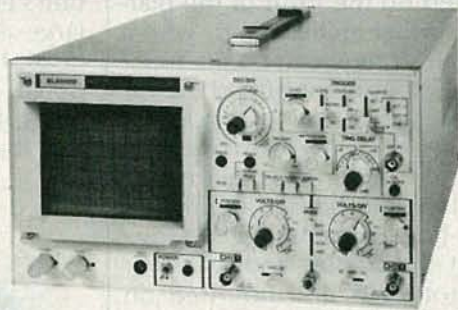

35 MHz DUAL TRACE OSCILLOSCOPE

\$545 MO-1252

Top quality scopes at a very reasonable price. Contains all the desirable features. Elenco's 2 year guarantee assures you of continuous service. Two 1x, 10x probes, diagrams and manual included. Write for specifications.



MULTI METER with
CAPACITANCE and
transistor tester

\$65 Model
CM-1500

Reads Volts, Ohms,
Current, Capacitors
Transistors & Diodes



TRUE RMS 4 1/2
DIGIT MULTIMETER

\$135 Model
M-7000

.05% DC Accuracy
.1 % Resistance
with Freq. Counter
& Deluxe Case



AUTO RANGING
plus
MANUAL RANGING
3 1/2 DIGIT METER
28 FUNCTIONS
FULLY PROTECTED

M-1180 .7% ACY \$36.95
M-1182 .25% ACY \$39.95
M-1181 .1% ACY \$42.95



GF-8016 Function Generator
with Freq. Counter

\$219

- Sine, Square, Triangle,
- Pulse, Ramp, .2 to 2 MHz
- Frequency .1 thru 10 MHz

GF 8015 without Freq. Meter \$169

10 MHz OSCILLOSCOPE

\$190

S-3000



10 MHz DC or AC
Triggered Sweep
Calibrated Vert & Hor
Reads Volts & Freq

BREADBOARD

Shown
9434



9430 1,100 pins \$15
9434 2,170 pins \$25
9436 2,860 pins \$35

Triple Power Supply XP-660



\$149.50

0-20V @ 1A
0-20V @ 1A
5V @ 5A

Fully Regulated, Short Circuit Protected with 2
Limit Cont. 3 Separate Supplies.

50 MHz LOGIC PROBE

\$23



LP-700

20 nec with memory

LOGIC PULSER

\$25



LP-600

2 us pulse @ 1A

3 Amp Power Supply XP-650

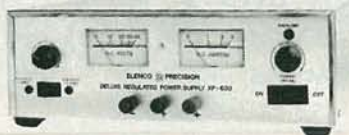

\$119.50

0-40V @ 1.5A
0-20V @ 3A

Fully regulated, short circuit protected current
limit control



DIGITAL LCR METER

Model LC-1800
Measures: Inductors
Capacitors, Resistors

\$148

Inductors .1μH to 200 H
Capacitor .1Pf to 200μf
Resistor .01Ω to 20M Ω
Ranges 6 Ind, 7 cap, 7 res

C&S SALES, 8744 W. North Ter. Niles, IL 60648
800-292-7711 (312) 459-9040



15 DAY MONEY
BACK GUARANTEE ASK FOR CATALOG

2 Year Limited Guarantee! Add 5% for Postage (\$10 max.), IL Res., 7% Tax

CIRCLE 109 ON FREE INFORMATION CARD

BUILD THIS



Closed-Caption Decoder

J. DANIEL GIFFORD

Closed-captioning—what's it all about? Find out here, and build a high-performance, low-cost closed-caption decoder, too.

MORE AND MORE GOOD PROGRAMS ARE appearing on TV lately, especially on the cable channels. And more and more good films are coming out on videotape. But until recently not everyone could fully enjoy those programs—especially people with a hearing disability. Since 1979, however, many TV shows have been broadcast and many videotapes have been released that use *closed captioning*—a method whereby hearing-impaired persons can read dialog and narration on the screen in real time—while the actor or announcer is speaking!

All it takes is our inexpensive adapter to allow a hearing-impaired person to enjoy all the benefits of modern programming. Because most of the circuitry comes on a pre-built module, the decoder can be built easily in an evening or two for under \$150.

To use the decoder, feed the audio and video outputs of a VCR, a component-TV tuner, or a satellite receiver to the adapter, and connect its outputs to the corresponding inputs of your receiving device. If your receiver has no audio and video inputs, you can add an RF modulator to provide input directly to your receiver's antenna terminals.

How it works

Closed captioning is the term for the written subtitles that are encoded in a television program or on a videotape. An often-asked question is why the captions are "closed," or normally invisible, instead of "open" and visible all the time. The answer is that, although captions are a boon to the hearing-impaired viewer, they can annoy and distract other viewers.

Normally the subtitles are not visible on the screen, but when a video signal carrying closed-caption data is passed through a decoder, that data can be extracted from the signal and converted into visible captions that can be placed just about anywhere on the screen. The captions usually appear at the bottom of the picture and provide, in a readable (and slightly edited) form, both dialogue and narration.

To avoid blocking on-screen action, or to better identify who is speaking when more than one person is visible, the captions can be placed on the screen strategically. Significant sounds that are not apparent from the on-screen action (such as off-camera screams, door slams, and gunshots) can also be captioned, and usually are placed in brackets: [gunshot], [shouts], etc.

There are numerous closed-captioned programs on TV these days. For example, almost half of the network movies, most of the regular prime-time series, and many news and educational programs are currently closed-captioned. The three networks (most notably ABC) and the PBS system carry more than a hundred hours of captioned programming a week. Many pay-TV services also carry captioned programs (some 30 hours a week), including HBO/Cinemax and Showtime/The Movie Channel.

In addition to broadcast programming, hundreds of popular video-taped movies have also been captioned. The total number of titles that are available at press time should exceed 600; approximately 25 titles are added every month. Cap-

tioned movies are identified by a closed-caption symbol on the package.

Closed-captioning provides more than just captions. There are nationwide full-page text services that summarize news, sports scores, special information for the hearing impaired, and even provide a complete list of currently broadcast closed-captioned programs.

As you might suspect, all that information cannot be packed into a single captioning channel. In fact, there are two captioning channels and two text channels, all of which operate simultaneously. Caption channel 1 (C1) is used for regular caption information. Caption channel 2 (C2) is largely unused at the present, but will most likely find use in "alternate-text" captioning. For example, second-language captioning, simplified text for children, and verbatim captions (which may move too fast for some viewers to read) are all possible uses for C2.

Both Text channel 1 (T1) and Text channel 2 (T2) are in wide use, however. On ABC, T2 is used more or less continuously to transmit the *Program Listing Update Service (PLUS)*, which is a rolling list of all current broadcast and pay-TV programs that are captioned, including movies.

T1 is used simultaneously to carry other text services such as The News Summary, which is broadcast Monday through Friday during the program "Nightline;" Weekend Scoreboard (a list of current sports scores and rankings), broadcast Saturdays between 8 and 11 PM and Sundays between 7 and 11 PM (Eastern times); and the *Hearing Impaired News*



INSTANT CAPTIONING can now be added to live programming.

Text Service (HINTS), a list of news and information of concern to the deaf and hearing impaired, broadcast Mondays and Thursdays between 8 and 9 PM. PLUS and the other services also can be found on some PBS stations.

Both the existence and the widespread use of the closed-caption system in the US are the result of an almost single-handed effort by the National Captioning Institute (5203 Leesburg Pike, Falls Church, VA 22041), a non-profit corporation whose sole purpose is to develop and further closed captioning. From its beginnings in 1979, NCI has moved closed captioning from the status of a novelty to that of a viable communications medium for a sizable portion of the population. NCI is responsible for all phases of captioning, from fundraising, to research and development of new equipment and techniques, to the actual production of captions for programs.

Making captions

Program captions are produced by a rather lengthy process in which the program to be captioned is viewed, trial captions are added, the result is reviewed and edited, and so on until a finished set of captions that accurately follows both dialogue and action has been produced. It takes about 30 hours of work to produce captions for a one-hour program, at a cost of about \$2,500.

For broadcast programs, the caption data is encoded on a floppy disk and sent to the broadcast center, where it is added to the video signal for transmission with the program. The caption data is added to videotapes during duplication.

Although most captioning is done in advance for pre-recorded programs, a recent development (by NCI) allows instant

captioning. In that type of captioning, which is used mostly for news programs and live speeches, a caption programmer listens to the program and enters the words spoken into a computer, using a keyboard similar to that of a court reporter's. A sophisticated computer program identifies the word groups, and converts them to caption form. The captions thus produced roll upwards on the bottom three lines of the screen at a rate more or less equal to the speed with which they are spoken. Although the captions lag slightly behind the spoken words (due to the time required for entry and translation), they appear very quickly and are, for all practical purposes, instantaneous.

The line-21 system

The text channels and closed captions are variations of a teletext system known as the Line-21 System, so called because data is transmitted on video line 21. A number of experimental teletext systems using the Line-21 format have come and gone in the US, most notably the original INFOTEXT service in Wisconsin. However, most teletext systems use either the WST (World System Teletext) or NABTS (North American Broadcast Tele-

text System) formats, because they offer better graphics and more flexibility than the Line-21 System. For more information on teletext, see the April 1986 issue of **Radio-Electronics**.

However, the Line-21 system, as unsophisticated as it may be, is by far the sturdiest and least expensive system available, and those facts make it ideal for closed-caption use. We call the system "sturdy" because a video signal can be received and decoded under less-than-ideal reception conditions. By contrast, the NABTS system requires a very good signal for operation, and the WST system cannot operate when there is more than slight noise and signal degradation. The Line-21 system, on the other hand, can operate with even an unwatchably noisy or snowy TV signal.

Video encoding

A diagram of the signal that encodes the data is shown in Fig. 1. The data is transmitted on video line 21, which is the last line of the normally-invisible vertical-blanking interval, and it is the line immediately preceding the video image.

To synchronize the decoder's data clock, a seven-cycle burst of a 503-kHz

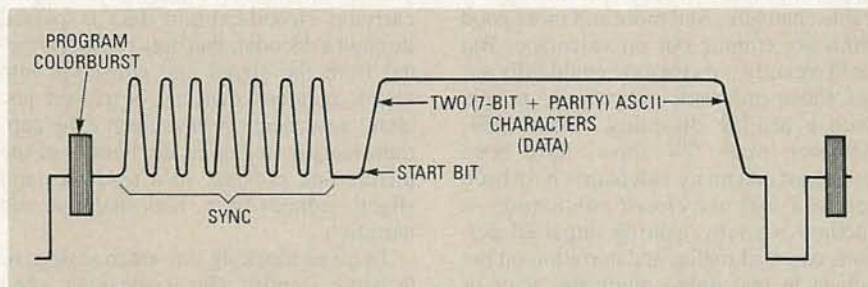

FIG. 1—THE 21ST LINE of each frame of a TV picture contains 17 bits of information. One is a start bit, and two are parity bits. The remaining 14 bits comprise two seven-bit characters of ASCII-like data.

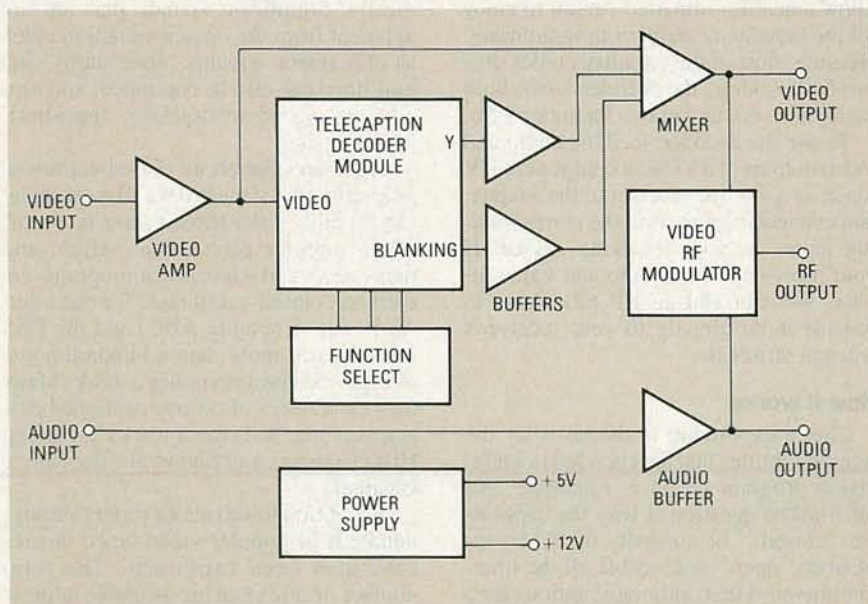

FIG. 2—AFTER BUFFERING, the video signal passes through the decoder module, which extracts the caption data. That data is recombined with the video signal and delivered for output.

signal is transmitted first. That is followed by a start bit and then two seven-bit bytes of data, each of which has an eighth (parity) bit for error detection. That makes a total of 17 bits per frame. So, at 30 frames per second, the overall data rate is 510 bits per second. Although that may seem slow, (particularly when compared with WST's 5.7-megabaud rate), it is fast enough to carry the limited data needed for captions. In addition, it is the slow speed of the Line-21 system that gives it its sturdiness.

Most of the symbols, upper-case, and lower-case letters conform to the standard seven-bit ASCII format. However, there are some 55 special character and control codes in the Line-21 system. Among them are codes that direct the following data to one of the four display channels, codes to position the captions vertically, and codes to position the captions horizontally.

Among the special symbols is a musical note, which is used to indicate the presence of music. The symbol may be present at the beginning, the end, or both of a caption to indicate that the caption is being sung. (And yes, program these songs and the like are captioned!)

Although captions are currently composed of white characters on a black background, the Line-21 system can provide different background colors, which could be used, for example, to differentiate between speakers on the screen, or simply to provide a more attractive display—which could be particularly effective in the text mode.

The decoder

A decoder is required at the viewer's end of things to extract the caption or text data from line 21, convert it into displayable characters and backgrounds, and insert those characters into the video signal at the appropriate time.

As you may have guessed, NCI has developed a decoder. The current model, the *Telecaption II*, is priced at \$200, is available from Sears and JC Penney's, and incorporates a cable-ready tuner and an IR remote controller. But if you'd like to save some cash and have the satisfaction of building your own—read on!

Circuit description

Since our decoder does not have a built-in tuner, it requires connection to the video and audio outputs of a VCR or other device with audio and video outputs. The decoder in turn has both direct outputs for connection to a VCR or monitor, and an optional RF modulator output that can deliver a signal to either Channel three or Channel four through your TV's antenna-input terminals. A block diagram of the decoder is shown in Fig. 2.

The heart of the device is NCI's Telecaption Decoder Module. The module detects and extracts the caption data, and then converts it for video output. The

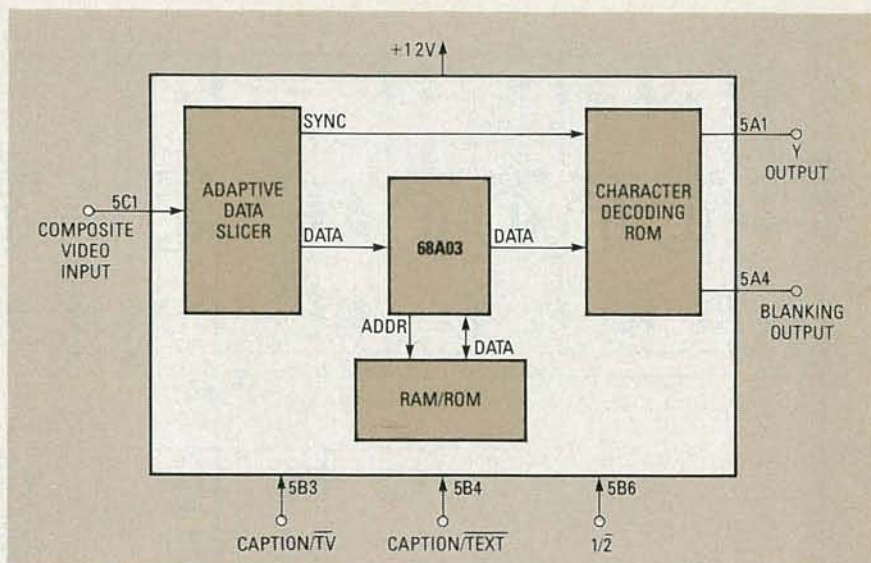

FIG. 3—THE TELECAPTION DECODER MODULE contains a microprocessor, RAM, ROM, and a number of other components that allow it to extract caption and text data from a video signal.

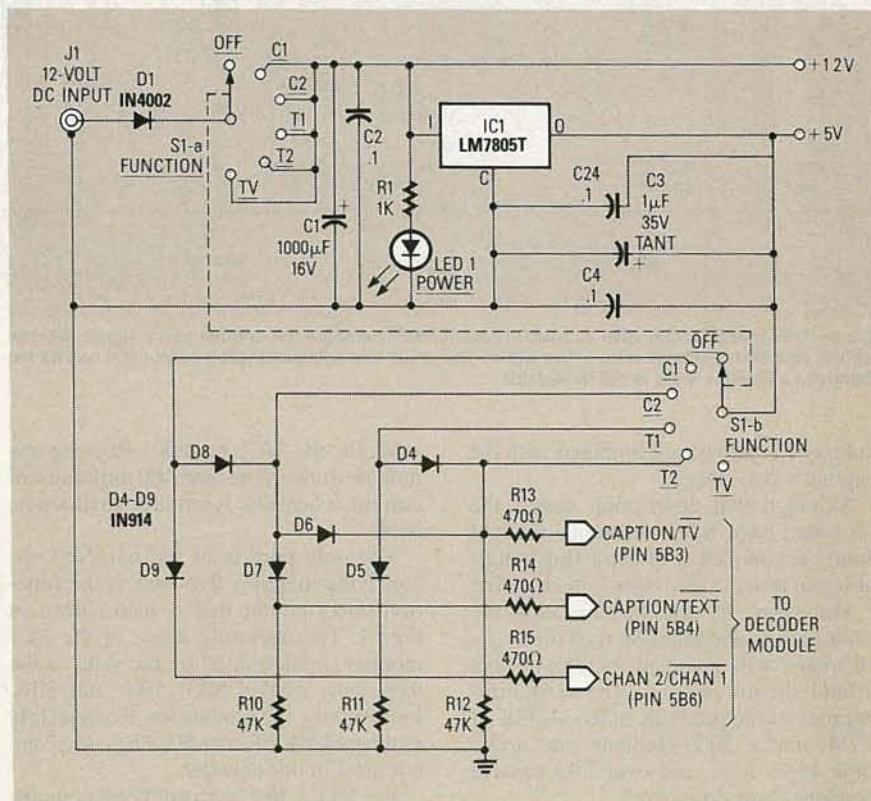

FIG. 4—THE FIVE-VOLT POWER SOURCE supplies power to the NCI decoder module and to the mode-select circuit. The video-mixer circuit in Fig. 5 runs from the unregulated 12-volt supply.

module is so complete that the only external circuitry required are a power supply, audio and video amplifiers, and the (optional) RF modulator. The module has only six external connections, and it has no internal adjustments or settings. A simplified block diagram of the module is shown in Fig. 3.

The most important portion of the circuitry is the input section, which is called an adaptive data slicer. That circuit locates and locks onto the video data, ex-

tracts it, and sends it to the module's controller in digital form. It is termed an adaptive circuit because it can adapt to varying signal, frequency, and noise conditions to extract the data.

Next the data flows to a 68A03 microprocessor where it is processed by a program stored in ROM. If the data is valid, look-up tables in ROM are used to determine the meaning of the data—i. e., whether it is displayable characters or control codes. Then captions are formed

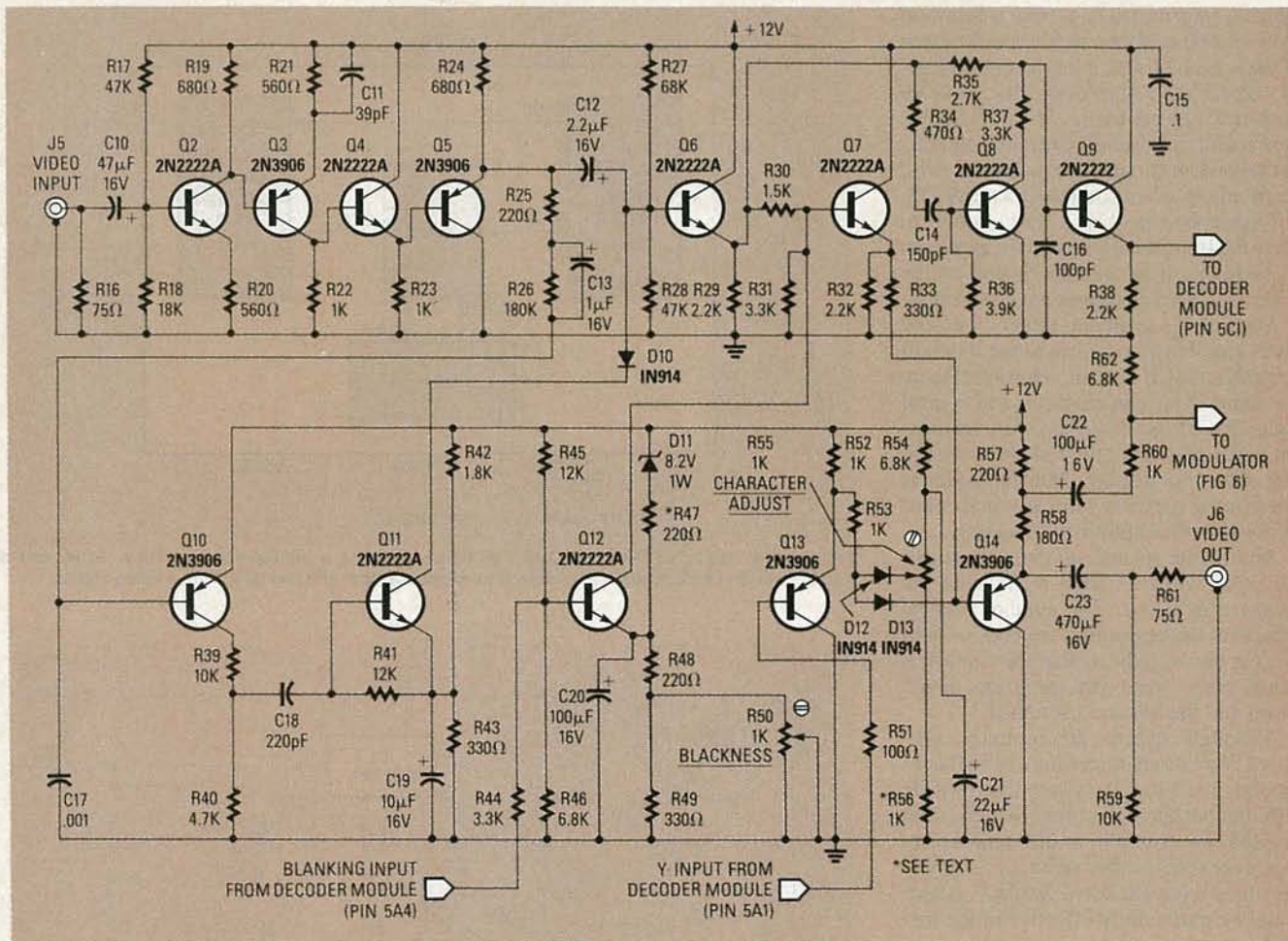

FIG. 5—THE VIDEO MIXER AND BLANKING AMPLIFIER combine the original video signal with the caption data that is extracted from that signal. The result is a baseband video output that can be fed directly to a monitor, VCR, or RF modulator.

and passed on to be re-combined with the original video image.

Although that description makes the job sound easy, a few moments' thought about the complexity of extracting a digital signal from a video signal, interpreting it, converting it, and then inserting the result in sync and in phase with the original image will give you an idea of how difficult the job really is. The 68A03 microprocessor requires 2K of RAM, 12K of ROM, and a 2000-element gate array, some logic IC's, and over 200 passive components to do its job!

Although the module does most of the work, additional circuitry is required to combine text data with the video signal, to provide power, and to select the desired function. Let's look at that circuitry now, starting with power supply and switching circuits, which are shown in Fig. 4.

The decoder is powered by a 12-volt, 500-milliamp wall transformer. Power is routed from jack J1 to FUNCTION switch S1-a via diode D1, which protects the decoder from an accidentally reversed power input. Capacitors C1 and C2 filter the 12-volt input, and LED1 lights up when power is on. IC1 provides a regulated five

volts for the NCI module. Because the module draws more than 400 milliamps of current, a heatsink is required to dissipate heat.

The only portion of the non-NCI circuitry that requires five volts is the function-select circuit that is also shown in Fig. 4. The operating mode of the NCI module is determined by the state of the three pins labeled 5B3, 5B4, and 5B6. Incidentally, the module has 6 connectors numbered 5A-5F, and 5D, 5E, and 5F are not used in our decoder.

Pin 5B3 is the CAPTION/TV select input. When that pin is low, the module's decoding functions are inhibited and the video signal is displayed without captions or text. The inputs at the other two pins are also ignored. When that pin is brought high (to +5 volts), the module is placed in decoding mode.

Pin 5B4 is the CAPTION/TEXT select input. When that pin is low, the decoder will seek one of the two text channels; when that input is high, the decoder will seek one of the two caption channels.

Pin 5B6 is the CHAN1/CHAN2 select input. It allows you choose between Text Channel 1 and 2, or Caption Channel 1

and 2, depending on the state of pin 5B4. When 5B6 is low, T2 or C2 will be selected. When 5B6 is high, T1 or C1 will be selected. Switch S1-b, in conjunction with resistors R10-R15 and the array of diodes (D4-D9), allows you choose between OFF, C1, C2, T1, T2, or TV.

We have also designed an all-electronic function-select circuit which we'll present next time. That circuit uses several additional IC's, and it provides a more elegant way of choosing which mode the decoder operates in.

Video circuit

Figure 5 shows the bulk of the non-NCI circuit. That circuit has two main functions. First, it provides the module with a clean, buffered composite-video signal from which the caption data can be extracted. Second, it combines the Blanking and Y (character) outputs from the module with the original video signal, thus providing a composite signal composed of both captions and images.

The composite-video signal from J5 is fed to the video buffer composed of transistors Q2-Q5. That signal is then routed via R25, R26, and C13 to a sync separator

PARTS LIST

All resistors are 1/4-watt, 5% unless otherwise noted.

R1, R22, R23, R52, R53, R56, R60—1000 ohms
 R2—15,000 ohms
 R3—270,000 ohms
 R4—100,000 ohms
 R5—22,000 ohms
 R6—390 ohms
 R7, R40—4700 ohms
 R8, R58—180 ohms
 R9, R20, R21—560 ohms
 R10—R12, R17, R28—47,000 ohms
 R13—R15, R34—470 ohms
 R16, R61—75 ohms
 R18—18,000 ohms
 R19, R24—680 ohms
 R25, R47, R48, R57—220 ohms
 R26—180,000 ohms
 R27—68,000 ohms
 R29, R32, R38—2200 ohms
 R30—1500 ohms
 R31, R37, R44—3300 ohms
 R33, R43, R49—330 ohms
 R35—2700 ohms
 R36—3900 ohms
 R39, R59—10,000 ohms
 R41, R45—12,000 ohms
 R42—1800 ohms
 R46, R54, R62—6800 ohms
 R50, R55—1000 ohms, PC-mount, trimmer potentiometer
 R51—100 ohms

Capacitors

C1—1000 μ F, 16 volts, electrolytic
 C2, C4, C6, C15, C24—0.1 μ F, ceramic disk
 C3—1 μ F, 35 volts, tantalum
 C5, C13—1 μ F, 16 volts, electrolytic
 C7, C8, C19—10 μ F, 16 volts, electrolytic
 C9, C21—22 μ F, 16 volts, electrolytic
 C10—47 μ F, 16 volts, electrolytic
 C11—39 pF, ceramic disk

C12—2.2 μ F, 16 volts, electrolytic
 C14—150 pF, ceramic disk
 C16—100 pF, ceramic disk
 C17—0.001 μ F, ceramic disk
 C18—220 pF, ceramic disk
 C20, C22—100 μ F, 16 volts, electrolytic
 C23—470 μ F, 16 volts, electrolytic

Semiconductors

IC1—LM7805T, 5-volt regulator
 D1—1N4001, rectifier
 D2—not used
 D3—1N4735 6.2-volt, 1-watt Zener diode
 D4—10, D12, D13—1N914 switching diode
 D11—1N4738 8.2-volt, 1-watt Zener diode
 LED1—standard red
 Q1, Q2, Q4, Q6—Q9, Q11, Q12—2N2222A NPN
 Q3, Q5, Q10, Q13, Q14—2N3906 PNP

Other components

J1—1/8-inch miniature phone jack
 J2—J6—RCA phono jack
 S1—2P6T miniature rotary switch
 S2—SPST miniature slide switch
Miscellaneous: Astec UM1285-8 video modulator, NCI Telecaption Decoder Module, PC board, 12-volt 500-ma wall-mount transformer, case, panels, wire, solder, etc.

Note: A kit (no. K-6314) including PC board, case, and all parts except RF modulator and power transformer is available for \$139 plus \$7.55 shipping and handling from Dick Smith Electronics, Inc., P. O. Box 8021, Redwood City, CA 94063. The modulator (no. K-6040) is available for \$9.95 and the power transformer (no. M-9526) is available for \$6.95. Allow shipping of \$1.50 plus 5% of order. California residents must add 6.5% sales tax. Orders outside the U. S. must include U. S. funds and add 20% of total for shipping.

sistor Q9; it is the latter which drives the video input (pin 5C1) of the NCI decoder module.

Between Q6 and Q9 is a noise-cancellation circuit composed of Q8 and the components around Q8. That circuit helps remove impulse noise from the video signal and therefore reduces the module's error rate.

The blanking signal provides the black background for the captions and text. It is produced at pin 5A4 of the module. That signal is buffered and amplified by Q12. The output of Q12 is coupled, along with the original video signal, to the base of blanking buffer Q7. The combined signals are then applied to the base of the video output buffer, Q14.

The blanking "blackness" level is set by components D11 and R47-R49. The level, which is stabilized by C20, can be adjusted by means of rear-panel trimmer potentiometer R50.

The Y (character) output comes through pin 5A1 of the module. It is then buffered and amplified by Q13. The output of Q13 is added to the video and blanking signals at the base of transistor Q14.

Diode D13 prevents any Y level below the blanking level from reaching the output and perhaps disturbing the picture sync.

Diode D12 and resistors R54-R56 are used to clip the upper portion of the Y signal and limit the brightness of the characters. The clipping level is set by R55, another rear-panel trimmer.

Output transistor Q14 combines the original video image with the blanked-out boxes and the white captions. That transistor delivers a signal to video output jack J6 and it drives the video input of the RF modulator.

The final portion of the decoder's circuitry is shown in Fig. 6. Since the audio signal plays no part in the caption decoding process, it is merely buffered by Q1 and routed to audio output jack J4 and the audio input of the RF modulator. The latter delivers a standard video signal on either Channel three or Channel four; a switch is provided that allows you to choose the desired channel.

The RF modulator requires a six-volt supply, which is derived from the 12-volt rail by R8 and D3, and which is smoothed and stabilized by C9.

That completes the circuit description of our closed-caption decoder for the hearing impaired. Unfortunately, we have run out of room for this month. When we continue next time we will present complete instructions for building the unit. We will also present the details for the electronic function-select circuit we mentioned earlier. Finally, we'll show how to hook up and use the unit. In the meantime, you may want to get a head start by gathering the required parts. **R-E**

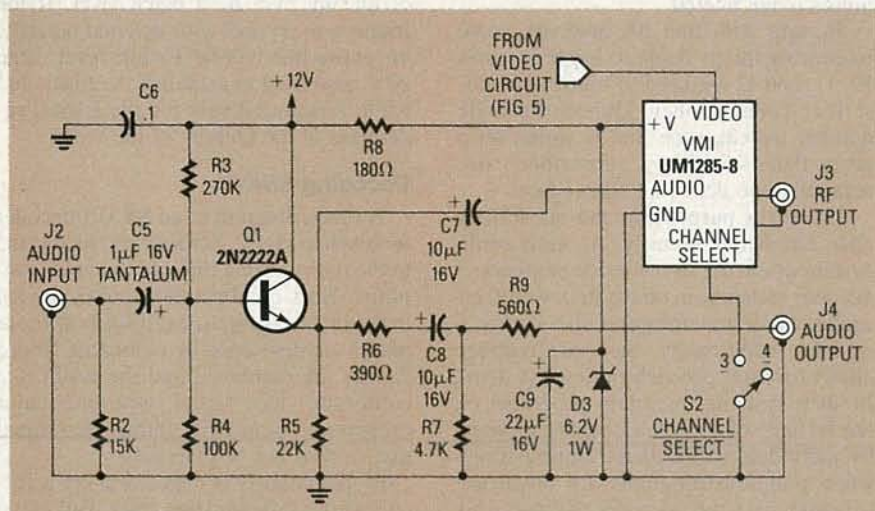

FIG. 6—THE AUDIO BUFFER is a simple emitter follower. Like the video signal, the audio signal can be fed directly to a monitor, a VCR, or the optional RF modulator.

and DC clamp composed of transistors Q10 and Q11. The output of that circuit is then coupled, along with the original sig-

nal, to the base of buffer transistor Q6. The output of Q6 drives both blanking transistor Q7 and the output buffer tran-

TV SIGNAL DESCRAMBLING

A look at one of the more sophisticated analog scrambling systems.

RUDOLF GRAF and WILLIAM SHEETS

Part 5 MOST OF THE SYSTEMS that we've looked at so far share a common problem. That problem is security. As we've seen, although the systems appear formidable at first glance, the circuitry required for descrambling is not very sophisticated, especially because most of it is built around commonly available IC's. As a result, it is a relatively simple task to assemble an unauthorized descrambler. Further, "black-market" units are readily available from several sources.

To many programming distributors that is an intolerable situation. In response, sophisticated scrambling techniques that use dynamic scrambling algorithms and/or digital techniques have been developed.

One such system is the Scrambled Sync And Video Inversion (SSAVI) system. SSAVI has four modes of operation. Those are: suppressed sync and inverted video, suppressed sync and normal video, normal sync and inverted video, and normal sync and normal video (not scrambled). We touched on that system briefly in the September issue. This month, we'll look at SSAVI in detail.

The SSAVI system

In the SSAVI system lines 27 to 260 are scrambled. All of the other lines of a 262-line field are sent normally. That means that the vertical-blanking interval is not scrambled. But that doesn't mean that there's nothing of interest there. In fact, the vertical-blanking interval, or rather the information that is placed on the video waveform during that period, is the key to descrambling the signal.

The vertical-blanking interval of an SSAVI-encoded video waveform is shown in Fig. 1. The first nine lines of that interval are normal. That is, the sequence of six horizontal-equalizing pulses, fol-

Over the next few months, **Radio-Electronics** will be presenting a series of articles describing the techniques used by pay-TV and cable companies to scramble their signals. While specific circuits for specific scrambling systems will be discussed, they are presented for *informational and experimental purposes only*. Therefore, parts lists, parts suppliers, and additional technical support *will not be available* for those circuits.

The authors are currently preparing a book with a working title of *Descrambling and Scrambling TV and Video Signals, with Projects* (Catalog number 22499) to be published by Tab Books (Blue Ridge Summit, PA 17214). It will cover many of the scrambling systems discussed in this series.

lowed by six vertical-sync pulses, followed by six more horizontal-equalizing pulses is not altered.

Starting with line 10, however, some interesting things begin to happen. Lines 10, 11, and 12 are used to transmit a subscriber code number. Unless the code number matches one that is stored on a prom that is within a subscriber's descrambler, no decoding takes place.

The main purpose of the subscriber code number is security. As each cable system would use its own code numbers, a decoder stolen from one system would be useless for descrambling another system's signals. Additionally, the code number allows for a pay-per-view or tiered system. In such systems, premium programs or levels (tiers) of programs could be ordered by individual subscribers. During times when premium programs are broadcast (or cablecast), the decoders of those who have not ordered the programs are shut off via the code. Another advantage that pay programmers like is that the code gives the programmer a way to remotely disconnect the service of those that have fallen behind in their payments.

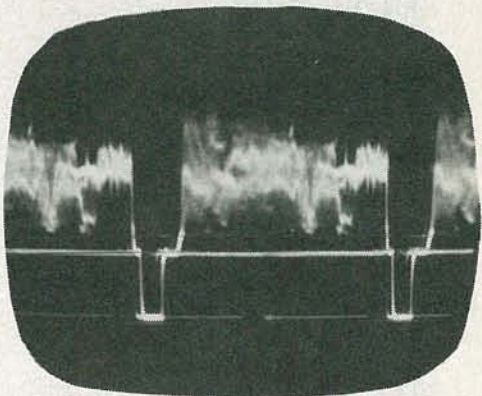
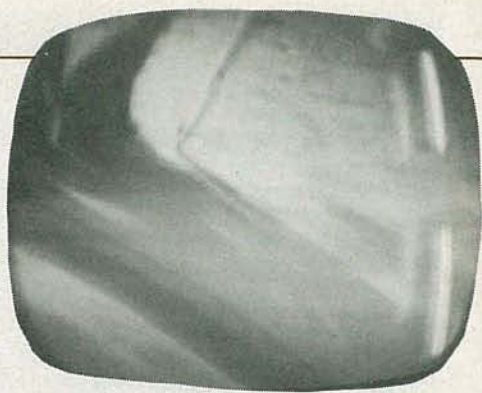

We will not discuss the subscriber code any further as it is not needed to descramble a signal. An SSAVI decoder can be operated without the subscriber-code security feature simply by bypassing it.

The other important line is line 20. It is used by the decoder to determine whether or not a frame will have its video polarity inverted. If the frame is to be sent with normal polarity, the first half of the line will be a white level, while the second half of the line will be a black level. If the frame is to be sent with inverted polarity, the entire line will be a white level. Line 20 is also used to establish the black and white reference-levels for the frame, regardless of the polarity of the video.

Decoding SSAVI

A block diagram of an SSAVI decoder is shown in Fig. 2. Scrambled video is fed to the noninverting input of the video amplifier. Horizontal blanking pulses are fed to the inverting input; we'll see how those pulses are developed in a moment. Those signals are combined and the result is a composite video signal, with one major exception: The polarity of the video signal may or may not be inverted.

Proper polarity is restored using a video-inverter stage and two gates. Part of the output of the video amplifier is sent to a video inverter stage and part bypasses it. If the transmitted video has the proper polarity, no further processing is needed and the bypass signal is fed to the output. Otherwise, the gates are switched in such

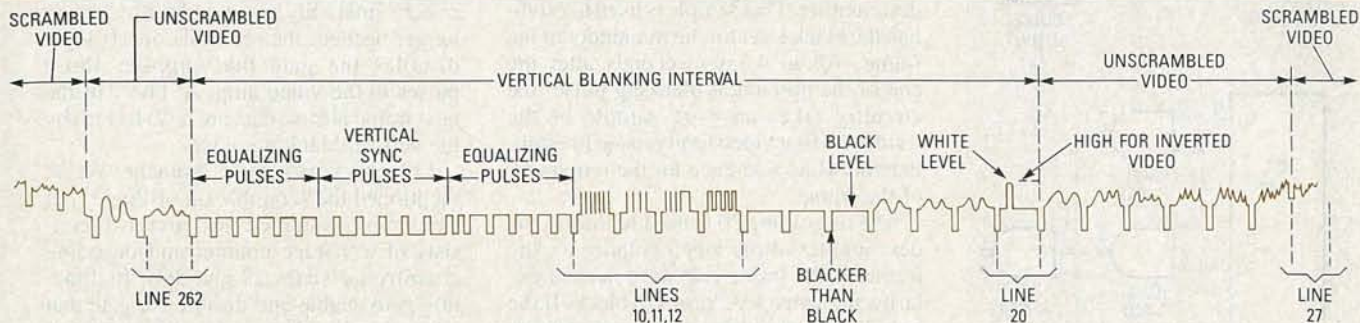

FIG. 1—THE VERTICAL BLANKING INTERVAL of an SSAVI-encoded signal. Line 20 is used by the decoder to establish the black and white reference levels for the frame, and to determine the polarity of the transmitted video.

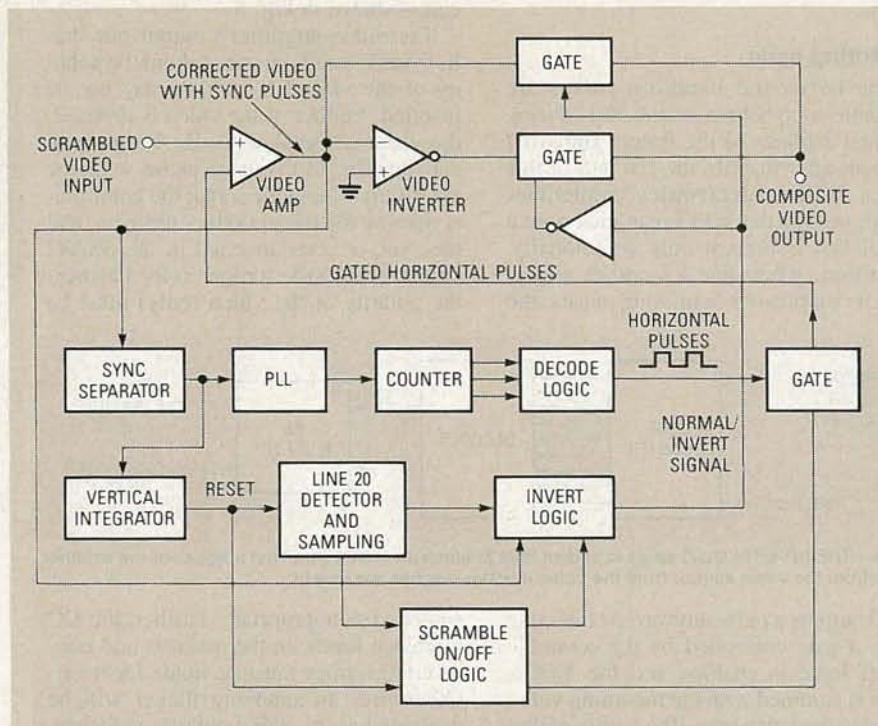

FIG. 2—IN THE SSAVI SYSTEM, four different scrambling modes are used. Here, a block diagram of an SSAVI descrambler is shown.

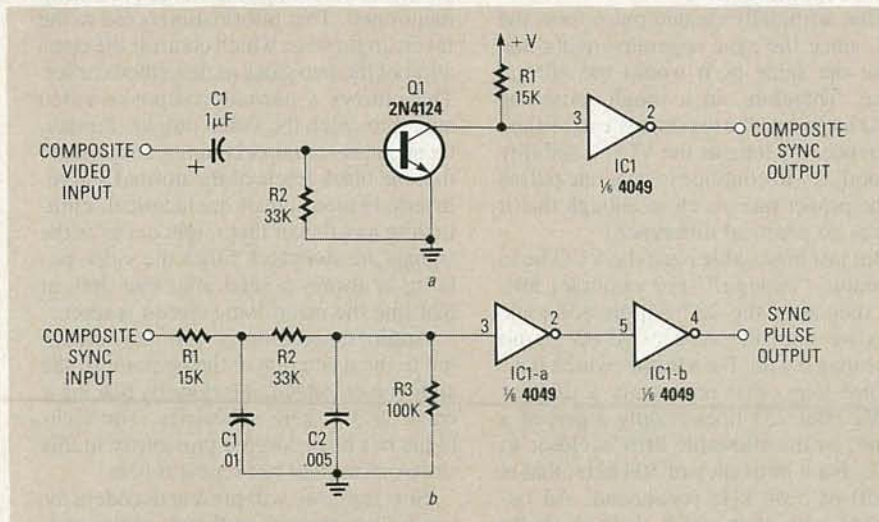

FIG. 3—PART OF THE VIDEO AMPLIFIER'S OUTPUT is picked off and fed to a sync separator, which is similar to the ones found in standard TV sets. The output of the separator is used to recover the video sync via a vertical integrator. Typical versions of those two circuits are shown here. The vertical integrator is shown in a; the sync separator is shown in b.

a manner that the output signal consists of the re-inverted video from the inverter stage and the sync pulses from the signal that bypasses the inverter. Operation of the gates is controlled by the invert logic.

Also, part of the video amp's output is picked off and fed to a sync separator. That circuit is identical to the one found in any standard TV receiver. The output of the separator is a composite sync signal. Part of that signal is used to recover the video sync via a vertical integrator. Typical versions of those circuits are shown in Fig. 3. The integrator in Fig. 3-a, the separator is shown in Fig. 3-b.

The rest of the composite sync signal is used as a reference for a Phase Locked Loop (PLL). That PLL is set up to provide a 504-kHz (nominal) signal that is phase locked to the horizontal signal. (Remember that the horizontal frequency is 15.75 kHz, which is $\frac{1}{32}$ of 504 kHz.) We'll look at how that's done in a moment, but first let's see how the 504-kHz signal is used to derive the horizontal blanking pulses.

A 504-kHz signal has a period of 1.98 μ s. If that signal is used to clock a $\div 32$ counter, by using 5 consecutive count states a 9.92- μ s pulse can be formed. That is very close to the nominal 10- μ s period of a normal blanking pulse. Therefore, all that's needed to derive the blanking pulses is a counter as described, along with a handful of gates to decode the counter's output. That circuit can take many forms, but one simple design is shown in Fig. 4. Note that only the first 5 stages of the 12-stage ($\div 4096$) 4040 counter are used. If you wish, the $\div 32$ counter could also be implemented using a $\div 2$ and a $\div 16$ counter or by cascading 5 flip-flops.

Getting back to the PLL, a $\div 32$ counter is also needed there if the circuit is to output a 504-kHz signal as required. One of the characteristics of a PLL is that if a $\div n$ counter is placed between the VCO (Voltage Controlled Oscillator) or the phase comparator, the output is equal to $n \times$ the input frequency. Therefore, with a $\div 32$ counter and a 15.7-kHz input, the output is 504 kHz.

The PLL could of course be built using

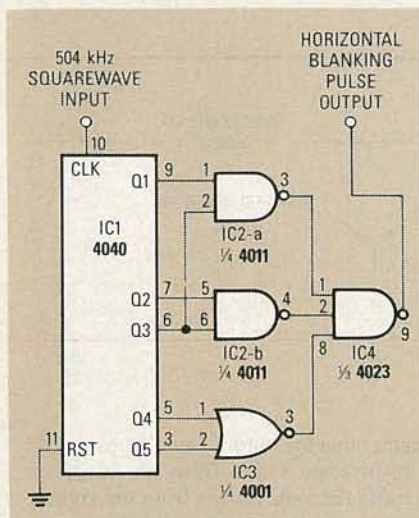

FIG. 4—THE FIRST FIVE COUNTS of a divide-by-32 counter can be used to recreate a horizontal blanking pulse.

a phase comparator IC, such as a MC4044P, and a VCO, but it is easier to use one of the PLL IC's currently on the market, such as the NE565 or the CD4046B. Figure 5 shows a PLL circuit built around the 4046. The output of the

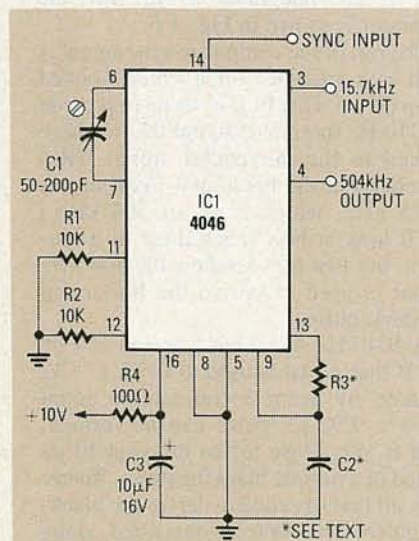

FIG. 5—A 4046-BASED PLL. A divide-by-32 counter should be inserted between pins 3 and 4. The output of the circuit is taken from pin 4.

sync separator is applied to pin 14 of the PLL. A 50–200-pF trimmer, C1, is used to adjust the VCO's center frequency. The ÷32 counter is inserted between pins 3 and 4. The output of the PLL stage is also taken from pin 4. Under locked-loop conditions, the output from the ÷32 counter, which should be set up to output on the zero count, should be in phase with the sync signal. The values of the components in the loop filter, R3 and C2, should be chosen for proper loop stability and lock-up time.

As mentioned previously, line 20 is critical in the SSAVI system. About 7 μ s after the leading edge of the line-20 hori-

zontal-blanking pulse, a 2- μ s sample of that pulse's back porch is taken by the descrambler. That sample is used to establish the black level for the remainder of the frame. About 4 microseconds after the end of the horizontal-blanking pulse, the circuitry takes an 8- μ s sample of the "video." That video level is used to establish the white reference for the remainder of the frame.

The rest of line 20 is used to inform the descrambler of the video polarity for the frame. If the frame is to have normal polarity, the video level drops to black. If the polarity is to be inverted, the level remains white. The video level is sampled and used to control the operation of the invert logic.

Restoring sync

The horizontal blanking pulses are available to synchronize the PLL during the first 26 lines of the frame. But what happens after that? In the last part of this series (*Radio-Electronics*, September 1986), we saw that a PLL can lock onto a signal that is present only occasionally. Therefore, when line 27 comes along, with its suppressed or missing pulses, the

At line 260, the incoming video once again has normal sync. Since the decoder's internally generated pulses are no longer needed, the scramble on-off logic disables the gate that supplies those pulses to the video amp. At line 7 of the next frame all counters are reset to zero by the vertical blanking pulse.

Let's backtrack for a moment. We've mentioned the scramble on-off logic, but we haven't examined that circuit. It consists of a 9-stage counter and decoding circuitry for states 27 and 260. Its function is to enable and disable the gate that feeds the decoder's internally generated sync pulses to the video amp. A block diagram of a typical scramble on-off circuit is shown in Fig. 6.

The video amplifier's output now has its sync restored, but what about the polarity of the video? It may or may not be inverted. Further, if the video is inverted, the chroma signal will also be inverted and thus be 180° out of phase with the color burst. Remember that the color burst rides on the back porch of the sync, and the sync is never inverted in the SSAVI system. To restore proper color balance, the polarity of the video (only) must be

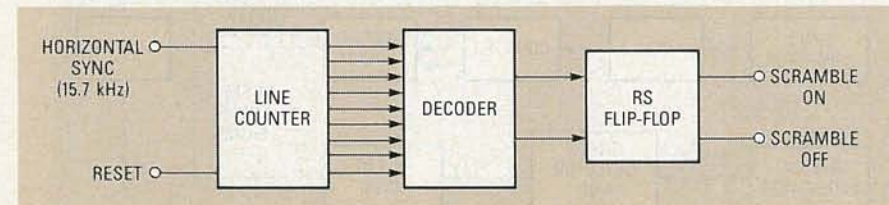

FIG. 6—THE INVERT-LOGIC stage is shown here in block diagram form. That stage controls whether video from the video amp or from the video inverter reaches the output.

VCO outputs a pulse anyway. At the same time, a gate controlled by the scramble on-off logic is enabled and the VCO's pulse is summed with the incoming video signal in the video amp. The output of that amp is a video signal with an artificially created blanking pulse.

That artificially created pulse fools the PLL since the sync separator treats that pulse the same as it would the normal pulse. Therefore, in a rough sense the VCO locks into the previously established reference. As long as the VCO's stability is good, it will continue to generate pulses at the proper rate (or close enough that it makes no practical difference).

But just how stable must the VCO be to be stable "enough?" For example, let's say that after the 233 suppressed-sync lines we want the sync to be off by no more than 0.1 μ s. For a frame, which is 1/60 second long, that represents a drift of 0.16%. But 233 lines is only a part of a frame, so the allowable drift is closer to 0.1%. For a frequency of 504 kHz, that is a drift of 5.04 kHz-per-second. An oscillator with that much drift is pretty lousy. Therefore the lack of a reference signal for about 15 milliseconds should present no problem for a PLL.

switched as appropriate. Further, the DC reference levels on the inverted and non-inverted frames must be made identical. Otherwise, an annoying flicker will be generated as the video polarity switches.

The polarity of the frame's video is detected by sampling line 20 as previously mentioned. That information is fed to the invert-logic stage which controls the operation of the two gates as described earlier. That allows a normal composite-video signal to reach the video output. Further, those gates contain clamping circuitry so that the black levels of the normal and re-inverted video signals are identical, eliminating any flicker that might occur as the signals are switched. Since the video polarity is always normal after line 260, at that line the invert logic circuit is reset.

Audio scrambling is optional, and is left to the discretion of the operator. If the audio is scrambled, it is done by placing it on a 39.335 kHz subcarrier. The technique has been covered previously in this series so we will not repeat it here.

Next time, we will present decoders for use with sinewave, outband, and gated-pulse scrambling systems. Complete construction details, including PC diagrams, will be provided. **R-E**

LATCHING CONTINUITY TESTER

ELDON L. KNIGHT

A CONTINUITY TESTER IS A MUST on every service bench for testing cables, PC boards, switches, plugs, jacks, motors, relays, and many other kinds of components. But there are times when a simple continuity test doesn't tell the whole story. For example, vibration-induced problems in automobile wiring can be extremely difficult to detect because a short or open is not maintained long enough for a non-latching continuity tester to respond.

Our latching continuity tester detects intermittent (and steady state) opens and shorts. The tester will detect and latch on an intermittent condition with a duration of less than one microsecond. In addition, it provides both visual and (defeatable) audio indicators, uses only one inexpensive and easy-to-find IC, and can be built from all new parts for about \$25, or less if you have a well-stocked junkbox.

Circuit elements

The heart of the circuit is a 4093 quad two-input NAND Schmitt trigger, one gate of which is shown in Fig. 1-a. The gate functions as shown in Fig. 1-b. Nothing happens until the ENABLE input goes high. When that happens, the output responds to the input as follows.

As long as the input voltage stays between V_H and V_L , the output stays high. But when the input goes above V_H , the output goes low. The output will not go high again until the input goes below V_L . That characteristic is what gives the Schmitt trigger its ability to "square up" a slowly changing input signal. The Schmitt trigger is ideally suited for our application because it is not dependent on edge triggering, and because both slow and fast signals trigger it when either threshold is exceeded.

We use two gates of the 4093 as a combination detector and latch. The gates are cross connected to form an SR (Set-Reset) flip-flop. When pin 12 goes low, pin 11 will go high. That high may be used to enable an LED or other indicator. Switch S1 is used to select whether the tester will provide output when it detects an open or a short. In the OPEN position, pin 12 is held low, so the output of the gate is normally high. When the test leads are connected across a short, pin 12 is pulled high, so the output drops low. The circuit works in the con-

verse manner when S1 is in the CLOSED position.

As shown in Fig. 2-a, we use another Schmitt trigger to build a gated astable oscillator. A gated astable oscillator produces output as long as the GATE input is high. Figure 2-b shows the waveforms that are present at various points in the circuit. When the pin-8 input goes high, pin 10 goes low, and C1 starts discharging through R1. When V_C falls below V_L , the output of the gate goes high, so C1 starts charging through R1. When V_C exceeds V_H , the output again drops low. Oscillation continues in that way as long as the gate input remains high. The frequency of oscillation is given by a fairly complex equation that can be simplified, for purposes of approximation, as $f = 1 / R1C1$.

Putting it all together

The complete circuit is shown in Fig. 3. In that circuit, IC1-a and IC1-b function as the flip-flop/detector. The output of IC1-a is routed through S4, AUDIO. When that switch is closed, IC1-d is enabled, and an audio tone will be output by BZ1. The frequency of that tone can vary from 1000 Hz to well above the audio range (100 kHz), according to the setting of R4. In addition, R4 varies frequency and volume simultaneously, so you can set it for the combination that pleases you best.

Originally we used a PM (Permanent Magnet) speaker for output, but we switched to a piezoelectric buzzer because the buzzer consumes about one tenth the power of a speaker. When the detector has not been tripped, the full power-supply voltage is across the buzzer, but no current is drawn. The reason is that the piezo element is like a capacitor and does not conduct DC current. When the circuit is oscillating, the buzzer consumes a current of only about 1/2 milliamp.

The output of the flip-flop/detector circuit also drives IC1-c. If S2 is in the AUTO position, the output of IC1-c will automatically reset the flip-flop after a period of two to six seconds, depending on the position of R7. If S2 is in the MANUAL position, the LED will remain lit (and the buzzer will continue buzzing, if S4 is on) until manual RESET switch S3 is pressed.

Construction

The circuit may be built on a small piece of perforated con-



Our latching continuity tester can help you locate those difficult-to-find intermittent shorts and opens that other testers always seem to miss.

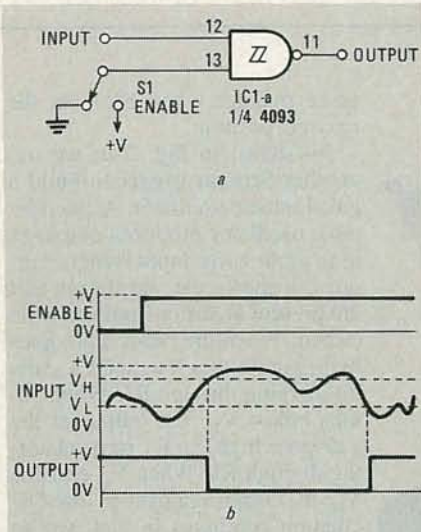

FIG. 1—A SCHMITT TRIGGER (a) is insensitive to input signals between V_H and V_L (b). The output changes state only when the enable input is high.

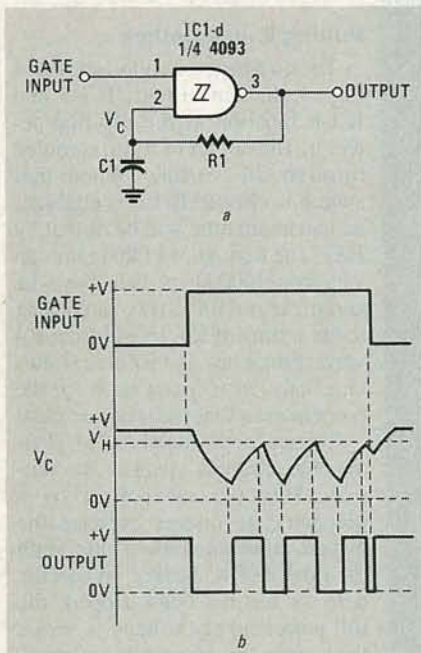

FIG. 2—AN ASTABLE OSCILLATOR (a) may be built from a single gate, a resistor and a capacitor. The circuit oscillates at a frequency of about $1/R1C1$ whenever the gate input is high (b).

struction board or on a PC board. Foil patterns for the latter are included in PC Service; also, an etched, drilled, and plated PC board is available from the source mentioned in the Parts List. The PC board is designed to use board-mounted switches, which makes a neat package and eliminates a rat's nest.

Referring to Fig. 4, mount and solder the components in this order: diodes, fixed resistors, IC socket, capacitors, variable resistors, and last the PC-mounted switches. Mount the buzzer and LED last as described below. Trimmer potentiometer R7 is manufactured by

PARTS LIST

All resistors are 1/4-watt, 5% unless otherwise noted.

R1—10,000 ohms

R2, R3—470,000 ohms

R4—100,000 ohms, trimmer potentiometer (Radio Shack 271-338, Piher PT10YV 100K, or Mouser ME321-1100-100K)

R5—not used

R6—1800 ohms

R7—1 megohm trimmer potentiometer (Piher PT-15WD-1 Meg with #2 shaft, or Digi-Key Q1A16, Screwdriver adjust)

R8—10 megohms

Capacitors

C1—0.1 μ F ceramic disk

C2, C4—0.01 μ F ceramic disk

C3—4.7 μ F, 16 volts, electrolytic

Semiconductors

IC1—4093B quad NAND Schmitt trigger

D1, D2—1N914 or 1N4148 switching diode

LED1—standard red

Other components

BZ1—piezo buzzer (Digi-Key 9924 or Radio Shack 273-069)

S1—DPDT, miniature toggle, PC-mount

S2, S4, S5—SPDT, miniature toggle, PC-mount

S3—SPST, momentary pushbutton, normally open

Miscellaneous: Plastic case (4.75 × 2.5 × 1.4 inches), 14 pin IC socket, battery clip, battery snap, banana jacks (optional), test leads (optional), wire, solder, etc.

Note: The following parts are available from Alltech Associates, Dept. LCT, 1441 W. Colonial Parkway, Roseville, CA 95678: PC board, \$5.95 plus \$0.55 shipping and handling; complete kit less test leads and battery, \$24.95 plus \$2.40 S & H; complete assembled and tested unit with battery and test leads, \$39.95 plus \$2.40 S & H. California residents add 6% sales tax.

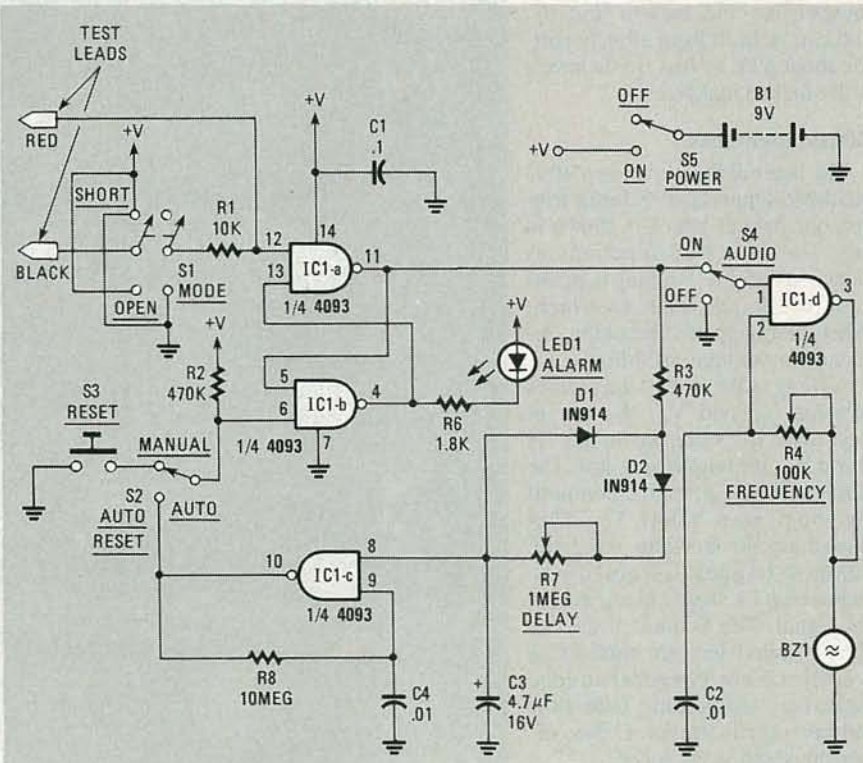

FIG. 3—THE COMPLETE CIRCUIT of the continuity tester is shown here. Three of the gates function as shown in Fig. 2 and Fig. 3; the last, IC1-c, provides an automatic reset that is enabled by switch S2.

Piher (903 Feehanville Drive, Mount Prospect, IL 60056); it has a shaft that extends through the panel. If the Piher pot is unavailable, an alternate is available from Digi-Key (701 Brooks Ave. South, P. O. Box 677, Thief River Falls, MN 56701). The disadvantage of the alternate is that it has no shaft, so it must be adjusted using a miniature screwdriver.

The circuit board is held approximately 1/2-inch from the cover by the shafts of the switches. The LED and the buzzer should be inserted in the appropriate holes in the

PC board now. Then install the top cover, and adjust the height of the LED so that it protrudes through the top cover. Then solder its leads. Attach the buzzer to the top cover, using silicone rubber adhesive (RTV) or double sided foam tape.

We mounted a pair of banana jacks on the top of our prototype's case, but you could solder wires directly to the appropriate points on the circuit board, tie strain reliefs in the wires, and then solder alligator clips to the ends of the wires. The

continued on page 84

Part 2 PRIOR TO JANUARY 1, 1984, IF YOU WISHED to install a telephone, add an extension, or otherwise modify or update your telephone setup, all work had to be performed by the telephone company, for a fee. Since that date, which marked the break up of AT&T, you could still have that work performed by your local telephone company, but for a rather substantial fee; or you could do the work yourself. The catch to the second alternative is that you need to know what you are doing. In this article we are going to present a primer on basic telephone installation and maintenance. The information that it contains will allow you to perform many of the most common tasks yourself.

Telephone-system basics

For many years now, all new telephone installations have been made using a modular system. The advantage of the modular system is that it allows for quick, easy, and sure connection of various types of equipment to the telephone system. But prior to that, all connections between telephone equipment and the system were of a permanent nature (hard-wired). Since the connections in your home or office easily could be either modular or hardwired, let's examine both types.

Starting with the older system, the point where the telephone line en-

This month we show you how to install and troubleshoot your telephone equipment.



Inside The TELEPHONE

RUDOLF GRAF and CALVIN GRAF

ters your premises is called the connection point. At that point is a device called a lightning protector. Connected to a cold-water pipe or copper rod driven into the ground, that device provides lightning protection for the equipment.

From the connection point the wiring is brought into the house and terminated at a connecting block. The most common type of connecting block is called a 42A block, as shown in Fig. 12. The telephone is wired directly to the block as shown in Fig. 13. Note that the wires from the telephone are color-coded, allowing for

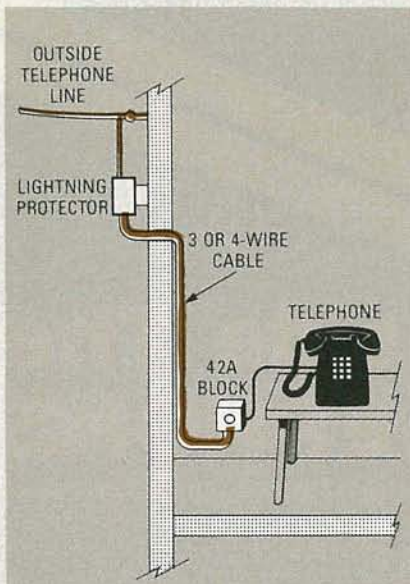

FIG. 12—IN OLDER TELEPHONE SYSTEMS, the telephone was permanently connected to a 42A block.

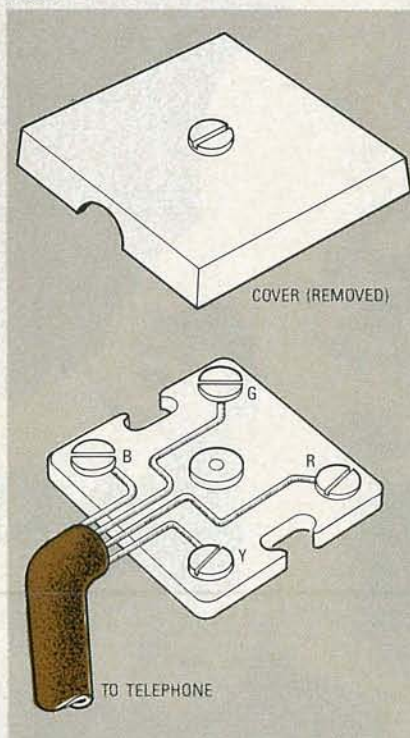

FIG. 13—INSIDE THE 42A BLOCK. Note that color coding was used to make the installation job easier, but only for the telephone company!

TABLE 4—

Symptom	Possible Causes	Corrective Action
No dial tone	Telephone not plugged in Handset not plugged in Defective wall cord Defective handset cord Defective receiver Defective cradle switch	Check wall jack Check set jack receptacle Check handset receptacle Replace phone-to-wall cord Replace handset-to-base cord Replace receiver (earpiece) in handset Check for stuck hook-switch plunger with phone up Jiggle hook rapidly
Dial tone does not stop when dialing	Insufficient current from central office when off hook System busy Tip and ring conductors reversed	Check current supplied by central office (it should be greater than 21 mA). Wait few minutes; try again Reverse tip and ring conductors at wall jack or network interface
No DTMF tones	Defective dial pulse contacts Dial pulsing off speed Insufficient current Defective DTMF dial electronics Tip and ring conductors reversed Defective polarity guard	Replace dial mechanism Replace dial mechanism Check current supplied by central office Replace DTMF dial electronics Reverse tip and ring conductors at wall jack or network interface Replace polarity guard, if possible, or replace telephone set
Receiver "clicks" when dialing Bell "dings" or taps when rotary dialing	Defective dial Tip and ring conductors reversed; defective multi-party ringer	Replace dial mechanism Reverse tip and ring conductors at wall or network interface. Check for improperly connected ringer, wrong frequency ringer, incorrect ringer spring bias, or replace ringer.
Rotary dialing produces wrong numbers	Dial pulsing off speed	Replace dial mechanism

quick, accurate connections. However, that only made things easier for the telephone-company installer; customers were forbidden to install or even relocate their equipment on their own. That meant that once a location for a telephone was chosen, it could not be changed without involving the telephone company.

To satisfy customers who demanded more flexibility, the telephone company developed a jack and plug system that allowed customers to relocate their telephones to a limited extent. If the customer wished, the telephone company would install a number of four-prong jacks (see Fig. 14) throughout the premises. Those jacks were wired in parallel so that all had equal access to the telephone line. The customer's phone cord was terminated in a matching four-prong plug.

The modular system

As you know, the modular system allows for even greater customer flexibility. However it also offers some benefits for the telephone company. It has greatly sim-



FIG. 14—THIS FOUR-CONNECTOR JACK allowed the user to connect and disconnect a telephone with a suitable plug at will.

plified most common installation and repair tasks. It also has helped to clearly define where the telephone system ends and where your house wiring and equipment begins. Prior to the breakup of AT&T that definition was not important, because the telephone company was responsible for servicing the wiring and equipment on your premises. Now,

TELEPHONE TROUBLESHOOTING GUIDE

Symptom	Possible Causes	Corrective Action
Telephone will not ring but has audible dial tone when off-hook	Insufficient current	Check current supplied by central office
	Volume control off	Check volume control
	Defective multiparty ringer	Check for improperly connected ringer, wrong frequency ringer, incorrect ringer spring bias, or replace ringer. Also, check for good ground from telephone to earth. Check for bent clapper. Check each ringer coil for continuity. Check for loose connections, or replace ringer.
Telephone rings on wrong line (multiparty line only)	Defective ring capacitor	Replace ringer capacitor
	Defective speech network	Replace speech network
	Defective cradle switch	Check for contacts not closing when handset is in cradle; adjust contacts or replace switch
Telephone rings but ringer volume is low	Defective multiparty ringer	Check for improperly connected ringer, wrong frequency ringer, incorrect ringer spring bias, or wrong value ringer capacitor. Exchange phone set for one with correct REN
	Volume control off	Check volume control
	Clapper obstructed	Check clapper and remove any obstruction
Telephone rings, you can hear caller but caller cannot hear you	Too many extensions on your line	Check REN of all devices on line; in total must not exceed 5
	Defective transmitter	Replace transmitter

however, you are responsible for that servicing. That leaves you with two alternatives: You can hire someone else to do the servicing, such as the telephone company or an independent contractor, or you can do the servicing yourself.

So where does the telephone company's responsibility end? Since 1982 the telephone company has been including a *network interface* as part of its standard wiring installation. Located near the point where the wiring enters your premises, its function is to isolate the telephone system from the premises wiring and to serve as the demarcation point between the two.

Older telephone installations do not have a network interface. For those, the demarcation point is the lightning protector. The telephone company is responsible for all wiring up to and including that protector; you are responsible for everything that comes after it.

In a typical installation, a modular cable connects the network interface to a *junction box* (see Fig. 15). From the junction box, one or more two-wire lines run

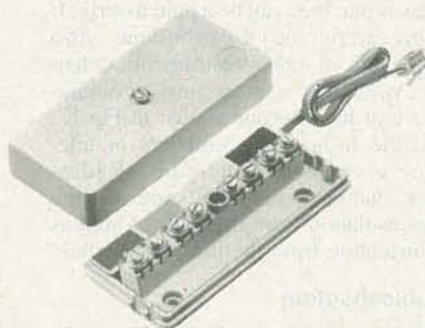

FIG. 15—A JUNCTION BOX connects directly to the network interface. All telephone lines on the premises are connected to the junction box.

to each modular jack; the modular jack takes the place of the connecting block. The telephone itself connects to one of those jacks.

Installing telephone equipment

Any telephone or accessory that you install must be compatible with the telephone system. To that end, all equipment must be approved by the FCC.

Further, several pieces of information should be displayed on the outside of the device (usually on a surface that normally is not seen). There must be a statement that the device complies with Part 68 of the FCC rules and regulations; and the FCC registration number and the *Ringer Equivalence Number (REN)* must be shown. Also, the *Universal Service Order Code (USOC)* designation may be displayed. We discussed the REN and its significance last time. The USOC designation tells you the type of standard jack that the device accepts. A USOC RJ11 designation tells you that the device requires a single line (four conductor) jack; a RJ14 designation tells you that the device requires a two-line (eight-conductor) jack. Both types of jacks are shown in Fig. 16. If the USOC designation is not provided, it is safe to assume that it is RJ11.

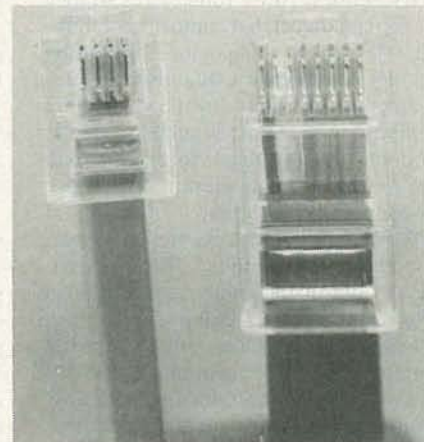

FIG. 16—MODULAR PLUGS. A single-line (four-conductor) plug is shown on the left. A dual-line (eight-conductor) plug is on the right.

Before installing any piece of telephone equipment, FCC rules require that you notify the telephone company of the device's FCC registration number and its REN.

Practical hints

As with any other task, there's a right way and a wrong way to go about installing telephone equipment. We are going to give you some do's and don'ts that will help you do the job right the first time.

You can install a telephone or telephone equipment almost anywhere, but there are a few locations that should be avoided. Damp locations are unsuitable because of the dangers of electric shock and corrosion. Extremely hot locations should also be avoided because the plastics used could warp. And, as common sense dictates, avoid mounting equipment on temporary structures.

A telephone is an electrical device. That means that unless precautions are taken during installation, dangerous conditions could be present during such installation, or afterwards. Either the 90-

volt, 20-pps ringer signal or the 48-volt DC battery voltage can give the unsuspecting installer or user quite a tingle!

When working on an older telephone installation (one without a network interface), take the telephone off-hook. That will eliminate the danger of an electric shock if the telephone rings. If there is a network interface, simply remove all power to the system by unplugging it from that interface. If you wish to receive or make calls while the system is disconnected, you can do so by simply plugging a telephone directly into the interface.

When routing wires, installing outlets, etc., be sure to follow safe construction practices. Note the locations of gas lines, electrical conduits, and water pipes and plan to place outlet boxes so that there is no danger of cutting into those when installing the boxes. Never route wires through conduits or outlet boxes used for electrical lines. Never route wires so they pass near an object that could attract lightning. Obviously, that includes lightning rods; not so obviously, that also includes TV antennas and their downloads. Before fastening a wire to a metal surface, such as aluminum siding, check to be sure that there are no voltages present. Also, use non-conductive fasteners.

When routing lines between buildings, use underground conduit. That will prolong the life of the cable, and minimize the possibility of its coming in contact with dangerous voltages, such as from a lightning strike. When doing outside wiring, avoid routing the telephone lines anywhere near power lines or transformers.

To prolong the life of the wiring, avoid placing it in hostile environments. That means don't route it near hot-water or steam pipes, or air-conditioning or heating ducts. For best voice quality, keep runs of wire as short as possible and avoid splicing.

As with any other job, it's always wise to be sure that you have the proper tools on hand before you begin. Fortunately, telephone installation work requires nothing in the way of exotic or expensive tools. It is highly likely that you own most or all of the following: Several sizes of screwdrivers, with insulated handles; diagonal wire-cutters or needlenose pliers with wire-cutters and with insulated handles; hammer; staple gun; a small keyhole saw (to cut holes in the wall for flushed-mounted jacks); and a drill and bits.

Once you've planned out the installation, and bought whatever components are needed, it's time to get to work. Let's look at some general procedures you should follow to ensure a trouble-free job.

First of all, most components that require installation (junction box, modular converter, wall telephone mount, etc.) will be packaged with complete installation instructions. Read those instructions and be sure to follow all steps.



FIG. 17—STRIPPING MODULAR TELEPHONE cable is made much easier with this simple tool. Similar tools are available from a number of suppliers.

If you are wiring or rewiring an entire system, be sure to install a junction box near the network interface or entrance point. Run a short cord between the two and wire the remainder of the system to the junction box. Remember: For safety, don't connect the junction box to the telephone system until all installation work is completed.

Modular jacks should be mounted either on the baseboard, or on the wall at a height of about two to three feet. Use wood screws to mount the jacks on baseboards or other wood surfaces. To mount the jacks on plaster or plasterboard walls, use anchors or expanding anchor bolts.

It's always best to run the wires in dedicated conduits located within a structure's walls. However, unless the wiring job is part of the initial construction or major remodeling of the structure, it is often not practical to route the lines in that manner. When routing the lines along baseboards, etc., fasten the wire every 8 to 12 inches and be sure to allow enough slack at the jacks to make the required electrical connections. Never route wires under rugs, or anywhere else where they might be subject to unusual wear.

One problem with modular telephone cables is that they can be a pain to strip. If you are careful, the job can be done with a sharp knife or other instrument. Otherwise, you might want to consider obtaining a tool like the one shown in Fig 17. Available from many suppliers of telephone accessories, including Radio-Shack, that low-cost tool lets you strip the outer insulation from the cable as well as the insulation from the individual wires.

Troubleshooting

After you have made a telephone installation in a new home, added an extension line, or installed a modular interface jack, you will want to check out your work. In this section, we will cover a number of troubleshooting procedures that will help you pinpoint the cause of any problems you might experience.

The most important part of any troubleshooting is determining where the problem lies. If it is in the system's wiring (that is, outside of your premises) then the telephone company is obligated to repair it at no charge.

The simplest way to determine whether the telephone system or your wiring is at fault is to plug a known-good telephone directly into the system interface. If you can get a dial tone, and can successfully call an outside party, the problem lies in your wiring. Otherwise, call the telephone company.

Once you've determined that the problem is within your system, you need to determine its cause. Often that cause can be found by conducting a simple inspection. Look for telltale signs of trouble such as disconnected modular cords or broken plastic.

If inspection does not reveal the fault, the next step is to check out each telephone in your system. That is easy to do with a modular system. Simply attach each instrument to the system interface and verify correct operation.

Once you determine that a telephone is

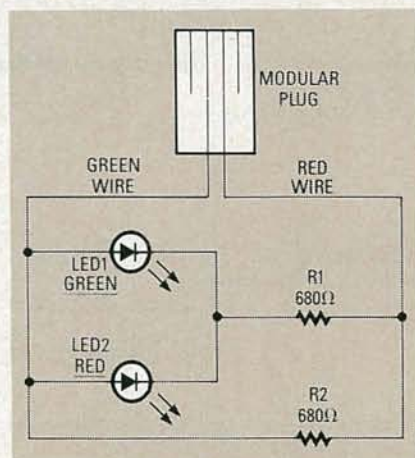

FIG. 18—A SIMPLE TELEPHONE-LINE TESTER. The LED's indicate whether a line or jack is wired correctly, has reversed polarity, or is disconnected from the telephone system.

not operating properly, you must determine the source of the problem. Some common problems, their causes, and their cures are shown in Table 4. Many of the problems are easy to clear up. Others are not and may require knowledge of specific telephone circuits. Often, it is easier, and cheaper, to simply replace the phone.

Many telephone-line problems can be diagnosed using a simple line tester. Testers are relatively low-cost and can be obtained from a number of sources (including Radio-Shack). If you wish, you could also build a tester. An appropriate schematic for a simple tester is shown in Fig. 18.

The circuit of Fig. 18 simply plugs into a modular jack. The unit's LED's give a quick indication of the telephone line's status. If the green LED lights, the jack is wired properly and the outlet is operational. If the red LED lights, the wiring to the jack is reversed. If neither LED lights, the jack is not connected to the telephone system.

R-E

BUILD THIS

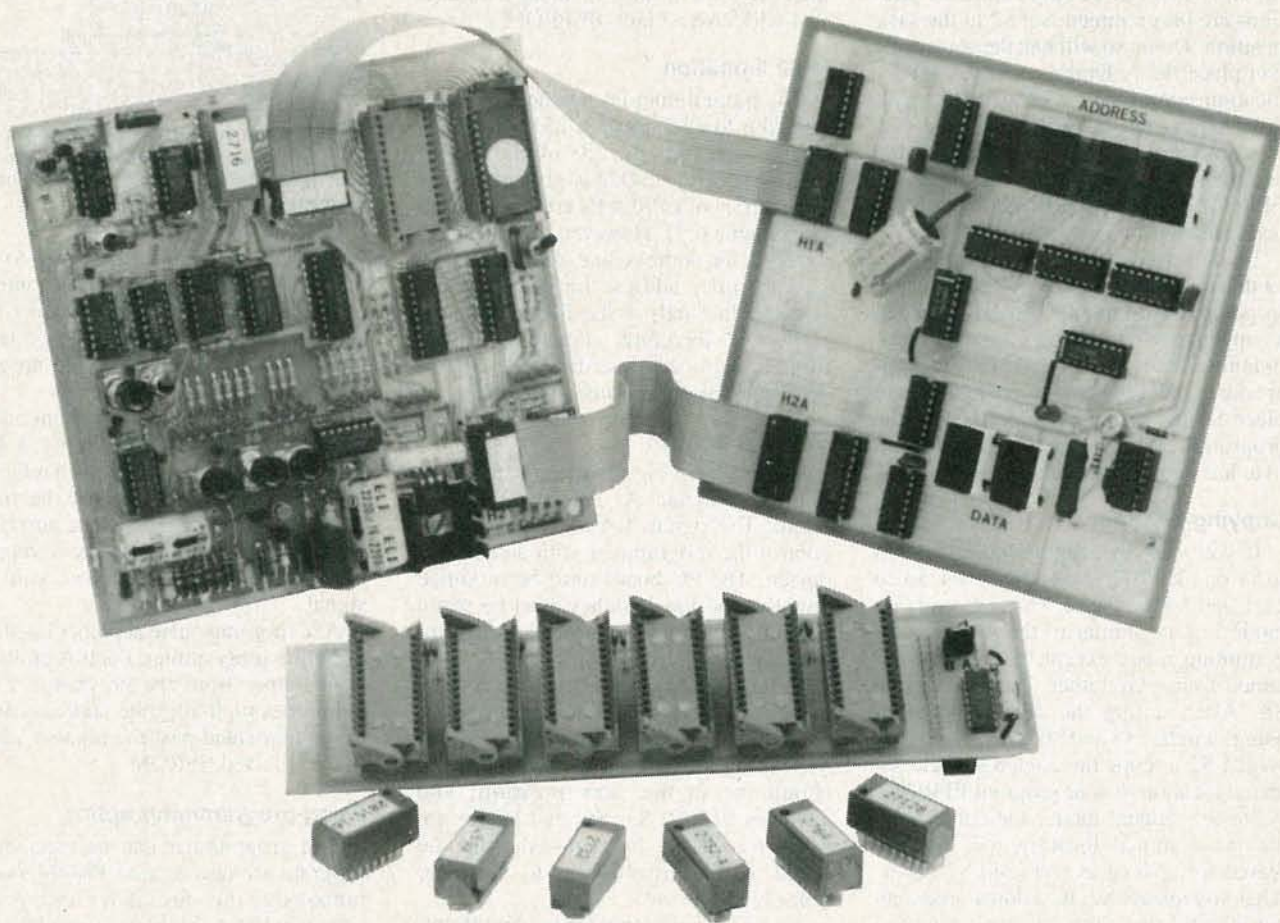

EPROM PROGRAMMER

This time we discuss the programmer's many modes of operation and hardware options that increase its ease of use.

LUBOMIR SAWKIW

Part 2 WE HAD JUST FINISHED building and testing the programmer when we left off last time. Let's continue now and explain the programmer's four modes of operation. Then we'll discuss adding an optional gang-programming board that allows you to program as many as six EPROM's at once, and a display board that allows you to view addresses and data in hexadecimal on seven-segment LED's.

Manual programming

The programmer's modes of operation, and the switch settings that enable them, are summarized in Table 1. To program a

TABLE 1—MODES SELECTION

Mode	Switch Settings	
	S3	S4
Manual	Step	Switches
Copy EPROM	Run	EPROM
Copy byte	Step	EPROM
Repeat program	Run	Switches

byte manually, place S3 in the STEP position and S4 in the SWITCHES position. Set the data switches in DIP switch S8 to the desired values and then set the address using S5 and S6, as discussed last time. If the byte at that address is properly erased, all eight DATA LED's (LED15-LED22) will light up (indicating a value of FF hex).

If that location is erased, you can press PROGRAM switch S2 to program the new value. The programming occurs in 50 ms, and the new data will be visible for as long as you continue to press S2. If the LED's indicate an incorrect value, the EPROM may not be fully erased, or it may be damaged. Try erasing the EPROM; and if problems persist, try a new one.

When you release S2 after programming a location, the board advances to the next address. You can program that address or use S5 and S6 to go to another.

Copying

To copy an entire EPROM, place S4 in

the EPROM position and S3 in the RUN position. Then reset the circuit by pressing S7. Now place your EPROM's in their sockets. The source EPROM goes in SO2, and the blank EPROM in SO1. *Don't reverse them!*

To start the copying process, press PROGRAM switch S2. To stop before all locations are programmed, set S3 to the STEP position. Doing so will halt the copy cycle and place the programmer in the single-location copy mode. You can now continue to program the EPROM one location at a time. Later you can resume copying automatically, if desired. When the entire EPROM has been copied, the board will reset and await a new command.

It's not a good idea to use the RESET switch to halt the copying process because stopping the programmer in the middle of a copying cycle may leave a partially-programmed byte in your EPROM. The proper way to halt the copying procedure is to place S3 in the STEP position. Then the programmer will stop after the current byte has been programmed.

Copying bytes

If you want to copy a single location from one EPROM to another, set S3 to STEP and S4 to EPROM. The byte-copying mode is very similar to the manual-programming mode except that data is obtained from SO2 rather than DIP switch S8. After setting the desired location using switches S5 and S6, press PROGRAM switch S2 to copy the contents of the selected location to your program EPROM. As in the manual mode, the contents of the programmed location will be displayed for as long as you hold S2 down. After you release S2, the address counters advance by one. You can then program that location, or move to any other, using S5 and S6.

Switch S1 is handy when you are copying an EPROM one location at a time. Normally, the data LED's (LED15-LED22) display the contents of the program EPROM. But when you press S1, that switch allows you to view the contents of the source EPROM.

Repeat programming

The repeat mode allows you to program successive EPROM locations with the data byte in DIP switch S8. Why would you want to program many locations with the same byte? A delay or timing loop might require one byte to be programmed into a number of locations. You could also use repeat programming to erase an EEPROM.

To enter the repeat program mode, set switch S3 to RUN and set switch S4 to SWITCHES. Then set the switches in S8 to the desired value. As usual, to begin programming, press PROGRAM switch S2. To halt programming, move S3 to the STEP position. Now you can proceed in the

manual programming mode. As mentioned earlier, do not use RESET switch S7 to halt the programmer.

To erase a 2815 or 2816 EEPROM, plug the appropriate personality module into SO3. Then set S8 to FF (hex), S3 to RUN, and S4 to SWITCHES. Reset the board and then press S2 to start. In about 2 minutes you will have a blank EEPROM.

2532 limitation

The programmer is capable of copying only the lower half of a 2532 EPROM. That is because pin 20 of the source EPROM socket (SO2) is grounded. The 27xx series of EPROM's uses that pin for chip enable (\overline{CE}). However, the 2532 uses that pin for address line A11. Since the highest-order address line is held low, only the first half of the EPROM can be read, and, therefore, copied. Pin 20 of SO1 is not grounded, so the upper half of a 2532 may be programmed manually.

External control

As we saw in Fig. 2 last time, there are 7 points labeled A through G on the board. The signals there may be used to control the programmer with an external device. The PC board must be modified slightly, and the switches must be set in certain positions to control the programmer externally.

Remove DIP switch S8 from its socket, and connect your data source at that point. Switch S4 must, of course, be in the SWITCHES position. In addition, S3 should be in the STEP position, and switches S1, S2, S5, S6, and S7 are not used. S2 should be removed from the board, or the ground trace to its center pole should be cut.

An active-low signal fed to point B presets IC1-a and starts the programming cycle. There must be no noise, glitches, or bouncing at that input. If the input signal isn't clean, you could program ten locations with what you thought was one pulse. After each location is programmed, a low must be fed to point C to clear IC1-a. The circuit shown in Fig. 5 may be used; that circuit can save you the trouble of having to supply a separate clear signal to point C. Just make sure that your input signal stays low for at least 67 ms, or else you will increment the address before the programmer finishes programming the current location.

Point D can be used as both an input and an output. When S3 is in the STEP position, point D carries a narrow active-low pulse at the end of a programming cycle when IC3-a reaches the count of nine. That point can be used to indicate when the board has completed programming one location and is ready for another cycle.

When S3 is in the RUN position, point D carries a narrow low-going pulse when the board has programmed an EPROM's last

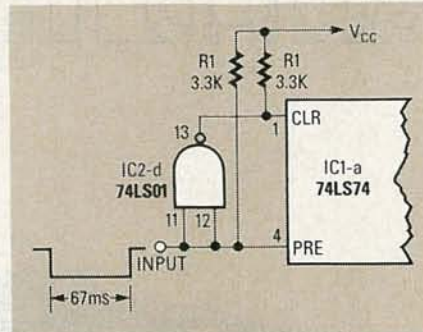

FIG. 5—TO AUTOMATE PROGRAMMING, connect the unused gate of IC2-d as shown here. Your control signal should be low-going and have a width of at least 67 ms.

address. That signal can be used to indicate when a copy operation is complete.

In addition, bringing point D low at any time during the programming cycle will clear IC1-b and will abort the programming operation.

You can increment the current address location by one by delivering a high-going pulse to point F. Point E has the 120-Hz clock signal that drives the timing chain. Your controller can connect that signal to point F for fast address stepping, or you can pulse point F with your own signal.

A high-going pulse at point G will reset the entire programmer. Point A provides a reset output from the programmer; that point goes high after the address counter has incremented past the highest address of the selected EPROM.

Gang-programming option

The programmer can be expanded to program as many as six EPROM's simultaneously; the circuit for doing so is shown in Fig. 6. In order to avoid possible data-bus contention, the board has logic that (optionally) disables the verification capability for sockets two through six. In other words, only the EPROM in SO1 would be read during verification. That feature was included because, if one or more of the EPROM's in SO2-SO6 were defective or did not program properly, both highs and lows could be present on the data bus simultaneously. An EPROM (especially a CMOS type) could be damaged thereby, but, even worse, a bad or misprogrammed EPROM might pass verification and wreak havoc later. To avoid that possibility, if you gang-program EPROM's, we recommend that you verify each one separately at a later time.

Notice the terminals labeled A, B, and C in Fig. 6. With A connected to B, SO2-SO6 will not be read during verification. But if you should wish to read all six sockets simultaneously, connect A to C.

The parts-placement diagram for the gang-programming board is shown in Fig. 7; the foil patterns for the PC board are shown in PC Service. Note that all components except PL1 mount on the compo-

ment side of the board. You probably won't be able to find a 28-pin male IDC (Insulation Displacement Connector), so use a 34-pin model and cut off pins 29-34. Then solder it to the board.

A cable that connects plus PL1 to socket SO2 (on the main PC board) is built using a 28-pin DIP socket header on the end that goes to SO2 on one end and a 34-pin female IDC header on the other end.

GANG BOARD PARTS LIST

- R1—10,000 ohms, ¼ watt
- C1—220 μ F, 10 volts, electrolytic
- C2-C10—0.1 μ F, 50 volts, disc
- IC1—4001 quad NOR gate
- D1—1N751A 5.1-volt, 1-watt Zener diode
- SO1-SO6—28-pin zero insertion force sockets
- PL1—34-pin PC-mount right-angle IDC connector
- 34-pin female IDC cable connector
- 28-pin IDC DIP plug
- ribbon cable

Since there will be only 28 wires coming from the DIP end, be sure to leave a gap at the correct end of the female connector. Of course, you could simply solder the wires at both ends of the cable directly to the board but a cable is neater and affords you greater flexibility and we highly recommend that you use one.

There is no difference in operation when using the gang-programming board.

Hexadecimal display option

The circuit for the display board is shown in Fig. 8. The display board's operation is straightforward. IC2 on the display board replaces IC8 on the main board by means of a 16-conductor cable connected from socket SO1 on the display board to IC8's socket on the main board. The outputs of the two counters (IC1 and IC2) on the display board drive the display decoder/drivers (IC5-IC8), which in turn drive the address displays (DISP1-DISP4) directly.

You'll notice that there are no current-limiting resistors connected to any of the displays. Instead, Q1, driven by op-amp IC12, functions as a dynamic resistor that keeps the voltage across the segments of the display constant, thereby maintaining constant brightness. Any variation in display brightness causes a corresponding change in the brightness of LED2, which changes Q2's base bias. That varies the voltage at the non-inverting input of IC12-a, which varies Q1's bias, and thus its effective resistance to ground. Trimmer potentiometer R4 allows you to adjust the brightness of the display.

The transistor used for Q2 can be al-

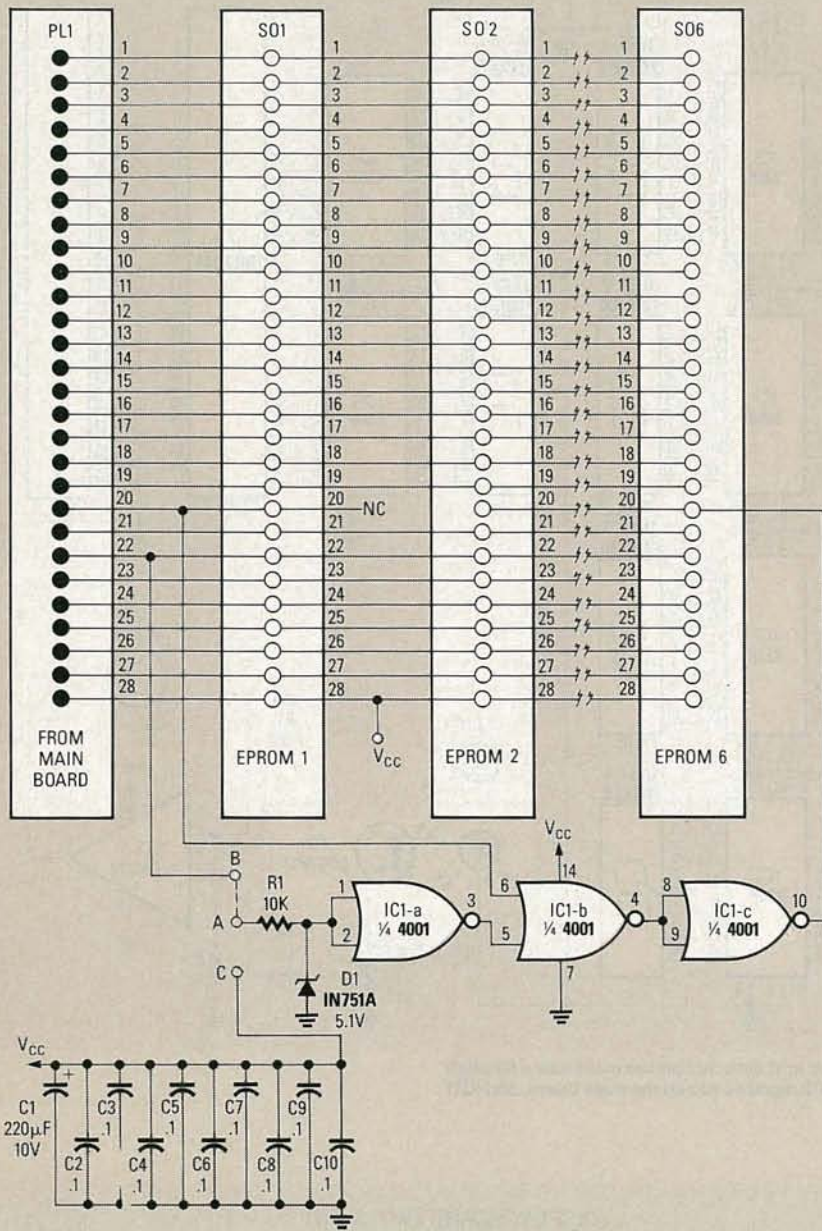

FIG. 6—THE GANG-PROGRAMMING BOARD connects to the main board via a cable connected to PL1. To avoid the possibility of data-bus conflict, the gates of IC1 allow you to disable reading EPROM's in sockets SO2-SO6 (when the jumper is connected between A and B).

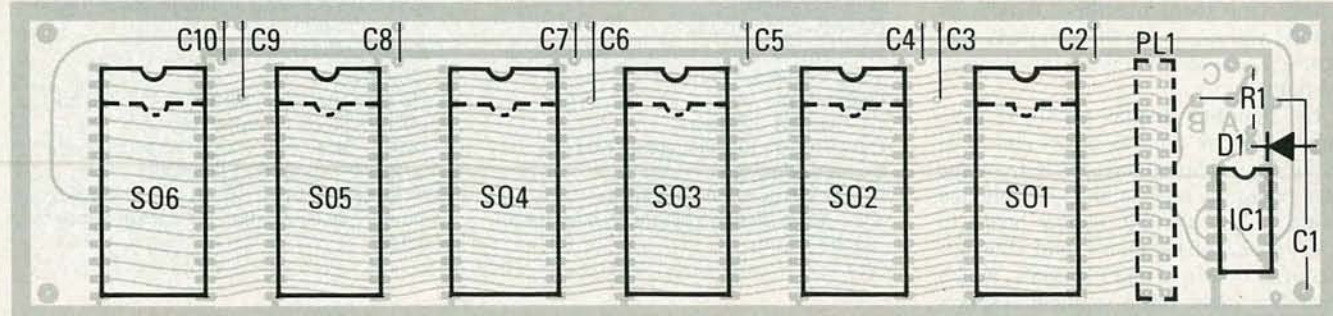

FIG. 7—MOUNT ALL PARTS except PL1 on the component side of the board. The jumper connecting points A and B disables reading from sockets SO2-SO6.

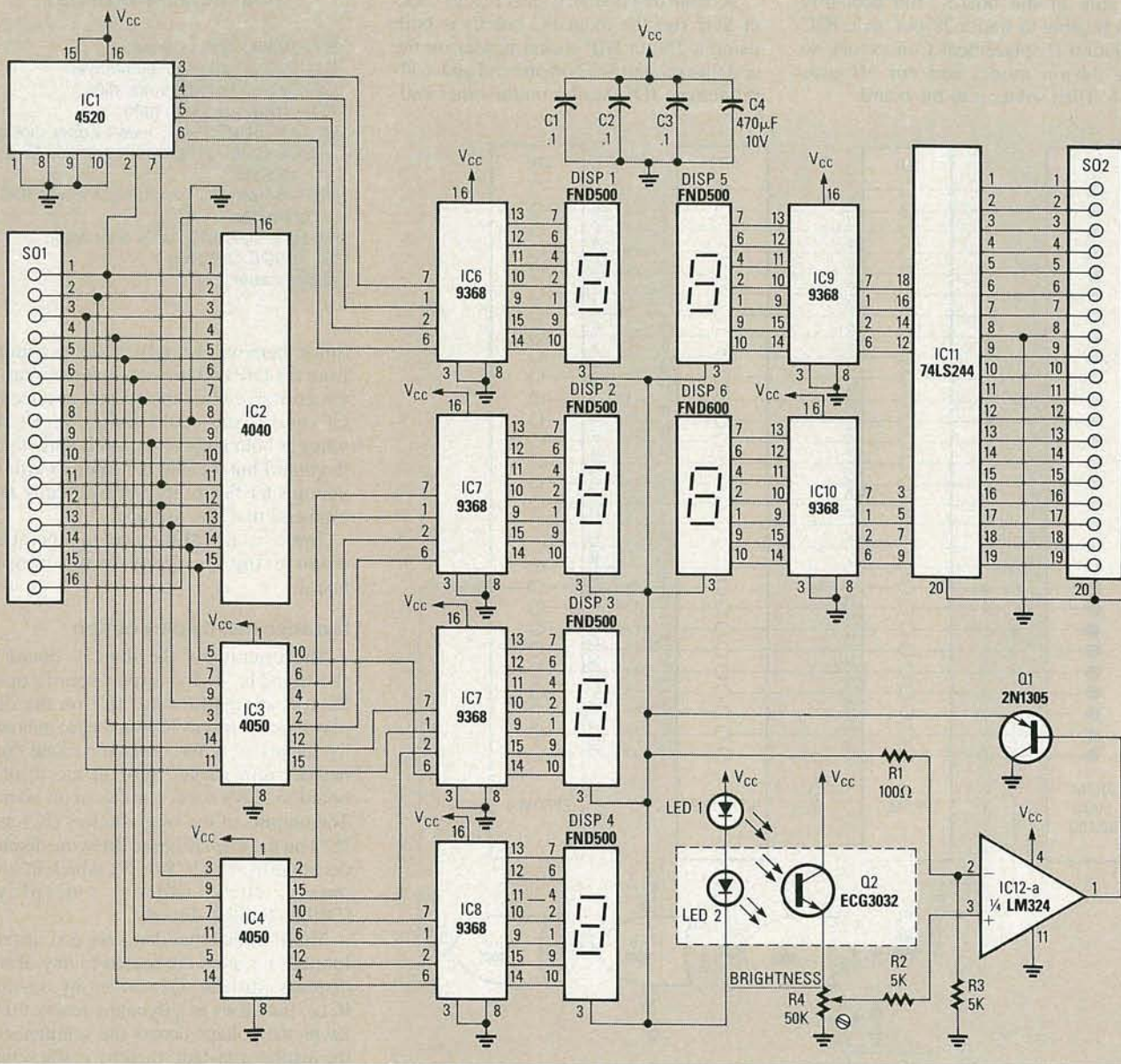

FIG. 8—THE DISPLAY BOARD attaches to the address bus and data bus on the main board through cables connected to SO1 and SO2, respectively. Counter IC2 replaces IC8 on the main board, and IC11 replaces IC13.

most any NPN phototransistor that will respond to the LED driving it. Use a good quality, efficient LED for LED2. You can mount it face to face with Q2 inside a short piece of heat-shrink tubing, or you can simply tape them together. Whichever method you use, keep the two parts very close to each other, and keep out all external light.

The data-bus display circuit is even simpler than the address-bus circuit. IC11 on the display board replaces IC13 on the main board via a 16-conductor cable that connects SO2 on the display board to IC13's socket on the main board. The outputs of IC11 drive a pair of 9368's, which drive two more seven-segment displays (DISP5 and DISP6).

Mount all components on the display

DISPLAY BOARD PARTS LIST

All resistors are 1/4-watt, 5% unless otherwise noted.

R1—100 ohms
 R2, R3—5000 ohms
 R4—50,000 ohms, trimmer potentiometer, 20 turns, PC mount

Capacitors
 C1—C3—0.1 μ F disc
 C4—470 μ F, 10 volts, electrolytic

Semiconductors
 IC1—4520 dual binary counter
 IC2—4040 12-stage binary counter (from main board)

IC3, IC4—4050 hex buffer
 IC5—IC10—9368 decoder/display driver
 IC11—74LS244 octal tristate driver (from main board)
 IC12—LM324 op amp
 Q1—2N1305
 Q2—ECG3032 or Radio Shack 276-130
 LED1, LED2—Standard red LED
 DISP1—DISP6—FND500 common-cathode, 7-segment LED display

Miscellaneous: 20-pin DIP-socket jumper cable, 16-pin DIP socket jumper cable.

board as shown in Fig. 9. The foil pattern for that board is shown in PC Service.

Note that there are three jumpers on the board. Mount them first, then the re-

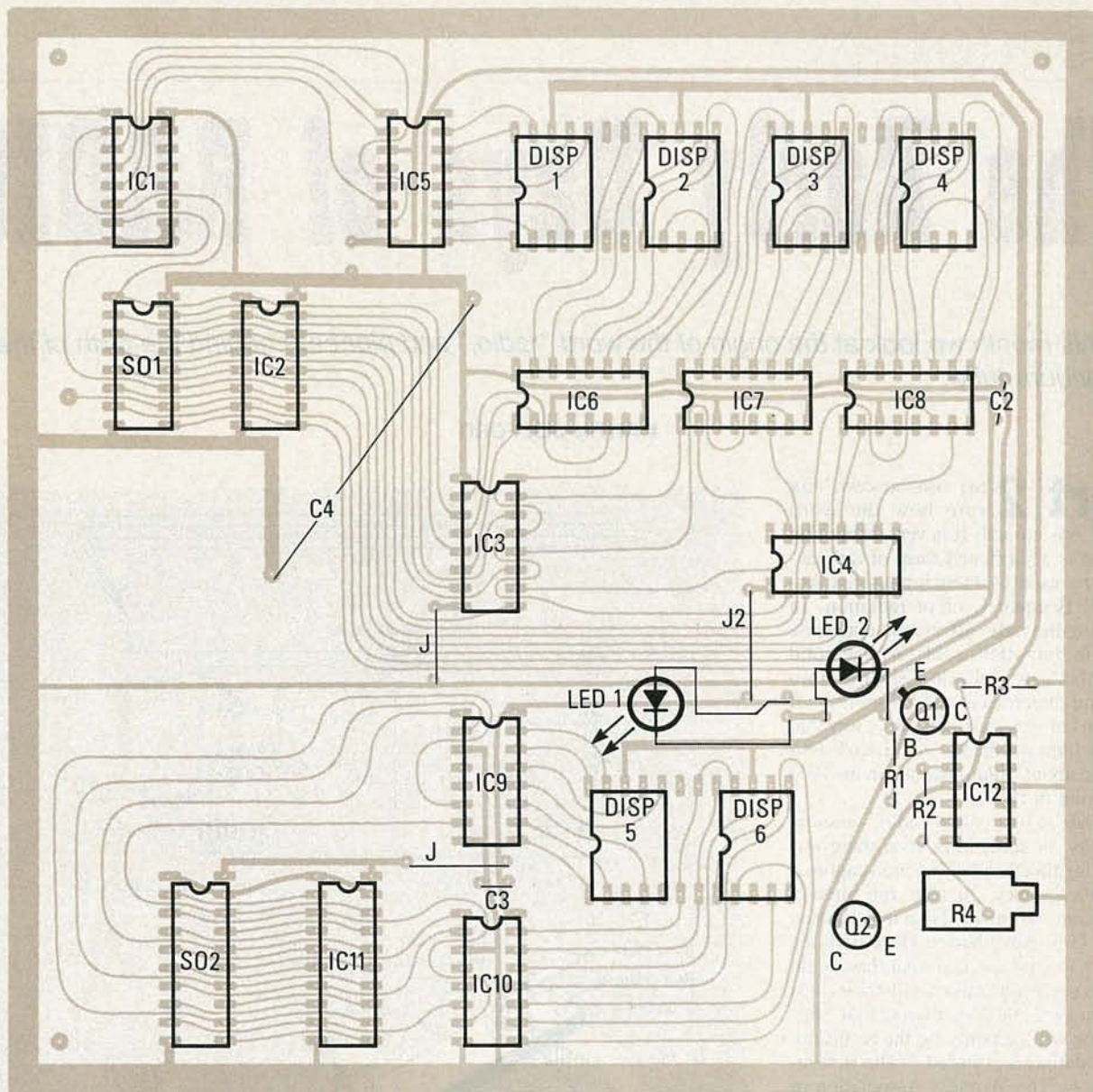

FIG. 9—PHOTOTRANSISTOR Q2 AND LED2 must be mounted so that their receptive and transmissive surfaces receive no ambient light. Heatshrink or tape them together. The foil pattern for this board is shown in PC service.

sistors, and so on. Its best to use sockets for all IC's; the six LED displays can be

ORDERING INFORMATION

The following are available from Lubomir Sawkiw, P.O. Box 555, Rensselaer, NY 12144: A transformer with 25 and 10 volt AC secondaries, \$8.00 plus \$3.00 shipping and handling; 9368 Fairchild IC's, \$4.25 each postpaid. New York residents must add 7% sales tax.

The following are available from E²VSI, P.O. Box 72100, Roselle, IL 60172: main circuit board, \$25.00; hex display board, \$15.00; gang board, \$10.00; set of three boards, \$45.00.

mounted in 24-pin 0.6" DIP sockets. A red filter will improve their readability.

To install the display board, remove IC13 from the main board and install it in the space allocated for IC11 on the display board. Then connect a 20-pin DIP jumper cable between socket SO2 on the display board and IC13's socket on the main board.

You could also solder all of connections directly to the appropriate points on the two boards, eliminating the need for a DIP cable or socket. In either case, make absolutely certain that every pin is connected correctly.

Remove IC8 from its socket on the main board and install the IC in the socket provided for IC2 on the display board. Connect a 16-conductor DIP jumper between SO1 on the display board and IC8's socket on the main board. Make sure that the correct pins line up on both ends. Do

not plug the jumpers in or remove them (or IC's) while power is applied.

Remove IC9 and IC10 from the main board. Because they drive the 14 address LED's (LED1-LED14), they're no longer necessary. Removing the IC's will conserve some much needed power for the display board.

The voltage regulator (IC14) on the main board can normally run quite warm—as high as 70°C maximum. However, with the display board plugged in we would be pushing the regulator to the limit. So, to let it run a little cooler, solder a 25-ohm, 5-watt power resistor (R57) to the main board in the pads provided near the regulator. If you add that resistor, be sure that you do not run the programmer without the display board connected.

R-E

HISTORY

The Early Days of RADIO

This month we look at the origin of the word "radio," and pioneers behind the birth of the vacuum tube.

MARTIN CLIFFORD

Part 2 NO ONE KNOWS FOR sure how the word "radio" was coined. It is very likely that the word is a shortened form of radioactivity, first used by French physicist Antoine H. Becquerel, or of radiation. In describing the radio effect, the magazine *Strand* in July 1896 said "At the solid object the new radiation springs into being and then travels away from it in all directions in very much the same way that ordinary light would do." Dr. Lee de Forest wrote about "radio waves" in his PhD dissertation in 1899.

Whether it was called radio, wireless telegraphy, or something else, there was no denying that the phenomenon captured the public's fancy. In fact, the airways soon became so crowded that it is reported that the U.S. Navy had to plead with the amateurs to shut down so that they could maintain communications with their ships at sea. In 1903, de Forest wrote that "Radio chaos will certainly be the result until...regulation is afforded." The first radio society, The Wireless Association of America, was formed in New York in 1908. With de Forest as its president and Hugo Gernsback as its chairman and business manager, that organization attracted over 3000 members in just its first few months.

The first radios were often simple, home-made, spark-gap units. A schematic diagram of an early "transceiver" made up of a spark-gap transmitter and a crystal receiver is shown in Fig. 1-a; a more detailed view of the spark-gap coil is shown in Fig. 1-b. Note the lack of a tuning mechanism in the transmitter. When our forefathers said that they were "modulating the spectrum," they weren't kidding around. A single low-frequency broadband spark-gap signal would effectively occupy the entire useable spectrum.

The first sound transmission

Let's backtrack for a moment and give some mention to an individual who today is not well known, but deserves to be.

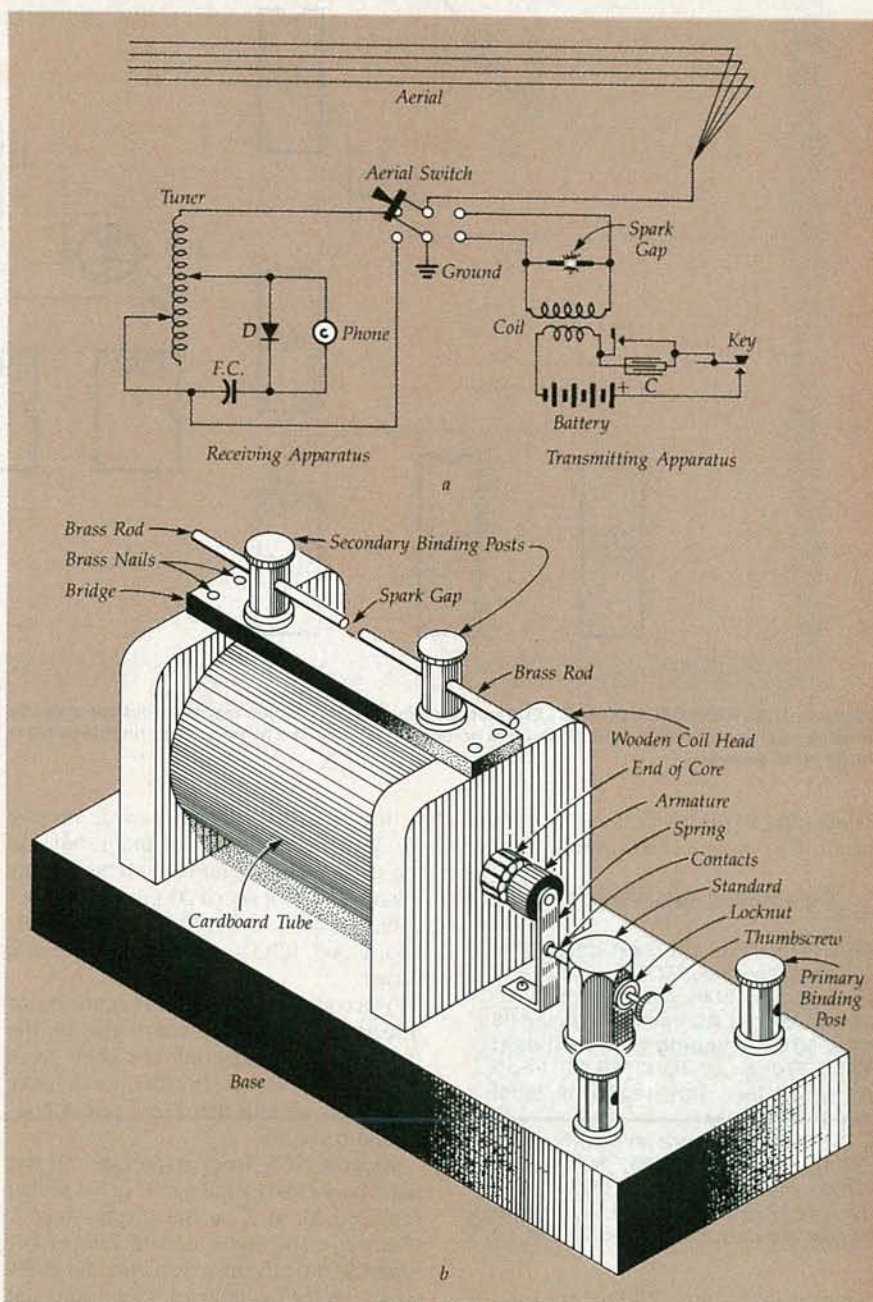

FIG. 1—AN EARLY SPARK "TRANSCIEVER" is shown in a. The spark coil is shown in detail in b.

Most students of radio and electronics know of Hertz, Marconi, Maxwell, and Tesla. But how many know of Nathan B. Stubblefield? Yet it is Mr. Stubblefield who, in 1892, became the first to succeed in transmitting sound via radio. He conducted two public demonstrations of his achievement in 1902.

Crystal-radio specifications

Early crystal sets were judged on two measures of performance. Those were volume and selectivity.

Remember that a simple crystal radio offers no amplification. That made volume the most important criterion. If a crystal set could supply enough volume so that sound could be heard from a pair of headphones lying on a table, the set was considered to be top quality.

Selectivity was next in importance. Figure 2 shows three methods that were used to improve selectivity. One method was to use a tapped antenna-tuning coil, as shown in Fig. 2-a. Another was to use a tapped vario-coupler as an antenna tuning coil, as shown in Fig. 2-b; vario-couplers were discussed in the first installment of this series (**Radio-Electronics**, July

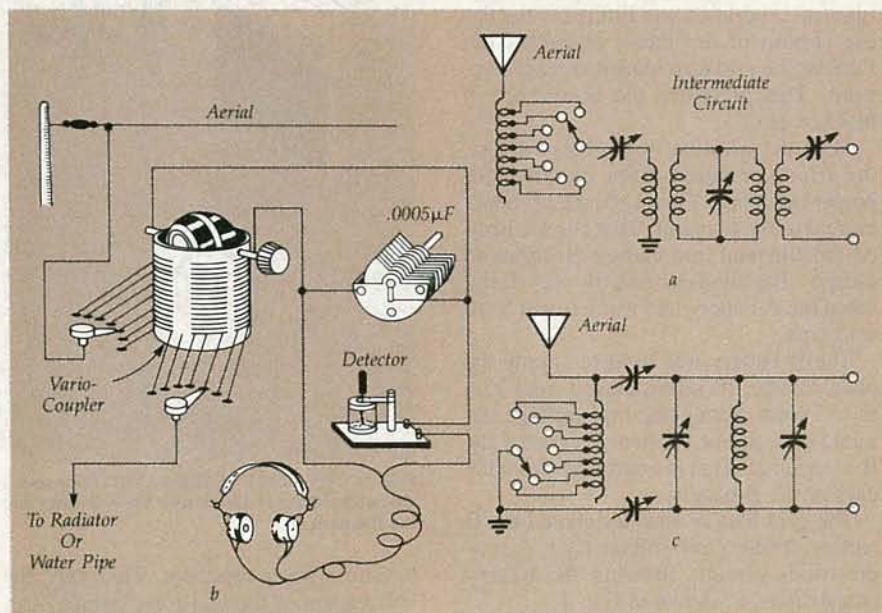
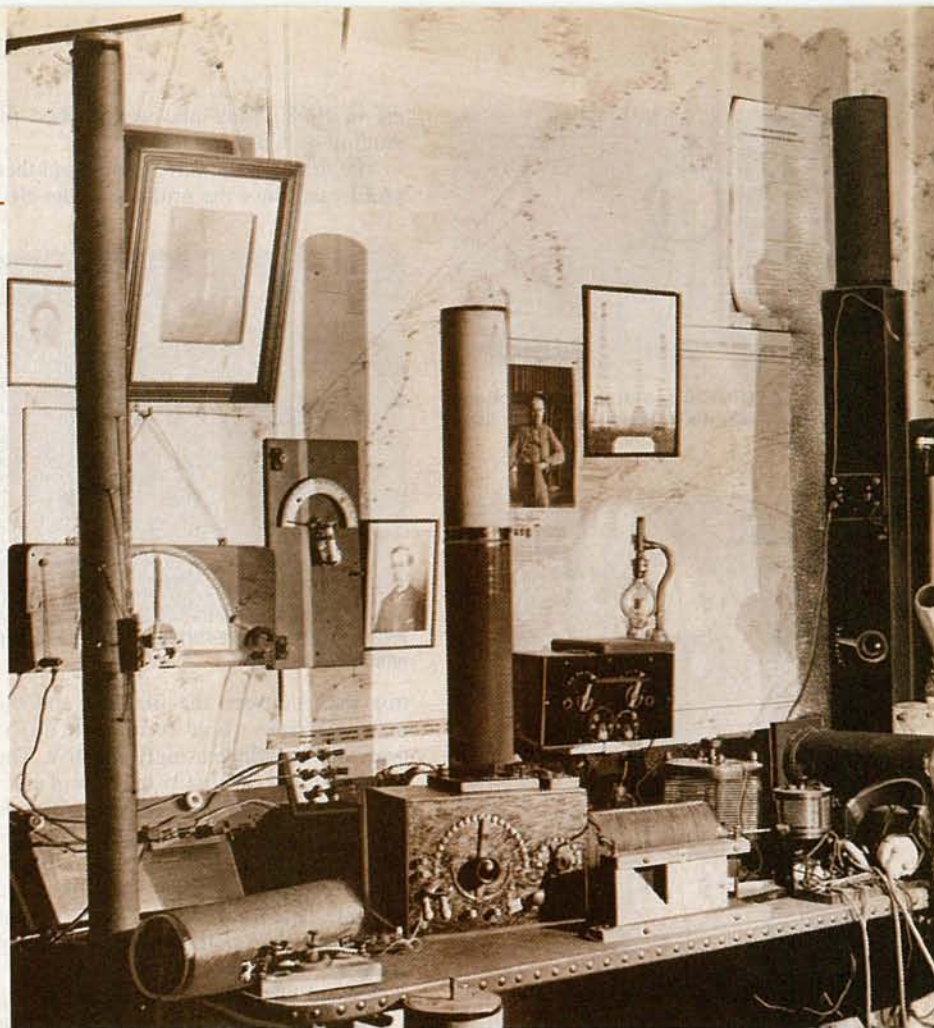

FIG. 2—SELECTIVITY OF EARLY RECEIVERS was improved by using a tapped antenna coil (a), a vario-coupler (b), or multiple tuning capacitors (c).

1986). A third arrangement was to use multiple tuning capacitors, as shown in Fig. 2-c. Note that those capacitors are not ganged. To tune in a station, each capacitor has to be adjusted separately.

Unfortunately, even with those techniques, or any others for that matter, competing signals could often be heard in the

background. Further, all of the methods of improving selectivity did so at the expense of volume.

One of the problems with early crystals is that the most sensitive spot on the crystal had to be found using trial and error. One method of making that task easier is shown in Fig. 3. There, a buzzer circuit is

inductively coupled to a radio circuit. As the movable catwhisker is used to probe the crystal surface, the most sensitive spot is detected by monitoring for changes in buzzer volume.

The triode

Problems with volume and selectivity led experimenters to seek some method of signal amplification. They met with success by adding a third element to the diode, creating the triode. The first triode was actually two back-to-back diodes. It was developed by de Forest, and patented in 1907. That device was described as an amplifier, although it is debatable whether

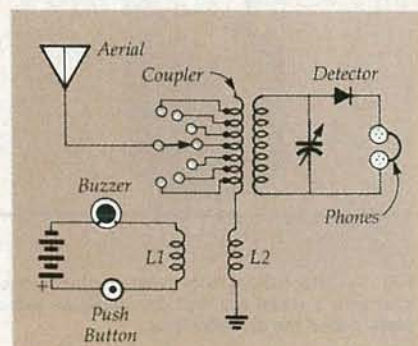

FIG. 3—A BUZZER CIRCUIT was often used to help find the most sensitive spot on the surface of a crystal. The buzzer was inductively coupled to the radio circuit as shown here.

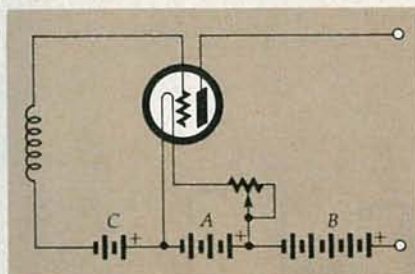

FIG. 4—A TRIODE requires three voltage sources. Initially, those were supplied by three batteries.

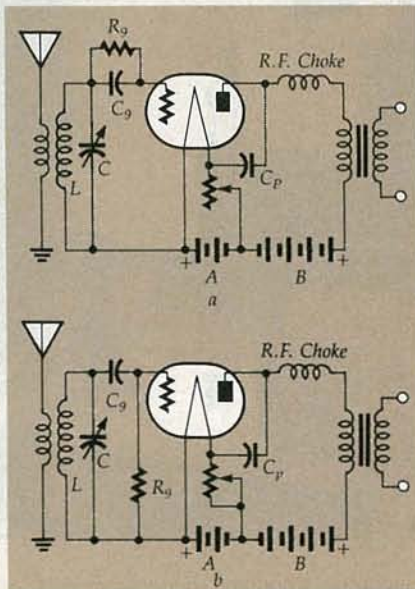

FIG. 5—A GRID-LEAK RESISTOR, R_G , and its shunting capacitor, C_G , eventually were used to eliminate the C battery. Two variations of the grid-leak arrangement are shown in a and b.

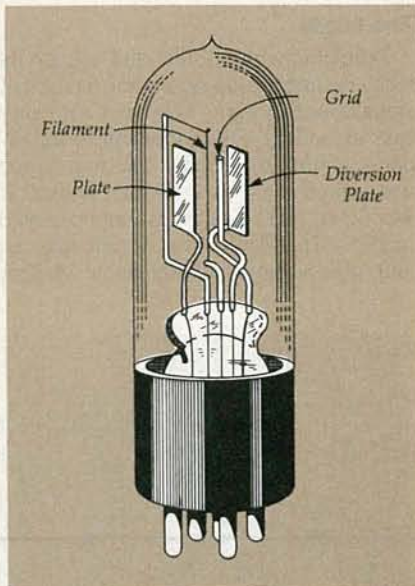

FIG. 6—THE NEGATRON TUBE replaced the grid with a metal rod and contained an extra plate, called the diversion plate.

or not it could actually amplify.

The first true triode, containing a plate, filament, and grid was patented by de For-

est in 1908. That tube was dubbed the Audion by Clifford D. Babcock

The first triodes were not without their problems. Since the grid was in the elec-

The problem with such an arrangement was that the bias voltage developed in that manner varied with signal strength. That difficulty was sidestepped by shunting the

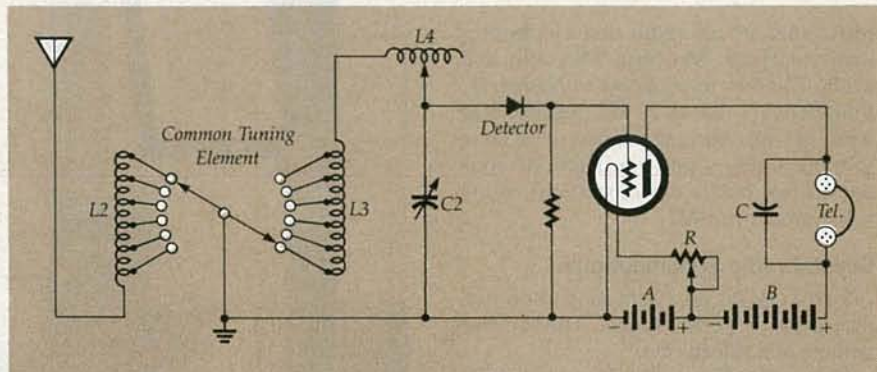

FIG. 7—TUBES WERE INITIALLY USED in hybrid receivers. Those used a crystal detector, and a triode amplification stage.

tron path between the filament and the plate, electrons would accumulate on the grid, making it increasingly negative. The result was that eventually the flow of electrons would be cut off. That condition is known as a blocked grid. Further, the tube was operated without a bias voltage, meaning that it operated over its entire characteristic (not just over the linear portion of that characteristic), creating distortion.

Both problems were solved by applying a negative voltage to the grid. Since that made the grid negative with respect to the filament, operation was limited to the linear portion of the tube's characteristic. Further, the grid now tended to repel electrons. That prevented the occurrence of blocked grid.

With the addition of the bias voltage, the triode required three batteries for proper operation. One was used to supply current to the filament. That current heated the filament and caused electrons to escape. The filament battery was designated the A battery and was a 6-volt lead-acid type.

The B battery was used to supply the plate voltage. Its rating ranged from 22½ to 135 volts. Today, the high-voltage terminal of a circuit is often designated the B+ terminal. That is a carryover from the days of the B battery.

The grid battery was designated the C battery. It was a low-voltage type. A simple triode circuit, showing the battery connections, is shown in Fig. 4.

Later on, the grid's ability to capture and hold electrons was put to work. The captured electrons were allowed to escape the grid via a resistor connected between it and the filament. The resistor is termed a *grid-leak resistor*. The flow of electrons from the grid was such that a voltage was developed across the resistor, with the grid more negative than the filament. That development eliminated the need for the C battery.

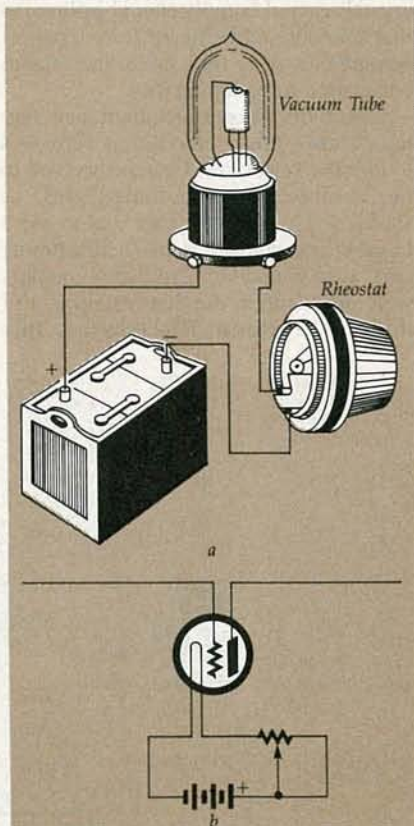

FIG. 8—THE FIRST VOLUME CONTROL was a rheostat placed in series with the A battery and the filament.

resistor with a capacitor. That kept the voltage across the resistor constant. Two variations of the grid-leak circuit are shown in Fig. 5.

Many of the experimenters that followed de Forest devised variations of his triode design. In one, the grid was mounted outside the tube envelope. In another, devised by J. Scott-Taggart in England, the grid was replaced by a metal rod. There was also an extra plate, called a diversion plate. See Fig. 6. The tube,

continued on page 82

How to

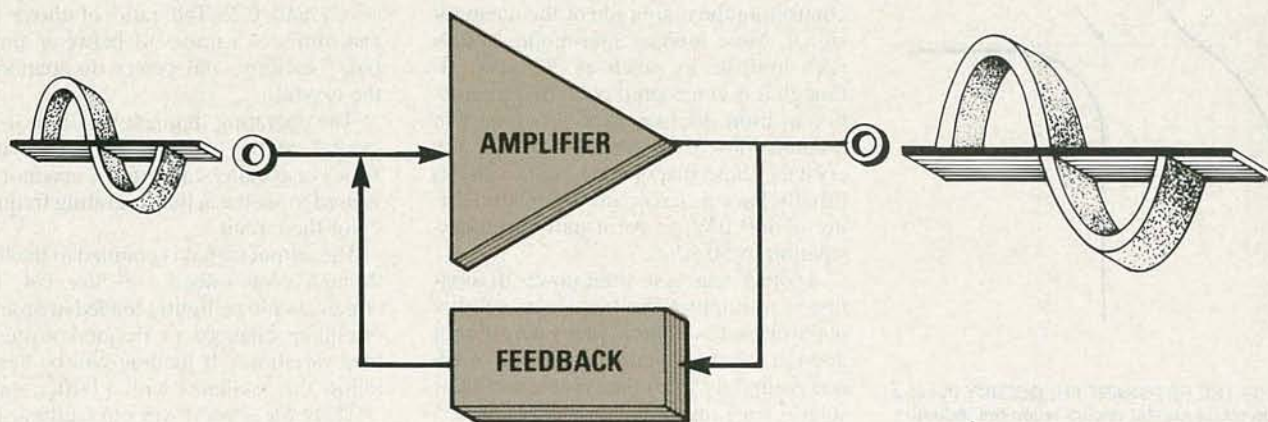

Design OSCILLATOR Circuits

JOSEPH J. CARR

Our series continues with a discussion of crystal-controlled sinewave oscillators.

Part 5 THERE ARE MANY ways of generating sinewaves, but the most stable and the most accurate method uses a piezoelectric crystal to control frequency. Some naturally-occurring elements, notably quartz, possess the property of piezoelectricity. Other man-made ceramic materials also possess that property.

A material is said to be piezoelectric if it generates an electrical potential when it is mechanically deformed. Conversely, when we apply a voltage across the faces of a piezoelectric crystal, the crystal will mechanically deform in a precise and predictable way. Associated with each crystal is a resonant frequency that depends on the dimensions of the crystal.

By way of analogy, consider the ordinary tuning fork. When it is struck, it vibrates at its resonant frequency. Mechanical losses in the tuning fork cause the oscillations to die out gradually. Similarly, losses in a crystal cause the amplitude of its mechanical oscillations to die out exponentially. The crystal differs from the tuning fork in that, while it is oscillating, its piezoelectric property causes it to produce an AC voltage with a frequency that is equal to the resonant frequency. It is that signal that is amplified and fed back to sustain oscillation.

Crystals used in electronic circuits are commonly mounted in a "can" as shown

in Fig. 1. The can protects the crystal slab from the environment; in addition, electrical contact is made there. The slab is sandwiched between two electrodes. In older crystals, those electrodes maintained contact with spring tension; in

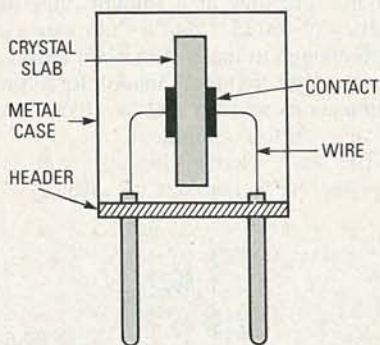

FIG. 1—THE CONTACTS OF A MODERN CRYSTAL are electro-deposited on opposite faces of the crystal slab.

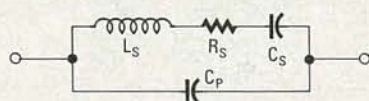

FIG. 2—EQUIVALENT CIRCUIT of a crystal has inductance, resistance, and both series and parallel capacitance.

modern crystals, contacts are electro-deposited directly onto the surface of the crystal slab. The crystal element is then mounted so that the pins protrude through the header.

Figure 2 shows the equivalent electrical circuit of a piezoelectric crystal. The circuit includes series resistance (R_s), series inductance (L_s), and series capacitance (C_s). There is also parallel capacitance (C_p). To understand the following discussion of how those circuit elements interact, see the frequency response curve shown in Fig. 3.

That graph plots reactance vs. frequency. Note that there are two different resonant modes for the crystal: series and parallel. You might have guessed that from the fact that the crystal has both series and parallel internal capacitance.

The series resonant frequency, f_s , is that at which the inductive reactance is exactly cancelled by the series capacitance. At that point the total reactance of the crystal is zero, and the series resistance determines the impedance of the crystal. Impedance is minimum in the series resonant mode.

The parallel resonant frequency (f_p) of the crystal is usually 1 to 15 kHz higher than the series resonant frequency. A parallel-mode crystal will operate in the series mode if a small capacitor is connected in series with the crystal. The value of the

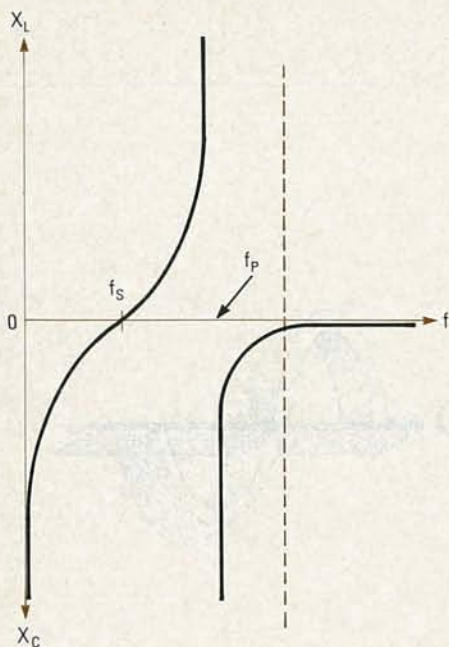

FIG. 3—THE RESONANT FREQUENCY (f_s) of a series-mode crystal occurs when the inductive and capacitive reactances are both zero. The resonant frequency (f_p) of a parallel-mode crystal occurs when capacitive reactance is zero.

capacitor must be equal to the specified load capacitance of the crystal.

Modes of oscillation

Crystals can oscillate in two different ways: fundamental and overtone. In the fundamental mode, the crystal oscillates at its natural resonant frequency, i. e., at the mechanical frequency at which the slab oscillates when it is stimulated. The frequency of oscillation in the fundamental mode depends upon factors such as the crystal's mechanical dimensions, the way it has been cut, temperature, and others.

In the overtone mode, the crystal oscillates at a frequency that is *approximately* an integer multiple of the fundamental frequency. Note, however, that the overtone is not a *harmonic* of the fundamental. For example, if you divide the frequency of oscillation of a fifth overtone crystal by 5, the result will be a number nearly, but not exactly, equal to the fundamental frequency.

The overtone frequencies are usually (approximately) an odd multiple (3, 5, 7, . . .) of the fundamental. However, some circuits use the fourth overtone, which is an even number. The case of an overtone crystal is marked with the intended frequency of oscillation, not the fundamental frequency. An overtone crystal always operates in the series mode.

When ordering crystals for frequency control, you must specify not only the frequency of operation, but also the load capacitance, especially when a crystal will be operated in the parallel mode.

The operating frequency in the fundamental mode is usually less than about 20 MHz because above 20 MHz the crystal

slab becomes so thin that it can fracture under normal operating conditions. Fundamental-frequency crystals are usually parallel mode, except below 500 kHz.

The power that a crystal dissipates must be limited in order to avoid fracturing the slab. It is the *Equivalent Series Resistance* (ESR) of the crystal that determines power dissipation. In a practical crystal oscillator circuit we limit dissipation by controlling the amplitude of the feedback signal. Most fundamental-mode crystals will dissipate as much as 200 μ W, although it is considered good design practice to limit dissipation to less than that amount. For example, low-frequency crystals (those that operate below 1 MHz) usually have a maximum dissipation rating of 100 μ W, so we usually limit dissipation to 50 μ W.

Another reason to limit power dissipation is to improve the frequency stability of the crystal oscillator. That's why it's not good practice to obtain a great deal of RF power directly from the crystal oscillator stage of a transmitter. For example, 25 years ago amateur radio handbooks often carried transmitter circuits that produced as much as 50 watts of power. Modern designs limit the dissipation of the oscillator circuit, and then use a linear amplifier to increase overall output.

Example circuits

As we have seen, a crystal is equivalent to a complex LC circuit with both series and parallel sections. Therefore a crystal can be used in many of the same circuits as an actual LC resonant tank circuit. Often the crystal or LC network is the only difference between two circuits.

Figure 4 shows a simple circuit for a low-frequency crystal oscillator. The oscillator operates at a fundamental frequency of 100 kHz, but its harmonics go high enough to make the circuit ideal for use as a high-frequency marker for a communications receiver and for aligning receivers and test equipment.

The active element in the circuit is a bipolar NPN transistor; although a

2N2222 is specified, the actual type is not critical. Almost any transistor with a beta between 50 and 125, and a gain-bandwidth product of at least 50 MHz, will work.

That circuit is similar to the LC Colpitts oscillator discussed in Part Two of this series (in the August issue of *Radio-Electronics*). Feedback level is a function of the capacitive voltage divider composed of C1 and C2. The ratio of those two capacitors is a trade-off between amplitude, stability, and power dissipation in the crystal.

The operating frequency of almost any crystal can be "pulled" a little bit with a series or parallel capacitor. Capacitor C3 is used to set the actual operating frequency of the circuit.

The output signal is coupled to the load through a low-valued capacitor, C4. The circuit should be lightly loaded in order to minimize changes in frequency due to load variations. If loading will be heavy, follow the oscillator with a buffer stage.

There are several ways to calibrate the operating frequency of the oscillator. You can use a digital frequency counter, or you can use a radio, either a communications receiver or a standard AM radio. If you use the latter, tune it to a station with a frequency that is an even multiple of 100—1500 kHz, for example.

If you have a communications receiver, then tune in station WWV (located in Fort Collins, CO) or WWVH (Hawaii). Those stations transmit accurate signals on 5, 10, 15, and 20 MHz. To reduce error, tune in the highest frequency station that produces a usable signal in your area. It's best to use the 15- or 20-MHz signal.

Whatever you use for a standard, loosely couple the output of the oscillator into your receiver, perhaps at the antenna terminal. Then adjust C3 for zero beat with the radio station. If you have an S-meter on your receiver, you can tell you're approaching zero beat when the pointer of the meter indicates a null reading.

If you have no meter, you can use your ear. As the signals from the station and the oscillator mix, sum and difference frequencies will be produced. Some of those signals will be in the audio range. As you adjust C3, the pitch of those signals will vary. When the frequencies of the two signals are equal, you'll hear no output.

Miller oscillator

The classic Miller oscillator used a crystal resonator in the grid circuit of a vacuum tube, and a parallel-tuned LC tank circuit in the plate circuit. Shown in Fig. 5 is an updated version of that circuit using a junction FET in place of the tube.

The crystal is connected between gate and ground in parallel with a 10-megohm resistor. Bias for the FET is set by source resistor R2, which is bypassed for RF to

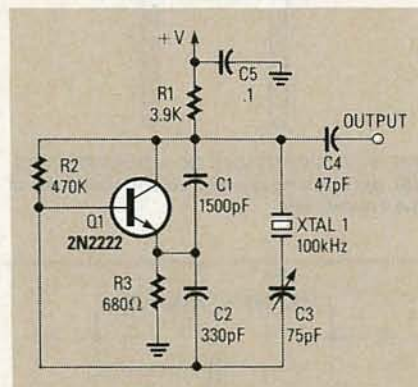

FIG. 4—A COLPITTS OSCILLATOR can be built from a garden-variety NPN transistor and several resistors and capacitors. Capacitor C3 is used for fine tuning.

PC SERVICE

One of the most difficult tasks in building any construction project featured in **Radio-Electronics** is making the PC board using just the foil pattern provided with the article. Well, we're doing something about it.

We've moved all the foil patterns to this new section where they're printed by themselves, full sized, with nothing on the back side of the page. What that means

for you is that the printed page can be used directly to produce PC boards!

Note: The patterns provided can be used directly only for *direct positive photoresist methods*.

In order to produce a board directly from the magazine page, remove the page and carefully inspect it under a strong light and/or on a light table. Look for breaks in the traces, bridges between traces, and in

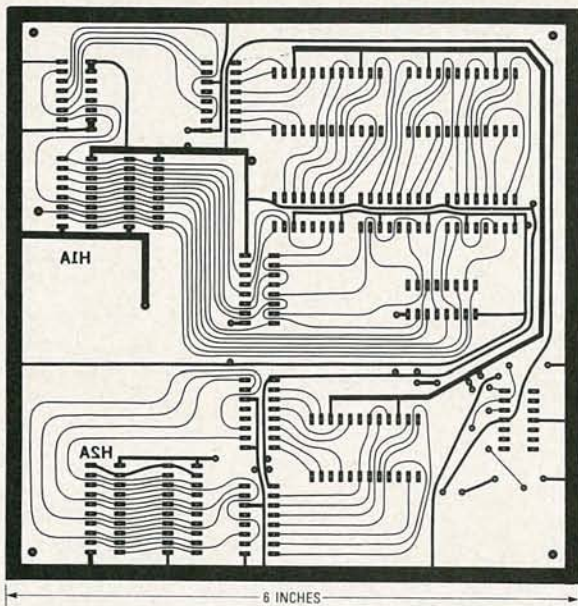

ADD A HEX DISPLAY BOARD to your EPROM programmer using this PC board. Note that the board is shown half sized. It will have to be enlarged photographically before it can be used to produce the board.

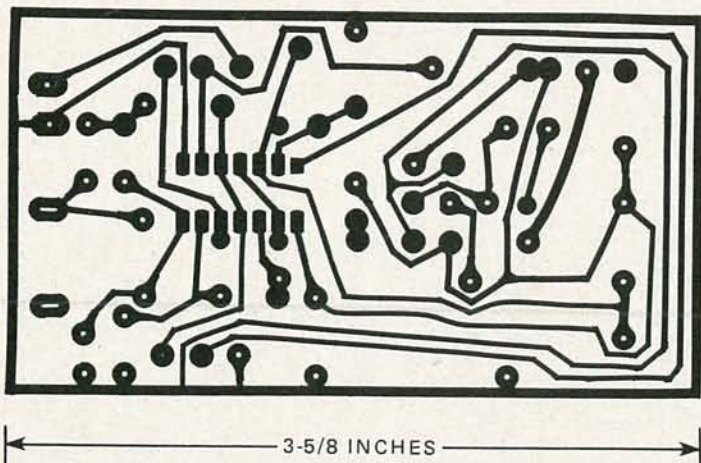

THE LATCHING CONTINUITY TESTER can find faults that other testers miss. Nearly all of the circuitry mounts on this simple PC board.

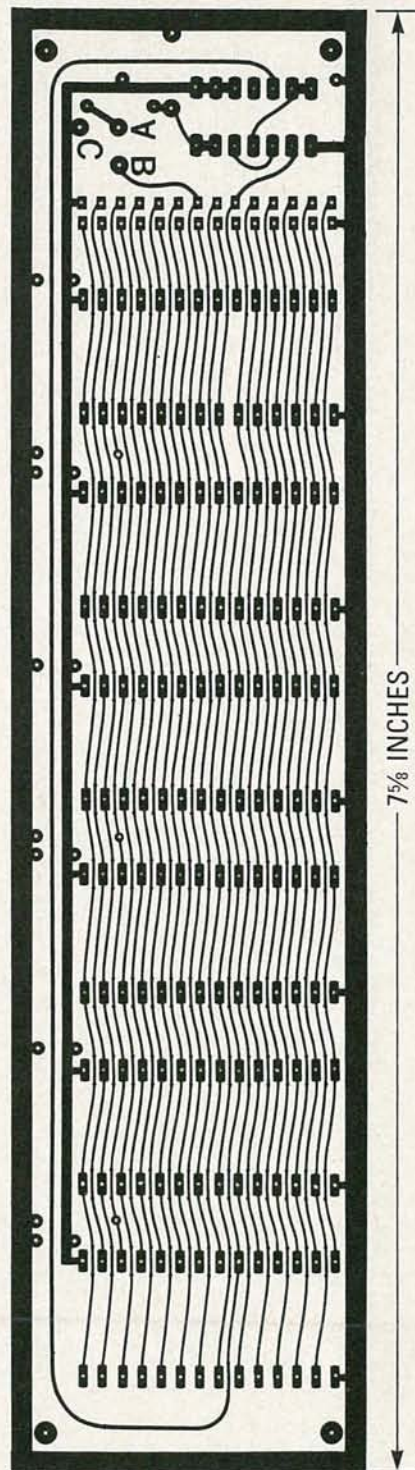

THE GANG PROGRAMMING BOARD for the EPROM programmer is shown here.

PC SERVICE

PC SERVICE

PC SERVICE

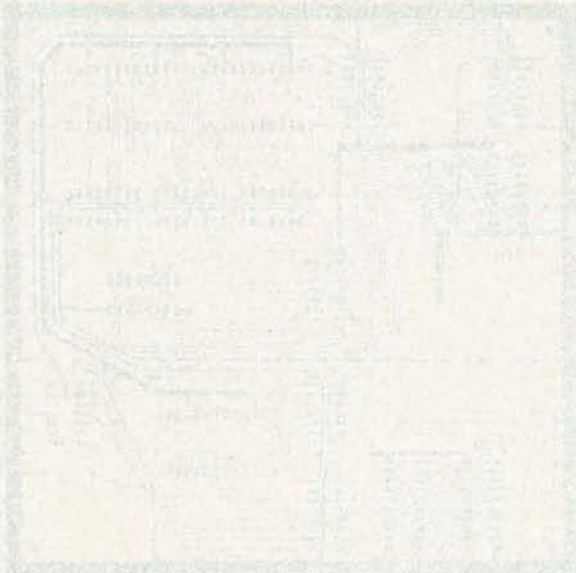
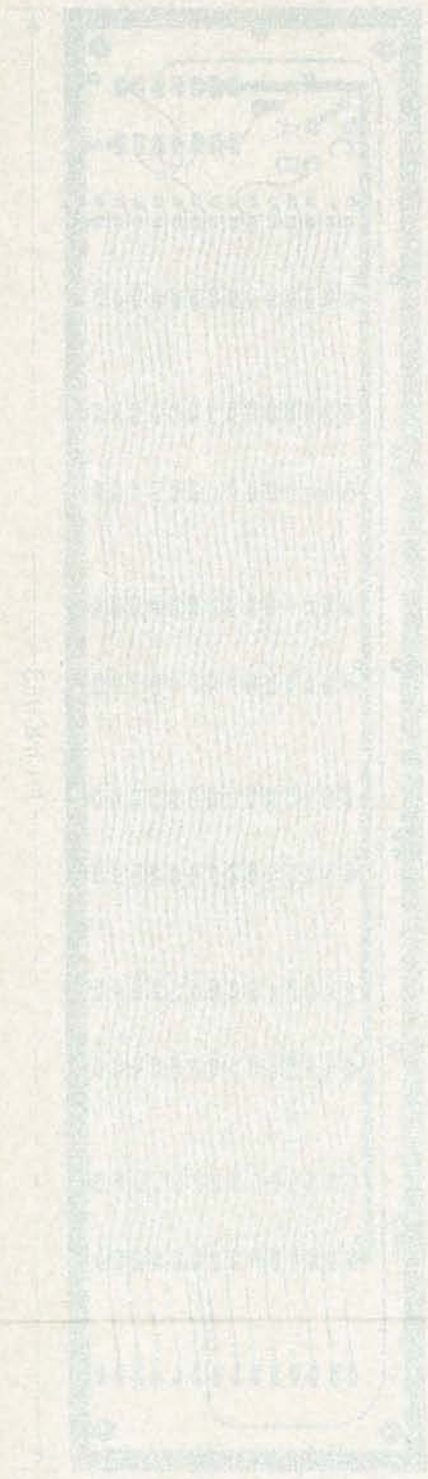

PC SERVICE

general, all the kinds of things you look for in the final etched board. You can clean up the published artwork the same way you clean up your own artwork. Drafting tape and graphic aids can fix incomplete traces and doughnuts, and you can use a hobby knife to get rid of bridges and dirt.

An optional step, once you're satisfied that the artwork is clean, is to take a little bit of mineral oil and carefully wipe it across the back of the artwork. That helps make the paper translucent. Don't get any on the front side of the paper (the side

with the pattern) because you'll contaminate the sensitized surface of the copper blank. After the oil has "dried" a bit—patting with a paper towel will help speed up the process—place the pattern front side down on the sensitized copper blank, and make the exposure. You'll probably have to use a longer exposure time than you are used to.

We can't tell you exactly how long an exposure time you will need as it depends on many factors but, as a starting point, figure that there's a 50 percent increase in

exposure time over lithographic film. But you'll have to experiment to find the best method for you. And once you find it, stick with it.

Finally, we would like to hear how you make out using our method. Write and tell us of your successes, and failures, and what techniques work best for you. Address your letters to:

Radio-Electronics
Department PCB
500-B Bi-County Blvd.
Farmingdale, NY 11735

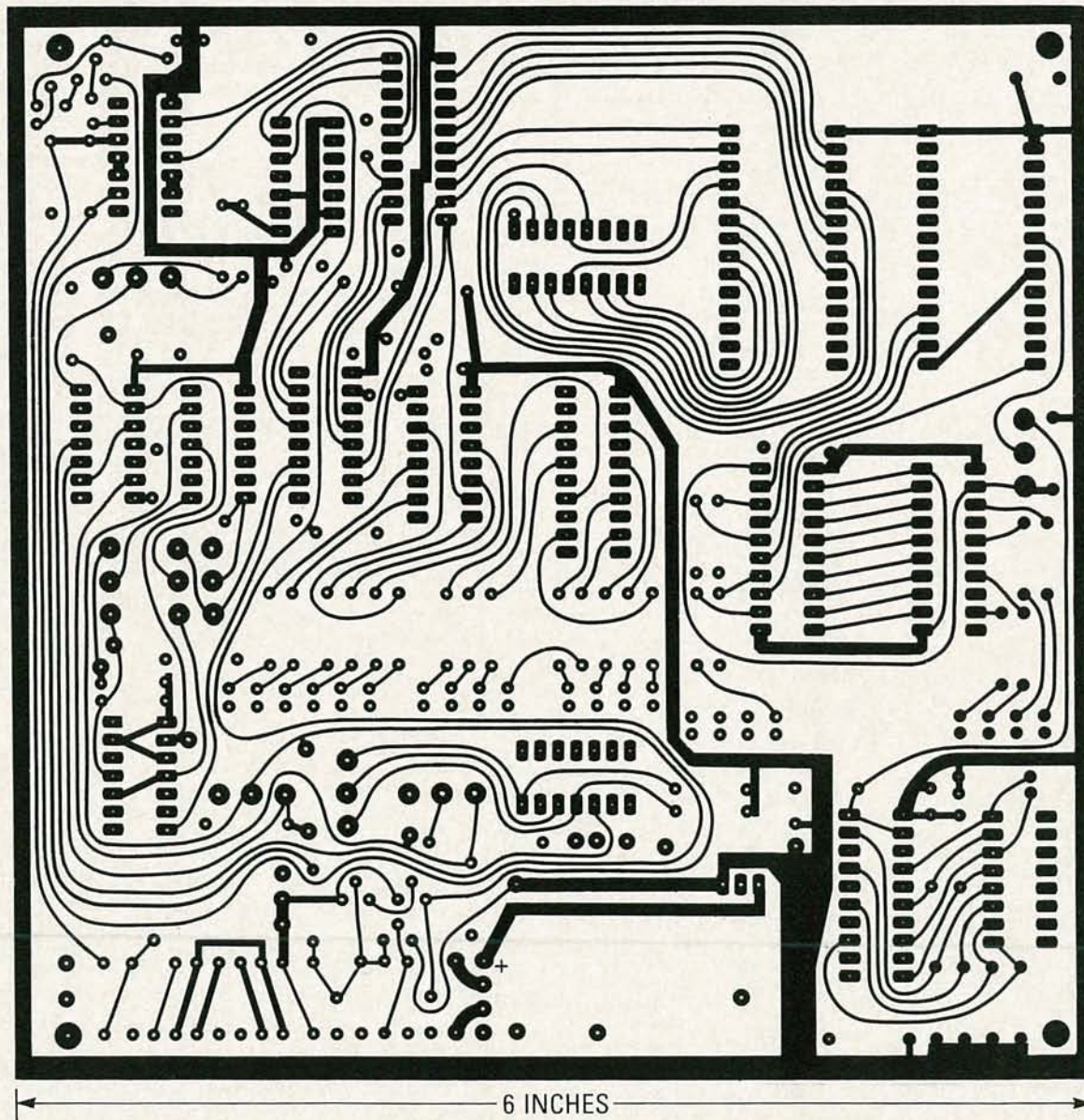

THE SOLDER SIDE of the EPROM programmer's main board. The component side was shown last month.

PC SERVICE

...the most common cause of PC problems is a bad connection. Check the power supply, keyboard, mouse, and monitor cables. Make sure they are plugged in correctly and that the connections are secure. If you are using a modem, check the phone line connection. If you are using a printer, check the printer cable connection. If you are using a scanner, check the scanner cable connection. If you are using a mouse, check the mouse cable connection. If you are using a keyboard, check the keyboard cable connection. If you are using a monitor, check the monitor cable connection. If you are using a printer, check the printer cable connection. If you are using a scanner, check the scanner cable connection. If you are using a mouse, check the mouse cable connection. If you are using a keyboard, check the keyboard cable connection. If you are using a monitor, check the monitor cable connection.

...the most common cause of PC problems is a bad connection. Check the power supply, keyboard, mouse, and monitor cables. Make sure they are plugged in correctly and that the connections are secure. If you are using a modem, check the phone line connection. If you are using a printer, check the printer cable connection. If you are using a scanner, check the scanner cable connection. If you are using a mouse, check the mouse cable connection. If you are using a keyboard, check the keyboard cable connection. If you are using a monitor, check the monitor cable connection. If you are using a printer, check the printer cable connection. If you are using a scanner, check the scanner cable connection. If you are using a mouse, check the mouse cable connection. If you are using a keyboard, check the keyboard cable connection. If you are using a monitor, check the monitor cable connection.

...the most common cause of PC problems is a bad connection. Check the power supply, keyboard, mouse, and monitor cables. Make sure they are plugged in correctly and that the connections are secure. If you are using a modem, check the phone line connection. If you are using a printer, check the printer cable connection. If you are using a scanner, check the scanner cable connection. If you are using a mouse, check the mouse cable connection. If you are using a keyboard, check the keyboard cable connection. If you are using a monitor, check the monitor cable connection. If you are using a printer, check the printer cable connection. If you are using a scanner, check the scanner cable connection. If you are using a mouse, check the mouse cable connection. If you are using a keyboard, check the keyboard cable connection. If you are using a monitor, check the monitor cable connection.

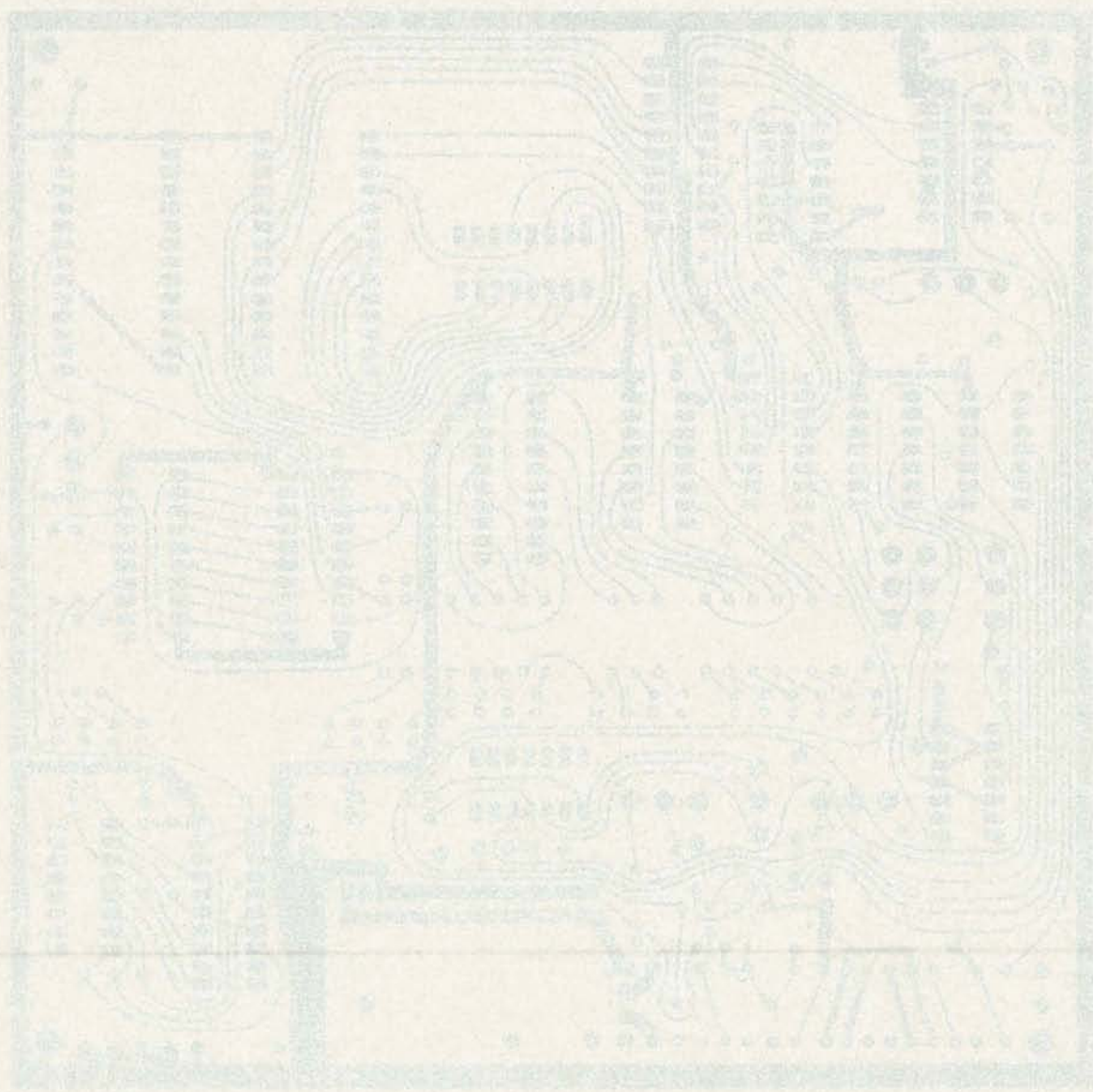

COMPUTER DIGEST

VOL. 3 NO. 11 NOV. 1986

A NEW KIND OF MAGAZINE FOR ELECTRONICS PROFESSIONALS

TAPE BACKUP

A natural choice for adding storage

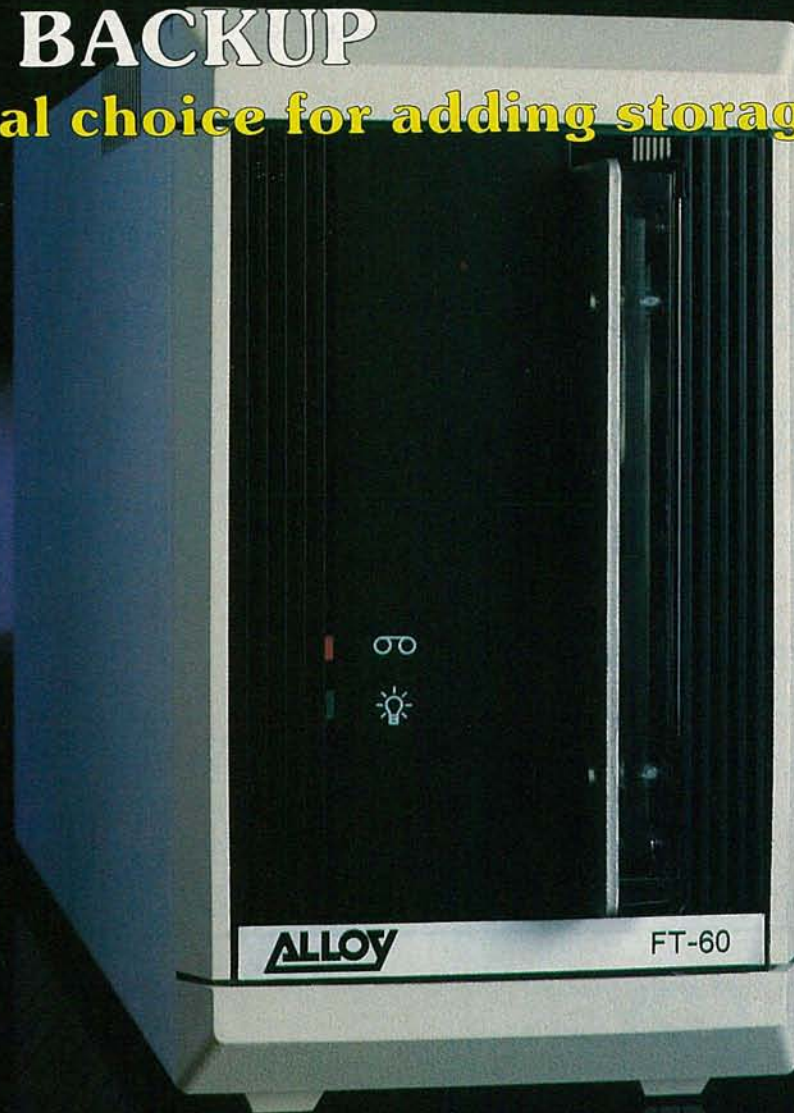

A
GERNSBACK
PUBLICATION

SCHMITT TRIGGER DESIGN

Your computer does the heavy work

NO-FRILLS MODEM

Build a modem without the "fancies"

CONTENTS

Vol. 3 No. 11

November 1986

6 Tape Backup

"Never anything new under the sun?" Take another guess. And sometimes that something new can *really* be something old. **Marc Stern**

8 Schmitt Trigger Design

This program will quickly and easily give you the necessary resistor values when you're designing Schmitt Triggers. Any computer you have can use this program, too. **Vince O'Connor**

9 No-Frills Modem

Can you use a modem without all the bells and whistles? And would you like to build it yourself and save some of the cost? This might prove the answer for you! **Rodney A. Kreuter**

3 Editorial

4 Letters

4 Computer Products

5 Software Review

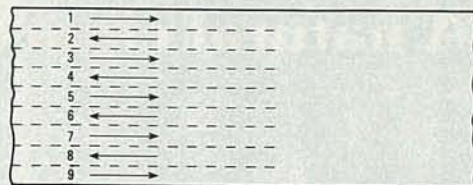

See Page 6

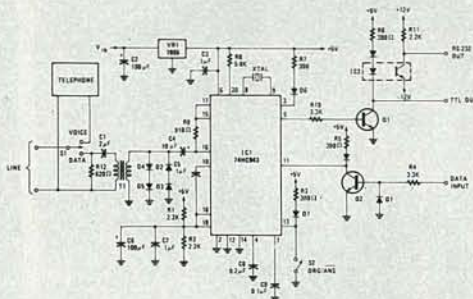

See Page 9

ON THE COVER

If you'll turn to Page 6, you'll find an article on Tape Backup. And that beautiful unit on the cover this month, is **ALLOY's** FT-60 Streaming 1/4-inch Cartridge tape backup. It provides 60 megabytes formatted data capacity and automatic backup.

COMING NEXT MONTH

Check it out! You're going to find a neat way to use your computer for helping to design regulators, and then we're going to run the first of a two-part article on Interfacing that will answer a lot of questions you haven't even thought of yet. And finally, (yes, there's more) we'll show you how to use your computer for power control.

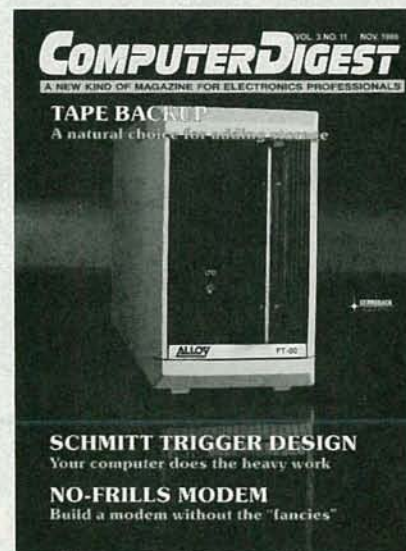

EDITORIAL

Systems

■People involved in marketing have been using that word "Systems" to bleed the market dry. And it isn't in the computer field alone that we find this. Buy a camera today, and all you're liable to get is a camera body. If you want a lens, film back and all the other accoutrements that are needed to take photos, you want a "camera system."

Likewise, in the computer field, a "computer" consists of a black box that—by itself—can do absolutely nothing. To get any work out of it, you have to add "peripherals" such as a keyboard, and a monitor at the very least. And if you want additional peripherals, such as a modem, a printer, a mouse or a joystick, you're building a "computer system."

It goes a good deal further than that. If you buy a basic computer and open it up, you'll find all sorts of empty card slots so that at a later date, you can plug in those cards that can provide anything from added memory to increased function.

The manufacturers explain that they are unable to predict exactly which cards and peripherals a given buyer will want. What it all comes down to, is that we, the consumers, must know up front exactly what we want, how we want it, and total up *all* of the costs before spending any of our dollars. There are computers out there that are available at ridiculously low prices, but when you get them home, you find out that they are unsupported by suitable software, are difficult if not impossible to modify, and that frankly, you'd have been far-better off to have waited to make a purchase until you *could* get what you want and need.

In almost every other field, you can buy a basic commodity and learn all about it as you use it. In our field, you have to buy first, before you learn.

What it all comes down to, is that you've simply got to take the time to educate yourself thoroughly, before you start to shop.



Byron G. Wels
Editor

ComputerDigest is published monthly as an insert in Radio-Electronics magazine by Gernsback Publications, Inc., 500-B Bi-County Blvd., Farmingdale, N.Y. 11735. Second-Class Postage Paid at New York, N.Y. and additional mailing offices. Copyright © 1986 Gernsback Publications, Inc. All rights reserved. Printed in U.S.A.

A stamped self-addressed envelope must accompany all submitted manuscripts and/or artwork or photographs if their return is desired should they be rejected. We disclaim any responsibility for the loss or damage of manuscripts and/or artwork or photographs while in our possession or otherwise.

COMPUTER DIGEST

M. Harvey Gernsback,
editor-in-chief, emeritus

Larry Steckler,

EHF, CET: publisher & editor in chief

Art Kleiman,
editorial director

Byron G. Wels,
editor

Brian C. Fenton,
managing editor

Carl Laron,
associate editor

Robert A. Young,
assistant editor

Jeff Holtzman
technical editor

Teri Scaduto Wilson
editorial assistant

Ruby M. Yee,
production director

Karen Tucker,
production advertising
Robert A. W. Lowndes,
production associate

Geoffrey S. Weil,
production assistant

Andre Duzant,
technical illustrator

Jacqueline P. Cheeseboro
circulation director

Arline R. Fishman,
advertising director

Computer Digest
Gernsback Publications, Inc.
Executive offices
500-B Bi-County Blvd.,
Farmingdale, NY 11735
516-293-3000
President: Larry Steckler
Vice President: Cathy Steckler

ADVERTISING SALES 516-293-3000

Larry Steckler
Publisher

NATIONAL SALES

Joe Shere
1507 Bonnie Doone Terrace
Corona Del Mar, CA 92625
714-760-8967

LETTERS

Power Control

I'd like to get a means of controlling power to my computer, modem, drives, printer, etc. individually, without having to reach behind each unit. I'd also like some indicator lamps to tell me what's on or off. Don't suggest a multiple switched-outlet strip, as I had one of those. T.P., Paterson, NJ.

Under separate cover, I'm sending you a schematic of one I built that works like a charm. It's fused, has surge protection, and a latching relay that turns everything off in case of line dropouts. I think you'll like it!

Ann Landers?

In your July Issue, S.D. complains that he bought an expensive computer system and now it's used only for games. He should have written to Ann

Landers, not **ComputerDigest!** If he and his family would take the time and trouble to learn how to program the many fascinating things into their computer they'd get a lot more out of it!—J.J.H., Menasha, WI.

Amen!

Versatility!

I've noticed that in your magazine you often print a story about an add-on circuit that I'd like to have, but it's for a different computer than mine. One that I tried anyway, just didn't work. Can't you publish the necessary modifications so that the circuits can be made to work with any computer?—F.T., Portland, OR.

Not really. That would require the use of excessive space that we just can't afford. Stick to those projects designed for your computer. We do try to please as

many readers as possible each month.

Old Timer

I was going through some old magazines stored in my attic. One of the first of the computer-oriented magazines was called "Data Product News," which I have since its first issue. The Editor's name seemed familiar. Was that you?—S.L., New York, NY.

Yup! Thanks for remembering.

G.E.D.

Do you know of any software that would help make the obtaining of a New York State General Equivalency Diploma an interesting project?—J.A., Farmingdale, NY.

Can anybody help? This sounds like a fine idea! Write directly to John K. Allison, 25 Elizabeth Street, Farmingdale, NY 11735.

COMPUTER PRODUCTS

For more details use the free information card inside the back cover

DISKETTE HOLDER, the *Disk-O-Tier*, organizes and protects diskettes close at hand using minimum space. This storage tier helps copmputer operators avoid "wipe-outs" caused by scratches, coffee spills, and cigarette ashes. The upright design allows diskette titles to be read easily.

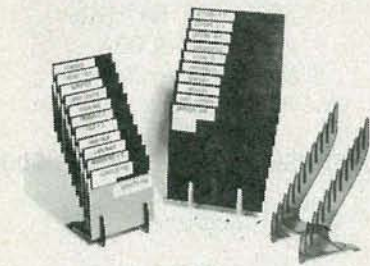

CIRCLE 18 ON FREE INFORMATION CARD

Disk-O-Tier is molded of ABS plastic and holds eleven 5¼ inch or 8 inch diskettes, in or out of jackets. The suggested retail price is \$9.50 each or

\$15.00 for a twin pack.—**ETS Center**, 35026-A Turtle Trail, Willoughby, OH 44094.

CONTROL UNITS, the *OASys 66* and the *OASys 66/es* provide faster performance and permit more PC users to access files and the software library simultaneously. Both systems connect up to 64 PC's in an office network, and up to 48 concurrent sessions may be held on the *OASys66* and the *OASys66/es* at one time. MS-DOS operations, such as spreadsheets, can be updated much faster with the new controller.

Both units use an Intel 80286 processor, plus four subprocessors, and come standard with two megabytes of RAM. In addition, the *OASys 66/es* is available with 76 or 168 megabytes of disk drive in a streamlined tower cabinet design. The model *OASys 66* is available with 60 or 120 megabytes of disk storage with an 8-inch disk drive.



CIRCLE 19 ON FREE INFORMATION CARD

The model *OASys 66/es* is priced from \$27,400 depending on the amount of storage and number of workstations attached. The model *OASys 66* is priced from \$21,400.—**NBI**, P.O.Box 9001, Boulder, CO 80301.

SOFTWARE REVIEW

Media Master Plus

■Media Master Plus is a package of two programs that permits a PC-compatible computer to read and write 72 disk formats, and to directly run generic 8-bit CP/M software on PC-compatible computers.

Most people are not ready to discard software because they upgraded to a PC-compatible. They use their old computers because it's too time-consuming to re-enter the software for the new computer. The ideal solution would be to use the old software on the new computer but this isn't always possible because the disk formats or microprocessors are mutually exclusive—incompatible. Because much CP/M software is similar to, or has the same kind of data files as an MS-DOS version, data can be interchanged if one of the MS-DOS disk drives can function as a "foreign" drive.

An early version of the Media Master program could program an IBM PC so drive A: retains the IBM format, drive B: emulates any of almost 70 CP/M disk formats from *Actrix* to *Zorba*. The emulation was so good, that the PC-compatible could directly read from or write to the foreign disk: MS-DOS WordStar could edit text (data) on a disk originally written by a Televideo computer using a CP/M version of WordStar.

It is possible to use the MS-DOS computer as translator to exchange data between normally-incompatible 8-bit computers. If you have a mailing list on a Radio Shack Model 4 disk that you need on a Kaypro disk, using Media Master Plus, set the PC-compatible's B: drive for the Model 4 format and copy the data file to an MS-DOS disk in drive A:. Then use Media Master Plus to program drive B: to emulate the Kaypro format and copy the data from drive A: to drive B: The result is a copy of the Model 4 data on a Kaypro disk.

But data isn't a program. You can't run a CP/M program on an MS-DOS machine because the microprocessor's *op codes* are different. While there have been attempts to use CP/M computer modules in PC-compatibles so the CP/M programs could be used as *is*, such devices have been expensive.

A better approach is Media Master Plus' utility called ZPEM, which creates a CP/M emulator that runs under MS-DOS at an equivalent processor speed of 1 MHz. When you load ZPEM, the screen prompt

changes from > to "bracket," indicating that the computer is running the CP/M emulator and will load and run CP/M programs. But the CP/M file must be on an MS-DOS disk, not a foreign CP/M disk. For example, if you wanted to run an Osborne CP/M version of a program called CARDFILE.COM you must first transfer CARDFILE.COM and its data files to an MS-DOS formatted disk. When making the transfer, the extension has to be changed from COM to CPM so the *filename* becomes CARDFILE.CPM. The MS-DOS computer's operating system when running the CP/M emulator is MS-DOS which recognizes any program with a .COM extension as being MS-DOS rather than CP/M. The computer becomes confused. By changing the extension to CPM the extension is recognized only by the CP/M emulation.

That means that you can now run your CP/M programs from an 8-bit computer directly on a PC-compatible. You can run your CP/M programs and work entirely in CP/M using conventional CP/M commands and utilities such as PIP and SUBMIT: As far as you are concerned, the MS-DOS computer functions as an 8-bit CP/M machine.

Media Master Plus provides three versions of ZPEM—the "plain vanilla" ZPEM, ZPEMH19 which also emulates the Heath/Zenith H19 terminal, ZPEMOSB which emulates the Osborne terminal functions, and ZPEMKAY which emulates the Kaypro terminal functions. The special terminal emulations include such things as arrow keys, function keys, screen underline, reverse video, etc.

The CP/M emulation proved excellent. It easily ran generic CP/M programs such as WordStar and Cardfile. Even certain hardware-specific CP/M programs for Heath, Osborne and Kaypro could run using the special ZPEM versions. However, the emulator's speed can be annoying. Since the CP/M program is translated to run on the MS-DOS machine, there is a translation delay. About half speed.

Media Master Plus runs on any PC-compatible computer having at least 192K of RAM. It is \$59.95 from Intersecting Concepts, 4573 Heatherglen Ct., Moorpark, CA 93021. 

CIRCLE 17 ON FREE INFORMATION CARD

TAPE BACKUP

Have you thought about streaming tape for backup? Maybe you should!

Marc Stern

■ Hard disks are natural choices for computer users who have vast amounts of data to store. With capacities ranging from 10 to 60 megabytes, a 5.25-inch hard disk holds as much data as 30 to 180 floppy disks.

The chances of having a problem with the fixed disk, are high. At that time, it's likely you'll find the data damaged and you realize how important it is to have backed up the platter. A backup copy assures that your program and data files are still usable because copies are stored off-disk.

Floppy alternative

For many, that backup is handled with floppy disks, an expensive solution and not the most convenient one. Even at a cost of \$1.50 a disk, you can use over 30 disks to backup a 10 megabyte hard disk, which is a \$45 layout. A high-density fixed disk — 20 or 30 megabytes or more — means higher layouts. And, you must shuffle the disks in and out of a floppy disk drive to assure the backup is properly made.

When backups are made, they are done infrequently and only those files which have changed may be backed up at all (the backup option on an IBM PC/XT and compatibles allows this type of selectivity).

Imagine a device which makes backing up a hard disk easy and assures data integrity at a reasonable cost. The streaming tape drive offers efficient backup of up to 60 or more megabytes of data in half an hour.

You simply type one command and the tape drive springs to life. That's easier than shuffling disks. Such convenience means the job is likely to be done fairly frequently.

Lots of storage

It may seem strange that the storage medium of the early years of microcomputers, discarded when disks became available has regained popularity. A 300-foot tape is capable of storing up to 30 megabytes of data, while a 400-foot tape can store upwards of 45 megabytes.

With streaming tape, data are continuously laid down by the read-write head. To facilitate speed, data compression is used to enable maximum data storage in minimum space.

To ensure data integrity, each major tape storage system uses some form of error-checking and error-correction, such as Cyclical Redundancy Checking (CRC), a form of checksumming.

Tape backup isn't a recent development, although it may seem so from a microcomputer user's point of

view. Tape backup has been around since the computer explosion of the 1960s. Then, open-reel half-inch tape was the standard for storage. This changed about 1971 when the quarter-inch data cartridge appeared.

That width became standard and is used today in lengths from 300 to 600 feet. As tape formulations got better through the years, data storage capability has increased. A 600-foot tape can be pushed to 134 megabytes of storage.

When you look at data storage cartridges for the first time you see they aren't all like the Phillips cassette that you used in a digital tape storage drive, as you may have expected.

A common variety is the DC300 and DC600 series. They are about 4 by 6 by $\frac{5}{8}$ inches. A more recent alternative is the DC1000. It is about 2 by 3 by $\frac{1}{2}$ -inch. This type of tape is $\frac{1}{4}$ inch wide and can store about 10 megabytes of data on nine tracks.

The DC2000 tape cartridge was only recently introduced, but features high-density $\frac{1}{4}$ -inch tape that can handle 20 to 40 megabytes of data. Shirt-pocket-sized, the DC2000 uses 12 to 24 separate tracks for information.

There is one tape which looks like audio tape, the real digital cassette. A high-speed unit, it operates at 90 inches per second and is capable of up to 20 megabytes of storage. It uses four recorded tracks.

Little compatibility

You're probably thinking that like an audio cassette the tapes generated by one system can be used by another, but, that isn't true because of differing storage standards.

There are three quarter-inch systems contending for leadership in the storage market: the Quarter-Inch Committee (QIC); a standard called PC/T, which was only recently introduced, and "floppy tape."

The basic QIC-24 standard calls for the use of nine tracks, recorded in a serpentine pattern. With this data

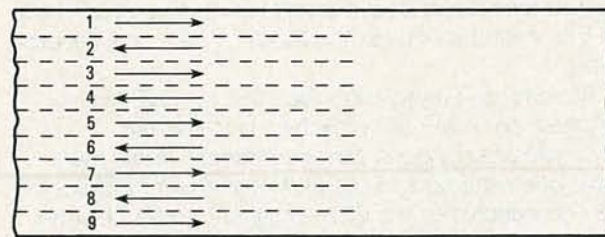

Fig. 1—STANDARD NINE-TRACK tape cartridge stores back-up information by recording front-to-back then beginning at the next track at the back, and recording to the front. It takes nine passes to fill a tape.

encoding scheme, when the end of one recording track is reached, the recording direction is reversed and the read-write head is repositioned. In its new position, the head begins recording the new data track opposite the first. In this manner, the tape doesn't have to be rewound during the nine recording passes. (See Fig. 1)

The head has separate read and write head elements. Because it has two elements, data written to the tape can be instantly checked and verified, by comparing it against the original data.

Tape erasure is done on a wholesale basis, with Track 0 controlling the entire tape. When Track 0 is erased the whole tape is cleaned in a single pass.

With this system, tapes need not be preformatted before they're used. Image or file-by-file backups can be made.

The QIC standard defines everything that makes up a tape backup system including interconnections, formats, interfaces and error correction.

Such systems are not compatible across-the-board. Although the QIC system defines nearly every aspect of performance, it doesn't define data compatibility. A backup tape created with one system can't be read by another manufacturer's system. This problem seems much the same as the microcomputer disk world before the advent of PC-DOS. It was true that 5.25-inch floppy disks were the same size and used the same media and their construction was essentially the same. It's also true that the physical requirements of the disk drive unit itself were nearly universal. What wasn't universal was the compatibility of data. A 5.25-inch CP/M disk couldn't be read in an Apple and an Apple couldn't read a Radio Shack disk.

But the advent of PC-DOS (MS-DOS) created a standard that seems to be even more universal than CP/M, which was the former 8-bit standard, and let one system read the media of another. Experts note that software changes will allow this compatibility among QIC systems, but no one has implemented it yet.

A newer standard

The second of the three competing tape backup systems is called PC/T. PC/T stands for Personal Computer/Tape. Its biggest difference from the QIC standard is its method of data verification.

In the QIC system, data is corrected as soon as it is written to tape. Bad data are written and rewritten until they are recorded correctly. Ignoring such issues as tape wear and tear, there is no way to detect future data errors that might be brought on by plain wear and tear or machine problems.

PC/T on the other hand, uses a single head and



Fig. 2—THE PC/T APPROACH uses a single head to write data to tape in two 4K blocks. Using the same data as in the first two blocks, a third parity block is constructed by performing an exclusive or operation. In this way, should data be lost, it can be more-easily reconstructed during an error recovery pass. This does increase system overhead.

writes data to tape in two 4K blocks at a time. After the first two blocks are recorded, a third block, using data derived from the first two, is written to the tape. This is the error-checking box and works in an exclusive-or (XOR) fashion.

With the XOR block ready, a tape can be read back and if the data are corrupted, the algorithm polls the XOR box which is then used to correct and reconstruct the corrupted data. The data are reconstructed using XOR techniques.

This technique is more wasteful than the QIC standard. Since error-checking and correcting XOR blocks are written, more space is needed for this function alone. To get around this, manufacturers have increased the number of recording tracks to 11. Also, PC/T tapes must be formatted before use, which can be a lengthy process. This does have an unexpected benefit, since it allows a directory to be set up and the tape controller to use that directory to determine where a file is and then read it off the tape, much as is done with a disk's random access capability. In this way, specific files can be updated without having to rewrite the whole tape. (See Fig. 2)

Hard disk backup is a function of the IBM PC/XT or compatible world, with an open architecture. All functions of these microcomputers is built into the boards that are inserted on the motherboard. And add-in space can be a premium when you've populated the motherboard with video, floppy and hard disk controllers, memory and multifunction boards. Still, to use a tape backup system you have to insert a tape controller card, in most cases.

And this brings us to the "floppy tape." This type of tape backup system uses the floppy disk controller card, rather than a separate tape controller card. A "floppy tape" acts as a floppy disk and is subject to the same requirements. Floppy disks require formatting and so do "floppy tapes." And, the formatting marks out bad areas and builds a bad-sector table, which keeps those sectors from being used.

Because they run under the constraints for the disk operating system, "floppy tapes" limit to the upper edge of the storage capability of the system. A formatted "floppy tape" in an IBM setting will store about 25 megabytes of data.

In a "floppy tape" system a single read-write head is used. Six tracks are recorded in 16 sector chunks. A 17th is then written which acts as a parity checking sector. This data-protection scheme only covers one bad sector and if two or more are found during a replay, the area is flagged and you are asked whether you want to rewrite the tape.

The error rate for any of these systems isn't high. It's on the order of 1×10^{-11} , so these are reliable systems with low error rates.

Of the three systems, QIC still stands to emerge the victor for market share because it is the most widely adhered to. This could change as technology changes.

Whatever standard emerges, hard disks and tape backup go hand-in-hand. It was a marriage everyone was waiting for and one which is a welcomed change. ◀▶

SCHMITT TRIGGER DESIGN

Let your computer do the heavy work.

Vince O'Connor

■ Schmitt triggers are used to convert sine waves or other shaped signals into square-wave pulses. They compare an incoming signal to upper and lower threshold voltages, then produce a square wave at the same frequency as the input.

This program quickly calculates the standard resistor value for resistors needed in a two-transistor Schmitt trigger circuit. You must enter the upper and lower threshold voltages, the supply voltage (Vcc), the base-to-emitter voltage drop of the transistors, and the load resistance.

Use any computer

The program is written so that it can be run on almost any computer without modification. The only change you should need to make is the HOME command. This clears the screen, and you should substitute the command your machine uses, if it's different.

Because ideal circuits are ideal only on paper, the program calculates theoretical resistor values, and then changes them to the nearest standard value. Since these changes alter the actual threshold voltage values, the actual values are calculated and printed.

No attempt has been made to draw the circuit within the program, because universal ASCII symbols are inadequate, and graphics are unique to each machine. A diagram of the circuit and the four calculated resistors (R1, R2, R3 and R4) are shown in Figure 1. Figure 2 shows a sample run.

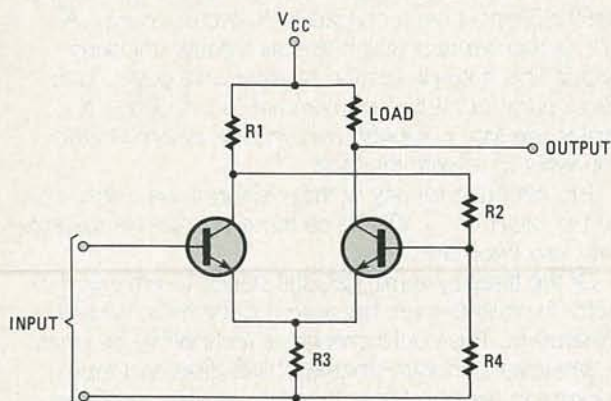

FIG. 1—CIRCUIT DIAGRAM and the four calculated resistors is shown above.

LIST

```

10 REM SCHMIDT TRIGGER
15 REM BY
20 REM VINCE O'CONNOR
25 REM DESIGN A 2 TRANSISTOR
30 REM SCHMIDT TRIGGER
35 HOME
40 PRINT
45 PRINT
50 INPUT 'UPPER THRESHOLD VOLTAGE (VOLTS): ',UV
55 INPUT 'LOWER THRESHOLD VOLTAGE (VOLTS): ',LV
60 INPUT 'SUPPLY VOLTAGE (VOLTS): ',SV
65 INPUT 'EMITTER-BASE VOLTAGE (VOLTS): ',EB
70 INPUT 'LOAD IMPEDANCE (OHMS): ',LI
75 INPUT 'RESISTOR TOLERANCE (%): ',RT
80 PRINT
85 INPUT 'IS THIS CORRECT (Y/N)';A#
90 IF A# = 'N' THEN GOTO 35
95 R3 = (UV - EB) * LI / (SV - UV + EB)
100 G = R3
105 GOSUB 400
110 R3 = G
115 R1 = (SV - LV + EB) * R3 / (LV - EB)
120 G = R1
125 GOSUB 400
130 R1 = G
135 R4 = R3 * 10
140 R2 = R4 * SV / UV - R4 - R1
145 G = R2
150 GOSUB 400
155 R2 = G
160 TL = EB + R3 * SV / (R1 + R3)
165 TL = INT (TL * 100 + .5) / 100
170 TU = R4 * SV / (R1 + R2 + R4)
175 TU = INT (TU * 100 + .5) / 100
180 HOME
185 PRINT
190 PRINT
195 PRINT
200 PRINT
205 PRINT 'THE FOLLOWING ARE THE RESISTOR VALUES'
210 PRINT 'FOR A SCHMIDT TRIGGER WITH AN UPPER*'
215 PRINT 'THRESHOLD VOLTAGE OF ',UV,' VOLTS*'
220 PRINT 'AND A LOWER THRESHOLD VOLTAGE OF ',LV
225 PRINT 'VOLTS: '
230 PRINT
235 PRINT 'R1=:R1,' OHMS, ':RT:':%
240 PRINT 'R2=:R2,' OHMS, ':RT:':%
245 PRINT 'R3=:R3,' OHMS, ':RT:':%
250 PRINT 'R4=:R4,' OHMS, ':RT:':%
255 PRINT
260 PRINT 'THE ACTUAL THRESHOLD VOLTAGES ARE:'
265 PRINT
270 PRINT 'UPPER THRESHOLD VOLTAGE=:TU,' VOLTS'
275 PRINT 'LOWER THRESHOLD VOLTAGE=:TL,' VOLTS'
280 PRINT
285 INPUT 'ENTER NEW VALUES (Y/N)';A#
290 IF A# = 'Y' THEN GOTO 35
295 HOME
300 END
400 TEMP(6) = RT
405 TEMP(4) = 1.19927E - 2 * INT (1 + 1.5 * RT + .004 * RT ^ 2)
410 TEMP(3) = INT (LOG (G) / LOG (10)) - INT (2.2 - 3 * TEMP(4))
415 G = G / 10 ^ TEMP(3)
420 TEMP(1) = INT (EXP (TEMP(4)) * (INT (LOG (G) / TEMP(4)))) + .5)
425 TEMP(5) = 1.88E - 5 * TEMP(1) ^ 3 - .00335 * TEMP(1) ^ 2 + .164 * TE
MP(1) - 1.284
430 TEMP(1) = TEMP(1) + INT (TEMP(5)) * INT (3 * TEMP(4) + .8)
435 TEMP(2) = INT (EXP (TEMP(4)) * (INT (LOG (G) / TEMP(4)) + 1)) + .5)
440 TEMP(5) = 1.88E - 5 * TEMP(2) ^ 3 - .00335 * TEMP(2) ^ 2 + .164 * TE
MP(2) - 1.284
445 TEMP(2) = TEMP(2) + INT (TEMP(5)) * INT (3 * TEMP(4) + .8)
450 G = INT (10 ^ TEMP(3)) * TEMP(G / SQR (TEMP(1) * TEMP(2) + 1) + .5)
455 RETURN

```

IPR#0

You could easily alter the program to direct the output to a printer, or use a screen dump. The screen layout will nicely fill a 40-column screen, but will appear squashed to the left on an 80-column screen. ◀▶

NO-FRILLS MODEM

Can you build your own modem? Sure you can!

Rodney A. Kreuter

■Until recently, a single chip modem meant that a 300 baud Bell 103 compatible modem could be built using about six chips: The answer filter, the originate filter, an RS-232 driver, an RS-232 receiver, the implement hybrid, and the modem. Add a limiter, precision resistors and capacitors, and a one evening project becomes a major engineering and procurement feat.

Thanks to the newer modem chips, that's a thing of the past. Using National Semiconductor's MM74HC942 or MM74HC943, a single chip Bell 103 compatible modem can be built with one chip if a TTL compatible output is acceptable. If you must have the swing of RS-232, the chip count rises to two. Actually, most micros use a 1489 type line receiver which works quite well with a TTL input.

Add to this a 3.58 MHz crystal, a 600 ohm isolation transformer, and a source of 5 volts at 12 milliamps and you're home free. I sprinkle with LEDs—call it 5 volts at 35 milliamps.

Most important is that the only precision part necessary is the 3.58 MHz crystal.

The only difference between the 74HC942 and the 943 is that the 942 requires + and - 5 volt supplies and can drive the phone line to 0 DBm (1 mw into 600 ohms). The 74HC943 requires only + 5 volts, but can only drive the line to - 9 DBm which is all you're permitted to drive it.

Circuit description

As you can see from Figure 1, the circuit is fairly straightforward. VR1 is more important than it may seem

at first glance. National points out that the modem chips are susceptible to noise on the power supply lines and suggests that a three-terminal regulator dedicated to the modem will prevent problems. Unless you have a very clean supply, use the regulator. It also regulates a calculator-type DC supply (9 volts, 100 ma) very well.

The modem is AC coupled to the phone line or data

PARTS LIST

Semiconductors

IC1—MM74HC943
IC2—TIL113 or 4N33 optoisolator (for \pm 12 volts)
Q1, Q2—2N2222 transistor
VR1—7805 voltage regulator
XTAL1—3.58 MHz colorburst crystal

Resistors

(All resistors $\frac{1}{4}$ watt unless otherwise specified)
R1, R2, R11—2200 ohms
R3, R5, R6, R7—390 ohms
R4, R10—910 ohms (see text)
R12—620 Ohms, $\frac{1}{2}$ watt

Capacitors

C1—2 μ F, 200 volt
C2, C6—100 μ F, 10 volt
C3, C5, C7, C9—0.1 μ F
C4—10 μ F, 16 volt
C8—0.2 μ F (see text)

Miscellaneous Parts

S1—SPDT toggle switch
S2—SPST toggle switch
T1—600:600 ohm transformer (Radio Shack 273-1375 or equal)
Power supply, PC board, cabinet, wire, solder, Etc.

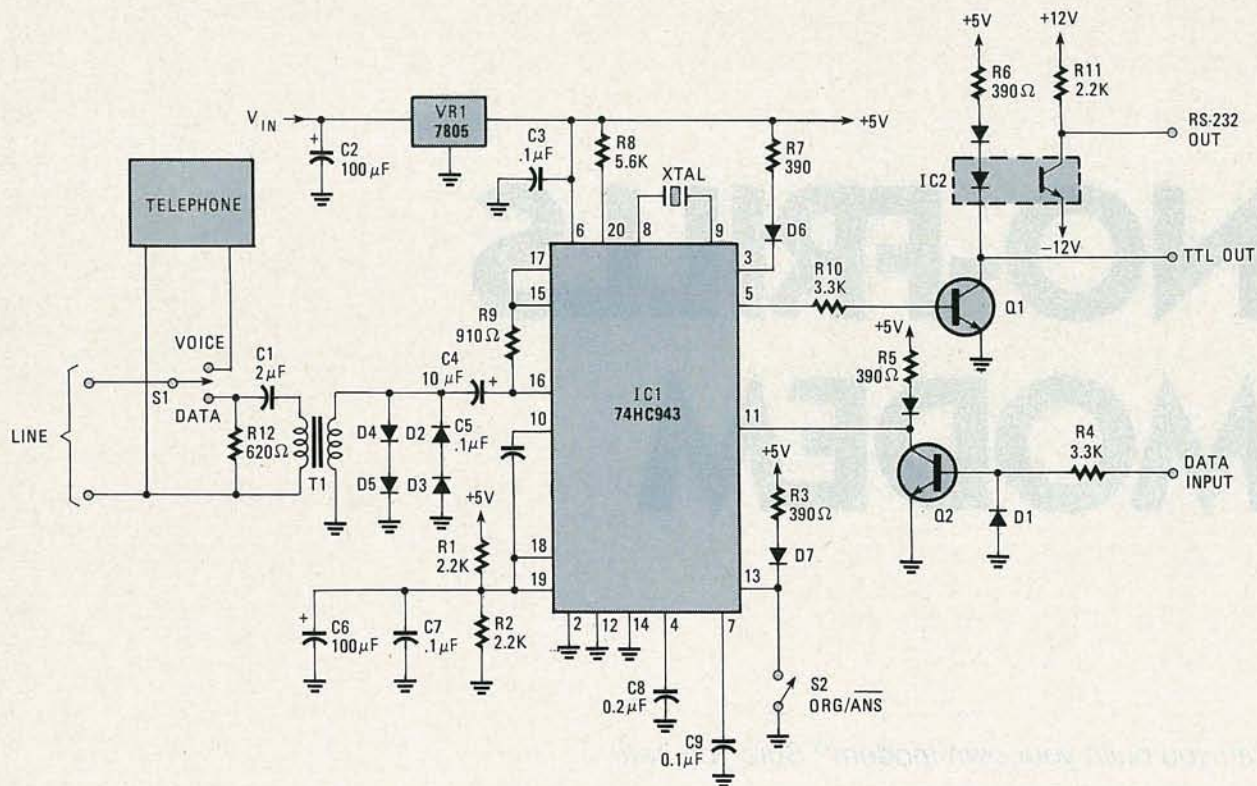

FIG. 1—SCHEMATIC DIAGRAM reveals that this is about as basic as you can get in a modem. Thanks to the 74HC943, it becomes a one-chip circuit.

Description of pin functions

1. DSI Driver Summing Input. This input may be used to transmit externally generated tones such as dual tone multifrequency (DTMF) dialing tones.
2. ALB Analog Loop Back. A logic high on this pin causes the modulator output to be connected to the demodulator input so that data is looped back through the entire chip. This is used for self test. If ALB and SQT are simultaneously held high, the chip will power down.
3. CD Carrier Detect. This goes to a logic low when a carrier is sensed by the carrier detect circuit.
4. CDT Carrier Detect Timing. A capacitor on this pin sets the time interval that the carrier must be present before CD goes low.
5. RXD Received Data. This is the data output pin.
6. VCC Positive power supply (+5 volts)
7. CDA Carrier Detect Adjust. Used to set the threshold for the carrier detect.
8. XTALD Crystal Drive. XTALD and XTALS connect to a 3.5795 MHz crystal to generate a clock for chip. If an external circuit requires this clock XTALD should be used to drive the external circuit. If a suitable clock is available in the system, XTALD can be driven.
9. XTALS Crystal Sense. Refer to pin 8 for details.
10. FTLC Filter Test/Limiter Capacitor. This is connected

- to a high impedance output of the receiver filter. It may thus be used to evaluate filter performance. This pin may also be driven to evaluate the demodulator. RXA1 and RXA2 must be grounded during this test. For normal operation FTLC is AC grounded via a 0.1μF bypass capacitor.
11. TXD Transmitted Data. Data input pin.
 12. GND Ground
 13. O/A Originate/Answer mode. High = Originate
 14. SQT Squelch Transmitter. Disables the modulator when held high
 15. RXA2 Receive Analog #2. RXA1 and RXA2 are analog inputs. When connected as recommended they produce a 600 ohm hybrid.
 16. RXA1 Receive Analog #1. See RXA2 for details.
 17. TXA Transmit Analog. This is the output of the line driver.
 18. EXI External Input. This is a high impedance input to the line driver. This input may be used to transmit externally generated tones. When not used for this purpose it should be grounded. (To the analog ground pin!)
 19. GNDA Analog ground reference.
 20. TLA Transmit Level Adjust. A resistor from this pin to VCC sets the transmit level.

coupler (see legalities section) through capacitor C1 and transformer T1. Remember, no one said you have to connect this or any other modem to the phone line. In a factory environment any twisted pairs of wires that you supply will do. Resistor R12 provides a DC path for the phone company which maintains the telephone connection after the dialing phone is hung up. National recommends a constant-current sink which is about 3 DB better than a simple resistor at the cost of five diodes and two transistors, which is not in the spirit of a "no frills" modem. If you need the performance, check National's Comparison Report for more details. If you are using your own twisted pair, forget the resistor.

Diodes D2-D5 provide protection for the modem during ring which may induce 120 volts on the line. National recommends back-to-back Zeners but 1N914's are fast and cheap. Resistor R9 is the hybrid balance resistor. The National hybrid is balanced for 1200 ohms, so R9 should be 1200 minus the impedance looking into the line. In this case it's R12 in parallel with 600

ohms or 300 ohms. 910 ohms for R9 should be close enough. Since there are 19 op amps in the 74HC943, and the power supply is a single-ended 5 volts, resistors R1 and R2 provide an analog ground reference of 2.5 volts. Capacitors C6 and C7 provide decoupling.

Capacitor C8 determines how long the carrier must be present before it is detected by the modem. The time in seconds is equal to the capacitance in microfarads multiplied by 6.4.

Transistor Q2 provides level shifting of the TTL or RS-232 input and gives a proper voltage swing for the CMOS modem chip D8 provides a visual indication of data arriving from the terminal equipment. If this isn't desirable, jumper out D8 and raise R5 to 560 ohms. Q1 level shifts the modem's output to a level required for a TTL compatible device. If this is adequate, jumper out pins 1 and 2 of IC2 and forget the + and - 12 volt power supplies. D9 can be omitted also—raise R6 to 560 ohms and jumper D9.

Omitting D6 is not recommended since it is the carrier detect LED. However, D7 only lets you know if

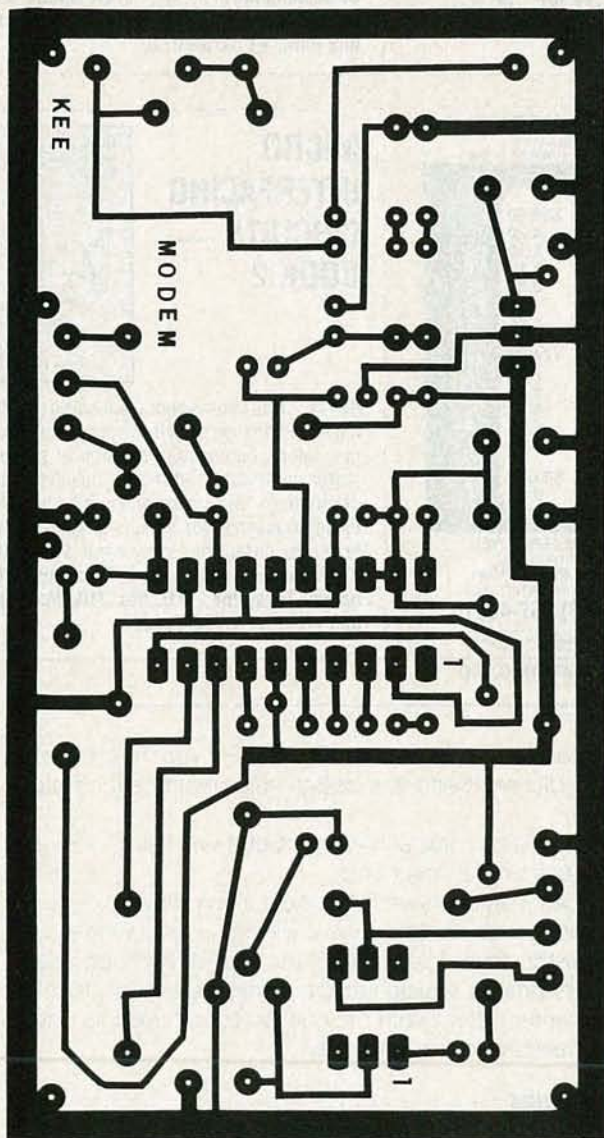

FIG. 2—FULL SIZE PATTERN for the circuit board is shown here. You can easily transfer this from the printed page and make your own circuit board.

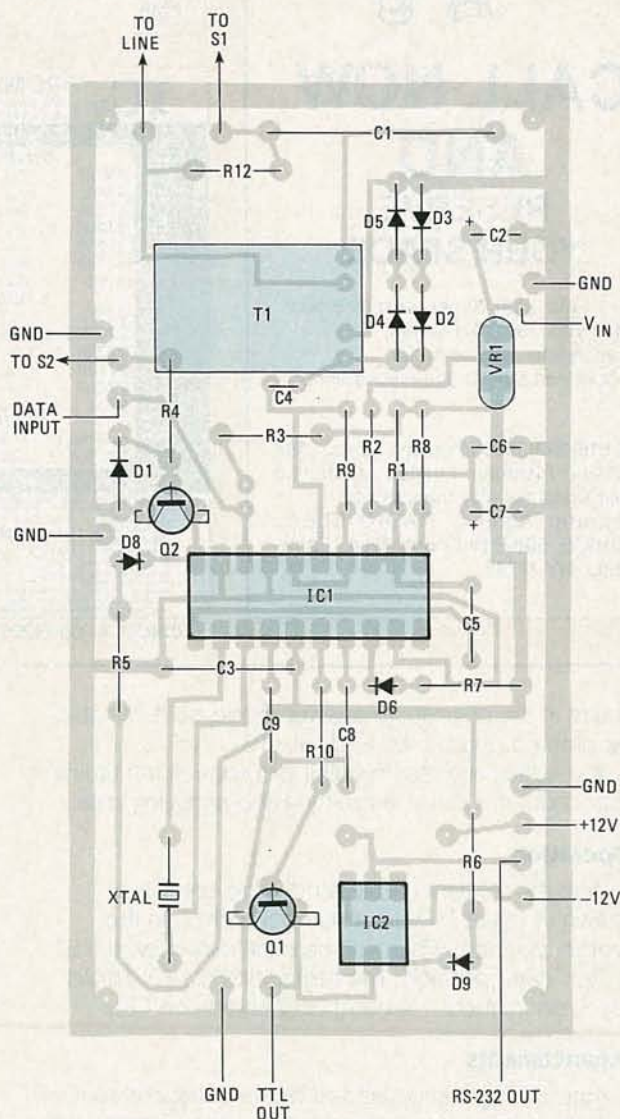
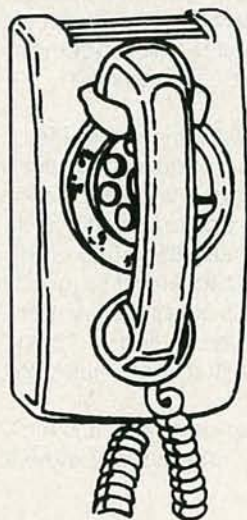

FIG. 3—AND WHEN YOU'RE READY to start populating the board, here is where all the components should be placed.

R-E Computer Admart

Rates: Ads are 2 1/4" x 2 7/8". One insertion \$825. Six insertions \$800 each. Twelve insertions \$775. each. Closing date same as regular rate card. Send order with remittance to **Computer Admart**, Radio Electronics Magazine, 500-B Bi-County Blvd., Farmingdale, NY 11735. Direct telephone inquiries to Arline Fishman, area code-516-293-3000. **Only 100% Computer ads are accepted for this Admart.**



CALL NOW AND RESERVE YOUR SPACE

- 6 x rate \$800.00 per each insertion.
- Reaches 239,312 readers.
- Fast reader service cycle.
- Short lead time for the placement of ads.

Call 516-293-3000 to reserve space. Ask for Arline Fishman. Limited number of pages available. Mail materials to: Computer Admart, RADIO-ELECTRONICS, 500-B Bi-County Blvd., Farmingdale, NY 11735.

COMPUTER MUSIC PROJECTS

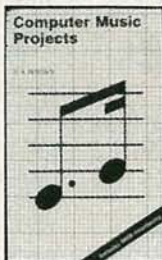

BP173—Computer Music Projects shows how to use your home computer to produce electronic music. Many circuits. Mostly jargon free. Send **\$6.95 plus \$1.75 shipping** to **ELECTRONIC TECHNOLOGY TODAY INC., PO Box 240, Massapequa Park, New York 11762-0240.**

AN INTRODUCTION TO Z-80 MACHINE CODE



BP152—Machine code programming is direct programming of the microprocessor without using a built-in high-level computer language such as BASIC. You can increase running speeds dramatically by using machine code. Learn how to write your own machine code programs. Some simple demo programs are included. Get your copy by sending **\$5.95 plus \$1.00 shipping** in the U.S. to **Electronic Technology Today Inc., P.O. Box 240, Massapequa Park, NY 11762-0240.**

ICs PROMPT DELIVERY!!!

SAME DAY SHIPPING (USUALLY)
QUANTITY ONE PRICES SHOWN FOR AUGUST 24, 1986

OUTSIDE OKLAHOMA. NO SALES TAX

DYNAMIC RAM			
1Mbit	1000Kx1	100 ns	\$69.50
4464	64Kx4	150 ns	4.20
41256	256Kx1	100 ns	5.10
41256	256Kx1	120 ns	3.10
41256	256Kx1	150 ns	2.93
41128	128Kx1	150 ns	4.99
4164	64Kx1	150 ns	1.45
EPROM			
27512	64Kx8	250 ns	\$24.00
27C256	32Kx8	250 ns	7.00
27256	32Kx8	250 ns	5.46
27128	16Kx8	250 ns	4.15
27C64	8Kx8	200 ns	5.15
2764	8Kx8	250 ns	3.75
STATIC RAM			
43256L-12	32Kx8	120 ns	\$33.00
6264LP-15	8Kx8	150 ns	3.10

OPEN 6 1/2 DAYS 7AM-9PM: SHIP VIA FED-EX ON SAT

SUNDAYS & HOLIDAYS: SHIPMENT OR DELIVERY, VIA U.S. EXPRESS MAIL

SAT DELIVERY INCLUDED ON FED-EX ORDERS RECEIVED BY:

MasterCard VISA or UPS CASH COD

Factory New, Prime Parts MICROPROCESSORS UNLIMITED, INC.

24,000 S. Peoria Ave., (918) 267-4961

24,000 S. Peoria Ave., BEGGS, OK. 74421

Please call for current prices because prices are subject to change. Shipping & insurance extra. Cash discount prices shown. Orders received by 9 PM CST can usually be delivered to you the next morning, via Federal Express Standard Air in \$6.00, or Priority One in \$13.00

MICRO INTERFACING CIRCUITS — BOOK 2



BP131—This book is about real-world interfacing including topics such as sound and speech generators, temperature and optical sensors, motor controllers and more. Includes circuit descriptions and background info to aid in using or adapting the circuits to your applications. To order your copy send **\$5.75 plus \$1.00 shipping** in the U.S. to **Electronic Technology Today Inc., P.O. Box 240, Massapequa Park, NY 11762-0240.**

CIRCLE 61 ON FREE INFORMATION CARD

you're in the originate or answer mode, so it can also be omitted. Jumper D7 and raise R3.

You gotta have the crystal! It provides all the timing information for both transmitting and receiving data.

Operation

Wire the modem and a standard telephone as shown in Figure 1. Dial the number with S1 in the "voice" position. When you hear the carrier, switch S1 to the "data" position. The carrier detect LED should come on in about 1 second (depending on C8).

Enhancements

Auto dialing can be added by summing dial tones with the output of the modem, but since phones with redial are being given out for opening a checking account, why bother? If worse comes to worse and you have to buy a phone, where else can you get a

keypad and a dialer chip for \$6.95? If you must have auto dial see National's design guide application note 347.

Is it Hayes compatible? No, but it will talk to a Hayes if one is on the other end.

Does it auto answer? No. Add a ring detector (a capacitor, optoisolator, and a diode), a relay with a transistor driver (don't forget the snubbing diode), tie the transmitter squelch to the carrier detect and NAND the carrier detect with the ring detect delayed to drive the transistor driver and relay.

Legalities

This modem, like other telephone line connected equipment should only be connected to the phone line through an FCC approved interface such as the Tele-Path Industries model 381 or other data coupler.

OSCILLATORS

continued from page 64

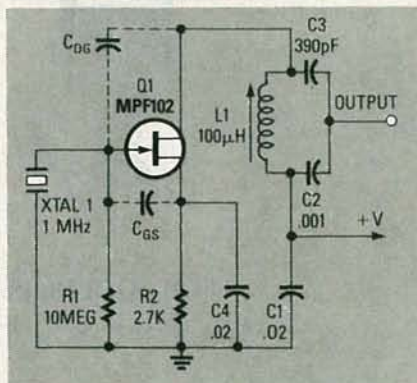

FIG. 5—A MILLER OSCILLATOR uses a FET and a tuned-drain circuit. The latter is tuned to a frequency near the resonant frequency of the crystal.

make a low-impedance path to ground for the feedback signal. The reactance of the capacitor is usually set at less than $\frac{1}{10}$ of the resistance that it bypasses.

The drain terminal of the FET in this circuit is connected to the resonant tank circuit. The resonant frequency of the LC circuit is not exactly that of the crystal. Usually the tank circuit is tuned to a frequency below that of the crystal.

On first glance the Miller oscillator doesn't look like an oscillator at all, because there is no apparent feedback network. The circuit depends upon the "hidden" capacitances shown as C_{GS} and C_{DG} in Fig. 5. Those capacitors represent the interelectrode (gate-to-source and drain-to-gate) capacitances of the FET. They form a capacitive voltage divider that feeds some of the output signal back to the input.

If you own older equipment that uses a Miller oscillator, it is possible that the ferrite core in the tank circuit has changed enough to make the oscillator inoperable. For example, we found that to be the problem with two different Heath *DX-60B* transmitters that were fired up after many years of disuse. The symptom was unreliable keying on CW. Sometimes when the key was closed the oscillator refused to start, and other times it started fine. The oscillator in the *DX-60B* is a Miller circuit, and its coil had changed inductance.

Another Colpitts oscillator is shown in Fig. 6. That circuit is somewhat different from the previous configuration, but may

actually be more popular. The circuit in Fig. 6 operates over the 1- to 20-MHz frequency range, although we have found that that operation may be unreliable above 15 MHz or so.

Feedback is controlled by the C_2/C_3 capacitor voltage divider, which is what identifies that circuit as a Colpitts oscillator. As with the previous Colpitts circuit (shown in Fig. 4), almost any NPN transistor can be used for Q1.

Last, shown in Fig. 7 is an overtone

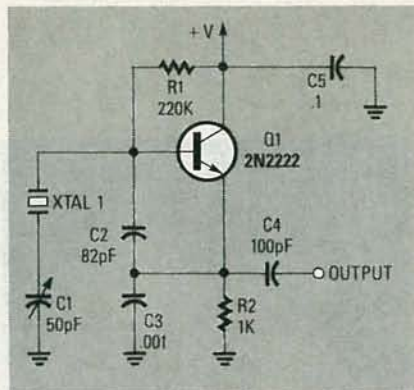

FIG. 6—THE COLPITTS OSCILLATOR comes in various forms; the one shown here is probably more widely used than the one shown in Fig. 4.

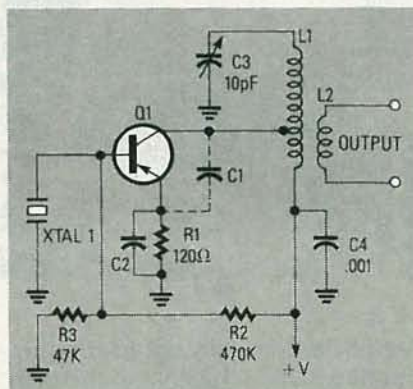

FIG. 7—AN OVERTONE OSCILLATOR also requires few components. As with the Miller oscillator, the L_1/C_3 circuit should be tuned to a frequency that is near, but not equal to, the frequency of the crystal.

oscillator. The crystal is connected between the base of the transistor and ground, and capacitor C_1 is used to increase feedback around transistors that have insufficient internal capacitance. In some cases, C_1 will not be needed, but if it is used it must be mounted as close as possible to the body of the transistor.

The tank circuit (L_1/C_3) connected to the collector of the transistor is tuned approximately to the overtone frequency. Bypass capacitor C_2 should have a reactance of about 90 ohms at the frequency of operation; values for several frequencies are given in Table 1. You may have to juggle the values of R_2 and R_3 to get reliable operation.

R-E

TABLE 1—BYPASS CAPACITOR

Frequency (MHz)	Capacitance (pF)
50	36
150	12
220	8
450	3

ATTENTION! ELECTRONICS TECHNICIANS

EARN YOUR B.S.E.E. DEGREE



THROUGH HOME STUDY

Our New and Highly Effective Advanced-Placement Program for experienced Electronic Technicians grants credit for previous Schooling and Professional Experience, and can greatly reduce the time required to complete Program and reach graduation. No residence schooling required for qualified Electronic Technicians. Through this Special Program you can pull all of the loose ends of your electronics background together and earn your B.S.E.E. Degree. Upgrade your status and pay to the Engineering Level. Advance Rapidly! Many finish in 12 months or less. Students and graduates in all 50 States and throughout the World. Established Over 40 Years! Write for free Descriptive Literature.

COOK'S INSTITUTE
OF ELECTRONICS ENGINEERING

347 RAYMOND ROAD
P.O. BOX 20345
JACKSON, MISSISSIPPI 39209

CIRCLE 192 ON FREE INFORMATION CARD

SUPER LONG PLAY TAPE RECORDERS

10 Hour Model — \$95.00*
14 Hour Model — \$159.00*

Modified Panasonic Slimline, high quality, AC-DC Recorders provide 5 or 7 continuous hours of quality recording & playback on each side of cassette for a total of 10 or 14 hours depending on model. Built-in features include • Voice level control, • Digital counter, etc. TDK DC 180 Cassette Furnished.

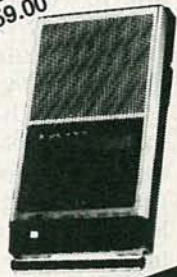

PHONE RECORDING ADAPTER

Records calls automatically. All Solid state connects to your telephone jack and tape recorder. Starts recording when phone is lifted. Stops when you hang up. \$24.50* FCC APPROVED

VOX VOICE ACTIVATED CONTROL SWITCH

Solid state. Self contained. Adjustable sensitivity. Voices or other sounds automatically activate and control recorder. Uses either recorder or remote mike. \$24.95*
*Add for ship & hdg. Phone Adapter & Vox \$1.50 ea. Recorders \$4.00 ea. Cal. Res. add tax. Mail order, VISA, M/C, COD's OK. Money Back Guarantee. Qty. disc. avail., Dealer Inquiries invited, Free data.
AMC SALES, Dept. A, 9335 Lubec St., Box 928, Downey, CA (213) 90241 Phone 869-8519

CIRCLE 108 ON FREE INFORMATION CARD

NOVEMBER 1986

69

SATELLITE TV

A budget DBS system

MUCH HAS BEEN WRITTEN ABOUT THE promise of DBS (Direct Broadcast from Satellite). DBS has been assigned the Ku band (11-12 GHz), which is about three times higher in frequency than the C band (4-GHz). Satellite signals for home reception have been broadcast on the C band since the late 1970's; DBS on the Ku band is the promise of the future.

Originally, the DBS system was to be driven by several high-powered satellites that had as much as 250 watts of transmitter power per transponder. The theory was that, if a great deal of power were beamed down from over the equator, and if carefully shaped antennas were used for the down-link to earth, the size, cost, and complexity of ground-based receiving terminals could be reduced greatly.

That plan has yet to be realized for several reasons that we've talked about here in the past (in the January and February issues). However, we now have an interim technology that should be of general interest. It is based on RCA's pair of satellites called Ku-1 and Ku-2; each satellite has 16 transponders with a nominal power-per-transponder of 50 watts. Recently, New Jersey satellite enthusiast Peter Sutro and I put together a low-cost home-receiving system to see just what might be done with those 50-watt channels.

We used a 32-inch diameter spun-metal dish from DH Satellite, Inc. (P. O. Box 239, Prairie du Chien, WI 53821). DH is the largest-volume manufacturer of satellite antennas in the world today. Their 32-inch dish is the largest that can



FIG. 1

be packed and accepted for shipment by UPS. The cost of the dish, a simple ring mount, and the feed-support tripod is well under \$100 at the dealer price level.

For the electronics, we chose an Echostar LNB with a 2.2-dB noise figure. The Echostar converts the 12-GHz signals down to a typical 900- or 950-1400 MHz IF. The TVRO receiver is a *DX 500* (from DX Communications, Inc., 10 Skyline Drive, Hawthorne, NY 10532) which connects to a stock television receiver tuned to channel 3 for the modulated RF output of the *DX 500*. The total cost of the antenna and the electronics was less than you might pay for a quality name-brand 15-inch television set.

It took less than five minutes to unpack and set up everything. If we had been in a hurry, the whole



BOB COOPER, JR.,
SATELLITE-TV EDITOR

exercise might have been completed in half the time. The dish slips onto the ring mount; the whole assembly turns to adjust azimuth. To adjust elevation you use a simple slip-rod system that angles the dish on the circular mount.

You don't get much gain from a 32-inch dish on Ku band. So you hope that the 50 watts of power from the satellite is enough. On the other hand, by using a small dish, you have the advantage of simple setup. You can locate the satellite and then peak the reception by fine-tuning the azimuth and elevation. If you know which direction is south, and if you remember that the satellite belt is above the southern horizon, you will have close to instant success in obtaining some sort of picture.

The downside of this report is that the signals transmitted by the RCA satellites are not intended for home reception. There are both scrambled signals (from HBO, Cinemax, etc.) and unscrambled signals (from NBC and others) on those two birds. That means that you can watch all the NBC network feeds you want with the system described above—but not much else at the present time. By the way, we're not encouraging you to intercept NBC's signals; we're merely talking about the equipment that might be used to do so.

With the equipment we've described and only a few minutes of effort we were able to obtain very good reception. It wasn't difficult to do so either; the relatively wide beam pattern of the 32-inch dish is really an advantage. In fact, it was about as difficult to find Ku-1 and

NEW!

MOVIE TIME presents the **VIEWSTAR VSC 2500** **66-CHANNEL, REMOTE** **CABLE CONVERTER**



VIDEO TUNER WITH **VOLUME CONTROL!**

- **66-Channel Wireless Remote**
- **Switches TV on and off**
- **Remote Volume Control** raises and lowers TV audio
- **Receives ALL channels** offered by your cable company
- **Compatible with all brands** of decoders
- **Decoder Input/Output Jacks**
- **Remote channel changing**
- **Last channel recall**
- **Remote fine tuning**
- **Special Mute Button** instantly silences TV sound — great for answering the phone or 'Killing' commercials
- **Optional Audio and Video Outlets** for direct hookup to VCR, TV Monitor or Video Transmitter

SPORTS FANS!

One button instant channel switching lets you easily switch n' watch two events.

24-MONTH GUARANTEE

ORDER TODAY — SHIPPED WITHIN 24-HOURS

(On C.O.D. and Credit Card Orders)

ORDERS RECEIVED UP TO DEC. 12 GUARANTEED DELIVERY BEFORE XMAS

\$119⁹⁵

CALL 305-652-3971 or 305-652-1981
FOR MORE INFORMATION

MOVIE TIME, 20203 N.E. 15 Ct., Miami, FL 33179 ^R

Yes, rush me

___ **Cable Converters with volume control @ \$119.95**

___ **Cable Converters without volume control @ \$89.80**

plus \$3.95 per item shipping. (Fla. residents add 5% tax.)

I enclose check M.O. American Express for

\$ _____ **TOTAL**

SIGNATURE _____

ACCT. NO. _____ Exp. Date _____

NAME _____

ADDRESS _____

CITY _____ STATE _____ ZIP _____

Ku-2 with our 32-inch dish as it would be to find a C-band bird with an 8-foot dish. In other words, not difficult at all.

No programming

It's fair to say that low-cost, easy-to-install, and easy-to-use DBS is here. What is missing, however, is effective use of DBS by those would-be programmers who have dreamed of the day when millions of homes would be equipped with

those tiny dishes. And things aren't likely to change in the near future.

Part of the problem is that RCA has sold or traded most of the 32 50-watt transponders on Ku-1 and Ku-2 to the large corporate users, including TV networks, ad-hoc TV-oriented programmers, and, of course, cable programmers like HBO, and communications giants like AT&T. Not one of the present or future users of Ku-1 and Ku-2,

SEND COOP \$20



and **HE WILL SEND YOU \$63!**

NOPE - not a new fangled 'chain letter'. TVRO pioneer Bob Cooper, Jr. has put together the most useful 'Data-pack' possible to bring you up to full speed on satellite television scrambling. It will cost you \$20 to receive all of the following valuable information:



1) YOU RECEIVE the 3 'current issues' of **CSD Magazine**; literally, 'the bible' of the home dish industry. The most complete insider look at the new equipment, scrambling strategies, worldwide satellite explosive growth anywhere. You receive 3 issues starting with the now-current issue. A great introduction to TVRO! This is an **\$18 value**.

2) YOU RECEIVE the current plus two recent back issues of **SCRAMBLE-FAX**, the hot-news 'Newsletter' that details the rapid changes taking place in scrambling, who is scrambling, how; who is working to break scrambling, their progress to date. This is a **\$30 value**.

3) YOU RECEIVE the special 180 page **COMMEMORATIVE EDITION** OF **Coop's Satellite Digest**, the full, unabridged history of home satellite television. This is the handiest, one-source reference recording the home dish industry; a **\$15 value**.

YOU RECEIVE all of the facts, all of the history, and all of the current, hard-to-find news about TVRO and scrambling. From Coop; the industry's most authoritative information source. Send your check or money order to the address below, or, with your Visa or Mastercharge card handy, call in your order to 305/771-0505 weekdays between 9 AM and 4 PM. Join the Coop team and learn ALL the facts today!

CSD/Coop's Satellite Digest

P.O. Box 100858/Ft. Lauderdale, FL 33310
- Telephone 305-771-0505 -

SCRAMBLE-FAX HOTLINE? Call 305-771-0575 for 3 minute update NOW!

Interested in TVRO?

For nearly two years Bob Cooper has provided a no-charge kit of printed materials that describes the challenges of and opportunities in selling TVRO systems today. With the present intense interest in scrambling systems, Coop's *CSD* has made available a new no-charge service.

The **SCRAMBLE FAX** hotline is a 24-hour-per-day telephone service that provides accurate, detailed, and hard-to-find facts concerning the changeover to scrambling in the satellite communications industry. Information describing satellite receivers tested for scrambling compatibility, sources for authorized descramblers, wholesale rates of scrambling equipment and services—all are provided on the **SCRAMBLE FAX** hotline. There is no charge for that service, other than your long-distance telephone expenses. Simply dial (305) 771-0575 for a concise and timely three-minute capsule report that covers the latest in scrambling news.



FIG. 2

shown prior to its launch last year in Fig. 2, has made public its plans regarding use of the transponders for DBS. Even the third (and last) RCA Ku bird, Ku-3, which is scheduled for launch some time after the Shuttle failure is sorted out, is pre-sold for non-DBS uses.

The equipment required to create a DBS service is in place and working. But the software for such a service is not in place, and there are indications that that software may not be in place prior to at least 1989.

The technology for small-dish DBS service is here, but small-dish DBS is not. Technical experimenters will find the challenge of receiving low-cost Ku-band signals interesting. But TVRO businessmen will probably have little use for the smaller dishes and the easy Ku-band reception that is now possible.

R-E

OUR DISTRIBUTORS... YOUR LOCAL WHERE-HOUSE

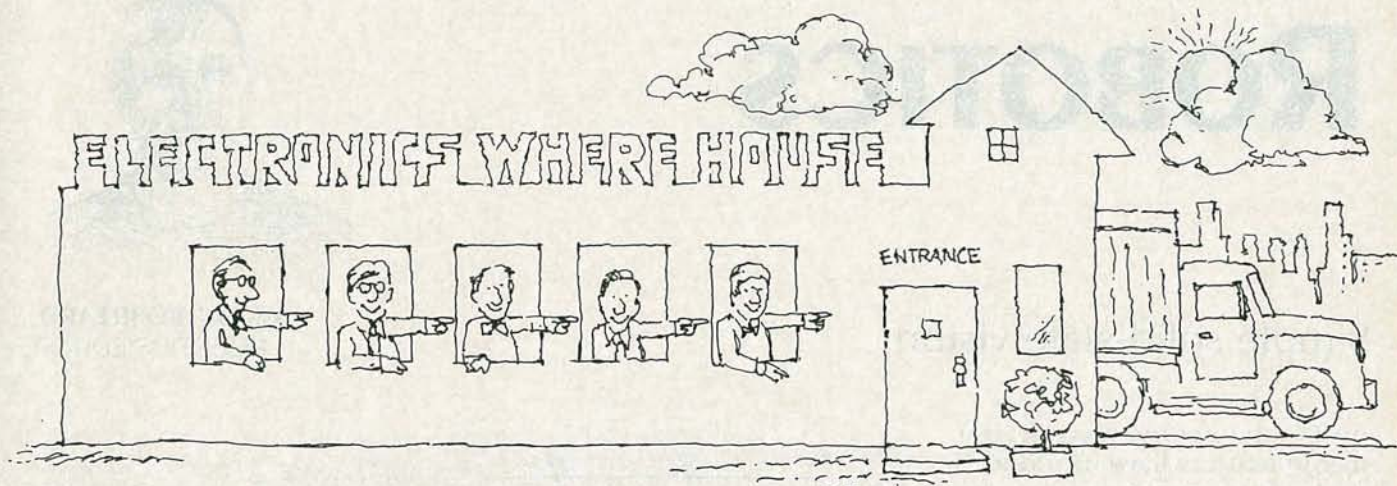

YOUR DISTRIBUTOR—YOUR LOCAL WHERE-HOUSE FOR

WHERE can you find the components you need? Our local distributors are your where-house.

As electronics manufacturers, we serve you better by getting our wares to you through distributors. Our distributor speeds our standard products to you, faster than we could deliver them. He extends our sales, warehouse, and credit capabilities, and thus helps us keep down our costs, and hence your price!

We call him "our distributor," because he handles our product. But he's also "your distributor," because he solves your procurement problems!

WHERE do you have a convenient, nearby source for product? **YOUR DISTRIBUTOR**

WHERE do you find the important piece you suddenly need? **YOUR DISTRIBUTOR**

WHERE can you have quantity inventories put into stock, to parallel your production schedules? **YOUR DISTRIBUTOR**

WHERE do you go when you need those hard-to-find replacement parts? **YOUR DISTRIBUTOR**

The sponsors of this message believe in the distribution system. Our local warehouse is your local wherehouse. You find *what* you need, *when* you need it, *where* you need it. We are among over 150 member firms of the Electronic Industries Association, Distributor Products Division, all committed to advancing the state of the art of marketing through distributors. Want more information? Contact Herbert Rowe, Senior Vice President, EIA Components Group, 2001 Eye Street, N.W., Washington, D.C. 20006. Telephone (202) 457-4930.

ALPHA WIRE CORPORATION

Wire, Cable, Tubing, Thermocouple Sensors, Flat Cable and Connectors

AMPEREX ELECTRONIC CORPORATION/A NORTH AMERICAN PHILIPS COMPANY

Tubes, Discrete Semiconductors, Loudspeakers, Imaging and Display Devices, Electronic Components and Materials

AMPHENOL PRODUCTS

Amphenol, Bendix & Spectra-Strip Connectors, Cables and Cable Assemblies

AVX CORPORATION

Multilayer Ceramic Capacitors—Chips, Radials, Axials, Dippguards, Arrays, and Special Products

BELDEN ELECTRONIC WIRE AND CABLE

Thermosetting, Thermoplastic Wire and Cable for Electronic Applications

BOURNS, INC.

Resistor Networks, Trimming Potentiometers, Precision Potentiometers, Panel Controls, Attenuators

CAROL CABLE COMPANY, INC.

Electronic Cable, Plastic & Rubber Molded Power Supply Cords, Electrical Wire & Cable

CENTRALAB, INC./A NORTH AMERICAN PHILIPS COMPANY

Ceramic Disc and Monolithic Capacitors, Rotary, Pushbutton and Membrane Switches, Resistor Networks

CORNELL-DUBILIER

ELECTRONICS, INC.
Capacitors, Relays, EMI Filters and EMI Systems Engineering Services

CORNING ELECTRONICS

Capacitors, Resistors, Networks

DALE ELECTRONICS, INC.

Resistors, Networks, Oscillators, Displays, Connectors, Inductors & Thermistors, Electronic Components

DIALIGHT CORPORATION/A NORTH AMERICAN PHILIPS COMPANY

LED, Incandescent & Neon Indicators; Illuminated & Rocker/Toggle Switches; LED Readout Displays

DYNASCAN CORPORATION/ B&K-PRECISION

Electronic Test Instrumentation

FUJITSU AMERICA, INC.

COMPONENT DIVISION
Electronic Components

G.C. ELECTRONICS, A HOUSEHOLD INTERNATIONAL COMPANY

Tools, Chemicals, Wire, Switches, Connectors, Telephone, Video, Audio, Computer Accessories, P.C. Board Products

GRAYHILL, INC.

Solid State Relays; Rotary, Pushbutton and Dip Switches; Key Pads; Electronic Hardware

KEYSTONE ELECTRONICS CORPORATION

Battery Holders & Accessories, Terminal Boards & Strips, Spacers & Standoffs, Metal Stampings, Electronic Hardware

KULKA SMITH, INC./A NORTH AMERICAN PHILIPS COMPANY

Terminal Boards, Commercial, Military; Hardware, Spacers, Binding Posts, Test Leads

MATRIX SCIENCE CORPORATION

Cylindrical and Rectangular MIL-Spec Connectors, Terminal Junction Systems and Connector Accessories

MURATA ERIE NORTH AMERICA, INC.

Disc and Monolithic Capacitors, Potentiometers, Resistor Networks, Piezo Alarms, EMI Filters and Crystals

NEW-TONE ELECTRONICS, INC.

Semiconductors, Flameproof Resistors, Wire-ties

OKTRON INDUSTRIES, INC.

Background Music, Paging, Foreground Music and General Replacement Loudspeakers and Related Accessories

OHMITE/A NORTH AMERICAN PHILIPS COMPANY

Resistors, Rheostats, and Control Components

PANASONIC INDUSTRIAL COMPANY ELECTRONIC COMPONENTS DIVISION

Capacitors, Resistors, Semiconductors, Surge Absorbers, Printers, Power Supplies, Light Touch Switches, Transducers

PERMA POWER ELECTRONICS, INC.

Portable Sound Systems, Amplifiers, Power Line Surge Suppressors & Multiple Outlet Strips

PHILIPS ECG/A NORTH AMERICAN PHILIPS COMPANY

Semiconductors, Picture Tubes, Receiving Tubes & Chemicals

QUAM-NICHOLS CO., INC.

Loudspeakers for Commercial and Industrial Applications

RCA DISTRIBUTOR AND SPECIAL PRODUCTS DIVISION

Electronic Parts, Semiconductor Devices, Receiving, Industrial & Picture Tubes, Video Tape & Accessories

SL WABER, A DIVISION OF SL INDUSTRIES, INC.

Surge and Noise Suppressors, Uninterruptible Power Supplies, Multiple Outlet Strips

SIMPSON ELECTRIC CO.

Analog and Digital Panel Meters, Meter Relays, VOM's, DMM's, Electrical-Electronic Test Equipment, Elapsed Time and Frequency Meters

SPRAGUE ELECTRIC COMPANY, DISTRIBUTION DIVISION

Capacitors, Resistor Networks, Pulse Transformers, Interference Filters, Transistors, Integrated Circuits

SWITCHCRAFT, INC.

Switches, Connectors, Fiber Optic Connectors, Jacks, Plugs, Keyboards, Jackfields and Audio Accessories

UNION CARBIDE CORPORATION ELECTRONIC DIVISION—KEMET CAPACITORS

Tantalum, Ceramic, Film Capacitors



ROBOTICS



MARK J. ROBILLARD,
ROBOTICS EDITOR

Simple solid-state vision

DURING THE PAST FEW YEARS, SEVERAL manufacturers have introduced relatively inexpensive video-camera interfaces for personal computers. Many of those products are simply analog-to-digital converters that, through the use of special timing circuits, transform standard NTSC video information from the camera into bytes of data that the computer can store, display, and process. The camera interfaces usually come with software that can store and display the digitized images; processing is then up to you. And that's where things get difficult.

It's not terribly difficult to design a robot vision system that can distinguish between different objects. However, there is a difference between distinguishing and recognizing. In fact, recognition is a tremendous task. That's the reason why manufacturers of PC vision interfaces do not provide you with fully functional vision software. Fortunately, it is not difficult to build a vision system that is suitable for experimental and hobbyist purposes.

Many people ask about simple and inexpensive ways to start experimenting in the field of robot

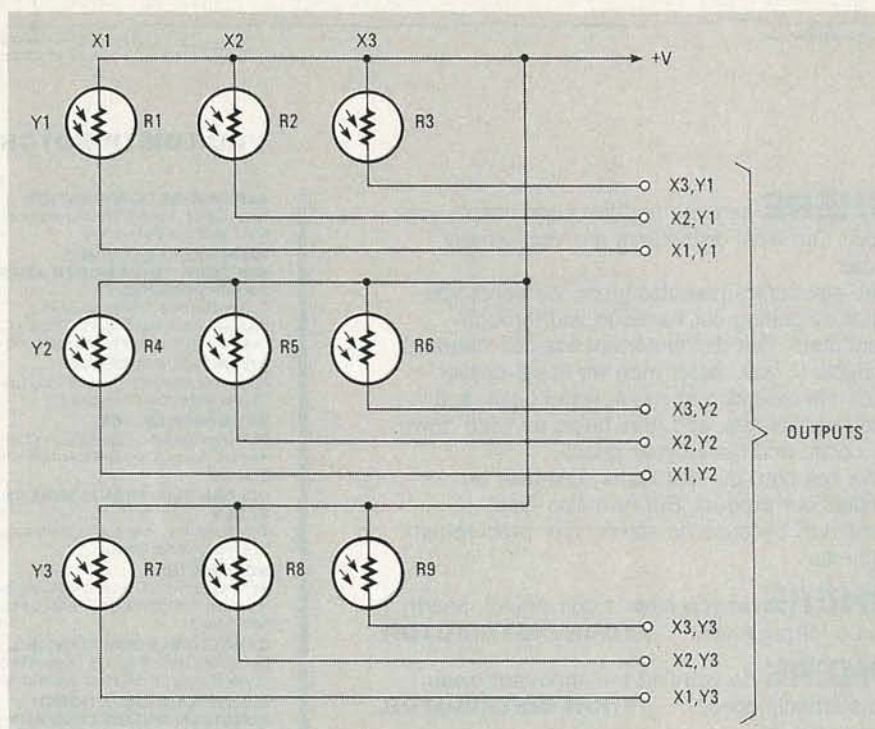

FIG. 2

vision. The answer we give is that it depends on what you want your robot to "see."

Vision systems may be divided into two categories: high and low resolution. If you're working with a mobile rover, and if vision is to be its primary navigational aid, then a high-resolution system may be appropriate. On the other hand, if you're working with a robot arm that must distinguish between round and square blocks, or other simple shapes, then a low-resolution system may suffice.

The PC-based interfaces are often categorized as high resolution by their manufacturers, but they're really medium resolution

(640 × 400 pixels). At the low end of the scale, a very low resolution interface (32 × 32, or even less) can be surprisingly useful, however.

A photodiode-based vision system

An extremely-low-resolution (3 × 3) sensor can be built for under \$20; it provides surprisingly accurate results. The sensor can distinguish between a multitude of shapes, and it will allow you to carry out a number of useful experiments. Limited character recognition is possible, as are color and pattern recognition.

The sensor uses the same basic technology as a photographic light

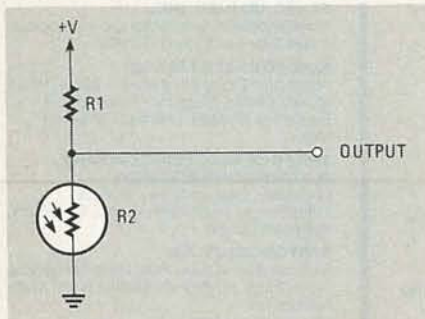

FIG. 1

meter: a photocell and some means of measuring voltage. Many light meters use a moving-vane DC meter. The more light that strikes the sensor, the farther the meter's needle deflects. That's because the resistance of the photocell varies with the amount of light that is striking its surface. The output of the photocell can be converted to a varying voltage merely by including it in a simple resistive voltage divider, as shown in Fig. 1.

The trick in using the photocell as a robot-vision device is in the way you measure that varying voltage. The DVM updates its display very slowly, so you don't see the minute, rapidly occurring variations in output. A robot needs a method of converting that quickly varying output into discrete values. As you have guessed, an A/D converter performs that task.

Most personal computers (including the IBM-PC) that are used for robot experimentation have eight-bit data buses. Therefore one byte of information in the computer can store any one of 256 (2^8) values. Therefore it is appropriate to build an eight-bit A/D converter for the sensor. Such a converter will allow the computer to distinguish 256 individual levels of light—and that's quite a few for experimental purposes.

If you require higher resolution, twelve-bit A/D converters are readily available. A 12-bit converter will resolve 4096 (2^{12}) levels of light. The disadvantage of a 12-bit converter is that it requires additional circuitry to multiplex the extra four bits onto an eight-bit bus. Is an inexpensive photocell sensitive enough to allow 4096 bits of resolution? The answer is yes, and even more. (Linearity may be a problem, however.—*Editor*)

Obviously a single photocell is insufficiently accurate as the basis of a robot vision system. Figure 2 depicts an experimental vision sensor array composed of nine photocells in a 3×3 matrix.

The mechanical dimensions of the array will depend on the size of the photocells, but by using commonly available cells, you should be able to squeeze the entire array into an area about 0.75" on a side.

One lead of each device is tied to the common voltage source.

The other lead of each device will be connected directly to one input of an A/D converter. We'll show the circuit details of the A/D converter next time.

An easy way to mount the photocells is on a solderless breadboard. Four standoffs can support a piece of clear plastic that acts as a dust shield for the photocells. Also, you should isolate the photocells from one another; doing so increases the accuracy with which an object can be scanned. You can cut short plastic or paper tubes to fit over the sensors.

Pattern recognition

When the sensor confronts an object, that object should be centered in the array. Centering can be accomplished in a variety of ways, including mechanical and optical limit switches, and others.

Let's consider how we might use the sensor to recognize two different objects, a square and a triangle. Assume that the square has the same outer dimensions as the sensor, and that the triangle is slightly smaller.

The square completely blocks all nine sensors, but the triangle blocks only the center sensor completely, and partially obscures the others. Assuming that the output of each sensor is either high or low, depending upon the light hitting it, it would be easy for a computer to distinguish between the two shapes.

Normally we can't simply lay an object directly on top of a sensor array. So we can direct light from another source, creating shadows. Doing so will result in a similarly easy recognition task.

The program controlling overall operation must have a threshold value that indicates when an opaque surface is detected. You could just perform a daily sensitivity adjustment, but minute changes in the ambient light level can affect the reading tremendously. One way around variable sensitivity is to allow the sensor to carry its own source of light. You could use a photographic flash unit, and trigger it whenever the computer must read the array.

Next time complete details of a vision circuit like that discussed here will be presented.

R-E

Our guaranteed savings plan.



Fluke 70 Series Analog/Digital multi-meters are like money in the bank. Buy one, and you're guaranteed to save both time and money.

Money, because you get longer battery life and longer warranty coverage — 3 years vs. 1 year or less on others.

And time, because 70 Series meters are easier to operate and have more automatic measurement features.

So before buying any meter, look beyond the sticker price. And take a closer look at the new low-priced \$79 Fluke 73, the \$99 Fluke 75, and the deluxe \$139 Fluke 77. In the long run, they'll cost less, and give higher performance, too.

And that, you can bank on.

For a free brochure, and your nearest distributor, call toll-free **1-800-227-3800, ext. 229.**

FROM THE WORLD LEADER
IN DIGITAL MULTIMETERS.

FLUKE[®]

© 1985 Fluke
CIRCLE 121 ON FREE INFORMATION CARD

ANTIQUE RADIOS

Restoring AC-DC radios

IT HAS BEEN YEARS SINCE MANY OF YOU worked on a vacuum-tube radio; perhaps you've never worked on one. And many young antique-radio enthusiasts know a great deal about solid-state circuits and computers, but nothing about troubleshooting a vacuum-tube set. This column is dedicated to all of you who have just come (or have just come back) to antique-radio servicing.

The antique of the month

One of the first things someone new to vacuum-tube servicing must learn is to be careful, because the chassis of an antique may be "hot." In other words, there may be 117-volts AC between the chassis and ground. You can get a dangerous shock if you touch a cold-water pipe or any other grounded metallic object at the same time that you touch the chassis of an antique radio.

The Temple radio shown in Fig. 1 is safer than many other radios because of its wooden cabinet and recessed chassis bolts and set screws. The complement of tubes include: a 35Z5 rectifier, a 12SQ7 2nd detector and 1st audio amplifier, a 12SK7 IF amplifier, a 12SA7 first detector and oscillator, and a 50L6 for audio output. The Temple is not truly an antique, but it's collectible, and is representative of the type of post-WWII radio that you are likely to run across.

Filament voltages

If you're new to tube servicing, it's helpful to know that the digits preceding the letters in a tube number often indicate the tube's filament voltage. For example, the



50L6 mentioned above has a 50-volt filament. If you add the filament voltages of the Temple's tubes, you'll find that their sum (121 volts) is approximately equal to the line voltage. By wiring all those filaments in series, no dropping resistor or step-down transformer is necessary to connect the filament string directly to the AC power lines.

But in early five-tube AC-DC sets you will find a voltage-dropping resistor in the filament circuit, because the sum of the voltages used by early tubes didn't equal the line voltage. And even though the line voltage might dip as low as 100-volts AC, engineers designed for a peak of 120-volts AC. It was better to underpower a component than to overpower and possibly damage it.

Sometimes, instead of an on-chassis dropping resistor, a resistor was incorporated in the power cord. The line-cord resistor is covered with asbestos and cotton, and the cord looks like the heavy cord that is used with an electric iron. Of course the line-cord resistor generates heat, so it is not recommended that excess cord be tucked inside the cabinet.



RICHARD D. FITCH,
CONTRIBUTING EDITOR

Also, that type of line cord shouldn't be shortened, or the resistance may be reduced.

Another method of reducing voltage in some very early AC-DC receivers was to use a ballast tube in the filament circuit. The tube plugged into the chassis, and usually functioned as a pilot lamp.

Tools and test equipment

Newcomers may also appreciate a few hints about the types of tools and test equipment that are necessary to service vacuum-tube sets. Many of the small tools used in servicing modern electronic gear are simply inadequate when working on older radios.

Large screwdrivers, pliers, wirecutters, and strippers that you wouldn't think of using on 1980's equipment are a must. But most important is a soldering iron or gun. The small pencil-type soldering irons used today are virtually useless on an antique radio chassis—sometimes the heat of a blow torch is needed! Drills and hack saws also come in handy.

As for test equipment, you can often get by with just a multimeter, because most problems can be traced to shorts and opens. Ohmmeter tests must be done on a "cold" (unpowered) set. Even tubes can be tested with an ohmmeter. If you don't measure a short between the prongs of an old radio tube, there's a good chance that it will light up and produce some sort of signal.

Troubleshooting hints

It's a good idea to do as much testing as possible on a cold set, because a cold set is safest for the

service man, for his test instruments, and for the equipment being tested. A cold test should be done only when the set being tested is unplugged. Turning the power switch off *never* makes a set completely safe for cold testing, or even for handling. With the switch off, even if the chassis is not "hot" with respect to ground, one side of the switch (and anything connected to it) is hot. A good way to remember to unplug a set before testing it is to get into the habit of making a continuity test across the prongs of the power plug first.

To increase safety, some antique radios include a double-pole power switch. But even if your set has that type of switch, it's much safer to unplug the set before doing any testing.

In the early days of radio, polarized AC power plugs and receptacles were not required. That's why the chassis could be "hot." However, there were several ways the radio repairman could prevent shocks and still work on a live set. First, he could buy an expensive isolation transformer. But there was another way. Despite the absence of polarized receptacles, one side of the house wiring was always grounded. However, there was no way to tell (just by looking) which way to insert the plug into the wall socket. So the repairman used to mark the grounded side of the receptacle near his work bench.

Symptoms

A problematic AC-DC radio most often exhibits one of two major symptoms: it's completely dead, or it has a great deal of hum. A dead radio is usually easier to fix than one with other problems, because the source of the problem is usually easy to find. For example, a simple test with an ohmmeter will show whether the line cord is any good.

Excluding obvious problems like an open power cord or a broken power switch, the most usual source of problems in an AC-DC set occurs in the filament circuit. If a dropping resistor or filament develops an open, the entire set will be disabled. Of course there still may be high voltages present, so be careful!

Analyze defective waveforms faster, more accurately, and more confidently — every time or your money back

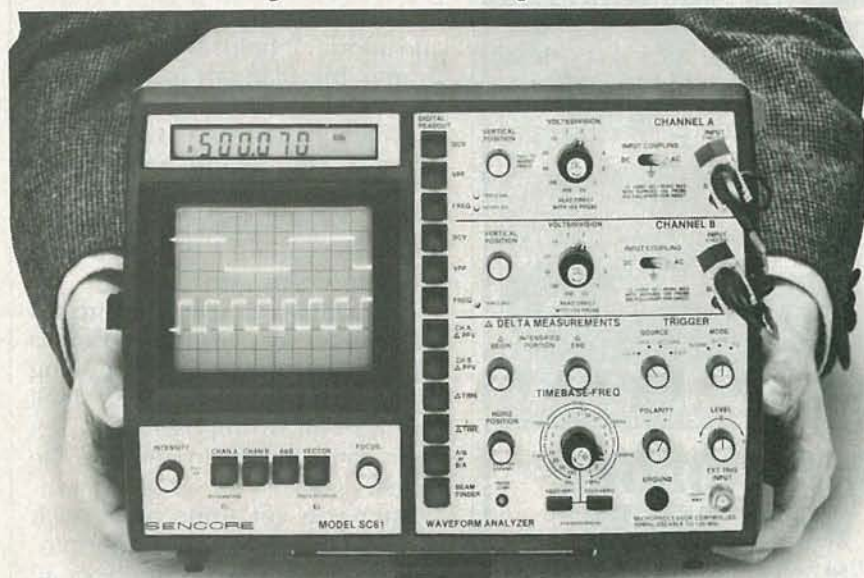

with the SC61 Waveform Analyzer
Patented \$2,995

If you value your precious time, you will really want to check out what the exclusively patented SC61 Waveform Analyzer can do for you. 10 times faster, 10 times more accurate, with zero chance of error.

End frustrating fiddling with confusing controls. Exclusive ultra solid ECL balanced noise cancelling sync amplifiers, simplified controls, and bright blue dual trace CRT help you measure signals to 100 MHz easier than ever.

Accurately and confidently measure waveforms from a tiny 5 mV all the way to a whopping 3,000 V without hesitation with patented 3,000 VPP input protection — eliminates expensive "front end" repairs and costly equipment downtime.

Make only one circuit connection and push one button for each circuit parameter test: You can instantly read out DC volts, peak-to-peak volts and frequency 100% automatically with digital speed and accuracy. It's a real troubleshooting confidence builder.

Confidently analyze complex waveforms fast and easily. Exclusive Delta measurements let you intensify any waveform portion. Analyze glitches, interference signals, rise or fall times or voltage equivalents between levels; direct in frequency or microseconds.

Speed your digital logic circuit testing. Analyzing troublesome divide and multiply stages is quicker and error free — no time-consuming graticule counting or calculations. Simply connect one test lead to any test point, push a button, for test of your choice, for ERROR FREE results.

To see what the SC61 can do for your troubleshooting personal productivity and analyzing confidence, CALL TODAY, WATS FREE, 1-800-843-3338, for a FREE 15 day Self Demo.



Call Today Wats Free 1-800-843-3338

SENCORE

3200 Sencore Drive
Sioux Falls, SD 57107
605-339-0100 In SD Only

*innovatively designed
with your time in mind.*

CIRCLE 186 ON FREE INFORMATION CARD

COMB

Authorized Liquidator

**FACTORY
NEW!
FIRST
QUALITY!**



COMMODORE

COMMODORE® VICMODEM™

- Use with the Commodore® C64™, the SX-64 or the VIC-20 Computer.
- Bell 103 Compatible.
- Full Duplex; 300 Baud.
- Manual Dial Direct Connecting.
- FCC Registered.

This Modem is **LOW liquidation priced** because it was closed out by Commodore®. Add it to your computer for access to timely financial information, news and reference libraries...as near as your phone! An affordable introduction to phone/computer services; and you can communicate with computer users who also own modems!

Use with data cassette (included), or with terminal program software, available at computer stores.

90-Day Limited Factory Warranty.

Mfr. List Price **\$59.00**

Liquidation
Priced At Only **\$19**

Item H-1646-7041-072

Shipping, handling: \$4.00 each

Commodore is a registered trademark of Commodore Electronics, Ltd.

Credit card customers can order by phone,
24 hours a day,
7 days a week.

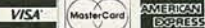

Toll-Free: 1-800-328-0609

Sales outside the 48 contiguous states are subject to special conditions. Please call or write to inquire.

SEND TO: Item H-1646

C.O.M.B. Direct Marketing Corp.

1405 Xenium Lane No./Minneapolis, MN 55441-4494

Send ___ Modem(s) Item H-1646-7041-072 at \$19 each plus \$4 each for shipping, handling. (Minnesota residents add 6% sales tax. Sorry, no C.O.D. orders.)

My check or money order is enclosed. (No delays in processing orders paid by Check.)

Charge: VISA® MasterCard® American Express®

Acct. No. _____ Exp. _____

PLEASE PRINT CLEARLY

Name _____

Address _____

City _____

State _____ ZIP _____

Phone (____) _____

Sign Here _____

You can often check tubes without removing them from the chassis. You should measure some resistance between the filament pins, and no resistance between any combination of plate, grid(s), and anode. It helps to know which prongs the filament is connected to. Miniature tubes often connect the filament to prongs 3 and 4. The tubes in the Temple radio mentioned earlier have filaments on prongs 2 and 7, except the 12SQ7, which uses 7 and 8. Check a tube guide to make sure.

If you must remove tubes from a later model set, it is often easier to remove the chassis before pulling tubes. Newer cabinets are so small that it's almost impossible to get your hand inside to remove the tubes.

After you get some practice, it should take only about one minute to check the continuity of all five tubes, the power switch, the line cord, and a dropping resistor, if present.

The other common problem in AC-DC sets is hum. Since those radios lack many of the hum-causing components of the early AC-only sets, hum is easier to locate. Often it's due to a leaky electrolytic capacitor. The best way to test a suspect capacitor is by bridging it with a good one. Make sure that the voltage rating of the bridging device is at least as high as that of the suspect.

Electrolytics often have two or three sections in a single cardboard tube (or can). You may find that only one section is bad, but it's best to replace the entire component. If you can't find an exact substitute, you can use two or three individual capacitors, as long as both capacitance and voltage ratings are attended to. When replacing an electrolytic, be sure to install the new one with the correct polarity.

Printed-circuit boards

Another source of shorts and opens is the PC board, which was perfected during World War II, although it was conceived of at least twenty years earlier.

As with most innovations, servicemen had problems with the PC board at first. Pushing tiny resistor and capacitor leads through

ELECTRONIC COMPONENTS



FREE CATALOG

Manufacturers of Quality Electronic Components

Serving the Nation from Texas and California

- BATTERY HOLDERS & CLIPS • COILS
- CAPACITORS • CONNECTORS • FUSES
- JACKS • KNOBS • LAMPS • PLUGS
- MICROPHONES • POTENTIOMETERS
- RELAYS • RESISTORS • SWITCHES
- TRANSFORMERS • SPEAKERS • LEDS
- SEMICONDUCTORS • RF COILS

OVER 16,000 DIFFERENT ITEMS IN STOCK!
CATALOGS MAILED OUTSIDE USA SEND \$2.00

MOUSER ELECTRONICS

2401 HWY. 287 NORTH MANSFIELD, TX 76063

PHONE 817-483-4422

CIRCLE 117 ON FREE INFORMATION CARD

Power Supplies Discount Prices!

VERSATILE LAB POWER SUPPLY



ELECTRO INDUSTRIES MODEL 3002A

Reg. \$125.00 Sale Price **\$99⁹⁵**

- 0-30 VDC at 0-2A • Fully adjustable current limiting • Constant voltage/constant current modes — automatic crossover • Excellent regulation with low ripple • Floating output • Built-in short-circuit and overload protection. Options: 10-Turn Voltage & Current Controls, \$25 each. Both for \$45.

EPSCO MODEL EC-2 POWER SUPPLY

- 0-16 VDC at 5A • Comb. V/A meter • Benchtop
- 1.8 volt/amp load change • 0.5% ripple @ 5A

Reg. \$169.50 Sale Price **\$130⁰⁰**

Check, Money Order or C.O.D. Add \$4.50 per unit for shipping & insurance. Outside U.S. \$9.00. IL residents add 7% tax. 15-Day Money Back Guarantee.

Salen Enterprises

P.O. Box 915, Morton Grove, IL
60053 Area 312-465-1424

CIRCLE 185 ON FREE INFORMATION CARD

small holes and then soldering them to the other side of the board seemed awkward to many of us. It was easy to destroy the fragile copper traces with the large soldering irons that were popular at the time. We then had to repair the damaged board with wire. Weak copper traces can be a nagging problem; a trace can be stripped from the board just by pulling a tube out of a socket. In fact, many sets have notices on the back warning of that problem.

But manufacturers soon offered proper instructions and tools for servicing the printed circuit board. The introduction of smaller components went a long way toward preventing damage to the board.

Voltage readings

If you look at the schematics of many early receivers, you'll see that the voltage readings at corresponding points in various circuits are very similar. Voltage readings take more time to make than continuity tests, and they require some training on the part of the serviceman. A few general rules can be stated, however.

The plates of the converters (12BE6, 12SA7) and IF amplifiers (12BA6, 12SK7) should show under 100 volts. The first audio stages (12AT6, 12SQ7) should show between 30 and 60 volts. The cathodes of the audio output tubes (50C5, 50L6) should show about 6 volts, and the rectifier cathodes (35W, 35Z5) should show over 100 volts. The grid of the first audio tube should show about -1 volt, and the oscillator grid of the converter should show between -6 and -12 volts.

The end of an era

Although few wanted to believe it at the time, the 1950's was the beginning of the end for the tube industry. Tubes were the mainstay of the electronics industry. Wholesaler's walls were covered with shelves of every type of tube imaginable. The radio repairman carried an impressive tube caddy, and kept a rack of popular tubes in his shop. Even more impressive was the repairman's tube tester. No person or piece of equipment did

continued on page 88

Exclusive, triple patented dynamic cap and coil analyzing . . . guaranteed to pinpoint your problem every time or your money back



with the all new LC75 "Z METER 2"
Capacitor Inductor Analyzer
Patented \$995

The "Z METER" is the only LC tester that enables you to test all capacitors and coils dynamically — plus, it's now faster, more accurate, and checks Equivalent Series Resistance (ESR) plus small wire high resistance coils.

Eliminate expensive part substitution and time-consuming shotgunning with patented tests that give you results you can trust every time. Test capacitor value, leakage, dielectric absorption, and ESR dynamically; with up to 600 volts applied for guaranteed 100% reliable results — it's exclusive — it's triple patented.

Save time and money with the only 100% reliable, in- or out-of-circuit inductor tester available. Dynamically test inductors for value, shorts, and opens, automatically under "dynamic" circuit conditions.

Reduce costly parts inventory with patented tests you can trust. No more need to stock a large inventory of caps, coils, flybacks, and IHVTs. The "Z METER" eliminates time-consuming and expensive parts substituting with 100% reliable LC analyzing.

Turn chaos into cash by quickly locating transmission line distance to opens and shorts to within feet, in any transmission line.

Test troublesome SCRs & TRIACs easily and automatically without investing in an expensive second tester. The patented "Z METER 2" even tests SCRs, TRIACs, and High-Voltage Diodes dynamically with up to 600 volts applied by adding the new SCR250 SCR and TRIAC Test Accessory for only \$148 or FREE OF CHARGE on Kick Off promotion.

To try the world's only Dynamic LC Tester for yourself, CALL TODAY, WATS FREE, 1-800-843-3338, for a FREE 15 day Self Demo.



Call Today Wats Free 1-800-843-3338

SENCORE

3200 Sencore Drive
Sioux Falls, SD 57107
605-339-0100 In SD Only

*innovatively designed
with your time in mind.*

CIRCLE 187 ON FREE INFORMATION CARD

COMMUNICATIONS CORNER



HERB FRIEDMAN,
COMMUNICATIONS EDITOR

Private amateur communications

IT IS QUITE LIKELY THAT TEN YEARS AGO an amateur radio operator would have responded with utter disbelief if someone had asked whether he could foresee a need for private communications in his radio service.

Of course, private communications is useful—to a degree—for repeater use, particularly where a freebie telephone patch is provided. After all, if someone is going to enjoy expensive communication functions he should be willing to pay “club” dues.

Repeater access is usually made private through the same kind of PL (Private Line) circuits that are used in commercial VHF/UHF gear. Generally, the true PL systems employ a sub-audible tone that is transmitted with the carrier; the tone keeps the receiver’s squelch open. In some cases, a tone burst is used to keep squelch open.

But controlled repeater access isn’t the only application for private amateur-band communications. For example, you might want your equipment to determine who you’ll talk with or listen to. And, although that might be difficult to do using audible or sub-audible tones, it would be convenient to be able to do so just by punching a few numbers on a keypad. Of course, that kind of controlled access can only be done with a transceiver that uses digital-computer circuits.

Digital codes

Thanks to LSI (Large Scale Integration), a single microprocessor and a support chip or two can provide a complete digital

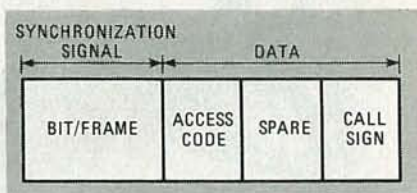

FIG. 1

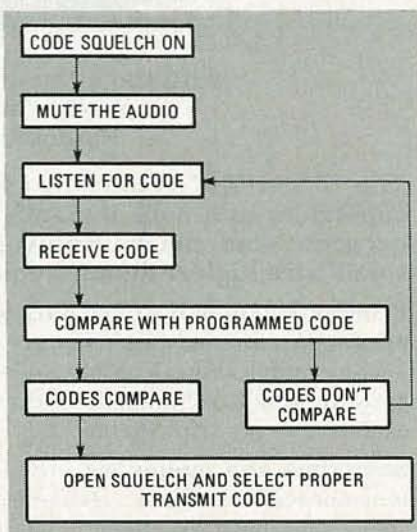

FIG. 2

encoding and decoding system. With the new-technology controlling squelch, it's now possible to limit access to desired stations only. And a mere five-digit code group provides 100,000 access-code combinations.

What kind of non-commercial communications needs that kind of privacy? Beats me—but Kenwood now builds it into their amateur-band two-meter and 70-centimeter mobile and hand-held transceivers.

Typical microprocessor-controlled communications equipment these days usually has some kind of special readout and con-

trols, or an interface for a personal computer. The Kenwood equipment can work with an optional display, use of which is discussed below.

The access code

The Kenwood DCS (Digital Code Squelch) is triggered by a signal composed as shown in Fig. 1. At the instant the transmitter's PTT switch is pressed, the transmitter sends a digital control signal consisting of a synchronizing signal, a 5-digit access code, several spare bits reserved for future use, and an ASCII representation of the user's call-sign. All that happens in less than 200 ms. The transmitter automatically withholds audio modulation until the control signal has been sent.

At the receiver, the five-digit code is passed on to the digital squelch. If the squelch is programmed to accept that code, it opens; otherwise it remains closed. If the listener wants to wait for transmission from a specific station, he simply punches that station's five-digit code into his keypad.

A flow chart that illustrates how the squelch circuit works is shown in Fig. 2. There's really nothing special about that circuit; what is interesting is that micro-miniaturization makes it commercially viable.

However, the way the transceiver handles the ASCII call-sign is interesting. An optional accessory for the digital squelch transceivers is a device called a "Call Sign Display." It has an LCD readout and 20 memories. What

continued on page 83

KENWOOD

...pacesetter in Amateur radio

NEW

Hear it All!



R-5000

High performance receiver

THE high performance receiver is here from the leader in communications technology—the Kenwood R-5000. This all-band, all mode receiver has superior interference reduction circuits, and has been designed with the highest performance standards in mind. Listen to foreign music, news, and commentary. Tune in local police, fire, aircraft, weather, and other public service channels with the VC-20 VHF converter. All this excitement and more is yours with a Kenwood R-5000 receiver!

- Covers 100 kHz-30 MHz in 30 bands, with additional coverage from 108-174 MHz (with VC-20 converter installed).
- Superior dynamic range. Exclusive Kenwood DynaMix™ system ensures an honest 102 dB dynamic range. (14 MHz, 500 Hz bandwidth, 50 kHz spacing.)

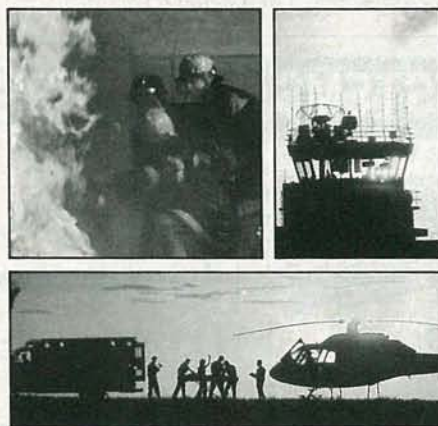

- 100 memory channels. Store mode, frequency, antenna selection.
- Voice synthesizer option.
- Computer control option.
- Extremely stable, dual digital VFOs. Accurate to ± 10 ppm over a wide temperature range.
- Kenwood's superb interference reduction. Optional filters further enhance selectivity. Dual noise blankers built-in.
- Direct keyboard frequency entry.

- Versatile programmable scanning, with center-stop tuning.
- Choice of either high or low impedance antenna connections.
- Kenwood non-volatile operating system. Lithium battery backs up memories; all functions remain intact even after lithium cell expires.
- Power supply built-in. Optional DCK-2 allows DC operation.
- Selectable AGC, RF attenuator, record and headphone jacks, dual 24-hour clocks with timer, muting terminals, 120/220/240 VAC operation.

Optional Accessories:

- VC-20 VHF converter for 108-174 MHz operation
- YK-88A 1.6 kHz AM filter
- YK-88S 2.4 kHz SSB filter
- YK-88SN 1.8 kHz narrow SSB filter
- YK-88C 500 Hz CW filter
- YK-88CN 270 Hz narrow filter
- DCK-2 DC power cable
- HS-5, HS-6, HS-7 headphones
- MB-430 mobile bracket
- SP-430 external speaker
- VS-1 voice synthesizer
- IF-232C/IC-10 computer interface.

More information on the R-5000 and R-2000 is available from Authorized Kenwood Dealers.

KENWOOD

TRIO-KENWOOD COMMUNICATIONS
1111 West Walnut Street
Compton, California 90220

R-2000

150 kHz-30 MHz in 30 bands
• All modes • Digital VFOs tune in 50 Hz, 500 Hz, or 5 kHz steps • 10 memory channels
• Programmable scanning • Dual 24-hour digital clocks, with timer • 3 built-in IF filters (CW filter optional)
• All mode squelch, noise blanker, RF attenuator, AGC switch, S meter • 100/120/220/240 VAC operation • Record, phone jacks
• Muting terminals • VC-10 optional VHF converter (108-174 MHz)



Specifications and prices are subject to change without notice or obligation.

CIRCLE 102 ON FREE INFORMATION CARD

OVER 2,000 TUBE TYPES IN-STOCK

78% - 90% off list

Plus thousands of
electronic parts
including

- VCR/Cable Accessories
- Telephone Accessories
- Audio Accessories
- Computer Accessories
- Capacitors, Resistors, Diodes, etc.
- Speakers
- Many other items

Send for FREE
Catalog

Steven



MAIL ORDER ELECTRONICS CORP.
P.O. Box 698 Melville, New York 11747
(516) 752-0060

CIRCLE 188 ON FREE INFORMATION CARD

EARLY RADIO

continued from page 62

called a Negatron, had a negative resistance characteristic, making it useful as an oscillator.

Early receivers

The first sets that made use of tubes were actually hybrids. One such receiver is shown in Fig. 7. That set uses a crystal detector, but follows it with a tube-amplifier stage. Since that increases the volume at the headphones, more selective tuning schemes can be used.

With amplification, one volume problem was solved, but another was created: too much volume. To control volume, a rheostat is placed in series with the filament and its voltage supply. See Fig. 8.

Another circuit variation was the early heterodyne receiver designed by Fessenden. Shown in Fig. 9, in that receiver the incoming signal was mixed with one generated locally, resulting in a difference or beat frequency that was detected by the diode.

The local signal was generated by an arc connected to the 110-volt lines. The sparking of the arc produced a signal that could be tuned by L4 and C1.

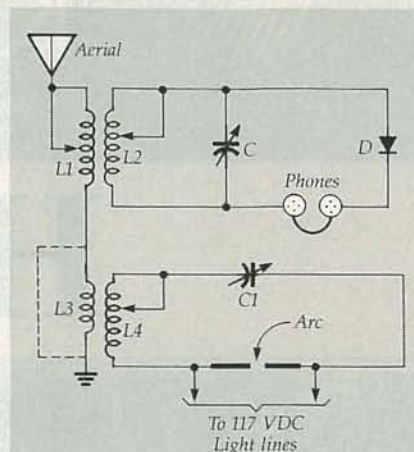

FIG. 9—AN EARLY HETERODYNE RECEIVER. Designed by Fessenden, it used a tuned electric arc as the local oscillator.

The change to tubes also brought about other changes. Crystal sets were bread-board affairs. But when tubes came along, they brought with them a host of controls.

Variable capacitors, resistors, and inductors needed to be mounted somewhere, so front panels were introduced. Later, the receivers were completely enclosed in cabinets. Before long, the receiver came to resemble the units that are now so familiar. R-E

HOME SECURITY SYSTEMS

Deluxe Wireless For Home, Apartment, Offices, Mobile Homes

FEATURES

- Main Module/Receiver is capable of telling what kind of alarm is triggered: Intrusion, fire, maintenance, medical emergency, etc., and where the alarm is originated - 5 zones designated by the user.
- This system can only be activated or deactivated by entering a 3 to 10 digit Secret Code selected by the user.
- In case of emergency, the built-in siren speaker and the Remote Horn can be triggered instantly by pressing the "EMERGENCY" key.
- Adjustable Exit Delay time allows the user to leave his/her home before the system is activated.
- Adjustable Entry Delay time with flashing "INST/DLY" LED to remind the user to deactivate the system when he/she enters the protected premise.
- Built-in Window Reminder LED reminds the user if any or all windows are left open.
- Once triggered, the system will emit an ear-piercing sound for five minutes before it resets itself to continue providing protection.
- 5 sets of Wireless Magnetic Sensors/Transmitters are included to detect any door or window opening.
- When the battery in the Main Module is low, the "BATTERY LOW" indicating light will light up to remind the user of low battery condition.
- The Main Module is DC powered with AC adaptor provided and backed up by six 1½ Volt Size "AA" cells.
- The Magnetic Sensor/Transmitter is powered by a 9 Volt battery.
- System is expandable with the following options:
 - Remote Wireless Siren Speaker to be turned on or off remotely by the Main Module.
 - Wireless Panic Switch capable of activating the alarm instantly at the push of a button.
 - Wireless Remote Turn-off allows the user to turn off the system from outside of the protected premise. Additional Magnetic Sensor/Transmitters.



\$149.95
Plus \$6.00 shipping and handling



\$39.95
Plus \$3.00 shipping and handling



\$14.95 For Each
Plus \$2.00 shipping and handling

STUN GUN

- The ultimate non-lethal defense weapon. Can immobilize your attacker in seconds.
- \$39.95, Mass. 5% Sales Tax, \$3.00 shipping and handling.



1-800-522-2636 For Orders Only
617-871-5611 For Information



Cameo Enterprises, Inc.
P.O. Box 63, Accord, MA 02018



CIRCLE 89 ON FREE INFORMATION CARD

COPPER ELECTRONICS

4200 PRODUCE ROAD - LOUISVILLE, KENTUCKY 40218

Call us FREE 1-800-626-6343

or write for FREE Flyer.

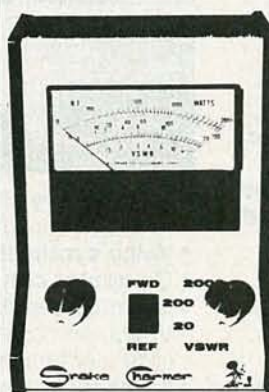

Snake Charmer

WATTMETER

59.95

6 LOT 12 LOT
54.95 49.95

SPECIFICATIONS:

- * Power Range: 20, 200, 2000 Watts
- * VSWR: Voltage Standing Wave Reading
- * Peak Reading During modulation
- * Accuracy +/-5 percent on dead carrier

We have a national factory warranty service on many brands, and we service All CB, Amateur, and Commercial Equipment.

THE LOWEST PRICES IN THE COUNTRY!

CIRCLE 125 ON FREE INFORMATION CARD

R-E Engineering Admart

Rates: Ads are 2 1/4" x 2 7/8". One insertion \$825. Six insertions \$800 each. Twelve insertions \$775 each. Closing date same as regular rate card. Send order with remittance to **Engineering Admart**, Radio Electronics Magazine, 500-B Bi-County Blvd., Farmingdale, NY 11735. Direct telephone inquiries to Arline Fishman, area code-516-293-3000. *Only 100% Engineering ads are accepted for this Admart.*

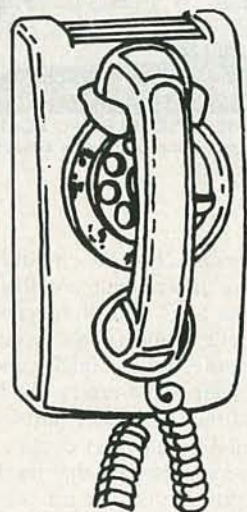

**CALL NOW
AND
RESERVE
YOUR SPACE**

- 6 x rate \$800.00 per each insertion.
- Reaches 239,312 readers.
- Fast reader service cycle.
- Short lead time for the placement of ads.

Call 516-293-3000 to reserve space. Ask for Arline Fishman. Limited number of pages available. Mail materials to: Engineering Admart, RADIO-ELECTRONICS, 500-B Bi-County Blvd., Farmingdale, NY 11735.

IBM-PC Schematic Design

A professional package enabling you to design, edit, print & plot electronic schematics. Supports "A" — "E" size sheets, over 2000 Unique Library Parts, Auto Panning, Part Rotation, 5 Zoom Levels, Rubberbanding, Powerful Macros, Hi-Res Color & Monochrome Graphics, Much More! \$495 Includes Everything.

Call to Receive Free Demo Disk.

OrCAD Systems Corporation 
1049 S.W. Baseline St.
Hillsboro, OR 97123
(503) 640-5007

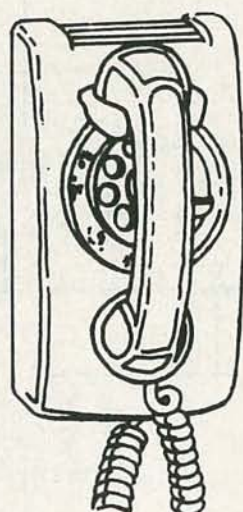

**CALL NOW
AND
RESERVE
YOUR SPACE**

- 6 x rate \$800.00 per each insertion.
- Reaches 239,312 readers.
- Fast reader service cycle.
- Short lead time for the placement of ads.

Call 516-293-3000 to reserve space. Ask for Arline Fishman. Limited number of pages available. Mail materials to: Engineering Admart, RADIO-ELECTRONICS, 500-B Bi-County Blvd., Farmingdale, NY 11735.

LINEAR IC EQUIVALENTS & PIN CONNECTIONS

Linear IC
Equivalents
and Pin
Connections

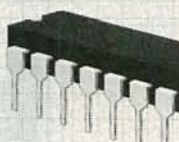

BP141—Shows equivalents & pin connections of a popular user-oriented selection of European, American and Japanese linear IC's 320 pages, 8 x 10 inches. \$12.50 Plus \$2.75 shipping. **ELECTRONIC TECHNOLOGY TODAY INC., PO Box 240, Massapequa Park, New York 11762-0240.**

COMMUNICATIONS CORNER

continued from page 80

the device does is extract and display the ASCII call-sign from the digital control signal. So even before the user hears the caller's voice he knows the call-sign.

Alternately, the user can leave the receiver on and unattended. The call-sign of any suitably encoded signal that is received will be stored in one of the 20 memories. When the user returns to his shack, he can "flip" through those memories; the display will show

the call-sign of anyone who tried to reach the station. Another option is an internal alarm, which sounds only when a suitably encoded signal has been received.

(For those of you who were pioneers—so to speak—in RTTY using the surplus equipment of the late 1940's and '50's, many of the functions provided by the digital "privatizing" of communications sounds very familiar. Back when we were into RTTY using teletypewriters so generously donated to the amateur fraternity, one of the features we all strived to build and install allowed other

RTTY'ers to "call in" and leave a message when we weren't home. Back then, getting unattended operation to work was quite an achievement, and even today, it still is.)

As you can see, digital squelch does provide the amateur with full privacy, even more so than many conventional VHF/UHF rigs. The operator can actually limit not only the stations he is willing to "work," but also those he is willing to hear. He need not even know that the world outside his select group exists. But that isn't what amateur radio is all about. **R-E**

CONTINUITY TESTER

continued from page 50

nine-volt battery is secured to the side of the case with a metallic battery clip. Your

completed PC board should appear as in Fig. 5.

Usage hints

Set S1 for SHORT or OPEN depending on the condition to be tested. Then connect

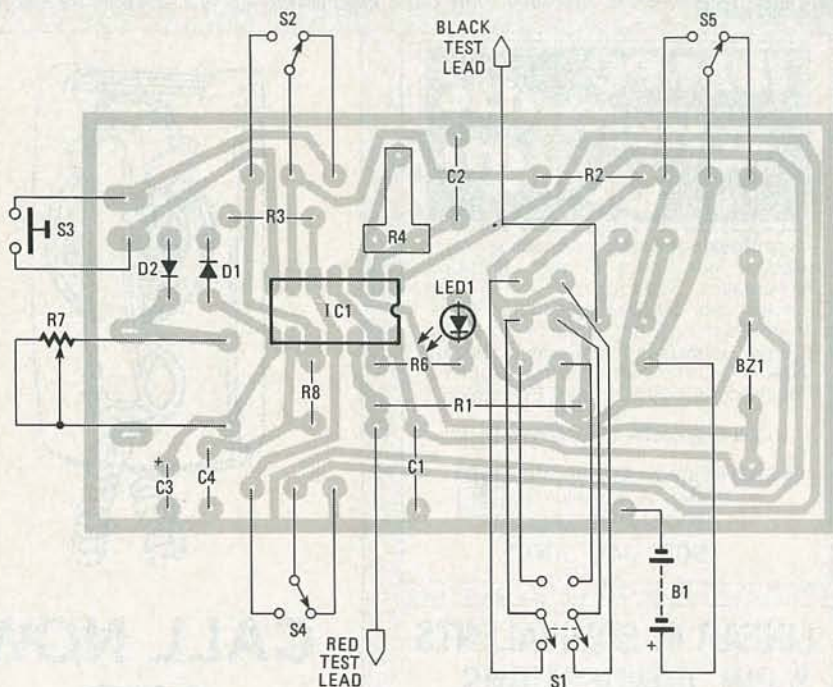

FIG. 4—MOUNT ALL COMPONENTS as shown here. The height of all components, especially the LED and the buzzer, must be carefully planned for.

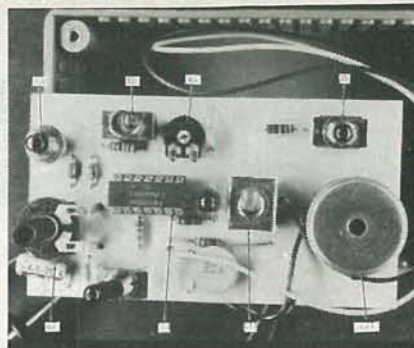

FIG. 5—THE ASSEMBLED PC BOARD reveals the low parts-count and easy assembly of the continuity tester.

the test leads across the circuit to be tested. If an intermittent condition is detected, the LED will illuminate, and the buzzer will sound (if S4 is on). If you don't remove the test leads (assuming if S2 is set for AUTO reset), the LED will flash and the audio will warble at a rate determined by the reset circuit.

It is very important that the test leads make a positive connection with the circuit to be tested. In fact, clips should be used rather than test probes. The detector circuit is so sensitive that, when it is initially connected across a long length of parallel wires, it may latch due to capacitance between the wires. If that occurs, simply press RESET switch S3. R-E

FLUKE



70 Series Digital Multimeters

3½ digit multimeters combine a 3200 count LCD display with an analog bar graph for quick visual checks of continuity, peaking, nulling and trends. The unparalleled operating ease, instant autoranging and 2,000+ hour battery life make this a lot of meter for the price. 3 year warranty.

FLUKE 73

•0.7% basic DC accuracy •Autoranging only

Reg.\$79.00

SALE
\$76.50

FLUKE 75

•0.5% basic DC accuracy •Autoranging w/range hold •10 amp + autoranged mA ranges •Continuity & diode •Test beeper

Reg.\$99.00

SALE
\$89.00

FLUKE 77

•0.3% basic DC accuracy •Autoranging w/range hold •10 amp + autoranged mA ranges •Continuity & diode •Test beeper •Touch-Hold

Reg.\$139.00

SALE
\$125.00

Send now for your **FREE** catalog of electronic tools & test equipment

Call TOLL-FREE
1-800-638-6405

w.s. JENKS & Son



1933 Montana Ave. NE Washington DC 20002

NOISE REDUCTION FOR UNDER \$10.

MIXING CONSOLES
SWITCHES
MICROPHONE CONNECTORS
SNAKE CABLES
BATTERY CONTACTS

ALL PLUGS & JACKS
(XLR, PHONE, PHONO, DIN, MIDI, ETC.)
PATCHBAYS
FADERS, POTS
TERMINAL STRIPS
SPEAKER TERMINALS

CRAMOLIN®

Even the finest equipment in the world cannot guarantee noise-free operation. One "dirty" connection anywhere in the electrical path can cause unwanted noise or signal loss.

"MORE THAN A CONTACT CLEANER"

CRAMOLIN® is a fast-acting, anti-oxidizing lubricant that cleans and preserves all metal surfaces, including gold.

When applied to metal contacts and connectors, **CRAMOLIN®** removes resistive oxides as it forms a protective molecular layer that adheres to the metal surfaces and maintains maximum electrical conductivity.

CRAMOLIN® - USED BY THOSE WHO DEMAND THE BEST:

Bell & Howell	Hewlett Packard	MCI(Sony)	Nakamichi
Capitol Records	John Fluke Mfg.	Motorola	RCA
Dolby Laboratories	McIntosh Labs	NASA	Switchcraft

SINCE 1956

CAIG LABORATORIES INC

1175-O Industrial Ave., (P.O. Box J) - Escondido, CA 92025-0051 U.S.A. • (619) 743-7143

MARKET CENTER

FOR SALE

TUBES new, unused. Send self-addressed, stamped envelope for list. **FALA ELECTRONICS**, Box 1376-2, Milwaukee, WI 53201.

LINEAR parts, tubes, transistors—MRF454 \$16.00, MRF455 \$12.00, MRF477 \$11.00, MRF492 \$18.00. Catalog. **RFPC**, Box 700, San Marcos, CA 92069 (619) 744-0728.

RESTRICTED technical information: Electronic surveillance, schematics, locksmithing, covert sciences, hacking, etc. **Huge selection. Free brochure: MENTOR-Z**, 135-53 No. Blvd., Flushing, NY 11354.

OLDTIME radio programs on high quality tapes. Comedy! Adventure! Music! Free catalog. **CARL F. FROELICH**, Heritage Farm, New Freedom, PA 17349.

T.V. tunable notch filters, free brochure. **D.K. VIDEO**, Box 63/6025, Margate, FL 33063 (305) 752-9202.

TEST equipment, reconditioned. For sale. \$1.25 for catalog. **WALTER'S**, 2697 Nickel, San Pablo, CA 94806 (415)724-0587.

LASERS, components and accessories. Free catalog. **M.J. NEAL COMPANY**, 6672 Mallard Ct., Orient, OH 43146.

DESCRAMBLER plans for Jerrold. Theory, schematic, parts list, waveforms. For speedy delivery send \$10.00 cash or money order. **BAY STATE ELECTRONICS**, P.O. Box 63, Accord, MA 02018.



Quality Microwave TV Antennas

Multi-Channel 1.9 to 2.7 GHz
40dB Gain True Parabolic 20 Inch Dish
Complete System \$99.95 (plus shipping)
Dealerships, Qty. Pricing, Replacement Parts
Phillips-Tech Electronics
P.O. Box 8583 • Scottsdale, AZ 85252
(602) 947-7700 (\$3.00 Credit all phone orders!)
MasterCard • Visa • COD's

WHOLESALE catalog of unusual money making electronic items. Dealers wanted. Rush \$1. **CROSLY (A)**, Box 840, Champlain, NY 12919.

FREE Transistors: Sample of PN2222 and 2N3904 with our catalog of budget priced Electronic Components for hobbyists and industry. Send \$2.00 P&H (refundable) **BUDGET ELECTRONICS**, Box 1477, Moreno Valley, CA 92388 (714)653-1663.

BUGGED? Wiretapped? Find out fast. Countermeasures equipment catalog \$1.00 **CAPRI ELECTRONICS**, Route 1R, Canon, GA 30520.

WHOLESALE car-radio computer telephone audio video accessories antenna catalog (718) 897-0509 **D&WR**, 68-12 110th St., Flushing, NY 11375.

WORLDS best channel 3 notch filter. \$19.95. (Dealer inquiries invited). **CROSLY (A)**, Box 840, Champlain, NY 12919.

SPECTACULAR strobe light chasers, stroboscopic devices, **Helium-Neon Laser** components, scientific items, more! Free catalog. **ALLEGRO ELECTRONIC SYSTEMS**, #3R Mine Mountain, Cornwall Bridge, CT 06754.

ELECTRONICS. \$1.50 brings flyer, grab bag. **LYNN JOHNSON**, 2221 The Alameda #176, Santa Clara, CA 95050.

CABLE-TV converters and equipment. Plans and parts. Build or buy. Free information. **C&D ELECTRONICS**, PO Box 1402, Dept. RE, Hope, AR 71801.

HIGH Gain Descramblers, CRT automatic dimmer, SCR Tester, plus other unusual electronic devices. Send \$3.00 for info. **RB ELECTRONICS ENGINEERING**, PO Box 643, Kalamazoo, MI 49005.

SCIENTIFIC Atlanta stand alone—8500 series (Original units), remote control. Fully guaranteed. \$250.00. **N.A.S.**, (213) 631-3552.

FREE electronic parts. All sorts, for inventors, designers, experimenters. How and where to get them. No exaggeration. Send single fee \$4.95 to **AMERICAN TRANS-GLOBAL**, Box 7033, Huntington, WV 25775.

SURPLUS military/commercial test and communications equipment—1986 catalog. Send \$1.00. **MIL-COM EXCHANGE ELECTRONICS**, Box 982-RE, Orange Park, FL 32067-0982.

CLONE kits, modems, hard drive kits, disk drives, diskettes and printers, memory, and IC's. Distributor pricing to end users and dealers. For catalog call **1-800-833-2600**. In Ohio call (513) 531-8866. Free shipping.

THE BEST PLACE to BUY, SELL or TRADE NEW and USED EQUIPMENT
NUTS & VOLTS MAGAZINE
BOX 1111-E • PLACENTIA, CA 92670
(714) 632-7721
Join Thousands of Readers Nationwide
Every Month
ONE YEAR U.S. SUBSCRIPTIONS
\$10.00 - 3rd Class • \$15.00 - 1st Class
\$35.00 - Lifetime - 3rd Class

NUTS & VOLTS
HAM GEAR
COMPUTERS
SOFTWARE
SCANNERS • OPTICS
TEST EQUIPMENT
MICROWAVE
SATELLITE
AUDIO VISUAL
NEW PRODUCTS
COMPONENTS • KITS
ANTIQUE ELECT.
PUBLICATIONS
PLANS • SERVICES

WIREWRAP lables. Identify ICs, pins. Easier, errorless wrapping. All DIPs 8-40 pins. Inexpensive, 363 lables \$6.00. **PAUL'S LABLES**, 7320 Embassy, Miramar, FL 33023.

FAST A/D converters. Five bit 90 nanosecond, \$25.00. Eight bit 160 nanosecond, \$40.00. Eight bit 13 nanosecond, \$250.00. Send business size SASE for details. **DIPAC ASSOCIATES**, 645 Executive Center Drive #204, West Palm Beach, FL 33401.

DISK of software for IBM. Six tools for office. \$3.00 postpaid. **SMUG**, Asheville, NC 28806-4158.

TV SCR Tester. Hand-held will also test TRIACS, diodes, transistors, ECG 89 HO transistors in operational mode. Defines AKG. Will save time. \$49.95; send check or money order. **BFE**, P.O. Box 3942, Albany, GA 31706-3942.

PHONE directory program for IBM PC. \$39.95. Free info. **ASD CORP.**, P.O. Box 590163, Orlando, FL 32859-0163.

TRIPLE regulated, metered benchtop power supplies. Fixed $\pm 5VDC$, two variable $\pm 15VDC$, 1-amp maximum. Short and overload protected, current limited. Supplies stackable to $\pm 35VDC$. \$119.95. Year warranty. **USI**, Box 332R, Weatogue, CT 06089. (203) 658-4318.

DIGITAL trainers, powered breadboards, power supplies. Kits or assembled. Lowest prices. Free catalog. **TERA ELECTRONICS**, Box 2482-N, Evergreen, CO 80439.

FREE Adapter (Limited offer) with Assortment #103—consisting of **Toko Coils** 144LY-120k, 520 HN-3000023, **BKAN-K555AXX** (2); **PCB; Transistors** 2N3904 (2), **BFQ85** (sub); **IC's** 7812, 74123, **MC1330A1P**; **Diodes** 1N914, 1N5231B. Only \$25.00 10% discount for 5 or more. Shipping \$3.00/order **MC/Visa/COD. Toll free 1-800-821-5226 Ext. 426** (orders). **JIM RHODES, INC.**, 1025 Ransome Lane, Kingsport, TN 37660.

TUBES, name brands, new, 80% off list. **KIRBY**, 298 West Carmel Drive, Carmel, IN 46032.

INDIVIDUAL Photofact-folders #1 to #1400. \$3.00 postpaid. **LOEB**, 414 Chestnut Lane, East Meadow, NY 11554.

ELECTRON tubes—radio, TV & industrial types—huge inventory. Call toll free (800) 221-5802 or write Box **ESC TRANSLETTERONIC, INC.**, 1365 39th St., Brooklyn, NY 11218 (718) 633-2800.

MAKE money in mail order. SASE +\$1 for info. SASE +\$20.00 for kit. **ALPHA**, 102 Belle, San Rafael, CA 94901.

CABLE television converter, descrambler, and microwave television antenna equipment accessories. Video catalog free. **CABLE DISTRIBUTORS UNLIMITED**, 116 Main Road, Washington, AR 71862.

FREE microprocessors, memory chips, etc. Free electronics magazine subscriptions. Free education in computers. For information write **MICROSAT CORPORATION**, 2401 N.E. Cornell, Bldg. 133, Hillsboro, OR 97124.

SURPLUS boards and computers. All kinds available: S-100, Multibus, VME—to name a few. Free catalog. **MEGATECH**, P.O. Box 4213, Yalesville Station, CT 06492. (203) 634-4593.

BRAND new Oak descramblers, \$35.00 each; Vari-sync Oak \$45.00 each; SB-3 \$89.00; Tri-mode \$125.00; Bi-state \$125.00; call us, we ship UPS COD. **PONDEROSA COMPANY**, (303) 634-6666.

A/D Converter, eight channel, RS232C interface for any computer. \$199.00 complete. Free spec sheet. **U-TAP RESOURCES**, Rt 1, Box 354A, Mechanicsville, MD 20659.

CATALOG: cable converters, descramblers, satellite descramblers, N12 mini-code \$98.00. SB3 only \$99.00. Pulse descrambler kit assembles in half hour \$79.00, built \$120.00. Satellite descrambler kit assembles in one hour \$120.00, built \$190.00. COD OK. Send \$1.00. **MJ INDUSTRY**, Box 531, Bronx, NY 10461.



A SINGER'S DREAM!

REMOVES VOCALS FROM RECORDS!

Now You can sing with the world's best bands! The Thompson Vocal Eliminator can remove most or virtually all of a lead vocal from a standard stereo record and leave the background! Write or call for a free brochure and demo record. **LT Sound, Dept. R-1, P.O. Box 338, Stone Mountain, GA 30086 (404) 493-1258**

CABLE and satellite equipment; major brand; wholesale prices. Free catalog. **HMR SALES**, 116 Main Street, Washington, AR 71862.

POLYMER based PC board resist ink, for speedball, technical, and plotter pens. Water clean-up, ammonia strippable; 8 oz. \$11.00, plus \$1.50 shpg. SASE gets free sample. **SYNDULE ELECTRONICS**, P.O. Box 344, Somers, MA 02144.

TELEPHONE extension in your car. Morse Code for the untalented. TV descramblers. Legal police radar blocker. Detective electronics. Home video production equipment. 50 page catalog \$3.00. **DBE**, POB G, Waikiki, HI 96815.

CB Tune-Up Manual Volume II. Specific adjustments, modifications for peaking all popular CBs. Covers over 1300 radios. \$19.95, Visa, Mastercard to: **THOMAS PUBLISHING**, 127-R Westwood, Paris, IL 61944.

WARNING (Cable Equip. Buyer's) Let the Oak's Rot!!! Don't buy used equipment when you can buy new for less. **N-1200** \$75.00, Vari Sync add \$10.00. **10-\$58.00**, Case of 20 \$48.00 Channel 2 or 3. **SB-3000** with auto switch \$75.00, 10 or more \$65.00, case of 20 \$55.00. Vari Sync plans and parts list \$10.00. Remotes, Converters, Video Accessories. 90-day Guarantee. Free catalog. Call or write today. **M.C., VISA, C.O.D.** (402) 331-4957. **M.D. ELECTRONICS**, 5078 So. 108th #115, Omaha, NE 68137.

CB MODIFICATIONS

Increase channels, range, privacy! We specialize in frequency expanders, speech processors, FM converters, PLL & slider tricks, how-to books, plans, kits. Expert mail-in repairs & conversions. 16-page catalog \$2. Our 11th year!

CBC INTERNATIONAL, P.O. BOX 31500RE, PHOENIX, AZ 85046

TUBES! 59 cents. Year Guarantee. Free catalog. Tube tester \$8.95. **CORNELL**, 4215 University, San Diego, CA 92105.

DESCRAMBLER manuals, sinewave, gated pulse, SSAVI, \$4.00 each, all three \$10.00. **BMF**, 6690 7 Mile, S. Lyon, MI 48178.

TUBES: "oldest," "latest." Parts, components, schematics. SASE for list. **STEINMETZ**, 7519 Maplewood Ave., R.E., Hammond, IN 46324.

TI-99/4A software/hardware bargains. Hard to find items. Huge selection. Fast service. Free catalog. **DYNA**, Box 690, Hicksville, NY 11801.

SCIENTIFIC Atlanta—cable equipment. Original 8500's and 8550's all turned on and waiting for you! See it all! Customer satisfaction guarantee. Our units keep on ticking. **Advanced Tech Systems**, Box 316, Auburn, MA 01501. (617) 832-2339.

VIDEO scrambling techniques. Original "secret manual" covers Sinewave, Gatedpulse, and SSAVI systems. 56 pages of solid, useful, legible information. Only \$14.95. **ELEPHANT ELECTRONICS, INC.**, Box 41865-J, Phoenix, AZ 85080. (602) 581-1973.

LOTTO Buster. Analyzes all 6 digit lotto games. \$22.50. IBM and compatibles. **LOTTO BUSTER**, 912 North Hampton, Bay City, MI 48708.

IS it true...Jeeps for \$44 through the government? Call for facts! **1(312)742-1142**, ext. 4673.

SSWIN with thoroughbred/harness, Greyhound handicapping software...\$29.95, enhanced...\$49.95. Professional football handicapping system...\$39.95. For most computers. Free information: **SOFTWARE EXCHANGE**, Box 5382RE, W. Bloomfield, MI 48033. (313) 626-7208.

CABLE TV equipment, Scientific Atlanta, Zenith, Jerrold, Oak, send \$2.00 for catalog. **K.D. VIDEO**, P.O. Box 29538 Mpls., MN 55429.

PLANS AND KITS

CATALOG: Hobby/broadcasting/1750 meters/ham/CB: transmitters, amplifiers, antennas, scramblers, bugging devices, more! **PANAXIS**, Box 130-F11, Paradise, CA 95969.

CRYSTAL radio sets, plans, parts, kits, catalog \$1.00. **MIDCO**, 660 North Dixie Highway, Hollywood, FL 33020.

BUILD this five digit panel meter and square wave generator including an ohms, capacitance and frequency meter. Detailed instructions \$2.50. **BAGNALL ELECTRONICS**, 179 May, Fairfield, CT 06430.

CABLE TV Converters: Jerrold Products include "New Jerrold Tri-Mode," SB-3, Hamlin, Oak VN-12, M-35-B, Zenith, Magnavox, Scientific Atlanta, and more. (Quantity discounts) 60 day warranty. Service converters sold here. For fast service C.O.D. orders accepted. Send SASE (60 cents postage) or call for info (312) 637-4408. **HIGGINS ELECTRONICS**, 5143-R, W. Diversey, Chicago, IL 60639. No Illinois orders accepted.

VOICE disguisers! Telephone bugs! FM bugs! Other kits! Send stamped envelope: **XANDI**, Box 25647, Dept. 60E, Tempe, AZ 85282.

EXPERIMENT with fiber optics! Send your voice over a beam of light via an optical fiber. Complete kit (\$39.95) includes microphone, speaker, fiber, PCBs and all parts. Easily assembled. Complete plans package only \$5.95. Send to: **FIBER SCIENCES**, Box 5355, Chatsworth, CA 91313-5355. CA residents add 6.5%.

INFRARED 6032 tubes (tested and guaranteed), infrared kits, complete line of engineering and surveillance viewers. **IR SCIENTIFIC, INC.**, Box 110, Carlisle, MA 01741. (617) 667-7110.

JERROLD gated pulse theory. Twelve information packed pages covering DI & DIC converter operation. Includes introduction to trimode system. \$6.95 plus \$1.50 postage and handling. **ELEPHANT ELECTRONICS, INC.**, Box 41865-J, Phoenix, AZ 85080. (602) 581-1973.

CABLE and **Subscription TV** secret manual. New expanded edition. Build your own **descramblers**, converters. Instructions, schematics for Sinewave, Inband/Outband Gated Sync Pulse, SSAVI—(HBO, Showtime, Cinemax, UHF, etc.) Send \$8.95 to **CABLETRONICS**, Box 30502R, Bethesda, MD 20814. (For immediate delivery add \$1.00.)



WRITE FOR
McGEE'S

SPEAKER & ELECTRONICS CATALOG

1001 BARGAINS IN SPEAKERS

toll free 1-800-346-2433 for ordering only.

1901 MCGEE STREET KANSAS CITY, MO. 64108

HI-FI speaker systems, kits and speaker components from the world's finest manufacturers. For beginners and audiophiles. Free literature. **A&S SPEAKERS**, Box 7462R, Denver, CO 80207. (303) 399-8609.

RADIO-ELECTRONICS
ALL SALES SUBJECT TO THE TERMS OF OUR 90 DAY LIMITED WARRANTY. FREE COPY UPON REQUEST.

THE NEW 65/9028 VT ANSI VIDEO TERMINAL BOARD!

★ FROM LINGER ENTERPRISES ★

A second generation, low cost, high performance, mini sized, single board for making your own RS232 Video Terminal. Use as a computer console or with a MODEM for hook up to any of the telephone-line computer services.

FEATURES:

- ★ Uses the new SMC 9028 Video Controller Chip coupled with a 6502A CPU.
- ★ RS-232 at 16 Baud Rates from 50 to 19,200
- ★ On board printer port!
- ★ 24 X 80 format (50/60 Hz).
- ★ For 15,750 Hz (Horiz.) monitors.
- ★ 3 Terminal Modes: H-19, ADM3A, and ANSI X 3.64-1979
- ★ Wide and thin-line graphics.
- ★ White characters on black background or reversed.
- ★ Character Attributes: De-Inten, Inverse or Underline.
- ★ Low Power: 5VDC @ .7A, ± 12VDC @ 20MA.
- ★ Mini size: 6.5 X 5 inches.
- ★ Composite or split video.
- ★ 5 X 8 Dot Matrix characters (U/L case).
- ★ Answer back capability.
- ★ Battery backed up status memory.
- ★ For ASCII parallel keyboard.

MICRO SIZE!



\$99⁹⁵
(Full Kit)

SOURCE DISKETTE:
PC/XT FORMAT
5 1/4 IN. \$15

ADD \$40 FOR A&T

Digital Research Computers

(OF TEXAS)

P.O. BOX 381450 • DUNCANVILLE TX 75138 • (214) 225-2309

Call or write for a free catalog on Z-80 or 6809 Single Board Computers, SS-50 Boards, and other S-100 products.

TERMS: Add \$3.00 postage. We pay balance. Orders under \$15 add 75c handling. No C.O.D. We accept Visa and MasterCard. Texas Res. add 5-1/8% Tax. Foreign orders (except Canada) add 20% P & H. Orders over \$50 add 85c for insurance.

VIDEO TERMINAL BOARD

FROM MORROW DESIGN

- RS-232 FROM 300 TO 19.2 K BAUD
- 8 CHARACTER SETS
US, UK, FRENCH, GERMAN, SPANISH, DANISH, NORWEGIAN, SWEDISH, FINNISH, ITALIAN, AND GRAPHICS
- GRAPHICS
THICK & THIN LINE SEGMENTS, BAR GRAPH & CIRCLES
- 21 TELEVIDEO MODE FUNCTION KEYS
- 80 CHARACTER BY 24 LINE
- USUAL ATTRIBUTES
NORMAL, REVERSE, UNDERLINE, 1/2 INTENSITY AND COMBINATIONS OF THE ABOVE
- AUTO SCROLLING
WHEN DATE REACHES 24TH LINE
- MONITOR MODE
CAUSES TERMINAL TO DISPLAY ALL 32 CONTROL CODES
- SCREEN SAVER
TURNS TUBE OFF IF NO KEY IS PRESSED FOR 15 MINUTES. HIT ANY KEY AND IT TURNS ON AGAIN



\$30

ASSEMBLED BOARDS
NOT KITS !!!

MONITOR BOARD

BY ZENITH DATA SYSTEMS

DRIVES MOST CRT'S
12VDC OPERATION
TTL INPUTS

AMBER DISPLAY TUBE

BY ZENITH DATA SYSTEMS

9 BY 5 INCH AMBER TUBE
OTHER SIZES/COLORS AVAIL. CALL FOR PRICE

135 KEY KEYBOARD

FEATURES

- NUMERIC KEYPAD
- KEY CLICK/BELL SPEAKER
- LOW PROFILE
- FULL SIZE QWERTY LAYOUT
- 21 FUNCTION KEYS
- CAPS LOCK WITH LED
- ENTER KEY WITH LED
- KEYS AUTO REPEAT



\$30

\$14

\$30

THESE PARTS WERE DESIGNED TO WORK TOGETHER

64K SINGLE BOARD COMPUTER WITH BOOT DISK (CP/M) WORKS WITH ABOVE ONLY\$45
POWER SUPPLY FOR TERMINAL, MONITOR, AND COMPUTER.....\$55
MANY MORE BARGAINS SEND \$1 FOR CATALOG REFUND WITH PURCHASE

ALL FOUR PIECES ONLY
99⁰⁰
WE PAY THE FREIGHT

SILICON VALLEY SURPLUS
415-261-4506
10AM-6PM CLOSED SUN & MON

4401 OAKPORT
OAKLAND
CA. 94601
AT
HIGH & 880

CA. ADD 6.5% TAX. COD OR PREPAY ONLY. TRY IT FOR 15 DAYS - IF YOU ARE NOT HAPPY THEN RETURN IT. FREIGHT PAID FOR A PROMPT REFUND

CIRCLE 183 ON FREE INFORMATION CARD

PROJECTION TV... Convert your TV to project 7 foot picture. Results comparable to \$2,500 projectors. Total cost less than \$30. Plans and 8" lens \$21.95. Illustrated information free. **MACROCOMAGC**, Washington Crossing, PA 18977. Credit card orders 24 hours (215) 736-3979.

TELEPHONE bug, FM room bug schematics with detailed construction procedures using Radio Shack's numbered parts. Both, \$6.00. Receivers available. **SHEFFIELD ELECTRONICS**, 7223 Stony Island, Chicago, IL 60649.

STRANGE stuff. Plans, kits, new items. Build satellite dish \$69.00. Descramblers, bugs, adult toys. Informational photo package \$3.00 refundable. **DIRJO CORPORATION**, Box 212, Lowell, NC 28098.

ASTRONOMER; Sidereal telescope drive inverter, quartz controlled, 11-14.4 VDC input, 115 VAC output, 12 watts power. Sidereal clock fully portable, 6 LCD digits, latch easy setting. Ask for free flyer. **SHLEGG ELECTRONICS**, P.O. Box 795, Oshawa, Ontario, L1H 7N1, Canada.

DESCRAMBLE the latest video cassette copy protection scheme. Our simple Line Zapper circuit takes the jitter out of your picture. Complete plans and theory only \$9.95 plus \$1.50 postage and handling. **ELEPHANT ELECTRONICS, INC.**, Box 41865-J, Phoenix, AZ 85080. (602) 581-1973.

MINIATURE FM Transmitter kit. Size of postage stamp, up to one mile range. Kit includes PC board and all board mounted parts, \$24.95. **CAS ELECTRONICS**, 1559-J Amar Road, Suite 457, West Covina, CA 91792.

MEGAWOOFER enclosure capable of producing earth tremors—guaranteed! Most efficient bass design possible. Build it yourself. Complete technical data, \$3.00. **CHENEY INNOVATIONS INDUSTRIES**, 125 A-Okay #D, St. Charles, MO 63301.

KITS! Radar detector, lab power supply, wireless microphone and more. Semi-assembled and tested. Write for free literature. **SERENA INDUSTRIES**, 1180-A Aster Ave., Sunnyvale, CA 94086.

COMMODORE 64/128 owners. Design your own custom circuits. Just enter specifications and the computer designs the circuit. Free information. Send today! **WEASELGRAPHICS**, Dept. RE1086, 606 Thomasville, Pocahontas, AR 72455.

SURVEILLANCE transmitters. Dozen proven schematics, parts lists. \$10.00. **SEAL**, PO Box 15253, Plantation, FL 33318.

PRINTED-CIRCUIT BOARDS

PRINTED—circuit boards and artwork. Design Cad/Cam plated through holes. Competitive pricing. Sm Artwork supported. **EXPRESS CIRCUITS**, 314 Cothren Street, P.O. Box 58, Wilkesboro, NC 28697. (919) 667-2100.

LOW quotes, high quality, quick service. Single, double sided, multilayered boards. Prototypes through production quantities. Design/layout capabilities. Call or write for quotes—**T.O.R.C.C.C.**, Box 47148, Chicago, IL 60647. (312)342-9171.

INVENTORS

INVENTORS! Can you patent and profit from your idea? Call **AMERICAN INVENTORS CORPORATION** for free information. Over a decade of service. 1(800)338-5656. In Massachusetts or Canada call (413) 568-3753.

CABLE-TV DESCRABLERS

ALL brands available. "We won't be undersold." Dealer inquiries welcome. We ship C.O.D.'s. For catalog send \$3.00 to **CONSUMER VIDEO CORP.**, P.O. Box 913, Clifton Park, NY 12065. (518) 783-5636 M-F 9AM-5PM E.S.T.

EPROM PROGRAMMING

HOBBYISTS; Pretested EPROMS sold with your programming installed. Program listing provided. Fast service. Write or call: **ROMULUS MICROCONTROL**, Box 8669, Rockville, MD 20856; (301) 540-8863.

CABLE-TV

WE'LL MATCH OR BEAT ANYONE'S ADVERTISED RETAIL OR WHOLESALE PRICES!

BONANZA!

ITEM	SINGLE UNIT PRICE	DEALER 10-UNIT PRICE
RCA 36 CHANNEL CONVERTER (CH. 3 OUTPUT ONLY)	29.95	18.00 ea.
PIONEER WIRELESS CONVERTER (OUR BEST BUY)	88.95	72.00 ea.
LCC-58 WIRELESS CONVERTER	92.95	76.00 ea.
JERROLD 450 WIRELESS CONVERTER (CH. 3 OUTPUT ONLY)	105.95	90.00 ea.
SB ADD-ON UNIT	109.95	58.00 ea.
BRAND NEW — UNIT FOR SCIENTIFIC ATLANTA	Call for specifics	
MINICODE (N-12)	109.95	58.00 ea.
MINICODE (N-12) VARISYNC	119.95	62.00 ea.
MINICODE VARISYNC W/AUTO ON-OFF	179.95	115.00 ea.
M-35 B (CH. 3 OUTPUT ONLY)	139.95	70.00 ea.
M-35 B W/AUTO ON-OFF (CALL FOR AVAILABILITY)	199.95	125.00 ea.
MLD-1200-3 (CALL IF CH. 2 OUTPUT)	109.95	58.00 ea.
INTERFERENCE FILTERS — CH. 3	24.95	14.00 ea.
JERROLD 400 OR 450 REMOTE CONTROLLER	29.95	18.00 ea.
ZENITH SSAVI CABLE READY (DEALER PRICE BASED ON 5 UNITS)	225.00	185.00 ea.
SPECIFY CHANNEL 2 or 3 OUTPUT Other products available — Please Call		

Quantity	Item	Output Channel	Price Each	TOTAL PRICE
			SUBTOTAL	
			Shipping Add \$3.00 per unit	
			COD & Credit Cards — Add 5%	
			TOTAL	

California Penal Code #593-D forbids us from shipping any cable descrambling unit to anyone residing in the state of California.

Prices subject to change without notice.

PLEASE PRINT

Name _____
 Address _____ City _____
 State _____ Zip _____ Phone Number () _____
 Cashier's Check Money Order COD Visa Mastercard
 Acct # _____ Exp. Date _____
 Signature _____

FOR OUR RECORDS:

DECLARATION OF AUTHORIZED USE — I, the undersigned, do hereby declare under penalty of perjury that all products purchased, now and in the future, will only be used on cable TV systems with proper authorization from local officials or cable company officials in accordance with all applicable federal and state laws.

Dated: _____ Signed: _____

Pacific Cable Company, Inc.

7325½ RESEDA BLVD., DEPT. R-11 • RESEDA, CA 91335
 (818) 716-5914 • No Collect Calls • (818) 716-5140

IMPORTANT: WHEN CALLING FOR INFORMATION
 Please have the make and model # of the equipment used in your area. Thank You

Pay TV and Satellite Descrambling All New 6th Edition!

Now over 100 pages of working schematics, theory and "hard" information on all the major cable and over the air scrambling systems. Schematics and theory for all 4 satellite descrambling systems used currently: HBO, Anik-D, Fantasy, Extasy etc. New sections on digital audio coding and bypassing. Insider information included. Still the most complete source of descrambling info available **\$14.95**. Satellite Systems Under **\$600, \$11.95**. MDS Handbook **\$10**. Stun gun schematics **\$5**. Enlarged product catalog of PC's, kits and low cost satellite equipment **\$2**.

**Shojiki Electronics Corp., 1327R
Niagara St., Niagara Falls, NY
14303. COD's 716-284-2163**

SATELLITE TV

CABLE TV Secrets—the outlaw publication the cable companies tried to ban. HBO, Movie Channel, Showtime, descramblers, converters, etc. Suppliers list included **\$8.95**. **CABLE FACTS**, Box 711-R, Pataskala, OH 43062.

CABLE TV Source Book—a complete listing of suppliers for hard-to-find converters, descramblers, technical information, schematics and much much more. Full refund if not satisfied. Send **\$4.95** to **CABLE**, Box 12505-R, Columbus, OH 43212.

PATENTED optical process satellite sound system. For information send **\$3.00** to: **BEDINI ELECTRONICS**, PO Box 769, San Fernando, CA 91341.

SATELLITE systems **\$349.00** up, catalog **\$3.00**. Also: KU, exports. **STARLINK, INC.**, 2603-16R Arlie, Huntsville, AL 35805.

BUILD your own satellite system and save! Instructions, schematics, parts! Send stamped envelope: **XANDI**, Box 25647, Dept. 21G, Tempe, AZ 85282.

QUALITY products—low prices—no gimmicks—send for free brochure and 800 number to **S.S.E.**, POB 3833, Ocala, FL 32678.

AMAZING DEVICES

PHASORS
PLANS—All Parts Available in Stock

- LC5 BURNING CUTTING CO2 LASER ... \$20.00
- RUB3 RUBY LASER RAY PISTOL ... 20.00
- BTC5 1.5 MILLION VOLT TESLA COIL ... 15.00
- PTG1 PLASMA TORNADO GENERATOR 10.00
- GRA1—GRAVITY GENERATOR ... 10.00
- MAGNETIC CANNON PROJECTOR ... 10.00

LASERS
KITS—Includes Plans and Parts

- LH2K SIMULATED RED/GRN/YEL LIGHT LASER ... 34.50
- BTC3K 250,000 VOLT TESLA COIL ... 159.50
- 10G1K ION RAY GUN ... 109.50
- PSP3K PHASOR SHOCK WAVE PISTOL 49.50
- STG1K—STUN/PARALYZING GUN ... 39.50
- INF1K INFINITY TRANSMITTER ... 134.50
- MFT1K 2-3 MILE RANGE FM VOICE XMTR PC BOARD ... 49.50

SECURITY
ASSEMBLED AND TESTED PRODUCTS

- LGU30 RED 1MW PORTABLE HENE LASER ... 349.50
- TCL30 SOLID STATE TESLA COIL 35KV 84.50
- IPG50 POCKET PAIN FIELD GENERATOR 64.50
- BLS10 BLASTER DEFENSE WEAPON ... 89.50
- ITM10—100KV SHOCK AND STUN GUN 99.50
- PPF10 PHASOR PAIN FIELD PORTABLE 249.50
- SNP20 SECURITY PHONE LISTENER ... 99.50

• CATALOG CONTAINING DESCRIPTIONS OF ABOVE PLUS HUNDREDS MORE AVAILABLE FOR \$1.00 OR INCLUDED FREE WITH ALL ABOVE ORDERS.

PLEASE INCLUDE \$3.00 PH ON ALL KITS AND PRODUCTS. PLANS ARE POSTAGE PAID. SEND CHECK. MO, VISA, MC TO:

INFORMATION UNLIMITED
P.O. BOX 716, DEPT. N1 AMHERST, NH 03031

NEW satellite descrambler manual—Decode HBO, Showtime, Cinemax, Anik-D, Fantasy, Extasy. Theory, schematics, thorough explanation of digital audio encoding. **\$10.95**. Design manual for constructing **parabolic satellite dish antenna** **\$9.95**. **CABLETRONICS**, Box 30502RE, Bethesda, MD 20814. (For immediate delivery add \$1.00)

DISCOUNT CATV converters and video accessories. Free information. **EASY VIEW**, Box 221B, Arlington Heights, IL 60006. (312) 952-8504. Ask for Rudy Valentine.

OAK orion "turn-on" modifications: "Chip-Kit" or "Remote Keypad." **Satellite descramblers** (non-addressable). **"Triple-X"** Adult movies and/or sports channel. Fully assembled. **\$225.00**. **NAS-SAT**, Box 5261, Long Beach, CA 90805. (213) 631-3552.

TUNE subcarriers on FM receiver. Including multiplex stereo. Plans **\$8.65**, Components **\$14.60**, Board **\$9.50**. **I.F. IN-NOVATIVE**, Box 745, Madras, OR 97741.

59 degree brand name LNAs! LNBS! Ku-Band LNBS! Discount pricing! Send stamped envelope: **LNA**, 201 E. Southern, Suite 100G, Tempe, AZ 85282.

BIG PROFITS ELECTRONIC ASSEMBLY BUSINESS

Start home. spare time. Investment knowledge or experience unnecessary. **BIG DEMAND** assembling electronic devices. Sales handled by professionals. Unusual business opportunity.

FREE: Complete illustrated literature
BARTA, RE-O Box 248
Walnut Creek, Calif. 94597

BUSINESS OPPORTUNITIES

MECHANICALLY inclined individuals desiring ownership of small electronics manufacturing business—without investment. Write: **BUSINESSES**, 92-R, Brighton 11th, Brooklyn, NY 11235.

YOUR own radio station! AM, FM, TV, Cable. Licensed/unlicensed. **BROADCASTING**, Box 130-F11, Paradise, CA 95969.

PROJECTION TV ... Make \$\$\$'s assembling projectors ... easy ... results comparable to \$2500.00 projectors ... Your total cost less than \$30.00 ... **plans, 8" lens** and dealers information **20.50** ... illustrated information **free** ... **MACROCOMA-GCX**, Washington Crossing, PA 18977. Creditcard orders 24 hours (215) 736-2880.

\$10.00—\$360.00 weekly! Become circular mailer. No quotas. Sincerely interested, rush stamped envelope: **NATIONAL MAILING**, Box 19759-RA11, San Diego, CA 92119.

DEALERS wanted! DMM's, solderless breadboards, soldering tools. Individuals welcome. **CENTURY INTERNATIONAL COMPANY**, Box 29762, Dallas, TX 75229.

RECOVER pure gold from old circuit boards, computers, electronic junk. Easy method. Send **\$5.00**. **RECYCLING**, Box 11216R, Reno, NV 89510-1216.

CABLE-TV

DEALERS wanted: channel 2, 3, and 4 notch filters. Money back guarantee. Send **\$15.00** for sample and quantity price list. Specify channel(s). **GARY KURTZ**, Box 291394, Davie, FL 33329.

ELECTRONIC SUPPLIES

ELECTRONIC projects, components, P.C. board supplies, and test instruments. Oscilloscopes from **\$229.00**, 2 year guarantee. Call or send SASE for your free catalog—**T.O.R.C.C.C.**, Box 47148, Chicago, IL 60647. (312) 342-9171.

DO IT YOURSELF TV REPAIR

NEW...repair any TV...easy. Retired serviceman reveals secrets. Write, **RESEARCH**, Rt3, Box 601BR, Colville, WA 99114.

EDUCATION & INSTRUCTION

F.C.C. Commercial General Radiotelephone License. Electronics home study. Fast, inexpensive! "Free" details. **COMMAND**, D-176, Box 2223, San Francisco, CA 94126.

COMPUTER Repair career training in 5 months by accredited Florida electronics school. Lifetime placement. Financial assistance if qualified. Call **SYSTEMS TECHNOLOGY INSTITUTE**. (305) 331-2840.

TROUBLESHOOTING electronic components and digital electronic programs available on video cassettes. Rental **\$19.95**. **TWI** (616) 361-1777.

WANTED

INVENTORS! AIM wants—ideas, inventions, new products, improvements on existing products. We present ideas to manufacturers. Confidentiality guaranteed. Call toll free **1(800) 225-5800** for information kit.

INVENTIONS, ideas, new products wanted! Industry presentation/national exposition. Call free **1(800) 528-6050**. Canada, 1-800-528-6060. X831.

ANTIQUÉ RADIOS

continued from page 79

more to sell tubes or to perpetuate the tube's image as king of the industry than the tube tester. The big pointer on the over-sized dial told the customer when a tube was BAD, and the customer was quick to buy a new tube when one showed up BAD.

So it was no wonder that few could see the coming of the end. Wholesalers couldn't survive without tube sales, and if they didn't add other lines or diversify, they went under. Servicemen who didn't keep up, or retrain for solid-state servicing, also didn't survive.

Conclusion

This column is dedicated to people who are interested in discussing radio history and preserving radio equipment. I read with interest all the letters from readers who tell me about their equipment. From time to time, as space permits, the column includes items of general interest from those letters. Next month's column will be devoted to answering reader's questions. Also, we'll present information on building a simple filament checker. **R-E**



WE'RE FIGHTING FOR YOUR LIFE

Radio Shack Parts Place™

EXCLUSIVE VALUES AT THE SHACK® NEAR YOU

Builder's Helpers

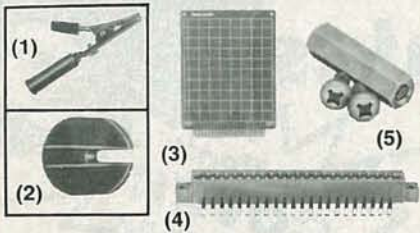

- (1) 2 1/4" Clips. Open to 7/16". Screwdriver terminals. 5 red, 5 black. #270-347 **Set of 10/1.59**
- (2) Antenna Insulators. Strong, ideal for antenna and guy wire installation. #270-1518 **Pkg. of 2/69¢**
- (3) Plug-In Board With Ground Plane. Masked on both sides to prevent solder bridges. Has 2066 indexed, solder-ringed holes, 4 1/2 x 5 1/16" component area. Fits 44-position socket. #276-188 **4.99**
- (4) 44-Position Socket. #276-1551 **2.99**
- (5) PCB Standoffs. .25/.52" high all-metal hex studs hold PC boards in place. #276-195 **Set of 4/99¢**

Power Supply Components

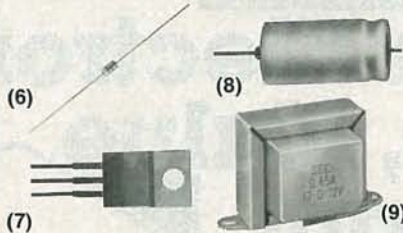

- (6) 40-Volt, 1-Amp Schottky Barrier Diodes. #276-1165 **Pkg. of 2/99¢**
- (7) LM317T Voltage Regulator. Adjustable from 1.2 to 27 VDC output. Heatsink (such as our #276-1367) is required for maximum current rating of 1.5 amps. TO-220 case. With pinout and specs. #276-1778 **1.99**
- (8) 1000 µF Electrolytic Capacitor. 50 WVDC. Perfect for filtering. #272-1047 **1.99**
- (9) Power Transformer. 120 VAC primary, 12.6 VAC center-tapped secondary is rated 1.2 amps. For chassis or PC board mounting. #273-1352 **4.99**

Touch-Tone Decoder



High-Performance DTMF Receiver in One 18-Pin DIP

SSI 202. Ideal for any remote-control circuitry—use a standard touch-tone phone as the controller! Features built-in switched-capacitor filters—no input filtering is required. Provides selectable hexadecimal or binary coded 2 of 8 output. Clocked by low-cost 3.58 MHz crystal (not incl.). With data, circuit examples. #276-1303 **12.95**

Voice Synthesizer Team



SPO256-AL2 Speech Synthesizer. Easy to interface with most computers. With detailed data and circuit examples. 28-pin DIP. #276-1784 **12.95**

CTS256-AL2 Text-to-Speech IC. Translates ASCII characters into control data for synthesizer. Connects to RS-232. With data. 40-pin DIP. #276-1786 **16.95**

Wiring / Testing Needs



- (10) Solid Bus Wire. 50 feet of pretinned 24-gauge copper wire on a plastic spool. #278-1341 **1.49**
- (11) Magnet Wire. 3-spool set includes 40-ft. of 22-gauge, 75-ft. of 26-ga., 200-ft. of 30-ga. #278-1345 **4.49**
- (12) Set of 10 Test Cables. 14" long with insulated clip at each end. #278-1156 **3.79**

Assortment Bargains!

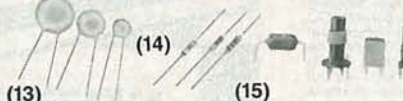

- (13) 100 Disc Capacitors. Includes NPOs, Hi-Qs, N-750s, Mylar and ceramics. #272-801 **Set 1.98**
- (14) 1/4-Watt Carbon-Film Resistors. 5% tolerance. Jumbo 500-piece set has 54 popular values from 10 ohms to 10 megohms. #271-312 **Set 7.95**
- (15) Inductors. 30-piece assortment may include RF, IF and video peaking coils, various small chokes and transformers, toroids. #273-1601 **1.98**

Switch-A-Rama!



- (16) Illuminated SPDT Push-On/Push-Off. 3 amps at 120 VAC. Lamp requires 12 volts. #275-676 **4.95**
- (17) Round-Button Version. #275-677 **4.95**
- (18) SPST Rocker Switch. Rated 6 amps at 125 VAC. Mounts in 3/4" hole. #275-690 **1.89**
- (19) DPDT Knife Switch. Screwdriver terminals. Ideal for projects, antenna switching, model trains. Rated 0.5 amp at 250 VAC. #275-1537 **99¢**

Hobby Lamp Values



- (20) 12-Volt Flashing Lamps. One each: yellow, red, green. 4" wire leads. #272-1097 **Pkg. of 3/99¢**
- (21) Colored Mini Lamps. Ideal for doll houses, model trains and cars. One each: yellow, red, green. 6-Volt. #272-1098 **Pkg. of 3/69¢**
- 12-Volt. #272-1099 **Pkg. of 3/69¢**
- (22) Flashing Green LED. T-1 1/4. #276-030 **1.19**
- (23) Flashing Red LED. T-1 1/4. #276-036 **1.19**

Unique Sounders



- (24) Tri-Sound Siren. Wiring options permit three different outputs. Requires 3 VDC. #273-072 **5.95**
- (25) Electronic Chime. Pleasant "ding-dong" output. Operates from 6 to 18 VDC. #273-071 **6.95**
- (26) UMC 3482 Melody Synthesizer IC. Preprogrammed with 12 popular tunes including Happy Birthday, Oh My Darling, Home Sweet Home. Operates on 1.5 VDC. 16-pin DIP with data. 276-1797 **2.99**

Antennas—Selection and Installation

Improve Your Reception!

This new book is packed with information on TV, FM, CB, Cellular phone, Satellite and shortwave antennas. It helps you choose the best antenna for your particular needs and provides valuable installation tips. Illustrated. #62-1083 **3.95**



Digital Logic Probe and Pulsar Speed Up Testing



Probe **16⁹⁵**

Pulsar **17⁹⁵**

(27) Logic Probe. The fast way to test TTL, LS and CMOS digital circuits. Color-coded LEDs indicate high, low or pulsed logic states (up to 10 MHz). Simultaneous tone output frees your eyes for faster testing. 36" leads with clips provide power from circuit under test. With instructions. #22-303 **16.95**

(28) Logic Pulsar. Together, the pulsar and probe make an effective diagnostic team for testing today's digital circuits. Produces single 5 µs pulse or a continuous 5 Hz pulse train at the push of a button. Overload protected. With instructions. #22-304 **17.95**

76-Function Solar Scientific Calculator

Never Needs **29⁹⁵** Batteries!

Radio Shack EC-4018 is powered by room light. Features nine physical constants, 10-digit mantissa and 2-digit exponent, memory, random number generator. Uses true algebraic logic. Fold-up case. #65-982



Jumbo LED Clock



Easy to Read

One of our most popular models—check the features! Selectable 12/24-hour display, huge 1.8" digits, snooze control, 24-hour alarm, hi/lo brightness, super styling. Battery backup preserves accuracy if AC power fails. UL listed AC. Backup battery extra. #63-765 **24.95**

Dual DC Power Supply

Selectable Independent/Slave Modes

59⁹⁵



Quality and features you wouldn't expect at this low price! Adjustable 0 to 15 volts, up to 30 volts in series mode. Has front-panel meter for current/voltage monitoring, fuse protection, vented steel cabinet. Maximum current: 1 amp per channel. UL listed AC. #22-121

Bench Digital Multimeter

99⁹⁵

Memory Storage!



All-pushbutton operation plus features that compare with meters costing much more! Built-in 31-position bargraph in addition to a high-contrast digital LCD. Full autoranging. Built-in transistor checker and buzzer continuity mode. 2 1/16 x 8 x 4 3/4". With probes and manual. Batteries extra. #22-195

Over 1000 items in stock: Binding posts, Books, Breadboards, Buzzers, Capacitors, Chokes, Clips, Coax, Connectors, Fuses, Hardware, ICs, Jacks, Knobs, Lamps, Multitesters, PC Boards, Plugs, Rectifiers, Relays, Resistors, Switches, Tools, Transformers, Transistors, Wire, Zeners, more!

Radio Shack®
A DIVISION OF TANDY CORPORATION

Prices apply at participating Radio Shack stores and dealers

CHECK US OUT!

Dick Smith Electronics for Service, Value & Innovation!



This Month's
**COVER
STORY**



Open up the world of Closed Captions!

Many TV programs carry specially encoded signals to provide captions that allow hearing-impaired people to follow dialogue & narration! Educators find captions improve reading skills!

The DSE SuperText TC is a low-cost alternative to the more expensive NCI Telecaption II. Using the same decoding technology (under license from NCI), the SuperText TC offers super performance (displaying crisp white text in a black background) and easy operation. Cost & complexity are minimized by eliminating the tuner & remote control features of the expensive NCI version. The SuperText TC connects to the audio/video outputs of newer model TVs or VCRs or component TV tuners (an RF modulator for direct antenna connection is optional) to provide two separate captioning channels as well as two full-screen text services. (A fifth "channel" bypasses all captions & text to display the regular TV image without disconnecting the decoder.) All channels & power are controlled by a single front-panel knob. The text channels include program listings of upcoming captioned broadcasts.

SUPERTEXT TC TELECAPTION ADAPTER & LINE-21 TELETEXT DECODER

Cat K-6314

\$139

This kit is fairly simple and easy to build. All components except the decoder module & front panel switch mount on a single PCB. Any hobbyist with basic bench tools, a multimeter, and good soldering technique can build the adapter. Once it is built and a few basic tests are made, the adapter can be hooked up. The remaining adjustments (for caption display contrast) can be made with the case assembled. No special tools are required! The kit comes with a handsome gray-brown case, punched & screened front and rear panels, all parts, instructions - even solder! Includes "Sorry, Dick" repair coupon: If your kit fails to operate when assembled, return it with coupon & fixed service fee, and we'll get it up & running!

Features:

- Direct audio & video inputs & outputs
- Single all-function control
- External contrast adjustment
- Compact size
- No dangerous internal voltages
- Easy assembly & set-up
- Full closed caption & text service operation

Options:

Power Supply	Cat M-9526	\$6.95
RF Modulator	Cat K-6040	\$9.95



Featured in April & May
Radio-Electronics

TELETEXT Decoder Kit
Cat K-6315 **\$199**

Get the latest scores, weather, & stock prices at the touch of a button! This easy-to-build kit features pre-adjusted, pre-assembled decoder module & 21 button wired remote. You get TV Teletext, TV Teletext, & newflash modes - all without user fees!

Teletext Infra-Red Remote Control
Upgrade to wireless remote! Cat K-3425 **\$34.95**



TV Oscilloscope Adapter Kit

Cat K-6030 **\$24.95**

Turn your old TV into an Oscilloscope.

Don't let that old B & W set gather dust in your attic - with this remarkable kit you can turn it into a 10Hz to 300KHz oscilloscope. Good display at low frequencies makes it ideal for hi-fi & audio applications. It needs only 100MV to drive it to full screen deflection, and the large screen size provides a dramatic display. Think of the non-technical uses: classroom displays, promotions, hi-fi showrooms, etc. If you can't afford a regular scope, this could be the kit for you!

The kit comes with direct audio/video output connections (Channel 3/4 RF modulator, K-6042, \$9.95, is optional. Power your new scope with an AC adaptor (not included) - M-9514, \$9.95 is ideal - or use a 9V battery (\$-3286, \$2.95, also optional)

Get a whole new source of TV!



\$99.95
DSE # D-6350

Get the DSE Microwave Receiver

This dual polarity, multi-channel, wide band microwave TV tuner allows you to tune an entire 800 MHz from 1.9 to 2.7 GHz. An excellent system for use nationwide! Features: 19" aluminum true parabolic dish ● Up to 50 mile range ● Completely weather-sealed ● Includes fully tunable temperature-compensated LNC, control unit, 50' coax cable, 3' jumper cable, 2 matching transformers, 90 day warranty.

WARNING

Although this device can receive unscrambled pay TV signals, such usage is illegal. Violators are subject to civil & criminal penalties. DSE offers this product with the express understanding that it will be used for lawful purposes only.



Made in USA
Cat T-5250
C clamps not included

What? You can't bend steel in your bare hands?

Now you can form boxes, covers, trays, & more with this versatile, compact brake bar. Make clean, smooth bends & forms up to 90° in metals up to 16 gauge thickness & 18" width. Adjustments for stock thickness, sharpness of bends, & accuracy are quick & easy. Rugged construction & simple design assure a lifetime of trouble-free service.

Ideal for one-shot or production runs. Great for shop or lab, schools or hobbyists. Shipping weight 4 lbs.

Little Giant Brake

DSE's RDF rates outstanding technical reviews!

"After spending considerable time playing with the RDF, I have a lot of confidence in it. . . . If you are considering an FM DF'ing application, the Dick Smith RDF is certainly worth looking at. When you consider that similar commercial items may cost as much as \$500-600, it seems to be a good value at \$100."

Bruce Williams WA6IVC, QST Aug '86

- 12V Operation ● 50-500 MHz range
- Internal alignment reference ● 170' calibration
- Stable digital circuitry
- Adjustable internal monitor speaker ● Self-aligning commutating filters

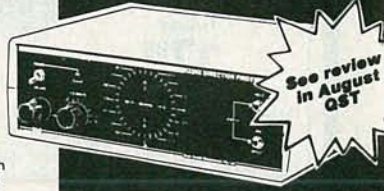

Radio Direction Finder Kit
Cat K-6345 **\$99.95**

See review in August QST

RDF at a Base Station?

Use 12V@1.2A power supply (M-9530, \$13.95 each).

2 Meter Operation?

Use four whip antennas (D-4205, \$15.50 each).

CIRCLE 95 ON FREE INFORMATION CARD

RADIO-ELECTRONICS

SAVE 35%

Buy 1 sheet of Red Film, 1 sheet of Red Aluminum, & developer, and get 1 sheet of Black Aluminum FREE!

Offer valid 9/20 thru 11/30/86.

ANYONE can make pro-quality PCB's & panels with SCOTCHCAL!

The Scotchcal system is fast & easy! Use the photosensitive reversal film to make a negative from your translucent art. Use this neg to expose the self-adhesive photosensitive aluminum sheet (with red or black emulsion), and there's your panel. All materials expose with sunlight (or you can use DSE bulb # S-3905, \$11.95)

Reversal Film (10" x 12")	H-5690	\$4.95
Black Emuls. Alumin Sh1 (10" x 12")	H-5694	\$6.95
Red Emuls. Alumin Sh1 (10" x 12")	H-5692	\$6.95
Developer (1.75 fl.oz.)	H-5696	95

Return with us now to those thrilling days of yesteryear!

What could be more reminiscent of yesterday's electronics than a 1920's wireless receiver? DSE has an exclusive selection (but limited supply) of genuine antique radio kits for builders & collectors.

Unidyne 1 Tube	K-9001	\$99.95
Reinartz 2 All-Band	K-9000	\$99.95
Variometer Super Crystal	K-9002	\$79.95



130 Watt Switching Regulated Power Supply
IBM COMPATIBLE
was \$89.95 now \$69.95
Cat X-1110

Keyboards
84-key was \$79.95
Cat X-1122 \$59.95

100-Key Enhanced
was \$99.95 Cat X-1124 \$79.95

XT compatible Case
was \$49.95 Cat X-1120 \$39.95

Check out our new low prices on computer gear!
Effective September 20, 1986.

Description	Cat No.	Was	Now
● XT compatible Motherboard	X-1001	\$149.	\$129.95
● Non-Infringing BIOS	X-1000	\$39.95	\$29.95
● Multi-Function Card Serial & parallel interfaces, clock/calendar	X-1005	\$149.95	\$89.95
● Color Graphics Adapter Card	X-1007	\$189.95	\$69.95
● Multi I/O Card Serial, parallel, clock game, disk drive	X-1016	\$129.95	\$89.95
● Floppy Disk Controller	X-1009	\$44.95	\$34.95

ONLY \$599

IBM PC/XT® Compatible Computer Kit
Easy to assemble! Save money & gain satisfaction by building it yourself!

Look at the savings this system offers!

XT Motherboard	X-1001	\$129.00
BIOS for Motherboard	X-1000	29.95
64K RAM	X-1187	14.95
Monochrome Graphics	X-1012	89.95
Floppy Disk Controller	X-1009	34.95
130W Power Supply	X-1110	69.95
IBM-style case	X-1120	39.95
1/2 Height Disk Drive	X-7506	99.95
Monochrome Monitor	X-1132	99.95
84-key Keyboard	X-1122	59.95

Individual Components Total \$668.95
DSE Package Price saves you \$69.55!

More IBM-compatible options:

- 512K RAM Card X-1014 \$37.95
- Winchester Hard Disk Controller Card X-1018 \$174.95

12" Monitor
Monochrome
● Apple compatible Cat X-1130
● IBM compatible Cat X-1132

Joystick \$19.95
IBM & Apple Compatible Cat X-1135

Power Command Monitor Stand
Tilt, swivel, surge & spike protection, push-button peripheral control.
\$39.95
Cat X-1128

Switch Boxes
RS 232 A/B X-3586 \$24.95
Parallel A/B X-3585 \$29.95

Don't let them steal your secrets!

Protect your communications from monitoring, bugs & taps with this self-contained voice privacy device. The Scrambler is compact and works with all standard telephone handsets (including mobile & cordless). Two units are required to set up a system.

the Scrambler \$299
Cat F-1009

TELEPHONE ACCESSORIES

6' Modular Extension Cord	F-5015	\$3.95
25' Modular Extension Cord	F-5016	6.95
Wall Phone Jack Assembly	F-5006	5.95
Single Modular Wall Jack	F-5000	3.45
Double Modular Wall Jack	F-5008	4.95
Modular Duplex Adapter	F-5020	4.95
Mod. Surface Jack Cover Assembly Converts terminal block system to modular jack	F-5004	3.49
Modular Plug	F-5022	.23
Modular Plug Tool	F-5045	7.95
Mute Switch	F-5039	5.95
Phone-Lite	F-5018	6.95
4-core Phone Cable(price/ft.)	W-2122	.09
24-core Phone Cable(price/ft.)	W-2124	.08

ATTENTION BULK BUYERS!
Schools, Colleges, Manufacturers-
Call 415-368-8844 for special quantity pricing!

DEALER INQUIRIES WELCOME!

RECHARGEABLE Batteries

NICADS	GEL CELLS
AAA S-3305 \$1.95	6V/1.2Ah S-3313 \$6.95
AAA S-3305 \$1.95	12V/1.2Ah S-3315 \$7.95
AA S-3300 \$1.99	12V/3Ah S-3320 \$13.95
C S-3301 \$2.95	12V/9Ah S-3321 \$34.95
D S-3303 \$2.95	
246 S-3308 \$9.95 (9V)	

NICAD CHARGING CABINET \$9.95
Cat M-9519

GEL CELL CHARGERS
3 voltage rates available. Please specify gel cell size.
\$9.95 EACH

World Radio-TV Handbook
Comprehensive listing of long, medium & short wave broadcasts by frequency, time, & language, and more!
\$19.95
Cat B-2086

Shortwave Antenna Kit
Ready to assemble. Requires no soldering. Instructions included.
\$11.95
Cat K-3490

World Band Receiver
Get AM/FM as well as long, medium, & shortwave broadcasts. 5 tuning functions (including 9 station memory), LED signal meters, sleep timer, & much more!
AM: 150-29999 KHz
FM: 87.5-108 MHz
LW: 15-281 KHz
SW: 11.120-1620 KHz
SW: 11,13,16,19,25,31, 41,49,60,75,90,& 120M
\$149.95
Cat D-2831

NEWS FLASH!
The famous Dick Smith FunWay Into Electronics books will now be published & sold right here in the U.S.A. by Howard Sams check your bookstore for availability

Visit our Retail Centers!

BERKELEY 2474 Shattuck Ave (415) 486-0755
REDWOOD CITY 390 Convention Way (415) 348-8844
SAN JOSE 4580 Stevens Creek Blvd (408) 241-2266
LOS ANGELES 1830 Westwood Blvd (213) 474-1246
HEAD OFFICE 390 Convention Way Redwood City CA 94063

Special Purchase!
Supplies are limited, so take advantage of this superb receiver while supplies last! Check out these features:

- Tuning: all electronic quartz PLL-crystal; 3-speed hi-res manual; continuous; auto-search; direct frequency key-in; 16 station memory; local/dx; 9/10 kHz AM tuning matrix switch
- Frequencies: 1.1SW bands - 120/90/60/49/41/31/25/24/16/13/11M; AM/FM/LW
- Double superhet for selectivity & image rejection
- Switchable variable pitch BFO for CW & SSB reception
- Switchable RF gain control
- Hi-power amp for 7" woofer/3" tweeter
- Headphone jack
- 12/24hr LCD clock w. alarm
- 110/127/220/240V, 50/60 Hz switchable
- 12VDC or battery operation.

Magnavox 11 Band World Receiver \$299
Cat D-2838

DICK SMITH ELECTRONICS
EVERYTHING FOR THE ELECTRONICS ENTHUSIAST

Did you get your FREE CATALOG?
The new 1986/7 DICK SMITH ELECTRONICS catalog is 148 colorful pages packed with thousands of fantastic products, incredible values, and an exclusive 15 page data section. We ship our catalogs first class mail, so you'll get yours with no delay!
Send \$1 for postage & handling to DSE, P.O. Box 2249, Redwood City, CA 94064

Name _____
Address _____
City _____ State _____ Zip _____

We ship UPS Ground unless otherwise requested. Add 5% of order total (\$1.50 min) for shipping. Outside USA add 20% (\$4 min). There is an additional \$1.50 handling fee. California residents please add sales tax.

Order Toll Free 1-800-332-5373
Call Monday - Friday 10a.m. - 6p.m. Pacific Time. In California call 415-368-1066
CIRCLE 95 ON FREE INFORMATION CARD

cable tv

DESCRAMBLER PARTS!

We stock the exact parts, PC board and AC adaptor for Radio Electronics February 1984 article on building your own **Cable TV Descrambler**.

#701 PARTS PACKAGE..... \$29.95

Includes all the original resistors, capacitors, diodes, transistors, integrated circuits, coils, IF transformers (toko BKAN-K5552AXX).

#702 PC BOARD..... \$12.95

Original etched & drilled silk-screened PC board used in the article.

#704 AC ADAPTOR..... \$12.95

Original (14 volts DC @ 285ma) ac adaptor used in the article.

S □ P □ E □ C □ I □ A □ L □ S

BOTH #701 & #702..... NOW \$39

ALL THREE #701, #702 & #704 NOW \$49

Add \$2.50 shipping and handling — \$4.50 for Canadian orders
We also offer quantity Discounts on 5 or more units

FREE Reprint of Radio Electronics article (February 1984) on Building Your Own **CABLE TV DESCRAMBLER** with any purchase of above.

**60-CHANNEL
CABLE
CONVERTER**
WITH INFRARED REMOTE CONTROL



SC-60R CONVERTER..... \$69.95

Thousands of these converters sold nationally for \$119.95
We offer you this same type of converter for only \$69.95
All converters are NEW, with Full manufacturer's WARRANTY.

FEATURES:

- Full 60 Channel Capability
- Cordless Infrared remote control
- Ultra-Stable Synthesized tuning
- Microprocessor controlled PLL
- Works on all TV models, channel 3 output
- Standard/HRC Switch for compatibility with all Cable Systems
- Will work with all types of external descramblers

Add \$3.50 Shipping and Handling
\$4.50 on Canadian Orders

**ORDER
TOLL FREE
1-800-227-8529**



inside MA 617-695-8699
VISA, MASTERCARD or C.O.D.



**J & W
ELECTRONICS, INC.**

P.O. BOX 800R • MANSFIELD, MA 02048

TENMA

© 1986, MCM Electronics

TENMA Combination Function Generator and Frequency Counter

■ Six digit display ■ Output range: .2Hz-2MHz: seven ranges ■ Counter range: .1Hz-10MHz ■ 5-15V TTL and CMOS output ■ Wave forms: sine, triangle, square, pulse, and ramp. For detailed specifications call for a complete Tenma catalog.

#72-380

\$21990
(ea.)



THE NAME YOU CAN TRUST IN ELECTRONIC TEST EQUIPMENT

TENMA 0-18V 3A Power Supply

■ Regulated outputs — constant volt or constant current, both are continuously variable ■ Can be connected in series or parallel for more voltage or current output ■ Reverse polarity and overload protected ■ Isolated output. For detailed specifications call for a complete Tenma catalog.

#72-420

\$9950
(ea.)



TENMA 120MHz Frequency Counter

■ Eight digit LED display ■ Measurement range: .1Hz-120MHz ■ High input sensitivity of 20mV RMS. For detailed specifications call for a complete Tenma catalog.

#72-375

\$18995
(ea.)



TENMA Resistance Selector Box

■ Quickly substitute any resistor in a circuit from 1ohm to over 11Mohm, up to 1/2 watt ■ All resistors are 1% tolerance. ■ Dimensions 4" (W) x 6" (H) x 1" (D) ■ 90 day warranty

#72-405

\$2850
(ea.)



TENMA Digital LCR Meter

■ Measures inductance, capacitance and resistance ■ L = 1μH-200H, C = .1pF-200μF, R = .01ohm-20Mohm ■ Carrying case included. For detailed specifications call for a complete Tenma catalog

#72-370

\$14995
(ea.)



TENMA Clamp-On/DMM

■ Measures AC current via clamp ■ High quality built-in DMM measures DC volts, AC volts, resistance, AC current ■ Peak hold ■ Data hold ■ Audible continuity buzzer ■ Test leads and carrying case included. For detailed specifications call for a complete Tenma catalog.

#72-395

\$7995
(ea.)



TENMA 4 1/2" Digit Multimeter

■ True RMS AC voltage and current functions ■ Built-in frequency counter, 20KHz and 200KHz range ■ Data hold feature ■ Measures AC & DC voltage/current, resistance and frequency ■ Carrying case included.

#72-430

\$16980
(ea.)



NEW

TENMA 20MHz Dual Trace Oscilloscope

■ Two high quality 10:1 probes included. For detailed specifications call for a complete Tenma catalog.



#72-320

~~\$38995~~

SPECIAL!
\$34995
(ea.)

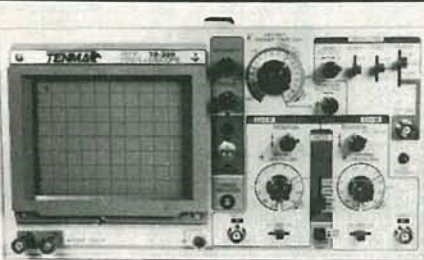

Be Sure To Call For Your FREE Catalog! Over 6,000 Items!

We also have ... a full line of test equipment, computer accessories, telephone accessories, speakers, television parts, flybacks, yokes, switches, fuses, lamps, capacitors, resistors, cartridges, styli, wire, CATV equipment, the largest selection of original Japanese semiconductors in the country and more.



- Terms:**
- \$10 minimum order. \$1.00 charge for orders under \$10.
 - \$20 minimum charge card order.
 - Orders shipped UPS C.O.D.
 - Most orders shipped within 24 hours.
 - Sales office open 8:30 am to 7:00 pm Saturdays 10:00 am to 3 pm EST.
 - For prepaid orders add \$2.75 for shipping and handling.
 - Should shipping and handling charges exceed \$2.75, the balance due will be sent C.O.D.



858 E. CONGRESS PARK DR. • CENTERVILLE, OH 45459
(513) 434-0031



MCM ELECTRONICS

A PREMIER Company

SOURCE NO. RE-26

CALL TOLL FREE 1-800-543-4330
In Ohio 1-800-762-4315 • In Alaska and Hawaii 1-800-858-1849
CIRCLE 87 ON FREE INFORMATION CARD

NOVEMBER 1986

20MB HARD DISK SYSTEM ONLY \$389.95!

CMOS

4001	.19	14419	4.95
4011	.19	14433	14.95
4012	.25	4503	.49
4013	.35	4511	.69
4015	.29	4516	.79
4016	.29	4518	.85
4017	.49	4522	.79
4018	.69	4526	.79
4020	.59	4527	1.95
4021	.69	4528	.79
4024	.49	4529	2.95
4025	.25	4532	1.95
4027	.39	4538	.85
4028	.65	4541	1.29
4035	.69	4553	5.79
4040	.69	4585	.75
4041	.75	4702	12.95
4042	.59	74C00	.29
4043	.85	74C14	.59
4044	.69	74C74	.59
4045	1.98	74C83	1.95
4046	.69	74C85	1.49
4047	.69	74C95	.99
4049	.29	74C150	5.75
4050	.29	74C151	2.25
4051	.69	74C161	.99
4052	.69	74C163	1.95
4053	.69	74C164	1.39
4056	2.19	74C192	1.49
4060	.69	74C193	1.49
4066	.29	74C221	2.49
4069	.19	74C240	1.89
4076	.59	74C244	1.89
4077	.29	74C373	1.95
4081	.22	74C905	10.95
4085	.79	74C911	8.95
4086	.89	74C917	12.95
4093	.49	74C922	4.49
4094	2.49	74C923	4.95
14411	9.95	74C926	7.95
14412	6.95	80C97	.95

7400/9000

7400	.19	74147	2.49
7402	.19	74148	1.20
7404	.19	74150	1.35
7406	.29	74151	.55
7407	.29	74153	.55
7408	.24	74154	1.49
7410	.19	74155	.75
7411	.25	74157	.55
7414	.49	74159	1.65
7416	.25	74161	.69
7417	.25	74163	.69
7420	.19	74164	.85
7423	.29	74165	.85
7430	.19	74166	1.00
7432	.29	74175	.89
7438	.29	74177	.75
7442	.49	74178	1.15
7445	.69	74181	2.25
7447	.89	74182	.75
7450	.35	74184	2.00
7473	.34	74191	1.15
7474	.33	74192	.79
7475	.45	74194	.85
7476	.35	74196	.79
7483	.50	74197	.75
7485	.59	74199	1.35
7486	.35	74221	1.35
7489	2.15	74246	2.95
7490	.39	74247	1.25
7492	.50	74248	1.85
7493	.35	74249	1.95
7495	.55	74251	.75
7497	2.75	74265	1.35
74100	2.29	74273	1.95
74121	.29	74278	3.11
74123	.49	74367	.65
74125	.45	74368	.65
74141	.65	9368	3.95
74143	5.95	9602	1.50
74144	2.95	9637	2.95
74145	.60	96S02	1.95

74S00

74S00	.29	74S163	1.29
74S02	.29	74S168	3.95
74S03	.29	74S174	.79
74S04	.29	74S175	.79
74S05	.29	74S188	1.95
74S08	.35	74S189	1.95
74S10	.29	74S195	1.49
74S15	.49	74S196	2.49
74S30	.29	74S197	2.95
74S32	.35	74S226	3.99
74S37	.69	74S240	1.49
74S38	.69	74S241	1.49
74S74	.49	74S244	1.49
74S85	.95	74S257	.79
74S86	.35	74S253	.79
74S112	.50	74S258	.95
74S124	2.75	74S280	1.95
74S138	.79	74S287	1.69
74S140	.55	74S288	1.95
74S151	.79	74S299	2.95
74S153	.79	74S373	1.69
74S157	.79	74S374	1.69
74S158	.95	74S471	1.95
74S161	1.29	74S571	2.95

VOLTAGE REGULATORS

TO-220 CASE		
7805T	.49	7905T .59
7808T	.49	7908T .59
7812T	.49	7912T .59
7815T	.49	7915T .59
TO-3 CASE		
7805K	1.59	7905K 1.69
7812K	1.39	7912K 1.49
TO-93 CASE		
78L05	.49	79L05 .69
78L12	.49	79L12 1.49
OTHER VOLTAGE REGS		
LM323K	5V 3A	TO-3 4.79
LM328K	Adj. 5A	TO-3 3.95
78H05K	5V 5A	TO-3 7.95
78H12K	12V 5A	TO-3 8.95
78P05K	5V 10A	TO-3 14.95

LINEAR

TL066	.99	LM733	.98
TL071	.69	LM741	.29
TL072	1.09	LM747	.69
TL074	1.95	LM748	.59
TL081	.59	MC1330	1.69
TL082	.59	MC1350	1.19
TL084	1.49	MC1372	6.95
LM301	.34	LM1414	1.59
LM309K	1.25	LM1458	.49
LM311	.59	LM1488	.49
LM311H	.89	LM1489	.49
LM317K	3.49	LM1496	.85
LM317T	.95	LM1812	8.25
LM318	1.45	LM1889	1.95
LM319	1.25	ULN2003	.79
LM320	7900	XR2206	3.95
LM322	1.95	XR2211	2.95
LM323K	4.79	XR2240	1.95
LM324	.49	MPQ2907	1.95
LM331	3.95	LM2917	1.95
LM334	1.19	CA3046	.89
LM335	1.79	CA3081	.99
LM336	1.75	CA3082	.99
LM337K	3.95	CA3086	.80
LM338K	6.95	CA3089	1.95
LM339	.59	CA310E	.99
LM340	7800	CA3146	1.29
LM350T	4.60	CA3160	1.19
LF353	1.59	LM314	.79
LF356	.99	MC3480	8.95
LF357	.99	MC3487	2.95
LM358	.59	LM3900	.49
LM380	.89	LM3909	.98
LM383	1.95	LM3911	2.25
LM386	.89	LM3914	2.39
LM393	.45	MC4024	3.49
LM394H	5.95	MC4044	3.99
TL494	4.20	RC4136	1.25
TL497	3.25	RC4558	.69
NE555	.29	LM13600	1.49
NE556	.49	75107	1.49
NE558	1.29	75110	1.95
NE564	1.95	75150	1.95
LM565	.95	75154	.95
LM566	1.49	75188	1.25
LM567	.79	75189	1.25
NE570	2.95	75451	.39
NE590	2.50	75452	.39
NE592	.98	75453	.39
LM710	.75	75477	1.29
LM722	.49	75492	.79
ZIF-TEXT001			
H-T-5 CAN, K-T-3, T-T-220			

EDGE CARD CONNECTORS

100 PIN ST	S-100	.125	3.95
100 PIN WW	S-100	.125	4.95
62 PIN ST	IBM PC	1.00	1.95
50 PIN ST	APPLE	1.00	2.95
44 PIN ST	STD	.156	1.95
44 PIN WW	STD	.156	4.95

36 PIN CENTRONICS

MALE		6.95
IDCEN36	RIBBON CABLE	
CEN36	SOLDER CUP	4.95
FEMALE		
IDCEN36/F	RIBBON CABLE	7.95
CEN36PC	RT ANGLE PC MOUNT	4.95

INTERSIL

ICL7106	9.95
ICL7107	12.95
ICL7660	2.95
ICL8038	4.95
ICM7207A	5.95
ICM7208	15.95

DATA ACQ INTERFACE

ADC0800	15.55	8T26	1.29
ADC0804	3.49	8T28	1.29
ADC0809	4.49	8T95	.89
ADC0816	14.95	8T96	.89
ADC0817	9.95	8T97	.59
ADC0831	8.95	8T98	.89
DAC0800	4.49	DM8131	2.95
DAC0806	1.95	DP8304	2.29
DAC0808	2.95	D88833	2.25
DAC1020	8.25	D88835	1.99
DAC1022	5.95	D88836	.99
MC1408L8	2.95	D88837	1.65

IC SOCKETS

8 PIN ST	1.99	100+
14 PIN ST	.11	.10
16 PIN ST	.11	.09
18 PIN ST	.12	.10
20 PIN ST	.15	.13
22 PIN ST	.18	.15
24 PIN ST	.15	.12
28 PIN ST	.20	.15
40 PIN ST	.22	.16
64 PIN ST	.30	.22
ST-SOLDERAL	1.95	1.49
8 PIN WW	.55	.69
14 PIN WW	.69	.52
16 PIN WW	.69	.58
18 PIN WW	.99	.90
20 PIN WW	1.09	.98
22 PIN WW	1.39	1.28
24 PIN WW	1.49	1.35
28 PIN WW	1.69	1.49
40 PIN WW	1.99	1.80
WW-WIREWRAP		
16 PIN ZIF	4.95	CALL
24 PIN ZIF	5.95	CALL
28 PIN ZIF	6.95	CALL
40 PIN ZIF	9.95	CALL
ZIF-TEXT001		
(ZERO INSERTION FORCE)		

DIP CONNECTORS

DESCRIPTION	ORDER BY	CONTACTS								
		8	14	16	18	20	22	24	28	40
HIGH RELIABILITY TOOLED ST IC SOCKETS	AUGATxxST	.62	.79	.89	1.09	1.29	1.39	1.49	1.69	2.49
HIGH RELIABILITY TOOLED WW IC SOCKETS	AUGATxxWW	1.30	1.80	2.10	2.40	2.50	2.90	3.15	3.70	5.40
COMPONENT CARRIES (DIP HEADERS)	ICCxx	.49	.59	.69	.99	.99	.99	1.09	1.49	
RIBBON CABLE DIP PLUGS (IDC)	IDPxx	---	.95	.95	---	---	---	1.75	---	2.95

FOR ORDERING INSTRUCTIONS SEE D-SUBMINIATURE BELOW

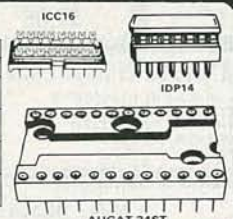

DIODES/OPTO/TRANSISTORS

1N751	.25	4N26	.69
1N759	.25	4N27	.69
1N4148	25/1.00	4N28	.69
1N4004	10/1.00	4N33	.89
1N5402	.25	4N37	1.19
KBP04	.55	MCT-2	.59
KBUSA	.95	MCT-6	1.29
MDA990-2	.35	TIL-111	.99
N2222	.25	2N3906	.10
PN2222	.10	2N4401	.25
2N2905	.50	2N4402	.25
2N2907	.25	2N4403	.25
2N3055	.79	2N6045	1.75
2N3904	.10	TIP31	.49

D-SUBMINIATURE

DESCRIPTION	ORDER BY	CONTACTS						
		9	15	19	25	37	50	
SOLDER CUP	MALE	DBxxP	.82	.90	1.25	1.25	1.80	3.48
	FEMALE	DBxxS	.95	1.15	1.50	1.50	2.35	4.32
RIGHT ANGLE PC SOLDER	MALE	DBxxPR	1.20	1.49	---	1.95	2.65	---
	FEMALE	DBxxSR	1.25	1.55	---	2.00	2.79	---
WIRE WRAP	MALE	DBxxPWW	1.69	2.56	---	3.89	5.60	---
	FEMALE	DBxxSww	2.76	4.27	---	6.84	9.95	---
IDC RIBBON CABLE	MALE	IDBxxP	2.70	2.95	---	3.98	5.70	---
	FEMALE	IDBxxS	2.92	3.20	---	4.33	6.76	---
HOODS	METAL	MHOODxx	1.25	1.25	1.30	1.30	---	---
	GREY	HOODxx	.65	.65	---	.65	.75	.95

ORDERING INSTRUCTIONS: INSERT THE NUMBER OF CONTACTS IN THE POSITION MARKED 'x' OF THE ORDER BY PART NUMBER LISTED.

EXAMPLE: A 15 PIN RIGHT ANGLE MALE PC SOLDER WOULD BE DB15PR

MOUNTING HARDWARE \$1.00

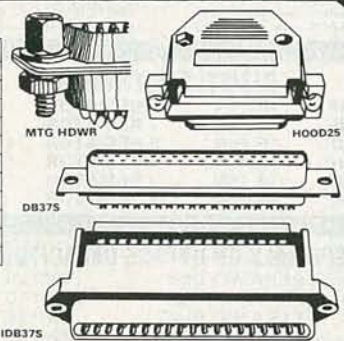

IDC CONNECTORS

DESCRIPTION	ORDER BY	CONTACTS					
		10	20	26	34	40	50
SOLDER HEADER	IDHxxS	.82	1.29	1.68	2.20	2.58	

20MB HARD DISK SYSTEM ONLY \$389⁹⁵!

BARGAIN HUNTERS CORNER

ENHANCED GRAPHICS ADAPTOR

100% IBM COMPATIBLE—PASSES IBM EGA DIAGNOSTICS

- COMPATIBLE WITH IBM EGA, COLOR GRAPHICS ADAPTOR AND MONOCHROME ADAPTOR
- DISPLAYS 16 COLORS OUT OF 64 COLORS
- COMES WITH 256K DYNAMIC RAM
- DUAL SCANNING FREQUENCIES WORKS WITH STANDARD OR EGA TYPE RGB MONITORS
- LIGHT PEN INTERFACE

**NOW ONLY
\$259.95**

EGA MONITOR

FULL ONE YEAR WARRANTY

- EGA AND CGA COMPATIBLE
- SCANNING FREQUENCIES: 15.75 KHz / 21.85 KHz
- 14" BLACK MATRIX, NON-GLARE SCREEN
- RESOLUTIONS: 640 x 200" / 640 x 350"
- .31mm DOT, 25MHz
- 16 COLORS OUT OF 64
- TEXT SWITCH—GREEN / AMBER

\$499.95

SPECIALS END 10/31/86



PAGE WIRE WRAP WIRE PRECUT ASSORTMENT

IN ASSORTED COLORS \$27.50
100ea: 5.5", 6.0", 6.5", 7.0"
250ea: 2.5", 4.5", 5.0"
500ea: 3.0", 3.5", 4.0"

SPOOLS

100 feet \$4.30 250 feet \$7.25
500 feet \$13.25 1000 feet \$21.95

Please specify color:
Blue, Black, Yellow or Red

EMI FILTER

\$4.95

- MANUFACTURED BY CORCOM
- LOW COST
- FITS LC-HP BELOW
- 6 AMP 120/240 VOLT



6 FOOT LINE CORDS

LC-2 2 CONDUCTOR .39
LC-3 3 CONDUCTOR .99
LC-HP 3 CONDUCTOR W/ STD FEMALE SOCKET 1.49

MUFFIN FANS

3.15" SQ ROTRON 14.95
3.63" SQ ETRI 14.95
3.18" SQ MASUSHITA 16.95

WIRE WRAP PROTOTYPE CARDS

FR-4 EPOXY GLASS LAMINATE WITH GOLD-PLATED EDGE-CARD FINGERS



IBM-PR2

IBM

BOTH CARDS HAVE SILK SCREENED LEGENDS AND INCLUDES MOUNTING BRACKET

IBM-PR1 WITH -5V AND GROUND PLANE . . . \$27.95
IBM-PR2 AS ABOVE WITH DECODING LAYOUT \$29.95

S-100

P100-1 BARE - NO FOIL PADS . . . \$15.15
P100-2 HORIZONTAL BUS . . . \$21.80
P100-3 VERTICAL BUS . . . \$21.80
P100-4 SINGLE FOIL PADS PER HOLE . . . \$22.75

APPLE

P500-1 BARE - NO FOIL PADS . . . \$15.15
P500-3 HORIZONTAL BUS . . . \$22.75
P500-4 SINGLE FOIL PADS PER HOLE . . . \$21.30
7060-45 FOR APPLE IIe AUX SLOT . . . \$30.00

SOCKET-WRAP I.D.™

- SLIPS OVER WIRE WRAP PINS
 - IDENTIFIES PIN NUMBERS ON WRAP SIDE OF BOARD
 - CAN WRITE ON PLASTIC, SUCH AS IC #
- | PINS | PART # | PCK. OF | PRICE |
|------|-----------|---------|-------|
| 8 | IDWRAP 08 | 10 | 1.95 |
| 14 | IDWRAP 14 | 10 | 1.95 |
| 16 | IDWRAP 16 | 10 | 1.95 |
| 18 | IDWRAP 18 | 5 | 1.95 |
| 20 | IDWRAP 20 | 5 | 1.95 |
| 22 | IDWRAP 22 | 5 | 1.95 |
| 24 | IDWRAP 24 | 5 | 1.95 |
| 28 | IDWRAP 28 | 5 | 1.95 |
| 40 | IDWRAP 40 | 5 | 1.95 |
- PLEASE ORDER BY NUMBER OF PACKAGES (PCK. OF)



FRAME STYLE TRANSFORMERS

12.6V AC CT 2 AMP 5.95
12.6V AC CT 4 AMP 7.95
12.6V AC CT 8 AMP 10.95
25.2V AC CT 2 AMP 7.95

25 PIN D-SUB GENDER CHANGERS

\$7.95



SWITCHING POWER SUPPLIES

PS-IBM \$69.95

- FOR IBM PC-XT COMPATIBLE
- 135 WATTS
- +5V @ 15A, +12V @ 4.2A
- -5V @ .5A, -12V @ .5A
- ONE YEAR WARRANTY

PS-IBM



PS-IBM-150 \$79.95

- FOR IBM PC-XT COMPATIBLE
- 150 WATTS
- +12V @ 5.2A, +5V @ 16A
- -12V @ .5A, -5V @ .5A
- ONE YEAR WARRANTY

PS-130

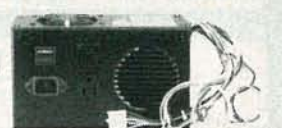

PS-130 \$99.95

- 130 WATTS
- SWITCH ON REAR
- FOR USE IN OTHER IBM TYPE MACHINES
- 90 DAY WARRANTY

PS-A



PS-A \$49.95

- USE TO POWER APPLE TYPE SYSTEMS, 79.5 WATTS
- +5V @ 7A, +12V @ 3A
- -5V @ .5A, -12V @ .5A
- APPLE POWER CONNECTOR

PS-SPL200



PS-SPL200 \$49.95

- +5V @ 25A, +12V @ 3.5A
- -5V @ 1A, -12V @ 1A
- UL APPROVED
- ALUMINUM ENCLOSURE

CAPACITORS

TANTALUM

1.0µf	15V	.35	47µf	35V	.45
6.8	15V	.70	1.0	35V	.45
10	15V	.80	2.2	35V	.65
22	15V	1.35	4.7	35V	.85
.22	35V	.40	10	35V	1.00

DISC

10pF	50V	.05	680	50V	.05
22	50V	.05	.001µf	50V	.05
27	50V	.05	.0022	50V	.05
33	50V	.05	.005	50V	.05
47	50V	.05	.01	50V	.07
68	50V	.05	.02	50V	.07
100	50V	.05	.05	50V	.07
220	50V	.05	.1	12V	.10
560	50V	.05	.1	50V	.12

MONOLITHIC

.01µf	50V	.14	.1µf	50V	.18
.047µf	50V	.15	.47µf	50V	.25

ELECTROLYTIC

RADIAL		AXIAL			
1µf	25V	.14	1µf	50V	.14
2.2	35V	.15	10	50V	.16
4.7	50V	.15	22	16V	.14
10	50V	.15	47	50V	.20
47	35V	.18	100	35V	.25
100	16V	.18	220	25V	.30
220	35V	.20	470	50V	.50
470	25V	.30	1000	16V	.60
2200	16V	.70	2200	16V	.70
4700	25V	1.45	4700	16V	1.25

DATARASE EPROM ERASER

\$34.95

- ERASES 2 IN 10 MINUTES
- COMPACT-NO DRAWER
- THIN METAL SHUTTER PREVENTS UV LIGHT FROM ESCAPING



1/4 WATT RESISTORS

5% CARBON FILM ALL STANDARD VALUES FROM 1 OHM TO 10 MEG. OHM

10 PCS	same value	.05	100 PCS	same value	.02
50 PCS	same value	.025	1000 PCS	same value	.015

RESISTOR NETWORKS

SIP	10 PIN	9 RESISTOR	.69
SIP	8 PIN	7 RESISTOR	.59
DIP	16 PIN	8 RESISTOR	1.09
DIP	16 PIN	15 RESISTOR	1.09
DIP	14 PIN	7 RESISTOR	.99
DIP	14 PIN	13 RESISTOR	.99

SPECIALS ON BYPASS CAPACITORS

.01 µf	CERAMIC DISC	100/\$5.00
.01 µf	MONOLITHIC	100/\$10.00
.1 µf	CERAMIC DISC	100/\$6.50
.1 µf	MONOLITHIC	100/\$12.50

WISH SOLDERLESS BREADBOARDS

PART NUMBER	DIMENSIONS	DISTRIBUTION STRIP(S)	TIE POINTS	TERMINAL STRIP(S)	TIE POINTS	BINDING POSTS	PRICE
WBU-D	.38 x 6.50"	1	100	---	---	---	2.95
WBU-T	1.38 x 6.50"	---	---	1	630	---	6.95
WBU-204-3	3.94 x 8.45"	1	100	2	1260	2	17.95
WBU-204	5.13 x 8.45"	4	400	2	1260	3	24.95
WBU-206	6.88 x 9.06"	5	500	3	1890	4	29.95
WBU-208	8.25 x 9.45"	7	700	4	2520	4	39.95



LITHIUM BATTERY

AS USED IN CLOCK CIRCUITS

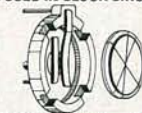

3 VOLT BATTERY \$3.95
BATTERY HOLDER \$1.49

NEW EDITION!

1986 IC MASTER
THE INDUSTRY STANDARD

\$129.95

VISIT OUR RETAIL STORE LOCATED AT 1256 SOUTH BASCOM AVENUE IN SAN JOSE



1224 S. Bascom Avenue, San Jose, CA 95128

Toll Free 800-538-5000 • (408) 995-5430

FAX (408) 275-8415 • Telex 171-110

© COPYRIGHT 1986 JDR MICRODEVICES

THE JDR MICRODEVICES LOGO IS A REGISTERED TRADEMARK OF JDR MICRODEVICES. JDR INSTRUMENTS AND JDR MICRODEVICES ARE TRADEMARKS OF JDR MICRODEVICES. IBM IS A TRADEMARK OF INTERNATIONAL BUSINESS MACHINES. APPLE IS A TRADEMARK OF APPLE COMPUTER.

HOURS: M-W-F, 9-6 TU-TH, 9-9 SAT, 9-5

PLEASE USE YOUR CUSTOMER NUMBER WHEN ORDERING

TERMS: Minimum order \$10.00. For shipping and handling include \$2.50 for UPS Ground and \$3.50 for UPS Air. Orders over 1 lb. and foreign orders may require additional shipping charges - please contact our sales department for the amount. CA residents must include applicable sales tax. All merchandise is warranted for 90 days unless otherwise stated. Prices are subject to change without notice. We are not responsible for typographical errors. We reserve the right to limit quantities and to substitute manufacturer. All merchandise subject to prior sale.

20MB HARD DISK SYSTEM ONLY \$389⁹⁵!

DISK DRIVES FOR APPLE COMPUTERS

AP-150
\$99.95

- 1/2 HT. DIRECT DRIVE
- 100% APPLE COMPATIBLE
- SIX MONTH WARRANTY

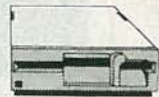

BAL-500
\$129.95

- TEAC MECHANISM-DIRECT DRIVE
- 100% APPLE COMPATIBLE
- FULL ONE YEAR WARRANTY

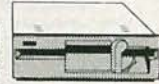

AP-135
\$129.95

- FULL HT SHUGART MECHANISM
- DIRECT REPLACEMENT FOR APPLE DISK II
- SIX MONTH WARRANTY

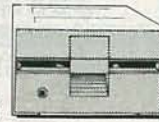

DOUBLE SIDED!
MAC535
\$249.95

- 3.5" ADD-ON DISK DRIVE
- 100% MACINTOSH COMPATIBLE
- DOUBLE SIDED 800K BYTE STORAGE
- HIGH RELIABILITY DRIVE
- HAS AUTO-EJECT MECHANISM
- FULL ONE YEAR WARRANTY

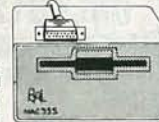

AD-3C
\$139.95

- 100% APPLE IIc COMPATIBLE
- READY TO PLUG IN, W/ SHIELDED CABLE & MOLDED 19 PIN CONNECTOR
- FAST, RELIABLE SLIMLINE DIRECT DRIVE
- SIX MONTH WARRANTY

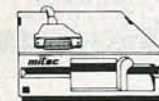

DISK DRIVE ACCESSORIES
FDD CONTROLLER CARD \$49.95
IIc ADAPTOR CABLE \$19.95
ADAPTS STANDARD APPLE DRIVES FOR USE WITH APPLE IIc

KB-1000 **\$79.95**

- CASE WITH KEYBOARD FOR APPLE TYPE MOTHERBOARD
- USER DEFINED FUNCTION KEYS
- NUMERIC KEYPAD WITH CURSOR CONTROL
- CAPS LOCK
- AUTO-REPEAT



KEYBOARD-AP **\$49.95**

- REPLACEMENT FOR APPLE II KEYBOARD
- CAPS LOCK KEY, AUTO-REPEAT
- ONE KEY ENTRY OF BASIC OR CP/M COMMANDS



EXTENDER CARDS

IBM-PC	\$45.00
IBM-AT	\$68.00
APPLE II	\$45.00
APPLE IIe	\$45.00
MULTIBUS	\$86.00

APPLE COMPATIBLE INTERFACE CARDS

EPROM PROGRAMMER \$59.95

MODEL RP525

- DUPLICATE OR BURN ANY STANDARD 27xx SERIES EPROM
- EASY TO USE MENU-DRIVEN SOFTWARE IS INCLUDED
- MENU SELECTION FOR 2716, 2732, 2732A, 2764 AND 27128
- HIGH SPEED WRITE ALGORITHM
- LED INDICATORS FOR ACTIVITY
- NO EXTERNAL POWER SUPPLY NEEDED
- ONE YEAR WARRANTY

16K RAMCARD \$39.95

- FULL TWO YEAR WARRANTY
- EXPAND YOUR 48K APPLE TO 64K
- USE IN PLACE OF APPLE LANGUAGE CARD
- BARE PC CARD W/ INSTRUCTIONS \$9.95

IC TEST CARD \$99.95

- QUICKLY TESTS MANY COMMON ICs
- DISPLAYS PASS OR FAIL
- ONE YEAR WARRANTY
- TESTS: 4000 SERIES CMOS, 74HC SERIES CMOS, 7400, 74LS, 74L, 74H & 74S

300B MODEM \$49.95
FOR APPLE OR IBM

INCLUDES ASCII PRO-EZ SOFTWARE

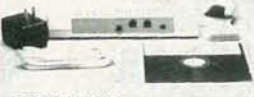

- FCC APPROVED
- BELL SYSTEMS 103 COMPATIBLE
- INCLUDES AC ADAPTOR
- AUTO-DIAL
- DIRECT CONNECT
- CABLE FOR APPLE IIc \$14.95

JOYSTICK CR-401 \$7.95

FOR ATARI 400, 800, 2600, VIC 20/64 AND APPLE IIe

DISKFILE
HOLDS 70 5 1/4" DISKETTES



\$8⁹⁵
3.5" DISKFILE HOLDS 40 \$9⁹⁵

POWER STRIP

• UL APPROVED
• 15A CIRCUIT BREAKER
\$12.95



BAL 3-WAY SWITCH BOXES

- SERIAL OR PARALLEL
- CONNECTS 3 PRINTERS TO ONE COMPUTER OR VICE VERSA
- ALL LINES SWITCHES
- HIGH QUALITY ROTARY SWITCH MOUNTED ON PCB
- GOLD CONTACTS
- STURDY METAL ENCLOSURE



SWITCH-3P CENTRONICS PARALLEL **\$99.95**
SWITCH-3S RS232 SERIAL **\$99.95**

BAL PRINTER BUFFERS

- FREES COMPUTER FOR OTHER TASKS WHILE PRINTING LONG DOCUMENTS
- STAND-ALONE DESIGN; WORKS WITH ANY COMPUTER OR PRINTER
- ALL MODELS FEATURE PRINT PAUSE MEMORY CHECK, GRAPHICS CAPABILITY

SP120P PARALLEL **\$139.95**

- 64K UPGRADABLE TO 256K
- LED INDICATOR SHOWS VOLUME OF DATA IN BUFFER

SP120S RS232 SERIAL **\$159.95**

- 64K UPGRADABLE TO 256K
- 6 SELECTABLE BAUD RATES, FROM 600B-19,200B

SP110P PARALLEL **\$249.95**

- 64K UPGRADABLE TO 512K
- SPOOLS OUTPUT OF UP TO 3 COMPUTERS
- LED BARGRAPH DISPLAYS AMOUNT OF DATA IN BUFFER
- RESET FUNCTION CLEARS DATA IN BUFFER
- REPEAT FUNCTION CAN PRODUCE MULTIPLE COPIES OF A DOCUMENT



NASHUA DISKETTES DEALS

5 1/4" SOFT SECTOR
DS/DD WITH HUB RINGS

\$9⁹⁰ **69C^{ea}** **59C^{ea}**
BOX OF 10 BULK QTY 50 BULK QTY 250

NASHUA DISKETTES WERE JUDGED TO HAVE THE HIGHEST POLISH AND RECORDED AMPLITUDE OF ANY DISKETTES TESTED ACCORDING TO "COMPARING FLOPPY DISKS", BYTE 9/84

DISKETTES NASHUA 5 1/4"

N-MD2D	DS/DD SOFT	\$9.90
N-MD2F	DS/QUAD SOFT	\$34.95
N-MD2H	DS/HD FOR AT	\$49.95

NASHUA 8"

N-FD1	SS/DD SOFT	\$27.95
N-FD2D	DS/DD SOFT	\$34.95

NASHUA 3.5"

N-3.5SS	3.5" SS/DD FOR MAC	\$32.95
---------	--------------------	---------

VERBATIM 5 1/4"

V-MD1D	SS/DD SOFT	\$23.95
V-MD2D	DS/DD SOFT	\$29.95
V-MD110D	SS/DD 10 SECTOR HARD	\$23.95

BUILD STEVE CIARCIA'S INTELLIGENT EPROM PROGRAMMER

AS SEEN IN BYTE, OCT. 86

- STAND-ALONE OR RS-232 SERIAL OPERATION
- MENU SELECTABLE EPROM TYPES—NO CONFIGURATION JUMPERS
- PROGRAMS ALL 5V 27XXX EPROMS FROM 2716 TO 27512
- READ, COPY OR VERIFY EPROM
- UPLOAD/DOWNLOAD INTEL HEX FILES
- PROGRAMMER DRIVER USER MODIFIABLE

ONLY \$199

KIT INCLUDES PCB AND ALL COMPONENTS EXCEPT CASE AND POWER SUPPLY

5 1/4" FLOPPY DISK DRIVES

TEAC FD-55B 1/2 HT DS/DD (FOR IBM)	\$109.95
TEAC FD-55F 1/2 HT DS/QUAD (FOR IBM)	\$124.95
TEAC FD-55GFV 1/2 HT DS/HD (FOR IBM AT)	\$154.95
TANDON TM100-2 DS/DD (FOR IBM)	\$119.00
TANDON TM50-2 1/2 HT DS/DD (FOR IBM)	\$79.95
MPI-B52 DS/DD (FOR IBM)	\$79.95
QUME QT-142 1/2 HT DS/DD (FOR IBM)	\$79.95

8" FLOPPY DISK DRIVES

FD 100-8 SS/DD (SA/801 EQUIV)	\$119.00
FD 200-8 DS/DD (SA/851R EQUIV)	\$159.00

DISK DRIVE ACCESSORIES

TEAC SPECIFICATION MANUAL	\$5.00
TEAC MAINTENANCE MANUAL	\$25.00
1/2 HT MOUNTING HARDWARE	\$2.95
MOUNTING RAILS FOR IBM AT	\$4.95
"Y" POWER CABLE FOR 5 1/4" FDDs	\$2.95
5 1/4" FDD POWER CONNECTORS	\$1.19

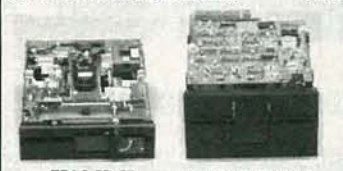

DISK DRIVE ENCLOSURES

CAB-APPLE APPLE TYPE CABINET W/OUT POWER SUPPLY	\$24.95
CAB-1FH5 FULL HT 5 1/4" BEIGE CABINET W/POWER SUPPLY	\$69.95
CAB-2SV5 DUAL SLIMLINE 5 1/4" CABINET W/POWER SUPPLY	\$49.95
CAB-2SV8 VERTICAL DUAL SLIMLINE 8" CABINET W/POWER SUPPLY	\$209.95
CAB-2FH8 HORIZONTAL DUAL FULL HT 8" CABINET W/POWER SUPPLY	\$219.95



TEST EQUIPMENT FROM JDR INSTRUMENTS

DIGITAL MULTIMETER PEN DPM-1000
AUTO RANGING, POLARITY AND DECIMAL!
\$54.95

- LARGE 3.5 DIGIT DISPLAY
- DATA HOLD SWITCH FREEZES READING
- FAST, AUDIBLE CONTINUITY TEST
- LOW BATTERY INDICATOR
- OVERLOAD PROTECTION

20MHZ DUAL TRACE OSCILLOSCOPE	MODEL 2000	\$389.00
35MHZ DUAL TRACE OSCILLOSCOPE	MODEL 3500	\$549.00

FOR MORE INFORMATION ON THE OSCILLOSCOPES, CALL US FOR FREE PRODUCT BRIEFS.



CALL FOR VOLUME QUOTES © COPYRIGHT 1986 JDR MICRODEVICES

CIRCLE 178 ON FREE INFORMATION CARD

20 MEGA BYTE HARD DISK SYSTEM ONLY \$389.95!

SEAGATE ST-225 20 MB HARD DISK SYSTEM

INCLUDES HARD DISK CONTROLLER, CABLES AND INSTRUCTIONS. ALL DRIVES ARE PRE-TESTED AND COME WITH A ONE YEAR WARRANTY.

\$389.95

XT COMPATIBLE MOTHERBOARD

\$129.95

- 4.77 MHz 8088 CPU, OPTIONAL 8087 CO-PROCESSOR
- 8 EXPANSION SLOTS
- 0K RAM INSTALLED, EXPANDABLE TO 640K ON-BOARD MEMORY
- ALL ICs SOCKETED-HIGHEST QUALITY PC BOARD
- ACCEPTS 2764 OR 27128 ROMS

PRO-BIOS \$19.95

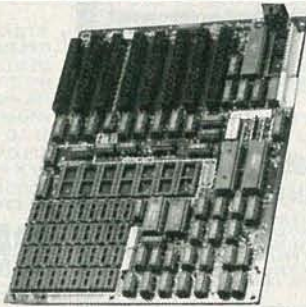

IBM COMPATIBLE INTERFACE CARDS

ALL WITH A ONE YEAR WARRANTY

MULTI I/O FLOPPY CARD \$89.95

PERFECT FOR THE 640K MOTHERBOARD



- 2 DRIVE FLOPPY DISK CONTROLLER
- 1 RS232 SERIAL PORT; OPTIONAL 2nd SERIAL PORT
- PARALLEL PRINTER PORT
- GAME PORT
- CLOCK/CALENDAR
- SOFTWARE: CLOCK UTILITIES, RAMDISK, SPOOLER
- OPTIONAL SERIAL PORT \$15.95

MULTIFUNCTION CARD \$84.95

ALL THE FEATURES OF AST'S 6 PACK PLUS AT HALF THE PRICE



- CLOCK/CALENDAR
- 0-384K RAM
- SERIAL PORT
- PARALLEL PORT
- GAME PORT
- SOFTWARE INCLUDED
- PRINTER CABLE \$9.95
- 64K RAM UPGRADE 9/\$11.61

COLOR GRAPHICS ADAPTOR \$69.95

FULLY COMPATIBLE WITH IBM COLOR CARD



- 4 VIDEO INTERFACES: RGB, COMPOSITE COLOR, HI-RES COMPOSITE MONOCHROME, CONNECTOR FOR RF MODULATOR
- COLOR GRAPHICS MODE: 320 x 200
- MONO GRAPHICS MODE: 640 x 200
- LIGHT PEN INTERFACE

MONOCHROME GRAPHICS CARD \$89.95

FULLY COMPATIBLE WITH IBM MONOCHROME ADAPTOR & HERCULES GRAPHICS



- LOTUS COMPATIBLE
- TEXT MODE: 80 x 25
- GRAPHICS MODE: 720 x 348
- PARALLEL PRINTER INTERFACE
- OPTIONAL SERIAL PORT \$19.95

MONOCHROME ADAPTOR \$49.95

ANOTHER FANTASTIC VALUE FROM JDR!

• IBM COMPATIBLE TTL OUTPUT

• 720 x 350 PIXEL DISPLAY

PLEASE NOTE: THIS CARD WILL NOT RUN LOTUS GRAPHICS AND DOES NOT INCLUDE A PARALLEL PORT

FLOPPY DISK DRIVE ADAPTOR \$34.95



- INTERFACES UP TO 4 STANDARD FDDs TO IBM PC OR COMPATIBLES
- INCLUDES CABLE FOR TWO INTERNAL DRIVES
- STANDARD DB37 FOR EXTERNAL DRIVES
- RUNS QUAD DENSITY DRIVES WHEN USED WITH JFORMAT

1200 BAUD MODEMS

HAYES COMPATIBLE, AUTO-DIAL, AUTO-ANSWER, AUTO RE-DIAL ON BUSY, POWER-UP SELF TEST, FULL ONE YEAR WARRANTY

MODEL 1200B*	MODEL 1200H*	SMARTTEAM
• INTERNAL DESIGN	• INTERNAL DESIGN	• EXTERNAL DESIGN
• 10 INCH CARD	• HALF LENGTH (5") CARD	• WITH POWER SUPPLY
• SERIAL PORT INCLUDED	• INCLUDES SPEAKER	• LED STATUS INDICATORS
\$169.95	\$149.95	\$169.95
*FOR IBM, INCLUDES PC TALK III COMMUNICATIONS SOFTWARE		

CRT MONITORS FOR ALL APPLICATIONS



LUXOR HI-RES RGB MONITOR
MODEL 190-9528

- DIGITAL RGB-IBM COMPATIBLE
- 14" SCREEN
- 16 TRUE COLORS
- 25 MHz BANDWIDTH
- RESOLUTION > 640 x 262
- 31mm DOT PITCH
- CABLE FOR IBM PC INCLUDED

\$299.95



SAKATA COMPOSITE COLOR
MODEL SC-100

- TOP RATED FOR APPLE
- 12" COMPOSITE VIDEO
- RESOLUTION: 280H x 300V
- INTERNAL AUDIO AMP
- ONE YEAR WARRANTY

\$169.95



CENTER SYSTEMS MONOCHROME
MODEL KLM-1211

- IBM COMPATIBLE TTL INPUT
- 12" NON-GLARE SCREEN
- P39 GREEN PHOSPHORUS
- VERY HIGH RESOLUTION: 25 MHz BANDWIDTH 1100 LINES (CENTER)
- AMBER VERSION \$109.95

\$99.95

BUILD YOUR OWN 256K XT COMPATIBLE SYSTEM

XT MOTHERBOARD	\$129.95
PRO-BIOS	\$19.95
256K RAM	\$26.55
130 WATT POWER SUPPLY	\$69.95
FLIP-TOP CASE	\$39.95
DKM-2000 KEYBOARD	\$59.95
1/2 HEIGHT QUME DRIVE	\$79.95
FLOPPY DISK CONTROLLER	\$34.95
MONOCHROME ADAPTOR	\$49.95
MONOCHROME MONITOR	\$98.95
TOTAL:	\$811.10

MONITOR STAND



TILTS AND SWIVELS

ONLY \$12.95

IBM PRINTER CABLE



• DB25 TO CENTRONICS SHIELDED CABLE **\$8.95**

IBM STYLE COMPUTER CASE

AN ATTRACTIVE STEEL CASE WITH A HINGED LID FITS THE POPULAR PC/XT COMPATIBLE MOTHERBOARDS

- SWITCH CUT-OUT ON SIDE FOR PC/XT STYLE POWER SUPPLY
- CUT-OUT FOR 8 EXPANSION SLOTS
- ALL HARDWARE INCLUDED

\$39.95



IBM COMPATIBLE KEYBOARDS

DKM-2000 \$59.95

IBM-5151 \$79.95

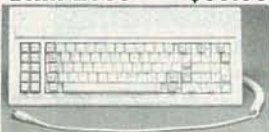

- "5150" STYLE KEYBOARD
- FULLY IBM COMPATIBLE
- 135 WATTS
- LED STATUS INDICATORS FOR CAPS & NUMBER LOCK
- 83 KEY - SAME LAYOUT AS IBM PC/XT KEYBOARD



- REPLACEMENT FOR KEYTRONICS KB-5151™
- SEPARATE CURSOR & NUMERIC KEYPAD
- CAPS LOCK & NUMBER LOCK INDICATORS
- IMPROVED KEYBOARD LAYOUT

POWER SUPPLY



NOW ONLY \$69.95

- FOR IBM PC-XT COMPATIBLE
- 135 WATTS
- +5V @ 15A, +12V @ 4.2A
- -5V @ .5A, -12V @ .5A

150 WATT MODEL \$79.95

DISK DRIVES TANDON TM50-2

\$79.95

- 1/2 HT DS/DD
- IBM COMPATIBLE
- EXTREMELY QUIET!

TEAC FD-55B	DS/DD	\$109.95
TEAC FD-55F	DS/QUAD	\$124.95
TEAC FD-55H	DS/HD	\$154.95
QUME QT-142	DS/DD	\$79.95
MOUNTING HARDWARE		\$2.95
AT/RAILS		\$4.95

JDR Microdevices

1224 S. Bascom Avenue, San Jose, CA 95128

Toll Free 800-538-5000 • (408) 995-5430 • FAX (408) 275-8415 • Telex 171-110

★ QUALITY PARTS ★ DISCOUNT PRICES ★ FAST SHIPPING!

SEND FOR FREE 1986 CATALOG... 48 PAGES!

ALL ELECTRONICS CORP.

SPECIAL PURCHASE

COMMODORE PRINTER/PLOTTER

Commodore Model # 1520
Four color X-Y plotter. Standard VIC serial interface allows easy connection to Commodore 64 computers. Up to 80 characters per line (upper and lower case) in four sizes.



CAT # COM-1520 \$49.95 each
EXTRA pen sets \$1.50 per set.

EDGE CONNECTORS

ALL ARE 1.56" SPACING.

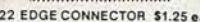

- 22 EDGE CONNECTOR \$1.25 ea solder lug style 10 for \$11.00
- 22/44 EDGE CONNECTOR \$2.00 ea PC style 10 for \$18.00
- 22/44 EDGE CONNECTOR solder lug style \$2.50 each
- 28/56 EDGE CONNECTOR \$2.50 ea PC style 10 for \$22.00
- 36/72 EDGE CONNECTOR PC style \$3.00 each
- 43/86 EDGE CONNECTOR PC style \$4.50 each

TRANSISTORS

- 2N706 4 for \$1.00
- 2N2222A 3 for \$1.00
- PN2222A 4 for \$1.00
- 2N2904 3 for \$1.00
- 2N2905 3 for \$1.00
- MJ2955 \$1.50
- 2N3055 \$1.00
- PMD 10K40 \$1.00
- TIP 121 75¢
- TIP 125 75¢

TRANSFORMERS

- 120 volt primaries
- 5.6 volts @ 750 ma. \$3.00
- 6 volts @ 150 ma. \$1.25
- 6.3 volt @ 600 ma. \$3.00
- 12 V.C.T. @ 200 ma. \$2.00
- 12 V.C.T. @ 400 ma. \$3.00
- 12 V.C.T. @ 1 amp \$4.00
- 12 V.C.T. @ 2 amp \$4.85
- 12 V.C.T. @ 4 amp \$7.00
- 18 volts @ 650 ma. \$3.50
- 24 V.C.T. @ 200 ma. \$2.50
- 24 V.C.T. @ 1 amp \$4.85
- 24 V.C.T. @ 2 amp \$6.75
- 24 V.C.T. @ 3 amp \$9.50
- 24 V.C.T. @ 4 amp \$11.00
- 36 V.C.T. @ 135 ma. \$3.00

WALL TRANSFORMERS

- all plug directly into 120 vac outlet
- 4 VDC @ 70 ma. \$2.00
- 6 VDC @ 500 ma. \$3.50
- 6 VDC @ 750 ma. \$4.50
- 9 VDC @ 500 ma. \$5.00
- 12.5 VAC @ 265 ma. \$3.00
- 18 VAC @ 18 VA and 8.5 VAC @ 1.28 VA \$3.50
- 24 VAC @ 250 ma. \$3.00
- MULTI-VOLTAGE @ 500 ma. \$4.50
- 3.4 1/2, 6.7 1/2, 9 or 12 VDC \$7.50

MINI-BOX

Heavy-duty black phenolic project box with cover and screws. 2 1/2" X 1 1/2" X 1 1/2"

Pomona # 2104. \$1.00 EACH

FUSES

- 3AG (AGC) SIZE 1 1/2, 2, 2 1/2, 3, 4, 5, 6 AMP
- GMA SIZE 1, 2, 3, 4, 5 AMP
- 5 of any ONE amperage 75¢

SPECIALS

1 AMP 50 VOLT DIODES IN4001 TAPE AND REEL 100 for \$4.50 1000 for \$30.00

SOLDER TAIL I.C. SOCKETS

24 PIN 10 for \$2.50 100 for \$22.00 1000 for \$200.00

+SPECIAL PRICE+ TRANSISTOR

plastic transistor PN3569 TO-92 N.P.N. 100 for \$8.00 1000 for \$60.00 LARGE QUANTITIES AVAILABLE

48 KEY ASSEMBLY FOR COMPUTER OR HOBBYIST



NEW T.I. KEYBOARDS. Originally used on computers, these keyboards contain 48 S.P.S.T. mechanical switches. Terminates to 15 pin connector. Frame 4" x 9" CAT # KP-48 \$6.50 each 2 for \$11.00

TI SWITCHING POWER SUPPLY

Compact, well-regulated switching power supply designed to power Texas Instruments computer equipment.

SPECIAL PRICE \$3.50 each

13.8 VDC REGULATED POWER SUPPLY

These are solid state, fully regulated 13.8 vdc power supplies. Both feature 100% solid state construction, fuse protection, and L.E.D. power indicator. U.L. listed.

- 2 amp constant, 4 amp surge \$20.00 each
- 3 amp constant, 5 amp surge \$27.50 each

AUTOMOTIVE CASSETTE PLAYER

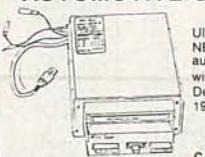

Ultra Spec #DAT-80-CD NEW stereo cassette player with auto reverse, 12 Vdc. neg. ground with pre-amp output. Designed for underdash use in 1980 Datsuns. \$15.00 each CAT # ACP-80 case of 6 - \$75.00

MICRO-CASSETTE MECHANISM

Micro-cassette tape transport for standard MC60 or MC45 micro-cassettes. 3 Vdc operation. Contains: drive motor, belt, head, capstan, pinch wheel and other components. 3 1/2" X 2 1/4" X 5/8" CAT # MCMEC \$3.00 each 10 for \$27.50

COMPUTER GRADE CAPACITORS

- 2,000 mfd. 200 Vdc 1 3/4" x 5" high \$2.00
- 6,400 mfd. 60 Vdc 1 3/8" x 3 3/4" high \$2.50
- 9,700 mfd. 50 Vdc 1 3/8" x 4 1/2" high \$3.00
- 31,000 mfd. 15 Vdc 1 3/4" x 4" high \$2.50
- 50,000 mfd. 40 Vdc 3" x 5 3/4" high \$4.50
- 60,000 mfd. 40 Vdc 3" x 5" high \$3.50
- 66,000 mfd. 15 Vdc 3" x 3" high \$3.00
- 86,000 mfd. 30 Vdc 3" x 5 1/4" high \$3.50

\$1.00 SPECIALS

- 5,500 mfd. 30 Vdc 1 3/8" x 3 1/2" high \$1.00
- 5,900 mfd. 30 Vdc 1 3/8" x 2 1/4" high \$1.00
- 9,900 mfd. 50 Vdc 2" x 4 1/2" high \$1.00
- 18,000 mfd. 10 Vdc 1 3/8" x 2 5/8" high \$1.00
- 48,000 mfd. 10 Vdc 2 1/2" x 3 1/4" high \$1.00
- 100,000 mfd. 10 Vdc 2 1/2" x 6" high \$1.00
- 185,000 mfd. 6 Vdc 2 1/2" x 4 1/2" high \$1.00

RELAYS

10 AMP SOLID STATE CONTROL: 3 - 32 vdc LOAD: 140 vac 10 amp SIZE: 2 1/2" x 1 1/4" x 1 1/4"

\$9.50 EACH 10 FOR \$90.00

ULTRA-MINIATURE 5 VDC RELAY

Fujitsu # FBR211NED005M20 High sensitivity COIL: 120 ohms CONTACTS: 1 amp Mounts in 14 pin DIP socket \$1.25 each 10 for \$10.00

MINIATURE 6 VDC RELAY

Aromat #RSD-6V Super Small S.P.D.T. relay GOLD colbat contacts rated 1 amp @ 30 vdc. Highly sensitive. TTL direct drive possible. 120 ohm coil Operate from 4.3 - 6 vdc. COIL: 120 ohms \$1.50 each 1 1/2" x 1 1/2" x 7/16" 10 for \$13.50

13 VDC RELAY

CONTACTS: S.P.N.C. 10 amp @ 120 vac Energize coil to open contact. COIL: 13 vdc 650 ohms

SPECIAL PRICE \$1.00 each

4PDT RELAY

14 pin KH style. 3 amp contacts. USED but fully tested \$1.70 each Specify coil voltage desired Either 24 vdc or 120 vac LARGE QUANTITIES AVAILABLE

RECHARGEABLE NI-CAD BATTERIES

- AAA SIZE 1.25V 500MAH \$1.85
- AA SIZE 1.25V 500MAH \$1.85
- AA with solder tab \$2.00
- C SIZE 1.2V 1200MAH \$3.50
- SUB-C SIZE solder tab \$3.50
- D SIZE 1.2V 1200MAH \$3.50

UNIVERSAL CHARGER

Will charge 4-AA, C, D, or AAA ni-cads or one 9 volt ni-cad at one time... \$11.00 per charger

SOLID STATE BUZZER



2K 10 TURN MULTI-TURN POT SPECTROL #MOD 534-7161 \$5.00 EACH

Star #SMB-06L 6 vdc TTL compatible. \$1.00 each 10 for \$9.00

± 12 Vdc or 24Vdc POWER SUPPLY

DELTRON MODEL QD12/15-1.7 Dual plus and minus 12Vdc open frame power supply. Can be used as 24Vdc @ 1.5 amp INPUT either 115 Vac or 230 Vac. Fully regulated computer grade supply. 7" x 4 1/2" x 2 1/4"

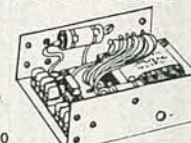

\$12.50 each 10 for \$110.00

PHOTO-FLASH CAPACITORS

170 mf 330v 75¢ ea.

CAT # PPC-170 400 mf 330v

CAT # PPC-400 1.00 ea. 800 mf 330v

CAT # PPC-800 1.35 ea.

3 1/2" SPEAKER

8 ohm impedance. Full range speaker. 8 oz magnet. 4" diagonal mounting centers. \$2.50 each 10 for \$20.00

SPRING LEVER TERMINALS

Two color coded terminals on a sturdy 2 1/4" x 3 1/4" bakelite plate. Great for speaker enclosures or power supplies. 75¢ EACH 10 for \$6.00

LINE CORDS

TWO WIRE 6' 18/2 SPT-1 flat 3 for \$1.00

6' 18/2 SPT-2 flat 2 for \$1.00

6' 18/2 SJT round \$1.25 each

THREE WIRE 6' 18/3 flat \$1.50 each

8' 18/3 round \$2.00 each

TELEPHONE COUPLING TRANSFORMER

Stancor # TTPC-8 or Triad # TY-304 P 600 ohms c.t. to 600 ohms c.t. P.C. board mount 3/4" x 5/8" x 3/4" CAT - TCTX \$2.50 each

XENON FLASH TUBE

3/4" long X 1/8" dia. Flash tube designed for use in compact camera flash units. Ideal for experimenters. CAT # FLT-1 2 for \$1.00

MINIATURE TOGGLE SWITCHES

ALL ARE RATED 5 AMPS @ 125 VAC

S.P.D.T. (on-on) PC style non-threaded bushing. 75¢ each 10 for \$7.00

S.P.D.T. (on-off-on) Solder lug terminals. \$1.00 each 10 for \$9.00

S.P.D.T. (on-on) PC lugs threaded bushing. 75¢ each 10 for \$7.00

D.P.D.T. (on-on) Solder lug terminals. \$2.00 each 10 for \$19.00

FLASHER LED 5 volt operation red jumbo T 1 1/4 size \$1.00 each

NEW GREEN FLASHER CAT # LED-4G \$1.00

BI-POLAR jumbo T 1 1/4 size 2 for \$1.70

LED HOLDERS Two piece holder for jumbo LED 10 for \$5.00

CLEAR CLEIPLITE LED HOLDER Make LED a fancy indicator. Clear. 4 for \$1.00

D.R.S.T. LIGHTED ROCKER SWITCH

115 vac lighted rocker. Snap mounts in 1/2" x 1 1/2" hole. Orange lens. 16 amp contact \$1.50

MINI-PUSH BUTTON S.P.S.T. momentary normally open 1/4" bushing. Red button. 35¢ each 10 for \$3.00

SNAP ACTION SWITCH

Cherry elect. #E-21. N.O. or N.C. 0.1A contacts. Suitable for alarms and other low energy circuits. 1 1/2" lever. 45¢ EACH 10 FOR \$4.20

220 Vac COOLING FAN

ROTRON # MX77A3 Multin XL 220 Vac 4 1/8" square metal frame fan. CAT # CF-220 \$6.50 ea. 10 for \$60.00; 100 for \$500.00

QUANTITIES AVAILABLE

ALL ELECTRONICS CORP. LOS ANGELES, CA STORE 905 S. Vermont Ave. 213 380-8000

MAIL ORDERS TO: P.O. BOX 20406 Los Angeles, CA 90006



TOLL FREE ORDERS ONLY 1-800-826-5432 (ORDER ONLY) (IN CALIFORNIA: 1-800-258-6666) ALASKA, HAWAII, OR INFORMATION (213) 380-8000 NO C.O.D.

QUANTITIES LIMITED MINIMUM ORDER \$10.00 USA: \$3.00 SHIPPING FOREIGN ORDERS: INCLUDING SUFFICIENT SHIPPING CALIF RES. ADD 6 1/2%

QUANTITIES AVAILABLE

Worldwide • Since 1974

• QUALITY COMPONENTS • COMPETITIVE PRICING
• PROMPT DELIVERY

Mail Order Electronics • Worldwide
Jameco
ELECTRONICS

COMMODORE COMPATIBLE ACCESSORIES



Now Compatible With C-128!
RS232 Adapter for VIC-20, C-64 and C-128

The JE232CM allows connection of standard serial RS232 printers, modems, etc. to your VIC-20, C-64 (excluding the SX-64 Portable), and C-128. A 4-pole switch allows the inversion of the 4 control lines. Complete installation and operation instructions included.

• Plugs into User Port • Provides Standard RS232 signal levels
• Uses 6 signals (Transmit, Receive, Clear to Send, Request to Send, Data Terminal Ready, Data Set Ready).

JE232CM \$39.95

Voice Synthesizer VIC-20 & C-64
Plug-In - Talking in Minutes!

JE520CM \$99.95

External Power Supply
CPS-10 (For C-64) \$39.95

Parallel Printer Interface
2K Buffer, Expandable to 10K!
MW350 (For VIC-20, C-64 & C-128) \$54.95

TRS-80 COMPATIBLE ACCESSORIES

E-X-P-A-N-D TRS-80 MEMORY
All kits come complete with documentation

TRS-80 MODEL I, III
TRS-16K3 200ns (Model III) \$5.95
TRS-16K4 250ns (Model I) \$5.49

TRS-80 COLOR AND COLOR II
TRS-64K-2 \$11.95
New models only -
TRS-CoCo-Incl. 2-50464's (41464's) \$12.49

TRS-80 MODEL 4, 4P
TRS-64K-2 \$11.95
Expands Model 4 from 16K-64K or Model 4P from 64K-128K
TRS-64K-2PAL \$29.95
Expands Model 4 from 64K to 128K

TRS-80 Model 100 • NEC • Olivetti
M1008K \$24.95 ea. or 3 for \$59.95
TRS-80 Model 100 Expansion
NEC8KR \$24.95 ea. or 3 for \$59.95
NEC Model PC-8201A Expansion
OM108K \$24.95 ea. or 3 for \$59.95
Olivetti Model M10 Expansion

TANDY 200
M200R \$74.95 ea. or 2 for \$129.95
Tandy Model 200 Expansion

UV-EPROM ERASER



Erases all EPROMs. Erases up to 8 chips within 21 minutes (1 chip in 15 minutes). Maintains constant exposure distance of 1". Special conductive foam liner eliminates static build-up. Built-in safety lock to prevent UV exposure. Compact - 9.00" L x 3.70" W x 2.60" H. Complete with holding tray for 8 chips.

DE-4 UV-EPROM Eraser \$74.95
UVS-11EL Replacement Bulb \$17.95

DATA BOOKS

30003 National Linear Data Book (82) \$14.95
30009 Intersil Data Book (85) \$ 9.95
30013 Zilog Data Book (85) \$14.95
30032 National Linear Supplement (84) \$ 6.95
210830 Intel Memory Handbook (86) \$17.95
230843 Intel Microsystem Hndbk. Set (86) \$24.95

MUFFIN/SPRITE-STYLE FANS

MUF60 (SPN3-15-2462) \$9.95
Howard Industries (4.68" sq., 60 cfm)
SU2C7 \$9.95
EG&G Rotron (3.125" square, 20 cfm)

NEW PRODUCTS!

DISK DRIVE SALE!
MPI52S Double-sided 48TPI. . . IBM PC/XT Compatible! . . \$89.95
TM100-4 Double-sided 96TPI. QUAD Drive! \$59.95

ZUCKERBOARD
Expansion Memory Half-Card for IBM-PC, XT, Portable, Tandy 1200 and Compatible Computers
Expand your computer to its full capacity of 640K. It will accept either 64K memory chips (4164) or 256K memory chips (41256).
EM-100 Expansion Memory Half Card with 0K RAM \$59.95
EM-D RAM Disk and Printer Spooler Software \$39.95



Multifunction Board with Clock Calendar for the Tandy 1000
The Zuckerboard Multifunction Board allows you to expand the memory on your Tandy 1000 to as much as 640K. The Multifunction Board comes complete with an RS232 port for your serial expansion needs, a clock/calendar and RAM Disk Printer Spooler. The Zuckerboard Multifunction Board is made in the U.S.A. and comes with a standard 2 year warranty.

MTAN-256K Includes 256K RAM and Manual \$199.95
MTAN-512K Includes 512K RAM and Manual \$239.95

Expansion Memory Half-Card and Clock/Calendar for the Tandy 1000 - DMA Controller Chip on board!
TAN-EM256K Includes 256K RAM and Manual \$ 99.95
TAN-EM512K Includes 512K RAM and Manual \$139.95

Options for TAN-EM256K/512K
TAN-C Includes Plug-in Clock Option Chip (only) \$39.95
TAN-D Includes RAM Disk Spooler Software (only) \$39.95

3.5" Micro Floppy Disk Drive for Tandy 100 & 200, NEC8201A, IBM PC, XT, AT and Compatible Computers
Now your IBM PC or compatible can read and write the same disks as your portable!

FD-103 Includes 3.5" Disk Drive, Cable, AC Adapter, Blank Diskette and Documentation. \$179.95

Software for the FD-103 Disk Drive (Software needed for operation)
TS1 Tandy 100 TSDOS Disk Operating System Software \$49.95
TS2 Tandy 200 TSDOS Disk Operating System Software \$49.95
TSN NEC PC8201A Disk Operating System Software \$49.95
LAPDOS IBM PC, XT, AT and Compatible LAPDOS Disk Operating System Software \$79.95

13" Color Composite Monitor for VIC-20 and C-64
Also compatible with other computers with composite output (i.e. Apple II, II+, IIe)
Ideal for color graphics and games
• Resolution: 260H x 300V • Recommended Display Character Number: 960 Characters (40 Characters x 24 Rows on 5x7 Dot Matrix)
• CRT: 13" diagonal • Size: 14.6"W x 13.5"H x 15.5"D • Weight: 25.3 lbs.
CMON \$129.95 each or 2/\$219.95
RCA-3-DIN (Universal Computer to Monitor Cables for Atari, Commodore & TI) \$3.49



IBM COMPATIBLE ACCESSORIES



Identical layout as original IBM PC Keyboard • Highly desirable case with palm rest • Complete with cable and data
JUST PLUG IN!

KB83 SALE \$29.95

Build an IBM PC/XT™ Compatible!
IBM-64K(2) 64K RAM Chips (18) \$ 24.98
KB-83 83-Key Keyboard \$ 29.95
IBM-FCC Floppy Controller Card \$ 49.95
IBM-Case Case \$ 49.95
IBM-MCC Monochrome Card \$ 79.95
IBM-PS Power Supply \$ 79.95
FD55B Disk Drive \$119.95
IBM-MON Monochrome Monitor \$ 99.95
IBM-MB Motherboard \$139.95
Regular List \$674.58

IBM™-Special (Incl. 9 items above) . . . \$599.95

Additional Add-Ons Available!
IBM-KB 83-Key Keyboard \$ 69.95
IBM-ENH Enhanced Keyboard \$ 99.95
IBM-ICB Integrated Color Board \$ 99.95
IBM-EGA Enhd. Graphics 256K RAM \$299.95
IBM-20MBK 20MB Hard Disk Drive \$499.95
IBM is a registered trademark of IBM Computers

NEW! 64K/256K NEW! Printer Buffer
JOHNATHON FREEMAN DESIGNS



The UBUFFER Universal Printer Buffer is a hi-speed data buffer that accepts data at a high rate, and then outputs this data to your printer. You save valuable computer time. The UBUFFER can be connected to practically any computer or printer. There are four possible combinations: 1) Serial to Serial, 2) Serial to Parallel, 3) Parallel to Parallel, 4) Parallel to Serial. Manual included. Size: 9-1/3"L x 4 1/4"W x 1 1/8"H

UBUFFER-64K . . . \$199.95
UBUFFER-256K . . \$229.95

IBM Compatible! DISK DRIVES
Documentation Included

FD55B Teac 5 1/4" DS 1/2-Height \$119.95
SA455 Shugart 5 1/4" DS 1/2-Height \$119.95
TM100-2 Tandon 5 1/4" DS Full-Height \$109.95

JMR 5 1/4" DISK DRIVE ENCLOSURES
Complete with power supply, switch, power cord, fuseholder and connectors.
DDE-1FH \$69.95
Houses 1 Full-Height 5 1/4" Floppy Drive.
DDE-2HH \$79.95
Houses 2 Half-Height 5 1/4" Floppy Drives - Vertical
HDDE-1FH \$199.95
Houses 1 Hard Disk Drive

\$20 Minimum Order - U.S. Funds Only
Shipping: Add 5% plus 1.50 Insurance

California Residents: Add 6% or 6 1/2% Sales Tax

Spec. Sheets - 50¢ each
Prices Subject to Change

Send stamped, self-addressed envelope to receive a Quarterly Sales Flyer - FREE!
11/86



Mail Order Electronics • Worldwide
Jameco
ELECTRONICS



Send \$1.00 Postage for a FREE 1986 JAMECO CATALOG

1355 SHOREWAY ROAD, BELMONT, CA 94002 • PHONE ORDERS WELCOME 415-592-8097 Telex: 176043

MARK V ELECTRONICS INC.,

248 EAST MAIN STREET, SUITE 100,
ALHAMBRA, CA 91801.
TELEX: 3716914 MARK 5.

INFORMATION: 1-818-282-1196
MAIL ORDERS: P.O. BOX 6610
ALHAMBRA CA 91802.

1-800-423-3483

TOLL FREE FOR ORDERS PAID
BY MASTER OR VISA CARD
IN CAL.: 1-800-521-MARK

CALL OR WRITE FOR A **FREE CATALOG** — OVER 60 HOT & WELL-QUALIFIED ITEMS FOR YOUR SELECTION!

MULTIPURPOSE MELODY GENERATOR

SPECIFICATIONS:

Output Power: 500mw
Output Impedance: 4-8 Ω
Power Supply: DC 1.5-5V 100mA
It can also be used as a doorbell, musical box and electronic alarm.

TA-50A/B

Best kit for X'mas!

TA-50A CIC-481E

- Jingle Bell
- Silent night
- Rudolph, the red-nosed reindeer
- O come, All ye faithful

- Santa Claus is coming to town
- Joy to the world
- I wish you a merry X'mas
- Hark, the herald Angels sing

TA-50B CIC-482E

- London Bridge is falling Down
- Are you Sleeping
- Toy Symphony
- Wiegenlied

- Row your Boat
- Happy Birthday
- Home sweet home
- Melody on purple bamboo

CORDLESS SOLDERING IRON RECHARGEABLE

No. 620



The most perfect handy, lightweight soldering iron for Workshop, Home, Hobby & Outdoor work... Includes UL approval charger & cleaning sponge. With build-in solder point illumination.

Each set \$22.80

TALKING CLOCK

AMAZING VALUE!
GOLDEN & BLACK ARE AVAILABLE!



1. Talk: push button for voice announcement of time.
2. Read out: twelve hours system display for hour, minute, second (by color flash), AM & PM
3. Display: three display modes of time, alarm time & date
4. Alarm: on/off switch with thirty seconds voice alarm.
5. Snooze: reminder voice alarm of thirty seconds after 4 minutes of first voice alarm.
6. Volume: two level of voice output.
7. Language available: English, Mandarin.

PARROT 8501 \$17.75 NOT A KIT!
MYNAH 8504 \$16.90

100W DYNAMIC CLASS "A" MAIN POWER AMPLIFIER

TA-1000A



NOW PAY LESS!

This powerful dynamic bias class "A" circuit makes this unit unique in its class. Crystal clear 100W R.M.S. POWER output will satisfy the most picky HI - FI fans. This is a single channel amplifier. If you need a stereo effect you can buy two to make a total of 200W DYNAMIC POWER!
Over 3000 KITS ARE SOLD IN THE STATE!

Kit \$45.50

60W VERSATILE STEREO POWER BOOSTER

TA-302



Kit \$50.00
Ass. with tested \$60.00

80W + 80W DC LOW TIM PRE-MAIN AMPLIFIER

TA-800



Kit \$49.85
Metal Cabinet/X'Former (Optional) \$23.90/\$22.00

150MC Universal Digital Frequency Counter SM-100



Frequency Range: 10Hz - 150MHz
Event Counter: 0 to 99999999 counts. (8 Digit)
Input sensitivity: KHz range 10Hz - 10MHz 50mVrms.
MHz range 1MHz - 150MHz 40mVrms.
Response time: 0.2 second.
Hold Function: Hold the last input signal.
Power Supply: DC6V Battery or DC9V 250MA Adaptor.
Dimension: 9 7/8" x 6 1/16" x 2 3/4"

Assembled with tested \$99.00

NF-CR BI-FET IC PRE-AMPLIFIER WITH 3 WAY TONE CONTROL!

TA-2800



Kit \$36.80

STEREO SIMULATOR

TA-3000

SPECIAL KITS OFFER!



KIT ONLY \$25.00

You can own a stereo TV from today! This simulator is a special design of using the most advance monoized L.S.I. It produced a superior analog stereo effect since the L.S.I. is equalled 60 pcs. of LOW NOISE FET & TRANSISTOR. The simulator can even help you to promote your television from a normal one to a special one with a Hi-Fi STEREO function. Our simulator is also applicable to any other 'mono sources' in covering it to ANALOG STEREO. Undoubtedly, it is the most advanced equipment for every family, while it should contribute to your listening pleasure.

Ass. with tested \$30.00

COLOR LIGHT CONTROLLER

TY-23B

Best for Party!



As a result of the advanced technology, this unit can control various colorful light bulbs, the visual effect of which is most suitable in places like party, disco, electronic game centre and also in lightings for advertisement. Total output power is 3000W (1000W/Ch.) which means that it can control 30 pieces of 100W or 600 pieces of 5W color light which is enough for most usages.

Kit \$65.00
Ass. with tested \$75.00

TA-2400A ELECTRONIC ECHO AND REVERBERATION AMPLIFIER

REMIX records yourself!



This unit combines the most advanced B.B.D. technique with high quality Japan made components; It has the following FEATURES:

It can generate various reflection and reverberation effects. It has 3 special effect controls which include reverberation control, delay control and depth control. Special effect can be made in your record tapes by using this model. All kinds of infield sound effect can be obtained by skilful use of this control. It has LED display to show reflection and reverberation.

Ass. with tested \$ 99.85

HIGH QUALITY MULTIPURPOSE PRE-AMPLIFIER

TA-2500

GREAT VALUE!



This specially designed pre-amplifier includes a professional GRAPHIC EQUALIZER TONE control system and has a gain of ±12dB. Frequency response extends from 5Hz to 20KHz, so as to ensure best performance in whatever adverse condition. It can accept input from various magnetic cartridge, record deck, CD player and tuner; its output can be connected to all kinds of power amplifier!

Assembled with tested \$82.00

120W MOSFET POWER AMPLIFIER

TA-477



This amplifier consists of three super low TIM differential stages, and Hitachi 2SJ49/2SK 134 match pair "MOSFET" as output component whose frequency response and transient response is superior to the other power transistor. Therefore this amplifier has high-fidelity and superior analytic power over the entire Audio Spectrum. It is suitable for reproducing classic and modern music. Heavy Duty Heat Sink with 28 radial fins is included!

Kit \$55.00
Metal Cabinet/X'Former (Optional) \$23.90/\$19.88

Model No.	Description	Kit/Assembled	Unit Price	Model No.	Description	Kit/Assembled	Unit Price
TA-001	1W Mini Amplifier	Kit	\$3.90	TR-355 A, B	3-5A REGULATED DC POWER SUPPLY	Kit	\$10.68
TA-006	6W Mini Amplifier	Kit	\$4.92	TR-503	0-50V/3A POWER SUPPLY WITH SHORT CIRCUIT BREAK & OVERLOAD PROTECTOR	Kit	\$12.30
TA-007	12W Stereo Power Booster	Kit	\$8.00	TR-100	0-15V 2A REGULATED DC POWER SUPPLY	Ass	\$69.50
TA-008	AC/DC SHOULDER AMPLIFIER	Ass	\$48.00			Kit	\$3.99
TA-10	STEREO PRE-AMPLIFIER WITH MAGNETIC MIC AMP	Kit	\$6.00	TY-1A MK4	BATTERY FLUORESCENT LIGHT	Kit	\$5.50
TA-50 A, B	MULTI-PURPOSE MELODY GENERATOR	Kit	\$10.76	TY-7	ELECTRONIC TOUCH SWITCH	Kit	\$3.99
TA-120	PURE CLASS "A" MAIN POWER AMPLIFIER	Kit	\$25.00	TY-11A	MULTI-FUNCTIONAL CONTROL RELAY	Kit	\$3.99
TA-202	20W AC/DC STEREO AMPLIFIER	Ass	\$60.00	TY-12A	DIGITAL CLOCK WITH TWO TIMER	Kit	\$13.86
TA-300	30W Multi-Purpose Single Channel Amp.	Kit	\$11.07	TY-13	COLOR LED VU METER	Kit	\$17.50
TA-302	60W Stereo Power Booster	Ass	\$50.00	TY-14	ELECTRONIC SHOCK	Kit	\$3.00
		Kit	\$24.60	TY-18	HIGH PRECISION SOUND CONTROL SWITCH	Kit	\$7.68
TA-323A	High Quality 30W+30W Stereo Amplifier	Kit	\$29.50	TY-20	SUPER SENSITIVE AUDIO LEVEL INDICATOR	Kit	\$19.50
TA-322	60W IC Stereo Pre-Amplifier & Power Amplifier	Kit	\$13.84	TY-23B	COLOR LIGHT CONTROLLER	Kit	\$65.00
TA-400	40W TRANSISTORIZED MONO-AMPLIFIER	Kit	\$55.00			Ass	\$75.00
TA-477	120W MOSFET POWER AMPLIFIER	Kit	\$48.95	TY-25	SPEAKER PROTECTOR	Kit	\$9.50
TA-800	160W DC LOW TIM PRE-AMPLIFIER & POWER AMP.	Kit	\$39.95	TY-35	FM WIRELESS MICROPHONE	Kit	\$7.68
TA-802	160W PURE DC ST. POWER AMP. W/SPK. PROTECTOR	Kit	\$43.00	TY-36	AC/DC QUARTZ DIGITAL CLOCK	Kit	\$16.92
TA-820A	120W OCL DC PRE-MAIN & STEREO AMPLIFIER	Kit	\$45.50	TY-38	MAIN OR TOUCH CONTROL SWITCH	Kit	\$10.00
TA-1000A	100W DYNAMIC CLASS "A" MAIN POWER AMP (MONO)	Kit	\$67.00	TY-41 MKIII	INFRARED REMOTE CONTROL UNIT	Kit	\$25.00
TA-1500	200W NEW CLASS "A" DC STEREO PRE-MAIN AMP	Ass	\$99.85			Ass	\$30.00
TA-2400A	ELECTRONIC ECHO AND REVERBERATION AMP	Ass	\$82.00	TY-42	BAR/DOT LEVEL METER	Kit	\$21.00
TA-2500	HIGH QUALITY MULTI-PURPOSE PRE-AMPLIFIER	Kit	\$38.00	TY-45	BAR/DOT AUDIO LEVEL DISPLAY	Kit	\$34.95
TA-2200	DC FET SUPER CLASS "A" PRE-AMPLIFIER	Kit	\$36.80	TY-47	SUPERIOR ELECTRONIC ROULETTE	Kit	\$16.92
TA-2800	NF-CR BI-FET PRE-AMP (WITH 3WAY TONE CONTROL)	Kit	\$30.00	YAMATO 4001	3 1/2 DIGITAL MULTIMETER	© SET	\$33.80
TA-3000	STEREO SIMULATOR	Kit	\$25.00		LCD THERMOMETER CLOCK WITH & OUT DOOR SENSOR	© SET	\$20.00
		Kit	\$28.00		T2 LCD THERMOMETER CLOCK WITH & C' MEASURING	© SET	\$18.00
SM-43	3 1/2 MULTI-FUNCTIONAL LED D.P.M.	Ass	\$29.23	8504	TALKING CLOCK MYNAH (GOLDEN OR BLACK)	© SET	\$25.00
SM-48	4 1/2 HI-PRECISION D.P.M.	Ass	\$35.00	NO. 620	CORDLESS SOLDERING IRON RECHARGEABLE	© SET	\$22.80
SM-100	150MC UNIVERSAL DIGITAL FREQUENCY COUNTER	Ass	\$43.00				
TY-43	3 1/2 DIGITAL PANEL METER	Kit	\$28.00				

Ass=Assembled form, it is fully checked and tested.

TERMS: Minimum order: \$10.00. Charge card order \$20.00. No C.O.D.! Check & Money order, phone order accept. CA. residents must include 6.5% sales tax. Prices are subject to change without notice. All merchandise subject to prior sale. Shipping & handling: Inside L.A. 5% of total order (Min. \$1.50). Outside L.A. 10% of total order (Min. \$2.50). Outside U.S.A. 20% of total order (Min. \$5.00). Shipped by UPS ground. HOURS: Mon-Fri 9:30 to 5:00, Sat 9:30 to 1:00 (PACIFIC TIME)

NATION-WIDE DISTRIBUTORS WANTED FOR OUR PRODUCTS, QUANTITY DISCOUNTS AVAILABLE!



Saratoga Electronics

12380 SARATOGA-SUNNYVALE RD. SARATOGA, CA 95070



DYNAMIC RAMS

4164-150NS \$.99
41256-150NS 2.95

INTEGRATED CIRCUITS

65C02 \$8.95 MC10231P \$.39
ADC0816CCN 6.95 LF347 .95
FD1797B-02 7.95 LM350K 2.00
WD2143M-02 4.95 MSM5832 1.95
PAL20L10NC 2.95

EPROMS

2716-450NS \$2.95
2732A-450NS 2.25
2764-450NS 3.00
2764-250NS 3.75
27256-300NS 6.75

DRIVES

Teac 55B \$ 85.00
Fujitsu M2551A 79.00
MIT 4853 Quad/DS 96 TPI 69.95
Seagate 20MB 1/2 Ht. 299.00
Quantum 40MB Full Ht. 795.00
Hard Disk Controller (Omti 5510) 109.00

PC/AT COMPATIBLE SYSTEM BOARD \$749.00

1 Megabyte Installed

PC/XT COMPATIBLE SYSTEM BOARD \$129.00

Turbo/640KB w/o Bios & Ram

PC/XT SYSTEM KIT \$795.00

Turbo/640KB

HARD DISK DRIVE \$895.00

PC/AT Compatible
70MB — 25msec Access

408/446-4949

TOLL FREE
800/621-0854 ext. 245

PRICES SUBJECT TO CHANGE
\$25 MIN. ORDER



CIRCLE 97 ON FREE INFORMATION CARD

ADVERTISING INDEX

RADIO-ELECTRONICS does not assume any responsibility for errors that may appear in the index below.

Free Information Number	Page		Page		
—	"2001"	CV3	—	OrCad Systems	83
81	A.I.S. Satellite	33	—	Pacific Cable	87
108	AMC Sales	69	198	Pilgrim Video	33
76	AP Products	12	204	Portasol	32
107	All Electronics	99	126	RAG Electronics	5
—	Amazing Devices	88	—	RCA D&SP	11
84	Appliance Service	33	78	Radio Shack	89
77	B&K Precision	25	185	Salen Enterprises	78
98	Beckman Industrial	39	97	Saratoga Electronics	104
85	Blue Star Industries	33	186,187	Sencore	77,79
109	C & S Sales	40	195	Siber Hegner	31
—	C.O.M.B.	78	183	Silicon Valley Surplus	84
60	CIE	16	94	Star Circuits	33
190	Cabletronics	32	188	Steven Mail Order Electronics	82
180	Caig Laboratories	84	92	Tektronix	CV2
89	Cameo Enterprises	82	193	Transleteronic	39
—	Command Productions	22	102	Trio-Kenwood	81
79,197	Communications Electronics	3,29	203	U.S. Cable	71
192	Cook's Institute	69	201	United Electronic Supply	30
—	Coop's Satellite Digest	72	202	United Imports	33
125	Copper Electronics	82	66	W.S. Jenks	84
191	Crosley	33	103	Wm B Allen	28
—	DAK Industries	8,9			
127	Deco Industries	32,33			
56	Del-Phone Industries	32			
95	Dick Smith Electronics	90,91			
82	Digi-Key	103			
—	Digital Research Computers	84			
199	ESI	20			
—	Elec. Industry Association	73			
189	Electronics Book Club	13			
120	Elephant Electronics	33			
111	Etronix	17			
100	Firestik II	24			
—	Fischertechnik	14			
121	Fluke Manufacturing	75			
—	Fordham Radio	CV4			
—	Grantham College of Engineering	27			
62	Hameg	22			
86	Heath	21			
65	J & W	92			
59	JDR Instruments	15			
113,176	JDR Microdevices	94,95			
177,178	JDR Microdevices	96,97			
179	JDR Microdevices	98			
114	Jameco	100,101			
115	Jensen Tools	32			
—	Joseph Electronics	7			
194	Keystone Electronics	24			
87	MCM Electronics	93			
93	Mark V. Electronics	102			
61	Microprocessors Unltd.	CD12			
117	Mouser	78			
—	NRI	34			
200	NTS	32			
110	Omnitron	26			

Gernsback Publications, Inc.
500-B Bi-County Blvd.
Farmingdale, NY 11735
(516) 293-3000
President: Larry Steckler
Vice President: Cathy Steckler

Larry Steckler
publisher
Arline Fishman
advertising director
Shelli Weinman
advertising associate
Lisa Strassman
credit manager
Christina Estrada
advertising assistant

SALES OFFICES
For Advertising ONLY

EAST/SOUTHEAST
Stanley Levitan
Eastern Sales Manager
Radio-Electronics
259-23 57th Avenue
Little Neck, NY 11362
718-428-6037, 516-293-3000

MIDWEST/Texas/Arkansas/Okla.
Ralph Bergen
Midwest Sales Manager
Radio-Electronics
540 Frontage Road—Suite 339
Northfield, IL 60093
312-446-1444

PACIFIC COAST/ Mountain States
Marvin Green
Pacific Sales Manager
Radio-Electronics
15335 Morrison St.—Suite 227
Sherman Oaks, CA 91403
818-986-2001

2001 IS COMING IN MAY



The electronics revolution is in the making, but you don't have to wait until 2001 to find out how it will change your life in the 21st century. Radio-Electronics will forecast the coming changes and how they will affect you in the May 1987 issue!

Created by a special editorial task force—two years in preparation—this unique issue, 2001, takes you into the research laboratories of Westinghouse, Texas Instruments, Ford and Bell Labs where the future is being invented today!

You'll get an advance look at what's coming in artificial intelligence... new cars and highways (cleaner, quieter and more efficient)... futuristic energy sources like magneto-hydrodynamic and particle-beam generators... personal communications systems that will give you instant access to anyone anywhere... super computers and teaching breakthroughs that will multiply your capacity to learn!

Arthur Clarke introduces 2001. Isaac Asimov explores the marvels of robotics. But it is not science fiction. Rather it is

emerging technology with a solid foundation in current research and development.

And its impact will be enormous. It will change the way you work... the way you think... the way you live!

2001 is the kind of special publishing event that can only happen once in any magazine's lifetime and it will happen to Radio-Electronics in May, 1987.

With extra features and extra pages, 2001 will bear a premium cover cost, but you can reserve your copy now at less than the regular cover cost by mailing any one of the subscription orders in this issue.

2001 is coming in May. Make sure now that you don't miss it!

Radio-Electronics®

BP Video Processor gives you precision picture control.



You'll get 5 units in one! The BP Video Processor functions as a **Stabilizer** to end video guard distortion...as an **Enhancer** to provide peak sharpness...as an **RF Converter** to feed signals from video cameras, computer or VCR in your TV...as a **Video Fader** for professional fade-in and fade-out effects...and as a **Dual Output Distribution Amplifier** to send TV signals to other sets.

\$79⁹⁵

Model V-1880

Preserve your memories on videotape



The video-cine converts your slides and home movies to VCR tape with any video camera. This easy to use model features precision optics and rear projection. Macro lens attachment available for cameras without close-up capability.

Model V-1701
\$34⁹⁵

Macro Lens Attachment
Model V-14 **\$14⁹⁵**

Increase the life of your VCR head and tape with BP VHS or Beta Tape Rewinders.



Don't risk worn-down heads and tape damage by rewinding on your VCR. BP Tape Rewinders feature counter, soft button action, controlled speed and automatic shutoff.

Model V-7779
VHS **\$59⁹⁵**

Model V-7780
BETA **\$59⁹⁵**

A small investment...buys
BIG VIDEO
PERFORMANCE!
Get the most out of your video and stereo equipment

Add Stereo to your Video



The mini speaker with maxi sound. 3" long throw woofer; 1" soft dome tweeter; 2" extended midrange speaker. Max power 50 watts.

\$29⁹⁵
per pair

Model HF-9

FM Antenna fine-tunes your fm/stereo reception.



You'll get clear, crisp, undistorted sound from this high quality, directional FM antenna. Mounts instantly indoors, comes complete with coaxial cable and transformer.

\$34⁹⁵

Model FM-9700

Get true-to-life color...and reduce noise...with Audio Video Color Processor.



This versatile color processor corrects off color tape, eliminates single color dominance and restores sharpness in detail. Plus, it stabilizes copy guarded tapes and filters audio noise.

\$149⁹⁵

Model V-1895

Send for **FREE** catalog of hundreds of items. Money orders, checks accepted. C.O.D.'s require 25% deposit.



Fordham

260 Motor Parkway, Hauppauge, NY 11788

Toll Free
800-645-9518
In NY State 800-832-1446

Service & Shipping Charge Schedule Continental U.S.A.	
FOR ORDERS	ADD
\$25-\$100	\$4.50
\$101-\$250	\$6.00
\$251-500	\$8.00
\$501-750	\$10.50
\$751-1,000	\$12.50
\$1,001-1500	\$18.50
\$1,501-2000	\$20.00
\$2,001 and up	\$25.00