

48783

Radio - STEREO AUDIO FOR TV - IT'S HERE NOW!

Electronics

\$1.95 FEB. 1985
IN CANADA \$2.25

TECHNOLOGY - VIDEO - STEREO - COMPUTERS - SERVICE

How to select the best resistor or capacitor for your project ▶

Build this cassette-tape streamer for your computer

All about thermistors and their applications

New back-to-school series! How to design circuits using digital IC's

Build R-E's Atari duplicator and transfer your game cartridges to cassette tape

Step-by-step guide to repairing your videodisc player



Special 16-page tear-out section.

COMPUTER DIGEST

A
GERNSBACK
PUBLICATION

PLUS:

- ★ New Antique Radio Column
- ★ Bob Cooper on Satellite TV
- ★ New Idea ★ Designers Notebook
- ★ Equipment Reports ★ Service Clinic



Now! Tek quality and expert advice are just a free phone call away!

100 MHz dual time base scope.

Easy-to-read CRT; bright, full-sized 8x10 cm; 14 kv accelerating potential complete with BEAM FIND, separate A/B dual intensity controls, FOCUS and TRACE ROTATION.

Wide range vertical sensitivity.

Choose from 2 mV/div (1x probe) to 50 V/div (10x probe); color-keyed for 1x and 10x probes; variable control increases scale factor by 2.5 to 1.

Two 100 MHz, high sensitivity channels.

3.5 ns risetime; dc to \geq 100 MHz bandwidth from 5 V/div to 5 mV/div; extended sensitivity of 2 mV/div at \geq 90 MHz.

A/B sweep selection.

Calibrated A sweeps from 50 ns/div to 0.5 s/div; B sweeps from 50 ns/div to 50 ms/div; variable control for up to 2.5 to 1 reduction and 10x magnification for sweeps to 5 ns/div.

Dual time base measurements.

Select either A or B sweeps, or both alternately with A intensified by B.

B trigger slope and level.

Use B trigger level to select B-triggered or run-after-delay modes; use B TRIGGER SLOPE to select transitions.



Our direct order line gets you the industry's leading price/performance portables... and fast answers from experts!

The 60 MHz single time base delay 2213A, the 60 MHz dual time base 2215A and the 100 MHz dual time base 2235 offer unprecedented reliability and affordability, plus the industry's first 3-year warranty* on labor and parts, CRT included.

The cost: just \$1200 for the 2213A, \$1450 for the 2215A, \$1650 for the 2235.† Even at these low prices, there's no scrimping on performance. You

have the bandwidth for digital and analog circuits. The sensitivity for low signal measurements. The sweep speeds for fast logic families. And delayed sweep for fast, accurate timing measurements. All scopes are UL Listed and CSA approved.

You can order, or obtain literature, through the Tek National Marketing Center. Technical personnel, expert in scope applications, will answer your questions and expedite delivery. Direct orders include comprehensive 3-year warranty*, operator's

manual, two 10X probes, 15-day return policy and worldwide service backup.

Order toll free: 1-800-426-2200, Ask for Rick.

In Oregon, call collect (503) 627-9000.
Or write Tektronix, Inc.
P.O. Box 500, Delivery Station Y6-088
Beaverton, OR 97077

Tektronix®
COMMITTED TO EXCELLENCE

VIDEO ACCESSORIES

■ Highest quality ■ Highest performance ■ Lowest prices

bp VIDEO-CINE CONVERTER

The BP Video-Cine Converter is an optical device that allows the easy transfer of slides, 8mm or 16mm movie film to VCR tape. The Video-Cine Converter's precision optics put the image from your movie or slide projector on a high-contrast, rear projection screen. Your video camera shoots that image, can color-correct faded pictures, add narration to other sound. Can be used with any video camera or slide projector. If your video camera lacks close-up capability, you will need a macro lens attachment.

MODEL V-1701 **\$34⁹⁵**



FOR ULTIMATE VIEWING

TEKNIKA WIRELESS REMOTE CONTROL TV TUNER & CABLE CONVERTER WITH VOLUME CONTROL

Model 6510
\$169⁹⁵



Wireless remote control with volume for cable TV, VHF-UHF antenna systems upgrades any TV to 140 channel capability.

- Works with any TV set
- Quick, easy installation
- Off-air and cable compatible
- Quartz frequency synthesizer tuning
- Direct access/memory scan selector
- Ultra-compact, hand-held wireless remote control

bp 61 CHANNEL WIRELESS REMOTE CONTROL Model V7661 **\$79⁹⁵**



Wireless remote control on/off, channel selection and fine tuning.

- Works with any TV
- 61 channel capability
- Microcomputer controlled PLL operation
- Converter panel controllable for channel up, down, on/off, fine tuning.
- LED display
- Compatible with CATV systems.

bp STABILIZER/IMAGE ENHANCER/RF CONVERTER/VIDEO FADER/2-WAY DISTRIBUTION AMPLIFIER Model V1880 **\$99⁹⁵**



Hook-up cable kit
\$11.75

The most versatile, all-in-one video processor. Can be used as a video guard remover for video tapes, enhancer, video to RF converter, professional video fade in and out and a dual output distribution amplifier.

bp VIDEO SWITCH



Model V4804 **\$49⁹⁵**

Record a pay channel while viewing a standard channel. You can also connect an antenna/cable, VCR, video disc player, home computer and video game.

bp VIDEO TAPE REWINDER Model V7777 VHS **\$49⁹⁵** Model V7778 BETA **\$49⁹⁵**



Reduce wear and tear of your VCR heads with the AC powered circuit protected rewinders, LED power-on indicators.

Charge it with VISA/MASTERCARD. Phone orders accepted.

Fordham

260 Motor Parkway, Hauppauge, NY 11788

Toll Free
800-645-9518
In NY State 800-832-1446

Service and Shipping Charge Schedule	
FOR ORDERS	ADD
\$25-250	\$4.50
\$251-500	\$6.50
\$501-750	\$8.50
\$751-1,000	\$12.50
\$1,001 and up	\$15.00

NEW!

Regency[®] Scanners

Communications Electronics,[™] the world's largest distributor of radio scanners, introduces new models with special savings on all radio scanners. Chances are the police, fire and weather emergencies you'll read about in tomorrow's paper are coming through on a scanner today.

We give you excellent service because CE distributes more scanners worldwide than anyone else. Our warehouse facilities are equipped to process thousands of scanner orders every week. We also export scanners to over 300 countries and military installations. Almost all items are in stock for quick shipment, so if you're a person who prefers fact to fantasy and who needs to know what's really happening around you, order your radio today from CE.

NEW! Regency[®] MX5000-E

List price \$599.95/CE price \$359.00
6-Band, 20 Channel • No-crystal scanner
Search • Lockout • Priority • AC/DC
Selectable AM-FM modes • LCD display
World's first continuous coverage scanner
Frequency range: 25-550 MHz. continuous coverage.
Never before have so many features come in such a small package. The Regency MX5000 mobile or home scanner has continuous coverage from 25 to 550 MHz. That means you can hear CB, Television audio, FM broadcast stations, all aircraft bands including military and the normal scanner bands, all on your choice of 20 programmable channels.

Regency[®] MX3000-E

List price \$319.95/CE price \$179.00
6-Band, 30 Channel • No-crystal scanner
Search • Lockout • Priority • AC/DC
Bands: 30-50, 144-174, 440-512 MHz.
The Regency Touch MX3000 provides the ease of computer controlled, touch-entry programming in a compact-sized scanner for use at home or on the road. Enter your favorite public service frequencies by simply touching the numbered pressure pads. You'll even hear a "beep" tone that lets you know you've made contact.

In addition to scanning the programmed channels, the MX3000 has the ability to search through as much as an entire band for an active frequency. The MX3000 includes channel 1 priority, dual scan speeds, scan or search delay and a brightness switch for day or night operation.

Regency[®] Z30-E

List price \$279.95/CE price \$169.00
6-Band, 30 Channel • No-crystal scanner
Bands: 30-50, 144-174, 440-512 MHz.
Cover your choice of over 15,000 frequencies on 30 channels at the touch of your finger.

Regency[®] C403-E

List price \$99.95/CE price \$59.00
5-Band, 4 Channel • Crystal scanner
Channel indicator LED • AC only • Low cost
Bands: 30-50, 148-174, 450-470 MHz.
Regency's basic scanner, the C403 gives you the excitement of police, fire and emergency calls at a budget price. It can tune in to any of five public service bands and brings the signal in loud and clear...on any of four possible channels. It comes with detachable telescope antenna and AC power cord. Order one crystal certificate for each channel you want to receive.

Regency[®] HX1000-E

List price \$329.95/CE price \$209.00
6-Band, 30 Channel • No Crystal scanner
Search • Lockout • Priority • Scan delay
Sidelit liquid crystal display • Digital Clock
Frequency range: 30-50, 144-174, 440-512 MHz.
The new handheld Regency HX1000 scanner is fully keyboard programmable for the ultimate in versatility. You can scan up to 30 channels at the same time. When you activate the priority control, you automatically override all other calls to listen to your favorite frequency. The LCD display is even sidelit for night use. A die-cast aluminum chassis makes this the most rugged and durable hand-held scanner available. There is even a backup lithium battery to maintain memory for two years. Includes wall charger, carrying case, belt clip, flexible antenna and nicad battery. Order your Regency HX1000 now.

Regency[®] R106-E

List price \$159.95/CE price \$92.00
5-Band, 10 Channel • Crystalscanner • AC/DC
Frequency range: 30-50, 146-174, 450-512 MHz.
A versatile scanner, The Regency R-106 is built to provide maximum reception at home or on the road. Rugged cabinet protects the advanced design circuitry allowing you years of dependable listening.

NEW! Regency[®] R1050-E

List price \$179.95/CE price \$109.00
6-Band, 10 Channel • Crystalscanner • AC only
Frequency range: 30-50, 144-174, 440-512 MHz.
Now you can enjoy computerized scanner versatility at a price that's less than some crystal units. The Regency R1050 lets you in on all the action of police, fire, weather, and emergency calls. You'll even hear mobile telephones.

Programming the R1050 is easy. Merely touch the keyboard and enter any of over 15,000 frequencies on your choice of 10 channels.

Regency[®] HX650-E

List price \$129.95/CE price \$79.00
5-Band, 6 Channel • Handheld crystal scanner
Bands: 30-50, 146-174, 450-512 MHz.
Now you can tune in any emergency around town, from wherever you are, the second it happens. Advanced circuitry gives you the world's smallest scanner. Our low CE price includes battery charger/A.C. adapter.

NEW! Regency[®] HX-650P-E

List Price \$189.95/CE price \$104.00
Now, Communications Electronics offers a special packaged price on the Regency HX-650 scanner and the following items for only \$104.00. You get the Regency HX-650 scanner, a set of 4 AAA Ni-cad batteries, the MA-506 carrying case, six crystal certificates, AC adapter/charger and flexible rubber antenna for only \$104.00 per package plus \$10.00 shipping/handling. To order this special package, use CE special order number HX-650P-E.

QUANTITY DISCOUNTS AVAILABLE

Order two scanners at the same time and deduct 1%, for three scanners deduct 2%, four scanners deduct 3%, five scanners deduct 4% and six or more scanners purchased at the same time earns you a 5% discount off our super low single unit price.

NEW! Regency[®] MX7000-E

List price \$699.95/CE price \$449.00
10-Band, 20 Channel • Crystalscanner • AC/DC
Frequency range: 25-550 MHz. continuous coverage and 800 MHz. to 1.2 GHz. continuous coverage
In addition to normal scanner listening, the MX7000 offers CB, VHF, and UHF TV audio, FM Broadcast, all aircraft bands (civil and military), 800 MHz communications, cellular telephone, and when connected to a printer or CRT, satellite weather pictures.

The Regency Touch MX7000 provides the ease of computer controlled, touch-entry programming in a compact-sized scanner for use at home or on the road. Enter your favorite frequencies by simply touching the numbered pressure pads. You'll even hear a "beep" tone that lets you know you've made contact.

In addition to scanning the programmed channels, the MX7000 has the ability to search through as much as an entire band for an active frequency. When a call is received, the frequency will appear on the digital display.

Regency[®] Z10-E

List price \$239.95/CE price \$138.00
6-Band, 10 Channel • No-crystal scanner
Priority control • Search/Scan • AC/DC
Bands: 30-50, 140-174, 440-512 MHz.
Cover your choice of over 15,000 frequencies on 10 channels at the touch of your finger.

OTHER RADIO ACCESSORIES

B-4-E 1.2 V AAA Ni-Cad batteries (set of four) \$9.00
A-135C-E Crystal certificate \$3.00
A60-E Magnet mount mobile antenna \$35.00
A70-E Base station antenna \$35.00
Add \$3.00 shipping for all accessories ordered at the same time.
Add \$3.00 shipping per scanner antenna.

BUY WITH CONFIDENCE

To get the fastest delivery from CE of any scanner, send or phone your order directly to our Scanner Distribution Center.[™] Be sure to calculate your price using the CE prices in this ad. Michigan residents please add 4% sales tax or supply your tax I.D. number. Written purchase orders are accepted from approved government agencies and most well rated firms at a 10% surcharge for net 10 billing. All sales are subject to availability, acceptance and verification. All sales on accessories are final. Prices, terms and specifications are subject to change without notice. All prices are in U.S. dollars. Out of stock items will be placed on backorder automatically unless CE is instructed differently. A \$5.00 additional handling fee will be charged for all orders with a merchandise total under \$50.00. Shipments are F.O.B. Ann Arbor, Michigan. No COD's. Most products that we sell have a manufacturer's warranty. Free copies of warranties on these products are available prior to purchase by writing to CE. International orders are invited with a \$20.00 surcharge for special handling in addition to shipping charges. Non-certified checks require bank clearance.

Mail orders to: Communications Electronics,[™] Box 1002, Ann Arbor, Michigan 48106 U.S.A. Add \$7.00 per scanner for U.P.S. ground shipping and handling in the continental U.S.A. For Canada, Puerto Rico, Hawaii, Alaska, or APO/FPO delivery, shipping charges are three times continental U.S. rates. If you have a Visa or Master Card, you may call and place a credit card order. Order toll-free in the U.S. Dial 800-521-4414. In Canada, order toll-free by calling 800-221-3475. WUI Telex CE anytime, dial 671-0155. If you are outside the U.S. or in Michigan dial 313-973-8888. Order today.

Scanner Distribution Center[™] and CE logos are trademarks of Communications Electronics Inc.
‡Regency is a federally registered trademark of Regency Electronics Inc. AD #080384-E

Copyright © 1984 Communications Electronics

Order Toll Free... call 1-800-521-4414

COMMUNICATIONS ELECTRONICS[™]

Consumer Products Division

818 Phoenix □ Box 1002 □ Ann Arbor, Michigan 48106 U.S.A.
Call TOLL-FREE 800-521-4414 or outside U.S.A. 313-973-8888

Regency
MX3000



Regency
MX5000

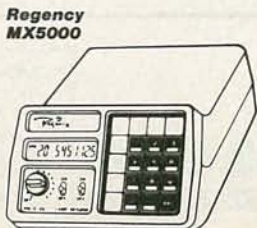

Regency
HX1000



Regency
HX650



CIRCLE 79 ON FREE INFORMATION CARD

FEBRUARY 85

**Radio-
Electronics**

Electronics publishers since 1908

Vol. 56 No. 2

SPECIAL FEATURE:

- 47 SELECTING THE BEST RESISTOR/CAPACITOR**
Finding the right value for your components is the easy part—there's a lot more to consider when choosing parts for your projects. **Victor Meeldijk**

BUILD THIS

- 55 TAPE STREAMER FOR YOUR COMPUTER**
Can a cassette tape really be an alternative to a disk drive? This high-speed cassette interface comes close. And it works with any computer equipped with an RS-232 port! **Mike Huddleston**
- 69 ATARI GAME RECORDER**
Part 3. In the concluding part of this article, we give you all the construction details you'll need to record Atari videogames on audio-cassette tape.
David A. Chan and Guy Vachon

TECHNOLOGY

- 14 SATELLITE TV**
A look at how LNA's have changed during the brief history of satellite TV.
Bob Cooper, Jr.
- 51 STEREO AUDIO FOR TV**
Stereo TV is here at last! Here's an in-depth look at the FCC decision on multichannel television sound and what it means.
Brian C. Fenton

CIRCUITS AND COMPONENTS

- 73 ALL ABOUT THERMISTORS**
Part 2. This month we finish our look at the basics and start to use thermistors in real circuit applications. **Harry L. Trietly**
- 77 DESIGNING WITH DIGITAL IC's**
If digital logic left you behind, it's time to catch up with our new "Back-to-School" series. **Joseph J. Carr**
- 82 HOBBY CORNER**
Building a DC power supply.
Earl "Doc" Savage, K4SDS
- 90 NEW IDEAS**
A melodious telephone ringer.
- 92 DRAWING BOARD**
Understanding memory IC's.
Robert Grossblatt
- 96 STATE OF SOLID STATE**
High-power FET's. **Robert F. Scott**

RADIO

- 84 COMMUNICATIONS CORNER**
Computers and communications.
Herb Friedman
- 88 ANTIQUE RADIOS**
Here's our new column!
Richard D. Fitch.

VIDEO

- 63 SERVICING VIDEODISC PLAYERS**
Part 3. Here are some practical troubleshooting and servicing hints.
John D. Lenk
- 12 VIDEO NEWS**
The present and future of the fast-changing video scene. **David Lachenbruch**
- 98 SERVICE CLINIC**
Servicing electronic test equipment. **Jack Darr**
- 99 SERVICE QUESTIONS**
Answers from Radio-Electronics' service editor.

COMPUTERS

- 86 COMPUTER CORNER**
All about printers.
Lou Frenzel
- COMPUTER DIGEST**
The computer on a wrist is here!

Following
page 90

EQUIPMENT REPORTS

- 32 Cardco Card/? Universal Printer Interface**
- 81 Beckman DM10 Multimeter**

DEPARTMENTS

- 122 Advertising and Sales Offices**
- 122 Advertising Index**
- 123 Free Information Card**
- 22 Letters**
- 101 Market Center**
- 38 New Products**
- 6 What's News**

Radio-Electronics, (ISSN 0033-7862) Published monthly by Gernsback Publications, Inc., 200 Park Avenue South, New York, NY 10003. Second-Class Postage paid at New York, NY and additional mailing offices. Second-Class mail authorized at Ottawa, Canada. One-year subscription rate U.S.A. and possessions \$15.97, Canada \$20.97, all other countries \$23.47. subscription orders payable in US funds only, international postal money order or check drawn on a U.S.A. bank. Single copies \$1.95. © 1985 by Gernsback Publications, Inc. All rights reserved. Printed in U.S.A. POSTMASTER: Please send address changes to RADIO-ELECTRONICS, Subscription Dept., Box 2520, Boulder, CO 80322. A stamped self-addressed envelope must accompany all submitted manuscripts and/or artwork or photographs if their return is desired should they be rejected. We disclaim any responsibility for the loss or damage of manuscripts and/or artwork or photographs while in our possession or otherwise.

For Hz, people choose this DMM with amazing frequency.

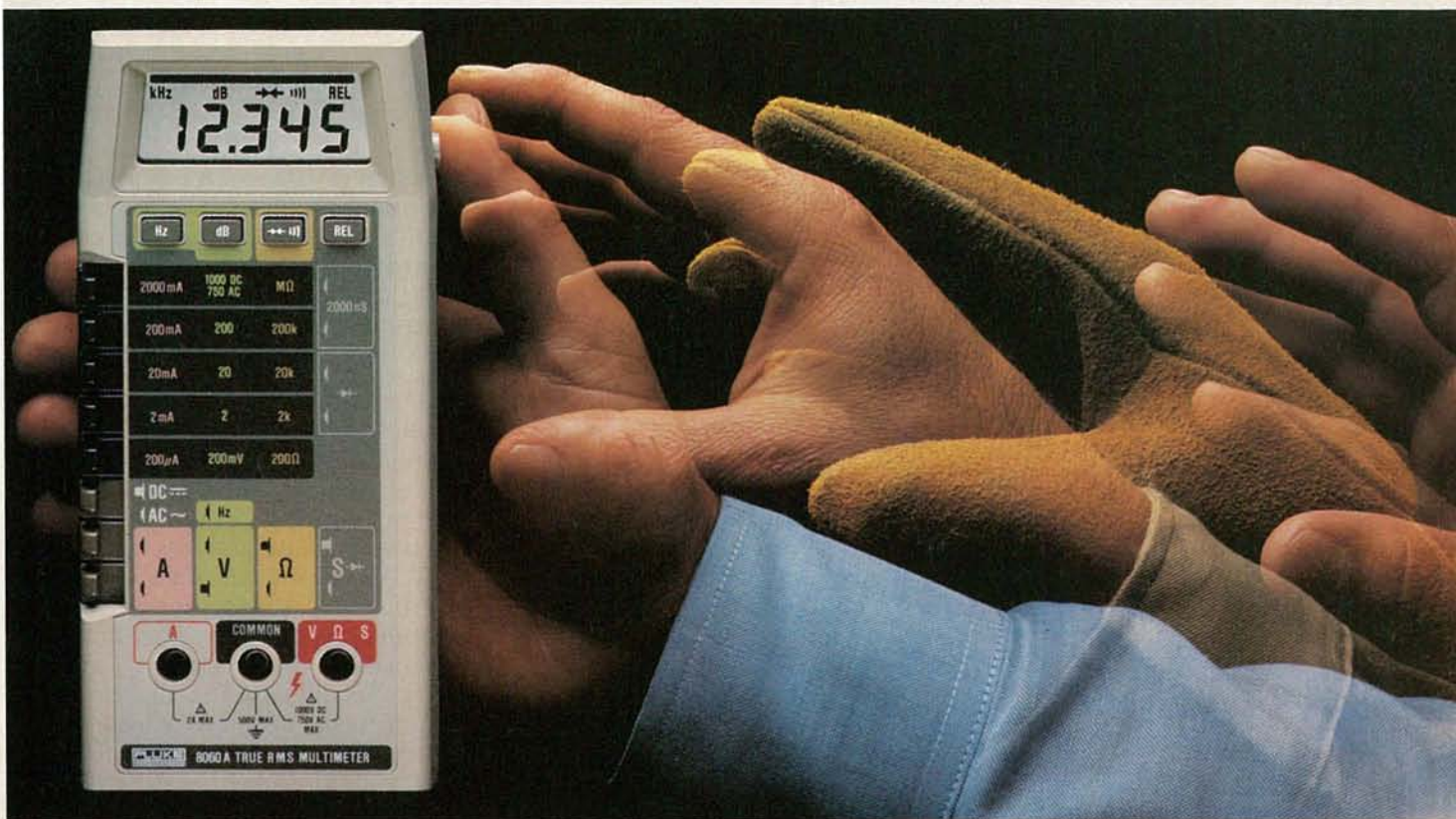

Our 8060A has four unique buttons you won't find on any other 4½-digit handhelds.

Push the *Hz* button, and you're ready to measure frequencies from 12 Hz to 200 kHz. And that's just the beginning.

Select *dB* for automatic conversion from voltage measurements. *Continuity* for quick checks for opens and shorts. And *Relative Reference* for relative or offset measurements — in any function or range you're working in.

Put them together and it's obvious this is not ordinary DMM.

The 8060A also offers true RMS ac measurements, 0.04% basic dc accuracy and 10 μ V resolution. Plus Fluke's traditional quality, precision, ruggedness and value. In all, the most powerful handheld DMM you can buy.

But don't take our word for it.



The next time you're comparing DMMs, take a closer look. Because compared to the competition, something will become very clear.

There isn't any.

That's why for Hz and many other reasons, people choose the Fluke 8060A — with *amazing frequency*.

To learn more about the top-of-the-line 8060A, the lower-cost 8062A and the bench/portable 8050A, contact your local Fluke Distributor, or call toll-free **1-800-426-0361**.

FROM THE WORLD LEADER IN DIGITAL MULTIMETERS.

8060A DMM	8062A DMM	8050A DMM
\$349*	\$279*	\$389*
0.04% basic dc accuracy	0.05% basic dc accuracy	0.03% basic dc accuracy
Frequency measurements	Conductance	dBm readout with 16 selectable reference impedances
dBm, Relative dB	Relative reference	True rms ac
Conductance	True rms ac	Continuity and Diode test
Relative reference	Continuity and Diode test	Conductance
True rms ac	Autoranging megohms	Relative reference
Continuity and Diode test	One-year calibration cycle and warranty	True rms ac
Autoranging megohms	UL 1244 listed	Diode test
One-year calibration cycle and warranty		One-year calibration cycle and warranty
UL 1244 listed		Factory Mutual approved/CSA Certified

* Suggested U.S. list price.

IN THE U.S. AND NON-EUROPEAN COUNTRIES:
John Fluke Mfg. Co., Inc.
P.O. Box C9090, M/S 250C
Everett, WA 98206
(206) 356-5400, Tlx: 152662

IN EUROPE:
Fluke (Holland) B.V.
P.O. Box 5053, 5004 EB
Tilburg, The Netherlands
(013) 673973, Tlx: 52237



WHAT'S NEWS

PROTECTION FOR A COMPUTER



A ROOM AS BIG AS A BASKETBALL COURT is needed to hold the 1,840 storage batteries at the Boeing Computer Services data center in Bellevue, Washington. The 1,840 Allied C & D batteries, with an output equal to that of 3,300 standard car batteries, are part of a fail-safe plan to provide instantaneous backup power in case of electrical failure. Protection is temporary only—the batteries are intended to provide 4,100 kilowatts of power for 15 minutes, while the company's diesel generators can be started. The center is designed to withstand natural disasters, and the batteries are installed on earthquake-resistant racks.

American company locates in Japan

Last October, Applied Materials Japan, a subsidiary of Applied Materials, Inc., of Santa Clara, CA, dedicated a new Technology Center in Marita, Japan, just outside of Tokyo. Applied Materials calls it "the first major research and development facility in Japan established by an American semiconductor production systems manufacturer."

The 57,000-square-foot facility was built at a cost of \$9.2 million, part of which was provided by a

\$3.4 million loan from the Japanese Development Bank, an agency of the Japanese government.

New lab investigates silicon-on-sapphire IC's

The Marconi Co. is establishing a fully-equipped Silicon Systems Laboratory in Lincoln, England. It will provide advanced processing facilities for 1.5-micron silicon-on-sapphire technology IC's.

The advantages of silicon-on-sapphire are improved speed or reduced power, combined with high packing density and proven

radiation resistance. A particularly important application is for electronics in satellites, where the cost of providing electrical power is high, and where the circuits are exposed to continuous natural radiation for years.

NASA contracts for advanced space system

NASA's Lewis Research Center, Cleveland, OH, has awarded a \$260 million contract to a team of electronics manufacturers headed by RCA's Astro-Electronics Group of Princeton, NJ, for design, development and fabrication of an Advanced Communications Technology Satellite (ACTS). That is expected to be the most advanced and complex space-communications system known. It is scheduled for launch by the Space Shuttle in 1989.

The contract specifications call for a flight spacecraft, ground systems, and operations. The work will be split among the several contractors. Lewis has project-management responsibility for the program; RCA Astro-Electronics will be responsible for construction of the spacecraft and integration and testing of the ACTS system. COMSAT will take care of the design and development of a master control station, a NASA ground station, and operations and maintenance, and TRW will develop the multibeam communications package.

The technologies to be tested in the ACTS program, says a NASA spokesman, could lead to at least a five-fold increase in satellite-communications capabilities in the 1990's. Those include multiple spot beam transmission, message switching on board the satellite, and use of a new higher-frequency band between 20 and 30 GHz. R-E



New protection – especially in stormy weather – for the electronics you use, sell or service!

A brief, high voltage surge – or spike – can occur in any AC line system and, at amplitudes lower than 600V, cause little or no damage.

But at greater amplitudes, a spike can do real damage. And the greater the high voltage surge – resulting from nearby lightning, for example – the greater the risk of harm, especially to solid-state devices.

That's why Zenith now announces the availability of two Spike Suppressors – one with a grounding plug and the other without.

Both are designed to provide susceptible TV receivers, household appliances and other electronics with two-way protection from high-voltage surges.

First, a Zenith Spike Suppressor absorbs a wide range of voltage spikes so only a safe voltage level reaches the protected equipment.

Second, heavy or prolonged voltage surges cause a Zenith Spike Suppressor to cut off power completely to protected equipment thereby signaling the need for a replacement Spike Suppressor.

That's double-duty protection against spikes for the electronics you use, sell or service. And ample reason for you to lay in a supply of Zenith Spike Suppressors soon.

Chances are they're available at your Zenith dealer's now. Call and pick up several before the next storm hits!

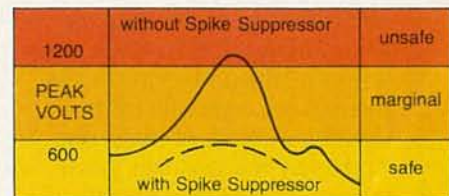

In this graph, the solid curve represents the excess voltage or "spike" imposed on an electric system and, represented by the dotted line, the protection provided household appliances as the Zenith Spike Suppressor absorbs the excess voltage and prevents it from surging thru the system.

ZENITH
®

The quality goes in before the name goes on.®

Train for the Fastest Growing Job Skill in America

Only NRI teaches you to service and repair all computers as you build your own 16-bit IBM-compatible micro

As computers move into offices and homes by the millions, the demand for trained computer service technicians surges forward. The Department of Labor estimates that computer service jobs will actually *double* in the next ten years—a faster growth than any other occupation.

Total System Training

As an NRI student, you'll get total hands-on training as you actually build your own Sanyo MBC-550-2 computer from the keyboard up. Only a person who knows *all* the underlying fundamentals can cope with *all* the significant brands of computers. And as an NRI graduate, you'll possess the up-to-the-minute combination of theory and practical experience that will lead you to success on the job.

You learn at your own convenience, in your own home, at your own comfortable pace. Without classroom pressures, without rigid night-school schedules, without wasted time. Your own personal NRI instructor and NRI's complete technical staff will answer your questions, give you

New from NRI—the only home study course that trains you as you assemble a top-brand computer!



After you construct this digital logic probe, you'll install the "intelligent" Sanyo detached keyboard, with its dedicated microprocessor.

You next assemble the power supply into the main unit of the computer. Using the digital multimeter, you check all keyboard connections and circuits.

After you install the disk drive and monitor, you'll make a backup copy of the MS-DOS operating disk, explore the 8088 microchip and additional circuits.

guidance and special help whenever you may need it.

The Exciting Sanyo MBC-550-2—Yours To Keep

Critics hail the new Sanyo as the "most intriguing" of all the IBM-PC compatible computers. It uses the same 8088 microprocessor as the IBM-PC and the MS/DOS operating system. So, you'll be able to choose thousands of off-the-shelf software programs to run on your completed Sanyo.

As you build the Sanyo from the keyboard up, you'll perform demonstrations and experiments that will give you a total mastery of computer operations and servicing techniques. You'll do programming in BASIC language. You'll prepare interfaces for peripherals such as printers and joysticks. Using utility programs, you'll check out 8088 functioning. NRI's easy step-by-step instructions will guide you all the way right into one of today's fastest growing fields as a computer



service technician. And the entire system, including all the bundled software and extensive data manuals, is yours to keep as part of your training.

How the pro computer critics rate the Sanyo 550:

"Sanyo BASIC is definitely superior to IBM Microsoft... lets you use two or three keystrokes for entering BASIC commands."

—MICROCOMPUTING Magazine

"... compares favorably with the IBM PC, even surpassing it in computational speed..."

—COMPUTERS & ELECTRONICS Magazine

Your NRI Course Includes a Sanyo MBC-550-2 Computer with 128K RAM, Monitor, Disk Drive, and "Intelligent" Keyboard; The NRI Discovery Lab®, Teaching Circuit Design and Operations; a Digital Multimeter; Bundled Spread Sheet and Word Processing Software Worth \$1500 at Retail—and More.

"I went to have a look at the MBC-550... what I found made me an owner the next day!"

—Bill Sudbrink, BYTE Magazine

100-Page Free Catalog Tells More

Send the postage-paid reply card today for NRI's big 100-page color catalog, which gives you all the facts about NRI training in Microcomputers, Robotics, Data

Communications, TV/Video/Audio Servicing, and other growing high-tech career fields. If the card is missing write to NRI at the address below.

NRI SCHOOLS

McGraw-Hill Continuing Education Center
3939 Wisconsin Avenue, NW
Washington, DC 20016

We'll Give You Tomorrow.

IBM is a Registered Trademark of International Business Machine Corporation.



VIDEO NEWS



DAVID LACHENBRUCH
CONTRIBUTING EDITOR

• **German Flat-Screen Color TV.** Siemens of Germany, with government backing, has developed a plasma color display less than 2½ inches thick, providing a 12-inch picture on a panel measuring 14-inches diagonally, which the German government says is ready for production. The system uses a plasma cathode, no electron gun, and is addressed by a matrix system. The phosphor screen is said to be a conventional type, currently with 288 lines, each made up of 720 phosphor points, or 240 sets of three colors. The tube reportedly is scheduled for production in an IIT German plant. However, the matrix system currently is very expensive and development of special VLSI IC's is required to bring costs down. Germany claims the flat tube is the most advanced such display device ever built.

• **All-in-One.** Pioneer has introduced a combination Laservision videodisc player and CD compact digital audiodisc player. To be priced at more than \$1,000, it automatically adjusts itself to play back 4½-inch CD discs, or 8- or 12-inch LV videodiscs, and the solid-state laser automatically changes in intensity to read either the audio or video disc. With the introduction of the combination player, Pioneer also is adding a digital-audio track to its new Laservision videodiscs. The analog track is also preserved for compatibility with old model players. As it introduced its new model, Pioneer cut the list price of its older videodisc player to \$300.

• **Camcorder update.** The all-in-one camera-VCR, or camcorder, is coming into its own, and the three formats now in production will be joined by a fourth in 1985. Currently available or on the way are 8mm camcorders by Kodak, Polaroid, and GE; Betamovie camcorders by the Beta group, including Sony, Sanyo, Toshiba, and NEC, and VHS-C VideoMovie camcorders using the 20-minute compatible mini-VHS cassette by JVC, Zenith, and the European Thomson Group.

The VHS group has been accelerating development of a camcorder combining the

advantages of all three systems without the disadvantages, and both Matsushita (Panasonic and Quasar) and Hitachi (which also manufactures for RCA) have come up with units combining a full-sized VHS cassette with a video camera. The aim is to produce a basic camcorder model to sell in the U.S. for less than \$1,000. The companies believe they have overcome the disadvantages of the three other systems introduced to date—unlike the 8mm models, they will use standard cassettes; unlike Betamovie, they'll be able to play back as well as record, and unlike VideoMovie (and currently 8mm), they'll be able to record a full two hours on a cassette.

• **Multichannel TV Sound.** Stereophonic sound will be added to the television signal of more than 100 TV stations in 1985, according to a recent survey. The survey, conducted by the trade newsletter, *Television Digest*, indicated that the stations would be located in most major metropolitan areas. The new multichannel TV sound (MTS) system also provides for transmission of a *Second Audio Program*, or SAP, in addition to stereo. The survey found that SAP transmissions would be much slower than stereo in starting up. Only 19 percent of the stations planning to broadcast in stereo indicated they would also originate such program-related SAP transmission as second-language translation, while 3.5 percent planned to originate non-program-related SAP's. Under the FCC rules, stations may originate virtually any non-program-related audio material they wish—anything from paging service to radio-type programming for the public.

A survey of set manufacturers by the EIA, meanwhile, indicates that they expect multichannel sound sets to comprise 10 percent of color-TV shipments by mid-1986, rising to 30 percent by mid-1987 and leveling off at 45 percent in mid-1988. MTS adaptor jacks should be in 10 percent of sets sold by mid-1985, in 20 percent by mid-1986, and peaking at 30 percent in mid-1988. (See story on page 51.)

R-E

Here's The Savvy-est True Dual Trace 10 MHz
Digital Storage Scope You Ever Saw
... At The Saving-est Price. Only \$595.

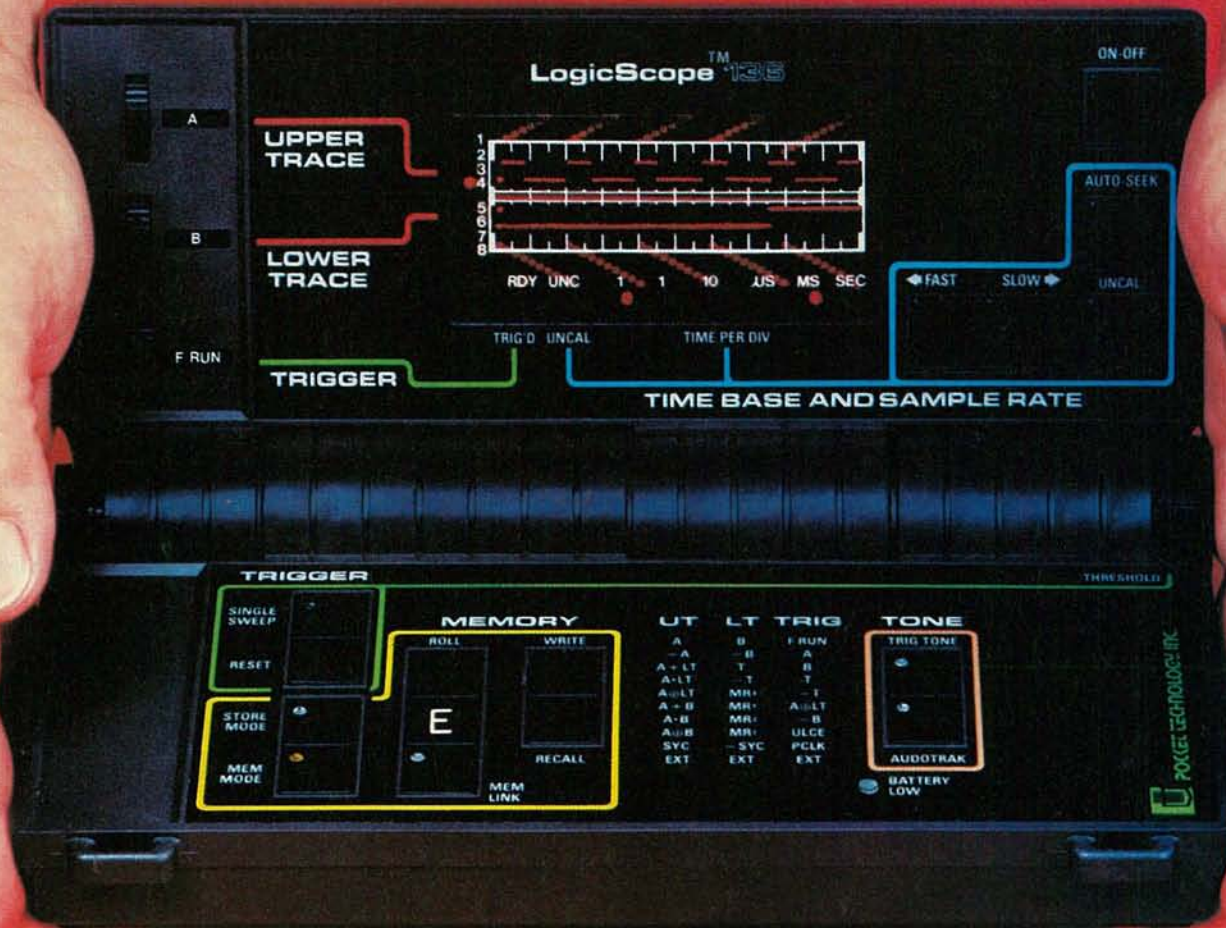

The Handy New LogicScope™ 136

True Dual Trace • 10 MHz Real Time Bandwidth • 3 Input Channels • I/O Port
Digital Waveform Storage • Boolean Waveform Operations • Audio Functions
8.0 (L) x 4.5 (D) x 1.75 (H) Inches • 1.25 Pounds • 9 Volt Battery/AC Operation

Consider the LogicScope 136

- The LogicScope 136 is the next logical step in test instrumentation for you. It combines many of the features and capabilities of sophisticated logic analyzers and oscilloscopes . . . and it fits in your hand. Never before has so much technology been available in so small an instrument, at such a low price.
- The pocket-sized LogicScope 136 is made possible by a patented breakthrough in display technology. The conventional CRT has been replaced by a unique array of 400 LED's that permits simultaneous display of two digital waveforms.
- The 136 can be used for viewing single shot events, or repetitive waveforms. It can be operated in real time mode, or in memory mode which permits acquisition and storage of up to 50-100 bit waveforms. These can be recalled, logically compared (AND, OR, EXCLUSIVE OR) to other input waveforms, or output to an external device via an I/O port. This I/O port will also accept future add-on 136 Modules.
- Its very low cost, convenience and ease-of-use make the LogicScope the ideal instrument, for designing, troubleshooting or repairing digital systems. Made in U.S.A.

Consider its Engineering & Field Service Applications:

- On microprocessor-based systems, check the timing relationship of various parameters relative to the system clock and other key events. Its storage capability allows visual and logical comparison of non-repetitive waveforms to known reference signals. Output in the start-up of the digital device can be compared to reference signals to determine the operating state of the device. Questionable waveforms can be stored for analysis.
- Its light weight and small size make the LogicScope convenient to take on every service call. The 136 provides much more information for trouble shooting a digital system or peripheral than a logic probe or digital counter without having to lug an oscilloscope or logic analyzer along.

Contact us for the name of your local distributor



POCKET TECHNOLOGY, INC.

7320 Parkway Drive, Hanover, MD 21076 U.S.A.
301-796-3300 TELEX 908207
Division of Renaissance Technology Corp.

CIRCLE 264 ON FREE INFORMATION CARD

SATELLITE TV

LNA's and downconverters

THE PAST FEW MONTHS, WE'VE LOOKED at the evolution of the home TVRO. This time, let's continue with a look at how LNA's and downconverters have changed.

LNA changes

A Low-Noise Amplifier (LNA) has always been a substantial part of the home-TVRO system. Since 1979, that portion of the system has seen the most dramatic change in pricing. In 1979, the basic LNA had a 120-degree noise temperature (figure) with 50 dB of circuit gain at a cost of over \$1500 per unit; but by year's end, prices had dropped to around \$1195. Not only that, but its original function and use has been significantly modified by creative system designers, as well.

In 1979, an LNA was simply a "low-noise gain block" designed to provide a suitable low-noise front-end for the receiver that followed. Its job was to supply enough RF signal-gain to overcome the coaxial cable's line losses between the LNA and the receiver. It was powered by a DC supply that ranged from 15–25 volts. Power was fed to the LNA through a pair of weather-proof wires from a power connector located on or at the receiver. Back then, the basic LNA was virtually the only one offered.

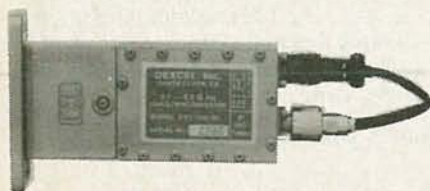

FIG. 1

* Publisher, CSD magazine

BOB COOPER, JR.*
SATELLITE EDITOR

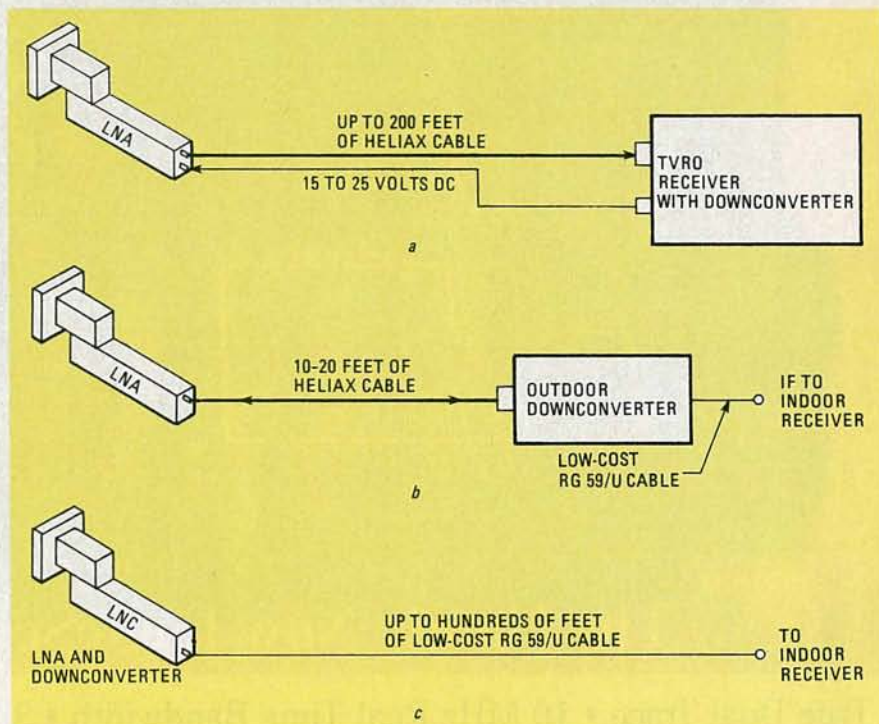

FIG. 2

Today, however, the dealer has a wide list of options available: Virtually any noise temperature from 120 degrees down to 60 degrees; almost any gain from 30–55 dB, and models with or without isolators. Also, the price of an LNA has dropped significantly. Now dealers are paying under \$100 for an LNA.

The basic LNA (see Fig. 1) now has a 100-degree or lower noise figure. (Lower noise temperature means lower noise contribution, hence, improved system sensitivity.) In addition, the unit is now powered through the same coaxial cable that connects the LNA to the downconverter portion of the receiver.

Downconverters

In 1979, the 3.7–4.2 GHz output of the LNA had to be driven indoors through (relatively) "lossy" cable—sometimes as much as 200 feet of the stuff—to the downconverter located inside the receiver, as shown in Fig. 2-a. In those days, *bulk gain* in an LNA was important because immediately after the LNA was *bulk loss* because of the interconnecting cable. (What was lossy cable at 4 GHz was probably not lossy at 70 or even 1200 MHz.) However, that situation soon changed.

First, downconverters were taken out of the receivers (see Fig. 2-b) and installed in their own weather-resistant housings, allow-

Electricity and water don't mix. At least not in our Heavy Duty Digital Multimeters. Because these Oops Proof™ instruments are protected by a system of seals to ensure contamination-free dependability in even the cruddiest conditions.

Other abuse-proof features include the best mechanical protection ever built into a precision Digital Multimeter. In fact, every one of our Oops Proof multimeters will survive a drop from ten feet onto a concrete surface!

All the Heavy Duty series meters measure up to 1000 volts AC and 1500 volts DC, with full overload protection to those maximum voltages even on the lowest range settings. Overload circuitry also provides transient protection to 6KV on all voltage ranges and up to 600 volts on all resistance ranges.

We also invented a unique, long-life rotary switch for our Digital Multimeters. You can actually feel the difference just by

rotating the function selector knob.

You'll find these features in a full line of Heavy Duty DMMs that offer a 4½ digit readout, 0.05% VDC accuracy, a 10-amp current range, a 2000-hour battery life, diode test, true RMS and temperature measurement. All this and a no-questions, one-year warranty.

You'll want to try one out, of course, so drop into your nearest electronics distributor and drop one.

Our lips are sealed.



ing them to be mounted right at the dish (usually to the rear). Now the microwave energy had to travel only about 10 to 20 feet through lossy cable before it was downconverted to a lower frequency (i.e. the IF), which meant less signal loss.

With less signal loss expected, the gain of the LNA could be scaled down to the 30-45 dB region. That helped reduce the price of LNA's (fewer gain stages equals lower cost). Next, prices for GaAs

FET's, used in LNA's, dropped dramatically—from \$500 each in 1978 under to \$5 in 1984—as volume went up.

Then some clever engineers found that the isolator portion of the LNA could be eliminated if you were extremely careful about how you designed the balance of the LNA, and were equally careful about how you installed and used the unit. (The isolator cost \$30 and up and also added circuit noise to the LNA in front of the GaAs-FET

TVRO dealer "Starter Kit" available

Bob Cooper's *CSD Magazine* has arranged with a number of TVRO equipment suppliers to provide a single-package of material that will help introduce you to the world of TVRO dealership. A short booklet written by Bob Cooper describes the start-up pitfalls to be avoided by any would-be TVRO dealer, in addition, product data and pricing sheets from prominent suppliers in the field are included. That package of material is free of charge and is supplied to firms or individuals in the electronics service business as an introduction to the 1984/85 world of selling TVRO systems retail.

You may obtain your *TVRO Dealer Starter Kit* free of charge by writing on company letterhead, or by enclosing a business card with your request. Address your inquiries to: *TVRO STARTER KIT*, P.O. Box 100858, Fort Lauderdale, FL 33310. That kit *not* available to individuals not involved in some form of electronics sales and service.

SATELLITE TV/

The First Five Years!



THE MOST COMPLETE report on the mushrooming home 'TVRO' industry ever compiled, written as only the 'father of TVRO' could have prepared. More than **1000 pages** (!) tracing the complete story of home TVRO, lavishly illustrated with equipment photos, schematic diagrams, equipment analysis reports. **Bob Cooper**, the first private individual to own and operate a TVRO (1976) has collected and polished hundreds of individual reports into a unique 'collector's edition' which clearly explains the TVRO phenomenon in North America. From Coop's first 20 foot 'monster' dish to the present day 5 foot 'C-band' TVROs, the fascinating growth of TVRO equipment and its legal status unfolds for you.

THIS TWO VOLUME SET totaling more than 1,000 pages is available for the first time to readers of *Radio-Electronics* at special discount pricing. **Originally sold** at \$100 per two-volume set, a limited supply is now available **ONLY** through this advertisement. **PLUS**, you will also receive a special extraordinary bonus; the 200 page (+) **October 1984** edition of *CSD/Coop's Satellite Digest*. This very special edition of *CSD* is a best-seller in the TVRO industry, with the most comprehensive collection of TVRO facts and figures ever compiled. Combined with the 1,000 page 'CSD ANTHOLOGY' report, you have instant reference to **everything** you will ever need to know about the state of the home TVRO industry. It is **MUST** reading for every person in, or thinking about 'getting into,' **any** segment of the home TVRO world.

amplifier stages.) Seemingly, that was the best of both worlds—lower cost and better performance!

Finally, firms such as Dexcel/Gould created hybrid units that combined the LNA plus the downconverter into a single container (see Fig. 2-c), eliminating the short section of coax between the LNA and the downconverter. Those packages, called *Low-Noise Converter (LNC)*, reduced by 1 the number of pieces in a typical TVRO system, thus, simplifying dealer installation.

Synopsis of trends

As we enter 1985, LNA prices have come down dramatically, while quality (performance and reliability) has gone up. Many had predicted that the development of LNC's would doom LNA's. After all, who'd want to install an LNA plus downconverter when one LNC could replace the pair? However, things didn't quite work out that way because LNC's are designed (typically) to work with one model receiver.

The dealer has learned or believes, that his maximum flexibility occurs when he can separate the LNA or LNC from the receiver so you can "mix-and-match" to get

continued on page 120



— **SEND CSD ANTHOLOGY/2 Vols. + CSD Bonus.**
— **SEND CSD** October '84 Special Issue **ONLY.**

NAME _____ COMPANY _____

ADDRESS _____

CITY _____ STATE _____ ZIP _____

Payment: \$60 US funds (Anthology + Bonus), \$15 US funds CSD Oct. ONLY; payable "CSD ANTHOLOGY."

Shipping charges pre-paid. Enter order to: **CSD Anthology**, Radio-Electronics Magazine, 200 Park Av. S., New York, NY 10003; or call 305-771-0505 for credit card orders ONLY.

FREE high tech catalog



Metal Detector



Triple-Trace Oscilloscope/Time-Voltage Display



Ham Radio Transceiver



Real Time Spectrum Analyzer



Most Accurate Clock



HERO® 1 Robot



IBM-PC Compatible Computers



40-Channel Scanner



Heath Company
Dept. 020-264
Benton Harbor, Michigan 49022
Please send me the latest
Heathkit Catalog Free.

Name _____

Address _____

City _____ State _____

Zip _____

CL-774A



More than just a catalog, a trustworthy guide to what's new in computers and electronics.

Ever since radio grew into electronics, the illustrated Heathkit catalog has been a guide to new and exciting kit products for people like you to build. To enjoy and learn from, while saving money in the process.

What sets the Heathkit catalog apart is its range of high quality products and accurate information on every product offered. And that's a lot of products — over 450 separate items, including:

- Computer hardware and software
- Robots
- Precision test instruments
- Computerized weather instruments
- Solar hot water systems
- Automotive and home energy products
- Security devices
- Color TVs and video accessories
- Quality stereo components
- Amateur radio gear
- Educational courses that lead from the basics of electronics all the way to high tech.

Computerized Weather Station



Microprocessor Trainer & Course



Discover the pride.

With Heathkit, you'll discover the pride of accomplishment that comes with creating handbuilt quality that is uniquely yours.

And you'll develop skills and abilities in many technologies as you follow the step-by-step directions through the building process.

You work confidently, always backed by our simple promise, "We won't let you fail."

If you don't have the latest Heathkit Catalog, you're missing something great, so mail the coupon now, while you're thinking about it.

Send NOW for your
FREE Heathkit Catalog

It's the beginning of something great for the whole family.

Heathkit®
Heath
Company

A subsidiary of Zenith Electronics Corporation

CIRCLE 86 ON FREE INFORMATION CARD

Professional Books That Help You Get Ahead—And Stay Ahead!

Join the **Electronics and Control Engineers' Book Club**® and...

- Keep up with current technology
- Sharpen your professional skills
- Be ready for new career opportunities
- Boost your earning power

THE MCGRAW-HILL COMPUTER HANDBOOK: Applications, Concepts, Hardware, Software. Edited by H. Helms. 992 pp., 475 illus. Everything you need to know about today's computer science and engineering is here in this massive treasure trove of information. Covers everything from Boolean algebra to hardware selection techniques to artificial intelligence. A handy reference work that brings you right up to the minute!

279/721 Pub. Pr., \$84.50 Club Pr., \$49.95

TRANSDUCERS: Theory and Applications. By J.A. Allocca and A. Stuart. 497 pp., 328 illus. Thoroughly describes and illustrates the theory and operation of all important transducers used in industrial, communication, medical, and other applications. Photographs, drawings, and diagrams are included throughout this outstanding introduction to a key element in electronic instrumentation.

582997-5 Pub. Pr., \$29.95 Club Pr., \$24.95

ANTENNA ENGINEERING HANDBOOK, 2/e. Edited by R. C. Johnson and H. Jasik, with contributions by 57 recognized authorities. 1,408 pp., 946 illus. This widely acclaimed Handbook gives you the guidance you need to solve problems in antenna design and application. It provides detailed information on physical fundamentals, patterns, structures, and design techniques for practical modern antennas.

322/910 Pub. Pr., \$95.00 Club Pr., \$62.50

RADIO HANDBOOK, 22/e. By W. Orr. 1,136 pp., more than 1,300 illus. Here's the latest edition of what is universally regarded as the most useful reference in the industry. It's a "course" in communications, a fact-packed reference, and a how-to guide—all in a single book!

582442-6 Pub. Pr., \$21.95 Club Pr., \$17.95

MICROPROCESSOR APPLICATIONS HANDBOOK. Editor-in-Chief, D. F. Stout. 472 pp., 284 illus. At last—a reference guide to microprocessor applications to help you make your systems timely, versatile, and cost-effective.

617/988 Pub. Pr., \$41.95 Club Pr., \$31.45

MICROPROCESSOR AND MICRO-COMPUTER DATA DIGEST. By W. H. Buchsbaum and G. Weissenberg. 336 pp., 93 block diagrams, 106 pin configurations. If you work with electronic devices that use microprocessor or microcomputer integrated circuits, this much-needed book contains all the detailed technical data for every microprocessor IC that is currently listed as a "standard," off-the-shelf item.

582835-9 Pub. Pr., \$29.95 Club Pr., \$22.50

HANDBOOK OF ELECTRIC POWER CALCULATIONS. Edited by A. Seidman, H. Mahrous and T. G. Hicks. 448 pp., 300 illus. Here are 285 tested and proven procedures for handling the electric power problems most frequently encountered in actual practice. You'll find ingenious, time-saving ways to calculate fuel costs, motor efficiency, and power output.

560/617 Pub. Pr., \$41.50 Club Pr., \$31.50



New members!
Any one of these great
professional books
for only **\$2.89**
as a premium with your
1st selection!

Spectacular values up to **\$95.00**

HANDBOOK OF PRACTICAL ELECTRICAL DESIGN. By J. F. McPartland. 416 pp., 300 illus. This volume provides a step-by-step explanation of designing electrical systems for industrial, commercial, and residential applications. Packed with helpful tips for saving time and complying with code requirements from branch circuits to wiring size.

456/95X Pub. Pr., \$40.95 Club Pr., \$27.50

DIGITAL LOGIC DESIGN. By B. Holdsworth. 338 pp., 192 illus. All of the recent advances in digital design techniques are presented here in depth. It's both a text covering basic concepts and a practical guide to design techniques for combinational, clock-driven, and event-driven circuits.

582852-9 Pub. Pr., \$39.95 Club Pr., \$27.50

ELECTRONIC COMMUNICATIONS SYSTEMS. By W. D. Stanley. 566 pp., illus. Emphasizing the signal-processing functions of modulation and demodulation operation, this book presents the essentials of electronic communications in a logical, step-by-step sequence.

582834-0 Pub. Pr., \$25.95 Club Pr., \$20.95

MODERN ELECTRONIC CIRCUITS REFERENCE MANUAL. By J. Markus. 1,264 pp., 3,666 circuit diagrams. Complete with values of components and suggestions for revisions—plus the original source of each circuit in case you want additional performance or construction details.

404/461 Pub. Pr., \$76.95 Club Pr., \$57.95

ELECTRONICS ENGINEERS' HANDBOOK, 2/e. Edited by D. G. Fink & D. Christiansen. 2,272 pp., 2,189 illus. This updated and enlarged edition covers all the latest knowledge in the field, including new advances in integrated circuits, pulsed and logic circuits, laser technology, telecommunications, and much more.

209/812 Pub. Pr., \$83.50 Club Pr., \$63.95

DIGITAL CIRCUITS AND MICRO-PROCESSORS. By H. Taub. 608 pp., heavily illus. This fast-paced, carefully written guide gives you thorough explanations of all the basic principles of digital systems and logic design—plus a solid introduction to microprocessors and microprocessor-based designs.

629/455 Pub. Pr., \$37.00 Club Pr., \$26.50

INTRODUCTION TO MICROWAVE ELECTRONICS. By T.C. Edwards. 76 pp., illus., softbound. Eliminating unnecessary theory and mathematics, this book provides you with a lucid overview of microwave engineering and the devices and circuits being used today. Helpful even if you have only limited experience with microwave electronics.

583030-2 Pub. Pr., \$14.95 Club Pr., \$10.95

THERMAL COMPUTATIONS FOR ELECTRONIC EQUIPMENT. By G. Ellison. 336 pp., 220 illus. Arms you with the mathematical tools you need to predict, quickly and accurately, the temperatures in electronic equipment cooled by conduction, radiation, and natural or forced convection. Includes ready-to-run computer programs that utilize both continuous analytic and finite element approaches.

582964-9 Pub. Pr., \$34.50 Club Pr., \$24.95

PRACTICAL DIGITAL DESIGN USING ICS, 2/e. By J. D. Greenfield. 717 pp., illus. This revised and expanded Second Edition of a popular guide shows how to get the most out of a wide range of popular integrated circuits. What's more, it contains the specialized know-how today's designer needs to interface ICs with microprocessors.

582853-7 Pub. Pr., \$25.95 Club Pr., \$19.95

INTRODUCTION TO RADAR SYSTEMS, 2/e. By M. I. Skolnik. 698 pp., 244 illus. This new edition of a widely used text on radar from the systems engineer's point of view brings you full discussions of the many major changes that have occurred in the field recently.

579/091 Pub. Pr., \$43.00 Club Pr., \$31.00

STANDARD HANDBOOK FOR ELECTRICAL ENGINEERS, 11/e. By D. G. Fink and H. Beaty. 2,448 pp., 1,414 illus. Today's most widely used source of electrical engineering information and data serves you as no other single work when you need detailed, timely, and reliable facts.

209/74X Pub. Pr., \$79.95 Club Pr., \$62.95

MICROWAVE SEMICONDUCTOR CIRCUIT DESIGN. By W. A. Davis. 416 pp., heavily illus. Provides in-depth coverage on microwave circuit analysis, passive microwave components, impedance transformers and circuits, broadband directional couplers, mechanical realization of selected transmission lines, CAD, CAM and CAT, characteristics of amplifiers and oscillators, noise, statistical thermodynamics and PN junction theory.
58044-2 Pub. Pr., \$47.50 Club Pr., \$35.50

OPTICAL FIBER SYSTEMS: Technology, Design, and Applications. By C. K. Kao. 197 pp., illus. From a basic explanation of optical fiber systems to the economic ramifications of their use, this volume provides full coverage of a rapidly changing field.
332/770 Pub. Pr., \$33.50 Club Pr., \$23.95

McGraw-Hill Encyclopedia of Electronics and Computers. By S. P. Parker, Editor-in-Chief. 960 pp., 1,266 illus., outsized 8 1/2 x 11 format. It's a single-volume library that covers the entire world of electronics from Edison's pioneering work in electricity right up to optical fiber communications, control systems, lasers, radar, TV receivers, artificial intelligence, and computer storage technology.
454/876 Pub. Pr., \$67.50 Club Pr., \$41.50

ELECTRONICS ENGINEERING FOR PROFESSIONAL ENGINEERS' EXAMINATIONS. By C. R. Hafer. 336 pp., more than 200 illus. Actually two books in one—a quick preparation manual to help you pass your P.E. exams on the first try and a rich source of practical electronics engineering information and know-how.
254/303 Pub. Pr., \$32.50 Club Pr., \$25.50

HANDBOOK OF MICROCOMPUTER-BASED INSTRUMENTATION AND CONTROLS. By J. D. Lenk. 307 pp., 227 illus. Digital or microcomputer-based instrumentation and control systems can be very complicated—or relatively simple—depending on the application. In this book both systems are described and illustrated—and many examples of actual systems now in use in industry are included throughout.
582866-9 Pub. Pr., \$22.95 Club Pr., \$18.95

COMPUTER METHODS FOR CIRCUIT ANALYSIS AND DESIGN. By J. Vlach and K. Singhal. 656 pp., 148 illus. Computational methods have become an integral part of circuit analysis and design. And a solid understanding of the basics of computer-aided design is a must for engineers who want to achieve their career objectives. This self-teaching book provides that know-how in a logical, easy-to-follow presentation.
582855-3 Pub. Pr., \$42.50 Club Pr., \$33.95

SENSOR AND ANALYZER HANDBOOK. By H. N. Norton. 562 pp., illus. Covers solid- and fluid-mechanical quantities as well as acoustic, thermal, optical, nuclear, electrical, and magnetic quantities . . . chemical properties and composition . . . electrometric, thermal, ionization, chromatographic, and spectrometric analyzers . . . magnet resonance and mass spectrometers . . . and surface analysis instruments.
582808-1 Pub. Pr., \$39.95 Club Pr., \$29.95

Be sure to consider these important titles as well!

LARGE SCALE INTEGRATION: Devices, Circuits, and Systems. By M. J. Howes & D. V. Morgan
582851-0 Pub. Pr., \$35.95 Club Pr., \$29.95

MICROWAVE SEMICONDUCTOR ENGINEERING. By J. F. White.
582553-8 Pub. Pr., \$32.50 Club Pr., \$25.95

MICROPROCESSOR SUPPORT CHIPS: Theory, Design, and Applications. By T. J. Byers.
095/183 Pub. Pr., \$39.50 Club Pr., \$31.00

ENGINEERING FORMULAS, 4/e. By K. Gieck.
232/199 Pub. Pr., \$16.95 Club Pr., \$13.50

ELECTRONICS CIRCUITS NOTEBOOK. Edited by S. Weber.
192/448 Pub. Pr., \$35.50 Club Pr., \$27.50

ANALYSIS AND DESIGN OF DIGITAL INTEGRATED CIRCUITS. By D. A. Hodges and H. G. Jackson.
291/535 Pub. Pr., \$31.00 Club Pr., \$23.95

HANDBOOK OF OPERATIONAL AMPLIFIER CIRCUIT DESIGN. By D. E. Stout & M. Kaufman.
617/97X Pub. Pr., \$39.50 Club Pr., \$29.00

ENGINEERING MATHEMATICS HANDBOOK, 2/e. By J. J. Tuma.
654/298 Pub. Pr., \$34.50 Club Pr., \$26.95

PCM & DIGITAL TRANSMISSION SYSTEMS. By F. F. Owen.
479/542 Pub. Pr., \$34.95 Club Pr., \$25.95

SIGNALS AND SYSTEMS. By A. Oppenheim, A. Willsky, and I. Young.
582674-7 Pub. Pr., \$32.50 Club Pr., \$25.95

DIGITAL COMMUNICATIONS. By J. Proakis
509/271 Pub. Pr., \$37.50 Club Pr., \$29.50

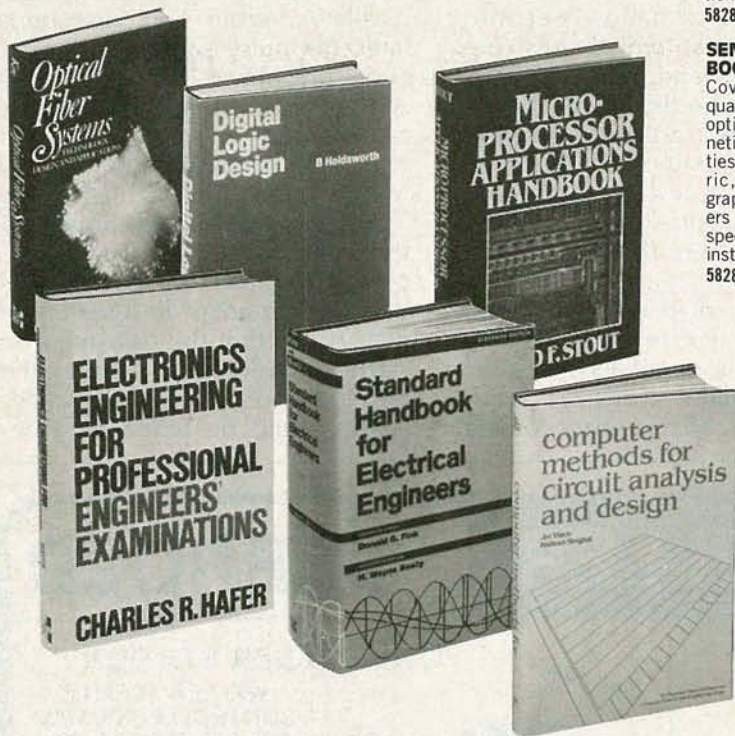

Why YOU should join now!

- **BEST AND NEWEST BOOKS IN YOUR FIELD** — Books are selected from a wide range of publishers by expert editors and consultants to give you continuing access to the best and latest books in your field.
- **BIG SAVINGS** — Build your library and save money too! Savings ranging up to 30% or more off publishers' list prices — usually 20% to 25%.

BONUS BOOKS—You will immediately begin to participate in our Bonus Book Plan that allows you savings up to 70% off the publishers' prices of many professional and general interest books!

- **CONVENIENCE**—12-14 times a year (about once every 3-4 weeks) you receive the Club Bulletin FREE. It fully describes the Main Selection and Alternate Selections. A dated Reply Card is included. If you want the Main Selection, you simply do nothing — it will be shipped automatically. If you want an Alternate Selection — or no book at all — you simply indicate it on the Reply Card and return it by the date specified. You will have at least 10 days to decide. If, because of late delivery of the Bulletin you receive a Main Selection you do not want, you may return it for credit at the Club's expense.

As a Club member you agree only to the purchase of three books (including your first selection) during your first year of membership. Membership may be discontinued by either you or the Club at any time after you have purchased the first selection plus two additional books.

Other McGraw-Hill Book Clubs:
Architects' Book Club • Byte Book Club • Chemical Engineers' Book Club
• Civil Engineers' Book Club • Mechanical Engineers' Book Club
For more information, write to:
McGraw-Hill Book Clubs, P.O. Box 582, Hightstown, New Jersey 08520

MAIL THIS COUPON TODAY

McGraw-Hill Book Clubs
Electronics and Control Engineers' Book Club®
P.O. Box 582, Hightstown, New Jersey 08520

Please enroll me as a member and send me the two books indicated, billing me for the \$2.89 premium and my first selection at the discounted member's price, plus local tax, shipping, and handling charges. I agree to purchase a minimum of two additional books during my first year of membership as outlined under the Club plan described in this ad. A shipping and handling charge is added to all shipments.

Write Code No. of
\$2.89 selection here

Write Code No. of
first selection here

Signature _____

Name _____

Address/Apt. # _____

City _____

State _____ Zip _____

This order subject to acceptance by McGraw-Hill. All prices subject to change without notice. Offer good only to new members.

E33716

LETTERS

WRITE TO:

LETTERS
Radio-Electronics
200 Park Ave South
New York, NY 10003

CLOSED-CAPTION TV SIGNALS

Perhaps we can provide some of the information John Bunting asked for in the August 1984, "Letters" column relative to closed caption TV signals. PBS stations helped pioneer the process, first with the National Bureau of Standards system in the 70's, and then with the current system.

In theory, it should be relatively easy to extract the transmitted characters, but one will not be able to obtain the full caption function with "a few dollars worth of chips." First, it is necessary to look in the right place for the cap-

tion signal: line 21, the last line of vertical blanking before the start of picture information. Second, the decoder has to distinguish between field 1 and field 2 of each frame, because the actual characters are only transmitted during field 1. (Only half of line 21 can be used in field 2, and that is reserved for a framing code that determines when and where the text will appear on the screen.)

The format of field 1, line 21, is as follows: 10 microseconds after the start of the horizontal-sync pulse, exactly 7 cycles of 503 kHz sine-wave appear. That is phase-locked

to horizontal sync, and is used for synchronizing the decoder clock oscillator. About 4 microseconds later, the pulse sequence begins, consisting of two 7-bit (plus parity) ASCII characters in non-return-to-zero (NRZ) format. The two characters occupy a little under 34 microseconds. That is true for only 7 consecutive frames, however; the eighth is used for a reference pulse that allows the commercial decoders to adapt to a variety of distortions that the transmission system may induce. Neither the framing code nor the equalizer pulse would be feasible to de-

BK PRECISION

WELLER

JERROLD

Jerrold Cordless Cable T.V. Converter

MODEL LCC-58 (Special)



SPECIAL!

\$69⁹⁵

ANY QUANTITY



Weller Xcelite

NEW!
SPECIAL!



MODEL WTCP-R
\$69⁹⁵

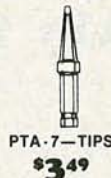

PTA-7-TIPS
\$3⁴⁹

BK PRECISION

MODEL DM-2802
\$49⁹⁵

The DM2802 is the smallest digital multimeter on the market. Its probe-style design makes it ideal for taking measurements in hard-to-reach test area.

Features Include:

- small size
- complete autoranging
- "touch hold"
- audible continuity checking



NEW!
SPECIAL!

OMNITRON

ELECTRONICS
770 Amsterdam Ave., New York, NY 10025

■ Write for FREE 136 page Catalog ■

SHIPPING CHARGES

For Orders	ADD
\$25 - 100	\$6.50
\$100 - \$500	\$8.50
\$500 - \$750	\$10.50
\$750 and up	\$15.00
Parcel Post	\$20.00

MASTER CARD • VISA

Send Purchase Order, Check,
Money Order or C.O.D.

or Call Toll Free

800-223-0826

in N.Y. State (212) 865-5580

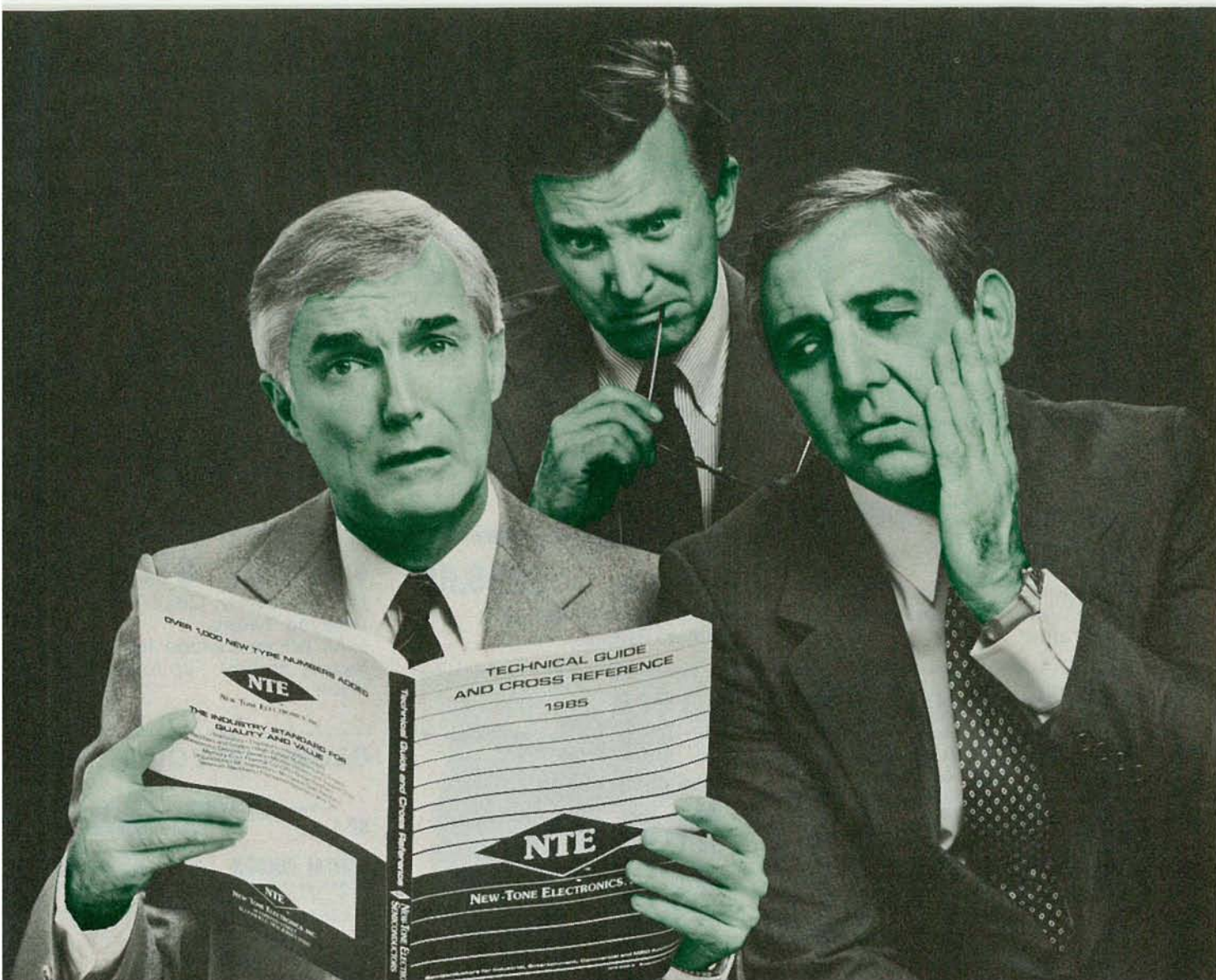

WE'RE TURNING THE COMPETITION GREEN WITH ENVY.

NTE is the red hot success story of the electronics industry and the big boys are green with envy. They don't like the fact that we've built our reputation on giving you more of what you're looking for in a replacement part. More quality. More reliability. And, more parts to choose from. That's why more and more technicians across the country are picking the package with the green NTE diamond on the front.

NTE parts are extensively tested on state-of-the-art equipment during every phase of production to ensure top performance — performance that's backed by the industry's only two year warranty.

What's more, NTE uses a special computer controlled inventory system, so when you replace or design with NTE, you can be sure that the part you need is on your distributor's shelf. Our new 1985 Technical Guide and Cross Reference manual, which has over 3,100 NTE types cross-referenced to over 220,000 industry part numbers, is now available.

Why settle for our competitor's parts when you get more quality and service with NTE? Look for NTE's replacement parts in the bright green polybags and cartons at your distributor today.

Don't forget to ask about our new Flameproof Resistors and Wire Ties, too!



NEW-TONE ELECTRONICS, INC.

44 FARRAND STREET, BLOOMFIELD, NEW JERSEY 07003

CIRCLE 272 ON FREE INFORMATION CARD



ELECTRONICS, INC.



PORTABLE OSCILLOSCOPES

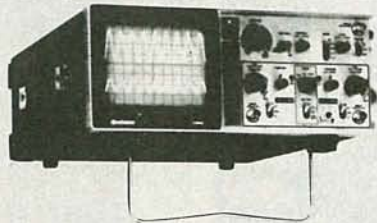

MODEL V-212 **\$461.00**
 DC to 20MHz, 1 mV/div, Dual Trace
 Feature 6" Rectangular CRT
 Full 2 year parts and labor warranty.

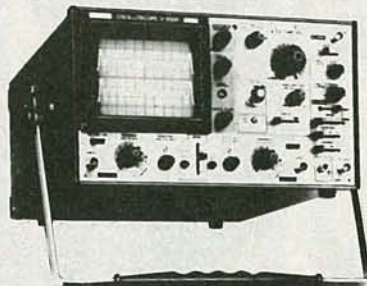

MODEL V-650F **\$956.00**
 DC to 60MHz, Dual Trace
 Delayed Sweep

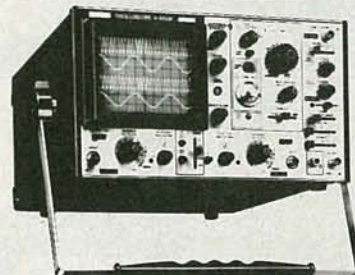

MODEL V-1050F **\$1276.00**
 DC to 100MHz, Quad Trace,
 Delayed Sweep.
 - All prices include full set of
 factory probes - up to \$120.00
 value.

Polaroid CR-10 Camera

Now you can get an instant
 picture in black & white or color
 from any oscilloscope screen.
 Includes CRT hood.
 *Large hoods also available to fit
 computer terminals and CAD/
 CAM screens.



\$369.00

GLOBAL SPECIALTIES TRIPLE OUTPUT POWER SUPPLY



MODEL 1301 **\$219.00**

- Fully regulated triple output
- Fixed 5VDC, 1A
- V1 + 5 VDC to 18 VDC .5A
- V2 - 5 VDC to 18 VDC .5A
- Fully automatic current limiting

BK PRECISION TRIPLE OUTPUT POWER SUPPLY

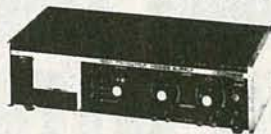

MODEL 1650 **\$319.00**

- Functions as three separate supplies
- Exclusive tracking circuit
- Fixed output 5 VDC, 5A
- Two 0 to 25 VDC outputs at 0.5A
- Fully automatic, current-limited overload protection
- + and - terminals of each output are fully isolated, in all modes
- All three outputs may be connected in series or parallel for higher voltage or current



ELECTRO INDUSTRIES, INC.
Precision Test Instruments



DC POWER SUPPLY

\$125.00

MODEL 3002A/0-30 VDC/0-2A

GLOBAL SPECIALTIES

DP-1



DIGITAL PULSER **\$83.00**

- Senses state of node, presets pulse polarity
- Short circuit protected, circuit powered
- Handheld digital signal injector

PROTO-BOARD

- Length = 7.4"
- Width = 4.5"
- 14 pin IC capacity = 12
- Terminals = 248
- Tie points = 1240



MODEL PB-102 **\$34.95**

LP-1



DIGITAL LOGIC PROBE **\$19.95**

- Use to 50 ns, 10 MHz
- Circuit powered, portable
- Compatible with most logic families

DIGITAL CAPACITANCE METER

- Battery operated
- 3 1/2 digit LCD display
- Range 1 PF to 2,000 UF
- 0.2% basic accuracy



MODEL 3000
\$139.00

CALL US TOLL FREE
1-800-732-3457
 IN CALIFORNIA TOLL FREE
1-800-272-4225

- Master Charge
- VISA
- COD
- Money Order
- Check



ADD FOR SHIPPING AND INSURANCE	
\$0 to \$250.00	\$4.50
\$251.00 to \$600.00	\$6.50
\$601.00 to \$750.00	\$8.50
\$751.00 to \$1000.00	\$12.50
over \$1000.00	\$15.00

COD's extra (required 25% deposit)

RAG ELECTRONICS, INC. / 21418 Parthenia Street / Canoga Park, CA 91304 / 1-818-998-6500

GIANT 14th ANNIVERSARY SALE!

FLUKE 70 SERIES MULTIMETERS



- Analog Display • Rotary Knob • Volts AC & DC • Resistance to • 32 MΩ • 10 Amps • Diode Test • 3200 Counts • Fast Autoranging • Function Annunciators in Display • Power-Up Self Test • 2000+ Hour Battery Life w/Power Down "Sleep Mode" • New Test Leads • VDE & UL Approval

73 \$85.00

- 0.7% Accuracy
- Autorange Only
- 10 Amp Only

75 \$99.00

- 0.5% Accuracy
- Manual or Autorange
- 10 A + 300 mA Range
- Beeper

77 \$129.00

- 0.3% Accuracy
- Manual or Autorange
- 10A + mA Range
- Beeper
- "Touch-Hold" Function

WE CARRY A FULL LINE OF FLUKE MULTI-METERS, COUNTERS, AND DIGITAL TEMPERATURE METERS

4 1/2 DIGIT MULTIMETER

- Frequency measurements to 200KHz
- dB measurements
- Basic dc accuracy 0.4%;
- 10μV, 10 nA and 10 mΩ sensitivity
- True RMS
- High-speed Beeper

MODEL 8060A



\$349.00

PORTABLE OSCILLOSCOPES

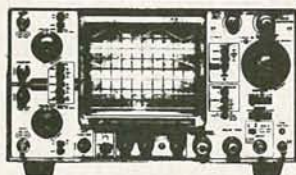

MODEL SS-5705 \$899.00

- DC to 40MHz
Vertical and horizontal deflection accurate within ±2%. CRT acceleration voltage 12KV. 3 channels, 6 traces. High precision calibrator (±1%). Fastest sweep rate: 10 ns.
- High sensitivity 1 mv/div
 - CH1 signal output
 - Beam finder
 - Delayed sweep
 - Alternate time base



MODEL SS-5702 \$535.00

- DC - 20MHz, 5 mV/div
Dual trace
6 inch rectangular internal graticule CRT.
Includes 2 each x1/x10 probes and full factory warranty; 2 years on parts, labor and CRT.

CIRCLE 266 ON FREE INFORMATION CARD

LEADER Instruments Corporation

Audio Sine/Square Wave Generator

- Distortion from <0.03%
- 10 Hz to 1 MHz



LAG-120A

\$259.95



BK PRECISION

FUNCTION GENERATOR

MODEL 3010

\$189.00

- Sine, square and triangle output
- Variable and fixed TTL outputs
- 0.1 Hz to 1 MHz in six ranges
- Typical distortion under 0.5% from 1 Hz to 100 kHz
- Variable DC offset
- VCO input for sweep tests

VIZ

MULTI-FUNCTION COUNTER



MODEL WD-755

\$259.00

- 5 Hz to 125 MHz
- 8 Digit LED Display
- Period Measurement 5 Hz to 2 MHz
- Totalizes to 99,999,999 Plus Overflow
- Frequency Ratio Mode
- Time Interval Mode
- Switchable Attenuator & Low Pass Filter

RELAY VOM . . . 5-way protection



\$49.00

MODEL WV-532A

- Fast relay opens input circuit on overload
- Lamp indicates when relay is open
- Easy-access battery compartment and test-lead storage
- High-accuracy: ±2% DCV, ±3% ACV
- 3-to-1 ranges (like VTVM)
- Large, 5 1/2" mirror meter
- Front panel and meter scales coded in 3 colors for quick function identification
- Battery-condition indicator for overload protection circuit

STACO ENERGY PRODUCTS CO.

VARIABLE TRANSFORMER



\$145.00

MODEL 3PN1010V

RAG CARRIES THE COMPLETE STACO VARIABLE TRANSFORMER LINE. CALL US WITH YOUR REQUIREMENTS.

code, so the experimenter would probably want to display the data stream on a separate monitor.

It would appear that teletext and closed-caption signals are quite different, which is reasonable considering the difference in targeted audiences. The closed-caption signal transmits data at a much slower rate and might appear to be less efficient. It is still capable of transmission faster than most people can read, though, and the slower

rate enables reliable data recovery even at the outer regions of a station's coverage.

Teletext, on the other hand, must be more things to more people, so it necessarily must be faster. That is accomplished by higher baud rates and use of more lines. Mr. Bunting might be interested to know that lines 10-13 are not in general use, but according to the FCC's timetable (Section 73.682, Schedule 1) will become available

in 1988. Lines 14-18 and 20 (both fields) are currently used, although some stations still use certain of those lines for test signals.

We hope that information will be useful to Mr. Bunting and any others interested in this new area of TV technology.

JOHN H. DAVIS

WJSP-TV

Warm Springs, GA

ANOTHER ONE JOINS THE RANKS

You can add my name to the list of those who joined your ranks from *Computer & Electronics*, (formerly *Popular Electronics*.)

I had been reading and/or subscribing to *Popular Electronics* since 1964, but no more once they became *Computer & Electronics*.

By the way I've got nothing against computers, since I design PC boards using a CAD (computer-aided design) system and have a Radio Shack *TRS-80 Color Computer* at home. But everything has its place, and changing their format to one that covered computers almost entirely was a bad move. I had always looked forward to building the various projects they (and also your magazine) published.

Before I sign off, maybe you or your readers can help me. I need a schematic and parts list for a Southwest Technical Products Corp. project called *Psychedelia III*, a color organ kit that needs repair. I hope you can help.

RICHARD C. POLK

Streamwood, IL

ZX81 OWNERS ALIVE AND WELL

Thanks to you for running the article on "Interfacing the ZX81." I just received my July issue of *Radio-Electronics*, (the mail takes a while) and I am delighted with the article. Also appreciated was the previous article by Paul W.W. Hunter on the 8K transparent memory for the ZX81. I estimate that there are on the order of two million ZX81 and Timex 1000 owners scattered about, and although our prime supplier (Timex) and prime publication (Sync) have bitten the dust, we remain alive and well.

JESS PEELER

Costa Rica, Central America R-E

VIEW 8 TRACES ON YOUR SINGLE OR DUAL TRACE SCOPE WITH THIS LOW COST DEVICE!!

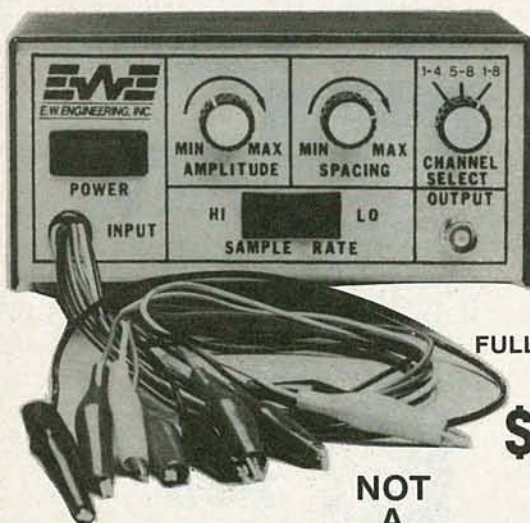

Now you no longer have to spend thousands on an expensive multi-trace oscilloscope - our single trace Hitachi scope combined with this module will allow you to view up to 8 simultaneously occurring analog or digital (or both) signals in their real time and amplitude relationship. The MPX 101 may be used on any oscilloscope, whether single, dual or multiple traces. Its low cost makes it a particular favorite for designers, testers, hobbyists and repairmen who want to compare and analyze displayed signals in a timing diagram format. The controls on the front panel of the metal case allow you to vary amplitude and spacing of the displayed signals.

MODEL MPX101
FULLY ASSEMBLED & TESTED!

\$99⁸⁸

FULL 1
YEAR
REPLACE-
MENT
WARRANTY

NOT
A
KIT

- Made In The United States -

SPECIFICATIONS

Inputs: 8 signals plus ground via 9 input leads terminated with alligator clips
Bandwidth: ± 1 dB to 5 MHz
Impedance: 10.9 K
Input Voltage: ± 5 V peak (diode clamped to ± 5 Volt supplies)
Output: Staircase waveform summed with input signals, 0-800 mV full scale
Step Amplitude: Variable 0 to 150 mV/step
Signal Voltage: Variable 0 to

150 mV/step @ 5V Input
Multiplex Rate: Switch selectable, 40 KHz or 4 KHz
Impedance: 50 Ohms
Power: 105-135 VAC @ 1 V a
Dimensions: 6.25" x 3.25" x 4.75" (WxHxD)
Operating Temperature: 0-40°C
Weight: 1 lb. 10.5 oz.
Warranty: one year full replacement warranty from date of purchase
Lighted on/off power switch
Wood grain finished metal case

DISTRIBUTOR AND REPRESENTATIVE INQUIRIES INVITED



VISA, MASTERCARD, AMEX TELEPHONE ORDERS ACCEPTED!
6 Herman Drive, E. Granby, CT 06026 □ 203/651-0285

CIRCLE 61 ON FREE INFORMATION CARD



- 77**
- 0.3% Accuracy
 - Manual or Autorange
 - 10A + mA Range
 - Beeper
 - "Touch-Hold" Function

Sale
\$119⁹⁵

WE CARRY A FULL
LINE OF FLUKE
MULTI-METERS.
IN STOCK NOW

Sale ends Jan. 85

BECKMAN'S CIRCUITMATE[®] ALL UNDER \$100

AVAILABLE NOW. . . .

\$64⁹⁵

Circuitmate DM 20—
3½-digit, pocket-size
multimeter; 0.8% Vdc
accuracy, diode test,
hFE test, conductance,
10 amps AC and DC
ranges, auto-polarity
auto-zero, auto-
decimal



\$79⁹⁵

Circuitmate DM-25—
3½ digit, pocket-size
multimeter; 0.5% Vac
accuracy, diode test,
capacitance, continuity
beeper, conductance,
10 amps AC and DC
ranges, auto-polarity,
auto-zero, auto-
decimal



\$69⁹⁵

Circuitmate DM-40 —
3½-digit multimeter;
0.8% Vdc accuracy,
diode test, auto-
polarity, auto-zero,
auto-decimal



\$89⁹⁵

Circuitmate DM 45 —
3½-digit multimeter;
0.5% Vdc accuracy,
diode test, continuity
beeper, 10 amps AC
and DC ranges, auto-
zero, auto-polarity,
auto-decimal



BECKMAN
CIRCUITMATE DM10

\$39⁹⁵

IN STOCK NOW



The DM73 is the smallest digital
multimeter on the market. Its
probe-style design makes it ideal
for taking measurements in hard-
to-reach test areas.

\$63⁹⁵

- Small Size
- Complete Autoranging
- "Touch Hold"
- Audible continuity checking

FLUKE 70 SERIES MULTIMETERS

- Analog Display • Rotary Knob • Volts AC & DC • Resistance to • 32 MΩ • 10 Amps • Diode Test • 3200 Counts • Fast Autoranging • Function Annunciators in Display • Power-Up Self Test • 2000+ Hour Battery Life w/ Power Down "Sleep Mode" • New Test Leads • VDE & UL Approval



\$99⁰⁰

75

\$79⁹⁵

and free C70
holster **73**



- 0.5% Accuracy
- Manual or Autorange
- 10A + 300 mA Range
- Beeper

- 0.7% Accuracy
- Autorange Only
- 10 Amp Only

NEW!



TOLL FREE HOT LINE
800-223-0474

212-730-7030

26 WEST 46th STREET, NEW YORK, N.Y. 10036

THE TEST EQUIPMENT SPECIALISTS

**ADVANCE
ELECTRONICS**

IF YOU WANT TO GET YOU HAVE TO GET INTO

Learn PC Servicing By Building Your Own NTS/HEATH HS-15 Desk-Top Computer, Circuit-By-Circuit

NTS Intrinsic Home Training Takes You Below The Surface

NTS gets you right down into the heart of computer circuitry. You learn how microprocessors function, how they are designed, how they operate and are used to solve problems. Your program includes a wide variety of tests and projects, as you assemble your PC. You experience the excitement of seeing your own skills grow, the security of knowing you really understand what makes a computer tick.

A Career in PC Servicing

The world of computers is constantly expanding. Applications have spread from business to manufacturing, from industry to medical and scientific fields. Computer-aided design, engineering, and production have revolutionized drafting, graphics, and prototyping. Computer sales figures point to a continuing need for service technicians as well as installation and maintenance specialists. The type of training you receive will largely determine your ability to take advantage of these opportunities and nothing beats the practical, down-to-earth training you get from NTS.

The NTS/HEATH 16-Bit HS-151

This desk-top PC is the most powerful and versatile ever offered in any home training program. Check the advanced features listed below:

1. 128 KB RAM user memory on board, expandable to 640 KB
2. 16-bit 8088 Microprocessor accepts advanced software, speeds word processing; also allows selection from the huge library of IBM software.
3. 5.25-inch floppy disk drive, double density, IBM formatted, stores up to 360 KB. (Expandable to dual disk drive, and optional 10.5 MB hard-disk drive.)
4. MS-DOS operating system, IBM compatibility, make a wide choice of software programs available.
5. Four open IBM-compatible slots provide for future expansion, printer, modem, etc. Will accept most peripheral boards designed for IBM-PC.
6. Two video outputs for color or monochrome display monitor. Your NTS course includes a high resolution monitor displaying 80 characters by 25 lines, or graphics.
7. Editing capabilities help you insert or delete characters and lines, erase, jump or smooth scroll, etc.

Your NTS training course will teach you to program on this outstanding PC, using lessons, texts, and diagrams to make full use of its capabilities. Catalog contains complete details.



Learning circuitry through the construction of this equipment offers practical training for which there is no substitute. Test equipment is included.

Field servicing is interesting and rewarding. Technicians may work for a service company, manufacturer, or major users.

The NTS/HEATH HS-151 PC completed, includes monitor and full-function keyboard with calculator style keypad, and typewriter format.



NTS TO PC SERVICING A MICROCOMPUTER

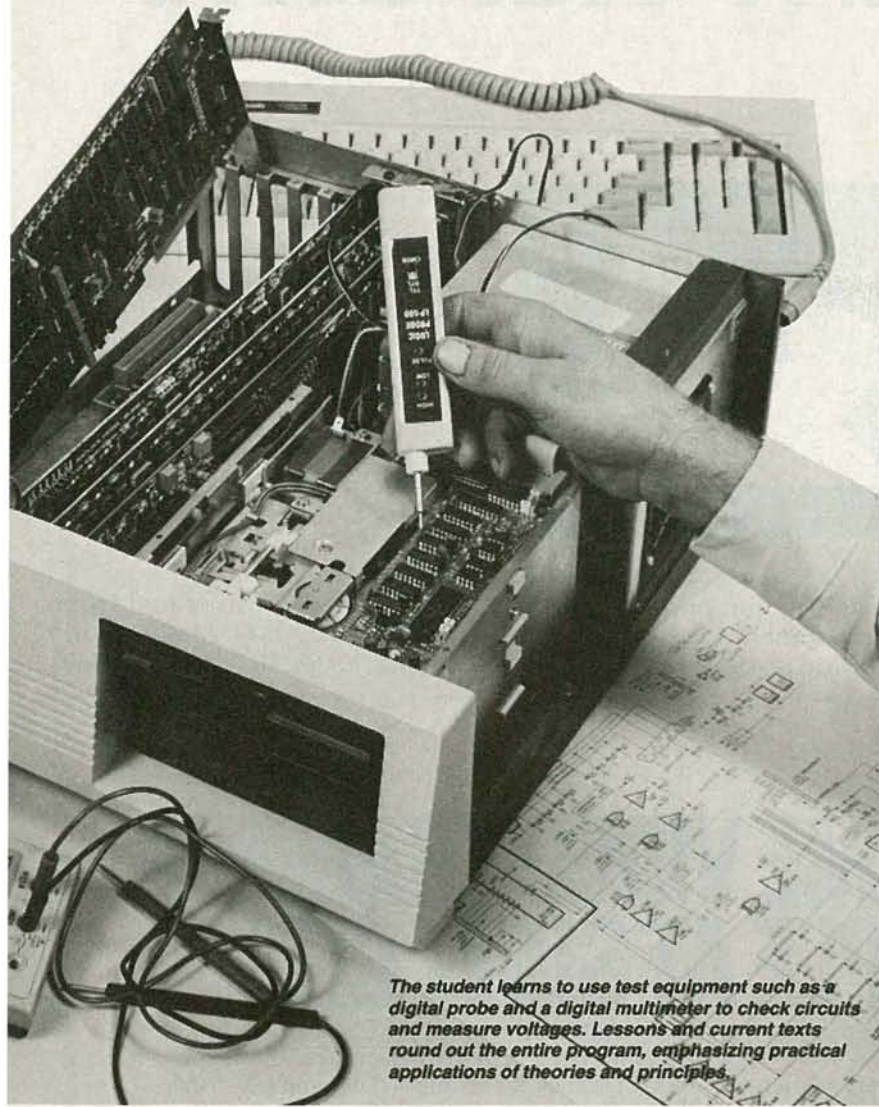

The student learns to use test equipment such as a digital probe and a digital multimeter to check circuits and measure voltages. Lessons and current texts round out the entire program, emphasizing practical applications of theories and principles.

Installing the disk-drive in the PC is one of the final stages in the assembly of the microcomputer. Learning the use of test equipment to check circuits is an integral part of the training which, with field experience, develops invaluable career skills.

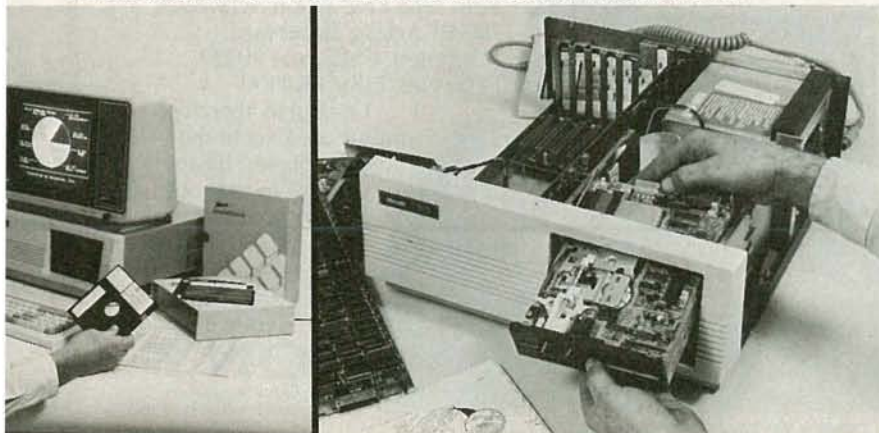

NTS COURSES COVER MANY AREAS OF SPECIALIZATION IN ELECTRONICS:

Robotics: Build the NTS/HEATH Hero 1 Robot as you learn robotic programming. Robot is complete with arm and gripper, voice synthesizer. Robotics is becoming increasingly important in industry as almost daily news features attest.

Video Technology: Build one of the most advanced Color TV sets in America as you learn circuit diagnostics, and the use of digital test instruments. Course covers color TV, video tape recorders, computer fundamentals, solid-state devices.

Industrial and Microprocessor Technology covers circuit analysis, microprocessors and automation applications, lasers, and basic industrial robotics.

TV & Radio Servicing is a specialized course offering an excellent foundation in the use and application of both analog and digital test equipment as applied to the TV servicing field. Learn circuits, adjustments, trouble-shooting, and servicing of Color and monochrome monitors.

Digital Electronics offers the student the opportunity to get involved with computer concepts, computer technology fundamentals, and digital equipment by training on the NTS Compu-Trainer.

Basic Electronics is a course designed for those wishing to have an over-view of electronics in many of its aspects including radio receivers, solid state devices, and electronic components.

NTS Intronic training programs include a variety of superb equipment, most of which is classified as field-type, making the training practical and career oriented. Texts and lessons have been tested in our Resident School in Los Angeles to assure home study students their courses of training are easy to understand. NTS, now in its 80th. year, continues to be at the leading edge in Electronics home training.

* IBM is a trademark of International Business Machines Corp.

* MS is a trademark of Microsoft Corp.

If card is missing, simply write to the address shown below stating the course you are interested in. A FREE color catalog with all details will be sent to you by return mail.

**NTS NATIONAL
TECHNICAL
SCHOOLS**

TECHNICAL TRADE TRAINING SINCE 1905
Resident and Home-Study Schools

4000 So. Figueroa St., Los Angeles, CA 90037

FEBRUARY 1985

EQUIPMENT REPORTS

Cardco Card/? Universal Printer Interface

This interface lets you use almost any printer with your Commodore 64.

CIRCLE 5 ON FREE INFORMATION CARD



BECAUSE OF ITS HIGH PERFORMANCE and low cost, the *Commodore 64* has become one of the most popular computers for home-and-fam-

ily and school use. Unfortunately, its matching line printer leaves a lot to be desired when it comes to word processing of any kind. In

fact, there is no low cost formed-character (daisy-wheel type) or high-quality dot-matrix printer presently available for that computer.

The way to get high quality printouts from the *Commodore 64* (or *VIC-20*) is to use one of the better printers and a *Card/?* interface, a device that lets you use a Centronics-type parallel printer in place of a Commodore printer.

The Card/?

The *Card/?* interface from Cardco, Inc. (313 Mathewson, Wichita, KS 67214) is priced at \$69.

GET THE SAME VIDEO TRAINING THE PEOPLE AT SONY GET.

Now you can be trained by Sony even if you aren't employed by Sony.

Because we're making our vast library of training videotapes available to you. The very tapes that teach our own engineering, service and sales personnel.

The tapes cover the products and concepts of video and its related technologies. You can learn the basics of video recording. Color systems. Digital video and electronics. Television production. And more.

Plus you can learn how to service cameras, VTR's, and other video products. As professionally as Sony does.

The tapes are produced entirely by Sony and contain up-to-the-minute information. They communicate clearly and simply. And some of them are even programmed for interactive learning.



And learning through video can be done at your own pace, in the convenience of your home, shop or school. Reviewing is quick and easy. And the tapes are always available for reference.

Send for your catalog, which lists more than 250 titles. In your choice of 3/4" or 1/2" formats.

Write Sony Video Products Company, Tape Production Services, 700 W. Artesia Boulevard, Compton, California 90220. Or call (213) 537-4300.

Of course, there's no obligation. Except the obligation you have to yourself: to find out about the best training available in one of the country's fastest-growing, most lucrative fields.

SONY
Video Communications
Sony is a reg. trademark of Sony Corp.

CIRCLE 261 ON FREE INFORMATION CARD

B&K OSCILLOSCOPES

LOWEST PRICES
OFF-THE-SHELF
DIRECTLY TO YOU

CALL TOLL FREE
FOR FAST DELIVERY

800-645-9518

In New York State 800-832-1446

B&K 100 MHz DUAL TRACE, DUAL TIME BASE OSCILLOSCOPE



Model 1580
\$1249⁹⁵
(Reg. \$1,595.00)

FEATURES • 1 mV/div sensitivity • 23 calibrated sweeps • Rectangular CRT with internal graticule and scale illumination • Signal Delay Line • Video Sync Separators • 20 MHz Limiter • X-Y Operation • Z axis input • 16 kV Accelerating Voltage • X10 Sweep Mag-

nification • Delayed Sweep/Dual Time Base • Single Sweep • V Mode - display two signals unrelated in frequency • Sum and Difference Capability • Channel 1 Output • Includes Probes

B&K 80 MHz QUAD INPUT DUAL TIME BASE OSCILLOSCOPE



Model 1570
\$1095⁰⁰
(Reg. \$1395.00)

FEATURES • 1 mV/div sensitivity to full bandwidth • 500 uV/div cascade sensitivity to 40 MHz • 22 calibrated sweeps • Rectangular CRT with internal graticule and scale illumination • 12 kV accelerating voltage • Mode - display four signals unrelated in frequency •

• Alternate timebase operation • Signal delay line • 20 MHz bandwidth limiter • Lighted pushbutton function switching • Video sync separators • Includes probes

B&K 60 MHz TRIPLE TRACE OSCILLOSCOPE



Model 1560
\$899⁹⁵
(Reg. \$1150.00)

FEATURES • 1 mV/div sensitivity • 22 calibrated sweeps • Rectangular CRT with internal graticule and scale illumination • Signal delay line • Video sync separators • X-Y operation • Z axis input • 16 kV accelerating voltage • X10 sweep

magnification • Delayed sweep dual time base • Single sweep • Auto focus • V mode-displays two signals unrelated in frequency • Sum & difference capability • Channel 1 output • Includes probes

B&K 40 MHz DUAL TRACE OSCILLOSCOPE



Model 1540
\$799⁹⁵
(Reg. \$950.00)

FEATURES • 1 mV/div sensitivity • 21 calibrated sweeps • Rectangular CRT with internal graticule and scale illumination • Signal delay line • Video sync separators • X-Y operation • Z axis input • 12 kV accelerating voltage • X10 sweep

magnification • Delayed sweep/dual time base • Single sweep • Auto focus • V mode-displays two signals unrelated in frequency • Sum & difference capability • Channel 1 output • Includes probes

B&K 20 MHz DUAL TRACE TRIGGERED SWEEP OSCILLOSCOPE



Model 1522
\$569⁹⁵
(Reg. \$695.00)

FEATURES • 1 mV/div sensitivity • 20 calibrated sweeps • Rectangular CRT with internal graticule and scale illumination • Video sync separators • X-Y operation • Z axis input • 6kV accelerating voltage • X10 sweep magnification • Auto sweep • V mode-displays two signals unrelated in frequency • Sum & differ-

ence capability • Channel 1 output • Includes probes

MASTERCARD/VISA ACCEPTED



PHONE ORDERS ACCEPTED

Service and Shipping Charge Schedule

FOR ORDERS	ADD
\$501-750	\$8.50
\$751-1,000	\$12.50
\$1,001 and up	\$15.00

Fordham

260 Motor Parkway, Hauppauge, New York 11788

The unit consists of a small, light-weight plastic box that measures approximately $3\frac{1}{2} \times 3 \times \frac{7}{8}$ inches with a Centronics-type connector on one end and a cable on the other end that terminates in a DIN connector that matches the serial output connector on the Commodore computer or its disk drive. (When using a disk drive, the printer connection is moved from the computer to the disk drive.) A single wire trailing from the *Card/?*'s DIN connector is attached

to an adapter that slips over the computer's edge connector that provides power and signal I/O for the Commodore *Datassette* (cassette) tape recorder. The wire provides the 5-volt power supply for the interface and still allows the *Datassette* to be used.

The interface plugs directly into the Centronics type connector on the printer. (An earlier version of the *Card/?* interface—called the Model A; the model we are describing is the Model B—was

larger and had a ribbon connector between the cabinet and the printer connector.) Its operation is completely automatic. When the computer is told to output to the printer, the interface converts the Commodore's unusual ASCII output to the standard ASCII of the printer. As far as the computer is concerned, it "sees" a simulated Commodore printer.

Cardco	Card/?
OVERALL PRICE	7
EASE OF USE	8
INSTRUCTION MANUAL	6
PRICE/VALUE	9
	1 2 3 4 5 6 7 8 9 10
	Poor Fair Good Excellent

Now, a low cost way to fill your DC power requirements...the new Global 1301 Triple Power Supply

The new Model 1301 Triple Power Supply from Global Specialties is designed to meet your DC voltage requirements for product development, testing, quality control, servicing and education applications. This fully regulated power source is especially useful for analog and digital circuit design and offers a fixed 5 VDC, 1.0 A output which is ideal for TTL applications. In addition, the Model 1301 offers two continuously variable ± 5 to ± 18 VDC, 0.5 A supplies. The three voltage supplies are completely isolated and outputs are available through six front panel, color-coded binding posts. A separate binding post is connected to the chassis and ground.

Each of the two continuously variable outputs has a separate voltage adjust control. Two front panel meters provide for the monitoring of voltage from 0-20 V and current from 0-1 A. Current limiting protects against short circuiting and outputs may be interconnected to increase voltage range without short circuit damage.

The Model 1301 is a versatile general purpose power supply which provides precision performance in engineering laboratory applications, schools, testing and servicing, and production lines. Because of its low price — under \$250.00 — the 1301 is also excellent for use by hobbyists. Rugged construction and a durable metal case permit the 1301 to withstand the wear and tear of regular use and provide many years of trouble-free service.

See the new Model 1301 Triple Power Supply at your electronics distributor, or, for the name of your local distributor, call our toll-free **Product Availability Phone: 1-800-243-6077.**



GLOBAL SPECIALTIES An Interplex Electronics Company
 70 Fulton Terr., New Haven, CT 06509-1819 (203) 624-3103, TWX 710-465-1227
 OTHER OFFICES: San Francisco (415) 648-0611, TWX 910-372-7992
 Europe: Phone Saffron-Walden 0799-21682, TLX 817477

CIRCLE 62 ON FREE INFORMATION CARD

To avoid problems caused by differences in response to ASCII control codes between the computer and the printer, the interface automatically makes the required conversions. For example, when listing a program, the Commodore's CHR\$(19) "home cursor" command would stop an Epson printer dead in its tracks because CHR\$(19) is the Epson-printer command for "stop printing." To avoid that hassle, the interface automatically changes the listing from CHR\$(19) to an "[HM]" (home cursor). Other ASCII codes from 1 to 31 and 128 to 160, that might be inconsistent with the non-Commodore printer commands, are similarly designated within brackets. For example, CHR\$(150), which is the Commodore command for the color "light red," is listed as "[LR]".

The interface normally defaults to the "normal printing mode," which is upper case only with automatic linefeed after carriage return. A short software command can be used to temporarily or "permanently" lock (until power reset) the interface to provide upper case only with no line feed, upper and lower case with no line feed, upper and lower case with automatic linefeed, graphics mode with line feed, or graphics mode with no line feed.

Where's Your **ELECTRONICS** Career Headed?

your move!

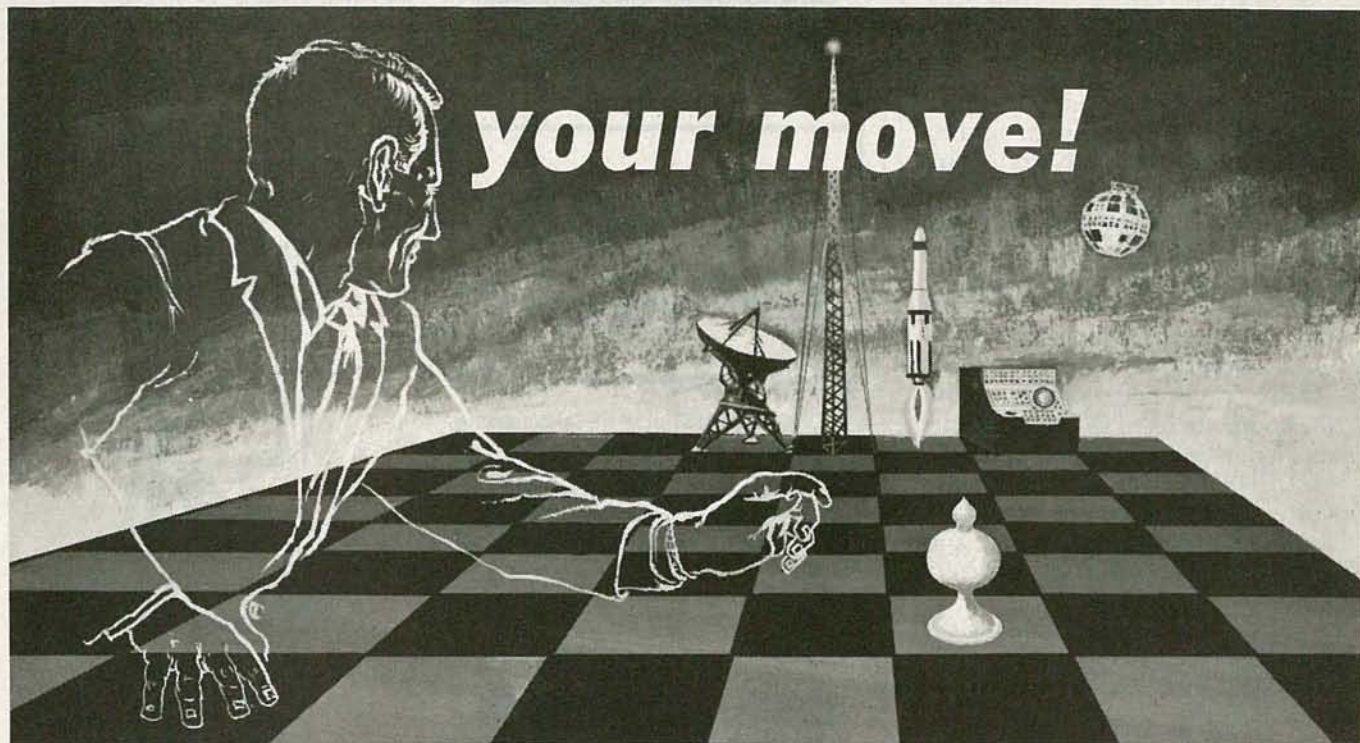

The Move You Make Today Can Shape Your Future

Yes it's your move. Whether on a chess board or in your career, you should plan each move carefully. In **electronics**, you can *move ahead* faster and further with a

B. S. DEGREE

Put professional knowledge and a COLLEGE DEGREE in your electronics career. Earn your degree through independent study at home, with Grantham College of Engineering. No commuting to class. Study at your own pace, while continuing your present job.

The accredited Grantham non-traditional degree program is intended for mature, fully employed workers who want to upgrade their careers . . . and who can successfully study electronics and supporting subjects through

INDEPENDENT STUDY, AT HOME

Free Details Available from:

Grantham College of Engineering
10570 Humbolt Street
Los Alamitos, California 90720

Independent Home Study Can Prepare You

Study materials, carefully written by the Grantham staff for independent study at home, are supplied by the College, and your technical questions related to those materials and the lesson tests are promptly answered by the Grantham teaching staff.

Recognition and Quality Assurance

Grantham College of Engineering is accredited by the Accrediting Commission of the National Home Study Council.

All lessons and other study materials, as well as communications between the college and students, are in the English language. However, we have students in many foreign countries; about 80% of our students live in the United States of America.

Grantham College of Engineering R 2-85
10570 Humbolt Street, Los Alamitos, CA 90720

Please mail me your free catalog which explains your B.S. Degree independent-study program.

Name _____ Age _____

Address _____

City _____ State _____ Zip _____

The graphics mode has the ability to pass any character string to the printer unchanged. It's primarily intended for use with word processors and other programs that can function with non-Commodore printers, and that can access the advanced graphics features of certain printers. A semi-permanent selection of the graphics mode can be made by an internal DIP-switch on the printed-circuit board.

Three other DIP switches on the PC board are used to automatically exchange the function of CHR\$(15) and CHR\$(20); enable or disable software selection of automatic linefeed after carriage return, and enable or disable the ASCII correction described above.

The reason for the automatic exchange of the CHR\$(20) and CHR\$(15) functions is because Commodore uses CHR\$(15) to cancel the expanded print mode, but other printers use CHR\$(15) for condensed print with CHR\$(20) used to cancel the expanded mode. By automatically swapping CHR\$(15) for CHR\$(20), the Commodore command to "cancel expanded print mode" will work properly with just about any non-Commodore printer currently on the market.

For listings, user written programs, and word processing, the *Card/?* works as claimed, doing an effective job of emulating a Commodore printer, while providing the enhancements of the higher-performance printers. The few problems that arise, such as dropped spaces between words and stepping of the printer through each blank space (no character) on a line comes about through some off-the-wall programming used in some commercial programs—even some better quality software. Fortunately, programs for the Commodore computers are in BASIC, so it's possible to get into the listings and make whatever changes are necessary to provide rational printer operation.

Overall, the *Card/?* interface is the way to go for "professional quality" printouts from the Commodore 64 and VIC-20 computers. **R-E**

continued on page 81

100 JOB OFFERS?

A COMPLETE LIST of HI TECH companies compiled by executive with inside knowledge of companies on the move. Updated monthly listing contains employers located in California's famous Silicon Valley. Only \$5.00 - "CAREER 1", P.O. BOX 221, SUNNYVALE, CA. 94086.



TIMEX/SINCLAIR 1000, 1500, 2068, ZX81, Hardware & Software for all computers: **NEW!** Floppy disk interface. Std format. Order FLOPPY: \$200. **PRTR I/F**—Centronics printer interface. Order PRTIF: \$50. **ASM/DSM**—Full featured assembler/disassembler. Order ASMDSM: \$40. **ALSO,** Cables for all products. Write for prices and descriptions. When ordering, specify type of computer. **Research Service Laboratories, P.O. Box 19124, OKC, OK 73144.**
CIRCLE 259 ON FREE INFORMATION CARD

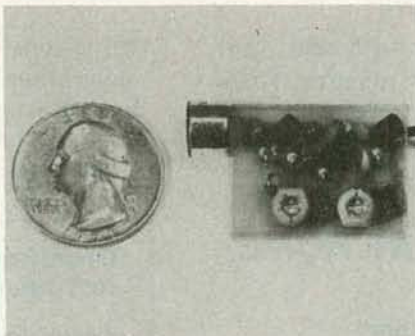

THE MOST EXCITING KIT YOU WILL EVER BUILD The model WAT-50 miniature FM transmitter uses a 4-stage circuit NOT to be confused with a simple wireless microphone. Up to 1 mile range. So sensitive, it will pick-up a whisper 50 feet away! Use with any FM radio. Complete kit only **\$29.95** tax incl. **FREE SHIPPING.** **DECO INDUSTRIES, BOX 607, BEDFORD HILLS, NY 10507.**
CIRCLE 274 ON FREE INFORMATION CARD

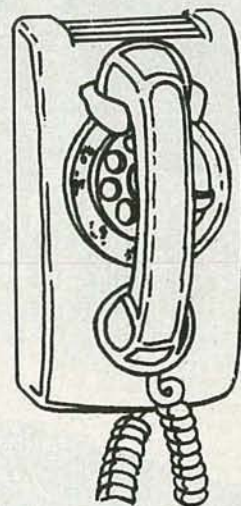

CALL NOW AND RESERVE YOUR SPACE

- 6 x rate \$650 per each insertion.
- Reaches 225,016 readers.
- Fast reader service cycle.
- Short lead time for the placement of ads.
- We typeset and layout the ad at not additional charge.

Call **212-777-6400** to reserve space. Ask for Arline Fishman. Limited number of pages available. Mail materials to: mini-ADS. RADIO-ELECTRONICS, 200 Park Ave. South. New York, NY 10003.



ELECTRO IMPORTING CO. CATALOG. This reprint of the historic 176-page catalog No. 20 gives you an accurate look at the state of electronics in 1918. Contains everything from a Zinc Spark Gap to a 1000-Mile Receiving Outfit. You can get your own copy of this modern antique, profusely illustrated, for only **\$4.95** plus \$1.00 P&H. Order yours from **R-E BOOKSTORE, Radio-Electronics, 200 Park Avenue South, New York, NY 10003.**

Radio-Electronics mini-ADS



UNIVERSAL CRT ADAPTER—Use any CRT Tester/Restorer/Rejuvenator on all 2500 Color CRT's. Use functions of your tester on any Color CRT from 9" to 26", including foreign. Checks: Quintrex, InLine, Trinitrons, Tri-Potential, etc. Replaces over 50 Adapters & guaranteed for all Makes/Models of CRT Testers. Instructions/Set-up Manual included. Check/MO/Visa/MC/COD. **\$61.95 + \$2.00 P&H.** To order call 1-800-331-9658, (OK 918 68 2 4286) **DANDY MFG. COMPANY, 2300 GIBSON ST., MUSKOGEE, OK 74403.**

CIRCLE 270 ON FREE INFORMATION CARD

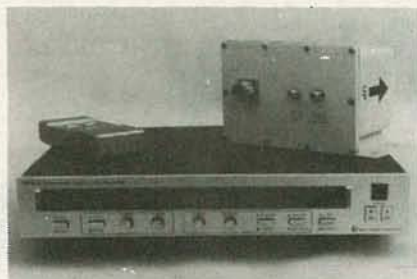

SATELLITE TELEVISION RECEIVER SEMIKIT with dual conversion downconverter. Features infrared remote control tuning, AFC, SAW filter, RF or video output, stereo output, Polarator controls, LED channel & tuning indicators. Install six factory assembled circuit boards to complete. **Semikit \$400.00.** Completed downconverter add **\$100.** Completed receiver and downconverter add **\$150.** **JAMES WALTER SATELLITE RECEIVER, 2697 Nickel, San Pablo, CA 94806. Tel 415-724-0587.**

CIRCLE 124 ON FREE INFORMATION CARD

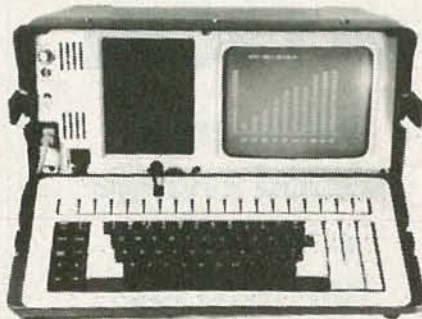

ZORBA 64K PORTABLE COMPUTER 9" Green or Amber CRT. Two 400 K DSSD Drives. CP/M 2.2 Operating System. **\$799.00.** **Gemini Electronics, Inc., 130 Baywood Ave., Longwood, FL 32750. 1-800-327-7182, 305-830-8886.**

CIRCLE 256 ON FREE INFORMATION CARD

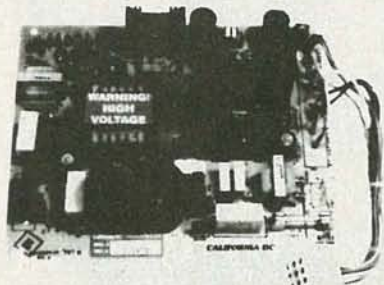

California-DC Regulated Switching Power supply +5v dc @ 5 amp + 12v dc @ 2.8 amp + 12v dc @ 2 amp -12v dc @ .5 amp 115-230v ac input, fused. EMI filtered. Removable DC Power Harness and Schematics included. 7.4" x 6.2" x 1.7" ht. Visa/MC/M.O./check; when clears. **\$37.50 ea. (Free shipping in U.S.) **1-800-327-7182/305-830-8886. Power Plus, 130 Baywood Ave., Longwood, FL 32750.** (Call for quantity price).**

CIRCLE 125 ON FREE INFORMATION CARD



TEL-TONE'S TRK-957 KIT makes breadboarding a low-power, central office quality DTMF detection system easy and inexpensive. The included M-957 receiver decodes 12 or 16 digits and operates from 5 to 12V dc. Its sensitivity, wide dynamic range, noise immunity, and low power consumption are ideal for telephone switching, computer and remote control applications. Only **\$24.75.** To order, call: **TEL-TONE, 1-800-227-3800, ext. 1130.**

CIRCLE 122 ON FREE INFORMATION CARD



SUBSCRIPTION TV MANUAL. This information packed book details the methods used by subscription TV companies to scramble and descramble video signals. Covers the Sinewave, Gated Pulse, SSAVI system, and the methods used by most cable companies. Includes circuit schematics, theory, and trouble shooting hints. **Only \$12.95 plus \$2.00 first class P&H.** **ELEPHANT ELECTRONICS INC., (formerly Random Access) Box 41770-R, Phoenix, AZ 85080.**

CIRCLE 120 ON FREE INFORMATION CARD



FREE CATALOG OF HARD-TO-FIND TOOLS is packed with more than 2000 quality items. Your single source for precision tools used by electronic technicians, engineers, instrument mechanics, schools, laboratories and government agencies. Also contains Jensen's line of more than 40 tool kits. Send for your free copy today! **JENSEN TOOLS INC., 7815 46th St., Phoenix, AZ 85040. (602) 968-6231.**

CIRCLE 115 ON FREE INFORMATION CARD

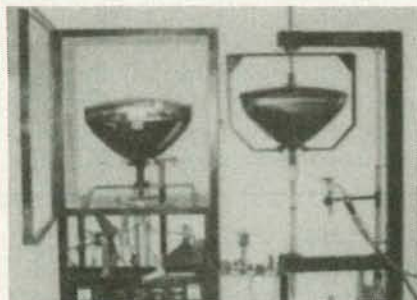

ONE MAN CRT FACTORY, easy operation. Rebuild CRT's for tv's, bus. machines, monitors, scopes, etc. Color, b&w, 20mm, foreign or domestic. 3x6 ft. space required. Profits??? Average CRT rebuilding costs—\$5. Sell for \$100 = \$95 profit; x 5 CRT's = \$475 daily; x 5 days = \$2375 weekly profit. Higher profits overseas. Investigate this opportunity today. We service the entire world Contact: **CRT Factory, 1909 Louise St., Crystal Lake, IL 60014, (815) 459-0666.**

CIRCLE 80 ON FREE INFORMATION CARD

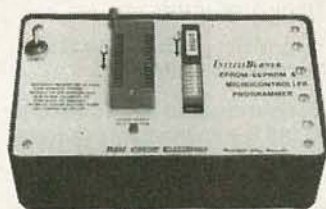

IntelliBurner EPROM-EEPROM & MICROCONTROLLER PROGRAMMER \$299 Communicates through the serial port of any personal computer. Use your PC's modem software to read, verify, or program all popular EPROMs, EEPROMs and 87xx series micro controllers. Custom software included for IBM, CP/M or Radio Shack PCs. Other programmers from **\$149.** Bare PC boards with software from **\$39.** **ROSS CUSTOM ELECTRONICS, 1307 Darlene Way #A12, Boulder City, NV 89005. 702-293-7426.**

CIRCLE 265 ON FREE INFORMATION CARD

Measures frequency to 1.2GHz

With period,
period average
and totalize
functions too,
for only \$750



Model 1855
\$750

The B&K-PRECISION Model 1855 is a high accuracy multifunction counter with ± 1 ppm temperature stability (TCXO), with all these features:

- 5 Hz to 1.2GHz range
- 0.5 μ S to 200,000 μ S period range
- Totalizes to 99,999,999
- Selectable resolution • 8 digit LED display
- Low pass filter • Display hold
- Switchable X1/X10 attenuator
- Remote start-up
- kHz, MHz, μ SEC, Gate and overflow indicators

For measurements to 520MHz, the Model 1851, with the same features as the Model 1855, sells for \$575.

Both Models are available for immediate delivery from B&K-PRECISION distributors.

BK PRECISION
DYNASCAN
CORPORATION

6460 West Cortland Street
Chicago, Illinois 60635 • 312/889-9087
International Sales: 6460 W. Cortland St., Chicago, IL 60635
Canadian Sales: Atlas Electronics, Ontario
South and Central American Sales:
Empire Exporters, Plainview, NY 11803

CIRCLE 77 ON FREE INFORMATION CARD

NEW PRODUCTS

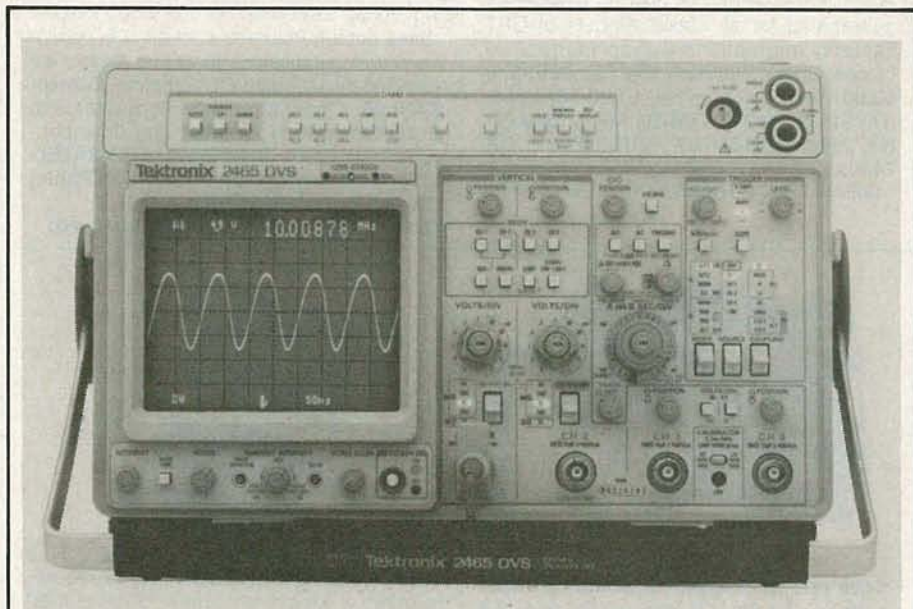

CIRCLE 11 ON FREE INFORMATION CARD

OSCILLOSCOPES, the 2465 DVS (Digital Video System) Special Edition (shown in photo); the 2465 DMS (Digital Multimeter System), Special Edition, and the 2465 CTS (Counter-Timer System) Special Edition. All three are programmable using the IEEE-488 GPIB.

The 2465 DVS has five new measurement capabilities. It incorporates: 1. a talker/listener IEEE-488 GPIB; 2. a counter/timer/trigger; 3. a word recognizer; 4. an auto-

ranging digital multimeter, and 5. comprehensive television-waveform measurement capability. That oscilloscope is priced at \$8550.

The 2465 DMS incorporates all of the above features except the TV capability. It is priced at \$7850.

The 2465 CTS has all the above features except the TV and digital multimeter capability. It is priced at \$6650.—Tektronix, Inc., PO Box 500, Beaverton, OR 97077.

SATELLITE TV RECEIVER, model SR-1000 has three variable controls for video and audio tuning, dual threshold extension switches, and an LED "climbing" bar-graph tuning meter. A front-mounted Chapparral Polarator control helps optimize reception for the desired satellite, and helps reject interference from adjacent satellites.

A composite baseband output provides optimum signal quality

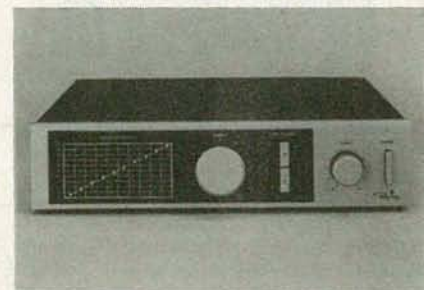

CIRCLE 12 ON FREE INFORMATION CARD

continued on page 43

MASTER THE NEW ELECTRONICS WITH MCGRAW-HILL'S

Contemporary Electronics Series

The fast, easy and low cost way to meet the challenges of today's electronic innovations. A unique learning series that's as innovative as the circuitry it explains, as fascinating as the experiments you build and explore.

From digital logic to the latest 32-bit microprocessor, the McGraw-Hill Contemporary Electronics Series puts you into the electronic picture one easy step at a time. Fifteen unique Concept Modules, sent to you one every 4-6 weeks, give you a handle on subjects like optoelectronics, robotics, integrated circuits, lasers, fiber optics and more.

Each Concept Module goes right to the heart of the matter. You waste no time on extraneous material or outdated history. It's a fast, efficient, and lively learning experience... a non-traditional approach to the most modern of subject matter.

Unique Interactive Instruction

With each module, you receive a McGraw-Hill Action Audio Cassette. Each tape is a dynamic discussion that drives home the key facts about the subject. Your learning

With your first module, you get this solderless breadboarding system. You'll use it throughout the series to build electronic circuits and bring concepts to life.

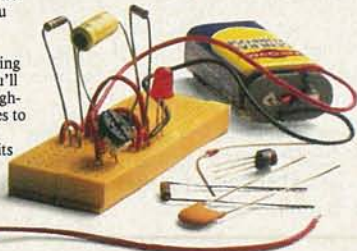

experience is reinforced through interaction with vividly illustrated text, audio cassettes, and actual electronic experiments. Indexed binders preserve backup material, notes, and tapes for convenient referral.



Perform Experiments in Contemporary Electronics

Throughout your series, laboratory experiments reinforce every significant point. This essential experience

...dynamic, hands-on demonstrations of theory in practice... will help you master principles that apply all the way up to tomorrow's latest VLSI (Very Large Scale Integrated) circuitry.

In your very first module, you'll use integrated circuits to build a digital oscillator, verifying its operation with a light emitting diode (LED). You'll learn to identify passive and active components, understand concepts common to all electronic circuits.

For Anyone Interested in Electronics

The Contemporary Electronics Series is designed for anyone from hobbyist to professional. It's for you if you're looking for new fields of interest...if you're a teacher who

wants an update in contemporary circuits... a manager or supervisor in an electronics plant... a doctor, an engineer, a chemist who finds electronics playing an increasingly important role in your work. It's even for electronics engineers or technicians who feel their training needs freshening up. It's the quickest, most convenient, probably least expensive way to do it. And the only one that gives you hands-on experience.



15-Day No-Risk Trial

To order your first module without risk, send the postage-paid card today. Examine it for 15 days under the terms of the order form and see how the Contemporary Electronics Series gets you into today's electronics. If card has been used, write us for ordering information.



McGraw-Hill
Continuing Education Center
3939 Wisconsin Ave.
Washington, D.C. 20016

The Book-Sized
Microcomputer
That's A Hands On
Library Of
Hardware And
Software
Instruction.

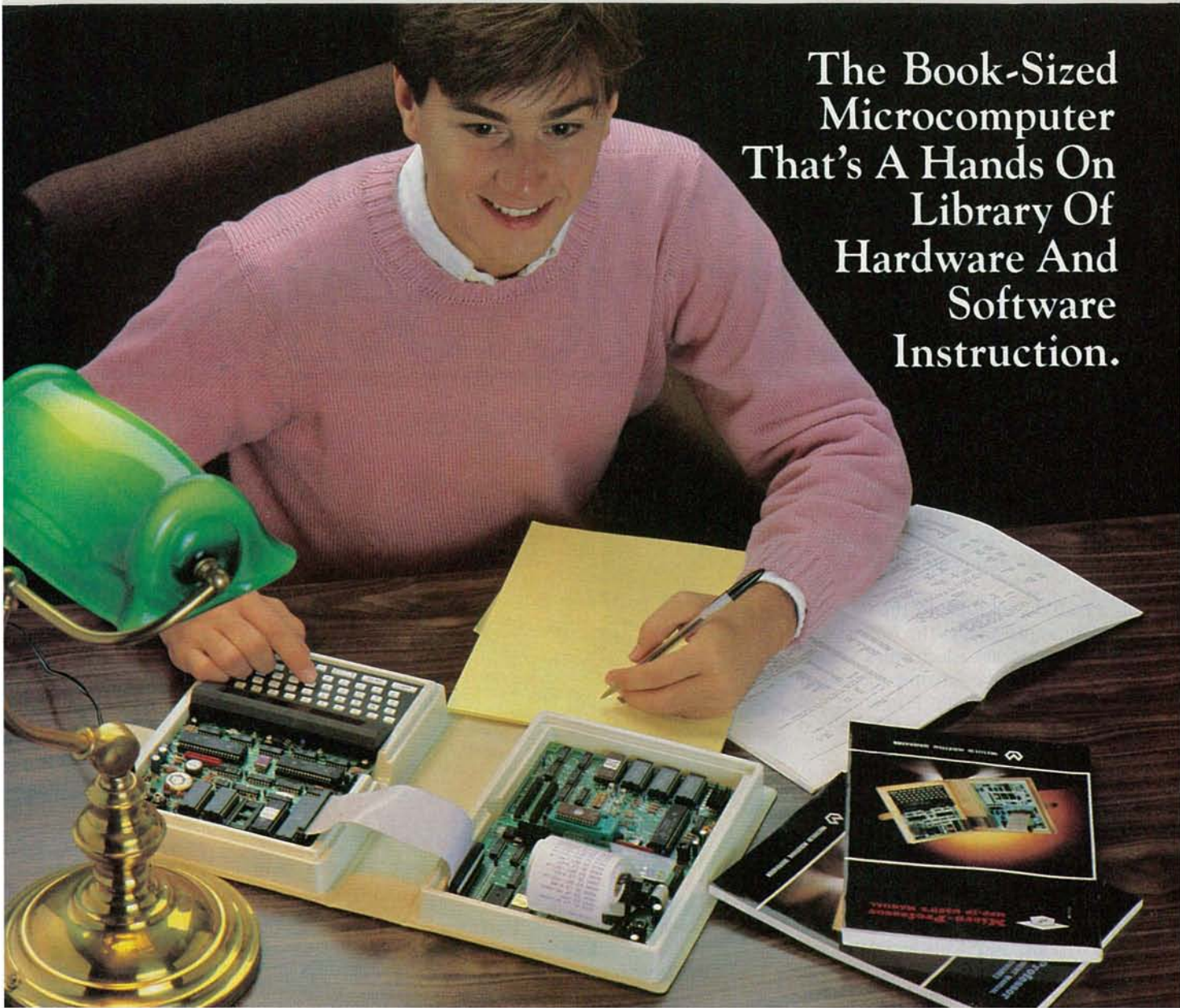

MEET THE MICROPROFESSOR

A portable learning center.

Learning shouldn't be limited to the classroom. That's why we made the MicroProfessor lighter and less bulky than the average textbook. Supported by easy-to-understand documentation, the MicroProfessor leads you through dozens of experiments. And with a wealth of accessories to choose from, including a printer, EPROM programming board and sound and speech synthesis, there's virtually no limit to the kinds of applications you can try your hand at.

Custom tailored to a variety of educational needs.

Whether you're a computer novice or prodigy, interested in guided instruction or independent learning, the MicroProfessor will meet your educational objectives. A teaching tool without peer, the MicroProfessor

puts hundreds of hands on lessons in programming, system architecture and circuit design right at your fingertips. Your computer skills will increase dramatically as the MicroProfessor translates important concepts into practical experience.



The most cost-effective instructional microcomputer on the market.

Today, tight budgets are a fact of life and doubly so for educators and students. At under \$200.00 including Instruction Manual and AC Power Supply—less than half the price of any competitive product—the MicroProfessor is a very attractive educational resource.

For more information about putting the MicroProfessor advantage to work in your computer education, please write or call:

 **Multitech** ELECTRONICS
INC.
Unique Microcomputer Products for Education.

195 West El Camino Real, Sunnyvale
California 94097
Outside California call (800) 538-1542
In California call (408) 773-8400

CIRCLE 267 ON FREE INFORMATION CARD

NEW PRODUCTS

continued from page 38

for equipment capable of using it (including upcoming stereo decoders); for use with standard TV sets, a built-in modulator puts the signal on Channel 3 or 4. The model *SR-1000* is priced at \$499.00. — **Regency Electronics, Inc.**, 7707 Records Street, Indianapolis, IN 46226-9989.

COMPONENT GRIPPER, model *E-90*, lets you remove IC's from boards or sockets safely. It grips on high-density circuits, and eliminates strain and breakage on IC bodies because it grips from the pin centers rather than from the ends. The *Little Gripper* is effective on IC's, as well as on ZIF sockets. It can be adjusted for package tolerances, and can be safely used on static-sensitive devices.



CIRCLE 13 ON FREE INFORMATION CARD

The *Little Gripper*, model *E-90*, comes with a lifetime guarantee. There are no springs, knobs, or screws to break or wear. It is priced at \$29.95. — **Techni-Tool, Inc.**, 5 Apollo Road, PO Box 368, Plymouth Meeting, PA 19462.

AUDIO OSCILLATOR, model *1100*, features low distortion, fixed and variable output levels, and frequency coverage from 20 Hz to 50 kHz. Total harmonic distortion measures 0.01% at 1 kHz and is specified as less than 0.03% from 400 Hz to 25 kHz. A fixed 1-volt



CIRCLE 14 ON FREE INFORMATION CARD

output and a variable 10-millivolt to 8-volt output are both accurate to 0.5%, with a typical flatness of 0.2% from 20 Hz to 20 kHz.

Manual control is by means of front-panel numeric and function keys. Entries are shown on a 4-digit display, and functions indicated by appropriate annunciators. The entire status of instrument functions can be stored in any one of 190 nonvolatile memory locations for later recall. GPIB control provides full talk and listen capability, including return of values in the talk mode and recall of memory contents. A free-form number-entry system, triggering in immediate or wait modes, choice of end-of-string terminators, SRQ function, and front-panel return to local control all contribute to bus versatility.

The model *1100* is priced at \$1795.00. — **Boonton Electronics Corporation**, 791 Route 10, Randolph, NJ 07869.

PRECISION TRIMMER POTENTIOMETERS, the *ME323-422* series lets the user see the wiper setting. These rectangular trimmers are housed in transparent nylon. The user can see exactly where the wiper is positioned for quick adjustments at a glance. The cermet element has an essentially infinite resolution output. It is precision-adjustable over a wide resistance



CIRCLE 15 ON FREE INFORMATION CARD

range. It features a screwdriver-adjusted mechanism (20 turns nominal), $\pm 10\%$ tolerance, and a miniature size that saves board space.

These potentiometers are

EKI

ELECTRONIC KITS INTERNATIONAL, INC.
(Formerly PPG Electronics)

NEW!

EKI MICRO-MENTOR™

Build your own Microprocessor System while learning about the latest technology with the New EKI Microprocessor Course. With this up-to-date course you will completely build, step-by-step, a useful Microprocessor System. This system uses the 8085 microprocessor chip and the 8155 support chip. You will learn how microcomputers work and how to program your system using machine language. You will also be able to interface your system with the EKI Speech Synthesizer Interface Board, enabling your system to talk to you!

COMPLETE COURSE WITH MICROPROCESSOR SYSTEM KIT
only
\$129.95

Speech Synthesizer Kit
\$89.95

DISCOUNTS AVAILABLE TO EDUCATORS

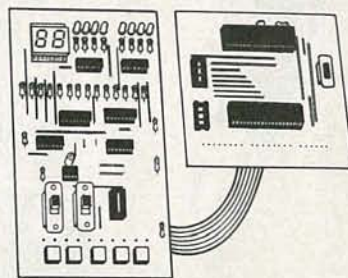

OVER 50 KITS AVAILABLE

KIT

- | | |
|--------------------------------------|--|
| 801 Pocket Dice | 842 12-volt Color Organ |
| 802 Signal Injector | 844 T.V. Jammer |
| 803 Space War Gun | 846 12-volt Strobe Stick |
| 804 Metal Detector | 850 Whooper Alarm |
| 805 Logic Probe | 852 Combination Lock/Alarm Control |
| 806 Burglar Alarm | 856 Electronic Tennis |
| 808 Decision Maker | 858 Digital Roulette |
| 809 LED Pendulum Metronome | 860 5-24 Volt Regulated Power Supply |
| 811 Double Decision Maker | 861 Big Sound Portable Organ |
| 812 Siren Oscillator | 862 Full-wave Motor Speed Control |
| 814 Robot Blinker | 866 Digital Slot Machine |
| 816 Mini-wink | 868 Digital Dice |
| 818 Fish Caller | 870 Horn Tactile |
| 820 Shimmer Lights | 876 8-digit Digital Clock |
| 821 Christmas Tree | 878 Digital Bird |
| 822 One Channel Color Organ | 880 12-volt, 2-amp Regulated Power Supply |
| 824 Automatic Siren | 882 Musical Horn |
| 826 Fuzz Box | 884 Sound Activated Color Organ, 1-channel |
| 828 9-Volt Power Supply | 886 Audio Amp/Intercom |
| 830 Multi-purpose Power Supply | 888 Librarian Terminator |
| 834 Color Organ 3-channel, 1-control | 890 Stop-action Timing Tester |
| 836 3-channel, 4-control Color Organ | 892 Telephone Hold Button |
| 840 Variable Strobe Light | 894 Phaser Gun/Sound Generator |
| | 898 Binary Clock |

FREE CATALOG OF ALL KITS

Available nationwide at your local electronics store.
(Or send \$1.00 shipping & handling to address below.)

EKI ELECTRONIC KITS INTERNATIONAL, INC.

791 RED ROCK ROAD
ST. GEORGE, UTAH 84770

Call TOLL FREE
1-800-453-1708
For store nearest you.

Special Prices for Educators

CIRCLE 99 ON FREE INFORMATION CARD

Get your hands on the scanner the pro's use.



Whether it's firemen, paramedics, reporters or policemen, more professionals use a Uniden® Bearcat® 100 than any other no-crystal hand-held scanner.

It's not just that more professionals use a Uniden® Bearcat® 100 that's important. It's *why*.

The Uniden® Bearcat® 100 will do more for you than many table-top or mobile scanners twice its size.

With 16 channels, four public service bands, two amateur bands, plus military and government land-mobile frequencies, it gives you complete

scanning coverage that fits in your coat pocket. Lockout, hold, manual and automatic search, direct channel access and liquid crystal readouts make it easier to use. And like no other hand-held scanner, the Uniden® Bearcat® 100 has Track Tuning to pull in weak signals wherever you go. It comes complete with rechargeable batteries, charger, and professional quality carry case.

The Uniden® Bearcat® 100. The scanner made for born leaders.

For the name of the dealer nearest you, call 1-800-S-C-A-N-N-E-R.

Uniden Corporation of America, 200 Park Avenue, New York, New York 10166.

uniden®
Bearcat®



BC 100

UNIDEN

Commercial Communications
Marine Communications
Personal Communications
Satellite Technology
Telecommunications

© 1984 UNIDEN CORPORATION OF AMERICA

CIRCLE 271 ON FREE INFORMATION CARD



Uniden® Bearcat® scanners are approved for use in neighborhood crime prevention programs.

power-rated at 0.75 watt at 40°C and come in values from 500 ohms to 1 megohm. Their operating power is 300 volts; dielectric strength is 350-volts AC, and insulation resistance is 100 megohms.

The unit price of the ME323-422 series is 80 cents in quantities of 500.—Mouser Electronics, 11433 Woodside Ave., Santee, CA 92071.

HAND-HELD TERMINALS, the DATA-MAC 8 and the DATA-MAC 16 (shown) are small, light-weight, and calculator-shaped "data collectors." Their 40-key keyboards include 10-key numeric keypads, and letters arranged in alphabetic order. Each key can be defined with a second, 10-character function



CIRCLE 16 ON FREE INFORMATION CARD

The DATA-MAC 8 has an 8,000 character data storage, includes carrying case and battery pack. It is priced at \$1,295.00.

The DATA-MAC 16 has a 16,000 character data storage, and includes carrying case and battery pack. The unit is priced at \$1,495.00.—Definable Data Devices, Inc., PO Box 769, Wilsonville, OR 97070-0769.

WAVEFORM ANALYZER, the model SC61, brings wideband peak-to-peak voltage readings to the IEEE bus. That allows the designer to feed signals to the IEEE bus that agree directly with conventional oscilloscope readings.

The model SC61's includes the following features: Its autoranging

DC voltage circuits read to a full 2000 volts from two different test



CIRCLE 17 ON FREE INFORMATION CARD

points. Its autoranging frequency counter reads from 10 Hz (with 0.01-Hz resolution) to 100 MHz (with 6-digit resolution) from either of two channels. Its ratio function automatically calculates the ratio of two frequencies; that function is handy for testing multiplier or divider stages.

The model SC61 is priced at \$3275.—Sencore, 3200 Sencore Drive, Sioux Falls, SD 57107. R-E

A QUALITY TRIPLE-REGULATED POWER SUPPLY AT A LOW, LOW PRICE!!

NOT A KIT!



MODEL PS101
FULLY ASSEMBLED & TESTED!

\$119⁸⁸
FULL 1 YEAR REPLACEMENT WARRANTY
— Made In The United States —

SPECIFICATIONS

3 outputs:
Fixed 5 VDC \pm 0.2V
2 variable \leq 1 1/2 V to \geq 15 VDC
Polarity - floating; can be used as pos. or neg.
Ripple less than 10mV at full load,
Regulation \leq 1% no load to full load,
Line Regulation $<$ 0.2% 108 VAC to 135 VAC.
Current:
Fixed supply 1.0 amp max.
Variable supplies 0.5 amp max.

Protection built in, current limiting, with thermal shutdown.
Power: 108-135 VAC.
Dimensions: 8 1/4" x 3 1/4" x 7 1/4" (WxHxD)
Wood grain finished metal case.
Weight: 4 lbs., 9 ozs.
Lighted on/off power switch, easy-to-read Voltmeter and large binding posts.
Warranty: one year full replacement warranty from date of purchase.

DISTRIBUTOR AND REPRESENTATIVE INQUIRIES INVITED



VISA, MASTERCARD, AMEX TELEPHONE ORDERS ACCEPTED!
6 Herman Drive, E. Granby, CT 06026 □ 203/651-0285

CIRCLE 255 ON FREE INFORMATION CARD

**New
800 MHz models**

Regency Scanners

*Bring you the Excitement of Police,
Fire, Emergency Radio, and more.*



MX5000

Our radios deliver the local news. From bank hold-ups to three alarm fires. It's on-the-scene action. While it's happening from where it's happening . . . in your neighborhood.

You can also listen to weather, business and marine radio calls. Plus radio telephone conversations that offer more real life intrigue than most soap operas. And with our new models, there's even more.

Unique Capabilities

Introducing two all new Regency scanners. First, there's the MX7000, a 20 channel, no-crystal unit that receives continuously from 25 to 550 MHz and 800 MHz to 1.2 GHz. That's right! Continuous coverage that includes VHF and UHF television audio, FM Broadcast, civil and military aircraft bands and 800 MHz communications. Next in line is the new MX4000. It's eight band coverage includes standard VHF and UHF ranges with the important addition of 800 MHz and aircraft bands. Both units feature keyboard entry, a

multifunction liquid crystal display and selectable search frequency increments.

Practical Performance

If you don't need the 800 MHz range coverage, Regency offers two exciting new units. The MX5000 is a 20 channel, no-crystal scanner that receives continuously from 25 to 550 MHz with all the same features as the MX7000. Then there's the 30 channel MX3000. It's digitally synthesized so no crystals are necessary, and the pressure sensitive keyboard makes programming simple. What's



MX4000



MX3000

more, it has a full function digital readout, priority, search and scan delay, dual scan speed, and a brightness switch for day or night operation.

At Home Or On The Road

With compact design, easy access front panel and mounting bracket these Regency scanners are ideal for mobile* use. But we also supply each radio with a plug-in transformer and a telescoping antenna so you can stay in touch at home. The MX4000 even has a rechargeable battery pack so it's fully portable.

See your Regency Scanner Authorized Dealer for a free demonstration on these and other new Regency Scanners. Or, write Regency Electronics, 7707 Records Street, Indianapolis, IN 46226.

ELECTRONICS, INC.®

7707 Records Street
Indianapolis, IN 46226-9989

*Mobile use subject to restriction
in certain localities.

VICTOR MEELDIJK

DID YOU KNOW THAT:

Polystyrene foil capacitors may be better for timing circuits than polycarbonate types?

Tantalum capacitors are not recommended for any application where current spikes are present?

A **hybrid potentiometer** consisting of a wirewound element and a conductive plastic track will have a life span that is 10 times greater than that of a wirewound potentiometer?

Power wirewound resistors can be operated with a body temperature of 275°C, and that some can be operated at body temperatures of as high as 500°C?

From the above, it should be clear that there's a lot to know about the many different types of resistors and capacitors available. That's because each type has its own unique characteristics, and those characteristics make some types of resistors and capacitors far better for certain applications than others. Selecting the proper component for a particular application is vital in order to ensure the reliability of your design. In this article, we'll look at the various factors that you should consider when selecting resistors and capacitors for your projects.

Resistors

When selecting a resistor, consider stability, noise, power dissipation, environment, AC requirements, and resistance. Actual resistance value is a function of tolerance, voltage coefficient, temperature coefficient, and drift with time. The power rating is based upon ambient temperature and derating. Derating, which is the operation of a component at something less than 100% of its specified rating, may be necessary because of environmental conditions.

Resistor compositions include carbon, film, and wirewound for fixed resistance units, and cermet and conductive plastic for variable resistors. Figure 1 shows many of the types of resistors available.

Carbon resistors

Carbon-composition units have a resistive element that is molded from carbon powder that has been mixed with a phenolic binder to form a uniform resistive body. That device, molded with end leads, is a general purpose resistor capable of withstanding temperature and electrical transient shocks. The carbon-

SELECTING THE BEST RESISTOR/CAPACITOR

There's much more to selecting components for your designs and projects than meets the eye. In this article, we'll look at the various types of resistors and capacitors, and what factors you should consider when selecting which type to use.

composition resistor is used in applications where initial tolerance need not be closer than $\pm 5\%$ with long term stability no better than $\pm 20\%$.

For variable resistors, one problem is that the carbon element requires a high contact force to ensure that any variation in the contact resistance remains within acceptable limits. That results in high shaft-torque and poor adjustability.

Carbon elements are susceptible to moisture absorption and such moisture absorption can cause the resistance to change by as much as 20%. That resistance shift can be reversed if the device is baked at high temperatures (100°C).

Film resistors

Metal-film devices are used in applications requiring higher stability and precision than available from carbon devices. In addition, metal-film resistors should be used in applications where AC is present. Operation is satisfactory from DC to the MHz range. Metal-film units have low temperature coefficients and suffer little degradation to ambient temperatures of 125°C and higher. Film resistors can be

classified according to the techniques used in their manufacture.

One such technique is vacuum deposition, which is also known as evaporated metal film. In it, a nickel-chromium alloy is superheated in a vacuum. The alloy vaporizes and is deposited on a ceramic substrate. Small quantities of contaminants

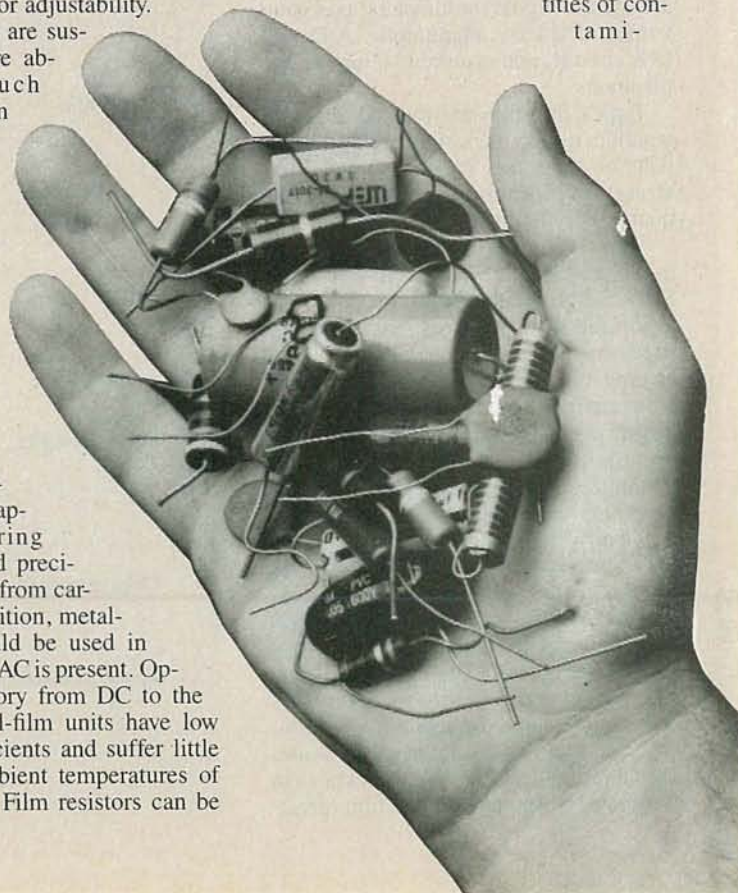



FIG. 1—THERE ARE MANY DIFFERENT resistor compositions and types. Among them are carbon, film, wirewound, cermet, and conductive plastic.

nants, called dopants, are used to control resistor characteristics such as resistance range. Those resistors are used in applications that require an extreme degree of precision.

In sputtering, a nichrome target is heated and bombarded by argon atoms. That results in metal atoms being knocked off and deposited on a substrate. Resistors manufactured using that sputtering technique are also suitable for applications that require a high degree of precision.

In metal-oxide deposition, a chemical vapor is used to deposit a tin-oxide film onto a glass substrate. That technique, which is primarily used by Corning is used to produce resistors for general-purpose, semi-precision, and precision applications.

Thin-film resistors are highly stable, have low-noise characteristics, and have a very low temperature-coefficient. They are used in digital multimeters, precision voltage-dividers, attenuators, A/D and D/A circuits, and in current-summing applications.

Typical thin-film resistors are sputtered tantalum nitride, deposited chromium cobalt, or nichrome, on a substrate. Substrates of alumina, sapphire, glass, quartz, beryllia or silicon are used.

Thin-film resistor networks are also available; those are housed in DIP's and SIP's (Single In-line Package).

In individual resistors, the terminals used may be either surface or wrap-around types. Wrap-around terminals wrap around the side of the substrate allowing connections to the underside. Terminals of solder, silver over nickel, platinum, or platinum gold are available. Trimming of the resistor is done either mechanically or by using a laser.

In thick-film resistors, a ceramic substrate is coated (silk screened—a mechanized stenciling process) with a glass-metal material and then fired (to cure it) at a high temperature. The glass-metal materials include nichrome, silver palladium, platinum, ruthenium, rhodium, gold and a tantalum-modified tin oxide. That film is up to 100 times thicker than evaporated or sputtered metal film (great-

er than .0001 inches thick) and is used in applications requiring high power density or the capability of surviving power spikes or overloads. Those units are suitable for some precision applications, but not those requiring an extremely high degree of precision.

Bulk metal resistors, made in a process that is proprietary to the Vishay Corporation, metal foil is laminated to a substrate and then chemically etched to produce a conductive path. The flat element is used exclusively for high-precision applications and has tight tolerances and an excellent temperature coefficient.

TABLE 1—RESISTOR SELECTION GUIDELINES

TYPE	SPECIFICATIONS AND NOTES
Carbon composition	Resistance range: 2.7 ohms to 100 megohms Power rating: to 2 watts Tolerance: 5% to 20% Temperature coefficient: -200 to -8000 PPM/°C Noise: less than 6 μ V/V Derating factors: 50% power, 80% voltage Notes: General purpose. Excellent transient and surge handling capabilities. RF produces capacitive effects end to end, and operation at VHF or higher frequencies reduces effective resistance due to dielectric losses. Resistance increases by 20% during storage under humid conditions.
Carbon composition potentiometer	Resistance range: 50 ohms to 10 megohms Power rating: to 5 watts Temperature coefficient: 1000 PPM/°C Derating factors: 50% power, 80% voltage Life expectancy: 5,000,000 rotations Failure mode: noise Notes: High shaft torque causes poor adjustability
Carbon Film	Resistance range: 10 ohms to 25 megohms Power rating: 0.1 to 10 watts Tolerance: 2% to 10% Temperature coefficient: -200 to -1000 PPM/°C Noise: less than 10 μ V/V Derating factors: 50% power, 80% voltage Notes: General purpose, cost less than carbon-composition units
Metal film	Resistance range: 10 ohms to 3 megohms (high voltage types: 1 kilohm to 30 gigohms) Power rating: to 10 watts (high voltage types: to 6 watts) Tolerance: 0.1% to 2% Temperature coefficient: ± 25 to ± 175 PPM/°C Noise: less than 0.1 μ V/V Life expectancy (potentiometers): 100,000 rotations Failure mode: resistance change or catastrophic failure Derating factors: 50% power, 80% voltage Notes: Fair degree of precision in lower value units. High stability, long life, and excellent high-frequency performance. Resistance values stable to about 100 MHz; begin to decrease beyond that frequency. Used in high-frequency tuning circuits, measuring circuits, filters, etc.
Film networks	Resistance range: 10 ohms to 33 megohms Power rating: to 0.2 watts per element, to 1.6 watts per network Tolerance: 0.1% to 5% Operating temperature range: -55 to +125°C Temperature coefficient: ± 25 to ± 300 PPM/°C Notes: Tracking between resistors 5 PPM/°C
Chip resistors	Resistance range: 1 ohm to 100 megohms Power rating: to 2 watts Tolerance: 1% to 20% Operating temperature range: -55 to +125°C
Power wirewound	Resistance range: 0.1 ohm to 180 kilohms Power rating: to greater than 225 watts Tolerance: 5% to 10% Temperature coefficient: less than ± 260 PPM/°C Noise: low static, high dynamic noise levels Derating factors: 50% power, 80% voltage

Carbon-film resistors were introduced to perform the same basic functions as carbon-composition resistors, but at a lower price. Just like composition types, they lack the ability to withstand transient voltage spikes and have a poor temperature coefficient.

An axial-lead, carbon-film resistor is made by screening carbon based resistive inks on a ceramic rod and then firing the assembly. Alternate techniques include depositing pure carbon by cracking a hydrocarbon gas or by depositing a nickel film for resistor values of less than 10 ohms. The resistive element may also be

sprayed on, applied with a transfer wheel, or dipped on.

The rod is then cut to size, leaded end caps are attached, and the unit is trimmed to a precise value. The resistor is then coated with an insulating material. Carbon-film resistors are available in the same resistance values as carbon-composition units and have a typical tolerance of $\pm 5\%$.

Wirewound resistors

Wirewound resistors are used where large power dissipation is required and where AC performance is relatively unim-

portant. Those devices are generally satisfactory for use at frequencies up to 20kHz. They are available with various insulating/moisture preventative coatings such as vitreous enamel, cement, molded phenolic, glass sleeves, or silicone.

Vitreous enamel units have excellent moisture-resistance properties and will not burn (although they may melt) under high overload conditions since they are made from a glass type material.

Silicone, which also has excellent moisture-resistance characteristics, is an organic material and is more flammable at lower overload conditions than vitreous enamel. It will also emit gases under overload conditions leaving deposits on electrical contacts.

Cement coatings are composed of inorganic materials. Those coatings are essentially flameproof but can be made to burn if subjected to high overloads for long periods. Resistors coated with that material are also subject to changes in value with exposure to moisture.

Aluminum and water-cooled housings are also available. Those housings facilitate the transfer of heat away from the resistive element.

In wirewound resistors, three alloys are commonly used for the resistive element. They are nickel-chromium, Copper-nickel, and gold-platinum. Nickel-chromium is the most common due to its excellent temperature coefficient (less than ± 5 PPM/ $^{\circ}\text{C}$) and its availability in many different diameters. Copper-nickel is the next most popular, with a temperature coefficient of ± 20 PPM/ $^{\circ}\text{C}$. The gold-platinum alloy, that is actually a complex alloy of gold, platinum with small amounts of copper and silver has a high temperature coefficient of ± 650 PPM/ $^{\circ}\text{C}$, but has low resistance. That resistance is 85 ohms/cm (cmf is a circular mil foot, a hypothetical quantity equivalent to one foot of wire that is .001 inches in diameter) while nickel-chromium has a resistivity of 800 ohms/cm. The gold-platinum alloy can also withstand harsh environments.

The ceramic core of a wirewound resistor is either beryllium oxide, which has a high cooling capability, alumina (aluminum oxide) or steatite, which has the lowest thermal conductivity of the three materials but is low cost. Figure 2 shows some steatite cores.

Wirewound resistors are most often used in voltage divider circuits, as power-supply bleeder resistors, or as series dropping resistors. Variable devices are used where voltage and current variations are expected, such as motor-speed and heater controls. Precision variable types are used in servo systems requiring precise electrical and mechanical performance.

Other resistor types

For low resistance/high current applications, edgewound ribbon type power

TABLE 1 CONTINUED

TYPE	SPECIFICATIONS AND NOTES
Precision wirewound	<p>Resistance range: 0.1 ohm to 800 kilohms</p> <p>Power rating: to 15 watts</p> <p>Tolerance: .01% to 1%</p> <p>Temperature coefficient: varies with resistance</p> <p>Noise: low static, high dynamic noise levels</p> <p>Life expectancy (potentiometers): 200,000 to 1,000,000 rotations</p> <p>Failure mode: Catastrophic failure</p> <p>Derating factors: 50% power, 80% voltage</p> <p>Notes: Wirewound resistors are used in low-tolerance, high-power dissipation applications where AC performance is not critical. Power dissipation depends on heat sink or air flow around the device. When mounting on a PC board, standoffs should be used to prevent charring the board. Not suitable for use at frequencies above 50 kHz. Wirewound potentiometers do not suffer from contact resistance variations. The units can be manufactured with low temperature coefficients and tight tolerances. Applications include motor speed controls, lamp dimmers, heater controls, etc. Precision types are used in servo mechanisms.</p>
Cermet	<p>Resistance range: 50 ohms to 5 megohms</p> <p>Power rating: to 2 watts</p> <p>Life expectancy (potentiometers): 50 to 500,000 rotations</p> <p>Failure mode: noise</p> <p>Derating factors: 50% power, 80% voltage</p> <p>Notes: Very stable under humid conditions. Low temperature coefficients. Low end resistance (2 ohms). Short life expectancy. High resolution of the resistive element allows for more precise trimmer settings. Less reactance in high-frequency applications than wirewound units, and are lower in price. Cermet is also the thick film used in resistor networks and chip resistors.</p>
Conductive plastic potentiometers	<p>Resistance range: 150 ohms to 5 megohms</p> <p>Power rating: to 1 watt</p> <p>Temperature coefficient: -600 to -300 PPM/$^{\circ}\text{C}$</p> <p>Life expectancy: 100,000 to 4,000,000 rotations</p> <p>Failure mode: Noise</p> <p>Derating factors: 50% power, 80% voltage</p>
General purpose conductive plastic potentiometers	<p>Resistance range: 1 ohm to 15 kilohms, depending on power rating</p> <p>Power rating: to 1000 watts</p>
Precision conductive plastic potentiometer	<p>Resistance range: 100 ohms to 500 kilohms</p> <p>Power rating: to 7 watts</p> <p>Tolerance: 3%</p> <p>Temperature coefficients: less than 70 PPM/$^{\circ}\text{C}$</p> <p>Life expectancy: Greater than 2,000,000 rotations</p>
Conductive plastic trimmers	<p>Resistance range: 10 ohms to 100,000 ohms</p> <p>Power rating: to 1 watt</p> <p>Notes: Conductive plastic potentiometers have a long life expectancy and low-noise characteristics. Resistance will shift if exposed to humidity.</p>
Hybrid potentiometers	<p>Resistance range: 200 ohms to 250,000 ohms</p> <p>Power rating: to 7 watts</p> <p>Tolerance: 5%</p> <p>Temperature coefficient: less than ± 100 PPM/$^{\circ}\text{C}$</p> <p>Life expectancy: 10,000,000 rotations</p>

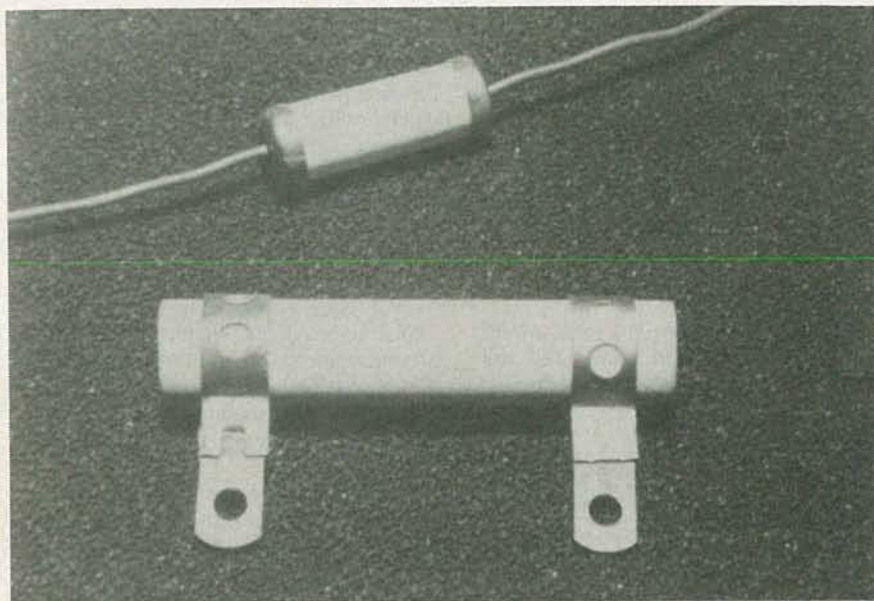

FIG. 2—MANY WIREWOUND RESISTORS use Steatite cores, such as the ones shown here.

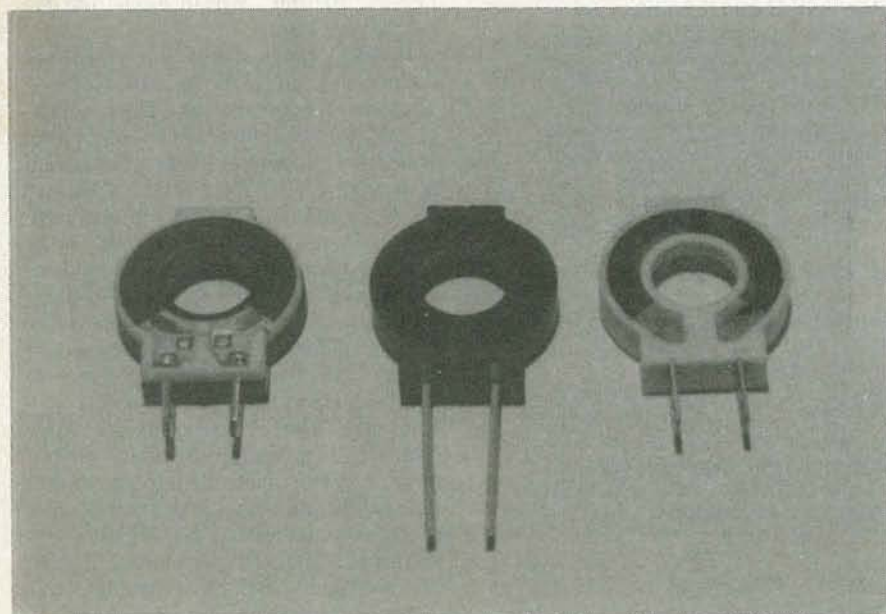

FIG. 3—POTENTIOMETERS can use resistive elements made of many different materials. Three such materials, shown above from left to right, are cermet, carbon, and conductive plastic.

resistors are available. Designed for power handling up to 1000 watts (at currents up to 100 amps) these devices are made up of steel ribbons wound into a coil and supported by ceramic insulators. They are generally rated for normal operation with a temperature rise of 375°C. Those units are used in power-supply testing and in motor-breaking systems. (You may have seen them underneath subway cars, especially the older trains in New York City.)

Cermet devices have a resistive element made by combining very fine particles of ceramic, or glass, with precious metals.

Cermet devices are very stable under humid conditions and have low temperature coefficients of ± 100 PPM/°C. Conductive-plastic or hot-molded carbon potentiometers, for example, have an average temperature coefficient of ± 1000 PPM/°C. In variable resistors, however, the cermet element is abrasive and long periods of rotational cycling will wear out the wiper long before similar use would wear out the wiper in resistive-film or conductive-plastic units. Cermet potentiometers are available in low resistance values, which makes them useful in many audio applications.

Cermet is also the thick film used in resistor networks and in chip resistors.

Conductive plastic potentiometers have a resistive element consisting of a blend of resin (epoxy, polyester, phenolics, or polyamides) and a carbon powder applied to a plastic or ceramic substrate. The plastic substrate results in a better temperature coefficient due to greater compatibility between the ink and the substrate. Those devices have a long rotational life and excellent contact resistance variation, or low noise. End resistance is low, two ohms maximum.

Conductive plastic units are suitable for use in applications that require a consistent temperature coefficient over a limited temperature range, such as -25°C to 75°C . Temperature coefficient values of -200 PPM/°C may be attained by special processing of the carbon material or by incorporating metal powders, or flakes, into the element. Nickel, silver, and copper are frequently used in low-resistance devices. Conductive-plastic elements, like carbon units, vary in resistance when exposed to humid conditions. Figure 3 shows cermet, carbon, and conductive plastic units.

Hybrid potentiometers are wirewound units with a conductive-plastic track deposited along the contact path of the resistive element. That results in a device that has a better resolution and a longer life, by a factor of 10, over wirewound types. Compared to conductive-plastic units, hybrid devices have a higher power handling capability, due to the wirewound element. Like wirewound units however, they have stray capacitance at higher frequencies and have high contact resistance and marginal output smoothness when drawing current through the wiper contact.

Table 1 summarizes the resistor types available, their characteristics, recommended applications, and suggested derating factor. Use of a derating factor is an effective means to decrease the failure rate of most devices since device life is stress and temperature dependent. Derating is accomplished by either decreasing part stresses such as power/voltage or current or by selecting a higher rated part. Optimum derating occurs at or below the point where an increase in stress or operating temperature results in a large increase in the device failure rate.

One note about Table 1: The values and ratings shown are provided as guidelines. While they apply to the most commonly found units, it is not impossible to find units with slightly, or greatly, different specifications.

While that concludes our look at resistors, our look at component selection is far from over. In the next part of this article, we'll turn our attention to the factors that should be considered when selecting capacitors.

R-E

ALL ABOUT

STEREO Audio For TV



BRIAN C. FENTON, TECHNICAL EDITOR

A recent FCC decision has set the stage for multichannel television sound. Here's a look at that decision, its technical aspects, and the new dimension in TV sound that it makes possible.

STEREO TV IS FINALLY HERE! IT'S THE most exciting development in television since the introduction of the videodisc player and VCR. Interestingly enough, while the idea of stereo television has been on the minds of the industry for some time, it was the *consumer's* interest—stimulated by videodisc players and VCR's—that was the driving force behind making it a reality. But *Multichannel Television Sound (MTS)* is not just stereo TV—it's a completely new way of using television's audio signal.

The FCC decision

The Federal Communications Commission authorized multichannel TV sound in late March 1984 by adopting new, very general rules regarding TV audio signals. As a result of that action, stereo TV sound, as well as second-language programming and many other services, are now possible.

As has been the the FCC's policy of late, the Commission did not adopt a single system as a stereo TV standard. Remember the FCC's "let the marketplace decide" decision on AM stereo, and the uncertainty and inaction in the marketplace that it caused. (AM stereo is yet to really get off the ground.) But thanks to the television industry, that's not about to happen to stereo TV!

The main difference between the two cases is that the industry—with the knowledge of what happened with AM stereo—presented a single proposal to the FCC for adoption. Both broadcasters and equipment manufacturers worked to-

gether through the EIA (Electronic Industries Association) whose Broadcast Television Systems Committee (BTSC) worked 5 years selecting a system as a standard. The transmission system that was chosen by the BTSC was developed by Zenith, and the noise reduction system was developed by dbx Corporation. (Those were selected over transmission systems developed by the Electronic Industries Association of Japan and Tele-sonics Systems, Inc. and noise-reduction systems developed by Dolby and CBS Laboratories.)

Together, the Zenith transmission system and the dbx-TV noise reduction system make up the BTSC multichannel television sound or MTS system. We'll take a close look at both systems a little later on in this article.

Even though the FCC was presented with a proposal for a single MTS system, the Commission's decision still followed an "open marketplace" policy. That was based on the (correct) belief that MTS technology will continue to advance beyond the BTSC system. However, because the FCC was aware both of what happened with AM stereo and the industry's proven desire for a single standard, they endorsed the BTSC system by protecting its *pilot tone*. That means that the pilot frequency may be used only by broadcasters using the BTSC system. By restricting the use of the pilot frequency, BTSC-type receivers are protected from falsely detecting other MTS formats, but any other MTS system can be used *if the marketplace calls for it*.

The BTSC system

Before late March, 1984, the TV-audio baseband—the band of frequencies from 0 to 120 kHz that contains a TV signal's audio information—was limited to carrying only audio in the *main channel* (the portion of the baseband from 50 Hz to 15 kHz). Now, thanks to the FCC decision, the audio baseband is virtually unregulated. For most of us, that means that we can now listen to TV in stereo or in a second language. But for broadcasters, it means a number of options.

Figure 1 shows a "fully loaded" MTS audio baseband. We'll call it stereo + SAP service. The frequency-modulated main-channel audio is contained from 50 to 15 kHz, just as it is in any TV broadcast. What is different from conventional TV signals is that the baseband also includes an amplitude-modulated *stereo-difference* subcarrier, a pilot signal, a SAP (Second-Audio-Program) channel, and a *professional channel*. But that is only *one* of the possible configurations. Figure 2 shows three other possible configurations: stereo service without SAP capability, mono service with SAP capability, and mono service without SAP capability. Note that each configuration leaves room for a professional channel.

The professional channel can be used for a wide variety of non-program-related uses. A TV station can use it to relay broadcast materials to other stations, to communicate with remote crews, etc. But the professional channel could also be used to transmit signals to *you*—or, to be more precise—to your TV receiver. For

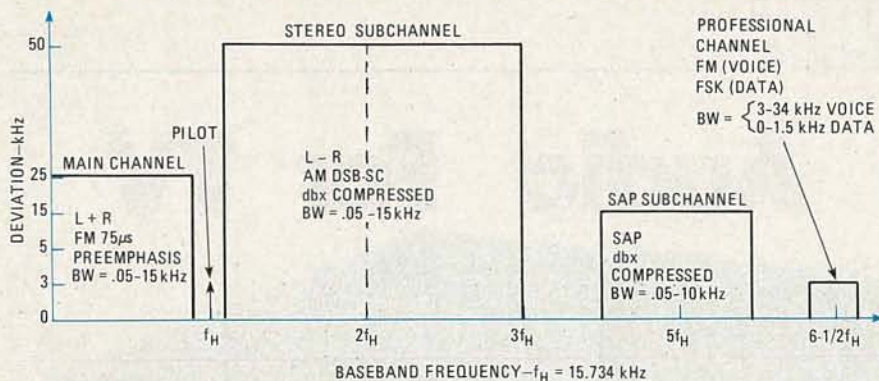

FIG. 1—THE "FULLY LOADED" AUDIO BASEBAND for multichannel television sound contains the frequency-modulated main channel, amplitude-modulated stereo subchannel, an amplitude-modulated SAP subchannel, and a professional channel.

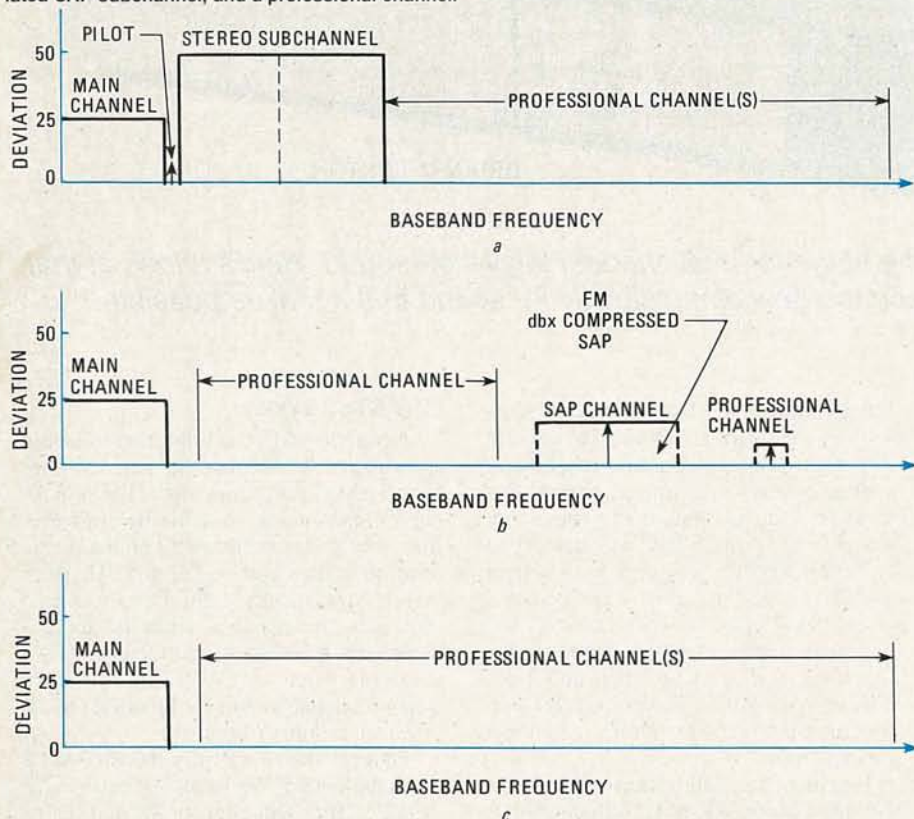

FIG. 2—THE AUDIO BASEBAND can be configured in many ways under the new regulations. Here we see stereo-only service (a), mono service with SAP (b), and mono service (c). Note that each configuration leaves room for a professional channel. That professional channel can be used for a variety of non-program related applications.

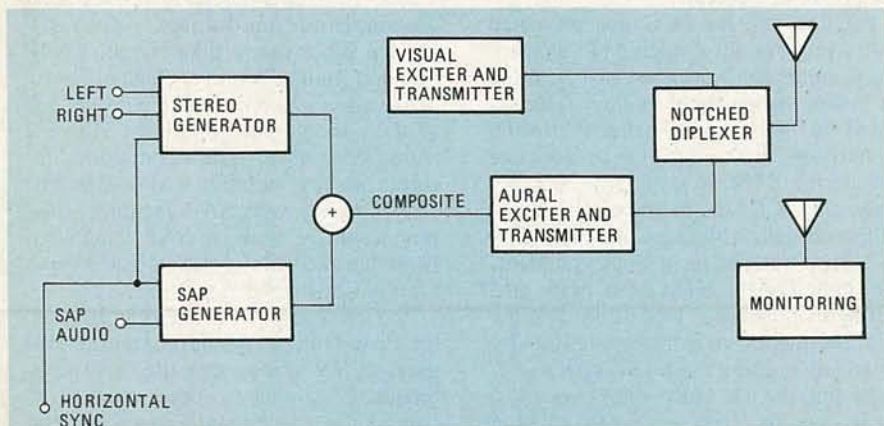

FIG. 3—BTSC TRANSMISSION SYSTEM. The signal that drives the audio (aural) transmitter is the sum of the stereo and SAP-generator outputs. A diplexer is used so that the video transmitter and audio transmitter can use the same antenna. The notch filter at 4.5 MHz reduces one source of audio buzz: the direct spillover of video sideband components into the audio carrier spectrum.

example, a signal could be sent to turn on receiver noise-reduction circuitry. Another—though unlikely—possibility is that a TV station could transmit control signals to your VCR so that it wouldn't record commercials.

The professional channel is not restricted to carrying TV-related signals; it can also be used for subsidiary communications services (much like the broadcast FM SCA services).

It's really here!

Before we go into some of the theory behind MTS, let us emphasize that stereo television and multichannel TV sound are here for real. The first commercial television broadcast with stereo sound took place during coverage of the 1984 Summer Olympics in Los Angeles. Television digest, the industry newsletter, notes that as of November 1, 1984, 7 stations were on the air with almost 200 others either testing or planning MTS. Table 1 is a list of those stations.

The Zenith transmission system

The MTS system that was chosen by the industry and endorsed by the FCC is made up of a transmission system and a noise-reduction system. The transmission system selected was developed by Zenith.

An important aspect of the Zenith system is that it is compatible with the existing NTSC standard. That is important because any MTS system not compatible with existing TV's would be useless—neither the broadcasters nor the equipment manufacturers would support it.

In order for MTS signals to be compatible with conventional signals, the main channel must be compatible. Therefore, the main channel of the Zenith system signal contains the monaural signal, which is the sum of the left- and right-channel signals. (We'll refer to the monaural signal as the *stereo sum* or L+R signal). That L+R signal frequency-modulates the TV carrier in the same way that a conventional mono signal does.

The *stereo difference* signal (L-R) amplitude-modulates a subcarrier centered at a 31.468 MHz—twice the horizontal scanning frequency, $2f_H$. A pilot signal, which is used by the receiver to decode the stereo information, is located in the audio baseband at the horizontal scanning frequency, f_H (15,734 kHz). As we mentioned previously, while the rest of the audio baseband is virtually unregulated, that pilot frequency is protected under FCC rules.

A standard (mono) TV set will ignore everything but the main channel and will recover the L+R audio just as it would any mono signal. A stereo-capable set, however, will use the pilot signal both to recognize that a stereo signal is present and to generate a carrier for decoding the L-R component.

TABLE 1—MTS BROADCASTERS

All stations stereo, non-SAP, unless otherwise indicated in footnote.

Now broadcasting regularly in stereo:

WTTW	Chicago, IL	(PBS)
WTIC-TV	Hartford, CT	(ind.)
KTLA	Los Angeles, CA	(ind.) ^a
KIRO-TV	Seattle, WA	(CBS)
KOMO-TV	Seattle, WA	(ABC)
WDBB-TV	Tuscaloosa, AL	(ind.)
WTXX	Waterbury, CT	(ind.)

Planning fall 1984 start:

WZTZ-TV	Boston, MA	(ind.)
WEDH	Hartford, CT	(PBS)
WFSB	Hartford, CT	(CBS)
WTLV	Jacksonville, FL	(ABC)
KABC-TV	Los Angeles, CA	(ABC)
KTLA	Los Angeles, CA	(ind.) ^a
KMSO-TV	Missoula, MT*	(CBS) ^f
WNET	N.Y.-Newark	(PBS)
KATU	Portland, MT	(ABC)
KRBK-TV	Sacramento, CA	(ind.)
KPLR-TV	St. Louis, MO	(ind.)
KSL-TV	Salt Lake City, MO	(CBS)
WMHT	Schenectady-Albany-Troy, NY	(PBS)
WTVG	Toledo, OH	(NBC)
WNJT	Trenton, NJ	(PBS) ^b
KPOL	Tucson, AZ*	(ind.) ^f

Planning winter 1984-85 start:

KTVA	Anchorage, AK	(CBS)
WGNX-TV	Atlanta, GA	(ind.)
WBZ-TV	Boston, MA	(NBC)
WVIZ-TV	Cleveland, OH	(PBS)
KERA-TV	Dallas, TX	(PBS) ^a
KOOD	Hays-Russell-Gt. Bend, KS	(PBS)
KVVU-TV	Henderson-Las Vegas, NV	(ind.)
WIUD	Lakeland, FL*	(ind.)
WMFP	Lawrence, MA*	(ind.)
WPBT	Miami, FL	(PBS)
WYES-TV	New Orleans, LA	(PBS)
WEDN	Norwich, CT	(PBS)
KTIE-TV	Oxnard, CA*	(ind.)
WPSD-TV	Paducah, KY	(NBC)
WEEK-TV	Peoria, IL	(NBC)
KPHO-TV	Phoenix, AZ	(ind.)
KSBW-TV	Salinas-Monterey, CA	(NBC)
KUED	Salt Lake City, UT	(PBS) ^a
KSAT-TV	San Antonio, TX	(ABC) ^c
KOVR-TV	Sacramento, CA	(ABC)
WFSU-TV	Tallahassee, TN	(PBS)

Planning spring 1985 start:

WTBS	Atlanta, GA	(ind.)
WJZ-TV	Baltimore, MD	(ABC) ^a
WTTQ	Birmingham, AL	(ind.)
KWHP	Boise, ID*	(ind.)
new,	Cedar City, UT*	
WMAQ-TV	Chicago, IL	(NBC)
WCET	Cincinnati, OH	(PBS) ^a
KHBS	Ft. Smith, AR	(ABC) ^e
KMSG	Fresno (Sanger), CA*	(ind.)
WXII	Greensboro-High Point-Winston-Salem, NC	(NBC)
WITF-TV	Harrisburg, PA	(PBS)
new,	Idaho Falls, ID*	(ind.)
WFYI	Indianapolis, IN	(ind.)
WRLR	Las Vegas, NV*	(ind.)
WIYE	Leesburg, FL	(ind.)

KNBC-TV	Los Angeles, CA	(NBC)
KWHY-TV	Los Angeles, CA	(ind.)
WBFS-TV	Miami, FL*	(ind.) ^a
WMVS	Milwaukee, WI	(PBS) ^a
WMVT	Milwaukee, WI	(PBS) ^a
WLCT	New London*	(ind.)
WNOL-TV	New Orleans, LA	(ind.)
WNBC-TV	New York, NY	(NBC) ^a
WCFE-TV	Plattsburg, NY	(PBS) ^a
WXXI	Rochester, NY	(PBS)
KCRA-TV	Sacramento, CA	(NBC)
KETC	St. Louis, MO	(PBS)
WOIO	Shaker Heights, OH*	(ind.)
KSMW	Spokane, WA*	(ind.)
WACO	Waco, TX*	(ind.)
WRC-TV	Washington, DC	(NBC)
WHYY-TV	Wilmington-Phila., PA	(PBS)

Planning start in late 1985:

KNME-TV	Albuquerque, NM	(PBS) ^f
KOAT-TV	Albuquerque, NM	(ABC)
KTUU-TV	Anchorage, AK	(NBC)
WATL-TV	Atlanta, GA	(ind.)
WCBB	Augusta-Lewiston-Portland, ME	(PBS)
WSKG	Binghamton, NY	(PBS) ^a
WGBH-TV	Boston, MA	(PBS) ^a
WNEV-TV	Boston, MA	(CBS)
WNJS	Camden, NJ	(PBS) ^e
WKYC-TV	Cleveland, OH	(NBC)
KLBY	Colby, KS*	(ind.)
WCMH-TV	Columbus, OH	(NBC)
WOSU-TV	Columbus, OH	(PBS)
WTVN-TV	Columbus, OH	(ABC)
WJBK-TV	Detroit, MI	(CBS) ^a
WKBD-TV	Detroit, MI	(ind.)
WTVS	Detroit, MI	(PBS) ^f
WXYZ-TV	Detroit, MI	(ABC)
KTSM-TV	El Paso, TX	(NBC)
KVIA-TV	El Paso, TX	(ABC) ^a
KJEO	Fresno, CA	(ABC) ^c
WLRE	Green Bay	(ind.)
KHOU-TV	Houston, TX	(CBS) ^a
WVSN-TV	Humacao, PR*	(ind.)
KIFI-TV	Idaho Falls, ID	(NBC) ^e
WJXT	Jacksonville, FL	(CBS)
KATV	Little Rock, AR	(ABC)
KHJ-TV	Los Angeles, CA	(ind.) ^a
WMAZ-TV	Macon, GA	(CBS)
WCIX-TV	Miami, FL	(ind.)
WCCO-TV	Minneapolis-St. Paul, MN	(CBS) ^f

WNJM	Montclair, NJ	(PBS) ^e
WNJB	New Brunswick, NJ	(PBS) ^e
WEDY	New Haven, CT	(PBS)
WNYC-TV	NY	(PBS)
KETV	Omaha, NE	(ABC)
WOFL	Orlando, FL	(ind.) ^a
WXEX-TV	Richm'd-Petersb'g, VA	(ABC)
KTSP-TV	Phoenix, AZ	(CBS)
WPBO-TV	Portsmouth, OH	(PBS)
KBYU-TV	Provo, UT	(PBS)
KTSL	Sacramento, CA	(ind.) ^a
KSDK	St. Louis, MO	(NBC) ^e
KRON-TV	San Francisco, CA	(NBC) ^f
KTEH	San Jose, CA	(PBS) ^e
WSJU	San Juan, PR*	(ind.) ^e
WMHT	Schenectady-Albany-Troy, NY	(PBS)

WVIA-TV	Scranton-Wilkes Barre-Hazleton, PA	(PBS)
KTBS-TV	Shreveport, LA	(ABC) ^e
KREM-TV	Spokane, WA	(CBS)
KSCH-TV	Stockton-Sacramento*	(ind.)

WEDU	Tampa-St. Petersburg, FL	(PBS)
KCEN-TV	Temple-Waco, TX	(NBC) ^a
WNJT	Trenton, NJ	(PBS) ^d
KUAT-TV	Tucson, AZ	(PBS)
WILL-TV	Urbana-Champaign, IL	(PBS) ^e
KMPH	Visalia-Fresno, CA	(ind.)
WPEC	West Palm Beach, FL	(ABC) ^a

Planning 1986 start:

WSBK	Boston, MA	(ind.)
WUFT	Gainesville, FL	(PBS)
WJKS-TV	Jacksonville, FL	(NBC)
WFMY-TV	Greensboro-High Point-Winston-Salem, NC	(CBS)
KSHB-TV	Kansas City	(ind.)
WHA-TV	Madison, WI	(PBS)
WFTV	Orlando, FL	(ABC)
KDNL-TV	St. Louis, MO	(ind.)
WGGB-TV	Spfld.-Holyoke, MA	(ABC)

Planning start after 1986:

KMTF	Fresno, CA	(PBS)
WLFJ-TV	Lafayette-Kokomo, IN	(CBS)
WNMU-TV	Marquette, MI	(PBS)
WITI-TV	Milwaukee, WI	(CBS)
WTSP-TV	St. Petersburg-Tampa, FL	(ABC)
KVIE	Sacramento, CA	(PBS) ^a
KCTS-TV	Seattle, WA	(PBS)

Planning MTS, no date:

WNUV-TV	Baltimore, MD	(ind.)
WRBT	Baton Rouge, LA	(NBC)
WBNG-TV	Binghamton, NY	(CBS) ^e
WBMG	Birmingham, AL	(CBS)
KFYR-TV	Bismarck, ND	(NBC)
KTVB	Boise, ID	(NBC)
KMGH-TV	Denver, CO	(CBS) ^a
WGPR-TV	Detroit, MI	(ind.)
WFIQ	Florence, AL	(PBS)
WSWP-TV	Grandview, WV	(PBS)
KHON-TV	Honolulu, HI	(NBC)
WISH-TV	Indianapolis, IN	(CBS)
WJCT	Jacksonville, FL	(PBS)
KHGI-TV	Kearney-Hastings, NE	(ABC)
KARK-TV	Little Rock, AR	(NBC)
KTHV	Little Rock, AR	(CBS) ^e
KCET	Los Angeles, CA	(PBS)
WISN-TV	Milwaukee, WI	(ABC)
WTVF	Nashville, TN	(CBS)
WDSU-TV	New Orleans, LA	(NBC)
WJTC	Pensacola, FL*	(ind.)
KAET	Phoenix, AZ	(PBS)
KOLO-TV	Reno, NV	(ABC)
KXTV	Sacramento, CA	(CBS)
KPBS-TV	San Diego, CA	(PBS) ^a
KPIX	San Francisco, CA	(CBS)
KSAF-TV	Santa Fe, NM	(ind.)
WAKA	Selma, AL	(CBS)
KOLR-TV	Springfield, MO	(CBS)
WTOV-TV	Steubenville, OH-Wheeling, WV	(NBC, ABC)
KAIL-TV	Wailuku, HI	(NBC)
KAUZ-TV	Wichita Falls, TX	(CBS)

* Construction permit, not on air.

^a Stereo & program-related SAP

^b Non-program-related SAP only

^c Program-related SAP only

^d Adding stereo to SAP

^e Stereo and non-program-related SAP

^f Stereo, program and non-program SAP

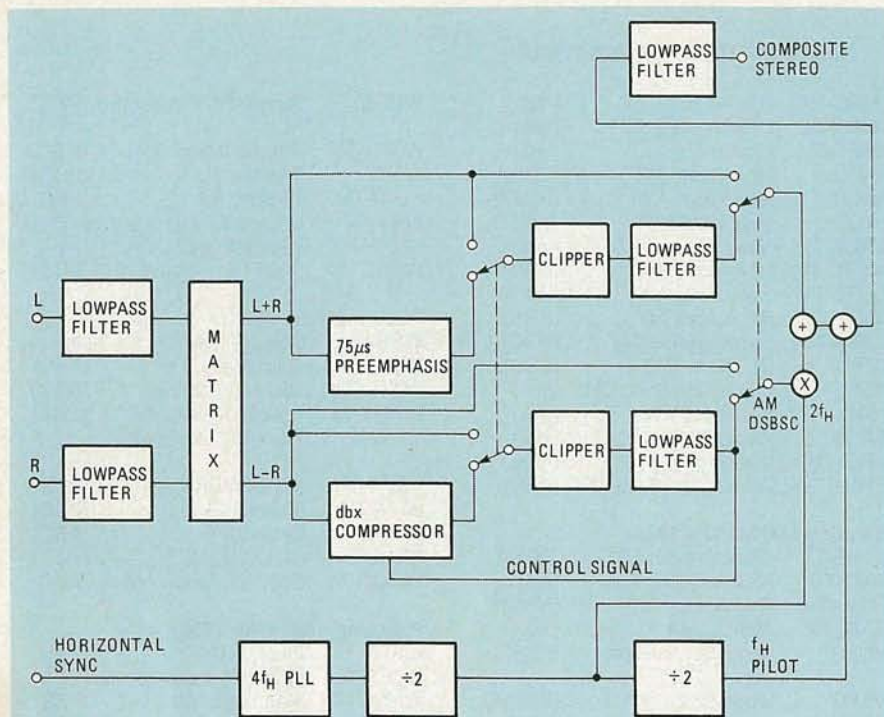

FIG. 4—STEREO GENERATOR BLOCK DIAGRAM. The composite stereo output contains L + R, L - R, and pilot signals.

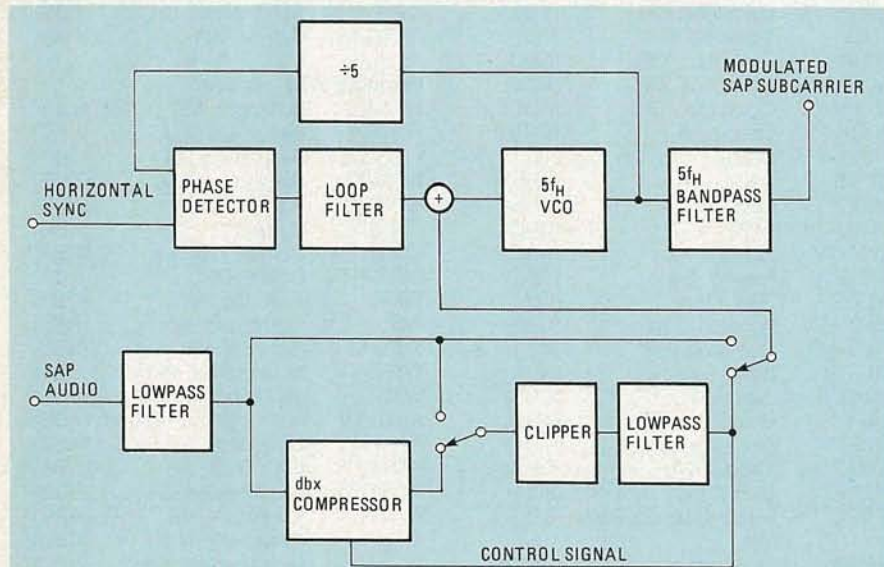

FIG. 5—SAP GENERATOR BLOCK DIAGRAM. The SAP generator can use the same compressor that is used in the stereo-signal generator.

By combining the stereo sum and difference signals in-phase and out-of-phase, the stereo decoder can reconstruct the individual left- and right-channel signals. That can be seen by the following equations:

$$(L + R) + (L - R) = 2L$$

$$(L + R) - (L - R) = 2R$$

If you're familiar with broadcast FM stereo, you've probably noticed that stereo TV uses a somewhat similar encoding method. There are some differences. The most important—which we'll describe in detail—is that the AM stereo-difference subcarrier is compressed.

A block diagram of the Zenith transmission system is shown in Fig. 3. Note

that the Zenith composite signal that drives the aural (audio) transmitter is the sum of two signals—the stereo-generator and SAP-generator outputs.

The stereo generator

The input to the stereo-generator, as shown in Fig. 4, is made up of three signals: the left- and right-channel signals and the horizontal-sync signal. The L and R signals are first fed through lowpass filters to remove out-of-band components that could cause crosstalk and intermodulation. The L and R signals are then fed to a matrix circuit that forms the stereo-sum (L + R) and -difference (L - R) signals. Note that the L + R signal under-

goes a 75µs preemphasis (as FM radio signals and mono TV-audio signals normally do) while the L - R signal undergoes a variable compression (the amount of compression is determined by the dbx compressor). We'll look at preemphasis and compression circuitry next month.

To prevent overmodulation and interference with other portions of the baseband (including the pilot and SAP channel), both signals are fed through clippers and lowpass filters.

Although not shown in Fig. 4, equalizers are normally included in one or both of the L + R and L - R paths. They are placed there to help ensure proper stereo separation.

Because the dbx-compressor output may contain a large amount of noise, it may be difficult to measure such things as stereo separation. To overcome that, as shown in Fig. 4, switches are provided to take the compressor and/or the clippers and lowpass filters out of the circuit.

A subcarrier at $2f_H$, twice the horizontal line frequency, is AM-DSBSC (AM double-sideband, suppressed carrier) modulated by the compressed L - R signal and is summed with the preemphasized L + R signal. The $2f_H$ subcarrier signal is also divided by two to supply the pilot tone. The composite stereo signal that is output from the stereo generator contains the stereo sum (mono) signal, the stereo difference signal, and the pilot tone.

The SAP generator

A block diagram of the other major component of the Zenith transmission system—the SAP generator—is shown in Fig. 5. The SAP audio is processed in much the same way that the stereo-difference signal is. A lowpass filter is used to remove high-frequency components that could overload the compressor, and a clipper is used to prevent overmodulation of the SAP subcarrier and thus prevent interference with the rest of the audio baseband. Equalization, which was used in the stereo generator to preserve stereo separation, is not needed here.

Note the $5f_H$ phase-locked loop in Fig. 5. The compressed audio is added to the PLL control voltage and thus frequency-modulates the VCO (voltage controlled oscillator). The frequency modulated subcarrier is then passed through a bandpass filter to protect the other audio signals from SAP spillover interference.

Now, if we look back to the block diagram of the Zenith transmission system (Fig. 3), we see that the outputs of the stereo generator and SAP generator are added together to form the composite signal, which frequency-modulates the TV audio carrier.

Next time, we'll look at the noise reduction techniques used in the BTSC system and why it's so important. **R-E**

BUILD THIS

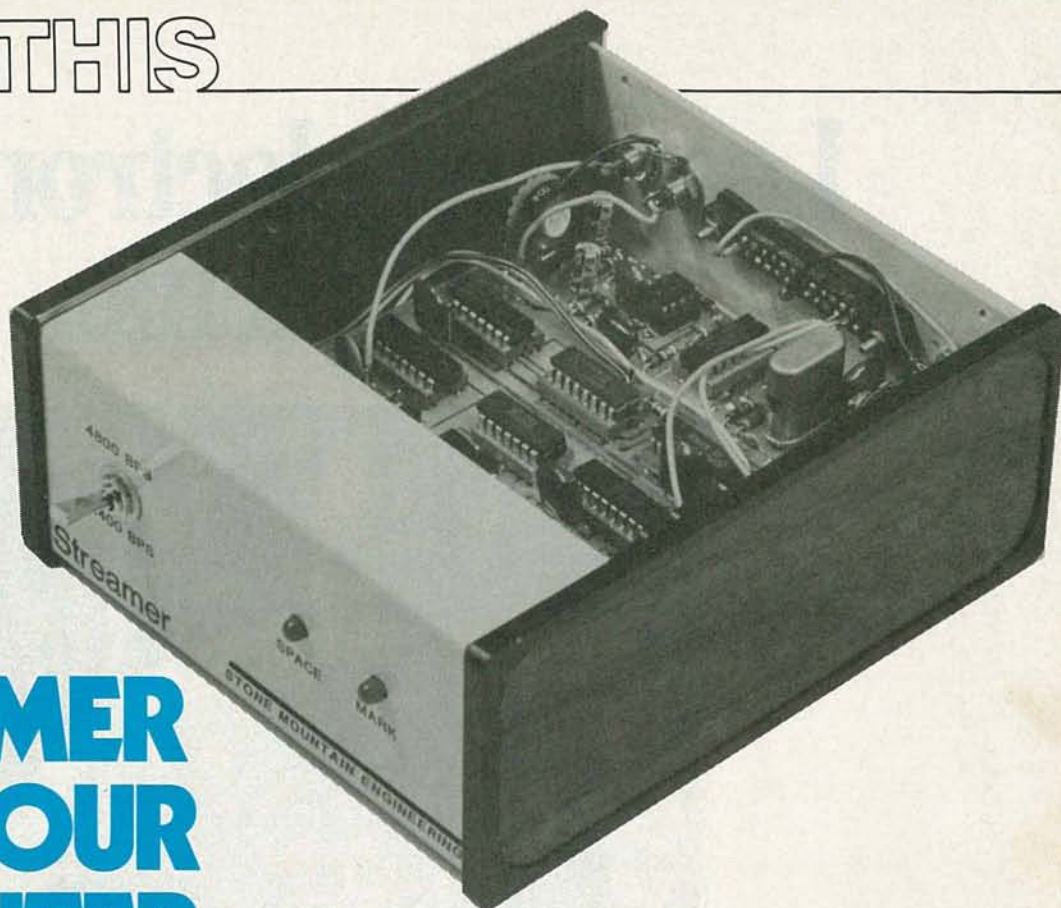

TAPE STREAMER FOR YOUR COMPUTER

MIKE HUDDLESTON

Are incompatible disk formats keeping you from transferring files from one computer to another? This universal cassette interface can solve that problem. And at 4800 baud, it can do it in a hurry!

THE COST OF MICROCOMPUTER components seems destined to continue to drop. Now you can build or buy computers at prices that seemed unbelievable just a few years ago. But when you add floppy-disk drives, the picture changes. Disk drives haven't dropped in price like other computer hardware has—and it seems likely that disk-drive prices will stay high. Is there a low-cost alternative?

Many of you probably have answered, "audio cassettes." Yes, they can be used but—when compared to disk drives—their slow and unreliable performance leaves much to be desired. We'll show you, however, an easy-to-build cassette interface that may change all that.

That interface, which we'll call a Streamer, is a very fast, highly reliable *universal* audio cassette interface designed to be a low-cost alternative to floppy disks. If your computer has an RS-232 port, you can use the Streamer to transfer data to any other computer similarly equipped. You can transfer *any* program, written on *any* computer, to *any other* computer using a compatible language. For example, the author routinely writes and debugs assembly-language programs

at work on an Intel development system, and brings them home on a cassette so that they can be run on his "homebrew" 8080-based computer. He has also transferred BASIC listings from a 6502-based system to cassette so that the programs could be run on his system. (Of course, while the BASIC implementation may vary from one system to another, those differences are usually easy to work around.)

The same thing can be done with other high-level language programs, like FORTRAN or Pascal: The listings can be transferred from one computer to cassette tape and then they can be loaded into your next computer, without worry of disk compatibility. Obviously, doing the same thing in these days of endless 5¼-inch disk formats would be virtually impossible if the systems were not identical.

Streamer basics

The name "Streamer" is computer-shop talk for "streaming tape interface," a term normally used to refer to magnetic-tape systems that are used for disk backup. If you're looking for something to *replace* floppy-disk drives, you should first understand that a streamer is *not* a random-

access drive like a floppy disk—the tape moves in one direction only, and files must be accessed sequentially.

The Streamer has no provisions for motor controls, which greatly simplifies its construction and interfacing, but restricts its operation to the manual mode. If you use short (5-minute) cassettes, and put only one program or one file on each, the interface will be easier to use. The cassettes are cheap and reliable, but their random accessibility is limited by the time it takes me to remove one cassette and replace it with another.

In the course of designing of the Streamer, several encoding techniques—from Kansas City Standard to FSK and PWM—were tried. The method chosen was *Manchester encoding*, which we'll look at in some detail next month. Methods of data recovery evolved from the use of filters and phase-locked loops to digital timing. The result is a low-cost but high-performance cassette interface.

Just what do we mean by "high performance?" The data-transfer rate is 4800 baud or bps (*Bits Per Second*). What that means is that a 16-kilobyte program can be loaded in as little as 38 seconds. The

**Learning electronics
is no picnic.**

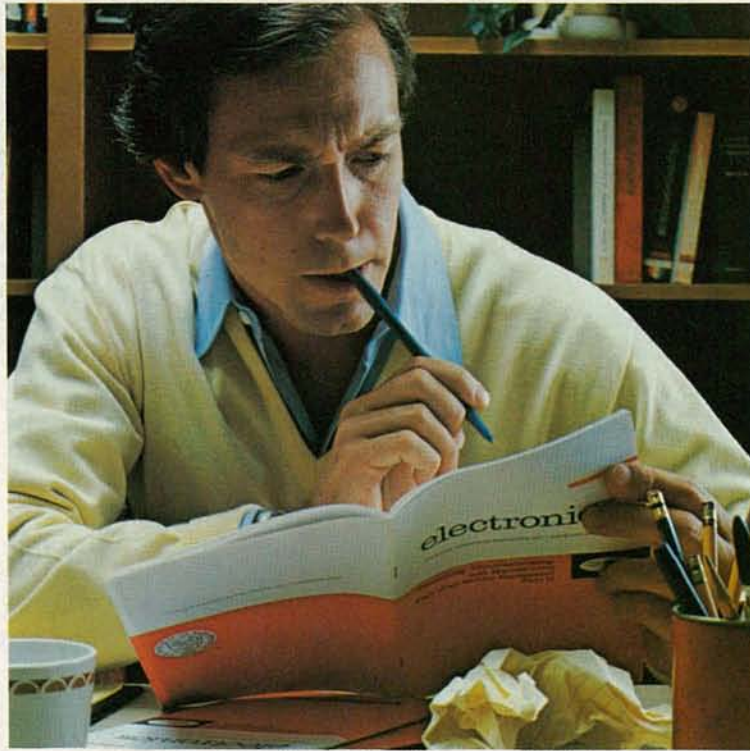

**At any level it takes
work and a few
sacrifices. But with
CIE, it's worth it.**

Whoever said, "The best things in life are free" was writing a song, not living a life. Life is not just a bowl of cherries, and we all know it.

You fight for what you get. You get what you fight for. If you want a thorough, practical, working knowledge of electronics, come to CIE.

You can learn electronics by spending some hard-working time at home. Or, would you rather go bowling? Your success is up to you.

At CIE, you *earn* your diploma. It is not handed to you simply for putting in hours. But the hours you do put in will be on your schedule, not ours. You don't have to go to a classroom. The classroom comes to you.

Why electronics training?

Today the world depends on technology. And the "brain" of technology is electronics. Every year, companies the world over are finding new ways to apply the wonders of electronics to control and program manufacturing, processing...even to create new leisure-time products and services. And the more electronics applications there are, the greater the need will be for trained technicians to keep sophisticated equipment finely tuned and operating efficiently. That means career opportunities in the eighties and beyond.

Which CIE training fits you?

Beginner? Intermediate? Advanced? CIE home study courses are designed for ambitious people at all entry levels. People who may have:

1. No previous electronics knowledge, but do have an interest in it;
2. Some basic knowledge or experience in electronics;
3. In-depth working experience or prior training in electronics.

You can start where you fit and fit where you start, then go on from there to your Diploma, an Associate Degree if you want it, and career.

Many people can be taught electronics.

There is no mystery to learning electronics. At CIE you simply start with what you know and build on it to develop the knowledge and techniques that make you a specialist. Thousands of CIE graduates have learned to master the simple principles of electronics and operate or maintain even the most sophisticated electronics equipment.

CIE specializes in electronics.

Why CIE? CIE is one of the largest independent home study schools that specializes in electronics. Nothing else. CIE has the elec-

tronics course that's right for you.

Learning electronics is a lot more than memorizing a laundry list of facts about circuits and transistors. Electronics is interesting! It is based on recent developments in the industry. It's built on ideas. So, look for a program that starts with ideas and builds on them. Look to CIE.

Programmed learning.

That's exactly what happens with CIE's Auto-Programmed® Lessons. Each lesson uses famous "programmed learning" methods to teach you important principles. You explore them, master them completely, before you start to apply them. You thoroughly understand each step before you go on to the next. You learn at your own pace.

And, beyond theory, some courses come fully equipped with electronics gear (the things you see in technical magazines) to actually let you perform hundreds of checking, testing, and analyzing projects.

Experienced specialists work closely with you.

Even though you study at home, you are not alone! Each time you return a completed lesson, you can be sure it will be reviewed, graded, and returned with appropriate instructional help. When you need additional individual help, you get it fast and in writing from the faculty technical specialist best qualified to answer your question in terms you can understand.

CIE offers you an Associate Degree.

One of the best credentials you can have in electronics — or any other career field — is a college degree. That's why CIE gives you the opportunity to earn an Associate in Applied Science in Electronics Engineering Technology. Any CIE career course can offer you credit toward the degree...more than half of the number needed in some cases.

You can also prepare for the government-administered FCC (Federal Communications Commission) Radiotelephone License, General Class. It can be a real mark in your favor...government-certified proof of your specific knowledge and skills.

Today is the day. Send now.

Fill in and return the postage-free card attached. If some ambitious person has removed it, cut out and mail the coupon. You'll get a FREE school catalog plus complete information on independent home study. For your convenience, we'll try to have a CIE representative contact you to answer any questions you may have.

Mail the card or the coupon or write CIE (mentioning the name and date of this magazine) at:
1776 East 17th
Street, Cleveland,
Ohio 44114.

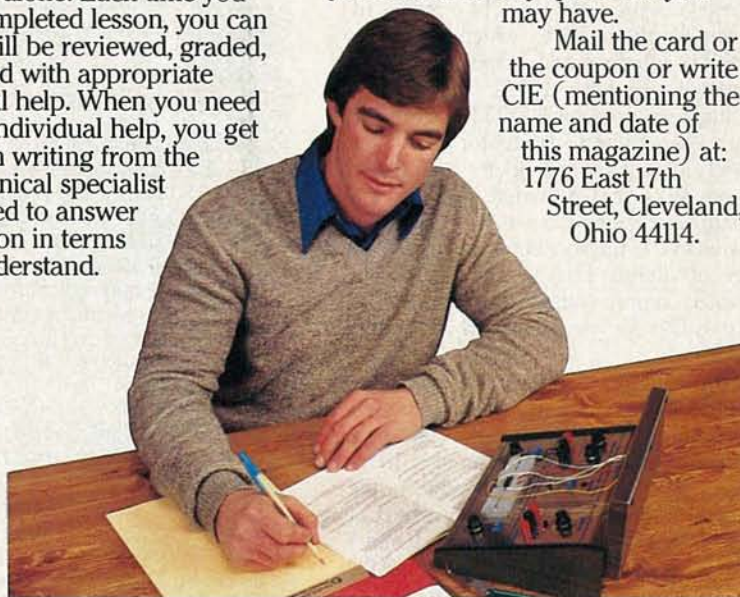

CIE Cleveland Institute of Electronics, Inc.

1776 East 17th Street, Cleveland, Ohio 44114

Accredited Member National Home Study Council

YES...I want to learn from the specialists in electronics — CIE. Send me my FREE CIE school catalog...including details about the Associate Degree program... plus my FREE package of home study information.

Print Name _____

Address _____ Apt. _____

City _____ State _____ Zip _____

Age _____ Area Code/Phone No. _____ / _____

Check box for G.I. Bill bulletin on Educational Benefits: Veteran Active Duty

MAIL TODAY!

RE03

Streamer is reliable, too—the cassette deck is the limiting factor, so a high-fidelity type deck is recommended. (The author has used a \$69 stereo unit for over a year, and has had no permanent errors. When a read error occurs, a simple cleaning of the heads and capstan eliminates the problem.)

Along with its speed and universality, the cassette streamer has another attractive feature: It can be built for about \$60. All the electronic parts are standard, and all are available from the vendors who regularly advertise in **Radio-Electronics**.

The Streamer circuit

Figure 1 is a schematic of the interface circuit—we'll start our look at it with the power supply. The circuit requires a voltage supply between 8 and 16 volts DC at a typical current drain of only about 30 mA. That can be supplied by an external wall plug DC supply or it may be "stolen" from the computer or the tape deck. If the computer supply is to be used, the power can be run through pin 25 of the DB25 connector. If you use a miniature closed-circuit phone jack (J3) and wire it as shown in the schematic, then you can conveniently have your choice of either.

Electrolytic capacitor C14 provides filtering for the raw DC (which powers the RS-232 interface and is the input to the five-volt regulator, IC15). The negative voltage required for RS-232 is furnished by a charge pump: Transistor Q1 is alternately turned on and off by a 76.6-kHz clocking signal provided by IC3, and charges developed across C16 are transferred to C15 through D3. A negative voltage of slightly less magnitude than the positive supply voltage will be developed across C15 for use by the RS-232 output stage.

The circuit's clock is made up of a 2.4576-MHz crystal (XTAL1), and an EXCLUSIVE-OR gate (IC2-d) that's connected as an inverter. The clock's output is divided by IC3, a 4040 ripple counter, for the various frequencies needed by the rest of the circuit. The outputs at pins 2, 3, and 5 of IC3 are baud-rate clocks for the UART (Universal Asynchronous Receiver/Transmitter).

The UART uses a clock at 16 times the data rate, so the signals at pins 5, 3, and 2 (which are 153.6, 76.8, and 38.4 kHz) correspond to UART baud rates of 9600, 4800, and 2400 bits per second, respectively. The UART transmitter (which sends data back to the computer) always runs at 9600 baud, so its TRANSMITTER REGISTER CLOCK, (pin 40) is directly connected to pin 5 of IC3. However, since data from the computer to the Streamer may be either 2400 or 4800 baud, a switch is provided to select different RECEIVER REGISTER CLOCK (pin 17) connections.

RS-232 interfaces are usually crystal controlled. Fortunately, UART's are for-

PARTS LIST

All resistors ¼ watt, 10% unless otherwise noted

R1—1000 ohms, PC-mount, trimmer potentiometer
R2, R5, R6, R11, R16, R17, R20, R28, R29—1000 ohms
R3, R4, R7, R8, R13, R14, R18, R19, R22, R23, R25, R26, R30—10,000 ohms
R9—1 Megohm
R10—100,000 ohms
R12, R21, R27—47,000 ohms
R15—10 Megohms
R24—2200 ohms
R31—330 ohms

Capacitors

C1, C4, C13—10 µF, 25 volts, electrolytic
C2, C21—0.001 µF, ceramic disc
C3, C12, C16—0.1 µF ceramic disc
C5, C7, C17, C18, C20, C22, C23, C24—0.01 or .1 µF bypass capacitors (not shown in schematic)
C6, C10—20 pF, ceramic disc
C8, C9—250 pF ceramic disc
C11—5 pF, ceramic disc
C14—100–330 µF, 25 volts, electrolytic
C15—47–220 µF, 25 volts, electrolytic
C19—0.01 µF, ceramic disc

Semiconductors

IC1—LM392 or LM2924 op-amp/comparator
IC2—4070 or 74C86 quad XOR gate
IC3—4040 12-stage binary ripple counter
IC4, IC6—4029 presettable up/down counter
IC5—4520 dual 4-bit synchronous counter
IC7—4011 quad 2-input NAND gate
IC8—4027 dual J-K flip-flop
IC9, IC12—74C74 dual D-type flip-flop
IC10—4015 dual 4-bit static shift register
IC11—6402 CMOS UART (Intersil)
IC13—4021 8-stage static shift register
IC14—LM339 quad comparator
IC15—78L05 low power 5-volt regulator
D1–D5—1N914 or similar
D6, D7—standard red LED
Q1, Q3—2N3904
Q2, Q4—2N3906
XTAL1—2.4576 MHz crystal

MISCELLANEOUS: PC board, enclosure, DPDT switch, DB25 connector, phono jacks for tape deck connectors, hardware, solder, etc.

The following are available from Stone Mountain Engineering Co., PO Box 1573, Stone Mountain, GA, 30086: Printed circuit board, double-sided with plated-through holes, solder masked and silkscreened, for \$28; Enclosure, with all holes punched and legends silkscreened, \$16; Both PC board and enclosure for \$40. All orders must include \$1.50 shipping and handling, and Georgia residents please enclose 3% sales tax.

giving of small differences between clocking frequencies. That's important because an RS-232 data stream is continuous—that is, the stop bit of one word is followed immediately by the start bit of the next. Although it would seem there is no margin for error, UART's do allow for

some timing variations by accepting stop bits that are either short or long, then resynchronizing on the following start bit.

The Streamer extends that idea by sending bits to the cassette tape at a slightly faster rate than its UART receives them. (For an RS-232 input with a data-rate of 4800 bps, the output sent to the tape is at 5486 bps, allowing a timing mismatch of 12.5%.) If the computer's baud-rate clock is a little too fast, the Streamer's UART will be overrun. As we mentioned previously, RS-232 can accept stop bits that are either long or short (1½ bits for example). But there is no way to represent a half bit in Manchester encoding. (That will become obvious when we discuss the encoding next month.) So, when the Streamer UART is overrun, it fills its idle bit times with marks (which is the convention), and inserts them as needed to make up an integral number of stop bits.

That accounts for the difference in speed from UART-to-UART, but not for the (typically worse) cassette-playback variations. Tape timing is reliably recovered by timing each bit (Manchester encoding is bit-synchronous), but since the data may play back faster than it was recorded, it may be returned to the computer at a still faster rate. To keep things compatible with RS-232 standards, the bits from the tape are gathered in one at a time, grouped into 8-bit words, and returned to the computer at 9600 bps.

Synchronous counter IC4 provides the Streamer with the tape-data rates. For an RS-232 rate of 4800 bps, the tape, as mentioned earlier, is recorded at 5486 bps; while at 2400 bps, the tape-data rate is 2560 bps. IC4 and IC2-c form a counter that divides by either 7 or 15, depending on the bit rate selected by S1. Since its input is 614.4 kHz, its output will be either 87.77 kHz or 40.96 kHz, sixteen times the tape bit rate. That 16× bit rate will be used by both the receiver and the transmitter sections.

The receiver

The CMOS UART, IC11, has two separate functional sections; an NRZ receiver with parallel output, and a parallel-input NRZ transmitter. (We'll discuss NRZ encoding—and compare it to the Manchester coding that this interface uses—later on in this article.) The receiver section of the UART, in conjunction with IC12, IC13, IC14-d, IC5-b, IC8-b, and IC7-d comprise the RS-232-to-Manchester converter. Comparator IC14-d, along with its associated discrete components, converts incoming RS-232 data to TTL-level NRZ code. That code is applied to the serial input (pin 20) of the UART receiver section, which is clocked (on pin 17) at the appropriate rate for RS-232 standard compatibility.

An 8-bit shift register (IC13) and a flip-flop (IC12-b) are connected together to

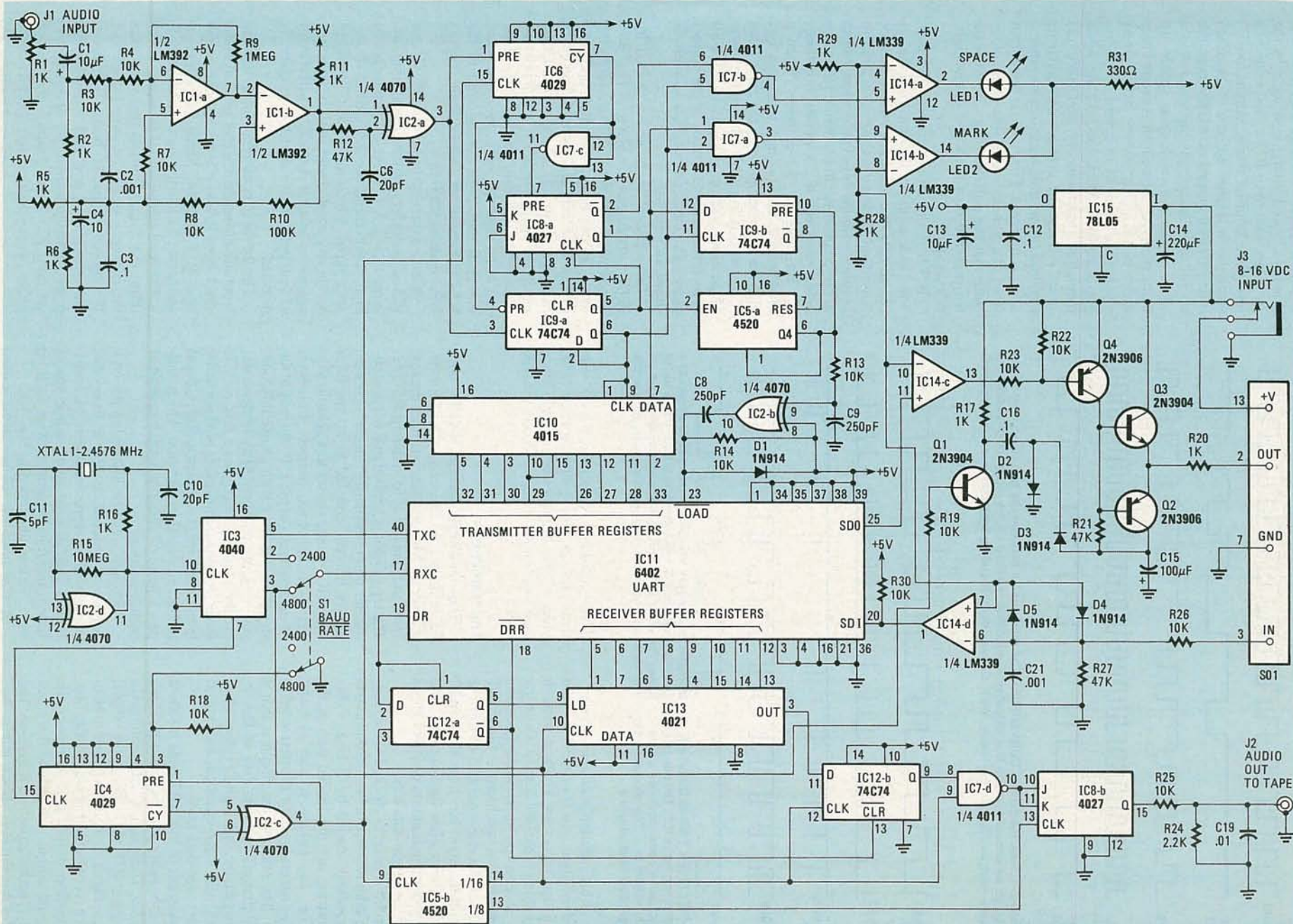

FIG. 1—CASSETTE INTERFACE SCHEMATIC. The main sections of the circuit are the power supply, crystal-controlled clock, RS-232-to-Manchester converter, and the Manchester-to-RS-232 converter. Although not shown, bypass capacitors (0.1 or 0.01 μ F) should be located at some of the IC's.

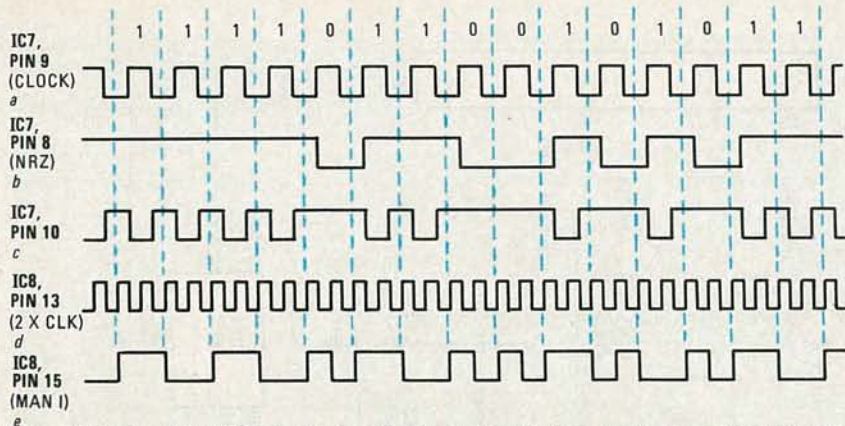

FIG. 2—NRZ-TO-MANCHESTER CONVERSION. The relationship between the two codes may not be apparent, so we should mention that Manchester encoding is based on the presence or absence of transitions—not on high or low levels. We'll discuss both encoding methods in more detail next month.

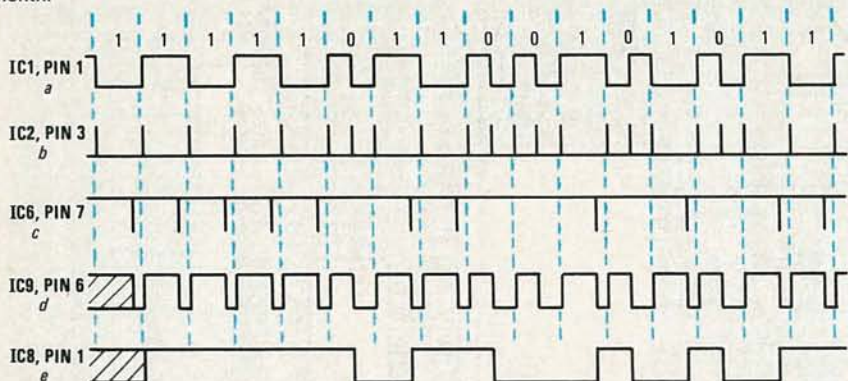

FIG. 3—RECEIVER TIMING DIAGRAM. The Manchester signal received from the tape is shown in a (after conditioning by IC1). The output of the transition detector (IC2-a) is shown in b. Each transition of the Manchester code produces a positive pulse. The carry output from IC6 (used to determine bit sense) is shown in c. The recovered clock is shown in d, while the reconstructed NRZ code at the output of IC8-a is shown in e.

form a 9-bit parallel-load shift register. Their serial input, pin 11 on IC13, is held high so that marks are clocked through when nothing is parallel-loaded. Once the UART receives a serial word from the computer, IC12-a synchronizes the UART to the tape-data rate from IC5-b, loading IC13 with the eight bits from the UART, and IC12-b with a low for a start bit. The 9-bit register combination now includes a start bit and eight data bits.

The shift register is clocked at the tape-bit rate from IC5-b, pin 14. As soon as it is synchronously loaded by IC12-a, it begins shifting out the loaded data at the tape rate, and follows it with as many marks as necessary until the next word is loaded. The effect of the circuit is that it simply changes the data rate of the received word; the shift register output from IC12-b is still NRZ-encoded, but now at the faster tape-data rate.

An example of this NRZ code is shown in Fig. 2-b, along with the tape rate clock in Fig. 2-a. Those signals are combined in NAND gate IC7 to produce the signal shown in Fig. 2-c. This is applied to IC8-b, which is configured as a toggle flip flop. The flip-flop will toggle whenever the NAND gate output is high and the clock (Fig. 2-d) makes a positive transition. The output of this flip flop, shown in Fig. 2-e,

is the resulting Manchester code. Resistors R24 and R25, with capacitor C19, round off the Manchester bits and reduce their amplitude for application to the tape deck.

The transmitter

The transmitter section of IC11, with the remainder of the circuit components, recover the Manchester code from the cassette and convert it to standard RS-232. The tape signal is applied to R1, a potentiometer that is normally full on. It is then lightly filtered, coupled to an amplifier stage (IC1-a) and passes to a Schmitt trigger (IC1-b), which outputs TTL-level Manchester data at pin 1. If you look at the signal on IC1 pin 1 with an oscilloscope, you'll see the recovered Manchester code, as shown in Fig. 3-a. Since that code is sensitive only to transitions (and not to the level), the signal is applied to R12, C6 and IC2-a, a transition detector, which outputs a pulse of about one-microsecond at each transition.

Although we'll be discussing the coding format in detail, for now let us say that marks will be represented here by transitions a full bit time apart, while spaces have transitions occurring twice each bit time. That is illustrated in Fig. 3-b.

A 4-bit up/down counter (IC6) is used

here as a synchronous one-shot. It is continually clocked at its COUNT input by the $16\times$ tape rate from IC2-c, and outputs a low pulse from its CARRY output (pin 7) whenever it reaches a count of 15. Each time a transition is received, however, the output of IC2-a presets the counter to a value of four. So, as long as spaces are being received, the counter is preset every eight or so clock pulses, so it never reaches the count of 15 before it is again preset to four. Mark bits, on the other hand, have transitions only half as often as space bits, so the counter will reach its terminal count, and output a carry, when a mark is received. Figure 3-c is the output from the synchronous one-shot, IC6. Note that the pulses in Fig. 3-c indicate the presence of a mark; no output indicates a space.

IC9-a is the clock-recovery flip-flop. The clock signal is derived from the received data; the Streamer's internal clock is used only to test the sense of each bit, in keeping with the bit-synchronous nature of this Manchester code. While spaces are being received, IC2-a pulses two times per bit, toggling IC9-a twice. When a mark is received, its single transition toggles the flip-flop, and then the carry from IC6 presets IC9-a. That corrects the phase of the clock so that, as soon as a mark bit is received, the clock runs in the correct phase. The clock output, IC9-a, pin 6, is shown in Fig. 3-d.

The sense of each bit is detected by IC8-a—its output is shown in Fig. 3-e. Wired as a R-S flip-flop, IC8-a is set by the mark-detector output from IC6, and reset by clocking from the inverted data clock from IC9-a, pin 5. The clock and data inputs are applied to IC10, which is wired as an 8-bit serial-load shift register. At the end of an eight-bit word, the contents of this shift register are transferred to the UART transmitter, which then outputs NRZ code at 9600 bps.

A bit counter is made up of IC9-b and IC5-a. To understand their operation, assume that IC5-a has its Q4 output (pin 6) high. That output is connected to its ENABLE input, which means that it will not accept any input clocks until Q4 goes low again (i.e., until it is reset). It will remain in that state until a start bit, a space, is detected.

On the next occurrence of a start bit from the bit-sense detector (IC8-a) and a clock from IC9-a, IC9-b's inverted output (pin 8) goes high. Since that output is connected back to the RESET input on IC5-a, the reset operation takes place, which drops the output from Q4 and re-enables the counter. As the Q4 output goes low, IC9-b becomes preset, bringing its inverted output back low and removing the reset command from IC5-a. It is held preset until IC5-a has counted eight clock pulses, corresponding to eight bits being

continued on page 116

Servicing Videodisc Players

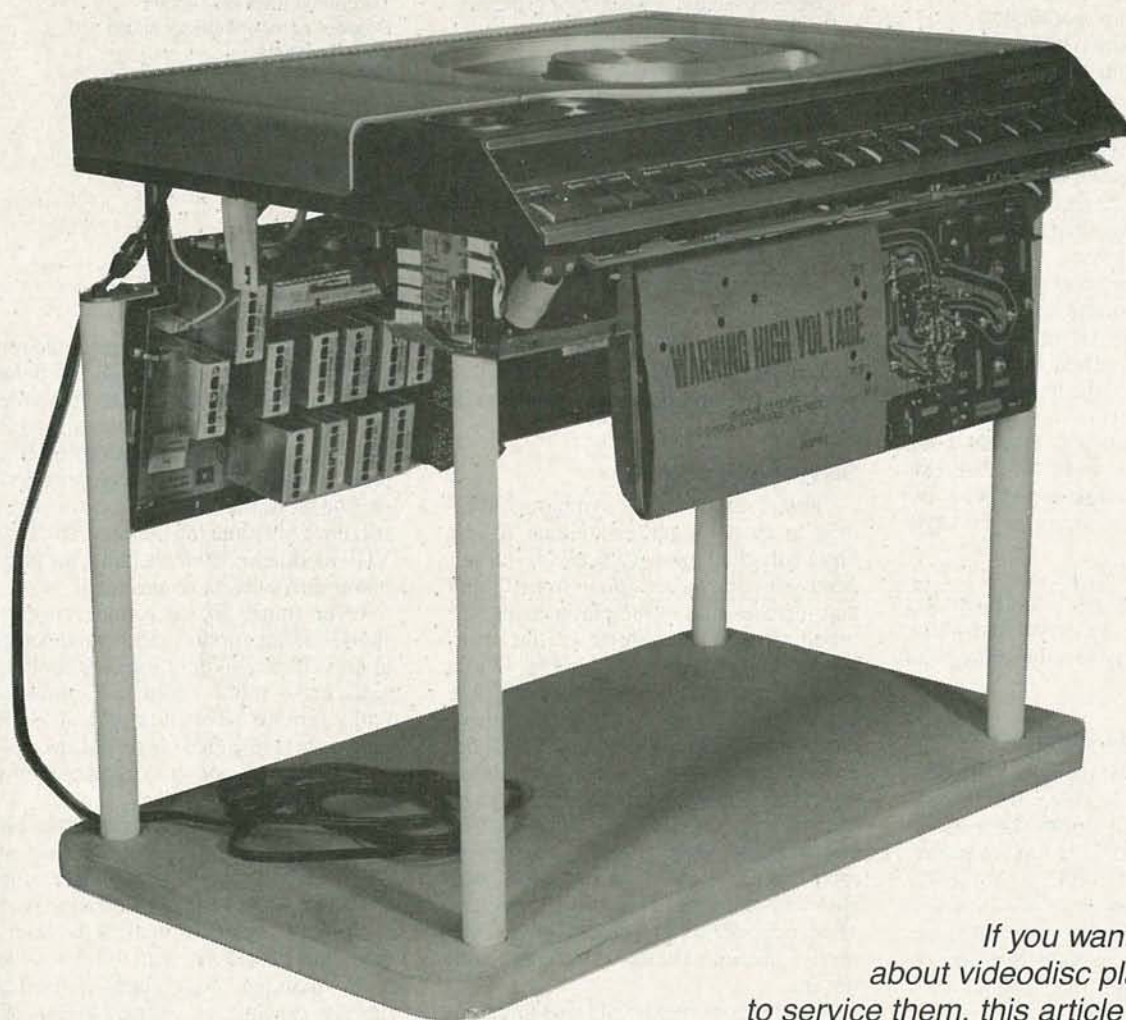

JOHN LENK

If you want to learn more about videodisc players and how to service them, this article is for you. In it we cover both LV and CED players.

NOW THAT WE'VE SEEN HOW THE LV AND CED systems work, we are ready to turn our attention to our main topics—how to properly troubleshoot and service videodisc players.

Tools

Although there is no standardization, most videodisc players require some form of special tools for full service. Study the service literature and use the recommended tools. If the tools appear in the literature, they should be available from the manufacturer. Of course, there are fac-

tory assembly tools that may not be available for field service (not even to factory service-centers, in some cases). That is the manufacturer's subtle way of telling service technicians that they should not attempt any adjustment (electrical or mechanical) not recommended in the service literature. Take that hint! The author has heard many horror stories about "disaster area" players brought in to factory service people after "a few simple adjustments." Also keep in mind that most players are manufactured to *metric standards* and your tools must match.

Checkout and preliminary troubleshooting

Before concluding that the player is out of order, run through the following notes and make sure that there is not a simple remedy for the problem.

If the lid does not open on an LV player, check that power is on. Try pressing the STOP/EJECT button to release the lid latch.

If the caddy entry door on a CED player does not open, make sure the FUNCTION lever is in load (for manual players), or that power is applied and the operation

switch is set to on (for automatic load players).

If the disc does not appear to rotate (you can't hear the disc motor running), check that power is on. On LV players, check that the lid is properly closed (to close the interlocks).

If the disc stops rotating soon after starting, it is possible that you are playing an unrecorded side of the disc. Try turning the disc over.

If the disc rotates, but there is no picture check the following: Are the connections between player and set correct? Are the player and TV set on the same channel? Is the player in pause mode?

If the picture quality is bad (with proper connections and both the player and the TV set on the same channel), check the fine tuning on the TV set. The player output is on an inactive TV channel and, since that channel is not ordinarily used, fine tuning may not be precisely adjusted. If picture quality is still bad, try a different disc (a known good disc).

If the TV no longer receives other channels after being connected to the player, make sure that the antenna cable is connected to the player. Then check that the player is off (FUNCTION lever set to off, power switch off, etc.)

If a particular part of a disc does not produce a good picture, the disc is possibly damaged. Try pressing the SCAN (or similar) buttons to skip over the damaged portion.

If the remote control does not work, try replacing the batteries (on those remotes that do not have direct wiring). Also check for obstructions between the player and remote.

Servicing videodisc players

If none of the above cures the problem, you must go inside the player. It is impossible to describe full troubleshooting or service procedures for any type of player within the limits of this article. You must read the service literature. But we will, in the balance of this article, give you some service notes that can make the job of servicing either a CED or LV player a lot easier.

As a starting point for either type of player, insert a known good disc and run through all operating procedures. If one or more of the operating features is absent or abnormal, install the recommended test disc and run through the adjustment procedures. That can often lead to the source of the problem, since the adjustment procedures usually require that you monitor the inputs and/or outputs of all circuits and sections in the player.

If the player is still not functioning properly, go through the following service notes, and compare them to any procedures recommended in the service literature. Keep in mind that the circuits referenced in the following are "typical"

TABLE 1—LV TROUBLESHOOTING GUIDE

Symptom	Circuits To Check
Power on indicator does not light	Low-voltage power supply circuits
Power on; picture, sound not muted	Mute circuits
No picture, no sound, disc does not spin	low-voltage power supply circuits, and start-up sequence-motor accelerator circuits
No picture, no sound, disc speeds up and slows	Low-voltage power supply, laser power supply, and start-up sequence-focus circuits
No picture, no sound, objective lens focused	Signal processing circuits
No picture, sound is normal	Signal processing circuits
Erratic picture, picture shakes and skips	Radial tracking circuits
Picture loses sync, picture jitters, disc speed varies	Turntable motor circuits
Color streaking or loss of color in picture	Tangential tracking circuits
Excessive dropout in picture	Dropout compensation circuits
No sound, picture is normal	Sound circuits
Distorted sound, picture is normal	Sound circuits
Either sound channel does not nute	Sound circuits
Picture sticks and repeats (disc known to be good)	Slide drive and search circuits
No search forward or reverse	Slide drive and search circuits
Index numbers missing or incorrect, index number background missing	Index circuits
No special effects, erratic special effects, skips during special effects	Track jumping circuits

for a cross-section of videodisc players. You must check at the corresponding points on the circuits of the player you are servicing.

Servicing LV players

Table 1 lists various symptoms common to most LV players. Figure 13 is a block diagram of a typical LV player. After selecting the symptom from Table 1 that matches that of the player being serviced, follow the steps in the troubleshooting procedures using Fig. 13 as a guide. The procedures described help isolate the problem to a defective module or component. Keep in mind that a high degree of integration is used in videodisc players and, thus, defective sections must usually be replaced in their entirety. The adjustments listed at the beginning of each procedure are those usually associated with the related circuit. If possible, always check the adjustments (using the service literature) before proceeding with service.

Prior to replacing the slide assembly, or making any substantial mechanical adjustments, always check for any purely mechanical problems that can affect player operation. If the picture skips or repeats, check for a misadjusted slide drive, poor lead dress, misadjusted slide rails, or anything that can inhibit slide movement. The slide must move freely beneath the disc. If a "ratcheting" noise is heard, it is possible that the slide is adjusted too loosely.

Low-voltage power-supply circuits. Monitor all of the supply output voltages. Typically, that includes ± 12 - and ± 24 volt outputs, and possibly ± 5 -volts for microprocessor or other control logic.

Mute circuits. When power is first ap-

plied, both sound and picture should mute (dark screen, low volume). If the picture does not mute, check to see if a video-mute signal to the video processor is missing; if so, replace the mode control. If it is present, try grounding the composite-video line from the video processor. If that still does not mute the picture, replace the VHF modulator, after checking for proper power and antenna connections.

If the sound does not mute, check for sound-muting inputs to the sound demodulators. If they are missing at either input, replace the mode control. If present at both, remove demodulator I. If sound then mutes replace demodulator I. If sound still does not mute, replace demodulator II.

Laser power-supply circuits. First check the laser adjustments (if any), and then check for 5-volts at the laser supply test point. Most LV players provide such a test point for a quick check of the laser so that a direct measurement of high voltage is not required. Also check if the laser tube is glowing. A strong glow usually indicates that the high-voltage is present and the laser is good.

Start-up sequence-motor accelerator circuits. If the disc does not spin after the lid is closed, check connections between the lid switch and motor drive. If that is fine, ground the motor-acceleration line from the sequence logic to the motor drive. If the disc starts spinning, remove the ground and check the motor-speed signal to the sequence logic. If the signal is present, replace the sequence logic. If missing, replace the search adaptor. If the disc does not spin when the motor acceleration line is grounded, remove the ground and check the lid switch and turntable motor.

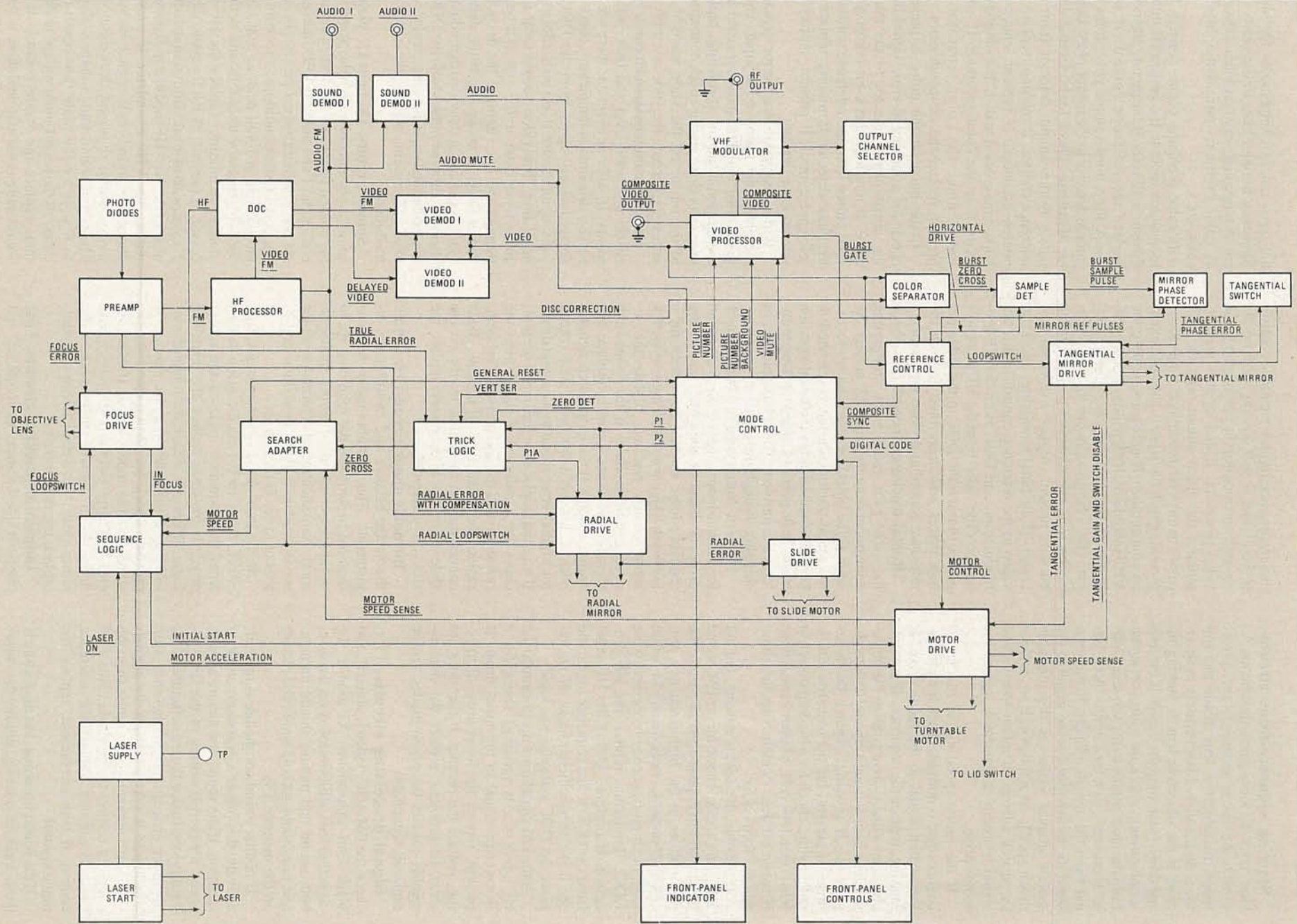

FIG 13—BLOCK DIAGRAM of the electronic and mechanical systems in an LV videodisc player.

Start-up sequence-focus circuits.

First check the focus gain adjustments. As soon as the disc is spinning at the correct speed, the objective lens should rise and focus on the disc. Listen closely to determine if the objective lens is moving up and down (searching for focus). If the lens is not moving, check for a laser-on signal from the laser supply to the sequence logic. If present check for a motor-speed signal from the search adapter. If missing, see if the motor-speed-sense signal to the search adapter varies as the turntable motor speeds up and down. If so, replace the search adapter. If motor-speed-sense signal is absent or abnormal, replace the motor drive.

If the motor-speed signal to the sequence logic is normal, check for a focus-loopsignal to the focus drive. If missing, replace the sequence. If present, check for a focus-drive pulse to the objective lens (that is usually about 1-volt peak-to-peak). If missing, replace the focus drive. If present, but the objective lens is not moving, check for a binding objective lens, open lens coil, or poor connections between the lens (which is on the slide) and the focus drive.

If the objective lens is moving, but not achieving focus, check for an FM signal (about 100-mV peak-to-peak) from the preamplifier to the high-frequency processor. If present, check for an FM output from the high-frequency processor to the DOC. If missing, replace the HF processor. If present, ground the HF input from the DOC to the sequence logic, and see if the lens achieves focus. If not replace the DOC and sequence logic.

If the FM signal from the preamp to the HF processor is missing, check for a focus-error signal to the focus drive. If present, replace the focus drive. If missing, replace the preamp. If that does not clear the problem, replace the slide assembly (unless the photo-diodes can be replaced separately).

Signal-processing circuits. First check the FM AGC, video I, video II, and black-level adjustments. As soon as the objective lens achieves focus on the disc, both sound and picture should unmute, and you should get both sound and picture on the monitor TV.

If neither sound nor picture is present, activate the player's FORWARD SEARCH function. If the sound and picture appear, check for correct setting of the slide-assembly stop (using the manufacturer's adjustment procedures). If the slide-stop adjustment is correct, check for digital-code and composite-sync signals from the reference control to the mode control. If either is missing, replace the reference control. If both are present, replace the mode control.

If the sound is normal, but the picture is dark, weak, or missing, ground the video-mute input to the video processor. If the

picture appears, replace the mode control. If the picture is still missing, remove the ground, and monitor the video input to the video processor. If that input is present, monitor the video output from the processor to the VHF modulator. If that too is present, check the signal cable and antenna connections. If necessary, replace the VHF modulator. If there is no video signal to the VHF modulator, check for a burst-gate (DC-clamp) signal to the video processor from the reference control. If the burst is present, replace the video processor. If the burst is missing, check for video to the reference control, video demodulators, and DOC from the HF processor. (The video from the HF processor passes through the DOC to the video demodulators and delay lines to both the reference control and video processor).

Radial-tracking circuits. First check the radial gain, radial limit, and grating adjustments found on most LV players. As soon as the objective lens achieves focus, the radial-tracking circuit is activated to keep the focused beam on the information track. Indications of radial tracking problems are: garbled sound, shaky picture, or skipping through the picture.

If any of those symptoms occur, check for a radial-loopsignal to the radial drive. If absent or abnormal, remove the sequence-logic module and check for a loopsignal again. If the loopsignal is now restored, replace the sequence-logic module. If the loopsignal is still not correct, replace the search adapter. If the loopsignal is normal, but the symptoms remain, check for a radial-error signal to the radial drive. If missing, replace the preamp. If present, check for a radial-error signal from the radial drive to the slide drive. If missing, replace the radial drive. If present, check connections to the radial mirror on the slide assembly. If necessary, replace the slide-drive assembly.

Turntable motor circuits. First check the bridge-balance and motor-phase adjustments. The turntable-motor servo is required to maintain the rotational speed of the disc constant (to reduce timing errors). An indication of a turntable-motor servo problem is horizontal jitter (and/or loss of sync) in the picture.

If the disc speed is not constant, first check for a motor-acceleration signal from the sequence logic to the motor drive. If missing, replace the sequence logic. If present, check for a motor-control signal from the reference control. If present, check for motor-speed-sample signals to the motor drive. If missing, check wiring between the motor and drive. If all signals are present to the motor drive, but speed is not constant, replace the motor drive.

Tangential-tracking circuits. First check bridge-balance, motor-phase, and tangential-gain adjustments. The tangen-

tial-servo circuit compensates for high-frequency timing errors in the video signal. A tangential-servo problem shows up as color problems (streaking, loss of color, etc.).

If color problems occur, connect the loopsignal input to the tangential-mirror drive to +12 volts. If the picture clears up, replace the reference control. If not, check for a burst-sample pulse from the sample detector to the mirror-phase detector. If missing, check for horizontal-drive pulses to the sample detector from the reference control. If missing, replace the reference control. If present, check for burst-zero-cross signals to the sample detector from the color separator. If missing, replace the color separator. If present, replace the sample detector.

If the burst-sample pulse is present, check for a tangential-error signal from the mirror-phase detector to the mirror drive. If missing, check for mirror-reference pulses from the reference control to the phase detector. If missing, replace the reference control. If present, replace the mirror-phase detector.

If the tangential-phase-error signal is present at the mirror-drive input, check for an error signal from the mirror drive to the tangential mirror. If missing, replace the mirror drive and/or check connections to the mirror on the slide assembly. If necessary, replace the slide assembly.

Dropout compensation circuits. First check any video-level and DOC adjustments. If, after adjustment, there are excessive dropouts in the picture, check the delayed-video signal from the DOC to video demodulator II, on both sides of the delay line. The video should drop from about 1-volt down to 0.3-volt as it passes through the line. Replace the delay line and/or DOC as necessary. If the delayed video is present at the video demodulator, check for dropout pulses from the DOC to the demodulator. If missing, replace the DOC. If present, replace the video demodulator.

Sound circuits. On most LV players, sound is present only when the player is in the normal play mode, and when either or both audio I and audio II LED indicators are on. If sound (but not picture) is missing under those conditions, check for audio FM (about 1-volt peak-to-peak) from the HF processor to both sound demodulators. If missing, replace the HF processor. If present, check for audio (about 2-volts peak-to-peak) from sound demodulator II to the VHF modulator. If present, replace the VHF modulator. If missing, check the sound-mute signal from the mode control to sound demodulator II. The normal sound-mute voltage is about 5 to 6 volts for the mute (no sound) condition. If the sound-mute voltage is abnormal, replace the mode control. If the sound mute is normal, and there is sound from the HF processor, but not from the

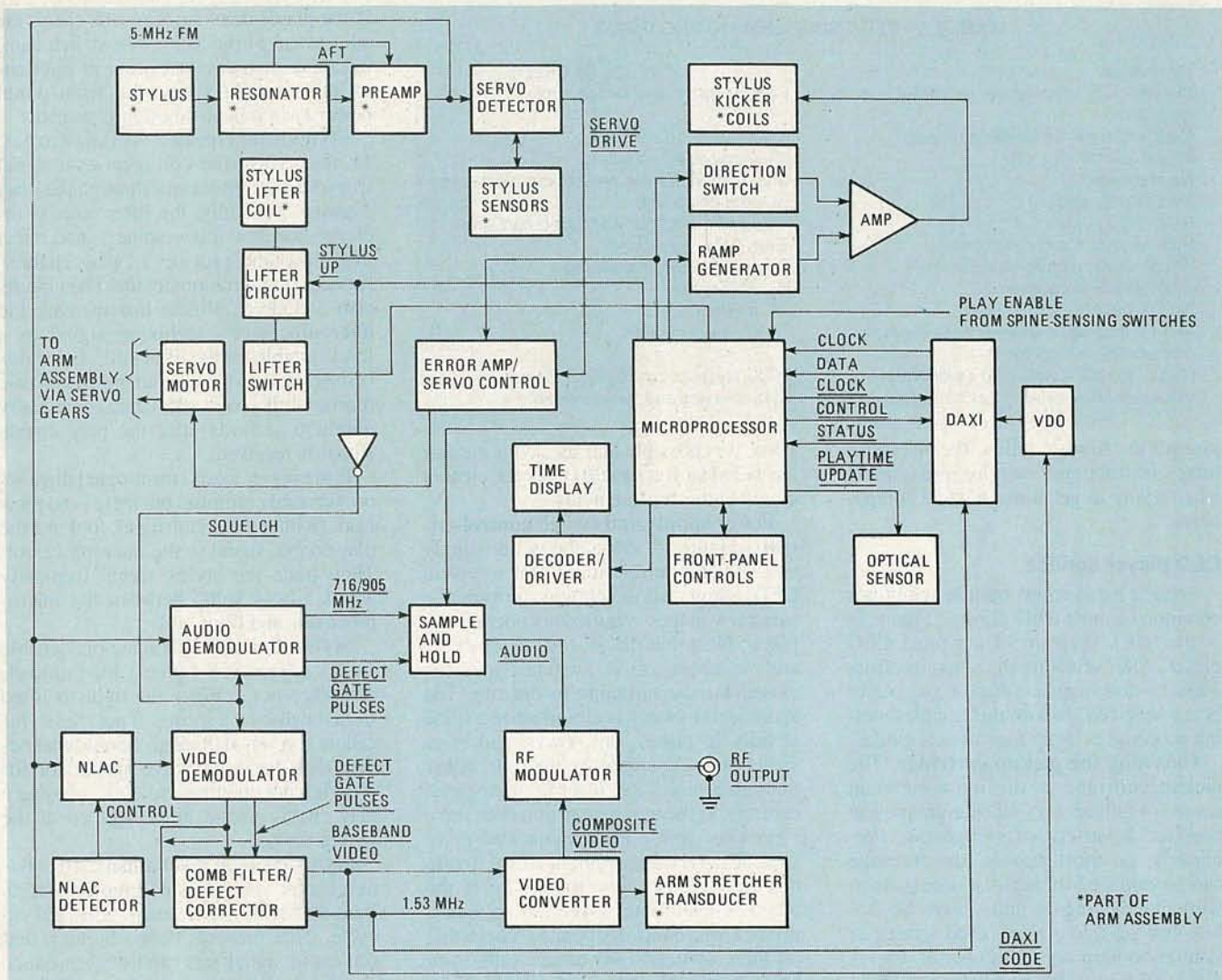

FIG. 14—BLOCK DIAGRAM of the electronic and mechanical systems in a CED videodisc player. The blocks noted with an asterisk are located in the player's arm.

sound demodulators to the VHF modulator, replace the sound demodulators (starting with demodulator II).

If sound is distorted, first check if the distortion is on one or both audio channels. Then replace the corresponding sound demodulator (I, II, or both). If that does not clear the problem, replace the VHF modulator. On most players, it is possible to monitor the sound via the rear panel audio connectors (left and right).

Slide drive and search circuits. The slide-drive servo is responsible for moving the slide assembly radially beneath the disc. A problem in the slide-drive servo can cause the repeating of sections of the disc. If the player sticks or repeats, check for drive signals to the slide motor from the drive. Generally, the drive signals are on the order of 1 to 8 volts, and the polarity of that voltage is positive in forward and negative in reverse. If the voltages are absent or abnormal, replace the slide drive.

If the SEARCH functions (forward or reverse) are not normal, try grounding the

corresponding inputs (from the SEARCH controls) to the mode control. If that produces correct operation, replace the SEARCH control and/or wiring. If not, check the search signal from the mode control to the slide drive. If absent or abnormal, replace the mode control. If normal, but there is no search, replace the slide drive and/or check the wiring between the drive and slide motor.

Index circuits. First check any video level adjustments. If the index numbers are present on the TV screen, but the background blanking is missing, check for a picture-number background signal from the mode control. If present, replace the video processor. If the background blanking is present, but the index numbers are missing, check for a picture-number signal from the mode control to the video processor. If missing, replace the mode control. If present, replace the video processor. If both numbers and background are missing, check the INDEX switch and the connections to the mode control.

Track jumping circuits. First check any jump-pulse adjustments. The track-jumping circuit is used only when a special mode of operation is selected (still, slow motion, fast forward, fast reverse, etc.). A malfunction in the track-jumping circuit can cause loss of special modes (tricks), erratic special modes, or skipping through sections of the disc.

First press the play-reverse button and check for vertical-sync-serration pulses from the mode control to the trick logic. If missing, replace the mode control. If present, check for a PIA pulse from the trick logic to the radial drive. If missing, replace the trick logic. If present, check for a zero-detect pulse from the trick logic to the mode control. If missing, replace the mode control and/or trick logic. If present, replace the radial drive.

Mechanical adjustments. Mechanical adjustments should only be made using the manufacturer's procedures, and (generally) only after there has been major replacement of mechanical parts (such as manufacturer's replacement of the slide

TABLE 2—CED TROUBLESHOOTING GUIDE

Symptom	Circuits To Check
Player totally inoperative, or turntable on but no picture	Power supply and switch control
Caddy can not be loaded/unloaded	Mechanical adjustments
Player will not turn off	Mechanical adjustments
No playback	Stylus lifter/cleaner and pickup electronics
No or noisy audio	Audio demodulator
No or noisy video	Video demodulator and video converter
Picture and/or color instability	Time-base corrector
Wrong color, picture not in sync	Comb filter/defect corrected
Soundbeats in picture	NLAC circuits
No RF output	RF modulator
Picture and audio repeat, visual search inoperative or incorrect	DAXI signal circuits
Rapid access inoperative or incorrect	DAXI, system control, time display
VISUAL SEARCH OR RAPID ACCESS problems	Stylus kicker and servo control

assembly). Always follow the manufacturer's instructions, even for disassembly when trying to get at mechanical components.

CED player service

Table 2 lists various trouble symptoms common to most CED players. Figure 14 is the block diagram of a typical CED player. After selecting the symptom from Table 2 that matches that of the player being serviced, follow the troubleshooting procedures using Fig. 14 as a guide.

Checking the pickup cartridge. The pickup cartridge is the most common source of failure in a CED player, and can produce a variety of symptoms. Fortunately, on most players, the cartridge can be replaced through an access door, without removing the unit's cover. So, before you get into any involved service or troubleshooting on a CED player, try replacing the cartridge as a first step. Make sure you use a known good cartridge.

Also, it is possible that the stylus cleaner has failed so you should check the cleaner circuits after replacements.

Power supply and switch control-circuits. Figure 15 shows the power supply and switch control-circuits for a typical CED player. Those circuits provide the various voltages required to operate the player. Note that the AC POWER, AC PLAY, and AC SPINE-SENSE switches must be closed for the turntable to operate. The SPINE SENSE switch is closed when a spine is fully in place. The POWER and PLAY switches are operated by the user, either through a FUNCTION lever or front-panel controls. If the unit in question does use a FUNCTION lever, the POWER and PLAY switches are usually operated by a cam that may require adjustment. So if the player is dead (with power available, disc in place, and controls operated) check that all three switches are closed (after you have checked the fuses, of course). Then monitor all of the power-supply voltages.

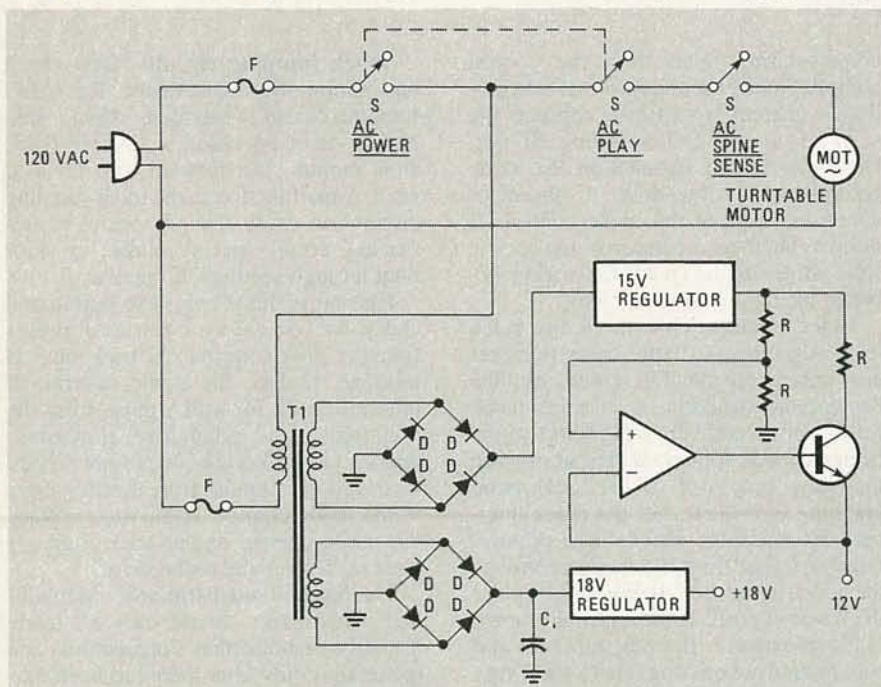

FIG 15—THE POWER SUPPLY and AC switch controls in a typical CED player. Note that the AC POWER, AC PLAY, and AC SPINE-SENSE switches must all be closed for the turntable motor to receive power.

If the player does not turn off, check the adjustment of the AC POWER switch cam. (That problem does not occur in automatic-load models where the front-panel power switch is pushbutton-operated.)

Stylus lifter circuits. As shown in Fig. 14, the stylus lifter coil receives a signal from the microprocessor through the lifter circuits. Generally, the lifter circuits include switches (play, spine sense, etc.) that close and provide a "play enable" signal to the microprocessor. The circuits also include amplifiers that increase the microprocessor's stylus-up signal to a level suitable for the lifter coil. The stylus is lowered onto the disc after the turntable reaches full speed (450 rpm), generally within 6 seconds after the play enable signal is received.

If the player loads (front-panel displays on, turntable running) but there is no playback (with a good cartridge), look for the play-enable signal to the microprocessor. Then trace the stylus signal (typically about 3 or 4 volts) between the microprocessor and lifter coil.

Stylus damage. When the play enable signal is removed (during load/unload, and when not in play), the stylus is lifted from the disc by a spring. If not, the stylus can be severely damaged. Should that occur, look for a defective spring, or for switches not opening and, thus, causing a play enable signal to be applied at the wrong time.

Stylus-cleaner mechanism. The stylus cleaner mechanism removes debris from the stylus during each caddy-unload cycle. That prevents debris buildup that can cause signal loss (and often produce the same symptoms as cartridge failure). So if a cartridge is replaced, and trouble symptoms disappear temporarily only to reappear shortly afterwards, check the stylus-cleaner mechanism. Also, if you find a defective cleaner, "clean" the original cartridge by loading and unloading the disc several times, then check player operation.

It is possible to check cleaner operation through the cartridge access door on some models. Open the door and remove the cartridge. Load and unload a disc while viewing operation of the lifter plate and cleaner (which is usually viewable through the bottom of the pickup arm). As the caddy is removed past the spindle, the stylus lifter-plate should lower, and the cleaner pad should move across the bottom of the arm (where the stylus is located if the cartridge were left in the player). After the pad as moved, the lifter plate should again rise as the caddy is completely removed. If not, you have problems with the stylus lifter and/or cleaner.

There's a lot more to servicing videodisc players. But, unfortunately, that's all the room we have for now. Next time, we'll finish up by showing you more on the CED player. **R-E**

BUILD THIS

ATARI Game Recorder

GUY VACHON and DAVID A. CHAN

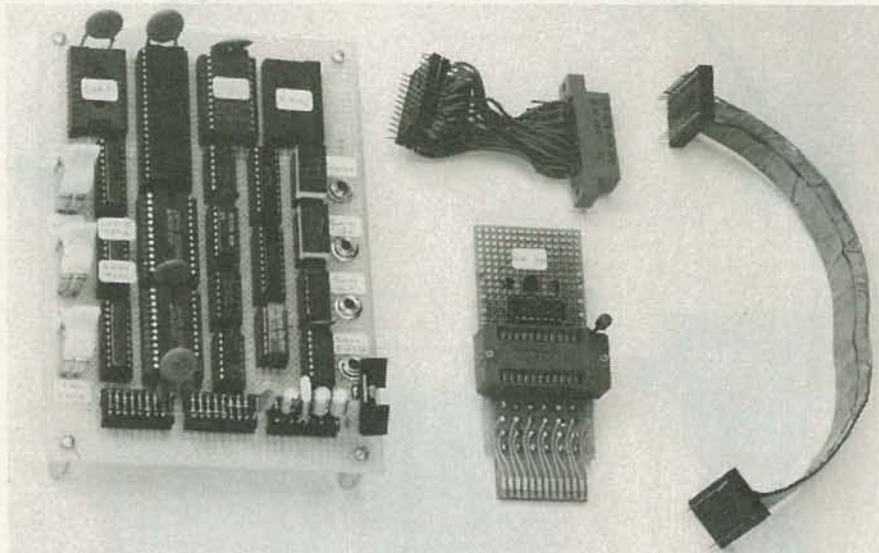

You can record the contents of your Atari 2600 videogame cartridges on audio cassette tape! This month, in the conclusion of this article, we'll show you how to build the game recorder and how to put it to use.

Part 3

WHEN WE LEFT OFF last time, we were describing the memory mapping technique that the game recorder uses. The last thing that we want to mention on that subject is that, for simplicity's sake, all ROM's were treated as if they were $4K \times 8$. That doesn't present any problems with $2K \times 8$ ROM's because they ignore the most-significant address bit. However, we end up with two copies of the cartridge in the $4K \times 8$ space—the top and bottom halves are identical. For the time being, remember that all $2K \times 8$ and $4K \times 8$ ROM's can be read by inputting to the ROM 4096 addresses (all that can be obtained from all possible combinations of 12 address bits), and saving the data patterns that the ROM returns.

One of the goals of the design of the game recorder was to keep the IC count down. Therefore, the extra memory IC's that would be required to make room for the system stack were not added. That conflicted with our desire to use subroutines (whose return addresses are usually stored in the stack). To get around that conflict, return addresses are kept in the Z80's internal registers. Thus, before a subroutine is called, the return address desired is stored in an internal register; the particular register is determined by which subroutine is to be called. The number of Z80 registers allows for up to three levels of subroutines. Besides that "trick," the software that we showed you last month is quite straightforward.

Building the game recorder

The author's prototype, shown in Fig. 6, was built on perforated construction board. Most of the connections were wire-wrapped. (Even the discrete components were wire-wrapped by first installing them in DIP headers, and then installing the header in a wire-wrap socket.) Eighth-inch phone jacks were used for cassette I/O and power connections, and 24-pin DIP sockets were used for connections to the Atari 2600 and to the game cartridge. Note that a simple power supply, whose schematic is shown in Fig. 7, was also mounted on board. The input to the supply is from a 9-volt, 500-mA DC wall transformer—similar to the transformer that the Atari 2600 itself uses.

Turning to Fig. 8, we see the con-

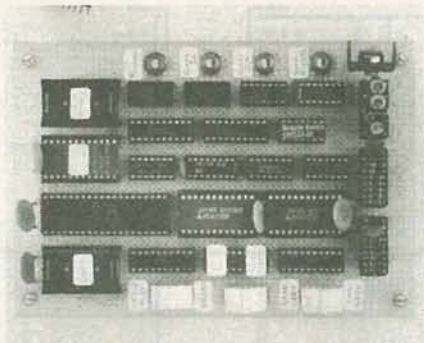

FIG. 6—THE MAIN BOARD of the author's prototype. Three SPDT switches, two 24-pin sockets, and 3/4-inch phone jacks are used for input/output. The fourth jack is used for connection to a wall transformer.

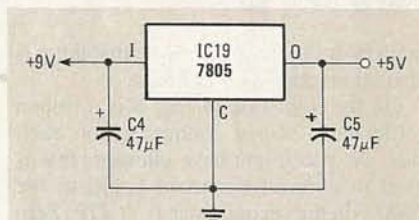

FIG. 7—A SIMPLE VOLTAGE REGULATOR circuit can be mounted on the main board.

nectors we need to connect the main board to the game cartridge and to the Atari 2600. At the top left is the cartridge connector. In the author's prototype, that was basically a DIP-to-card-edge converter: One side plugs into the 24-pin DIP socket on the main board, while the other side is a 24-pin card-edge connector with standard 0.1-inch spacing. Note that to make wiring the connector easier, two 12-pin jumper headers are used to plug into the 24-pin socket. The wires from the headers then connect to the 24-pin edge connector. If you look closely at the photograph, you might note that an inverter is mounted between the socket and the card-edge connector. That's needed to invert the ENABLE line because the program ROM in the cartridge—as opposed to a 4K EPROM—is active high. The foil patterns that we'll show you shortly incorporate the inverter on the board.

Below the cartridge connector is a second board—which we'll call the *adapter board*—that is needed to connect the

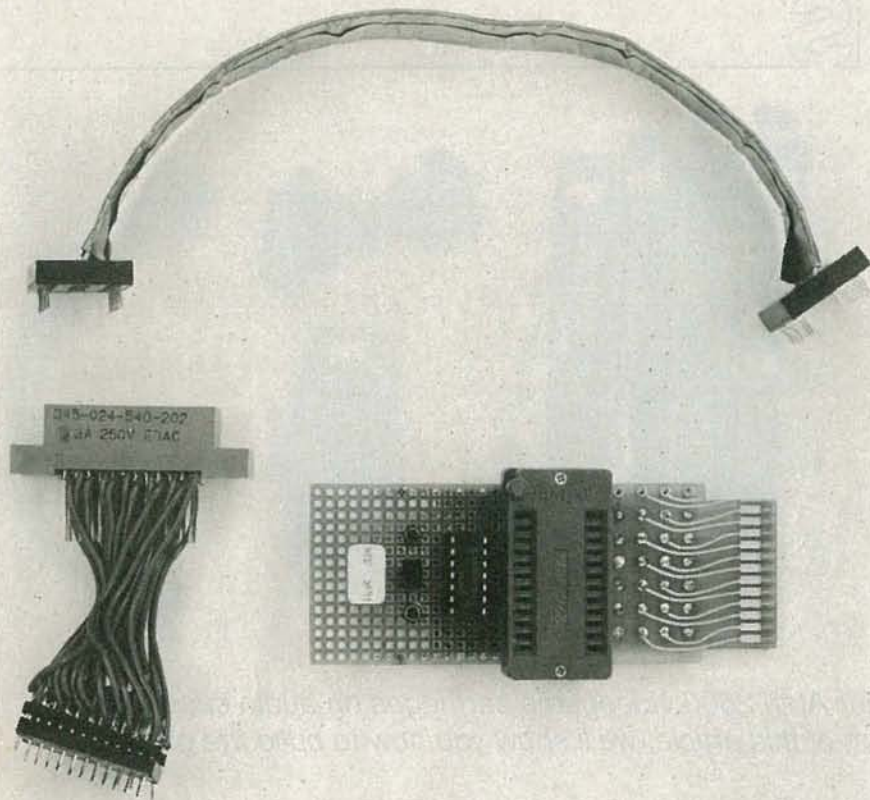

FIG. 8—TO CONNECT THE MAIN BOARD to the Atari 2600 and to the game cartridges, you need to make up special connectors.

main board to the 2600. Note that there is also an inverter on that board.

On the right side of Fig. 8 is a ribbon cable with 24-pin connectors on each side. As you might have guessed, that is used to connect the main board to the 2600 (via the second board). A ZIF (Zero Insertion Force) socket is mounted on the second board for convenience. Note that the ribbon cable is shielded by copper foil. You will most likely find that shielding the cable will be necessary.

Wire-wrapping a circuit of this complexity is possible but, since wire wrapping sometimes leads to problems in troubleshooting and in mechanical integrity, a printed-circuit board is a desirable

alternative. Foil patterns for the component and solder sides of the main board are shown in Figs. 9 and 10 respectively. A supplier of that board is available: See the parts list for information.

The parts-placement diagram for the main board is shown in Fig. 11. Note that there are a few differences between the PC board and the author's prototype. For example, while all the switches and jacks were mounted on the main board of the prototype, the PC board is meant to be used with panel-mounted components. Also, the inverters that were mounted on the prototype's connectors are now located on the board. Note that pull-up resistors for some of the switches are located

off-board. Those resistors, which were not shown in the schematic, are shown in Fig. 11.

You will still need an adapter board to connect main board to the 2600, and you will have to wire up special cables to connect the main board to both the 2600 and to the game cartridge. The foil patterns for the adapter are shown in Figs. 12 and 13. Figure 14 shows the card-edge pinout of a game cartridge. That, along with Figs. 11-13 should help you wire your cables correctly.

When you build the game recorder—or any other device that uses IC's—be sure to use IC sockets. Start by installing those sockets, followed by the discrete components. Don't install any of the IC's except the voltage regulator. If you use a wall-mounted transformer, install an 1/8-inch phone jack off the board for power connections. Apply power to that jack and check for +5 volts at the appropriate IC pins. Remove power and double check the board for shorts between traces (solder bridges) or for any other potential problems. When you're confident that the board is in good shape, install the IC's, the two displays, and the relay.

Next, you'll have to install the other jacks and the switches. Since those are meant to be panel-mounted, you'll have to cut wires to the appropriate length. Once that is done, you're ready to test the unit out.

Using the game recorder

Throughout this article, we've referred to the various switches and displays that are used on the game recorder. Now it's time to tell you how to use them.

Six switches, two seven-segment displays, and three phone jacks are used for input and output to the game recorder. If you look at the photo in Fig. 6, you'll see only three switches—each single-pole, double-throw switch is used for two functions. You may want to follow the same setup: After all, you can't read and write to the cassette tape at the same time!

Let's give a brief overview of what the switches and displays do. Then we'll go

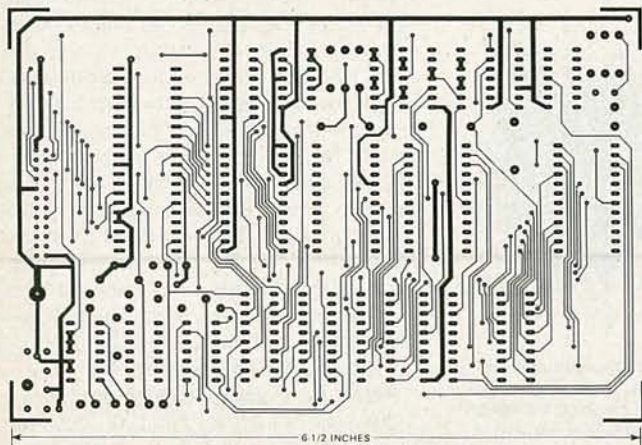

FIG. 9—THE COMPONENT SIDE of a PC board for the Atari game recorder.

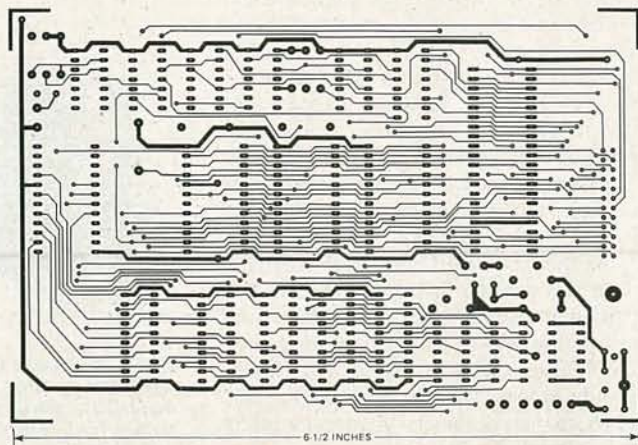

FIG. 10—THE SOLDER SIDE of the game recorder board.

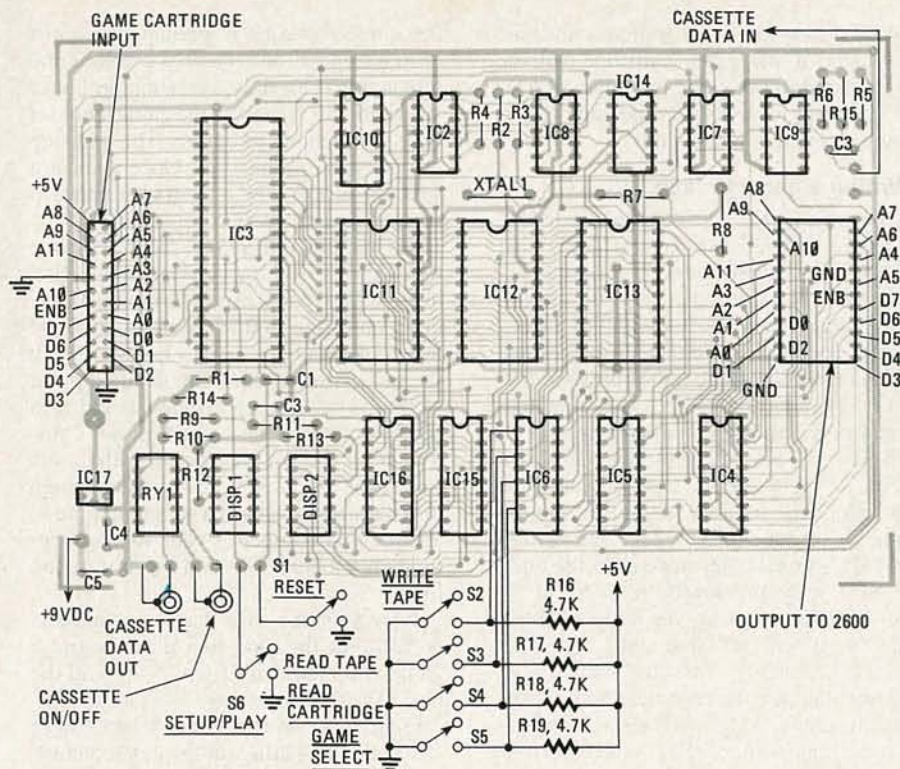

FIG. 11—PARTS-PLACEMENT DIAGRAM for the main board. Note the connector pinouts. You will have to wire up a cable to connect the main board to game cartridges and to the adapter board.

PARTS LIST

All resistors are 1/4-watt, 5%, unless otherwise specified.

R1—220,000 ohms
 R2, R3—1000 ohms
 R4—330 ohms
 R5, R7—R9—10,000 ohms
 R6, R15—100,000 ohms
 R10—3300 ohms
 R11—47,000 ohms
 R12, R13—120 ohms
 R14—4700 ohms

Capacitors

C1—1 μ F, 10 volts, electrolytic
 C2, C3—.01 μ F, ceramic disc
 C4, C5—47 μ F, 10 volts, electrolytic

Semiconductors

IC1, IC8, IC14—74LS00 quad 2-input NAND gate
 IC2—74LS74 dual D-type flip-flop
 IC3—Z80 microprocessor
 IC4—IC6—74LS244 octal buffer
 IC7—74LS125 quad bus buffer
 IC9—LM3900 quad op-amp
 IC10—74LS138 3-to-8 line decoder

IC11—2716 EPROM containing the computer's operating system
 IC12, IC13—2016 2K \times 8 static RAM
 IC15, IC16—74LS273 octal D-type flip-flop
 IC17—7805 5-volt regulator
 DISP1, DISP2—MAN74A or similar seven-segment display

Other components

S1—S5—SPST momentary switch
 S6—SPST toggle switch

Miscellaneous: 1/24 card-edge connector, ZIF socket, wiring harnesses to connect main board to 2600 and cartridge, etc.

An EPROM containing the game-recorder program is available for \$15 postpaid from J&L Associates, 1133 Broadway Room 906, New York, NY 10010. New York residents must add sales tax.

A set of two etched, drilled, and plated-through boards are available from E²VSI, PO Box 72100, Roselle, IL 60172 for \$32.50 postpaid.

into detail on each function. The first switch we'll consider is the GAME SELECT switch, S1, which is used to reset the game recorder in case of failure. The WRITE TAPE switch, S2, is used to initiate the transfer of data from the game recorder's RAM to a cassette tape. Switch S3, READ TAPE, does just the opposite: It initiates data transfer from cassette tape to the

game recorder's RAM. The READ CARTRIDGE switch, S4, initiates the transfer of data from the game cartridge to the game recorder's RAM. Switch S5, GAME SELECT, is used to select the name of the game that you want to save on tape, or the name of the game you want to find on a tape. You have 16 choices for a name: the hexadecimal digits 0-F. The final switch,

S6, is the SETUP/PLAY switch which is used to put the game recorder in the mode to play a game on the 2600.

The first of the two displays, GAME SELECT, shows the name of the game that you want to save or the one you are trying to find on a tape. The name is selected by the GAME SELECT switch. The LAST GAME FOUND display is used to indicate the name of the game that the recorder is "listening to" on the tape. We'll see that the decimal points of those displays serve another important function.

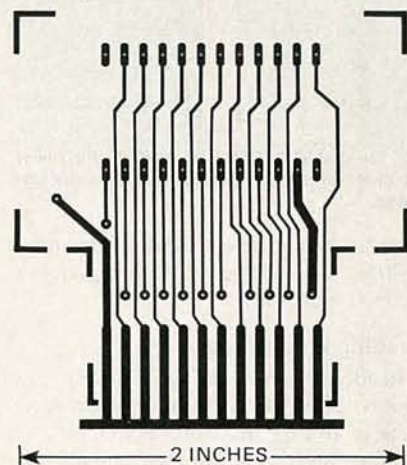

FIG. 12—THIS ADAPTER BOARD is used to connect the main board to the Atari 2600. We recommend that you use a DIP socket for convenience.

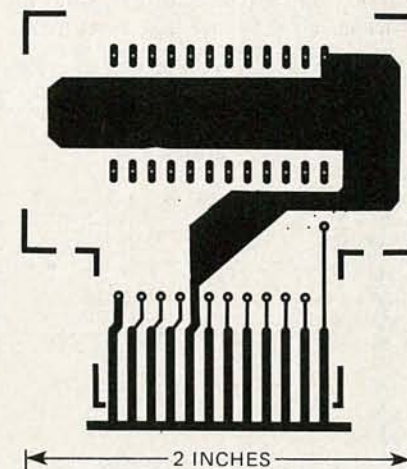

FIG. 13—THE FOIL SIDE OF the adapter board.

There is one cassette input to the game recorder (CASSETTE DATA IN) and two cassette outputs (CASSETTE DATA OUT and CASSETTE ON/OFF). Note that the schematic does not show the CASSETTE ON/OFF output. Instead, the output of IC7-c is labeled "TO CASSETTE-CONTROL RELAY." Although the relay is not shown on the schematic, the board has provision for a DIP mounted relay that can be controlled by the output of IC7-c.

Before you use your game recorder, keep the following notes of caution in mind: NEVER plug a game cartridge in while the game recorder is on. The 2600 should be turned OFF before the game

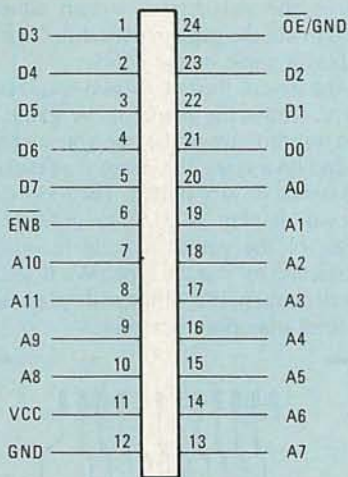

FIG. 14—GAME CARTRIDGE PINOUT. Pin 1 is at the lower left of the front (label side) of the cartridge.

recorder is connected. **NEVER** turn the 2600 on while the game recorder is not in the PLAY position.

Reading a cartridge

Reading a game cartridge is perhaps the easiest task that the game recorder has. It's also an easy function for you to initiate. First make sure that the game recorder's power is off and that it is properly hooked up to the 2600. Then make sure that the SETUP/PLAY switch is in its SETUP position. Apply power to the game recorder and close S4, the READ CARTRIDGE

switch. In a matter of milliseconds, the contents of the game cartridge will be transferred to the game recorder's RAM. If you want to verify that the copy is correct, you can play the game.

Writing a game to tape

Once you have a game stored in RAM, you can transfer it to cassette tape. First make sure that the game is set up as before. If you're using a cassette control relay, attach the cassette output to the REMOTE jack of the cassette recorder. Select the name of the game (a hex digit from 0-F) by pushing the GAME SELECT switch. Each time you push it, the GAME SELECT display will increment by one. That will place a "label" on the tape that the game recorder will be able to find at another time. It's a good idea to name your games in the order that they appear on the tape.

Next set your cassette recorder to record. (If you are using the remote control option, it will not start until the game recorder is ready. Push the WRITE TAPE switch; the cassette recorder should start, and the data transfer will begin. Note that the decimal point of the GAME SELECTED display will light. After the game has been transferred, the decimal point will again go dark. That's your signal to stop your cassette recorder if you're not using the remote control option.

Reading a tape

Loading a game from cassette tape to

the game recorder is perhaps the most difficult operation. But if you follow the instructions carefully, you shouldn't have any problems. Hook up the game recorder in its setup mode as before. The first step is to set the volume level. Once you learn what the proper level is, you won't have to repeat this step every time.

Set your tape to play a recorded game (which you can recognize by the high- and low-pitched tones). Then turn the volume down and connect the cassette's earphone jack to the CASSETTE-DATA IN input. Push the READ TAPE button; the decimal point of the GAME SELECT display should turn on. Now turn up the cassette player's volume until the decimal point of the LAST GAME FOUND display just turns on. Then turn the volume up just a slight bit more—about a half number, if your volume control is numbered. But don't turn it up too loud.

Now to make sure that the volume is correct, set the tape to a place before a game you recorded. Then try to read the tape. The LAST GAME FOUND should indicate the name of the game. When you're finished with setting up the game recorder, press the RESET button.

Now try to load back a game you recorded by selecting its name, setting up the recorder, and hitting the read tape button. The LAST GAME FOUND display will indicate the name of each game the game recorder finds. When it finds the selected game, it will read it and stop the cassette player when it's finished (if the remote option is used).

Playing a game

Now that you have a game in the game recorder's memory—either from a tape or from a game cartridge—you can play it on the 2600. Just move the SETUP/PLAY switch to the PLAY position and turn the 2600 on. Your game should be ready to play. Be sure to turn the 2600 off before moving the SETUP/PLAY switch back to SETUP.

Expanding the game recorder

As a final note, we should note that many new games for the Atari 2600 are 8K long. The basic ideas of this game recorder can be used to record those games on cassette tape. However, you will have to make both hardware and software modifications. We won't go into detail on how those modifications are made, but we will give you a head start.

Figure 15 shows one way of adding to the the address decoder to obtain bank-switching ability. The software would have to be written to turn the memory-mapped bankswitching mechanism on and off (by setting and resetting a flip-flop, for example). The software should include some way to detect and record the ROM size. The last two bits of the header could be used for that purpose. **R-E**

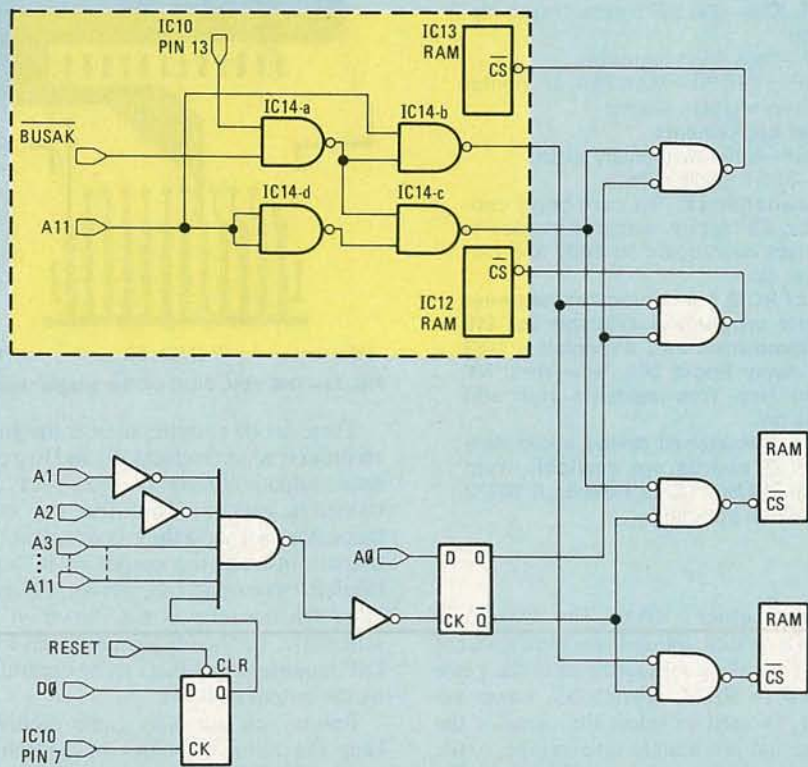

FIG. 15—EXPANDING THE RECORDER to record larger games is possible. The software will have to be changed, as will the address decoder. Here is a possible decoder scheme to use for bankswitching.

ALL ABOUT THERMISTORS

HARRY L. TRIETLEY

Last month we studied thermistor basics—what they are, how they behave, etc. This month, we'll finish our look at the basics, and then we'll show you design techniques so that put thermistors to work in your circuits.

Part 2 BEFORE WE GET TO circuit applications for thermistors, we have some basic points to mention about thermal runaway PTC thermistors, and probe assemblies.

The negative-resistance behavior makes it possible for a thermistor to go into thermal runaway and destroy itself. Figure 5 shows one of the lines from Fig. 4 (see the January 1985 issue of **Radio-Electronics** page 50) replotted with voltage on the horizontal axis, current vertical. From that plot you can see that if you connect the thermistor to a voltage source, the current will increase more rapidly than the voltage due to the ther-

mistor's decreasing resistance. When the voltage becomes high enough to enter the negative-resistance part of the curve, the resistance will decrease because the thermistor is getting hotter. That results in increased current, heating the thermistor even more, increasing the current more, etc. If there is no current limiting, the thermistor will continue to heat until it destroys itself. Always be careful, when connecting a thermistor to a voltage source, to either limit the voltage to safe values or else provide some means to limit the current. We would point out that the curves we've just described depend very much on the application and must be de-

termined experimentally. Changing the surrounding temperature, connecting the thermistor to a heat sink, changing the air flow, or putting it in an enclosure will create a new set of curves.

The fact that a thermistor heats itself when power is applied is a drawback when measuring temperature—the power must be kept well below a milliwatt to avoid errors. In other uses, however, thermistors are purposely self-heated. For example, if you self-heat a thermistor well above the surrounding air temperature and then increase the air flow, its temperature will drop, increasing its resistance. You now have a sensor to detect wind or air cur-

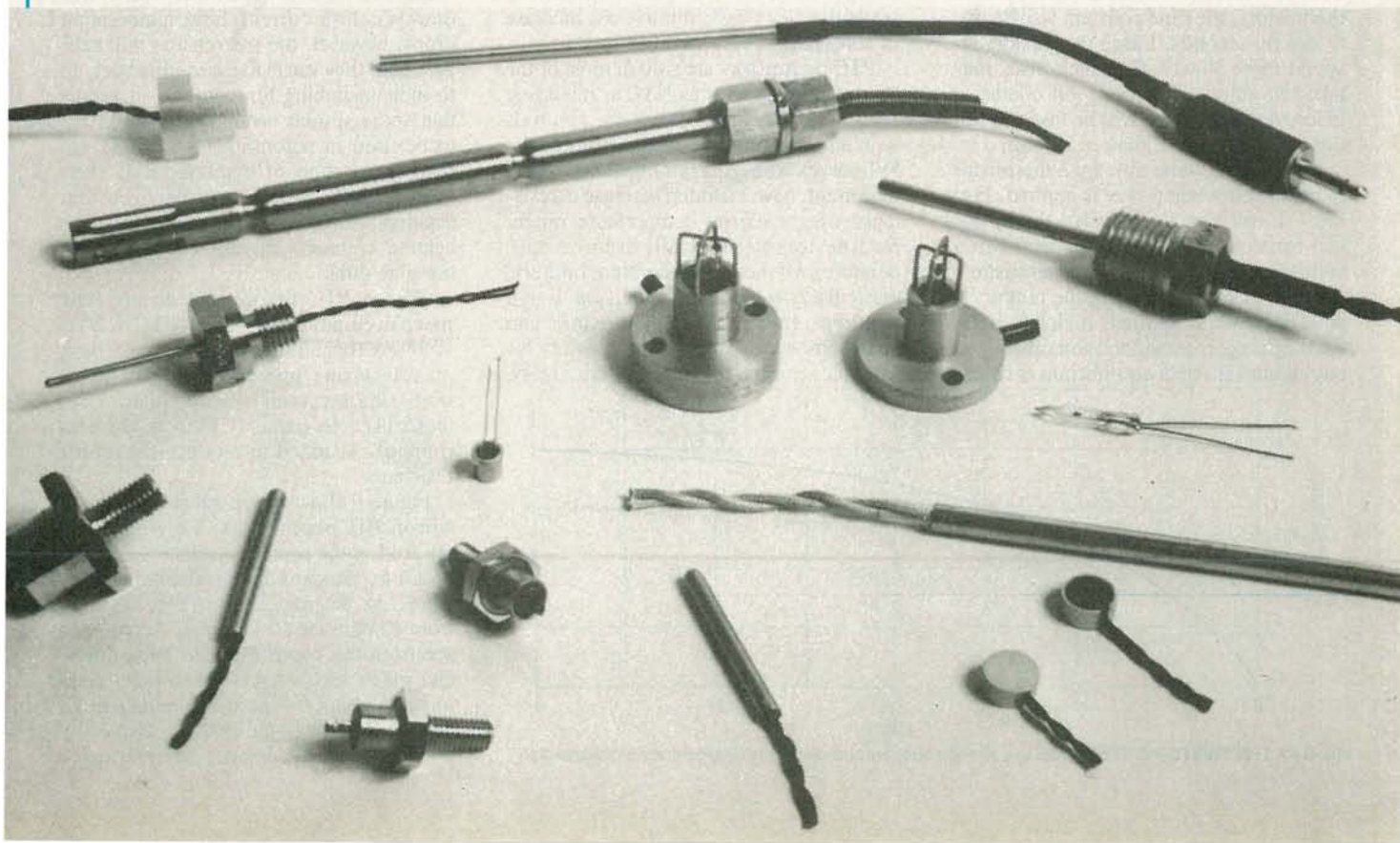

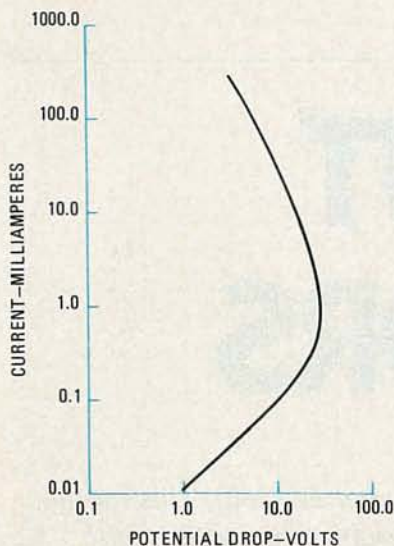

FIG. 5—A THERMISTOR MAY ENTER THERMAL RUNAWAY if neither voltage nor current are limited.

rents. Likewise, a self-heated thermistor's temperature will drop when it comes in contact with liquid, making it useful as a liquid-level sensor.

Response time

Suppose you suddenly move a thermistor from one temperature to another. Like any thermometer, it will take a while to respond. The mass of the thermistor must heat up or cool down to match the surrounding temperature. The response will look fairly much like an exponential R-C time response as shown in Fig. 6, with the 63% response time indicated by time constant, τ . For small disc or bead thermistors, the time constant will be one to several seconds. Large thermistors respond more slowly: One-inch discs may take two minutes or more. Of course, a thermistor's response will be faster in liquid or in moving air than in still air.

It also takes some time for a thermistor to heat itself when power is applied. Figure 7 shows what happens if a thermistor and resistor in series are connected to a voltage source. At first, the thermistor's resistance is high, limiting the output. If enough power is applied, it slowly heats up, dropping its resistance and raising the output until thermal equilibrium is reached.

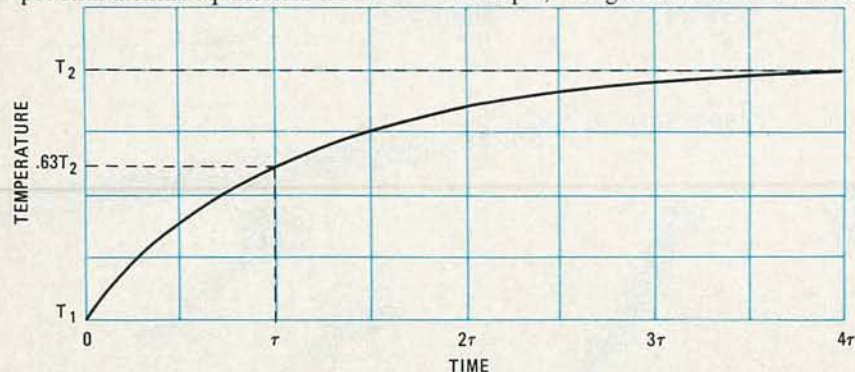

FIG. 6—A THERMISTOR'S RESPONSE to a sudden temperature change is approximately exponential.

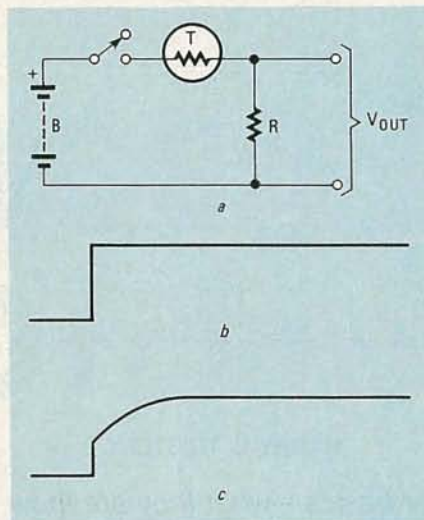

FIG. 7—CREATING A TIME DELAY is one popular use for thermistors.

ed. Thermistors are often used in this way to create delay times or to protect against sudden inrush currents. We will study such applications in more detail a bit further on in this article.

PTC thermistors

As we mentioned at the beginning of this article, there are two distinctly different types of positive temperature coefficient (PTC) thermistors: those sintered from powdered metal compounds and those made from silicon. The most common of the sintered types are those made from barium titanate, with various doping materials added. Thermistors of that type have resistances that increase with temperature as shown in Fig. 8. Note that the vertical scale is logarithmic—the increase in resistance is very rapid.

PTC thermistors are sold in most of the same configurations as NTC's, including small and large discs, washers, and rods with and without leads and coatings. The R-T curves are highly nonlinear and, more important, have a sudden increase in resistance over a narrow temperature range. Such devices are especially useful as temperature switches or temperature limiters, particularly when high precision is not required. Larger PTC thermistors can switch moderate amounts of power; for example, enough to control a series relay.

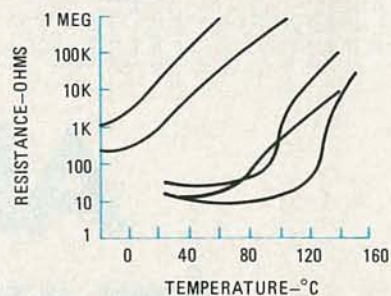

FIG. 8—RESISTANCE-TEMPERATURE CURVES for five typical PTC thermistors.

Simply place the relay and PTC thermistor in series with a voltage source and the relay will drop out somewhere along the steep portion of the curve. The switching point is controlled by varying the doping used in the thermistor.

PTC thermistors also can be used as current limiters. When their current becomes too large they will self-heat to the point where their resistance increases rapidly.

An interesting use of larger PTC thermistors is as self-regulating heaters. When power is applied, the thermistor will heat itself until it reaches the steep portion of the curve, at which point the current will decrease rapidly. A fairly constant temperature will be maintained regardless of changes in the ambient temperature or thermal load. One manufacturer has created a heater for liquid-crystal displays by epoxying several PTC thermistors to a metal strip. The strip is glued or clamped to the back of an LCD and connected to a 24-volt power source. When the LCD is warm, the heater will draw very little current. If the temperature drops, however, the thermistors will self-heat until they warm the assembly back up to their switching temperature. It seems that some similar arrangement will have to be used in automobiles if LCD's are used for dashboard displays. PTC thermistor material is also formed into custom designed shapes to form self-regulating heating elements in appliances such as hot-glue guns.

Silicon PTC thermistors do not have much in common with either PTC or NTC sintered thermistors—at least in their manufacturing process. They are made from single-crystal silicon wafers (like those used to make IC's) with dopants (impurities) added to produce the proper resistance.

Figure 9 shows a typical R-T curve for silicon PTC thermistors. They generally are sold in the same resistance values (at 25°C) as standard 10% resistors; that is, 10, 12, 15, 18, and 22 ohms etc, in values from 10 ohms to 10 kilohms. As you can see from the curve they are fairly linear and much less sensitive than other thermistors, about 0.7 percent per degree C. The exact shape of the curve is affected by the dopant added; hence, different resis-

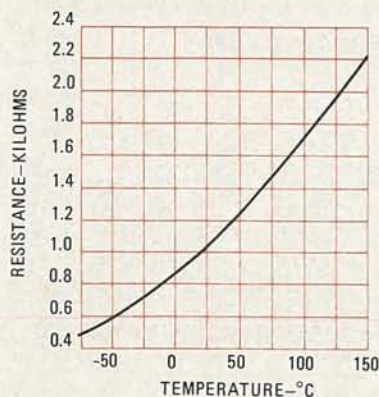

FIG. 9—SILICON PTC THERMISTORS have nearly linear resistance-temperature characteristics.

tance values have slightly different curves.

The operating range of silicon PTC thermistors runs from around -80°C (-112°F) to $+150$ or 200°C ($+302$ to 392°F), depending on the style and manufacturer. Tolerances are generally $\pm 10\%$ to $\pm 20\%$ (at 25°C) although tolerances to $\pm 1\%$ are available. Keep in mind that that is poorer than similarly specified NTC thermistors: Their $0.7\%/^{\circ}\text{C}$ sensitivity means that a ten percent error equals 14°C (as opposed to 2.5°C for a $4\%/^{\circ}\text{C}$ NTC thermistor). Again, the tolerance is wider at higher and lower temperatures.

Silicon PTC thermistors are most often sold in diode or transistor-type packages. They also are available mounted on two parallel leads and covered with epoxy, similar to small disc thermistors.

Thermistor probe assemblies

An unprotected thermistor is poorly suited to most temperature measurements. You can't dip it in water or any other conducting liquid since the liquid will shunt the leads, producing false readings. Also, except for hermetically sealed glass units, the liquid will eventually creep into the thermistor, most likely finding a path in minute voids between the leads and the epoxy coating. Nonconductive liquids may attack or soften the epoxy; corrosive liquids may destroy the leads. Even continued exposure to high-humidity air may eventually produce electrical leakage inside the thermistor. Sealing the thermistor can also provide protection for mechanical ruggedness.

Thermistors are often mounted inside temperature probes, such as those seen in Fig. 10. Usually, the probe consists of a length of stainless steel, glass or other tubing welded closed at the measurement end. The thermistor is soldered to a length of wire or cable and inserted into the probe, generally with a bit of epoxy in the probe tip to give mechanical strength and to create better thermal contact with the probe. Additional epoxy is used to seal the back end. A probe may be simply a

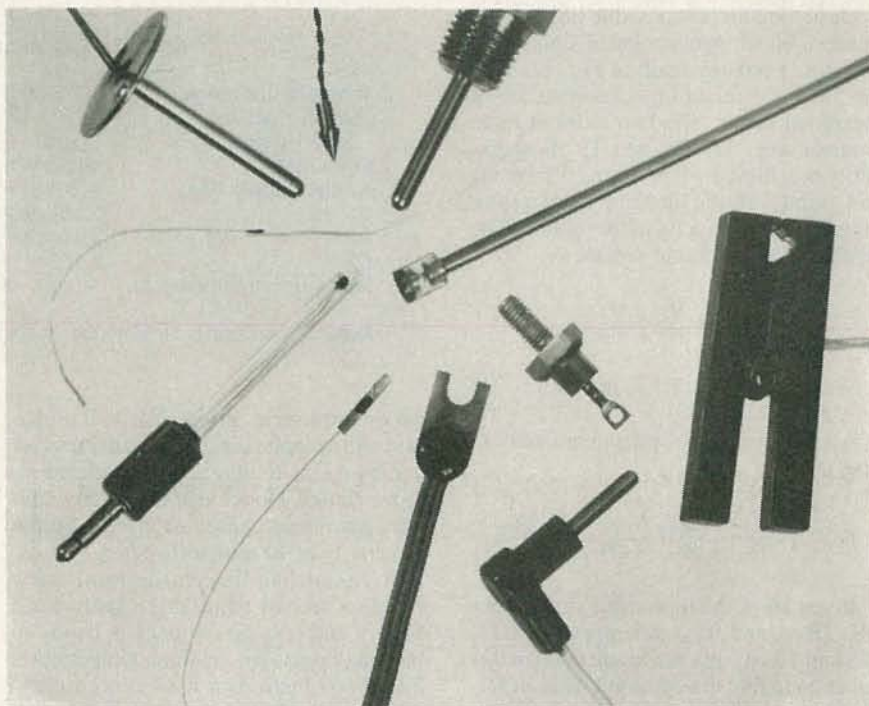

FIG. 10—A WIDE VARIETY OF THERMISTOR mountings and assemblies are available.

“straight stick” for laboratory use, or it may be welded to pipe-threaded fittings or other mountings for permanent installation.

Of course, thermistors may be mounted in other ways. For example, they may be epoxied into a drilled-out bolt for installation into a tapped hole. The possibilities are limited only by your imagination. For commercial and OEM customers, many thermistor manufacturers will build their thermistors into probes or other assemblies to meet users' needs.

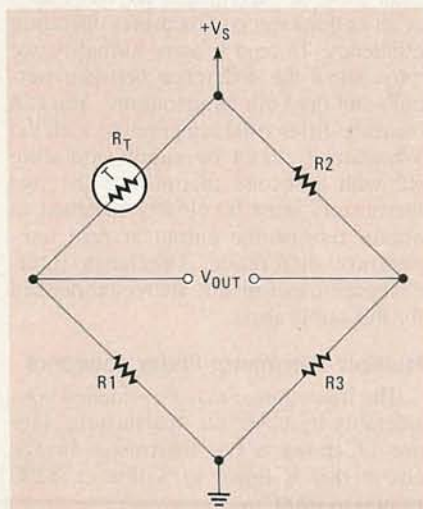

FIG. 11—A WHEATSTONE BRIDGE with a thermistor arm will produce an output that increases with temperature.

Bridge circuits

If we connect an NTC (Negative Temperature Coefficient) thermistor in a Wheatstone bridge as shown in Fig. 11, we

can generate a voltage that increases with temperature. If we choose our resistors properly, we can insure that the voltage will vary fairly linearly with respect to temperature (if only over a narrow temperature range).

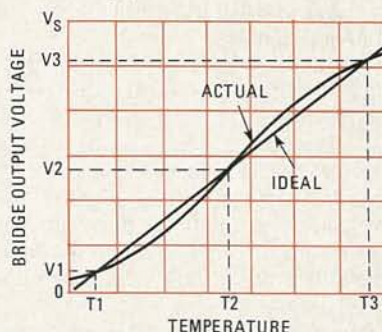

FIG. 12—THE WHEATSTONE BRIDGE OUTPUT is fairly linear near the middle of its range.

Figure 12 shows the output voltage of a Wheatstone bridge as a function of temperature. Note that the curve is S-shaped, approaching—but never reaching—the supply voltage at high temperatures (low thermistor resistance). The sensitivity is highest near the midrange, where the thermistor resistance is close to the resistance of R_1 .

While it is not possible to change the basic shape of this curve, you can choose R_1 so that the center of your temperature range is on the most linear (center) portion of it. For narrow temperature ranges (not more than about 20°C), you can achieve a quite linear output by making R_1 equal to the thermistor's resistance at the center of the temperature range. Linearity becomes poorer as the temperature range gets wider.

Designing for best possible linearity requires a bit of algebra, but it's not at all difficult. Looking again at Fig. 12, note the "ideal" straight line drawn on top of the actual curve. The two cross at three temperatures, T1, T2, and T3. Best linearity is achieved when T1 and T3 are the end points of the desired temperature range and T2 is exactly in the middle. The equation for the output voltage is:

$$V_{OUT} = \frac{V_S \times R1}{R1 + R_T}$$

We wish to select R1 so that: $V3 - V2 = V2 - V1$ when $T3 - T2 = T2 - T1$

All this may be solved algebraically to give us:

$$R1 = \frac{R_{T1} R_{T2} + R_{T2} R_{T3} - 2R_{T1} R_{T3}}{R_{T1} + R_{T3} - 2R_{T2}}$$

If you know the thermistor's resistance (R_{T1} , R_{T2} , and R_{T3}) at temperatures T1, T2, and T3, simply substitute them in this equation to find the optimum value of R1. The thermistor's values may be taken from the manufacturer's data or by measurement at the three temperatures.

You still need to choose R2, R3, and the supply voltage, V_S . Choosing the resistors is easy—set R3 equal to R1, then make R2 equal to the thermistor's resistance at the temperature where you want zero output voltage from the bridge. You may want to make R2 adjustable for calibration purposes.

The supply voltage, V_S , determines the output sensitivity (millivolts-per-degree). You may need to do some trial-and-error here. Choose a reasonable voltage—say, one volt—and calculate the output voltage from the bridge at T1 and T3. This will give you a sensitivity for that particular supply voltage. Next, raise or lower V_S in proportion to the increase or decrease in sensitivity needed.

Remember that making the supply voltage too high will cause the thermistor to self-heat, causing measurement errors. For a typical small thermistor in air, one milliwatt of dissipation will cause a 1°C error. The power dissipation will be highest when the thermistor equals R1 and will be:

$$P_D = \frac{(0.5V_S)^2}{R1}$$

where P_D is in watts. For precise work you will want to keep the power dissipation to 0.1 milliwatt or less.

Table 2 lists the calculated resistor and supply-voltage values for three different temperature ranges. Notice that linearity is very good for narrow ranges, but gets worse rapidly as the temperature range widens. The thermistor used in this design is a Yellow Springs Instrument Co. (Box 465, Yellow Springs, OH 45387) model

TABLE 2—EXAMPLES OF BRIDGE DESIGNS

Temperature range	10 to 30°C	0 to 50°C	0 to 70°C
Temperature for zero output	10°C	0°C	0°C
Sensitivity	10 mV/°C	10mV/°C	10 mV/°C
Bridge supply (V_S)	916.2 mV	1017.3 mV	1147.0 mV
R1	2,168 ohms	1,763 ohms	1,164 ohms
R2	4,482 ohms	7,355 ohms	7,355 ohms
R3	2,168 ohms	1,763 ohms	1,164 ohms
Maximum nonlinearity	+0.07 -0.06°C	+0.85 -0.95°C	+2.0 -2.3°C

Note: Thermistor is a YSI 44004, 400 series probe or equivalent, 2,252 ohms at 25°C.

44004, 400-series probe. You will probably have to create series or parallel resistor combinations to obtain the calculated resistor values. Notice that the supply voltages have been chosen to give an output sensitivity of 10 millivolts-per-°C.

A circuit like this, made from a few resistors and an adjustable supply (or a battery and voltage divider), is handy in the laboratory for reading temperature. The 44004 thermistor itself is accurate to 0.2 °C or better. Since sensitivity is about 4%-per-°C, a resistor or supply error of one percent causes a temperature error of only 0.25%. The bridge output may be read directly on a DVM, or fed into a high-impedance differential amplifier for other instrumentation needs. Calibration may be checked by substituting a precision decade box for the thermistor and, if need be, changed by adjusting R2 or R3 to set the zero point. The supply voltage can also be adjusted to set sensitivity.

Differential temperature, the difference between two temperatures, is often useful. For example, the difference between the inlet and outlet temperatures of a solar collector, heat exchanger, heat pump or air-conditioner coil measures operating efficiency. To read relative humidity, we must know the difference between wet-bulb and dry-bulb temperatures. You can measure differential temperature with the Wheatstone circuit by simply replacing R2 with a second thermistor. The two thermistors must be closely matched to obtain zero-bridge output at zero temperature difference. Precision interchangeable thermistors are recommended for this application.

Multiple-thermistor linear networks

The linear range may be widened considerably by using two thermistors. Figure 13 shows a two-thermistor bridge circuit that is linear to within $\pm .22^\circ\text{C}$ from 0 to 100°C.

At very low temperatures, the resistance of thermistor R_{T2} is so large (95K at 0 °C) that it has very little effect on the circuit. The circuit behaves much like a 6K thermistor in series with a 6.25K fixed resistor, which has a linear range centered around 15°C. As the temperature increases, the resistance of thermistor R_{T1}

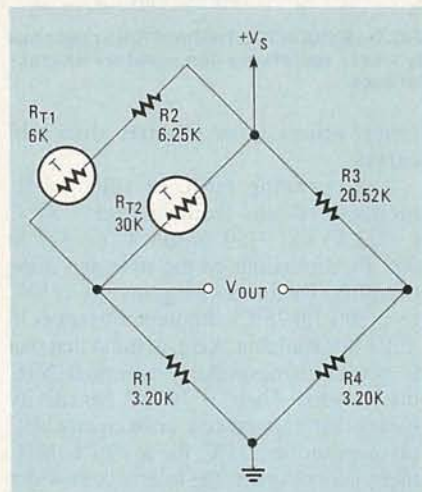

FIG. 13—A THERMISTOR-PAIR can be used in a Wheatstone bridge to improve the output linearity. This circuit is linear to within $\pm 0.216^\circ\text{C}$ from 0-100°C.

drops and begins to shunt the R_{T1} -R2 combination. Thus, while the output sensitivity provided by R_{T1} is dropping off (the high end of the S curve in Fig. 12), R_{T2} begins providing an additional "boost". In the middle of the temperature range, both thermistors are influencing the output.

At higher temperatures, R_{T1} becomes so much smaller than the 6.25K resistor (408 ohms at 100 °C) that its effect is unimportant. Now the circuit behaves as if thermistor R_{T2} was in parallel only with R2. This combination has a linear region near 100 °C. Overall, as we raise the temperature from 0 to 100 °C, the influence of R_{T1} gradually decreases while the influence of R_{T2} increases, providing a linear output over a much wider range.

Selection of an optimum set of resistors and thermistors for the circuit shown in Fig. 13 is not easy. A lot of trial-and-error calculation is needed to find the best values, and it helps to use a computer program with the circuit equations and thermistor tables (or the Steinhart and Hart equation, discussed last month) built in. Fortunately, you don't have to do this. That's because at least two manufacturers sell preselected sets of resistors. We'll tell you who, and look at some more thermistor topics, next time. **R-E**

DESIGNING WITH DIGITAL IC'S

A look at logic families, logic levels, and other digital electronics basics.

JOSEPH J. CARR

IT DOESN'T TAKE A LOT OF INSIGHT TO SEE that digital electronics has really come into its own over the past ten years. Where that field was once the sole province of a few wild-eyed computer "hackers" stuffed into the backrooms of corporate engineering departments, digital electronics now seems to be "a game for all." Unfortunately, training has not kept pace with demand, and there are many out there who would benefit from some basic material on the subject. So much of what is published these days, especially in magazines dedicated to microcomputers, seems to assume prior knowledge; beginners are left out in the cold.

Digital electronics

Unlike analog circuits, voltages in digital circuits are constrained to be one of two values. Those values are referred to as logic high and logic low; other names for those two values are logic 0 and logic 1, and, even more simply, on and off. In most practical IC logic circuits, the high and low states are voltage ranges that are separated by an "invalid" or undefined zone. That is shown in Fig. 1. In that figure, the valid low is the voltage range between zero and V_1 , while a valid high is any voltage from V_2 to V_3 . Of course, voltages greater than V_3 represent a dangerous condition. If such voltages are applied to the IC, its life expectancy would likely be shortened.

The invalid logic-level zone between V_2 and V_3 is critical. In that area, the IC does not know what to do. You may even find, for any given type number, different responses according to the manufacturer of the device. Three alternatives are possi-

ble: the invalid logic level is seen as a valid high, a valid low, or it will create no change in the output from the previous state.

Common Logic Levels

Logic levels vary according to the logic "family" that a device belongs to. Transistor-transistor-logic (TTL or T²L), is probably the most common single family. Those devices bear type numbers in the 74xx and 74xxx series for commercial devices, and 54xx/54xxx in military quality devices.

The TTL family operates from a monopolar regulated DC-supply of +5 volts. The low logic-level is represented by a voltage of 0 to 0.8 volt, while the high is represented by a voltage that is greater than +2.4 volts (but less than the TTL maximum supply voltage). Reverse voltages (negative), or voltages greater than +5 volts, are dangerous to the TTL device. In most cases, a TTL device output will be less than 4 volts, so this is no problem.

CMOS devices work from power supplies of ± 4.5 -volts DC to ± 15 -volts DC. In many cases, we find CMOS devices operating from TTL power supplies, especially where a circuit contains mixed TTL and CMOS devices. In most cases, we can use a 12-volt DC bipolar power supply for CMOS circuits. Since CMOS devices draw considerably less current than TTL, we can use current levels of ± 100 mA to ± 1 ampere.

A variable output-voltage, DC power supply may seem like something nice to have, but they have a hidden potential for disaster. If the output voltage-level is ad-

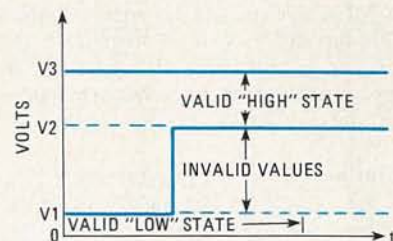

FIG. 1—IN MOST LOGIC IC'S, the high and low states are separated by an invalid or undefined zone.

justed too high, especially for a TTL device, the IC can be ruined.

A breadboard can prove to be very useful, especially if it contains built-in DC power-supplies. Heath offers several, of which the *ET-3300* is a good choice. Also recommended is the AP Products *Powerace-102*. That breadboard contains a +5-volt DC power supply, a squarewave clock (1 to 100 kHz), a pulse source, logic level sources, and logic level detectors.

The breadboard may look expensive on first glance, but is well worth the price if you plan to go into digital electronics in any depth. With the breadboard you can build, modify, and troubleshoot digital circuits before committing them to more permanent configurations such as wire wrap or printed circuit boards. You will find that breadboard circuits are a lot easier to modify.

Perhaps the principal advantage of logic breadboards is that they contain one or more multi-dozen pin IC socket blocks that can be used to mount components. Interconnections are made with No. 22 to No. 28 solid hook-up wire pushed into socket holes. The somewhat less than permanent nature of such connections is one reason circuits built on breadboards are so easy to modify.

Another nice to have (and highly recommended) device is a logic probe. Those probes are used to detect either high or low states. In addition, some models can detect whether or not a pulse has occurred or generate pulses of their own at the push

of a button. Such probes are exceptionally useful for troubleshooting and debugging circuits. The cost may be high, but the usefulness is a compensating factor.

An oscilloscope is also nice to have, even though high cost tends to limit the number of hobbyists who can own such an instrument. The selected model should have a wide bandwidth. We recommend bandwidth of 4.5 MHz or better as a minimum—but get one with as wide a bandwidth as possible.

A voltmeter is always useful. Since digital circuits operate on pulses, however, the meter will only be useful during the static tests of logic levels, and DC power-supply voltages. Use any electronic voltmeter (digital or analog), or VOM with a sensitivity of 30,000 ohms/volt or more.

CMOS devices can be operated from either bipolar ($-V$, 0, $+V$) power supplies, or, a monopolar (0, $+V$) power supply. In most cases of monopolar operation, the $-V$ -power supply is set to zero ($-V = 0$).

The high logic-level is represented by a voltage close to the $V+$ supply, while the low by a voltage close to the $-V$ supply. The transition between states occurs near the mid-point between $-V$ and $+V$ (or, where monopolar supply is used, at $\frac{1}{2} +V$). The value of $-V$ and $+V$ can be any voltage between ± 4.5 volts and ± 15 volts; the two voltages do not have to be equal.

High noise immunity logic (HNIL) devices, like TTL, are made using bipolar transistors. The difference is that it takes larger voltages ($+12$ in one series, $+15$ in another) to supply HNIL, and, consequently, higher voltage logic levels. Those higher voltages are what creates the improved noise immunity.

We'll look a bit more at these and the other logic families a bit later in this article.

Positive vs. negative logic

The terms "positive logic" and "negative logic" tend to confuse the newcomer to digital electronics. It becomes especially unnerving when you see the same devices designated both ways. The TTL 7400 NAND gate, for example, is listed some places as a NAND/NOR gate. That designation means that that device is both a positive logic NAND gate and a negative logic NOR gate.

The difference between positive and negative logic is as follows: Positive logic uses a positive voltage for high (i.e. logic 1), and either zero or a negative voltage for low (i.e. logic 0). Negative logic, on the other hand, uses a negative voltage for high (logic 1) and either zero or a negative voltage for low (logic 0).

Unless otherwise specified by the manufacturer, IC logic device function names reflect positive logic. Thus, the 7400 is generally called a NAND gate.

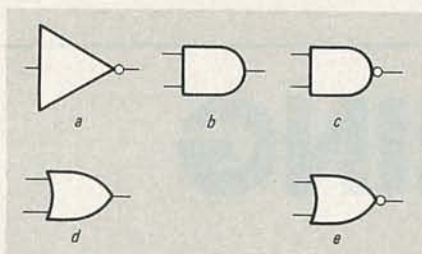

FIG. 2—THESE SYMBOLS are used to represent logic devices in schematic diagrams. A NOT gate (inverter) is shown in a, an AND gate in b, a NAND gate is shown in c, an OR gate in d, and a NOR gate in e.

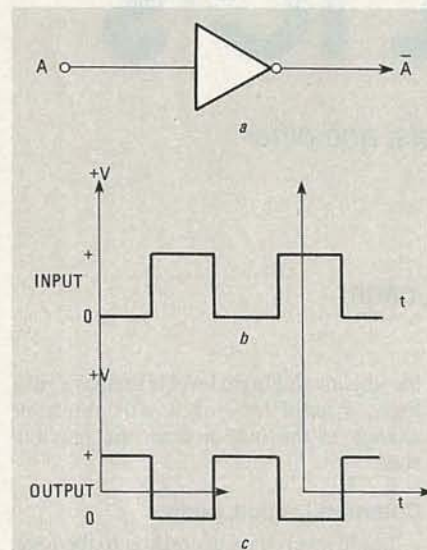

FIG. 3—AN INVERTER is shown in a, the timing diagram for that device in b.

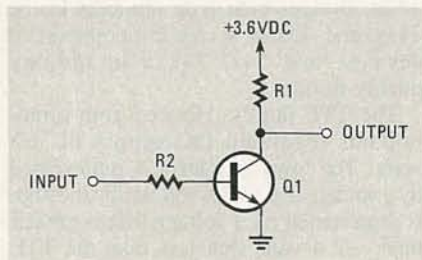

FIG. 4—AN RTL INVERTER. Note that RTL technology is now obsolete.

Logic symbols

Each type of logic device has its own schematic symbol, and those will be used in the rest of this series (as well as in all other articles on digital electronics). They are shown in Fig. 2. While different symbols have been used in the past, the ones shown in the figure are the ones that are now considered standard.

Some practical matters

If you wish to perform experiments or build projects with digital devices, then you will need certain pieces of equipment. Not all of the equipment listed here will be absolutely necessary all the time, but their availability will make things considerably easier.

You will, of course, require one or more DC power-supplies that are compatible with the digital IC logic families that you intend using. For TTL devices, which are probably the most common, you will need at least one $+5$ -volt DC, regulated power-supply. Since TTL devices tend to use high currents (10–30 mA per device), plan on a DC supply of at least 1 amp at $+5$ -volts DC; it is not unreasonable to obtain supplies of 1 to 5 amperes.

Logic families

An IC logic family is a group of digital logic devices that share a common fabrication technology and are matched as to input and output voltage and current levels. Thus, interconnection of logic devices within any one family is grossly simplified. A TTL device, for example, can drive up to ten TTL devices without the need for impedance matching and other niceties that plague analog circuits.

In the remainder of this article we will look at the common IC logic families. For purposes of comparing the families, we will center our discussions around a single device, the simple inverter. That device is also called a NOT-gate. Figure 3-a shows the usual logic symbol for inverters as used in schematics. The circle at the output is the standard way an inversion function is noted.

An inverter is a circuit that will produce an output level that is the opposite of its input signal level (See Fig. 3-b). In other words, a high at the input produces a low output, while a low input produces a high output. We consider inverters in our discussions of logic families because they are simple circuits that easily demonstrate the differences between families.

Resistor-transistor logic (RTL)

The RTL family was one of the earliest to become commercially available in IC form. It is, however, now completely obsolete. RTL is not used in new designs, and is currently stocked only for replacement purposes in repairs. Figure 4 shows the standard RTL inverter circuit. This device operates from a monopolar DC power supply; the largest power supply that can safely be used is $+4$ volts DC, with $+3.6$ -volts DC being more common.

Note in Fig. 4 that there are resistors in both input (i.e. base) and power supply (i.e. collector) leads. An advantage of RTL is that no combination of opens or shorts will destroy the device, provided that no voltage greater than $+4$ (DC) exists on the circuit board. A disadvantage of RTL, however, is that the operating frequency is limited to 4 or 5 MHz.

Diode-transistor logic (DTL)

The DTL family was also among the earliest types available in IC form. Figure

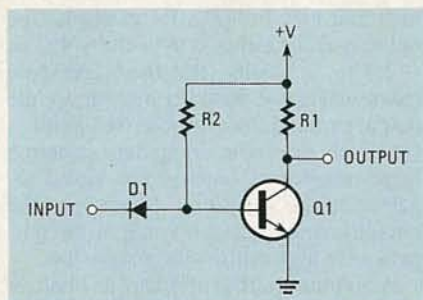

FIG. 5—A DTL inverter.

5 shows a typical DTL inverter circuit. Like the RTL inverter, DTL inverters use a single transistor in the common-emitter configuration. The main difference between the two is the diode (D1) connecting the input to the base of the transistor.

If the input is high, diode D1 is reverse biased, so it does not affect the circuit. Under that condition, resistor R2 forward biases transistor Q2 forcing it into saturation and the output of the circuit is low. If, on the other hand, the input is low diode D1 will be forward biased by R2, which keeps the base of the transistor unbiased. Under that condition, the transistor is cut off, so its collector voltage rises to +V and the output is high.

DTL devices operate from DC voltages of 5 to 6, and are now regarded obsolete except for repair purposes.

Transistor-transistor logic (TTL)

The transistor-transistor-logic family is, perhaps, the most common of all digital IC logic families. These are the devices that carry type numbers of 74xx and 74xxx.

A principal advantage of TTL devices is speed of operation. Almost all TTL devices operate to 18 or 20 MHz, while some trip along nicely at 80 MHz or so. A disadvantage that goes along with high speed, however, is high power dissipation and high current requirements.

Logic levels of TTL devices are 0 to +0.8 volt for low, and +2.4 to +5 volts

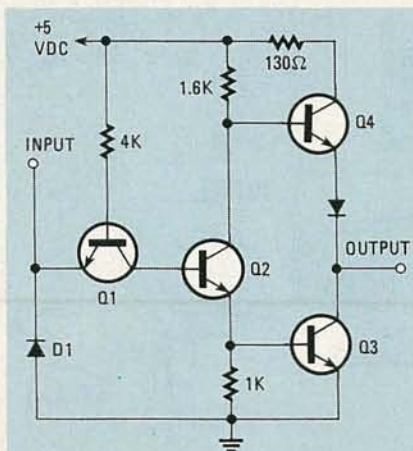

FIG. 6—TTL TECHNOLOGY is among the most popular used for logic circuitry. Here, a TTL inverter is shown.

for high. TTL devices typically require 10–40 mA of current per device from the DC supply. All TTL devices must operate from a regulated 5-volt (nominal) DC power supply. Officially, the +5-volt supply must provide a voltage between +4.75 and +5.25 volts DC. Our experience, however, suggests that narrower limits are sometimes prudent. If the voltage is greater than about +5.05-volts DC, then reliability is reduced. Under about +4.80-volts DC, on the other hand, certain TTL devices operate in a flakey manner.

A typical TTL inverter stage is shown in Fig. 6. Note that NPN bipolar transistors are used. A TTL output operates as a current sink. In the high-output condition, Q3 is cut off and Q4 is turned on, connecting the output terminal to +V. When the output is low, however, Q4 is turned off, and Q3 is turned on. In that condition, the output line is connected to ground through the saturated collector-emitter path of Q3.

The input of a TTL device is a current source formed of emitter follower Q1. The standard TTL input will source 1.6 mA of current.

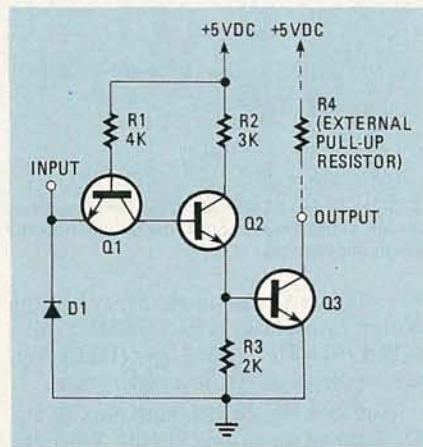

FIG. 7—AN OPEN-COLLECTOR TTL inverter. Note the addition of an external resistor between the output and +V.

Normally, electronic amplifier circuits can be cascaded only by considering matters such as drive power and impedance matching. IN TTL, however, cascade interfacing is greatly simplified by standardizing input/output conditions. An implication of that is that we can standardize loads ("fan-in") and output drive capacity ("fan-out"). Thus, the standard 1.6 mA at 5-volts DC, TTL current-source input is defined as a fan-in of 1. Every output can be specified as to fan-out rating, which is the number of standard TTL inputs the device will drive. The standard TTL output on 74xx/74xxx devices has a fan-out of ten. That means that it will drive up to ten standard TTL inputs. A fan-out of ten means that the output will sink 10×1.6 mA, or 16 mA.

Figure 7 shows an alternate form of TTL output called an open-collector TTL

Device	Maximum Current (mA)	Maximum Voltage (VDC)
7405	16	5
7406	30	30
7407	30	30
7416	40	15
7417	40	15

output. The output transistor, Q3, does not have a collector load. An external "pull-up" resistor (R4), or other pull-up load, must be connected between the output terminal and +V.

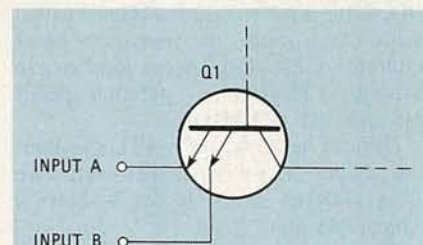

FIG. 8—MULTIPLE INPUTS on TTL devices are created by using input transistors with multiple emitters.

There are several different TTL open-collector devices. The 7405, 7406, 7407, 7416, and 7417 devices are open-collector hex inverters. Table 1 shows the output specifications for those devices. Note that several of those devices can handle voltages higher than the +5-volts DC used on other TTL devices. These devices must be connected to +5 volts DC at the package +V terminal. We can, however, use the output stage to drive higher voltage loads than +5-volts DC. Those limits are, once again, shown in Table 1.

Figure 8 shows how TTL devices accommodate multiple inputs. The input transistor (Q1) is essentially the same, except that there are two or more emitters, each of which is an input.

There are several sub-families of TTL devices: high-power, low-power, Schottky, and low-power Schottky. Those differ a little from ordinary TTL, but generally can interface with standard TTL and each other. The sub-families use variations on the 74xx/74xxx numbering.

High-power TTL devices carry part numbers in the 74Hxxx series. High-power TTL fan-out ratings are typically 10–12, but the fan-in is 1.3 or so. That means that a 74H device input sources 2.08 mA. In general, a regular TTL output can use its fan-out of 10 to drive 6–7 74H inputs.

The power consumption of the 74H-series devices is approximately twice that of regular TTL. The operating speed is also about twice that of regular TTL. Thus, counters and flip-flops typically operate to speeds in the 40–60 MHz region. High-power TTL devices have less noisy

outputs than regular TTL, so they are particularly useful for data converters and other such applications.

Low-power TTL devices carry type numbers in the 74Lxx/74Lxxx series. The power consumption is roughly one-tenth that of regular TTL, but that advantage costs us a reduction in operating speed. Thus, 74L counters and flip-flops operate only to about 3 MHz.

One of the factors that inhibits the operating speed of a logic device is the minimum storage time of the electric charge in a saturated transistor. In Schottky TTL devices there are special "Schottky diodes" connected across the inputs. Those diodes have a voltage drop of 0.3-volts DC, so the input voltage is clamped to that value. As a result, the transistors never saturate so operating speeds increase. In Schottky TTL devices, operating speeds can approach 125 MHz.

Devices in the schottky-TTL sub-family carry type numbers in the 74LSxx/74LSxxx series. Figure 9 shows a typical 74S input stage.

Low-power schottky TTL devices, which carry part numbers in the 74LSxx/74LSxxx series, sacrifice some of the blistering speed of the Schottky sub-family in favor of lower operating power. Typically, 74LS devices consume about one-fourth to one-sixth the power of 74S devices.

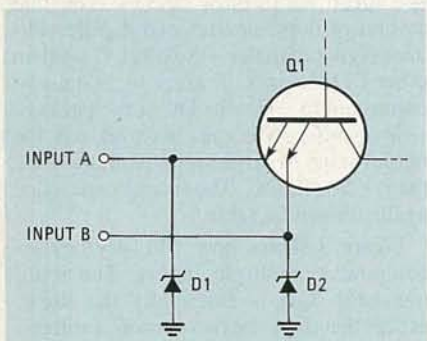

FIG. 9—INPUT CIRCUIT for a Schottky inverter (74S series). The balance of the inverter is standard TTL, as shown in Fig. 6.

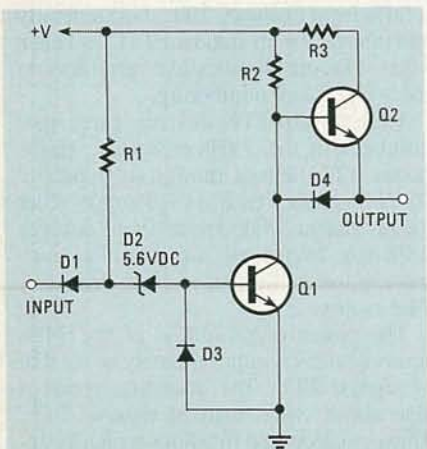

FIG. 10—FOR IMPROVED noise immunity, HNIL circuitry can be used.

TABLE 2

cs	Input	Output
H	H	X
H	L	X
L	H	L
L	L	H

H = High
L = Low
X = Disconnected

High-noise-immunity logic (HNIL)

A problem sometimes seen in TTL logic is lack of noise immunity. The difference between high and low thresholds is so small that noise impulses riding on the signal can drive a device to the incorrect logic level. For example, a low TTL level with noise can be made to appear during the noise impulse as if it were high. Similarly, a noisy high may look low.

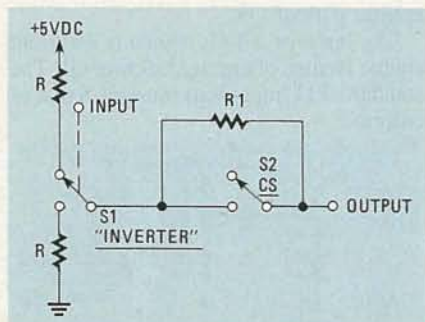

FIG. 11—IN TRI-STATE DEVICES, the output may be one of three states: high, low, or unconnected (high impedance).

A solution to that problem may be High Noise Immunity Logic (HNIL), also called High Threshold Logic (HTL). Figure 10 shows an HNIL inverter stage.

Notice in Fig. 10 that transistors Q1 and Q2 form an interesting circuit. When the base of Q1 is high, its collector is low, so Q2 is turned off. A current-source input (similar to TTL) will allow current to flow to ground through D4 and the saturated collector-emitter path of transistor Q1. If the base of Q1 is low, on the other hand, its collector is high, so D4 is turned off and Q2 is turned on. In that case, the output terminal is connected to +V through R3 and the saturated collector-emitter path of Q2—forming a high.

The high threshold required to turn on Q1 (which is what gives this device its high noise immunity) is a function of D2, a 5.6-volt Zener. Other than that, the circuit is similar to the DTL logic family.

There are two general classes of HNIL logic. One uses logic levels of 0 and +12 volts DC, while the other uses 1 and +15 volts DC.

Tri-state logic

Digital logic is said to be "binary" because it responds to two input states—

high and low. In TTL, for example, the output will be either 0 to +0.8 volts, or +2.4 to +5 volts. But there are some cases where we want to disconnect the output terminal from the internal circuitry. One such case is in computers, where a large number of outputs are bused together on the same line. Damage to the circuitry could occur if some of the outputs were high while others were low.

A solution to that problem is what we call tri-state logic. Such devices have three states—high, low, and disconnected (i.e. high impedance).

In the "third state," the output terminal sees a high impedance to both +V and ground. That state is entered upon the receipt by the device of a \overline{CS} signal at the appropriate terminal. Figure 11 shows how a tri-state inverter works. Switch S1 represents the inverter. When the input is low, S1 will be in the position shown—the output is connected to +V (i.e. high) through a low resistance. Similarly, if the input is high, S1 will be in the other position so the output is connected to ground through a low resistance.

The "tri-state" function is provided by switch S2. When S2 is closed, the output terminal is connected to the S1 circuitry. Alternatively, if S2 is open, then the output terminal is disconnected (that's because the value of R1 is, of course, extremely high). The output state is controlled by an active-low chip select terminal (\overline{CS}). When \overline{CS} is high, the output is floating (disconnected). If \overline{CS} is low, on the other hand, S2 is closed and the output is connected to the S1 circuit.

A tri-state inverter will follow the truth table shown in Table 2. Examples of tri-state devices are the 74125 and 74126.

Next time, we'll take a look at CMOS devices

R-E



"That siren was a test. We wanted to determine whether you are awake and watching our program."

EQUIPMENT REPORTS

continued from page 36

Beckman DM10 Multimeter

Here's a low-priced multimeter that's made for electronics hobbyists.

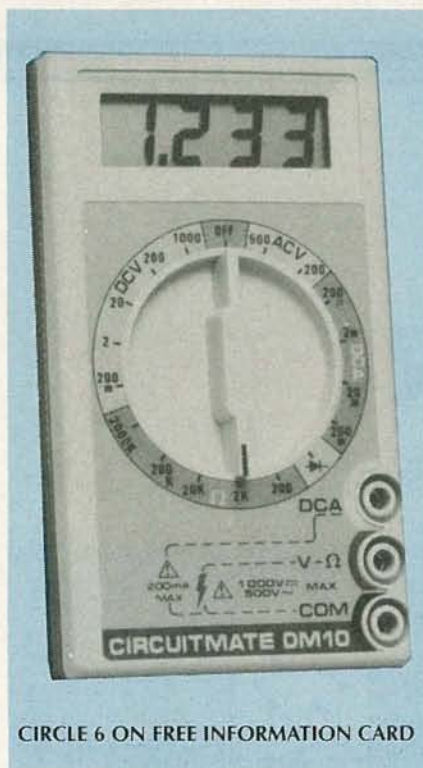

CIRCLE 6 ON FREE INFORMATION CARD

MOST "POCKET" DIGITAL MULTIMETERS won't fit in your pocket. We've recently come across one that will: the *DM10* from Beckman Industrial Corporation (630 Punte Street, Brea, CA 92621). Despite its small size, the *DM10* has many of the features you'd expect only in a bigger meter.

The *DM10* is part of Beckman's *Circuitmate* series of multimeters. It can be used to measure DC volts in five ranges (200 mV to 1000 V) and AC volts in two ranges (200 V and 500 V). There are five resistance ranges (200 ohms to 2 megohms) and 4 DC-current

ranges (200 μ A to 200 mA). The meter also features a handy diode-test function.

We mentioned that the *DM10* is small—it's approximately 5 x 3 x 1 inches. That means that it really will fit in your shirt pocket. And because it weighs only 5½ ounces (with battery!), carrying it there should not prove to be at all uncomfortable.

The *DM10* features a 3½-digit liquid-crystal display with easy-to-read ½-inch high digits and automatic negative-polarity indication. Overranging is indicated by a display of only a leading "1," and a LOW-BATT annunciator tells you when to replace the 9-volt battery (which has an expected lifetime of 150–200 hours).

As is common with many meters, the function/range selector switch is a rotary type that dominates the front of the unit. Three input jacks (COM, V- Ω , and DCA) also share the front panel. (You have to switch a test lead to measure current.)

When measuring DC volts, you can expect an accuracy of $\pm 0.8\%$, +1 digit. With an input impedance continued on page 100

QUALITY COMPONENTS - NOT MAIL ORDER "SECONDS"

Send \$1.00 postage and handling for FREE COMPLETE CATALOG which includes coupon for \$1.00 OFF purchase.

ARIES ZERO INSERTION FORCE SOCKETS

cam actuated, true zero insertion - tin plated solder tail pins - capable of being plugged into dip sockets, including wire wrap.

Stock No.	No. of Pins	1-9	10-49	50
11055	24	4.98	\$4.35	\$3.90
11056	28	5.15	4.50	4.05
11057	40	6.81	5.95	5.35
11058	64	12.02	10.50	9.45

IC-KOOLERS™ from UNITRACK™

disperse over 2 watts of heat from IC's producing longer life and better performance. Just push IC-Kooler on top and bottom of IC and dissipated heat won't shake loose!

Stock No.	No. Pins	Price
22225	14	\$.29
22226	16	.28

WILD ROVER

Touch switch capsule. Operating motion is .005" without the use of a levered arm. Extremely fast on and off with low noise. Normally operated 115 VAC, 1.6 amp-30 milliohm resistance - .615 radius by .160 thick.

Stock No.	1-9	10 & Up
12098	\$1.42	\$1.28

SCREW MACHINED SOCKET PINS

loose, packaged in bags of 100. Stock No. 11310 is solder tail with gold collet tin shell. Stock No. 11311 is wire wrap with gold collet gold shell.

Stock No.	Description	1 Bag	5 Bags	10 Bags
11310	Bag of 100 solder tail pins	\$ 4.95	\$ 4.45	\$3.95
11311	Bag of 100 wire wrap pins	11.95	10.75	9.50

3 X 4 Elastomeric Keyboards
Each keyboard has a p.c. board, elastomeric pad with contacts, ABS bodies and double shot molded keys. Max rating: 12 VDC @ 20mA.
Contact Res: less than 500 ohms Bounce: less than 10 ms.
Stock No. 11292 80x40g 2.0x.5mm \$4.95 \$4.50
11291 80x40g 1.5x.5mm 3.95 3.60

TI WIRE WRAP SOCKETS

Tin plated phosphor bronze contact - 3 wrap

Stock No.	No. Pins	1-99	499	500
11301	8	\$.40	\$.36	\$.30
11302	14	.59	.54	.45
11303	16	.64	.58	.48
11304	18	.73	.66	.55
11305	20	.99	.90	.75
11306	22	1.12	1.02	.85
11307	24	1.25	1.14	.95
11308	28	1.52	1.38	1.15
11309	40	2.05	1.86	1.55

TI LOW PROFILE SOCKETS

Tin plated copper alloy 688 contact pins with gas tight seal.

Stock No.	No. Pins	1-24	25-99	999
11201	8	\$1.10	\$0.99	\$0.88
11202	14	.14	.13	.12
11203	16	.18	.15	.14
11204	18	.18	.17	.15
11205	20	.20	.18	.16
11206	22	.22	.20	.18
11207	24	.24	.22	.20
11208	28	.28	.26	.25
11209	40	.40	.37	.33

SUB CUB I and SUB CUB II

are high quality, complete LSI Counter Modules with LCD readout. Modules plug in p.c. board (Stock No. 51071). Complete function evaluation kit (Stock No. 51070) contains: p.c. board, 4.5V battery and variable frequency oscillator to supply train of count pulses. Stock No. 51070 has LATCH, RESET and TEST functions (3 buttons). P.C. board unplugs for bread-board work.

6 Digit LSI Counter Modules with LCD Readouts and Associated Mounting Assemblies

Stock No.	Description	Price
51070	Complete Function Evaluation Kit (includes batteries but does not include display counter)	\$45.00
51071	Mounting P.C. Board only	7.50
51072	SUB-CUB I display counter module only	18.00
51073	SUB-CUB II display counter module only	24.00
51074	Panel Bezel Evaluation Kit for SUB-CUB II (does not include SUB-CUB II counter module)	12.00
51075	DATA SHEET	.25

SINGLE ROW SOCKETS

Strip of 25 collet sockets/pins - mount odd-center components easily. Gold plated contacts. Both styles breakable to any number of contact positions wanted.

Stock No.	1-99	100	500	1000
10850	\$1.09	\$0.90	\$0.82	\$0.72

Strip of 40 pins with single beam sockets. Tin plated contacts.

Stock No.	Price
10240	\$1.70
10241	\$1.50
10242	\$1.30

OPCOA

Single Digit Displays - Common Cathode

Stock No.	Color	1	100
12082	Red	\$1.12	\$.99
12085	Green	1.84	1.63
12087	Yellow	1.92	1.70
12089	Orange	2.08	1.84

Right Angle Socket for Above Displays

Stock No.	1	100
11010	\$1.24	\$.99

OPTEL LCD's with pins

Stock No.	Description	1	10
47005	3½ dig. 5"	\$ 9.58	\$ 5.50
47006	4 dig. 5"	5.95	5.50
47007	4 dig. 7"	11.90	11.00

Stock No. 47005
Stock No. 47006
Stock No. 47007

The Battery Just Wrap™ Tool
New battery powered tool wraps insulated wire around 025" square posts without need for pre-cutting and pre-stripping. Complete with bit and 100 ft. 30 AWG wire.
Stock No. Description Price
13340 Battery just wrap tool with bit and 100 ft. 30 AWG wire \$59.95
13341 Replacement bit 10.35
13342 100 ft. blue replacement wire 7.54
13343 100 ft. white replacement wire 7.54
13344 100 ft. yellow replacement wire 7.54
13345 100 ft. red replacement wire 7.54

MICRO Charts - colorful 8½" x 11" charts eliminate the need to stumble through manuals and summaries. Fully decoded - instant access - totally comprehensive - gives pin outs, cycle times, buy notes, etc. etc.
Stock No. Reference Price
23010 Z80 CPU \$5.95
23011 8080/8085 \$5.95
23012 6502 (65XX) 5.95
23013 8048 and relatives 5.95
23014 547/600 TTL Resets 5.95
23015 Basic Algorithms 5.95
23016 8088/8086 5.95
23017 How to generalize from a sample 5.95
23018 Wordstar 5.95

PIN FORMING TOOL
puts IC's on their true row to row spacing. One side is for .300 centers. Flip tool over for devices .600 centers. Put device in tool and squeeze.
ONE TOOL DOES 8 thru 40 PINS!
Stock No. Price
11059 \$12.95
NEW! ANTI-STATIC MODEL 10200 \$14.95

OK MACHINE AND TOOL
IC INSERTION/EXTRACTION KIT
Includes DIP IC extractors and inserters to accommodate all IC's from 14 to 40 pins. Tools that engage conductive surfaces are CMOS safe and include grounding lugs. Stock No. 13309 \$41.34

SOCKET WRAP ID
Dip socket-sized plastic panels with numbered holes in pin locations. Slip onto socket before wire wrapping to identify pins. Also write on them for location, IC part number, function, etc. Simplifies initial wire wrapping, troubleshooting and repair. \$1.95 per pack.
13295 14 pin \$1.95
13296 16 pin 1.95
13297 18 pin 1.95
13298 20 pin 1.95
13299 22 pin 1.95
13300 24 pin 1.95
13301 28 pin 1.95
13302 40 pin 1.95
13303 96 pin 1.95

THERMOPROBE: Identifies Dead Components - Replaces Volt Meters!
Identify dead components which do not emit heat. Just point thermistor probe within 1/16" of board - move over components and see which are dead.
Stock No. Price
22300 \$21.95

SINTEC CO. 28 8th St., Box 410 Frenchtown, NJ 08825



TOLL 800-526-5960
FREE in NJ (201) 996-4093

We accept VISA, MC, C.O.D., CHECK, or M.O. INCLUDE SHIPPING CHARGES - 0 to \$100 - \$3.00 \$100 to \$250 - \$4.00 over \$250 - \$5.00

HOBBY CORNER

Building a simple power supply

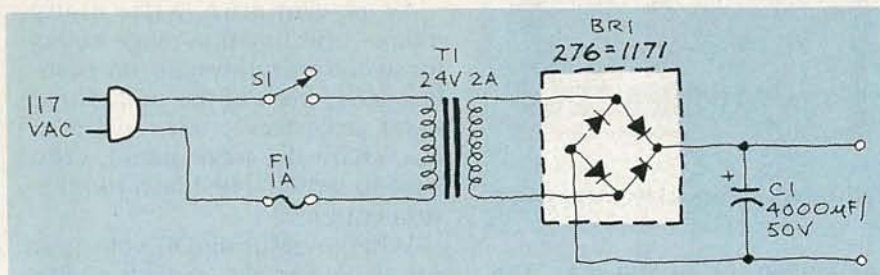

FIG. 1

THE MOST IMPORTANT PART OF ANY electronic device is the power supply—ranging from the simple to the elaborate. After all, without power, electronic circuits serve no useful purpose. Although power supplies are available commercially, it is just as easy to build one and better yet, it's often cheaper!

One of our readers, Carl Muller (CA), is looking for a power supply to operate a 24-volt, 2-amp DC motor. He specifies that the circuit contain a full-wave bridge rectifier. Well, Carl, because the voltage and regulation do not appear to be critical, the circuit in Fig. 1 should fill the bill.

Note the ratings given for the components. If you can't find those values, use the next largest values you can find (except the fuse, of course). The bridge itself can be made of individual diodes (arranged in the same way) or you may prefer the packaged type (which is nothing more than a four-diode arrangement sealed in a plastic case). In the latter category, a 4-amp, 100-PIV (*Peak Inverse Voltage*) full-wave bridge like the Radio Shack 276-1171 shown in Fig. 1, will probably work all right. But we'd prefer the extra margin of safety provided by 6-amp diodes.

AC-operated devices

Dexter Kalloo (West Indies), you are exactly right: most electronic devices *do* operate on direct current (DC), while alternating current (AC) *does* come out of the wall socket. Therefore, it is necessary to convert the AC to DC before it is applied to an electronic circuit.

That conversion is called "rectification." There are several rectifier arrangements that may be used—*half-wave*, *full-wave*, and *full-wave bridge*. The power supply shown in Fig. 1 is a good example; it uses the full-wave bridge arrangement. Note that the circuit does two jobs: First, the transformer reduces the 117-volt AC to 24 volts. Second, the bridge rectifier takes in that lower AC and "spits out" a proportionate DC voltage. The capacitor simply smoothes (filters) out the ripple a bit.

Where you mount the power supply is up to you. You can mount it externally with wire running to the device it is to power or it may be built right into the device so that you don't even know it's there! Be warned that circuits requiring a DC voltage can be ruined if AC is applied, and the same



EARL "DOC" SAVAGE,
HOBBY EDITOR

holds true if DC is applied in reverse (i.e., the positive lead connected to the negative terminal). That is true whether the supply is a battery or a rectifier circuit.

One diode in the power lead of the device will protect it from reverse-voltage damage. Figure 2 shows how the diode should be inserted in the line. It is a good practice to put a diode in the supply line of each device you build, whether it uses a battery or external power supply. Doing so is really cheap insurance and can save you headaches in the future.

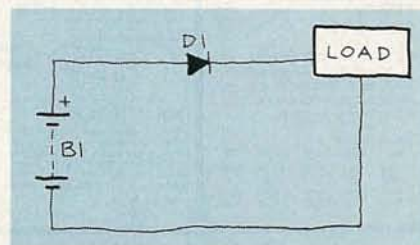

FIG. 2

A new service

As the new year starts, it's appropriate that we take a look at where we are and where we want to go. My thoughts along that line have led me to the point of suggesting a new service for our readers. After all, the entire point of "Hobby Corner" is to help you. Judging from the letters we've received, that job is getting done in a reasonable manner. But, as we all know, there always room for improvement—"Hobby Corner" definitely included!

I am very much aware that there is one group of readers who could be getting a great deal more. They are the ones asking for help in

learning about electronics, transistors, IC's, or some other phase of our hobby. Sorry to say, there is no way I can correspond with everyone who needs a bit of special attention. There simply isn't enough time in the day. I regret it, I wish that I could do more, but that's the way it is.

Therefore, my proposal is to list the names and addresses of readers who need help, and would like to correspond with others who are a little farther along in our hobby. I'll try to find space to list a name or two each month and when you see someone who wants information that you have, drop him or her a line and offer to share your knowledge. Of course, the success or failure, and the value of the program depends entirely on your willingness to share what you've already learned with someone who has hit a snag.

Remember when you needed help and someone provided it just in time to boost your interest even higher? Well, now it's your turn to return the favor. I'm reminded of a fellow years ago who pulled me out of the ditch in the wee hours of the morning. (Boy, was I desperate.)

While traveling cross-country with the family, my car ran into a ditch. Two hours went by without any response from a wrecker in either direction. Finally someone came by and offered his assistance. As we put the chain back in his car, I offered to pay him for his trouble. "Oh no," he replied, "I'll be paid when you do the same for someone else some day." (That unknown gentlemen might be surprised to know that I still carry a tow line in my trunk.)

We in ham radio used to call the guys on whom we leaned when the going got rough as our "Elmers." I've had several "Elmers," and, in turn, I've been an "Elmer" to many others. What we need is more "Elmers." I am sure that many of you will be willing to be an "Elmer" by mail to another reader.

All you have to do is to pick a name next month, or the month after, and offer to help. Those of you who would like to have an "Elmer," write and tell me the general area in which you need help

getting started. But because our policy is not to print a name and complete address without permission, be sure to give that permission in your letter.

There is, however, one slight catch: I would like one or both of the learning partners to let me know how the process is working.

Voice-activated switch

M. Kuszniak (NY) wants a circuit for a voice-activated switch to con-

trol his recorder by sound from a police scanner. Well, that is no great problem, but I surely would not build one today!

Several suppliers advertising in this publication have been offering such devices for just a few dollars. At such a low cost for something already built and ready to use, I would spend my construction time making the interconnections and building another project.

R-E

Introducing the analog/digital handheld multimeter.

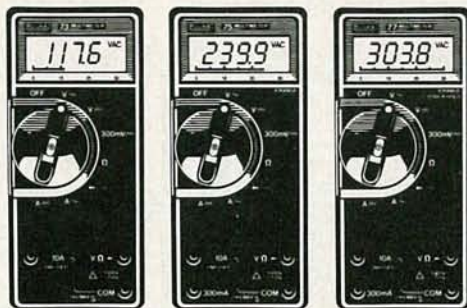

Fluke 73
\$85

Analog/digital display
Volts, ohms, 10A, diode test
Autorange
0.7% basic dc accuracy
2000+ hour battery life
3-year warranty

Fluke 75
\$99

Analog/digital display
Volts, ohms, 10A, mA, diode test
Audible continuity
Autorange/range hold
0.5% basic dc accuracy
2000+ hour battery life
3-year warranty

Fluke 77
\$129

Analog/digital display
Volts, ohms, 10A, mA, diode test
Audible continuity
"Touch Hold" function
Autorange/range hold
0.3% basic dc accuracy
2000+ hour battery life
3-year warranty
Multipurpose holster

FROM THE WORLD LEADER
IN DIGITAL MULTIMETERS



The Professional Test Equipment Source

The Instrument Mart

295 Community Drive, Great Neck, New York 11021
(516) 487-7430 Outside N.Y. (800) 645-6535

Sales, Service, Rental/Leasing Programs
... and Pre-Owned Test Equipment also Available

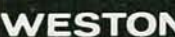
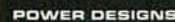
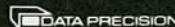
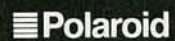
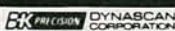
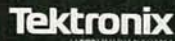

COMMUNICATIONS CORNER



HERB FRIEDMAN,
COMMUNICATIONS EDITOR

Computers and communications

THE WAYS IN WHICH WE COMMUNICATE have changed dramatically over the years. For instance, I grew up in an era when radiotelephone was replacing CW (Continuous Wave) for communications. In those days, almost everyone, including children, could recognize an S-O-S when listening to the radio, or while watching a movie in which the ship's operator pounds out his S-O-S on a brass key. There was no fractured French to produce a "mayday." An S-O-S was an

S-O-S—even when spoken into a microphone.

Back then, I sat through endless ham-radio club meetings, while "old timers" argued—and proved—that radiotelephone would never replace CW. Similarly, I've sat through numerous meetings as the *new* "old timers" argued and proved that SSB (Single SideBand) would never replace AM. But today, I sit through seemingly endless seminars listening to arguments proving that

digital will never replace voice communications.

In reality, we are probably the last generation that will ever use voice communications for anything other than low-cost local traffic. (That does not include the police and fire departments—they are local.) For long-path communications, or when there is no room for error or misinterpretation, digital is the modern way to go.

Then there's the questions of convenience, time zones, and Ma Bell. With businesses and families spread out across the world, there's a good chance that the person with whom you want to communicate is asleep, out to lunch, or on holiday. And with Ma Bell planning to start charging for long-distance calls that are never completed (even if the line is busy or there's no one at home, etc.), communication costs are going to skyrocket even though you never complete a single exchange of information.

For many years, businesses have handled hard-copy convenience and the moderate cost aspects of communications through teletype or terminals connected to a Telex network; a dial-up communications system that either communicates in real-time with another Telex terminal or uses a store-and-forward technique. (By "store-and-forward" we mean that the message or document is stored in a computer for automatic transmittal at a predetermined time, or when reliable circuits are available.)

With the boom in personal computing, we've seen adaptations of Teletype communications evolve

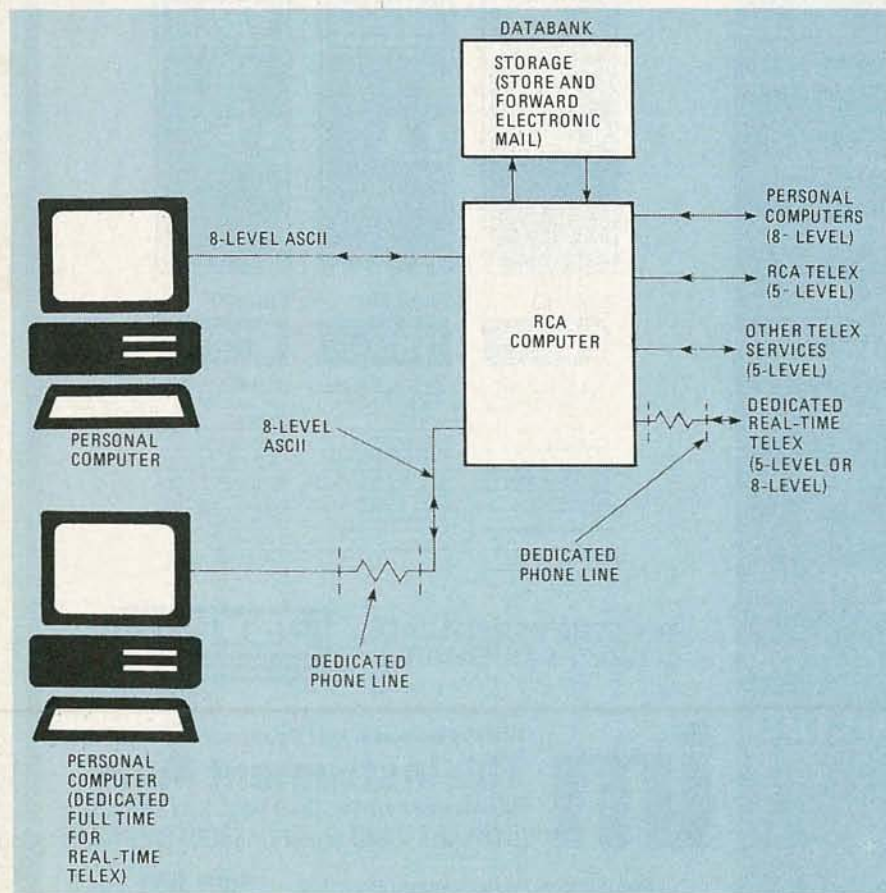

FIG. 1

into a kind of everyman's (or everywoman's) electronic mail system. For example, CompuServe has a computer-to-computer electronic mail system for its subscribers. Unfortunately, there are less than 100,000 CompuServe subscribers—so it's a safe bet that the person or business with whom you want communicate is not using CompuServe's electronic mail-service. Although you could get a special program to convert your computer's 8-level ASCII code to 5-level Baudot for standard Telex use, you'd have to subscribe to a Telex service to communicate with other Telex-connected stations.

Fortunately, there is always someone who sees the next horizon before he really gets to it. In this instance, it's RCA or, to be more precise, RCA Global Communications (which just happens to run a Telex network). Of course, there are other systems as well—Western Union, ITT, and MCI are among the most recognizable names. Having more-or-less anticipated the need for digital communications, RCA has instituted a special Telex service for personal computers—all personal computers, not just a few well-known brands or models. Not surprisingly, it's called the RCA Computer-Originated Telex Service.

Computer-originated Telex

Figure 1 shows most of the services provided by RCA's personal-computer Telex service. The key to everything is RCA's computer, which provides the electronic mailbox, store-and-forward, the intersystem Telex interconnect, and the 8-level to 5-level conversion. Basically, RCA automatically converts the normal 8-level ASCII code from a personal computer into 5-level Baudot. It then transmits the message to its own or some other Telex system, stores and forwards, or provides an electronic mailbox for personal-computers connected to their Telex service.

The electronic mailbox works this way: Let's assume you transmit a message via 8-level ASCII to the RCA system and direct it to another personal computer station by entering the RCA-assigned Telex number. Once a day, that

person (or station) can dial into RCA and get the electronic mail. If the receiving station replies to your message, you will find the message waiting when you call into your mailbox. When you access your mail, RCA automatically converts the message to 8-level ASCII code for your personal computer.

Alternately, RCA will convert your 8-level computer signal to 5-level Baudot for transmittal to standard Telex stations using RCA or other Telex networks; and will reverse the process, converting their 5-level to 8-level. (Yes, you can direct communicate, via RCA, with Western Union, ITT, etc.)

Whether you're originating a message or accessing your mailbox, the call to RCA is toll-free both ways; the only charge is for the length of messages input from you to RCA. If you get tangled up in the protocol—which is as simple as one can imagine—you are not charged for connect- or use-time. In addition, there is at this time no charge of any kind for ac-

cessing your mailbox, or for special software. Plus another bonus is that any ASCII communications software that you may already be using will work.

Note: At the time this article was prepared there were no charges for RCA registration, minimum fee, or use other than for the Telex message itself. But, as with all other successful communication enterprises, we can fully expect that some charges will creep in along the way.

With 10-million personal computers already in use in the U.S. alone, it seems that here is the way that personal and small-business communications will be handled in the immediate future. Even now, through RCA, you can send an error-free Telex message that was originated on a personal computer to California for less money than it would cost to accomplish the same thing by voice. Plus, you don't have to wait three hours for the California office to open—and what would be more convenient than that? **R-E**

Enter A Whole New World of TV Entertainment

Regency invites you to enter the exciting world of home satellite television. Imagine being able to choose from over 100 channels, including movies, sports, news, and educational programs, all at the touch of a button. Regency offers a complete selection of satellite system components including the new SR5000 remote controlled satellite receiver pictured here. For more information on

the whole line of Regency satellite products, see your Regency dealer or write us at the address below.



Regency Electronics Inc. • 7707 Records Street • Indianapolis, IN 46226

COMPUTER CORNER

Printer literacy

THE MOST POPULAR PERIPHERAL DEVICE used with personal computers is a printer. (You may argue that video monitors and disk drives are more popular, but they are so essential that it's hard to consider them to be add-on peripherals.) Because so many computer applications require a hardcopy output, most personal computers in use today are linked to a printer.

Businesses deal with large volumes of paper; and without printers, everything would grind to a halt. But even hobby- and home-computer applications often require a printer. Though a computer may be a great "tool" for storing and retrieving information, or for processing data, the final output almost always has to be in printed form. And even though you can sometimes get by without a printer, it is always more convenient and desirable to have one.

The great demand for personal computers has created an equally large need for printers. As the demand has grown, so has the number of printer manufacturers and types of printers available. The competition in the marketplace and several significant technological developments have given us some extremely high-quality, good-performance, and low-cost printers.

While that may be great for the consumer, it has only served to make the job of selecting a printer more difficult. Given all the choices and complexities of printers, it is just about as difficult to select one as it is to make your first personal-computer purchase. What you need is some kind of



FIG. 1

"printer literacy" before you go searching for your first printer.

Printer classification

Printers are classified by the way they put copy onto paper. First, there's the impact type, in which a print element(s) of some kind strikes an inked ribbon to imprint a character (like a typewriter). Then there are the thermal units that use a heat-sensitive paper. Here, the characters are formed by increasing the temperature of a particular area on the paper. Next we have electrostatic printers: This type uses a special electro-sensitive paper to form characters by burning them into the paper. And finally, ink-jet printers, which, as the name implies, spray ink onto the paper.

By far, the most popular type is the impact printer. Impact printers are fast, and the print quality can be outstanding. And better still, no special paper is required. About the only disadvantage of impact printers is that they are noisy. While a significant amount of engineering goes into noise reduction, the noise has not been (and never will be) eliminated.



LOU FRENZEL
CONTRIBUTING EDITOR

In contrast, thermal and electrostatic printers are almost silent and low in cost. But they require special paper and the print contrast is usually poor. The output of many of the low-cost types is not truly suitable for professional applications; therefore, the impact type is generally preferred. Their speeds are reasonably high and the output print-quality is excellent. Even multiple copies can be made when carbon paper is used. For most applications, an impact printer is the way to go!

Impact printers

There are two basic types of impact printers: dot-matrix and formed-character printers (such as daisywheel types). A dot-matrix printer forms characters on a page by printing them as patterns of tiny multiple dots. The characters are created with a grid (matrix) of dots that are printed on the paper. The greater the number of dots used, the higher the definition and the better the quality of the printed character. The big advantage of dot-matrix printers is their high speed and low cost. When a small dot matrix (5×7, 7×9, or 9×9) is used, character quality is only moderate. Larger dot grids (9×18, 9×24, 18×48) give superb definition and print quality.

A relatively new type of impact printer, called Near Letter Quality (NLQ) printer, is really a dot-matrix machine that is capable of creating a letter-quality output. Figure 1 shows an example an NLQ type printer—the Printek (1515 Towline Road, Benton Harbor, Michigan 49022) models 910 and 920. Dot-

matrix printer technology now permits printing with far more dots in the matrix. In addition to using more dots, the dots are printed twice and are also slightly overlapped.

The result is an exceptionally high-quality character that is often hard to distinguish from the characters printed by a daisywheel unit. Of course, there is a price to pay for the high quality of the print: the speed is reduced when compared to other dot-matrix units—although it's still much faster than a formed-character printer. However, most NLQ printers allow you to print in several modes. For example, a draft mode will print with a less-dense matrix, but at higher speeds than the denser "letter-quality" mode. While such printers are higher in price than more conventional dot-matrix units, you get so much more for your money. And most of those printers also have graphics-output capabilities as well.

The highest quality printers available today are the formed-character printers, or Letter-Quality Printers (LQP). These devices work in much the same manner as a typewriter, in that a fully-formed character is printed on the paper (no dots). Each character is formed on one leaf or petal of a *print wheel*, *thimble*, or *daisywheel*. (We should not neglect to note that the daisywheel is usually interchangeable—it can be replaced with a wheel that prints a different *font*.) The daisywheel (or thimble) rotates to select the desired character, while an electrically driven solenoid hammer taps the appropriate petal against the ribbon, which then contacts the paper. The result is a high-quality typewriter-like output. But, while the print quality is exceptional, the speed is not. It takes time to rotate the daisywheel into position and print the character. As a result, formed-character printers are significantly slower than dot-matrix types.

However, formed-character printers are widely used in business where a high-quality output is required. The choice between a dot-matrix or a formed-character printer will largely depend on your needs. If you are going to use the

printer for word-processing applications, where you must create letters, memos, reports and other such documents, a letter-quality printer is probably your best choice. But remember, you pay for the quality in lower speeds and higher prices.

If your application does not require maximum print quality, you can probably get by with a dot-matrix machine. For example, if your output is mostly numerical in nature, a dot-matrix printer is

more than adequate. Its lower cost and higher speed are ideal for printing large volumes of tabular numerical data.

There are, of course, other factors that may influence your choice of printers. For instance, there's the type of printer interface, either serial or parallel, that your computer uses. Make sure that the printer you select is equipped to communicate through that type of interface. Otherwise, you'll get nowhere. R-E

Buy Name Brand Parts At The Lowest Prices!

 <p>SANYO</p> <p>PART NO. ZSC1308K</p> <p>\$3⁹⁵ 1-9</p>  <p>\$249 10-UP</p>	 <p>audio-technica</p> <p>*Pinpoint cartridge *Tracking 1-1.5 grams *TBA-1 "True" conical stylus *Response 20-20 KHZ</p> <p>PART NO. 4C1-503</p> <p>\$55⁰⁰ LIST PRICE</p>  <p>\$1195 EACH</p>
 <p>SSS</p> <p>PART NO. BUY69A</p> <p>\$3⁹⁵ 1-9</p>  <p>\$275 10-UP</p>	 <p>MATSUSHITA</p> <p>PART NO. AN214Q</p> <p>\$17⁹⁹ 1-9</p>  <p>\$139 10-UP</p>
 <p>NEC</p> <p>PART NO. UPC1185H</p> <p>\$37⁹⁹ 1-9</p>  <p>\$285 10-UP</p>	 <p>Toshiba</p> <p>PART NO. TA7205AP</p> <p>\$16⁹⁹ 1-9</p>  <p>\$129 10-UP</p>
 <p>BSR</p> <p>PART NO. 4T6-110</p> <p>INTRODUCTORY PRICE</p> <p>\$2595 EACH</p> 	 <p>HITACHI</p> <p>PART NO. HA1377</p> <p>\$33⁹⁹ 1-9</p>  <p>\$285 10-UP</p>

Consolidated Electronics, Incorporated

Your Complete Electronic Parts Source



You can count on Consolidated Electronics to have thousands of name brand parts you need at the lowest prices. Common or hard to find, we have what you want when you need it. Your order is quickly and accurately expedited by our staff. Call today for a free catalog.

Call Your Order Toll Free

1-800-543-3568

NATIONAL WATS

1-800-762-3412

OHIO WATS

705 WATERVLLET AVE, DAYTON, OHIO. 45420

CIRCLE 81 ON FREE INFORMATION CARD

FEBRUARY 1985

ANTIQUE RADIOS

Collecting antique radios

COLLECTING OBJECTS FROM A BYGONE era is as old as time itself. Such objects are often referred to as either *antiques* or *junk*—depending, of course, on whether you're buying or selling. Since World War II, all kinds of collectables have come into their own—coins and stamps, for instance, are old favorites. But that's not what we're going to talk about—after all, this is an *electronics* magazine!

The antique-radio hobby is different from other "collecting" hobbies. With radios, unlike other collectables, you are not as likely to get ripped off by unscrupulous characters who deal in "fakes." While making an authentic-looking reproduction of an antique-radio cabinet is possible, the same does not hold true for the tubes and other chassis components!

American antiques are objects considered by knowledgeable collectors to be over a hundred years old. Clearly, if that time frame were applied to old radios, there would be slim pickings for collectors. Even the set used by Marconi in 1888 won't be considered a true antique for a few years!

Many antiquaries—those who deal in or study antiques—divide the items into categories: *antiques*, *semi-antiques* and *collectables*. (Although there are no hundred year-old radios in my limited collection, there are a few that can be called semi-antiques!)

A look at early radios

It wasn't until the mid-1920's that complete radios, like the Crosley *Model 51* shown in Fig. 1, became available to the general public. Corporate contention seemed to

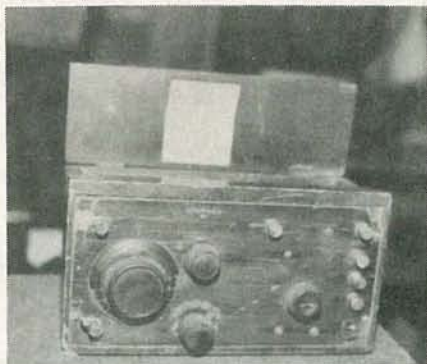

FIG. 1

hamper the growth of the industry. Designs, innovations, and patents were not generously shared by the early radio manufacturers—huge lawsuits, which tied up production for months, were not uncommon in the early days of radio.

Improvements and new inventions came fast in those early pioneer days. Back then, the average person had a better working knowledge of radios than now. Those people who got in at the beginning were able to follow advances in the industry. Any radio receiver was pretty much a do-it-yourself project; anyone interested in radio could read a schematic in those developing days.

The early enthusiast knew if he wanted to hear what was "on the air," he would have to build his own set. Therefore, what he wound up with was a custom-built set. A wealth of information and parts was available in early radio publications. And as radio progressed, complete information and schematics were offered.

In the early 1900's there was little commercial interest in radio—despite the development of the two- and three-element tubes (diodes



RICHARD D. FITCH

and triodes).

After World War I, there were a number of production portables on the market that came complete with cabinet and tubes (two WD11 tubes). While those sets appeared to be small portables, their portability was certainly limited. The aerial, ground, as well as batteries and earphones, were connected to terminals on the front panel. The Crosley *Model 51*, (shown in Fig. 1) was one such set. That boxy-looking radio (with a cabinet that measured about ten inches across) contained 1.5-volt DC tubes and was battery-operated. Even at that time, only about a quarter of the homes in America were "wired." So the need for battery operated sets prevailed through most of the late 1920's and well into the 1930's!

The stock market crash and great depression of that era had little effect on the evolution of radio. By 1929, most new homes and many old ones were being wired. And with the licensing of more and more broadcast stations, the sale of commercially-built radios began to grow. The big corporations settled many of their differences (Some went all the way to the Supreme Court.)

By 1920, Grigsby Grunow, for example, sold 1,000,000 *Majestics* (see Fig. 2). Most old radios, as well as other manufactured products, had character right through the 1930's. (Civilian radio-production was reduced during the early 1940's—the years of World War II).

There were small AC-powered models with cabinets less than a foot wide that could fit on top of a bread box (fine collectors' items or



FIG. 2

the depression. While fidelity may have been sacrificed in those models (with their smaller speakers), by today's standards, their sound quality is above average. The midget radio is the forerunner of the modern table models.

The radio industry in the early 1930's hoped the midget radio would replace the millions of "antique" radios of that era. (But with its cost of around \$100.00, listeners were holding on to their older models.) Those custom mail-order

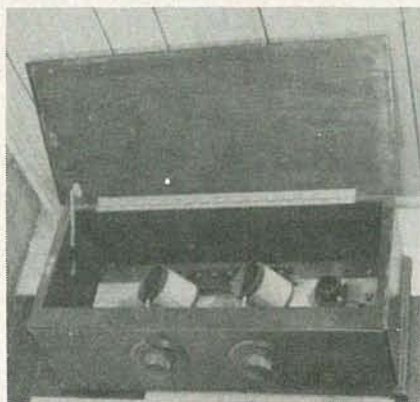

FIG. 3

or kit radios that were considered antiques in the early thirties will be hard to come by today. The set shown in Fig. 3 is an early antique radio. However, unlike the set in Fig. 1, its terminals for connecting the batteries, earphones, etc. are inside the box.

The radio industry hoped to induce those not enjoying modern radio to discard their obsolete equipment, and join the listeners of modern radio. For radio dealers, the big profit was in the console. At least half of the market still wanted, or could afford the big-console radios. The massive cabinet with huge dynamic speakers and two shortwave bands was a prestigious addition to the home in the thirties. (How many tubes you had in your radio became as important as how many cylinders you had in your car!)

conversation pieces). Those small antique radios, called "midget receivers" are much in demand—the small cabinets are relatively easy to restore.

During the 1930's the midget radio was the industry's answer to

Buying antique radios

Old radios that can be called antiques can be bought for as little as \$5.00! You might even find a free

continued on page 112

This unique line of 12 lightweight and comfortable precision cutters, pliers and crimpers are specially adapted to meet the demanding requirements of the electronic industries. All the tools feature custom contoured ribbed handles which provide a non-slip gripping surface, and specially designed lifetime return springs which eliminate operator fatigue.

Precision Pliers, Cutters and Crimpers

- Flush cutters
- Semi-flush cutters
- Reverse cutters
- Cutter/crimper
- Cutter/bender
- Pliers

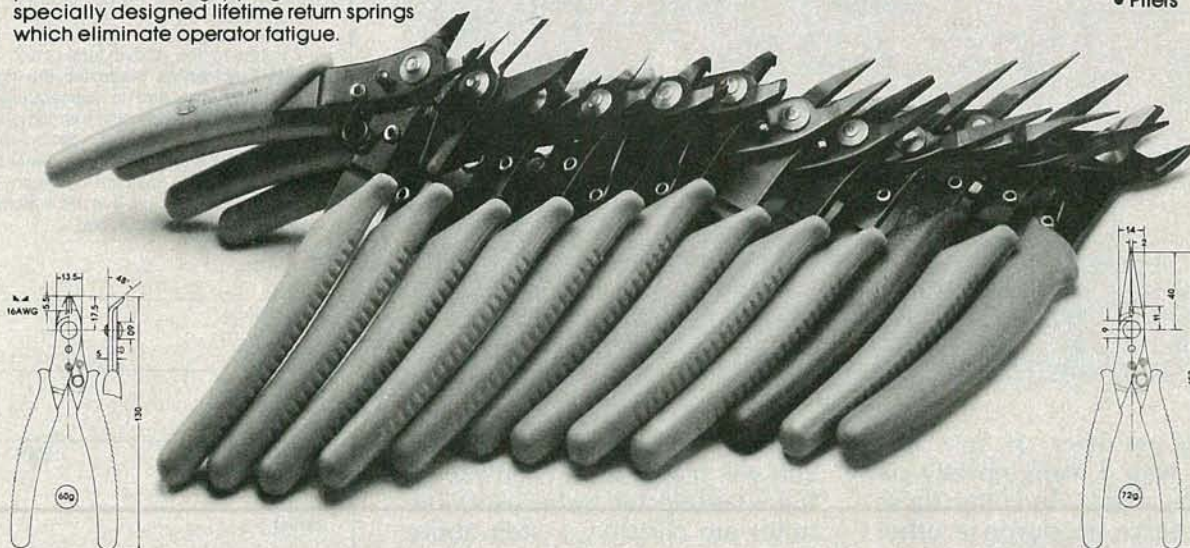

3455 Conner Street, Bronx, New York, 10475, U.S.A.
Telex 125091 OK NYK. Telex 232395 OK NY UR.
Phone (212) 994-6600.



NEW IDEAS

Musical telephone ringer

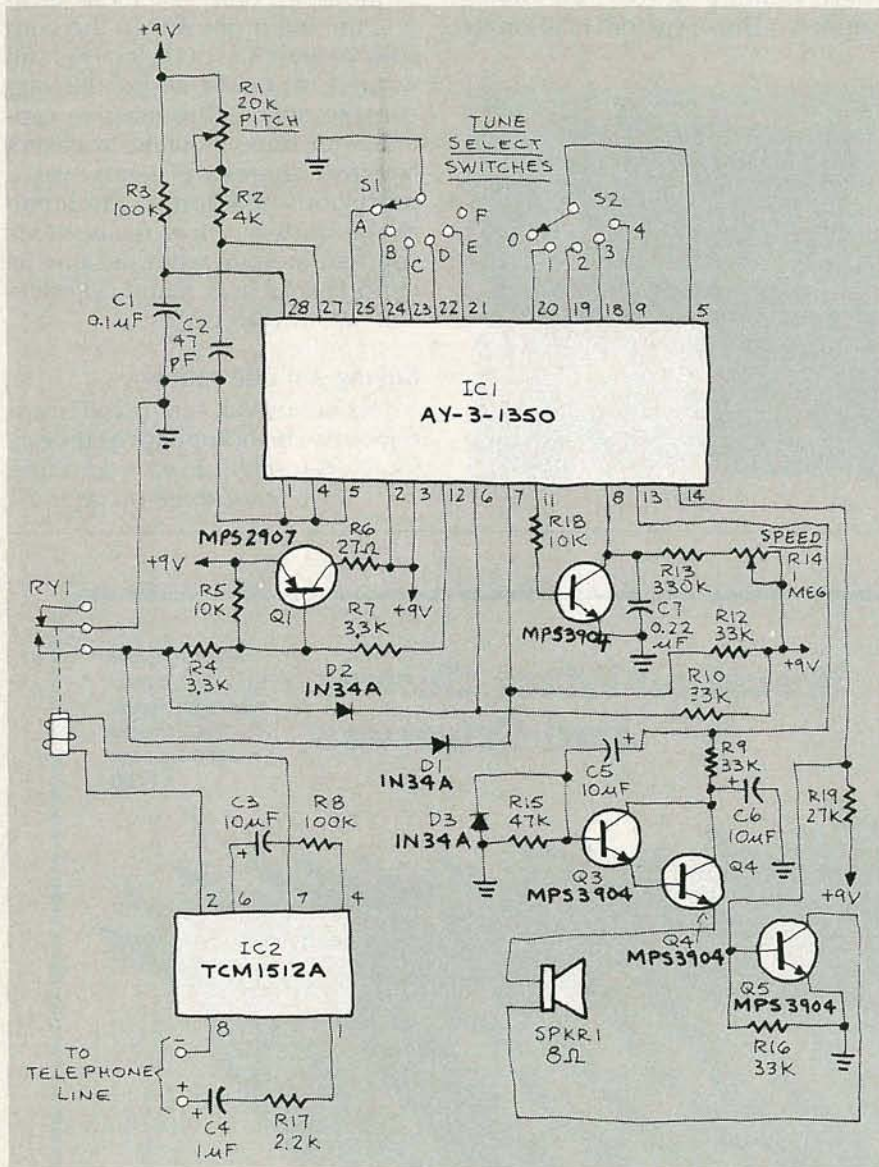

FIG. 1

THE DEVELOPMENT OF IC'S HAS brought with it many novelty circuits and gadgets. And often those circuits serve no purpose other than to entertain. Although this telephone-ringer circuit is a novelty, it doesn't fall into that category. The melody ringer can be used in place of, or as an extension to, your present ringer system.

When the phone rings, the circuit will play one of twenty-eight tunes (as selected by the user). The tunes are certainly a step above the old clanging bell—which at times can be quite startling. Some of the tunes, which are listed in Table 1, are ideal for special occasions, adding another dimension to the circuit's many uses.

NEW IDEAS

This column is devoted to new ideas, circuits, device applications, construction techniques, helpful hints, etc.

All published entries, upon publication, will earn \$25. In addition, for U.S. residents only, Panavise will donate their model 333—The Rapid Assembly Circuit Board Holder, having a retail price of \$39.95. It features an eight-position rotating adjustment, indexing at 45-degree increments, and six positive lock positions in the vertical plane, giving you a full ten-inch height adjustment for comfortable working.



I agree to the above terms, and grant **Radio-Electronics Magazine** the right to publish my idea and to subsequently republish my idea in collections or compilations of reprints of similar articles. I declare that the attached idea is my own original material and that its publication does not violate any other copyright. I also declare that this material has not been previously published.

Title of Idea

Signature

Print Name

Date

Street

City

State

Zip

Mail your idea along with this coupon to: **New Ideas Radio-Electronics**, 200 Park Ave. South, New York, NY 10003

VOL. 2 No. 2 February 1985

COMPUTER DIGEST

NEW KIND OF MAGAZINE FOR ELECTRONICS PROFESSIONALS

SEIKO'S NEW WRIST-WATCH COMPUTER SYSTEM

An in-depth look at the world's first wrist-watch that forms part of a complete computer system.

HIGH-RESOLUTION MONITORS

How to unscramble all those specifications.

A GERNSBACK PUBLICATION

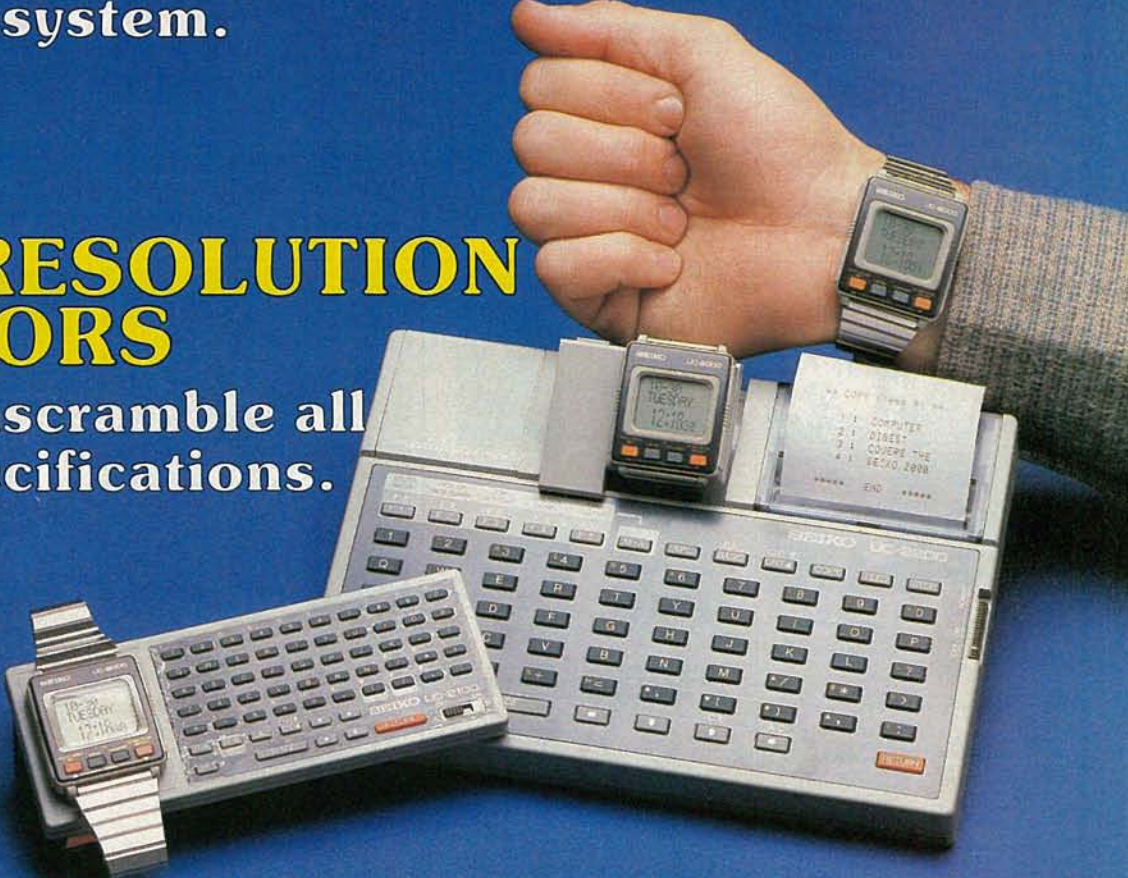

RECEIVING COMPUTER PROGRAMS VIA BROADCAST RADIO

Standards are being proposed that will enable you to receive computer programs from your radio receiver.

Electronics Paperback Books

Quality Paperbacks at Affordable Prices



- 30 SOLDERLESS BREADBOARD PROJECTS BOOK-1.** \$5.75. Whenever possible the same parts are used in several projects. Even a first-time builder can complete these circuits.
- HOW TO GET YOUR ELECTRONIC PROJECTS WORKING.** \$5.00. Helps you troubleshoot and repair home-built projects of every description.
- MINI-MATRIX BOARD PROJECTS.** \$5.00. A variety of projects that can all be built upon a mini-matrix board that has 10 strips and is 24 holes long.
- MODERN OP-AMP PROJECTS.** \$5.00. Wide range of specialized op-amp circuits including lo-noise, lo-distortion, ultra-hi input impedance, etc.
- MULTI-CIRCUIT BOARD PROJECTS.** \$5.00. 21 fairly simple projects that can all be built on a single printed-circuit board. All are powered by a 9V battery.
- IC PROJECTS FOR BEGINNERS.** \$5.00. Inexpensive digital and linear IC's are used to assemble this selection of circuits intended for the beginner.

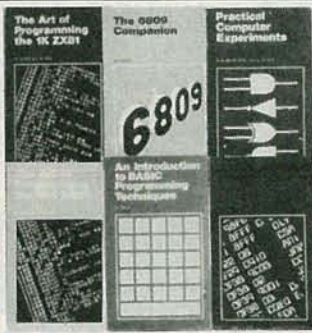

- THE ART OF PROGRAMMING THE 1K ZX81.** \$6.25. Topics include full screen, scrolling, PEEK & POKE, plus actual working programs.
- THE 6809 COMPANION.** \$5.00. Written for the average assembly language programmer. A discussion of 6809 features & reference work for the 6809 programmer.
- PRACTICAL COMPUTER EXPERIMENTS.** \$4.50. Fills in background to microprocessor by constructing typical computer circuits using discrete logic components.
- ART OF PROGRAMMING THE 1K ZX81.** \$5.00. How to use the features of the ZX81 in programs that fit the 1K machine and are still fun to use.
- INTRODUCTION TO BASIC PROGRAMMING TECHNIQUES.** \$5.00. Based on author's own experience in learning BASIC and helping others to learn to program.
- A MICROPROCESSOR PRIMER.** \$4.50. Painless approach to computing for the beginner. Step-by-step explains computer operations and assembly.

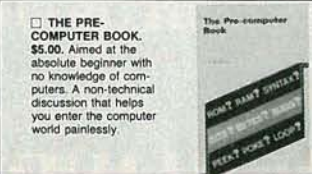

- THE PRE-COMPUTER BOOK.** \$5.00. Aimed at the absolute beginner with no knowledge of computers. A non-technical discussion that helps you enter the computer world painlessly.
- AN INTRODUCTION TO VIDEO.** \$5.00. Perfect for the person just about to buy a VCR. Discusses pros & cons of the various formats: video discs, videotext, tape copying and more.



- BASIC & PASCAL.** \$4.00. Takes BASIC & Pascal and develops programs in both languages simultaneously.
- FIRST BOOK OF TRANSISTOR EQUIVALENTS, & SUBSTITUTES.** \$3.75.
- PRACTICAL COMPUTER EXPERIMENTS.** \$4.50.
- ELECTRONICS SIMPLIFIED CRYSTAL SET CONSTRUCTION.** \$4.50.
- ELECTRONIC HOUSEHOLD PROJECTS.** \$4.50.

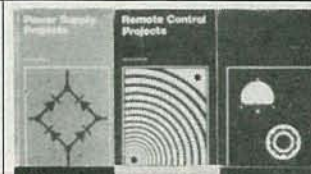

- POWER SUPPLY PROJECTS.** \$4.50. Contains designs and construction details for almost any power supply the experimenter is likely to need.
- ELECTRONIC PROJECTS USING SOLAR CELLS.** \$5.00. Simple circuits that have numerous applications around the home.
- ELECTRONIC TIMER PROJECTS.** \$5.00. Timing circuits for almost any application the experimenter might need. A most valuable reference.
- COUNTER DRIVER & NUMERICAL DISPLAY PROJECTS.** \$4.50. Features applications & projects using various types of numerical-display devices.



- PRACTICAL ELECTRONICS CALCULATIONS AND FORMULAE.** \$7.50. A basic reference work that bridges the gap between complicated technical theory & cut and tried methods.
- INTERNATIONAL DIODE EQUIVALENTS GUIDE.** \$5.75. Helps you find substitutes for the many different types of semiconductor diodes in use today.
- INTERNATIONAL TRANSISTOR EQUIVALENTS GUIDE.** \$7.50. Products of more than 100 manufacturers are listed & cross-referenced with possible replacements.
- HOW TO MAKE WALKIE TALKIES.** \$5.00. Describes equipment for low-power handheld operation. 112 pages of must reading for the dedicated experimenter.
- ELECTRONIC CALCULATOR USERS HANDBOOK.** \$3.95. Presents formulae data, methods of calculation, conversion factors & more from the view of the calculator user.
- LINEAR IC EQUIVALENTS AND PIN CONNECTIONS.** \$8.25. Shows equivalents & pin connections of a popular user-oriented selection of linear IC's.

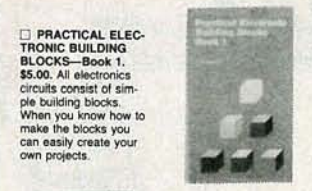

- PRACTICAL ELECTRONIC BUILDING BLOCKS—Book 1.** \$5.00. All electronics circuits consist of simple building blocks. When you know how to make the blocks you can easily create your own projects.
- PRACTICAL ELECTRONIC BUILDING BLOCKS—Book 2.** \$5.00. Circuits that process signals. Combines with those in Book 1.

- SPECIAL OFFER Book 1 & Book 2 PRACTICAL ELECTRONIC BUILDING BLOCKS.** \$9.00. Shipping included. Save \$1.75.
- RADIO CONTROL FOR BEGINNERS.** \$4.50.
- ELECTRONIC GAMES.** \$4.50.
- SINGLE IC PROJECTS.** \$4.25.
- RADIO CIRCUITS USING IC'S.** \$4.50.
- ELECTRONIC HOUSEHOLD PROJECTS.** \$4.50.
- ELECTRONIC MUSIC PROJECTS.** \$4.50.
- POPULAR ELECTRONIC PROJECTS.** \$3.75.
- PROJECTS IN OPTO-ELECTRONICS.** \$5.00.



- ANTENNA PROJECTS.** \$5.00. Covers practical antenna designs including active, loop & ferrite types that are easy & inexpensive to build.
- RADIO STATIONS GUIDE.** \$4.75. Comprehensive listing of transmitters around the world. Presents location, frequency, power.
- LONG DISTANCE TV RECEPTION (TVDX) FOR THE ENTHUSIAST.** \$5.00. Practical & authoritative introduction to this unusual aspect of electronics.
- CB PROJECTS.** \$5.00. A number of useful and interesting designs for CB accessories. Speech processor, interference filter & more.
- CRYSTAL SET CONSTRUCTION.** \$4.50. Packed full of easy to duplicate designs for crystal radio receivers.
- AN INTRODUCTION TO RADIO DXING.** \$5.00. Listen, in your home, to broadcasts originating thousands of miles away. Tells how you can do it.

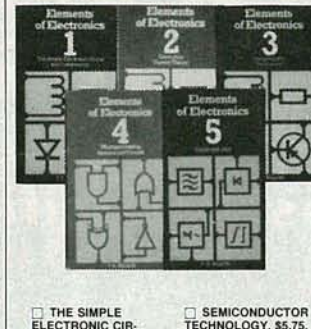

- THE SIMPLE ELECTRONIC CIRCUIT & COMPONENTS.** \$5.75. All the fundamental theory needed to lead to a full understanding of the simple electronic circuit and its components.
- ALTERNATING CURRENT THEORY.** \$5.75. Alternating current theory without which there can be no comprehension of speech, music, radio, or television.
- MICROPROCESSING SYSTEM & CIRCUITS.** \$7.50. A truly comprehensive guide to all of the elements of a microprocessing system.
- SEMICONDUCTOR TECHNOLOGY.** \$5.75. Everything you always needed to know about solid-state devices in one volume.
- COMMUNICATIONS.** \$7.50. Covers most modern communication systems. Line, microwave, submarine, satellite, digital multiplex, radio & telegraphy.
- FIRST BOOK OF HI-FI SPEAKER ENCLOSURES.** \$4.50.
- SOLID STATE NOVELTY CIRCUITS.** \$3.50.
- 28 TESTED TRANSISTOR PROJECTS.** \$4.25.

ELECTRONIC TECHNOLOGY TODAY INC.
P.O. Box 240, Massapequa Park, NY 11762

RE 2/85

Number of books ordered

Total Price of Books\$

Sales Tax (NY State Residents)

Shipping (75¢ 1st two books, 30¢ ea additional)

TOTAL ENCLOSED\$

Name _____

Address _____

City _____ State _____ ZIP _____

CONTENTS

Vol. 2 No. 2

February 1985

7 Seiko's New Wrist Computer

When Dick Tracy takes a look at this newest innovation from Seiko—a "wrist computer"—he's sure to turn green with envy. **Mark Stern**

10 Basicode

Get free software via shortwave radiol! **Herb Friedman**

13 High-Resolution Color Monitors

There's more to computer displays than meets the eye. **Herb Friedman**

4 Letters

5 Computer Products

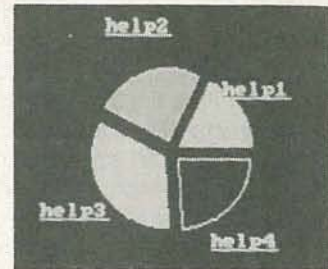

Find out more about high-resolution displays, low-resolution displays, and everything in between. The story begins on **page 13**.

The conclusion of Machine Code Development System for the Timex Sinclair 1000 will appear in the March issue of Computer Digest.

ON THE COVER

Just about everyone knows about Dick Tracy's wrist radio. Well, a new innovation from the people of Seiko has left that once speculative device in the dust. The innovation is a tiny "wrist computer" complete with an LCD wrist-watch-like readout, a pocket-sized keyboard, and 2K of RAM. **See page 7.**

ComputerDigest is published monthly as an insert in Radio-Electronics magazine by Gernsback Publications, Inc., 200 Park Avenue South, New York, NY 10003. Second-Class Postage Paid at New York, N.Y. and additional mailing offices. All rights reserved. Printed in U.S.A.

A stamped self-addressed envelope must accompany all submitted manuscripts and/or artwork or photographs if their return is desired should they be rejected. We disclaim any responsibility for the loss or damage of manuscripts and/or artwork or photographs while in our possession or otherwise.

LETTERS

NO COMMODORE PRINTER PROBLEMS

Our company, Martec Associates, Inc., sells a dot-matrix printer together with the Cardco, Inc. Card+ interface for the Commodore 64 and VIC 20 computers. Naturally, we were very interested by Herb Friedman's article in the September issue of **ComputerDigest**, "Printer Delay for the Commodore 64."

A phone call to Cardco yielded the following information. In 1983, Cardco changed their ROM due to a problem like the one described in the article. However, since then, they have not had any problems. Is it possible that Herb Friedman used an old Cardco CARD?—Arthur Kingsnorth, Vice President, Martec Associates, Elk Grove Village, Illinois

Although both the Commodore computer and Cardco interface were bought shortly before the article was prepared, it is possible that the Cardco interface was sitting around in stock for some time and therefore contained the old ROM. The Customer Service Department at Cardco assures us that all problems have been corrected with the printer adapter. If anyone runs into a situation like the one Herb Friedman did, Cardco will gladly replace the defective interface if it is sent to the Customer Service Department at Cardco (300 S. Topeka, Wichita, KS 67202) along with proof of purchase and a description of the problem.

TI COMPUTERS

You say that you're not "just another computer magazine." Well, so far all you do is talk about the same things that the other computer magazines do.

I have a TI 99/4A, and I haven't seen anything written about it in

ComputerDigest. For that matter, I haven't seen much written about it in any of the other magazines. That is one of the reasons that I'm writing this letter. I would like to know how to make a phone modem, and a few other things for my computer. I'm sure that there are many more people like me that have a TI 99/4 computer.

I enjoy **Radio-Electronics**, but if **ComputerDigest** is going to be like the rest of the computer magazines, then we can do without it.—Brian E. Sparling, Northfield, IL

If you're a TI owner and think you have an article for publication, consider this an open invitation for you to let us know about it.

PUBLISH YOUR PROGRAMS

The Blacksburg Group writes and produces books about using small computers. Since 1977, we have developed over 60 titles on electronics and computer subjects, and our books are published by major U.S. publishers.

One of our new projects is the collection and publication of useful engineering and scientific routines and subroutines. We know that many people have written interesting programs to solve a specific problem or because they couldn't find a special routine they needed. Our book gives these people a way to share their programs with other scientists and engineers so that others can benefit.

Useful programs include those that do graphing, numerical analysis, statistics, equation solving, 3-D plotting, controlling real-time clocks, controlling analog converters, and so on. We are interested in almost *all* programs that could be used by scientists and engineers to answer specific or general needs. We know from

COMPUTER DIGEST

Hugo Gernsback (1884-1967)
founder

M. Harvey Gernsback, editor-in-chief

Larry Steckler, CET, publisher

Art Kleiman, editorial director

Byron G. Wels, editor

Brian C. Fenton, technical editor

Carl Laron, associate editor

Robert A. Young, assistant editor

Ruby M. Yee, production manager

Robert A. W. Lowndes, production associate

Dianne Osias, production assistant

Karen Tucker, production assistant

Jacqueline P. Weaver, circulation director

Arline R. Fishman, advertising coordinator

Gernsback Publications, Inc.
200 Park Ave. South
New York, NY 10003
Chairman of the Board:
M. Harvey Gernsback
President: Larry Steckler

ADVERTISING SALES 212-777-6400

Larry Steckler
Publisher

EAST/SOUTHEAST

Stanley Levitan
Radio-Electronics
200 Park Ave. South
New York, NY 10003
212-777-6400

MIDWEST/Texas/Arkansas/Okla.

Ralph Bergen
Radio-Electronics
540 Frontage Road—Suite 325
Northfield, Illinois 60093
312-446-1444

PACIFIC COAST Mountain States

Marvin Green
Radio-Electronics
15335 Morrison St., Suite 227,
Sherman Oaks, CA 91403
818-986-2001

LETTERS

continued

personal experience that most people don't want to become professional programmers just to be able to use a computer, so we strongly feel that a collection of useful program segments will be invaluable.

If readers are interested, they should write or call us first, and we will send them guidelines and other information about submitting a program or subroutine. Our number is 703-951-9030 (which is in the Eastern time zone).

Right now, we're particularly interested in BASIC-language programs for popular desktop computers. This is NOT a vanity publication, and authors retain the copyrights to their material.—

Jonathan A. Titus, Ph.D, President, The Blacksburg Group, Inc. PO Box 242, Blacksburg, VA 24060

Thanks for the information—we're happy to pass it along to our readers.

Competition

I'd like to make what I think is an important point that we'd all better understand. I know nothing at all about spectator sports, and could not care less. I think that it was for that reason alone that my young son developed his own interest, and learned to quote the batting averages of every football player in the major leagues. It gave him the opportunity to know something that I didn't. He once challenged me to ask him any question about baseball, so I asked him how far it was between first base and home plate, and he became angry. "What kind of question is that?"

Being an old electronics nut myself, he shied away from that field until he realized that my knowledge of computers was miniscule. He jumped on that too. He became an overnight computer "expert" and kept asking questions of a technical nature that he already knew the answers to. I quickly caught on to the game, and began to seriously read—and wonder of wonders—to understand, thanks to

ComputerDigest.

Things are beginning to settle down now around the house. We're starting to learn more together, and we're enjoying it more all of the time. Just thought you'd like to know. Keep up the good work.—J.P., San Francisco, CA.



COMPUTER PRODUCTS

For more details use the free information card inside the back cover

PRODUCTIVITY TOOL. *Speed Key*, is designed for business software programs and languages. It makes them easier to learn and to be customized to each user's special needs. *Speed Key* supports the following business-application programs: *Lotus 1-2-3*, *WordStar*, *MultiPlan*, *SuperCalc*, *VisiCalc*, *dBASE II*, and IBM's DOS and BASIC programming language.

With *Speed Key* and Koala's touch tablet, a user can bypass the standard computer keyboard to run the leading business-software programs. *Speed Key* converts the Koala touch tablet into a custom keyboard with up to 37 programmable function keys and a cursor controller with the features of a "mouse" pointing device.

Each *Speed Key* overlay has 36 squares, with each square representing a softkey designed to give specific



CIRCLE 21 ON FREE INFORMATION CARD

instructions to the IBM PC or IBM PC-XT. When a softkey on the overlay is pressed, the computer and application software will think that the user is typing on the computer

keyboard. Thus, the user does not have to remember lengthy commands and multiple keystrokes required by conventional keyboards.

Speed Key has a suggested retail price of \$99.00.—**Koala Technologies Corp.**, 3100 Patrick Henry Drive, Santa Clara, CA 95052-8100.

GRAPHICS SUBSYSTEM, the model *DT2750*, is a full-color raster subsystem that allows any Q-Bus processor to generate and display mixed graphics and alphanumerics on a monochrome or standard RGB color monitor.

The model *DT2750* contains a 192K graphics-display memory that organized as two independent display buffers with 512 × 512 × 3 pixels each. The framesize may be jumped to 512 × 156 × 3 pixels. The 3-bit depth permits display of eight colors at one



CIRCLE 22 ON FREE INFORMATION CARD

time, selected via a lookup table from a palette of 512 colors. When used with a monochrome monitor, there are eight levels of gray scale available.

Applications for the model DT1750 graphics board are found in process monitoring and control, medical

electronics, business graphics, and visual network control. It is priced at \$1995.00.—**Data Translation**, 100 Locke Drive, Marlboro, MA 01752.

EDUCATIONAL SOFTWARE GAME, States & Traits, challenges families and children ages nine and above to sharpen their knowledge of United States geography, history, and current trivia.

The map-maker/user has two options: In "states," he or she charts states into their proper locations on a colorful master map. In "traits," the cartographer's challenge is to plot topographical features into their correct geographic positions and to answer questions on U.S. landmarks, history, and trivia.

Players can choose to test their geographic knowledge of the whole United States, or to concentrate on one of four regions. If the player selects "states," the labeled outline of a state appears on the screen next to a map of the total U.S. or region. Using a joystick or keyboard, the player then leads the state to its correct position

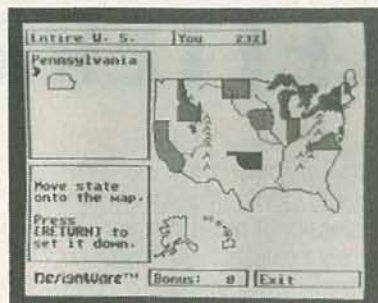

CIRCLE 23 ON FREE INFORMATION CARD

on the map. The state appears to "march" across the country as the player moves and charts its course.

In the "traits" portion of the game, a map and a question appear on the screen. State capitals, neighboring states, historical facts, and current events are all fair game. To answer, the user draws an arrow to the correct state. For example: "What state claims fame as the boyhood home of Abraham Lincoln?" The player must point to the state of Illinois. *States & Traits* is priced at \$44.95.—

Designware, 185 Berry Street, San Francisco, CA 94107.

THIS SPACE CONTRIBUTED AS A PUBLIC SERVICE

A defense against cancer can be cooked up in your kitchen.



There is evidence that diet and cancer are related. Follow these modifications in your daily diet to reduce chances of getting cancer:

1. Eat more high-fiber foods such as fruits and vegetables and whole-grain cereals.
2. Include dark green and deep yellow fruits and vegetables rich in vitamins A and C.
3. Include cabbage, broccoli, brussels sprouts, kohlrabi and cauliflower.
4. Be moderate in consumption of salt-cured, smoked, and nitrite-cured foods.
5. Cut down on total fat intake from animal sources and fats and oils.
6. Avoid obesity.
7. Be moderate in consumption of alcoholic beverages.

No one faces cancer alone. **AMERICAN CANCER SOCIETY**

DATA-ACQUISITION BOARD, the DASH-16, is a high-speed, plug-in data-acquisition board for the IBM PC and other bus-compatible computers.



CIRCLE 24 ON FREE INFORMATION CARD

DASH-16 provides 12-bit A/D conversion and speeds up to 40,000 samples per second, with transfer to memory at that speed using DMA (level 2 or 3). Sixteen single-ended or eight differential analog input channels are available (switch selectable), as is an instrumentation amplifier with switch-selectable gains of 0.5, 1, 2, 5, 10, and a special "user gain" for specific application gain requirements. Data conversions may be initiated by the program, an internal timer, or by an external trigger. Converted data may be transferred by program interrupt or DMA. The interrupt and DMA modes support background operation. Input-voltage range is ± 10 to ± 0.5 volts.

The *DASH-16* is priced at \$895.00.—**MetraByte Corp.**, 254 Tosca Drive, Stoughton, MA 02072.

SEIKO'S NEW WRIST COMPUTER

It had to happen, and Seiko did it... Here's a look at the new Wrist Computer!

Marc Stern

■ If you've been following Dick Tracy through the years, you've probably seen him talking to Sam, his sidekick, on his wrist radio. Well, today that can be updated. Instead of talking to Sam on his wrist radio, Dick Tracy will probably use his wrist computer to exchange information with him.

Although that may sound like science fiction, it really isn't because of a recent development from Seiko, the people who normally bring you high-quality watches and mini-televisions, among other things.

Seiko does it

The Seiko *Datagraph* system, which consists of a wrist module, pocket keyboard, and controller is the result of several years of development by the Japanese electronics giant Hattori Corp. It relies on large scale integration (LSI) techniques and the first use of inductive wireless transmission technology in the computer industry.

When you first look at the wrist module, you'll notice that it isn't especially unique-looking. In fact, it looks just like a watch (which is what you'd expect from Seiko). It's what the company has done with technology and how they have managed to squeeze some computing power into a wrist-sized package that sets it apart from all the other wrist watches of the world.

The wrist module

The basic component of the information system is the wrist module. It contains five CMOS LSI IC's that include a four-bit central processing unit; a 2K RAM, and three display drivers for the liquid-crystal display. A block diagram of the wrist module is shown in Fig. 1.

The LCD readout consists of a 10-column by four-row matrix that has a resolution of 1,400-pixels. The LCD not

only serves as the display for the computer, but—as you would expect of a watch manufacturer—it also displays all the timekeeping functions, including day, date, chronograph, and alarm. It is powered by a lithium battery that Seiko claims will supply power to the wrist module for 1.5 years.

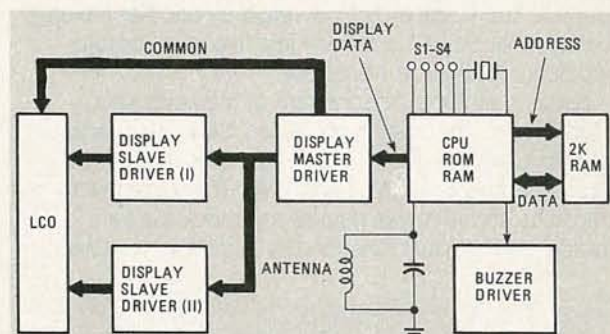

FIG. 1—THE DISPLAY MODULE contains an LCD display, two display drivers, a master display driver, CPU and 2K of RAM, a loop antenna and a buzzer.

The keyboard module

Data is entered into the wrist module by a pocket-sized keyboard unit. The keyboard measures only $5\frac{1}{2} \times 2\frac{1}{4} \times \frac{5}{16}$ inches, and contains 61-keys through which data is input to the wrist module. The wrist module itself has only four buttons that are used to access pre-programmed functions. So, as you can see, the keyboard is an important device. You can use the keyboard unit to input notes, calculations, etc. into the wrist module. You can even store telephone numbers, appointments, and just about anything else in the device.

Data is transferred from the keyboard unit to the



THIS IS NOT a wrist watch! It is the display module for the Seiko Datagraph computer.

wrist module through induction. The wrist module fits on a small plate at the left of the keyboard and communicates with the controller at a rate of 2048 baud (bits per second). The communications is duplex. The keyboard is powered by another lithium battery that Seiko claims will last five years before replacement will be necessary.

Looking at the block diagram of the keyboard module shown in Fig. 2, you'll see it is really made up of two parts. The first is the keyboard circuit and the second is the inductive transceiver. The transceiver both transmits and receives data as the block diagram indicates. That dual functionality is built into a CMOS

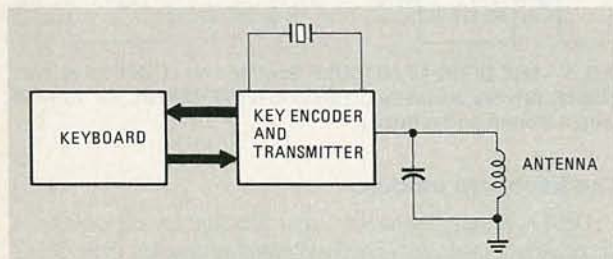

FIG. 2—THE KEYBOARD MODULE contains the keyboard, a keyboard encoder and transmitter, and a loop antenna.

LSI IC that handles not only key scan, but also character generation, as well as wireless transmission. It runs at a clock rate of 32.768 kHz.

Master control

Rounding out the *Datagraph* system is the module that turns this system into a true 8-bit microcomputer,

the *UC-2200* controller. Communicating inductively, the controller uses the wrist module as its display device. As shown in Fig. 3, the *UC-2200* controller contains an 8-bit CMOS Z80-equivalent microprocessor. It boasts not only a complete, typewriter-style QWERTY keyboard with function keys, but also a dot-matrix mini-printer. The controller also features 4K of RAM



THE UC-2200 CONTROLLER turns the display module into an 8-bit micro-computer. The controller is shown here with an application ROM pack in place.

memory and a ROM applications pack that includes scheduling, a 26K BASIC interpreter, as well as other programs. The ROM can contain as much as 32K. The entire unit measures only 5 × 7-inches and it can be powered by alkaline batteries.

The importance of the *Seiko Datagraph* system lies equally in its size and capability, as well as its method of transferring data from one device to another. It is the first system in the industry to employ inductive transmission and reception techniques.

It brings major computer capability to a unit whose key part—the wrist module—is intended to be worn

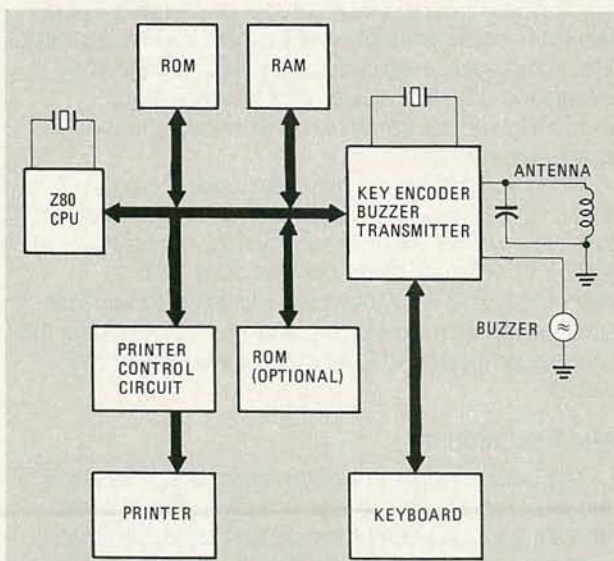

FIG. 3—THE CONTROLLER MODULE contains a CPU, RAM, ROM, an optional ROM containing applications software, a keyboard encoder, buzzer driver and transmitter, a keyboard, printer controller, printer, buzzer, and loop antenna.

on your wrist. And, the system itself is small enough that it can be easily used by the "man on the go." Ten years ago, when the first microcomputers were making their appearance, it was impossible to have a computer at your fingertips wherever you went. Of course, that situation changed about four years ago with the introduction of such transportable computers as the Osborne I and the Kaypro. But, let's face it, those computers were far from conveniently sized for hauling. Briefcase computers did put true computing power at your fingertips wherever you went, but they were still fairly large. However, the Seiko *Datagraph* system now puts computing power on your wrist—a very convenient package.

Inductive coupling

Rather than relying on traditional radio transmission techniques, Seiko chose to use inductive coupling to transfer data between the various modules. Figure 4 shows the basic approach.

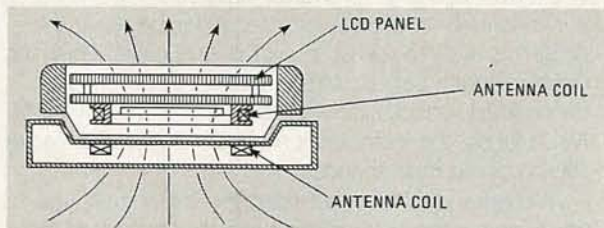

FIG. 4—ANTENNA COILS are used for inductively transferring data between the various modules.

Each module contains an antenna coil that resonates at 32 kHz. That frequency was chosen because the other clock frequencies contained within each of the modules could be easily filtered out. The bit stream modulates a 32-kHz signal that is applied to the transmitting antenna. If the bit is at a logic 1 level, then the 32-kHz signal is applied to the antenna, if the bit is at a logic 0 level, then no signal is applied to the transmitting antenna. The magnetic field produced by the transmitting antenna cuts across the windings in the receiving antenna. The receiving antenna produces a current in response to the magnetic field. The output of the receiving antenna is an exact duplicate of the original signal applied to the transmitting antenna. The 32-kHz signal is filtered out of the received signal and the original bit stream is recovered.

An eight-bit digital word is transferred in very much the same format that is used when two computers communicate via a modem. The actual transfer of the eight-bit digital word consists of a start bit, followed by eight data bits, a parity bit and finally, a stop bit.

Seiko chose inductive technology for several reasons. First, it could keep everything inside a hermetically sealed unit so it is humidity resistant. Second, it helps to keep the unit portable because of its small size. Next, the company chose this method because of the ease of interfacing the units. There are no cables to worry about and it allows duplex communication through one loop. Last, but not least, the technique is easy to implement and since the circuitry needed to

accomplish it is simple, few parts are needed. In fact, the data transmission and receiving circuits can be connected to one antenna coil.

Packaging

None of this would have been possible without developments in LSI packaging. For instance, all parts of the transmitting-receiving circuits, other than the coils and tuning capacitors, are located on a single integrated circuit.

Look at Fig. 5 and you'll see how the wrist module is put together. The main substrate—epoxy glass resin—contains three LSI packages. In turn, a ceramic substrate, which contains the wrist module's 4-bit CPU and 2K RAM, is soldered to the rear. In other words,

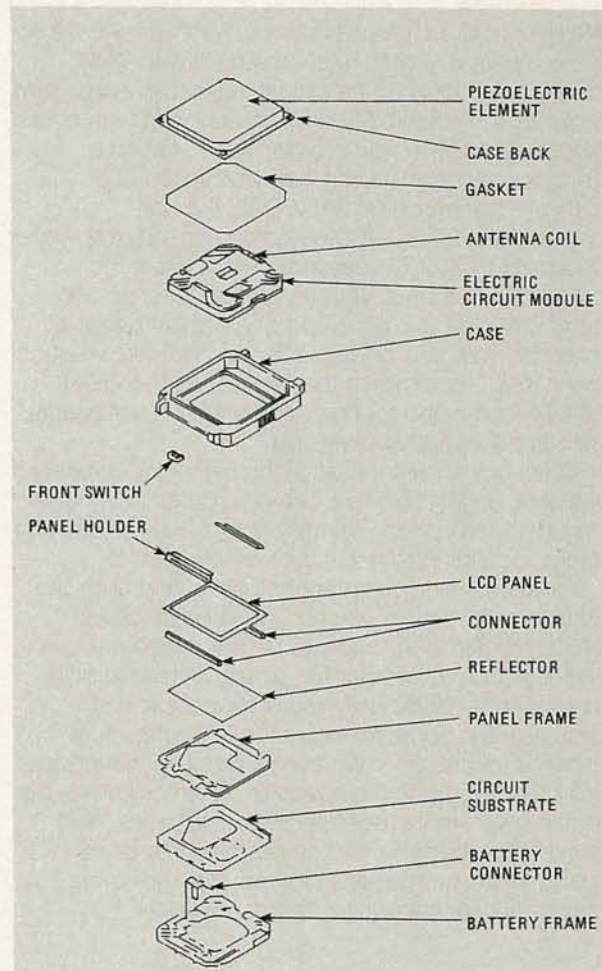

FIG. 5—CONSTRUCTION OF THE WRIST MODULE.

two substrates contain the five LSI chips needed for the entire module. This was made possible by a breakthrough that allowed Seiko to combine two display and control functions onto an individual substrate.

Even the pickup loops have been carefully merged into this plan. They are wound around the battery frame, eliminating the need for extra space.

With all this, the day of the wrist information system has dawned and just like Dick Tracy, we can now have our own "wrist radios," but they're really computers, of course. ◀▶

BASICODE

You can get free software via shortwave radio.

HERB FRIEDMAN

■Some things are carved in stone. For example, we all know that as a general rule, cassette-based BASIC computer programs aren't interchangeable. A program recorded on a Radio Shack computer won't run on an Apple, while an Apple program won't run on a Commodore 64, etc. Until the introduction of a software system called BASICODE, the non-compatibility of tape-based computer software was an accepted fact for two reasons: First, there is the cassette tape format. With few exceptions, no two computers use the same kind of electrical signals to store the programs or data. Second, there are variations in the BASIC commands themselves; i.e., the CLEAR SCREEN command for one computer isn't necessarily the same for another computer.

When one knows the facts, the problems associated with exchanging software between different computer models often appear insurmountable. But as with many things, facts tend to get in the way of real life.

For many years, computer hobbyists and users in Europe have routinely exchanged cassette-based BASIC programs on almost every imaginable subject. These included software for games, arithmetic skills, reading skills (particularly useful for people with dyslexia), and some rather high-level stuff such as titrations (chemistry), and even a program that creates a 555 timer circuit on the screen and then calculates the required values for user-selected frequencies. And there's even software for computerists interested in music, such as a graphics program that shows the correct fingering for guitar chords. (The screen

photographs that appear later in this article illustrate two of the typical exchange programs.)

"Aha!" you say, "This is too good to be true. There must be a catch!" Yes, there is a catch. Here in the U.S. you can't exchange software unless you have a short-wave receiver and a cassette recorder, because the programs are broadcast as part of an English language radio program called "Media Network," which is transmitted worldwide via short-wave radio by *Radio Nederlands*, the independent international short-wave station of the Netherlands.

And after you have recorded the broadcast, you must use a special *translator* program to convert the broadcast into the hardware and software format required by your computer.

Difficult? No. It only appears to be difficult. For most commonly-used computers, it's as simple as pressing the PLAY button on the cassette machine. The translator program—which is available for many popular computers—works on two distinct levels; hardware and software. It processes the received electrical signals into the format required by your computer, and then interprets the handful of non-standard BASIC statements into the format required by your computer's particular version of BASIC.

Hobbyscoop

The translator software is part of a system called NOS-BASICODE, which was developed by Dutch and other European hobbyists for the "Hobbyscoop" (Hobbyscope) radio program NOS—the Dutch

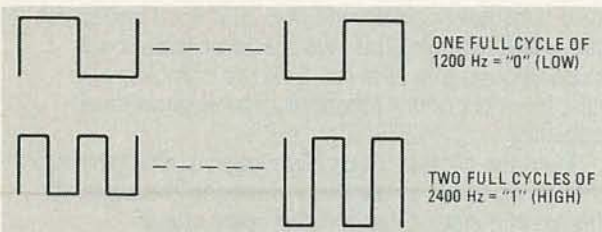

FIG. 1—REPRESENTING ONE FULL CYCLE of 1200 Hz, is a "0" (low), while a "1" (high) is represented by two full cycles of 2400 Hz. A byte of data uses standard teletypewriter format of 1 start bit (logic 0), 8 data bits (logic 1), 2 stop bits (logic 1).

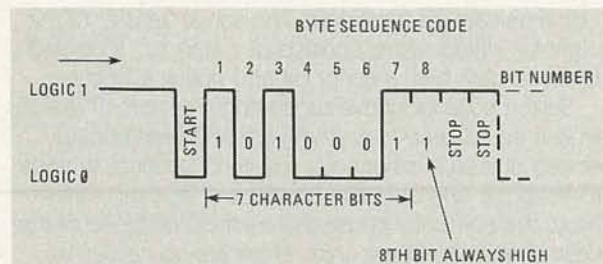

FIG. 2—THE LETTER 'E' shows the byte sequence code. You'll find a start bit, seven character bits, the eighth bit and two stop bits, a total of eleven bits.

Broadcasting Corporation. Hobbyscoop features news of new and unusual developments in electronics which would be of interest to hobbyists. When personal computers came along in 1977, it was natural for Hobbyscoop to cover the subject and to broadcast software for the few home/hobby computers available at that time.

Originally, Hobbyscoop broadcast individual computer programs. A single program for three different computers required three separate broadcasts. As more computer models were introduced, the amount of time needed to broadcast a single program for the various computers became burdensome, and so a "universal language" called BASICODE, which incorporated a *translator*, was developed. The purpose of the BASICODE system was to use a single broadcast to transmit a program to many different computers, all having different electrical and software requirements. Eventually, BASICODE would translate for 20 different computers.

The broadest tones

Transmitted at 1200 baud, the tone frequencies of 1200 Hz and 2400 Hz are used to broadcast the software to the receiver/cassette recorder. As shown in Figure 1, a "0" (low) is represented by one full cycle of 1200 Hz, while a "1" (high) is represented by two full cycles of 2400 Hz. A byte of data uses the standard teletypewriter format of 1 start bit (logic 0), 8 data bits (logic 1), and 2 stop bits (logic 1).

All characters are represented in ASCII (American Standard Code for Information Interchange). Since only seven bits are used to represent an ASCII character, the eighth bit is always automatically set high (1). The complete character consists of a start bit, seven character bits, the eighth bit, and two start bits. A total of eleven bits; exactly the same format as used for a standard 110 baud teletypewriter. Figure 2 shows how the character "E" would be transmitted. Figure 3 shows the tone sequence used for the actual broadcast transmission, which is eventually recorded by the user. The complete off-the-air signal consists of: Leader, 5 seconds of 2400 Hz; Start text, ASCII "Start Text" (Hex 82); Program, BASIC in ASCII; Checksum, and Trailer, 5 seconds of 2400Hz. The checksum at the end is derived from the bit indication of exclusive-OR of the previous bytes, and is expressed as an 8-bit term. The purpose of the Checksum is to allow the user to test whether the program has been read from the tape

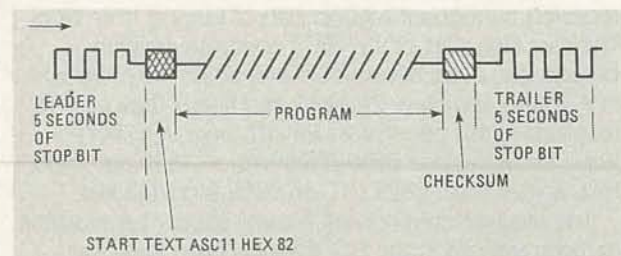

FIG. 3—THE TONE SEQUENCE used for the actual broadcast transmission, which is eventually recorded by the user.

without error. Even if the Checksum is not correct—indicating an error—BASICODE will load the program and permit a listing of what has been read. Since the program is in BASIC and not op code (binary), the user can correct the errors and then SAVE the program in the usual way.

The translator converts

Since no computer reads the the transmitted cassette format directly, the user must first load the translator program into his or her computer. (The translator is written in the precise software and hardware format required by the computer.) Then the BASICODE cassette program is loaded. The translator, which is already in the computer, causes the computer to read the BASICODE cassette signals, and then converts the BASICODE into the format required by the computer.

Obviously, not all BASICODE cassette programs can be loaded in the usual way because some of the cassette interfaces used in home computers are going to reject anything that isn't precisely formatted, and the translator can't do anything until the signals get into the computer.

Generally, if the computer refuses to load non-conforming cassette signals, a hardware accessory will get the received cassette signal into the computer. For example, while the BASICODE cassette tape can be fed directly into an Apple or Commodore computer, a TRS-80 requires a simple interface such as the one shown in Figure 4. On the other hand, an OSI Model 1P computer (an early hobbyist model) requires only the the addition of a three-way switch and a wire jumper, while for CP/M computers, the BASICODE signal is fed into what is normally the computer's parallel printer output.

A few computers require a somewhat extensive accessory interface. Circuits for those computers that require accessory interfaces are given in the BASICODE Handbook. We'll tell you how to get one later in this article.

Once the BASICODE program has been loaded into the computer and translated it can be SAVED as a standard cassette file—even as a disk file. As far as the computer is concerned, the translated program is a "standard" program for that particular computer and can be used on any similar computer without need for the translator.

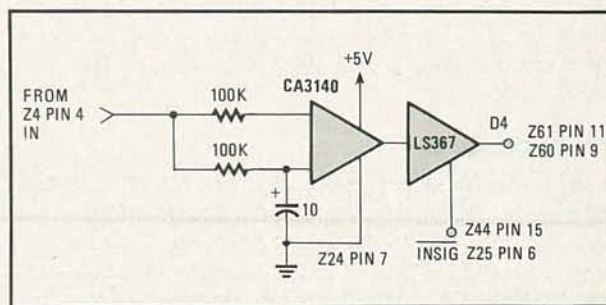

FIG. 4—A SAMPLE INTERFACE for the TRS Model I/III as shown in the BASICODE Handbook.

Universal basic

BASICODE is not an "...all bells and whistles" version of BASIC; instead, BASICODE is more like the high-performance *time-share* BASIC from the era when schools used teletypewriter terminals connected via the telephone system to mainframe computers. The supported statements in BASICODE are: ABS, AND, ASC, ATN, CHR\$, COS, DATA, DIM, END, EXP, FOR, GOSUB (GO SUB), GOTO, IF, INPUT, INT, LEFT\$, LEN, LET, LOG, MID\$, NEXT, NOT, ON, OR, PRINT, READ, REM, RESTORE, RETURN, RIGHT\$, RUN, SGN, SIN, SQR, STEP, STOP, TAB, TAN, THEN, TO, and VAL.

The translator automatically accommodates the various idiosyncracies of BASIC through special BASICODE software routines located in the reserved area of program lines 0-999. (Since lines 0-999 are reserved for the translator, user written code starts at line 1010.)

The program translation works this way: Assume you want to write a program that will be used by others having different computers and a BASICODE translator. You want your program to clear the screen first. Since the CLEAR SCREEN statement varies from computer to computer, a BASICODE program would not use the "normal" CLEAR SCREEN command for your computer; instead, the program would use the statement GOSUB 100.

Each translator program has the correct CLEAR SCREEN routine for a specific computer at line 100. The GOSUB command sends the program to line 100 for the correct CLEAR SCREEN statement, and then returns to the program. Another example is a random number variable. That's a GOSUB 260, which the translator uses to generate the correct "random" statement for each computer. Actually, there's not more than a handful of conversions. Having lines 0-999 available insures that BASICODE has room to grow.

It's all in a kit

A kit consisting of the BASICODE handbook (with English translation) and an English-language cassette of translators for 17 popular or commonly-used computers (the ZX-81 is not one of them) is available (sent airmail) for f 38,- (f=Dutch guilders), payment in an international money order (IMO). The kit can be ordered from: BASICODE, Administratie Algemeen Secretariaat, NOS, P.O. Box 10, 1200 JB Hilversum, The Netherlands. Since the translators are updated periodically, information regarding the availability of specific translators should be addressed to: Jonathan Marks, Media Network, English Section, Radio Netherlands, P.O. Box 222, 1200 JG Hilversum, The Netherlands.

You're on the air

All programs broadcast by Hobbyscoop and Media Network are submitted by listeners and are in the public domain. Many programs are in Dutch and/or English, or only English. It depends on who submitted the program. While you might not be able to read the Dutch labels of non-English programs, you can certainly understand or figure out what's going on. You can also

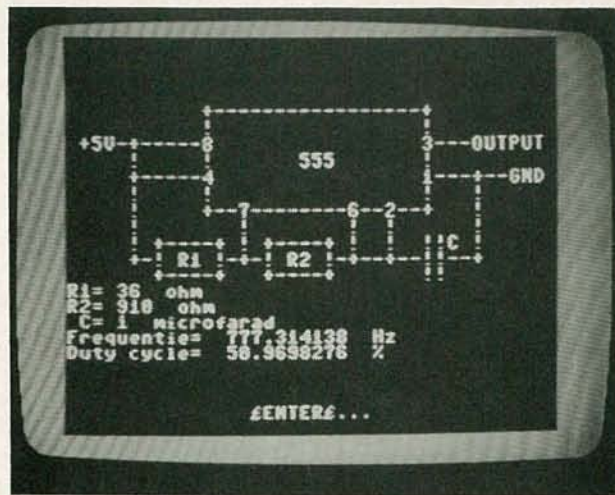

A BASICODE PROGRAM created this schematic of a 555 timer and then asked for the desired frequency and duty cycle. In the blink of an eye, part values were displayed for the nearest standard values. The requested frequency was 800Hz.

rewrite the listed programs because the BASIC function statements—not necessarily the PRINT statements—are usually in English.

If you have some favorite programs you would like to share with others around the world you can submit them to Media Network, or Hobbyscoop for consideration. The BASICODE programs are presently

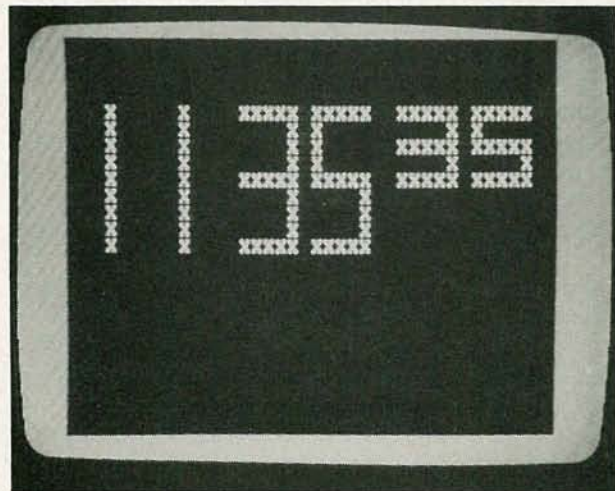

JUST FOR FUN, BASICODE has broadcast a program that creates a video clock.

received throughout a good part of Europe from NOS. They are also part of the BBC's computer-training broadcasts. Local transmitters broadcast the programs in Australia and New Zealand; and finally, they can be received in this country via English language short-wave broadcasts at 0230-0325 UTC on 9590 and 6165 kHz, and at 0530-0625 UTC on 9715 and 6165 kHz.

The Media Network program will shortly be available to radio stations in the U.S. for local broadcast, but until then, you'll have to get your "free" software via shortwave. ◀▶

HIGH RESOLUTION COLOR MONITORS

There's more to computer-display resolution than meets the eye!

HERB FRIEDMAN

■Almost from the beginning of personal computing, we have referred to color displays in terms of resolution; there is low resolution, medium resolution, and high resolution. The individual picture elements that make up the display have been described in terms of dots, pixels, PELS, and total resolution of dots \times lines.

What is resolution?

In fact, the picture resolution—meaning the number of individual picture elements that can be displayed—is relative to the existing technology: Yesterday's "high resolution" is today's "medium resolution" while today's "high resolution" is tomorrow's "low resolution."

Unlike a monochrome monitor, whose *apparent* visual sharpness depends almost entirely on the unit's bandwidth, color-monitor resolution is presently a combination of several variables, the most important being the size of the triad (a triad is made up of one red, one green, and one blue phosphor), the number of triads in a picture element, and the size of the displayed characters in terms of the number of active scanned lines. "Active lines" are those lines used for the computer display; it does not include the lines left unused to compensate for overscanning.

For multi-color reproduction, approximately 320 individual horizontal picture-elements per line is about the best we can do under normal circumstances. (That used to be considered *high-res*, but today, it's medium resolution.) The primary limitation on the number of horizontal elements is the size of a single dot of a character's matrix on standard color CRT's used for personal computer monitors, which translates into the maximum number of horizontal characters.

For example, characters for the so-called 80 \times 25 screen are usually formed from an 8 \times 8 dot matrix. In non-technical terms, it means each character is 7 dots

high and 6 or 7 dots wide; the unused dots providing the spacing between characters and rows. Therefore, 80 columns of characters require 80 \times 8 or 640 dots per horizontal line. A 40-character display requires 40 \times 8 or 320 dot resolution.

It is the same thing going vertically. 25 lines requires 25 \times 8 or 200 horizontal lines. (Aha! Now you see how screen resolution values are derived.)

Therefore, a high-res screen—80 characters \times 25 lines—requires 640 \times 200 resolution. A medium-res screen—40 characters \times 25 lines—requires 320 \times 200 resolution. Anything less, such as 32 characters \times 16 lines is low resolution.

Standards

How did we come to more or less standardize on 32 \times 16, 40 \times 25, etc.? Mostly, to accommodate existing monitor equipment such as overscanned TV sets; sometimes because it's the most that can be safely put on the screen. To increase the size of the characters by going to a 9 \times 9 or 10 \times 10 matrix would reduce the number of columns or rows, or would require special monitors if the display wasn't to be "stretched" right off the top, bottom, and sides of the screen.

TV is a compromise

Until very recently, personal computer color displays were intended to be viewed on a TV receiver (through an RF modulator), or on a composite monitor originally intended for TV viewing; hence, the computer's color resolution was designed to function within the limitations of TV equipment, for which a resolution of 240 elements (dots) per line was—and still is—excellent. In relative terms, however, it is "low resolution."

Also, a computer's vertical resolution is designed for approximately 100–200 lines, depending on whether it

is intended for viewing on a
(For our discussion, let's assume
an even greater visual conce
because of the larger-than-n
lines that make up the disp

Half a frame

A standard TV picture u
receiver first scans a field (i
lines. During the vertical re
equalizing pulses transmit
the start of the next field's
start—and fall—in the spa
scanned lines. The lines fr
with those of the first field
persistence, and the reter
the two fields are combin
frame. Because some hor
CRT's vertical retrace, the
field lines is less than 26
That, of course, gives
frame. But, due to oversc
make use of less than ha

TV transmitting standa
ratio of 4×3 (width to
little picture information
manufacturers of TV sets
"larger-than-life" even o
have designed their set
it overscans the edges
usually isn't missed, un
movie and happen to
an eyebrow, or an ear.
But imagine what w

"full frame" the display; that is, the monitor's scanning is adjusted so the actual corners of the display barely touches the sides of the CRT, creating a complete picture rectangle on the CRT with dark (no picture) areas at the top, bottom and sides. If you turn up the monitor's brightness or contrast controls, you will actually see a complete rectangle on the CRT, right down to the corners. (Try this on a modern Radio Shack or IBM monitor—you'll see why their displays are uniformly sharp from corner to corner.)

By keeping the color guns away from the circumference of the CRT, the focusing and overall convergence error is reduced. And while the display might be smaller in size than an overscan on the same CRT, the overall definition is higher.

By the way, the 200-line non-interlaced scanning is how one form of "highlighting" is created. Imagine for a moment a screen display of a word processing document. The normal character intensity is produced by scanning the characters for two fields per frame. For "highlighting"—actually reduced intensity—the highlighted characters are only scanned for one field. Simple but effective.

Good but not great

While the lower-cost computers—those usually called "home and family"—use TV sets or composite-video monitors for the computer's display, the business computers, almost without exception, provide for the so-called RGB monitor, even if they also have a composite video output connection. The problem with using composite monitors with computers is that they use analog video signals. While they can do a good job of creating computer displays, they are not the equal of an RGB monitor whose three color guns are controlled individually by the computer.

The RGB monitor

As shown in Figure 1—a block diagram of the RGB high-performance, high-resolution Princeton SR-12 monitor—the computer outputs digital data for each individual color gun along with a digital signal representing intensity. A matrix interpolates the digital data into individual R, G, and B drive signals, which produce 8 colors: black, green, red, blue, brown, cyan, magenta and white. (There's no error in the preceding. While RGB should produce yellow, not brown, in a high-performance monitor such as an IBM, a Quadram HX-12, or a Princeton SR-12, the base color is brown, and the intensity-modified brown is yellow.)

When the intensity bit is combined with the computer's RGB data in the monitor's color matrixing circuit, the resultant colors are: dark grey (intensified black), light blue, light green, light cyan, light red (which is the only red provided by some monitors), light magenta, yellow (a true yellow), and pure white (a super white). Altogether, 16 colors.

Tiny dots

But whether the monitor is mono or color, the average monitor is still 200 lines, so the apparent sharpness is determined by the size of each dot, and

the smaller the dot, the sharper the appearance.

High-resolution monitors appear to be similar to conventional high-performance monitors but the dot size is smaller. For example, the Quadram HX-12 and Princeton SR-12 have a 0.31mm dot compared to IBM's 0.43mm dot size. Thus, the Quadram/Princeton characters appear sharper than those of the IBM monitor. Unfortunately, both Quadram and Princeton stretch the screen display to make the characters appear sharper than they would appear when full-framed, which pushes some of the display into the corners of the CRT—just the place you would want a high-resolution display because of reduced focus and convergence, and diagonal stretch caused by even minimal pincushioning.

400 lines

Within the limits of moderate cost, there is only so much resolution that can be attained from a conventional high-performance monitor. For a further increase in *apparent* resolution, we must still fill in the gaps in the display so the eye is tricked into believing the display has more information than is actually there. This is accomplished through a 400-line display.

Since the computer's normal character and graphics generators produce 200 lines per field, we obtain 400 lines by generating artificial lines of information. The "extra" lines are positioned directly between the normal scanning lines in the normal "interlace" location. The inherent "bloom" of each dot blends the lines together, and the eye sees a continuous character.

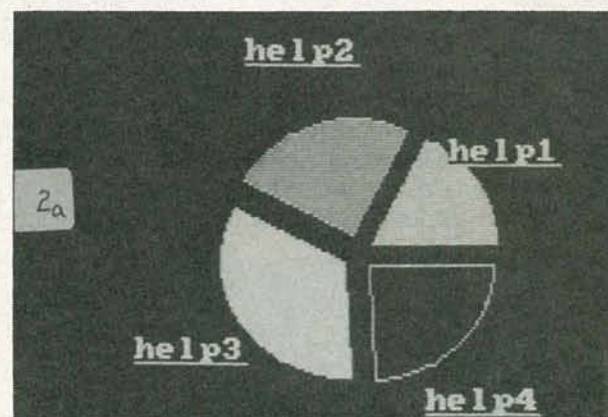

FIG. 2—A DISPLAY as seen on the screen of a Quadram HX-12 640 × 200 high-performance monitor shows that though the characters are "sharp as a tack" (for a color monitor) there is an illusion of unsharpness because of the space between the scanning lines.

Figures 2 and 3, photographs from two high-performance, moderate-cost monitors, show how it's done. Figure 2 is from a Quadram HX-12, one of the highest performance 200-line monitors: By any standards, it is sharp! Figure 3 is the same display from the Princeton SR-12. Note that no scanning lines can be seen. While the edges of the characters displayed on the SR-12 are not as sharp as those of the HX-12, the SR-12's *apparent* sharpness is greater because the normal scanning lines are "filled in."

A good question at

"full frame" the display; that is, the monitor's scanning is adjusted so the actual corners of the display barely touches the sides of the CRT, creating a complete picture rectangle on the CRT with dark (no picture) areas at the top, bottom and sides. If you turn up the monitor's brightness or contrast controls, you will actually see a complete rectangle on the CRT, right down to the corners. (Try this on a modern Radio Shack or IBM monitor—you'll see why their displays are uniformly sharp from corner to corner.)

By keeping the color guns away from the circumference of the CRT, the focusing and overall convergence error is reduced. And while the display might be smaller in size than an overscan on the same CRT, the overall definition is higher.

By the way, the 200-line non-interlaced scanning is how one form of "highlighting" is created. Imagine for a moment a screen display of a word processing document. The normal character intensity is produced by scanning the characters for two fields per frame. For "highlighting"—actually reduced intensity—the highlighted characters are only scanned for one field. Simple but effective.

Good but not great

While the lower-cost computers—those usually called "home and family"—use TV sets or composite-video monitors for the computer's display, the business computers, almost without exception, provide for the so-called RGB monitor, even if they also have a composite video output connection. The problem with using composite monitors with computers is that they use analog video signals. While they can do a good job of creating computer displays, they are not the equal of an RGB monitor whose three color guns are controlled individually by the computer.

The RGB monitor

As shown in Figure 1—a block diagram of the RGB high-performance, high-resolution Princeton SR-12 monitor—the computer outputs digital data for each individual color gun along with a digital signal representing intensity. A matrix interpolates the digital data into individual R, G, and B drive signals, which produce 8 colors: black, green, red, blue, brown, cyan, magenta and white. (There's no error in the preceding. While RGB should produce yellow, not brown, in a high-performance monitor such as an IBM, a Quadram HX-12, or a Princeton SR-12, the base color is brown, and the intensity-modified brown is yellow.)

When the intensity bit is combined with the computer's RGB data in the monitor's color matrixing circuit, the resultant colors are: dark grey (intensified black), light blue, light green, light cyan, light red (which is the only red provided by some monitors), light magenta, yellow (a true yellow), and pure white (a super white). Altogether, 16 colors.

Tiny dots

But whether the monitor is mono or color, the average monitor is still 200 lines, so the apparent sharpness is determined by the size of each dot, and

the smaller the dot, the sharper the apparent image.

High-resolution monitors appear to be sharper than conventional high-performance monitors because the dot size is smaller. For example, the Quadram HX-12 and Princeton SR-12 have a 0.31mm dot compared to IBM's 0.43mm dot size. Thus, the Quadram/Princeton characters appear sharper than those of the IBM monitor. Unfortunately, both Quadram and Princeton stretch the screen display to make the characters larger than they would appear when full-framed, which puts some of the display into the corners of the CRT—the last place you would want a high-resolution display because of reduced focus and convergence, and diagonal stretch caused by even minimal pincushioning.

400 lines

Within the limits of moderate cost, there is only so much resolution that can be attained from a conventional high-performance monitor. For a further increase in *apparent* resolution, we must still fill in the gaps in the display so the eye is tricked into believing the display has more information than is actually there. This is accomplished through a 400-line display.

Since the computer's normal character and graphics generators produce 200 lines per field, we obtain 400 lines by generating artificial lines of information. The "extra" lines are positioned directly between the normal scanning lines in the normal "interlace" location. The inherent "bloom" of each dot blends the lines together, and the eye sees a continuous character.

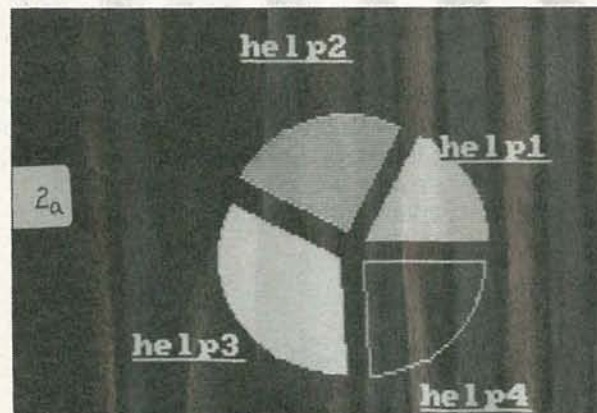

FIG. 2—A DISPLAY as seen on the screen of a Quadram HX-12 640 × 200 high-performance monitor shows that though the characters are "sharp as a tack" (for a color monitor) there is an illusion of unsharpness because of the space between the scanning lines.

Figures 2 and 3, photographs from two high-performance, moderate-cost monitors, show how it's done. Figure 2 is from a Quadram HX-12, one of the highest performance 200-line monitors: By any standards, it is sharp! Figure 3 is the same display from the Princeton SR-12. Note that no scanning lines can be seen. While the edges of the characters displayed on the SR-12 are not as sharp as those of the HX-12, the SR-12's *apparent* sharpness is greater because the normal scanning lines are "filled in."

A good question at this point, is "How can the SR-12

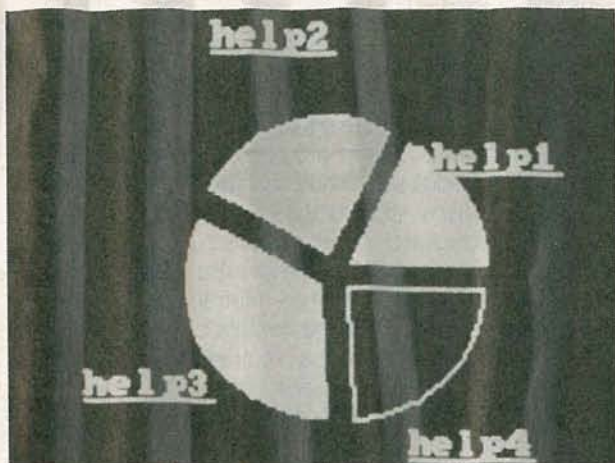

FIG. 3—THE SAME DISPLAY from a Princeton SR12640 \times 400 high-performance monitor shows no spaces because an additional 200 lines repeating the same data has been interleaved with the original 200 lines. While the edges of the characters are not as sharp as those on the 200-line monitor, visually the display appears sharper and seems to have greater resolution because there are no spaces between the scanning lines.

get sufficient time to scan two lines in the conventional horizontal scanning period?" By using a device known as a *scan doubler*—A plug-in adapter board for IBM-compatible computers (see Fig. 4).

It works this way. The horizontal scan rate of the SR-12 monitor runs at a nominal 31.4 kHz, which is twice the conventional horizontal scanning rate of 15.75 kHz. During the conventional horizontal scan period, the SR-12 scans two lines. But the computer still puts out its signal at 15.75 kHz: If fed directly to the SR-12, the single-line display would be spread over two lines and the screen would be a scramble of "garbage."

That's where the scan doubler comes in. Instead of the computer's RGB signal being fed to the monitor, it is fed to the scan doubler, which contains two memory banks and an output switcher. The computer's first line

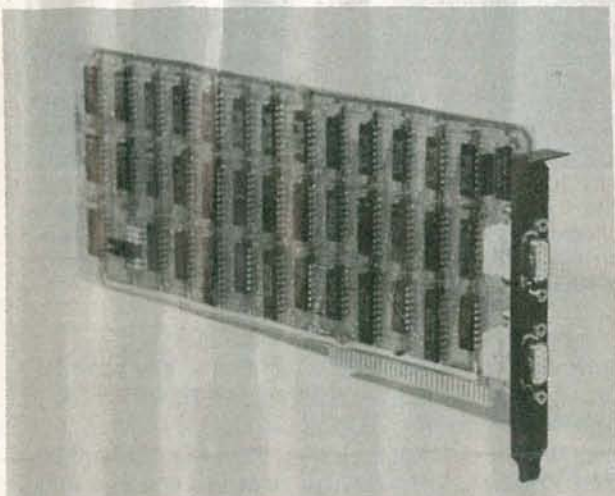

FIG. 4—THE SCAN DOUBLER is a special adapter board that generates 400 lines of display from what is normally a 200-line screen. The computer's normal signal is fed into the lower jack instead of to a monitor. The synthesized 400-line display exits at the top connector to the monitor.

of data is stored in the scan doubler's first memory bank. When memory is full, its data is output twice to the SR-12 at twice the normal horizontal scanning frequency, so two complete lines are scanned in the same time period of one standard scan; hence, the computer's first display line is scanned on two sequential monitor lines—scan line 1, and what we will call scan line R1—for repeat line 1.

While the monitor is scanning line 1 and R1—each of which corresponds to a single line of data from the computer—the scan doubler's second memory bank is being filled by the computer with the second line of data. When the monitor is finished scanning the first line of data for the second time, the scan doubler switches its output to its second memory bank, which provides the data for monitor lines 2 and R2.

As the scan doubler's second memory bank is being dumped into the monitor, the first memory bank is overwritten by the computer with the data for line 3 and R3.

By continuously switching its output between memories 1 and 2, the scan doubler creates a 400-line monitor display from only 200 lines of data.

The visual effect is spectacular. The display has no visible lines; it is continuous.

Voodoo resolution

Nothing stands still. If equipment has reached the stage beyond which there is no improvement in performance, then someone will invent improvements.

For reasons we have mentioned earlier, a business computer display is more or less standardized at a maximum of 640 dots \times 200 lines in order to put everything on the screen within the area of maximum definition. Naturally, if it were possible to fill each complete horizontal line end-to-end, and if it were possible to use the unused vertical lines at the top and bottom of the screen, theoretically, the screen would resolve more dots. And that's precisely the assumption being used to create the illusion of even greater monitor resolution. Manufacturers are now starting to include the "phantom" data in the overall screen specifications, and we get claimed resolutions of 690 dots, 900 dots, 360 lines, 480 lines.

Yes, all that is possible, but not with conventional "business" computer equipment. Some specially-designed graphics and "text" adapters are capable of generating those seemingly unbelievable displays, but their common use is somewhere down the road. We'll cover them when they are generally available and cost-effective. Meanwhile, keep those *magic figures* in mind: 640 \times 200 and 320 \times 200. For "medium resolution," multi-color displays, a 320 \times 200 resolution is required. And though we call that "medium" resolution, it is actually high resolution for color, because the so-called high resolution display of 640 \times 200 is used for only two colors, which happens to be monochrome (black-and-white is two colors, as is any monochrome display). Presently, within the constraints of moderate costs, we cannot generate higher multi-color resolution than approximately 320 \times 200 lines unless we artificially create a 400-line display through the use of a scan doubler. ◀▶

TABLE 1

A0—Toreador
B0—William Tell
C0—Hallelujah Chorus
D0—Star Spangled Banner
E0—Yankee Doodle
A1—John Brown's Body
B1—Clementine
C1—God Save the Queen
D1—Colonel Bogey
E1—Marseillaise
A2—America, America
B2—Deutschland Laid
C2—Wedding March
D2—Beethoven's 5th
E2—Augustine
A3—O Solo Mio
B3—Santa Lucia
C3—The End
D3—Blue Danube
E3—Brahms' Lullaby
A4—Hell's Bells
B4—Jingle Bells
C4—La Vie en Rose
D4—Star Wars
E4—Beethoven's 9th
F1—Westminster Chime
F2—Simple Chime
F3—Descending Octave Chime

How it works

As we can see from the ringer schematic in Fig. 1, the heart of circuit is IC1, General Instrument's AY-3-1350 melody-synthesizer IC. Since power consumption is extremely low in the standby mode, the entire circuit can be powered by a single 9-volt transistor-radio type battery. IC2 is a TCM1512 telephone ring detector IC that is powered by the telephone line.

The circuit's operation begins when IC2 senses a ring pulse on the telephone line. The detector (internally) rectifies the ring signal and then outputs a voltage to relay RY1 (a SPST reed-type relay with 5-volt contacts), causing its contacts to close. That pulls pin 12 (the ON/OFF control) of IC1 low (logic "0"), causing it to output a signal—the selected tune—to transistor amplifier Q2. The amplified signal is then fed to the speaker.

The melody continues to play either until the tune is finished (at which time IC1 returns to the standby mode), or until someone takes the phone off the hook. Taking the phone off the hook discontinues the ring pulses to IC2, which opens RY1. When the relay contacts open, pin 12 of IC1 goes high, returning the circuit to the standby mode to wait for the next incoming phone call.

When connecting the circuit to the telephone line, it's a good idea to use a meter to distinguish the positive side of the line from the negative. That's important for proper operation. Pin 1 is the positive (tip) input and pin 8 is the negative (ring) input, as shown in Fig. 1.

The desired tune is selected using two double-pole, 6-position switches, S1 and S2. Each tune is assigned a letter/number combination. To select a tune, dial the switches to the combination that corresponds to the tune desired as shown in Table 1. For instance, if the theme from Star Wars is desired, S1 is dialed to "D" and S2, to "4."

All components are available from a wide range of sources (including Radio Shack). Potentiometer R1 controls the pitch of each note, while R2 is used to set the speed at which the tune is played. Therefore, each can be set to satisfy personal taste (which is what the circuit is all about).—*John P. Keyerleber*
R-E

SAVE BY BUILDING OUR RACK MOUNT STUDIO EQUIPMENT

QUADRAFUZZ — for separate frequency bands of distortion are mixed for the smoothest fuzz you've ever heard. no. 6720 \$ 39.88

HYPERFLANGE/CHORUS — the cleanest, widest range, most versatile flanger anywhere at any price. no. 6750 \$149.95

VOCODER — unmatched performance in a versatile, low cost rack package. no. 6710 \$99.95

HOT SPRINGS — user's agree, short of studio plate systems, you won't find a better reverb at any price. no. 6740 \$59.95

**ADD \$3 SHIPPING
FOR EACH KIT ORDERED**

Innovative, cost effective designs by Craig Anderton in easy to assemble kits from:

PAI Electronics, Inc.

Direct mail orders and inquiries to: Dept. 11R
1020 W. Wilshire, Oklahoma City, OK 73116 - (405) 843-9626

Ask for your free catalog.

CHARGE TO VISA OR MC TOLL-FREE
1-800-654-8657 9AM to 5PM CST MON-FRI

CIRCLE 90 ON FREE INFORMATION CARD



"In Just A Few Days, I'll Show You How To Do

REAL MATH

$\int_a^b f$ $\sum_{n=1}^{\infty} a_n$ $\frac{df}{dx}$ $\lim_{n \rightarrow \infty}$ **On Your Calculator!"**

•Quick. •Guaranteed.
•Easy. •Fun, Too!

INTRIGUED BY CALCULATORS? Then you can step up your math skills fast! Use my new method in guidebook form. It's called **CALCULATOR CALCULUS**. This space-travel spinoff is sure-fire, so it has a **simple guarantee** — just return it for an immediate refund if you are not astounded at the problems you're solving with it!

But the point is - you won't want to send it back. For this is the **easiest, fastest shortcut ever!** The day you receive your copy in the mail you'll want to put it to work. It's that exciting and helpful.

My name is Dr. George McCarty. I teach math at the University of California. I wrote this guidebook to cut through the confusion. I guide you with examples you follow step-by-step on your calculator — you do simple exercises — then you solve practical problems with real precision!

POWER METHODS. Need to evaluate functions, areas, volumes — solve equations — use curves, trig, polar coordinates — find limits for sequences and series? It's all here!

If you're in the biological, social or physical sciences, you'll be doing Bessel functions, carbon dating, Gompertz growth curves, half-life, future value, marginal costs, motion, cooling, probability, pressure — and plenty more (even differential equations).

Important numerical techniques? Those algorithms are here, too: rational and Padé approximation, bracketing, continued fractions, Euler's method, Heun's method, iteration functions, Newton's method, predictor-corrector, successive substitutions, Simpson's method and synthetic division.

LOOK AT WHAT USERS SAY: Samuel C. McCluney, Jr., of Philadelphia writes:

"**CALCULATOR CALCULUS IS GREAT!** For ten years I have been trying to get the theory of calculus through my head, using home-study courses. It was not until I had your book that it became clear what the calculus was all about. Now I can go through the other books and see what they are trying to do. With your book and a calculator the whole idea becomes clear in a moment, and is a MOST REFRESHING EXPERIENCE. I program some of the iterative prob-

lems you suggest and it always GIVES ME A THRILL to see it start out with a wild guess and then approach the limit and stop."

Professor John A. Ball of Harvard College (author of the book *Algorithms for RPN Calculators*) writes: "I wish I had had as good a calculus course."

Professor H. I. Freedman of the U. of Alberta, writing in *Soc. Ind. Appl. Math Review*, states:

"There can be no question as to the usefulness of this book...lots of exercises...very clearly written and makes for easy reading."

Tektronix Engineer Bill Templeton says "CALCULATOR CALCULUS is the best, most clearly written book I have seen for improving your math skills."

I WANT YOU TO DO THIS. Get my complete kit, with a TI-35 calculator, plus its 200 p. Student Math Book, AND the guidebook, ALL for \$44.95 (for shipping to USA add \$2, or \$5 by AIR; Foreign \$5, or \$10 AIR; in Calif. add \$2.70 tax).

If you already have a scientific calculator, you can invest in the guidebook, **CALCULATOR CALCULUS**, for only U.S. \$19.95 (to USA or foreign: add \$1 for shipping, or \$4 by AIR; in Calif. add \$1.20 tax).

As pennywise Ben Franklin said, "An investment in knowledge pays the best dividends." GET STARTED NOW—Tax deductible for professionals.

MONEY-BACK GUARANTEE! Send for it today. Be sure to give me your complete mailing address with your check or money order. If you want to charge it (Visa or MC), tell me your card no. and exp. date. Prompt shipment guaranteed.

Thank you!
George McCarty
EduCALC Publications, Dept. D-1
27953 Cabot Road, Laguna Niguel, CA 92677
For fast service, phone MC or VISA orders
TOLL FREE to (800) 633-2252, Ext. 340.

TELETYPE UNIT MAIL TODAY
FEBRUARY 1985

DRAWING BOARD

Understanding memory IC's

THERE'S NO DOUBT THAT THE ELECTRONIC superstar of the 1980's is the computer. People are buying them like umbrellas in a rainstorm, whether they need them or not. In what has to be the classic case of consumer brainwashing, the public has been convinced that the list of life's basic necessities now includes a 64K memory. Well, it just ain't so!

There's a lot more to electronics than just computers. Died in the wool "hardware hackers" like you and me should look at computers the same way we look at any other piece of electronic equipment—as "hardwired databooks."

Understanding a few of the techniques used in putting those machines together can go a long way in solving problems that show up in our own designs. The nice

part about dealing with computers on that level is that you don't have to buy one. All you really need is a good databook that describes computer circuitry and explains its operation.

Computers are heavily memory-dependent machines, and plenty of design time has gone into developing memory techniques that are as efficient as possible. Memory can make your life on the bench a lot easier as well, so it's definitely worth the time to take a good look at memory devices.

Computers use both ROM, (Read-Only Memory) and RAM (Random-Access Memory). We'll start with the RAM since it's a lot more fun to play around with your own data. (We'll talk about ROM in a future discussion.)

RAM comes in two flavors—

static and *dynamic*. The difference between the two has to do with how data is stored. Static RAM will hold data as long as its powered up, while dynamic RAM must be refreshed every so often. But before we get into the details, take a look at Fig. 1, a block diagram of a typical static RAM.



ROBERT GROSSBLATT

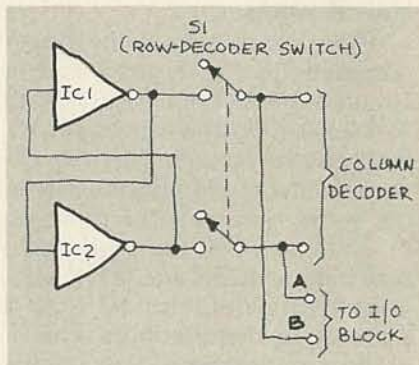

FIG. 2

Static RAM

There are three main parts to the static RAM IC: The memory-cell array; the address decoders, and the input/output (I/O) block. The heart of the device is the memory array (a matrix of storage cells). Each cell is capable of storing one bit of data (either a one or a zero). The actual construction of the cell depends on the logic being used, but the basic idea is the same for all families.

Figure 2 shows the basic storage principle; two inverters are set up as a simple latch with switches at the outputs to control read and write operations. The cells are arranged in a matrix. The number of rows and columns in the matrix are what determine the size of the memory.

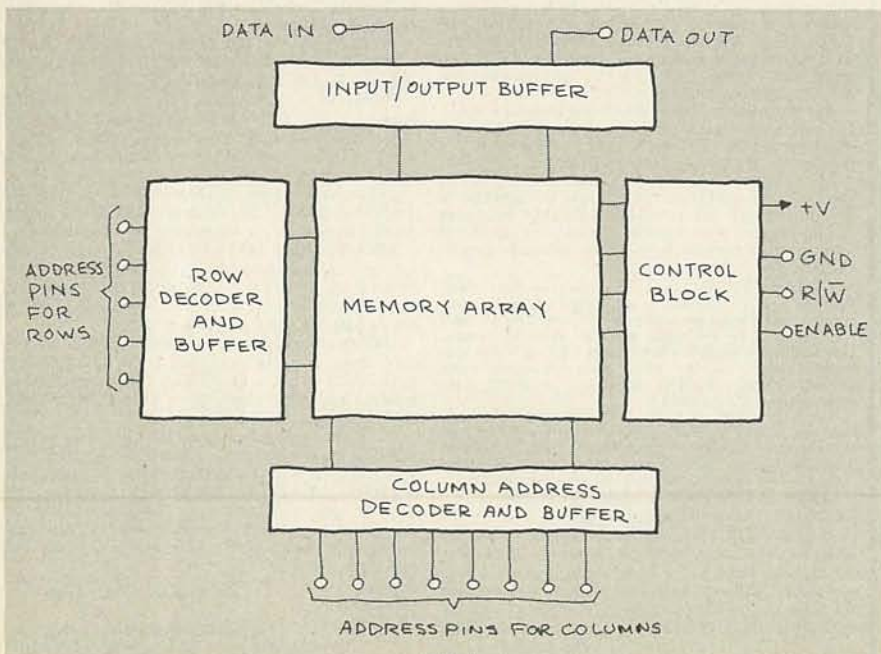

FIG. 1

When you want to do something to one cell, you put the address on the address bus, and the row and column decoders are used to close the switches surrounding the cell you've selected. The thing to note here is that as long as any cell remains unselected, it's not connected to anything; and whatever data you have there will stay there.

The same operation that picks a particular cell also connects it to the I/O logic in the IC, giving you the option of reading or writing data to that cell. Reading is simple because merely selecting the cell connects it to the I/O block and the data that's there to be read.

Of course, the data from that cell has to be conditioned before it can be used in the real world, since the inverters used in each cell won't have enough punch. That conditioning takes the form of an amplifier called, naturally enough, the *sense amplifier*. That amplifier has a very high input-impedance so it doesn't load down the cell and run the risk of glitch-

ing the data that's already stored there.

Writing new data into memory is just as simple; select the location, set up the data, and then flash a write pulse to the IC. The "nuts and bolts" of it is really no different from writing to a home-made latch. Since the two outputs of the storage cell will always be opposite in sense (remember that it's just a simple latch), a write operation is accomplished by grounding

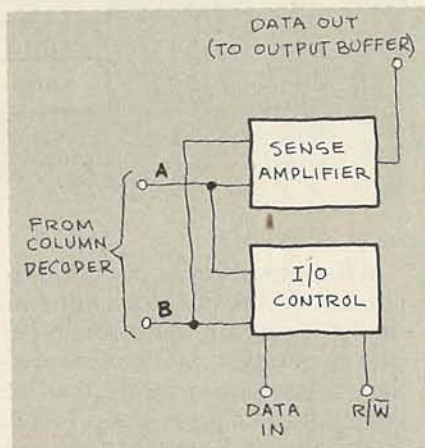

FIG. 3

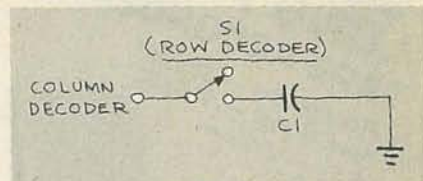

FIG. 4

the column decode lines.

Figure 3 is a simplified representation of what happens. To keep the design of the device as simple as possible, the column lines are used to carry the cell outputs to the I/O block. Data is read off one line, but both lines are needed to write. If you want to store a zero, you ground the A line and for a one, ground the B line.

The I/O block has a few other jobs to do as well. It selects the line that is to be grounded during a write, and it also has the circuitry that controls the overall status of the IC. How extensive the block is depends on the particular memory you're using. Most RAM's have a CHIP ENABLE pin that will let the outputs be three-stated. That is important if you have several memories sharing the same data.

Versatile Lab Power Supply



EXCEPTIONAL VALUE!

Only \$125.00

MODEL 3002A

- 0-30 VDC at 0-2A • Excellent Regulation • Ripple & Noise — 500 μ V RMS • Built-in Short-Circuit and Overload Protection

Model 3002A features continuously adjustable current limiting and precision constant voltage/constant current operation with "automatic crossover." This lab-grade unit can also be used as a current regulated power source. Options: 10-Turn Voltage and Current Controls, \$25.00 ea. (can be ordered individually).

Also available...TRIPLE MIGHTY-MITE LAB POWER SUPPLY: Three Fully Regulated DC Outputs; two 0-25V/0.5A and one fixed 5V/3A, Variable Tracking & Independent Modes, Dual Panel Meters. Other models to 60 VDC, to 12A.

TERMS: Check, Money Order or COD. COD's \$2.00 extra. Add \$3.50 for shipping & insurance in 48 states. Please contact our Sales Department for other shipping rates. Illinois residents add 7% sales tax.



Free Literature On Request

ELECTRO INDUSTRIES

4201 W. IRVING PK., CHICAGO, IL 60641

312/736-0999

PRICE SLASHERS

CONVERTERS

ONLY \$59.95
FACTORY
REFURBISHED



- 60 Channel Capacity
- P.L.L. Tuning
- 6 Channel Memory
- TV On-Off Feature
- Infra-Red Wireless Remote Control

OTHER MODELS ALSO AVAILABLE

Jerrold JRX-3 \$49.95* Jerrold DRX-3 \$69.96*

Jerrold RSC-3 \$39.95*

*Reconditioned Units With 30 Day Warranty

VIDEO SWITCHERS



DW42K
\$49.95

- MasterCard & Visa Add 5%
- Checks — Allow 14 Working Days
- Freight Charges: Sent Collect
- Order 20 or More — Freight Prepaid



DW63K
\$74.95

- Special Price on New Factory Fresh Units — \$69.95
- Warranty Not Valid After 15 Days From Receipt

Phoenix Electronics

1 Midwood • Allendale, NJ 07401
(201)848-8229

SUPER LONG PLAY TAPE RECORDERS

10 Hour Model — \$95.00*
14 Hour Model — \$159.00*

Modified Panasonic Slimline, high quality, AC-DC Recorders provide 5 or 7 continuous hours of quality recording & playback on each side of cassette for a total of 10 or 14 hours depending on model. Built-in features include • Voice level control • Digital counter, etc. TDK DC 180 Cassette Furnished.

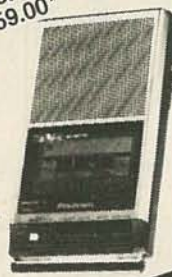

PHONE RECORDING ADAPTER

Records calls automatically. All Solid state connects to your telephone jack and tape recorder. Starts recording when phone is lifted. Stops when you hang up.

\$24.50*

FCC APPROVED

VOX VOICE ACTIVATED CONTROL SWITCH

Solid state. Self contained. Adjustable sensitivity. Voices or other sounds automatically activate and control recorder. Uses either recorder or remote mike. \$24.95*

*Add for ship & hdg. Phone Adapter & Vox \$1.50 ea. Recorders \$4.00 ea. Cal. Res. add tax. Mail order, VISA, M/C, COD's OK. Money Back Guarantee. Qty. disc. avail... Dealer Inquiries invited. Free data. ©

AMC SALES INC. Dept A 9335 Lubec St., Box 928, Downey, CA 90421 (213) 869-8519

CIRCLE 108 ON FREE INFORMATION CARD

Be an FCC LICENSED ELECTRONIC TECHNICIAN!



Earn up to \$600 a week and more!

Learn at home in spare time. No previous experience needed.

No costly School. No commuting to class. The Original Home-Study course that prepares you for the FCC Radiotelephone license exam in your spare time! An FCC Government license is your "ticket" to thousands of exciting jobs in Communications, Radio & TV, Mobile two-way, Microwave, Computers, Radar, Aerospace and more. You don't need a college degree to qualify, but you do need an FCC License. **No need to quit your job or go to school!** You learn how to pass the FCC License exam at home at your own pace with this easy-to-understand, proven course. It's easy, fast and low cost! **GUARANTEED PASS**—You get your FCC License or money refunded. Write for free details. Soon you could be on your way to being one of the highest workers in the electronics field. **Send for FREE facts now. MAIL COUPON TODAY!**

COMMAND PRODUCTIONS

FCC LICENSE TRAINING, Dept. 90
P.O. Box 2223, San Francisco, CA 94126

Rush FREE facts on how I can get my FCC License in spare time. No obligation. No salesman will call.

NAME _____
ADDRESS _____
CITY _____ STATE _____ ZIP _____

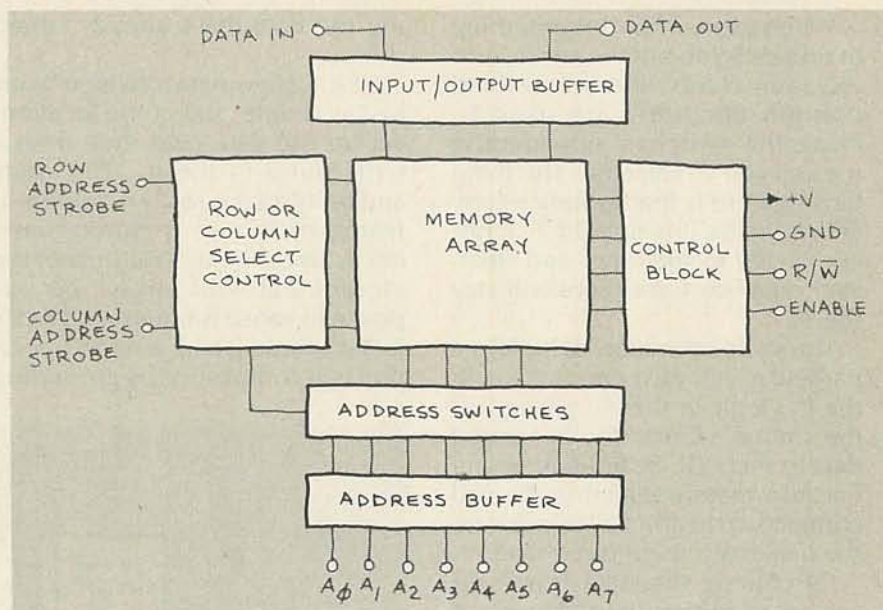

FIG. 5

What other kinds of "goodies" you find in the I/O block depends on the logic technology the memory is using. CMOS memories have a low-power mode that lets you "put the chip to sleep," while saving all data. Some of the memories we'll be looking at need as little as 1 μ A (or less) to save data! That should bring all sorts of battery-backup schemes to mind. (You can be sure that we'll get into that in some detail in a future discussion, but for now, let's stick to memories.)

Memories that are organized to handle more than one bit at a time (256×4 , 512×8 , etc.) have to have a separate memory matrix for each data line. A 256×4 memory will be four arrays deep, and each of them will have its own set of I/O circuits. When you get to the point where you are stacking things eight layers deep, the design is getting really hairy and, as you would expect, it shows up in the price. That's why a 2048×1 memory is a lot cheaper than a 256×4 . The total storage is the same but the complication of the internal design is much greater.

Static RAM's are easy to use; most modern designs are really forgiving of the screw-ups that always manage to show up during breadboarding. When you start talking about dynamic RAM, however, all notions of friendliness have to be thrown out the window.

Dynamic RAM

Because of the way a dynamic RAM stores data, it can be a nightmare to use: Instead of nice stable inverters, it uses a single capacitor...and nothing else! (See Fig. 4.) Since the leakage time is usually measured in microseconds, some scheme is necessary to make sure that the data stored in memory stays put. That problem is solved is by periodically rewriting the data in each cell. That process, called *refresh*, is handled by the sense amplifier that's connected to each column.

When a row and column are selected, the first thing the sense amplifier does is to read the data from each cell in the row and then write it back in. Since only one column is selected, only that cell has its output channeled to the data bus. Every read, then, refreshes the entire row. Modern RAM has built-in circuitry to refresh the entire IC during a read, and a whole row can be refreshed by just addressing it. However, that doesn't make refreshing any better—just a little bit easier!

Many popular dynamic RAM's use the same pin for both row and column addressing. Two control pins—the row and column strobes—are used to tell the RAM which addresses are on the bus. It's still up to us, however, to make sure that the right stuff is at the right place at the right time.

Figure 5 is a block diagram of a

dynamic RAM and if you study it you'll be able to see how its pins relate to each other. Keep in mind that there's plenty of detail in the IC that has not been drawn in. If you're morbid enough to want to get into the anatomy of a dynamic RAM, you can find a complete diagram in any good databook. (You might also drop me a line and give me your reason.)

The question that should come to mind at this time, however, is: Why in the world would anybody decide to use dynamic, rather than static, RAM? The answer is simple—it makes more economic sense: Because the cells are smaller, you can stuff more of them into the same size IC. That means that more memory is available for a lot less money.

By now you probably know more than you ever wanted to know about what goes on inside RAM...and believe me when I tell you that there's a lot more we could talk about. But, being practical minded, let's end the whole discussion here. After all, what we're interested in is not so much how those things work, but how we can use them.

Over the next few months we'll see how memory IC's can cut "brain-blasting" circuit hassles down to nothing, and we'll also design some circuits that you can adapt for your own purposes. You'll find that memories are good for a lot more than just remembering! And if you want to use huge amounts of memory, we'll design refresh circuitry that can not only handle any amount of memory you want, but is completely transparent as well.

So that you can get ready for it, let me remind you of a short corollary to Grossblatt's 18th rule: Get it in writing. In other words, pick up a databook containing the specifications for both *static* and *dynamic* RAM. The timing diagrams are invaluable design aids and are sure to prove their worth since there won't be room to print them in the column. You'll find that having well-drawn timing diagrams in front of you as you're working is the only known cure for the dreaded memory disease known as "electronic amnesia" or, more technically, "silicon senility." R-E

FREE McIntosh STEREO CATALOG and FM DIRECTORY

Get all the newest and latest information on the new McIntosh stereo equipment in the McIntosh catalog. In addition you will receive an FM station directory that covers all of North America.

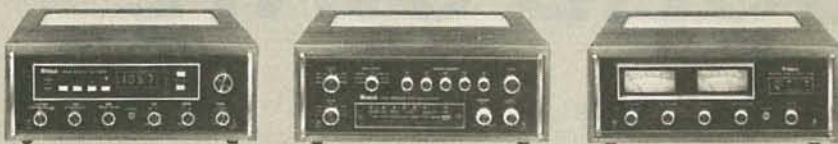

**SEND
TODAY!**

McIntosh Laboratory Inc.
East Side Station P.O. Box 96
Binghamton, N.Y. 13904-0096

RE

NAME _____
ADDRESS _____
CITY _____ STATE _____ ZIP _____

If you are in a hurry for your catalog please send the coupon to McIntosh.
For non rush service send the Reader Service Card to the magazine.

CIRCLE 67 ON FREE INFORMATION CARD

Qualitone

MONTHLY SPECIALS
MINIMUM ORDER \$35.00

**MEMOREX T120 VHS
VIDEO CASSETTE**

5²⁹ EA.
MINIMUM 12
(MULTIPLES OF 12)
No. Q20

**VIDEO TAPE
STORAGE BOX**
(FOR VHS
FORMAT) **90¢ EA.**
MINIMUM 48
No. Q47

**ADC XLM MK III
PHONO CARTRIDGE**

WITH STYLUS,
MOUNTING HARDWARE
AND DISPLAY BOX
9⁹⁰ EA.
No. Q48

WE SELL TO THE DEALER ONLY!
C.O.D. ORDERS - 800-431-2490

**FOR FULL LINE 164 PAGE CATALOG
PLEASE USE BUSINESS CARD
OR LETTERHEAD**

QUALITONE INDUSTRIES INC.
DEPT. C - 696 LOCUST ST. - BOX 214
MT. VERNON, NEW YORK 10552

LEARN COMPUTER REPAIR



**Train at home in spare time...
No previous experience needed**

Sales of small computers are running over a billion dollars a year. That's why a whole new business is starting up—devoted entirely to small computer repair. And right now is the time to get in on the ground floor—either working for someone else or in your own computer repair business.

Start making money in electronics

No need to quit your job, change your daily routine or take time from family responsibilities. And you don't waste time going to and from class because you train at home in spare time. The ICS Microcomputer Repair Course is designed for beginners—people with no previous experience who want to get started fast. And you should be ready for an entry-level job repairing small computers even before you finish this course.



You receive microprocessor trainer, digital V.O.M. and much more included with course.

**Experts show you what to do...
how to do it!** We start you fast with the basics, and everything is explained in easy-to-understand language complete with plenty of diagrams and drawings

**GET INTO
SMALL
COMPUTER
REPAIR**

SEND FOR FREE FACTS!

ICS School of Computer Repair, Dept. DE015
(SINCE 1891) Scranton, Pennsylvania 18515
Send free facts and color brochure telling how I can get into computer repair at home in my spare time. No obligation. No salesman will call.

Name _____ Age _____
Address _____
City/State/Zip _____

FEBRUARY 1985

STATE OF SOLID STATE

High power FET's

UNTIL A FEW YEARS AGO, FET'S COULD handle only about 1 watt and, therefore, could not compete with SCR's or bipolar power devices. That's because, as shown in Fig. 1, the planar technology used has the drain, gate, and source on the top surface of the die.

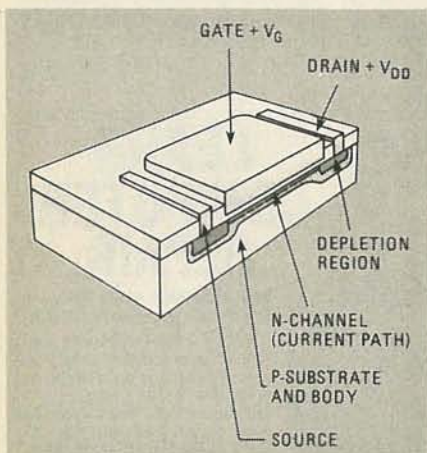

FIG. 1

High-power devices require relatively large metalized terminals to handle the high drain and source currents. Therefore, for increased power-handling capacity, the die size must be increased. Unfortunately, increasing the size results in high inter-electrode capacitances that severely limit the high-frequency response of the device. Further, the high current traveling through the narrow lateral channel develops a significant voltage drop (producing a correspondingly high R_{ON} resistance).

However, about seven or eight years ago, a new technology aimed at increasing the current density of the MOSFET was de-

veloped. In that structure (dubbed VMOS), the gate and source are side-by-side on the top surface of the die, while the drain is on the bottom.

Impurities are added (by a process called *doping*) to an epitaxial (single crystal) layer of silicon to promote vertical current flow. In addition, some versions of the VMOS device have a V-shaped notch etched through the source and channel regions to enhance vertical current flow.

Enter TMOS

The TMOS name identifies the technology of Motorola's vertical-channel MOSFET's. Its structure is illustrated in Fig. 2. The unique TMOS design, with thousands of "source" sites connected in parallel on a single die, makes possible a very short vertical channel that carries heavy currents, but still has a low R_{ON} -state voltage drop. A polysilicon gate material enhances switching speed, while an oxide

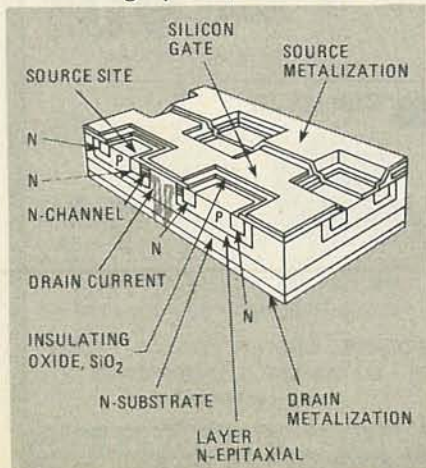

FIG. 2



ROBERT F. SCOTT,
SEMICONDUCTOR EDITOR

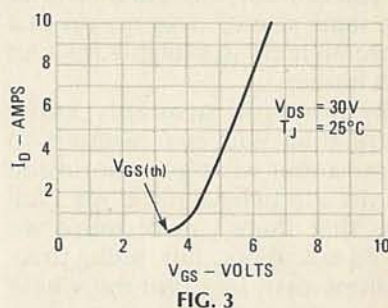

FIG. 3

layer electrically isolates the gate from the source.

The input resistance of TMOS devices is extremely high— 10^9 ohms—resulting in a leakage current of only a few nanoamperes. Source-to-drain current is controlled by applying a positive voltage to the gate that's just slightly higher than the gate-to-source threshold voltage, $V_{GS(th)}$. The graph in Fig. 3 shows the transfer characteristics for Motorola's MTM5N35/40 devices, which is typical of N-channel, enhancement-mode FET's.

The extremely high input-impedance and the relatively low gate-drive voltage requirement make the TMOS ideally suited for control of high-power directly from low-level CMOS and TTL logic circuits, if enough current is supplied to charge the input capacitance, C_{iss} .

The TMOS FET has inter-electrode capacitances—gate-to-drain (C_{gd}), drain-to-source (C_{ds}), and gate-to-source (C_{gs})—similar to those of a triode vacuum tube. The input capacitance is $C_{iss} = C_{gd} + C_{gs}$; output capacitance, $C_{oss} = C_{gd} + C_{ds}$; and the reverse trans-

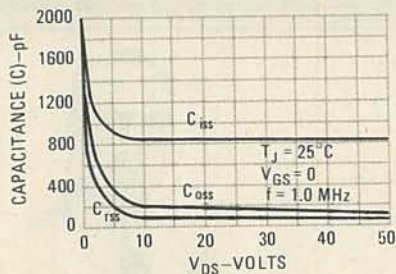

FIG. 4

fer capacitance, $C_{rss} = C_{gd}$. Figure 4 shows the relationship between those capacitances, which are a function of the drain voltage.

The input capacitance of a MOSFET is important and must be considered in circuit design. On a transient basis, gate current flows to charge C_{iss} before the gate gains control over drain current. The driving (or generator) impedance, R_{gen} , and C_{iss} affect the switching speed. The lower R_{gen} the faster the switching speed.

For additional information on T MOS technology and device characteristics, refer to Motorola's 20-page *Power MOSFET Selector*

Guide and Cross-Reference (SG56, Rev. 5). Request your copy from **Motorola Semiconductor Products**, PO Box 20912, Phoenix, AZ 85036.

RCA Solid-state product guide

The Solid-State Devices Product Guide is a new 56-page publication covering basic descriptions of RCA's extensive product line of solid-state devices. It includes power MOSFET transistors and ultra-fast recovery rectifiers (two new additions to RCA's family of semiconductors).

Other selections include bipolar power-transistors, thyristors, IR emitters, injection lasers, linear and digital logic IC's, microprocessors, and numerous other devices. The guide summarizes the devices in each product category and highlights their pertinent features and applications.

Single copies of the Solid-State Devices Product Guide (No. SPG-201M) are available from RCA distributors and from **RCA, Solid**

State Div., Route 202, Somerville, NJ 08876 or by calling toll-free number (800) 526-2177.

Low bias-current op-amps

The 1346 and 1347 are two new high-performance op-amp IC's that combine JFET and bipolar technologies with dielectric isolation to provide superior AC and DC characteristics. Their 2-MHz, unity-gain bandwidth and 7 V/ μ s slew rate make them ideal for such applications as high-impedance, high-performance buffers, precision track/hold amplifiers, and long-term precision integrators.

Available in TO-99 packages, the 1346 and 1347 are specified over a temperature range of 0°C to +75°C, while the 1346-01 and 1347-01 are specified for the -55°C to +125°C temperature range. Each unit features ± 250 mA bias current, ± 0.5 millivolt maximum offset, 2 μ s settling to $\pm 0.1\%$, and 300 millivolt maximum power consumption.—**Teledyne Philbrick, Microcircuits**, Allied Drive at Route 128, Dedham, MA 02026. **R-E**

Copies of articles from this publication are now available from the UMI Article Clearinghouse.

For more information about the Clearinghouse, please fill out and mail back the coupon below.

UMI Article Clearinghouse

Yes! I would like to know more about UMI Article Clearinghouse. I am interested in electronic ordering through the following system(s):

- DIALOG/Dialorder ITT Dialcom
 OnTyme OCLC ILL Subsystem
 Other (please specify) _____
 I am interested in sending my order by mail.
 Please send me your current catalog and user instructions for the system(s) I checked above.

Name _____
 Title _____
 Institution/Company _____
 Department _____
 Address _____
 City _____ State _____ Zip _____
 Phone (____) _____

Mail to: University Microfilms International
 300 North Zeeb Road, Box 91 Ann Arbor, MI 48106

DESOLDER-IT,
 CLEAN-IT, COAT-IT,
 FREEZ-IT...SEND FOR IT!

Our new electronic problem solving catalog!



Chemtronics
 681 Old Willets Path
 Hauppauge, NY 11788
 800-645-5244
 In NY 516-582-3322
 Telex 968567

CIRCLE 54 ON FREE INFORMATION CARD

FEBRUARY 1985

SERVICE CLINIC

Servicing electronic test equipment

EVERY NOW AND THEN, WE ALL FEEL THE need to check up on some of our test equipment. (Nagging doubts about the accuracy of test instruments are bound to crop up ever so often.) Contrary to what you've been led to believe, verifying the accuracy of test instruments is really a simple task—although that can't always be said for repairing them.

Perhaps the easiest measuring devices to check and repair are VOM's (volt-ohmmeters) and DVM's (digital voltmeters)—the most basic and widely used test instruments in any collection. Once you know that your basic instruments are working accurately, you can go a long way in repairing other equipment as well, so let's start there.

Meter repair

There are several ways to verify voltmeter accuracy. The quickest is with a known voltage source (batteries). A new battery, even the common Leclanche (dry cell), has a relatively stable voltage—close to 1.56 volts—if it hasn't been used. A mercury cell is a better voltage source in test procedures where a reference is needed; it will hold its open-circuit voltage for an amazingly long time. Various voltages are available in mercury cells, so check to make sure that you're getting exactly what you want.

Let's assume that we are using a standard dry cell, whose voltage is usually around 1.56 volts. In checking your meter's accuracy, set it to the voltage range and apply the dry-cell voltage directly to the meter's input. If the meter indica-

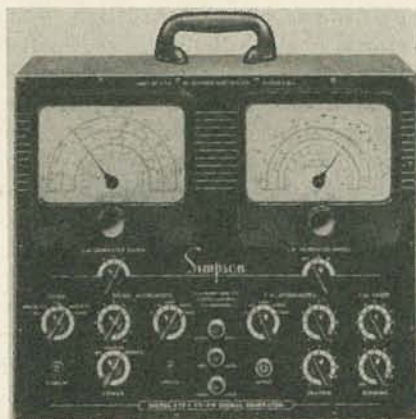

FIG. 1

tion agrees with the reference (1.56V), then it's a safe bet that range is OK! If not, then you'll have to find the voltage-divider network, locate the resistor that's causing the problem, and replace it.

A word of warning: The resistive elements in a meter are wire-wound, precision types—so replacements should be the exact values specified. Also, the resistors called for are usually not standard values; that can be handled by paralleling several resistors to obtain the value needed.

You can also check the higher meter ranges to make sure that the resistors in the voltage-divider network have not changed in value. To check higher ranges, remove the back of the meter and locate the divider network, using the schematic of your unit. Change the meter setting to the next higher range and apply the reference voltage to the point that corresponds to the input of that range.

If your unit is a DVM, the read-



JACK DARR,
SERVICE EDITOR

ing will be about .156, because of its 10× ratio. Analog meters, on the other hand, may show a slightly reduced voltage. However, a difference of a few microvolts in both cases is OK.

In checking the resistance ranges, set the switch to ohms and check the swing of the needle to see that it travels all the way over past zero and then swings back freely. If it sticks anywhere, look out; you've got a problem!

One thing that makes the needle stick is "foreign matter," a small piece of iron, for example, lodged in the small gap between the coil and the core. Such objects physically impair the swing of the needle, or block it by getting caught up in the field around the movement's magnetic core. Carefully take the face plate off the meter and look inside the gap with a jeweler's loupe or strong magnifying glass.

The chances are you will be able to spot the obstruction. If so, take a small piece of tape, and carefully slip it into the gap; you should be able to catch particles on the sticky side. Caution: Never use a high-pressure air hose to remove tiny particles around the movement. A high-pressure air hose will scatter parts all over the bench and the meter will never be the same.

Signal-generator repair

Signal generators are probably the easiest instruments to check (and the hardest to fix). To check them, all you need is a radio! Simply zero-beat the signal generator with a broadcast station's carrier: Connect the signal generator to the receiver's antenna terminals

and set the unit's attenuator to a low output. Tune the receiver to a station of known frequency.

Now vary the generator frequency in the direction of the station's carrier frequency. You should hear a descending or ascending tone, depending on whether you're headed toward or away from the carrier frequency. As the generator frequency nears that of the carrier, the tone will fade and, at some point, completely disappear. The tolerance of the calibration should be held to within ± 5 cycles of the assigned carrier frequency. (I've had to wrestle with a few that wouldn't reach that tolerance.)

If you can get your hands on a communication-type receiver, you can check several other things. By tuning to the fundamental frequency, you can use the second harmonic, 1250 kHz, 2950 kHz, and so on, to get a more accurate indication.

Similarly, a TV station's video carrier may be used. Here the object is to set the generator for the lowest number of "bars" on the screen. Simply follow the same hookup procedure used with the radio receiver, and watch the number of bars on the screen. When you reach the point where the least number of bars are shown, you're right on the station's frequency.

Often, signal generators (like the one in Fig. 1) have a built-in crystal, sometimes on 4.5 MHz, etc, which can be used for checking. Others have 1,000 kHz (1.0 MHz) crystals, which can be used by checking for "birdies" every 1.0 MHz. If a signal generator is badly off, (which seldom happens) you can reset it. Look in the owner's manual for the location of the trimmer capacitors for the different bands.

You can also tune in WWV (the standard time and frequency station) on 2.5, 5.0, 10.0, and 15.0 MHz. For audio checks, the tone modulation is the standard 440 Hz, which can be very handy. Follow the calibration procedure to the letter, especially the adjustment sequence. Doing so will make the job a breeze.

In addition, lower frequencies can be checked using harmonics.

For example, you can check 1.25 MHz (1250 kHz) by beating its second harmonic against 2.5 MHz from WWV, or some other source.

Oscilloscope repair

Oscilloscopes can be checked using a squarewave audio signal. That is done by feeding the squarewave signal to the input of the vertical amplifiers, and watching the display for signs of rounding corners, or any other distortion. If the display shows a good clean squarewave, those stages are all OK. But if they're not, the trouble is most likely in the coupling capacitors! I speak with the voice of experience. (I've fixed many old scopes in the past.) R-E

SERVICE QUESTIONS

INTERMITTENT STARTING

I've got an RCA CTC 68 that's giving me the fits. Sometimes it starts, sometimes it doesn't. When it fails to start, I hear a squeal, and then the circuit breaker trips. I've changed the two SCR's and diodes CR401 and CR402.—C.M., Franklyn, KY

The solder connections under T401, 402, and 405, especially T405, have been known to give a great deal of intermittent problems. I would also not overlook the possibility of an intermittently open filter capacitor.

HOT SET

On a GE 10HD chassis, I have bottom foldover and poor linearity. The vertical tube and the linearity control both run too hot. The oscillator grid reads -25 volts instead of the -35 volts I should have.—R.D., Greenville, SC

I would be more interested in the reading on the output grid. If that is too low, the output section of the twin-triode tube will draw too heavily, accounting for all that heat. My first suspect would have to be the coupling capacitor, C203, followed by the grid return resistors. R-E

Learn micro-processing with the new MICRO-PROFESSOR 1P



Students, engineers or technicians—upgrade your micro-processing skills with the new Micro-Professor 1P.

The MPF-1P features:

- extensive software support
- more built-in memory
- improved keyboard
- larger display

Three tutorial guides help cover all capabilities. The ideal training tool! MPF-1P will deliver you into the growing world of micro-processing. Invest now!

Plus—FREE GIFT Only \$179.95

Check this box for FREE Z-80 Microprocessor Programming and Interfacing textbook when you order within 7 days. \$12.95 value. (Include \$5.00 postage & handling)

ETRONIX
Dept. RE0285
14803 N.E. 40th
Redmond, WA 98052

For immediate action call TOLL FREE:

1-800-426-1044

Full money back guarantee.



CIRCLE 111 ON FREE INFORMATION CARD

SEE YOUR DEALER TODAY

FROM

Firestik®
ANTENNAS
ACCESSORIES

HERE'S A TIP
THAT'S PERFECT!

AM/FM AUTO RADIO
AND CB

Firestik® II

GOLDEN SERIES

BARE-HANDS TUNABLE
"NO TOOLS NEEDED"
HIGH PERFORMANCE ANTENNAS

ALSO ANTENNAS FOR
CORDLESS TELEPHONES
MONITOR SCANNERS

Dealer & Distributor Inquiries Invited
SEND FOR FREE CATALOG

'Firestik' Antenna Company
2614 East Adams/Phoenix, AZ 85034

Name _____
Street _____
City _____
State _____ Zip _____

Serving the CB and
Communications Market Since 1962.

5-YEAR REPLACEMENT WARRANTY

CIRCLE 100 ON FREE INFORMATION CARD

ACCuCOM INC.

P.O. BOX 863537
 PLANO, TEXAS 75086
 (TEXAS) 214-985-1842
 (CALIF.) 818-307-5409



130 W/CH STEREO POWER AMP KIT	\$79.95	
120 W/CH MOSFET POWER AMP KIT	75.95	
LOW TIM PREAMP KIT	32.95	
SUPER CLASS A STEREO PRE-AMP KIT	75.95	
20 W/CH STEREO AMP WITH CASE	71.95	
20 STEP POWER LEVEL INDICATOR KIT	32.95	
5W 1C AMP KIT	17.95	
0-50V 3A POWER SUPPLY	19.95	
0-18V 10A POWER SUPPLY	29.95	
DIGITAL DESIGNER KIT	69.96	
	17 x 6.5 x 12	\$34.95
RACK MOUNT CABINET 15.5 x 5.5 x 9	24.50	
	11.5 x 1.75 x 7	14.95
LOGIC PROBE	\$25.95	
LOGIC PULSER	32.95	
DESOLDERING TOOL DT-200	12.95	
MINI-DRILL WITH STAND	45.00	



TERMS: ALL PRICES SUBJECT TO CHANGE WITHOUT NOTICE. ALLOW TIME FOR UNCERTIFIED CHECKS TO CLEAR. MASTERCARD-VISA ADD 3%. TEXAS RESIDENTS ADD 6.125% SALES TAX. MINIMUM ORDER \$15.00. ADD 10% or \$3.50 MINIMUM FOR SHIPPING.

EQUIPMENT REPORTS

continued from page 81

of 1 megohm, circuit loading should be minimal in most cases. The *DM-10* is protected against excessive voltage to 500 volts DC and 350 volts AC on the 200 mV range. On the higher ranges, the protection ratings are twice those figures.

The AC voltage accuracy specification is $\pm 1.2\%$, +1 digit. The input impedance is 450 kilohms in the AC-volts mode, and the meter is protected up to 500 volts AC or DC.

The accuracy specifications for the resistance mode should also please any hobbyist: $\pm 1\%$, +3 digits is the worst-case specification. The open-circuit voltage is less than that needed to turn on a semiconductor junction, so you can make some in-circuit measurements without sacrificing accuracy.

The accuracy of the meter in the DC current mode is $\pm 1.2\%$, +1

digit. Overload protection is provided by a 800-mA, 250-volt fuse in that mode, and the voltage burden is 325 mV.

The final mode of the *DM-10* is its diode-test mode, which lets you quickly test semiconductor p-n junctions. The maximum open-circuit voltage is 3.2 volts, and the maximum current is 1.2 mA—just enough to dimly light a standard LED.

Beckman		DM10										
OVERALL PRICE												
EASE OF USE												
INSTRUCTION MANUAL												
PRICE/VALUE												
		1	2	3	4	5	6	7	8	9	10	
		Poor		Fair			Good			Excellent		

The manual

The manual we received with the *DM10* was not what we'd normally expect from Beckman. While that manual did contain acceptable operating instructions and a specifications sheet, it did not have any calibration instructions, parts list, or circuit schematic. In fairness, we should point out that our manual was only a preliminary copy. We hope that the finished manual is much more informative.

The *DM10* may not have all the features you want: It does not include an audible continuity beeper, a high-current range, a tilt stand, or autoranging, for example. However, even without those features, it is a good, basic meter for most hobbyists. The meter should also be at home in a technicians toolbox—its small size makes it ideal for field work. Perhaps the best feature of the *DM10*, however, is its price, which is just \$39.95. Beckman was able to keep the price down by not including the "extra" features that we mentioned. They also kept manufacturing costs down: Most of the circuitry is contained on a VLSI analog-to-digital converter chip, and all of the circuitry—including the switch contacts—is contained on a single PC board.

R-E

ELECTRONIC COMPONENTS

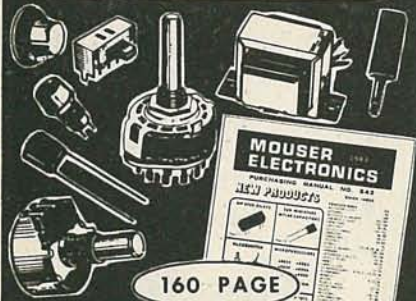

160 PAGE
FREE CATALOG

MANUFACTURERS OF QUALITY ELECTRONIC COMPONENTS

- BATTERY CLIPS & HOLDERS
- CABLE SETS • CONNECTORS • CAPACITORS
- DISPLAYS • LEDs • FUSES • JACKS & PLUGS
- KNOBS • LAMPS • POTENTIOMETERS
- RF COILS • RELAYS • RESISTORS
- SWITCHES • SEMICONDUCTORS • SPEAKERS
- TEST EQUIPMENT • TRANSFORMERS • TOOLS
- WIRE & CABLE

OVER 15,000 DIFFERENT ITEMS IN STOCK!

- Sales and Order Desk Open from 6:00a.m. (PST)
- TERMS: C.O.D., Visa, MasterCard (Open Accounts Available)
- Phone and Mail Orders Welcome
- Catalogs Mailed Outside USA Send \$2.00

MOUSER ELECTRONICS

11433 WOODSIDE AVE. SANTEE, CA 92071
 PHONE (619) 449-2222 TWX 910-331-1175

CIRCLE 117 ON FREE INFORMATION CARD

Get this catalog to **SAVE MONEY!** It's free!



Quality Crystals Available for
 Communications Industry
 Marine VHF Scanners
 Amateur Bands CB Standard
 Microprocessor CB Specials
 "Just One or Hundreds"

Our low prices result from modern equipment and technology, efficient trained employees, and low sales costs. Call us.

JAN CRYSTALS



P.O. Box 06017
 Ft. Myers, FL 33906
 Call (813) 936-2397



CIRCLE 104 ON FREE INFORMATION CARD

MARKET CENTER

FOR SALE

CABLE-TV Secrets—the outlaw publication the cable companies tried to ban. HBO, Movie Channel, Showtime, descramblers, converters, etc. Suppliers list included. \$8.95. **CABLE FACTS**, Box 711-R, Pataskala, OH 43062.

RESISTORS ¼W&½W5% 3 cents. 1% metal films, precision custom wirewounds, \$1.00 refundable to: **JR INDUSTRIES**, 5834-B Swancreek, Toledo, OH 43614.

FREE catalog featuring scanner accessories, carrier/subcarrier detectors, voice scramblers, unusual kits. **CAPRI ELECTRONICS**, Route 1R, Canon, GA 30520.

THE Intelligence Library—Restricted technical information & books on **electronic surveillance, surveillance-device schematics, lock-picking, investigation, weapons, identification documents, covert sciences**, etc. The best selection available. **Free brochures**. **MENTOR**, (Dept. Z), 135-53 No. Blvd., Flushing, NY 11354.

CABLE-TV equipment, tunable notch filters for "beeping" channels. Information \$1.00. **DK VIDEO**, PO Box 63/6025, Margate, FL 33063.

RECONDITIONED test equipment. \$1.00 for catalog. **JAMES WALTER TEST EQUIPMENT**, 2697 Nickel, San Pablo, CA 94806.

DIGITALKER Speech Synthesizer has 136 word vocabulary. Interfaces with parallel port of your computer. PCB and plans \$12.00. **JIM RHODES, INC.**, 1025 Ransome Lane, Kingsport, TN 37660.

WHOLESALE F-59 cable connector \$80.00/1000. Free MATV catalog. S.A.S.E. (212) 897-0509. **D&WR**, 68-12 110 Street, Flushing, NY 11375.

TI-99/4A software/hardware bargains. Hard-to-find items. Huge selection. Fast service. Free catalog. **DYNA**, Box 690, Hicksville, NY 11801.

WANTED: RCA, Cunningham, Western Electric, Genalex, Telefunken, GE, Sylvania, McIntosh, Marantz, Altec, JBL, Tannoy; **Tubes**, amplifiers, speakers. (713) 728-4343. **MAURY**, 11122 Atwell, Houston, TX 77096.

TUBES, new, unused. Send self-addressed, stamped envelope for list. **FALA ELECTRONICS**, Box 1376-2, Milwaukee, WI 53201.

FREE Pay-TV reception. "How-To" book. HBO, Showtime, Cinemax. \$5.00. **DIPTRONICS**, Box 80 (E3), Lake Hiawatha, NJ 07034.

RADAR JAMMER!



- Causes speed radar guns to read out either: —a percentage of your true speed, or whatever speed you dial in
 - Activated by your Escort and most other detectors
 - Especially effective against instant-on radar
 - Operates on both X and K bands (not FCC approved)
 - **MONEY-BACK GUARANTEE**, if not satisfied.
- WARNING: The device described in this literature is not legal for use against police radar.

Complete literature & plans package, send \$14.95 to:
Phillips Instrument Design Co. Inc.
 9513 S.W. Barbur Blvd. #109S, Portland, OR. 97219
 VISA and M/C order line: (503) 626-6764

NICAD batteries, G.E. Gold Top premium cells 250 MAH for ICOM Handie-Talkie, cordless phones, memory-backup, radio control, etc., \$1.00 ea. Data cassette recorders with plugs for VIC-20 and C-64 computers \$39.00 ea. Balley home computer mother boards \$15.00. **E. YOST & CO.**, R.R.#1, Box #37, Sauk City, WI 53583.

3,000 tips color TV repairs, 31 brands, 116 pages. Send \$21.00, **TONY FERNANDEZ**, Box 54-6110, Surfside, FL 33154.

BIG PROFITS ELECTRONIC ASSEMBLY BUSINESS

Start home, spare time. Investment knowledge or experience unnecessary. **BIG DEMAND** assembling electronic devices. Sales handled by professionals. Unusual business opportunity.

FREE: Complete illustrated literature
 BARTA, RE-O Box 248
 Walnut Creek, Calif. 94597

TAPE—We're cheaper! Ampex/Scotch 2400'/7" reels, first quality, used once. \$0.79/ea + shipping. **COMPUTER PARTS MART**, 3200 Park Blvd, Palo Alto, CA 94306. (415) 493-5930.

"SATELLITE descramblers"—lowest prices anywhere! Dealer inquiries welcome. Send \$3.00 for catalog. We ship C.O.D.'s. **STARVIEW INC.**, PO Box 103, Rexford, NY 12148, (518) 785-1288.

CABLE-TV products. Jerrold, Hamlin, and Oak converters. Send \$3.00 for information. **ADDITIONAL OUTLET CORP.**, 1041 W. Commercial Blvd., Ft. Lauderdale, FL 33309.

TOKO coils and printed circuits. Quantity discounts. **JIM RHODES, INC.**, 1025 Ransome Lane, Kingsport, TN 37660.

AUTOMOTIVE AM/FM stereos \$49.95 up. 40 piece socket set, lifetime warranty \$39.95. Free catalog. **NEPTUNES CAVE**, Box 8837, Fort Worth, TX 76124-0837.

SURPLUS test equipment, oscilloscopes, B&K, Leader, HP, Tektronix, catalog \$2.00. **ROTARY CONVERTER SPECIALISTS**, Box 1382, Washington, DC 20013.

ALPHANUMERIC vacuum fluorescent display Model SG20. Includes all timing, refresh and character generation circuitry. TTL/CMOS compatible. Serial and parallel port, 5VDC power, \$85.00 in single quantity. Free manual. **TOMANTRON, INC.**, 17942 So. 66th Avenue, Tinley Park, IL 60477.

CONVERT videotapes, PAL - SECAM - NTSC (overseas). 110-220 Audio, VCR, televisions, Canon copying machines, discounted. **APPLE AUDIO**, 74-18, 37th Avenue, Queens, NY 11372, (718) 507-5800.

UHF descramblers. Gated, sinewave, Zenith. Low prices! **SSAV11**-\$169.00. Catalog \$1.00. Dealers wanted! Visa/Mastercard. **AIS SATELLITE**, Box 1226-S, Dublin, PA 18917, (215) 249-9411.

QUALITY MICROWAVE TV SYSTEM

COMPLETE SYSTEM FROM

\$89.95 & up

1.9-2.6 GHz antennas
90 Day Warranty

—SPECIAL QUANTITY PRICING DEALERS WANTED—C.O.D.'s—

ACE RECEPTION 212-655-3281

CLASSIFIED RATES

15 word minimum: \$2.50 per word commercial, minimum \$37.50. \$2.00 per word personal, minimum \$30.00. Expanded type ad, \$3.75 per word. Ads set in all bold-face type at 20% premium. Ads set with back-ground screen at 25% premium. Display ads 1" x 2¼" - \$270.00; 2" x 2¼" - \$540.00; 3" x 2¼" - \$810.00. General Information: frequency rates and prepayment discounts are available. Payment must accompany order. Copy subject to publishers approval. Must be typewritten or printed. Only first word and name set in bold caps. Additional bold face (not available as all caps) at 25c per word. Advertisers using P.O. Boxes must supply permanent address and telephone numbers. Orders are not acknowledged. They will appear in the next available issue after receipt. Copy to be in our hands on the 20th of the third month preceding the date of the issue (i.e. August issue closed May 20th). When normal closing date falls on Saturday, Sunday or a holiday issue closes on preceding working day. Send order and remittance to **Classified Advertising Radio-Electronics, 200 Park Avenue South, New York, New York 10003**. For your convenience a simplified order form is provided on this page.

ORDER FORM

PLEASE INDICATE in which category of classified advertising you wish your ad to appear. For special headings, there is a surcharge of \$20.00.

- () Plans/Kits () Business Opportunities () For Sale
 () Education/Instruction () Wanted () Satellite Television

- () Special Category: \$20.00

PLEASE PRINT EACH WORD SEPARATELY, IN BLOCK LETTERS.

1	2	3	4	5
6	7	8	9	10
11	12	13	14	15
16	17	18	19	20
21	22	23	24	25
26	27	28	29	30
31	32	33	34	35

MAIL ORDER WITH CHECK TO: Radio-Electronics Classified Ad Department, 200 Park Avenue South, New York, NY 10003.

FINEST QUALITY SOLDER

SN 60/40 Rosin Core (RA)

One lb. Reels	
16 swg. (.064)	\$7.95
18 swg. (.048)	\$8.45
19 swg. (.040)	\$8.95
20 swg. (.036)	\$9.45
21 swg. (.032)	\$9.95



FREE Freight On All Orders
Over \$25
 Under \$25 add \$2.50 per order.
 Minimum order \$10.

1/2 lb. Reels	
22 swg. (.028)	\$5.95
24 swg. (.022)	\$7.95

SN 62 (2% Silver)

Rosin Core	
21 swg. (.031)	\$19.95

FREE Desoldering Wick with each pound of solder

Check Money Order VISA
 MasterCard N.Y. State residents add appropriate sales tax.

SolderCraft™
 P.O. Box 666 Jericho, NY 11753

Call TOLL FREE 800-645-4808
 In NY (516) 334-2660

CIRCUIT boards: Your artwork, quick delivery, reasonable. **ATLAS CIRCUITS**, Dept. A, PO Box 892, Lincolnton, NC 28092. (704) 735-3943.

ELECTRONIC catalog. Over 4,500 items. Parts & components. Everything needed by the hobbyist or technician. \$2.00 postage & handling (United States only), refundable with first \$15.00 order. **T & M ELECTRONICS**, 472 East Main Street, Patchogue, NY 11772. (516) 289-2520.

OPTICAL character reader input any computer. Construction cost \$75.00. Plans \$29.95. 50 page catalog \$3.00. **DBE**, Box G, Waikiki, HI 96815, MC/VISA orders (808) 395-7458.

CABLE-TV converters, police radar detectors and scanners. Send \$1.00 for catalog. **GREAT LAKES COMMUNICATIONS, INC.**, 0-2026 Chicago Dr. Jenison, MI 49428

IMPORTS—car stereos, boosters, speakers, tools, much, much more! List \$1.00. **JRC**, 329-76th, N. Bergen, NJ 07047.

CABLE and Subscription TV secret manual. Build your own descramblers, converters—HBO, Showtime, Movie Channel, UHF. Latest theory, schematics, instructions, suppliers list. Send \$8.95 to: **CABLETRONICS**, Box 30502, Bethesda, MD 20814.

CANADIANS. Pay-TV and satellite descramblers and kits for all areas. Send \$1.00 for details to **F.T. ELECTRONICS**, Box 2126, Niagara Falls, NY 14302.

SPACE age spawned gasoline additives. Free booklet and sample—\$2.00 handling. Dealers invited. **MIDWEST LABORATORIES**, Rt. 1, Box 278, Summerville, OR 97876.

THE BEST PLACE to BUY, SELL or TRADE NEW and USED EQUIPMENT
NUTS & VOLTS MAGAZINE
 BOX 1111-E • PLACENTIA, CA 92670
 (714) 632-7721

Join Thousands of Readers Nationwide Every Month
ONE YEAR U.S. SUBSCRIPTIONS
 \$10.00 - 3rd Class • \$15.00 - 1st Class
 \$35.00 - Lifetime - 3rd Class



AUTOMOTIVE Security Catalog. 1984, 24-page color catalog, \$2.00. **ASE**, Dept. 1, PO Box 382, Plainview, NY 11803.

CORDLESS-phone owners. Increase distance, reduce static on 1.7/49MHz phones. Details \$1.00 refundable. **HP PHONES**, Box 273, Mesa, AZ 85201.

COCO owners—Free color computer software and hardware catalogue. **SPECTRUM**, Box 9866, San Jose, CA 95157-0866.

INDIVIDUAL photofact folders. No. 1 to no. 1400, \$3.00 postpaid. **LBT**, 414 Chestnut Lane, East Meadow, NY 11554.

WRITE FOR McGEE'S SPEAKER & ELECTRONICS CATALOG
1001 BARGAINS IN SPEAKERS
 Tel.: 1 (816) 842 5092
1901 MCGEE STREET KANSAS CITY, MO. 64108

DESCRAMBLERS for downconverters. High gain. Send \$2.00. **RB ELECTRONICS**, PO Box 643, Kalamazoo, MI 49005.

CABLE-TV converters, Zenith, Scientific Atlanta, Jerrold, Oak, others available. Fast service. **UNITED ELECTRONICS SUPPLY**, PO Box 1206, Elgin, IL 60121. (312) 697-0600.

TOKO coil set (four) \$8.00. **BFQ85 substitute transistor** \$2.00. **JIM RHODES, INC.**, 1025 Ransome Lane, Kingsport, TN 37660.

TRANS AM ELECTRONICS monthly special: Two digit display with drivers—\$2.95. Watch for our ads. R.F. modulator \$9.95—has audio and video output. **383 Canal Street**, New York, NY 10013, (212) 226-3893.

TECNICA 140 channel cable converter fully remote sound and video unit only \$149.00. **Jerrold LCC58** converter only \$79.00. **Jerrold DRZ450** converter 90 channel auto tuning only \$89.00. All units carry full manufacturers warranty, specials while they last. For catalog send \$3.00. Thanks. **REDCOAT ELECTRONICS**, 104-20 68th Drive, Forest Hills, NY 11375. (212) 459-5088.

LASERS, Siemens LGR7630, new \$99.00. Amazing selection of **opto-electronics**, **motion control** (steppers, DC & AC, servo, linear motors) etc. Send S.A.S.E. for **free catalog**. **COMPUTER PARTS MART**, 3200 Park Blvd, Palo Alto, CA 94306. (415) 493-5930.

WM. B. ALLEN'S



SELL-A-BRATION

START A NEW YEAR WITH GREATER SAVINGS ON TEST EQUIPMENT!
WM. B. ALLEN HAS THE FULL HICKOK LINE — IN STOCK & READY FOR SHIPMENT NOW

LX-306 DMM
PIED PIPER

SAVE \$35
\$120

HAND-HELD WITH VARI-PITCH
 Full Function, Variable, Audible Tone • 3 1/2 Digit • 0.25% Accuracy • 10A Range AC/DC • Decimal • Auto 0 • Diode Test • Overload Protection With Self-Resetting Circuits

9V Battery & Carrying Case Included

MX-333 DMM
VARI-PITCH • LOGI-TRAK

SAVE \$70
\$220

WORLD'S FASTEST TROUBLESHOOTER
 Instant Audible, Variable Response With Exclusive VARI-PITCH • Fast LOGI-TRAK (5 nsec) Combines Logic probe & Voltmeter In One • 3 1/2 Digit LCD • 0.1% Accuracy • Auto 0 • Decimal • Polarity • 10A Range • 9V Battery • Overload Protection • Handheld, On Belt or Shelf.

Includes 9V Battery and Probes

NEW! 115 PLP
POWER LINE PROBE

SAVE \$40
\$199

"REAL WORLD" POWER LINE PROBER
 Instantly Identifies Power Line Problems • Continuous Monitoring • Immediate Alarm For High & Low Voltage, Voltage Drops, Spikes, Power Failures or High Frequency Sounds • 120V • 60Hz • Field Adjustable Test Volts.

COMPLETE INVENTORY FROM 18 TEST EQUIPMENT MANUFACTURERS — PLUS OVER 70,000 ITEMS FROM 350 MANUFACTURERS OF ELECTRONIC PARTS & SUPPLIES. WM. B. ALLEN IS ALSO A FULL SYSTEMS HOUSE. OPEN SATURDAYS UNTIL 1:00 P.M.

WM. B. ALLEN SUPPLY COMPANY

ALLEN SQUARE

300 BLOCK NORTH RAMPART, NEW ORLEANS, LA 70112

800 535-9593

LOUISIANA 800 462-9520

STOP DREAMING START BUILDING

HANDY MAKES IT EASY!

Build anything from computers to LED flashers... any project you want the fast, easy, fun way. Use HANDY solderless breadboards to build, test, modify and expand your ideas.

**SATISFACTION GUARANTEED
OR YOUR MONEY BACK!**

JUST LOOK AT THESE SOCKET FEATURES...

- Full contact labeling — simplifies component layouts
- New durable clip design assures reliable, low resistance, corrosion-free interconnections
- High temp plastic — no warping or melting...ever!
- Self-adhesive backing — mounts anywhere
- Big 9 14-pin IC capacity per socket
- Expands horizontally and vertically

HB-0100. 1 Buss Strip.
100 tie points. Compares
at \$3.00!
\$2²⁵

HB-1000. 1 Socket Strip.
640 tie points. 9 14-pin
IC capacity. Compares at
\$12.50!
\$9⁹⁵

HB-4714. 4 Socket Strips.
7 Buss Strips. 4 Binding
Posts. 3260 tie points.
36 14-pin IC capacity.
Compares at \$89.00!
\$63⁹⁵

HB-2312. 2 Socket Strips.
3 Buss Strips. 3 Binding
Posts. 1580 tie points.
18 14-pin IC capacity.
Compares at \$51.50!
\$31⁰⁰

HB-2112. 2 Socket Strips.
1 Buss Strip. 2 Binding
Posts. 1380 tie points
18 14-pin IC capacity.
\$24⁹⁵

HB-1110. 1 Socket Strip.
1 Buss Strip. Ground plate.
740 tie points 9 14-pin
IC capacity. Compares at
\$15.50!
\$11⁹⁵

HB-1210. 1 Socket Strip.
2 Buss Strips. Ground plate.
840 tie points. 9 14-pin
IC capacity. Compares at
\$18.50!
\$13⁹⁵

HB-3514. 3 Socket Strips.
5 Buss Strips. 4 Binding
Posts. 2420 tie points.
27 14-pin IC capacity.
Compares at \$66.00!
\$47⁹⁵

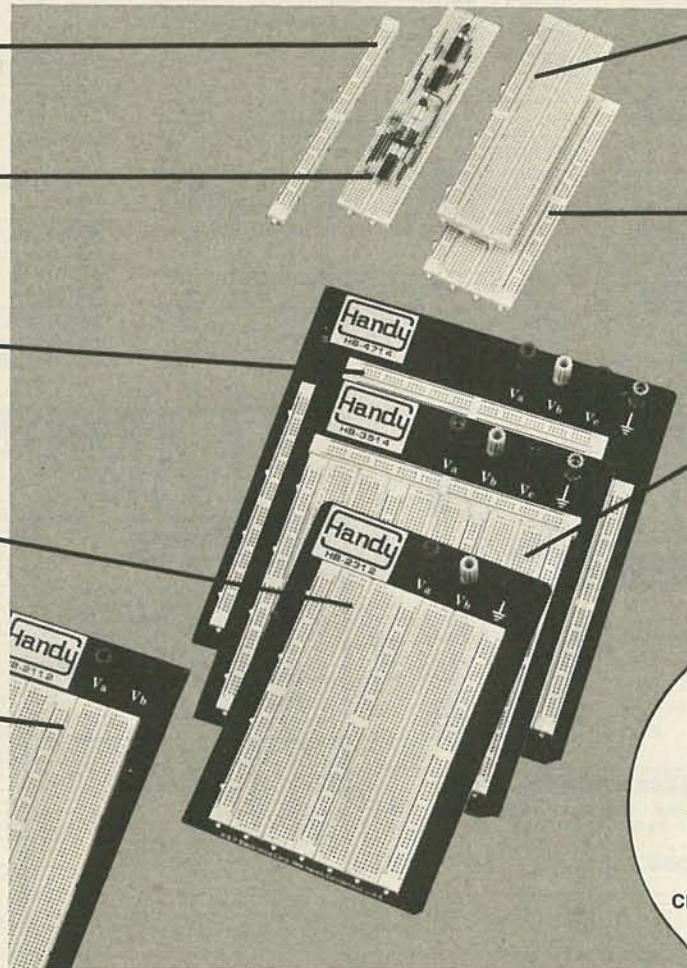

Clear, easy-to-read and identify
contact markings simplify
layout, wiring and
documentation.

FOR LESS!

**SEND FOR
FREE
Colorful
Brochure!**

Available at Selected Distributors throughout the USA and Canada
HANDY PRICES ARE UP TO 25% LESS THAN COMPETITORS!



a division of RSP Electronics Corp.
7 Business Park Drive • P.O. Box 699 • Branford, CT 06405
Telephone: (203) 488-6603 CompuServe: 71346, 1070
TWX: (910) 997-0648 Easy Link Mail Box: 62537580



ORDER TOLL FREE

1-800-34-HANDY
... charge with VISA or
MasterCard. All items
off-the-shelf for
Immediate Shipment!

Mail Orders: Please add \$3 (Canada & Int'l add \$5) for shipping/handling.
Charge Cards: (Min. \$15). Please include Acct. No., Exp. Date and your sig-
nature. Checks: drawn in U.S. Dollars on U.S. banks only. C.O.D.'s accepted.
Connecticut Residents: Add 7.5% Sales Tax.

CIRCLE 71 ON FREE INFORMATION CARD

FEBRUARY 1985

103

SATELLITE TV VIEWERS
Get the most complete weekly listings.
Send \$1 for sample copy.

Satellite TV Week

P.O. Box 308E, Fortuna, California 95540
800-358-9997 (U.S.) • 800-556-8787 (Calif.)
707-725-2476 (all others)

SATELLITE TELEVISION

SATELLITE-TV receiver breakthrough! Build your own system and save! Instruction manuals, schematics, circuit boards! Send stamped envelope: XANDI, Box 25647, Dept. 21H, Tempe, AZ 85282.

MULTI channel microwave antennas, highest quality, low prices, dealers welcome. D.T. compact \$38.00, PT-1 \$48.00, SR-1 \$65.00, D.T. grid \$69.00, PTS-33 \$75.00, all units complete. **DAISY TENNA**, Box 42010, Phoenix, AZ 85080, (1-800) 874-9033.

SATELLITE systems and accessories. Dishes, receivers, LNAs, actuators. Top brands, low prices. \$5.00 catalog. **B & T ELECTRONICS**, PO Box 3156, Grand Rapids, MI 49501.

PCB for Satellite Stereo Project in October article is now only \$15.00. **JIM RHODES, INC.**, 1025 Ransome Lane, Kingsport, TN 37660.

ENJOY SATELLITE TV

Save money with easy, guaranteed, do-it-yourself antenna plans/kits. Electronic knowledge not necessary. Send \$1.00 for catalog or \$8.95 for 1984 "Consumer Guide to Satellite Television."



GFI-D9
Box 9108
Missoula, MT 59807

SATELLITE Television Information Service. 104 channel program guide, existing satellites, satellite launchings next few years, Basic system theory, recommended Dish sizes, LNAs. Send \$2.00 to SAT/FLORIDA INFO, 2910 SE 19 Ave., Gainesville, FL 32601.

SATELLITE-TV! Lowest prices, absolutely complete systems! Major brands. Complete installation/programming guide \$3.00. Catalog only \$1.00. Dealers wanted. **Visa/MasterCard. AIS SATELLITE**, Box 1226-RE, Dublin, PA 18917, (215) 249-9411.

INVENTORS!

IDEAS have value! Ever think of an idea, forget it, and see it later on the market? Many people don't forget, act quickly, and are rewarded by American industry. Write down your idea! We offer free disclosure registration and initial consultation regarding your idea's potential value. Call or write without delay for your free information package. **AMERICAN INVENTORS CORPORATION**, 82 Broad Street, Dept. RE, Westfield, MA 01086, (413) 568-3753. A fee based marketing company. Offices coast to coast.

NEWSLETTERS

ELECTRONIC SYSTEMS NEWSLETTER is a monthly publication written especially for the electronics hobbyist/experimenter. Fascinating projects, new ideas, sources. Free details. **AF PUBLISHING**, Dept. R2, PO Box 524, So. Hadley, MA 01075.

DO-IT-YOURSELF TV REPAIR

NEW!...Repair any TV...Easy. Anyone can do it. Write, **RESEARCH**, Rt. 3, Box 601 BR, Colville, WA 99114.

Govt. SURPLUS ELECTRONIC EQUIPMENT CATALOG

New ITEMS . . . New BARGAINS!
FREE UPON REQUEST!
Send today for FREE copy of OUR BIG CATALOG, Dept. RE

FAIR RADIO SALES
1016 E EUREKA • Box 1105 • LIMA, OHIO • 45802

EDUCATION & INSTRUCTION

UNIVERSITY degrees by mail! Accredited Bachelors, Masters, PhD's. Free facts revealed. **CAREERS**, RE2, Box 470886, Tulsa, OK 74147.

WANTED

OLD tubes: 2A3, 10's, 45's, 50's, 80's, 81's, 211, 242, 845, VT-52, VT-62. **WESTERN ELECTRIC EQUIPMENTS:** (818) 576-2642, David POB 832, M-Park, CA 91754

INVENTIONS, ideas, new products wanted! Industry presentation/national exposition. Call free (1-800) 528-6050. Arizona, (1-800) 352-0458. X831.



SUPER LED's
2 amp. rating w/heat sink
ME2 IR (a) 25A pulse
ME5 IR (b)
MV4 RED (a) \$4.95 each

RESISTOR SALE

OUR IMPORTER SHIPPED THE 1/4W 5 PERCENT RESISTORS IN PACKS OF 200 INSTEAD OF THE 100 PACKS WE USUALLY GET. WE HAVE ALL THE STANDARD VALUES FROM 1 TO 4.7 MEGS.
EACH 200 PAK \$2.35
FIVE PAKS \$11.00
25 or more-only \$2 ea.

MEMORY SALE

	MS	ea.	3for
4164 dyn 1x64k	300	4.00	\$8.00
4164 " " 150	4.20	8.40	
4116 " 1x16k	150	1.75	3.50
6116 stat 8x 2k	150	6.95	13.90
2114 " 4 x 1k	150	2.30	4.60

GERMANIUM SIGNAL DIODES

LOW FORWARD VOLTAGE- IDEAL FOR TTL CIRCUITS. HALF INCH LEADS. ALL DIODES PRIME.....
1 OUNCE over 100 \$3.50

BUY A POUND

UNTESTED DIGITAL INTEGRATED CIRCUITS THESE ARE MARKED AND CONTAIN SOME HOUSE NUMBERS. WE HAVE REPORTS OF A GOOD YIELD OF FUNCTIONAL FAXX AND DTL IC's. PUT YOUR TESTER TO PROFITABLE USE...
HUNDREDS of ICs \$10

SILICON SIGNAL DIODES

HIGH QUALITY (ALL PRIME), SIGNAL DIODES. MARKED WITH IXXXX OR WITH COLOR CODE. PULL LEADS...
10 OUNCES over 1000 \$7.95

BABYLON ELECTRONICS 4811 Myrtle Ave. Sacramento, CA 95841

(916) 334 2161
we pay post on orders for \$15 or more payment must be in U.S. funds. Foreign orders must include post B&C, inc are not prepaid and shipping is added.



HI-GAIN, LO-NOISE 2.1-2.5 GHz. MICROWAVE RECEIVING SYSTEM. COMPLETE READY TO INSTALL- INCLUDES A 20" DISH, DOWN CONVERTER AND POWER SUPPLY WITH ALL CABLES AND INSTR. FOR EASY INSTALLATION. 12 MONTHS PARTS AND LABOR GUARANTEE.
\$74.95

send for FREE FLYER

TRANSISTOR BONANZA

FIRST QUALITY- NEW 7092 PNP DEVICES MADE FOR A LARGE COMPUTER COMPANY. THESE HOUSE NUMBERED PARTS ARE NOT SECONDS OR REJECT PARTS...
100 for \$6

WE WELCOME VISA-MC PHONE ORDERS. ORDERS RECEIVED BEFORE NOON (PACIFIC) WILL BE SHIPPED UPS THAT DAY...

MICRO MART

508 Central Ave. Westfield, N.J. 07090 (201) 654-8008

UHF-TV PREAMP
(As featured in Radio Electronics March/May articles, 1982)

This inexpensive antenna mounted pre-amp can add more than 25 dB of gain to your system. Lots of satisfied customers and repeat orders for this high quality kit, which includes all component parts, PC BD, Case, Power Supply and Balun \$34.50 Assembled Version..... \$57.50

APPLE Heart Rate Monitor KIT-\$39.95

- ROTARY SWITCH(3 POSITION, 5A 125V) 2/1.00
- PRECISION TRIM POTS-100 ohm, 500 ohm, 1K, 2K 5K, 10K, 20K, 50K, 100K, 200K, 500K, 1M. 3/1.95
- 7812 VOLTAGE REGULATOR (PRIME) 2/1.00
- 7912 VOLTAGE REGULATOR (PRIME) 2/1.00
- TAPPED TRANSFORMER(7A) 7.5, 9, 15, 18V-89.95
- WALL PLUG TRANSFORMER- 24V 525MA. 84.50
- 4164 DYNAMIC RAM(HEC 84 DATE CODE, PRIME) IDEAL FOR IBM PC'S & CLONES(1500) 4.50
- 1 OHM CRYSTALS. 1.95
- JUMBO RED LED'S-DIFFUSED LENS, PRIME (TI) NO COSMETIC REJECTS. ALL 100%.....15/1.00, 100/4.00, 1,000/37.50.
- COILS FOR RADIO ELEC'S FEB 84 TV PROJECT, TOKO #1'S T-1, T-2, L-1(112UH) & L-2(107UH) COMPLETE SET OF ALL 5 COILS..... 8.50
- MC1330- PRIME (MOTI)..... 1.19
- 8FC-85 TRANSISTOR..... 1.50
- 355 TIMERS- PRIME, (TI)..... 3/1.00
- 8 PIN IC SOCKETS..... 15/1.00
- 1,000UF 50V RADIAL (NICHICON)..... 4/1.00
- 47UF 25V RADIAL (NICHICON)..... 10/1.00
- TEXAS INST#4974A KEYBOARD- INC/DATA FOR PINS MADE WHEN EACH KEY DEPRESSED..... 4.95
- 8 INSTRUCTIONS- \$2.25. PROJECT CASE 82 DISPLAY/12VDC/TIME SET SWITCHES/DATA-4.95
- 18V/18IC/COOLANT/MOISTURELEVEL DETECTOR KIT- FOR AUTOMOTIVE OR ANY FLUID LEVEL APPLICATIONS. INCLUDES PC BD, ALL PARTS, & INSTRUCTIONS..... \$2.25. PROJECT CASE 82 POTS- 1 MEG, LINEAR TAPER..... 5/1.00
- DIP SWITCH- 3 POSITION..... 10/1.00
- MOTION DETECTOR BOARDS-82 EACH..... 7/10.00
- MOTION DETECTOR IC'S(ULN2221/3/82, 20/810 BLACK, PLASTIC PROJECT BOX FOR ABOVE-1.95
- EXTENSIVE CONSTRUCTION ARTICLE FOR DET.#1, 1,000 PC RESISTOR ASS'T(30 VALUES) 12W-83
- 7808 VOLTAGE REGULATORS..... 10/1.00
- .22UF 50V MINI DISC..... 20/1.00
- 3200UF 50V TWIST LOCK (IDEAL FOR POWER SUPPLIES)..... 3/2.00
- .33UF 100V DIP NYLON..... 10/1.00

- 4,7UF 40V RADIAL..... 13/1.00
- TRIM POTS-PIHER P10V, HOR, 3/8"-MIX/MATCH, 100 OHM, 1K, 10K, 25K, 50K, 100K, 200K... 4/1.00
- LM1310'S..... 2/1.00
- CD4047..... .95
- LN380 (LN3280)..... .95
- BERN TO-5 HIGH QUALITY HEAT SINKS.10/1.00
- " TO-18 10/1.00
- MOLEX PINS- 7 PIN/STRIP-500/4.00, 1,000/84
- HEAT SENSITIVE SWITCHES..... 10/1.00
- LED MOUNTING CLIPS/RINGS..... 15/1.00
- ZENER DIODES- 20V 1W..... 30/1.00
- 1N4002'S..... 20/1.00
- ZENITH TV REPLACEMENT IS SPECIAL \$1 EACH
- 221-42, 221-43, 221-45, 221-48, 221-69, 221-79, 221-87, 221-96, 221-104, 221-105, 221-104.....
- 221-132..... 2.50
- 221-140(INDUSTRY REPLACEMENT#845)..... 4.90
- REPLACEMENT #844(CA3217), 28 PIN IC..... 8.90
- 25C1172B TOSHIBA- HORIC. OUTPUT..... 1.95
- 3.579548MHz COLOR BURST CRYSTAL..... .85
- 2732 EPROMS..... 4.95
- SIGNALHARK 1 MODER(300 BAUD)..... 859
- GORILLA HIGH RESOLUTION GREEN MONITOR 879
- " AMBER..... 886
- HIGH QUALITY COOLING FAN(PANFOTOR)..... 59
- TRANSFORMERS- 6.3V 1.2AMP..... 1.50
- 1UH FIXED CHOKES, RFC-102..... 3/1.00
- 22MFG & 27MFG WIRE..... 50/1.00
- VOLTAGE-RATE SWITCHING REGULATOR KIT..... 4.95
- THIS PROJECT FEATURES ADJUSTABLE DC/DC OUTPUT- (-124 TO +130VDC, STEP UP, DOWN AND INVERSION MODES..... 18.50
- CHIP CAPS- SET OF 4,2 EACH 2.7k3.3p-1.75
- ZENER DIODES- 15V 1W, GLASS..... 30/1.00
- BNC "T" CONNECTOR (AMPHENOL)UG-274..... .95
- RIBBON CABLE, 26 CONDUCTOR, 28 AVG. - 50/FT..... 50
- 11,000UF 40V COMPUTER GRADE(MALLORY)-2.00
- FREQUENCY COUNTER IC-INTERIL 7225..... 9.00
- CRYSTAL-CONTROLLED PULSE GENERATOR KIT YOU PICK THE FREQUENCY FROM 1 HZ TO ANY MULTIPLE OF 10 UP TO 1 MHz (SAME KIT AS FEATURED IN RADIO ELEC'S SPECIAL PROJECTS MAGAZINE), SPRING- 84..... 7225..... 9.95
- MINIATURE GEAR MOTOR(AURORA)..... 2/1.00
- 10,000UF 75V COMPUTER GRADE CAP..... 1.95
- 5,000UF 25V LYTIC..... 2/1.00
- 1UF 50V MONOLITHIC..... 10/1.00
- 22/44 PIN CONNECTOR(FURPH212-44MT) 2/1.00
- 22/44 (WIREWRAP-GOLD) #SAU22D/3-2H- 2/1.00
- LN545, PRIME, HOUSERSL60505..... 2/1.00
- VOLT-DMH CENTER IO-1K OHM, 0-300V..... 4.95
- AMMETER IO-15 A.C. AMPERES..... 4.95
- OHMMETER IO-100..... \$259
- BNC-BX800 PRINTER..... \$249
- SHURBAT 1/2 HEIGHT #425 DOUBLE-SIDED, DOUBLE-SENSITIVITY- ALL BRAND NEW..... \$152

Terms: MICRO-MART accepts Visa, MC and telephone COD's. Minimum order \$10.00. Shipping—U.S. orders, \$2.00. Canada and other countries \$3.50 (includes ins.). Shipping rate adjusted where applicable. NJ residents add 5% sales tax.
MICRO-MART • 508 CENTRAL AVE., WESTFIELD, NJ 07090 • (201) 654-8008

Radio Shack Parts Place™

Over 1000 Items in Stock. The Store for Builders and Fixers!

Computer / Game Connectors

Type	Positions	Cat. No.	Each
Solder Sub-D Male	9	276-1537	1.99
Solder Sub-D Female	9	276-1538	2.49
Hood for Above	9	276-1539	1.99
Solder Sub-D Male	15	276-1527	2.49
Solder Sub-D Female	15	276-1528	3.49
Hood for Above	15	276-1529	1.99
Solder Sub-D Male	25	276-1547	2.99
Solder Sub-D Female	25	276-1548	3.99
Hood for Above	25	276-1549	1.99
Solderless Sub-D Male	25	276-1559	4.99
Solderless Sub-D Fem.	25	276-1565	4.99
Printer Connector	36	276-1534	6.99
Cable Socket	34	276-1525	3.19

1/4 Watt, 5% Resistors

Pkg. of 5 **39¢**

Ohms	Cat. No.	Ohms	Cat. No.
10	271-1301	10k	271-1335
100	271-1311	15k	271-1337
150	271-1312	22k	271-1339
220	271-1313	27k	271-1340
270	271-1314	33k	271-1341
330	271-1315	47k	271-1342
470	271-1317	68k	271-1345
1k	271-1321	100k	271-1347
1.8k	271-1324	220k	271-1350
2.2k	271-1325	470k	271-1354
3.3k	271-1328	1 meg	271-1356
4.7k	271-1330	10 meg	271-1365
6.8k	271-1333		

4000-Series CMOS ICs

With Pin-Out and Specs

Type	Cat. No.	Each
4001	276-2401	.99
4011	276-2411	.99
4013	276-2413	1.19
4017	276-2417	1.49
4049	276-2449	1.19
4066	276-2466	1.19

TTL Digital ICs

With Pin-Out and Specs

Type	Cat. No.	Each
7400	276-1801	.89
7404	276-1802	.99
7408	276-1822	1.29
7447	276-1805	1.59
7490	276-1808	1.09

MOV Transient Protectors

Power Diss.	Cat. No.	Each
600 mW	276-570	1.59
1 watt	276-568	1.69

Fast-Acting 5x20 mm Fuses

Pkg. of 2 **89¢**

Amps	Cat. No.	Amps	Cat. No.
0.315	270-1249	2	270-1244
1/2	270-1241	2.5	270-1245
3/4	270-1242	3	270-1246
1	270-1250	4	270-1247
1.5	270-1243	5	270-1248

Tantalum Capacitors

■ 20% Tolerance
■ IC PCB Spacing

µF	VWDC	Cat. No.	Each
0.1	35	272-1432	.49
0.47	35	272-1433	.49
1.0	35	272-1434	.49
2.2	35	272-1435	.59
10	16	272-1436	.69
22	16	272-1437	.79

Monolithic Ceramic Capacitors

Epoxy Dipped ■ 50 WVDC

Value	Temperature Coefficient	Cat. No.	Each
100 pF	NPO	272-152	.69
470 pF	NPO	272-153	.69
1000 pF	Z5U	272-154	.69
4700 pF	Z5U	272-155	.69
.01 µF	Z5U	272-156	.69
.047 µF	Z5U	272-157	.69
.1 µF	Z5U	272-158	.79

Mini SPDT Relays

Only 1 x 1 1/16 x 3/4". Typical drain 12 mA—ideal for battery-powered circuits. Contacts: 1 amp at 125VAC.

6-9 VDC Coil. 275-004 . . . 2.99
12 VDC Coil. 275-003 . . . 2.99



Wire Wrapping DIP Sockets

Square 0.25" posts accept 3 levels of wrap.

Pins	Cat. No.	Pkg. of 2
8	276-1988	1.19
14	276-1993	1.29
16	276-1994	1.39

Solder DIP Sockets

Type	Cat. No.	Price
8-Pin	276-1995	2/59¢
14-Pin	276-1999	2/89¢
16-Pin	276-1998	2/89¢
18-Pin	276-1992	.49
20-Pin	276-1991	.59
24-Pin	276-1989	.79
28-Pin	276-1997	.89
40-Pin	276-1996	.99

Replacement Transistors

Type	Cat. No.	Each
2N1305 PNP	276-2007	1.19
MPS2222A NPN	276-2009	.79
PN2484 NPN	276-2010	.89
MPS3904 NPN	276-2016	.69
TIP31 NPN	276-2017	.99
TIP3055 NPN	276-2020	1.59
MPS2907 PNP	276-2023	.79
MJE34 PNP	276-2027	1.49
2N3053 NPN	276-2030	.99
MPS3638 PNP	276-2032	.79
TIP120 NPN	276-2068	1.29
2N3055 NPN	276-2041	1.99
MJ2955 PNP	276-2043	2.19
2N4401 NPN	276-2058	.59
MPSA06 NPN	276-2059	.59
MPSA13 NPN	276-2060	.59
MPSA42 NPN	276-2061	.69
2SC945 NPN	276-2051	.79
2N3819 N-FET	276-2035	.99
MPF102 N-FET	276-2062	.99
IRF511 V-FET	276-2072	2.59
IRFD1Z3 V-FET	276-2073	1.49
2SC1308 NPN	276-2055	7.95

RS-232C Line Driver, Receiver

Type	Cat. No.	Each
MC1488 Driver	276-2520	1.79
MC1489 Receiver	276-2521	1.79

CMOS and Bipolar Timers

TLC555. New CMOS design with very low power consumption—typically one milliwatt with 5 VDC supply. Same pinout as 555 but works with smaller, less expensive capacitors. 276-1718 1.59

Bipolar. Resettable timing from one µsecond to one hour.

Type	DIP	Cat. No.	Each
555 (Single)	8-pin	276-1723	1.19
556 (Dual)	14-pin	276-1728	1.49

Dictionary of Microcomputer Terms

NEW!

Defines over 1200 modern day microcomputer terms with clear and concise descriptions. Large, easy-to-read typeface. Over 100 illustrations. Special up-front section contains over 200 common abbreviations, acronyms and special symbols. 96 pages. 62-1392 2.79



Continuity Tester Chassis



SPECIAL PURCHASE 1⁹⁵

Circuit continuity produces a warbling tone. Many possible uses including security alarms, capacitor/diode checker, more. Operates from 9V transistor battery. Great experimenter's item at a bargain price. 277-1014 1.95

TV RF Modulator Chassis



SPECIAL PURCHASE 4⁹⁵

Selectable channel 3/4 output. 5-pin DIN plug accepts video, audio and 12 VDC power inputs. On/off switch with built-in TV antenna/modulator switching. Auto shutdown circuit in case of signal input overload. 277-1015 4.95

Power Supply Chassis

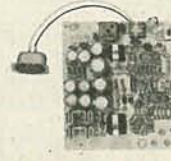

SPECIAL PURCHASE 4⁹⁵

Our big buying power brings you a compact switching power supply for an incredibly low 44¢ a watt! Input: 18 VAC (use our #273-1515 transformer). Outputs: 12VDC at 400 mA, +5 VDC at 1.1 amp and -5 VDC at 200 mA. 277-1016 4.95

A DIVISION OF TANDY CORPORATION

Radio Shack®

Prices apply at participating Radio Shack stores and dealers

OVER 8800 LOCATIONS WORLDWIDE

CIRCLE 78 ON FREE INFORMATION CARD

FEBRUARY 1985

FREE KIT Catalog

FUNCTION GENERATOR KIT \$59.95
Auto-Ranging Cap-meter kit \$79.95

Phone 209-772-2076

Write or Phone for FREE CATALOG

DAGE SCIENTIFIC INSTRUMENTS
BOX 144 VALLEY SPRINGS CA 95252

contains
**TEST &
EXPERI-
MENTER'S
EQUIP.**

PLANS AND KITS

PRINTED-circuit boards. Quick prototypes, production, design, reflow solder. Send print or description for quote to **KIT CIRCUITS**, Box 235, Clawson, MI 48017.

FREE catalog, 99-cent kits—audio, video, TV, computer parts. **ALLKIT**, 434 West 4th Street, West Islip, NY 11795.

HI-FI speaker kits, auto speaker systems and speaker components from the world's finest manufacturers. For beginners and experts. Free literature. **A & S SPEAKERS**, Box 7462R, Denver, CO 80207 (303) 399-8609.

CABLE-TV converters: Jerrold, Hamlin, SB-3, AN-3, Mini-Code, Zenith and more. UHF converters: Deluxe II sinewave kits \$95.00, gated pulse add on \$70.00. Complete units \$195.00, with gated pulse \$255.00. (Quantity discounts.) Repairs of all converters & cable boxes. Send S.A.S.E. (54 cents postage) or call for info. 1 (312) 637-4408. **HIGGINS ELECTRONICS**, 6014 W. Nelson, Chicago, IL 60634. No. Illinois orders accepted.

PROJECTION TV...Convert your TV to project 7 foot picture...Results comparable to \$2,500.00 projectors...Total cost less than \$30.00...Plans and 8" lens \$19.95...Illustrated information free. **MACROCOMA-GF**, Washington Crossing, PA 18977. Creditcard orders 24 hours, (215) 736-3979.

PHOTO circuit boards. Your idea becomes a finish board in one hour. Cost complete about 12 cents per square inch. Equipment cost about \$30.00. Send \$3.00 for instruction book and catalog. **I.D.S.**, 160 No. Main St., West Salem, OH 44287.

CB/HAM new automatic V.S.W.R. meter modification kit for your V.S.W.R. meter. Continuously monitors V.S.W.R., Hivswr alarm, eliminates set power step. Kit \$32.50, California add 6%. **RJ FROST ELECTRONICS**, 11106 Ironwood Rd., San Diego, CA 92131. Allow 8-10 weeks.

ELECTRONIC kits: Polyphonic digital synthesizer, digital sound sampler and accessories. Build a professional system at low cost. The VMS synthesizer system is compatible with most microcomputers, (Apple, Commodore, Sinclair, etc...) Complete software packages available for the Commodore 64. Imported from West Germany. Send \$5.00 for brochure and demo-cassette. Mail to: **CEDOS ELECTRONICS**, PO Box 101, Waukesha, WI 53187.

CUSTOM printed circuit board design. For price quotation send schematic diagram and \$1.00, refundable with order to: **MARK MISIAK**, 5035 So. Kostner Ave., Chicago IL 60632.

CATALOG: Hobby, radio broadcasting, CB, lowers. Transmitters, linears, active antennas, converters, scramblers, bugging devices, more! **PANAXIS**, Box 130-F2, Paradise, CA 95969.

DIGITAL Klock Kit plays 1-of-12 melodies each quarter hour. Displays time, date, and other features. Send \$2.50 for assembly plans and pricing to **KERBER KLOCK KO**, 36117 Hillcrest, Eastlake, OH 44094.

DESCRAMBLER plans. New design decodes gated sync suppressed signals—newest pilotless method. Circuit boards, most parts from Radio Shack. Detailed theory, drawings, schematics, instructions \$14.95 plus \$2.00 shipping. **DIRIJO CORP.**, Box 212, Lowell, NC 28098.

CONTROL your world with your computer! Control up to 48 devices easily. Complete plans, schematics, programs \$9.95. **B & W ELECTRONICS**, 3621 Lowden, Kalamazoo, MI 49008.

REEL-TO-REEL TAPES

AMPEX professional series open reel tape, 1800-or 2400-feet on 7-inch reels, used once. Case of 40, \$45.00. 10 1/2 x 3600 feet and cassettes available. MasterCard/Visa. **VALTECH ELECTRONICS**, Box 6-RE, Richboro, PA 18954 (215) 322-4866.



ORGAN & PIANO KITS

ALPHA DX 300



**fully
DIGITAL
RS232
Interface**

For Free Sound Info
Call 1-800-233-3865
or write **WERSI USA**
Dept. M 8 P.O. Box 5318
Lancaster, PA 17601

THE WORLD LEADER

ALUMINUM EQUIPMENT CABINET

9" X 12" X 3-1/2" ORIG COST \$40. NEW HEAVY GAUGE ALUMINUM (1/8" SIDEWALLS) WITH ATTRACTIVE BLACK FINISH, GREAT FOR ALL SORTS OF TEST AND COMPUTER EQUIP. FRONT PANEL IS PUNCHED FOR COUNTER/DVM USE (EASILY COVERED), REAR PANEL HAS OPENINGS FOR LINE PLUG, SWITCH, ETC.

X-8000 WT 5 LB \$9.95 10/\$89 100/\$75



END STACKABLE

LED VU METER

M-4275
WT 0.1 LB

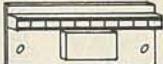

NATIONAL NSM 3916-9 INCLUDES A 10 ELEMENT LED LINEAR ARRAY WITH AN LM3916 DECODER/DRIVER. THRESHOLDS ARE SET AT COMMON VU POINTS THE FIRST 7 LEDS ARE GREEN, THE LAST 3 ARE RED. 2" X 0.85" OVERALL, OPERATES FROM 3 TO 24 VDC, 1% ACCURACY. DATA - .50¢

\$3.75 10/\$34 100/\$300.

SOUND EFFECTS



COMPLETE, OPERATING ASSY. HAS FLASHING LIGHTS, HEAVY DUTY 2-1/4" SPEAKER, RUNS ON 9-12 VDC! MAKES SIREN & EXPLOSION SOUNDS, BUT YOU CAN RE-PROGRAM THE SN76487 TO MAKE LOTS OF OTHERS!

X-1560 WT 0.2 LB
\$1.95 10/\$17.50

YOU SAY YOU WANT A FREE FLYER AND YOU WANT IT NOW? JUST SEND US A SELF ADDRESSED STAMPED BUSINESS SIZE ENVELOPE.

DIAMONDBACK
ELECTRONICS COMPANY
PO BOX 12095
SARASOTA, FL. 33578

Phone Orders (813) 953-2829

Continental US add \$1.80 for the first pound and 50¢ for each additional pound. Canada add \$3.50 first lb and \$1 for each additional. Florida add 5% sales tax.

MAIL ORDER \$7 MINIMUM
COD, UPS CASH ONLY \$15 MIN.
VISA & MASTERCARD \$15 MIN.

7-12 VDC LED CLOCK

\$2.75



NATIONAL MA-6008 IS A COMPLETE DC POWERED CLOCK WITH KEYBOARD TIME/DATE ENTRY, TIME BASE CONSISTING OF AN MM5369 AND 3.579 MHZ CRYSTAL, ALL IN A 2-3/8 X 3-1/4 MODULE. BRAND NEW, 100% FUNCTIONAL. DATA-.25¢

10/\$25 100/\$200.
M-6008 WT 0.1 LB

CIRCLE 254 ON FREE INFORMATION CARD

MICROWAVE TV ANTENNA SYSTEMS

Freq. 2.1 to 2.7 GHz . 34 db Gain +

COMPLETE SYSTEMS:

(as Pictured)

Commercial 40" Rod Style \$99.95

Parabolic 20" Dish Style \$79.95

COMPONENTS

Down Converters (either style) \$34.95

Power Supplies (12V to 16V. DC+) \$24.95

Data Info (Plans) \$ 9.95

CALL OR WRITE FOR KITS, PARTS, OR MORE INFORMATION

Shipping & Handling Add \$5.00
We Repair Most Types Down Converters & Power Supplies

Phillips-Tech
Electronics

P.O. Box 34772
Phoenix, AZ 85087
(602) 967-8972

Special Quantity Pricing
Dealers Wanted

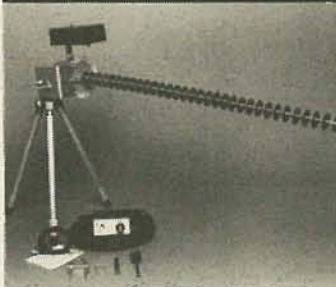

LIFETIME LIMITED WARRANTY
PARTS & LABOR

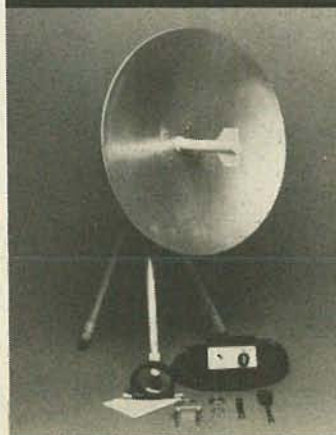

CIRCLE 116 ON FREE INFORMATION CARD

AMAZING DEVICES

PERSONAL DEFENSE AND PROPERTY PROTECTION UTILIZE SPACE AGE TECHNOLOGY.
CAUTION THESE DEVICES CAN BE HAZARDOUS AND MAY SOON BE ILLEGAL.

POCKET PAIN FIELD GENERATOR — IPG50
Assembled.....\$64.50
IPG5 Plans.....\$8.00 IPG5K Kit/Plans.....\$44.50
PHASOR PAIN FIELD CROWD CONTROLLER — PPF10
Assembled.....\$250.00
PPF1 Plans.....\$15.00 PPF1K Kit/Plans.....\$175.00
BLASTER— Provides a plasma discharge capable of puncturing a can.
BLS10 Assembled.....\$89.50
BLS1 Plans.....\$10.00 BLS1K Kit/Plans.....\$69.50
SHOCKER/PARALYZING DEVICE— Very intimidating and effective. 5 to 10 feet
SHG60 Assembled.....\$99.50
SHG6 Plans.....\$10.00 SHG6K Kit/Plans.....\$69.50

RUBY LASER RAY GUN— Intense visible red beam burns and welds hardest of metals. **MAY BE HAZARDOUS.**
RUB3 All Parts Available for Completing Device \$15.00
CARBON DIOXIDE BURNING, CUTTING LASER— Produces a continuous beam of high energy. **MAY BE HAZARDOUS.**
LCS. All Parts Available for Completing Device. \$15.00
VISIBLE LASER LIGHT GUN— produces intense red beam for sighting, spotting, etc. Hand held complete.
LGU3 Plans.....\$10.00 (Kit & Assembled Units Available)
IR PULSED LASER RIFLE— Produces 15-30 watt infra-red pulses at 200-2000 per sec.
LRG3.....All Parts & Diodes Available.....\$10.00
BEGINNERS LOW POWER VISIBLE LASER— Choice of red, yellow, green— provides an excellent source of monochromatic light.
LHC2.....Plans.....\$5.00 LHC2K.....Kit.....\$34.50

SNOOPER PHONE— Allows user to call his premises and listen in without phone ever ringing.
SNP20 Assembled.....\$89.50
SNP2 Plans.....\$9.00 SNP2K Plans/Kit.....\$59.50
LONG RANGE WIRELESS MIKE— Miniature device clearly transmits well over one mile. Super sensitive, powerful.
MFT1 Plans.....\$7.00 MFT1K Plans/Kit.....\$49.50
WIRELESS TELEPHONE TRANSMITTER— Transmits both sides of phone conversation over one mile, shuts off automatically.
WVPM5 Plans.....\$8.00 WVPM5K Plans/Kit.....\$39.50
TALK & TELL AUTOMATIC TELEPHONE RECORDING DEVICE— Great for monitoring telephone use.
TAT20 Assembled.....\$24.50
TAT2 Plans.....\$5.00 TAT2K Plans/Kit.....\$14.50

Our phone is open for orders anytime. Technicians are available 9-11 a.m., Mon-Thurs for those needing assistance or information. Send for free catalog of hundreds more similar devices. Send check, cash, MO, Visa, MC, COD to: **INFORMATION UNLIMITED**
DEPT RB, P.O. Box 716, Amherst, N.H. 03031 Tel: 603-673-4730

CIRCLE 72 ON FREE INFORMATION CARD

NICAD BATTERY ZAPPER KIT
This is one of the most useful and money saving kits you can buy! The Nicad Zapper kit repairs those nicads that you no longer use because they won't recharge. Many nicads quit taking a charge after a period of time because they grow internal "whiskers". The only way to make them take a charge again is to "blow" these "whiskers". This small kit operates from 6VDC (4 AA cells, etc.), and produces 300VDC which it applies momentarily to the nicad to "blow the whiskers" without damaging the battery. Repairs about 90% of nicads in sizes from AA to C cells. After zapping, the nicad is ready to be fully charged again and again (just like it did when it was new). The nicad zapper produces absolutely amazing results! Stop throwing those expensive nicads away! The kit comes with all parts, PC board and instructions (less batteries and case).
C6278 \$14.95

STYLISH CASE
Here's the case you need to make that professional looking project. Ultra-stylish black case with chrome edged red front bezel. Complete with screws. Size: 3 1/2" x 3 1/2" x 1 1/2". Nice of Bezel: 3 1/2" x 1 1/2".
C6252 \$4.95

PHONE ORDERS: 303-973-7291

120 VAC Xenon Strobe Kit
C3071 \$10.95
Complete variable rate strobe light kit produces brilliant flashes of light. Operates from standard 120VAC. Reliable design—thousands of these are in use throughout the world. Overall size of complete board: 1 1/2" x 2 1/2" x 3 1/2".

BOX OF ELECTRONICS
Super surprise of resistors, capacitors, IC's, transistors, sub-assemblies, diodes, switches, notes, etc. in a 4"x6"x5" box. Lots of "Gonads"! Note, because of shipping costs we can only ship this via UPS.
C6282 \$10.00

2732 EPROM
Blank Hitachi 450NSEC Eprom
C6299 \$1.49
C4972 \$2.95

SEND FOR YOUR FREE COPY OF OUR 1985 CATALOG LISTING:
*Over 70 electronic kits which include parts and pc board!
*A million dollars worth of hand held games at giveaway prices!
*Tremendous electronic bargains!

CHANEY electronics inc.
P.O. BOX 27038
DENVER, COLORADO 80227

- Minimum AD Order \$9.00
- Please include \$2.00 for postage (UPS)
- VISA, MC accepted
- Phone orders are welcome

Send for our free catalog of unique items

CIRCLE 109 ON FREE INFORMATION CARD

UHF, CABLE-TV UNITS

ZENITH VHF/UHF "Super Z" kit in stock (also works on Zenith cable units, Z-Tac) only \$179.95. Put a little sting in those faraway UHF stations with our 25dB preamp kit, the "Scorpion" \$22.95. Large quantity discounts on cable units, N-12's, SB, MLD-1200's, filters. We buy surplus parts, excess inventory. We now have over a 1/4 of million dollars in parts stocked, resistors/capacitors/coils/IC's many more. Check out our low prices. Dealers give us a call on quantity pricing. Will ship anywhere. FOB/Balt. COD welcome. Carte Blanch/Diners Club accepted. UPS Daily. Add 3% shipping. Maryland residents 5% state tax. Credit card orders, information, COD's and dealer pricing call (301) 574-7882 or 7883. Call or write for free catalog to S.E. CORPORATION, PO 9534, Baltimore, MD 21237.

SCANNERS

JOIN 30,000 other scanner owners in the nation's largest not-for-profit association of scanner owners. Bi-monthly publication with tech tips, fascinating true stories, news of new listening adventures. Plus member benefit package including car rental discounts, no-extra-cost insurance coverage, free classified ad service, and more. Send just \$9.75 for 10-month trial membership to: **SCANNER ASSOCIATION OF NORTH AMERICA**, 240-A Fencil Lane, Hillside, IL 60162.

CABLE TV NOTCH FILTERS

SUPER powered notch filters. Eliminate any unwanted signals. Channels available: 2-6, 14-22 (A-I). Only \$19.00 each. **Money back guarantee.** Quantity discounts, CATV, PO Box 17621, Plantation, FL 33318.

CABLE CONVERTERS & DESCRAMBLERS

HAMLIN OAK JERROLD SCIENTIFIC SYLVANIA ZENITH

ALL TYPES OF CABLE TV EQUIPMENT
MICROWAVE ANTENNAS & ACCESSORIES
— FREE ILLUSTRATED BROCHURE —
— CALL OR WRITE —
H.M.R. SALES
221 E. CAMELBACK #1
PHOENIX, AZ 85012
(602) 993-0398

BUSINESS OPPORTUNITIES

US \$8.00 including disk thousand name brand programs for Apple IBM-PC details **RELIANT**, PO Box 33610, Sheungwan, Hong Kong.

MECHANICALLY inclined individuals desiring ownership of small electronics manufacturing business—without investment. Write: **BUSINESSSES**, 92-R, Brighton 11th, Brooklyn, NY 11235.

PROJECTION TV...Make \$\$\$'s assembling projectors...Easy...Results comparable to \$2,500.00 projectors...Your total cost less than \$200.00... **Plans, 8" lens & dealer's information \$17.50...** Illustrated information free... **MACROCOMA GFX**, Washington Crossing, PA 18977. Creditcard orders 24 hours (215) 736-2880.

YOUR own radio station! AM, FM, cable. Home operation possible. **BROADCASTING**, Box 130-F2, Paradise, CA 95969.

BURGLAR alarms—booming business. Get in now. Starting information \$2.00. **DYNAMIC SECURITY**, PO Box 1456-T, Grand Rapids, MI 49501.

QUALITY ELECTRONICS, 2305 Old Buncombe Rd., Greenville, SC 29609, (803) 235-8691. Mail or bring in service for Comodor Phone Mate, Panasonic dealer distributor. Inquiries invited for other electronic service quotes.

CB MODIFICATIONS

Increase channels, range, privacy! We specialize in frequency expanders, speech processors, FM converters, PLL & slider tricks, how-to books, plans, kits. Expert mail-in repairs & conversions. 16-page catalog \$2.

CBC INTERNATIONAL, P.O. BOX 31500RE, PHOENIX, AZ 85046 (602) 996-8700

P.C. BOARDS AND ART SERVICES

FACE PLATES ENCLOSURES
WRITE OR CALL
For Literature or Quotes

Let us quote you on any stage of your product from proto types to production.
FABTRON DIV.
P.O. Box 925
Columbia, TN 38401
(615) 381-1143

PRINTED CIRCUIT BOARDS

PRINTED circuit boards, double sided with plated through holes or single sided. No set up charge. **CAUDILL INC.**, 205 East Westwood Ave., Highpoint, NC 27262, (919) 884-0229.

SINE WAVE QUESTIONS?

TROUBLE shooting, alignment, antenna hookup, improvements manual, \$6.00. **STV authorization control**, \$3.00. Both, \$8.00. **SIGNAL**, Box 2512-R, Culver City, CA 90231.

DESCRAMBLERS

AMERICAN—CANADIAN
New Satellite Descramblers
C-1000 / ZENITH TYPE

Descrambles "over the air" and "cable" sync suppressed active video inversion signals
Ready to go C-1000.....\$379.95
Complete Kit C-1000K.....\$274.95
Printed Circuit & Manual.....\$24.95

C-100 / JERROLD TYPE

Cable Descrambler for in-band gated suppressed systems
Ready to go C-100.....\$119.95
Complete Kit C-100K.....\$54.95

SEND \$2 FOR COMPLETE INFORMATIVE CATALOG TO DETERMINE WHAT TYPE YOU NEED

J & D ENGINEERING
P.O. Box 6099
Falmouth, Maine 04105
(617) 837-8431
Dealers Wanted
Special Quality Pricing
COD'S—OK

Buy 1 kit
Get 2nd kit
at 1/2 price

All J & D products are engineered, not copied, all are guaranteed 90 days & we stand behind our products where others fail to

GRAPHIC EQUALIZERS, ETC.

NOISE eliminators, expanders, power meters, others. Twelve-24 bands/channel equalizers from \$89.00 Kit see R-E 5-6/78, 2/80, 3-4/81. Catalog: **SSS**, 856R Lynnrose, Santa Rosa, CA 95404. (707) 546-3895.

CABLE TV

DEALERS wanted: Channel 2, 3, and 4 notch filters. **Money back guarantee.** Send \$15.00 for sample and quantity price list. Specify channel(s). **LEE KURTZ**, PO Box 291394, Davie, FL 33329.

24" DEEP DISH MICROWAVE TV ANTENNAS

1.9 to 2.6 GHz Frequency Range

24" Parabolic Dish. Pre-assembled Probe with Down Converter. Power Supply and Tuner Switch. 63' of Coax Cable with Connector. Transformer for 75-300 Ohms. Mounting Hardware for Fast and Easy Installation.

ORION ELECTRONICS
P.O. Box 26420
Tempe, Arizona 84282
(602) 897-2321

Dealers Wanted
Suggested Retail \$259.00

SPECIAL \$74.95

ADVANCED COMPUTER PRODUCTS, INC.



\$5,000,000 SALE CELEBRATION
SAVE NOW AT NEW LOW PRICES!
9th Year Anniversary SALE!

IF YOU DON'T SEE IT HERE CALL TOLL FREE

SINCE 1976

1985 CATALOG **Send \$1.00**

MAIL ORDER PRICING ONLY

Corporate Buyers ...
 Call For Volume Quotes!

APPLE COMPATIBLE PERIPHERALS

ALS CFM 3.0 PLUS CARD	SALE \$199.00
COEX 180 RAM CARD	SALE 39.95
COEX PAR. PRINTER CARD w/CABLE	49.95
COEX 80 COL EXT 84K CARD	SALE 99.95
15" PRASO I/O (80cops) SVSA	139.95
KENNINGTON SYSTEM SAVER	69.95
KENNINGTON PC SAVER	39.95
KPMFT JOYSTICK	39.95
MOCT SPEED 2800 SYSTEM	249.95
MICROSOFT 2.80 SOFTCARD	219.95
GRAPPLER PLUS	149.95

8000

6000U	\$48.95	6010	\$ 2.85	6050	\$ 3.25
6000L	69.95	6020	3.75	6052	5.65
6002	2.90	6021	2.00	6060	7.90
6003	18.95	6028	14.50	6075	7.75
6009E	14.50	6040	12.75	6080	2.20

(CALL FOR 8000E FAMILY)

LINEAR

LM100AH	\$3.95	NE590	\$2.45	LM301A	\$2.95
LM3000	99	NE920	2.70	LM3015	2.95
LM301N	35	LM700N	55	LM3016	2.95
LM304H	1.88	LM700H	1.90	MC4024	3.76
LM304N	95	LM700N	95	MC4024	3.76
LM3008	4.75	LM711	75	RC4131	3.75
LM307H	4.00	LM715	3.95	RC4136	1.19
LM308N	65	LM723N	55	RC4151	3.75
LM310CN	65	LM723H	75	CA3003	2.75
LM311CN	62	LM733	98	CA3039	1.25
LM312H	1.75	LM739	1.85	CA3046	1.25
LM312N	1.55	LM740N	1.85	CA3059	2.85
LM318H	1.55	LM741H	4.00	CA3080	2.85
LM319N	1.19	LM741N	2.9	CA3085	1.69
LM320 (see VRA)		LM747	65	CA3090	1.10
LM322N	1.25	LM1696	1.90	CA3091	1.10
LM339N	95	LM1014	1.15	CA3092	1.60
LM340 (see VRA)		LM1303	1.90	CA3093	1.50
LM342N	1.45	LM1310	1.45	CA3098	8.00
LM352CN	65	MC1330	6.85	CA3099	2.85
LM359	1.75	MC1349	8.55	CA3096	3.45
LM359N	2.95	MC1350	1.15	CA3130	1.29
LM370N	4.55	MC1358	1.85	CA3131	1.29
LM373N	3.95	MC1372	6.75	CA3146	1.79
LM378N	3.75	LM1414	1.55	CA3190	1.40
LM377H	1.90	LM1558H	2.99	LM13080	1.25
LM348N	1.45	LM1696	1.90	LM1309	1.25
LM380N	1.05	LM1812	8.10	LM13700	1.45
LM381N	1.59	LM1830	3.40	LF347	2.19
LM382N	1.35	LM1831	6.45	LF351	6.00
LM383N	1.95	LM1872	5.45	LF353	9.00
LM384N	1.78	LM1877	3.20	LF355	1.10
LM386N	89	LM1889	1.90	LF356	1.10
LM387H	1.29	LM1896	1.70	LF357	1.39
LM389N	1.15	ULN2001	1.95	TL071CP	7.90
LM392N	69	ULN2003	1.49	TL072CP	1.90
LM723N	48	XR2208	3.75	TL074CN	1.35
LM723H	55	XR2208	4.00	TL084CN	1.90
NE551	2.85	XR2211	3.75	TL494	4.10
NE555	1.45	LM2877P	2.25	TL498	8.55
NE558	1.49	LM2878P	2.25	TL497	3.20
NE561	23.50	LM2900	83	LM3023	1.49
NE564	2.85	LM2901	99	MC3403	4.95
NE567	95	LM2907	2.45	MC3406	2.85
NE569	1.45	LM2917	2.85	MC3459	3.75
NE570	85	LM3900	55	MC3499	5.25
NE571	2.90	LM3905	1.15	MC3470	7.95
NE572	2.90	LM3909	95		

7400

7400	\$ 10	7440	\$ 68	74123	\$ 45	74176	\$ 69
7401	10	7447	65	74123	42	74200	1.80
7402	10	7448	68	74128	44	74170	1.34
7403	10	7449	10	74128	49	74180	7.50
7404	10	7450	19	74132	45	74181	7.50
7405	23	7453	19	74136	75	74184	1.15
7406	40	7454	19	74141	85	74184	2.25
7407	40	7459	25	74142	295	74180	2.25
7408	24	7460	37	74143	370	74190	1.87
7409	10	7470	29	74144	295	74191	67
7410	10	7472	29	74145	59	74192	67
7411	24	7473	33	74147	149	74193	67
7412	38	7474	40	74148	149	74194	67
7413	34	7475	38	74150	109	74195	67
7414	49	7476	34	74151	65	74196	67
7415	69	7477	40	74152	67	74197	68
7416	40	7480	69	74153	53	74198	115
7417	10	7482	95	74154	119	74199	115
7421	35	7483	45	74155	69	74201	119
7422	45	7485	65	74156	69	74202	119
7423	58	7486	35	74157	99	74203	165
7425	20	7489	195	74158	165	74206	119
7426	20	7490	35	74159	115	74207	119
7427	25	7491	65	74160	79	74208	140
7428	55	7492	45	74161	40	74209	140
7429	10	7493	35	74162	69	74205	200
7430	15	7494	35	74163	69	74206	200
7431	25	7495	50	74164	69	74208	140
7432	29	7496	69	74165	69	74205	55
7433	58	7497	27	74166	55	74206	55
7434	58	7498	27	74167	55	74207	55
7435	58	7499	27	74168	55	74208	55
7436	58	7500	27	74169	55	74209	55
7437	58	7501	27	74170	55	74210	55
7438	58	7502	27	74171	55	74211	55
7439	58	7503	27	74172	55	74212	55
7440	58	7504	27	74173	55	74213	55
7441	58	7505	27	74174	55	74214	55
7442	58	7506	27	74175	55	74215	55
7443	58	7507	27	74176	55	74216	55
7444	58	7508	27	74177	55	74217	55
7445	58	7509	27	74178	55	74218	55
7446	58	7510	27	74179	55	74219	55
7447	58	7511	27	74180	55	74220	55
7448	58	7512	27	74181	55	74221	55
7449	58	7513	27	74182	55	74222	55
7450	58	7514	27	74183	55	74223	55
7451	58	7515	27	74184	55	74224	55
7452	58	7516	27	74185	55	74225	55
7453	58	7517	27	74186	55	74226	55
7454	58	7518	27	74187	55	74227	55
7455	58	7519	27	74188	55	74228	55
7456	58	7520	27	74189	55	74229	55
7457	58	7521	27	74190	55	74230	55
7458	58	7522	27	74191	55	74231	55
7459	58	7523	27	74192	55	74232	55
7460	58	7524	27	74193	55	74233	55
7461	58	7525	27	74194	55	74234	55
7462	58	7526	27	74195	55	74235	55
7463	58	7527	27	74196	55	74236	55
7464	58	7528	27	74197	55	74237	55
7465	58	7529	27	74198	55	74238	55
7466	58	7530	27	74199	55	74239	55
7467	58	7531	27	74200	55	74240	55
7468	58	7532	27	74201	55	74241	55
7469	58	7533	27	74202	55	74242	55
7470	58	7534	27	74203	55	74243	55
7471	58	7535	27	74204	55	74244	55
7472	58	7536	27	74205	55	74245	55
7473	58	7537	27	74206	55	74246	55
7474	58	7538	27	74207	55	74247	55
7475	58	7539	27	74208	55	74248	55
7476	58	7540	27	74209	55	74249	55
7477	58	7541	27	74210	55	74250	55
7478	58	7542	27	74211	55	74251	55
7479	58	7543	27	74212	55	74252	55
7480	58	7544	27	74213	55	74253	55
7481	58	7545	27	74214	55	74254	55
7482	58	7546	27	74215	55	74255	55
7483	58	7547	27	74216	55	74256	55
7484	58	7548	27	74217	55	74257	55
7485	58	7549	27	74218	55	74258	55
7486	58	7550	27	74219	55	74259	55
7487	58	7551	27	74220	55	74260	55
7488	58	7552	27	74221	55	74261	55
7489	58	7553	27	74222	55	74262	55
7490	58	7554	27	74223	55	74263	55
7491	58	7555	27	74224	55	74264	55
7492	58	7556	27	74225	55	74265	55
7493	58	7557	27	74226	55	74266	55
7494	58	7558	27	74227	55	74267	55
7495	58	7559	27	74228	55	74268	55
7496	58	7560	27	74229	55	74269	55
7497	58	7561	27	74230	55	74270	55
7498	58	7562	27	74231	55	74271	55
7499	58	7563	27	74232	55	74272	55
7500	58	7564	27	74233	55	74273	55

FARADAY IBM PC®

Compatible CPU Board w/84K, MS DOS

\$349.95

MOST MAJOR LINES IN STOCK CALL TOLL FREE

IBM PC HARDWARE

AST "COMBOPUS" 64K	\$199.00	KEYTRONIC 515051	158.00/199.00
SIGMA "MAXIMIZER" 64K	249.95	MOUSE SYSTEMS MOUSE W/5W	149.95
SIGMA DISK CONTROLLER	189.95	QUADBOARD W/84K	253.00
HARD DISK CONTROLLER	249.95	TECMAR GRAPHICS MASTER	545.00
10 Mb INTERNAL HARD DISK	795.00	TECMAR CAPTAIN 64K	319.00
10 Mb EXTERNAL HARD DISK	895.00	CURTIS PC FEDESTAL	39.00
10 Mb INTERNAL HARD DISK	1895.00	EMERALD 16	59.00
10 Mb EXTERNAL HARD DISK	1095.00	POS OR QUADROCARD CAPTOR	9.00
80 WATT BOOSTER SUPPLY	149.95	TILT AND SWIVEL STAND	21.00
10 WATT IBM SUPPLY	174.95	SYSTEM STAND	21.00
PC COMPATIBLE KEYBOARD	129.95	EXTENSION CABLE IBM MONO	38.00
IBM PC CHASSIS	129.95	KEYBOARD EXTENSION CABLE	28.00
PLANTRONICS "COLORPLUS" 389.95		SURGE SUPPRESSORS	
10 Mb INT. TAPE STREAMER	1159.00	DIAMOND (LEMON)	39.00
PERYST MONO CARD	199.00	DIAMOND (LIME)	49.00
PARADISE MONO/COLOR	409.95	SAPPHIRE (PEACH)	39.00
HERCULES MONO CARD	399.00	RUBY (ORANGE)	69.00

PRINTERS

BROTHER HI-15P15 (13cps)	SALE \$399.00
BROTHER RX-25P15 (25cps)	SALE 699.00
BROTHER RX-35P15 (35cps)	979.00
NEW BROTHER M2024 (24pin)	1299.00
COEX 80FPT (80cps)	SALE 149.00
EPSON RX-80B0FPT (100cps)	

Commodore Accessories

RS232 ADAPTER FOR VIC-20 AND COMMODORE 64

New!



New!

The JE232CM allows connection of standard serial RS232 printers, modems, etc. to your VIC-20 and C-64. A 4-pole switch allows the inversion of the 4 control lines. Complete installation and operation instructions included.

Plugs into User Port • Provides Standard RS232 signal levels • Uses 6 signals (Transmit, Receive, Clear to Send, Request to Send, Data Terminal Ready, Data Set Ready).
JE232CM \$39.95

VOICE SYNTHESIZER FOR APPLE AND COMMODORE

Great Educating Tool!



JE520AP

JE520CM

Over 250 word vocabulary affixes allow the formation of more than 500 words • Built-in amplifier, speaker, volume control, and audio jack • Recreates a clear, natural male voice • Plug-in user ready with documentation and sample software • Case size: 7 1/4" L x 3 3/4" W x 1-3/8" H

APPLICATIONS: Security Warning • Telecommunication • Teaching • Handicap Aid • Instrumentation • Games

Part No.	Description	Price
JE520CM	For Commodore 64 & VIC-20	\$114.95
JE520AP	For Apple II, II+, and IIe	\$149.95

Computer Memory Expansion Kits

IBM PC, PC XT and Compatibles
Most of the popular Memory Boards (e.g. Quadram™ Expansion Boards) allow you to add an additional 64K, 128K, 192K or 256K. The IBM64K Kit will populate these boards in 64K byte increments. The Kit is simple to install—just insert the 9-64K RAM chips in the provided sockets and set the 2 groups of switches. Complete conversion documentation included.
IBM64K (Nine 200ns 64K RAMs) \$43.95

IBM PC AT
Each kit comes complete with nine 128K dynamic RAMs and documentation for conversion.
IBM128K (Nine 200ns 128K RAMs) \$199.95

APPLE IIe
Extended 80-Column/64K RAM Card. Expands memory by 64K to give 128K when used with programs like VisiCalc™. Fully assembled and tested.
JE864 \$99.95

TRS-80 MODEL I, III
Each kit comes complete with eight MM5290 (UPD416/4116) 16K Dynamic RAMs and documentation for conversion. Model I: 16K equipped with Expansion Interface can be expanded to 48K with 2 Kits. Model III: Can be expanded from 16K to 48K using 2 Kits. Each Kit will expand computer by 16K increments.
TRS-16K3 200ns (Model III) \$8.95
TRS-16K4 250ns (Model I) \$6.95

TRS-80 MODEL IV & 4P
Easy to install Kit comes complete with 8 ea. 4164N-20 (200ns) 64K Dynamic RAMs and conversion documentation. Converts TRS-80 Model IV computers from 16K to 64K. Also expands Model 4P from 64K to 128K.
TRS-64K-2 \$38.95
(Converts the Model IV from 16K to 64K or will expand the Model 4P from 64K to 128K)

TRS-64K2PAL (Model IV only) \$59.95
(8-4164's with PAL Chip to expand from 64K to 128K)

TRS-80 COLOR AND COLOR II
Easy to install Kit comes complete with 8 ea. 4164N-20 (200ns) 64K Dynamic RAMs and documentation for conversion. Converts TRS-80 Color Computers with D, E, ET, F and NC circuit boards to 32K. Also converts TRS-80 Color Computer II to 64K. Flex DCS or CS-9 required to utilize full 64K RAM on all computers.
TRS-64K-2 \$38.95

INDUSTRIES Protect Yourself... DATASHIELD Surge Protector

Eliminates voltage spikes and EMI-RFI noise before it can damage your equipment or cause data loss • 6 month warranty • Power dissipation (100 microseconds): 1,000,000 watts • 6 sockets • 6 foot power cord • Normal line output voltage indicator light • Brown out/black out reset switch
Model 100 \$69.95

Protect Yourself... DATASHIELD Back-Up Power Source

Provides up to 30 minutes of continuous 120 VAC 60Hz power to your computer system (load dependent) when you have a black out or voltage sag • Six month warranty • Weight (PC200): 24 lbs. — (XT300): 37.5 lbs.
PC200 (Output rating: 200 watts) \$299.95
XT300 (Output rating: 300 watts) \$399.95

ProModem 1200 and Options



Intelligent 300/1200 Baud Telephone Modem with Real Time Clock/Calendar

The ProModem™ is a Bell 212A (300/1200 baud) intelligent stand-alone modem • Full featured expandable modem • Standard features include Auto Answer and Auto Dial, Help Commands, Programmable Intelligent Dialing, Touch Tone™ and Pulse Dialing & More • Hayes command set compatible plus an additional extended command set • Shown w/alphanumeric display option.

Part No.	Description	Price
PM1200	RS-232 Stand Alone Unit	\$349.95
PM1200A	Apple II, II+ and IIe Internal Unit	\$369.95
PM1200B	IBM PC and Compatible Internal Unit	\$269.95
PM1200BS	IBM PC & Comp. Int. Unit w/ProCom Software	\$319.95
MAC PAC	Macintosh Package, (Includes PM1200, Cable, & ProCom Software)	\$399.95

OPTIONS FOR ProModem 1200

PM-COM	(ProCom Communication Software)	\$79.95
Please specify Operating System.		
PM-OP	(Options Processor)	\$79.95
PMO-16K	(Options Processor Memory - 16K)	\$10.95
PMO-32K	(Options Processor Memory - 32K)	\$20.95
PMO-64K	(Options Processor Memory - 64K)	\$39.95
PM-ALP	(Alphanumeric Display)	\$79.95
PM-Special	(Includes Options Processor, 64K Memory and Alphanumeric Display)	\$189.95

KEYBOARDS



13 1/4" L x 4 1/4" W x 1 1/4" H

Mitsumi 54-Key Unencoded All-Purpose Keyboard
• SPST keyswitches • 20 pin ribbon cable connection • Low profile keys • Features: cursor controls, control, caps (lock), function, enter and shift keys • Color (keycaps): grey • Wt.: 1 lb. • Pinout included
KB54 \$14.95



16-9/16" L x 6 1/4" W x 1 1/4" H

76-Key Serial ASCII Keyboard
• Simple serial interface • SPST mechanical switching • Operates in upper and lower case • Five user function keys: F1-F5 • Six finger edge card connection • Color (keys): tan • Weight: 2 lbs. • Data incl.
KB76 \$29.95



NEW!

Apple Keyboard and Case for Apple II and II+
• Keyboard: Direct connection with 16-pin ribbon connector • 26 special functions • Size: 14 1/2" L x 5 1/2" W x 1 1/4" H
• Case: Accommodates KB-A68 • Pop-up lid for easy access • Size: 15 1/2" W x 18" D x 4 1/4" H
KB-EA1 Apple Keyboard and Case (pictured above) \$134.95
KB-A68 68-Key Apple Keyboard only \$79.95
EAEC-1 Expanded Apple Enclosure Case only \$59.95

POWER SUPPLIES



TRANSACTION TECHNOLOGY, INC.
5VDC @ 1 AMP Regulated Power Supply
• Output: +5VDC @ 1.0 amp (also +30VDC regulated) • Input: 115VAC, 60 Hz
• Two-tone (black/beige) self-enclosed case • 6 foot, 3-conductor black power cord • Size: 6 1/2" L x 7" W x 2 1/4" H • Weight: 3 lbs.
PS51194 \$14.95



Power/Mate Corp. REGULATED POWER SUPPLY
• Input: 105-125/210-250 VAC at 47-63 Hz • Line regulation: ±0.05% • Three mounting surfaces • Overvoltage protection • UL recognized • CSA certified
Part No. Output Size Weight Price
EMA5/6B 5V @ 3A/6V @ 2.5A 4 1/4" L x 4 1/4" W x 2 1/4" H 2 lbs. \$29.95
EMA5/6C 5V @ 6A/6V @ 5A 5 1/4" L x 4 1/4" W x 2 1/4" H 4 lbs. \$39.95



KEPCO/TDK 4-OUTPUT SWITCHING POWER SUPPLY
• Ideal for disk drive needs of CRT terminals, microcomputers and video games • Input: 115/230VAC, 50/60Hz • Output: +5V @ 5 amp, +12V @ 1.8 amp, +12V @ 2 amp, -12V @ 0.5 amp • UL recognized • CSA certified • Size: 7 1/4" L x 6-3/16" W x 1 1/4" H • Weight: 2 lbs. **\$59.95 each or \$99.95**
MRM 174KF \$2 for \$99.95



Switching Power Supply for APPLE II, II+ & IIe™
• Can drive four floppy disk drives and up to eight expansion cards • Short circuit and overload protection • Fits inside Apple computer • Fully regulated +5V @ 5A, +12V @ 1.5A, -5V @ 5A, -12V @ 5A • Direct plug-in power cord included • Size: 9 1/4" L x 3 1/2" W x 2 1/4" H • Weight: 2 lbs.
KHP4007 (SPS-109) \$59.95



4-CHANNEL SWITCHING POWER SUPPLY
• Microprocessor, mini-computer, terminal, medical equipment and process control applications • Input: 90-130VAC, 47-440Hz • Output: +5VDC @ 5A, -5VDC @ 1A, +12VDC @ 1A, -12VDC @ 1A • Line regulations: ±0.2% • Ripple: 30mV p-p • Load regulation: ±1% • Overcurrent protection • Adj: 5V main output -10% • Size: 6 1/4" L x 1 1/4" W x 4-15/16" H • Weight: 1 1/2 lbs.
FCS-604A \$69.95

\$10.00 Minimum Order — U.S. Funds Only
California Residents Add 6 1/2% Sales Tax
Shipping — Add 5% plus \$1.50 Insurance
Send S.A.S.E. for Monthly Sales Flyer!

Spec Sheets — 30¢ each
Send \$1.00 Postage for your
FREE 1985 JAMECO CATALOG
Prices Subject to Change



1355 SHOREWAY ROAD, BELMONT, CA 94002
2/85 PHONE ORDERS WELCOME — (415) 592-8097 Telex: 176043

Apple Accessories



5 1/4" APPLE™ Direct Plug-In Compatible Disk Drive and Controller Card

The ADD-514 Disk Drive uses Shugart SA390 mechanics—143K formatted storage • 35 tracks • Compatible with Apple Controller & ACC-1 Controller • The drive comes complete with connector and cable — just plug into your disk controller card • Size: 6" L x 3 1/2" W x 8-9/16" D • Weight: 4 1/2 lbs.

ADD-514 (Disk Drive) \$169.95
ACC-1 (Controller Card) \$49.95

More Apple Compatible Add-Ons...

AFP-1	(Cooling Fan with surge protection)	\$39.95
KHP4007	(Switching Power Supply)	\$59.95
JE614	(Numeric/Aux. Keypad for IIe)	\$59.95
KB-A68	(Keyboard w/Keypad for II & II+)	\$79.95
MON-12G	(12" Green Monitor for II & IIe, IIc)	\$99.95
JE864	(80 Col. + 64K RAM for IIe)	\$99.95
ADD-12	(5 1/4" Half-Height Disk Drive)	\$179.95

DISK DRIVES



Documentation Included	Best Buys!	Price
MPI515	(MPI 5 1/4" SS full-ht.)	\$ 89.95
RFD480	(Remex 5 1/4" DS full-ht.)	\$129.95
TM100-2	(Tandon 5 1/4" DS full-ht.)	\$159.95
FD55B	(Teac 5 1/4" DS half-ht.)	\$149.95
SA455	(Shugart 5 1/4" DS half-ht.)	\$159.95
FDD100-8	(Siemens 8" SS full-ht.)	\$139.95
PKC-5	(5 1/4" Power Cable Kit)	\$2.95
PKC-8	(8" Power Cable Kit)	\$3.95

UV-EPROM Eraser

8 Chips - 21 Minutes
Erases all EPROMs. Erases up to 8 chips within 21 minutes (1 chip in 15 minutes). Maintains constant exposure distance of one inch. Special conductive foam liner eliminates static build-up. Built-in safety lock to prevent UV exposure. Compact — only 8.00" L x 3.70" W x 2.60" H. Complete with holding tray for 8 chips.

1 Chip - 15 Minutes
Erases all EPROMs. Erases up to 8 chips within 21 minutes (1 chip in 15 minutes). Maintains constant exposure distance of one inch. Special conductive foam liner eliminates static build-up. Built-in safety lock to prevent UV exposure. Compact — only 8.00" L x 3.70" W x 2.60" H. Complete with holding tray for 8 chips.

DE-4 UV-EPROM Eraser \$74.95
UVS-11EL Replacement Bulb \$16.95



JE664 EPROM PROGRAMMER
8K to 64K EPROMS — 24 & 28 Pin Packages
Completely Self-Contained — Requires No Additional Systems for Operation
• Programs and validates EPROMs • Checks for properly erased EPROMs • Emulates PROMs or EPROMs • RS232C Computer Interface for editing and program loading • Loads data into RAM by keyboard • Changes data in RAM by keyboard • Loads RAM from an EPROM • Compares EPROMs for content differences • Copies EPROMs • Power Input: 115VAC, 60Hz, less than 10W power consumption • Enclosure: Color-coordinated, light tan panels with molded end pieces in mocha brown • Size: 15 1/4" L x 8 1/4" D x 3 1/4" H • Weight: 5 1/2 lbs.

The JE664 EPROM Programmer emulates and programs various 8-Bit Word EPROMs from 8K to 64K-Bit memory capacity. Data can be entered into the JE664's internal 8K x 8-Bit RAM in three ways: (1) from a ROM or EPROM; (2) from an external computer via the optional JE665 RS232C BUS; (3) from its panel keyboard. The JE664's RAMs may be accessed for emulation purposes from the panel's test socket to an external microprocessor. In programming and emulation, the JE664 allows for examination, change and validation of program content. The JE664's RAMs can be programmed quickly to all "1"s (or any value), allowing unused addresses in the EPROM to be programmed later without necessity of "UV" erasing. The JE664 displays DATA and ADDRESS in convenient hexadecimal (alphanumeric) format. A "DISPLAY EPROM DATA" button changes the DATA readout from RAM word to EPROM word and is displayed in both hexadecimal and binary code. The front panel features a convenient operating guide. The JE664 Programmer includes one JM15A Jumper Module (as listed below).

JE664-A EPROM Programmer \$995.00
Assembled & Tested (Includes JM15A Module)

JE665 — RS232C INTERFACE OPTION — The RS232C Interface Option implements computer access to the JE664's RAM. This allows the computer to manipulate, store and transfer EPROM data to and from the JE664. A sample program listing is supplied with MBASIC for CP/M computers. Documentation is provided to adapt the software to other computers with an RS232C port. 9600 baud, 8-bit word, odd parity with 2 stop bits.

EPROM Programmer w/JE665 Option JE664-ARS \$1195.00
Assembled & Tested (Includes JM15A Module)

EPROM JUMPER MODULES — The JE664's JUMPER MODULE (Personality Module) is a plug-in Module that pre-sets the JE664 for the proper programming pulses to the EPROM and configures the EPROM socket connections for that particular EPROM.

JEM4 EPROM Jumper Mod. No.	EPROM	Programming Pulses	EPROM MANUFACTURER	PRICE
JM05A	2708	25V	AMD, Motorola, Nat. Semi, TI, AMD, Philips, Mitsubishi	\$14.95
JM16A	2716, TM2216 (T)	25V	Intel, Motorola, Nat. Semi, TI, AMD, Philips, Mitsubishi	\$14.95
JM11B	TM2216 (C) (V)	5V + 5V + 12V	Motorola, TI, Intel	\$14.95
JM23A	TM2202	25V	Motorola, TI, Intel, OKI	\$14.95
JM23B	2732	25V	AMD, Fujitsu, NEC, Hitachi, Intel, Mitsubishi, National	\$14.95
JM33C	2732A	27V	Fujitsu, Intel	\$14.95
JM04A	MC38074, MC38074A	27V	Motorola	\$14.95
JM04B	2764	27V	Intel, Fairchild, OKI	\$14.95
JM04C	TM2504	25V	TI	\$14.95

FEBRUARY 1985



Active

YOUR ELECTRONIC COMPONENTS CENTER

TOP QUALITY, CURRENT DATE CODE PRODUCTS

7400			
ACT #	Pkg'd Qty	Pkg Price	
05500	7400	3	1.10
05512	7404	5	1.85
05592	7475	2	1.00
05640	74121	2	1.00

74 ALS - ADVANCED LS			
ACT #	Pkg'd Qty	Pkg Price	
05A01	74ALS00	3	1.15
05A13	74ALS04	3	1.15
05A37	74ALS20	3	1.15
05A70	74ALS74	2	1.00

Did you receive our new 1985 catalog?

NAME.....
 ADDRESS.....
 CITY.....
 STATE.....
 ZIP CODE.....

MAIL COUPON TO:
 USA: P.O. Box 9100
 Westborough, Mass. 01581
 CANADA: 5651 Ferrier St.
 2RE Montreal, Quebec H4P 1N1

74LS			
ACT #	Pkg'd Qty	Pkg Price	
05770	74LS00	4	1.20
05776	74LS02	4	1.20
05780	74LS04	4	1.20
05848	74LS74	3	1.00
05888	74LS123	2	1.30

74F ADVANCED SCHOTTKY			
ACT #	Pkg'd Qty	Pkg Price	
05F01	74F00	2	1.00
05F05	74F04	2	1.00
05F07	74F08	2	1.00
05F17	74F74	2	1.10

74S			
ACT #	Pkg'd Qty	Pkg Price	
05S04	74S04	2	1.00
05S08	74S08	2	1.00
05125	74S74	1	.55
05329	74S138	1	1.25

74HC HIGH SPEED CMOS			
ACT #	Pkg'd Qty	Pkg Price	
16100	74HC00	3	1.20
16105	74HC04	3	1.25
16130	74HC14	1	.89
16200	74HC244	1	1.50

ACT # 9300 TTL			
ACT #	Pkg'd Qty	Pkg Price	
11004	9368PC	2	2.65
11006	9374PC	2	2.65
11120	9314PC	1	1.60
11125	9324PC	1	1.40

Mail orders shipped within 48 hours STORES OPEN AT 8:00 am

MICROPROCESSORS		
ACT #		Pkg Price
12001	6502	7.13
12005	6522	10.50
12010	6551	16.25
12014	6802	11.25
12017	6821	4.45
12021	6850	4.80
41002	Z-80A-CPU-PS	6.39
41004	Z-80-PIO-PS	5.50
12053	8088DC	39.50
12029	8224	12.50
12038	8284APC	12.36
12041	8212	3.39
12073	68000	71.95
12074	68230	27.39

STATIC RAMS		
ACT #		Pkg Price
48049	P5101-45L (256x4) 450 NS	4.50
48002	P2114-20 (1Kx4) 200 NS	1.99
48003	P2114-20L* (1Kx4) 200 NS	2.90
48005	P2016-15L (2Kx8) 150 NS	5.95
48008	P6116-15L (2Kx8) 150 NS	7.95
48050	P5516-25L* (2Kx8) 250 NS	8.25
* Low Power		

DYNAMIC RAMS		
ACT #		Pkg Price
48011	P4164-15 (64Kx1) 150 NS	5.65
48037	P4116-15 (16Kx1) 150 NS	.99

PROMS		
ACT #		Pkg Price
71017	32X8-TS-16PC 16 Pin	2.79
71004	256X4-TS-16PC 16 Pin	3.69
71020	512X8-TS-20PC 20 Pin	9.09
71019	256X8-TS-20PC 20 Pin	6.69

EPROMS		
ACT #		Pkg Price
48014	C2516-45 (2Kx8) 450 NS Intel Pinout	5.25
48021	C2532-45 (4Kx8) 450 NS T.I. Pinout	5.95
48041	C2708-45 (1Kx8) 450 NS	7.25

LINEAR		
ACT #		Pkg Price
06011	317UC	2 1.50
06017	324PC	3 1.15
06114	358TC	3 1.10
06116	555TC	3 1.00
06118	556PC	2 1.10

INTERFACE		
ACT #		Pkg Price
28145	SN75150P	1 .75
28150	SN75154N	1 .72
28225	SN75477P	2 1.55
28235	SN75492AN	2 1.00

CMOS		
ACT #		Pkg Price
08340	4011BPC	4 1.00
08545	4066BPC	3 1.00
08725	4538BPC	1 1.00
08375	4016BPC	3 1.00

REGULATORS		
ACT #		Pkg Price
09210	78L05AWC	3 1.00
09220	7805UC	2 1.00
09370	7905UC	2 1.10
09425	7915UC	2 1.10

LEDS		
ACT #		Pkg Price
13268	LED-209A (Red-5MM)	6 1.19
13056	LED-220 (1 3/4-Red-5MM)	7 1.00
13271	LED-211 (1 3/4-Green-5MM)	5 1.00
13277	LED-224 (1 3/4-Yellow-5MM)	5 1.00

OPTO COUPLERS		
ACT #		Pkg Price
13193	MCT2E	2 1.79
13067	4N26	2 1.79
13184	4N35	1 1.00
13072	MOC3010	1 1.19
13202	MOC3011	1 1.29

TOLL FREE: 1-800-343-0874

ORDERING INFORMATION

Use only the ACT # when ordering. Some packages contain multiples other than one. Please note that these multiples will not be broken. Pkg'd Quantity is One (1) unless otherwise indicated.

MAIL ORDER: (U.S.)
 P.O. Box 9100
 Westborough, Mass. 01581
 Toll Free 1-800-343-0874
 (outside Mass. only)

MAIL ORDER: (Canada)
 Toll Free 1-800-361-5884

STORE LOCATIONS:
 133 Flanders Rd.
 Westborough, Mass.
 (617) 366-9684
 13107 Northup Way
 Bellevue, Wash.
 (206) 881-8191

ANTIQUe RADIOS

continued from page 89

one if you're in the right place at the right time. (The right place at the right time is when someone is cleaning out old junk.) The price you pay depends on how much you want to pay, how badly do you want the set, and the radio's age, condition, and classic value.

Antique-radio collectors will have more in common with each other than most other collectors. Many (or most) will have some formal electronics training. Besides being able to repair and restore the chassis, they will have to learn how to restore cabinets. (Some radio and TV servicemen may have at least some ability in this area. Repairing minor scratches or marks often went with being able to repair a chassis.)

Bringing back the deep rich tone of an antique radio will be a satisfying experience. While everything has its price, a collector will find it difficult to part with a set that he has spent many tedious hours restoring. That's true even with a handsome profit in sight. And those who do a good professional restoring job can ask their own prices.

If you are going to have only one antique radio, the console is the only way to go. Of course it will take up some room. But like expensive cars, most of those large sets had better care and less misuse than their cheaper counterparts of the same era.

There is a market developing for antique radios for those other than collectors. Homeowners who want to decorate their houses in a 1930's motif need all the furnishings from that era. Restoring an antique radio is not something the average home decorator can do. An expertly restored antique radio is a fine addition to the rest of the decor.

There is really no age bracket for antique-radio collectors. I have often seen antique radios go to young persons who get to a sale before me. And older folks, of course, will feel nostalgic about having an antique radio that they might have owned or had at a younger age.

R-E

MCM ELECTRONICS

WE HAVE WHAT YOU NEED AT
THE PRICES YOU WANT!

CALL TOLL FREE
1-800-543-4330
(IN OHIO, 1-800-762-4315)



TENMA®

3 1/2 DIGIT LCD MULTIMETER

- DC input impedance 10M ohm
- Diode and HFE Transistor tests
- Overload protection ■ Auto polarity ■ 2 year limited Warranty

#72-050 **\$3680**
\$39.80 (1-9) (10-up)

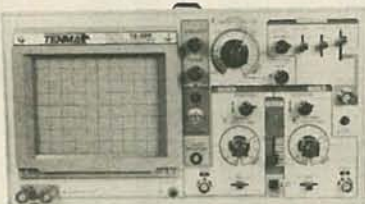

TENMA®

20MHZ DUAL TRACE OSCILLOSCOPE

Two High Quality 10:1 probes included.
Backed by our 2 year limited warranty.
For specifications see MCM Catalog #9
page 118

#72-320 **\$38995**



TENMA® COMBINATION DMM/ CAPACITANCE METER (With Transistor Gain Tester)

- User can easily read Voltage, AC and DC current, resistance up to 20M ohms, capacitance up to 20 microfarad, and HFE on a clear 1/2 inch, 3 1/2 digit LCD display
- 2 year limited Warranty

#72-045 **\$6995**
\$74.95 each (2 or more)



LOGIC PROBE WITH MEMORY

- Multi-family compatibility—DTL/TTL/HTL/CMOSIC
- Detects pulses as short as 50 nanoseconds

#72-190 **\$1995**

2-WAY SPLITTER



- Zinc diecast construction
 - Power passive
 - 5-900MHZ
- #33-070 **89¢** (min 10)

6 1/2" POLYPROPYLENE WOOFER

- Magnet Weight: 15 oz.
- Structure Weight: 3 lbs.
- Voice Coil: 1.5"
- Impedance: 8 ohms
- Power Handling: RMS/PEAK 45w/80w
- Free Air Res: 30 Hz
- Freq. Response: 35-2500 Hz
- Sensitivity SPL 1 WATT/1 METER:



#55-055 **\$1390**
\$15.90 (1-3) \$14.90 (4-19) (20-up)

10" PYLE WOOFER

- Magnet Weight: 16 oz.
- Structure Weight: 4.5 lbs.
- Voice Coil: 1.5"
- Impedance: 8 ohms
- Power Handling: RMS/PEAK 75w/150w
- Free Air Res: 40 Hz
- Freq. Response: 30-5500Hz
- Sensitivity SPL 1 WATT/1 METER: 95dB
- Manufacturer: #W10C170-F



#55-100 **\$1990** each

POPULAR REPLACEMENT HI-FI TWEETER

- Phenolic ring design used in hundreds of domestic speaker systems
- Trim profile for easy mounting in tight spaces
- 4 1/4" diameter ■ 10 watt power handling capacity
- 3 oz. magnet ■ 2K-20K ■ 8 ohms



#53-020 **\$290**
\$4.20 (1-3) (20-up)

150 WATT CROSSOVER (With protection circuit)

- Build your own high-quality 5-way speaker system. ■ These units can handle 150 watts RMS and feature a built-in protection circuit.
- Same crossover used in Jensen's System B ■ Crossover points: 0-300HZ, 300-1800HZ, 1800-7KHZ, 7KHZ-up; rear hi frequency 7KHZ-up. ■ Two L-pad controls included for upper mid frequency and high frequency. ■ 12 dB octave. ■ Comes complete with hook-up wire and instructions.



#50-170 **\$1995** each

OSCILLOSCOPE PROBE KIT



- Bandwidth: 10:1 position: 100MHZ at—3dB into 20pF
 - Rise Time: 10:1 position less than 3.5ns nominal
 - Kit contains: 10" earth lead, retractable hook, Ic test tip, insulator, BNC adaptor and trimming tool.
- #72-010 **\$26.95** (1-4)
\$2495 (5-up)

AUDIO TECHNICA CARTRIDGE AT11E

- Bi-Radial (elliptical) diamond stylus
- Thin-wall tubular stylus cantilever
- Excellent replacement for older cartridges
- Frequency response 15 to 25,000Hz
- Tracking force 1 1/2 to 2 1/2 grams
- Audio Technica No. AT11E



#39-020 **\$945** (10-up)
\$9.95 (1-9)

BE SURE TO
CALL FOR
YOUR FREE
128 PAGE
CATALOG!
OVER 4,800
ITEMS



We Also Have... a full line of test equipment, computer accessories, telephone accessories, speakers, television parts, flybacks, yokes, switches, fuses, lamps, capacitors, resistors, cartridges, styli, wire, CATV equipment, and many more. **Over 4,800 Items AT THE LOWEST PRICES AROUND!**

Terms:



- \$10 minimum order. \$1.00 charge for orders under \$10.
- \$20 minimum charge card order.
- Orders shipped UPS C.O.D.
- Most orders shipped within 24 hours
- Sales office open 8:30 am to 6:00 pm. Saturdays 10:00 am to 3 pm. EST.
- For prepaid orders add \$2.50 for shipping and handling.

**MCM
ELECTRONICS**

858 East Congress Park Drive
Centerville, Ohio 45459
513-434-0031

We have the Largest
Selection of Original
Japanese Semiconductors
in the Country!

SOURCE NO. RE-6

Do Kay

COMPUTER
PRODUCTS,
Inc.

ORDER TOLL FREE

(800)
538-8800

(CALIFORNIA RESIDENTS)

(800)
848-8008

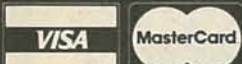

STATIC RAMS

2101	256 x 4 (450ns)	1.90
5101	256 x 4 (450ns) (cmos)	3.90
2102-1	1024 x 1 (450ns)	.88
2102L-1	1024 x 1 (450ns) (LP)	.98
2102L-2	1024 x 1 (250ns) (LP)	1.45
2111	256 x 4 (450ns)	2.45
2112	256 x 4 (450ns)	2.95
2114	1024 x 4 (450ns)	.99
2114-25	1024 x 4 (250ns)	1.10
2114L-4	1024 x 4 (450ns) (LP)	1.20
2114L-3	1024 x 4 (300ns) (LP)	1.30
2114L-2	1024 x 4 (200ns) (LP)	1.40
2125	1024 x 1	2.49
2147	4096 x 1 (55ns)	4.90
TMS4044-4	4096 x 1 (450ns)	3.45
TMS4044-3	4096 x 1 (300ns)	3.95
TMS4044-2	4096 x 1 (200ns)	4.45
MK4118	1024 x 8 (250ns)	9.90
TMM2016-200	2048 x 8 (200ns)	4.10
TMM2016-150	2048 x 8 (150ns)	4.90
TMM2016-100	2048 x 8 (100ns)	6.10
HM6116-4	2048 x 8 (200ns) (cmos)	4.70
HM6116-3	2048 x 8 (150ns) (cmos)	4.90
HM6116-2	2048 x 8 (120ns) (cmos)	5.90
HM6116LP-4	2048 x 8 (200ns) (cmos) (LP)	6.90
HM6116LP-3	2048 x 8 (150ns) (cmos) (LP)	8.95
HM6116LP-2	2048 x 8 (120ns) (cmos) (LP)	9.95
Z-6132	4096 x 8 (300ns) (Qstat)	33.95
HM6264P-15	8192 x 8 (150ns) (cmos)	38.95
HM6264LP-15	8192 x 8 (150ns) (cmos)	48.95

LP = Low Power Qstat = Quasi-Static

DYNAMIC RAMS

TMS4027	4096 x 1 (250ns)	1.95
UPD411	4096 x 1 (300ns)	1.95
MM5280	4096 x 1 (300ns)	1.95
MK4108	8192 x 1 (200ns)	1.90
MM5298	8192 x 1 (250ns)	1.80
4116-200	16384 x 1 (200ns)	.79
4116-150	16384 x 1 (150ns)	1.20
2118	16384 x 1 (150ns) (5v)	4.90
4164-250	65536 x 1 (250ns)	4.45
4164-200	65536 x 1 (200ns) (5v)	5.00
4164-150	65536 x 1 (150ns) (5v)	5.00

5V = Single 5 Volt Supply

EPROMS

1702	256 x 8 (1va)	4.45
2708	1024 x 8 (450ns)	2.49
2758	1024 x 8 (450ns) (5v)	5.90
2716	2048 x 8 (450ns) (5v)	2.95
2716-1	2048 x 8 (350ns) (5v)	5.90
TMS2516	2048 x 8 (450ns) (5v)	5.45
TMS2716	2048 x 8 (450ns)	6.95
TMS2532	4096 x 8 (450ns) (5v)	5.90
2732	4096 x 8 (450ns) (5v)	4.45
2732-250	4096 x 8 (250ns) (5v)	8.90
2732-200	4096 x 8 (200ns) (5v)	10.95
2764	8192 x 8 (450ns) (5v)	6.45
2764-250	8192 x 8 (250ns) (5v)	7.45
2764-200	8192 x 1 (200ns) (5v)	16.45
TMS2564	8192 x 8 (450ns) (5v)	16.95
MC68764	8192 x 8 (450ns) (5v) (24 pin)	38.95
27128	16384 x 8 Call	24.95

5v = Single 5 Volt Supply

74LS00

74LS00	.23	74LS125	.48	74LS260	.58
74LS01	.24	74LS126	.48	74LS266	.54
74LS02	.24	74LS132	.58	74LS273	1.45
74LS03	.24	74LS133	.58	74LS275	3.30
74LS04	.23	74LS136	.38	74LS279	.48
74LS05	.24	74LS137	.98	74LS280	1.95
74LS08	.27	74LS138	.54	74LS283	.68
74LS09	.28	74LS139	.54	74LS290	.88
74LS10	.24	74LS145	1.15	74LS293	.88
74LS11	.34	74LS147	2.45	74LS295	.98
74LS12	.34	74LS148	1.30	74LS298	.88
74LS13	.44	74LS151	.54	74LS299	1.70
74LS14	.58	74LS153	.54	74LS323	3.45
74LS15	.34	74LS154	1.85	74LS324	1.70
74LS20	.24	74LS155	.88	74LS352	1.25
74LS21	.28	74LS156	.88	74LS353	1.25
74LS22	.24	74LS157	.84	74LS363	1.30
74LS26	.28	74LS158	.58	74LS364	1.90
74LS27	.28	74LS160	.88	74LS365	.48
74LS28	.34	74LS161	.84	74LS366	.48
74LS30	.24	74LS162	.88	74LS367	.44
74LS32	.28	74LS163	.84	74LS368	.44
74LS33	.54	74LS164	.88	74LS373	1.35
74LS37	.34	74LS165	.94	74LS374	1.35
74LS38	.34	74LS166	1.90	74LS377	1.35
74LS40	.24	74LS168	1.70	74LS378	1.13
74LS42	.48	74LS169	1.70	74LS378	1.30
74LS47	.74	74LS170	1.45	74LS385	1.85
74LS48	.74	74LS173	.88	74LS386	.44
74LS49	.74	74LS174	.54	74LS390	1.15
74LS51	.24	74LS175	.54	74LS393	1.15
74LS54	.28	74LS181	2.10	74LS395	1.15
74LS55	.28	74LS189	8.90	74LS399	1.45
74LS63	1.20	74LS190	.88	74LS424	2.90
74LS73	.38	74LS191	.88	74LS447	.36
74LS74	.34	74LS192	.78	74LS490	1.90
74LS75	.38	74LS193	.78	74LS824	3.95
74LS76	.38	74LS194	.88	74LS840	2.15
74LS78	.48	74LS195	.88	74LS845	2.15
74LS83	.58	74LS196	.78	74LS868	1.65
74LS85	.68	74LS197	.78	74LS869	1.85
74LS86	.38	74LS221	.88	74LS870	1.45
74LS90	.54	74LS240	.94	74LS874	9.80
74LS91	.88	74LS241	.98	74LS882	3.15
74LS92	.54	74LS242	.98	74LS883	3.15
74LS93	.54	74LS243	.98	74LS884	3.15
74LS95	.74	74LS244	1.25	74LS885	3.15
74LS96	.88	74LS245	1.45	74LS888	2.35
74LS107	.38	74LS247	.74	74LS889	3.15
74LS109	.38	74LS248	.98	74LS763	23.95
74LS112	.38	74LS249	.98	81LS95	1.45
74LS113	.38	74LS251	.58	81LS96	1.45
74LS114	.38	74LS253	.58	81LS97	1.45
74LS122	.44	74LS257	.58	81LS98	1.45
74LS123	.78	74LS258	.58	25LS2521	2.75
74LS124	2.85	74LS259	2.70	25LS2569	4.20

CRT CONTROLLERS

1771	14.95	2797	84.85
1791	23.95	6843	33.95
1793	25.95	8272	38.95
1795	28.95	UP0765	38.95
1797	48.95	M88876	23.95
2791	79.95	M88877	25.95
2793	79.95	1691	16.95
2795	84.95	2143	17.95

DISC CONTROLLERS

1771	14.95	2797	84.95
1791	23.95	6843	33.95
1793	25.95	8272	38.95
1795	28.95	UP0765	38.95
1797	48.95	M88876	23.95
2791	79.95	M88877	25.95
2793	79.95	1691	16.95
2795	84.95	2143	17.95

QUV-T8/1 EPROM Eraser

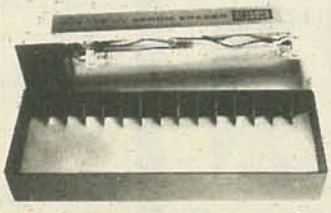

QUV-T8/1 Economy Model:
Low cost EPROM eraser in plastic enclosure. The UV element is in the lid and you place the EPROMS in the bottom half. No timer or switch option.

- Erases up to 8 EPROMS in 15 - 20 minutes.
- 12,000 uWatts at 1" distance.
- 90-Day Warranty

49.95

6500

1 MHZ		2 MHZ	
6502	4.90	6502A	6.90
6504	6.90	6522A	9.90
6505	8.90	6532A	10.95
6507	9.90	6545A	26.95
6520	4.30	6551A	10.95
6522	6.90		
6532	9.90		
6545	21.50		
6551	10.85		

6800

68000	58.95	6860	9.90
6800	3.90	6862	10.95
6802	7.90	6875	6.90
6808	12.90	6880	2.20
6809E	18.95	6883	21.95
6809	10.95	68047	23.95
6810	2.90	68488	18.95
6820	4.30		
6821	3.20		
6828	13.95		
6840	11.95		
6843	33.95		
6844	24.95		
6845	13.95		
6847	10.95		
6850	3.20		
6852	15.70		

8000

8035	5.90	8089	88.95
8039	6.90	8155	6.90
INS-8060	16.95	8155-2	7.90
INS-8073	49.95	8156	6.90
8080	3.90	8185	28.95
8085	5.90	8185-2	38.95
8085A-2	10.95	8086	28.95
8086	199.00	8741	38.95
8088	38.95	8748	48.95
		8755	23.95

8200

8202	23.95	8255-5	5.20
8203	38.95	8257	7.90
8205	3.45	8257-5	8.90
8212	1.75	8259	6.85
8214	3.80	8259-5	7.45
8216	1.70	8271	75.00
8224	2.20	8272	38.95
8225	1.75	8275	28.95
8228	3.45	8279	8.90
8237	18.95	8279-5	9.00
8237-5	20.95	8282	6.45
8238	4.45	8283	6.45
8243	10.95	8284	14.95
8250	16.95	8286	6.45
8251	4.45	8287	6.45
8253	6.90	8288	24.00
8253-5	7.90	8289	48.95
8255	4.45	8292	16.95

Z-80

2.5 MHZ		4.0 MHZ	
Z80-CPU	3.90	Z80A-CPU	4.29
Z80-CTC	3.95	Z80A-CTC	4.90
Z80-DART	10.95	Z80A-DART	9.95
Z80-DMA	13.95	Z80A-DMA	12.95
Z80-PIO	3.95	Z80A-PIO	4.29
Z80-SIO/0	11.95	Z80A-SIO/0	12.95
Z80-SIO/1	11.95	Z80A-SIO/1	12.95
Z80-SIO/2	11.95	Z80A-SIO/2	12.95
Z80-SIO/9	11.95	Z80A-SIO/9	12.95

6.0 MHZ

Z80B-CPU	9.95
Z80B-CTC	12.95
Z80B-PIO	12.95
Z80B-DART	12.95

ZILOG

Z8132	33.95
Z8671	38.95

DIP SWITCHES



4 POSITION	.84
5 POSITION	.89
6 POSITION	.89
7 POSITION	.94
8 POSITION	.94

1984 - THE IC MASTER -

Your ticket to fast and easy IC selections



\$ 89.95

INTERFACE CHIPS

8726	1.54	8798	.88
88728	1.84	DM8131	2.90
8795	.88	DP8304	2.24
8798	.88	DS8835	1.94
8797	.88	DS8836	.98

CRYSTALS

1.0000 MHz	3.69	8.0000 MHz	2.69
1.8432 MHz	3.69	10.0000 MHz	2.69
2.0000 MHz	2.99	10.7386 MHz	2.69
2.0972 MHz	2.99	12.0000 MHz	2.69
2.4576 MHz	2.99	14.3182 MHz	2.69
3.2768 MHz	2.69	15.0000 MHz	2.69
3.5795 MHz	2.69	16.0000 MHz	2.69
4.0000 MHz	2.69	17.4300 MHz	2.69

IC SOCKETS
(1 to 99)

8 pin ST..... .12	8 pin WW..... .58
4 pin ST..... .14	14 pin WW..... .68
6 pin ST..... .16	16 pin WW..... .68
8 pin ST..... .19	18 pin WW..... .98
10 pin ST..... .28	20 pin WW..... 1.04
12 pin ST..... .29	22 pin WW..... 1.34
14 pin ST..... .29	24 pin WW..... 1.44
18 pin ST..... .39	28 pin WW..... 1.64
10 pin ST..... .48	40 pin WW..... 1.94

ST = Soldertail WW = Wirewrap

ZIF SOCKETS

16 pin ZIF..... 5.90
24 pin ZIF..... 7.90
28 pin ZIF..... 8.90

ZIF = TEXTTOOL (Zero Insertion Force)

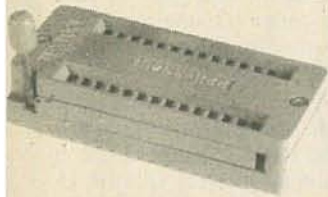

DISKETTES
5 1/4"
— **ATHANA** —

SS/SD..... 15.90
SS/DD..... 16.90
DS/DD..... 22.90

SOFT SECTOR with HUB RING

BULK 5 1/4" DISKETTES
(NO LABEL)

SS/DD ... 10 for 14.90
100 up..... 139.00

(Lifetime Warranty)

The FLIP SORT™

The new Flip Sort™ has all the fine qualities of the original with some added benefits: a new design and 50% greater capacity. Holds 75 diskettes and the price is now lower than ever— **\$16.95**



The Flip Sort PLUS™

The new Flip Sort PLUS™ adds new dimensions to storage. Its smoked acrylic elegance holds over 100 diskettes with all the features you expect from the Flip Sort Family— **\$24.95**



IBM ACCESSORIES

MEMORY EXPANSION KIT



4164 150ns
9 for \$45.00

MULTIFUNCTION CARD



- 64K to 384K RAM
- Parallel Port
- Serial Port
- Clock Calendar
- Software Included
- 1-Year Warranty

\$249.95

MEMORY CARD



- Expandable to 512K
- Fully compatible with IBM software
- Fully compatible w/IBM diagnostic utilities
- Serial Port Available
- 1-Year Warranty

\$199.95

— **VUTEK** —

Color • Parallel • Serial Card



- Full bit-mapped Color Graphics
- Printer Port (LPT1, LPT2, LPT3)
- Serial Port (Com1, Com2)
- IBM PC, XT and Portable compatible
- Full software compatibility
- Compatible with Lotus 1-2-3, Multi-Plan and Flight Simulator
- Full 2-Year Warranty Parts and Labor

\$299.00

DISK DRIVES

Tandon TM100-2	DS/DD	199.00
Teac FD-55B	DS/DD	159.00

KEYBOARD EXTENSION CABLE

\$19.95

APPLE ACCESSORIES

80 Column Apple II+ ...	149.95
80 Column Apple IIE ...	129.95
Z80 Apple II+	89.00
Z80 Apple IIE	89.00
16K Card	39.95
Cooling Fan	38.95
Power Supply	74.95
Joystick	29.95
RF Modulator	13.95
Disk Drive	199.00
Controller Card	59.95
Paddles	7.95

APPLE COMPATIBLE JOYSTICK

29.95



COOLING FAN

38.95

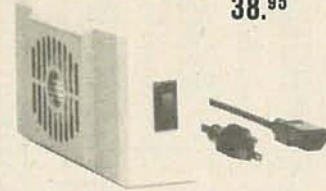

APPLE COMPATIBLE POWER SUPPLY

74.95

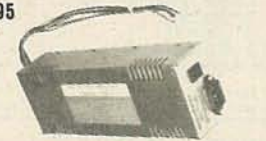

- Powers Apple type systems
- +5V @ .5A +12V @ 3A
- -5V @ .5A -12V @ .5A
- includes instructions

16K RAM Card - Apple II+

- 2-Year Warranty



Assembled & Tested ... **39.95**

APPLE COMPATIBLE DISK DRIVE

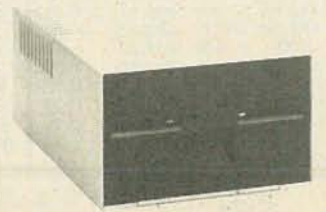

199.00

- Shugart mechanism, made in U.S.A.
- Directly replaces Apple Disk II
- Fully compatible with Apple Controller or other Apple compatible controllers.
- One Year Warranty

micromax

VIEWMAX-80 149.95

- 80 Col. card for Apple II+
- Video Soft Switch
- Inverse Video
- 2 Year Warranty



VIEWMAX-80e 129.95

- 80 Col. card for Apple IIE
- 64K RAM Expandable to 128K

64K RAM Upgrade 40.00



Reg. Power Supply Model 4A/PS (99/4)

3 DC Outputs:

12V @ .4A, +5V @ 1.1A
-5V @ .2A Highly Filtered

6.95



TERMS: Minimum order \$10.00. For shipping and handling, include \$2.50 for UPS ground or \$3.50 for UPS Blue (air). For each additional air pound, add \$1 for UPS Blue shipping and handling. California residents must include 6% sales tax. Bay area and LA residents include 6 1/2% sales tax. Prices are subject to change without notice. We are not responsible for typographical errors. We reserve the right to limit quantities and to substitute manufacturers. All merchandise subject to prior sale.

CALL for VOLUME Quotes

HOURS: Mon - Fri 7:30 to 5:00
Saturdays 10:00 to 3:00

VISIT OUR RETAIL STORE

2100 De La Cruz Blvd
Santa Clara, CA 95050
(408) 988-0697

ALL MERCHANDISE IS 100% GUARANTEED

Telex: 756440

DoKay

CPU's & SUPPORT CHIPS

Z80A CPU 4.75	8195.2	8.00	
Z80B CPU 9.00	8202	19.95	
Z80A CTC 4.50	8212	3.00	
Z80A DART 0.00	8214	4.50	
Z80A PIO 4.50	8216	3.00	
Z80A SIO 10.95	8226	3.50	
82C43	10.00	8237	16.00
AMD2901	8.95	8238	3.95
6802	4.75	8250	10.95
6800	2.50	8251	8.00
6803L	12.95	8253	8.00
6809	8.95	8255A.5	8.00
6810	4.00	8257	8.00
6821	4.50	8259	8.00
6845	13.95	8272A	25.00
6850	3.50	8275	24.50
6875	4.50	8279.5	6.95
D7220-1	24.00	8288	17.00
8035	8.95	8355	12.95
9080A	4.75	8748	20.00
8085A	10.00	TMS9927NL	9.95
8086	22.50	68000L	39.50
8155	8.00		

INTER FACE & DRIVERS

AYS-1013A	3.75
AYS-1015D	5.75
A95	9.90
TR1602B	3.95
IR1941L	8.95
AYS-3500PRO	9.95
CR5037	18.95
MMS307	7.95
MMS369	2.50
8130	2.50
8830	2.50
8834	2.00
8837	2.00

SHIFT REGISTERS

MM1402	1.75	D756C	10.00	1795	17.00
MM1403	1.75	1771	5.95	1797	17.00
MM1404	1.75	1791	14.00	6167P-3	9.00
MM5053	2.50	1793	17.00		
MM5056	2.50				
MM5057	2.50				
MM5058	2.50				
MM5060	2.50				

RAM's

21L02-3	9.00
2101A	4.15
2112	1.95
2114-2	1.40
2118-4	2.50
2124-3	2.50
3147	6.00
TMS3409	1.75
MK4027-3	1.75
TMS4052NL	2.95
MK4096-11	1.25
4108-3	1.50
4116-2	1.00
4118-4	4.00
MK4802-5	3.579
2104-4	5.00
2104-3	6.75
8118-12	4.95

NO. 30 WIRE WRAP WIRE SINGLE STRAND 100' \$1.40

CRYSTALS

1.843	6.000
2.000	6.144
3.000	9.000
4.000	18.000
3.579	10.000
5.000	18.000
5.000	18.000
5.000	18.000
5.000	18.000
5.000	18.000

3.00 ea.

LINEAR CIRCUITS

DA008EQ	3.75	LM380	1.20	LM1310	1.40
TL062CP	95	LM384	1.60	LM1391	1.60
TL064CN	1.50	LM386	1.00	1458	80
TL072	1.25	LM387	1.25	1458	50
TL084	1.50	LM393	75	LM1808	1.75
LM201	75	LF398A	3.00	AD2700L	4.95
LM301/748	50	LM555	50	LM2901	95
LM307	45	LM556	45	CA2018	1.95
LM308	66	558	1.75	CA3078A	1.50
LM310	1.10	564	2.50	CA3080	1.00
LM311	75	565	90	CA3089E	1.75
LM318	1.25	566	1.25	CA3094	1.30
LM319	1.30	567	95	CA3130	1.00
LM324	75	NE592	95	CA3140	1.00
LM339	90	709C	80	CA3822	75
LM348	90	LM710	60	LM3909	80
LF351	80	733	95	4136	85
LF353	1.25	741CV	50	NE595A	1.50
LF365	90	747	50	8700CJ	5.95
LM358	70	CA758	1.75	LM13080	95
LM370	1.60	LM798CT	60		
LM377	1.60				

TOGGLE SWITCHES

106D	SPDT	1.00
206D	DPDT	1.40
206P	DPDT	CENTER OFF 1.80

IN4148 (IN914) 15/1.00

L1411-IR DETECTOR 3/81.00

FP 100 PHOTO TRANS. \$.50

RED LED'S 2' 8/81.00

YEL. GREEN Y. AMBER LARGE LED'S 2' 6/81.00

RED-GREEN BIPOLAR LED .90

RED-YELLOW BIPOLAR LED .90

MLED92 IR LED .40

MRD148 PHOTO DARL. XTOR .60

MCT2 OPTO ISOLATORS .60

1 WATT ZENERS: 3.3, 4.7, 5.1, 5.6, 6.8, 8.2, 9.1, 10, 12, 15, 18, or 22V .6/51.00

DIP SWITCHES

CTS 206-4	4 POSITION	.75
CTS 206-7	7 POSITION	.95
CTS 206-8	8 POSITION	.95
CTS 206-10	10 POSITION	1.25

8 PIN .10 DIP 22 PIN .25

14 PIN .15 SOCKETS 24 PIN .25

16 PIN .18 28 PIN .35

18 PIN .20 40 PIN .40

20 PIN .25

WIRE WRAP SOCKETS

14 PIN	.45
16 PIN	.50
18 PIN	.65
20 PIN	.90
24 PIN	1.10
28 PIN	1.25
40 PIN	1.80

20KV DIODES 250 ma \$1.95

DB CONNECTORS

DB9P	\$.20	DB25P	\$.20
DB9S	\$.30	DB25S	\$.30
HOODS	\$.10	HOODS	\$.10

EPOXY GLASS VECTOR BOARD

1/16" thick with 1/10" spacing

4 1/2" x 6 1/2" \$1.95

SCR's

1.5A	6A	35A	PRV	1A	10A	25A	
100	35	40	1.40	100	35	60	1.40
200	40	50	1.80	200	50	80	1.90
400	60	70	2.40	400	70	1.00	2.60
600	80	100	3.60	600	100	1.20	3.60

C/MOS

74C00	50	74C915	1.10	4028	1.25	4071	30
74C02	40	74C921	3.50	4027	45	4072	30
74C04	40	4001	30	4028	75	4072	80
74C10	40	4002	30	4029	75	4077	50
74C14	40	4006	85	4030	40	4081	30
74C20	40	4007	30	4034	1.75	4082	30
74C32	40	4008	90	4035	85	4093	70
74C42	1.20	4009	40	4040	75	4099	1.75
74C76	75	4010	45	4041	75	4501	95
74C83	1.20	4016	40	4049	35	4515	1.60
74C85	1.25	4012	30	4083	85	4506	75
74C86	40	4013	35	4044	80	4510	1.20
74C93	1.00	4014	75	4046	90	4511	85
74C194	3.00	4015	40	4047	95	4514	1.20
74C157	1.70	4016	40	4049	35	4515	1.60
74C161	1.10	4017	75	4050	35	4516	1.50
74C174	1.10	4018	75	4051	80	4518	85
74C175	1.10	4019	40	4052	1.00	4520	85
74C192	1.40	4020	75	4053	80	4528	1.10
74C193	1.40	4021	75	4050	70	4529	1.40
74C245	1.75	4022	75	4066	40	4538	1.50
74C901	40	4023	35	4068	40	4539	1.50
74C903	80	4024	65	4069	35	4583	90
74C907	90	4025	30	4070	40	4586	75

74S SERIES

74S00	35	74S74	50	74S163	1.75
74S02	35	74S85	1.25	74S165	1.50
74S03	35	74S86	50	74S174	90
74S04	35	74S89	2.00	74S175	90
74S05	35	74S112	60	74S181	3.00
74S08	35	74S113	60	74S182	2.00
74S09	45	74S124	2.20	74S189	1.60
74S10	35	74S133	45	74S194	1.30
74S11	35	74S135	85	74S195	1.30
74S15	35	74S138	80	74S241	2.00
74S20	35	74S139	80	74S244	1.25
74S30	35	74S151	90	74S251	1.20
74S32	40	74S153	1.25	74S257	90
74S40	40	74S157	90	74S260	75
74S42	85	74S158	90	74S373	2.00
74S51	35	74S161	1.75	74S374	2.00

2114-4 \$1.00

4116-25 \$.75

4164-2 \$4.00

4164-15 \$4.50

6264-15 \$3.00

HM 50256 \$3.00

T IS 73 N FET .45

ER 900 TRIGGER DIODES 4/S1.00

2N2646 UJT .45

2N3820 P FET .45

2N 6028 PROG. UJT .65

DISC CAPACITORS

1UF 16V	10 \$1.00	100 \$8.00
01UF 35V	16 \$1.00	100 \$5.00

PRINTED CIRCUIT BOARD

4" x 6" DOUBLE SIDED EPOXY BOARD 1/16" THICK

60 ea. \$52.60

FULL WAVE BRIDGE

PRV	2A	6A	25A
100	1.40		
200	80	1.30	2.20
400	1.00	1.65	3.30
600	1.30	1.90	4.40

12V DC RELAYS TTL SIZE

S.P. 1200 ohm coil .75

D.P. 400 ohm coil .95

SILICON POWER RECTIFIERS

PRV	1A	3A	12A	50A	125A	240A
100	.05	.14	.35	.90	5.00	6.00
200	.05	.17	.50	1.30	7.00	9.00
400	.09	.25	.85	1.50	10.00	12.00
600	.11	.30	.80	2.00	13.00	15.00
800	.13	.35	1.00	2.50	16.00	18.00
1000	.20	.45	1.25	3.00	20.00	26.00

REGULATORS

78L12	\$.40	LM337T	\$1.95
LM3095	\$.75	LM339K	\$5.75
LM317T	\$.15	340T-5, B, 8, 12	
320T 5, 12, 15	15, 18 or 24V	\$.75	
or 24	\$.85	723	\$.50
323K (LA1405)	\$1.75	LA51412 + 12V3A	\$3.95

TANTALUM CAPACITORS

22UF 35V	5/1.00	15UF 16V	3/1.00
47UF 35V	5/1.00	30UF 6V	5/1.00
68UF 35V	5/1.00	33UF 15V	\$.50
1UF 20V	5/1.00	47UF 20V	\$.85
2.2UF 20V	5/1.00	68UF 16V	1.00
3.3UF 20V	4/1.00	200UF 20V	1.75
4.7UF 35V	4/1.00	150UF 16V	1.30
6.8UF 20V	4/1.00	330UF 10V	1.75
10UF 20V	\$.40		
22UF 10V	\$.30		

50 PIN EDGEBOARD CONN. 3.95

40 PIN EDGEBOARD CONN. 3.00

34 PIN EDGEBOARD CONN. 3.00

26 PIN EDGEBOARD CONN. 2.50

60 PIN RIBBON CABLE CONN. 4.00

50 PIN RIBBON CABLE CONN. 3.50

40 PIN RIBBON CABLE CONN. 3.00

34 PIN RIBBON CABLE CONN. 2.75

26 PIN RIBBON CABLE CONN. 2.50

20 PIN RIBBON CABLE CONN. 2.00

TRANSISTOR SPECIALS

TIP 318 NPN S1 TO-220	\$.40
TIP 328 PNP S1 TO-220	\$.40
TIP 34 PNP S1	\$.95
TIP 111	\$.10
TIP 121 PNP S1 UJ4	\$.10
TIP 141 NPN S1 UJ7	\$.10
TIP 145	\$.15
BU205	\$.15
2N4004 PNP GE TO-5	\$.25
2N1307 PNP GE TO-5	\$.40
DP52000 - DUAL POWER DARL.	\$.35
2N2222 PNP S1 TO-18	\$.50
2N2907 PNP S1 TO-18	\$.75
TIP 2955 PNP S1	\$.70
2N3055 NPN S1 TO-3	\$.60
AL3055S	\$.60
2N3904 NPN S1 TO-92	\$.75
2N3906 PNP S1 TO-92	\$.75
2N4010 NPN S1 TO-3	\$.75
2N4018 PNP S1 TO-220	\$.75
2N6233-NPN SWITCHING POWER	\$.75
MEF-8004 CM FR. TRANSISTOR NPN S1	\$.95
MEF 8014 - PNP GE TO-3	\$.95

TTL IC SERIES

74162	70
74163	70
74164	95
74165	85
74166	1.00
74167	1.50
74168	1.50
74169	1.50
74170	1.50
74171	1.50
74172	1.50
74173	1.50
74174	1.50
74175	1.50
74176	1.50
74177	1.50
74178	1.50
74179	1.50
74180	1.50
74181	1.50
74182	1.50
74183	1.50
74184	1.50
74185	1.50
74186	1.50
74187	

WE HAVE QUALITY PARTS, DISCOUNT PRICES AND FAST SHIPPING!

TRANSFORMERS

120 volt primaries

5.6 VOLTS @ 750 MA \$3.00
 6 VOLTS @ 150 MA \$1.25
 12 VCT @ 200 MA \$2.00
 18 V. @ 650 MA \$3.50
 18 VOLTS @ 1 AMP \$4.50
 24 VOLTS @ 250 MA \$2.50
 24 VCT @ 1 AMP \$4.50

RS-232 EXTENSION

9 LINE CONNECTED LINES 1 THROUGH 8 & 20. DB25 MALE TO FEMALE. 10 FEET SHIELDED. \$11.00 EACH

MIKE CONNECTOR

5 CONDUCTOR IN-LINE PLUG AND CHASSIS MOUNT JACK. TWIST LOCK STYLE. SAME AS SWITCHCRAFT 12CL5M. \$2.50 PER SET

7 CONDUCTOR RIBBON CABLE

SPECTRA-STRIP RED MARKER STRIP. 28 GA STRANDED WIRE. \$5.00 PER ROLL (100 FT.)

REVERBERATION UNIT

ACCUTRONICS COIL SPRING TYPE UNITS. USED IN ELECTRONIC ORGANS TO PROVIDE ACOUSTIC DELAY SOUND EFFECTS. INPUT IMPEDANCE 8 OHMS, OUTPUT IMPEDANCE 2250 OHMS. 4 1/2" x 16 1/4" x 1 1/2" \$7.50 EACH

TRANSFORMER WALL

ALL ARE 115 VAC PLUG IN

4 VDC @ 70 MA \$2.00
 6 VDC @ 100 MA \$2.50
 6 VDC @ 500 MA \$5.00
 9 VAC @ 1 AMP \$3.00
 15 VAC @ 300 MA \$3.00
 16.5 VAC @ 10 VA \$3.50
 17 VAC @ 500 MA \$4.00

MULTI-SWITCHES

3 STATION NON-INTERLOCKING
 3-2PDT SWITCHES. EACH OPERATES INDEPENDENTLY.
 1 3/4" BETWEEN MOUNTING CENTERS. \$1.75 EACH

5 STATION INTERLOCKING
 MADE BY ALPS. 3-2PDT AND 2-6PDT SWITCHES ON FULLY INTERLOCKING ASSEMBLY. 3 3/4" BETWEEN MOUNTING CENTERS. \$2.50 EACH

5 STATION NON-INTERLOCKING
 SAME AS ABOVE, EXCEPT EACH SWITCH OPERATES INDEPENDENTLY. \$2.50 EACH

METER 0 - 15 V.D.C.

THIS 2-1/4" SQUARE METER MEASURES 0-15 VDC. \$4.50 EACH

SUB-MINIATURE D TYPE CONNECTOR

SOLDER TYPE SUB-MINIATURE CONNECTORS USED FOR COMPUTER HOOK UPS.
 DB-15 PLUG \$2.75
 DB-15 SOCKET \$4.00
 DB-15 HOOD \$1.50
 DB-25 PLUG \$2.75
 DB-25 SOCKET \$3.50
 DB-25 HOOD \$1.25

"PARALLEL" PRINTER CONNECTOR

SOLDER STYLE 36 PIN MALE USED ON "PARALLEL" DATA CABLES. \$5.50 EACH

I.D.C. MALE

SAME AS ABOVE. WILL PRESS FIT ON STANDARD RIBBON CABLE. \$8.00 EACH

2K 10 TURN MULTI-TURN POT

SPECTROL #MOD 534-7161 \$5.00 EACH

ROTARY SWITCH 1 POLE 6 POSITION

1 1/4" DIA x 1 1/2" HIGH 75¢ EACH 10 for \$6.00

PUSHBUTTON POWER SWITCH

DOUBLE POLE POWER SWITCH PUSH-ON, PUSH-OFF. \$1.00 EACH

SWITCHES MINI-PUSH BUTTON

S.P.S.T. MOMENTARY NORMALLY OPEN 1/4" BUSHING 35¢ EACH 10 FOR \$3.25 100 FOR \$30.00
 SPECIFY COLOR: RED, BLACK, WHITE, GREEN, YELLOW.

SOUND AND VIDEO MODULATOR FOR T.I. COMPUTER

T.I. # UM1381-1. DESIGNED FOR USE WITH T.I. COMPUTERS. CAN BE USED WITH VIDEO SOURCES, BUILT-IN A/B SWITCH, CHANNEL 3 OR 4 SELECTION SWITCH, OPERATES ON 12 VDC. HOOK UP DIAGRAM INCLUDED. \$10.00 EACH

48 KEY ASSEMBLY FOR T.I. COMPUTER

NEW TEXAS INSTRUMENTS KEYBOARD. UNENCODED. 48 S.P.S.T. MECHANICAL SWITCHES. TERMINATES TO 15 PIN CONNECTOR. SOLID METAL FRAME 4" X 9". \$6.50 EACH 2 FOR \$11.00

SPRING LEVER TERMINALS

TWO COLOR CODED TERMINALS ON A STURDY 2 3/4" x 3 3/4" BAKELITE PLATE. GREAT FOR SPEAKER ENCLOSURES OR POWER SUPPLIES. \$1.00 EACH 10 FOR \$9.00

2 CHANNEL LIGHT ORGAN

EASILY HOOKS INTO STEREO SPEAKERS AND ALLOWS 110 VAC LIGHTS TO DANCE WITH MUSIC. TWO SEPARATE 110 VAC OUTPUTS FOR HIGH AND LOW FREQUENCY AUDIO SIGNALS. USE TWO ORGANS FOR STEREO... \$6.50 PER UNIT
 COLOR LIGHT STRING AVAILABLE \$1.75 EA

EDGE CONNECTORS

ALL ARE .156" SPACING
 10 PIN EDGE CONNECTOR TRW #50-10-A-20 \$2.00 EACH
 18/36 GOLD SOLDER EYELET \$2.00 EACH
 22/44 TIN P.C. STYLE: NO MOUNTING EARS. \$1.50 EACH 10 FOR \$14.00
 22/44 GOLD P.C. STYLE \$2.00 EACH 10 FOR \$18.00
 28/56 GOLD 28/56 GOLD PLATED CONTACTS .156 CONTACT SPACING. \$2.50 EACH 10 FOR \$22.00

120V INDICATOR

NEON INDICATOR. RATED 120 V 1/3 W. MOUNTS IN 5/16" HOLE... RED LENS. 75¢ EACH 10 FOR \$7.00 100 FOR \$65.00

GEL CELL BATTERY

12 VDC @ 1.2 AMP HOUR 4" X 1 13/16" X 2 1/8" \$15.00 EACH

FREE! FREE! FREE! SEND FOR **NEW LARGER!** 48 PAGE CATALOG FREE! FREE! FREE!

LINE CORDS

TWO WIRE 6' 18ga TWO WIRE 3 FOR \$1.00
 THREE WIRE 18 INCH 18ga THREE WIRE 2 for \$1.00
 8 FOOT 18ga THREE WIRE \$2.00 EACH

KEY ASSEMBLY 5 KEY

\$1.00 EACH
 CONTAINS 5 SINGLE-POLE NORMALLY OPEN SWITCHES. MEASURES 3 3/4" LONG

6 KEY \$1.25 EACH

CONTAINS 6 SINGLE-POLE NORMALLY OPEN SWITCHES. MEASURES 4 1/4" LONG.

DC-DC CONVERTER

DESIGNED TO PROVIDE A STEADY -5 VDC @ 240 MA FROM A BATTERY SUPPLY OF 3.5 TO 6.25 V. 2 1/16" X 1 1/16" X 1 11/16" HIGH. \$1.50 EACH

RELAYS SOLID STATE RELAY

HEINEMANN ELECTRIC #101-5A-140-5 AMP CONTROL: 3-32VDC LOAD: 140VAC 5 AMPS SIZE: 2" X 1" X 3/4" HIGH \$5.00 10 FOR \$45.00

MINIATURE 6 VDC RELAY

SUPER SMALL SPDT RELAY; GOLD COBALT CONTACTS. RATED 1 AMP AT 30 VDC; HIGHLY SENSITIVE. TTL DIRECT DRIVE POSSIBLE. OPERATES FROM .43 TO 6 V. COIL RES. 220 OHM. 1 3/16" x 13/32" x 7/16" AROMAT # RSD-6V \$1.50 EACH 10 FOR \$13.50

13 VDC RELAY

CONTACT: S.P.N.C. 10 AMP @ 120 VAC ENERGIZE COIL TO OPEN CONTACT... COIL: 13 VDC 650 OHMS SPECIAL PRICE \$1.00 EACH

4 PDT RELAY

14 pin style
 3 amp contacts
 24 volt d.c. or 120 volt a.c. coil
 Used but fully tested \$1.70 EACH specify coil voltage
 LARGE QUANTITIES AVAILABLE SOCKETS FOR RELAY 50¢ each

COMPUTER GRADE CAPACITORS

2,000 mfd. 200 VDC 1 3/4" DIA. x 5" HIGH \$2.00
 3,600 mfd. 40 VDC 1 3/8" DIA. x 3 3/4" HIGH \$1.00
 6,400 mfd. 60 VDC 1 3/8" DIA. x 4 1/4" HIGH \$2.50
 22,000 mfd. 40 VDC 2" DIA. x 6" HIGH \$3.00
 31,000 mfd. 15 VDC 1 3/4" DIA. x 4" HIGH \$2.50
 72,000 mfd. 15 VDC 2" DIA. x 4 3/8" HIGH \$3.50
 185,000 mfd. 6 VDC 2 1/2" DIA. x 4 1/2" HIGH \$1.50
 CLAMPS TO FIT CAPACITORS 50¢ ea.

SLIDE POTS

100K linear tape 2" LONG 75¢ EACH
 1 5/8" TRAVEL 75¢ EACH
 500K linear taper 2 7/8" LONG 75¢ EACH
 DUAL 100K audio taper 3 1/2" LONG \$1.50 EACH
 2 1/2" TRAVEL. \$1.50 EACH

CRYSTALS

CASE STYLE HC33/U 2 MHZ \$3.50 EACH
 COLORBURST 3579.545 KC \$1.00 EACH

METAL OXIDE VARISTOR

G.E. # V82A12 50 VOLTS, NOMINAL D.C. VOLTAGE. 5/8" DIAMETER 2 FOR \$1.50

L.E.D.'S STANDARD JUMBO DIFFUSED

RED 10 FOR \$1.50
 GREEN 10 FOR \$2.00
 YELLOW 10 FOR \$2.00
 FLASHER LED 5 VOLT OPERATION RED JUMBO SIZE \$1.00 EACH
 BI POLAR LED 2 FOR \$1.70

LED HOLDERS

TWO PIECE HOLDER FOR JUMBO LED 10 FOR 65¢ 200 FOR \$10.00

CLEAR CLIPLITE HOLDER

MAKE LED A FANCY INDICATOR. CLEAR. 4 FOR \$1.00

3 1/2" SPEAKER

8 OHM IMPEDANCE. FULL RANGE SPEAKER. 8 OZ MAGNET. 4" DIAGONAL MOUNTING CENTERS. \$2.50 EACH 10 FOR \$20.00

SOLDERING IRON STAND

SPRING STEEL IRON HOLDER ON WEIGHTED BASE. \$5.00 EACH

TRANSISTORS

2N706 4 FOR \$1.00
 2N2222A 3 FOR \$1.00
 2N2222 4 FOR \$1.00
 2N2904 3 FOR \$1.00
 2N2905 3 FOR \$1.00
 2N2907 3 FOR \$1.00

POWER SUPPLY W/ PRE-AMP

THIS SUPPLY WAS USED TO POWER AN 8 TRACK/CASSETTE UNIT. IT WILL SUPPLY APPROX. 18 VDC AND INCLUDES A SMALL PRE-AMP TO BOOST SIGNAL LEVEL. RCA PLUGS FOR LINE IN/OUT. \$4.50 EACH

MINIATURE TOGGLE SWITCHES

ALL ARE RATED 5 AMPS @ 125 VAC
 S.P.D.T. (on-on) P.C. STYLE. NON-THREADED BUSHING. 75¢ EACH 10 FOR \$7.00
 S.P.D.T. (on-on) SOLDER LUG TERMINALS. \$1.00 EACH 10 FOR \$9.00 100 FOR \$80.00
 S.P.D.T. (on-off-on) P.C. STYLE. THREADED BUSHING. \$1.00 EACH 10 FOR \$9.00 100 FOR \$80.00
 D.P.D.T. (on-on) SOLDER LUG TERMINALS. \$2.00 EACH 10 FOR \$19.00 100 FOR \$180.00

SOLID STATE BUZZER

STAR #5MB-06L. 6 VDC. TTL COMPATIBLE. \$1.00 EACH 10 FOR \$9.00

TOLL FREE ORDERS ONLY
 1-800-826-5432 (ORDER ONLY)
 (IN CALIFORNIA: 1-800-258-6666)
 ALASKA, HAWAII, OR INFORMATION (213) 380-8000

ALL ELECTRONICS CORP.

905 S. VERMONT AVE. P.O. BOX 20406 LOS ANGELES, CA 90006

6228 SEPULVEDA BLVD. VAN NUYS, CA 91411

QUANTITIES LIMITED
 MINIMUM ORDER \$10.00
 USA \$2.50 SHIPPING
 FOREIGN ORDERS INCLUDE SUFFICIENT SHIPPING CALIF. RES. ADD 6 1/2% NO C.O.D!

FEBRUARY 1985

PARTIAL LISTING ONLY- PLEASE CALL OR WRITE FOR FREE CATALOG.

STATIC RAMS

2112	256x4 (450ns)	2.99
2114	1024x4 (450ns)	8/9.95
2114-25	1024x4 (250ns)	8/10.95
2114L-4	1024x4 (450ns)(LP)	8/12.95
2114L-3	1024x4 (300ns)(LP)	8/13.45
2114L-2	1024x4 (200ns)(LP)	8/13.95
TMM2016-200	2048x8 (200ns)	4.15
TMM2016-150	2048x8 (150ns)	4.95
TMM2016-100	2048x8 (100ns)	6.15
HM6116-4	2048x8 (200ns)(cmos)	4.75
HM6116-3	2048x8 (150ns)(cmos)	4.95
HM6116LP-4	2048x8 (200ns)(cmos)(LP)	4.95
HM6116LP-3	2048x8 (150ns)(cmos)(LP)	5.95
HM6264P-15	8192x8 (150ns)(cmos)(LP)	24.95

LP = Low Power

DYNAMIC RAMS

4116-250	16384x1 (250ns)	8/6.95
4116-200	16384x1 (200ns)	8/8.95
4116-150	16384x1 (150ns)	8/10.95
4164-200	65536x1 (200ns)(5v)	9/39.95
4164-150	65536x1 (150ns)(5v)	9/44.95
TMS4164	65536x1 (150ns)(5v)	7.95

5v = Single 5 Volt Supply

EPROMS

2708	1024x8 (450ns)	3.95
2716	2048x8 (450ns)(5v)	3.95
2716-1	2048x8 (350ns)(5v)	4.95
TMS2532	4096x8 (450ns)(5v)	4.95
2732	4096x8 (450ns)(5v)	4.95
2732A-4	4096x8 (400ns)(5v)(21vPGM)	4.95
2732A-35	4096x8 (350ns)(5v)(21vPGM)	4.95
2732A	4096x8 (250ns)(5v)(21vPGM)	6.95
2732A-2	4096x8 (200ns)(5v)(21vPGM)	10.95
2764	8192x8 (450ns)(5v)	5.95
2764-250	8192x8 (250ns)(5v)	6.95
2764-200	8192x8 (200ns)(5v)	11.95
27128	16384x8 (250ns)(5v)	19.95

5v = Single 5 Volt Supply
21vPGM = Program at 21 Volts

SPECTRONICS CORPORATION

EPROM ERASERS

Timer	Chip Capacity	Intensity (uW/Cm ²)	
PE-14	9	8,000	83.00
PE-14T	X	9	119.00
PE-24T	X	9	175.00

8000

8035	5.95
8039	5.95
8080	3.95
8085	4.95
8085A-2	11.95
8087	175.00
8088	19.95
8155	6.95
8155-2	7.95
8156	6.95
8748	24.95
8755	24.95

8200

8203	39.95
8205	3.50
8212	1.80
8216	1.75
8228	3.49
8237-5	15.95
8243	4.45
8250	10.95
8251A	4.49
8253	6.95
8253-5	7.95
8255	4.49
8255-5	5.25
8259	6.90
8259-5	7.50
8272	19.95
8275	29.95
8279	6.95
8282	6.50
8284	5.50
8286	6.50
8288	14.95

Z80 2.5 Mhz

Z80-CPU	2.49
Z80-CTC	2.95
Z80-PIO	2.95
Z80-SIO/0	9.95

4.0 Mhz

Z80A-CPU	2.49
Z80A-CTC	3.95
Z80A-DART	8.95
Z80A-PIO	3.95
Z80A-SIO/0	10.95

6.0 Mhz

Z80B-CPU	8.95
----------	------

6500

6502	4.95
6520	2.95
6522	5.49
6532	9.95
6551	9.95
6502A	5.95
6522A	9.95
6551A	11.95

6800

68000-8	39.95
6800	2.95
6802	7.95
6809E	8.95
6809	8.95
6821	2.95
6845	12.95
6850	3.25
6883	22.95

DISK CONTR

1771	15.95
1791	23.95
1793	23.95
UPD765	19.95

INTERFACE

8T26	1.59
8T28	1.98
DM8131	2.95
DP8304	2.29

CLOCK CHIPS

MM5314	4.95
MM5369	1.95
MM58167	8.95
MSM5832	3.95

DATA ACQ

ADC0804	3.49
ADC0809	4.49
ADC0817	9.95
DAC0808	2.95
MC1408L8	2.95

SOUND CHIPS

76477	3.95
76488	5.95
AY3-8910	12.95
SSI263	39.95

74LS00

74LS00	.24	74LS157	.65
74LS01	.25	74LS158	.69
74LS02	.25	74LS160	.69
74LS03	.25	74LS161	.65
74LS04	.24	74LS163	.65
74LS05	.25	74LS164	.69
74LS08	.28	74LS165	.95
74LS09	.29	74LS166	1.75
74LS10	.25	74LS169	1.75
74LS11	.35	74LS173	.69
74LS12	.35	74LS174	.55
74LS13	.45	74LS191	.89
74LS14	.59	74LS192	.79
74LS20	.25	74LS193	.79
74LS21	.29	74LS194	.69
74LS26	.29	74LS195	.69
74LS27	.29	74LS197	.79
74LS32	.29	74LS221	.89
74LS33	.55	74LS240	.95
74LS37	.35	74LS241	.99
74LS38	.35	74LS242	.99
74LS40	.25	74LS243	.99
74LS42	.49	74LS244	1.29
74LS47	.75	74LS245	1.49
74LS51	.25	74LS251	.59
74LS73	.39	74LS253	.59
74LS74	.35	74LS257	.59
74LS75	.39	74LS258	.59
74LS76	.39	74LS259	2.75
74LS85	.69	74LS260	.59
74LS86	.39	74LS266	.55
74LS90	.55	74LS279	.49
74LS92	.55	74LS280	1.98
74LS93	.55	74LS283	.69
74LS107	.39	74LS290	.89
74LS109	.39	74LS293	.89
74LS112	.39	74LS299	1.75
74LS122	.45	74LS323	3.50
74LS123	.79	74LS365	.49
74LS124	2.90	74LS367	.45
74LS125	.49	74LS368	.45
74LS126	.49	74LS373	1.39
74LS132	.59	74LS374	1.39
74LS136	.39	74LS377	1.39
74LS138	.55	74LS390	1.19
74LS139	.55	74LS393	1.19
74LS145	1.20	74LS640	2.20
74LS148	1.35	74LS645	2.20
74LS151	.55	74LS670	1.49
74LS153	.55	74LS682	3.20
74LS154	1.90	74LS688	2.40
74LS155	.69	81LS95	1.49
74LS156	.69	25LS2521	2.80

7400

7400	.19	7492	.50
7401	.19	7493	.35
7402	.19	74100	1.75
7403	.19	74107	.30
7404	.19	74116	1.55
7405	.25	74121	.29
7406	.29	74122	.45
7407	.29	74123	.49
7408	.24	74125	.45
7409	.19	74126	.45
7410	.19	74132	.45
7411	.25	74145	.60
7413	.35	74148	1.20
7414	.49	74150	1.35
7416	.25	74151	.55
7417	.25	74153	.55
7420	.19	74154	1.25
7421	.35	74155	.75
7425	.29	74157	.55
7427	.29	74159	1.65
7430	.19	74161	.69
7432	.29	74163	.69
7437	.29	74164	.85
7438	.29	74165	.85
7442	.49	74166	1.00
7445	.69	74173	.75
7447	.69	74174	.89
7448	.69	74175	.89
7473	.34	74185	2.00
7474	.33	74192	.79
7475	.45	74193	.79
7476	.35	74194	.85
7483	.50	74259	2.25
7485	.59	74367	.65
7489	2.15	74368	.65
7490	.35	74393	1.35

74S00

74S00	.32
74S02	.35
74S04	.35
74S05	.35
74S08	.35
74S10	.35
74S11	.35
74S20	.35
74S32	.40
74S37	.88
74S74	.50
74S86	.50
74S112	.50
74S124	2.75
74S132	1.24
74S133	.45
74S138	.85
74S139	.85
74S140	.55
74S151	.95
74S153	.95
74S157	.95
74S158	.95
74S161	1.95
74S163	1.95
74S174	.95
74S175	.95
74S240	2.20
74S241	2.20
74S244	2.20
74S287	1.95
74S287	1.90
74S288	1.90
74S373	2.45
74S374	2.45
74S471	4.95

★★★★HIGH TECH★★★★

NEC μPD7220 \$39.95
GRAPHICS DISPLAY CONTROLLER
 * FOUR MEGABIT BIT-MAPPED DISPLAY MEMORY
 * DRAWS LINES, ARCS, CIRCLES & RECTANGLES AT 1.2 MILLION PIXELS PER SECOND
 * ZOOM, PAN, WINDOWING, AND LIGHT PEN CAPABILITIES
 * DMA TRANSFER WITH 8257 OR 8237
 * UP TO 1024 x 1024 PIXEL GRAPHICS OR 256 x 100 CHARACTERS

★★★★SPOTLIGHT★★★★

32.768Khz	1.95
1.0Mhz	3.95
1.8432	3.95
2.0	2.95
2.4576	2.95
3.579545	2.95
4.0	2.95
5.0	2.95
5.0688	2.95
6.0	2.95
6.144	2.95
8.0	2.95
10.0	2.95
10.738635	2.95
14.31818	2.95
15.0	2.95
16.0	2.95
17.430	2.95
18.432	2.95
20.0	2.95

CRYSTALS

UARTS

AY5-1013	3.95
AY3-1015	6.95
TR1602	3.95
2651	8.95
IM6402	7.95

BIT-RATE GENERATORS

BR1941	11.95
4702	12.95
COM8116	10.95
14411	11.95

MISC.

3242	7.95
MC3470	4.95
AY5-3600 PRO	11.95
HD46505SP	15.95
CRT5027	19.95

LINEAR

TL084	2.19	NE564	2.95
LM301	.34	LM565	.99
LM307	.45	LM566	1.49
LM308	.69	NE592	.98
LM309K	1.25	LM733	.98
LM310	1.75	LM741	.35
LM311	.64	LM747	.69
LM317T	1.19	LM1370	1.49
LM317K	3.95	MC1330	1.69
LM318	1.49	MC1372	6.95
LM323K	4.95	LM1458	.59
LM324	.59	LM1488	.69
LM331	3.95	LM1489	.69
LM334	1.19	LM1496	.85
LM335	1.40	LM1800	2.37
LM336	1.75	LM1812	8.25
LM337T	1.95	LM1889	1.95
LM338K	3.95	ULN2003	1.29
LM339	.99	XR2006	3.75
LM348	.99	XR2211	5.25
LM350K	4.95	CA3146	1.85
LF351	.60	LM3900	.59
LF353	1.00	LM3911	2

PARTIAL LISTING ONLY- PLEASE CALL OR WRITE FOR FREE CATALOG.

CAPACITORS

ELECTROLYTIC

RADIAL		AXIAL	
.47uf	50v .14	10	50v .16
10	50v .15	22	16v .14
47	35v .18	47	50v .20
100	16v .18	100	15v .20
220	35v .20	150	25v .25

50v MONOLITHIC

.01uf	.14	.1	.05
.047	.15	.47	.25

50v DISC

10pf	.05	470	.05
22	.05	560	.05
25	.05	680	.05
27	.05	820	.05
33	.05	.001uf	.05
47	.05	.0015	.05
56	.05	.0022	.05
68	.05	.005	.05
82	.05	.01	.07
100	.05	.02	.07
220	.05	.05	.07
330	.05	.1	.12

SPECIALS ON BYPASS CAPS

.01uf disc	50v	100/6.00
.1uf disc	12v	100/8.00
.01uf mono	50v	100/12.00
.1uf mono	50v	100/15.00

ACCESORIES & PERIPHERALS

FOR IBM

MAXIMIZER Memory Multifunction	259.95
HAYES SMARTMODEM 1200B	419.95
PC PEACOCK Color Display Adaptor	239.95
130W POWER SUPPLY	175.00
PROTOTYPE CARD	27.95
PROTOTYPE CARD With Decoding	29.95

FOR APPLE

JDR 16K RAM CARD	39.95
BAL-500 1/2 Ht. Disk Drive, Teac Mechanism	169.95
MITAC AD-1 Full Height, Shugart Mechanism	179.95
DISK CONTROLLER CARD	49.95
OMNIGRAPH Parallel Graphics Card	79.95
VIEWMAX-80 80 Column For Apple II+	159.95
VIEWMAX-80e 80 Column For Apple IIe	129.95
THUNDERCLOCK Official PRODOS Clock	129.95
KRAFT JOYSTICK	39.95
60W POWER SUPPLY	49.95

MISCELLANEOUS

ZENITH ZVM-123 15 MHz Green Monitor	105.00
NEC JB1201M 20 MHz Green Monitor	169.00
BMC BM-AU9191U Comp. 13" Color Monitor	279.00
BMC BX-80 PRINTER	249.00
NASHUA DISKETTES SS/SD Box of 10	19.95
VERBATIM DATALIFE DISKETTES DS/DD	34.95
DISKETTE FILE Holds 70 Diskettes	16.99

BARGAIN HUNTERS CORNER

2 LEVEL WIRE WRAP SOCKETS

THESE SOCKETS HAVE .50" LEADS, JUST A LITTLE SHORTER THAN THE STANDARD 3 LEVEL WIRE WRAP SOCKETS WITH .67" LEADS.

8 PIN WW-2	1.99	100-UP
8 PIN WW-2	.40	.35
14 PIN WW-2	.45	.39
16 PIN WW-2	.45	.39
20 PIN WW-2	.75	.59
22 PIN WW-2	.50	.39
24 PIN WW-2	.89	.75
28 PIN WW-2	.89	.75
40 PIN WW-2	.89	.75

SPECIALS END 1/31/85

5 1/4" DISK DRIVES

TANDON TM100-2	DS/DD	199.00
SHUGART SA400L	SS/DD	199.95
MPI B52	DS/DD	139.95
TEAC FD55B 1/2 Ht.	DS/DD	139.95
TEAC FD55F 1/2 Ht.	DS/Quad	200.00

8" DISK DRIVES

SIEMENS FD200-8	DS/DD	195.00
SIEMENS FD100-8	SS/DD	149.95

SWITCHING POWER SUPPLIES

KEPCO/TDK	ASTEC
MODEL MRM174KF	MODEL AA11190
+5V @ 5A	+5V @ 4A
+12V @ 2A	+12V @ 2.5A
+12V @ 2.8A	-5V @ .25A
-12V @ .5A	-12V @ .30A
49.95	39.95

LIGHT EMITTING DIODES

JUMBO	1-99	100-up	MAN-72 CA .3"	.99
RED	.10	.09	MAN-74 CC .3"	.99
GREEN	.18	.15	FND-500 CC .5"	1.49
YELLOW	.18	.15	FND-507 CA .5"	1.49

IC SOCKETS/DIP CONNECTORS

LEADS	LOW PROFILE SOLDER TAIL		3 LEVEL WIREWRAP		TEXT TOOL ZERO INSERTION		COMPONENT CARRIES		IDC PLUG RIBBON CABLE	
	1-99 pcs. 100&up		1-99 pcs. 100&up		ZIFxx		ICCxx		IDPxx	
8	.13	.11	.59	.49	---	---	.49	---	---	---
14	.15	.12	.69	.52	4.95	---	.59	---	.95	---
16	.17	.13	.69	.58	4.95	---	.69	---	.95	---
18	.20	.18	.99	.90	---	---	.99	---	---	---
20	.29	.27	1.09	.98	---	---	.99	---	---	---
22	.30	.27	1.39	1.28	---	---	.99	---	---	---
24	.30	.27	1.49	1.35	5.95	---	.99	---	1.75	---
28	.40	.32	1.69	1.49	6.95	---	1.09	---	---	---
40	.49	.39	1.99	1.80	9.95	---	1.49	---	2.95	---
64	4.25	---	---	---	---	---	---	---	---	---

IDC CONNECTORS

DESCRIPTION	ORDER BY	CONTACTS				
		20	26	34	40	50
RIBBON HEADER SOCKET	IDSxx	.99	1.39	1.59	1.99	2.25
RIBBON EDGE CARD	IDExx	2.25	2.65	2.75	3.80	3.95

ORDERING INSTRUCTIONS: Insert the number of contacts in the position marked "xx" of the "order by" part number listed. EXMAMPLE: A 20 pin ribbon edge card would be IDE 20.

D-SUBMINIATURE

DESCRIPTION	ORDER BY	CONTACTS				
		9	15	25	37	
SOLDER CUPS	MALE	DBxxP	1.19	1.59	1.90	2.85
	FEMALE	DBxxS	1.50	1.85	2.25	3.90
RT. ANGLE	MALE	DBxxPR	1.65	2.20	3.00	4.83
	FEMALE	DBxxSR	2.18	3.03	3.00	6.19
PC SOLDERS	MALE	IDBxxP	2.95	3.90	4.75	6.95
	FEMALE	IDBxxS	3.25	4.29	5.25	7.95
HOODS	BLACK	HOOD-B	---	---	.99	---
	GREY	HOOD	.89	.99	.99	1.09

MOUNTING HARDWARE-\$1.00

FOR ORDERING INSTRUCTIONS, SEE IDC CONN. ABOVE.

RIBBON CABLE

CONTACTS	SINGLE COLOR		COLOR CODED	
	1'	10'	1'	10'
25	.45	4.00	1.32	11.80
34	.61	5.40	1.65	14.50
50	.89	7.50	2.50	22.00

36 PIN CENTRONICS

CEN36 MALE SOLDER CUP	7.95
IDCEN36 MALE RIBBON CABLE	8.95
IDCEN36F FEMALE RIBBON CABLE	8.95

VOLTAGE

REGULATORS

7805T	.75	7915T	.85
78M05C	.35	7805K	1.39
7808T	.75	78H05K	9.95
7812T	.75	7812K	1.39
7815T	.75	7912K	1.49
7824T	.85	78L05	.69
7905T	.85	79L05	.79
7912T	.85	79L12	.79

C, T-TO-220, K-TO-3, L-TO-92

9000

9334	2.50
9368	3.95
9602	1.50

INTERSIL

ICL7107	12.95
ICL7660	2.95
ICL8038	3.95

DIP SWITCHES

4 position	.85
6 position	.90
7 position	.95
8 position	.95

TRANSISTORS

2N2222	.25	PN2907	.25
PN2222	.10	2N3055	.79
2N2905	.50	2N3904	.10
2N2907	.25	2N3906	.10

DISCRETE

1N751	5.1v zener	.25
1N759	12.0v zener	.25
1N4148	(1N914) switching	25/1.00
1N4004	400PIV rectifier	10/1.00
KBP02	200PIV 1.5a bridge	.45
4N33	OPTO-ISOLATOR	1.75

CMOS

4001	.25	4027	.45	4066	.39	4538	1.95
4002	.25	4028	.69	4069	.29	4543	1.19
4011	.25	4029	.79	4070	.35	4553	5.79
4012	.25	4040	.75	4071	.29	4584	.75
4013	.38	4042	.69	4081	.29	74C00	.35
4015	.39	4046	.85	4082	.29	74C04	.35
4016	.39	4047	.95	4093	.49	74C14	.59
4017	.69	4049	.35	4503	.65	74C74	.65
4018	.79	4050	.35	4511	.85	74C906	.95
4020	.75	4051	.79	4518	.89	74C922	4.49
4023	.29	4053	.79	4520	.79	74C923	4.95
4024	.65	4060	.89	4528	1.19	74C926	7.95

Dear Sir,

Thank you and your company for the fine service you afforded me. I was in a hurry due to the fact that other companies had not been able to fill my order. Not only was your service fast, but it also included a special no-substitutions part. All of the parts I received on time and in perfect condition. I will be using your parts from now on. Again, Thank you

Mark P. Dell

© Copyright 1985 JDR Microdevices



ORDER TOLL FREE
800-538-5000
800-662-6279
 (CALIFORNIA RESIDENTS) -

FEBRUARY 1985

QUALITY SPECIALS

DELUXE 46 CHANNEL CABLE TV CONVERTER



With Fine Tuning Dial

- Shifts all cable channels to UHF
- Extend pay TV to all your TV sets without extra monthly fee
- Allows taping pay TV (decoder required) while viewing another channel
- Restores TV remote control and VCR programming ability

\$24.95

BICYCLE COMPUTER

A Dashboard for your Bike

Handsome matte black console with keyboard input. Displays your speed, distance & calories burned on 2 sq. in. LCD screen. Quartz clock/stopwatch built in. Complete with MAG pickup & all mounts.

\$49.95

Upgrade any bike to a deluxe exercise machine



NEW DIGITAL SCALE

Lab accuracy at an everyday price...reads 1 gram or .1 oz.

Gives fast, exact weight in ounces or grams for the lab, dieting, postage, photography. Capacity: 1999 grams/70 oz. with automatic tare. Free postage & diet chart.

Best Value \$74.95



SOPHISTICATED I.C.'S

DATA SHEETS ARE PROVIDED FREE

LS7232	TOUCH SENSITIVE LIGHT DIMMER SWITCH. MOMENTARY TOUCH TO SENSOR PLATE TURNS LIGHTS ON	\$4.50
LS7226	14 PIN DIP AUTOMOTIVE MARINE ANTI-THEFT DIGITAL LOCK CIRCUIT. HAS 5,040 4-DIGIT COMBINATIONS	\$3.50
UGN3501T	HALL EFFECT SENSOR FOR MAGNETIC FIELD CHANGES TOO SMALL TO OPERATE THE HALL SWITCHES. OUTPUT IS A LINEAR FUNCTION OF MAGNETIC FIELD INTENSITY	\$2.80
UGN3604M	HALL EFFECT SENSOR WITH DIFFERENTIAL OUTPUT. A LINEAR FUNCTION OF MAGNETIC FLUX. SUPPLIED WITH IN-DIVIDUAL CALIBRATION CHART AT 29 DEGREES CELSIUS & V	\$8.50

GOLDSMITH SCIENTIFIC CORPORATION

720 E. Industrial Park Dr., Manchester, NH 03103

PHONE ORDERS WELCOME (603) 624-8030

FREE CATALOG OF NEW DEVICES

POSTAGE—ADD 5% PLUS \$1.50 INSURANCE, C.O.D. \$2.00 EXTRA SATISFACTION FULLY GUARANTEED

CIRCLE 251 ON FREE INFORMATION CARD

DON'T BLAME THE SOFTWARE!

Our Isolators eliminate equipment interaction, clean up interference, curb damaging power line spikes and lightning bursts.



ISO-1 ISOLATOR

3 isolated sockets; quality spike suppression; basic protection. . **\$81.95**

ISO-3 SUPER-ISOLATOR

3 dual isolated sockets; suppressor; commercial protection. **\$122.95**

ISO-17 MAGNUM ISOLATOR

4 quad isolated sockets; suppressor; laboratory grade protection. . **\$213.95**

ESP Electronic Specialists, Inc.

171 S. Main, Natick, MA 01760 (617) 655-1532

Toll Free Order Desk 1-800-225-4876
MasterCard, VISA, American Express

CIRCLE 60 ON FREE INFORMATION CARD

SATELLITE TV

continued from page 16

the best combination of LNA and downconverter, plus receiver. When the LNA and converter are one, mixing components is extremely difficult.

LNA's as stand-alone units have held on, as their use in the American industry has grown to the 50,000-per-month range. American OEM's manufacturing LNA's have raced to keep up with the demand and Japanese manufacturers have risen to meet the challenge. By September, the Japanese industry was capable of supplying upward of 40,000 LNA's per month to the North American market at prices that American suppliers are having difficulty in matching.

Since the world market for 4-GHz LNA's is virtually a North-American (only) market, that tremendous production capability cannot be marketed elsewhere effectively. With too many LNA's in so many warehouses, the expected happened—prices tumbled. The price for 120-degree LNA's dipped below \$100 in June of this year, and by September, even the higher-grade, 100-degree units dropped below \$100 (to dealers, in modest quantities).

Through all that, the dealer is more confused than ever. When prices were in the \$250 to \$300 region for standard 120-degree units, lower-priced (no-isolator or lower-gain) LNA's seemed like worthwhile alternative components. However, with the price of standard units dropping below \$100, the pricing advantage for lower-gain or non-isolator models has eroded.

Of the four major component areas (antenna, LNA, receiver, and motor drive), the motor-drive remains the last area where intense competition and traditional price-cutting has not been applied. That will, of course, change during 1985 since there's significant profit out there for OEM's or importers who are able to reduce costs while not getting the industry back to the "dog-days" of 1981 (when motor-drives were the bane of every dealer's existence). **R-E**

HIGH QUALITY up to 75dB GAIN

MICROWAVE TV SYSTEM

Variable from 1.9 to 2.5 GHz

The latest advance in microwave technology with a SNOW-FREE PICTURE.

Two Models to choose from.

Both Models Include:

- 20" Parabolic Dish
- Pre-assembled Probe with Down Converter

- Power Supply and Coax Switch
- 60' of RG-59/U Coax with Connector
- Transformer for 75 to 300 Ohms
- All Mounting Hardware for Fast and Easy Installation

20" Fiberglass Dish
Up to 55dB Gain
Special **\$98⁹⁵**

20" Aluminum Dish
Up to 55dB Gain
Low Priced **\$98⁹⁵**

Add 10% for Foreign orders or U.S. Parcel Post

High Gain Yagi Antenna with Down Converter and Power Supply. Complete System. Ready to Use. **\$89⁹⁵**

Send \$2.00 for Catalog. Refundable with first purchase. Available thru Mail and Phone Orders only. 20% deposit for COD. CA Res add 6 1/2% Tax. Send Cashiers Check or Money Order to: (Personal Checks, allow 2-5 weeks to clear)

PROFESSIONAL VIDEO, Inc.
4670 Hollywood Blvd., Hollywood, Calif. 90027

For C.O.D. Orders Call (213) 219-0227

CIRCLE 119 ON FREE INFORMATION CARD

ACTIVE RECEIVING ANTENNA

Gives excellent reception, 50 KHz to 30 MHz.

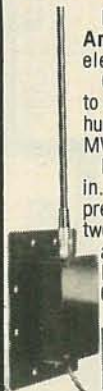

New MFJ-1024 Active Receiving Antenna mounts outdoors away from electrical noise for maximum signal.

Gives excellent reception of 50 KHz to 30 MHz signals. Equivalent to wire hundreds of feet long. Use any SWL, MW, BCB, VLF or Ham receiver.

High dynamic range RF amplifier. 54 in. whip. 50 foot coax. 20 dB attenuator prevents receiver overload. Switch between two receivers. Select auxiliary or active antenna. Gain control. "ON" LED. Remote unit, 3x2x4 in. Control, 6x2x5 in. 12 VDC or 110 VAC with optional adapter, MFJ-1312, \$9.95.

\$129⁹⁵ (+\$4.00 shipping)

Order from MFJ and try it. If not delighted, return within 30 days for refund (less shipping).

One year unconditional guarantee.

Order today. Call TOLL FREE 800-647-1800.

Charge VISA, MC. Or mail check, money order.

Write for free catalog. Over 100 products.

CALL TOLL FREE 800-647-1800

Call 601-323-5869 in Miss., outside continental USA, tech/order/repair info. TELEX 53-4590.

MFJ ENTERPRISES, INCORPORATED

Box 494, Mississippi State, MS 39762

CIRCLE 105 ON FREE INFORMATION CARD

RAMSEY

THE FIRST NAME IN ELECTRONIC TEST GEAR

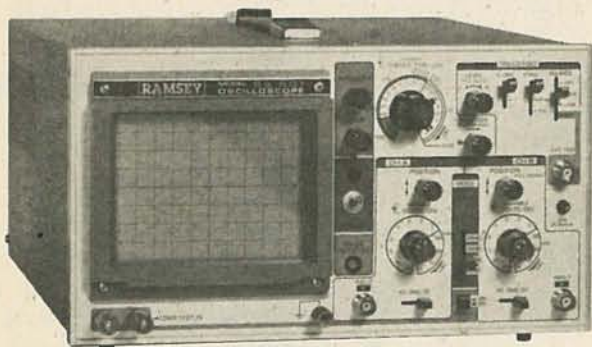

20 MHz DUAL TRACE OSCILLOSCOPE

Unsurpassed quality at an unbeatable price, the Ramsey oscilloscope compares to others costing hundreds more. Features include a component testing circuit for resistor, capacitor, digital circuit and diode testing • TV video sync filter • wide bandwidth & high sensitivity • internal graticule • front panel trace rotator • Z axis • high sensitivity x-y mode • regulated power supply • built-in calibrator • rock solid triggering

*USA—Add \$10.00 per unit for postage, overseas orders add 15% of total order for insured surface mail.

\$39995*

high quality hook on probes included

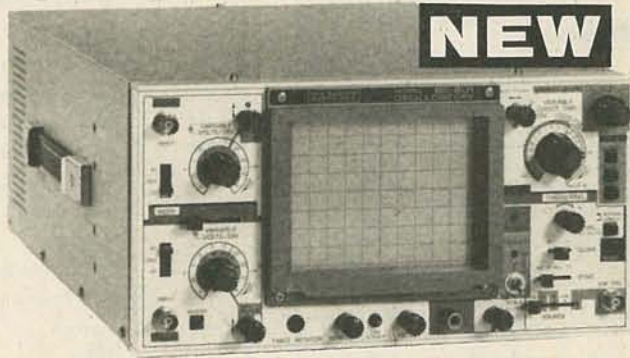

NEW

45 MHz DUAL SWEEP OSCILLOSCOPE

The Ramsey 825 is a dual time base, delayed sweep unit that includes a built-in signal delay line to permit clear viewing during very short rise times of high frequency waveforms. Other features include: variable trigger holdoff • 20 calibrated sweep time ranges from 0.5 s/div to 0.2 μs/div • fully adjustable sweep time • X5 sweep magnification • five trigger sources, CH1, CH2, LINE EXTERNAL and INTERNAL (V mode) • front panel x-y operation, Z axis input • sum difference of CH1, and CH2 waveforms displayed as single trace • sweep gate and sweep output • auto focus • single sweep

*Same as unit to left.

\$79995*

high quality hook on probes included



RAMSEY D-1100 VOM MULTITESTER

Compact and reliable, designed to service a wide variety of equipment. Features include • mirror back scale • double-jeweled precision moving coil • double overload protection • an ideal low cost unit for the beginner or as a spare back-up unit.

\$1995 test leads and battery included



NEW RAMSEY 1200 VOM MULTITESTER

Check transistors, diodes and LEDs with this professional quality meter. Other features include: decibel scale • 20K volt metering system • 3 1/2" mirrored scale • polarity switch • 20 measuring ranges • safety probes • high impact plastic case

\$2495 test leads and battery included



RAMSEY D-3100 DIGITAL MULTIMETER

Reliable, accurate digital measurements at an amazingly low cost • in-line color coded push buttons, speeds range selection • abs plastic tilt stand • recessed input jacks • overload protection on all ranges • 3 1/2 digit LCD display with auto zero, auto polarity & low BAT. indicator

\$4995 test leads and battery included



CT-70 7 DIGIT 525 MHz COUNTER

Lab quality at a breakthrough price. Features • 3 frequency ranges each with pre amp • dual selectable gate times • gate activity indicator • 50mV @ 150 MHz typical sensitivity • wide frequency range • 1 ppm accuracy

\$11995 wired includes AC adapter

CT-70 kit \$99.95
BP-4 nicad pack 8.95



CT-90 9 DIGIT 600 MHz COUNTER

The most versatile for less than \$300. Features 3 selectable gate times • 9 digits • gate indicator • display hold • 25mV @ 150 MHz typical sensitivity • 10 MHz timebase for WWV calibration • 1 ppm accuracy

\$14995 wired includes AC adapter

CT-90 kit \$129.95
OV-1 0.1 PPM oven timebase 59.95
BP-4 nicad pack 8.95



CT-125 9 DIGIT 1.2 GHz COUNTER

A 9 digit counter that will outperform units costing hundreds more. • gate indicator • 24mV @ 150 MHz typical sensitivity • 9 digit display • 1 ppm accuracy • display hold • dual inputs with preamps

\$16995 wired includes AC adapter

BP-4 nicad pack 8.95



CT-50 8 DIGIT 600 MHz COUNTER

A versatile lab bench counter with optional receive frequency adapter, which turns the CT-50 into a digital readout for most any receiver • 25 mV @ 150 MHz typical sensitivity • 8 digit display • 1 ppm accuracy

\$16995 wired

CT-50 kit \$139.95
RA-1 receiver adapter kit 14.95



DM-700 DIGITAL MULTIMETER

Professional quality at a hobbyist price. Features include 26 different ranges and 5 functions • 3 1/2 digit, 1/2 inch LED display • automatic decimal placement • automatic polarity

\$11995 wired includes AC adapter

DM-700 kit \$99.95
MP-1 probe set 4.95



PS-2 AUDIO MULTIPLIER

The PS-2 is handy for high resolution audio resolution measurements, multiplies UP in frequency • great for PL tone measurements • multiplies by 10 or 100 • 0.01 Hz resolution & built-in signal preamp/conditioner

\$4995 wired

PS-2 kit \$39.95



PR-2 COUNTER PREAMP

The PR-2 is ideal for measuring weak signals from 10 to 1,000 MHz • flat 25 db gain • BNC connectors • great for shifting RF • ideal receiver/TV preamp

\$4495 wired includes AC adapter

PR-2 kit \$34.95



PS-1B 600 MHz PRESCALER

Extends the range of your present counter to 600 MHz • 2 stage preamp • divide by 10 circuitry • sensitivity: 25mV @ 150 MHz • BNC connectors • drives any counter

\$5995 wired includes AC adapter

PS-1B kit \$49.95

ACCESSORIES FOR RAMSEY COUNTERS

Telescopic whip antenna—BNC plug \$ 8.95
High impedance probe, light loading 16.95
Low pass probe, audio use 16.95
Direct probe, general purpose use 13.95
Tilt ball, for CT-70, 90, 125 3.95



PHONE ORDERS CALL
716-586-3950

TELEX 466735 RAMSEY CI

TERMS: • satisfaction guaranteed • examine for 10 days; if not pleased, return in original form for refund • add 6% for shipping and insurance to a maximum of \$10.00 • overseas add 15% for surface mail • COD add \$2.50 (COD in USA only) • orders under \$15.00 add \$1.50 • NY residents add 7% sales tax • 90 day parts warranty on all kits • 1 year parts & labor warranty on all wired units.

RAMSEY

RAMSEY ELECTRONICS, INC.
2575 Baird Rd.
Penfield, N.Y. 14626

FEBRUARY 1985

CIRCLE 70 ON FREE INFORMATION CARD

121

SPARTAN Electronics Inc
 CALL (516) 499-9500 MAIL
 6094 Jericho Tpke.
 Commack, N.Y. 11725

CTC9R Philips Remote Cable Converter

 • Micro computer technology • Quartz controlled IC's lock in picture & prevent drift • 60 channel selections • Programmable time on & off • 24 hour LED digital clock • Favorite channel memory & recall plus scan • Wireless hand held infra-red transmitter system • Automatic fine tune • Adaptable to any brand television • One year warranty service.
\$139.95

RS232 TRANSMISSION LINE TESTER
 Features: *Male to Female connector for easy insertion into RS232 Line. *Test 7 Lines (TD, RD, RTS, CTS, DSR, CD, DTR) using LED's to indicate status of each. *Directly powered by RS232 Line no AC power needed.

\$23.95

SOUND ACTIVATED SWITCH MODEL R-1 \$29.95 For Home Security. Hears a Noise, Turns On Lights!

 When lights turn on, intruders are frightened away...ask any policeman. The new SOUND activated SWITCH automatically turns on lights at any sound, so it looks like you're home even when you're not.
 SOUND activated SWITCH protects your home better than timers. It turns on lights at the sound of an attempted break-in, and automatically turns them off when it's safe.
 SOUND activated SWITCH. It's the lightwatchman you can't afford to be without.
 • Entry Hall • Nursery • Sick Room • Family Room • Stairways and Halls • Children's Rooms • Attics • Basements • Garage • Closets

REFURBISHED MONITORS
 9" and 12" Bell & Howells or GBC Commercial Grade as low as \$10.00 off with a purchase of 2 refurbished monitors

\$39.95

RS232 TRANSMISSION LINE TESTER
 Features: *All 25 Signal lines accessible. *Dual Color: Red Green.
 Accessories: 1 Cable 10' male to Female Extension Jumper Set: 6 Straight 1 T-Jumper
 Vinyl Case
 Call for quantity prices. **\$169.95**

Jerrold 58 Channel Wireless Remote Converter \$109.95
Jerrold 36 Channel Remote CATV Converter w/on/off Fine Tuning \$94.95

40 Channel VHF to UHF Block Converter

 28.95 Ea. 24.95 4 & up
 Deluxe Version - Features fine tuning knob, matching X former & 2 cables \$38.95

BEFORE YOU PAY \$\$ FOR A TELEPHONE SERVICE CALL, TEST IT YOURSELF
 Telephone Line Analyze Model #1042 **EK PRECISION**

 — Tests telephone line functions that affect telephone operation
 — Verifies line and ring voltage levels
 — Checks condition of telephone line from central office to user's telephone jack
 — Verifies telephone line polarity that can affect polarity sensitive telephones
\$19.95

EK PRECISION PROFESSIONAL TELEPHONE PRODUCT TESTER
 Features: **MODEL 1045**

 • Provides basic operation tests for corded and cordless telephones, answering machines, and automatic dialers
 • Checks telephone line cords and handset cords for continuity, shorts and intermixes
 • Verifies number dialed and redialed for pulse or touch tone telephones
 • Provides low and normal level ring test sequence
 • Verifies that voice and DTMF (Dual Tone Multiple Frequency) levels are above minimum required level
 • Can be used by the consumer without the aid of a salesperson—an easy-to-follow instruction card is provided with the tester.
 • Can be used by the salesperson to demonstrate operation and features of telephone products and to screen returns before making an exchange
\$335.95

Volume Discounts
 Min. Order \$25.00
 International shipping Add 1
 Prices subject to change without notice
 COD 2.00 Extra
 Add 1 shipping for monitors
 (516) 499-9500
 Mon Th Tu W F Sa
 9-8 9-6 9:30-5
 TEL EX: 551427 SPARTAN

ADVERTISING INDEX

RADIO-ELECTRONICS does not assume any responsibility for errors that may appear in the index below.

Free Information Number	Page	
—	ACCuCOM	100 252
51	Active Electronics	112 90
—	Advance Electronics	27 116
106	Advanced Computer Products	109 —
107	All Electronics	117 264
72	Amazing Devices	108 101
108	AMC Sales	94 125
263	Babylon	104 119
98	Beckman Instruments	15 —
77	B&K Precision	38 78
—	Career 1	36 266
81	CEL	87 70
—	CIE	56, 57 257, 258
109	Chaney	108 259
54	Chemtronics	97 265
—	Command Productions	94 73
79	Communications Electronics	2 74
55	Contact East	37 261
—	Coop's Satellite Digest	16 75
80	CRT	37 —
270	Dandy Manufacturing	37 122
274	Deco Industries	36 271
254	Diamondback	106 103
82	Digi-Key	107 —
110	Dokay	114, 115 —
—	Educac Publications	91 —
99	EKI	43 —
—	Electro Industries	93 —
60	Electronic Specialists	120 —
61, 255	Electronic Warehouse	26, 45 —
120	Elephant Electronics	37 —
111	Etronix	99 —
—	ETT	CD2 —
100	Firestik II	99 —
262	Fluke Manufacturing	5 —
—	Fordham Radio	1, 33, CV4 —
256	Gemini Electronics	37 —
62	Global Specialties	34 —
251	Goldsmith Scientific	120 —
—	Grantham College of Engineering	35 —
71	Handy Prods./RSP Elec.	103 —
86	Heath	17 —
—	ICS Computer Training	95 —
63	Instrument Mart	83 —
114	Jameco	110, 111 —
124	James Walter Satellite Rec.	37 —
104	Jan Crystals	100 —
—	JDR Microdevices	118, 119 —
87	MCM Audio	113 —
105	MFJ	120 —
—	McGraw-Hill Book Club	18, 19, 39 —
67	McIntosh Labs	95 —
253	Micro-Mart	104 —
117	Mouser	100 —
267	Multitech	42 —
272	New-Tone Electronics	23 —
113	NRI	8, 9 —
—	NTS	28, 29 —
268	OK Industries	89 —
—	Omnitron	22 —
—	Paia	91 —
—	Phillips Tech	106 —
—	Phoenix Electronics	93 —
—	Pocket Technology	13 —
—	Pomona Electronics	CV3 —
—	Power Plus	37 —
—	Professional Video	120 —
—	Qualitone Industries	95 —
—	Radio Shack	105 —
—	RAG Electronics	24, 25 —
—	Ramsey	121 —
—	Regency	46, 85 —
—	Research Service Lab	36 —
—	Ross Custom	37 —
—	Sintec	81 —
—	Solid State Sales	116 —
—	Sony Video	32 —
—	Spartan Electronics	122 —
—	Tektronix	CV2 —
—	Telton	37 —
—	Uniden Bearcat	44 —
—	Wm B Allen	102 —
—	Zenith	7 —

Gernsback Publications, Inc.
 200 Park Ave. South
 New York, NY 10003
 (212) 777-6400
 Chairman of the Board:
 M. Harvey Gernsback
 President: Larry Steckler

ADVERTISING SALES 212-777-6400

Larry Steckler
 publisher
 Shelli Weinman
 advertising associate
 Arline Fishman
 advertising coordinator
 Lisa Strassman
 credit manager
 Donna Sala
 credit associate
 Naomi Matten
 advertising assistant

Sales Offices

EAST/SOUTHEAST

Stanley Levitan
 Radio-Electronics
 200 Park Ave. South
 New York, NY 10003
 212-428-6037, 212-777-6400

MIDWEST/Texas/Arkansas/Okla.

Ralph Bergen
 Radio-Electronics
 540 Frontage Road—Suite 325
 Northfield, IL 60093
 312-446-1444

PACIFIC COAST/ Mountain States

Marvin Green
 Radio-Electronics
 15335 Morrison St.—Suite 227
 Sherman Oaks, CA 91403
 818-986-2001

Our book has more adapter varieties and combinations than you'll care to count. The point is, we want to make sure that one or more of our adapter models will suit your design and test requirements to a tee.

And now that you have an idea of our

depth and variety, you should also be aware that the adapters we design and manufacture are considered by electronic design engineers to be right at the top. No question.

A superior product? You know you've got that. And you should know, also, that we

make sure you receive fast service and specified quantity through your favorite electronic parts distributor.

After all, we wrote the book.

And it's free. Our products are described and illustrated in our 1985 general catalog.

Just call (714) 623-3463 or 623-6751. Or, write to us at ITT Pomona Electronics, a division of ITT Corporation, 1500 E. Ninth St., Pomona, CA 91769.

ITT

Pomona Electronics

Pomona wrote the book on adapters. Don't miss it.

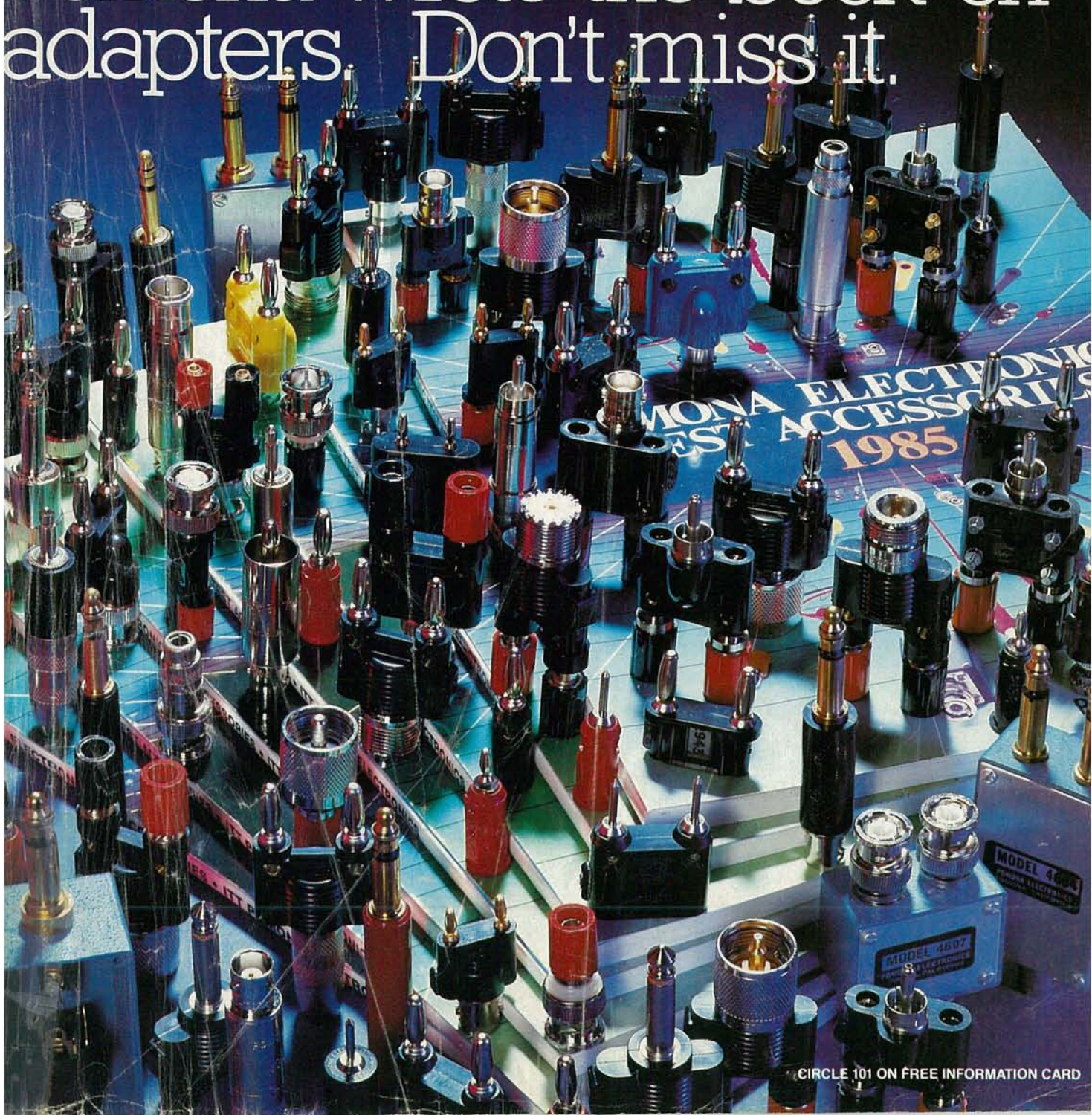

CIRCLE 101 ON FREE INFORMATION CARD

PERFORMANCE

SCOPE HAND-HELD DIGITAL CAPACITANCE and MULTIMETERS

- 0.5% DC Accuracy
- Highest Quality
- Highest Performance
- Lowest Prices

THE ULTIMATE TEST



Model DCM-602
\$7995

Digital Capacitance Meter

8 ranges with full scale values to 2000 uF

FEATURES • Broad test range - 1 pF to 2000 uF • LSI circuit provides high reliability and durability • Lower power consumption • Clear readout even in bright light • Crystal time base • Easy to operate, compact, lightweight • Protected from charged capacitors • Frequency range - 800 Hz to 8 Hz



Model DVM-634
\$4875

7 functions, 32 ranges. Transistor measurement included.

Digital Multimeters

- DC Voltage 100 uV - 1000 V
- AC Voltage 100 uV - 750 V
- AC/DC Current 200 uA - 10 Amps
- Resistance 20 Megohms
- Capacitance (DVM 636/638) 1 pF - 20 uF



Model DVM-638
\$7995

11 functions, 38 ranges. Includes logic level detector, audible visual continuity, capacitance and conductance measurement.



Model DVM-636
\$6275

8 functions, 37 ranges. Capacitance measurement included.

FEATURES • Overload Protection • Auto-decimal LCD readout • Polarity Indication • 3000 hour battery life with 9V transistor battery • Low battery indication

Charge it with VISA/MASTERCARD. Money orders, checks accepted. C.O.D.'s require 25% deposit.

Fordham

260 Motor Parkway, Hauppauge, NY 11788

Toll Free
800-645-9518
In NY State 800-832-1446

Service and Shipping Charge Schedule

FOR ORDERS	ADD
\$25-250	\$4.50
\$251-500	\$6.50
\$501-750	\$8.50
\$751-1,000	\$12.50
\$1,001 and up	\$15.00