

Radio- Electronics

WHAT'S NEW
IN BATTERIES.

SPECIAL
TEAR OUT SECTION
COMPUTER DIGEST

\$1.75 SEPT. 1984
IN CANADA \$2.25

COMPUTERS - VIDEO - STEREO - TECHNOLOGY - SERVICE

Stop That Burglar!

Build R-E's Sonic Motion Sensor and use it to trigger your home burglar alarm.

Electronics In Medicine.

A look at electronic instruments and the role they play in diagnosing cardiac and pulmonary disorders.

Build R-E's Computerized IC Tester.

An S-100 plug-in board tests IC's automatically.

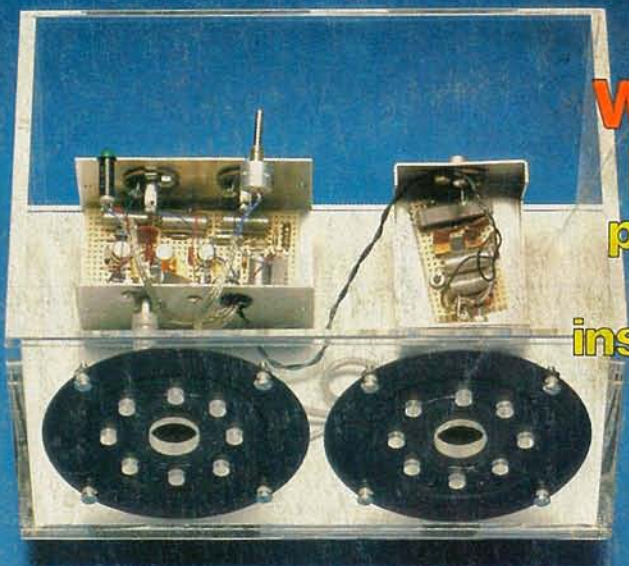

Designing With Linear IC's.

How to put difference and instrumentation amplifiers to work.

CMOS Generator Circuits.

More alternatives to the common clock generator circuit.

A
GERNSBACK
PUBLICATION

PLUS:

- ★ Equipment Reports
- ★ Hobby Corner
- ★ Designers Notebook
- ★ Service Clinic
- ★ New Idea
- ★ State-Of-Solid-State



Take home a world champion.

\$85* gets you a technical knockout.
The Fluke 70 Series.
Winners of the digital vs. analog battle.

Since their debut, they've become the worldwide champions of the industry.

Never before have such tough, American-made meters offered so many professional features at such unbeatable prices.

Each comes with a 3-year warranty, 2,000+ hour battery life, and instant autoranging.

You also get the extra resolution of a 3200-count LCD display, plus a responsive analog bar graph for quick visual checks of continuity, peaking, nulling and trends.

Choose from the Fluke 73, the ultimate in simplicity. The feature-packed Fluke 75. Or the deluxe Fluke 77, with its own protective holster and unique "Touch Hold" function** that captures and holds readings, then beeps to alert you.

So don't settle for just a contender. Take home a world champion.

For your nearest distributor or a free brochure, call toll-free anytime
1-800-227-3800, Ext. 229. From outside the U.S., call 1-402-496-1350, Ext. 229.

**FROM THE WORLD LEADER
IN DIGITAL MULTIMETERS.**



FLUKE 73

\$85*
Analog/digital display
Volts, ohms, 10A, diode test
Autorange
0.7% basic dc accuracy
2000+ hour battery life
3-year warranty

FLUKE 75

\$99*
Analog/digital display
Volts, ohms, 10A, mA, diode test
Audible continuity
Autorange/range hold
0.5% basic dc accuracy
2000+ hour battery life
3-year warranty

FLUKE 77

\$129*
Analog/digital display
Volts, ohms, 10A, mA, diode test
Audible continuity
"Touch Hold" function
Autorange/range hold
0.3% basic dc accuracy
2000+ hour battery life
3-year warranty
Multipurpose holster

* Suggested U.S. list price, effective July 1, 1984.
** Patent pending.

FLUKE®

Iwatsu's Four Independent Channel Scope.

There's 30 years of oscilloscope design and manufacturing experience behind the SS-5710-11 Series. Experience that translates to 27,000 hours MTBF. Four independent channels with no trace shift. A 3 year warranty. And that's just the beginning.

Add up our features and you'll see no other scope measures up.

The list starts with easy to read controls that make any Iwatsu scope, a pleasure to work with.

Then there's features like excellent linearity for high-frequency measurement. A special jitterless circuit, making it easier to trigger signals. Independent A and B triggers for digital applications. Plus a guaranteed time difference between channels.

More reasons for choosing Iwatsu.

- 20 kV 6" CRT with auto focus
- Maximum sweep speed of 2ns
- Separate intensity controls for A & B sweep
- Wide operating temperature range from -10°C to 50°C
- SS-5711C includes an optional counter/timer
- SS-5711D comes with DMM and counter/timer
- 60MHz Model SS-5710 is our 4-channel scope...just \$1,245 including probes, front cover and pouch
- SS-5710 is also available with optional counter/timer as well as DMM



HERE'S A FACE ANY ENGINEER COULD LOVE.

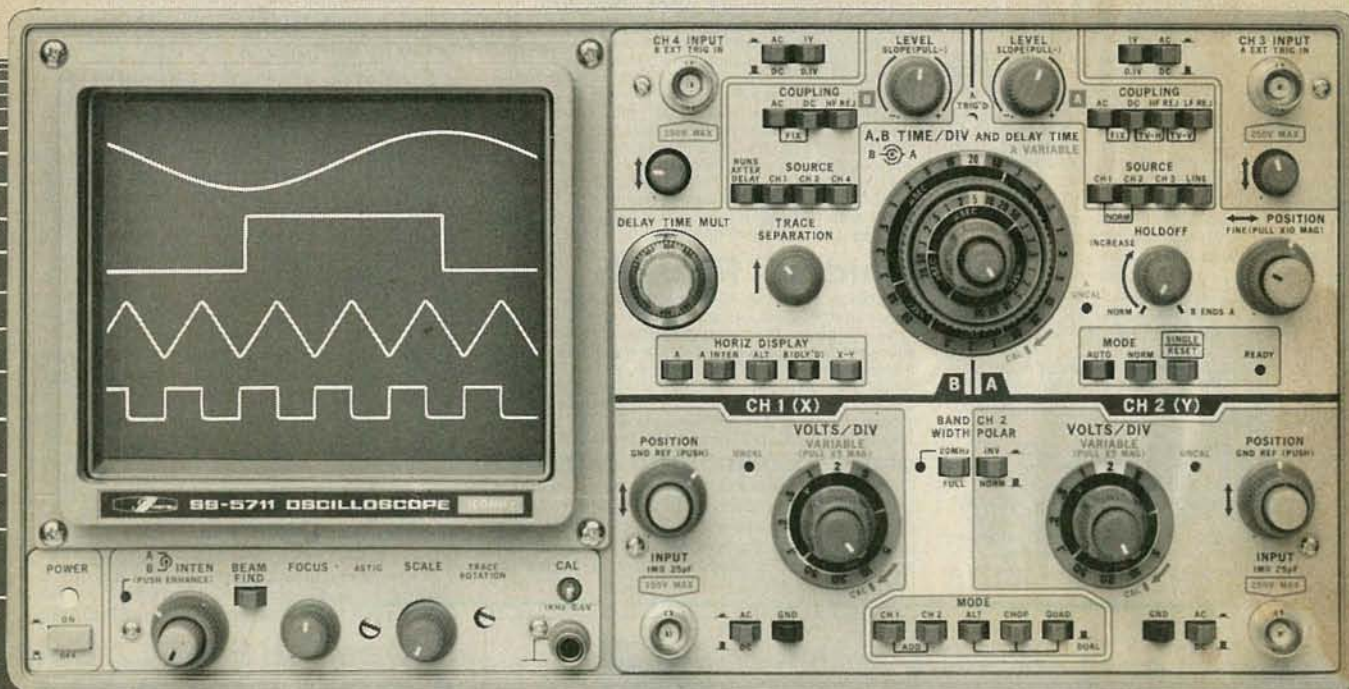

SS-5711 4-Independent Channel 100 MHz Scope including probes, pouch, and front cover: \$1,695.



IWATSU INSTRUMENTS INC.

120 COMMERCE ROAD, CARLSTADT, N.J. 07072 PHONE: (201) 935-5220, TWX: 710-989-0255

CIRCLE 53 ON FREE INFORMATION CARD

NEW!

uniden®

Bearcat®

Products

Communications Electronics,™ the world's largest distributor of radio scanners, is pleased to announce that *Bearcat* brand scanner radios have been acquired by Uniden Corporation of America. Because of this acquisition, Communications Electronics will now carry the complete line of Uniden *Bearcat* scanners, CB radios and Uniden *Bandit*™ radar detectors. To celebrate this acquisition, we have special pricing on the Uniden line of electronic products.

Bearcat® 300-E

List price \$549.95/CE price \$339.00
7-Band, 50 Channel • Service Search • No-crystal scanner • AM Aircraft and Public Service bands. • Priority Channel • AC/DC Bands: 32-50, 118-136 AM, 144-174, 421-512 MHz.
 The *Bearcat* 300 is the most advanced automatic scanning radio that has ever been offered to the public. The *Bearcat* 300 uses a bright green fluorescent digital display, so it's ideal for mobile applications. The *Bearcat* 300 now has these added features: Service Search, Display Intensity Control, Hold Search and Resume Search keys, Separate Band keys to permit lock-in/lock-out of any band for more efficient service search.

Bearcat® 20/20-E

List price \$449.95/CE price \$269.00
7-Band, 40 Channel • Crystalless • Searches AM Aircraft and Public Service bands • AC/DC Priority Channel • Direct Channel Access • Delay
 Frequency range 32-50, 118-136 AM, 144-174, 420-512 MHz. Find an easy chair. Turn on your *Bearcat* 20/20 and you're in an airplane cockpit. Listening to all the air-to-ground conversations. Maybe you'll pick up an exciting search and rescue mission on the Coast Guard channel. In a flash, you're back on the ground listening as news crews report a fast breaking story. Or hearing police and fire calls in your own neighborhood, in plenty of time so you can take precautions. You can even hear ham radio transmission, business phone calls and government intelligence agencies. Without leaving your easy chair. Because you've got a *Bearcat* 20/20 right beside it.

The *Bearcat* 20/20 monitors 40 frequencies from 7 bands, including aircraft. A two-position switch, located on the front panel, allows monitoring of 20 channels at a time.

Bearcat® 210XL-E

List price \$349.95/CE price \$209.00
6-Band, 18 Channel • Crystalless • AC/DC
 Frequency range 32-50, 144-174, 421-512 MHz. The *Bearcat* 210XL scanning radio is the second generation scanner that replaces the popular *Bearcat* 210 and 211. It has almost twice the scanning capacity of the *Bearcat* 210 with 18 channels plus dual scanning speeds and a bright green fluorescent display. Automatic search finds new frequencies. Features scan delay, single antenna, patented track tuning and more.

Bearcat® 260-E

List price \$399.95/CE price \$249.00
8-Band, 16 Channel • Priority • AC/DC
 Frequency range 30-50, 138-174, 406-512 MHz. Keep up with police and fire calls, ham radio operators and other transmission while you're on the road with a *Bearcat* 260 scanner. Designed with police and fire department cooperation, its unique, practical shape and special two-position mounting bracket makes hump mounted or under dash installation possible in any vehicle. The *Bearcat* 260 is so ruggedly built for mobile use that it meets military standard 810C, curve y for vibration rating. Incorporated in its rugged, all metal case is a specially positioned speaker delivering 3 watts of crisp, clear audio.

NEW! Bearcat® 201-E

List price \$279.95/CE price \$179.00
9-Band, 16 Channel • Crystalless • AC only Priority • Scan Delay • One Key Weather
 Frequency range 30-50, 118-136 AM, 146-174, 420-512 MHz. The *Bearcat* 201 performs any scanning function you could possibly want. With push button ease, you can program up to 16 channels for automatic monitoring. Push another button and search for new frequencies. There are no crystals to limit what you want to hear.

NEW! Bearcat® 180-E

List price \$249.95/CE price \$149.00
8-Band, 16 Channel • Priority • AC only
 Frequency range: 30-50, 138-174, 406-512 MHz. Police and fire calls. Ham radio transmissions. Business and government undercover operations. You can hear it all on a *Bearcat* 180 scanner radio. Imagine the thrill of hearing a major news event unfold even before the news organizations can report it. And the security of knowing what's happening in your neighborhood by hearing police and fire calls in time to take precautions. There's nothing like scanning to keep you in-the-know, and no better way to get scanner radio performance at a value price than with the *Bearcat* 180.

Bearcat® 100-E

The first no-crystal programmable handheld scanner.
 List price \$449.95/CE price \$234.00/SPECIAL!
8-Band, 16 Channel • Liquid Crystal Display Search • Limit • Hold • Lockout • AC/DC
 Frequency range: 30-50, 138-174, 406-512 MHz. The world's first no-crystal handheld scanner has compressed into a 3" x 7" x 1 1/4" case more scanning power than is found in many base or mobile scanners. The *Bearcat* 100 has a full 16 channels with frequency coverage that includes all public service bands (Low, High, UHF and "T" bands), the 2-Meter and 70 cm. Amateur bands, plus Military and Federal Government frequencies. It has chrome-plated keys for functions that are user controlled, such as lockout, manual and automatic scan. Even search is provided, both manual and automatic. Wow...what a scanner!

The *Bearcat* 100 produces audio power output of 300 milliwatts, is track-tuned and has selectivity of better than 50 dB down and sensitivity of 0.6 microvolts on VHF and 1.0 microvolts on UHF. Power consumption is kept extremely low by using a liquid crystal display and exclusive low power integrated circuits.

Included in our low CE price is a sturdy carrying case, earphone, battery charger/AC adapter, six AA ni-cad batteries and flexible antenna. The *Bearcat* 100 is in stock for quick shipment, so order your scanner today.

Bearcat® DX1000-E

List price \$649.95/CE price \$489.00
 Frequency range 10 kHz to 30 MHz. The *Bearcat* DX1000 shortwave radio makes tuning in London as easy as dialing a phone. It features PLL synthesized accuracy, two time zone 24-hour digital quartz clock and a built-in timer to wake you to your favorite shortwave station. It can be programmed to activate peripheral equipment like a tape recorder to record up to five different broadcasts, any frequency, any mode, while you are asleep or at work. It will receive AM, LSB, USB, CW and FM broadcasts.

There's never been an easier way to hear what the world has to say. With the *Bearcat* DX1000 shortwave receiver, you now have direct access to the world.

Uniden® PC22-E

List price \$159.95/CE price \$99.00
 The *Uniden* PC22 is a 40 channel AM remote mobile CB radio. It's the answer for today's smaller cars which don't always provide adequate space for mounting. Since all the controls are on the microphone, you can stash the "guts" in the trunk. The microphone has up/down channel selector, digital display, TX/RX indicator and external speaker jack. Dimensions: 5 3/4" W x 7 7/8" D x 1 1/2" H. 13.8 VDC, positive or negative ground.

QUANTITY DISCOUNTS AVAILABLE

Order two scanners at the same time and deduct 1%, for three scanners deduct 2%, four scanners deduct 3%, five scanners deduct 4% and six or more scanners purchased at the same time earns you a 5% discount off our super low single unit price.

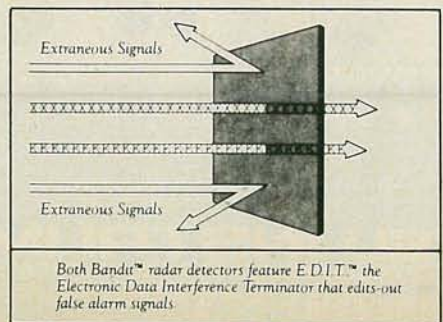

Uniden® PC33-E

List price \$59.95/CE price \$44.00
 The *Uniden* PC33 boasts a super-compact case and front-panel mike connector to fit comfortably in today's smaller cars. Controls: Power & Volume, Squelch; Switches: ANL. Other features of the PC33 include Graduated LED "S"/RF Meter, Digital channel indicator. Dimensions: 6" W x 6" D x 1 1/4" H. ±13.8 VDC.

Uniden® PC55-E

List price \$89.95/CE price \$59.00
 The full featured *Uniden* PC55 front-panel mike connector makes installation easier when space is a factor. It has ANL, PA-CB, Channel 9 and RF Gain switches. LED "S"/RF meter, TX lite, PA & external speaker jacks. Dimensions: 6" W x 6" D x 1 1/4" H. ±13.8 VDC.

Bandit™ Radar Detectors

Now that everyone else has taken their best shot at radar detection, the *Uniden* Bandit™ has done them one better...with E.D.I.T.™, the Electronic Data Interference Terminator that actually edits-out false alarm signals.

The *Bandit* 55, features a convenient brightness/dimmer control for comfortable day or night driving, plus a handy highway/city control for maximum flexibility wherever you drive. The *Bandit* 95 Remote, is a two-piece modular unit that lets you mount the long-range radar antenna behind the grill, out of view. The ultra-compact control unit can then be inconspicuously tucked under the dash or clipped to the visor. Order *Bandit* 55-E for \$119.00 each or the *Bandit* 95-E Remote for \$139.00 each.

OTHER RADIOS AND ACCESSORIES

FB-E-E Frequency Directory for Eastern U.S.A. \$12.00
 FB-W-E Frequency Directory for Western U.S.A. \$12.00
 BC-WA-E Bearcat Weather Alert! \$35.00
 A60-E Magnet mount mobile antenna \$35.00
 A70-E Base station antenna \$35.00
 Add \$3.00 shipping for all accessories ordered at the same time. Add \$3.00 shipping per scanner antenna.

BUY WITH CONFIDENCE

To get the fastest delivery from CE of any product in this ad, send or phone your order directly to our Scanner Distribution Center.™ Michigan residents please add 4% sales tax or supply your tax I.D. number. Written purchase orders are accepted from approved government agencies and most well rated firms at a 10% surcharge for net 10 billing. All sales are subject to availability, acceptance and verification. All sales on accessories are final. Prices, terms and specifications are subject to change without notice. All prices are in U.S. dollars. Out of stock items will be placed on backorder automatically unless CE is instructed differently. A \$5.00 additional handling fee will be charged for all orders with a merchandise total under \$50.00. Shipments are F.O.B. Ann Arbor, Michigan. No COD's. Most products that we sell have a manufacturer's warranty. Free copies of warranties on these products are available prior to purchase by writing to CE. International orders are invited with a \$20.00 surcharge for special handling in addition to shipping charges. Non-certified checks require bank clearance.

Mail orders to: Communications Electronics,™ Box 1002, Ann Arbor, Michigan 48106 U.S.A. Add \$7.00 per scanner, radar detector or CB or \$12.00 per shortwave receiver for U.P.S. ground shipping and handling in the continental U.S.A. For Canada, Puerto Rico, Hawaii, Alaska, or APO/FPO delivery, shipping charges are three times continental U.S. rates. If you have a Visa or Master Card, you may call and place a credit card order. Order toll-free in the U.S. Dial 800-521-4414. In Canada, order toll-free by calling 800-221-3475. WUI Telex CE anytime, dial 671-0155. If you are outside the U.S. or in Michigan dial 313-973-8888. Order today.

Scanner Distribution Center™ and CE logos are trademarks of Communications Electronics.™ Ad # 070184-E † *Bearcat* is a registered trademark of Uniden Corporation. Copyright © 1984 Communications Electronics

Order Toll Free ... call
1-800-521-4414

COMMUNICATIONS ELECTRONICS™

Consumer Products Division

818 Phoenix □ Box 1002 □ Ann Arbor, Michigan 48106 U.S.A.
 Call TOLL-FREE 800-521-4414 or outside U.S.A. 313-973-8888

BUILD THIS

51 SONIC MOTION DETECTOR

No alarm system is complete without a motion sensor. **David M. Benzel**

63 COMPUTER-CONTROLLED IC TESTER

You can test digital IC's by hand, but your computer can do it better! **Floyd L. Oats**

TECHNOLOGY

12 VIDEO NEWS

Tomorrow's news and technology in this quickly changing industry. **David Lachenbruch**

55 ELECTRONIC MEASUREMENTS IN MEDICINE

Here's a rundown on all of the "test instruments" that are used to monitor your heart. **Ray Fish, Ph.D., M.D.**

59 WHAT'S NEW IN BATTERIES

How do you choose the right battery for your project? Just how good are lithium batteries? Find out the answers to those, and other, questions. **Robert Grossblatt**

CIRCUITS AND COMPONENTS

46 NEW IDEAS

This pulsating doorbell will get your attention!

67 SQUAREWAVE GENERATOR CIRCUITS

We'll show you many practical variations of the squarewave generator—one of the building blocks of modern electronics. **Ray M. Marston**

77 DESIGNING WITH LINEAR IC'S

Part 5. A look at the current-difference amplifier and the operational transconductance amplifier, and how they are used. **Joseph J. Carr**

80 DESIGNER'S NOTEBOOK

Designing with Schmitt triggers. **Robert Grossblatt**

82 HOBBY CORNER

Modify your intercom to fit your needs. **Earl "Doc" Savage, K4SDS**

84 DRAWING BOARD

A look at the 4089 binary rate multiplier. **Robert Grossblatt**

86 STATE OF SOLID STATE

The COMFET—a new kind of FET. **Robert F. Scott**

VIDEO

90 SERVICE CLINIC

The most valuable test equipment. **Jack Darr**

90 SERVICE QUESTIONS

Radio-Electronics' Service Editor solves readers' problems.

COMPUTERS

71 INTERFACING THE ZX81

Part 3. Your once-lowly ZX81 (or Timex Sinclair 1000) computer can control a security system and any AC device, and can even act as a thermometer. **Neil Bungard**

Following
page 82

COMPUTER DIGEST

How to use a non-Commodore printer with a Commodore computer. A look at computer-aided PC-board design, and much more!

88 COMPUTER CORNER

Yesterday's personal computers. **Les Spindle**

EQUIPMENT REPORTS

32 Paladin Screwdrivers

37 Hickok MX-333 DMM

43 Krista Model 30B-240 Digital Capacitance Meter

DEPARTMENTS

6 Advertising and Sales Offices

114 Advertising Index

6 Editorial

115 Free Information Card

22 Letters

95 Market Center

48 New Products

16 What's News

COVER 1

The most effective (hard-to-defeat) burglar-alarm systems are those that include some way to sense motion. While motion detectors are usually expensive, they don't have to be: We'll show you how to build an inexpensive motion sensor for your alarm system. Not only will the motion detector save you money, it may save your possessions, too.

Don't think that the motion detector is only for those with burglar alarms. Even if you don't have an alarm system, you can use the motion detector to create a hands-off light switch, an automatic door opener, or simply a high-tech doorbell! The story begins on page 51.

NEXT MONTH

On Sale September 20

Satellite TV.

A look at components, systems, specifications, and prices.

Stereo Demodulator for Satellite TV.

You have a TVRO without stereo? Build this and hear what you've been missing.

Digital IC Tester.

In Part 2, we'll expand the IC tester to do more than just test IC's.

And lots more!

Radio-Electronics, (ISSN 0033-7862) Published monthly by Gernsback Publications, Inc., 200 Park Avenue South, New York, NY 10003. Second-Class Postage Paid at New York, N.Y. and additional mailing offices. One-year subscription rate: U.S.A. and U.S. possessions, \$14.97. Canada, \$17.97. Other countries, \$22.47 (cash orders only, payable in U.S.A. currency). Single copies \$1.75. © 1984 by Gernsback Publications, Inc. All rights reserved. Printed in U.S.A.

POSTMASTER: Please send address changes to RADIO-ELECTRONICS, Subscription Dept., Box 2520, Boulder, CO 80322.

A stamped self-addressed envelope must accompany all submitted manuscripts and/or artwork or photographs if their return is desired should they be rejected. We disclaim any responsibility for the loss or damage of manuscripts and/or artwork or photographs while in our possession or otherwise.

Radio-Electronics

Hugo Gernsback (1884-1967) founder

M. Harvey Gernsback, editor-in-chief

Larry Steckler, CET, publisher

Arthur Kleiman, editor

Carl Laron, WB2SLR,
associate editor

Brian C. Fenton,
assistant technical editor

Robert A. Young, assistant editor

Jack Darr, CET, service editor

Robert F. Scott,
semiconductor editor

Herb Friedman,
communications editor

Gary H. Arlen, contributing editor

David Lachenbruch,
contributing editor

Earl "Doc" Savage, K4SDS,
hobby editor

Lou Frenzel, contributing editor

Ruby M. Yee, production manager

Robert A. W. Lowndes,
production associate

Dianne Osias, production assistant

Karen Tucker, production assistant

Jacqueline Weaver, circulation director

Arline R. Fishman,
advertising coordinator

Radio-Electronics is indexed in *Applied Science & Technology Index* and *Readers Guide to Periodical Literature*.

Gernsback Publications, Inc.
200 Park Ave. South
New York, NY 10003
Chairman of the Board, M. Harvey Gernsback
President: Larry Steckler

ADVERTISING SALES 212-777-6400

Larry Steckler
Publisher

EAST/SOUTHEAST

Stanley Levitan
Radio-Electronics
200 Park Ave. South
New York, NY 10003
212-777-6400

MIDWEST/Texas/Arkansas/Okla.

Ralph Bergen
Radio-Electronics
540 Frontage Road—Suite 325
Northfield, Illinois 60093
312-446-1444

PACIFIC COAST Mountain States

Marvin Green
Radio-Electronics
15335 Morrison St., Suite 227,
Sherman Oaks, CA 91403
818-986-2001



Your West Coast Alternative!

FRIENDLY SERVICE — KNOWLEDGEABLE AND COURTEOUS SALES PEOPLE

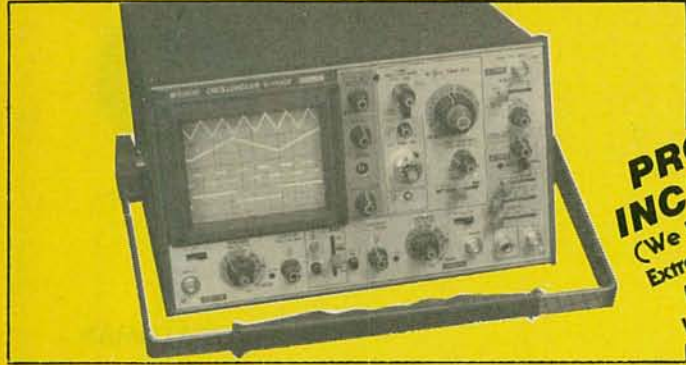

PROBES INCLUDED!
(We Don't Charge
Extra for what the
Manufacturer
Includes FREE!)

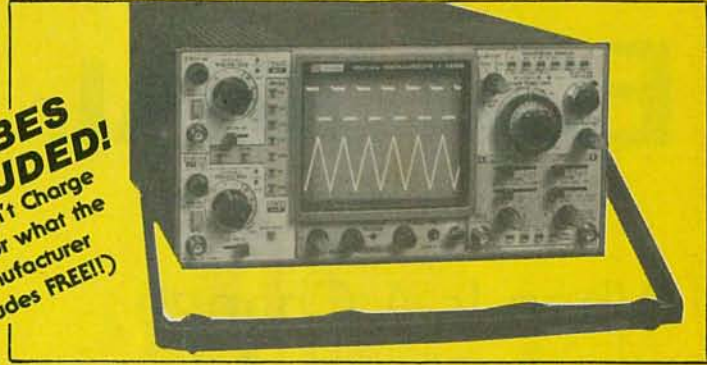

2 YEAR WARRANTY!!



HITACHI
Hitachi Denshi, Ltd.

BK PRECISION DYNASCAN CORPORATION

1 YEAR WARRANTY

**100 MHz
QUAD TRACE**

RIHITV1050F List Price: \$1595.00

\$1279

**60MHz
TRIPLE TRACE**

RIHITV650F List Price: \$1195.00

\$985

**100 MHz
QUAD TRACE**

RIBKP1580P List Price: \$1595.00

\$1349

**80MHz
QUAD TRACE**

RIBKP1570P List Price: \$1395.00

\$1145

**40 MHz
DUAL TRACE**

RIHITV422 List Price: \$885.00

\$649

**20 MHz
DUAL TRACE**

HITV222 List Price: \$695.00

\$545

**60 MHz
TRIPLE TRACE**

RIBKP1560P List Price: \$1150.00

\$1045

**40 MHz
DUAL TRACE**

RIBKP1540P List Price: \$950.00

\$795

FLUKE DIGITAL MULTIMETERS

from **PRIORITY ONE ELECTRONICS**
**YOUR AUTHORIZED FLUKE
INDUSTRIAL DISTRIBUTOR**



3 YEAR WARRANTY!

**SERIES 70
Autoranging
3 3/4 Digit With Analog Bar Graph**

- Full 3200 count instead of the normal 2000
- ULTRA-Fast analog bar graph
- Beeper included in the 75 & 77
- True touch and hold on the 77

RI FLU73	RI FLU75	RI FLU77
7% accur	5% accur	3% accur
\$85	\$99	\$129

RI FLU70	Custom Holster (included w/FLU77)	\$ 9.00
RI FLU71	Soft Vinyl Case	\$ 9.00

**8060 SERIES
4 1/2 Digit .05% DMM**

- True RMS • dBm range (8060 only)
- Relative reference and continuity test
- .01 to 200KHz frequency range (8060 only)
- Conductance range • One year warranty!

RI FLU8060A	RI FLU8062A
w/Freq. and Continuity Test	4 1/2 Digit .05% DMM
\$349	\$279

RI FLU81	115V AC adaptor/Battery Eliminator	\$ 20.00
RI FLU80J10	10A Current shunt	\$ 30.00
RI FLU80	Vinyl carrying case	\$ 10.00



BK PRECISION



Signal & Pulse Generators:

Part Number	Description	List Price	OUR PRICE
RIBKP3010	1 MHz Function Generator	\$229.00	\$189.95
RIBKP3015	200 KHz Sweep/Function Generator	\$281.00	\$225.00
RIBKP3020	2 MHz Sweep/Function with Pulse	\$394.00	\$319.95
RIBKP3025	5 MHz Sweep/Function Generator	\$468.00	\$369.00
RIBKP3030	5 MHz Sweep/Funct. Lin/Log Sweep	\$671.00	\$549.00
RIBKP3300	5 MHz Pulse w/Pulse Burst	\$390.00	\$295.00

Frequency Counters:

Part Number	Description	List Price	OUR PRICE
RIBKP1805	80 MHz Frequency Counter	\$290.00	\$229.00
RIBKP1822	175 MHz Frequency Counter	\$450.00	\$325.00
RIBKP1851	520 MHz Frequency Counter	\$575.00	\$459.00
RIBKP1855	1.2 GHz Frequency Counter	\$750.00	\$599.00

**GSC LP-1
LOGIC PROBE**
50 nS Response time
With Pulse and
Memory Modes!



**WAS \$50.00
NEW LOW
PRICE:
\$19.95**

PRIORITY ONE ELECTRONICS

9141 Diering Ave., Chatsworth, CA 91311

Terms: (Check, VISA, MasterCard or Money Order). Minimum Order is \$15.00. CA residents add 6 1/2% sales tax. Prices valid through September 30, 1984. Pre-Paid Orders — Shipping and Insurance (48 States):

\$0 to \$500	\$ 4.50
\$500 to 1000	\$10.00
\$1000 and up	\$15.00

Credit Card Orders Will Be Charged Appropriate Freight



ORDER TOLL FREE (800) 423-5922 - CA, AK, HI CALL (818) 709-5111

CIRCLE 20 ON FREE INFORMATION CARD

EDITORIAL

When Is A Change Not A Change?

When you flip through the pages of this issue of **Radio-Electronics**, you may notice something different. No, it's not a change in content. This issue covers the broad gamut of consumer electronics in the same dedicated fashion that you've become accustomed to. What you will notice is a change in appearance. We've re-designed the "front-of-the-book" and the "back-of-the-book" departments to give them a brand-new "look."

The last time you saw a change was in May 1984. That issue contained the first copy of **Computer Digest**, our magazine-within-a-magazine concept. Let me take this opportunity to once again reinforce the fact that **Radio-Electronics will not** become another computer magazine. Even after four issues of **Computer Digest**, I'm still receiving a large number of letters pleading with us not to change **Radio-Electronics**. We are dedicated to not letting that happen.

As a magazine, our primary responsibility is to you, our readers. We provide an information service. For us to succeed, we must provide the information

that our audience wants to read and we must deliver it accurately, concisely, and in an interesting format. Although there's always room for improvement, we feel that we consistently meet those goals. However, we're a technical publication, and when we set that information down on a magazine page, the page can sometimes appear dull and lackluster. The information isn't dull, but the page can sometimes appear to be dull. This is especially true in our regular departments where we lack the same kind of flexibility that we have in our feature articles. Our re-design is an attempt to prevent dullness.

The "new look" in our departments that begins in this issue is a major step in that direction. We recognize that there is always room for improvement both in content and graphics. We would like to hear from you, our readers, for your reaction to our new look and your suggestions for further improvements. If you would take a moment to jot them down and send them to me at **Radio-Electronics**, 200 Park Ave. South, New York, NY 10003, I'll take the time to read them.



ART KLEIMAN

Art Kleiman

ART KLEIMAN
EDITOR

SUPERSALE

We will beat any advertised price

BECKMAN Circuitmate® DMM

MODEL DM73
\$63⁹⁵

• Smallest digital multimeter on the market. • Probe-style design makes it ideal for taking measurements in hard-to-reach test areas.



\$64⁹⁵

• 3½-digit, pocket-size multimeter • 0.8% Vdc accuracy • diode test • hFE test • conductance • 10 amps AC and DC ranges • Autopolarity • Auto-Zero • Auto-decimal



\$79⁹⁵

MODEL DM25

• 3½-digit, pocket-size multimeter • 0.5% Vdc accuracy • diode test • capacitance • continuity beeper • conductance • 10 amps AC and DC ranges • auto-polarity • auto-zero • auto-decimal



B&K PRECISION

100 MHz FREQUENCY COUNTER



MODEL 1803
REG. \$169.95
OUR PRICE \$144⁵⁰

• 5 Hz to 100 MHz range • 8 digit LED display • Leading zero blanking • Low pass filter • BNC Connector Input • Overflow Indicator • Battery or AC powered • Charger/AC Adaptor included with Model 1803.

NTSC COLOR BAR GENERATOR

MODEL 1251
REG. \$995.00

OUR PRICE
\$849⁹⁵



• Generates a wide variety of test signals and patterns for comprehensive testing servicing and adjustment of virtually all types of television and video equipment • Video patterns include standard NTSC color bars, -IWQ, and staircase at two levels of burst phase chrominance • A full assortment of convergence patterns, raster colors-gated or full field multiburst.

HITACHI PORTABLE OSCILLOSCOPES

MODEL V-222 (20 mHz)
REG. \$695.00

MODEL V-422 (40 mHz)
REG. \$895.00

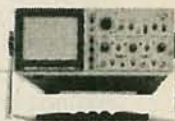

CALL FOR SPECIAL PRICING

• New series of scopes provides high performance and light weight • Large 6-inch rectangular, internal graticule CRT • Autolocus circuit and scale illumination • DC offset function • Voltage and frequency reading outputs • High accuracy - ±3%

BP DIGITAL CAPACITANCE METER



MODEL DCM-601
REG. \$149.95

OUR PRICE
\$79⁹⁵

• Digital display easy and correct readout • High accuracy, 100 PPM 0.5% • LSI-circuit provides high reliability and durability • LCD display provides low power consumption.

FORDHAM 550 MHZ FREQUENCY COUNTER



MODEL FM-8
REG. \$199.95
OUR PRICE \$149⁹⁵

• 8-digit high frequency counter with a switch selectable input using single BNC • Completely assembled • Pre-Calibrated, Pre-tested.

LEADER NTSC WAVEFORM MONITOR



MODEL LBO-5860
REG. \$2050.00

OUR PRICE
\$1850

Permits displaying vertical interval test and reference signals by front panel line selector.



NTSC VECTORSCOPE

MODEL LVS-5850
REG. \$2050.00

OUR PRICE
\$1850

Convenient method for observing and measuring the relative phase and amplitude of chrominance signal components.

FLUKE 70 73

• Analog Display • Rotary Knob • Volts AC & DC • Resistance to 32 MΩ • 10 Amps • Diode Test • 3200 Counts • Fast Autoranging • Function Annunciators in Display • Power-Up Self Test • 2000+ Hour Battery Life w/Power Down "Sleep Mode" • New Test Leads • VDE & UL Approval

\$74⁹⁵

• 0.7% Accuracy • Autorange Only • 10 Amp Only



75
\$95⁰⁰

• 0.5% Accuracy • Manual or Autorange • 10A ± 300 mA Range • Beeper



77
\$125⁰⁰

• 0.3% Accuracy • Manual or Autorange • 10 A ± 300mA Range • Beeper • "Touch-Hold" Function



VIZ DC TRIPLE POWER SUPPLY

MODEL WP-708
REG. \$489.00

OUR PRICE
\$399⁹⁵

• Dual DC Voltmeter • Triple DC Power Supply • Three separate completely isolated DC power supplies; two 0-20V at 0-2A, one fixed 5V at 4A.



WELLER SOLDERING STATION

MODEL EC1000
OUR PRICE
\$109⁹⁵

• Identical to the EC2000 except LED Digital temperature readout • The EC1000 is dial controlled.



SOLDERING STATION

MODEL EC2000
OUR PRICE
\$139⁹⁵

• Continuously variable tip temperature from 350 to 850 F • Positive temperature coefficient sensor inside the tip provides temperature feedback to maintain tip temperature at a set point.



FORDHAM

260 Motor Parkway, Hauppauge, N.Y. 11788

- Master Charge
- VISA
- Money Order
- Check

N.Y. State residents add appropriate sales tax.

ADD FOR SHIPPING AND INSURANCE:	
\$0-\$250.00	\$ 4.50
\$251.00 to \$ 500.00	\$ 6.50
\$501.00 to \$ 750.00	\$ 8.50
\$751.00 to \$1000.00	\$12.50
over \$1000.00	\$15.00

COD's extra (required 25% deposit)

Free Catalog on Request

TOLL FREE
(800) 645-9518
in N.Y. State call 800-832-1446

ONLY NRI TOTAL COMPUTER



**COMPUTER • MONITOR •
DISC DRIVE • PRINTER • AND
SOFTWARE . . .**

It's all included with NRI at-home training in Microcomputers and Microprocessors. And only with NRI training.

If you really want to learn how to work on computers, you have to learn how to work on computer systems. Only NRI includes a complete system with your training . . . total training that gives you hands-on experience with computers, peripherals, and software. Training that builds the knowledge, skill and confidence you need to become a computer professional.

Get Inside the Famous TRS-80 Model 4 Computer

You'll work with one of the most popular computers ever designed. And explore it inside and out. You'll learn programming techniques for troubleshooting. You go inside to expand its RAM from 16K to a powerful 64K. You'll even install a double density floppy disc drive.

You'll become familiar with computer languages . . . BASIC, the most popular microcomputer programming language, and machine language for diagnosis and repair work. You'll run software that demonstrates computer operation, even learn to do your own programming. You'll become proficient at

modifying programs to fit your business or family computing needs.

Add High Performance Peripheral Printer

Only NRI gives you a total system training by including the flexible Gemini 10X printer as part of your hands-on learning. Working with it, you'll get practical experience in adding peripherals, learn maintenance and servicing operations like adjusting the printer head gap or replacing the 100-million-character head. You'll learn how to create computer graphics, change type faces, even create your own characters.

And you'll use it for hard copies of important programs, business records, and word processing.

Understanding You Build Only Through Experience

You need no experience or previous knowledge to succeed with NRI. You start with the basics, rapidly build on the fundamentals of

Built-in **monitor** displays up to 80 characters in six modes. Offers the flexibility and capacity for easy word processing and spread sheet programs.

Electronics comes to life on your NRI **Discovery Lab**®. You set up and modify prototype circuits, demonstrate action of components, gain valuable bench experience in construction, diagnosis, and repair of circuitry.

Professional 3 1/2 digit **multimeter** features liquid crystal display and four key functions. Action Audio Cassette talks you through operation and professional use of your meter.

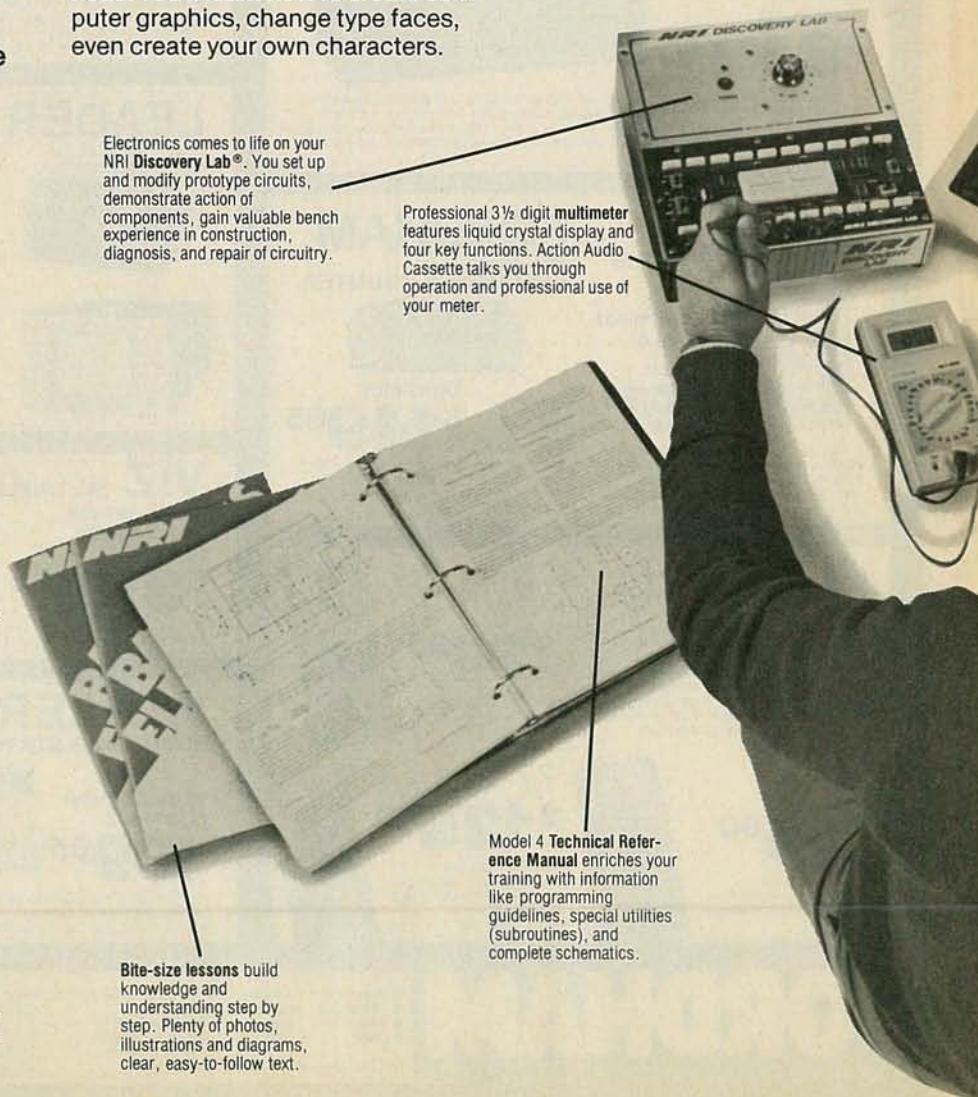

Bite-size lessons build knowledge and understanding step by step. Plenty of photos, illustrations and diagrams, clear, easy-to-follow text.

Model 4 Technical Reference Manual enriches your training with information like programming guidelines, special utilities (subroutines), and complete schematics.

GIVES YOU SYSTEM TRAINING

electronics with bite-size lessons to master advanced concepts like digital logic, microprocessors, and computer memories.

You'll reinforce this new understanding with hands-on, practical demonstrations

and experiments that give you real-world experience and build almost intuitive skills. You'll use the exclusive NRI Discovery Lab® to see what makes transistors tick, build and test working electronic circuits that duplicate key computer circuitry, construct digital logic circuits that

by your own NRI instructor and the entire NRI staff of educators and engineers. They're always ready to answer questions, give you guidance, follow your progress and help you over the rough spots to keep you moving toward your goal.



Your hands-on training takes you inside your TRS-80 Model 4 computer to install integrated circuits and enlarge memory to 64K. Full-function keyboard includes number pad and single-stroke data entry.

More practical experience as you install double-density floppy disk drive. Each disk stores up to 180,000 characters of information.

9 x 9 dot matrix printer completes your computer system to give you training with peripheral hardware installation, operation, and maintenance. Prints graphics, scientific symbols, and foreign languages in four type sizes.

NRI-supplied software includes TRSDOS® operating system, DOSPLUS® operating system, NBUG machine language monitor, and two game programs.

demonstrate computer performance. And, you'll probe into the very heart of your computer using the Discovery Lab and professional digital multimeter included in your training program.

Do It at Home in Your Spare Time

NRI trains you in your own home at your convenience. You learn at your own pace, backed at all times (TRS-80 is a trademark of the Radio Shack division of Tandy Corp.)

Free Catalog Tells Much More . . . Send Today

See all the interactive training equipment you get in this state-of-the-art course in today's technology. Look over the lesson outlines and descriptions of the exciting experiments you'll perform. And look at other high-tech career fields like Robotics, TV/Video/Audio Servicing and Data Communications.

Mail the postage-paid card today to see how NRI can give you the skills and confidence you need to start a good-paying career as a microcomputer technician. If the card has been used already, please write.

NRI SCHOOLS
McGraw-Hill Continuing
Education Center

3939 Wisconsin Ave.
Washington, DC 20016



WE'LL GIVE YOU TOMORROW.

VIDEO NEWS



DAVID LACHENBRUCH
CONTRIBUTING EDITOR

• **First digital TV's.** A dark horse—Toshiba—appears to have won the race to be first in the United States with a color-TV set in which all signal processing is digital. At least, it had taken the lead at presstime, estimating deliveries to start here around October 1. The set will be assembled in Toshiba's U.S. plant, using a 20-inch "Flat Square Tube" (FST). The set has a stereo amplifier and is designed to receive the new multi-channel TV sound transmissions. In addition, it features "picture-in-picture," which permits a picture from an external video source (VCR, computer, etc.) to be superimposed in the corner of the main picture. A button on the wireless remote control permits the viewer to switch the main and subsidiary pictures. Another remote-control button "freezes" the small picture. It will sell for about \$1,200.

A similar set from Matsushita went on the market in Japan this summer at about \$1,000, and is scheduled to appear here under the Panasonic brand name next spring. The first digital set to be marketed was the ITT Standard Elektrik in Germany, which went on sale early this year. In other news, barring last-minute glitches, Zenith is now expected to introduce its first digital set in January 1985. Little is known about the features of that receiver, except that it will be a large-screen set (25 inches or larger) and that it will contain some special features possible only in digital sets.

General Electric, which once had planned to introduce a digital set in 1984 using the ITT IC's, has now backed away and says it isn't interested in running a "horse race to see who can be first." GE says now that its R&D on the digital chassis isn't finished. In Germany, ITT's Standard Elektrik is now marketing digital sets, and Panasonic says it will introduce one in Japan this year with a "picture-in-picture" feature, probably exporting it to the United States in 1985.

All digital sets announced so far are based on VLSI IC's made by ITT in Germany.

• **LCD color TV.** Here come the flat-screen color sets. A tiny 2-inch set, which looks like a transistor radio with a picture, is scheduled for

marketing here under the Seiko and Epson brand names this fall at about \$500. The set uses a backlighted color liquid crystal display of the twisted nematic type with 52,800 pixels, each driven by a thin-film transistor. Either bright sunlight or a fluorescent built-in backlight will provide the set's illumination. It can be powered by five "AA" cells. Seiko and Epson brands are both owned by the maker of Seiko watches. Next year, a larger color LCD set is scheduled to be introduced by another Japanese watch maker, Citizen. This one has a larger screen—2.7 inches—and is somewhat smaller in overall dimensions. It will be priced at around \$350. A five-inch version is understood to be under development by Sanyo.

• **"Two-channel" TV.** In an unexpected twist, the FCC has ruled that it's perfectly legal to manufacture TV sets with tuners designed to receive only one or two of the standard television channels. The ruling came in response to a petition by Sanyo Manufacturing Company, which makes TV sets in Forrest City, Ark. for Sears, Sanyo, and others. Since the early 1960's, it has been illegal to manufacture TV sets that can't receive all allocated RF channels. That regulation has been known as the "all-channel rule," and was designed to encourage the growth of UHF.

Sanyo asked to be permitted to build sets that could tune only to Channels 3 and 4 for attachment to cable-TV systems, VCR's, videogames, and home computers that feed their RF signals through those channels. The Commission ruled that such a two-channel set was perfectly legal under the all-channel rules so long as it was "marketed without an antenna and not intended to receive over-the-air broadcast signals." Sanyo estimated, when it filed the petition early in 1982, that a simple RF switch on such a set in place of an all-channel tuner could save customers \$30 to \$40 per set. If such two-channel sets are actually built, their principal use is expected to be for connection to cable systems that supply their own tuner boxes to convert all incoming channels to Channel 3 or 4. **R-E**

Now! This season!

SWITCH YOUR TV TO SIX DIFFERENT PROGRAM SOURCES ELECTRONICALLY!

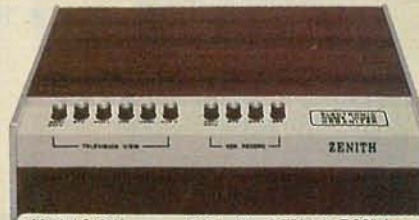

Model S10W 10.8" wide; 2.7" high; 7.28" deep

Now, with the Zenith Video Organizer at your command, you switch your TV *electronically*...from one function or program source to another...free of the nuisance of changing cable connections by hand.

You select any one of six different program sources for viewing, including up to three different sources for recording. You can even watch one program source while recording another.

Fact is, you can watch your favorite football team in action while simultaneously recording another game...the news...or some other program for playback at another time. All this without having to change cable connections by hand!

Thanks to the Zenith Video Organizer, you do all your TV switching electronically – from one program source or function to another with push-button ease.

It's this crisp, electronic push-button versatility of the Video Organizer – achieved by typically Zenith advanced engineering – that brings the television receiver closer to its promised service as a combination home entertainment and information center all-in-one.

If you're not yet in tune with the variety of functions and program sources addressable with Zenith's Video Organizer, check with your Zenith dealer soon.

There you will see that today there's more to Zenith than meets the eye! The broadest-ever line of Zenith video accessories, for example!

ZENITH

The Quality Goes In Before The Name Goes On.®

Zenith Sales Company
Service, Parts & Accessories Division
Franklin Park, Illinois 60131



PHILIPS

KEITHLEY

WESTON



Non-Linear Systems



BK PRECISION

LEADER



- 77
- 0.3% Accuracy
 - Manual or Autorange
 - 10A + mA Range
 - Beeper
 - "Touch-Hold" Function

\$129⁰⁰

WE CARRY A FULL LINE OF FLUKE MULTI-METERS. IN STOCK NOW

FLUKE 70 SERIES MULTIMETERS

- Analog Display • Rotary Knob • Volts AC & DC • Resistance to • 32 MΩ • 10 Amps • Diode Test • 3200 Counts • Fast Autoranging • Function Annunciators in Display • Power-Up Self Test • 2000+ Hour Battery Life w/ Power Down "Sleep Mode" • New Test Leads • VDE & UL Approval



\$99⁰⁰

75

- 0.5% Accuracy
- Manual or Autorange
- 10A + 300 mA Range
- Beeper



\$85⁰⁰

73

- 0.7% Accuracy
- Autorange Only
- 10 Amp Only



4 1/2 DIGIT MULTIMETERS

\$349⁰⁰

MODEL 8060A



- Frequency measurements to 200KHz
- dB measurements
- Basic dc accuracy 0.4%; 10μV, 10 nA and 10 mΩ sensitivity
- Relative measurements
- True RMS
- High-speed Beeper



POWER SUPPLIES



\$299⁹⁵ MODEL 1601

- Isolated 0-50VDC, continuously variable; 0-2A in four ranges
- Fully automatic shutdown, adjustable current limit
- Perfect for solid state servicing



\$329⁹⁵ MODEL 1650

- Functions as three separate supplies
- Exclusive tracking circuit
- Fixed output 5VDC, 5A
- Two 0 to 25VDC outputs at 0.5A
- Fully automatic, current-limited overload protection



INDUSTRIAL TRANSISTOR TESTER

\$199⁹⁵

MODEL 520B



- Now with HI/LO Drive
- Works in-circuit when others won't
- Identifies all three transistor leads
- Random lead connection
- Audibly and visually indicates GOOD transistor



70 MHz Dual Time Base SCOPE

MODEL 1570



\$995⁰⁰

PRICE DOES NOT INCLUDE PROBES

- 1mV/division sensitivity to 70 MHz
- 500 μV/division cascade sensitivity
- Four-input operation provides trigger view on 4 separate inputs
- Alternate time base operation
- Switching power supply delivers best efficiency and regulation at lowest weight



FUNCTION GENERATORS

\$189⁹⁵

- Sine, square and triangle output
- Variable and fixed TTL outputs
- 0.1 Hz to 1MHz in six ranges
- Push button range and function selection
- Typical sine wave distortion under 0.5% from 1 Hz to 100kHz

MODEL 3020 \$319⁹⁵

SWEEP FUNCTION

- Four instruments in one package — sweep generator, function generator, pulse generator, tone-burst generator
- Covers 0.02Hz-2MHz
- 1000:1 tuning range
- Low-distortion high-accuracy outputs



CAPACITANCE METERS

\$199⁹⁵

MODEL 830

- Automatically measures capacitance from 0.1pF to 200mF
- 0.1pF resolution
- 0.2% basic accuracy
- 3 1/2 digit LCD display



\$159⁹⁵

MODEL 820

- Resolves to 0.1pF
- 4 digit easy-to-read LED display
- Fuse protected against charged capacitors
- Overrange indication



V-222

HI-PERFORMANCE PORTABLE OSCILLOSCOPES

ALL FEATURE 6" RECTANGULAR CRT
Full 2 year parts & labor warranty.



\$599⁹⁵

V-422
DC to 40 MHz,
1mV/div, dual-trace,
DC offset function

\$499⁹⁵

V-222
DC to 20 MHz,
1mV/div, dual-trace,
DC off. func., Alt.
magnify function

\$439⁹⁵

V-212
DC to 20 MHz,
1mV/div, dual-trace



V-1050

\$1,249⁹⁵

V-1050F
100 MHz Quad Trace
w/delay sweep

\$939⁹⁵

V-650F
60 MHz Dual Trace
w/delay sweep

PRICE DOES NOT INCLUDE
PROBES. PROBES \$50. A PAIR
WHEN PURCHASED WITH SCOPE.
\$15 SHIPPING WITHIN
CONTINENTAL U.S.

BECKMAN'S CIRCUITMATE[®] ALL UNDER \$100

AVAILABLE NOW. . . .



\$64⁹⁵

Circuitmate DM 20—
3½-digit, pocket-size
multimeter; 0.8% Vdc
accuracy, diode test,
hFE test, conductance,
10 amps AC and DC
ranges, auto-polarity,
auto-zero, auto-
decimal



\$69⁹⁵

Circuitmate DM-40 —
3½-digit multimeter;
0.8% Vdc accuracy,
diode test, auto-
polarity, auto-zero,
auto-decimal



\$89⁹⁵

Circuitmate DM 45 —
3½-digit multimeter;
0.5% Vdc accuracy,
diode test, continuity
beeper, 10 amps AC
and DC ranges, auto-
zero, auto-polarity,
auto-decimal



\$79⁹⁵

Circuitmate DM-25—
3½ digit, pocket-size
multimeter; 0.5% Vac
accuracy, diode test,
capacitance, continuity
beeper, conductance,
10 amps AC and DC
ranges, auto-polarity,
auto-zero, auto-
decimal



The DM73 is the smallest digital
multimeter on the market. Its
probe-style design makes it ideal
for taking measurements in hard-
to-reach test areas.

\$63⁹⁵

- Small Size
- Complete
Autoranging
- "Touch Hold"
- Audible
continuity
checking



\$76⁹⁵

The DM 77 gives you
the convenience of
autoranging plus 10
amps ac/dc
measurement
capability. You simply
select the function
you want, and the
DM 77 automatically
sets the required
range.

TOLL FREE HOT LINE
800-223-0474

26 WEST 46th STREET, NEW YORK, N.Y. 10036
212-730-7030

THE TEST EQUIPMENT SPECIALISTS

**ADVANCE
ELECTRONICS**

WHAT'S NEWS

CED disc production to continue

The RCA VideoDisc Division will continue to market videodiscs ac-

tively after production of CED players is phased out by the end of 1984, reports RCA Group VP Jack Sauter. Disc-pressing operations

are planned to continue for three years or as long as reasonable demand continues, he said, quoting "The extremely high level of consumer satisfaction with VideoDisc" as motivation.

The decision to phase out VideoDisc players was due to "continuing financial losses and narrow prospects that the business would turn profitable," stated Mr. Sauter, citing "pressure of pricing competition from other video products." From an introductory retail price of \$499, RCA's player was forced down to \$199 in less than three years, he said.

It is expected that by the end of the year there will be more than 700,000 CED players in use.

Optical digital disc to improve education

"Immensely sophisticated educational software" that would open "hitherto unimagined vistas" to educators, and "silence the critics of today's limited-capability offerings" are expected from the tremendous storage capacity of the erasable optical disc. That is the substance of a 174-page report by International Resource Development, a Norwalk, CT, market research firm.

The report points out that "the dubious quality" of many existing educational programs is due, at least partly, to the fact that software quality depends on—among other things—the amount of space with which software developers have to work, and that limited space invariably means limited software. The merits of the erasable disc will show up particularly in sophisticated forms of computer-aided instruction, such as simulation and model building, which require large amounts of storage to be effective.

R-E

Caption generator for video viewers

A device that helps TV viewers operate their video players with greater efficiency, ease, and convenience has been patented by RCA. Called a caption generator, it produces printed instructions on the TV screen when operated with a videodisc or tape player.

Some typical captions that the device can write on the TV screen are: "Please load the disc," "End of side, 1," "End of side 2," and band numbers that help the viewer to locate desired selections on the disc. Discs are banded to permit the player to access any segment,

using the RCA random-access player. For the first time, users have the capability to program their own selections.

A unique feature is that information can be displayed even when there is no disc or cassette in the player. In the past, some players produced on-screen displays, but only when a disc or tape was playing. When there was no disc or tape in the player, there were no sync signals to operate an on-screen display. The new caption generator detects the absence of sync and generates its own.



A NEW RCA DEVICE generates TV captions for videodisc and tape players, giving viewers instructions on use, prompting, and timing of the player.

Our new 4½ digit DMM only acts expensive.



Now you can get 4½ digit resolution plus an unmatched combination of high performance features for just \$239.

Performance Power

The Beckman Industrial Corp. Model 4410 DMM gives you precise readings with resolutions down to 10 microvolts and 10 nanoamps. The 4410 offers you 0.05% basic Vdc accuracy plus true RMS Vac

capability for accurate readings of complex waveforms. Add to this RF shielding and high input impedance, and you have superior 4½ digit performance.

Easy to use

Build-in 10A ac/dc capability eliminates the need to carry an external shunt. For fast continuity tests,

the INSTA-OHMS® continuity indicator works at the speed of a glance. For even more convenience, the single rotary switch makes function and range selection simple and sure.

Built to last

Packed with overload protection, the 4410 is designed for reliable service. It withstands 1500 Vdc or 1000 Vac on all voltage ranges as well as 6kV transients. A rugged 2A/600V fuse protects current ranges and resistance ranges against overloads up to 500 Vdc. For extra long life, the 4410 uses the Beckman Industrial Corp. custom designed switch and self-cleaning gold contacts.

With so much performance and reliability at your convenience, you'd expect the Beckman Industrial Corp. 4410 DMM to be expensive—not just \$239.

For more information, see your local distributor today. For the one nearest you, call or write: Instrumentation Products Division, Beckman Industrial Corp. a Subsidiary of Emerson Electric Company. 630 Puente St., Brea, CA 92621; (714) 773-8111.



Beckman Industrial™

CIRCLE 100 ON FREE INFORMATION CARD

SEPTEMBER 1984

17

If you have put off learning more electronics for any of these reasons, act now!

- I don't have the time.*
- High school was hard for me and electronics sounds like it may be hard to learn.*
- I can't afford any more education.*
- I have a family now.*
- I'm here. You're there. I've never learned that way before. I'm not sure it will work for me.*

Read the opposite page and see how you can get started today!

Be honest with yourself. Are the reasons really excuses? You already know enough about electronics to be interested in reading this magazine. So why not learn more? If you need encouragement, read on and see how excuses can be turned into results.

You don't have the time.

Be realistic. All you have in life is a period of time. Use it. Try to know more tomorrow than you do today. That's the proven way to success.

Electronics sounds like it may be hard to learn.

You already know something about electronics or you wouldn't be reading this. Now, build on that. CIE Auto-Programmed® Lessons help you learn. Topics are presented in simple, logical sequence. All text is clear and concise for quick, easy understanding. You learn step by step, at your own pace. No classes to attend. Nobody pressures you. You *can* learn.

You can't afford any more education.

Actually, you can't afford NOT to gain the skills that can put you ahead of the others. It makes sense to invest in yourself through education — learning a skill. If you are not able to pay full tuition now, convenient monthly payments can be arranged.

You have a family now.

All the more reason why you have the responsibility to advance yourself. For the sake of your family. Do you want them to have what you had or have *more* than you had? The choice is yours. Electronics is a rewarding career choice. CIE can help you to get started on that career.

You're there. We're here. How does CIE help you learn?

First, we *want* you to succeed. You may study at home, but you are not alone. When you have a question about a lesson, a postage stamp gets you your answer fast. You may find this even better than having a classroom teacher. CIE understands people need to learn at their own pace. When CIE receives your completed lesson before noon, it will be graded and mailed back to you the same day with appropriate instructional help. Your satisfaction with your progress comes by return mail. That's how CIE helps you learn.

NOW, IF YOU AGREE CIE TRAINING CAN WORK FOR YOU, HOW ELSE CAN CIE HELP YOU?

CIE is one of the largest independent home study schools in the world that specializes in electronics. Although "big" does not always mean "best," it is evidence that CIE is a strong, successful institution with the people and resources to help you succeed.



Step-by-step learning includes "hands-on" training.

The kind of professional you want to be needs more than theory. That's why some of our courses include the Personal Training Laboratory, which helps you put lesson theory into actual practice. Other courses train you to use tools of the trade such as a 10MHz, solid-state, triggered-sweep oscilloscope. Or a Digital Learning Laboratory to let you apply the digital theory that's essential today for anyone who



wants to keep pace with electronics in the eighties. Or a Microprocessor Training Laboratory you learn to program and interface with displays, memories, switches, and more.

Your credentials can impress employers.

One of the best credentials you can have in electronics — or any other career field — is a college degree. That's why CIE gives you the opportunity to earn an Associate in Applied Science in Electronics Engineering Technology. Any CIE career course can offer you credit toward the degree...more than half the number needed in some cases.

You can also prepare for the government-administered FCC (Federal Communications Commission) Radiotelephone License, General Class. It can be a real mark in your favor...government-certified proof of your specific knowledge and skills.

Find out more! Today. Now.

There's a card with this ad. Fill it in and return. If some other ambitious person has already removed it, use the coupon.

You'll get a copy of CIE's free school catalog, along with a complete package of personal home study information.

For your convenience, we'll try to arrange for a CIE representative to contact you to answer any questions you may have.

If you are serious about a rewarding career, about learning electronics or building on your present skills, your best bet is to go with the electronics specialists — CIE. Mail the card or coupon today or write CIE (please mention the name and date of this magazine), 1776 East 17th Street, Cleveland, Ohio 44114.

This could be the best decision you've made all year.

RE-92

CIE **Cleveland Institute of Electronics, Inc.**
 1776 East 17th Street, Cleveland, Ohio 44114
 Accredited Member National Home Study Council

YES...I want to learn from the specialists in electronics — CIE. Send me my FREE CIE school catalog...including details about the Associate Degree program... plus my FREE package of home study information.

Print Name _____

Address _____ Apt. _____

City _____ State _____ Zip _____

Age _____ Area Code/Phone No. _____ / _____

Check box for G.I. Bill bulletin on Educational Benefits: Veteran Active Duty

MAIL TODAY! RE-92

LETTERS

SAM—NOT SARA!

My thanks to the editorial department of **Radio-Electronics** for their fine handling of my article, "Hugo Gernsback: A Man with Vision +" in the August issue. Unfortunately, due to a glitch that popped up when the final corrections were made, an embarrassing misprint appears twice on page 75: Sam Moskowitz is referred to as Sara Moskowitz.

It was Sam—not Sara—who edited Hugo Gernsback's final science-fiction magazine, *Science-Fiction +*, in 1953; and again, Sam—not Sara—who edited Hugo

Gernsback's posthumous novel, *The Ultimate World*.

Sam Moskowitz is among the most prominent historians of science-fiction. He was a member of the Science Fiction League, the very first international science-fiction fan organization. The League was founded and sponsored by Hugo Gernsback in *Wonder Stories* in 1934. Moskowitz was the first to write a book about early science-fiction fandom and has written many other books dealing with science-fiction and science-fiction personalities, as well as editing innumerable anthologies. He

WRITE TO:

LETTERS





Radio-Electronics
200 Park Ave South
New York, NY 10003

has been a consistent champion of Hugo Gernsback from the first.
ROBERT A. W. LOWNDES
Hoboken, NJ

PUBLISHER'S PROPAGANDA

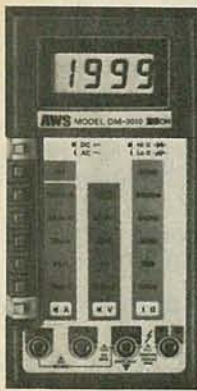
The "Publisher's Letter", in your April, 1984 issue is one of the great-

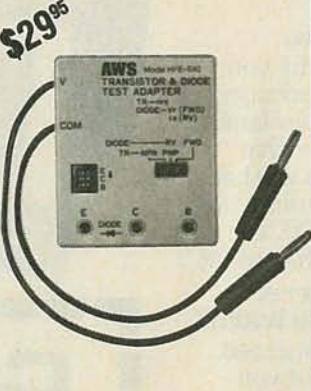
The new AWS DM-3010. It's not just another DMM. It's a complete electrical/electronic testing system.

<p>DM-3010 DIGITAL MULTIMETER</p> <p>\$80</p> 	<p>SJA-870 JAW ADAPTOR</p> <p>\$65</p> 	<p>HFE-840 TEST ADAPTER</p> <p>\$29⁹⁵</p> 	<p>HVP-860 HIGH VOLT PROBE</p> <p>\$49⁹⁵</p> 
---	--	---	---

Today's electrical and electronic testing requirements call for equipment that can handle a wide range of applications. That's why now more than ever you need the new AWS DM-3010 Testing System.

To start off with, the **DM-3010 Digital Multimeter** has an unbelievable \$80 price tag. It offers 34 ranges with push-button control plus features usually found in much more expensive models such as: 10 Amp AC/DC range; UL1244 type test leads; overload protection on all ranges; Hi and Low power ohms in all resistance ranges and more.

Complete the system by simply adding the following accessories as you need them...

SJA-870 Snap-Around Jaw Adaptor. Reads 0-1200 Amps AC. Its large jaws fit easily around any conductor up to 2-15/16" in diameter.

HFE-840 Test Adapter. If your work requires transistor and diode testing, this pocket-size adapter is a must.

HVP-860 High Voltage Probe. Provides safe, easy and reliable readings of 0-50KVDC on low power high impedance circuits.

So compare the DM-3010 Testing System for yourself. You'll find that no other company offers a comparable system at these low prices.

For more information on the AWS DM-3010 Testing System, see your local distributor today or contact A.W. Sperry Instruments Inc., P.O. Box 9300, Smithtown, N.Y. 11787. Call Toll-Free 800-645-5398 (N.Y., Hawaii, Alaska call collect 516-231-7050).

**A.W. SPERRY
INSTRUMENTS INC.**

CIRCLE 78 ON FREE INFORMATION CARD

Meet Our New LogicScope 136. ... A True Dual Trace 10 MHz Digital Storage Scope. Only \$495.

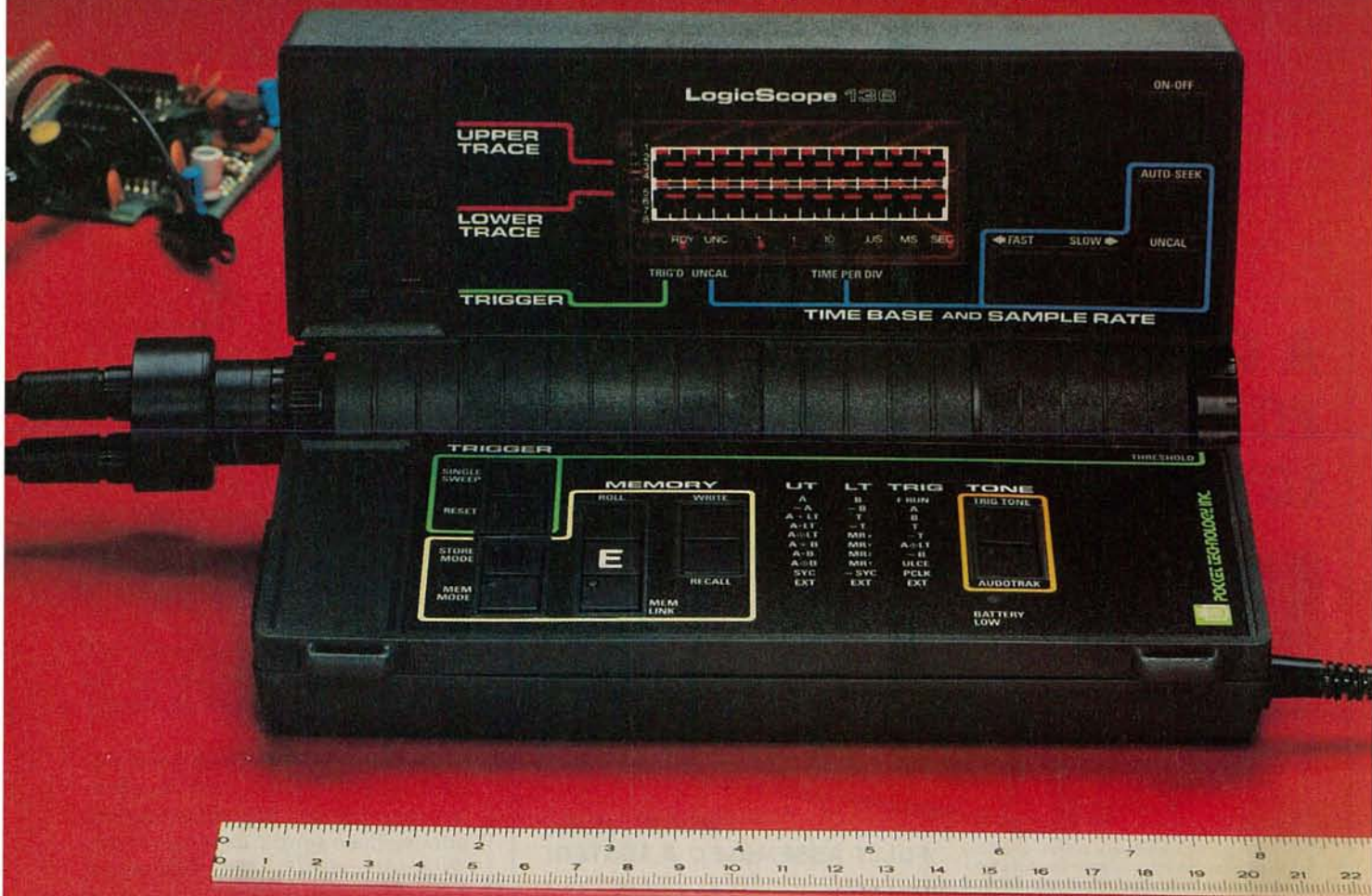

True Dual Trace • 10 MHz Real Time Bandwidth • 3 Input Channels • I/O Port
Digital Waveform Storage • Boolean Waveform Operations • Audio Functions
8.25 (L) x 4.5 (D) x 1.75 (H) Inches • 1.25 Pounds • 9 Volt Battery/AC Operation

Consider the LogicScope 136

- The LogicScope 136 is the next logical step in test instrumentation for you. It combines many of the features and capabilities of sophisticated logic analyzers and oscilloscopes... and it fits in your hand. Never before has so much technology been available in so small an instrument, at such a low price.
- The pocket-sized LogicScope 136 is made possible by a patented breakthrough in display technology. The conventional cathode ray tube has been replaced by a unique array of 400 LED's that permits simultaneous display of two digital waveforms.
- The 136 can be used for viewing single shot events, or repetitive waveforms. It can be operated in real time mode, or in memory mode which permits acquisition and storage of up to 24 128-bit waveforms. These can be recalled, logically compared (AND, OR, EXCLUSIVE OR) to other stored/input waveforms, or output to an external device via an RS 232 port.
- Its very low cost, convenience and ease-of-use make the LogicScope the ideal instrument, for designing, troubleshooting or repairing digital systems.

Consider its Engineering & Field Service Applications:

- On microprocessor-based systems, check the timing relationship of various parameters relative to the system clock and other key events. Its storage capability allows visual and logical comparison of non-repetitive waveforms to known reference signals. Output in the start-up of the digital device can be compared to reference signals to determine the operating state of the device. Questionable waveforms can be stored for analysis.
- Its light weight and small size make the LogicScope convenient to take on every service call. The 136 provides much more information for trouble shooting a digital system or peripheral than a logic probe or digital multimeter, without having to lug an oscilloscope or logic analyzer along.

Contact us for the name of your local distributor



POCKET TECHNOLOGY, INC.
7320 Parkway Drive, Hanover, MD 21076
301-796-3300

CIRCLE 32 ON FREE INFORMATION CARD

est pieces of propaganda of all time. In it, you are trying to justify the insertion of computer articles in your magazine by indicating that it is the result of "reader interest," and you further indicate that we the readership, are going to receive a big bonus in **ComputerDigest**.

As far as "reader interest" is concerned, I suggest that it is more a case of the usual chasing after the "God Almighty Dollar" since there are plenty of computer magazines

on the market for those nuts to subscribe to.

As far as your "bonus" tear-out section, you can tear mine out before my magazine is mailed. As a service technician, I have absolutely no use for it.

Your magazine is not the same one that I subscribed to years ago and now you tell me that it is getting better! The only thing left of interest in your magazine is the advertising. With the advent of **ComputerDigest**, you will no doubt

attract computer advertising (its primary object) and ruin my last remaining interest.

FRANK R. ANTAL
West Springfield, MA

You are right and I believe you are wrong.

*Certainly, we intend to sell advertising in the **ComputerDigest** section currently enclosed in **Radio-Electronics** magazine, but this section is truly a bonus to the **Radio-Electronics** reader who does want to know something about computers. It is an added editorial section. You will note that the pages are numbered separately and do not inflate the number of pages in each issue of **Radio-Electronics**.*

*If we are successful with **ComputerDigest**, and that means if we sell enough advertising and the section continues to grow, it will then be removed from **Radio-Electronics** and become a magazine of its own.*

*Either way, **Radio-Electronics** will continue to carry the same type of editorial coverage it currently provides.*

*Certainly, **Radio-Electronics** has changed, but the entire electronics industry has also changed and we have simply kept up with it. To graphically illustrate this point, I am enclosing a reprint of the first publication we ever produced. Volume 1, Number 1 of **Modern Electrics** in 1908. I am sure you will agree that electronics has changed substantially since that time and it is the duty of a publication covering a field to keep track of those changes and follow them for its readers.*

*I am surprised to learn, although our advertisers will be happy, that the only thing left of interest in **Radio-Electronics** is the advertising. I would have thought that a person such as yourself, a practicing service technician, would be greatly interested in the things that are happening in our industry and those include projection TV, satellite TV, stereo TV, the compact audio disc, telephone technology, and of course, the computer.*

*My final point: Including **ComputerDigest** in **Radio-Electronics** does not change the rest of the*

A QUALITY TRIPLE-REGULATED POWER SUPPLY AT A LOW, LOW PRICE!!

NOT A KIT!



MODEL PS101

FULLY ASSEMBLED & TESTED!

\$ **119** ⁸⁸

FULL 1 YEAR REPLACEMENT WARRANTY

- Made In The United States -

This DC triple regulated variable power supply has all the features you could ask for plus a full 1 year guarantee. Fully adjustable from 1½ VDC to 35 VDC! Three completely independent supplies that offer many advantages! They can be either a pos. supply or a neg. supply... they can also be stacked in series so that a 5V and two 15V supplies can total a 35 VDC supply or any combination of the three... (after one of the terminals is grounded to give it a reference)... for the first time you can now purchase this American made fully adjustable power supply at a price that is one-half of what you'd expect to pay!

SPECIFICATIONS

3 outputs:

Fixed 5 VDC ± 0.2V
2 variable ≤ 1½ V to ≥ 15 VDC
Polarity - floating; can be used as pos. or neg.

Ripple less than 10mV at full load,
Regulation ≤ 1% no load to full load,
Line Regulation < 0.2% 108 VAC to 135 VAC.

Current:

Fixed supply 1.0 amp max.
Variable supplies 0.5 amp max.

Protection built in, current limiting, with thermal shutdown.

Power: 108-135 VAC.

Dimensions: 8¼" x 3¼" x 7¼" (WxHxD)

Wood grain finished metal case.

Weight: 4 lbs., 9 ozs.

Lighted on/off power switch, easy-to-read

Voltmeter and large binding posts.

Warranty: one year full replacement

warranty from date of purchase.

DISTRIBUTOR AND REPRESENTATIVE INQUIRIES INVITED

E.W.E.
E.W. ENGINEERING, INC.

VISA, MASTERCARD, AMEX TELEPHONE ORDERS ACCEPTED!
6 Herman Drive, E. Granby, CT 06026 □ 203/651-0285

CIRCLE 81 ON FREE INFORMATION CARD



Micro-Professor

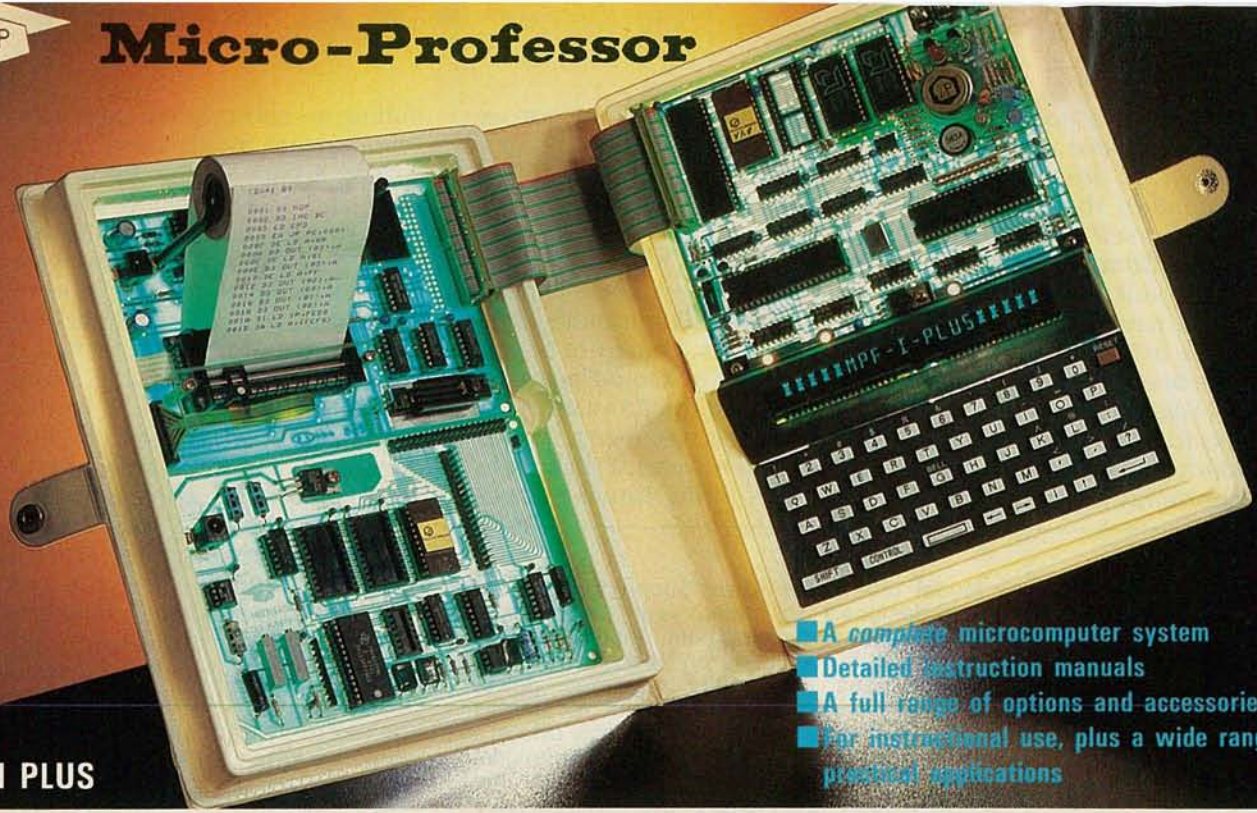

- A complete microcomputer system
- Detailed instruction manuals
- A full range of options and accessories
- For instructional use, plus a wide range of practical applications

PF-I PLUS

Learn Computing! Take a Course from Micro-Professor!

You've seen it all. Fancy software, powerful hardware, and ironclad warranties.

Total Learning Tool

If you haven't seen a computer that offered you a comprehensive introduction to both hardware and software. One that gives you hands-on training in troubleshooting, burning chips, and developing applications while giving you a solid grounding in programming.

Versatility and Convenience

Multitech proudly presents the unique Micro-Professor MPF-IP—the most versatile Z-80*-based educational computer for its price on the market today.

For only \$199.95, you get a state-of-the-art CPU, display, and full ASCII keyboard—in a casing that easily fits on your bookshelf. And to make sure you use your Micro-Professor to its fullest, each unit comes with impressive documentation, leading you step by step through the world of microprocessors.



A Wealth of Options

But that's only the beginning. Now you can buy miniature options that fit snugly to your unit: a printer, an EPROM programming board, and a speech synthesizer, to name a few. Add to that standard assembly language programming, plus optional BASIC and FORTH chips, and you've got a total learning tool.

Learning Can Be Fun

And with the Micro-Professor, learning can be an adventure. Design an electronic clock. Or a burglar alarm. Or anything else that suits your fancy.

So don't just program. Discover what a computer *really* can do for you!

*Z-80 is a trademark of Zilog Inc.

U.S. DISTRIBUTOR LIST

ARNING LABS, INC.
P.O. Box 122
Athens, GA 30701
(404) 629-1521

L.A.B. CORPORATION
4416 River Road
Afton, MN 55001
(612) 436-1169

MULTITECH ELECTRONICS INC.
195 West El Camino Real Sunnyvale, CA
94087 U.S.A.
TLX: 176004 MAC SUVL FAX: (408) 749-8032
Tel: (408) 773-8400

CHEMICAL LABORATORY SYSTEMS, INC.
P.O. Box 218609
Houston, TX 77218
(713) 463-7652

ETRONIX
3928 148th N.E.
Redmond, WA 98052
(206) 881-0857



OTHER U.S. STATES (800) 538-1542

CIRCLE 7 ON FREE INFORMATION CARD

magazine, in any way nor does it take any editorial space away from those readers who are not interested in computers. You can prove this point to yourself very simply. Tear out the *ComputerDigest* section and throw it away. If you do that, what you have left is exactly the same issue of *Radio-Electronics* that you have been receiving these past several years.

My thanks for taking the time to express your views and for giving me the opportunity to present our

reasons for taking the direction we have with *ComputerDigest*.
LARRY STECKLER,
Publisher

PLEASED READER

Although I have been familiar with Gernsback Publications for at least forty years, I have not been a regular reader of *Radio-Electronics* during the past fifteen years or so. Apparently this has been a serious oversight on my part. I shall try to correct this in the future by sub-

mitting my subscription right now.

Somewhat by accident, I purchased a copy of the April, 1984 issue and was extremely pleased with what I found. To begin with, I was pleased to find that you were not sacrificing everything else to become a computer magazine. The balance of first-rate technical articles was most gratifying. More important, however, I found something that has got to be evidence of an editorial policy that I am pleased to see (and support).

What pleased me most in the April issue were the three articles in which reference to electric current direction was made in terms of the direction convention accepted, recommended, and advocated by professionals in physics, engineering, and electronics science. Joseph Carr's article, "Designing with Linear IC'S," described the differential amplifier in correct engineering terms instead of the fouled-up electron convention that many vocational electronics instructors prefer. Doc Savage ("Hobby Corner") explicitly referred to "conventional current" in his fine tutorial on transistor testing, and Bob Scott's ("State of Solid State") article on true RMS converters showed the analysis in conventional current terms, just the way that the manufacturer's application literature would.

This pleases me very much. I hope it will have the effect of waking up some of the "Rip Van Winkles" that still refuse to accept the science and industry standard definition for electric current.

Good going. Keep it up!
LUCIUS B. DAY, JR.
Lakewood, CO

3-D TV

I thoroughly enjoyed your article on 3-D television in the May, 1984 issue of *Radio-Electronics*. However, I would like to comment on increasing the field rate for the *StereoDimensional* system to reduce flicker.

The article states, "Changing the number of fields per second does not affect such signal factors as bandwidth. Thus, altered signals could be broadcast over the air, used in a closed-circuit system, or

continued on page 79

Now, a low cost way to fill your DC power requirements ...the new Global 1301 Triple Power Supply

The new Model 1301 Triple Power Supply from Global Specialties is designed to meet your DC voltage requirements for product development, testing, quality control, servicing and education applications. This fully regulated power source is especially useful for analog and digital circuit design and offers a fixed 5 VDC, 1.0 A output which is ideal for TTL applications. In addition, the Model 1301 offers two continuously variable ± 5 to ± 18 VDC, 0.5 A supplies.

The three voltage supplies are completely isolated and outputs are available through six front panel, color-coded binding posts. A separate binding post is connected to the chassis and ground.

Each of the two continuously variable outputs has a separate voltage adjust control. Two front panel meters provide for the monitoring of voltage from 0-20 V and current from 0-1 A. Current limiting protects against short circuiting and outputs may be interconnected to increase voltage range without short circuit damage.

The Model 1301 is a versatile general purpose power supply which provides precision performance in engineering laboratory applications, schools, testing and servicing, and production lines. Because of its low price — under \$250.00 — the 1301 is also excellent for use by hobbyists. Rugged construction and a durable metal case permit the 1301 to withstand the wear and tear of regular use and provide many years of trouble-free service.

See the new Model 1301 Triple Power Supply at your electronics distributor, or, for the name of your local distributor, call our toll-free customer service number: 1-800-243-6077.



GLOBAL SPECIALTIES An Interplex Electronics Company
70 Fulton Terr., New Haven, CT 06509-1819 (203) 624-3103, TWX 710-465-1227
OTHER OFFICES: San Francisco (415) 648-0611, TWX 910-372-7992
Europe: Phone Saffron-Walden 0799-21682, TLX 817477
Canada: Len Finkler Ltd., Downsview, Ontario

CIRCLE 33 ON FREE INFORMATION CARD



Heathkit instruments. Some buy them for pride...some, to save money.

Professional specs for serious users

Whether you're pursuing a proud hobby...or earning a living, don't trust the accuracy of your measurements to anything less than Heathkit instruments. Our kits are a little bigger, more rugged than "disposable" instruments that discourage self-servicing. Performance is superior, too. Just check the specs on our new IO-4360 Scope and IOA-4200 Time-Voltage Module.

Get to know our full line of instruments. They're built by experienced hands. Your hands. So they'll save money and help you do a better job. Heathkit instruments. Don't trust your pride or money to anything less.

- 1 IG-4244 Scope Calibrator. <1 ns rise time. 0.015% tolerance.
- 2 IO-4205 Dual-Trace 5 MHz Scope. 10mV/cm sensitivity.
- 3 IT-2232 Component Tracer. Checks circuits without power.
- 4 IP-2718 Power Supply. Fixed or adjustable supply. 5 to 20 VDC.
- 5 IG-1271 Function Generator. Sine, square, triangle waveforms. 0.1 Hz to 1 MHz.
- 6 IG-1277 Pulse Generator. 100 ns to 1 sec width pulses.
- 7 IT-5230 CRT Tester. Tests, cleans, restores CRT's.
- 8 IM-2264 DMM. True RMS readings. Analog metering, too.
- 9 IM-2420 Frequency Counter. 5Hz to 512 MHz. Ovenized oscillator. Includes period and frequency modes.
- 10 IM-2215 Hand-held DMM. Five DC ranges. Accuracy: $\pm 0.25\%$ of reading + 1 count.
- 11 IT-2250 Capacitance Meter. 199.9 pF to 199.9 mF. Auto ranging.
- 12 IO-4360 Scope and IOA-4200 Time/Voltage Module. Triple trace, 60 MHz, <7 ns rise time. IOA-4200 controls CRT cursor and multi-function display.

Heathkit instruments.
The professional instruments.

more measurement for your money

Heathkit[®]
Heath
Company

A subsidiary of Zenith Electronics Corporation

CIRCLE 15 ON FREE INFORMATION CARD



Take another look at the instruments you should be building.

FREE
COLOR HEATHKIT CATALOG

Mail this coupon to:
Heath Company, Dept. 020-214
Benton Harbor, MI 49022

Name _____

Address _____

City _____

State _____ Zip _____

GX-393

Professional Books That Help You Get Ahead—And Stay Ahead!

Join the **Electronics and Control Engineers' Book Club**® and...

- Keep up with current technology
- Sharpen your professional skills
- Be ready for new career opportunities
- Boost your earning power

THE MCGRAW-HILL COMPUTER HANDBOOK: Applications, Concepts, Hardware, Software. Edited by H. Helms. 992 pp., 475 illus. Everything you need to know about today's computer science and engineering is here in this massive treasure trove of information. Covers everything from Boolean algebra to hardware selection techniques to artificial intelligence. A handy reference work that brings you right up to the minute!
279/721 Pub. Pr., \$79.50 Club Pr., \$49.95

INTUITIVE IC ELECTRONICS: A Sophisticated Primer for Engineers and Technicians. By T. M. Frederiksen. 208 pp., illus. Covering both the simplest and the most complicated IC designs, this lively, easy-to-read volume provides a sophisticated, nonmathematical explanation of the basic internal mechanisms common to all semiconductor devices.
219/230 Pub. Pr., \$24.95 Club Pr., \$18.95

ANTENNA ENGINEERING HANDBOOK, 2/e. Edited by R. C. Johnson and H. Jasik, with contributions by 57 recognized authorities. 1,408 pp., 946 illus. This widely acclaimed Handbook gives you the guidance you need to solve problems in antenna design and application. It provides detailed information on physical fundamentals, patterns, structures, and design techniques for practical modern antennas.
322/910 Pub. Pr., \$95.00 Club Pr., \$62.50

RADIO HANDBOOK, 22/e. By W. Orr. 1,136 pp., more than 1,300 illus. Here's the latest edition of what is universally regarded as the most useful reference in the industry. It's a "course" in communications, a fact-packed reference, and a how-to guide—all in a single book!
582442-6 Pub. Pr., \$39.95 Club Pr., \$33.95

MICROPROCESSOR APPLICATIONS HANDBOOK. Editor-in-Chief, D. F. Stout. 472 pp., 284 illus. At last—a reference guide to microprocessor applications to help you make your systems timely, versatile, and cost-effective.
617/988 Pub. Pr., \$39.95 Club Pr., \$31.45

MICROPROCESSOR AND MICRO-COMPUTER DATA DIGEST. By W. H. Buchsbaum and G. Weissenberg. 336 pp., 93 block diagrams, 106 pin configurations. If you work with electronic devices that use microprocessor or microcomputer integrated circuits, this much-needed book contains all the detailed technical data for every microprocessor IC that is currently listed as a "standard," off-the-shelf item.
582835-9 Pub. Pr., \$29.95 Club Pr., \$22.50

VLSI SYSTEM DESIGN: When and How to Design Very-Large-Scale Integrated Circuits. By S. Muroga. 496 pp., illus., includes self-test problems. This book provides a straight-forward explanation of how to design the integrated circuit chips that are causing this electronics revolution. It focuses on every significant aspect of LSI/VLSI system design.
582823-5 Pub. Pr., \$34.95 Club Pr., \$26.50



New members!
Any one of these great
professional
books
for only **\$2⁸⁹**
as a premium with your
1st selection!

Spectacular values up to **\$95.00**

INTEGRATED CIRCUITS APPLICATIONS HANDBOOK. By A. H. Seidman. 673 pp., illus. This Handbook presents information on everything from TTL, ECL, MOS, and CMOS logic families to semiconductor and bubble memories. The emphasis is on applications, with a minimum of theory. The math used is essentially limited to simple arithmetic and elementary algebra.
582860-X Pub. Pr., \$39.95 Club Pr., \$29.95

INTRODUCTION TO RADAR SYSTEMS, 2/e. By M. I. Skolnik. 698 pp., 244 illus. This new edition of a widely used text on radar from the systems engineer's point of view brings you full discussions of the many major changes that have occurred in the field recently.
579/091 Pub. Pr., \$40.95 Club Pr., \$31.00

CIRCUITS AND SOFTWARE FOR ELECTRONICS ENGINEERS. By H. Bierman. 352 pp., 200 illus., outsized 8 1/2 x 11 format. This collection of over 340 proven—reliable circuits, computer programs, test methods, and design tools have been selected because of the ingenious ways they adapt devices to other uses.
052/433 Pub. Pr., \$35.00 Club Pr., \$27.95

HANDBOOK OF ELECTRIC POWER CALCULATIONS. Edited by A. Seidman, H. Mahrous and T. G. Hicks. 448 pp., 300 illus. Here are 285 tested and proven procedures for handling the electric power problems most frequently encountered in actual practice. You'll find ingenious, time-saving ways to calculate fuel costs, motor efficiency, and power output.
560/617 Pub. Pr., \$39.50 Club Pr., \$29.95

STANDARD HANDBOOK FOR ELECTRICAL ENGINEERS, 11/e. By D. G. Fink and H. Beaty. 2,448 pp., 1,414 illus. Today's most widely used source of electrical engineering information and data serves you as no other single work when you need detailed, timely, and reliable facts.
209/74X Pub. Pr., \$74.95 Club Pr., \$53.95

HANDBOOK OF PRACTICAL ELECTRICAL DESIGN. By J. F. McPartland. 416 pp., 300 illus. This volume provides a step-by-step explanation of designing electrical systems for industrial, commercial, and residential applications. Packed with helpful tips for saving time and complying with code requirements from branch circuits to wiring size.
456/95X Pub. Pr., \$39.50 Club Pr., \$27.50

DIGITAL LOGIC DESIGN. By B. Holdsworth. 338 pp., 192 illus. All of the recent advances in digital design techniques are presented here in depth. It's both a text covering basic concepts and a practical guide to design techniques for combinational, clock-driven, and event-driven circuits.
582852-9 Pub. Pr., \$39.95 Club Pr., \$27.50

ELECTRONIC COMMUNICATIONS SYSTEMS. By W. D. Stanley. 566 pp., illus. Emphasizing the signal-processing functions of modulation and demodulation operation, this book presents the essentials of electronic communications in a logical, step-by-step sequence.
582834-0 Pub. Pr., \$25.95 Club Pr., \$20.95

MODERN ELECTRONIC CIRCUITS REFERENCE MANUAL. By J. Markus. 1,264 pp., 3,666 circuit diagrams. Complete with values of components and suggestions for revisions—plus the original source of each circuit in case you want additional performance or construction details.
404/461 Pub. Pr., \$74.95 Club Pr., \$57.95

ELECTRONICS ENGINEERS' HANDBOOK, 2/e. Edited by D. G. Fink & D. Christiansen. 2,272 pp., 2,189 illus. This updated and enlarged edition covers all the latest knowledge in the field, including new advances in integrated circuits, pulsed and logic circuits, laser technology, telecommunications, and much more.
209/812 Pub. Pr., \$79.90 Club Pr., \$57.50

DIGITAL CIRCUITS AND MICRO-PROCESSORS. By H. Taub. 608 pp., heavily illus. This fast-paced, carefully written guide gives you thorough explanations of all the basic principles of digital systems and logic design—plus a solid introduction to microprocessors and microprocessor-based designs.
629/455 Pub. Pr., \$34.95 Club Pr., \$26.50

ELECTRONICS ENGINEERING FOR PROFESSIONAL ENGINEERS' EXAMINATIONS. By C. R. Hafer. 336 pp., more than 200 illus. Actually two books in one—a quick preparation manual to help you pass your P.E. exams on the first try and a rich source of practical electronics engineering information and know-how.

254/303 Pub. Pr., \$29.95 Club Pr., \$21.50

PRACTICAL DIGITAL DESIGN USING ICs, 2/e. By J. D. Greenfield. 717 pp., illus. This revised and expanded Second Edition of a popular guide shows how to get the most out of a wide range of popular integrated circuits. What's more, it contains the specialized know-how today's designer needs to interface ICs with microprocessors.

582853-7 Pub. Pr., \$25.95 Club Pr., \$19.95

OPTICAL FIBER SYSTEMS: Technology, Design, and Applications. By C. K. Kao. 197 pp., illus. From a basic explanation of optical fiber systems to the economic ramifications of their use, this volume provides full coverage of a rapidly changing field.

332/770 Pub. Pr., \$29.50 Club Pr., \$23.95

MCGRAW-HILL ENCYCLOPEDIA OF ELECTRONICS AND COMPUTERS.

By S. P. Parker, Editor-in-Chief. 960 pp., 1,266 illus., oversized 8½ x 11 format. It's a single-volume library that covers the entire world of electronics from Edison's pioneering work in electricity right up to optical fiber communications, control systems, lasers, radar, TV receivers, artificial intelligence, and computer storage technology.

454/876 Pub. Pr., \$59.50 Club Pr., \$41.50

DIGITAL CONTROL SYSTEM ANALYSIS AND DESIGN. By C. L. Phillips and H. T. Nagle, Jr., both Auburn University. 556 pp., 316 illus., 7 ready-to-run computer programs. It analyzes and designs closed-loop systems to which digital computers have been added to modify system dynamics. The book develops a wide range of control-system techniques applicable to linear, time-invariant, discrete-time system models.

582944-4 Pub. Pr., \$39.95 Club Pr., \$31.95

HANDBOOK OF MICROCOMPUTER-BASED INSTRUMENTATION AND CONTROLS. By J. D. Lenk. 307 pp., 227 illus. Digital or microcomputer-based instrumentation and control systems can be very complicated—or relatively simple—depending on the application.

In this book both systems are described and illustrated—and many examples of actual systems now in use in industry are included throughout.

582866-9 Pub. Pr., \$22.95 Club Pr., \$18.95

COMPUTER METHODS FOR CIRCUIT ANALYSIS AND DESIGN. By J. Vlach and K. Singhal. 656 pp., 148 illus. Computational methods have become an integral part of circuit analysis and design. And a solid understanding of the basics of computer-aided design is a must for engineers who want to achieve their career objectives. This self-teaching book provides that know-how in a logical, easy-to-follow presentation.

582855-3 Pub. Pr., \$42.50 Club Pr., \$33.95

Be sure to consider these important titles as well!

LARGE SCALE INTEGRATION: Devices, Circuits, and Systems. By M. J. Howes & D. V. Morgan. 582851-0 Pub. Pr., \$35.95 Club Pr., \$29.95

MICROWAVE SEMICONDUCTOR ENGINEERING. By J. F. White. 582553-8 Pub. Pr., \$32.50 Club Pr., \$25.95

MICROPROCESSOR SUPPORT CHIPS: Theory, Design, and Applications. By T. J. Byers. 095/183 Pub. Pr., \$39.50 Club Pr., \$31.00

ENGINEERING FORMULAS, 4/e. By K. Gieck. 232/199 Pub. Pr., \$16.95 Club Pr., \$13.50

ELECTRONICS CIRCUITS NOTEBOOK. Edited by S. Weber. 192/448 Pub. Pr., \$35.50 Club Pr., \$27.50

ANALYSIS AND DESIGN OF DIGITAL INTEGRATED CIRCUITS. By D. A. Hodges and H. G. Jackson. 291/535 Pub. Pr., \$31.00 Club Pr., \$23.95

HANDBOOK OF OPERATIONAL AMPLIFIER CIRCUIT DESIGN. By D. E. Stout & M. Kaufman. 617/97X Pub. Pr., \$39.50 Club Pr., \$29.00

ENGINEERING MATHEMATICS HANDBOOK, 2/e. By J. J. Tuma. 654/298 Pub. Pr., \$34.50 Club Pr., \$26.95

PCM & DIGITAL TRANSMISSION SYSTEMS. By F. F. Owen. 479/542 Pub. Pr., \$34.95 Club Pr., \$25.95

SIGNALS AND SYSTEMS. By A. Oppenheim, A. Willsky, and I. Young. 582674-7 Pub. Pr., \$32.50 Club Pr., \$25.95

DIGITAL COMMUNICATIONS. By J. Proakis. 509/271 Pub. Pr., \$37.50 Club Pr., \$29.50

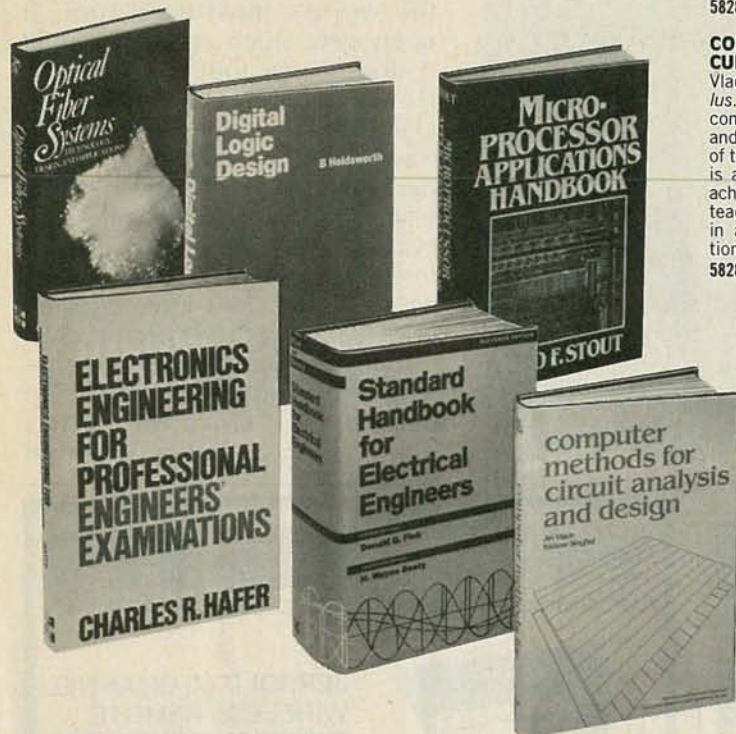

Why YOU should join now!

■ **BEST AND NEWEST BOOKS IN YOUR FIELD**—Books are selected from a wide range of publishers by expert editors and consultants to give you continuing access to the best and latest books in your field.

■ **BIG SAVINGS**—Build your library and save money too! Savings ranging up to 30% or more off publishers' list prices—usually 20% to 25%.

BONUS BOOKS—You will immediately begin to participate in our Bonus Book Plan that allows you savings up to 70% off the publishers' prices of many professional and general interest books!

■ **CONVENIENCE**—12-14 times a year (about once every 3-4 weeks) you receive the Club Bulletin FREE. It fully describes the Main Selection and Alternate Selections. A dated Reply Card is included. If you want the Main Selection, you simply do nothing—it will be shipped automatically. If you want an Alternate Selection—or no book at all—you simply indicate it on the Reply Card and return it by the date specified. You will have at least 10 days to decide. If, because of late delivery of the Bulletin you receive a Main Selection you do not want, you may return it for credit at the Club's expense.

As a Club member you agree only to the purchase of three books (including your first selection) during your first year of membership. Membership may be discontinued by either you or the Club at any time after you have purchased the first selection plus two additional books.

Other McGraw-Hill Book Clubs:
Architects' Book Club • Byte Book Club • Chemical Engineers' Book Club
• Civil Engineers' Book Club • Mechanical Engineers' Book Club

For more information, write to:
McGraw-Hill Book Clubs, P.O. Box 582, Hightstown, New Jersey 08520

MAIL THIS COUPON TODAY

McGraw-Hill Book Clubs
Electronics and Control Engineers' Book Club®
P.O. Box 582, Hightstown, New Jersey 08520

Please enroll me as a member and send me the two books indicated, billing me for the \$2.89 premium and my first selection at the discounted member's price, plus local tax, shipping, and handling charges. I agree to purchase a minimum of two additional books during my first year of membership as outlined under the Club plan described in this ad. A shipping and handling charge is added to all shipments.

Write Code No. of
\$2.89 selection here

Write Code No. of
first selection here

Signature _____

Name _____

Address/Apt. # _____

City _____

State _____ Zip _____

This order subject to acceptance by McGraw-Hill. All prices subject to change without notice. Offer good only to new members.

E33678

EQUIPMENT REPORTS

PALADIN SCREWDRIVERS

When your screwdriver fails, you realize that it's as important to your electronics workbench as your multimeter or any other tool.

CIRCLE 101 ON FREE INFORMATION CARD

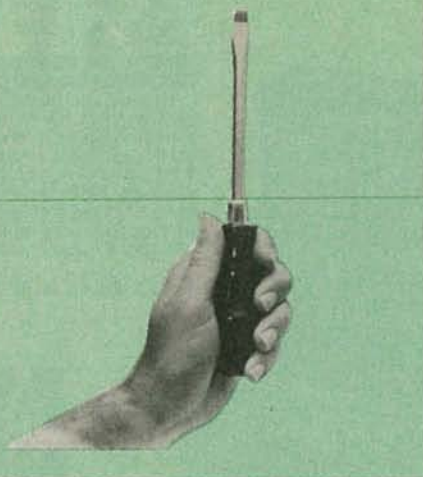

ALTHOUGH THE SCREWDRIVER IS LIKELY the world's most-used tool, it rarely gets much attention—until it doesn't do the job properly. However, Paladin Corporation (3545 Old Conejo Road, #102, Newbury Park, CA 91320) claims to have given the screwdriver "some respect" and say that they have the "world's best" screwdrivers. Before we take a look at what they have to offer, let's look at some potential screwdriver problems.

One of the most common problems with screwdrivers is that of tip deformation. Once the tip has been deformed, a screwdriver will

\$ 100,000.00 CABLE TV CONVERTER LIQUIDATION

- 60 Channel Capacity
- P.L.L. Tuning
- 6 Channel Memory
- TV On-Off Feature
- Infra-Red Wireless Remote Control

ONLY **\$59.95**



- 10% Off On All Quantities Over 50
 - Available Only While Quantities Last
 - Warranty Restricted to 15 Days After Receipt of Goods
 - Allow 2 Weeks for Personal Checks to Clear
- SPECIAL -**
- Factory Re-Furbs Available at \$49.95 Each With Full Guarantee

SUNSET CABLE
1 Madison Street • East Rutherford NJ
(201) 777-6733
Master Charge • C.O.D. • Visa

MULTIVISION ELECTRONIC EQUIPMENT WHOLESALERS AND EXPORTS



JERROLD 60 CHANNEL WIRELESS REMOTE CONTROL CONVERTER
LCC 58-3 **\$99⁹⁵**
EXTRA HAND REMOTES **\$19⁹⁵**

PHILIPS 67 CHANNEL WIRELESS REMOTE CONVERTER with VOLUME CONTROL and MUTEING. FINE TUNING CENTERING. **\$189⁰⁰**

PIONEER 57 CHANNEL WIRELESS REMOTE CONTROL with PARENTAL LOCKOUT and 10 CHANNEL FAVORITE MEMORY RECALL. DEALERS WE HAVE VIDEO RECORDERS, ENHANCERS, STABILIZERS AND ACCESS.

12' GALVANIZED RADAR MESH SATILITE DISH \$1075⁰⁰
Dealers call for pricing!

SATILITE RECEIVERS WIRELESS REMOTE CONTROL - HIGHEST QUALITY \$599⁰⁰



RETAIL - WHOLESALE

305-981-1112 • 305-981-1113

CIRCLE 17 ON FREE INFORMATION CARD

do nothing but destroy the head of any screw you want to remove—and make it impossible to remove the screw with any other screwdriver. That can be frustrating, to say the least.

If the tip of the screwdriver survives, another potential problem is that of a handle that falls off the shaft—even without the abuse that many people treat their screwdrivers with. (Remember: Screwdrivers are meant to remove screws. They are *not* meant to be used as chisels or crowbars.)

Paladin		Screwdrivers									
OVERALL PRICE											
EASE OF USE											
INSTRUCTION MANUAL											
PRICE/VALUE											
		1	2	3	4	5	6	7	8	9	10
		Poor		Fair		Good		Excellent			

Preventing problems

The screwdrivers that Paladin sells (which are imported from Germany) show that they have recognized screwdriver problems and have taken some steps to prevent them. For example, to prevent tip deformation, the shaft and blade are made of very hard chrome-vanadium steel (a steel alloy that contains up to 1.1% chromium and about 0.15% vanadium). Both chromium and vanadium increase the toughness and tensile strength of steel. The tip of the screwdriver's blade is hardened by a heat blasting process to a rockwell hardness of about 57. (Rockwell hardness is determined from the rockwell test, in which a diamond cone is pressed into the steel to a standard depth to determine its resistance to penetration).

The handle is injection-molded to the shaft to reduce the chances of its coming loose, and it is apparently made from a very hard plastic that is resistant to chipping and cracking.

We looked at a random sample of the screwdrivers from Paladin's Series 100, 200, and 300. The series 100 screwdrivers have hex shafts and feature a hex nut where the

shaft meets the handle. That allows you to use a wrench for more torque, if necessary. The screwdrivers in that series are available with slotted or Phillips tips, in shaft lengths from 2 $\frac{3}{8}$ to 11 inches; the prices range from less than \$4 to more than \$17. (Shaft lengths are measured from the screwdriver tip to where it enters the handle.)

Paladin's series 200 feature round shafts and slimmer profiles and are well suited to the electronics workbench. Slotted and

Phillips styles are available in lengths from 2 $\frac{3}{8}$ to 12 inches; prices range from about \$2.50 to \$6.50. Another series 200 driver that we saw was a multi-tip, $\frac{1}{4}$ -inch hex-shaft model. Six magnetic screwdriver bits (3 slotted, 3 Phillips) store in the handle. A handy feature that we liked is a shield that prevents more than one bit at a time from dropping from the handle. The shaft length of the model PA1955 is about 4 $\frac{1}{2}$ inches. It is priced at about \$16.

Where's Your **ELECTRONICS CAREER** Headed?

Put Professional Knowledge and a
COLLEGE DEGREE
in your Electronics Career through
HOME STUDY



Earn Your **DEGREE**

No commuting to class. Study at your own pace, while you continue on your present job. Learn from easy-to-understand lessons, with help from your instructors when you need it.

Grantham has been training students for electronics degrees longer than any other home-study, independent-study, or correspondence institution. *Grantham is the only school in the United States offering an accredited B. S. Degree in electronics by home study, independent study, or correspondence.*

Our free bulletin gives full details of the home-study program, the degrees awarded, and the requirements for each degree. Write for our free

Bulletin 9-84 .

Grantham College of Engineering is a specialized institution catering to mature individuals who are employed in electronics and allied fields such as computers. The field of electronics is so enormous that opportunity for advancement is always present. Promotions and natural turnover make desirable positions available to those who are *prepared to move up!*

Advancement in electronics is made easier and more certain by (1) superior knowledge, and (2) documentation of that knowledge. Grantham specializes in making both 1 and 2 as listed above available to you.

Grantham's home-study program leading to the

B. S. DEGREE

may fill an important need for you. This is a comprehensive correspondence program in which you first review some things you already know, in preparation for the studies that come later. Some previous knowledge in the field is presumed, but is thoroughly reviewed in depth, so as to give you a thorough foundation for the level of studies you have not previously undertaken. Even though some students hold associate degrees before enrolling, an A. S. Degree is awarded along the way toward the B. S. Degree.

For full information, write for Bulletin 9-84

Grantham College of Engineering
2500 So. La Cienega Blvd.
P. O. Box 35499
Los Angeles, CA 90035

Diskette Users...

When you've heard from all the animals in the diskette zoo, but you need fast delivery and high quality diskettes...

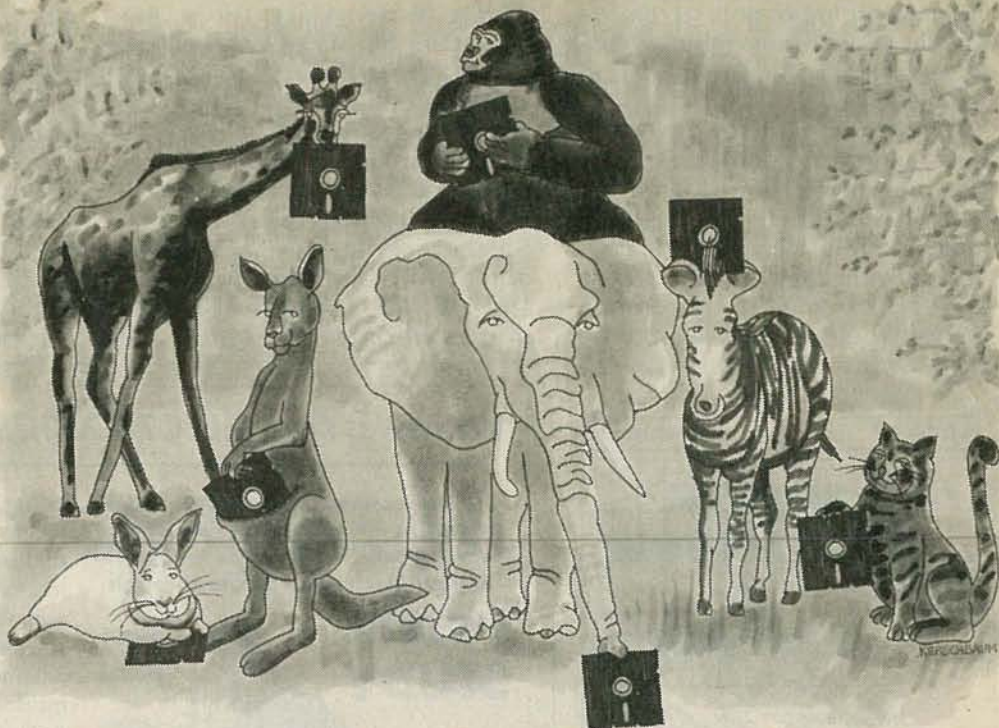

Call Communications Electronics

Diskette order desk

800-USA-DISK

In Canada 800-CA1-DISK

Choose your brand
Choose your price



Super Disk
diskettes for as low as
\$0.94 each



Wabash
diskettes for as low as
\$0.99 each



BASF
diskettes for as low as
\$1.44 each



3M
diskettes for as low as
\$1.44 each

Product Description	Super Disk Part #	CE quant. 100 price per disk (\$)	Wabash Part #	CE quant. 100 price per disk (\$)	BASF Part #	CE quant. 100 price per disk (\$)	3M Part #	CE quant. 100 price per disk (\$)
8" SSSD IBM Compatible 128B/S, 26 Sector	_____	_____	F111-P	1.59	_____	_____	8SSSD-P	1.94
8" SSSD Shugart Compatible, 32 Hard Sector	_____	_____	F31A-P	1.79	_____	_____	_____	_____
8" SSSD IBM Compatible (128 B/S, 26 Sectors)	_____	_____	F131-P	1.89	_____	_____	8SSDD-P	2.39
8" DSDD Soft Sector (Unformatted)	_____	_____	F14A-P	2.09	_____	_____	8DSDD-P	2.89
8" DSDD Soft Sector (256 B/S, 26 Sectors)	_____	_____	F144-P	2.09	_____	_____	_____	_____
8" DSDD Soft Sector (512 B/S, 15 Sectors)	_____	_____	F145-P	2.09	_____	_____	_____	_____
8" DSDD Soft Sector (1024 B/S, 8 Sectors)	_____	_____	F147-P	2.09	_____	_____	8DSDD-1024-P	2.89
5 1/4" SSSD Soft Sector w/Hub Ring	6431-P	1.14	M11A-P	1.19	_____	_____	_____	_____
5 1/4" SSSD Same as above but bulk product	6437-P	0.94	M11AB-P	0.99	_____	_____	_____	_____
5 1/4" SSSD 10 Hard Sector w/Hub Ring	_____	_____	M41A-P	1.19	_____	_____	_____	_____
5 1/4" SSDD Soft Sector w/Hub Ring	6481-P	1.29	M13A-P	1.34	54974-P	1.44	5SSDD-RH-P	1.64
5 1/4" SSDD Same as above, but bulk product	6487-P	1.09	M13AB-P	1.14	_____	_____	5SSDD-BL-P	1.44
5 1/4" SSDD Soft Sector Flippy (use both sides)	_____	_____	M18A-P	1.99	_____	_____	_____	_____
5 1/4" SSDD 10 Hard Sector w/Hub Ring	_____	_____	M43A-P	1.34	_____	_____	_____	_____
5 1/4" DSDD Soft Sector w/Hub Ring	6491-P	1.54	M14A-P	1.59	54980-P	1.79	5DSDD-RH-P	2.19
5 1/4" DSDD Same as above, but bulk product	6497-P	1.34	M14AB-P	1.39	_____	_____	_____	_____
5 1/4" DSDD 10 Hard Sector w/Hub Ring	_____	_____	M44A-P	1.59	_____	_____	_____	_____
5 1/4" DSDD 16 Hard Sector w/Hub Ring	_____	_____	M54A-P	1.59	_____	_____	_____	_____
5 1/4" DSDD Soft Sector w/Hub Ring (96 TPI)	6501-P	2.44	M16A-P	2.49	54992-P	2.99	5DSDD-96RH-P	3.09
3 1/2" SSDD Soft Sector micro-floppy	_____	_____	_____	_____	54112-P	2.74	3SSMD-P	3.74

For more information about this brand call:

Lifetime warranty
For more info on Super Disk call
800-USA-DISK
In Michigan 313-973-1111

6 year warranty
For more info on Wabash call
800-323-9868
In Illinois 312-593-8383

Lifetime warranty
For more info on BASF call
800-343-4600
In Massachusetts 617-271-4000

Lifetime warranty
For more info on 3M call
800-328-9438
In Minnesota 612-736-9524

CE...your best source for diskettes

For you the diskette buyer, it's a jungle out there. There are so many different brands to choose from, you need to go on a safari to find a good brand at a reasonable cost. Fortunately, CE has already hunted for the best diskettes and offers you an excellent choice at a CE price. To save you even more, CE also offers bulk product where 100 diskettes are packed in the same box without envelopes or labels. Since we save packaging costs, these savings are passed on to you. Diskette envelopes are also available from CE. These super strong and tear resistant Tyvek® envelopes are only \$15.00 per 100 pack. Use order # TE-5 for a 100 pack of 5 1/4" diskette envelopes.

Quantity Discounts Available

Our diskettes are packed 10 disks to a carton and 5 or 10 cartons to a case. The economy bulk pack is packaged 100 disks to a case without envelopes or labels. Please order only in increments of 100 units for quantity 100 pricing. With the exception of bulk pack, we are also willing to accommodate your smaller orders. Quantities less than 100 units are available in increments of 10 units at a 20% surcharge above our 100 unit price. **Quantity discounts** are also available. Order 300 or more disks at the same time and deduct 1%; 500 or more saves you 2%; 1,000 or more saves 3%; 2,000 or more saves 4%; 5,000 or more saves 5%; 10,000 or more saves 6%; 50,000 or more saves 7%; 100,000 or more saves 8%; 500,000 or more saves 9% and 1,000,000 or more disks earns you a 10% discount off our super low quantity 100 price. Almost all our diskettes are immediately available from CE. Our efficient warehouse facilities are equipped to help us get you the quality product you need, when you need it. If you need further assistance to find the flexible diskette that's right for you, call the appropriate manufacturers compatibility hotline telephone number listed at the bottom of this ad. Dealer inquiries invited.

Buy your diskettes from CE with confidence

To get the fastest delivery of your diskettes, phone your order directly to our order desk and charge it to your credit card. Written purchase orders are accepted from approved government agencies and most well rated firms at a 10% surcharge for net 10 billing. For maximum savings, your order should be prepaid. All sales are subject to availability, acceptance and verification. All sales are final. All prices are in U.S. dollars. Prices, terms and specifications are subject to change without notice. Out of stock items will be placed on backorder or substituted for equivalent product at no extra cost to you unless CE is instructed differently. A \$5.00 additional handling fee will be charged for all orders with a merchandise total under \$50.00. All shipments are F.O.B. CE warehouse in Ann Arbor, Michigan. COD terms are available, in U.S. UPS areas for \$5.00 extra, and are payable with cash or certified check.

For **shipping charges** add \$8.00 per 100 diskettes and/or any fraction of 100 8-inch diskettes, or \$6.00 per 100 diskettes and/or any fraction of 100 5 1/4-inch or 3 1/2-inch diskettes for U.P.S. ground shipping and handling in the continental U.S. UPS 2nd day air rates are *three* times continental U.S. rates. For Canada, Puerto Rico, Hawaii, Alaska, or APO/FPO delivery, shipping is *three* times the continental U.S. rate.

Mail orders to: Communications Electronics, Box 1045, Ann Arbor, Michigan 48106 U.S.A. If you have a Visa or Master Card, you may call and place a credit card order. Order toll-free in the U.S. Dial 800-USA-DISK. In Canada, order toll-free by calling 800-CA1-DISK. If you are outside the U.S. or in Michigan dial 313-973-8888. WUI telex anytime 671-0155. Order today.

Copyright © 1984 Communications Electronics Inc.

Ad #080284



Computer Products Division

Box 1045 □ Ann Arbor, Michigan 48106-1045 U.S.A.
Call toll-free 800-USA-DISK or outside U.S.A. 313-973-8888



Verbatim diskettes for as low as
\$1.59 each

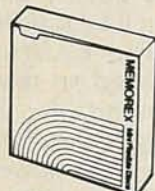

Memorex diskettes for as low as
\$1.59 each



Ultra diskettes for as low as
\$1.59 each



TDK diskettes for as low as
\$1.59 each



Fuji diskettes for as low as
\$1.59 each



Dysan diskettes for as low as
\$1.94 each

Verbatim Part #	CE quant. 100 price per disk (\$)	Memorex Part #	CE quant. 100 price per disk (\$)	Ultra Part #	CE quant. 100 price per disk (\$)	TDK Part #	CE quant. 100 price per disk (\$)	Fuji Part #	CE quant. 100 price per disk (\$)	Dysan Part #	CE quant. 100 price per disk (\$)
_____	_____	3062-P	1.94	81726-P	1.94	F1-S-P	2.34	FD1S-128N-P	1.94	800501-P	2.49
_____	_____	3015-P	1.94	_____	_____	_____	_____	_____	_____	800605-P	2.69
_____	_____	3090-P	2.39	_____	_____	F2D-S-P	2.89	FD2D-P	2.89	800803-P	3.14
_____	_____	3102-P	2.89	82701-P	2.89	_____	_____	_____	_____	_____	_____
_____	_____	_____	_____	_____	_____	F2D-S1024-P	2.89	FD2D-1024-P	2.89	800839-P	3.14
_____	_____	3104-P	2.89	82708-P	2.89	_____	_____	_____	_____	_____	_____
_____	_____	_____	_____	_____	_____	M1D-S-P	1.59	MD1D-P	1.59	801187-P	1.94
_____	_____	_____	_____	51401-P	1.59	_____	_____	_____	_____	_____	_____
_____	_____	_____	_____	52402-P	1.99	_____	_____	_____	_____	_____	_____
28820-P	1.59	3481-P	1.59	52401-P	2.19	M2D-S-P	2.19	MD2D-P	2.19	802060-P	2.64
_____	_____	_____	_____	_____	_____	_____	_____	_____	_____	_____	_____
_____	_____	_____	_____	_____	_____	_____	_____	_____	_____	_____	_____
28821-P	2.54	3491-P	2.19	_____	_____	M2DX-S-P	2.99	MD2D-96TPI-P	2.99	802067-P	3.99
_____	_____	_____	_____	_____	_____	MF1D-P	2.99	_____	_____	_____	_____
_____	_____	_____	_____	_____	_____	_____	_____	_____	_____	_____	_____
28823-P	3.39	3501-P	2.99	52801-P	2.99	_____	_____	_____	_____	_____	_____
_____	_____	6100-P	3.74	_____	_____	_____	_____	_____	_____	_____	_____

Lifetime warranty
For more info on Verbatim call
800-538-8589
In California 408-245-4400

5 year warranty
For more info on Memorex call
800-448-1422
Monday-Friday 9 am-4 pm ET

Lifetime warranty
For more info on Ultra call
408-728-7777
Monday-Friday 9 am-4 pm PT

Lifetime warranty
For more info on TDK call
800-645-6571
In New York 516-825-0100

Lifetime warranty
For more info on Fuji call
800-223-6535
In New York 212-736-3335

Lifetime warranty
For more info on Dysan call
800-552-2211
In California 408-970-6096

CIRCLE 35 ON FREE INFORMATION CARD



THE RIGHT STUFF.

The growth of NTE quality replacement parts has been nothing short of astronomical. And the proof is in our new 1984 Replacement Master Guide, destined to be the standard directory for technicians across the country. In excess of 3,000 quality NTE types are cross-referenced to more than 220,000 industry part numbers.

YOU'LL FIND ALL THE RIGHT STUFF FOR REPLACEMENT, MAINTENANCE AND REPAIR:

- Transistors
- Thyristors
- Integrated Circuits
- Rectifiers and Diodes
- High Voltage Multipliers and Dividers
- Optoelectronic Devices
- Zeners
- Microprocessors and Support Chips
- Memory IC's
- Thermal Cut-Offs
- Bridge Rectifiers
- Unijunctions
- RF Transistors
- Microwave Oven Rectifiers
- Selenium Rectifiers
- NEW! The Protector 6000™ Transient Voltage Protection Strip

Look for our Replacement semiconductors in the bright green polybags and cartons that list rating limits, device type, diagrams and competitive replacement right on the package. NTE quality parts are available from your local NTE distributor and come backed by our exclusive two-year warranty. Ask for your FREE NTE Replacement Master Guide and take off with NTE!



NEW-TONE ELECTRONICS, INC.

44 FARRAND STREET • BLOOMFIELD, NEW JERSEY 07003

DON'T FORGET



USE
YOUR
READER
SERVICE
CARD

The series 300 screwdrivers feature round shafts. They are anti-static and are insulated to 1000 volts. We examined the model PA1971 slotted screwdriver, which is one of the screw-holding drivers in the 300 series. We found it a refreshing change from other screw-holding models we've used in the past: The main advantage is that three quarters of the screw head is firmly held in place. The series 300 includes both slotted and Phillips heads in shaft lengths from 3½ to 7 inches; prices range from \$3.50 to about \$10.

Paladin also has two other series of screwdrivers. The series 400 consists of ball-style hex drivers. The series 500 is round-shafted screwdrivers that range in size from 2¾ to 8 inches, and in price from \$1.20 to about \$6.50.

Paladin's screwdrivers are obviously well made. They are—not surprisingly—a bit more expensive than most screwdrivers. But they appear to be made to last a long time. So if you can appreciate the quality of good tools, then you'll be satisfied with them.

The *Craftform* handles are shaped so that they're not only comfortable; they help to reduce fatigue and, Paladin claims, let you use your power up to 50% more efficiently than standard screwdriver handles. While we couldn't confirm those exact figures, we could agree qualitatively, most noticeably with the larger models.

For general electronics work, we'd recommend drivers of either the 200 or 300 (insulated) series. For heavier work (auto mechanics, for example), the 100-series drivers



"What do you have in the way of a TV that uses an indoor antenna?"

are hard to beat.

Paladin claims that their screwdrivers are the world's best. While we wouldn't be willing to go that far, we do admit that we have yet to see any better. **R-E**

Hickok MX-333 DMM

This high-quality instrument even lets you "troubleshoot by ear."



CIRCLE 102 ON FREE INFORMATION CARD

A GOOD DMM IS ESSENTIAL FOR ANYONE planning to do any amount of electronics work. But for some individuals, especially those for whom electronics is a profession, the quality of the device is paramount. After all, the unit must stand up to the strain of constant use and be capable of delivering highly accurate measurements. We recently had a chance to examine an instrument that in our opinion meets that description. That instrument is the Hickok (10514 Dupont Ave., Cleveland, OH 44108) MX-333.

There's quite a bit of measurement capability packed into that 2.2 x 6.7 x 6-inch, 22-ounce unit. Of course it measures resistance, AC and DC current, and AC and DC voltage, and provides a diode test feature; but it also offers a little more by including both 20-ohm and 10-amp ranges. Those ranges are not found on many meters. Also provided is an audible output feature, called *Vari-Pitch*. As that name implies, the pitch of the audible output varies as the reading changes. Finally there is a logic-testing capability, called *Logic-Trak*, that works with *Vari-Pitch* to provide rapid troubleshooting of logic circuits.

Specifications

Let's turn next to the unit's specifications. It can measure AC and DC voltage over five ranges from 200 mV to 1000 volts full scale. For DC voltage, accuracy is specified as $\pm 0.1\%$ of the reading ± 1 digit. For AC voltage, accuracy is specified as $\pm 0.75\%$ of the reading ± 2 digits over all ranges for signals from 45 Hz to 500 Hz. For signals from 500 Hz to 5 kHz, the accuracy is $\pm 2\%$ of the reading ± 5 digits; that specification is valid for the

200-mV to 20-volt ranges.

Resistance is measured over seven ranges from 20 ohms to 10 megohms full scale. Specified accuracy varies according to the range from a high of $0.1\% \pm 1$ digit for the 2-kilohm through the 2-megohm range, to a low of $3\% \pm 1$ digit for the 20-ohm range. The voltage output by the meter for the resistance tests is 0.25 volts maximum at full scale, 3.2 volts maximum into an open circuit.

continued on page 42

Here's one phone book worth buying ...and reading.

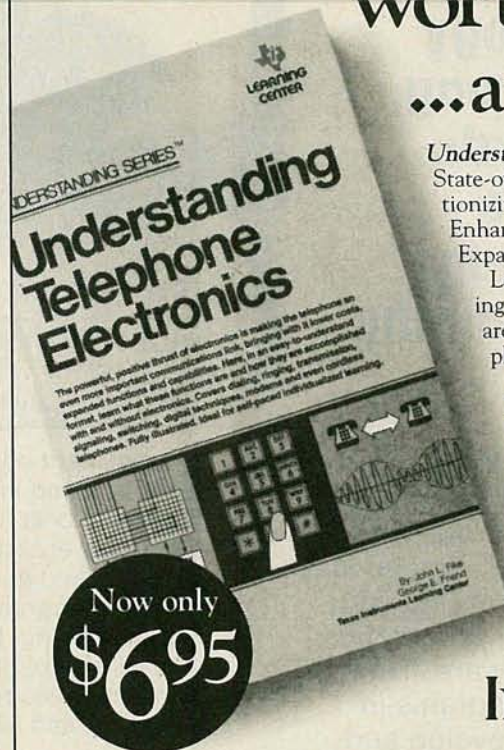

Understanding Telephone Electronics. State-of-the-art technology is revolutionizing telephone communications. Enhancing capabilities. Lowering costs. Expanding functions.

Learn why digital systems are replacing analog. Why cordless phones are practical. How cellular mobile phones work.

Fully illustrated, *Understanding Telephone Electronics* is written in concise, nontechnical language, ideal for self-paced learning.

To order *Telephone Electronics*, or any other book in the *Understanding Series*,™ use the coupon below.

TEXAS INSTRUMENTS

Creating useful products and services for you.

™ Trademark of Texas Instruments Incorporated

<p>Please send me:</p> <p>Understanding Series Titles:</p> <p><input type="checkbox"/> Understanding Telephone Electronics—(LCB7141) _____ @ \$6.95</p> <p><input type="checkbox"/> Understanding Solid-State Electronics—3rd edition (LCB3361) _____ @ \$5.95</p> <p><input type="checkbox"/> Understanding Digital Electronics—(LCB3311) _____ @ \$6.95</p> <p><input type="checkbox"/> Understanding Microprocessors—(LCB4023) _____ @ \$6.95</p> <p><input type="checkbox"/> Understanding Calculator Math—(LCB3321) _____ @ \$6.95</p> <p><input type="checkbox"/> Understanding Communications Systems—(LCB4521) _____ @ \$6.95</p> <p><input type="checkbox"/> Understanding Computer Science—(LCB5471) _____ @ \$6.95</p> <p><input type="checkbox"/> Understanding Optonics—(LCB5472) _____ @ \$6.95</p> <p><input type="checkbox"/> Understanding Automotive Electronics—(LCB5771) _____ @ \$6.95</p> <p><input type="checkbox"/> Understanding Electronic Security Systems—(LCB7201) _____ @ \$6.95</p> <p><input type="checkbox"/> Understanding Electronic Control of Energy Systems—(LCB6642) _____ @ \$6.95</p> <p><input type="checkbox"/> Understanding Electronic Control of Automation Systems—(LCB6641) _____ @ \$6.95</p> <p><input type="checkbox"/> Understanding Data Communications—(LCB7981) _____ @ \$6.95</p> <p>Self Study Courses:</p> <p><input type="checkbox"/> AC Audio (LCB6651)/AC Text (LCW8168) _____ @ \$24.95</p> <p><input type="checkbox"/> DC Audio (LCB5922)/DC Text (LCW8161) _____ @ \$24.95</p>	<table border="0"> <tr> <td style="text-align: right;">Quantity</td> <td style="text-align: right;">Price</td> <td></td> </tr> <tr> <td>_____</td> <td>@</td> <td>_____</td> </tr> </table>	Quantity	Price		_____	@	_____	<p>Mail to:</p> <p style="text-align: center;">Texas Instruments P.O. Box 3640, M/S 54 Dallas, Texas 75285</p> <p>Add \$1.25 per book for postage and handling. Prices subject to change without notice.</p> <p>Enclose check or money order with sales tax (except AK, DE, NH, OR). Foreign orders must be in U.S. dollars and include shipping charges. No phone orders, please.</p> <p>Name _____</p> <p>Address _____</p> <p>City _____</p> <p>State _____ Zip _____</p> <p>27-2116 ©1984 TI RE984</p>
Quantity	Price							
_____	@	_____						

In Computer Electronics...

NTS INTRONIC™ HOME TRAINING GIVES YOU THE EDGE

The competition for High-Technology careers is strong, and the rewards are great. Give yourself the edge you need by training with NTS.

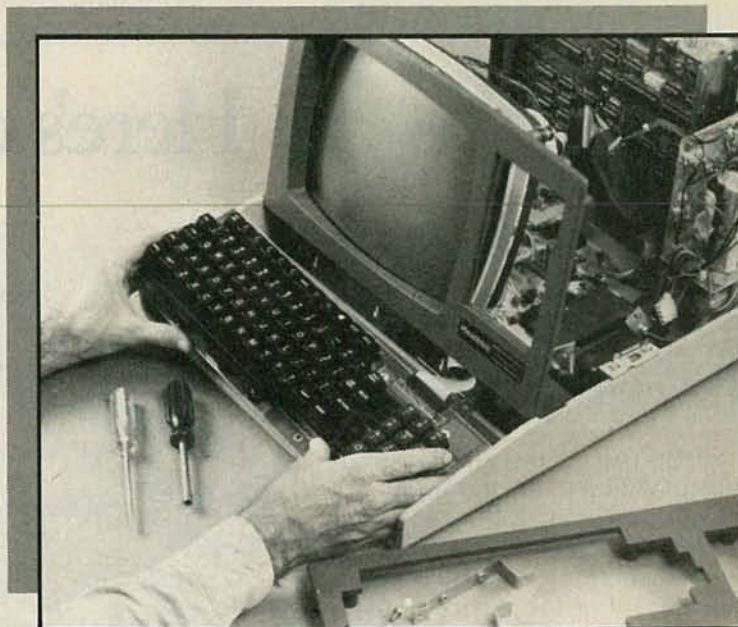

NTS INTRONIC home training provides you with a special kind of "Hands-On" experience that prepares you better, develops your skills faster. You advance as quickly as you wish, working with actual circuits, diagrams, schematics, and state-of-the-art hardware. There are a dozen different NTS programs in electronics to help you develop and reach your potential. They range from basics to advanced areas in several fields. And the ALL-NEW NTS course catalog spells it all out. It's free, and does not obligate you in any way. Send for it today.

A GROWTH INDUSTRY

High-Technology is a growth industry. The evidence is clear, and most observers predict a steady expansion due to a relatively strong flow of investment capital into computers, electronics and precision instruments. Sales of computers alone will reach an estimated ten million units this year. This means challenges and new

employment opportunities, especially in servicing and maintenance. Computer servicing skills can best be learned by working directly on field-type equipment. NTS electronic hardware is selected and developed especially for the training program with which it is associated. You learn by doing, by assembling, by performing tests and experiments, covering principles of computer electronics, microprocessor troubleshooting, and circuitry.

MICROCOMPUTERS

NTS offers three programs in computer electronics. You will receive training covering solid-state devices, digital logic circuitry, and the fundamentals of the computer itself. Instruction includes micro-control technology and detailed operation of microcomputers. These courses will prepare you for entry-level in many facets of the computer industry such as field service and customer engineering as well as programming. In addition to written texts your course includes the NTS/HEATH disc-drive computer which you assemble as part of the training process. The assembly and use of the computer will serve to reinforce practical application of principles.

MICROPROCESSOR TECHNOLOGY

The field of industrial and microprocessor technology encompasses the application of electronic microprocessor control principles. Your course takes you from fundamentals of digital electronics and associated circuitry through the application of the microprocessor as a control device. You will learn how to move and manipulate instructions and information. The microprocessor trainer included in your course is a microcomputer system designed as a practical tool for learning the use of software and hardware techniques utilized in the linking of microprocessors to various systems.



DIGITAL ELECTRONICS

The NTS Compu-Trainer is a fascinating solid-state device which you will build in order to perform over ninety logic circuit experiments. These experiments serve to emphasize an area of electronics which is essential to the understanding of state-of-the-art control equipment; they are also extremely important to those wanting to pursue a career in computer servicing. Separate courses involving the Compu-Trainer are also available in Microcomputer Servicing and Digital/Analog Electronics.

ROBOTICS & VIDEO TECHNOLOGY

Other NTS courses cover a wide range of specialization. In Robotics, the NTS/Heath Hero I is included to train you in robotic applications in

manufacturing processes. In Video technology, a new course features the advanced NTS/Heath Z Chassis "Smart Set" color TV with computer space command remote control and space phone. This is an excellent program for those interested in a career in video servicing with microcomputer basics.

EARN CEU CREDITS

America's industrial giants are turning more and more frequently to home study as an effective way to upgrade employee skills. You benefit from the experience NTS has gained in its 79 years as a leader in technical training. The skills and experience gained in the building of kits and test equipment provide you with training that cannot be duplicated. And, depending on the program you select, you can earn up to 30 CEU credits for successful completion. Complete details included in the catalog.



Use the mail-in card or fill out and mail the coupon. Indicate the field of your choice. (One, only please.) FREE full color catalog will be sent to you by return mail.

NATIONAL TECHNICAL SCHOOLS Dept. 206-094
4000 South Figueroa Street, Los Angeles, CA 90037

Please send FREE color catalog on course checked below:

- | | |
|---|---|
| <input type="checkbox"/> Robotics | <input type="checkbox"/> Computer Electronics |
| <input type="checkbox"/> Digital Electronics | <input type="checkbox"/> Video Technology |
| <input type="checkbox"/> Auto Mechanics | <input type="checkbox"/> Home Appliances |
| <input type="checkbox"/> Air Conditioning/Solar Heating | |

Name _____ Age _____
Address _____ Apt. _____
City _____ State _____
Zip _____ Phone () _____

- Check if interested ONLY in classroom training in Los Angeles
 Check if interested in G.I. Bill Information.

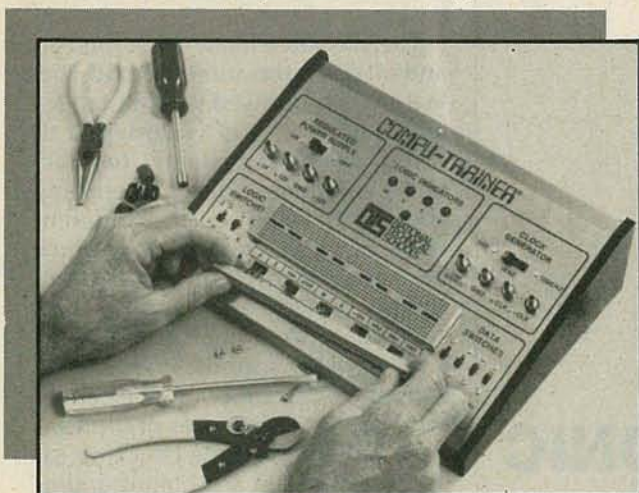

NO OBLIGATION

NO SALESMAN WILL CALL

NTS NATIONAL TECHNICAL SCHOOLS

TECHNICAL TRADE TRAINING SINCE 1905
Resident and Home-Study Schools

4000 So. Figueroa St., Los Angeles, CA 90037

EQUIPMENT REPORTS

continued from page 37

Both AC and DC currents are measured over five ranges from 2 mA to 10 amps full scale. Accuracy for the DC ranges varies from $1\% \pm 1$ digit (2 mA–200 mA) to $1.5\% \pm 1$ digit (2 amps). Accuracy for the AC ranges, for input signals from 45–400 Hz, is $1.5\% \pm 2$ digits; the exception to that is the 2-mA

range, which has an accuracy of $2.5\% \pm 2$ digits.

Use

All of the meter's ranges and functions are selected from the front panel. The four test-lead connectors are located on the side of the unit. Those connectors, v/ω , COM, MA, and 10A, are of the recessed variety for safety. A set of color-coded test probes (red-black) are provided with the unit, as is an alligator clip attachment that can

screw onto the end of either probe.

Using the meter is simple. It is merely a matter of plugging the test probes into the appropriate connectors and selecting the required function and range. The ranges are color coded for each function. The resistance ranges are shown in green, the AC and DC voltage and current ranges are shown in yellow, and the special functions are shown in blue.

All readings are displayed on a $3\frac{1}{2}$ -digit LCD readout. The readout features a polarity indicator, decimal points, and a low-battery annunciator that lights when battery life is down to 20% (a 9-volt transistor-radio-type battery is used by the meter). The display is tilted upward at a 45° angle for easy viewing on the bench. A belt-clip is also provided for portable use.

WHAT WILL YOU FIND IN CEI'S FREE 1984 FALL CATALOG ?



ALL OF YOUR ELECTRONIC PARTS NEEDED!

OVER 500 NEW ITEMS!

CALL TOLL FREE TODAY!

1-800-543-3568

NATIONAL WATS

705 WATERVLIT AV,
IN DAYTON:(513) 252-5662

1-800-762-3412

OHIO WATS

DAYTON, OHIO. 45420

TELEX NO. 288-229

CIRCLE 18 ON FREE INFORMATION CARD

Hickok		MX-333												
OVERALL PRICE														
EASE OF USE														
INSTRUCTION MANUAL														
PRICE/VALUE														
		1	2	3	4	5	6	7	8	9	10			
		Poor		Fair			Good			Excellent				

The *Vari-Pitch* feature is turned on and off using the AUDIO SWITCH. That feature can be used with all ranges and functions, and is designed to respond almost instantly to practically all inputs. What is interesting about that feature is that different kinds of input signals will produce characteristic and distinctive sounds. Once you've used the instrument for a while and have learned those sounds, there's quite a bit of troubleshooting that can be done by ear. Other uses of the *Vari-Pitch* function include checking capacitors in circuit and nulling and/or peaking a circuit.

The *Logic-Trak* feature has its own separate BNC input connector and requires the use of a 10:1, 80 MHz or better oscilloscope probe (one is not supplied but is available from the manufacturer). Because of the high input impedance and low capacitance of that type of probe, it will have minimum effect on the circuit under test. That allows you to easily

find the presence of logic highs and lows, as well as opens, floating inputs, and shorts to either the power supply or ground. Individual pulses, pulse trains, or changes in voltage levels, are indicated by the presence of the colon in the display. Any such change will cause the colon to appear for about 0.1 second. If the changes in level are occurring rapidly, the colon will appear to be on continuously and the display will show the average DC level.

The *Logic-Trak* function is especially useful when used with *Vari-Pitch*. That's because the various logic states, and pulse activity, can be identified quickly without looking at the display by using that feature. High logic-levels cause a high-frequency tone to be generated, low logic-levels cause a low-frequency sound (or no sound at all) to be generated, and pulse activity is signaled by a chirping sound.

The instruction manual that accompanies the unit is excellent. It features everything that you would expect, including information on use, applications, calibration, and maintenance. There is also a complete parts list, parts-placement diagrams, and a schematic.

In summary, the Hickok MX-333 is an excellent and well-made instrument that would be a welcome addition to any electronics bench. It is covered by a one-year warranty and sells for \$290.00. **R-E**

Krista Model 30B-240 Capacitance Meter

*A low-cost, easy-to-use
meter*



CIRCLE 103 ON FREE INFORMATION CARD

THERE'S LITTLE DOUBT THAT A CAPACITANCE meter is a handy instrument to have around the workshop or lab. The problem is that many of those instruments are either expensive or terribly inconvenient to use. We recently had the pleasure of examining an instrument that fits neither description. It is the Krista (PO Box 3423, Torrance, CA 90510) model 30B-240 digital capacitance meter.

This is a small (7.1 × 3.2 × 1.5-inch, 9.9 ounce) hand-held unit.

Measurements are displayed on a ½-inch, 3½-digit LCD readout. Controls are simple, but to the point. They consist of a front-panel ON/OFF switch and a front-panel ZERO ADJUST control. The instrument is not auto-ranging. Eight ranges from 200 pF to 2000 µF full scale are selected, using a series of pushbuttons located on the side of the case.

Capacitors can be tested in one of two ways. Smaller capacitors can be plugged directly into a set

IT WASN'T OUR IDEA TO ADD TWO NEW SIZES TO OUR LINE OF ACE BREADBOARDS. IT WAS YOURS.



Good idea! You told us you wanted to build larger projects. And, that you needed bigger breadboards to build them. Well, our two new A P PRODUCTS All Circuit Evaluators are just what you had in mind.

The ACE 245 has 25% more capacity than our previous largest breadboard. It has a circuit building matrix of 4520 solderless, plug-in tie-points. And, if bigger is better our new ACE 254 has a circuit building matrix of 5424 solderless tie-points.

**For the
A P PRODUCTS
dealer near you
call TOLL FREE
800-321-9668.
(In Ohio, call
collect
(216) 354-2101.)**

A P PRODUCTS INCORPORATED
9450 Pineneedle Dr. • Box 540
Mentor, Ohio 44060
(216) 354-2101
TWX: 810-425-2250

In Europe, contact A P PRODUCTS • GmbH
Bäumlesweg 21 • D-7031 Weil 1 • West Germany



CIRCLE 87 ON FREE INFORMATION CARD

of spring-loaded test terminals on the front panel. Larger devices can be tested, using a set of leads (supplied). Those leads plug into the front of the unit directly below the test terminals. The connectors used are of the recessed type for safety.

Krista		30B-240											
OVERALL PRICE													
EASE OF USE													
INSTRUCTION MANUAL													
PRICE/VALUE													
		1	2	3	4	5	6	7	8	9	10		
		Poor		Fair		Good		Excellent					

Specifications

The eight full-scale ranges covered by the unit are 200 pF, 2 nF, 20 nF, 200 nF, 2 μ F, 20 μ F, 200 μ F, and 2000 μ F. The accuracy, which is specified at 25°C \pm 5°C, is 0.5% of the full-scale reading \pm 1 least-significant-digit; that specification is valid for the 200-pF to 200- μ F ranges. For the 2000- μ F range, the accuracy is claimed to be 1% of full scale \pm 1 least-significant-digit.

The device is powered by a 9-volt transistor-radio-type battery. The specified power consumption is 3-4 mA. The expected battery life is 200 hours if an alkaline type is used; 100 hours for a carbon-zinc unit. A low-battery condition is indicated by a LOBAT annunciator on the readout. The specified operating environment is 0°C to 40°C (32°F to 104°F) and a maximum relative humidity of 85%.

Use

The meter is extremely easy to use. All that needs to be done is turn on the unit, select the appropriate range, zero the display, insert the capacitor into the test terminals (or use the test leads in the case of larger units), and read the value on the display. The units of the displayed reading are the same as indicated by the selected range switch. If the value of the capacitor is completely unknown, such as in the case of unmarked units, simply start at the lowest range (200 pF) and work upward

continued on page 92

Radio-Electronics mini-ADS



ELECTRO IMPORTING CO. CATALOG.

This reprint of the historic 176-page catalog No. 20 gives you an accurate look at the state of electronics in 1918. Contains everything from a Zinc Spark Gap to a 1000-Mile Receiving Outfit. You can get your own copy of this modern antique, profusely illustrated, for only \$4.95 plus \$1.00 P&H. Order yours from R-E BOOKSTORE, Radio-Electronics, 200 Park Avenue South, New York, NY 10003.



FREE 1984 ELECTRONIC TOOL & INSTRUMENT CATALOG is packed with over 5,000 quality technical products for assembling, testing and repairing electronic equipment. All products fully illustrated with photographs, detailed descriptions and pricing to allow for easy ordering by phone or mail. Most orders are shipped within 24 hours. 100% satisfaction guarantee. **CONTACT EAST, 7 Cypress Drive, Burlington, MA 01803. (617)272-5051.**

CIRCLE 50 ON FREE INFORMATION CARD

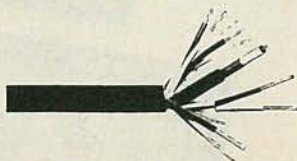

SATELLITE CONTROL CABLE—NEMAL ELECTRONICS has designed a new series of combination cables for TVRO installations. These cables provide all necessary wires for signal, motor and receiver power and sense circuits together in one direct burial jacket. **TYPE-1** RG-59 + 9 conductor (2-18gu) \$495/1000', **TYPE-2** RG-59 + 11 conductor (2-12gu) \$689/1000', **TYPE-3** dual RG-59 + 11 conductor (2-12gu) \$879/1000', all made with milspec RG59, 96% copper shield, tinned drain wires. Over 500 types of cable, connectors, SMATV products in stock. Authorized distributor Kings-Amphenol-Columbia. **NEMAL ELECTRONICS Inc., 12240 N.E. 14th Ave., N. Miami, FL 33161 (305) 893-3924.**

CIRCLE 96 ON FREE INFORMATION CARD

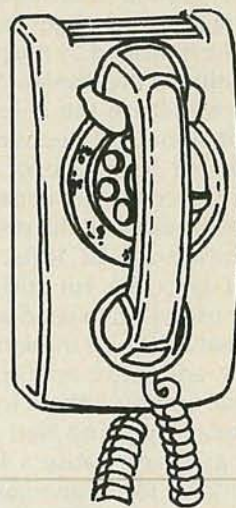

CALL NOW AND RESERVE YOUR SPACE

- 6 \times rate \$605 per each insertion.
- Reaches 215,460 readers.
- Fast reader service cycle.
- Short lead time for the placement of ads.
- We typeset and layout the ad at no additional charge.

Call 212-777-6400 to reserve space. Ask for Arline Fishman. Limited number of pages available. Mail materials to: mini-ADS, RADIO-ELECTRONICS, 200 Park Ave. South, New York, NY 10003.



MODERN ELECTRICS. Miniature souvenir of the first publication ever produced by Gernsback Publications. This issue appeared in April 1908—just 75 years ago. You can own your own reprint of this unique first edition for just \$2.50 plus 75c P&H. It's available from R-E BOOKSTORE, Radio-Electronics, 200 Park Avenue South, New York, NY 10003

Radio-Electronics mini-ADS



DIGITAL BOARD TESTING COURSE—This 18 lesson course, including lesson books, cassette tapes, and workbooks, will give you the information you need to enter the field of test engineering and to learn the latest techniques used in automatic test equipment. Earn your certificate from the Test Engineering Institute. Check/M.O./Mastercard/Visa. \$450 plus shipping. 10 DAY NO RISK TRIAL. Logical Solutions, Inc., 1799 S. Winchester, Suite 201, Campbell, CA 95008. (408) 374-3650.

CIRCLE 46 ON FREE INFORMATION CARD



APPLIANCE REPAIR HANDBOOKS—13 volumes by service experts; easy-to-understand diagrams, illustrations. For major appliances (air conditioners, refrigerators, washers, dryers, microwaves, etc.), elec. housewares, personal-care appliances. Basics of solid state, setting up shop, test instruments. \$2.65 to \$5.90 each. Free brochure. **APPLIANCE SERVICE**, PO Box 789, Lombard, IL 60148. 1-(312) 932-9550.

CIRCLE 92 ON FREE INFORMATION CARD

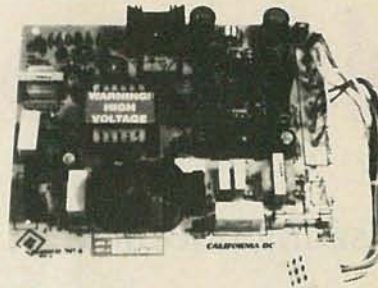

California-DC Regulated Switching Power supply +5v dc @ 5 amp +12v dc @ 2 amp +12v dc @ 1.8 amp -12v dc @ .5 amp 115-230v ac input, fused. EMI filtered. Removable DC Power Harness and Schematics included. 7.4" x 6.2" x 1.7" ht. New units, identical to the Kepco/TKD Supplies as seen at \$59.95.

\$37.50 ea. freight pre-paid in U.S.
1-800-327-7182 Power Plus.
(Call for Quantity Price)

CIRCLE 8 ON FREE INFORMATION CARD



SUBSCRIPTION TV MANUAL. This information packed book details the methods used by subscription TV companies to scramble and descramble video signals. Covers the Sinewave, Gated Pulse, SSAVI system, and the methods used by most cable companies. Includes circuit schematics, theory, and trouble shooting hints. Only \$12.95 plus \$1.50 first class P&H. Info \$2.00, refundable. **RANDOM ACCESS**, Box 41770-R, Phoenix, AZ 85080.

CIRCLE 31 ON FREE INFORMATION CARD



TIMEX/SINCLAIR 1000, 1500, 2068, ZX81, SPECTRUM PRTR I/F—A Centronics parallel printer interface. Order PRTIF: \$50. **EPROMMER**—Programs 2716, 2732, 2764's Order EPRMR: \$75. *Software for TS2068, Spectrum: ASM/DSM*—A full featured assembler/disassembler. Order ASMDSM: \$40. **TEXTEDIT**—A very complete editor, including 64-column mode. Order EDIT: \$40. When ordering, specify type of computer. Money orders or C.O.D. only. Send to **RESEARCH SERVICE LABORATORIES P.O. Box 19124, OKC, OK 73144.**

CIRCLE 10 ON FREE INFORMATION CARD



FREE CATALOG OF HARD-TO-FIND TOOLS is packed with more than 2000 quality items. Your single source for precision tools used by electronic technicians, engineers, instrument mechanics, schools, laboratories and government agencies. Also contains Jensen's line of more than 40 tool kits. Send for your free copy today! **JENSEN TOOLS INC., 7815 46th St., Phoenix, AZ 85040. (602) 968-6231.**

CIRCLE 37 ON FREE INFORMATION CARD

CALL NOW AND RESERVE YOUR SPACE

- 6 x rate \$605 per each insertion.
- Reaches 215,460 readers.
- Fast reader service cycle.
- Short lead time for the placement of ads.
- We typeset and layout the ad at no additional charge.

Call 212-777-6400 to reserve space. Ask for Arline Fishman. Limited number of pages available. Mail materials to: mini-ADS, RADIO-ELECTRONICS, 200 Park Ave. South, New York, NY 10003.



ZENITH Z-TAC CABLE T.V. DESCRAMBLER. Brand new tag-along. Positive and negative video \$225.00 plus 5% shipping and handling. Visa, MasterCard, C.O.D. accepted. For Complete information and our Catalog send \$5.00 to **R&M DISTRIBUTORS, P.O. Box 266-R15, Boston, Ma. 02190. (617) 871-5838.**

CIRCLE 24 ON FREE INFORMATION CARD

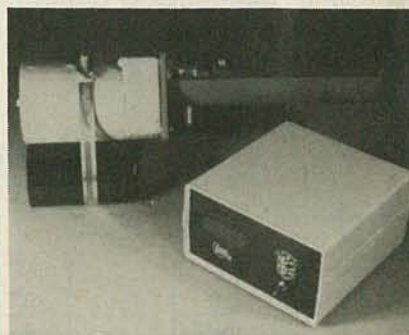

THE LE COUNT 24 is a unique satellite antenna positioning system because it is the first do-it-yourself system, and it is the only low voltage AC (QUITE) system on the market today. Retro Fit motor and 4 digit control—power unit is available direct at \$239.95. Motor unit alone is 109.95, counter as add on unit: 135.00. **THE SPACEAGE ELECTRONICS CORP., P.O. Box 15730, New Orleans, La. 70175, (504) 891-7210.**

CIRCLE 23 ON FREE INFORMATION CARD

NEW IDEAS

Pulsating doorbell

CONVENTIONAL DOORBELLS CAN often fail to get your attention. That can happen when you are in a remote part of your house, such as your basement or attic, or when there are other loud noises, such as when you are working with power tools. While it is possible to replace your doorbell with a loud, pulsating buzzer, such buzzers will pulsate only as long as the doorbell button is pressed. In addition, they can be rather expensive. However, as we'll see, there is a better solution.

Figure 1 shows a simple doorbell circuit that, when activated, will emit a loud, pulsating sound. The circuit is easy to build and uses readily available parts. Unlike other doorbells, this one will continue to sound for about 1½ minutes before it automatically turns off. An additional feature of the circuit is that it will automatically shut off if the door is opened before the 1½ minutes is up.

How it works

The operation of the circuit is centered around transistor Q1 (a 2N3819 general-purpose FET) and IC1 (a 555 timer configured as an astable multivibrator). The door-

bell circuit is powered by two power supplies, 12- and 18-volts DC, made from several batteries. If you don't like the idea of using batteries, you can, of course, use a DC power supply.

Capacitor C1 determines the on-time for the buzzer, while D1 provides a discharge path for that capacitor. When S1 (the doorbell button) is closed, C1 charges to the supply rail and a voltage is applied to the gate of transistor Q1, turning it on. Turning on Q1 provides a ground path for the rest of the circuit. With Q1 on, current flows and a trigger pulse is developed at the junction of C2 and R1. That trigger pulse is applied to pin 2 of IC1, causing it to begin the timing operation.

The output of IC1 (at pin 3) is used to turn relay RY2 on and off. Here, the output is used to sink current. When that output is low, current flows through the coil; when it is high, no current flows. As the output of the 555 is changing states rapidly, the relay contacts open and close repeatedly. The relay, of course, controls the sounding of the buzzer, so that it is continually being turned on and off, causing the pulsing effect.

When C1 has discharged (timed out), the gate voltage is removed and Q1 turns off, effectively opening the signal path and turning off the buzzer. But, as stated earlier, if the door is opened before that time, the buzzer automatically shuts off. That action is caused by S2. When the door is opened, S2 closes and shorts the charge on C1 to ground. That removes the Q1 gate-voltage and turns the transistor off, cutting off the path to ground. Switch S2 (Radio Shack 49-496, or equivalent) is a magnet-

continued on page 102

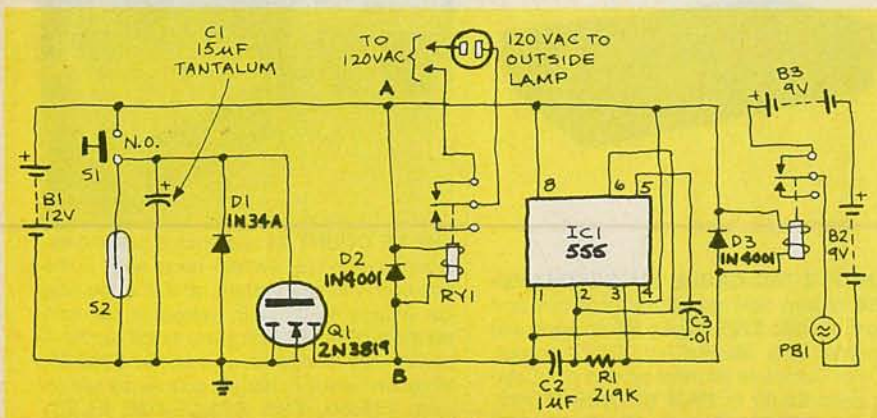

FIG. 1

NEW IDEAS

This column is devoted to new ideas, circuits, device applications, construction techniques, helpful hints, etc.

All published entries, upon publication, will earn \$25. In addition, for U.S. residents only, Panavise will donate their *model 333*—The Rapid Assembly Circuit Board Holder, having a retail price of \$39.95. It features an eight-position rotating adjustment, indexing at 45-degree increments, and six positive lock positions in the vertical plane, giving you a full ten-inch height adjustment for comfortable working.

I agree to the above terms, and grant **Radio-Electronics** Magazine the right to publish my idea and to subsequently republish my idea in collections or compilations of reprints of similar articles. I declare that the attached idea is my own original material and that its publication does not violate any other copyright. I also declare that this material has not been previously published.

Title of Idea

Signature

Print Name

Date

Street

City

State

Zip

Mail your idea along with this coupon to: **New Ideas Radio-Electronics**, 200 Park Ave. South, New York, NY 10003

What's New at AMERICAN SURPLUS TRADING?

"The Source" of electro-mechanical components for the hobbyist.

We warehouse 60,000 items at American Surplus Trading—expensive, often hard-to-find components for sale at a fraction of their original cost!

You'll find every part you need—either brand new, or removed from equipment (RFE) in excellent condition. But quantities are limited. Order from this ad, or visit our retail showroom and find exactly what you need from the thousands of items on display. Open Mon.—Sat., 9–5.

THERE'S NO RISK.

With our full 90 day warranty, any purchase can be returned for any reason for full credit or refund.

A. 160 CFM BLOWER



8 3/4" H x 6 29/32" W x 8 1/16" D. Air Outlet: 3" H x 3 3/8" W. 115VAC, 60HZ. Used in heating, ventilating, and exhausting. **\$9.95 RFE**

B. 35 CFM SPRITE FAN



Compact 3 1/2". For cooling equipment where space is at a premium. Universal air flowing, reversible air flow. 115VAC, 60HZ. Dim: 3 1/4" sq. x 1 1/8" D. Rotron or equiv. **\$6.95 RFE**

C. 115 CFM MUFFIN FAN



Metal frame with 5 high-impact plastic blades. For cooling HiFi, electronic equipment, computers, etc. Mounts for intake or exhaust. 115VAC, 60HZ. Dim: 4 1/16" x 1 1/2" D. **\$7.95 RFE**

D. VACUUM PUMP & MOTOR



Rotary vane pump, oil-less. 4CFM/15PSI max. (or 26" HG). Directly connected to a (GE 1/3HP, 1625RPM, 115VAC/60HZ) thermally protected motor. Mounted on a metal base. Mfr: GE & Gast **\$39.95 RFE**

E. WINDJAMMER BLOWER



Creates high volume of air at low pressures, or light vacuum for small enclosures. 120VAC, 60HZ, 1.5amp., 3400RPM. Vacuum approximately 12" of H₂O at "0" CMF, 9" of H₂O at 25CFM and 2" of H₂O at 52CFM with pressure side open. Air flow speed 3" from outlet, 6000 ft. per minute. Inlet at top: 1 3/4" L. Outlet at side: 1" L. Dim: 7 1/4" H x 9 1/4" Dia. **\$59.95 RFE**

F. DC STEPPING MOTOR



2 Phase-4 wire type. Shaft advances 200 steps/Rev., 1.8 deg. step. Input: 1.8VDC @ 2.8 amp. 65 deg. C rise, holding torque 72 oz/in. Dim: 2 3/16" L x 2 3/16" OD. Shaft: 1/4" Dia. x 3/4" L. Mounts on 2 3/16" plate, 15" wire leads. Mfr: Superior Electric #MO61FF-6201B **\$37.50 NEW**

G. AC SYNCHRONOUS STEPPING MOTOR



120V, 60HZ, 1.1amp. 72RPM. Torque 700 oz/in. Continuous duty, rapid starting/stopping and reversing. Stainless steel keyed shaft: 1/2" Dia. x 2" L. Dim: 4 1/4" Dia. x 7 1/4" L. Mfr: Superior Electric #SS400-1122U **\$39.95 RFE**

H. CONSTANT VOLTAGE TRANSFORMER



Protect your computer from voltage surges. Save your programs from crashing. 500VA-provides 120V/60HZ continuously, with input variations as great as +/- 15%. Input voltage: 95-130 or 190-260VAC, 60HZ. (accepts either voltage) Dim: 6 7/16" H x 7 29/32" W x 12 7/16" L. Mfr. Sola. **\$99.00 NEW**

J. LASER SCANNER

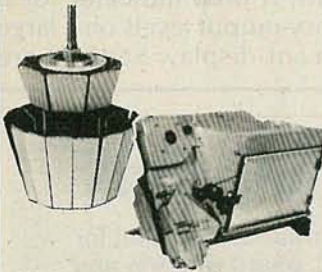

Contains an assortment of optical elements that can be used for many purposes. Includes: front surfaced and partially silvered mirrors, plastic double convex magnifying lens (12" focal length), two-faced mirror, plus others. The heart of the unit is a 2-tier multi-mirrored rotating assembly with ball bearing shaft, consisting of two decks. It would be suitable as a rotatable reflector (with a light source and a low speed motor), giving a "disco" effect. All of this and more is housed in a heavy cast white metal enclosure 14" L x 11 1/2" W x 9" H. Opens easily with a screwdriver. **\$39.95 RFE**

K. HIGH QUALITY INTELLIGENT KEYBOARD



60 Key Typewriter Layout Utilizes 8041 8 bit microprocessor, 8243 10 expander, 2316 ROM and more. Charcoal grey key caps with sound transducer. Power requirement: 5 VDC. 26 pin header connector. Mfr: Brothers Ind. Ltd. 556-504 **\$14.95 NEW**

L. RESET TIMER 0-30 minutes



Synchronous, motor driven, provides accurate & adjustable "off" delay timing. 1 min. minimum setting. Setting knob calibrated in 2 minute increments. 120VAC, 60HZ. 3 3/4" L x 2 9/16" W x 3 3/4" H. Base mount. Mfr: Eagle Signal #BR19A601 **\$24.50 NEW**

M. HEATER/HOT PLATE/AIR WARMER

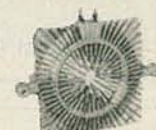

Consists of a 5" Dia. 1.5kW, 120V heating element, cast into a multi-finned, heavy white metal radiator: Dim: 8" sq. x 1 1/2" H. 2-Hole mounting. Mfr: Electromode #3954 **\$14.95 NEW**

N. 24V @ 6 Amp DC POWER SUPPLY



Industrial quality-regulated, providing variable output from 20-28VDC. Input: 105-125 VAC, 60HZ. Compact solid state package with integral heat sink. AC fuse protection, terminals are quick-connect slide on type. Dim: 4" x 8 1/2" x 7 3/4" D. **\$19.95 RFE**

PUMPS—COMPRESSORS—BLOWERS—MOTORS—POTENTIOMETERS—COUNTERS TIMERS—RELAYS—VOLTAGE REGULATORS—POWER SUPPLIES

S. 19" COLOR X-Y DISPLAY



Originally designed for use in Atari coin-operated games. Contains a 19VLUP22 3-gun color tube, focus and brightness controls. Has electromagnetic deflection and solid state circuitry with three "Z" amp inputs (red, green, blue). Ideal for arcade replacement or, with the addition of external circuitry, for color graphics display. **\$129.00 NEW**

O. 12V BATTERY PACK-NICKEL CADMIUM



Pkg. of 10-1.2V AA cells. Delivers 12V @ 450ma. Recharge rate 45mA, 16-18 hours. Case with tab output connections. Dim: 2 7/16" H x 1 1/4" x 2 15/16" L. Mfr: GE #123233 or equiv. **\$5.95 RFE**

P. TIMEX SINCLAIR 1000 COMPUTER



Factory returns. TV tested. Utilizes 280A CPU (socketed) 2016P and other chips. **\$14.95 RFE**

Q. 4" FULL RANGE SPEAKERS



9.3 oz. magnet, 20 watts RMS. Frequency response: 50-18,000HZ. Free air response: 86HZ. 8 Ohm, Voice coil Dia: 1" **\$15.00/pair NEW**

R. MAGNETIC RECORDING TAPE



Pre-recorded bulk erased, by a variety of manufacturers such as: Ampex, 3M, or Scotch. 7" Reels. 1800 ft.—1 mil. 2400 ft—.75 mil. Bakers Dozen 13 reels/ **\$9.95**

American Surplus Trading 62 Joseph St., Moonachie, NJ 07074 (201) 939-2710

AMERICAN SURPLUS TRADING, 62 JOSEPH STREET, MOONACHIE, N.J. 07074

YES! Please send me the following items:

A, B, C, etc.	How Many?	Description	Price	Total
				Total
				ORDER TOTAL

Shipping and handling, we ship UPS unless otherwise specified. Add \$3 plus 10% total. Canada: \$3 plus P.P. cost. Charge only. Sales Tax. (N.J. residents only, please add 6% of total)

FREE CATALOG of electro-mechanical devices sent with every order.

My check or money order is enclosed.
 Charge my credit card.
 Visa Master Card RE-94

Card No _____
Exp. Date _____
Signature _____
Telephone Area Code _____ Number _____
Name _____
Address _____
City _____
State _____ Zip _____

All inquiries and free catalog requests call 201-939-2710.

For all phone orders, call TOLL-FREE 800-228-2028 ext. 825. In Nebraska, 800-642-8300 ext. 825.

NEW PRODUCTS

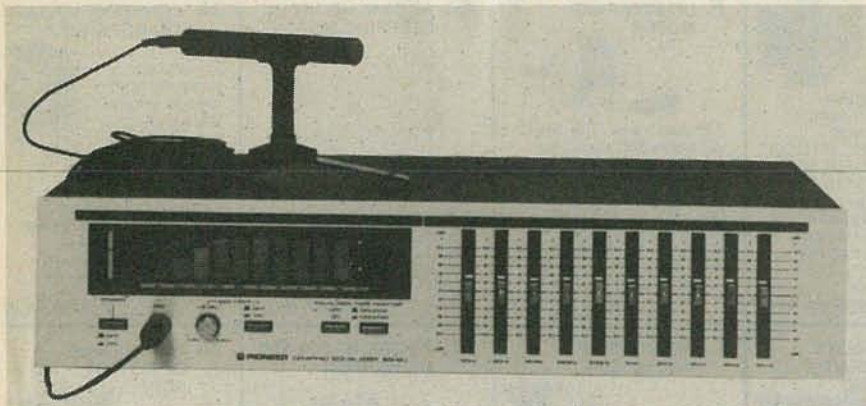

CIRCLE 121 ON FREE INFORMATION CARD

GRAPHIC EQUALIZER/ANALYZER,

the Pioneer model *SG-50M*, is a ten-band graphic equalizer that has been combined with a spectrum analyzer to evaluate and indicate the acoustic settings for any room.

The model *SG-50M* uses its own microphone and a built-in pink-noise generator to determine electronically the most desirable acoustic settings for the room in question. It then indicates ideal frequency-output levels on a large fluorescent display. Settings are

THE PLATT CIRCUIT BOARD CASE. IT WON'T GIVE YOU ANY STATIC.

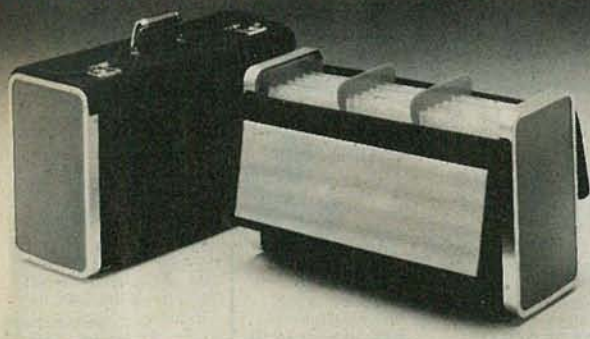

Platt introduces the ultimate static-free circuit board case*. Circuit boards can now be transported safely from job to job with protection from electrostatic discharge (ESD) as well as cushioned protection from shock and vibration.

Platt's circuit board case is made of lightweight, handsome jet black static free cotton duck and RCAS™ 1200 Pink Poly anti-static end shells.

Inside, circuit boards are further protected from damage and degradation in a compact, static-free, cushioned environment.

The adjustable separators make it possible to carry a number of circuit boards of varying sizes.

So, if you're looking for a way to safely carry sensitive circuit boards, remember Platt's case won't give you any static.

Write or call Michael Platt for complete information on our great new circuit board case and full line of tool cases.

platt
LUGGAGE

*Patent Pending.

Professional cases for business and industry
2301 S. Prairie Ave., Chicago, Ill. 60616
Toll free number: 1-800-222-1555

CIRCLE 89 ON FREE INFORMATION CARD

Electric Mini-Drill

This precision electric mini-drill is ideal for prototype work; P.C. board revision and redesign, solder removal; lead hole cleaning; grinding and polishing.

Comes supplied with detachable finger guard and 6 collets:



Use with transformer EDG-03

dt DAVLE TECH INC.
ELECTRONIC TOOLS & ACCESSORIES
™ 2 D5 Banta Place Fair Lawn NJ 07410 USA Tel 201-796-1720

CIRCLE 54 ON FREE INFORMATION CARD

made manually, and can be adjusted either by following the visual recommendations or by setting them for individual tastes.

The model *SG-50M* uses 10 sliding frequency controls for precise tonal adjustment. Each control is illuminated by its own LED for quick and easy visual reference. The suggested price for the Pioneer model *SG-50M* is \$259.95.—**Pioneer Electronics**, 1925 E. Dominguez St., Long Beach, CA 90810.

DIGITAL PANEL METER, the model *X-34 Thriftmeter*, is an LED-readout digital panel meter with a 0.5-inch depth behind the case. The 3½-digit, 2000-count meter features automatic polarity indication for positive and negative input voltages, out-of-range overload indication, and accuracy to 0.001 volt.



CIRCLE 122 ON FREE INFORMATION CARD

The 0.563-inch LED readout, with programmable decimal point, is readable from 30 feet. The meter is designed for scientific analytical equipment, medical equipment, and test and process-control equipment, as well as applications for hobbyists and electronics experimenters. Calculations involving meter loading are eliminated, in most cases, by the high-impedance input.

The model *X-34 Thriftmeter* comes with a case, red readout-filter, and mounting hardware, and is priced at \$38.50.—**Non-Linear Systems**, 533 Stevens Avenue, Solana Beach, CA 92075.

TEST LINE SIMULATOR, model *TLS-2*, is designed to provide a telephone/telephone system installer a means to perform operational and functional checks of telephone and system installations when central-office lines are not available.

The model *TLS-2* includes the



CIRCLE 123 ON FREE INFORMATION CARD

following features: It provides loop and ground-start operation;

two lines are provided with separate battery feeds; it accepts tone and rotary input; it has a unique station number for each line; there is a ringing-voltage source with short-circuit protection, and there are three ways to apply ringing to on-hook lines. The *TLS-2* sells for \$290.00.—**Teltone Corporation**, 10801 120th Avenue, NE, PO Box 657, Kirkland, WA 98033.

TEST SET, model *HX-93*, is designed for testing installed cables.

For Quality 3½ or 4½ Digit Hand-Held DMMS

Ask for
Simpson®

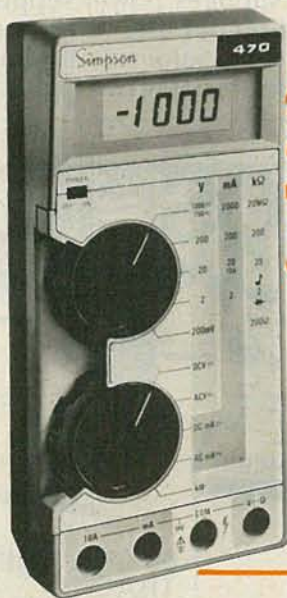

MANUFACTURED
Both
IN U.S.A.



4½ Digit 474™
.03% Basic DC Accuracy
\$219

3½ Digit 470™
.15% Basic DC Accuracy
\$139

FULL FUNCTION DMMS WITH THESE MOST WANTED FEATURES . . .

- ✓ Full Measurement Capability
- ✓ 6 kV Transient Protection
- ✓ Double Fusing System
- ✓ Audible Continuity Indication
- ✓ Diode Test Function
- ✓ User Engineered Range/Function Selector Knobs
- ✓ Large, Easy-to-Read LCD Display
- ✓ High Impact ABS Case
- ✓ 2-Way Tilt Stand
- ✓ Extended Battery Life
- ✓ UL Recognized Test Leads
- ✓ Full Line of Optional Accessories
- ✓ Full Simpson Warranty

AT LEADING ELECTRICAL/ELECTRONICS DISTRIBUTORS



SIMPSON ELECTRIC COMPANY

A Katy Industries, Inc. Subsidiary
853 Dundee Avenue, Elgin, Illinois 60120-3090
(312) 697-2260 • Telex 72-2416
Cable SIMELCO

CIRCLE 34 ON FREE INFORMATION CARD



CIRCLE 124 ON FREE INFORMATION CARD

The unit features interchangeable adapter plates for one cable end, while the remote cable end connects to a passive connector block. All lines are checked electronically for shorts and opens, as well as miswires. Testing can be initiated at either end; a PASS/FAIL indicator is included on the remote-connector block.

Spring-loaded probes on the tester assure reliable connection to the adaptor plates. The model HX-93 is priced at \$1195.00.—**Hollex, Inc.**, 81 W. Wyoming Avenue, MA 02176.

INTERFACE, model 200-C488, is an IEEE-488 GPIB (General Purpose Interface Bus) interface that provides talker-listener functions for the full series of Bertan's expanded 205A/210 laboratory high-voltage power supplies now available. (Those supplies have output voltages to 75 kilovolts and output power to 250 watts.)



CIRCLE 125 ON FREE INFORMATION CARD

Commands that are implemented via the interface include output-voltage setting, voltage limit, and current limit. In response to a controller request, the interface supplies power-supply status and output data. It can be programmed to automatically shut down a power supply and request

service for an overvoltage or over-current condition.

The model 200-C488 interface is priced at \$1,000.00.—**Bertan Associates, Inc.**, 3 Aerial Way, Syosset, NY 11791.

SATELLITE RECEIVER, the System 70, features detent tuning, polarity control, a signal-strength meter, built-in modulator, scan tuning, and wide and narrow audio-filters. It is available either as the standard model 70x or the stereo version,



CIRCLE 126 ON FREE INFORMATION CARD

model 70s, which decodes both matrix and discrete stereo sound.

The System 70x is priced at \$750.00; the System 70s costs \$900.00.—**Lowrance Electronics, Inc.**, 12000 E. Skelly Drive, Tulsa, OK 74128. **R-E**

BK PRECISION OSCILLOSCOPES

Fall Specials!



THE SCOPE!

~~REG \$1995~~

**100 MHz 8-TRACE
4 CHANNEL
DUAL TIME
MODEL 1590P**

- 100 MHz response and 3.5ns rise time
- 120 MHz response at -6dB • 1mV/division sensitivity to 100 MHz • 500mV/division cascade sensitivity • 2ns/division sweep rate with 10x magnifier • Four-input operation provides trigger views or four separate inputs • Selectable 1M Ω or 50 Ω inputs
- Alternate timebase operation • 20 MHz bandwidth limiter for best view of low frequency signals • Lighted function pushbuttons employing electronic switching with non-volatile • Includes probes

Now \$1489⁹⁵



GOODBYE HITACHI!

~~REG \$1595~~

**100 MHz, DUAL
TRACE, DUAL
TIME BASE
MODEL 1580**

- 1 mV/div sensitivity • 23 calibrated sweeps • Rectangular CRT with internal graticule and scale illumination • Signal Delay Line • Video Sync Separators • 20 MHz Limiter • X-Y Operation • Z axis Input • 16 kV Accelerating Voltage • X10 Sweep Magnification • Delayed Sweep/Dual Time Base • Single Sweep • V Mode — display two signals unrelated in frequency • Sum and Difference Capability • Channel 1 Output • Includes Probes

Now \$1199



VIDEO & COMPUTER!

~~REG \$1750~~

**60 MHz TRIPLE
TRACE
MODEL 1560P**

- 1 mV/div sensitivity • 22 calibrated sweeps • Rectangular CRT with internal graticule and scale illumination • Signal Delay Line • Video Sync Separators • X-Y Operation • Z Axis Input • 16 kV Accelerating Voltage • X10 Sweep Magnification • Delayed Sweep/Dual Time Base • Single Sweep • Auto Focus • V Mode — displays two signals unrelated in frequency • Sum & Difference Capability • Includes Probes

Now \$899⁹⁵



VIDEO!

~~REG \$950~~

**40 MHz DUAL
TRACE
MODEL 1540P**

- 1mV/div sensitivity • 21 calibrated sweeps • Rectangular CRT with internal graticule and scale illumination • Signal Delay Line • Video Sync Separators • X-Y Operation • Z Axis Input • 12 kV Accelerating Voltage • X10 Sweep Magnification • Delayed Sweep/Dual Time Base • Single Sweep • Auto Focus • V Mode — displays two signals unrelated in frequency • Sum & Difference Capability • Channel 1 Output • Includes Probes

Now \$799⁹⁵

OMNITRON

ELECTRONICS
770 Amsterdam Ave., New York, NY 10025

■ Write for FREE 112 page Catalog ■

SHIPPING CHARGES

For Orders	ADD
\$25-100	\$6.50
\$100 - \$500	\$8.50
\$500 - \$750	\$10.50
\$750 - and up	\$15.00
Parcel Post	\$20.00

MASTER CARD • VISA

Send Purchase Order. Check. Money Order or C.O.D.

or Call Toll Free
800-223-0826
in N.Y. State (212) 865-5580

CIRCLE 90 ON FREE INFORMATION CARD

BUILD THIS

SONIC MOTION DETECTOR

Here's a unique project that uses sound to detect motion. Use it with a burglar alarm, a door opener, or in a number of other applications.

DAVID M. BENZEL

IN THIS ARTICLE, WE'LL BE LOOKING AT A low-cost motion-detector sensor suitable for a wide variety of applications. Among other things, the project can be used to detect intruders, turn on the lights when someone enters a room, or open a door when it is approached. Presently, five of the units, controlled by a KIM computer, are being used in various rooms of the author's home as a burglar alarm system. They have been in use successfully for over a year.

Theory of operation

The theory behind this project is not new. In fact, the original idea for it came about while discussing police-radar fundamentals. The basic principle behind the operation of both police radar and this project is the doppler shift. Most people have observed that effect at one time or another. Remember that train whistle or car horn that sounds high pitched while coming toward you, and drops to a lower pitch as it moves away? That phenomenon is caused by the doppler shift, and the change of frequency of the sound can be expressed mathematically for reflection from a moving object as follows:

$$f_R = f_S \frac{V_M}{V_M \pm V_O}$$

where f_R is the frequency of the return wave, f_S is the frequency of the source wave, V_M is the velocity of a sound wave at 70°F at sea level and is equal to 1119 feet/second, and V_O is the velocity of the moving object.

That same formula applies to any type of wave by substituting the correct V_M ; i.e. for radar using radio waves, V_M is 186,300 miles per second. The above formula simply means that if a wave of known frequency is sent out, the reflected wave will be different in frequency if the reflecting object is moving. Therefore by having a device that is able to determine if

the reflected wave is different in frequency from the one sent out, moving objects in the range of the device can be detected.

The above formula provides important information for the choice of bandwidths and cutoff frequencies. The value for f_S for the project was chosen as 17 kHz because that is about where the inexpensive tweeters used start to roll off and because that frequency is inaudible, or barely au-

several component values in the circuit. Referring to Fig. 1, a block diagram of the circuit, the high-frequency bandpass amplifiers must be able to pass frequencies from about 16.5 kHz to 17.5 kHz while attenuating all other frequencies. They must be able to pass and amplify the source and reflected frequencies, while rejecting other tones such as talking, outside noise, etc. The low-frequency amplifier must be able to pass the frequencies of 17.2 kHz - 17.0 kHz and 17 kHz - 16.8 kHz, or frequencies from 0 to 200 Hz.

The amount of audio power needed to drive the transmitter and amount of amplification needed in the receiver, were determined experimentally. Incidentally, be sure to use high-frequency tweeters capable of operating at 17 kHz. Do not substitute small radio replacement-speakers, as they generally do not have the proper frequency response. The project was almost abandoned in its early stages, due to insufficient sensitivity of those small speakers.

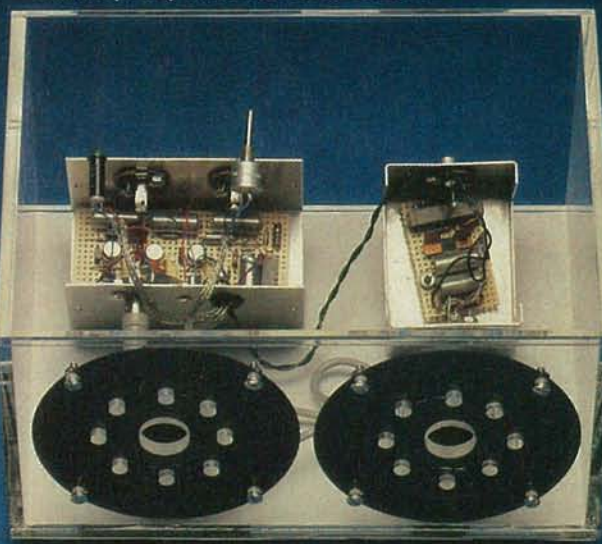

dible, to most people.

Seven miles-per-hour (or ten feet-per-second) is a reasonable maximum speed for a walking person. Substituting those values in the above equation, we can find the range of return frequencies. If moving toward the source:

$$f_R = 17,000 \times \frac{1119}{1119 - 10} = 17153.9 \text{ Hz}$$

If moving away from the source:

$$f_R = 17,000 \times \frac{1119}{1119 + 10} = 16849.4 \text{ Hz}$$

The above values are used to determine

Circuit description

The circuit operates in a fairly straightforward manner. Turning first to the receiver (see Fig. 2), the first stage is a high-Q, high-gain bandpass amplifier. It provides a voltage gain of about 100. The active-filter components were scaled to 17 kHz and bandpass characteristics suitable to pass the desired 16.5 kHz to 17.5 kHz, while maintaining high attenuation at higher and lower frequencies. Note the decoupling circuit at R2 and C1, used to ensure stability and to isolate the op-amp from any supply noise. Capacitor C2 is

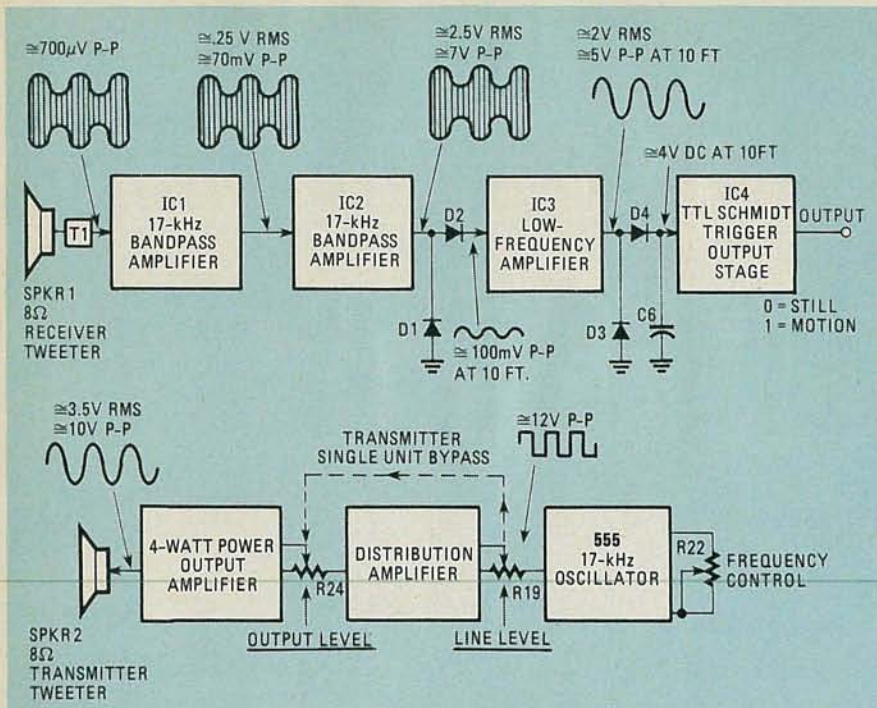

FIG. 1—BLOCK DIAGRAM of the sonic motion-detector system. Voltages given assume an object located 10 feet away.

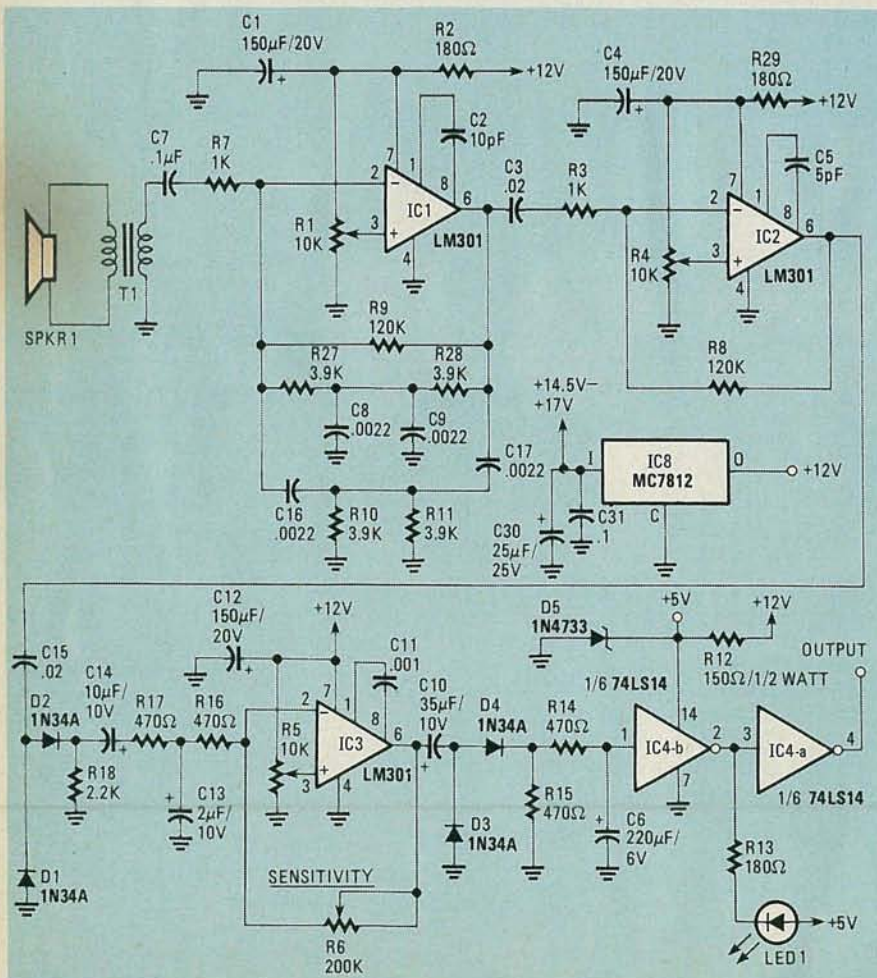

FIG. 2—A TWEETER, SPKR 1, is used as a sound-detection element by the receiver as shown in this schematic.

used to set the high-frequency rolloff characteristics of the op-amp and helps prevent IC1 from oscillating. Integrated circuit IC1 should be a fairly high-frequency op-amp; the same holds true for IC2 and IC3. If you are substituting a device other than the one specified, check the manufacturer's data sheet to be sure it has sufficient gain at 17 kHz. Impedance matching and voltage step-up between the tweeter (used here as a sound detector rather than a sound source) and the first stage is done by T1, an 8-ohm/1000-ohm audio transformer. That transformer is placed in the circuit so that the 8-ohm side is connected to the speaker.

The second stage is a high-frequency amplifier with a gain of about 100. Low-frequency attenuation is provided by C3 and R3. High-frequency attenuation and stability is provided by C5. Power-supply decoupling is taken care of here by R5 and C4. The magnitude of the received 17-kHz signal at this point should be about 4 to 8 volts P-P.

If there is a moving object in the range of the device, there will be another frequency present at the output of that stage. In addition to the 17 kHz being reflected from the walls, doors and other stationary objects, there is also a weaker signal whose frequency is determined by the speed of the moving object. Those two signals (a strong 17-kHz signal and a weaker \pm doppler signal) appear as an amplitude-modulated waveform. Germanium diodes D1 and D2 are used to detect that AM signal, much like a crystal radio.

The third stage is a variable-gain low-frequency bandpass amplifier that rolls off slowly below 15 Hz and above 200 Hz. Those frequencies represent the average range of doppler-shifted frequencies as determined earlier in the article. That stage uses a potentiometer, R6, to control unit sensitivity; it varies gain from 1 to about 200. The output of that stage should be about 5 volts P-P, if there is motion in the range of the device.

That AC signal is rectified by D3 and D4. The DC produced by those diodes is fed to an integrator. The integrator makes sure that motion is detected for about two-tenths of a second before setting off the Schmitt trigger (the fourth stage). That ensures that random system noise and room noise will not trip the unit. In addition, by placing C6 on the input of the TTL Schmitt trigger, the unit will always power up in the "not tripped" or still mode.

The transmitter circuit (see Fig. 3) is quite simple in operation. A 555 timer is used as an oscillator to produce the 17-kHz carrier. It is a good idea to use a polystyrene capacitor for C26 (the .01 μ F

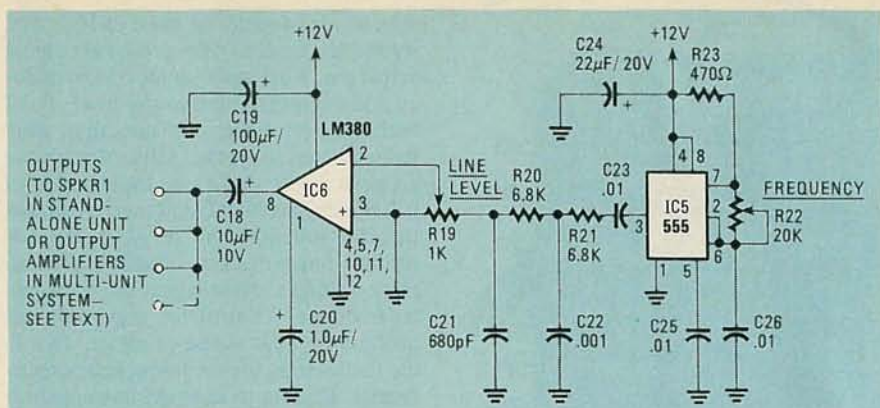

FIG. 3—THE OUTPUT OF the LM380, IC1, is used to either drive a speaker in a stand-alone system, or an output amplifier in a multi-unit system.

in the 555-oscillator timing circuit) to reduce frequency drift with temperature. The signal can take one of two paths after that depending on whether a single- or multiple-unit setup is involved.

In single-unit systems, a 555 timer and a single LM380, or other suitable audio power-amplifier, are used to drive the tweeter directly (see Fig. 3). An LM380 is a high-gain audio-power amplifier capable of producing about 3 watts of audio power. Other desirable characteristics of that amplifier are that it requires only one power supply, and its inputs are ground referenced.

In the author's set-up, which uses units in five different rooms, the LM380 shown in Fig. 3 serves as a distribution amplifier. Its output is fed to a second LM380, which serves as an output amplifier, in each unit (see Fig. 4).

The project requires 12 volts. Here, that voltage was derived by feeding 14.5–17 volts from a wall-plug supply to a 12-volt regulator housed in the receiver case.

One problem with that set-up is that the system becomes disabled if power in the house is interrupted. A solution to that problem is to supply a battery back-up as shown in Fig. 5. The circuit shown in that figure will enable B1, a battery pack made up of 10 NiCd cells in series, to cut in any time that power is interrupted. It will also trickle charge the cells so that the batteries will not become depleted during the long (hopefully!) periods between uses.

Construction

Although there is little that is critical about the circuit, good construction practices should be followed. The author's prototypes were built on perforated construction board and point-to-point wiring was used with good results. Figure 6 shows the receiver and output-amp board layout used by the author. Note that R6 and LED1 are brought outside of the box housing the receiver circuit and are cemented to the cover of that box. Also 1/8-watt resistors were used in the prototype. As those resistors can be difficult to come

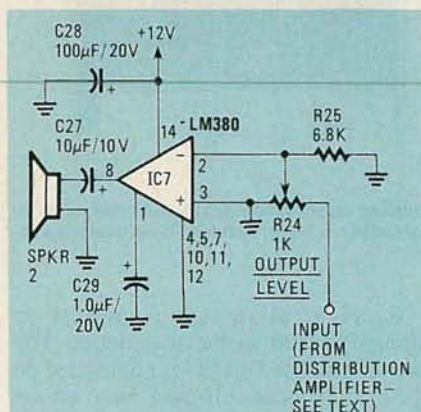

FIG. 4—IN MULTI-UNIT SYSTEMS, only a single oscillator/distribution-amplifier is used. The output from that circuit (shown in Fig. 5) is fed to an output amplifier, such as the one shown here, located in each unit.

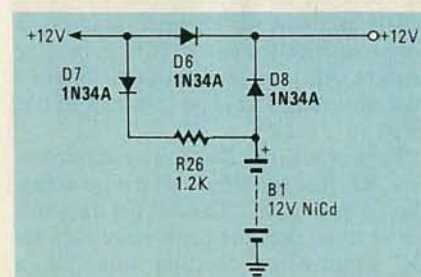

FIG. 5—A BATTERY BACK-UP will keep the system active in case of a power interruption.

by, we suggest using 1/4-watt units instead.

Here are some tips: The ground leads should be of heavier wire to reduce inductance. Make an attempt to separate inputs from outputs on the gain stages. Keep leads short. Make absolutely sure to use a regulated, filtered power supply as shown; remember, the three stages have a combined gain of around 1,000,000. It is a good idea to house the receiver in a shielded box separate from the transmitter. And be sure to use shielded cable from the tweeter to the receiver.

Common parts are used in this design, and they are easy to obtain from a number of sources. Where performance would not

PARTS LIST

All resistors 1/4-watt, 10% unless otherwise noted

- R1, R4, R5—10,000 ohms, trimmer potentiometer
- R2, R13, R29—180 ohms
- R3, R7—1000 ohms
- R6—200,000 ohms, potentiometer
- R8, R9—120,000 ohms
- R10, R11, R27, R28—3900 ohms
- R12—150 ohms, 1/2 watt
- R14—R17, R23—470 ohms
- R18—2200 ohms
- R19, R24—1000 ohms, multi-turn trimmer potentiometer
- R20, R21, R25—6800 ohms
- R22—20,000 ohms, multi-turn trimmer potentiometer
- R26—1200 ohms

Capacitors

- C1, C4, C12—150 μ F, 20 volts, electrolytic
- C2—10 pF, ceramic disc
- C3, C15—.02 μ F, ceramic disc
- C5—5 pF, ceramic disc
- C6—220 μ F, 6 volts, electrolytic
- C7—0.1 μ F, ceramic disc
- C8, C9, C16, C17—.0022 μ F, polystyrene
- C10—35 μ F, 10 volts, electrolytic
- C11, C22—.001 μ F, ceramic disc
- C13—2 μ F, 10 volts, electrolytic
- C14, C18, C27—10 μ F, 10 volts, electrolytic
- C19—100 μ F, 20 volts, electrolytic
- C20, C29—1 μ F, 20 volts, electrolytic
- C21—680 pF, ceramic disc
- C23, C25—.01 μ F, ceramic disc
- C24—22 μ F, 20 volts, electrolytic
- C26—.01 μ F, polystyrene
- C28—100 μ F, 20 volts, electrolytic
- C30—30 μ F, 25 volts, electrolytic

Semiconductors

- IC1—IC3—LM301 operational amplifier
- IC4—74LS14 hex Schmitt trigger
- IC5—555 timer
- IC6, IC7—LM380 operational amplifier
- IC8—MC7812 12-volt regulator
- D1—D4, D6—D8—1N270 or 1N34A
- D5—1N4733 Zener
- LED1—green LED with holder (Radio-Shack 276-019 or equivalent)
- T1—transformer, 1000-ohm primary, 8-ohm secondary (Radio-Shack 273-1380 or equivalent)
- SPKR1, SPKR2—tweeter (Radio-Shack 40-1270 or equivalent)

Miscellaneous: Perforated construction board, metal project boxes (2), cabinet materials (see text), wire, solder, etc.

be compromised, the least expensive suitable components were used. With careful shopping, the cost of building a unit should run about \$35.00, or less if you have a well stocked junkbox.

The cabinet shown here and on the cover was made out of acrylic plastic for appearance reasons. The author's prototypes, however, were made from plywood, which is cheaper and easier to work with. When you make your cabinet, be sure that it is large enough to accommodate the two tweeters and the two boards. The tweeters can be mounted on the front panel of the cabinet with either

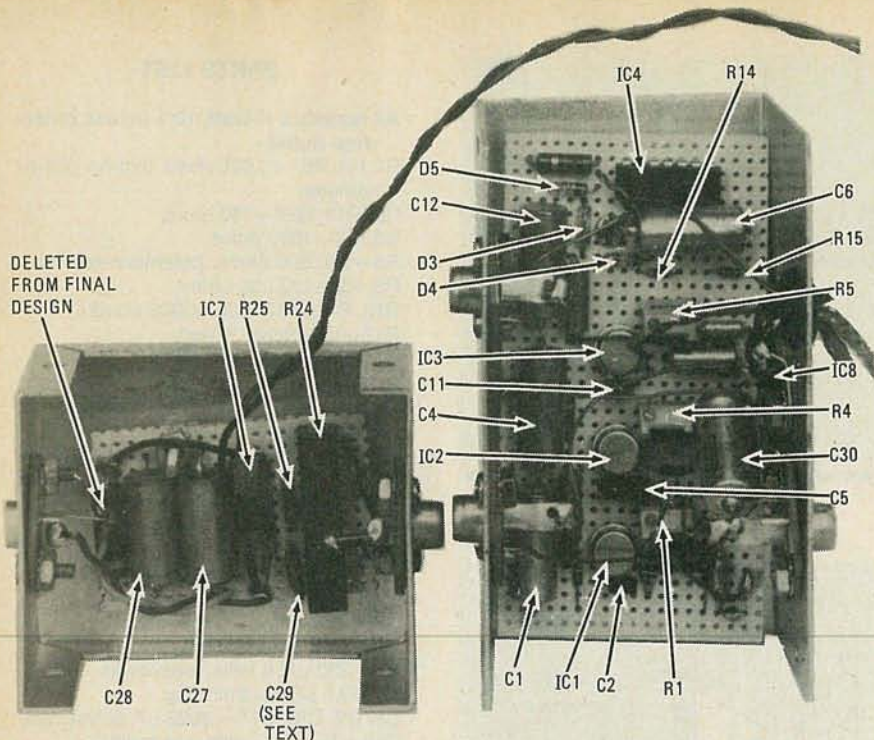

FIG. 6—THE AUTHOR'S PROTOTYPE was built on perforated construction board. Note that the unit shown here, the receiver/output-amplifier combination used in multi-unit systems, is a prototype and differs slightly from the final design.

screws or glue. Be sure to cut holes out of the front piece to allow sound to leave or reach the tweeters unimpeded.

Circuit alignment

The easiest way to align the circuit is with an oscilloscope, although it can also be done with a VOM or VTVM.

Let's first check out the transmitter, referring back to Fig. 3 as we go. Power up the transmitter with the speaker connected. If the circuit is operating, there is a good chance a loud high-pitched tone will be emitted from the tweeter, so you may want to do this part of the checkout in a secluded part of your house! Connect your test instrument to pin 3 of the 555 timer. If using a scope, you should see a 12-volt P-P squarewave. If using a VOM, you should see about 6 volts on the DC scale. Moving on to the output of the LM380, connect to the speaker side of the output coupling capacitor. When using a scope, you should see a fairly distorted sinewave of about 10-volts P-P. If using a VOM, there should be about 3.5 volts on the AC scale. The level control of the line driver and/or output amplifier should be adjusted to obtain the above values. If you have a frequency counter, adjust the frequency potentiometer to get about 17 kHz. If you don't have a counter, a rough adjustment can be made by turning the frequency potentiometer so that a loud high pitched tone is heard. Then adjust the potentiometer so that the tone gets higher in frequency. Continue turning the pot until you can barely hear the tone produced. For the average ear, you should now be adjusted to around 17 or 18 kHz.

Receiver alignment is almost as straightforward as the transmitter. You probably noticed that T1 is not located on the receiver board. To save room on the circuit board, it is mounted on the receiver tweeter. Connecting the receiver tweeter to the receiver board and applying power to the unit, we are ready to proceed. Note: to align the receiver, the transmitter must be operating as it is the signal source. It will help to have both tweeters pointing in the same direction and away from moving objects. Also, try to point them toward a wall or surface that is no less than 10 feet away.

First of all, the DC-level potentiometers, R1, R4, and R5 on all the op-amps, should be adjusted. Disable the transmitter for those measurements since they are DC adjustments. Starting with IC1, a scope or meter should be connected to pin 6 of each respective op-amp. Adjust IC1 and IC2 to read about 5.25-volts DC. Adjust IC3 to get about 6-volts DC.

Now turn on the transmitter. Looking at signal at pin 6 of IC1 with a scope, you should see some indication of a 17-kHz sinewave. You should be able to see some small amount on the AC scale of your VOM or VTVM. Depending on your meter, you may need to put a 1- μ F capacitor in series with the meter to block the DC level at the measurement points. If you see no signal at that point, it is time to adjust the transmitter frequency to obtain maximum signal. It will help to point the transmitter tweeter directly toward the receiver tweeter.

Assuming you have a 17-kHz signal at IC1, we can now check out IC2. Connect

your scope or meter to pin 6 of IC2. You should see several volts of 17-kHz signal at that pin. Next we'll set the 555 frequency and the transmitter-output level. Point both speakers in the same direction, away from nearby objects. Observing your scope or meter, make sure the signal level is less than 7-volts P-P on the scope or less than 2.5-volts RMS on the AC meter. Adjust the transmitter-level control to obtain those voltages. Now adjust the transmitter-frequency control for maximum indication on your scope or meter. That is the final setting for the frequency potentiometer. Be sure to have the level potentiometer set for about 7- volts P-P at IC2. It is interesting at this point to observe the amplitude modulation of the 17-kHz signal that is caused by movement.

On to the final amplifier stage. Detector diodes D1 and D2 and the following low-frequency bandpass filter feed a signal to IC3 that is proportional to the low-frequency amplitude variations of the 17-kHz carrier. IC3 amplifies that voltage to a useful level. Connect your scope or meter to pin 6 of IC3. With the sensitivity control set to mid-range, you should see about 1-volt P-P or $\frac{1}{3}$ -volt RMS, which represents circuit noise etc. Moving your hand in front of the speakers should cause the output of this stage to hit both rails. Your scope should see a squarewave down to about 1 volt and up to about 11 volts when a moving object is near the tweeter. An AC voltmeter should see greater than 3 volts with nearby movement.

The last stage of the receiver is a 74LS14 Schmitt trigger, IC4. Its signal comes from diodes D3 and D4, which rectify the low-frequency AC of the previous stage. The output of the diodes is connected to an integrator, which is connected to the input of the 74LS14. If all is well, when the voltage at that point reaches about 1.7 volts, pin 4 of IC4 will go high and LED1 will light, indicating movement in front of the detector.

Interfacing

Interfacing the unit to the outside world is a matter of preference. Using an intruder alarm as an example, the easiest way to do something useful with the circuit would be to connect the output directly to a "noise maker" of some type. You would probably want to have an outside hidden or key switch to turn the unit on or off.

A more sophisticated approach would be to drive a one-shot (possibly made from the unused sections of the 74LS14 and some capacitors) to keep the alarm on for a minute or so to ensure that the intruder leaves! In the author's home, a KIM computer and interface provides power and monitors the outputs of five units. A one-key code on the KIM keypad enables the units when the house is empty, and a six-key code turns off the units when the house is occupied.

R-E

Electronic Measurements In Medicine

Ray Fish, Ph.D., M.D.

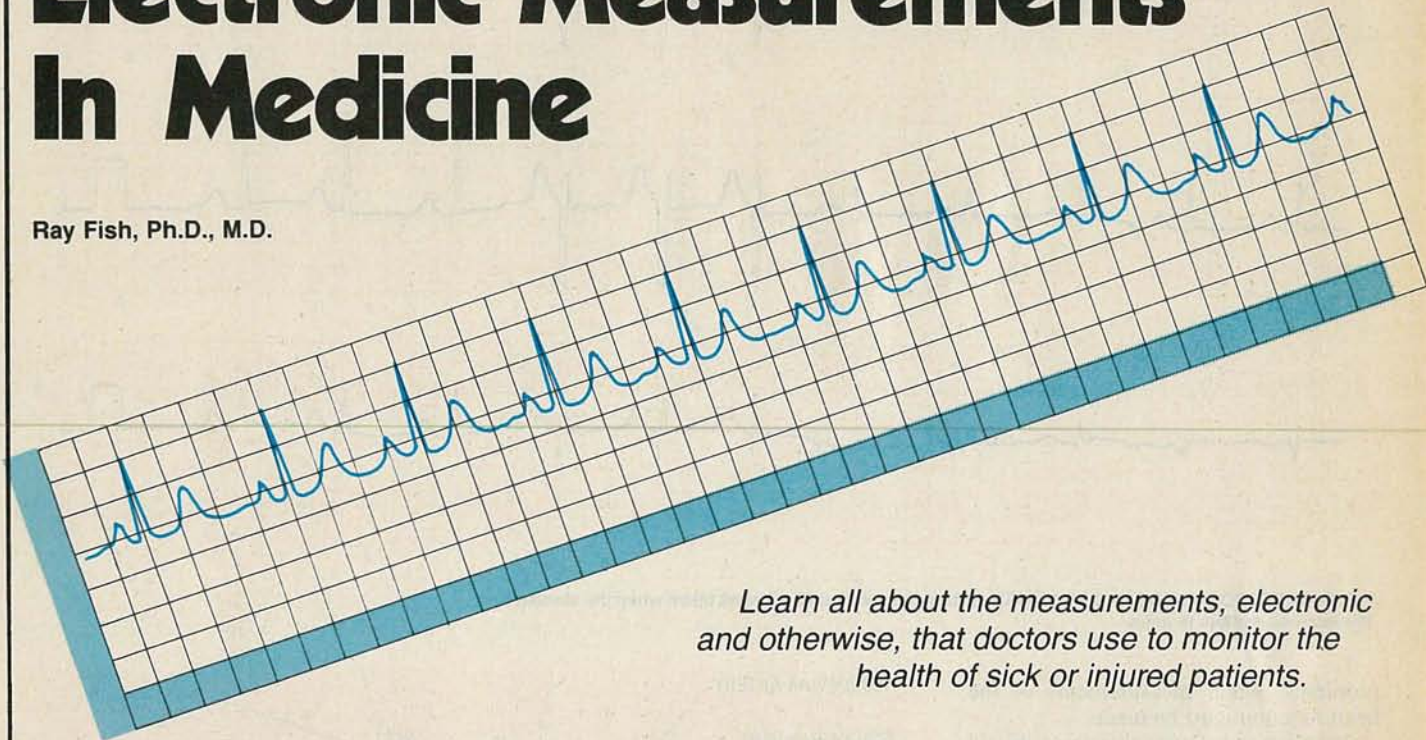

Learn all about the measurements, electronic and otherwise, that doctors use to monitor the health of sick or injured patients.

A VARIETY OF ELECTRONIC MEASUREMENTS are made on people who are ill or injured. Those measurements tell the physician, nurses, and other health-care personnel much needed information about the condition of the patient that would not be obvious from outward appearances. This article will discuss some of the measurements that are routinely used in many hospitals today.

The first article in this series described the anatomy (structure) and physiology (function) of the heart. The manner in which electrical signals originate in heart cells and cause contraction of heart muscle was described. Problems with heart rhythm, including cardiac arrest, were discussed. This article will go into more depth in telling how electronic instruments are used to measure the effectiveness of cardiac (heart) and pulmonary (lung) functions. The importance of measuring blood pressure, as well as blood flow, pH, and gas content in various parts of the body will be explained. The techniques used for measuring those and other physiological parameters will be examined.

The electrocardiogram

The electrocardiogram is a record of a voltage that's obtained by connecting wires (electrodes) to a person's chest, arms, and legs. That voltage is generated

by heart-muscle cells. Much about the functioning of a person's heart can be learned by studying the electrocardiogram.

Figure 1 shows a standard, normal electrocardiogram. Twelve different voltages are recorded, being measured from standard combinations of 10 electrodes placed at prescribed locations on the skin surface (a subject to be explained in another article). Three types of problems caused by the recording equipment can be seen here. In traces I (Fig. 1-a to Fig. 1-d) and III (Fig. 1-i to Fig. 1-l), high-frequency signals from muscle tremor can be seen. In Fig. 1-f, the baseline is not positioned properly, leading to pinning of the pen at the bottom of the tracing. In Fig. 1-k, the baseline has shifted at A, possibly due to movement of the electrode. The square pulse at the end of the tracings (Fig. 1-d, Fig. 1-h, and Fig. 1-l) is a 1-millivolt calibration signal. Modern electrocardiograph machines will print out the 12 tracings, as shown in Fig. 1, after the electrodes are connected and one button is pressed. The signals can be interpreted by a computer with surprising accuracy.

With myocardial infarction (a heart attack), one of the arteries that supply blood throughout the thickness of the heart muscle becomes blocked. That blockage causes a lack of oxygen and nutrients in a portion of the heart muscle. The injured

cells may not conduct electrical signals (may not depolarize) as they should. At other times, the injured cells become irritable and depolarize more frequently than they should. Thus, a signal to depolarize may be blocked. Also, extra signals may cause inappropriate contractions and harmful signals to propagate throughout the heart muscle.

Similar problems can occur with any condition that interferes with oxygen or blood supply to the heart. Thus, the heart will often develop unusual rhythms (dysrhythmias or arrhythmias), function weakly, or stop when there is lack of oxygen. Lack of oxygen may occur due to poor breathing, drugs, head injury, chest injury, drowning, or lung trouble. Arrhythmias can also occur as a result of injury to the heart, blood loss, or dehydration (depletion of body water). The heart's electrical function and strength are also predictably affected by an imbalance of salts and other substances in the blood such as calcium and potassium. Many drugs affect the electrical function of the heart.

The electrocardiogram is one means of electronically monitoring the patient with a myocardial infarction or other heart problem. The electrocardiogram does not tell the whole story, however. Sometimes the electrocardiogram will look normal but the person will be having significant

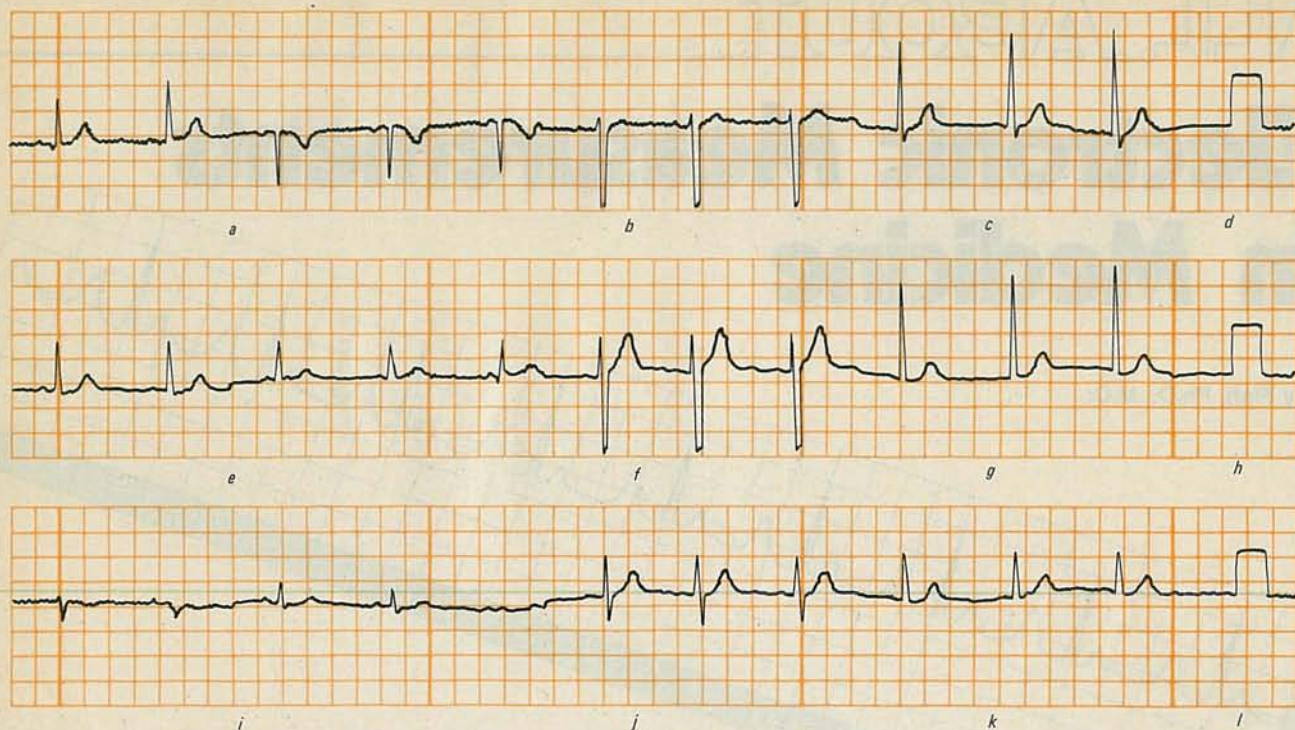

FIG. 1—ELECTROCARDIOGRAM TRACINGS. Shown here are the 12 voltages taken when the standard 10-electrode system is used.

problems. Other measurements of the heart function must be made.

The heart is the pump that moves blood throughout the body. As shown in Fig. 2, the heart receives blood from the body. Blood from the top half of the body comes to the heart through the superior vena cava. Blood from the bottom half of the body comes from the inferior vena cava.

Figure 3 shows a chest X-ray in which an intravenous catheter has been placed through the subclavian vein into the superior vena cava. The catheter is a plastic tube that is connected to a bag of sterile fluid (see Fig. 4). A manometer (calibrated plastic tube) connected to the intravenous tubing can be used to measure the pressure in the superior vena cava. An electronic pressure transducer can also be used, as shown in Fig. 4. The pressure measured is referred to as the central-venous pressure (CVP). In a person who is dehydrated or has been bleeding, one would expect that blood return to the heart will be decreased, and the central-venous pressure will be low. If a person had received too much intravenous fluids, or if the heart is too weak to pump out the blood returning to it, the central-venous pressure will be abnormally high. The central-venous pressure is normally 5 to 12 centimeters of water. The measurement is made with the person laying down, using the level of the right atrium as the zero-pressure level.

After returning to the heart, blood first goes into the right atrium. The right atrium is the first of the four compartments, or "chambers" of the heart

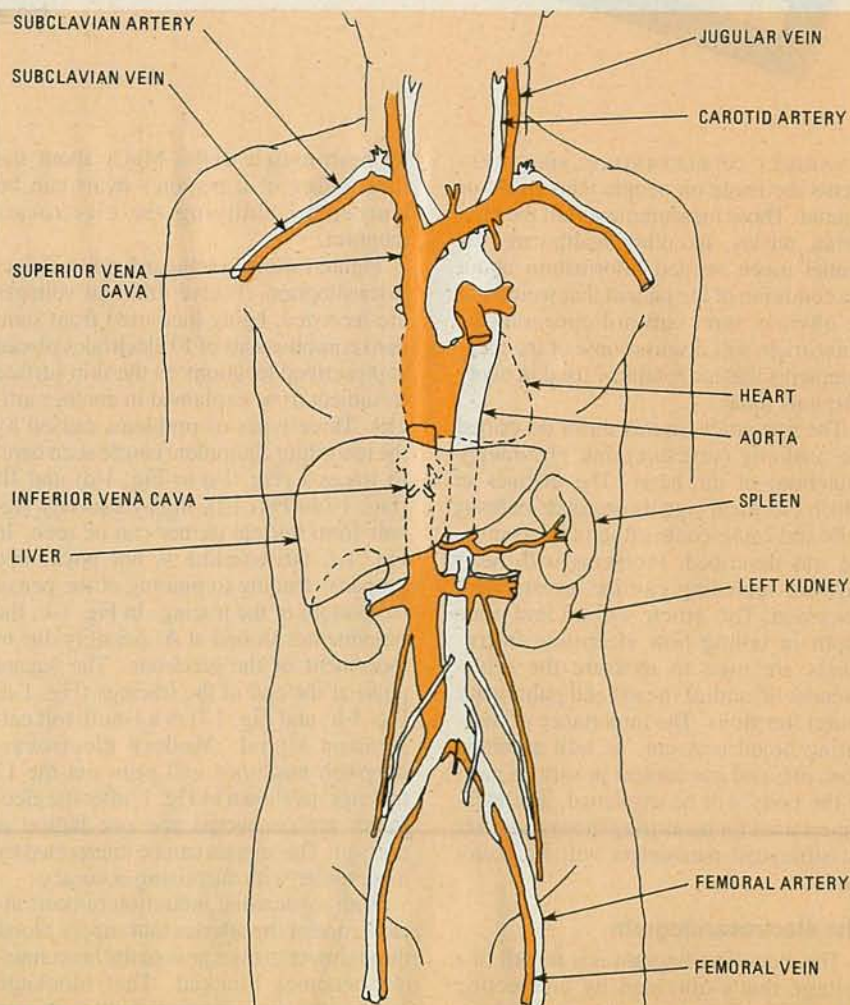

FIG. 2—CIRCULATORY SYSTEM. Some of the major arteries and veins that carry blood throughout the body are shown here.

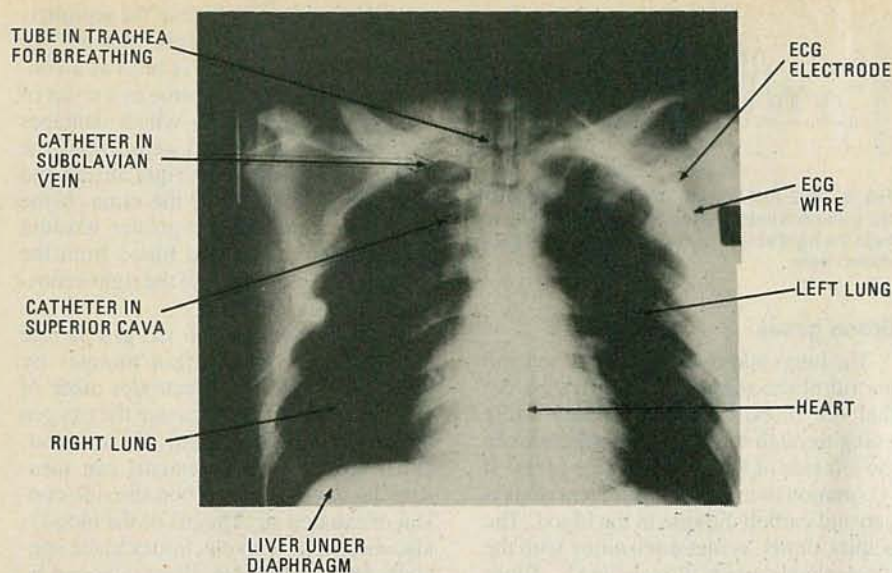

FIG. 3—THIS X-RAY shows an intravenous catheter that has been placed through the subclavian vein into the superior vena cava.

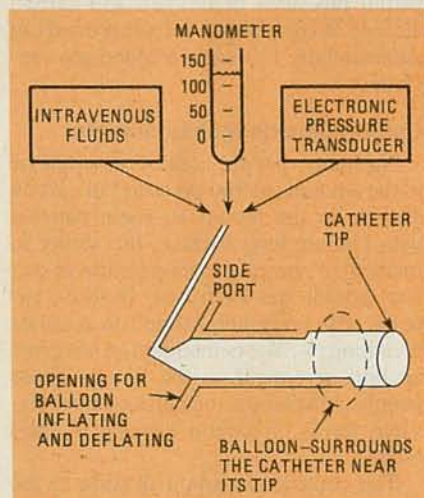

FIG. 4—CROSS-SECTIONAL DIAGRAM of an intravenous catheter. Pressure measurements and blood samples can be taken from the side port or the tip.

through which the blood will pass. Blood goes from the right atrium to the right ventricle. The tricuspid valve keeps the blood from flowing backward. The right ventricle will pump blood to the lungs.

Pulmonary-artery wedge pressure

If a catheter was inserted in the superior vena cava and advanced further, it would go into the right atrium, the right ventricle, and eventually through the pulmonary artery. The catheter would wedge in one of the smaller branches of the pulmonary artery (see Fig. 5). If a balloon near the tip of the catheter were inflated, the pressure measured in that wedge position, the "pulmonary-artery wedge pressure," would be indicative of pressures in the left atrium and left ventricle. Commercially available catheters are used to make those measurements and to obtain blood samples from various locations along the length of the catheter by means of multi-

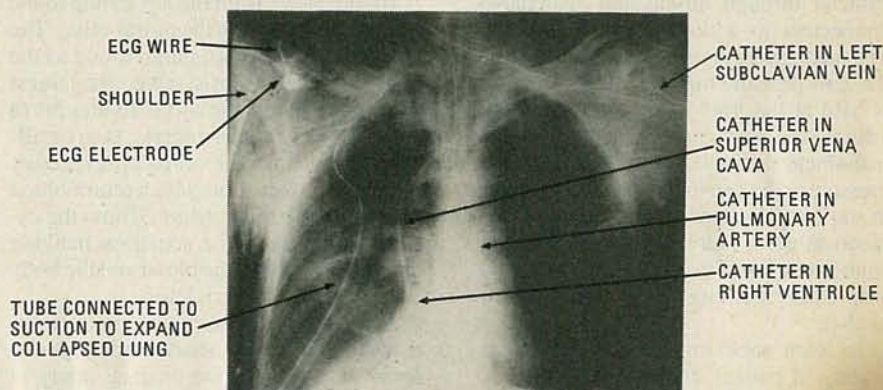

FIG. 5—THE CATHETER in this X-ray has been placed wedged in one of the smaller branches of the pulmonary artery in order to measure the pulmonary-artery wedge pressure.

ple channels (side ports) within the catheter.

The pulmonary-artery wedge pressure measurement is valuable in patients with myocardial infarction because in such patients it often happens that the left ventricle does not function strongly enough to pump blood out of it. The pressure in the lungs becomes abnormally high, although this might not be reflected in the central-venous-pressure measurements. It is important to notice as early as possible when the wedge pressure becomes high, as high pressures will lead to the leakage of fluid into the lung tissue. The fluid leaks into the lung tissue because of the high pressure and interferes with oxygen intake and carbon-dioxide removal from the blood. The condition of fluid in the lungs is common in heart attacks, but occurs at other times also. The condition is known as congestive heart failure or pulmonary edema.

At times, a person with a suspected myocardial infarction will have a low blood pressure. It may be that the left ventricle is simply too weak to produce a normal blood pressure. In that case, giv-

ing additional intravenous fluids will just put more of a load on the heart, leading to pulmonary edema. On the other hand, in other patients with myocardial infarction and low blood pressure, the reason for the low blood pressure is that the person is dehydrated. That person needs to be given fluids.

Dehydration is a lack of fluids in the body and can be caused by a number of conditions that accompany myocardial infarction (and many other illnesses); those conditions include sweating, decreased liquid intake due to nausea or being too weak to eat and drink, and losses due to vomiting. Dehydration can be made worse if the person is taking blood-pressure medication (diuretics or "water pills") that causes increased urination.

The central-venous pressure measurement will not always be sufficient to determine if there is fluid overload or dehydration. The reason for that is that some

people with lung disease chronically have higher than normal central-venous pressures, even when they are somewhat dehydrated. In other patients, with normal central-venous pressures, the overload of the weakened left ventricle is not reflected in the central-venous pressure measurement early on because the right ventricle is functioning well.

In the patient with suspected myocardial infarction and low blood pressure, giving fluids can be harmful or can be of great help. Whether fluids are needed or not can be determined by measuring the pulmonary-artery wedge pressure. If the pressure is low, it is an indication that the left ventricle is not pumping out enough blood because there is not enough blood going to it. More fluids would help this situation. If the pressure is high or normal, it indicates that additional fluid would just overload the left ventricle more; the problem is a weak left ventricle. Thus, measurement of the pulmonary-artery wedge pressure can tell the physician whether the patient needs more or less fluids to correct the low-blood pressure.

Measurement of the pulmonary-artery

wedge pressure is accomplished with a catheter placed as shown in the chest X-ray in Fig. 5. The end of the catheter outside the body is connected by a saline filled tubing to a pressure transducer. The pressure waveforms occurring with each heartbeat as the catheter moves from the right atrium to the pulmonary artery are shown in Fig. 6. The pressure is measured in mmHg (millimeters of mercury). When the end of the catheter is wedged into a small branch of the pulmonary artery, the balloon at the end of the catheter is inflated. The resulting pressure is the pulmonary-artery wedge pressure.

Figure 4 shows how measurements are actually made using a catheter. Catheters used to measure the pulmonary-artery wedge pressure have several channels. However, even if the catheter had just one channel, it would be suitable for giving fluids, drawing blood samples, and measuring pressures. The pressure measurement can be made by connecting the catheter through tubing and switchable connectors to a fluid-filled manometer. The manometer is simply a plastic tube. If the zero-pressure mark on the manometer is held at the level of the patient's right atrium (the mid chest), the fluid in the manometer will rise to a level equal to the pressure at the end of the catheter which is in the body. Instead of a manometer, an electronic pressure-transducer can be connected. Oscilloscope monitoring and strip-chart recording of pressures can then be done.

To learn about cardiac function in an acutely ill patient, the blood pressure is often measured in the superior vena cava, and in the pulmonary and systemic arteries. The systemic arteries are the branches from the aorta, such as the femoral or radial (wrist) arteries. Those measurements are done with catheters similar to that shown in Fig. 4.

Cardiac output measurements

The actual function of the heart can be determined by measuring the cardiac output; the blood flow coming from the heart as measured in liters-per-minute. The measurement of cardiac output can be accomplished by injecting a known amount of sterile solution of known temperature into the right atrium or superior vena cava and measuring the resultant change in the blood temperature in the pulmonary artery. The change of temperature over time is measured by a thermistor near the tip of the catheter. The change in temperature over time will depend on the amount of blood flowing. Calculations are made by a "cardiac-output computer" using the data from the thermistor. That is known as the thermodilution technique of measuring cardiac output. A dye-dilution technique involves injecting a colored dye and calculating cardiac output in a similar fashion.

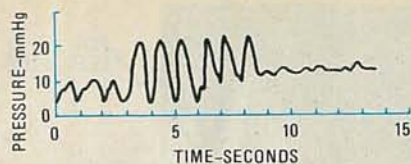

FIG. 6—THE PRESSURE WAVEFORMS that occur with each heartbeat as the catheter is moved from the right atrium to the pulmonary artery are shown here.

Blood gases

The lungs add oxygen to the blood and get rid of the waste gas (carbon dioxide) that the blood had accumulated while going through the body. Blood returns to the left side of the heart from the lungs. It is common to measure the content of oxygen and carbon dioxide in the blood. The acidity, or pH, is measured along with the oxygen and carbon-dioxide levels. Those three measurements are called the "blood gases."

Blood passes from the left atrium to the left ventricle through the mitral valve. The left ventricle can then pump blood to the body through the aortic valve. The largest artery in the body, the aorta, divides into a succession of smaller arteries, then capillaries, then veins. The veins come together to form the great veins which return blood directly to the right atrium. Thus, the cycle is completed. The actual exchanging of oxygen between the blood and the body occurs at the capillary level.

Arterial blood gases are commonly obtained by sticking a needle into the radial artery at the wrist, the brachial artery at the elbow, or the femoral artery at the top of the thigh.

Oxygen measurements

The air we breathe contains 21% oxygen. The brain will be damaged by a lack of oxygen for over five minutes. A low level of oxygen in the blood will cause mental confusion and poor cardiac function. A person may have a low oxygen content in the blood because of injury to the lungs, pulmonary edema, pneumonia, and a variety of other acute conditions. The situation may be worsened if the person has chronic lung disease. It is desirable to give oxygen to a person who needs it, but giving too much oxygen can be harmful; if given 60% oxygen or more for over 24 hours, the lungs will start to be damaged. Just how much oxygen is needed can be determined by measuring the content of blood in the arteries, the arterial blood gases. If a person needs over 60% oxygen, it can be given for a short time or lesser amounts of oxygen can be given under pressure. Also, the underlying problem can be corrected.

Measuring the oxygen content in the right atrium and right ventricle can determine if there is a hole in the wall between the right and left ventricles. The wall is

called the septum. A hole in the septum is called a "ventricular septal defect," or VSD. VSD's can occur at birth as a congenital problem or can come as a result of a myocardial infarction which damages the septum. One would expect that the content of oxygen in the right atrium and right ventricle would be the same. If the content in the ventricle is greater, it would suggest that oxygenated blood from the left ventricle is going into the right ventricle through a VSD.

The measurement of oxygen in the blood can be done within minutes by blood-gas machines. Electrodes made of various materials can measure the oxygen or carbon-dioxide content of the blood. Other electrode arrangements can measure the oxygen and carbon-dioxide content of exhaled air. The pH of the blood is also measured with electrodes made specially for that purpose. Electrodes can be pasted on the skin to measure oxygen content of the blood. Digital readouts of the partial pressures of oxygen and carbon dioxide along with the pH are printed out automatically by modern blood-gas machines.

Carbon-dioxide measurements

Normally, people breathe in response to the amount (partial pressure) of carbon dioxide in the blood. In some patients with chronic lung disease, the ability to maintain a normal partial pressure of carbon dioxide has been lost. In those patients, the body has learned to regulate breathing in order to maintain an adequate amount of oxygen in the blood. Those people with chronic lung disease have elevated levels of carbon dioxide in their blood.

The content of carbon dioxide in the blood gives an indication of the efficiency of breathing. Carbon dioxide diffuses out of the lungs much more easily than oxygen enters, so a person with an acutely high carbon-dioxide level is really having trouble breathing. That can happen in a patient with chest trauma, drug overdose, pneumonia, or pulmonary edema, but probably occurs most frequently in patients with asthma. When an asthmatic tires of breathing and has an even slightly elevated arterial carbon-dioxide level that does not respond to treatment within an hour, the person must be put on a respirator until the condition improves.

Carbon dioxide combines with water to form carbonic acid, which in turn can combine with sodium to form sodium bicarbonate. Those chemicals constitute one of the major acid-base systems in the blood. Decreased breathing will lead to an increased carbon-dioxide level in the blood. That in turn will lead to an acid pH, a pH of less than 7.40. That is referred to as a respiratory acidosis. Let's find out more about acid-base balance in the body.

continued on page 81

THERE'S NO GETTING AROUND THE FACT that as modern electronics becomes more and more sophisticated, batteries have become an increasingly important part of the electronics world. The development of CMOS and all the other low-power technologies have changed even the way we buy batteries—these days, it isn't as easy as just zipping down to the supermarket and pulling the right-sized blister pack from the rack.

Modern batteries come in a mind boggling array of configurations so there are lots of ways you can categorize them. Probably the most basic categories are "throw-away" and "rechargeable." There can be a major difference in cost, capacity, and characteristics between those two types. Deciding which one is best suited to your particular application requires a good understanding of each. This month, we'll look at the throw-away or disposable battery.

Before we go any further, though, we should point out what we mean by the words "battery" and "cell." A *cell* is the basic building block of a *battery*. A battery is generally thought of as a single,

What's New in BATTERIES

Ever since electricity was first discovered, people have been working on ways to store it. Let's take a look at today's battery technology and how you can choose the right battery for your application.

ROBERT GROSSBLATT

integral unit made up of one or more cells. If a single cell is packaged with terminations and insulation (such as a "D" cell), it can be correctly called either a battery or a cell.

Disposable batteries

Disposable (non-rechargeable) batteries are available in a huge range of sizes. And as if that wasn't confusing enough, every one of those sizes is available with a variety of electrochemical systems (what we'll call "chemistries"). And even if the voltages of two batteries with different chemistries are the same, just about every other characteristic—from the power capacity to the price—can be different. Like most things, you get what you pay for—more power means more bucks.

So far I haven't said anything earth-shaking, but let me give it a shot: For some applications, batteries that use the more expensive chemistries won't perform any better than cheaper batteries. As we'll soon see, battery life isn't *always* dependant on the battery type.

The voltage of a disposable battery, no matter what the chemistry, is always stamped on the package. What is (almost) never stamped anywhere is the other essential piece of information you need to be able to make an intelligent choice about which battery to use: that is the amp-hour capacity.

The amount of energy that a battery can deliver (sometimes called its service capacity) is usually expressed in amp-hours, or milliamp-hours. It would be nice if the amount of power available from a battery was a fixed amount, kind of like a pail of water. Unfortunately, things aren't that simple and when you're dealing with batteries of *any* kind, linearity is usually out the window.

How much current you can get from a throw-away battery depends on a number of things:

1. The temperature of the battery.
2. The rate of discharge.
3. The chemistry of the battery.
4. The frequency of use.
5. What you call a dead battery.
6. Other stuff.

In order to give us a starting point, we decided to find the short-circuit current of disposable batteries of different sizes and chemistries. Table 1, which lists short-circuit currents, is the result of sacrificing a bunch of new batteries on the altar of science. Even though you would never use

a battery in a short-circuit situation, we felt that it would be a good starting point for understanding just how much electricity we're talking about.

Of course, Table 1 doesn't list *all* available battery sizes and chemistries, but the batteries listed are the most commonly used. The figures for other battery sizes, such as "AAA" and "N" will be less than those listed for "AA" cells since they're smaller and, consequently, their energy capacity is less.

There are two main things that stand out when you look over Table 1. The first is that the amount of energy stored in any of the batteries is surprisingly large. Second, you can see that the chemistry of the cell makes a tremendous difference to the total amount of energy that you can pack into a battery.

Battery construction

The internal construction of most throw-away batteries is very similar: Basically you have two electrodes separated by an electrolyte. The construction of a typical disposable cell is shown in Fig. 1 and the chemicals used in the various cells are listed in Table 2. The electrolyte used in all the cells has two basic purposes.

First and foremost, it is the current-conducting medium between the electrodes of the cell. But the chemical reaction that produces the current also generates gas as a by-product. The second main job of the electrolyte is to absorb the gas. The warnings on the side of batteries about excessive drain, recharging, and so on are all related to the gas. If gas is produced faster than it can be absorbed by

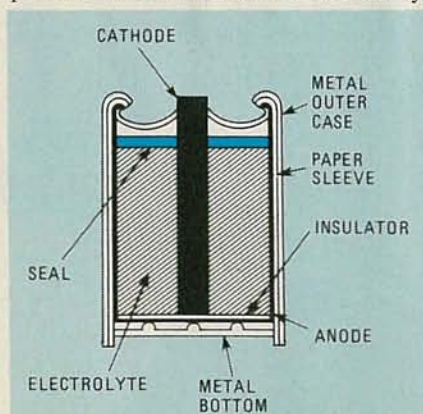

FIG. 1—ZINC-CARBON CELL CONSTRUCTION. This cutaway view shows that the standard cell consists, basically, of two electrodes and electrolyte.

the electrolyte, the battery will explode. It's as simple as that.

The outer cases of all batteries are made out of steel because the gas creates pressure. (Alkaline batteries, as shown in Fig. 2 also have an inner case.) If the jacket warps and destroys the seal of the case, the electrolyte will dry out and that will be the end of the battery. But that's not the only problem. Some of the chemicals used in the cell are dangerous and a blown seal means that they'll leak. Since a lot of battery changing is done by children, it pays to make sure that you don't abuse the battery.

Battery life

The short-circuit current shown for the batteries in Table 1 is, unfortunately, nothing like the working current. Remember that the unit for measuring battery capacity is the amp-hour—a product of current *and* time. And as mentioned before, the rate of discharge is going to have a major influence on the useful life of the battery. As a general rule for all disposable cells, the more current you pull from it, the shorter its life is going to be. There's a fixed amount of energy available in a new battery and the lower the current drain, the more efficiently the battery can convert its stored energy into electricity. Heavy drain means that some of the energy is going to be transformed into heat, the conductivity of the electrolyte is going to decrease, and other factors are going to all contribute to a significantly shortened battery life.

Figure 3 is a graph showing the discharge rates for both a carbon-zinc and alkaline "C" cell. To obtain data for the graph, an appropriately sized resistor was used to load the cell and the time for the cell voltage to drop one volt was measured. The graph clearly shows that both types of cells are more efficient at lower current drains. It also shows that at low current drains, the efficiency of carbon-zinc and alkaline cells is pretty much the same.

Translated into more practical terms, the less current your circuit needs to operate, the less of a difference there is between the efficiencies of carbon-zinc and alkaline cells. So unless your device draws a lot of current (like a photo flash, etc.) there's no reason to spend the extra money for alkaline cells.

Don't forget that the graph was plotted by putting the batteries under a *constant*

TABLE 1—TYPICAL DATA

Size Type	AA			C		D		9V		
	Zinc	Alkaline	Mercury	Zinc	Alkaline	Zinc	Alkaline	Zinc	Alkaline	Mercury
Rated voltage (volts)	1.50	1.50	1.40	1.50	1.50	1.50	1.50	9.00	9.00	8.40
Measured voltage (volts)	1.49	1.56	1.46	1.50	1.55	1.48	1.58	8.90	9.20	8.41
Short-circuit current (amps)	4.40	7.70	10.3	5.50	9.70	6.80	11.8	0.60	1.40	1.70

TABLE 2—ELECTROCHEMICAL SYSTEMS

Cell type	Anode	Cathode	Electrolyte
Zinc-Carbon	Zinc	Manganese Dioxide	Ammonium and Zinc Chlorides
Alkaline Mercury	Zinc Zinc & Mercury	Manganese Dioxide Mercuric Oxide	Potassium Hydroxide Potassium Hydroxide & Zinc Oxide

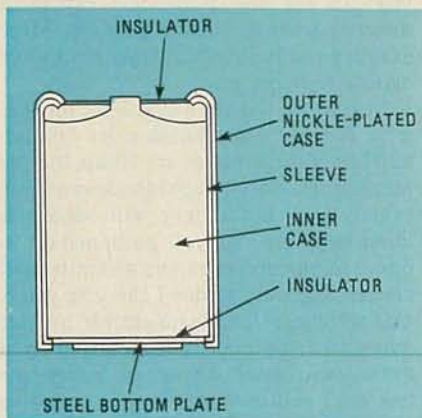

FIG. 2—ALKALINE CELLS are built with an inner case, making them more rugged than zinc-carbon cells.

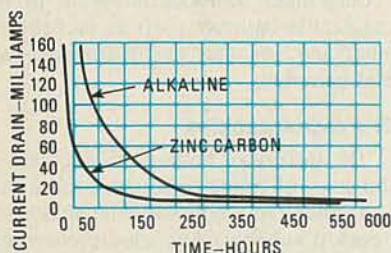

FIG. 3—ENERGY DISCHARGE CURVES for typical alkaline and carbon "C"-sized cells show that for low-current applications, there is not much difference between the two types.

current drain. So the battery life time shown is for a worst-case situation. A more realistic test might include rest time for the battery. The amount of rest time would have a large effect on the life of the battery.

The more rest time the battery has, the longer it's going to last. There's nothing really surprising about that and anybody who owns a car is familiar with the occasionally miraculous recuperative powers a battery will exhibit when it has a bit of time off. Treat the information in Fig. 3 as a guide rather than the gospel. The data there reflects constant current draw—worst case operation. You can only do better.

In Fig. 3, we chose a cutoff point of one volt. If your circuit can operate with less voltage, your results, naturally enough, will be better. If you're feeding raw battery voltage into a regulator, what your cutoff point is will depend on how far the battery voltage is above the regulated voltage. If you can live with a cell voltage of .5 volt, for example, you can reasonably

expect your usable battery life to be more than twice as long.

Temperature is a major consideration in judging battery life. It's also one of those things that everyone has a tendency to ignore. Every data sheet I've ever seen lists acceptable temperature ranges for the operation of various devices and everybody I know pays almost no attention to the information. (Maybe it's because we don't have any control over the weather.) In any event, since a battery produces electricity as a result of a chemical reaction, the lower the temperature, the slower the reaction, and the less electricity the battery is going to produce. The effects of that are often quite dramatic. Once again, all of us with cars are familiar with what starting the car is like on a cold winter morning!

The effect of temperature on the capacity of a battery varies with different cell chemistries. Again another general rule: The more constant the voltage of the battery under load, the less effect temperature will have on the ability of the cell to deliver current.

Figure 4 is a graph that compares the two extremes among the common disposable batteries, carbon-zinc and mercury. It's immediately obvious that the zinc-carbon cell is extremely sensitive to temperature—a 30°F rise in temperature will raise the capacity of the battery by more than a third! Mercury cells, on the other hand, are much more stable: The same 30°F rise (from 70°–100°) will have only a 6% effect on the cell. Don't forget that while increasing the temperature will raise the capacity of the cell, we've already seen that heat will shorten the life of the cell as well. Put another way, a hot battery will put out a greater amount of current, but it won't last as long as a cooler one. (There's no such thing as a free lunch!)

Mercury cells have a slightly lower open-circuit voltage than carbon-zinc or alkaline cells, but the voltage is almost constant over the life of the cell. As a matter of fact, the voltage is so constant that mercury cells used to be used in circuits as precision voltage references. They are still used in equipment, such as smoke alarms, where a constant voltage and high energy capacity are important considerations. Two newer chemistries have been developed that have produced batteries with even more stable voltages and higher energy densities. Those are silver-oxide

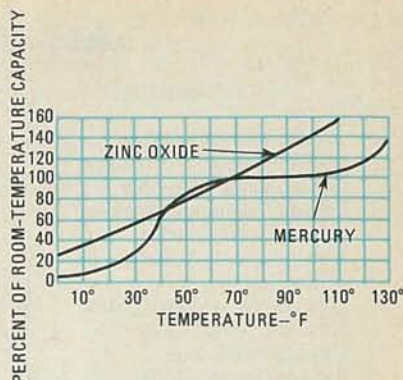

FIG. 4—EFFECT OF TEMPERATURE ON CELL CAPACITY is shown for zinc-oxide and mercury batteries. You can draw more current from a battery at high temperatures, but, of course, the battery won't last as long.

and lithium cells.

The most common use for silver-oxide cells is in digital watches and small calculators. Although their energy density is high, they are usually packaged as small button cells and the available current is, to be generous, limited.

All the batteries we've discussed so far use some form of zinc as the anode material. By changing the cathode and the electrolyte, cells with different energy densities and other characteristics can be made. Recently though, batteries have been introduced that have a different anode material and are the result of more than a decade of research and development. The devices I'm referring to are lithium cells.

Lithium cells

Since lithium is the element with the highest oxidation potential in the periodic table, cells with lithium anodes will have the greatest open-circuit voltage. Just as it is with zinc-based cells, lithium cells can be made with a variety of chemistries and the composition of the cell will determine the operating characteristics of the battery. Table 3 is a list of the possible lithium cell chemistries and the open-circuit voltages they produce.

Lithium-thionyl chloride cells have an open circuit voltage of 3.7 volts (3.4 volts when connected to a 1 kilohm load) and more than ten times the energy density of the lead-acid battery in your car. They have a shelf life of over ten years and a battery that is packaged in a standard "D" size provides an energy capacity of 14 amp-hours!

The energy-discharge curve of those cells is so flat that they come in packages that are made to be soldered directly to circuit boards to provide semi-permanent backup systems for CMOS circuitry and low-power memories. Specially made cells are surgically implanted in the human body to provide long-term power for cardiac pacemakers.

Battery engineers have known for years

TABLE 3—LITHIUM-CELL CHEMISTRIES

Cell chemistry	Open circuit voltage (volts)
Lithium-Thionyl Chloride	3.7
Lithium-Vanadium Pentoxide	3.4
Lithium-Silver Chromate	3.3
Lithium-Manganese Dioxide	3.0
Lithium-Sulfur Dioxide	2.9
Lithium-Carbon Monofluoride	2.8
Lithium-Iodine	2.8
Lithium-Lead Copper Sulfide	2.2
Lithium-Copper Sulfide	2.1
Lithium-Iron Sulfide	1.8
Lithium-Copper Oxide	1.8

about the potential advantages (no pun intended) of lithium-based batteries. The development of a working cell, however, has involved overcoming the kind of problems that are usually associated with the development of any high-energy-density system.

In its simplest terms, a battery is a device that stores a quantity of energy and the secret of a successful design is the ability to provide some means to regulate the release of the energy. The more energy there is in the battery, the more danger there is from a sudden, uncontrolled release of that energy. High current demand, spikes, heat, physical damage, charging current, and overvoltage are a few of the conditions that can lead to potentially dangerous situations.

Heat, as we've already seen, is one of the major enemies of any battery. Lithium has a melting point of 180° C and thermal runaway in the cell caused by physical damage, environmental or circuit conditions can lead to a situation where the entire energy of the cell is released in a split second. That causes what is known in scientific circles as a big problem. Rapid generation of gas will make the battery explode and spew out highly corrosive material and 180° molten lithium—an undesirable situation, to say the least. Modern cell design has overcome those problems by building a pressure-release valve into the seal of the cells and, in case of high temperatures, providing a means for the free lithium at the anode to combine into more stable lithium compounds.

The last two major areas of concern with the lithium cell are really problems with all throw-away batteries—reverse voltage and charging. The difference between the two is that the former problem occurs normally in any series battery set-up and the latter problem is the result of circuit conditions.

No two batteries have exactly the same characteristics. Since the action of the cell is chemical, it's impossible to predict exactly when the end of battery life will come. If a few cells are connected in series, they will discharge naturally and a time is going to come when one cell will

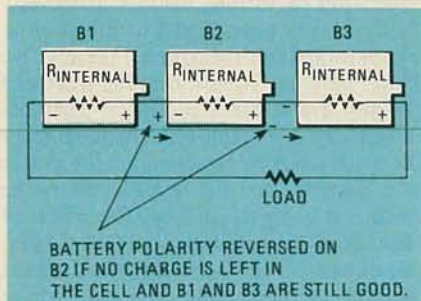

FIG. 5—A REVERSE-VOLTAGE CONDITION occurs because all batteries of the same type do not discharge at the same rate. Above, battery B2 has discharged, and a negative voltage is developed across it.

be completely exhausted while the others are still producing power. As you can see in Fig. 5, current will still flow through the circuit and the dead cell will be acting as a resistor. A reverse voltage will be present at the terminals of the dead battery. Heat will be produced and chemical reactions will take place that can lead to explosive venting. The higher the reverse voltage, the more potentially dangerous the situation is. Battery engineers have designed several methods to handle that hazardous situation.

By making the potential of the cathode less than that of the lithium anode, there will always be some free lithium left when the total potential of the cell is zero. When current flows through the battery in a reverse-voltage situation, it will be carried by lithium ions from the anode instead of ions created by a dangerous chemical reaction in the electrolyte. Altus Corporation has gone one step further to handle that problem by designing an electrochemical switch into all of their batteries. When the battery voltage goes negative, from either reversal or charging, the switch closes, the current through the cell is shunted, and the actual cell voltage is never allowed to exceed -0.1 volt. And that voltage is too low to cause any of the possibly dangerous chemical reactions mentioned above.

Now that we've covered throw-away batteries from Alkaline to Zinc, the ob-

vious question is which battery should you use. Well, we don't have a definite answer: Which battery you need depends on what you want to use it for. Make a list of the parameters of your circuit and then see which battery comes closest to satisfying them.

If your requirements aren't very strict, you can use one of the less expensive batteries such as zinc or alkaline. More exacting needs almost always mean more expensive batteries.

In general, the more expensive the battery, the more predictable its characteristics. Zinc batteries are cheap, but the number of factors that go into determining exactly how the battery will behave is mind boggling. As you go upmarket in price, things become more scientific and clearer. The only advice I can give you is that whichever ones you decide to use, make sure you buy the best constructed throw-away batteries you can. Every battery uses and produces highly corrosive chemicals. A poorly constructed battery can't withstand a lot of abuse and any adverse conditions will cause the cell to rupture—with highly unpredictable and frequently disastrous consequences.

Let's next turn our attention to rechargeable batteries such as nickel-cadmium and, yes, they're still around, lead-acid batteries.

The rechargeables

The history of battery development is the story of trying to squeeze more into less. Research is constantly being done to develop schemes and electrochemical systems that will increase the energy density of the cell and make the energy-discharge curve as flat as possible. In other words, the primary goal of every battery company is to make a battery with the capability of lasting, if not forever, then at least a very long time.

The two basic approaches to the problem can be called the idealistic and the pragmatic. Up to now we've looked at the idealistic approach—designing batteries that can store greater and greater amounts of energy. There are problems with that: The more energy a battery contains, the more engineering it requires to guard against the uncontrolled release of the energy. In the rest of this article we'll concentrate on the more pragmatic approach—designing batteries that can be reused.

The most popular rechargeable batteries use either a nickel-cadmium or lead-acid chemistry. Yes, that's the very same lead-acid chemistry that came into being with running boards and horseless carriages. It's been improved, refined, and made more efficient, but it's still basically two electrodes and a container of acid electrolyte.

When we continue this article we will take a closer look at the rechargeables. R-E

BUILD THIS



Computer Controlled IC Tester

FLOYD L. OATS

Use your computer to test digital IC's and eliminate your troubleshooting guesswork!

HOW DO YOU TEST IC'S? IF YOU'RE A DIGITAL enthusiast on a tight budget, then you probably go about it the low-cost way: You set up your breadboard, a handful of jumpers, a power supply, and a measuring instrument such as a logic probe or oscilloscope. Manual operation of such a crude setup can quickly become tedious—especially when the circuit being tested has multiple edge-sensitive inputs.

There's a bigger problem with such a setup, however: Since you must perform the tests one gate at a time or one latch at a time, you can expect to find only the most obvious failures. The more subtle types of failures—such as interaction between separate circuits within the same package—are best found by some kind of automated tester.

If you have a computer, you can easily build an automated tester for digital IC's. The tester we'll describe permits automatic testing of digital integrated circuits with up to sixteen pins. The host may be an eight-bit or a sixteen-bit microcomputer

and can have either separate input and output data busses or a bi-directional data bus. While the author's prototype was built as a tester for TTL IC's, the principles that we'll discuss apply equally well to other popular logic families.

Although the tester we'll describe was designed for use with an S-100 system, you should be able to adapt the circuit for virtually any computer. We should note here that using the tester will require some programming proficiency. While the article will describe what the software has to do, actual program instructions are not included.

Figure 1 shows the basic idea behind the IC testing scheme. A host computer is used as a *stimulus generator*: It sends data patterns, called *stimuli*, to the circuit under test. Each stimulus is sixteen bits wide—one bit is assigned to each pin of the test circuit. After the stimulus is sent, the host will accept a response (also sixteen bits wide) from the circuit under test and will perform an analysis of that re-

sponse. Response analysis begins with a comparison between the actual response and some known expected response. If they are equal, the host continues with the next stimulus. What happens if they're not equal depends on the software that is used by the host system.

Stimulus generation

How do we determine the set of stimuli that we want the host system to generate? We must ensure that the set of stimuli for a given type of integrated circuit is both valid and complete. At first glance, you might think that a set of stimuli that presents every possible bit combination to the input pins of the circuit under test would meet those requirements. Those stimuli could be created very easily simply by causing the host to "count through" the input pins. Consider the simple hex inverter with six input pins and six output pins. Using bit-masking techniques, the host could "count through" those six input bits from zero to sixty-three and thereby

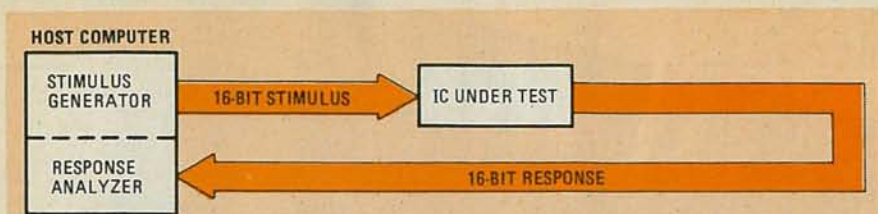

FIG. 1—THE IC TESTER SENDS a 16-bit stimulus to the IC to be tested, and then examines the response.

present sixty-four stimuli for the hex inverter.

That counting scheme does generate a complete and valid set of stimuli for IC's that contain nothing but raw gating. But it falls short with IC's that have edge-sensitive inputs. For example, counting through the input pins of an ordinary flip-flop allows the clock pin to change simultaneously with the data pin(s) at some counts. Those counts lead to an indeterminate response of the flip-flop, rendering the set of counting stimuli invalid.

Let's assume further that the clock pin is assigned to, say, the fourth significant bit of the stimulus generator and a data pin is assigned to the second or third significant bit. Due to the nature of the up-count function, the clock pin will change only when the data pin is high—the stimuli set is incomplete as well as invalid. In that particular case, the problem is partially solved by counting downward. But with multiple edge-sensitive inputs, the problem quickly becomes unmanageable. As we'll see, we'll need to use methods other than the counting stimuli to overcome those difficulties.

Response analysis

Once we present the stimulus to an IC, we have to look at the response. Response analysis includes all 16 pins of the test circuit. You might wonder why we want to look at all 16 pins—after all, we don't

have to look at the input pins to determine the output response. There are two reasons why we do look at all pins. First, it is simpler from the software standpoint—it eliminates the extra steps required to exclude certain pins from analysis. The second and better reason is that if we examine the input pins of the test circuit, we can detect failures associated with input loading problems. Also, we can verify that the stimulus was actually presented to the test circuit. In other words, we can give the tester self-diagnostic capability.

If the host is going to analyze the response of an IC, it has to know what type of response to expect. The only way it can know what to expect is if we teach it. A set of good responses can be generated by presenting stimuli to an IC that is known to function properly. The responses along with the stimuli used to produce them can then be stored on disk or tape for future use.

Functional description

Figure 2 is a block diagram of the tester; it should help to make our description of the schematic (Fig. 3) clearer. As shown in both figures, data or stimuli from the host system comes into a set of latches made up of IC1, IC2, IC4, and IC5. (In eight-bit systems, eight data lines and the lower eight address lines are used to feed the stimulus latches.) As shown in Fig. 3, the STIMULUS LOAD signal (which enables

the latches) is connected to all four latch IC's. Therefore, it's essential that all sixteen stimulus bits be presented to the latches simultaneously. The use of eight address lines to carry stimulus information causes the tester to occupy 256 memory locations. (In 8-bit systems, that corresponds to 256 bytes. In 16-bit system, those 256 locations correspond to 512 bytes.)

The outputs of the four 4-bit latches are fed to sixteen isolation switches, S1-S16. Only the switches that feed the input pins of the IC to be tested will be closed. Switches connected to the output pins of the test circuit will be open to prevent interference between stimulus latches and output signals. Switches connected to the power supply pins will be open to prevent possible damage to stimulus latches.

The lines from the isolation switches go to test socket SO1. As you can see from the schematic, the isolation-switch numbers correspond to the test-circuit pin that they feed. For example, switch S11 feeds pin 11 of test socket SO1. That makes determining the switch positions a little easier.

The power supply consists of a five-volt regulator (IC11), filter capacitor C1, and a power-supply-source socket, SO3. (The regulator can be omitted from many systems that contain central five-volt power supplies.) Notice that the voltage is wired into SO3 according to standard convention: V_{CC} on pin 14, and ground on pin 7.

Power is supplied to the IC under test by a pair of movable jumpers connected from the power-supply-source socket, SO3, to the power-supply-select socket, SO2 (which is wired in parallel with the test socket). If, for example, you wanted to test a 7475, you would connect a jumper from pin 14 of SO3 to pin 5 of SO2. You would also jumper pin 7 of SO3 to pin 12 of SO2.

Response data are accepted by the host

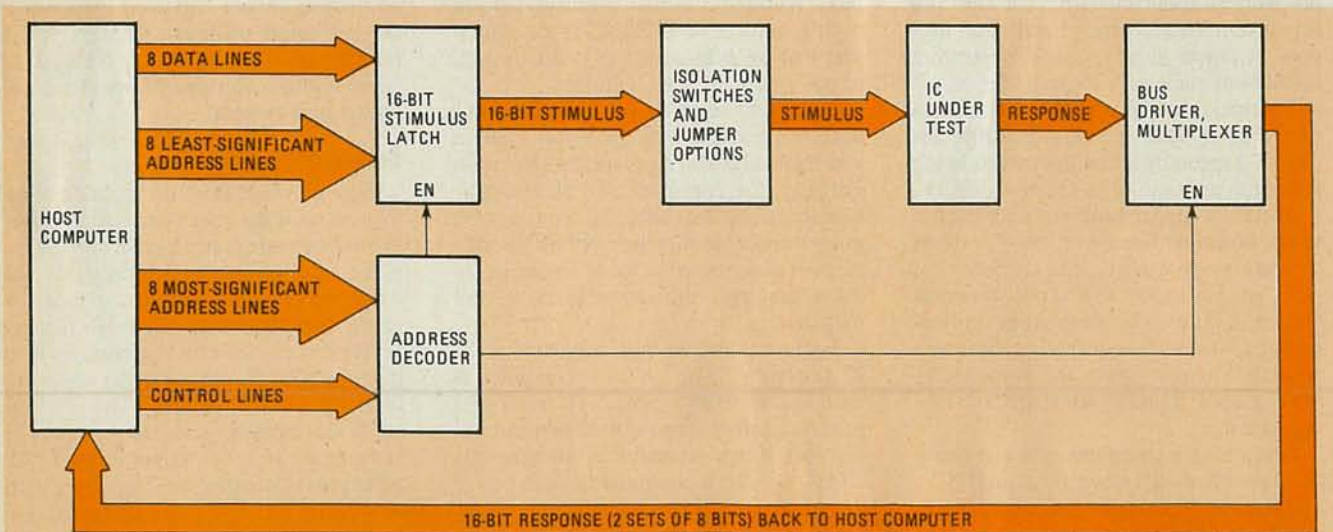

FIG. 2—BLOCK DIAGRAM OF THE IC TESTER shows how the host computer's data, address, and control lines are used to control the tester.

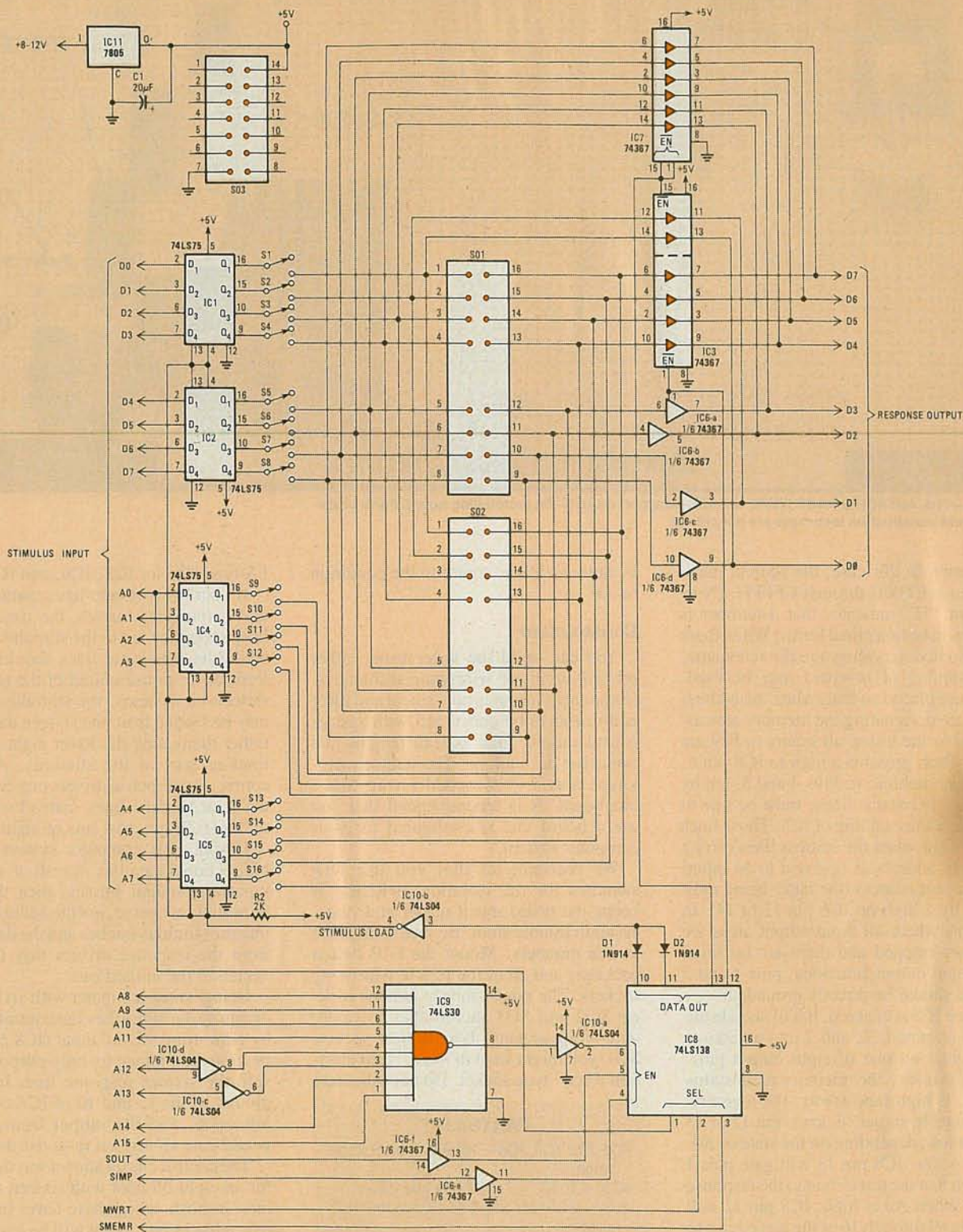

FIG. 3—IC TESTER SCHEMATIC. If you use a 16-bit system, you do not have to use address lines for the stimulus input—use the 16 data lines instead. Note that to make building and troubleshooting easier, you should use DIP switches for S1–S16.

one byte at a time. Pins 1–8 of the test socket SO1 are gated to the host system through drivers made up of IC7 and part of IC3. Pins 9–16 are gated through portions of IC's 3 and 6. The two sets of drivers are

enabled by control signals from IC8.

Control logic, made up of IC8, IC9, and IC10 develops signals that control the loading of the stimulus latches and the gating of response data to the host. The

eight most significant address lines are brought into an address-recognition circuit consisting of IC9 and part of IC10. Two address lines, A12 and A13, are inverted before being applied to IC9. That selective inversion controls the address range of the memory space occupied by

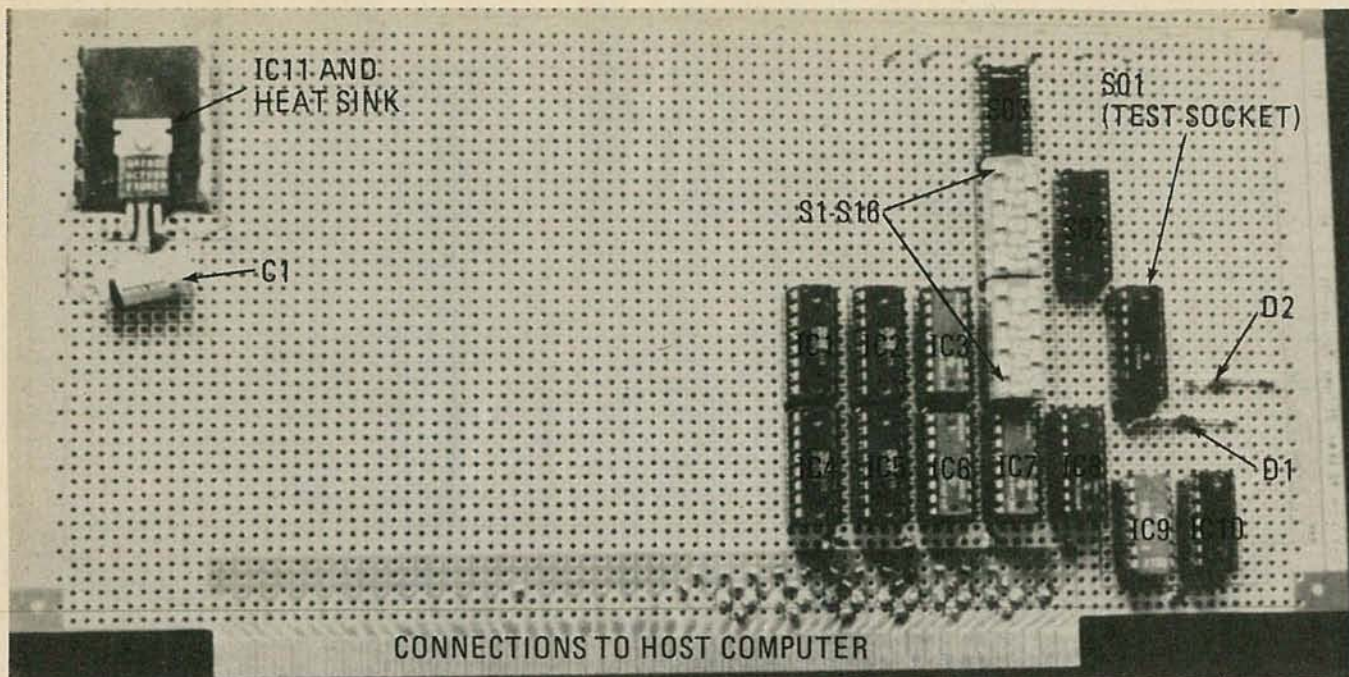

FIG. 4—THE AUTHOR'S PROTOTYPE was wire-wrapped on an S-100 prototyping board. Parts placement and construction technique are not critical.

the tester. In this case, the address range chosen is CF00H through CFFFH. (Note that an "H" indicates that a number is written in hexadecimal form.) While there are two inverters shown in the schematic, any number of inverters may be used. They are placed so that, when the address lines are designating the memory area assigned to the tester, all inputs to IC9 are high. That, presents a high to IC8 pin 6, partially enabling it. Pins 4 and 5, fed by inverted I/O-status lines, must be low to complete the enabling of IC8. Those lines will be low when the address lines carry a memory address as opposed to an input/output port address (the latter being indicated by a high on IC6 pin 12 or 14). In systems where all input/output areas are memory-mapped and there are no separate input/output functions, pins 4 and 5 of IC8 should be directly grounded.

When IC8 is enabled, it will decode the inputs on pins 1, 2, and 3 into an active-low signal on one of eight output pins. When SMEMR, the memory-read status signal, is high (and MWRT, the memory-write enable signal, is low), pin 12 or 13 will be low, depending on the state of A0. If A0 is low, IC8 pin 13 will gate pins 1 through 8 of the test circuit to the response lines. When A0 is high, IC8 pin 12 will gate pins 9 through 16 of the test circuit to the response lines.

To write to the stimulus latches, MWRT is brought high while SMEMR is low. That causes either pin 10 or 11 of IC8 to go low. Since A0 is part of the stimulus information, the STIMULUS LOAD signal must be insensitive to the state of A0. This is accomplished by the diodes D1 and D2 connected to IC8 pins 10 and 11—they permit the STIMULUS LOAD signal to be generated

by MWRT without regard to the condition of A0.

Construction

You can build the tester using either printed-circuit or wire-wrap techniques. Component layout is not critical and there is no need to be concerned with special considerations such as lead lengths and extensive decoupling. The author's prototype was wire-wrapped on an S-100 plugboard. It is recommended that you use a board that is configured for your computer system.

We recommend that you use DIP switches for the isolation switches: It keeps the board much neater and, thus, easier to troubleshoot. Be sure to label the switch numbers. Mount the DIP switch packages and all of the IC's in wire-wrap sockets. The power-supply jumper sockets SO2 and SO3 should also be empty wire-wrap sockets. For the test socket, SO1, you might want to use a "zero insertion force" type socket. Do not substitute

LS-type IC's for IC3, IC6, and IC7.

If your 8-bit system has separate input and output data busses, the data-output lines should be fed to the stimulus latches while the data-input lines should be fed from the response output of the tester. In sixteen-bit systems, the stimulus latches may be loaded from the sixteen data lines rather than using the lower eight address lines as part of the stimulus. And, of course, the response drivers may be tied to the sixteen data lines instead of being multiplexed into two sets of eight.

If your host computer system uses a bidirectional data bus instead of separate input and output busses, then the data lines (but, of course, *not* the address lines) into the stimulus latches and the data lines from the response drivers may be connected to the unified bus.

Using a host computer with sixteen-bit organization simplifies the control circuit by permitting the A0 input (IC8 pin 1) to be grounded (since its only purpose is to split the sixteen response lines into two groups.) Pins 12 and 10 of IC8 could be left open, and the output from pin 13 would gate all sixteen response drivers.

The control circuit shown was designed for an eight bit host with sixteen address bits. In hosts which have fewer than sixteen address bits, there will be fewer than eight lines feeding into IC9. Consider a system with only fourteen address bits. The eight least-significant address bits will be assigned as stimulus bits, leaving only six bits for the address recognition function. The two unused pins of IC9 may be connected together and tied to +5 volts through a one-kilohm resistor.

When we continue, we'll begin by testing the tester. **R-E**

PARTS LIST

IC1, IC2, IC4, IC5—74LS75 4-bit bistable latch
 IC3, IC6, IC7—74367 hex bus driver
 IC8—74LS138 3-to-8 line decoder/multiplexer
 IC9—74LS30 8-input positive NAND gate
 IC10—74LS04 hex inverter
 D1, D2—1N914
 R1, R2—2000 ohms
 S1-S16 SPST switch (DIP switches are recommended)
 C1—20 μ F, 10 volts, electrolytic
Miscellaneous: IC sockets, plugboard, wire-wrap wire, hardware, power-supply jumper wires, +5-volt DC power source, etc.

ALL ABOUT

SQUAREWAVE GENERATOR CIRCUITS

In this article we'll show you how to use transistors, op-amps, and 555 timers to make a variety of squarewave or "clock" generator circuits.

RAY M. MARSTON

THE SQUAREWAVE GENERATOR IS ONE OF the most basic circuit building-blocks used in modern electronics. It can be used for flashing LED indicators, for generating audio tones, for clocking logic or counter/divider circuitry, etc. The generators themselves may produce either symmetrical or non-symmetrical waveforms, and may be of either the free-running or the gated type.

Squarewave-generator circuits are quite easy to design, and may be based on a wide range of semiconductor technologies, including the humble bipolar transistor, the op-amp, the 555 timer, or CMOS logic elements. In this article, we'll confine our discussion to designs based on the transistor, the op-amp, and the 555; CMOS-based circuits will be saved for a later date.

Transistor astable circuits

One of the easiest and cheapest ways of generating repetitive square and rectangular waveforms is to use the basic two-transistor astable multivibrator circuit shown in Fig. 1. A major advantage of that rather old-fashioned transistor circuit is that it can quite happily operate from supply voltages as low as 1.5 volts or, with a slight modification, from supply voltages up to several tens of volts.

The Fig. 1 circuit acts essentially as a self-oscillating regenerative switch, in which the on and off periods of the circuit are controlled by the C1-R1 and C2-R2 time constants. If those time constants are equal ($C1 = C2$ and $R1 = R2$), the circuit acts as a squarewave generator and operates at a frequency of approximately $1/(1.4C1R1)$. Thus, the frequency can be decreased by raising the values of C1-C2 or R1-R2, or vice versa. The frequency

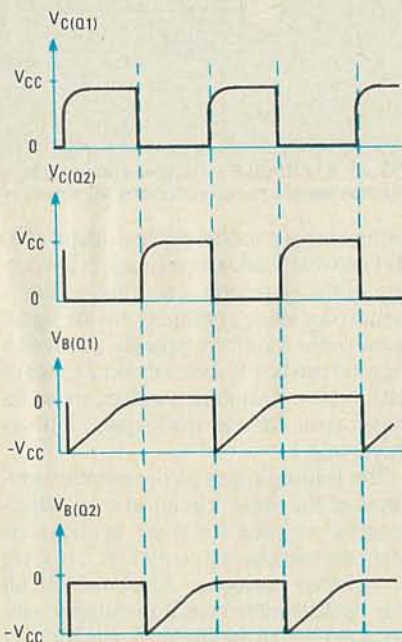

FIG. 2—VOLTAGE WAVEFORMS at the base and collector of Q1 and Q2. Note that the two outputs, which can be taken from the collector of either transistor, are opposite in phase.

can be made variable by using two ganged variable resistors (in series with 10-kilohm limiting resistors) in place of R1 and R2.

Outputs can be taken from the collector of either transistor, and the two outputs are opposite in phase. The operating frequency of the circuit is substantially independent of power-supply levels in the range of 1.5 to 9 volts. The upper supply-voltage limit is set by the fact that, as the transistors switch regeneratively at the end of each half-cycle, the base-emitter junction of one transistor is reverse-biased by an amount roughly equal to the supply

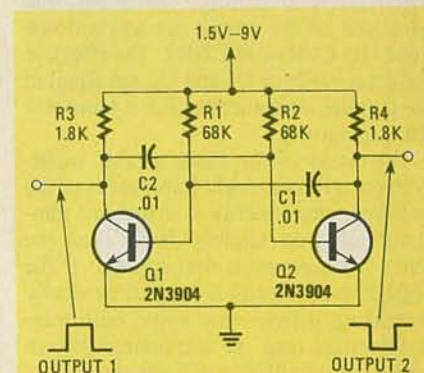

FIG. 1—A BASIC 1 kHz astable multivibrator using a pair of bipolar transistors.

voltage. Consequently, if the supply voltage exceeds the reverse base-emitter breakdown voltage of the transistor (typically about 9 volts), the timing operation of the circuit will be upset. That snag can be overcome by connecting a 1N4148 diode in series with the base input terminal of each transistor. That effectively raises the reverse base-emitter breakdown voltage of each transistor to about 80 volts. The maximum supply voltage of the circuit is then limited only by the collector-emitter breakdown characteristics of the transistors, and may be several tens of volts. In practice, such a "protected" circuit gives a frequency variation of only 2% when the supply voltage is varied between 6 and 18.

Figure 2 shows the collector and base voltages of Q1 and Q2. Note that the leading edges of the output waveforms (V_C) are slightly rounded. The lower the values of R1 and R2 become relative to collector resistors R3 and R4, the worse that rounding becomes. Conversely, the larger the values of R1 and R2 relative to R3 and R4, the better the waveshape will be. The maximum permissible values of R1 and R2 are equal to the products of transistor current gain (say 90) and the R3 (or R4) values (1.8 kilohms in this case), so the maximum possible values of R1 and R2 is 162 kilohms.

The rounding of the leading edges of the basic astable circuit occurs because the collector voltage of each transistor is prevented from rising immediately to the positive rail voltage as the transistor turns off because of loading by its cross-coupled timing capacitor. That deficiency can be overcome, and excellent squarewaves obtained, by effectively disconnecting the capacitor from the collector of its tran-

sistor as it turns off. That is what's done in the 1-kHz generator shown in Fig. 3. There, D1 and D2 are used to disconnect the timing capacitors at the moment of regenerative switching. The main time constants of the circuit are again determined by C1-R1 and C2-R2. The effective collector loads of Q1 and Q2 are equal to the parallel resistances of R3-R4 and R5-R6 respectively.

Operation of the basic astable multivibrator relies on slight imbalances of the transistor characteristics, so that one transistor turns on slightly faster than the other when power is first applied. If the voltage to the circuit is applied by slowly increasing it from zero volts, both transistors may turn on simultaneously, in which case oscillation will not occur. That snag can be overcome by using the sure-start circuit of Fig. 4. In that circuit, the timing resistors are connected to the transistor collectors in such a way that only one transistor can ever be turned on at a given moment.

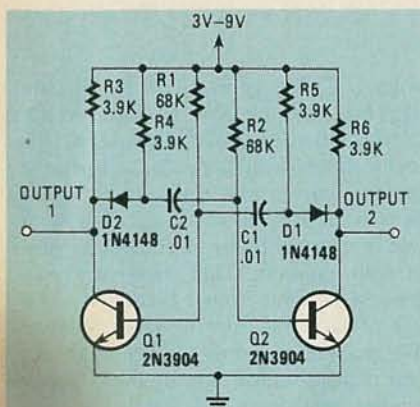

FIG. 3—AN IMPROVED VERSION of the circuit in Fig. 1; waveform correction is supplied here by D1-D2.

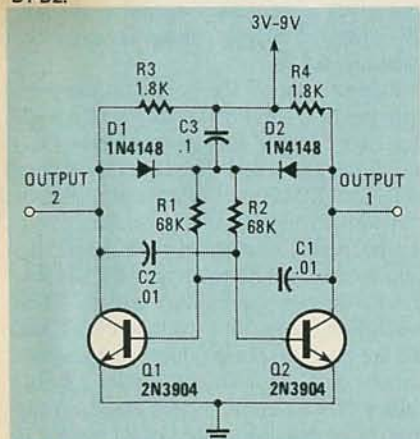

FIG. 4—THIS CIRCUIT is configured to ensure that the transistors will not turn on simultaneously.

The transistor astable circuits that we have looked at so far are designed to give a symmetrical output waveform. A non-symmetrical waveform can be obtained by simply making one set of astable time-constant components larger than the other. Figure 5-a shows the connections

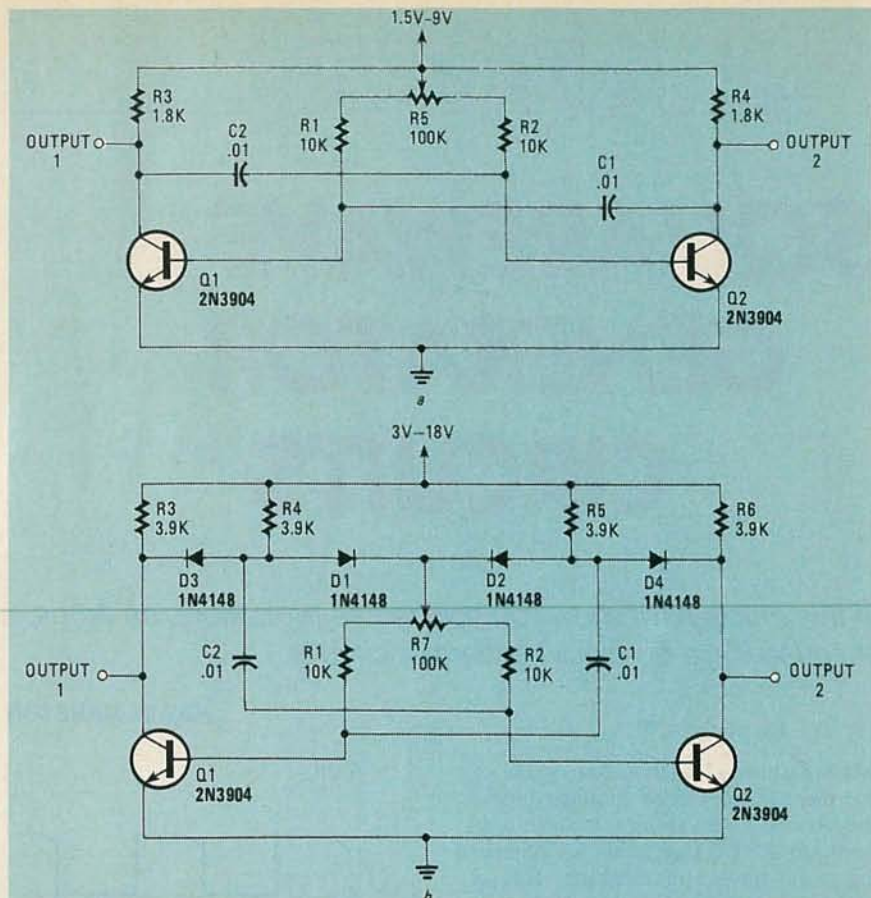

FIG. 5—A VARIABLE mark/space (duty cycle) squarewave generator operating at 1100 Hz. The circuit in *b* has waveform correction and sure-start added.

for making a fixed-frequency (about 1100 Hz) variable mark/space (mark is the portion of the waveform where the signal is high, space is the portion where the signal is low) ratio waveform generator, in which the ratio can be fully varied over a range of 1:10 to 10:1. (Another, perhaps more familiar term for the mark/space ratio is duty cycle.)

The leading edges of the output waveforms of the above circuit may be objectionably rounded for some applications when the mark/space control, R5, is set to its extreme positions. Also, the circuit may be difficult to start if the supply voltage is applied to the circuit slowly. Both of those snags can be overcome by using the circuit shown in Fig. 5-b. That circuit features sure-start and waveform-correction diodes.

Op-amp squarewave generators

Good squarewaves can be generated by using a fast op-amp, such as the LF351, in the basic relaxation-oscillator configuration shown in Fig. 6. That circuit requires the use of dual power supplies and, because of the slew-rate limitations of op-amps, its output-waveform rise and fall times are not as good as those obtained from transistor, 555, or CMOS astables. The op-amp circuit has, however, some distinct advantages over those alternative types of squarewave generator. Specifically,

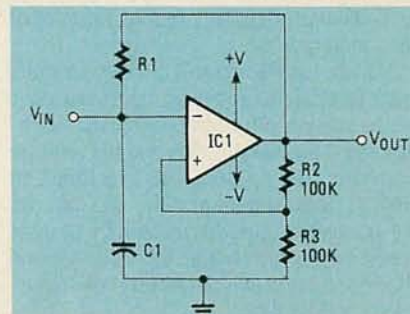

FIG. 6—A SIMPLE operational amplifier relaxation oscillator.

ly, it has excellent frequency stability and waveform symmetry, and its operating frequency can be varied over a wide range by altering any one of R1-R3 or C1.

The basic operation of the Fig. 6 circuit is fairly easy to follow. As configured, the output of the op-amp alternately switches between the positive and negative supply voltages (+V and -V). Thus, a positive or negative reference voltage is applied to the non-inverting terminal of the op amp, with that reference voltage being a fixed fraction (determined by the ratio of R2 to R3) of the supply voltage.

Let's see what happens in more detail. Suppose initially that C1 is discharged and the op-amp output has just switched to +V. In that case, C1 will charge positively via R1 until its voltage reaches the reference voltage applied to the non-

inverting terminal of the op-amp, at which point the op-amp output voltage (and thus the reference voltage) will start to fall and thus initiate a switching action in which the output switches abruptly to the negative supply voltage. Capacitor C1 will then start to charge in a negative direction via R1 until its voltage reaches the new (negative) reference value at the non-inverting terminal, at which point the op-amp output will again switch high and initiate a new action in which the whole sequence repeats itself.

The action of the op-amp circuit is such that a symmetrical squarewave is developed at the output of the op-amp and a non-linear triangle waveform is developed across C1. Each waveform swings symmetrically around zero volts. Note that the operating frequency is virtually independent of the supply voltages, but can be varied by altering the R1 or C1 values, or by altering the R2-R3 ratios.

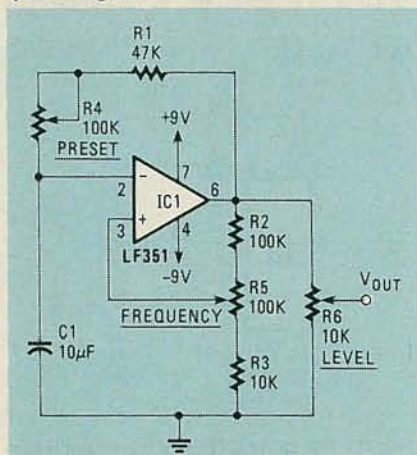

FIG. 7—A 500 Hz to 5 kHz squarewave generator.

frequency range of the R5 frequency control to a precise minimum value. Potentiometer R6 is used as an output amplitude control.

Figure 8 shows how the circuit shown in Fig. 7 can be modified to make a general-purpose squarewave generator that covers 2 Hz to 20 kHz in four switched decade ranges. Note that preset controls R7 to R10 are used to precisely set the minimum frequencies of the 2 Hz–20 Hz, 20 Hz–200 Hz, 200 Hz–2 kHz, and 2 kHz–20 kHz ranges respectively, without requiring the use of precision components.

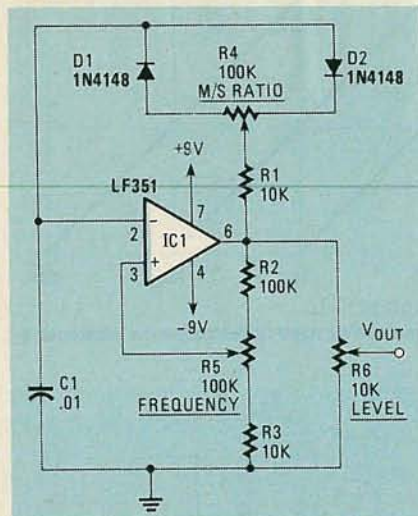

FIG. 9—THIS SQUAREWAVE GENERATOR features a variable mark/space ratio (duty cycle).

Finally, Fig. 9 shows how the basic relaxation-oscillator circuit can be modified so that it provides both a variable frequency and a variable mark/space ratio output.

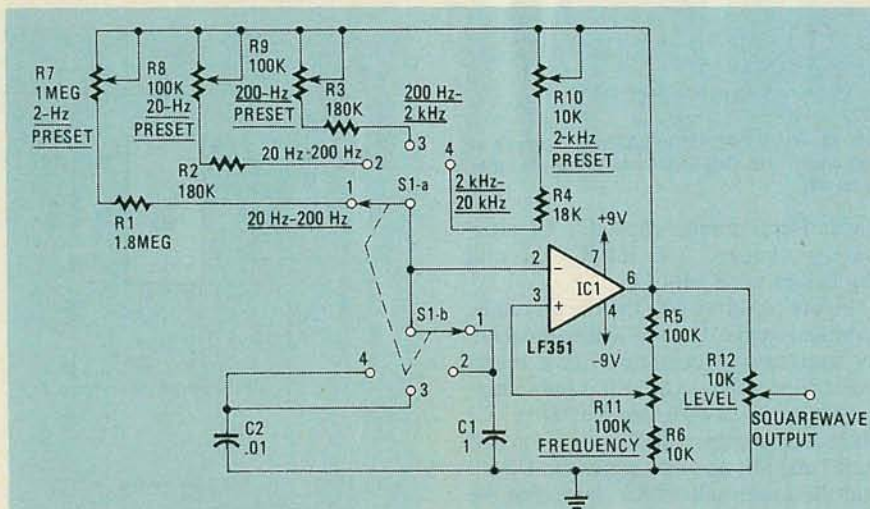

FIG. 8—A FOUR DECADE, 2 Hz to 20 kHz squarewave generator. The four PRESET potentiometers allow the circuit to use a single calibrated frequency scale.

Figure 7 shows the practical circuit of a simple 500 Hz to 5 kHz op-amp squarewave generator, in which the frequency variation is obtained by altering the attenuation ratio of the R2-R3-R5 voltage divider. Trimmer R4 is used to preset the

mark/space ratio is variable via R4, and the circuit action is such that C1 alternately charges positively via R1-D1 and the left-hand side of R4, and charges negatively via R1-D2 and the right-hand side of R4. The mark/space ratio is varia-

ble over the range of 11:1 to 1:11, and the frequency is variable over an approximate range of 650 Hz to 6.5 kHz via R5. Varying the mark/space ratio setting causes only slight interaction with the frequency control.

Note that the Fig. 6 to 9 circuits can be used with virtually any type of op-amp, but that the maximum usable frequency and the output rise and fall times depends on the slew rate of the op-amp that is used. The LF361, for example, gives a performance that is about ten times better than the 741 in those respects. Also note that although we've shown the circuits as being powered from 9-volt split supplies, they can in fact be powered from any split supplies in the range 5 to 18 volts.

555 astable circuits

The IC known as the 555 timer makes an excellent squarewave generator when used in the astable mode. The device is readily available and inexpensive. It can be powered by any supply in the range 4.5 to 15 volts, has a low-impedance output that can source (supply) or sink (absorb) load currents up to 200 mA and, when used in the astable mode, generates output squarewaves with typical rise and fall times of about 100 ns. The 555 astable has excellent frequency stability, can span the frequency range from near-zero to about 100 kHz, and its frequency and mark/space ratio can be accurately controlled by using two external resistors and one capacitor.

Figure 10-a shows a practical 1-kHz squarewave generator built around a 555 in the astable mode. The formulas used to define the timing of the circuit are shown in 10-b. The circuit operation is such that C1 first charges exponentially via the series R1-R2 combination until eventually

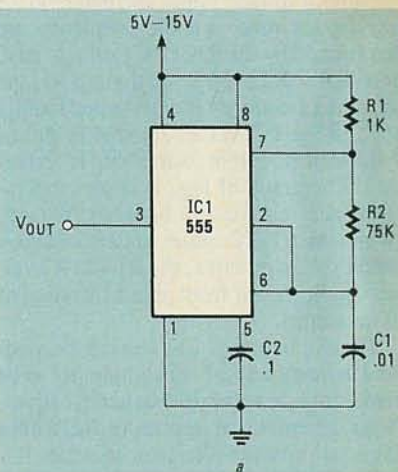

$$t_1 = 0.7 (R_1 + R_2) C_1$$

$$t_2 = 0.7 (R_2) C_1$$

$$T = 0.7 (R_1 + 2R_2) C_1$$

$$f = \frac{1}{T}$$

FIG. 10—A SQUAREWAVE GENERATOR using a 555 timer IC in the astable mode. Formulas used to calculate the circuit timing are shown in b.

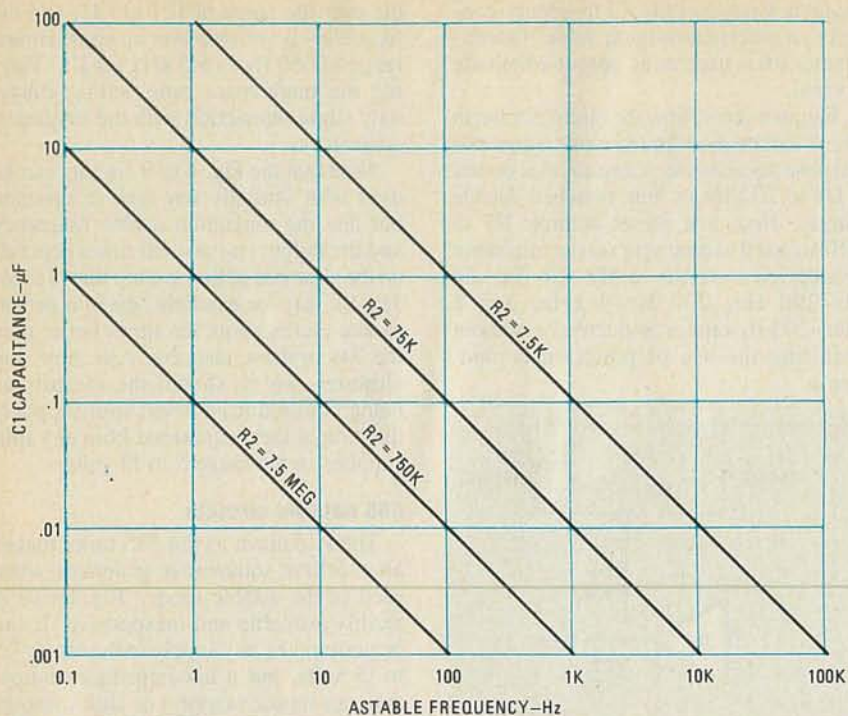

FIG. 11—WHEN R2 IS MUCH LARGER than R1, this chart can be used to determine the relationship between R2, C1, and the frequency of the 555.

its voltage rises to $\frac{2}{3}$ of the supply voltage. At that point a switching action takes place and C1 starts to discharge exponentially via R2 until eventually its voltage falls to $\frac{1}{3}$ of the supply voltage, at which point a second switching action takes place and C1 starts to recharge towards $\frac{2}{3}$ of the supply voltage via R1-R2, and the whole sequence repeats. Capacitor C2 is used in this circuit (and those that follow) to decouple the 555 from the effects of supply line transients.

Note that the operating frequency of the above circuit is virtually independent of the supply-voltage value, and that both the mark/space ratio and the frequency are determined by the R1-R2-C1 values. Also note that if R2 is large relative to R1, the operating frequency is determined mainly by the R2 and C1 values and that an almost symmetrical output waveform is generated. The graph of Fig. 11 shows the approximate relationship between frequency and the C1-R2 values under the above condition. In practice, the R1 and R2 values can be varied from about 1 kilohm to 10 megohms.

The circuit in Fig. 10-a can be modified in many ways. For example, it can be made into a variable-frequency square-wave generator by replacing R2 with a fixed and a variable resistor in series.

Figure 12 shows how the circuit can be used as a two-LED flasher in which one LED turns off as the other turns on, and vice versa. The circuit operates at a frequency of just under 1 Hz.

Figure 13 shows how the circuit can be modified so that its mark and space periods are independently variable over the approximate range 15 to 1.5 microsec-

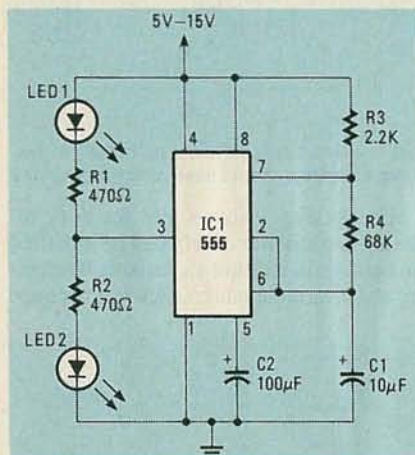

FIG. 12—THIS TWO-LED FLASHER operates at just under 1 Hz. One LED turns on as the other turns off.

onds. Here, timing capacitor C1 alternately charges via R1-R3-D1 and discharges via R2-R4-D2.

Figure 14 shows how the circuit can be modified so that it acts as a fixed-frequency square-wave generator with a mark/space ratio or duty cycle that is fully variable from 1% to 99% via R3. Here, C1 alternately charges via R1 and the top half of R3 and D1, and discharges via D2-R2 and the lower half of R3. Note that the sum of those two timing periods is virtually constant, so the operating frequency is almost independent of R3.

The 555 astable circuit can be gated on and off (enabled or disabled) either by applying a gate signal to pin 4 or by disabling or enabling the main timing capacitor via a transistor switch.

Figure 15-a shows how the circuit can be gated via the pin 4 (reset) terminal. The

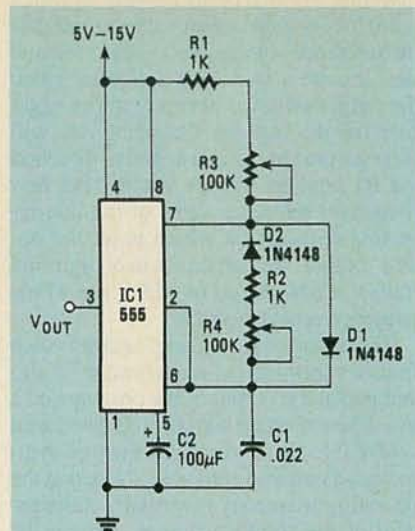

FIG. 13—THE MARK AND SPACE periods of this circuit are independently adjustable over the range of 15 microseconds to 1.5 milliseconds.

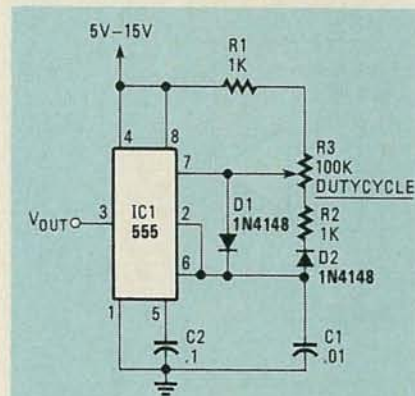

FIG. 14—THE DUTY CYCLE of this circuit is variable from 1 to 99% via R3. The frequency is almost constant at 1.2 kHz.

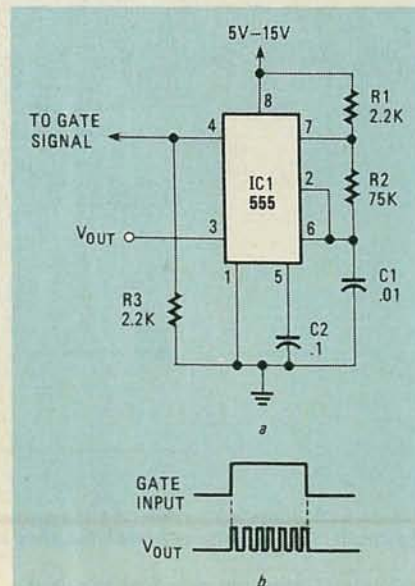
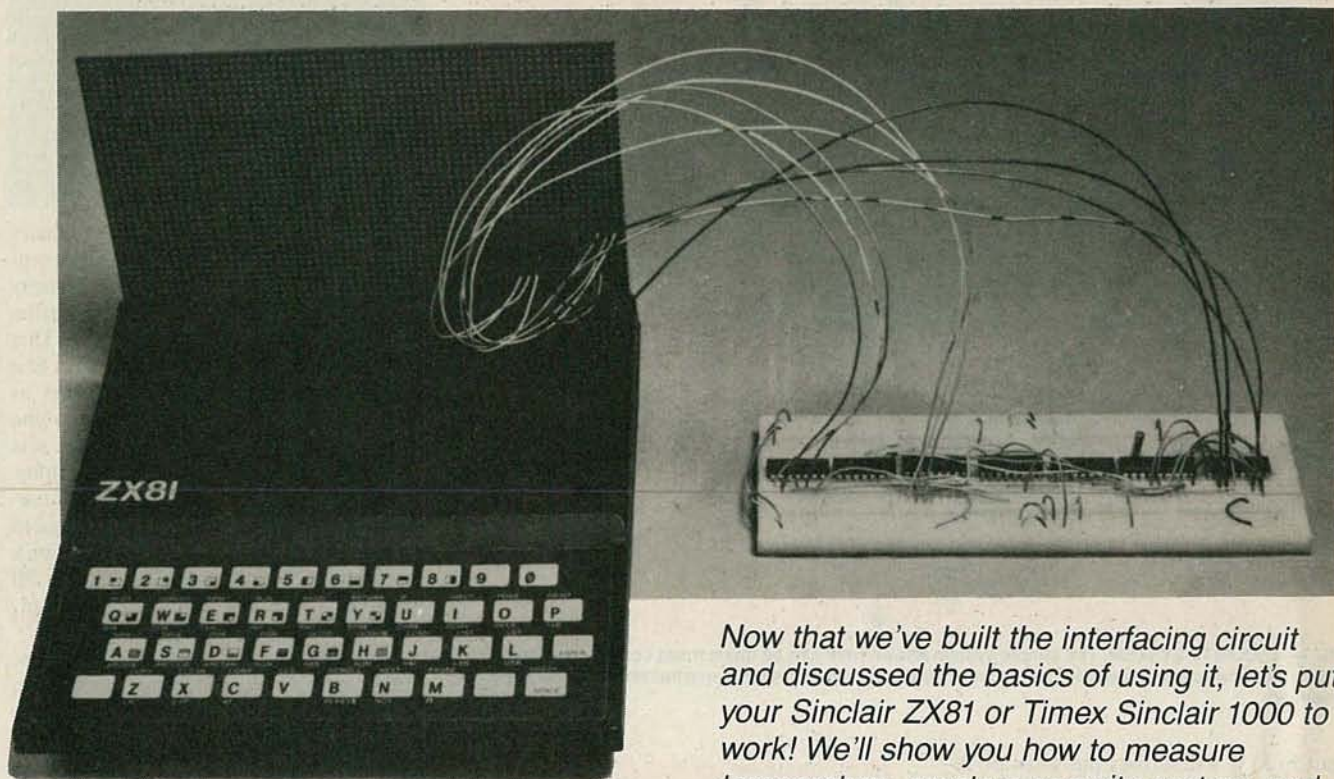

FIG. 15—THE 555 CAN be electronically gated by applying a signal to pin 4.

characteristic of that terminal is such that, if the terminal is biased above a nominal *continued on page 94*



Now that we've built the interfacing circuit and discussed the basics of using it, let's put your Sinclair ZX81 or Timex Sinclair 1000 to work! We'll show you how to measure temperature, create a security system, and control high-power devices.

Interfacing the ZX81

NEIL BUNGARD

Part 3 THIS MONTH WE'LL use the principles established in the first two parts of this series to build some fun and useful microcomputer projects. They include a home-security system, a temperature-sensing circuit, and methods of controlling high-current devices with the microcomputer.

The number of things you can do with your microcomputer and interface are endless. In other words, the methods and principles that we'll use may be applied to any number of projects that you might dream up yourself. And you can combine all of the circuits we present to do numerous things. So don't be afraid to take what we start with and improve and expand on it. Your imagination is the only limit on what can be done.

TV interference

Before we get started building the add-on circuits, we should address a problem that is created by those circuits—TV-picture deterioration. As more integrated circuits are added to the Sinclair interface, you will notice interference on your TV picture. (Many ZX81 users have trouble

with screen interference even *without* hooking anything up to the computer!) You might want to try some of the following quick-fix tips to help clear up your picture.

One trick that sometimes works is to roll up the connecting cable that goes between the ZX81 and the antenna/ZX81 switching box. Another trick that helps a little is to move the Sinclair away from the TV set—elevating the TV set seems to have the most favorable results. Perhaps the easiest way to improve your picture is to ground the antenna switching box to the UHF-antenna input on the back of your TV set. That can be done by wrapping a copper wire around the switching box and attaching its end to the UHF antenna input. If you do those three simple things, you should be able to obtain a picture that's almost as clear as the picture without the interface circuit attached. Although shielding the interface and associated circuits in a metal case is a bit more work than the previous fixes, it will give better results.

A home-security system

The first interface add-on we'll look at is a home-security system. We'll present

only a minimum-security system. But you can add as much sophistication as you want. The limiting factor is the amount of program memory available on your microcomputer.

Figure 7 shows the security system's schematic. To guard eight doors and/or windows, all you need are eight magnets, 8 reed switches, and one eight-bit three-state latch (IC11, a 74LS373). You could, of course, use other alarm switches (such as pressure mats, or door-mounted plunger switches). But we'll discuss reed switches because they're easy to mount.

You should mount the normally open reed switch so that the magnet holds the switch closed when the window or door is closed. Then, when the window or door is closed, the line associated with that window or door will be at a logic 0. If the window or door is opened, the associated reed switch will also open, and IC11 will see a logic 1 (because of the pull-up resistor). To check the status of the eight windows or doors, all you have to do is have the ZX81 periodically generate an "IN 05" device-code pulse. That inputs the window/door status information into the accumulator of the Z80 where the status of each bit can be checked. The flow

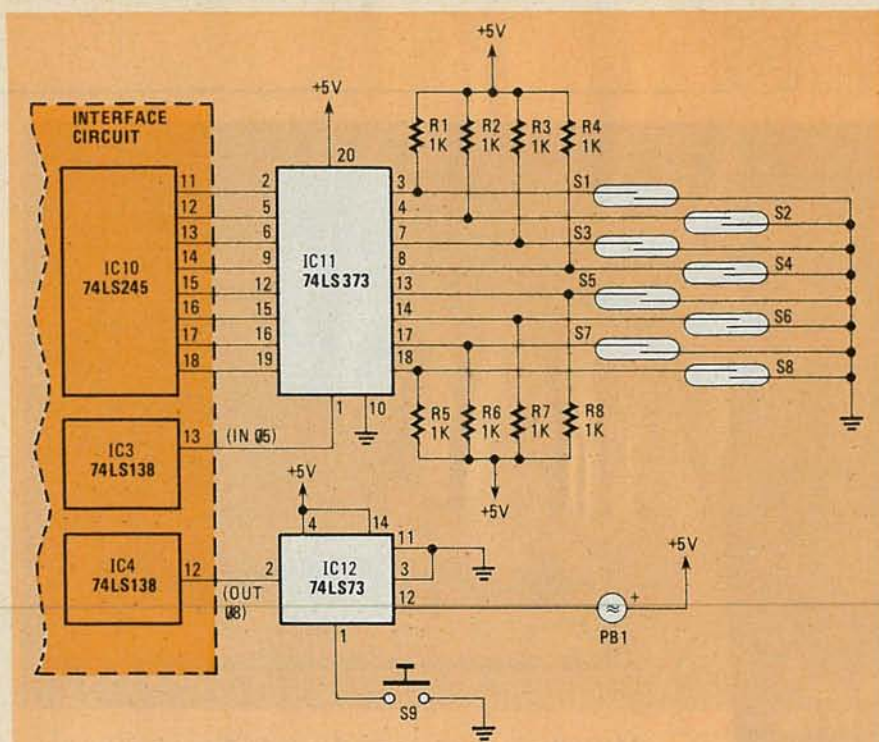

FIG. 7—SECURITY SYSTEM. The simple system shown here can be made more complex—either by adding more switches (or sensors) or by controlling some device other than a buzzer when a break-in is sensed.

chart in Fig. 8 describes the software required to operate the security system.

You can, of course, make the program a little more extensive. For example, you can check each bit of the status information to determine *which* window or door was opened. Or, if you want to note the time of the security breach (or to keep track of when your teenage daughter comes home) you can use the clock/calendar circuit developed over the last two months in conjunction with the security system.

But because we have so much to cover, we'll keep things simple. The machine-code and BASIC programs in Tables 16 and 17 will accomplish the task expressed by the flow chart in Fig. 8. To load the above programs, first type "10 REM 123456789012." Next use the machine-language entry program presented in Table 5 (Part 2) to load the machine-language subroutines into the REM statement. Once the machine language is loaded, erase the entry program and enter the remainder of the BASIC routine.

Now let's look at how the programs control the security-system circuit. Line 20 calls the machine-language routine located at memory address 16514. The first two instructions there define where the security information is going to be stored in memory once it is retrieved from the 74LS373. The command "IN A,05" fetches the security information from the 74LS373. (Remember: You must use odd input-device codes or bits D6 and D7 will be masked out when you input. That's one

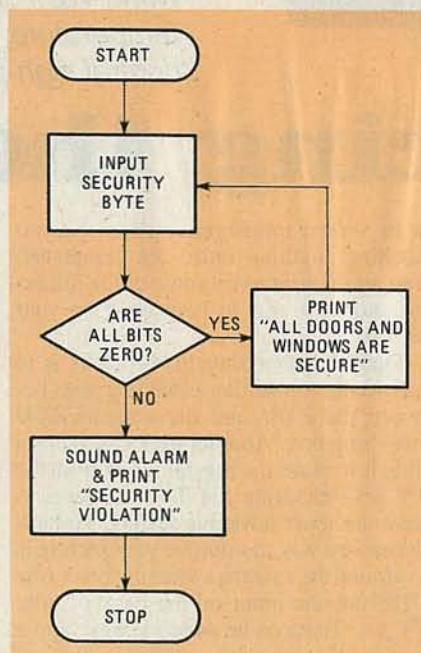

FIG. 8—THE SOFTWARE needed to control the basic security system can be as simple as this flowchart shows.

TABLE 16—SECURITY MONITORING

06 40	LD B,40
0E 8D	LD C,8D
DB 05	IN A,05
02	LD (BC),A
C9	RET
D3 08	OUT 08,A
C9	RET

TABLE 17—SECURITY MONITORING

10	REM 123456789012
20	LET A =USR 16514
30	LET B =PEEK 16525
40	IF B =0 THEN GOTO 80
50	LET A =USR 16522
60	PRINT "SECURITY VIOLATION"
70	STOP
80	PRINT "ALL DOORS AND WINDOWS SECURE"
90	GOTO 20

of those strange Sinclair idiosyncrasies that you have to get used to.) The command "LD (BC),A" places the security information into the memory location pointed to by the BC register pair. That storage location was defined in the first two machine-language instructions as 408DH (16525). Execution returns to line 30 of the BASIC program, which sets variable "B" equal to the security information just placed in memory by the machine-language routine. If "B" is equal to zero in line 40 (no security violation), program execution branches to line 80 where an "all secure" message is printed, and the entire process is repeated.

If, in line 40, "B" does not equal zero, then a security violation has occurred. In that case, program execution continues to line 50, where another short machine-code routine is called. That routine does one thing: It generates an "OUT 08" device-code pulse. As you can see in Fig. 7, that device-code pulse is fed to pin 2 of a 74LS73 flip-flop (IC12). When the 74LS73 sees a negative-going pulse on pin 2, it sets its output (pin 12) to a logic 0. That causes the piezoelectric buzzer, PB1, to turn on. After the alarm circuit is turned on, program execution returns to line 60 in the BASIC program, where "security violation" is written to the TV screen. In line 70, program execution stops. When pin 1 of the 74LS73 (IC12) is grounded by pressing S9, the output of the 74LS73 is reset to a logic 1 and the alarm is turned off.

If you want to monitor more doors and windows (or pressure mats, etc.) you can add additional three-state devices to the circuit and read the states by using a different input device-code pulse.

Temperature sensing

The next circuit we'll discuss will allow you to monitor temperature. It has a measurement range from 0 to 100 degrees

PARTS LIST—SECURITY SYSTEM

Resistors 1/4-watt, 5% unless otherwise noted

R1-R8—1000 ohms

Semiconductors

IC11—74LS373 octal D-type latch

IC12—74LS73 dual J-K flip-flop

Other components

S1-S8—Reed switches. See text

PB1—Piezoelectric buzzer

Celsius with an accuracy of a couple of degrees Celsius. You can see that it's not a precision thermometer, but you can use the circuit to measure ambient temperature or the temperature of a developer bath in a darkroom. Based on the temperature, you can have the computer turn heaters or fans on or off (using control circuits that we'll get to shortly).

Referring to Fig. 9, the thermometer circuit consists of National Semiconductor's LM335 temperature sensor and the ADC0804 single-channel, eight-bit analog-to-digital (A/D) converter.

The ADC0804 connects directly to the interface circuit developed in Part 1, and only two signals are necessary to control the circuit's operation. The ADC0804 control lines are connected to the two 74LS138's (IC's 3 and 4) of the Sinclair interface circuit. An "OUT 0C" device code pulse starts an analog-to-digital conversion of the LM335's output voltage. At the end of the conversion (about 100 microseconds), a digital value representing the sensor's temperature is input into the Z80's accumulator with an "IN 09" device-code pulse.

The temperature-sensing circuit can be adjusted via resistors R11 and R12 so that the temperature will be read directly in degrees Celsius. Potentiometers R11 and R12 should be ten-turn (at least) potentiometers so that a fine adjustment of the zero setpoint and the span can be accomplished.

The LM335 should be soldered to a pair of small-gauge, twisted wires and a small amount of silicone rubber should be placed on the leads to insulate them from liquids in which the sensor might be submerged.

Once you have the sensor prepared, you can calibrate the circuit. You'll need a glass of ice water, a glass of boiling water, and a Celsius thermometer that you know to be accurate. You will also need some software.

Enter, for line 10, a 12-character RE-Mark statement to reserve room for two machine-language subroutines. Use the machine-language entry program presented in Part 2, Table 5 to load the machine-language routines in Table 18. Then load the BASIC program in Table 19.

Line 20 of that program calls the first of the two machine-language subroutines—the instruction "OUT 0C,A," which generates an output device-code pulse that starts an analog-to-digital conversion by the ADC0804. Once the device-code pulse has been sent, program execution returns to line 30 of the BASIC program, which calls the second machine-language subroutine (at memory location 16517).

The first two instructions, "LD B,40" and "LDC,8D," set the memory location where the temperature information is to be stored. That location is 408DH or 16525. The third instruction, "IN A,09,"

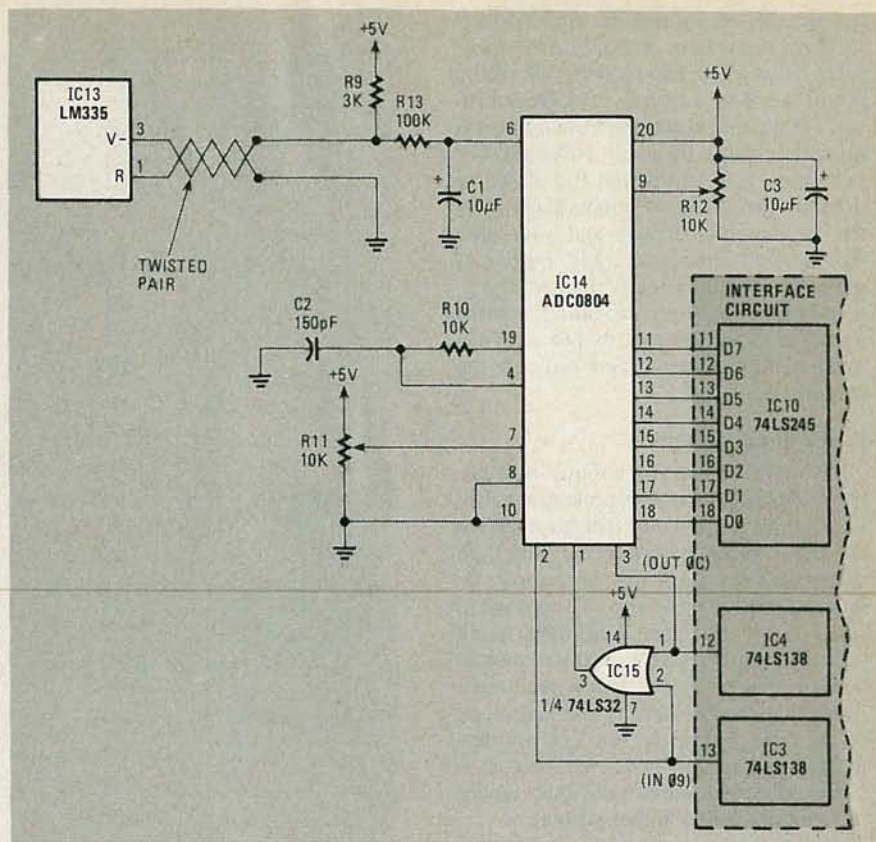

FIG. 9—TEMPERATURE SENSING CIRCUIT. Note that R11 and R12 should be multi-turn-type potentiometers—it makes calibration easier.

TABLE 18—TEMPERATURE MEASURING

D3 0C	OUT 0C,A
C9	RET
06 40	LD B,40
0E 8D	LD C,8D
DB 09	IN A,09
02	LD (BC),A
C9	RET

TABLE 19—TEMPERATURE MEASURING

20	LET A =USR 16514
30	LET A =USR 16517
40	LET B =PEEK 16525
50	CLS
60	PRINT "THE TEMPERATURE IS ":B;"CENTIGRADE"
70	PAUSE 100
80	GOTO 20

reads the temperature information from the ADC0804 and "LD (BC),A" stores the temperature information in memory. Program execution returns in line 40 of the BASIC routine, which sets the variable "B" equal to the temperature information just placed in memory by the machine-language subroutine. Line 50 clears the screen and line 60 prints the new temperature. After a pause, the entire sequence is repeated.

To calibrate the sensing circuit, run the

PARTS LIST—TEMPERATURE SENSOR

Resistors 1/4 watt, 5% unless otherwise noted

R9—3000 ohms
R10—10,000 ohms
R11, R12—10,000 ohms, multi-turn potentiometer
R13—100,000 ohms

Capacitors

C1, C3—10- μ F, 10 volts, electrolytic
C2—150 pF, ceramic disc

Semiconductors

IC13—LM335 temperature sensor
IC14—ADC0804 analog-to-digital converter
IC15—74LS32 quad OR gate

above program and place the LM335 into the glass of ice water along with the known-accurate thermometer. Allow the sensor and thermometer to sit for a few minutes and then adjust resistor R1 until the thermometer reading and the number printed on the screen are the same. That adjusts the zero setting. (If the temperature of the ice water is not zero, or very close to zero, suspect that something is wrong.)

Now place the LM335 and the mercury thermometer into the glass of boiling water. After you allow them to set for a few minutes, adjust R2 until the reading on the screen matches that of the mercury thermometer. That sets the span of the

temperature-sensor circuit. With the calibration complete, temperatures measured between the two setpoints should be accurate within a couple of degrees Celsius. While that is not great accuracy, it is accurate enough for many purposes. For example, you could use the ZX81 to monitor two different temperatures, say the outdoor temperature and your attic temperature. Then, you could use one of the power-control circuits (that we'll discuss next) to turn on your attic fan when the attic temperature is higher than the outside temperature. (But only in the summer, of course.)

A power controller

An interface that can control logic circuits certainly has many applications. But we're sure you'll agree that an interface that can control devices that require high voltage or current has many more possible applications. For instance, if you want to use a large siren and floodlights along with the security system, or if you want to activate a heater or fan, you'll need more power than the ZX81 or the interface alone can provide. However, let's look at a few devices that can be connected directly to the interface to control loads that require higher voltage and higher current.

The first device we will consider for power handling is the mechanical relay. The relay is a simple device to use and can be used for either AC or DC loads. Figure 10-a shows a typical relay/microcomputer hookup. If a logic 1 is written to the latch (a 74LS373) through D0 of the microcomputers data bus, the relay will be de-energized. If a logic 0 is written to the latch, the relay will be energized and the load will be switched on. The disadvantage of this configuration is that mechanical relays that can be controlled with logic-level signals typically can only handle loads up to 0.5 amp at 120 volts.

Another kind of relay which has gained popularity in the past five years is the solid-state relay (SSR). Like its mechanical counterpart, the SSR can be activated with a logic-level signal, but it is generally used to switch AC loads. The new-generation solid-state relay can switch both AC and DC loads so that it is becoming a direct replacement for the mechanical relay. The real advantage of the SSR is

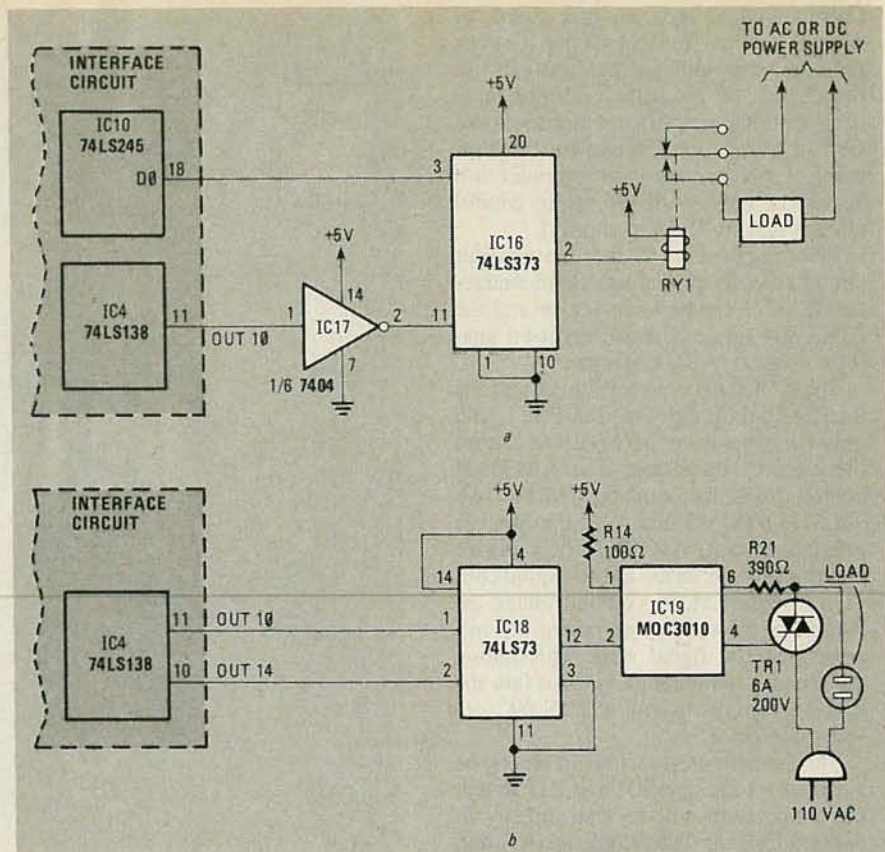

FIG. 10—YOU CAN CONTROL high-voltage circuits by either adding a solid-state or mechanical relay (as in a) or by using a triac driver and triac (as in b).

that it can handle a great deal of power (for example 35 amps at 110 volts), and has no moving parts. That means that your ZX81 can indirectly control a 3850-watt device—a formidable sized heater, for example. The interface circuit for the solid-state relay is the same as that for the mechanical relay. The solid-state relay's particular disadvantage is that it is relatively expensive (about \$18.00 for a 120 volt AC, 20-amp model).

The software listed in Table 20 is to control the relay circuits. When the two routines are stored in a REM statement, they can be called with a simple "RAND USR xxx" statement, where xxx is the starting address of the routine.

The third power-handling device we'll look at is a solid-state device for controlling AC loads. The device is called a triac; the interface circuit is shown in Fig. 10-b. Connected to the gate of the triac is an optically-coupled triac driver (which allows a logic signal to control the triac). Since the driver is optically coupled to the triac, the power circuit is electrically isolated from the computer.

To control the circuit, instead of writing to a latch (as was done in the relay circuit), a set/reset flip-flop (a 74LS73) is used to generate the bistable logic-levels that control the power circuit. When an "OUT 10" pulse is generated, it sets the flip-flop's output to a logic 1, turning the triac off. When an "OUT 14" pulse is

TABLE 20—RELAY CONTROL

3E	00	LDA, 00	Relay
D3	10	OUT 10, A	on
C9		RET	
3E	01	LD A, 01	Relay
D3	10	OUT 10, A	off
C9		RET	

generated, it resets the flip-flop's output to a logic 0 and the triac is turned on. The triac circuit is best suited for AC loads up to 300 watts, and will not work on DC loads at all.

The software to control the triac circuit is a little different from the relay-circuit software. The data bus is not needed for control, instead, two output device-codes are used. One device code turns the load circuit on and the other device code turns the load circuit off. The following machine language routine is all that is required to control the triac circuit:

To turn the triac on: OUT 10, A

To turn the triac off: OUT 14, A

Each of the three power-handling circuits has its own specific advantages, and depending upon your application you can choose the device that best suits your needs.

We've saved the best add-on—a speech synthesizer—for last. Unfortunately, that means that you'll have to wait until next month for its description. **R-E**

PARTS LIST—POWER CONTROLLER

Resistors 1/4-watt, 5%

R14—100 ohms

R21—390 ohms

Semiconductors

IC16—74LS373 octal D-type latch

IC18—74LS73 D-type flip-flop

IC17—74LS04 hex inverter

IC19—MOC3010 optically coupled triac driver

TR1—triac, 6 amps, 200 volts

Other components

RY1—SPDT relay, 5-volt, 72 mA coil

DESIGNING WITH LINEAR IC'S

Although operational amplifiers are widely used in a variety of applications, there are some op-amps types that are still relatively unknown. In this article we'll look at two such devices, the CDA and the OTA, and see how they are used.

JOSEPH J. CARR

Part 5 MOST DESIGNERS USE the operational amplifier because it is a versatile device that can be used in a wide range of applications. Gain can be set using only a pair of resistors, and the device can be made stable by adding a few external components.

Some devices, called frequency-compensated op-amps are unconditionally stable—a decided plus in some applications. There is a trade-off, however, as those devices suffer in terms of frequency response.

Despite its popularity, the "standard" op-amp is not the be-all and end-all for all applications. There are times when some other type of op-amp should be used. In this article, we are going to discuss two lesser-known operational IC amplifiers: The Current-Difference Amplifiers and Operational Transconductance Amplifiers (CDA's and OTA's).

Current-difference amplifiers

The CDA is sometimes called a Norton amplifier, after Norton's network theorem, because it can be modeled as a current-source and resistance. The symbol for the CDA is shown in Fig. 1.

The CDA is an AC amplifier, although it will also handle DC signals provided that a large DC output offset potential can be tolerated.

Figure 2 shows the basic inverting follower CDA circuit. Outwardly, there is similarity between that circuit and the inverting follower op-amp circuit, especially when configured for AC signals

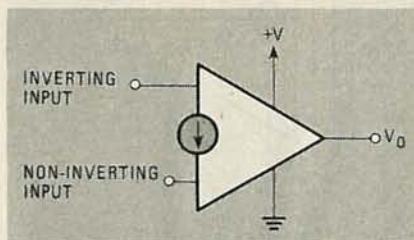

FIG. 1—SCHEMATIC SYMBOL for the CDA or Current Difference Amplifier. Another name for the CDA is the Norton amplifier.

only. There is a feedback resistor (R_2) between the output and the inverting input. Signal is applied to one end of the input resistor (R_1); both R_1 and R_2 form a junction with the inverting input. Capacitors C_1 and C_2 block DC components, passing only AC signals. A DC bias current ($5 \mu\text{A}$ to $100 \mu\text{A}$), I_{REF} , is applied to the non-inverting input of the CDA.

Unlike the conventional op-amp, the gain of the current-difference amplifier is given only approximately by the ratio of feedback to input resistances (R_2/R_1). The actual gain may be slightly different in practice.

The first step in the design process is to set a quiescent point, that is, the output voltage, V_O , when the input signal is zero. The equation governing the quiescent point is:

$$V_O = \frac{V_{REF}R_2}{R_3} + .7V_O \left(\frac{R_2}{R_1} + 1 \right)$$

where V_O is the quiescent output potential in volts, V_{REF} is the reference potential in

volts, and the resistances (R_1 – R_3) are expressed in ohms.

Equation 1 looks imposing on first glance (at least more so than R_2/R_1), but it is really not that bad. The term V_{REF}/R_3 , for example is merely Ohm's law for current I_{REF} as the lefthand term reduces to a simpler term $I_{REF} \times R_2$. The right-hand term is used to account for the contribution of an input transistor junction potential to the total output offset voltage. Since that transistor junction potential is effectively applied to the non-inverting input, the gain it sees is $(R_2/R_1) + 1$.

The key to designing current-difference amplifier circuits is to set a reference current (I_{REF}) that will set the desired quiescent value of V_O . The $5 \mu\text{A}$ to $100 \mu\text{A}$ constraint noted earlier must be observed however, in which case the gain is approximately $-R_2/R_1$.

Selection of values for the circuit components is further constrained by certain other factors. The gain, for instance, will help determine R_2/R_1 , while the minimum required input impedance sets a lower limit on the value of R_1 . Similarly, the reference potential (V_{REF}) may be constrained by other factors. If economics or some pressing need for a specific potential intervenes, for example, we may not be able to influence V_{REF} . In many cases, especially where low cost is a factor, V_{REF} might actually be the ordinary $+V$ power supply, especially if $+V$ is normally regulated.

In still other cases, the V_{REF} potential might be derived from a special power-supply circuit whose main function is to serve as the V_{REF} source. Low-cost three-terminal IC regulators make that alternative more attractive, especially when there are several CDA devices in the circuit so that the cost is spread out.

The frequency response of the circuit in Fig. 2 is governed on the high end by the properties of the CDA, and on the low end by the values of C_1 and C_2 . The values of those capacitors should be high enough to pass the lowest frequency that you nor-

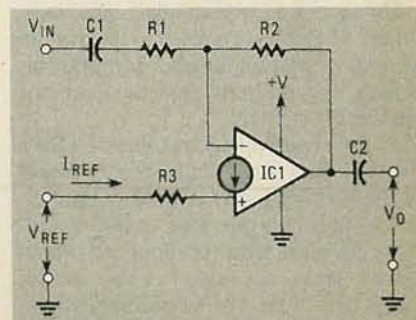

FIG. 2—BASIC INVERTING FOLLOWER CDA circuit. Note the similarity between this and a conventional op-amp inverting follower.

mally expect the amplifier to encounter. In general, that is found from the equation, $f = 1/6.28RC$.

A non-inverting follower circuit is shown in Fig. 3. Note that that circuit is also similar to its operational amplifier counterpart.

The signal is applied through an RC network to the non-inverting input of the CDA, and a feedback resistor is connected between the output and the inverting input. Note, however, that the circuit departs from the op-amp version in that there is no input resistor between the inverting input and ground. As in the previous circuit, a reference current is also applied to the non-inverting input. Again, the reference current is $5 \mu\text{A}$ to $100 \mu\text{A}$. The voltage gain of the circuit in Fig. 3 is given by the following:

$$A_V = \frac{I_{REF}R_2}{25 R_1}$$

where I_{REF} is V_{REF}/R_3 . Again, we have some constraints besides the reference current range. The gain determines R_2/R_1 , and input impedance sets a lower limit to R_1 .

The lower-end frequency response is set by network R_1 - C_1 . The values of those components are selected according to $f = 1/6.28R_1C_1$, with the minimum value of R_1 set by the input impedance requirements. As with all non-inverting followers, that Z_{IN} value should be not less than ten times the source impedance of the stage or device preceding the current-difference amplifier.

The CDA is especially suited to applications requiring AC amplification but where only single-sided DC power-supplies are available. If bipolar DC supplies are available, then it might be reasonable to use an ordinary operational amplifier in its place.

An example of a CDA is the National Semiconductor LM-3900. That IC contains four CDA amplifiers in one IC package.

The OTA

The OTA is, in many respects, similar to the ordinary operational amplifier. In fact, the OTA resembles an op-amp even more than the CDA does.

So what is a "transconductance" amplifier? Most of us are used to thinking in terms of voltage amplifiers, or current amplifiers, but the term transconductance amplifier is strange.

To get a better understanding of what's involved, let's first discuss what is meant by the transfer function of an amplifier. This term is an expression of the "gain" of the circuit in terms of input and output signals, and is expressed as the ratio of output over input. For an ordinary operational amplifier, therefore, the transfer function is V_O/V_I . In earlier installments of this series, we discussed voltage gain

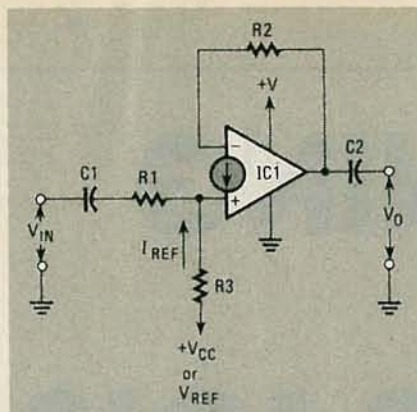

FIG. 3—THE NON-INVERTING FOLLOWER CDA circuit also strongly resembles its conventional op-amp counterpart.

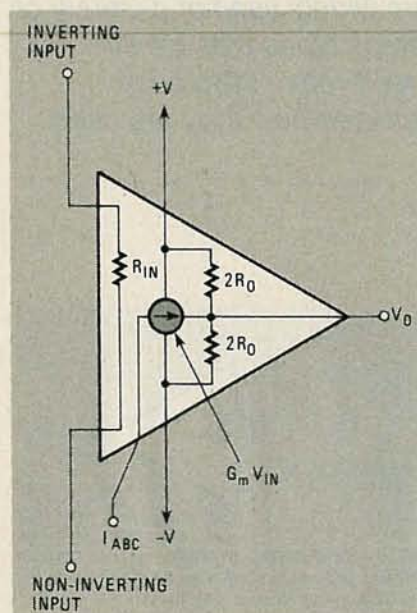

FIG. 4—THIS MODEL of the OTA shows the equivalent circuit of that device.

(A_V) and gave a resistor-ratio equation to describe gain. For the op-amp inverting follower, the gain transfer function is given by:

$$\frac{V_O}{V_{IN}} = A_V = -\frac{R_F}{R_{IN}}$$

For a transconductance amplifier, the transfer function is defined as an output current over an input voltage, I_O/V_I . Since that ratio also defines electrical conductance (in mhos or siemens), the amplifier is called a transconductance amplifier. Its "gain" is expressed by the following equation:

$$A_g = \frac{I_O K}{V_{IN}} = G_m$$

where G_m is the transconductance in siemens (note: 1 sieman = 1 mho), V_{IN} is the input potential in volts, I_O is the output current in amperes, and K is a propor-

tionality constant. The value of that proportionally constant may be 1.

Figure 4 shows a model for the operational transconductance amplifier. The input circuit models as a resistance (R_{IN}) and is essentially the same as an operational amplifier input circuit. If the OTA were ideal, then R_{IN} would be infinite, but for practical (in other words, real) devices R_{IN} is simply "very, very high".

The output circuit of a conventional op-amp can be modeled as a Thevenin equivalent circuit, which consists of a voltage source and a series "looking back" (source) resistance. The OTA differs from the op-amp in that its output is a Norton equivalent circuit consisting of a current source in parallel with the looking back resistance (R_O). For those OTA devices that use a programming bias current (I_{ABC}), the value of R_O is given approximately by

$$R_O \approx 7.5 (I_{ABC})$$

where R_O is the output resistance in megohms and I_{ABC} is the programming current in milliamperes.

The programming bias current is the key to not only normal OTA operation, but also several special applications for which the OTA seems specially suited. We know that the transconductance G_m is set by

$$G_m = 19.2 (I_{ABC})$$

and

$$A_{VO} = G_m R_L$$

where G_m is the transconductance in millisiemens, I_{ABC} is the programming current in milliamperes, A_{VO} is the open-loop voltage gain, and R_L is the OTA output resistance.

From the foregoing equations it should be evident that current I_{ABC} controls the operation of the OTA.

The CDA and OTA differ from the normal operational amplifier, but each have special applications for which they are uniquely well-suited. In some cases, those special IC amps are better suited to an application than the op-amp, and so should be used.

The CDA, for example, is well-suited to mobile, portable, and vehicular applications in which only a single power supply is available. The op-amp, if used in such applications, requires two external resistors to bias the non-inverting input to a potential of 0.25 to 0.7 volt.

The OTA generally uses two power supplies; $+V$ and $-V$, and so will not be used in some applications for which the CDA may be suited. There are situations where the OTA is preferred. The ability to modulate the reference current permits a wide range of applications.

In the next installment of this series we will consider some devices that are probably not familiar to many readers, including such devices as isolation and logarithmic amplifiers

R-E

LETTERS

continued from page 26

distributed via cable without any problems."

Assuming that the existing 262.5 lines per field is maintained, then doubling the field rate to 120 Hz would double the line rate (and writing speed). The bandwidth requirements would approximately double. If the existing NTSC system would support 120 fields-per-second, you can bet that it would be in use by now! Even if the standard 60-Hz field rate were maintained for the transmission medium and each field were displayed twice, then some type of complicated (expensive) frame storage system would be required for the monitor.

Incidentally, a different 3-D system intended for computer generated images has been developed at Georgia Tech's Engineering Experiment Station. According to the inventor, the image is coded by the computer for viewing through inexpensive eyeglasses which are not electronically controlled in any way.

LEN CAYCE
Marietta, GA

HOME CONTROL COMPUTER

Your article on the "Home Control Computer," (*Radio-Electronics*, April, May, and June 1984), was both interesting and informative. In it you discussed the implementation of home control with one of the many home computers available. We could not agree more with your conclusion that this is a terrible waste of computing power and money, because it requires full dedication of all computer resources available to a single task. Your approach was to construct a computer controller to free up the other machine.

We feel there is an additional alternative available to individuals who haven't either the time or expertise to construct your project. You correctly maintained that home computers are too expensive to have sitting around doing home control all the time. We feel this is correct only if the computer is expensive.

Our company, Minotaur Engineering, has developed a "BSR" interface for the Timex Sinclair 1000 (ZX81) computer that will do many of the tasks described by your project, and very inexpensively. It has a real-time clock, all the necessary software, and it connects to the expansion bus of the computer. It will also control 256 lights and appliances over the AC wiring of a house or apartment. As an option we have available a thermostat controller and we include

Federal tax forms to apply for the Energy Saver's Credit.

At \$74.95 for the main controller, we feel that it could be a very cost-effective add-on to an inexpensive machine, and a profitable solution for individuals seeking home energy management/control solutions. We remain your avid readers.

CORDON CROSS
Minotaur Engineering
1840 East University
Mesa, AR 85203

R-E

Service it!



The world famous Super Case. Complete with 48 of the most popular and professional problem-solving tools. From screwdrivers and nutdrivers to pliers, wrenches, crimping tools and more. A super variety and super value. All unconditionally warranted from Vaco, of course. The Super Case and all the fine Vaco tools can be seen in our latest catalog. It's free, just write.

VACO

The
Professional
Super Case
70260

VACO Builds tools
like your job
depends on it.™

Vaco Products Company 1510 Skokie Blvd. Northbrook, IL 60062 U.S.A.

CIRCLE 13 ON FREE INFORMATION CARD

DESIGNER'S NOTEBOOK



ROBERT GROSSBLATT

Designing with the Schmitt trigger

THE SCHMITT TRIGGER IS AN INCREDIBLY useful circuit element whose popularity has increased since the introduction of the integrated circuit (IC). You can make a Schmitt trigger out of discrete components, but it requires that careful attention be paid to the math, plus the frequent use of non-standard component values. And even then, the results of hours of paperwork have a nasty habit of "blowing-up" when they're translated into real-world circuitry.

However, integrated circuits (and the control possible in manufacturing them) have changed all that. Today, Schmitt triggers show up in many applications, and, because of their unique properties, have simplified what used to be some really hairy circuit problems. This month we'll look at just one of the ways those circuits can eliminate all kinds of design hassles.

Schmitt-trigger oscillators

Everybody has seen the circuit in Fig. 1. If you have one Schmitt trigger, a resistor, and a capacitor, your clocking problems are solved. Any time you need an oscillator for some down-and-dirty clocking, you couldn't ask for anything simpler. Its output is a typical example of why Schmitt trigger IC's are such useful design elements. The symmetry of the out-

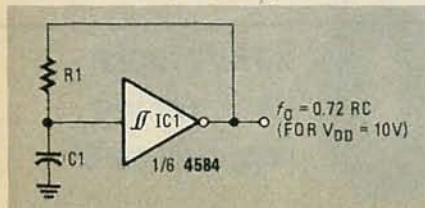

FIG. 1

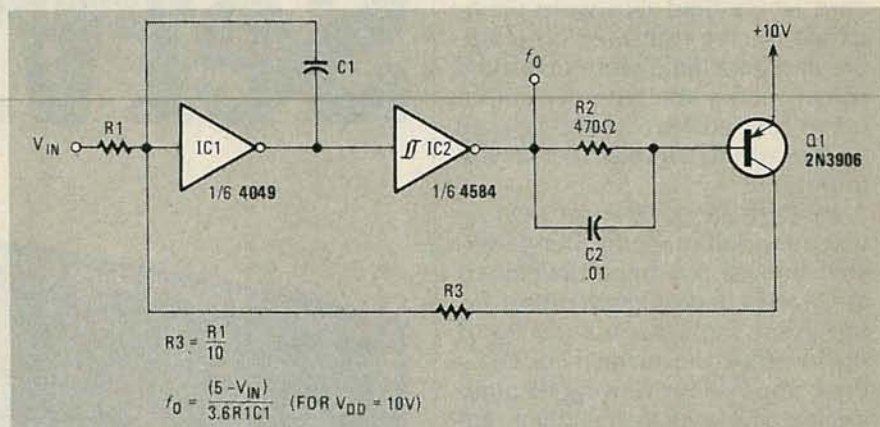

FIG. 2

put duty-cycle is well within shouting distance of a perfect 50-50; power requirements are low; and the circuit oscillates pretty much between ground and the supply rail. The output frequency, however, will depend on several factors including the supply voltage, and the threshold voltages for the IC. For 10-volt operation, the output frequency, f , of that circuit will be close to:

$$f = 0.72(RC)$$

A much more useful application of the Schmitt trigger in building an oscillator is shown in Fig. 2. That circuit is a low-power VCO (Voltage Controlled Oscillator) that is easy to build and has the added advantage of being linear over a wide range of voltages. The circuit is a bit more complicated, but much more versatile than the previous one. For openers, the output frequency can be calculated with a high degree of precision. For 10-volt operation, its output frequency is:

$$f = (5 - V_{in}) / (3.6(R1C1))$$

There are, however, some unusual things to watch out for when using it. For starters, the expression that shows how the frequency varies with the voltage is:

$$\frac{\Delta f}{\Delta V} = \frac{-1}{3.6(R1C1)}$$

Don't worry about where that expression came from—the important thing to note is that the minus sign indicates that as the voltage increases, the frequency decreases.

To understand what the limits of the circuit are, let's see how it works.

How it works

The inverter (IC1, a 4049) acts as an integrator and produces a ramp voltage at its output. (A ramp is a linearly rising sawtooth wave, so named for its resemblance to an incline—like a staircase.) The integrator continues producing the ramp until its threshold voltage is reached. Because we're talking about a CMOS inverter, the threshold voltage is equal to half the supply voltage.

continued on page 94

MEASUREMENTS IN MEDICINE

continued from page 58

Acid-base balance

If the pH of the blood is not near normal, the heart and other organs will not function properly. Cardiac arrhythmias may occur, making the problem worse. It is possible to have a respiratory or a metabolic acidosis. A respiratory acidosis occurs when the content of carbon dioxide in the blood is abnormally high. Metabolic acidosis occurs when there are acidic chemicals present in abnormal amounts or there is less than the usual amount of sodium bicarbonate.

A type of metabolic acidosis called lactic acidosis occurs when the body inefficiently uses glucose to obtain energy. When that happens, lactic acid is produced and released into the blood. Inefficient use of glucose will occur when there is not enough oxygen to permit the efficient use of glucose. That would occur when pulmonary function was insufficient or when there is shock.

Thus, when a person is not breathing well, it is possible to have an acidosis that is partially respiratory and partly metabolic. Metabolic acidosis can also occur when there are acids in the blood in greater than normal amounts, as with certain poisons. Also, when diabetics do not have enough insulin and use fat to obtain energy, enough acids may be produced to cause a metabolic acidosis.

Knowing how severe an acidosis is and whether it is respiratory or metabolic will help the physician determine what treatments are needed to bring the patient back to normal. Chronic disturbances to which the patient has adjusted are not changed by the physician, as they are normal for that patient. Acute, new disturbances should be corrected. In general, respiratory acidosis is corrected by improving breathing. Metabolic acidosis may be corrected by giving intravenous sodium bicarbonate as well as by treating the underlying condition, depending on the reason for the acidosis.

Blood pressure

Any interference in the function of the heart may decrease the blood pressure. Loss of blood volume, as with bleeding or dehydration, will also lower the blood pressure. During myocardial infarction it is desirable to keep the blood pressure from being too high so as to reduce the work of the injured heart. During brain surgery it is sometimes necessary to lower the blood pressure to reduce bleeding.

If the blood pressure becomes too low, a person will become confused due to decreased circulation to the brain. With low blood pressure, the heart will not receive enough oxygen through its own nu-

trient arteries, the coronary arteries. Also, after several hours of low blood pressure the kidneys will suffer damage.

Blood pressure can be controlled on a minute-by-minute basis by giving intravenous fluids or drugs and by applying external pressure to the abdomen and legs with pneumatic compression devices, sometimes called anti-shock trousers.

Measuring blood pressure

Blood pressure can be measured in about 30 seconds by inflating and deflating a pneumatic cuff about the arm. Listening over the front of the elbow with a stethoscope will allow one to measure blood pressure during deflation. The blood pressure measured is that of the brachial artery, which one can feel by pressing firmly on the front of the elbow. When the pressure in the cuff becomes less than the maximum (systolic) blood pressure, turbulent blood flow will cause sounds to be heard with each heartbeat. When the cuff pressure becomes less than the minimum (diastolic) pressure, turbulent flow is less, and the sounds become greatly decreased.

Electronic instruments are available that inflate and deflate a blood-pressure cuff and listen with a microphone to determine the systolic and diastolic blood pressures. The heart rate is also measured by some of those instruments.

When the blood pressure is low, sounds are difficult to hear. It is then useful to detect blood flow with an ultrasonic flow-detector. Such devices transmit an ultrasound signal. The ultrasound signal is produced by a crystal transducer that causes a mechanical vibration. Ultrasonic frequencies of 1 to 10 MHz are commonly used in clinical applications. A portion of the energy transmitted is reflected back to the transducer (or a separate receiving transducer) within milliseconds. When the returned signal has been reflected by moving blood, the frequency of the signal is shifted by several hundred to several thousand Hz. That is the Doppler shift, similar to that encountered in radar. The Doppler shift is detected by mixing the received signal with the transmitted-oscillator signal. The high-frequency carrier signal is then easily filtered out. The Doppler flow detector can be used with a loudspeaker to help one listen for the blood pressure.

It is sometimes desirable to place a catheter (a plastic tube) in an artery in order to continuously measure the blood pressure. The catheter is connected by plastic tubing containing saline ("physiological salt water") solution to a pressure transducer. The blood pressure can then be continuously measured. Blood for arterial blood gases and other tests can be drawn from the same catheter, avoiding repeated needle sticks in patients who require many blood tests.

R-E

60MHz or 100MHz scope?

Look at all the
features of
B&K-PRECISION's
60MHz 3-trace model!

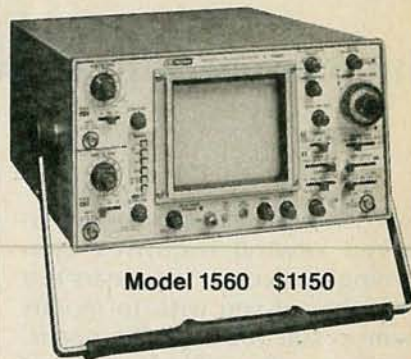

With most of the features you would expect to find on 100MHz scopes, the Model 1560 is the ideal scope for situations where a 100MHz unit is not essential.

Check these features:

- 1 mV/div sensitivity
- Signal delay line
- Video sync separators
- X-Y operation • Z axis input
- 16 kV accelerating voltage
- X10 sweep magnification
- Delayed sweep/dual time base
- Single sweep • Auto focus
- V mode - displays two signals unrelated in frequency
- Sum & difference capability
- Channel 1 output
- Includes probes

For \$950, the 40MHz, Model 1540 has all the same features, except it is dual trace with 12kV accelerating voltage.

In stock for immediate delivery from your B&K-PRECISION Distributor.

B&K PRECISION

DYNASCAN CORPORATION

6460 West Cortland Street
Chicago, Illinois 60635 • 312/889-9087
International Sales: 6460 W. Cortland St., Chicago, IL 60635
Canadian Sales: Atlas Electronics, Ontario
South and Central American Sales:
Empire Exporters, Plainview, NY 11903

CIRCLE 16 ON FREE INFORMATION CARD

HOBBY CORNER



EARL "DOC" SAVAGE, K4SDS,
HOBBY EDITOR

Intercom modifications

OVER THE PAST FEW MONTHS WE RECEIVED several inquiries concerning intercoms: It appears that a number of you wish to modify them to suit your specific needs. So, this month, we'll take a look at a couple of the changes that you want to make and see what must be done to make those modifications work.

Our first request comes from Dick Ryszykow (NY), who wants to know how a speaker can be made to function as a microphone as well as a speaker. Well, all speakers are actually crude microphones. You can prove that to yourself by taking your stereo headphones and using them as microphones for your tape deck. In order to use a speaker more efficiently as a microphone, however, you have to be concerned about impedance matching. The impedance-matching de-

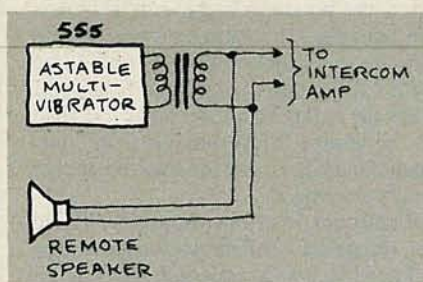

FIG. 2

1000 ohms) side of the transformer is connected to the amplifier and the low side (say, 8 ohms) to the speaker. Thus, both devices "see" the proper impedance and they work well together. But how can we use a speaker as an input device or microphone?

First, consider that a microphone must produce electrical signals corresponding to the audio

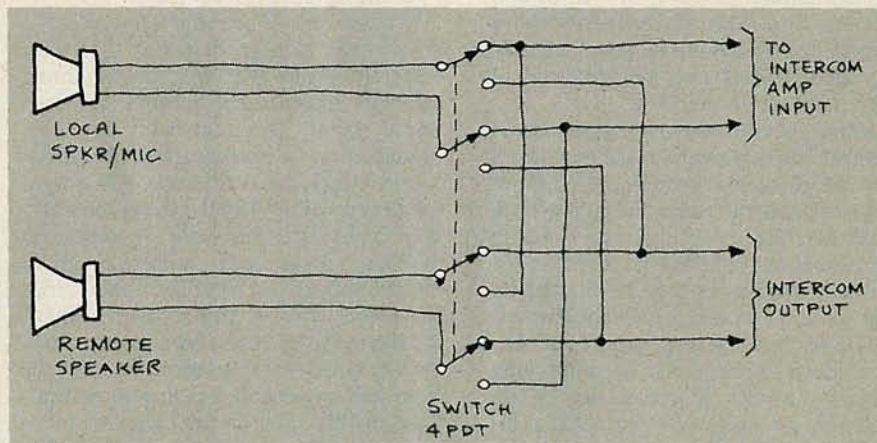

FIG. 3

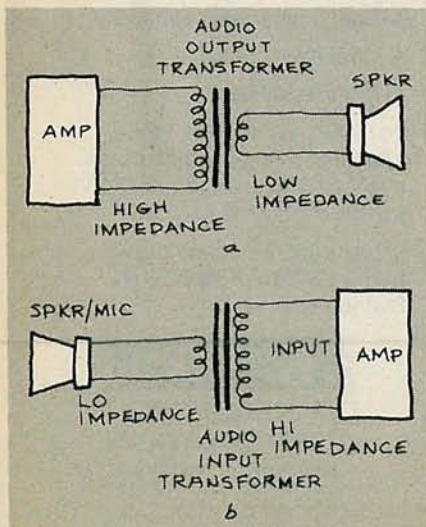

FIG. 1

vice usually used is an audio transformer.

Speakers are low-impedance devices, normally on the order of 3.2 to 16 ohms. Most amplifiers, whether for intercoms or whatever, have high-impedance input and output circuits. In order to avoid distortion and signal losses, the impedances of the speaker and amplifier-output must be matched.

You are familiar with the use of an output transformer between an amplifier and speaker, as shown in Fig. 1-a. The high-impedance (say,

source. A speaker normally does just the opposite—it produces audio that corresponds to electrical signals. But if sound waves strike the speaker cone, it vibrates; that, in turn, vibrates the voice coil. When the coil moves, it cuts across the flux lines of the magnetic field (produced by the speaker's permanent magnet) and an electric current is generated. Thus, you have an electrical signal that corresponds to the audio source.

Unfortunately, you can't just connect the speaker to the high-impedance input of a typical am-

COMPUTER DIGEST

VOL. 1 No. 5 Sept. 1984

NEW KIND OF MAGAZINE FOR ELECTRONICS PROFESSIONALS

**BUILD THIS PRINTER DELAY
AND CONNECT YOUR COMMODORE 64
TO A WIDE VARIETY OF PRINTERS**

CIRCUIT-BOARD DESIGN BY COMPUTER
Use your computer to turn schematics into PC board patterns



MEMORIES—
Everything you always wanted to know and
didn't know who to ask!

A
GERNSBACK
PUBLICATION

Radio- Electronics Software Store

New for our readers....A mailorder source of software for Atari 400, Atari 800, IBM P C, Commodore VIC-20, Apple II, and other personal computer systems.

IBM PC



FLIGHT SIMULATOR by Microsoft ... List \$49.95. Our price ... \$43.00. Highly accurate simulation of flight in a single-engine aircraft. Working instruments. Out the window graphics. Real-time flight conditions. (IBM P C, 64k, color graphics, disc)

EASYWRITER II by Information Unlimited ... List \$350.00. Our price ... \$300.00. Turns your computer into a word processor. You see everything on the screen. There are no imbedded commands. (IBM P C, disc)



DEADLINE by Infocom ... List \$49.95. Our price ... \$43.00. A locked door. A dead man. You have 12 hours to solve the mystery. One false move, and the killer strikes again. (IBM P C, 48k, disc)

ALGEBRA, Vol. 1 by Eduware ... List \$39.95. Our price ... \$34.00. A first year algebra tutorial covering definitions, number line operations, sets, etc. (IBM P C, 48k, color graphics, disc)



MICRO/TERMINAL by Microcom ... List \$94.95. Our price ... \$83.00. Allows access to remote mainframes and minis, information data banks, and other personal computers. (IBM P C, disc)

PC TUTOR by Comprehensive Software ... List \$79.95. Our price ... \$69.00. Interactive program teaches you how to use your IBM Personal Computer, including hardware and software. (IBM P C, 64k, disc)



APPLE



PRISONER2 by Interactive Fantasies ... List \$32.95. Our price ... \$28.00. Escape is hardly possible. The island keeps you under surveillance. Just try and get out! (Apple II, 48k, disc)

PRISONER2 by Interactive Fantasies ... List \$39.95. Our price ... \$34.00. (Atari disc)

THE MASK OF THE SUN by Ultrasoft Inc ... List \$39.95. Our price ... \$34.00. An animated adventure through a series of hi-res screens. An ultimate adventure challenge. (Apple II, 48k, disc)



MASTERTYPE by Lighting Software ... List \$39.95. Our price ... \$34.00. A typing instruction system in an exciting hi-res game format. Learn to type while battling waves of attacking enemy words. (Apple II, 48k/64k, disc)

THE GRAPHICS MAGICIAN by Penguin Software ... List \$59.95. Our price ... \$53.00. Make your own animated graphics. Handles up to 32 independent objects. Stores hundreds of color pictures. (Apple II, 48k, disc)



RENDEZVOUS by Eduware ... List \$39.95. Our price ... \$34.00. In four phases, simulates an actual space-shuttle flight from Earth Liftoff through Orbital Rendezvous and Approach to Alignment Docking with a space station. Hi-res graphics (Apple II, disc)

SAT WORD ATTACK SKILLS by Eduware ... List \$49.00. Our price ... \$43.00. A tutorial for mastering vocabulary, deciphering new or unfamiliar words, and taking tests. (Apple II, disc)



COMMODORE VIC-20



PIPES by Creative Software ... List \$39.95. Our price ... \$34.00. Connect a pipeline from the water supply tank to every house. Watch out for leaks. Use as little pipe as possible. 5 skill levels. (Commodore VIC-20 cartridge)

SHAMUS by Human Engineered Software ... List \$39.94. Our price ... \$34.00. Only you can stop the Shadow's mad reign of terror. Two levels with 20 rooms each. A joystick challenge. (Commodore VIC-20 cartridge)



HOUSEHOLD FINANCE by Creative Software ... List \$17.95. Our price ... \$15.00. Home utility program records and analyzes your monthly income, expenses and budget in 16 categories. (Commodore VIC-20 tape cassette)

HOME OFFICE by Creative Software ... List \$29.95. Our price ... \$25.00. Combines VICPRO, a flexible and efficient word processor with VICDATA a powerful and sophisticated information storage and retrieval system. (Commodore VIC-20, cassette tape, 8k additional memory required)



ATARI



SUBMARINE COMMANDER by Thorn EMI ... List \$49.95. Our price ... \$43.00. A submarine patrol simulator to hunt and destroy enemy ships. 9 skill levels. Plug-in cartridge. (Atari Cartridge 400/800)

APPLE

MINER 2049 by MicroLab ... List \$39.95. Our price ... \$34.00. Chase into a Uranium mine thru 10 levels of traps and capture Yukon Yohan. Scale ladders, jump from moving platforms, and win—if you can. (Apple II, 48k, disc)



Radio-Electronics Software Store

200 Park Avenue South
New York, NY 10003

Number of items ordered

Name _____

Total Price of Software \$ _____

Address _____

Sales Tax (NY State Residents Must Include)

City _____ State _____ ZIP _____

Shipping (\$2.00 per item)

TOTAL ENCLOSED (Sorry, No COD's) \$ _____

SORRY - NO CREDIT CARD OR COD ORDERS

CONTENTS

Vol. 1 No. 5

September 1984



Page 10

7 Printer Delay for the Commodore 64

Build this quick-and-easy project to trick your Commodore 64 into thinking it's working with a Commodore printer. **Herb Friedman**

10 Computer-Aided Circuit Board Design

Use your computer to design PC boards and you save a lot of time and money. Here's how the professionals do it. **Glenn Calderone**

14 Memories are Bits and Pieces

Let's clear up some of the confusion and misinformation about computer memories. An in-depth report from our expert.

Herb Friedman

4 Editorial

5 Letters

5 New Products

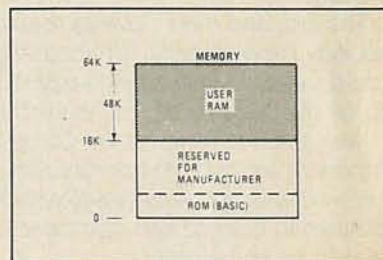

Page 14

ON THE COVER

The small device shown connected to the Commodore 64 is one that you build yourself. With it, the Commodore won't lock up, and will operate even though the printer in use is not a Commodore unit! See page 7.

COMPUTER DIGEST Vol. 1 No. 5 — Sept. 1984
NEW KIND OF MAGAZINE FOR ELECTRONICS PROFESSIONALS

**BUILD THIS PRINTER DELAY
and connect your Commodore 64
TO A WIDE VARIETY OF PRINTERS**

CIRCUIT-BOARD DESIGN BY COMPUTER
Use your computer to turn schematics into PC board patterns.

MEMORIES—
Everything you always wanted to know and
didn't know who to ask!

EDITORIAL

Getting friendlier

■ In an obvious appeal to those who have little or no experience with computers (and that's *still* practically everybody), many manufacturers have used the words "User Friendly" in their advertising. Well, that may be all well and good, but just *how* user friendly can a computer be without going completely overboard? Let's face it: Computers really burst on the scene with a suddenness that rivals an atomic explosion. The technology came screaming at us out of no place, and actually caught most of us completely unprepared for the veritable onslaught! The point is, that unless you learn *something* about computer technology, *no* computer will seem "user friendly."

The first, and most obvious result of the computer boom was that—since nobody knew an awful lot about the subject—*anybody* with an interest could become an overnight expert. The kids latched onto that, and picked up on the buzzwords first, the technology later.

Well, the first wave is over. Computers are here, they perform an important and worthwhile function in nearly every business you might be involved with and, wonder-of-wonders, you do *not* have to learn to program to operate and gain benefit from the use of a computer. You don't have to be an "expert."

So what happened? Those of us who warily eyed this new phenomenon and decided to dip a toe in the water, quickly learned about the benefits of computers. Our approach to computing became more and more daring. We experimented, met (usually) with success, and went on to bigger and better things. Our expertise—in spite of ourselves—grew. We learned, often by trial and error, what the computer could and could not do. And "user friendly" began to have some good, solid meaning for us.

As the trust between man and machine began to grow, and as the computer proved itself in value, something else became patently obvious. There is a large segment of the community out there that still hesitates to take the big step. They probably recognize the inevitability, yet they procrastinate. That's why I feel that we, as regular computer users, owe it to them and to ourselves to "convert" those people. We all know who they are. Take a positive step. Invite them to see how the computer works. Give them an opportunity to get some hands-on time on your computer. Sell them on the benefits. Remember that as more people buy more computers, not only will the prices will drop, but the technology will advance—and that's going to be good for all of us.

Tell your non-computing friends, "C'mon in. The water's fine!"

Byron G. Wels
Editor

COMPUTER DIGEST

Hugo Gernsback (1884-1967)
founder

M. Harvey Gernsback, editor-in-chief

Larry Steckler, CET, publisher

Art Kleiman, editorial director

Byron G. Wels, editor

Brian C. Fenton, technical editor

Carl Laron, associate editor

Robert A. Young, assistant editor

Ruby M. Yee, production manager

Robert A. W. Lowndes, production associate

Dianne Osias, production assistant

Karen Tucker, production assistant

Jacqueline Weaver, circulation director

Arline R. Fishman,
advertising coordinator

Gernsback Publications, Inc.
200 Park Ave. South
New York, NY 10003

Chairman of the Board:

M. Harvey Gernsback

President: Larry Steckler

ADVERTISING SALES 212-777-6400

Larry Steckler
Publisher

EAST/SOUTHEAST

Stanley Levitan
Radio-Electronics
200 Park Ave. South
New York, NY 10003
212-777-6400

MIDWEST/Texas/Arkansas/Okla.

Ralph Bergen
Radio-Electronics
540 Frontage Road—Suite 325
Northfield, Illinois 60093
312-446-1444

PACIFIC COAST

Mountain States

Marvin Green
Radio-Electronics
15335 Morrison St., Suite 227,
Sherman Oaks, CA 91403
818-986-2001

ComputerDigest is published monthly as an insert in Radio-Electronics magazine by Gernsback Publications, Inc., 200 Park Avenue South, New York, NY 10003. Second-Class Postage Paid at New York, N.Y. and additional mailing offices. All rights reserved. Printed in U.S.A.

A stamped self-addressed envelope must accompany all submitted manuscripts and/or artwork or photographs if their return is desired should they be rejected. We disclaim any responsibility for the loss or damage of manuscripts and/or artwork or photographs while in our possession or otherwise.

LETTERS

Likes us

Just wanted to tell you that I'm a neophyte when it comes to computers, and the instruction manuals that came with my own unit were so complex that an engineering degree would be needed to make head or tails of 'em. I've been tentatively using a "poke-and-try" system to learn about the computer, but it wasn't until I started reading *ComputerDigest* that I really began to make some headway and understand what was going on.—L. R., Fargo, SD

There's an old saying among us writer-types... "Write to express, not to impress." It's our credo here

at *ComputerDigest*, and we wish more of the computer magazines would adhere to it.

Here we go again!

I'm concerned that *Radio-Electronics* will go the way of other electronics magazines and orient themselves more towards computer technology exclusively. While *ComputerDigest* is only 16 pages now, I suspect that in a couple of months, you'll be making it 17 pages, then 18 pages, and so on...—D. P., Fresno, CA

No. 'Tain't so! Radio-Electronics will always remain Radio-Electronics, and that's the way it's going to be. ComputerDigest is in

no way going to ever be more than an offspring. Please don't be the least bit concerned that this supplement will in any way dilute the wonderful content of the magazine you have come to know and love.

Wants to subscribe!

I've been looking all through both *Radio-Electronics* and *ComputerDigest* to find a card that will let me subscribe to *ComputerDigest* magazine. How can I subscribe to *ComputerDigest*?—P. D., New York, NY

Right now, you can't. The only way to get ComputerDigest is to subscribe to Radio-Electronics! ◀▶

COMPUTER PRODUCTS

For more details use the free information card inside the back cover

COLOR-GRAPHICS PACKAGE, *Flying Colors*, for the Commodore 64 is the latest in a series of computer-graphics products for microcomputers. A windowed screen menu lets the user pick the desired functions for drawing.

Users can adjust their drawing speed for exacting detail work, and paint with a selection of different colors and brush sizes. Text can be added anywhere on the screen, and a grid feature helps users to align their pictures. The pictures can be saved and retrieved from disk. *Flying Colors*



CIRCLE 131 ON FREE INFORMATION CARD

is priced at \$39.95—**The Computer Colorworks**, 3030 Bridgeway, Sausalito, CA 94965.

PORTABLE LINE CONDITIONERS, the *KLR* series, are designed to protect sensitive computer equipment. Available for 250-, 500-, 1000-, and



CIRCLE 132 ON FREE INFORMATION CARD

2000-watt loads, the *KLR* line conditioners deliver 120 volts at 3% regulation for 90- to 140-volt variations. With 3% THD sinewave output, the series offers input-spike suppression, transformer-spike suppression,

wideband prefiltering, and isolated line-noise elimination.

The 250-watt units are priced at \$292.00, and 500-watt units at \$391.00 and are enclosed in a 7 × 14 × 8-inch case. A larger case (9 × 17 × 10-inches) houses the 1000-watt model at \$562.00 and the 2000-watt unit at \$977.00.—**Electronic Specialists, Inc.**, 171 South Main Street, PO Box 398, Natick, MA 01760.

OUTLET EXPANSION, model *P22*, model *P2*, and model *P12* occupies one grounded outlet, providing four to six in its place. Each is individually controlled by a labeled front-panel switch, each switch has a pilot light, and *Power Director* adds a master switch for collective system power-control. Each outlet is protected against surges, spikes, and RF noise. A circuit breaker safeguards against problems caused by equipment overloads. Cord clutter is counteracted by *Power Director's* all-in-a-row outlet organization.

The stand-alone model *P22* (sized to stack with disk drives, modems, or small video monitors) offers four



CIRCLE 133 ON FREE INFORMATION CARD

outlets and is priced at \$99.00. The monitor-base model P2 (sized to fit under a CRT or video monitor) offers five outlets and is priced at \$139.00. Model P12 (sized to fit atop an IBM PC system) offers six outlets, a digital clock, and a disk-storage bin; it is priced at \$199.00.—**CA Computer Accessories**, 7696 Formula Place, San Diego, CA 92121.

TERMINAL, the *Fame-2*, features a 14-inch, green phosphor screen (amber is optional) and 132 columns of data. There are 20 user-programmable function keys, with room in memory for up to 1000 characters. The pre-programmed function keys offer complete editing capabilities, screen-

display control, and quick data transmissions from either of two independently configurable ports. Flexible features, such as a print mode, are provided by two ports, which



CIRCLE 134 ON FREE INFORMATION CARD

support baud rates to 19.2 kilobaud for communication with the host and other peripheral devices. Standard ports provide RS-232C interfaces and options, including RS-422 or current loop, are available.

The *Fame-2*'s split-screen feature offers smooth scrolling and a wide range of video attributes, including underline, reverse video, blinking, and blanking. Screen attributes do not

occupy screen space. The *Fame-2* is priced at \$795.00.—**Falco Data Products**, 1286 Lawrence Station Road, Sunnyvale, CA 94089.

DIRECT-CONNECT MODEM, the *Mark X*, is a smart, 300-baud auto dial/auto answer modem. The unit operates on most popular software communications packages (such as *ASCII Express*), and can work manually through a keyboard, without computer coding; or automatically, to answer and originate calls at 300 bps for Bell-103 compatibility. The *Mark X* detects dial tone and busy signals and automatically displays dialing status on the CRT.

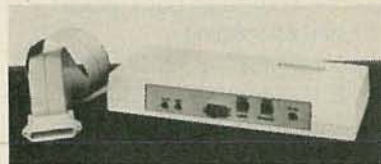

CIRCLE 135 ON FREE INFORMATION CARD

The *Mark X* uses a standard RS-232 serial interface. It comes equipped with a built-in cable and two telephone jacks, and a 12-volt power supply. The *Mark X* directly connects to a modular telephone outlet. It is priced at \$169.00.—**Anchor Automation, Inc.**, 6913 Valjean Ave., Van Nuys, CA 94106.

DOT MATRIX PRINTER, the *Imagewriter*, is available in both standard and wide-carriage models. Both print in a 7 x 9 dot-matrix rate of up to 120 characters per second. They also feature eight character-fonts, and

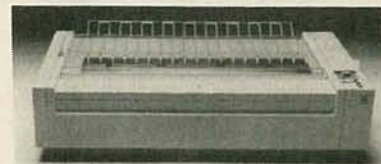

CIRCLE 136 ON FREE INFORMATION CARD

provide variable resolution, pitch, and line spacing. Various fonts, underscoring, and sub- and superscripts can be mixed in the same line. Both printers use either friction-feed or adjustable-width pin-feed tractors. Each also comes with an accessory kit that contains the appropriate connector cables, a user's guide, an applications manual, and software for printing high-resolution graphics.

The standard *Imagewriter* has a retail price of \$595.00. The wide-carriage *Imagewriter* is suited for producing documents that require wide paper. It is priced at \$749.00.—**Apple Computer, Inc.**, 20525 Mariani Avenue, Cupertino, CA 95014. ◀▶

END OF SUMMER SPECIALS



NEW 19-INCH (DIAGONAL) COLOR MONITORS

- X and Y inputs for Hi-Resolution.
- Red, Green and Blue Inputs.
- IDEAL for Hi-Reso. Applications.
- Originally designed for Video Games.

\$199.00

Needs horizontal and vertical oscillators for standard monitor operating. Requires 4V/Color Beam Drive plus 15VP-P for X & Y inputs, plus center-tapped power and XFR complete.

DATAPRODUCTS D-50 DAISY WHEEL TERMINAL:

- "35" Character per second print rate.
- RS-232 Input ("Receive-only" configured).
- 300-9600 Baud rate for fast print speed.
- Takes standard Diablo Daisywheels.
- Offers 10 pitch and 12 pitch.
- Full 13 1/2" carriage width.
- 6 & 8 lines per inch.



BUY NOW
SUPPLY LIMITED

\$695.00

These off-lease Daisy Wheel terminals are cleaned and adjusted and ready to use. With data and info

Now Only

DEX 4100 FACSIMILE (FAX) MACHINES

Ideal for Experimental Page Scanner

Found in offices everywhere, these units can transmit & receive to and from other Standard Telecopier Machines over standard phone lines. Transmits documents and photos. Features auto feed of originals, built-in roll feed, page cutter for automatic sizing & "photo" mode for the grey scale & halftones.

\$169.00

OPERATIONAL!



SSDD, Dual Minidiskette Drive

w/supply & 2 TEAC... (w/SA-400 interface) Mini-Floppy Drives in DEC case. Made for Digital Equipment Corp. Incl: Pwr Supply, Case.

\$349.00

UNUSED



PARALLEL, TTL INPUT I/O "SELECTRIC"

TYPEWRITER/PRINTER These machines have built-in driver and decoder circuitry and take TTL level, 6-bit character, plus a 4-bit function input signals. Easily driven by most any micro. Use a typewriter (with add'l "repeat circuitry") or as a KSR I/O printer or both. "Table Top" style case.



NEW, UNUSED
IN BOXES

\$369.00

Prices do not include packaging and shipping.

Write or Call for Our Latest Flyer NOW!!! "Selectric" is a registered trademark of IBM Corporation

**Computer
Products &
Peripherals
Unlimited**

WAREHOUSE: 18 Granite St. Haverhill, Mass 01830
MAIL ORDERS: Box 204, Newton, New Hampshire 03858

617/372-8637

Sorry No Collect Calls
MasterCard & VISA Accepted

CIRCLE 68 ON FREE INFORMATION CARD

PRINTER DELAY

FOR THE COMMODORE 64

Here's how to fool your Commodore 64 into thinking it's working with a Commodore printer.

HERB FRIEDMAN

Just when you begin to think you're ahead of the game something comes along to remind you that "...You can't win... you can't break even... you can't even quit the game!" Well, that's *almost* true, because with our printer delay for the Commodore 64 computer, you finally get a chance to win one.

The Commodore 64 is one of the best values in home-and-family and school computers (why it is a subject for another time), but like most computer manufacturers, Commodore has put in a few *zingers* to keep the customers from using non-Commodore peripherals. One of the *zingers* is an unusual serial printer output that works only with Commodore printers. Unfortunately, the Commodore printers for the 64 aren't all that great, and there is no inexpensive daisy printer that will work with the 64—which precludes low-cost "letter quality" word processing.

The entire printer problem for the Commodore 64 and the VIC-20 was resolved with a relatively low-cost interface known as the CARD? (from Cardco, Inc., 313 Mathewson, Wichita, Ks 67214), which converts the "Mickey Mouse" serial output of the 64 and VIC-20 computers to a standard Centronics-compatible output. Centronics-compatible means you can use the Commodore 64 and VIC-20 computers with the most popular high-performance printers from Epson, Okidata, etc. Even the low-cost daisy wheel printers from Smith-Corona, Comrex and Brother.

But good things don't last. Commodore changed the ROM's in the most recent 64's. The result is that the 64 will lock up if you attempt to use the CARD? interface and a popular printer instead of a Commodore printer. The way around the lock-up is to disconnect the interface from the computer, power up the system, and then re-connect the interface... a heck of a way to do things.

A more-convenient way to avoid the lock-up without going through the disconnect-connect hassle is to build our printer delay, a device that delays the power to the interface for about 6-10 seconds when the computer is first turned on. When the printer delay's LED glows, you can go ahead and print without fear or worry that the computer is locked up. (Once again, another manufacturer's *zinger* is defeated!)

How it works

The CARD? interface has two computer connections.

One is a DIN connector that handles the serial output signals; it plugs into any serial connector on the computer or disk drive(s). The other connection is a combination socket/plug adapter for the computer's Datasette (cassette recorder) connector; it provides only the 5 volts DC needed by the CARD? interface; no signals come through the adapter connection. The adapter slips over the regular Datasette connector and the plug from the Datasette's umbilical cord plug slips over the adapter. A single wire from the adapter to the CARD? carries the 5 volts (the ground is provided through the serial DIN connector).

Refer to Figure 1. The printer delay is connected in series with the 5 volt wire from the adapter. When the computer is first turned on, 5 volts is applied to the 555 timer, which does not interfere with the computer. After 6 to 10 seconds, the timer provides a voltage to Q1's base, causing Q1 to conduct. The current through Q1's collector flows through reed relay RY1. The relay's contact closes and applies power to the CARD? interface. LED1 indicates that power is applied to the interface.

Construction

While component values are not really critical, it is suggested that you do not substitute for relay RY1. The

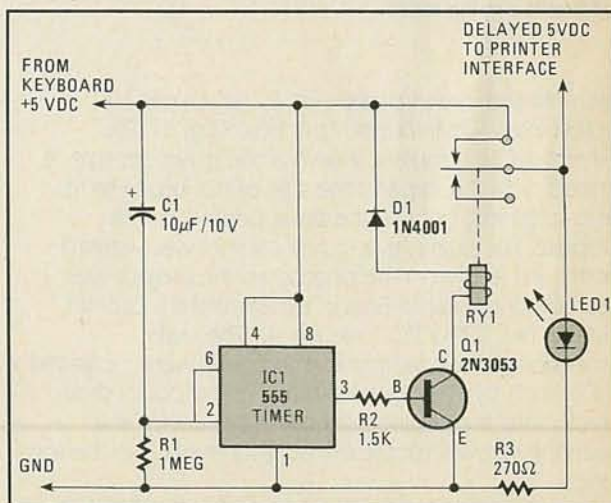

FIG.1—SCHEMATIC DIAGRAM OF THE PRINTER DELAY is simple and straightforward with most parts junk-box available. Do not substitute for relay RY1. Other components are not critical.

CARD? interface taps slightly more than 100 mA from the computer, and the printer delay shown uses about another 25 mA, most of it for RY1. Other relays will probably require much higher current, which might prove to be an excessive current load.

The entire project is assembled on a 1 $\frac{3}{8}$ -inch by 2 $\frac{7}{16}$

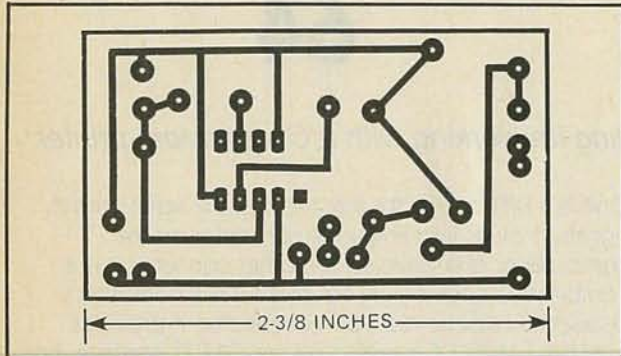

FIG. 2—FULL-SIZE CIRCUIT BOARD DIAGRAM is provided for those who desire to make their own boards. The above pattern can be reproduced photographically, or traced and etched.

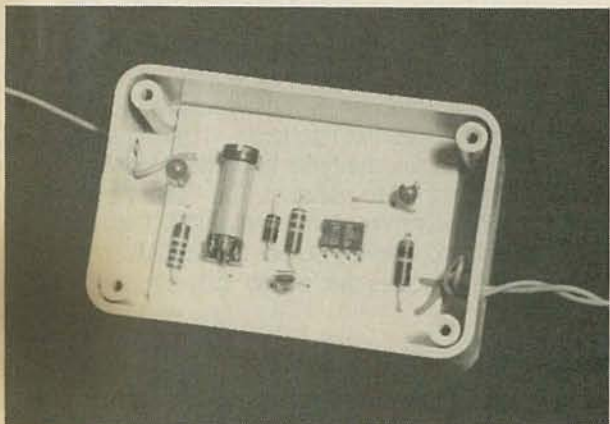

FIG. 3—USE THE RECOMMENDED CABINET, and the PC assembly just drops into place. Giving the wires a twist or two will provide strain relief.

-inch printed circuit board (Fig. 2) which can be tucked into a small plastic "pill box" (Fig. 3). The printed circuit template shown is the minimum size. If desired, you can expand the size of the board to fit larger cabinets, but use the same printed circuit template. For example, a sturdy cabinet was wanted for the unit shown in the photos, so the project was assembled in a Radio Shack "Experimenter's Cabinet," (catalog No. 270-230). (See Fig. 4.) The outer dimensions of the printed circuit board were increased to 1 $\frac{7}{8}$ inch by 2 $\frac{7}{16}$ -inches so the board could drop directly into the cabinet without the need for any mounting screws. Locate the hole for the LED in the top panel.

All component holes are made with a No. 57 drill. Even RY1's terminals will fit the No. 57 hole. If the relay's terminals don't line up with the holes, just bend the terminals to fit (they normally have substantial play and

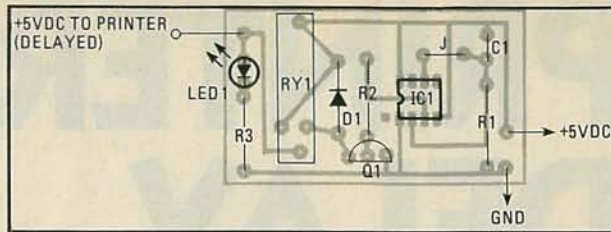

FIG. 4—POSITION THE PARTS on the printed circuit board as shown in this reversed view. The LED mounts atop the board and protrudes through the drilled hole in the cabinet cover.

can be repositioned slightly without bending). (See Fig. 4.)

You will find no assembly problems whatever. Just be sure the right IC and transistor terminals are in the right holes. Note that as shown in the parts placement diagram, the lead arrangement for Q1, from left to right is CBE. Should you substitute with a transistor having a different arrangement, either modify the template, or bend the transistor leads to suit.

LED1 can be any kind of light-emitting diode, though the diffused-lens type is easier to see from any angle. If you use the Radio Shack cabinet, pass the leads of the LED only $\frac{1}{4}$ -inch through the printed circuit board and solder. The LED will stick up about one inch above the board and will just pass through a hole that you drill in the cabinet's metal cover panel.

Using 12-inch lengths of No. 22 or No. 24 color-coded insulated stranded wire, connect a red wire to the positive (+) DC power-input hole and a red wire to the output hole. Connect a black wire to the input

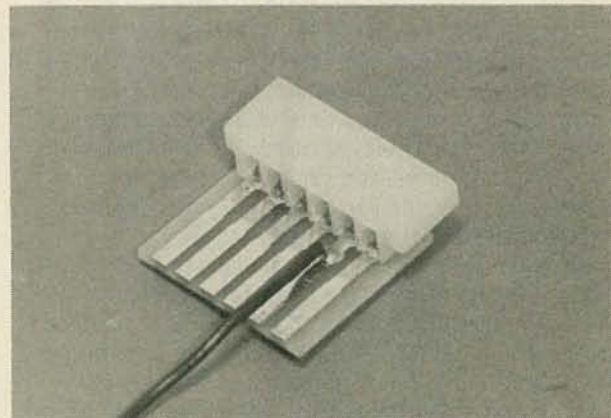

FIG. 5—THE ORIGINAL WIRING of the Datasette adapter. The wire connects to the 5-volt terminal. It will be replaced with the wire from the delay circuit. The terminal to the immediate right of the wire is ground. Tack-solder the ground wire from the delay circuit to this terminal.

ground hole and twist it (not too tightly) with the red input wire.

Drill a $\frac{1}{4}$ -inch wire-exit hole in each end of the cabinet. Set the printed circuit assembly into the cabinet (just drop it in), pass the wires through the cabinet, and secure the top cover. If you used the suggested Radio Shack cabinet, the LED will just fit

through the drilled hole in the panel.

Set the assembly aside for the moment.

Examine the Datasette connector/adaptor supplied with the *CARD?*. Take careful notice which side of the adapter has the power wire (there is only one wire). See Figure 5. Using *Solder Wick* and a soldering iron

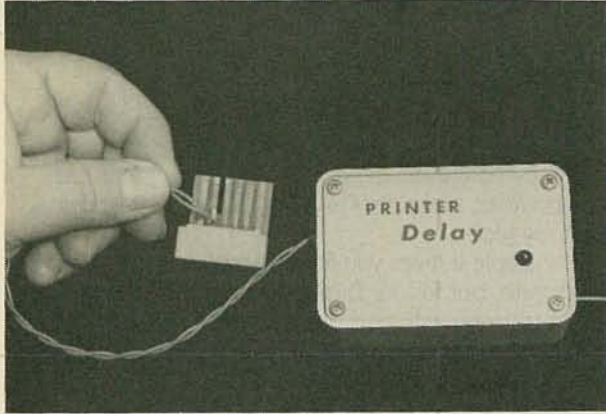

FIG. 6—THE MODIFIED ADAPTER. Note that both connections are to the left of the slot in the adapter. Use #22 or #24 stranded insulated wire for the connections.

rated at 25 watts or less, unsolder the wire. (Be sure to use the *Solder Wick* or similar desoldering braid. If the solder runs, you'll be creating problems.) The red power-input wire from the printer delay circuit—the one twisted together with the black wire—will be connected in place of this wire (Fig. 6).

The power supply ground for the printer delay is the #1 adapter terminal, which is located at the edge of the adapter, *immediately adjacent* to the terminal with the red wire. Tack-solder the black wire from the printer delay to this terminal *in the same relative location as the red wire*. Use just a touch of solder so it doesn't flow down the terminal.

Cut the original wire from the adapter to the *CARD?*'s DIN connector about three inches behind the connector. Cut the remaining red wire from the printer delay to size and solder it to the wire stub from the *CARD?* connector. Wrap the connection with a few turns of tape.

The installation is now complete.

Checkout and use

Connect the *CARD?*'s DIN connector to the matching socket on the computer or disk drive and install the *CARD?*'s Datasette adapter on the computer's Datasette connector (see Fig. 7). Notice that the adapter has a polarizing slot that engages a "key" on the computer connector. You cannot reverse the adapter unless you force it and break the "key" or the adapter. If you use a Datasette cassette recorder, slip its umbilical cord connector over the adapter.

Now turn on only the computer.—No peripherals. The computer should "come up" with its usual READY screen display and the LED on the printer delay should be off. In 6 to 10 seconds, the LED should light. If it doesn't, something is wrong with the printer delay

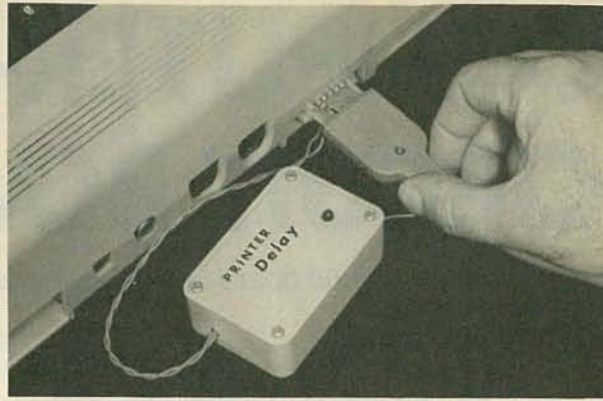

FIG. 7—THE ADAPTER WIRE SLIPS ONTO the computer's Datasette then onto the adapter.

circuit or the red and black connections to the Datasette adapter.

If the LED lights, all is okay. Turn the computer off. Now turn on the computer, the printer and the disk drives, if used, in any order you want. After 6-10 seconds, the printer delay's LED will light and the system is ready for use.

To check the system, simply enter the program:

```
10 OPEN 4,4
20 PRINT#4, "I DID IT"
30 CLOSE 4
40 END
```

and then run the program.

If everything is working properly, the printer will print "I DID IT."

Next, check your disk drive. Place a disk with a known file in the drive and LOAD it. If it loads, everything is working properly.

By using the printer delay it should make no difference in what sequence the peripherals are turned

PARTS LIST (All resistors ¼ watt, ± 10%)

R1—1 megohm

R2—1500 ohms

R3—270 ohms

Capacitors

C1—10 µF, 10 volts, tantalum

Semiconductors

IC1—555 Timer

Q1—2N3053

D1—1N4001 Silicon rectifier, 50 PIV or higher

LED1—Diffused lens LED

Other Components

RY1—5-volt reed relay, Radio Shack 275-232

See text

Miscellaneous—Cabinet, printed circuit board, wire, etc.

on. There will be no lock-up of the computer regardless of the power-up sequence, and it won't be necessary to fuss or fiddle with any of the peripheral connections. ◀▶

COMPUTER-AIDED CIRCUIT BOARD DESIGN

Design printed-circuit board layouts using your Apple II.

GLENN CALDERONE

■CAD—Computer-Aided Design. In the manufacturing of anything from automobiles to spacecraft, a design can make its debut and be tested long before a physical device that uses the design is actually built. Tests, modifications and improvements can all be implemented at the touch of a keyboard or the sweep of a light pen.

Circuit-board design systems, like most industrial CAD systems, are usually reserved for big spenders—the necessary hardware and software cost a bundle. Until recently, it wasn't practical for the small scale (or part time) designer to even consider using a computer for circuit-board layouts. However, using an *Apple II* and a dot-matrix printer, just about anyone can create even complex printed-circuit artwork without drawing on paper or pasting lines and dots on acetate. The end result will be a professional-looking, highly accurate circuit board which you can expose, etch, and drill yourself. Of course, you can also send the computer-generated artwork to a PC-board specialist for the actual board making.

After drawing the circuit trace pattern on the *Apple II* computer screen, you can store it as binary data on a diskette, and then "dump it" to a dot-matrix printer. The image printed on paper can then be converted into a film positive (or negative) by the camera person at your local graphic arts or offset print shop.

The *Apple* high-resolution graphics screen consists of 53,760 square dots or *pixels* (picture elements) arranged in a pattern of 280 across by 192 down. On the computer screen, each pixel may or may not appear as a square—it depends on the quality of your CRT and how it's adjusted. For example, a pixel may look more like an oblong dot on your screen. But when the hi-res image is transferred to paper, each pixel will appear as a nice square.

Drawing on the *Apple II*

Although drawing on the *Apple II* hi-res screen can be done with simple *Applesoft* commands such as HPLLOT and XDRAW, it is far easier to use one of the popular graphics software packages. (All samples shown in this article were done with *E.Z. Draw 3.3* from Sirius Software). Those let you use either the keyboard, joystick, drawing tablet, or light-pen to put lines on the screen. Master the art of drawing straight lines—starting and stopping on the same X or Y axis coordinate, before you start your first circuit design. Most programs offer a continuous on-screen readout of your drawing cursor location, so you can make sure you

are lined up before you draw. Your best PC-board design will have all lines and rectangles drawn either perfectly horizontal or vertical. Avoid diagonal and curved lines, since they take up too much space and look ragged.

The *Apple II* gives you four colors (plus black) to work with, but for our project, you should always use white to draw with and black to erase. If you try to use colors, some lines will not show up, and those that do will print as dotted lines. When viewed on a color screen, vertical lines may appear either green or violet even when you've selected the color white. That's normal for the *Apple II*, but distracting when you are designing circuits. In fact, the resolution and sharpness of most color sets when used with the *Apple II* is unsatisfactory for high-resolution artwork, since you need to clearly see each pixel as a separate dot. So use a monochrome display screen (green, amber or white) if possible. Or if you do use a color screen, turn the chroma intensity all the way down.

Scale

We have chosen 1 pixel to represent the smallest line, dot, or hole on our circuit board. A distance of 60 pixels represents 1 inch on the finished board. That scale means that our minimum foil trace size must be 0.0167 inches (1/60 of an inch), and we can locate parts to plus or minus half that (.00834 inches). On a 12-inch CRT you will have a working area of about 5 by 7 inches. It really doesn't matter what size screen you design your circuit on—the finished circuit board pattern will be a rectangle 3.2 inches high and 4.67 inches wide.

But is it large enough for your project? It depends on how complicated your circuit is and how densely you package the components on the board. You should be able to easily lay out eight socketed 16-pin ICs plus the necessary resistors, capacitors and diodes on a board, including input/output connectors. With mounting hardware and connectors, the little circuit board will fit nicely on readily available, pre-sensitized PC blanks (4 or 4½ by 6 inches).

Since we have chosen a scale of 60 pixels-per-inch, we need to translate our component-lead spacing and mounting sizes into pixel units. Common DIP sockets all use 0.1-inch pin spacing, so we use six pixels. The width of a 16-pin DIP is about .325 inches—or 20 pixels. Suggested spacing for other IC's and discrete devices is shown in Fig. 1.

With care, you can safely make PC board patterns one pixel wide with only one pixel space separating

them. If you have the room make all foil patterns as wide as possible. This keeps resistance to a minimum and makes it easier to expose the board and reduces the chance of etching away a trace.

How to begin

Outline the on-screen working area by marking the four corners (or tracing the entire rectangle). Lay out your power-supply rails, inputs and outputs first. If your software permits it, draw and store images of the patterns you use most often, such as DIP sockets, small transistors, and edge connectors. Recalling them from disk and moving them about as necessary is much faster than drawing identical patterns over and over.

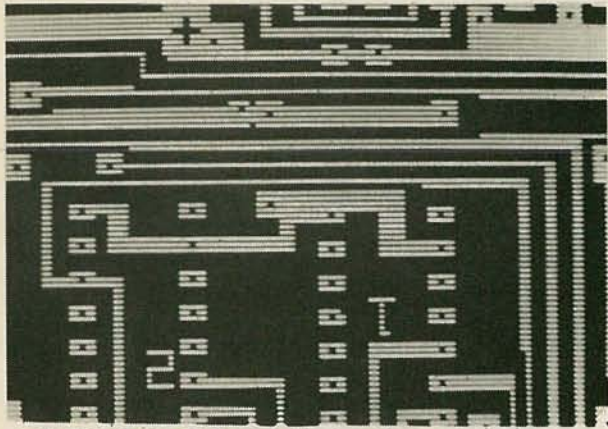

A CLOSEUP OF THE CRT display. Hi-res pixels appear as oblong, rounded points of light.

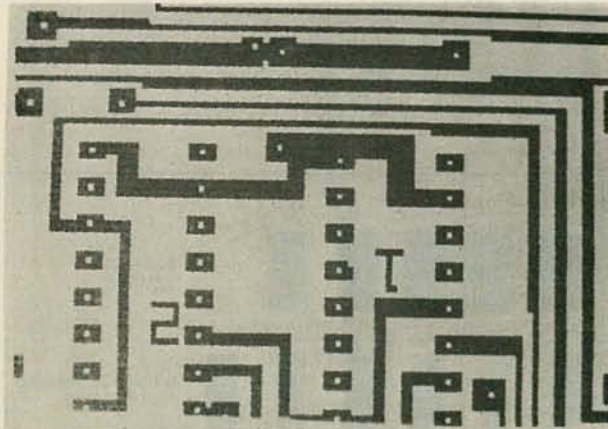

CLOSEUP OF PRINTOUT FROM a dot-matrix printer. Pixels now appear as squares.

Remember you are designing the foil side of the board, which is a mirror-image of the component side. For DIP sockets, "pin 1" will be on the upper right hand corner. Use normal PC board layout practices:

- Keep inputs and outputs separate.
 - Allow enough room for components on the other side of the board.
 - Double check every trace against your schematic.
- As a beginner you may want to sketch a rough layout on paper before going to the computer, but after awhile it should be easy to design and draw right on the screen. The ease of design at this point depends

somewhat on the available features of your drawing software. Some programs allow you to mark an area and duplicate it several times at different locations on the screen. That is useful when your circuit uses identical stages, such as a decoder-driver/LED assembly. Draw it once, and create two or three side-by-side duplicates. Use your program's "fill", "color", or "paint," feature to fill-in large areas, especially parts of the board where no components will be mounted and no traces will go. The less copper you have to remove from the board, the longer your etchant will last and the less time you'll have to wait to see the results.

Since IC's, resistors, and capacitors all require different size holes, you can code your pattern to the proper size drills. For example, all dip sockets could use a 3×5 pad with a 1-pixel hole in it; resistors, a 4×5 pad with a 1×2 hole; capacitors, a 4×6 pad with a 2×2 hole. (See Fig. 2.) Adjust the pad and hole sizes to match the lead diameter of the components you are using. Hint: Make all pads at least 3 by 4 pixels. If they are any smaller you risk lifting the copper foil off the board when soldering.

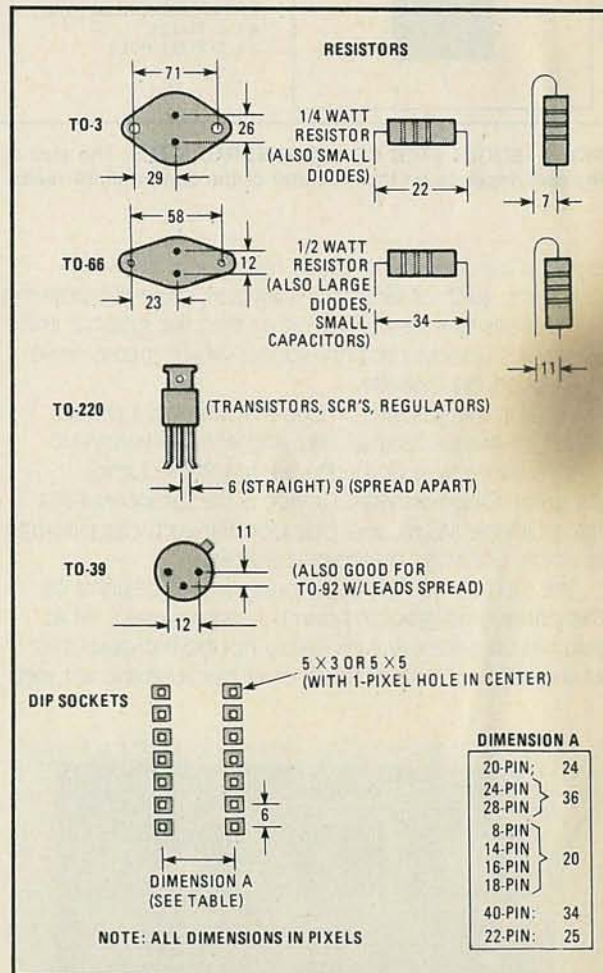

FIG. 1—SUGGESTED SPACINGS REQUIRED for some of the common components you may find yourself dealing with.

Storing and printing

The Apple II stores its hi-res graphics page (8192 bytes) on disk as a 34 sector binary file, and one 5.25

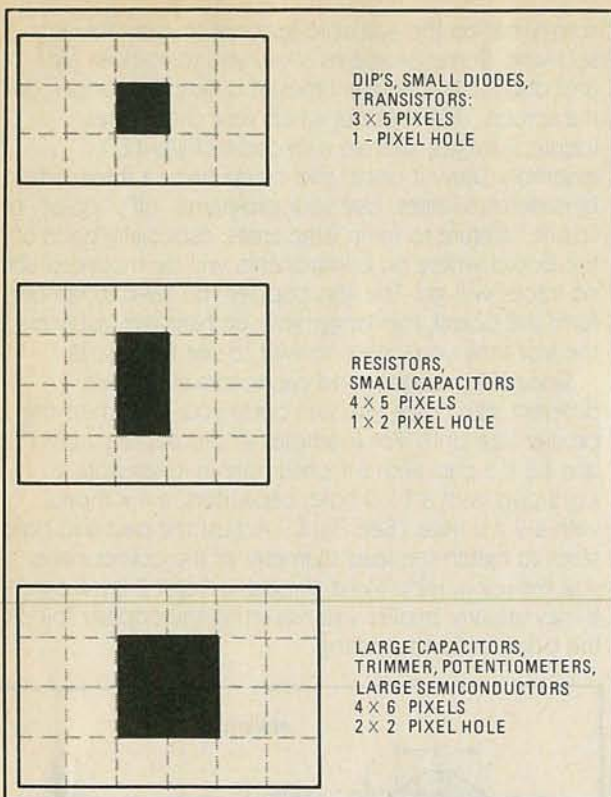
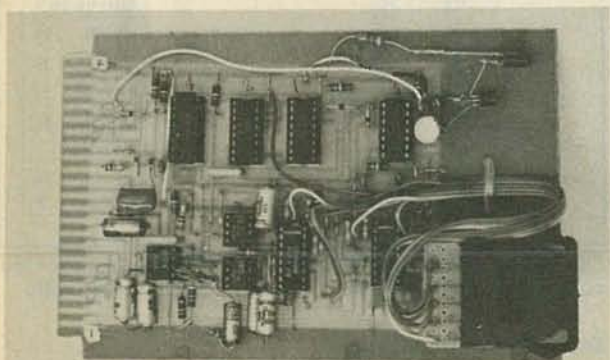

FIG. 2—SUGGESTED COMPONENT-PAD SIZES. The size of the pad depends on the diameter of the components' leads.

diskette can hold 14 of those files. Some drawing programs, such as *Graphics Magician*, store the drawing instructions as a binary file rather than the graphic itself. That takes up less memory space, which means fewer sectors on the diskette.

To print the graphic on paper you need a printer with dot-graphics capability, and either a hardware graphics interface or a software graphics dump program. One hardware device is the *Grappler* card from Orange Micro, and one popular software package is *Zoom Graphics* by Phoenix Software.

The size of the hardcopy printout will depend on the printer and graphics dump program used. What you get on paper will probably not be the exact size of the finished board. That's okay, because the last step



FINISHED AND TESTED PC board made using the Apple CAD method.

is making a film positive for contact-printing onto a light-sensitive PC board—and there the size can be adjusted. At this point you may wish to send your artwork out to a PC board fabricator. If you're going to etch the boards yourself, have your artwork photographed by a commercial offset printer. Rates vary, but expect to spend about \$5.00 for a finished piece of film up to 8 × 10 inches, including the necessary image size reduction. Need a negative instead of a positive film? Your computer graphics dump program can reverse the image before it gets to the printer. Or the print shop can make a negative. Of course, if you're handy with a large-format (press, view or process) camera and have access to a darkroom, you can keep the entire project in-house.

Doing more than one board design? Put them all together and shoot them all on one piece of film and cut them apart later. When choosing the size to make your hard copy, it's best to go larger than life and have it reduced when it's photographed. That way you can more easily touch up any defects in the printout (or errors in your design that you didn't previously catch). The circuit boards in the pictures here were printed on a dot-matrix printer with the graphics-dump software set for 2 × enlargement, so that each pixel printed as a 2 × 2 dot pattern. The resulting paper printout was larger than the finished board, so we made a reduction to 60% with the film camera.

Here's how to determine the amount of reduction: measure exactly the distance between 60 pixels on your hard copy, in inches. Take the reciprocal (divide into 1) to arrive at the necessary percentage. Hint: Make two marks on your PC board layout that are exactly 60 pixels apart. They needn't be larger than one dot each.

For edge connectors using .1-inch (on centers) spacing, make your lines 3 pixels wide, centered every

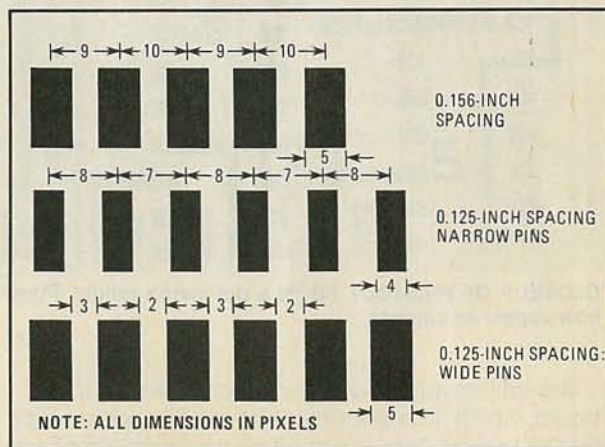

FIG. 3—SPACING REQUIREMENTS for typical edge connectors are shown here. You could use edge-connector decals on your film positive, if you prefer.

6 pixels. Spacings such as .125 and .156 are shown in Fig. 3. If you wish, you can apply edge-connector decals to your actual-size film positive, and draw connecting lines with an opaque-ink pen.

With some practice you will find it faster and easier

Software listing

This is a partial listing of currently available graphics programs for the Apple II+ and IIe:

Apple Graphics Tablet from Apple
Applegraphics II from Apple
The Complete Graphics System from Penguin Software for joystick or tablet
E.Z. Draw 3.3 from Sirius Software
Graphic Solution from Accent Software
Graphics Magician from Penguin
The Artist from Sierra On-Line Software
Versa-Writer from Versa Computing

Commercial circuit-board CAD systems

Commercial circuit board designers use elaborate computer-aided design systems to create the artwork (or even actual boards) for large, complicated double-sided circuit boards without ever lifting a pencil. Combine CAD with CAM (Computer Aided Manufacturing) and even the film and etching processes can be eliminated.

Commercial systems are a dream-come-true for design engineers, considering some of the things the computer can do. For example, the engineer can digitize a hand-drawn schematic, or draw the circuit on the computer screen directly. Next, the computer routes the traces as desired, and checks the schematic to make sure all connections are made. It also lists all unconnected pins and wiring errors. Using advanced rule-checking, the CAD system looks for traces, pads or components that are too close together. The ultimate design aid is a feature that automatically moves parts around to make room for design changes.

Commercial CAD systems offer very high-resolution displays using RGB color-monitors, so that parts outlines and traces on each side of the board appear in different colors. The circuit-board design is not stored as pixel data, but as vectors. What you see on the screen is independent of the actual design data, so resolution is not limited by the computer hardware. That lets you pick an area on the circuit board, magnify or "zoom-in" to draw the traces, and drop down to a lower magnification to see the entire board.

Printing the finished circuit-board pattern is done on either a pen plotter or laser imaging-system. Plotted images are usually very large, and reduced by photographic means to an actual size negative or positive film. Direct imaging by laser can be done on film or directly onto the resist coating of a copper-clad circuit board.

Some CAD/CAM systems actually machine the circuit board traces, using a computer-controlled router to grind away the thin layer of copper on a blank circuit board.

If you have an IBM PC (or compatible computer) with 512K memory, two disk drives and color-graphics board, you can get into the "big time" for as little as \$4500. Personal CAD SYSTEMS, Inc. markets a software package called *PC-CARDS* for designing boards up to 60 by 60 inches, with 500 components or 10,000 pins, whichever comes first. Ready to spend more? For about \$37,000 there's *ICON* by Summagraphics Corporation. Other contenders in the large system category include *Insight* by Scitex; *Excellon Automation*; and *EAS Series 700* by Engineering Automation Systems, Inc.

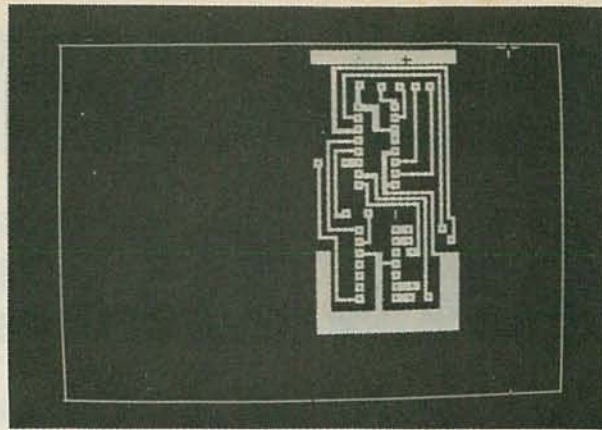

TYPICAL USEFUL DESIGN. CMOS 4511 (seven-segment decoder/driver) and MAN-7 LED display. This one-stage display circuit (stored on diskette) becomes a building block for more complicated designs.

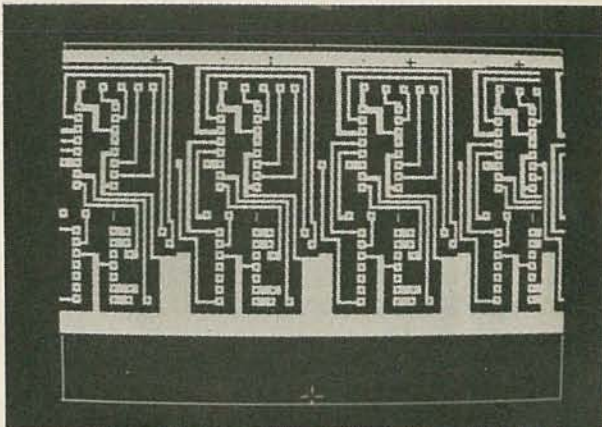

FOUR STAGES OF THE DECODER/DRIVER and LED. It took only 30 seconds to assemble from the one shown in the previous photo.



CAD FOR PCB'S: Workstation for *Insight*, a computer circuit board design system by Scitex Corporation (Israel). Drawn, photographed or digitized artwork can be entered, along with drilling information. The computer enhances the design, checks for errors and draws the finished pattern on its laser scanner.

to design and draw PC boards on your *Apple II* than any other way. For larger, more complicated designs, you can draw them in sections and paste the printed images together. ◀▶

MEMORIES ARE BITS & PIECES

HERB FRIEDMAN

Computers are often purchased based on the answer to the question "How much memory is there, rather than "Can this computer do the job I need done?"

■ If you're an old hand at personal computing, you probably know the ins and outs of every memory location in your computer. But if you're new to personal computing (or haven't yet gotten beyond contemplating which entry-level computer to purchase for the family), then you may still be confused by the terms RAM and ROM.

RAM and ROM are two kinds of computer memory: There is actually a third kind, WOM—Write Only Memory (no joke)—but we will not get into that at this time. RAM is an acronym for Random Access Memory, also known as read/write memory. A user can store information in RAM, read the data stored there, and change the information stored as well. The data in RAM is volatile—it vanishes when its power supply is turned off.

ROM is an acronym for Read Only Memory, ROM is memory that has been preprogrammed with *permanent* data that cannot be changed; the user can only read the data stored in the cell. The data cannot be modified or erased: it is always there when power is applied to the computer.

What is 64K

RAM and ROM can be employed in any combination up to the maximum number of memory cells that can be addressed by the microprocessor that runs the computer. Without going into the mathematics of how it's done, an 8-bit computer can address (or work with) a maximum of 65,536 individual memory cells—what we call 64K. (We'll explain why 65,536 is called 64K—for 64,000—in a moment). A 16-bit computer can theoretically address tens of thousands of memory locations, but because of design considerations for personal computers, the present limit is about 786K. To keep the numbers simple and easy to comprehend, we

will limit our discussion to 8-bit computers.

First, the "missing" memory. What happened to the missing 1536 memory cells in the 64K computers, such as Radio Shack's 64K *Color Computer* and the *Commodore 64*? There is no missing memory: 64K is *electronic shorthand* for 65,536. We use that "shorthand" as a convenient way to describe partial blocks, such as 1K, 2K, 4K, 16K, etc.

Anyway, back to ROM and RAM. The computer doesn't care whether the theory it works with is ROM or RAM: there can be one single cell of ROM and 65,535 cells of RAM, or one cell of RAM and the remainder ROM. The total of RAM and ROM can be less than the maximum. But without *bank switching* it can't be more.

Memory configurations

In the typical home computer, part of the available memory is used for the ROM having built-in BASIC, the video-screen memory, and assorted utilities needed to run the computer. In the early models of the Radio Shack and Apple computers, the first 16K of memory was reserved for the manufacturer: the user-available memory started at 16K. Since the first 16K was reserved, it meant that a maximum of 48K was available for user RAM. There could be as little as 4K of user RAM, but the maximum was 48K.

Bear in mind that contrary to the implications in the advertising by their competitors, the Radio Shack and Apple computers weren't inferior to a 64K computer; they were, in fact, 64K machines that allowed only 48K for the user. Depending on the software, the 48K machines could be—and usually were—superior to the so-called 64K computers.

Figure 1 shows how it was done. Depending on the particular computer, the resident BASIC, the video

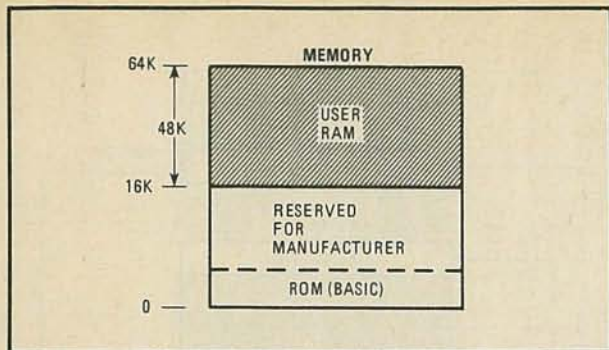

FIG. 1.—THE EARLY, SUCCESSFUL, PERSONAL COMPUTERS handled future expansion by reserving all memory addresses below 16K for the manufacturer's use. Enhancements were tucked into the unused memory below 16K and did not interfere with the user RAM located above 16K.

memory, and the I/O took up between 4K and 12K, leaving at least 4K available for future expansion. When, for example, Radio Shack upgraded their version of BASIC, they tucked the improvements into the "free" memory below 16K. In that way, Radio Shack and Apple upgrades did not usually interfere with existing software, or the user-written programs that used the free RAM above 16K. When Radio Shack introduced a disk system for their computer they were able to tuck the disk controller's address into the reserved area below 16K, and again, did not cause unnecessary problems for users upgrading their basic computer.

Computers that don't have memory-mapped video or BASIC in ROM have almost the entire 64K of RAM available for user use, as shown in Figure 3. (If the video screen is memory-mapped, the RAM used for the video is not available to the user.) Note that the CPU (the microprocessor) "sees" both the 64K of RAM and a small start-up program in a ROM separate from the main memory. The start-up ROM program causes the CPU to read a small *loader* program from the associated disk drive to RAM; the loader in turn reads the disk operating system in from the disk to RAM. (If the computer uses CP/M, the operating system loads into both the top and bottom of memory—the user area is between the two.)

If the user decides to then program or run a BASIC program, he would use the operating system to load BASIC into another part of memory—above the RAM containing the disk operating system. Depending on the particular version of BASIC, the total RAM required for both the operating system and the BASIC interpreter could easily total 24K. Add in a few required utilities here and there, and the original 64K of RAM shrinks to about 32K of user-available memory; which is about what we had from the so-called "48K" Radio Shack and Apple computers when they were running disk BASIC. (There is no such thing as a "free lunch" or "free memory.")

The advantage to having the full 64K of memory available comes when you are running a non-BASIC applications program. If an applications program is written in BASIC, BASIC must be resident in the computer for the program to run. But if the program is in pure binary code there is no need for a resident

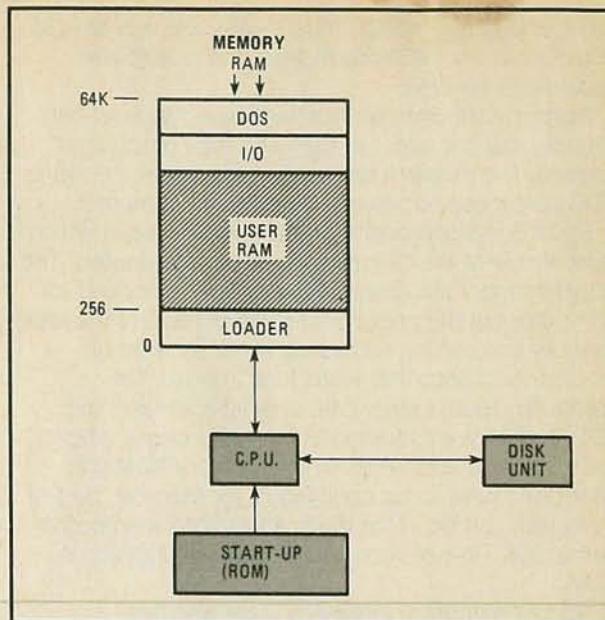

FIG. 2.—WHEN THE ENTIRE MEMORY IS FREE (empty), an operating system must be loaded in from a disk. (Early non-disk personal computers loaded BASIC and its utilities from cassette tape.) The loading process is usually started by a small start-up program of less than 256 bytes located in ROM outside the main memory. In the case of CP/M, the operating system loads into both the top and bottom of RAM; the user RAM is between the two.

BASIC. Referring back to Figure 2, instead of the monitor loading BASIC in from disk to RAM, it can load an applications program into the RAM above the operating system, with the remaining RAM being available to the user.

But consider what would happen if we tried the same thing with the arrangement shown in Figure 1, where only the RAM available above 16K is free. The applications program would have to go in above 16K. Without going into the arithmetic, the same applications program would leave from 4K to 12K less RAM available for the user in the ROM-BASIC computer than in the computer with a full 64K of memory available.

In their latest computers Radio Shack and Apple make an extra 16K of RAM available by switching the ROM's containing the BASIC in and out of the circuit. In the simplest terms, Radio Shack does it this way: The computer starts and attempts to load an operating system from the disk drive. If the CPU senses that the disk contains the CP/M operating system the ROM's are switched out and replaced with RAM, thereby making a full 64K of RAM available to the user, and the CP/M system loads into memory. If the computer senses the disk is loading a TRSDOS-like operating system such as NEWDOS or DOSPLUS, the ROM's are left in-circuit and user-memory starts at 16K.

When the ROM is a cartridge

That kind of juggling of memory works out well when done smoothly, but it doesn't adapt well to the home-and-family computers such as Radio Shack's *Color Computer* and the IBM *PCjr*. The reason is that the

home-and-family models must have some way to load in programs from ROM cartridges, and possibly an expansion disk drive.

Program cartridges are nothing more than read-only memory that the user can plug into the computer as needed. The memory addresses used for the cartridge ROM's are those not usually used by the computer.

Figure 3 is a composite of the various ways in which ROM and RAM are intermixed by home computers. The actual memory addresses will vary from computer to computer, but the concept of reserving part of the *total* memory that can be addressed is the same for all models. And keep that word *total* in mind. The computer doesn't really care at what addresses the ROM and RAM are located as long as it knows where the memory is and what's in the memory. ROM and RAM don't have to be contiguous; for example, part of a program can be in the lower 8K of RAM and another part at 32K. (In-between can be several functions in ROM.)

Home computers, in general, have a socket (connector) into which a program cartridge can be inserted. When the socket is empty the computer's CPU "sees" only the first 32K of memory, which contains the start-up sequence, video memory, BASIC, etc. When you turn on the power, the computer "comes up" in BASIC, with the screen displaying a prompt such as OK or READY.

The program cartridge that plugs into the socket has its ROM(s) installed on a printed-circuit board. The circuit board's connector—called an edge-connector—consists of foil "fingers" that match the socket's terminals. Two (or more) of the fingers serve as a "switch" for the computer's CPU.

When the cartridge is inserted into the socket the "switch" finger contacts force the CPU to "see" the ROM in the cartridge. The CPU carries out the instructions (program) stored in the ROM, which is usually a complete program: a game, a word processor, a spreadsheet, etc. As a general rule, cartridge software is completely resident in the memory locations above 32K (except for the common computer functions that are normally resident in ROM below 32K, such as the printer and cassette-tape I/O, color control, etc.). Also, though the program is located above 32K, it uses the free RAM located below 32K for transient data.

In the IBM PCjr, the cartridge called *Cartridge BASIC* is actually overlay enhancements to the BASIC already in ROM. The cartridge starts the computer, applies the enhancements, and then uses the original ROM functions.

While we generally speak of cartridges containing software in ROM, there is nothing to prevent the cartridge from also having RAM. There are several cartridge programs that require more RAM than is normally supplied with the computer. In those instances, the program cartridge also contains the extra RAM required by the program; but the "extra" RAM is lost when the cartridge is removed.

While we tend to associate plug-in cartridges with software, they also can be used for disk systems; the controller and the operating system. In that instance,

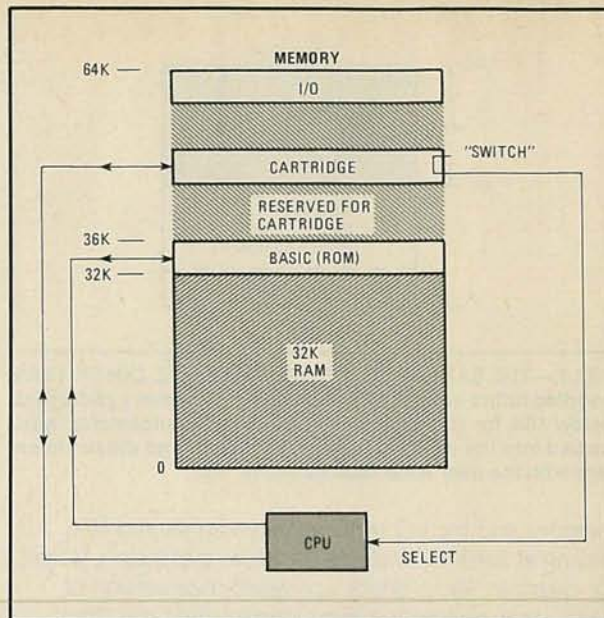

FIG. 3.—THE HOME/FAMILY COMPUTERS generally use specific areas of memory for user RAM, BASIC, and I/O. They can be positioned anywhere within the *memory map*. A cartridge, with ROM preprogrammed for a game, applications program or a disk operating-system, makes use of the unoccupied addresses of the memory map. Special switching contacts within the cartridge force the CPU to look at the cartridge for its start-up instructions.

the cartridge contains a disk controller, the complete disk operating system in ROM and, in some instances, extra RAM for the disk operating system's transient functions. One side of the cartridge connects to the computer, the other side has connections for the disk-drive mechanism. (Or, the disk-operating ROM's are built directly into the disk drive's cabinet, and a connecting cord connects the ROM's to the computer.) Once again, "switch" fingers on the cartridge's edge-connector forces the CPU to "see" the cartridge. There's no need to load an operating system in from the disk because it's already in memory, ready to go the instant the computer is turned on.

Bank switching

Though we have been speaking in terms of 64K of memory for 8-bit computers, many 8-biters now address 128K of RAM. Bank switching is exactly what the term implies: The memory is arranged in two (or more) banks of 64K. Special hardware and software automatically switches in the correct bank as needed. Generally, the software for a computer with bank-switched memory will provide some means whereby the total memory can be partitioned. For example, the total memory of a Radio Shack *Model 4* computer can be partitioned so that some of the RAM functions as a *RAM-disk*. As far as the computer is concerned, the partitioned memory is actually a disk, only the data can flow into and out of the "electronic disk" a lot faster than it can from a real disk. Unlike a real disk however, when the computer is turned off, all the data in the RAM-disk is lost unless previously saved in a physical disk. ◀▶

plifier. Remember, the impedances must be matched. Figure 1-b shows how an audio-input transformer is used to match two different impedances.

You may have noticed that the transformers in diagrams 1-a and 1-b of the figure are alike, except that their primaries and secondaries are reversed. Actually, the only difference between input and output transformers is the name—you can use an output transformer as an input device and vice-versa. A transformer doesn't care whether a signal is going from its high side to its low side or the other way around—just hook it up in the direction you need!

That information can be very handy for things other than intercoms. For instance, a few years ago, I needed to record the sounds from a large area that was some distance from the tape machine. Of course, I could have used a standard microphone and a long run of microphone cable, but that stuff is expensive and the cable has fairly high signal losses. So instead, I simply connected an output transformer "backwards" (with high impedance side going to the recorder) and ran a long length of old lamp cord between it and a speaker.

My "microphone" (in this case the speaker) was quite sensitive and the recording was perfect. That setup can be used for recording anything, for instance bird calls, from a remote location!

Multiple inputs

David O'Brien (MN) would like to add several call stations to his intercom and have each of them give a distinctive sound, so that he can tell which is being used. There are a number of ways to accomplish that, David, but I'll show you one that does not require fooling around with the intercom's amplifier wiring.

Take a look at Fig. 2; it shows an astable multivibrator (oscillator) connected across the remote speaker/microphone wires of an intercom. (The oscillator circuit is not given because of the large number of 555 oscillators that have appeared in past "Hobby Corner" columns and other places.)

When the oscillator is turned

on, an audio signal is input to the intercom and you'll hear it just as you would a voice in the remote speaker. By making the frequency of the oscillator adjustable, and using several at different stations, you can tell from which location the tone is coming. For example, you could put an oscillator with a high pitch at the front door and one with a low pitch at the back. Any practical number of oscillators may be used at various locations to tell you which one is activated. Just

remember: You must be able to distinguish between the tones.

Although Fig. 2 shows that we used a transformer as coupling device between the oscillator's output and the intercom wires, you'll have to do a bit of experimenting to determine just what to put in the circuit there. It depends on the input circuit of the amplifier and the number of oscillators you add. Direct connection *might* work but you'll most likely have to add a

continued on page 94

VIEW 8 TRACES ON YOUR SINGLE OR DUAL TRACE SCOPE WITH THIS LOW COST DEVICE!!

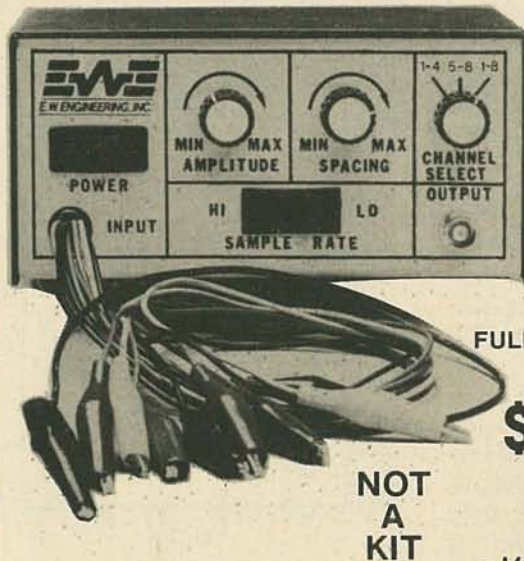

Now you no longer have to spend thousands on an expensive multi-trace oscilloscope — our single trace Hitachi scope combined with this module will allow you to view up to 8 simultaneously occurring analog or digital (or both) signals in their real time and amplitude relationship. The MPX 101 may be used on any oscilloscope, whether single, dual or multiple traces. Its low cost makes it a particular favorite for designers, testers, hobbyists and repairmen who want to compare and analyze displayed signals in a timing diagram format. The controls on the front panel of the metal case allow you to vary amplitude and spacing of the displayed signals.

**MODEL MPX101
FULLY ASSEMBLED & TESTED!**

\$99⁸⁸
FULL 1 YEAR REPLACEMENT WARRANTY

— Made In The United States —

SPECIFICATIONS

Inputs: 8 signals plus ground via 9 input leads terminated with alligator clips
Bandwidth: ± 1 dB to 5 MHz
Impedance: 10.9 K
Input Voltage: ± 5 V peak (diode clamped to ± 5 Volt supplies)
Output: Staircase waveform summed with input signals, 0-800 mV full scale
Step Amplitude: Variable 0 to 150 mV/step
Signal Voltage: Variable 0 to

150 mV/step @ 5V Input
Multiplex Rate: Switch selectable, 40 KHz or 4 KHz
Impedance: 50 Ohms
Power: 105-135 VAC @ 1 V a
Dimensions: 6.25" x 3.25" x 4.75" (WxHxD)
Operating Temperature: 0-40°C
Weight: 1 lb. 10.5 oz.
Warranty: one year full replacement warranty from date of purchase
Lighted on/off power switch
Wood grain finished metal case

DISTRIBUTOR AND REPRESENTATIVE INQUIRIES INVITED



VISA, MASTERCARD, AMEX TELEPHONE ORDERS ACCEPTED!
6 Herman Drive, E. Granby, CT 06026 □ 203/651-0285

CIRCLE 82 ON FREE INFORMATION CARD

DRAWING BOARD

Special-purpose IC's

WORKING ALONE IN AN ISOLATED CORNER of the basement is great for the concentration, but there are certain inherent disadvantages. Floods and poor lighting, for example, go with the territory. However, the biggest problem is the isolation: It's impossible to keep up with *all* the literature and learn about all the latest time-saving devices if you remain tucked away in your cocoon. Furthermore, we all have a tendency to stick with familiar components—so certain IC's that could save us loads of design time never find their way onto the workbench. We saw an example of just that over the last several months with the 4018.

Well, there are a couple of other IC's that can make certain design problems shrink from formidable to trivial. Even though they have been around for a long time, they are special-purpose IC's and, as such, can handle only the job for which they were designed. This month we're going to examine the *rate multiplier*, which is another type of special IC. We'll find out what it can do and how we can use it.

Rate multipliers

One of the least understood special-purpose IC's in use today is the *rate multiplier*. This special-purpose counter, available in either CMOS or TTL versions, comes in two basic configurations—binary and BCD (Binary-Coded Decimal). Figure 1 lists some of the various rate multipliers available. To put it in simple terms, a rate multiplier is a number cruncher. It allows us to do all



ROBERT GROSSBLATT

FAMILY	DEVICE	TYPE	MAXIMUM COUNT
TTL	7497	BINARY	64
TTL	74167	BCD	10
CMOS	4089	BINARY	16
CMOS	4527	BCD	10

FIG. 1

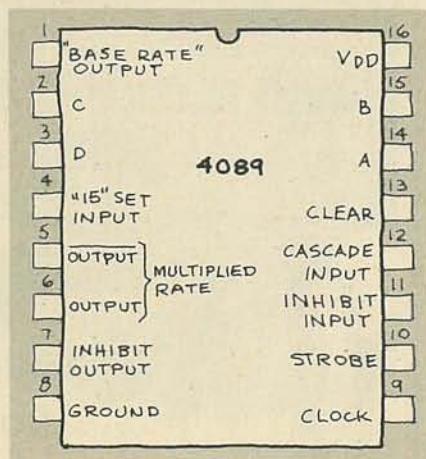

FIG. 2

kinds of arithmetic from simple operations (like multiplication and division) to more complex functions (like logarithms and square roots). Which rate multiplier you use depends on the logic family you are using and the kind of counting you want to do.

There are minor differences between the TTL and CMOS versions, but we won't get into that until we have a better idea of what rate multipliers are all about. Because we need *some* starting place, we'll look at the CMOS binary version (4089).

Figure 2 shows the pinout for the 4089. In simple terms, a frequency is fed into the IC at the clock input (pin 9) and it, in turn,

provides us with two kinds of outputs. The first (at pin 1) is called the *BASE-RATE* output. That output frequency is equal to the input clock frequency divided by 16. The second output is at pin 6 (the complement of which is at pin 5): For want of an official name, we'll refer to it as the *MULTIPLIED RATE* output. That output is equal to the base-rate frequency multiplied by whatever binary number is presented at its weighted inputs (at pins 14, 15, 2, and 3). If all that seems bit complicated at first, don't worry; you'll soon see that it really isn't.

The 4089 takes an input clock frequency and divides it internally by 16. The *BASE-RATE* output (at pin 1) will put out one pulse for every 16-pulses fed to the clock input at pin 9. The weighted inputs, pins 14, 15, 2, and 3, are preprogrammed to represent a numerical value ($A=1$, $B=2$, $C=4$, and $D=8$ respectively). Now let's assume we present a binary 5 or 0101 at the weighted inputs. In other words, a high A, low B, high C, and a low D is equal to 5. The multiplied output is going to be the base-rate multiplied by 5.

If a frequency of 16 kHz is fed to the clock input, the base-rate output will be 1 kHz. The frequency at the multiplied output then becomes 5 times that, or 5 kHz. The rest of the pins are used either to

control the operation of the IC or to cascade several IC's together. The easiest way to understand what they do is to look at Fig. 3: There you see a complete listing of the various input possibilities along with their outputs. But before we go into the details of the device's operation, let's take a look at what was once called the *big picture*.

Output symmetry

It sounds as though the IC is doing all kinds of useful things that we would ordinarily accomplish with a circuit board full of gates. Things, such as selectable frequency-division with nothing more than a clock, an IC, and a rotary switch is a wonderful idea. But take a look at the example we've just gone through. Everything seems to work out fine, but consider this: Let's suppose that the input clock isn't some convenient multiple of 16.

Let's see what's going to happen here if, for example, the input clock frequency is 17 kHz. Are you beginning to catch my drift? Obviously things are going to get really messy, because that would make the base rate 17,000/16, or 1062.5 Hz. Now, if we stick with a chosen rate of 5, the multiplied-rate output would be 1062.5 x 5 or 5312.5 Hz. Even that wouldn't be too bad—but there's another bit of nastiness that hasn't been mentioned yet.

The rate-multiplier is designed to output one base-rate pulse, plus the dialed-up number (the base rate multiplied by the number at weighted input) for every 16 pulses fed to the clock input. Now, if we look at the base rate on a scope, there's no problem. The pulses are evenly spaced and will track along at one-sixteenth the input clock-rate, but the multiplied rate is another story. Well, as we all know, 16 is not a multiple of 5. But we will see 5 pulses for every 16 incoming pulses.....so what does that mean?

What it means is that the symmetry of the multiplied-rate pulses are out the window. Remember that the multiplied-rate output is tied to the incoming clock, not the base-rate output! The width of the multiplied-rate pulses will be the

same as the incoming clock pulses, but the spacing will be determined by whatever number we decide to use. If the number divides evenly into 16, the output pulse-train is going to be picture perfect. On the other hand, if the number we choose doesn't divide evenly into 16, we'll get the right number of pulses but the output waveform is going to look like a broken comb.

Rate multipliers are perfectly designed to be used in circuits in

which what we're interested in finding out is "how many over a period of time," rather than the frequency at any one instant of time. In other words, we're talking about arithmetic, *not* frequency measurement. Of course, there's nothing preventing you from paying absolutely no attention whatsoever to this discussion and using a rate multiplier to get some quick and simple means of dial-up frequency division. After all, the

continued on page 93

Instrument Mart and Leader



For Instruments You Can Count On

PRICES START AT \$210.00
2-YEAR WARRANTY

LEADER frequency counters lead a shielded life and are built to last. That's why **INSTRUMENT MART** recommends them to customers in severe RF and educational environments.

Buying a counter can be a confusing job. There are optional time base stabilities, different gate times and resolutions, and any number of variables that affect performance. Call **INSTRUMENT MART** to discuss which of our more than 20 counters are right for your application. We've been doing it for over 15 years.

All available at competitive prices. Call us and compare.



The Professional Test Equipment Source

The Instrument Mart

295 Community Drive, Great Neck, New York 11021
(516) 487-7430 Outside N.Y. (800) 645-6535

Sales, Service, Rental/Leasing Programs
...and Pre-Owned Test Equipment also Available

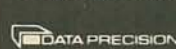

STATE OF SOLID STATE



ROBERT F. SCOTT,
SEMICONDUCTOR EDITOR

A different kind of FET

SEMICONDUCTOR TECHNOLOGY HAS given us some interesting and versatile components. In fact, since their introduction, semiconductors have been continuously upgraded and redesigned so that each new device can do the work of several of its predecessors.

In keeping with that trend, RCA has introduced a new "breed" of MOSFET devices that combines the characteristics of a MOS power transistor, a bipolar transistor, and a thyristor. Called a COMFET—for Conductivity-Modulated Field Effect Transistor—this device has an on-resistance, $R_{DS(ON)}$, that is substantially lower than that of MOSFET's with the same chip area. That is illustrated in Fig. 1.

The COMFET's on-resistance is typically less than 0.1 ohm with a maximum drain current of 20 amperes flowing through the device.

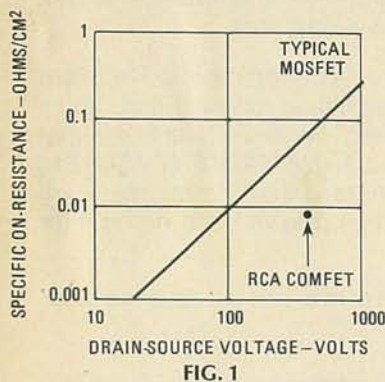

FIG. 1

The COMFET, with a chip area of 120 mils², blocks 400 volts in the forward direction and 100 volts in the reverse direction. Those characteristics make it suitable for high-voltage, high-power applica-

tions. Conventional power MOSFET's are less useful because their high $R_{DS(ON)}$ values cause excessive voltage drops and power losses.

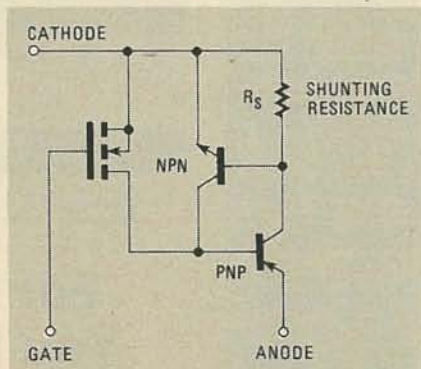

FIG. 2

The COMFET acts like a power MOSFET feeding a direct-coupled bipolar compound-connected transistor (see Fig. 2). The specifications for COMFET's device are similar to those of bipolar power transistors, except that COMFET's have a high input-impedance, like that usually associated with conventional power MOSFET's. Its high input-impedance makes it simple and easy to drive from a relatively low-power, low-voltage source (such as a logic IC). In addition, they do not require the expensive high-power drivers and complex drive-circuitry that bipolar transistors need. Thus, circuits using COMFET's can be less expensive to operate.

The COMFET's switching speeds are about the same as bipolar devices, but somewhat slower than conventional MOSFET devices. Its typical turn-on time is less than 100 nanoseconds, and turn-off is

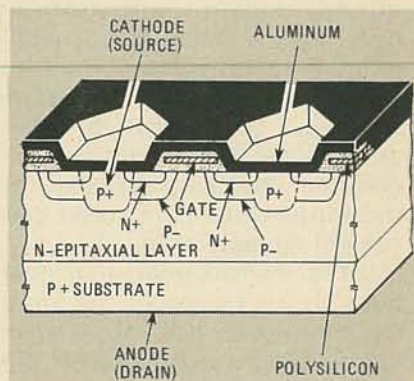

FIG. 3

somewhere between 5–20 microseconds. The COMFET's switching speed and low source-to-drain ON resistance—when considered together—put this device on the same plane as bipolar transistors for most medium-frequency applications.

The device's unusual high-voltage and low-resistance characteristics are produced by applying a P-type substrate on the drain side of a conventional N-channel MOSFET. (See Fig. 3). When a positive voltage is applied to the COMFET's gate, electrons enter the N-type gate drain region. That causes a corresponding hole to be injected into the drain from the P-type substrate. The carriers or holes modulate the conductivity of the high-resistance drain, thereby substantially reducing the overall value of $R_{DS(ON)}$.

The P+ substrate, implanted at the device's cathode, allows the control of the NPN transistor's shunt resistance (R_S), and prevents the sharp voltage drop at high-current levels that is characteristic of a four-layer thyristor. Therefore, the

COMFET's current/voltage characteristics resemble that of an ordinary bipolar transistor.

For the most up-to-date information on the COMFET, including device types, characteristics, and availability, contact Tom McNulty, **RCA, Power Marketing, Solid State Div.**, Somerville, NJ 08876.

IF system IC

National Semiconductor has announced its latest series of FM IF systems, the LM1865/1965/2065, for use in electronically and manually tuned radio applications.

The LM1865 and LM2065 feature a *stop* detector for electronic tuning. All versions offer a low total-harmonic-distortion (THD) of 0.1% at 100% modulation with a single tuned quadrature coil. And THD is not adversely affected if the radio or quadrature coil is mistuned.

The only difference between the LM1865 and LM2065 is the direction of the AGC control voltage. The LM2065 develops forward AGC. The three devices have dual-threshold AGC's to eliminate the need for a local/distance switch. The AGC threshold-voltage is low when strong out-of-band signals are present—signals that might develop an interfering third-order intermodulation (IM3) product. If there are no strong out-of-band signals present, the AGC threshold is high for best signal-to-noise performance.

The three devices are housed in 20-pin plastic DIP packages and sell for \$2.45 in lots of 100 and up.—**National Semiconductor Corp.**, 2900 Semiconductor Drive, Santa Clara, CA 95051 **R-E**

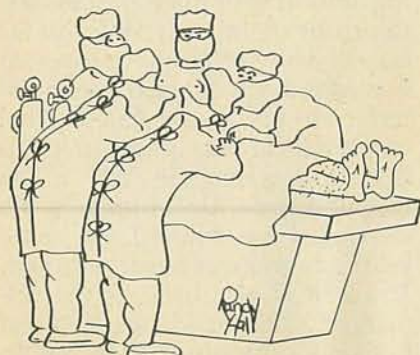

"He should have known better than to tangle with a solid-state computer."

MODULAR PROBES FOR SALE

For All Oscilloscopes
To 300MHz
X1 to X100
Attenuation

*Pictured
Accessories
Included*



INSTANT REPAIR

Probe tip, Head, BNC and Cable all screw into place easily and quickly.

TEST PROBES, INC. TPI

Your Probe Specialists

Coline U.S. Sales & Stocking Source P.O. Box 2113, La Jolla, CA 92038 (619) 459-4197

COMPARE PRICE — COMPARE PERFORMANCE

Model	Attenuation	Bandwidth	Price
M12SW	X1-X10 Switchable	X1-10MHz X10-250MHz	\$69.00
M12X10	X10	250MHz	59.00
M12X10AP	X10 with Readout	250MHz	65.00
M15X100	X100	250MHz	89.00
M15X10HF	X10	300MHz	75.00
M12X1	X1	30MHz	36.00

CIRCLE 52 ON FREE INFORMATION CARD

FREE

McIntosh STEREO CATALOG and FM DIRECTORY

Get all the newest and latest information on the new McIntosh stereo equipment in the McIntosh catalog. In addition you will receive an FM station directory that covers all of North America.

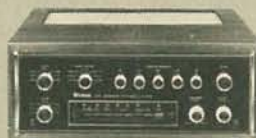
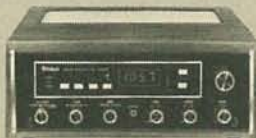

SEND TODAY!

McIntosh Laboratory Inc.
East Side Station P.O. Box 96
Binghamton, N.Y. 13904-0096

RE

NAME _____

ADDRESS _____

CITY _____ STATE _____ ZIP _____

If you are in a hurry for your catalog please send the coupon to McIntosh. For non rush service send the Reader Service Card to the magazine.

CIRCLE 93 ON FREE INFORMATION CARD

COMPUTER CORNER

Yesterday's personal computers

KEEPING YOUR COMPUTER UP-TO-DATE with the latest peripherals often results in a pile of unnecessary equipment building up around the house. For example, just recently, while cleaning up the basement, I happen to run across all kinds of old personal-computer equipment that had been accumulated over the years—most of which still has some life left in it. But while sorting through all that stuff, I wondered whether any of it would ever again be of any use. There are probably others out there who like myself have been fooling around with microcomputers since the very beginning and have also accumulated a variety of odds-and-ends that today are more nostalgic than practical. The only problem with that is figuring out what to do with all of it.

The old timers

One piece of equipment found in that mountain of antiquity was the first microcomputer that I was ever involved with, the NRI model 832. The unit was designed back in the early '70's when I was working for the National Radio Institute—a home-study school. That computer, designed before microprocessor IC's became available, came in kit form and was included as part of NRI's computer-technology course. The unit, housed in a large metal cabinet, used 7400-series TTL (Transistor-Transistor-Logic) IC's mounted on ten printed-circuit boards. The whole idea behind the kit was to give students hands-on experience in working with TTL integrated circuits. The kit was also used to demonstrate the principles of



FIG. 1

computer operation and programming, and to teach the student good troubleshooting techniques. It featured an 8-bit-word, serial processing, and an instruction set of 15 operational codes. The memory consisted of a large slide-switch-diode matrix that formed a programmable-read-only-memory or PROM. Its memory capacity was 16 eight-bit words.

The computer also contained sixteen bytes of random-access-memory (RAM) built around the old TTL 7489 16-bit RAM. That machine worked pretty well and could be programmed to do almost anything. But today it just



LOU FRENZEL

wouldn't be practical because it has no I/O instructions, and its memory-expansion capabilities are limited. Nevertheless, since its introduction, in 1972, several thousand of those units have been shipped to students, and it has aided them in learning about digital logic and computer fundamentals. In fact, the unit is still included with NRI's home-study digital-electronics course. Though it's nice to have one of those units around as a reminder of the past, it's doubtful that it will ever be of use again. It's been sitting in a box in the basement for about twelve years now and will probably go on sitting there.

Another unit, found in that nostalgic heap in the basement, was my Teletype ASR-33 hard-copy terminal (see Fig. 1). That terminal was once the most popular I/O device available for those early personal computers and sold for \$1200 back in 1976. It featured a 10-CPS (Character-Per-Second) printer with keyboard and a 10-CPS paper-tape reader and punch. The first time that the unit was ever used was when I first started playing around with microprocessors. Later, one of the early Motorola D2 boards with a 6800 microprocessor was added, which used a serial interface to talk to the ASR-33. That combination was used to learn how to program the 6800 in hex machine-code. Unfortunately, the D2 board was loaned out some years ago and was never returned. The ASR-33 was used as the primary I/O device for my first real personal computer, which was an IMSAI 8080.

The IMSAI 8080 was built from a

kit and was used for a number of years. Quite a bit of machine-language programming was done on it. An 8K BASIC was also available in paper-tape form, but it took about 20 minutes to load it on the 10-CPS ASR-33. At times the program didn't load properly on the first try, so the procedure had to be repeated. Today, waiting for 20 minutes to load a program is unacceptable and having to repeat the sequence is totally out of the question. But, we've come a long way since then.

Overall, the ASR-33 is still in pretty good shape and though it did get damaged slightly during the recent move, there's nothing wrong with it that can't be fixed. But I have no idea of what in the world I'd ever use that machine for, and doubt that the time that it would take to repair it would be justified. Anyway, it's large, takes up lots of space, and anyone who ventures into my basement is usually impressed and asks about it.

One of the more useful machines found lying around down

there, was one of the old Commodore PET 2001 computers. You may recall that machine with its built-in 9-inch CRT, audio-cassette player/recorder, and the tiny calculator-like keyboard. That unit was acquired in 1976 and has been in use most of the time since then. Several years ago, there was a failure in the RAM, which was promptly repaired. The most difficult problem encountered during that repair was trying to locate a supplier for one of the old odd-ball MOS-technology 22-pin 4K static RAM's. And beside that, it cost a fortune! The unit's BASIC and graphics capability are still pretty good by today's standards; however it doesn't feature color, and the audio-cassette mass storage is slow. Still my 13-year-old son continues to use the unit for practicing his programming homework, and he has even written a number of his own applications programs for his *Dungeons & Dragons* game. However, the games for the PET are nothing compared to *Flight Simulator*,

Decathlon, *Temple of Apshai*, and a host of other neat games for the newer IBM PC.

Another item discovered in that computer treasure trove was an H8-5 accessory board, which is a serial-port and cassette-interface card for Heathkit's original model H8 computer. The serial port and cassette interface board was removed from the unit when the floppy-disk controller became available and was never used again. In fact, my older son took the H8 computer, an H9 terminal, and the H17 floppy-disk unit off to college with him and I haven't seen it since. I suppose the IC's on the accessory board might be useful for experiments, but I haven't the foggiest idea of what I could build with them.

Continuing the search, I also discovered an old RCA VIP Cosmac computer. That unit was purchased sometime in 1977, but the proposed application escapes me now. That computer features RCA's unusual 1802 micro-
continued on page 102

Business Opportunity



It's plenty tough being an electronics sales and service dealer these days.

That's why we're working so hard to make it easier for you to operate a cost-effective business.

NESDA offers business contacts, technical and management certification, substantial savings on bank-card and insurance rates — and **that's just the beginning!**

NESDA members are kept informed about industry developments and are offered the most comprehensive managerial and technical training programs available. Besides, NESDA is your representative at the national level — including your voice to manufacturers and the agencies of the federal government.

Opportunity knocks . . . National Electronics Sales & Service Dealers Association
Answer it! **NESDA**

For more information and an application, write to:
NESDA, 2708 W. Berry St., Ft. Worth, TX 76109; Ph (817) 921-9061

Name _____

Bus. Name _____

Address _____

State _____ Zip _____ Phone _____

Member of State Local Assn. _____

NEW!

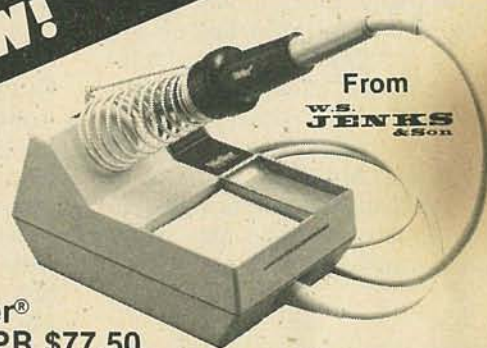

Weller® WT CPR \$77.50

Safe for IC soldering. Closed loop, low-voltage circuit automatically controls output. 700 F 1/16" screwdriver tip provided. 600 F and 800 F tips available. Power unit has non-heat sinking iron holder, storage tray for extra tips and tip cleaning sponge with receptical. Send for free W.S. Jenks & Son electronics tool catalog for complete accessories.



SEND NOW!

FREE CATALOG!

Over 100 pages. Wide selection of tool sets, test equipment, soldering and desoldering equipment, telecommunications and specialized electronics assembly tools.

W.S. JENKS & Son



2024 West Virginia Ave. NE
Washington, D.C. 20002
TOLL-FREE ORDER LINE: 1-800-638-6405

Please send the indicated material:

Weller WT CPR Soldering Station @ \$77.50

FREE W.S. Jenks & Son 84 Catalog

Check/Money Order

MasterCard Visa Am. Exp.

Card No. _____ Exp. _____

Signature _____

Name _____

Address _____

City _____ State _____ Zip _____

VA residents add 4% tax; DC residents add 6% tax.

SERVICE CLINIC

A valuable piece of equipment

A LONG TIME AGO, BACK WHEN THIS column first began to appear, I had the habit of saying "This will fix it!" whenever I was confronted by a problem. These days, I've learned to say "This will fix it, I hope!" instead. In other words, I found out that there is always the chance that the cause of the problem is something other than the obvious one. That's how I learned that of all your tools, the most valuable is—a completely open mind.

I have bored quite a few groups of technicians by asking: "What do you use to make a diagnosis?" Someone, (or more) would always say: "Test equipment." To which I said: "Wrong!" Test equipment, such as an oscilloscope (see Fig. 1), is very important because it is used to get data, but you still need to feed that data into the one instrument that can make the diagnosis—your brain.



FIG. 1

What I mean is this; your brain is the only "instrument" that can take the data your test equipment gathers, put it together, and come up with a conclusion as to the cause of the problem. The success of that process, of course, de-

pends on how well your brain can work. If something interferes with it, it will come up with the wrong answers.

For instance, rarely will talking to a set that has been giving you trouble help. Sure, it might seem that the set refuses to work just to spite you, but talking to (or yelling at) a device is not productive and does not lend itself to a calm and reasoned analysis of the problem. Such an analysis is needed if the cause of the problem is to be found and fixed.

Another common occurrence that interferes with an orderly analysis is jumping to conclusions. Guessing the cause of a problem from the symptoms, or from a few measurements, can sometimes lead to a fast solution. But more often, it can send you on a wild goose chase. Sure, you get tired sitting at the workbench all day, but jumping to conclusions is a poor way to get your exercise.

The proper approach

So what should you do to help your brain make the proper analysis. Above all, approach each set with an open mind. Don't guess at the cause; that can lead you to making tests for the sole purpose of proving that your guess was right. You really do not care what's wrong with the set; you just want to find the problem and fix it.

Of course you already know what the proper procedure is; it's one you've followed many times. Quite simply, it's to make all of the standard tests, looking to be sure that the various signals and voltages are what they should be. Once you have found something



JACK DARR

that is off, track down the cause. That's all there is to it.

Finally, a kind word on behalf of coffee breaks! If you do find yourself stuck, get up, walk out of the shop, and go get a cup of coffee! I have long used that method, and it works. Don't even think about the job. You'll find that many times when you go back, the solution "comes to you in a flash." That's because all the time you were drinking coffee and making conversation, a small corner of your brain was working on the problem. I've seen that happen hundreds of times!

So, keep an open mind, be calm and confident, and you will fix many more of those "dogs" in a lot less time. Good luck, and easier servicing!

SERVICE QUESTIONS

CLEANING TUNERS

What would you recommend to clean the VHF tuner in a Quasar TS-476? The stationary contacts are etched pads on PC boards, and the movable contacts are attached to cylindrical plastic caps. Silicone spray helped only a little.—J.H., Bettendorf, IA

I'm not familiar with the tuner you describe, so I can't discuss it specifically, but I will say this: Tuners that are far-gone need more than just a chemical spray. The contacts need to be wiped clean with a pencil eraser, a finger, anything. The problem that you

cable TV

DESCRAMBLER PARTS

We stock the exact parts and PC Board for Radio Electronic's February Article on building your own Cable TV Descrambler.

#701 PARTS PACKAGE \$29.95

Includes all the original resistors, capacitors, diodes, transistors, integrated circuits, coils and IF transformers (BKAN-K552AXX).

#702 PC BOARD \$12.95

Original etched & drilled silk-screened PC Board used in the article.

#704 AC ADAPTOR \$12.95

(14 volts DC @ 285MA)

Both #701 & #702 \$39.00

FREE!! Reprint of Radio Electronics Article on Building Your Own Cable TV Descrambler with any purchase.

Add \$4.00 Postage & Handling

TOLL FREE (24 HRS.)

1-800-522-1500 Ext. 708 (Orders Only)

(9am to 5pm) 1/617-339-5372 (Information)

J & W ELECTRONICS, INC.

P.O. Box 52
Cumberland, RI 02864

CIRCLE 45 ON FREE INFORMATION CARD

SUPER LONG PLAY TAPE RECORDERS

10 Hour Model — \$95.00*
14 Hour Model — \$159.00*

Modified Panasonic Simline. high quality, AC-DC Recorders provide 5 or 7 continuous hours of quality recording & playback on each side of cassette for a total of 10 or 14 hours depending on model. Built-in features include • Voice level control, • Digital counter, etc. TDK DC 180 Cassette Furnished.

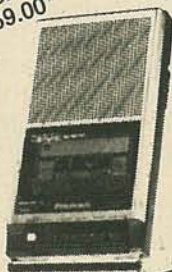

PHONE RECORDING ADAPTER

Records calls automatically. All Solid state connects to your telephone jack and tape recorder. Starts recording when phone is lifted. Stops when you hang up. **\$24.50***

FCC APPROVED

VOX VOICE ACTIVATED CONTROL SWITCH

Solid state. Self contained. Adjustable sensitivity. Voices or other sounds automatically activate and control recorder. Uses either recorder or remote mike. **\$24.95***

*Add for ship & hdg. Phone Adapter & Vox \$1.50 ea. Records \$4.00 ea. Cal. Res. add tax. Mail order, VISA, M/C, COD's OK. Money Back Guarantee. Qty. disc. avail. Dealer Inquiries invited. Free data.

AMC SALES INC., Dept. A 9335 Lubec St., Box 928, Downey, CA 90421 (213) 869-8519

CIRCLE 67 ON FREE INFORMATION CARD

describe suggest to me a trick that I use when I want to clean up relay contacts. I put a double-sided piece of very fine sandpaper between the contacts and slide it back and forth a couple times. For delicate contacts, such as you have in your tuner, I would use a strip of rough paper wet with cleaner.

A VERY DIFFICULT PROBLEM

I received a basket-case Sony KV-1750 as a gift. I found the regulator transistor, the GCS, the damper diode and the 4A fuse missing. I put them in, and using a Variac, I moved slowly, monitoring with a scope, when suddenly everything blew again. Any ideas?—J.T., Sierra Vista, AZ

The reason you received as a gift a Sony with those parts removed was because someone gave up on it. You are dealing with what is probably the most difficult repair in TV today. Any instantaneous glitch in the horizontal sweep system starts that chain of failures, and it gets awfully expensive to fix.

If you can't locate a bad solder connection, using first a 19-volt supply and very low AC, the possibilities become awesome: flyback, horizontal output transistor, tripler, mica insulator; and none of them can be checked other than by substitution and/or very sophisticated troubleshooting.

DEAD SET

I have been banging my head against a stone wall for a month now—the stone wall being a Sylvania E-21-2 that is in the "shut-down" mode. I've changed so many parts I should have kept a journal, but the enclosed list of parts and voltage measurements will have to suffice.—R.B., Orinda, CA

If you removed SCR430, the shut-down switch, as you say, and the set still does not come alive, I would say you've got to give up that approach. With SCR430 lifted, treat the repair like any other "dead set" condition. Is the horizontal oscillator working? I would think not, with that missing voltage on pin 6 of the IC400 oscillator. You've changed the IC, but have you followed pin 6 back to its 20-

FREE MAIL ORDER CATALOG

**Tuners,
amplifiers,
effects,
keyboards,
studio equipment,
drum computers,
easy to assemble kits,
books & more**



name _____
address _____
city _____ state _____ zip _____

RAIA Electronics, Inc.

Dept. 5R, 1020 W. Wilshire Blvd.
Oklahoma City, OK 73116
800-654-8657 9AM-5PM CST M-F

CIRCLE 51 ON FREE INFORMATION CARD

SEE YOUR DEALER TODAY

FROM



HERE'S A TIP
THAT'S PERFECT!

AM/FM AUTO RADIO
AND CB

'Firestik' II

GOLDEN SERIES

BARE-HANDS TUNABLE
"NO TOOLS NEEDED"
HIGH PERFORMANCE ANTENNAS

ALSO ANTENNAS FOR
CORDLESS TELEPHONES
MONITOR SCANNERS

Dealer & Distributor Inquiries Invited
SEND FOR FREE CATALOG

'Firestik' Antenna Company
2614 East Adams/Phoenix, AZ 85034

Name _____
Street _____
City _____
State _____ Zip _____

Serving the CB and
Communications Market Since 1962.

5-YEAR REPLACEMENT WARRANTY

CIRCLE 40 ON FREE INFORMATION CARD

Radio-Electronics REPRINT BOOKSTORE

- | | | | |
|--|---------|---|--------|
| <input type="checkbox"/> Build Your Own Satellite TV Receiver | \$7.00 | <input type="checkbox"/> Special Projects (Spring 1981) | \$4.50 |
| <input type="checkbox"/> 8-Ball Satellite TV Antenna | \$5.00 | <input type="checkbox"/> Special Projects #4 (Summer 1982) | \$4.50 |
| <input type="checkbox"/> Build Your Own Robot | \$12.00 | <input type="checkbox"/> Special Projects #5 (Winter 1983) | \$4.00 |
| <input type="checkbox"/> TV Descrambler (January, February 1981) | \$3.00 | <input type="checkbox"/> Special Projects #6 (Spring 1983) | \$4.00 |
| <input type="checkbox"/> Radio-Electronics back issues (1984) | \$3.00 | <input type="checkbox"/> Special Projects #7 (Summer 83) NOT AVAILABLE | |
| <input type="checkbox"/> Radio-Electronics back issues (1983) | \$3.50 | <input type="checkbox"/> Special Projects #8 (Fall 83) | \$4.00 |
| Write in issues desired | | <input type="checkbox"/> Special Projects #10 (Spring 84) | \$3.00 |
| <input type="checkbox"/> Radio-Electronics back issues (1983) | \$3.50 | <input type="checkbox"/> Radio-Electronics Annual 1983 | \$3.50 |
| (January, February 1983 not available) | | <input type="checkbox"/> Radio-Electronics Annual 1984 | \$2.50 |
| Write in issues desired | | <input type="checkbox"/> How to Make PC Boards | \$2.00 |
| <input type="checkbox"/> Radio-Electronics back issues (1981) | \$4.00 | <input type="checkbox"/> All About Kits | \$2.00 |
| (Jan., Feb., March, Dec. 1981 not available) | | <input type="checkbox"/> Modern Electronics (Vol. 1, #1 April 1908) | \$2.25 |
| Write in issues desired | | <input type="checkbox"/> Electro Importing Co. Catalog (1918) (176 pp) | \$4.95 |
| <input type="checkbox"/> Etch your own PC boards | \$3.00 | <input type="checkbox"/> Low Frequency Receiving Techniques Building and using VLF Antennas | \$6.00 |

To order any of the items indicated above, check off the ones you want. Complete the order form below, include your payment, check or money order (DO NOT SEND CASH), and mail to Radio-Electronics, Reprint Department, 200 Park Ave. South, New York, NY 10003. Please allow 4-6 weeks for delivery.

If you need a copy of an article that is in an issue we indicate is unavailable, you can order it directly from us. We charge 50¢ per page. Indicate the issue (month & year), pages and article desired. Include payment in full, plus shipping and handling charge.

ARTICLE _____

MONTH _____ YEAR _____

PAGES _____

TOTAL PAGES _____ @ 50¢ each TOTAL PRICE _____

MAIL TO: **Radio-Electronics** 9.84
 Reprint Department, 200 Park Ave. South, New York, NY 10003 All payments must be in U.S. funds

Total price of order \$ _____

Sales Tax (New York State Residents only) \$ _____

Shipping & Handling (U.S. & Canada only) (Includes FIRST CLASS POSTAGE) \$1.00 per item \$ _____

All other countries (\$2.00 per item, sea mail) \$ _____

(\$4.00 per item, air mail) \$ _____

Total Enclosed \$ _____

Name _____

Address _____

City _____ State _____ Zip _____

volt source? Don't be intimidated by the shut-down circuit. Turn on the scope, and get the sweep system to work.

FLYBACK PROBLEMS?

I have been working on RCA, CTC97A, that has streaking in the picture. When I'm off station, I get vertical lines similar to Barkhausen oscillations. I suspect high-voltage breakdown, but have run out of places to look.—B.P., Kinnewick, WA

The place you probably would find what you are looking for may be where you can't look—inside the integrated flyback. Turn off all the lights and look around for an arc, if there is one to be seen, there's one to be corrected. If you're not lucky that way, you will have to change the flyback, cross your fingers, and hope that's it. They do have a history of that type of failure. **R-E**

EQUIPMENT REPORTS

continued from page 44

HEATHKIT

Auction Company liquidating million dollar inventory of Heathkit Brand Electronics in kit form.

UP TO **75% OFF** **5 Mhz Oscilloscope \$119.00**



Model 10-4540—Compact, versatile, easy to build Electronic instrument. Measures frequency and AC or DC voltages.

PAY ONLY \$119

25" COLOR TV

HEATHKIT Solid State Color T.V. Model GRD 900 Automatic UHF and VHF channel selector, instant on, automatic fine tuning. Perfect for custom installation. CRT and Cabinet not included.

PAY ONLY \$119

Note: All NEW Heathkits in Factory Sealed Cartons w/Step-by-Step instructions... as sold in electronic stores and technical schools across the nation.

MasterCard • Visa or send check with order

Call your order today
CERTIFIED ASSOCIATES, INC.
 1912 W. 170th Street
 Hazel Crest (Chicago), IL 60429
 (312) 335-0043

9 AM-5 PM. Mon. to Fri.

Be an FCC LICENSED ELECTRONIC TECHNICIAN!



Learn at home in spare time. No previous experience needed.

No costly School. No commuting to class. The Original Home-Study course that prepares you for the FCC Radiotelephone license exam in your spare time! An FCC Government license is your "ticket" to thousands of exciting jobs in Communications, Radio & TV, Mobile two-way, Microwave, Computers, Radar, Aerospace and more. You don't need a college degree to qualify, but you do need an FCC License. **No need to quit your job or go to school!** You learn how to pass the FCC License exam at home at your own pace with this easy-to-understand, proven course. It's easy, fast and low cost! **GUARANTEED PASS** You get your FCC License or money refunded. Write for free details. Soon you could be on your way to being one of the highest workers in the electronics field. **Send for FREE facts now. MAIL COUPON TODAY!**

COMMAND PRODUCTIONS
 FCC LICENSE TRAINING, Dept. 90
 P.O. Box 2223, San Francisco, CA 94126

Rush FREE facts on how I can get my FCC License in spare time. No obligation. No salesman will call.

NAME _____
 ADDRESS _____
 CITY _____ STATE _____ ZIP _____

until the overrange indicator (a displayed 1) disappears.

The unit is supplied with a pair of color-coded test leads, a spare fuse, a 9-volt transistor type battery, and an instruction manual. The manual in this case is really not much more than a pamphlet. It provides only the sketchiest of detail concerning the unit, and there is no theory-of-operation section, schematics, or parts lists. On the positive side, the manual does describe a useful setup for testing large valued capacitors. It also provides a handy table for converting between pF, nF, and μF. Finally, there's a table that summarizes some of the most typical capacitor characteristics.

Above all else, what really makes the model 30B-240 jump out at you is the price. Remember, we are dealing here with a hand-held, digital-readout capacitance meter with a fair degree of accuracy. The cost for that is an outstanding \$51.95. The unit is covered by a one-year warranty and is available from your local distributor or from Fuji-Svea (PO Box 3375, Torrance, CA 90510). **R-E**

DRAWING BOARD

continued from page 85

temptation is strong and parts suppliers don't ask questions. Just remember that the outputs you get will probably be wrong in the short run, but right in the long run—and how much time is covered by "the long run" is anybody's guess.

Using the 4089 is simple. You just route a clock to pin 9, pick a number for the weighted inputs, and pick off the output frequency on either pin 5 or pin 6. All the control inputs, pins 4, 8, 10, 11, 12, and 13, should be connected directly to ground for normal use. The base rate is available on pin 1 and the remaining output, pin 7, is used for cascading more than one 4089. That's all there is to it. But, as you no doubt expected, if you want to make the IC do really useful work, you have to learn how it works.

A glance at the table in Fig. 3

should tell you that there's a lot left to discuss. The result of bringing the CLEAR input high depends on the state of pin 3, the D input. If pin 3 is high, the frequency at the multiplied-rate output will be the same as that at the clock input and the base-rate output will be zero. If the D input is high when you activate the CLEAR input, both the multiplied- and base-rate outputs will be zero. Things are not as straightforward as they might seem at first; therefore making a rate multiplier work for you means spending time with it. There's no other way.

Once you get a handle on the IC, however, you'll find that, like most other specialized IC's, it can save you an unbelievable amount of brain damage in solving particular circuit problems.

Go over the data in Fig. 1 and pick up a few of the rate multipliers to fool around with. Next month we'll start to put those special IC's to work. **R-E**

LOGIC STATE (ASSUMING 16 INPUT CLOCK PULSES)						NUMBER OF PULSES (OR LOGIC STATE)										
INPUT/PIN NUMBER						OUTPUT/PIN NUMBER										
D/3	C/2	B/15	A/14	INH/11	STR/10	CAS/12	CLR/13	SET/4	OUT/6	OUT/5	INH/7	M.R./1				
0	0	0	0						L	H						
0	0	0	1						1	1						
0	0	1	0						2	2						
0	0	1	1						3	3						
0	1	0	0						4	4						
0	1	0	1						5	5						
0	1	1	0						6	6						
0	1	1	1						7	7						
1	0	0	0						8	8						
1	0	0	1						9	9						
1	0	1	0						10	10						
1	0	1	1						11	11						
1	1	0	0						12	12						
1	1	0	1						13	13						
1	1	1	0						14	14						
1	1	1	1						15	15						
DOESN'T MATTER						1	0	0	0	0						
						0	1	0	0	0			L	H	I	I
						0	0	1	0	0			H	*	I	I
						0	0	0	1	0			16	16	H	L
						0	0	0	0	1			L	H	H	L
0	0	0	0	0	1			L	H	L	H					

HELD LOW FOR NORMAL OPERATION

ONE PULSE PER CYCLE DURING NORMAL OPERATION

FIG. 3



ELECTRONIC KITS INTERNATIONAL, INC.
(Formerly PPG Electronics)



**AM RADIO
6 TRANSISTOR
#854/754**

A "Fun to Build" super sensitive 6-transistor AM radio. Exciting hands-on experience. Learn the how and why of a radio by building it yourself. All parts necessary are included, so tune in and discover the fun of building your own! Features: Low power consumption, low cost, easy step-by-step instructions with each kit, alignment procedure and troubleshooting instructions included. Circuit operations explained, wrist strap and cabinet included.



NEW!

FROG PHONE W/CB & CASE

This kit has over 76 electronic parts including speaker, microphone, microswitch, 12 button keypad, two circuit boards, transformer, two LED's eight transistors, one integrated circuit, twelve diodes, five electrolytic capacitors and sixteen resistors. Comes with step-by-step instruction and learning manual.

**#815/715
NEW!**



Learn about:

- Large scale integration pulse generator IC's
- Matrix keyboards and decoders
- Dial tone generation
- Busy tone generation
- Ring pulse generation
- How to repair electronic telephones

OVER 50 KITS AVAILABLE

KIT #

- | | |
|--------------------------------------|--|
| 801 Pocket Dice | 847 12-volt Color Organ |
| 802 Signal Injector | 848 T.V. Jammer |
| 803 Space War Gun | 849 12-volt Strobo Stick |
| 804 Metal Detector | 850 Whooper Alarm |
| 805 Logic Probe | 851 Combination Lock/Alarm Control |
| 806 Burglar Alarm | 852 Electronic Tennis |
| 808 Decision Maker | 853 Digital Roulette |
| 809 LED Pendulum Matronome | 854 5-24 Volt Regulated Power Supply |
| 811 Double Decision Maker | 861 Big Sound Portable Organ |
| 812 Siren Oscillator | 862 Full-wave Motor Speed Control |
| 814 Robot Blinker | 865 Digital Car Machine |
| 816 Mini-wink | 868 Digital Dice |
| 818 Fish Caller | 870 Nerve Tester |
| 820 Stimmer Lights | 876 6-digit Digital Clock |
| 821 Christmas Tree | 878 Digital Bird |
| 822 One Channel Color Organ | 880 12-volt, 2-amp Regulated Power Supply |
| 824 Automatic Siren | 882 Musical Horn |
| 826 Fuzz Box | 884 Sound Activated Color Organ, 1-channel |
| 828 5-Volt Power Supply | 886 Audio Amp/Intercom |
| 830 Multi-purpose Power Supply | 888 Librarian Terminator |
| 834 Color Organ 3-channel, 1-control | 890 Stop-action Timing Tester |
| 836 3-channel, 4-control Color Organ | 892 Telephone Hold Button |
| 840 Variable Strobo Light | 894 Phaser Gun/Sound Generator |
| | 896 Binary Clock |

FREE CATALOG OF ALL KITS
Available nationwide at your local electronics store.
(Or send \$1.00 shipping & handling to address below.)

EKI ELECTRONIC KITS INTERNATIONAL, INC.

791 RED ROCK ROAD
ST. GEORGE, UTAH 84770

**Call TOLL FREE
1-800-453-1708**
For store nearest you.

Special Prices for Educators

CIRCLE 58 ON FREE INFORMATION CARD

CIRCLE 58 ON FREE INFORMATION CARD

Radio-Electronics Software Store

New for our readers....A mail order source of software from Apple

Home Business

	Recommended List Price	You Pay
<input type="checkbox"/> Bank Street Writer (Broderbund) (Disk)	\$69.95	\$49.95
<input type="checkbox"/> dBase II (Ashton-Tate) (Disk)	700.00	400.00
<input type="checkbox"/> Home Accountant (Continental Software) (Disk)	74.95	49.95
<input type="checkbox"/> Tax Advantage (Continental Software) (Disk)	59.95	39.95
<input type="checkbox"/> Wordstar w/ free CPM card (Micropro Intl.) (Disk)	612.00	385.00
<input type="checkbox"/> PFS: File IIE + II + (Software Publishing) (Disk)	125.00	85.00
<input type="checkbox"/> PFS: Graph IIE + II + (Software Publishing) (Disk)	125.00	85.00
<input type="checkbox"/> PFS: Report IIE + II + (Software Publishing) (Disk)	125.00	85.00
<input type="checkbox"/> Visicalc IIE (Visicorp) (Disk)	250.00	179.95

Education

<input type="checkbox"/> Mastering the SAT (CBS Software) (Disk)	150.00	110.00
<input type="checkbox"/> Success: Addition-Subtraction (CBS Software) (Disk)	24.95	19.95
<input type="checkbox"/> Success: Multiplication Division (CBS Software) (Disk)	24.95	19.95
<input type="checkbox"/> Spelling (Designware) (Disk)	39.95	29.95
<input type="checkbox"/> Algebra I (Eduware) (Disk)	39.95	29.95
<input type="checkbox"/> Rocky's Boots (The Learning Company) (Disk)	49.95	39.95
<input type="checkbox"/> Juggler's Rainbow (The Learning Company) (Disk)	29.95	24.95
<input type="checkbox"/> Master Type (Lighting Software) (Disk)	39.95	29.95
<input type="checkbox"/> Master Type (Scarborough Systems) (Disk)	39.95	29.95
<input type="checkbox"/> Alphabet Zoo (Spinnaker Software) (Disk)	29.95	24.95
<input type="checkbox"/> Kindercomp (Spinnaker Software) (Disk)	29.95	24.95
<input type="checkbox"/> Story Machine (Spinnaker Software) (Disk)	34.95	25.95
<input type="checkbox"/> The Graphics Magician (Penguin Software) (Disk)	59.95	42.50
<input type="checkbox"/> Sat Word Attack (Eduware) (Disk)	49.00	35.00

Entertainment

<input type="checkbox"/> Chopflifer (Broderbund) (Disk)	34.95	25.95
<input type="checkbox"/> Lode Runner (Broderbund) (Disk)	34.95	25.95
<input type="checkbox"/> Zaxxon (Datasoft) (Disk)	39.95	29.95
<input type="checkbox"/> Zork I (Infocom) (Disk)	39.95	29.95
<input type="checkbox"/> Zork II (Infocom) (Disk)	39.95	29.95
<input type="checkbox"/> Prisoner 2 (Interactive Fantasies) (Disk)	32.95	25.95
<input type="checkbox"/> The Mask Of The Sun (Ultrasoft) (Disk)	39.95	29.95
<input type="checkbox"/> Miner 20-49er (Microlab) (Disk)	39.95	29.95
<input type="checkbox"/> Wizardry: Proving Grounds (Sir-Tech Software) (Disk)	49.95	39.95
<input type="checkbox"/> Wizardry: Knight of Diamonds (Sir-Tech Software) (Disk)	34.95	27.95
<input type="checkbox"/> Flight Simulator II (Sublogic Corporation) (Disk)	33.50	25.95
<input type="checkbox"/> Temple of Apshai (Epyx, Inc.) (Disk)	39.95	29.95
<input type="checkbox"/> Rendezvous (Eduware) (Disk)	39.95	29.95

Radio-Electronics Software Store
200 Park Avenue South
New York, NY 10003

Number ordered

Total Price \$

Sales Tax (NY State Residents only)

Shipping and Handling (\$2.00 per item)

TOTAL ENCLOSED \$

Name

Address

City State Zip

SORRY - NO CREDIT CARD OR COD ORDERS

DESIGNER'S NOTEBOOK

continued from page 80

When the voltage at the input of IC2 reaches its threshold voltage, the output of the 4584 goes low and turns on transistor Q1.

Capacitor C2 begins to discharge rapidly, which produces a narrow negative-pulse at the output of the 4584. Capacitor C1 discharges as well, but the inherent hysteresis of the Schmitt trigger keeps the 4584 output low. Don't forget that the inverter changes state at half the supply voltage, and the Schmitt trigger changes at higher voltage than that. That's what hysteresis is all about.

In any event, the inverter finally changes states and the whole business starts over again. Now, the lower the input frequency, the faster both C1 and C2 will discharge. That means that as the voltage applied to the inverter decreases, the output frequency of the oscillator will increase, and vice versa.

The lowest frequency will be when the input voltage is zero and the maximum will be when the input voltage is equal to the threshold voltage of the Schmitt trigger. This is because the inverter and the 4584 will be changing states very close to each other. The circuit is extremely easy to use, and its advantages over other VCO's include a minimal parts count, high reliability, and, of course, excellent linearity. **R-E**

HOBBY CORNER

continued from page 83

dropping resistor or an impedance-matching (audio) transformer.

Intercom switching

Another reader, John Carson (IN), has asked about the switching arrangement in intercom speakers. Well John, it's all in a four-pole, double-throw (4PDT) switch, as seen in Fig. 3. When the switch is in one position, the local speaker/microphone is connected to the intercom's amplifier input and the remote is connected to the output. When the switch is in the other position, the connections are reversed and the remote speaker is an input device. **R-E**

GENERATOR CIRCUITS

continued from page 70

0.7 volts, the astable is enabled; but if it is biased below 0.7 volts by a current greater than 100 μ A (by taking pin 4 to ground via a resistance less than 7 kilohms, for example) the astable is disabled and its output is grounded. Thus, in the Fig. 15 circuit, the astable can be turned on by applying a high or logic 1 signal to pin 4, or off by applying a low or logic 0 signal to pin 4. The appropriate waveforms are shown in Fig. 15-b.

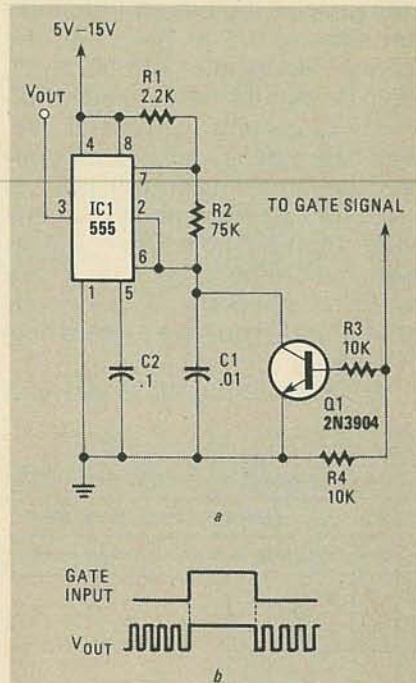
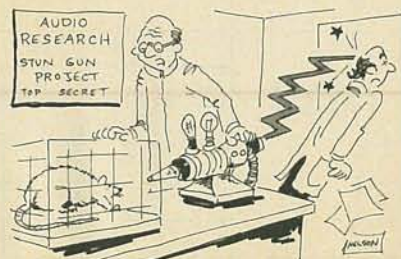

FIG. 16—ANOTHER WAY of electronically gating the 555 circuit. Here the gate signal is applied to C1 via Q1.

Finally, to complete this month's look at squarewave generator circuits, Fig. 16-a shows how the 555 can be gated on and off via a transistor wired across main timing capacitor C1. Here, with zero gate drive applied, Q1 is cut off and the astable is free to operate in the normal way, but when a high gate signal is applied, Q1 is driven on and discharges C1, thus disabling the 555. Note that the output of that circuit is driven high when the 555 is disabled in this way (see Fig. 16-b). **R-E**



"Nope—it still doesn't work."

T199/4A. Explore abandoned spaceship, an exciting text style adventure. Cassette and listing \$10.00 postpaid or write for info: **J-TECH**, Box 1573, Santa Barbara, CA 93102.

CABLE-TV manual: How to turn on cable-TV, converters and descramblers for all programmable and addressable systems. Send \$10.00 cash or money order to **MODERN TECHNOLOGIES**, PO Box 419-A1, Boston, MA 02186.

BRADFORD parts 50% off—"JOE", **TROY TV PARTS**, 76 Second Ave., Troy, NY 12180

TI-99/4A owners. Get your free catalog of new, exciting, low cost software. **DYNA**, Box 690, Hicksville, NY 11801.

FREE Pay-TV reception. "How-To" book. HBO, Showtime, Cinemax. \$4.95. **DIPTRONICS**, Box 80 (R1), Lake Hiawatha, NJ 07034.

NEW computer hardware/software debugging tool. Memory activity monitor saves time with Sinclair, Commodore & more. **SASE** brings complete information. **SYNCHRONICITY RESEARCH**, PO Box 153, Tonkawa, OK 74653.

TOP-quality imported, domestic kits, surplus, discount electronics, computer components. Free catalog. **TEKTRASONIX**, 175 Fifth Ave., Suite 3194, N.Y., NY 10010.

SATELLITE descramblers—Late night movies send \$5.00 for catalog. **MODERN TECHNOLOGY**, Box 419, Boston, MA 02186. (617) 871-5838.

ELECTRONIC surveillance: Amazing report reveals secret techniques \$15.00. Catalog \$3.00. **A.T.I.S.**, 61 Gatchell, Buffalo, NY 14212.

IMPROVE TV RECEPTION

UHF/VHF/FM signals will come alive with this remarkable 24dB amplifier. **Not a kit**, but a preassembled amplifier that features indoor mounting, integrated circuit design, low noise figure and tremendous gain to really pull in those weak TV stations. Price \$39.95. Include this ad with your prepaid order and receive a TV stereo simulator **absolutely free**. Great for concerts, movies and even adapts to VCR's. Maryland residents include 5%. **HOWARD RESEARCH AND DESIGN**, Box 204, Ellicott City, MD 21043. (301) 465-8116.

DESCRAMBLERS-CABLE-UHF-TVRO

"**SINEWAVE**" TV descrambler, video and sound in TV or VCR. Complete kit and instruction manual ready to go \$114.95 plus \$6.10 S & H. "Free flyer information." **CABLE SEARCHER**, P.O. Box 182, Carle Place Station, NY 11514.

EDUCATION & INSTRUCTION

EARN your university degree through evaluation assessment, of existing education, experience, achievements. Call, (614) 863-1791, or write, **ASSESSMENT**, Box 13130R, Columbus, OH 43213.

F.C.C. General Radiotelephone license. Home study. Fast, Inexpensive! "Free" details. **COMMAND**, D-91, Box 2223, San Francisco, CA 94126.

BASIC gate relationships building blocks of computers and electronic control circuits, 2 hr VHS video tape \$47.98 plus \$3.75 for S and H, send check or money order to **INTREPIDTEC INC.**, PO Box 175, Fountain Green, UT 84632.

LEARN HOW TO USE A COMPUTER



Train at home in spare time! No previous experience needed! Now you can learn it all! Computer programming... computer applications... computer games... everything you ever wanted to know about computer operations. Use hundreds of programs already available or write your own... budgeting, real estate, bookkeeping, expenses, investments, interest, taxes, shopping lists, vacation planning, addresses, phone numbers... even foreign languages and graphics. Experts explain everything in easy-to-understand language with step-by-step directions. Computer included with your training... plugs into your TV. Send for free facts!

Rush free facts how I can learn computer applications, programming and operation at home in spare time.

ICS COMPUTER TRAINING, Dept. DE084
Scranton, Pennsylvania 18515

Name _____ Age _____
Address _____
City/State/Zip _____
Phone No. including area code (____) _____

MORSE code keeping you from ham radio? International Morse Code trainer for your 64 computer. **AC3L SOFTWARE**, Box 7, New Derry, PA 15671. Tape or diskette \$14.95.

REPAIR any solid state amp or receiver with just your VOM. No experience necessary. Average repair time one hour. Mike's Monster Method on VHS T120 or BETA 500. Send \$39.95 shipping \$3.50 to **MKW ELECTRONICS**, 12345 Lake City Way N.E., Suite 115., Seattle, WA 98125.

UNIVERSITY offers state authorized degree programs in Business or Computer Management. Low tuition. No class attendance. Write, including phone, for brochure: **UNIVERSITY OF SANTA MONICA**, 5161 Venice Blvd., Los Angeles, CA 90019. Call: (213) 933-4200.

ATTENTION ELECTRONIC TECHNICIANS



Highly Effective Home Study BSEE Degree Program for Experienced Electronic Technicians Our New Advanced Placement Program grants Credit for previous Schooling & Professional Experience. Advance Rapidly! Our 40th Year!
FREE DESCRIPTIVE LITERATURE!

Cook's Institute of Electronics Engineering
P.O. BOX 20345, JACKSON, MS 39209



Active



The One Stop Electronic Shop!

Call Toll FREE 1-800-343-0874

In the United States:

Mail Orders P.O. Box 8000 Westborough, Mass. 01581 (Mass) (617) 366-0500	Boston 133 Flanders Road Westborough, Mass. 01581 (617) 366-9684	Seattle 13107 Northup Way Bellevue, Wash. 98004 (206) 881-8191
---	---	---

In Canada:

Montréal 5651 Rue Ferrier Montréal, Québec H4P 1N1 (514) 731-7441	Toronto 14 Carlton Street Toronto, Ontario M5B 1K5 (416) 977-7692	Downsview 86 St. Regis Cr. N. Downsview, Ontario M3J 1Y8 (416) 630-0400
Ottawa 1023 Merivale Road Ottawa, Ontario K1Z 6A6 (613) 728-7900	Calgary 3220-5th Ave. N.E. Bay 2 Calgary, Alberta T2A 5N1 (403) 235-5300	Vancouver 3070 Kingsway Vancouver, B.C. V5R 5J7 (604) 438-3321

Visit your nearest Active store, call, write or circle the Reader Service Card for your copy of Active's new catalog.

CIRCLE 77 ON FREE INFORMATION CARD

HIGH QUALITY ^{UP} 75dB GAIN

MICROWAVE TV SYSTEM

Variable from 1.9 to 2.5 GHz



The latest advance in microwave technology with a **SNOW-FREE PICTURE.**

Two Models to choose from.

Both Models Include:

- 20" Parabolic Dish
- Pre-assembled Probe with Down Converter

- Power Supply and Coax Switch
- 60' of RG-59/U Coax with Connector
- Transformer for 75 to 300 Ohms
- All Mounting Hardware for Fast and Easy Installation

20" Fiberglass Dish
Up to 55dB Gain
Special **\$98⁹⁵**

20" Aluminum Dish
Up to 55dB Gain
Low Priced **\$98⁹⁵**

Add 10% for Foreign orders or U.S. Parcel Post

High Gain Yagi Antenna with Down Converter and Power Supply. Complete System, Ready to Use. **\$89⁹⁵**

Send \$2.00 for Catalog. Refundable with first purchase.

Available thru Mail and Phone Orders Only

20% deposit for COD. CA Res add 6 1/2% Tax.

Send Cashiers Check or Money Order to:

(Personal Checks, allow 2-5 weeks to clear)

PROFESSIONAL VIDEO, Inc.

4370 Hollywood Blvd., Hollywood, Calif. 90027

For C.O.D. Orders Call (213) 219-0227

CIRCLE 21 ON FREE INFORMATION CARD

ACTIVE RECEIVING ANTENNA

Gives excellent reception, 50 KHz to 30 MHz.

New MFJ-1024 Active Receiving Antenna mounts outdoors away from electrical noise for maximum signal.

Gives excellent reception of 50 KHz to 30 MHz signals. Equivalent to wire hundreds of feet long. Use any SWL, MW, BCB, VLF or Ham receiver.

High dynamic range RF amplifier. 54 in. whip. 50 foot coax. 20 dB attenuator prevents receiver overload. Switch between two receivers. Select auxiliary or active antenna. Gain control. "ON" LED. Remote unit, 3x2x4 in. Control, 6x2x5 in. 12 VDC or 110 VAC with optional adapter, MFJ-1312, \$9.95.

\$129⁹⁵
(\$4.00 shipping)

Order from MFJ and try it. If not delighted, return within 30 days for refund (less shipping).

One year unconditional guarantee.

Order today. Call TOLL FREE 800-647-1800. Charge VISA, MC. Or mail check, money order. Write for free catalog. Over 100 products.

CALL TOLL FREE 800-647-1800

Call 601-323-5869 in Miss., outside continental USA, tech/order/repair info. TELEX 53-4590.

MFJ ENTERPRISES, INCORPORATED

Box 494, Mississippi State, MS 39762

CIRCLE 66 ON FREE INFORMATION CARD

BUSINESS OPPORTUNITIES

VIDEO game repair business. Start your own. Information/parts list \$5.00. **BEST ELECTRONICS**, 4440 Sheena, Phoenix, AZ 85032.

64K 6502/Z80 dual processor computer US\$420.00. Hundreds Apple-compatible softwares. Details US\$1.00. **RELIANT**, PO Box 33610, Sheungwan, Hongkong.

BUY direct from Taiwan/Hong Kong. Details \$1.00. Refundable. **TONY COLUCCI**, 56 Central Blvd., Merrick, NY 11566.

DEALERS: Sell solderless breadboards IC DIP sockets. Very competitive prices. **LICATEK**, 26051 Vermont Ave. 203C, Harbor City, CA 90710, (213) 539-8997.

MECHANICALLY inclined individuals desiring ownership of small electronics manufacturing business—without investment. Write: **BUSINESSES**, 92-R, Brighton 11th, Brooklyn, NY 11235.

MAKE money by the minute around the clock for doing 8 hours a week from home. Grows to a lifetime income. Totally new ultra modern project unlike anything before. Still ground floor. No experience or education requirement. 3,000 people already doing division of major U.S. corporation. For details write: **MULTIMARKETING**, 225 S.W. Walnut, Dept. No.1, Dallas, OR 97338.

PROJECTION TV... Make \$\$\$'s assembling projectors... Easy... Results comparable to \$2,500.00 projectors... Your total cost less than \$20.00... Plans, 8" lens & dealer's information \$17.50... Illustrated information free... **MACROCOMA GAX**, Washington Crossing, PA 18977. Creditcard orders 24 hours (215) 736-2880.

BIG PROFITS ELECTRONIC ASSEMBLY BUSINESS

Start home. spare time. Investment knowledge or experience unnecessary. **BIG DEMAND** assembling electronic devices. Sales handled by professionals. Unusual business opportunity.

FREE: Complete illustrated literature
BARTA, RE-O Box 248
Walnut Creek, Calif. 94597

PLANS & KITS

PRINTED-circuit boards. Quick prototypes, production, design, reflow solder. Send print or description for quote to **KIT CIRCUITS**, Box 235, Clawson, MI 48017.

HI-FI speaker kits, auto speaker systems and speaker components from the world's finest manufacturers. For beginners and experts. Free literature. **A & S SPEAKERS**, Box 7462R, Denver, CO 80207 (303) 399-8609.

INCREASE radar detector effectiveness, or use without detector, distort true speed. Easily assembled, plans \$10.95. **APG ASSOCIATES**, 6040A Six Forks Road, Suite 138, Raleigh, NC 27609.

DESCRAMBLERS

AMERICAN—CANADIAN

New Satellite Descramblers

C-1000 / ZENITH TYPE

Descrambles "over the air" and "cable" sync suppressed active video inversion signals

Ready to go C-1000 379 95

Complete Kit C-1000K 274 95

Printed Circuit & Manual 24.95

C-100 / JERROLD TYPE

Cable Descrambler for in-band gated suppressed systems

Ready to go C-100 119 95

Complete Kit C-100K 54 95

SEND \$2 FOR COMPLETE INFORMATIVE CATALOG TO DETERMINE WHAT TYPE YOU NEED.

J & D ENGINEERING

P.O. Box 6099

Falmouth, Maine 04105

Dealers Wanted
Special Quantity Pricing
COD's—OK

Buy 1 kit
Get 2nd kit
at 1/2 price

All J & D products are engineered, not copied, all are guaranteed 90 days & we stand behind our products where others fail to

SERIAL and parallel printer interfaces Centronics, Selectric, Teletype. **CULLINS**, 917 Prestwick, Bedford, TX 76022.

SPEECH synthesis PC board for SP0256-017. Minimum external parts, easy 30 minute construction. PCB and plans \$7.50. **JV CIRCUITS**, 1209 Hunter Ct., Addison, IL 60101.

PROJECTION TV... Convert your TV to project 7 foot picture... Results comparable to \$2,500.00 projectors... Total cost less than \$30.00... Plans and 8" lens \$19.95... Illustrated information free. **MACROCOMA-GA**, Washington Crossing, PA 18977. Creditcard orders 24 hours, (215) 736-3979.

WERSI electronics ORGAN & PIANO KITS

ALPHA DX 300



fully
DIGITAL
RS232
Interface

For Free Sound Info
Call 1-800-233-3865
or write WERSI USA
Dept. M 8 P.O. Box 5318
Lancaster, PA 17601

THE WORLD LEADER

NEW!... repair any TV... easy. Anyone can do it. Write **RESEARCH**, RR No.3, Box 601BR, Colville, WA 99114.

CABLE-TV converters: Jerrold, Hamlin, SB-3, AN-3, Mini-Code, Zenith & more. UHF converters: Deluxe II sinewave kits \$95.00, gated pulse add/on \$70.00. Complete units \$195.00 with gated pulse \$255.00. (Quantity discounts.) Repairs of all converters & cable boxes. Send SASE (54 cents postage) or call for info. 1 (312) 637-4408. **HIGGINS ELECTRONICS**, 6014 W. Nelson, Chicago, IL 60634.

QUALITY light chaser/color organ kits. Refundable \$1.00 for flyer. **DESIGN SPECIALTY**, Box 1995, Huntington Beach, CA 92647.

PCB and **TOKO** coils for TV project in February 1984 article only \$17.00. **JIM RHODES**, 1025 Ransome Lane, Kingsport, TN 37660.

SPEECH synthesizer—Unlimited vocabulary. Schematics and programs for Apple, VIC, Comm 64, TRS 80, and Color Computer, \$6.00. **Talking Clock** for VIC, Comm 64, \$3.00. All Radio Shack parts. **MICROTALK**, 39 Raymond St., Providence, RI 32901.

200 electronics kits, projects, plans, send stamps for list, **MATCO ELECTRONICS** Box 316R, Cadillac, MI 49601.

ZX81 joystick adaption plans \$8.79, keyboard adaption plans \$9.25. **J. WILLIS**, 4043H Harpers Road, VA Beach, VA 23454-5321.

SCANNERS

SCANNERS—discount prices Bearcat BC-100 \$279.99; Bearcat 210XL \$214.99; Bearcat 300 \$335.99; Regency MX3000 \$186.99; JIL SX100 \$138.99; JIL SX200 \$269.99; Bearcat 20/20 \$275.99; Spectrum radar detector \$214.99; plus \$3.00 shipping. Free discount catalog. Lowest prices anywhere on scanners, radar detectors, marine radios, two-way accessories. **SCANNER WORLD**, 10-RE New Scotland, Albany, NY 12208 (518) 436-9606.

SATELLITE TELEVISION

UNSCRAMBLE secret satellite channels watch all the good stuff. Plans \$19.95—kits \$169.95—complete units \$395.00—Details and order forms \$3.00. **SCRAMCO**, 8688 Royal Drive, Noblesville, IN 46060.

SATELLITE-TV receiver breakthrough! Build your own system and save! Instruction manuals, schematics, circuit boards! Send stamped envelope: **XANDI**, Box 25647, Dept. 21C, Tempe, AZ 85282.

MULTI channel microwave antennas, highest quality, low prices dealers welcome D.T. compact \$38.00, PT-1 \$48.00, SR-1 \$65.00, D.T. grid \$69.00, PTS-33 \$75.00, all units complete. **DAISY TENNA**, Box 42010, Phoenix, AZ 85080, (1-800) 874-9033.

MOTORIZED satellite dish drives, gear motors, mounting bracket, control \$99.95, Jack shafts \$40.00, AC DC voltage, **ISS**, 4970 Apache, Pocatello, ID 83204.

ENJOY SATELLITE TV

Save money with easy, guaranteed, do-it-yourself antenna plans/kits. Electronic knowledge not necessary. Send \$1.00 for catalog or \$8.95 for 1984 "Consumer Guide to Satellite Television."

GFI-D9
Box 9108
Missoula, MT 59807



GRAPHIC EQUALIZERS, ETC.

NOISE eliminators, expanders, power meters, others. Twelve-24 bands/channel equalizers from \$89.00 Kit see **R-E** 5-6/78, 2/80, 3-4/81. Catalog: **SSS**, 856R Lynnrose, Santa Rosa, CA 95404. (707) 546-3895.

SINE WAVE PATENT SECRETS

INCLUDES patent, complete explanations of authorization and control, video signal correction, audio system, internal design, \$20.00. **SIGNAL** Box 2512-P, Culver City, CA 90231.

CB EQUIPMENT

PALOMAR/Pride electronics—exclusive repair facility. Service—update—improvements on these and similar equipment. **PALOMAR-PRIDE REPAIR**, 1320-4 Grand, San Marcos, CA 92069 (619) 744-0720.

CB MODIFICATIONS

Increase channels, range, privacy! We specialize in frequency expanders, speech processors, FM converters, PLL & slider tricks, how-to books, plans, kits. Expert mail-in repairs & conversions. 16-page catalog \$2.

CBC INTERNATIONAL, P.O. BOX 31500RE,
PHOENIX, AZ 85046 (602) 996-8700

NEWSLETTERS

ELECTRONIC SYSTEMS NEWSLETTER is a monthly publication written especially for the electronics hobbyist/experimenter. Fascinating projects, new ideas, sources. Free details. **AF PUBLISHING**, Dept. R2, PO Box 524, So. Hadley, MA 01075.

EPROM PROGRAMMERS

EPROM, **EEPROM**, & microcontroller programmers operate through your personal computer's RS-232 communications port. PC boards from \$25.00; assembled \$139.00 to \$269.00; custom software included for IBM, CP/M, or Radio Shack computers. Free brochure. **ROSS CUSTOM ELECTRONICS**, 1307 Darlene, Suite A12, Boulder City, NV 89005. (702) 293-7426.

REEL-TO-REEL TAPES

AMPEX professional series open reel tape, 1800- or 2400-foot on 7-inch reels, used once. Case of 40, \$45.00. 10½" x 3600 foot and cassettes available. MasterCard/Visa. **VALTECH ELECTRONICS**, Box 6-RE, Richboro, PA 18954 (215) 322-4866.

ELECTRONICS, PHYSICS, PSYCHIC PHENOMENA

PSYCHIC phenomena explained, learn to read minds, develop a photographic memory and more No.1 \$3.50, How U.F.O.s work, produces spiraling lines of electricity, artificial gravity No.2 \$3.50, How to Transmute the Elements, the secrets been around since 1899 No.3 \$4.00, Prophecies of Nostradamus over 80 prophecies, two showing the destruction of the M.X., explains biblical, mythological mysteries, best interpretations around. No.4 \$10.00. Many electronics kits, modulated door lock, ruby crystal laser, electronic bug devices, just a few. Free catalog. No COD, or charge cards. Add \$2.00 postage, handling, **MIKE REILLY**, 3520 SE 5th Ave., Cape Coral, FL 33904.

WANTED

INVENTIONS, ideas, new products wanted for presentation to industry and exhibition at national technology exposition. Call **1-800-528-6050**. Arizona 1-800-352-0458. X831.

OLD tubes: 2A3, 10s, 45s, 50s, 80s, 81s, 211, 242, 845, VT-52, VT-62. **WESTERN ELECTRIC EQUIPMENTS**: (818) 576-2642, David, POB 832, M-Park, CA 91754

CABLE TV

DEALERS wanted: Channel 2, 3, and 4 notch filters. **Money back guarantee**. Send \$15.00 for sample and quantity price list. Specify channel(s). **LEE KURTZ**, PO Box 291394, Davie, FL 33329.

INVENTORS!

INVENTORS! IDEAS HAVE VALUE! Ever think of an idea, forget it, and see it later on the market? Many people don't forget, act quickly, and are rewarded by American industry. Write down your idea! We offer free disclosure registration and initial consultation regarding your idea's potential value. Call or write without delay for your free information package. **AMERICAN INVENTORS CORPORATION**, 82 Broad Street, Dept. RE, Westfield, MA 01086, (413) 568-3753.

NORTH AMERICAN SOAR corporation PEN-STYLE DIGITAL MULTIMETER

MODEL 3100
GREAT PRICE **\$49.00**

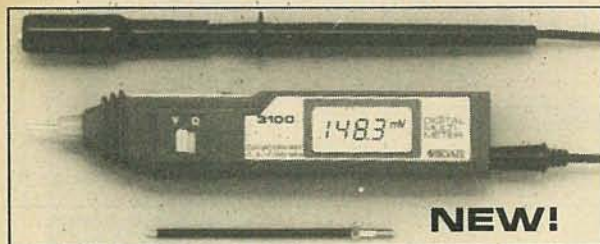

NEW!

Hand Held LCD Display - Fast One Hand Operation

SPECIFICATIONS:

Display: LCD 3½ digits maximum reading of 1999/continuity beeper built-in
Range: Auto ranging
Polarity: Automatic no indication for positive polarity, minus sign for negative polarity
Overrange Indication: MBS 1 or -1 indication
Data Hold: Data hold in all ranges with hold switch on
Low Battery Indication: 'B' mark displayed when battery drops below operating voltage
Sampling: 2 Times/second
Power Supply: SR-44 battery (1.55V) X2
Power Consumption: 5.5mW
Size: 6" x 1¼" LWH (less probe tips) includes ½" and 2" probes

Add \$2.50 For Shipping

STOCKING DISTRIBUTOR



KCS ELECTRONICS CORPORATION
SEMICONDUCTOR PARTS AND PRODUCTS

1043 N. STADEM DR.
TEMPE, AZ 85281

(602) 967-6945

Call or Write for **FREE**
Semiconductor Parts & Products Catalog

MICROWAVE TV ANTENNA SYSTEMS

Freq. 2.1 to 2.6 GHz • 34 db Gain +



COMPLETE SYSTEMS

(as Pictured)

Commercial 40"

Rod Style \$ 99.95

Parabolic 20"

Dish Style \$ 79.95

COMPONENTS

Down Converters

(both types) \$ 34.95

Power Supplies

(12V to 16V) \$ 24.95

Data Info (Plans) \$ 9.95

CALL OR WRITE FOR
KITS, PARTS, INDIVIDUAL
COMPONENTS

We Repair All Types Down
Converters & Power Supplies

**Phillips-Tech
Electronics**

P.O. Box 34772
Phoenix, AZ 85067
(602) 967-6972

Special Quantity Pricing
Dealers Wanted



AMAZING DEVICES

PERSONAL DEFENSE AND PROPERTY PROTECTION UTILIZE SPACE AGE TECHNOLOGY. CAUTION THESE DEVICES CAN BE HAZARDOUS AND MAY SOON BE ILLEGAL.

PHASORS

POCKET PAIN FIELD GENERATOR — IPG50
 Assembled.....\$59.50
 IPG5 Plans.....\$7.00 IPG5K Kit/Plans.....\$39.50

PHASOR PAIN FIELD CROWD CONTROLLER — PPF10
 Assembled.....\$250.00
 PPF1 Plans.....\$15.00 PPF1K Kit/Plans.....\$175.00

BLASTER — Provides a plasma discharge capable of puncturing a can.
 BLS10.....Assembled.....\$79.50
 BLS1 Plans.....\$10.00 BLS1K Kit/Plans.....\$59.50

SHOCKER/PARALYZING DEVICE — Very intimidating and effective.
 SHG60.....Assembled.....\$99.50
 SHG6 Plans.....\$10.00 SHG6 Kit/Plans.....\$79.50

LASERS

RUBY LASER RAY GUN — Intense visible red beam burns and welds hardest of metals. **MAY BE HAZARDOUS.**
RUB3 All Parts Available for Completing Device \$15.00

CARBON DIOXIDE BURNING, CUTTING LASER — Produces a continuous beam of high energy. **MAY BE HAZARDOUS.**
LC5 All Parts Available for Completing Device \$15.00

VISIBLE LASER LIGHT GUN — produces intense red beam for sighting, spotting, etc. Hand held complete.
 LGU3 Plans.....\$10.00 (Kit & Assembled Units Available)

IR PULSED LASER RIFLE — Produces 15-30 watt infra-red pulses at 200-2000 per sec.
 LRG3.....All Parts & Diodes Available.....\$10.00

BEGINNERS LOW POWER VISIBLE LASER — Choice of red, yellow, green — provides an excellent source of monochromatic light.
 LHC2 Plans.....\$5.00 LHC2K Kit.....\$29.50

SECURITY

SNOOPER PHONE — Allows user to call his premises and listen in without phone ever ringing.
 SNP20.....Assembled.....\$89.50
 SNP2 Plans.....\$9.00 SNP2K Plans/Kit.....\$59.50

LONG RANGE WIRELESS MIKE — Miniature device clearly transmits well over one mile. Super sensitive, powerful.
 MFT1 Plans.....\$7.00 MFT1K Plans/Kit.....\$39.50

WIRELESS TELEPHONE TRANSMITTER — Transmits both sides of phone conversation over one mile. shuts off automatically.
 VVPM5 Plans.....\$8.00 VVPM5K Plans/Kit.....\$34.50

TALK & TELL AUTOMATIC TELEPHONE RECORDING DEVICE — Great for monitoring telephone use.
 TAT20.....Assembled.....\$24.50
 TAT2 Plans.....\$5.00 TAT2K Plans/Kit.....\$14.50

Our phone is open for orders anytime. Technicians are available 9-11 a.m., Mon-Thurs for those needing assistance or information. Send for free catalog of hundreds more similar devices. Send check, cash, MO, Visa, MC, COD to: **INFORMATION UNLIMITED**
 DEPT RB, P.O. Box 716, Amherst, N.H. 03031 Tel: 603-673-4730

CIRCLE 88 ON FREE INFORMATION CARD

COMPUTER CORNER

continued from page 89

processor, a hex keyboard, and video output. It also has 2K of RAM and an audio-cassette interface. The unit has never been used and is still packed in its original box. I suppose it might be good for learning about microprocessors or as a special controller for some project. But the 1802 is not exactly what you'd call a mainstream CPU.

Also among my basement collection was a Heathkit ET-320, a 6800-based microprocessor trainer. The unit works fine and is outstanding for learning microprocessor operation and applications. Heath still sells that unit, but I suspect that mine will reside in a cardboard box in my basement along with some of the other goodies that I hate to give up.

Just recently, a pair of Tandon 100-1 floppy-disk drives were added to my basement junkbox. Those single-sided double-density 160K byte drives came out of an IBM PC, which was purchased when that computer first became available late in 1981. Since most of the newer software for the PC uses double-sided drives, I was forced to upgrade to a couple of Control Data double-sided drives. Now the question is what to do with the Tandon units? They are probably worth a couple of hundred dollars apiece if purchased separately, but who wants single-sided drives when double-sided drives seem to be the most popular thing?

Computer components

Finally, we come to my component junkbox. Beside all the old TTL devices, a number of 256-bit bipolar RAM IC's, some 4K NMOS RAM IC's, a 1702A PROM, and some LED displays were found. Also in that junkbox were a couple of microprocessors that had been acquired somewhere along the way. One type was Intel's original 8088 8-bit microprocessor and the other a Signetics 2650 8-bit microprocessor.

So far, I haven't really decided what to do with all that stuff; most of it has been around for years, so there's no great rush to get rid of it. Perhaps some of it will be sold,

particularly those items that may still be useful. Other items will remain in the basement for old times sake, and then there may be a few items that will just be thrown away or cannibalized.

In any case, most of the stuff is in pretty good shape and could be used for experimenting or learning. Other than using it for experimental and learning applications, the best thing to do may be to give the stuff away to somebody who can use it. Anyway, the basement is straighter now—or at least some of it is!

My next chore will be to sort through the old magazines: There must be every issue of every personal computer and electronics magazine since the early '70's down there. Most of them should be thrown away, since they take up so much space. But I just can't bring myself to do that, because those magazines contain the history of personal computing—again, nostalgia! Anyway, going through all of those magazines is more than a week's project (especially since I'll probably try to read every issue). I wonder if I'll ever get around to it. R-E

NEW IDEAS

continued from page 46

ic burglar-alarm type switch with normally open contacts (the type that's mounted recessed in the door frame).

Relay RY1 is optional; it's used to turn on an outside lamp so that you can see the person that's at the door.

Relay RY1 is a SPDT 12-volt coil relay with 125-volt, 3-amp contacts (if you wish, Radio-Shack sells a DPDT relay, 275-206, that is rated appropriately and can be used here; with that relay, one set of contacts is simply not used) and RY2 is a mini SPDT relay with a 6-9-volt coil and contacts rated at 1-amp at 125 volts (Radio Shack 275-004). To make RY2 operate properly, it is necessary to strip off 4 or 5 turns of wire from the coil tension spring to increase its tension. Transistor Q1 and diode D1 are general-purpose devices. The buzzer is a 2-20-volt piezo type (Radio Shack 273-060).—Fred Jellison, Jr.

QUALITY SPECIALS

DELUXE 46 CHANNEL CABLE TV CONVERTER



With Fine Tuning Dial

- Shifts all cable channels to UHF
- Extend pay TV to all your TV sets without extra monthly fee
- Allows taping pay TV (decoder required) while viewing another channel
- Restores TV remote control and VCR programming ability

\$24.95

BICYCLE COMPUTER

A Dashboard for your Bike

Handsome matte black console with keyboard input. Displays your speed, distance & calories burned on 2 sq. in. LCD screen. Quartz clock/stowwatch built in. Complete with MAG pickup & all mounts.



\$49.95

Upgrade any bike to a deluxe exercise machine

NEW DIGITAL SCALE

Lab accuracy at an everyday price...reads 1 gram or .1 oz.



Gives fast, exact weight in ounces or grams for the lab, dieting, postage, photography. Capacity: 1999 grams/70 oz. with automatic tare. Free postage & dist chart.

Best Value \$74.95

POCKET MICROSCOPE



USA Made precision 4 lens optics gives sharp undistorted image. Easily detects hairline faults. Internal scale accurate to 1%. Rugged metal case, only 5 inches long.

10X has 265 in. field, .005 in. scale divisions
 20X has 150 in. field, .002 in. scale divisions

\$14.95

GOLDSMITH SCIENTIFIC CORPORATION

720 E. Industrial Park Dr., Manchester, NH 03103

PHONE ORDERS WELCOME (603) 624-8030

FREE CATALOG OF NEW DEVICES

POSTAGE—ADD 5% PLUS \$1.50 INSURANCE, C.O.D. \$2.00 EXTRA

SATISFACTION FULLY GUARANTEED

CIRCLE 63 ON FREE INFORMATION CARD

TECHNICIANS!

We Have What You Need At
The Prices You Want!

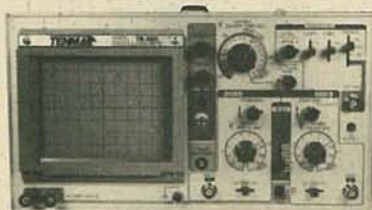

TENMA
20MHz DUAL TRACE
OSCILLOSCOPE **\$389.95**

Backed By Our 2 Year Warranty
High Quality Hook-On Probes Included **#72-320**



TENMA
DIGITAL
MULTIMETER
HFE TEST
0.5" LCD display
DC input impedance
10MΩ

\$39.80
#72-050

AGC FUSES
STANDARD
1 1/4x1/4

25A 4A
.5A 5A
.75A 6A
1A 7A
1.5A 8A
2A 10A
2.5A 15A
3A 20A
(100-up pcs.)
(NO MIXED QTYS.)



3.5¢
each

36 PIN PARALLEL
CONNECTOR



\$3.95
#83-310

PANASONIC 2-4 HOUR
VIDEO HEAD REPLACES
PANASONIC PART #VEH-0070



\$39.95
#32-160

JAPANESE SEMICONDUCTORS

• D1341 1.92 • M51515BL 2.49
• BUY69A 2.99 • STK0050 3.95
• HA1377 2.49 • 4116-200NS 1.38

(min. 10 pcs.)

We have the Largest
Selection of Original
Japanese Semiconductors
in the Country!

We Also Have... a full line of: test equipment,
computer accessories, telephone accessories, speakers,
television parts, flybacks, yokes, switches, fuses, lamps,
capacitors, resistors, cartridges, styli, wire, CATV equipment,
and many more. **Over 4,500 items AT THE LOWEST PRICES
AROUND!**

Terms: • \$10 minimum order. \$1.00 charge for orders under \$10.
• \$20 minimum charge card order.
• Orders shipped UPS C.O.D.
• Most orders shipped within 24 hours.
• Sales office open 8:30am to 6:00pm. Saturdays 10:00am to
3pm, EST.



CALL TOLL FREE
1-800-543-4330
(in Ohio, 1-800-762-4315)

mcm THE ONLY
ELECTRONICS PARTS COMPANY
YOU'LL EVER
NEED

858 East Congress Park Drive
Centerville, Ohio 45459
513-434-0031

**CALL OR WRITE TODAY
FOR YOUR FREE 120 PAGE
CATALOG! OVER 4500 ITEMS!**

PRICES SUBJECT TO CHANGE WITHOUT NOTICE



SOURCE NO. RE-1

**DON'T
FORGET**



USE
YOUR
READER
SERVICE
CARD

NEW! MULTI-CHANNEL MICROWAVE

Complete Antenna Systems from \$69⁹⁵

Full 800 Mhz Range
Tune 1.9-2.7 Ghz
Includes all
ITFS Channels

DEALERS WANTED

COD's and Credit Card
Orders call TOLL FREE
1-800-247-1151

GALAXY
ELECTRONICS
5644 N. 53rd Avenue
Glendale, AZ 85301
1-602-247-1151



THE BEST PLACE TO BUY, SELL or
TRADE NEW and USED EQUIPMENT
NUTS & VOLTS MAGAZINE
BOX 1111-E • PLACENTIA, CA 92670
(714) 632-7721
Join Thousands of Readers Nationwide
Every Month
ONE YEAR U.S. SUBSCRIPTIONS
\$7.00 - 3rd Class • \$12.50 - 1st Class
\$25.00 - Lifetime - 3rd Class

NUTS & VOLTS

HAM GEAR
COMPUTERS
SOFTWARE
SCANNERS • OPTICS
TEST EQUIPMENT
MICROWAVE
SATELLITE
AUDIO VISUAL
NEW PRODUCTS
COMPONENTS • KITS
ANTIQUE ELECT.
PUBLICATIONS
PLANS • SERVICES

REPLACEMENT FOR

ECG®/TRIPLERS/MULTIPLIERS

(MIN. 50 PC. PER TYPE)

TYPE NO.	YOUR COST	TYPE NO.	YOUR COST	TYPE NO.	YOUR COST
500A	7.65	530	10.65	537	11.73
521	10.98	531	10.45	538	9.84
522	9.50	532	12.40	539	9.84
523	7.75	533	9.90	549	14.55
526A	7.75	534	10.48	550	10.05
528	9.40	535	11.48	556	11.90
529	8.90	536A	13.85	557	11.75
				564	11.55

REPLACEMENT FOR ECG® TYPES

TYPE NO.	YOUR COST	TYPE NO.	YOUR COST
85	FOUR for .99	125	SEVEN for .99
102A	THREE for .99	159AP	FOUR for .99
123A	FIVE for .99	177	EIGHT for .99
123AP	SIX for .99	199	FIVE for .99

SUPER SPECIAL (MIN. 5 PC. EACH)

TYPE NO.	YOUR COST	TYPE NO.	YOUR COST	TYPE NO.	YOUR COST
124	.85	165	2.25	375	.90
128	.45	171	.65	506	.55
129	.45	184	.45	500A	8.95
130	.80	185	.45	523	9.95
152	.40	238	2.25	526A	10.20
153	.40	276	6.95	529	13.75
154	.60	291	.95	712	1.25

JAPANESE TYPES (MIN. 5 PC. EACH)

2SC867A	2.75	HA1366W	1.85	STK0029	3.80
2SC1114	3.25	HA1377A	2.90	STK0080	9.99
2SC1308K	1.95	LA4102	1.25	TA7205AP	1.50
AN214Q	1.45	M51515BL	2.95	TA7208P	1.85
AN239A	4.60	STK433	3.95	TA7222AP	1.95
BA532	1.80	STK435	3.95	UPC1181H	1.25
GH3F	.89	STK437	6.25	UPC1182H	1.25
HA1342A	2.30	STK439	6.50	UPC1185H	2.99

COD ORDERS WELCOME (\$25 MIN. ORDER)

For Complete Component Catalog Call or Write

DIGITRON ELECTRONIC
110 HILLSIDE AVENUE, SPRINGFIELD, N.J. 07081
TOLL FREE: 800-526-4928
In N.J.: 201-379-9016

*ECG IS A TRADE MARK OF PHILIPS ECG.
DIGITRON ELECTRONIC IS NOT ASSOCIATED IN ANY WAY WITH PHILIPS ECG.

60W + 60W O.T.L. AMP

Stereo pre-amp + tone control + power amp. All in on unit, fully assembled! Compact in size; 7"x4"x2 1/2". Can be fitted into most cabinets. Power transistors using 25C1667 X 4 to give a max output of 60W + 60W (8Ω)
 • Frequency response: 20Hz - 85KHz (-1dB) • Total harmonic distortion: 0.02% (1KHz) • Signal/Noise Ratio: 88 dB (open loop) • Tone control: 100 Hz ± 16 dB 10 KHz ± 14dB • Dynamic range: 60 dB • Power Supply: 48V - 70V 5 Amp. • Filter Capacitor: 4700 μF 75V or better.

MODEL: SA-4520

Assembled Model \$39.95
 Transformer (Optional) \$22.50
 Filter Capacitor 4700 μF 75V (Optional) \$6.50 ea.



★ REDUCED PRICE ★

LOW T.I.M. TRANSISTORS
 100W + 100W

• Employs Hitachi low noise I.C. for pre-amp • Max. output 16 V P-P (non distortion) • With hi-low filter, and tone defeat circuit • Rear power amp with short circuit protection • Giant heat sink for maximum results • Tone controls - 14dB • All components (except pots for volume, and tone controls) are pre-assembled, the quality is guaranteed. • Power supply DC-35V-50V

MODEL: SA802C

Fully Assembled \$75.00
 Transformer (Optional) \$22.50 ea.
 Filter Capacitor 4700 μF 75V (Optional) \$6.50 ea.



100 WATTS

CLASS A
 POWER AMP
 KIT
 \$49.50

Dynamic Bias Class "A" circuit design makes this unit unique in its class. Crystal clear, 100 watts power output will satisfy the most picky fans. A perfect combination with the TA-1020 low TIM stereo pre-amp.

Specifications • Output power 100W RMS into 8Ω. 125W RMS into 4Ω • Frequency response 10Hz-100KHz • THD less than 0.01% • S/N ratio better than 80dB • Input sensitivity 1V max. • Power supply ±40V at 5A.

Power Transformer (Optional) \$24.00

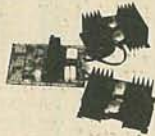

NOW WITH ON-BOARD LED LEVEL DISPLAY



★ SPECIAL ★
 Excellent Price!
 Model 001-0034
 \$29.50 per Kit
 Transformer
 \$10.50 ea.

TA-322 30 WATTS TOTAL
 15W + 15W STEREO AMP KIT

This is a solid state all transistor circuitry with on board stereo pre-amp for most microphone or phone input. Power output employs a heavy duty Power Hybrid IC. Four built on board controls for, volume, balance, treble and bass. Power supply requires 48VCT 2.5A transformer. THD of less than 0.1% between 100Hz-10KHz at full power (15 Watts + 15 Watts loaded into 8Ω).

LOW TIM DC STEREO PRE-AMP KIT TA-1020

Incorporates brand-new DC design that gives a frequency response from 0-100KHz ± 0.5dB. Added features like tone defeat and loudness control let you tailor your own frequency supplies to eliminate power fluctuations!

Specifications: • THD/TIM less than .005% • Frequency response DC to 100KHz ± 0.5dB • RIAA deviation ± 0.2dB • S/N ratio better than 70dB • Sensitivity: Phone 2mV 47KΩ, Aux 100mV 100KΩ • Output level 1.3V • Max output 15V • Tone controls: Bass ± 10dB @ 50Hz, Treble ± 10dB @ 15Hz • Power supply ± 24VDC @ 0.5A. Kit comes with regulated power supply. All you need is a 48VCT transformer @ 0.5A.

Only \$44.50
 Transformer
 \$4.50 ea.



MAGNETIC HEAD EQUALIZER

• Standard RIAA curve for all kinds of magnetic heads • 3 stages crossover circuit for best results • Output voltage guaranteed to be stable without any oscillation • Power Supply: 24 V.D.C.

MODEL: MA-142

Part #370-370 \$6.95 ea.



STEREO MICROPHONE AND ECHO MIXER FOR STEREO AMPLIFIER SYSTEM

The circuitry employs all integrated circuits, BBD type echo circuit, echo time can be adjusted (max. .30 Msec.) Also with a microphone preamp on the board. Fully assembled.

MODEL: MX205

Part #370-0360 \$29.95 ea.



20 STEPS LED TRI COLOR LEVEL INDICATOR KIT

This new stereo level indicator kit consists of 40 3-color LED's to indicate sound level output of your amplifier from -57dB to 0dB. Comes with an attractive silk screen printed panel. Has selector switch to allow floating or gradual output indicating. Kit includes all parts. Front panel and power supply.



MODEL: TY-45 \$29.50 per Kit

0-15V 2 AMP VARIABLE DC POWER SUPPLY KIT

All solid state circuitry with high efficiency power transistor 2SD388 and IC voltage regulator MC1733. Output voltage can be adjusted from 0-15V at 2A current limited. Internal resistance is less than 0.005Ω, ripple and noise less than 1mV, dual on panel meters for voltage and current reading, also with on board LED and audible over load indicator. Kit comes with pre-drilled PC Board, instructions, all necessary electronic components, transformer and a professional looking metal cabinet. The best project for school and the most useful instrument for repairmen. Build one today!

MODEL: TR 100
 \$59.50 ea.



INFRA-RED BEAM REMOTE CONTROL SWITCH KIT



This Infra-red Control switch can be used to control appliances on/off up to 500 watts.

Has effective control up to 30 feet. No antenna needed. Kit comes with transmitter and receiver unit, case and all components.
 Easy to build!

MODEL TK-41 KIT \$19.95 ea.

IBM PC/XT COMPATIBLES

and Full Line of Peripherals
 and Accessories
 Please Call

PC/XT COMPATIBLE
 Bare PC Board \$88.00

pinecom™ 64K STARTER SYSTEM



with: 64K Computer Unit (expandable to 192K)
 12" Green Monitor
 Monitor Cable
 1 Disk Drive
 1 Disk Controller Card
 1 Auto Center Joystick
 10 Double Density Diskettes
 1 'SOFTAPPLE' Software
 1 'Know Your Apple' Software

for all these goodies, you only pay **\$699⁰⁰**
 Computer Unit only \$399.00

pinecom™ DP-64E THE BUSINESS VERSION OF AN APPLE COMPATIBLE



APPLE II + COMPATIBLE!
 DP-64E

\$1099⁰⁰

Without Disk Drives
 and 80 Column Card
\$599⁰⁰

FEATURES

Dual Processors Can Run Both Apple and CP/M Programs.
 64K On Board Memory Expandable to 192K.
 80/40 Column Display w/Soft Switch.
 Dual Slim Disk Drives Built In.
 Detached Keyboard w/Numeric Keypad.
 Auto Repeat on Every Key and Cursor Control.

REDUCED PRICES

APPLE COMPATIBLE COMPUTER PRODUCTS

ADD ON CARDS

AUTOTERM 80 Column Card w/Siftswitch	\$89.00
80 COLUMN CARD (Videx Compatible)	69.00
SOFTSWITCH for 80 Column Card	35.00
Z80 CARD (CP/M)	69.00
16K RAM CARD w/Cable (Language Card)	49.00
16K RAM CARD (Language Card) Cables	39.00
PARALLEL PRINTER CARD (Universal)	59.00
GRAPHIC PRINTER CARD Supports Most Printers	89.00
PRINTERFACE CARD (Practical Peripheral)	69.00
SERIAL INTERFACE CARD (RS-232 Card)	59.00
SUPER SERIAL INTERFACE CARD	120.00
DISK CONTROLLER CARD	45.00
DISK CONTROLLER CARD 3.2/3.3 Auto Select	55.00
EPROM WRITER CARD (2716/2732/2764)	75.00
128K RAM CARD	199.00
TTL IC TESTER CARD (for Known/Unknown TTL IC's)	160.00
RGB COLOR INTERFACE CARD	89.00
PAL SYSTEM TV INTERFACE CARD	45.00
R.F. MODULATOR (NTSC Channel 3 & 4)	12.95
COPY CARD (Wildcard Compatible)	55.00
6809 INTERFACE CARD	170.00

DISK DRIVES

SUPER 5 SLIM (TEAC Drive)(Red Label)(40 Track)	\$225.00
SUPER 5 SLIM (ALPS Drive) (Green Label)	189.00
AUSUKA SLIM (w/Opto Sensor)(Blue Label)	225.00
μSCI FULL HEIGHT A-2 Drive (Shugart)	199.00
PINECOM SUPER DRIVE (Full Height Seimens)	199.00

MONITORS

FORMULA IBM Style 12" Green, Hi Resolution	\$130.00
EA 12" Green, Hi-Resolution	99.00
EA 12" Amber, Hi-Resolution	120.00
AMDEK VIDEO 300 12" Green, Hi-Resolution	145.00
AMDEK VIDEO 300A 12" Amber, Hi-Resolution	165.00
AMDEK COLOR I 13" Color	290.00
GORILLA 12" Green, Hi-Resolution	99.00

OTHER PRODUCTS

TILTABLE MONITOR STAND (for 12"/13" Monitors)	\$24.95
DISKETTE HOLEPUNCH (Conv. Disk to Double Side)	8.99
DISKETTE BOX w/Keylock (Holds 100 5 1/4" Disks)	16.50
POWER STRIPE w/Surge Suppressor & switch, 6 Outlets.	19.95
APPLE FAN w/Surge Suppressor & Switch, 2 Outlets	39.00
HEAVY DUTY JOYSTICK w/Auto Center and Fine Trim	29.00
GENERIC BRAND DISKETTES S.S.D.D. (Box of 10)	16.50
3M DISKETTES S.S.D.D. (Box of 10)	21.00
SENTINEL DISKETTES S.S.D.D. (Box of 10)	21.00
DATALIFE DISKETTES S.S.D.D. (Box of 10)	26.00

For Outside U.S.A. Purchases, Order Direct from Our Hong Kong Office.

PINEAPPLE COMPUTER PRODUCTS (HK) LTD.,

L-55 Peninsula Centre, Mody Rd. East, Tsim Sha Tsui East, Kowloon, Hong Kong. Telex: 50026 LTCAL HK.

FORMULA INTERNATIONAL INC.

12603 Crenshaw Blvd., Dept. B, Hawthorne, CA 90250

For information (213) 973-1921 • Orders Only (outside Calif.) (800) 672-8758

IBM is a registered trade mark of IBM.
 CPM is a registered trade mark of Digital Research.

MINIMUM ORDER \$10.00. CA Residents add 6.5% Sales Tax.
 Phone orders accepted on VISA or Mastercard only. No COD's.
 Prices subject to change without notice.

SHIPPING AND HANDLING CHARGES

	Under \$50.00 Purchase	Over \$50.00 Purchase
Inside CA	10%	5%
Outside CA	15%	10%
Outside USA	25%	20%

STORE HOURS

Mon.-Fri 10am-7pm
 Sat. 10am-6pm

PLEASE NOTE: A 15% re-stocking charge will be made to customer for all returned merchandise.

DISC CONTROLLERS

1771	14.95	2797	84.95
1791	23.95	6843	33.95
1793	25.95	8272	38.95
1795	48.95	UPD765	38.95
1797	48.95	MB8876	28.95
2791	79.95	MB8877	33.95
2793	79.95	1691	16.95
2795	84.95	2143	17.95

CRYSTALS

1.0000 MHz	3.99	8.0000 MHz	2.69
1.8432 MHz	3.99	10.0000 MHz	2.69
2.0000 MHz	2.99	10.7386 MHz	2.69
2.0972 MHz	2.99	12.0000 MHz	2.69
2.4576 MHz	2.99	14.3182 MHz	2.69
3.2768 MHz	2.99	15.0000 MHz	2.69
3.5795 MHz	2.99	16.0000 MHz	2.69
4.0000 MHz	2.99	17.4300 MHz	2.69
4.1943 MHz	2.99	18.0000 MHz	2.69
4.9160 MHz	2.99	18.4320 MHz	2.69
5.0000 MHz	2.69	19.6608 MHz	2.69
5.0688 MHz	2.69	20.0000 MHz	2.69
5.1850 MHz	2.69	22.1184 MHz	2.69
5.2429 MHz	2.69	32.0000 MHz	2.69
5.7143 MHz	2.69	36.0000 MHz	2.69
6.0000 MHz	2.69	48.0000 MHz	2.69
6.1440 MHz	2.69	49.4350 MHz	2.69
6.4000 MHz	2.69	49.8900 MHz	2.69
6.5536 MHz	2.69		

32.768 KHz. 1.69

CRYSTAL CLOCK OSCILLATORS

PART NO.	FREQUENCY	PRICE
1.000	1.0000 MHz	9.95
1.843	1.8432 MHz	9.95
2.000	2.0000 MHz	9.95
4.000	4.0000 MHz	9.95
8.000	8.0000 MHz	9.95
10.000	10.0000 MHz	9.95
16.000	16.0000 MHz	9.95
18.432	18.4320 MHz	9.95
19.660	19.6608 MHz	9.95
20.000	20.0000 MHz	9.95
32.000	32.0000 MHz	9.95

VOLTAGE REGULATORS

7805T	.74	7905T	.84
78M05C	.34	7908T	.84
7808T	.74	7912T	.84
7812T	.74	7915T	.84
7815T	.74	7924T	.84
7824T	.74	7905K	1.44
7805K	1.34	7912K	1.44
7812K	1.34	7915K	1.44
7815K	1.34	7924K	1.44
7824K	1.34	79L05	.78
78L05	.68	79L12	.78
78L12	.68	79L15	.78
78L15	.68	LM323K	4.90
78H05K	9.90	UA78S40	1.90
78H12K	9.90		

C,T = TO-220 K = TO-3
L = TO-92

DIP SWITCHES

4 POSITION84
5 POSITION89
6 POSITION89
7 POSITION94
8 POSITION94

IC SOCKETS

(1 to 99)

8 pin ST12	8 pin WW58
14 pin ST14	14 pin WW68
16 pin ST16	16 pin WW68
18 pin ST19	18 pin WW98
20 pin ST28	20 pin WW	1.04
22 pin ST29	22 pin WW	1.34
24 pin ST29	24 pin WW	1.44
28 pin ST39	28 pin WW	1.64
40 pin ST48	40 pin WW	1.94

ST = Solder Tail WW = Wirewrap

ZIF SOCKETS

16 pin ZIF	5.90
24 pin ZIF	7.90
28 pin ZIF	8.90

ZIF = TEXTOL (Zero Insertion Force)

1984

– THE IC MASTER –
Your ticket to fast and easy IC selections

\$ **89.95**



IBM Expansion KIT Upgrade Chips
4164 200ns 9 @ 5.45 ea.

micromax

VIEWMAX-80 149.95

- 80 Column card for Apple II+
- Video Soft Switch
- Inverse Video
- 2 Year Warranty



VIEWMAX-80e 129.95

- 80 Column card for Apple IIE
- 64K RAM expandable to 128K

64K RAM Upgrade 43.60



QUV-T8/1 EPROM Eraser

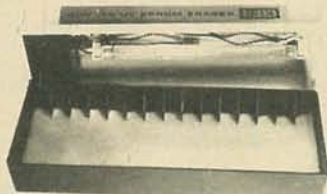

QUV-T8/1 Economy Model:

Low cost EPROM eraser in plastic enclosure. The UV element is in the lid and you place the EPROMS in the bottom half. No timer or switch option.

- Erases up to 8 EPROMS in 15 - 20 minutes.
- 12,000 uWatts at 1" distance.
- 90-Day Warranty **49.95**

The FLIP SORT™

The new Flip Sort™ has all the fine qualities of the original with some added benefits: a new design and 50% greater capacity. Holds 75 diskettes and the price is now lower than ever— **\$16.95**



ATHANA

BULK 5 1/4" DISKETTES
(NO LABEL)

\$\$/SD	15.90	\$\$/DD	10/14.90
\$\$/DD	16.90	100 up	—	CALL
DS/DD	22.90			

APPLE ACCESSORIES

80 Column Apple II+	149.95
80 Column Apple IIE	129.95
Z80 Apple II+	89.00
Z80 Apple IIE	89.00
16K Card	39.95
Cooling Fan	38.95
Power Supply	74.95
Joystick	29.95
RF Modulator	13.95
Disk Drive	199.00
Controller Card	59.95

APPLE COMPATIBLE DISK DRIVE

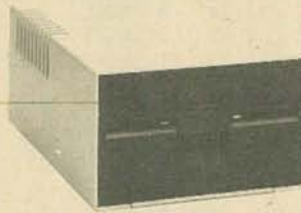

199.00

- Shugart mechanism, made in U.S.A.
- Directly replaces Apple Disk II
- Fully compatible with Apple Controller or other Apple compatible controllers.
- One Year Warranty

CONTROLLER CARD... 59.95

COOLING FAN

38.95



APPLE COMPATIBLE POWER SUPPLY

74.95



- Powers Apple type systems
- +5V @ 5A +12V @ 3A -5V @ .5A -12V @ .5A
- includes instructions

The Flip Sort PLUS™

The new Flip Sort PLUS™ adds new dimensions to storage. Its smoked acrylic elegance holds over 100 diskettes with all the features you expect from the Flip Sort Family— **\$24.95**



APPLE COMPATIBLE JOYSTICK

29.95



16K RAM Card – Apple II+
• 2-Year Warranty



Assembled & Tested 39.95
For the APPLE HOBBIEST DoKay KITS:

- 16K RAM card..... 24.95
 - 80 Column Card II+... 89.95
 - Z80 Card..... 69.95
 - Printer Card..... 24.95
 - 80 Column Card IIE ... 89.95
- KEYBOARD (99/4)**
48 keys 4" x 10" **6.95**



Reg. Power Supply Model 4A/PS (99/4)
3 DC Outputs:

12V. @ .4A, +5V @ 1.1A
-5V @ .2A Highly Filtered

6.95

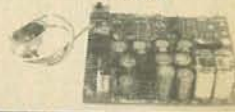

TERMS: Minimum order \$10.00. For shipping and handling, include \$2.50 for UPS ground or \$3.50 for UPS Blue (air). For each additional air pound, add \$1 for UPS Blue shipping and handling. California residents must include 6% sales tax; Bay area and LA residents include 6½% sales tax. Prices are subject to change without notice. We are not responsible for typographical errors. We reserve the right to limit quantities and to substitute manufacturers. All merchandise subject to prior sale.

CALL for VOLUME Quotes

HOURS: Mon. – Fri. 7:30 to 5:00
Saturdays 10:00 to 3:00

VISIT OUR RETAIL STORE

2100 De La Cruz Blvd.
Santa Clara, CA 95050
(408) 988-0697

ALL MERCHANDISE IS 100% GUARANTEED

Telex: 756440

DoKay

7400

**Number of Pins of each IC for easy Socket purchase

Table listing 7400 series components including Part No., Pins, Price, and Part No., Pins, Price. Includes items like SN7400N, SN7401N, SN7402N, etc.

Table listing 74LS series components including Part No., Pins, Price, and Part No., Pins, Price. Includes items like 74LS00, 74LS01, 74LS02, etc.

Table listing 74S series components including Part No., Pins, Price, and Part No., Pins, Price. Includes items like 74S00, 74S01, 74S02, etc.

Table listing 74ALS series components including Part No., Pins, Price, and Part No., Pins, Price. Includes items like 74ALS00, 74ALS01, 74ALS02, etc.

MICROPROCESSOR COMPONENTS

Table listing MICROPROCESSOR CHIPS including Part No., Pins, Price, and Part No., Pins, Price. Includes items like 2650, M55001, M55002, etc.

Table listing 8000/8000/8000 SERIES including Part No., Pins, Price, and Part No., Pins, Price. Includes items like M8000, M8001, M8002, etc.

Table listing DISK CONTROLLERS including Part No., Pins, Price, and Part No., Pins, Price. Includes items like IN5177-1, FD1791, etc.

Table listing SPECIAL FUNCTION including Part No., Pins, Price, and Part No., Pins, Price. Includes items like D50026C, IN20521, etc.

Table listing LOW PROFILE (TIN) SOCKETS, SOLDERTAL STANDARD (TIN), SOLDERTAL (GOLD) STANDARD, and WIRE WRAP SOCKETS (GOLD) LEVEL #3. Includes items like 8 pin LP, 16 pin LP, etc.

Digitalker™

DT1050 — Applications: Teaching aids, appliances, clocks, automotive, telecommunications, language translations, etc.

DT1050 Digitalker™ Processor Chip \$34.95 ea. MM54104 Processor Chip \$14.95 ea.

DT1057 — Expands the DT1050 vocabulary from 137 to over 260 words. Includes 2 ROMs and specs. \$24.95 ea.

Table listing EVALUATION KITS including Part No., Pins, Price, and Part No., Pins, Price. Includes items like 7045HP, 7106CP, etc.

NEW PRODUCT! 74HC High Speed CMOS

Table listing 74HC series components including Part No., Pins, Price, and Part No., Pins, Price. Includes items like 74HC00, 74HC01, 74HC02, etc.

Table listing 74C series components including Part No., Pins, Price, and Part No., Pins, Price. Includes items like 74C00, 74C01, 74C02, etc.

Table listing LINEAR components including Part No., Pins, Price, and Part No., Pins, Price. Includes items like LM741CN, LM742CN, etc.

Table listing WIRE WRAP SOCKETS (GOLD) LEVEL #3 including Part No., Pins, Price, and Part No., Pins, Price. Includes items like 8 pin WW, 16 pin WW, etc.

\$10.00 Minimum Order — U.S. Funds Only California Residents Add 6 1/2% Sales Tax Shipping — Add \$ 5.00 Insurance Send S.A.S.E. for Monthly Sales Flyer!

Spec Sheets — 30¢ each Send \$1.00 Postage for your FREE 1984 AMECO CATALOG Prices Subject to Change

1355 SHOREWAY ROAD, BELMONT, CA 94002 9/84 PHONE ORDERS WELCOME — (415) 592-8097 Telex: 176043

CIRCLE 41 ON FREE INFORMATION CARD

30003 1982 Nat. Linear Data Book (1952 pgs.) \$11.95



Learn micro-processing with the new
MICRO-PROFESSOR 1P

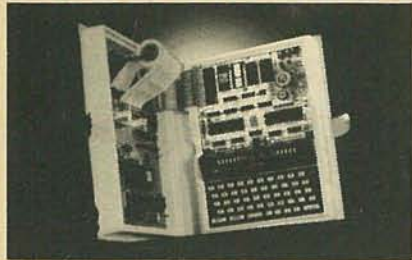

Students, engineers or technicians—
upgrade your micro-processing skills
with the new Micro-Professor 1P.

The MPF-1P features:

- extensive software support
- more built-in memory
- improved keyboard
- larger display

Three tutorial guides help cover all
capabilities. The ideal training tool!
MPF-1P will deliver you into the growing
world of micro-processing. Invest now!

Plus—FREE GIFT Only **\$179.95**

Check this box for FREE
Z-80 Microprocessor
Programming and
Interfacing textbook when
you order within 7 days.
\$12.95 value.

ETRONIX

Dept. RE094
14803 N.E. 40th
Redmond, WA 98052

For immediate action call TOLL FREE:

1-800-426-1044

Full money back guarantee.



CIRCLE 39 ON FREE INFORMATION CARD

STATE OF THE ART KITS

HAL 2304 MHZ AMATEUR DOWN CONVERTERS
(FREQ. RANGE 1900/2500 MHZ)

- 2304 MODEL #1 KIT..... \$19.95
BASIC UNIT WITH PRE-AMP LESS DIE-CAST CASE & FITTINGS
- 2304 MODEL #2 KIT..... \$29.95
BASIC UNIT WITH PRE-AMP WITH DIE-CAST CASE & FITTINGS
- 2304 MODEL #3 KIT..... \$39.95
BASIC WITH HI-GAIN PRE-AMP WITH DIE-CAST CASE & FITTINGS
- POWER SUPPLY..... \$19.95
FOR THE ABOVE COMPLETE WITH ALL PARTS LESS CASE
- POWER SUPPLY CASE..... \$5.00
- BLACK PLASTIC CASE UNDRILLED..... \$49.95
- CONIFER PARACEPTOR ANTENNA..... \$49.95
PERFECT FOR THE 2304 MOD 2 & 3 - 6 DB OVER ANY DISH
- HAL-PA-2.1 GHZ 2 STAGE PRE-AMP (KIT) \$34.95
DESIGNED FOR THE 2304 DOWN CONVERTER. MADE TO PIGGIE
BACK ON THE 2304 BOARD. OFFERS 22 DB MORE GAIN. HAS IM-
AGE REJECTION FILTER.
- PRE-AMP TRANSISTOR EXCHANGE..... \$5.00
EXCHANGE TRANSISTOR IN 2304 WITH NEC 64535
- SLOTTED ARRAY ANTENNA..... \$29.95
16 DB GAIN USE WITH 2304 MOD 1 KIT, NO CASE REQUIRED



2100-2500 MHZ
*AMR COMPLETE UNIT
COMPLETE SYSTEM AS SHOWN, NOT A
KIT. INCLUDES A PRE-ASSEMBLED PROBE
DOWN CONVERTER, DISH, POWER SUPP-
LY, CABLES AND CONNECTORS. TESTED
UNIT. OFFERS 24 DB GAIN OR GREATER.
BUY ONE AT..... \$99.95
BUY THREE OR MORE..... \$89.95 ea.
*AMATEUR MICROWAVE RECEIVER

EPRO 2000 PROGRAMMER..... \$199.95
EASY TO USE NO COMPUTER NEEDED. FREE STANDING EPROM
AND GAME CARTRIDGE PROGRAMMER. EASY TO USE. NOW
MAKE ARCHIVAL COPIES FOR YOUR OWN RECORDS. THE EPRO
2000 CAN ALSO MAKE BACK-UP COPIES OF 2732 AND 2716
EPROMS, OR OF THEIR RESPECTIVE EQUIVALENTS. IN EPROMS
OR ROMS SAVE ON THOSE INDUSTRIAL SERVICE CALLS. EXTRA
BLANK CARTRIDGES ARE AVAILABLE AT THE LOW COST OF
\$6.50 EA OR \$6.00 IN LOTS OF 10 LESS EPROM.

PRE-AMPLIFIERS

- HAL PA 19..... \$9.95
WIDE BAND - 2-200 MHZ - 19 DB - BUILT AND TESTED
- HAL PA 14..... \$12.95
WIDE BAND - 10 MHZ TO 1.4 GHZ - 12 DB - BUILT AND TESTED

SHIPPING INFORMATION: ORDERS OVER \$25 WILL BE SHIPPED
POST-PAID EXCEPT ON ITEMS WHERE ADDITIONAL CHARGES
ARE REQUESTED. ON ORDERS LESS THAN \$25, PLEASE INCLUDE
ADDITIONAL \$2.50 FOR HANDLING AND MAILING CHARGES.
MICHIGAN RESIDENTS ADD 4% SALES TAX. SEND 30¢ STAMP OR
BASE FOR FREE FLYER.

COMPLETE SETS OF P.C. BOARDS AVAILABLE FOR UNICORN
ROBOT PROJECT, HEAR-A-MATIC PROJECT, GRAND MATIC
PROJECT, AND MANY, MANY OTHER KITS AVAILABLE

HAL-TRONIX, INC.
P.O. BOX 1101 - DEPT. R
SOUTHGATE, MICH. 48195
PHONE (313) 285-1782



CIRCLE 75 ON FREE INFORMATION CARD

**DON'T
BLAME THE
SOFTWARE!**

Our Isolators eliminate equipment
interaction, clean up interference,
curb damaging power line spikes
and
lightning
bursts.



ISO-1 ISOLATOR

3 isolated sockets; quality spike
suppression; basic protection.. **\$81.95**

ISO-3 SUPER-ISOLATOR

3 dual isolated sockets; suppressor;
commercial protection. . . . **\$122.95**

ISO-17 MAGNUM ISOLATOR

4 quad isolated sockets; suppressor;
laboratory grade protection. . **\$213.95**

ESF Electronic Specialists, Inc.

171 S. Main, Natick, MA 01760 (617) 655-1532

Toll Free Order Desk 1-800-225-4878
MasterCard, VISA, American Express

CIRCLE 6 ON FREE INFORMATION CARD

**THE WM. B. ALLEN
WINNER'S DEAL**

UP TO 25% OFF



ON
LARGEST FULL-LINE INVENTORY OF
HAND HELD METERS

FROM THE LEADING MANUFACTURERS OF TEST EQUIPMENT

PLUS SPECIAL DISCOUNT PRICES ON SCOPES, INCLUDING HITACHI

SOAR SX220..... \$ 22	FLUKE 73..... \$ 75	BBC MA1H..... \$ 46
SOAR MES40..... \$ 44	FLUKE 75..... \$ 88	BBC M2031..... \$199
HICKOK LX304X..... \$ 94	FLUKE 77..... \$115	B&K 2806..... \$ 64
HITACHI 3510..... \$136	FLUKE 8022B..... \$125	KEITHLEY 128..... \$137

IN STOCK AND AVAILABLE NOW!

WM. B. ALLEN SUPPLY
ALLEN SQUARE

300 BLOCK NORTH RAMPART, NEW ORLEANS, LA 70112
LOUISIANA TOLL FREE 800 462-9520

CALL TOLL FREE FOR
SAME DAY SHIPMENT

800 535-9593

CIRCLE 56 ON FREE INFORMATION CARD

RAMSEY

THE FIRST NAME IN ELECTRONIC TEST GEAR

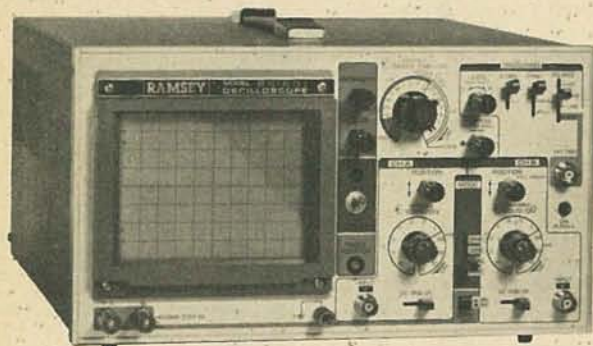

NEW FROM RAMSEY-20 MHz DUAL TRACE OSCILLOSCOPE

Unsurpassed quality at an unbeatable price, the Ramsey oscilloscope compares to others costing hundreds more. Features include a component testing circuit that will allow you to easily test resistors, capacitors, digital circuits and diodes • TV video sync filter • wide bandwidth & high sensitivity • internal graticule • high quality rectangular CRT • front panel trace rotator • Z axis • high sensitivity x-y mode • very low power consumption • regulated power supply • built-in calibrator • rock solid triggering • high quality hook-on probes

\$399.95 high quality hook-on probes included



RAMSEY D-1100 VOM-MULTITESTER

Compact and reliable, designed to service a wide variety of equipment. Features include • mirror back scale • double-jeweled precision moving coil • double overload protection • an ideal low cost unit for the beginner or as a spare back-up unit.

\$1995
test leads and battery included



RAMSEY D-2100 DIGITAL MULTITESTER

A compact easy to use unit designed to operate like a pro. Featuring • 3½ digit LCD • low BAT. indicator • all range overload protection • overrange indication • auto-polarity • Transistor tester • dual-slope integration • vinyl carrying case

\$5495
hFE test leads, battery & vinyl carrying case included



RAMSEY D-3100 DIGITAL MULTIMETER

Reliable, accurate digital measurements at an amazingly low cost • In-line color coded push buttons; speeds range selection • abs plastic tilt stand • recessed input jacks • overload protection on all ranges • 3½ digit LCD display with auto zero, auto polarity & low BAT. indicator

\$5995
test leads and battery included



CT-70 7 DIGIT 525 MHz COUNTER

Lab quality at a breakthrough price. Features • 3 frequency ranges each with pre amp • dual selectable gate times • gate activity indicator • 50mV @ 150 MHz typical sensitivity • wide frequency range • 1 ppm accuracy

\$11995
wired includes AC adapter
CT-70 kit \$99.95
BP-4 nicad pack 8.95



CT-90 9 DIGIT 600 MHz COUNTER

The most versatile for less than \$300. Features 3 selectable gate times • 9 digits • gate indicator • display hold • 25mV @ 150 MHz typical sensitivity • 10 MHz timebase for WWV calibration • 1 ppm accuracy

\$14995
wired includes AC adapter
CT-90 kit \$129.95
OV-1 0.1 PPM oven timebase 59.95
BP-4 nicad pack 8.95



CT-125 9 DIGIT 1.2 GHz COUNTER

A 9 digit counter that will outperform units costing hundreds more. • gate indicator • 24mV @ 150 MHz typical sensitivity • 9 digit display • 1 ppm accuracy • display hold • dual inputs with preamps

\$16995
wired includes AC adapter
BP-4 nicad pack 8.95



CT-50 8 DIGIT 600 MHz COUNTER

A versatile lab bench counter with optional receive frequency adapter, which turns the CT-50 into a digital readout for most any receiver • 25 mV @ 150 MHz typical sensitivity • 8 digit display • 1 ppm accuracy

\$16995
wired
CT-50 kit \$139.95
RA-1 receiver adapter kit 14.95



DM-700 DIGITAL MULTIMETER

Professional quality at a hobbyist price. Features include 26 different ranges and 5 functions • 3½ digit, ½ inch LED display • automatic decimal placement • automatic polarity

\$11995
wired includes AC adapter
DM-700 kit \$99.95
MP-1 probe set 4.95



PS-2 AUDIO MULTIPLIER

The PS-2 is handy for high resolution audio resolution measurements, multiplies UP in frequency • great for PL tone measurements • multiplies by 10 or 100 • 0.01Hz resolution & built-in signal preamp/conditioner

\$4995
wired
PS-2 kit \$39.95



PR-2 COUNTER PREAMP

The PR-2 is ideal for measuring weak signals from 10 to 1,000 MHz • flat 25 db gain • BNC connectors • great for sniffing RF • ideal receiver/TV preamp

\$4495
wired includes AC adapter
PR-2 kit \$34.95



PS-1B 600 MHz PRESCALER

Extends the range of your present counter to 600 MHz • 2 stage preamp • divide by 10 circuitry • sensitivity: 25mV @ 150 MHz • BNC connectors • drives any counter

\$5995
wired includes AC adapter
PS-1B kit \$49.95

ACCESSORIES FOR RAMSEY COUNTERS

Telescopic whip antenna—BNC plug .. \$ 8.95
High impedance probe, light loading .. 16.95
Low pass probe, audio use .. 16.95
Direct probe, general purpose use .. 13.95
Tilt bail, for CT-70, 90, 125 .. 3.95



PHONE ORDERS CALL
716-586-3950
TELEX 466735 RAMSEY CI

TERMS: • satisfaction guaranteed • examine for 10 days; if not pleased, return in original form for refund • add 6% for shipping and insurance to a maximum of \$10.00 • overseas add 15% for surface mail • COD add \$2.50 (COD in USA only) • orders under \$15.00 add \$1.50 • NY residents add 7% sales tax • 90 day parts warranty on all kits • 1 year parts & labor warranty on all wired units.

RAMSEY

RAMSEY ELECTRONICS, INC.
2575 Baird Rd.
Penfield, N.Y. 14626

SEPTEMBER 1984

SPARTAN Electronics Inc.



CALL
(516) 499-9500
MAIL
6094 Jericho Tpke.
Commack, N.Y. 11725

Philips Remote Cable Converter

CTC9R
 • Micro computer technology • Quartz controlled IC's lock in picture & prevent drift • 60 channel selections • Programmable time on & off • 24 hour LED digital clock • Favorite channel memory & recall plus scan • Wireless hand held infra-red transmitter system • Automatic fine tune • Adaptable to any brand television • One year warranty service

\$139.95

SPEAKER PHONE

Model #30-9558
 Hands Free Conversation
 Modular Connectors
 Push Button Dial
 Volume Control
 Mute/Hold Button
 Pulse Tone Switchable
 Last Number Redial

\$44.95



GREEN AND AMBER MONITORS

12" Sakata Green **\$119.00**
 12" Sakata Amber **\$129.00**

REFURBISHED MONITORS

9" and 12" Bell & Howells
 or GBC Commercial Grade
 as low as
\$10.00 off with a purchase
 of 2 refurbished monitors

\$39.95



BECKMAN CIRCUITMATE DM73

• .5% basic Vdc Accuracy
 probe-sized dmm
 • 4 ac/dc voltage ranges (autoranging)
 • 4 resistance ranges (autoranging)
 • continuity beeper
 • "touch hold" button
 Other Circuitmate Meters Available.

\$63.95



Jerrold 58 Channel Wireless Remote Converter

\$109.95
 Jerrold 36 Channel Remote CATV Converter w/on/off Fine Tuning **\$94.95**



40 Channel VHF to UHF Block Converter

28.95 Ea.
24.95 4 & up
 Deluxe Version - Features fine tuning knob, matching X former & 2 cables **\$38.95**

BEFORE YOU PAY \$\$ FOR A TELEPHONE SERVICE CALL, TEST IT YOURSELF

EX PRECISION
 Telephone Line Analyzer Model #1042
 — Tests telephone line functions that affect telephone operation
 — Verifies line and ring voltage levels
 — Checks condition of telephone line from central office to user's telephone jack
 — Verifies telephone line polarity that can affect polarity sensitive telephones

\$19.95



PROFESSIONAL TELEPHONE PRODUCT TESTER

EX PRECISION
MODEL 1045
 Features:
 • Provides basic operation tests for corded and cordless telephones, answering machines, and automatic dialers
 • Checks telephone line cords and handsets for continuity, shorts and interferences
 • Verifies number dialed and redialled for pulse or touch-tone telephones
 • Provides low and normal level ring test sequence
 • Verifies that voice and DTMF (Dual Tone Multiple Frequency) levels are above minimum required level

• Can be used by the consumer without the aid of a salesperson—an easy-to-follow instruction card is provided with the tester.
 • Can be used by the salesperson to demonstrate operation and features of telephone products and to screen returns before making an exchange

\$335.95



Dealers Welcome
 Visa MC, BAC, Amex. All above prices include 4% cash discount.
 C.O.D. money order, check Add for Shipping

Min. Order \$25.00	to 75.00	\$2.50
International shipping Add'l	76.00 to 250.00	\$4.50
Prices subject to change without notice	251.00 to 500.00	\$6.00
COD 2.00 Extra	501.00 to 750.00	\$8.50
*Add'l shipping for monitors	751.00 to 1000.00	\$12.00
	Over 1000.00	\$12.50

(516) Mon Th Tu W F Sa
 499-9500 9-8 9-6 9:30-5

ADVERTISING INDEX

RADIO-ELECTRONICS does not assume any responsibility for errors that may appear in the index below.

Free Information Number	Page		
77	Active Electronics	96	19
80	Advanced Computer Products	97	66
—	Advance Electronics	14,15	7
12	All Electronics	103	17
88	Amazing Devices	102	96
67	AMC Sales	91	—
—	American Surplus	47	—
92	Appliance Service	45	—
87	AP Products	43	98
72	AW Sperry	22	90
100	Beckman Instruments	17	51
16	B&K	81	29
—	Brad Cable Electronics	32	89
—	C&D	77	32
18	CEI	42	85
—	Certified Assoc.	92	8
—	CIE	18-21	20
—	Command Productions	92	21
26,35	Communications Electronics	2,34-35	61
50	Contact East	44	79
68	CPU	CD Section 2	31
65	Digikey	99	—
11	Digitron	106	10
99	Dokay	108,109	27
54	Davle Tech.	48	24
58	EKI	93	34
—	Electronic Book Club	73-74	23
6	Electronic Specialists	112	36
81,82	Electronic Warehouse	24,83	52
39	Etronix	112	—
40	Firestik II	91	13
—	Fluke Manufacturing	Cover 2	56
—	Fordham Radio	7	48
76	Formula	107	—
33	Global Specialties	26	—
63	Goldsmith Scientific	102	—
—	Grantham College of Engineering	33	—
75	Haltronix	112	—
15	Heath	27	—
28	Instrument Mart	85	—
53	Iwatsu	1	—
41	Jameco	110,111	—
74	JDR	104,105	—
37	Jensen	45	—
45	J&W	91	—
83	KCS	100	—
46	Logical Solutions	45	—
—	McGraw Hill Co.	28-31	—
—	McIntosh Labs	87	—
—	MCM	100	—
—	MFJ	98	—
—	Multitech	25	—
—	Multivision	32	—
—	Nemal Electronics	44	—
—	Newtone Electronics	36	—
—	NRI	8-11	—
—	NTS	38-41	—
—	OK Industries	Cover 4	—
—	Omnitron	50	—
—	Paia	91	—
—	Philips Tech Electronics	100	—
—	Platt Luggage	48	—
—	Pocket Tech	23	—
—	Pomona Electronics	Cover 3	—
—	Power Plus	45	—
—	Priority One	5	—
—	Professional Video	100	—
—	Radio Shack	101	—
—	Ramsey	113	—
—	Random Access	44,45	—
—	RE Bookstore	92	—
—	Research Service Lab.	45	—
—	RF Electronics	100,106	—
—	R&M Distributors	45	—
—	Simpson	49	—
—	Spaceage Electronics	44,45	—
—	Spartan Electronics	114	—
—	Test Probes	97	—
—	Texas Instruments	37	—
—	Vaco	79	—
—	WM B Allen	112	—
—	WS Jenks	89	—
—	Zenith	13	—

CABLE TV VALUABLE NOTICE - SAVE HUNDREDS OF DOLLARS - DO NOT BE MISLED.

Before you purchase learn the latest technology on the correct converters and descramblers to fit your system. For this important information and catalog send \$3.50 to Star Base Video, P.O. Box 7362 Johnston, R.I. 02919

FREE KIT Catalog

FUNCTION GENERATOR KIT \$59.95
 Auto-Ranging Cap-meter kit \$79.95

Phone 209-772-2076
 Write or Phone for FREE CATALOG

DAGE SCIENTIFIC INSTRUMENTS
 BOX 144 VALLEY SPRINGS CA 95252

BUY BONDS

THE POMONA PROMISE

Our constant goal is to provide the design engineer with the best banana plugs and jacks made in this country. Or anywhere.



And we've been doing it for a long time. Since 1951 in fact.

That's when we promised there wouldn't be anyone in the world who could design and produce banana plugs and jacks the way we could.

The world agreed.

Naturally, as the years have passed, we've improved upon our original designs. So much so that today, our banana plugs and jacks are out there alone. In their own class.

The same can be said for every other product we design and

produce. And each and every one of them is trusted by the professionals of the electronics industry.

At ITT Pomona Electronics, we know there is no such thing as standing pat. We also know that your needs change and your expectations become greater as the demands become more severe. To this end we will continue to create a better way. A better product.

That's a promise.

All of our products are described and illustrated in our General Catalog, and it's free. Just call (714) 623-3463 or 623-6751.

TWX 910-581-3822. Write to us at ITT Pomona Electronics, a Division of ITT Corporation, 1500 E. Ninth St., Pomona, CA 91766.

In Europe: ITT CANNON BELGIUM S.A./N.V. Rue Colonel Bourg Str. 105 Space A (B.3) 1140 Brussels, Belgium. Phone: 02-735-6094.

Our products are available through your favorite electronics parts distributor.

ITT Pomona Electronics

OK's Hot Tip for Desoldering Problems

SA-6 DESOLDER IRON

Revolutionary new electric desoldering iron combines the ease and portability of a hand-held, manual, desolder pump, with performance of an industrial desolder station. This unique AC powered compact tool features portable, one-hand desoldering eliminating the need for separate soldering iron and desolder pump. No shop air required. Essential for all tool kits, field service technicians, and repairmen, as well as production applications. Vacuum chamber is easily removed for cleaning or replacement. Replacement tips available. Tool is supplied with SAT-6-059 tip; diameter .059 inch (1,5mm).

FEATURES:

- Self contained suction power and heating element.
- Economical.
- Lightweight 4oz. (113gms).
- Compact size 10¼ inches (26cm).
- Replacement nozzles available.

MODEL NO.	INPUT VOLTAGE	
SA-6-115	115V AC 50/60Hz	
SA-6-230	230V AC 50/60Hz	
NOZZLE	NOZZLE HOLE DIAMETER	
	INCH	MM
SAT-6-059	.059	1,5
SAT-6-070	.070	1,77

3455 Conner Street, Bronx, New York, 10475, U.S.A.
Telex 125091 OK NYK. Telex 232395 OK NY UR.
Phone (212) 994-6600.

OK
Industries
Inc.



CIRCLE 98 ON FREE INFORMATION CARD