

Radio- Electronics

BUILD A DELUXE
VIDEO TEST GENERATOR

SPECIAL SECTION
YOUR OWN COMPUTER

\$1.75 APR. 1984
U.K. 85p

DGS

COMPUTERS - VIDEO - STEREO - TECHNOLOGY - SERVICE

Stop those annoying
wrong telephone numbers!!!
Build our add-on and
STOP WRONG NUMBERS

New back-to-school
series starts this issue
**DESIGNING WITH
LINEAR IC'S**

Automate your home
Build our
**HOME CONTROL
COMPUTER** →

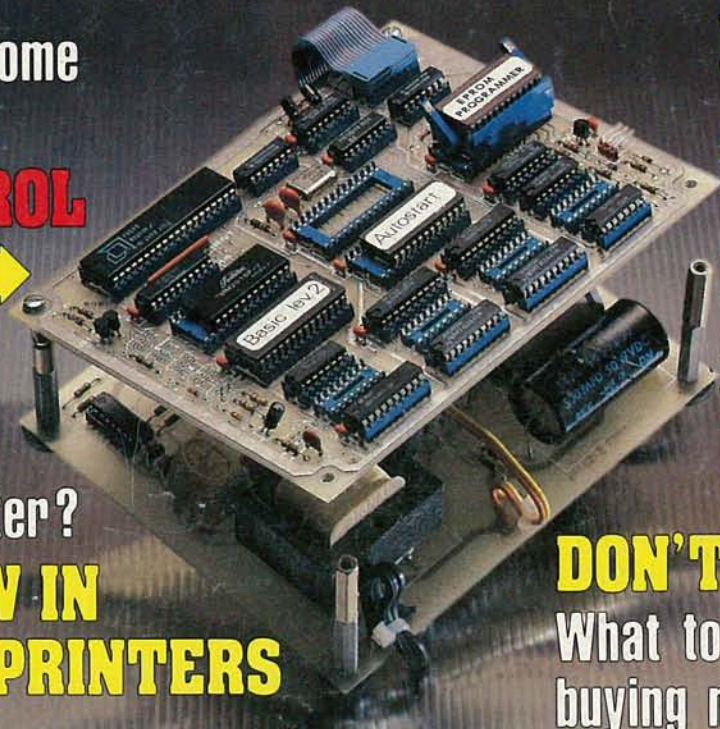

**PORTABLE
AND
TODABLE
COMPUTERS**
Are they more
than just toys?

Should I buy that
new ink-jet printer?
**WHAT'S NEW IN
COMPUTER PRINTERS**

DON'T GET STUCK
What to look for when
buying new software

PLUS:

- ★ Equipment Reports
- ★ New Idea
- ★ Drawing Board
- ★ Service Clinic
- ★ State-Of-Solid-State



**GERNSBACK
PUBLICATION**



Drop-proof



Overload-proof



Contamination-proof

Oops proof.

Now there's a new breed of Beckman hand-held DMMs tough enough to withstand accidental drops, input overloads and destructive environments.

The new HD100 and HD110 DMMs are drop-proof, packed with overload protection and sealed against contamination. You won't find more rugged meters than the Beckman HDs. Inside or out.

Drop Proof

Constructed of double-thick thermoplastics, the HD100 series DMMs resist damage even after repeated falls. All components are heavy-duty and shock mounted.

Contamination Proof

The HD series meters are designed to keep working even around dirt, heavy grime, water and oil. The special o-ring seals, ultrasonically-welded display window and sealed input jacks protect the internal electronics of the HD meters. The oops-proof meters are sealed so tightly, they even float in water.

Accidental Overload Protection

All DC voltage inputs are protected up to 1500 Vdc or 1000 Vrms. Current ranges are protected to 2A/600V with resistance ranges protected to 600 Vdc. Transient protection extends up to 6KV for 10 microseconds.

More Meter for Your Money

For starters you can get 2000 hours of continuous use from a

common 9V transistor battery. You can run in-circuit diode tests and check continuity. You even get

a one year warranty.

The 0.25% basic dc volt accuracy HD meters serve you with 7 functions and 27 ranges. The HD 110 also gives you 10 AMPS ac and dc. With one simple turn of the single selector switch, you can go directly to the function and range you need. There's less chance of error.

Also available is the electrical service kit. It includes the meter of your choice, a current clamp, deluxe test leads and a heavy-duty case designed to carry both meter and accessories, conveniently.

Feature for feature you can't find a more dependable meter with prices starting at just \$169 (U.S. only).

To locate your nearest distributor, write Beckman Instruments, Inc., Instrumentation Products, 2500 Harbor Blvd., Fullerton, CA 92634 or call (714) 993-8803.



CIRCLE 100 ON FREE INFORMATION CARD

BECKMAN



A new concept in sitting.

THE BACK CHAIR



CONVENTIONAL CHAIR

Sitting in a conventional chair forces your lower back forward, creating excess stress on your spine & back muscles.



THE BACK CHAIR

The Back Chair allows you to sit comfortably with your spine & back muscles in perfect alignment.



ONLY \$89⁹⁵

Computer desk designed by

Island Computer Desks, Santa Barbara, CA

THE FIRST INTELLIGENT CHAIR

Consider the alternative — THE BACK CHAIR, the new chair designed with one goal in mind, the care of your back, spine, health & well-being.

REDUCE THE EFFECT OF GRAVITY ON YOUR BACK

If you're sitting regularly in a conventional chair, your lower back is supporting the **total weight** of your body, plus additional weight due to the downward effect of gravity on your body. **No wonder millions of people complain about backaches every year!** Most doctors have long recognized that many back and neck problems are the result of improper posture when sitting. Unfortunately most chairs are designed for appearance, not for the health of your back. The BACK CHAIR'S therapeutic design was created by a team of designers collaborating with doctors and physical therapists.

THE BACK CHAIR SOLUTION

Sitting on the BACK CHAIR relieves your back from supporting the total weight of your body by distributing the weight between your lower back and legs. The BACK CHAIR design is nothing more than simple common sense. Your legs support you when standing, your lower back supports you when sitting — combine them both in a comfortable sitting posture and you relieve the unnecessary stress on your back. When sitting on the BACK CHAIR you'll surprisingly feel much more relaxed, you'll

sit up absolutely and comfortably straight; and with the pressure off your lower back you'll breathe deeper with less effort. **At home or especially at work** the BACK CHAIR will help you in improving your posture and enhance your fitness and exercise program throughout the day. Made of multiple layers of hardwood with a final layer of oak, the BACK CHAIR assembles in 15 minutes with a screwdriver. Enjoy one for two weeks as our guest and see how intelligent chair design can soothe your aching back and greatly improve your sense of wellbeing throughout the day.

■■■■■■ MAIL COUPON WITH ORDER ■■■■■■

SHOP FASTER BY PHONE
1 - 805 - 966 - 7187

Or send a check or your credit card # (Diner's Club, VISA, MasterCard, American Express) for THE BACK CHAIR @ \$89.95 ea. plus \$5.95 shipping (Canadian orders \$13.00 shipping). CA residents add 6% sales tax. Sorry no C.O.D. If not satisfied return within 15 days for a refund (less shipping).

ITEM NO.	QUAN.	ITEM	PRICE EA.	SHIPPING	TOTAL
825		BACK CHAIR	\$89.95		

STARSHINE OF SANTA BARBARA
816B State Street, Dept. BC989, Santa Barbara, CA 93101

NEW!

Regency

Scanners

Communications Electronics,™ the world's largest distributor of radio scanners, introduces new models with special savings on all radio scanners. Chances are the police, fire and weather emergencies you'll read about in tomorrow's paper are coming through on a scanner today.

We give you excellent service because CE distributes more scanners worldwide than anyone else. Our warehouse facilities are equipped to process thousands of scanner orders every week. We also export scanners to over 300 countries and military installations. Almost all items are in stock for quick shipment, so if you're a person who prefers fact to fantasy and who needs to know what's really happening around you, order your radio today from CE.

NEW! Regency® MX5000

List price \$599.95/CE price \$379.00
Multi-Band, 20 Channel • No-crystal scanner
Search • Lockout • Priority • AC/DC
Selectable AM-FM modes • LCD display
World's first continuous coverage scanner
 Frequency range: 25-550 MHz. continuous coverage. Never before have so many features come in such a small package. The Regency MX5000 mobile or home scanner has continuous coverage from 25 to 550 MHz. That means you can hear CB, Television audio, FM broadcast stations, all aircraft bands including military and the normal scanner bands, all on your choice of 20 programmable channels.

NEW! Regency® MX3000

List price \$299.95/CE price \$181.00
6-Band, 30 Channel • No-crystal scanner
Search • Lockout • Priority • AC/DC
 Bands: 30-50, 144-174, 440-512 MHz.
 The Regency Touch MX3000 provides the ease of computer controlled, touch-entry programming in a compact-sized scanner for use at home or on the road. Enter your favorite public service frequencies by simply touching the numbered pressure pads. You'll even hear a "beep" tone that lets you know you've made contact.

In addition to scanning the programmed channels, the MX3000 has the ability to search through as much as an entire band for an active frequency. The MX3000 includes channel 1 priority, dual scan speeds, scan or search delay and a brightness switch for day or night operation.

NEW! Regency® Z30

List price \$269.95/CE price \$179.00
6-Band, 30 Channel • No-crystal scanner
 Bands: 30-50, 144-174, 440-512 MHz.
 Cover your choice of over 15,000 frequencies on 30 channels at the touch of your finger.

NEW! JIL SX-200

CE price \$264.00/NEW LOW PRICE
8-Band, 16 Channel • No-crystal scanner
Quartz Clock • AM/FM • AC/DC
 Bands: 26-88, 108-180, 380-514 MHz.
 Tune Military, F.B.I., Space Satellites, Police & Fire, D.E.A., Defense Department, Aeronautical AM band, Aero Navigation Band, Fish & Game, Immigration, Paramedics, Amateur Radio, Justice Department, State Department, plus thousands of other restricted radio frequencies no other scanner is programmed to pick up.

Regency® HX1000

Allow 60-120 days for delivery after receipt of order due to the high demand for this product.
 List price \$329.95/CE price \$209.00
6-Band, 20 Channel • No Crystal scanner
Search • Lockout • Priority • Scan delay
Sidelit liquid crystal display
 Frequency range: 30-50, 144-174, 440-512 MHz.
 The new handheld Regency HX1000 scanner is fully keyboard programmable for the ultimate in versatility. You can scan up to 20 channels at the same time. When you activate the priority control, you automatically override all other calls to listen to your favorite frequency. The LCD display is even sidelit for night use. A die-cast aluminum chassis makes this the most rugged and durable hand-held scanner available. There is even a backup lithium battery to maintain memory for two years. Includes wall charger, carrying case, belt clip, flexible antenna and nicad battery. Reserve your Regency HX1000 now.

Regency® R106

List price \$149.95/CE price \$92.00
5-Band, 10 Channel • Crystal scanner • AC/DC
 Frequency range: 30-50, 146-174, 450-512 MHz.
 A versatile scanner, The Regency R-106 is built to provide maximum reception at home or on the road. Rugged cabinet protects the advanced design circuitry allowing you years of dependable listening.

NEW! Regency® D810

List price \$399.95/CE price \$244.00
8-Band, 50 Channel • Crystalless • AC only
 Bands: 30-50, 88-108, 118-136, 144-174, 440-512 MHz.
 This scanner offers Public service bands, plus Aircraft and FM broadcast stations. You can listen to Bach or a Boeing 747, the Rolling Stones or the riot squad, or any of 50 channels. Plus special direct access keys let you listen to police, fire, emergency, or any of your favorite channels just by pushing a button.

Regency® R1040

List price \$199.95/CE price \$124.00
6-Band, 10 Channel • Crystalless • AC only
 Frequency range: 30-50, 144-174, 440-512 MHz.
 Now you can enjoy computerized scanner versatility at a price that's less than some crystal units. The Regency R1040 lets you in on all the action of police, fire, weather, and emergency calls. You'll even hear mobile telephones.
 Programming the R1040 is easy. Merely touch the keyboard and enter any of over 15,000 frequencies on your choice of 10 channels.

NEW! Regency® HX650

List price \$119.95/CE price \$79.00
5-Band, 6 Channel • Handheld crystal scanner
 Bands: 30-50, 146-174, 450-512 MHz.
 Now you can tune in any emergency around town, from wherever you are, the second it happens. Advanced circuitry gives you the world's smallest scanner. Our low CE price includes battery charger/A.C. adapter.

QUANTITY DISCOUNTS AVAILABLE
 Order two scanners at the same time and deduct 1%, for three scanners deduct 2%, four scanners deduct 3%, five scanners deduct 4% and six or more scanners purchased at the same time earns you a 5% discount off our super low single unit price.

OTHER RADIOS & ACCESSORIES

Regency® C403 Scanner.....	\$59.00
Regency® Z10 Scanner.....	\$149.00
Panasonic RF-9 Shortwave receiver.....	\$64.00
Panasonic RF-B50 Shortwave receiver.....	\$129.00
Panasonic RF-799 Shortwave receiver.....	\$219.00
Panasonic RF-2600 Shortwave receiver.....	\$199.00
Panasonic RF-2900 Shortwave receiver.....	\$249.00
Panasonic RF-3100 Shortwave receiver.....	\$279.00
Panasonic RF-B600 Shortwave receiver.....	\$195.00
Panasonic RF-6300 Shortwave receiver.....	\$429.00
Panasonic RF-6300 Shortwave receiver.....	\$539.00
Bearcat® 350 Scanner.....	\$399.00
Bearcat® 300 Scanner.....	\$349.00
Bearcat® 260 Scanner.....	\$259.00
Bearcat® 250 Scanner.....	\$279.00
Bearcat® 200 Scanner.....	\$189.00
Bearcat® 210XL Scanner.....	\$229.00
Bearcat® 20/20 Scanner.....	\$289.00
Bearcat® 151 Scanner.....	\$169.00
Bearcat® 100 Scanner.....	\$289.00
Bearcat® Five-Six Scanner.....	\$129.00
Bearcat® DX1000 Shortwave Receiver.....	\$489.00
Bearcat® Weather Alert.....	\$49.00
Freedom Phone® 4000 Cordless telephone.....	\$239.00
Fanon FCT-200 Cordless telephone.....	\$139.00
SP55 Carrying case for Bearcat Five-Six.....	\$15.00
MA-506 Carrying case for Regency HX650.....	\$15.00
FB-E Frequency Directory for Eastern U.S.A.....	\$12.00
FB-W Frequency Directory for Western U.S.A.....	\$12.00
TSG® Top Secret® Registry of U.S. Government Freq.....	\$15.00
RRF Railroad Frequency Directory.....	\$10.00
ESD Energy Services Directory.....	\$10.00
ASD Frequency Directory for Aircraft Band.....	\$10.00
SRF Survival Radio Frequency Directory.....	\$10.00
TIC Techniques for Intercepting Comm. Manual.....	\$12.00
CIE Covert Intelligence, Elect. Eavesdropping Man.....	\$12.00
B-4 1.2 V AAA Ni-Cad batteries (set of four).....	\$9.00
B-6 1.2 V AA Ni-Cad batteries (set of four).....	\$12.00
A-135c Crystal certificate.....	\$3.00
A60 Magnet mount mobile antenna.....	\$35.00
A70 Base station antenna.....	\$35.00
Add \$3.00 shipping for all accessories ordered at the same time.	
Add \$12.00 per shortwave receiver for U.P.S. shipping.	
Add \$3.00 shipping per scanner antenna.	

BUY WITH CONFIDENCE

To get the fastest delivery from CE of any scanner, send or phone your order directly to our Scanner Distribution Center.™ Be sure to calculate your price using the CE prices in this ad. Michigan residents please add 4% sales tax or supply your tax I.D. number. Written purchase orders are accepted from approved government agencies and most well rated firms at a 30% surcharge for net 30 billing. All sales are subject to availability, acceptance and verification. All sales on accessories are final. Prices, terms and specifications are subject to change without notice. All prices are in U.S. dollars. Out of stock items will be placed on back-order automatically unless CE is instructed differently. A \$5.00 additional handling fee will be charged for all prepaid orders under \$50.00 or purchase orders under \$200.00. Shipments are F.O.B. Ann Arbor, Michigan. No COD's. Most products that we sell have a manufacturer's warranty. Free copies of warranties on these products are available prior to purchase by writing to CE. International orders are invited with a \$20.00 surcharge for special handling in addition to shipping charges. All shipments are F.O.B. Ann Arbor, Michigan. No COD's please. Non-certified and foreign checks require bank clearance.

Mail orders to: Communications Electronics,™ Box 1002, Ann Arbor, Michigan 48106 U.S.A. Add \$7.00 per scanner for U.P.S. ground shipping and handling in the continental U.S.A. For Canada, Puerto Rico, Hawaii, Alaska, or APO/FPO delivery, shipping charges are three times continental U.S. rates. If you have a Visa or Master Card, you may call and place a credit card order. Order toll-free in the U.S. Dial 800-521-4414. In Canada, order toll-free by calling 800-265-4828. Telex CE anytime, dial 810-223-2422. If you are outside the U.S. or in Michigan dial 313-973-8888. Order today.

Scanner Distribution Center™ and CE logos are trademarks of Communications Electronics.™

† Bearcat is a federally registered trademark of Electra Company, a Division of Masco Corporation of Indiana.
 ‡ Regency is a federally registered trademark of Regency Electronics Inc. AD #031584A

Copyright ©1984 Communications Electronics

Order Toll Free ... call
1-800-521-4414

COMMUNICATIONS
ELECTRONICS™

Consumer Products Division

818 Phoenix □ Box 1002 □ Ann Arbor, Michigan 48106 U.S.A.
 Call TOLL-FREE 800-521-4414 or outside U.S.A. 313-973-8888

Regency
MX3000



Regency
MX5000



Regency
HX1000



Regency
HX650



CIRCLE 35 ON FREE INFORMATION CARD

SPECIAL FEATURE

- 59 **YOUR OWN COMPUTER**
What to look for in accessories and software for your personal computer, and what's new in portable and totable systems, are among the highlights of this special section.
- 61 **DON'T GET STUCK.** Herb Friedman
- 64 **PORTABLES AND TOTABLES.** Herb Friedman
- 67 **WHAT'S NEW IN PRINTERS.** Marc Stern
- 73 **GADGETS AND GIZMOS.** Herb Friedman
- 76 **WORKING WITH DATABASES.** Herb Friedman

TECHNOLOGY

- 6 **VIDEO ELECTRONICS**
Tomorrow's news and technology in this quickly changing industry. **David Lachenbruch**
- 10 **SATELLITE/TELETEXT NEWS**
The latest happenings in communications technology. **Gary H. Arlen**

BUILD THIS

- 47 **HOME CONTROL COMPUTER**
This device lets you put your appliances under computer control, without tying up your personal computer. **Steven E. Sarns**
- 56 **VIDEO TEST GENERATOR**
Part 2. A low-cost, general-purpose video test generator that you can build. **Gene Roseth**
- 83 **NO MORE WRONG NUMBERS**
Part 2. We continue our look at a handy accessory for keeping those annoying, unwanted calls away. **Gary McClellan**

CIRCUITS AND COMPONENTS

- 39 **NEW IDEAS**
A light-sensitive timer.
- 40 **DRAWING BOARD**
Generating sinewaves with the 4018. **Robert Grossblatt**
- 45 **DESIGNER'S NOTEBOOK**
Low-voltage amplifier circuits. **Robert Grossblatt**
- 89 **DESIGNING WITH LINEAR IC'S**
The debut of our new back-to-school series. **Joseph J. Carr**
- 96 **HOBBY CORNER**
How to test transistors. **Earl "Doc" Savage, K4SDS**
- 98 **STATE OF SOLID STATE**
Making true RMS measurements. **Robert F. Scott**

VIDEO

- 99 **SERVICE CLINIC**
VCR control circuits. **Jack Darr**
- 107 **SERVICE QUESTIONS**
Our service editor solves technician's problems.

RADIO

- 106 **COMMUNICATIONS CORNER**
RF power measurements. **Herb Friedman**

EQUIPMENT REPORTS

- 22 **B&K Model 1822 Universal Counter**
- 29 **Heath EE-3202 CMOS Digital Techniques Course**

DEPARTMENTS

- | | |
|---------------------------------|--------------------|
| 4 Advertising and Sales Offices | 12 Letters |
| 144 Advertising Index | 114 Market Center |
| 8 April 1 What's News | 110 New Books |
| 4 Publisher's Letter | 112 New Literature |
| 145 Free Information Card | 43 New Products |

ON THE COVER

Owners of personal computers know that one of the natural uses for those devices is as a controller for the appliances, lights, or what have you in your home. But if you use it for that, your computer can not be used for any other task at the same time. This month we show you a way around that problem—a computer that you can build that's specifically for use as a controller. The story begins on page 47.

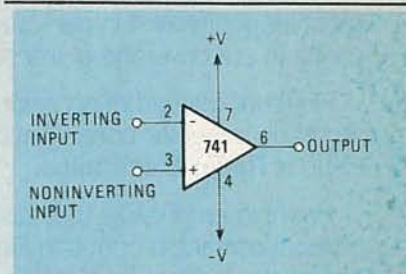

KNOWING ABOUT LINEAR IC's and how to use them in your designs can greatly improve your enjoyment of electronics. But if you missed out on learning about those devices, where can you get the information you need to use them successfully? One place is in our new back-to-school series on designing with linear IC's. It all begins on page 89.

COMING NEXT MONTH On Sale April 19

- **Automotive Exhaust Analyzer.** A unique device to help get your car ready for those tough emissions tests.
- **3-D TV.** A look at what's coming in 3-D television.
- **Home Control Computer.** Part 2 of our build-it-yourself computer.
- **And lots more!**

Radio-Electronics, (ISSN 0033-7862) Published monthly by Gernsback Publications, Inc., 200 Park Avenue South, New York, NY 10003. Second-Class Postage Paid at New York, N.Y. and additional mailing offices. One-year subscription rate: U.S.A. and U.S. possessions, \$14.97; Canada, \$17.97; Other countries, \$22.47 (cash orders only, payable in U.S.A. currency). Single copies \$1.75. © 1984 by Gernsback Publications, Inc. All rights reserved. Printed in U.S.A.

POSTMASTER: Please send address changes to RADIO-ELECTRONICS, Subscription Dept., Box 2520, Boulder, CO 80322.

A stamped self-addressed envelope must accompany all submitted manuscripts and/or artwork or photographs if their return is desired should they be rejected. We disclaim any responsibility for the loss or damage of manuscripts and/or artwork or photographs while in our possession or otherwise.

PUBLISHER'S LETTER

About "Your Own Computer"®

"Your Own Computer" has appeared as a special section in **Radio-Electronics**, twice a year, for the past several years. It has ranged from as small a section as 16 pages to as large a section as 101 pages.

We know from the mail that our editors received that there is great reader interest in personal computers and we intend to continue our coverage of the subject.

However, instead of occasional, large-space sections, we will report on a regular, consistent basis with 16-page units in every issue of **Radio-Electronics**.

I want to emphasize that this will be an expansion of our editorial content; a bonus to **Radio-Electronics** readers over and above the regular features to which they are accustomed on every facet of the fast-moving world of electronics—video, computers, stereo, MRO, servicing, and technology.

So, starting next month, in the May issue of **Radio-Electronics**, you will find a special 16-page tear-out section titled, "ComputerDigest". It is a complete magazine within a magazine.

It's entirely possible that continued reader response may encourage us to convert this section into a separate magazine rather than an insert within the covers of **Radio-Electronics**.

So watch for Volume I Number I of "ComputerDigest". We think you'll like it!

And this month, enjoy "Your Own Computer".

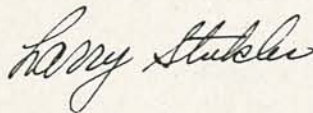

LARRY STECKLER
Publisher

Radio-Electronics

Hugo Gernsback (1884-1967) founder

M. Harvey Gernsback, editor-in-chief

Larry Steckler, CET, publisher

Arthur Kleiman, editor

Carl Laron, WB2SLR, associate editor

Brian C. Fenton, assistant technical editor

Robert A. Young, assistant editor

Jack Darr, CET, service editor

Robert F. Scott, semiconductor editor

Herb Friedman, communications editor

Gary H. Arlen, contributing editor

David Lachenbruch, contributing editor

Earl "Doc" Savage, K4SDS, hobby editor

Lou Frenzel, contributing editor

Ruby M. Yee, production manager

Robert A. W. Lowndes, production associate

Dianne Osias, production assistant

Joan Roman, circulation director

Arline R. Fishman, advertising coordinator

Cover photo by Robert Lewis

Radio-Electronics is indexed in *Applied Science & Technology Index* and *Readers Guide to Periodical Literature*.

Gernsback Publications, Inc.

200 Park Ave. South
New York, NY 10003

President: M. Harvey Gernsback
Vice President: Larry Steckler

ADVERTISING SALES 212-777-6400

Larry Steckler
Publisher

EAST/SOUTHEAST

Stanley Levitan
Radio-Electronics
200 Park Ave. South
New York, NY 10003
212-777-6400

MIDWEST/Texas/Arkansas/Okla.

Ralph Bergen
Radio-Electronics
540 Frontage Road—Suite 325
Northfield, Illinois 60093
312-446-1444

PACIFIC COAST Mountain States

Marvin Green
Radio-Electronics
15335 Morrison St., Suite 227,
Sherman Oaks, CA 91403
818-986-2001



Tek's best-selling 60 MHz scopes: Now 25 ways better for not a penny more!

Now Tek has improved its 2213/2215 scopes with brighter displays. Greater accuracy. And more sensitive triggering. At no increase in price.

The 60 MHz 2213 and dual time base 2215 have been the most popular scopes in Tektronix history. Now, Tek introduces an "A" Series update with more than 25 specification and feature enhancements—things you have asked for such as single sweep—all included at no added cost.

A brighter display and new vertical amplifier design provides sharp, crisp traces.

That makes the 2213A/2215A a prime candidate for tasks like TV troubleshooting and testing, where fast sweeps are typical.

New features include 10 MHz bandwidth limit switch, separate A/B dual intensity controls (2215A only), and power-on light: additions customers have suggested for



1-800-426-2200



giving these scopes the final measure of convenience.

Triggering, sweep accuracy, CMRR and many more major specifications are better than ever. Check the performance chart: not bad for scopes already considered the leaders in their class!

The price: still \$1200* for the 2213A, \$1450* for the 2215A. Or, step up to the 100 MHz 2235 for just \$1650*! You can order, obtain literature, or get expert technical advice, through Tek's National Marketing Center.

Direct orders include operator manuals, two 10X probes,

15-day return policy, world-wide service back-up and comprehensive 3-year warranty.

Talk to our technical experts.

**Call toll-free:
1-800-426-2200
Ext. 153.**

In Oregon call collect:
(503) 627-9000 Ext. 153.

Specification enhancement	2213/2215 "A" Series	2213/2215
CRT brightness	14 kv accel. potential	10 kv accel. potential
Vertical accuracy	3%, 0° to 50°C	3%, +20° to 30°C
Chop rate	500 kHz	250 kHz
Input capacitance	20 pF	30 pF
CMRR	10 to 1 at 25 MHz	10 to 1 at 10 MHz
Channel isolation	100:1 at 25 MHz	Not specified
A Trigger sensitivity (int)	0.3 div at 5 MHz	0.4 div at 2 MHz
TV triggering	1.0 div compos. sync	2.0 div compos. sync
Sweep accuracy (in 10X)	4%, 15° to 35°C	5%, 20° to 30°C
Delay jitter	20,000 to 1 (2215A) 10,000 to 1 (2213A)	10,000 to 1 (2215) 5,000 to 1 (2213)
Holdoff Range	10:1	4:1

*Price F.O.B. Beaverton, OR.
All scopes are UL Listed and CSA approved. 3-year warranty includes CRT and applies to 2000 family oscilloscopes purchased after 1/1/83

VIDEO ELECTRONICS

DAVID LACHENBRUCH
CONTRIBUTING EDITOR

DIGITAL TV DELAY?

The planned introduction of digital television sets in the United States this year could stretch out into 1985. ITT Semiconductors is said to be behind schedule in delivering the VLSI IC's. At least some of the delay is attributed to the fact that American manufacturers wanted such special features as automatic tint-correction and comb filter as part of the special NTSC-system IC. The two manufacturers known to be planning to field digital sets—General Electric and Zenith—say there's still hope they'll introduce the sets late this year, but full-scale deliveries may not start until 1985.

GERMAN TVs— MADE IN U.S.

The newest American TV brand name is an old familiar German one—Grundig. An American-owned firm, Display Devices, Inc., has purchased a former TV-cabinet plant in Monticello, IN from RCA and will assemble color-TV sets from modular kits produced in Germany by Grundig, one of Europe's largest television manufacturers. The company will specialize in deluxe sets, priced in the same range as those from Sony, JVC, and Mitsubishi. It plans to have a capacity of 120,000 sets a year to start. Grundig will be the 13th foreign brand to have assembly operations in the U.S.—all of the others are Japanese, Korean, or Taiwanese.

“NEW LOOK” FOR TV

RCA has revealed a two-step plan to change the appearance of the television set in the United States. Though the Japanese were first to announce the FST (Flatter Squarer Tube), a tube with a flatter faceplate and squared-off corners, RCA has outlined the American approach to the new look—and it will make the transition in two steps. The first step will be squaring off the corners without flattening the faceplates, with new versions of the 25-, 19- and 13-inch tubes in completely rectangular shapes—measured diagonally as 26, 20, and 14 inches. These FS (for Full Square) tubes will be followed by two new tubes to be called SP (Square Planar). The SP tubes are computer-designed and have a surface that appears flat, but actually is in the shape of a plateau when viewed in profile. RCA will make SP tubes available in 27- and 20-inch sizes.

The FS tubes, whose faceplates have the same curvature as today's tubes, will start appearing in TV sets this summer. RCA thinks that the introduction of the new tube sizes means the end of the line for the 25-inch tube in 1986 or 1987, while the 19-inch will last a little longer because it will fill a need in the more price-competitive smaller-screen area.

VHS vs. BETA

Although Sony claims that the Beta format is increasing its share of the market thanks to the new Beta Hi-Fi sound system, the VHS format appears to be gaining new adherents in the VCR-format race. The two developers of the competing Video-2000 format in Europe—Philips and Grundig—both will be introducing VHS recorders there this year. Sanyo, a pioneer Beta follower, already is producing VHS recorders through its subsidiary, Tokyo Sanyo, which is making them for sale under the Fisher label. Zenith, which has been marketing Sony-made Beta VCR's, is expected to add VHS recorders this year. Toshiba, a pioneer in the Beta group, will make VHS recorders in Europe for sale there. And another Beta proponent, NEC, probably will add VHS soon. Sony, the inventor of Beta, says it will not succumb to VHS fever and will continue to field Beta recorders only, although it manufactures cassettes for both Beta and VHS formats. VHS recorder sales outnumber Beta by at least three to one.

DBS GETS STARTED

The first direct-to-home satellite broadcasting system, owned by United Satellite Communications Inc. (USCI), is now transmitting to homes in the East and Midwest. The initial transmissions are on three channels, to be increased to five, on a monthly subscription basis. Radio Shack is the exclusive sales agent for the receiving equipment, which it sells for \$750 installed (including a four-foot dish) if the buyer subscribes for at least one year's service at \$29.95 monthly. Radio Shack will also lease the receiving systems at \$300 for installation plus \$39.95 monthly for one year (reception service included). RCA Service Co. is handling installation and service.

R-E

The Digital vs. Analog battle is over.

\$85* buys you the new champion. **The new Fluke 70 Series.**

They combine digital and analog displays for an unbeatable two-punch combination.

Now, digital users get the extra resolution of a 3200-count LCD display.

While analog users get an analog bar graph for quick visual checks of continuity, peaking, nulling and trends.

Plus unparalleled operating ease, instant autoranging, 2,000+ hour battery life and a 3-year warranty.

All in one meter.

Choose from three new models. The Fluke 73, the ultimate in simplicity. The feature-packed Fluke 75. Or the deluxe Fluke 77, with its own multipurpose protective holster and unique "Touch Hold" function (patent pending) that captures and holds readings, then beeps to alert you.

Each is Fluke-tough to take a beating. American-made, to boot. And priced to be, quite simply, a knockout.

For your nearest distributor or a free brochure, call toll-free anytime **1-800-227-3800, Ext. 229.** From outside U.S., call 1-402-496-1350, Ext. 229.

FROM THE WORLD LEADER
IN DIGITAL MULTIMETERS.



Fluke 73

\$85*
Analog/digital display
Volts, ohms, 10A, diode test
Autorange
0.7% basic dc accuracy
2000+ hour battery life
3-year warranty



Fluke 75

\$99*
Analog/digital display
Volts, ohms, 10A, mA, diode test
Audible continuity
Autorange/range hold
0.5% basic dc accuracy
2000+ hour battery life
3-year warranty



Fluke 77

\$129*
Analog/digital display
Volts, ohms, 10A, mA, diode test
Audible continuity
"Touch Hold" function
Autorange/range hold
0.3% basic dc accuracy
2000+ hour battery life
3-year warranty
Multipurpose holster

* Suggested U.S. list price, effective October 1, 1983.



APRIL 1 WHAT'S NEWS

SYMBOL



CODE (h)

60

OFFICIALLY
DESIGNATED
MEANING

HAVE A
NICE DAY



COOL IC'S

A major advance in semiconductor cooling techniques was announced last month by YoYodyne of Los Angeles. The encapsulating material of the semiconductor is cast with a series of channels buried inside it. All the channels are interconnecting and join a pair of common input and exhaust fittings at one end of the IC (see above). A small gate valve is incorporated in the device and it controls the flow of coolant being pumped through the IC by a compressor located on the circuit board. YoYodyne claims that one compressor can adequately cool up to twelve standard 7400 series IC's and that power requirements are minimal, although the special compressor used in the new technique requires a separate three-phase, 440-volt line.

The actual coolant can be as simple as distilled water, but a special fitting is needed if a pressurized refrigerant such as freon is used. Preliminary literature from YoYodyne indicates that the results of supercooling have produced dramatic results. A standard 78-series regulator didn't fail until over three hundred amperes were drawn from it. That was accomplished by using liquid nitrogen as a coolant, and YoYodyne was quick to point out that the techniques involved were still "in the early experimental stages."

CALLING DICK TRACY

Rumors that have been flying around the computer industry for months were confirmed at last November's Comdex show in Las Vegas. A new breakthrough in ULSI (Ultra Large Scale Integration) fabrication techniques has produced a new computer. All the circuitry needed for the device is contained on one chip that is housed in a package that measures less than 1/4-inch square. The display is an improved version of the LCD's currently being used in miniature TV sets. The increased efficiency of the new LCD's, however, has made possible resolution fine enough to feature an 80 x 24 character display, with each character being formed by an impressive 18 x 26 matrix. The keyboard for the new computer is similar to the ones found on the calculator watches, and features 56 keys for input of a complete ASCII character set including upper- and lower-case letters. Because of the single IC design, the computer measures only 1 x 2 inches. It is powered by body heat, with a silver-oxide battery for memory backup. Dubbed the *Wrist Computer*, it is available with either a stainless steel or brushed gold finish. An executive, deluxe model is planned that will have all of the above features as well as a numeric keypad and ten user-definable keys.

NICE DAY

The American National Standards Institution has announced the introduction of a new symbol to be incorporated in the standard ASCII character set (see above). The code will be 96 decimal or \$60h. A spokesman said that this was only the beginning of a new series of characters to be introduced over the next year or so.

QUICK NOTES

Sosy Corporation has announced a working prototype of the long expected "TV on a chip." At the present time the prototype IC measures 2 x 3 feet, and is 6 inches thick.

The FCC is considering standards for stereo CB-transmission.

BCB has introduced a new series of fast-recovery diodes designated the FR4000 series. Those are special application parts that feature two paralleled inverted diodes on the same substrate. As a result they will pass current in either direction and BCB engineers claim that new doping techniques make the voltage drop across the diode less than one microvolt in either direction.

Ball Labs has announced the discovery of a new atomic particle, the anti-neutrino. According to the report issued by the researchers, the particle has all the characteristics of the neutrino but is opposite in charge.

R-E

Do your skills suffer from half-life crisis?



Five years is the average half-life of technical information. Skill upgrading is critical because, every five years, half of your electronics skills can become outdated. But Heathkit/Zenith Educational Training Systems will put you back in the lead. We've helped thousands keep pace with high-tech self-instruction courses. From fundamentals to state-of-the-art. Learn more about us. We can pull you through the half-life crisis.

FUNDAMENTAL ELECTRONICS

A complete six-course core curriculum covering DC and AC Electronics, Semiconductors, Electronic Circuits, Electronic Communications and Test Instruments.

DIGITAL AND MICROPROCESSORS

Six comprehensive courses spanning the spectrum of Microprocessor Technology. From Digital Techniques through Microprocessors to the latest in Voice Synthesis.

ADVANCED MICROPROCESSING

A valuable course in advanced 16-bit Microprocessor Technology. Course uses a new state-of-the-art trainer that becomes a fully capable 16-bit computer.

ROBOTICS TECHNOLOGY

A complete, comprehensive education in robotics theory and applications. Train on "HERO 1," a mobile programmable robot with arm, gripper, voice and sensors.

INDUSTRIAL ARTS

Seven exceptional courses for overview, or beginning training: Soldering, Printed Circuits, Concepts of Electricity or Microprocessors plus Automotive Electronics and Ignition Systems.

COMPUTER PROGRAMMING/OPERATING SYSTEMS

Eight courses on operating systems and languages: MS-DOS, CP/M, Assembly, BASIC, MBASIC, Pascal, FORTRAN and COBOL.

ADVANCED ELECTRONICS

Eight advanced courses: Op-Amps, Active Filters, IC Timers, Phase-locked Loops, Opto-Electronics, Fiber Optics, Passive and Transistor Circuit Design. Come up to speed by building actual working circuits.

NEW VIDEO HIGH TECH COURSES

Send for our brochure of new High Tech Video Training Courses. Fully animated courses demonstrate complex concepts in a step-by-step approach. Can be used with compatible course texts and trainers for hands-on learning. A bold, new approach to technical training!

TOTAL SUPPORT MATERIAL

Heathkit/Zenith builds its own course-compatible trainers for hands-on learning reinforcement. And we're the only leading education group that manufactures a full line of computers and peripherals.



Don't let your technical skills fall behind. Send for our free Education Catalog. Check the boxes that match your needs.

- | | |
|--|---|
| <input type="checkbox"/> FUNDAMENTAL ELECTRONICS | <input type="checkbox"/> ADVANCED ELECTRONICS |
| <input type="checkbox"/> DIGITAL AND MICROPROCESSOR | <input type="checkbox"/> COMPUTER PROGRAMMING |
| <input type="checkbox"/> ADVANCED MICROPROCESSING | <input type="checkbox"/> INDUSTRIAL ARTS |
| <input type="checkbox"/> ROBOTICS TECHNOLOGY | <input type="checkbox"/> NEW VIDEO COURSES |
| <input type="checkbox"/> COMPUTERS OR TEST EQUIPMENT | <input type="checkbox"/> ALL COURSES |

Mail to: Heathkit/Zenith Educational Systems
Heath Company, Dept. 020-166
Benton Harbor, MI 49022

Name _____

Address _____

City _____

State _____ Zip _____

Heathkit/Zenith Educational Systems is a division of
Heath Company, Benton Harbor, MI 49022

ED-209

Heathkit®
Heathkit/Zenith
Educational Systems

SATELLITE/TELETEXT NEWS

GARY ARLEN
CONTRIBUTING EDITOR



AROUND THE SATELLITE CIRCUIT

Scientific-Atlanta has introduced a dual-beam prime-focus feed assembly designed to receive simultaneous signals from two adjacent C-band satellites spaced 3° or 4° apart. The new dual-beam device, which can be used with 4.6- and 5-meter earth stations, allows single-dish reception from Satcom III R and Galaxy 1, the major cable programming birds.

Paradigm Manufacturing has incorporated an innovative hub design and rib configuration in its new 3.8-meter aluminum-mesh antenna. The new design is said to improve structural integrity and reduce weight. A redesigned LNA tube support increases rigidity and reduces noise temperature and side lobes for the polar-mounted, eight-rib unit. (Paradigm Manufacturing, 6911 Eastside Road, Redding, CA 96001).

National Microtech has introduced the *Apollo Elite* receiver/dish-rotator system. The receiver and the rotator-control units feature individual microprocessors and an infrared remote-control unit with a 25-foot range (see photo). All remote command functions can be sent to either the receiver or rotator control units. Thus, you can mount one unit at each of two TV's and use your remote control at either location to change the channel, volume, antenna, or audio fine tuning. The system can be programmed for up to 100 satellite locations. (National Microtech, PO Drawer E, Grenada, MS 38901)

Ka-BAND BIRD

Hughes Communications has asked the FCC for permission to build and launch two Galaxy satellites using the Ka-band (30 GHz), a virtually unused part of the spectrum that could handle several times the capacity of current birds. The \$450 million Hughes system has a 1988 timetable and will mainly be used for teleconferencing, data transmission, and paging/signalling services. The medium-powered satellites would send signals to two-meter dishes via "spot beams" aimed at 150-mile radius areas around 16 major cities.

SATELLITE-PHONE

"Personal Satellite Phone," a five-pound cordless communicator, has been proposed as a system to take advantage of two electronic rages: portable phones and satellite transmission. Skylink Corp., a Colorado firm, is seeking FCC authorization to develop the service that will use a high-powered satellite to relay voice and data signals from Personal Satellite Phones into the conventional phone system. Skylink sees the system as one which will let people talk from vehicles as well as from remote areas. The Skylink system could be launched by 1987. (Skylink, 3000 Pearl St., Boulder, CO 80301).

VIDEO RETRIEVAL SYSTEM

Warner Electronic Home Services hopes to launch a video-on-demand retrieval system in Pittsburgh by mid-1984. The service, a spin-off of Warner Amex Cable's QUBE interactive technology, would offer text as well as full video images that could be requested by viewers using a hybrid arrangement involving phone lines and cable-TV circuits. Videodisc players at the cable-TV offices would feed short programs—including music-video clips, teleshopping demonstrations and other material—directly into customers' homes.

R-E



The Bearcat® DX1000 makes tuning in London as easy as dialing a phone.

Direct access keyboard tuning brings a new level of simplicity to shortwave radio. With the Bearcat® DX 1000, dialing in the BBC in London is as easy as dialing a telephone. And you can switch from the BBC to Peruvian Huayno music from Radio Andina instantly. Without bandswitching.

Featuring the innovative microprocessor digital technology made famous by Bearcat scanner radios, the DX 1000 covers 10 kHz to 30 MHz continuously, with PLL synthesized accuracy. But as easy as it is to tune, it has all the features even the most sophisticated "DXer" could want. 10 memory channels let you store favorite stations for instant recall—or for faster "band-

scanning" during key openings.

The digital display measures frequencies to 1 kHz, or at the touch of a button, doubles as a two time zone, 24-hour digital quartz clock. A built-in timer wakes you to your favorite shortwave station. Or, it can be programmed to activate peripheral equipment like a tape recorder to record up to ten different broadcasts—any frequency, any mode—while you are asleep or at work.

The DX 1000 also includes independent selectivity selection to help you separate high-powered stations on adjacent

frequencies. Plus a noise blanking system that stops Russian pulse radar interference.

There's never been an easier way to hear what the world has to say. With the Bearcat DX 1000 shortwave radio, you have direct access to the world.

For the name of your nearest retailer dial toll-free... 1-800-SCANNER.



Frequency Range: 10 kHz to 30 MHz continuously. **Tuning:** Direct keyboard entry, selectable 3 or 24 kHz per revolution knob tuning, or manual step tuning in selectable 1-99 kHz steps. **Sensitivity:** 1.0 μ V AM, 0.5 μ V CW/SSB/FM, 1.6-30 MHz. **Image and IF Rejection:** 70 dB or more. **Memory:** 10 frequency capacity. **Frequency Stability:** Better than 100 Hz after warm-up. **Modes:** AM/LSB/USB/CW/FM. **AGC:** Selectable Fast/Slow release times. **Filter Bandwidths:** 2.7 kHz, 6 kHz and 12 kHz. **Filter Selection Independent of Mode.**

Bearcat® DX 1000 shortwave radio.

Direct Access To The World.



© Copyright 1983, Masco Corporation of Indiana

Electra

Electra Company
Division of Masco Corp. of Indiana
300 East County Line Road
Cumberland, Indiana 46229

CIRCLE 81 ON FREE INFORMATION CARD

LETTERS

Address your comments to: Letters, **Radio-Electronics**,
200 Park Avenue South, New York, NY 10003

OOOOOPS!

For those of you who want to order a kit of parts for the MHD generator that we described in our February issue, the correct address is: Images Co., PO Box 313, South Richmond Hill Station, Jamaica, NY 11419. (The address given in the Parts List had the box number omitted.)

Readers: don't forget to let us know about your results with MHD generators!—*Editor*

SHORT PROGRAM

Radio-Electronics, my favorite hobby magazine, has given me so many usable ideas that I would like to pass on an item that may be of help to those who, like me, are still learning how to write good programs for the

Sinclair ZX81 and the Timex/Sinclair 1000.

Although those computers provide a total of 24 lines on the screen, the lower two are reserved for inputs and reports, unlike several other home or hobby computers. The 22 remaining lines are often just one or two lines short of what a programmer would like the computer to display.

The short program below will result in screen printing on the bottom two lines, lines 22 and 23 in the Sinclair line-numbering method, which numbers the top line as "0". The first two statements provide the text input for lines 22 and 23 respectively. Warning: neither text can exceed 32 characters in length.

```
9000 LET A$ = "(INSERT TEXT FOR
LINE 22)"
```

```
9001 LET B$ = "(INSERT TEXT FOR
LINE 23)"
```

```
9002 FOR N = 0 TO LEN A$ - 1
```

```
9003 POKE (727 + N + PEEK 16396 +
256 * PEEK 16397), CODE B$(
```

(N+1)

```
9004 NEXT N
```

```
9005 FOR N = 0 TO LEN B$ - 1
```

```
9006 POKE (760 + N + PEEK 16396
+ 256 * PEEK 16397), CODE B$(
N+1)
```

```
9007 NEXT N
```

If the display on line 22 only is wanted, delete statements 9001, 9005, 9006 and 9007. If line 23 only is wanted, delete statements 9000, 9002, 9003, and 9004.

The computer will probably crash if either line of text exceeds 32 characters, or if any character is used that takes up more than one space. Thus, characters like " ", the quote image, and **, the exponent operator, cannot be used.

This method of obtaining screen printing on the bottom two lines is much simpler than poking the print-position system variable, 16398, 16399, as hinted at by the ZX81 manual. Note that this program does not POKE

NEW!



From
W.S. JENKS & Son

Weller® WTCPR \$77.50

Safe for IC soldering. Closed loop, low-voltage circuit automatically controls output. 700 F 1/16" screwdriver tip provided. 600 F and 800 F tips available. Power unit has non-heat sinking iron holder, storage tray for extra tips and tip cleaning sponge with receptacle. Send for free W.S. Jenks & Son electronics tool catalog for complete accessories.

SEND NOW!

FREE CATALOG!
Over 100 pages. Wide selection of tool sets, test equipment, soldering and desoldering equipment, telecommunications and specialized electronics assembly tools.

W.S. JENKS & Son

2024 West Virginia Ave. NE
Washington, D.C. 20002
TOLL-FREE ORDER LINE: 1-800-638-6405

Please send the indicated material
 Weller WTCPR Soldering Station @ \$77.50
 FREE W.S. Jenks & Son 84 Catalog
 Check/Money Order
 MasterCard Visa Am Exp
 Card No. _____ Exp _____
 Signature _____
 Name _____
 Address _____
 City _____ State _____ Zip _____
 VA residents add 4% tax. DC residents add 5% tax

CIRCLE 57 ON FREE INFORMATION CARD

THE IC TEST CLIPS "CHIP-CLIP"

CIRCLE 54 ON FREE INFORMATION CARD



- Snap Ring Action
- Secure Positive Contact
- Gentle to the I.C.
- Hard Gold Plated Contacts
- High Dielectric Nylon Body
- Connector Compatible

Unlike "clothespin" type test clips which can stress IC's and even accidentally loosen or extract them, the CHIP-CLIP attaches by means of a snap-action locking ring that ensures reliable contact but with virtually no stress to the device under test. The clamshell design is spring loaded in outward direction instead of inward. Spacing in the "open" position is just enough to allow the CHIP-CLIP to be placed over the IC without any stress to the chip. Molded separators eliminate shorts between legs. Simply slide the locking ring down to snap the CHIP-CLIP into its closed position.

DTI CORPORATION
ELECTRONIC TOOLS & ACCESSORIES

2-05 Banta Place - Fair Lawn, NJ 07410 - USA Tel: 201-796-1720

The complete library of replacement semi's.

ECG212L
Suggested Price \$3.25

• ECG[®] Semiconductors

Master Replacement Guide

- Entertainment • Industrial • Commercial
- Equipment Maintenance and Repair



**If it's ECG, it fits.
And it works.**

Sylvania Electronic Components

Here's the one guide that has it all—the new ECG[®] Master Guide. It's 545 pages, packed with over 3000 ECG semiconductors that replace over 200,000 industry numbers. And our replacements meet or exceed the specs of the original parts. So if it's ECG, you can count on it to fit and work.

Reduce equipment downtime and save yourself endless hours of parts hunting. For everything from analog amplifiers to zener diodes, go with replacement semiconductors from ECG. Get your new ECG Master Guide and our "Counterpoints" product updates from your nearest distributor. For his name and number, call 1-800-225-8326 toll-free (in Massachusetts, dial 1-617-890-6107). Or just send \$3.25 for your ECG Master Guide to Philips ECG, Inc., Dept. RE, 70 Empire Drive, West Seneca, NY 14224.

**If it's ECG, it fits.
And it works.**

Philips ECG

A North American Philips Company

CIRCLE 47 ON FREE INFORMATION CARD

the D_FILE system variable, an action that the manual warns against, but finds the D_FILE start address and then pokes the desired character codes into the addresses of the display file proper.

Any report from the computer will overwrite the first several characters of line 23, which is only occasionally a problem when a program is run. If the program here is typed in for a test by itself, a program line such as PAUSE 4E4 can be added. Then pressing any key except SHIFT will "unlock" the computer and display the overwriting report.

If printout on lines 22 and 23 is used several times in a program, it might be best to use statements 9002 through 9007 as a subroutine. Don't forget to add the RETURN statement. The main program would then need only statements 9000 and 9001. If one

or the other, only, of the two lines is wanted at a particular place in the program, the empty string can be the text for the unwanted line.
H. E. FELLHAUER
Mabank, TX

NEED FULFILLED

Congratulations to you and your publication for remaining a magazine dedicated to the electronics enthusiast and not going the way of all the other electronics publications (into computers).

This is the first time that I have ever written to a publication in this way, and I will say that if your publication changes over to computer articles, or leans heavily toward computer circuitry and accessories, then I will cancel my subscription.

Computers have a place in our society, but

let the others in the electronics field go that way—as most of them have done.

This country needs a publication like yours, so that the younger generation has a place to learn and experiment with the many projects that your magazine has published in the past and, I hope, will continue to print.

I have enjoyed the many articles printed over the years, so please continue that way and thanks for a job well done.

RONALD STORCK
Dallas, PA

TRANSIENT SUPPRESSOR

In reference to the "Transient Suppressor" article in *Radio-Electronics*, September 1983: That item sounds like a good thing to have; however, I would like to discuss a *safety problem*. The article shows the line neutral, the white wire, being switched by the relay. That is an extremely unhealthy practice. The hot side of the line, the black wire, remains unswitched as shown in the article. Even though the device has its current path interrupted by the relay, whatever is plugged into the receptacle still has full line voltage from the hot (black wire) side of the line. An accidental ground path through a person who believes that the device is off can occur even when relay RY 1 is unlatched. The suggestion of adding an ON/OFF switch in the article further increases the chance of an electric shock.

I would suggest that both sides of the line be switched by RY 1 using a similar relay, but having an extra set of contacts. The ground wire, of course, should be carried through the suppressor uninterrupted.

If you do not want to change the relay type, then at a minimum the builder should be very careful to keep the hot (black wire) side of the line and the neutral (white wire) side of the line functions consistent with standard wiring practices—that is, *not* switching the neutral. Good wiring practices in dwellings, and electric codes, should be thought about when distributing line current around places where we work and live. Safety first, etc.

STUART MARCINIAK
San Francisco, CA

AUDIO TAPES

In reference to "Audio Tapes—How Different Are They?" in the November 1983 *Radio-Electronics*, that article is very misleading. The main difference in cassette tapes is not the tape, but the mechanics of the cassette—the little wheels that start to squeak. Take a look at the tape-head pressure mechanics. Will it fall apart or wear out? Those are the big differences.

One of the companies mentioned in your article will just disappear if you try to get replacements for bad junk.

GUS OSITIS
Orinda, CA

THE 55-MILE-PER-HOUR SPEED LIMIT

In reading the letter from Mr. Raymond Kostanty ("Letters," *Radio-Electronics*, November 1983), I find myself a bit miffed at an over-simplistic view of the 55-mile-per-hour speed limit and its "minimal" benefits. I feel that this department would be far better serving to your readers if the content were kept to matters concerning the industries and

continued on page 20



What fits in your pocket... gives fast, simple 16-channel Logic Analysis ...and costs only \$150.00?

The all new **LM-2A 16-Channel Logic Monitor**... the smallest, most compact, easy-to-use logic test instrument available today. With input impedance of over 1 MΩ, the LM-2A simultaneously monitors logic states of 8, 14 and 16-pin DIP ICs or up to 16 physically independent points in a circuit.

MORE LOGIC ANALYSIS FOR LESS

Flip a switch and monitor TTL or CMOS logic levels. Turn a thumb-wheel and select 1 V through 9 V thresholds for DTL, HTL, RTL and other non-standard logic levels. Fast, instant readout from 16 individually numbered high intensity LEDs.

Why use klutzy meters? The new LM-2A is small...easy-to-use... saves time and money...and makes troubleshooting multifamily logic systems a breeze.

Want to know more about the all NEW LM-2A?

Call Today, Toll Free.



GLOBAL SPECIALTIES CORPORATION

70 Fulton Terr. New Haven, CT 06509
(203) 624-3103 TWX 710-465-1227

OTHER OFFICES:

San Francisco (415) 648-0611, TWX 910-372-7992,
Europe: Phone Saffron-Walden 0799-21682, TLX (851) 817477

Call toll free for details 1-800-243-6077 during business hours (E.S.T.)

CIRCLE 96 ON FREE INFORMATION CARD

SUPERSALE

BECKMAN Circuitmate® DMM

MODEL DM73
\$72⁹⁵

• Smallest digital multimeter on the market. • Probe-style design makes it ideal for taking measurements in hard-to-reach test areas.



\$64⁹⁵ MODEL DM20

• 3½-digit, pocket-size multimeter • 0.8% Vdc accuracy • diode test • hFE test • conductance • 10 amps AC and DC ranges • Autopolarity • Auto-Zero • Auto-decimal.



\$79⁹⁵ MODEL DM25

• 3½-digit, pocket-size multimeter • 0.5% Vdc accuracy • diode test • capacitance • continuity beeper • conductance • 10 amps AC and DC ranges • auto-polarity • auto-zero • auto-decimal.



B&K PRECISION

100 MHz FREQUENCY COUNTER

MODEL 1803
REG. \$169.95 **OUR PRICE \$144⁵⁰**



• 5 Hz to 100 MHz range • 8 digit LED display • Leading zero blanking • Low pass filter • BNC Connector Input • Overflow Indicator • Battery or AC powered • Charger/AC Adaptor included with Model 1803.

NTSC COLOR BAR GENERATOR

MODEL 1251

REG. \$995.00

OUR PRICE
\$849⁹⁵



• Generates a wide variety of test signals and patterns for comprehensive testing, servicing and adjustment of virtually all types of television and video equipment • Video patterns include standard NTSC color bars, -IQ, and staircase at two levels of burst phase chrominance • A full assortment of convergence patterns, raster colors gated or full field multiburst.

HITACHI

PORTABLE OSCILLOSCOPES

MODEL V-222 (20 MHz)
REG. \$695.00

MODEL V-422 (40 MHz)
REG. \$895.00

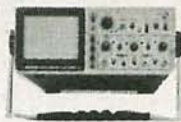

CALL FOR SPECIAL PRICING

• New series of scopes provides high performance and light weight • Large 6-inch rectangular, internal graticule CRT • Autofocus circuit and scale illumination • DC offset function • Voltage and frequency reading outputs • High accuracy - ±3% • High sensitivity - 1 mV/div.

BP DIGITAL CAPACITANCE METER



MODEL DCM-601
REG. \$149.95

OUR PRICE
\$79⁹⁵

• Digital display easy and correct readout • High accuracy: 100 PPM 0.5% • LSI-circuit provides high reliability and durability • LCD display provides low power consumption.

FORDHAM

550 MHZ FREQUENCY COUNTER



MODEL FM-8
REG. \$199.95 **OUR PRICE \$149⁹⁵**

• 8-digit high frequency counter with a switch selectable input using single BNC • Completely assembled • Pre-Calibrated, Pre-tested.

LEADER

NTSC WAVEFORM MONITOR



MODEL LBO-5860
REG. \$2050.00

OUR PRICE
\$1850

Permits displaying vertical interval test and reference signals by front panel line selector.



NTSC VECTORSCOPE

MODEL LVS-5850
REG. \$2050.00

OUR PRICE
\$1850

Convenient method for observing and measuring the relative phase and amplitude of chrominance signal components.

FLUKE 70 73

• Analog Display • Rotary Knob • Volts AC & DC • Resistance to 32 MΩ • 10 Amps • Diode Test • 3200 Counts • Fast Autoranging • Function Annunciators in Display • Power-Up Self Test • 2000+ Hour Battery Life w/Power Down "Sleep Mode" • New Test Leads • VDE & UL Approval

\$85⁰⁰

• 0.7% Accuracy • Autorange Only • 10 Amp Only



75
\$99⁰⁰

• 0.5% Accuracy • Manual or Autorange • 10A + 300 mA Range • Beeper



77
\$129⁰⁰

• 0.3% Accuracy • Manual or Autorange • 10 A + 300mA Range • Beeper • "Touch-Hold" Function



VIZ DC TRIPLE POWER SUPPLY

MODEL WP-708
REG. \$479.95

OUR PRICE
\$399⁹⁵

• Dual DC Voltmeter • Triple DC Power Supply • Three separate completely isolated DC power supplies; two 0-20V at 0-2A, one fixed 5V at 4A.



WELLER SOLDERING STATION

SOLDERING STATION

MODEL EC1000
OUR PRICE
\$109⁹⁵

• Identical to the EC2000 except LED Digital temperature readout • The EC1000 is dial controlled.



MODEL EC2000
OUR PRICE
\$139⁹⁵

• Continuously variable tip temperature from 350 to 850 F • Positive temperature coefficient sensor inside the tip provides temperature feedback to maintain tip temperature at a set point.



FORDHAM

260 Motor Parkway, Hauppauge, N.Y. 11788

■ Master Charge
■ VISA ■ COD
■ Money Order
■ Check

N.Y. State residents add appropriate sales tax.

COD's extra (required 25% deposit)

ADD FOR SHIPPING AND INSURANCE:
\$0-\$250.00 \$ 4.50
\$251.00 to \$ 500.00 \$ 6.50
\$501.00 to \$ 750.00 \$ 8.50
\$751.00 to \$1000.00 \$12.50
over \$1000.00 \$15.00

TOLL FREE
(800) 645-9518

in N.Y. State call 800-832-1446

Free Catalog on Request

APRIL 1984

Everybody's making money selling microcomputers. Somebody's going to make money servicing them.

Now NRI Trains You At Home To Make Money Servicing, Repairing,
and Programming Personal and Small Business Computers



Learn At Home to Service Any Computer

NRI can train you for this exciting, rewarding field. Train you at home to service not only microcomputers, but word processors and data terminals, too. Train you at your convenience, with clearly written "bite-size" lessons that you do evenings or weekends, without going to classes or quitting your present job.

Your training is built around the latest model of the world's most popular computer. It's the amazing TRS-80™ Model 4, now with disk drive and the capabilities and features to perform a host of personal and business functions. No other small computer has so much software available for it, no other is used and relied on by so many people. And it's yours to keep for personal and business use.

You get plenty of practical experience. Under NRI's carefully planned training, you even install a *disk drive*

as an alternative to the Model 4. The same technique for getting inside is enhanced by using the new NRI-developed Computer Access Card. Only NRI offers you a choice to fit your specific training needs.

Become the Complete Computer Person

In addition to training in BASIC and advanced machine language, you gain hands-on experience in the operation and application of the latest computers for both business and personal jobs. You're trained to become the fully rounded, new breed of technician who can interface with the operational, programming, and service facets of all of today's computers. You're ready to take your place in the new electronic age.

Other Opportunities

NRI has been giving ambitious people new electronic skills since 1914. Today's offerings also include TV/Audio/Video Systems servicing with training on our exclusive Heath/Zenith computer-programmable 25" diagonal color TV... Industrial Electronics, Design Technology... and other state-of-the-art courses.

Training now includes either the TRS-80 Model 4 Microcomputer with *Disk Drive* or the TRS-80 Color Computer with *Computer Access Card*; professional LCD multimeter; the NRI Discovery Lab; and hundreds of demonstrations and experiments.

Seems like every time you turn around, somebody comes along with a new computer for home or business use. And what's made it all possible is the amazing microprocessor, the tiny little chip that's a computer in itself.

Using this new technology, the industry is offering compact, affordable computers that handle things like payrolls, billing, inventory, and other jobs for business of every size...perform household functions including budgeting, environmental systems control, indexing recipes. And thousands of hobbyists are already owners, experimenting and developing their own programs.

Growing Demand for Computer Technicians

This is only one of the growth factors influencing the increasing opportunities for qualified computer technicians. The U.S. Department of Labor projects over a 600% increase in job openings for the decade; most of them *new* jobs created by the expanding world of the computer.

(TRS-80 is a trademark of the Radio Shack division of Tandy Corp.)



verifying its operation at each step. Using the NRI Discovery Lab® that also comes as part of your course, you build and study circuits ranging from the simplest to the most advanced. You analyze and troubleshoot using the professional 4-function LCD digital multimeter you keep to use later in your work. Then you use the lab and meter to actually access the interior of your computer...build special circuits and write programs to control them. You "see" your computer at work and demonstrate its power.

Same Training Available With Color Computer

NRI offers you the opportunity to train with the TRS-80 Color Computer

The Catalog is Free. The Training is Priceless.

Send the postage-paid card for our 104-page catalog showing all courses with equipment and complete lesson plans. There's no obligation other than to yourself. See how NRI can help you take advantage of the exciting job and earnings opportunities in the exploding field of microcomputers. If card has been removed, please write to us.



NRI SCHOOLS
McGraw-Hill Continuing
Education Center
3939 Wisconsin Ave.
Washington, DC 20016

We'll give you tomorrow.

LETTERS

continued from page 14

trends that your publication serves so well. But if highway safety is a viable topic, I would like to make a response to several remarks that I found to be somewhat flawed.

The 55-mile-per-hour speed limit was enacted by Congress, not by local state or local law-enforcement agencies, for several reasons (faulty or otherwise). It is therefore unfair to attribute the speed limit to a tactic or means for traffic officers to keep up to their quotas. The principal duties of a highway patrolman or traffic officer is the enforcement of highway regulations that are duly enacted into law by elected officials. Investigating murders, rob-

beries, and drug dealing are matters assigned to officers who specialize in criminal activities.

I feel, personally, that 10,000 lives saved each year is a significant figure. That reflects a 20% reduction in highway fatalities. It's quite a significant number, especially when we consider the increase in the number of licensed vehicles and drivers during the ten years that the law has been in effect.

But the bottom line remains this: Driving over 55 miles per hour is *illegal*. The only way to change that fact is to convince our federal legislators that there is a valid reason for increasing the legal speed limit. I doubt that belittling highway officers, or stating that 10,000 lives annually is not in perspective, will get much favorable attention from any of our congressmen.

You have a fine magazine, but I still feel that there are more appropriate places to deal with issues on highway regulation than **Radio-Electronics**. (*Does that include issues on radar detectors?*—Ed) I am one of your most devoted readers and will continue to be so. HULBERT F. SATTERFIELD
Memphis, TN

AUTO-ALARM SYSTEM

Just a short note to tell you about the "Auto Alarm System" by Ed Loxterkamp in the May 1983 issue of **Radio-Electronics**. I built it; I installed it—and it works *great!*

I have also incorporated a motion detector into the system, which works off the hood and trunk switches. It's an excellent system and I am well pleased. Keep up the great job you're doing with "do-it-yourself" projects.

J. JOSEPH HLASNEY
Whitehall, PA

NO RECORDS

In the November 1983 **Radio-Electronics**, the writeup on Heathkit's Electronics Course EE-3104 ("Equipment Reports") states that the course includes instructional records. That *isn't* so.

My course arrived without any records. Checking back on their catalog for the past six months, I find that Heath does not include records with their course.

BILL TOMPKINS
Oakland, CA

Author's Reply: *Our review copy of EE-3104 was received some time ago and, did, indeed, include instructional records. Apparently, Heathkit has decided to make those instructional aids optional. Our copy of the latest catalog confirms that; and while you can do the course without them, they do help personalize things. So we'd suggest buying them.*

THE 7805

I suppose that by now you must have received many letters supporting the circuit in National Semiconductor's *Voltage Regulator Handbook* that was mentioned in the letter from Mr. Lawrence J. Jones, appearing in the January 1984 **Radio-Electronics**. That book explains how to use their regulators, and how to hook up the circuit indicated. I myself find National Semiconductor's arguments persuasive.

The 7805 is a hard-to-damage IC. When the output of the IC is held to ground (shorted), the chip will supply current until it overheats. When the IC overheats, it will supply reduced current so as to prevent its being damaged. If you really want to burn out a 7805, you must supply it with excessive voltages—either inputs or outputs. The circuit described in Mr. Jones's letter cannot damage the 7805. The only danger is that the transistor, or some other discrete components, will be damaged. Believe me; the circuit works.

PIANOMATIC PROBLEMS

Two errors crept into the parts-placement diagrams for the Pianomatic project. In Fig. 12 (page 67 of the October 1983 **Radio-Electronics**), IC4 is shown upside down. It must be turned around, with pin 1 pointing toward the top left of the diagram, for the project to work correctly. Also, in Fig. 14, C22 is actually C16.—Robert Grossblatt.

All This...



Telephones

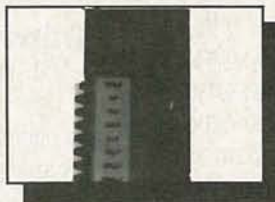

Test Equipment



Soldering Equipment



Semiconductors



Speakers

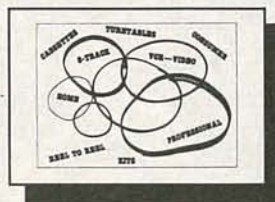

Belts



Tubes

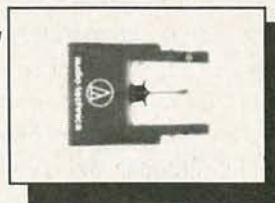

Styli

CALL TOLL FREE TODAY!

1-800-543-3568

National

1-800-762-3412

Ohio

"Your Complete Electronics Parts Source!"



Consolidated Electronics, Inc.

705 Watervliet Ave., Dayton, Ohio 45420
In Dayton call 252-5662

CIRCLE 18 ON FREE INFORMATION CARD

MAKE MORE MONEY



TRAIN FOR ELECTRONICS

You say you're *already* trained in electronics but that you're *not* making enough money??? Well then, maybe you don't have an accredited bachelor's degree to prove that your education is *up to snuff!* Check out the Grantham Independent-Study B. S. Degree Program. It could make a *dollars and sense* difference in your electronics career.

Grantham offers this program, complete but without laboratory, to electronics technicians whose objectives are to upgrade their level of technical employment. Since the field of electronics is so enormous, opportunity for advancement is always present. Promotions and natural turnover make desirable positions available to the man who is ready to *move up*.

Grantham College of Engineering
2500 South LaCienega Blvd.
P. O. Box 35499
Los Angeles, CA 90035

This booklet FREE!

This free booklet explains the Grantham B.S. Degree Program, offered by independent study to those who work in electronics.



for **FREE** Booklet **CLIP COUPON** and mail in envelope or paste on postal card.

Do You REALLY Want to Make More Money?

Yes it does take *work* and a few sacrifices to climb up the electronics ladder to where the bigger money is. But, if that's where you want to be, then that's what you must do — *work* harder at learning and getting the right credentials, even if it takes a few sacrifices. A *B. S. degree* and the knowledge that rightly goes along with it can give you powerful ladder-climbing equipment in your search for *success in electronics*.

The accredited Grantham non-traditional B.S. Degree Program is intended for mature, fully-employed workers who want to upgrade their electronics careers.

Put Professional Knowledge and a COLLEGE DEGREE in your Electronics Career through Independent Home Study

Study materials, carefully written by the Grantham College staff for independent study at home, are supplied by the College. Your technical questions related to these materials and the lesson tests are promptly answered by the Grantham home-study teaching staff.

Recognition and Quality Assurance

Grantham College of Engineering is accredited by the Accrediting Commission of the National Home Study Council, as a degree-granting institution.

We are located at 2500 S. LaCienega Blvd., Los Angeles, California, but for faster response please use our mailing address: P. O. Box 35499, Los Angeles, CA 90035.

Grantham College of Engineering R-4-84
P. O. Box 35499, Los Angeles, CA 90035

Please mail me your free catalog which explains your B.S. Degree independent-study program.

Name _____ Age _____

Address _____

City _____ State _____ Zip _____

APRIL 1984

EQUIPMENT REPORTS

B&K Precision Model 1822 Universal Counter



CIRCLE 101 ON FREE INFORMATION CARD

B&K Precision		1822												
OVERALL PRICE														
EASE OF USE														
INSTRUCTION MANUAL														
PRICE/VALUE														
		1	2	3	4	5	6	7	8	9	10			
		Poor		Fair		Good		Excellent						

WHETHER YOU'RE INVOLVED WITH THE design or repair of electronic equip-

ment—be it analog or digital—at some point you're sure to need a frequency

counter. We recently had the opportunity to examine a counter that can be used for more than just measuring frequency. (Thus it is called a "universal counter.") So if you've ever needed to make duty-cycle measurements of, say, a power supply, or if you ever had to measure the frequency ratio of two signals, or the length of time between two once-only events, then the following should interest you.

Recently the B&K Precision Co. (a division of Dynascan Corp., 6460 West Cortland St., Chicago, IL 60635) introduced the latest in its rather lengthy line of electronic test equipment—the model 1822 150-MHz universal counter. That counter has several features that make it versatile including: two separate input
continued on page 28

GET THE SAME VIDEO TRAINING THE PEOPLE AT SONY GET.

Now you can be trained by Sony even if you aren't employed by Sony.

Because we're making our vast library of training videotapes available to you. The very tapes that teach our own engineering, service and sales personnel.

The tapes cover the products and concepts of video and its related technologies. You can learn the basics of video recording. Color systems. Digital video and electronics. Television production. And more.

Plus you can learn how to service cameras, VTR's, and other video products. As professionally as Sony does.

The tapes are produced entirely by Sony and contain up-to-the-minute information. They communicate clearly and simply. And some of them are even programmed for interactive learning.

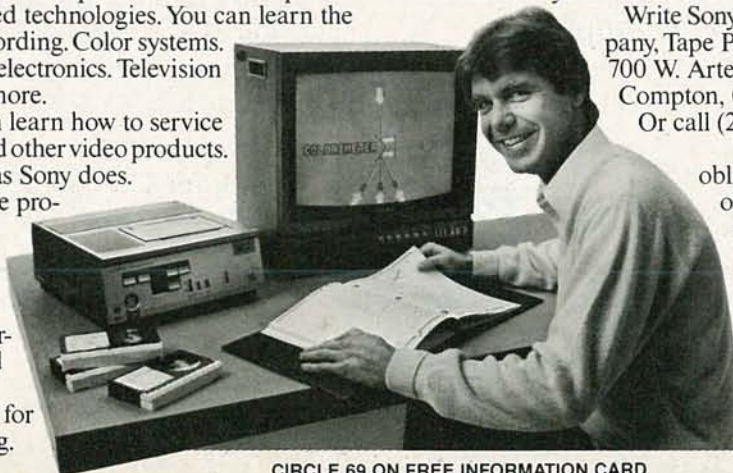

CIRCLE 69 ON FREE INFORMATION CARD

And learning through video can be done at your own pace, in the convenience of your home, shop or school. Reviewing is quick and easy. And the tapes are always available for reference.

Send for your catalog, which lists more than 250 titles. In your choice of 3/4" or 1/2" formats.

Write Sony Video Products Company, Tape Production Services, 700 W. Artesia Boulevard, Compton, California 90220. Or call (213) 537-4300.

Of course, there's no obligation. Except the obligation you have to yourself: to find out about the best training available in one of the country's fastest-growing, most lucrative fields.

SONY
Video Communications
Sony is a reg. trademark of Sony Corp.

The best 60MHz scope costs only \$1150. It's from Kikusui.



That's right. Only \$1150 for Kikusui's top-of-the-line 5060 model oscilloscope. And we also have four other scopes for as low as \$600 in our new 5000 Series.

Not only that, we're offering a two year warranty on each of them, compared to other big name companies' limited one year warranties.

When it comes to performance, our 5000 Series has the edge over the Tektronix 2200 Series in lab quality, chop frequency, and trigger view. Ours also have more display modes, higher acceleration for better brightness, and sharper focus for better resolution.

Each scope in our 5000 Series is crafted so that it can be used for production, field service, consumer electronics servicing, or even personal use. The 5060 is a 60MHz scope with 3 channels, eight traces, delayed sweep, delay line and alternate sweep, and priced at \$1150. Models 5040 and 5041 are 40MHz, dual channel scopes, featuring peak-to-peak automatic triggering, automatic focus control and a delay line. If you're interested in a 20MHz scope, we have our 5020 and 5021 models with features similar to our 40MHz scopes. Both the 5041 and 5021 also have delayed sweep. Prices at \$920 for the 5041, \$795 for the 5040, \$690 for the 5021 and \$595 for the 5020. So, whatever model suits you best, you can't get a better scope for the money.

Of course, there's a reason we're able to offer these bargains and quality. We're one of the biggest manufacturers of scopes in the world, with over 30 years in the business. Another reason is KIK's nationwide network of lab quality maintenance facilities.

Write us and we'll send complete specifications back to you. Or just take a little time to call us. It's a small price to pay to get big time quality and service.

For sales and technical information
call toll free **800-421-5334**
(in Calif., Alaska, Hawaii 213-515-6432).

Order Toll Free
800-421-5334



17819 Figueroa Street
Gardena, Calif. 90248
TWX 910-346-7648

☀ In Canada call: Interfax Systems, Inc. 514-366-0392

Subsidiary of Kikusui Electronics Corp., 3-1175 Shinmaruko-Higashi, Nakaharu-Ku, Kawasaki City, Japan (044) 411-0111



CIRCLE 48 ON FREE INFORMATION CARD

APRIL 1984

23



PHILIPS

KEITHLEY

WESTON



Non-Linear Systems



BK PRECISION

LEADER



- 77
- 0.3% Accuracy
 - Manual or Autorange
 - 10A + mA Range
 - Beeper
 - "Touch-Hold" Function

\$129⁰⁰

WE CARRY A FULL
LINE OF FLUKE
MULTI-METERS.
IN STOCK NOW

FLUKE 70 SERIES MULTIMETERS

- Analog Display • Rotary Knob • Volts AC & DC • Resistance to • 32 M Ω • 10 Amps • Diode Test • 3200 Counts • Fast Autoranging • Function Annunciators in Display • Power-Up Self Test • 2000+ Hour Battery Life w/ Power Down "Sleep Mode" • New Test Leads • VDE & UL Approval

**\$99⁰⁰**

75

- 0.5% Accuracy
- Manual or Autorange
- 10A + 300 mA Range
- Beeper

**\$85⁰⁰**

73

- 0.7% Accuracy
- Autorange Only
- 10 Amp Only



4 1/2 DIGIT
MULTIMETERS

\$349⁰⁰

MODEL
8060A

FLUKE

- Frequency measurements to 200KHz
- dB measurements
- Basic dc accuracy 0.4%; 10 μ V, 10 nA and 10 m Ω sensitivity
- Relative measurements
- True RMS
- High-speed Beeper

BK PRECISION POWER SUPPLIES

**\$299⁹⁵** MODEL 1601

- Isolated 0-50VDC, continuously variable; 0-2A in four ranges
- Fully automatic shutdown, adjustable current limit
- Perfect for solid state servicing

**\$329⁹⁵** MODEL 1650

- Functions as three separate supplies
- Exclusive tracking circuit
- Fixed output 5VDC, 5A
- Two 0 to 25VDC outputs at 0.5A
- Fully automatic, current-limited overload protection

BK PRECISION INDUSTRIAL TRANSISTOR TESTER

**\$199⁹⁵**

MODEL 520B

- Now with HI/LO Drive
- Works in-circuit when others won't
- Identifies all three transistor leads
- Random lead connection
- Audibly and visually indicates GOOD transistor

**\$995⁰⁰**

PRICE DOES NOT INCLUDE PROBES

- 1mV/division sensitivity to 70 MHz
- 500 μ V/division cascade sensitivity
- Four-input operation provides trigger view on 4 separate inputs
- Alternate time base operation
- Switching power supply delivers best efficiency and regulation at lowest weight



FUNCTION GENERATORS

\$189⁹⁵

- Sine, square and triangle output
- Variable and fixed TTL outputs
- 0.1 Hz to 1MHz in six ranges
- Push button range and function selection
- Typical sine wave distortion under 0.5% from 1 Hz to 100kHz

MODEL 3020 **\$319⁹⁵**

SWEEP FUNCTION

- Four instruments in one package — sweep generator, function generator, pulse generator, tone-burst generator
- Covers 0.02Hz-2MHz
- 1000:1 tuning range
- Low-distortion high-accuracy outputs

CAPACITANCE METERS

**\$199⁹⁵**

MODEL 830

- Automatically measures capacitance from 0.1pF to 200mF
- 0.1pF resolution
- 0.2% basic accuracy
- 3 1/2 digit LCD display

**\$159⁹⁵**

MODEL 820

- Resolves to 0.1pF
- 4 digit easy-to-read LED display
- Fuse protected against charged capacitors
- Overrange indication

BECKMAN'S CIRCUITMATE® ALL UNDER \$100

AVAILABLE NOW....



Circuitmate DM 20—
3½-digit, pocket-size
multimeter; 0.8% Vdc
accuracy, diode test,
hFE test, conductance,
10 amps AC and DC
ranges, auto-polarity,
auto-zero, auto-
decimal

\$64⁹⁵



Circuitmate DM-40 —
3½-digit multimeter;
0.8% Vdc accuracy,
diode test, auto-
polarity, auto-zero,
auto-decimal

\$69⁹⁵



Circuitmate DM-25—
3½ digit, pocket-size
multimeter; 0.5% Vac
accuracy, diode test,
capacitance, continuity
beeper, conductance,
10 amps AC and DC
ranges, auto-polarity,
auto-zero, auto-
decimal

\$79⁹⁵



Circuitmate DM 45 —
3½-digit multimeter;
0.5% Vdc accuracy,
diode test, continuity
beeper, 10 amps AC
and DC ranges, auto-
zero, auto-polarity,
auto-decimal

\$89⁹⁵

BK PRECISION

70 MHz Dual Time BASE SCOPE



PRICE DOES
NOT INCLUDE
PROBES

\$1,595⁰⁰

MODEL 1590

- 1mV/division sensitivity to 100MHz
- 500 V/division cascade sensitivity
- 2ns/division sweep rate with 10 x magnifier
- Four-input operation provides trigger views or four separate inputs
- Selectable 1MΩ or 50Ω inputs
- Alternate timebase operation
- 20MHz bandwidth limiter for best view of low frequency signals
- Lighted function pushbuttons employing electronic switching with non-volatile RAM memory
- Switching power supply delivers best efficiency and regulation at lowest weight
- Selectable frequencies for chop operation



The DM73 is the smallest digital multimeter on the market. Its probe-style design makes it ideal for taking measurements in hard-to-reach test areas.

\$63⁹⁵

- Small Size
- Complete Autoranging
- "Touch Hold"
- Audible continuity checking



The DM 77 gives you the convenience of autoranging plus 10 amps ac/dc measurement capability. You simply select the function you want, and the DM 77 automatically sets the required range.

\$76⁹⁵

TOLL FREE HOT LINE

800-223-0474

26 WEST 46th STREET, NEW YORK, N.Y. 10036
212-730-7030

THE TEST EQUIPMENT SPECIALISTS

**ADVANCE
ELECTRONICS**



V-222

HI-PERFORMANCE PORTABLE OSCILLOSCOPES

ALL FEATURE 6" RECTANGULAR CRT Full 2 year parts & labor warranty.

HITACHI

V-422 **\$599⁹⁵**

DC to 40 MHz, 1mV/div, dual-trace, DC offset function

V-222 **\$499⁹⁵**

DC to 20 MHz, 1mV/div, dual-trace, DC off. func., Alt. magnify function

V-212 **\$439⁹⁵**

DC to 20 MHz, 1mV/div, dual-trace



V-1050

\$1,249⁹⁵

V-1050F 100 MHz Quad Trace w/delay sweep

\$939⁹⁵

V-650F 60 MHz Dual Trace w/delay sweep

PRICE DOES NOT INCLUDE PROBES. PROBES \$50. A PAIR WHEN PURCHASED WITH SCOPE. \$15 SHIPPING WITHIN CONTINENTAL U.S.

A.W. SPERRY AUTO RANGING



DM-6500

\$74⁹⁵

DC Volts

RANGE	ACCURACY
200mV	±(0.5% rdg + 4d)
2V	
20V	±(0.7% rdg + 4d)
200V	
1000V	+ (1% rdg + 4d)

AC Volts

RANGE	ACCURACY 40-500 Hz
2V	
20V	±(1% rdg + 8d)
200V	
600V	±(1.2% rdg + 8d)

DC Current

RANGE	ACCURACY
200mA	±(1.5% rdg + 4d)
10A	±(1.7% rdg + 4d)

AC Current

RANGE	ACCURACY 40-500 Hz
200mA	±(2% rdg + 8d)
10A	±(2.2% rdg + 8d)

Resistance

RANGE	ACCURACY	SHORT CIRCUIT CURRENT (approx.)	
200		Hi	1.5mA
2K	±(0.8% rdg + 5d)	Lo	—
20K	±(1% rdg + 10d)	Hi	300µA
200K		Lo	30µA
2000K	±(2% rdg + 10d)	Hi	3µA
		Lo	0.15µA

MULTI-METERS.

THE RELIABLE ONES.

2 YEAR NO NONSENSE GUARANTEE



DM-6590

RANGES

DC VOLTS

RANGE	ACCURACY
2V	±0.5% rdg ± 4 dgt
20V	
200V	±0.7% rdg ± 4 dgt
500V	
500V	±1.0% rdg ± 4 dgt

\$63⁷⁵

AC VOLTS

RANGE	ACCURACY
2V	
20V	
200V	±1.0% rdg ± 8 dgt
500V	

RESISTANCE

RANGE	ACCURACY
2KΩ	
20KΩ	±0.7% rdg ± 4 dgt
200KΩ	
2000KΩ	±1.2% rdg ± 4 dgt

ORDERING INFORMATION

We don't just take orders, we ship them
Advance Electronics
endeavors to keep everything we advertise in stock for immediate delivery.



- Mastercharge & Visa shipped within 24 hours.
- Bank checks or Money Orders shipped within 24 hours.
- Personal checks — please allow 3 weeks for check to clear.
- All prices plus shipping charges. Please call for appropriate charges. Use our toll free number.
- New York State residents add appropriate sales tax.
- PRICES SUBJECT TO CHANGE WITHOUT NOTICE.

Quantities are limited



V-151F

HITACHI

\$329⁹⁵

15 MHz TRIGGERED SCOPE

QUANTITIES ARE LIMITED

SPECIFICATIONS

Vertical Deflection Sensitivity	5mV/div to 5V/div $\pm 5\%$, 10 calibrated steps 1mV/div to 1V/div $\pm 6\%$ (When using x5 amplifier) Uncalibrated continuous control between steps 1: < 2.5 (provided with click-positioning function)									
Bandwidth	DC to 15MHz, -3dB (at 4 div) DC to 7MHz, -3dB (at 4 div) (When using x5 amplifier) 24ns, (for x5) 70ns typ									
Rise Time	-									
Signal Delay Line	-									
Max. Input Voltage	600Vp-p or 300V (DC + AC peak, at 1kHz)									
Input Coupling	AC, GND, DC									
Input Impedance	Direct 1M ohm, approx. 30pF									
Operating Modes	Single-trace									
X-Y Operation	External trigger Input: X axis, Vertical Input: Y axis X axis: approx. 200mV/div, Y axis: same as Vertical input DC to 10kHz within 3° DC to 500kHz, -3dB 4 div or more									
Sensitivity	-									
Phase Difference	-									
X Bandwidth	-									
Dynamic Range	-									
Vertical Output	20mV/div or more (terminated into 50 Ω)									
Output Voltage	50Hz to 5MHz, -3dB									
Bandwidth	Approx. 50 Ω									
Output Impedance	-									
Horizontal Deflection	AUTO, NORM, TV (+), TV (-)									
Trigger Modes	LINE, EXT									
Trigger Source	AC									
Trigger Coupling	TV sync-separation circuit									
TV Sync	1 div or more (V sync-signal)									
Internal	1Vp-p or more (V sync-signal)									
External	-									
Trigger Sensitivity	<table border="1"> <thead> <tr> <th>Frequency</th> <th>Internal</th> <th>External</th> </tr> </thead> <tbody> <tr> <td>20Hz to 2MHz</td> <td>0.5div</td> <td>200mV</td> </tr> <tr> <td>2 to 15MHz</td> <td>1.5div</td> <td>800mV</td> </tr> </tbody> </table>	Frequency	Internal	External	20Hz to 2MHz	0.5div	200mV	2 to 15MHz	1.5div	800mV
Frequency	Internal	External								
20Hz to 2MHz	0.5div	200mV								
2 to 15MHz	1.5div	800mV								
AUTO Low Bandwidth	30Hz									
Trigger Slope	\pm									
External Trigger Input	Input impedance: approx. 1M ohm, 30pF or less Max. input voltage: 100V (DC + AC peak at 1kHz)									
Sweep Time	0.2 μ s/div to 0.2s/div, $\pm 5\%$ 19 calibrated steps Uncalibrated continuous control between steps 1: < 2.5 (provided with click-positioning function)									
Sweep Time Magnifier	10 times ($\pm 7\%$)									
Max. Sweep Time	100ns/div (20ns/div and 50ns/div, not calibrated)									
Amplitude Calibrator	Approx. 1kHz $\pm 10\%$ (typ), square wave									
Waveform	0.5V $\pm 5\%$									
Voltage	-									
Power Requirements	100/120/220/240V $\pm 10\%$ 50 to 60Hz, approx. 40W									
Dimensions	Approx. 275(W) x 190(H) x 400(D) mm									
Weight	Approx. 8.5kg									

FEATURES

- 1mV/div high sensitivity design. Effective for measurement of weak signals.
- Employs TV sync separator circuitry with one touch synchronization of both TV horizontal and vertical signals.
- Delayed sweep function with one touch control 10 \times magnification.
- Trace rotation system for easily adjusting trace inclination caused by terrestrial magnetism.
- Fine adjusting click positioning function enhances measuring efficiency.
- Signal output: Vertical output terminal to Frequency Counter, etc.
- Z axis input provided — possible to use as CRT display.
- One touch shifting of waveform slopes for easy observation of rise and fall of waves.



MODEL 302F

DUAL TRACE
W/DELAY

All HITACHI Oscilloscopes
feature 2 year parts & labor
warranty.

HITACHI 30 MHz SCOPE

\$549⁹⁵

Price does not include
probes. Probes \$50, a pair
when purchased with
scope. \$15. shipping
within continental U.S.

Price does not include probe. Probe \$20. when
purchased with oscilloscope.

Full 2 year parts & labor warranty.

WE CARRY A FULL LINE OF HITACHI
OSCILLOSCOPES



TOLL FREE HOT LINE
800-223-0474

212-730-7030

26 WEST 46th STREET, NEW YORK, N.Y. 10036

THE TEST EQUIPMENT SPECIALISTS

ADVANCE ELECTRONICS

EQUIPMENT REPORTS

continued from page 22

channels, a time-interval mode, and a frequency-ratio mode, just to name a few. We'll look a little more closely at some of its capabilities in a moment; but first, let's look at its outward appearance.

The model 1822 is housed in a $3.5 \times 9.5 \times 12.6$ -inch aluminum cabinet with a bail mounted at its sides. The bail can be locked in any one of several positions for easy reading on a bench and it doubles as a carrying handle. The unit has an eight-digit 0.43-inch LED display at the top of the front panel. There are also MHz, kHz, ms, μ s, and GATE annunciator LED's to the right of the display. Decimal-point placement is automatic.

Below the display is a row of thirteen pushbutton switches. Going from left to right, the first seven switches are used to power-up the unit and select its various functions (frequency, period, ratio, time-interval, totalize, and the self-test function). The unit has four decades of resolution (in each operating mode) that are selected using the next four switches. There is a handy chart printed on the panel (directly over those switches) that shows you which one you're using. The next

switch in that line is used to select either kHz/ μ s or MHz/ms. The right-most switch is for the display-hold function. Just above the HOLD switch is the RESET button that's used to clear the stored count.

To the far right of the front-panel are five more pushbutton switches and a rotary control. That rotary control selects the trigger level (for channel A only). The top pushbutton switch is used to select the degree of attenuation of the A input (either $\times 10$ or $\times 1$). The next switch, labeled -SL, is used to select the slope of the trigger signal so that the measurement can start on either the positive or negative edge of the input signal. The third switch, labeled LPF, is used to engage the low-pass filter. (That filter has a 10-MHz 3-dB corner frequency.) The last two switches are the attenuator and slope-selection switches for the B channel.

We mentioned that the 1822 has two input channels. Let's look at their characteristics and how each is used. Each channel has an input impedance of 1 megohm in parallel with 40 pF and uses a standard BNC connector. Those characteristics make it possible to use standard oscilloscope probes. The A channel has a bandwidth of 5 Hz-175 MHz and its sensitivity ranges from 20 to 100 mV RMS over its full frequency range. (Note: Al-

though the instrument's front panel claims that the 1822 is a 150-MHz frequency counter, an addendum to the service manual says that the unit operates well beyond 150 MHz at slightly reduced sensitivity. Operation is extended to at least 175 MHz at a sensitivity of 100 mV rms. That takes care of any possible problems that might arise when using the unit in the 150-174 MHz public-service band application.) The B channel has an input bandwidth of 5 Hz-2 MHz with a sensitivity of 30 mV RMS. The A channel is used when measuring frequency, period, or for totalizing events. The B channel is used along with the A channel when ratio and time-interval measurements are made.

Operating modes

The first operating mode we'll look at is the frequency mode. In that mode, the unit measures signal frequencies from 5 Hz to 175 MHz in two ranges. In the frequency mode, its resolution is .1 Hz to 1 kHz (depending on the scale chosen), with a rated accuracy of ± 1 count, \pm the timebase error. The basic unit comes with a crystal timebase that's stable to ± 1 ppm-per-year.

The 1822 can also measure the period of input signals from 5 Hz to 2 MHz and display the result in either milliseconds or microseconds. Accuracy in this mode is

**YOU CAN
JUDGE
THIS BOOK
BY ITS
COVER.**

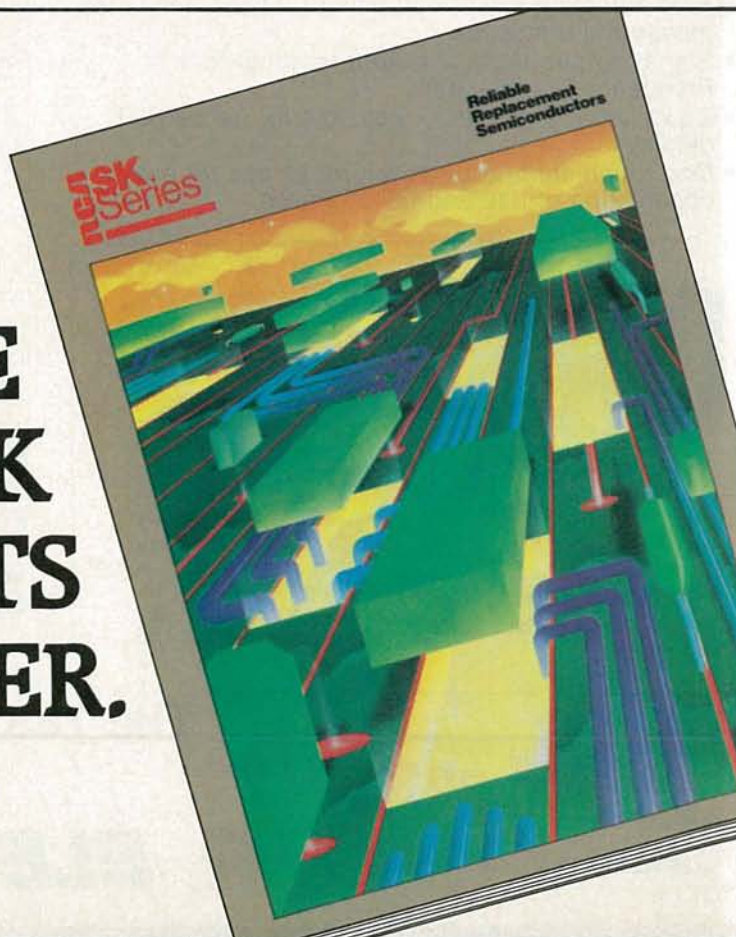

rated at ± 1 count, \pm timebase error, \pm trigger error. The trigger error is typically $\pm 0.3\%$ of the reading, divided by the average number of cycles for signals with a better than 40-dB signal-to-noise ratio and an amplitude greater than 100 mV. The period mode is useful because you can more accurately determine the frequency of low-frequency signals by first measuring the period and then converting that value to its equivalent frequency.

Besides simply measuring the frequency and period of an input signal (as most frequency counters do), the 1822 can work in other modes. In the frequency-ratio mode, the unit compares the frequencies of two input signals and displays their ratio. That's useful, for example, when you want to calibrate a timebase against a frequency standard.

The time-interval mode can be used to read the elapsed time (in microseconds) between two once-only events. The counter can also be used in that mode to make duty-cycle measurements. (Duty cycle is defined as the ratio of ON time to idle or OFF time expressed as a decimal or percentage.) To make that measurement, both probes are connected to the same signal source. Using the SLOPE switches, one channel is set to trigger on the leading or positive-going edge of the signal and the other on the negative edge. The counter

measures the time between those two events and displays to ON time. Now, reverse the triggering so that the first channel triggers on the negative edge and the other channel triggers on the positive edge. The counter now measures the OFF time.

Another useful feature of that counter is its totalize mode. Using the switch labeled TOTAL the unit will count events and display their total. The counting process can be gated either by using the front-panel HOLD and RESET switches, or by using an external gating pulse fed through a jack on the rear panel.

The HOLD switch can be used to freeze (store) the displayed value. That value can be cleared from the display and storage by simply pressing the RESET button. When that button is pressed, the counter is ready to start a new measurement. A self-test function is also provided. When the SELF-TEST button is pressed, the frequency of the internal clock, a 10 MHz crystal-controlled oscillator, is displayed. That clock's stability is rated at 10 ppm (parts-per-million) over a temperature range of from 0°C to 50°C.

The unit is provided with a clearly written instruction manual that contains all the information needed to run the counter in any range or operating mode. The manual also provides full maintenance and

calibration instructions, along with circuit descriptions and parts-placement diagram. There are some extremely handy tables for frequency and period measurements and B&K has also included some time-interval examples and handy circuits for contact debouncing.

There are three available accessories: the PR-45- $\times 10$ probe priced at \$52.20, the PR-37- $\times 10$ direct probe at \$44.75, and the optional TCXO (temperature-compensated crystal-oscillator), available through the manufacturer's service department, at \$130. That TCXO has a temperature stability that's rated at better than .0001% variation (± 1 ppm) from 0°C to 50°C ambient.

All in all, the model 1822 frequency counter (priced at \$450) is quite a handful of test equipment. It should give good service for a long time to come. **R-E**

Heath EE-3202 Digital CMOS Techniques Course

IF THERE'S ONE THING CERTAIN ABOUT electronics it is that you never outgrow

New SK Guide to reliable solid state replacements.

Inside the striking cover of the new SK Guide is all the information you need to make quick, reliable solid state replacements. Over 2,300 RCA SK and KH types replace over 193,000 industry types.

RCA has been designing, manufacturing and testing solid state devices for decades. When RCA introduces new types, they can be expected to perform reliably. So get in the habit of consulting the SK Guide.

When you reach for a solid state replace-

ment, don't reach in a barrel. Reach for reliability . . . RCA SK solid state replacements.

The SK Guide is available from RCA SK Distributors or by mail. Send \$2.75 in check or money order to RCA Distributor and Special Products Division, Box 597, Woodbury, NJ 08096.

RCA SK Replacement
Solid State



CIRCLE 102 ON FREE INFORMATION CARD

Heath		EE-3202									
OVERALL PRICE											
EASE OF USE											
INSTRUCTION MANUAL											
PRICE/VALUE											
		1	2	3	4	5	6	7	8	9	10
		Poor			Fair			Good			Excellent

your need for knowledge. That's true whether you are a hobbyist or an advanced electronics professional. Things are changing so fast that the knowledge you have today can easily be outmoded by the developments of tomorrow.

Look at the changes of the last 15 years and you'll see what we mean. Back then, much of the circuitry we worked with was discrete, consisting of the usual variety of transistors, resistors, capacitors, diodes, and other components. But that has changed drastically. With the advent of large-scale integrated-circuitry techniques, those discrete components have been replaced by a variety of IC's, all handling the same functions and more. Even such things as simple transistor

switching circuits are now available in IC form.

One of the most exciting developments of this period has been the introduction of CMOS (Complementary Metal-Oxide-Semiconductor) technology. That low-power-consumption logic family allows you to do things that just can't be done with other types of IC logic. Its flexibility allows you to build devices that incorporate analog switching, oscillators, pulse shapers, phase-locked loops, and more. But, what's even better, its low power consumption and its virtual immunity to noise make its use very attractive in a wide range of applications.

But there is a drawback with CMOS. Because of its sensitivity to high voltages,

including static electricity, it requires some special handling.

All that leads us to one question: How does one learn more about CMOS technology and how to use it? One excellent way is through another of the excellent Heath (Benton Harbor, MI 49022) Educational Systems Courses. This one is their \$79.95 CMOS Digital Techniques Course (EE-3202), and it is a good one. As usual, this course is complete in itself, but it does fit neatly into the overall Heath Educational Systems series of continuing-education courses. Heath does, however, urge anyone considering the course to be sure they have a knowledge of the material covered by their Digital Techniques course (EE-3201) first.

The key to this course is learning-by-doing. While we were completing it, we found many hands-on experiments dealing with CMOS technology, and, in truth, we found the hands-on portions more instructive than the well-written course material. In fact, much of the written material seems to act only as a backup to the hands-on portion.

As usual, Heath provides you with all the components you will need to complete the varied experiments in the course, including many 74C00 series CMOS devices, as well as all the capacitors, resistors and other devices needed.

QUALITY COMPONENTS - NOT MAIL ORDER "SECONDS"

Send SASE for FREE Flyer or send \$1.00 postage and handling for FREE COMPLETE CATALOG which includes coupon for \$1.00 OFF purchase.

ARIES ZERO INSERTION FORCE SOCKETS



cam actuated, true zero insertion - tin plated solder tail pins - capable of being plugged into dip sockets, including wire wrap.

Stock No.	No. Pins	1-9	10-49	50
11055	24	4.98	4.35	4.30
11056	28	5.15	4.50	4.95
11057	40	6.81	5.95	5.35
11058	64	12.02	10.50	9.45

IC-KOOLERS from UNITRACK[®] dissipate over 2 watts of heat from IC's producing longer life and better performance. Just push IC-Kooler on - heat is collected from top and bottom of IC and dissipated. Won't shake loose!

Stock No.	No. Pins In IC	Price
22225	14	\$.29
22226	16	\$.29
22228	18-20	\$.29

MIC 6000Z DIGITAL MULTIMETER
Single rotary switch operation. Large, easy to read 5^{1/2}-digit display. 800 hours operating life with single 9v battery. Seven functions - DC Volts, DC Amps, Ohms, AC Volts, AC Amps, Diode and Resistor Junction. Audible Continuity Check.

Stock No. 62503 \$75.00
Full 1 year warranty

Stock No. Carry-over with \$2504 belt loop \$10.00

TI WIRE WRAP SOCKETS

Tin plated phosphor bronze contact - 3 wrap

Stock No.	No. Pins	1-99	499	500
11301	8	\$.40	\$.36	\$.30
11302	14	.59	.54	.45
11303	16	.64	.58	.48
11304	18	.73	.66	.55
11305	20	.99	.90	.75
11306	22	1.12	1.02	.85
11307	24	1.25	1.14	.95
11308	28	1.52	1.38	1.15
11309	40	2.05	1.86	1.55

TI LOW PROFILE SOCKETS

Tin plated copper alloy 688 contact pins with gas tight seal.

Stock No.	No. Pins	1-24	25-99	999
11201	8	\$ 1.0	\$.09	\$.08
11202	14	.14	.13	.12
11203	16	.16	.15	.14
11204	18	.18	.17	.15
11205	20	.20	.18	.16
11206	22	.22	.20	.18
11207	24	.24	.22	.20
11208	28	.28	.26	.25
11209	40	.40	.37	.33

WILD ROVER Touch switch capsule. Operating motion is 005" without the use of a levered arm. Extremely fast on and off with low noise. Normally operated 115 VAC, 1.6 amp-30 milliohm resistance - .615 radius by .160 thick.

Stock No.	1-9	10 & Up
12098	\$ 1.42	\$ 1.28

60/40 ROSIN CORE SOLDER

Stock No.	Dia (feet)	Length (oz)	Price
50075	.062	9	1.16
50076	.062	25	4
50077	.062	50	8
50078	.032	33	1.5
50079	.032	88.5	4
50080	.032	175	8

EKI KITS come with all parts necessary to assemble!

- Stock No. 88844 TV Jammer Kit "wipes out" your TV screen... \$ 7.71
- Stock No. 88850 Whooper Alarm Kit makes a great alarm or siren... \$11.33

MANY, MANY MORE KITS AVAILABLE IN FULL LINE CATALOG

ELPAC POWER SUPPLIES - DC/DC CONVERTERS

SINTEC Stock No.	ELPAC No.	Input Voltage (VDC)	Output Voltage (VDC)	Output Current (mA)	Dimensions (HxWxD) in inches	Price
13825	CB3801	3.0-7.0	12±0.6	0-25	48x.51x3.05	\$ 7.95
13826	CB3811	3.0-7.0	-12±0.6	0-25	48x.51x3.05	7.95
13827	CB3802	3.0-7.0	15±0.7	0-20	48x.51x3.05	7.95
13828	CB3812	3.0-7.0	-15±0.7	0-20	48x.51x3.05	7.95
13829	CB3804	4.0-7.0	28±0.7	0-10	48x.51x3.05	7.95
13830	CB3814	4.0-7.0	-28±0.7	0-10	48x.51x3.05	7.95
13831	CL3801	4.0-7.0	12±0.6	125	651x1.2x1.77	\$24.95
13832	CL3811	4.0-7.0	-12±0.6	125	651x1.2x1.77	24.95
13833	CL3802	4.0-7.0	15±0.7	100	651x1.2x1.77	24.95
13834	CL3812	4.0-7.0	-15±0.7	100	651x1.2x1.77	24.95
13835	CL3804	4.0-7.0	28±1.4	50	651x1.2x1.77	24.95
13836	CL3814	4.0-7.0	-28±1.4	50	651x1.2x1.77	24.95
13825-1	DATA SHEET FOR DC/DC CONVERTERS..... 25					

Special of the Month!

MODUTEC BATTERY TESTER
Tests all batteries ranging from 1.35V to 4.5V.

Controls:
3-position switch provides ranges: 1.35-1.5V; 2.7-3.0V; 4.05-4.5V. Durable, pocket size, self-contained. Test leads are permanently attached.

Stock No. 13733 \$6.95!

OPCOA Single Digit Displays - Common Cathode

Stock No.	Color	1	100
12082	Red	\$1.12	\$.99
12085	Green	1.84	1.63
12087	Yellow	1.92	1.70
12089	Orange	2.08	1.84

Right Angle Socket for Above Displays

Stock No.	1	100
11010	\$1.24	\$.99

The Battery Just Wrap[™] Tool
New battery powered tool wraps insulated wire around .025" square posts without need for pre-cutting and pre-stripping. Complete with bit and 100 ft. 30 AWG wire.

Stock No.	Description	Price
13340	Battery just-wrap tool with bit and 100 ft. 30 AWG wire	\$49.95
13341	Replacement bit	9.95
13342	100 ft. blue replacement wire	6.95
13343	100 ft. white replacement wire	6.95
13344	100 ft. yellow replacement wire	6.95
13345	100 ft. red replacement wire	6.95

MINI-DRILL This portable hand drill is appropriate for circuit board drilling. Runs at 2500 RPM on 4 "AA" batteries (not included). Supplied with one .039 dia. drill bit. Drill stand is designed like a drill press for precise hole drilling.

Stock No.	Description	Price
13346	Hand drill with .039 dia. bit (no batteries)	\$24.95
13347	Replacement bits 2 each of .040 and .060 dia.	5.95
13348	Drill stand	13.95

PIN FORMING TOOL
puts IC's on their true row to row spacing. One side is for 300 centers. Flip tool over for devices on .600 centers. Put device in tool and squeeze.

NEW! ANTI-STATIC MODEL Stock No. 10200 \$14.95

ONE TOOL DOES 8 THRU 40 PINS! Stock No. 11059 \$12.95

OPTEL LCD's with pins

Stock No.	Description	1	10
47005	3 1/2 dig. 5"	\$ 5.95	\$ 5.50
47006	4 dig. 5"	5.95	5.50
47007	4 dig. 7"	11.90	11.00

OK MACHINE AND TOOL

IC INSERTION/EXTRACTION KIT
Includes DIP IC extractors and inserters to accommodate all IC's from 14 to 40 pins. Tools that engage conductive surfaces are CMOS safe and include grounding lugs. Stock No. 13309 \$37.74

SOCKET WRAP ID

Stock No.	Description	Price
13295	14 pin	13.99
13296	16 pin	16.99
13297	18 pin	18.99
13298	20 pin	20.99
13299	22 pin	22.99
13300	24 pin	24.99
13301	28 pin	28.99
13302	40 pin	40.99
13303	96 pin	96.99

\$1.82 per pack

IC EXTRACTOR
One-piece, spring steel construction. Will extract all LSI, MSI and SSL devices with 8 to 24 pins. Stock No. 13313 \$2.10

SINTEC 28 8th St., Box 410 Frenchtown, NJ 08825

VISA MasterCard

TOLL 800-526-5960
FREE in NJ (201) 996-4093

We accept VISA, MC, C.O.D., CHECK, or M.O. *INCLUDE SHIPPING CHARGES - 0 to \$100 - \$3.00 \$100 to \$250 - \$4.00 over \$250 - \$5.00



NEW Tech VOM WV-547C

Drop-proof. Fuse protected.
High impact ABS plastic case.

Rugged,
accurate taut-band meter.

Sensitivity
20,000 ohms-per volt DC
9,000 ohms-per volt AC

21 color coded ranges.

Snap action,
dual detent range switch.

Temperature scale
(optional accessory)

User oriented
"right angle" test leads.

For \$35.⁵⁰ Here's your best VOM value.



It's compact, drop-proof (3 feet) and provides 21 color-coded ranges—volts, milliamps, ohms, temperature scale and decibels. True quality instrument for your portable applications. Tough, accurate, taut-band meter, fuse-protected. Sensitivity 20,000 ohms/volt DC. High-impact case, colored bright orange. Snap action, dual-detent range switch. Range limits: 1000V DC and AC, 250 mA DC, one megohm, +200°C. Battery Test provision. Meter OFF position. Temperature scale (special probe optional).

WV-547D. Same instrument in impact-resistant carrying case. Handle converts to tilt stand.

\$39.95

Want full technical details and a demonstration? Call toll-free, 1-800-523-3696, for the VIZ distributor near you.

VIZ

**Look to VIZ for value, quality, availability.
Over 70 instruments in the line—PLUS full accessories.**

VIZ Mfg. Co., 335 E. Price St., Philadelphia, PA 19144

CIRCLE 91 ON FREE INFORMATION CARD

What's covered

As to the course material itself, just about every aspect of CMOS digital technology that you might need to know is covered in seven units. For instance, Unit One discusses CMOS basics and summarizes them. It then moves on through CMOS logic gates and how the devices are packaged. It also discusses CMOS characteristics including such things as input protection, propagation delay, and power-supply requirements.

Unit Two takes that basic knowledge, which is also tested during the chapter by

two programmed review tests, and applies it to interfacing considerations, such as logic levels, output drive, and fan-out. Interfacing techniques for various types of logic systems, including TTL and ECL, as well as such devices as operational amplifiers, LED's, and optocouplers are discussed.

Taking that knowledge even further, Unit Three goes into CMOS logic, including basic logic gates, and discusses logic-gate topics including state definitions, the one-input logic gate, the two-input logic gate, and the use of logic gates as switches. It then goes through the vari-

ous types of gates—AND, NAND, OR, NOR, EXCLUSIVE OR and EXCLUSIVE NOR as well as other two-input gates and then discusses gates with more than two inputs. From there it goes on to DeMorgan's equivalence, transmission-gate logic, and three-state logic. The unit concludes with a discussion of advanced logic techniques including data-selector logic, read-only memories, programmable logic arrays, and microprocessors.

Unit Four takes the knowledge you have acquired in the previous three units and applies them to CMOS multivibrators. It discusses direct-logic circuits, bistable circuits, astable circuits, crystal oscillators, voltage-controlled oscillators, monostable circuits, and duty-cycle integrators. It also presents some application guidelines and then moves through clocked-logic circuits and master-slave flip-flop applications.

Building on that knowledge, Unit Five discusses counters and registers, including CMOS counters, counter applications, and shift registers.

Unit Six discusses some practical applications of CMOS analog devices and includes a discussion of operational amplifiers and their uses, as well as their limitations. Also covered is using CMOS analog-switches in such applications as sample-and-hold circuits, tracking filters, microprocessor data-entry, and as video combiners. It also discusses the CMOS phase-locked loop and how it can be used as a low-frequency counter, digital tachometer, or a frequency synthesizer.

All the knowledge you accumulate in the previous units is applied to advanced CMOS applications in Unit Seven. That unit goes into using CMOS information processing circuits, such as analog-to-digital and digital-to-analog, sample-and-hold, and peak-detector circuits; frequency modulation and demodulation, and multiplexing and demultiplexing. It also discusses commutating filters and then moves onto various CMOS projects, including a code-practice radio transmitter, a camera shutter delayed-release timer, a capacitance meter, a multichannel adapter for single-trace oscilloscopes, and a CMOS electronic watch circuit.

One thing you must note about the course is that you need certain items to complete it successfully, including the ET-3200B breadboard/trainer, an oscilloscope, and a digital multimeter. Now, if you have a well-equipped bench available, it should be no problem. But if you are just equipping yourself for this course, you will find the cost of the course rising significantly above the \$79.95 price. The breadboard/trainer alone costs \$99.95 and a good, inexpensive oscilloscope can cost \$300, or more. Still, those items are things that any workbench should have, and once they are purchased they are yours to use for many years to come. **R-E**

COMPUTER PAPERBACK BOOKS

Great Books For The Computer Hobbyist

CHECK OFF THE BOOKS YOU WANT

PROGRAMMING THE ZX SPECTRUM...\$7.50. Make this color computer do its stuff. With this book in hand, it's easy.

BEGINNERS' GUIDE TO DIGITAL TECHNIQUES...\$3.75. A guide to the essential areas of number systems, codes, logic, and analog/digital conversion.

Digital IC Projects

DIGITAL IC PROJECTS...\$5.00. Simple & more advanced projects intended to help develop a knowledge of digital circuits.

THE PRE-COMPUTER BOOK...\$5.00. Aimed at the beginner with no knowledge of computing. An entirely non-technical discussion.

BEGINNERS' GUIDE TO MICRO-PROCESSORS & COMPUTERS...\$4.50. An introduction to the basic theory and concepts of binary arithmetic, microprocessor operation & machine-language programming.

An Introduction to BASIC Programming Techniques

AN INTRODUCTION TO BASIC PROGRAMMING TECHNIQUES...\$5.00. Based on the author's own experience in learning Basic & helping others to learn to program & understand the language.

20 Programs for the ZX Spectrum & 16K ZX81...\$5.00. Included with each program is a detail flow chart for both games and practical applications in filing, statistics and engineering.

A MICRO-PROCESSOR PRIMER...\$4.50. We start by designing a small computer, and look at how the microprocessor plays its role in making the unit work effectively.

THE 6809 COMPANION...\$5.00. Discusses the features of the 6809 and a reference work for 6809 programmers.

THE ART OF PROGRAMMING THE 16K ZX81

THE ART OF PROGRAMMING THE 16K ZX81...\$6.25. What happens when you add the RAM pak. Scrolling, PEEK, POKE, Page graphics and more.

Elements of Electronics, Vol. 4—Microprocessing Systems & Circuits...\$7.50. Comprehensive guide to the elements of microprocessing systems. An economical & interesting initiation into the world of microprocessors.

THE ART OF PROGRAMMING THE 16K ZX81

THE ART OF PROGRAMMING THE 16K ZX81...\$5.00. Shows how to use the features of the ZX81 in programs that fit into the 1K machine and are still fun to use.

EASY ADD-ON PROJECTS FOR SPECTRUM, ZX81, & ACE...\$6.50. Pulse detector, picture digitizer, 5-key pad, model controller, light pen and more.

Practical Computer Experiments

PRACTICAL COMPUTER EXPERIMENTS...\$4.50. Fills in the background to the microprocessor by constructing typical computer circuits in discrete logic.

A Z-80 WORKSHOP MANUAL...\$6.95. Describes typical machine-code instructions followed by a detailed description of the Z-80 instruction set. Assembly-language programming is also covered.

20 Programs for the ZX Spectrum & 16K ZX81...\$5.00. All were written for the Spectrum and ZX 81, but most will run on any computer with a good Basic interpreter and at least 5K of RAM.

BASIC & PASCAL IN PARALLEL...\$4.25. Develops programs in both languages simultaneously. Sample programs illustrate structure.

An Introduction to Programming the ORIC-1

AN INTRODUCTION TO PROGRAMMING THE ORIC-1...\$5.00. A new authoritative manual for owners of this new personal computer.

PRICES GOOD UNTIL MARCH 31, 1984

ELECTRONIC TECHNOLOGY TODAY INC. 384
P.O. Box 240, Massapequa Park, NY 11762-0240

Number of books ordered

Total Price of Books _____

Sales Tax (NY State Residents only) _____

Shipping and Handling (75¢ 1 or 2 books 30¢ each addl. book) _____

TOTAL ENCLOSED _____

Name _____

Address _____

City _____ State _____ Zip _____

NEW! The first complete line of telephone testers designed for the phones you service.

From B&K-PRECISION, the Test Instruments Group of Dynascan Corporation...
makers of Cobra Telephone products.

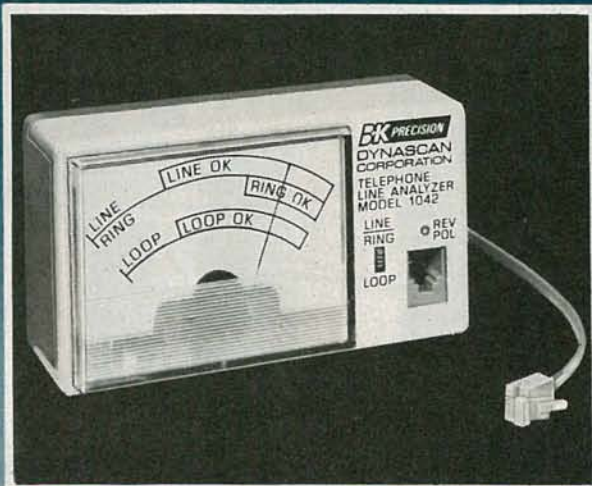

For quick line checks



For comprehensive performance tests

the telephone line analyzer

Allows you to quickly determine if the problem is in the phone itself or in the phone company lines. Tests for telephone line and ringing circuit operation and for defects in the telephone line cord. Small, compact, fast and easy to use. No external power required. No batteries to replace. Blister packed for quick merchandising; the Model 1042 sells itself at a suggested retail price of **\$19.95**

the telephone product tester

An in-shop or in-store tester that can be a profit source when you charge for telephone testing. A great way to instantly check-out customer returns. Tests corded and cordless phone operation and automatic phone dialers for all basic functions; defects in line and hand set cords, tone or pulse dial operation, ringing circuit operation, sound volume and voice quality. Can also be used by non-technical personnel to screen returns before giving them to repair technicians. Statistics show that over half the returns are good. Model 1045 - **\$395**

FOR MORE COMPLETE TESTING

Coming soon!

The Model 1047 cordless telephone tester allows full radio frequency testing and alignment of base and portable units of cordless phones, without expensive signal generators and deviation meters.

Coming soon!

The Model 1050 telephone analyzer combines the features of the 1045 and 1047 for full analyzing and servicing of corded and cordless phones, answering machines and automatic dialers.

Don't miss out on this expanding new service market!
LEARN MORE AT YOUR LOCAL B&K-PRECISION DISTRIBUTOR

B&K PRECISION DYNASCAN CORPORATION

6460 West Cortland Street • Chicago, Illinois 60635 • 312/889-9087

International Sales, 6460 W. Cortland St., Chicago, IL 60635

Canadian Sales, Atlas Electronics, Ontario

South and Central American Sales, Empire Exporters, Plainview, NY 11803

Professional Books That Help You Get Ahead—And Stay Ahead!

Join the **Electronics and Control Engineers' Book Club**® and...

- Keep up with current technology
- Sharpen your professional skills
- Be ready for new career opportunities
- Boost your earning power

THE MCGRAW-HILL COMPUTER HANDBOOK: Applications, Concepts, Hardware, Software. Edited by H. Helms. 992 pp., 475 illus. Everything you need to know about today's computer science and engineering is here in this massive treasure trove of information. Covers everything from Boolean algebra to hardware selection techniques to artificial intelligence. A handy reference work that brings you right up to the minute!
279/721 Pub. Pr., \$79.50 Club Pr., \$49.95

INTUITIVE IC ELECTRONICS: A Sophisticated Primer for Engineers and Technicians. By T. M. Frederiksen. 208 pp., illus. Covering both the simplest and the most complicated IC designs, this lively, easy-to-read volume provides a sophisticated, nonmathematical explanation of the basic internal mechanisms common to all semiconductor devices.
219/230 Pub. Pr., \$19.95 Club Pr., \$15.50

SIGNALS AND SYSTEMS. By A. Oppenheim, A. Willsky, and I. Young. 869 pp., more than 350 illus. Presenting a comprehensive discussion of methods for analyzing discrete-time systems, this book thoroughly integrates discrete- and continuous-time concepts, covers underlying theories, and explores real-world applications. Includes a look at feedback, convolution, and other concepts not treated in depth elsewhere.
582674-7 Pub. Pr., \$32.50 Club Pr., \$25.95

RADIO HANDBOOK, 22/e. By W. Orr. 1,136 pp., more than 1,300 illus. Here's the latest edition of what is universally regarded as the most useful reference in the industry. It's a "course" in communications, a fact-packed reference, and a how-to guide—all in a single book!
582442-6 Pub. Pr., \$39.95 Club Pr., \$33.95

MICROPROCESSOR APPLICATIONS HANDBOOK. Editor-in-Chief, D. F. Stout. 472 pp., 284 illus. At last—a reference guide to microprocessor applications to help you make your systems timely, versatile, and cost-effective.
617/988 Pub. Pr., \$39.95 Club Pr., \$31.45

MICROPROCESSOR AND MICRO-COMPUTER DATA DIGEST. By W. H. Buchsbaum and G. Weissenberg. 336 pp., 93 block diagrams, 106 pin configurations. If you work with electronic devices that use microprocessor or microcomputer integrated circuits, this much-needed book contains all the detailed technical data for every microprocessor IC that is currently listed as a "standard," off-the-shelf item.
582835-9 Pub. Pr., \$29.95 Club Pr., \$22.50

VLSI SYSTEM DESIGN: When and How to Design Very-Large-Scale Integrated Circuits. By S. Muroga. 496 pp., illus., includes self-test problems. This book provides a straight-forward explanation of how to design the integrated circuit chips that are causing this electronics revolution. It focuses on every significant aspect of LSI/VLSI system design.
582823-5 Pub. Pr., \$34.95 Club Pr., \$26.50

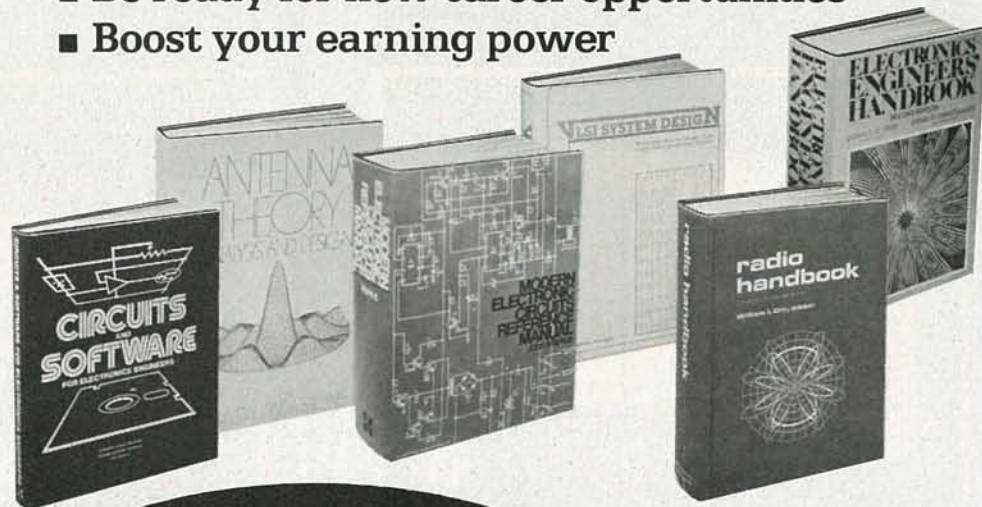

New members!
Any one of these great professional books for only **\$2⁸⁹** as a premium with your 1st selection!

Spectacular values up to **\$82.50**

INTRODUCTION TO RADAR SYSTEMS, 2/e. By M. I. Skolnik. 698 pp., 244 illus. This new edition of a widely used text on radar from the systems engineer's point of view brings you full discussions of the many major changes that have occurred in the field recently.
579/091 Pub. Pr., \$40.95 Club Pr., \$31.00

CIRCUITS AND SOFTWARE FOR ELECTRONICS ENGINEERS. By H. Bierman. 352 pp., 200 illus., outsized 8½ x 11 format. This collection of over 340 proven—reliable circuits, computer programs, test methods, and design tools have been selected because of the ingenious ways they adapt devices to other uses.
052/433 Pub. Pr., \$35.00 Club Pr., \$27.95

ANTENNA THEORY: Analysis and Design. By C. A. Balanis. 816 pp., illus. Packed with equations, design procedures, and plenty of nuts-and-bolts know-how, this is the first place to turn for answers.
582493-0 Pub. Pr., \$41.95 Club Pr., \$31.95

HANDBOOK OF ELECTRIC POWER CALCULATIONS. Edited by A. Seidman, H. Mahrous and T. G. Hicks. 448 pp., 300 illus. Here are 285 tested and proven procedures for handling the electric power problems most frequently encountered in actual practice. You'll find ingenious, time-saving ways to calculate fuel costs, motor efficiency, and power output.
560/617 Pub. Pr., \$39.50 Club Pr., \$29.95

DIGITAL COMMUNICATIONS. By J. G. Proakis. 624 pp., illus. Two features make this reference and guide a real standout: (1) minimal math is required to understand it, and (2) it contains a wealth of never-before-published material, including information about spread spectrum signals.
509/271 Pub. Pr., \$37.50 Club Pr., \$29.50

MODERN ELECTRONIC CIRCUITS REFERENCE MANUAL. By J. Markus. 1,264 pp., 3,666 circuit diagrams. Complete with values of components and suggestions for revisions—plus the original source of each circuit in case you want additional performance or construction details.
404/461 Pub. Pr., \$74.95 Club Pr., \$57.95

ELECTRONIC COMMUNICATIONS SYSTEMS. By W. D. Stanley. 566 pp., illus. Emphasizing the signal-processing functions of modulation and demodulation operation, this book presents the essentials of electronic communications in a logical, step-by-step sequence.
582834-0 Pub. Pr., \$24.95 Club Pr., \$19.95

ANALYSIS AND DESIGN OF DIGITAL INTEGRATED CIRCUITS. By D. A. Hodges and H. G. Jackson. 448 pp., illus. One of the most comprehensive books in this field, this is a valuable working tool for those who design ICs as well as those who use them. It is the only book now available that covers its subject from a quantitative viewpoint.
291/535 Pub. Pr., \$29.50 Club Pr., \$23.95

PCM AND DIGITAL TRANSMISSION SYSTEMS. By R. Owen. 320 pp., 186 illus. A highly useful volume that allows newcomers to the field to familiarize themselves with its problems and equipment in two weeks—instead of the three months it would ordinarily take.
479/542 Pub. Pr., \$34.95 Club Pr., \$25.95

ELECTRONICS ENGINEERS' HANDBOOK, 2/e. Edited by D. G. Fink & D. Christiansen. 2,272 pp., 2,189 illus. This updated and enlarged edition covers all the latest knowledge in the field, including new advances in integrated circuits, pulsed and logic circuits, laser technology, telecommunications, and much more.
209/812 Pub. Pr., \$79.90 Club Pr., \$57.50

DIGITAL CIRCUITS AND MICRO-PROCESSORS. By H. Taub. 608 pp., heavily illus. This fast-paced, carefully written guide gives you thorough explanations of all the basic principles of digital systems and logic design—plus a solid introduction to microprocessors and microprocessor-based designs.
629/455 Pub. Pr., \$33.95 Club Pr., \$25.50

HANDBOOK OF PRACTICAL ELECTRICAL DESIGN. By J. F. McPartland. 416 pp., 300 illus. This volume provides a step-by-step explanation of designing electrical systems for industrial, commercial, and residential applications. Packed with helpful tips for saving time and complying with code requirements from branch circuits to wiring size.

456/95X Pub. Pr., \$39.50 Club Pr., \$27.50

DIGITAL LOGIC DESIGN. By B. Holdsworth. 338 pp., 192 illus. All of the recent advances in digital design techniques are presented here in depth. It's both a text covering basic concepts and a practical guide to design techniques for combinational, clock-driven, and event-driven circuits.

582852-9 Pub. Pr., \$39.95 Club Pr., \$27.50

OPTICAL FIBER SYSTEMS: Technology, Design, and Applications. By C. K. Kao. 197 pp., illus. From a basic explanation of optical fiber systems to the economic ramifications of their use, this volume provides full coverage of a rapidly changing field.

332/770 Pub. Pr., \$29.50 Club Pr., \$23.95

ELECTRONICS ENGINEERING FOR PROFESSIONAL ENGINEERS' EXAMINATIONS. By C. R. Hafer. 336 pp., more than 200 illus. Actually two books in one—a quick preparation manual to help you pass your P.E. exams on the first try and a rich source of practical electronics engineering information and know-how.

254/303 Pub. Pr., \$29.95 Club Pr., \$21.50

ELECTRONIC COMMUNICATION, 4/e. By R. L. Shrader. 801 pp., 870 illus. This thoroughly updated edition offers all the theory and fundamentals you need to prepare yourself for the FCC commercial and amateur grade license examinations—and pass them the first time!

571/503 Pub. Pr., \$28.50 Club Pr., \$20.95

STANDARD HANDBOOK FOR ELECTRICAL ENGINEERS, 11/e. By D. G. Fink and H. Beaty. 2,448 pp., 1,414 illus. Today's most widely used source of electrical engineering information and data serves you as no other single work when you need detailed, timely, and reliable facts.

209/74X Pub. Pr., \$74.95 Club Pr., \$53.95

INTEGRATED CIRCUITS APPLICATIONS HANDBOOK. By A. H. Seidman. 673 pp., illus. This Handbook presents information on everything from TTL, ECL, MOS, and CMOS logic families to semiconductor and bubble memories. The emphasis is on applications, with a minimum of theory. The math used is essentially limited to simple arithmetic and elementary algebra.

582860-X Pub. Pr., \$39.95 Club Pr., \$29.95

Be sure to consider these important titles as well!

LARGE SCALE INTEGRATION: Devices, Circuits, and Systems. By M. J. Howes & D. V. Morgan. 582851-0 Pub. Pr., \$35.95 Club Pr., \$29.95

MICROWAVE SEMICONDUCTOR ENGINEERING. By J. F. White. 582553-8 Pub. Pr., \$28.50 Club Pr., \$23.50

MICROPROCESSOR SUPPORT CHIPS: Theory, Design, and Applications. By T. J. Byers. 095/183 Pub. Pr., \$39.50 Club Pr., \$31.00

ENGINEERING FORMULAS, 4/e. By K. Gieck. 232/199 Pub. Pr., \$16.95 Club Pr., \$13.50

DIGITAL HARDWARE DESIGN. By J. B. Peatman. 491/321 Pub. Pr., \$35.50 Club Pr., \$27.50

ELECTRONICS DESIGNERS' HANDBOOK, 2/e. By L. J. Giacoletto & R. Landee. 231/494 Pub. Pr., \$82.50 Club Pr., \$59.95

HANDBOOK OF OPERATIONAL AMPLIFIER CIRCUIT DESIGN. By D. E. Stout & M. Kaufman. 617/97X Pub. Pr., \$39.50 Club Pr., \$29.00

ENGINEERING MATHEMATICS HANDBOOK, 2/e. By J. J. Tuma. 654/298 Pub. Pr., \$34.50 Club Pr., \$28.95

MICROELECTRONICS. By J. Millman. 423/27X Pub. Pr., \$38.50 Club Pr., \$27.50

INTRODUCTION TO THE THEORY AND DESIGN OF ACTIVE FILTERS. By L. P. Huelsman & P. E. Allen. 308/543 Pub. Pr., \$35.50 Club Pr., \$27.00

ELECTRONICS CIRCUITS NOTEBOOK. Edited by S. Weber. 192/448 Pub. Pr., \$35.50 Club Pr., \$27.50

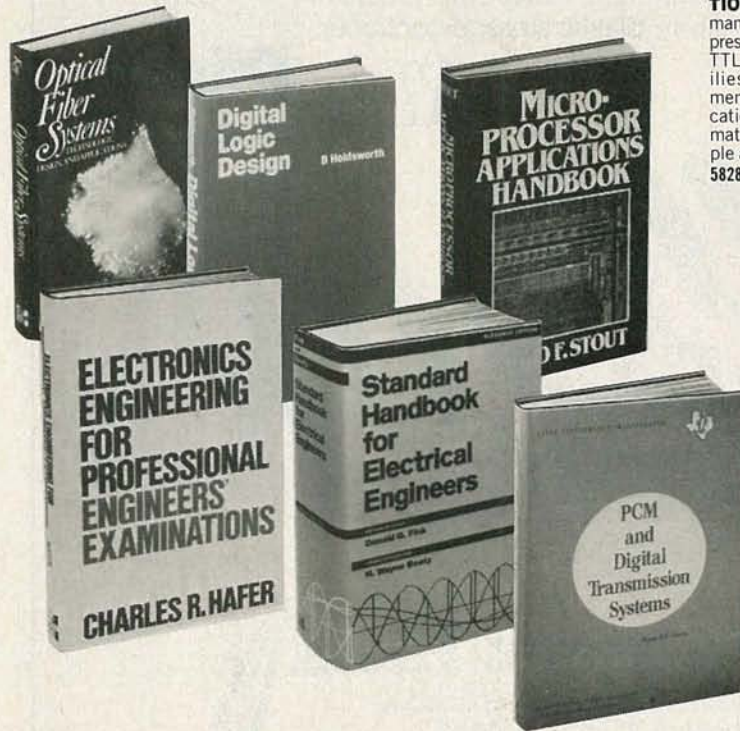

Why YOU should join now!

■ **BEST AND NEWEST BOOKS IN YOUR FIELD** — Books are selected from a wide range of publishers by expert editors and consultants to give you continuing access to the best and latest books in your field.

■ **BIG SAVINGS** — Build your library and save money too! Savings ranging up to 30% or more off publishers' list prices — usually 20% to 25%.

BONUS BOOKS — You will immediately begin to participate in our Bonus Book Plan that allows you savings up to 70% off the publishers' prices of many professional and general interest books!

■ **CONVENIENCE** — 12-14 times a year (about once every 3-4 weeks) you receive the Club Bulletin FREE. It fully describes the Main Selection and Alternate Selections. A dated Reply Card is included. If you want the Main Selection, you simply do nothing — it will be shipped automatically. If you want an Alternate Selection — or no book at all — you simply indicate it on the Reply Card and return it by the date specified. You will have at least 10 days to decide. If, because of late delivery of the Bulletin you receive a Main Selection you do not want, you may return it for credit at the Club's expense.

As a Club member you agree only to the purchase of three books (including your first selection) during your first year of membership. Membership may be discontinued by either you or the Club at any time after you have purchased the first selection plus two additional books.

Other McGraw-Hill Book Clubs:
Architects' Book Club • Byte Book Club • Chemical Engineers' Book Club
• Civil Engineers' Book Club • Mechanical Engineers' Book Club

For more information, write to:

McGraw-Hill Book Clubs, P.O. Box 582, Hightstown, New Jersey 08520

MAIL THIS COUPON TODAY

McGraw-Hill Book Clubs
Electronics and Control Engineers'
Book Club®
P.O. Box 582, Hightstown, New Jersey 08520

Please enroll me as a member and send me the two books indicated, billing me for the \$2.89 premium and my first selection at the discounted member's price, plus local tax, shipping, and handling charges. I agree to purchase a minimum of two additional books during my first year of membership as outlined under the Club plan described in this ad. A shipping and handling charge is added to all shipments.

Write Code No. of
\$2.89 selection here

Write Code No. of
first selection here

Signature _____

Name _____

Address/Apt. # _____

City _____

State _____ Zip _____

This order subject to acceptance by McGraw-Hill. All prices subject to change without notice. Offer good only to new members.

E33648

GET A GRIP ON PRECISION WORK.

With Vaco's Ultra Precise™ Pliers.

Vaco's finest quality pliers. Superior design for maximum precision in cutting, bending, forming and assembly work. In 14 of the most popular styles and shapes. Each precision machined of fine alloy steel for long life.

With cutters finely hand-honed to assure perfect alignment. Pliers come packed in handy, plastic storage container.

VACO®

ULTRA PRECISE Pliers

Vaco's finest quality pliers

Very precision longer life

Finely Honed Design
Perfect jaw alignment
Scientifically designed for fatigue-free use
Unconditionally

With Vaco's Professional Pliers.

Today's outstanding value in compact, high-efficiency pliers for delicate precision work. Made of forged steel for exceptional strength. With triple hardened cutting edges, hand-honed and mated. 9 styles cover range of uses from cutting to gripping.

Handy plastic storage container. Write: Vaco Products Co., 1510 Skokie Blvd., Northbrook, IL 60062.

PROFESSIONAL Pliers

High efficiency compact pliers

precision constant durability

Smooth, easy operation
Perfectly aligned jaws
Strong, top quality steel

Unconditionally

VACO® **PRECISION PLIERS**

Builds tools like your job depends on it.™

NEW IDEAS

Light-sensitive timing circuit

MANY LIGHTS AROUND THE HOUSE ARE turned on at sunset and kept on for say three or four hours, and then turned off. Because the same routine is followed almost every day, the lights can be automatically controlled by a light-sensitive circuit combined with a timer. The circuit could be used to turn on not only lamps or security lights; it could also turn on an electric blanket or any other electrical device when the light level falls to a predetermined point. Then, the timer could keep that device turned on for a pre-set time period before it shut it off. Figure 1 shows such a circuit.

How it works

The circuit is powered by a single-ended 12-volt DC supply (not shown) consisting of a 12.6-volt transformer and a 7812 voltage regulator. Though a regulated supply isn't really necessary, it does improve the timer's accuracy. The 741 op-amp is used to form a comparator with *hysteresis* that monitors the outside light level using a photoresistor. That means that the comparator's output goes high only after the input to pin 3 crosses a certain DC value (determined by R2). The feedback applied to pin 3 of the comparator causes the output to remain high until a negative voltage of sufficient quantity to overcome the feedback is applied. Only then will the output change states. Note that there are two switching voltages. In the *dead zone* (the area between the two switching voltages), the output will re-

main in the same state that it was previously set to. In other words, if the output is high, it will remain so as long as the input is in the dead zone.

Resistor R1 and photoresistor SR1 form a voltage divider. R1 should be selected to have the same resistance as SR1 at the light level at which the lamp is to be turned on. The photoresistor should be mounted near a window and shielded from the lamp that it is to control; or it can be mounted in the same enclosure as the other components if the device is to be mounted near a window. As the light level drops, the photoresistor increases in resistance. That increased resistance causes a greater voltage drop across the photoresistor; an equal voltage is applied to the non-inverting input to the comparator through the 120-kilohm resistor. When the voltage at the non-inverting input reaches a level that's about equal to the voltage at the inverting input of the op-amp, its output goes from low to high. The level at which that change occurs is controlled by R2.

When the comparator's output goes high, a pulse is generated through capacitor C1 that triggers the 2240 timer. The timer stays on for a set period that is determined by capacitor C_T (10 μF) and resistor R_T (8.2 megohm). With the component values shown, the timer period is about 3 hours with switch S3 open and about twice as long with it closed.

The timer's output is sent to the inverter, transistor Q1. The output of that transistor, taken from the collector, is used to

turn transistor Q2 on and off. When Q2 is turned on it completes a path to ground through the MOC3010 optocoupler for an internal LED. That LED triggers a triac driver or diac and that, in turn, triggers the triac in the lamp circuit. When the triac is turned on current flows to the lamp.

The LED in series with the optocoupler serves as a pilot light. The LED lights to indicate that the circuit is in operation.

Switch S1 is used to manually start the timer by applying a high input to the timer at pin 11; while, S2 is used to stop its operation by applying a high to the timer's reset at pin 10. Any or all of the switches control are not needed. The optocoupler and triac can be replaced by a relay if desired.—John A. Wert **R-E**

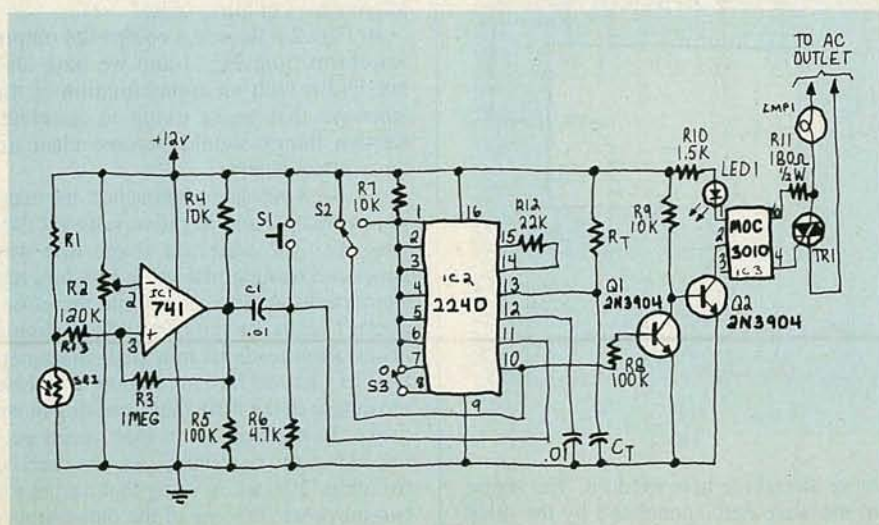

FIG. 1

NEW IDEAS

This column is devoted to new ideas, circuits, device applications, construction techniques, helpful hints, etc.

All published entries, upon publication, will earn \$25. In addition, for U.S. residents only, Panavise will donate their model 333—The Rapid Assembly Circuit Board Holder, having a retail price of \$39.95. It features an eight-position rotating adjustment, indexing at 45-degree increments, and six positive lock positions in the vertical plane, giving you a full ten-inch height adjustment for comfortable working.

I agree to the above terms, and grant **Radio-Electronics** Magazine the right to publish my idea and to subsequently republish my idea in collections or compilations of reprints of similar articles. I declare that the attached idea is my own original material and that its publication does not violate any other copyright. I also declare that this material has not been previously published.

Title of Idea

Signature

Print Name

Date

Street

City

State

Zip

Mail your idea along with this coupon to: **New Ideas Radio-Electronics**, 200 Park Ave. South, New York, NY 10003

THE DRAWING BOARD

Generating sinewaves with the 4018

ROBERT GROSSBLATT

BY THIS TIME WE SHOULD ALL BE FAMILIAR with the unbreakable first rule of electronic design: *Brainwork before board work*. If you can't get it down clearly on paper, you can't design it, much less build it. (I believe that there's some sort of natural law that governs the relationship between the weight of the finished product and the paperwork it generates. If anyone knows what it is, please let us know!) Paperwork always chops mind-boggling design problems down to a manageable size and also lets you concentrate all your energy on specific design problems.

Last month we spent a little time breaking down the problem of using the 4018 to generate sinewaves. Although that's certainly not the most complex problem you'll ever see, it is important to remember that the design approach that you take is as important as the design itself. As a matter of fact, the initial approach will more often than not shape the final product.

Generating sinewaves

Take a look at the output waveforms of the 4018 shown in Fig. 1. It puts the procedure to follow (and the problem it causes) in black and white for us to look at. And it should give you some idea as to how to go about using that IC. As you can see, the 4018 provides phase-shifted outputs that are delayed by exactly one incoming clock pulse. Not only that, but we've already seen that the output duty cycle is nice and square. If we sum the outputs together properly, we can produce a digital waveform that can be filtered to any degree of smoothness desired by the circuitry that's tied to its output.

If the outputs (Q_1 through Q_5) of the 4018 are added together using equal value resistors, we're going to wind up with the very familiar and entirely predictable waveform shown in Fig. 2-a. If you squint your eyes and imagine the waveform to be all smoothed out you'll see that the best that we can hope to get from the circuit in Fig. 2-b is a triangular wave. Obviously, our approach is on the right track but the problem is a little more complex than it first appeared. While, it is evident that we have to add the IC's outputs together, it should also be evident that we have to give

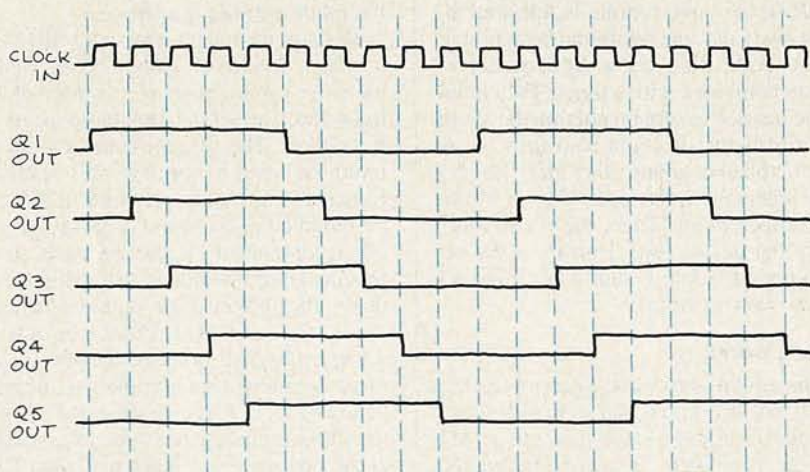

FIG. 1

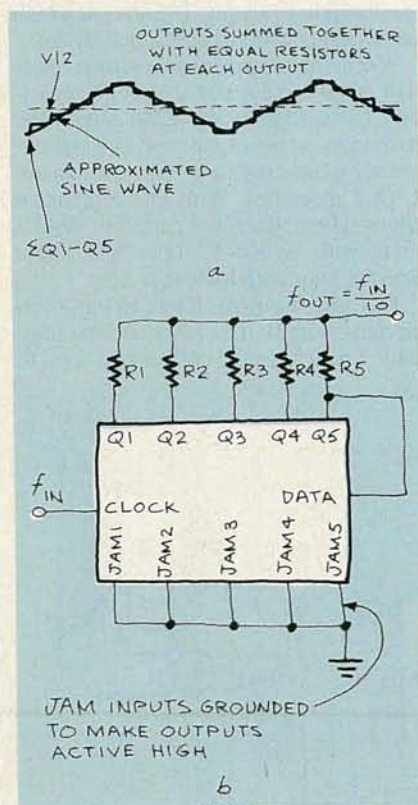

FIG. 2

more thought to how we do it. The shape of the wave that's generated by the 4018 depends on the values chosen for the sum-

ming resistors. Determining the values of those resistors, however, is something else. There's no way to avoid doing some math; but let's see if there's some way to at least cut the required calculations down to a slightly less formidable size. Once again we have some paperwork to do.

Now, as everybody knows, there are lots of different ways to go about solving a problem. Which one you pick depends on the problem, but remember that the idea behind all of them is to cut down the amount of work you have to do. Let's attack our problem with the most basic approach—common sense!

In Fig. 2-a we see a composite output waveform from Fig. 1 and we have also overlaid it with an approximation of the sinewave that we're trying to generate. Certain things should become clear almost immediately.

As the sinewave approaches its maximum positive and negative values it flattens out. The staircase shape that was generated using equal value resistors has sharp peaks at those points and therefore, doesn't really fit the curve. That simple observation leads us to a sledgehammer-type fix. All we have to do now is to lose the output of the 4018 that's causing those peaks. In practical terms that means getting rid of the Q_5 output. As you can see from Fig. 2-b, we're using that output for two purposes: It's one of the data outputs

continued on page 113

The best-looking way to keep your TV performing up to par may be right here before your eyes!

CHROMATENNA^{T.M.}

Antennas



What an eye-ful! All six of these Zenith Chromatenna indoor antennas! So handsome, each in its own way, you'll swear we paid a designer's fee. But we didn't.

Now, look close and picture for yourself how well any one will adapt to your decor and actually add what appears to be a decorator's touch to a room interior.

That's why we refer to these Zenith Chromatenna models as "America's First Family of Indoor Antennas."

We think you, too, will be equally generous with your praises when you price them at your Zenith dealer's.

And chances are any one of these beautiful, top-performing Zenith indoor antennas could be the easiest, fastest, and most reasonably-priced way to keep your TV set performing up to par.

Be sure to see them all at your Zenith dealer's soon - certainly before trying to improve your TV's performance with a no-name indoor antenna!

*The quality goes in before the name goes on.**

The World Famous Simpson 260

over 3,000,000 Sold
and Still the World's
Most Preferred,
Multimeter...
Analog or Digital



**Does Things
That Even the Best Digitals
Are Unable to Do, Including Ours**

(And We Have 16 of the Best!)

- "Instant" continuous null, peak, trend and continuity indications
- High immunity to transients and RF interference
- Does not generate EMI (electromagnetic interference)
- dB ranges at no extra cost
- Highest common mode and normal mode rejection
- Resistance indication from zero to infinity
- Self-powered on all voltage, current and dB ranges—no batteries or AC line connections
- Reliable, accurate performance, even under extreme environments
- Easy, low-cost maintenance — no expensive "chips" to fail
- UL Listed per UL 1244 "Standard for Safety—Electrical and Electronic Measuring and Testing Instruments"
- Plus a complete line of UL Recognized test accessories — test leads, amp-clamps, H.V. probes
- Options include mirrored scale, overload relay protections, ever ready case, roll top carrying case, et al.

The Simpson 260
Family Includes
12 UL Listed VOMs



Simpson

1984 - OUR 50th ANNIVERSARY YEAR

SIMPSON ELECTRIC COMPANY

A Katy Industries, Inc. Subsidiary
853 Dundee Avenue, Elgin, Illinois 60120-3090
(312) 697-2260 • Telex 72-2416 • Cable SIMELCO
IN CANADA: Bach-Simpson, Ltd., London, Ontario
IN ENGLAND: Bach-Simpson (U.K.) Ltd., Wadebridge, Cornwall
IN INDIA: Ruttonsha-Simpson Private, Ltd., Vikhroli, Bombay

And for Those People Who Want a Digital as Well as an Analog VOM... Simpson Has the Largest Line of Hand-Held, Hand Portable and Bench-Portable DMMs

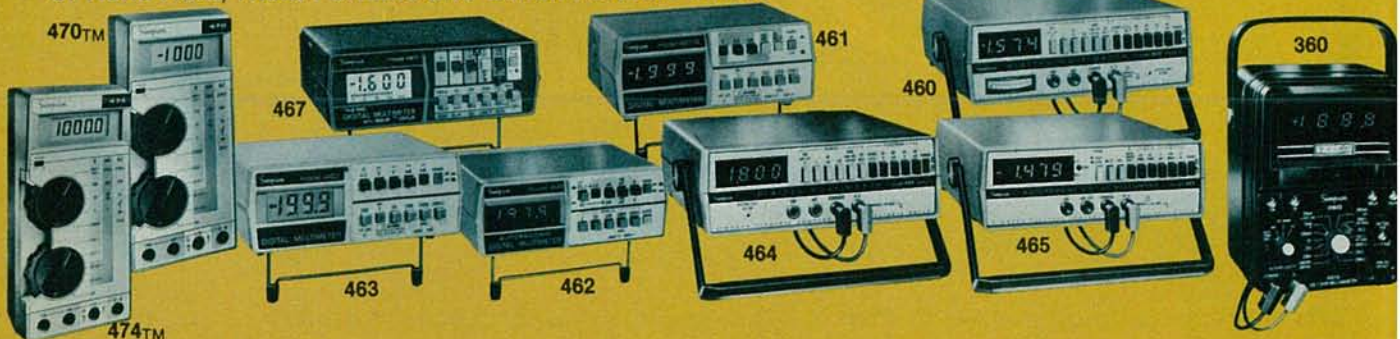

CIRCLE 25 ON FREE INFORMATION CARD

NEW PRODUCTS

For more details use the free information card inside the back cover

WIRE-WRAPPER, model *BJW-3*, is a battery-powered version of the *Just Wrap* tool. A bit compresses insulated wire against the wrap post in such a way that the post edge cuts through the insulation and makes contact with the wire conductor. That allows the user to wrap directly from a wire reel or spool without precutting or prestripping, and makes it possible to wire continuous strings across any number of points with a single, continuous insulated wire. The string may be ended at any point with a built-in cutting mechanism.



CIRCLE 103 ON FREE INFORMATION CARD

The model *BJW-3* is operated by two rechargeable nickel-cadmium batteries (not included). It comes with a bit and sleeve, and a 100-foot spool of 30 AWG wire. Refill spools are available in 100-foot lengths and in four colors: blue, red, white, and yellow.

The model *BJW-3* is priced at \$59.95.—**OK Industries, Inc.**, 3455 Conner Street, Bronx, NY 10475.

DATA-ACQUISITION SYSTEM, model *DT2818*, is a simultaneous sample-and-hold data-acquisition system for the IBM personal computer. It provides simultaneous analog-input and analog-output capabilities, as well as digital I/O and clock functions. With an analog input throughput rate of up to 27,500 samples per second, the model *DT2818* is useful for physiological and speech research, as well as multiparameter materials testing and applications requiring auto- and cross-correlation techniques.

The model *DT2818* combines the utility of multi-channel signal freezing with the flexibility and low cost of personal-computer-controlled data acquisition. Using a 12-bit simultaneous sample and hold analog-to-digital converter system, the user is allowed to take a snapshot of up to four high-level analog-input channels, freezing their values instantaneously (within ± 5 nanoseconds).

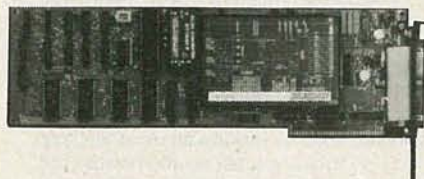

CIRCLE 104 ON FREE INFORMATION CARD

Subsequent analog-to-digital conversions can occur at up to 27,500 samples per second.

An accessory available for use with the model *DT2818* is the model *DT707* screw terminal panel with integral cable. The model *DT707* provides an easy connection scheme, via screw terminals, for all analog and digital signals.

The single unit price for the model *DT2818* is \$1585.00. The model *DT707* is priced at \$149.00. The model *DT2818* is shipped complete with a comprehensive user manual, which includes example BASIC programs.—**Data Translation**, 100 Locke Drive, Marlboro, MA 01752.

RECHARGEABLE SPRAY CAN, the *Jenni Can* can be pressurized to about 50 psi with a bicycle pump, footpump, or service station airline. It is useful in the garage, workshop and in engineering jobs, delivering lubricants, rust inhibitors, cleaning solvents, penetrating oil, and de-icer. In electronics, it is useful to



CIRCLE 105 ON FREE INFORMATION CARD

apply contact cleaner, light lubricants, and for dust blowing. The *Jenni Can* is priced at \$19.50.—**Scandex, Inc.**, 87 Crescent Road, Needham, MA 02194.

MARINE DEPTH INDICATOR, the *Polaris DI480*, has an alarm which sounds if the

AUDIO KITS POWER AMPLIFIERS



MOSFET



120 WATT
RMS (Mono)

Model UP70
\$219.95

ILP MOSFET power amplifiers are the logical choice for superb performance, compact size, excellent design, ease of assembly, and bargain prices! All models use famous ILP audio power amplifier modules, factory pre-assembled with bonded heat-sink and tested. Assembly is quick, easy, and assured. Each model features an ILP toroidal power transformer: half the weight and size of conventional transformers, toroids are also much quieter. ILP MOSFET power amps give no-compromise state-of-the-art performance: frequency response 15Hz - 100kHz (-3db), harmonic distortion 0.005% (1kHz), signal-to-noise ratio 100db, slew rate 20v ps. Each kit mounts into a precision die-cast aluminum chassis. Like all ILP products, MOSFET power amp kits carry a five year limited warranty. Also available: MODEL UP60 60 watts RMS MOSFET amplifier \$159.95. Available direct and from selected dealers. Write for details.

CALL TOLL-FREE TO ORDER 800-833-8400

In New York call (716) 874-5510.

Mail orders accepted. VISA, Mastercard or checks.

GLADSTONE ELECTRONICS, INC.

1585 Kenmore Avenue Buffalo, New York 14217

In Canada: Gladstone Electronics, Toronto 800-268-3640

CIRCLE 30 ON FREE INFORMATION CARD

TOROIDAL Power Transformers



TYPE	SERIES No	SECONDARY VOLS	RMS CURRENT	TYPE	SERIES No	SECONDARY VOLS	RMS CURRENT	
50VA 80 x 35 mm (3.1 x 1.4 in) 0.9 Kg (2.0 lbs) Regulation 1%	2X010	6 + 6	4.16	225VA 110 x 45 mm (4.3 x 1.8 in) 2.2 Kg (4.9 lbs) Regulation 7%	6X012	12 + 12	9.38	
	2X011	9 + 9	2.77		6X013	15 + 15	7.50	
	2X012	12 + 12	2.08		6X014	18 + 18	6.25	
	2X013	15 + 15	1.66		6X015	22 + 22	5.11	
	2X014	18 + 18	1.38		6X016	25 + 25	4.50	
	2X015	22 + 22	1.13		6X017	30 + 30	3.75	
	2X016	25 + 25	1.00		6X018	35 + 35	3.21	
	2X017	30 + 30	0.83		6X019	40 + 40	2.81	
\$21.95	2X028	110	0.45	6X025	45 + 45	2.50		
	2X029	220	0.22	6X033	50 + 50	2.25		
	2X030	240	0.20	6X028	110	2.04		
				6X029	220	1.02		
				6X030	240	0.91		
	80VA 90 x 30 mm (3.5 x 1.2 in) 1 Kg (2.2 lbs) Regulation 1%	3X010	6 + 6	6.64	300VA 110 x 50 mm (4.3 x 2 in) 2.6 Kg (5.7 lbs) Regulation 6%	7X013	15 + 15	10.00
		3X011	9 + 9	4.44		7X014	18 + 18	8.33
		3X012	12 + 12	3.33		7X015	22 + 22	6.87
3X013		15 + 15	2.66	7X016		25 + 25	6.00	
3X014		18 + 18	2.22	7X017		30 + 30	5.00	
3X015		22 + 22	1.81	7X018		35 + 35	4.78	
3X016		25 + 25	1.60	7X026		40 + 40	3.75	
3X017		30 + 30	1.33	7X025		45 + 45	3.33	
\$23.95	3X028	110	0.72	7X033	50 + 50	3.00		
	3X029	220	0.36	7X028	110	2.72		
	3X030	240	0.33	7X029	220	1.36		
				7X030	240	1.25		
	120VA 90 x 40 mm (3.5 x 1.6 in) 1.2 Kg (2.6 lbs) Regulation 1%	4X010	6 + 6	10.00	500VA 140 x 60 mm (5.5 x 2.4 in) 4 Kg (8.8 lbs) Regulation 4%	8X016	25 + 25	10.00
		4X011	9 + 9	6.66		8X017	30 + 30	8.33
		4X012	12 + 12	5.00		8X018	35 + 35	7.14
		4X013	15 + 15	4.00		8X026	40 + 40	6.25
4X014		18 + 18	3.33	8X025		45 + 45	5.55	
4X015		22 + 22	2.72	8X033		50 + 50	5.00	
4X016		25 + 25	2.40	8X042		55 + 55	4.54	
4X017		30 + 30	2.00	8X028		110	4.54	
\$26.95	4X018	35 + 35	1.71	8X029	220	2.27		
	4X028	110	1.09	8X030	240	2.08		
	4X029	220	0.54					
	4X030	240	0.50					
	160VA 110 x 40 mm (4.3 x 1.6 in) 1.8 Kg (4.0 lbs) Regulation 8%	5X011	9 + 9	8.89	625VA 140 x 75 mm (4.3 x 3 in) 5 Kg (11.0 lbs) Regulation 4%	9X017	30 + 30	10.41
		5X012	12 + 12	6.66		9X018	35 + 35	8.91
		5X013	15 + 15	5.33		9X026	40 + 40	7.81
		5X014	18 + 18	4.44		9X025	45 + 45	6.94
5X015		22 + 22	3.63	9X033		50 + 50	6.25	
5X016		25 + 25	3.20	9X042		55 + 55	5.68	
5X017		30 + 30	2.66	9X028		110	5.68	
5X018		35 + 35	2.28	9X029		220	2.84	
\$29.95	5X026	40 + 40	2.00	9X030	240	2.60		
	5X028	110	1.45					
	5X029	220	0.72					
	5X030	240	0.66					

ILP toroidal transformers are half the weight and height of standard laminated transformers. Supplied with mounting kit, 5 year limited warranty. Trade and OEM enquiries welcome. Note: Regulation - all voltages quoted are full load. Add regulation figure to secondary voltage to obtain full voltage.

CALL TOLL-FREE TO ORDER 800-833-8400
In New York call (716) 874-5510.

Mail orders accepted. VISA, Mastercard or checks.

GLADSTONE ELECTRONICS, INC.

1585 Kenmore Avenue Buffalo, New York 14217

In Canada: Gladstone Electronics, Toronto 800-268-3640

CIRCLE 74 ON FREE INFORMATION CARD

FREE MAIL ORDER CATALOG

**Tuners,
amplifiers,
effects,
keyboards,
studio equipment,
drum computers,
easy to assemble kits,
books & more**



name _____

address _____

city _____ state _____ zip _____

PAIA Electronics, Inc.

Dept. 4-R, 1020 W. Wilshire Blvd.
Oklahoma City, OK 73116

800-654-8657 9AM-5PM CST M-F

CIRCLE 52 ON FREE INFORMATION CARD

**Tests LEDs, UJTs, SCRs,
bipolar transistors,
diodes FAST!
(Logic
pulser
too.)**



Read and you'll agree: Pulsar 3R is the most sophisticated go-nogo probe-style tester in the business—which is why thousands are using it for fast out-of-or-in-circuit analysis. Using it how? Here are some ways.

- Identifies emitter, base, collector; pnp or npn; silicon or germanium.
- Spots leaky, open, shorted, low-gain transistors.
- Checks LEDs; identifies cathode and anode; and segments of numeric and alphanumeric LEDs.
- Tests P-channel and N-channel FETs.
- Functions as a logic pulser: pulls low to high, high to low.

After a week with the 3R you'll wonder how you ever did without it.

Pulsar Technology Systems Inc.
126-16 Northern Blvd. Flushing, N.Y. 11368
Telephone 212-457-5553

Ship _____ 3R Transistor Testers at \$69.95 ea. for which I enclose my check money order . Please ship C.O.D. .
We pay shipping in USA. Dealer inquiries invited.

NAME _____

ADDRESS _____

CITY _____ STATE _____ ZIP _____
New York State residents add applicable sales tax.

CIRCLE 71 ON FREE INFORMATION CARD



CIRCLE 106 ON FREE INFORMATION CARD

depth varies above or below any range the user specifies. The unit can read depth up to 480 feet. It also features a backlit liquid-crystal display that shows normal depth and shallow- or deep-alarm depth settings. The display can be set to read out in either feet or fathoms in tenths. Variable controls are used to set the shallow- and deep-alarm functions. Additional features include an external buzzer jack, a mounting bracket, and power cord. The Polaris DI480 is priced at \$329.00 — Regency Electronics, 7707 Records St., Indianapolis, IN 46226.

AUDIBLE CONTINUITY TESTER, model 137, comes complete with an adaptable probe end that allows it to accept any probe in Desco's catalog. The standard probe, which is shipped with the unit, will meet most common testing needs. The model 137 gives a combination audible and visual response to a complete circuit, and is capable of polarity

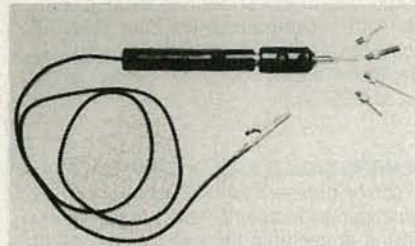

CIRCLE 107 ON FREE INFORMATION CARD

testing. Input impedance is 150 ohms. The model 137 comes complete with two 1.5-volt AA batteries, operates at 3 volts, and draws 5 mA current. It is priced at \$22.50 — Desco Industries, Inc., 761 Penarth Avenue, Walnut, CA 91789.

TWIST-ON BNC CONNECTOR, model 203040, has a body length of only 1.23 inches, for applications where space is limited. No solder or special tools are required for installation. The model 203040 is in one piece and there are no loose parts. It is designed for operation in the 0-4 GHz frequency range at

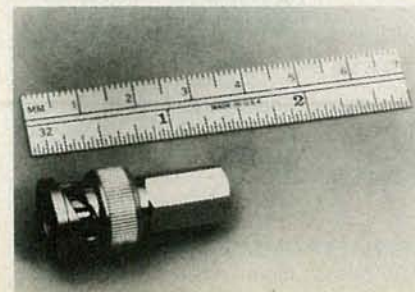

CIRCLE 108 ON FREE INFORMATION CARD

500 volts, has an impedance rating of 50 ohms nominal, and is for installation on RG-59 or RG-62 cable. The model 203040 twist-on BNC connector is priced at \$2.29 — Ava Electronics Corp., 4000 Bridge Street, Drexel Hill, PA 19026.

FIBER-OPTIC LINK SYSTEM, the *EDU-LINK*, is a TTL data-transmission system, designed specifically as an educational tool. The *EDU-LINK* package includes a transmitter, receiver, and a 1-meter length of preterminated fiber-optic cable. The kit, sold in unassembled form, demonstrates the principles of fiber-optic transmitter and receiver design. It comes with instructions, theory of operation, and tutorial information. The *EDU-*

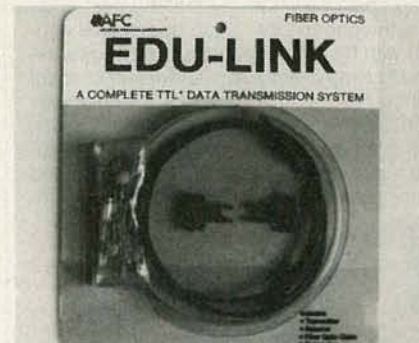

CIRCLE 109 ON FREE INFORMATION CARD

LINK is priced at under \$20.00 — Advanced Fiberoptics Corp., 637 S. Hayden Road, Tempe, AZ 85281.

CONTACT ENHANCER, *Tweek*, is a fluid designed to reduce contact resistance in low-power circuits. The better the contact, the cleaner the signal. Connections treated with *Tweek* act as if either the conductivity of the contacting metal surfaces has increased or the contact surface area has been multiplied by a significant factor.

Tweek is a nonconductive fluid that increases conductivity on a molecular level when applied as a thin coating. By filling in microscopic gaps in a metal-to-metal contact, *Tweek* multiplies the apparent contact sur-

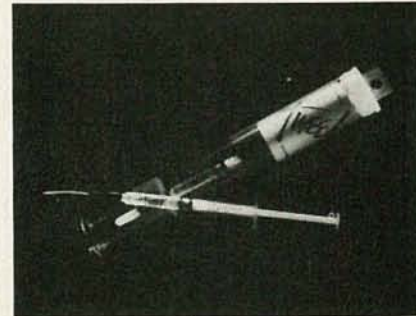

CIRCLE 110 ON FREE INFORMATION CARD

faces and decreases contact resistance. Among its applications are audio and video interconnects, phono cartridge and headshell pins, antenna connections, computer connections, and battery terminals. It is sold in 0.5-cc applicator tubes, and the suggested list price is \$15.00 — Umiko, PO Box 5046, Berkeley, CA 94705.

R-E

DESIGNER'S NOTEBOOK

Low-voltage amplifier circuits

ROBERT GROSSBLATT

DIGITAL AND ANALOG CIRCUITS EACH have their own unique set of design problems. Very often what is a major consideration in one field doesn't even appear in the other. There is, however, one problem that is common to both analog and digital circuits: the problem of tailoring real world signals so that they can be handled by whatever circuitry that is being designed to follow them.

The output of many real-world sensors (from microphones to keyboards to transducers) need a certain amount of conditioning before they can be reliably processed by either analog or digital circuitry. One of the most frequent problems that turns up is that the voltage level coming out of the input device is just too low to be used by the following circuitry. Because of that, those signals must be amplified to a usable level. This month we'll look at two general-purpose amplifier circuits. The first uses a single transistor and the other a CMOS IC. Either one can really come in handy when you're faced with the problem of low-voltage input signals. We'll look at the transistor amplifier first.

Transistor amplifier

Figure 1 shows a simple single-transistor amplifier that can be used anytime you need a boost for a signal that's in the microvolt range. That circuit can be assembled from the sort of spare parts that fall into the cracks of your parts box. Not only that, but the it uses so few parts that it takes up less space on a PC-board than an IC. In addition, the circuit has a flat frequency response across the audio spectrum and a gain of about 100 with the component values shown. None of the component values are particularly critical, therefore a wide range of substitutions can be made without seriously affecting the performance of the circuit.

The gain of the circuit can be lowered by dropping the value of feedback resistor R2. And the capacitor values shown can be changed if you don't happen to have those values on hand. Transistor Q1 is a small-signal high-gain NPN transistor; substitutions can be made here as well. A 2N2222 transistor can be used but it will give you a lower gain than the 2N3391 shown; again it's a matter of trial and error

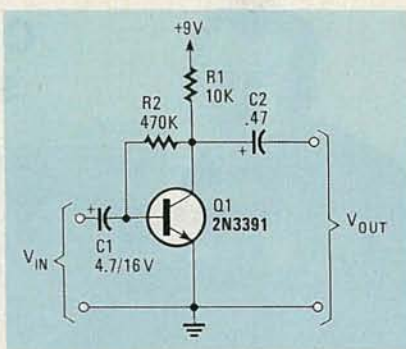

FIG. 1

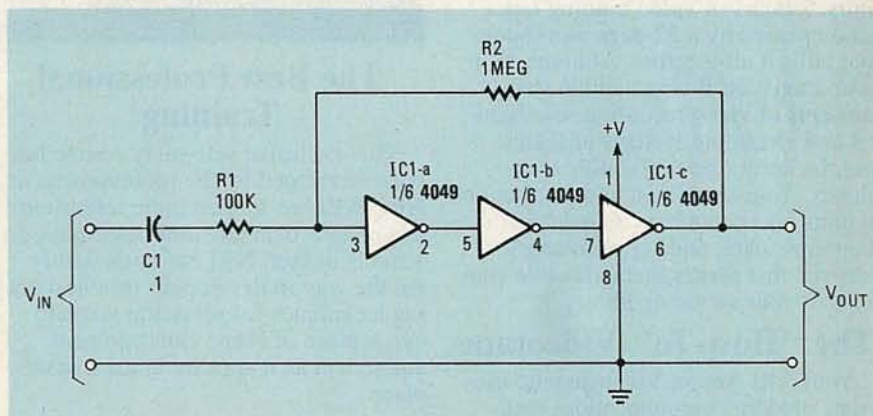

FIG. 2

on one hand, and how much gain you need on the other.

The circuit can be used anytime that a really low input signal needs to be boosted to a workable level. Anyone who has ever had to deal with the output level of a dynamic microphone (in the microvolt range) will find that little amplifier really handy because it will boost the mike's output signal level enough so that it can be fed into a standard line input. The other low-voltage amplifier circuit that we will look at uses CMOS inverters rather than a single transistor.

CMOS amplifier

The second amplifier circuit is shown in Fig. 2. It uses three sections of a CMOS 4049 hex inverter IC (but any CMOS inverter can be used). It features a high input impedance. It also features all the good things we've come to expect from CMOS: a wide power-supply range, high noise-immunity, an output that swings from

ground to just about the supply rail, and so on. The response of the circuit can be easily tailored to satisfy a wide range of circuit conditions.

The gain of that circuit is determined solely by the ratio of the feedback resistor (R2) to the input resistor (R1). And the frequency response is a function of the input capacitor. Keep this circuit in mind, it can make life a lot easier when the output signal for the circuit you're designing needs a bit of amplification. Just round up three spare inverters and your problem is solved. The only thing to re-

member is that the output voltage won't be at ground potential when you remove the input signal. Since we're using the inverters in a linear mode, the output voltage will always return to $V/2$ (where V is the supply voltage). If that presents a problem you can always take care of it with a capacitor or some other scheme at the output.

R-E



"Dad, tell me about your deprived childhood ... no computers, videogames ..."

Now electronics technicians can get into VCR Servicing quickly and easily

Learn professional VCR servicing at home or in your shop with exclusive videotaped demonstrations

Today, there are more than 10 million VCRs in use, with people standing in line to have them serviced. You can bring this profitable business into your shop with NRI professional training in VCR servicing. This top-level training supports the industry's claim that the best technicians today are those who service VCRs.

Integrated Three-Way Self-Teaching Program

In one integrated program, NRI gives you a study guide, 9 instructional units, 2 hours of video training tapes accompanied by a 32-page workbook that pulls it all together. At home or in your shop, you'll cover all the basic concepts of video recording, mechanical and electronic systems analyses, and the latest troubleshooting techniques. Your workbook and instructional units also contain an abundance of diagrams, data, and supplementary material that makes them valuable additions to your servicing library.

The "How-To" Videotape

Your NRI Action Videocassette uses every modern communications technique to make learning fast and easy. You'll enjoy expert lectures and see animation and video graphics that make every point crystal-clear. You'll follow the camera eye into the heart of the VCR as step-by-step servicing techniques are shown. Both electronic and mechanical troubleshooting are covered . . . including everything from complete replacement and adjustment of the recording heads to diagnosing micro-processor control faults.

Plus Training On All The New Video Systems

Although your course concentrates on VCRs covering Beta, VHS, and 3/4" U-Matic commercial VCRs, NRI also brings you up to speed in other key areas. You'll get training in capacitance and optical video disc players, projection TV, and video cameras. All are included to make you the complete video technician. There's even an optional final examination for NRI's VCR Professional Certificate.



Covers Beta and VHS systems with actual instruction on videotape.

The Best Professional Training

This exclusive self-study course has been developed by the professionals at NRI. NRI has trained more television technicians than any other electronics school! In fact, NRI has consistently led the way in developing troubleshooting techniques for servicing virtually every piece of home entertainment equipment as it appears in the marketplace.

Satisfaction Guaranteed . . . 15-Day No-Risk Examination

Send today for the new NRI Self-Study Course in VCR Servicing for

Professionals. Examine it for 15 full days, look over the lessons, sample the videotape. If you're not fully satisfied that this is the kind of training you and your people need to get into the profitable VCR servicing business, return it for a prompt and full refund, including postage. Act now, and start adding new business to your business.

Special Introductory Offer

This complete VCR training course with two hour videotape is being offered for a limited time only, on orders received from this ad, at our low introductory price of \$179.95. Save \$20 by acting now!

NRI Training For Professionals
McGraw-Hill Continuing Education Center
3939 Wisconsin Avenue Washington, DC 20016

YES! Get me started in profitable VCR servicing. Rush me my NRI self-study course in VCR Servicing for Professionals. I understand I may return it for a full refund within 15 days if not completely satisfied.

PLEASE SPECIFY TAPE FORMAT DESIRED VHS BETA

Name (please print) _____

Company _____

Street _____

City/State/Zip _____

Enclosed is my check money order for \$179.95 (D.C. residents add 6% tax) Make check payable to NRI

Charge to VISA MasterCard _____

Interbank Number _____

Card Number _____ Expiration Date _____

Signature _____

(required for credit card sales)



NRI Training For Professionals
McGraw-Hill Continuing
Education Center
3939 Wisconsin Avenue
Washington, DC 20016

HOME CONTROL COMPUTER

If you've ever wanted to use your computer to control external appliances or systems—but didn't want to tie up your computer solely for that purpose—then this controller is for you!

STEVEN E. SARNS

HOW OFTEN HAVE YOU THOUGHT: "IF ONLY I COULD hook my computer up to that furnace (or model train, coffee pot, security system, etc.), then I could really get it to do what I want"? You probably gave up the idea for one of two reasons. First, your computer is too expensive to be relegated to turning on a coffee pot 15 minutes before you wake up (especially when you can buy inexpensive timers to do the same thing). Second, your computer is not designed for such control tasks and requires some modifications.

Those are good reasons to abandon the idea. But what if you had an inexpensive computer that could be programmed easily and had an I/O structure designed *specifically* for control applications? Then you could put some of your ideas into action. This control computer that you can build has—along with its many other I/O capabilities—the ability to control BSR-type wireless remote-control modules. And the computer can be programmed in BASIC using any terminal (or a computer configured as a terminal) that has an RS-232 serial port.

Let's take a quick look at the abundance of applications for a control computer that surround you—some of which you've probably considered and, perhaps, some you've never even thought of. We won't go into detail on how to use the controller for the following applications. Keep in mind that your programming capabilities may limit what you want to do. (You need to know at least BASIC programming to use the controller.) But we will explain how to use the control computer in enough detail so that you'll be able to tailor it to your own applications.

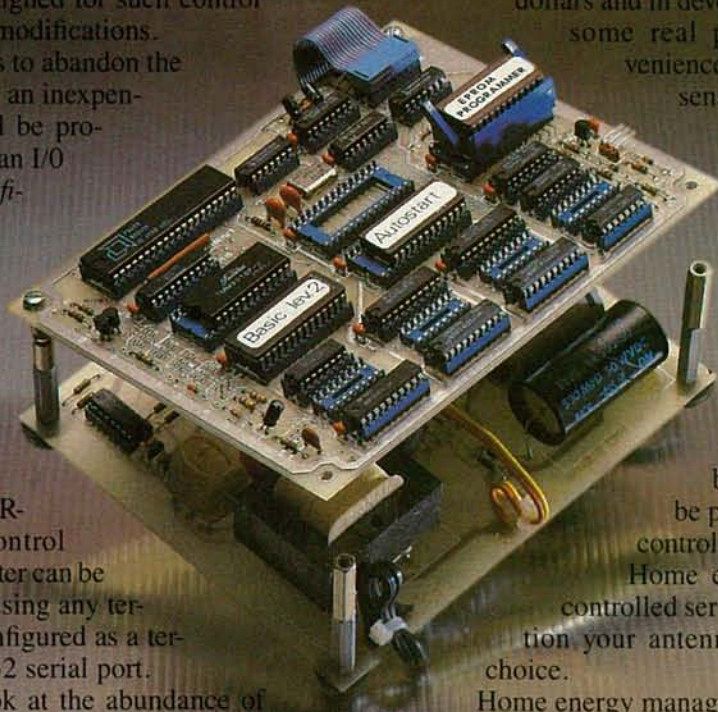

Security systems: A "smart" security system could arm itself in your absence. And the alarm could be dependent on the type or source of breach. For example, with external circuitry, the system could be interfaced to the telephone to alert the police if it sensed a break-in, or it could phone the fire department if it sensed a fire.

Robotics: Even the most drole robot requires some amount of "smarts." Now you can afford—both in dollars and in development time—to give him some real power. Imagine the convenience of independent drive- and sensory-systems. Imagine how much faster your development would be with a complete computer system for each function.

Model control: Imagine the complexity that you could build into a computer-controlled model-train layout, or the acrobatic maneuvers that could be programmed into your radio-controlled model airplane.

Home entertainment: A computer-controlled servo tracking system can position your antenna on the satellite of your choice.

Home energy management: (This is what the author's prototype was designed for.) The living-room thermostat could be the first target—it could automatically set back when you are at work and warm up before you return (but not on weekends). If you have electric heat, and if your electric company has peak and off-peak rates, your electric bills could be cut in half by averaging your power requirements instead of turning everything on at once. Remember—any equipment you purchase for energy management or control might be a tax credit for you. You'll have to check your own state's

laws. If you're lucky, you might effectively cut the cost of your project in half!

Features of the controller

The underlying design goal for this controller was a small, inexpensive, yet powerful control computer with its own development system. That design had to achieve a successful balance: We wanted the board size and the cost to be kept down, yet we still wanted to include as many features as we could. However, if we tried to give the board too many bells and whistles, the resulting high cost would limit its practical (economical) applications. On the other hand, a cost-conservative approach would result in a board with only limited applications. Of course, we searched for a happy medium.

The result was a rather small board (about $5\frac{1}{2} \times 6\frac{1}{2}$ inches) that has enough power to do its job at a competitive cost—take a look at the controller's features:

- A total of 46 inputs and outputs: Seven high-current, individually addressable outputs; 7 individually addressable inputs; 2 eight-bit input ports, and 2 eight-bit output ports.

- An RS-232 serial port: a terminal can be used for program entry.

- An eight-channel, 8-bit analog-to-digital converter with provisions for digital-to-analog conversion.

- A choice of two operating systems: BASIC or Forth. The high-level language will cut your programming time by 90%.

- An on board EPROM programmer makes a permanent copy of your RAM-based program.

- A real-time clock for time-of-day functions.

- Auto start of ROM-based programs.

- BSR-type remote controller is on a companion power-supply board. That system communicates to readily available receiver modules that you simply plug into the AC lines. All of the hassles of stringing wires from the controller to the control point are eliminated.

A closer look

Now that we have an idea of the basic features of the controller, let's discuss some of the theory behind it. Unfortunately, we won't be able to cover all of the points that we just mentioned this month—they will be discussed in upcoming installments of this article.

We'll start by describing the microprocessor and the support circuitry required to test, debug and program the basic system. The design will be discussed in enough detail so that even those who are not familiar with microprocessor design techniques will be able to get an overview of the process. The control computer's schematic is shown in Fig. 1.

The microprocessor selected for this project is the Intel 8088—the 16-bit microprocessor that forms the heart of IBM's

personal computer. (Anyone who owns an IBM PC has a complete set of development tools for this board.) The 8088 can be thought of as being made up of two units. The first is the BIU or *Bus Interface Unit*, which prefetches instructions while the rest of microprocessor (the EU—*Execution Unit*) is working on the current instruction. Besides speeding execution, that has an even more fortunate (economical) effect: Memory IC's with access times as slow as 400 ns will work on the board.

The bus structure

The microprocessor is connected to the memory and I/O through the *data bus*, the *address bus* and the *control bus*. Those busses are shown in the computer's schematic in Fig. 1.

The data bus is the group of eight lines (D0–D7) over which data can be transferred between the microprocessor and any memory or I/O (*Input/Output*) device.

The address bus is made up of 20 lines, some of which are time multiplexed. Don't worry about now—we'll get to it shortly. You should know, however, that the microprocessor uses the address bus to select the desired memory address or I/O device to send data to or receive data from. That address is represented by the unique combination of address-line states.

We will be concerned with three lines of the control bus. The $\overline{\text{READ}}$ ($\overline{\text{RD}}$) and $\overline{\text{WRITE}}$ ($\overline{\text{WR}}$) lines determine whether the data is to be transferred to (read by) or from (written by) the microprocessor on the bi-directional data lines. The third line, $\text{IO}/\overline{\text{M}}$, is used to distinguish between a memory access or an I/O access.

The 8088 can address 1 megabyte (2^{20}) of memory with its 20 address lines. If we use only the lower 16 lines, we can address 64K. The 8088 combines the data bus and the lower eight address lines into what is called a time-multiplexed bus. That was done so that the 8088's package could be kept to 40 pins. The first design question is to decide whether to demultiplex the data and address bus or use it as is. Intel (and others) supports the multiplexed bus with an extensive range of products. Leaving the bus multiplexed will result in a smaller board that is easy to lay out. (That is one of our design goals.) However, because of the popularity of the non-multiplexed bus, peripheral IC's designed for it are more available and are less expensive. Because another of our design goals is to design a low-cost board, we must stick to popular components—or at least ones that we expect to become popular. Fortunately, demultiplexing the bus is an easy matter; it requires only a set of latches. A 74LS373 octal latch (IC15) is used. It is enabled by the ALE (Address Latch Enable) pin of the microprocessor (pin 25). Now we have 8 high-order ad-

dress lines, $\text{A}_{15}\text{--}\text{A}_8$, (IC18 pins 39, 2–8), and 8 low-order address lines coming from the latch outputs, $\text{A}_7\text{--}\text{A}_0$, (IC15 pins 7, 12, 6, 15, 5, 16, 2, 19). We also have 8 bi-directional data lines, $\text{AD}_7\text{--}\text{AD}_0$ from the input side of the latch (IC18 pins 9–16). Note that the data lines still contain the multiplexed address-information. They will contain data at the time the appropriate control line ($\overline{\text{RD}}$ or $\overline{\text{WR}}$) is active.

The memory field must be divided into appropriate banks (or peripheral IC's). We must make sure that only a single peripheral IC can be active at any one time. If more than one device attempts to place data on the bi-directional data bus simultaneously, a condition known as *bus contention* rises. The result of bus contention is an undefined bus state and, consequently, undefined operation. Thus the output of our memory decoder will be a one-of-N type—only one output will be active at any one time. Each of those outputs will be connected to the chip-enable ($\overline{\text{CE}}$) input of a peripheral IC.

The selection of the size and type of memory is heavily influenced by our need to convert our finished program into ROM. If we can simply remove a RAM IC and replace it with a pin-compatible ROM, we will have a compact yet flexible board. The 2016 2K \times 8 RAM and the 2716 2K \times 8 EPROM are pin-compatible, so they will be used. We also need memory space for ROM-ed development tools that can be used during the program testing, and an empty socket for the blank EPROM to be programmed.

Throughout the remaining description of the board, the highest order address lines ($\text{A}_{19}\text{--}\text{A}_{16}$) will be ignored. The address lines $\text{A}_{15}\text{--}\text{A}_8$ will be called the high-order address lines. The most significant high order address line (A_{15}) can be used to chip-select the system ROM. Address lines A_{11} and A_{12} are used as the inputs to a 74LS139 one-of-4 decoder (IC16), which will be used to chip-select the other memory IC's. We have mapped our system ROM and 4 memory sockets uniquely into the 64K address space. Table 1 shows

TABLE 1—MEMORY MAP

Address (hex)	IC/Function
0000–07FF	1C12/RAM
0800–0FFF	IC10/RAM
1000–17FF	IC13/RAM
1800–1FFF	IC14/RAM and EPROM programming socket
8000–FFFF	IC9/System ROM

a memory map of our system. Note that A_{15} is inverted by IC19 to select the system ROM and that the one-of-4 decoder (IC16) is qualified by IC17-d: when A_{15} and the $\text{IO}/\overline{\text{M}}$ lines are low, a memory-field operation is indicated.

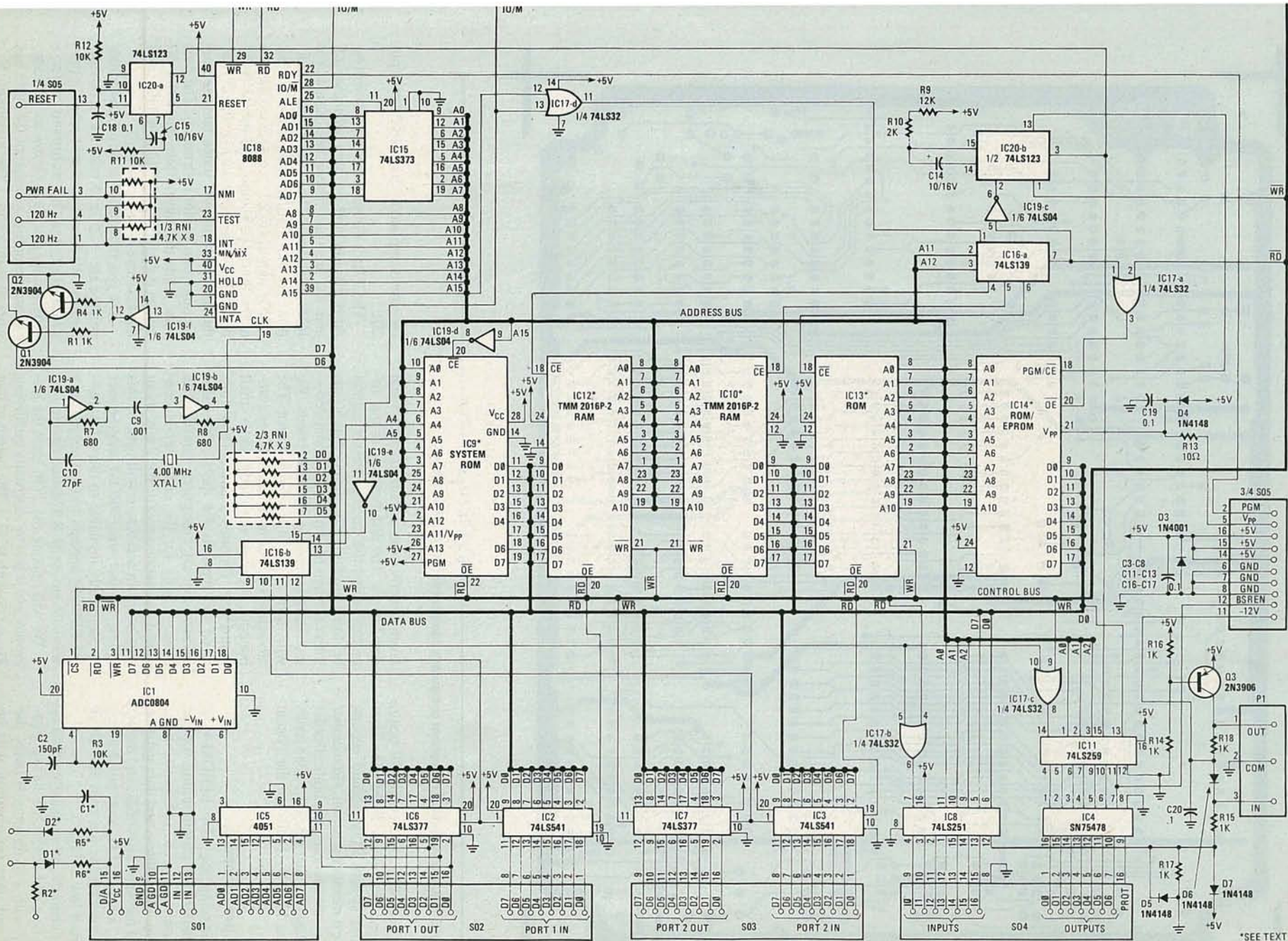

FIG. 1—THE CONTROL COMPUTER SCHEMATIC. Note that IC9 is the system memory. It is contained in ROM and is available from the supplier indicated in the Parts List. Then pin numbers shown for IC9 are socket pins. If a 2732 or 2764 is used, then pin 23 should be connected to A11 and not 5 volts. Also, pin 26 should be connected to A13, and not 5 volts. In both cases, you have to cut a trace and add a wire jumper.

*SEE TEXT

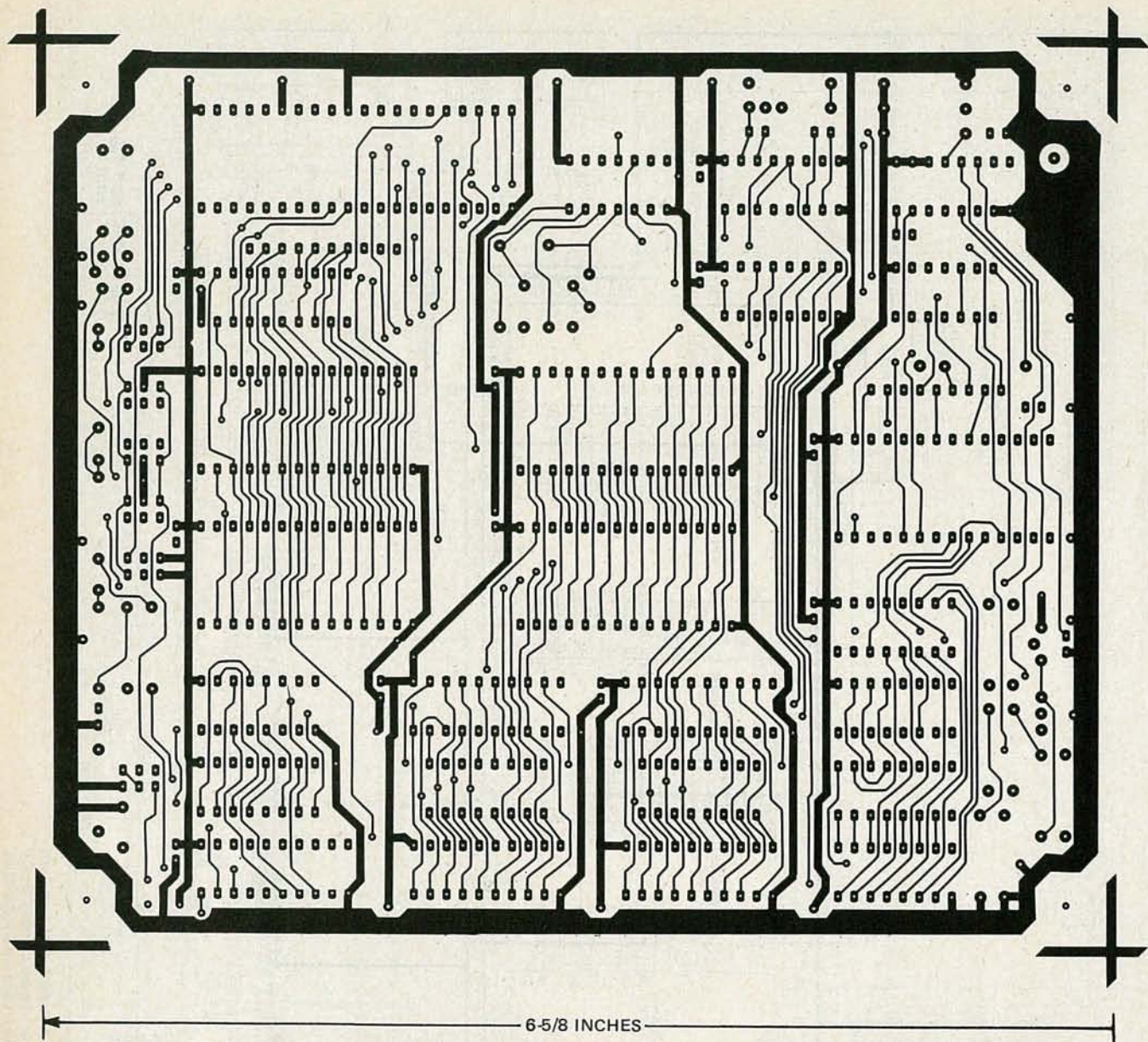

FIG. 2—THE FOIL PATTERN FOR the control computer's component side is shown above.

When the 8088 is reset, it will begin execution at address FFFF0H. That means our system ROM should occupy the highest memory position. (Remember that we're not decoding the highest-order address lines, so that when the 8088 looks at address FFFF0, it will see the system ROM.)

EPROM programming

Programming the 2716 EPROM is a simple matter. The programming voltage may be applied as a DC voltage to pin 21, the V_{pp} pin. The address and data must be stabilized for 50 milliseconds, and during that time, a single TTL-level pulse is applied to the \overline{CE}/PGM pin (pin 18). (It is pulsed from low to high.)

Rather than the more usual method of surrounding the EPROM being programmed with a bi-directional latch, the address and data information will be

taken directly from stabilized address and data busses. The disadvantage of our approach is that the microprocessor cannot be doing anything else during that 50-ms interval when the busses are stabilized—including timing the 50 milliseconds. We will have to use a hardware timer. The advantages of our method are fewer components, software simplicity, and a small board size. (Figures 2 and 3 show full-sized foil patterns for the double-sided printed-circuit computer board. The power supply for the computer is contained on a second board. We'll talk about that board in a future installment of this article.) In fact, the EPROM programmer is completely invisible to the software—the EPROM appears to the operator as a very slow-to-write RAM-like device.

We will operate the 2716 from the microprocessor bus by externally qualifying \overline{RD} and \overline{CS} with IC17-a. The output of that

OR gate is applied to the 2716 \overline{OE} pin (pin 20).

The 2716's \overline{CE}/PGM line (pin 18) will be normally low and go high whenever \overline{CS} and \overline{WR} are true. Those two signals (at IC20, pins 1 and 2) are the trigger conditions for the 74LS123 50-ms one shot whose output (IC20, pin 4) is connected to the 8088 RDY input and the 2716 \overline{CS}/PGM input. Whenever the RDY line is low, the 8088 inserts wait states into the current microprocessor instruction. The wait state holds the current bus status (for 50 ms, as determined by C14 and R10) until the RDY line is returned high.

The specifications for the programming voltage are $+25 \pm .5$ volts DC at 30 milliamps. We have found that reliable programming can be achieved with a programming voltage as low as 22 volts. (A programming voltage of 24 volts has worked well for us.) The maximum V_{pp}

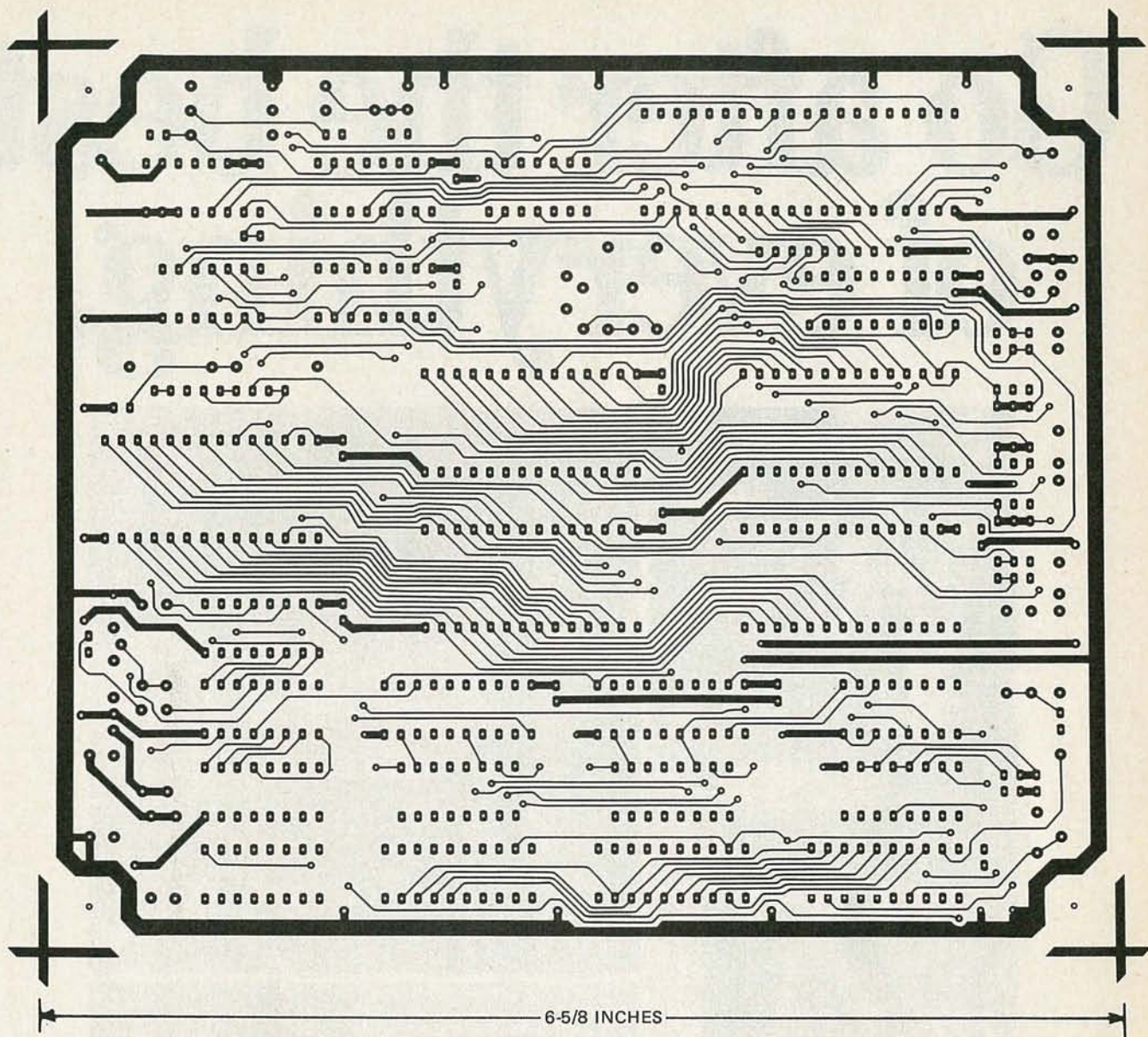

FIG. 3—THE SOLDER SIDE of the computer printed-circuit board.

voltage specification is an extremely important one to follow. We met up with disaster with a programming voltage of 26 volts. If the V_{pp} voltage is exceeded *even for a few nanoseconds*, the EPROM will fry! That means that the V_{pp} supply must not overshoot during turn-on or turn-off. Because we need to control the ramp-on and -off characteristics we will use a power supply design that always switches the supply on and off for each byte programmed. (The switching supply makes the control computer more versatile because it allows you to use other EPROM's—for example the 2732—that require a switched V_{pp} supply. The 2716 doesn't require a switched supply.) That switching programming supply is located on the separate power supply board. We'll discuss that circuit and its construction in a future part of this article.

Programming an EPROM involves

only setting appropriate locations to "0." A fully erased EPROM has all of its memory locations filled with 1's.

The time will come—either because of a programming mistake or because you no longer need a particular program—that you'll want to erase your programmed EPROM. You can erase the EPROM's by exposing them to ultraviolet light. Direct sunlight will erase an EPROM in about a week. Room-level fluorescent light will erase an EPROM in about 3 years. (Although that's not an efficient erasure method, it is still a good idea to cover the window with a label to block out room/sun light.) A commercial EPROM eraser is simply a source of ultraviolet (UV) light that irradiates the EPROM. You can make one yourself with a General Electric G15TB 18-inch germicidal bulb in a conventional fluorescent-lamp holder. **Do not look into the bulb when it is on.** The

light is much more intense than it appears and quickly damages the eyes. Place the EPROMS to be erased within one inch of the bulb and leave it on for 10–15 minutes. That should change all the bits in the EPROM to 1's.

The microprocessor requires a system clock signal, which we obtain with a conventional TTL-type crystal oscillator (IC19, XTAL1, and other associated components). The frequency of the clock is 4.00 MHz, even though the 8088 could run at 5 MHz. The 33% duty-cycle constraint on the clock signal would require either a special clock generator or additional TTL chips.

A reset pulse is also required by the 8088, which we generate by using one-half of a 74LS123 (IC20-a) during power-up or whenever the reset line is grounded and released.

continued on page 94

Go after the best of everything.

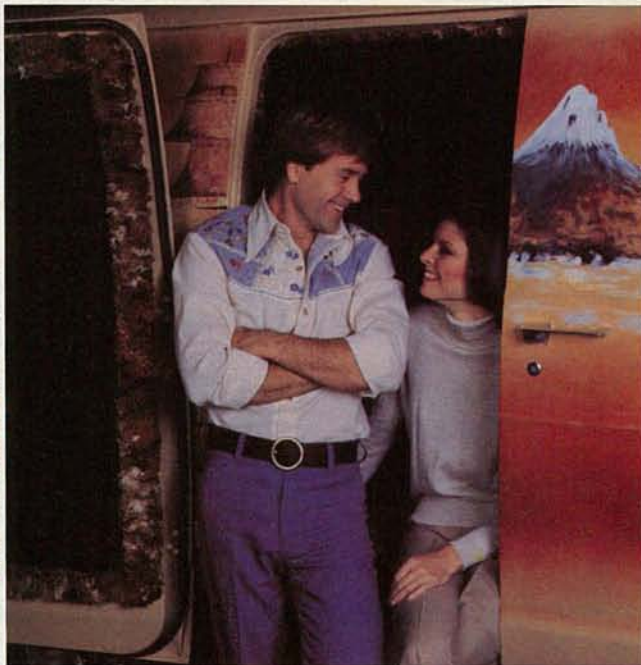

Don't settle for less. Especially when it comes to electronics training...because everything else in your life may depend on it. That's why you ought to pick CIE!

You've probably seen advertisements from other electronics schools. Maybe you think they're all the same. They're not!

Meet the Electronics Specialists.

When you pick an electronics school, you're getting ready to invest some time and money. And your whole future depends on the education you get in return.

That's why it makes so much sense to go with number one... with the specialists...with CIE!

There's no such thing as bargain education.

If you talked with some of our graduates, chances are you'd find a lot of them shopped around for their training. Not for the lowest priced but for the best. They pretty much knew what was available when they picked CIE as number one.

We don't promise you the moon. We do promise you a proven way to build valuable career skills. The CIE faculty and staff are dedicated to that. When you graduate, your diploma shows employers you know what you're about. Today, it's pretty hard to put a price on that.

Because we're specialists, we have to stay ahead.

At CIE, we've got a position of leadership to maintain. Here are some of the ways we hang onto it...

Our step-by-step learning includes "hands-on" training.

At CIE, we believe theory is important. And our famous Auto-Programmed® Lessons teach you the principles in logical steps.

But professionals need more than theory. That's why several of our courses get you started fast with "hands-on" training. Depending on your course selection, you could start with CIE's Personal Training Laboratory, including multimeter. Then, progress to the Digital



Learning Laboratory and build your own security control device from a kit. Continue your education with CIE's Microprocessor Training Laboratory. You'll build a working microprocessor "from scratch" and learn how to program and interface it with displays, memories, switches, and more.



Our specialists offer you personal attention.

Sometimes, you may even have a question about a specific lesson. Fine. Write it down and mail it in. Our experts will answer you promptly in writing. And the answer you get becomes a part of your permanent reference file. You may find this even better than having a classroom teacher.



Pick the pace that's right for you.

CIE understands people need to learn at their own pace. There's no

pressure to keep up...no slow learners to hold you back. If you're a beginner, you start with the basics. If you already know some electronics, you move ahead to your own level.

Enjoy the promptness of CIE's "same day" grading cycle.

When we receive your lesson before noon Monday through Saturday, we grade it and mail it back — the same day. You find out quickly how well you're doing.

Progress to an Associate Degree, an FCC License, or both.

One of the best credentials you can have in electronics — or any other career field — is a college degree. That's why CIE gives you the opportunity to earn an Associate in Applied Science in Electronics Engineering Technology. Any CIE career course can offer you credit toward the degree...more than half the number needed in some cases.

You can also prepare for the government-administered FCC (Federal Communications Commission) Radiotelephone License, General Class. It can be a real mark in your favor...government-certified proof of your specific knowledge and skills.

Send for more details and a FREE school catalog.

Mail the card today. If it's gone, cut out and mail the coupon. You'll get a FREE school catalog plus complete information on independent home study. For your convenience, we'll try to have a CIE representative contact you to answer any questions you may have.

Mail the card or the coupon or write CIE (mentioning the name and date of this magazine) at: 1776 East 17th Street, Cleveland, Ohio 44114.

CIE **Cleveland Institute of Electronics, Inc.** RE-82
 1776 East 17th Street, Cleveland, Ohio 44114
 Accredited Member National Home Study Council

YES...I want the best of everything! Send me my FREE CIE school catalog... including details about the Associate Degree program...plus my FREE package of home study information.

Print Name _____

Address _____ Apt. _____

City _____ State _____ Zip _____

Age _____ Area Code/Phone No. _____ / _____

Check box for G.I. Bill bulletin on Educational Benefits: Veteran Active Duty

MAIL TODAY!

BUILD THIS

Part 2 IN THE FIRST PART OF this article we showed you how to build the video test generator. However, due to space limitations, we could not show you Figs. 6-11; As promised, those appear this month. Now it's time to check out the unit and learn how to use it.

Checkout and alignment

Once you're sure that all the circuit connections are OK and that there are no inadvertent shorts to the chassis, you can apply power. Check the power-supply voltages and verify proper outputs. If the voltages are not correct, be sure to rectify the problem before proceeding.

Set S1 to the EXT position. Connect an oscilloscope to TP1 and trigger the scope

from TP9 (or the horizontal-rate output from J4 on the front panel). Adjust the scope until the display shows approximately one line of video as depicted in Fig. 12. Be sure that the scope is DC-coupled, because you want to adjust R2 and R3 until the blanking level is at zero volts, and the peak-to-peak amplitude of the signal is two volts. Now set S1 to the UP/DOWN STEP position, and adjust R5 until the blanking level is again at zero.

At this point you should verify that the up/down-step and the gray-level signals resemble those shown in Fig. 1. The gray level should be selectable (8 levels) by momentarily pushing S2. When S2 is held closed, the generator should "walk through" the gray levels successively.

The next step is to align the multiburst

generator. To do that, set S1 to the MULTIBURST position. Put the scope probe on test-point TP1, and trigger the scope from TP6. Adjust R34 until the signal on the scope is about 500 kHz. Then, trigger the scope from TP5 and adjust R36 for 1 MHz. Continue in a similar manner with the other test points, adjusting for the frequencies (at TP1) shown in Table 1.

Leave the probe on TP1 and trigger from the HORIZONTAL RATE jack (or TP9) again. Verify that the multiburst signal looks like the one shown in Fig. 1. Next, place the scope probe on TP7 (with the scope set to trigger internally). Adjust R52 for the best-looking sinewave.

You are now ready to align the RF section. Using 75-ohm coaxial cable, connect a TV to J2 (RF OUT). Be sure to use

Build this low-cost, general-purpose video test generator and service TV receivers, video amplifiers, monitors, VCR's, and other video equipment.

GENE ROSETH



VIDEO TEST GENERATOR

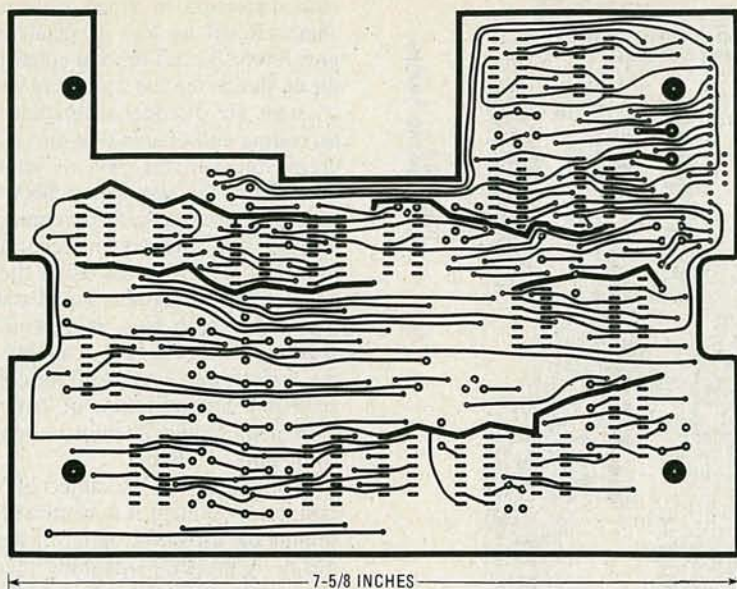

FIG. 6—THE BOARD B component-side foil pattern is shown here reduced 50 percent.

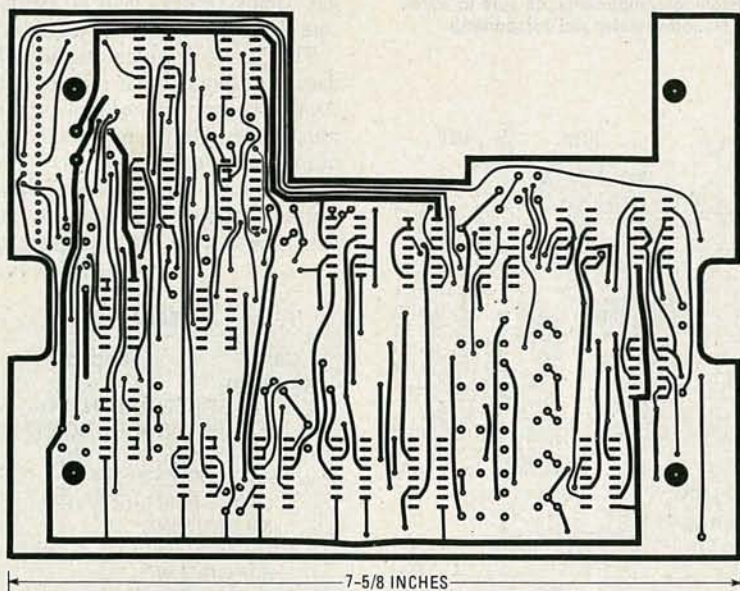

FIG. 7—THE BOARD B solder-side foil pattern is shown here, also reduced 50 percent.

the 75-ohm input of the TV or use a balun for impedance matching, if necessary. Set the TV tuner to channel 3, put the fine tuning at mid-range, and disable the AFT if possible. Adjust coil L1 (with a nonconductive tool) until the best display appears. Rotate S1 through 6 positions (don't worry about the EXT position) and check all signals for proper display. At this point, don't be concerned if there is no color on the color-bar display. Place S3 in the INTERNAL-audio position and adjust

TABLE 1

Scope trigger	Adjustment	Frequency (at TP1)
TP6	R34	500 kHz
TP5	R36	1 MHz
TP4	R38	2 MHz
TP3	R40	3 MHz
TP2	R42	3.58 MHz

L2 until the 1500-Hz tone is heard.

The last step is to accurately adjust the frequency of the master oscillator. The best way to do that is to use a frequency counter at TP14, and adjust C22 until the counter reads 3.579545 MHz. Alternatively, you can adjust C22 by using the TV; Set S1 to the CLR BARS position and turn C22 until the color locks in. That method is less accurate than using a frequency counter. Whether that is acceptable depends on your application.

Using the video test generator

The video test generator is used, in general, as the source of video reference signals. The output of the generator is connected to the device or system under test, and the output from that device or system is observed on an oscilloscope. By knowing what the system's output *should*

be, and then comparing that to the actual output for any deviations, you can locate the causes of many problems.

In this section, we'll first discuss some of the problems and distortions commonly found in video equipment and systems and how they can be identified using one or more test signal(s). Some of the problems are peculiar to a particular class of equipment (receivers, for example), and some may be found in most or all types of video gear, including receivers, videocassette recorders (VCR's), distribution amps, repeaters, switches, routing systems, etc. After we look at some of the common problems, we'll address the subject of interfacing for the purpose of gen-locking and, finally, we'll look at the external digital video input.

To begin, let's consider poor frequency response: That is a general class of distortions which we must break up into different cases for closer examination. We'll start by saying that the video signal has a wide bandwidth (from DC to 4 MHz) and all that spectrum plays an important part.

Low-frequency distortions usually show up as gradual picture-shading changes, typically right after an abrupt scene change. The problem can be caused by a poor DC-restoration circuit somewhere in the video chain. Power-line hum can also cause a similar, gradual shading change. To test for that situation, do the following: Place the test generator in either the up/down-step or the gray-level mode. Depress and hold S2, the auto-step button; That sends gray-level changes to the system under test at a 1-Hz rate. Trigger your oscilloscope from the vertical-rate jack and observe the system output (DC coupled). If the blanking level changes, then low-frequency distortion exists. A good companion check for problems in this part of the spectrum is to use the gray-level mode at its highest level (maximum white). Observe the system output on a DC-coupled oscilloscope at a sweep rate of about 30-Hz, so that two or three fields are visible. Distortion will cause a tilt to the signal such that the sync tips within the vertical-blanking interval are not at the same level as those during the active portion of the picture. And the entire scope display will have a sawtooth component to it. That problem is most frequently caused by insufficiently sized coupling capacitors between stages of a video chain or between stages of individual amplifiers.

Mid- and high-frequency distortions cause problems ranging from simple left/right shading changes to loss of picture detail or image ringing. To test for that problem use the multiburst signal. Observe the output of the system under test at the horizontal rate. If the white-flag portion of the multiburst test signal is tilted, mid-frequency distortion is indicated. Higher-frequency problems show up as

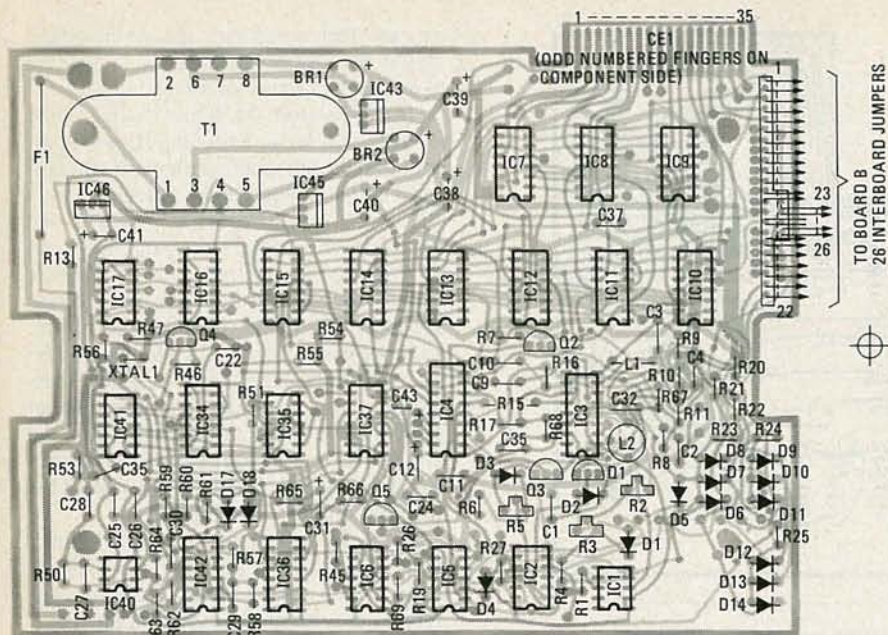

FIG. 8—BOARD A: ON-BOARD PARTS-PLACEMENT. When installing components, be sure to watch the polarity of the diodes, transistors, electrolytic capacitors, and other polarized components.

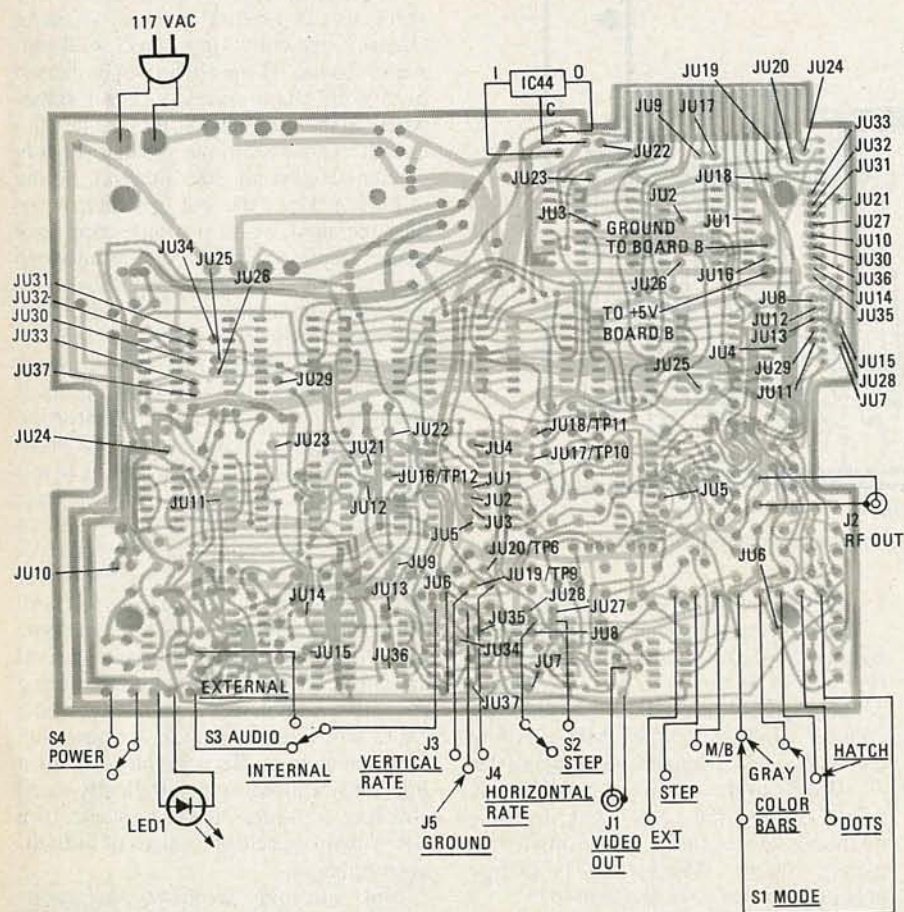

FIG. 9—BOARD A: OFF-BOARD PARTS PLACEMENT and jumper diagram. Note that besides the 37 on-board jumpers, there are also 26 inter-board signal jumpers as well as +5V and ground inter-board jumpers.

amplified or attenuated burst packets. The multiburst test signal is versatile and convenient. It will give a quick indication of system performance. An interesting exercise is to apply this signal to a properly

adjusted VCR. The output signal from the VCR may surprise you—it is a result of the various compromises that are made in its design.

Amplifier non-linearity is another com-

mon distortion in video systems. It is characterized by loss of detail at some gray levels. To test for that condition, use the up/down step test signal and verify that all steps are of equal magnitude in both ascending and descending directions. Increase the vertical gain of your scope when doing this test. Also, check the step transitions for overshoot or round corners.

Scan non-linearity in receivers and monitors is best tested using the hatch-and-dot-pattern signals. Equidistant spacing within each axis as viewed on the screen indicates proper scanning. Those two signals also serve well for color-convergence adjustments; of course, the alignment should attempt to achieve all white dots and lines.

While we are on the subject of receiver/monitor alignment it is worthwhile mentioning the use of the up/down step signal again. A properly operating receiver or monitor should easily resolve all eight of the gray-level steps contained in the signal. That's a quick check and should indicate if further testing is called for.

The color-bars signal provides the standard six colors (three primary and three complementary) in order of ascending luminance level (blue, red, magenta, green, cyan, yellow). That signal is primarily used for subjective system evaluation, as well as for adjustment of receivers. But if you have access to a vectorscope, the

continued on page 139

TABLE 2

Card-edge pin	Function
1	GREEN LSB IN (2 ⁰)
2	VERT RESET CONTROL IN
3	BLUE MSB IN (2 ²)
4	HORIZ RESET IN
5	GREEN MSB IN (2 ²)
6	GROUND
7	GREEN 2 ¹ IN
8	GROUND
9	BLUE 2 ¹ IN
10	GROUND
11	RED LSB IN (2 ⁰)
12	GROUND
13	RED 2 ¹ IN
14	GROUND
15	EXT AUDIO IN
16	GROUND
17	COMPOSITE SYNC OUT
18	GROUND
19	BLUE LSB IN (2 ⁰)
20	GROUND
21	RED MSB IN (2 ²)
22	GROUND
23	BURST GATE OUT
24	GROUND
25	+ 5 VDC (10 mA) OUT
26	GROUND
27	BLANKING OUT
28	GROUND
29	HORIZ DRIVE OUT
30	GROUND
31	VERT DRIVE OUT
32	GROUND
33	VERT RESET IN
34	GROUND

**Radio
Electronics.**

YOUR OWN

APRIL 1984

Computer®

Portables and Totables

Gadgets and Gizmos

Telecommunications

What's New in Printers

Working with Databases

Don't Get Stuck



80 COLUMN PRINTER SALE—\$149.00*

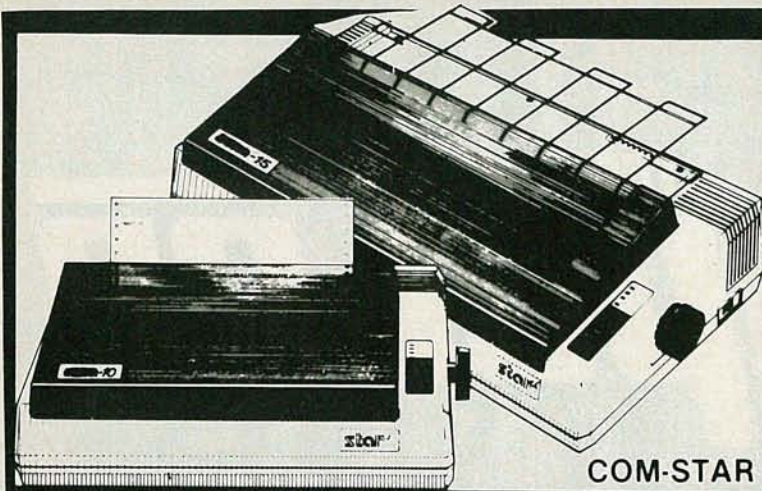

COM-STAR T/F

Tractor
Friction
Printer

only **\$199****

• **15 Day Free Trial -180 Day Immediate Replacement Warranty**

• **Lowest Priced, Best Quality, Tractor-Friction Printers in the U.S.A.**

- **Fast 80-120-160 Characters Per Second**
- **40, 46, 66, 80, 96, 132 Characters Per Line Spacing**
- **Word Processing**
- **Print Labels, Letters, Graphs and Tables**
- **List Your Programs**
- **Print Out Data from Modem Services**
- **"The Most Important Accessory for Your Computer"**

*STX-80 COLUMN PRINTER—\$149.00

Prints full 80 columns. Super silent operation, 60 CPS, prints Hi-resolution graphics and block graphics, expanded character set, exceptionally clear characters, fantastic print quality, uses inexpensive thermal paper! Best thermal printer in the U.S.A.! (Centronics Parallel Interface).

**DELUXE COMSTAR T/F 80 CPS PRINTER—\$199.00

The COMSTAR T/F (Tractor Friction) PRINTER is, exceptionally versatile. It prints 8½" x 11" standard size single sheet stationary or continuous feed computer paper. Bi-directional, impact dot matrix, 80 CPS, 224 characters. (Centronics Parallel Interface).

Premium Quality—120 CPS COMSTAR T/F SUPER-10X PRINTER—\$289.00

COMSTAR T/F (Tractor Friction) SUPER-10X PRINTER gives you all the features of the COMSTAR T/F PRINTER plus a 10" carriage, 120 CPS, 9 x 9 dot matrix with double strike capability for 18 x 18 dot matrix (near letter quality), high resolution bit image (120 x 144 dot matrix), underlining, back spacing, left and right margin settings, true lower decenders with super and subscripts, prints standard, italic, block graphics

and special characters, plus 2K of user definable characters! The COMSTAR T/F SUPER-10X PRINTER was Rated No. 1 by "Popular Science Magazine." It gives you print quality and features found on printers costing twice as much!! (Centronics Parallel Interface) (Better than Epson FX 80).

Premium Quality—120 CPS COMSTAR T/F SUPER-15½" PRINTER—\$379.00

COMSTAR T/F SUPER 15½" PRINTER has all the features of the COMSTAR T/F SUPER-10X PRINTER plus a 15½" carriage and more powerful electronics components to handle large ledger business forms! (Better than Epson FX 100).

Superior Quality SUPER HIGH SPEED—160 CPS COMSTAR T/F 10" PRINTER—\$489.00

SUPER HIGH SPEED COMSTAR T/F (Tractor Friction) PRINTER has all the features of the COMSTAR SUPER-10X PRINTER plus SUPER HIGH SPEED PRINTING—160 CPS, 100% duty cycle, 8K buffer, diverse character fonts, special symbols and true decenders, vertical and horizontal tabs. RED HOT BUSINESS PRINTER at an unbelievable low price!! (Serial or Centronics Parallel Interface)

Superior Quality SUPER HIGH SPEED—160 CPS COMSTAR T/F 15½" PRINTER—\$579.00

SUPER HIGH SPEED COMSTAR T/F 15½" PRINTER has all the features of the SUPER HIGH SPEED COMSTAR T/F 10" PRINTER plus a 15½" carriage and more powerful electronics to handle larger ledger business forms! Exclusive bottom paper feed!!

PARALLEL INTERFACES

For VIC-20 and COM-64—\$49.00

For All Apple Computers—\$79.00

NOTE: Other printer interfaces are available at computer stores!

Double Immediate Replacement Warranty

We have doubled the normal 90 day warranty to 180 days. Therefore if your printer fails within "180 days" from the date of purchase you simply send your printer to us via United Parcel Service, prepaid. We will IMMEDIATELY send you a replacement printer at no charge, prepaid. This warranty, once again, proves that WE LOVE OUR CUSTOMERS!

Add \$17.50 for shipping, handling and insurance. WE DO NOT EXPORT TO OTHER COUNTRIES EXCEPT CANADA.

Enclose Cashiers Check, Money Order or Personal Check. Allow 14 days for delivery, 2 to 7 days for phone orders, 1 day express mail! Canada orders must be in U.S. dollars. VISA — MASTER CARD ACCEPTED. We ship C.O.D.

SUPER-10"

ABCDEFGHIJKLMN OPQRSTUVWXYZ
ABCDEFGHIJKLMN OPQRSTUVWXYZ 1234567890

CIRCLE 51 ON FREE INFORMATION CARD

PROTECTO ENTERPRIZES (WE LOVE OUR CUSTOMERS)

BOX 550, BARRINGTON, ILLINOIS 60010
Phone 312/382-5244 to order

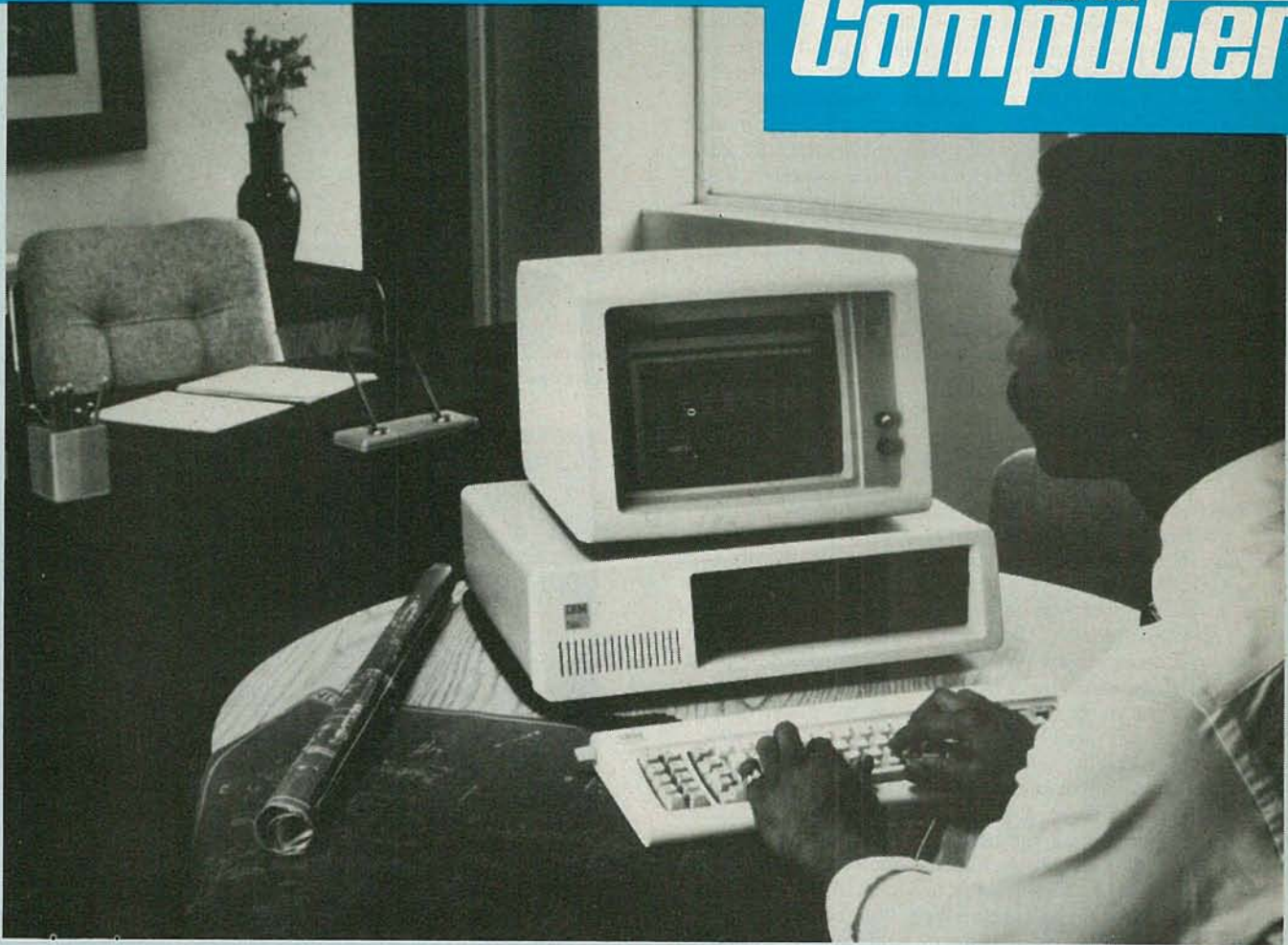

Don't Get Stuck

HERB FRIEDMAN

It's not what the advertisements say that you should watch out for—it's what they don't say! Here's some things you should look out for if you want to avoid "getting stuck."

SOFTWARE IS ONE OF THE FEW THINGS SOLD IN THIS COUNTRY that is *not* guaranteed to do the job you expected or paid for. Unfortunately, software advertising—and in many instances the newspaper and magazine reviews of the software—has something in common with the pitch used to sell Indian Snake Oil. You know: "Two slugs of the stuff will cure everything from 'the vapors' to Saint Vitus's dance."

The difficulty with much of the software sold for personal computers is that the user is rarely told what it *doesn't* do; and often, the very thing it doesn't do is the reason why you purchased the software in the first place. It often appears that software advertising works on the principle that if you make an almost endless list of claims for a particular software—all of which are true—the user will infer that it will also do other things.

When it comes to software not doing what the user expects, it doesn't matter whether it's a small \$20 software package from someone running a part-time business from the kitchen table or a program from one of the "major" houses whose software prices start somewhere around \$500 and head for the stratosphere. The object of both enterprises is to sell software, and as long as they don't make an unsubstantiated claim the "missing" performance is your problem, not theirs.

We're going to look at some of the "missing" features or unusual performance we've run across when testing software for coverage in **Radio-Electronics**. To avoid embarrassing anyone we're not going to name brands or mention names; instead we'll give you an idea of the kind of problems to look for. Often, what bugs us will be of absolutely no concern to you because you have no need for that feature. But maybe our discoveries will give you an insight into what to look for in the software you're interested in.

Sorting problems

A "sort" has always plagued low-cost personal-computer software. A few years back one of the major software suppliers came out with a rather good mailing list that had only one substantial problem: it took nominally 20 minutes to sort (alphabetize) 100 names and addresses. That was never mentioned in the advertising or even in the reviews. Several years later a few magazine columnists got up their courage and mentioned the long sort. But that was about 12 months after the software had been replaced with a mailing list that could sort 500 names in under 15 seconds—and even that's not fast.

Well, you would assume that programmers have finally learned how to write a sort program. Not so! A recent mini-database

filing system, intended primarily for cataloging, which can locate random information before your finger gets off the RETURN key, takes just short of 9 minutes to sort two entries (that's correct, *two* entries). It has some form of "breakthrough in the state of the sorting art" whose speed increases with the number of entries. If you have 500 entries the sort zips through and in seconds everything is alphabetized. But if you have maybe five or ten entries you could prepare lunch while waiting for the sort to finish.

Now you might think that low cost is the reason for sloppy software. That's not necessarily true. Price often has no relationship to sloppy programming or missing features. Three relatively expensive programs, that cost from \$200 to almost \$1000 prove that price does not go hand in hand with a program's performance or conveniences.

Word processing

Whenever **Radio-Electronics** runs an article on word processing in which we make any reference whatsoever to MicroPro's (33 San Pablo Ave, San Rafael, CA 94903) *WordStar*, we invariably get mail from software suppliers to the effect their software is better. (For some reason saying *WordStar* is like waving a red flag at a bull.) Two recent responses illustrate the difficulty we have in selecting software for coverage. The first "better than *WordStar* word processor" came with a 140-page reference manual and a 256-page book on how the program was developed. (Right away we knew we were in for trouble because of the principle: "The thinner the documentation the better the program." A tutorial should not be necessary for general use.)

The truth is that the software was dynamite—actually, more like slightly damp dynamite. While it had almost every feature one could think of, it automatically stored each page on the disk. In order to re-read what had been written you had to go into a review mode and search through each page. Also, if you decided to change a word or character, you had to enter a review mode, find the desired page, edit the change, and then the page was saved as a new page—leaving you with both the old page and the new page. Unlike CP/M systems, which make one automatic backup, if you edit a page five times you have five disk files, one for each page. By the sixth page you will probably be climbing the walls.

Now the "automatic page save" was never mentioned in the advertisements. It is, in fact, a carryback to the old dedicated word processors that were intended for the preparation of business letters. You get a lot of work out of the typing pool with auto-saves at the end of the letter, but personal computers are rarely used for that kind of work. The people who wrote the program had their training on the older word processors and simply did not know it wasn't right for personal computers. But the user did not know about the "page save" feature until he or she owned the software.

Another respondent pointed out to us that his word processor, which cost almost three times as much as *WordStar* (and that piece of software has never been called "inexpensive" to begin with) was better, and provided a long checklist of features to prove the point. Comparing the two features for feature, they were almost identical, except that the competitor's product could do a screen print—the screen display could be printed exactly as shown (which *WordStar* cannot do). But the competition did not have a "page break," a line across the screen that shows where one page ends and another begins.

While a screen print is a much desired feature, in this day and age there is no excuse for new word-processing software not to have a page break so a user can quickly check and edit a multi-page document. And we don't mean a page break called up by exiting the edit mode and loading a view or review mode—we mean an on-screen page break. When you're paying "big bucks" for software you're entitled to *all* the modern features.

OK, we'll compromise: for inexpensive software a "view mode" page break is all right if it shows the page number being

viewed. Either way, if you're into multi-page documents, that is almost a must-have feature; but few advertisements state clearly whether a word processor has a page break, and even fewer tell you what form it takes. One program displays the page formatting in graphics that zips through so fast that if you blink you'll miss two pages.

Databases

Our third problem came up with a rather decent database-management system that impressed us because it wasn't necessary to take a course in programming to use it. Naturally, it claimed to outperform Ashton-Tate's (9929 West Jefferson Boulevard, Culver City, CA 90230) *dBase II*. (For competition, *dBase II* is to database management what *WordStar* is to word processing.) The problems we ran into were due to the fact that

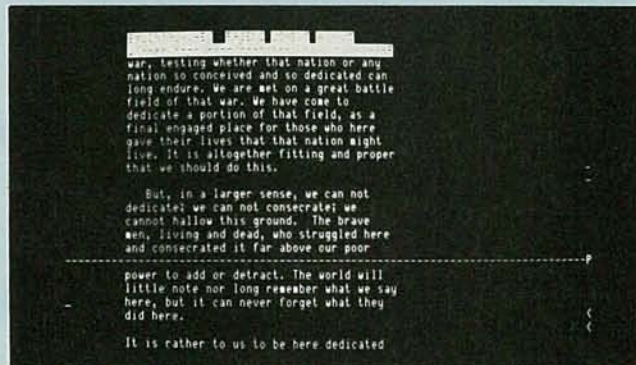

THE STANDARD against which all others are compared, *WordStar*, from Micropro, is considered to be among the most complete word processors on the market.

the program was written in BASIC, and really consisted of three separate programs that auto-loaded each other.

Now there is nothing wrong with BASIC—some truly great software is written in BASIC—but BASIC is very fussy about error trapping. First it turned out there were a few unusual conditions during data entry when the errors were not trapped: The program closed the files and recycled from the beginning: no real loss but it's very time consuming and frustrating. But the sort program was even worse. A mistake in the keyboard entry could produce a RESET to BASIC, with all the files on the disk remaining open. In our usual error-trapping tests, the software worked well; it was the unusual error that crashed the program—but error trapping is supposed to catch everything.

Graphics

Graphics software is another award-winner at creating problems; and we have a good number of examples to keep you on your toes. First, there's the software house with an absolutely superb budget-priced graphics program that's suitable for use in school for instruction in graphics; it's also excellent for home-and-family and small business use. The problem is that the printer routines are not standard and just a few of the latest model printers will print the graphic display. Unfortunately, unless the salesperson that you are dealing with is an expert, you're not going to find out about the printing problem until after you purchase the software and take it home.

Then we have a superb graphic program that makes those multi-function charts you see in the IBM advertisements. The problem here is that the programmer did not know or realize that the printer for which it was specifically written came in two models. One printer simply zipped through the print; the other would put a single tick on the paper, then return the print head to the left hand edge of the paper, move it across the page to the position for the next tick, then return to the left, and continue to repeat the process until the print was made. A simple six-bar graph took almost 30 minutes to print, and we could hear the

head-positioning motor start to slow down from the excessive back-and-forth motion.

Another graphics program had everything going for it: price, performance, ease of use. It was a really nice little program. We wanted to use one of its graphs to illustrate how it worked. Typically, we run articles through a printer buffer to free the computer for other work, particularly when we're processing graphics—which can seemingly tie up the computer forever. Low and behold the whole right column of the display didn't print when using our regular printer buffer. Whether the problem was in the software on the buffer we didn't take time to uncover. Suffice to say, if you do graphics and you use a printer buffer as a matter of course, make certain the buffer and the software work with each other, or disconnect the buffer.

It doesn't take big, expensive software to give you heartburn. When evaluating software we often have to transfer the program from one computer to another. That is generally done through a "null modem" at 4800 to 9600 baud; anything slower and we would fall asleep waiting. When we were evaluating software for a particular computer we were limited to transfers at 1200 baud maximum. So we tried some very inexpensive software that claimed it would allow us to do the job at 9600 baud. Only after getting the software did we discover we also had to make a somewhat sophisticated modification to the computer. We had had enough trouble getting that computer to run; there was no way we were going into its guts and mess around with the circuit.

The thing was that the software was so cheap that it didn't pay to send it back through the whole insurance and return-receipt hassle. (We have to wonder how many others didn't return the software for the same reason.)

We've had several experiences with software it didn't pay to return. Often, they involve a "screen dump"—a means to print hardcopy of exactly what appears on the screen.

From the early days of personal computing we have had the luxury of the NEWDOS "JKL" screen dump. For those of you not familiar with Radio Shack computers using the NEWDOS operating system, by simply pressing the JKL keys simultaneously the user gets a print of what appears on the screen, often with some degree of graphics representation. (It depends on the printer.) We have evaluated many "screen-dump" routines that profess to print exactly what you see on the screen. Unfortunately, they often turn out to be BASIC subroutines that must be appended to BASIC programs. If the BASIC program runs and produces a screen display, then the routine dumps the screen to the printer. On the other hand, if you were writing the program and wanted a quick screen-dump (instead of a listing) it doesn't work; the screen-dump must be part of the program.

Another variation of the screen-dump is software that can be integrated with disk BASIC to run as a command file. The problem is that the instant it's called up as a command file it prints exactly what's on the screen, which is usually the screen prompt and the command line for the program—that's all. If you need screen-dump software, doublecheck on whether it will work when you need it, even for word processing.

Another thing to watch out for is that the software you purchase is convenient and accurate. First, let's look at convenience. We had heard about what was supposed to be an absolutely spectacular income-tax package that had all the major and most of the minor schedules. So we assumed that some **Radio-Electronics** readers with their own business would be interested. The program was fantastic, a magnificent job. The only problem was the printout, which was in an electronic spreadsheet format that had to be laboriously transferred by hand to the Internal Revenue Service forms. Income-tax software should really print on the IRS forms, most of which are generally available in tractor feed for those of you who are accountants or do tax preparation.

Admittedly, some electronic spreadsheet programmers (for that's what they are) are skilled artists; we have seen spreadsheet work that the software house that sells the program claims cannot

	Jan	Feb	Mar	Dec	Total
ASSETS					
Acct.'s Receivable	1000.00	1050.00	1102.50	1710.34	15917.13
Cash	300.00	500.00	525.00	814.45	7403.39
Unsold Goods	250.00	262.50	275.63	427.50	3979.28
Total Assets	1550.00	1812.50	1903.13	2952.37	27299.80
LIABILITIES					
Acct.'s Payable	1000.00	916.67	840.28	384.00	7776.05
Storage Costs	50.00	50.00	50.00	50.00	600.00
Labor	100.00	105.00	110.25	171.03	1591.71
Materials	50.00	52.50	55.13	85.52	795.86
Total Liabilities	1200.00	1124.17	1055.65	690.55	10763.62
NET	350.00	688.33	847.47	2261.83	16536.18
Dep. Allowance	100.00	100.00	100.00	100.00	1200.00

Width: 9 Memory:15 Last Col/Row:025 ? for HELP
Function Keys: RED=Help; BLUE=Keypad Shift; ON

SUPERCALC, from Sorcim (405 Aldo Ave., Santa Clara, CA 95050) is one of the better electronic spreadsheets currently available.

be done. There are spreadsheets for just about everything under the sun, even complete payroll systems that include formatted printout for paychecks and W2 forms. We have also seen spreadsheets that are simply wrong. (In fact, for some three years the "tutorial" software supplied with one of the spreadsheets had an accounting error.) We were once demonstrating an IRA retirement spreadsheet that had received many favorable reviews when a financial planner in the audience rose to claim the demonstration was defective because an annuity value was substantially in error. Now the formula was so long that it literally ran off the screen, but the financial advisors in the audience whipped out their calculators and after almost 30 minute's effort established that not only was the retirement formula incorrect, but so was the compound-interest income formula.

That taught us a good point: namely, before using any calculating software check it out with values you know to be correct. (And if you don't know, ask an expert.)

Finally, consider whether the software really makes your life or work any easier. Sometimes the effort isn't worth the result—and you rarely find out about that until you run the software. Our introduction to unnecessarily expanding the workload was a family income-tax program that made the user go through every single entry; there was no way to skip over any of the screen prompts. In our evaluation we did the income tax for a college student whose entire income was on a W2, with no interest or dividends. It could have been written up on IRS form 1040-EZ in about 5 minutes. Some 50 minutes later we managed to get it through the income-tax program, after constantly pressing ENTER (no value) in response to prompts. And then the final tax was in error; by just a few pennies, but nevertheless it did not agree with the tax tables.

By the way, the tax programs offer an interesting thought. In order to keep up with the changes in the tax rates, forms, and laws it's generally necessary to purchase yearly updates. If you add the cost of the updates to the cost of the basic software, and consider that the program is good for about four years, it will most likely be less expensive and faster to have an accountant or professional tax preparer do your income taxes. (Don't forget. You must add in the cost of the extra-support software for the income tax forms for your own state.)

We've shown just a few of the things that can go wrong with what otherwise appears to be perfectly satisfactory software. The point to keep in mind is always be suspicious about features that aren't claimed, and always worst-case check your software for features that even the programmer doesn't know exist. **R-E**

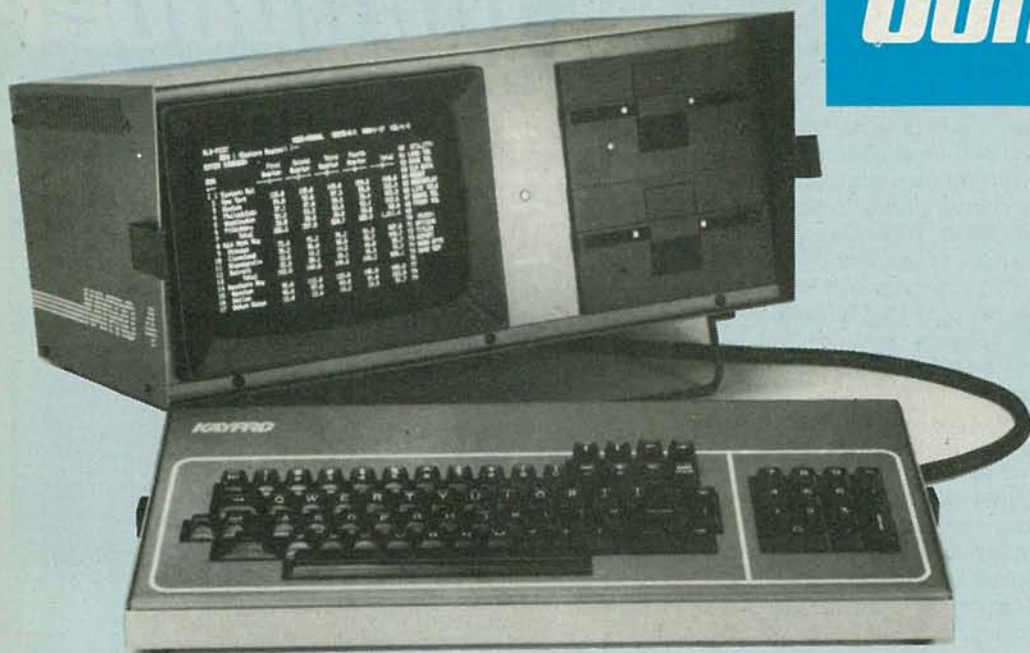

HERB FRIEDMAN

Portables and Totables

Portable and tatable computers are the latest rage in personal computers. In this article we'll find out more about them, including if they're right for you.

TWO OF THE HOTTEST SELLING ITEMS IN THE COMPUTER MARKET-place are the portable and tatable computers. No, they are not the same thing. If it can fit into an attache case or your shirt pocket—and that covers rather a broad range of sizes and weights—it's a portable. On the other hand, a tatable is really a desktop computer that's been scrunched into a case that will just about slip under an airplane seat. It would normally be called a desktop computer except for the fact that the case has a handle. The tatable weighs in at a little under 30 pounds, and is best moved by using a luggage carrier; one of those collapsible hand trucks with small wheels that travellers use to move their luggage to and from airports.

Looking at value and performance versus cost, portables, and to a lesser degree totables, grade out relatively expensive. If you get one or the other you are buying convenience, not necessarily performance. In many instances you must trade off performance for something with a handle.

The first of the true portable computers—not a programmable calculator—was Radio Shack's (One Tandy Center, Ft. Worth, TX 76102) *PC-1*, which was manufactured by Sharp (10 Sharp Plaza, Paramus, NJ 07652); it was also sold directly by Sharp. (The only real difference was that the unit sold by Sharp had a more informative manual.) The *PC-1* was a real attention-getter. Powered by camera-type batteries, it had a one-line LCD read-out, a moderately sized but decent version of BASIC, a small CMOS memory that "remembered" the program even when the computer was turned off, and a built-in calculator that could be used independent of the computer. Priced at slightly over \$200 it was a great gift, particularly for high-school graduates going on to study computer science.

The *PC-1* also had connections for an accessory battery-powered cassette tape interface, or a device that combined a cassette interface with a small printer that used rolls of adding-machine paper. The printouts were small and best-suited for

making program listings.

Over the years, pocket-computer features have been greatly expanded. The latest models—though still having single-line displays—feature extended BASIC, have limited graphic capability (though there's not much you can do on one line), have built-in quartz clocks, expandable memory, and even optional printers that can print graphics. On the flip side of the coin, the latest base-model pocket portables, with features similar to those available on the original models, sell for under \$100.

The problem with the pocket portables, however, is that they are inconvenient for general use. Among the major limitations are itty-bitty calculator-type pushbuttons, which means each program must be punched in a key at a time—a long, error-prone process even if the computer has some form of single-key-entry for BASIC programming functions. What does "single-key entry" mean? It means that if you touch the "P" key the entire command `PRINT` is entered; touch, perhaps, the key "L" and the computer loads a program from the cassette. The computer has its own internal program that knows when a "P" is the letter "P" and when a "P" is the command `PRINT`.

Programming problems notwithstanding, for persons who work in the field (such as civil engineers, architects, salespersons, and the like), who need immediate access to a few fixed computer programs, or some means of quick data entry and storage, the pocket portables are an unquestioned asset. That's particularly true if all the user needs is information that can be displayed on a single line. (Yes, a printer can be used for multi-line output, but a combined computer and printer assembly is too large for the pocket.) Then again, if the primary purpose of the pocket portable is computations, a programmable calculator will possibly do the same thing at substantially lower cost.

And if you're thinking about getting a pocket portable for someone going into computer science, think about it twice. Most schools want the students to have a particular kind of

computer, or one with specific features, and pocket portables rarely meet either requirement.

In your lap

But no matter how the performance of a pocket computer might be rationalized, a one-line display simply is not convenient for anything more than minimal data entry, or a series of individually displayed values.

For portable computer power that's something more than a substitute for a programmable calculator, the real choice is something usually called a "lap" computer. A lap computer has a full-size keyboard with typewriter keys, yet it is small enough to fit on the user's lap or slip into an attache case.

Those units are powered by alkaline or rechargeable batteries, or a plug-in AC adapter; the adapter can also operate as a battery charger if the computer has rechargeable batteries. Lap computers feature a multi-line LCD readout, an enhanced BASIC, a substantial amount of CMOS memory that will retain your program and information even after the power switch is turned off, and, at the very least, has some kind of built-in text-editing software. Other features depend on the particular model.

Presently, there are three lap computers generally available: the Radio Shack *Model 100*; the NEC (1401 Estes Ave., Elk Grove Village, IL 60007) *PC-8201A* (which is very similar to the *Model 100*), and the Epson (3415 Kashiwa St., Torrance, CA 90505) *HX-20*. The *Model 100* is the most systemized of the lap portables, meaning it can be used to its maximum potential without the need for external accessories. Its basic hardware features include a 40-column by 8-line LCD readout, 8K of RAM (expandable to 24K), a direct-connect answer/originate modem, a parallel printer (Centronics type) output, and a cassette-tape interface.

But all things considered, the *Model 100's* strength is its internal ROM-based software, which includes extended Microsoft BASIC; a decent text editor suitable for the preparation of documents; an address/telephone index file that will automatically dial a telephone number through the internal modem; a mini-database called *Schedule* that will keep track of appointments, daily expenses, and personal notes (such as who you took to dinner), and a full telecommunications package that controls the data exchange through the modem.

The NEC *PC-8201A* is similar in appearance to *Model 100*, and other than the different location of a few keys and a somewhat superior keyboard layout it's difficult to tell them apart at first glance. Even the display is the same 40 columns \times 8 lines. In fact, both start out with essentially the same basic package, but they diverge in the concept of their final purpose. Whereas the *Model 100* is intended primarily for material that will eventually be used for telecommunications or dumped into a larger computer, the NEC *PC-8201A* is part of a complete portable package that includes several battery-powered devices: a cassette recorder, a thermal printer, a direct-connect modem, optional nickel-cadmium batteries (the NEC's basic power supply is alkaline batteries), and outboard adapters to drive an 80-character \times 24-line monitor or a TV modulator that produces a 40-character \times 16-line display on a TV set.

The NEC's internal ROM software is similar to the *Model 100's*: it includes enhanced Microsoft BASIC, a text editor, and telecommunications software. As for RAM, the NEC is supplied with 16K versus the *Model 100's* 8K. The NEC's internal RAM can be expanded to 64K, the *Model 100's* can be expanded to 32K. (Actually, it's possible that even 24K might be sufficient because text processing gets somewhat slow once the document exceeds about 20K.) A port on the side permits an additional 32K of RAM with battery backup to be plugged in. The program or text can be dumped to the plug-in RAM, which can then be unplugged and stored for up to two years without losing its "memory." (Super-memory isn't all that much of a blessing for either unit, because it can make the computer start to run so slowly that the typing gets several words ahead of the display.)



THE KAYPRO LINE of totable computers. Shown here are the Kaypro 2, Kaypro 4, and Kaypro 10.

As for what to do with the computers: Both obviously can be used for moderate document preparation since they can feed a standard printer, and both can dump their stored text into a larger personal computer for extensive processing by standard word-processing software. (Radio Shack's *Scipsit* works very well on text prepared with a lap computer). For the journalist, reporter, salesperson, or anyone else in the field, both lap computers are superior to a pencil and a pad, and copy can be submitted by modem rather than telephoned to the rewrite desk.

The original lap computer was the Epson *HX-20*, which simply didn't work out as conveniently as the later two units. In fact, there are two models of the *HX-20*, the original which came only with enhanced BASIC in ROM and empty sockets for future ROM programs, and the new model, which is simply the old model with a "word processing" ROM added. Though the *HX-20* is about the same size as the Radio Shack and NEC lap computers, its screen is much smaller, only 20 columns \times 4 lines, which is simply too small for convenient word processing.

One reason for the small display is the inclusion of a miniature printer that uses small rolls of adding-machine-type paper, and provisions have been made for an optional cassette recorder that slides directly into the top of the case. The printer is fine for listing programs. There is also a standard serial output port so that a standard printer can be used for both BASIC listings and word processing. The cassette recorder, which uses special sub-miniature cassettes, has its own 80-page manual, which should give you some idea of complexity of its use and operation.

The *HX-20* has an RS-232-C I/O that can be used with an optional acoustic-coupled modem. Unfortunately, the computer does not have built-in telecommunications software. Also, the modem accommodates the older series-500 telephone handsets; the newer "princess" type handsets do not fit into the acoustic cups at all.

Essentially, the *HX-20* appears to have been intended for BASIC programming, with word processing and communications an afterthought. But if your needs are for writing sophisticated BASIC programs when away from your desktop computer, the *HX-20* will do it nicely.

The totables

A "tortable" (sometimes also called a "transportable") is a desktop computer that has somehow been shoehorned into a



AMONG THE NEWEST of the totables, the Radio Shack Model 4P is a transportable version of that company's desktop Model 4.

cabinet that will just about fit under an airline seat. Weighing in somewhere between 25 and 30 pounds they are not the kind of thing you're likely to stroll with down the street; hence, we do not call them portables even though they have a handle and are called "portables" by some manufacturers.

The first of the totables, the one that literally created the genre, was Osborne's (26538 Danti Court, Hayward, CA 94545) *Osborne-1*, which had virtually no standard features. It also used single-density disk drives when almost everyone else had switched to double-density drives. The *Osborne-1* is no longer manufactured. Those currently being sold are warehouse stock and demonstrators.

The first truly well-done tatable was the *Kaypro II*, which is still Kaypro's (PO Box N, Del Mar, CA 92014) standard model and the basis for the company's two other models. The *Kaypro II* has a 9-inch screen with an 80-column \times 24-line display, 64K of RAM, and two double-density disk drives providing nominally 200K storage per drive (400K total). The same model with double-sided double-density drives, having 400K storage per drive, is sold as the *Kaypro 4*. Both models feature the CP/M-80 operating system in a standard configuration, meaning it will run just about all CP/M software. The exceptions are CP/M variations that are hardware dependent. There is a standard parallel output for Centronics-type printers and a standard RS-232-C serial output for a serial printer or a modem. The computer is bundled with a software package that varies from time to time. One software option consists of CP/M, Microsoft BASIC, and *Wordstar*; another consists of CP/M, Microsoft BASIC, *SBasic*, *Perfect Writer*, *Perfect Speller*, *Perfect Calc*, *Perfect Filer*, *The Word* (spelling checker), and a program called *Uniterm*, which can read six other 5/4-inch computer disk formats.

Both Kaypro models have unusually good reputations for ruggedness, even when manhandled. They are essentially desktop systems that happen to close up. Though the software packages are extensive, do not be carried away by quantity; many users will have no need for Microsoft BASIC, *SBasic*, or perhaps the filing program. To get your money's worth, select the package with the software you really need.

Dual-purpose models of the *Kaypro II* and *Kaypro 4* are designated *plus 88*, which means they can be software-switched from an 8-bit Z80 mode to a 16-bit 8088 mode for the MS-DOS operating system. Do not assume, however, that *plus 88* means you can run IBM software. If the IBM software is hardware dependent—meaning it uses or requires specific or proprietary hardware features of the IBM PC—then it won't run on the Kaypro or any other MS-DOS computer that isn't IBM hardware compatible.

An even more advanced version of the Kaypro computer is the *Model 10*, which features a built-in 10-megabyte hard disk as well as a double-sided double-density floppy disk. It comes bundled with the larger software package on the hard disk. A significant variation in features between the *Kaypro Model 10* and the other models is that the *Model 10* has a parallel printer output and two serial I/O's; one for a modem, the other for a printer or any other purpose, and each can be individually configured (baud rate, etc.).

An important consideration when using a hard-disk drive is that the heads must be parked in a safe area on the disk to prevent rough handling or jarring from causing the head to crash on an active part of the magnetic coating. The "parking" software for the computer is not automatic; it must be specifically run when the user closes down, thereby leaving open the possibility that the computer will be moved with unparked heads. That's something you must consider if you have any intention of transporting the computer by plane or vehicle.

All three Kaypros deliver about the maximum performance you can expect from an 8-bit computer. They aren't fancy, and won't do color or complex graphics, but they will run just about every piece of major 8-bit software. If you need something for small business use, those computers will probably handle all your needs. In fact, some computer dealers will deliver a *Kaypro II* complete with a daisywheel printer for under \$2000—an attractive price.

Among the most recent tatable computers is the Radio Shack *Model 4P*, a tatable version of their desktop *Model 4*. The *Model 4P* is supplied with 64K of RAM which can be expanded to 128K. It has a 9-inch monitor with an 80-column \times 24-line display, two double-density 184K disk drives (368K total), a parallel Centronics-type printer output, and room for a user-installed 300 baud modem. As for software, it is supplied with the TRS-DOS version 6.0 operating system and Microsoft Disk BASIC.

Though the *Model 4P* is similar to the *Model 4* there are a few significant differences between the two that you should be aware of. Firstly, the *Model 4* contains the *Model III* ROM's, which means the *Model 4* will automatically function as a *Model III* if the user runs a *Model III* program. For both CP/M and the *Model 4* mode the *Model III* ROM's are automatically switched out. In the *Model 4P* computer the *Model 4* ROM's are replaced by software. The user loads software that simulates the *Model III* ROM's in the lower 16K of RAM; thus the *Model 4P* will also run *Model III* programs.

The second variation between the two machines involves the serial output. The dual-disk-drive version of the *Model 4* has a built-in RS-232-C interface. The *Model 4P* does not have the serial interface; instead, there is space for an optional 300-baud auto-dial/auto-answer direct connect modem that can be installed by the user.

Since CP/M *Plus* was not available when this article was prepared (It is now—*Editor*), the computer could run only TRS-DOS programs intended for the *Model III*, *Model 4*, and *Model 4P*. However, the non-Radio Shack Montezuma Micro Version 2.2 CP/M is specifically designed to run on the *Model 4/4P* computers; it opens up the computer to most of the available CP/M software.

Do you need a portable or tatable?

While the concept of the portable and tatable computers is interesting, the major consideration should be: "Does it have any real value for me?" Even the best models trade off something for size: color capability, screen size, speed, or expansion capability—there is always something. However, if your requirements dictate that you simply must have a computer or even just a word processor tucked in your attache case, or bouncing in the trunk of your car, you have no choice—you must select the model with the specific features needed to make your work easier or more productive.

R-E

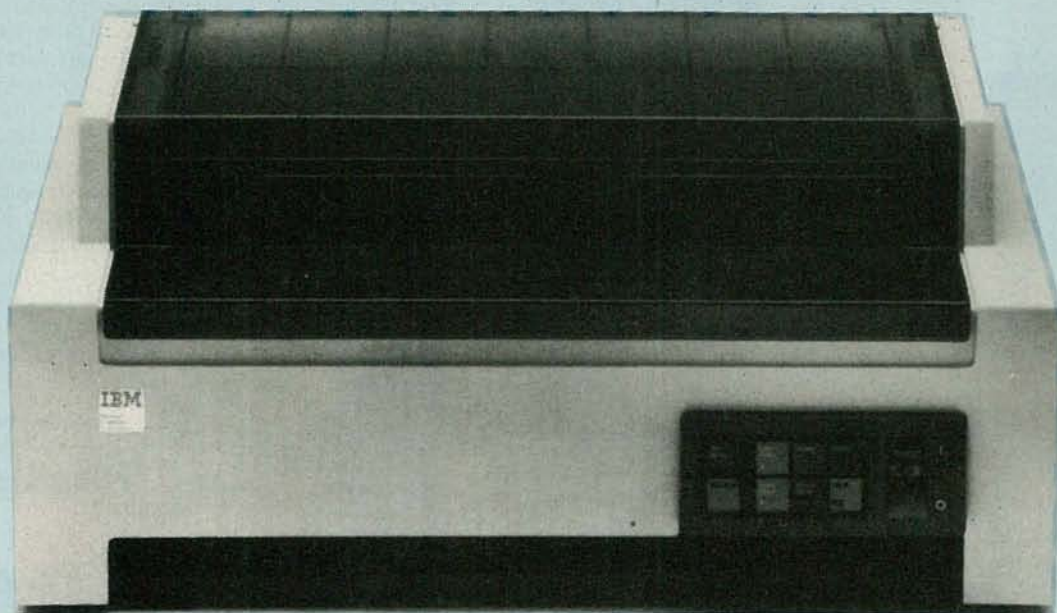

What's New in Printers

New technologies, new features, and falling prices can make shopping for a printer more exciting, and confusing, than ever before. In this article we'll show you what's new and what's coming in printers for your home and office.

MARC STERN

WHEN YOU TALK ABOUT PRINTERS, THERE'S ONE THING THAT you can be certain of—that is that the state-of-the-art is constantly changing. For instance, technologies that once cost thousands of dollars are now coming within the reach of the average home computerist. Also, conventional printers, such as dot-matrix and daisywheel types, are enjoying both improved performance and decreased cost.

In this article we are going to take a look at the current state-of-the-art in printers. Included will be both a look at what's new in such familiar printer technologies as thermal, dot-matrix, and daisywheel, and a look at some new technologies that are now, or may someday be, practical and affordable for the personal-computer owner.

Ink-jet printers

Take the ink-jet printer, for instance. Only a few years ago, a sophisticated ink-jet printer's cost ranged from well over \$2,500 to as much as \$50,000. Today, those prices have dropped to as low as \$895, with the most sophisticated units on the market running upwards of \$30,000. What's more, today's ink-jet printers are capable of full-color printing as well as graphics work.

There are basically two main technologies used in ink-jet printing—continuous-stream and drop-on-demand. In continuous-stream printing, a constant stream of ink is ejected from a single channel and letters are formed by the movement of the printhead. As the ink is ejected, it is selectively charged using a pair of electrodes. The charged ink is applied to the paper,

forming the output. The uncharged ink falls into a reservoir and is recycled through the printer, after passing through a filtering system. Continuous-stream technology is used in very sophisticated printers, that cost upwards of \$30,000.

Drop-on-demand technology is far less expensive, and is available to the personal computer owner in printers from, among others, Siemens Communications Systems, Inc. (240 E. Palais Rd., Anaheim, CA 92805) in its *PT88-T2* and *2717-M203* printers.

Let's take a closer look at drop-on-demand ink-jet printers.

Ink-jet basics

If you were to look at the output of a typical drop-on-demand ink-jet printer, you would probably wonder how the unit differs from a dot-matrix printer because the result looks much same; ink dots are still used to form the characters. But, the technology used to produce those characters is radically different.

Unlike the dot-matrix (and daisywheel) impact printers that you might be familiar with, the drop-on-demand ink-jet printer is a non-impact type. An impact printer is any printer whose printhead element or a part of it actually strikes the paper, while a non-impact printer's printhead never does. For example, a dot-matrix printer has a tiny printhead filled with wires. Each one of those wires is controlled by the printer's logic circuitry and fires after it is activated by a small solenoid. The firing is controlled by the logic and the print produced is based on the character set contained within a special ROM in the printer.

Ink-jet machines also make use of a printhead and platen, but

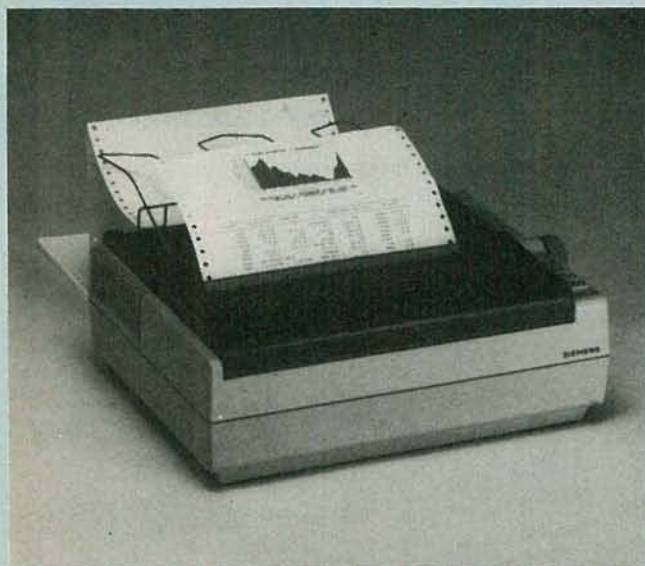

THE SIEMENS PT-88, an ink-jet printer available to personal-computer owners, makes use of drop-on-demand technology.

unlike impact printers, no part of the printhead in an ink-jet machine touches the paper. The result is that there is very little noise, one of the more common complaints about impact printers, whether they are dot-matrix or daisywheel.

Instead, tiny drops of ink are sprayed out of a series of nozzles and those are used to form the letters or graphics of the final output. Either a low-pressure area or special electrostatic circuitry is used to form the characters after the ink is fired at the paper. The nozzles are connected to a series of ink-filled channels, which are linked to an ink cartridge, which supplies the ink for the printing process.

A closer look

If you were to look at the printhead of a drop-on-demand printer, you would see a series of nozzles; the number and pattern of nozzles will vary from machine to machine. Those nozzles are connected to the ink channels. A piezoelectric crystal tube in each channel is stimulated by an electrical pulse, causing the crystal to expand slightly and this increases the pressure inside the channel. In turn, the increased pressure pushes the ink away from the crystal and toward the nozzle, where a tiny ink droplet forms.

As the pressure is decreased when the crystal contracts, the droplet breaks away from the ink stream and is, in turn, deposited on the surface of the paper. Like the dot-matrix-type printers, the dots are arranged in a pattern that forms the letter.

To keep the ink from being deposited where it isn't supposed to be, the ink-jet printer uses a slight negative pressure to keep the ink inside the channel when that particular jet nozzle isn't being used. Thus, if you were to look at a cutaway of the print head, you would see a slightly concave indentation in the surface of the ink.

Ink-jet advantages

An ink-jet printer has several advantages over a dot-matrix or a daisywheel impact printer and the first is the noise level. Quite typically, the ink-jet printer is a fairly quiet machine, one which will fit in well with a home computer setup. Its noise level contrasts quite markedly with the rat-tat-tat of the daisywheel machine or the loud whirring of the dot-matrix printer.

Another advantage is low maintenance cost. Since there are few moving parts in the typical ink-jet printer, its maintenance requirements are very low. Further, because the printhead never touches the paper, it isn't degraded as are those of impact machines. Thus, its life can be much longer. The life of the typical ink-jet printhead is in the vicinity of 10-billion characters,

as opposed to about 200-million for the average sophisticated dot-matrix printhead. And, because the ink-jet machine doesn't depend on a ribbon that is subject to wear, the print quality remains constant over time.

Another advantage of ink-jet printers is speed. Quite typically, those machines race along at between 150 to nearly 300 characters-per-second. In contrast, the top print speed of an average dot-matrix machine is about 200 characters-per-second. Most letter-quality printers—daisywheel printers—run from 12 to 40 characters-per-second.

The primary disadvantage of a drop-on-demand ink-jet printer lies in its inability to produce more than one copy at a time and in the fact that its output still looks like a "computer" printout—the dots in its matrix are quite evident. Further, top-quality print runs require special absorbent papers, although bond paper does the job adequately.

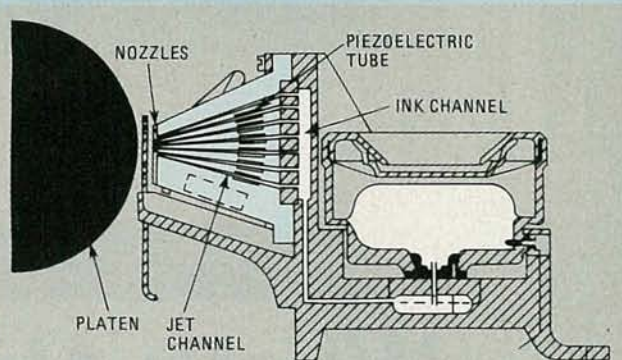

AN INK-JET PRINTER'S PRINthead. This cross-section shows the key parts in a drop-on-demand system.

Graphics capability

One of the beauties of the ink-jet printer is its graphics capability. Because of their precise tracking capability and because they are not limited to using dot-matrix impact pins, the ink-jet printer is capable of very highly detailed graphics. For instance, it is possible to program the Siemens PT88 printer in $1/72$ -inch increments. That means you can produce some highly complex graphics with subtle variations of grey, black, and white.

Another area where the ink-jet printer shines is in color-graphics printing. Although dot-matrix printers are capable of color printing, they have some drawbacks. Since they are limited to the use of multi-color ribbons, dot-matrix machines take a longer time to produce a color output. Each color or color combination requires a different pass of the printhead and that slows things down more than just a little bit. Also, since the separate dots never completely line up, it is possible that there will be gaps in the final printout and solid areas may end up incompletely filled. Finally, since dot-matrix machines must rely on ribbons and since ribbons tend to wear out fairly quickly, outputs produced later in the ribbon's lifetime will be lighter than those produced earlier.

In contrast, a color ink-jet printer uses a special four-color ink cartridge and applies the colors, or combinations of color, when called upon by the graphics programming in the microcomputer. Since it is capable of multi-color output, the time needed to create the final output is shortened considerably. Further, solid-color areas appear much more uniform in density because it is possible to overlap the ink dots. Also, since it is possible to mix the colors directly on the printout, the ink-jet printer is capable of printing many more color combinations and hues than a dot-matrix machine.

Because the printhead of the ink-jet machine is micro-processor-controlled, it is possible to have the printhead dither. When the printhead dithers, it mixes the ink droplets in different intensities, thus creating darker or lighter color intensities.

To master the computer, master the software

Challenge your ability.
Take charge of your computer.
Take pride in the results.

You've invested in the computer. Now invest in yourself. Writing your own software lets you define your own boundaries, broaden your problem-solving resources and puts you in complete command at the keyboard. It's challenging. It's exciting. And now it's easier than ever before with Self-Study Computer Courses from Heathkit/Zenith.

Master today's most powerful contemporary languages including Microsoft BASIC, PASCAL and FORTRAN. And learn the popular CP/M and MS-DOS operating systems, too. When you need to know, we'll take you as far as you want to go.

For more information,
write: Heath Company,
Benton Harbor, MI 49022
Or circle the reader service number.



Heathkit®
Heathkit/Zenith

Cost comparisons

In general, you will find that the cost of ink-jet printers has fallen markedly during the last year, as have the prices of just about all computer printers. Roughly a year ago, it wasn't uncommon for a good reasonable-cost ink-jet printer to cost between \$2,500 and \$6,000, with some of the top-quality machines costing up to \$50,000. Now, the cost of a good ink-jet printer is approaching that of some of the more capable dot-matrix machines on the market, about \$895. Even top-quality machines have had price drops, too, to the \$30,000 region. As for a good color ink-jet printer, you'll still have to wait some time until the prices drop even further. Even though their prices have dipped in the recent months, you'll still find them expensive pieces of equipment, ranging in price from \$5,500 to nearly \$12,000.

Laser printing

Although their cost puts them beyond the means of most personal computer owners, if you own a large business, or have need of offset-printer-quality output, you may be interested in some of the laser printers currently on the market.

One such machine is the Xerox (Printing Systems Division, 880 Apollo Street, El Segundo, CA 90245) 5700. That system can produce documents in a wide variety of type styles (up to 256 can be stored), and in type sizes ranging from 6 to 24 points. Graphics can also be accommodated. Printing can be done on both sides of a page, plain paper is used, and up to 43 pages a minute can be produced.

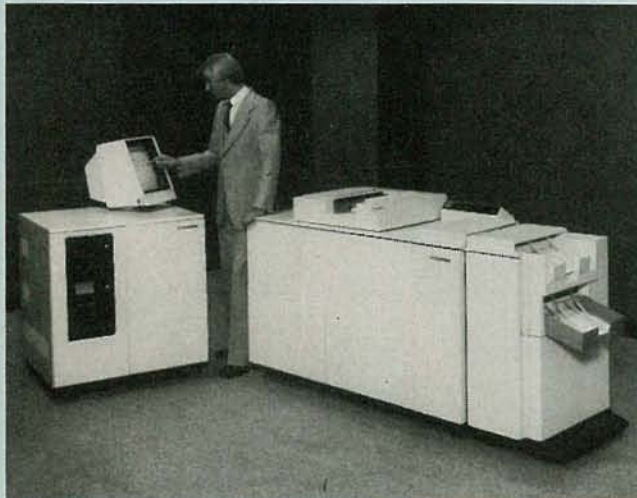

CAPABLE OF OFFSET-QUALITY PRINTING, this Xerox 5700 laser printer can produce documents with a wide variety of type styles and sizes.

The key to the printer is a laser-imaging system. That imaging system has a resolution of up to 90,000 dots-per-square-inch, which is why the system can produce copy that compares favorably with offset printing. The key to the machine's versatility is the fact that the location of each dot on the page can be individually controlled. Thus almost any image can be reproduced. Once the image is created, the actual printing is done using Xerox's xerographic (photocopy) process.

You may be wondering about the cost for all of this. Well, the basic 5700 system can be had for about \$65,000.

Dot-matrix developments

Perhaps the key development in the dot-matrix printer realm during the last year is the increasing density of the printhead. Quite typically, printheads used to have dot densities of 5×7 or 7×7 and now they routinely feature 9×7 or 9×9 dot densities in standard (draft) mode, and as many as 18 or 24×7 or 9 in the near-letter-quality mode.

The dot density of a printhead isn't hard to determine. It

merely means the number of pins the printhead contains in vertical and horizontal rows. For instance, if the density of a printhead is 7×7 , it would have 49 little metal pins enclosed in the printhead in seven horizontal rows and seven vertical rows. If the density is 9×7 , then there are nine vertical rows and seven horizontal ones.

The biggest criticism of the dot-matrix printer in the past has been its "computerish" hardcopy output. That means that the printout is made up of very noticeable dots, no true descenders, and is very hard to read. However, that criticism has been pretty much nullified by the near-letter-quality output of some dot-matrix printers.

Using overlapping vertical rows of pins, those printers actually lay down two slightly offset dots during its print run. Those dots give the hard-copy a more "typed" look when it is printed. The dot-matrix manufacturers are able to achieve this thanks to the fact that they are using printheads with finer wires, which permits greater density (18 or 24×9). Since those heads also usually feature two extra horizontal rows of pins, they are also capable of having true descenders on such letters as "g" or "y."

At one time—about a year-and-a-half-ago, that type of output was available only on machines costing more than \$1,200, but now it is available on dot-matrix printers costing little more than \$495. And, even low-cost printers—\$199 to \$499—have printhead densities of 7×7 or 9×7 , so that their output has a more professional quality.

One problem with the new near-letter-quality dot-matrix printers is that they take away one of the dot-matrix printer's biggest advantages—speed. That's because generating the slightly offset dots needed to produce the nicer looking output requires that each letter be actually printed twice, slowing down the entire process. But printer manufacturers have found a way to let us "have our cake and eat it, too." That is, all but the least expensive dot-matrix machines these days are dual-mode. They offer a high-quality but slow near-letter-quality mode as well as a less attractive looking, but much faster draft mode. Typically, the print speeds on those machines vary from 40 to 80 characters-per-second in the near-letter-quality mode and from 160 to 200 characters and more in the draft mode.

Dot-matrix printheads

Let's look at the typical printhead. A dot-matrix printer is called an impact printer with good reason. Its printhead contains fine wires that are fired electrically into a ribbon, which strikes a piece of paper, thus producing the image.

The firing of the pins is controlled by solenoids that are activated by electrical pulses received from the character-generation ROM. That ROM contains the ASCII code for the characters and the pins corresponding to that code are all fired at the same time to produce the required letter.

As are ink-jet machines, dot-matrix printers are almost universally bidirectional printing units—they print on both passes across the paper—and they usually feature logic-seeking printheads. Logic-seeking printheads seek the shortest path between two printing points thus cutting printing time. Because they are logic-seeking and microprocessor-controlled, dot-matrix printheads are usually capable of graphics output. Typically, most of them have a special programmable graphics mode that is capable of laying down nearly 80×80 dots-per-inch, and, even more if special graphics software is used.

Since there are few moving parts in a dot-matrix printer, other than the linefeed motor and motor used to move the printhead, those units tend to be fairly reliable. Printheads last a long time, on the order of 200 million characters, although that isn't as long as a typical ink-jet printer.

The biggest drawbacks of dot-matrix printers are their noise and the fact that ribbons wear out fairly quickly. Most dot-matrix machines emit noise in the 65- to 85-dB range, which makes them rather uncomfortable to be near for any length of time. Newer machines, however, tend to be a little quieter.



**INTRODUCING THE
IBM-PC® ALTERNATIVE...**

IBM-PC*
SOFTWARE
COMPATIBLE

THE SANYO MBC550

AT ONLY \$895⁰⁰* PLUS

16 BIT
MS-DOS REG. \$995⁰⁰

FREE BUSINESS SOFTWARE

INCLUDING:
MICROPRO WORDSTAR • CALCSTAR
PLUS EASYWRITER
AND THE SYSTEM DISK

- IBM PC Compatible
- Single-Dual Disc Drive
- 128K Memory
- Centronics Printer Port Included
- Color Graphics Capability
- 8088 CPU
- Self-Diagnostics

*IBM PC registered trademark of IBM Corporation

LETTER-QUALITY PRINTERS

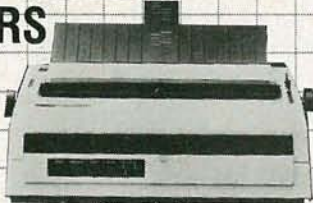

PR 5500

- 16 characters per second
- Bi-Directional printing
- Quiet operation
- Choice of 10, 12 or 15 characters per inch

\$795⁰⁰
Reg. \$995⁰⁰

not shown

PR 5000 10 characters per second
\$495⁰⁰* REG \$595⁰⁰

*When purchased with Computer

SANYO MBC555

\$1295⁰⁰* PLUS
FREE SOFTWARE

REG. \$1395⁰⁰

DUAL-DISK DRIVE

MICROPRO SOFTWARE (\$2000⁰⁰ VALUE)

- WORDSTAR • SPELLSTAR • CALCSTAR
- MAILMERGE • INFOSTAR

SANYO MONITOR CRT-36

MATCHING 12" SCREEN
HIGH-RESOLUTION
GREEN MONITOR

\$169⁹⁵*
REG \$199⁹⁵

*When Purchased with Computer



ADVANCE COMPUTERS
THE PEOPLE WHO KNOW

**TOLL FREE HOT LINE
800-223-0474**

26 WEST 46th STREET, NEW YORK, N.Y. 10036 212-730-7030

* When purchased with monitor and printer. (Model MBC550 \$995 if purchased separately. Model MBC555 \$1395 if purchased separately.)



THE SMITH-CORONA TP-1 was one of the first low-cost, bidirectional daisywheel printers for personal computer use.

Dot-matrix machines also seem to run through ribbons very quickly, especially if they are used a great deal. That means that early printouts are good quality, but later printouts tend to be lighter and harder to read. And, if those ribbons aren't used quickly, they tend to dry out and also produce lighter printouts.

Daisywheel developments

The other type of impact printer on the market is the letter-quality or daisywheel printer and its variant, the thimble printer. Both rely on essentially the same technology, but, during the last year, their capabilities have been increased markedly.

At one time, the average low-cost daisywheel printer was a unidirectional, noisy, slow-speed affair. It did produce top-quality printing, but the tradeoff was that it took forever to complete a printout. Those units tended to operate very slowly—12 to 18 characters-per-second—tying up the computer for long periods as they slowly worked their way through documents. If you wanted higher-speed, bi-directionality, and microprocessor control in you daisywheel, you had to spend nearly \$3,000.

But, the last year or so has seen a change in this, beginning with the Smith-Corona (65 Locust Ave., New Canaan, CT 06840) TP-1. That was the first low-cost, bidirectional daisywheel printer for personal computer use. It debuted at a price of under \$800 and set the trend toward lower-priced home units, whose prices seemed to keep on dropping. Now, it seems most major printer manufacturers have a low-cost daisywheel available.

The key to the change in the daisywheel market was the introduction of microprocessors in those devices. That development allowed low-cost daisywheel printers to gain bidirectionality and logic-seeking capability. It also enables the daisywheel to be used for something that was once the province of the dot-matrix printer—graphics. Because the printhead can now be controlled with computer precision, the low-cost daisywheel printer can be programmed for a minimal level of graphics. It can produce such things as charts, graphs, and some limited pictorial matter.

Let's take a look at a daisywheel printhead. Where a dot-matrix machine uses solenoids and pins, the daisywheel uses a whirling disk with flexible petals, and a small hammer. Each letter is fully formed on a petal of the printwheel, which somewhat resembles a daisy; it's from the printwheel that the machine gets its name.

As the printhead moves across the page, it receives the ASCII codes output from the character-generation ROM. However, instead of those pulses activating a series of wires, they cause the

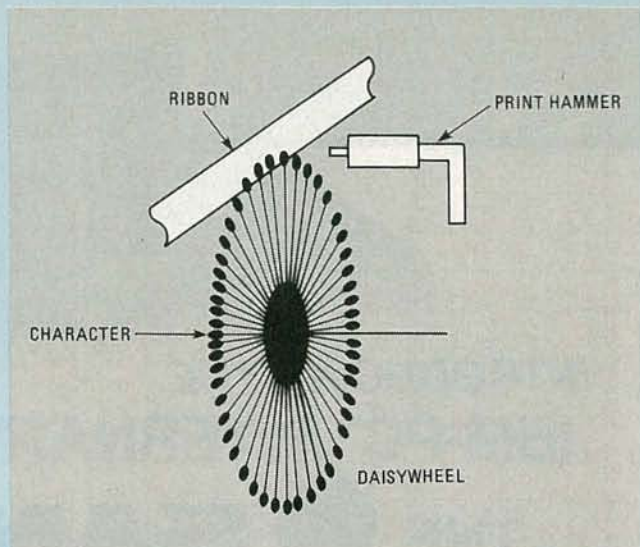

THE CHARACTERS on a daisywheel are located at the ends of the "petals," when a hammer strikes the petal, the character is printed.

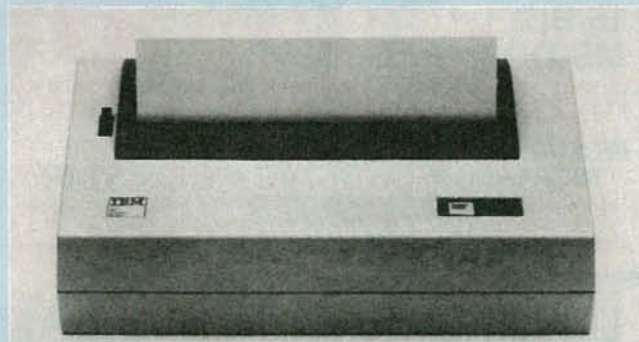

ONE OF THE NEWEST thermal printers, this unit from IBM (P.O. Box 2989, Delray Beach, FL 33444) is for use with the PCjr.

whirling disk to align the appropriate letter-petal with the ribbon. The petal is then struck by the hammer, which produces the letter.

The key drawbacks of this machine, again, involve noise and speed. Even at their quickest, they are only about one-quarter to one-half as fast as the slowest dot-matrix machines on the market. But, the quality of the print they produce, since the letters are fully formed, can't be topped. Also, those printers give you the capability of changing typefaces or type sizes easily as the daisywheels themselves can be changed.

A variation of the daisywheel printer is the thimble printer. In those machines, rather than a daisywheel, the print element resembles an upside-down thimble with spokes. As with the daisywheel, each of the spokes contains a fully formed letter.

Thermal printers

Thermal printers are dot-matrix devices. However, rather than using ink to do the printing, they use special heat-sensitive paper and pass it over a series of heated pins to create the printout. Thermal printers have always been among the least expensive devices on the market, but have suffered from the fact that the required paper is expensive and their output is often of poor quality. On the plus side, those printers are fairly fast.

The picture for thermal printers has gotten much better of late. For one thing, many of the new machines are capable of using plain paper. What's more, thermal printers capable of multi-color output have now reached the market. Those use plain paper and heat-sensitive dye. The paper is drawn over a heater bar after the dyes are laid down creating the image. The result is a fairly inexpensive color printer.

R-E



HERB FRIEDMAN

Gadgets and Gizmos

A look at some genuinely useful devices that can make life with your computer a bit more pleasant.

WITH THE POSSIBLE EXCEPTION OF IBM—WHO LEARNED QUICKLY from the mistakes of others—most manufacturers of personal computers went out of their way to “marry” the user to one brand of hardware. Through the use of non-standard connectors and signal lines, unusual hardware both in the computer and disk drives, and in some instances off-the-wall software, the object was to preclude the purchase of third-party hardware and software.

Fortunately, as with all things, there was more intelligence outside the companies than inside, and so a vast third-party hardware and software marketplace was created by unaffiliated entrepreneurs who manufacture or sell all sorts of gadgets, gizmos, and accessories for personal computers. In some instances the third-party vendors are so successful they eventually force the original manufacturer into providing similar equipment.

In this article we are going to take a look at some of the interesting and useful products that are available. Some you might have read about, others will be new ideas; some were developed on a kitchen table, others by the largest manufacturers.

While we’re going to discuss specific devices for specific hardware, bear in mind that similar equipment is usually available for other systems. For example, if we cover an accessory add-on clock for a Radio Shack computer, it pays to ask if there’s one available for your Apple, because there is.

Whether the accessories come from someone’s basement or garage, or the manufacturer of the computer hardware, they add a notable degree of performance to personal computing, particularly to the low cost computers or those no longer supported by a manufacturer.

Standard I/O

For example, Osborne sold many *Osborne-1* computers before

the company went bankrupt. To say that the computer had many quirks would be kind, but because there are so many users and because the computer is still being sold let’s look at how third-party gadgets handle two of the machine’s more prominent hassles. First, the remote video monitor output. The *Osborne-1* has an itty-bitty built in screen, so for extended viewing an accessory external monitor is needed to avoid eye strain. The computer’s video monitor output, however, isn’t standard composite video; it was intended for an Osborne monitor never seen in this neck of the woods. The second difficulty is the modem interface—it used a circuit known only to Osborne. Again, the object was to force the user to purchase an Osborne peripheral—a modem.

Third-party vendors take care of both problems at reasonable prices. The *Exmon* panel plug-in adapter (no wiring changes) from JMM Enterprises, Inc. (115 Battersby Ave., Enumclaw, WA 98022) provides the *Osborne-1* with a composite-video output, which allows any standard composite-video monitor to be used with the original 52-column screen computer. If the computer was upgraded to 80/104 columns the adapter still works in the 52-column mode. (It moderately “scrambles” an 80-column display.)

As for the modem port, that’s handled by a device called an *Osbreak* from Image Sales (Box 200, 2442 N.W. Market St., Seattle, WA 98107). The device connects to the Osborne’s 9-pin modem connector and creates a standard 25-pin DB-25 RS-232-C input/output as well as a “true break” signal. A small push-button switch on the *Osbreak’s* cabinet produces the “true break” required by some time-share computer and database networks. The *Osbreak* also permits a serial printer to remain connected to the computer while using a modem because the modem and printer no longer have to share a single RS-232 connector on the front panel.

Speaking of RS-232 interfaces, if you’re into using different



THERE ARE MANY double-density disk upgrades for the *Model 1*, including this one from Radio Shack itself.

modems, printers, and other RS-232 peripherals you have probably learned the hard way that there is really no such thing as an RS-232 "standard." What's a handshaking line for one device is nothing for another. If you run into RS-232 matching problems, one of the handiest gadgets you can have around is the *RS-232 Wiring Adapter* from B&B Electronics (Box 475, Mendota, IL 61342); that device lets you patch RS-232 connections in any pattern. It has DB-25 connectors at each end of a small printed circuit board whose foils terminate in a row of minisockets (two rows of sockets). To test a connection, you install a supplied jumper from an input socket to an output socket. When you get the connections down pat you simply wire a standard RS-232 connector to conform to your jumpers.

Upgrading the *Color Computer*

One of the computers for which there is a seemingly endless list of gadgets is Radio Shack's *Color Computer*. No one can quite figure out what Radio Shack had in mind for the color computer because expansion possibilities appeared—at first glance—to be sharply limited. It received some bad press, was even rumored to be on the verge of being discontinued, but here it is full of life, due mostly to third-party gadgets.

Let's run through some of the gadgets that made the unit a real winner—you might find just the item you're looking for. First off, there's the calculator-key keyboard of the pre-1983 model. No problem here; replacement with a keyboard having typewriter keys is a 15-minute job for anyone. The keyboard is from Spectrum Projects (93-15 86th Drive, Woodhaven, NY 11421). You open the cabinet, unplug the old keyboard, plug in the new keyboard, close the cover, and you're ready to type on real keys.

How about some "letter quality" word processing from a *Color Computer* using a daisywheel printer with a polyethylene ribbon, the same kind of ribbon used on IBM typewriters that produce "camera ready" (for offset printing) documents. There are some real cheap but excellent printers that can do this, such as the Smith-Corona *TP-1* and the Brother *HR-1* and *HR-15*. But how do you connect those Centronics-type parallel printers to the "mickey mouse" 600-baud serial output of the *Color Computer*? You do it with a *Color-Computer-to-Centronics* printer interface from Botek Instruments (4949 Hampshire, Utica, MI 48087). Unlike other hardware of every kind, the Botek unit comes with every cable and connector you will need, there are no extras. Just plug it in the way you get it. (Will wonders never cease?) By the way, by changing the unit's Radio-Shack compatible input connector for a DB-25 you can use the device to interface other serial-output computers with a Centronics-type printer.

Finally, before we leave the *Color Computer*, consider the expansion port, of which there is only one. You can plug in a ROM program cartridge or a disk-drive interface, but not both at the same time. At least that's the way it was designed. But one of the most successful add-on's for that computer is a six-slot ROM port extender that allows the user to keep up to six ROM or RAM cartridges and/or the disk controller plugged in and ready to go at the touch of a switch. The device is from J-Nor Industries, Inc.

(6272 W. North Ave., Chicago, IL 60639).

As the *Color-Computer* blossomed from a basic instructional machine into a rather sophisticated but inexpensive professional quality computer (lots of dynamite software is now available, among them one of the very best word processors), the single expansion port proved too limiting even for Radio Shack, and their latest catalog lists a port expansion unit that will accommodate up to four program cartridges and/or disk drive controller.

Updating older computers

Were you one of the original computer hobbyists who built the Heathkit *H8* computer? The *H8* remains a good, rugged computer, but its single density hard-sectored disk drives are now somewhat behind the times. In fact, it's often difficult just to locate hard-sectored disk media, not to forget up-to-the-minute modern software. But the plug-in *FDC-H8* controller from C.D.R. Systems, Inc. (7210 Clairemont Mesa Blvd., San Diego, CA 92111) will upgrade your *H8* to both hard and soft-sectored operation in double density. The unit allows use of both hard and soft-sectored 5¼-inch disks, 8-inch disks, and double-density. If you also use one of the *Z80* upgrade cards available for the *H8* you should be able to read or run just about any modern CP/M software.

Speaking of "Old Timers," the grand-daddy of them all is the Radio Shack *Model I* computer. About 300,000 were sold, most of which appear to be still in use. (They are hard to come by in the used-equipment marketplace and command almost their original price.) A *Model I* with the expansion interface has lots of I/O ports and busses sticking out and ready for use. Give a hobbyist an accessible I/O or buss and he'll probably build something to use the connection. That's exactly what happened. Until the introduction of the *IBM PC*, there were more gadgets and gizmos for the *Model I* than for any other computer—perhaps more than for all other personal computers put together.

The *Model I* has never really gone out of style and there are some exceptionally useful gadgets and gizmos still being produced for that computer. The list is almost endless, but here are a few highlights you might find useful. First off, a disk-system double-density upgrade which more or less doubles the storage capacity of the disk. There are several upgrade kits available including Radio Shack's own (which must be installed by a Radio Shack service center). For many, the least troublesome installation will be the Percom *Doubler* from Percom Data (11220 Pagemill Rd., Dallas, TX 75243). Percom's upgrade is user installed; it simply plugs in. It is supplied with the *Dosplus* 3.4 operating system, a good system presently being used by many independent software houses because they can provide a full run-time program for the *Model I* using it. (Radio Shack does not usually permit independent software houses to provide a run-time TRSDOS.)

If you want to experiment with voice synthesis, but have a tight budget, the old *Model I* is the way to go. For under \$100 Alpha Products (79-04 Jamaica Ave., Woodhaven, NY 11421) will provide you with the software and a voice synthesizer that plugs right into the side of a *Model I* computer, using the old screen printer port on the expansion interface. Voice synthesizers are also available for other computers, most notably those from Apple and IBM, but not at \$70 including the software.

Other *Model I* gadgets also available from Alpha Products include a plug-in clock module with a battery backup that displays time and/or date, a selector switch for two printers that plugs into the printer port of the expansion interface, and even a plug-in joystick for games.

Getting away from the computer itself, do you find yourself connecting and disconnecting plugs and cables when you change peripherals? Does going on line to a database through a modem mean you must disconnect your serial printer? Does changing to a daisywheel printer require you to disconnect the high-speed line printer? Maybe you need something like the active serial port expander, from Bay Technical Associates, Inc.

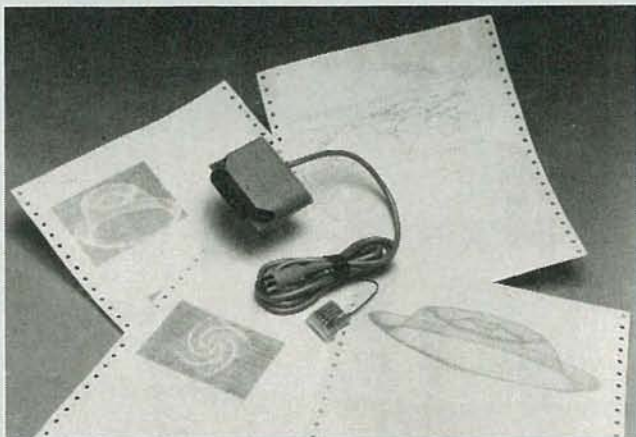

PRINTER INTERFACE, the *Card-7* from Cardco (313 Mathewson, Wichita, KS 67214) lets you use a Centronics-type printer with a Commodore computer.

(Highway 603, Bay St. Louis, MS 39520). An active port expander isn't just a simple switch. It has separate UART's, buffers, and handshaking, and each port can operate with a different configuration (ie., baud rate, stop bits, and handshaking) so you can drive any attached device without taking peripherals apart to move internal DIP switches.

Printer accessories

While we're on the subject of peripherals, one of the most commonly used printers is the Epson *MX-80* (and the newer version, the *RX-80*). Unfortunately, the printer accommodates only tractor-feed paper, the kind with the holes punched along the edges. If you want to use single sheets such as letterheads you must insert the sheet in a special plastic carrier that must first be pushed through past the print head before it reaches the tractor mechanism, a procedure that has been known to cause more print head damage than anything else. A better way to handle single sheets such as letterheads is to retrofit the printer with a *Micro-Grip Friction Feed* from Bill Cole Enterprises, Inc. (Box 60, Wollaston, MA 02170-0060). That device provides a small friction feed area for single sheets, yet it doesn't interfere when feeding tractor paper. While it isn't exactly a factory modification it does work. The device requires only a screwdriver and the opening of an *MX-80's* cabinet (no soldering). The same job can be done on an *RX-80* without opening the cabinet.

For those with the opposite problem—that of using continuous tractor feed paper or forms on a single-sheet daisywheel printer—the manufacturer usually has a tractor feed accessory, though they often cost in the hundreds of dollars. The popular Smith-Corona *TP-1* and *TP-2* printers used with budget priced computer systems also have a tractor feed option, whose selling price, however, bears no relationship to the list price of about \$200. With some careful shopping you should be able to pick up *TP-1* or *TP-2* tractors for about \$60. (It's the same tractor for both.) They are not the easiest thing to install, but all it takes is a screwdriver, perhaps pliers, and a lot of patience.

One of the all-time award-winning gadgets for printers is *Fingerprint* from Dresselhouse Computer Products (837 East Alostia Ave., Glendora, CA 91740). *Fingerprint* installs inside Epson printers, including the versions of that printer from computer manufacturers such as IBM and Texas Instruments. It will also retrofit the Okidata *Microline 82* printer. The device provides 8 to 10 functions that are normally under software control by just touching the printer's off-line, formfeed, and linefeed operating keys in the proper order. The extra functions include condensed printing, emphasized (double-strike), double-size characters, automatic 8-space left indent so you can punch binder holes without cutting into text, automatic perforation skip-over, even italic print. It's a plug-in device and installation requires opening of the cabinet and a modest degree of



PRINTER BUFFERS like the *Microbuffer* from Practical Peripherals free the computer for other tasks during printing.

dexterity. If you have ever plugged a integrated circuit having 20 or more pins into a socket, installation shouldn't take you more than 15 minutes from beginning to end.

While on the subject of printers, don't overlook some interesting interfaces that allow the use of standard printers with the Commodore and Atari computers, both of which have proprietary printer I/O's for their own printers. If you want to connect one of the inexpensive daisywheel printers to those computers, it normally can't be done. But there are a number of printer interfaces that will allow you to use a centronics-compatible printer with those computers. Just about any retailer that carries Atari or Commodore accessories will stock one or more of those.

In closing we'll cover what is rapidly becoming one of the most desired peripherals: the "printer buffer." Basically, a printer buffer is a memory device connected between the computer and the printer. When you want to print, you dump the contents of the computer's RAM to the printing buffer, which in turn feeds the printer. Within seconds your computer is free for use while the buffer takes minutes or even hours to feed your documents to the printer. Buffers are available with 16K to 256K of RAM; the bigger your documents the more RAM needed for a total dump. (This article's manuscript was handled by a 16K buffer, and took almost 23 minutes to print on a rather slow daisywheel printer. But, instead of staring at a "dead" screen for 23 minutes, we were able to use the computer to process a mailing list.)

Printer buffers are usually available as stand alone devices—complete unto themselves. But several models can be integrated directly into the computer. The *Microbuffer* line from Practical Peripherals (31245 La Baya Drive, Westlake Village, CA 91363) has "bare" models that plug directly into the *Apple II* series of computers and the Epson family of printers. Orange Micro (1400 N. Lakeside Ave., Anaheim, CA 92804) has a buffer that "docks" directly onto their *Grappler+*, Epson *APL*, and Apple parallel interfaces.

The list of gadgets and gizmos available for personal computers is almost endless, ranging from super-colossal "professional" joysticks (whatever "professional" is supposed to mean) to disk emulators for the IBM that require a second mortgage on the old homestead. We have only attempted to look at accessories that provide greater computing power or convenience for the user with a low cost computer system.

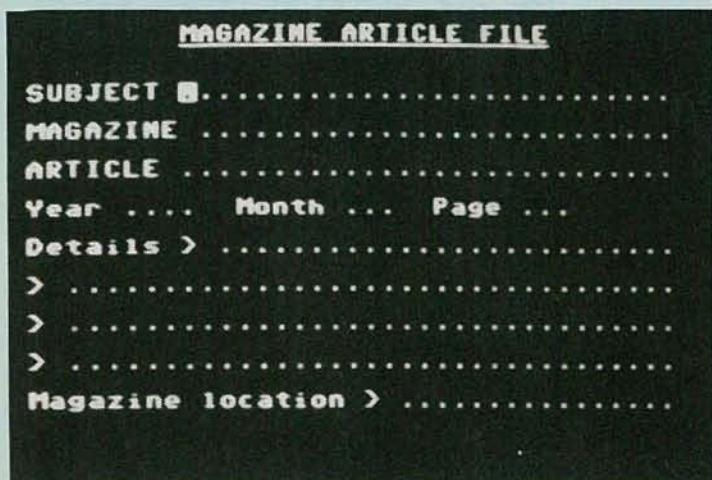

HERB FRIEDMAN

Working with Databases

One of the best uses for a computer is to organize your records. Here's a look at some software that can help make that task easy.

PERSONAL COMPUTERS DO TWO THINGS WITH EXTRAORDINARY speed, reliability, and patience: They "crunch" numbers and shuffle data. When we say a computer can "crunch numbers" we mean it will allow you to feed in seemingly endless numerical data and mathematically process the data until the end of time if that's what it takes to arrive at the solution to your question or problems.

When we say a computer can shuffle data we mean a computer will accept any kind of information—alpha (letters and punctuation), numeric, (numerals) and alphanumeric (any string of characters such as I23XY4D?)—store it, relate it to other data, extract specific bits and pieces of the data, rearrange the data in a convenient or desired order, or display to the user any of the data in any preferred order.

Depending on the kind of data, how sophisticated the processing by the computer, and the way in which the information is displayed to the user, the software that shuffles data is called a database, personal information management system, mailing list, checkfile, or just a plain old-fashioned filing program. For simplicity we'll refer to all data-handling software as a "database."

Most of the database software for personal computers, particularly for the lower cost models, handle all the data through RAM, eventually storing it on disk or tape. What the software does is create electronic storage bins in which the user-supplied data are placed, with the information usually entered through the keyboard. The program keeps track of what data goes where by reserving specific labeled areas in memory. The labels might be LAST NAME, FIRST NAME, TELEPHONE NUMBER, STOCK NUMBER, INSURANCE POLICY, FURNITURE, or almost anything. Depending on the particular kind of filing program, the data might be stored under the name provided by the user, or it might be a numerical representation created by the computer for its own use in handling the data. Even if stored under a name or numeric designation created by the computer, when the information is eventually fed back to the user as a screen display or printout it will be accessed by the user-assigned name, such as NAME, ADDRESS, etc.

When you need a particular kind of information, the computer reaches into the appropriate bin, shuffles through the assorted data you have placed there, and then extracts what you asked for.

For example, if we wanted an electronic file of our property for insurance purposes we might use a program such as Hayden's *Personal Property Inventory* (Hayden Book Co., Rochelle Park, NJ 07662), which creates four electronic bins named ITEM, DESCRIPTION, SERIAL NUMBER, and VALUE. Each of the electronic bins is called a field. There is the "ITEM" field, the "DESCRIPTION" field, etc. In a sense, the word "field" is generic for "storage bin." You can put any kind of information in the bins. But when your files have different fields, each bin, or field, must contain the same kind of information.

For example, an ITEM field is the storage bin for the name of the item. The DESCRIPTION field stores the characteristics of the item. The SERIAL NUMBER field holds the date the item was purchased. The VALUE field stores the cost of the item.

To ensure you get the information out correctly, the computer relates the data in one field with the data in other fields, so that if you specify a search for data on a "widget" the screen would fill with all the information on the widget: the description, serial number, and value.

Depending on the particular software, the program might even create new field data from the other fields. For example, assume that we had stored five items, each having a value of \$5. We might possibly create another field called TOTAL VALUE whose data will be the sum of all the individual entries in the VALUE field. In this case, if we asked for a report on the TOTAL VALUE field, the screen would display TOTAL VALUE = \$25, representing five items of \$5 each. If we added data on a sixth item whose value was \$6, the TOTAL VALUE field would contain the value \$31.

Programs that simply file information that can be accessed at will are logically called "electronic files." Files that permit the data to be compared, mathematically processed, and whose data can be extracted in random bits and pieces and presented in a final report in numerous configurations are called "database managers"—meaning the user can not only file but manipulate the stored data so it produces a report in a specific format.

Report software for an associated database can produce a report on anyone or anything. Push a button and the computer will print paychecks from the payroll records stored in the database. Push another button and it will not only tell how many widgets were sold for each minute of last week, it will project how many widgets will be sold per minute in 1987; and will tell

Sams Books And Software. For Faster Computing,

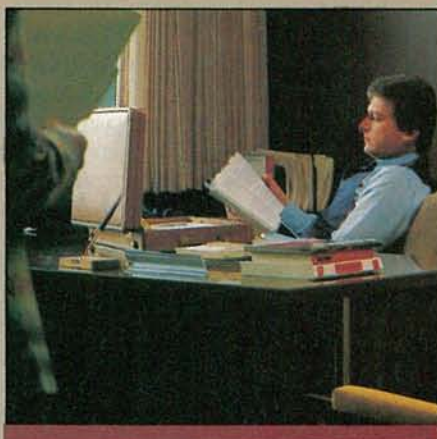
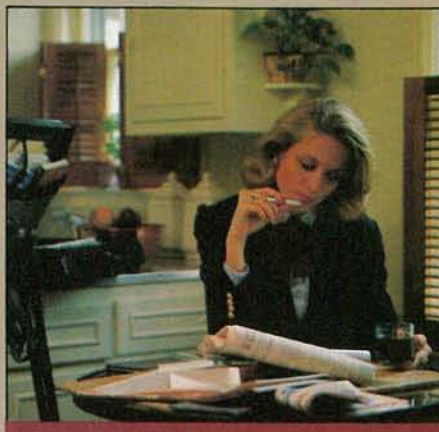
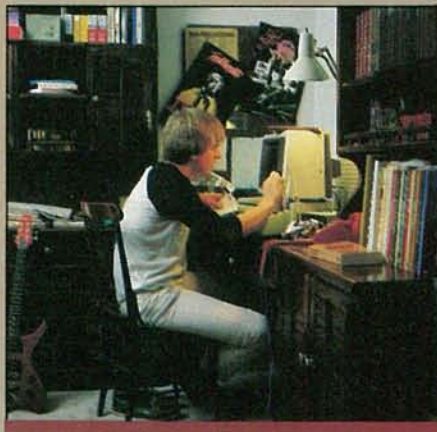

No Matter Which Computer You're Using.

SAMS™

What Technology Is All About.

CIRCLE 44 ON FREE INFORMATION CARD

APRIL 1984

77

What Technology Is All About.

If you're a computer hobbyist interested in the new IBM® PCjr™, an Apple® owner anxious to learn about Applesoft®, or anyone captivated by the Commodore, you need Sams books. Because when it comes to computer technology, Sams knows all about it.

Sams makes understanding technology easy for everyone. Since 1946, Sams philosophy has been to offer technical books and software that are not only easy to understand, but enjoyable to use. As a result, Sams is one of the leading and most respected technical publishers.

Because of this reputation, Sams attracts some of the most respected authors and programmers in their fields. Expert writing combined with quality publishing make Sams your best choice for technical books and software.

Here are Sams newest releases:

- **APPLESOFT FOR THE IIe®** is written especially for Apple IIe owners. Read it and you'll quickly learn Applesoft syntax, programming techniques, commands, functions, and more. No. 22259, \$19.95.
- **PERSONAL COMPUTERS HANDBOOK** (Second Edition). Completely updated, comprehensive introduction to popular 8-, 16-, and 32-bit microcomputer CPUs. No. 22094, \$14.95.
- **INTRODUCING THE IBM PCjr** covers everything about the PCjr including how it works, what software will run on it, how expandable it is, and more. It's written by Andrew M. Seybold, one of the industry's foremost authorities on personal computers and the first person to break the story on the PCjr. No. 22317, \$12.95.

- **INTRODUCING THE APPLE MACINTOSH™** is the most exciting book to hit the computer market. It's the first and only book available on the new Macintosh computer. Like the computer itself, this book is designed especially for professionals who take an active role in major business decisions. Its two-color text and illustrations show you everything you need to know about the system including how it works, how it is different from other Apple computers, what software will run on it, and more. A must for any new or prospective Macintosh owner. No. 22361, \$12.95.

So for faster computing on any computer, get the books you need from Sams today. Visit your local Sams dealer or call OPERATOR 136 at 317-298-5566 or 800-428-SAMS

Offer good in USA only. Prices and availability subject to change without notice. In Canada, contact Lenbrook Electronics, Markham, Ontario L3R 1H2. Apple, IIe and Applesoft are registered trademarks of Apple Computer, Inc. Macintosh is a trademark of Apple Computer, Inc. Timex/Sinclair 2068 is a trademark of Timex Computer Corporation. IBM is a registered trademark of International Business Machines, Inc. PCjr is a trademark of International Business Machines, Inc. Commodore 64 and VIC 20 are trademarks of Commodore Business Machines.

SAMS™

HOWARD W. SAMS & CO., INC.
4300 West 62nd Street, P.O. Box 7092, Indianapolis, IN 46206

CIRCLE 44 ON FREE INFORMATION CARD

Sams Books And Software.

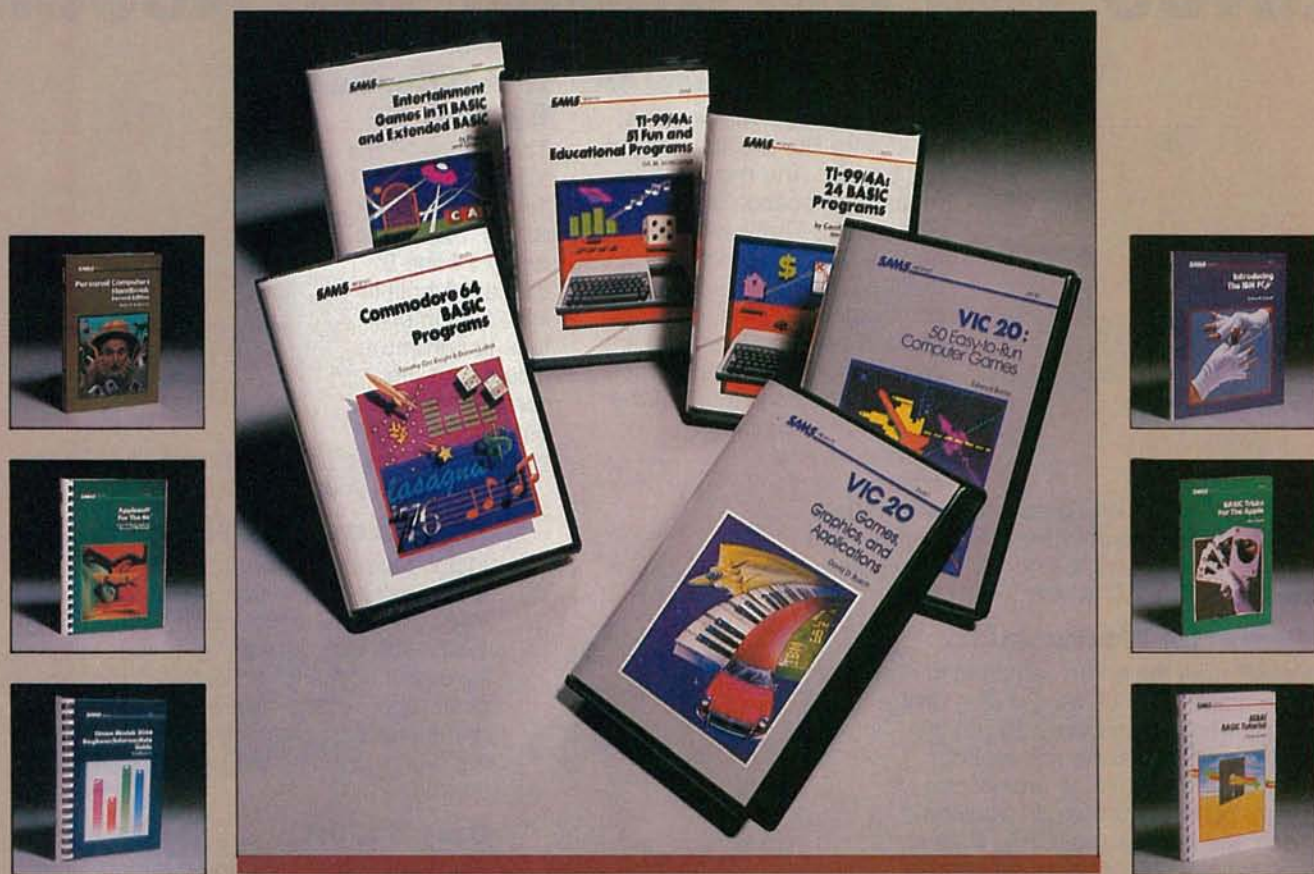

All Book/Software Combinations are available alone or securely packed in a vinyl hard-cover binder with diskette or tape of programs to save you manual entry.

- **COMMODORE 64™ BASIC PROGRAMS**, Book: No. 22171, \$9.95; Tape: No. 22289, \$7.95; Book/Tape: No. 26171, \$16.95.
- **VIC 20™: 50 EASY-TO-RUN COMPUTER GAMES**, Book: No. 22188, \$5.95; Tape: No. 22287, \$7.95; Book/Tape: No. 26170, \$12.95.
- **VIC 20: GAMES, GRAPHICS AND APPLICATIONS**, Book: No. 22189, \$8.95; Tape: No. 22280, \$7.95; Book/Tape: No. 26167, \$15.95.
- **ENTERTAINMENT GAMES IN TI BASIC AND EXTENDED BASIC**, Book: No. 22204, \$8.95; Tape: No. 22285, \$7.95; Book/Tape: No. 26169, \$15.95.
- **TI-99/4A: 24 BASIC PROGRAMS**, Book: No. 22247, \$12.95; Tape: No. 22291, \$7.95; Book/Tape: No. 26172, \$19.95.

- **TI-99/4A: 51 FUN AND EDUCATIONAL PROGRAMS**, Book: No. 22192, \$4.95; Tape: No. 22283, \$7.95; Book/Tape: No. 26168, \$11.95.
- **PERSONAL COMPUTERS HANDBOOK (Second Edition)**, No. 22094, \$14.95.
- **APPLESOFT FOR THE IIe**, No. 22259, \$19.95.
- **TIMEX/SINCLAIR 2068™ BEGINNER/INTERMEDIATE GUIDE** covers BASIC fundamentals and more advanced programming with the 2068, plus color graphics and sound. No. 22225, \$9.95.
- **INTRODUCING THE IBM PCjr**, No. 22317, \$12.95.
- **BASIC TRICKS FOR THE APPLE** provides all the tricks you need to make your BASIC programs more useful and efficient. Guides you through the logic, creation and integration of over 35 routines. No. 22208, \$8.95.
- **ATARI BASIC TUTORIAL** is a hands-on, step-by-step guide through the ATARI BASIC language. No. 22066, \$12.95.

Available Soon

- **BASIC PROGRAMS FOR THE IBM PCjr** is a beginner's book that shows how to program the PCjr in BASIC, and how to use the many advanced BASIC features unique to the computer. Also contains a BASIC tutorial, programming hints and many useful programs. No. 22359, \$12.95.
- **ASSEMBLER LANGUAGE PROGRAMMING: THE IBM PCjr** shows how to program Junior in 8088 assembler language, and how to control its video, keyboard, disk and other hardware. Includes many sample programs and hints. No. 22360, \$12.95.
- **BASIC TRICKS FOR THE IBM** shows the novice or advanced IBM user how to make the BASIC language perform a number of useful tasks for quick and efficient programming. No. 22250, \$8.95.

What Technology Is All About.

CIRCLE 44 ON FREE INFORMATION CARD

Tired of Desktop Computer Clutter?

New TRS-80[®] Transportable Gives You the Space You Need.



The TRS-80 Model 4P

Many "desktop" computers look more like a giant science-fair project. And moving one to another location is next to impossible. That's why you need a Model 4P. Not only is the Model 4P the desktop computer that gives you back needed desk space, it also lets you be more productive when business takes you out of the office. Why? Because it has a handle.

Which means

you simply slip the keyboard into the hi-impact case, snap on the protective cover and go! The Model 4P weighs just 26 pounds, and works anywhere there's AC power.

A Powerful Workstation

Model 4P runs the entire selection of "off-the-shelf" TRS-80 Model III/4 disk software. That means you can put the 4P right to work, solving scheduling problems, updating sales projections and revising your memos. In addition, you can add the optional CP/M Plus operating system, allowing you to choose from thousands of additional ready-to-run programs.



A Self-Contained System

The Model 4P features 64K RAM. Two 184K built-in disk drives. 80-character by 24-line 9" display. A built-in RS-232C interface to communicate with other computers, plus a parallel printer interface. To top it off, the keyboard slips underneath—out of your way—when not in use.



Expand as Your Needs Grow

Install Model 4P's internal modem board and access information services by phone. You can increase the internal memory to 128K, and expand with up to four external hard disk drives for an extra 20 megabytes of storage. And to create sophisticated graphs, tables, charts and more, add our high-resolution (640 x 240) graphics upgrade.

Only \$1799

Compare Model 4P's price, features and expansion options with that of other portables, and you'll see why the Model 4P is the computer to take along. In addition, your company has the option of leasing the Model 4P for just \$65 per month*.

Available at over 1100
Radio Shack Computer Centers and at
participating Radio Shack stores and dealers

Radio Shack[®]
COMPUTER CENTERS

A DIVISION OF TANDY CORPORATION

Send me your new TRS-80 Catalog RSC-11.

Mail To: Radio Shack, Dept. 84-A-1011
300 One Tandy Center, Fort Worth, Texas 76102

NAME _____
COMPANY _____
ADDRESS _____
CITY _____
STATE _____ ZIP _____
TELEPHONE _____

*Plus applicable use/sales tax. Prices apply at Radio Shack Computer Centers and at participating Radio Shack stores and dealers. CP/M Plus is a trademark of Digital Research.

CIRCLE 92 ON FREE INFORMATION CARD



TYPE "END" FOR ITEM TO EXIT.

ITEM? CAMERA LENS
DESCRIPTION? 150 MM TELEPHOTO
SER. NO.? 176543RM-81
VALUE? 175

ITEM?

IN A SIMPLE FILING PROGRAM, the on-screen prompts are kept to a minimum. The "?" is used by this program to tell you when to enter data.

the boss how many keys per minute each word processor operator types, and the length of everyone's coffee break, and the exact second (not minute) the assembly line workers punched in.

While database managers have enormous power in the sense the user can virtually write the data-handling program itself, they often prove to be extremely complex and difficult to use. For example, *dBase II* from Ashton-Tate (9929 West Jefferson Boulevard, Culver City, CA 90230), the best known of the personal computer database managers, is usually difficult to learn. There is even a separate training course (tutorial) for *dBase II*, and yet another expensive program to interpret the user's ideas into the *dBase II* "language." While some users can get a grip on the program in a matter of weeks, there are others who spend better than a half year and still cannot write the database.

The problem with these super database-management programs is the myth that everyone needs one. In fact, when run on a small personal computer—meaning 64K of RAM or less and a 5¼-inch disk system with a storage capacity of about 200K per side, the super database is often difficult to organize, time consuming to use, and relatively expensive. Most home-and-family and small-business users simply don't need that much "sophistication"—here sophistication is a euphemism for complexity.

The truth is that many users can get by with discrete data filing software—meaning individual programs that perform one particular database function—rather than a super-database that can process every conceivable file and record. To help you understand the kind of programs available in dedicated software, we'll take a look at some of the simple data-filing systems.

Let's start off with something very simple but very convenient: a random-access information file—a computer simulation of a 3 × 5 file card. Such a file is a good way to organize the bits and pieces of information we would like to have at our fingertips. Such information might include who we're supposed to meet for lunch next Thursday; where we hid Mom's gold wedding band when we went on vacation; where we filed that issue of **Radio-Electronics** with the article on direct-broadcast satellites; how much we paid for our cameras and where we placed the original sales slips (for insurance); the name of the person who refinished the office desks, etc.

There are many so-called "filing systems" but none the equal of *SeekEasy* (Correlation Systems, 81 Rockinghorse Rd., Rancho Palos Verdes, CA 90274). *SeekEasy* is self-contained; it does not require a word processor for data entry. It is totally random for both entry and search, with the entered information treated as a single field. The user can enter up to two lines (160 characters) of anything in any order. One entry might be: "Lunch, Feb. 3, 2 PM, Joe Smith, Widgets, Inc." while another entry might be: "IRA Account 1983, East Bank Of The Missouri, 145-5678."

TYPE "END" FOR ITEM TO EXIT.

ITEM?
DESCRIPTION?
SER. NO.?
VALUE?

THIS IS HOW the simple filing program may look when data has been entered. It is nothing spectacular, but it does work.

If on Feb. 3 the user simply enters "Lunch," "Feb. 3," "Joe," "Smith," "2 PM," or any combination, the entire entry will be displayed. Similarly, entering any piece of information from the IRA entry will call up the entire entry.

Even if the user gets the spelling or numbers incorrect a random access file will display and/or print the nearest equivalent. Naturally, the more precise and detailed the search-data entries, the narrower the range of displayed file information.

Random access files such as *SeekEasy* have no fields, no definitions, no report structure, nothing except total search of every character. If the information is there it will find it. Unfortunately, some random access programs are slower than others, anywhere from a few seconds to almost an hour. Again, for conventional personal computers the fastest we have seen or used is *SeekEasy*, which will random access 2.5K per second. Under the most difficult search conditions—the least amount of descriptive information—the program takes only 10 seconds to locate one of 100 records on a 5¼-inch double-density disk system.

We have gone into a little extra detail on *SeekEasy* so that as we cover other types of filing systems you can put them in the proper perspective in terms of complexity of data entry, search and reports, speed, and ease of use.

When you need it all!

One of the real heavyweights in database management that doesn't require a college course in how to program to use is *Infostar* from MicroSoft (10700 Northup Way, Bellevue, WA 98004). That program really consists of two separate programs *Datastar*, which is the filing system, and *Reportstar*, which creates screen and printed reports. The user can purchase either program separately, or the complete package. *Datastar* allows the user to create a specific screen layout for entering data by simply moving the cursor around the screen and then typing in both graphic and character prompts.

A typical *Datastar* screen might contain lines composed of dots, with each dot representing a possible character entry. The



THE SCREEN DISPLAY generated by a more advanced filing program. Note the full set of "help" prompts that appear at the top.

screen can also have special automatic formatting for such things as telephone numbers or Social Security numbers. The program then "remembers" the screen. The nice part about *Datastar* is that it works on every conceivable level, from rank beginner to advanced programmer. Once the screen is created it can be used as-is, or each prompt can be keyed to accept only certain types of information, or even convert information. For example, a NAME field can be keyed to accept only alpha characters, no numerals, with all entries automatically converted to upper case letters. In addition, some fields might be designated numeric only, while still others can be derived from other fields. For example, if five fields have numerical entries, a sixth field, one that is perhaps called TOTAL, or SUM will be the value of the sum of the five numerical fields, or a field might contain derived information within a specific range.

The major point is that you only use as much of *Datastar* as you can handle. The more you learn the more you use.

Same thing with *Reportstar*. You can create either screen or printout formats—even new report fields—from the information in the *Datastar* file. Again, you can limit your reports to only the features you can handle comfortably.

An extra value of the *Infostar* system—particularly for the small businessman whose filing requirements might be constantly changing—is that as the user gets greater skill with the program, he or she can usually upgrade the formats without having to redo the entire database.

Basic systems

SeekEasy and *Infostar* are rather expensive programs, even though they run on moderate cost 8-bit machines. Similar features, although they are not as convenient to use or as flexible, are available in budget priced software for the low-priced personal computers.

For example, there's *Filewriter*, from Dynateck MicroSoftware, Inc. (7847 North Caldwell Ave., Niles, IL 60648), for the Commodore 64. That is a "program generator," which means that you create the screen prompts you want and the software then writes a program in BASIC that will perform exactly the functions you indicated on the screen.

The created program will store your information, retrieve it, and allow you to make updates and deletions. You can even moderately customize the entry fields for alpha or numerics only, date only, etc., much as you would do when using *Datastar*. You don't get the flexibility of a "professional" filing system such as *Datastar*, and the entry for each field can be no longer than a single line, but you get a lot of performance at the lowest possible price in a system that can be handled by the newcomer to

personal computing. Also, *Filewriter* comes with a very thin but excellent manual that's easily understood by the beginner. It's also an excellent training aid for those who want to learn something about database management.

If you can put up with a program that's relatively slow to load and relatively slow to run, and you know nothing about programming or database management but need somewhat extensive computerized files, consider one of the more sophisticated program generators. Among the better ones is *The Producer* (Software of the Future, Inc., PO Box 1245, Arlington, TX 76004-1245).

That program is particularly well suited for the beginner because it comes with unusually good cassette-based training tapes. It's more sophisticated, and requires more skill than *Filewriter*, but you can eventually end up with a full-featured database that will do just about anything you want—the trade-off is that it will do it quite a bit slower than the super-database management systems.

Basement bargains

Now that the youngsters who used to hang out at Radio Shack in the late 1970's have grown up and graduated as computer-science majors, we're getting some really excellent low-cost database software for the budget priced home-and-family computers. Even though the programs might be priced as cheaply as a discounted "arcade game," some of them are good enough to be considered for part-time or small business use. For example, consider the basic Radio Shack *Color Computer* package consisting of the computer and a cassette recorder (no disk). One of the most convenient filing systems you're likely to run across for any computer is the \$25 ROM-cartridge *Color File* for that minimum system.

Color File's power is an almost unbelievable sorting facility for what is obviously a rock-bottom price. The screen comes up with eight field selections. Seven are data fields with the usual home-and-family database labels such as ADDRESSES, WARRANTIES, CAR MAINTENANCE, etc. The eighth selection permits the user to define seven fields of his own choosing, each field having a limit of up to 32 characters each including the prompt. Each field can accept as many different entries (words, descriptions, or numerals) as will fit on the line. For example, if one field is designated INSURANCE, the entries might read: LIABILITY, AUTO, EQUIPMENT.

Now here's where the super-sort feature of *Color File* comes in. Once the data is stored in memory, the user can then sort on any field, sort again on any of the data for that field, sort yet again, then call up the records from that sort, pick a second field, sort once or more on the second field, and then repeat the whole procedure for the remaining five fields. *Color File* will even sort on partial data. For example, if a field contains, widgets, gizmos, and gadgets, *Color File* will locate the record if you sort the "widg." To do that with almost any top-of-the-line database-management system would take anyone other than an expert several weeks of effort, and that's assuming, of course, they had the programming skill to start with.

Color File does not create its own fields, nor will it sum fields, and its 32 character line length including screen prompts is somewhat limiting, but for filing and retrieving information it's hard to do better.

As you can see, there are sharp differences in the way ordinary data can be processed by a personal computer, not to overlook the fact that the software can range in price from almost pocket change to several hundred dollars. Also, the same type of sophisticated feature, such as a multi-field sort, really doesn't depend on price. Surprisingly enough, the lowest-cost software might very well have the exact data-handling feature most needed for your use. When it comes to shuffling data, don't look at the brand name, the price, nor even the myth. Quite often, the best data-handling software is designed to do only one specific job, but do it extremely well.

BUILD THIS

Telephone Add-On

NO MORE WRONG

NUMBERS!

Receive only the calls you want to receive with this inexpensive and easy-to-build telephone accessory.

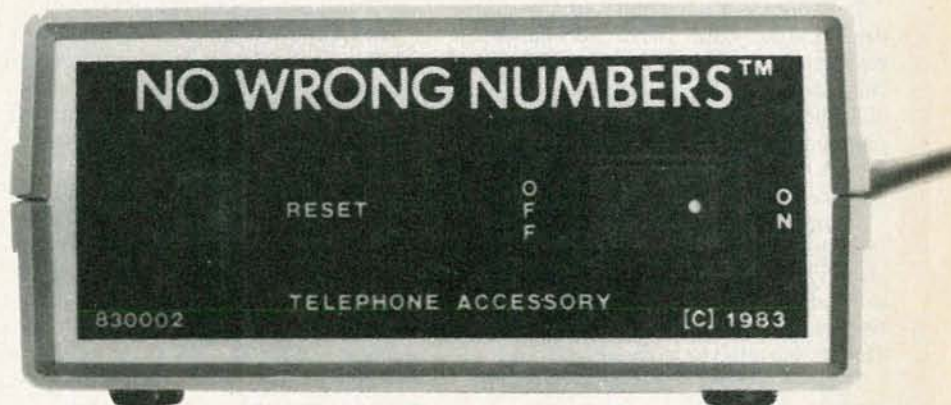

GARY McCLELLAN

Part 2 LAST TIME WE STARTED building a device that keeps unwanted telephone calls from reaching you. It's time now to finish assembling the main board. Once that's done, we'll turn our attention to the second part of the project, the decoder board. Incidentally, the decoder board has fewer parts and is easier to build than the main board, so it shouldn't take as long to complete.

Before we continue, an incorrect Radio Shack number was given in the Main Board Parts List for RY1; the correct number is 275-213. Now, picking up from where we left off last time, let's turn to the diodes.

Be sure to observe the polarities of those devices. Install four 1N4002 diodes at D8-D11, next to the fuse. Then go to SO1 install a 1N4148 diode at D7. Move over to IC5 and install four 1N4002 diodes at D3-D6. Finish up by installing 1N4002 diodes at D2 and D1 as shown.

The capacitors are installed next. Since there are many, they will be installed a few at a time. Be sure to push the capacitor bodies firmly against the board before soldering in place. Also, double-check the

polarities before soldering the tantalum or electrolytic capacitors in place.

Start by installing a 0.01- μ F disc at C2. Then install a 0.22- μ F film at C1. Move to the right and install a 47- μ F electrolytic at C3. Then install a 1- μ F tantalum at C4. Make sure the capacitors are installed properly before continuing.

Continue by installing a 0.1- μ F polyester at C5. Then a 1- μ F tantalum at C6. (Be careful not to install it in the R5 or R7 positions.) Install another 1- μ F tantalum at C7. And install a 0.1- μ F disc capacitor at C8.

Continue by installing another 1- μ F tantalum at C10. Then install a 0.1- μ F polyester at C12. After that, install another 0.1- μ F polyester at C11, just below IC5. Move over the IC4 socket and install a third 0.1- μ F polyester at C9.

At this point, the remaining capacitors are installed. First install 0.1- μ F discs at C16 and C17. Then install a 470- μ F electrolytic at C15. Make sure it is installed properly before soldering in place. Finally, install 0.01- μ F discs at C13 and C14, next to F1.

Now the transistors and two IC's may be installed. Be sure to position the flat

side of the transistor cases as shown in the parts-placement diagram. Start at the top of the board. Install a 2N2222 transistor at Q2. Then install the other 2N2222 at Q1, near RY1. Move on to the IC's, install a 78L05A at IC7 and another 78L05A at IC6.

Some wire jumpers are required and they will be installed now. Use pieces of leftover resistor or capacitor leads for them. Note that there are four jumpers and that they are located around the IC3 and IC4 sockets. Start with the jumper above IC3. Bend a lead to fit, then install it as shown. Move to the right of IC3 and install another jumper as shown. Finally, move to SO1 and install two jumpers above it. Be careful not to put a jumper in place of R16. Two other jumpers, located on the foil side of the board, will be installed later.

The resistors are installed next. Since there are so many, they will be installed a few at a time.

Start by installing a 10K potentiometer at R12. Then move to the left and install a 1K resistor at R1. Then install a 10K resistor at R13 and a 4.7K resistor at R4. Then install a 100K unit at R6.

Continue by installing a 33K resistor at R8 and a 22K resistor at R9. Move to the left, next to IC1, and install a 10K resistor at R2. Then install a 1K resistor at R3. Jump over the capacitors and install a 270K resistor at R5. Then install a 10K unit at R7.

The remaining resistors, which are grouped around the IC4 socket, are installed next. Install a 100K resistor at R16, a 10-megohm resistor at R14, and a 2.2K resistor at R20.

The next step is to install the two insulated wire jumpers on the foil side of the board. Simply cut to pieces of insulated wire to the appropriate length and carefully solder them in place.

Finish up the assembly by installing the IC's. Install the M290 into the IC2 socket. Then install a CD4538 into the IC3 socket and a CD4093 into the IC4 socket.

The decoder board

Lets discuss the circuitry briefly and then build the board. The decoder has one basic job; to detect tone pairs from *Touch-Tone* phones or detect pulses from rotary-dial phones. A desired code number is programmed into the board, and whenever that number is detected, the board produces an output.

Returning to the main board, an output from the decoder triggers a one-shot. The one-shot enables a 2-Hz oscillator. As a result, the project produces a distinctive beep-beep-beep sound for ten seconds. That is what tells you to answer the phone.

Figure 5 shows a simplified schematic diagram of the board; the complete schematic is shown in Fig. 6. Incoming dial pulses or tones from the phone line appear on the DIAL pin of PL1. The tones or pulses drive IC1-a, an analog comparator. That device provides gain and squares up all signals.

The output from IC1-a branches in two directions; to the tone-detector circuitry and to the dial-pulse circuitry. The tone-detector circuitry consists of two phase-locked tone-detectors, IC3 and IC4. Recall that pushbutton tone telephones produce two tones; low and high. (That's why the system is known as DTMF or *Dual-Tone Multi-Frequency*.) The low tones have frequencies of less than 1 kHz, while the high tones have frequencies that are above 1 kHz. At any rate, when the appropriate low and high tones are present, IC3 and IC4 produce logic-low outputs. Gate IC5 detects that condition and produces a logic-high output. The output from IC5 goes to a timer circuit that will be discussed shortly.

Note that the tone detectors are adjusted to respond to the number "7." That means that the low-tone detector, IC3, is adjusted for 842 Hz and the high-tone detector, IC4, for 1209 Hz.

The dial-pulse circuitry consists of three parts—a pulse discriminator, a one-

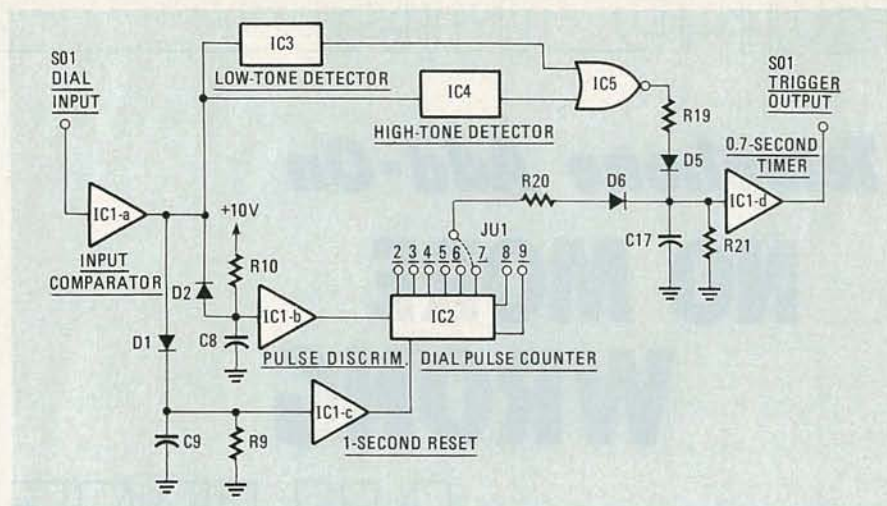

FIG. 5—THE VARIOUS STAGES of the decoder board are shown in this simplified schematic diagram.

second reset, and a dial-pulse counter. Comparators are used for everything except for the dial-pulse counter.

The purpose of the pulse discriminator is to prevent tones from pushbutton phones, as well as any other stray audio, from clocking the dial-pulse counter. In effect, that circuit works as a low-pass filter.

In operation, input signals cause the output of IC1-a to pulse high. If the frequency is too high, diode D2 prevents capacitor C8 from charging. As a result, comparator IC1-b never triggers, and no output goes to the counter. But if the frequency is low, C8 has time to charge through resistor R10. The comparator then triggers and each pulse clocks the dial-pulse counter. Note that the values of R10 and C8 are set for 45 milliseconds, or half the pulse width of a standard rotary-dial phone.

The purpose of the one-second reset circuitry is to reset the dial-pulse counter one second after the pulses stop. That way, the circuitry will be ready for the next call. In operation, input signals cause the output of IC1-a to pulse high. That causes capacitor C9 to charge through diode D1. At the same time comparator IC1-c triggers, removing the reset from the dial-pulse counter so that the counter is free to count pulses. About one second after the pulses stop, C9 is discharged through resistor R9. Thus, comparator IC1-c is untriggered and resets the dial-pulse counter.

The purpose of the dial-pulse counter, IC2, is to count pulses from rotary-dial type phones. It has eight decoded outputs and each output represents the number dialed. Note that there are two other outputs, but they are reserved for housekeeping purposes. Also note that the desired output, "7", is jumpered to the 0.7-second timer circuitry. Note that for simplicity, only the "7" output is shown in Fig. 6.

The remaining bit of circuitry on this board is a 0.7-second timer. The purpose

of that circuit is to prevent false triggering, mainly by the tone detectors, which can sometimes be tricked by human speech. For that circuit to produce an output, either the decoded tones or the dial pulse must be present for at least 0.7 second. For times less than that, the circuit will not produce an output.

In operation, a good pair of tones makes the output of IC5 high. That causes capacitor C17 to charge through resistor R19 and diode D5. If the tones last over 0.7 second, comparator IC1-d triggers and produces a high output. That triggers the beeper circuitry on the main board through the TRIG output of PL1. In the case of a rotary-dial phone, a good number makes the jumpered output of IC2 high. So capacitor C17 charges through resistor R20 and diode D6.

Note that after the tones or dial pulses disappear, resistor R21 discharges capacitor C17, untriggering the comparator. So the TRG output goes low and the circuitry is ready for the next call.

That completes the theory—on to assembly!

Assembly

Start by referring to the Parts List for the decoder board and obtaining all of the parts. Here are a few suggestions that may be helpful as you shop.

The IC's are all industry standard, and many manufacturers make them. For example, the National LM567CN is also made by Signetics (NE-567N) and Exar (XR-567CP).

The only capacitor that might cause problems is C17—a 1 μ F tantalum type. A low-leakage electrolytic may be substituted for that capacitor if needed.

As for the resistors, R14 and R17 may require some searching. To make things easier, a supplier and part number is given in the Parts List. Also, two odd-value resistor types are used; 6.2 kilohms and 180 kilohms. If you can't get the 6.2-kilohm units, simply parallel a 6.8-kilohm resis-

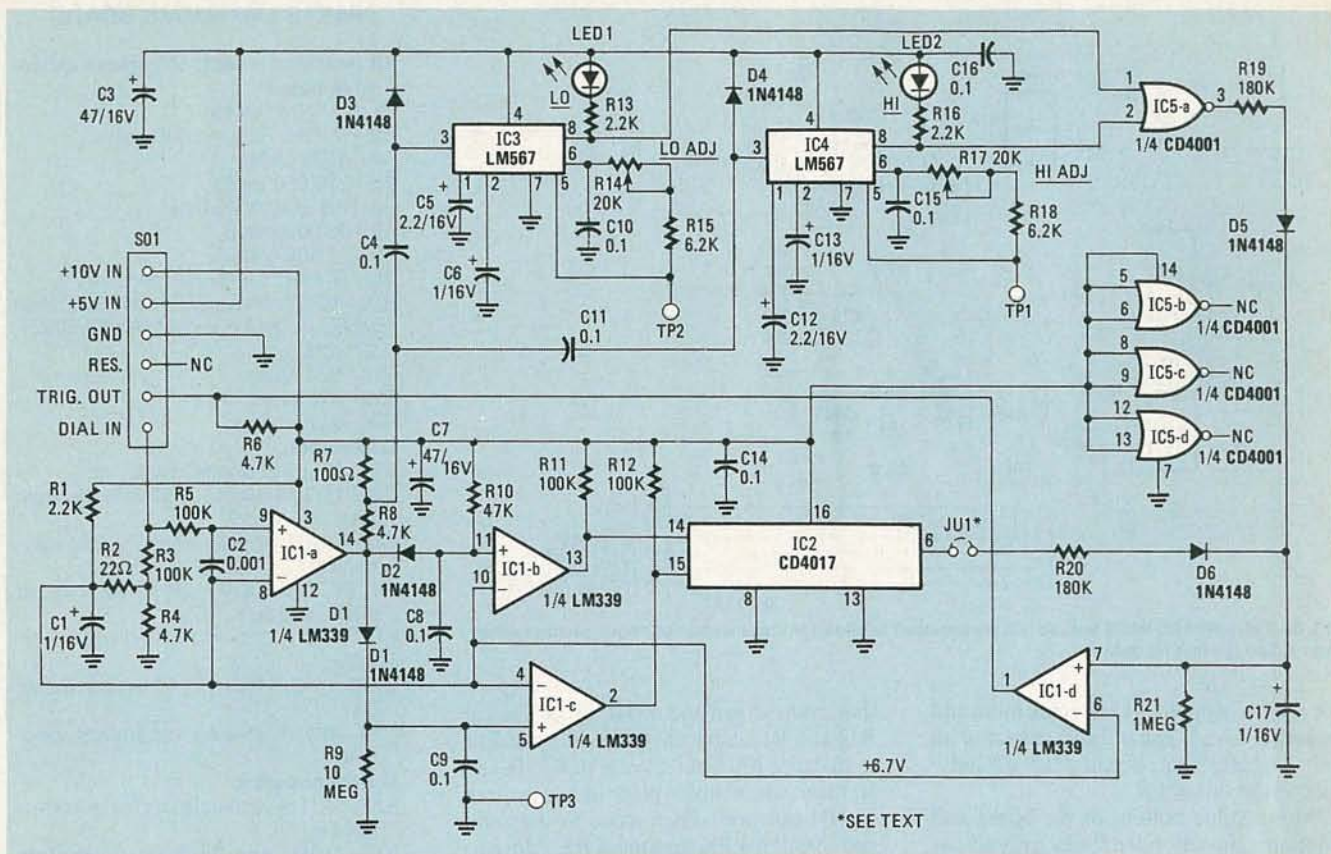

FIG. 6—SCHEMATIC DIAGRAM of the decoder board. Note that all signals to and from the main board are routed via S01.

tor with a 68-kilohm unit. As for the 180-kilohm unit, simply parallel a 220-kilohm resistor with a 1-megohm unit.

You'll also need a PC board. If desired, order the set from the supplier given in the Parts List. Otherwise, you can make your own using the pattern shown in Fig. 7.

Once you have the parts, assembly can begin. Refer to Fig. 8, the parts-placement diagram, and position the board as shown.

Start with the IC sockets. Install a 14-pin socket at IC1 and solder in place. Then install another 14-pin IC socket at IC5. After that, install a 16-pin unit at IC2. Finish up the IC sockets by installing 8-pin units at IC3 and IC4.

Continue assembly with the two LED's. Be sure to look at the plastic cases carefully; one side should be flattened. And the lead closest to the flattened side should be shorter than the other. Install each LED with the flattened side (and short lead) to your right. Install LED2 first, near the top of the board. Then install LED1 in the same manner.

Continue assembly by installing the capacitors. Since there are so many, they will be installed a few at a time. Be sure to install the polarized capacitors with the + sign as shown in the figure, and double-check your work after soldering.

Install a 1-µF tantalum capacitor at C17 along the top of the board. Then move to your left and install a 0.1-µF disc capaci-

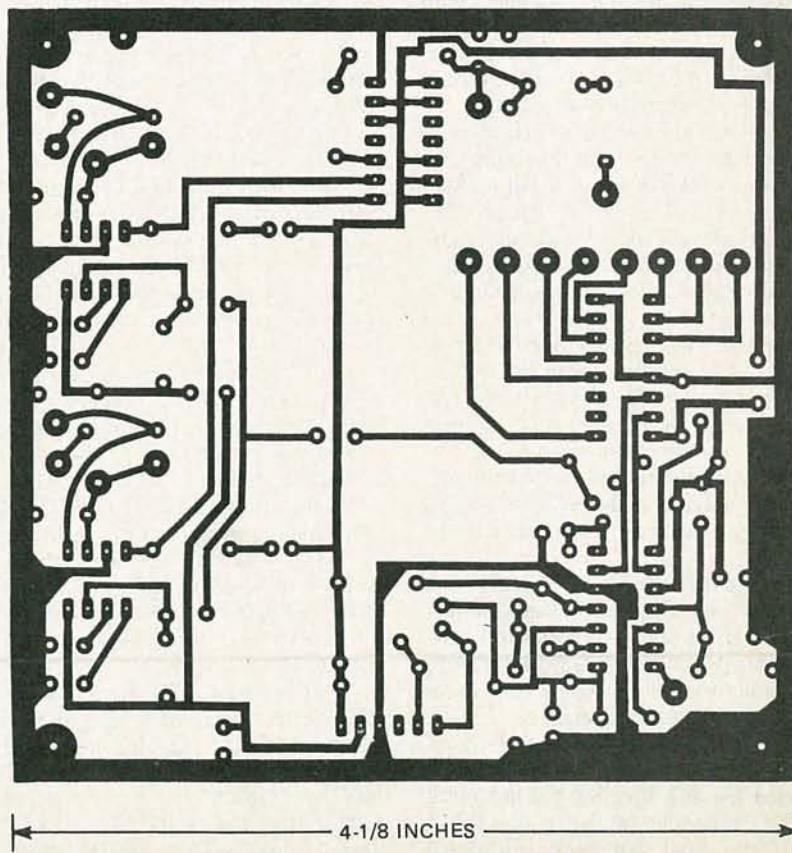

FIG. 7—FOIL PATTERN for the single-sided decoder board is shown here full size.

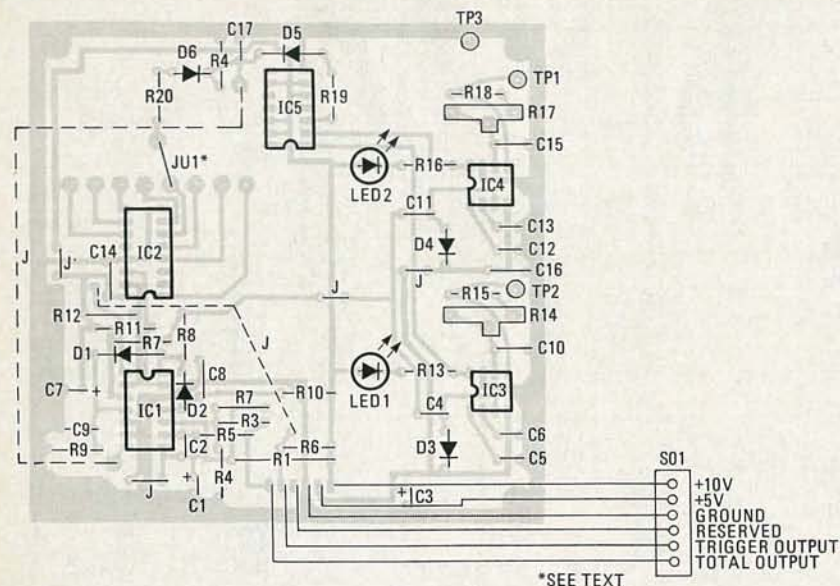

FIG. 8—THE UNUSED PADS around IC2 are provided to allow for the selection of a code number other than 7. See the text for details.

tor at C14. Move to the left some more and install a 47- μ F electrolytic capacitor at C7. And after that, install a 0.1- μ F polyester capacitor at C9.

Move to the bottom of the board and continue. Install a 1- μ F electrolytic capacitor at C1. Then move up and install a 0.001- μ F polyester capacitor at C2. Next, install a 0.1- μ F polyester unit at C8.

Install another 47- μ F electrolytic capacitor at C3. Then move up and install 0.1- μ F polyester units at C4 and C10. Back up and install a 2.2- μ F electrolytic capacitor at C5. Then above it, install another 1- μ F electrolytic unit at C6.

Move up and install a 0.1- μ F disc capacitor at C16. Be careful not to install it at R15 by mistake. Then install another 2.2- μ F electrolytic capacitor at C12. After that, install another 1- μ F electrolytic capacitor at C13. Finish up the capacitors by installing 0.1- μ F polyester units at C11 and C15.

Continue with the four component-side jumpers. Use short pieces of leftover capacitor leads for those. Install the first jumper next to C14, along the lefthand side of the board. Then move to the bottom left side and install another jumper. Move to the center of the board and install the two remaining jumpers between the LED's.

Next, install jumper JU1. When that jumper is installed as shown the pulse-dial circuitry will respond to a dialed 7. The remaining pads in that area are provided to allow you to select a different code number and are normally unused.

Continue assembly with the resistors. Since there are so many, they will be installed a few at a time. Start at the top of the board by installing a 1-megohm unit at R21. Then install 180K units at R20 and R19 on either side of the IC5 socket. After

that, move down and install 100K units at R12 and R11, adjacent to the IC2 socket.

Install a 100-ohm resistor at R7, below R11. Be careful not to place that resistor in the D1 position. Then move to the right and install a 4.7K resistor at R8. Move to the lower lefthand corner of the board and install a 10-megohm resistor at R9. After that, move to the right and install another 4.7K resistor at R4.

Install two more 100K resistors at R5 and R3. Then move up and install a 22-ohm unit at R2. Move to the right and install a 47K resistor at R10. After that, install another 4.7K resistor at R6. Next, install a 2.2K unit at R1. Bend the leads to size first, then install.

Move to the top of the board and install a 6.2K resistor at R18. After that, install a 20K potentiometer at R17. Be sure to push the body of the potentiometer firmly against the board before soldering it in place. After that, install another 2.2K resistor at R16.

Install another 6.2K resistor at R15. Then install another 20K potentiometer at R14. Push the body firmly against the board before soldering. Finish up the by installing another 2.2K unit at R13.

Continue assembly by installing three short pieces of wire at the pads marked TP1-TP3. Use short pieces of leftover resistor wire, cut to a length of $\frac{3}{8}$ -inch for that. Install two of the wires at the holes above R18. Then install the remaining one next to R15.

Next, we turn to the diodes. When installing the diodes, be sure to position them as shown. Double-check your installation after soldering. Note that all diodes are 1N4148's.

Install a diode at D5 as shown. Then install a diode at D6 to the left of it. Move down to the IC1 socket and install diode

PARTS LIST—MAIN BOARD

All resistors 1/4-watt, 5% unless otherwise noted

R1, R3—1000 ohms
 R2, R7, R11, R13—10,000 ohms
 R4—4700 ohms
 R5—270,000 ohms
 R6, R16—100,000 ohms
 R8—33,000 ohms
 R9—22,000 ohms
 R10, R14, R15, R19—10 megohms
 R12—10,000 ohms, potentiometer, linear taper, PC-board mount (Radio Shack 271-218)
 R17—330 ohms
 R18—470 ohms
 R20—2200 ohms

Capacitors

C1—0.22 μ F, 250 volts, metal film
 C2, C13, C14—0.01 μ F, 50 volts, ceramic disc
 C3—47 μ F, 16 volts, radial leads, electrolytic
 C4, C6, C7, C10—1 μ F, 16 volts, radial leads, tantalum
 C5, C9, C11, C12—0.1 μ F, 50 volts, polyester
 C8, C16, C17—0.1 μ F, 16 volts, ceramic disc
 C15—470 μ F, 25 volts, radial leads, electrolytic

Semiconductors

IC1—TIL-119 optoisolator (Texas Instruments)
 IC2—M290 ring-detector subsystem (Mendakota—see below)
 IC3—CD4538 CMOS one-shot (RCA)
 IC4—CD4093BE CMOS Schmitt trigger NAND gates
 IC5—MOC-5010 optoisolator (Motorola)
 IC6, IC7—78L05ACP 5-volt, 100-mA regulator (Motorola)
 Q1, Q2—2N2222 NPN transistor
 D1—D6, D8—D11—1N4002 diodes
 D7—1N4148 diode
 F1—0.25 amp, 3AG fuse
 PL1—6 pin male PC-header (GC Electronics 41-046 or similar)
 RY1—DPDT relay, 12-volt DC coil (Radio Shack 27S-213 or equivalent)
 PB1—Piezoelectric buzzer (Radio Shack 273-060 or equivalent)
 S1—SPST momentary pushbutton switch (Radio Shack 275-618 or equivalent)

Miscellaneous: PC board, solder, wire, 2 PC-mount fuse clips (Littlefuse 122087), IC sockets, etc.

The following is available from Mendakota Products, Ltd., PO Box 20HC, 1920 W. Commonwealth Ave., Fullerton, CA 92633: A set of three PC boards and the M290 ring detector IC (order part No. NWR). The cost is \$26.00 postpaid in the U.S. and Canada. The M290 is available for \$12. California residents please add 6% sales tax. Sorry, no C.O.D's or credit-card orders.

D1 next to it. Then install diode D2 to the right of it. Move to the IC3 socket and install diode D3 next to it. And finally, move to the IC4 socket and install diode D4 next to it.

Continue by installing two insulated foil-side wire jumpers. Note that they are shown as dashed lines in Fig. 8.



Make Up To \$275.00 or More Extra Per Week As A "MAILING LIST PROTECTION AGENT"!



**Best of all . . . No Selling •
No Handling Orders • No
Mailings Required • No
Envelope Stuffing • No
Placing Ads • No Telephone
Soliciting.**

Do you want to pick up some extra easy cash? If so, we have an opportunity that you can take advantage of and it will actually supplement your present income. This fabulous way for you to make money takes very little time and virtually no effort. Plus, we will make payments directly to you. What could be better?

Dear Friend:

We are looking for a few honest and responsible individuals to act as our "MAILING LIST PROTECTION AGENTS". This is an on-going endeavor that you can participate in for as long as you like, and really earn up to \$275.00 per week or more in the process.

What Is A Mailing List Protection Agent?

We are the U.S. LIST PROTECTION COMPANY and we protect mailing list owners from having their valuable list of customers stolen or used without authorization. In addition, at the same time, we monitor the delivery of the United States Postal Service. This is a very important service for a mailing list owner to have. He has to protect his mailing list because in many cases, it cost him hundreds of thousands of dollars to compile. If a mailing list was stolen and left undetected, it could very well put the list owner out of business.

Here is where you come in and how we protect our clients from having their mailing lists used without authorization. We have thousands of mailing list owners who allow many authorized mailings on their list each year. Each time an authorized mailing is made, they are vulnerable to having their list stolen. Therefore, we supply the mailing list owners with a secret list of "decoy" names and addresses. He inserts these "decoys" into his mailing list without making anybody aware of it. Then if an unauthorized mailing is made on the list, the "decoys" will receive more mail than they are supposed to. The mailing list owner will have solid evidence of any unauthorized mailings and can pursue legal action on that basis.

You, as a Mailing List Protection Agent, will have your address and a code name used as a decoy. For example, if your name is Robert Smith, you may give yourself the code name of James Smith. This way you can distinguish your personal mail from the decoy mail. Now, when you get your daily mail, you will simply sort the coded mail from the personal mail and put the date on the face of the envelopes of the coded mail. Each week you will take all of your coded mail and put it in a special package that we will supply. Then you will forward it to us for payment. What could be easier?

What Happens Next?

When your package of coded dated mail arrives at our office, we will count the number of pieces in the package and send you a check the same day along with another special package for your next group of coded dated mail. We then match the mail you sent us and forward it to the proper list owner for his use.

When you receive the next correspondence from us, it will include the following: 1) A payment of 30¢ for each coded dated piece of mail inside. 2) A payment for the postage money you spent to send us the previous package. 3) Another special package for the next group of mail.

Examples: Suppose various packages contained the following quantities of coded dated mail on different occasions. Here is how much money you would receive . . .

Group One contains 384 pieces in the package you forwarded us - WE PAY YOU \$115.20 plus the postage money you spent to send us the package!

Group Two contains 671 pieces in the package you forwarded us - WE PAY YOU \$201.30 plus the postage money you spent to send us the package!

Group Three contains 917 pieces in the package you forwarded us - WE PAY YOU \$275.10 plus the postage money you spent to send us the package!

We want you because we have a current need for agents with decoy addresses all over the United States. Our address is so well known that it could never be used as an effective decoy. Not to mention, many of our list owner clients are involved in regional mailings, thus we need decoys in all 50 states. Consequently, it doesn't matter where you live, you can become a Mailing List Protection Agent as long as you have an address in the United States or Canada.

How You Can Get Started So You Can Make Extra Money As A Mailing List Protection Agent

In order to get officially registered as a Mailing List Protection Agent, you must pay a one time fee as indicated on the LIFETIME

REGISTRATION CERTIFICATE. The fee covers all the computer costs of getting your code name and address integrated into the system, setting up your file for payment in our office, and start-up kit we will send you as soon as you register.

Your start-up kit consists of easy-to-follow instructions, an easy-to-complete form you must fill out one time for our files, and your first special package to forward coded dated mailing pieces back to us for payment.

Imagine making extra money as a Mailing List Protection Agent. There isn't an easier way to make an honest income. And the best part is that you can make a substantial second income and spend only a few short minutes each week doing it!

The amount of openings we have for Mailing List Security Agents is severely limited. We only need a few honest dependable individuals in each area. Therefore, you must register within the next two weeks to qualify. You have 14 days to forward to us the LIFETIME REGISTRATION CERTIFICATE along with your payment. If you send your registration in after that time, we reserve the right to refuse your request and, of course, immediately return your remittance, if you're rejected because you didn't meet the deadline.

Now is your chance to get in on the easiest way of accumulating extra money that has never been made available. For the next 14 days, you have the chance to join others who are reaping the financial rewards by acting as a Mailing List Protection Agent. Don't lose out on this opportunity to cash in. Say "YES" and ACT NOW before time runs out and it is too late!

Offer good in Canada - U.S. funds only.

Sincerely,

Susan Williams

Susan Williams, U.S. List Protection Co.

P.S. Please do not request that we register you without payment and later deduct it from your first check. We do not operate in such a manner because there are too many people willing to pay in advance. Furthermore, it creates an unnecessary bookkeeping problem if we have to keep records to remind us to make such deductions.

LIFETIME REGISTRATION CERTIFICATE (MAIL TODAY)

- YES, I accept your invitation to become a Mailing List Protection Agent.
Enclosed is \$25.00 Cash Money Order Check
for my lifetime registration and start-up kit.
(Note - Prompt shipment guaranteed if you pay by cash or by money order.)
- I'm in a hurry to make money! Enclosed is an extra \$2.00. Please rush my start-up kit by first class mail

(PLEASE PRINT) Name _____

Code Name (Select any name you want to use) _____

Address _____

City _____ State _____ Zip _____

Mail to: U.S. LIST PROTECTION COMPANY
Suite 760 • Keystone Exec. Plaza • 12555 Biscayne Blvd. • Miami, Florida 33181

Designing with Linear IC's

This month we inaugurate our new back-to-school series. This time around we'll be looking at linear IC's, and how you can use them in your own designs.

JOSEPH J. CARR

INTEGRATED-CIRCUIT TECHNOLOGY HAS made the job of circuit design much simpler. That's because those devices have progressed to the point that very few external components are needed to form a fully functional circuit. Consider, for instance, an operational amplifier: when setting the gain of those devices, the design simply entails picking the *ratio* of two resistors.

That's not to say, however, that working with linear IC's does not present its own unique problems. The purpose of this article, and the ones that will follow, is to introduce you to the various types of linear IC's. In the coming months we'll be looking at how those devices work, and how to use them successfully in your circuit designs.

IC construction

As you can see in Fig. 1-a, an IC is made up of layers of p-type and n-type semiconductor material. The bottom-most layer of the IC is called the substrate. The substrate is about 6 mils thick and its area can measure from 50×50 to 160×160 . In our example, the substrate is p-type material. In other IC's it could just as easily be n-type; it all depends on the design of the particular device.

The IC is fashioned by stacking alternating layers of p-type and n-type semiconductor material on the substrate as shown in Fig. 1-a. Each layer measures about 5- to 30-micrometers thick.

That brings us to one of the most basic design considerations that must be remembered when designing IC circuits. The p-type substrate and n-type next layer

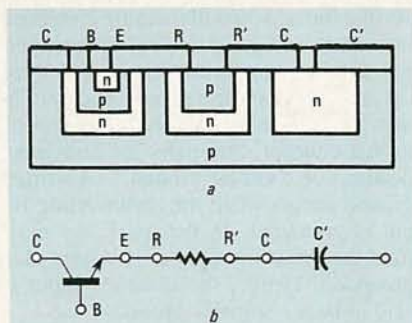

FIG. 1—ALL THE COMPONENTS in an IC are formed from layers of p-type and n-type semiconductor material. The circuit for the device shown in a is shown in b.

form a PN "diode" junction that must be reverse biased under normal conditions. The circuit designer must keep that constraint in mind. Although some clever designers are able to use forward bias for that junction, accidental reverse bias can destroy the device. In general, then, the substrate should be connected to either ground or to the case if it is made of metal.

Incidentally, the circuit formed by the IC is shown in Fig. 1-b.

Differential amplifiers

The heart of most linear IC amplifiers is the transistor differential amplifier shown in Fig. 2. A differential amplifier is designed to produce an output signal that is proportional to the difference between two input signals.

Transistors Q1 and Q2 form a differential pair because their emitters are tied together and their emitter currents are determined by a common constant-current source. Since the current, I_3 , from the constant-current source can not vary, it can neither increase nor decrease in response to changes in load. Since the sum of the transistor's emitter currents, $I_1 + I_2$, is equal to I_3 , we may conclude that keeping the sum constant, because I_3 is

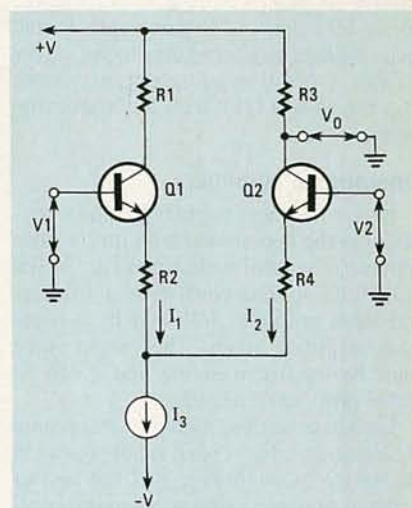

FIG. 2—THE DIFFERENTIAL AMPLIFIER, shown here, is the circuit on which the operational amplifier is based.

constant, requires one of the currents to decrease if the other increases. In other words: If I_1 increases, then I_2 will decrease, and if I_1 decreases, then I_2 will increase. Those relationships are critical to understanding the operation of the differential amplifier circuit.

For purposes of this discussion, we will assume that the collector and emitter currents of the transistors are identical. (In fact, however, those currents differ by the amount of the base current.) We will therefore assume further: that I_1 and I_2 are also the collector currents of Q1 and Q2 respectively.

The voltage appearing at the collector of Q2 is our output signal V_0 . The base of Q2 is designated the inverting input (symbolized by a $-$ sign), while the base of Q1 is the noninverting input (symbolized by a $+$ sign). By definition, those two inputs produce equal but opposite effects on the output signal. That means the two inputs will produce out-of-phase outputs. The output signal produced by the noninverting input is in phase with the input signal; the output signal produced by the inverting input is out of phase with the input signal. A consequence of that action is that identical voltages applied to both inputs will cancel each other and produce zero output.

Let's first examine the operation of the inverting input—the base of Q2. When both V_1 and V_2 are zero, then V_0 is at a quiescent value, or zero. If V_2 is made positive, current I_2 will increase (Q2 is

NPN). The voltage drop across R3 will also increase, so V_O will go down. In other words, a positive-going input signal produces a negative-going output; the input is an inverting input.

The noninverting input is the base of Q2. When V1 is made positive, current I_1 will increase. Since the sum $I_1 + I_2$ is constant, current I_2 must therefore decrease. With I_2 decreased, the voltage across R3 is less, so V_O increases. In that case, then, a positive-going input signal creates a positive-going output signal; thus the base of Q1 is truly a noninverting input.

Operational amplifiers

By far the most popular IC linear amplifier is the operational amplifier, whose schematic symbol is shown in Fig. 3. The typical IC op-amp consists of a differential input amplifier followed by a high-gain amplifier chain. The output stage must be bipolar, meaning that it can go either positive or negative.

Let's examine the pinout of an op-amp for a moment. First, what is not present in the device shown in Fig. 3-a? The answer to that is that no ground or common terminal is used! There are two power-supply terminals ($V+$ and $V-$), but no ground. Rest with that mystery for a bit; we'll explain it shortly.

Finishing up with the pinout, the two inputs, inverting and noninverting, are the same as discussed previously. The output terminal is self-explanatory.

The ideal op-amp has the following properties: Infinite open-loop gain, infinite input impedance, zero output impedance, zero noise contribution, infinite bandwidth, and, finally, inputs that "stick together."

Open-loop gain means the gain with no feedback, and for the ideal op-amp it is infinite. The open-loop gain for real op-amps is not infinite, but it is very, very high (20,000 for inexpensive devices, over 1,000,000 for premium-grade ones).

Infinite input impedance implies that the ideal op-amp input will neither sink nor source current. Again, real op-amps differ from the ideal. The input impedance is not infinite, but is very, very high (1 megohm to over 10^{12} ohms).

The output impedance of real op-amps is not zero, but is very low (usually under 100 ohms). That property makes it a nearly ideal voltage source to drive any following stages.

Zero noise contribution means the op-amp supplies no noise of its own to the output signal. That ideal is rarely met, however, and one must use premium-grade "low noise" devices if noise is a factor.

What about infinite bandwidth? Few op-amps have gain-bandwidth products over 2-3 MHz, and frequency-compensated types (e.g. 741) will provide sub-

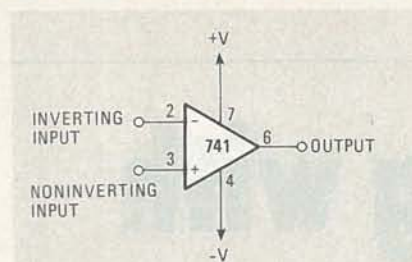

FIG. 3—SCHEMATIC SYMBOL for an op-amp. Note that there is provision for positive and negative supplies, but no ground terminal.

stantial gain only to 10 kHz.

What does "inputs that stick together" mean? It means we must treat both inputs the same. If we apply a voltage to one input, then we must treat the other as if the same voltage were applied to it also! And that is not just some theoretician's mumbo-jumbo. If you apply 2 volts to the inverting input, you will measure 2 volts on the noninverting one as well! That property will be very important when we analyze op-amp circuits in the months to come. In fact, you may have already been exposed to that concept, but under the confusing heading of "virtual ground." A virtual ground occurs when the noninverting input is grounded. In that case, we must treat the inverting input as if it were also grounded! Hence, the inverting input is said to be at "virtual" ground.

Designing circuits around the operational amplifier is made a lot easier by the fact that gain is set simply by the ratio of feedback and input resistors. We can tailor frequency response with simple R-C networks, or even just a capacitor in parallel with the feedback resistor.

The operational amplifier also simplifies the design of electronic integrators, differentiators, and logarithmic amplifiers. In fact, it was in those kinds of circuits that the op-amp was first used. The name "operational" amplifier came about because that type of amplifier could perform mathematical operations in analog computer circuits.

The power supply for operational amplifiers, and many other linear IC's, is shown in Fig. 4. Although batteries are shown here, electronic regulated power supplies may be substituted. The typical op-amp will operate at any potentials between ± 4.5 volts and ± 18 volts, with some operating at ± 22 volts.

There are actually two separate supplies used: $+V$ and $-V$. The $+V$ power supply is positive with respect to ground, while $-V$ is negative with respect to ground. There is no ground terminal on the op-amp. The signal common is the ground terminal of the power supply. The inverting and non-inverting input signals, and the output signal, are referenced to the power-supply common!

Power-supply decoupling capacitors are not always needed, but it is a good idea

to include them. Generally those decoupling capacitors are placed close to the body of the op-amp, rather than at the power supply. For frequency-compensated devices such as the 741, you might be able to get away with no decoupling at all. But for all uncompensated types use 0.1- μ F capacitors to ground both the $+V$ and $-V$ inputs. It is also wise to use 1- μ F tantalum capacitors in parallel with the 0.1- μ F units in order to take care of low frequency decoupling.

Power-supply specifications for op-amps can be a little confusing. We have two basic problems: supply-rail limit and maximum allowable voltages.

The supply-rail limit refers to the minimum difference between the power-supply potential and the maximum output signal voltage. For common 741-type devices, that potential is about 3.5 volts. The maximum signal output potential, therefore, is 3.5 volts below the power-supply voltage.

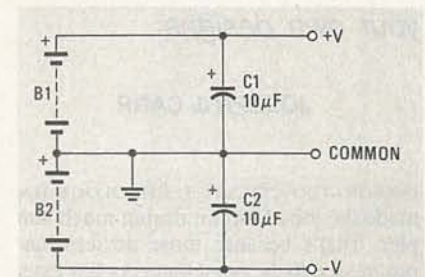

FIG. 4—POWER SOURCE for an op-amp. Note that regulated voltage sources could be used in place of the batteries.

How does that affect the designer? Suppose you are designing the input signal amplifier for a 10-volt A/D converter. You want the maximum signal amplitude to be 10-volts, obviously. The DC power-supply potential must be $10 + 3.5$, or 13.5-volts DC. If you had planned to use ± 12 -volt DC supplies, then your signal would clip on peaks! For 12-volt DC supplies, the maximum output signal would be $12 - 3.5$, or 8.5 volts!

Some op-amps have small supply-rail limits. The BiMOS devices, for example, can come within 0.5 volt of the supply rail. The usual way of guessing that limit (if it isn't published) is to count the number of PN junctions (base-emitter or base-collector) in the transistors between the output terminal and either power supply terminal, then multiply by 0.6 volt. The positive ($+V$) and negative ($-V$) supply-rail limits may be different on some op-amps.

The problem of maximum supply potential comes about only when trying to operate the device at maximum, and not thoroughly reading the spec sheet. The V_{MAX} ratings might be ± 18 -volts DC, leading one to believe that $+V$ and $-V$ may both be 18-volts DC. That's not always true! Look for the specified termi-

nal-to-terminal maximum voltage; that is, the maximum voltage that may safely be applied between +V and -V terminals of the op-amp.

Let's look at a "for instance!" The 741 device has maximums for -V and +V of ± 18 -volts DC, but a terminal-to-terminal maximum of only 30 volts. If we applied 18-volts DC to both +V and -V, the potential would be $+V - -V = 18 - (-18) = 36$ volts. That potential exceeds the 30-volt limit. If we apply maximum potential to one terminal, then the other must be derated to stay within the specification. For example, in the case above let's assume +V is 18-volts DC. The maximum allowable for -V is $30 - 18$, or 12 volts DC. In that case, we would set +V = 18 volts DC and -V = 12 volts DC.

We also sometimes see a related problem that causes op-amp burn-out at strange times. If the supply voltages rise unevenly at turn-on, or decay unevenly at turn-off, it is possible that some op-amps will burn out. Such problems occur mostly when one supply has a lot more capacitance than the other, or when one supply is a lot more heavily loaded than the other.

A similar problem occurs if the input voltage is allowed to rise higher than a supply voltage. The result can be an incorrectly biased substrate and burn-out of the device. That problem usually occurs only when there is some energy-storage device, such as a large capacitor, at the input

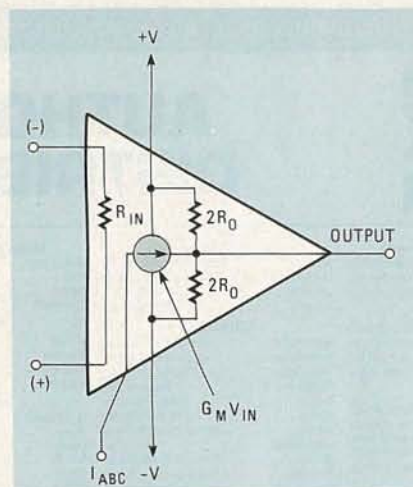

FIG. 5—AS THIS MODEL of the operational transconductance amplifier shows, the input of that device acts as a simple resistance while the output acts as a current source.

terminal. In that case, the input voltage may decay at a slow enough rate that some voltage remains at the inputs after power to the device has been removed.

Current-difference amplifiers

The operational amplifier is only one form of linear IC. There are, of course, dozens of others. Many of them are special-function devices (e.g. cassette-tape recorder pre-amplifiers, etc), but at least two devices have quite a bit in common with the op-amp.

One of those devices is the current-difference amplifier (CDA); that device is also called the Norton amplifier. In essence, the CDA is a current-input/voltage-output device, so it can be called a trans-resistance amplifier.

The CDA is particularly useful in automotive applications, or other cases where a single monopolar power supply is used. Although the CDA never caught on like the op-amp, it is nonetheless very useful. We will examine the CDA in detail in a future article.

The OTA

The other device that has a lot in common with an op-amp is the OTA (Operational Transconductance Amplifier). Figure 5 is a circuit model for that device. The input is modeled as a simple resistance much like an ordinary operational amplifier. The output, however, is modeled as a current source, where the magnitude of the current is equal to $G_M V_{IN}$; the "gain," therefore is the transconductance (G_M).

The transconductance operational amplifier will also be discussed in full in a future article.

In the next part of this series we will get down to brass tracks with the op-amp. Discussed will be the inverting-follower circuit configuration, how to set gain, and how to determine minimum input resistances. We will also introduce you to certain op-amp problems—and their solutions.

R-E

Save the clouds.

I want to help. Enclosed is my tax-deductible check for \$ _____
Please send me information about protecting the eyesight
of myself and my family.

Name _____
Address _____
City _____ State _____ Zip _____



National Society to Prevent Blindness
Box 2020, Madison Square Station, New York, N.Y. 10159

When you lose your vision, you lose the clouds.
You lose the sunsets. The seashells. The moonlight
and snowflakes.

This year, 50,000 Americans will lose all that
and more. Forever.

Yet with your help, half of all blindness can be prevented.
We're the National Society to Prevent Blindness.
We fight to save all the things people lose when they
lose their eyesight.

Help us save the clouds.
Give to Prevent Blindness.



AUTHORIZED DISTRIBUTORS

<p>ALABAMA</p> <p>Birmingham American Electronic Supply Birmingham J.L.S. Electronics Birmingham Long's Electronics Birmingham Microlog, Inc. Florence Fuller Distributing Huntsville Industrial Electronic Supply Huntsville W&W Electronics Mobile Forbes Electronics Montgomery Handley's Electronic Center Opelika Southern Electronic Corp. Tuscaloosa Radio Parts Inc.</p> <p>ALASKA</p> <p>Anchorage Electronic Supply Center Anchorage The Electronic Company Anchorage Wapato</p> <p>ARIZONA</p> <p>Lake Havasu City Electronics 4-U Sierra Vista B&S Electronics Tucson Electronic City Tucson Heathkit Electronic Center Yuma Yuma Electronics</p> <p>ARKANSAS</p> <p>Little Rock Southern Electronics</p> <p>CALIFORNIA</p> <p>Anaheim Heathkit Electronic Center Anaheim R.F. Electronics Antioch Goodrich Electronics Bakersfield Jay Kern Electronics Berkeley Al Lasher's Electronics Buena Park Fort Electronics Campbell Heathkit Electronic Center Chico Payless Wholesale Chula Vista Lion Electronics Chula Vista Sago Electronics Clearlake Clearlake Electronics Concord Pacific Radio Supply Corning Nor-Cal Electronics Costa Mesa Mar-Vac Electronics Covina G&H/AMCO Elect. Supply Cucamonga AdElectronics Cypress S.C.H. Electronics Davis Paradise Consumer Elect. El Cajon Radio Shack Eureka Redwood Electronics Fontana Fontana Electronics Fresno National Computer Fresno Sparky Electronics Fresno Whittom Electronics Fullerton Industrial Electronics Glendale Eagle Electronics Glendale Bill's Stereo Half Moon Bay Strawflower Elec./Radio Shack Harbor City Bluff Electronics Hawaiian Gardens Carson Electronics Hollywood Pacific Radio Exchange Inglewood Radioland/Inglewood Elect. La Habra A.B.C. Electronics La Mesa Heathkit Electronic Center Lancaster Consumer Electronics Los Angeles Heathkit Electronic Center Mission Viejo Heathkit Electronic Center Modesto Inland Electronics Modesto Pacific Radio Monterey Zackit Morro Bay Coast Electronics National City Willy's Electronics Oakland Cass Electronics Oceanside Calco Digital Oceanside Electronic Center Oroville Radio Mart Palo Alto U.S. Electronics Palo Alto Zack Electronics Pasadena Dow Radio Paso Robles Mission Electronics Pomona Heathkit Electronic Center Reading Radio Mart Sacramento Cal Radio TV Sacramento The Radio Place Sacramento Zackit Salinas Salinas Radio San Bruno Bruce Electronics San Carlos J&H Outlet San Diego Radio Shack/Mesa San Fernando San Fernando Electronics San Francisco Zack Electronics San Jose Peninsula Elect. Supply San Jose United Radio and TV San Luis Obispo Mid State Electronics San Rafael Electronics Plus Santa Clara Digital Pacific Santa Cruz Santa Cruz Electronics Santa Maria Caps Communications Santa Maria Electronic Parts Supermart South Lake Tahoe Calpine Electronics Sunnyvale Sunnyvale Electronics Torrance Signal Electronics Torrance Torrance Electronics Tustin A.B.C. Electronic Supply Vallejo Thrifty Zackit Westminster J.K. Electronics Whittier Whittier Electronics Woodland Hills Heathkit Electronic Center Yuba City Electronic World</p> <p>COLORADO</p> <p>Boulder Hasco Colorado Springs Calco Digital Equip Colorado Springs Centennial Electronics Denver Fiste's Electronics</p>	<p>COLORADO (Continued)</p> <p>Denver Fiste's Microelectronics Denver Mountain Coin Machine Lakewood D.H. Crump Co.</p> <p>CONNECTICUT</p> <p>Avon Heathkit Electronic Center New Haven Customized Computer Center Wallingford Tron Town USA Westport Computer Works</p> <p>DELAWARE</p> <p>Newark Computerland New Castle Delaware Amateur Supply Wilmington Laraco/Lafayette Radio Wilmington Micro Products Wilmington Wholesale Electronics</p> <p>FLORIDA</p> <p>Coral Gables Olson Electronics Clearwater Amateur Electronic Supply Fort Lauderdale Tecktron Enterprises Gainesville Skipper Electronics Hialeah Heathkit Electronic Center Hollywood Erica Inc. Jacksonville Heathkit Electronic Center Miami Olson Electronics Orlando C&S Electronics Orlando Lafayette Stereo & Elect. Oakland Park Lafayette Radio Panama City Bay-Mar Electronics Pensacola Forbes Electronics Pensacola Pensacola Electronics Pensacola Quad Electronics Plantation Heathkit Electronic Center Tampa Heathkit Electronic Center</p> <p>GEORGIA</p> <p>Atlanta A.C.M. Computer Mart Atlanta Heathkit Electronic Center Dalton A.C.M. Computer Mart La Grange Electronic Supply Stone Mountain Coleman's Electronics Warner Robbins C&L Electronics</p> <p>HAWAII</p> <p>Hilo Al's Electronics Honolulu Industrial Electronics Honolulu Integrated Circuit Supply Pearl City Heathkit Electronic Center</p> <p>IDAHO</p> <p>Boise Kimball Electronics Boise R.J.M. Electronics Caldwell A-Gem Supply Pocatello Kimball Electronics Twin Falls Central Electronics</p> <p>ILLINOIS</p> <p>Addison Digital World, Inc. Berwyn B.B. & W. Electronics Carbondale Pock's Electronics Chicago Meyer Electronics Chicago Howard Electronic Sales Chicago Olson Electronics Chicago University of Illinois Bookstore Decatur Main Street Computer Downers Grove Heathkit Electronic Center Chicago Mayer Electronics Harvey George Electronics Melrose Park Olson Electronics Mount Prospect Tri-State Electronic Corp. Niles Computerland of Niles Niles Joseph Electronic Peoria Computerland Peoria Warren Radio Co. Rockford Computer Store of Rockford Rock Island Team Electronics Skokie Lilliput Computer South Holland Union Electronic Dist.</p> <p>INDIANA</p> <p>Lakeland Electronics Bedford Eliek Mart Bloomington Stangler Radio Chesterton Chesterton Electronics Evansville Hutch & Son Gary Calumet Electronics Indianapolis Heathkit Electronic Center Indianapolis Warren Radio Co. Lafayette Von's Electronics Muncie Pierce Electronics South Bend Genesis Electronics South Bend TV Supply Co. Terre Haute Industrial Electronics</p> <p>IOWA</p> <p>Ames Electronic Supply, Inc. Burlington Union Supply Co. Clinton R.J.S. Electronics Davenport Warren Radio Co. Des Moines Gifford Brown Inc. Des Moines Radio Trade Supply</p> <p>KANSAS</p> <p>Hutchinson Hutchinson Electronics Kansas City Electronic Surplus Sales Mission Heathkit Electronic Center Salina Stangler Radio Shawnee Mission Burstein & Assoc. Topeka Carroll Radio & TV Supply Wichita Amateur Radio Equipment Wichita Lloyd's Radio & Elect. Wichita R.S.C. Electronics</p>	<p>KENTUCKY</p> <p>Lexington Radio Electronic Equip. Co. Louisville Heathkit Electronic Center Louisville Peerless Electronic Equip. Co. Paducah Warren Radio Co.</p> <p>LOUISIANA</p> <p>Baton Rouge Davis Electronic Supply Baton Rouge Industrial Elect. Supply Baton Rouge Menard Electronics Covington Electronic Mart Gretna Pelican Electronics Houma Pelican Electronics Kenner Heathkit Electronic Center Lake Charles W.R.E. Inc. Metairie Pelican Electronic Supply Meridian Hooper Electronic Supply New Orleans Wm. B. Allen Supply Co. Shreveport Electronic Supply of Shreveport Shreveport Industrial Electronic Supply Shreveport Southern Electronics Sidlet Electronic Mart</p> <p>MARYLAND</p> <p>Aberdeen Harco Electronics Annapolis Computers, Etc. Baltimore Heathkit Electronic Center Beltsville Mark Electronics College Park Electronics Plus Darnestown Damascus C.B. Glen Burnie Revacto of Maryland Laurel The Comm Center Lanvale J&M Electronics Rockville Heathkit Electronic Center Rockville Revacto Electronics Severna Park Futronics Inc. Suitland Suburban Wholesalers Towson Bayview Electronics Towson Computers Unlimited</p> <p>MASSACHUSETTS</p> <p>Danvers Computer Electronic Consultants Littleton Tel-Com Inc. Peabody Heathkit Electronic Center Pittsfield Pittsfield Radio Equipment Waltham Computer Mart Inc. Wellesley Heathkit Electronic Center</p> <p>MICHIGAN</p> <p>Adrian E&B Electronics Allen Park Olson Electronics Ann Arbor Wedemeyer Elect. Supply Battle Creek Warren Radio Bay City Kinde Distributing Canton The Electronic Connection Dearborn Westside Radio Detroit A.F. Electronic Parts Detroit Electronic Parts Co. Detroit Heathkit Electronic Center East Detroit S&S Electronics East Detroit Heathkit Electronic Center Fenton Tri-County Electronics Flint Shand Electronics Grand Haven K.S. Electronics Grand Rapids Micro World Inc. Grand Rapids Radio Parts Inc. Grand Rapids T&W Electronics Grand Rapids Warren Radio Holland Bits & Bytes Houghton Technetronics Jackson Fulton Radio Supply Kalamazoo Warren Radio Lansing Fulton Radio Supply Lansing Wedemeyer Elect. Supply Livonia Northwest Electronics Madison Heights Olson Electronics Madison Heights Warren Radio Midland Computronix Mount Clemens Olson Electronics Muskegon H&R Electronics Niles Niles Radio Supply Owosso Warren Radio Port Huron Main TV Radio Electric Saginaw Electronic Mart Saint Clair Shores Bell Electronics Co. Sterling Heights Electronic Supermarket Taylor Electronic World Taylor Tel Van Electronic Supply Traverse City Elect. Supply Westland Olson Electronics</p> <p>MINNESOTA</p> <p>Bedmij Electronics Duluth Northwest Radio of Duluth Hopkins Heathkit Electronic Center Minneapolis Acme Electronics Saint Paul Heathkit Electronic Center Winona Hiawatha Electronics</p> <p>MISSISSIPPI</p> <p>Biloxi Hooper Electronic Supply Jackson Ellington Electronic Supply Oxford Oxford Software Pascagoula Hooper Electronic Supply</p> <p>MISSOURI</p> <p>Bridgeton Heathkit Electronic Center Columbia Show Me Electronics Kansas City Burstein & Associates Kansas City Electronic Supply Co. Inc.</p>	<p>MISSOURI (Continued)</p> <p>Kansas City Walters Radio Rolla Show Me Electronics Sedalia Show Me Electronics Springfield Show Me Electronics</p> <p>MONTANA</p> <p>Billings Conley Radio Supply Bozeman Electronic Service & Dist. Great Falls Art's Electronics Great Falls Electric City Radio</p> <p>NEBRASKA</p> <p>Grand Island G.I. Electronics Lincoln Computer Systems Inc. Lincoln Scott Electronic Supply Norfolk Cauweus Gun & Hobby Shop Omaha Heathkit Electronic Center Omaha Scott Electronics</p> <p>NEVADA</p> <p>Las Vegas Century 23</p> <p>NEW JERSEY</p> <p>Edison William Electronic Supply Fairlawn Heathkit Electronic Center Mantua Electronic World Ocean Heathkit Electronic Center Trenton Lafayette Radio Supply Vineland Laraco/Vineland</p> <p>NEW MEXICO</p> <p>Alamogordo Basin Electronics</p> <p>NEW YORK</p> <p>Albany Greylock Electronics Amherst Heathkit Electronic Center Buffalo Olson Electronics Buffalo Radio Equipment Corp. Commack Spartan Electronics Hornell Hornell Electronics Hornell Rad-Tronics Jamestown Warren Radio Jericho Heathkit Electronic Center Johnson City Unicorn Electronics Kingston Greylock Electronics Middleton Greylock Electronics Newburgh Action Audio Inc. New York Manhattan Electronics New York Taft Electronics New York Greylock Electronics Rensselaer Electronic Stockroom Rochester Heathkit Electronic Center Seneca Olson Electronics Troy Trojan Electronic Supply Utica Central Electronics White Plains Computer Corner White Plains Heathkit Electronic Center</p> <p>NORTH CAROLINA</p> <p>Greensboro Heathkit Electronic Center Winston-Salem Trayer-Yelverton Inc.</p> <p>NORTH DAKOTA</p> <p>Fargo Radio & TV Equipment Fargo S/S Electronics</p> <p>OHIO</p> <p>Akron Akron Electronic Supply Akron Warren Radio Canton Mead Electronics Canton Electronic Center Inc. Cincinnati Heathkit Electronic Center Cleveland Heathkit Electronic Center Columbus Olson Electronics Columbus T.V. Specialties Lima Warren Radio Massillon M. H. Martin Co. Mogadore Olson Electronics Parma Superior Electronics Piquetteburg Universal Amateur Radio Toledo Heathkit Electronic Center Toledo Warren Radio Youngstown Olson Electronics Youngstown Ross Radio Co.</p> <p>OKLAHOMA</p> <p>Oklahoma City Trice Wholesale Electronics</p> <p>OREGON</p> <p>Albany Oregon Ham Sales Beaverton Nonvac Electronics Corvallis Electronic Super Store Corvallis Nonvac Electronics Dallas Nonvac Electronics Portland Portland Radio Supply Roseburg Roseburg Musical Instrument Salem Computer Specialties Salem Nonvac Electronics</p> <p>PENNSYLVANIA</p> <p>Braddock Leff Electronics Butler Computer Center Chambersburg Sunrise Electronic Dist. Drexel Hill Kass Electronic Dist. Erie Warren Radio Fairview Bell Electronics Fraser Heathkit Electronic Center McKeesport Barrio Radio Norristown Computer Corner Philadelphia Heathkit Electronic Center Philadelphia Spectrum Electronics Phoenixville Stevens TV & Electric Pittsburgh Heathkit Electronic Center Pittsburgh Pittsburgh Computer Store Pittsburgh South Hills Electronics Pittsburgh The Computer House York G.Y.C. Co.</p>	<p>RHODE ISLAND</p> <p>Cranston Jabour Electronics Pawtucket Jabour Electronics Providence Hope Electronics Warwick Heathkit Electronic Center</p> <p>TENNESSEE</p> <p>Bristol Shields Electronics Concord National Electronics Cookeville Wagon's Stereo Center Dyersburg Warren Radio Knoxville Shield's Electronic Supply Memphis Bluff City Electronics Memphis Memphis Amateur Electronics Memphis Warren Radio Murfreesboro Murfreesboro Radio & Elect. Murfreesboro Standard Auto Parts Nashville Eddie Warners Parts Co. Nashville Electric Dist. Co. Oak Ridge Mr. Radio Oak Ridge National Electronics Smyrna Delker Electronics Tulahoma H&H Electronics</p> <p>TEXAS</p> <p>Brownsville George's Electronic Mart Dallas Heathkit Electronic Center Dallas Trice Electronics Fort Worth Heathkit Electronic Center Harlingen George's Electronic Mart Houston Heathkit Electronic Center Lubbock Trice Electronics McAllen Carlie Franco Electronics McAllen George's Electronic Mart Richardson Martin Wholesale Electronics Richardson Trice Electronics San Antonio C&K Electronics San Antonio Heathkit Electronic Center Waco L&M Wholesale</p> <p>UTAH</p> <p>Midvale Heathkit Electronic Center Ogden Carter Supply Co. Provo Alpine Electronic Supply Salt Lake City Best Distributing Salt Lake City Kimball Electronics Salt Lake City Mountain Con Distributing Salt Lake City RA-ELCO Inc.</p> <p>VERMONT</p> <p>Burlington Greylock Electronics Essex Junction I.E.S. Lafayette Radio</p> <p>VIRGINIA</p> <p>Alexandria Heathkit Electronic Center Annandale Arcade Electronics Arlington Arlington Electronic Wholesalers Blacksburg Scotty's Radio & TV Charlottesville Graves Electronics Falls Church Crossroad Elect. Wholesalers Harrisonburg Electrical Wholesalers Hopewell B&G Electronics Lynchburg Electronic Service Co. Norfolk AVEC Electronics Norfolk Gain Electronics Norfolk Prest Electronics Richmond AVEC Electronics Roanoke AVEC Electronics Vienna Electronic Equipment Bank Virginia Beach Heathkit Electronic Center Woodbridge E.G.E.</p> <p>WASHINGTON</p> <p>Bellevue A.B.C. Communications Bellingham Cascade Electronics Everett A.B.C. Communications Hoquiam Harbor Electronics Kennewick C&L Electronics Kent Electronic Supermart Moses Lake Ron's Electronics Olympia The Electronic Shop Pasco Radio Shack Pullman H&O Electronics Richland Radio Shack Seattle A.B.C. Communications Seattle Amateur Radio Supply Seattle Electronic Supply Co. Seattle Heathkit Electronic Center Spokane D.S.C. Sales Spokane Personal Computer Tacoma C&G Electronics Tukwila Heathkit Electronic Center Vancouver Heathkit Electronic Center</p> <p>WEST VIRGINIA</p> <p>Elkins Williams Electronics Fairmont T.P.S. Electronics Morgantown Computer Corner Morgantown Electro Dist. Co. Morgantown State Electronics Wheeling Industrials</p> <p>WISCONSIN</p> <p>Kenosha Chester Electronic Supply Milwaukee Amateur Electronic Supply Milwaukee Heathkit Electronic Center Milwaukee Olson Electronics Rock Springs D.C. Electronics</p> <p>WYOMING</p> <p>D.C. Electronics</p> <p>FOREIGN</p> <p>Guam: Agana Marianas Electronics Guatemala: Electronica Pan Americana Panama: Sonitel S.A. Panama: Tropico S.A. Puerto Rico: Rio Pedras Microcomputer Store Puerto Rico: Rio Pedras Radio Shack Singapore: Applied Digital Systems West Indies: Trinidad The Hobby Center</p>
---	--	--	---	---

For Distributor Information, write or phone JIM-PAK, 1355 Shoreway Road, Belmont, CA 94002 (415) 595-5936

CONNECTORS AND ACCESSORIES

DOUBLE-ROW MALE HEADERS



• Solder to PC boards for instant plug-in access • .025" square posts on a .10" x .10" matrix

Part No.	Description
923862R	20 post double row male
923863R	26 post double row male
923864R	34 post double row male
923865R	40 post double row male
923866R	50 post double row male

GENDER CHANGERS



Used to connect 2 cables which have the same gender.

Part No.	Description
JRSM-M	Connects 2 male (DB25P) cables
JRSF-F	Connects 2 female (DB25S) cables

D-SUB CONNECTORS



SOLDER-TYPE CONTACTS

Part No.	Description
DE9P	9 Pin Plug
DE9S	9 Pin Socket
DE9H	Hood for DE9 Series Connectors
DA15P	15 Pin Plug
DA15S	15 Pin Socket
DA15H	Hood for DA15 Series Connectors
DB25P	25 Pin Plug (Meets RS232)
DB25S	25 Pin Socket (Meets RS232)
DB25H	Hood for DB25 Series Connectors
DC37P	37 Pin Plug
DC37S	37 Pin Socket
DC37H	Hood for DC37 Series Connectors
DD50P	50 Pin Plug
DD50S	50 Pin Socket
DD50H	Hood for DD50 Series Connectors

MICRO CHARTS



Instant Data on the Most Popular Computer and Microprocessor Parts

- Fully decoded data
- Compact 8½" x 11" size
- Durable credit card plastic
- Clear and concise two-sided tables for: Full instruction set, disassembly, ASCII, base conversion, pinout & much more...

Part No.	Description
MLZ80	Z80 CPU
ML6502	6502 (65XX)
ML7400	5400/7400 TTL Pinouts
ML8080A	8080A/8085A

JE750 4-Digit Fluorescent Alarm Clock Kit



The JE750 Alarm Clock Kit is a versatile 12-hour digital clock with 24-hour alarm. The clock has a bright 0.5" high blue-green fluorescent display. The display will automatically dim with changing light conditions. The 24-hour alarm allows the user to disable the alarm and immediately re-enable the alarm to activate 24 hours later. The kit includes all documentation, case and wall transformer. Other features: flashing colon, alarm tone 500Hz once per sec., 10 minute snooze alarm, am/pm indicator. Size: 6½"L x 3¼"H x 1¾"D.

Part No. JE750 Kit

Insulation Displacement Connectors

Dip Plug Connectors



Part No.	Description
609-14	14 Contact Dip Plug Connector
609-16	16 Contact Dip Plug Connector
609-24	24 Contact Dip Plug Connector
609-40	40 Contact Dip Plug Connector

Socket Connectors



Mates 2 rows of .025" sq. dia. posts on patterns of .100" centers.

Part No.	Description
S20	20 Contact Socket Connector
S26	26 Contact Socket Connector
S34	34 Contact Socket Connector
S40	40 Contact Socket Connector
S50	50 Contact Socket Connector

Card-Edge Connectors



Mates with double-sided 1/16" PC board with contact fingers on .100" centers.

Part No.	Description
C20	20 Contact Card-Edge Connector
C26	26 Contact Card-Edge Connector
C34	34 Contact Card-Edge Connector
C40	40 Contact Card-Edge Connector
C50	50 Contact Card-Edge Connector

D-Sub Connectors



Part No.	Description	FLAT CABLE CONTACTS
CDE9P	9 Contact Plug	
CDE9S	9 Contact Socket	
CDA15P	15 Contact Plug	
CDA15S	15 Contact Socket	
CDB25P	25 Contact Plug	
CDB25S	25 Contact Socket	
CDC37P	37 Contact Plug	
CDC37S	37 Contact Socket	

DATA BOOKS

Part No.	Description
210830	Intel Memory
210844	Intel Microprocessor
30001	National CMOS
30003	National Linear
30005	National TTL Logic
30009	Intersil Data
30013	Zilog Microprocessor



SPEAKER

1-3/16" Square • 5/32" Thick
8 Ohm • .40 Watt

- Stainless steel diaphragm • Ultra Slim
- For alarms, music sounds, telephone equipment, computers, speech aids, etc.

Part No. TS30S



JOYSTICKS

Part No.	Description
JS100K	100K Linear Taper Pots (with knob)
JS150K	150K Linear Taper Pots (with knob)
JVC-40	40K Video Controller in case (w/knob)



Jim-pak

DIODES
CRYSTALS
TRANSISTORS
SOCKETS
KITS
SWITCHES
RESISTORS
LEDS
HEAT SINKS
KEYBOARDS
WIRE
SPEAKERS
TOOLS
CORDS
SOLDER
IC'S
BOOKS
CAPACITORS
and more...

CENTRONICS

⇐ Solder Type Insulation Displacement Type ⇐

Part No.	Description
CEN36M	36 Contact Male-Insulation Displace.
CEN36F	36 Contact Female-Insulation Displace.
57-30360	36 Contact Male - Solder
57-60360	36 Contact Female - Solder

INSULATION DISPLACEMENT CABLE ASSEMBLIES

Part No.	Description
S20-36	20-pin 36" Single-End Socket
S26-36	26-pin 36" Single-End Socket
S34-36	34-pin 36" Single-End Socket
S40-36	40-pin 36" Single-End Socket
S50-36	50-pin 36" Single-End Socket
S20-6-S	20-pin 6" Double-Ended Socket
S20-18-S	20-pin 18" Double-Ended Socket
S26-18-S	26-pin 18" Double-Ended Socket
S50-18-S	50-pin 18" Double-Ended Socket
DB25P-10-P	25-pin male 10' Double-Ended Plug
DB25P-10-S	25-pin male 10' 25-pin female
CEN36M-5	36-pin Centronics 5' male
CEN36M-5-F	36-pin Centronics 5' male to female
CEN36M-5-M	36-pin Centronics 5' male to male

CONTROL COMPUTER

continued from page 51

The I/O

The RS-232 port is really part of I/O system, which we'll be discussing in a

future installment of this article. However, we must introduce it now because it is required for any operator I/O. It also must be used to confirm proper operation of the basic system.

The RS-232 port can be implemented in two distinctly different manners. The first and easiest is to use a UART (Univer-

sal Asynchronous Receiver Transmitter) IC. The UART constantly waits for an incoming character, receives it according to whatever protocol has been programmed, and stores the character in a holding register until the microprocessor requires it. Transmission is simply a matter of writing the character to the UART's transmit register.

The other alternative—the one that we'll use—is to use one input and one output of the board to send and receive the serial data. That method requires the microprocessor to assume control of the entire process of data reception and transmission. However, it eliminates the requirement for a large and expensive component. The principal limitation of this approach is that the microprocessor must know when to expect a character and it must be executing its input routine before the character is sent to the board. That's not a problem for most applications. In the case of BASIC, it means that all console commands and program INPUT statements are handled easily. However, there can be no INKEY\$ statement.

The eighth output and eighth input of the bit-addressable I/O port will be used to implement the RS-232 port. The requirement for a negative voltage supply for the RS-232 link can be avoided with a bit of foxy circuit design. The incoming RS-232 signal is normally at the "mark" or negative level. Every character transmission ends with a stop bit designed to return the line to the negative level. We can generate our level from the incoming RS-232 line. That approach works fine for cables of less than 10 feet long. If longer cables are used, a separate negative supply between -5 and -12 volts DC should be used. Such a supply is available from the power-supply board, which—as we mentioned previously—we'll discuss in a future installment.

When examining serial asynchronous waveforms, remember that a logic one is less than -3 volts DC and a logic zero is greater than +3 volts DC. The line is held in the mark or one state when not active. The transmission always begins with a start bit = 0 and ends with a stop bit = 1. The stop bit returns the line to the mark state.

Full duplex serial operation that means separate wires carry data to and from the control computer (and terminal). Pin 2 of the RS-232 connector is transmitted data to the computer. Pin 3 is received data from the computer. At the terminal, those two pins are reversed so that pin 2 is an output and pin 3 an input. If you are using a personal computer as a terminal, you must determine if the RS-232 port of your computer is configured as a terminal or as a computer. Whatever the case may be, connect the board's input to the terminal's output and vice versa.

PARTS LIST—COMPUTER BOARD

All resistors ¼-watt, 5% unless otherwise noted

R1,R4,R14-R18—1000 ohms
R2,R5,R6—user-determined. To be discussed next month
R3,R11,R12—10,000 ohms
R7—680 ohms
R8—390 ohms
R9—12,000 ohms
R10—2,000 ohms
RN1—4.7K × 9 resistor network

Capacitors

C1—user-determined. To be discussed next month
C2—150 pF, ceramic disc
C3-C8,C11-C13,C16-C20—0.1 μF, ceramic disc
C9—0.001 μF
C10—27 pF
C14,C15—10 μF, 16 volts, electrolytic

Semiconductors

IC1—ADC0804 A/D converter (National)
IC2,IC3—74LS541 octal buffer and line driver
IC4—SN75478 seven high-current darlington drivers (TI, also Sprague ULN-2003, Motorola MC1413)
IC5—4051 8-input analog multiplexer
IC6,IC7—74LS377 octal latch
IC8—74LS251 8-input digital multiplexer
IC9—System ROM. 2716, 2732, or 2764. 450 ns maximum access time.
IC10,IC12—TMM 2016P-2 (Toshiba or similar) 2K × 8 static RAM, 450 ns.
IC13—Programmed EPROM (2716)

IC14—EPROM to be programmed
IC11—74LS259 8-bit addressable latch
IC15—74LS373 octal latch
IC16—74LS139 dual 2-to-4 line decoder/multiplexer
IC17—74LS32 quad OR gate
IC18—8088 microprocessor
IC19—74LS04 hex inverter
IC20—74LS123 dual one-shot
Q1,Q2—2N3904
Q3—2N3906
D1,D2, D4-D8—1N4148
D3—1N4001

Miscellaneous: IC sockets, PC board, mounting hardware, etc.

The following are available from Vesta Technology, Inc., 2849 W. 35th Ave., Denver, CO 80211: KIT 1—Kit of all parts needed to control 7 LS-TTL outputs, monitor 7 inputs, program EPROM's, RS-232 serial port, and 2K RAM (does not include operating system—see below), \$99.95; KIT 2—Kit of all parts for full-capacity I/O and 4K RAM (does not include operating system—see below), 169.95; Operating systems contained in ROM: BASIC I operating system, \$12.95; BASIC II operating system, \$29.95; Forth operating system, \$79.95; Assembled, tested, and burned-in control computer with BASIC II operating system, \$279; RS-232 cable, \$24.95; 2716 EPROM, \$6.95. Add \$6 for shipping, handling, and insurance.

PARTS LIST—POWER-SUPPLY/BSR LINK BOARD

All resistors ¼ watt, 5% unless otherwise noted

R1,R19—200 ohms
R2,R7,R8,R20—100 ohms
R3,R4,R11,R12,R15—1000 ohms
R6,R10—4700 ohms
R9—1 ohm (a jumper works fine)
R13—10,000 ohms trimmer potentiometer
R14—15,000 ohms
R16—220 ohms
R17—10,000 ohms
R18—470 ohms

Capacitors

C1,C2—0.1 μF, ceramic disc
C3,C5—0.01 μF, ceramic disc
C4,C6—0.047 μF, ceramic disc
C7—10 μF, 25 volts, tantalum
C8—150 pF, ceramic disc
C9—1 μF, 16 volts, electrolytic
C10—0.14 to 0.47 μF, 200 volts, electrolytic
C11—3300 μF, 16 volts, electrolytic
C12—500 μF, 50 volts, electrolytic

Semiconductors

IC1—ULN2003 darlington array

(Sprague)
IC2—TL497 switching regulator
IC3—74LS00 quad NAND gate
IC4—LM340-5 +5-volt regulator
IC5—LM320-5 -5-volt regulator
Q1—2N3904
Q2—2N3906
D1,D3,D5,D6,D10—1N4001
D2,D4,D7-D9—1N4148
T1—11Z2100 1:1:1 pulse transformer (Sprague)
T2—16 volts, center tapped, 0.4 amps. (Signal ST-4-16 or similar)
S1—normally open momentary pushbutton switch
Miscellaneous: line cord, printed-circuit board, IC sockets, heat sink for regulator, mounting hardware, etc.

The following are available from Vesta Technology, Inc., 2849 W. 35th Ave., Denver, CO 80211: Power-supply/BSR-link kit, including all components, \$59.95; Assembled, tested, and burned in power supply, \$109. Add \$6 for shipping, handling and insurance.

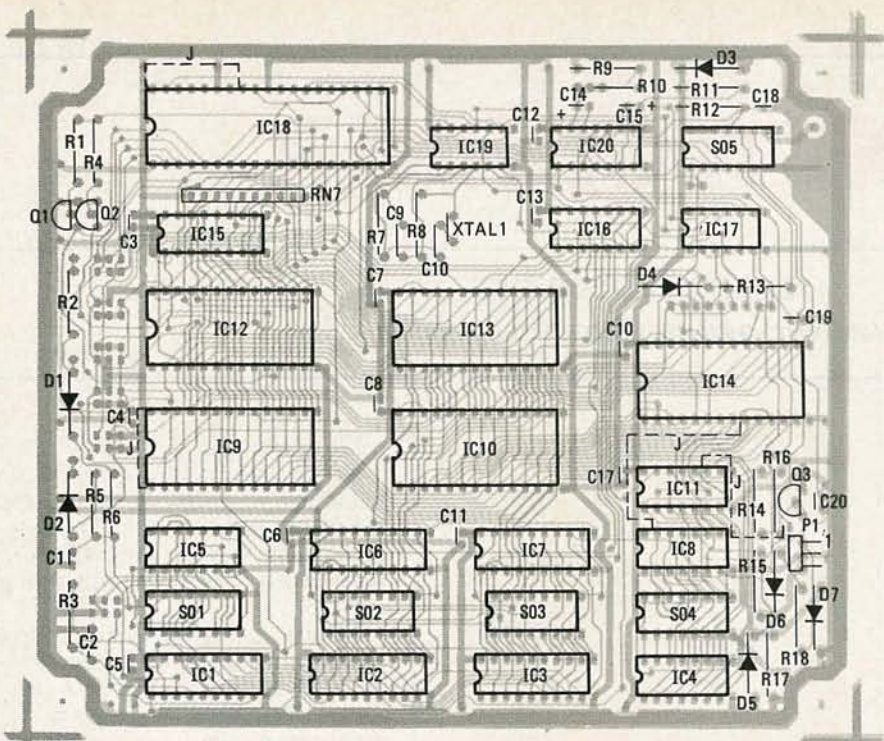

FIG. 4—PARTS-PLACEMENT DIAGRAM for the computer board. The dashed lines represent foil-side jumpers. There are many "unused" pads; they are for future expansion and experimentation. For example, note that a 28-pin socket is provided for the 24-pin 2716 (IC14). That allows larger EPROM's to be programmed. Simply plug the 2716 (or other 24-pin device) into the socket leaving pins 1 and 2 of the socket unoccupied.

Building the control computer

The actual assembly of the assembly of the controller requires no special techniques. You can use a printed-circuit board (we showed the foil patterns for the double-sided board in Figs. 2 and 3) or you can wire-wrap the project. You are probably better off with the PC board. Troubleshooting will be easier, and assembly will be quicker—about an hour, assuming you already have the board. (If you are not able to make your own board, see the Parts List for a supplier). Wire-wrapping the project will take about 16 hours. One note on wire-wrapping: Do not give into the temptation of wire-wrapping directly to the leads of the discrete components. The integrity of a wire-wrap joint depends on the square corners of the posts.

If you have the printed-circuit board, simply follow the parts-placement diagram in Fig. 4. Be careful not to create solder bridges, and when you are finished, wash the board in flux solvent. That will remove any flux residues left on the board. Don't forget that we've showed the foil and parts-placement diagrams for only the computer board. The power supply and BSR-type controller will be located on a separate board of the same size. We'll discuss that single-sided board next time, and we'll give you some more hints on the control computer's construction.

Troubleshooting

After you install all the parts, carefully inspect your board. You should check that all IC's are in the correct sockets and that

they are correctly oriented. Transistors and diodes should also be checked. Then measure the power-supply voltages. Although we have not yet discussed the board for the power supply and BSR-type controller, you can test the computer board if you have a +5-volt DC regulated supply.

Regardless of what supply you use, ensure that it is the correct voltage, and be sure to orient it correctly. Reversing the power-supply polarity is like reversing an IC, only it's more efficient—it will burn out *all* of the IC's. The BASIC operating system should be inserted into the system ROM socket (IC9). The first memory socket (IC12) should contain a 2016 RAM IC. Do not insert additional memory yet. Also, unneeded I/O should be removed. Get your terminal to the proper protocol (4800 baud, no parity, 8 data bits, full duplex, caps lock on) and connect it to the board. Apply +5 volts DC. If the BASIC prompt (>) appears, we can assume that the basic microprocessor circuits are correct. (If you use the BASIC II operating system, then you do not have to set your terminal to 4800 baud. Simply hit the space bar within 7 seconds after the board is turned on or reset.)

If the BASIC prompt does not appear, then we have some troubleshooting to do. Unfortunately, though, we've run out of room to talk about it this month. But it's the first thing we'll deal with next time.

Along with the troubleshooting hints, we'll look at the power supply, remote controller, and also the I/O capabilities of the computer

R-E

The "OUT FRONT" DMM



HICKOK'S LX-306 PIED PIPER with exclusive Vari-Pitch®

... combines the best of DMM's, analog meters, logic probes, tracers and continuity testers into one compact unit. The LX-306 offers 0.25% accuracy and all functions and ranges featured by other leading DMMs; PLUS, VARI-PITCH, the audible DMM tone system that obsoletes all others.

VARI-PITCH changes tone proportionate to the signal input. Its usage is limited only by your imagination. Imagine:

- Troubleshooting by character or "signature" sound.
- Detecting ripple or noise on the power supply line.
- Quickly locating intermittents.
- Locating and testing capacitors in a circuit.
- Making analog-type peaking and nulling adjustments.
- Reducing troubleshooting time by 25% or more.

The LX-306 is the ideal DMM for tough jobs and busy schedules. Built to fit your hand and your budget!

LIST PRICE ~~\$155.00~~

LIMITED TIME OFFER \$139.00

See your Hickok distributor, or contact:

HICKOK
the value innovator

THE HICKOK ELECTRICAL INSTRUMENT CO.
10514 Dupont Avenue • Cleveland, Ohio 44108
(216) 541-8060 • TWX: 810-421-8286

CIRCLE 85 ON FREE INFORMATION CARD

HOBBY CORNER

Testing transistors

EARL (DOC) SAVAGE, K4SDS, HOBBY EDITOR

IN THE FEBRUARY 1984 "HOBBY CORNER," we discussed how to make realistic battery tests. Well, this month we'll turn to another testing problem. Glen Gartner (PA) asked a question about how to test bipolar transistors. He needs a procedure that uses minimal equipment—such as only a multimeter. Since that topic is sure to interest many of you, we'll spend some time on it. We'll start with a look at some transistor basics.

Essentially, a transistor is a couple of diodes that share a common element. That sharing causes one diode to be affected by what happens in the other. Of course, that is an over-simplification—you could not make a transistor using two discrete diodes—but that model does generate a mental picture that is helpful to us.

Current flow in a transistor

You know that a diode is a two-terminal device that passes current in one direction, but has a very high resistance to current flowing in the opposite direction. Conventional current flows freely from the diode's anode to cathode. Figure 1 shows the schematic symbol for a diode—current flows in the direction of the arrow.

Now let's get back to the transistor. You know that there are two bipolar types: PNP and NPN. The symbol for the PNP



FIG. 1

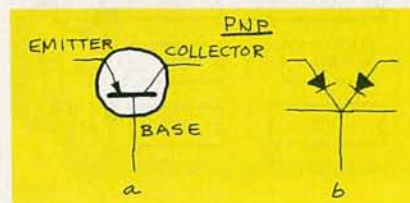

FIG. 2

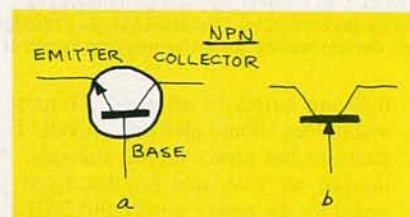

FIG. 3

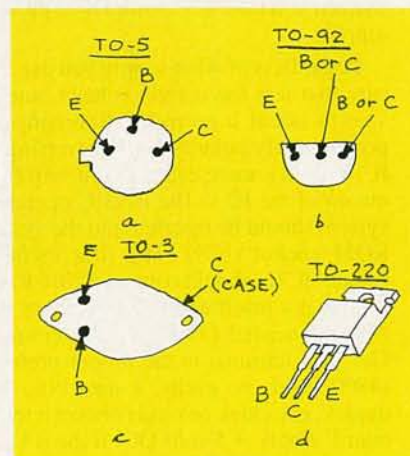

FIG. 4

transistor is shown in Fig. 2-a. Figure 2-b shows how you can think of the PNP transistor. In effect, there are two diodes with a common cathode (the base). From our discussion of diodes, it is clear that the PNP transistor has low resistance to current flow from emitter to base and also from the collector to base.

Figure 3-a shows the symbol for an NPN transistor. Figure 3-b shows how you can think of it—two diodes with a common anode (the base). Thus, the NPN transistor should have a low resistance from the emitter to base and also form the

collector to base.

Now that we know how to think of the transistors, we can go about testing them. But first we have to be able to identify the leads. Figure 4 shows some common transistor-package types along with their pinouts.

The next task is to determine the polarity of your multimeter probes when it is in the resistance-reading mode. *Do not assume that the black one is negative!* You can test the polarity by tracing the internal wiring of the meter or by using a second meter. Of course, you can use a marked diode and measure its resistance in both directions—the resistance will be greater when the negative probe is on the anode. Once you determine the probe polarities, mark your meter permanently so that you won't have to check it again.

Now you're finally ready to find out whether the transistor is a PNP or NPN type. Before I tell you, think about the information we've gone over so far. You have everything you need to make the test. Can you figure it out?

Connect one meter probe (in the high-resistance range) to the base of the transistor. Measure the resistance to the emitter and, again, to the collector. Then connect the other probe to the base and repeat the measurements. Both of the first two readings will be higher than both of the second set of readings. If not, you either have a defective transistor or you have identified the three leads incorrectly.

Assuming that both readings in one set are greater than both in the other set, apply this rule: If the readings are higher when the negative probe is on the base, the transistor is an NPN type. Otherwise, it is a PNP transistor. Once you get the hang of making this measurement, you can test transistors quickly—at least in less time than it takes to explain it!

Is it good?

Now you have the leads identified and you know the transistor type. However, you still do not know if the transistor works! There are several ways to test a transistor. First you can substitute a transistor known to be good for a suspect one in a circuit. If the circuit then functions, the original transistor is bad. On the other hand, if it doesn't function, you cannot be

AN INVITATION

To better meet your needs, "Hobby Corner" has undergone a change in direction. It has been changed to a question-and-answer form. You are invited to send us questions about general electronics and its applications. We'll do what we can to come up with an answer or, at least, suggest where you might find one.

If you need a basic circuit for some purpose, or want to know how or why one works, let us know. We'll print those of greatest interest here in "Hobby Corner." Please keep in mind that we cannot become a circuit-design service for esoteric applications; circuits must be as general and as simple as possible. Please address your correspondence to:

Hobby Corner
Radio-Electronics
200 Park Ave. South
New York, NY 10003

sure of the transistor—either it or another component could be bad.

You can also test many transistors with a multimeter. In this procedure, start with the highest resistance scale each time and move down as necessary. Here are the steps:

1. Connect the probes to the base and collector.
2. Note the resistance.
3. Reverse the probes and note the resistance.
4. Connect the probes in the direction of the highest resistance.
5. Short the emitter to the base. If the transistor is good, the reading will decrease.
6. Change the base probe to the emitter.
7. Short the emitter to the base. If the transistor is good, the reading will increase.

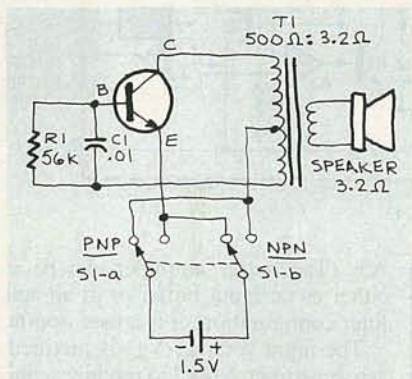

FIG. 5

A simpler and more reliable way to test a transistor is to put it in a test circuit. The simple audio oscillator shown in Fig. 5 will beep softly with every good bipolar transistor that you plug into it. The resistor and capacitor values are not critical—almost anything in the ballpark will work. In addition, the voltage is so low that the transistor won't be damaged if you plug the leads in wrong or if the switch is in the wrong position. For convenience, you can build this little tester in a small utility box, so that it will be on hand whenever you need it.

There is, of course, a fourth way to test transistors. I have admitted my laziness to you in the past, so it will come as no surprise that I use a handy-dandy commercial transistor checker. You, too, might take a look at Radio Shack's 22-025. It's small, versatile, and costs less than \$15. It will check transistors both in-circuit and out-of-circuit, and will even give a relative beta measurement. You can also use it as a continuity checker or as an audio oscillator. Like the checker circuit we built, the tester is safe—you can plug transistors in backward and not damage them.

All right, Glen, you and other readers can surely find one suitable way to do your
continued on page 113

FREE

McIntosh STEREO CATALOG and FM DIRECTORY

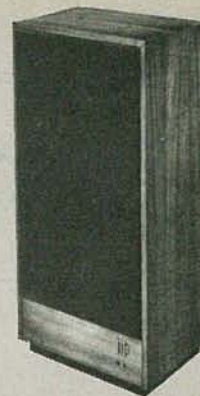

Get all the newest and latest information on the new McIntosh stereo equipment in the McIntosh catalog. In addition you will receive an FM station directory that covers all of North America.



**SEND
TODAY!**

McIntosh Laboratory Inc.
East Side Station P.O. Box 96
Binghamton, N.Y. 13904-0096

RE

NAME _____
ADDRESS _____
CITY _____ STATE _____ ZIP _____

If you are in a hurry for your catalog please send the coupon to McIntosh.
For non rush service send the Reader Service Card to the magazine.

CIRCLE 93 ON FREE INFORMATION CARD

CABLE TV

CONVERTERS DESCRAMBLERS

Largest Selection
of Equipment Available
\$ Buy Warehouse Direct & Save \$



36 channel
converter
\$4595

36 channel
wired remote
converter
only
\$8895

Send \$2 for complete catalog
of converters and unscramblers

Quantity Discounts • Visa • Master Charge
Add 5% shipping—Mich. residents add 4% sales tax

C&D Electronics, Inc.
P.O. Box 21, Jenison, MI 49428
(616) 669-2440

ACTIVE RECEIVING ANTENNA

Gives excellent reception,
50 KHz to 30 MHz.

New MFJ-1024 Active Receiving Antenna mounts outdoors away from electrical noise for maximum signal. Gives excellent reception of 50 KHz to 30 MHz signals. Equivalent to wire hundreds of feet long. Use any SWL, MW, BCB, VLF or Ham receiver.

High dynamic range RF amplifier. 54 in. whip. 50 foot coax. 20 dB attenuator prevents receiver overload. Switch between two receivers. Select auxiliary or active antenna. Gain control. "ON" LED. Remote unit, 3x2x4 in. Control, 6x2x5 in. 12 VDC or 110 VAC with optional adapter, MFJ-1312, \$9.95.

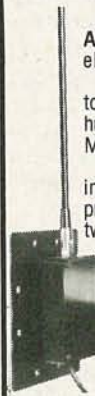

\$129.95
(+\$4.00 shipping)

Order from MFJ and try it. If not delighted, return within 30 days for refund (less shipping). One year unconditional guarantee.

Order today. Call TOLL FREE 800-647-1800. Charge VISA, MC. Or mail check, money order. Write for free catalog. Over 100 products.

CALL TOLL FREE 800-647-1800

Call 601-323-5869 in Miss., outside continental USA, tech/order/repair info. TELEX 53-4590.

MFJ ENTERPRISES, INCORPORATED
Box 494, Mississippi State, MS 39762

CIRCLE 66 ON FREE INFORMATION CARD

STATE OF SOLID STATE

Making true RMS measurements

ROBERT F. SCOTT, SEMICONDUCTOR EDITOR

THE ACCURACY OF MEASURED RMS VALUES OF AC voltages has always been questionable. That's because the shape of the AC wave being measured can drastically affect the readings of many voltmeters. In most multimeters and AC panel-meters, the AC wave is rectified to develop a DC voltage that is proportional to the RMS value. For example: two popular analog multimeters specify their AC voltage accuracy as 5% of full-scale value when measuring a 60-Hz sine wave. Accuracy "goes out the window" if the input signal's shape is nonsymmetrical or if the signal approaches a triangle or pulsed waveform.

Semiconductor manufacturers have developed monolithic RMS-to-DC converters that permit AC voltages to be measured with maximum errors that are a small fraction of one percent. A recent addition to this category of devices is the AD637 from Analog Devices (One Technology Way, PO Box 280, Norwood, MA 02062).

That IC is a monolithic, high-accuracy RMS-to-DC converter that can be used to compute the true RMS value of any complex AC waveform. In addition, the device computes the square, mean-square, and absolute values of complex AC (or AC superimposed on DC) input waveforms. Its circuit features a wide bandwidth: 8 MHz when the input is 2 volts RMS or above, and 600 kHz with a 100-millivolt RMS input. The circuit includes built-in compensation for crest factor and handles signals with crest factors of up to 10 with less than a 1% increase in error. Crest factor, CF, is the ratio of a signal's peak amplitude to its RMS value: $CF = (V_{PEAK}) / (V_{RMS})$. Sine and triangle waves have low crest factors that do not exceed 2. Pulse trains with low duty-cycles have much higher crest factors. For example, a rectangular pulse series with a 1% duty cycle has a crest factor of 10.

A voltage equal to the logarithm of the RMS output signal is brought out to a separate pin on the AD637 so that the user can make direct measurements in decibels. The dB-measurement range is 60 dB: the 0-dB voltage-reference level can be set to between 0.1 volt and 2.0 volts RMS by providing an external reference current.

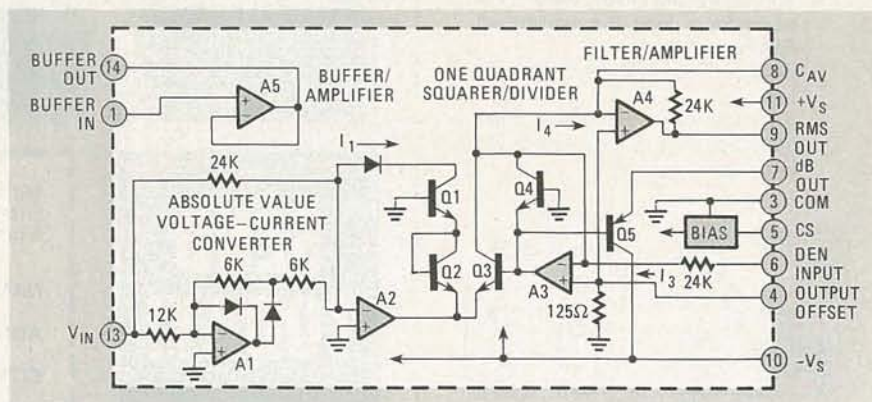

FIG. 1

How the circuit functions

The only external component required for RMS-to-DC conversion is a capacitor that controls the averaging-time period and determines the low-frequency accuracy, ripple level, and settling time.

Figure 1 is a functional diagram of the IC. We can think of it as being made up of 4 main sections. The first is an absolute-value circuit (active rectifier) made up of A1, A2, and their associated components. The second is a squarer/divider made up of A3 and Q1-Q5. Third is a filter/amplifier, A4, and fourth is buffer/amplifier

A5. (The buffer amplifier can be used either as an input buffer or in an active-filter configuration; it is a user option.)

The input voltage, V_{in} , is rectified by active rectifier A1-A2 to produce a unipolar current, I_1 . That current drives one input to the squarer/divider which has the transfer function: $I_4 = I_1^2 / I_3$

The output current of the squarer/divider, I_4 , drives A4 which, along with the external averaging capacitor connected to pin 9, forms a lowpass filter. If we make the R-C time constant of the filter much longer than the longest period of the input signal, A4's output will be proportional to the average value of I_4 . The output is taken back to A3 to provide current I_3 , the denominator of the transfer-function equation above. See the standard RMS conversion circuit in Fig. 2. Current I_3 equals the average value of I_4 and is returned to the squarer/divider to complete the operation: $I_4 = \text{Avg} [I_1 / I_4] = I_{IRMS}$ and $V_{out} = V_{in RMS}$

The averaging time constant

The AD637 can handle both DC and AC input voltages. Its DC output will track exactly the absolute value of a DC input and will approach the true RMS value of an AC input. The deviation from the true RMS value is the averaging error caused by AC ripples riding on the DC output signal. That is a factor of the input signal's frequency and the averaging time constant, τ , ($25 \text{ ms}/\mu\text{F} \times C_{AV}$) and is defined as the peak value of the AC ripple component plus the DC error. That is illustrated in Fig. 3.

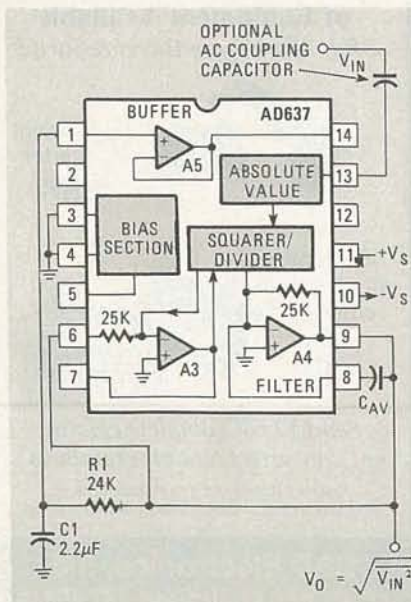

FIG. 2

The peak value of the AC ripple as a percentage of the output signal is

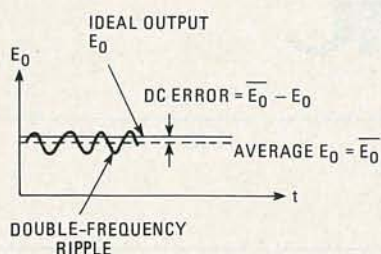

FIG. 3

$50/6.3\pi f$, where τ is greater than $1/f$ and f is the signal frequency. The DC error is also frequency dependent; it varies as the percentage of the reading by $1/(0.16 + 6.4\tau^2 f^2)$. The magnitude of ripple decreases the accuracy of the measurements being made. The amount of error can be reduced by increasing the value of the averaging capacitor, C_{AV} . However, that has two disadvantages: 1) The capacitance of C_{AV} can become extremely high. 2) The settling time of the AD637 increases in direct proportion to the value of the averaging capacitor. Settling time T_S equals $115 \text{ ms}/\mu\text{F} \times C_{AV}$.

A preferred method of reducing ripple is to add a one- or two-pole filter network connected between output terminal pin 9 and the buffer amplifier input, pin 14. A single-pole filter, such as the R1-C1 network in Fig. 2, provides the best compromise between ripple and settling time.

When C1 is made 3.3 times C_{AV} , the magnitudes of the AC and DC errors are equal at 50 Hz. If we set C_{AV} to $1 \mu\text{F}$ and C1 to $3.3 \mu\text{F}$, we reduce the ripple for a 60-Hz input signal from 5.3% (when C_{AV} is used alone) to 0.15% and settling time increases by not more than three times.

The AD637 is available with two accuracy ranges (types J and K) for a 0 to $+70^\circ\text{C}$ temperature range. A type S is available with a operating-temperature range of -55°C to $+125^\circ\text{C}$. All devices are packaged in ceramic 14-pin DIP's. For additional information, write to Analog Devices, PO Box 280, Norwood, MA 02062. Ask for a copy of the booklet *High Precision Wide-Band RMS-DC Converter, the AD637*.

New Darlington power transistors

RCA recently introduced a family of six 2-amp Darlington power transistors. The six complementary devices, three NPN and three PNP, are housed in TO-220AB packages. The TIP110, TIP111, and TIP112 are NPN devices and are rated for a collector-to-emitter breakdown voltage (V_{CEOSUS}) of 60, 80, and 100 volts, respectively. The TIP115, TIP116, and TIP117 PNP devices have the same V_{CEO} ratings, respectively. R-E

DON'T FORGET



USE
YOUR
READER
SERVICE
CARD

"Maybe
it will
go
away."

The five most
dangerous
words in the
English
language.

American
Cancer
Society



THE RIGHT STUFF.

The growth of NTE quality replacement parts has been nothing short of astronomical. And the proof is in our new 1984 Replacement Master Guide, destined to be the standard directory for technicians across the country. In excess of 3,000 quality NTE types are cross-referenced to more than 220,000 industry part numbers.

YOU'LL FIND ALL THE RIGHT STUFF FOR REPLACEMENT, MAINTENANCE AND REPAIR:

- Transistors
- Thyristors
- Integrated Circuits
- Rectifiers and Diodes
- High Voltage Multipliers and Dividers
- Optoelectronic Devices
- Zeners
- Microprocessors and Support Chips
- Memory IC's
- Thermal Cut-Offs
- Bridge Rectifiers
- Unijunctions
- RF Transistors
- Microwave Oven Rectifiers
- Selenium Rectifiers
- NEW! The Protector 6000™ Transient Voltage Protection Strip

Look for our Replacement semiconductors in the bright green polybags and cartons that list rating limits, device type, diagrams and competitive replacement right on the package. NTE quality parts are available from your local NTE distributor and come backed by our exclusive two-year warranty. Ask for your FREE NTE Replacement Master Guide and take off with NTE!



NEW-TONE ELECTRONICS, INC.

44 FARRAND STREET • BLOOMFIELD, NEW JERSEY 07003
(FORMERLY TCG)

SERVICE CLINIC

Microprocessors and VCR's

JACK DARR, SERVICE EDITOR

MICROPROCESSORS HAVE BEEN INCORPORATED into almost every type of electronic device in use today. For instance, in many stereo and TV sets, they are often used along with sensors to control the AFC (Automatic Frequency Control) so that if the tuned frequency begins to drift, the microprocessor can automatically compensate for that change. But that's not the only thing that they can be used for. VCR's use them to stop or start operations according to the condition of the system. For example, RCA's VJP900 VCR uses a rather complex system of sensors and microprocessors to monitor the operation of the system. Other microprocessors control such things as the tuning process, the time-delayed recording, and the remote control functions. This month we'll see how some of those microprocessors are used to control the tuning and sensing operations of that VCR. We'll start with the sensing circuitry.

Sensing circuit

Take a look at Fig. 1; it shows a diagram

of the trouble-sensing circuitry found on the system-control board. That board contains two IC's and various sensing devices that are used to detect such things as moisture, end of the tape, and the rotation of the take-up reel. The two IC's, IC802 (system-control microprocessor-B—one of five microprocessors in the unit) and IC806 (a quad comparator) are used to monitor the output of the sensors and act according to the signals they receive.

The dew sensor is a moisture-sensitive resistive-semiconductor device that is used to tell the microprocessor when the moisture level in the system offers a threat to the operation of the unit. With all the delicate electronics in a VCR—so say nothing of its intricate machinery—excess moisture could damage the machine. The dew sensor, a small flat device about an inch square, is mounted near the middle of the "works" in most VCR's. In Fig. 1, that device is connected to the non-inverting input (pin 9) of one of the op-amps contained in IC806. During normal operation (when there is little or no mois-

ture detected), the resistance of the dew sensor is high—around 80,000 ohms. That causes a logic high to be developed at pin 9 of IC806. (Any voltage below 1.2 volts is a logic low, anything else is a logic high.) When that happens, a high is passed on to the system-control microprocessor (IC802) at pin 6. That input signal tells IC802 that the moisture level is safe. On the other hand, when the dew sensor detects an excessive amount of moisture, its resistance decreases, which causes a logic low to be applied to the comparator. That, in turn, causes the comparator to output a logic low to IC802, and the microprocessor places the VCR in the stop mode.

In the rewind mode, an infrared-sensitive phototransistor is used to detect the end of the tape. When the end of the tape is reached, an infrared light is passed through the clear segment of tape at the end of the reel. That infrared light causes Q903 to generate a logic-high signal that is input at pin 5 to another of the comparators contained in IC806. That comparator, in turn, outputs a high signal that is fed to the system-control microprocessor at pin 28. On receiving the signal, the microprocessor places the unit in the stop mode. Note that as long as there is tape on the reel, no infrared signal is detected by the sensor, and the microprocessor will allow the operation to continue. The fast-forward sensor operates in the same manner, with its output applied to pin 7 of IC806.

One of the novel things about this VCR is the takeup-reel-rotation detector. Detection of take-up-reel rotation is accomplished by the combination of an LED and light-sensitive transistor in one package (Q905). The sensor (located at the bottom of the take-up turntable) is used along with a segmented disk that has eight reflective and non-reflective areas. The disk is located at the bottom of the take-up reel. When the segmented disk is rotating, the reflected light is detected by Q905 and causes a squarewave to be generated. That signal is capacitively coupled to the final op-amp in IC806. The op-amp's output is then fed to the microprocessor at pin 3. If that signal were to disappear during tape operation, the microprocessor would put the VCR in the stop mode.

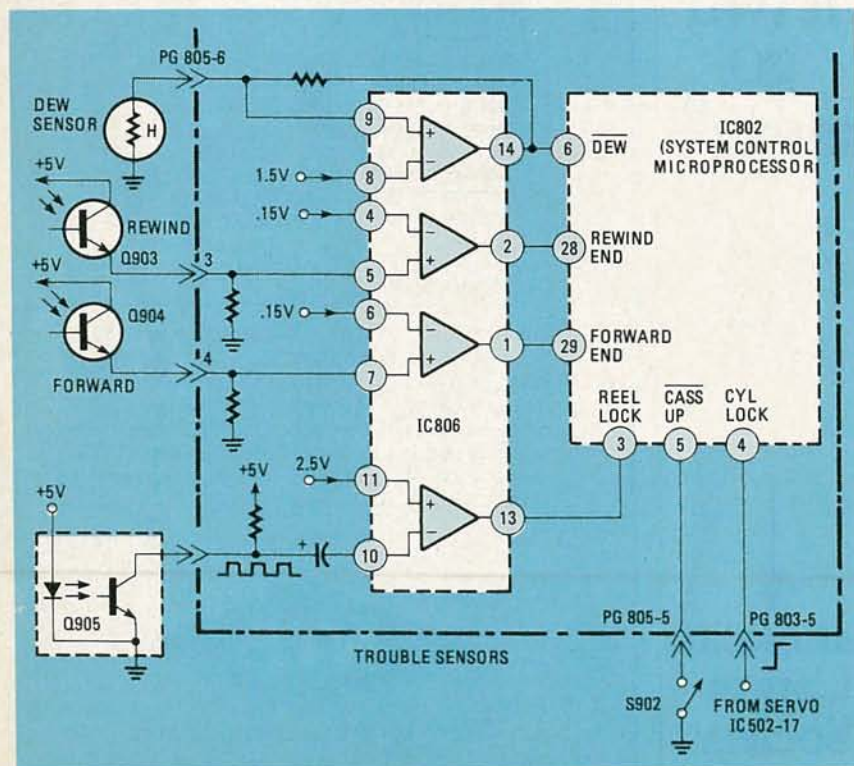

FIG. 1

The cassette-up switch, connected to pin 5 of IC802, is used to tell the microprocessor when the cassette basket is loaded and in the down position. With the basket in that position, switch S902 is closed and a high signal is input to IC802. That signal causes the system-control microprocessor to enable the VCR. On the other hand, if the cassette is placed in the basket but the basket isn't pushed down, the cassette-up switch opens and the VCR stops.

The last sensor operation that we'll look at is the cylinder-lock detector. The cylinder-lock signal is supplied by cylinder-servo circuit IC502 (not shown) and is input to the microprocessor at pin 4. During normal operation the cylinder servo generates a logic low signal. If the cylinder's motor speed were to decrease, a logic high would be generated by the servo IC. That signal is then passed to the microprocessor, which will shut down the VCR upon receiving that signal.

Service tips

If the VCR does not go into the play mode, check the outputs of all the trouble sensors. The dew sensor should have less than 1.5 volts at its input. If the correct voltage is present, check the output of the end-of-reel sensors (rewind and forward) at PG805 pins 3 and 4. Both outputs should be less than 0.15 volt. Also, confirm that there is a logic high input at pin 5 of the system-control microprocessor. If any of those voltage levels are incorrect, service the appropriate sensing section. In addition, if the VCR makes no attempt to load the tape from the cassette, the problem can most likely be found in the reel-rotation or the cylinder-lock detectors. Those two detectors will turn on the system only after the tape-loading sequence has been completed.

If, after loading the cassette in the basket, the VCR immediately ejects (unloads) the tape, check to make sure that there is a 1-volt peak-to-peak squarewave during the time of load completion. If that's missing you may have a bad rotation-detector (Q905) or capstan servo problems. If it's normal, check the cylinder-lock signal; it should be a logic high before the loading sequence is completed. At the end of that sequence it should go to a logic low. If not, you could have a problem in either the cylinder-servo circuitry or the drive IC.

Tuning section

As we said earlier, there are many microprocessors in the VJP900. Almost as many as Presidential candidates! And they're like politicians in more ways than one. When the VCR is turned on they all "shake hands" with one another. (We're not kidding; there are lines labelled *handshake* lines, which are separated into two parts; one is RDY (ready) and the other is

acknowledge). Those lines are shared by the timer and remote-control microprocessors. When one of the microprocessors is ready to send data, it pulls the RDY line on the receiving microprocessor low. The receiving microprocessor, in turn, outputs a high on the ACK line, meaning "ready when you are." The sending microprocessor then transmits a 16-bit word. Each bit of the data confirms the ready status of the receiving microprocessor. Note that you cannot see these signals on a conventional oscilloscope. However, you can usually monitor the receiver by reading the logic

level at the input.

The remote-control microprocessor monitors the status of the whole unit by checking the microprocessor on the sensor board. If anything is wrong with any one of the five microprocessors, the VCR will be shut down. Also, if the tab on the cassette is missing you cannot record; the VCR shuts down and will not start.

The VJP900 also has a PLL (Phase-Locked Loop) electronic tuner that is controlled by the PLL microprocessor. That microprocessor also keeps track of the remote-control micro-

continued on page 107

The Professionals' Choice

PTS

Module Update

PTS logs every component failure in over a million boards repaired each year. PTS computers spot repeat failures. Research technicians improve circuitry design and recommend automatic updates, often before the manufacturer.

Many automatic updates are designed to upgrade modules to universal specifications. The universal modules will have greater capabilities, performance, and work in more televisions.

In addition to the automatic module updates each module is cleaned, fully rebuilt, air tested in a live chassis, subjected to heat, cold and shock tests, and five separate quality control checks.

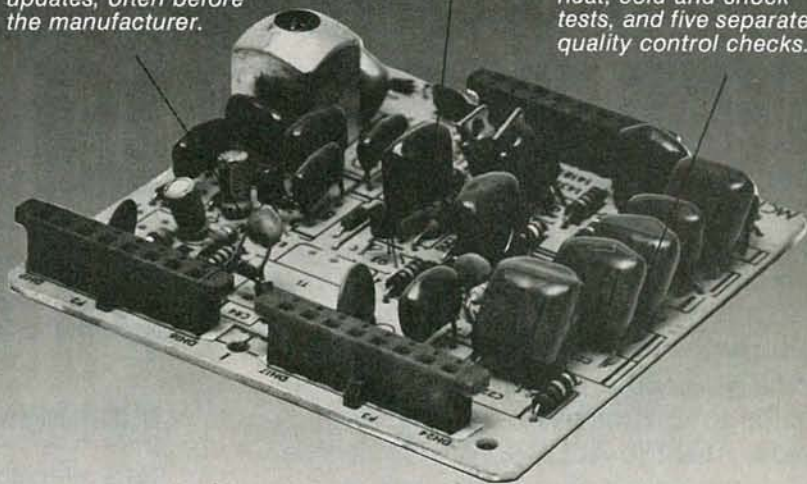

Module updates are only one reason to depend on quality PTS rebuilt television products. PTS also offers fast eight hour tuner rebuilding or immediate exchange of tuners and modules at 20 Servicenters nationwide and over 1500 distributors. Quality and service from the nation's leader backed by our full year limited warranty.



PTS Corporation

The world's largest independent electronics rebuilder.

P.O. Box 272
Bloomington, IN 47402
(812) 824-9331

And ask for our free Price and Technical Information Guide.

In Computer Electronics...

NTS INTRONIC™ HOME TRAINING GIVES YOU THE EDGE

The competition for High-Technology careers is strong, and the rewards are great. Give yourself the edge you need by training with NTS.

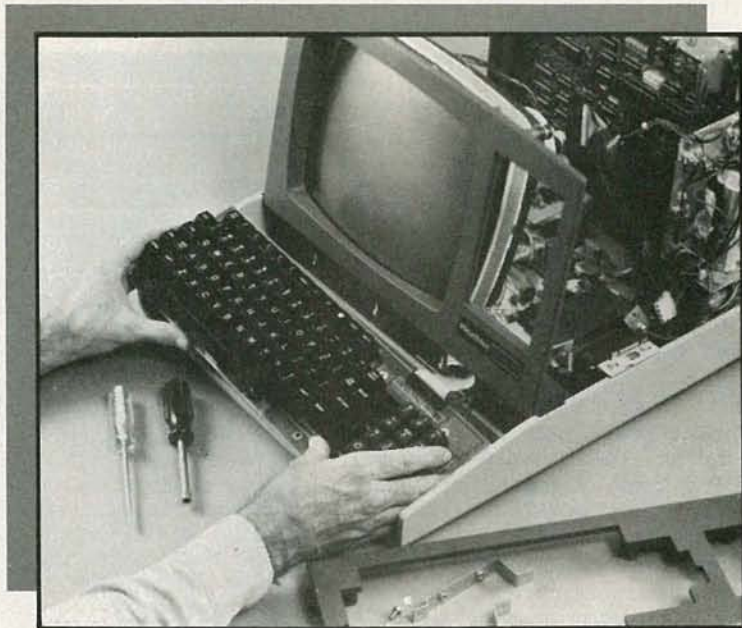

NTS INTRONIC™ home training provides you with a special kind of "Hands-On" experience that prepares you better, develops your skills faster. You advance as quickly as you wish, working with actual circuits, diagrams, schematics, and state-of-the-art hardware. There are a dozen different NTS programs in electronics to help you develop and reach your potential. They range from basics to advanced areas in several fields. And the ALL-NEW NTS course catalog spells it all out. It's free, and does not obligate you in any way. Send for it today.

A GROWTH INDUSTRY

High-Technology is a growth industry. The evidence is clear, and most observers predict a steady expansion due to a relatively strong flow of investment capital into computers, electronics and precision instruments. Sales of computers alone will reach an estimated ten million units this year. This means challenges and new

employment opportunities, especially in servicing and maintenance. Computer servicing skills can best be learned by working directly on field-type equipment. NTS electronic hardware is selected and developed especially for the training program with which it is associated. You learn by doing, by assembling, by performing tests and experiments, covering principles of computer electronics, microprocessor troubleshooting, and circuitry.

MICROCOMPUTERS

NTS offers three programs in computer electronics. You will receive training covering solid-state devices, digital logic circuitry, and the fundamentals of the computer itself. Instruction includes micro-control technology and detailed operation of microcomputers. These courses will prepare you for entry-level in many facets of the computer industry such as field service and customer engineering as well as programming. In addition to written texts your course includes the NTS/HEATH disc-drive computer which you assemble as part of the training process. The assembly and use of the computer will serve to reinforce practical application of principles.

MICROPROCESSOR TECHNOLOGY

The field of industrial and microprocessor technology encompasses the application of electronic microprocessor control principles. Your course takes you from fundamentals of digital electronics and associated circuitry through the application of the microprocessor as a control device. You will learn how to move and manipulate instructions and information. The microprocessor trainer included in your course is a microcomputer system designed as a practical tool for learning the use of software and hardware techniques utilized in the linking of microprocessors to various systems.

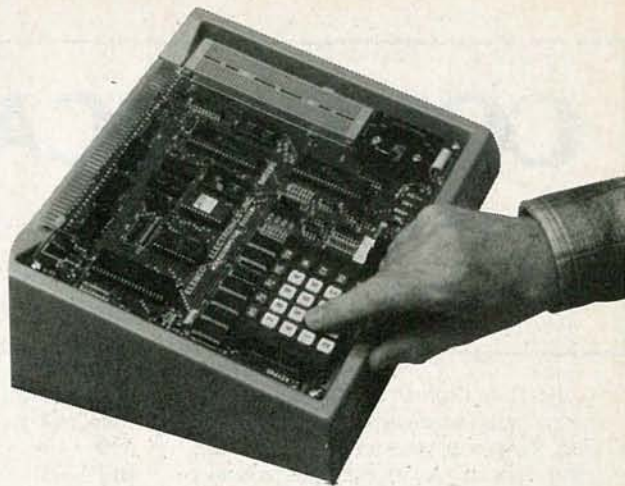

DIGITAL ELECTRONICS

The NTS Compu-Trainer is a fascinating solid-state device which you will build in order to perform over ninety logic circuit experiments. These experiments serve to emphasize an area of electronics which is essential to the understanding of state-of-the-art control equipment; they are also extremely important to those wanting to pursue a career in computer servicing. Separate courses involving the Compu-Trainer are also available in Microcomputer Servicing and Digital/Analog Electronics.

ROBOTICS & VIDEO TECHNOLOGY

Other NTS courses cover a wide range of specialization. In Robotics, the NTS/Heath Hero I is included to train you in robotic applications in

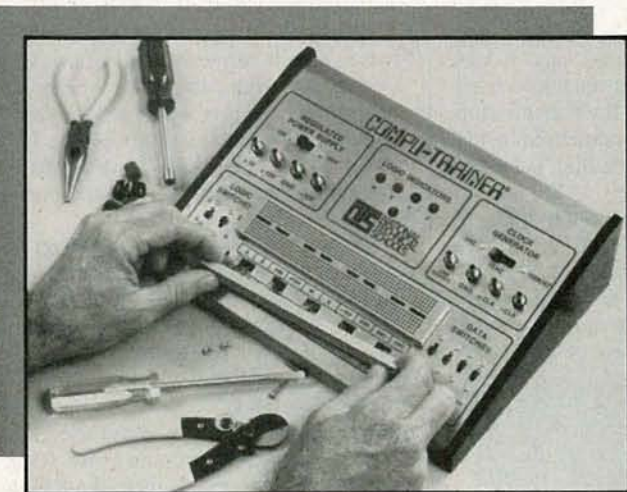

NO OBLIGATION NO SALESMAN WILL CALL

NTS NATIONAL TECHNICAL SCHOOLS

TECHNICAL TRADE TRAINING SINCE 1905
Resident and Home-Study Schools
4000 So. Figueroa St., Los Angeles, CA 90037

manufacturing processes. In Video technology, a new course features the advanced NTS/Heath Z Chassis "Smart Set" color TV with computer space command remote control and space phone. This is an excellent program for those interested in a career in video servicing with microcomputer basics.

EARN CEU CREDITS

America's industrial giants are turning more and more frequently to home study as an effective way to upgrade employee skills. You benefit from the experience NTS has gained in its 79 years as a leader in technical training. The skills and experience gained in the building of kits and test equipment provide you with training that cannot be duplicated. And, depending on the program you select, you can earn up to 30 CEU credits for successful completion. Complete details included in the catalog.



Use the mail-in card or fill out and mail the coupon. Indicate the field of your choice. (One, only please.) FREE full color catalog will be sent to you by return mail.

NATIONAL TECHNICAL SCHOOLS Dept. 206-044
4000 South Figueroa Street, Los Angeles, CA 90037

Please send FREE color catalog on course checked below:

- | | |
|---|---|
| <input type="checkbox"/> Robotics | <input type="checkbox"/> Computer Electronics |
| <input type="checkbox"/> Digital Electronics | <input type="checkbox"/> Video Technology |
| <input type="checkbox"/> Auto Mechanics | <input type="checkbox"/> Home Appliances |
| <input type="checkbox"/> Air Conditioning/Solar Heating | |

Name _____ Age _____

Address _____ Apt. _____

City _____ State _____

Zip _____ Phone () _____

- Check if interested ONLY in classroom training in Los Angeles
 Check if interested in G.I. Bill Information.

COMMUNICATIONS CORNER

RF power measurements

HERB FREIDMAN, COMMUNICATIONS EDITOR

AS ANY ELECTRONICS ENGINEER OR TECHNICIAN, radio amateur, or CB'er can tell you, RF power measurements can be a real headache. As an example, consider the problem we ran into recently.

We were involved in a project that called for the upgrading of an existing two-transmitter set up where one transmitter was the backup for the other. All that was really being done was replacing one of the older transmitters with a new one. The completed installation was to resemble the one shown in Fig. 1; a rather simple circuit that switched either transmitter to the transmission line. (For simplicity, the dummy load, safety interlocks, etc. are not shown.)

Note the location of the output-power meter. It's really part of a combination power/VSWR metering panel; in effect, two meters in one. One of the meters was for VSWR calibration and measurement; the other was calibrated directly in watts for RF output power.

The problem

Now, let's look at the problem. With both transmitters working into a dummy load, a 6-kW output was measured. But when switched to the transmission line the original transmitter produced a meter indication of almost 6 kW, while the new one produced a meter reading of only 4.2 kW. What was the cause of the apparent loss of nearly 2 kW when operating into the transmission line? In reality, there was no loss of any kind. The problem was simply an incorrect reading caused by *standing waves*.

If you think about it for a moment,

you'll realize that an RF-power meter is simply a forward-power VSWR indicator, with its own calibration adjustment and an RF-watts scale. Consider how such a device works. A sample of RF energy is picked off the center conductor of the transmission line by a probe that is inserted under the coaxial shield. It is then rectified and the resulting DC is passed through a calibration potentiometer to the meter indicator. If the meter's indication is to serve as the calibration for a VSWR meter, then the meter scale simply has a calibration mark and the calibration potentiometer is adjusted so the forward power causes the meter pointer to fall on that mark. If the same meter has a scale calibrated in RF watts, the potentiometer is adjusted until the meter indicates either the calculated output, or the value indicated by a precision wattmeter when the transmitter is working into a dummy load. (Obviously, that is not intended to be a precision measurement, but a relatively accurate guide for a technician.)

Now we are ready to tackle the question of what caused the apparent loss of power when the second transmitter was switched in. In reality, there was no loss; it was simply an incorrect meter reading caused by the standing waves on the transmission line. The RF power that was sensed by the meter was affected by standing waves at the location of the probe.

Let's look at what we mean by that. If the line is flat with almost a 1:1 VSWR, the current and voltage at any probe location along the line will be equal to any other location (excluding normal copper losses). So that, regardless of where the

probe is located, it will always sense the same amount of RF and the meter calibration would be valid anywhere along the line. But if there is any amount of mismatch, standing waves will be produced along the line and the RF sensed by the VSWR probe will depend on the magnitude of the standing wave at the location of the probe. That's why there is a potentiometer for forward power calibration.

But why wasn't the location or magnitude of the standing wave the same when the transmitters were switched? Actually, in the old transmitter installation they were constant regardless of which transmitter was used. That's because the designers of the original installation used exactly one wavelength of transmission line between the transmitters and the coaxial selector-switch. Regardless of which transmitter was switched in, the transmission line length remained the same. By now you should have figured out the problem. If not, think about what happens if there is any change in the length of the transmission line? Correct—the relative magnitude, and possibly the position, of the standing waves can change. The probe, which formerly might have been located at a node, might now be on the peak of the standing wave, so that the RF sensed by the probe will not be the same and it will be necessary to re-adjust the calibration potentiometer for the correct power reading.

Because of the new location of one transmitter, a low ceiling, and other such irreversible considerations, it was impossible to maintain equal lengths of transmission line (or multiples) between the transmitters and the selector switch, so the physical length of the line depended on the particular transmitter in use. That, in turn, affected the amount of RF sensed by the VSWR probe. Hence, the RF output power indication was incorrect when the transmitters were switched unless the meter was recalibrated.

Now it might be logical to assume that there's real big trouble with the antenna system if a change in transmission line length can produce a variation of almost 33% in output power measurement. Actually, the system was very good—the measured VSWR being a shade over 1.1:1.

Keep all of this in mind for the next

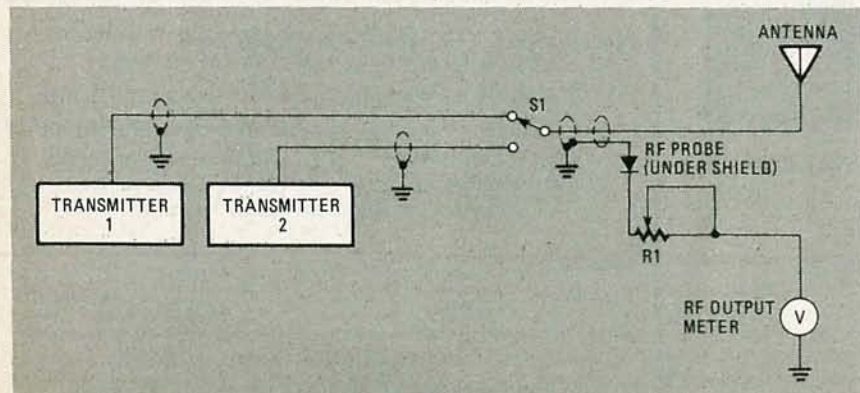

FIG. 1

time you're working on a transmitter/antenna installation and you get VSWR-derived output power values that you know are too good to be true, such as a 6-watt output from a CB rig with a 4-watt input. (Some people really believe, you can get more out than you put in.) Or, on the other side of the coin, if there's excessively low output power. Say for example, you're working on an HF or VHF transmitter rated for 100-watts RF output. Working into a dummy load you get that 100-watt output, but when working into a transmission line you get considerably less. Suspect the location of the RF probe before you start fixing the transmitter. If possible, connect a 1/4-wavelength section of transmission line between the transmitter and the output end of the transmission line. If the meter reading changes drastically you know the problem is caused by the location of the standing waves and requires changing the calibration of the meter or the location of the probe rather than a repair to the transmitter. **R-E**

SERVICE CLINIC

continued from page 101

processor as well as the system-control microprocessor to make sure all systems are go. If no fault is detected in any of the sub-systems, you can go ahead with the recording; if not, nothing happens. A microprocessor is like a politician in many ways; however, you can trust them for one thing. They won't shake your hand and then go back to Washington and raise your taxes! **R-E**

SERVICE QUESTIONS

LET'S TRY AGAIN

When I disconnect the yoke on this Sony KV 9000 color TV, the sound comes on and the vertical sweep returns. Several things were suggested by you in the last letter but none helped. Could you try polishing up the crystal ball again for me because I am up against a wall on this one.—J.A.H., Colorado Springs, CO

Let's give it another go. You know, this may be a silly question to ask, but did you completely overrule the possibility of an intermittent short in the yoke winding? Shorted turns in the horizontal windings would load down the 17- and 20-volt supplies, which are scan derived. Those voltage sources are used to power the audio and also vertical circuitry. A simple resis-

9 reasons why the real pros prefer Endeco desoldering irons



1. Operates at 120v, 40w. Idles at 20w for longer tip life
2. Flexible, burn resistant Neoprene cord set
3. Cool, unbreakable polycarbonate handle
4. Exclusive bracket insures alignment, prevents damage
5. Safety light in handle tells when it's on
6. Stainless steel construction
7. Temperature control. Low, high or off.
8. Eight tip sizes. Comes with .063 I.D.
9. Converts to soldering iron with 1/4" shank type tip

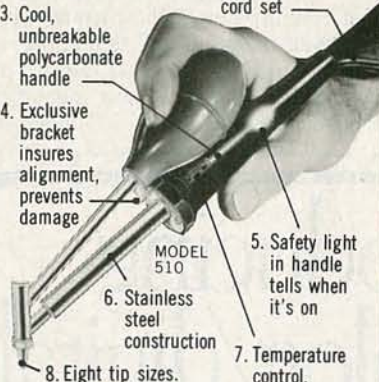

See your distributor or write . . .

Enterprise Development Corp.

5127 E. 65th St. • Indianapolis IN 46220
PHONE (317) 251-1231

CIRCLE 94 ON FREE INFORMATION CARD

SEE YOUR DEALER TODAY

FROM

'Firestik'
ANTENNAS
ACCESSORIES

HERE'S A TIP THAT'S PERFECT!

AM/FM AUTO RADIO AND CB

'Firestik' II
GOLDEN SERIES

BARE-HANDS TUNABLE
"NO TOOLS NEEDED"
HIGH PERFORMANCE ANTENNAS

ALSO ANTENNAS FOR
CORDLESS TELEPHONES
MONITOR SCANNERS

Dealer & Distributor Inquiries Invited
SEND FOR FREE CATALOG

'Firestik' Antenna Company
2614 East Adams/Phoenix, AZ 85034

Name _____
Street _____
City _____
State _____ Zip _____

Serving the CB and
Communications Market Since 1962.

5-YEAR REPLACEMENT WARRANTY

CIRCLE 40 ON FREE INFORMATION CARD

TRAIN AT HOME IN SPARE TIME!
NO PREVIOUS EXPERIENCE NEEDED!

LEARN HOW TO USE A COMPUTER



FOR HOME OR BUSINESS!
WHAT...WHEN...HOW

Learn how and why a computer can help you. Learn to write your own computer programs. See how easy it is to use different programs already available. See how they fit into your home or business operations...budgeting, real estate, bookkeeping, inventories, expenses, pricing, profit margins, investments, interest, taxes, shopping lists, vacation planning, addresses, phone numbers, routing...hundreds more including foreign languages, computer games and graphics. Never again be at the mercy of a so-called "computer expert." Know what really happens when you get a computer problem from a bank, store, loan company, oil company, utility or anyone else. You'll be able to talk their language...understand why and how things happen...be able to take the offensive when you're the victim of a computer error.

EXPERTS SHOW YOU WHAT TO DO, HOW TO DO IT...TO MAKE YOUR LIFE EASIER

Everything is explained in easy-to-understand language with plenty of examples. Step-by-step directions take you through basic computer programming. You learn everything you need to know to use the computer. You'll be able to understand computer experts and talk their language...storage, systems, terminals...you'll learn it all and much, much more.

NOW...ALL THIS IN ONE COURSE!

- Computer Training • Computer Programming
 - Computer Applications • Computer Games
- Find out what you need to know about computer operations



TIMEX COMPUTER INCLUDED WITH YOUR TRAINING
Plugs into any TV!

SEND FOR FREE FACTS!

ICS COMPUTER TRAINING, Dept. DE034
SINCE 1891 Scranton, Pennsylvania 18515

Please rush me free facts and color brochure that tells how I can learn computer applications, programming and operation at home in spare time. NO SALESMAN WILL CALL.

Name _____ Age _____
Address _____
City/State/Zip _____

APRIL 1984

tance check of the coils will not suffice in the case of an intermittent short. Some sort of a "ringing" test should be done; that will tell you much more about the yoke's true quality. Good luck and keep us posted.

HELPFUL HINT

I never miss "Service Clinic" and have found your articles very helpful in my work. I also appreciate your printing of tips from readers. Here's one I discovered.

Last fall, the video-detector diode in our old RCA CTC-17 went out. Not being

able to find another, I ended up installing a new Schottky-barrier UHF diode which was available at a local Radio Shack store (catalog No.5082-2835).

With the new diode in place, the picture came on with extremely high contrast and, although the PIV rating of the device is only 5 volts, a VTVM measured 18 volts across the detector output. Also, When the AGC was adjusted to obtain the normal contrast range, the picture showed improved sharpness and saturation.

I have tried that on other sets and their owners have remarked how much better their picture looked. Also, I have yet to

have any callbacks in regards to making that substitution.

PICTURE SLIPS

On a Zenith 12CB12ZX the problem is that the picture slips sideways. The horizontal tubes check good on a tube tester. I tried replacing Q404 (sync separator) and Q407 (the horizontal-phase detector) without success. The voltage measurements around Q407 are: 10.6 volts at the collector, -9.42 volts at the base, and 1.04 volts at the emitter—R.S., Oklahoma City, OK

The first thing I would do is change the 6LN8. That failing, I would want to know why the voltages around Q407 are so far out of the ballpark. My schematic calls for 0.82 volts on the collector. The base is likewise far off. Resistance readings from the collector and base to ground, should be 47K and 10K respectively.

TUNER DRIFTS

The tuner in my 13JC10 Zenith seems to drift and then go into a snowy picture. By switching the channel selector back and forth, you can lock the picture back in. The trouble is intermittent. I replaced the tuner twice, but the problem still exists.—B.G., Shawnee, KS

If one is available, a tuner subber could help a great deal on this one. If the picture is still unreliable, you should then look for an intermittent condition in the IF strip. If the problem disappears when you use the substitute tuner, you can focus on the tuner feeds. Monitor the B+, AGC, and AFC terminals on the set's tuner and look for changes. If you're still unsure, you can substitute these different feeds with appropriate external voltages.

FAULTY TUNER

I have a Sylvania E46 to repair. I think the tuner is bad. I can get channel 7 (some of the time) but no others. The channel-indicator readout works only sometimes, but even then, the numbers are wrong. I think the memory module will have to be replaced, but I know it's expensive. Can I tune the set to Channel 3 and use the cable box? How about using a solid state tuner from a discarded TV set?—S.M., W. Palm Beach, FL

A new memory module would no doubt solve all your problems, but you do have alternatives. If you inject a small variable voltage into the tuning voltage input to the tuner you should be able to scan through and stop at Channel 3. You can then measure the voltage and duplicate it with a fixed voltage. Your readout will be inaccurate, but as you state in the rest of your letter, that doesn't matter. As for using an external tuner, sure. I made my own tuner subber with one I pulled out of a scrap set. The only factor that has to be watched carefully is the B+. AGC requirements are fairly standard.

R-E

Introducing the analog/digital handheld multimeter.



Fluke 73

\$85

Analog/digital display
Volts, ohms, 10A, diode test
Autorange
0.7% basic dc accuracy
2000+ hour battery life
3-year warranty



Fluke 75

\$99

Analog/digital display
Volts, ohms, 10A, mA, diode test
Audible continuity
Autorange/range hold
0.5% basic dc accuracy
2000+ hour battery life
3-year warranty



Fluke 77

\$129

Analog/digital display
Volts, ohms, 10A, mA, diode test
Audible continuity
"Touch Hold" function
Autorange/range hold
0.3% basic dc accuracy
2000+ hour battery life
3-year warranty
Multipurpose holster

FROM THE WORLD LEADER
IN DIGITAL MULTIMETERS



The Professional Test Equipment Source

The Instrument Mart

295 Community Drive, Great Neck, New York 11021
(516) 487-7430 Outside N.Y. (800) 645-6535

Sales, Service, Rental/Leasing Programs
... and Pre-Owned Test Equipment also Available

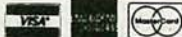

VIDEO GENERATOR

continued from page 139

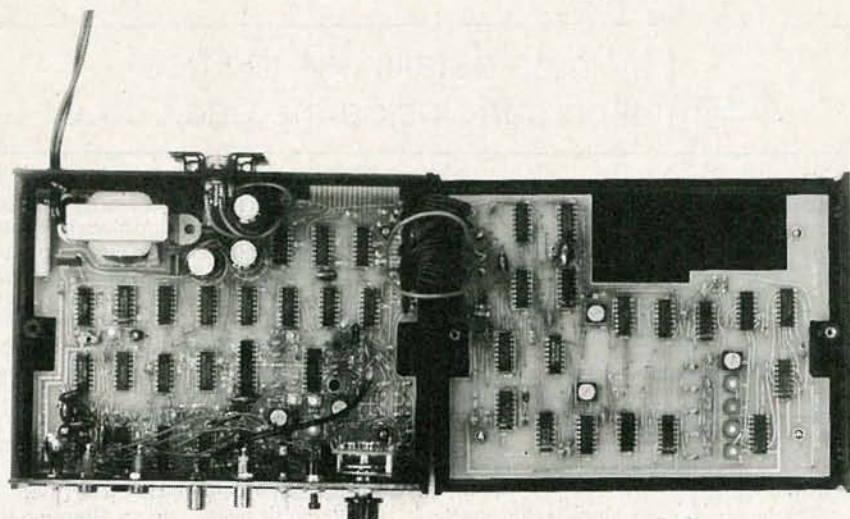

FIG. 11—SUGGESTED MOUNTING METHOD of the two boards is shown here in a photograph of the author's prototype.

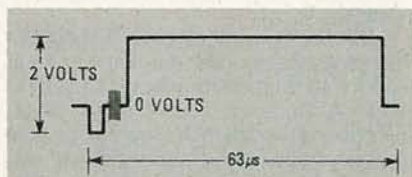

FIG. 12—ONE HORIZONTAL LINE of video should be seen at TP1 when the test generator is in the EXT mode.

The inputs are connected via the same 34 pin edge connector and consist of the audio input, three sync inputs for gen-locking, and nine RGB digital video inputs. The audio input is used only for the RF-modulated output and can replace the generator's internal 1500-Hz oscillator.

There are various ways you might gen-lock the unit using the three sync inputs. The vertical and horizontal reset can be driven separately (you must use pulses of less than 800 ns duration). If you do that with the vertical-reset control high (or not connected) then the vertical timing is reset to the beginning of each field. If the vertical-reset control is "low" then the vertical timing is reset to the fifth vertical separa-

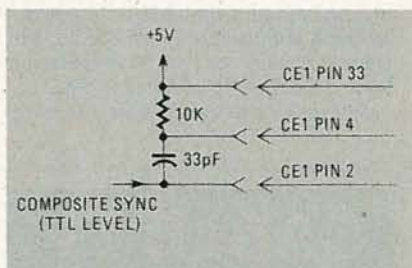

FIG. 13—THIS CIRCUIT can be used to allow gen-locking from a source of composite sync (LS-TTL level).

tion pulse. That allows it to act like a conventional integrated sync-separator circuit.

Another possibility is to use a circuit such as shown in Fig. 13. That allows gen-locking from a source of composite sync (at LS-TTL levels). It should be noted that those schemes will lock the scanning timing but not the chrominance oscillator: color can still be produced, however.

One of the more intriguing capabilities of the test generator is its ability to accept digital RGB data, format the data with the proper sync signals, and then output the

TABLE 3

Color out Card-edge pin	Red inputs			Green inputs			Blue inputs		
	21	13	11	5	7	1	3	9	19
WHITE	1	1	1	1	1	1	1	1	1
LIGHT GRAY	1	0	1	1	0	1	1	0	1
DARK GREY	0	1	1	0	1	1	0	1	1
BLACK	0	0	0	0	0	0	0	0	0
BRIGHT RED	1	1	1	0	0	0	0	0	0
PALE RED	0	1	0	0	0	0	0	0	0
BRIGHT GREEN	0	0	0	1	1	1	0	0	0
BRIGHT BLUE	0	0	0	0	0	0	1	1	1
BRIGHT YELLOW	1	1	1	1	1	1	0	0	0
ORANGE	1	1	1	1	0	0	0	0	0
FLESH	1	1	1	1	1	0	1	0	1

ELECTRONIC COMPONENTS



MANUFACTURERS OF QUALITY ELECTRONIC COMPONENTS

Battery Clips & Holders
Cable Sets Connectors Capacitors
Displays, LED Fuses Jacks & Plugs
Knobs Lamps Potentiometers
RF Coils Relays Resistors
Switches Semiconductors Speakers
Test Equipment Transformers Tools
Wire & Cable

WE STOCK What We Catalog!

- Sales and Order Desk Open from 6:00a.m.(PST)
- Phone and Mail Orders Welcome
- TERMS: C.O.D., Visa, MasterCard (Open Accounts Available)
- Over 10,000 Different Items in Stock

MOUSER ELECTRONICS

11433 WOODSIDE AVE., SANTEE, CA 92071
PHONE: (619) 449-2222 TWX: 910-331-1175

CIRCLE 95 ON FREE INFORMATION CARD

EARN BIG MONEY REPAIR GAMES & COMPUTERS

ATARI 2600, 2600A
ATARI 400, 800 COMPUTERS
COLECOVISION • INTELLIVISION

EXCLUSIVE! All popular game and computer parts now available from a single source!

EWC is the exclusive national distributor of the Electronic Institute's repair courses and Kurz-Kasch Signature Analyzers and Test Fixtures, and the largest distributor of test instruments and supplies for digital servicing.

Over 28 years of proven quality, affordable prices, fast service, and guaranteed satisfaction at EWC, your one-stop electronic parts supplier.

COMPARE OUR LOW PRICES AND TRY US FOR YOUR EVERY-DAY REQUIREMENTS.

GENERAL ELECTRIC
TUBES
10 pc. minimum
may be assorted
75% OFF LIST

THORDARSON
#VMT-08
TRIPLERS
Replaces GE-528, ECG-523, SK-3306. First line, boxed premium quality.
\$9.95 each

Call toll-free on our 24 hour order hotline and ask for your copy of our new 92 page catalog.



ELECTRONICS WAREHOUSE CORP.

1910 Coney Island Avenue
Brooklyn, N.Y. 11230 • (212) 375-2700
CALL TOLL FREE: (800) 221-0424

CIRCLE 9 ON FREE INFORMATION CARD

data. The possibilities range from the creation of other simple test patterns, to interfacing with a microcomputer for the production of dynamic video color imagery for computer games, interactive learning, etc.

Table 3 lists the digital inputs that can be used to produce blank rasters for several colors. Note that each primary color (red, green, and blue) has three inputs, and thus, $2^3 = 8$ input levels. Other colors (a total of 512) are possible.

As a simple example, suppose you wish to have the signal generator provide a solid red raster (perhaps for adjusting receiver purity). Simply connect the three red inputs (RLSB, R, RMSB) high, and the six green and blue inputs low. Now when the generator is in the EXT mode, it supplies a composite-video signal with a constant red image.

For complicated applications involving computer control you must choose between two general approaches. In the first method, the signal generator acts as the master timing source and the computer software synchronizes to the vertical- and horizontal- drive signals. In the second approach, the computer is the master clock and provides sync and reset signals to the signal generator in addition to the RGB data. **R-E**

NEW BOOKS

For more details use the free information card inside the back cover

COMPUTING SYSTEM FUNDAMENTALS, by Kenneth J. Danhof & Carol L. Smith; Addison-Wesley Publishing Company, Inc., South Street, Reading, MA 01867; $6\frac{1}{2} \times 9\frac{1}{2}$ inches; 323 pages, including appendices, bibliography, and index; hardcover; \$26.95.

Intended as a textbook for an introductory course on computer organization and systems at the sophomore or junior level, this book assumes that the reader has had a first course in programming with a high-level language such as FORTRAN or PL/1.

The course presented here is structured in terms of programming "levels" and four "modules" support the development. The first Module (chapters 1-5) introduces the specific microcomputers that will be studied: the Motorola 6800 and the Intel 8085. Here the student is taken from the machine-language level to the assembly-language level.

Module II (chapters 6 and 7) is an introduc-

tion to system I/O programming. Module III (chapters 8, 9, and 10) introduces students to the high-level programming language: PL/M, and Module IV (chapters 11 and 12) contains a discussion of interrupt I/O and some of the many applications areas of microprocessors.

The course presupposes a rather modest laboratory, which includes the microcomputers themselves (at least one which has an extended memory) and a terminal.

CIRCLE 121 ON FREE INFORMATION CARD

TELEMETRY COMPUTER SYSTEMS, An Introduction, by O.J. Strock; Prentice-Hall, Inc., Englewood Cliffs, NJ 07632; 366 pages, including appendices, glossary, and index; $7\frac{1}{4} \times 10\frac{1}{4}$ inches; hardcover; \$49.95.

This book was prepared as a textbook for two-day classes that the author has presented at more than a dozen locations in North America and Asia. It is the first of its kind to explain telemetry technology from a systems-development perspective; document theory with concrete, substantive examples presented through application analysis; give practical theory and application of the dedicated microcomputer in telemetry use, and show uniquely derived computer software in the real-time system.

This work is an overview of both theory and practice, and is especially keyed to the information needs of persons directly involved in procurement and application of today's telemetry systems.

CIRCLE 122 ON FREE INFORMATION CARD

LEARNING AND TEACHING WITH COMPUTERS, Artificial Intelligence in Education, by Tim O'Shea and John Self; A Spectrum Book, Prentice-Hall, Inc., Englewood Cliffs, NJ 07632; 307 pages, including glossary, acronymography, bibliography, acknowledgements, and index; $6 \times 9\frac{1}{4}$ inches; softcover, \$12.95 (also available in hardcover, \$18.95).

This book gives educators and students a balanced view of what has already been achieved in computer-assisted learning, together with a description of research that is likely to affect the role of computers in tomorrow's education.

The author's main conclusion is that, by taking account of the nature of artificial intelligence, the designers of educational computer systems may provide facilities that are considerably more sophisticated than those available today.

Blackboards and chalk may soon be replaced by visual-display units. This book will be valuable for all teachers and parents who want to adapt quickly and successfully to the new opportunities opened up by computer-assisted learning. **R-E**

CIRCLE 123 ON FREE INFORMATION CARD



MASTER COMPUTERS

LEARN PROGRAMMING IN YOUR OWN HOME

Now you can learn about computers, operations, programming, applications, software. Everything you always wanted to know. Write your own programs. Or customize pre-written programs. Make a computer do exactly what you want it to do. Benefit from becoming "computer-wise" today. It's all in this one educational package!

A COURSE IN COMPUTERS AND BASIC PROGRAMMING

NO PREVIOUS COMPUTER EXPERIENCE NEEDED. The entire course is "user friendly", written in simple language, that's easy for a beginner to understand. You will LEARN BY DOING - programming from the very first lesson using any computer, IBM, APPLE, ATARI, COMMODORE, TRS, II.

A CONVENIENT WAY TO LEARN

Progress at your own speed, in your spare time, in your own home. Take the mystery out of word processing... computerized accounting... maintaining data files and much, much more.

Get started now in the fast-growing field of computers, and **CATCH ON** to the technology of the future... **COMPUTERS!**

Send today for your free information package. Or call toll-free (800) 624-7760. In California call toll-free (800) 824-8646. No obligation.

HALIX INSTITUTE
1743 South Vermont Ave., Los Angeles, CA 90006

... if you don't have a computer yet, don't buy one until you receive this free information.

halix
INSTITUTE

An affiliate of Hemphill Schools and IPIG.

... THE INTERNATIONAL CHOICE SINCE 1920

HALIX INSTITUTE, CENTER FOR COMPUTER EDUCATION
1743 SO. VERMONT AVE.
LOS ANGELES, CA 90006

YES! Send me Catalog No. 49-B054 on how I can learn about computers and programming at home!

Name _____

Address _____

City _____ State/Zip _____

I already have a computer available.

Make _____ Model _____

CABLE TV

Buy Direct & Save

SUPER SPECIALS





40 CHANNEL
CONVERTER
\$29⁹⁵

Advanced Solid State design and circuitry allows you to receive mid & super band channels. Restores programming to Video Recorders.



36 CHANNEL
REMOTE CONTROL
CABLE CONVERTER
\$69⁹⁵

JERROLD 400
THE ULTIMATE CABLE TV
CONVERTER





60 CHANNEL
INFRARED
REMOTE CONTROL
\$129⁹⁵

Send \$5 for Complete Catalog

DIRECT VIDEO SALES
P.O. BOX 1329
JEFFERSONVILLE, INDIANA 47130
CALL
1-812-282-4766

CIRCLE 53 ON FREE INFORMATION CARD

Radio-Electronics mini-ADS

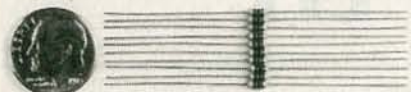

MINIATURE 1/8W 5% CARBON FILM RESISTORS offer superior overall performance characteristics compared to carbon composition resistors - at significant cost savings! EIA color coding. 1 ohm thru 10 megohm. **\$3.75** per hundred per value. Mastercard, Visa, American Express, accepted. Please add **\$2.00** for shipping. California residents add 6% Sales Tax. No C.O.D. **ACORN INDUSTRIAL ELECTRONICS P.O. Box 10846, SANTA ANA Ca. 92711. 1300-D E. Edinger Ave., Santa Ana, Ca. 92705. (714) 547-8424.**

CIRCLE 46 ON FREE INFORMATION CARD

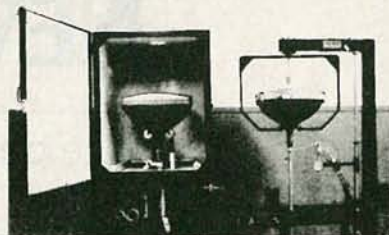

ONE MAN CRT FACTORY, easy operation. Process new or rebuild old CRT's for tv's, bus. machines, monitors, scopes, etc. Color, b&w, 20mm, foreign or domestic. 3x6 ft. space required. Profits?? Average CRT rebuilding cost — \$5. Sell for \$100 = \$95 profit; x 5 CRT's = \$475 daily; x 5 days = \$2375 weekly profit. Higher profits outside U.S.A. Investigate this opportunity today. We service the entire world. Write or call: **CRT Factory, 1909 Louise St., Crystal Lake, Il. 60014, (815) 459-0666.**

CIRCLE 5 ON FREE INFORMATION CARD



CA28 UNIVERSAL CRT ADAPTER—Now you can use your CRT Tester/Restorer/Rejuvenator on all 2500 Color CRT Types. No need to buy a new tester! Use the functions of your present tester on any Color CRT listed from 9" to 26", including foreign types. Checks: Quintrex, InLine, Trinitrons, Tri-Potential, Pinless, Japanese & European. Replaces over 50 Adapters & guaranteed for all Makes/Models of CRT Testers. Instructions & Obsolescence proof perpetual Set-up Manual included. Check/Money Order/Visa/Mastercard/COD. **\$61.95 + \$2.00 P&H.** To order call 1-800-331-9658, (OK 918 68 2 4286) **DANDY MFG. COMPANY, 1313 N. MAIN ST., MUSKOGEE, OK 74401. REMIN-1024.**

CIRCLE 89 ON FREE INFORMATION CARD



TS-1 AUDIO TEST SET — \$269. *As reviewed in Nov '83 RADIO ELECTRONICS. **Low Distortion Sine Wave Oscillator:** Less than 0.3% THD 20 Hz to 20 kHz. ±0.1 dB Flat. **Frequency Counter:** 1 Hz to 9999 Hz autoranging to 10.00 kHz to 99.99 kHz. **dB Meter:** ±0.1 dB 20 Hz to 20 kHz @ 0 dBV, ±1 dB -50 dBV to +20 dBV. 3 Precision audio test instruments in one compact (2 lbs), easy to use package. Great for troubleshooting, field service, and tape recorder alignment. The 87 page user's manual can also be purchased separately for **\$3.** Call or write: **PHOENIX SYSTEMS, INC., 91 Elm Street, Manchester, Ct. 06040. (203) 643-4484.** M/C and VISA accepted. REMIN-1021

CIRCLE 50 ON FREE INFORMATION CARD

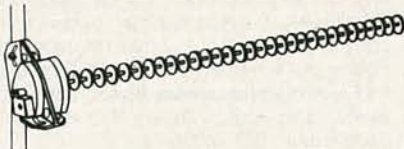

MAE-3, YAGI MICROWAVE ANTENNA — High quality up to 60 dB gain 1.9-2.5 GHz-50 mile range possible clear TV picture, pre assembled probe with down converter, 1.9-2.5GHz, power supply and RF amplifier, 1.9-2.5GHz, 30dB gain, with co-ax cable included. All mounting hardware, for fast and easy installation. Special **\$89.95.** Available by phone or mail order only. Check or money order, 5% Shipping and Handling on all orders. **KASHIWAGI ELECTRONICS CORP., 3555 So. Highland Suite 14 Las Vegas, Nevada 89103, 702-367-1241. REMIN-1020.**

CIRCLE 63 ON FREE INFORMATION CARD

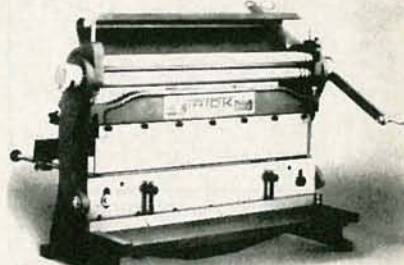

SHEET METAL WORKER—The 24" TRIOK is a Press Brake, Shear and Slip-roll machine-perfect for research and development or maintenance shops. Over a thousand machines world wide in little to the largest companies. For free literature on this and our other sheet metal working machines contact: **PACIFIC ONE CORPORATION, 513 Superior Ave. Suite K402, Newport Beach, CA 92663, (714) 645-5962. REMIN-1025.**

CIRCLE 31 ON FREE INFORMATION CARD



SUBSCRIPTION TV MANUAL. This information packed book details the methods used by subscription TV companies to scramble and descramble video signals. Covers the Sinewave, Gated Pulse, SSAVI system, and the methods used by most cable companies. Includes circuit schematics, theory, and trouble shooting hints. **Only \$12.95** plus **\$1.50** first class P&H. Info **\$2.00**, refundable. **RANDOM ACCESS, Box 41770-R, Phoenix, AZ 85080. REMIN-1009**

STATIEX[®] 10⁵ OHM. CM

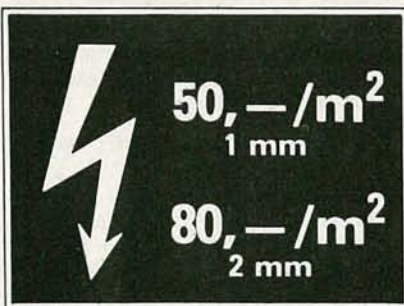

STATI-EX[®] High wear and solder heat resistant anti-static bench cover. Can be cut with scissors to needed size. Priced under **\$3.50** per sq. ft. Stati-Ex[®] mat 1m x 1m x 1mm thick **\$39.00.** Free sample. **SOLDER ABSORBING TECHNOLOGY, INC., South End Bridge Circle, Agawam, MA 01001. Toll free #1-800-628-8862. REMIN-1023**

CIRCLE 14 ON FREE INFORMATION CARD

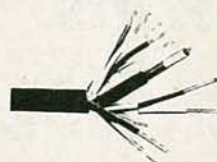

SATELLITE CONTROL CABLE—NEMAL ELECTRONICS has designed a new series of combination cables for TVRO installations. These cables provide all necessary wires for signal, motor and receiver power and sense circuits together in one direct burial jacket. **TYPE-1** RG-59 + 9 conductor (2-18gu) \$495/1000', **TYPE-2** RG-59 + 11 conductor (2-12gu) \$689/1000', **TYPE-3** dual RG-59 + 11 conductor (2-12gu) \$879/1000', all made with milspec RG59, 96% copper shield, tinned drain wires. Over 500 types of cable, connectors, SMATV products in stock. Authorized distributor Kings-Amphenol-Columbia. **NEMAL ELECTRONICS Inc., 12240 N.E. 14th Ave., N. Miami, FL 33161 (305) 893-3924. REMIN-1022**

CIRCLE 84 ON FREE INFORMATION CARD

SUPER LONG PLAY TAPE RECORDERS

10 Hour Model — \$95.00*
14 Hour Model — \$159.00*

Modified Panasonic Slimline,
high quality, AC-DC
Recorders provide 5 or 7
continuous hours of quality
recording & playback on
each side of cassette for a
total of 10 or 14 hours
depending on model. Built-in
features include • Voice
level control • Digital
counter, etc. TDK DC 180
Cassette Furnished.



PHONE RECORDING ADAPTER

Records calls automatically. All Solid
state connects to your telephone
jack and tape recorder. Starts
recording when phone is lifted.
Stops when you hang up.

\$24.50*

FCC APPROVED

VOX VOICE ACTIVATED CONTROL SWITCH

Solid state. Self contained. Adjust-
able sensitivity. Voices or other
sounds automatically activate and
control recorder. Uses either re-
corder or remote mike. \$24.95*

*Add for ship & hdg. Phone Adapter & Vox \$1.50 ea.
Recorders \$4.00 ea. Cal. Res. add tax. Mail order, VISA,
M/C, COD's OK. Money Back Guarantee. Qty. disc.
avail., Dealer Inquiries invited. Free data. ©
AMC SALES INC. Dept A 9335 Lubec
St., Box 928, Downey, CA
90421 (213) 869-8519

CIRCLE 67 ON FREE INFORMATION CARD

cable tv

DESCRAMBLER PARTS

We stock the exact parts and PC Board for
Radio Electronic's February Article on building
your own Cable TV Descrambler.

#701 PARTS PACKAGE \$29.95
Includes all resistors, capacitors, diodes, transistors,
integrated circuits, coils and IF transformers
(BKAN-K5552AXX).

#702 PC BOARD \$16.95
Etched and drilled silk-screened PC Board as shown
in article.

BOTH #701 & #702 \$39.00
Add \$2.50 Postage & Handling



Orders only 1-617-339-5372

J & W ELECTRONICS, INC.

P. O. Box 52
Cumberland, RI 02864

CIRCLE 4 ON FREE INFORMATION CARD

NEW LIT

For more details use the free
information card inside the back cover

COMPUTERS, *How to Buy a Home Computer*, is a 50-page book organized in the form of 11 step-by-step practical questions. 1. What do I want my computer to do? 2. What software programs do I want? 3. How do the computers compare? 4. How much memory does the software need? 5. Should I buy cassettes, cartridges, or diskettes? 6. What kind of keyboard will I like? 7. What kind of display do I want? 8. Do I need a printer? 9. What other peripherals should I consider? 10. What's my budget? 11. Do I want to program?

The booklet provides fill-in-the-blank questions that the consumer should ask about each software package and computer, as well as a convenient budget form for planning expenditures. Consumers can obtain a free copy by sending a 5 x 7 inch (or larger) self-addressed envelope with 54 cents postage to: **Electronic Industries Association/Consumer Electronics Group**, PO Box 19100, Washington, DC 20036.

IC's, Product Reliability Report, is 24 pages on coated paper, 8½ x 11 inches, and deals with reliability programs instituted by Precision Monolithics, Inc., for its linear circuits.

Covered in the report are device and package reliability monitor programs; data analysis; temperature accelerated life testing programs; PMI assigned activation energies, and failure mechanisms with failure-rate calculations. The brochure is free from **Precision Monolithics, Incorporated**, 1500 Space Park Drive, Santa Clara, CA 95050.
CIRCLE 131 ON FREE INFORMATION CARD

TEST INSTRUMENTS, short-form catalog is a 6-page color brochure, 8½ x 11 inches, that covers signal generators, modulation-meters, mobile radio test sets, white-noise test sets, spectrum analyzers, broadcast test systems, PCM & digital test sets, Eddystone receivers and microwave products, with photographs and specifications. Free from **Marconi Instruments**, 100 Stonehurst Ct., Northvale, NJ 07647.
CIRCLE 132 ON FREE INFORMATION CARD

PACKAGING catalog is 68 pages, and describes 920 electronic-packaging, breadboarding, and prototyping items. Special sections are devoted to circuit boards, racks and cages, connectors, terminals, accessories, tools, and breadboarding equipment.

A 21-page section covers microcomputer prototyping boards for VME-bus, S-100, STD, Multi-Bus, IBM-PC, Exorcisor, Apple II, DEC, and TI980 systems. There are a number of general-purpose boards, in a wide variety of sizes. The drilled boards have several power and ground-plane patterns, along with pad arrangements that accommodate both soldered or wire-wrapped connections. Also in-

cluded are mother-boards for S-100, STD, and Multi-Bus systems.

Another section describes 57 card racks and cases in a wide variety of sizes and configurations. The catalog is free upon request.—**Vector Electronic Company**, 12460 Gladstone Avenue, Sylmar, CA 91342.

CIRCLE 133 ON FREE INFORMATION CARD

TEST EQUIPMENT brochure, is four color, eight pages, and describes Hewlett-Packard's family of RF signal generators. Included are selection guides based on both applications and specifications for each of the programmable and manually-tuned generators, and a spectral-purity-comparison graph. Free upon request.—**Hewlett-Packard**, 3000 Hanover Street, Palo Alto, CA 94305.
CIRCLE 134 ON FREE INFORMATION CARD

ELECTRONICS EQUIPMENT and products catalog is 55 pages, two-color, and features computers, microcomputer components, integrated circuits, crystals, rectifiers, diodes, transistors, heat sinks, capacitors, resistors, multimeters, meters, LED and LCD readouts, kits, amplifiers, and many special items. Free upon request.—**Formula International, Inc.**, 12603 Crenshaw Boulevard, Hawthorne, CA 90250.
CIRCLE 135 ON FREE INFORMATION CARD

TOOLS catalog is 145 pages and features tools and equipment for electronics and telecommunications manufacturing, field service, and labs, as well as schools and hobbyists. The large, full-color, glossy catalog is divided into nine sections, covering a complete line of wire-wrapping tools, wire and cable, assembly products and aids of various types, including wire-wrapping machines and support systems. There is also a line of low-cost tools and products especially for educational and home use. Free upon request.—**OK Industries, Inc.**, 3455 Conner Street, Bronx, NY 10475.
CIRCLE 136 ON FREE INFORMATION CARD

TEST-EQUIPMENT catalog is two-color and features an entire line of test equipment, including oscilloscopes, analog and digital multimeters, power meters, insulation testers, indicating devices, and accessory items. Each item is accompanied by a list of its features, full specifications, packaging information, optional accessories, and black-and-white photograph. An alpha/numerical chart aids in locating any of the over 165 items in the catalog by model number. There is also a complete listing and description of every accessory item. Free upon request.—**A.W. Sperry Instruments, Inc.**, 245 Marcus Boulevard, Hauppauge, NY 11788.
R-E
CIRCLE 137 ON FREE INFORMATION CARD

DRAWING BOARD

continued from page 40

and since it's the last output in the chain, we're connecting it back to the data input of the IC. Remember that we have to make sure that the incoming data at the clock input is constantly recirculated around and around the daisy-chained flip-flops in the 4018. Any change in the input data to the IC has to be fed into it at the clock input and not the data input. All that we're using the data input for is to make sure that whatever we feed into the 4018 stays there.

Losing the Q₅ output means that we

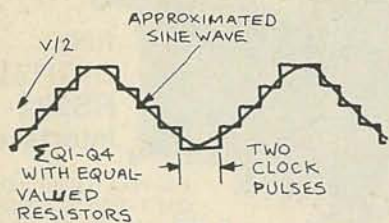

FIG. 3

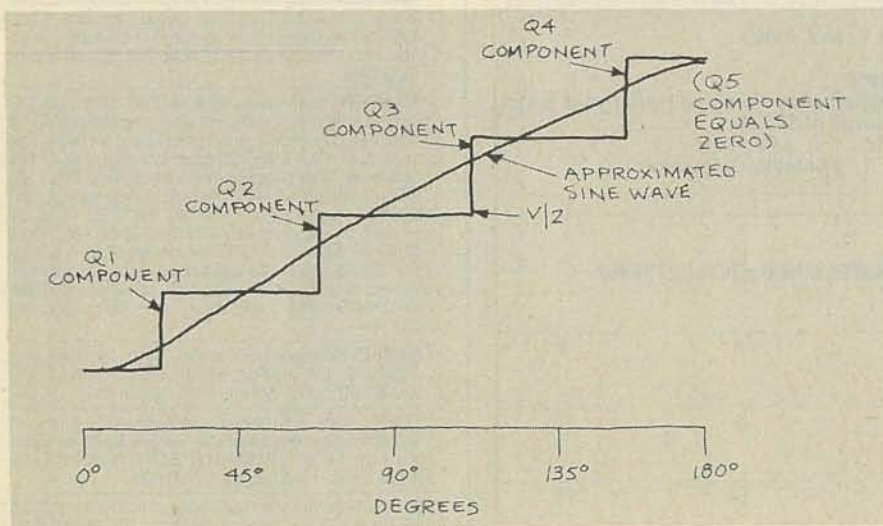

FIG. 4

don't use it to generate the sine wave but we still need it to recirculate the data. The result of eliminating that output is shown in Fig. 3: There have been two changes, the one we expected and one that's just one of those lucky breaks. The most obvious change is the flattening at the top of the waveform. That's what we expected and isn't really any great surprise. We've overlaid the output waveform with a sine wave again and you can see that it is a better fit than we got earlier in Fig. 2-b. Even though the drawing of the sine wave is crude, you can see that it's going to be a much better fit.

The second change isn't quite as obvious because the drawings aren't exactly to scale. Since we've lost one of the outputs (the one that produced the top of the

output waveform) the top only remains for two incoming clock periods instead of three, as it did in Fig. 2-b. That not only helps us fit the crest of the sine wave but gives the rise and fall on either side a better shape making the fit even better. Of course, as we've seen over and over again, you can't get something for nothing and we're paying a price here as well. Let's not forget that while we may have an easier time fitting the curve, we've lost one of the outputs and consequently our resolution has suffered. But, as with so many other things, trade-offs are the name of the game in electronics as well.

Picking the ideal resistor values to give us the best approximation of a sine wave involves a lot of math. The principle behind the whole thing, however, isn't really that hard to visualize. Figure 4 gives us a graphic representation of the problem. What we're looking at there is the first 180 degrees of the sine wave. The generating of the sine wave means that all of the outputs are going to come into play during each half of the full-cycle. Take another look at Fig. 1, you'll see that the sequential rise and fall of the flip-flop outputs

determine the shape of the summed waveform. Because each of the outputs is out of phase (or delayed) by exactly one incoming clock pulse, each of the outputs controls the amplitude of the output waveform at 45 degree (or 180/4) intervals. (We're dividing by four instead of five because the Q₅ output is not being used. Even though we're allowing for the time it takes to change state, it adds nothing to the amplitude of the output waveform.)

Finding the correct resistor values, therefore, means a bit of trigonometry and some more analysis. Don't be put off by the math; it's not all that difficult and understanding it only involves common sense and curiosity—two very important tools for anyone who wants to be involved in electronics.

R-E

HOBBY CORNER

continued from page 97

transistor checking. I recommend the methods in this order: 1) commercial tester/test circuit; 2) substitution; 3) multimeter. The multimeter method should be considered only as an emergency measure—that's because it does not work with all transistors.

Cat-birds

Leroy Jack (NE) needs some ideas on how to protect birds from his cats. It seems that they particularly relish wrens and Leroy wants to give the birds more of an even chance. He says that he has tried attaching bells to the cat's collars but that has produced only limited success. He wonders about putting a small audio oscillator on those collars.

Sure, you could do that, Leroy, but battery weight could be a problem if the oscillator is to operate very long. We would be more inclined to use a little 3909 IC—usually referred to as an "LED flasher."

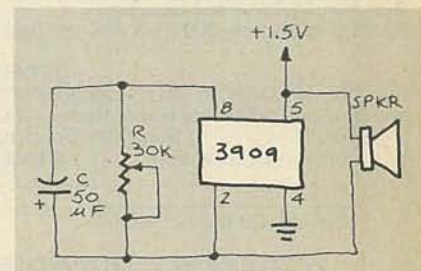

FIG. 6

If you put the 3909 in the circuit shown in Fig. 6, you can get sound with a low current requirement. We're not sure as to what kind of sound will be most effective in this application. Probably an occasional "click" will work as well as anything else. That is what you will get from the circuit shown. Other frequencies can be generated by varying the value of potentiometer and the capacitor.

That's all we have room for this time. Hang in there—your question may be coming up next month.

By the way, you may be wondering how the questions are chosen for answering here in the column. What I try to do is to select those questions that will be of the greatest interest to the greatest number of readers. That depends on the subject to the question and the range of the possible applications of the answer.

I am sure that you know that your questions are appreciated by all of us. Keep them coming. Oh yes, you don't have to wait until you have a question before you write—I'll be glad to see your comments and suggestions, too.

R-E

MARKET CENTER

FOR SALE

CABLE TV SECRETS—the outlaw publication the cable companies tried to ban. HBO, Movie Channel, Showtime, descramblers, converters, etc. Suppliers list included. Send \$8.95 to **CABLE FACTS**, Box 711-R, Pataskala, OH 43062.

RESISTORS 1/4 & 1/2 W 5% C.F. 3 cents. 1% M.F. All values. **No minimums.** Volume discounts. Write **JR INDUSTRIES**, 5834-B Swancreek, Toledo, OH 43614.

SCANNER monitor accessories—kits and factory assembled. Free catalog. **CAPRI ELECTRONICS**, Route 1R, Canon, GA 30520.

ALARM! VIC 20/64 CoCo Sinclair become \$1000.00 burglar fire system. Cassette, documentation (specify microprocessor) \$29.00. Catalog \$2.00 refundable. **SKIDMORE'S H'N'S**, PO Box 5097, Greensboro, NC 27403. Auto dialer with telephone book program \$49.00 Commodore, Sinclair.

DESCRAMBLERS for downconverters, high gain. Send \$1.00. **RB ELECTRONICS**, PO Box 643, Kalamazoo, MI 49005.

PICTURE flyer lists quality electronics surplus at low prices. Since 1970. Send for the last 3 issues. **STAR-TRONICS**, Box 683, McMinnville, OR 97128.

World's Most Remarkable Radar Jammer!



Causes speed radar guns and devices to read out your choice of either a percentage of your true speed when in automatic mode (example: Your speed: 76 mph, auto mode set for 75%, speed displayed — 57 mph), or the speed that you dial in when in manual mode. Transmits only in the presence of speed radar, or by manual override. Operates on both X and K bands. **WARNING:** The device described in this literature is not legal for use against police radar, and is not FCC approved.

For complete literature and plan package, send \$14.95 to:

Phillips Instrument Design Co. Inc.
9560 S.W. Barbur Blvd., Suite #109 S
Portland, Oregon 97219

THE Intelligence Library—Restricted technical information & books on **electronic surveillance, surveillance-device schematics, lock-picking, investigation, weapons, identification documents, covert sciences**, etc. The best selection available. **Free brochures.** **MENTOR**, (Dept. Z), 135-53 No. Blvd., Flushing, NY 11354.

WERSI electronics ORGAN & PIANO KITS

ALPHA DX 300



fully
**DIGITAL
RS232
Interface**

For Free Sound Info
Call 1-800-233-3865
or write **WERSI USA**
Dept. M 8 P.O. Box 5318
Lancaster, PA 17601

THE WORLD LEADER

To run your own classified ad, put one word on each of the lines below and send this form along with your check for \$2.15 per word (minimum 15 words) to:

Radio-Electronics, 200 Park Avenue South, N.Y., N.Y. 10003

ORDER FORM

PLEASE INDICATE in which category of classified advertising you wish your ad to appear. For special headings, there is a surcharge of \$20.00.

() Plans/Kits () Business Opportunities () For Sale
() Education/Instruction () Wanted () Satellite Television

Special Category: \$20.00

PLEASE PRINT EACH WORD SEPARATELY, IN BLOCK LETTERS.

1	2	3	4	5
6	7	8	9	10
11	12	13	14	15
16	17	18	19	20
21	22	23	24	25
26	27	28	29	30
31	32	33	34	35

PLEASE INCLUDE FOR OUR FILES YOUR PERMANENT ADDRESS AND PHONE NUMBER.

CLASSIFIED COMMERCIAL RATE for firms or individuals offering commercial products or services. \$2.15 per word prepaid (no charge for zip code)...**MINIMUM 15 WORDS.** 5% discount for 6 issues, 10% for 12 issues within one year, if prepaid.

NON-COMMERCIAL RATE (for individuals who want to buy or sell a personal item) \$1.50 per word prepaid...no minimum.

ONLY FIRST WORD AND NAME set in bold caps. Additional bold face (not available as all caps) at 20¢ per word. All copy subject to publisher's approval. **ADVERTISEMENTS USING P.O. BOX ADDRESS WILL NOT BE ACCEPTED UNTIL ADVERTISER SUPPLIES PUBLISHER WITH PERMANENT ADDRESS AND PHONE NUMBER.** Copy to be in our hands on the 20th of the third month preceding the date of the issue (i.e., August issue closes May 20th). When normal closing date falls on Saturday, Sunday, or a holiday, issue closes on preceding working day.

LATEST bug-detection equipment for home or office. Literature, \$1.00. **CLIFTON**, Box 220-X, Miami, FL 33168.

MILITARY communications radios: CPRC-26 Canadian field radio, compact size, transceives 42-54 MHz FM, 6 channels, with battery box, antenna, one crystal: \$19.50, 2/\$37.50 good condition. PRC-510 backpack radio (Canadian version of U.S. PRC-10), transceives 38-54 MHz FM continuous tuning, with headset, battery box: \$39.50, 2/\$77.50. ARC-27 aircraft guard receiver, 220-250 MHz AM single channel: \$12.50 mint. R-108 receiver, 20-28 MHz FM: \$27.50 mint. 45-day replacement guarantee. Schematics included. Add \$5/unit shipping. **BAY-TRONICS**, Dept. RE, Box 591, Sandusky, OH 44870.

CABLE TV equipment, notch filters for "beeping" channels. Information \$1.00. **GOLDCOAST**, PO Box 63/6025 RE, Margate, FL 33063.

FORTY-nine educational electronics kits with self-learning project manual. Details \$2.00 refundable with order. **TRIANGLE ELECTRONICS**, 89 Arkay Drive, Hauppauge, NY 11788.

RF parts/Motorola transistors. MRF454 \$16.50, MRF455 \$13.50. Catalog available. **RF PARTS CO.**, 1320 Grand, San Marcos, CA 92069. (619) 744-0720.

UP to \$500.00 per month. Sell computer software in your home. Write to: **COMPUTER SERVICES**, PO Box 7748, Tucson, AZ 85725.

CORDLESS—telephone owners. Increase range. Reduce static. Simple add on. Details \$1.00. **PHONES**, PO Box 273, Mesa, AZ 85201.

CABLE-TV products Jerrold, Hamlin, and Oak converters. Send \$3.00 for information. **ADDITIONAL OUTLET CORP.**, 111 E. Commercial Blvd., Ft. Lauderdale, FL 33334.

UNUSUAL surplus items—low prices—guaranteed quality—free flyer. **ELECTRONIX LTD.**, 3214 South Norton, Sioux Falls, SD 57105.

ELECTRONIC touch light control pad. Free brochure. **EXOTIC ELECTRONIC IDEAS**, PO Box 446, Lake Bluff, IL 60044.

RECONDITIONED test equipment. \$1.00 for catalog. **JAMES WALTER TEST EQUIPMENT**, 2697 Nickel, San Pablo, CA 94806.

7,000,000 tubes, 6000 different types. World's largest inventory. Free catalog. **UNITY ELECTRONICS**, Dept R, PO Box 213, Elizabeth, NJ 07206.

ADVANCED COMPUTER PRODUCTS

SEND \$2.00 for 1984 CATALOG

RAM UP-GRADES

64K D RAM (4164-200ns)

9 pcs for \$50.00

16K D RAM (4116-200ns)

8 pcs for \$12.95

REPEAT OF SELL-OUT

58 Key Unencoded Keyboard



\$19.95 ea.

This is a new 58 key terminal keyboard manufactured by a major manufacturer. It is unencoded with SPST keys unattached to any PC board. Solid molded plastic base measures 11" x 4".

Unencoded Key Pad

15 key keypad with 1-10 keys and tab, return, (.), (:) and (.). Only \$9.95 ea.

STEPPER MOTOR

Operates by applying 12VDC in one direction and then reversing polarity (or square wave) Uses 12VDC. Clock Wise Rotation. Rated 3 RPM at 4 P.P.S. with a 5 degree stepping angle.



ACP Price \$3.95

10 for \$34.95

RS232 SIGNAL TESTER

COEX RS232 LINE TESTER (7) LED Indicators

Only \$24.95 Other Styles Also Available

CONNECTORS

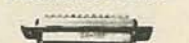

DB25P (RS232)	\$2.95
DB25S Female	3.25
Hood	1.49
Set with Hood, Sale	6.95
25.50 S/T, Apple	3.95
25.50 W/W, Apple	4.95
31.62 S/T, IBM	4.95
31.62 W/W, IBM	4.95
50.100 W/W, S-100 Connector	4.95
50.100 S/T, S-100 Connector	3.95

CRT CONTROLLERS

6845	\$14.75	8275	\$34.95
68845	17.50	7220	89.50
6847	11.50	CM5027	17.95
HC4665SP	15.75	CM5037	22.00
MC1372	6.75	8350	39.95
TM5918	39.95	6545	21.50

DATA ACQUISITION

DAC01	\$5.95	ADC0800	\$15.25
DAC08	7.50	ADC0804	3.95
DAC100	7.50	ADC0809	4.95
DAC0800	4.95	ADC0817	9.95
DAC0808	2.95	MC3470	4.95
DAC1020	8.95	MC1018	1.50
DAC1022	5.95	1408L8	2.95
F9708	4.95	DAC86EX	8.95

DISK SUPPORT

1691	\$16.95	2791	\$49.50
1771	16.00	2793	49.50
1791	22.95	2795	55.50
1793	25.95	2797	55.50
1795	27.95	6843	31.50
1797	44.50	8272	36.00
2143	18.95	UP0765A	36.00

INTERFACE

75188	\$1.19	8795	\$.85
75189	1.19	8796	.85
8726	1.75	8797	.85
8728	1.85	8798	.85
8731	2.75	75150	1.50
9636	3.75	75154	1.50
9637	3.75		

CLOCK CHIPS

MM5369	\$3.50	MM58174	\$10.95
MM5817	11.95	MSM5832	3.95

OSCILLATORS

1.000	\$10.95	8.000	\$10.95
1.8432	10.95	10.000	10.95
2.000	10.95	12.000	10.95
4.000	10.95	16.000	10.95
5.000	10.95	18.432	10.95
5.0688	10.95	19.608	10.95
6.000	10.95	20.000	10.95
6.144	10.95	22.184	10.95

ZERO INSERT SOCKETS

14PIN21F	\$5.75	24PIN21F	\$7.95
16PIN21F	5.95	28PIN21F	9.95
18PIN21F	7.75	40PIN21F	10.95
20PIN21F	7.95	64PIN21F	19.75

MICROPROCESSORS

68000	\$47.95	6504	\$6.75	8749	\$49.95
6800	3.95	6505	8.95	8755	39.95
68800	10.50	6507	9.95	Z-800	3.75
6802	7.95	6508	8.95	Z-800A	4.30
68002	20.95	8039	11.95	Z-800B	9.50
8803	18.50	8080	3.50	Z8000	44.95
8808	13.50	8085	4.75	Z8002	49.95
6809E	12.95	8085A-2	11.00	F-36892	19.95
6809E	27.95	8088	29.95	2650	16.95
6809	11.50	8087	199.00	1802	5.95
6809D	27.95	8088	39.95	8008-1	18.95
6502	4.75	8089	84.95	2901	6.95
6502A	6.50	8741	34.95	2901A	8.95
6502B	9.75	8748	39.95	28871	37.95

WE STOCK IN DEPTH

CALL FOR VOLUME PRICING

EPROMS

1702	\$4.25	2732	\$4.75	2764-250	\$7.75
2708	3.85	2732-250	8.25	2764-200	16.50
2716	4.95	2732-200	9.95	68764	39.95
2716	3.85	2732A4	6.75	68766	41.95
2716-1	5.75	2732A	9.75	27128	27.95
TM52716	7.50	2732A2	13.75	5203AQ	14.50
TM52916	5.25	2764	6.00	5204AQ	13.50
TM52532	5.75				

STATIC RAMS

2101	\$2.75	2147	\$4.75	5516	\$11.95
2102-1	.99	2016-200	4.95	6116-4	4.95
2102L-4	1.29	2016-100	5.95	6116-2	8.75
2102L-2	1.49	2016-100	6.95	6116LP-4	5.90
2111	2.75	4044-4	6.50	616LP2	10.95
2112	2.89	4044-2	6.50	23132	32.50
2114	1.49	4118	9.50	HM6264	47.50
2114L-2	1.89	5514	3.50	6167	9.95

DYNAMIC RAMS

MK4027	\$1.85	4116-200	\$1.49
UPD4110	8.95	616-200	4.95
UPD4111	4.95	4164-150	6.75
MM5280	2.95	MC6905	8.50
MM5290	1.49	TM54164-15	8.50
MM5298	1.49	41256	79.95

WE STOCK MOST OBSOLETE RAMS.

CALL FOR YOUR HARD TO FIND PARTS.

8000 SUPPORT

8155	\$9.95	8238	\$4.75	8271	\$74.95
8156	9.95	8243	5.50	8272	37.50
8202	23.50	8250	10.50	8275	34.95
8203	36.50	8251	5.95	8279	8.95
8205	3.25	8251A	9.95	8279-5	9.95
8212	1.95	8253	6.50	8282	7.95
8214	4.50	8253-5	9.95	8283	9.95
8216	1.95	8255	5.95	8284	7.95
8224	2.20	8255A	9.95	8286	7.95
8226	2.75	8257	7.25	8287	7.95
8228	3.35	8257-5	9.95	8288	24.95
8237	19.50	8259	7.25	8289	48.50
8237-5	21.50	8259-5	37.50		

6500 SUPPORT

6520	\$4.25	6532	\$9.75	6545A	\$26.50
6522	6.75	6532A	11.75	6551	11.50
6522A	8.50	6545	21.50	6551A	12.95

6800 SUPPORT

6810	\$2.75	68840	\$17.95	68850	\$5.75
6812	1.95	6843	31.50	68852	5.50
6820	4.25	6844	25.00	6860	7.75
6821	3.75	6845	14.75	6867	6.25
6822	6.75	68845	17.50	6880	2.50
6828	12.50	6889	17.50	6847	22.95
6840	12.50	6890	3.50	68488	19.50

Z-80 SUPPORT

Z80CT	\$3.95	Z80DART	\$10.75	Z80S01	\$12.50
Z80ACTO	4.75	Z80DART	10.95	Z80S02	11.50
Z80BCTC	9.75	Z80DART	18.95	Z80S03	12.50
Z80PIO	3.95	Z80S01	11.50	Z80S02	36.00
Z80PIO	4.75	Z80S01D	12.50	Z80S019	11.90
Z80PIO	12.50	Z80S01	11.50	Z80S019	12.50

SOCKETS

LOW PROFILE SOCKETS (TIN)

8 pin LP	.16	.15	.14
14 pin LP	.20	.19	.18
16 pin LP	.22	.21	.20
18 pin LP	.29	.28	.27
20 pin LP	.34	.32	.30
22 pin LP	.40	.37	.34
24 pin LP	.38	.37	.36
26 pin LP	.45	.44	.43
40 pin LP	.60	.59	.58

3L WIREWRAP SOCKETS (GOLD)

8 pin WW	.55	.54	.49
10 pin WW (Tin)	.65	.63	.58
16 pin WW	.75	.73	.67
18 pin WW	.80	.77	.70
15 pin WW	.95	.90	.81
20 pin WW	1.15	1.08	.99
22 pin WW	1.45	1.35	1.23
24 pin WW	1.35	1.26	1.14
26 pin WW	1.60	1.53	1.38
40 pin WW	2.20	2.09	1.89

CRYSTALS

32.768KHz	\$1.95	2.4576	\$2.95	5.7143	\$2.95	14.318MHz	\$2.95
1.000MHz	3.75	3.2768MHz	2.95	6.000MHz	2.95	15.000MHz	2.95
1.844MHz	3.75	3.5795MHz	1.95	6.144MHz	2.95	16.000MHz	2.95
2.000MHz	2.95	4.000MHz	2.95	6.5536MHz	2.95	18.000MHz	2.95
2.010MHz	2.95	5.000MHz	2.95	8.000MHz	2.95	18.432MHz	2.95
2.097152MHz	2.95	5.0688MHz	2.95	10.000MHz	2.95	32.000MHz	2.95

TOLL FREE

800-854-8230

LINEAR

78H05K	\$5.95	LM1414N	\$1.90
78M06	1.49	LM1458CN	.49
78M10	1.49	MC1488N	.99
LM1084H	2.95	MC1489N	.99
LM300H	.99	LM1498N	.99
LM301CN	.35	LM1566N	1.50
LM304H	1.98	LM1820N	.95
LM305H	1.89	LM1850N	.95
LM307CN	3.25	LM1889N	3.10
LM308CN	1.75	LM2111N	1.75
LM309K	.98	LM2900N	.99
LM310CN	1.49	LM2901N	2.50
LM311CN	.85	LM2917N	2.95
LM311D1CN	1.29	CA3013T	2.19
LM312H	1.70	CA3018T	1.99
LM317	1.70	CA3021T	3.49
LM318CN	1.49	CA3023T	2.99
LM319H	1.25	CA3035T	2.75
LM320K-XX	1.35	CA3039T	1.29
LM320T-XX	1.39	CA3046N	1.29
LM320H-XX	1.25	LM3053N	1.49
LM323K	4.95	CA3059N	3.19
LM324N	.95	CA3060N	3.19
LM337K	5.95	CA3062N	4.95
LM338K	6.95	LM3065N	1.49
LM339N	9.95	CA3080T	1.29
LM340K-XX	1.75	CA3081N	1.69
LM340T-XX	1.25	CA3082N	1.69
LM340H-XX	1.25	CA3083N	1.55
LM344H	1.95	CA3086N	.80
LM348N	1.20	CA3089N	2.99
LM350K	3.75	CA3096N	3.49
LM360N	5.60	CA3097N	1.99
LM372N	1.95	CA3130T	1.30
LM376N	3.75	CA3140T	1.19
LM377N	2.75	CA3160T	1.19
LM380CN	1.95	CA3162N	2.49
LM381N	1.79	CA3410N	1.95
LM383T	1.95	MC3423N	1.49
LM386N	1.25	MC3460N	3.95
LM387N	1.40	SG3524N	3.95
LM390N	1.95	CA3600N	3.39
NE531V/T	3.75	LM3900N	1.99
NE555V	.99	LM3905N	1.19
NE556N	.98	LM3909N	.98

TUBE SPECIALS

NEW TUBES IN INDIVIDUAL CARTONS

TYPE	PRICE	TYPE	PRICE
1R2	1.00	39-44	2.00
6BD6GTB	1.00	50Y8	1.50
6XW5T	1.00	71A	2.50
7Y4	1.00	7E	2.00
10	2.50	807	2.00
27	3.50	807	1.00
30	2.00	808A	1.00

MINIMUM ORDER: 5 PER TYPE

*Type 80 from Japan. All others are major U.S. brands; G.E., R.C.A., etc.

Limited quantities. Sale prices good thru 4-30-84.

CURRENT RECEIVING TYPES

PRICED AT 70% BELOW LIST.

WRITE FOR NEW 16 PAGE WHOLESALE CATALOG - SPECIALIZING IN TUBES AND PARTS FOR TUBE TYPE RADIOS - TRANSFORMERS, CAPACITORS, SOCKETS, ETC.



ANTIQUE ELECTRONIC SUPPLY
1725 W. University • Tempe, Arizona • 85281
(602) 894-9503



POLICE code unscramblers, other scanner accessories, telephone recording device, **DNE, Inc.**, Rt. 7, Box 257, Hot Springs, AR 71901 (501) 623-6027.

ELECTRONICS, technical, and miscellaneous used-book list. \$1.00 refundable. **SOFTWARE COMMUNICATIONS**, 1515 Sashabaw, Ortonville, MI 48462.

"THE robots are coming! The robots are coming! (Batteries not included)." Multicolor print on quality baseball cap plus bumper sticker. Or "Join the information revolution (Let's talk BASIC)." Cap plus sticker. Or official space shuttle logo cap plus NASA patch (distributed at California landings). Each set \$5.00. **SIGNS ETC. BY KNOX**, Dept. R-1, Box 628, Carmichael, CA 95608.

NEW!... repair any TV... easy. Anyone can do it. Write, **RESEARCH**, RR3, Box 601BR, Colville, WA 99114.

EXACT same PCB for descrambler in February article only \$11.95. **JIM RHODES**, 1025 Ransome Lane, Kingsport, TN 37660.

Be an FCC LICENSED ELECTRONIC TECHNICIAN!

Earn up to \$600 a week and more!

Learn at home in spare time. No previous experience needed.

No costly School. No commuting to class. The Original Home-Study course that prepares you for the FCC Radiotelephone license exam in your spare time! An FCC Government license is your "ticket" to thousands of exciting jobs in Communications, Radio & TV, Mobile two-way, Microwave, Computers, Radar, Aerospace and more. You don't need a college degree to qualify, but you do need an FCC License. **No need to quit your job or go to school!** You learn how to pass the FCC License exam at home at your own pace with this easy-to-understand, proven course. It's easy, fast and low cost! **GUARANTEED PASS** - You get your FCC License or money refunded. Write for free details. Soon you could be on your way to being one of the highest workers in the electronics field. **Send for FREE facts now. MAIL COUPON TODAY!**

COMMAND PRODUCTIONS

FCC LICENSE TRAINING, Dept. 90
P.O. Box 2223, San Francisco, CA 94126

Rush FREE facts on how I can get my FCC License in spare time. No obligation. No salesman will call.

NAME _____
ADDRESS _____
CITY _____ STATE _____ ZIP _____

CIRCLE 23 ON FREE INFORMATION CARD

VCR rewinder BETA/VHS minimize wear and tear \$32.96 + \$5.00 shipping. **PHILTRONICS**, PO Box 70386, Sunnyvale, CA 94086.

CONVERTERS all types for all systems, lowest prices anywhere, quantity discounts, dealer inquiries accepted. Send \$1.00 for catalog. **PG VIDEO CORP.**, PO Box 296, Latham, NY 12110 (518) 374-2988.

CAMP base station CB antennas for back woods. Ground plane antenna for portable use \$14.95 plus \$2.50 shipping and handling. **NIMROD ELECTRONICS**, PO Box 20421, Reno, NV 89515-0421.

9-CODE telephone scrambler, several new unscramblers for scanners, telephone and scanner accessories, tone encoders/decoders. All factory built. Free catalog. **KRYSTAL KITS**, PO Box 445, Bentonville, AR 72712 (501) 273-5340.

COMPUTERS, video recorders, CCTV cameras. Buy direct from U.S. government. Many brand new. Save up to 99%! Resell for huge profits! Complete details, directory, \$2.00. Guaranteed. **KENTCO**, Dept. EL, Morganton, GA 30560.

"CABLE" satellite microwave UHF video accessories. S.A.S.E. 40 cents. **H.M.S.**, 2011 W. 11th St., Upland, CA 91786.

TRS80III/4-48K enter sheet music. Computer prompts with selected animated guitar finger positions. Full neck, 108 chords. Keyboard displays. Sounds. Transpose keys. Disk, tape, manual. \$29.95. Listings \$14.95. Free brochure **SASE**. **GIT-PICKER**, 96 Charro Place, Santa Rosa, CA 95401.

ELECTRONICS test equipment. Catalog 25 cents. **EF ELECTRONICS**, 10 Afton, Aurora, IL 60538.

OVER 1200 electronics parts, kits, and computer products. Lowest prices. Send \$1.00 (redeemable) for catalog. Stamp brings flyer. **DAYTAPRO ELECTRONICS**, 3029 N. Wilshire, Arlington Hts., IL 60004.

BEST prices: CBs, telephones, radar detectors, scanners. Free list. **CRS**, 1587 Central Ave., Yonkers, NY 10710.

ZX81/TS1000 high resolution graphics program 16K \$8.00. **CRAIG BIRD**, 2091 Carrick Street, Victoria, BC Canada V8R 2M5.

SSSSS super savings on electronics parts, components, supplies. Free 40-page catalog for **SASE**. Get on our mailing list. **BCD ELECTRO**, PO Box 830119, Richardson, TX 75083. Or call (214) 690-1102.

ELECTRONIC surveillance! Incredible manual, "Homebrew Bugging" reveals secret techniques used by professionals (schematics included)—\$15.00. Send \$3.00 for our catalog of books and electronics products. **A.T.I.S.**, Dept. R, 61 Gatchell St., Buffalo, NY 14212.

STV kits—specify sinewave or gated pulse & UHF channel number. Complete—all parts & case included! Shipped U.P.S.—\$295.00. Free information. **DEALERS WANTED-STV**, Box 1226, Dublin, PA 18917.

DESCRAMBLERS

AMERICAN—CANADIAN

C-1000 / ZENITH TYPE
Descrambles "over the air" and "cable" sync suppressed active video inversion signals
Ready to go C-1000... 379.95
Complete Kit C-1000K... 274.95
Printed Circuit & Manual... 74.95

C-100 / JERROLD TYPE
Cable Descrambler for in-band gated suppressed systems
Ready to go C-100... 119.95
Complete Kit C-100K... 54.95

SEND \$2 FOR COMPLETE INFORMATIVE CATALOG TO DETERMINE WHAT TYPE YOU NEED

FALL SPECIAL
Buy 1 kit
Get 2nd kit
at 1/2 price
Offer ends 7/1/84

J & D ENGINEERING
P.O. Box 6099
Falmouth, Maine 04105

Dealers Wanted
Special Quantity Pricing
COD's—OK

All J & D products are engineered, not copied, all are guaranteed 90 days & we stand behind our products where others fail to

NEW! MULTI-CHANNEL MICROWAVE

Complete Antenna Systems from \$69⁹⁵

Full 800 Mhz Range
Tune 1.9-2.7 Ghz
Includes all ITFS Channels

DEALERS WANTED

COD's and Credit Card Orders call TOLL FREE
1-800-247-1151

GALAXY ELECTRONICS
6009 N. 61 Avenue
Glendale, AZ 85301
1-602-247-1151

PLANS & KITS

PRINTED-circuit boards. Quick prototypes, production, design, reflow solder send print or description for quote to **KIT CIRCUITS**, Box 235, Clawson, MI 48017.

CABLE TV converters and equipment. Plans and parts. Build or buy. For information send \$2.00. **C & D ELECTRONICS**, PO Box 21, Jenison, MI 49428.

HI-FI speaker kits, auto speaker systems, and raw drivers from the world's finest manufacturers. For beginners or experts. Free literature. **A&S SPEAKERS**, Box 7462R, Denver, CO 80207 (303) 399-8609.

PROJECTION TV... Convert your TV to project 7-foot picture... Results comparable to \$2,500.00 projectors... Total cost less than \$30.00... Plans & 8" lens \$19.95... Illustrated information free... **MACROCOMA-GH**, Washington Crossing, PA 18977. Creditcard orders 24 hours. (215) 736-3979.

HOBBYISTS... simplify digital circuit design using EPROM. How to guidebook also includes nine projects you can build. \$15.00 to **TECHNOLOGIK**, PO Box 45, Essex, VT 05451.

MOST advanced sine converter descrambler available. PCB and plans \$15.00. **JIM RHODES**, 1025 Ransome Ln., Kingsport, TN 37660.

AUTOMATIC fine tuning (AFT) for UHF/VHF converter board Deluxe I, II—never again readjust fine tuning, state of the art design, plans, circuit, parts list \$15.00. Deluxe I, II get clear picture as normal commercial TV channel, improve sound adjustment, stop vertical jitter \$11.00. **ADVANCE ELECTRONICS**, PO Box 3298, Culver City, CA 90230.

CATALOG: Hobby, CB, broadcasting! Linears, transmitters, bugs, scramblers, downconverters, antennas, modifications, more! **PANAXIS** Box 130-F4, Paradise, CA 95969.

FREE KIT Catalog

FUNCTION GENERATOR KIT \$59.95
Auto-Ranging Cap-meter kit \$79.95

contains TEST & EXPERIMENTER'S EQUIP.

Phone 209-772-2076

Write or Phone for FREE CATALOG

DAGE SCIENTIFIC INSTRUMENTS
BOX 144 VALLEY SPRINGS CA 95252

FLEAS? Rid your house of bugs/rodents ultrasonically. Plans \$2.95. **KIDD**, 4925 Seawolf, Santa Rosa, CA 95405.

HIGH quality electronics kits and products. Send \$1.00 for colorful catalog and one free flasher **LED**. **INTERNATIONAL POLYTECHNIQUES**, PO Box 862B, New York, NY 10002.

NEW!... repair any TV... easy. Anyone can do it. Write **RESEARCH**, RR3, Box 601BR, Colville, WA 99114.

DALBANI CORPORATION

Japanese Components

AN SERIES

AN-124Q	\$.88
AN-203C	.69
AN-210	.81
AN-214P	.77
AN-214Q	.77
AN-225	1.90
AN-228W	1.76
AN-234	2.22
AN-236	1.29
AN-239Q	2.68
AN-240P	.55
AN-241P	.55
AN-245	2.00
AN-247	1.46
AN-252	1.14
AN-253	.71
AN-259	.65
AN-262	.78
AN-264	1.00
AN-271	.99
AN-274	1.20
AN-277	1.04
AN-285	2.01
AN-303	2.30
AN-313	1.55
AN-315	.75
AN-316	1.98
AN-318	3.28
AN-328	2.10
AN-331U	1.41
AN-360	.31
AN-362	.75
AN-366P	.61
AN-610	.64
AN-612	.64
AN-5111	2.23
AN-5132	1.46
AN-5250	.94
AN-5310	1.72
AN-5320	1.27
AN-5411	1.65
AN-5510	1.41
AN-5722	.55
AN-5730	.66
AN-5732	.50
AN-5753	.69
AN-5763	1.32
AN-6100	1.79
AN-6120	1.50
AN-6344	2.62
AN-7110	.50
AN-7114E	.58
AN-7115E	.68
AN-7120	.63
AN-7130	.63
AN-7145M	1.16
AN-7146M	1.23
AN-7150	.17
AN-7151	.17
AN-7154	1.10
AN-7156N	1.55
AN-7254	.73
AN-7311	.35
AN-7363	1.22

BU SERIES

BU-205A	\$.94
BU-208A	.99

CX SERIES

CX-130	\$3.65
CX-143A	5.46
CX-186	5.46
CX-187	5.46

HA SERIES

HA-1125	\$.61
HA-1137W	.58
HA-1156	.54
HA-1199	.59
HA-1306W	1.13
HA-1319	1.21
HA-1322	1.25
HA-1339A	1.13
HA-1342A	1.16
HA-1366W	.66
HA-1366WR	.66
HA-1368	.94
HA-1368R	.94
HA-1371	1.58
HA-1377	1.20
HA-1377A	1.20
HA-1388	1.41
HA-1389	.95
HA-1389R	.95
HA-1392	1.28
HA-1394	1.67
HA-1397	1.71
HA-1398	1.63
HA-11211	.57
HA-11215	2.14
HA-11221	1.60
HA-11227	.46
HA-11229	.83
HA-11235	1.05

LA SERIES

LA-1111P	\$.48
LA-1130	.71
LA-1150	.35
LA-1201	.40
LA-1210	.61
LA-1222	.25
LA-1230	.59
LA-1231N	.69
LA-1240	.63
LA-1245	.85
LA-1320	.54
LA-1352	.98
LA-1354	.53
LA-1357	1.34
LA-1363	.64
LA-1364	.71
LA-1367	.50
LA-1368	1.27
LA-1369	1.17
LA-1385	.78
LA-1387	1.84
LA-1388	1.84
LA-1390	1.61
LA-1460	1.16
LA-1464	1.48
LA-2100	1.14
LA-2101	1.16
LA-2200	.75
LA-3101	.60
LA-3110	.32
LA-3115	.35
LA-3120	.35
LA-3122	.60
LA-3130	.33
LA-3133	.60
LA-3150	.30

BA SERIES

BA-301	\$.34
BA-311	.36
BA-313	.39
BA-511A	.68
BA-514	.79
BA-521	.61
BA-526	.50
BA-527	.61
BA-532	.65
BA-536	.97
BA-1310	.72
BA-1320	.64
BA-1330	.77

LA-3155	.59
LA-3160	.29
LA-3161	.30
LA-3201	.33
LA-3210	.26
LA-3300	.76
LA-3301	.68
LA-3350	.23
LA-3361	.45
LA-3365	.44
LA-3370	.64
LA-3375	.78
LA-3380	1.20
LA-4030	.75
LA-4031P	.55
LA-4032P	.69
LA-4050	1.09
LA-4051P	1.13
LA-4100	.35
LA-4101	.41
LA-4102	.41
LA-4110	.49
LA-4112	.43
LA-4120	1.14
LA-4121	1.06
LA-4125	1.09
LA-4126	1.07
LA-4135	.75
LA-4137	.73
LA-4140	.31
LA-4160	.63
LA-4170	.53
LA-4175	.53
LA-4182	.88
LA-4185	1.14
LA-4190	.89
LA-4200	.64
LA-4201	.70
LA-4220	.59
LA-4230	.93

LA-4250	1.17
LA-4400	1.50
LA-4420	.64
LA-4422	.75
LA-4430	.53
LA-4440	1.20
LA-4460	1.38
LA-4461	1.38
LA-5110	.71
LA-5112	.56
LA-5700	.80
LA-7003	1.29
LA-7802	.92

LA-1111P	\$.48
LA-1130	.71
LA-1150	.35
LA-1201	.40
LA-1210	.61
LA-1222	.25
LA-1230	.59
LA-1231N	.69
LA-1240	.63
LA-1245	.85
LA-1320	.54
LA-1352	.98
LA-1354	.53
LA-1357	1.34
LA-1363	.64
LA-1364	.71
LA-1367	.50
LA-1368	1.27
LA-1369	1.17
LA-1385	.78
LA-1387	1.84
LA-1388	1.84
LA-1390	1.61
LA-1460	1.16
LA-1464	1.48
LA-2100	1.14
LA-2101	1.16
LA-2200	.75
LA-3101	.60
LA-3110	.32
LA-3115	.35
LA-3120	.35
LA-3122	.60
LA-3130	.33
LA-3133	.60
LA-3150	.30

LB SERIES

LB-1405	\$.49
LB-1409	.90
LB-1415	.49
LB-1416	.52
LB-1426	.52
LB-1551	1.02

LC SERIES

LC-7120	\$1.78
LC-7130	1.64
LC-7200	5.03
LC-7250	3.79
LC-7800	.75

M SERIES

M-5102	\$.77
M-5115	2.61
M-5152	.39
M-5155	.86
M-51513L	.77

M-51514	.86
M-51515BL	1.43
M-51516	1.16
M-51517	1.21
M-51518	1.08

MB SERIES

MB-3705	\$.96
MB-3712M	.68
MB-3715A	1.01
MB-3730M	1.29
MB-3731M	1.33
MB-3756M	.94
MB-8719	2.35

STK SERIES

STK-0025	\$2.57
STK-0029	2.37
STK-0030	2.75
STK-0039	2.30
STK-0040	3.28
STK-0049	4.14
STK-0050	3.38
STK-0059	4.95
STK-0060	5.14
STK-0080	5.02
STK-0111	2.99
STK-0113	5.07
STK-0114	2.99
STK-0115	2.99
STK-0116	2.99
STK-0117	2.99
STK-0118	2.99
STK-0119	2.99
STK-0120	2.99
STK-0121	2.99
STK-0122	2.99
STK-0123	2.99
STK-0124	2.99
STK-0125	2.99
STK-0126	2.99
STK-0127	2.99

STK-2028	4.55
STK-2029	4.08
STK-2030	5.78
STK-2139	4.92
STK-2139	5.38
STK-3041	2.92
STK-3042	3.46
STK-3062	3.57
STK-3082	3.85

TA SERIES

TA-7054P	\$1.56
TA-7063	.28
TA-7070	1.21
TA-7072	1.50
TA-7073A	.93
TA-7092	2.92
TA-7108P	.99
TA-7109A	1.41
TA-7119P	1.29
TA-7120P	.28
TA-7130P	.29
TA-7133	.65
TA-7137	.32
TA-7142	.55
TA-7146	1.32
TA-7157	.71
TA-7193	2.55
TA-7200	.79
TA-7201	1.29
TA-7202	1.82
TA-7203P	1.22
TA-7204P	.66
TA-7205	.77

UPC SERIES

UPC-16C	\$.94
UPC-20C	1.16
UPC-30C	1.19
UPC-554C	.86
UPC-555H	.28
UPC-566H	.23
UPC-571H	1.13
UPC-574	.25
UPC-575C	.50
UPC-576H	1.14
UPC-577	.33
UPC-580	1.68
UPC-592C	.29
UPC-595C	.65
UPC-596	.66
UPC-1001H	1.16
UPC-1020	1.10
UPC-1023	.20
UPC-1025H	1.38
UPC-1026C	.43
UPC-1028H	.32
UPC-1031H	.68
UPC-1032	.22
UPC-1155	.91
UPC-1156H	.69
UPC-1181H	.50
UPC-1182H	.50
UPC-1185	1.12
UPC-1230H	1.11
UPC-1350	.61
UPC-1363C	1.65
UPC-1384	2.22
UPC-1447H	.34
UPC-1458C	.39

2SA SERIES

2SA-1105	1.44
2SA-1106	1.82
2SB-22	\$.17
2SB-32A	.26
2SB-411	1.78
2SB-507	.34
2SB-539	2.14
2SB-554	2.85
2SB-557	1.57
2SB-560	.16
2SB-563	2.22
2SB-595	.45
2SB-596	.39
2SB-616	.61
2SB-618A	.96
2SB-633	.45
2SB-636	.07
2SB-681	1.65
2SB-754	.42
2SB-755	1.14
2SB-844	.67
2SC-373	\$.08
2SC-398	.50
2SC-460	.06
2SC-461	.06
2SC-495	.21
2SC-710	.06
2SC-730	1.33
2SC-792	1.58
2SC-828	.06
2SC-829	.06
2SC-867A	2.04
2SC-940	.95
2SC-945	.06
2SC-980	.32
2SC-998	2.43
2SC-1034	2.56
2SC-1047	.14
2SC-1060	.26
2SC-1061	.26
2SC-1074	.43
2SC-1096	.24
2SC-1114	2.60
2SC-1115	2.28
2SC-1124	.54
2SC-1162	.18
2SC-1165	2.15
2SC-1172B	1.38
2SC-1177	8.76
2SC-1226A	.31
2SC-1305	1.50
2SC-1306	.44
2SC-1306	.44
2SC-1307	.95
2SC-1308K	1.60
2SC-1313	.10
2SC-1316	2.56
2SC-1317	.11
2SC-1318	.09
2SC-1342	.06
2SC-1345	.07
2SC-1358	.36
2SC-1364	.20
2SC-1383	.13
2SC-1384	.15
2SC-1413	1.82
2SC-1449	.19
2SC-1501	.41
2SC-1507	.22
2SC-1675	.06
2SC-1678	.53
2SC-1815GR	.15
2SC-1826	.21
2SC-1881	.48
2SC-1913	.44
2SC-1946	6.60
2SC-1947	1.68

2SC SERIES

2SC-1956	4.05
2SC-1960	4.02
2SC-1968	12.84
2SC-1972	4.05
2SC-1975	.86
2SC-2026	.24
2SC-2028	.60
2SC-2029	.71
2SC-2073	.32
2SC-2075	.41
2SC-2098	3.28
2SC-2120	.07
2SC-2131	1.85
2SC-2153	.22

200 electronics kits, projects, plans send stamp for list. **MATCO ELECTRONICS**, Box 316 R, Cadillac, MI 49601.

REPAIRS of all converters and cable boxes with prompt service. Deluxe sinewave kits \$95.00. 90% complete also available (quantity discounts) UHF converters of all types available. Send SASE (54 cents postage) for information. I-(312) 637-4408. **HIGGINS ELECTRONICS**, 6014 W. Nelson, Chicago, IL 60641.

VIC-20 interface drives ANY recorder. Connects two for parallel read/write and copying. Detailed plans \$7.95. Free information on kit. **EDWARDS**, Box 4723, Culver City, CA 90230.

DESCRAMBLER kits Numbers 60, 65, 67, 68. Boston station went under! My loss is your gain! Kits \$59.95; assembled \$69.95 (may need alignment). Includes everything needed and highest quality PC board: silk-screened, double-sided, plated-through holes. Chassis: silkscreened; pre-painted; punched. Any doubts about quality? References furnished. Include \$5.00. S&H. Also: tuners ELA1045, \$9.95, and other components. Send SASE. **ALLEN SHOPE**, 21 Kelly, Londonderry, NH 03053 (603) 434-8582.

RF MODULATORS for the video industry

Satellite modulators from channel 2 thru UHF! Kits & assembled models for all Microcomputers...including our new Apple-verter designed to mount inside computer. Also an extensive line of monitors, cameras and kits. **FREE CATALOG**

PHONE (402) 981-3771
ATV Research
13-RE BROADWAY
DAKOTA CITY, NE 68731



SATELLITE TELEVISION

HOW to build a satellite-TV receiver, LNA, down-converter! Save hundreds! Satisfaction guaranteed! Free information! Send stamped envelope: **XANDI**, Box 25647, Dept. 21X, Tempe, AZ 85282.

SATELLITE TV VIEWERS
Get the most complete weekly listings.
Send \$1 for sample copy.

Satellite TV Week
P.O. Box 308, Fortuna, California 95540
800-358-9997 (U.S.) • 800-556-8787 (Calif.)
707-725-2476 (all others)

FREE! Information on 100 satellite-television channels plus free catalog of proven do-it-yourself plans/kits for easy, low-cost, attractive satellite antennas. Also, wholesale electronics components. **GFI-5**, Box 9108, Missoula, MT 59807. (406) 642-3405. "Consumer Guide to Satellite Television"—\$6.95.

SATELLITE systems—quick assembly high quality antennas, LNAs, receivers, lowest prices anywhere. Catalog \$2.00. **STATE SATELLITE**, 5 Broadway, Troy, NY 12180 (518) 272-1130.

COMPLETE 8' satellite system \$999.00. Complete 10' satellite system \$1299.00. **SATELLITE CONSULTANTS**, (615) 984-7872.

HOME satellite handbook and buyer's guide, tells everything about TVRO and may save you hundreds even thousands in your selection and installation of a system. \$10.00 **H&G HOMESAT**, Box 422, Seaford, NY 11783.

SATELLITE parabolic dish antenna manual formulas and facts \$15.00. Write **J. FOX**, 21617 Collier, Battle Creek, MI 49017.

SATELLITE TV!—Lowest prices on complete systems! All popular brands available. Free information. Complete installation instructions and programming guide \$2.00. Dealers wanted—**ANTENNA INSTALLATION SERVICE**, PO Box 1226-R, Dublin, PA 18917 (215) 249-9254.

BUSINESS OPPORTUNITIES

WHOLESALE MATV/CATV/VCR equipment, an-

tennas, audio cables, adapters, original/replacement cartridges & styli, telephone accessories, radios, cassette recorders, speakers, etc., send letterhead for free catalog (212) 897-0509 **D&WR**, 68-12 110th St., Flushing, NY 11375.

MECHANICALLY inclined individuals desiring ownership of small electronics manufacturing business—without investment. Write: **BUSINESSES**, 92-R, Brighton 11th, Brooklyn, NY 11235.

VIDEO game repair business. Start your own. Information/parts list \$5.00. **BEST ELECTRONICS**, 4440 Sheena, Phoenix, AZ 85032.

PROJECTION TV... Make \$\$\$s assembling projectors... Easy... Results comparable to \$2,500.00 projectors... Your total cost less than \$20.00... **Plans, 8' lens**, & dealers information \$17.50... Illustrated information free... **MACROCOMA-GHX**, Washington Crossing, PA 18977. Creditcard orders 24 hours. (215) 736-2880.

TECHNICAL writers make big money... writing short sentences! Free details: **TEK PUBS**, Box 2458-E, Oroville, CA 95965.

48K computer US\$380.00 and hundreds Apple-compatible softwares. Details US\$1.00. **RELIANT** PO Box 33610, Sheungwan, Hongkong.

YOUR own radio station! AM, FM, Cable, licensed, unlicensed, transmitter kits! Write: **BROADCASTING**, Box 130-F4, Paradise, CA 95969.

SECURITY alarm industry booming. Get in now. Tremendous demand. Employment—business terrific. Information \$2.00. (redeemable) **DYNAMIC SECURITY MARKETING**, PO Box 1456-SF Grand Rapids, MI 49501.

BIG PROFITS **ELECTRONIC ASSEMBLY BUSINESS**

Start home, spare time. Investment knowledge or experience unnecessary. **BIG DEMAND** assembling electronic devices. Sales handled by professionals. Unusual business opportunity.

FREE: Complete illustrated literature
BARTA, RE-O Box 248
Walnut Creek, Calif. 94597

CB EQUIPMENT

CB radio books, kits, modifications, catalog \$1.00 refundable. **APS**, POB 263RE, Newport, RI 02840.

PALOMAR/Pride electronics—exclusive repair facility. Service—update—improvements on these and similar equipment. **PALOMAR PRIDE REPAIR**, 1320 Grand, San Marcos, CA 92069 (619) 744-0720.

CB MODIFICATIONS

Increase channels, range, privacy! We specialize in frequency expanders, speech processors, FM converters, PLL & slider tricks, how-to books, plans, kits. Expert mail-in repairs & conversions. 16-page catalog \$2.

CBC INTERNATIONAL, P.O. BOX 31500RE, PHOENIX, AZ 85046 (602) 996-8700

COMMUNICATIONS EQUIPMENT

VIDEOSCAN 1000 slow scan TV—high resolution (amateur, phone line, surveillance, teleconferencing). **CODE*STAR**—decode Morse, RTTY, ASCII. Large LED display. Connect VIC-20 computer/printer. Tri-voltage power supply. Kits/assembled. Free brochures. **MICROCRAT CORPORATION**, Box 513-RE, Thiensville, WI 53092. (414) 241-8144.

DESCRAMBLER TROUBLES

SINE wave descrambler problems? Manual includes trouble shooting, alignment, antenna hookup, improvements, theory. \$10.00 **SIGNAL**, Box 2512-R, Culver City, CA 90230.

REEL-TO-REEL TAPES

AMPEX professional series open reel tape, 1800- or 2400-feet on 7-inch reels, used once. Case of 40, \$45.00, 10 1/2 x 3600 feet and cassettes available. MasterCard/Visa. **VALTECH ELECTRONICS**, Box 6-RE, Richboro, PA 18954 (215) 322-4866.

THE BEST IN **POPULAR TELEVISION CIRCUITS**

New! **SAT-X PROCESSOR** Digital Circuitry

- KSD-2412 Sat Process Kit \$349.95 + \$7.95 S/H
- PCS-3000 Sat Process PCB \$75.00 + \$4.00 S/H
- RFM-3040 RF Modulators \$24.95 + \$3.00 S/H
- UAA-1000 UHF Amplifier Kit \$19.95 + \$3.00 S/H

NOW READY! Our new catalog!

ZENITH M1 09-151-0 **FV-5** Phase Video Sync. Suppression M1 & FV-5 used as a system

SINewave SUPER BOARD

- KSW 1483 Sinewave Kit \$119.95 + \$5.95 S/H
- KSO 1484 Sinewave Minus PCB \$99.95 + \$5.95 S/H
- PCS 6252 Sinewave PCB only \$20.00 + \$3.00 S/H

State of the art technology brings you this superior Sinewave Superboard. It has no internal connection to TV. RF modulator built on the board, AGC for stability and tunes the entire band with a varactor tuner and multi-turn pot. A high quality plated-thru circuit board with silk-screened parts layout, easy to follow, fully illustrated instructions and quality parts make this kit easy to assemble. The beautifully finished cabinet will add a touch of class to the many hours of enjoyment you will receive building and using this kit.

MICROWAVE PROBE SKY RANGER \$69.95

- KMP 2030 Micro Probe Kit \$24.95 + \$3.00 S/H
- MPD 2000 Micro 20" Dish \$14.95 + \$5.95 S/H
- PCM 2000 Micro PCB only \$4.95 + \$3.00 S/H
- KMP 1218 Micro Power Supply Kit \$19.95 + \$3.00 S/H

UNSURE? Order any manual for only \$9.95 post paid. Refundable with order of kit

* HOBBY USE ONLY. NOT FOR UNAUTHORIZED RECEPTION OF TV SIGNALS.
* AVAILABLE BY MAIL ONLY * SEND FOR INFORMATION ON OTHER ITEMS
* COMPLETE REPAIR SERVICE * CHECKS HELD 3 WEEKS FOR CLEARANCE

4218 S. 36TH PL., PHOENIX, ARIZONA 85040

ORDERS ONLY: **(800) 243-6700**

WESTECH WESTECH ELECTRONICS (602) 437-0100

MasterCard NATIONAL DELIVERY VISA



FORMULA INTERNATIONAL INC.

12603 Crenshaw Blvd., Dept. B, Hawthorne, CA 90250

For information (213) 973-1921 • Orders Only (outside Calif.) (800) 672-8758



MARK IV — 15 STEP LED POWER LEVEL INDICATOR KIT

This new stereo indicator kit consists of 36 4-color LED's (15 per channel) to indicate the sound level output of your amplifier from -36dB to +3dB. Comes with a well designed silk screen printed plastic panel and has a selector switch to allow floating or gradual output indicating. Power supply is 6-12VDC with THG on board input sensitivity controls. This unit can work with any amplifier from 1W to 200W. Kit includes 70 pcs driver transistors, 38 pcs matched 4-color LED's, all electronic components, PC Board and front panel. **MARK IV KIT \$31.50**

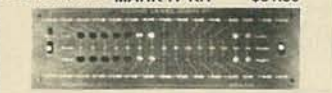

No FCC License Required
OUR PRICE \$49.50
Additional Microphone (Transmitter) Available at \$28.00 ea.
MURA WMS-49



CRYSTAL CONTROLLED WIRELESS MICROPHONE SYSTEM
Transmitter: FET mic for flat 30Hz-18KHz response. X'tal controlled 49MHz AM Band for drift-free performance. 100mW output (range approx. 1/4 mile) for reliable long range transmission. Powered by a 9V radio battery.
Receiver: X'tal controlled locks on 49MHz transmitter signal. On panel VU meter, monitors the signal strength from the microphone. Standard phone jack outlet connection to a P.A. or other phone input, 9V battery included. This professional set is ideal for on stage, in field, church, in house or outdoor use.



pinecom™ DP-64



- Dual Processor (6502 and Z80A)
- Detached Keyboard
- 64K RAM Expandable to 192K
- 25 Function Key Keyboard
- Auto Repeat Keys w/Upper/lower Case
- 2 Slim Disk Drives (optional)
- 100% Apple II Compatible
- 40/80 Column Display (optional)
- Runs Both Apple Soft and CP/M Software

Model DP-64 Fully Assembled... **\$650⁰⁰**

TA-1000 KIT \$51.95 Power Transformer \$24.00 ea. 100W CLASS A POWER AMP KIT



Dynamic Bias Class "A" circuit design makes this unit unique in its class. Crystal clear, 100 watts power output will satisfy the most picky fans. A perfect combination with the TA-1020 low TIM stereo pre-amp.
Specifications • Output power 100W RMS into 8Ω, 125W RMS into 4Ω • Frequency response 10Hz-100KHz • THD less than 0.01% • S/N ratio better than 80dB • Input sensitivity 1V max • Power supply ±40V at 5A.

LOW TIM DC STEREO PRE-AMP KIT TA-1020
Incorporates brand-new DC design that gives a frequency response from 0-100KHz ±0.5dB. Added features like tone defeat and loudness control let you tailor your own frequency supplies to eliminate power fluctuations!
Specifications: • THD/TIM less than .005% • Frequency response DC to 100KHz ±0.5dB • RIAA deviation ±0.2dB • S/N ratio better than 70dB • Sensitivity: Phone 2mV 47KΩ, Aux 100mV 100KΩ • Output level 1.3V • Max output 15V • Tone controls: Bass ±10dB @ 50Hz, Treble ±10dB @ 15Hz • Power supply ±24VDC @ 0.5A. Kit comes with regulated power supply. All you need is a 48VCT transformer @ 0.5A.

Only \$44.50 Transformer \$4.50 ea.



pinecom™

Pioneer of Low Cost Apple* Compatible Computer



Now with New Improved Keyboard and 64K RAM

No Copyright Problems!

Compare These Features with Our Competitors:

- Powerful Utility Program (100% Apple Compatible)
- 68-Key Upper & Lower Case Keyboard with Numeric Keypad
- 25 Pre-programmed Function Keys
- 2 Speed Auto Repeat Function
- 64K User Memory—expandable to 192K
- 5A Switching Power Supply (110/220VAC)
- All ICs Are Socketed for Easy Service
- Nation-wide Dealer Network for Convenient Technical Support

And best of all, the price Assembled and Tested is just.....

\$499⁰⁰



★ SPECIAL ★ Excellent Price!
Model 001-0034 \$29.50 per Kit
Transformer \$10.50 ea.

TA-322 30 WATTS TOTAL 15W + 15W STEREO AMP KIT
This is a solid state all transistor circuitry with on board stereo pre-amp for most microphone or phone input. Power output employs a heavy duty Power Hybrid IC. Four built on board controls for volume, balance, treble and bass. Power supply requires 48VCT 2.5A transformer. THD of less than 0.1% between 100Hz-10KHz at full power (15 Watts + 15 Watts loaded into 8Ω).

MAGNETIC HEAD EQUALIZER
• Standard RIAA curve for all kinds of magnetic heads • 3 stages crossover circuit for best results • Output voltage guaranteed to be stable without any oscillation • Power Supply: 24 V.D.C.



MODEL: MA-142
Part #370-370 \$6.95 ea.

PROFESSIONAL REGULATED VARIABLE DC POWER SUPPLY KIT
All solid state circuitry with high efficiency power transistor 2SD388 and IC voltage regulator MC1733. Output voltage can be adjusted from 0-30V at 1A current limited or 0-15V at 2A current limited. Internal resistance is less than 0.005Ω, ripple and noise less than 1mV, dual on panel meters for voltage and current reading, also with on board LED and audible over load indicator. Kit comes with pre-drilled PC Board, instructions, all necessary electronic components, transformer and a professional looking metal cabinet. The best project for school and the most useful instrument for repairmen. Build one today!



Model TR88A 0-15VDC @ 2A
Model TR88B 0-30VDC @ 1A
\$59.50 per Kit

60W + 60W O.T.L. AMP
Stereo pre-amp + tone control + power amp. All in one unit, fully assembled! Compact in size: 7"x4"x2 1/2". Can be fitted into most cabinets. Power transistors using 25C1667 X 4 to give a max output of 60W + 60W (8Ω)
• Frequency response: 20Hz-85KHz (-1dB) • Total harmonic distortion: 0.02% (1KHz) • Signal/Noise Ratio: 88 dB (open loop) • Tone control: 100 Hz ±16 dB 10 KHz ±14dB • Dynamic range: 60 dB • Power Supply: 48V-70V 5 Amp • Filter Capacitor: 4700µF 75V or better.

MODEL: SA-4520



Part #370-0350 \$39.95 ea.
1 Transformer Part #670-0230 \$22.50 ea.
2 Filter Capacitor 4700µF 70V \$6.50 ea.

STEREO MIC. AND ECHO MIXER FOR STEREO AMPLIFIER SYSTEM
The circuitry employs all integrated circuits, BBD type echo circuit, echo time can be adjusted (max. 30 Msec.) Also with a microphone preamp on the board. Fully assembled.



MODEL: MX205
Part #370-0360 \$29.95 ea.

LOW T.I.M. TRANSISTORS 100W + 100W
• Employs Hitachi low noise I.C. for pre-amp • Max. output 16 V P-P (non distortion) • With hi-low filter, and tone defeat circuit • Rear power amp with short circuit protection • Giant heat sink for maximum results • Tone controls: 14dB • All components (except pots for volume, and tone controls) are pre-assembled, the quality is guaranteed. • Power supply DC ±35V-50V



MODEL: SA802C
Part #370-0340 \$85.00
POWER TRANSFORMER (68V-80V CT 6 AMP)
Part #670-0220 \$24.50

SEND ONE DOLLAR FOR OUR DETAIL CATALOG

Shipping & Handling Charges	
Under \$50.00	Over \$50.00
Purchase 10%	Purchase 5%
15%	10%
25%	20%

Minimum Order \$10.00/Calif. Residents add 6.5% Sales Tax. Phone Orders Accepted on VISA or MC ONLY. NO C.O.D.'s. Prices subject to change without notice.



STORE HOURS
MON-FRI-10-7
SAT-10-6

*Apple and Apple II are the trademark of APPLE COMPUTERS, INC.

EDUCATION & INSTRUCTION

EARN your university degree through evaluation assessment, of existing education, experience, achievements. Call, (614) 863-1791, or write, **ASSESSMENT**, Box 13130R, Columbus, OH 43213.

FCC general radiotelephone license. Home study. Fast, inexpensive! Free details. **COMMAND**, D-91, Box 2223, San Francisco, CA 94126.

UNIVERSITY degrees by mail! Bachelors, Masters, Ph.D.s... Free revealing details. **COUNSELING**, Box 317-RE4, Tustin, CA 92680.

LEARN computer math easily! Binary, Octal, Boolean, Logic. Simple non-technical "Self-Study" guidebook. Proven. \$9.95 postpaid. **COMPUTER TRAINING**, 107 I.C.B. Building, Sausalito, CA 94965.



LEARN SMALL COMPUTER REPAIR

Train at home in spare time. No previous experience needed. Experts show you what to do, how to do it! Even beginners can learn how to repair small computers. Everything explained in easy-to-understand language. You learn by doing with tools and materials included in your course. Easy home-study plan shows how you can get in on ground floor of this fast-growing business. Send for free facts. No obligation. No salesmen will call.

ICS
SINCE 1891
School of Computer Repair, Dept. DE034
Scranton, Pennsylvania 18515

Yes! I want to get into small computer repair. Rush me free facts and color brochure.

Name _____ Age _____
Address _____
City/State/Zip _____

TS1000/ZX81 SOFTWARE

MORSE code translator—reads and generates Morse code (2K)cass. \$9.95. **Talking TS1000**—software only, pronounces hex bytes from memory. (16K)cass. \$9.95. **TS1000 music box**—compose music. (16K)cass. \$9.95. **THOMSON SOFTWARE**, Box 1266, Lombard, IL 60148.

UHF, CABLE TV UNITS

BRAND new, Deluxe gated-pulsewave UHF unit. Finally video and audio to TV. Easy instructions, no more messy coil tuning or winding. Prebuilt tuner and IF. \$169.95 the "Raider." Also Zenith UHF Super Z kit in stock \$179.95. Scorpion UHF, 25 dB preamp kit, written up in Radio Electronics. Put a sting in those faraway UHF stations \$22.95. Full line of cable units, mini-codes, starbases, filters. Add 3% shipping, MD residents 5% tax. Information, COD orders call (301) 882-9362. Send \$2.00 for complete catalog to **SATELLITE ELECTRONICS CORP.**, PO 9534, Baltimore, MD 21237.

LASERS

LASERS: complete units \$150.00. Ruby rods from \$25.00. Laser surplus parts best prices anywhere. **MEREDITH INSTRUMENTS**, 6517 West Eva, Glendale, AZ 85302.

WRITE FOR
McGEE'S
SPEAKER & ELECTRONICS CATALOG
1001 BARGAINS IN SPEAKERS
Tel.: 1 (816) 842 5092
1901 MCGEE STREET KANSAS CITY, MO. 64108

WANTED

WANTED: old Western Electric & RCA tubes, speakers, amps, McIntosh, Marantz, tube amps, old Thorens, JBL, Altec, Garrard. (713) 728-4343. **MAURY CORB**, 11122 Atwell, Houston, TX 77096.

INVENTIONS, ideas, new products wanted for presentation to industry and exhibition at national technology exposition. Call **1-800-528-6050**. Arizona 1-800-352-0458. X831.

HALLICRAFTERS S-40, S-52, S-77. Any condition. Paying \$20.00-\$40.00 each. **FALA ELECTRONICS**, Box 04134-2, Milwaukee, WI 53204.

TI-99/4A SOFTWARE

TI-99/4A owners. Get your free catalog of new, exciting, low cost software. **DYNA**, Box 690, Hicksville, NY 11801.

SCANNERS

SCANNERS—discount prices Bearcat BC-100 \$279.99; Bearcat 210XL \$214.99; Bearcat 300 \$335.99; Regency MX3000 \$186.99; JIL SX100 \$138.99; JIL SX200 \$269.99; Bearcat 20/20 \$275.99; Spectrum radar detector \$214.99; plus \$3.00 shipping. Free discount catalog. Lowest prices anywhere on scanners, radar detectors, marine radios, two-way accessories. **SCANNER WORLD**, 10-RE New Scotland, Albany, NY 12208 (518) 436-9606.

SUPERIOR UHF PREAMP KIT

MOST advanced UHF preamp kit ever to be offered! Unit will drastically improve picture quality of all UHF-TV stations and even find stations you never thought existed. Great for generating that extra gain decoders need for maximum stability. Kit includes all parts, power supply, enclosure and instructions for only \$29.95. Free postage/handling for prepaid orders. COD's \$1.75, catalog \$2.00. **HOWARD RESEARCH AND DESIGN**, PO Box 204, Ellicott City, MD 21043 (301) 465-8116.

CABLE TV

DEALERS wanted: Channel 2, 3, and 4 notch filters. Money back guarantee. Send \$15.00 for sample and quantity price list. Specify channel(s). **LEE KURTZ**, PO Box 291394, Davie, FL 33329.

MICRO-PROFESSOR
MPF-1 USER'S AND EXPERIMENTAL MANUAL

Dear Electronic Enthusiast:
Now... Let the Micro-Professor usher you into the microcomputer revolution.
The Micro-Professor™ is the first really low-cost learning system designed for personal use. It will truly become your "Personal Computer".
Sincerely,
Chris Johnson, Customer Service

only \$12995

Z-80 BASED

MICROCOMPUTER

A superb learning tool for students, instructors, hobbyists.

Nothing else needed. Just plug in and start learning! Complete experimenters manual, easy instructions. 18 experiments. Fully expandable for Z80-CTC, Z80-PIO, EPROM, Breadboarding and prototyping. Invest with confidence. Now only \$129.95, two for only \$239.95. 2KB BASIC interpreter now available, only \$19.00. Full money back guarantee!

Plus-FREE GIFT
 Check this box for FREE Z-80 Microprocessor Programming and Interfacing textbook when you order within 7 days. \$12.95 value.

ETRONIX
Dept. RE-034
14803 N.E. 40th
Redmond, WA 98052

For immediate action call TOLL FREE:
1-800-426-1044

NAME _____
ADDRESS _____
CITY _____ ST _____ ZIP _____
 VISA MSTRCD EXP _____
ACCT. NO. _____

CIRCLE 39 ON FREE INFORMATION CARD

PREVENT HI-TECH HEADACHES

Our Isolators eliminate equipment interaction, clean up interference, curb damaging power line spikes and lightning bursts.

ISO-1 Isolator
3 isolated sockets; quality spike suppression; basic protection. . . \$76.95

ISO-3 Super-Isolator
3 dual isolated sockets; suppressor; commercial protection. 115.95

ISO-17 Magnum Isolator
4 quad isolated sockets; suppressor; laboratory grade protection. . . 200.95

ESP® Electronic Specialists, Inc.
171 S. Main St., Box 389, Natick, MA 01760
Toll Free Order Desk 1-800-225-4876
MasterCard, VISA, American Express

CIRCLE 6 ON FREE INFORMATION CARD

THE BEST PLACE to BUY, SELL or TRADE NEW and USED EQUIPMENT

NUTS & VOLTS MAGAZINE
BOX 1111-E • PLACENTIA, CA 92670
(714) 632-7721

Join Thousands of Readers Nationwide Every Month

ONE YEAR U.S. SUBSCRIPTIONS
\$7.00 - 3rd Class • \$12.50 - 1st Class

\$25.00 - Lifetime - 3rd Class

NUTS & VOLTS
HAM GEAR
COMPUTERS
SOFTWARE
SCANNERS • OPTICS
TEST EQUIPMENT
MICROWAVE
SATELLITE
AUDIO VISUAL
NEW PRODUCTS
COMPONENTS • KITS
ANTIQUE ELECT.
PUBLICATIONS
PLANS • SERVICES

7 FREE tip sizes with Deluxe desoldering/resoldering iron

Endeco's finest model 510, dual temperature 20/40w iron with switch & handle safety light plus 7 FREE desoldering tip sizes. Ideal for all your desoldering jobs. Save big. Only \$37.87 postpaid. Send check, M.O., Visa or MC number with exp. date to: Enterprise Development Corp., 5127 E. 65th Street, Indianapolis, IN 46220 or phone (317) 251-1232.

REVERBERATION FOR ORGANS

Solid state with controls for reverberation and room size.

EVERY ORGAN SHOULD OWN ONE. Send for free flyer—
DEVTRONIX ORGANS, INC.
6101 WAREHOUSE WAY
SACRAMENTO, CALIFORNIA 95826 Dept. B

Which would YOU buy?

Global Specialties QT-59S Socket

- 590 Tie Points
- 8-I.C. Capacity
- No Grid Labeling
- Horizontal Expansion only
- Screw-Down Mounting



\$12.50

HANDY HB-1000 Socket

- 640 Tie Points
- 9-I.C. Capacity
- Alphanumeric Grid Labeling
- Both Horizontal and Vertical Expansion
- Self-Adhesive Mounting



\$9.95

If you have two similar products, both designed for the same function... and one offers you MORE features for LESS money... which would YOU buy? The answer is obvious!

Just look at all these EXTRAS built into every HANDY test socket and buss strip...

- **Total contact labeling...** simplifies circuit design/layout
- **Self-adhesive backing...** for one-step simplified alignment and mounting
- **Full 9 14-Pin I.C. Capacity**
- **Expands both horizontally and vertically...** interlocks can't break or twist off
- **High temperature plastic housing...** to 80°C...no warping or melting ever!
- **Prices always up to 25% less than other leading brands**

To all these add: Long Life, low resistance and wide range contacts that accept combinations of resistors, capacitors, diodes, transistors, I.C.s, etc. with leads from .012 - .032" or 20 - 29 AWG. Clear, easy-to-read-and-identify contact markings simplify layout, wiring and documentation. Socket rows are labeled 1-to-64, and columns are marked A-to-E and F-to-J. Mating buss strip rows are labeled

A-to-D and consist of 25 contacts each. Bold red and blue lines show where contact strips begin and end.

Finally, we have a full line of breadboarding equipment, from discrete sockets and buss strips to multi-board assemblies, available at comparable lower-than-low prices.

Let's face it. If you get all this... and the prices are ALWAYS to 25% less... there's no doubt which you'll buy. HANDY. It's our name...and it tells you what we do.

What are you waiting for? Order your HANDY breadboarding products today. A toll-free call is all it takes!

Here's how to order...

HANDY Sockets and Buss Strips

Part Number	Socket Strips	Buss Strips	Ground Plate	Tie Points	14 pin IC's	Price
HB-0100	N/A	1	no	100	N/A	2.25
HB-1000	1	N/A	no	640	9	9.95
HB-1110	1	1	yes	740	9	11.95
HB-1210	1	2	yes	840	9	13.95

HANDY Breadboard Assemblies

Part Number	Socket Strips	Buss Strips	Binding Posts	Tie Points	14 pin IC's	Price
HB-2112	2	1	2	1380	18	25.95
HB-2312	2	3	2	1980	18	31.00
HB-3514	3	5	4	2420	27	47.95
HB-4714	4	7	4	3260	36	63.95

Mail Orders: Please add \$3 (Canada & Int'l add \$5) to cover cost of shipping/handling. **Sorry! No C.O.D. orders.**
Charge Cards: (Min. \$15). Please include Acct. No., Exp. Date, Bank No. (M/C only) and your signature.
Checks: Drawn in U.S. Dollars on U.S. banks only. **Connecticut Residents:** Add 7% Sales Tax.



To order... call **(203) 488-6603 Collect**
 ...charge with VISA, MasterCard or American Express.
 All items off-the-shelf for Immediate Shipment!

a division of RSP Electronics Corp.

7 Business Park Drive • P.O. Box 699 • Branford, CT 06405 • (203) 488-6603 • TWX: (910) 997-0684
 U.S. and Canadian Distributor inquiries welcomed.

CIRCLE 55 ON FREE INFORMATION CARD

DIGI-KEY 800-346-5144

IN MN., AK., HI. CALL 218-681-6674

QUALITY - Name brand products from nationally recognized manufacturers. **SAVINGS** - Computerized order processing and inventory control. **Service** - Volume Discounts • OEM Quantity Pricing • Toll Free 800 Number

THE DIGI-KEY Difference - Buy From Us, Buy From Us, Buy From Us. **THE DIGI-KEY Difference** - Buy From Us, Buy From Us, Buy From Us.

INTEGRATED CIRCUITS

Part No.	Manufacturer	Part No.	Manufacturer	Part No.	Manufacturer	Part No.	Manufacturer
7400 TTL	7400 TTL	7400 TTL	7400 TTL	4000 CMOS	4000 CMOS	4000 CMOS	4000 CMOS
7400N	7400N	7400N	7400N	4000B	4000B	4000B	4000B
7401N	7401N	7401N	7401N	4001B	4001B	4001B	4001B
7402N	7402N	7402N	7402N	4002B	4002B	4002B	4002B
7403N	7403N	7403N	7403N	4003B	4003B	4003B	4003B
7404N	7404N	7404N	7404N	4004B	4004B	4004B	4004B
7405N	7405N	7405N	7405N	4005B	4005B	4005B	4005B
7406N	7406N	7406N	7406N	4006B	4006B	4006B	4006B
7407N	7407N	7407N	7407N	4007B	4007B	4007B	4007B
7408N	7408N	7408N	7408N	4008B	4008B	4008B	4008B
7409N	7409N	7409N	7409N	4009B	4009B	4009B	4009B
7410N	7410N	7410N	7410N	4010B	4010B	4010B	4010B
7411N	7411N	7411N	7411N	4011B	4011B	4011B	4011B
7412N	7412N	7412N	7412N	4012B	4012B	4012B	4012B
7413N	7413N	7413N	7413N	4013B	4013B	4013B	4013B
7414N	7414N	7414N	7414N	4014B	4014B	4014B	4014B
7415N	7415N	7415N	7415N	4015B	4015B	4015B	4015B
7416N	7416N	7416N	7416N	4016B	4016B	4016B	4016B
7417N	7417N	7417N	7417N	4017B	4017B	4017B	4017B
7418N	7418N	7418N	7418N	4018B	4018B	4018B	4018B
7419N	7419N	7419N	7419N	4019B	4019B	4019B	4019B
7420N	7420N	7420N	7420N	4020B	4020B	4020B	4020B
7421N	7421N	7421N	7421N	4021B	4021B	4021B	4021B
7422N	7422N	7422N	7422N	4022B	4022B	4022B	4022B
7423N	7423N	7423N	7423N	4023B	4023B	4023B	4023B
7424N	7424N	7424N	7424N	4024B	4024B	4024B	4024B
7425N	7425N	7425N	7425N	4025B	4025B	4025B	4025B
7426N	7426N	7426N	7426N	4026B	4026B	4026B	4026B
7427N	7427N	7427N	7427N	4027B	4027B	4027B	4027B
7428N	7428N	7428N	7428N	4028B	4028B	4028B	4028B
7429N	7429N	7429N	7429N	4029B	4029B	4029B	4029B
7430N	7430N	7430N	7430N	4030B	4030B	4030B	4030B
7431N	7431N	7431N	7431N	4031B	4031B	4031B	4031B
7432N	7432N	7432N	7432N	4032B	4032B	4032B	4032B
7433N	7433N	7433N	7433N	4033B	4033B	4033B	4033B
7434N	7434N	7434N	7434N	4034B	4034B	4034B	4034B
7435N	7435N	7435N	7435N	4035B	4035B	4035B	4035B
7436N	7436N	7436N	7436N	4036B	4036B	4036B	4036B
7437N	7437N	7437N	7437N	4037B	4037B	4037B	4037B
7438N	7438N	7438N	7438N	4038B	4038B	4038B	4038B
7439N	7439N	7439N	7439N	4039B	4039B	4039B	4039B
7440N	7440N	7440N	7440N	4040B	4040B	4040B	4040B
7441N	7441N	7441N	7441N	4041B	4041B	4041B	4041B
7442N	7442N	7442N	7442N	4042B	4042B	4042B	4042B
7443N	7443N	7443N	7443N	4043B	4043B	4043B	4043B
7444N	7444N	7444N	7444N	4044B	4044B	4044B	4044B
7445N	7445N	7445N	7445N	4045B	4045B	4045B	4045B
7446N	7446N	7446N	7446N	4046B	4046B	4046B	4046B
7447N	7447N	7447N	7447N	4047B	4047B	4047B	4047B
7448N	7448N	7448N	7448N	4048B	4048B	4048B	4048B
7449N	7449N	7449N	7449N	4049B	4049B	4049B	4049B
7450N	7450N	7450N	7450N	4050B	4050B	4050B	4050B
7451N	7451N	7451N	7451N	4051B	4051B	4051B	4051B
7452N	7452N	7452N	7452N	4052B	4052B	4052B	4052B
7453N	7453N	7453N	7453N	4053B	4053B	4053B	4053B
7454N	7454N	7454N	7454N	4054B	4054B	4054B	4054B
7455N	7455N	7455N	7455N	4055B	4055B	4055B	4055B
7456N	7456N	7456N	7456N	4056B	4056B	4056B	4056B
7457N	7457N	7457N	7457N	4057B	4057B	4057B	4057B
7458N	7458N	7458N	7458N	4058B	4058B	4058B	4058B
7459N	7459N	7459N	7459N	4059B	4059B	4059B	4059B
7460N	7460N	7460N	7460N	4060B	4060B	4060B	4060B
7461N	7461N	7461N	7461N	4061B	4061B	4061B	4061B
7462N	7462N	7462N	7462N	4062B	4062B	4062B	4062B
7463N	7463N	7463N	7463N	4063B	4063B	4063B	4063B
7464N	7464N	7464N	7464N	4064B	4064B	4064B	4064B
7465N	7465N	7465N	7465N	4065B	4065B	4065B	4065B
7466N	7466N	7466N	7466N	4066B	4066B	4066B	4066B
7467N	7467N	7467N	7467N	4067B	4067B	4067B	4067B
7468N	7468N	7468N	7468N	4068B	4068B	4068B	4068B
7469N	7469N	7469N	7469N	4069B	4069B	4069B	4069B
7470N	7470N	7470N	7470N	4070B	4070B	4070B	4070B
7471N	7471N	7471N	7471N	4071B	4071B	4071B	4071B
7472N	7472N	7472N	7472N	4072B	4072B	4072B	4072B
7473N	7473N	7473N	7473N	4073B	4073B	4073B	4073B
7474N	7474N	7474N	7474N	4074B	4074B	4074B	4074B
7475N	7475N	7475N	7475N	4075B	4075B	4075B	4075B
7476N	7476N	7476N	7476N	4076B	4076B	4076B	4076B
7477N	7477N	7477N	7477N	4077B	4077B	4077B	4077B
7478N	7478N	7478N	7478N	4078B	4078B	4078B	4078B
7479N	7479N	7479N	7479N	4079B	4079B	4079B	4079B
7480N	7480N	7480N	7480N	4080B	4080B	4080B	4080B
7481N	7481N	7481N	7481N	4081B	4081B	4081B	4081B
7482N	7482N	7482N	7482N	4082B	4082B	4082B	4082B
7483N	7483N	7483N	7483N	4083B	4083B	4083B	4083B
7484N	7484N	7484N	7484N	4084B	4084B	4084B	4084B
7485N	7485N	7485N	7485N	4085B	4085B	4085B	4085B
7486N	7486N	7486N	7486N	4086B	4086B	4086B	4086B
7487N	7487N	7487N	7487N	4087B	4087B	4087B	4087B
7488N	7488N	7488N	7488N	4088B	4088B	4088B	4088B
7489N	7489N	7489N	7489N	4089B	4089B	4089B	4089B
7490N	7490N	7490N	7490N	4090B	4090B	4090B	4090B
7491N	7491N	7491N	7491N	4091B	4091B	4091B	4091B
7492N	7492N	7492N	7492N	4092B	4092B	4092B	4092B
7493N	7493N	7493N	7493N	4093B	4093B	4093B	4093B
7494N	7494N	7494N	7494N	4094B	4094B	4094B	4094B
7495N	7495N	7495N	7495N	4095B	4095B	4095B	4095B
7496N	7496N	7496N	7496N	4096B	4096B	4096B	4096B
7497N	7497N	7497N	7497N	4097B	4097B	4097B	4097B
7498N	7498N	7498N	7498N	4098B	4098B	4098B	4098B
7499N	7499N	7499N	7499N	4099B	4099B	4099B	4099B
7500N	7500N	7500N	7500N	4100B	4100B	4100B	4100B

TEXAS INSTRUMENTS I.C. SOCKETS

Body - 54 VVO Insulator with Copper Alloy contacts. Accommodates standard ICs up to 0.40" thick and 0.60" wide. Contains a design feature for the inclusion of a ground lead. "Easy" IC lead insertion, allowing for low insertion and high retention force. Socket is constructed from a high strength plastic. Socket is available in standard and low profile versions.

SOLDER TAIL DIP SOCKETS

• Single beam
• Low profile
• YOUR CHOICE: TIN OR GOLD
• 20, 28, 36, 44, 52, 60, 68, 76, 84, 92, 100, 108, 116, 124, 132, 140, 148, 156, 164, 172, 180, 188, 196, 204, 212, 220, 228, 236, 244, 252, 260, 268, 276, 284, 292, 300, 308, 316, 324, 332, 340, 348, 356, 364, 372, 380, 388, 396, 404, 412, 420, 428, 436, 444, 452, 460, 468, 476, 484, 492, 500, 508, 516, 524, 532, 540, 548, 556, 564, 572, 580, 588, 596, 604, 612, 620, 628, 636, 644, 652, 660, 668, 676, 684, 692, 700, 708, 716, 724, 732, 740, 748, 756, 764, 772, 780, 788, 796, 804, 812, 820, 828, 836, 844, 852, 860, 868, 876, 884, 892, 900, 908, 916, 924, 932, 940, 948, 956, 964, 972, 980, 988, 996, 1004, 1012, 1020, 1028, 1036, 1044, 1052, 1060, 1068, 1076, 1084, 1092, 1100, 1108, 1116, 1124, 1132, 1140, 1148, 1156, 1164, 1172, 1180, 1188, 1196, 1204, 1212, 1220, 1228, 1236, 1244, 1252, 1260, 1268, 1276, 1284, 1292, 1300, 1308, 1316, 1324, 1332, 1340, 1348, 1356, 1364, 1372, 1380, 1388, 1396, 1404, 1412, 1420, 1428, 1436, 1444, 1452, 1460, 1468, 1476, 1484, 1492, 1500, 1508, 1516, 1524, 1532, 1540, 1548, 1556, 1564, 1572, 1580, 1588, 1596, 1604, 1612, 1620, 1628, 1636, 1644, 1652, 1660, 1668, 1676, 1684, 1692, 1700, 1708, 1716, 1724, 1732, 1740, 1748, 1756, 1764, 1772, 1780, 1788, 1796, 1804, 1812, 1820, 1828, 1836, 1844, 1852, 1860, 1868, 1876, 1884, 1892, 1900, 1908, 1916, 1924, 1932, 1940, 1948, 1956, 1964, 1972, 1980, 1988, 1996, 2004, 2012, 2020, 2028, 2036, 2044, 2052, 2060, 2068, 2076, 2084, 2092, 2100, 2108, 2116, 2124, 2132, 2140, 2148, 2156, 2164, 2172, 2180, 2188, 2196, 2204, 2212, 2220, 2228, 2236, 2244, 2252, 2260, 2268, 2276, 2284, 2292, 2300, 2308, 2316, 2324, 2332, 2340, 2348, 2356, 2364, 2372, 2380, 2388, 2396, 2404, 2412, 2420, 2428, 2436, 2444, 2452, 2460, 2468, 2476, 2484, 2492, 2500, 2508, 2516, 2524, 2532, 2540, 2548, 2556, 2564, 2572, 2580, 2588, 2596, 2604, 2612, 2620, 2628, 2636, 2644, 2652, 2660, 2668, 2676, 2684, 2692, 2700, 2708, 2716, 2724, 2732, 2740, 2748, 2756, 2764, 2772, 2780, 2788, 2796, 2804, 2812,

Bargains !!!

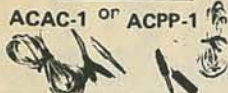

10 ft. audio extension cable. \$ 1.50

JAVANCO

YOUR PARTS SUPERMARKET

5011 12th Ave. South
Nashville, TN 37203

72 ECKA-72 Mini-axial Kit \$ 6.85
PCS. PER. KIT

ECKR-72 Mini-lytic Kit
PC Leads \$ 6.85

Calculator keyboard switch \$2.25

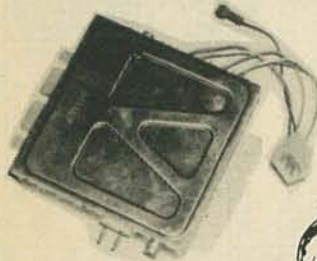

UVE1-A Mitsumi UHF/VHF combo



SPECIALS!!!

SPK-1,000 PIEZO TWEETER \$6.75 each or \$4.65 with \$15 order! FLAT RADIATING PIEZO \$3.35. This quality speaker is easily installed without crossover.

ECK-251 \$9.35 assorted miniature electrolytics, all good useable values, in a plastic bag. 251 PCS.

1000 long lead resistors, 1/2 and 1/4 watt assortment \$ 6.75



Out-of-state orders over \$15 call Toll Free 1-800-251-5555
Tennessee residents and information requests call 1-800-JAVANCO

JAVANCO

YOUR PARTS SUPERMARKET

5011 12th Ave. South
Nashville, TN 37203



FPK-7 \$5.75
7 assorted sizes
FP twist-lok can
filter capacitors



6 ea. of 6 assorted useable mylar capacitors with PC leads in a reuseable plastic box.

THE ULTIMATE SPEAKER

ADD210 SQ8 \$12.50 ea. 2/\$22.50
Philips 8 ohm mid-range full power speaker

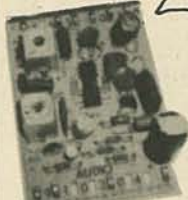

9-103-04 \$6.75
Zenith audio module

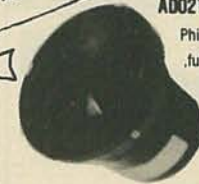

If'n yer not satisfied, we'll get ya full credit within 30 days



ADA-1001 \$1.25
60 M.A.

6 volt DC wall transformer in reuseable plastic container 7 ft. cord with 1/8" pin plug.



ECK-50 \$3.75
50 assorted PC and axial lead electrolytics

Fuse Kit 90 \$9.75

Bargains !!!
90 assorted fuses(5 each of 18 types)
3 AG & 5x20 mm sizes in good useable amperes

Call toll free 1-800-251-5555 (TN. 1-800-JAVANCO)
\$15.00 minimum order plus \$2.75 shipping and handling(\$4.75 shipping on COD orders)
Tennessee residents add 6.75% tax Visa and Mastercharge accepted.

CIRCLE 42 ON FREE INFORMATION CARD

TECHNICIANS & SERVICEMEN
COMPONENTS FOR YOUR MAINTENANCE & REPAIR WORK
SPECIAL: OUR LOW LOW PRICES
REPLACEMENT FOR ECG® TYPES

TYPE NO.	YOUR COST	TYPE NO.	YOUR COST
85	FOUR for .99	125	SEVEN for .99
102A	THREE for .99	159AP	FOUR for .99
123A	FIVE for .99	177	EIGHT for .99
123AP	SIX for .99	199	FIVE for .99

SUPER SPECIAL (MIN. 5 PC. EACH)

TYPE NO.	YOUR COST	TYPE NO.	YOUR COST	TYPE NO.	YOUR COST
124	.85	165	2.25	375	.90
128	.45	171	.65	506	.55
129	.45	184	.45	500A	8.95
130	.80	185	.45	523	9.95
152	.40	238	2.25	526A	10.20
153	.40	276	6.95	529	13.75
154	.60	291	.95	712	1.25

JAPANESE TYPES (MIN. 5 PC. EACH)

TYPE NO.	YOUR COST	TYPE NO.	YOUR COST	TYPE NO.	YOUR COST
2SC867A	2.75	HA1366W	1.85	STK0029	3.80
2SC1114	3.25	HA1377A	2.90	STK0080	9.99
2SC1308K	1.95	LA4102	1.25	TA7205AP	1.50
AN214Q	1.45	M51515BL	2.95	TA7208P	1.85
AN239A	4.60	STK433	3.95	TA7222AP	1.95
BA532	1.80	STK435	3.95	UPC1181H	1.25
GH3F	.89	STK437	6.25	UPC1182H	1.25
HA1342A	2.30	STK439	6.50	UPC1185H	2.99

COD ORDERS WELCOME (\$25 MIN. ORDER)
For Complete Component Catalog Call or Write
DIGITRON ELECTRONIC
110 HILLSIDE AVENUE, SPRINGFIELD, N. J. 07081
Toll Free: 800-526-4928 In NJ: 201-379-9016
*ECG IS A TRADE MARK OF PHILIPS ECG.
DIGITRON ELECTRONIC IS NOT ASSOCIATED IN ANY WAY WITH PHILIPS ECG.

Active Electronics
NUMBER ONE IN
QUALITY
SERVICE
AVAILABILITY
THE WORLD'S MOST
COMPLETE PROFESSIONAL
AND HOME ELECTRONICS
ENTHUSIAST INVENTORY

- Semiconductors + Memories
- Microprocessors + Support Circuits
- Microcomputer Systems + Peripherals
- Passive Electronic Components
- Hand Tools, Wire Wrapping, Soldering Equipment + Hardware

NOW AVAILABLE — FREE
1983 80-page catalog
A complete listing of products and specifications

Call, write or circle the inquiry card for your free copy today.

P.O. Box 8000, Westboro, Mass. 01581
CALL TOLL FREE: 1-800-343-0874
Mass customers call (617) 366-0500
CIRCLE 3 ON FREE INFORMATION CARD

TOLL FREE ORDERS • 1-800-826-5432
(IN CALIFORNIA: 1-800-258-6666)
INFORMATION • (213) 380-8000

SOLID STATE RELAYS
2 AMP
MOTOROLA
#MP 12002
RATED:
CONTROL—3-6 VDC
LOAD—120VAC 2 AMPS
T.T.L. COMPATIBLE
SIZE: 1 1/4" x 1/2" x 1" HIGH
\$3.50 EACH 10 FOR \$32.00

13 VDC RELAY
CONTACT: S.P.N.C.
10 AMP @ 120 VAC
ENERGIZE COIL TO
OPEN CONTACT
COIL: 13 VDC 650 OHMS
SPECIAL PRICE \$1.00 EACH

10 AMP
TELEDYNE P/N 615-1
CONTROL:
3-32 VDC
LOAD: 10 AMP
140 VAC
\$9.50 EACH

KEY ASSEMBLY
5 KEY
\$1.00 EACH
CONTAINS 5 SINGLE-POLE
NORMALLY OPEN SWITCHES
MEASURES 3 3/4" LONG

6 KEY
\$1.25 EACH
CONTAINS 6 SINGLE-POLE
NORMALLY OPEN SWITCHES
MEASURES 4 1/4" LONG

EDGE CONNECTORS

22/44 22/44 GOLD PLATED CONTACTS
156 CONTACT SPACING
\$2.00 EACH 10 FOR \$18.00

28/56 28/56 GOLD PLATED CONTACTS
156 CONTACT SPACING
\$2.50 EACH 10 FOR \$22.00

50/100 MICRO PLASTIC
#MP-0125-50-DS-1
STANDARD S-100 CONNECTOR
125 SPACING, GOLD PLATED
P.C. MOUNT
\$3.75 EACH 10 FOR \$35.00

SUB-MINIATURE D TYPE CONNECTOR

SOLDER TYPE SUB-MINIATURE CONNECTORS USED FOR COMPUTER HOOK UPS.

DB-15 PLUG \$2.75
DB-15 SOCKET \$4.00
DB-15 HOOD \$1.50
DB-25 PLUG \$2.75
DB-25 SOCKET \$3.50
DB-25 HOOD \$1.25

MULTI-SWITCHES
5 STATION INTERLOCKING
3-2PDT AND 2-6PDT SWITCHES ON FULLY INTERLOCKING ASSEMBLY. 3/4" BETWEEN MOUNTING CENTERS. **\$2.50 EACH**
5 STATION NON-INTERLOCKING
SAME AS ABOVE, EXCEPT EACH SWITCH OPERATES INDEPENDENTLY. **\$2.50 EACH**

FREE! SEND FOR NEW LARGER 48 PAGE CATALOG

COMPUTER GRADE CAPACITORS

1700 mfd. 150 VDC \$2.00
2 1/2" DIA. x 4 3/4" HIGH
3,600 mfd. 40VDC \$1.00
1 3/8" DIA. x 3" HIGH
6,400 mfd. 60 VDC \$2.50
1 3/8" DIA. x 4 1/4" HIGH

22,000 mfd. 15 VDC
2" DIA. x 2 1/2" HIGH **\$2.00**
22,000 mfd. 40 VDC
2" DIA. x 6" HIGH **\$3.00**
24,000 mfd. 30 VDC
1 3/4" DIA. x 4" HIGH **\$3.50**
31,000 mfd. 15 VDC
1 3/4" DIA. x 4" HIGH **\$2.50**
72,000 mfd. 15 VDC
2" DIA. x 4" HIGH **\$3.50**
180,000 mfd. at 6V
2 1/2" DIA. x 4 1/2" HIGH **\$1.50**

CLAMPS TO FIT CAPACITORS 50¢ ea.

POWER SUPPLY
REGULATED FULLY ADJUSTABLE 5 VDC AT 3 AMPS
\$18.50 EACH

BCD DIP SWITCH
10 POSITION ROTARY SCREWDRIVER ADJUST. FITS 6 PIN DIP
\$1.85 EACH

WALL TRANSFORMER
ALL ARE 115 VAC PLUG IN

4 VDC at 70 MA \$2.50
9 VDC at 225 MA \$3.00
16.5 VAC at 10 VA \$3.50
17 VAC at 500 MA \$4.00

MINIATURE TOGGLE SWITCHES
ALL ARE RATED 5 AMPS @ 125 VAC

S.P.D.T. (on-on)
P.C. STYLE NON-THREADED BUSHING
75¢ EACH 10 FOR \$7.00

S.P.D.T. (on-on)
SOLDER LUG TERMINALS
\$1.00 EACH 10 FOR \$9.00 100 FOR \$80.00

S.P.D.T. (on-off-on)
SOLDER LUG TERMINALS
\$1.00 EACH 10 FOR \$9.00 100 FOR \$80.00

S.P.D.T. (on-off-on)
NON-THREADED BUSHING
P.C. STYLE
75¢ EACH 10 FOR \$7.00

S.P.D.T. (on-on)
P.C. LUGS, THREADED BUSHING
\$1.00 EACH 10 FOR \$9.00 100 FOR \$80.00

D.P.D.T. (on-on)
SOLDER LUG TERMINALS
\$2.00 EACH 10 FOR \$19.00 100 FOR \$180.00

ALL ELECTRONICS CORP.

905 S. VERMONT • P.O. BOX 20406 • LOS ANGELES, CA 90006

QUANTITIES LIMITED • FOREIGN ORDERS
MINIMUM ORDER \$10.00 • INCLUDE SUFFICIENT SHIPPING
USA \$2.50 SHIPPING • CALIF RES ADD 6.12%

FOR YOUR SOCKETS SWITCHES KNOBS & IDC PRODUCTS

...CHOOSE **AUGAT**



VISIT US AT EDS LAS VEGAS APRIL 25, 26, 27 BOOTHS R10, 12

Hundreds of styles are now available to you through your local Electronics Store. For the store closest to you please contact our Sales Representatives or contact us directly.

'the Single Source' for Sockets, Interconnection Products, IDC Products, Switches, Lamps, Knobs and much more.

AUGAT PACKAGED PRODUCTS

P.O. Box 659, 40 Perry Avenue
Attleboro, MA 02703 (617) 222-2202/Ext. 2272

AUGAT Manufacturers of Quality Electronic Products for over 50 Years



REPRESENTATIVES

KEENE SALES CO., INC.
*156 Broad St., Lynn, MA 01901
(617) 595-2300
321 Prospect St.
E. Longmeadow, MA 01028
(413) 785-1158

STEVE FISHER SALES CORP.
221 DeGraw Ave.
Teaneck, NJ 07666
(201) 837-1200
LEONARD D. ALLEN, INC.
19 Eastern Ave.
Syracuse, NY 13211
(315) 437-8387

AUSTIN ASSOCIATES
*50 Windsor Ln.
Willingboro, NJ 08046
(609) 871-9290

2527 Quebec School Rd.
Middletown, MD 21769
(301) 371-9390

MANDABACH-LEHNER CO.
*155 South Hamilton Rd.
Columbus, OH 43213
(614) 235-0265

1221 Temple Trail
Stow, OH 44224
(216) 686-1965

WALLACE ELECTRONIC SALES
*127 Armfield St.,
Kernersville, NC 27284
(800) 672-4290

8571 Kennesaw Ct.,
Jonesboro, GA 30236
(800) 334-3518
401 Chase Lane,
Norcross, GA 30093
(800) 334-3518

SEACOM SALES CO., INC.
*3500 N. State Rd. #7
Lauderdale Lakes, FL 33319
(305) 486-0260

4602 El Prado Blvd.
Tampa, FL 33629
(813) 837-0055

ROBERT MILSK CO., INC.
*24240 Telegraph Rd.
Southfield, MI 48037
(313) 354-3310

4321 East 82nd St.
Indianapolis, IN 46250
(317) 842-3400

ELECTRONIC SPECIALISTS, INC.
*381 North York Rd.
Elmhurst, IL 60126
(312) 941-0710

11080 West Forest Home Ave.
Hales Corners, WI 53130
(414) 529-2653

BOB GUNN & ASSOCIATES
*3201 Skylane Dr.
Carrollton, TX 75006
(214) 733-1222

5560-B NW 72nd St.
Oklahoma City, OK 73132
(405) 721-9400

2437 Taffy Dr., Kenner LA 70065
(504) 443-5072

8610 Lamppost Ln.
Houston TX 77064
(713) 466-8673

5934 Spring Valley
San Antonio, TX 78247
(512) 655-1041

MORE SALES, INC.
3625 North 16th St.
Phoenix, AZ 85016
(602) 265-9201

FEATHERSTONE SALES CO.
28817 Granada Dr.
Hayward, CA 94544
(415) 785-1926

LESSING ASSOCIATES
*24325 San Fernando Rd.
Newhall, CA 91321
(213) 348-6662

1677 James Dr.
Carlsbad, CA 92008
(619) 434-6913 *Main Office

APRIL 1984

4164

64K DYNAMIC
200 NS

\$595

TMM2016

2KX8 STATIC
200 NS

\$415

STATIC RAMS

2101	256 x 4 (450ns)	1.95
5101	256 x 4 (450ns) (cmos)	3.95
2102-1	1024 x 1 (450ns)	.89
2102L-4	1024 x 1 (450ns) (LP)	.99
2102L-2	1024 x 1 (250ns) (LP)	1.49
2111	256 x 4 (450ns)	2.49
2112	256 x 4 (450ns)	2.99
2114	1024 x 4 (450ns)	8/9.95
2114-25	1024 x 4 (250ns)	8/10.95
2114L-4	1024 x 4 (450ns) (LP)	8/12.95
2114L-3	1024 x 4 (300ns) (LP)	8/13.45
2114L-2	1024 x 4 (200ns) (LP)	8/13.95
TC5514	1024 x 4 (650ns) (cmos)	2.49
TC5516	2048 x 8 (250ns) (cmos)	9.95
2147	4096 x 1 (55ns)	4.95
TMS4044-4	4096 x 1 (450ns)	3.49
TMS4044-3	4096 x 1 (300ns)	3.99
TMS4044-2	4096 x 1 (200ns)	4.49
MK4118	1024 x 8 (250ns)	9.95
TMM2016-200	2048 x 8 (200ns)	4.15
TMM2016-150	2048 x 8 (150ns)	4.95
TMM2016-100	2048 x 8 (100ns)	6.15
HM6116-4	2048 x 8 (200ns) (cmos)	4.75
HM6116-3	2048 x 8 (150ns) (cmos)	4.95
HM6116-2	2048 x 8 (120ns) (cmos)	8.95
HM6116LP-4	2048 x 8 (200ns) (cmos)(LP)	5.95
HM6116LP-3	2048 x 8 (150ns) (cmos)(LP)	6.95
HM6116LP-2	2048 x 8 (120ns) (cmos)(LP)	10.95
Z-6132	4096 x 8 (300ns) (Qstat)	34.95
HM6264	8192 x 8 (150ns) (cmos)	49.95

LP = Low Power Qstat = Quasi-Static

EPROMS

1702	256 x 8 (1us)	4.50
2708	1024 x 8 (450ns)	3.95
2758	1024 x 8 (450ns) (5v)	5.95
2716	2048 x 8 (450ns) (5v)	3.95
2716-1	2048 x 8 (350ns) (5v)	5.95
TMS2516	2048 x 8 (450ns) (5v)	5.50
TMS2716	2048 x 8 (450ns)	7.95
TMS2532	4096 x 8 (450ns) (5v)	5.95
2732	4096 x 8 (450ns) (5v)	4.95
2732-250	4096 x 8 (250ns) (5v)	8.95
2732-200	4096 x 8 (200ns) (5v)	11.95
2732A-4	4096 x 8 (450ns) (5v) (21vPGM)	6.95
2732A	4096 x 8 (250ns) (5v) (21vPGM)	9.95
2732A-2	4096 x 8 (200ns) (5v) (21vPGM)	13.95
2764	8192 x 8 (450ns) (5v)	6.95
2764-250	8192 x 8 (250ns) (5v)	7.95
2764-200	8192 x 8 (200ns) (5v)	19.95
TMS2564	8192 x 8 (450ns) (5v)	14.95
MCM68764	8192 x 8 (450ns) (5v) (24 pin)	39.95
MCM68766	8192 x 8 (350ns) (5v) (24 pin)(pwr dr.)	42.95
27128	16384 x 8 (300ns) (5v)	29.95

5v = Single 5 Volt Supply 21vPGM = Program at 21 Volts

CRYSTALS

32.768 khz	1.95
1.0 mhz	3.95
1.8432	3.95
2.0	2.95
2.097152	2.95
2.4576	2.95
3.2768	2.95
3.579545	2.95
4.0	2.95
5.0	2.95
5.0688	2.95
5.185	2.95
5.7143	2.95
6.0	2.95
6.144	2.95
6.5536	2.95
8.0	2.95
10.0	2.95
10.738635	2.95
14.31818	2.95
15.0	2.95
16.0	2.95
17.430	2.95
18.0	2.95
18.432	2.95
20.0	2.95
22.1184	2.95
32.0	2.95

CMOS

4000	.29	4528	1.19
4001	.25	4531	.95
4002	.25	4532	1.95
4006	.89	4538	1.95
4007	.29	4539	1.95
4008	.95	4541	2.64
4009	.39	4543	1.19
4010	.45	4553	5.79
4011	.25	4555	.95
4012	.25	4556	.95
4013	.38	4581	1.95
4014	.79	4582	1.95
4015	.39	4584	.75
4016	.39	4585	.75
4017	.69	4702	12.95
4018	.79	74C00	.35
4019	.39	74C02	.35
4020	.75	74C04	.35
4021	.79	74C08	.35
4022	.79	74C10	.35
4023	.29	74C14	.59
4024	.65	74C20	.35
4025	.29	74C30	.35
4026	1.65	74C32	.39
4027	.45	74C42	1.29
4028	.69	74C48	1.99
4029	.79	74C73	.65
4030	.39	74C74	.65
4034	1.95	74C76	.80
4035	.85	74C83	1.95
4040	.75	74C85	1.95
4041	.75	74C86	.39
4042	.69	74C89	4.50
4043	.85	74C90	1.19
4044	.79	74C93	1.75
4046	.85	74C95	.99
4047	.95	74C107	.89
4049	.35	74C150	5.75
4050	.35	74C151	2.25
4051	.79	74C154	3.25
4053	.79	74C157	1.75
4702	12.95	74C160	1.19
COM5016	16.95	74C161	1.19
COM8116	10.95	74C162	1.19
MMS307	10.95	74C163	1.19
4070	.35	74C164	1.39
4071	.29	74C165	2.00
4072	.29	74C173	.79
4073	.29	74C174	1.19
4075	.29	74C175	1.19
4076	.79	74C192	1.49
4078	.29	74C193	1.49
4081	.29	74C195	1.39
4082	.29	74C200	5.75
4085	.95	74C221	1.75
4086	.95	74C244	2.25
4093	.49	74C373	2.45
3341	4.95	74C374	2.45
MC3470	4.95	74C901	.39
MC3480	9.00	14409	12.95
11C90	13.95	14410	12.95
95H90	7.95	14411	11.95
2513-001 UP	9.95	14412	12.95
2513-002 LOW	9.95	14419	7.95
14433	14.95	74C908	2.00
4502	.95	74C909	2.75
4503	.65	74C910	9.95
4508	1.95	74C911	8.95
4510	.85	74C912	8.95
4511	.85	74C914	1.95
4512	.85	74C915	1.19
4514	1.25	74C918	2.75
4515	1.79	74C920	17.95
4516	1.55	74C921	15.95
4518	.89	74C922	4.49
4519	.39	74C923	4.95
4520	.79	74C925	5.95
4522	1.25	74C926	7.95
4526	1.25	74C928	7.95
4527	1.95	74C929	19.95

UARTS

AY3-1014	6.95
AY5-1013	3.95
AY3-1015	6.95
PT1472	9.95
TR1602	3.95
2350	9.95
2651	8.95
IM6402	7.95
IM6403	8.95
INS8250	10.95

GENERATORS

MC14411	11.95
BR1941	11.95
4702	12.95
COM5016	16.95
COM8116	10.95
MMS307	10.95
FUNCTION	
MC4024	3.95
LM566	1.49
XR2206	3.75
8038	3.95

MISC.

UPD7201	29.95
TMS99532	29.95
ULN2003	2.49
3242	7.95
3341	4.95
MC3470	4.95
MC3480	9.00
11C90	13.95
95H90	7.95
2513-001 UP	9.95
2513-002 LOW	9.95

CLOCK

MM5314	4.95
MM5369	3.95
MM5375	4.95
MM58167	12.95
MM58174	11.95
MSM5832	3.95

KEYBOARD

AYS-2376	11.95
AYS-3600	11.95
AYS-3600 PRO	11.95

DYNAMIC RAMS

TMS4027	4096 x 1 (250ns)	1.99
UPD411	4096 x 1 (300ns)	3.00
MMS280	4096 x 1 (300ns)	3.00
MK4108	8192 x 1 (200ns)	1.95
MMS298	8192 x 1 (250ns)	1.85
4116-300	16384 x 1 (300ns)	8/11.75
4116-250	16384 x 1 (250ns)	8/7.95
4116-200	16384 x 1 (200ns)	8/12.95
4116-150	16384 x 1 (150ns)	8/14.95
4116-120	16384 x 1 (120ns)	8/29.95
2118	16384 x 1 (150ns) (5v)	4.95
MK4332	32768 x 1 (200ns)	9.95
4164-200	65536 x 1 (200ns) (5v)	5.95
4164-150	65536 x 1 (150ns) (5v)	6.95
MCM6665	65536 x 1 (200ns) (5v)	8.95
TMS4164-15	65536 x 1 (150ns) (5v)	8.95

5V = single 5 volt supply

EPROM ERASERS

SPECTRONICS CORPORATION

	Timer	Capacity Chip	Intensity (uW/Cm ²)	
PE-14		9	8,000	83.00
PE-14T	X	9	8,000	119.00
PE-24T	X	12	9,600	175.00
PL-265T	X	30	9,600	255.00
PR-125T	X	25	17,000	349.00
PR-320T	X	42	17,000	595.00

- * Computer managed inventory — virtually no back orders!
- * Very competitive prices!
- * Friendly staff!
- * Fast service — most orders shipped within 24 hours!

6800

68000	49.95
6800	2.95
6802	7.95
6803	19.95
6808	13.90
6809E	14.95
6809	11.95
6810	2.95
6820	4.35
6821	2.95
6828	14.95
6840	12.95
6843	34.95
6844	25.95
6845	14.95
6847	11.95
6850	3.25
6852	5.75
6850	7.95
6875	6.95
6880	2.25
6883	22.95
68047	24.95
68488	19.95

6800 = 1MHZ

68B00	10.95
68B02	22.25
68B09E	29.95
68B09	29.95
68B10	6.95
68B21	6.95
68B40	19.95
68B45	19.95
68B50	5.95
68B00 = 2 MHZ	

6500

6502	4.95
6504	6.95
6505	8.95
6507	9.95
6520	4.35
6522	6.95
6532	9.95
6545	22.50
6551	11.85
2 MHZ	
6502A	6.95
6522A	9.95
6532A	11.95
6545A	27.95
6551A	11.95
3 MHZ	
6502B	9.95

DISC CONTROLLERS

1771	16.95
1791	24.95
1793	26.95
1795	29.95
1797	29.95
2791	54.95
2793	54.95
2795	59.95
2797	59.95
6843	34.95
6845	34.95
8272	39.95
UPD765	39.95
MB8876	29.95
MB8877	34.95
1691	17.95
2143	18.95

8000

8035	5.95
8039	5.95
INS-8060	17.95
INS-8073	49.95
8080	3.95
8085	4.95
8085A-2	11.95
8086	24.95
8087	29.95
8088	29.95
8089	89.95
8155	6.95
8155-2	7.95
8156	6.95
8185	29.95
8185-2	39.95
8741	29.95
8748	24.95
8755	24.95

CRT

6845	14.95
68B45	19.95
HD46505SP	15.95
6847	11.95

2114

450 NS

8/\$995

2114

250 NS

8/\$1095

74LS00

74LS00	.24	74LS173	.69
74LS01	.25	74LS174	.55
74LS02	.25	74LS175	.55
74LS03	.25	74LS181	2.15
74LS04	.24	74LS189	8.95
74LS05	.25	74LS190	.89
74LS08	.28	74LS191	.89
74LS09	.29	74LS192	.79
74LS10	.25	74LS193	.79
74LS11	.35	74LS194	.69
74LS12	.35	74LS195	.69
74LS13	.45	74LS196	.79
74LS14	.59	74LS197	.79
74LS15	.35	74LS221	.89
74LS20	.25	74LS240	.95
74LS21	.29	74LS241	.99
74LS22	.25	74LS242	.99
74LS26	.29	74LS243	.99
74LS27	.29	74LS244	1.29
74LS28	.35	74LS245	1.49
74LS30	.25	74LS247	.75
74LS32	.29	74LS248	.99
74LS33	.55	74LS249	.99
74LS37	.35	74LS251	.59
74LS38	.35	74LS253	.59
74LS40	.25	74LS257	.59
74LS42	.49	74LS258	.59
74LS47	.75	74LS259	2.75
74LS48	.75	74LS260	.59
74LS49	.75	74LS266	.55
74LS51	.25	74LS273	1.49
74LS54	.29	74LS275	3.35
74LS55	.29	74LS279	.49
74LS63	1.25	74LS280	1.98
74LS73	.39	74LS283	.69
74LS74	.35	74LS290	.89
74LS75	.39	74LS293	.89
74LS76	.39	74LS295	.99
74LS78	.49	74LS298	.89
74LS83	.60	74LS329	1.75
74LS85	.69	74LS323	3.50
74LS86	.39	74LS324	1.75
74LS90	.55	74LS352	1.29
74LS91	.89	74LS353	1.29
74LS92	.55	74LS363	1.35
74LS93	.55	74LS364	1.95
74LS95	.75	74LS365	.49
74LS96	.89	74LS366	.49
74LS107	.39	74LS367	.45
74LS109	.39	74LS368	.45
74LS112	.39	74LS373	1.39
74LS113	.39	74LS374	1.39
74LS114	.39	74LS375	.95
74LS122	.45	74LS377	1.39
74LS123	.79	74LS378	1.18
74LS124	2.90	74LS379	1.35
74LS125	.49	74LS385	3.90
74LS126	.49	74LS386	.45
74LS132	.59	74LS390	1.19
74LS133	.59	74LS393	1.19
74LS136	.39	74LS395	1.19
74LS137	.99	74LS399	1.49
74LS138	.55	74LS424	2.95
74LS139	.55	74LS447	.95
74LS145	1.20	74LS490	1.95
74LS147	2.49	74LS624	3.99
74LS148	1.35	74LS640	2.20
74LS151	.55	74LS645	2.20
74LS153	.55	74LS668	1.69
74LS154	1.90	74LS669	1.89
74LS155	.69	74LS670	1.49
74LS156	.69	74LS674	14.95
74LS157	.65	74LS682	3.20
74LS158	.59	74LS683	3.20
74LS160	.69	74LS684	3.20
74LS161	.65	74LS685	3.20
74LS162	.69	74LS688	2.40
74LS163	.65	74LS689	3.20
74LS164	.69	81LS95	1.49
74LS165	.95	81LS96	1.49
74LS166	1.95	81LS97	1.49
74LS168	1.75	81LS98	1.49
74LS169	1.75	25LS2521	2.80
74LS170	1.49	25LS2569	4.25

74S00

74S00	.32	74S132	1.24	74S225	7.95
74S02	.35	74S133	.45	74S240	2.20
74S03	.35	74S134	.50	74S241	2.20
74S04	.35	74S135	.89	74S244	2.20
74S05	.35	74S138	.85	74S251	.95
74S08	.35	74S139	.85	74S253	.95
74S09	.40	74S140	.55	74S257	.95
74S10	.35	74S151	.95	74S258	.95
74S11	.35	74S153	.95	74S260	.79
74S15	.35	74S157	.95	74S273	2.45
74S20	.35	74S158	.95	74S274	19.95
74S22	.35	74S161	1.95	74S275	19.95
74S30	.35	74S162	1.95	74S280	1.95
74S32	.40	74S163	1.95	74S287	1.90
74S37	.88	74S168	3.95	74S288	1.90
74S38	.85	74S169	3.95	74S289	6.89
74S40	.35	74S174	.95	74S301	6.95
74S51	.35	74S175	.95	74S373	2.45
74S64	.40	74S181	3.95	74S374	2.45
74S65	.40	74S182	2.95	74S381	7.95
74S74	.50	74S188	1.95	74S387	1.95
74S85	1.99	74S189	6.95	74S412	2.98
74S86	.50	74S194	1.49	74S471	4.95
74S112	.50	74S195	1.49	74S472	4.95
74S113	.50	74S196	1.49	74S474	4.95
74S114	.55	74S197	1.49	74S482	15.25
74S124	2.75	74S201	6.95	74S570	2.95
				74S571	2.95

VOLTAGE REGULATORS

7805T	.75	7905T	.85
78M05C	.35	7908T	.85
7808T	.75	7912T	.85
7812T	.75	7915T	.85
7815T	.75	7924T	.85
7824T	.75	7905K	1.49
		7912K	1.49
7805K	1.39	7915K	1.49
7812K	1.39	7924K	1.49
7815K	1.39	79L05	.79
7824K	1.39	79L12	.79
78L05	.69	79L15	.79
78L12	.69	LM323K	4.95
78L15	.69	UA78S40	1.95
78H05K	9.95		
78H12K	9.95		

C, T = TO-220 K = TO-3
L = TO-92

7400

7400	.19	74123	.49
7401	.19	74125	.45
7402	.19	74126	.45
7403	.19	74132	.45
7404	.19	74136	.50
7405	.25	74143	4.95
7406	.29	74145	.60
7407	.29	74147	1.75
7408	.24	74148	1.20
7409	.19	74150	1.35
7410	.19	74151	.55
7411	.25	74153	.55
7413	.35	74154	1.25
7414	.49	74155	.75
7416	.25	74157	.55
7417	.25	74159	1.65
7420	.19	74160	.85
7421	.35	74161	.69
7425	.29	74163	.69
7427	.29	74164	.85
7430	.19	74165	.85
7432	.29	74166	1.00
7437	.29	74167	2.95
7438	.29	74170	1.65
7442	.49	74173	.75
7445	.69	74174	.89
7446	.69	74175	.89
7447	.69	74177	.75
7448	.69	74181	2.25
7451	.23	74184	2.00
7473	.34	74185	2.00
7474	.33	74191	1.15
7475	.45	74192	.79
7476	.35	74193	.79
7482	.95	74194	.85
7483	.50	74195	.85
7485	.59	74197	.75
7486	.35	74198	1.35
7489	2.15	74221	1.35
7490	.35	74246	1.35
7492	.50	74247	1.25
7493	.35	74259	2.25
7495	.55	74273	1.95
7497	2.75	74276	1.25
74100	1.75	74279	.75
74107	.30	74366	.65
74109	.45	74367	.65
74116	1.55	74368	.65
74121	.29	74393	1.35
74122	.45		

DATA ACQUISITION

ADC0800	15.55	DAC0808	2.95
ADC0804	3.49	DAC1020	8.25
ADC0809	4.49	DAC1022	5.95
ADC0817	9.95	MC1408L6	1.95
DAC0800	4.95	MC1408L8	2.95

INTERFACE

8T26	1.59
8T28	1.89
8T95	.89
8T96	.89
8T97	.89
8T98	.89
DM8131	2.95
DP8304	2.29
DS8833	2.25
DS8835	1.99
DS8836	.99
DS8837	1.65
DS8838	1.30

CENTRONICS

IDCEN36	
Ribbon Cable 36 Pin Male	8.95
IDCEN36/F	
Ribbon Cable 36 Pin Female	8.95
CEN36	
Solder Cup 36 Pin Male	7.95



MICROCOMPUTER HARDWARE HANDBOOK FROM ELCOMP — \$14.95

Over 800 pages of manufacturers data sheets on most commonly used IC's.

Includes:

- * TTL — 74/74LS and 74F
- * CMOS
- * Voltage Regulators
- * Memory — RAM, ROM, EPROM
- * CPU's — 6800, 6500, Z80, 8080, 8085, 8086/8
- * MPU support & interface — 6800, 6500, Z80, 8200, etc.

FEDERAL EXPRESS SERVICES AVAILABLE!

CONNECTORS

RS232 Male	2.50
RS232 Female	3.25
RS232 Hood	1.25
S-100 ST	3.95

EXAR

XR 2206	3.75
XR 2207	3.75
XR 2208	3.75
XR 2211	5.25
XR 2240	3.25

INTERSIL

ICL7106	9.95
ICL7107	12.95
ICL7660	2.95
ICL8038	3.95
ICM7207A	5.59
ICM7208	15.95

9000

9316	1.00
9334	2.50
9368	3.95
9401	9.95
9601	.75
9602	1.50
96S02	1.95

LINEAR

LM301	.34	LM340 (see 7800)		LM565	.99	LM1558H	3.10
LM301H	.79	LM348	.99	LM566	1.49	LM1800	2.37
LM307	.45	LM350K	4.95	LM567	.89	LM1812	8.25
LM308	.69	LM350T	4.60	NE570	3.95	LM1830	3.50
LM308H	1.15	LM358	6.99	NE571	2.95	LM1871	5.49
LM309H	1.95	LM359	1.79	NE590	2.50	LM1872	5.49
LM309K	1.25	LM376	3.75	NE592	2.75	LM1877	3.25
LM310	1.75	LM377	1.95	LM709	.59	LM1889	1.95
LM311	.64	LM378	2.50	LM710	.75	LM1896	1.75
LM311H	.89	LM379	4.50	LM711	.79	ULN2003	2.49
LM312H	1.75	LM380	.89	LM723	.49	LM2877	2.05
LM317K	3.95	LM380N-8	1.10	LM723H	.55	LM2878	2.25
LM317T	1.19	LM381	1.60	LM733	.98	LM2900	.85
LM318	1.49	LM382	1.60	LM741	.35	LM2901	1.00
LM318H	1.59	LM383	1.95	LM741N-14	.35	LM3900	.59
LM319H	1.90	LM384	1.95	LM741H	.40	LM3905	1.25
LM319	1.25	LM386	.89	LM747	.69	LM3909	.98
LM320 (see 7900)		LM387	1.40	LM748	.59	LM3911	2.25
LM322	1.65	LM389	1.35	LM1014	1.19	LM3914	3.95
LM323K	4.95	LM390	1.95	LM1303	1.95	LM3915	3.95
LM324	.59	LM392	.69	LM1310	1.49	LM3916	3.95
LM329	.65	LM393	1.29	MC1330	1.69	MC4024	3.95
LM							

CABINETS FOR 5 1/4" DISK DRIVES

CABINET #1 \$29.95

- * DIMENSIONS 8 5/8 x 5 1/4 x 3 1/4"
- * COLOR MATCHES APPLE
- * FITS STANDARD 5 1/4" DRIVES, INCL. SHUGART
- * INCLUDES MOUNTING HARDWARE AND FEET

CABINET #2 \$79.00

- * COMPLETE WITH POWER SUPPLY, SWITCH, LINE CORD, FUSE & STANDARD POWER CONNECTOR
- * DIMENSIONS: 11 1/2 x 5 3/4 x 3 1/4"
- * +5V @ 1 AMP, +12V @ 1.5 AMP
- * FITS STANDARD 5 1/4" DRIVES
- * PLEASE SPECIFY GRAY OR TAN

NOTE: Please include sufficient amount for shipping on above items.

TRANSISTORS

2N918	.50	MPS3706	.15
MPS918	.25	2N3772	1.85
2N2102	.75	2N3903	.25
2N2218	.50	2N3904	.10
2N2218A	.50	2N3906	.10
2N2219	.50	2N4122	.25
2N2219A	.50	2N4123	.25
2N2222	.25	2N4249	.25
PN2222	.10	2N4304	.75
MPS2369	.25	2N4401	.25
2N2484	.25	2N4402	.25
2N2905	.50	2N4403	.25
2N2907	.25	2N4857	1.00
PN2907	.125	PN4916	.25
2N3055	.79	2N5086	.25
3055T	.69	PN5129	.25
2N3393	.30	PN5139	.25
2N3414	.25	2N5209	.25
2N3563	.40	2N6028	.35
2N3565	.40	2N6043	1.75
PN3565	.25	2N6045	1.75
MPS3638	.25	MPS-A05	.25
MPS3640	.25	MPS-A06	.25
PN3643	.25	MPS-A55	.25
PN3644	.25	TIP29	.65
MPS3704	.15	TIP31	.75
		TIP32	.79

DISK DRIVES TANDON

TM100-1 5 1/4" (FOR IBM) SS/DD 229.00
 TM100-2 5 1/4" (FOR IBM) DS/DD 259.00

SHUGART

SA 400L 5 1/4" (40 TRACK) SS/DD 199.95
 SA 400 5 1/4" (35 TRACK) SS/DD 189.95

PERTEC

FD-200 5 1/4" SS/DD 179.95
 FD-250 5 1/4" DS/DD 199.95

MPI

MP-52 5 1/4" (FOR IBM) DS/DD 249.00

NOTE: Please include sufficient amount for shipping on above items.

DIODES

1N751	5.1 volt zener	.25
1N759	12.0 volt zener	.25
1N4148	(1N914) switching	25/1.00
1N4004	400PIV rectifier	10/1.00
KBP02	200PIV 1.5amp bridge	.45
KBP04	400PIV 1.5amp bridge	.55
VM48	Dip-Bridge	.35

IC SOCKETS

8 pin ST	1-.99	100
14 pin ST	.13	.11
16 pin ST	.15	.12
18 pin ST	.17	.13
20 pin ST	.20	.18
22 pin ST	.29	.27
24 pin ST	.30	.27
28 pin ST	.40	.32
40 pin ST	.49	.39
64 pin ST	4.25	call
ST = SOLDER TAIL		
8 pin WW	.59	.49
14 pin WW	.69	.52
16 pin WW	.69	.58
18 pin WW	.99	.90
20 pin WW	1.09	.98
22 pin WW	1.39	1.28
24 pin WW	1.49	1.35
28 pin WW	1.69	1.49
40 pin WW	1.99	1.80
WW = WIREWRAP		
16 pin ZIF	5.95	call
24 pin ZIF	7.95	call
28 pin ZIF	8.95	call
ZIF = TEXT TOOL		
(Zero Insertion Force)		

NEW UN-USED MUFFIN FANS

4.68" Square 14.95
 3.125" Square 14.95

HEAT SINKS

TO-3 style .95
 TO-220 style .35

SWITCHES

SPDT mini-toggle 1.25
 DPDT mini-toggle 1.50
 SPST mini-pushbutton .39

OPTO-ISOLATORS

4N26	1.00	MCA-7	4.25
4N27	1.10	MCA-255	1.75
4N28	.69	IL-1	1.25
4N33	1.75	ILA-30	1.25
4N35	1.25	ILQ-74	2.75
4N37	1.25	H11C5	1.25
MCT-2	1.00	TIL-111	1.00
MCT-6	1.50	TIL-113	1.75

EDGE-CARD CONNECTORS

S-100 ST	3.95
S-100 WW	4.95
72 pin ST	6.95
72 pin WW	7.95
50 pin ST	4.95
44 pin ST	2.95
44 pin WW	4.95

RESISTORS

1/4 WATT 5% CARBON FILM ALL STANDARD VALUES FROM 1 OHM TO 10 MEG OHM
 50 PCS. SAME VALUE .025
 100 PCS. SAME VALUE .02
 1000 PCS. SAME VALUE .015

OUR BUYER BLEW IT... & BOUGHT TOO MANY OF THESE!

4116 250NS 8/7.95

RIBBON CABLE

CONTACTS	SINGLE COLOR		COLOR CODED	
	1'	10'	1'	10'
10	.50	4.40	.83	7.30
16	.55	4.80	1.00	8.80
20	.65	5.70	1.25	11.00
25	.75	6.60	1.32	11.60
26	.75	6.60	1.32	11.60
34	.98	8.60	1.65	14.50
40	1.32	11.60	1.92	16.80
50	1.38	12.10	2.50	22.00

D-SUBMINIATURE

DESCRIPTION	SOLDER CUP		RIGHT ANGLE PC SOLDER		IDC RIBBON CABLE		HOODS	
	MALE	FEMALE	MALE	FEMALE	MALE	FEMALE	BLACK HOOD-B	GREY HOOD
ORDER BY	DBxxP	DBxxS	DBxxPR	DBxxSR	IDBxxP	IDBxxS		
CONTACTS 9	2.08	2.66	1.65	2.18	3.37	3.69	---	1.60
15	2.69	3.63	2.20	3.03	4.70	5.13	---	1.60
25	2.50	3.25	3.00	4.42	6.23	6.84	1.25	1.25
37	4.80	7.11	4.83	6.19	9.22	10.08	---	2.95
50	6.06	9.24	---	---	---	---	---	3.50

For order instructions see "IDC Connectors" below.

MOUNTING HARDWARE 1.00

IDC CONNECTORS

DESCRIPTION	SOLDER HEADER	RIGHT ANGLE SOLDER HEADER	WW HEADER	RIGHT ANGLE WW HEADER	RIBBON HEADER SOCKET	RIBBON HEADER	RIBBON EDGE CARD
ORDER BY	IDHxxS	IDHxxSR	IDHxxW	IDHxxWR	IDSxx	IDMxx	IDExx
CONTACTS 10	.82	.85	1.86	2.05	1.15	---	2.25
20	1.29	1.35	2.98	3.28	1.86	5.50	2.36
26	1.68	1.76	3.84	4.22	2.43	6.25	2.65
34	2.20	2.31	4.50	4.45	3.15	7.00	3.25
40	2.58	2.72	5.28	4.80	3.73	7.50	3.80
50	3.24	3.39	6.63	7.30	4.65	8.50	4.74

ORDERING INSTRUCTIONS: Insert the number of contacts in the position marked "xx" of the "order by" part number listed. Example: A 10 pin right angle solder style header would be IDH10SR.

VISIT OUR RETAIL STORE

HOURS: M-W-F, 9-5 T-Th., 9-9 Sat. 10-3

PLEASE USE YOUR CUSTOMER NUMBER WHEN ORDERING

TERMS: Minimum order \$10. For shipping and handling include \$2.50 for UPS Ground and \$3.50 for UPS Air. Orders over 1 lb. and foreign orders may require additional shipping charges — please contact our sales department for the amount. CA residents must include 6% sales tax, Bay Area and LA residents include 6 1/2%. Prices subject to change without notice. We are not responsible for typographical errors. We reserve the right to limit quantities and to substitute manufacturer. All merchandise subject to prior sale.

© Copyright 1984 JDR Microdevices



1224 S. Bascom Avenue, San Jose, CA 95128
 800-538-5000 • 800-662-6279 (CA)
 (408) 995-5430 • Telex 171-110

FOR APPLE COMPUTER USERS

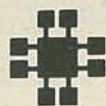

JDR Microdevices

THOUSANDS SOLD!

JDR 16K RAM CARD FOR APPLE II+

- ★ Expand your 48K Apple to 64K
 - ★ Fully compatible with Apple Language System — Use in place of Apple Language card
 - ★ Highest quality card features: gold edge connector, sockets for all IC's.
 - ★ 2 YEAR WARRANTY
- Kit with Instructions \$40.95 **\$44.95**
 Bare PC Card \$14.95

GET SLIM IN 1984! JDR HALF-HEIGHT DISK DRIVE

- ★ 35 Track if used with Apple Controller
- ★ 40 Track Controller and DOS Available (Call for Price)

\$209.95

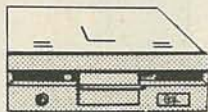

MA SYSTEMS FD-35 DISK DRIVE

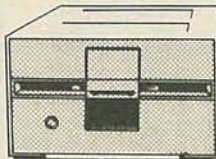

\$199.95

- ★ Shugart Mechanism — Made in U.S.A.
- ★ Direct Replacement for Apple Disk II
- ★ Compatible with Apple Controller or other Apple compatible controllers
- ★ Specially designed electronics with low power consumption
- ★ DOS 3.3 and 3.2 compatible
- ★ One Year Warranty

**CONTROLLER CARD
\$69.95**



APPLE COMPATIBLE POWER SUPPLY

- ★ Use To Power Apple-Type Systems
- ★ +5V @ 5A +12V @ 3A
- ★ -5V @ .5A -12V @ .5A
- ★ Instructions Included

\$79.95

BMC BMX-80 PRINTER

- ★ 80 CPS Dot Matrix Printer
- ★ Prints Bi-Directional in 40, 80, 71 or 142 Columns in Normal, Double Width or Compressed Text.
- ★ Print Superscript As Well As Superb Graphics in Character or Bit Image

\$279



micromax

VIEWMAX-80 NOW ONLY \$159.95

- ★ 80 Column Card for Apple II+
- ★ Video Soft Switch
- ★ Inverse Video
- ★ 2 Year Warranty

VIEWMAX-80e NEW \$129.95

- ★ 80 Column Card for Apple IIe
- ★ 64K RAM Expandable to 128K
- ★ 64K RAM Upgrade \$47.60

GRAPHMAX \$129.95

- ★ Hi Resolution Graphics
- ★ Printer Card
- ★ Centronics Parallel Interface

Graphmax with Color & Zoom Options... **\$149.95**

NASHUA DISKETTES

5 1/4" WITH HUB RING

MD1 SOFT SECTOR, SS/SD	19.95
MD1D SOFT SECTOR, SS/DD	26.25
MD2D SOFT SECTOR, DS/DD	30.75
MD2F SOFT SECTOR, DS/QUAD DENSITY	45.00
MD110 10 SECTOR HARD, SS/SD	19.95
MD210D 10 SECTOR HARD, DS/DD	30.75

8" WITHOUT HUB RING

FD1 SOFT SECTOR, SS/SD	24.75
FD1D SOFT SECTOR, SS/DD	30.00
FD2D SOFT SECTOR, DS/DD	36.75

OTHER ACCESSORIES FOR APPLE II

THUNDERCLOCK \$129.95

- ★ Real-Time Clock Calendar
- ★ Software Included
- ★ Mountain Software Compatible
- ★ BSR Control Options Available

KRAFT JOYSTICK \$39.95

VERBATIM DATALIFE DISKETTES

SS/DD SOFT SECTOR

\$29.95

SS/DD 10 HARD SECTOR

\$29.95

5 1/4" DISKETTE FILE

- ★ ATTRACTIVE, FUNCTIONAL DISK STORAGE SYSTEM
 - ★ 75 DISK STORAGE CAPACITY
 - ★ MOLDED FROM DURABLE SMOKED PLASTIC WITH FRONT CARRYING HANDLE
- \$16.99**

MONITORS

BMC MONITOR STAND
MODEL PA-900

Your Display Will
Tilt & Swivel **\$29.95**

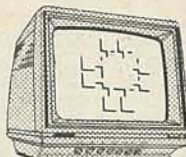

MONOCHROME

BMC BM 12AUW GREEN 12"	\$89.95
BMC BM 12EUY 18 MHZ AMBER	\$139.95
BMC BM 12EUN 18 MHZ HIGH RES GREEN	\$115.00
NEC JB1201M - 20 MHZ GREEN	\$169.00
ZENITH ZVM-121 - 15 MHZ GREEN	\$99.00

COLOR

BMC BM-AU9191U COMPOSITE 13" **\$279.00**

NO C.O.D. ORDERS PLEASE

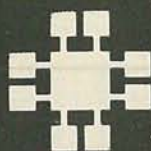

JDR Microdevices

1224 S. Bascom Avenue, San Jose, CA 95128
 800-538-5000 • 800-662-6279 (CA)
 (408) 995-5430 • Telex 171-110

Apple is a trademark of Apple Computer Corporation

VISIT OUR RETAIL STORE

HOURS: M-W-F, 9-5 T-Th., 9-9 Sat. 10-3

PLEASE USE YOUR CUSTOMER NUMBER WHEN ORDERING

TERMS: Minimum order \$10. For shipping and handling include \$2.50 for UPS Ground and \$3.50 for UPS Air. Orders over 1 lb. and foreign orders may require additional shipping charges — please contact our sales department for the amount. CA residents must include 6% sales tax, Bay Area and LA residents include 6.75%. Prices subject to change without notice. We are not responsible for typographical errors. We reserve the right to limit quantities and to substitute manufacturer. All merchandise subject to prior sale.

© Copyright 1984 JDR Microdevices

CIRCLE 49 ON FREE INFORMATION CARD

APRIL 1984

VOICE SYNTHESIZER FOR APPLE AND COMMODORE



NEW!
JE520AP
 • Over 250 word vocabulary - affixes allow the formation of more than 500 words • Built-in amplifier, speaker, volume control, and audio jack • Recreates a clear, natural male voice • Plug-in user ready with documentation and sample software • Case size: 7 1/4" x 3 1/4" x 1-3/8"

APPLICATIONS: • Security Warning • Telecommunication • Teaching • Handicap Aid • Instrumentation • Games

The JE520 VOICE SYNTHESIZER will plug right into your computer and allow you to enhance almost any application. Utilizing National Semiconductor's DIGITALKER™ Speech Processor IC (with four custom memory chips), the JE520 compresses natural speech into digital memory, including the original inflections and emphases. The result is an extremely clear, natural vocalization.

Part No.	Description	Price
JE520CM	For Commodore 64 & VIC-20	\$114.95
JE520AP	For Apple II, II+, and IIe	\$149.95

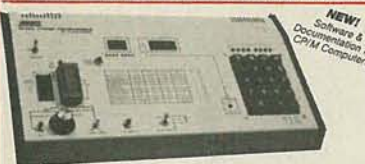

JE664 EPROM PROGRAMMER 8K to 64K EPROMS — 24 & 28 Pin Packages

NEW! Software & Documentation for IBM Computers
 Completely Self-Contained — Requires No Additional Systems for Operation
 • Programs and validates EPROMs • Checks for properly erased EPROMs • Emulates PROMs or EPROMs • RS232C Computer Interface for editing and program loading • Loads data into RAM by keyboard • Changes data in RAM by keyboard • Loads RAM from an EPROM • Compares EPROMs for content differences • Copies EPROMs • Power input: 115VAC, 60Hz, less than 10W power consumption • Enclosure: Color-coordinated, light tan panels with molded end pieces in mocha brown • Size: 15 1/2" x 8 3/4" x 3 1/4" • Weight: 5 1/2 lbs.

The JE664 EPROM Programmer emulates and programs various 8-Kilobyte EPROMs from 8K to 64K-bit memory capacity. Data can be entered into the JE664's internal 8K x 8-bit RAM in three ways: (1) from a ROM or EPROM; (2) from an external computer via the optional JE665 RS232C BUS; (3) from its panel keyboard. The JE664's RAMs may be accessed for emulation purposes from the panel's test socket to an external microprocessor. In programming and emulation, the JE664 allows for examination, change and validation of program content. The JE664's RAMs can be programmed quickly to all "1"s (or any value), allowing unneeded addresses in the EPROM to be programmed later without necessity of "UV" erasing. The JE664 displays DATA and ADDRESS in convenient hexadecimal (alphanumeric) format. A "DISPLAY EPROM DATA" button changes the DATA readout from RAM word to EPROM word and is displayed in both hexadecimal and binary code. The front panel features a convenient operating guide. The JE664 Programmer includes one JM16A Jumper Module (as listed below).

JE664-A EPROM Programmer \$995.00
 Assembled & Tested (Includes JM16A Module)

JE665 — RS232C INTERFACE OPTION — The RS232C interface option implements computer access to the JE664's RAM. This allows the computer to manipulate, store and transfer EPROM data to and from the JE664. A sample program listing is supplied in BASIC for CPM computers. Documentation is provided to adapt the software to other computers with an RS232C port, 9600 baud, 8-bit word, odd parity and 2 stop bits.

FOR A LIMITED TIME A SAMPLE OF SOFTWARE WRITTEN IN BASIC FOR THE TRS-80™ MODEL I LEVEL II COMPUTER WILL ALSO BE PROVIDED.

JE664-ARS EPROM Prog. w/ JE665 Option \$1195.00
 Assembled & Tested (Includes JM16A Module)

EPROM JUMPER MODULES — The JE664 JUMPER MODULE (Proprietary Module) is a plug-in module that pre-sets the JE664 for the proper programming pulses to the EPROM and configures the EPROM socket connections for that particular EPROM.

JE664 EPROM Jumper Kit No.	EPROM	Programming Voltage	EPROM MANUFACTURER	PRICE
JM001	2708	25V	Intel, Motorola, Nec, Intel, TI	\$14.95
JM16A	2716 (M27016 (T))	25V	Intel, Motorola, Nec, NEC, TI, AMD, Hitachi, Musaki	\$14.95
JM16B	TM2716 (G-V)	5V, +5V, +12V	Motorola, TI	\$14.95
JM23A	TM2832	25V	Motorola, TI, Hitachi, OKI	\$14.95
JM23B	2732	25V	AMD, Fujitsu, NEC, Hitachi, Intel, Mitsubishi, National	\$14.95
JM30C	2725A	21V	Fujitsu, Intel	\$14.95
JM41A	MC68014, MC68014A	21V	Motorola	\$14.95
JM40B	2741	21V	Intel, Fairchild, OKI	\$14.95
JM42C	TM2551	25V	TI	\$14.95

4-Digit Fluorescent Alarm Clock Kit



NEW!
 • Bright 4-digit 0.5" high display • 10 minute snooze alarm • AMP/PM indicator • Automatic display dimmer

The JE750 Clock Kit is a versatile 12-hour digital clock with 24-hour alarm. The clock has a bright 0.5" high blue-green fluorescent display. The display will automatically dim with changing light conditions. The 24-hour alarm allows the user to disable the alarm and immediately re-enable the alarm to activate 24 hours later. The kit includes all documentation, components, case and wall transformer. Size: 6 1/2" x 3 1/4" x 1 1/4" D.

JE750 Alarm Clock Kit \$29.95



13 1/2" L x 4 1/4" W x 3/4" H

Misumi 54-Key Unencoded Matrix All-Purpose Keyboard
 • SPST keyswitches • 20 pin ribbon cable connection • Low profile keys • Features: cursor controls, control, caps (lock) function, enter and shift keys • Color (keycaps): grey • Weight: 1 lb.
KB54 \$14.95



18" L x 7 1/2" W x 1 1/2" H

71-Key ASCII Cherry Keyboard
 • 7 bit parallel ASCII with strobe • 11 key numeric keypad • SPST mechanical keyswitches • 15/30 card-edge connector • Features: escape, control, cursor controls, plus ten additional function keys • Color: white • Weight: 2 lbs. • Spec. included
KB1801 \$29.95



21 7/8" L x 9 8/16" W x 3 1/8" H

106-Key 8-Bit Serial ASCII Keyboard
 • Numeric and cursor keypad • 10 user definable keys • 7 LED function displays • Security lock • N-key rollover • Uses Intel 8048/8748 • Color: white w/black panel • Documentation included • Weight: 6 1/2 lbs.
KB139 \$59.95



EMAS/6B

Power/Mate Corporation REGULATED POWER SUPPLY +5VDC @ 3 Amp / +6VDC @ 2.5 Amp
 • Input: 105-125/210-250VAC at 47-63 Hz • Output: 5VDC @ 3.0 Amps/6VDC @ 2.5 Amps • Line regulation: 0.05% • Load reg.: 0.1% • Open frame mounts on any one of 3 surfaces • Size: 4 1/2" L x 4" W x 2 1/4" H • Weight: 2 lbs.
EMAS/6B \$29.95



EMAS/6C

Power/Mate Corporation REGULATED POWER SUPPLY +5VDC @ 6 Amp / +6VDC @ 5 Amp
 • Input: 105-125/210-250VAC at 47-63 Hz • Output: 5V @ 6A/6V @ 5A • Line reg.: 0.05% • Load reg.: 0.1% • Open frame mounts on any one of three surfaces • Size: 5 1/2" L x 4 1/4" W x 2 1/4" H • Wt: 4 lbs.
EMAS/6C \$39.95



Part No. PS94VOS

POWER SUPPLY +5VDC @ 7.6 AMP 12VDC @ 1.5 AMP SWITCHING
 • Input: 115VAC, 50-60Hz @ 3 amp/230VAC, 50Hz @ 1.6 amp • Fan volt/ power supply select switches (115/230VAC) • Output: 5VDC @ 7.6 amp, 12VDC @ 1.5 amp • 8 foot black power cord • Size: 11 1/2" W x 13 1/2" D x 3 1/4" H • Weight: 6 lbs.
Part No. PS94VOS \$39.95



Part No. FCS-604A

POWER SUPPLY 4-Channel Switching
 Microprocessor, mini-computer, terminal, medical equipment and process control applications. Input: 90-130VAC 47-400Hz. Output: +5VDC @ 5A, -5VDC @ 1A, +12VDC @ 1A, -12VDC @ 1A. Line reg.: ±0.2%, Ripple: 30mV p-p. Load reg.: ±1%. Overcurrent protection. Adj. 5V main output 10A. 6-3/8" L x 1-7/8" W x 4-15/16" H. Wt. 1 1/2 lbs.
Part No. FCS-604A \$69.95 each



KHP4007

Switching Power Supply for APPLE II, II+ & IIe™
 • Can drive four floppy disk drives and up to eight expansion cards • Short circuit and overload protection • Fits inside Apple computer • Fully regulated +5V @ 5A, +12V @ 3A, -5V @ 5A, -12V @ 5A • Direct plug-in power cord included • Size: 9 1/2" L x 3 1/2" W x 2 1/4" H • Weight: 2 lbs.
KHP4007 \$79.95

DISKETTES AND ACCESSORIES

5 1/4" and 8" Diskettes

Part No.	Description	Based	PRICE
UM51401	5 1/4" 5500 Soft Sector with Hub Ring and Envelope	10	\$24.95
UM50098	5 1/4" 5500 Soft Sector with Hub Ring (Bulk)	100	169.95
UM52281	5 1/4" 5500 Soft Sector with Hub Ring and Envelope	10	22.95
UM50140	5 1/4" 5500 Soft Sector with Hub Ring (Bulk)	100	238.95
UM51801	5 1/4" 5500 Soft Sector with Envelope (RPT)	10	24.95
UM50214	5 1/4" 5500 Soft Sector with Envelope (RPT)	100	268.95
UM52081	5 1/4" 5500 Soft Sector with Envelope (RPT)	10	41.95
UM50217	5 1/4" 5500 Soft Sector 96TI (Bulk)	100	289.95
8" DISKETTES			
SK10	5 1/4" 5500 Soft Sector with Hub Ring and Envelope	10	20.95
SK10B	5 1/4" 5500 Soft Sector with Hub Ring (Bulk)	100	149.95
SK20	5 1/4" 5500 Soft Sector with Hub Ring and Envelope	10	26.95
SK20B	5 1/4" 5500 Soft Sector with Hub Ring (Bulk)	100	189.95
ULTRA MAGNETICS — 8" DISKETTES			
UM81728	8" 5500 IBM Compatible (128 Bits, 26 Sectors and Envelope)	10	34.95
UM80053	8" 5500 IBM Compatible (128 Bits, 26 Sectors Bulk)	100	239.95
UM80281	8" 5500 Soft Sector (Unformatted with Envelope)	10	49.95
UM80440	8" 5500 Soft Sector (Unformatted Bulk)	100	289.95

All quantities listed above are per sector. All have Hub Rings with the exception of the Quad Density and the 8" Series.

DISKETTE ACCESSORIES

Disk Minder
 • Attractive, functional disk storage system • 50 (8 1/2") or 75 (5 1/4") disk storage capacity • Easy filing and retrieving • Protects disk from dust contamination • Molds from durable smoked plastic with front carrying handle • Size: 7" W x 6 1/2" H x 9 1/2" D • Weight: 2 lbs.

Diskette Envelopes
 • Tear proof • Lockdown-resistant flap • Anti-static protect • Wear resistant
 Part No. Description Price
 MP5201 10 White 5 1/4" Envelopes 10 for \$ 1.49
 MP5201-100 100 White 5 1/4" Envelopes 100 for \$10.95
 MP5201 10 White 8" Envelopes 10 for \$ 1.95
 MP5201-100 100 White 8" Envelopes 100 for \$17.95

Vinyl Pages
 For 3-Ring Binders
 Protects disks from dirt, scratches, dust, spills and other contaminants. Reduces the risk of getting dirt near your disk drive head. Size: 8 1/2" x 11"

Part No. Description Price
 PC001 2 Pocket 5 1/4" Vinyl Page 10 for \$7.95
 PC001-2 4 Pocket 5 1/4" Vinyl Page 10 for \$8.95
 PC014 10 White 8" Vinyl Page 10 for \$7.95
 PC014-2 2 Pocket 8" Vinyl Page 10 for \$8.95

Mail Pak™
 • Holds up to 3 diskettes • Ideal for mailing and retail packaging • Dust proof and durable • Transparent allows easy identification

Part No. Description Price
 MP-05 Holds 3 ea. 5 1/4" Diskettes \$2.49 each
 MP-08 Holds 3 ea. 8" Diskettes \$3.95 each

\$10.00 Minimum Order — U.S. Funds Only
 California Residents Add 6 1/2% Sales Tax
 Shipping — Add 5% plus \$1.50 Insurance
 Send S.A.S.E. for Monthly Sales Flyer!

Spec Sheets — 30c each
 Send \$1.00 Postage for your
FREE 1984 JAMECO CATALOG
 Prices Subject to Change

MasterCard **Jameco ELECTRONICS** VISA

1355 SHOREWAY ROAD, BELMONT, CA 94002
 4/84 PHONE ORDERS WELCOME — (415) 592-8097 Telex: 176043

8" FLOPPY DISK DRIVE



• Single-Sided
 • 77 Tracks
 • 400/800K Bytes Capacity
 • Industry Standard

The FDD100-8 8" Floppy Disk Drive (Industry Standard) features single or double density. Recording mode: FM single, MFM double density. Transfer rate: 250K bits/sec. single density, 500K bits/sec. double density. The FDD100-8 is designed to work with the single-sided soft sector IBM Diskette II, or eq. disk cartridge. Power: 115VAC @ 50-60Hz, +24VDC @ 1.7 amp max., +5VDC @ 1.2 amp max. Unit as pictured above (does not include case, power supply, or cables). Size: 8.55" W x 14" L x 4.53" H. Weights: 12 lbs. Incl. 96-pg. manual.

FDD100-8 . . . \$169.95 ea.

5 1/4" APPLE™ Direct Plug-In Compatible Disk Drive

• Uses Shugart SA390 mechanics • 14K formatted storage • 25 track compatible with Apple controller • Complete with connector and cable — just plug into your disk controller card • Size: 6" L x 3 1/2" W x 8-7/16" D • Weight: 4 1/2 lbs.
Part No. ADD-514 \$195.95

5 1/4" TEAC DISK DRIVE Single-Sided Half-Height 5 1/4" Drive

• Single or double density • 48 TPI • 40 tracks • 6ms track to track • 5W power consumption • Brushless DC direct-drive motor • 160K Bytes formatted storage • One year warranty parts and labor

Double the work space with the TEAC 5 1/4" FLOPPY DISK DRIVE. Because the TEAC FD55A Drive is half the height of conventional drives, you can fit up to four TEAC drives in the same space where two conventional drives fit. Or, have room for two floppy disk drives and a hard disk drive. Includes operating manual. Requires: +5VDC @ 55A and +12VDC @ 3A. Size: 5 1/4" W x 1 1/4" H x 8" D. Wt: 3 lbs.
FD55A \$249.95

5 1/4" SHUGART DISK DRIVE Double-Sided Half-Height 5 1/4" Drive

• Single or double density • 48 TPI • 40 tracks • 409K Bytes formatted storage • 6ms track to track • Brushless DC direct-drive motor • One year warranty parts and labor • Media and interface compatible with the SA450 Backed by the industry's largest and most experienced engineering, sales and service organization, the SA455 is the smart solution for a wide range of desktop applications. Includes operating manual. Requires: +5VDC @ 7A and +12VDC @ 75A. Size: 5.88" W x 1.53" H x 8" D. Wt: 3.3 lbs.
SA455 \$259.95

5 1/4" PANASONIC DISK DRIVE Double-Sided Half-Height 5 1/4" DRIVE Shugart SA455 Equivalent

• Single or double density • 48 TPI • 40 tracks • 6ms track to track • 327K Bytes formatted storage • One year warranty parts and labor

The JA551 is perfect for word processors, personal and portable computers, small business computers and terminal add-ons. Includes operating manual. Requires: +5VDC @ 9A and +12VDC @ 1A. Size: 5.88" W x 1.63" H x 8" D. Wt: 3.3 lbs.
JA551-2 \$239.95

DISK DRIVE — CABLE — CUSTOM

We stock a wide variety of signal cables and 3 power cable kits to meet your disk drive requirements. We also customize cable assemblies for many other applications. Call for a price quote.

IBM MEMORY EXPANSION KIT COMPAQ COMPATIBILITY

SAVE HUNDREDS OF \$\$\$ BY UPGRADING MEMORY BOARDS YOURSELF!

Most of the popular memory boards allow you to add an additional 64K, 128K, 192K, or 256K. The IBM64K Kit will populate these boards in 64K bit increments. The kit is simple to install — just insert the nine 64K RAM chips in the provided sockets and set the two groups of switches. Directions are included.

IBM64K (Nine 200ns 64K RAMs) \$49.95

EXPAND YOUR MEMORY

TRS-80 to 16K, 32K, or 48K
 **Model 1 = From 4K to 16K Requires (1) One Kit
 Model 3 = From 4K to 48K Requires (3) Three Kits
 Color = From 4K to 16K Requires (1) One Kit
 **Model 1 equipped with Expansion Board up to 48K Two Kits Required
 — One Kit Required for each 16K of Expansion —

TRS-16K3 *200ns for Color & Model III \$12.95
 TRS-16K4 *250ns for Model I \$10.95

TRS-80 Color 32K or 64K Conversion Kit

Easy to install kits complete with 8 ea. 4164-2 (200ns) 64K dynamic RAMs and conversion documentation. Converts TRS-80 color computers with D, E, ET, F and NC circuit boards to 32K. Also converts TRS-80 color computer II to 64K. Flex DOS or OS-9 required to utilize full 64K RAM on all computers.
TRS-64K2 \$44.95

UV-EPROM Eraser

8 Chips — 51 Minutes

1 Chip — 37 Minutes

Erases 2708, 2716, 2732, 2764, 2516, 2532, 2564. Erases up to 8 chips within 51 minutes (1 chip in 37 minutes). Maintains constant exposure distance of one inch. Special conductive foam liner eliminates static build-up. Built-in safety lock to prevent UV exposure. Compact — only 9.00" x 3.70" x 2.60". Complete with holding tray for 8 chips.

DE-4 UV-EPROM Eraser . . . \$79.95
UVS-11EL Replacement Bulb . . \$16.95

AMERICAN RESEARCH & ENGINEERING K-40

WORLD'S SMALLEST DIP SWITCHES

Same Size as an I.C.!

Better Heat Convection

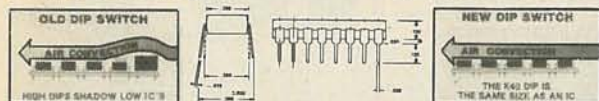

You Can Use Automatic Insertion Equipment

The 8-position programmable SPST K40 uses a bifurcated slide contact that allows two point contacts for each switch contact, doubling the contact reliability. The bifurcated contact travel of .026" eliminated many of the intermittent problems that plague dip switches.

The K40 shows excellent Electrical, Mechanical and Physical specifications.

1 THRU 8 POSITION DIP SWITCHES AVAILABLE

8 POSITION DIP SWITCHES	
1 ea. \$1.95	100 ea. \$1.30
10 ea. \$1.60	1000 ea. \$.95
Include \$2.50 For Shipping	

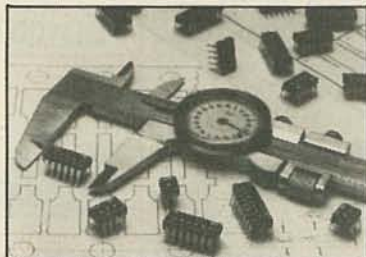

Call or Write For Quotes Over 1,000 Pieces.



STOCKING DISTRIBUTOR

KCS ELECTRONICS CORPORATION

SEMICONDUCTOR PARTS AND PRODUCTS

1043 N. STADEM DRIVE
TEMPE, ARIZONA 85281

(602) 967-6945

Call or Write for FREE

Semiconductor Parts & Products Catalog

CIRCLE 83 ON FREE INFORMATION CARD

MICROWAVE TV ANTENNA SYSTEMS

Freq. 2.1 to 2.6 GHz • 34 db Gain +



TWO YEAR WARRANTY
PARTS & LABOR



COMPLETE SYSTEMS
(as Pictured)

Commercial 40"

Rod Style \$ 89.95

Parabolic 20"

Dish Style \$ 79.95

COMPONENTS

Down Converters

(both types) \$ 34.95

Power Supplies

(12V to 16V) \$ 24.95

Data Info (Plans) \$ 9.95

CALL OR WRITE FOR
KITS, PARTS, INDIVIDUAL
COMPONENTS

We Repair All Types Down
Converters & Power Supplies

Phillips-Tech
Electronics

1043 N. STADEM DR.
TEMPE AZ. 85281
(602) 967-6972

Special Quantity Pricing
Dealers Wanted



CIRCLE 29 ON FREE INFORMATION CARD

Radio-Electronics REPRINT BOOKSTORE

- | | |
|--|--|
| <input type="checkbox"/> Build Your Own Satellite TV Receiver \$7.00 | <input type="checkbox"/> Special Projects (Spring 1981) \$4.50 |
| <input type="checkbox"/> 8-Ball Satellite TV Antenna \$5.00 | <input type="checkbox"/> Special Projects #4 (Summer 1982) \$4.50 |
| <input type="checkbox"/> Build Your Own Robot \$12.00 | <input type="checkbox"/> Special Projects #5 (Winter 1983) \$4.00 |
| <input type="checkbox"/> TV Descrambler (January, February 1981) \$3.00 | <input type="checkbox"/> Special Projects #6 (Spring 1983) \$3.50 |
| <input type="checkbox"/> Radio-Electronics back issues (1984) \$3.00 | <input type="checkbox"/> Special Projects #7 (Summer 83) NOT AVAILABLE |
| <input type="checkbox"/> Radio-Electronics back issues (1983) \$3.50 | <input type="checkbox"/> Special Projects #8 (Fall 83) \$3.50 |
| (January, February 1983 not available) | <input type="checkbox"/> Special Projects #9 (Winter 84) \$3.00 |
| Write in issues desired..... | <input type="checkbox"/> Radio-Electronics Annual 1983 \$3.50 |
| <input type="checkbox"/> Radio-Electronics back issues (1982) \$4.00 | <input type="checkbox"/> Radio-Electronics Annual 1984 \$2.50 |
| (January 1982 not available) | <input type="checkbox"/> How to Make PC Boards \$2.00 |
| Write in issues desired..... | <input type="checkbox"/> All About Kits \$2.00 |
| <input type="checkbox"/> Radio-Electronics back issues (1981) \$4.00 | <input type="checkbox"/> Modern Electronics (Vol. 1, #1 April 1908) \$2.25 |
| (February, March, December 1981 not available) | <input type="checkbox"/> Electro Importing Co. Catalog \$4.95 |
| Write in issues desired..... | (1918) (176 pp) |
| <input type="checkbox"/> Etch your own PC boards \$3.00 | <input type="checkbox"/> Low Frequency Receiving Techniques \$6.00 |
| | Building and using VLF Antennas |

To order any of the items indicated above, check off the ones you want. Complete the order form below, include your payment, check or money order (DO NOT SEND CASH), and mail to Radio-Electronics, Reprint Department, 200 Park Ave. South, New York, NY 10003. Please allow 4-6 weeks for delivery.

If you need a copy of an article that is in an issue we indicate is unavailable you can order it directly from us. We charge 50¢ per page. Indicate the issue (month & year), pages and article desired. Include payment in full, plus shipping and handling charge.

ARTICLE _____

MONTH _____

YEAR _____

PAGES _____

TOTAL PAGES _____

@ 50¢ each

TOTAL PRICE _____

MAIL TO: **Radio-Electronics**

Reprint Department, 200 Park Ave. South, New York, NY 10003

All payments must be in U.S. funds

4/84

Total price of order \$ _____
 Sales Tax (New York State Residents only) \$ _____
 Shipping & Handling (U.S. & Canada only) (Includes FIRST CLASS POSTAGE) \$1.00 per item \$ _____
 All other countries (\$2.00 per item, sea mail) \$ _____
 (\$4.00 per item, air mail) \$ _____

Total Enclosed \$ _____

Name _____

Address _____

City _____ State _____ Zip _____

HIGH QUALITY UP TO 55dB GAIN

MICROWAVE TV SYSTEM

Variable from 1.9 to 2.5 GHz

The latest advance
in microwave
technology with a
SNOW-FREE
PICTURE.

Two Models to choose from.

Both Models Include:
• 20" Parabolic Dish
• Pre-assembled Probe
with Down Converter

- Power Supply and Coax Switch
- 60' of RG-59/U Coax with Connector
- Transformer for 75 to 300 Ohms
- All Mounting Hardware for Fast and Easy Installation

20" Fiberglass Dish
Up to 55dB Gain
Special **\$98⁹⁵***

20" Aluminum Dish
Up to 40dB Gain
Low Priced **\$74⁹⁵***

*Includes Shipping and Handling

High Gain Yagi Antenna with Down Converter and Power Supply, Complete System, Ready to Use. **\$89⁹⁵**

Send \$2.00 for Catalog. Refundable with first purchase. Available thru Mail and Phone Orders Only. 20% deposit for COD. CA Res. add 6 1/2% Tax. Send Cashiers Check or Money Order to: (Personal Checks, allow 2-5 weeks to clear)



PROFESSIONAL VIDEO, Inc.
4670 Hollywood Blvd., Hollywood, Calif. 90027

219-0227
For C.O.D. Orders Call (213) 352-9681

CIRCLE 21 ON FREE INFORMATION CARD

BUILD IT! FIX IT! WITH SHACK® PARTS

Low Prices!

No Minimum Order!

No Mail Order Delays!

Special Audio ICs

Save *2

Reg. 6.99



599 28-Pin

499

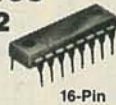

16-Pin

AY-31350 Melody Synthesizer. 28 built-in tunes! NMOS. Ideal for doorbells and musical funboxes. Pre-programmed with Yankee Doodle, Blue Danube, Star Wars, America, Beethoven's 5th, other favorites. You can add a PROM and create your own. With data. 276-1782 5.99

NE572 Audio Compressor/Expander. Two channels, either can be used for compression or expansion. Dynamic range greater than 110 dB. Ideal for hi-fi noise reduction, communications speech processing. With data. 276-1781 Sale 4.99

Operational Amplifiers

Type		Cat. No.	Each
741	(Single)	276-007	.79
MC1458	(Dual)	276-038	.99
LM324	(Quad)	276-1711	1.29
TL082	(Dual)	276-1715	1.89
TL084	(Quad)	276-1714	2.99
LM3900	(Quad)	276-1713	1.39
LM339	(Quad)	276-1712	1.49

Audio Power Amplifiers

Type	Cat. No.	Each
LM383/TDA2002	276-703	3.19
LM386	276-1731	1.09
TA7205AP	276-705	2.99
LM380	276-706	1.59

Ceramic Disc Capacitors

Low As 39¢ Pkg. of 2

For RF, Bypass and Coupling Applications. Hi-Q. Moisture-proof coating. 50 WVDC minimum.

pF	Cat. No.	Pkg. of 2	pF	Cat. No.	Pkg. of 2
4.7	272-120	.39	.001	272-126	.39
47	272-121	.39	.005	272-130	.39
100	272-123	.39	.01	272-131	.39
220	272-124	.39	.05	272-134	.49
470	272-125	.39	.1	272-135	.49

Radio Control Modules

Ideal for wireless remote control of toys, models and more. Prewired. Require just a few low-cost components to make a complete system. Four functions. Receiver controls two DC motors directly 27.145 Mhz. See Forrest Mims column, January Computers & Electronics. With data. 277-1012 Set, 16.95



1695 Set Receiver Transmitter



Archer® Paks

Only 198 Each

Archer Pak	Cat. No.
50 Silicon Diodes	276-1620
8 Digital ICs	276-1651
20 Electrolytic Capacitors	276-802
15 Silicon NPN Transistors	276-1617
6 Linear ICs	276-1652
25 Assorted Zener Diodes	276-1629
12 Potentiometers	271-1605
20 Assorted LEDs	276-1622
15 All-Purpose NPN Transistors	276-1603
15 PNP Transistors	276-1604
25 1N4000-Series Diodes	276-1653
5 Optocouplers	276-1654

1/4-Watt, 5% Resistors

39¢ Pkg. of 5

Ohms	Cat. No.	Ohms	Cat. No.
10	271-1301	10k	271-1335
100	271-1311	15k	271-1337
150	271-1312	22k	271-1339
220	271-1313	27k	271-1340
270	271-1314	33k	271-1341
330	271-1315	47k	271-1342
470	271-1317	68k	271-1345
1k	271-1321	100k	271-1347
1.8k	271-1324	220k	271-1350
2.2k	271-1325	470k	271-1354
3.3k	271-1328	1 meg	271-1356
4.7k	271-1330	10 meg	271-1365
6.8k	271-1333		

Voltage Regulator ICs

Type	Adjustable	Cat. No.	Each
LM723	0 to 40 VDC	276-1740	.89
LM317T	1.2 to 37 VDC	276-1778	2.79

Type	Fixed Output	Cat. No.	Each
7805	+5 VDC	276-1770	1.59
7812	+12 VDC	276-1771	1.59
7815	+15 VDC	276-1772	1.59
7905	-5 VDC	276-1773	1.59
7912	-12 VDC	276-1774	1.59

4000-Series CMOS ICs

With Pin-Out and Specs Low As 79¢

Type	Cat. No.	Each
4001	276-2401	.79
4011	276-2411	.79
4013	276-2413	.99
4017	276-2417	1.49
4023	276-2423	.99
4049	276-2449	.99
4066	276-2466	.99

Electrolytic Capacitors

Axial Leads

µF	WVDC	Cat. No.	Each
4.7	35	272-1012	.49
10	35	272-1013	.59
22	35	272-1014	.69
47	35	272-1015	.69
100	35	272-1016	.79
220	35	272-1017	.89
470	35	272-1018	.99
1000	35	272-1019	1.59
2200	35	272-1020	2.49
3300	35	272-1021	2.99
4700	35	272-1022	3.59
470	50	272-1046	1.59
1000	50	272-1047	1.99
2200	50	272-1048	3.49

PC-Mount Leads

µF	WVDC	Cat. No.	Each
220	16	272-956	.79
470	16	272-957	.89
1000	16	272-958	.99
4.7	35	272-1024	.49
10	35	272-1025	.59
22	35	272-1026	.69
47	35	272-1027	.69
100	35	272-1028	.79
220	35	272-1029	.89
470	35	272-1030	.99
1000	35	272-1032	1.59
100	50	272-1044	.89

TTL Digital ICs

With Pin-Out and Specs

Type	Cat. No.	Each
7400	276-1801	.59
7404	276-1802	.79
7408	276-1822	.79
7447	276-1805	1.19
7490	276-1808	.89

Replacement Transistors

Type		Cat. No.	Each
2N1305	PNP	276-2007	1.19
MPS222A	NPN	276-2009	.79
PN2484	PNP	276-2010	.89
MPS3904	NPN	276-2016	.69
TIP31	NPN	276-2017	.99
TIP3055	NPN	276-2020	1.59
MPS2907	PNP	276-2023	.79
MJE34	PNP	276-2027	1.49
2N3053	NPN	276-2030	.89
MPS3638	PNP	276-2032	.79
TIP120	NPN	276-2068	1.29
2N3055	NPN	276-2041	1.99
MJ2955	PNP	276-2043	2.19
2N4124	NPN	276-2057	.59
2N4401	NPN	276-2058	.59
MPSA06	NPN	276-2059	.59
MPSA13	NPN	276-2060	.59
MPSA42	NPN	276-2061	.69
MU4891	UJT	276-2029	.99
2SD313	NPN	276-2048	1.79
2SC945	NPN	276-2051	.79
2SC1308	NPN	276-2055	7.95
2N3819	N-FET	276-2035	.99
MPF102	N-FET	276-2062	.99

Compact SPST Reed Relays

NEW!

149 Each



Approx. 1" x 5/16". PC-mount pins. Contacts rated 1 amp at 125 VAC. Low-current coils.

Coil	Cat. No.
5 VDC, 20 milliamps	275-232
12 VDC, 11 milliamps	275-233

Digital Logic Probe With Tone and LED Indicators



1995

Overload and Polarity Protected

The fast way to "peek inside" TTL, LS and CMOS digital circuits. Color-coded LEDs indicate high, low or pulsed states. Simultaneous tone output frees your eyes. Min. detectable pulse width: 50 ns. With user's tips. 22-302 19.95

Auto Radio Installation Guide

Save \$100

Reg. 2.95

195



Helps you choose a replacement radio. Detailed instructions for installation and removal in 1975-1982 American cars, light trucks, and many imports. 101 pages. 62-1331 Sale 1.95

A DIVISION OF TANDY CORPORATION

Radio Shack®

Prices apply at participating Radio Shack stores and dealers

OVER 8800 LOCATIONS WORLDWIDE

CIRCLE 61 ON FREE INFORMATION CARD

APRIL 1984

133

DoKay

COMPUTER PRODUCTS, Inc.

ORDER TOLL FREE

(800)
538-8800

(CALIFORNIA RESIDENTS)

(800)
848-8008



TERMS: For shipping include \$2.00 for UPS Ground or \$3.00 for UPS Blue Air. \$10.00 minimum order. Bay Area and Los Angeles Counties add 6½% Sales Tax, other California residents add 6% Sales Tax. We reserve the right to limit quantities and substitute manufacturer. Prices subject to change without notice.

VISIT OUR RETAIL STORE

2100 De La Cruz Blvd.
Santa Clara, CA 95050
(408) 988-0697

DoKay

STATIC RAMS

2101	256 x 4 (450ns)	1.90
5101	256 x 4 (450ns) (cmos)	3.90
2102-1	1024 x 1 (450ns)	.88
2102L-4	1024 x 1 (450ns) (LP)	.98
2102L-2	1024 x 1 (250ns) (LP)	1.45
2111	256 x 4 (450ns)	2.45
2112	256 x 4 (450ns)	2.95
2114	1024 x 4 (450ns)	8/9.90
2114-25	1024 x 4 (250ns)	8/9.95
2114L-4	1024 x 4 (450ns) (LP)	8/11.95
2114L-3	1024 x 4 (300ns) (LP)	8/12.45
2114L-2	1024 x 4 (200ns) (LP)	8/12.95
2147	4096 x 1 (55ns)	4.90
TMS4044-4	4096 x 1 (450ns)	3.45
TMS4044-3	4096 x 1 (300ns)	3.95
TMS4044-2	4096 x 1 (200ns)	4.45
MK4118	1024 x 8 (250ns)	9.90
TMM2016-200	2048 x 8 (200ns)	4.10
TMM2016-150	2048 x 8 (150ns)	4.90
TMM2016-100	2048 x 8 (100ns)	6.10
HM6116-4	2048 x 8 (200ns) (cmos)	4.70
HM6116-3	2048 x 8 (150ns) (cmos)	4.90
HM6116-2	2048 x 8 (120ns) (cmos)	8.90
HM6116LP-4	2048 x 8 (200ns) (cmos) (LP)	5.90
HM6116LP-3	2048 x 8 (150ns) (cmos) (LP)	6.90
HM6116LP-2	2048 x 8 (120ns) (cmos) (LP)	9.95
Z-6132	4096 x 8 (300ns) (Qstat)	33.95

LP = Low Power Qstat = Quasi-Static

DYNAMIC RAMS

TMS4027	4096 x 1 (250ns)	1.95
UPD411	4096 x 1 (300ns)	2.95
MMS280	4096 x 1 (300ns)	2.95
MK4108	8192 x 1 (200ns)	1.90
MMS298	8192 x 1 (250ns)	1.80
4116-300	16384 x 1 (300ns)	8/10.75
4116-250	16384 x 1 (250ns)	8/10.95
4116-200	16384 x 1 (200ns)	8/11.95
4116-150	16384 x 1 (150ns)	8/13.95
4116-120	16384 x 1 (120ns)	8/28.95
2118	16384 x 1 (150ns) (5v)	4.90
4164-200	65536 x 1 (200ns) (5v)	CALL
4164-150	65536 x 1 (150ns) (5v)	CALL

5V = single 5 volt supply

EPROMS

1702	256 x 8 (1us)	4.45
2708	1024 x 8 (450ns)	3.90
2758	1024 x 8 (450ns) (5v)	5.90
2716	2048 x 8 (450ns) (5v)	3.90
2716-1	2048 x 8 (350ns) (5v)	5.90
TMS2516	2048 x 8 (450ns) (5v)	5.45
TMS2716	2048 x 8 (450ns)	7.90
TMS2532	4096 x 8 (450ns) (5v)	5.90
2732	4096 x 8 (450ns) (5v)	4.90
2732-250	4096 x 8 (250ns) (5v)	8.90
2732-200	4096 x 8 (200ns) (5v)	10.95
2764	8192 x 8 (450ns) (5v)	9.90
2764-250	8192 x 8 (250ns) (5v)	13.95
2764-200	8192 x 8 (200ns) (5v)	23.95
TMS2564	8192 x 8 (450ns) (5v)	16.95
MC68764	8192 x 8 (450ns) (5v) (24 pin)	38.95
27128	16384 x 8Call	Call

5v = Single 5 Volt Supply

74LS00

74LS00	.23	74LS92	.54
74LS01	.24	74LS93	.54
74LS02	.24	74LS95	.74
74LS03	.24	74LS96	.88
74LS04	.23	74LS107	.38
74LS05	.24	74LS109	.38
74LS08	.27	74LS112	.38
74LS09	.28	74LS113	.38
74LS10	.24	74LS114	.38
74LS11	.34	74LS122	.44
74LS12	.34	74LS123	.78
74LS13	.44	74LS124	2.85
74LS14	.58	74LS125	.48
74LS15	.34	74LS126	.48
74LS20	.24	74LS132	.58
74LS21	.28	74LS133	.58
74LS22	.24	74LS136	.38
74LS26	.28	74LS137	.98
74LS27	.28	74LS138	.54
74LS28	.34	74LS139	.54
74LS30	.24	74LS145	1.15
74LS32	.28	74LS147	2.45
74LS33	.54	74LS148	1.30
74LS37	.34	74LS151	.54
74LS38	.34	74LS153	.54
74LS40	.24	74LS154	1.85
74LS42	.48	74LS155	.68
74LS47	.74	74LS156	.68
74LS48	.74	74LS157	.64
74LS49	.74	74LS158	.58
74LS51	.24	74LS160	.68
74LS54	.28	74LS161	.64
74LS55	.28	74LS162	.68
74LS63	1.20	74LS163	.64
74LS73	.38	74LS164	.68
74LS74	.34	74LS165	.94
74LS75	.38	74LS166	1.90
74LS76	.38	74LS168	1.70
74LS78	.48	74LS169	1.70
74LS83	.59	74LS170	1.45
74LS85	.68	74LS173	.68
74LS86	.38	74LS174	.54
74LS90	.54	74LS175	.54
74LS91	.88	74LS181	2.10

74LS189	8.90	74LS363	1.30
74LS190	.88	74LS364	1.90
74LS191	.88	74LS365	.48
74LS192	.78	74LS366	.48
74LS193	.78	74LS367	.44
74LS194	.68	74LS368	.44
74LS195	.68	74LS373	1.35
74LS196	.78	74LS374	1.35
74LS197	.78	74LS377	1.35
74LS221	.88	74LS378	1.13
74LS240	.94	74LS379	1.30
74LS241	.98	74LS385	1.85
74LS242	.98	74LS386	.44
74LS243	.98	74LS390	1.15
74LS244	1.25	74LS393	1.15
74LS245	1.45	74LS395	1.15
74LS247	.74	74LS399	1.45
74LS248	.98	74LS424	2.90
74LS249	.98	74LS447	.36
74LS251	.58	74LS490	1.90
74LS253	.58	74LS624	3.95
74LS257	.58	74LS640	2.15
74LS258	.58	74LS645	2.15
74LS259	2.70	74LS668	1.65
74LS260	.58	74LS669	1.85
74LS266	.54	74LS670	1.45
74LS273	1.45	74LS674	9.60
74LS275	3.30	74LS682	3.15
74LS279	.48	74LS683	3.15
74LS280	1.95	74LS684	3.15
74LS283	.68	74LS685	3.15
74LS290	.88	74LS688	2.35
74LS293	.88	74LS689	3.15
74LS295	.98	74LS783	23.95
74LS298	.88	81LS95	1.45
74LS299	1.70	81LS96	1.45
74LS323	3.45	81LS97	1.45
74LS324	1.70	81LS98	1.45
74LS352	1.25	25LS2521	2.75
74LS353	1.25	25LS2569	4.20

6500 1MHZ

6502	4.90
6504	6.90
6505	8.90
6507	9.90
6520	4.30
6522	7.90
6532	9.90
6545	21.50
6551	10.85

2 MHZ

6502A	6.90
6522A	9.90
6532A	10.95
6545A	26.95
6551A	10.95

3 MHZ

6502B	13.95
-------	-------

6800

68000	58.95
6800	3.90
6802	7.90
6808	12.90
6809E	18.95
6809	10.95
6810	2.90
6820	4.30
6821	3.20
6828	13.95
6840	11.95
6843	33.95
6844	24.95
6845	13.95
6847	10.95
6850	3.20
6852	15.70
6860	9.90
6862	10.95
6875	6.90
6880	2.20
6883	21.95
68047	23.95
68488	18.95

6800

68B00	9.95
68B02	21.25
68B09E	28.95
68B09	28.95
68B10	6.90
68B21	6.90
68B45	18.95
68B50	5.90

8000

8035	5.90
8039	6.90
INS-8060	16.95
INS-8073	49.95
8080	3.90
8085	5.90
8085A-2	10.95
8086	28.95
8087	CALL
8088	38.95
8089	88.95
8155	6.90
8155-2	7.90
8156	6.90
8185	28.95
8185-2	38.95
8741	38.95
8748	49.95
8755	23.95

8200

8202	23.95
8203	38.95
8205	3.45
8212	1.75
8214	3.80
8216	1.70
8224	2.20
8226	1.75
8228	3.45
8237	18.95
8237-5	20.95
8238	4.45
8243	4.40
8250	9.95
8251	4.45
8253	6.90
8253-5	7.90
8255	14.95
8255-5	18.95
8257	7.90
8257-5	8.90
8259	6.85
8259-5	7.45
8271	38.95
8272	38.95
8275	28.95
8279	8.90
8279-5	9.00
8283	6.45
8284	14.95
8286	6.45
8287	6.45
8288	24.00
8289	48.95

Z-80

2.5 Mhz

Z80-CPU	3.90
Z80-CTC	4.45
Z80-DART	9.95
Z80-DMA	13.95
Z80-PIO	4.45
Z80-SIO/0	15.95
Z80-SIO/1	15.95
Z80-SIO/2	15.95
Z80-SIO/9	15.95

4.0 Mhz

Z80A-CPU	4.90
Z80A-CTC	4.90
Z80A-DART	10.95
Z80A-DMA	15.95
Z80A-PIO	4.90
Z80A-SIO/0	15.95
Z80A-SIO/1	15.95
Z80A-SIO/2	15.95
Z80A-SIO/9	15.95

6.0 Mhz

Z80B-CPU	12.95
Z80B-CTC	12.95
Z80B-PIO	12.95
Z80B-DART	18.95

ZILOG

Z6132	33.95
Z8671	38.95

DISC CONTROLLERS

1771	15.95
1791	23.95
1793	25.95
1795	48.95
1797	48.95
2791	53.95
2793	53.95
2795	58.95
2797	58.95
6843	33.95
8272	38.95
UPD765	38.95
MB8876	28.95
MB8877	33.95
1691	16.95
2143	17.95

UARTS

AY3-1014	6.90
AY5-1013	3.90
AY3-1015	6.90
PT-1472	9.90
TR1602	3.90
2350	9.90
2651	8.90
TMS6011	5.90
IM6402	7.90
IM6403	8.90
INS8250	9.95

INTERFACE

8T26	1.54
8T28	1.84
8T95	.88
8T96	.88
8T97	.88
8T98	.88
DM8131	2.90
DP8304	2.24
DS8835	1.94
DS8836	.98

VOLTAGE REGULATORS

7805T	.74	7905T	.84
7805C	.34	7908T	.84
7808T	.74	7912T	.84
7812T	.74	7915T	.84
7815T	.74	7924T	.84
7824T	.74	7905K	1.44
7805K	1.34	7912K	1.44
7812K	1.34	7915K	1.44
7815K	1.34	7924K	1.44
7824K	1.34	79L05	.78
78L05	.68	79L12	.78
78L12	.68	79L15	.78
78L15	.68	LM323K	4.90
78H05K	9.90	UA78S40	1.90
78H12K	9.90		

C,T = TO-220 K = TO-3 L = TO-92

DIP SWITCHES

4 POSITION	.84
5 POSITION	.89
6 POSITION	.89
7 POSITION	.94
8 POSITION	.94

IC SOCKETS

	1-99	100
8 pin ST	.12	.10
14 pin ST	.14	.11
16 pin ST	.16	.12
18 pin ST	.19	.17
20 pin ST	.28	.26
22 pin ST	.29	.26
24 pin ST	.29	.26
28 pin ST	.39	.31
40 pin ST	.48	.38
64 pin ST	4.20	call

ST = SOLDERTAIL

8 pin WW	.58	.48
14 pin WW	.68	.51
16 pin WW	.68	.57
18 pin WW	.98	.89
20 pin WW	1.04	.97
22 pin WW	1.34	1.23
24 pin WW	1.44	1.30
28 pin WW	1.64	1.44
40 pin WW	1.94	1.75

WW = WIREWRAP

16 pin ZIF	6.70	call
24 pin ZIF	9.90	call
28 pin ZIF	9.95	call

ZIF = TEXTTOOL (Zero Insertion Force)

CRYSTALS

32.768khz	1.90
1.0 mhz	4.90
1.8432	4.90
2.0	3.90
2.097152	3.90
2.4576	3.90
3.2768	3.90
3.579535	3.90
4.0	3.90
5.0	3.90
5.0688	3.90
5.185	3.90
5.7143	3.90
6.0	3.90
6.144	3.90
6.5536	3.90
8.0	3.90
10.0	3.90
10.738635	3.90
14.31818	3.90
15.0	3.90
16.0	3.90
17.430	3.90
18.0	3.90
18.432	3.90
20.0	3.90
22.1184	3.90
32.0	3.90

RESISTORS

1/4 WATT 5% CARBON FILM ALL STANDARD VALUES FROM 1 OHM TO 10 MEG OHM

50 PCS.	1.25
100 PCS.	2.00
1000 PCS.	15.00

BULK DISKETTES

5 1/4" DISKETTES
ATHANA OR NASHUA

SSSD	18.95
SSDD	22.95
DSDD	27.95

5 1/4" DISKETTES
NO LABEL

SINGLE SIDED DOUBLE DENSITY
(WITH JACKETS AND HUB RING)

Pack of Ten	\$ 16.95
Pack of 100	\$149.00

APPLE ACCESSORIES

80 Column Card	129.95
16 K Card	42.50
Fan	38.95
Power Supply	84.95
RF Mod	24.95
Joy Stick (Apple II)	29.95
Paddles Apple	9.95
Z80 Card	129.95
SCRG Switch-A-Slot	19.95
Paddle Adapple	24.95
Extend-A Slot	195.95
Disk Drive	224.95
Controller Card	69.95



Joy Stick



Cooling Fan



Disk Drive

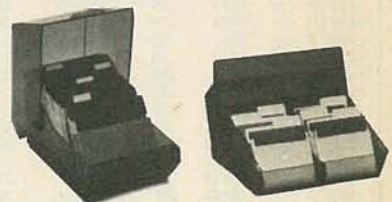

The Flip Sort Plus™

The Flip Sort Plus™ adds new dimensions to storage. Designed with similar elegant lines as the original Flip Sort™, in a transparent smoked acrylic. The Flip Sort Plus™ has a storage capacity of over 100 diskettes and has all the outstanding features you have come to expect from the flip sort Family. **24.95 each**

Do Kay

2100 De La Cruz Blvd.
Santa Clara, CA 95050

SEI, Inc.

641 Academy Drive • Northbrook, Illinois 60062
For information (312) 564-0104 • To order outside Illinois 1-800-323-1327

SOLID STATE STEREO REVERBERATION AMPLIFIER



Specifications: • Total harmonic distortion less than .05% • Frequency response 10 Hz to 50K Hz +10dB • S/N Ratio 90dB • Reverberation time 0 to 3 sec. • Input 150MV/50K ohm • Max. input 2V • Accepts input from tape, phono, or aux. Includes and LED Reverb Level display. Kit comes with all electronic components, transformer and instructions, and 19" rack mount cabinet.

Model TA-2400 \$89.95

AMATEUR MICROWAVE Receiver System 1.9-2.5 GHZ



MICROWAVE RECEIVER SYSTEM

• Commercial grade construction • Sturdy Parabolic aluminum reflector antenna • High gain 50 dBi • Line of sight distance 45 miles! • Complete system, power supply, cable, assembled reflector antenna, and downconverter. • Downconverter mounted in attractive cabinet.

90 day warranty on PS-5!
PS5 Assembled \$109.95
Kit Form \$ 79.95

Microwave Preamp!

NEW KIT

Use with PS-3 Kit. Adds 20-25 db gain to boost reception distance.

- Low Noise
- High Gain
- Can be used with all existing stop sign board receivers!
- 1.9-2.5 GHz Freq. Range

PS-4 (KIT) \$34.95

SOLID STATE STEREO GRAPHIC EQUALIZER PRE AMP KIT



Specifications: • Total Harmonic Distortion: Less than 0.05% • Intermodulation Distortion: (70Hz: 7KHz = 4:1 SMPTE Method) Less than 0.03% • Frequency Response: Overall 10Hz ~ 100KHz +0.2dB -1dB • RIAA Curve Deviation: (Phono) +0.2dB -0.2dB (30Hz ~ 15KHz) • Channel separation (at rated output 1KHz) • Phono, Tuner, Aux and Tape Monitor better than 70dB • Input sensitivity and impedance (1KHz for rated output)

Phono: 2MV 47K ohms Aux: 130MV 50K ohms Tuner: 130MV 50K ohms Tape: 130MV 50K ohms. Graphic Equalizer Control: 10 Band Slide Control. Frequency Bands: 31 5Hz: G3Hz: 125Hz: 250Hz: 500Hz: 1KHz: 2KHz: 4KHz: 8KHz: 16KHz also with on panel selector for Phono, Tuner, Aux 1 and Aux 2. Power Supply: 117 VAC. Kit comes with all electronic components, transformer, instructions and a 19" rack mount type metal cabinet.

TA-2500 (Kit) \$119.00

20 STEP LED POWER LEVEL INDICATOR KIT

This new stereo level indicator kit consists of 40 3-color LED's to indicate sound level output of your amplifier from -57 dB to 0 dB. Comes with an attractive silk screen printed panel. Has selector switch to allow floating or gradual output indicating. Kit includes all parts. Front panel and power supply

TY-45 (KIT) \$34.95

SPY EAR

A very popular device designed to listen to sounds & voices through rooms or 3 ft. thick concrete walls. Place listening sensor against wall and earphone in ear. Adjust volume control! Clearly hear things you may not want to!

CM-8 \$89.95

INFRA-RED REMOTE CONTROL SWITCH KIT



Infra-red Remote Control switch can be used to control appliances up to 500 W.

The TK-41 has effective control up to 10 meters. No antenna needed. Features latest IC controller which excludes interferences from light or AC pulse signal

TK-41 Kit \$24.95

STEREO AMP KIT 160 Watt Total 80W + 80W

This is a solid state all transistor circuitry on board stereo amplifier. Power output employs 2 pairs of matching Darlington transistors. T.H.D. less than .05% between DC to 200 KHz. Power supply requires 30 VCT 2 amp * FMR.

TA-802

\$39.95

Transformer (optional)

\$9.95



LOW TIM DC STEREO PRE-AM KIT TA-2800

Incorporates state of D.C. design that gives a frequency response from 0Hz-100KHz+. 5dB. • Features tone defeat switch, loudness, treble, midrange, bass, balance. • Contains quad BiFet op-amp to develop T.H.D. of .005% at rated output • Input sensitivity: phono 2.5 MV tuner, aux, tape play 100MV/100K • Power supply + 15 volt DC at 2A. Kit comes with regulated power supply, all you need is a 15-20 VCT 2 amp XFMR.

TA-2800

ONLY

\$44.50

XFMR

\$4.50 ea.



UHF TV PREAMP

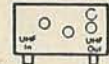

FEATURES:
• 25 dB gain!
• Kit

Your reception will dramatically improve! This unit will enable you to pull in signals you never knew were there! For both indoor and outdoor use. Input and output impedance 75 ohm. No adjustment! Easy assembly.

JH-0 Kit \$23.95

R.F. MODULATOR

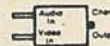

Combine both audio and video output onto channel 3 or 4 of your T.V. set. Single J.C. chip (MC 1374) makes for quick and easy assembly. Single adjustment control! A must for every video recording or computer enthusiast.

VH-0 Kit \$19.95

PHILIPS VARACTOR TUNER

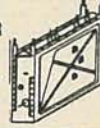

Comes with adaptor board to directly replace Mitsumi tuner! Can use this with any board drilled for Mitsumi! High gain and phenomenal picture quality.

Specifications: • Freq. Range: UHF 470-899 mHz • Output: Channel 3 • Input: 75 ohm • Gain: 18 dB

ELC 1045 \$23.95

DIGITAL MULTIMETER



- 3 1/2 digit LCD meter
- Input impedance 20 Ohm
- hFE measurement
- DC .5% accuracy
- DCA up to 10 amps
- Leads and battery included

MIC-3300A \$59.95

Carrying Case \$ 9.95

Add 10% shipping on orders under \$35.00. Orders over \$35.00, add 5%.
Catalog-\$1.00. Visa & Mastercharge accepted.

CIRCLE 60 ON FREE INFORMATION CARD

NETWORK SALES, INC.

7400		74LS00		CMOS		MISC.		RIBBON CABLE CONNECTOR							
7400	.19	7473	.29	74LS00	.23	74LS153	.55	4000	.29	4073	.29	9601	.75	These very popular 40 PIN ribbon cable connectors are used by a number of mfgs. of micros for internal board to board terminations and I/O port connections.	
7401	.19	7474	.33	74LS03	.24	74LS154	1.85	4001	.25	4075	.29	9602	1.50	W/strain relief \$1.95	
7402	.19	7485	.55	74LS04	.24	74LS157	.65	4002	.29	4076	.79	DS8640	.89	40 CONDUCTOR RIBBON CABLE gray color 70¢/ft.	
7403	.19	7486	.35	74LS05	.25	74LS162	.69	4007	.29	4078	.29	8811	.69	DIP SWITCHES High quality DIP switches mfg. by CTS. Available in the following configurations.	
7404	.19	7490	.35	74LS08	.28	74LS163	.65	4009	.39	4081	.29	DS8820	1.45	4 POS—80¢	
7405	.23	7491	.79	74LS10	.25	74LS164	.69	4010	.45	4082	.29	INS8060	15.95	5 POS—80¢	
7407	.29	7492	.55	74LS11	.34	74LS170	1.45	4011	.25	14412	8.95	DM8130	3.00	6 POS—80¢	
7408	.28	7494	.60	74LS15	.35	74LS174	.55	4012	.25	4502	.95	9300	.69	7 POS—80¢	
7409	.19	7496	.69	74LS20	.25	74LS175	.55	4013	.38	4503	.65	82S23	2.95	The most popular computer connector Mfg. by AMP. .025" gold PC pins with mfg. holes \$1.50	
7410	.19	74121	.29	74LS27	.29	74LS181	2.15	4014	.79	4510	.85	8233	1.95	DB-25 S (FEMALE)	
7411	.24	74123	.78	74LS30	.25	74LS190	.89	4015	.39	4512	.85	8234	1.95	Mfg. by AMP. .025" gold PC pins with mfg. holes \$1.50	
7414	.49	74145	.59	74LS32	.29	74LS194	.69	4017	.69	4516	1.45	8266	2.25	The most popular computer connector Mfg. by AMP. .025" gold PC pins with mfg. holes \$1.50	
7417	.25	74148	1.19	74LS38	.35	74LS197	.79	4018	.79	4518	.89	8273	3.25	Mfg. by AMP. .025" gold PC pins with mfg. holes \$1.50	
7420	.19	74150	1.19	74LS42	.49	74LS240	.95	4019	.39	4520	.79	8281	.69	Mfg. by AMP. .025" gold PC pins with mfg. holes \$1.50	
7423	.59	74151	.55	74LS47	.75	74LS241	.99	4020	.75	4526	1.25	82S123	2.95	Mfg. by AMP. .025" gold PC pins with mfg. holes \$1.50	
7430	.25	74153	.55	74LS74	.35	74LS244	1.29	4021	.79	4527	1.95	82S141	4.95	Mfg. by AMP. .025" gold PC pins with mfg. holes \$1.50	
7432	.29	74155	.69	74LS76	.39	74LS245	1.49	4023	.29	4536	4.25	8833	2.25	Mfg. by AMP. .025" gold PC pins with mfg. holes \$1.50	
7438	.29	74157	.55	74LS86	.39	74LS253	.53	4025	.29	4555	1.49	8709	1.25	Mfg. by AMP. .025" gold PC pins with mfg. holes \$1.50	
7439	.59	74159	1.65	74LS90	.55	74LS257	.59	4027	.45	4556	1.15	8737	1.75	Mfg. by AMP. .025" gold PC pins with mfg. holes \$1.50	
7442	.45	74160	.69	74LS92	.55	74LS273	1.49	4030	.39	4581	3.50	8797	1.50	Mfg. by AMP. .025" gold PC pins with mfg. holes \$1.50	
7446	.69	74165	.69	74LS113	.39	74LS279	.49	4034	1.95	4583	2.50	8554	2.25	Mfg. by AMP. .025" gold PC pins with mfg. holes \$1.50	
7447	.69	74170	1.29	74LS123	.79	74LS366	.49	4035	.85	4584	.75	NE510	3.95	Mfg. by AMP. .025" gold PC pins with mfg. holes \$1.50	
7451	.19	74174	.69	74LS125	.49	74LS367	.45	4041	.75	74C00	.35	3341	5.95	Mfg. by AMP. .025" gold PC pins with mfg. holes \$1.50	
7453	.19	74181	1.85	74LS136	.39	74LS373	1.49	4042	.69	74C02	.35	75107	.75	Mfg. by AMP. .025" gold PC pins with mfg. holes \$1.50	
7454	.19	74190	.69	74LS138	.55	74LS374	1.49	4043	.79	74C14	.59	75108	.75	Mfg. by AMP. .025" gold PC pins with mfg. holes \$1.50	
7472	.19	74191	.69	74LS139	.55	74LS670	1.49	4047	.95	74C15	.35	75110	2.25	Mfg. by AMP. .025" gold PC pins with mfg. holes \$1.50	
				74LS151	.55			4049	.35	74C154	3.20	75150	.95	Mfg. by AMP. .025" gold PC pins with mfg. holes \$1.50	
								4051	.79	74C161	1.19	75325	1.75	Mfg. by AMP. .025" gold PC pins with mfg. holes \$1.50	
								4066	.39	74C164	1.39	7545Z	.75	Mfg. by AMP. .025" gold PC pins with mfg. holes \$1.50	
								4069	.29	74C221	1.75	Z-80A-CPU	4.95	Mfg. by AMP. .025" gold PC pins with mfg. holes \$1.50	
								4070	.35	74C901	.39	Z-80A-510/0	16.95	Mfg. by AMP. .025" gold PC pins with mfg. holes \$1.50	
												8279	8.95	Mfg. by AMP. .025" gold PC pins with mfg. holes \$1.50	
												8279-5	10.00	Mfg. by AMP. .025" gold PC pins with mfg. holes \$1.50	
												2716	3.95	Mfg. by AMP. .025" gold PC pins with mfg. holes \$1.50	
												2732	4.95	Mfg. by AMP. .025" gold PC pins with mfg. holes \$1.50	

NETWORK SALES, INC.
2343 W. BELMONT AVE.
CHICAGO, IL. 60618
312-248-3202

Phone Orders Welcome.
WRITE FOR OUR MONTHLY UN-ADVERTISED SPECIALS
QUANTITIES MAY BE LIMITED

©COPYRIGHT 1984 NETWORK SALES, INC.

TERMS: Visa, M.C., Check, Money Order or COD (add. \$3.00). Min. Order \$10.00. Add \$2.50 S&H for USA. Ill. add 8% Tax. MAIL ORDER ONLY. Prices subject to change without notice.

RAMSEY

THE FIRST NAME IN ELECTRONIC TEST GEAR

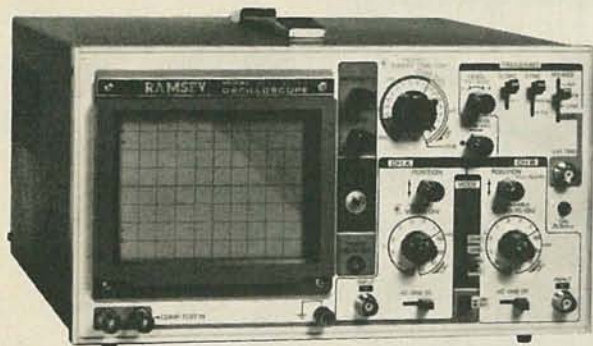

NEW FROM RAMSEY 20 MHz DUAL TRACE OSCILLOSCOPE

Unsurpassed quality at an unbeatable price, the Ramsey oscilloscope compares to others costing hundreds more. Features include a component testing circuit that will allow you to easily test resistors, capacitors, digital circuits and diodes • TV video sync filter • wide bandwidth & high sensitivity • internal graticule • high quality rectangular CRT • front panel trace rotator • Z axis • high sensitivity x-y mode • very low power consumption • regulated power supply • built-in calibrator • rock solid triggering • high quality hook-on probes

\$399⁹⁵ high quality hook-on probes included



RAMSEY D-1100 VOM-MULTITESTER

Compact and reliable, designed to service a wide variety of equipment. Features include • mirror back scale • double-jeweled precision moving coil • double overload protection • an ideal low cost unit for the beginner or as a spare back-up unit.

\$19⁹⁵

test leads and battery included



RAMSEY D-2100 DIGITAL MULTITESTER

A compact easy to use unit designed to operate like a pro. Featuring • 3 1/2 digit LCD • low BAT. indicator • all range overload protection • overrange indication • auto-polarity • Transistor Tester • dual-slope integration • vinyl carrying case

\$54⁹⁵

hFE test leads, battery & vinyl carrying case included

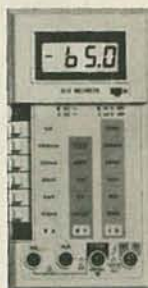

RAMSEY D-3100 DIGITAL MULTIMETER

Reliable, accurate digital measurements at an amazingly low cost • In-line color coded push buttons, speeds range selection • abs plastic tilt stand • recessed input jacks • overload protection on all ranges • 3 1/2 digit LCD display with auto zero, auto polarity & low BAT. indicator

\$59⁹⁵

test leads and battery included



CT-70 7 DIGIT 525 MHz COUNTER

Lab quality at a breakthrough price. Features • 3 frequency ranges each with pre amp • dual selectable gate times • gate activity indicator • 50mV @ 150 MHz typical sensitivity • wide frequency range • 1 ppm accuracy

\$119⁹⁵

wired includes AC adapter

CT-70 kit \$99.95
BP-4 nicad pack 8.95



CT-90 9 DIGIT 600 MHz COUNTER

The most versatile for less than \$300. Features 3 selectable gate times • 9 digits • gate indicator • display hold • 25mV @ 150 MHz typical sensitivity • 10 MHz timebase for WWV calibration • 1 ppm accuracy

\$149⁹⁵

wired includes AC adapter

CT-90 kit \$129.95
OV-1 0.1 PPM oven timebase 59.95
BP-4 nicad pack 8.95



CT-125 9 DIGIT 1.2 GHz COUNTER

A 9 digit counter that will outperform units costing hundreds more. • gate indicator • 24mV @ 150 MHz typical sensitivity • 9 digit display • 1 ppm accuracy • display hold • dual inputs with preamps

\$169⁹⁵

wired includes AC adapter

CT-125 kit \$149.95
BP-4 nicad pack 8.95



CT-50 8 DIGIT 600 MHz COUNTER

A versatile lab bench counter with optional receive frequency adapter, which turns the CT-50 into a digital readout for most any receiver • 25 mV @ 150 MHz typical sensitivity • 8 digit display • 1 ppm accuracy

\$169⁹⁵

wired

CT-50 kit \$139.95
RA-1 receiver adapter kit 14.95



DM-700 DIGITAL MULTIMETER

Professional quality at a hobbyist price. Features include 26 different ranges and 5 functions • 3 1/2 digit, 1/2 inch LED display • automatic decimal placement • automatic polarity

\$119⁹⁵

wired includes AC adapter

DM-700 kit \$99.95
MP-1 probe set 4.95

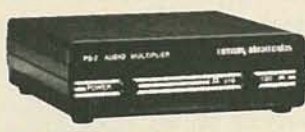

PS-2 AUDIO MULTIPLIER

The PS-2 is handy for high resolution audio resolution measurements, multiplies UP in frequency • great for PL tone measurements • multiplies by 10 or 100 • 0.01Hz resolution & built-in signal preamp/conditioner

\$49⁹⁵

wired includes AC adapter

PS-2 kit \$39.95



PR-2 COUNTER PREAMP

The PR-2 is ideal for measuring weak signals from 10 to 1,000 MHz • flat 25 db gain • BNC connectors • great for sniffing RF • ideal receiver/TV preamp

\$44⁹⁵

wired includes AC adapter

PR-2 kit \$34.95



PS-1B 600 MHz PRESCALER

Extends the range of your present counter to 600 MHz • 2 stage preamp • divide by 10 circuitry • sensitivity: 25mV @ 150 MHz • BNC connectors • drives any counter

\$59⁹⁵

wired includes AC adapter

PS-1B kit \$49.95

ACCESSORIES FOR RAMSEY COUNTERS

Telescopic whip antenna—BNC plug .. \$ 8.95
High impedance probe, light loading .. 16.95
Low pass probe, audio use .. 16.95
Direct probe, general purpose use .. 13.95
Tilt ball, for CT-70, 90, 125 .. 3.95



PHONE ORDERS CALL
716-586-3950

TELEX 466735 RAMSEY CI

TERMS: • satisfaction guaranteed • examine for 10 days; if not pleased return in original form for refund • add 6% for shipping and insurance to a maximum of \$10.00 • overseas add 15% for surface mail • COD add \$2.50 • orders under \$10.00 add \$1.50 • NY residents add 7% sales tax • all kits have a 90 day parts warranty. All wired units have 1 year parts and labor warranty.

RAMSEY

RAMSEY ELECTRONICS, INC.
2575 Baird Rd.
Penfield, N.Y. 14526

CIRCLE 79 ON FREE INFORMATION CARD

APRIL 1984

137

Radio Electronics

SAVE MONEY!
REPAIR YOUR OWN VCR

\$1.75 FEB. 1984

COMPUTERS VIDEO STEREO TECHNOLOGY SERVICE

Experimenter's delight!

CABLE-TV DESCRAMBLING
techniques and circuits

Build a working
MHD ELECTRIC GENERATOR
Energy source of the future?

How to use
DIGITAL PANEL METERS
in your projects

What you need to know!
CP/M
for your computer

How to design
SWITCHING CIRCUITS
using PUT's, UJT's, SCR's, etc.



PLUS:

- ★ Hobby Corner ★ Equipment Targets ★ Drawing Board
- ★ Service Clinic ★ New Idea ★ State Of Solid State

Radio-Electronics covers all aspects of the fast moving electronics field . . . featuring
COMPUTERS • VIDEO • STEREO TECHNOLOGY • SERVICE COMMUNICATIONS • PROJECTS

Get it all!

This will be coming to you when you subscribe to **Radio-Electronics:**

- **HELPFUL CONSTRUCTION ARTICLES** . . .
Test Equipment
Hi-Fi Accessories
Telephone Accessories
Music Synthesizers
Computer Equipment
Automotive Equipment
Intruder Alarms
Home & Car
Video Accessories
- **NEWS ON NEW TECHNOLOGY** . . .
Computers
Microprocessors
Satellite TV
Teletext
Automotive Electronics
Speech Synthesizers
IC Applications
- **FASCINATING "HOW TO DO IT" ARTICLES** . . .
Build Your Own Projects
Make Your Own PC Boards
Wiring Techniques
Soldering and Desoldering
Design and Prototyping

- **HOW YOU AND THE COMPUTER CAN BE FRIENDS** . . .
Getting Started
Programs, Circuit Design, Games
A/D-D/A Interfacing
Peripheral Equipment
- **NEW AUDIO DIMENSIONS FOR YOUR PLEASURE** . . .
Noise-Reduction Devices
How to Connect that Extra Add-On
Hi-Fi Accessories
New Technology
- **TV WONDERS FOR YOUR FUTURE** . . .
Latest Receivers and Circuits
The Home Entertainment Center
Projection TV Today
Satellite TV Receivers
Jack Darr's Monthly Service Clinic
Service Problems and Solutions
- **AND you also get these regular MONTHLY FEATURES:**
 - **LOOKING AHEAD** by Dave Lachenbruch
 - **HOBBY CORNER** by "Doc" Savage
 - **STATE-OF-SOLID-STATE** by Bob Scott
 - **WHAT'S NEWS**, new products, stereo news
 - **VIDEOGAMES**, new products, game reviews
 - **and NEW IDEAS, STEREO PRODUCTS, NEW COMPUTER PRODUCTS FOR HOME/JOB and MUCH MORE!**

Subscribe today to **Radio-Electronics**. Don't miss a single issue and . . . you save as much as \$13.03 off the newsstand price.

When you select one of the subscription offers listed on the handy coupon—you'll be assured of having your copy reserved, even if it sells out on the newsstand. Make sure you get all the excitement in every issue of **Radio-Electronics**, every month, by filling in and mailing the coupon, today.

Mail to: **Radio-Electronics**
P.O. Box 2520, Boulder, CO 80322

Every Month!
Get the Best—Mail Today!

7HD44

- 1 year—12 issues only \$14.97 (You save \$6.03 off newsstand price.)
- 2 years—(Save More)—24 issues—\$28.97 (Save \$13.03 off the newsstand price.)

- Payment Enclosed
- Bill Me

Name _____ (please print)

Address _____

City _____ State _____ Zip Code _____

Offer Valid In U.S. Funds Only

Allow 6-8 weeks for delivery of first issue

Canada—Add \$3.00 per year

All other countries—Add \$7.50 per year

PARTS LIST

All resistors 1/4-watt, 5%, unless noted

R1—68 ohms
 R2, R5, R36, R38, R40, R42, R52—5000 ohms, trimmer potentiometer
 R3—200 ohms, trimmer potentiometer
 R4, R12, R14, R39, R41, R53—1000 ohms
 R6, R23, R37—3300 ohms
 R7, R15, R18, R48—4700 ohms
 R8—75 ohms
 R9, R10—220 ohms
 R11—100 ohms
 R13, R47—470 ohms
 R16—27,000 ohms
 R17—2200 ohms
 R19, R20—R22, R24—R27, R29—R31, R33, R43, R45, R50, R51, R54—R56, R63, R65, R69—10,000 ohms
 R28—1 megohm
 R32, R62—47,000 ohms
 R34—10,000 ohms, trimmer potentiometer
 R35—68,000 ohms
 R44—50,000 ohms, trimmer potentiometer
 R46, R61, R66—100,000 ohms
 R49, R67, R68—15,000 ohms
 R57, R58, R60, R64—33,000 ohms
 R59—22,000 ohms

Capacitors

C1—0.002 μ F, ceramic disc
 C2, C4—0.001 μ F, ceramic disc
 C3—75 pF, mica
 C5, C8, C24—C26, C29—0.1 μ F, ceramic disc
 C6, C7—47 pF, ceramic disc
 C9, C10, C15, C16, C32—100 pF, ceramic disc
 C11, C28, C30, C34—C37, C42—0.1 μ F, ceramic disc
 C12, C31, C41, C43—1 μ F, 16 volts, tantalum
 C13—0.2 μ F, ceramic disc
 C14—330 pF, ceramic disc
 C17, C33—22 pF, ceramic disc
 C18, C19, C21—10 pF, ceramic disc
 C20—470 pF, ceramic disc

C22—5–40 pF, trimmer capacitor
 C23—10 pF, ceramic disc
 C27—5 pF, ceramic disc
 C38, C39—4700 μ F, 16 volts, electrolytic
 C40—1000 μ F, 16 volts, electrolytic

Semiconductors

IC1—LH0002CN current amplifier (National)
 IC2, IC21, IC27—4066 quad bilateral switch
 IC3—LM1889 TV video modulator
 IC4—LM1886 TV video matrix D/A converter
 IC5—74LS32 quad OR gates
 IC6—74LS03 quad NAND gates
 IC7—IC15—74LS151 one-of-eight selector/multiplexer
 IC16, IC23, IC24—74LS161 synchronous 4-bit counter
 IC17—74LS00 quad NAND gates
 IC18—74LS20 dual 4-input NAND gate
 IC19, IC28, IC30, IC42—4049 hex inverting buffer
 IC20—74LS191 synchronous up/down counter
 IC22—74LS73 dual J-K flip-flop
 IC25—74LS174 hex D-type flip-flop
 IC26, IC39—74LS123 dual retriggerable monostable multivibrator
 IC29, IC31—74C00 quad NAND gates
 IC32—74LS30 8-input NAND gates
 IC33—7402 quad NOR gate
 IC34—74LS169 4-bit synchronous up/down counter
 IC35—7473 dual J-K flip-flop
 IC36—MM5321 TV camera sync generator (National)
 IC37—74LS365 hex bus driver
 IC38—74LS93 4-bit binary counter
 IC40—LM318 op-amp
 IC41—74LS08 quad AND gate
 IC43—LM340T5 5-volt regulator, TO-220 case
 IC44—LM340K5 5-volt regulator, TO-3 case

IC45—LM340T12 12-volt regulator, TO-220 case
 IC46—LM320T12 12-volt negative regulator, TO-220 case
 Q1, Q4—2N2222A
 Q2, Q3—MPS918
 Q5—MPSA05
 D1, D3—D18—1N914 or 4148
 D2—1N746A
 S1—7-position rotary switch (Allied 7471001 or similar)
 S2—pushbutton switch, normally closed
 S3—SPDT toggle switch
 S4—SPST toggle switch
 LED1—standard red
 T1—Transformer (Triad F-166XP or similar), primary: 117 volts; secondary: 24 volts, center-tapped, .125 amps; 9 volts, center-tapped .5A
 BR1, BR2—bridge rectifier, 1.5 amps
 L1—0.071–0.082 mH adjustable coil (J.W. Miller 48A778MPC or similar)
 L2—7–12 μ H adjustable coil (J.W. Miller 23A105RPC or similar)
 XTAL1—14.31818 MHz crystal
 F1—fuse, 1 amp, pigtail leads
 J1—BNC jack
 J2—type N jack
 J3–J5—standard tip jacks

Miscellaneous—Heat sinks, cabinet (Pactec CM86-225), power cord, strain relief, T0-3 mounting kit, IC sockets, etc.

The following are available from Jengco, 3232 San Mateo, Suite 75, Albuquerque, NM, 87110: Complete kit including PC boards, all components, cabinet (no IC sockets), \$295; Etched, drilled, and silkscreened PC boards (boards A and B), \$49.50; Complete test generator, assembled and tested, \$395. Please add 5% for postage and handling, New Mexico residents add 4.25% sales tax, allow 6–8 weeks for delivery.

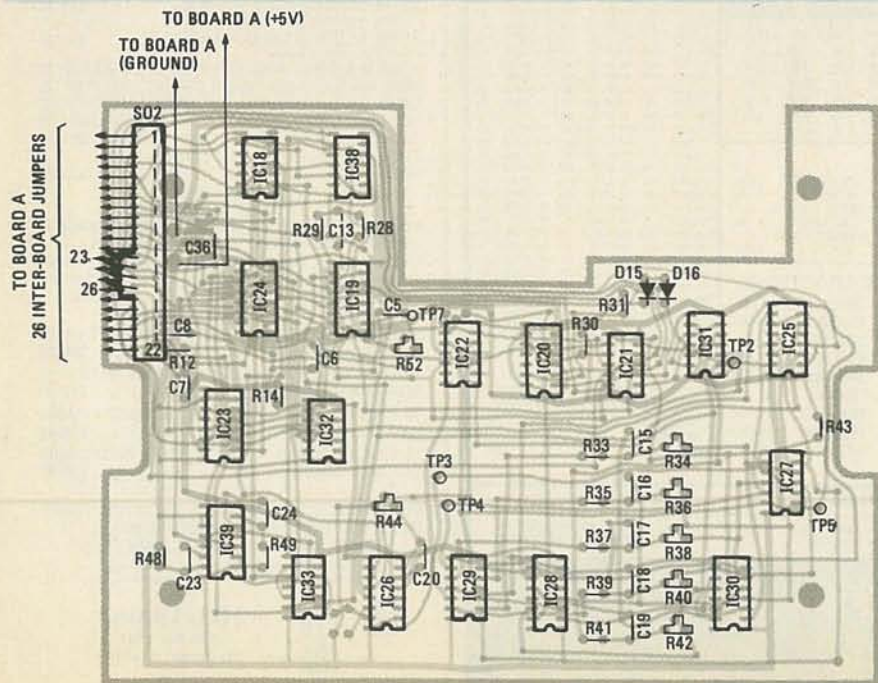

color-bars signal can also be used to check chroma demodulators.

Interfacing the generator

A standard 34-pin card edge is available at the back of the unit. Refer to Table 2 for the pinout configuration. Numerous sync-family signals are provided as TTL level outputs (horizontal drive, vertical drive, composite sync, composite blanking, and colorburst gate). Those signals are useful in a variety of applications such as driving switches. The vertical-drive and horizontal-drive signals are handy for driving two or three video cameras (for example: in a security system), thereby synchronizing them for input to a simple switcher or VCR. That avoids the loss of sync which usually causes picture roll. A composite sync at video levels can also be derived from the generator by using the gray-level signal adjusted for blanking (gray level = 0) and taking the output from the front-panel BNC VIDEO OUT connector.

continued on page 109

CPU'S & SUPPORT CHIPS		INTER FACE & DRIVERS	
8259	5.95		
8275	24.50		
8279-5	6.95		
8035	6.95	8288	25.00
8080A	2.75	8355	12.95
8085A	2.50	8356	19.95
8086	22.50	Z80A CPU	4.75 1488 1.50
AMD 2901	8.95	Z80B CPU	12.95 1489 1.50
8156	8.95	Z80A CTC	6.75 3341A 2.95
8202	19.95	Z80A DART	0.00 8130 2.50
8205	6.50	Z80A S10	10.95 8830 2.50
8212	3.50	Z80A P10	4.95 8833 2.50
8214	4.50	TMS 9927 NL	9.95 8834 2.00
8216	3.50	6502	5.75 8837 2.00
8224	4.50	8803L	12.95 8838 2.50
8226	3.50	8809	6.95 AY31015D 5.75
8237	14.00	8810	3.50 AY51013A 3.75
8238	3.95	6821	4.50 AY53600 9.95
8250	10.95	6845	13.95 BR1941L 8.95
8251	4.50	6850	3.95 CRT5037 18.95
8253	5.95	6875	4.00 MMS307 7.95
8257	7.95	6800L8	39.50 MMS369 2.50
		TR1602B	3.95

EPOXY GLASS VECTOR BOARD					
1/16" thick with 1/10" spacing					
4 1/2" x 6 1/2" \$1.95					
SCR's			TRIAC's		
100	6A	35A	PRV	1A	10A 25A
1.00	.35	.40	1.40	1.00	.35 .60 1.40
200	.40	.50	1.40	200	.50 .80 1.90
400	.60	.70	2.40	400	.70 1.00 2.60
600		1.00 3.60		600	1.00 1.20 3.60

C/MOS	
4001	40
4002	40
4006	80
4007	40
4008	70
4009	50
4010	60
4011	45
4012	45
4013	60
4014	70
4015	60
4016	70
4017	100
4018	70
4019	70
4020	80
4021	80
4022	100
4023	40
4024	70
4025	40
4026	95
4027	95

TRANSISTOR SPECIALS	
2N1307 PNP GE TO-18	\$.40
2N4004 PNP GE TO-18	\$1.00
HEP 00014 - PNP GE TO-18	\$.85
TIP 111 - .50 TIP 146	\$1.35
2N4223-NPN SWITCHING POWER	\$1.95
MRF-8004 CM RF TRANSISTOR NPN	\$1.75
2N4900 PNP SI TO-3	\$1.00
TIP 2665 PNP SI	\$.70
2N2222 NPN SI TO-18	\$1.00
2N2907 PNP SI TO-18	\$1.00
2N3006 NPN SI TO-3	\$.60
2N3904 NPN SI TO-92	\$1.00
2N3906 NPN SI TO-18	\$1.00
2N6109 PNP SI TO-220	\$.55
TIP 318 NPN SI TO-220	\$.40
TIP 320 PNP SI TO-220	\$.40
TIP 41 PNP SI	\$.95
TIP 121 PNP SI UM	\$.60
TIP 141 NPN SI U97	\$1.00
DISP2000 - DUAL POWER DARL	\$1.75
MAJEX66T	\$.80

SHIFT REGISTERS		DISC CONTROLLERS	
MM1402	1.75	1771	15.50
MM1403	1.75	1793	35.00
MM1404	1.75	1795	45.00
MM5013	2.50		
MM5056	2.50	1797	45.00
MM5056	2.50	D765C	35.00
MM5057	2.50		
MM5058	2.50		
MM5060	2.50		

RAM's		WIRE WRAP	
2101A-4	1.50	NO. 30	
2102-3	.90	WIRE SINGLE	
2111A	2.50	STRAND	
2532	7.95	100'	\$1.40
2708	3.50		
2712B	22.50		
2716 + 5V	4.95		
2732	7.95		
2764	9.95		
3628A-3	3.00		
6331	1.95		
TP818542	3.50		
TP8285166	9.50		
745474	3.95		
7463-5	3.95		
82523	2.50		
825126	1.95		
825130	1.95		
825181	6.95		
825191	9.50		

TTL IC SERIES	
7400	35
7401	30
7402	35
7403	35
7404	50
7405	50
7406	40
7407	40
7408	50
7409	40
7410	30
7411	30
7412	30
7413	45
7414	75
7415	75
7416	30
7417	30
7418	30
7419	30
7420	30
7421	30
7422	30
7423	110
7424	30
7425	30
7426	30
7427	30
7428	30
7429	30
7430	30
7431	30
7432	30
7433	30
7434	30
7435	30
7436	30
7437	30
7438	30
7439	30
7440	30
7441	30
7442	30
7443	30
7444	30
7445	30
7446	30
7447	30
7448	30
7449	30
7450	30
7451	30
7452	30
7453	30
7454	30
7455	30
7456	30
7457	30
7458	30
7459	30
7460	30
7461	30
7462	30
7463	30
7464	30
7465	30
7466	30
7467	30
7468	30
7469	30
7470	30
7471	30
7472	30
7473	30

LINEAR CIRCUITS	
DA008EQ	3.75
TL062 CP	.96
TL064 CN	1.50
TL072	1.25
TL082	1.50
LM201	.75
LM301/748	.50
LM307	.50
LM308	.65
LM310	1.10
LM311	.80
LM319	1.30
LM324	1.25
LM339	.90
LM348	.90
LF351	.80
LF353	.95
LF355	.90
LM358	.50
LM361	1.75

74S SERIES	
74S00	.40
74S02	.40
74S04	.40
74S06	.50
74S10	.40
74S11	.45
74S15	.50
74S20	.45
74S22	.40
74S32	.80
74S43	.85
74S51	.70
74S74	1.10
74S85	1.10
74S88	.90
74S89	2.20
74S112	.85
74S124	2.00
74S133	.50
74S138	1.25
74S139	1.10
74S140	.45
74S151	1.25
74S157	1.25
74S161	1.75
74S163	1.40
74S174	1.40
74S175	1.40
74S181	2.20
74S182	1.75
74S194	1.10
74S196	1.50
74S198	1.50
74S240	1.00
74S241	1.50
74S257	1.30
74S260	1.50
74S373	2.25
74S374	1.75

DISC CONTROLLERS	
1771	15.50
1793	35.00
1795	45.00
1797	45.00
D765C	35.00

TOGGLE SWITCHES	
106D - SPDT - 1.00	
206D - DPDT - 1.40	
296P - DPDT CENTER OFF 1.60	
IN4148 (IN914) 15/1.00	
1411-IR DETECTOR 3/61.00	
FP 100 PHOTO TRANS \$.50	
RED LED'S 2" 8/61.00	
YEL, GREEN or AMBER LARGE LED'S 2" 6/61.00	
RED-GREEN BIPOLAR LED \$.90	
RED-YELLOW BIPOLAR LED \$.90	
MLED92 IR LED \$.40	
MRD148 PHOTO DARL. XTOR \$.50	
MCT2 OPTO ISOLATORS \$.60	
1 WATT ZENERS: 3.3, 4.7, 5.1, 5.6, 6.8, 8.2, 9.1, 10, 12, 15, 18, or 22V 6/61.00	

4164-2 - \$6.25	
4164-15 - 100/\$660.00	
4116-3 - 100/\$100.00	
2114-3 - 100/\$100.00	
2N3820 P FET \$.45	
2N5457 N FET \$.45	
2N2646 UJT \$.45	
ER 900 TRIGGER DIODES 4/61.00	
2N 6028 PROG. UJT \$.65	

74LS SERIES	
74LS00	.50
74LS01	.50
74LS02	.50
74LS03	.50
74LS04	.50
74LS05	.50
74LS06	.50
74LS07	.50
74LS08	.50
74LS09	.50
74LS10	.50
74LS11	.50
74LS12	.50
74LS13	.50
74LS14	.50
74LS15	.50
74LS16	.50
74LS17	.50
74LS18	.50
74LS19	.50
74LS20	.50
74LS21	.50
74LS22	.50
74LS23	.50
74LS24	.50
74LS25	.50
74LS26	.50
74LS27	.50
74LS28	.50
74LS29	.50
74LS30	.50
74LS31	.50
74LS32	.50
74LS33	.50
74LS34	.50
74LS35	.50
74LS36	.50
74LS37	.50
74LS38	.50
74LS39	.50
74LS40	.50
74LS41	.50
74LS42	.50
74LS43	.50
74LS44	.50
74LS45	.50
74LS46	.50
74LS47	.50
74LS48	.50
74LS49	.50
74LS50	.50
74LS51	.50
74LS52	.50
74LS53	.50
74LS54	.50
74LS55	.50
74LS56	.50
74LS57	.50
74LS58	.50
74LS59	.50
74LS60	.50
74LS61	.50
74LS62	.50
74LS63	.50
74LS64	.50
74LS65	.50
74LS66	.50
74LS67	.50
74LS68	.50
74LS69	.50
74LS70	.50
74LS71	.50
74LS72	.50
74LS73	.50
74LS74	.50
74LS75	.50
74LS76	.50
74LS77	.50
74LS78	.50
74LS79	.50
74LS80	.50
74LS81	.50
74LS82	.50
74LS83	.50
74LS84	.50
74LS85	.50
74LS86	.50
74LS87	.50
74LS88	.50
74LS89	.50
74LS90	.50
74LS91	.50
74LS92	.50
74LS93	.50
74LS94	.50
74LS95	.50
74LS96	.50
74LS97	.50
74LS98	.50
74LS99	.50

DIP SWITCHES	
CTS 206-4	4 POSITION .75
CTS 206-7	7 POSITION .95
CTS 206-8	8 POSITION .95
CTS 206-10	10 POSITION 1.25
8 PIN .10	DIP 28 PIN .25
14 PIN .15	SOCKETS 24 PIN .25
16 PIN .18	28 PIN .35
18 PIN .20	40 PIN .40
20 PIN .25	
14 PIN - .45	
16 PIN - .50	
18 PIN - .65	
20 PIN - .80	
24 PIN - 1.10	
28 PIN - 1.25	
40 PIN - 1.80	

DISC CONTROLLERS	
1771	15.50
1793	35.00
1795	45.00
1797	45.00
D765C	35.00

PRINTED CIRCUIT BOARD	
4" x 6" DOUBLE SIDED EPOXY BOARDED 1/16" THICK	\$1.00
6" x 8"	\$1.60
8" x 10"	\$2.60

POSTAGE RATES	
ADD 10% FOR ORDERS UNDER \$25.00	
ADD 5% FOR ORDERS BETWEEN \$25.00 & \$50.00	
ADD 3% FOR ORDERS ABOVE \$50.00	

FULL WAVE BRIDGE	
PRV 2A 6A 25A	
100 1.40	
200 1.30 2.20	
400 1.00 1.65 3.30	
600 1.30 1.90 4.40	

SILICON POWER RECTIFIERS	
PRV 1A 3A 12A 50A 125A 240A	
100 .05 .14 .35 .90 5.00 6.00	
200 .06 .17 .50 1.30 7.00 9.00	
400 .09 .25 .85 1.90 10.00 12.00	
600 .11 .30 .80 2.00 13.00 18.00	
800 .13 .35 1.00 2.50 16.00 18.00	
1000 .20 .45 1.25 3.00 20.00 26.00	

REGULATORS	
LM338K \$5.75	
LM317T \$1.35	
78L05, 78L12 \$.40	
340T-5, 6, 8, 9, 12, 220T \$.50	
15, 18, or 24V \$.75	
320T 5, 12, 15 or 24 \$.85	
LAS1412 + 12V \$3	

CABLE TV CONVERTERS



A
LCC-91
TV Remote Controller

A. JERROLD LCC-91

- Remote Control Lets You Change TV Channels From the Comfort of Your Chair
- Turn Your TV Set On and Off Without Touching the Dial
- 66 Channel Capacity
- Lighted Digital Display On the Converter Indicates the Channel
- Simple Do It Yourself Installation In Minutes
- Works With All TV Models and Compatible With All Cable Systems
- Guaranteed One Year By More Than 300 General Instrument Warranty Stations



B
LCC-58
(Formerly Model DRX-105)
TV Remote Controller

B. JERROLD LCC-58

- Remote Control Lets You Change TV Channels From the Comfort of Your Chair
- Turn Your TV Set On and Off Without Touching the Dial
- 58 Channel Capacity
- Lighted Digital Display On the Converter Indicates the Channel
- Simple Do It Yourself Installation In Minutes
- Works With All TV Models and Compatible With All Cable Systems
- Guaranteed One Year By More Than 300 General Instrument Warranty Stations



Model JRX
Remote

C. JERROLD #JRX-3

- 37 Channel Capability
- Cord Type Remote Control
- Remote Channel Selection
- Remote-Fine Tuning



Model JSX
Set-top

D. JERROLD #JSX-3

- 37 Channel Converter
- Set-Top Model

	MANUFACTURE	MODEL #	RETAIL
A	JERROLD	LCC-91	129.00
B	JERROLD	LCC-58	119.00
C	JERROLD	300 JRX-3	79.00
D	JERROLD	300 JSX-3	69.00

LARGE QUANTITY DEALERS INVITED. SPECIAL PRICING ARRANGED.

G M HIGH TECH
"Your Cable Warehouse"

P.O. Box 694412
Miami, Florida 33269
305-651-2637

CIRCLE 26 ON FREE INFORMATION CARD

ATTENTION TECHNICIANS

ARE YOU TIRED
of being

"only a serviceman"
or
"just a technician"?

THE LETTERS "CET"
AFTER YOUR NAME SPELLS
"PRIDE"

TRY IT.

Take pride in
your profession—
Decide to be a CET



For information about: ___ exam dates,
___ requirements; ___ study guides,
other _____

Send to: NESDA/ISCET
2708 W. Berry St.
Fort Worth, TX 76109
(817) 921-9101

Name _____

Address _____

City _____ St. _____ Zip _____

SURPLUS "Unused" BARGAINS

NEW

SHIPMENT of EXPERIMENTERS SPECIALS! WHILE THEY LAST!!!



Dual SA-400 Mini-Floppy w/power supply fan,
Z-80 controller board w/2716 roms, in Bur-
roughs case. W/schematics

Unused
\$299⁰⁰ ea.



Dual Sided, Dual Minidiskette Drive w/supply
& 2 TEAC... (w/SA-400 interface) Mini-Floppy
Drives in DEC case.

Unused
\$250⁰⁰ ea.



9" Composite Video input CRT Monitor
requires approx. 12 VDC @ 1-2A VDC in attrac-
tive case. With schematics

Unused
\$89⁰⁰ ea.



I/O IBM "Selectric" Type-writer/Printer
w/TTL input, driver transistors & solenoids. With
220 VAC, motors installed, plus used spare 60
HZ, 110VAC motor included Free. With data.

Unused
\$459⁰⁰ ea.



CRT Terminals built by a major OEM, these
terminals include 3 microprocessor boards (In-
terface, CPU & CRT) plus composite video &
switching power supply 48 K of roms, "Ergo-
nomic" design and more. Experimenter spec-
ial, includes Data, Keyboard, RS-232 I/O plus
much more. Seems to be quite powerful.

Only!!
\$289⁰⁰ ea.

We Offer New & Used FLOPPY DRIVES, DISK DRIVES, PRINTERS, & MORE at BARGAIN PRICES!!

Write or Call for Our Latest Flyer NOW!!!

*Selectric is a registered trademark of IBM Corporation

Computer
Products &
Peripherals
Unlimited

WAREHOUSE: 18 Granite St., Haverhill, Mass. 01830
MAIL ORDERS: Box 204, Newton, New Hampshire 03858

617/372-8637

Sorry No Collect Calls
MasterCard & VISA Accepted

CIRCLE 68 ON FREE INFORMATION CARD

DON'T FORGET



USE
YOUR
READER
SERVICE
CARD

TUSA
A WHOLE NEW WORLD OF TV VIEWING WITH TUSA'S
NEW MODEL CVU-40, 40 CHANNEL CABLE TV CONVERTER
Receive all the EXTRA CABLE TV "MIDBAND" & SUPERBAND
CHANNELS on your UHF DIAL.
Eliminates the need for renting or leasing. This system takes
the "midband" and "superband" channels your TV, VCR or
projector can't receive and converts them to standard UHF
channels that any set can tune in.
A MUST FOR VIDEO-TAPING FROM CABLE TV!
The system allows you to program both pay per view TV decoder required and standard
cable channels for taping on any VCR - while you are
watching a different channel on your TV.
Simple to install and operate on any make of TV with UHF. **Now \$28.95 ea.**
PLUS POSTAGE

NOW AVAILABLE
NEW TUNEABLE DELUXE MODEL CVU-1000 **\$34.95 ea.**

WINGARD 7-ELEMENT
75 OHM UHF YAGI ANTENNAS
12 db GAIN
Specify Channel
\$8.95 ea.
8 OR MORE
\$39.95 ea.
\$7.95 ea.

Now Back in Stock!
SANYO UHF VARIATOR TUNERS
75 Ohm Input - 45 MHz Output
For Channels 14 - 83
MODEL 115-9-033A **\$18.95**
EACH
All units are brand new from Sanyo
Call for Quantity Price

UHF TUNERS
45 MHz
Output
Click Stop Detent Tune
model. Excellent for replace-
ment use or experimental
work building UHF receivers
for ham or TV.
WHILE THEY LAST
\$3.95 ea.
10 or more \$2.99 ea.

**POPULAR
MICROWAVE
PARTS**
MRF-601 \$2.39
8-Up 1.95
MRF-911 3.46
8-Up 3.12
MBO-10158
CHIP CAPS - .001 mfd30
2K-Up30
2N6603 (formerly MRF 902) 11.96

POPULAR IC's
TOP QUALITY
NO SECONDS

TYPE	DESCRIPTION	1-9	10-UP
LM-300N	2 watt Audio Power Amp	\$1.49	\$.89
LM-300N-3	Low Voltage Audio Amp	1.59	1.19
LM-600N	Phase Locked Loop	1.49	.99
LM-733N	Video Amp	1.69	.99
MC-1300	Video Detector	2.29	1.69
MC-1349	Video If Amp	2.06	1.55
MC-1350	Video If Amp	1.75	1.19
MC-1352	Video If Amp AGC	2.69	2.09
MC-1358	Audio If Amp	1.75	1.64
MC-1374P	R.F. Modulator	3.19	2.39
MC-1458	Dual Comp. Cip Amp	.89	.59
LM-1492N	Balanced Mod/Demodulator	1.79	1.34
LM-1889	Video Modulator	2.79	1.95
LM-7805	LINEX VOLTAGE REGULATORS	1.19	.89
LM-7808	5 Volt Positive Volt. Reg.	1.19	.89
LM-7812	12 Volt Positive Volt. Reg.	1.19	.89
LM-7815	15 Volt Positive Volt. Reg.	1.19	.89
LM-7818	18 Volt Positive Volt. Reg.	1.19	.89
LM-7824	24 Volt Positive Volt. Reg.	1.19	.89
LM-7805	LINEX VOLTAGE REGULATORS	1.19	.89
LM-7808	5 Volt Positive Volt. Reg.	1.19	.89
LM-7812	12 Volt Positive Volt. Reg.	1.19	.89
LM-7815	15 Volt Positive Volt. Reg.	1.19	.89
LM-7818	18 Volt Positive Volt. Reg.	1.19	.89
LM-7824	24 Volt Positive Volt. Reg.	1.19	.89

THE ORIGINAL NE-564 IS NOW BACK IN STOCK!
\$3.50 Each No minimum order.

**SPEAKER
CABINET**
Popular speaker
cabinets for those
famous homebrew
TV circuits.
Speakers included.
Dimensions: 7 1/2" wide x 9 1/2"
high x 5 1/2" deep. Removable 1/8"
thick back cover.
SC001 **\$10.95 ea.**
2 or more **\$8.95 ea.**

**QUALITY
POWER TRANSFORMERS**
24V CT, 500 mA.
\$3.19 ea. 10-49 \$2.75 ea.
50 or more \$2.25 ea.
For Larger Quantities Call

**NEW 1984
B&K AUTO/MANUAL
RANGING
MULTIMETER**
MODEL 2807
SPECIAL PRICE!
\$94.00 ea.
B&K PRECISION

WALH SOLDERING IRONS
Your Choice **\$42.50**
MODEL 7470
Temperature-Adjustable
More Soldering Station
Comps. 50W to 70W
Perfected for more circuits
and fine mg. Grounded
tip. Comes with 3/32"
8 type tip, lip wiping
sponge & stand
3 wire grounded
power supply cord

**JERROLD 400
DIGITAL CATV CONVERTER**
You can receive all cable channels including
the hyperband, with the convenience of an
integral remote control. This unit receives
up to 80 TV channels and outputs them to
Channel 3. With the remote control you can
change channels, turn your TV on or off, or
even tune to 2, without leaving your chair.
Note: To receive the cable
channels, the head
subsidiary to your TV
is a necessity. **\$119.95 ea.**

**PROJECT
BOXES**
Woodgrain
This box is 11 1/2" W - 4 1/2" H -
6 1/2" D with a removable alumi-
num U-shaped chassis 11" W -
3 1/2" H - 6" D inside.
\$12.50 ea.
4 or more **\$10.95 ea.**
PREPUNCHED &
SILKSCREWED **\$14.95 ea.**
For Larger Quantities Call!

**THE BRAND NEW WINGARD
Pho-ne-A-Fenn**
EXTENDS CORDLESS TELEPHONE
RANGE UP TO 3 TIMES!
Here's the best
quality, best
working phone
antenna on the
market. Simple
installation!
Mounts outdoors.
Does not void
telephone
warranty.
COMPLETE KIT
includes antenna,
40 coaxial cable,
adaptor and easy
instructions.

**SONY
SURPLUS UHF-VHF
VARIATOR TUNERS**
These tuners receive all chan-
nels 2-83, plus midband cable
channels and are perfect for
homebrew TV circuits, etc.
Output Freq. 45 MHz. Hookup
data included. Name Brand.
#852
NOW! **\$15.95 ea.**

Now Back in Stock!
MITSUBI
UHF
VARIATOR
TUNERS
75 Ohm Input - 45 MHz Output
For Channels 14 - 83
NEW LOW PRICE **\$15.95 ea.**
All units are brand new
Call for Quantity Price

**DELUXE
A-B
SWITCHES**
Specify
Pushbutton
or lever type
For CATV - MATV - VCR
75 ohm - 90 db isolation
\$6.50 ea.
2 or more **\$5.95 ea.**

**ORDER NOW
TOLL FREE
800-854-4655
OUTSIDE CALIFORNIA
714-635-5090
INSIDE CALIFORNIA**

R.F. ELECTRONICS
1086 G N STATE COLLEGE BLVD., DEPT. R
ANAHEIM, CALIFORNIA 92806

PERSONAL CHECKS HELD FOR CLEARANCE - NO MINIMUM ORDER
ALL PREPAID ORDERS 2 LBS OR LESS MUST INCLUDE \$2.50 SHIPPING & HANDLING - SHIPPED SAME DAY RECEIVED

OPEN
TUES - FRI
10-18
SAT 10-5
CLOSED SUN & MON

SEND
FOR
Mail Order
Catalog

**Call or Write Us
for Your Crystals**
- just one or hundreds -
for Communications -
for Industrial Use
for Your Technology

You will get
• Cost Savings
• Prompt Service
• High Stability

**JAN
CRYSTALS**

Serving Crystal Users Since 1958

JAN CRYSTALS
P.O. Box 16017, Fort Myers,
Florida 33906 All Phones
(813) 936-2397

VISA MasterCard

CIRCLE 27 ON FREE INFORMATION CARD

CIRCLE 38 ON FREE INFORMATION CARD

MOVING?

Don't miss a single copy of **Radio-Electronics**. Give us:

Six weeks' notice

Your old address and zip code

Your new address and zip code

ATTACH LABEL HERE

name (please print)

address

city state zip code

Mail to: Radio-Electronics
SUBSCRIPTION DEPT., P.O. BOX 2520,
BOULDER, COLO. 80322

FINEST QUALITY

Government Approved QQ-S-571e

SOLDER

SPECIAL FOR THE MONTH

SN 60/40 Rosin Core (RA)



One lb. Reels		
16	swg. (.064)	\$7.95
18	swg. (.048)	\$8.45
19	swg. (.040)	\$8.95
20	swg. (.036)	\$9.45
21	swg. (.032)	\$9.95
1/2 lb. Reels		
22	swg. (.028)	\$5.95
24	swg. (.022)	\$7.95

SN 62 (2% Silver) Eutectic-Rosin Core

21	swg. (.031)	\$19.95
----	-------------	---------

Plus FREE Desoldering Wick with each pound of solder

FREE Freight On All Orders Over \$25

Under \$25 add \$2.50 per order. Minimum order \$10

Check Money Order Master Charge Visa

N.Y. State residents add appropriate sales tax.

To place your order call:
TOLL FREE 800-645-4808

In NYS (516) 334-2660 No COD's accepted

SolderCraft™
P.O. Box 668 Jericho, N.Y. 11753

CIRCLE 58 ON FREE INFORMATION CARD

FREE GIANT CATALOG

Send for our FREE 1984 catalog of electronic components, kits, IC's, computer software, computer peripherals and unique items.

PARTS SUPER SPECIALS!

MICRO MINIATURE SPEAKER
Only 9/16" diameter mounted on a 1" square PC board. With 3" long flexible leads.
C4832 \$4.95



KESTER PC TYPE SOLDER
A foot coil of ultra thin diameter low melting temperature 60/40 rosin core solder for PC work. Its high quality solder is perfect for soldering our kits.
C4456 \$1.00

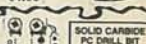

SOUND EFFECTS GENERATOR KIT
Exciting sound effects kit uses the popular T176477 chip to develop phaser, locomotive, siren, twirling bird, organ, Model T, etc. sounds. Uses dip switch for simple programming of the generator. Operates from 9V battery. Size of board: 3.25" x 2".
C4422 \$14.95

SOLD CARBIDE
PC ONLY KIT
55 .082" diameter
55 .082" diameter
55 .082" diameter
C4610 \$1.29 EACH

BOX OF RESISTORS

Tremendous bargain assortment contains all types of resistors including 1/4 watt, 1/2 watt, precision, power, slip resistors, etc. Adjustable, etc. At least 1000 resistors in a box.
C6063 \$5.00

BOX OF CAPS

Super assortment of disc, electrolytic, electrolytic, mica, etc. All marked and printed. Some have pc leads. Box contains at least 250 pieces.
C4610 \$5.00

VALUABLE SURPRISE PACKAGE

We have a tremendous quantity of various items which we have too few to advertise. We have packaged a good assortment containing various semiconductors, resistors, capacitors, hardware, etc. None of these items are surplus or rejects, all are factory prime and the package is really worth the price.
C3574 \$2.00

Super assortment of disc, electrolytic, electrolytic, mica, etc. All marked and printed. Some have pc leads. Box contains at least 250 pieces.
C4610 \$5.00

120VAC VARIABLE STROBE LIGHT KIT
Complete variable rate strobe light kit produces brilliant flashes of light. Operates from standard 120VAC. Reliable design—thousands of these are in use throughout the world. Overall size of completed board: 3" L x 2" W x 3" H.
C3071 \$9.99

PAC TEC ELECTRONIC ENCLOSURE
Professional looking case is great for instruments and projects. Black textured plastic finish with removable front panel. Size: 8" W x 8" H x 1 1/2" D. C6006 \$8.95

FASCINATION STAR KIT
Produces an "explosive" sound effect using 2x LR50 and 2x C-circuits. Kit with all parts and pc board.
C4432 \$10.95

3 CHANNEL COLOR ORGAN KIT
Handles up to 300W 25K channel and up to 25K input. Complete with all parts and pc board.
C4530 \$9.50

NEGATIVE ION GENERATOR BOARD
Brand new circuit board emits negative ions that remove dust, particles, dust, etc. from air. Only 1" square. Requires 12V to 18VDC for operation.
C6602 \$14.95

CHANEY electronics inc.
P.O. BOX 27038
DENVER, COLORADO 80227
303 781 5750

Phone Orders
303 781 5750

• Minimum AD Order \$9.00
• Please include \$2.00 for postage (LIPS)
• VISA, MC accepted
• Phone orders are welcome

Send for our free catalog of unique items

CIRCLE 34 ON FREE INFORMATION CARD



TEST EQUIPMENT DISCOUNT PRICES

V-209

DC-20MHz • Dual Trace
Battery Operated



MINI-PORTABLE
Reg. \$945
\$745 SAVE \$200

V-509

DC-50MHz • Dual Trace
Delayed Sweep



MINI-PORTABLE
Reg. \$1399
\$1149 SAVE \$250

OSCILLOSCOPES

COMPLETE LINE OF INSTRUMENTATION AT THE MOST COMPETITIVE PRICES

CALL TOLL FREE FOR SAME DAY SHIPMENT SAME DAY SAVINGS

V-650F

60MHz • Dual Trace
Delayed Sweep



Reg. \$1195
\$995 SAVE \$200

V-1050F

100MHz • Quad Trace
Delayed Sweep



Reg. \$1980
\$1280 SAVE \$600

V-222

DC-20MHz • Dual Trace



Reg. \$695
\$545 SAVE \$150

V-422

DC-40MHz • Dual Trace



Reg. \$895
\$695 SAVE \$200

DIGITAL MULTIMETERS

3 1/2 Digit • 8 Functions •
+18° - +28°C Accuracy •
AC & DC • Resist • 500 Hours • Data Hold • w/Battery, Test Leads & Fuse • Auto range

VR-3510
Reg. \$187
\$137
VR-3525
Reg. \$147
\$107
VR-3550
Reg. \$127
\$97



SAVE UP TO \$50

V-6015

1MHz/2 Channels • 1000
Words Per Channel



Reg. \$1995
\$1695 SAVE \$300

V-6041

40MHz/2 Channels • 4000
Words Per Channel



CALL FOR SPECIAL PRICING
IN STOCK

TOTAL ELECTRONICS CENTER • OVER 70,000 ITEMS IN STOCK

WM. B. ALLEN SUPPLY CO. INC.
ALLEN SQUARE

300 BLOCK NORTH RAMPART STREET, NEW ORLEANS, LOUISIANA 70112

CALL TOLL FREE

800 535-9593

LOUISIANA TOLL FREE 800 462-9529

CIRCLE 56 ON FREE INFORMATION CARD

ADVERTISING INDEX

RADIO-ELECTRONICS does not assume any responsibility for errors that may appear in the index below.

Free Information Number	Page				
46	Acorn	111	74.30	Fordham Radio	15
3	Active Electronics	124	96	Formula	119
80	Advanced Computer Products	115	26	Gladstone	43
—	Advance Electronics	24-27-71	—	Global Specialties	14
12	All Electronics	125	—	GM High Tech	141
67	AMC Sales	112	—	Grantham College of Engineering	21
87	AP Products	Cover4	75	Halix	110
78	Augat	125	15.97	Haltronix	140
72	BBC	Cover3	85	Heath	9.69
100	Beckman Instruments	Cover2	—	Hickok	95
16	B&K	33	—	ICS	107
—	C&D	97	28	Instrument Mart	108
18	CEI	20	41	Jameco	130-131
34	Chaney	143	38	Jan Crystal	142
—	CIE	52-55	42	Javanco	124
23	Command Productions	116	49	JDR	126-129
35.86	Communications Electronics	2-87	88	Jim Pack	92-93
68	CPU	142	4	J&W	112
5	CRT	111	63	Kashiwagi	111
89	Dandy Manufacturing Co.	111	83	KCS	132
10	Dalbani	117	48	Kikusui	23
65	Digikey	122, 123	—	McGraw Hill Books	34-37
11	Digitron	124	93	McIntosh Labs.	97
53	Direct Video	110	66	MFJ	97
99	Dokay	134, 135	95	Mouser	109
54	DTI	12	90	Network Sales	136
81	Electra	11	84	Nemal Electronics Inc.	111
6	Electronic Specialists	120	—	Newtone Electronics	99
9	Electronic Warehouse	109	—	NRI	16-19, 46
94	Enterprise Development	107	31	NTS	102-105
39	Etronix	120	52	Pacific One	111
			47	Paia	44
				Philips ECG	13
				Phillips Tech Electronics	132
				Phoenix Systems Inc.	111
				Professional Video	132
				Protecto	60
				PTS	101
				Pulsar Technology Systems	44
				Radio Shack	80, 133
				Ramsey	137
				Random Access	111
				RCA Dist. and Special Projects	28, 29
				RE Book Store	132
				RF Electronics	142
				RSP Electronics Corp.	121
				Sams Book Store	77-79
				Scientific Systems	140
				SEI	136
				Simpson	42
				Sintec	30
				Solder Absorbing Technology	111
				Solid State Sales	140
				Solder Craft	143
				Sony Video	22
				Spartan Electronics	144
				Starshine	1
				Tektronix	5
				U.S. List Protection	88
				Vaco	38
				VIZ	31
				WM B. Allen	143
				Westech	118
				WS Jenks and Son	12
				Zenith	41



SPARTAN

Electronics Inc.

6094 Jericho Tpke.
Commack, N.Y. 11725

CALL (516) 499-9500
MAIL

CTC9R

Philips Remote Cable Converter



Micro computer technology • Quartz controlled IC's lock in picture & prevent drift • 60 channel selections • Programmable time on & off • 24 hour LED digital clock • Favorite channel memory & recall plus scan • Wireless hand held infra-red transmitter system • Automatic line tune • Adaptable to any brand television • One year warranty service.

\$139.95

COMPUTER CARE KIT

The Preventative maintenance kit for the office and home computer

Contains: Precision Duster, Zero Charge Anti-Static Screen and Keyboard cleaner, Zero Charge Anti-Stat.

\$18.95

SGL WABER

Protect your computer and electronic equipment from voltage spikes

\$35.95

DG115P
DG115S
(6 Outlet)
\$45.95

WINEGARD FM CAR ANTENNA BOOSTER



\$26.95

Amplifies FM radio signals an average of 18db (8 times). Improves car radio reception and extends range to allow greater selection of stations. Switch and indicator light attached to lower edge of dash. 24" cable with Motorola plugs provided. Installs in minutes. Great for window antennas.

BECKMAN CIRCUITMATE 20

8 functions and 30 ranges - Diode/transistor test function - auto-polarity, auto-zero, and auto-decimal - 10 Amps AC and DC Current Capability - Transistor Gain Test (hFE) - Conductance



\$64.95

REFURBISHED MONITORS

9", 12", Commercial

Grade as low as **\$39.95**



Jerrold 36 Channel Remote CATV Converter

w/on/off Fine Tuning \$94.95
58 Channel Wireless \$109.95



40 Channel VHF to UHF Block Converter

28.95 Ea.
24.95 4 & up
Deluxe Version - Features fine tuning knob, matching X former & 2 cables \$38.95



AUTO ALARM SYSTEMS

Keyless Automatic Passive

-arms when ignition is turned off
-automatic turn-off and reset timer



\$64.95

2000 Auto Watchman

-prevents use of master keys or the removal of ignition lock to start vehicle
-protects all foreign and American cars



\$34.95

EProms

2708
1024 x 8 **\$1.95**
While Quantities Last

BEFORE YOU PAY \$\$ FOR A TELEPHONE SERVICE CALL, TEST IT YOURSELF!!!

EK PRECISION

Telephone Line Analyzer Model 1042

- Tests telephone line functions that affect telephone operation
- Verifies line and ring voltage levels
- Checks condition of telephone line from central office to user's telephone jack
- Verifies telephone line polarity that can affect polarity sensitive telephones



\$19.95

PROFESSIONAL TELEPHONE PRODUCT TESTER

EK PRECISION

Features: **MODEL 1045**

- Provides basic operation tests for corded and cordless telephones, answering machines, and automatic dialers
- Checks telephone line cords and handset cords for continuity, shorts and interminents
- Verifies number dialed and redialled for pulse or touch-tone telephones
- Provides low and normal level ring test sequence
- Verifies that voice and DTMF (Dual Tone Multiple Frequency) levels are above minimum required level
- Can be used by the consumer without the aid of a salesperson—an easy-to-follow instruction card is provided with the tester
- Can be used by the salesperson to demonstrate operation and features of telephone products and to screen returns before making an exchange



\$335.95

Volume Discounts

Min. Order \$25.00
International shipping Add'l
Prices subject to change without notice

Dealers Welcome
Visa MC BAC Amex. All above prices include 4% cash discount
C.O.D. money order check Add for Shipping

to 75.00 \$2.50
76.00 to 250.00 \$4.50
251.00 to 500.00 \$6.00
501.00 to 750.00 \$8.50
751.00 to 1000.00 \$12.00

(516) 499-9500
Mon Th 9-8
Tu W F 9-6
Sa 9:30-5

CIRCLE 36 ON FREE INFORMATION CARD



look closer at a DSM!

Here's a flat-panel scope, a transient recorder, and a 32-range DMM in a compact 4 lb. box.

Now you can use one instrument to capture 2 μ s transients, evaluate their waveform characteristics on a flat-panel LCD, and simultaneously measure their true RMS values.

It's all made possible with the first in a new class of instruments from BBC, the Digital Scope Multimeter, Model M 2050 DSM. By applying precision European engineering to the measurement needs of design and service engineers, BBC is revolutionizing test and measurement.

Large Flat-Paneled Scope Display

The LCD provides excellent resolution, 128 dots by 64 dots, for waveform displays. It measures 4-5/8 in. (118 mm) x 1-5/8 in. (42 mm). Simultaneous display capabilities let you use the scope portion of the LCD to evaluate signal characteristics while the DMM portion displays the true RMS signal value. Your measurement evaluations will be more accurate and consistent.



Transient Recording

Two independent memories of 512 words (horizontal dots) with 8-bit vertical resolution let users capture information about events ranging from 2 μ s to 1-hr in duration. Five selectable trigger points (0, 25%, 30%, 75%, and 100%) give users options as to how much data is stored before and after the triggering event.

True RMS Multimeter Measurements

You get 15 voltage ranges (to 650V), 15 current ranges (to 10A), and two resistance ranges (200 Ω and 20k Ω). True RMS and Averaging RMS modes are switch selectable. All ranges are overload-protected (Spikes to 6,000 V or 60A).

Performance Packed and Portable

An impact resistant case protects the M 2050 DSM. When open, the display angle is easily adjustable. When closed, the display and the controls are protected, the meter shuts itself off, and the tilt bail becomes a carrying handle.

Affordable and Available

The price of the M 2050 DSM is only \$1,795.00 (for the optional analog output, add \$200.00). Rechargeable batteries for 8 hours of portable operation are available for \$35.00

BBC's M 2050 DSM and other innovative instruments are available via select distributors throughout the U.S. If your instrumentation supplier doesn't carry BBC yet, we'll gladly tell you who does. Call toll free:

1-800-821-6327
(In CO, 303-469-5231)

BBC-Metrawatt/Goerz
6901 W. 117th Avenue
Broomfield, CO 80020, Telex 45-4540

Engineering Excellence in Test and Measurement

BBC **GOERZ**
METRAWATT

CIRCLE 72 ON FREE INFORMATION CARD

Imagine that there was a single source for all your Interconnection needs.

There is. A P PRODUCTS has the most complete line of Interconnection products and accessories. DIP, Socket and Card-Edge connectors, all styles and sizes of Headers, and D-Submin in both IDC and solder versions. A P PRODUCTS offers flat cable in both gray and rainbow, in a wide variety of widths. And, our new low cost IDC assembly tool can help put everything together without putting a crimp in your budget.

Imagine that you could find high quality IDC products at affordable prices.

You can. A P PRODUCTS understands your prototyping needs. Our IDC products are manufactured to give you the accurate, dependable connections you must

have. They are designed to save you time. And, they are priced to save you money.

Imagine that there's an easy way to find the AP PRODUCTS you need.

There is. The A P PRODUCTS Interconnection rack at your electronics dealer has the complete line of connectors, cable, tooling, and accessories. Over one hundred and sixty products in all. You'll be able to find what you need fast. So you can get back to your project in a hurry.



Imagine that you need more information.

No problem. Just call toll free 800-321-9668 for the name of the distributor nearest you. (In Ohio, call collect (216) 354-2101.)

IMAGINE THAT



A P PRODUCTS INCORPORATED
9450 Pineneedle Dr. • Box 540
Mentor, Ohio 44061-0540
(216) 354-2101
TWX: 810-425-2250

In Europe, contact A P PRODUCTS
GmbH • Baumlesweg 21
D-7031 Weil 1 • West Germany

CIRCLE 87 ON FREE INFORMATION CARD