

**VIDEOGAME CONTEST!
OVER \$10,000 IN PRIZES!
RULES AND ENTRY FORM INSIDE**

**HOW TO SELECT THE BEST
TV ANTENNA FOR YOUR NEEDS**

\$1.25 AUG. 1982

Radio- Electronics®

Build this
PICTURE PHONE
adapter for your telephone

Labor saving
CHEMICAL TOOLS
for your workbench

Build a
FURNACE ENERGY MISER
cuts your home heating costs

**FROM STYLUS
TO PHONO INPUT**
An inside look at
phono cartridges

R-E EXCLUSIVE!
Picture Phone adapter
you can build sends
video pictures
over your telephone

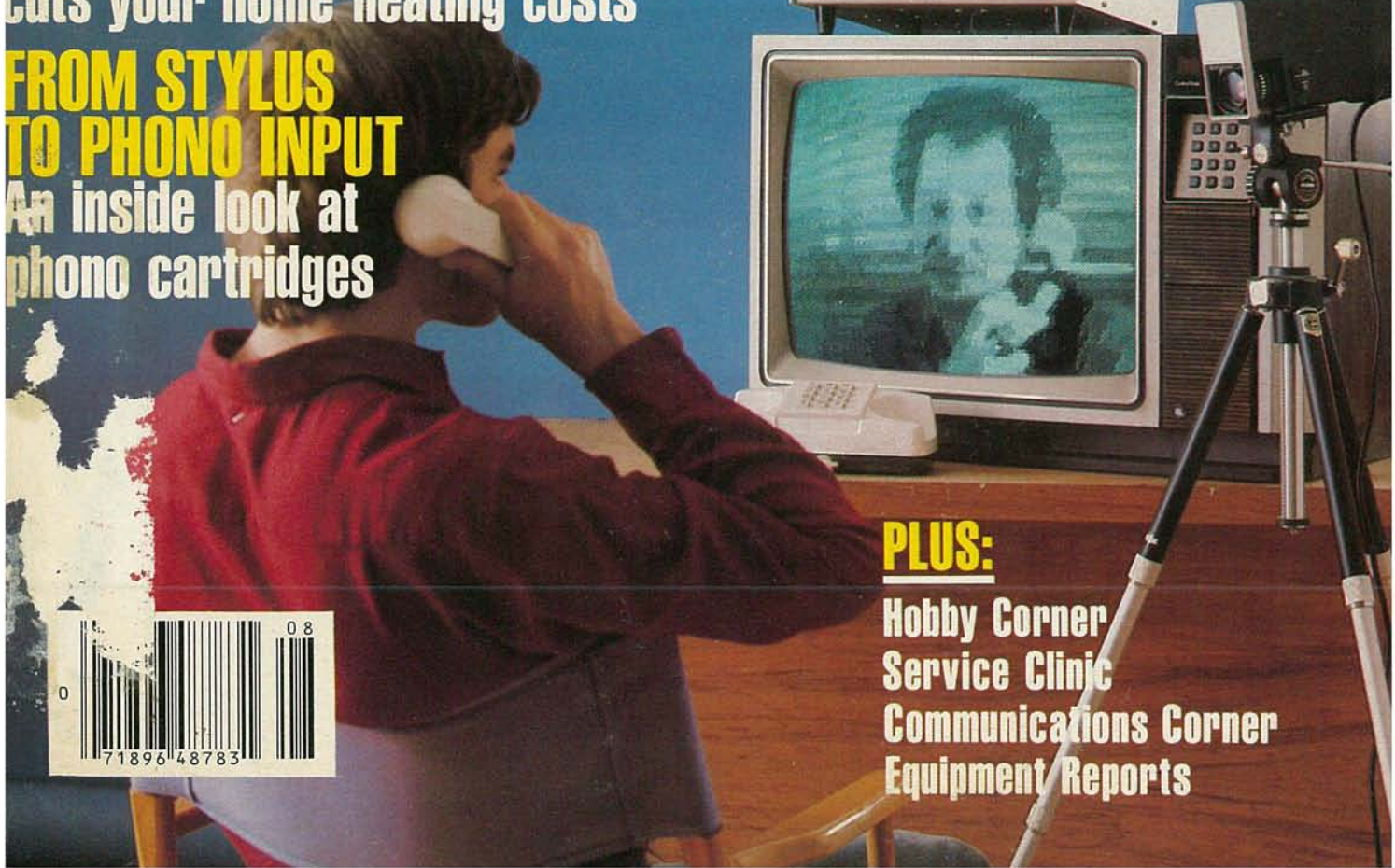

PLUS:
Hobby Corner
Service Clinic
Communications Corner
Equipment Reports





Turn to Xcelite.®

For nuts and screws in all the sizes you use – and in all the patterns you're ever likely to meet (including the new Torx® design that's becoming so widespread).

Choose from inches or metric, straight-on heads or ballpoints, regular or tee, fixed or ratchetting handles.

Buy individually, in packaged sets, or in comprehensive cased kits.

If you need to drive a nut or screw, trust Xcelite.

The Cooper Group PO Box 728 Apex NC 27502 USA Tel (919) 362-7510 Telex 579497

BOKER® CRESCENT® LUFKIN® NICHOLSON® PLUMB® WELLER® WISS® XCELITE®

CooperTools



Torx® is the trademark of Camcar Division of Textron Incorporated.
CIRCLE 2 ON FREE INFORMATION CARD



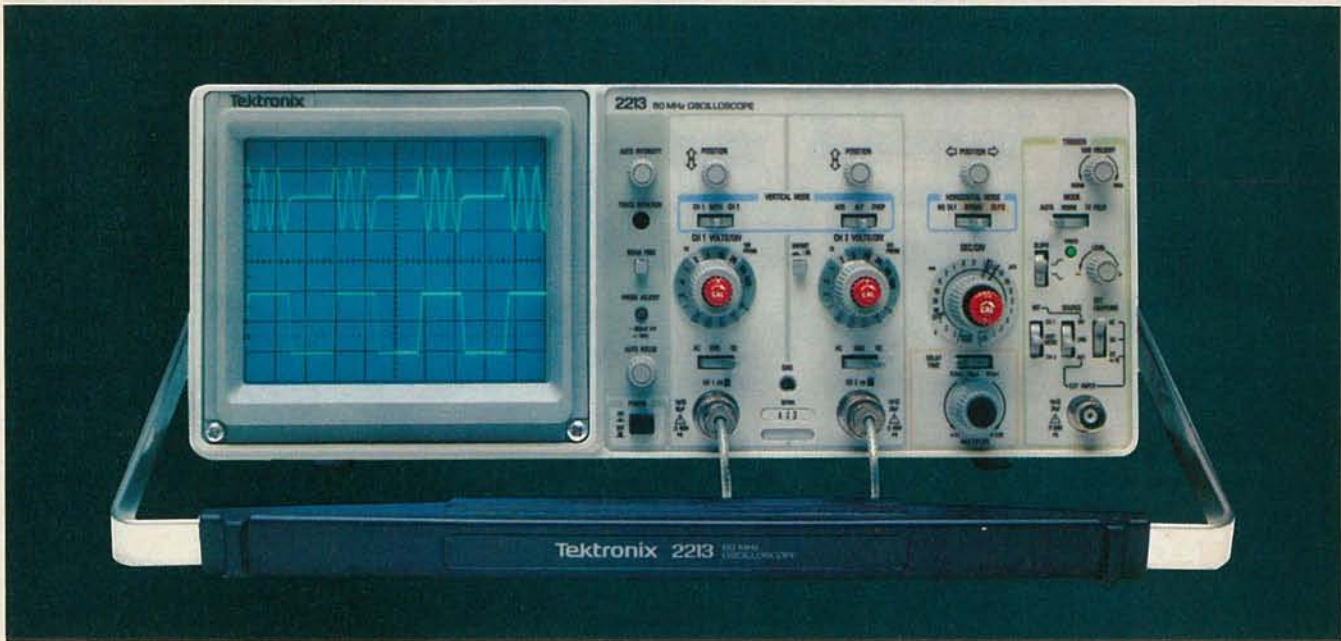

Introducing a direct line to a 60 MHz Tektronix scope built for your bench!

From the world's most respected name in oscilloscopes: a new scope, plus a new direct order number, that finally makes it practical to put Tektronix quality on your bench... at work or home.

Among professional engineers and technicians there is no substitute for the performance and reliability of Tektronix oscilloscopes.

Now, for the first time, Tektronix is offering an advanced scope at an unprecedented low price—and has a direct order line that lets you get your order processed today!

The scope: the 2213. Its radical new design brings you Tektronix quality for well below what you would pay for

lesser-name scopes.

The 2213's practical design includes 65% fewer mechanical parts, fewer circuit boards, electrical connectors and cabling. Result: a lower price for you plus far greater reliability.

Yet performance is pure Tektronix: there's 60 MHz bandwidth for digital and high-speed analog circuits. The sensitivity for low signal measurements. The sweep speeds for fast logic families. A complete trigger system for digital, analog or video waveforms. And new high-performance Tektronix probes are included!

2213 PERFORMANCE DATA

Bandwidth: Two channels, dc—60 MHz from 10 V/div to 20 mV/div. (50 MHz from

2 mV/div to 10 mV/div).

Sweep speeds: Sweeps from 0.5 s to 50 ns (to 5 ns/div with X10 mag).

Sensitivity: Scale factors from 100 V/div (10X probe) to 2 mV/div (1X probe). Accurate to $\pm 3\%$. Ac or dc coupling.

Delayed sweep measurements: Standard sweep, intensified after delay, and delayed.

(Need dual time-base performance and timing accuracy to $\pm 1.5\%$? Ask about our 2215 priced at \$1400.)

Complete trigger system: Modes include TV field, normal, vertical mode, and automatic; internal, external, and line sources; variable holdoff.

Probes: High perform-

ance, positive attachment, 10-14 pF and 60 MHz at the probe tip.

The price: Just \$1100 complete*. Order direct from Tektronix National Marketing Center. Phones are staffed by technical people to answer your questions about the 2213. Your direct order includes a 15-day return policy and full Tektronix warranty.

Now it's easier than ever to get your hands on a Tek scope!

ORDER TOLL-FREE

800-547-1845

Ask for Dept. A0128

(In Oregon, Alaska and Hawaii: 1-503-627-5402 collect.) Lines are open from 8 am EST to 5 pm PST.

*Price F.O.B., Beaverton, OR.

Why use their flexible discs:

BASF, Control Data, Dysan, IBM, Kybe, Maxell, Nashua, Scotch, Syncom, Verbatim or Wabash when you could be using

MEMOREX

high quality error free discs?

Product Description	Part #	CE quant. 100 price per disc (\$)
8" SSSD IBM Compatible (128 B/S, 26 Sectors)	3062	2.09
8" SSSD Shugart Compatible, 32 Hard Sector	3015	2.09
8" SSSD CPT 8000 Compatible, Soft Sector	3045	2.99
8" SSDD IBM Compatible (128 B/S, 26 Sectors)	3090	2.74
8" DSDD Soft Sector (Unformatted)	3102	3.34
8" DSDD Soft Sector (128 B/S, 26 Sectors)	3115	3.34
8" DSDD Soft Sector (256 B/S, 26 Sectors)	3103	3.34
8" DSDD Soft Sector (512 B/S, 15 Sectors)	3114	3.34
8" DSDD Soft Sector (1024 B/S, 8 Sectors)	3104	3.34
5 1/4" SSDD Soft Sector w/Hub Ring	3481	2.34
5 1/4" SSDD 10 Hard Sector w/Hub Ring	3483	2.34
5 1/4" SSDD 16 Hard Sector w/Hub Ring	3485	2.34
5 1/4" DSDD Soft Sector w/Hub Ring	3491	3.09
5 1/4" DSDD 10 Hard Sector w/Hub Ring	3493	3.09
5 1/4" DSDD 16 Hard Sector w/Hub Ring	3495	3.09
5 1/4" SSDD Soft Sector w/Hub Ring (96 TPI)	3504	2.99
5 1/4" DSDD Soft Sector w/Hub Ring (96 TPI)	3501	3.99

SSSD = Single Sided Single Density; SSDD = Single Sided Double Density
DSDD = Double Sided Double Density; TPI = Tracks per inch

Memorex Flexible Discs... The Ultimate in Memory Excellence

Free Memorex Mini-Disc Offer - Save 10%

Every carton of 10 Memorex 5 1/4 inch mini-discs sold by Communications Electronics, now has a coupon good for a free Memorex mini-disc. For every case of 100 Memorex mini-discs you buy from CE, you'll get 10 free mini-discs directly from Memorex. There is no limit to the number of discs you can purchase on this special offer. This offer is good only in the U.S.A. and ends on December 31, 1982.

Quality

Memorex means quality products that you can depend on. Quality control at Memorex means starting with the best materials available and continual surveillance throughout the entire manufacturing process. The benefit of Memorex's years of experience in magnetic media production, resulting, for instance, in proprietary coating formulations. The most sophisticated testing procedures you'll find anywhere in the business.

100 Percent Error Free

Each and every Memorex Flexible Disc is certified to be 100 percent error free. Each track of each flexible disc is tested, individually, to Memorex's stringent standards of excellence. They test signal amplitude, resolution, low-pass modulation, overwrite, missing pulse error and extra pulse error. Rigid quality audits are built into every step of the manufacturing process and stringent testing result in a standard of excellence that assures you, our customer, of a quality product designed for increased reliability and consistent top performance.

Customer-Oriented Packaging

The desk-top box containing ten discs is convenient for filing and storage. Both box labels and jacket labels provide full information on compatibility, density, sectoring, and record length. Envelopes with multi-language care and handling instructions and color-coded removable labels are included. A write-protect feature is available to provide data security.

Full One Year Warranty—Your Assurance of Quality
Memorex Flexible Discs will be replaced free of charge by Memorex if they are found to be defective in materials or workmanship within one year of the date of purchase. Other than replacement, Memorex will not be responsible for any damages or losses (including consequential damages) caused by the use of Memorex Flexible Discs.

Quantity Discounts Available

Memorex Flexible Discs are packed 10 discs to a carton and 10 cartons to a case. Please order only in increments of 100 units for quantity 100 pricing. We are also willing to accommodate your smaller orders. Quantities less than 100 units are available in increments of 10 units at a 10% surcharge. **Quantity discounts** are also available. Order 500 or more discs at the same time and deduct 1%; 1,000 or more saves you 2%; 2,000 or more saves you 3%; 5,000 or more saves you 4%; 10,000 or more saves you 5%; 25,000 or more saves you 6%; 50,000 or more saves you 7% and 100,000 or more discs earns you an 8% discount off our super low quantity 100 price. Almost all Memorex Flexible Discs are immediately available from CE. Our warehouse facilities are equipped to help us get you the quality product you need, when you need it. If you need further assistance to find the flexible disc that's right for you, call the Memorex compatibility hotline. Dial toll-free 800-538-8080 and ask for the flexible disc hotline extension 0997. In California dial 800-672-3525 extension 0997. Outside the U.S.A. dial 408-987-0997.

Buy with Confidence

To get the fastest delivery from CE of your Memorex Flexible Discs, send or phone your order directly to our Computer Products Division. Be sure to calculate your price using the CE prices in this ad. Michigan residents please add 4% sales tax. Written purchase orders are accepted from approved government agencies and most well rated firms at a 30% surcharge for net 30 billing. All sales are subject to availability, acceptance and verification. All sales are final. Prices, terms and specifications are subject to change without notice. Out of stock items will be placed on backorder automatically unless CE is instructed differently. Minimum prepaid order \$50.00. Minimum purchase order \$200.00. International orders are invited with a \$20.00 surcharge for special handling in addition to shipping charges. All shipments are F.O.B. Ann Arbor, Michigan. No COD's please. Non-certified and foreign checks require bank clearance.

Mail orders to: **Communications Electronics**, Box 1002, Ann Arbor, Michigan 48106 U.S.A. Add \$8.00 per case or partial-case of 100 8-inch discs or \$6.00 per case or partial case of 100 5 1/4-inch mini-discs for U.P.S. ground shipping and handling in the continental U.S.A. If you have a Master Card or Visa card, you may call anytime and place a credit card order. Order toll-free in the U.S. Dial 800-521-4414. If you are outside the U.S. or in Michigan, dial 313-994-4444. Order your high quality, error free Memorex discs today.

Copyright © 1982 Communications Electronics™

Ad #051782

Free disc offer Save 10%



Order Toll-Free!
(800) 521-4414

In Michigan (313) 994-4444

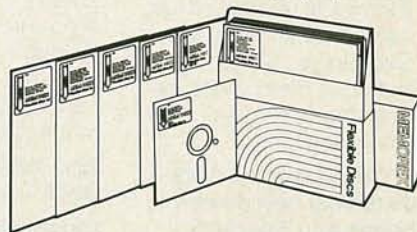

For Data Reliability—Memorex Flexible Discs

**COMMUNICATIONS
ELECTRONICS™**

Computer Products Division

854 Phoenix □ Box 1002 □ Ann Arbor, Michigan 48106 U.S.A.
Call TOLL-FREE (800) 521-4414 or outside U.S.A. (313) 994-4444

SPECIAL FEATURE

- 43 **PICTURE PHONE**
Add the dimension of *sight* to your telephone conversations with this device. **Josef Bernard**

BUILD THIS

- 65 **ENERGY MISER**
Bring down the high cost of heating. **Roland Gibson**

TECHNOLOGY

- 4 **VIDEO ELECTRONICS**
Tomorrow's news and technology in this quickly changing industry. **David Lachenbruch**
- 16 **SATELLITE/TELETEXT NEWS**
The latest happenings in communications technology. **Gary H. Arlen**
- 53 **HOW TO DESIGN ANALOG CIRCUITS**
An introduction to bipolar and FET transistors, and how they are used. **Mannie Horowitz**
- 57 **SOFT TOOLS**
These chemicals are useful in any workshop. **Kirk Vistain**

CIRCUITS AND COMPONENTS

- 36 **NEW IDEA**
A model-rocket launcher.
- 68 **HOBBY CORNER**
A reader survey and some odds and ends. **Earl "Doc" Savage, K4SDS**

VIDEO

- 49 **HOW TO SELECT THE BEST TV ANTENNA**
Consider these factors for the best possible reception. **Gary J. Arnold**
- 75 **SERVICE CLINIC**
Antenna rotators. **Jack Darr**
- 76 **SERVICE QUESTIONS**
R-E's Service Editor solves technician's problems. **Jack Darr**

AUDIO

- 61 **FROM STYLUS TO PHONO INPUT**
All about modern phono cartridges. **Len Feldman**

RADIO

- 72 **COMMUNICATIONS CORNER**
Maximizing antenna gain. **Herb Friedman**

EQUIPMENT REPORTS

- 26 **Tektronix Model 2213 Oscilloscope.**
- 28 **Fox Marketing BMP10/60 Scanning Receiver**

DEPARTMENTS

- | | |
|----------------------------------|------------------|
| 12 Advertising and Sales Offices | 22 Letters |
| 112 Advertising Index | 87 Market Center |
| 12 Editorial | 80 New Products |
| 113 Free Information Card | 6 What's News |

ON THE COVER

Up to now, about the only way you could add video to your telephone conversation was to go to one of a very few specially equipped Bell System centers. Even then, you could only talk with someone in another similarly equipped center—not a particularly convenient setup. Build a Picture Phone, and you can exchange pictures with anyone, anytime, anywhere, as long as both of you have one, and a telephone. The story starts on page 43.

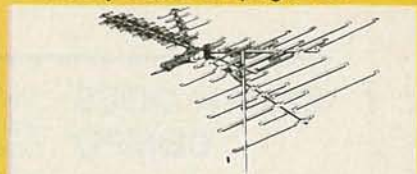

GOOD VHF and UHF TELEVISION RECEPTION depends on many factors. Choosing the best system or configuration for your particular situation can be difficult, but for information that will make the task easier, turn to page 49.

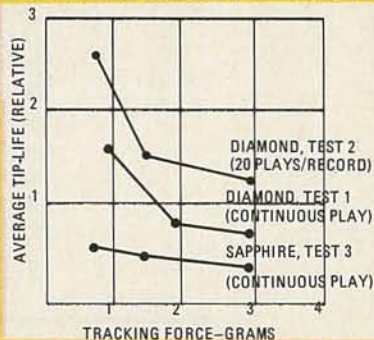

THE SOUND QUALITY of even the best stereo systems can only be as good as the signal that is input from the phone cartridge. Find out more about phono cartridges, and whether you are getting the most out of yours. The story begins on page 61.

For those of our readers who have been awaiting the second part of our article on the stereo image expander, we promise that it will run in next month's issue.

Radio-Electronics, (ISSN 0033-7862) Published monthly by Gernsback Publications, Inc., 200 Park Avenue South, New York, NY 10003. Second-Class Postage Paid at New York, N.Y. and additional mailing offices. One-year subscription rate: U.S.A. and U.S. possessions, \$13.00, Canada, \$16.00. Other countries, \$20.50 (cash orders only, payable in U.S.A. currency.) Single copies \$1.25. © 1982 by Gernsback Publications, Inc. All Rights reserved. Printed in U.S.A.

Subscription Service: Mail all subscription orders, changes, correspondence and Postmaster Notices of undelivered copies (Form 3579) to Radio-Electronics Subscription Service, Box 2520, Boulder, CO 80322.

A stamped self-addressed envelope must accompany all submitted manuscripts and/or artwork or photographs if their return is desired should they be rejected. We disclaim any responsibility for the loss or damage of manuscripts and/or artwork or photographs while in our possession or otherwise.

VIDEO ELECTRONICS

DAVID LACHENBRUCH
CONTRIBUTING EDITOR

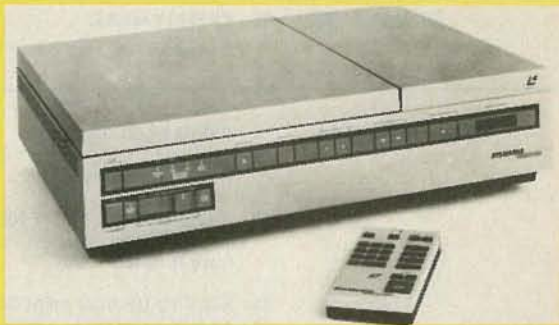

ZENITH GOES COMPO

The first American TV manufacturer to offer a true video-component system is Zenith, and its entry into the field is significant in several ways. First, as one of the top two TV brands in the United States, Zenith carries more influence with middle America than any other brand except perhaps RCA. Its entry into the field takes component TV out of the "esoteric" category and brings it to the mainstream. Second, Zenith is bringing video components out of the stratospheric price area pioneered by Sony's Profeel.

The third significant aspect of Zenith's entry is that it is the first component brand, as of presstime, which doesn't require the TV tuner to do double duty as a switcher. The heart of Zenith's system is the "source selector," a versatile switching and routing system. It allows connection of up to six different audio/video program sources to the color monitor or VCR. Each of six sets of input jacks may be switched either to RF or baseband video. To ease the tangle of wires around the AC outlet, the back of the selector contains two switched and six unswitched AC sockets. The other components are a 19-inch video monitor with audio amplifier and speaker built in, and with video/audio and RGB (Red-Green-Blue) inputs, a remote-control digital TV tuner, plus a stereo amplifier and speaker system. (See left-hand photo.) Zenith has priced all the components separately—the monitor at \$470, the source selector \$170, TV tuner \$280. Each piece has its own uses—for example, the monitor, added to a videocassette recorder (using its tuner) yields a high-quality TV set. The source selector is expected to have broad appeal as a building block with other video equipment.

NEW LV PLAYERS

LaserVision videodisc players got their first model change at midyear. Magnavox introduced a sleek new player, which will also be sold under the Sylvania brand name. (See right-hand photo.) The new model is built for North American Philips by Pioneer of Japan, which will field two redesigned models here under the Pioneer brand name. Functionally, the new players are similar to the earlier Pioneer model and have wireless remote-control units which can access discs by frame number (or time) and by chapter. Added to the system is the CBS-developed CX audio-noise-reduction feature—which also is on the new CED players.

STEREO WITH VIDEO

In addition to component systems, another trend in the new TV lines is the increasing number of high-end TV sets with stereo audio amplifiers, with the promise that they can be converted to stereo TV broadcasting when standards are adopted. In the meantime, they can be used with FM tuners for simulcasts, or with stereo VCR's and videodisc players.

This is the year that the home VCR will go stereo. Although Akai has had a stereo-sound video recorder for a year, almost every other brand will add stereo to its top-end unit this year. In the VHS format, Hitachi, JVC, GE, Quasar, RCA, and other VHS proponents had already announced stereo models at presstime, and the Beta group (Sony, Sanyo, Toshiba, Zenith) was expected to make a collective announcement about stereo standards.

Stereo finally came to the RCA-developed CED videodisc system. RCA now has introduced a total of three new player models—a "leader" mono unit designed to be sold for just below \$300, a "step-up" mono player which has a list price of \$349.95 and a stereo player at \$399.95. Hitachi followed suit with a stereo model also carrying a list price of \$399.95, as well as a stereo converter for its earlier model at \$59.95. Toshiba's stereo model carries an official \$595 price tag, but is also expected to sell for less than \$400.

R-E

No one else gives you as many functions in a handheld DMM.

Now you can move up to Fluke.

We've got great news for people who've been holding out for a high quality, high performance DMM at a moderate price: Fluke's new nine-function model D 804 is now available at select electronics supply stores.

With a suggested U.S. price of only \$249 and features you won't find in any other handheld DMM, the D 804 is an exceptional value. Here's why.

Logic level and continuity testing: A real time-saver for troubleshooting passive circuits in pcb's, cables, relay panels and the like. The D 804 has a switch-selectable audible tone and visual symbols to indicate continuity or logic levels.

Direct temperature readings in °C: Used with any K-type

thermocouple, the D 804 delivers fully-compensated readings in °C from -20°C to +1265°C, for checking heating and refrigeration systems.

Peak hold feature captures transients: A short-term memory in the D 804 captures and holds the peak reading of a motor starting current.

And more: 0.1% basic dc accuracy, conductance, 26 measurement ranges, battery, safety-designed test leads and a one year parts and labor warranty. A full line of accessories is also available to extend the measurement capabilities of your DMM.

Ask your dealer about the powerful, versatile D 804 and the rest of Fluke's new Series D line of low-cost digital multimeters.



From the world leader in DMM's. Now we've designed one for you.

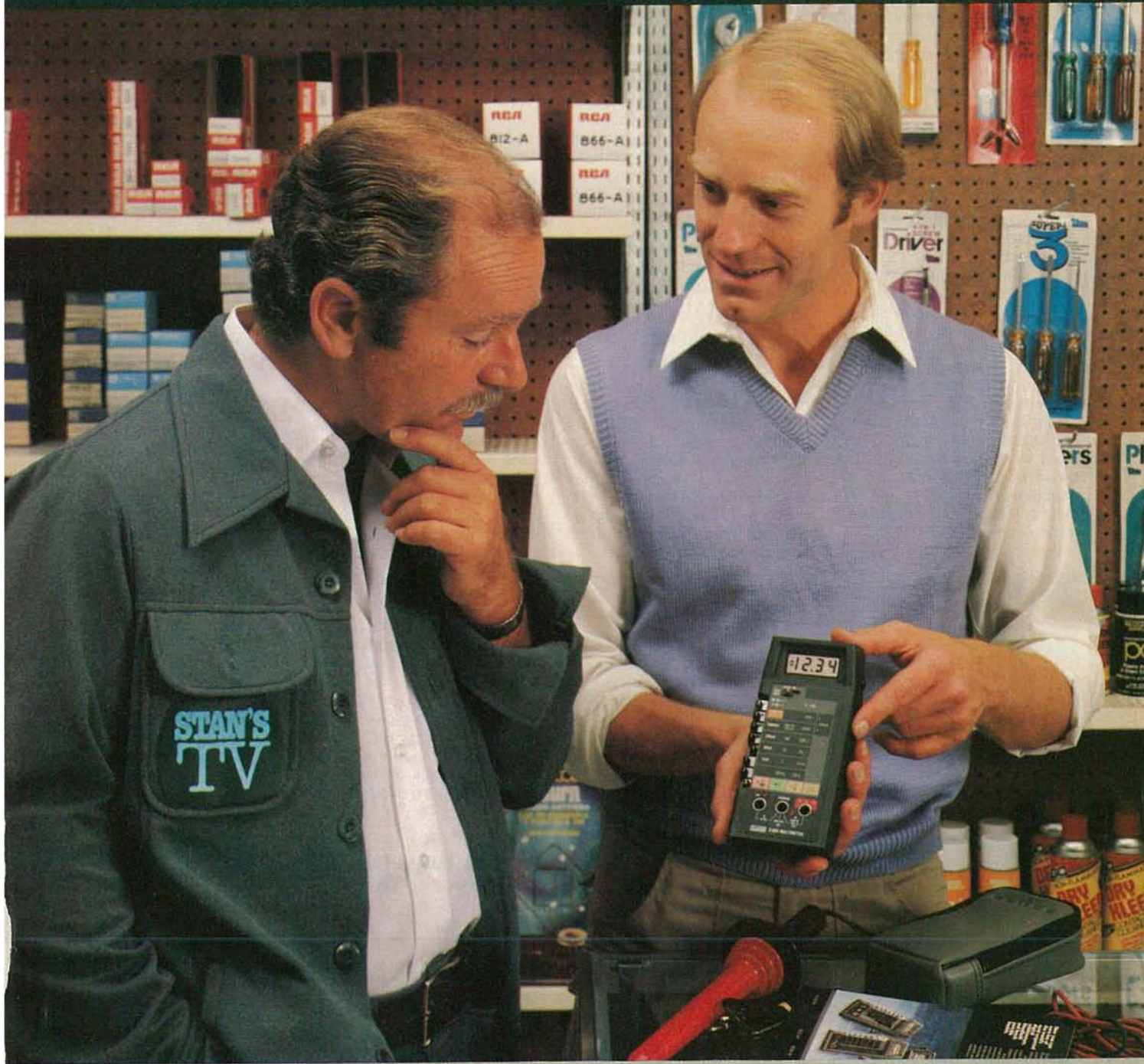

Suggested U.S. list price
technical data circle No. 15
1298-8/D804
RF 8/82

If your dealer doesn't carry Series D
Multimeters yet, call this number. We'll be
happy to tell you who does. 1-800-426-0361



WHAT'S NEWS

Magnetic monopole surfaces again

A Stanford University scientist, Blas Cabrera, believes he may have discovered a particle that is a magnet with only one pole, either S or N, but not both. The announcement has aroused great interest, because there is a gap in electromagnetic theory that would be filled neatly by magnetic monopoles (and magnetic current) and scientists have long searched for the elusive particle.

In 1931, physicist P. A. M. Dirac suggested that such a particle should exist, and that it would have a basic charge of 68.5 or a multiple of that number.

In 1944, the refugee Austrian scientist Felix Ehrenhaft, the former head of the Physics Institute of the University of Vienna, announced that he had discovered magnetic monopoles and tried to show evidence for a "magnetic current." **R-E's** predecessor *Radio-Craft* printed two articles and an editorial on the subject, and there was much discussion. Experiments proved to be inconclusive, however, and the monopole dropped out of sight for some decades.

It reappeared briefly in 1970,

with a report of a particle that reacted strongly in a magnetic field; and in 1975, scientists of the University of California reported the discovery of a particle that fitted the characteristics of a monopole as laid down by Dirac. Later, they decided the fit was not exact.

Cabrera's apparatus is a superconducting coil enclosed in a thin lead shield. The magnetic charge entering the coil caused the current through it to fluctuate. Only one such incident was reported in 185 days. (Physicists estimate that about one monopole a year would fall on each 100 square yards of the Earth's surface.) Cabrera is therefore building an apparatus 50 times larger, in the hope of attracting more monopoles.

Shielded room kills electronic pollution

A major car company has introduced a new kink in "shielded-room" testing. An ordinary shielded room protects the apparatus being tested from external radiation. But waves bounce around inside the chamber—from the car radio being tested, from the test equipment, or from other electronic systems in the car.

To absorb those internal waves, huge cones of a material that makes them absorbent at radio frequencies line the chamber walls. To shield against outside interference, a continuous conductive metal skin surrounds the chamber. The two types of shields produce an electronic "clean room," a near-ideal test environment.

Macrocells will supply next-generation needs

Honeywell has designed and completed computer simulation of 43 macrocells, key to its VHSIC (Very High Speed Integrated Circuit) contract with the Department of Defense. The macrocells vary in size and complexity, containing units down to 1.25 microns (a little over one-hundredth of the thickness of a human hair).

The macrocells will be interconnected on two integrated-circuit chips. Each chip will measure 360 mils (thousandths of an inch) on a side and will contain 125,000 devices. The two controller integrated circuits drive 32 programmable parallel processor chips to achieve a throughput of several billion operations a second. The chips will be used in an electro-optical processor being developed for the Air Force.

The controller and programmable parallel processor chips are expected to be the most powerful high-speed bi-polar chips ever produced, packing over 100 times more computing power than current-generation chips. They are designed to meet the signal-processing needs of many next-generation military systems.

Sony gets support for home-recording stand

Tremendous support has been received by Sony Corp. of America and its co-defendants in their efforts to bring before the Supreme Court the decision of a California judge that home video-recording is illegal. Seventeen *amici curiae* (friends of the court) briefs objecting to that ruling have been filed.

That record number of briefs includes 12 state attorneys general; several consumer groups, a num-

ber of videocassette manufacturers, an ad hoc committee on copyright law, the American Library Association, blank tape manufacturers, advertising agencies, and a publishing group.

The attorneys general of Missouri and 11 other states declared that it is legally unjustifiable to ban all home recording because a very few copyright owners object. The Association of Massachusetts Consumers, and consumer councils of seven other states, told the Supreme Court that the decision violates the First Amendment and other constitutional rights of Americans, without giving any member of the public a chance to defend his rights in court.

The National Retail Merchants' Association, five national advertising agencies, five tape-manufacturing companies and eleven manufacturers or suppliers of home recorders pointed out the economic effects of the decision, stating that it threatens the whole recording industry, and could deprive the American public of home video recorders and other technological advantages enjoyed by the rest of the world.

Oak Industries starts direct broadcast plans

As a start of a project to put satellite-TV signals direct into American homes before the competition, Oak Industries has leased four transponders on the Canadian satellite Anik C, to deliver scrambled TV programming direct to viewers in the Pacific Northwest and the Northeastern United States in 1983.

One of Anik's channels will be used to carry a program similar to Oak's present mix of movies, sports, and entertainment specials. The second will offer cultural material, news, and special events. Four transponders were leased, to allow east and west feeds of the two sets of signals. The programs will be received well in portions of 14 Eastern states, from Maine to Virginia. They will also be received in Washington, Oregon, as well as several other parts of the country's Northwestern states.

Plans are to have the system in operation by mid-1983. **R-E**



THE ABSORBING WEDGES, CONES, OR PYRAMIDS in this room make it look exactly like an acoustic anechoic chamber. Actually the cones are made of material designed to be especially absorptive to radio waves in the range of 14 kHz to 1 GHz. The chamber was installed by the Ray-Proof Division of Keene Corp. of Norwalk, CT.

NEW!

**WP-709.
Double-slot
Supplyst™
power supply.**

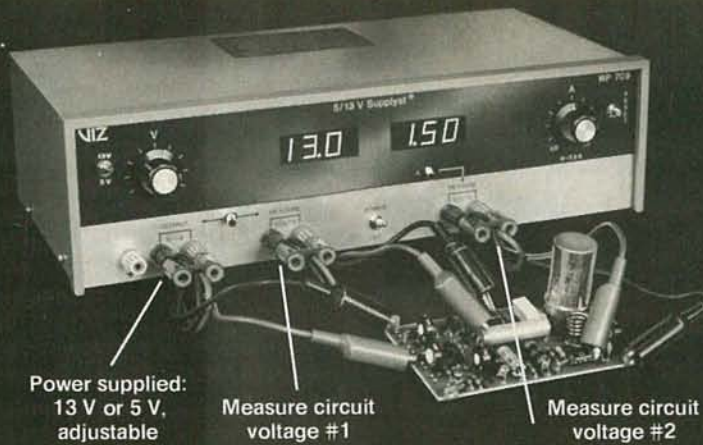

Outputs: 5V or 13V DC,
adjustable $\pm 1\frac{1}{2}$ V
Zero to 7.5 amp, each voltage.
Two LED displays,
monitor V or A—
or two DC voltmeters
Adjustable current limiting

Only
\$324.95

DC power to test logic or mobile equipment. Another VIZ Value

HERE'S REAL PRECISION
Select the precise voltage you want: 5V or 13V, adjustable $\pm 1\frac{1}{2}$ V at each range. Output is laboratory quality. Ripple less than 10mV, peak to peak. Regulation better than 0.1%.

HERE'S REAL POWER
Up to 7.5 amp. at each voltage—

plenty for computer circuits, PA systems, mobile transmitters, autos, boats, planes.

HERE'S REAL CONVENIENCE
Front panel controls for instant voltage adjustment and precise fine adjustment to within 0.1V. Two 3-digit LED displays permit continuous

monitoring of both voltage and current during use. Current limiting control with instant pushbutton reset.

The WP-709 is like two precision power supplies for a price less than you might pay for one— PLUS two digital DC voltmeters.

VIZ Supplyst™

power supplies with digital displays of voltage and current



WP-705 \$315.95

Single output
0-50VDC, 0-2A.



WP-707 \$409.95

Dual output
Two 0-25VDC, 0-2A.

WP-706 \$329.95

Single output
0-25VDC, 0-4A.



WP-708 \$479.95

Triple output Two 0-20VDC, 0-2A.
One 5VDC, 0-4A.



VIZ DC power supplies

Fully regulated, continuously adjustable voltage outputs with short circuit protection. Analog meters and overload indicators.



Dual WP-702A Two 0-20VDC, 0-200mA **\$167.00**



Single WP-703A
0-20VDC, 0-500mA **\$119.00**



Single WP-704A
0-40VDC, 0-250mA **\$125.95**

VIZ RELIABILITY

VIZ is a 50 year-old company. Our instruments are fully warranted, parts and labor, for a year. All items tested to NBS standards. We offer service and parts availability for a minimum of ten years. Over 15 repair depots in U.S.A.

Want full technical details and a demonstration? Call toll-free, 1-800-523-3696, for the VIZ distributor nearest you

**Look to VIZ for value, quality, availability.
Over 70 instruments in the line— PLUS full accessories.**

VIZ Mfg. Co., 335 E. Price St., Philadelphia, PA 19144

CIRCLE 5 ON FREE INFORMATION CARD

Now NRI takes you inside the new TRS-80 Model III microcomputer to train you at home as the new breed of computer specialist!

NRI teams up with Radio Shack advanced technology to teach you how to use, program, and service state-of-the-art microcomputers.

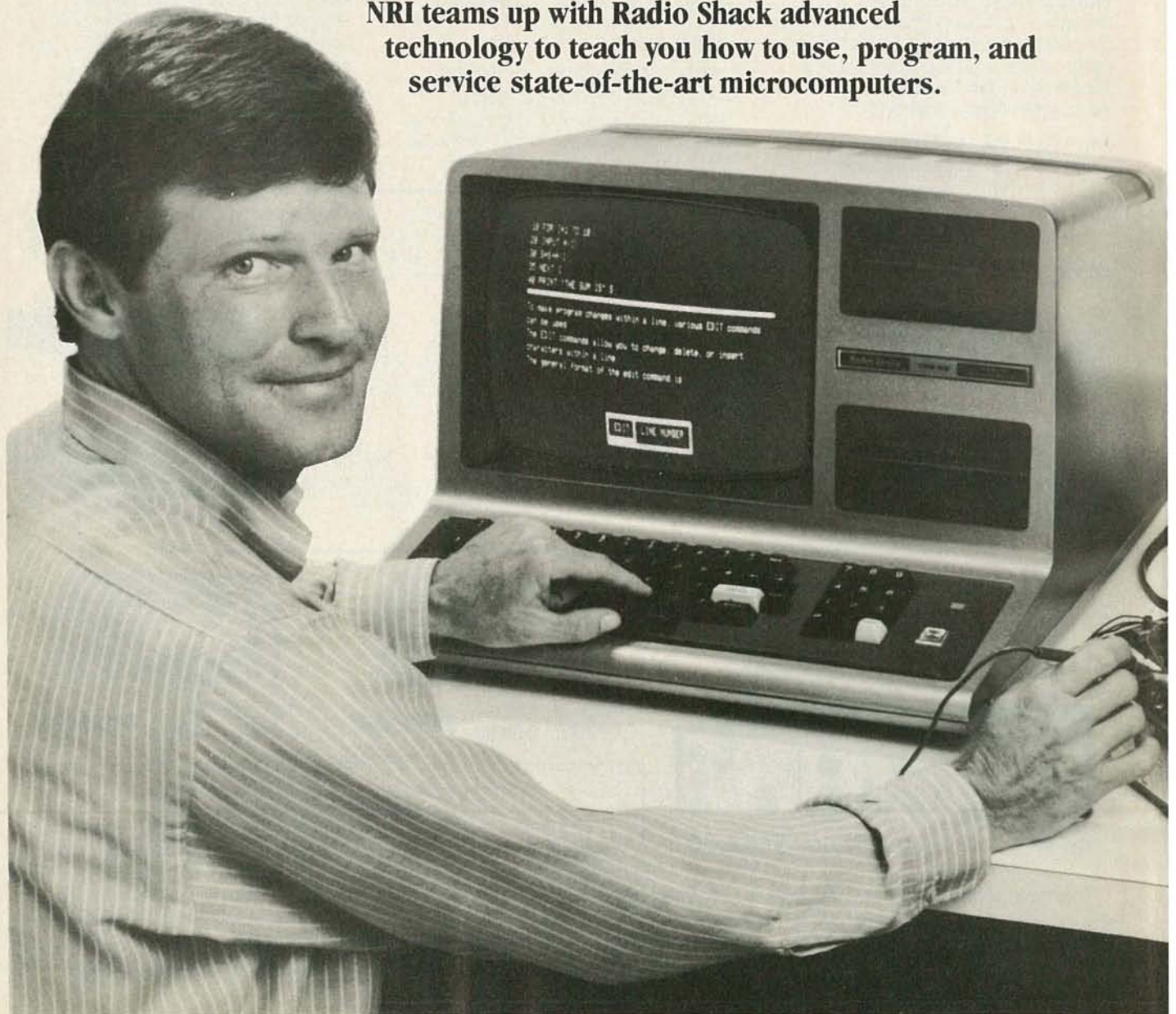

It's no longer enough to be just a programmer or a technician. With microcomputers moving into the fabric of our lives (over 250,000 of the TRS-80™ alone have been sold), interdisciplinary skills are demanded. And NRI can prepare you with the first course of its kind, covering the complete world of the microcomputer.

Learn at Home in Your Spare Time

With NRI training, the programmer gains practical knowledge of hardware, enabling him to design simpler, more effective programs. And, with advanced programming skills, the technician can test and debug systems quickly and easily.

Only NRI gives you both kinds of training with the convenience of home study. No classroom pressures, no night school, no gasoline wasted. You learn at your convenience, at your own pace. Yet you're always backed by the NRI staff and your instructor, answering questions, giving you guidance, and available for special help if you need it.

You Explore the New TRS-80 Model III Inside and Out

NRI training is hands-on training, with practical experiments and demonstrations as the very foundation of your knowledge. You don't just program your computer, you go inside it...watch how circuits interact... interface with other

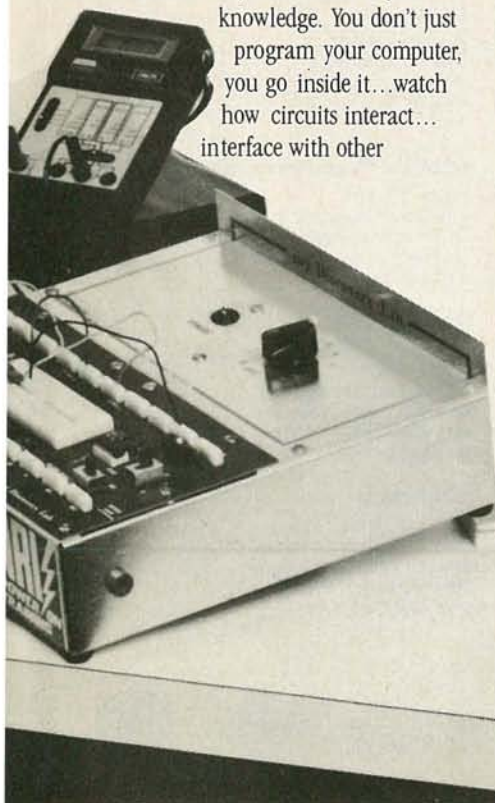

systems...gain a real insight into its nature.

You also work with a professional 4-function multimeter, featuring full portability and a 3½-digit liquid crystal display. Using it along with the exclusive NRI



Training includes the TRS-80 Model III microcomputer, professional LCD multimeter, the NRI Discovery Lab, Computer Assisted Instruction programs and hundreds of demonstrations and experiments.

Discovery Lab® and your TRS-80, you perform over 60 separate experiments. You learn how to troubleshoot and gain greater understanding of the information your testing procedures give you.

Advanced Technology Microcomputer Is Yours to Keep

As part of your training, NRI sends you the new, state-of-the-art TRS-80 Model III microcomputer. This functional unit is complete with 65-key keyboard and 12" display in one desk-top unit. It features high-speed cassette loading, built-in interface for parallel printer, and provisions for optional disk drive. Its 4K RAM is internally expandable to 16K or 48K and its BASIC language is compatible with most Model I software.

Along with your multimeter and the NRI Discovery Lab, this latest concept in

advanced microcomputers is yours to learn with, yours to keep and use for your own personal programs, business use, and other applications.

Computer Assisted Instruction

Your TRS-80 even helps train you. You receive 8 special lesson tapes in BASIC computer language. Using them in your microcomputer, you "talk" to it as you progress. Errors are explained, graphics and animation drive home key points. Within a matter of minutes, you'll be able to write simple programs yourself.

Send for Free Catalog...No Salesman Will Call

Get all the details on this exciting course in NRI's free, 100-page catalog.

It shows all equipment, lesson outlines, and facts on other electronics courses such as Electronic Design, Industrial Electronics, TV/Audio/Video Servicing...11 different career opportunities in all.

Send today, no salesman will ever bother you. Keep up with the latest technology as you learn on the world's most popular computer. If postcard has been used, write to NRI Schools, 3939 Wisconsin Ave., Washington, D.C. 20016.



NRI Schools
McGraw-Hill Continuing
Education Center
3939 Wisconsin Ave.
Washington, D.C. 20016

We'll give you tomorrow.

(TRS-80 is a trademark of the Radio Shack division of Tandy Corp.)

EDITORIAL

Magnetic Digital Storage - technology extends the frontier

Since the introduction of the first recorder in 1898, magnetic recording has gone through many changes. That first recorder stored analog signals on piano wire. Over the years, that technology evolved into today's high-fidelity tape recorder. But recording analog signals is only a part of today's magnetic-recording technology. Some 25 years ago, born out of a need created by the computer revolution, magnetic-recording technology progressed to the point where digitized data could be recorded. Today, the magnetic media for storing digitized data includes tape, floppy disks, and hard disks.

The biggest limitation in magnetic digital-storage technology is recording density. To be more practical and economical, and to find applications in areas other than computers (i.e.: audio and video), today's digital-storage devices must store more information in less space. Over the 25 years of its life, digital-storage technology has progressed to the point where, today, we can store 10,000 bits-per-inch on a magnetic surface.

Why is recording density limited? Basic magnetism tells us that a magnet should be several times longer than it is wide. Today's digital recorders place the magnets on the magnetic surface longitudinally—end-to-end—so the width of the magnet is determined by the track width, and the thickness of the magnet is determined by the thickness of the magnetic material. The number of magnets-per-inch (bits-per-inch), therefore, is related to the track width and the thickness of the magnetic material.

In research labs, much effort has been devoted to overcoming that limitation. Now it appears that the research has paid off. Instead of placing the magnets end-to-end, they are placed perpendicular to the magnetic surface. The length of the magnet is determined by the thickness of the magnetic material. The width of the magnet is along the magnetic surface, so that more magnets-per-inch can be recorded than previously possible. With that new technology, recording densities of 100,000 bits-per-inch should be attained easily. Experiments suggest that recording densities of 440,000 bits-per-inch should be feasible. Achieving a recording density of 30,000 bits-per-inch, Vertimag Corp. (Minneapolis, MN) has already demonstrated a 5-megabyte floppy-disk system that is expected to sell for \$750; it will be in production in mid-1983.

The new technology will have immense impact on consumer electronics as well as computers. For example, digital television is on the horizon and storage devices using the new technology will find application here. Breakthroughs such as those bring today's dreams of future technology one step closer to reality.



ART KLEIMAN
Editor

Radio- Electronics

Hugo Gernsback (1884-1967) founder
M. Harvey Gernsback, editor-in-chief
Larry Steckler, CET, publisher
Arthur Kleiman, editor
Josef Bernard, K2HUF, technical editor
Carl Laron, WB2SLR, assistant editor
Jack Darr, CET, service editor
Robert F. Scott, semiconductor editor
Herb Friedman, communications editor
Gary H. Arlen, contributing editor
David Lachenbruch, contributing editor
Earl "Doc" Savage, K4SDS, hobby editor
Ruby M. Yee, production manager
Robert A. W. Lowndes, production associate
Stefanie A. Mas, production assistant
Joan Roman, circulation director
Arline R. Fishman, advertising coordinator

Cover photo by Robert Lewis

Radio-Electronics is indexed in *Applied Science & Technology Index* and *Readers Guide to Periodical Literature*.

Gernsback Publications, Inc.
200 Park Ave. S., New York, NY 10003
President: M. Harvey Gernsback
Vice President: Larry Steckler

ADVERTISING SALES 212-777-6400

Larry Steckler
Publisher

EAST

Stanley Levitan
Radio-Electronics
200 Park Ave. South
New York, NY 10003
212-777-6400

MIDWEST/Texas/Arkansas/Okla.

Ralph Bergen
The Ralph Bergen Co., Inc.
540 Frontage Road—Suite 325
Northfield, Illinois 60093
312-446-1444

PACIFIC COAST Mountain States

Marvin Green
Radio-Electronics
413 So. La Brea Ave.
Los Angeles, Ca 90036
213-938-0166-7

SOUTHEAST

Paul McGinnis
Paul McGinnis Company
60 East 42nd Street
New York, N.Y. 10017
212-490-1021



**Finally
you can afford
to satisfy
your lust for
power.**



sinclair

ZX81

1	2	3	4	5	6	7	8	9	0
EDIT	AND	THEN	TO					GRAPHICS	DELETE
PLOT	UNPLOT	REM	RUN	RAND	RETURN	IF	INPUT	POKE	PRINT
Q	W	E	R	T	Y	U	I	O	P
SIN	COS	TAN	INT	RND	STRS	CHRS	CODE	PEEK	TAB
NEW	SAVE	DIM	FOR	GOTO	GOSUB	LOAD	LIST	LET	
STOP	LPRINT	SLOW	FAST	LLIST	**	-	+	=	FUNCTION
A	S	D	F	G	H	J	K	L	ENTER
ARCSIN	ARCCOS	ARCTAN	SGN	ABS	SOR	VAL	LEN	USR	
COPY	CLEAR	CONT	CLS	SCROLL	NEXT	PAUSE		BREAK	
SHIFT	Z	X	C	V	B	N	M	.	£
LN	EXP	AT		/	IN KEY\$	NOT	π	SPACE	

For \$99.95 you can have a full powered personal computer.

Most people know by now that the ZX81 from Sinclair Research is the lowest priced personal computer in the world.

But serious programmers are looking for more than a low price. They're looking for true computer power. And that's where the ZX81 surprises a lot of people.

Just look at the keyboard and you'll get some idea of the ZX81's power. It has more than 60 BASIC commands, 20 graphic symbols, and complete mathematical functions. And there's even more power that you can't see.

A breakthrough in personal computers. The ZX81 offers features found only on computers costing two or three times as much.

- Just look at what you get:
- Continuous display, including moving graphics
 - Multi-dimensional string and numerical arrays
 - Mathematical and scientific functions accurate to 8 decimal places
 - Unique one-touch entry of key words like PRINT, RUN and LIST
 - Automatic syntax error detection and easy editing
 - Randomize function useful for both games and serious applications
 - Built-in interface for ZX Printer
 - 1K of memory expandable to 16K
 - A comprehensive programming guide and operating manual



Sinclair programs are available

The ZX81 is also very convenient to use. It hooks up to any television set to produce a clear 32-column by 24-line display. And you can use a regular cassette recorder to store and recall programs by name.

What you get. When you order your ZX81, you get everything you need to start programming.

It comes with connectors for your TV and cassette recorder, an AC adaptor, and a free programming guide and operating manual that completely documents the capabilities of the ZX81.

Options and add-ons. Like any full-powered computer, the ZX81 can be expanded and upgraded.

Its 1K memory can be expanded to over 16K just by plugging the Sinclair Memory Module onto the back of the unit. The cost is only \$49.95.

Sinclair has also published pre-recorded programs on cassettes for your ZX81. We're constantly coming out with new programs, so we'll send you our latest software catalog when you order your computer.

How did we do it? The question most often asked about the ZX81 is, "How can so much computer power cost so little money?"

The answer is that Sinclair Research simply took a different approach. Our only goal was to make programming power as affordable as possible. So we developed a radical new design that cuts costs dramatically without cutting computer power. For example, our unique Master Chip replaces as many as 18 chips used in other personal computers.

The success of the ZX81 speaks for itself. It is now the fastest-selling personal computer in the world. And we stand behind our product. If anything goes wrong in the first 90 days, we'll repair or replace your unit free of

charge. Even after that, you can take advantage of our national service-by-mail facilities for a minimum fee.

Order now and try it out for 10 days. Simply send the coupon along with a check or money order. For faster delivery, call our toll-free number and use your MasterCard or VISA.

You have 10 days to try out the ZX81. If it isn't all we say it is, just send it back and we'll refund your money.

Why wait any longer? With the Sinclair ZX81, you can finally afford to have the computer power you've always wanted.

Call toll free 800-543-3000. Ask for operator #509. In Ohio call: 800-582-1364; in Canada call: 513-729-4300. Ask for operator #509.

Phones open 24 hours a day, 7 days a week. Have your MasterCard or VISA ready.

These numbers are for orders only. If you just want **Free guide to programming** information, please write: Sinclair Research Ltd., 2 Sinclair Plaza, Nashua, NH 03061.



16K Memory Module

To order call toll free: 800-543-3000.

AD CODE 08RE	MAIL TO: Sinclair Research Ltd., One Sinclair Plaza, Nashua, NH 03061.		
	PRICE*	QTY.	AMOUNT
ZX81	\$99.95		
16K Memory Module	\$49.95		
Shipping and Handling	\$4.95		\$4.95
*U.S. dollars	TOTAL		
Name			
Address			
City		State	Zip

Sinclair technology is also available in Timex/Sinclair computers under a license from Sinclair Research Ltd.

sinclair

SATELLITE/TELETEXT NEWS

GARY ARLEN
CONTRIBUTING EDITOR

TELETEXT VIA SATELLITE

A national teletext service, delivered via the vertical blanking-interval of Atlanta's superstation, WTBS-TV, is due to get under way by the end of this year. To pick up the teletext signal, viewers receiving WTBS will have to install a special decoder that uses British teletext technology. Field Electronic Publishing, which produces the Keyfax teletext service for WFLD-TV, Chicago, will expand Keyfax into a national teletext programming service. Satellite Syndicated Systems, the common carrier company that transmits the WTBS-TV signal out of Atlanta to cable-TV systems nationwide, will pick up the Keyfax service and insert it into the vertical blanking-interval of its signal on Satcom III, Transponder 6.

Zenith, which has been working closely with Field and with SSS, is already developing a text-decoder, based on the Z-TAC system, which it offers as a cable-TV converter. The Keyfax system will be offered to cable-TV customers who are already receiving WTBS. Initially, the teletext decoders may cost as much as \$300, although that price could be cut to the \$100 range rather quickly, if the plan catches on.

Details about the national teletext project are still being hammered out, although all the companies involved hope to begin offering the service during the next few months. Like the Chicago version of Keyfax, the national teletext service will include news reports, sports and business stories, videogames, and household and travel information, plus a variety of feature stories. Viewers can call up any page they'd like to see by pushing a few buttons on the teletext decoder.

The Keyfax announcement came as a big surprise to the cable-TV and broadcasting industry. It gives proponents of the British teletext technology a significant boost in their efforts to establish a foothold in the U.S. market, where they are competing with a rival format (combining French and Canadian technology); the latter system is endorsed by CBS, which itself plans to begin transmitting teletext nationwide this fall.

NEW SATELLITE PROGRAMMING

During the coming months, a new batch of satellite-TV programming will be introduced. For example, five transponders aboard the new Westar IV bird (at 99° west longitude) will be used by Satellite News Channels, the new all-news service jointly operated by Group W Satellite Communications and ABC Video Enterprises. Transponders 4X, 6D, 7X, 8X, and 9X will be used for the national and regional feeds.

Among the new program packages on Satellite Program Network (Satcom III, Transponder 9) is a "nostalgia" series, featuring classic TV shows of the '50s and '60s such as "Mr. Peepers," "Wyatt Earp" and the original "Life of Riley." It airs at 6 p.m. weeknights (eastern time) and noon Saturdays. Another new SPN show is the "Shopping Game," which allows home viewers a chance to win prizes along with the studio audience.

DBS SERVICE PLANNED

United Satellite TV, a new direct-broadcast satellite service that will include two pay-TV channels and two commercially supported channels, is scheduled to go into operation in 1983. The project is a joint venture of General Instruments Corp. and two new programming companies, Pop Satellite, Inc. and Allstar Satellite Network Inc. Initially, the new DBS channels will be transmitted via Canada's Anik-C satellite, scheduled for launch in November 1982, a Ku-band satellite at 190° west longitude. In 1984, the programming will be moved to a new GT&E satellite due to be launched in 1983. United Satellite expects that its DBS reception equipment will cost about \$1000 per site.

KU-BAND DOWNLINK

Scientific-Atlanta has introduced two small Ku-band satellite receivers—with a hint that a low-priced Ku-band uplink will soon be available—operating in the 14/12-GHz range. The small-dish equipment is primarily intended for data and video transmission users of the Satellite Business System, Anik, and OTS birds. Each of S-A's new configurations includes a manually steerable antenna, a series 361 Ku-band low-noise converter, and a series-6650 video receiver. The series-361 Ku-band converter is a combination LNA and block downconverter that generates an IF signal over the same band as S-A's C-band low-noise converter. Because the input of the low-noise converter is the same for both the C-band and Ku-band models, the identical video receiver is used for earth stations at both frequencies. The Ku-band downlink comes in a 1.8-meter (\$5,000) and a 2.8-meter (\$8,000) size. R-E

Get set to Splashdown and tool up!

Cash in on Acapulco, power tools and more in Philips ECG's Splashdown Sweepstakes.

We're putting it all on our tabs.

A holiday for two in Acapulco and a thousand more great awards are up for grabs in Philips ECG's new Splashdown Sweepstakes. And it's never been easier to get the winning tickets—they're right on our address tabs, bags and color picture tube serial numbers.

There'll be guaranteed winners from every state.* And there's no limit to the number of times you can win, so enter as often as you like. Just send your entry form (available from your local distributor) to Philips ECG Sweepstakes Award Headquarters, P.O. Box 4900, Fenton, MO 63026, attached to any of the following:

- 5 Sylvania receiving tube address tabs (one entry).
- 5 Sylvania ECG semiconductor address tabs or bags (one entry).
- 1 Sylvania color picture tube serial label (ten entries).

All entries must be postmarked by midnight, September 30, 1982. For all the details, ask your local Philips ECG distributor.

First Place—(1 winner) Trip for 2 to Acapulco.

Second Place—(5 winners) DeWalt® Power Shops.

Third Place—(45 winners) Shop-Vac® 10-gallon Wet/Dry Vacuums.

Fourth Place—(100 winners) Wen Scroll-Sabre Saws.

Fifth Place—(850 winners) Turner Propane Torch Kits.

Reach for the components you can always count on to fit and work. And start counting down to Splashdown time in Acapulco.

*The Philips ECG Splashdown Sweepstakes is available only to dealers and service technicians. Employees of Philips ECG, Inc., its authorized distributors, or their advertising agencies are not eligible to participate. No purchase required. Reasonable facsimile accepted. Void where prohibited by law.

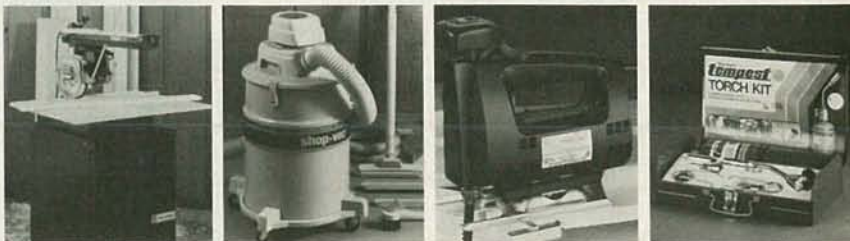
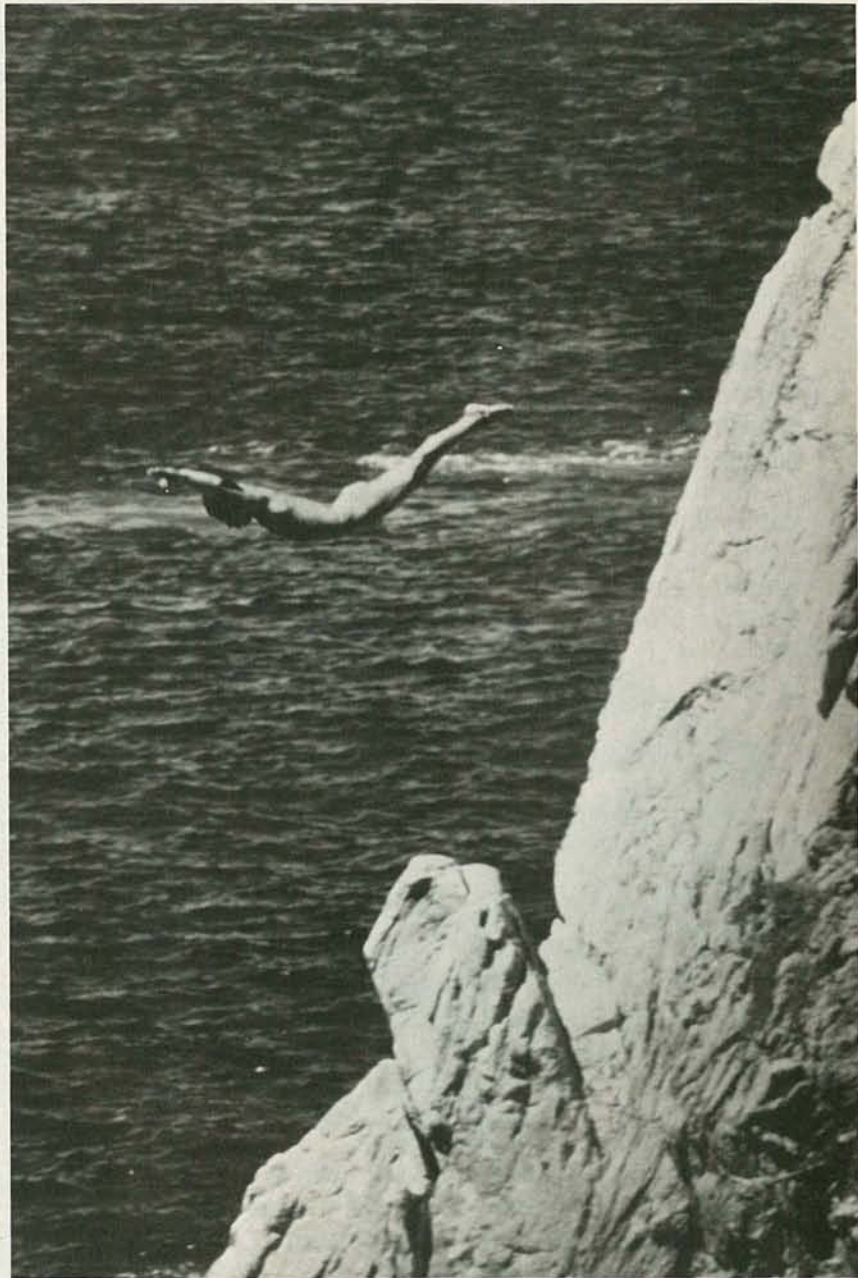

Philips ECG

A North American Philips Company

If it's ECG, it fits. And it works.

EQUIPMENT AND TRAINING NO OTHER SCHOOL CAN MATCH.

**NTS HOME TRAINING INVITES YOU TO EXPLORE MICROCOMPUTERS,
DIGITAL SYSTEMS AND MORE, WITH STATE-OF-THE-ART EQUIPMENT
YOU ASSEMBLE AND KEEP.**

Without question, microcomputers are the state of the art in electronics. And NTS is the only home study school that offers you training for this booming field with a choice of 3 production-model micro computers.

We'll explain the principles of troubleshooting and testing your microcomputer and, best of all, we'll show you how to program it to do what you want.

You'll use a digital multimeter, a digital logic probe and other sophisticated testing gear to learn how to localize problems and solve them.

Send for the full color catalog in the electronics area of your choice—discover *all* the advantages of home study with NTS!

NTS also offers courses in Auto Mechanics, Air Conditioning and Home Appliances. Check card for more information.



We believe that training on production-model equipment, rather than home-made learning devices, makes home study more exciting and relevant. That's why you'll find such gear in most of NTS's electronic programs.

For instance, to learn Color TV Servicing you'll build and keep the 25" (diagonal) NTS/HEATH digital color TV.

In Communications Electronics you'll be able to assemble and keep your own NTS/HEATH 2-meter FM transceiver, plus test equipment.

But no matter which program you choose, NTS's Project Method of instruction helps you quickly acquire practical know-how.

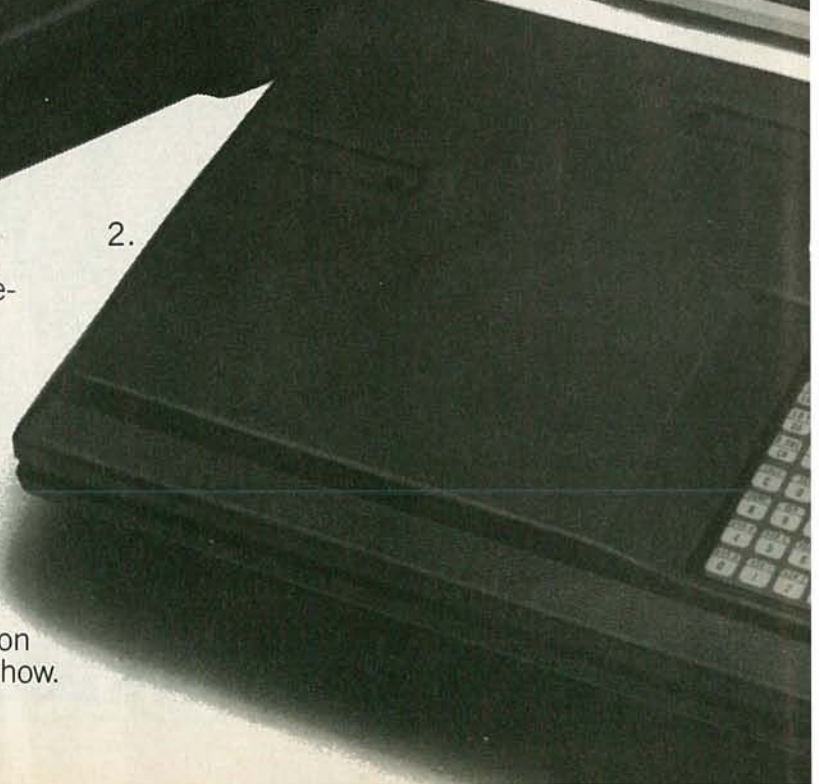



Simulated TV Reception 4.

3. The NTS/Heath HN-89A Microcomputer features floppy disk storage, "smart" video terminal, two Z80 microprocessors, with 32K RAM Memory, expandable to 64K on board. 4. The NTS/Heath GR 2001 Digital Color TV (25" diagonal) features specialized AGC-SYNC muting, filtered color and new solid-state high voltage tripler rectifier.

1. The NTS/Rockwell AIM 65 Dedicated Microcomputer A Single board unit featuring on board printer and display—4K RAM (expandable). Application Functions: Central processor—Controller/Monitor—Development System. 2. "The NTS/SYM-1 Microcomputer" 6502 Based CPU—4K bytes ROM (expandable)—1K RAM (expandable). 51 active I/O lines for versatile interfacing: disk drives, ASCII key boards, cassette tape, etc.

NTS NATIONAL TECHNICAL SCHOOLS

TECHNICAL-TRADE TRAINING SINCE 1905
Resident and Home-Study Schools
4000 SO. FIGUEROA ST., LOS ANGELES, CA. 90037



NATIONAL TECHNICAL SCHOOLS
4000 South Figueroa Street, Dept. 206-082
Los Angeles, California 90037

- Please rush FREE color catalog on course checked below
- | | |
|---|---|
| <input type="checkbox"/> MicroComputers/MicroProcessors | <input type="checkbox"/> Auto Mechanics |
| <input type="checkbox"/> Communications Electronics | <input type="checkbox"/> Air Conditioning |
| <input type="checkbox"/> Digital Electronics | <input type="checkbox"/> Home Appliances |
| <input type="checkbox"/> Industrial Technology | <input type="checkbox"/> Color TV Servicing |

Name _____ Age _____
Address _____
Apt. _____ City _____
State _____ Zip _____

- Check if interested in G.I. information.
 Check if interested ONLY in classroom training in Los Angeles.

LETTERS

Address your comments to: Letters, **Radio-Electronics**,
200 Park Avenue South, New York, NY 10003

THE PROM PROGRAMMER

I read Robert N. Beaber's article on how to build a 2716 Prom Programmer in the February 1982 **Radio-Electronics**, and found his design very simple and straightforward. I'm planning to build an EPROM programmer, using his designs with three small changes.

By using an SPDT switch, a 74LS244 buffer, and a 24-pin ZIF socket, I will have the capability of copying another 2716 EPROM in whole or in part.

The advantage of that is clear: Many times, an EPROM has one or two errors that could be fixed just by changing the byte at the location of the error(s). Instead of recopying the whole EPROM by hand, the majority is recopied by single-stepping then hitting the program button. The necessity of having another 2716 available is not a disadvantage, as they cost less than five dollars.

The disadvantage is that you can't copy a program to a different address. That would require the addition of three more

74LS193's, three more address-display LED's, one more 4071, and one more reset switch. The same clock from pin 4 of IC12 is used on each address counter. That circuit is more complex than I need, but someone else might like the added option.

The power supply should not be a concern with either one of the design additions. The design-change I plan to use is shown in Fig. 1.

JEFF McDONALD
Tucson, AZ

RADAR DETECTORS

Mr. M. J. Rybicki's letter in the February 1982 issue of **Radio-Electronics** strikes me as being particularly illogical. He says: "I don't believe for one moment that the policeman operating the radar unit is primarily interested in saving my life..." If it were only the lives of the drivers involved that were at stake, there would be some logic in letting them drive just as fast as they wanted to. Then, if they killed them-

selves, one could say, "Good riddance!" Unfortunately, all too often they kill someone else and not always themselves as well.

He also says: "To say that every radar-detector owner has it solely for the purpose of speeding without getting caught is like saying that anyone who owns a gun is planning a bank job or an assassination." Guns can be used for hunting, target-shooting, or self-defense—but I have yet to hear of a radar-detector in a car being used for any other purpose except to avoid getting caught when speeding. Perhaps Mr. Rybicki can tell us what he uses his for.

RICHARD KOLASINSKI
Richmond, MI

OOOOOPS

On page 59 of the March 1982 **Radio-Electronics**, there is a formula:

$$Nf(g) = 10 \log_{10} N$$

Where:

g = gain in dB

N = noise factor

Nf = noise figure.

The next formula:

$$N = \log^{-1} \frac{Nf(g)}{10} \text{ is incorrect!}$$

Solving equation (1) for (N) gives:

$$N = \log^{-1} \left(\frac{Nf(g)}{10} \right) \text{ which is the correct}$$

formula for the noise factor.

In the same way, power gain (G) should be:

$$G = \log^{-1} \left(\frac{g}{10} \right) \text{ not } G = \frac{\log^{-1}(g)}{10}$$

These are the correct relationships.

BILL HOSTMANN

INSUFFICIENCY ALERT

Before building the ambient illumination insufficiency alert ("Six Unique Projects for Your Car," April 1982 **Radio-Electronics**), interested readers should consider the spectral response of PC1 in Figure 10, page 48. That is so that the alert is not activated falsely by a failure to sense the illumination from the various types of lamps that may be present. The "colors" of the light from conventional tungsten-filament lamps, those of the halogen type (quartz-iodine), and those of the filtered amber fog lamp should be compared with the spectral response curve of the photocell.

A fringe benefit of your circuit became apparent to me, and I would like to mention it here so as to give the readers an additional

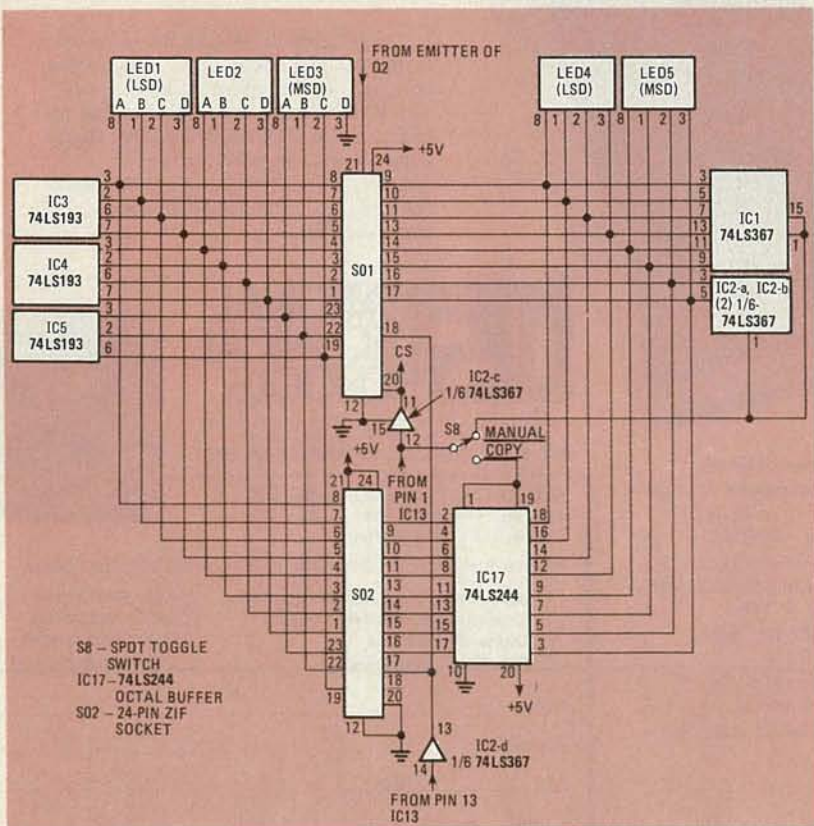
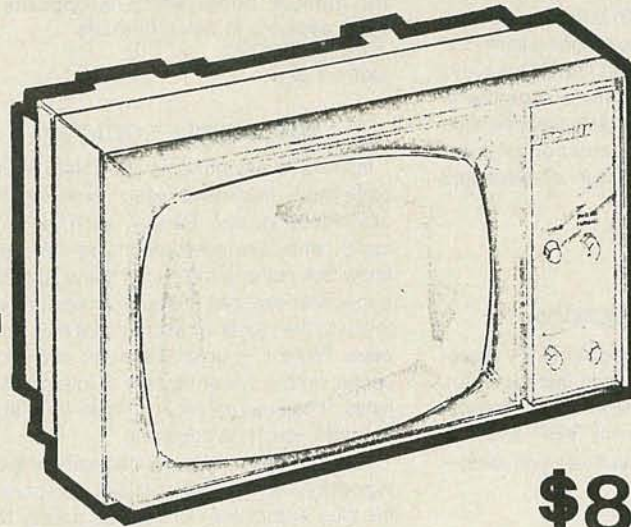

FIG. 1

VIDEO 100

12" Black and White Monitor

- Economical favorite for personal computing
- Light-weight cabinet with built-in handle.
- 12 MHz band width
- Plug-in compatible with most personal computers
- 90° deflection for clear, sharp characters
- 80 x 24 character display



\$8950

ITEM	SPECIFICATIONS
CRT	12" diag. 90° defl.
CRT Phosphor	P-4
Signal	Composite video input
Input Signal	1.0Vp-p, sync negative
Input Impedance	75 ohms
Scan Frequencies	Horizontal: 15600Hz Vertical: 50/60Hz
Display Size	210 (W) x 158 (H) mm
Deflection Linerity	Horizontal: 10% Max. (refer to EIA ball Chart and dot Pattern.) Vertical 8%
Video Response	12MHz (± 6dB)
Resolution	Center: 650 Corners: 550

Power Source	120V Ac, 50/60 Hz
Dimensions	11.375" (H) x 16.25" (W) x 11.25 (D)
Weight	6.5Kg (14.3 Lbs.) net

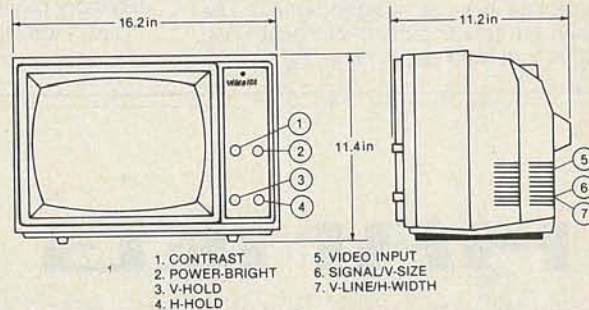

DISKETTES
5 1/4" BULK "OEM" PACK
FOR YOUR
APPLE
Box of 100
\$149

**16K APPLE II EXPANSION
CARD \$79⁹⁵**

TRACTOR FEED

120 COLUMN · FOR THE
DIABLO PRINTERS · BI-
DIRECTIONAL · BUILT
BY RUTISHAUSER

\$149^{new}

**MICROWAVE RECEIVER
SYSTEM**
1.8GHZ to
2.4 GHZ
BROAD BAND
only
\$295.00

With built-in-converter to channel
2, 3, or 4 of any standard TV set.

RANGE: Line of sight to 250 miles.

SCOPE: Will receive within the frequency band from satellites, primary microwave stations, and repeater microwave booster stations.

CONTENTS: Packaged in 19"x19"x4 1/2" corrugated carton complete with:

- 24" Dish
- Feed-Horn Receiver
- Mounting Bracket
- Mounting Clamp
- Instructions
- 300 Ohm to 75 Ohm Adapter
- 750 Ohm to 300 Ohm Adapter
- 60 Feet Coax Cable with Connectors
- 3 Feet Coax Cable with Connectors

MUFFIN FAN
120 VOLTS
\$995

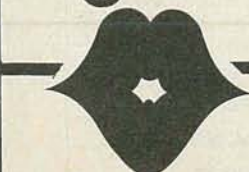

"HAVE YOU KISSED
YOUR COMPUTER LATELY?"

Components Express, Inc.

1380 E. Edinger, Santa Ana, CA 92705 (714) 558-3972

incentive to build the device.

If when driving, and after making a turn, an on-off pulsing of the alarm LED occurs, you can be certain that your turn-indicator lamp is still blinking, and possibly annoying or confusing other drivers. That fringe benefit, however useful, is able to manifest itself during the insufficient ambient conditions only.

Perhaps a reader with more expertise in circuit design will submit a circuit modification to make possible the detection of turn-indicator blinking under high ambient-light conditions.

RAYMOND E. VERNBICK
Detroit, MI

UHF-TV RECEPTION

I appreciate your article on UHF-TV reception (March 1982 issue, and last summer). Please continue with material on antenna-system improvements for VHF and FM. We're rural, where no cable will ever exist—and we need help!

ARNOLD B. HAWK
East Thetford, VT

SPEAKER-OVERLOAD PROTECTOR

In the December 1981 issue of **Radio-Electronics**, a circuit for a speaker-overload protector, by Mr. Willie Ward appeared in the "New Ideas" section. The design is simple and efficient, except that there has been a misinterpretation between the text and the circuit schematic. In the text, the right-channel signal is re-

ferred to as capacitor one (C1), contrary to the schematic which refers C1 to the left-channel input. The same error occurs when it is mentioned in that last paragraph that the right input is calibrated by resistor number three, which is opposite to what appears in the schematic.

JOSE A. EIJER
Detroit, MI

AUTOMOBILE LOCATER

I found a minor error on the "New Ideas" page (April, 1982 issue) which deals with the automobile locater. People, such as radio hams, who take direction-finding seriously, know that pointing the end of the whip at the transmitter exposes the least amount of antenna to the signal. That creates a null, not a peak. While it is usually sharper and more useful, unless you know how to interpret the lights, it can get confusing. Aside from that, the basic idea is a good one.

As for improvements, I would start by leaving out the switch. That would let me connect the plus lead directly to the plus battery terminal, and the negative lead to the hot side of the radio fuse. That assumes that the power for the radio goes through the key. When the radio is on, or the key is on, 12 volts on the negative connection would eliminate the voltage drop across the transmitter. When the key is off, the transmitter would have a ground connection through the radio or other accessory connected to that fuse.

Next, I would put in a Y connector in the radio-antenna lead. That would give me an

outside antenna that is as good as any other that I could get.

Next, I would use a ferrite antenna for the receiver. That would make a more compact unit, while not hindering the reception very much. Retuning an AM radio to cover that frequency would probably be just as easy.
HARWOOD PILLAR
Dowling, MI

CELLULAR MOBILE TELEPHONES

I read the article on cellular mobile telephone, by Danny Goodman, in your February issue, and found it very interesting because the company I work for manufactures mobile telephones and is presently developing cellular equipment.

Mr. Goodman made only one comment about which I think there is a misunderstanding. The present system configuration does not require two mobile antennas, one each for transmit and receive. The original concept called for two mobile antennas using diversity reception techniques. Only the base station will have separate receive and transmit antennas.

Also, I don't know who gave the installation figure of 4.5 to 5 hours per vehicle, but I think that the person is slow. My partner and I can knock one out in 1.5 to 2 hours, including testing. The cellular units aren't going to be much different, so far as installation goes, from presently existing ones.

TOM PORPIGLIA
Rochester, NY

R-E

HAMEG PRESENTS THE NEW HM 203



High performance
at
low cost.

\$605
(PROBES INCLUDED)

A quality scope,
by a company with
over 23 years
experience.

Hameg introduces high performance at low cost in the HM 203, a full featured, highly reliable, dual trace 20 MHz oscilloscope. The HM 203 has specifications normally associated with higher priced scopes. Bandwidth - DC → 20 MHz • Risetime 17.5 ns • Overshoot 1% max. • Y amp range 5 mv/cm to 20 v/cm • Max. input voltage 500V • Timebase .5 μs/cm to .2s /cm • Sweep mag. x5 • Trigger 5 Hz to 30 MHz • X:Y plot • Built-in probe calibrator and more. Its sturdy construction and light weight (13.2 lbs.) make the HM 203 equally at home in the field and on the test bench.

HAMEG
88-90 Harbor Rd.
Port Washington, N.Y., 11050
Tel: (516) 883-3837

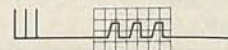



Don't miss this exceptional money-saving opportunity!

The ELECTRONICS BOOK CLUB

is the up-to-the-minute information source for hobbyists, experimenters, and do-it-yourselfers!

Select 5 outstanding volumes for only \$295 (total value up to \$101.75)

GET TWO EXCITING PROJECT BOOKS FREE!

1321 List \$10.95
ELECTRIC MOTOR TEST & REPAIR 3RD EDITION

1346 List \$19.95
THE RADIO HOBBYIST'S HANDBOOK

1169 List \$16.95
THE GIANT Handbook of Computer Projects

1225 List \$8.95 Paper
1316 List \$16.95
THE MASTER HANDBOOK OF TELEPHONES

1390 List \$14.95
THE HANDBOOK OF ELECTRONIC SAFETY PROCEDURES

1420 List \$17.95
THE VOM-VTVM HANDBOOK BY JOSEPH A. RISSE

1417 List \$17.95
HOW TO BUILD AND OPERATE YOUR OWN SMALL HYDROELECTRIC PLANT BY J. GEORGE BUTLER

1370 List \$22.95
DANGER HIGH VOLTAGE DO NOT THROW SWITCH CAUTION

1337 List \$9.95
30 COMPUTER PROGRAMS FOR THE HOMEOWNER IN BASIC

1380 List \$18.95
THE MASTER HANDBOOK OF IC CIRCUITS

1396 List \$13.95
THE MASTER IC COOKBOOK

1108 List \$13.95
LASERS THE LIGHT FANTASY

1277 List \$19.95
49 EASY-TO-BUILD ELECTRONIC PROJECTS

1338 List \$19.95
HOW TO DESIGN/BUILD REMOTE CONTROL DEVICES

1409 List \$15.95
BUILD A PERSONAL EARTH STATION FOR WORLDWIDE SATELLITE TV RECEPTION

1199 List \$16.95
MICROPROCESSOR INTERFACING

1306 List \$15.95
HOW TO MEASURE ANYTHING WITH ELECTRONIC INSTRUMENTS

1296 List \$18.95
THE MASTER HANDBOOK OF ACOUSTICS

1160 List \$13.95
1001 THINGS TO DO WITH YOUR PERSONAL COMPUTER

1218 List \$16.95
HOW TO TROUBLESHOOT & REPAIR ELECTRONIC CIRCUITS

1249 List \$15.95
103 PROJECTS FOR ELECTRONICS EXPERIMENTERS

1397 List \$16.95
BASIC ELECTRONICS THEORY

1296 List \$18.95
WHAT TO DO WHEN YOU GET YOUR HANDS ON A MICROCOMPUTER

1409 List \$15.95
MODERN CRYSTAL RADIOS

1409 List \$15.95
MODERN TRANSISTOR RADIOS

Join now . . . get two extra books absolutely free! Modern Transistor Radios and Modern Crystal Radios

7 very good reasons to try Electronics Book Club

Blue Ridge Summit, PA 17214

- **Reduced Member Prices.** Save up to 75% on books sure to increase your know-how
- **Satisfaction Guaranteed.** All books returnable within 10 days without obligation
- **Club News Bulletins.** All about current selections—mains, alternates, extras—plus bonus offers. Comes 13 times a year with dozens of up-to-the-minute titles you can pick from
- **"Automatic Order"**. Do nothing, and the Main selection will be shipped automatically! But . . . if you want an Alternate selection—or no books at all—we'll follow the instructions you give on the reply form provided with every News Bulletin
- **Continuing Benefits.** Get a Dividend Certificate with every book purchased after fulfilling membership obligation, and qualify for discounts on many other volumes
- **Bonus Specials.** Take advantage of sales, events, and added-value promotions
- **Exceptional Quality.** All books are first-rate publisher's editions, filled with useful, up-to-the-minute info

ELECTRONICS BOOK CLUB

Blue Ridge Summit, PA 17214

Please accept my membership in Electronics Book Club and send the 5 volumes circled below, plus a free copy of *Modern Crystal Radios* and *Modern Transistor Radios*. I understand the cost of the books selected is \$2.95 (plus shipping/handling). If not satisfied, I may return the books within ten days without obligation and have my membership cancelled. I agree to purchase 4 or more books at reduced Club prices during the next 12 months, and may resign any time thereafter.

1108 1128 1160 1169 1199 1218 1225 1249
1277 1296 1306 1316 1321 1337 1338 1346
1370 1380 1390 1396 1397 1409 1417 1420

Name _____ Phone _____

Address _____

City _____

State _____ Zip _____

(Valid for new members only. Foreign and Canada add 20%. Orders outside U.S. or Canada must be prepaid in U.S. dollars.)

This order subject to acceptance by Electronics Book Club RE-882

EQUIPMENT REPORTS

Tektronix Model 2213 Oscilloscope



CIRCLE 106 ON FREE INFORMATION CARD

Tektronix		2213									
OVERALL PRICE											
EASE OF USE											
INSTRUCTION MANUAL											
PRICE/VALUE											
		1	2	3	4	5	6	7	8	9	10
		Poor		Fair		Good		Excellent			

THE NEW *model 2213* oscilloscope from Tektronix (P.O. Box 500, Beaverton, OR 97077) is a low-cost dual-trace instrument with a 60-MHz response and an 80 × 100 mm CRT. The CRT has a bright trace and an internal graticule to eliminate any chance of

parallax. Automatic focus and intensity circuits are included. Set up the brightness and focus, and the automatic circuits will hold them, no matter what the sweep-speed is. If you can't locate the trace, push the **BEAM FINDER** button; the trace will be compressed

and returned to the viewing area. Center it and release the **BEAM FINDER** button; there you are.

The two vertical-input channels are identical. The **VOLTS/DIV** selector switch can be set for any sensitivity from 2 mV-per-division up to 10 volts-per-division in the familiar 1-2-5 sequence. There's a very useful feature on the switch; there are two panel labels around the outside of the selector switch about 45° apart. One label is **1X** and the other is **10X PROBE**. If you use a direct probe, set the selector switch using the **1X** label. If you use a **X10** probe, the **10X PROBE** label. There's also a variable control in the center of the selector switch; that can be used for minor adjustments, or left in the calibrated position. The probes furnished are the 10:1 low-capacitance type.

Above the left-hand **VOLTS/DIV** switch is the channel-selector switch that lets you dis-

good reasons

1. RCA SK Devices

More and more electronic technician dealers are reaching for reliable RCA solid state replacements . . . the line of integrity, with unsurpassed engineering excellence. Our warranty return rate is less than 0.5%, which helps reduce costly service call-backs. And SK devices are readily available, to help you do more jobs, more profitably.

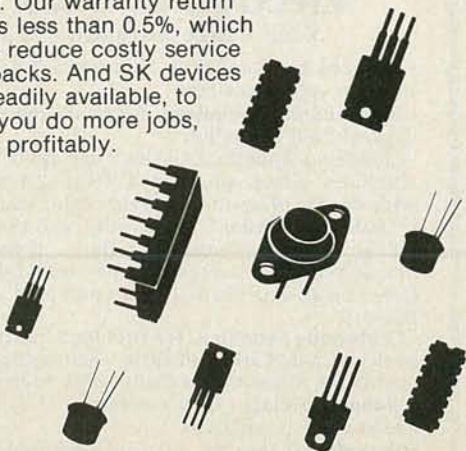

play either Channel 1 only, both at once, or Channel 2 only. Above the right-hand VOLTS/DIV switch is the vertical-mode selector switch. Setting that switch to the ADD position will let you see the algebraic sum of the Channel 1 and Channel 2 signals. The next position of the switch is the ALT position that displays alternate sweeps of each signal. The final CHOP position chops the signals at a 250-kHz rate. The CHOP mode is useful for viewing lower frequency signals that require sweep speeds from 0.5 milliseconds-per-division to 0.5 seconds-per-division. Vertical-positioning controls for each channel are located near the top of the front panel.

Located between the two VOLTS/DIV switches is a push-push switch that inverts and displays the Channel 2 signal when pushed in. That is handy for various tests.

The horizontal SEC/DIV switch sets the sweep speed, from 0.5 seconds-per-division to 0.05 microseconds-per-division. A variable control, in the center of the SEC/DIV switch can be used for minor adjustments to the sweep speeds. When that knob is pulled out, the sweep-speed is increased by 10 times, so that the highest sweep speed becomes only 5 nanoseconds-per-division. When the variable control is turned full counter clockwise, the SEC/DIV switch is calibrated. Finally, by setting the SEC/DIV to the X-Y position, both channels are displayed at once. The Channel-1 signal is

displayed on the X-axis (horizontal) and the Channel-2 signal is displayed on the Y-axis (vertical). That is for sweep-alignment, vectorscope analysis, and the like.

The model 2213 has a delayed-sweep feature that can control the starting position of the trace. The selector switch for that is located just above the horizontal SEC/DIV switch, and it has three positions. The left-hand position is labelled NO D'LY and it disables the delay feature. The center position is labelled INTEN and it causes an intensified zone (brighter) to appear on the waveform. The left-hand side of the intensified zone indicates the starting point of the sweep when the switch is moved to the right-hand D'LY position. Just below the SEC/DIV are two controls for the delay; a three-position switch that selects delays of 0.5 microseconds, 10 microseconds, and 10 milliseconds. Below that selector switch is a control that varies the sweep-delay from less than 1 to more than 20 times the setting of the selector switch.

At the far right-hand side of the front panel are the trigger controls. At the top is the MODE switch. That is a three-position paddle type. The AUTO position triggers the sweep on all waveforms with repetition rates faster than 20 Hz, and free-runs with no input so that the trace is visible at all times. The NORM position triggers the sweep only when a signal is applied. The LEVEL control sets the point at which the

sweep triggers. The last position is TV FIELD. That displays TV field signals; for viewing individual lines of a TV signal, use the NORM position.

Beside the LEVEL control is a two-position paddle switch that selects the slope of the signal waveform on which the sweep is triggered, either positive going or negative going. Between that and the LEVEL control is an LED indicator that lights when the sweep is triggered.

Below the LEVEL control is a row of three-position paddle switches. Those select the source of the triggering signal. One paddle switch selects either the signal from Channel 1, whichever signal is selected by vertical MODE switch (Channel 1-Both-Channel 2), or the Channel 2 signal. The center paddle switch selects either internal triggering, or triggering from a sample of the power line frequency, or from an external signal. At the bottom of the panel is a BNC jack for feeding in external trigger signals. The last paddle switch is labelled EXT COUPLING and it selects the type of coupling for the external trigger. The AC position selects capacitive coupling to the trigger circuit, the DC position selects direct coupling of trigger signals, and the DC 10 position attenuates the external signal by a factor of 10 times. At the very top of the front panel is the VAR HOLDOFF control. That varies the holdoff time between sweeps by at least a factor of four, making it

to reach for reliability.

2. RCA SK Series Replacement Guide

It's the book to turn to for top-performing transistors, rectifiers, thyristors, high-voltage multipliers and integrated circuits. 1800 SK and KH types let you make over 178,000 solid state replacements. That's interchangeability. The guide features a convenient, dual-numbering system—including REN, ECG and TM systems in corresponding SK numbers where applicable.



3. RCA's latest SK SKoop

Get all the latest news and service updates in the SK SKoop newsletter. Published periodically, it keeps you in tune with any changes in the RCA SK lineup, including product additions, deletions and modifications. The SK SKoop is full of handy service tips, technical information and helpful application advice. It's yours free, and right at your fingertips. Pick up your copy from the counter display at your local RCA SK Distributor.

With dealer support like this, it makes sense to visit your RCA SK Distributor and reach for reliability.



RCA SK Replacement Solid State

RCA Distributor and Special Products Division, Deptford, N.J. 08096

much easier to trigger on aperiodic waveforms such as complex digital waveforms.

A rear-panel BNC jack is for inputting Z-axis (brightness modulation) signals.

Despite the multiplicity of controls, the *model 2213* is a very easy instrument to use. All controls are grouped by function, and very plainly marked. The Operator's Manual is really complete. It gives full setup and check-out procedures, using only an external signal generator that will deliver a 1-kHz square wave signal. Set the output of the generator to read four divisions with the VOLTS/DIV switch set to 50 mV-per-division. Tests that check the operation of every control on the instrument are fully explained in great detail. That covers four

and a half pages! Nothing is left out, not even the Z-axis function. Setup and check-out of the 10:1 probes provided with the *model 2213* is accomplished by using the PROBE ADJUST jack on the front panel, located between the BEAM FIND and AUTO FOCUS controls. That jack provides a 0.5-volt positive-going square wave at about 1 kHz. With that, the compensation of the probes can be checked, and if necessary set, for minimum overshoot or undershoot.

The rest of the manual is devoted to basic applications of the *model 2213*. It covers all kinds of tests, including non-delayed and delayed measurements. All of the tests and suggested uses are well illustrated.

The *model 2213* is a very versatile instru-

ment. It's backed by the Tektronix name, which is a good recommendation. For any kind of electronic testing, lab or bench, it should be just what you need. The retail price of the *model 2213* is \$1100. **R-E**

Fox Marketing BMP 10/60 Scanning Receiver



CIRCLE 107 ON FREE INFORMATION CARD

Fox Marketing	BMP 10/60									
OVERALL PRICE										
EASE OF USE										
INSTRUCTION MANUAL										
PRICE/VALUE										
	1	2	3	4	5	6	7	8	9	10
	Poor			Fair			Good			Excellent

PEOPLE HAVE LONG BEEN INTERESTED IN listening to the public-service (police, fire, etc.) bands. That hobby has many attractions, including the thrill of hearing the news as it is being made. Interest in those bands, however, has grown even more with the introduction of frequency-synthesized, programmable scanners. Recently we've seen one of the newest of those, the *BMP 10/60* from Fox Marketing, Inc., a division of Comgeneral Corporation (4518 Taylorsville Road, Dayton, OH 45424); we would like to tell you about it.

First, and perhaps most important, is that the unit has all the features one would expect of a base-station scanner, but is still small enough to function well as either a mobile or portable unit. It measures just 6½ × 1½ × 9 inches and weighs 1½ pounds.

There is quite a bit packed into that small, black thermoplastic case. For one thing, the scanner offers 7-band, 70-channel capacity. Sixty of those channels (6 bands) are pre-programmed to include some of the most popular police, fire, marine, National Wea-

continued on page 32

Vector
introduces
New & More Versatile
Slit-N-Wrap® Tools
for Wire-
wrapping.

**Count Wire Wraps
Electronically**
Get 3 to 9 Wraps

**Eliminate Hand-
Held Wire End**
at Wrap Start with New
Wire Grip Housing!

**300 Foot
Wire Spool**
with Tension Regulator
to Reduce Wire Breakage
Six Wire Colors available

**P184-7
\$215.82
110V A.C.
60Hz**

Battery
& Manual
Models
Available

Advantantages:

- Faster and Easier Wrapping
- No Stripping
- No Precutting
- No Premeasuring
- No Loading
- Daisy Chain Wraps
- Quick Change Bits
- Reliable Wraps Meet MIL-STD 1130A, par. 5.6

U.S. & Foreign
Patents

Vector Electronic Company
INCORPORATED

12460 Gladstone Ave., P.O. Box 4336, Sylmar, CA 91342-0336, phone (213) 365-9661
Price Subject to Change Without Notice. 828108

View of wire at end of bit being wrapped on post.

HEATH/ZENITH & YOU... ONE STRONG PARTNERSHIP.

Buying a computer is only the beginning of a long-term partnership between you and the people from whom you buy. Your ongoing need for software, peripherals and accessories requires a partner who will stand by you. With a growing line of products to meet your needs with professional service and support, Heath/Zenith is that strong partner. Look at what we have to offer:

THE ALL-IN-ONE COMPUTER – The heart of the Heath/Zenith line is the stand-alone *89 Computer*. It's a complete system with built-in 5.25-inch floppy disk drive, professional keyboard and keypad, smart video terminal, two Z-80 microprocessors and three RS-232C Serial I/O Ports. It comes with 48K bytes of RAM, expandable to 64K.

PERIPHERALS AND ACCESSORIES – These include the popular *Heath/Zenith 19 Smart Video Terminal*, loaded with professional features. We also offer color and black and white monitors, modems, computer language courses, and high-speed typewriter-quality printers.

SOFTWARE – Our complete library of software includes the SuperCalc Spreadsheet and Condor Data Base Management System. *Word processing*, includes three different programs. *Small Business Programs* feature Peachtree's P5 Series, General Ledger and Inventory Control. *HUG, Heath Users' Group*, offers members a library of over 500 low-cost programs for home, work or play.

PROGRAMMING LANGUAGES – To write your own programs, Microsoft BASIC (compiler and interpreter), FORTRAN and COBOL Languages are available.

APPLICATIONS SOFTWARE – Expand the performance range of your computer with a broad selection of software, including the best of *Digital Research* and *Micropro* – as well as the complete line of *Softstuff™* products.

OPERATING SYSTEMS – Three versatile systems give you the capability to perform your specific tasks. *CP/M* by *Digital Research* makes your system compatible with thousands of popular CP/M programs. *UCSD P-System with Pascal* is a complete program development and execution environment. And *HDOS, Heath Disk Operating System* gives you a sophisticated flexible environment for program construction, storage and editing.

DISK SYSTEMS – The new *Heath/Zenith 67 Winchester Disk System*, for commercial use, adds nearly 11 megabytes of storage to your 89 computer. It includes an 8-inch



floppy disk drive for data portability. The new 5.25-inch 37 disk system, available with 1 or 2 drives, adds up to 1.28 megabytes of storage. Both plug-in systems have write protection.



SERVICE AND SUPPORT – Prompt and professional service and assistance is available nationally through Heathkit Electronic Centers, Zenith Data Systems for commercial users or through Heath factory servicing and phone-in technical assistance.

Complete, integrated computer hardware and software, designed to serve and grow with you – that's what to look for in a strong partner. And with Heath/Zenith, you get it all.

Heath/Zenith computer products are sold nationwide through Heathkit Electronic Centers* (check your white pages for locations). For a FREE colorful full-line catalog write: Heath Co., Dept. 320-924 Benton Harbor, MI 49022.



HEATH/ZENITH

Your strong partner



Product specifications are subject to change without notice.
Heath Company and Veritechnology Electronics Corporation are wholly-owned subsidiaries of Zenith Radio Corporation
*Heathkit Electronic Centers are operated by Veritechnology Electronics Corporation

EQUIPMENT REPORTS

continued from page 28

ther Service, and mobile-telephone frequencies. The remaining 10 channels can be programmed by the user for any frequency in the scanner's range (30-50 MHz, 144-174 MHz, and 420-511.9875 MHz).

However, it takes more than a wide frequency-range and ample channel capacity to make a full-featured scanner. This unit offers quite a bit more.

As with any other scanner, this unit will scan all of the channels in any band, stopping at any that are active. However, it is the

extra functions—PAUSE, SKIP, STEP, and ACTION—that give the *BMP 10/60* its versatility. Any or all of those functions can be selected for any channel or band.

Normally, the unit begins scanning the instant that the channel you are monitoring becomes inactive. However, the PAUSE feature, when selected, keeps the unit on frequency for two seconds after the end of a transmission.

The SKIP function lets you lockout unwanted channels, without erasing them from the unit's memory. The STEP function lets you "step" through any band, one channel at a time. ACTION samples channel 1 every two seconds, and switches to that channel any time that it is active.

While the pre-programmed channels include some of the most popular frequencies around, those may not necessarily be the most popular in your area. That is where the user-programmed frequencies come in handy—up to 10 frequencies can be programmed into the scanner by the user. Entering user-programmed frequencies into the unit is simple and straightforward; the procedure is completely described in the instruction manual that accompanies the scanner (more on that later). Those frequencies are retained in the unit's memory even after it is turned off, as long as it is connected to its power supply. If it is disconnected from its supply, a 9-volt battery back-up (supplied) will let the unit retain the frequencies for about a week.

If you are not sure what frequencies are active in your area, or just want to scan a wide range of frequencies, the scanner's SEEK function will come in handy. That function will let you scan up or down from any frequency you choose, in 5-kHz steps (12.5-kHz steps for frequencies from 420 to 511.9875 MHz).

The scanner is designed to be easy to use, even by someone who has never used such a device before. A color-coded, touch-sensitive keypad is used to control most of the scanner's functions. The only other controls are two knobs. One is used to turn the unit on and set the volume; the other is used to set the squelch. Ten channel-indicator LED's are used to tell you which channel in the band is being monitored. A small, but easily readable, LED readout is used to display such things as the frequency being monitored, whether the unit is in the pre-programmed or normal (allowing the user to program his own frequencies) mode, and which scanner functions are active. Rear-apron connectors are provided for an external antenna, external speaker, and the 12.5-volt DC power input. The unit also has a built-in speaker and telescoping antenna, and comes with a wall-plug-type power supply for base-station operation.

The instruction manual is just that, as it has little technical data and no schematic diagram, block diagram, theory of operation, etc.; in addition, only limited troubleshooting hints are provided. What it does provide, however, are complete, easy-to-follow instructions for use. Setting up the unit for the first time; how to use the pre-programmed frequencies; keypad functions, and programming the unit are among the topics covered in detail. Warranty information and the addresses of authorized service centers are also included.

All-in-all we were rather impressed with this small scanner. Its features and performance compare favorably with others in its class, and its ability to serve as a base, mobile, or portable unit gives it all the flexibility that anyone may need. Among the accessories available are a mobile mounting bracket and a *Porta-Pac* battery pack for portable use; those list for \$9.95 and \$39.95, respectively. The *BMP 10/60* has a suggested retail price of \$349.95. **R-E**

HAVE RTTY—WILL TRAVEL



Yes, now you can take it with you! The new **HAL CWR-6850 Telereader** is the smallest RTTY and CW terminal available, complete with CRT display screen. Stay active with your RTTY and CW friends even while traveling. Some of the outstanding features of the CWR-6850 are:

- Send and receive ASCII, Baudot, and Morse code
- RTTY and Morse demodulators are built-in
- RTTY speeds of 45, 50, 57, 74, 110, and 300 bau⁻¹
- High or Low RTTY tones
- Send and receive CW at 3 to 40 wpm
- Built-in 5 inch green CRT display
- Four page video screen display
- Six programmable HERE IS messages
- Pretype up to 15 lines of text
- External keyboard included
- Runs on +12 VDC @ 1.7 Amperes
- Small size (12.75" x 5" x 11.5")

Write or call for more details. See the CWR-6850 at your favorite HAL dealer.



HAL COMMUNICATIONS CORP.

BOX 365
URBANA, ILLINOIS 61801 217-367-7373

HEATH/ZENITH A GIANT STEP AHEAD IN

Computer power, printer speed, hard disk storage – all in one system.

The three elements you need for smooth, rapid data handling are together now in one Heath/Zenith system. For word processing, business and financial applications, or custom programming – this is the performance standard evolving in computer technology. It's what you expect from a *strong partner*.

All-In-One Computer

The heart of the system is the Heath/Zenith 89 Computer, a complete, stand-alone unit with professional keyboard, smart video terminal and 5¼-inch disk drive. It's easy to use for people having little or no experience – yet it can also run extended languages like BASIC, COBOL, FORTRAN and Pascal.

The 89 comes with 48K bytes RAM, expandable to 64K. It has two Z80 microprocessors, one for computer functions, one for terminal functions. And three serial I/O ports for interface with printers and modem.

The video display features a 12-inch diagonal, high-resolution CRT that's easy on the eyes. It displays up to 2,000 characters at a time, 24 lines (plus 25th status line) by 80 characters, with full cursor control. Also 33 block graphic characters for charts and graphs.

The heavy-duty keyboard follows standard typewriter format for easy operator training. All terminal functions are programmable from keyboard or I/O ports.

The 5¼-inch floppy diskette stores 100K bytes of information and interfaces on line with the Heath/Zenith 67 Hard Disk System.

Winchester Disk System

The 67 Disk System features one hard disk and one 8-inch, soft-sectored floppy for total on-line storage of 10.782 megabytes (formatted). That's a huge data base.

The floppy is double-sided, double-density and can also operate in single-sided or single-density modes, compatible with standard IBM 3740 format.

The 67 features write-protect switches for both drives to prevent accidental erasure of information. The average access time of the hard disk drive is 70 milliseconds.

High-speed printer

The Heath/Zenith 25 Printer is a heavy-duty, high-speed, dot matrix printer that gives you sharp, clear printouts. It prints over 150 characters per second with whisper-quiet smoothness.

The entire 95-character ASCII set prints in upper case and lower case with descenders, in a 9 x 9 matrix. Also, 33 block graphic characters let you create graphs and charts. All functions and timing are microprocessor-controlled.

It uses standard edge-punched papers and features a convenient cartridge ribbon for easy, no-mess replacement.



MICROCOMPUTERS— SYSTEM PERFORMANCE

Versatile software and accessories

The Heath/Zenith System offers you a choice of operating systems, including popular CP/M.

There are programs for word processing, business applications, and versatile utility functions. And the Heath User's Group offers a library of over 500 low-cost programs for home, work or play.

For your custom programs, Microsoft languages are available in BASIC (compiler and interpreter), FORTRAN and COBOL. Or learn to write and run your own programs with special self-study programming courses for Assembly, BASIC, Pascal or COBOL.

Free demonstration awaits you at your Heathkit Electronic Center

Pick the store nearest you from the list at right. And stop in today for a demonstration of a Heath/Zenith system. If you can't get to a store, send for our new, FREE Heath/Zenith Computer Catalog — with the latest, most advanced hardware and software available. Write to Heath Co., Dept. 020-926, Benton Harbor, MI 49022.



Visit Your Heathkit Electronic Center*

where Heath/Zenith Products are displayed, sold and serviced.

- | | | |
|--|--|--|
| PHOENIX, AZ
2727 W. Indian School Rd.
602-279-6247 | INDIANAPOLIS, IN
2112 E. 62nd St.
317-257-4321 | CINCINNATI, OH
10133 Springfield Pike.
Woodlawn
513-771-8850 |
| TUCSON, AZ
7109 E. Broadway
602-885-6773 | MISSION, KS
5960 Lamar Ave.
913-362-4486 | CLEVELAND, OH
28100 Chagrin Blvd.
216-292-7553 |
| ANAHEIM, CA
330 E. Ball Rd.
714-776-9420 | LOUISVILLE, KY
12401 Shelbyville Rd.
502-245-7811 | COLUMBUS, OH
2500 Morse Rd.
614-475-7200 |
| CAMPBELL, CA
2350 S. Bascom Ave.
408-377-8920 | KENNER, LA
1900 Veterans Memorial Hwy.
504-467-6321 | TOLEDO, OH
48 S. Byrne Rd.
419-537-1887 |
| EL CERRITO, CA
6000 Potrero Ave.
415-236-8870 | BALTIMORE, MD
1713 E. Joppa Rd.
301-661-4446 | OKLAHOMA CITY, OK
2727 Northwest Expressway
405-848-7593 |
| LA MESA, CA
8363 Center Dr.
714-461-0110 | ROCKVILLE, MD
5542 Nicholson Lane
301-881-5420 | FRAZER, PA
630 Lancaster Pike
(Rt. 30)
215-647-5555 |
| LOS ANGELES, CA
2309 S. Flower St.
213-749-0261 | PEABODY, MA
242 Andover St.
617-531-9330 | PHILADELPHIA, PA
6318 Roosevelt Blvd.
215-288-0180 |
| POMONA, CA
1555 N. Orange Grove Ave.
714-623-3543 | WELLESLEY, MA
165 Worcester Ave.
617-237-1510 | PITTSBURGH, PA
3482 Wm. Penn Hwy.
412-824-3564 |
| REDWOOD CITY, CA
2001 Middlefield Rd.
415-365-8155 | DETROIT, MI
18645 W. Eight Mile Rd.
313-535-6480 | WARWICK, RI
558 Greenwich Ave.
401-738-5150 |
| SACRAMENTO, CA
1860 Fulton Ave.
916-486-1575 | E. DETROIT, MI
18149 E. Eight Mile Rd.
313-772-0416 | DALLAS, TX
2715 Ross Ave.
214-826-4053 |
| WOODLAND HILLS, CA
22504 Ventura Blvd.
213-883-0531 | HOPKINS, MN
101 Shady Oak Rd.
612-938-6371 | FORT WORTH, TX
6825-A Green Oaks Rd.
817-737-8822 |
| DENVER, CO
5940 W. 38th Ave.
303-422-3408 | ST. PAUL, MN
1645 White Bear Ave.
612-778-1211 | HOUSTON, TX
1704 W. Loop N.
713-869-5263 |
| AVON, CT
395 W. Main St. (Rt. 44)
203-678-0323 | BRIDGETON, MO
3794 McKelvey Rd.
314-291-1850 | SAN ANTONIO, TX
7111 Blanco Road
512-341-8876 |
| FT. LAUDERDALE, FL
7173 W. Broward Blvd.
Plantation
305-791-7300 | OMAHA, NE
9207 Maple St.
402-391-2071 | MIDVALE, UT
58 East 7200 South
801-566-4626 |
| HIALEAH, FL
4705 W. 16th Ave.
305-823-2280 | ASBURY PARK, NJ
1013 State Hwy. 35
201-775-1231 | ALEXANDRIA, VA
6201 Richmond Hwy.
703-765-5515 |
| JACKSONVILLE, FL
8262 Arlington Expwy.
904-725-4554 | FAIR LAWN, NJ
35-07 Broadway (Rt. 4)
201-791-6935 | VIRGINIA BEACH, VA
1055 Independence Blvd.
804-460-0997 |
| TAMPA, FL
4019 W. Hillsborough Ave.
813-886-2541 | AMHERST, NY
3476 Sheridan Dr.
716-835-3090 | SEATTLE, WA
505 8th Ave. N.
206-682-2172 |
| ATLANTA, GA
5285 Roswell Rd.
404-252-4341 | JERICHO, L.I. NY
15 Jericho Turnpike
516-334-8181 | TUKWILA, WA
15439 53rd Ave. S.
206-246-5358 |
| HONOLULU, HI
98-1254 Kaahumanu St.,
Pearl City
808-487-0029 | ROCHESTER, NY
937 Jefferson Rd.
716-424-2560 | MILWAUKEE, WI
5215 W. Fond du Lac
414-873-8250 |
| CHICAGO, IL
3462-66 W. Devon Ave.
312-583-3920 | N. WHITE PLAINS, NY
7 Reservoir Rd.
914-761-7690 | |
| DOWNERS GROVE, IL
224 Ogden Ave.
312-852-1304 | GREENSBORO, NC
4620-C W. Market St.
919-299-5390 | |

HEATH/ZENITH

Your strong partner

NEW IDEAS

Model rocket launcher

MODEL ROCKETRY IS A FASCINATING HOBBY that is enjoyed by millions, young and old alike. It teaches the principles of aerodynamics and gravity, among other subjects, in a way that can't be duplicated by using a textbook or slide rule.

Model rockets are generally ignited by heating a nickel-chromium wire that is inserted into the engine so that it touches the propellant. The wire is heated by passing a current through it, and the usual power source is a standard lantern battery. The circuit described here adds some class to the launch procedure. It allows the user to move up to 300 feet away from the rocket (normally, you're limited to a distance of 10-15 feet). Among the advantages is that it aids tracking and recovery, not to mention safety. With a few modifications, the launcher could be used for such things as a timer, sequencer, or reflex tester.

The circuit, shown in Fig. 1, consists of two parts—the launch timer itself and an automatic-off timer. The heart of the launch timer is IC1, an LM3914 (National) bargraph display driver. When power is applied to that IC, the countdown LED's sequence on until they are all lit. When the last one, LED1, is fully lit, transistor Q1 saturates, energizing RY2. When that happens, a circuit between the lantern battery at

the launch pad and the nickel-chromium wire is completed; the wire heats up as before, and the rocket is launched. Resistor R4 and capacitor C3 determine the countdown timing; with the values shown it should be approximately 10 seconds. Resistors R3 and R5 set the LED brightness.

In a project of this type, safety is of the utmost importance. That's the purpose of the second half of the circuit. When RY2 opens, the current flow to Q2 is disrupted. But, because of the presence of R2 and C4 in the circuit, the transistor remains saturated for about 3 seconds. After that, however, the transistor stops conducting and RY1 is de-energized. That cuts off the power to the rest of the circuit, and RY2 de-energizes again, breaking the circuit to the launch pad. Speaking of safety, that's the purpose of S2—it is there so that the launch circuit can be disconnected from the timer; disconnecting that circuit eliminates the possibility of an accidental launch.

Operating the launcher is very simple. Switch S3 is used to reset the countdown. Once that is done, pressing S1 starts the launch sequence; the rest is automatic. Switch S4 is used to latch RY1 manually if needed. That's all there is to it.

The circuit can be built on perforated construction board using point-to-point wir-

ing. Assembly is very easy (incidentally, I'm only 13 and had very little trouble with it). As I said, with the values shown, the timing period is about 10 seconds; however, nothing in the circuit is very critical. Lead lengths should be kept as short as possible, however; if they get too long, oscillation may occur. To prevent that, C2 can be installed in the circuit as shown.

You can use any PNP transistor for Q1 and Q2, although the 2N404 seems to be a good choice. Switches S1 and S3 are normally open momentary pushbuttons. Switch S2 is DPDT, and S4 is SPST. The relays, RY1 and RY2, are SPDT, Radio Shack 275-004 or equivalent. The power source, B1, is 6 "C" cells wired in series—

John Miles

NEW IDEAS

This column is devoted to new ideas, circuits, device applications, construction techniques, helpful hints, etc.

All published entries, upon publication, will earn \$25. In addition, Panavise will donate their *model 333*—The Rapid Assembly Circuit Board Holder, having a retail price of \$39.95. It features an eight-position rotating adjustment, indexing at 45-degree increments, and six positive lock positions in the vertical plane, giving you a full ten-inch height adjustment for comfortable working.

I agree to the above terms, and grant **Radio-Electronics** Magazine the right to publish my idea and to subsequently republish my idea in collections or compilations of reprints of similar articles. I declare that the attached idea is my own original material and that its publication does not violate any other copyright. I also declare that this material had not been previously published.

Title of Idea _____

Signature _____

Print Name _____

Date _____

Street _____

City _____

State _____

Zip _____

Mail your idea along with this coupon to: **New Ideas Radio-Electronics**,
200 Park Ave. South,
New York, NY 10003

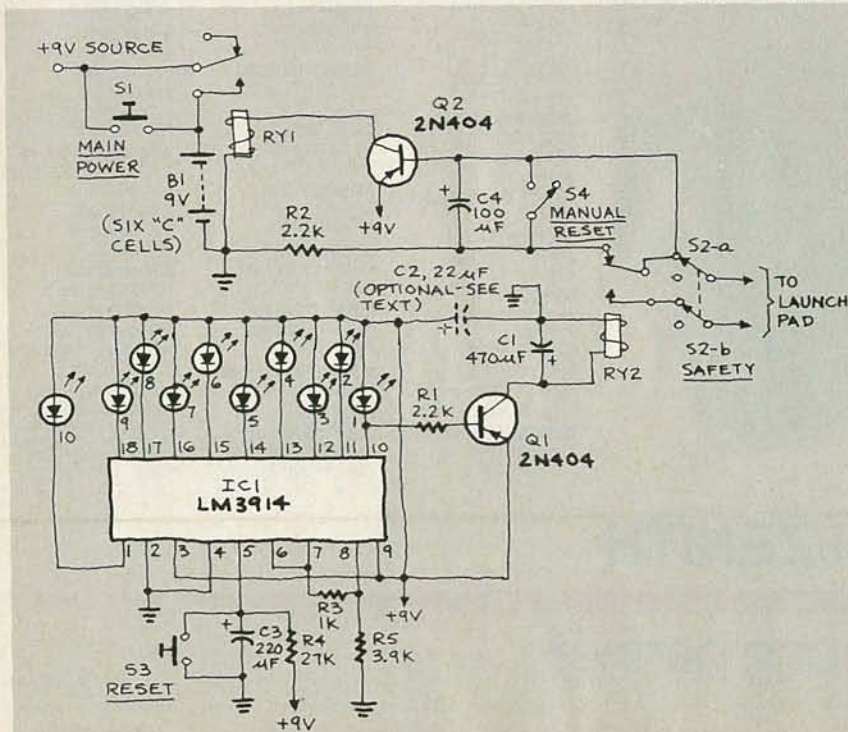

FIG. 1

Official Videogame Concert Contest Entry Form

(This form must accompany your entry)
(You must use an original entry form. No copies or facsimiles are acceptable.)

OFFICIAL RULES

This contest is designed to test your skills. By orchestrating your own home videogame or personal-computer-game sounds into a symphonic arrangement, short but sweet, and imaginatively editing them on a standard cassette tape, you can enter the Radio-Electronics Videogame Concert Contest and take a shot at winning some of the prizes described on the other side of this page.

1. Composition must not be less than 2 minutes in length and must not exceed 5 minutes. (Total playing time.)
2. Entry must be recorded on a standard cassette tape. It will be played back on a standard deck; no noise reduction (such as Dolby) will be used.
3. Each entry must be accompanied by a complete, signed, official entry form. Entries that do not have official forms attached or have forms that are not completed or signed, will be disqualified. Entry forms can be found in every copy of the July 1982 and August 1982 issues of Radio-Electronics. No copies or facsimiles will be accepted. In the event that you cannot locate an issue locally, these issues are available directly from Radio-Electronics. The cost is \$1.25 plus \$1.00 for first class postage. Payment must include your order, and must be payable in US funds.
4. All entries must be postmarked no later than August 30, 1982 and must be received no later than September 15, 1982.
5. Only one entry per individual in each category. An individual can enter all four categories (once in each category). You cannot enter the same category more than once.
6. All entries must be original compositions of the entrant.
7. All entries become the property of Radio-Electronics. By submitting an entry and in return for Radio-Electronics considering your entry, the entrant transfers all copyright rights to the submitted materials to Radio-Electronics.
8. No entries can be acknowledged or returned.
9. The decision of the judges is final.
10. Winners will be announced in the December 1982 issue of Radio-Electronics. If you wish to receive a list of the winners send a stamped self-addressed envelope to: Videogame Contest Winners, Radio-Electronics, 200 Park Ave. South, New York, NY 10003.

Void where prohibited by law.

Mail to:

Radio-Electronics®

Videogame Concert Contest

200 Park Ave. South
New York, NY 10003

Name _____

Address _____

City _____ State _____ ZIP _____

Category of entry:

- Atari Mattel (Intellivision)
 Magnavox (Odyssey)
 Other Videogame incl. personal computer (Type) _____

Listing of game cartridges or computer software used to form this composition. Cartridges are listed in the same order—and each time—that their sounds appear in this entry. I have listed the name of the cartridge or computer software and the name of the manufacturer. (You may continue this list on a separate sheet if it's too long to fit here.)

I have submitted this entry to the Radio-Electronics Videogame Concert Contest and will abide by the decision of the judges. I understand that in return for R-E considering my entry that I hereby transfer all copyright rights of the material submitted to Radio-Electronics and certify that all materials are original developments of mine.

Signature _____ Date _____

Age _____

If you are a minor, one of your parents or legal guardian must also sign this form.

Make a move that makes you a winner!



**Learning
electronics
is no picnic.**

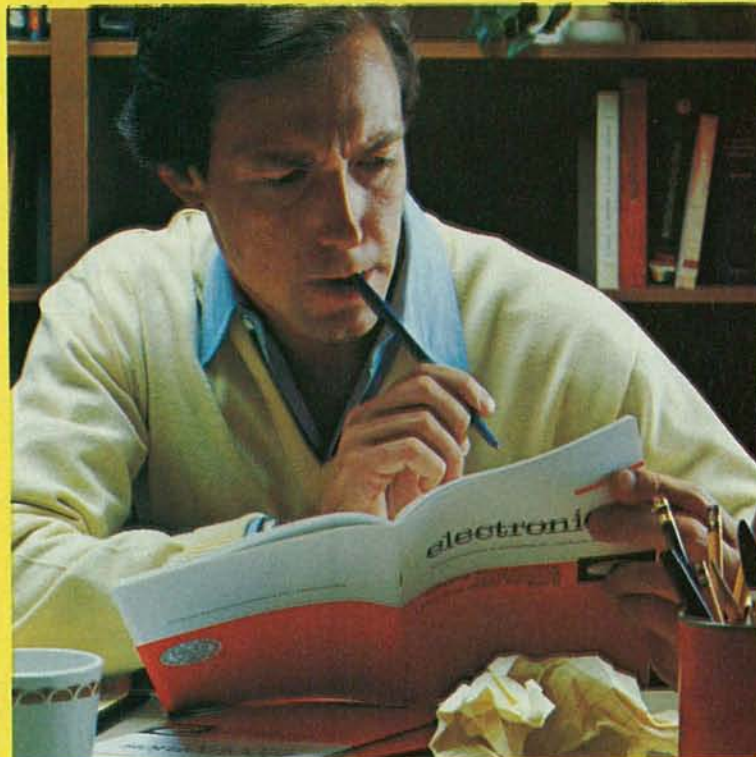

**At any level it
takes work and
a few sacrifices.
But with CIE,
it's worth it.**

Whoever said, "The best things in life are free," was writing a song, not living a life. Life is not just a bowl of cherries, and we all know it.

You fight for what you get. You get what you fight for. If you want a thorough, practical, working knowledge of electronics, come to CIE.

You can learn electronics at home by spending just 12 hard-working hours a week, two hours a day. Or, would you rather go bowling? Your success is up to you.

At CIE, you *earn* your diploma. It is not handed to you simply for putting in hours. But the hours you do put in will be on your schedule, not ours. You don't have to go to a classroom. The classroom comes to you.

Why electronics training?

Today the world depends on technology. And the "brain" of technology is electronics. Every year, companies the world over are finding new ways to apply the wonders of electronics to control and program manufacturing, processing...even to create new leisure-time products and services. And the more electronics applications there are, the greater the need will be for trained technicians to keep sophisticated equipment finely tuned and operating efficiently. That means career opportunities in the eighties and beyond.

Which CIE training fits you?

Beginner? Intermediate? Advanced? CIE home study courses are designed for ambitious people at all entry levels. People who may have:

1. No previous electronics knowledge, but do have an interest in it;
2. Some basic knowledge or experience in electronics;
3. In-depth working experience or prior training in electronics.

You can start where you fit and fit where you start, then go on from there to your Diploma, FCC License and career.

Many people can be taught electronics.

There is no mystery to learning electronics. At CIE you simply start with what you know and build on it to develop the knowledge and techniques that make you a specialist. Thousands of CIE graduates have learned to master the simple principles of electronics and operate or maintain even the most sophisticated electronics equipment.

CIE specializes exclusively in electronics.

Why CIE? CIE is the largest independent home study school that specializes exclusively in electronics. Nothing else. CIE has the electronics course that's right for you.

Learning electronics is a lot more than memorizing a laundry list of

facts about circuits and transistors. Electronics is interesting! It is based on recent developments in the industry. It's built on ideas. So, look for a program that starts with ideas and builds on them. Look to CIE.

Programmed learning.

That's exactly what happens with CIE's Auto-Programmed® Lessons. Each lesson uses famous "programmed learning" methods to teach you important principles. You explore them, master them completely, before you start to apply them. You thoroughly understand each step before you go on to the next. You learn at your own pace.

And, beyond theory, some courses come fully equipped with electronics gear (the things you see in technical magazines) to actually let you perform hundreds of checking, testing, and analyzing projects.

Experienced specialists work closely with you.

Even though you study at home, you are not alone! Each time you return a completed lesson, you can be sure it will be reviewed, graded and returned with appropriate instructional help. When you need additional individual help, you get it fast and in writing from the faculty technical specialist best qualified to

answer your question in terms you can understand.

CIE prepares you for your FCC License.

For some jobs in electronics, you must have a Federal Communications Commission (FCC) License. For others, some employers tend to consider your license a mark in your favor. Either way, your license is government-certified proof of your knowledge and skills. It sets you apart from the crowd.

More than half of CIE's courses prepare you to pass the government-administered exam. In continuing surveys, nearly 4 out of 5 graduates who take the exam get their licenses! You can be among the winners.

Associate Degree

Now, CIE offers an Associate in Applied Science Degree in Electronics Engineering Technology. In fact, all or most of every CIE Career Course is directly creditable towards the Associate Degree.

Today is the day. Send now.

Fill in and return the postage-free card attached. If some other ambitious person has removed it, cut out and mail the coupon. You'll get a FREE school catalog plus complete information on independent home study. For your convenience, we'll try to have a CIE representative contact you to answer any questions you may have.

Mail the card or the coupon or write CIE (mentioning name and date of this magazine) at: 1776 East 17th Street, Cleveland, Ohio 44114.



Pattern shown on oscilloscope screen is simulated.

CIE Cleveland Institute of Electronics, Inc.

1776 East 17th Street, Cleveland, Ohio 44114

Accredited Member National Home Study Council

YES... I want to learn from the specialists in electronics—CIE. Send me my FREE CIE school catalog...including details about the Associate Degree program...plus my FREE package of home study information.

Print Name _____

Address _____ Apt. _____

City _____

State _____ Zip _____

Age _____ Phone (area code) _____

Check box for G.I. Bill bulletin on Educational Benefits: Veteran Active Duty

MAIL TODAY!

HITACHI

NLS Non-Linear Systems

HICKOK

WESTON

DATA PRECISION

KEITHLEY

FLUKE

PHILIPS

BK PRECISION

VIZ R&A

DORIC

TRIPLETT

Simpson

LEADER

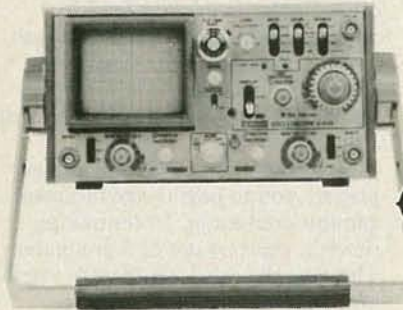

**NEW —
NOW
AVAILABLE**

HITACHI

**CALL FOR OUR
SPECIAL OFFER**

V209 20 MHz, Dual Trace, Portable, Complete with built-in Battery Pack.

V509 50 MHz, Dual Trace, Dual Time Base, Portable (Battery pack optional).

**PORTABLE
OSCILLOSCOPES**

BATTERY OPERATED

NLS Non-Linear Systems

Call For Our Prices

MS-15



Single Trace 15MHz

MS-215



Dual Trace 15 MHz

MS-230



Dual Trace 30MHz

New Sweep/Function Generator

BK PRECISION



Call For Our Price

MODEL 3020

- Four instruments in one package—sweep generator, function generator, pulse generator, tone-burst generator.
- Covers 0.02Hz-2MHz
- 1000: 1 tuning range
- Low-distortion high-accuracy outputs
- Three-step attenuator plus vernier control
- Internal linear and log sweeps
- Tone-burst output is front-panel or externally programmable

New Low Distortion Function Generator

BK PRECISION



Call For Our Price

MODEL 3010

- Generates sine, square and triangle waveforms
- Variable amplitude and fixed TTL square-wave outputs
- 0.1 Hz to 1MHz in six ranges
- Push button range and function selection
- Typical sine wave distortion under 0.5% from 0.1Hz to 100kHz
- Variable DC offset for engineering applications
- VCO external input for sweep-frequency tests

FLUKE DIGITAL MULTIMETERS

- Two New 4½-Digit Handheld DMM's from Fluke
- Wideband True RMS AC Measurements (100 kHz-8060A, 30 kHz-8062A)
- 0.04% Basic DC Accuracy (8062A = 0.05%)
- Full Range Capability (200 μ A, 200 mV, 200 Ω ranges)
- Autoranging M Ω to 300 M Ω
- Relative (Offset or Zero) Mode
- Audible and Visual Continuity Indicators
- Frequency Measurement to 200 kHz, 0.01 Hz Resolution to 200 Hz, 1 Second Response Time (8060A only)
- dBm Referenced to 600 Ω (8060A only)
- Relative dB measurement (8060A only)
- Conductance (8060A only)
- Separate Constant Current Source Diode Test
- Self Diagnostics

\$349.

8060A

\$279.

8062A



NEW

Display: 4½ digit duplex LCD (19,999 count)

A/D Converter: Dual slope converter, autozero, autopolarity.

Conversion: TRMS, AC coupled

Display Annunciators: BT, low battery indication.

REL, relative reference mode activated. [8060A: (k)Hz, frequency function activated. dB, dB function activated.] \rightarrow \leftarrow continuity activated.)), continuity tone activated.—, continuity detected indicator.

Temperature: 0° to +50°C operating, -35° to +60°C storage.

Temperature Coefficient: (0° to +18°C or +28° to +50°C) .1 times the applicable accuracy specification per degree C plus the initial +18° to +28° specification.



TOLL FREE HOT LINE
800-223-0474

THE TEST EQUIPMENT SPECIALISTS

**ADVANCE
ELECTRONICS**

54 WEST 45th STREET, NEW YORK, N.Y. 10036 212-687-2224

BUILD THIS

JOSEF BERNARD,
TECHNICAL EDITOR

R-E EXCLUSIVE!

PICTURE PHONE

Build the Picture Phone and you can use your telephone to send and receive live television pictures to and from almost anywhere. The first part of this series explains how the system works.

Part 1 THE TELEPHONE COMPANY has recently been urging us to "reach out and touch someone." The Picture Phone described here will allow you to do more than that—it permits still video-pictures to be sent over ordinary phone lines so you can not only hear and "touch" someone, but also see him (or her).

What do you need to send and receive pictures using the telephone? The most important piece of equipment, of course, is the Picture Phone. It turns an ordinary video

signal into a series of audio tones that the telephone equipment can handle and convey to a Picture Phone at the other end of the line. It also converts incoming video—in the form of tones—into a fast-scan video signal that can be viewed on a monitor or TV receiver. Fast-scan and slow-scan standards are compared in Table 1.

A video camera is necessary (there's an exception to that, which we'll get to in a moment), but it need not be elaborate or expensive. A camera of the type used in closed-circuit applications will do the job

	FSTV	SSTV
Line rate—lines/second	15,750	15
Frame rate—frames/second	30	1/8
Aspect ratio	4:3	1:1
Lines transmitted	525	128
Lines displayed	525	256

and can be purchased for about \$150. Of course, if you already own a color or black-and-white video camera, you can use that.

The picture can be viewed on a video



monitor or on a TV receiver fitted with an inexpensive RF-modulator that will convert the composite-video signal into one that can be received on an unused VHF or UHF TV-channel.

You'll also probably need a device from your local phone company to couple the Picture Phone to their lines.

The exception to the video-camera rule is due to the fact that, since what is being transmitted is a series of audio tones, none higher in frequency than 2300 Hz, pictures can be recorded on a standard audio-cassette. If you know what you want to send, and can borrow a camera, the pictures can be put on tape ahead of time and the tape played when you're ready. Pictures received via the Picture Phone can also be saved on cassette for future reference.

Oh yes, you'll need a telephone, too.

How it's used

How do you carry on a video conversation using the Picture Phone? You start out just as you would any telephone conversation, speaking with the party at the other end of the line.

When the time comes, though, to illustrate a point (or, perhaps, to show off a brand new addition to the family) you turn the MODE switch to TRANSMIT, push the VIDEO button, and a picture will be transmitted to the Picture Phone at the other end of the line. The picture can be "set up" ahead of time and stored in the Picture Phone's

memory or can be transmitted "live." The same frame can be repeated over and over or a new one can be "snatched" and sent every eight seconds. As you become more familiar with them, the capabilities of the Picture Phone will prove it to be an extremely versatile instrument.

At the other end, when video is ready to be received, the MODE switch is put into the RECEIVE position, the VIDEO button depressed, and, over a period of eight seconds, a still picture will appear from top to bottom on the screen of the monitor or TV set. The picture can be stored in the Picture Phone's memory and viewed even after the transmission is over and you are back in the VOICE mode. As was mentioned earlier, the pictures can be stored on audio cassettes for replay later.

The system used by the Picture Phone is described elsewhere in this article but, before we present instructions for building the device, we'll describe in some detail how it works. Not only will that help you to understand what's going on, but you will also receive something of an education in how digital circuitry works.

It must be mentioned that the construction of this project is *not* for beginners—the circuit uses nearly 100 IC's on a tightly packed double-sided PC board—but for those with previous construction experience, it should not prove difficult. Assembly is straightforward, and troubleshooting hints will be presented. Before we get to

that, though, let's see what's needed to make the Picture Phone system function, and look at the circuit section by section.

Signal conditioning

Refer to Figs. 1 and 2 as we discuss how the Picture Phone operates. Signals from a fast-scan source such as a video camera or VCR are applied to J8, CAMERA IN. The signals are attenuated by R305 and AC-coupled to the video-input amplifier. DC bias is added to the signal by R307.

The video-input amplifier consists of transistors Q4 and Q5. Its first stage has a gain of 10 and its second stage is an emitter follower whose low output-impedance drives the A/D converter.

Slow-scan signals (see box copy) are input through either the TAPE IN jack, J6, or from the telephone line. The incoming signal drives a limiter made from op-amp IC90-b. Following that limiter are two active bandpass filters with full-wave rectifiers at their outputs. The output of the rectifier is combined by IC91-b. That filter/rectifier/combiner network forms a tuned FM-discriminator having an "S"-shaped transfer function. Modulation ripple is removed from the demodulated FM by a 4-pole Butterworth low-pass filter made from sections of IC92 and IC93.

The recovered slow-scan video is then attenuated by R313 and DC-biased by R323. From there it is fed to the same amplifier used for fast scan. A section of switch

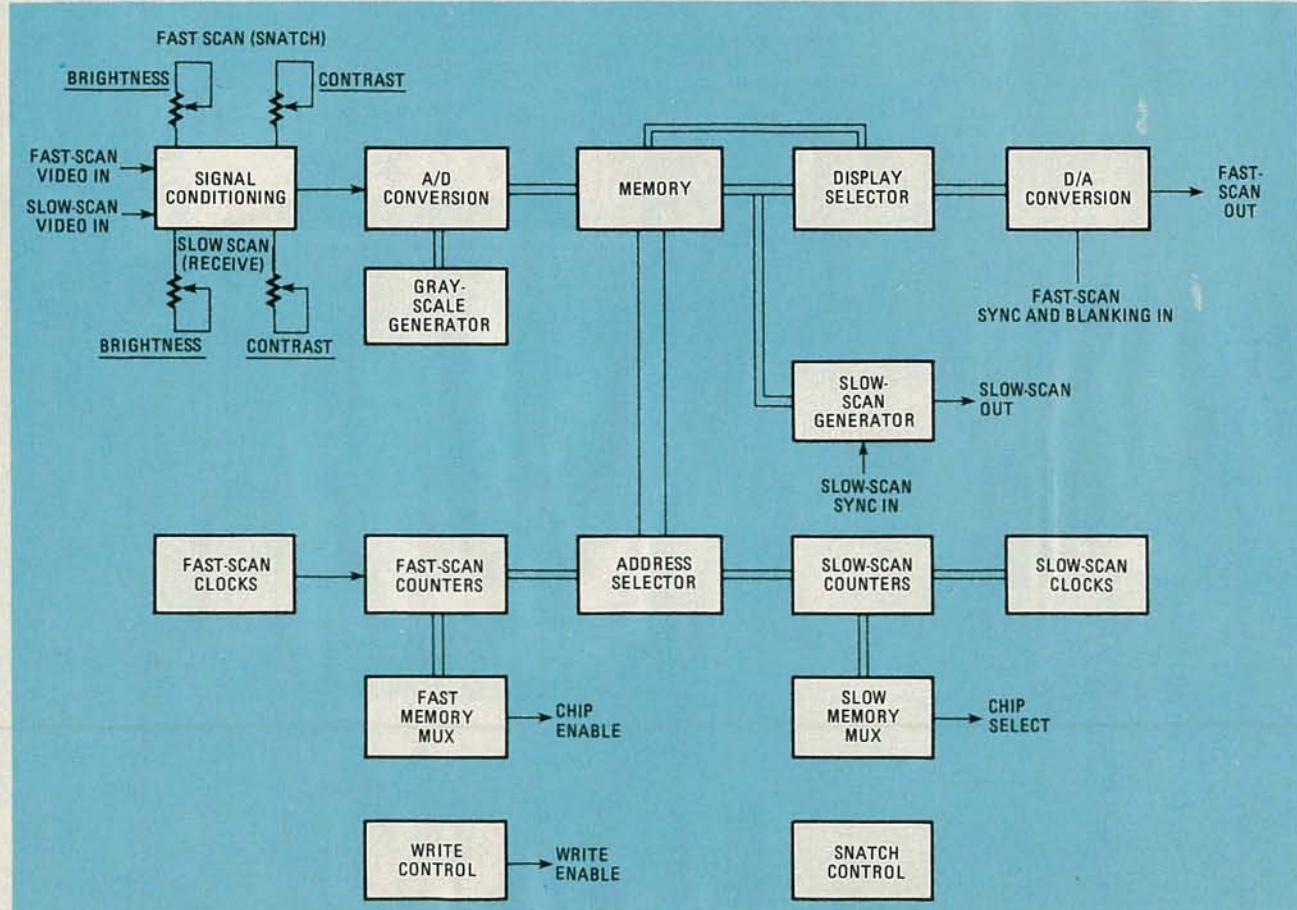

FIG. 1—LOGIC AND TIMING portions of Picture Phone circuit are shown at bottom of block diagram; video-processing blocks are at top.

HISTORY OF SSTV

Slow-scan television (SSTV) was developed during the 1960's by amateur radio operators to allow them to send pictures within the narrow (3-kHz) bandwidth permitted them by the FCC for transmissions on frequencies below 440 MHz.

Fast-scan television—the kind you're accustomed to watching in your living room—uses a bandwidth of about four MHz, so SSTV required a completely different technique to meet its restrictions.

SSTV uses a frame consisting of 128 lines, instead of the 525 used commercially. The horizontal-line rate is 1/15 of a second (as opposed to 1/15,734-second for fast scan), which means that it takes eight seconds to send—or receive—one slow-scan picture.

Audio tones are used to send the video and sync information—SSTV is frequency-modulated, unlike fast-scan TV, which is amplitude modulated. A frequency of 2300 Hz represents white, 1500-Hz represents black, and 1200-Hz is used for sync.

In the early days of SSTV, the output of a fast-scan camera was sampled over a period of eight seconds and converted into the tones required to transmit the video over the air. That means that, if a live subject was used, he had to sit still for that length of time.

At the receiving end, the image was viewed on a P7 (long-persistence) phosphor CRT of the sort used in radar displays. The picture started at the top and, eight seconds later, finished at the bottom. The top portion of the CRT was still glowing faintly at that point, and picture could be made out. There was no easy way, though, to keep the image on the screen after it had been sent, so a lot of imagination was required.

The first scan converters were analog.



FIG. 1

They used surplus (blemished) video storage-tubes that, if new and perfect, would have cost about \$50,000. With them, fast-scan video could be written onto the tube quickly and read out slowly, meaning that you could "snatch" a fast-scan picture in a 60th of a second and then read it out slowly for slow-scan conversion. Similarly, a slow-scan picture could be received and written onto the surface inside the storage tube and then read out quickly—and repeatedly. That allowed the image to be reproduced on a black-and-white monitor or TV set and viewed until all the details had been absorbed.

In the second half of the 1970's another technique for scan conversion was developed using digital IC's to store the video information. One of the earliest used 64 shift registers going around and around to store the data. Current scan converters, like the one described in this article, use RAM (Random-Access Memory) IC's—the same sort used in computers—to hold the data representing the picture.

One of the most impressive uses of SSTV has been made by the Jet Propul-

sion Laboratories Radio Club, W6V10, in Pasadena, CA. During the Viking missions to Mars, and the Voyager space probe encounters with the outer planets, the club station has retransmitted pictures from space on SSTV to amateur radio operators all over the world. (Figure 1 shows a view of Saturn's rings. The "spokes" can be clearly seen.) Many of those pictures were seen before they were reproduced on television or in the papers, and some of the material that was sent never even made it to the media.

Your use for SSTV will probably be more mundane (pun intended). The audio frequencies used for slow scan fit nicely into the bandwidth that can be carried on an ordinary telephone line, which means that you do not need radio equipment to send or receive pictures—you can do it by telephone.

For a number of years the Bell System has offered a very limited *Picturephone* service, which requires that you go to a special center—one of a very few, and only in large cities—to see and talk with someone at another similarly equipped center. That service is not cheap, and, as you can imagine, it has not been too convenient, either.

Now, using SSTV, you can exchange video with anyone, anywhere, as long as you both have a telephone. You can transmit and receive pictures for business—of the people involved in long-distance negotiations, for example, or of portions of schematics, charts, or photographs that might take days to get from coast to coast by conventional means.

On a more personal note, you can chat with—and see—far-away friends and family whenever you like. All you need is a telephone, TV camera, and the Picture Phone. What's more, slow-scan video, because it's transmitted as a series of tones, can be stored on an ordinary audio cassette and replayed whenever you like. Top that, Ma Bell! **R-E**

S2 selects either fast- or slow-scan video for input to the memory.

Slow-scan sync signals are derived from the composite slow-scan signal by a low-pass filter made from IC93-b. An automatic-threshold sync separator, Q1, strips the sync from the video. Horizontal and vertical sync signals are separately filtered by non-linear filters Q3 and Q2. The filtered sync signals are converted to fast-rise-time logic signals by Schmitt trigger IC63. (The legend "ESH" stands for *External Slow-scan Horizontal sync*, and "ESV" for *External Slow-scan Vertical sync*. A bar above the legend indicates that the signal goes to a logic-low state when sync is present.)

Fast-scan sync is derived from the input video by automatic-threshold sync separator Q7. The horizontal and vertical sync signals are separated by the differentiator/integrator formed by Q8 and Q9. The sync signals are inverted and buffered by IC61-c and IC61-d. (The legend "EFV" stands for *External Fast-scan Vertical sync* and "EFH" for *External Fast-scan Horizontal sync*.)

A/D conversion

The analog video signal is continuously digitized into a series of 4-bit nybbles (half-bytes). A 4-bit nybble can represent 16 shades of gray, which has been found to be sufficient to display an intelligible black-and-white image without either using excessive memory, as would be the case if a larger word-size were used, or inducing excessive contouring (abrupt transitions from one gray-shade to the next), as would be the case if a smaller word-size were used.

A voltage divider (R60-R75) with equally-spaced taps establishes the 16 amplitude levels representing the gray shades. Each tap is connected to a comparator (IC73-IC80), that outputs a signal indicating whether the amplitude (gray shade) of the video at its position is greater or less than that established by the voltage-divider chain.

The comparator outputs are combined by logic gates IC88 and IC57-a and IC57-b to form a 4-bit nybble representing the instantaneous luminance value of the video signal. The whole forms what's known as a

flash converter.

This type of A/D conversion has certain disadvantages, namely that the transition from one gray shade to another may involve changing the state of more than one bit of the 4-bit nybble. If several bits change at once, voltage spikes may occur, and be read as part of the video data. To avoid that, before the data is entered into memory it is converted from a straight binary number into one expressed in Gray code. In the Gray code, it is possible to go from any 4-bit value to the next one without changing more than a single bit, which tends to eliminate the glitches we want to avoid. Binary-to-Gray code conversion is shown in Table 2.

Memory

The heart of the digital scan-converter is its memory. It consists of 16 μ PD411D (MM5280) 4K \times 1 dynamic RAM's. (See Fig. 3) The memory is organized so the LSB (*Least Significant Bit*) of each nybble is stored in IC1-IC4. Higher-order bits are stored in succeeding rows in the same order as they occur in the nybble. The memory is

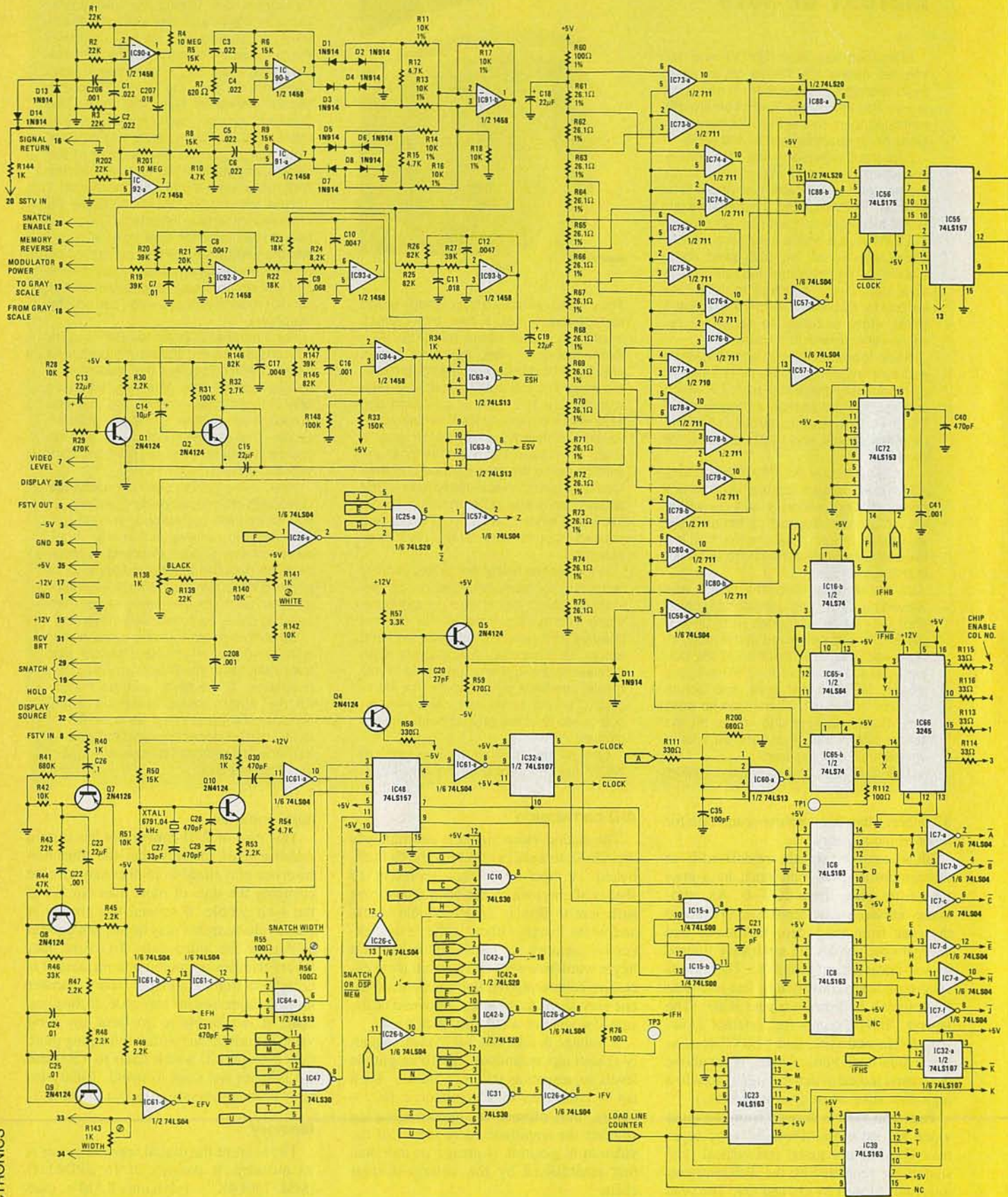
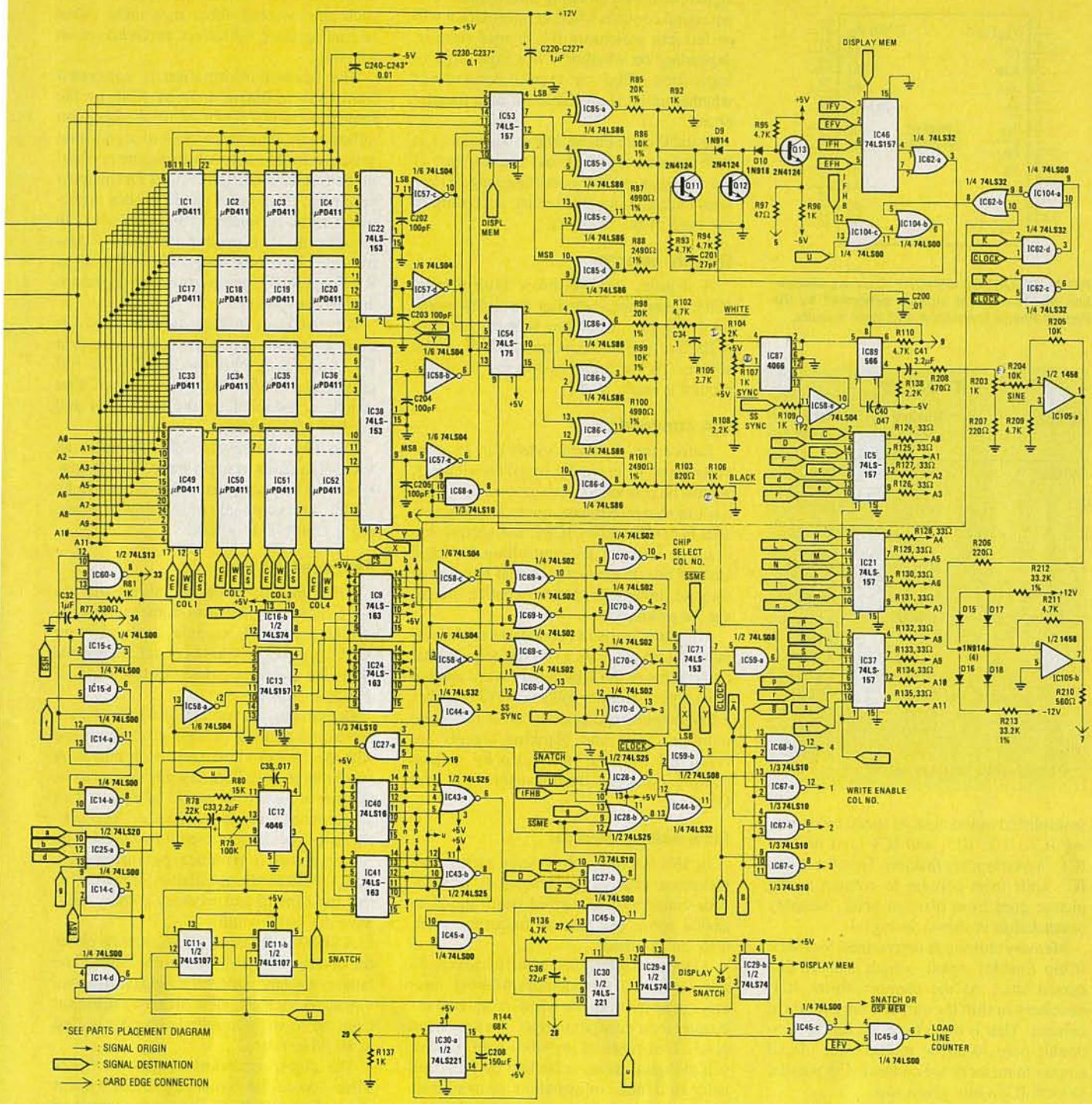

FIG. 2—HEART OF THE PICTUREPHONE is its memory, sixteen 4K-bit IC's that store video information prior to scan conversion.



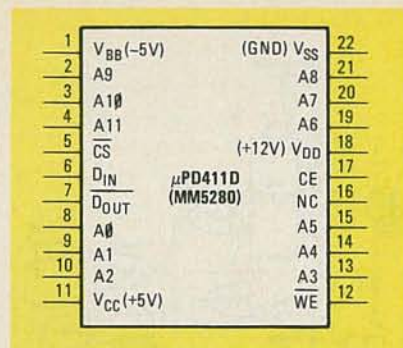

FIG. 3—PINOUT OF MEMORY IC shows destination of some of the signals generated by the Picture Phone's clocking and logic circuits.

Shade	Binary code	Gray code
White	0000*	0000*
	0001	0001
	0010	0011
	0011	0010
	0100	0110
	0101*	0111*
	0110	0101
	0111	0100
	1000	1100
	1001	1101
	1010*	1111*
	1011	1110
	1100	1010
	1101	1011
1110	1001	
Black	1111*	1000*

* Values used for gray scale

multiplexed to increase its speed by operating IC1, IC2, IC3, and IC4 (and back to IC1) in overlapping fashion. Thus the active IC's shift from column to column as the picture goes from pixel to pixel. Memory organization is shown in Fig. 4.

Memory shifting is determined by the CE (Chip Enable) signal, which will be discussed later. As the memory shifts, it is necessary to shift the output from column to column. That is done by IC22 and IC38—double-pole, 4-throw multiplexers. Input signals to memory are connected in parallel to each IC in any given row.

The memory-control signals are CE, WE (Write Enable) and CS (Chip Select). The CE

signal carries the clocking information. The WE signal controls whether information will be fed into a memory IC, or read from it, depending on whether it is a logic-high or logic-low. The CS signal determines whether an IC is available for data transfer or not.

In the Picture Phone, the CE signal acts as both the memory clock and as the source of the fast-scan memory multiplexing. Slow-scan multiplexing takes place according to the state of the CS signal.

Display selector

A 4-pole, double-throw multiplexer, IC55, determines whether the video monitor will display the picture stored in memory or the live (digitized) picture from the video source. The selection of the live or stored picture is made by S2.

D/A conversion

Before the digitized video can be converted back to an analog signal for viewing, it must be converted from gray-scale values back to standard binary ones. That conversion is performed by IC85, a 4-section EXCLUSIVE OR gate. By controlling the logic state of one of the inputs of that EXCLUSIVE OR gate, inverted video (a negative image) can be produced.

Weighting resistors connected to the outputs of IC85 generate a voltage proportional to the value of the 4-bit binary word applied to its inputs. Emitter follower Q13 provides a low output-impedance to drive the video monitor. Sync and blanking signals are combined with the raw video by voltage shifting produced by transistors Q11 and Q12.

Slow-scan generator

In this section, slow-scan picture information read from memory is latched, code-converted, converted from digital to analog form, and used to frequency modulate an oscillator.

At the end of each fast-scan line (every 63 microseconds) the memory-address lines are connected to the slow-scan address counter long enough to read one slow-scan pixel. That piece of the slow-scan picture, still in digital form, is latched by IC54 and held until new information is available. Slow-scan pixels occur at a rate such that a new one is available every 500 mic-

roseconds. At the 63-microsecond rate, each pixel is read about nine times. That re-reading does not affect performance in any way.

The latched information is converted from Gray to binary code by IC86 by the same process that was used for the fast-scan information. The same control signal that was used for black-to-white picture reversal in the fast-scan section is used for that purpose here. Because of the difference in picture polarity between fast and slow scan, an inverter, IC68, is used in the polarity control-line. Resistors R98-R101, as well as R103 and R106, are used for the digital-to-analog conversion.

An electronic analog-switch, IC87, is used to select either slow-scan video or a DC sync-signal level for input to the FM oscillator, IC89. The operation of that switch is triggered by the horizontal and vertical sync-pulses.

The FM oscillator, IC89, generates an audio-frequency triangle wave. That triangle wave is later converted to a sine wave by IC104. The amplitude of the slow-scan audio is controlled by R203.

Fast-scan clocks

All scan-conversion operations that do not require the fast-scan camera are controlled by clock signals derived from XTAL1, a 6791.04-kHz crystal. Transistor Q6 is the oscillator, and a section of IC61 acts as a buffer.

Operations that use the fast-scan camera use a free-running oscillator synchronized with the camera's horizontal-sync pulses. A synchronized oscillator avoids the horizontal jitter of pixels that would take place if an asynchronous clock were used. The synchronous oscillator is a section of IC64. The SNATCH WIDTH trimmer potentiometer, R56, controls the oscillator frequency so that the camera and memory displays will have the same width.

A 4PDT multiplexer, IC48, selects either the crystal- or synchronous-oscillator. The latter is used to "snatch" a field of fast-scan video and for the camera display; the output from the crystal-controlled oscillator is used at all other times.

The clock oscillators operate at 6.791 MHz—twice the frequency of the system clock. Flip-flop IC32 divides the output of the oscillator by two to obtain the actual clock pulse-string, which assures perfect symmetry of the waveform.

When we continue this article, we'll conclude our discussion of how the Picture Phone works. We'll also look at the power supply for the unit, the telephone interface circuit, and, space permitting, begin our discussion of how to build and align the device. **R-E**

Due to space restrictions, and the necessity for a lengthy technical discussion of the Picturephone circuitry, the parts list and foil patterns for the device will be presented in a future part of this article. The wait will be worth it.

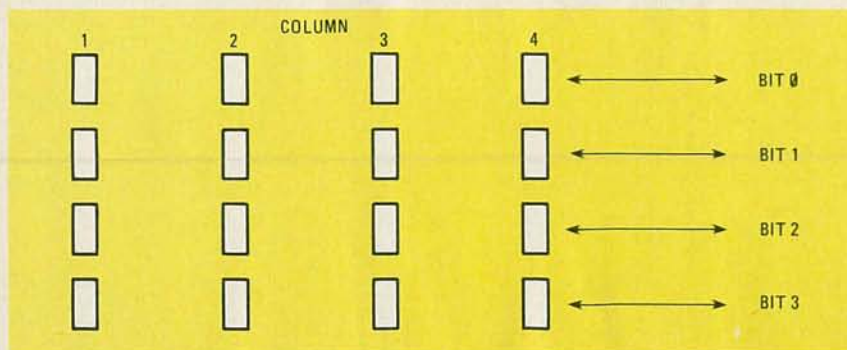
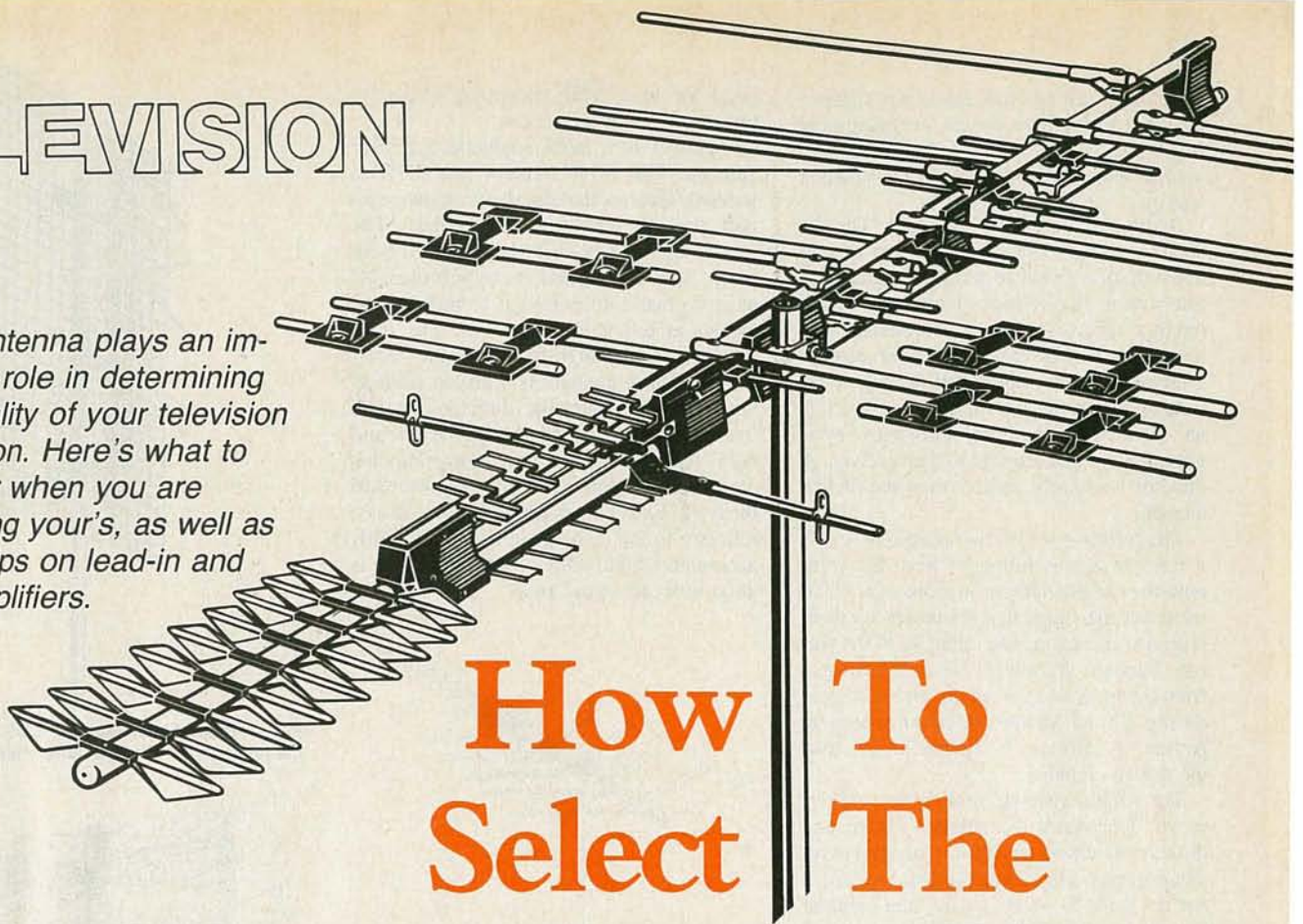

FIG. 4—MEMORY IC columns are multiplexed to provide speed needed for fast-scan applications.

Your antenna plays an important role in determining the quality of your television reception. Here's what to look for when you are choosing your's, as well as some tips on lead-in and pre-amplifiers.



How To Select The BEST TV ANTENNA

GARY J. ARNOLD

MANY FACTORS COMBINE TO DETERMINE UP the kind of television reception you have. A transmitted signal must be present; an antenna must pick it up; it must be transmitted to the television receiver, and the electronics inside the TV set then must convert that signal into picture and sound. In difficult reception areas, every one of those factors are critical. In this article we will concentrate on the antenna system.

In strong signal areas where interference is not a problem, just about any antenna will perform satisfactorily. When interference, weak signals, or congested, overlapping signals exist, reception problems become serious.

Our first step is to analyze our reception needs and problems. If signals are very weak, we need a high-gain antenna and perhaps a booster amplifier. If there are strong adjacent channels coming from different directions, a co-channel problem, or interference from power lines, power equipment, auto ignitions, strong FM signals, etc., a highly directional antenna is needed.

Remember: A strong signal is worthless if it is accompanied by strong interference. But an extremely weak signal, free of interference, can produce a watchable picture.

A highly-directional antenna can receive

signals from the front of the antenna while rejecting signals coming from the sides and rear of the antenna. Think of the antenna as having "tunnel vision," or a *narrow beam width*. It sees only what it is aimed at. To understand what makes an antenna work, let's "build" one, starting with one element.

A simple dipole antenna (Fig. 1) consists of two rods, or one "element." The element is cut to a length that best matches the desired frequency. Since the antenna must send electronic impulses to the receiver, the



FIG. 1—A SIMPLE DIPOLE ANTENNA. It is cut to the exact length for the frequency desired.

stronger those impulses, the better the reception. The element will deliver the strongest possible signal if it is cut to the exact length for the frequency desired. The lower the frequency, the longer the wavelength; thus, the longer the element. The directional characteristic of a simple dipole antenna is shaped like a figure 8 (see Fig. 2).

Now let's add two more elements to our simple dipole antenna, making it a three-

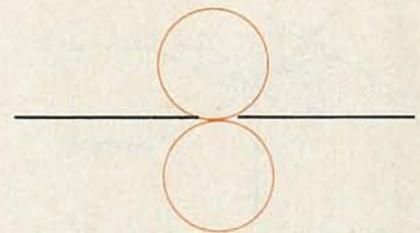

FIG. 2—THE DIRECTIONAL CHARACTERISTIC of a simple dipole is shaped like a figure eight.

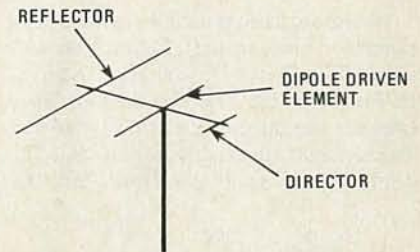

FIG. 3—THIS THREE-ELEMENT ARRAY consists of a dipole and two parasitic elements—the director and reflector.

element array (Fig. 3). The shorter element is the front of the antenna, and that element is called a *director*. The middle element is our dipole. The longest element is a *reflector*. Both the director and reflector are *parasitic* elements. They are not connected

directly to the antenna lead, but transfer received power to the *driven*, or *hot* element (the dipole in our example). The driven element is connected directly to the antenna lead in.

A director "pulls in" a signal. The director resonates when a signal hits it, and transfers that signal to the next element in line with it. In our three-element array, the director receives a signal, resonates, and transfers a part of the signal to the dipole. That increases the signal that the dipole receives, increasing the intensity of the signal. As a result, the dipole produces stronger impulses that are sent to the receiver. A director is slightly shorter than the driven element.

The reflector serves two purposes. First, it reflects signals hitting it from the front onto the driven element in front of it. That increases the signal that the driven element receives, increasing the intensity of the signal. Second, it reflects signals hitting it from the back *away from the antenna*, producing a more forward directional pick-up pattern. A reflector is slightly longer than the driven element.

The length, spacing, and number of elements determines the antenna's gain and directional characteristics. Unfortunately, ideal spacing and element length for gain is *not the same* as ideal spacing and element length for directivity. However, a good highly-directional antenna is only slightly lower in overall gain than an antenna made for highest gain. Generally speaking, the more elements in similarly designed antennas, the more directional the antenna, and the higher the gain.

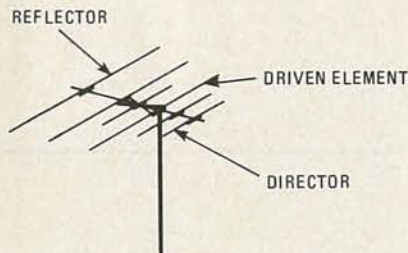

FIG. 4—A SIX-ELEMENT VHF antenna such as this is good for local TV reception.

With those basic principles in mind, let's examine a few antennas. Figure 4 shows a simple 6-element VHF antenna. The longest element is the reflector, the three short elements are directors, and the other two long elements are the driven elements. This is a low gain, slightly directional antenna,

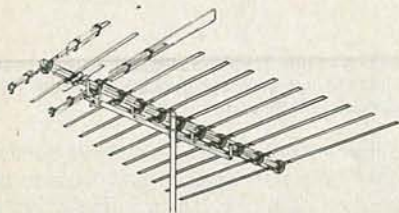

FIG. 5—FOR WEAK SIGNAL AREAS, a more sophisticated antenna, such as the one shown here, is required.

good for local VHF reception where interference is not a problem.

Figure 5 is a more sophisticated VHF antenna. The front element is a U-Wire parasitic director that has dual resonance on both the low and high VHF bands. The second element is an FM-control element that reduces FM signals; it can be broken off at score marks to permit it to receive FM signals at full gain, if desired. The third element is a VHF high-band parasitic director. The fourth element is a driven element with a U-Wire parasitic director attached that has dual resonance on both the low and high VHF bands. The remaining elements are all driven. Notice how they taper toward the front. Each longer element also acts as a reflector to the element in front of it. This antenna is a highly directional model that is good in weak signal areas.

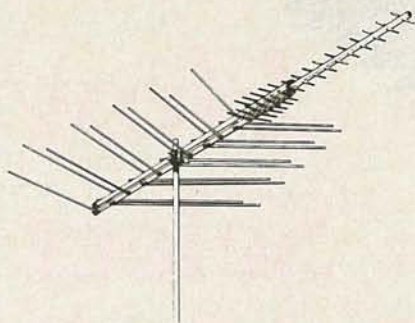

FIG. 6—THIS HIGHLY DIRECTIONAL ANTENNA is designed for both VHF and UHF reception.

Figure 6 shows a combination VHF-UHF antenna. The front of the antenna has 10 parasitic UHF directors. The next section of short elements has 11 UHF driven elements. The back section has 10 driven VHF elements. There are no VHF parasitic directors or reflectors. However, the longer VHF elements act as reflectors for the elements in front of them. The forward sweep angle of the VHF elements contributes to its directional characteristics. This antenna works well in medium-signal areas with strong interference since the antenna is extremely directional.

Figure 7 is a totally different approach to UHF antennas. This antenna has four driven elements and a reflector screen. This type of UHF antenna is widely used because of its high gain and low cost. It has a wide beam width from the front, so it picks up signals from various directions from the front of the antenna.

Figure 8 is a variation of Fig. 7. This antenna has 12 driven elements and a large reflector screen. It is extremely powerful, and very directional. It is a good choice in hilly or extremely weak UHF areas.

Figure 9 is a highly directional UHF antenna. It consists of a driven element, several parasitic directors, and a "corner reflector." That combination delivers good results in weak UHF areas where interference must be rejected from the sides and rear of the antenna.

Figure 10 is an extremely powerful combination VHF-UHF antenna with medium

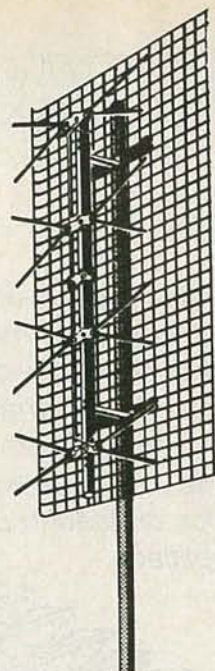

FIG. 7—HIGH GAIN AND LOW COST are among the reasons for this UHF antenna's popularity.

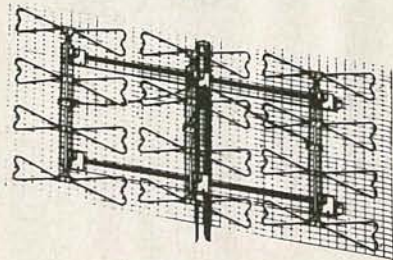

FIG. 8—WITH 12 DRIVEN ELEMENTS, this UHF antenna is a good choice for receiving weak signals.

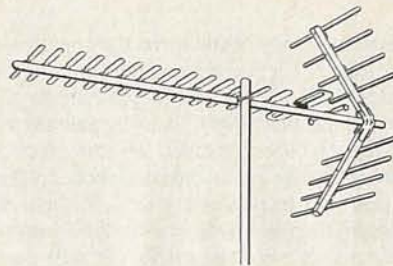

FIG. 9—THIS HIGHLY DIRECTIONAL UHF antenna is especially good when interference is persistent.

to good directional characteristics. The front of the antenna consists of a high-gain UHF section with multiple directors, one driven element, and a corner reflector. Some of the directors are made in three parts (Fig. 11). Each of the parts resonates on the high UHF frequencies while all three together act as a longer element and resonate on the low UHF frequencies.

The VHF section is on a split boom and is angled for more than one reason. First, it structurally strengthens the antenna. Second, it increases the "capture area" vertically. Third, it helps reduce VHF interference coming from above or below the antenna. This antenna is a good choice in very weak VHF-UHF areas with medium interference.

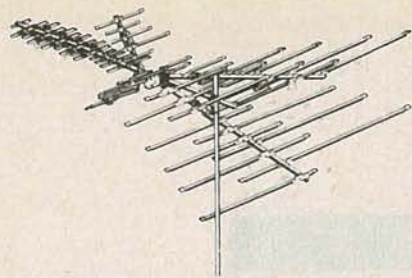

FIG. 10—SOME OF THE UHF DIRECTORS of this powerful antenna are made in three parts (see Fig. 11).

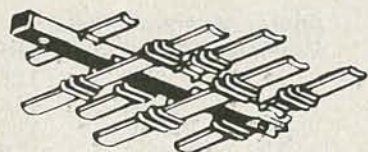

FIG. 11—EACH OF THE PARTS of this three-part UHF director resonates on the higher UHF frequencies. The three together act as a longer element and resonate on the lower frequencies.

Antenna specifications

There is no consistency among manufacturers as to what specifications they list, if any. However, let's examine the most common specifications used.

1. The number of elements an antenna has is listed by some manufacturers. That specification, however, has little value when comparing one line of antennas to another. Notice we say that the antenna in Fig. 4 has 6 elements. That is a conservative method of counting elements. Some manufacturers would count these same elements as 12. Some manufacturers count an element that is driven, but also used as a reflector, as two elements.

The "number" of elements is not important. The length, spacing, and arrangement of the elements is what really matters.

2. Antenna gain is a common specification. It is stated in decibels (dB). To compare gain figures, you must know what reference the manufacturer used to determine the gain figure. The most common reference is a half-wave dipole. However, some manufacturers use a theoretical isotropic antenna as a reference. To compare the two methods, it is necessary to add 2.1 dB to the dipole-referenced figure, or you can subtract 2.1 dB from the isotropic antenna reference figure.

When referring to antenna gain in this article, we are using the more common dipole reference method.

The gain figures given for the antenna shown in Fig. 5 is shown in Fig. 12. Notice how the gain is much higher at the VHF high band (channels 7-13). We mentioned earlier the higher the frequency, the shorter the wavelength. It's now time to mention that the shorter the wavelength, the weaker the signal will be.

In other words, given two transmitters, one on channel 2 and the other on channel 13, both at the same location and transmit-

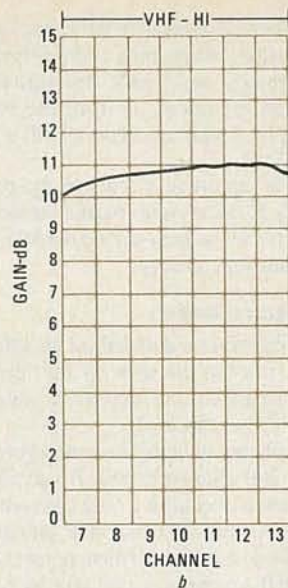
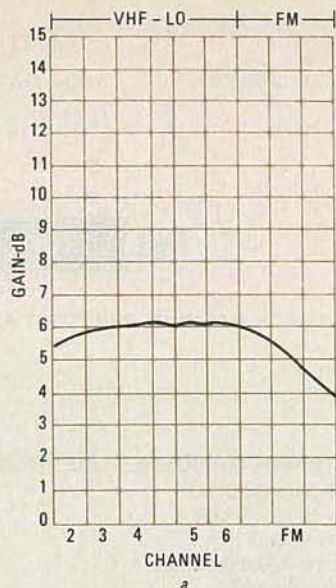

FIG. 12—THE GAIN OF THE ANTENNA SHOWN IN FIG. 5. The gain for the low band (channels 2-6) is shown in a; the gain for the high band (channels 7-13) is shown in b.

ing with the same amount of power, at any given distance from the transmitting antenna, the channel 2 signal will be much stronger than the channel 13 signal. The main cause is the fact that the lower frequencies tend to "bend" more with the earth's curvature than do higher frequencies, and that the higher frequencies lose more power in the air as they travel. Thus, the higher the frequency, the weaker the signal received, and the higher gain needed at the antenna. The average gain figures for several antennas are given in Table 1.

3. The antenna's front-to-back ratio, is another common specification. It is also expressed in dB's. Front-to-back ratio is defined as the ratio, expressed in decibels, of the gain of the peak of the main forward lobe to the gain of the peak of the largest lobe in the rear. In other words, it's the ratio of the forward gain to the rear gain. That specification is important in determining the antenna's directional pattern. The higher the F/B (front-to-back ratio), the more directional the antenna. A 22-dB figure is considered very good, and a 27 dB figure is quite impressive, to say the least. The average F/B ratio figures for several antennas are listed in Table 2.

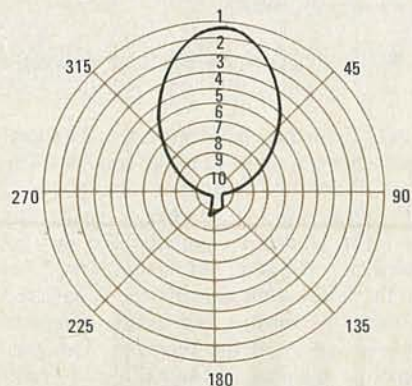

FIG. 13—GRAPH OF THE BEAM WIDTH of an antenna. This graph is of an antenna with a beam width specification of 53°.

4. The antenna's beam width is the maximum angle at which a signal can hit the antenna and still be at least half as strong, or no more than 3 dB down. Figure 13 is a graph of an antenna with a 53° beam width. The beam of the antenna shown in Fig. 6 averages 67° on channels 2-6, 29° on channels 7-13, and 31° on UHF channels 14-83. See Table 3 for beam width specifications on several antennas.

Generally speaking, the higher the antenna's front-to-back ratio, the narrower the beam width. Either specification is a good indication of the antenna's directivity.

Specialty antennas

Before continuing on to the rest of the "antenna system," it's important to note that many manufacturers custom-make antennas for particular reception needs. Single-channel antennas are available where additional gain and directivity is needed beyond that of the best all-channel antennas. Where extreme reception problems exist, check with your local antenna distributor, or the manufacturers themselves, to see if a special antenna has been designed for your particular problem.

For most extreme problem areas, separate VHF and UHF antennas will work wonders. Although the installation will not be as neat as a single antenna would be, the additional gain and directivity possible may be worth it.

When measuring the antenna's gain and front-to-back ratio we have used decibels. To compare one antenna to another, we must understand what a decibel is. A decibel merely expresses the relationship, or ratio, between two signals. It is important to know that 3 dB down, or 3 dB less means that the signal strength is cut in half.

When comparing gain specifications, if one antenna has a gain of 11 dB, an antenna with a gain of 8 dB (11 dB minus 3 dB) has only half the gain of the 11-dB antenna.

When comparing front-to-back ratio specifications, an antenna with a F/B ratio of 20 dB rejects only half the signal (or interference) hitting it from the rear when compared with an antenna with a F/B ratio of 23 dB.

It is important to choose the proper antenna to meet your particular needs. Between various high-priced models, directivity can vary greatly.

Antenna lead-in

Once you've decided on an antenna, the next item to consider is the lead-in. It's foolish to buy an expensive antenna and then use cheap lead-in.

Probably the most common type of lead-in is 300-ohm twin lead. It's available in a multitude of qualities. The conventional flat lead can be used on VHF antennas. The better-quality foam-filled is used for VHF or UHF antennas. Good quality foam 300-ohm twin lead has very low loss characteristics when new and dry. Losses increase, however, with moisture, and it is certainly degraded after sunlight destroys the dielectric. Twin lead has the distinct disadvantage of picking up any interference in the immediate area and carrying it with the desired signal to the receiver.

That type lead-in is good in strong-signal areas virtually free of interference. In weak signal areas it is recommended only if the lead-in is replaced every year or two.

Twin lead must never touch metal. It must be kept away from the antenna mast with stand-off insulators, and must be kept away from electrical wiring. Cut off any excess lead length; never coil it up. It is very important to install that type of lead properly.

Another common type of lead-in is 75-ohm coaxial cable, also known as "coax". There are fewer grades of "coax" than 300-ohm lead, but the differences are important.

If weak signals are to be received, then losses must be minimized. Foam coax losses are less than those of regular coax. The main advantages of coax over twin lead is that coax is immune (for the most part) to interference and moisture. If interference is a problem, then 100%-shielded coax is preferred. That can be done by purchasing a coax with a foil shielding covering 100% of the cable. A copper braid over the foil adds more durability and additional shielding properties (Fig. 14). The main disadvantage of coax is its higher losses.

The main objective of the total antenna system is to deliver a clean picture to your television set. If there is interference around—electrical; from a nearby highway; from strong signals overpowering weak signals on adjacent channels, or from co-channel interference—a highly directional antenna with 100% shielded foam coax might be the best solution.

Other considerations

To receive a clean picture at the receiver, we need a high *signal-to-noise ratio*. The highest signal to noise is at the antenna



FIG. 14—FOR MAXIMUM SHIELDING AND DURABILITY, this type of coaxial cable should be used.

TABLE 1

ANTENNA MANUFACTURER/MODEL	Approx. Average dB Gain		
	VHF-low	VHF-high	UHF
Winegard/CH-8100	6.8	10.6	11.8
Winegard/CH-8098	6.4	10.2	10.4
Finco/F-89-C	6.0	10.0	11.0
Channel Master/1160A	5.8	10.5	11.0
Jerrold/VU-937S	5.5	10.4	10.5
Channel Master/1162A	4.5	10.5	11.0
Jerrold/VU-935S	4.2	9.5	9.5
Blonder-Tongue/0719	4.3	7.3	8.0

NOTE: All the above are considered high-gain, top-quality TV antennas.

TABLE 2

ANTENNA MANUFACTURER/MODEL	Approx. Average F/B Ratio		
	VHF-low	VHF-high	UHF
Channel Master/1160A	27	29	*
Channel Master/1162A	27	28	*
Blonder-Tongue/0719	25	24	21
Jerrold/VU-937S	23	23	24
Finco/F-89-C	20	26	18
Jerrold/VU-934S	20	20	22
Winegard/CH-8100	20	20	20
Winegard/CH-8098	20	20	20

*Not available

NOTE: All the above are considered top-quality TV antennas.

TABLE 3

ANTENNA MANUFACTURER/MODEL	Approx. Average Beam Width in Degrees		
	VHF-low	VHF-high	UHF
Blonder-Tongue/0719	67	29	31
Jerrold/VU-937S	68	33	30
Jerrold/VU-935S	68	35	30
Finco/F-89-C	60	48	30
Winegard/CH-8100	69	48	33
Winegard/CH-8098	71	51	36

NOTE: All the above are considered top-quality TV antennas.

itself. From there it is degraded as the signal goes down the lead-in to the receiver. The lead-in can also contribute some noise. If the signal is too weak when it reaches the receiver, an antenna pre-amplifier may be needed. A pre-amplifier increases the level of the signal at the antenna and is powered through the antenna lead-in from a remote power supply at the receiver. The pre-amplifier maintains the signal-to-noise ratio from the antenna to the receiver. It cannot improve the ratio at the antenna, because it will amplify any noise picked up by the

antenna along with the desired signal.

There are many models of pre-amplifiers on the market. The main consideration to watch for is a low noise figure. The lower the better.

Another consideration is antenna height. Your immediate terrain affects reception. Any tall buildings or hills between your antenna and the transmitting antenna will have a direct bearing on your reception. Generally speaking, the higher the antenna the stronger the signal. Unfortunately,

continued on page 85

HOW TO DESIGN ANALOG CIRCUITS TRANSISTORS— BIPOLAR JFET MOSFET



This month, we turn our attention to a slightly more complex solid-state component—the transistor. We'll begin by looking at the structure and operation of both bipolar and FET devices.

MANNY HOROWITZ

THIS MONTH, LET'S TURN OUR ATTENTION TO a slightly more complex device—the *transistor*. In modern circuits that use discrete components, two types of transistors are found. One type is called a *bipolar* transistor; the other a *Field Effect Transistor*, or FET. A bipolar transistor is essentially an n-type or p-type slab of semiconductor material sandwiched between two slabs made of the opposite semiconductor material. Thus if the center slab, or *base* consists of p-type material, n-type material would be placed on either side of it. One of the slabs is called the *emitter* and the other is called the *collector*. Two junctions are formed by that type of construction. The amount of current flowing through one junction determines how much current will flow through the two slabs made of the same material.

FET's can be divided into two categories. In one, the *Junction FET* (or JFET), either p-type or n-type semiconductor material is used to form a channel that connects two terminals. One of those terminals is called the *source*; the other is called the *drain*. A

junction is formed by placing an opposite type of material around the channel. The amount of voltage applied between that opposite type of material, called the *gate*, and the source determines the resistance of the channel. The direction of the current flow is determined by what type (p-type or n-type) of semiconductor material is used for the channel.

The second type of FET's are the *MOS-FET's* (*Metal Oxide Semiconductor FET's*). They also have a source, drain, and gate, but in their case, the gate is insulated from the source and the drain. Because of that construction, those devices are sometimes referred to as *Insulated Gate FET's*, or IGFET's. We will take a closer look at FET's later in this article.

Bipolar transistors

A bipolar transistor can be one of two types. If a slab of p-type material is sandwiched between two n-type slabs, the transistor is an NPN device. The schematic symbol for that type of structure is shown in

Fig. 1-a; a transistor with the reverse structure is called a PNP device and is shown in Fig. 1-b.

Before we go any farther, let's adopt a few conventions that will simplify the rest of our discussion. Those conventions will be used throughout the remainder of this series.

1. We will use conventional current-flow, rather than electron current-flow, in our discussion. In electron current-flow, we assume that electrons flow from the negative terminal of a battery through the circuit to the positive terminal of that battery. Conventional current flows in the opposite direction. That is an especially convenient approach when dealing with transistors because the arrow in the symbol indicates the direction of current flow when using the conventional current-flow standard.
2. Although both NPN and PNP transistors are common, we will be repeating ourselves if we detail both types of devices. We will describe

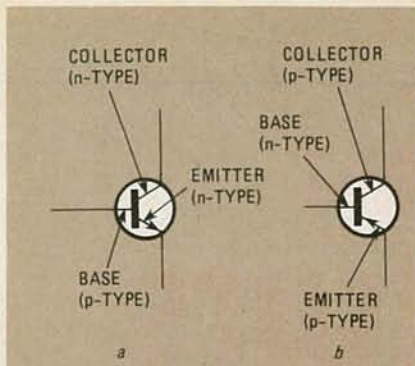

FIG. 1—THESE SYMBOLS are used to identify bipolar transistors in schematic diagrams. The symbol for an NPN transistor is shown in *a*; the one for a PNP transistor is shown in *b*.

both types whenever necessary, but we will concentrate on the NPN transistor. Everything said here about that device, including the applied voltage, also applies to the PNP transistor. The exceptions are that the polarity of the applied voltage and direction of the current flow must both be reversed. Thus if current flows from the base to the emitter in an NPN device, it flows from the emitter to the base in a PNP device. Similarly, voltage applied to the base of an NPN device must be positive with respect to that at the emitter, if that transistor is to be turned on. It is negative with respect to the emitter voltage for the PNP device.

- While Germanium transistors were popular in the past, currently silicon devices dominate the field. When describing circuits, we will be writing about silicon devices unless noted otherwise.

Except in switching and push-pull circuit applications, transistors are usually kept turned on at all times. That means that current will flow through the device as long as power is applied to the circuit. The proper voltage polarities for an NPN transistor, and the currents that are produced, are shown in Fig. 2. In that transistor, the base is positive with respect to the emitter and negative with respect to the collector. Because the base is made of p-type material and the emitter of n-type material, current flows from the base to the emitter. Little leakage current flows from the collector to the base; that is because of the polarity of the voltage applied to the n-type collector, with respect to the p-type base. However, current will flow from the collector to the emitter if the base-emitter junction is turned on and conducting.

One of the basic relationships in the performance of a bipolar transistor is how the collector current depends upon the base-to-emitter current in the circuit.

First, let us note that more emitter current, I_E , flows than does base current I_B , or collector current, I_C . Emitter current is essentially equal to the sum of base and collector currents. The ratio of collector current to emitter current has been given the

special symbol α (alpha) so that:

$$\alpha = \frac{I_C}{I_E} \quad (1)$$

Because almost all collector current flows into the emitter and very little into the base, and also because very little base-to-emitter current actually flows as compared to the collector current, I_E is just about equal to I_C and α is very close to 1.

A more useful ratio in most applications is the relationship between I_C and I_B . That ratio is called β (beta).

$$\beta = \frac{I_C}{I_B} \approx \frac{I_E}{I_B} \quad (2)$$

β can usually be any value between 10 and 1000. It is related to α as follows:

$$\alpha = \frac{\beta}{\beta + 1} \quad (3-a)$$

$$\beta = \frac{\alpha}{\alpha - 1} \quad (3-b)$$

Transistors can be used in circuits in any one of three arrangements. Those are called common-emitter, common-collector, and common-base.

Common-emitter circuit

A transistor supplies the maximum power gain when used in a common-emitter configuration; it will also supply a voltage and current gain. A typical common-emitter circuit is shown in Fig. 3. Here, the size of the base current depends upon the base-supply voltage E_{BB} ; the base resistor R_B ; the voltage drop V_{BE} across the base-emitter junctions (usually 0.2 to 0.3 volt for germanium transistor and 0.7 volt for silicon devices), and the emitter resistor R_E . Base resistor R_B is usually connected to $+E_{CC}$ rather than using the separate power supply shown here. Considering that base current I_B flows through base resistor R_B and that emitter current I_E flows through emitter resistor R_E , we can conclude that the entire base-supply voltage, E_{BB} , is equal to:

$$I_B \times R_B + V_{BE} + I_E \times R_E \quad (4-a)$$

From equation 2, $I_B \approx I_E/\beta$. Substituting this into equation 4-a:

$$E_{BB} - V_{BE} \approx \frac{I_E R_B}{\beta} + I_E R_E \quad (4-b)$$

Solving for I_E :

$$I_E \approx \frac{E_{BB} - V_{BE}}{R_E + R_B/\beta} \approx I_C \quad (4-c)$$

Equation 4-c is used to determine the DC collector current. That current is equal to the net voltage in the circuit divided by the resistance through which the emitter (and collector) current flows.

It is obvious that emitter current flows through R_E ; but what part does R_B/β play in equation 4-c? That term tells us that part of any resistance in the base circuit also appears in the emitter circuit—not the entire

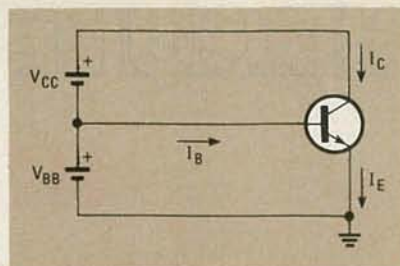

FIG. 2—THE VOLTAGE POLARITIES required to turn a bipolar NPN transistor on, as well as the currents that are produced. This circuit is used as an illustration only; do not attempt to build it, as it would most likely destroy the transistor.

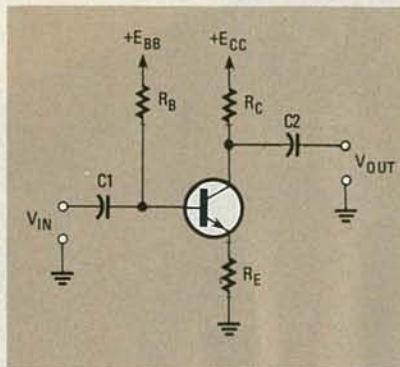

FIG. 3—A BIPOLAR NPN TRANSISTOR is shown here in a typical common-emitter circuit.

resistance, but that resistance divided by beta. Taking that discussion another step, any resistance in the emitter circuit appears in the base circuit as that resistance multiplied by beta. From that we can conclude that the base current is:

$$I_B = \frac{E_{BB} - V_{BE}}{\beta \times R_E + R_B} \quad (5)$$

That agrees with equation 2, for if we divide I_C in equation 4-c by I_B in equation 5, we end up with β as defined in equation 2.

In the common-emitter configuration, the base-collector junction is reverse biased but there is a slight leakage current flowing through that junction from the collector to the base. That leakage current is called I_{CBO} , and defined as the collector-to-base leakage current when the emitter circuit is open. That is the current that flows through the base-emitter circuit when that circuit is complete. Because the emitter current is equal to the base current multiplied by beta, the current in the emitter (and collector) circuit due only to the leakage is βI_{CBO} . A special symbol, I_{CEO} , is used for that term, and it is defined as the collector-to-emitter leakage current when the base circuit is open. The total collector current, including the leakage, is therefore:

$$I_C = \beta \times I_B + \beta \times I_{CBO} = \beta \times I_B + I_{CEO}$$

Because leakage is usually very small, it is rarely considered when doing designs.

The characteristics of a transistor are frequently shown as a graph; Fig. 4-a shows

what that looks like for a common-emitter circuit. That graph shows how the collector current varies with different collector-to-emitter voltages for various levels of base current. If, for instance, you want to know the collector current when there are 6 volts between the collector and emitter of the transistor, with the base current adjusted to 300 μA , just extend a vertical line from the V_{CE} axis at 6 volts to the $I_B = 300\text{-}\mu\text{A}$ characteristic. Next draw a horizontal line to the I_C axis. The line crosses that axis at about 32 mA as shown. That is the collector current flowing under those conditions. Obviously, at this point of operation, DC beta for the device is equal to $I_C/I_B = 32\text{ ma}/300\ \mu\text{A} = 107$.

The curves shown in Fig. 4 are plots of a complex equation relating the V_{CE} and I_C of the transistor. Because there are two unknowns, we must plot a second equation on the graph to determine the quiescent operating point of the transistor. That can be done by first writing an equation for the collector-emitter circuit of Fig. 3:

$$E_{CC} = I_C \times R_C + V_{CE} + I_E \times R_E$$

and, since $I_C = I_E$:

$$E_{CC} = I_C(R_C + R_E) + V_{CE} \quad (6)$$

Now we can plot that equation over the curves in the graph, as shown in Fig. 4-b. That plot is known as the *load line*. Two points are all that are required to plot it. Take one point to be where $I_C = 0$; then, substitute that into equation 6, $E_{CC} = V_{CE}$. That is a point on the horizontal axis. Take the second point to be where $V_{CE} = 0$; then, again substituting into equation 6, $I_C = E_{CC}/(R_C + R_E)$. That is a point on the vertical axis; connect those points and you have the load line.

Collector current and the collector-emitter voltage can be determined from where that load line crosses the base-current curve. Assume the base current has been adjusted to 200 μA . Put a dot where the load line and that base-current curve intersect. Draw a vertical line from that point to the V_{CE} axis. The point at which that line crosses the axis is the V_{CE} across the transistor. Now draw a horizontal line from the intersection point to the I_C axis. Where that line crosses that axis determines the collector current.

Note that the characteristic curves in Fig. 4 end somewhat before the I_C and V_{CE} axis. In the first case, the minimum voltage possible across the transistor is limited by a factor known as the transistor's *saturation voltage*. Useful minimum collector current is limited by the leakage current.

In Class A operation, it is desirable that a sine wave at the input of the circuit shown in Fig. 3 be reproduced with relatively little distortion at the output. To do that, the bias should be arranged so that the idling, or quiescent, voltage at the collector is about one-half of the supply voltage. Under those

conditions, the collector voltage can swing to near zero when the voltage at the input is at its peak in the cycle and swing to near $+E_{CC}$ when that input voltage is at the low point of its cycle. We'll look into that in more detail in a future article.

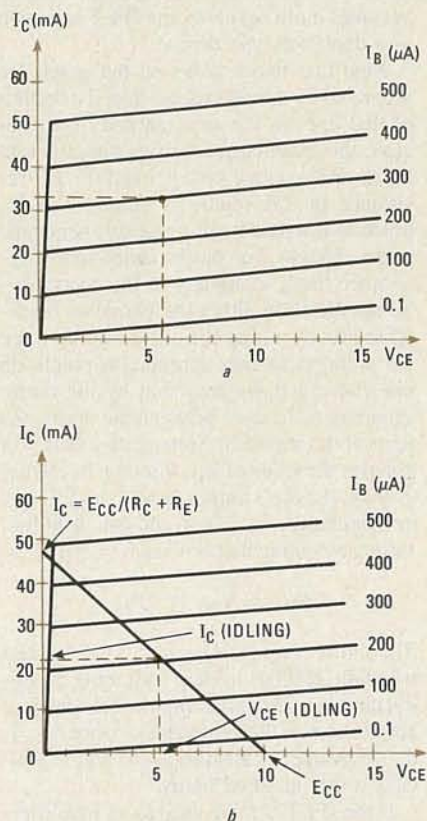

FIG. 4—COLLECTOR CHARACTERISTIC CURVES for a bipolar NPN transistor are shown in a; the load line is plotted over those curves in b.

Before a transistor is used in any circuit, it is important to be sure that it is not being used where its maximum ratings are exceeded. Manufacturers establish those ratings, and usually they can be found on the data sheet for that device. If those ratings are exceeded, the most likely result is the destruction of the device, as well as potential damage to the remainder of the circuit. Among the important ratings to look for are the emitter-base, collector-base, and collector-emitter breakdown voltages— BV_{EBO} , BV_{CBO} , and BV_{CEO} respectively. Those voltages are the maximum that can be applied between the two terminals mentioned. If it is exceeded, reverse breakdown, similar to what happens in a junction diode (see the June 1982 issue of **Radio-Electronics** for a discussion of that phenomenon), occurs. $I_{C(MAX)}$ refers to the maximum collector current that the device can safely handle. $P_{D(MAX)}$ is the total power dissipation across both junctions of the device. That power dissipation is determined by the device's maximum junction temperature, $T_{J(MAX)}$, as well as the device's thermal resistance, θ_{JA} . In many cases, the transistor's maximum power dissipation can be approximated by $V_{CE} \times I_C$.

Phototransistors

Transistors not enclosed in opaque containers, are useful as phototransistors. They are usually connected in a circuit similar to that shown in Fig. 3, but with the base left floating and the collector directly coupled to a following circuit. When light hits the device, the I_{CBO} increases with the intensity of the light striking the transistor. Since I_{CEO} flows due to the presence of I_{CBO} , and since I_{CEO} is a collector current, both I_{CEO} and collector current also increase with the intensity of light striking the phototransistor.

Common-collector circuit

The basic common-collector circuit is the same as the one drawn in Fig. 3, except that R_C is equal to 0 ohms. Now, however, the output is taken from the emitter rather than from the collector. R_E is much larger in this circuit than it was in the common-emitter circuit so that it can handle about one-half of the supply voltage when the desired amount of emitter current flows.

Emitter current is equal to the sum of the collector and base current, as before; if there is considerable leakage current, you must add I_{CEO} and I_{CBO} to the I_E determined under ideal conditions. Although here the current amplification is still equal to β , the voltage gain is just a trifle under 1.

Two very important characteristics of the circuit are high input resistance and low output resistance. Input resistance here is approximately equal to βR_E , in parallel with R_B . But now R_E is quite large so βR_E is of considerable size. The output resistance is equal to about R_B/β in parallel with R_E . That is usually much less than the R_C output resistance of the common-emitter circuit.

Common-base circuit

A common-base circuit is similar to the one in Fig. 3 except that the input capacitor, C_1 , is connected to the emitter rather than to the base. With the input fed to the emitter, the input impedance is just about equal to the emitter resistance of the device. In addition, the output impedance is approximately equal to R_C , the voltage gain is approximately equal to the ratio of R_C to R_E , and the current gain is equal to α , or about 1.

Field effect transistors

While bipolar transistors can be considered primarily as current amplifiers that provide voltage and power gain as well, when used in specific types of circuits, the FET is basically a voltage amplifier. The schematic symbols for the different types of FET's are shown in Fig. 5. Similar to what we did with bipolar transistors, we will concentrate here on the n-channel device and refer to the p-channel device only as required. Everything we say about n-channel devices will hold for p-channel devices, except that the applied voltage polarities and current directions are reversed.

JFET's

Power-supply voltage is applied between

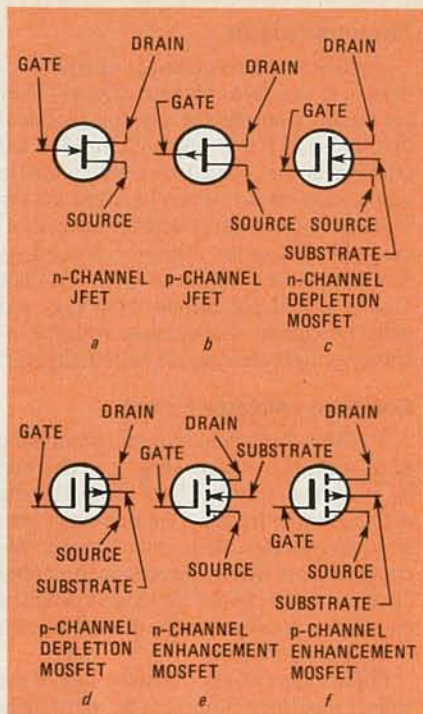

FIG. 5—THE DIFFERENT KINDS of FET's are identified in schematic diagrams by these standard symbols. Note that the depletion devices shown in *c* and *d* are also known as enhancement/depletion MOSFET's (see text).

the drain and source of the n-channel JFET. Polarity of the applied voltage is such as to make the drain positive with respect to the source. As with the bipolar transistor, the characteristics of an FET can be shown graphically; that is done in Fig. 6. Figure 6-a shows how the current flowing through the channel depends on V_{GS} , the voltage between the gate and source. The drain current, I_D , as shown on the graph, is at a maximum when V_{GS} is equal to zero. (Actually, V_{GS} can be made slightly positive—up to about 0.5 volt, and more drain current will flow.) When $V_{GS} = 0$, the drain current is called I_{DSS} . That is the drain current when the gate is shorted to the source. Drain current is reduced as the voltage at the gate is made more negative with respect to the voltage at the source. It reaches a low at V_p , the gate-to-source voltage when only an infinitesimal amount

of drain current still flows. V_p , known as the pinch-off voltage, can also be determined from the $V_{GS} = 0$ curve. It is identical to the minimum drain-to-source voltage, V_{DS} , that must be applied for the curve to become horizontal. Because drain current is reduced as the voltage between the gate and source becomes more negative, the JFET is known as a depletion-type device.

Note that two regions on the graph are separated by a bold dashed line. To the left of that line, in the area marked *ohmic region*, the drain current varies directly with the drain-to-source voltage, and the DC resistance in this region is simply V_{DS}/I_D , much as it would be in a resistor, hence the name. The AC- or output drain-source resistance, R_{DS} , along any of the curves can be calculated in either the ohmic or *pinch-off* region by noting the difference between the voltages at two appropriate points on one curve and dividing that by the corresponding difference between the drain currents at those points. Some data sheets will not give the value of R_{DS} directly, but rather give the device's output conductance, G_{OS} , or admittance, Y_{OS} . You can calculate R_{DS} simply by noting that at normal frequencies:

$$G_{OS} = Y_{OS} = 1/R_{DS}$$

The ohmic region is primarily of interest when the JFET is used in switching or digital circuits. Of special importance for those applications is the value of R_{DS} when V_{GS} is 0. That value is called $R_{DS(ON)}$, and is typically a few hundred ohms.

If the JFET is to be used as an amplifier, only the linear, or pinch off region is of interest. One of the important device parameters here is the JFET's *transconductance*, g_m , a measure of how much change there is in drain current for every change in gate-to-source voltage. It is defined by:

$$g_m = \frac{\Delta I_D}{\Delta V_{GS}} \quad (7)$$

Transconductance varies with the amount of drain current that is present. To determine g_m at a particular drain current, choose two points around that current and note the corresponding gate-to-source voltage needed to achieve those currents. The

difference of current at the two points is ΔI_D and the difference of voltage is ΔV_{GS} . Substituting those numbers into equation 7 will give you the transconductance.

Transconductance at the $V_{GS} = 0$ curve is denoted by g_{m0} . It may be specified in data supplied by the manufacturer of the transistor, or may be determined by using the method just described, or by using the following equation:

$$g_{m0} = \frac{2 \times I_{DSS}}{|V_p|} \quad (8)$$

Where $|V_p|$ is the absolute value of the pinch-off voltage.

Using the next equation, we can determine the g_m for any V_{GS} , without doing any approximate measurements on the curves.

$$g_m = g_{m0} \left(1 - \frac{|V_{GS}|}{|V_p|}\right) \quad (9)$$

Where $|V_{GS}|$ is the absolute value of V_{GS} .

Taking that one step farther, rather than using the curves, we can determine the drain current quite accurately from the following equation:

$$I_D = I_{DSS} \left(1 - \frac{|V_{GS}|}{V_p}\right)^2 = T_{DSS} \left(\frac{g_m}{g_{m0}}\right)^2 \quad (10)$$

Staying in the pinch-off region, if V_{DS} were increased enough, beyond what is shown in Fig. 6-a, the JFET's operation would enter the *reverse breakdown* region. What happens here is similar to what happens in the junction diode. If the value of V_{DS} exceeds a certain critical point, BV_{GSS} , the gate-to-source breakdown voltage with drain shorted to source, the flow of I_D will increase drastically. As the source and drain are normally interchangeable, BV_{GSS} is also used to specify the gate-to-drain breakdown voltage. Just as with the junction diode, operation in the breakdown region can easily damage a JFET and should be avoided.

JFET's, like bipolar devices, are usually put into opaque packages. If, however, the gate-channel junction is exposed to light, current will flow from the channel through the gate. Gate current increases with the intensity of the light. A gate-source voltage is developed due to the presence of the current. Because that gate-source voltage is due to the presence of gate current, that voltage also increases with the light intensity. Its polarity is such as to cause the drain current to increase as the voltage grows. Devices using that effect are known as *Fotofets*.

When in an opaque container, current can still flow from the channel to the gate. Rather than being desirable, as it was in the case of the fotofet, here the current is due to leakage. That leakage current, I_{GSS} , is defined as the current flowing in the reverse-biased gate-channel junction, when the drain is connected to the source.

continued on page 84

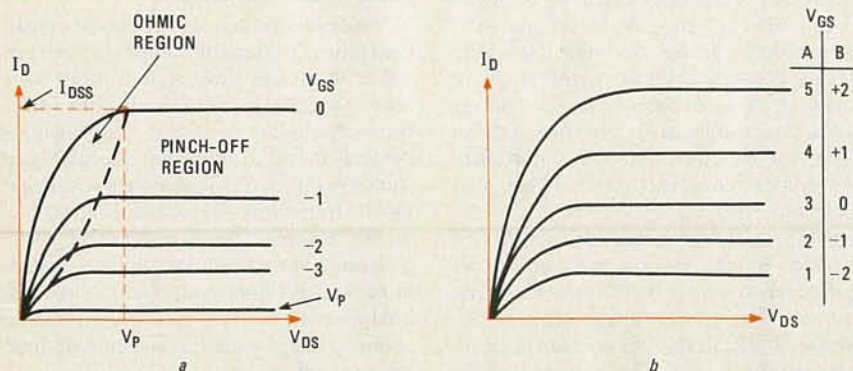

FIG. 6—DRAIN CHARACTERISTIC CURVES for the various types of FET's are shown here. The curves for a JFET are shown in *a*; the curves for enhancement and enhancement/depletion MOSFET's are shown in *b*.

ALL ABOUT



Often as useful as a screwdriver or pliers, these chemical "tools" can make repair jobs faster, easier, and less expensive.

KIRK VISTAIN

IMAGINE THIS: YOUR STEREO RECEIVER HAS developed a "scratchy noise" when you adjust the volume control; your tape recorder has some slipping belts, and when you jiggle the tuning knob on your TV set, the picture comes and goes. It certainly looks as if you're going to be spending quite a bit of time in your workshop putting everything back in order. You've got to replace that volume control and the belts, and your best bet for that tuner is to have it rebuilt professionally.

Of course, there is another answer, something that most service technicians use to make all of the above jobs a lot easier. All of those repairs could have been made using the proper chemical, or "soft" tool.

Tools mean money. A professional service technician's livelihood depends on repairing a unit as rapidly as possible. There is little room in any service department's budget for inefficiency. That's why the right tools are so important. The same holds true for a hobbyist; while his livelihood does not depend on it, a lot of time and aggravation can be saved if the right tools are used. Most of us are familiar with the traditional or "hard" tools, such as screwdrivers, wrenches, soldering irons, and the like, but

how many of us are making the best use of the chemical, or "soft" tools that are available? Those chemicals are every bit as important as a No. 2 Phillips screwdriver or a 1/4-inch nutdriver.

Chemical tools include solvents, adhesives, lubricants, etc. They are "soft" because they are all consumable. That is, part of the tool is used up when it performs its function. That is not true of hard tools such as a wrench, which has an indefinite life (unless you drop it across the AC line or use it as a hammer).

Spray solvents

Virtually all the aerosol, or spray solvents used in consumer servicing today contain either fluorocarbons or chlorinated hydrocarbons. Chlorinated hydrocarbons are compounds of hydrogen, carbon, and chlorine; the best known chlorinated hydrocarbon is carbon tetrachloride. Fluorocarbons are compounds of hydrogen, carbon, and fluorine; the most popular of these is Freon. One form of Freon, Freon TF, is often found in spray solvents. Because of its characteristics, it can be compounded with a variety of hydrocarbons or other solvents (even water), to make many specialized cleaners.

Spray cleaners can be broken up into two basic groups; those are the lubricating cleaners, and the non-lubricating, or "no-residue" types. Each has its place. The no-residue type should be used when lubrication is not needed, or when it could even do some harm. For example, one common use for such a solvent is to remove grit and dust from an open, ganged tuning-capacitor, such as the ones used in radio receivers. You would not want a lubricating cleaner as the lubricant is likely to cause more dust to accumulate quickly. No-residue cleaners are also preferred when cleaning tape heads, mechanical assemblies, or circuit boards.

On the other hand, lubricating cleaners are preferred for such things as potentiometers and switches. That's because those cleaners leave behind a coating of silicone that provides protection from oxidation and the resulting contact degradation. That type of solvent is also useful for cleaning the switch contacts in mechanical TV-tuners. Just remember that it's best to keep any type of residue off any of the frequency determining components, regardless of what the product label might claim.

One special caution concerning all spray cleaners: Even if the label says "safe for all

plastics," it is a good idea to keep it off any of the exterior parts, such as cabinets, dial scales, clear plastic windows, or the like. The chlorinated-hydrocarbon cleaners are likely to cause you the most problems in that respect, but since you can't always be sure of what a cleaner is made (most manufacturers don't list the contents on their chemical products), it is better to be safe than sorry.

Most fluorocarbon solvents are safe inside a unit, but even here, caution is recommended. I once used a product that was claimed to be safe for plastics, only to have it destroy a record/play switch by damaging the switch insert. That is the kind of thing that you can only learn the hard way. Generally, plastics such as nylon, delrin, and similar substances will not be harmed by most solvents. The types of plastic used in switch inserts are seldom harmed by fluorocarbon cleaners, but keep chlorinated-hydrocarbon sprays away from them. Under no conditions should chlorinated-hydrocarbon compounds be used on styrene plastic!

For TV-tuner cleaning, several specially formulated viscous spray-cleaners are available. Unlike most cleaners, those foam-type cleaners come out of the can thick. They are mainly proprietary compounds and contain mild abrasives, such as jeweler's rouge, in a viscous base. What those products do is to adhere to the metal contacts and continually clean and burnish the switch parts. When used correctly, they can extend tuner life, but again, care should be taken so that the cleaner is kept off the frequency-determining components. Any that is accidentally applied to such parts should be removed with a no-residue cleaner.

Foam cleaners also can be used to restore most wiping contacts, including those on wafer and slide switches. Just be sure to remove the abrasive completely, using a no-residue solvent, once the cleaning and burnishing is done. If that is not done, switch action will suffer. It doesn't hurt to finish up with a good lubricating cleaner (remember, do not use the chlorinated-hydrocarbon type) to reduce further oxidation.

Some of the spray cleaners that are currently available are listed in Table 1.

Other solvents

It is often necessary to clean the rubber drive surfaces in tape recorders, turntables, and the like. Bottled, rather than aerosol

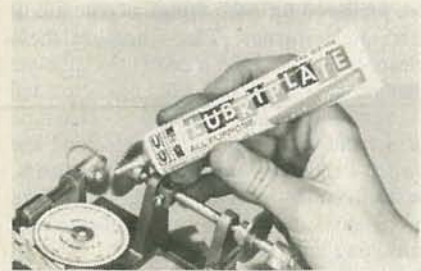

FIG. 1—SUITABLE FOR USE on wiping contacts. GC Electronics' Lubriplate reduces friction and wear.

TABLE 1
SPRAY CLEANERS

Type	Trade Name	Supplier	Recommended Usage
No-Residue	Tuner Bath	GC	Specially designed to clean TV tuners, also good general-purpose cleaner
	Big Bath	GC	General-purpose degreaser and cleaner
	Dry Kleen	GC	Heavy-duty chlorinated solvent; keep away from all plastics
	Blue Shower	Tech-Spray	Cleaner and degreaser for all parts of TV set
	Instant VTR/VCR Cleaner	Tech-Spray	Specially designed to remove dirt, nicotine film, and oxides from tape heads
	Instant FD	Tech-Spray	Designed for precision cleaning of electronic equipment
	Kleen-All	Tech-Spray	Heavy-duty chlorinated cleaner; keep away from all plastics
	Electro-Wash	Chemtronics	General-purpose degreaser/solvent
	Video-Renu	Chemtronics	Designed to remove deposits and particulate matter from tape heads
	Electro Contact Cleaner	Holt-Lloyd (LPS)	Multi-purpose cleaner designed for use on delicate mechanisms and switches
Lubricated	LPS 1	Holt-Lloyd	Penetrant, lubricant, water displacer for use on small mechanisms and switches
	Spra-Lube	GC	Designed to clean and lightly lubricate TV tuner contacts
	Spra-Kleen	GC	Heavy-duty version of Spra-Lube for general-purpose contact cleaning and lubrication. Keep away from plastic.
	Jif-Action	GC	General-purpose cleaner with silicone lubricants designed for use in adverse environments.
	Spray Pack Mark II	Quietrole	General-purpose tuner, switch, and control cleaner
	R _x First-Aid for Tuners	Tech-Spray	Specially designed to clean and lube TV tuners
	EZ-Kleen	Tech-Spray	Heavy-duty cleaner for switches, controls, and contacts. Keep away from plastics, such as polystyrene and polypropylene.
	Kontakt Restorer	Chemtronics	For cleaning all types of contacts and controls
	Tuner Renu	Chemtronics	Specially designed to clean and lube TV tuner contacts
	Foam	Blue-Stuff	Tech-Spray
Lube-A-Trol		Tech-Spray	Thick cleaner and lube for carbon and wirewound controls
Magic Vista		GC	Thick substance designed to clean, polish, and lubricate TV-tuner contacts.

products are generally used for that job. Alcohol-type cleaners are not recommended, because they tend to leach out the stabilizers in the rubber, causing it to become soft and sticky. The ketones, such as

acetone or MEK (MethylEthyl Ketone) are better, provided a few precautions are taken. First, remember that acetone and MEK are flammable and should not be used near sparks or open flame. Second, those

are potent solvents that will destroy the rubber if too much is used. The way to use those chemicals is to apply them sparingly to the rubber's surface with a cotton swab; that will let you take off the top layer of rubber and residue, without harming the good rubber beneath.

The chief advantage of the ketones, since both they and the alcohols affect the stabilizers in rubber, is that they evaporate very quickly and thus have little time in which to damage the good rubber. The ketones, however, are notorious for dissolving almost anything made of plastic (except nylon, which seems relatively immune), so be careful when you use them. One drop on the transparent door of a cassette recorder, and it will be permanently blemished.

Adhesives

The adhesives that are currently available represent a wide variety of chemical types that can fasten two pieces of almost anything together reliably, and quickly; a list of some of those is given in Table 2.

One of the most widely used adhesives is epoxy. Epoxies are universal adhesives that have a variety of setting times and viscosities; the viscosity and the setting time depends on the particular formulation used. They are solventless, two-component adhesives that must be mixed before application; the components should be mixed on a non-porous surface for best results. At room temperature, heat or pressure is not required for setting.

Epoxy will bond most materials, including metals, glass, ceramics, most plastics (except nylon and similar compounds), cardboard, wood, rubber, and fiber, with bond strength of up to 4000 pounds-per-square-inch; that is generally greater than the strength of the bonded materials themselves.

Viscosity tends to be related to setting time, with the quick setting glues being thinner than the slower setting ones. What type of epoxy you use will depend on both what is to be joined, as well as how many items are involved. If only one item is to be fastened, and the surfaces closely match, use one of the thin, quick-setting types. If you need more working time, or if there are gaps when the two surfaces are joined, use the slower-setting epoxies.

Epoxies can be especially useful if parts are either totally unavailable, or will take an extremely long time to arrive if ordered. That often happens with such things as cabinet assemblies, decorative parts, and other plastic pieces, especially if the unit being repaired is over five years old. Although it is usually best to replace a broken part with a new one, there are times when that is not possible or practical. I've also seen many cases where the original part, as well as the replacements, were not strong enough for their intended use, and reinforcing them with epoxy was the only way to insure reliability.

Cyanoacrylate adhesives (such as *Krazy Glue*) are relatively new, having been de-

TABLE 2
ADHESIVE USE AND COMPOSITION

Generic Name	Composition	Use	Trade Names
Cyanoacrylate	Alpha or ethyl cyanoacrylate	1,2,3,4* quick-set, light-duty	Permabond, Instant-Stick, Super-Glue, Krazy Glue
Thread lock	Dimethylacrylate	Metal or plastic threads	Permalok
Epoxy	Modified epoxy resin polymercaptan	1,2,4,5* quick-set, thin, medium-duty	Quik-Stik
Epoxy	Epoxide resins	1,2,4,5* non-running, 2-4 hour set, filler or heavy-duty bond	Epoxy Glue
Wood glue	Polyvinyl acetate copolymer resin	Wood, paper	Super Wood-Lok
	Synthetic thermoplastic	Most surfaces, 1 hour set, pliable, light-duty	Pliobond, GC Bond
Silicone adhesive	Vulcanized silicone rubber	Most surfaces, 24 hour cure, sealant, pliable medium-duty	Various
Solvent-release	Many different types for different materials, refer to manufacturer's data		

*1. Plastic 2. Metal 3. Glass 4. Non-porous 5. Porous

veloped for use as a needleless suture during the Vietnam war. They are single component, solvent-free glues that set very rapidly. They will bond almost any substance, providing good surface contact can be maintained. The key to using any of those adhesives is to apply them sparingly, to clean, dry, well-mating surfaces—one drop will hold an elephant, but two drops won't hold a feather! While advertisements claim setting times of only a few seconds, a few minutes is closer to the truth. To be safe, don't stress the joint for at least 10 or 15 minutes. Remember too that the cyanoacrylates *bond skin instantaneously*, so be very careful when using them.

Those adhesives are most useful for light-duty bonds such as trim and similar applications. While they have excellent tensile strength, and thus are ideal for the emergency repair of broken drive belts, their shear strength is not very good; using them to secure the base of a cantilevered assembly, for example, is not recommended. Also, in general, cyanoacrylates tend to be much less tolerant of careless application than are the epoxies.

The biggest advantage those adhesives have over epoxy is that they can be used to join such hard-to-glue materials as polyethylene, Teflon, vinyl, and silicone rubber, although the surfaces must be pretreated with a surface activator and cleaner. If irregular, non-mating surfaces, or porous materials are to be bonded, epoxy or a rubber-base glue is a better bet. It's also a good idea to have a bottle of special cyanoacrylate solvent around for cleanup, and to release misaligned parts.

Solvent-release adhesives are another type that is often useful in a workshop. That

type of adhesive includes a wide variety of resins and polymers that harden when the solvent either evaporates, or is absorbed. Some of the most useful of those are the thermoplastic adhesives. Those tan-colored compounds will provide a flexible, waterproof bond between virtually any two materials. They are often used to secure large electrolytic capacitors or the like to circuit boards. They also work well on decorative trim. Drying time ranges from 15 to 30 minutes. Those adhesives can also be used as a contact cement by coating each piece to be joined with a thin layer, waiting for the thermoplastic to become tacky, and then pressing the pieces together.

Another member of this group is silicone-rubber adhesive. Also called a *sealant*, it dries when it is exposed to the moisture in the air. It is best used to seal against air or moisture, or when a flexible bond is needed. It will adhere to almost any clean surface and can be easily removed with a scraper, if necessary. Its tensile strength is lower than either epoxy or cyanoacrylate, but its non-running consistency, one-component convenience, resilient bonding, and removability give it advantages over the other adhesives in situations where the tensile strength is not important. Since that substance also has dielectric properties, it can come in handy for potting components and sub-assemblies; it can also be used to damp the mechanical oscillations of components in a TV's horizontal circuits.

Lubricants

Many types of lubricants, other than the spray-solvent type mentioned earlier, are available. One word of caution: There is a tendency for inexperienced hobbyists, or

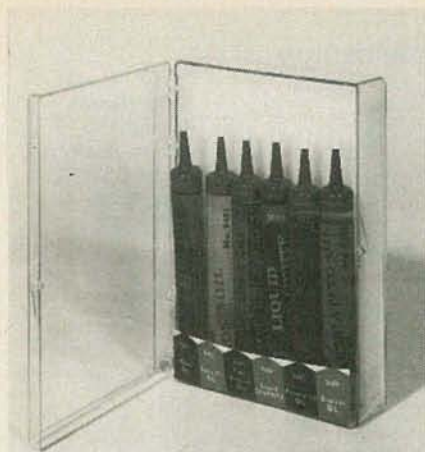

FIG. 2—THE RIGHT OIL FOR ANY NEED can be found in this selection of oils from GC Electronics.

even service technicians, to *overlubricate* the various small assemblies found in such things as phonographs and tape recorders. The widespread use of permanently lubricated bronze in most motors, idler wheels, and bearing assemblies makes oiling unnecessary under normal conditions. If oiling should ever be needed, either because of unusual use or perhaps after performing a motor overhaul, a light-grade machine oil is recommended.

Parts that slide against each other, such as head plate assemblies in cassette decks, do require occasional lubrication. In those cases, use a good molybdenum di-sulfide or lithium-based grease, such as *Lubrex* (GC Electronics). When lubricating those small mechanisms, always remember that less is better.

For gear trains, turntable main bearings,

CHEMICAL SUPPLIERS

For more information, circle the corresponding number on the Free Information card inside the back cover.

Chemtronics

681 Old Willets Path
PO Box 1800
Hauppauge, NY 11787
CIRCLE NO. 101

GC Electronics

400 S. Wyman St.
Rockford, IL 61101
CIRCLE NO. 102

Holt Lloyd Corporation

LPS Products
4647 Hugh Howell Rd.
Box 3050
Tucker, GA 30084
CIRCLE NO. 103

Quietrole Co.

455 Montgomery Bldg.
Spartanburg, SC 29301
CIRCLE NO. 104

Tech-Spray

Box 949
Amarillo, TX 79105
CIRCLE NO. 105

and the like, a good grade of light-bodied grease made of polymerized oil (such as GC Electronics' *Phonolube*) provides long lasting lubrication that will not oxidize or become gummy for many years under normal conditions.

It's handy to have a can of silicone spray, such as *Silkon 35* from Chemtronics, for lubricating such things as hinges and sliding plastic parts. Those sprays are especially useful if you are trying to restore proper operation to a slide potentiometer. Most manufacturers warn against cleaning them, because that would likely remove the lubrication needed for smooth movement. Unfortunately, that type of control is much more susceptible to contamination than rotary potentiometer because it has a slot along its length (for the slide handle) that can allow dust to enter the device. Another consideration here is that this type of potentiometer is also rather expensive, which makes cleaning the unit rather than replacement, an attractive alternative.

To do that, just clean out the pot with a very small amount of tuner cleaner or Freon TF, and carefully work the control until the crackling noise disappears. Remember, the solvent tends to remove all lubrication, and if you're too rough with the control, something inside will probably break. The next step is to apply an ample amount of pure silicone lubricant and work the control until the slider moves smoothly. Using that procedure usually restores the pot to like-new condition.

Specialty items

There are a number of products whose composition or use does not fall into one of the broad categories we have been discussing. Some of those specialty items were not specifically designed for use in the electronics servicing industry, but are very useful nonetheless. While there are a great many of such products, here are just few examples of what is available.

Most service technicians are familiar with freeze spray. It is used regularly to cool suspected noisy or intermittent components. Several types are available; all are either fluorocarbons or chlorinated hydrocarbons. The major difference between the sprays is the speed at which they evaporate.

In general, the quicker evaporation occurs, the colder the spray becomes. Fast evaporating sprays, such as GC Electronics' *Super Freeze Mist*, are best for components with good thermal conductivity, such as metal-cased transistors, small electrolytic capacitors, and thinly insulated devices such as metal film resistors. A longer evaporating time, in the range of 20-30 seconds, is best for plastic or epoxy-encased semiconductors, Mylar or cardboard insulated capacitors, or other parts with a heavy insulation; one such freeze spray is *Component Cooler* from Chemtronics. In addition to finding thermally sensitive components, freeze sprays can also be used to assemble or disassemble tight fitting metal



FIG. 3—HEAVY DUTY cleaner and lubricant from Quietrole is intended for switches, controls and contacts.

parts; cooling the inside piece will reduce its size temporarily. The types of plastic found on circuit boards are not harmed by freeze sprays, but, regardless of what the label says, don't trust them around decorative clear-plastic or cabinet-plastic, or any painted finish. Special anti-static freezes, such as *Instant Anti-Static Freeze Spray* from Tech Spray, are available for use with MOS, FET, and the various other static-sensitive components

Muriatic acid is a form of diluted hydrochloric acid. The substance is commonly used for etching concrete, so it is readily available at most hardware stores. That product, which must be used very carefully since it is quite corrosive, does an excellent job of restoring worn 8-track capstans to like-new condition.

Seized bearings can often be freed by a good penetrating lubricant under pressure; those are sold under many trade names including *LPS 1* and *WD-40*. A good light-weight belt dressing, such as *Permatex* (not the gasket compound) can extend the life of rubber parts, without making them sticky or gummy. Finally, sometimes the specially formulated chlorinated solvents in *Rubber Magic* will do the job when the generic rubber cleaners fail. Be especially careful around plastics when you are using that product, however, as it will likely damage most of them.

Soft tools can be among the most useful items in your workshop. While this article has given a broad view of the uses of those chemicals, it is up to you to find the ones that best suit your needs. You will have to do some experimenting, and may at first make some mistakes, but the long-term goal—faster, easier, and less expensive repairs—is well worth it. **R-E**

From STYLUS to PHONO INPUT



What you need to know about modern phono cartridges, plus how you can measure the frequency response of your cartridge, determine the proper load impedance and then alter the load impedance for maximum performance.

LEN FELDMAN

MOST OF US STILL RELY UPON THE PHONOGRAPH record for much of our music listening, and while futuristic promises of optical (laser) and digital discs seem close to realization, it will be many years before the vinyl analog LP record will be replaced to any significant degree. That means that we will be using phonograph cartridges as the first element in our home music systems for the foreseeable future. While volumes could be written about the design criteria for a "good" phono cartridge, we have chosen to concentrate on the input and output ends of this remarkable little device—the stylus assembly and the required load impedance of modern magnetic pickups. Much of the information for this discussion was derived from a series of technical papers assembled by the engineers at Shure Bros., and distributed during informative seminars. Shure held these seminars primarily for the purpose of informing audio enthusiasts as to what is involved in the design of high quality cartridges and secondarily, to educate the audio consumer regarding the importance of using only original manufacturer stylus replacements when it be-

comes necessary to replace a worn stylus in a high-fidelity cartridge.

Stylus tip design

The stylus tip provides the physical interface between the record groove and the rest of the phono cartridge. It must accurately translate the signal stored in the record grooves into an electrical signal that can be transmitted through the rest of the playback system. If the stylus assembly, excluding the tip, cannot cope with a given signal, the stylus will mistrack. Another important requirement is that a stylus must not cause additional noise while doing its job. Also, record and tip wear must be kept to a minimum.

As shown in Fig. 1, the dimensions of a standard record groove impose certain constraints upon stylus tip design. The groove is not a constant shape (unless it is unmodulated) but can become as narrow as 0.001 inch at the record surface. The tip, therefore, must be designed to accommodate this minimum groove width. And, since the bottom of the record groove is rounded (and not pointed) precautions must be taken to pre-

vent the tip from contacting the bottom of the groove. Unwanted noise and mistracking will result if adequate clearance between the tip and the bottom of the record groove is not maintained.

For other than spherical tips, the entire contact area of the tip must not be tilted forward or backward with respect to the groove modulation. Such tilting would cause distortion and tips with longer contact areas are more sensitive to such misalignment than are tips with shorter contact areas. Other design constraints include the need for the stylus tip to accommodate a moderate amount of dust and lint, the ability of the tip to slide along the record material without modifying, damaging, or destroying the record groove, and finally, the tip must be capable of being manufactured precisely and consistently.

Possible tip shapes

Offhand, one might suppose that the ideal shape of the stylus tip would be the same as the shape of the cutting stylus that made the record groove in the first place. As we see from Fig. 2, however, that is not the case, since stylus tilt of

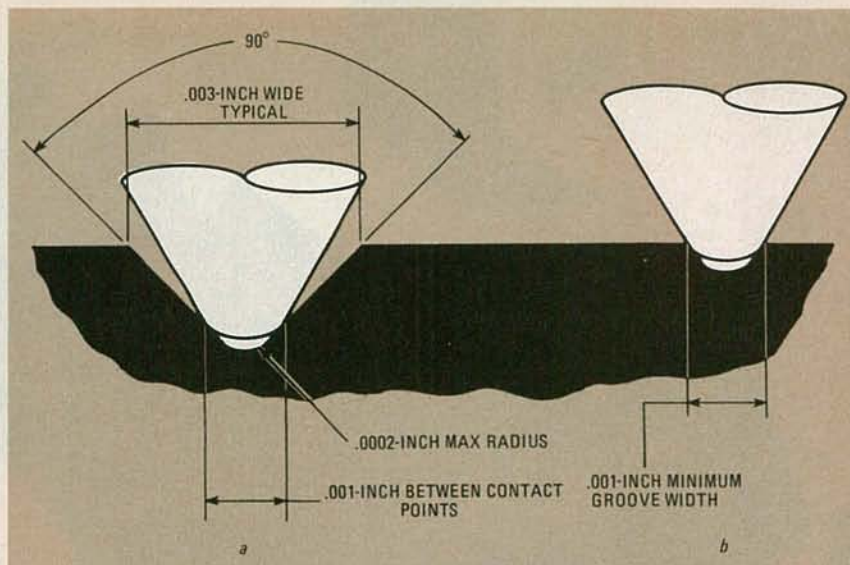

FIG. 1—GROOVE DIMENSIONS of standard lp record. The groove dimensions are constantly varying as a result of the modulation. The typical groove dimensions are shown in *a* while the minimum dimensions are shown in *b*.

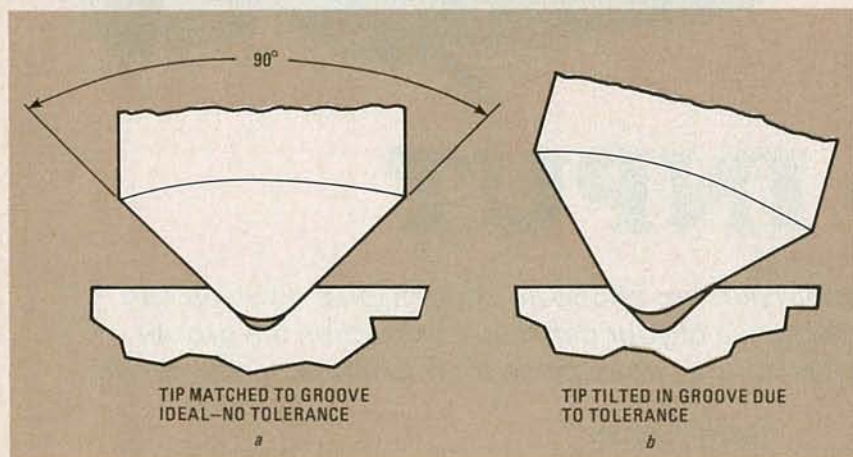

FIG. 2—THE STYLUS TIP must not be tilted left or right with respect to the record groove as shown in *a*. When stylus tip is tilted, proper contact with the record groove does not occur, as shown in *b*. This tilt angle is sometimes referred to as angular tolerance.

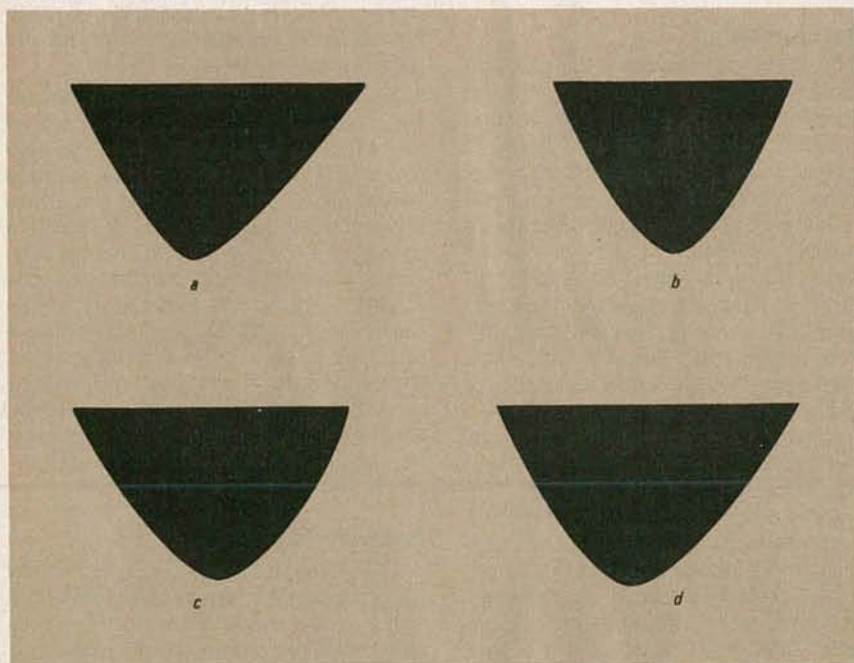

FIG. 4—BIRADIAL TIPS include several different shapes. The Shibata tip is shown in *a*, the Pramanik is shown in *b*, the quadrangular is shown in *c*, and the hyperbolic is shown in *d*.

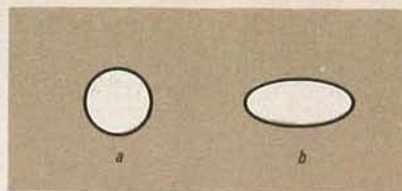

FIG. 3—SPHERICAL STYLUS TIPS produce a circular contact area with the record groove, as shown in *a*. Biradial tips produce an oval contact area as shown in *b*.

even a few degrees would lead to almost complete mistracking. Other possible tip design shapes include spherical tips, having circular cross sections and biradial tips having oval cross sections. These cross sections are shown in Fig. 3.

While the front profiles of a spherical tip and a biradial tip of equal major radius are the same, the advantage of the biradial tip is its smaller tracing radius that yields significantly lower tracing distortion. A class of tips having an elongated contact region evolved during the early and mid-1970's, when CD-4 quadraphonic records were being issued. As shown in Fig. 4, this classification now includes such tip shapes as Shibata, Pramanik, quadrangular, hyperbolic, etc. The chief difference between these and the biradial tip is the front profile, but we cannot tell from these views about the contact radius. In fact, all of the tips just named in this category have approximately the same average tracing radii as the typical biradial tip—0.0003 to 0.0035-inch.

Carefully controlled tests are necessary to evaluate tip performance. Such tests must not be limited to one kind of measurement, but must include distortion, noise, and wear tests. The results of the tests have shown that biradial and long contact tips with the same tracing radius yield about the same average distortion as expected from theory. All of these geometries will reproduce roughly the same amount of surface noise provided that they have adequate clearance to the bottom of the groove.

Record and stylus tip wear tests conducted over the years by Shure Bros. have yielded some results worth noting. For example, their data shows that diamond tips have a significantly longer life than sapphire, as shown in the plotted curves of Fig. 5. Another test revealed the increased abrasive action of playing a stylus continuously on the same record as opposed to a limited number of plays (20) on several different records. Downward tracking force is also a major factor of tip life, regardless of stylus tip shape, as shown in Fig. 6. These tests show a trend toward a faster rate of wear as tracking force increases.

The record wear tests demonstrate the importance of proper tracking and low stylus mass in preventing groove damage. In other record wear tests, re-

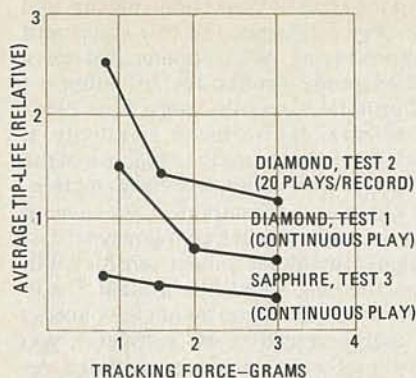

FIG. 5—TIP WEAR depends on the tip material and the tracking force.

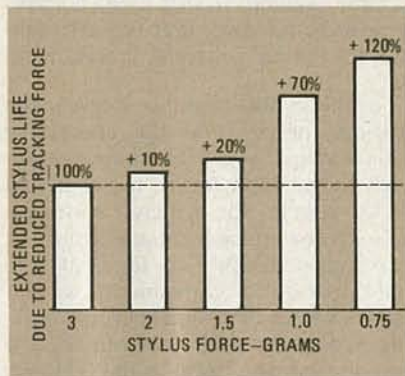

FIG. 6—AVERAGE TIP LIFE increases dramatically as the tracking force is reduced.

sults indicate some advantage to long contact tips, but the advantage is dependent on the groove modulation level and the tracking force. Low stylus mass (i.e. high trackability) and low tracking force are far more beneficial in achieving long record and tip life.

Proper cartridge loading

It is unfortunate that after dedicated engineering departments go to all the trouble that they do to create pickups that are capable of uniform frequency response, high trackability, and long life, so many users pay little or no attention to the proper mounting and impedance requirements of the cartridge. The subject of proper cartridge mounting is, in itself, a complicated one and requires a complete discussion on its own which would be too lengthy to include here. However, a few notes concerning proper cartridge loading are in order. The subject is not inordinately complex, but it is nevertheless often ignored.

Read any cartridge specification sheet or owner's manual supplied with a modern cartridge and you will find a specification called "load impedance". That specification consists of two parts, one resistance and the other capacitance. More often than not, the resistance component of that load impedance is specified as 47 kilohms, and you need do nothing about it since just about every phono preamp input presents that resistance. Some preamplifiers even have a choice of resistance values, from

around 22 kilohms to 100 kilohms (the latter value was often recommended for CD-4 quadrasonic cartridges when those were common a few years ago, but but is hardly ever called for in a modern cartridge). What may or may not be listed under the general heading of impedance, however, is the required value of load capacitance, given in pF when it is listed.

Both the load resistance and the load capacitance are extremely important if "flat" frequency response is desired. If the load impedance presented to the cartridge is far removed from the recommended values, the high-frequency portion of the response will be altered. To show how the response is altered, Shure Bros. provided us with a response curve of their V15 Type IV cartridge when it was loaded with 47 kilohms of resistance and 250 pF of capacitance per channel. This response curve is shown in Fig. 7. Note that there is no resonant peak within the frequency range from 40 Hz to 20 kHz.

To show the effects of proper and improper cartridge loading, we mounted a lower cost magnetic cartridge into our turntable; one known to have a resonant peak within the audio spectrum. The

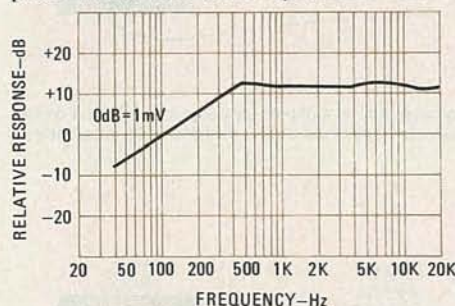

FIG. 7—FREQUENCY RESPONSE of the Shure V15 Type IV cartridge with a 47-kilohm 250-pF load impedance. The sloping response below 500 Hz is a result of the test record (see text.)

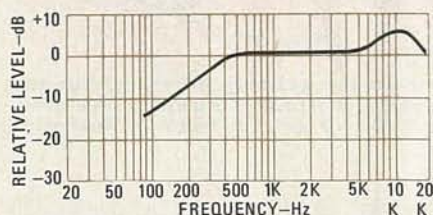

FIG. 8—FREQUENCY RESPONSE of a low-cost magnetic cartridge with a 100-kilohm 100-pF load impedance. Note the large resonant peak at 12 kHz.

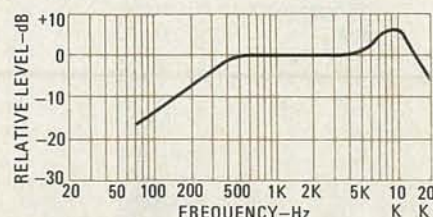

FIG. 9—INCREASING THE LOAD CAPACITANCE to 300 pF lowered the frequency of the resonant peak to 10.5 kHz. The load resistance is 100 kilohms.

make and model number are not important, but suffice it to say that it was not a cartridge from one of the better known, high-quality cartridge manufacturers. Two response curves were made each with a different load impedance. Results are shown in Figs. 8 and 9. Incidentally, in Figs. 7 through 9, the sloping response up to 500 Hz is a function of the test record (CBS STR-100), which is recorded with a constant amplitude below 500 Hz and with a constant velocity above that frequency. Since we were concerned only with the high-frequency end of the response as a function of load impedance, we did not pass the output of the cartridge through any equalization process to yield a horizontal line below 500 Hz.

In Fig. 8, we loaded the cartridge with 100 kilohms instead of 47 kilohms and added no loading capacitance other than that supplied by the connecting audio cables (about 100 pF for each channel). The resonant peak occurred at 12.0 kHz with a 6.3 dB rise in amplitude.

Next we added an additional 300 pF of capacitance across the cartridge output terminals, but left the higher-than-normal resistance of 100K ohms in the circuit. Results are shown in Fig. 9. Here, the resonant peak is shifted down in frequency to 10.5 kHz, but its amplitude has increased to +7.5 dB relative to our 0-dB point at 1 kHz.

From these response curves it should be clear that proper (or improper) cartridge loading can have a much greater effect upon the way a cartridge sounds when reproducing music than some of the more subtle, and often insignificant design elements promoted by some cartridge manufacturers. After you have selected a cartridge that can track your records properly, has low distortion, and will not wear out your records or its own stylus tip after a short time, it's still up to you to install it into a pickup arm that can work well with it and to load it with the recommended values of resistance and capacitance. Let's take a look at some tests you can perform in your home for determining whether your cartridge is loaded properly and what you can do if it isn't.

User tests

Often, a phono cartridge is installed by the manufacturer of the turntable system or by the dealer from whom the turntable and cartridge were purchased. Under those circumstances it is difficult to know whether or not the matter of proper cartridge loading has been properly taken care of. Furthermore, the instruction pamphlet supplied with most phono pickups is usually discarded when the cartridge is installed, so that you have no easy way of determining what the proper loading capacitance is for the cartridge in question.

In such case, proper loading of a cart-

TABLE 1-TEST RECORDS

Record catalog number	Source
STR-130	CBS Technology Center 227 High Ridge Road Stamford, CT 06905
STR-100	CBS Technology Center 227 High Ridge Road Stamford, CT 06905
AT-6606	Audio-Technica U.S., Inc. 1221 Commerce Drive Stow, OH 48224
QR-2011	B&K Instruments, Inc. 5111 W. 164th Street Cleveland, OH 44142
XG-7001	Denon America, Inc. P.O. Box 1139 West Caldwell, NJ 07006

response plot of your phono pickup, and the only other piece of test equipment required is an AC voltmeter that has a flat response (preferably to within +1 dB or better) over the range from 20 Hz to 20 kHz. As for meter sensitivity, if you plan to measure the response of the cartridge with no intermediary electronics (such as a preamplifier) and you are dealing with typical moving-magnet cartridges, the meter's most sensitive full-scale reading should be around 5 millivolts or lower. If you do not have access to such a sensitive AC voltmeter, you may prefer to measure cartridge response including the amplification and equalization characteristics of your associated preamp. In that case, sensitivity need be no lower than 0.5 volts full-scale for the AC voltmeter you intend to use.

To obtain the response curves, the cartridge output (via the connecting audio cables) would be connected directly to the voltmeter as shown in Fig. 10. Of course, for a stereo cartridge, the response of each channel would be measured separately. A terminal strip could be used for convenience, so that various values of capacitance and resistance could be used to terminate the cartridge output. Because the STR-100 record is recorded at constant amplitude below 500 Hz and at constant velocity above that frequency, the ideal response from a perfectly loaded and perfectly designed phono cartridge at the spot frequencies would have the output levels listed in Table 2 if we assume an arbitrary 0 dB at 1000 Hz.

Using the direct-hookup method shown in Fig. 10, the readings are likely to be very low in voltage and unless cable lengths are kept quite short, readings might be influenced by stray hum fields that could lead to erroneous results. Still, this method is worthwhile because only the cartridge performance is involved. There are no intermediate electronic circuits, with their possible frequency response errors, to detract from the accuracy of the measurements being made.

If this same test record (STR-100) is used to test cartridges that are already connected to the preamplifier, then the setup shown in Fig. 11 would be used. The "Y" connector, readily available from electronics parts stores, permits parallel connection of various load resistors and capacitors, each wired to a blank phono-tip plug. With this setup, the phono pickup itself remains connected to the preamplifier of the system. The voltmeter should then be connected to the TAPE OUT (sometimes identified as REC OUT) jack on the rear of the preamplifier (or integrated amp, or receiver) being used. Since RIAA equalization is being provided by the preamplifier of the system, a perfectly loaded ideal cartridge would yield the readings listed in Table 3 (again, re-

continued on page 86

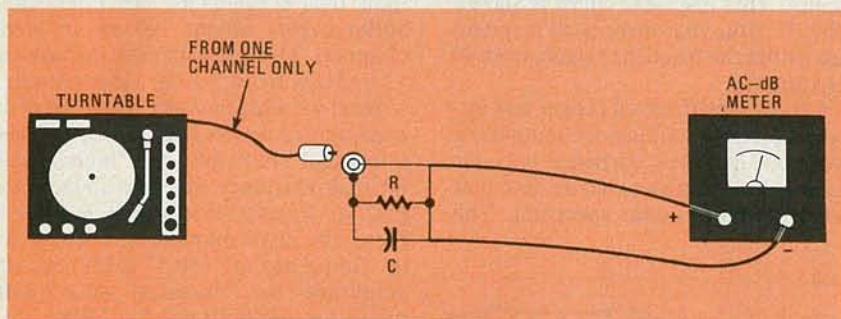

FIG. 10—TEST SETUP for measuring the frequency response of a phono cartridge at the output of the cartridge. The R-C load impedance network is connected across the output terminals of the cartridge.

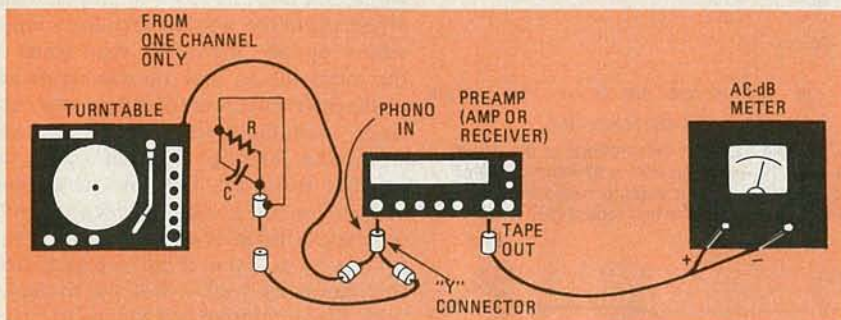

FIG. 11—TEST SETUP for measuring the frequency response of a cartridge with the cartridge connected to a preamplifier. In this case, the load impedance is the impedance of the phono input of the preamplifier. A "Y" connector is used to connect an R-C circuit across the output terminals of the cartridge if the load impedance needs to be altered.

ridge can be verified by direct measurement of frequency response, using any of a number of available test records, all of which contain tones on a one-at-a-time basis rather than on a continuous sweep basis that requires the use of a synchronized X-Y response plotter. A partial list of such test records will be found in Table 1, along with the names and addresses of the organizations from whom the record can be obtained.

The STR-100, ST-130, and AT-6606 test records contain single-tone frequencies, while the remaining two contain third-octave pink-noise bands rather than single frequencies. Either type may be used to obtain a frequency

TABLE 2

Frequency Hz	Meter Reading-dB
1000	0.0
20,000 to 500	0.0
400	-2.0
300	-4.4
200	-8.0
100	-14.0
80	-16.0
60	-18.4
50	-20.0
40	-22.0
30	-24.4
25	-26.0
20	-28.0

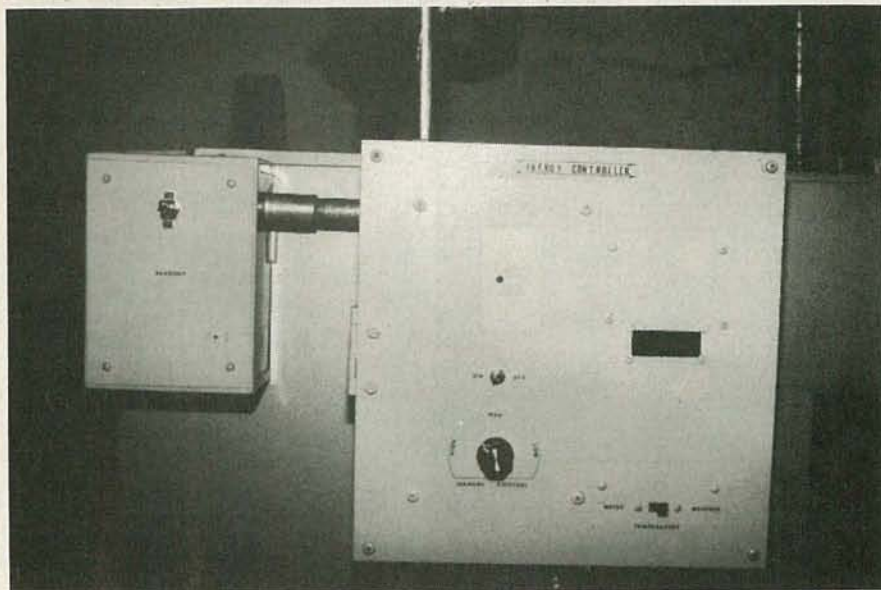

ENERGY MISER FOR YOUR FURNACE

Cut fuel costs and increase the efficiency of your home heating system with this easy-to-build energy controller.

ROLAND GIBSON

EVEN IN THESE TIMES OF UNCERTAIN FUEL costs, there is one fact that you can be sure of—if less fuel is consumed, the cost of energy will be lowered. That is the purpose of this project—it is an energy “controller” designed to minimize the amount of oil used by a hot-water heating system.

Oil hot-water heating systems use an aquastat to control the system’s water temperature. That aquastat has adjustable settings for hot-water temperature and circulator control. Before installing this controller, our fuel-oil supplier had recommended that the hot-water temperature be set at 180°F during the winter, and 160°F for the summer; the corresponding recommended circulator settings were 160°F and 140°F respectively. However, I did some tests and found that, except during periods of very cold weather, those settings were excessive and it should therefore be possible to reduce fuel-oil consumption if the circulator were set at 120°F and the water temperature were varied inversely with the outside temperature. From that idea grew the controller.

An energy controller

In the **AUTOMATIC** mode, the controller monitors the atmospheric temperature and compares that with the temperature of the water in the heating system’s boiler. Based on that comparison, the circuit either turns on or turns off the boiler’s burner, maintaining the water temperature at a level that is no

higher than needed for heating.

In addition, in the **MANUAL** mode, provision has been made so that the water temperature can be set by hand and then maintained at any level between 100°F. That is intended for use during periods when heat is not required.

The circuit design is relatively simple, supplementing but not eliminating any of the oil-burner’s control circuit. When the controller is switched **OFF**, oil-burner operation returns to normal.

The controller has a “fail-safe” design. But that we mean that if it fails during an “on” cycle, the oil burner will operate using the preset oil-burner controls. If a failure occurs during the “off” cycle, the burner will shut off and stay off until the controller switch is placed in the **OFF** position, returning the burner operation to the preset burner controls.

The components used in this project are readily available. Construction is straightforward and any technique can be used. A PC board can be used if desired, and will certainly make things a bit neater, but it is not *required*—none was used in building the prototype described here.

How it works

The controller’s schematic is shown in Fig. 1. The power supply for the circuit is shown in Fig. 2-a; the power supply for the temperature readout is shown in Fig. 2-b.

The two temperature sensors, IC5 and IC6, are AD590’s from Analog Devices. They have an output of 1 microamp-per-degree Kelvin. Accuracy is 0.5°.

As most oil-burner controls in the U.S. are calibrated in degrees Fahrenheit, for convenience it would be desirable to scale the sensor output to those units; 10 millivolts-per-degree Fahrenheit was the output we chose. Let’s see how that scaling is done. To keep things simple, we’ll only discuss the scaling for the water-temperature sensor, IC6; the procedure, and values used, are identical for the air-temperature sensor, IC5. To convert from Kelvin to Fahrenheit, the following equation is used:

$$\text{Temp (in } ^\circ\text{F)} = \text{Temp (in } ^\circ\text{K)} - 459.67$$

Remembering that we are scaling the output to 10 millivolts-per-degree Fahrenheit, the total resistance of R1 and R2 becomes:

$$1.8 \times \frac{10^{-2}}{10^{-6}} = 18000 \text{ ohms}$$

To create that resistance, a 16K resistor and a 5K pot are connected in series; the pot is used to trim the total resistance until it is the precise value needed. When that is done, the voltage drop across R1 and R2 will be equal to 10-millivolts-per-degree-Fahrenheit, plus 4.5967 volts. To complete

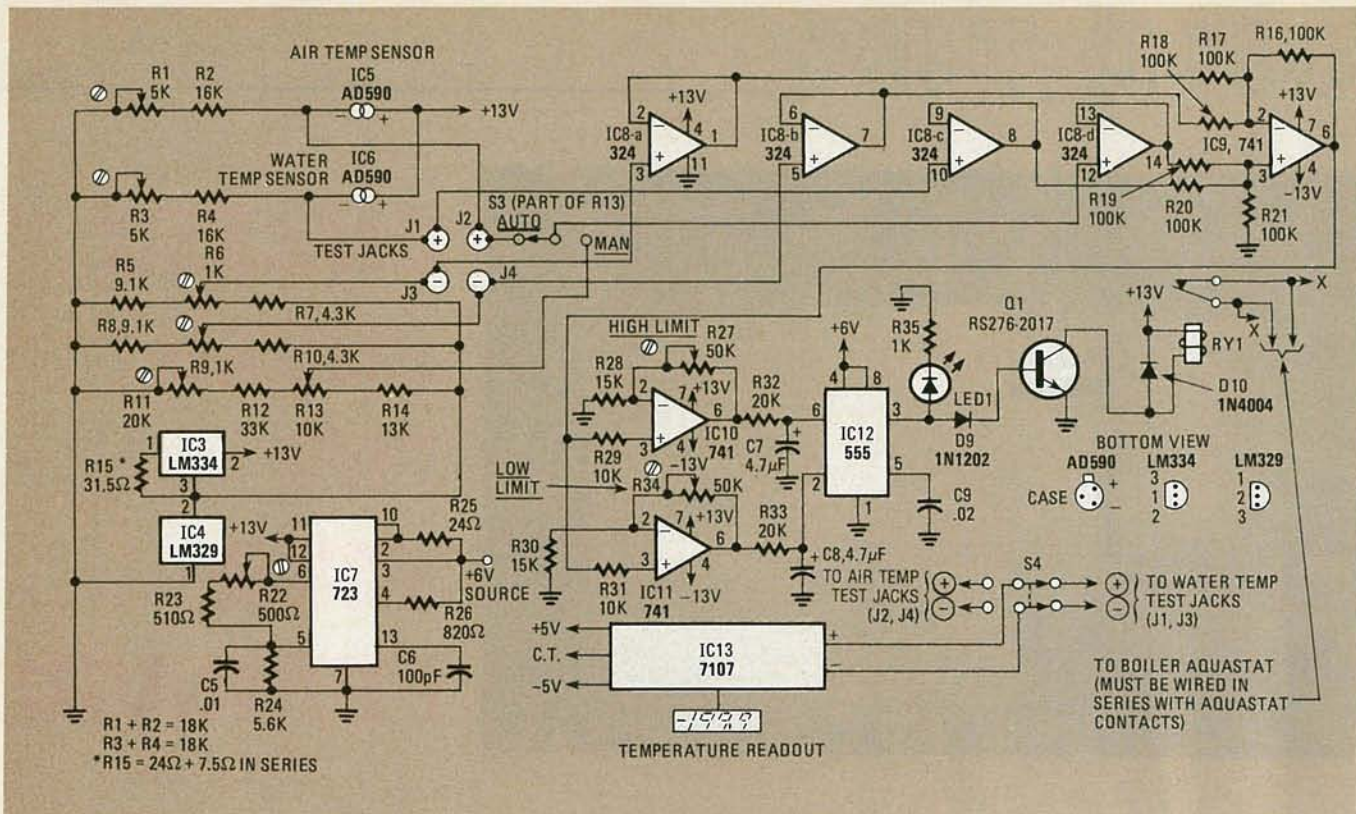

FIG. 1—SCHEMATIC DIAGRAM of the energy controller. Relay RY1's contacts must be wired in series with the oil burner aquastat's contacts.

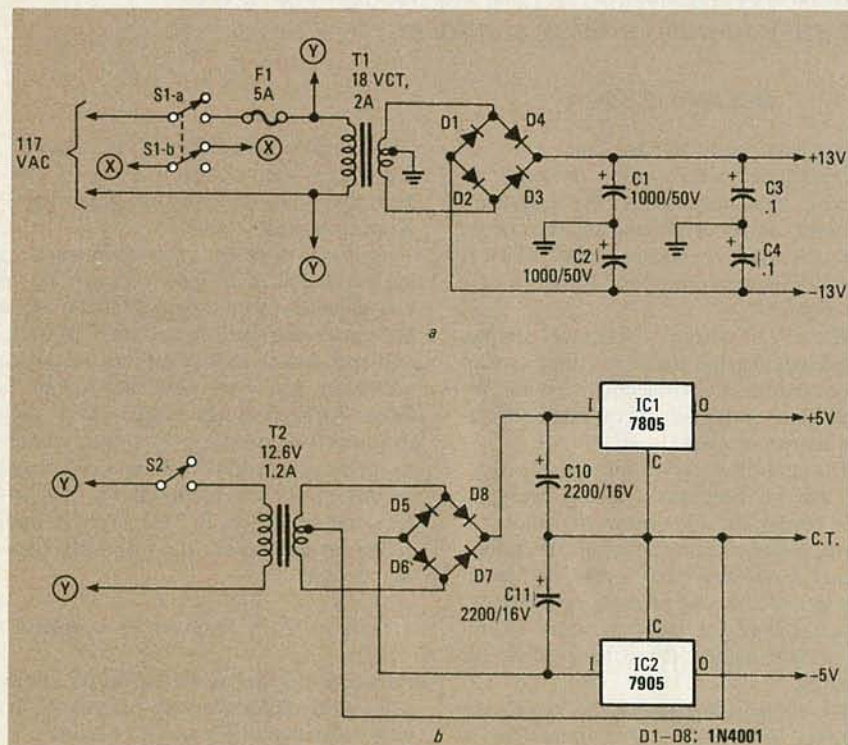

FIG. 2—POWER SUPPLY for the energy controller is shown in a; the power supply for the readout is shown in b.

that conversion, a 4.6-volt reference voltage is needed. That is done by generating a precise 6.9 volts using the combination of IC3, an LM334 constant-current source; IC4, an LM329 6.9-volt voltage reference, and R15. That voltage is then placed across a voltage divider network consisting of R8, R9, and R10. Trimpot R9 is used to balance

the divider, and the 4.6 volts is taken from its wiper.

In the manual mode, a resistor network, R11-R14, is used in place of the air-temperature sensor. With the values shown, R11 is adjusted so that the voltage at the junction of R12 and R13 is 4.6 volts. The output, taken from the wiper of R13, can be

adjusted so that it simulates an air-temperature of between 0°F and 100°F.

The outputs from the temperature sensors and reference voltages are buffered by IC8-a-IC8-d, a 324 quad op-amp. The op-amp outputs are connected to IC9, a 741 op-amp. That IC adds the two 4.60-volt reference voltages and subtracts them from the sum of the two temperature-sensor output voltages. The output of IC9 equals the sum of 10 millivolts-per-°F of outside temperature plus 10 millivolts-per-°F of water temperature.

The controller's operation is a function of the sum of the air temperature and the water temperature. Take a look at Fig. 3. You'll note that irrespective of whether water-temperature scale A or B is used, the sum of the air and water temperatures is the same. That is, using scale A, at an air temperature of 0°F, the water temperature is 180°F, for a total of 180°F; at an air temperature of 30°F, the water temperature is 150°F, for a total of 180°F, and so on. That works the same way for scale B, and would for any other scale, as long as that relationship was maintained.

To conserve fuel, we want to turn off the boiler's oil burner when the combined sensor readings equal that critical value. When that is done, the higher the air temperature, the lower the water temperature maintained by the boiler. For the rest of this discussion, let's assume that we've chosen 180°F for that value. Remembering our scaling factor of 10 millivolts per degree Fahrenheit, we are going to want to open the relay when IC9's output reaches 1.8 volts. That output is connected to IC10 and IC11, two additional 741 op-amps; those IC's are used here

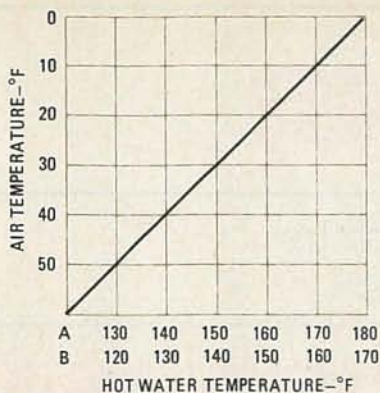

FIG. 3—WATER TEMPERATURE versus air temperature. At every point along this line, the sum of the air and water temperatures is the same.

to control the operation of IC12, a 555 timer configured as a Schmitt trigger. A 723 precision voltage regulator, IC7, is used to provide V_{CC} , a regulated +6 volts, for IC12. The output of IC12 (pin 3) depends on the voltages at its pins 6 and 12. If the voltage at pin 6 is $\frac{2}{3} V_{CC}$, or 4 volts, IC12's output will go high. If the voltage at pin 2 is $\frac{1}{3} V_{CC}$, or 2 volts, IC12's output will go low.

The output from IC12 drives Q1, which is used to control the operation of RY1, a normally closed relay. Ideally, RY1's contacts should be rated at 20 amps, but if such a relay is unavailable, a DPDT relay whose contacts are rated at 10 amps may be used; the contacts are tied together to double the rating. That's what was done here.

Relay RY1's contacts are wired in series with the aquastat water-temperature control contacts. Note that the aquastat's contact circuit will have to be broken for that to be done.

The $3\frac{1}{2}$ -digit temperature readout is an Intersil 7107 evaluation kit. That kit comes complete with all necessary components and a PC board, but not a power supply; an appropriate supply is shown in Fig. 2-b. As supplied, however, the meter's full-scale reading is 200 millivolts; it must be modified for this application so that the full-scale reading is 2.00 volts. That can be done by changing the value of three of the components in the evaluation kit. Those changes are C2 from 0.47 μ F to .047 μ F, R1 from 24K to 1.5K, and R2 from 47K to 470K.

Construction

Construction is straightforward and can be done using any technique. The prototype was built on perforated construction board, using point-to-point wiring with good results. Once the unit is built, but before it is housed or installed, it must be aligned.

To align the temperature sensors you'll need an accurate thermometer as well as a voltmeter. Making sure that the area that you are working in is not subject to sudden changes in temperature (caused by drafts, etc.), place the thermometer and the sensors next to each other. Turn the controller on and place it in the AUTOMATIC mode. With the meter's positive lead connected to J1

All resistors $\frac{1}{4}$ -watt, 5%

R1, R3—5000-ohm potentiometer, linear taper
 R2, R4—16,000 ohms
 R5, R8—9100 ohms
 R6, R9—1000-ohm potentiometer, linear taper
 R7, R10—4300 ohms
 R11—20,000-ohm potentiometer, linear taper
 R12—33,000 ohms
 R13—10,000-ohm potentiometer, linear taper
 R14—13,000 ohms
 R15—31.5 ohms (see text)
 R16-R21—100,000 ohms
 R22—500-ohm potentiometer, linear taper
 R23—510 ohms
 R24—5600 ohms
 R25—24 ohms
 R26—820 ohms
 R27, R34—50,000-ohm potentiometer, linear taper
 R28, R30—15,000 ohms
 R29, R31—10,000 ohms
 R32, R33—20,000 ohms
 R35—1000 ohms

Capacitors

C1-C4—1000 μ F, 50 volts or better, electrolytic
 C5—.014 μ F, ceramic disc
 C6—100 pF, ceramic disc
 C7, C8—4.7 μ F, 25 volts or better, electrolytic
 C9—.01 μ F, ceramic disc

and the negative lead to ground, adjust R6 until the meter reads exactly 4.6 volts. Next, connect the meter's positive lead to J4 and adjust R9 for 4.6 volts.

Once those adjustments have been made, connect the meter's positive lead to J1 and the negative lead to J3, and adjust R3 until the meter's reading agrees with the measured temperature. Remember—the voltage across those jacks has been scaled so that 10 millivolts equals 1°F. For example, an 80°F temperature would be read on the meter as 0.8 volts. After that has been done, connect the meter's positive lead to J2 and the negative one to J4, and adjust R1 until the meter reading agrees with the measured temperature. Finally, verify that the output of IC9 is twice the measured temperature. That is, if the measured temperature is 65°F, there should be 1.3 volts on pin 6 of IC9.

Next, we need to adjust the output of IC10 so that it is 4 volts when IC9's output is 1.8 volts. To do that, place the controller in the manual mode, and adjust R11 so that the voltage at the junction of R12 and R13 is 4.6 volts. Then adjust R13 so that you get a 1.8-volt output from IC9. Finally, adjust R27 for 4 volts at pin 6 of IC12.

The last adjustment to be made is to adjust the lower temperature-limit. Here we were interested in a temperature differential and selected a combined air- and water-temperature drop of 15°F. That differential is one that was convenient for our situation; any that works well for you can be used. In any event, the adjustment is made in the

PARTS LIST

C10, C11—2200 μ F, 1600 volts or better, electrolytic

Semiconductors

IC1—LM7805 5-volt positive voltage regulator (National)
 IC2—LM7905 5-volt negative voltage regulator (National)
 IC3—LM334 constant-current source (National)
 IC4—LM329 6.9-volt reference voltage, temperature stabilized (National)
 IC5, IC6—AD590 temperature sensor (Analog Devices)
 IC7—723 linear voltage-regulator (Intersil)
 IC8—324 quad op-amp (National)
 IC9-IC11—741 op-amp (National)
 IC12—555 timer (National)
 IC13—7107 evaluation kit (Intersil)
 Q1—RS276-2017 NPN transistor (Radio Shack), or equivalent
 D1-D8—1N4001
 D9—1N1202
 D10—1N4004
 LED1—jumbo red LED
 J1-J4—banana jacks
 RY1—DPDT relay, 12 VDC, 160 ohm coil, Radio Shack 275-218 or equivalent (see text)
 S1—DPDT switch
 S2—SPST switch
 S3—SPDT switch (part of R13)
 S4—DPDT switch

Miscellaneous: Perforated construction board, enclosures (see text), copper piping (see text), wire solder etc.

same manner. Adjust R13 until the IC9's output measures 1.65 volts (1.8 - .15). When that is done, simply adjust R34 until 2 volts is measured at pin 2 of IC12.

Final assembly and installation

With the exception of the readout's power supply, the unit was housed in a 12 × 12 × 4-inch recessed light-fixture box lined with asbestos. The readout's power supply was housed in a separate 5 × 7 × 3-inch metal case. Both units were mounted on the boiler using $\frac{3}{8}$ -inch standoffs. All external wiring, other than the sensor wires, must be enclosed in BX or conduit.

The outside air-temperature sensor was enclosed in a 3 × 2 × 1-inch case, such as the one shown in Fig. 4. A $\frac{1}{32}$ -inch hole was drilled in the bottom so that air could reach the sensor. A small hole was also drilled in the top for the cable. The sensor's cable should fit snugly through the hole, and any spaces sealed against leaks. Connections inside the case, of course, were soldered and insulated. The unit was fastened under a windowsill on the north side of the house.

Placement of the water-temperature sensor was not that simple. It would have been ideal if the sensor could have been placed in the same well as the aquastat, or if the temperature could be measured at the boiler's case. However, neither approach was feasible: the first due to insufficient space and the second due to temperature lag.

Figure 5 shows an acceptable solution. *continued on page 83*

HOBBY CORNER

It's easier to keep up than catch up

EARL "DOC" SAVAGE, K4SDS, HOBBY EDITOR

HOW THINGS DO CHANGE. WHY, I RECALL visiting Bell Laboratories in New Jersey in what seems just a few years ago. There, I saw for the first time, a "real live" transistor. A while later, I actually got my hands on one and, following instructions very carefully, built a simple audio amplifier. What a marvel it was—amplification without a glowing tube heater to be seen. It was a year or more before I had any idea how the little thing worked.

Now, of course, it is the tubes that are rare and the transistors that are common—in fact, you might say that transistors have come and started to fade away, largely replaced by integrated circuits.

Yes, there have been a multitude of changes in a short period of time—enough to boggle the mind. And who knows what we will have and what we will be doing a few years from now.

Those of us with snow on the roof will have to continue our struggle just to keep up. If you are just getting into electronics, you have an advantage on us oldsters! You are starting out where technology is *NOW!*. You don't have to "unlearn" the old before you can understand the new.

Make no mistake, however. Technology of NOW will be outdated soon. It will advance to something we do not know about yet. In a short time you, too, will be having to relearn and we'll both be doing it together. The process can get ahead of you if you are not very careful.

Now and then I receive a letter from a reader who says, in effect, "Where did all the tubes go? To me, transistors are foreign and IC's are alien. What is the best way to

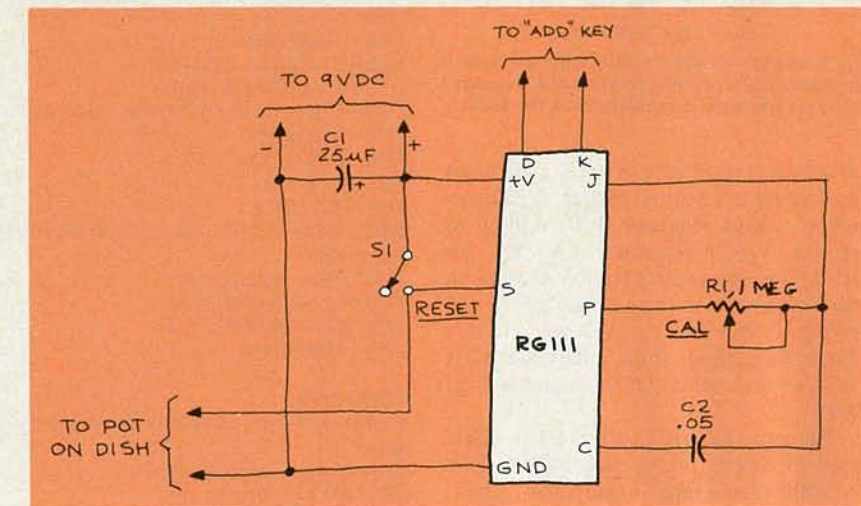

FIG. 1

get caught up?" I am hard pressed to come up with any advice better than to forget all that you "know" and start back at the very beginning.

The same thing will happen to you unless you keep up with the changes as they occur. The only way to do that is to keep reading, studying, building, and experimenting. Don't let things get so far ahead of you that you have to start over all at once.

Good idea

Daniel Fitzpatrick of Ashville, NC has come up with a good idea for the use of the RC-111 module—the module we discussed here in the March 1982 issue. He works

with satellite-TV systems and plans to use the RC-111 to give a remote reading to the area of the sky at which a dish is pointing. According to Daniel, very basic commercial remote-reading accessories cost \$150 and up.

The simple dish tracker consists of two parts. The first is mounted on the dish and is nothing more than a pot that is turned by the rotating arm that aims the dish. A small drive belt is used to turn the shaft of the pot. To avoid the effects of weather, the pot and belt system are housed in a waterproof case.

The readout portion of the tracker is located inside the house. It consists of a calculator and an RC-111. The module circuit is shown in Fig. 1. The pot labeled R1 is a 1-megohm CALIBRATION control. (You may wish to refer back to the March 1982 issue to see exactly what is taking place here.)

Daniel reports that calibration (R1) is adjusted by rotating the dish between satellites. Knowing the location of each satellite permits you to adjust R1 by trial and error until the calculator reads out directly in degrees.

Thanks for letting us know about this application, Daniel.

Five-year survey

Five years ago, the "Hobby Corner" first appeared in *Radio-Electronics*; that initial column was in the August, 1977 issue. Since then, we have covered a lot of territory together, but even more striking is the quantity and quality of the changes that have

- 1) NAME _____
- 2) MAIL ADDRESS _____
 _____ ZIP _____
- 3) OCCUPATION _____
- 4) HOW LONG HAVE YOU BEEN AN ELECTRONICS HOBBYISTS? _____ (YEARS)
- 5) HOW LONG HAVE YOU BEEN READING "HOBBY CORNER"? _____ (YEARS)
- 6) WHAT ARE YOUR SPECIAL INTERESTS?
 _____ GENERAL _____ TUBES (?)
 _____ DIGITAL _____ TRANSISTORS
 _____ ANALOG _____ INTEGRATED CIRCUITS
 _____ OTHER: _____
- 7) WHAT ARE YOUR ELECTRONIC-RELATED HOBBIES?
 _____ SWL RADIO _____ COMPUTER
 _____ CB RADIO _____ AUDIO
 _____ HAM RADIO _____ SATELLITE TV
 _____ OTHER: _____
- 8) WHAT AREA(S) OF ELECTRONICS WOULD YOU LIKE TO KNOW MORE ABOUT? _____

7+11 SWD PARTS KITS

MITSUMI VARACTOR UHF TUNER Model UES-A56F **\$34.95**

Freq. Range UHF470 - 889MHz
Antenna Input 75 ohms
Channels 14-83 Output Channel 3

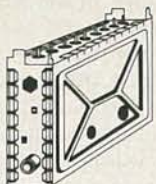

KIT NO	PART NO	DESCRIPTION	PRICE
1	VT1-SW	Varactor UHF Tuner, Model UES-A56F	\$34.95
2	CB1-SW	Printed Circuit Board, Pre-Drilled	18.95
3	TP7-SW	P.C.B. Potentiometers, 1-20K, 1-1K, and 5-10K ohms, 7-pieces	5.95
4	FR35-SW	Resistor Kit, 1/4 Watt, 5% Carbon Film, 32-pieces	4.95
5	PT1-SW	Power Transformer, PRI-117VAC, SEC-24VAC, 250ma	6.95
6	PP2-SW	Panel Mount Potentiometers and Knobs, 1-1KBT and 1-5KAT w/Switch	5.95
7	SS14-SW	IC's 7-pcs, Diodes 4-pcs, Regulators 2-pcs Heat Sink 1-piece	29.95
8	CE9-SW	Electrolytic Capacitor Kit, 9-pieces	5.95
9	CC33-SW	Ceramic Disk Capacitor Kit, 50 W.V., 33-pieces	7.95
10	CT-SW	Variable Ceramic Trimmer Capacitor Kit, 5-65pfd, 6-pieces	5.95
11	L4-SW	Coil Kit, 18mhs 2-pieces, 22µhs 1-piece (prewound inductors) and 1 T37-12 Ferrite Toroid Core with 3 ft. of #26 wire	5.00
12	ICS-SW	I.C. Sockets, Tin inlay, 8-pin 5-pieces and 14-pin 2-pieces	1.95
13	SR-SW	Speaker, 4x6" Oval and Prepunched Wood Enclosure	14.95
14	MISC-SW	Misc. Parts Kit Includes Hardware, (6/32, 8/32 Nuts, & Bolts), Hookup Wire, Ant. Terms, DPDT Ant. Switch, Fuse, Fuseholder, etc.	9.95
When Ordering All Items, (1 thru 14), Total Price			139.95

UHF ANTENNAS and ACCESSORIES

MDS-AMATEUR-ETV 32 ELEMENT YAGI ANTENNA

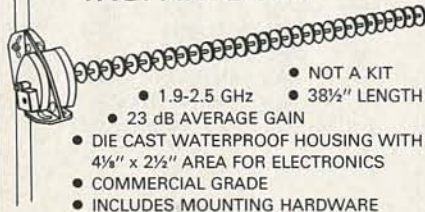

- 1.9-2.5 GHz
- 23 dB AVERAGE GAIN
- DIE CAST WATERPROOF HOUSING WITH 4 1/4" x 2 1/2" AREA FOR ELECTRONICS
- COMMERCIAL GRADE
- INCLUDES MOUNTING HARDWARE
- NOT A KIT
- 38 1/2" LENGTH

MAE-1 32 Element YAGI Antenna \$19.95

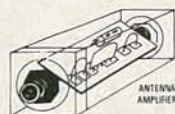

ZYZZX VHF-UHF WIDEBAND ANTENNA AMPLIFIER

MODEL ALL-1
50 MHz — 900 MHz
12 dB GAIN ± 0.5dB

A Revolutionary New One Stage HYBRID IC Broadband Amplifier

This unit is not available anywhere else in the world. One unit serves many purposes and is available in Kit or Assembled form. Ideal for outdoor or indoor use. I/O impedance is 75 ohms. Amplifier includes separate co-ax feed power supply. Easily assembled in 25 minutes. No coils, capacitors etc. to tune or adjust.

ALL-1 Complete Kit with power supply \$24.95
ALL-1 Wired and Tested with power supply \$34.95

Our New STVA 14.5 dB GAIN, 14 ELEMENT CORNER REFLECTOR YAGI ANTENNA



STVA-3 Yagi Antenna,
14.5 dB, 75 ohm, Chan. 60-68 \$16.95

STVA-4 Yagi Antenna,
14.5 dB, 75 ohm, Chan. 44-52 \$16.95

STVA-1 Yagi Antenna, 11.5 dB, 75 ohm, Chan. 42-54 \$9.95

RG-59/U 75 ohm Low Loss Coax Cable \$.12 p/ft
F-59 Coaxial Connectors, ea.39
MT-1 Special UHF 75-300 ohm Matching Transformer, ea. 1.45

Switch to Bambi!™

Electronically

Bambi Electronic Video Switch ... makes switching of your VCR/VTR, Pay TV Decoders, Cable TV, Video Discs, Video Games, Closed Circuit TV, Antennae and Microcomputer as easy as pushing buttons.

The Bambi Electronic Video Switch is an electronic switching network which can accept up to six different sources of video signals and provide the flexibility of directing the inputs to any or all of the three outputs.

Now you can eliminate ... the drudgery of disconnecting and reconnecting your video equipment each time you use it ... the tangled mess of cables which are impossible to trace out ... not being able to use more than one function at a time.

Bambi lets you enjoy using your video equipment the way it should be ... electronically and on line at the push of a button.

Model
BEVS-1 Wired

\$129.95



Bambi's front panel was designed with the user in mind. Computer styled construction, with soft-touch keyboard (rated for over 10 million operations), arranged in matrix form allows easy input/output selection without referring to charts. Functions selected through the keyboard are immediately displayed on the 18 LED status indicators.



Check the quality of Bambi against that of much higher priced competition. All solid state electronic switching provides low attenuation (3dB), wide frequency response (40-890 MHz), and excellent isolation between signal sources (each I/O section individually shielded for 65dB min. isolation).

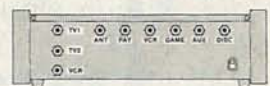

Bambi's Specifications:

- Input/Output Impedance 75 ohm
- Signal Loss 3dB ±1dB
- Noise 4dB ±1dB
- Input Return Loss 12dB min.
- Isolation 65dB min.
- Power Req. 117VAC 60 Hz, 2W
- Dimensions 10 1/4" W x 6 1/4" D x 3 1/4" H
- Weight 4 1/2 lbs

SWD-1 VIDEO CONVERTER



FOR CABLE TV

The SWD-1 Video Converter is utilized on cable TV systems to remove the KHz's signal from a distorted video (channel 3 in/out) and also pass thru the normal undistorted/detected audio signal. Rocker switch selects operating mode to remove KHz's distortion from the video or pass all other channels normally. Simple to assemble—less than 30 minutes. Pre-tuned. Input/output Channel 3. Impedance 75 ohms. 117VAC.

SWD-1 Video Converter Kit \$69.95

VTR ACCESSORIES

SIMPLE SIMON VIDEO STABILIZER



Simple Simon Video Stabilizer, Model VS-125, eliminates the vertical roll and jitter from "copy guard" video tapes when playing through large screen projectors or on another VTR. Simple to use, just adjust the lock control for a stable picture. Once the control is set, the tape will play all the way through without further adjustments. Includes 12V power supply.

VS-125 Video Stabilizer, wired \$54.95

SIMPLE SIMON VIDEO SWITCHING BOX



The Affordable Video Control Center

Excellent in isolation and no loss routing system. Simple Simons VSB-300 Video Switching Box enables you to bring a variety of video components together for easy viewing/dubbing. Also you gain the ability to record one channel while viewing another. Unit includes two F-type quick connector ended cables.

VSB-300 Video Switching Box, wired \$19.95

7+11 PWD PARTS KITS

INTRODUCING OUR 7+11 PWD PARTS KITS



KIT NO	PART NO	DESCRIPTION	PRICE
1	1VT1-PWD	Varactor UHF Tuner, Model UES-A56F	\$34.95
2	2CB1-PWD	Printed Circuit Board, Pre-drilled	18.95
3	3TP11-PWD	PCB Potentiometers 4-20K, 1-5K, 2-10K, 2-5K, 1-1K, and 1-50k. (11 pieces)	8.95
4	4FR-31-PWD	Resistor Kit, 1/4W, 5% 29-pcs, 1/2 W 2-pcs	4.95
5	5PT1-PWD	Power Transformer, PRI-117VAC, SEC-24VAC at 500ma.	9.95
6	6PP2-PWD	Panel Mount Potentiometers and Knobs, 1-1KBT and 1-5KAT with switch	5.95
7	7SS17-PWD	IC's 7-pcs, Diodes 4-pcs, Regulators 2-pcs Transistors 2-pcs, Heat Sinks 2-pcs	29.95
8	8CE14-PWD	Electrolytic Capacitor Kit, 14-pieces	6.95
9	9CC20-PWD	Ceramic Disk Capacitor Kit, 50 WV, 20-pcs	7.95
10	10CTS-PWD	Variable Ceramic Trimmer Capacitor, 5-65pfd, 5-pieces	4.95
11	11L5-PWD	Coil Kit, 18mhs 3-pcs, 22µhs 1-piece (prewound inductors) and 2 T37-12 Ferrite Toroid cores with 6 ft. #26 wire	6.00
12	12ICS-PWD	I.C. Sockets, Tin inlay, 8 pin 4-pcs, 14 pin 1-pc and 16 pin 2-pcs	2.95
13	13SR-PWD	Enclosure with PM Speaker and Pre-drilled Backpanel for mounting PCB and Ant. Terms	14.95
14	14MISC-PWD	Misc. Parts Kit, Includes Hardware, (6/32, 8/32 Nuts & Bolts), Hookup Wire, Solder, Ant. Terms DPDT Ant. Switch, Fuse, Fuseholder, etc.	9.95
15	15MC16-PWD	Mylar Capacitors, 14-pcs and Silver Mica Capacitors 2-pieces	7.95
When Ordering All Items, (1-15), Total Price			159.95

SIMPLE SIMON ELECTRONIC KITS,™ Inc.

3871 S. Valley View, Suite 12, Dept. R, Las Vegas, NV 89103

In Nevada Call: **702-871-2892**
1-800-782-3716

Outside Nevada Call:

Available by Mail Order Only
Send Check™ or Money Order. Minimum Order: \$16.95. Add 10% Shipping and Handling on orders under \$40.00. For orders over \$40.00, add 5%. Minimum Shipping and Handling \$2.00. Cat. \$1.00 — VISA and Mastercard Acceptable — *Check orders will be held 30 days before shipping.

taken place in our hobby in that short time. We have available to us many things that were only on the drawing boards then, and some that we didn't foresee!

Very complex integrated circuits at low prices are just a phone call or a quick trip to the parts store away. There are microprocessors, one-chip 64K random access memories, complex sound generators, and a host of others. "Computer boards" are controlling more and more of the conveniences and necessities of life.

Home reception of TV direct from satellites is a practical reality. "Microwave" ovens are common appliances in kitchens around the country. The ownership of videotape recorders has grown to the point

that video stores have sprung up everywhere just to sell and rent taped programs. Videodisc players are making a big splash in the market and I won't be surprised to discover that recorders will follow quickly.

There is no way that all the "wonders" could be listed, but there's one that cannot be omitted. That, of course, is the microcomputer, itself. The hundreds of thousands of microcomputers in homes, offices, and schools today have already had a great impact on our lives. The significant changes it has caused in education, business, and home entertainment are only the beginning of a revolution that will effect all of us.

This five-year point is a good place to

pause to see where we are and where we want to go. After all, "Hobby Corner" is *your* column and you should have a say in its content. Of course, I have a bit of an idea from the letters which you send me, but there are those of you who do not write.

This time, I would like to hear from ALL of you. To make it as easy as possible, I have made up a short survey. The questions have been pared down to a minimum and it should not take long to answer them. Of course, you may add any additional information that you would like—just attach a sheet to your survey form.

You may use the form printed here or, if you don't want to tear up the magazine, you can make a copy on the nearest copying machine. If that is inconvenient, just put the question numbers and your answers on a postcard. Send your answers any old way so that they can be added to the answers of other readers.

To sweeten the pot a bit, I'll have an independent party draw one survey from those received. If yours is selected, you will receive a small box of electronic "goodies" for your trouble.

Your real reward, however, will be to see "Hobby Corner" emphasize more of the things you like and want to know more about. Don't let the other readers decide that without your vote. Send me your survey now, before you forget. Address your response to

**Hobby Corner
Radio-Electronics**
200 Park Avenue South
New York, NY 10003

I'll be looking for your answers.

Mailbag

Stuart Engelke (Hackensack, NJ) would like a circuit for a 4-digit one hour "clock" that automatically resets when the time reaches 59 minutes and 59 seconds.

Vic Richter of Corpus Christi, TX is trying to find out how to address a 1024 x 8 memory IC using thumbwheel switches or a keyboard. **R-E**



"I agree, Harold, the reception up here would be great, but where would the children go to school?"

Book three is free.

Buy any two books in the Texas Instruments Understanding Series™ and get a third book... **Free.**

Important books. Important subjects. Learn quickly and easily how electronic technology is impacting today's automotive and energy control systems.

For a complete list of current book titles, send for a Learning Center Library catalog. It's free, too.

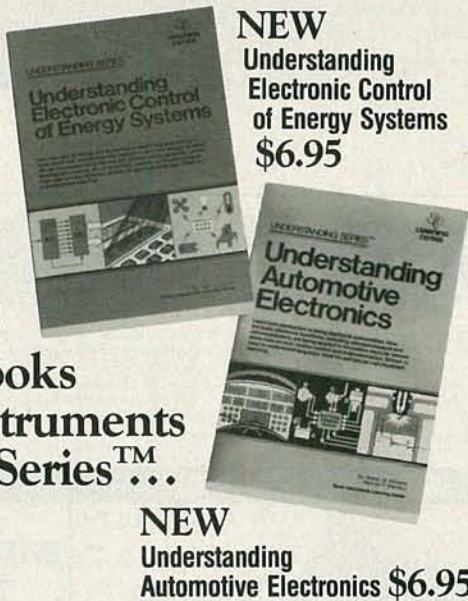

Send orders to:

Texas Instruments
P.O. Box 3640, M/S 84
Dallas, Texas 75285

All books \$6.95.
Check your choices below.



- | | |
|---|---|
| <input type="checkbox"/> Learning Center Library Catalog - CM10K (Free) | <input type="checkbox"/> Understanding Microprocessors-LCB4023 |
| <input type="checkbox"/> Understanding Electronic Control of Energy Systems - LCB6642 | <input type="checkbox"/> Understanding Calculator Math-LCB3321 |
| <input type="checkbox"/> Understanding Automotive Electronics - LCB5771 | <input type="checkbox"/> Understanding Communications Systems-LCB4521 |
| <input type="checkbox"/> Understanding Solid-State Electronics-LCB3361 | <input type="checkbox"/> Understanding Computer Science-LCB4571 |
| <input type="checkbox"/> Understanding Digital Electronics-LCB3311 | <input type="checkbox"/> Understanding Optronics-LCB4572 |

Enclose check or money order with sales tax (except AK, DE, NH, OR). Foreign orders must be in U.S. dollars and include shipping charges. No phone orders, please.

Name _____

Address _____

City _____ State _____ Zip _____

NOTE: Offer expires 11/1/82

Prices subject to change without notice
© 1982 Texas Instruments

TEXAS INSTRUMENTS
INCORPORATED

RE882
360116RE

Electronics Paperback Books

Quality Paperbacks at Affordable Prices

CHECK OFF THE BOOKS YOU WANT

CB Projects \$5.00. A variety of add-ons you'll want to build for your CB station.

Model Railroad Projects \$5.00. Controllers, signals and sound-effect generators make your system more realistic.

PROJECTS FOR CARS & BOATS \$5.00. Fifteen different circuits for 12-volt negative ground automotive and boat applications.

ELECTRONIC TIMER PROJECTS \$5.00. Many possible applications are covered. Simple and complex circuits are included.

AUDIO PROJECTS \$5.00. Preamps, mixers, power amps, tone control projects are just some of this book's contents.

50 Simple L.E.D. Circuits Book 2 \$3.75. More ways to use LED's in electronic circuits.

50 SIMPLE LED CIRCUITS \$3.50. 50 interesting and useful circuits and applications. A valuable reference book.

DIGITAL IC PROJECTS \$5.00. Simple & advanced projects that help the reader understand how digital circuits will ever need.

POWER SUPPLY PROJECTS \$4.95. One of our most popular books. Presents details of power supply you will ever need.

TEST EQUIPMENT CONSTRUCTION \$4.50. FET voltmeter, resistance bridge, field-strength meter and many more practical instruments for the hobbyist.

52 PROJECTS USING IC741 \$3.75. A common IC. Inexpensive and versatile. Here are 52 ways you can put it to work.

POPULAR ELECTRONIC PROJECTS \$4.00. Radio, audio, household and test-equipment projects that work.

POPULAR ELECTRONIC PROJECTS—Book 1 \$5.00. More circuits that build on those in the preceding volume.

POPULAR ELECTRONIC PROJECTS—Book 2 \$5.50. Latest in this 3-volume set. More projects for the hobbyist.

MUSIC PROJECTS \$4.50. Fuzz box, wah-wah pedal, sustain, reverb, phaser, tremolo and more. 4 big sections.

REMOTE CONTROL PROJECTS \$3.50. Radio control, infra-red, visible light and ultra-sonic systems are all covered.

RADIO CONTROL FOR BEGINNERS \$4.50. Transmitters, receivers, actuators. How they work and how you can build them.

PRACTICAL COMPUTER EXPERIMENTS \$4.75. Build typical computer circuits using discrete logic elements and learn how they work.

VMOS Projects \$5.00. Audio circuits, sound generators, DC and signal-control circuits using this special device.

Electronic Projects Using Solar Cells \$5.00. First learn how solar cells work. Then try the projects in this book.

HOUSEHOLD PROJECTS \$4.50. Door buzzer, intercom, smoke detectors, baby alarm, low lamp alarm and much more.

ELECTRONIC GAMES \$4.50. All kinds of games, both simple and complex are described. Complete construction info.

COUNTER DRIVER & NUMERICAL DISPLAY PROJECTS \$4.50. All kinds of displays are described and circuits for using them.

SINGLE IC PROJECTS \$3.75. Every project in this book requires only one IC. Easy to build. Fun to use.

28 TESTED TRANSISTOR PROJECTS \$3.50. Build modules that can be combined into larger circuits to implement your own ideas.

50 PROJECTS USING IC CA3130 \$3.50. Audio, RF, test equipment, household and misc projects all built around this one op amp.

50 CIRCUITS USING DIODES \$3.50. Germanium, silicon & Zener diode circuits of many different kinds.

50 Circuits Using Germanium Zener Diodes \$3.50.

Beginners Guide to Building Electronic Projects \$3.75. Component identification, tools, soldering, construction methods, cases, etc.

ESSENTIAL THEORY FOR THE HOBBYIST \$3.50. Background knowledge tailored to meet the needs of the electronics hobbyist.

IC 555 PROJECTS \$3.75. All kinds of applications wrapped around 555, 556, 558 and 559 IC's. You're bound to find circuits you'll want to try.

RADIO CIRCUITS USING IC'S \$3.00. Using ICs in receivers for AM or FM signals, Stereo decoders and quadraphonic included.

PROJECTS FOR BEGINNERS \$3.75. Newcomers will find this book a great way to get started. There are even circuits to build without soldering.

SECOND BOOK OF CMOS IC PROJECTS \$3.75. Useful yet simple circuits for both the beginner and more advanced experimenter.

SYNTHESIZER PROJECTS \$3.50. Build one a section at a time and then put all the pieces together and play.

INTERNATIONAL TRANSISTOR EQUIVALENTS GUIDE \$7.50. Fine substitutes for more than 100 transistors made by more than 100 manufacturers.

50 FET Field Effect Transistor Projects \$4.50. RF amps, converters, test equip, receivers, audio, tuners, controls and more.

ELECTRONIC TECHNOLOGY TODAY INC.
P.O. Box 83, Massapequa Park, NY 11762

Number of books ordered

Total Price of Books \$ _____

Sales Tax (NY State Residents) \$ _____

Shipping (60c 1st 2 books, 25c ea additional) \$ _____

TOTAL ENCLOSED \$ _____

Name _____

Address _____

City _____ State _____ ZIP _____

Prices good until Sept. 30, 1982

COMMUNICATIONS CORNER

Deciphering antenna specifications

HERB FRIEDMAN, COMMUNICATIONS EDITOR

BACK IN THE FIRST DEPRESSION (1930-1939), I worked after school for an uncle who re-packaged vinegar. Actually, he didn't re-package by filling small bottles from a multi-gallon "jobber's drum"; rather, he sold small bottles on which he slapped a cover label over the original. The new label read "Super-Sour Vinegar." When I asked why he didn't just call the stuff vinegar—which it was—he replied that no one would pay the few pennies extra he charged if people believed they were buying ordinary vinegar. But the public would splurge—even in the depression—for a super something. Essentially, Uncle Joe was saying that few would buy his product if he told the truth.

About thirty years later, antenna manufacturers were to fall under the spell of Uncle Joe's philosophy, and technicians and experimenters would be hard-pressed to unravel the mysteries of consumer-service antennas: those intended for SWL, CB, TV, amateur, and VHF-UHF monitoring.

From the time Jonah invented maritime-mobile by transmitting his S.O.S. from the belly of a whale (spark-gap, of course), the dipole antenna has been the standard of reference. The dipole is a $\frac{1}{2}$ -wavelength center-fed antenna. The energy radiated by that antenna in the horizontal direction is assumed to be in the shape of a figure eight—maximum at right angles to the wire; minimum off the ends.

The amount of radiation at right angles to the center of the dipole antenna, at the same height as the antenna, was the forward-power reference to which all other antennas for the same frequency were compared. If you built an antenna, which when substituted for the dipole resulted in an increase of twice the forward-radiated RF energy, you had built an antenna with a 3-dB gain compared to a dipole. (There is nothing like rational standards: it allows everyone to know what everyone else is talking about.)

The problem was, in a field where variations of 2-3 dB are the *minimal* practical value, the boys who wrote the advertising copy started to deal in tenths of a decibel. One way that was accomplished was to change the standard of reference. Soon, instead of seeing antenna gain referenced to the dipole, it became fashionable in some ads to use an "isotropic source" as the reference radiator. An isotropic source is an imaginary, theoretical antenna, that radiates equally in all directions; its output in any direction is slightly less than that of a dipole. Therefore, if you compare the forward gain (output) of an antenna to an isotropic source instead of a dipole it is possible to claim an additional 2.1-dB gain because an isotropic source has 2.1-dB less forward output than a dipole.

With such terms as isotropic source and negative tilt; and specifications that included front-to-back ratios translated to antenna gain, the ads became so bad that finally one manufacturer—tongue in cheek, of course—used a wet noodle in space as the radiating reference. As you might expect, that claim caused no end of amateur-radio club discussions concerning the practicality of boiling the noodle in salt water for a better impedance match to a 72-ohm transmission line.

Notwithstanding the wet noodle or isotropic source radiator, gain and front-to-back ratios, using a dipole as the reference will tell you a lot about the way an antenna will perform for you.

First off, an antenna cannot create radiation. It can only take the energy put in by the transmitter and re-arrange the way that it is radiated. For example, we mentioned that the radiation pattern of a dipole in the horizontal direction is shaped like a figure eight: that means that there is equal energy going out towards the front and rear. If we place an element near the dipole (at a calculated dis-

tance), and if it is a specific ratio longer than the dipole, it will reflect some of the energy. That will increase the amount of energy radiated forward while reducing the energy radiated to the rear. Within reasonable limits, adding additional elements (called parasitic elements) behind and in front of the radiator squeezes even more energy forward—the energy being taken from the rear of the basic dipole-radiation pattern. It is often easy to achieve between a 10-dB to 13-dB forward gain in a moderately priced antenna; though lesser gain is common at the lower HF frequencies because the antenna size becomes an important consideration.

When the antenna sensitivity has been squeezed forward, we come up with the "front-to-back ratio". That figure rarely indicates true reception conditions unless the user interpolates the values. For example: Assume that we have a "super" antenna that has a 10-dB forward gain. Since an antenna has the same "gain" for receiving as for transmitting, our "super" antenna provides a 10-dB gain to received signals arriving into the front of the antenna. Next, assume that the "super" antenna has a 25-dB front-to-back ratio (a not uncommon value). That does not mean that undesired signals arriving into the rear of our "super" antenna will be attenuated 25-dB below what it would be if we were using a dipole antenna. It means that signals arriving at the rear of our "super" antenna will be attenuated 25 dB compared to signals arriving at the front of our "super" antenna. Since our "super" antenna has a 10-dB forward gain, we must subtract 10 dB from 25 dB, and the unwanted signal will be attenuated 15-dB more than if received by a dipole.

The height of the antenna above ground also affects how the signals are received and radiated. Depending on the height above the ground, the signals might radiate either horizontally—actually a slight rise—called low angle, or high angle, or almost straight up where the best reception of the radiated signal would be by a receiver mounted in an airplane flying over the antenna. (See the *ARRL Handbook* for a complete discussion of directional antennas.)

As for vertical antennas, such as those used for CB and VHF: again, the reference antenna should be the "theoretically perfect" vertical dipole (shown in Fig. 1-a), or its cousin, the *coaxial antenna*—which has the same gain/radiation characteristics. One

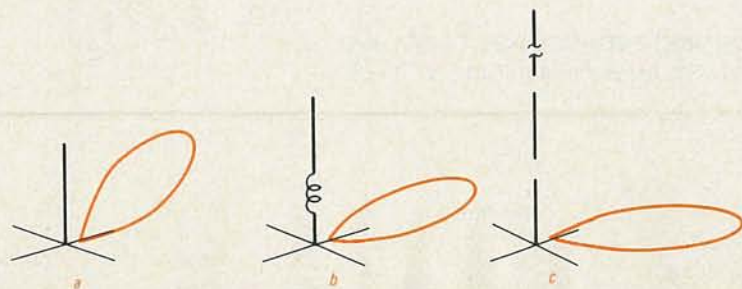

FIG 1

TRS-80™ by RADIO SHACK - BUY DIRECT-DISCOUNT PRICES

VIC-20
The friendly computer

PURE RADIO SHACK EQUIPMENT - FREE COPY OF WARRANTY UPON REQUEST

SCM SMITH-CORONA

TOLL FREE 1-800-841-0860

TRS-80 Model II. From *3098
 TRS-80 Model 16. From *4158
 TRS-80 Color Computer. From *309
 TRS-80 Model III. From *609
 Centronics 739-1. *499
Smith Corona TP-1 Daisy Wheel Printer... *695
VIC-20 Computer. *249



Thousands of Satisfied Customers Since 1978

TM - Tandy Corporation

WE CARRY THE FULL TRS-80 PRODUCT LINE
 WRITE FOR FREE CATALOG
MICRO MANAGEMENT SYSTEMS, INC.
 PARCEL DIVISION - DEPT NO. 15
 2803 Thomasville Road East
 Cairo, Georgia 31728
 GA. & INFO 912-377-7120

CIRCLE 18 ON FREE INFORMATION CARD

Radio-Electronics

mini-ADS

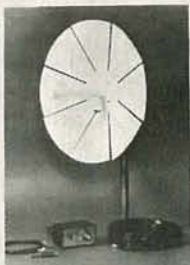

AMATEUR MICROWAVE RECEIVER SYSTEM (pictured) provides wide-band, high gain reception of amateur television transmissions from 2.1 GHz to 2.6 GHz. View on your television. Order MA1: **\$169.95**. **MICROWAVE TELEVISION EDUCATION MANUAL** includes detailed microwave downconverter, power-supply, and antenna plans: **\$16.25**. **SUBSCRIPTION TELEVISION EDUCATION MANUAL: \$14.95**. Add 5% shipping and handling. *Informative catalog: \$2.00*. **ABEX, P.O. Box 26601-RE, San Francisco, CA 94126-6601.**
 CIRCLE 37 ON FREE INFORMATION CARD

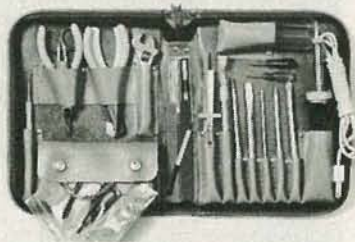

THE MEAN LITTLE KIT

New compact kit of electronic tools. Includes 7 screwdrivers, adjustable wrench, 2 pair pliers, wire stripper, knife, alignment tool, stainless rule, hex-key set, scissors, 2-flexible files, burnisher, soldering iron, solder aid, solder and desoldering braid. Highest quality padded zipper case. Send check or charge BankAmericard, Mastercharge, or American Express. The **JTK-6** sells for **\$90.00**—**Jensen Tools Inc., P.O. Box 22030, Tempe, Arizona 85282, (602) 968-6281.**
 CIRCLE 36 ON FREE INFORMATION CARD

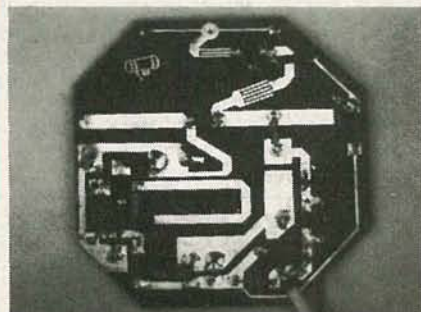

2300 MHz DOWNCONVERTER kit for Amateur microwave reception. \$35.00 postpaid. Highest quality components. Send SASE for information filled catalog of other converter kits, preamps, accessories and parts. VISA and MASTERCARD accepted.

SMP - Superior Microwave Products, Inc.
PO Box 1241 Vienna, VA 22180
 1-800-368-3028 1-703-255-2918

CIRCLE 32 ON FREE INFORMATION CARD



UNGAR'S NEW STATIC-FREE DESOLDERING PUMP, Pump 7874A features static free carbon tip preventing damage to micro-circuits. Easy-set plunger with built-in safety shield, press release switch, automatic tip cleaner and replaceable Tip #7876. Pump is 3/4" D. x 8 1/2" L., made of aluminum with durable anodized finish. Suggested Resale: **\$17.95 each**. Available through your Ungar Distributor or contact...**Ungar, Division of Eldon Industries, Inc., P.O. Box 6005, Compton, Ca. 90220 (213) 774-5950, (800) 421-1538.**
 CIRCLE 33 ON FREE INFORMATION CARD

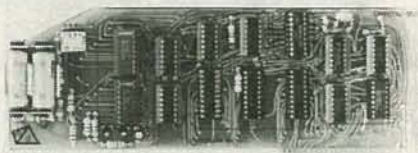

CHRONO-MODULE FOR APPLE II FEATURING: Y/M/D, H:M:S, day of week. SW. select int. H,M,S with software disable 1 K fast CMOS RAM, write disable SW. & battery backup makes RAM act like a fast eprom. 4 software selectable 256 byte pages. 3 drivers supplied to put time date on: video display, into a string, and time stamp disk files. **Price \$149.00. Microcomputer Division of US Module, Inc., 2801A Broadbent Parkway N.E., Albuquerque, New Mexico 87107, 1-800-545-6294**
 CIRCLE 34 ON FREE INFORMATION CARD



ANTI STATIC DESOLDERING TOOL. The new Anti-static desoldering tool, PA 1704, was designed with quality, versatility and performance in mind. The unit is entirely conductive, discharging static build-up once touched by a grounded operator. This desoldering pump will allow a grounding strap to be attached to the tool, thus alleviating the need to ground the operator or work surface. **Paladin Corporation, 31332 Via Colinas Suite 106, Westlake Village, CA 91362, 213-991-4970, TWX 910-494-2799**
 CIRCLE 35 ON FREE INFORMATION CARD

way to achieve omnidirectional radiation is to take a horizontal dipole and flip it 90°, running the transmission line away at right angles for ¼-wavelength to prevent induced RF currents in the line. Alternatively, the radiator dipole could be replaced with a coaxial radiator that allows the transmission line to be run inside a coax sleeve directly to the radiator.

For high forward gain we would simply use a vertical version of the directional beam antenna.

Most vertical antenna systems are designed for omnidirectional radiation with "gain." Gain is achieved by compressing some of the energy that is normally radiated skyward towards the ground. It is that "ex-

tra" energy at ground level that provides us with "gain." (At least it is gain at ground level.)

At the relatively lower frequencies, such as 27 MHz, where the antenna is somewhat large to begin with, we obtain the compression by using a radiator larger than 0.5 wavelength and a ground-plane, as shown in Fig. 1-b. The ground-plane can be a vehicle or elements arranged to form a ground-skirt. When using a ground-plane, the radiation pattern is formed by a "mirror image" from the ground; and it is even possible to tilt the signal towards true ground, providing a smidgen extra signal where it is most needed.

At the VHF/UHF frequencies where an-

tennas are relatively small, gain is attained by simply stacking several antennas one above the other, each fed through a matching section of transmission line. Alternately, several radiators using collinear feed (see Fig. 1-c) can be concealed within a plastic or fiberglass sleeve: those are the long-pole antennas that can often be seen sticking up over the tops of taxi and petroleum-dealer headquarters, just to name a few user examples.

Though there are many ways to achieve "antenna gain," the common thread between them must be comparison to the dipole if we are to have a reasonably accurate idea of how the antenna will function in actual practice. Any other reference is really make-believe. **R-E**

TO MAGAZINE RETAILERS:

Radio-Electronics Magazine is pleased to announce its "Retail Display Allowance Plan" available to retailers interested in earning a display allowance on **Radio-Electronics Magazine**. To obtain details and a copy of the formal contract, please write to the Marketing Department, Kable News Company, Inc., 777 Third Avenue, New York, New York 10017, our national distributor, who will act as administrator of our plan. Under our Retail Display Allowance Plan, in consideration for fulfilling conditions of the agreement, you will be entitled to receive a display allowance. This plan will become effective for all issues you receive subsequent to written acceptance on our behalf of your application.

COMPUTERS

Complete Microprocessors line, peripherals & Terminals.

Visicalc	200.00	SOROC IQ 135	795.00
Microsoft Z/80	320.00	TI-99/4A	340.00
IDS PRISM 80	call us	Epson MX-80	call us
IDS Prism 132	call us	Color Monitor	call us
Epson MX-100	call us	TI-810	1395.00
TI-745	1440.00	80 Column Board	245.00

Texas Instruments

Invest. Anal	\$ 42.00	TI-59	\$175.00
Accessories	Call us	TI-55 II	39.95
TI-58C	80.00	Speak & Spell	49.95
PC100C	155.00	TI Programmer LCD	54.95
TI BAII	39.00	MBA	49.95

HEWLETT-PACKARD

HP-37E	72.00	HP-11C NEW	call us
HP-33C	85.00	HP-12C NEW	call us
HP-34C	115.00	HP-41C Mem Module	26.00
HP-38C	114.99	HP-67	295.00
HP-41C Prog	180.00	HP-97	570.00
HP-41CV	234.00	Quad Ram	call us
HP-41C Printer	285.00	Application Pac	call us
HP-41C CRD RDR	169.00	HP/83	1670.00
HP/85	1990.00	HP/125 Computer	call us

SCM TYPEWRITER SPECIALS

SCM 2200	\$284.00	INTREPID	\$274.00
SCM 2500	294.00	CLASSIC 12	164.00

All units shipped in original cartons with accessories according to manufacturer's specification. Send money orders, personal check 2 weeks to clear. In Illinois add 6% sales tax. Add \$6.95 minimum shipping & handling charges per unit. We ship UPS. Subject to availability. Written warranty for specific products can be obtained free upon request. Above prices are for mail order and prepaid only. Prices and specifications subject to change without notice. Send mail orders..

Nabik's, Inc.

519 DAVIS EVANSTON, ILL. 60201 TEL 312-869-6144

How To Stand Out
In A Crowd
Of Imitators:

BE THE ORIGINAL

... and the ORIGINAL in tongue and groove pliers is CHANNELLOCK. We invented this style of plier. We improved it with patented undercut, can't slip adjustments. Improved it again with the patented stress resisting flange. Developed ten styles and sizes from 4 1/2" to 16".

All of which is why tongue-n-groovers by any other name can't match CHANNELLOCK, the original. Be sure THAT trade name is on the pliers you buy.

CHAN NEL LOCK

CHANNELLOCK, INC. • Meadville, Pennsylvania 16335
Meet The Rest Of The Family. Send For Our Free Catalog

CIRCLE 8 ON FREE INFORMATION CARD

regulate it. Off the bridge-rectifier output there is a 1.0 μ F, 160-volt electrolytic, C-808. Its "+" terminal is connected to +135-volts DC; the "-" terminal to 9-volts DC. If the capacitor develops any leakage it upsets things, and in some cases can self-destruct! Replace it with an exact duplicate—ECEA-160VIE or a similar part number. Watch the polarity when you install it!

Sylvania D-16: There may be color problems—ringing, etc. On a very high-frequency RF signal, the color may be better. There's a 48K, 2-watt resistor that feeds almost all of the B+ to the color stages. With age, that resistor changes in value, usually going lower (one dropped to 1.8K). The PC board may be scorched. Install a new resistor and recheck.

MULTIPLE IMAGES

After replacing the flyback in this Admiral 19P647C, I got a raster, but now I have three pictures overlapping on the screen! I checked the capacitors and resistors in the horizontal frequency-determining circuits, but without luck. Would you take a peak into the crystal ball?—E.A., Bronx, NY

Well, you're in the right area—the cause must be some part in the frequency-determining circuitry. It's sort of an oddball Colpitts oscillator, and the two capacitors across the coil, C421

and C422, are critical. Use exact duplicates for substitutes. Also, run the core all the way out of the horizontal-hold control (oscillator coil) and check to see whether a part of it has been broken off! That upsets the inductance and makes the oscillator run faster!

One more unlikely, but possible, cause. Check the polarity of the comparison pulse fed into the AFC: the new flyback may have it reversed! That can really mess things up!

LOW B+, SANYO 91C48N

Thanks for prompt reply to my question about low B+ on a Sanyo 91C48N. I found it: I had replaced Q901, the voltage regulator, and the replacement turned out to be the wrong type! (My parts supplier didn't have the original, and substituted another part for it.) After I got the proper part, the set worked fine!—N.G., Cardiff, NJ

When you replace a part, and find the same symptoms, readings, etc. that you got with the other, you should suspect that the replacement used wasn't right! It's a good idea to try a different one when that happens. R-E

BURNING RESISTOR

I get raster but no video in a Sharp 2K-39. Resistor R207, 470 ohms, in the plate feed to the last IF tube burns up. I tried a bigger resistor, but get no voltage on the

ELECTRONIC PROJECTS FOR MUSICIANS

Even if you don't know an ohm from a volt, Craig Anderson's newly revised and expanded book shows you how to build 27 accessories that enhance your sound and broaden your musical horizons.

If you're an old hand at musical electronics, you'll really appreciate that all of these processors, from Tube Sound Fuzz to Phase Shifter, are compatible and work together without creating noise, signal loss, bandwidth compression or any of the other problems common to interconnecting effects from different manufacturers. There's even a complete chapter on how to modify and combine effects to produce your own custom pedal board.

Low cost project kits available from PAIA help make even your first exposure to electronics a pleasant, hassle-free experience and thanks to the sound sheet demo record bound into the book you know just how the completed device will sound before you even start.

CHARGE TO VISA OR MC TOLL-FREE
1-800-654-8657 9AM TO 5PM CST MON-FRI

DIRECT INQUIRIES TO:

PAIA Electronics, Inc.

1020 W. Wilshire Blvd., Oklahoma City, OK 73116 - (405)843-9626

I RUSH MY COPY OF "ELECTRONIC PROJECTS FOR MUSICIANS", \$14.95 plus \$1 postage enclosed.

I SEND FREE CATALOG OF OTHER PAIA PRODUCTS.

name _____

address _____

city _____ state _____ zip _____

PAIA Electronics, Inc.

Dept. 8R, 1020 W. Wilshire Blvd., Oklahoma City, OK 73116.

CIRCLE 26 ON FREE INFORMATION CARD

MICROWAVE TV CONVERTERS

MODEL DCV-1-A

DOWN CONVERTER/ANTENNA COMBINATION

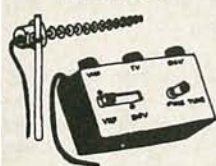

- 2 MICROWAVE PREAMP STAGES for maximum gain
- ONE PIECE CONSTRUCTION simplifies installation
- ALUMINUM AND ZINC PLATED STEEL for durability
- BUILT IN A/B SWITCH with more than 95dB isolation
- 2.1-2.6 GHz Covers all ham, commercial and ITFS channels

Years of enjoyment are yours with our model DCV-1-A. Two preamp stages coupled with the yagi antenna/housing provide a typical system gain of 53dB.

YOU GET: 75' downlead
3' jumper
300 ohm matching transformer
detailed instructions

ASSEMBLED & TESTED
LIST - \$175.00

ONLY
\$149.95

INTRODUCTORY PRICE

WE CARRY A COMPLETE LINE INCLUDING PARABOLICS

DEALER INQUIRIES INVITED

TRITON

MARKETING CORP.

VISA, MASTERCARD ACCEPTED

1933 ROCKAWAY PARKWAY
BROOKLYN, N.Y. 11236

212-531-9004

CIRCLE 20 ON FREE INFORMATION CARD

IBM PERSONAL COMPUTER?

Information-rich new magazine helps you pick the right system, then get the most out of it



Hundreds of colorful pages packed with news of add-on products, software programs, services, and how people are already using their IBM "PC's". Subscribe to *PC Guide*™ and save up to 25% off cover price. Six issues for only \$14.50 or 12 issues for \$27.*

Mail check with name, address and ZIP to:

PC Guide, 1528 Irving St.,
San Francisco, CA 94122.

Phone credit card numbers to 415/753/8092.

* Money-back guarantee: If not satisfied, return mailing label in ten days for full refund.

CIRCLE 17 ON FREE INFORMATION CARD

WE TAKE YOU BY THE HAND!

You'll learn all about computers: how to build, program, service, even play TV games—without knowing the first thing about it!

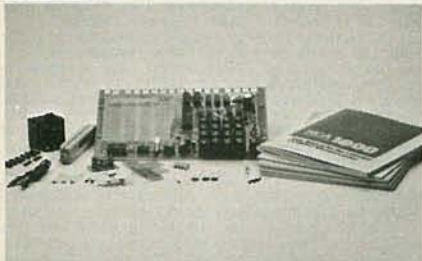

The New ELF II "Beginners" Package

Your own expandable micro-computer kit, 5 diagnostic analyzers plus circuit, programming, diagnostic manuals, even games you can play on TV. All only \$139.95.

Even if you don't know bits from bytes, now it's easy and inexpensive to build your own micro-computer, learn how it works, program it, service it—even play games with it on your TV! It's here in the New ELF II "Beginners" Package, only from Netronics. Only \$139.95. Here's the package: 1. your own micro-computer, the famous ELF II (featuring the RCA 1802 CMOS microprocessor) in kit form with step-by-step instructions on how to build it. Diagnostic Analyzers including 2. your own Logic Probe, 3. Pulse Catcher, 4. 8 bit Test Register, 5. Logic Analyzer, 6. Gate Arrays, 7. Non-Technical Manuals on how to use analyzers, how to get into the guts of the computer, what makes it tick, how to service it. 8. Sample Programs that teach you machine language programming plus how to correct or "debug" any programming mistakes. 9. TV games you can play. If your TV set has no video input, an optional converter (RF Modulator), is available. Then, once you've got this "Beginners" Package under your belt, keep on expanding your ELF II with additions like the Typewriter Key Board, added RAM, Full Basic Interpreter, Electric Mouth Talking Board, Color/Music, A/D-D/A Boards for Robot Controls and much, much more. We'll take you by the hand with the New ELF II "Beginners" Package. Only \$139.95. Mail or phone in your order today and begin.

Specifications: ELF II "Beginners" Package
The computer features an RCA CMOS 1802 8 bit microprocessor addressable to 64K bytes with DMA, interrupt, 18 Registers, ALU, 256 byte RAM expandable to 64K bytes. Professional-Hex keyboard, fully decoded so there's no need to waste memory with keyboard scanning circuits, built-in power regulator, 5 slot plug-in expansion BUS (less connectors), stable crystal clock for timing purposes and a double-sided, plated through PCB Board plus RCA 1861 video IC to display any segment of memory on a video monitor or TV screen along with the logic and support circuitry you need to learn every one of the RCA 1802's capabilities. The diagnostic analyzers aid in understanding and trouble shooting your ELF II, as well as other computer and microprocessor products.

Continental U.S.A. Credit Card Buyers Outside Connecticut

CALL TOLL FREE 800-243-7428

To Order From Connecticut or For Technical Assistance, Etc.,

Call (203) 354-9375

NETRONICS R&D LTD. (Dept. RE 32)
333 Litchfield Road, New Milford, CT 06776

Please send the items checked below:

- ELF II "Beginners" Kit \$139.95
 RF Modulator \$ 8.95

Plus \$3.00 for postage, handling and insurance
(\$6.00 Canada)

Connecticut Residents add sales tax

Total Enclosed \$

- Personal Check Cashier's Check/Money Order
 Visa Master Charge (Bank No. _____)

Acct. No. _____ Exp. Date _____

Signature _____

Print Name _____

Address _____

City _____

State _____ Zip _____

output end! I've changed the tube, and also the first-IF tube. I need ideas!—B.M., Coopers Mills, ME

It looks as if you've got some kind of a dead short in the plate or screen circuitry of the last IF. If it doesn't show up on an ohmmeter, something may be breaking down under load—the screen bypass-capacitor or some other part. Try this: Leave the resistor out of the circuit; then turn the set on and read the grid voltage on the last IF tube. If the interstage transformer is shorted, it would put a tremendous positive voltage on the grid of the 4JC6. Those tubes can carry very high currents—enough to burn the resistor.

The only other thing left to do would be to change T202, the IF output-transformer; something in the primary winding may be breaking down to ground. *Something* in here is breaking down... it's just a matter of finding it.

BREAKDOWN UNDER LOAD

I tried a new yoke and the capacitor you suggested on the Admiral T-1KB chassis that I was having problems with. I finally replaced the flyback, and that fixed it. The old one was breaking down under load, even though it checked OK.

Thanks to James Jiranek of Farmington, IA for that one.

DARK VERTICAL LINE

I wrote you about a dark vertical line on the right side of the screen of a GE 19YA and you suggested several possible causes. The problem turned out to be C702, a special capacitor (part no. EP 25X60). I hope this will help someone in the future.

It will. Thanks to L.P. of Lincoln, NE for this one.

FOCUS PROBLEMS

The size of the raster shrank on this Zenith 4B25C19. I found a bad voltage regulator on the +25-volts-DC source and replaced it. Now I've got a good picture and color, but the focus is poor. Any ideas?—C.B., Jamaica, NY

I've got a couple. If the focus voltage is OK, there are two things that could be causing your difficulty. Let's take the easy one first.

Take the socket off the CRT and examine the focus pin. If it's covered with a light-greenish powdery stuff, clean it very well and tighten the socket contacts. The oxidation may be keeping the voltage from even getting to the pin. To check your results, remove the CRT socket just far enough so you can get at the focus pin to measure the voltage on it. If it's there, and the focus is still poor, you've got a more serious problem—something's almost certainly wrong with the CRT. (It's probably gone "soft".)

In most cases, though, the cause turns out to be a bad socket-contact. Try the chassis on a test jig to make sure before you pull the picture tube.

DIGITAL MEASURING MACHINES

FROM



HAS LIMIT-SET

- Ideal for incoming QC testing.
- Easy to use by unskilled or non-technical personnel.
- Beeps whenever the voltage, current or resistance being measured is within the set limits, and simultaneously displays the precise reading.

MODEL 8010 shown above has 0.1% DC accuracy; five functions, 30 ranges continuity beeper; diode test; 7 Ohms ranges from 20Ω to 20MΩ with resolution down to 0.01Ω; 10 Ampere AC/DC ranges; low battery indicator; full overload protection; easy access battery and fuse compartment and comes complete with battery, spare fuse, test leads and one year parts and labor warranty.

AFFORDABLE

	1-9 Each	10 Up Each
MODEL 8010	\$199.95	\$170.00
MODEL 8025	\$169.95	\$145.00

MODEL 8025 has 0.25% DCV accuracy, limit-set on AC/DC V&A, 28 ranges, 5 functions.

NORTH AMERICAN



1126 Cornell Avenue, Cherry Hill, NJ 08002
Tel. (609) 488-1060

CIRCLE 21 ON FREE INFORMATION CARD

Vital protection for PC Boards



Be safe. Desolder PC components with Endeco irons. Get proper HEAT TO MELT and strong VACUUM ACTION TO LIFT solder and cool both PC board and component without damage.

These PC components replaced fast with Endeco desoldering or soldering tools.



Endeco professional features include safety light that denotes high, low and off on switch models, SS construction for long life, light weight and balance for easy use.

Contact your distributor for Endeco desoldering and soldering irons, kits and equipment—or write us today.

Enterprise Development Corp.

5127 East 65th Street
Indianapolis, IN 46220
Phone: (317) 251-1231

CIRCLE 27 ON FREE INFORMATION CARD

Audio Modules



MOSFET Power Amplifiers

*BUILT-IN HEATSINKS *ONLY 5 CONNECTIONS
REQUIRED * 5 YEAR WARRANTY

Choose ILP MOSFET power amps when you need the utmost in performance without spending big money. They provide the fastest possible slew rate, low distortion at high frequencies, + better thermal stability. MOSFET power amps work with complex loads without difficulty and without crossover distortion. Three models are available, with integral heatsink to mount on your own chassis (optional rack mount cabinet available). Connection is simple — via 5 pins. MOSFETs can be combined with other ILP modules to create almost any audio system, whatever your age or experience.

Ultra-II specifications: Slew rate 20V/us. Rise time 3 us. SN ratio 100 db. Frequency response (-3 db) 15 Hz - 100 kHz. THD (Typical at 1kHz) < 0.005%. IMD (50Hz/7kHz 4:1) < 0.006%.

MOS120 60W/4-8Ω (requires ± 45V) \$79.95
MOS200 120W/4-8Ω (requires ± 55V) \$129.95
MOS400 240W/4Ω (requires ± 55V) \$199.95

WRITE FOR FREE CATALOGUE LISTING:
*BIPOLAR POWER AMPLIFIERS *HI-FI PREAMPS
*MIXERS *POWER SUPPLY UNITS *CABINETS
*GUITAR PREAMP and more

GLADSTONE

Electronics 901 Fuhrmann Blvd., Buffalo, NY, 14203

CALL (716) 849-0735 to order. Have your VISA or MasterCard ready. For information call (416) 787-1448 or circle reader number. Dealer/OEM enquiries (416) 787-1488 in Canada. Gladstone Electronics, Toronto.

CIRCLE 28 ON FREE INFORMATION CARD

STARTUP PROBLEM SOLVED

Thanks for the helpful hint on the GE AB/AC chassis in the May 1982 **Radio-Electronics**. I solved an intermittent starting problem in one of those chassis by running jumpers between eyelets W41A-B and W42A-B, but there was still some doubt in my mind until I read the article. Now I feel better.

Thanks to C.H. in Alplaus, NY. I've had several other letters about the same problem and it has been fixed using the same method—just run short insulated jumpers between the points that you suspect. One case needed three different ones. Always look out for that when you run into intermittents in those sets.

ION BURN

We've got a ten-year-old, 19-inch, black-and-white Zenith in the shop. It's got a fuzzy dark spot in the center of the CRT, but you can see some picture behind it. The tube checks out a bit weak, but OK. Got any ideas?—D.S., Newton, IA

What you seem to be describing is an ion burn but, if the set is only 10 years old, it should have an aluminized screen and be immune to that problem. You say you can't see the spot with the set off, so it doesn't sound like the old ones—there the spot was visible all the time.

It looks like you've got me! The only thing I can suggest is trying another similar tube, using the set you've got as a kind of test jig, to see if there's any change. If there's anyone out there who's run into a similar situation, let me know.

MORE ON DYNACO PREAMP

I'd like to add a bit to your ideas on the Dynaco preamp problem presented by J.F. in the April 1981 **Radio-Electronics**. I've seen it quite often, and the cause turns out to be intermittent transistors. I'd recommend replacing Q1 and Q2.

That sounds like good advice. Thanks to E.S., Arrow Electronics of Corydon, IN.

MORE ON CRACKED 6LF6's

In the April 1982 issue of **Radio-Electronics** you replied to a technician who had a cracked 6LF6 tube in a Quasar. (That was a replacement—the original had also cracked.) I've run into similar things in some of those sets, and the damper tube is responsible for a lot of them. Always change the damper tube if the 6LF6 self-destructs in that manner.

Also, while the 6LX6 is a better tube than the 6LF6, don't use it in Quasar portables or the 0.6-amp fuse will blow. That fuse is not used in the console models, though.

Finally, the 6BL8 oscillator tube can cause the 6LF6 tube to fail, but won't crack the glass. Check pin 15 of the FA panel and make sure that you get at least -45-volts of drive. Some 6BL8's are "hotter" and will get up to -60 to -70 volts, but you need at least -45 volts.

Thanks very much to V.E. of Janesville, WI for those hints.

R-E

RECEIVE A GREAT TRANSMISSION FROM SAMS!

From its first printing in 1934 to today's newly revised 22nd edition, Sams highly popular **RADIO HANDBOOK** has remained the undisputed leader among textbooks in the field of short-wave radio communications.

This big, new 22nd edition explores the basic principles of radio communications, including signal propagation, equipment design and operation, and transistor and IC technology. You'll also find comprehensive comparisons of vacuum tubes and transistors, a complete discussion of amplifiers, power supplies, electronic test equipment, antenna designs, and construction techniques!

Order now and start taking the static out of your radio communication system today!



SAMS BOOKS™

Mail to: Howard W. Sams & Co., Inc., 4300 West 62nd St., P.O. Box 7092, Indianapolis, IN 46206

	Quantity	
RADIO HANDBOOK—		
22nd Edition No. 21874	\$39.95	\$34.95
	Amount of order	\$
	Add handling costs	\$ 2.00
	Add local sales tax where applicable	\$
	Total amount of order	\$

Full payment must accompany your order.
Payment enclosed: Check Money Order
 VISA MasterCard Interbank No. _____
Account No. _____ Expiration Date _____
Name (print) _____
Signature _____
Address _____
City _____ State _____ Zip _____

Call toll free 1-800-428-3696 for the name of your local Sams Book outlet or to order by phone. Offer good in U.S.A. only. Offer expires 12/31/82. Prices subject to change without notice. When phone ordering, give Sams Operator the code number in this box.

AD204

CIRCLE 11 ON FREE INFORMATION CARD

AUGUST 1982

79

FAST RELIEF

from
SOLID STATE HEADACHES

Model 216



SEMICONDUCTOR ANALYZER

Easy, automatic, "hands off" operation (Frees both hands for troubleshooting)

Simple to use — no set up — no data books

In, or out of circuit, GOOD-BAD analysis of NPN's, PNP's, FET's, diodes and SCR's

Instant, in or out-of-circuit leakage detection

Digital scanning circuit automatically determines lead configuration

Low-power CMOS design for extended battery life

Uses two standard 9V batteries (not included)

Weighs only 12 ounces — fits in your pocket

High impact thermoplastic case with snap-shut protective cover

PRICED UNDER \$150
THE MODEL 216 IS FAST,
RUGGED AND AFFORDABLE



THE HICKOK ELECTRICAL INSTRUMENT CO.
10514 Dupont Avenue • Cleveland, Ohio 44108
(216) 541-8060 • TWX: 810-421-8286

NEW PRODUCTS

For more details use the free information card inside the back cover.

SOUND AND MUSIC BOARDS, model PSGx2 and model PSGx4, are multiple programmable sound-generators for Heath/Zenith computers. They use the General Instruments AY3-8910 PSG IC that can produce a wide variety of complex sounds under software control. Each board comes with a speaker, and features a built-in audio monitor amplifier and crystal timebase.

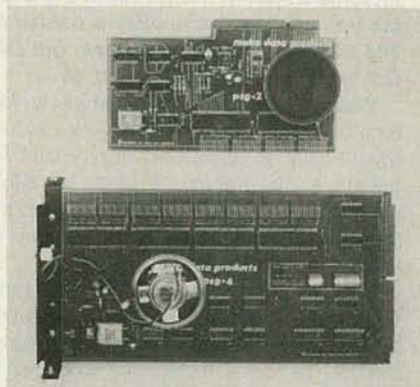

CIRCLE 141 ON FREE INFORMATION CARD

Multiple IC's give multiple complex sounds, and each IC has two 8-bit parallel I/O ports, which are brought out to connectors on the board. The boards create sound effects for games and enable you to play music from your keyboard. They are easy to program in any language that allows you to output data to a port. They come assembled, fully tested, and include demo software and documentation.

The model PSGx2 for the Z/H89 has two PSG IC's, plugs into P504 or P505 of the H89 bus and uses any decoded port address. It is priced at \$125.00, plus \$5 for shipping and handling.

The model PSGx4 contains four sound-generator IC's and plugs directly into the H8 bus. It is priced at \$225.00, plus \$5 for shipping and handling.—**Mako Data Products**, 1441-B N. Red Gum, Anaheim, CA 92806.

SURGE SUPPRESSOR, The Power Sentry-2, has been developed to "filter" electricity to insure against potentially disastrous voltage surges (transients). The Power Sentry-2 simply plugs into an electrical outlet, and your equipment plugs into the Power Sentry-2. Upon the occurrence of a transient spike 10% above line voltage, the Power Sentry-2 reacts in trillionths of a second to suppress the transient voltage to a safe, non-destructive level. It can suppress surges up to 6500 amperes for two milliseconds. It also reduces power-line noise with its built-in

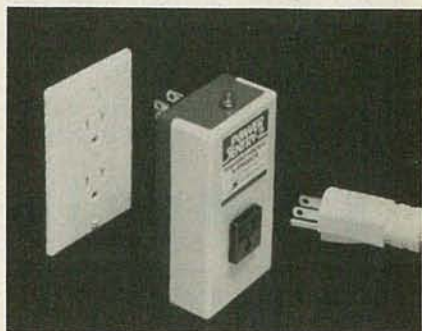

CIRCLE 142 ON FREE INFORMATION CARD

radio-frequency filter. (Line noise is usually caused by electrical equipment such as motors, fluorescent lighting, etc., and results in annoying static sounds on radios and TV's.)

The Power Sentry-2 is priced at \$49.95.—**Surgeonics, Ltd.**, 155 Kisco Avenue, Mount Kisco, NY 10549.

MULTITESTER, model M75, has seventeen ranges, chosen to place most measurement near midscale. For example: Midscale on the low ohm range, 12 ohms, facilitates testing motor windings, relays, and contactor coils. Accuracy specifications are DC $\pm 3\%$ full scale; AC $\pm 4\%$ full scale, and resistance $\pm 3\%$ full scale.

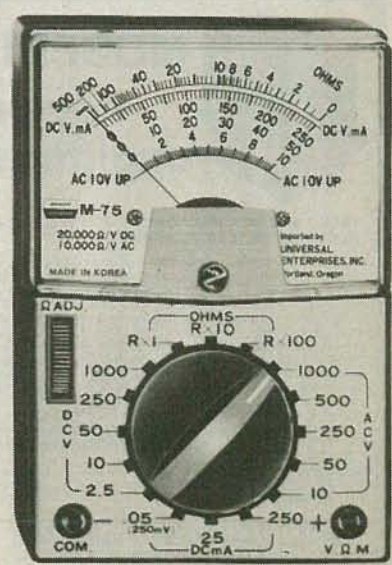

CIRCLE 143 ON FREE INFORMATION CARD

Features of the model M75 include a fuse-protected ohm circuit, easy-to-read three-color coded plate and front panel, diode-protected movement, sensitivity of 20,000

ohm/VDC and 10,000 ohm/VAC, and a one-year warranty.

The model M75 comes with carrying case, test leads, batteries, and instructions. It is priced at \$34.95.—**Universal Enterprises**, 14270 NW Science Park Drive, Suite 101, Portland, OR 97229.

MICROCOMPUTER ELECTRICAL FILTER, The Magnum Isolator, model ISO-17, incorporates heavy-duty spike/surge suppression and features four individually quad-Pi filtered AC sockets. Equipment interactions

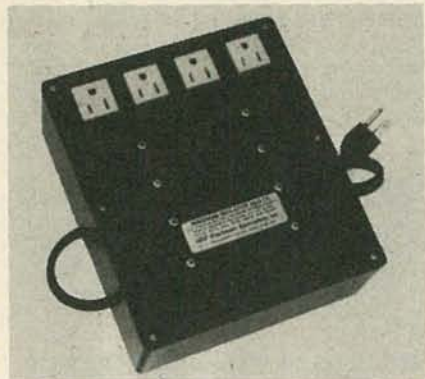

CIRCLE 144 ON FREE INFORMATION CARD

are thereby eliminated, and disruptive/damaging power-line "pollution" (transients, power-line noise, etc.) is controlled. The model ISO-17 is rated for an 1875-watt load, and each socket can handle a 1000-watt load.

The Magnum Isolator, model ISO-17 is

priced at \$181.95.—**ELECTRONIC SPECIALISTS, INC.**, 171 So. Main Street, PO Box 389, Natick, MA 01760.

CORDLESS SPEAKERPHONE, model EX-5000, enables the user to enjoy a hands-free conversation up to 700 feet from the base unit. It also provides two-way paging and clear, reliable intercom capability. A volume control permits the user to adjust



CIRCLE 145 ON FREE INFORMATION CARD

the audio to the most desirable level for individual comfort. Other features include a MUTE switch to put the other party on hold momentarily, automatic redial of the last number dialed, and automatic re-charging.

The model EX-5000 can be mounted on the wall or used on a desk or counter top. The suggested list price is \$299.95. Other models in the Extend-A-Phone line offer varying ranges and features, and their

The world of electronics gee-wizardry

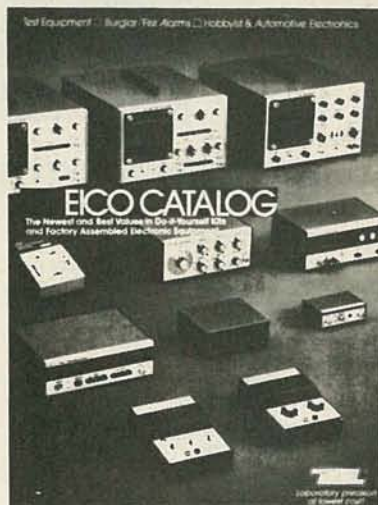

-YOURS FREE.

32-pages of test instruments—from the latest digital multimeters to the famous EICO scopes. Security systems. Automotive and hobbyist products. Kits and assembled. EICO quality. EICO value. For FREE catalog, check reader service card or send 50¢ for first class mail.

EICO® 108 New South Road
Hicksville, N.Y. 11801

CIRCLE 29 ON FREE INFORMATION CARD

DON'T FORGET



USE
YOUR
READER
SERVICE
CARD

An enclosure as good as your idea.

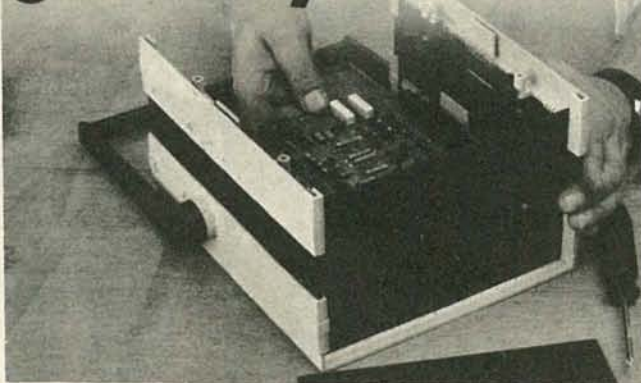

You've turned a good idea into a piece of equipment—now you need a good enclosure. Here's how PacTec can help you with our versatile enclosures:

- Attractive yet inexpensive.
- Durable ABS construction.
- Many sizes, colors, accessories.
- Built in bosses and slots speed component mounting.
- Available off-the-shelf from single unit to production quantities. See them at your PacTec Distributor. And ask him for your free catalog.



PACITEC™ Corp.
subsidiary of La France Corp.
Enterprise and Executive Avenues
Philadelphia, PA 19153 (215) 365-8400
CIRCLE 19 ON FREE INFORMATION CARD

Commodore VIC-20 Computer

\$209 sale price

(When you buy 6 tape programs)

You get this full sized extra featured computer with color, sound, music, 66 key expanded typewriter keyboard and extended level 11 basic for only \$209 (list price \$299) when you buy 6 tape programs! We stock more programs and accessories than anyone! IMMEDIATE REPLACEMENT WARRANTY! 2 to 7 days delivery! Order Now!

15 DAY FREE TRIAL

Protecto Enterprises
Box 550 • Barrington, IL 60010
Phone Orders (312) 382-5244

Write for Free Catalog

CIRCLE 30 ON FREE INFORMATION CARD

MICRO-PROFESSOR
MPF-1 USER'S AND EXPERIMENTAL MANUAL

Dear Electronic Enthusiast:
Now... Let the Micro-Professor™ usher you into the microcomputer revolution.
The Micro-Professor™ is the first really low cost learning system designed for personal use. It will truly become your Personal Computer.
Sincerely,
Chris Johnson
Chris Johnson, Customer Service

only \$149.95

Z-80 BASED

MICROCOMPUTER

A superb learning tool for students, instructors, hobbyists.

Nothing else needed. Just plug in and start learning! Complete experimenters manual, easy instructions. 18 experiments. Fully expandable for Z80-CTC, Z80-PIO, EPROM, Breadboarding and prototyping. Invest with confidence. Now only \$149.95, two for only \$279.95. 2KB BASIC interpreter now available, only \$19.00. Full money back guarantee!

plus-FREE GIFT

Check this box for FREE Z-80 Microprocessor Programming and Interfacing textbook when you order within 7 days. \$12.95 value.

ETRONIX
Dept. RE082
14803 N.E. 40th
Redmond, WA 98052

For immediate action call TOLL FREE:
1-800-426-1044

NAME _____
ADDRESS _____
CITY _____ ST _____ ZIP _____
 VISA MSTCRD EXP. _____
ACCT. NO. _____

CIRCLE 31 ON FREE INFORMATION CARD

price starts at \$99.95.—Uniden, Extend-A-Phone, 15161 Triton Lane, Huntington Beach, CA 92649.

POWER SUPPLY with dual auto-tracking outputs, the *model 1652*, provides two variable A and B 0-to-25-volt outputs at 0-to-1.5 amperes each. A general-purpose bench supply, the unit is designed for test and engineering applications involving both analog and MOS digital circuits.



CIRCLE 146 ON FREE INFORMATION CARD

Both outputs can be operated independently or in a tracking mode. In the tracking mode, the B output can be preset to any

percentage of the A supply voltage from 0 to 100%. When the A output is varied, the B output will track the variations. (For example: If the tracking percentage is preset to 50%, and the A supply is set to 20 volts, the B supply will operate at 10 volts. If the A supply is then changed to 15 volts, the B supply will change to 7.5 volts. Complete electrical isolation is always maintained.)

The *model 1652* is priced at \$465.00.—**B&K PRECISION**, Dynascan Corporation, 6460 West Cortland Avenue, Chicago, IL 60635.

EARTH STATION RECEIVER, *model ESR24*, is designed for satellite-TV reception, covers 3.7-4.2 GHz, and features digital channel display, preset and variable audio subcarrier selector, AFC for stability, and full

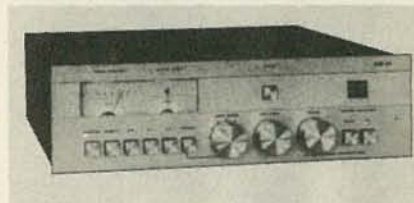

CIRCLE 147 ON FREE INFORMATION CARD

metering. For installation versatility, the downconverter module (supplied) may be mounted internally or at the antenna. Accessories for the *model ESR24* include a remote control, a remote tuning meter, and splash-proof housing.

The styling of this receiver makes it suitable for either commercial or private installations; the *model ESR24* is priced under \$1000.00.—**R.L. Drake Company**, 540 Richard Street, Miamisburg, OH 45342.

CIRCUIT-DESIGNERS' AIDS, the *Archer Circuit Symbols Template* (276-180—shown), and the *Archer PC Board Layout Template* (276-179) are tools for students and amateur or professional circuit designers and builders.

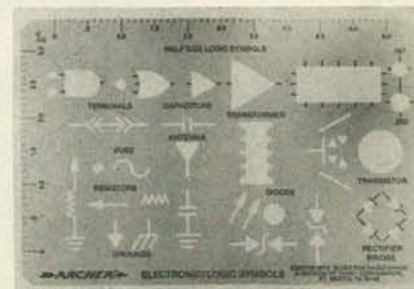

CIRCLE 148 ON FREE INFORMATION CARD

The *Circuit Symbols Template* offers a large selection of component and logic symbols, including symbols for fuses, antennas, transformers, transistors, rectifier bridges, terminals, capacitors, resistors, LED's, diodes, photodiodes, grounds, logic devices, and more. It also offers two ruled edges with 1/10th-inch graduations.

The see-through *PC Board Layout Template* has exact-size stencils for the most commonly used active and passive PC components, including integrated circuits and discrete devices.

The prices of these aids is \$3.95 each.—**Radio Shack**, 1800 One Tandy Center, Fort Worth, TX 76102. **R-E**

NEW 23 K PERSONAL COMPUTER

\$239

SPECIAL FACTORY SALE PRICE!!

You get this new APF IM-1 full size, extra featured Computer: Includes a powerful 6800 Motorola Microprocessor, 14,000 Bytes ROM with a simplified LEVEL 11 BASIC built in, 9,000 Bytes user RAM, Color, Sound, Full 53 professional keyboard. Two 10 key numeric pads, two controllers, high speed built in cassette that operates at 1200 baud, loads and reads 4 times faster than other computers. Has built in speaker with volume control, microphone jack, and 3-digit counter, high resolution graphics 256×192 (LIKE APPLE). Test display is 16 lines, 32 characters. It has 8 colors, will accept TAPE-DISK or PLUG IN CARTRIDGES. Includes owners manual and BASIC language book, 90 days parts and labor warranty, UL listed, FCC approved. All this in a beautiful black and white CONSOLE CASE. Weighs 20 pounds, list price \$599.95.

15 DAY FREE TRIAL Return within 15 days complete and undamaged for refund of purchase price.

DON'T MISS THIS FANTASTIC SALE!! Phone 312/382-5244 to order and get delivery in 7 days, or send a certified check, money order or personal check to **PROTECTO ENTERPRIZES, BOX 550, BARRINGTON, ILLINOIS 60010**. We honor Visa and Master Charge, Ship C.O.D. Add \$15.00 for shipping, handling and insurance. Illinois residents add 6% tax.

CIRCLE 74 ON FREE INFORMATION CARD

ENERGY MISER

continued from page 67

An offset connector was made by soldering together a 1/2-inch elbow, a short length of 1/2-inch pipe, and a 1/2-inch T-connector. Then a 1/2-inch copper end cap was drilled to accommodate a length of 3/8-inch (O.D.) copper pipe. The pipe was passed through the hole as shown, and soldered. Finally, a copper plug was soldered at the bottom of the 3/8-inch pipe. To place the sensor, the water supply to the boiler was shut off and the expansion tank drained. With the expansion tank drained and the boiler indicating zero pressure, the boiler was also drained to about one half of its capacity. The expansion tank's 1/2-inch copper feed-pipe was cut at about four inches above the boiler's outside metal enclosure. The 3/8-inch pipe was then inserted into the boiler through the bottom half of the expansion tank's pipe, and the top half of the expansion pipe was fitted

DRILL TO ACCEPT CABLE

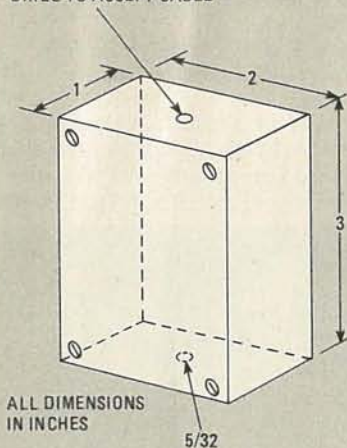

FIG. 4—THE AIR TEMPERATURE sensor is mounted in a box with these dimensions and mounted outdoors.

into the open end of the elbow. After soldering the top half of the expansion tank's pipe to the elbow, and the bottom half to the open end of the "T", the drain valves were closed and the boiler's water supply valve reopened. The boiler was then started and the radiators bled to release air pockets.

The water-temperature sensor was connected to the controller, using No. 22 gauge high-temperature insulated wire. Connections to the sensors were soldered and insulated. The sensor was inserted into the 3/8-inch pipe and the correct depth of insertion was determined by setting the aquastat's upper temperature limit at 150°F and moving the sensor up and down inside the pipe until the temperature readout agreed with the aquastat setting at the instant of boiler shut off.

For most installations, the aquastat circulator control should be set at 120°F; where you set the aquastat's high temperature limit depends on location and other factors. In our house, we found that a water tempera-

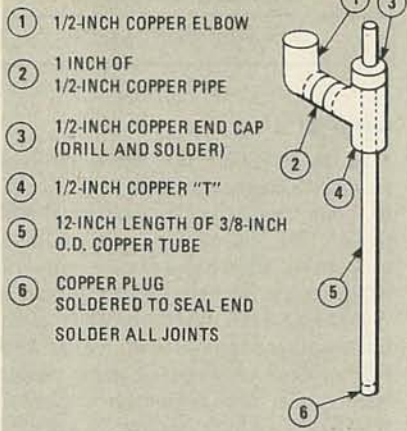

FIG. 5—USE THIS SETUP to place the water-temperature sensor. With it, temperature readings will be accurate, and normal boiler operation will be maintained.

ture of 150°F was sufficient for heating even in zero-degree weather. With that arrangement, the controller automatically controls the water temperature at outside temperatures of 20°F and higher. When the outside temperature drops below 20°F, the boiler maintains the water temperature at 150°F. That setup allowed for an 18-percent reduction in fuel use over the last year. In that time, there have been no problems or malfunctions with the system other than a defective toggle switch.

R-E

Put Professional Knowledge and a COLLEGE DEGREE in your Electronics Career through HOME STUDY



Earn Your DEGREE

No commuting to class. Study at your own pace, while continuing your present job. Learn from easy-to-understand lessons, with help from your home-study instructors whenever you need it.

In the Grantham electronics program, you first earn your A.S.E.T. degree, and then your B.S.E.T. These degrees are accredited by the Accrediting Commission of the National Home Study Council.

Our free bulletin gives full details of the home-study program, the degrees awarded, and the requirements for each degree. Write for Bulletin R-82.

Grantham College of Engineering
2500 So. LaCienega Blvd.
Los Angeles, California 90034

A 10 HOUR TAPE RECORDER NOW only \$95.00* LONG PLAY

Modified Panasonic Slimline high quality AC-DC Recorder provides 5 continuous hrs. of recording & play back of top quality sound on each side of cassette for a total of 10 hrs. Built-in features include:

- Voice level control
- Digital counter, etc.
- TDK DC-180 Cassette included.



PHONE RECORDING ADAPTER

Records calls automatically. All Solid state connects to your telephone jack and tape recorder. Starts recording when phone is lifted. Stops when you hang up. \$24.50* FCC APPROVED

VOX VOICE ACTIVATED CONTROL SWITCH

Solid state. Self contained. Adjustable sensitivity. Voices or other sounds automatically activate and control recorder. Uses either recorder or remote mike. \$24.95*

*Add for ship. & hdg. Phone Call Adapter & VOX \$1.50 ea.—Recorder \$4.00. Cal. Res. add tax. Mail order. VISA, M/C, cod's ok. Qty. disc. avail. Money back guar. Free data. Dir. inq. inv. AMC SALES, Dept. A, 9335 Lubec St., Box 928, Downey, CA (213) 90241 Phone 869-8519

CIRCLE 22 ON FREE INFORMATION CARD

Aaron-Gavin Kits



our most unique graphic equalizer!

LED meter



FEATURES

117 VOLT POWER SUPPLY

10 BAND LED METER

10 BAND LED METER

10 BAND LED METER

10 BAND LED METER

10 BAND LED METER

10 BAND LED METER

10 BAND LED METER

10 BAND LED METER

10 BAND LED METER

10 BAND LED METER

10 BAND LED METER

10 BAND LED METER

10 BAND LED METER

10 BAND LED METER

10 BAND LED METER

10 BAND LED METER

10 BAND LED METER

10 BAND LED METER

10 BAND LED METER

10 BAND LED METER

10 BAND LED METER

10 BAND LED METER

EQUALIZERS PRICED FROM \$119. to \$690. LED METERS PRICES \$48. to \$219.

A Unique MIXER for DJ's—Studio's—Broadcaster's

- Two MIC Inputs
- Two AUX channels
- 3 Turntable Inputs
- Talkover Switch
- Crossfade
- Auto Cue
- Beat Match
- Subsonic Filters
- Even Band Stereo EQUALIZER
- Headphones
- Metering
- Dual LED Meter

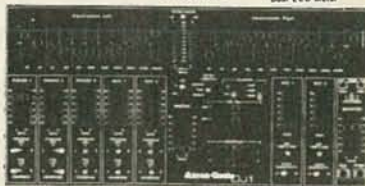

Call or write for full product information, and pricing to:
AARON-GAVIN
123 South McClay Street, Unit F,
Santa Ana, CA 92701. (714) 957-8710

BIG PERFORMANCE small PACKAGE

Model 240



Video Generator

- Video output for all VCR, CCTV and Monitor Applications † 1 volt into 75 Ω load
- RF output: CH 2, 3, 4
- Scope trigger output for V or H sync
- 10 step gray-scale staircase signal for video circuit analysis
- 10 bar and 3 bar gated rainbow pattern
- 8 other dot, bar and line patterns
- Operates from 2 std. 9V batteries or 115VAC
- Single slide switch control
- Complete with test leads, protective cover, AC adapter, comprehensive instruction manual

PRICED UNDER \$200.
THE 240 DOES SO MUCH
FOR SO LITTLE!!



THE HICKOK ELECTRICAL INSTRUMENT CO.
10514 Dupont Avenue • Cleveland, Ohio 44108
(216) 541-8060 • TWX: 810-421-8286

ANALOG CIRCUITS

continued from page 56

MOSFET's

In the MOSFET the gate is physically insulated from the rest of the device, usually by a thin layer of silicon dioxide. Here, as for the JFET, the amount of current flowing between the source and drain is influenced by the voltage between the gate and source.

The MOSFET's can be further divided into two groups—*enhancement MOSFET's*, which only operate in the enhancement mode, and *enhancement/depletion MOSFET's*, which operate in either the enhancement or depletion mode depending on the polarity of the gate voltage. Enhancement/depletion MOSFET's are often simply referred to as depletion MOSFET's. Let's start by examining the enhancement MOSFET. Its characteristics are shown in Fig. 6-b; the applicable V_{GS} voltages are in column A of that figure.

In the enhancement n-type device, shown in Fig. 7, two n-slabs are imbedded in a foundation or *substrate* made of highly resistive p-type material. Of the two n-type slabs, one is considered the source and the second the drain. In circuits, the substrate is usually connected to the source. As you can see, there is no channel between the source and the drain, but one can be induced elec-

trically if a positive voltage is applied to the gate with respect to the source. For current to flow, that voltage must exceed a certain *threshold* voltage, V_{GST} , defined as the gate-to-source voltage required for the device to conduct 10 μA of drain current, I_D . At voltages less than V_{GST} , the device is considered to be not operating, or in *cutoff*.

Enhancement/depletion n-type devices have basically the same structure as the enhancement-type MOSFET, but an n-type semiconductor joining the source and drain is added. The characteristics shown in Fig. 6-b still apply, but now the V_{GS} shown in column B should be used. Here the $V_{GS} = 0$ curve is at the center of the diagram. More

Common-source circuit

Just as was the case with the bipolar devices, FET's are commonly used in three different circuit arrangements. Although the circuits we'll discuss are for n-channel JFET's, the information supplied here applies as well to p-channel JFET's. In all instances, just change the polarity of the applied voltages and the directions of the resulting currents. MOSFET's can also be used in those arrangements. The substrate lead, if available, is connected to the source or to ground.

A typical common-source circuit using an n-channel JFET is shown in Fig. 8. The DC load line is established using the equation of the drain-source circuit:

$$E_{DD} = I_D \times R_D + V_{DS} + I_D \times R_S \quad (11)$$

$$= I_D (R_D + R_S) + V_{DS}$$

The concept used here is identical to what we did when we used equation 6 to establish the load line for a bipolar transistor in a common-collector circuit. The load line for

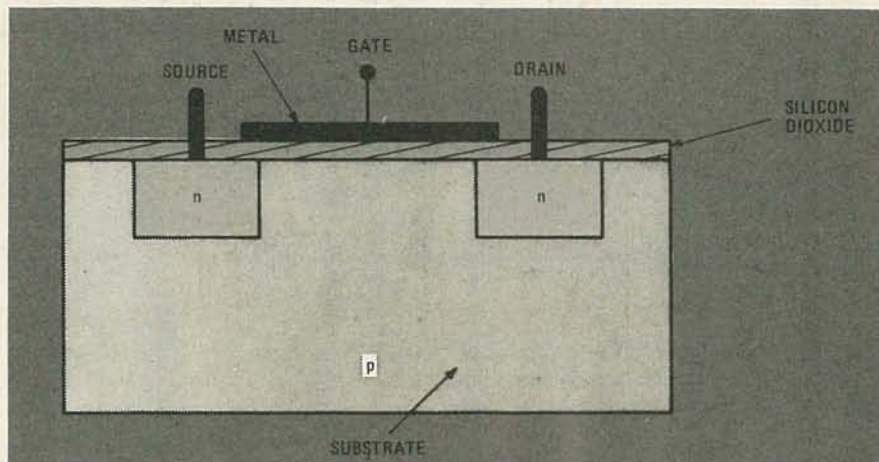

FIG. 7—THE STRUCTURE of an n-type enhancement MOSFET. In MOSFET's, the gate is insulated from the rest of the semiconductor by a thin layer of silicon dioxide.

trically if a positive voltage is applied to the gate with respect to the source. For current to flow, that voltage must exceed a certain *threshold* voltage, V_{GST} , defined as the gate-to-source voltage required for the device to conduct 10 μA of drain current, I_D . At voltages less than V_{GST} , the device is considered to be not operating, or in *cutoff*.

Enhancement/depletion n-type devices have basically the same structure as the enhancement-type MOSFET, but an n-type semiconductor joining the source and drain is added. The characteristics shown in Fig. 6-b still apply, but now the V_{GS} shown in column B should be used. Here the $V_{GS} = 0$ curve is at the center of the diagram. More

the JFET is plotted over the JFET characteristic curves in the same fashion.

Voltage is developed across R_S due to the source current, I_S ; that voltage is equal to $I_S R_S$. The voltage at the source is positive with respect to ground. Resistor R_G , which should be much larger than R_S , completes the circuit from the bottom of R_S (ground) to the gate. Due to that path, and because of the relative values of R_S and R_G , the voltage across R_S is essentially the voltage between the gate and source. That is the gate-to-source bias voltage; as a result, the gate is negative with respect to the source. Leakage current, I_{GSS} can upset that bias voltage, however. If I_{GSS} is large, a substantial volt-

age will be developed across R_G . That voltage is in series with the voltage across R_S , and when added to it, it will reduce the bias. To compensate for that, R_S must be increased. Despite the possible effects of I_{GSS} , we will ignore it here because it is usually negligible. The bias should be large enough to bring the drain voltage to about one half of E_{DD} .

In the common-source configuration, the signal is applied to the gate, amplified, and output from the drain. In the circuit shown in Fig. 8, voltage gain is about $g_m \times R_D$, where g_m is the transconductance of the JFET, if R_S is equal to zero ohms. Otherwise, gain as just noted must be divided by $(1 + g_m \times R_S)$. The input resistance seen by the signal looking into the gate circuit, is R_G , shunted by very little else in the gate

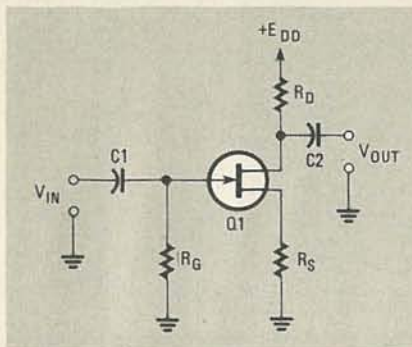

FIG. 8—AN N-CHANNEL JFET is used here in a common-source circuit.

circuit. When looking back into the drain circuit, the output impedance is about R_D .

Common-drain circuit

Should R_D be shorted and $C2$ connected to the source rather than to the drain, we would have a common-drain configuration. While its input impedance is not unlike that when the JFET is connected in the common-source configuration, its voltage gain is just under 1, as was the case for the bipolar transistor common-collector circuit. The output resistance is equal to R_S divided by $(1 + g_m \times R_S)$. That low-output impedance is the major feature of the arrangement.

Common-gate circuit

Here too, the basic circuit does not differ much from the one shown in Fig. 8. Now, however, the input is applied to the source rather than to the gate. The voltage gain and output impedance is equal to $R_S + 1/g_m$. The common-gate arrangement is most useful in RF applications, as is the bipolar transistor common-base circuit.

Next time

When we continue this series, we will take a look at biasing circuits. When those circuits are designed properly, and in an organized manner, they optimize the performance of a transistor. Among the topics we'll cover will be the different types of bias circuits, and how—as well as when—to use them most effectively.

R-E

TV ANTENNA

continued from page 52

theory and reality do not always coincide. It's best to experiment with height. Especially on UHF, a few feet up or down, or from left to right, can have a drastic effect on the signal received.

Generally, every 10 feet of height, starting from 40 feet from ground level will actually double the signal strength of weak, distant signals. When weak signals are overcome by strong adjacent channels, an extra 10 feet or so of antenna height will sometimes increase the strength of the weak signal significantly without increasing the already strong signal. In other cases a height of 10 feet above roof level will deliver excellent reception of all desired signals.

An antenna rotor is often needed when using an extremely directional antenna, or when signals are coming from various directions. Turning an antenna just a few degrees can make a big difference in reception.

Unfortunately, no one can guarantee what type of reception you will get using any given antenna system. Atmospheric conditions, local terrain, the buildings near you, etc. all affect reception. But if weak signals are present, you'll have a better chance at good reception if you use a good-quality antenna and lead-in. You pretty much get what you pay for.

R-E

OF THE EIGHT MAJOR CAPACITANCE INSTRUMENTS MADE, ONLY THE CM-100...

DETECTS LEAKAGE

(and at half the price!)

\$89⁹⁵



Usefulness — Measure capacitors 10pF — 500µF; leakage 1 nA or .005 C.V., whichever is greater. **Accuracy** — To 2% depending on range. **Dependability** — Ruggedized construction; 1 yr. warranty. **Versatility** — In circuit measurement of capacitance and leakage. Output signal proportionate to measurement. **Portability** — 350 Hr. Battery Life.

*To 25,000µF with external voltmeter

Send check, address (NO P.O. BOX) plus \$3.50 Handling. CT res. add 7½% tax.

Phone orders: (203) 423-7940

ANDERS PRECISION INSTRUMENT CO., INC.
4 Bridge St. Plaza, P. O. Box 75 Willimantic, CT 06226

CIRCLE 24 ON FREE INFORMATION CARD

A Classroom In Your Mailbox!

STUDY
Two-Way Radio

THROUGH THE
REVISED

MTI

Home Study Course

Send coupon below for free course outline
No obligation — No salesman will call

Professional Training in a Unique Career Field

Providing Training to the Industry Since 1960

study FM two-way
radio at home!

I am interested in learning more about professional FM two-way radio. Please send me full details on the MTI training program.

Name _____
Address _____
City/State/Zip _____

MTI

D34

Mobile Training Institute
Box 735, Camp Hill, PA 17011-U.S.A.

CIRCLE 23 ON FREE INFORMATION CARD

PAT. # 4,259,705

WARNING!
Electric Power Pollution, Spikes, Interference & Lightning
HAZARDOUS to HIGH TECH EQUIPMENT!!

ISO-3

MicroComputers, VTR, Hi-Fi, Lasers, Spectrometers are often damaged or disrupted due to Power Pollution.

High Tech components may interact!

Our patented ISOLATORS eliminate equipment interaction, curb damaging Power Line Spikes, Tame Lightning bursts & clean up interference.

Isolated 3-prong sockets; integral Spike/Lightning Suppressor. 125 V, 15 A, 1875 W Total, 1 KW per socket.

ISO-1 ISOLATOR. 3 Isolated Sockets; Quality Spike Suppression; Basic Protection \$69.95

ISO-3 SUPER-ISOLATOR. 3 DUAL Isolated Sockets; Suppressor; Commercial Protection \$104.95

ISO-17 MAGNUM ISOLATOR. 4 QUAD Isolated Sockets; Suppressor; Laboratory Grade Protection \$181.95

Master-Charge, Visa, American Express
TOLL FREE ORDER DESK 1-800-225-4876
(except AK, HI, MA, PR & Canada)

SATISFACTION GUARANTEED!

Electronic Specialists, Inc.
171 South Main Street. Natick, MA 01760
Technical & Non-800: 1-617-655-1532

CIRCLE 25 ON FREE INFORMATION CARD

A clean sweep!

Three new sweep/function generators from B&K-PRECISION



MODEL 3015—\$270 • MODEL 3025—\$450
MODEL 3030—\$645

The three new generators all feature low-distortion, high-accuracy outputs and selectable lin/log sweeps. The 3030 offers the widest capabilities. It generates all seven of the most commonly needed waveforms and has wide-range variable symmetry control. Kelvin-Varley dividers provide ultra-high accuracy sweep-limits.

With a range of 0.005 Hz to 5 MHz, the new 3025 is more than able to handle most lab and field applications. In addition to sine, square and triangle waveforms, the 3025 offers a haversine function for more specialized needs.

Also new, the 3015 is a very compact generator intended for audio and ultrasonic applications. Unique in its price class, it covers 2 Hz to 200 kHz. Both variable and fixed TTL level outputs are featured.

To receive a free brochure on the full line of B&K-PRECISION generators, or for the name of your local B&K-PRECISION distributor, call toll-free: **800-621-4627**

B&K PRECISION
DYNASCAN
CORPORATION

6460 West Cortland Street
Chicago, Illinois 60635 • 312/889-9087

Int'l. Sls., 6460 W. Cortland St., Chicago, IL 60635
Canadian Sales: Atlas Electronics, Ontario

STYLUS TO PHONO INPUT

continued from page 64

ferred to a 0-dB reference level at 1000 Hz).

After the spot frequency levels at the output of the preamp are noted in dB terms, they can be compared with the RIAA related readings listed in Table 2 and any differences between the two can be plotted on graph paper. Since cartridge loading primarily affects the high frequency response of a cartridge, it is not really necessary to plot frequencies below 1000 Hz. Omitting frequencies below 1000 Hz greatly reduces the time it takes to complete a single plot and, since several plots will probably be required until you have optimized the cartridge load for your system, you may want to simply concentrate on the upper part of the audio spectrum where changes in capacitance and resistive loads have their greatest effect.

The CBS test record, STR-130, is recorded using RIAA equalization in the first place. Therefore, when playing back the spot frequencies available from this record through a preamplifier, the perfectly-loaded ideal phono cartridge should deliver equal amplitude outputs at all of the available test frequencies. Any deviation from equal amplitude outputs indicates an inferior cartridge design or improper cartridge loading.

Modifying the load impedance

The results of the frequency-response tests will reveal much about the correct load impedance for the cartridge. High-end resonance peaks are usually tamed by increasing the capacitance across the cartridge terminals, by reducing the resistive load across the cartridge terminals, or by using a combination of both methods.

Generally speaking, the total load-resistance should be maintained at 47 kilohms and should only be changed if the overall response of a cartridge cannot be brought into line by changing the overall value of capacitance. Even then, the total load-resistance should not go below 27 kilohms or higher than 100 kilohms.

To increase the effective capacitance across the cartridge terminals and/or decrease the resistive load across the cartridge terminals it is necessary to use a parallel R-C circuit. Figures 10 and 11 show circuit examples. To increase the capacitance, a capacitor, C, may be connected in parallel with the cartridge output. I have found that it is best to experiment in steps of approximately 50 pF, increasing the capacitance until the desired results are obtained.

To decrease the resistive load, a resistor, R, may be connected in parallel with the output of the cartridge. If it is

TABLE 3

Frequency Hz	Meter Reading- dB
20000	-19.5
18000	-18.8
16000	-17.7
14000	-16.6
12000	-15.3
10000	-13.7
8000	-11.9
6000	-9.6
5000	-8.2
4000	-6.6
3000	-4.8
2000	-2.6
1500	-1.5
1000	0
800	+0.7
600	+1.8
500	+2.6
400	+1.9
300	+1.1
200	+0.2
150	-0.6
100	-0.9
80	-1.3
60	-2.3
50	-3.0
40	-4.2
30	-5.8
25	-7.0
20	-8.6

necessary to further decrease the resistive load, a smaller value resistor should be used.

A new frequency response test should be done each time the load impedance is altered to determine the best response and, therefore, the best load impedance for the cartridge. If the cartridge is a stereo cartridge, the response tests will have to be repeated to determine the best load impedance for the other stereo channel.

After the tests are completed, you will have two R-C networks, one for each stereo channel. There are two options for incorporating the two R-C networks into your stereo system. The first is to connect the resistor and capacitor to a male phono plug for use with a "Y" connector. The parallel R-C network is soldered between the "hot" (center) and "ground" (outer) terminal. When completed, the male phono plug with the R-C circuit is plugged into the "Y" connector. The cable from the turntable is plugged into the other jack on the "Y" connector and, finally, the "Y" connector is plugged into the input of the phono preamplifier, as shown in Fig. 15. Of course, two "Y" connectors and two R-C networks will be necessary for stereo systems.

The other alternative is to house the R-C circuit in a small metal box. In addition to the small metal box you'll need two jacks (one will be the input, the other the output) and a length of shielded cable (four jacks and two lengths of shielded cable for stereo. Connect the box in series with the audio cables from the turntable.

R-E

MARKET CENTER

BUSINESS OPPORTUNITIES

LAWYER Business litigation, patents, appeals. **JEROME FIELD**, B 292, Brooklyn 11230. Phone (212) 434-0781. Eves. 434-1825

USED TV's—tougher the economy—more the demand. Get started in this lucrative part or full time business out of your own home. Complete details on how to buy, sell, price, service tips, much more. \$5.00. **USED TV's**, Dept. RE, Box 19754, Indianapolis, IN 46219

ASSEMBLE profitable devices at home. Exceptional opportunities—without investment. **ENTERPRISES**, 1133-R, Linwood Place, Utica, NY 13501

THE trade forum—new service—buy, sell, trade. Subscribe now—SASE for complete info. **M. ANDREWS**, Rt. 7, Box 389, Lake City, FL 32055

ATARI repair business. Start your own. Send \$5.00 for more information to: **IRATA REPAIRS**, 2562 East Glade, Mesa AZ, 85204

HIGHLY PROFITABLE

ELECTRONIC FACTORY

Investment unnecessary, knowledge not required, sales handled by professionals. Ideal home business. Write today for facts!

Postcard will do, **Barta-RE-X**, Box 248, Walnut Creek, CA 94597.

SATELLITE TELEVISION

SATELLITE TV antenna, 10 ft. fiberglass, complete, polar mount, \$1950.00, electronics at cost also. **TRI-STAR COMMUNICATIONS**, Box 843, Erie, MI 48133 (419) 726-1095

SATELLITE television ... Howard/Coleman boards to build your own receiver. For more information write: **ROBERT COLEMAN**, Rt. 3, Box 58-ARE, Travelers Rest, SC 29690

INTERESTED in Home Satellite Television—Don't buy anything until you've read **Homesat Handbook & Buyers Guide**. Our book tells everything about home satellite TV and may save you hundreds, even thousands of dollars in your selection and installation of a system! \$10.00: **H & G HOMESAT SERVICES**, Box 422, Seaford, NY 11783

SATELLITE Super-Mixer: DBM-4150A. Clean up your TVRO receiver! Near theoretical performance; flat response, DC-1500IF SMA connectors; \$69.50—CK/MO/COD **RIGEL SYSTEMS**, 2974 Scott Blvd., Santa Clara, CA 95050 (408) 727-3628

LAST CHANCE for FREE \$200.00 value TVRO P.C. board set when you join our development group. Prices are going up. Build your own complete system low as \$700.00. Newest designs, group purchasing, etc. Aiming chart and data \$1.00. Construction plans \$10.00, membership \$50.00. PC board sets \$75.00. **COMPUTER SATELLITE SERVICES**, 1604 N Smith St., Spokane, WA 99207 (509) 534-8088 6-9 PM PST

SATELLITE equipment catalog. Over 25 of the best manufacturers and suppliers. LNA's, receivers, antennas, and complete systems covered in four different sections. Free satellite aiming chart and microwave interference handbook (\$10.00 value) included. \$9.95. **TMS CO.**, P.O. Box 8369, Roseville, MN 55113

SATELLITE TV low noise amplifier, build for under \$100! Satisfaction guaranteed! Complete, easy to follow instruction manual \$7.00! **XANDI**, Box 25647, Dept. 21B, Tempe, AZ 85282

SATELLITE television! Super discount prices. Don't spend too much—call us! **COMMUNICATIONS CONSULTANTS**. 501-452-3149

SATELLITE connectors, cable UG21-N \$3.00, UG27C-L \$4.95. RG-214 \$1.35/ft. RG-217 85¢/ft. 8-conductor 19¢/ft. Free catalog. **NEMAL** 1325 NE 119th St., Miami, FL 33161 (305) 661-5534

SATELLITE TV WEEK

The most complete weekly listings. We cover more than just SATCOM 3. Send \$1 for sample copy.

Satellite TV Week

P.O. Box 308, Fortuna, California 95540

Call toll free: (800) 358-9997 • California (707) 725-2476



SATELLITE TV FANTASTIC 80 TV CHANNELS

New antenna construction plans plus big 8x11 book loaded with aiming info, kits, LNAs and receivers at wholesale prices. Far better than cable TV! Enjoy crystal clear reception. Send \$9.95 today. Add \$2.00 for 1st class (air mail) or call our 24 hr. COD order line (305) 862-5068 Now.

Global TV Electronics, P.O. Box 219-F, Maitland, FL 32751

WANTED

SWTPC equipment: AC-30 cassette interface, CT-1024 terminal, CT-64 terminal, others. Contact **HARVEY**, 7827 Lorna Drive, Philadelphia, PA 19111 (215) 745-6283

IDEAS, inventions, new products wanted for presentation to industry. Call free 1-800-528-6050. Arizona 1-800-352-0458. X831.

QUALITY MICROWAVE TV SYSTEMS



2.1 to 2.6 GHz Ant.
34 db Gain (or Greater)
Complete System as pictured \$149.95
Down Converter Probe
Mntd. Assembled & Tested 64.95
Power Supply (12V to 16V)
Assembled & Tested 59.95
Data Info (Plans) 9.95

Phillips-Tech Electronics
P.O. Box 33205
Phoenix, AZ 85067
(602) 274-2885

C.O.D.'s Special Quantity Pricing



6 MONTH WARRANTY
PARTS & LABOR

THE SYSTEM 20 MICROWAVE TV RECEPTION AT IT'S BEST!

- FX-2300 Assembled Down Converter
- Power Supply / Antenna Switch
- 25" Parabolic Antenna
- All Coaxial Cables
- Full Year Warranty

\$289.95

+ \$5.00 shipping

TEM MICROWAVE CORPORATION
22518 - 97th Avenue North
Corcoran, Minnesota 55374



To run your own classified ad, put one word on each of the lines below and send this form along with your check for \$1.65 per word (minimum 15 words) to:
Radio-Electronics, 200 Park Avenue South, N.Y., N.Y. 10003

ORDER FORM

PLEASE INDICATE in which category of classified advertising you wish your ad to appear. For special headings, there is a surcharge of \$10.

- () Plans/Kits () Business Opportunities () For Sale
() Education/Instruction () Wanted () Satellite Television

Special Category: \$10

(PLEASE PRINT EACH WORD SEPARATELY, IN BLOCK LETTERS.)

1	2	3	4	5
6	7	8	9	10
11	12	13	14	15
16	17	18	19	20
21	22	23	24	25
26	27	28	29	30
31	32	33	34	35

PLEASE INCLUDE FOR OUR FILES YOUR PERMANENT ADDRESS AND PHONE NUMBER.

CLASSIFIED COMMERCIAL RATE (for firms or individuals offering commercial products or services). \$1.65 per word prepaid (no charge for zip code). . .MINIMUM 15 WORDS. 5% discount for 6 issues, 10% for 12 issues within one year, if prepaid.

NON-COMMERCIAL RATE (for individuals who want to buy or sell a personal item) \$1.00 per word prepaid. . .no minimum.

ONLY FIRST WORD AND NAME set in bold caps. Additional bold face (not available as all caps) at 10¢ per word. All copy subject to publisher's approval. **ADVERTISEMENTS USING P.O. BOX ADDRESS WILL NOT BE ACCEPTED UNTIL ADVERTISER SUPPLIES PUBLISHER WITH PERMANENT ADDRESS AND PHONE NUMBER.** Copy to be in our hands on the 26th of the third month preceding the date of the issue (i.e., August issue closes May 26). When normal closing date falls on Saturday, Sunday, or a holiday, issue closes on preceding working day.

UHF CONVERTERS

DELUXE sine wave UHF converter. Sound out of TV like normal with only antenna connection to TV or VCR. Kits \$175.00. (312) 267-3455. **LSR ENGINEERING**, Box 6075, Chicago, IL 60680

Govt. SURPLUS ELECTRONIC EQUIPMENT CATALOG

New ITEMS . . . New BARGAINS!

FREE UPON REQUEST!

Send today for FREE copy of
NEW CATALOG WS-82 Address: Dept. RE

FAIR RADIO SALES

1016 E. EUREKA • Box 1105 • LIMA, OHIO • 45802

EDUCATION & INSTRUCTION

UNIVERSITY degrees by mail! Bachelors, Masters, Ph.D.'s . . . Free revealing details. **COUNSELING**, Box 317-RE8, Tustin, CA 92680.

NORTHSTAR satellite antenna kit 12' system \$2400.00. Everything you ever wanted to know about satellite television \$7.95. Attention dealers: manufacturers direct pricing, we will not be undersold. Call or write **TOM SALLEE** (606) 356-7416, Rt. 5, Box 293A, Covington, KY 41015

RTTY. Only magazine and handbook **exclusively** for the RTTYer. Beginners Handbook \$8.00. Subscription \$7.00 USA. **RTTY JOURNAL**, Post Office Box RY, Cardiff, CA 92007

Be an FCC LICENSED Electronic Technician

Earn up to \$600 a Week & More!
No costly school — The Original FCC Tests-Answers exam manual that prepares you at home for FCC General Radiotelephone License. Newly revised multiple-choice exams cover all areas tested on the actual FCC Govt exam! No previous experience required. \$12.95 postpaid. Moneyback Guarantee.
Dept. E P.O. Box 26348, San Francisco, CA 94126



COMTAND PRODUCTIONS

ATTENTION ELECTRONIC TECHNICIANS



Highly Effective Home Study BSEE Degree Program for Experienced Electronic Technicians
Our New Advanced Placement Program grants Credit for previous Schooling & Professional Experience. Advance Rapidly! Our 36th Year!
FREE DESCRIPTIVE LITERATURE!
Cook's Institute of Electronics Engineering
DESK 15, P.O. BOX 20345, JACKSON, MS 39209

FOR SALE

MICROWAVE receiver system. Write: "Dealers Wanted," Dept. RE, POB 4181, Scottsdale, AZ 85258 (602) 941-9395

SCANNER/monitor accessories—kits and factory assembled. Free catalog. **CAPRI ELECTRONICS**, Route 1R, Canon, GA 30520

THE Intelligence Library. Restricted technical secrets—books on **electronic surveillance, lock-picking, demolitions, investigation**, etc. Free brochures: **MENTOR**, Dept. Z, 135-53 No. Blvd., Flushing, NY 11354

RESISTORS 1/4W, 1/2W 5% carbon films 3c ea. **NO MINIMUMS**. Cabinet assortments, 1% metal films. Request details. Bulk pricing available. **JR INDUSTRIES** 5834-C Swancreek, Toledo, OH 43614

SAVE up to 50% on name brand test equipment. Free catalog and price list. **SALEN ELECTRONICS**, Box 82-G, Skokie, IL 60077

CABLE TV converters, microwave antennas, cable parts, plans, parts and assembled units. For information send \$2.00. **SAT-TECH** P.O. Box 10026, Cleveland, OH 44110

HIGHEST quality & highest gain, state-of-the-art microwave receiver systems, kits, complete, catalog \$2.50. **Wholesale prices, dealers inquire** **VIDEO COMMUNICATIONS RESEARCH**, 13735 SW Bull Mtn. Rd., Tigard, OR 97223(503) 639-5139

HEWLETT-Packard 608C signal generator, 10-480 MHz, calibrated \$250.00. Test equipment catalog 25c. **EF ELECTRONICS**, 10 Afton, Aurora, IL 60538

LONG-play cassette recorder, 1 1/2 pounds, with two slow speeds for recording up to **15 hours** on a **single standard C-180 tape!** Unbelievable sensitivity and voice fidelity. Takes telephone recording and voice activator accessories. Perfect for professionals, students, security personnel. Excellent for radio and TV, security monitoring, home surveillance, lectures. Free brochure. **EXTENDO-TAPE SYSTEMS**, Dept. RE, Box 16000LC, Temple Terrace, FL 33687

TRANSFORMERS, triple secondary 10V-2A. 18V-1A, 18V-1A. 120V primary, **perfect for protoboard power supplies**. M.O. for \$12.50 + \$2.50 shipping to **J. MACSWAN**, POB 4697, Downey, CA 90241

CABLE TV CONVERTERS AND EQUIPMENT

BUY DIRECT & SAVE

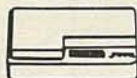

**40 CHANNEL
CONVERTER**
\$38 Regular \$69

AMATEUR MICROWAVE ANTENNA

- Microwave Parabolic Antenna
- 26 DB Gain
- Advanced Down Converter
- Power Supply Included
- Low-Loss Coaxial Cables
- Complete-Ready to Install

\$119 Elsewhere \$289

Send \$2 for Complete Catalog
Quantity Discount • VISA • COD

VIDEO RESEARCH

PO BOX 19462
LOUISVILLE, KY 40219

CALL 502/969-1810 502/969-4127



SUPER SALE

EPROM's

	1-7	8 up	50 up
2716 (5V, 450nS)	\$3.95	\$3.55	CALL
2732 (5V, 450nS)	7.85	6.95	CALL
2532 (5V, 450nS)	11.20	9.25	CALL

STATIC RAM

6116P-3 (150nS)	7.50	7.20	CALL
2114L-2 (200nS)	2.10	1.70	CALL

DYNAMIC RAM

4164 (200nS)	7.90	7.49	CALL
--------------	------	------	------

MISC

CPU Z80A	\$5.29 ea.
CDP-1854ACE (UART)	\$4.80 ea.
16K RAM Expansion Kit for TRS-80 Mod III	\$12.95/8



SUNTRONICS CO., INC.

12621 CRENSHAW BOULEVARD
HAWTHORNE, CALIFORNIA 90250

STORE HOURS: Mon-Fri, 10am to 6:30pm — Sat, 10am to 5pm
IN CALIFORNIA OUTSIDE CALIFORNIA TOLL FREE

(213) 644-1149 1-800-421-5775
Min Order: \$10, P/H: \$2, Accept VISA, Mastercard, Check or M.O.

Learn about COMPUTERS!

new!

"Bits, Bytes, and Buzzwords", by Craig Anderton and the CompuPro staff.

This primer for the business computer buyer covers the basics of computer systems, printers, terminals, mass storage, software, and more - even includes a glossary of common terms. Softcover; 26 pages. \$2.50 postpaid.

"Interfacing to S-100/IEEE 696 Microcomputers", by Mark Garetz and Sol Libes. Covers operating requirements and characteristics of the S-100 bus with clarity and precision. Osborne/McGraw-Hill; softcover; 321 pages. \$15.00

"Product User Manuals 1975-1980, Volume 1", by CompuPro staff. With schematics, test routines, operating information for 29 CompuPro products. Also defines and explains the S-100 bus. Softcover; 256 pages. \$20.00

"Product User Manuals, Volume 2", by CompuPro staff. Similar to above, but covers products released since 1980. Softcover; 307 pages. \$25.00

TERMS: Cal res add tax. Allow 10% shipping; excess refunded. VISA® and Mastercard® orders (\$25 minimum) call (415) 562-0636, 24 hrs. Include street address for UPS. Prices subject to change without notice.



CompuPro division, Godbout Electronics, Oakland Airport, CA 94614-0355

MINI FM MIC

Compact size, only 2"x1"x1/4". Transmit to FM radio 88-108 MHz. Exceptional audio quality. Transmits stable signal up to 900 ft. Complete kit incl. case, battery & instructions. Only \$13.95. Assembled \$18.95. Add \$1.55 S&H ea. Send 18c stamp for brochure.

S.E. Corp., Box 16969-R
Temple Terrace, FL 33687

30 CHANNEL CABLE TV CONVERTER

39⁹⁵
ADD \$2.50 FOR POSTAGE

FREE!
UNUSUAL 96 PAGE ELECTRONIC PARTS & IDEAS CATALOG!

ORDER No. 171AE047

ELSCO ROUTE 19N,
PLATTSBURGH, N.Y. 12901
Tel.: (518) 561-8700.

32K color computers \$499.95. Extended BASIC ROM's \$85.00. **SPECTRUM PROJECTS**, 93-15 86 Drive, Woodhaven, NY 11421

UHF TV Yagi antennas. Channels 14 to 70. MATV MFR's discount. Catalog 50 cents. C.E.D., 24, High Range Rd., Londonderry, NH 03053

"CHOMPERS" Pac-Man type game watch with sound effects and alarm. \$34.95. Order today. **KEITH ELECTRONICS**, 224 North Grove, Lock Haven, PA 17745

MICROWAVE television "downconverters." Introducing newest, 5-stage high gain design. Easily assembled. Catalogue: \$2.00 (refundable). **NDS**, Box 12652-R, Dallas, TX 75225

POLICE/fire scanners, scanner crystals, antennas, radar detectors. **HPR**, Box 19224, Denver, CO 80219

PICTURE tube rebuilding equipment—we sell and buy new and used equipment. Free training. **ATOLL TELEVISION**, 6425 Irving Park, Chicago, IL 60634, phone (312) 545-6667

FM stereo multiplex transmitter P.C.B. kit, range up to 1/2 mile. Frequency response 20-15,000 Hz \pm 1 dB. THD 0.5%. Crystal controlled 19 & 38 kHz subcarriers. 16-turn trimpot finely tunes ultra stable oscillator anywhere within 88-108 mHz. Accepts any line level audio source. Operates from \pm 12V. Kit includes all parts and 18-page assembly and technical manual. Mode FX-2, \$89.95 + \$3.00 shipping. Model FX-2A, 95% assembled-tested version (requires only r.f. osc assembly), \$109.95 + \$3.00. **STELLATRON/R**, 4942 Whitsett-205, N. Hollywood, CA 91607

SURPLUS electronic parts. Wide variety, limited quantity. Send SASE for flyer. **TEMPEST MARKETING**, Box D, Cedar Grove, NJ 07009

STAGGERED resistor assortment 1/4W 5% common values 40 each. Less common 10 each. 500 total \$10.00 **CI ELECTRONICS**, P.O. Box 3034, Camarillo, CA 93010

ATTENTION: hobbyist and technicians. Inexpensive device cuts semiconductor testing time in half. For more information send stamp to: **CAMCO PRODUCTS**, Route #1, Box 156, Walcott, IA 52773

RF MODULATORS
for the video industry

Satellite modulators from channel 2 thru UHF!
Kits & assembled models for all Microcomputers...including our new Apple-verter designed to mount inside computer. Also an extensive line of monitors, cameras and kits. **FREE CATALOG**

PHONE (402) 987-3771
ATV Research
13-RE BROADWAY
DAKOTA CITY, NE 68731

WRITE FOR
McGEE'S
SPEAKER & ELECTRONICS CATALOG
1001 BARGAINS IN SPEAKERS
Tel.: 1 (816) 842 5092
1901 MCGEE STREET KANSAS CITY, MO. 64108

SATELLITE antenna. 11 ft. metal dish, polar mount, gain 41 dB F/D. 44 new, crated, full warranty. Must sell at loss, \$950.00. **RON**, (313) 361-5146, 5700 Chopin, Detroit, MI 48210

MICROWAVE TV antennas. Best in the West! Rod disc type. Complete with cable, accessories, warranty. 52 dB \$125.00. Dealers wanted. **GAL-AXY ELECTRONICS**, 6007 N. 61st Ave., Glendale, AZ 85301 (602) 247-1151

MICROWAVE TV receiver. Factory assembled 18" dish, cables, hardware, power supply, and probe. \$139.95. Free shipping. MC, VISA, check, money order. **DBM ENTERPRISES**, 315 North Utica Ave., Massapequa, NY 11758 (516) 293-5698

PRINTED circuit boards: Your artwork, quick delivery, reasonable. Quantity discounts. **ATLAS CIRCUITS**, Dept. A, Box 892, Lincolnton, NC 28092 (704) 735-3943

MICROWAVE downconverters. Also UHF subscription TV kits. Catalog 20c. **TROJAN ENTERPRISES**, 2920 Shelby, Indianapolis, IN 46203

TELEPHONES: dial, used NASA Space Center, Western Electric, 5 buttons/hold, business, private, condition excellent. \$23.50. Delivered, except Alaska, Hawaii. **MAC'S SALES**, Box 26336, Birmingham, AL 35226

MAGIC TV machine. Amateur microwave receivers, 1 yr. warranty, \$99.95. **MICRO**, Box 3123, Tempe, AZ 85281. We repair most brands of amateur microwave receivers.

FREE speaker catalog! Woofers, mids, tweeters, hardware, crossovers, grille cloth, plans, kits, information, much more. **Discount prices.** **UNIVERSAL SOUND**, Dept. RE, 2253 Ringling Blvd., Sarasota, FL 33577 (813) 953-5363

TEST equipment, tools, parts, aids—save; free catalogue. **COLOR-TECH ELECTRONICS**, PO Box 12916, Rochester, NY 14612

FM wireless microphone, excellent range, audio quality and stability. Assembled and tested, in compact case. Only \$16.95. **TW ENGINEERING**, 2223 Virginia Avenue, Hagerstown, MD 21740

VIDEO DISCOUNTS

TEKNIKA WIRELESS REMOTE CONTROL TV TUNER
Model 6301
\$110.00 ea.

REMOTE TV CONVERTER
Wireless Remote Control 40 Channels
4 or more
139.95 ea. **125.00** ea.
Model CTC5R

36 CHANNEL UP CONVERTER FOR TV & VTR Cable VHF to UHF
Model V5736
1-3 pieces **\$29.95** ea.
4 pieces & up **\$24.95** ea.

VIDEO SWITCHER
Model V 4801 **\$29.95** ea.
Flip a switch to watch a program on any channel, while simultaneously recording a program on any cable or pay TV channel - or vice versa. Plus, you can use your recorder's programming feature to record TV programs while you're away.

VIDEO CONTROL CENTER
Model IV 4802 **\$39.95** ea.
Provides remote control access of all your Video, TV or Cable inputs to your TV set or Big Screen TV from one convenient location by merely flipping a switch.

COAXIAL SWITCHING FOR TV VIDEO CASSETTE RECORDERS
Model AB-370 **\$6.95** ea.
3-position coaxial push-button switch.

COAX AB SWITCHES
Model AB-27 **\$2.95** ea.
• Input: 75 ohm. • Output: 75 ohm.

Model AB-28 **\$2.95** ea. Model AB-29 **\$2.95**
• Input: 75 ohm. • Output: 300 ohm.
• Input: 75 & 300 ohm.

ANTENNA/CABLE TV SWITCH
Model AB-400 **\$10.95** ea.

ANTENNA/CABLE TV SWITCH
Model AB-410 **\$9.95** ea.
• Switches from cable to antenna system instantly. • Accepts 75 or 300 ohm inputs.

TV GAME SWITCH
Model IV 450 **\$2.95**
300 ohm in and out with RCA plug.

COAXIAL SWITCH
Model DCS-A/B **\$7.95**
A versatile product, with a range of consumer and MATV applications.

VHF/FM AMPLIFIERS
Model 7002 **\$9.95** ea.
• All solid state signal amplifier boosts weak signals. For 2 sets.
Model 7004 **\$12.95** ea.
• For up to 4 sets • Signal gain 3 dB

DISTRIBUTION AMPLIFIER VHF/UHF FM With FM Trap
Model DA-425 **\$29.95** ea.
• Designed for TV/VCR multiple-set installations.

QUICK CONNECT "F" PLUG & BALUN
Model IV 400 **\$1.50** ea.
10 for \$12.50

QUICK CONNECT "F" PLUG
Model IV 403 **.75**
10 for \$6.00
For 75 ohm cable. No wiring necessary.
Model IV 4036 **\$2.50** ea.
6 ft.

VHF/UHF MATCHING TRANSFORMERS
Model MT-1 **\$.75** ea.
10 for \$6.00
VHF/UHF 75-300 ohm matching unit. Miniature size completely shielded and balanced for reduction of direct pick-up.
Model MT-2 **\$1.10** ea.
10 for \$9.00
Completely plastic molded construction for weather-proofing. Supplied with rubber boot.

FORDHAM
855 Conklin St. Farmingdale, N.Y. 11735

Master Charge N.Y. State residents add
VISA COD appropriate sales tax
Money Order
Check
\$25.00 minimum order
COD's extra (requires 25% deposit)

ADD FOR SHIPPING AND INSURANCE
to \$250.00 \$ 4.50
\$251.00 to 500.00 6.00
501.00 to 750.00 8.50
751.00 to 1000.00 12.00
over 1000.00 12.50

TOLL FREE (800) 645-9518
in N.Y. State call (516) 752-0050

ARE YOU OUT OF CONTROL?

OUR 6502 BASED MICROCOMPUTER HAS
EVERYTHING UNDER CONTROL.

THE COMPUTER "SLIM"

- 6502 MICROPROCESSOR
 - 2K BYTES RAM
 - 2K OR 4K EPROM
 - FOUR 8 BIT I/O PORTS
 - POWER ON RESET
 - CRYSTAL CLOCK
 - BUFFERED SYM-AIM BUS
- PRICE 81-260A \$199.95 ASSM.
81-260K \$149.95 KIT
81-260B \$ 39.95 BARE BOARD

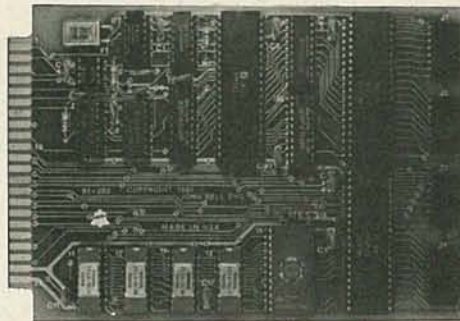

THE COMPUTER "SLIM"

THE PERIPHERALS

RAM EPROM MEMORY

- 32K BYTES OF RAM OR EPROM
- PRICE 81-330A \$ 99.95 ASSM. W/O MEMORY
81-330B \$ 49.95 BARE BOARD

6 SLOT MOTHER BOARD

- .750" BOARD SPACING 44 PIN BUS
- PRICE 81-320A \$ 99.95 ASSEMBLED
81-320B \$ 49.95 BARE BOARD

24 HOUR REAL TIME CLOCK

- FOUR DIGIT LED DISPLAY
 - ON BOARD POWER SUPPLY
- PRICE 81-350A \$149.95 ASSEMBLED
81-350B \$ 49.95 BARE BOARD

ANALOG I/O INTERFACE

- 16 ANALOG INPUT CHANNELS
 - 2 ANALOG OUTPUT CHANNELS
- PRICE 81-292A \$199.95 ASSEMBLED
81-292B \$ 49.95 BARE BOARD

12 PORT PARALLEL I/O BOARD

- 12 8 BIT I/O PORTS — 6 6522S
- PRICE 82-036A \$169.95 ASSEMBLED
82-036B \$ 49.95 BARE BOARD

MONITOR + TINY BASIC 2532 \$39.95

ALL BOARDS ARE 4.5 X 6.5 WITH
GOLD EDGE CONNECTORS
SOLDER MASK BOTH SIDES

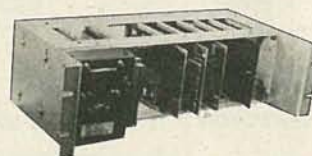
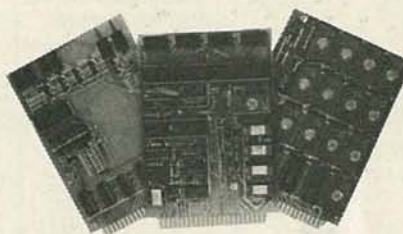

19" RACK MOUNTING

CALL 415 592-8411 FOR MORE
INFORMATION.

OUR SALES PEOPLE WILL BE
GLAD TO DEMONSTRATE OUR
PRODUCTS AT YOUR COMPANY.
OEM PRICING AVAILABLE.



JOHN BELL ENGINEERING, INC.

ALL PRODUCTS ARE AVAILABLE FROM JOHN BELL ENGINEERING, INC. • 1014 CENTER ST., SAN CARLOS, CA 94070
ADD SALES TAX IN CALIFORNIA • ADD 5% SHIPPING & HANDLING 3% FOR ORDERS OVER \$100

SEND FOR CATALOG

(415) 592-8411

10% OUTSIDE U.S.A.

WILL CALL HOURS: 9am - 4pm

CIRCLE 43 ON FREE INFORMATION CARD

VISA

QUALITY parts at DISCOUNT PRICES

STEREO 8 TRACK HOME UNIT



BRAND NEW UNITS...
ASSEMBLY INCLUDES;
TAPE HEAD, MOTOR BELT,
110VAC MOTOR, PRE-AMP,
LIGHTS, SWITCHES,
SOLENOID AND OTHER
USEFUL PARTS...
AN EXCEPTIONAL BUY!
\$7.25 PER ASSEMBLY

MINI BSR



AUTOMATIC RECORD CHANGER

* B.S.R. MODEL C136R/C/3
* PLAYS 33/45/78 RECORDS
* MINI SIZE: 8 1/4" X 12"
INCLUDES DUST COVER AND
PLASTIC CASE (NOT PICTURED)
WITH FRONT CUT OUT TO FIT
STEREO UNIT (NOT INCLUDED).

\$17.50 each

JOYSTICK

PRECISION
DEVICE...
CONTAINS 4
50K CENTER
TAPPED ALPS
POTS. \$4.75 ea



BLACK PLASTIC CASE



PAC-TEC
SERIES C
BLACK PLASTIC ENCLOSURE
ADJUSTABLE HEIGHT FROM
1.63" TO 2.93"; WIDTH
6.85"; DEPTH 8". BUILT-
IN STAND OFFS FOR P.C.
BOARDS... FRONT AND BACK
PANELS NOT INCLUDED...
\$5.25 PER CASE

VARACTOR DIODES

BB-103 3 FOR \$1.00
100 FOR \$30.00
MV2205 3 FOR \$1.00
100 FOR \$30.00

MITSUBI MODEL UES-A55F VARACTOR UHF TUNER

FREQ RANGE
470 - 889 MHz
ANTENNA INPUT
300 OHMS
\$25.00 each
10 for \$220.00

MINI SIZE SUZZERS

1 1/2 to 3 volts 75c ea
WITH WIRE LEADS
1 1/2 to 3 volts 75c ea
WITH PIN TERMINALS
3 to 7 volts
WITH PIN TERMINALS
75c each

PHOTO FLASH CAPACITORS

170 MFD 330 VOLT
1 1/2" X 7/8"
2 FOR \$1.50
10 FOR \$7.00
600 MFD 360 VOLT
3 3/4" HIGH X 1" DIA.
\$1.00 EA. 10 FOR \$9.00

SLIDE POTS

500K
linear taper
2 7/8" LG.
1 3/4" TRAVEL 75c EACH

COMPUTER GRADE CAPACITOR

1700 mfd. 150VDC \$2.00
2 1/2" DIA X 4 3/4" HIGH
3,600 mfd.
40VDC \$1.00
1 3/8" DIA. X 3" HI
6,400 mfd.
60VDC \$2.50
1 3/8" DIA X 4 1/4"
12,000 mfd. 40VDC \$3.00
2 1/2" DIA X 4 1/4" HIGH
18,000 mfd. 75VDC \$4.00
2 1/2" DIA X 4 1/2" HIGH
22,000 mfd. 15VDC
2 7/8" DIA X 2 1/2" HIGH \$2.00
22,000 mfd. 40VDC
2 1/2" DIA. X 6 1/4" HIGH \$3.00
25,000 mfd. 75VDC \$4.50
3 1/4" DIA X 4 3/8" HIGH
45,000 mfd. 25VDC \$3.50
2 1/2" DIA. X 4 1/4" HIGH
72,000 mfd. 15VDC
2 1/2" DIA. X 4 1/4" HIGH \$3.50
CLAMPS TO FIT CAPACITORS 50c ea.

L-PAD

STANDARD 8 OHM
50 DB L-PAD...
\$1.50 EACH

8' LINE CORD

18 - 3 SJT M/E
ROUND GRAY
\$2.00 EACH 10 FOR \$18.50

TRANSFORMERS

120 volt
primaries
5.6 VOLTS at 750 MA \$3.00
6 VOLTS at 150 mA \$1.25
12 V.C.T. at 500 mA \$2.50
16.5 V. at 3 AMPS \$6.50
18 VOLTS at 350 MA \$2.00
18 VOLTS at 1 AMP \$4.50
18 V.C.T. at 2 AMP \$5.50
25.2 V.C.T. at 2.8 AMP \$5.50
35 V.C.T. at 1 AMP \$3.50
42 V.C.T. at 1.2 AMP \$4.50
65 V.C.T. at 2 AMP \$5.50

L.E.D.'s

STANDARD JUMBO
DIFFUSED
RED 10 FOR \$1.50
GREEN 10 FOR \$2.00
YELLOW 10 FOR \$2.00
FLASHER LED
5 VOLT OPERATION
JUMBO SIZE
2 FOR \$1.70
BI POLAR LED
2 FOR \$1.70
SUB MINI LED

.079" X .098"
20mA at 1.75v
10 FOR \$1.00
200 FOR \$18.00
QUANTITY PRICES AVAILABLE

BLACK LIGHT (ULTRAVIOLET)

G.E. # F675BL \$2.50 each

FREE! SEND FOR OUR NEW 40 PAGE CATALOG FREE!

CONNECTORS

WEATHERPROOF
2 CONDUCTOR
POLARIZED SET, 18 GA.
WIRE... \$1.00 / SET
4 CONDUCTOR
\$1.50
PER SET
WEATHER-PROOF SOCKET
AND CONNECTOR SET...

EDGE CONNECTOR

ALL ARE .156" SPACING
15/30 GOLD
SOLDER EYELET \$2.00 EACH
18/36 GOLD
SOLDER EYELET \$2.00 EACH
22/44 GOLD
SOLDERTAIL (P.C. STYLE)
\$2.50 EA 10 FOR \$22.50
22/44 TIN
SOLDERTAIL (P.C. STYLE)
\$1.35 EA 10 FOR \$12.50
42/84 GOLD
SOLDER EYELET \$4.00 EACH

CANNON XLRA-3-13 CONNECTOR

3 PRONG
CHASSIS MOUNT
CONNECTOR
\$2.00 EACH
10 for \$19.00

2" ALLIGATOR CLIPS

7 clips for \$1.00
100 clips for \$12.00
500 clips for \$50.00

4PDT RELAY

14 pin style
3 amp contacts
24 volt d.c. or
120 volt a.c. coil
Used but fully tested
\$1.70 EACH
specify coil voltage
LARGE QUANTITIES AVAILABLE
SOCKETS FOR RELAY 50c each

6 VDC RELAY

MINIATURE
D.P.D.T.
3 AMP CONTACTS
FUJITSU # FBR321D006
\$1.75 EA 10 / 16.00

8-TRACK AND CASSETTE TAPE PLAYER / RECORDER



COMPLETE CHASSIS
READY TO INSTALL
INTO YOUR CABINET
\$20.00 PER UNIT.

MICROWAVE TRANSISTORS

BRAND NEW, COMPLETELY FUNCTIONAL TAPE DECKS
* RECORD AND PLAY 8 TRACK OR CASSETTE TAPES
* L.E.D. FUNCTION INDICATORS
* COMPLETE SCHEMATIC AND HOOK UP DIAGRAM
* REQUIRES 12.6 - 15 VDC POWER SUPPLY

75 ohm CO-AX

12
FOOT
R.C.A. PLUGS BOTH
ENDS... USED FOR VIDEO
GAMES, ETC \$1.25 EA

KEY SWITCH

S.P.S.T.
4 AMPS @ 125 VAC
KEY REMOVES BOTH
POSITIONS \$3.50 EA

4 POSITION

4 AMPS
USED FOR
@ 125 VAC
CASH REGISTERS
COMES WITH THREE KEYS
#1 OPERATES 2 POSITIONS
#2 OPERATES 3 POSITIONS
#3 OPERATES 4 POSITIONS
KEY REMOVES ONE POSITION
ONLY \$4.50 EACH

MULTI-SWITCH

8 STATION
INTERLOCKING ASSEMBLY
4-D.P.D.T./4-4.P.D.T.
6 1/2" MOUNTING CENTERS
\$3.00 PER ASSEMBLY

5 STATION

INTERLOCKING ASSEMBLY
3-4.P.D.T./2-D.P.D.T.
4 1/8" MOUNTING CENTERS
\$2.50 PER ASSEMBLY

3 STATION

NON-INTERLOCKING
2-D.P.D.T./1-4.P.D.T.
PUSH ON/PUSH OFF STYLE
2 1/2" MOUNTING CENTERS
\$1.50 PER ASSEMBLY

LIGHTED PUSH BUTTON

RED LIGHTED 120 VAC
10 AMP. S.P.S.T.
"POWER" PRINTED ON
FACE. MOUNTS IN
7/8" SQUARE HOLE...
\$1.50 EA 10/ \$13.50

6volt 9amp/hr RECHARGEABLE

ELPOWER # EP690
SOLID GEL CELL
5 1/2" X 4 1/4"
X 2 3/4".....
\$15.00 EACH

0-10 MINUTE TIMER

ADJ. TIMING
MOTOR FROM
0 - 10 MIN.
RATED 10 AMPS.
125 VAC MOUNTS
ON 1" CENTERS...
\$4.75 EACH

MANUFACTURERS - WE WILL PURCHASE YOUR EXCESS INVENTORY (213)380-8000

ALL ELECTRONICS CORP.

905 S. Vermont Ave.
P.O. BOX 20406
Los Angeles, Calif. 90006
(213) 380-8000
Mon. - Fri. Saturday
9 AM - 5 PM 10 AM - 3 PM

SEND SASE for picture of moon from our near perfect parabolic 10 foot reflector 500 dollar. Delivery 3 weeks, getting better. EXPO, 7514 Oak Bluff, Dallas 75240

SOFTWARE for Commodore and Tandy micro-computers. Send \$1.00 for catalogue packed with low prices for quality software. 12 LEELAND DR., Hauppauge, NY

ZX-81 circuit design programs for the Sinclair ZX-81. ZX-TECHNOLOGY, Rt 1, Box 125, Corinth, MS 38834

VIC-20 computer programs! "Adventure," "Races," \$9.95 ea/ppd. Free catalog. Dealers wanted! BYTEHOUSE, Box 981, Salem, NH 03079

CB RADIO

GET more CB channels and range! Frequency expanders, boosters, speech processors. FM converters, ignition noise blankers, how-to books, plans, modifications. Catalog \$2. CB CITY, Box 31500RE, Phoenix, AZ 85046

COMPUTER SOFTWARE

OSI & VIC-20 software and supplies available. Catalog \$1.00. BMS, Box 2132-RE, Oak Park, IL 60303

REEL-TO-REEL TAPES

TRUCKLOAD sale, Ampex Audio Tape. High quality reel to reel 1800' or 2400' on 7" reels, used once. \$45.00 case of 40. B. THIERS, Box 6, Richboro, PA 18954

COMPUTERS & PERIPHERALS

KITS, plans, parts, custom work. Catalog \$2.00. DIOGENES ELECTRONIC SYSTEMS, Box 3921, Amarillo, TX 79106

COMPUTER EQUIPMENT

XEROX, 820 CPU single board computer \$435.00 with 16K memory, 1771 controller for Shugart SA400 of SA800, 2 parallel ports. Catalog \$1.00. RONDURE COMPANY, dept. CW 2522 Butler St., Dallas, TX 75235 (214) 630-4621

WORDWANDS

WRITE messages and creative dot matrix designs in the air with lights! Free info SASE. Kit \$36.80. WORDWAND, P.O. Box 595, Ozona, FL 33560

This year, heart disease and stroke will kill another 200,000 Americans before age 65.

Give the gift of love.



American Heart Association

WE'RE FIGHTING FOR YOUR LIFE

Start Your Back-to-School Project at The Shack®

No Minimum Order! No Waiting! Low Prices!

Ready-to-Use TV RF Module

NEW!

Only
995



- Works With Any Television Set
- Requires Minimum Support Circuitry

UM1285-8. This completely assembled TV RF modulator is ideal for use with computers, video games, VCRs, projects such as video enhancers, adapters and satellite receivers. Accepts color or b/w video, line-level sound. Selectable output, VHF channels 3 or 4. Unique design reduces line-jitter and on-screen bar patterns. PC board mountable. 3 to 8VDC. With data, pin-out, suggested circuit. Why pay more? 277-221 9.95

Trimmer Capacitors



159
Pkg. of 2

NEW!

High "Q" — 300 or More!

5-60 pF. PC mountable, with mini screwdriver slot adjustment. For IF and low-level RF peaking. 272-1340 Pkg. of 2/1.50

IF Amp, FM, Video & PLL ICs

Low As
169



Simplify & Improve Your Designs!

Many applications for these versatile ICs! Check out the included specs and data and you'll probably discover some new uses!

MC1330 Video Detector. Used in many solid-state TV circuits. Replaces 3rd IF, detector, video and AFC buffers. High linearity. Outputs: Wideband video (to 8 MHz), AFT, narrow-band reverse video. 10-24VDC. 8-pin DIP. 276-1757 2.49

MC1350 Universal IF Amp With AGC. For radio and TV circuits. Usable from DC to beyond 60 MHz. Typical gain at 45 MHz: 50 dB. AGC range: 60 dB minimum. 12VDC. 8-pin. 276-1758 2.19

MC1358/CA3065 FM Detector. IF amp, limiter, FM detector, electronic volume attenuator and audio driver in a 14-pin DIP. Use as TV replacement or in homebrew receivers (100 kHz to 5.5 MHz IFs). Just the thing for converting CBs and communications receivers to receive NBFM! 10-24VDC. 276-1759 1.79

LM565 PLL. For FM SCA (background music) and RTTY decoders, modems, infrared communicators, frequency synthesizers and more. 141-pin. 276-1720 1.69

Computer-Project PC Boards

Radio Shack **NEW!** Exclusive!

Highest Quality Dual-Sided Glass

Great for peripheral and format conversion circuits. Fit card edge connectors, sockets and headers—check Shack's wide selection.

Connectors	Contact Points	Size	Cat. No.	Each
40 position	1520	4 1/4 x 5 1/4	276-163	4.95
50 position	2898	5 1/4 x 8 1/4	276-164	4.95
40 position	1520	4 1/4 x 5 1/4	276-165	9.95
50 position	2898	5 1/4 x 8 1/4	276-166	9.95

D-Submini 25 Connectors



Solder Type

NEW!

Can be chassis-mounted. Optional hood allows use of non-ribbon type multiconductor cables when less than 25 conductors are required.

- A Male. 276-1547 2.99
- B Female. 276-1548 3.99
- C Hood. 276-1549 2.19

High-Power Noise Filter



NEW!

Dual "brute-force" L-C sections greatly reduce automobile ignitor/alternator noise in CBs, boosters, tape players. 10 amps. 270-051 17.95

SPST DIP Switch

149

Fits 8-Pin DIP Socket



4-Position

Perfect for on-board low-current switching. 275-1304 1.49

120-Volt Neons

79¢

Pkg. of 2

NEW!

High brightness NE-2's prewired to dropping resistors for 120-volt AC/DC use. 272-1100 2/79¢

Whip Antenna

299

NEW!

Universal replacement with 5 sections, extends from 7 1/4" to 30 1/2". Mounting flange. Red plastic tip for safety. 270-1401 2.99

Autosound Faders And Selector



It's Fix-Up Time!

- A Tape/Radio Selector. 270-045 2.99
- B Selector With Stereo Fader. 270-046 5.99
- C High-Power Fader. Handles 50 watts. 270-048 6.99

Our Best-Ever Analog Multimeter

4995

NEW!



- Big 5-Inch Color-Coded Scale
- Built-In "Beep" Continuity Tester
- Fused and Overload Protected

"Pro" features and durability at a rock-bottom price! 21 ranges, 30,000 ohms-per-volt DC sensitivity, easy access to battery and fuse compartment. Timesaving audible continuity test. Measures to 1000 volts AC and DC in 12 ranges. DC current to 10 amps in five ranges. Resistance to 10 megs in four ranges and dB in five ranges. With manual, probes. Requires 9V and "C" batteries. 22-210 49.95

SPST Toggle Switch With LED Indicator

299



Great for dashboards and projects. LED glows when "on." Rated 5A, 12VDC use only. 7/16" mounting hole. 275-680 2.99

Charging System Analyzer

595



LEDs indicate condition of battery, regulator, alternator. Plugs into lighter socket. 22-1635 5.95

Knobs For 1/4" Shafts Cut 24%

Reg. 1.69
129
Pkg. of 2



"Top Hats" with finely tooled, 2-tone styling. Brass set-screw. 274-423 Sale, Pkg. of 2/1.29

RF Chokes

Now Low As **79¢** NEW LOW PRICE!

10 µH. 1.5 amps. (Was 89¢ in 1982 Catalog). 273-101 79¢
100 µH. 2.0 amps. (Was \$1.09 in 1982 Catalog). 273-102 99¢

Engineer's Notebook II

By Forrest Mims III

128-Page "Idea Book" Of Practical IC Circuits And Data

249



Revised to include more circuits, tips and data. Easy-to-read "graph paper" format. Useful for beginners and "pros" alike! 276-5002 2.49

Radio Shack®

A DIVISION OF TANDY CORPORATION • OVER 8400 LOCATIONS IN 80 COUNTRIES

Retail prices may vary at individual stores and dealers

CIRCLE 44 ON FREE INFORMATION CARD

2716 16K EPROMS **8/\$3.95** EACH

ALL MERCHANDISE 100% GUARANTEED!

2732 32K EPROMS **8/\$7.95** EACH

CALL US FOR VOLUME QUOTES

74LS00

74LS00 .25	74LS85 1.15	74LS168 1.75	74LS295 1.05
74LS01 .25	74LS86 .40	74LS169 1.75	74LS298 1.20
74LS02 .25	74LS90 .65	74LS170 1.75	74LS324 1.75
74LS03 .25	74LS91 .89	74LS173 .80	74LS352 1.55
74LS04 .25	74LS92 .70	74LS174 .95	74LS353 1.55
74LS05 .25	74LS93 .65	74LS175 .95	74LS363 1.35
74LS08 .35	74LS95 .85	74LS181 2.15	74LS364 1.95
74LS09 .35	74LS96 .95	74LS189 9.95	74LS365 .95
74LS10 .25	74LS107 .40	74LS190 1.00	74LS366 .95
74LS11 .35	74LS109 .40	74LS191 1.00	74LS367 .70
74LS12 .35	74LS112 .45	74LS192 .85	74LS368 .70
74LS13 .45	74LS113 .45	74LS193 .95	74LS373 1.75
74LS14 1.00	74LS114 .50	74LS194 1.00	74LS374 1.75
74LS15 .35	74LS122 .45	74LS195 .95	74LS377 1.45
74LS20 .25	74LS123 .95	74LS196 .85	74LS378 1.18
74LS21 .35	74LS124 2.99	74LS197 .85	74LS379 1.35
74LS22 .25	74LS125 .95	74LS221 1.20	74LS385 1.90
74LS26 .35	74LS126 .85	74LS240 1.29	74LS386 .65
74LS27 .35	74LS132 .75	74LS241 1.29	74LS390 1.90
74LS28 .35	74LS136 .55	74LS242 1.85	74LS393 1.90
74LS30 .25	74LS137 .99	74LS243 1.85	74LS395 1.65
74LS32 .35	74LS138 .75	74LS244 1.29	74LS399 1.70
74LS33 .55	74LS139 .75	74LS245 1.90	74LS424 2.95
74LS37 .55	74LS145 1.20	74LS247 .75	74LS447 .37
74LS38 .35	74LS147 2.49	74LS248 1.25	74LS490 1.95
74LS40 .35	74LS148 1.35	74LS249 .99	74LS624 3.99
74LS42 .55	74LS151 .75	74LS251 1.30	74LS668 1.69
74LS47 .75	74LS153 .75	74LS253 .85	74LS669 1.89
74LS48 .75	74LS154 2.35	74LS257 .85	74LS670 2.20
74LS49 .75	74LS155 1.15	74LS258 .85	74LS674 9.65
74LS51 .25	74LS156 .95	74LS259 2.85	74LS682 3.20
74LS54 .35	74LS157 .75	74LS260 .65	74LS683 2.30
74LS55 .35	74LS158 .75	74LS266 .55	74LS684 2.40
74LS63 1.25	74LS160 .90	74LS273 1.65	74LS685 2.40
74LS73 .40	74LS161 .95	74LS275 3.35	74LS688 2.40
74LS74 .45	74LS162 .95	74LS279 .55	74LS689 2.40
74LS75 .50	74LS163 .95	74LS280 1.98	74LS783 24.95
74LS76 .40	74LS164 .95	74LS283 1.00	81LS95 1.69
74LS78 .50	74LS165 .95	74LS290 1.25	81LS96 1.69
74LS83 .75	74LS166 2.40	74LS293 1.85	81LS97 1.69
			81LS98 1.69

WE HAVE

- ★ 74C00
- ★ 74S00
- ★ TRANSISTORS
- ★ 7400
- ★ LINEAR
- ★ ... and much more!

DISKETTES
5 1/4"

ANTHANA SS SD SOFT 24.95
MABASH SS SD SOFT 24.95
VERBATIM SS SD SOFT 29.95
VERBATIM 10 SECTOR HARD 29.95

8"

VERBATIM SS SD SOFT 44.95

APPLE FAN
\$69.00

- ★ Outlet on rear.
- ★ Simply snap over air vents.
- ★ Quiet motor.

MONITORS
ZENITH ZVM-121
\$119.95
NEC JB-1201M
\$169.00

EPSON PRINTERS
MX-80
MX-80FT
MX-100
CALL FOR PRICE

VOLTAGE REGULATORS

7805T .89	7905T .99
7808T .89	7908T .99
7812T .89	7912T .99
7815T .89	7915T .99
7824T .89	7924T .99
7805K 1.39	7905K 1.49
7812K 1.39	7912K 1.49
7815K 1.39	7915K 1.49
7824K 1.39	7924K 1.49
78L05 .69	79L05 .79
78L12 .69	79L12 .79
78L15 .69	79L15 .79

T = TO-220 K = TO-3
L = TO-92

ADD ON DISK DRIVE FOR Apple* II

- ★ Includes metal cabinet
- ★ Color matches Apple*
- ★ 35 Tracks/single side
- ★ Includes cable
- ★ Use with Apple* II Controller

\$375.00
*Apple is a trademark of APPLE COMPUTER INC.

16K APPLE* RAM CARD

- ★ Upgrade your 48K Apple* II to full 64K of RAM.
- ★ Fully software and hardware compatible with the Apple language card and microsoft Z80 card.
- ★ Eliminates the need for the Apple-soft or Integer Basic ROM card when used in conjunction with DOS 3.3.
- ★ Allows you to run Apple Fortran or Pascal with no difficulty.
- ★ Available as bare board, kit, or assembled and tested board.

BARE BOARD \$40.00
KIT 69.96
ASSEMBLED & TESTED ... 74.95
*Apple is a trademark of APPLE COMPUTER INC.



JDR MICRODEVICES, INC.

1224 S. Bascom Avenue
San Jose, CA 95128
800-538-5000 • 800-662-6279 (CA)
(408) 995-5430 • Telex 171-110

HOURS: Mon. - Fri., 9 to 5; Sat. 11 to 3

VISIT OUR RETAIL STORE!

TERMS: For shipping include \$2.00 for UPS Ground, \$3.00 for UPS Blue Label Air, \$10.00 minimum order. Bay Area residents add 6½% sales tax. California residents add 6% sales tax. We reserve the right to limit quantities and substitute manufacturer. Prices subject to change without notice. Send SASE for complete list.

B. G. MICRO

P. O. Box 280298 Dallas, Texas 75228
(214) 271-5546

Visa • MasterCard • American Express

STATIC RAM

21L02-1KX1 250 n.s. Low Power95
2114L-3 1KX4 300 n.s. Low Power	2.75 8/17.50
HM6116P-4-2KX8 + 5v-200 n.s. CMOS Low Power 2716 Style Pin Out	8/69.95
TMM2016-2KX8 +5v-NMOS 200 n.s. - 2716 Style Pin Out	69.95
6501-5 256X4 - CMOS - Data Retention 2 Volts - 22 Pin - 200 n.s. Typ. 5V Very Low Power	1.50
6514 J-5 1KX4-CMOS Super Low Power 350 n.s. Similar to 2114 Same Pin Out	2.95
8108-5 1KX8 NMOS 5V 500 NS 22 Pin	2.50

SOCKETS

Low Profile Solder

8 Pin	13/1.00
14 Pin	10/1.00
16 Pin	8/1.00
18 Pin	8/1.00
20 Pin	7/1.00
24 Pin	6/1.00
28 Pin	6/1.00
40 Pin	5/1.00

Buy \$10 Get \$1.00
FREE CHOICE

CPU

8035	6.95
8039	7.95
8748 Intel	15.95

74LS

LS00 .24	LS125 .95	LS243 1.49
LS02 .24	LS138 .79	LS244 .99
LS04 .24	LS139 .79	LS245 1.95
LS05 .24	LS151 .79	LS257 .79
LS08 .24	LS153 .79	LS266 .59
LS10 .24	LS154 1.75	LS283 .99
LS14 .89	LS157 .79	LS290 .99
LS20 .24	LS161 .99	LS293 1.75
LS27 .24	LS164 .99	LS298 .89
LS30 .24	LS166 .99	LS367 .79
LS32 .36	LS175 .89	LS368 .79
LS42 .49	LS181 1.99	LS373 .99
LS74 .44	LS192 .89	LS374 1.49
LS85 .95	LS193 .89	LS375 1.19
LS86 .39	LS221 1.10	LS377 1.49
LS90 .69	LS240 .99	LS390 1.19
LS109 .39	LS241 .99	LS393 1.19
LS123 .99	LS242 1.49	LS399 .99

MISCELLANEOUS

AY3-8910-Sound Chip with 60 page data manual	12.95
DM8131 6 Bit Unified Bus Comparator	2.99
8 Pin Dip Shunt	3/1.00
TR1602-UART same as AY5-1013	1.99
IM6402-5v High speed UART-AY5-1013 pin out	2.00
MC1408L6 D to A Converter 8 Bit	1.79
AD581J D to A Converter 10 Bit	1.79
1771 Single Density FDC	22.50
1791 Double Density FDC	29.95
5027-CRT Controller - Programmable - 24 x 80	14.95
68B45 - Motorola (HD46505SP) CRT Controller	17.59
82S123-32X8 Tri State Bi polar PROM	2.49
82S129 Tri State Bi Polar Prom	2.59

EPROM

1702A 256X8 1 us	2.50
2708 1KX8 450 n.s.	2.95
27A08 1KX8 350 n.s.	3.95
2716 2KX8+5v 450 n.s.	5.95
(Buy 2 Get 1 FREE.)	
2716-1 2KX8+5v 350 n.s.	9.95
2732 4KX8 450 n.s. Intel Pin Out	9.95
2732A-3 4K x 8 350 n.s. Intel Pin Out Low Power	12.95
2532 4KX8 450 n.s. T.I. Pin Out	9.95

Z80

Z80 2.5 MHZ CPU	4.95
Z80DMA-DMA Controller	9.95
Z80PIO - Parallel	5.95
Z80SIO/O Chan. Ser.	16.95
Z80A-4MHZ CPU	8.95
Z80A SIO/O	19.95

4K STATIC RAMS
LESS THAN 94¢ EACH
MK4104J-4 - 250 N.S. 18 Pin Ceramic
Computer Mfg. Surplus. PRIME. Fully
Static easy to Use. Has Same Pin Out as
TMS4044, but slightly different timing.
With Specs. (Mostek)

8 for 8.95 32 for 29.95
VERY LOW POWER!

DYNAMIC RAM

5280N-5 (2107B-4 • TMS4060) 4KX1 22 Pin	8/3.95
4027-4KX1-250 n.s.	1.75
4116-16KX1-200 n.s.	8/14.95
4164-+5v 64K	12.95 8/79.95

PRECISION HYBRID OSCILLATOR MODULE

Has both 1 MHZ and 2 MHZ TTL - outputs -
Hermetically sealed - Ultra high stability over
wide temp. range - originally cost over \$40.00
each - we made a super purchase from a major
computer manufacturer - 5 Volt operation - fits
standard 24 pin socket - Manufactured by
Motorola oscillator division

7.50 (w/data)
MC6871A

3/20.00

CALL OR WRITE FOR PRICES ON CMOS-8080 - BIT SLICE - TTL - 74S - CRYSTALS - DIP SWITCHES

TERMS: Add \$1.50 postage, we pay balance. Orders over \$50.00 add 85¢ for insurance. No C.O.D. Texas Res. add 5% Tax. 30 Day Money Back Guarantee on all items. All items subject to prior sale. Prices subject to change without notice. Foreign order. U.S. funds only. We cannot ship to Mexico. Countries other than Canada, add \$3.50 shipping and handling.

CIRCLE 56 ON FREE INFORMATION CARD

ELECTRONIC KITS FROM HAL-TRONIX

2304 MHZ DOWN CONVERTERS. TUNES IN ON CHANNELS 2 TO 7 ON YOUR OWN HOME T.V. HAS FREQUENCY RANGE FROM 2000 MHZ TO 2500 MHZ. EASY TO CONSTRUCT AND COMES COMPLETE WITH ALL PARTS INCLUDING A DIE-CAST ALUM CASE AND COAX FITTINGS, REQUIRE A VARIABLE POWER SUPPLY AND ANTENNA (Antenna can be a dish type or coffee can type depending on the signal strength in your area.)

2304 MOD 1 (Basic Kit)	\$49.95
(Less case & fittings)	
2304 MOD 2 (Basic / Pre-amp)	\$59.95
(Includes case & fittings)	
2304 MOD 3 (Hi-Gain Pre-amp)	\$69.95
(Includes case & fittings)	
POWER SUPPLY FOR EITHER MODEL ABOVE IS AVAILABLE. COMES COMPLETE WITH ALL PARTS, CASE, TRANSFORMER, ANTENNA SWITCH AND CONNECTORS (Kit)	\$24.95
Assembled	\$34.95
Slotted Microwave Antenna For Above Downverters	\$39.95

PREAMPLIFIERS

HAL PA-19—1.5 mhz to 150 mhz. 19db gain operates on 8 to 18 volts at 10ma. Complete unit \$8.95.
HAL PA-1.4—3 mhz to 1.4 ghz. 10 to 12 db gain operates on 8 to 18 volts at 10ma. Complete unit \$12.95.
(The above units are ideal for receivers, counters, etc.)

16 LINE TOUCH TONE DECODER KIT WITH P.C. BOARD AND PARTS

12 LINE TOUCH TONE DECODER KIT WITH P.C. BOARD AND PARTS

16 LINE ENCODER KIT, COMPLETE WITH CASE, PAD AND COMPONENTS

12 LINE ENCODER KIT, COMPLETE WITH CASE, PAD AND COMPONENTS

MANY, MANY OTHER KITS AVAILABLE

Send 20 cents stamp or S.A.S.E. for information and flyer on other HAL-TRONIX products. To order by phone: 1-313-285-1782.



HAL-TRONIX
P.O. Box 1101
Southgate, MI 48195

SHIPPING INFORMATION.

ORDERS OVER \$25.00 WILL BE SHIPPED POSTPAID EXCEPT ON ITEMS WHERE ADDITIONAL CHARGES ARE REQUIRED. ON ORDERS LESS THAN \$25.00 PLEASE INCLUDE ADDITIONAL \$3.00 FOR HANDLING AND MAILING CHARGES.

CIRCLE 66 ON FREE INFORMATION CARD

OMNITRON: The Source for Quality at Low Cost

Silicon H.V. Triplers

HIGH VOLTAGE MULTIPLIERS



SYLVANIA Triplers

ECG-500A
212-139
212-139-01
212-139-02
\$12⁹⁵ ea.

ECG-523
212-141
212-141-01
\$15⁰⁰ ea.

ECG-526A
212-141-02
212-141-03
212-141-04
\$16⁹⁹ ea.

REMEMBER!
Sylvania Tubes
70% + 10% OFF LIST

Sylvania ECG Replacement Semiconductors and Components
Full line in stock. The best quality semiconductor.

RG-59/U 75 OHM Co-Axial Cable
Copper Braided Shield
White or Black
\$44⁵⁰/1000 ft.

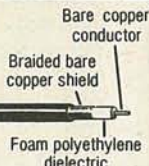

F-59 Connector with Separate Ferrule 10¢/100 lot



Matching Transformer 75-300 Ohm 59¢ ea. \$44⁰⁰/100



2 Way - 75 Ohm Coupler MT-2 \$14⁰⁰ ea. \$89⁰⁰/100



2 SC1172B \$1⁹⁹

VERY POPULAR

80 MFD x 450 Volts... .99
100 MFD x 450 Volts...1.09

SOLDER (60/40 Rosin Core) 1 lb. -.062 dia. (regular size) \$7⁹⁹ SOL-1

SOLDER WICK 99¢ Solder Removal SW-5 1/4" Wide (Thick Type)-5 feet

SILICON RECTIFIER 2.5 Amp/1000 PIV 100/\$9⁹⁵ SL-100

GLOBAR DISC - 120 Ohms Cold 107191 RCA 99¢

10 ASSORTED CIRCUIT BREAKERS 10/\$7⁹⁹ Good Assortment CB-10

CHEATER CORDS Polarized C Clip Price: 39¢ 24620 Standard C Clip Price: 39¢ 24623

REPLACEMENT RODS
4 Section LAR-4 69¢
5 Section LAR-5 89¢
6 Section LAR-6 99¢
7 Section LAR-7 99¢

G.E. OM-300 \$149
PANASONIC OM-500 \$159

OMNITRON

ELECTRONICS
770 Amsterdam Ave., New York, NY 10025

Also ask for Free 100 Page Catalog

Send Purchase Order, Check or Money Order
or Call Toll Free 800-223-0826

in NY STATE (212) 865-5580

ALL ORDERS SHIPPED UPS/COD F.O.B., N.Y.C.

MASTER CARD • VISA

ramsey**the first name in Counters!****9 DIGITS 600 MHz \$129⁹⁵ WIRED**

PRICES:

CT-90 wired, 1 year warranty	\$129.95
CT-90 Kit, 90 day parts warranty	109.95
AC-1 AC adapter	3.95
BP-1 Nicad pack + AC Adapter/Charger	12.95
OV-1, Micro-power Oven time base	49.95
External time base input	14.95

The CT-90 is the most versatile, feature packed counter available for less than \$300.00! Advanced design features include: three selectable gate times, nine digits, gate indicator and a unique display hold function which holds the displayed count after the input signal is removed! Also, a 10mHz TCXO time base is used which enables easy zero beat calibration checks against WWV. Optionally, an internal nicad battery pack, external time base input and Micro-power high stability crystal oven time base are available. The CT-90, performance you can count on!

SPECIFICATIONS:

Range:	20 Hz to 600 MHz
Sensitivity:	Less than 10 MV to 150 MHz Less than 50 MV to 500 MHz
Resolution:	0.1 Hz (10 MHz range) 1.0 Hz (60 MHz range) 10.0 Hz (600 MHz range)
Display:	9 digits 0.4" LED
Time base:	Standard-10,000 mHz, 1.0 ppm 20-40°C. Optional Micro-power oven-0.1 ppm 20-40°C
Power:	8-15 VAC @ 250 ma

7 DIGITS 525 MHz \$99⁹⁵ WIRED**SPECIFICATIONS:**

Range:	20 Hz to 525 MHz
Sensitivity:	Less than 50 MV to 150 MHz Less than 150 MV to 500 MHz
Resolution:	1.0 Hz (5 MHz range) 10.0 Hz (50 MHz range) 100.0 Hz (500 MHz range)
Display:	7 digits 0.4" LED
Time base:	1.0 ppm TCXO 20-40°C
Power:	12 VAC @ 250 ma

The CT-70 breaks the price barrier on lab quality frequency counters. Deluxe features such as; three frequency ranges - each with pre-amplification, dual selectable gate times, and gate activity indication make measurements a snap. The wide frequency range enables you to accurately measure signals from audio thru UHF with 1.0 ppm accuracy - that's .0001%! The CT-70 is the answer to all your measurement needs, in the field, lab or ham shack.

PRICES:

CT-70 wired, 1 year warranty	\$99.95
CT-70 Kit, 90 day parts warranty	84.95
AC-1 AC adapter	3.95
BP-1 Nicad pack + AC adapter/charger	12.95

**7 DIGITS 500 MHz \$79⁹⁵ WIRED****PRICES:**

MINI-100 wired, 1 year warranty	\$79.95
AC-Z Ac adapter for MINI-100	3.95
BP-Z Nicad pack and AC adapter/charger	12.95

Here's a handy, general purpose counter that provides most counter functions at an unbelievable price. The MINI-100 doesn't have the full frequency range or input impedance qualities found in higher price units, but for basic RF signal measurements, it can't be beat! Accurate measurements can be made from 1 MHz all the way up to 500 MHz with excellent sensitivity throughout the range, and the two gate times let you select the resolution desired. Add the nicad pack option and the MINI-100 makes an ideal addition to your tool box for "in-the-field" frequency checks and repairs.

SPECIFICATIONS:

Range:	1 MHz to 500 MHz
Sensitivity:	Less than 25 MV
Resolution:	100 Hz (slow gate) 1.0 KHz (fast gate)
Display:	7 digits, 0.4" LED
Time base:	2.0 ppm 20-40°C
Power:	5 VDC @ 200 ma

8 DIGITS 600 MHz \$159⁹⁵ WIRED**SPECIFICATIONS:**

Range:	20 Hz to 600 MHz
Sensitivity:	Less than 25 mv to 150 MHz Less than 150 mv to 600 MHz
Resolution:	1.0 Hz (60 MHz range) 10.0 Hz (600 MHz range)
Display:	8 digits 0.4" LED
Time base:	2.0 ppm 20-40°C
Power:	110 VAC or 12 VDC

The CT-50 is a versatile lab bench counter that will measure up to 600 MHz with 8 digit precision. And, one of its best features is the Receive Frequency Adapter, which turns the CT-50 into a digital readout for any receiver. The adapter is easily programmed for any receiver and a simple connection to the receiver's VFO is all that is required for use. Adding the receiver adapter in no way limits the operation of the CT-50, the adapter can be conveniently switched on or off. The CT-50, a counter that can work double-duty!

PRICES:

CT-50 wired, 1 year warranty	\$159.95
CT-50 Kit, 90 day parts warranty	119.95
RA-1, receiver adapter kit	14.95
RA-1 wired and pre-programmed (send copy of receiver schematic)	29.95

**DIGITAL MULTIMETER \$99⁹⁵ WIRED****PRICES:**

DM-700 wired, 1 year warranty	\$99.95
DM-700 Kit, 90 day parts warranty	79.95
AC-1, AC adaptor	3.95
BP-3, Nicad pack + AC adapter/charger	19.95
MP-1, Probe kit	2.95

The DM-700 offers professional quality performance at a hobbyist price. Features include: 26 different ranges and 5 functions, all arranged in a convenient, easy to use format. Measurements are displayed on a large 3 1/2 digit, 1/2 inch LED readout with automatic decimal placement, automatic polarity, overrange indication and overload protection up to 1250 volts on all ranges, making it virtually goof-proof! The DM-700 looks great, a handsome, jet black, rugged ABS case with convenient retractable tilt-bail makes it an ideal addition to any shop.

SPECIFICATIONS:

DC/AC volts:	100uV to 1 KV, 5 ranges
DC/AC current:	0.1uA to 2.0 Amps, 5 ranges
Resistance:	0.1 ohms to 20 Megohms, 6 ranges
Input impedance:	10 Megohms, DC/AC volts
Accuracy:	0.1% basic DC volts
Power:	4 °C cells

AUDIO SCALER

For high resolution audio measurements, multiplies UP in frequency.

- Great for PL tones
- Multiplies by 10 or 100
- 0.01 Hz resolution!

\$29.95 Kit \$39.95 Wired

ACCESSORIES

Telescopic whip antenna - BNC plug.....	\$ 7.95
High impedance probe, light loading.....	15.95
Low pass probe, for audio measurements.....	15.95
Direct probe, general purpose usage.....	12.95
Tilt bail, for CT 70, 90, MINI-100.....	3.95
Color burst calibration unit, calibrates counter against color TV signal.....	14.95

COUNTER PREAMP

For measuring extremely weak signals from 10 to 1,000 MHz. Small size, powered by plug transformer-included.

- Flat 25 db gain
- BNC Connectors
- Great for sniffing RF with pick-up loop

\$34.95 Kit \$44.95 Wired

ramsey electronics, inc.

2575 BAIRD RD. • PENFIELD, NY 14526



PHONE ORDERS
CALL 716-586-3950

TERMS

Satisfaction guaranteed, examine for 10 days, if not pleased return in original form for refund. Add 5% for shipping - insurance to a maximum of \$10. Overseas add 15%. COD, add \$2. Orders under \$10, add \$1.50. NY residents, add 7% tax.

CIRCLE 41 ON FREE INFORMATION CARD

AUGUST 1982

101



FORMULA INTERNATIONAL INC.

12603 CRENSHAW BOULEVARD • HAWTHORNE, CALIFORNIA 90250 • (213) 973-1921



Introducing THE Pineapple



48K Color Computer Kit

Easy to assemble! All components are clearly silk screened on the circuit board. Kit includes predrilled double sided PC Board, all integrated circuits, sockets, professional high-impact plastic casing, keyboards, connectors and switching power supply.

Features

- Numeric key pad
- Game paddle jacks on both sides
- Speaker volume control on the back.

\$645⁰⁰

per kit

No C.O.D. orders

Dealer inquiries invited.

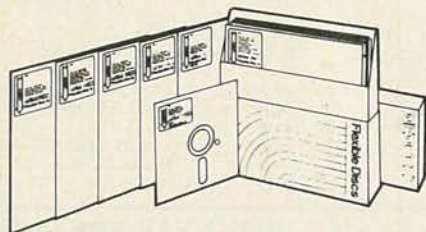

For Data Reliability—Memorex Flexible Discs

5 1/4" Flexible Disc Sale

Why buy other brands when you can buy MEMOREX disc for much less and backed by 1 year factory warranty.

ALL for these LOW PRICES:

1-9	10-99	100-499
\$2.45	\$2.15	\$2.00

500 & up
call for info.

5 1/4 Single Sided, Double Density, Soft Sector
 5 1/4 Single Sided, Double Density, 10 Hard Sector
 5 1/4 Single Sided, Double Density, 16 Hard Sector

BEC BULLET ELECTRONICS

P.O. BOX 401244R GARLAND, TX. 75040 (214) 278-3553

Sound Effects Kit \$18.50



The SE-01 is a complete kit that contains all the parts to build a programmable sound effects generator. Designed around the new Texas Instruments SN74477 Sound Chip, the board provides banks of MINI DIP switches and pots to program the various combinations of the 5LF Oscillator, VCO, Noise, One Shot, and Envelope Controls. A Quad Op Amp IC is used to implement an Adjustable Pulse Generator, Level Comparator and Multiplex Oscillator for even more versatility. The 3" x 5" PC Board features a prototype area to allow for user added circuitry. Easily programmed to duplicate Explosions, Phaser Guns, Steam Trains, or almost an infinite number of other sounds. The unit has a multiple of applications. The low price includes all parts assembly manual, programming charts, and detailed 76477 chip specifications. It runs on a 9V battery (not included). On board 100mV amp will drive a small speaker directly, or the unit can be connected to your stereo with incredible results! (Speaker not included) 76477 is included. Available separately for \$3.15 each.

The Super Music Maker REVISION 2 \$24.95 (Basic Kit) SEE SPECIAL OFFER BELOW



- Comes with 25 pre-programmed tunes.
- On board 7 watt amplifier drives 8 ohm speaker directly.
- Works on 12VAC or 12 VDC
- Uses either 2708 or 2716 EPROM for expanded tune playing capability. Listing available pre-programmed ROMs.

A true electronic music maker based on a microprocessor chip. The Super Music Maker is the only kit that allows easy addition of pre-programmed tunes by plugging in one memory chip (ROM). Over 20 different ROM's with over 500 tunes are available. Use the kit for a Car Horn, Doorbell, Door Announcer, etc. If you have an EPROM programmer our manual tells you how to program your own tunes. Kit includes quality plated and drilled PC Board and all components.

OPTIONAL ACCESSORIES

DIP SWITCHES One 8 pos., one 5 pos., for tune address 2.00/set
WALLPLUG TRANSFORMER For operation on 117VAC house current 3.00
INJECTION MOLDED PLASTIC CASE w/custom front & rear panels, hardware and 2 five pos. rotary switches (replaces DIP switches) 8.00
HORN SPEAKER 8 watt, 8 Ohm with mounting bracket 8.25

SPECIAL OFFER

Buy a Super Music Maker kit for \$24.95 and get FREE, a 2708 ROM pre-programmed with 35 popular tunes. This offer gives you over 60 songs to choose from!

7 Watt Audio Amp Kit \$6.95

SMALL, SINGLE HYBRIDIC AND COMPONENTS FIT ON A 2" x 3" PC BOARD (INCLUDED). RUNS ON 12VDC. GREAT FOR ANY PROJECT THAT NEEDS AN INEXPENSIVE AMP. LESS THAN 3% THD @ 5 WATTS. COMPATIBLE WITH SE-01 SOUND KIT.

Doomsday Alarm Kit \$9.95

If you have trouble sleeping and you would like the rest of the neighborhood to share your misery then this little kit will be for you! There is no way to accurately describe the unearthly howls, screams and tones that come out of this kit. Four separate tone oscillators are mixed, cancelled and stepped at a varying rate. 10 Watts of crazy sounds. A great fun kit or a practical burglar alarm. Complete with PC board and all necessary components less speaker. For 6-12 VDC. ORDER DA-02.

THE PRESIDENT SAYS: "HOGWASH!!"

After taking one look at the TRIPUT POWER SUPPLY our engineer declared that the units were worth several hundred dollars each. He pointed out the engineering, high quality construction and state-of-the-art integrated design in support of his position. The President of BEC more pragmatically pointed out the already full warehouse and the two trailer truck loads of power supplies waiting in the parking lot, and set the price to move them QUICKLY!

3 OUTPUTS
12V @ 8A (12A Int.)
5V @ 10A
-12V @ 5A
INPUT 105 - 125VAC



COMPLETE UNIT (as you receive it)

62.50

Plus \$5.00 Freight
21 lbs. 6 x 5 1/2 x 12
ONE TIME OFFER! LIMIT TWO (2) SUPPLIES PER CUSTOMER.

- UNIT IS COMPLETELY ASSEMBLED!
- Fused primary and DC sections
- HUGE SHIELDED TRANSFORMER
- 2% Load & Line Regulation
- Low Ripple <100mV
- Over 80,000 mfd of filters
- High Efficiency Switching Regulator reduces heat sink area
- Short Circuit Protection
- Schematics and service guide included
- Thermal Shutdown
- Static LED's (3)

• COD MINIMUM \$20.00 • ADD \$2.50 FOR COD'S
• UPS DELIVERY ADDRESS MUST ACCOMPANY ALL COD ORDERS
• \$1.00 HANDLING ON ORDERS UNDER \$10.00
• VISA, MC CARDS OR CHECK
• ADD 6% FOR SHIPPING
• TEXAS RESIDENTS ADD 5% STATE SALES TAX
• ALL FOREIGN ORDERS ADD 25% FOR SHIPPING (CANADA 15%) NO FOREIGN CDS
• CALL (214) 278-3553 TO PLACE CREDIT CARD OR COD ORDER

SPECIALS

8255 → \$5.95
8748-8 → \$31.00
3341PC → \$2.00
MM5060 → 35¢
MC6800 → \$7.75
MC6802 → \$14.95
MC6850 → \$4.50
MC6821 → \$4.95

REAL-TIME CLOCK CALENDAR (MSM 5832)

Description Mono Metal Gate CMOS IC
features
Time, Month, Date, Year, & Day of Week
• Bus Oriented
• 1 Bit Data Bus \$7.45 w/SPIC 1
• 1 Bit Address
• R/W Hold Select
• Inter Signal
• 32 768KHz xtal Control \$2.85
• 5V Pow Sup
• Low Power Dissipation

DISKETTE SALE!! 'WABASH'

5 1/4 8inch
SS/SD \$25.00 \$25.00
SS/DD 27.40 30.40
DS/DD 32.40 37.40

Box of 10 pcs

QTY. PRICE AVAIL

COMPUTERS ATARI® 800™ COMPUTER SYSTEM



400 w/16K \$350.00
800 w/16K \$699.00
*800 Computer w/48K
*BEST BUY \$825.00

ATARI PERIPHERALS:

Printer 825 - 650.00 Asteroids
Disk Dr 810 - 485.00 Missile Com. → 32.50
Record 410 - 82.00 Sup. Brk Out
Paddle (pr) 16.95 Assem. Edit - 49.00
Joystick (pr) 16.95 Star Raiders - 45.00
32k RAM - 179.95 Basketball - 28.00
Basic Cart - 49.00 Chess - 32.00

* MONITORS *

ZENITH 1 1 Green Phos
12in. 15MHz. Hi-Res. → \$118.50
J.C.S. 2 2 Green Phos.
12in. 18MHz. Hi-Res. → \$155.50
AMDEK 3 Non glare
12in. 12MHz. Screen
13in Color. 3 Green Phos. → \$165.50
3a Hi-Res. → \$375.50
3a Lo-Res. → \$375.50

CONCORD COMPUTER PRODUCTS

1971 SO STATE COLLEGE ANAHEIM CALIF 92806

(714) 937-0637

NO P.O. BOX SHIP

COMPONENTS

74LS SERIES				7400 SERIES			
74LS00	24	74LS83	70	74LS165	85	7400	18
74LS02	24	74LS86	38	74LS169	155	7402	18
74LS03	24	74LS90	60	74LS170	155	7404	18
74LS04	24	74LS91	85	74LS174	85	7408	23
74LS05	24	74LS92	65	74LS175	85	7409	18
74LS06	24	74LS93	60	74LS190	90	7410	18
74LS08	28	74LS95	80	74LS191	90	7411	22
74LS10	24	74LS107	38	74LS221	110	7412	22
74LS11	33	74LS109	38	74LS240	95	7413	32
74LS12	33	74LS112	40	74LS241	95	7414	45
74LS13	45	74LS113	40	74LS244	85	7415	24
74LS14	89	74LS114	45	74LS245	155	7416	24
74LS20	24	74LS122	40	74LS248	100	7417	24
74LS21	24	74LS123	35	74LS249	90	7418	24
74LS22	24	74LS125	90	74LS251	120	7419	24
74LS27	28	74LS126	85	74LS253	80	7420	18
74LS28	32	74LS132	70	74LS257	80	7421	30
74LS29	24	74LS136	50	74LS258	80	7422	25
74LS32	32	74LS138	65	74LS259	125	7423	25
74LS37	50	74LS139	65	74LS260	60	7424	45
74LS38	32	74LS145	110	74LS273	300	7425	25
74LS42	50	74LS151	70	74LS275	300	7426	25
74LS43	70	74LS153	70	74LS279	50	7427	25
74LS51	24	74LS157	70	74LS283	75	7428	25
74LS55	35	74LS158	70	74LS373	90	7429	25
74LS74	35	74LS161	85	74LS374	150	7430	25
74LS76	38	74LS163	85	74LS377	140	7431	25
74LS78	50	74LS164	85			7432	25
						7433	19

DYNAMIC RAMS				74S SERIES			
4027	2.00	8/1.75	ea	74S00	35	74S86	1.10
4116	200ns	11	8/13.00	74S02	38	74S12	1.45
4164	200ns	9.50		74S03	38	74S132	1.10
				74S04	45	74S138	95
				74S05	65	74S140	1.25
				74S08	40	74S158	1.25
				74S10	55	74S174	95
				74S15	55	74S175	95
				74S20	55	74S181	4.00
				74S22	75	74S182	2.75
				74S30	35	74S188	3.50
				74S37	1.25	74S240	3.50
				74S51	60	74S244	3.50
				74S55	95	74S248	3.50
				74S74	55	74S472	15.00
				74S75	2.00		

STATIC RAMS				EPROMS			
2111	2.85	8/2.50	ea	1702	4.25	8/3.95	ea
2112	2.85	8/2.50	ea	2708	2.95	8/2.85	ea
2114	2.00	4/1.00	ea	2716(SV)	5.00	8/4.50	ea
2114L	2.25	4/2.00	ea	TMS2716	8.95	8/8.00	ea
HM6116	200ns	11.50	4/10.50	MC6802	14.95	10.50	8/9.25
				MC6821P	4.95	TMS2532	11.50
				MC6850P	4.50		

MISC				I.C. SOCKETS			
8726	1.20			ww	p	at	
8728	1.20			8	8	10/1.20	
8038	2.75	8212	1.95	10/5/30	14	10/1.30	
8080A	3.75	8216	1.80	10/5/70	16	10/1.40	
8155	10.50	1103A	95	10/8/70	20	10/2.70	
8255	4.50	1103B	19.85	10/12/70	22	10/2.70	
MC1330	1.65	AY5 1013A	3.00	10/13/70	24	10/2.70	
MC1350	1.15	1488	95	10/14/70	28	10/3.00	
MC1358	1.50	1489	95	10/17/80	40	10/3.80	
MC1458	55	MC6802	14.95	wirewrap			
LM380	1.10	MC6821P	4.95				
LM385	1.40	MC6850P	4.50				
LM565	95						
LM741	25						
LM1310	2.90						
LM1800	2.95						
LM1889	1.45						

Table with 4 columns of part numbers and prices. Includes parts like SN7400N, SN7401N, SN7402N, etc.

Table with 4 columns of part numbers and prices. Includes parts like 74LS00, 74LS01, 74LS02, etc.

Table with 4 columns of part numbers and prices. Includes parts like 74S00, 74S01, 74S02, etc.

Table with 4 columns of part numbers and prices. Includes parts like CA3010H, CA3011H, CA3012H, etc.

Table with 4 columns of part numbers and prices. Includes parts like CD4000, CD4001, CD4002, etc.

MICROPROCESSOR COMPONENTS

Table with 4 columns of part numbers and prices. Includes sections for Static RAMs, Dynamic RAMs, EPROMs, Microprocessor Chips, ROMs, NMOS Read Only Memories, Data Acquisition, and Special Function.

Table with 4 columns of part numbers and prices. Includes sections for Microprocessor Manuals, 8080/8080 Support Devices, and 8080/8080A Support Devices.

INTER-SIL

Table with 4 columns of part numbers, functions, and prices. Includes parts like 7065PI, 7065E/KIT*, 7106CPL, etc.

Table with 4 columns of part numbers and prices. Includes parts like 74C00, 74C01, 74C02, etc.

Table with 4 columns of part numbers and prices. Includes parts like LM1002CN, LM1001LH, LM1111LH, etc.

★ SHIPMENT IN 24 HOURS ★
6:00 AM TO 6:00 PM (PST)
Call: (415) 592-8097

IC SOCKETS

Table with 4 columns of socket types and prices. Includes Low Profile (Tin) Sockets and Solderless Standard (Tin).

Table with 4 columns of wire wrap sockets and prices. Includes Wire Wrap Sockets (Gold) Level #3.

CAPACITOR CORNER

Table with 4 columns of capacitor specifications and prices. Includes 50 Volt Ceramic Disc Capacitors and 100 Volt Mylar Film Capacitors.

Advertisement for Jameco Electronics, 1355 Shoreway Road, Belmont, CA 94002. Includes phone number (415) 592-8097 and a 'NEW 1982 CATALOG' badge.

Table with 4 columns of capacitor specifications and prices. Includes Mini. Aluminum Electrolytic Capacitors.



AMAZING DEVICES

PHASORS
PHASOR PAIN FIELD — Patented and recently developed in our labs is being tested by Gov't for riot control. Soon to come under weapons restrictions as an infernal machine. Easily hand-held. Hazardous IF NOT USED WITH DISCRETION. **\$15.00**
PPF-1 PLANS (sold for animal control) **\$7.00**
INVISIBLE PAIN FIELD GENERATOR — Produces a directional field of moderately intense pain to back of head up to 50". Cigarette pack size enclosure is easily hidden. **\$44.50**
IPG-3 PLANS **\$7.00** **IPG-3K KIT & PLANS** **\$59.50**
IPG-30 (assembled for animal control) **\$59.50**
PHASOR STUN/BURNING WAND — Produces sufficient electrical energy capable of burning flesh. Intended as a personal defense device. **\$8.00** **PSW-3K KIT & PLANS** **\$59.50**

LASERS
RUBY LASER RAY PISTOL — Intense visible red, burns, hazardous, with parts sources. **\$15.00**
RUBY PLANS (includes all part sources) **\$15.00**
CARBON DIOXIDE LASER — Generates 20-40 watts of continuous power capable of burning, cutting, hazardous. (with all part sources) **\$15.00**
LASER RIFLE — Produces 200-3000 pulses of 30 watt optical energy. Portable and easily hand-held. **\$10.00**
LRG-3 PLANS **\$10.00**
LRG-3K KIT PLANS (minus diode) **\$129.50**
POCKET LASER — For the beginner, visible red 'optical version', non-hazardous. **\$5.00** **LHC-2K KIT & PLANS** **\$24.50**
HIGH POWERED PORTABLE ENERGY SOURCE FOR LASERS AND MAGNETIC WEAPONS — Exploding wires, shockwave, etc. Miniature size. **\$8.00** **HPS-1K KIT & PLANS** **\$49.50**
ARTICLE BEAM WEAPON — PLANS **\$15.00**

SECURITY
INFINITY XMTR — Uses telephone lines for selective home or office listening while away on business or vacation. **\$15.00**
INF-1 PLANS **\$15.00**
SEE IN DARK — Long range, total darkness. **\$10.00**
SD-4 PLANS **\$10.00**
LONG RANGE WIRELESS MIKE — Crystal clear quality — miniature. **\$7.00** **FBT-7K PLANS & KIT** **\$34.50**
WIRELESS TELEPHONE TRANSMITTER — Long range, automatic. **\$10.00** **VWPM-5K PLANS & KIT** **\$34.50**

Send for **FREE** catalog description of above plus hundreds more plans, kits and completed items. We accept MC or Visa or when ordering, send check or money order. We pay shipping charges on orders over \$50.00, otherwise include 10% with remittance.
SEND TO: SCIENTIFIC SYSTEMS
 DEPT. R8, BOX 716, AMHERST, N.H. 03031

CIRCLE 65 ON FREE INFORMATION CARD

over 1600 products!

includes technical tips & information

FREE CATALOG

Burglar/Fire Alarms Security Products



Alarm Controls • Remote Stations
 Infrared • Motion Detectors • Sirens
 Microwave • CCTV • Fire Detectors
 Vehicle Alarms • Phone Dialers
 Key Locks • Wireless Components
 Magnetic Contacts • Glass Protection
 Lights • System Parts • Tools • Books
 Bells • Ionization Smoke Detectors

mountain west
 4215 N. 16th Street Dept. RE-8
 Phoenix, AZ 85016
 1-800-528-6169

CIRCLE 64 ON FREE INFORMATION CARD

MICROWAVE EQUIPMENT and KITS
 ANTENNA parabolic fiberglass antenna 20", approx. 20db gain **\$49.95**
 HANVERT II hi-gain 4 transistor 2.1-2.4 GHz to VHF TV ch. 2-6, down converter w/metal case. KIT **39.95**
 ASSEMBLED & TESTED **59.95**
 POWER II precision 8-15VDC power supply for down converters... KIT **24.95**
 ASSEMBLED & TESTED **39.95**
 MICROWAVE RECEIVING SYSTEM - ALL THREE - ASSEMBLED AND TESTED **124.95**

SUPER LED's
 2amp. rating w/heat sink
 ME2 IR (a) 25A pulse
 ME5 IR (b) \$4.95 each
 MV4 RED (a) 6-32 stud

RESISTOR SALE
 .25W 5% carbon film- \$1.50 per 100 (one value)
 all standard values from \$2 per 1000
 2.7 to 4.7M ohms

SPECIALS
 8085 NEC CERAMIC 40 PIN CPU CHIP **\$6.95**
 MM5290J NSC 16K/1 DYNAMIC RAM(4116) **2.95**
 B2758 INTEL EPROM 1K/8 **8.95**
 TRIAC 8A-600V TO220 RCA **.75**
 VOX- MICROPHONE, AMP, 2A SCR, PC BD **.95**
 H11A2 C.E. OPTO ISOLATOR 6 PIN DIP **.25**
 5101 256X4 CMOS RAM 22 PIN DIP **4.95**
 TRIAC 25AMP 400V ON 3X6" HEAT SINK **2.95**
 7402 TTL QUAD 2 IN NOR GATE DIP **.10**
 7430 TTL 8 IN NAND GATE DIP **.10**
 7440 TTL DUAL 4 IN NAND BUFFER DIP **.10**
 TO-92 PNP TRANSISTOR PAK 100 PRIME **5.00**
 747 DUAL 741 OP-AMP 14 PIN DIP **.50**
 LH0021 NSC 1 AMP OP-AMP 8 PIN TO-3 **5.00**
 2504T 1024 BIT DYN. SHIFT REG-TO-5 **1.00**
 2416 INTEL 256X64 CCD SERIAL MEM. **2.50**
 5244 INTEL CCD DRIVER **3.00**

we pay post on orders for \$10 or more. All payment must be in U.S. funds. Foreign orders must include post. BAC & MC are not prepaid orders and shipping is added.
BOX 41778
 Sacramento, Ca. 95841
 916 334 2161 4811 MYRTLE AVE
BABYLON ELECTRONICS
 BANKAMERICAN

CIRCLE 67 ON FREE INFORMATION CARD



ORCA TECHNOLOGIES

74LS	
LS00	20
LS02	23
LS03	23
LS04	23
LS05	23
LS08	23
LS10	23
LS11	30
LS14	40
LS20	23
LS27	23
LS30	23
LS32	28
LS37	40
LS51	23
LS54	30
LS74	32
LS85	80
LS86	32
LS93	60
LS107	36
LS109	36
LS112	40
LS123	60
LS126	50
LS145	11.05
LS138	50
LS151	38
LS153	38
LS154	75
LS155	80
LS156	80
LS157	45
LS160	95
LS161	70
LS163	80
LS164	80
LS165	80
LS166	80
LS173	85
LS174	80
LS175	38
LS191	80

Z-80 2.5 MHz	
Z80 CPU	6.50
Z80 DMA	17.50
Z80 PIO	5.20
Z80 CTC	5.95
Z80 SIO/0	17.95
Z80 SIO/1	17.95
Z80 SIO/2	17.95
Z80 SIO/9	13.75
Z80 DART	14.95

6500	
SYNTERTECK	6.80
SYP6502	6.40
SYP6504	6.40
SYP6505	7.30
SYP6520	4.30
SYP6522	8.40
SYP6532	10.95
SYP6551	10.75

NEC		
4116	150ns	2.50
2114L	300ns	2.25
2114L	200ns	2.45

6800	
MOTOROLA	
MC6800P	6.25
MC6802P	9.95
MC6808P	10.50
MC6821P	4.25
MC6840P	9.95
MC6845P	15.95
MC6850P	4.25
MC6852P	4.80

INTEL		
2764	28.00	
Z80A	6.50	
2716-1	350ns	6.90

G.I. MICRO	
AY3-8910	10.50
AY5-3800	10.95
AY5-9100	13.95
AY5-9200	13.95
AY5-2376	8.50
AY5-1015D	5.95
AY5-1013A	4.60
coming AY3-9910	

HITACHI
 6116P-3 150ns 2Kx8 CMOS STATIC RAM 9.95
 6116P-4 200ns 2Kx8 CMOS STATIC RAM 8.50
 HN462532 4Kx8 EPROM 8.75
 HN462732 4Kx8 EPROM 9.75
 HN462716 4Kx8 EPROM 5.90

LED SPECIAL
 MINIATURE SANYO LED SLP135B2 red and orange T-1 .15
 REGULAR NATIONAL LED NSL5053 red only T-1 1/4 .12

COMPUTER CENTER
ZENITH DATA PRODUCTS
 ZENITH MONITOR 12" GREEN PHOSPHOR ZVM121 117.50
 ZENITH COLOR MONITOR 13" SCREEN GDZ-1320 349.95
 CALL ON ALL ZENITH PRODUCTS! • 8-BIT COMPUTER PRODUCTS • SOFTWARE FOR 8 BIT COMPUTER PRODUCTS

NEC SPINWRITER - 3500 SERIES • 7700 SERIES

APPLE COMPATIBLE PERIPHERALS BY ADVANCED LOGIC SYSTEMS AND RANA

ADVANCED LOGIC SYSTEMS
 Z CARD, FOR APPLE COMPUTERS, ALLOWS YOU TO RUN CP/UCARD 195.00
 SMART TERM, 80 COLUMN CARD W/SOFT SWITCH 280.00
 ADD RAM, 16K RAM CARD 125.00
 SYNERGIZER, INCLUDES ALL OF THE ABOVE AS ONE PACKAGE 475.00

KENSINGTON MICROWARE SYSTEM SAVER FAN FOR THE APPLE COMPUTER **84.00**

THE MICROWARE SYSTEM SAVER FAN FOR THE APPLE COMPUTER IS AN EXTERNAL. CLIP ON FAN THAT HAS TWO SWITCHED POWER PLUGS AND A SURGE SUPPRESSOR. YOU DO NOT HAVE TO USE YOUR OWN COMPUTER POWER CORD. YOUR SYSTEM SAVER FAN HAS ITS OWN LINE CORD THAT PLUGS DIRECTLY INTO YOUR COMPUTER. ALL OF YOUR COMPUTER PERIPHERALS CAN THEN BE PLUGGED RIGHT INTO YOUR SYSTEM SAVER FAN.

RANA SYSTEM RIVES FOR APPLE COMPUTERS RUN WITH APPLE CONTROLLER CARD.
 40 TRACK SINGLE SIDED 396.00
 80 TRACK DOUBLE SIDED 589.00
 40 TRACK DOUBLE SIDED 650.00

RANA CONTROLLER CARD. CAN RUN 4 RANA DISK DRIVES, PLUGS RIGHT INTO YOUR APPLE IN PLACE OF YOUR APPLE CONTROLLER CARD. **125.00**

CALL 201-868-0214
 MON-FRI 9AM-5PM EST
 TUE & THURS 9AM-10PM EST
 Or Write To Get On Our Special Mailing

Mail Order
 Orca Technologies
 P.O. Box 9128
 North Bergen, New Jersey 07047
 TELEX No. 960127 SWIFT NYK, Att: Dept. M
 TWX No. 710-582-5598 SWIFT NYK, Att: Dept. M

SEND 75 FOR CATALOG
 TERMS: 10 TO 30 MINIMUM ORDER. PAYABLE BY VISA OR MASTERCARD. MONEY ORDER. CASHIERS CHECK. PERSONAL CHECKS ALLOW 2 WEEKS TO CLEAR. NO C.O.D. ORDERS ACCEPTED. SHIPPING AND HANDLING—ADD 2.50 FOR POSTAGE. INSURANCE OPTIONAL 1.00. HEAVY EQUIPMENT CUSTOMER MUST PAY FREIGHT. N.J. RESIDENTS ADD 5% SALES TAX. PRICES SUBJECT TO CHANGE WITHOUT NOTICE

CIRCLE 51 ON FREE INFORMATION CARD

KITS KITS KITS KITS KITS KITS

ELECTRONIC KITS

We have one of the largest selections of inexpensive electronic kits (over 60 available) and we have been providing quality kits for over 10 years to thousands of schools, hobbyists and engineers worldwide. Remember, all of our kits contain all parts and quality PC board (no need to buy the PC board extra). Compare our prices, extra features and completeness—you just won't find any other kits that compare!

ATTENTION DEALERS

We are looking for dealers to sell our line of kits. We provide liberal discounts and prices that beat any competition. Less than \$100 gets you started! Write or call for more information.

NEW 120VAC LIGHT SEQUENCER KIT
Great for discos, billboards, special effects, roof top Christmas displays, etc. This reliable IC and SCR kit sequences 10 outputs. The board has 10 output pads and each output pad can light up to 150 watts of 120VAC lamps (your choice) connected to it. Features variable speed and fused input. Kit comes with all parts, PC board and instructions. Size of board: 4" x 8". Operates from 120 VAC. C4725 \$19.95



NEW 10 NOTE SOUND SYNTHESIZER KIT
Very unique simple music synthesizer features 10 adjustable notes, variable pitch, variable speed, flashing LED and individual or flowing notes. Make "robot" sounds, space war computer effects, etc. One of the most unusual kits. Circuit features 3 IC's and 12 trimmer resistors. Complete with all parts, PC board and instructions. Size of board: 2.8" x 4". Operates from 9V battery (not included). C4722 \$11.95



NEW ELECTRONIC SLOT MACHINE KIT
Realistic action slot machine features sound effects, digital readouts and flashing LED. Has 3 different symbols that "roll" and "come up" one at a time. When all symbols are the same a special winner note sounds. Circuit uses 7 IC's and 12 transistors. Kit comes complete with all parts, PC board and instructions. Size of board: 5.5" x 7". Operates from 9V battery (not included). C4723 \$29.95



NEW ELECTRONIC DIGITAL DICE KIT
Fun and exciting—this kit replaces conventional dice. Features bright jumbo LEDs and "roll" sound. Speed of roll is fully adjustable and dice stop individually! Circuit uses 4 IC's and 10 transistors. Kit comes complete with all parts, PC board and instructions. Size of board: 4" x 4.8". Operates from 9V battery (not included). C4724 \$15.95



P.O. BOX 27038
DENVER, COLORADO 80227
303-781-5750

Phone Orders: 303-781-5750
Minimum AD Order \$9.00
Please include \$1.50 for postage (UPS)
VISA, MC accepted
Phone orders are welcome
Send for our free catalog of unique items

CIRCLE 68 ON FREE INFORMATION CARD

FUJITECH AUDIO KITS

LATEST AUDIO TECHNOLOGY FROM JAPAN

Model A1033 Integrated Tube Amplifier

- Latest Japanese Design
- Distortionless Output Transformer using special winding techniques
- Most circuitry on PCB for easy assembly and humfree performance
- Output 30W x 2 Ultra Linear (Switchable to Triode) 15W x 2 Triode Output (near class A performance)
- THD under 0.4%
- Frequency Response 30~30,000 Hz (-1dB)
- Separate Pre-Out and Main-In

KIT ONLY \$499.00

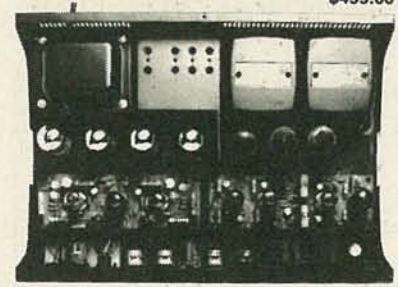

\$499.00

Send \$5.00 for each assembly manual, refundable with order.

Monarchy Engineering, Inc.
380 Swift Avenue, Unit 21
South San Francisco, CA 94080
Visa or Mastercharge acceptable.

Model A501 Power Amp

- Pure Class A 25W + 25W
- Switchable to Class AB 100W + 100W
- Switchable to Bridge Class A 100W mono
- Switchable to Bridge Class AB 300W mono
- Frequency Response 5-200KHz (-1dB)
- Signal-to-Noise Ratio 120dB
- Non-magnetic Chassis
- "Out-board" comprehensive protection circuitry
- DC circuitry with limited use of NFB
- High Efficiency Fluid Convection Cooling
- THD under 0.007%

KIT ONLY \$299.00



\$299.00

Model A502 DC Stereo Control Center

- Direct DC coupling from Input to Output
- DC servo circuitry
- Cascade FET Input in all stages
- Separate Moving Coil RIAA amplifier
- Distortion below 0.005% (3V)
- Max Output 15W
- Frequency Response 20Hz-20KHz ±0.2 dB
- Maximum Phono Input
MC = 16mv RMS (1KHz)
MM = 270mv RMS (1KHz)
- Built-in Headphone amplifier
- Relay Output Muting

KIT ONLY \$349.00



\$349.00



CALIFORNIA COMPUTER SYSTEMS

\$100

2032 32K STATIC RAM A & T. 200 NSEC	\$468.00
2116 16K STATIC RAM A & T. 200 NSEC	\$279.50
2065 64K DYNAMIC RAM A & T.	\$351.00
2200 S-100 MAIN FRAM A & T.	\$500.00
2422A FLOPPY DISC WITH CP/M 2.2™	\$329.95
2831A ARITHMETIC PROCESSOR A & T	\$552.50
2810A Z80 CPU A & T.	\$249.95
2710A 4 SERIAL I/O A & T.	\$291.95
2719A 2 SERIAL, 2 PARALLEL A & T.	\$305.95
2720A 4 PARALLEL A & T.	\$214.95
PROTO BOARDS WW	\$39.95

APPLE PRODUCTS

7114A 12K ROM/PROM	\$99.95
7424A CALENDAR/CLOCK	\$106.95
7440A PROGRAMMABLE TIMER	\$98.50
7470A A TO D CONVERTER	\$105.95
7490A GPIB (IE 488) INTERFACE	\$182.00
7710A ASYNC SERIAL	\$125.95
7712A SYNC SERIAL	\$153.95
7720A PARALLEL STANDARD	\$105.00
7720B PARALLEL CENTRONICS	\$105.00
7811B ARITHMETIC PROCESSOR W/DISC	\$342.95
7811C ARITHMETIC PROCESSOR W/ROM	\$342.95
7520A EXTENDER	\$23.50
7300A APPLE CLIP	\$8.00

SOFTWARE

23-01 CP/M™ MACRO ASSEMBLER ON DISK	\$76.95
24-01 CP/M™ SYMBOLIC INSTRUCTION DEBUGGER	\$64.25
25-01 CP/M™ TEXT FORMATER	\$64.25
26-01 CP/M™ BACKGROUND PRINT UTILITY	\$42.95

OTHER CCS PRODUCTS ARE AVAILABLE.
CALL FOR PRICE.



MICROCOMPUTER PRODUCTS

\$100 PRODUCTS

CB1A 8080 PROCESSOR PCBD	\$32.95
KIT	\$155.95, A & T \$215.95
CB-2 280 PROCESSOR BOARD	
KIT	\$198.95, A & T \$269.95
VB1C 64 x 16 VIDEO, PCBD	\$32.95
KIT	\$153.95, A & T \$199.95
VB2 64 x 16 VIDEO, PCBD	\$32.95
KIT	\$175.95, A & T \$234.95
VB3 80 CHARACTER VIDEO 4MHZ	
KIT	\$345.95, A & T \$425.95
UPGRADE RAMS FOR VB-3	\$42.00
104 2 PARALLEL, 2 SERIAL, PCBD	\$32.95
KIT	\$155.95, A & T \$194.95
PB-1 2708, 2716 PROGRAMMER BOARD	
KIT	\$135.95, A & T \$185.95
MB-10 16K STATIC RAM	
KIT	\$299.95, A & T \$339.95

APPLE PRODUCTS

A488 IEEE 488 INTERFACE	\$399.95
A10 - II SERIAL/PARALLEL INTERFACE	
A & T	\$178.00
AS10 SERIAL I/O	
A & T	\$97.95
AP10 PARALLEL I/O W/O CABLES	
A & T	\$87.95

OTHER SSM PRODUCTS ARE AVAILABLE.
CALL FOR PRICES.



MONDAY-FRIDAY, 8:00 TO 12:00, 1:00 TO 5:30
THURSDAYS, 8:00 TO 9:00 P.M.

(415) 728-9121

P.O. BOX 955 • EL GRANADA, CA 94018
PLEASE SEND FOR IC, XISTOR AND COMPUTER PARTS LIST

CIRCLE 53 ON FREE INFORMATION CARD

AUG. SPECIAL SALE ON PREPAID ORDERS

(CHARGE CARDS, C.O.D. OR P.O.'S NOT AVAILABLE)
MUST MENTION AD FOR SPECIAL PRICES

INTRODUCTION SPECIAL

SSM PB-1 EXPANSION KIT BY EXTEK ADAPTS PB-1 FOR PROGRAMMING 2732, 2732A AND 2764. BANK DISABLE FOR PROGRAMMING SOCKETS. CP/M SOFTWARE DISC INCLUDED. KIT... \$105.95, A & T... \$119.95

74 LS™ SERIES PRIME PARTS

EA 5 FOR	EA 5 FOR	EA 5 FOR
LS00 .25 1.23	LS132 .75 3.56	LS197 .85 4.04
LS02 .25 1.23	LS136 .50 2.38	LS221 1.15 5.46
LS04 .25 1.23	LS138 .75 3.56	LS240 1.80 8.55
LS05 .25 1.23	LS139 .75 3.56	LS243 1.75 8.31
LS08 .35 1.66	LS145 1.20 5.70	LS244 1.75 8.31
LS10 .25 1.23	LS147 2.49 -	LS245 2.15 -
LS13 .45 2.14	LS148 1.35 -	LS251 1.00 4.75
LS14 .90 4.50	LS151 .75 3.56	LS257 .85 4.04
LS20 .25 1.23	LS153 .75 3.56	LS258 .85 4.04
LS26 .35 1.66	LS155 .90 4.28	LS260 .65 -
LS27 .35 1.66	LS156 .90 4.28	LS266 .46 2.19
LS30 .25 1.23	LS157 .75 3.56	LS279 .50 2.38
LS32 .35 1.66	LS158 .75 3.56	LS290 .80 3.80
LS37 .55 2.50	LS160 .90 4.28	LS293 .80 3.80
LS38 .35 1.66	LS161 .95 4.51	LS295 1.05 4.99
LS42 .55 2.50	LS162 .95 4.51	LS367 .70 3.33
LS74 .45 2.14	LS163 .95 4.51	LS368 .70 3.33
LS75 .50 2.38	LS164 .95 4.51	LS373 1.85 8.79
LS85 1.15 5.46	LS166 1.75 8.31	LS374 1.80 8.55
LS86 .40 1.90	LS173 .80 3.80	LS377 1.45 6.89
LS90 .60 2.85	LS174 .95 4.51	LS378 1.18 5.61
LS92 .60 2.85	LS175 .95 4.51	LS620 2.25 -
LS93 .60 2.85	LS190 1.00 4.75	LS626 2.25 -
LS122 .45 2.14	LS191 1.00 4.75	LS629 1.44 -
LS123 .95 4.50	LS192 .85 4.04	LS682 3.20 -
LS125 .90 4.28	LS193 .95 4.51	LS683 2.30 -
LS126 .75 3.56	LS196 .85 4.04	LS688 2.40 -

QUANTITY OF 5 FOR MUST BE OF THE SAME DEVICE. THEY MAY NOT BE MIXED. AN ADDITIONAL 5% OFF PURCHASES OVER \$50 ON LS PARTS ON PREPAID ORDERS BY CHECK OR MONEY ORDER ONLY.

VISA or MASTERCHARGE: Send account number, interbank number, expiration date and sign your order. Approx. postage will be added. Orders with check or money order will be sent post paid in U.S. If you are not a regular customer, please use charge, cashier's check or postal money order. Otherwise there will be a two-week delay for checks to clear. Calif. residents add 6% tax. Money back 30-day guarantee. We cannot accept returned IC's that have been soldered to. Prices subject to change without notice. \$20 minimum order. \$2.00 service charge on orders less than \$20.00.

THIS MONTH'S SPECIAL !

2 for 1 SALE!!!



BUY 2 BAND PRINTER / TERMINALS FOR THE PRICE OF 1!

You Get 2 GENERAL ELECTRIC (GE) TERMINET 1200's

Features:

- RS32 ASCII Input •Fully Formed Type
- Up to 1200 Baud (120 cps) for almost 60 lpm
- 120 Columns at 10 "pitch" •Changeable Print Band
- Ultra Reliable •94 Characters (Upper & Lower Case)
- 115 VAC 60 Hz •MFG'R'S PRICE OVER \$5K

These unique, off-lease and used GE "Terminets" offer 3 input Baud rates for 3 print speeds, table-top operation. Continuous print band provides fast, fully formed characters far superior to Dot Matrix. LETTER QUALITY print at DOT MATRIX speed!! One unit is fully tested and operational, cleaned and ready to use. The other is clean and whole but UNTESTED (use as a spare or as parts machine). Line Cord & Forms Tractor NOT included (available from GE direct!) Tractor GE Part No. 44C414730-G02.

2 FOR 1 SALE PRICE... Only \$495.00 Pair (Add. \$30.00 for Pkg. - Pay Shpg. on Delivery)

G.E. TERMINET 340 LINE PRINTER

These excellent off-lease, used BAND-type Line Printers feature:

- 230 to 340 lines per minute.
- PARALLEL (TTL) Input.
- 132 Columns, 64 Char. ASCII Set
- Includes Stand & Sound Hood!
- TESTED & OPERATIONAL
- Schematics & I/O Data Included



Each machine includes Print Band, Parallel Input I/O Board, Schematics & info.

Each Printer is shipped tested and fully operational!! Nationwide service by General Electric. Original Price over \$4,000.00 Most are unused or new!!!

Only \$795.00 EACH!!

(Add. \$30.00 for Pkg. - Pay Shpg. on Delivery)

PARALLEL INPUT I/O SELECTRIC*



The manufacturer put them into storage to depreciate them. Now they are FINALLY AVAILABLE!! Removed from working systems, these fantastic machines have built-in driver and decoder circuitry and take TTL level, 6-bit character plus 4-bit functional input signals. Easily driven by most any micro. Use as a typewriter (with additional "repeat" circuitry) or as a KSR/O printer, or both. Requires 115, 60Hz for typewriter motor. 5 VDC for TTL and 24 VDC for solenoids. "Table Top" style case. Each "Selectric" I/O machine is complete and in operational condition. Includes schematics, data, case, platen, and ribbon. (Type element not included.)

I/O SELECTRIC... \$399.00 ea. (Add \$20.00 for Pkg. - Pay Shpg. on Delivery)

Write or Call for our Latest BARGAIN-PACKED FLYER!

"Selectric" is an IBM Trademark

Computer Products & Unlited

WAREHOUSE: 18 Granite St. Haverhill, Mass 01830
MAIL ORDERS: Box 204 Newton, New Hampshire 03858
TELEPHONE ORDERS: 617/372-8637
Sorry, No Collect Calls
Mastercard & VISA Accepted

SCOPE WAR SALE

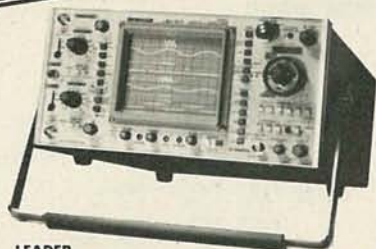

LEADER			
LBO-513A	Single	15MHz/1mV	\$ 550
LBO-514A	Dual	15MHz/1mV	695
LBO-522	Dual	20MHz/0.5mV	795
LBO-523	Dual	35MHz/0.5mV	995
LBO-524	Dual/D.S.	35MHz/0.5mV	1195
LBO-524L	Dual/D.S.	35MHz/0.5mV	1295
LBO-517	Quad/D.S.	50MHz/1mV	1695
HITACHI			
V-151F	Single	15MHz/1mV	520
V-152F	Dual	15MHz/1mV	670
V-202F	Dual	20MHz/1mV	750
V-352F	Dual	35MHz/1mV	Call
V-650F	Dual/D.S.	60MHz/1mV	Call
V-1050F	Quad/D.S.	100MHz/0.5mV	Call
SOLTEC			
515-1	Single	15MHz/1mV	495
515-2	Dual	15MHz/1mV	595
520	Dual	20MHz/1mV	695
530	Dual	30MHz/1mV	895

CALL FOR OUR LOWER PRICE

FREE FREIGHT for order paid with cashier's check or money order. Above prices are for prepaid order only. VISA/MC accepted. Allow 2 weeks to clear personal checks. California residents, add 6% sales tax. Prices and specifications subject to change without notice.

testek (213) 786-6890
TESTEK CORPORATION
6910 Hayvenhurst Ave., Van Nuys, CA 91406

YOUR EXCITING NEW HOBBY!

- Enjoy fantastic savings by assembling your own organ or piano.
- It's easy. No technical knowledge required.
- Just follow our clear, pictured instructions.
- Choose from many models from portables to consoles.
- Ask about our interest-free installment plan.

WERSI

ORGAN & PIANO KITS

For Free Information Pack M40

Call Toll Free

800 233 3865

In PA 717 299-4327

or send coupon below



WERSI Dept M40 P.O. Box 5318
Lancaster, PA 17601

- Free Info. Pack: Organ Piano
- Catalog & Demo Record (enclose \$6)

Name _____

Address _____

City _____ State _____ Zip _____

Phone (_____) _____

Rep inquiries invited

ETCO

CABLE TV CONVERTERS AND OTHER GOOD STUFF!

SMASHING ALL SALES RECORDS - OUR NEW 30 CHANNEL CABLE TV CONVERTER!

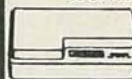

Converts mid & super band cable channels for viewing on your TV set!
No. 348A047

39⁹⁵ \$34.95 ea. / 5

HOT NEW IMPORT! REMOTE CONTROL 30 CHANNEL CABLE TV CONVERTER!



Includes remote TV on/off switch and fine tuning control!
No. 349VA275

89⁹⁵ \$79.95 ea. / 5 \$74.95 ea. / 10

ETCO MKII WIRELESS - THE ULTIMATE CABLE TV CONVERTER!



Set TV to channel 3, and the hand held remote control does it all!
No. 349ZA008

189⁰⁰

VIDCOR 2000 CONVERTER ELIMINATES PROBLEMS WHEN VIDEOTAPE FROM CABLE TV



Restores your VCR's capability for programming. Restores remote channel control. Enables videotaping of one cable program while watching another.
No. 349VA950

89⁹⁵ \$79.95 ea. / 5 \$74.95 ea. / 10

UNUSUAL FACTORY SURPLUS MID-BAND - SUPER-BAND CABLE TV TUNER



Converts cable channels to a common IF frequency. Experimenters - build cable converters, decoders, etc. With schematic. No. 349VA342

19⁹⁵ \$17.50 ea. / 10

349VA389 - Detailed schematic & spec sheet - \$1.50

FACTORY SURPLUS UHF TUNERS



Brand new production surplus. All solid state. Ideal for experimental work building, cable TV converters, etc. No. 349SU099

4⁹⁵ \$3.95 ea. / 10

MINIATURE FM WIRELESS MICROPHONE



Hides in the palm of your hand. Reception on any standard FM radio or receiver.
No. 349VA482

29⁹⁵ \$27.50 ea. / 5 \$24.95 ea. / 10

QUARTER-MILE WIRELESS MICROPHONE & RECEIVER SYSTEM



FCC approved crystal controlled wireless mike & receiver. All battery operated. Electric wide range response. VU meter.
No. 349VA093

69⁹⁵ \$49.95 ea. / 5

FACTORY SURPLUS VHF / UHF "TWIN" VARACTOR TUNERS!



Advised No. NC 31431 BRAND NEW! Ideal for building or repairing electronically tuned TV "FRONT ENDS". A hard to find item at a sensational price!
No. 349VC308

39⁹⁵ \$34.95 ea. / 5

DUMPING! NORELCO ENDLESS LOOP CASSETTES!



Impossible to find at any price!
3 minutes - No. 349VA605
6 minutes - No. 349VA606

4⁹⁵ \$4.49 ea. / 10

IN STOCK - THE MURA CORDLESS TELEPHONE SYSTEM!



Answer & originate calls with this wireless package. 400 ft. range! Rechargeable! Last number recall! Paging feature! Use with rotary, touch systems!
No. 349VA274

144⁸⁸ \$129.95 ea. / 5

SALE OF QUARTZ BATTERY-OPERATED CLOCK MOVEMENTS!



Accuracy of 1 min. / year, up to 4 years operation on 1 alkaline "C" cell. Imported from West Germany. No. 349VA561

9⁹⁵ \$8.95 ea. / 5

20 AMP REGULATED 12VDC POWER SUPPLY!



13.8 vdc no load, 12.5 vdc full load. Easily handles ham station, marine radio, SSB linears up to 400w P.E.P. Brand new, factory sealed. 110 VAC. No. 349VA394

69⁸⁸ \$59.88 ea. / 5

349VA395 at above, 10 amps - \$54.95 \$49.95 ea. / 5

FREE OUR LATEST 98 PAGE FASCINATING CATALOG - jam-packed with unique items, electronic bargains and unusual offers. Write or circle the information card number below.

ETCO ETCO ELECTRONICS NORTH COUNTRY SHOPPING CENTER PLATTSBURGH, N.Y. 12901

Check with order, please. Visa & Mastercard OK. (Sorry, no C.O.D.'s. Add 15% for UPS & Handling (Excess refunded). N.Y. State residents add 7% sales tax. Dealer & Export inquiries invited. Our telephone order desk never closes. Call 1-516-561-8700.



ELECTRONICS CO., INC.

SEND OR CALL for your

FREE Catalog

1982
A 48 page handbook with 48 SUPER exciting, low cost, electronic projects.
(Some projects as low as \$2.50).

CALL Toll-Free
1-800-453-1708

Utah residents 1-801-628-3627

NEW

These PPG Electronic Kits are available at your local electronic store.

Kit

- 801 POCKET DICE
- 802 SIGNAL INJECTOR
- 803 SPACE WAR GUN
- 804 METAL DETECTOR
- 805 LOGIC PROBE
- 806 BURGLAR ALARM
- 808 DECISION MAKER
- 809 LED PENDULUM METRONOME
- 811 DOUBLE DECISION MAKER
- 812 SIREN OSCILLATOR
- 814 ROBOT BLINKER
- 816 MINI-WINK
- 818 FISH CALLER
- 820 SHIMMER LIGHTS
- 821 CHRISTMAS TREE
- 822 ONE CHANNEL COLOR ORGAN
- 824 AUTOMATIC SIREN
- 826 FUZZ BOX
- 828 9-VOLT POWER SUPPLY
- 830 0-15 VOLT POWER SUPPLY
- 834 COLOR ORGAN 3-CHANNEL, 1-CONTROL
- 836 3-CHANNEL, 4-CONTROL COLOR ORGAN
- 838 12-VOLT POWER SUPPLY
- 840 VARIABLE STROBE LIGHT
- 842 12-VOLT COLOR ORGAN
- 844 T.V. JAMMER
- 846 12-VOLT SAFETY STROBE FLASHER
- 850 WHOOPEE ALARM
- 852 COMBINATION LOCK/ALARM CONTROL
- 856 ELECTRONIC TENNIS
- 858 DIGITAL ROULETTE
- 860 5-30 VOLT REGULATED POWER SUPPLY
- 861 BIG SOUND PORTABLE ORGAN
- 862 FULL-WAVE MOTOR SPEED CONTROL
- 866 DIGITAL SLOT MACHINE
- 868 DIGITAL DICE
- 870 NERVE TESTER
- 876 8-DIGIT DIGITAL CLOCK
- 878 DIGITAL BIRD
- 880 12-VOLT, 2-AMP REGULATED POWER SUPPLY
- 882 MUSICAL HORN
- 884 SOUND ACTIVATED COLOR ORGAN, 1-CHANNEL
- 886 AUDIO AMP/INTERCOM
- 888 LIBRARIAN TORMENTOR
- 890 STOP-ACTION TIMING TESTER
- 892 TELEPHONE HOLD BUTTON
- 894 PHASOR GUN/SOUND GENERATOR
- 898 BINARY CLOCK

Also available, complete Basic Electronics Course

Build Some TODAY!

PPG Electronics Co., Inc.
791 Red Rock Road,
St. George, Utah, 84770

Special Prices For Educators

MORE GAIN THAN A VARACTOR UHF TUNER

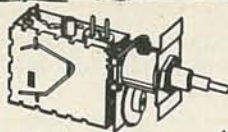

SATISFACTION GUARANTEED
\$15.00

Freq. Range UHF470-889Mhz Channels 14-83
Output Channel 3.

Available on request: Ch 2 or 4.

Part No. B20

Modified High Gain Tuner. \$15.00

1. The first thing we do is change the standard diode found in every tuner to a Hot Carrier Diode.
2. The tuners output is then measured and compared to our computer derived chart from which we determine the correct value coil to add across the IF output for maximum Pre-Peaked gain.
3. The tuner is fed a standard 10db antenna input, and while monitoring the output on our Spectrum Analyzer, the tuner is tuned to the desired channel and its oscillator is offset for the desired output frequency as follows:

Ch. 2:58Mhz Ch. 3: 63Mhz Ch. 4: 68Mhz

We call this step peaking because the tuners output looks like a peak on our spectrum analyzer and the highest point of that peak is actually adjusted for the desired output.

4. Finally, we measure the tuners output one more time which is again compared to our computer derived performance chart to ascertain the correct value of the second coil which is added to the tuners internal connections.

This procedure was developed by GILCO and its our computer derived performance charts that make our tuner better. That's because almost every tuner gets a different value coil before it's peaked and then a different value coil after it's peaked. The combinations are endless and the way we determine the values is our secret.

PRINTED CIRCUIT BOARDS

Part No. B21 Printed Circuit Board. \$17.00

1. This Printed Circuit Board uses only one jumper, others use 9.
2. The component layout is screen printed on the Component side of the pre-drilled P/C Board.
3. The solder side of the P/C Board is covered with High Temperature Solder Resist for ease of assembly.
4. This P/C board was designed to take advantage of the Gilco High-Gain Tuner which means its circuitry is simpler and more efficient than those circuits that require inferior Varactor Tuners.

ELECTRONIC PARTS KITS

Part No. B22 Complete Parts Kit. \$80.00

All resistors (30), Potentiometers (1-5K, 3-10K), Panel Mount Potentiometer (10K), Electrolytic Capacitors (6), Ceramic and Mylar Disc Capacitors (35), Variable Capacitors (4), All Intergrated Circuits (7), Voltage Regulator, Heat Sink, Diodes (4), IC Sockets (4-8 pin, 3-14 pin), Power Transformer (24V/1A), Coil Kit with No. 26 wire (4), Speaker (4" 3 Oz.), Standoffs, Coaxial cable, All misc. Hardware, etc. All parts are individually packaged and labeled.

All components including the wire, Hardware, Coaxial Cable and heat sinks are included in the parts kit. This means your assembly time from start to finish is only 4 hours.

Order all 3, B20, B21, B22. 110.00

Order 5 each, B20, B21, B22. 95.00/set

ACCESSORIES: AMPLIFIERS

Part No.

- A02 New 2 Stage Low Noise 28db gain RF Amplifier Specially designed for kit builders **Kit \$18.00**
- A03 New 1 Stage Low Noise 14db gain Amplifier **Kit \$10.50**
- A04 75-300 OHM matching Transformer. **\$1.00**
- F59 Coaxial Connectors. **.30**

Mail order only. Send check or money order to:

GILCO INTERNATIONAL, INC.

P. O. Box 8817, Coral Gables, FL 33124

Tel. (305) 823-5891 For COD orders add 10% shipping and handling or for orders over \$50, add 5%.

FL residents add 5% sales tax. Please write for more information

(602) 266-9758 (602) 234-3026



ARIZONA ELECTRONIC SURPLUS



6835 N. 16th St. • Phoenix, AZ 85016

MICRO WAVE DOWN CONVERTER KIT (HMR II type)

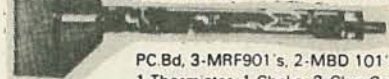

\$39.95

PC Bd, 3-MRF901's, 2-MBD 101's, 1 Thermistor, 1 Choke, 3-Chip Caps, 1 "F" Connector, 8 Resistors
+ Instructions

POWER SUPPLY

12-18v
D.C.

\$19.90

BUY BOTH FOR ONLY **\$53.99**

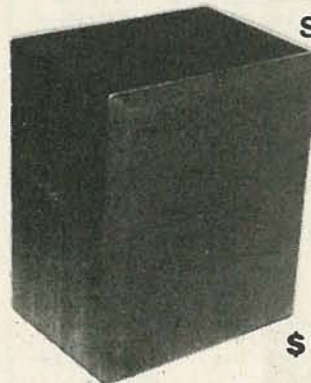

SPEAKER BOX

w/5" SPEAKER

\$11.95

PULSE RATE INDICATORS USED FOR HEART MONITORS 100% Functional

\$19.95

Includes:

- * 5" LCD Readout
- * ICL 7106 CPL A-D Decoder Driver
- * MC 14016
- * MC 14013

- * MC 14584
- * LM 32 YN
- * TL 064 CN
- * Piezo Buzzer
- * 9 V. Batt. Clip
- * Misc. Elect. Components

NEW PLASTIC CASE

Made for Heart Monitor above.

\$1.55

Includes:

- * 9 V. Batt. Holder
- * Front Bezel

Excellent for Frequency Counter.



4" LINE CORD



45¢

ALL ORDERS SHIPPED SAME DAY VIA UPS

Postage & Handling Not Included

(602) 266-9758 (602) 234-3026

CIRCLE 59 ON FREE INFORMATION CARD

COMPUTER AGE ELECTRONIC KITS

CIRCLE 60 ON FREE INFORMATION CARD

AUGUST

SPARTAN Electronics Inc.



CALL (516) 499-9500 MAIL
6094 Jericho Tpke.
Commack, N.Y. 11725

Remote T.V. Converter



PHILIPS 139.95 Ea.
4 & up 125.00
60 Channel
Wireless Control

Commodore Color-

VIC-20



Sound-
Graphics
\$259.

Logic Probe

Global Specialties #LP-2

\$28.49

DTL/TTL/CMOS



Beckman 310 Digital Multimeter



135.

3 1/2" Digit LCD
- Instant Ohms
- 10 Amp Scale

Direct Connect Modem



ANCHOR AUTOMATION

99.

Signalman MK2

Surge Stopper Brooks

4 Outlet w/circuit bkr.
led/sw \$59.79
1 Outlet \$43.50



Now you can have Maximum Protection
for your sensitive electronic equipment.

Refurbished

Monitors 12" diagonal
39.95



SPECIAL Atari 800

w/16K RAM \$659



Atari 400 w/16K \$325

42 Channel CATV Converter

w/on/off Fine Tuning
\$94.95



40 Channel VHF to UHF Block Converter



28.95 Ea.
24.95 4 & up

Volume Discounts

• Visa, MC, BAC, Amex, Check, COD, Money Order
• Add For Shipping

Min. Order \$10.00	to 75.00	\$2.50
Shipping Overseas 20% Add'l.	76.00 to 250.00	\$4.50
Prices subject to change without notice.	251.00 to 500.00	\$6.00
	501.00 to 750.00	\$8.50
COD 2.00 Extra	751.00 to 1000.00	\$12.00
	Over 1000.00	\$12.50

Mon Th Tu W F Sa
9-8 9-6 9:30-5

ADVERTISING INDEX

RADIO-ELECTRONICS does not assume any responsibility for errors that may appear in the index below.

Free Information Number Page

22	AMC Sales	83
—	ATV Research	92
—	Aaron Gavin	83
37	Abex	73
45	Active Electronics	89
46	Advance Computer Products	97
—	Advance Electronics	42
48	All Electronics	94
24	Anders Precision Instrument Co., Inc.	85
59	Arizona Electronics	111
56	B.G. Micro	100
16	B&K Precision Dynascan Corp.	86
67	Babylon Electronics	108
—	Karel Barta	87
6	Beckman Instruments	Cover III
—	Bullet Electronics	104
—	C&D Electronics, Inc.	112
—	CIE, Cleveland Institute of Electronics	38-41
63	Computer Products & Peripherals Unlimited	110
68	Chaney Electronics	109
8	Channelock, Inc.	74
—	Command Productions	90
3	Communications Electronics	2
—	Components Express	23
52	Concord Electronics	104
—	Cook's Institute	90
2	Copper Group	Cover II
—	Dage Scientific	88
—	Data Services Co.	87
—	Devtronix/Organ Products	88
42	Digi-Key Corp.	91
54	Dokay	88
—	Edu Calc Publications	76
29	Eico	81
25	Electronic Specialists Inc.	85
—	Electronic Technology Today	71
27	Enterprise Development	79
—,64	Etco Electronics	92,110
31	Etronix	82
—	Fair Radio Sales	90
15	Fluke Mfg. Co., Inc.	5
—	Fordham Radio	92
40	Formula International	102-103
—	Gilco International, Inc.	111
28	Gladstone Electronics	79
—	Global TV Electronics	87
58	Godbout Electronics	90
—	Gratham College of Engineering	83
73	Hal Communications Corp.	32
66	Hal-Tronix	100
9	Hameg, Inc.	24
—	Heath	29-31,34-35
12,13	Hickok Electrical Instruments	80,84
69	Hitech Electronics	104
65	Information Unlimited	108
39	JDR, Microdevices	98-99
—	J&W Electronics	88
38	Jameco Electronics	106-107
36	Jensen Tools, Inc.	73
7	Jim Pak	33
43	John Bell Engineering, Inc.	93
—	McGee's Radio	92
23	MTI	85
18	Micro Management Systems, Inc.	73
—	Microtenna Associates	88
53	Mikos Inc.	109
—	Monarchy Engineering, Inc.	109
64	Mountain West Alarm	108
—	NRI Schools	8-11
—	NTS Schools	18-21
—	Nabih's, Inc.	74
—	Netronics	78
21	North American Soar	78

49	Omnitron Electronics	100
51	Orca Tech	108
17	PC Guide	77
60	P.P.G. Electronics Co., Inc.	111
19	Pac-Tec Corp.	81
26	Paia Electronics	77
35	Paladin Corp.	73
—	Phillips ECG	17
—	Phillips-Tech Electronics	87
57	Poly Paks	105
30,74	Protecto Enterprises	81,82
72	RCA	26-27
44	Radio Shack	95
41	Ramsey Electronics	101
70	SCR Electronics, Inc.	105
32	SMP, Inc.	73
—	Sabadia Exports Corp.	92
11	H.W. Sams	79
—	Satellite TV	87
—	Simple Simon Electronics	69
—	Sinclair Research Ltd.	13-15
50	Sintec Co.	105
—	Sound & Video Research	90
55	Spartan Electronics	112
61	Spectrum Electronics	96
47	Solid State Sales	96
—	Suntronics Co., Inc.	90
57	Surplus Electronics	127
4	TAB Books	25
—	Tektronix	1
—	Testek	110
—	Test Probes	76
—	Texas Instruments	70
20	Triton Mktg. Corp.	77
34	U.S. Modules	73
49	Ungar	—
—	Div. of Eldon Industries	73
10	Vector Electronics Co.	28
5	Viz Mfg. Co.	7
71	Wersi Electronics	110
—	Zenith Radio Co.	Cover IV

CABLE TV

CONVERTERS DESCRAMBLERS

Largest Selection
of Equipment Available
\$ Buy Warehouse Direct & Save \$



36 channel
converter
\$4595

36 channel
wired remote
converter
only
\$8895



Send \$2 for complete catalog
of converters and unscramblers

Quantity Discounts • Visa • Master Charge
Add 5% shipping—Mich. residents add 4% sales tax

C&D Electronics, Inc.
P.O. Box 21, Jenison, MI 49428
(616) 669-2440

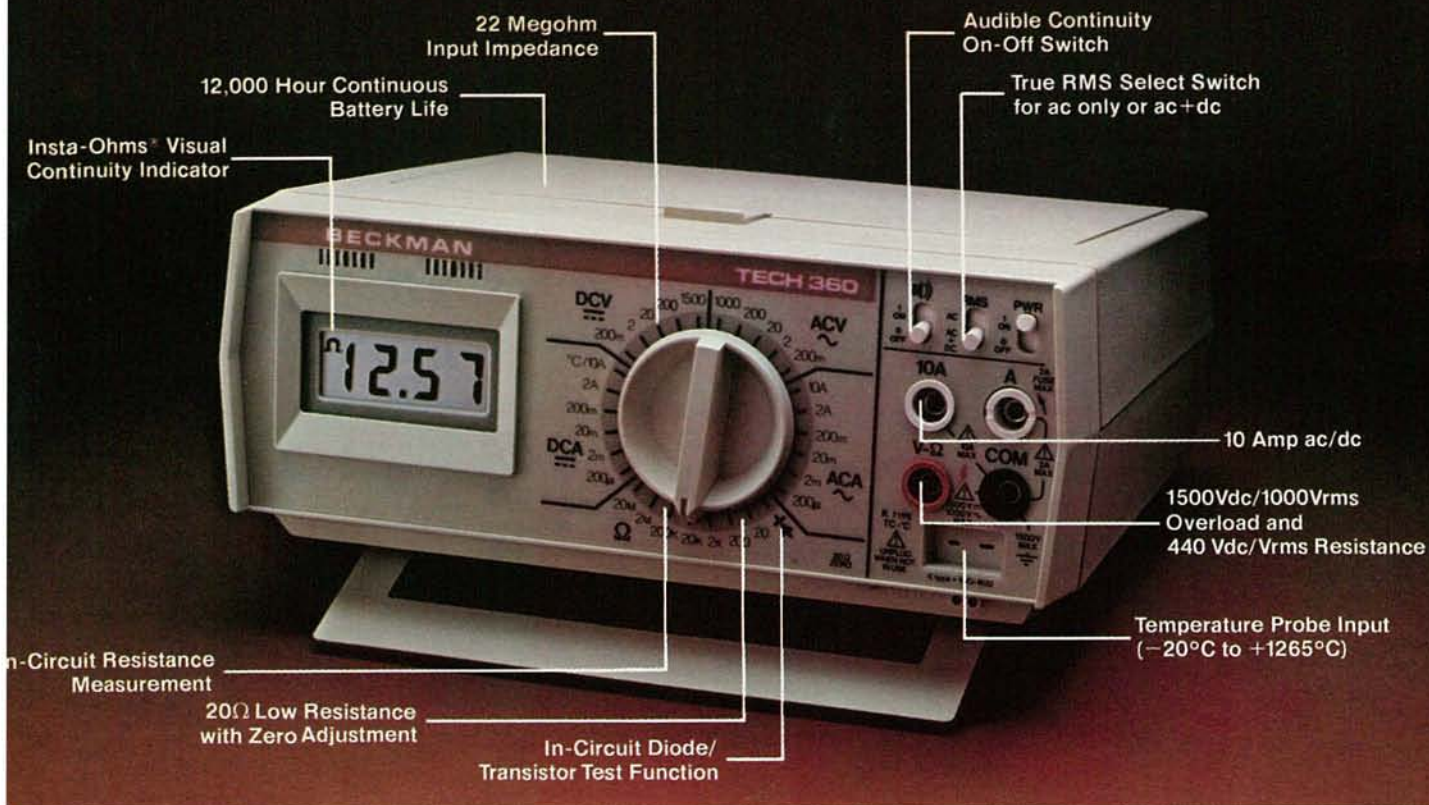

Introducing the TECH™ 360 DMM. Never has it been so easy to do so much for so little.

Beckman's TECH 360 bench/portable DMM puts unmatched capability and convenience at your fingertips.

You can select from 8 functions and 31 ranges with one turn of the single selector switch.

On or off the bench, you can accurately measure all complex waveforms with True RMS AC functions. Extend resistance measurement to 1/100 ohm resolution. Read temperatures from -20°C to 1265°C . Perform continuity checks

quickly, with audible and visible indications. Measure up to 10 amps without adding special adaptors. All with 0.1% basic Vdc accuracy.

12,000 hour battery life

Designed for ultimate ease of operation, the TECH 360 delivers 12,000 hours continuous service (up to 4 years of normal use) from standard heavy-duty batteries. You'll never have to search for power outlets or contend with ground loop errors. The expense of rechargeable battery packs is eliminated.

The TECH 360 is available for just \$289 (U.S. only), including batteries. The companion TECH 350 (without RMS and temperature measuring capability) is priced at \$229.

For information on the complete line of Beckman DMMs and accessories, call your local distributor today. For the one nearest you call: (714) 993-8803 or write Beckman Instruments, Inc., Electro-Products Group, 210 South Ranger Street, Brea, California 92621.



Convenient storage and multiple viewing angles are featured in the new line of Beckman bench/portable DMMs.

BECKMAN

Don't touch that connection!

New Zenith push-button VIDEO ORGANIZER permits switching from one program source to another without changing cable connectors. Lets you select up to six different program sources for viewing. Up to three different sources for recording. Even lets you view one program source while simultaneously recording another. All this without changing cable connections!



At last the nuisance of manually changing cable connections is a thing of the past!

With Zenith's new Video Organizer, separate input and output jacks enable you to make a complete connection of TV and VHF antenna or cable TV antenna, subscription TV decoder, video disc player, video cassette recorder, video game and home computer or other auxiliary video equipment.

So you switch from one program

source to another with pushbutton ease - without changing connections.

Equally important, the Video Organizer's advanced engineering design by Zenith results in low insertion loss and high isolation. Eliminates electromagnetic interference for maximum picture quality. And permits greater flexibility in use and ease of operation for more hours of uninterrupted home video enjoyment.

Write now for more information!

ZENITH
The quality goes in before the name goes on.*

Zenith Radio Corporation/Service, Parts & Accessories Division/11000 Seymour Avenue/Franklin Park, Illinois 60131