

Radio- Electronics

**BUILD A BACKYARD
SATELLITE TV RECEIVER**

\$1.25 APR. 1980

**Build an inexpensive keyboard organ
New specs for car stereo equipment
Affordable NTSC color-bar generator**

**How to fix VCR transport problems
Build a versatile 3 1/2-digit DMM
Circuits that talk back to you**

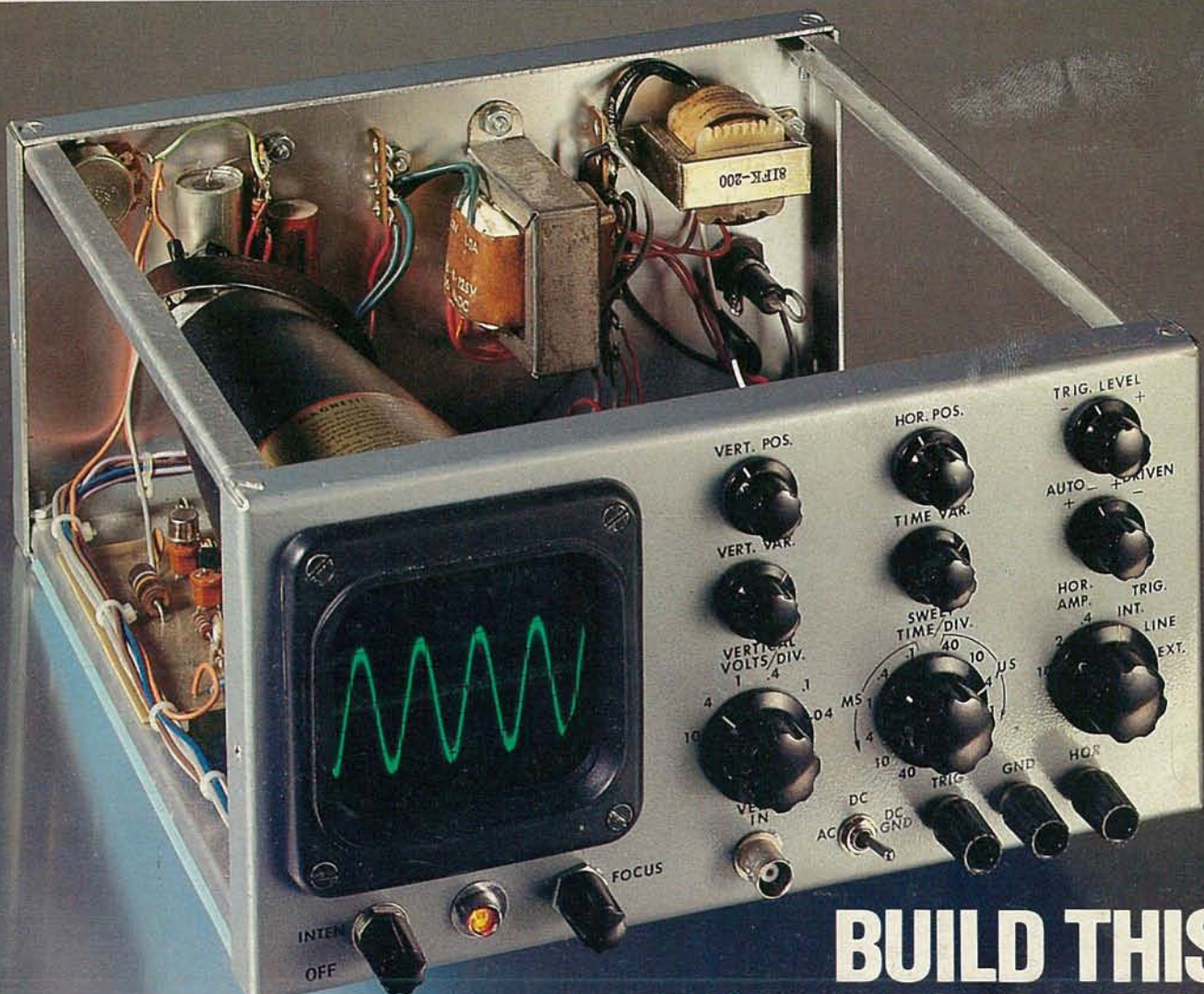

**BUILD THIS
TRIGGERED SCOPE
FOR UNDER \$125**



CSC's Model LM-3 Logic Monitor. It's a new breed of test instrument. Here in a single compact package are *forty* high-speed high-impedance precision-threshold logic state indicators with triggerable latching modes.

Just connect the LM-3 Logic Monitor to any combination of bus lines, test points, IC pins or other nodes. Pick the operating mode: the LM-3's display follows up to 40 channels of data in RUN; stores and displays 40 data channels when triggered in LATCH; or updates its latched data display with every trigger in RETRIG. There's even a pushbutton to manually latch the display.

The applications are endless. Connect to the pins of a processor, UART, memory—any IC—for device tests. Follow the action of a logic tree by

connecting to selected gates, flip-flops, registers, etc. Monitor up to 40 bus lines, checking data, address, I/O, flags—anything digital. Choose 40 test points on a single board, or perform side-by-side comparisons with a known-good board.

More? More than we have room to tell. Compatibility with past, present and future logic families from ECL to TTL to CMOS. Constant input impedance at every threshold level. 5 MHz channel response. A comprehensive instruction/application manual as innovative as the instrument itself. Plus cables and connectors to make the package complete.

40 logic channels. Triggerable memory. And more. At \$585*, it's probably underpriced. Call now and get the full story.

Insight.



Smarter tools for testing and design.

CONTINENTAL SPECIALTIES CORPORATION

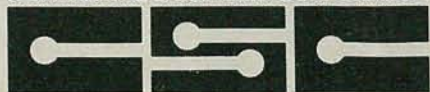

70 Fulton Terr., New Haven, CT 06509 (203) 624-3103, TWX 710-465-1227
OTHER OFFICES: San Francisco (415) 421-8872, TWX 910-372-7992
Europe: CSC UK LTD. Phone Saffron-Walden 0799-21682, TLX 817477
Canada: Len Finkler Ltd., Downsview, Ontario

Call toll-free for details
1-800-243-6077
During business hours

*Suggested U.S. resale. Prices, specifications subject to change without notice. © Copyright 1980 Continental Specialties Corporation.

CIRCLE 26 ON FREE INFORMATION CARD

NEW PRODUCT

Sports Radar^{T.M.}



Here's how an exciting new micro-electronic breakthrough will make your children heroes and improve your tennis game.

Just point the gun and read the results.

When Roger started pitching for his little league team, he was just another player. And his arm was no better than anybody else's.

Two months later a small miracle took place. Roger was the best pitcher on the team and had a fast ball that was the most powerful in his league—and all thanks to his father.

Roger's success came from a radar gun—the same type device used by police to catch speeding motorists.

SCRAMBLED EGGS

The minute Roger's father was able to clock his son's pitching speed, Roger was subconsciously given a daily challenge of pitching harder and faster to beat his previous speed. The more he practiced, the better he got.

Roger's father paid \$2,000 for the radar gun. But in his upper class neighborhood, it wasn't too unusual for a father to spend that kind of money to help his son.

SPEEDING CITATION

A large manufacturer of radar-type security devices saw what Roger's father had done and felt that there was a definite need to produce a low cost radar unit designed exclusively for the sports market.

The company, Solfan Systems, developed the Sports Radar gun—a major breakthrough in projectile speed detection as well as electronic radar circuitry.

Using the doppler effect of radar and phased-lock-loop circuits, Solfan has developed the Sports Radar gun that compares to even the most sophisticated of police radar units that cost \$2,000.

OVERLAND EXPRESS

The Sports Radar gun is held in your hand and pointed toward the pitcher. You turn it on, press the ready button, and point the gun. The gun will ignore the moving arm of the pitcher but will lock in on the moving ball. The radar unit would then follow the ball for approximately ten milliseconds and the built in computer measures and computes the speed and flashes the reading on the display. The gun registers the speed to the exact mileage within one-half miles per hour.

The gun can be mounted on a tripod so that the person taking the measurements can also catch the ball.

In tennis, the speed of the serve can be measured by aiming the gun at the person serving. You can also use the unit by yourself by setting the unit on a tripod and measuring the speed from behind.

WORKING AND PLAYING

Aside from its extreme accuracy and advanced electronics, the unit is priced to meet the budget of every sports-minded athlete or parent. It's only \$149.95 complete.

You can measure the speed of baseballs, soccer balls, tennis balls, golf balls, hockey pucks, downhill skiers, radio controlled model airplanes or anything that moves—even automobiles.



The speed is flashed on the large LED display and is shown in miles per hour.

The unit accepts two commercially available 6-volt lantern batteries which you can purchase locally or from JS&A for only \$2 each. The batteries will last for weeks with normal use.

SUCCESS AND GOOD THINGS

The unit comes in a sports blue color and weighs 38.4 ounces, exclusive of batteries. It's rugged, well built and designed to endure the typical use and abuse it would normally receive.

We urge you to test this exciting new product during our 30-day free trial. Order the Sports Radar gun. When you receive it, measure your child's pitching speed. Test it on your own tennis serve. See how knowing your speed will actually improve it as you try to outperform your previous record fast pitch or serve. Then decide if the Sports Radar gun doesn't make a very exciting addition to your sports equipment.

ONE FOR THE MONEY

If you are not convinced that the Sports Radar gun is something that you'll use constantly to help improve your game, return it for a prompt and courteous refund, including your \$3.50 postage and handling. You can't lose—and chances are your son will at least have the most popular new product in the neighborhood.

To order one for your test, simply send your check for \$149.95 plus \$3.50 for postage and handling to JS&A Group, Inc., at the address shown below. (Illinois residents please add 5% sales tax.) Credit card buyers may call our toll-free number below. If you wish to buy a set of two six-volt batteries, simply add \$4.00 to your order.

We'll then send your unit, the batteries (if you order them from us), a 90-day limited warranty and complete easy-to-understand instructions.

Radar electronics for the sports enthusiast is now a reality. Watch your game improve by ordering your Sports Radar gun at no obligation, today.

JS&A PRODUCTS
THAT THINK[®]

Dept. RA One JS&A Plaza
Northbrook, Ill. 60062 (312) 564-7000
Call TOLL-FREE 800 323-6400
In Illinois Call (312) 564-7000

©JS&A Group, Inc., 1979

APRIL 1980

Sabtronics gives you DMM and Frequency Counter kits with more features, better performance and incredibly lower prices

Model 2010A Bench/Portable DMM: \$69.95 kit

Features: 3½ digit LED display • 31 measurement ranges 6-Functions • 0.1% Basic DCV accuracy • Touch-and-hold capability • Hi-Lo Ohms • 40 Hz to 40 kHz frequency response • Auto Zero, Auto Polarity • Overload protected • Overrange indication • Single chip LSI logic • Laser-trimmer resistor network and ultra-stable band-gap reference for better long term accuracy • Built-in NiCd battery charging circuit.

Brief Specifications: DC Volts 100µV to 1000V in 5 ranges; AC Volts 100µV to 1000V in 5 ranges; DC Current 0.1µA to 10A in 6 ranges; AC Current 0.1µA to 10A in 6 ranges; Resistance 0.1Ω to 20MΩ in 6 ranges; Diode Test Current 0.1µA to 1mA in 3 ranges; Input impedance, 10MΩ on AC and DC volts; Power requirement, 4.5 to 6.5 VDC (4 "C" cells) or optional AC adapter/charger.



\$69.95



\$89.95

Model 2015A Bench/Portable DMM: \$89.95 kit

Same features and specifications as Model 2010A except with large, 0.5" LCD 3½ digit display.

Optional Accessories:

- #AC-115, AC adapter/charger \$7.95
- #THP-20, Touch and Hold Probe \$19.95
- #NB-120 NiCd Battery Set \$18.75

Model 8610A Frequency Counter: \$89.95 kit

Features: 8-digit LED display • 10 Hz to 600 MHz guaranteed frequency range (5 Hz to 750 MHz typical) • 3 Gate times • 10 MHz TCXO Time base • Auto decimal point • Overflow indicator • Leading zero blanking • Resolution to 0.1 Hz • Built-in charging circuit for NiCd batteries.

Brief Specifications: Frequency Range, switch selectable, 10 MHz, 100MHz, 600 MHz • Sensitivity, ± 10mV RMS to 100 MHz, ± 50mV RMS, 100 MHz to 450 MHz; 90mV RMS 450 MHz to 600 MHz • Impedance, 1 MΩ, 10 MHz and 100 MHz ranges; 50Ω, 600 MHz range • Gate time (switch selectable) 0.1 sec, 1 sec, 10 sec • Temperature stability, 0.1 ppm/°C • Ageing rate < ± 5 ppm/yr • Accuracy, 1 ppm or 0.0001% • Input protection, 150V RMS to 10 kHz (declining with frequency) • Power Requirement, 4.5 to 6.5V DC @ 300mA (4 "C" cells) or optional AC adapter/charger (7.5 to 9V DC @ 300mA).

Also available Model 8110A, same as 8610A except maximum frequency is 100MHz and without battery charging circuit: \$59.95 kit



\$89.95

Ordering Information

USA - Add \$5.00 per kit for shipping & handling. Personal checks have to clear before goods are shipped (allow 2-3 weeks). For faster delivery send cashiers check or money order. 10% deposit for C.O.D. orders. Florida residents and sales tax. CANADA - Add \$6.00 per kit for shipping & handling. No C.O.D. Payment in U.S. funds. OVERSEAS - Add \$21.00 per kit for airmail delivery. Payment by bank draft in U.S. funds.

To place orders only, call toll free
800-237-5567
For other information call
(813) 623-2631

sabtronics 
INTERNATIONAL INC.

5309 N. 50th Street, M/S 35, Tampa, FL 33610

Radio- Electronics®

THE MAGAZINE FOR NEW
IDEAS IN ELECTRONICS

Electronics publishers since 1908

APRIL 1980 Vol. 51 No. 4

- BUILD**
- 39 **TRIGGERED OSCILLOSCOPE**
A 2-MHz bandwidth and a zero-baseline display for under \$125.
Daniel Metzger and Dennis Perry
 - 47 **BACKYARD SATELLITE TV RECEIVER**
This concluding part describes how to recover the video and audio signals from the satellite signal and then display them on your TV set. Robert B. Cooper, Jr.
 - 53 **PORTABLE ELECTRONIC ORGAN**
Learn to play a keyboard instrument on either one of the two inexpensive organs described. One plays melody, the other plays melody and chords. I. Queen
 - 61 **3½ DIGIT DMM**
Specifically designed for accuracy and minimal cost, this DMM lets you select and add the features you need. Carson Chen

- TECHNOLOGY**
- 5 **LOOKING AHEAD**
Tomorrow's news today. David Lachenbruch
 - 6 **APRIL NEWS AROUND THE WORLD**
Exclusive report on the technological developments around the world during just the month of April. Martin Bradley Weinstein
 - 12 **SATELLITE TV NEWS**
The latest happenings in an exciting new industry. Robert B. Cooper, Jr.; Gary H. Arlen
 - 44 **SPEECH SYNTHESIZERS**
Part 2—A look at the hardware designed to talk back to you. Martin Bradley Weinstein
 - 72 **HOBBY CORNER**
An inexpensive wide-bandwidth preamplifier with many applications on your workbench. Earl "Doc" Savage, K4SDS
 - 77 **NEW IDEAS**
A winning circuit application from our readers.

- AUDIO**
- 56 **CAR STEREO STANDARDS**
The new standards and specifications to help you select car stereo equipment. Len Feldman
 - 59 **R.E.A.L. SOUND LAB TESTS NIKKO EQUALIZER**
Nikko Audio model EQ-II graphic equalizer rates excellent.

- VIDEO**
- 65 **TROUBLESHOOTING BETA TRANSPORT MECHANISMS**
A look at the transport mechanism in Beta-type videocassette recorders and how to troubleshoot it. Forest Belt
 - 69 **AFFORDABLE NTSC COLOR-BAR GENERATOR**
A new NTSC color-bar generator that is within reach of every service bench. Jack Darr
 - 82 **SERVICE CLINIC**
How to locate faults in all-electronic tuners. Jack Darr
 - 82 **SERVICE QUESTIONS**
R-E's Service Editor solves technicians' problems.

- COMPUTERS**
- 74 **COMPUTER CORNER**
How to interface a 7-segment display to a microprocessor. J. Titus, P. Rony, D. Larsen and C. Titus

- EQUIPMENT REPORTS**
- 24 Beckman Models Tech-300 and Tech-310 DMM's.
 - 24 JVC Model HR-6700U Video Cassette Recorder.
 - 33 Hitachi Model V-302 Dual Trace Oscilloscope.
 - 36 The BASIC Programmer's Toolkit for PET Computers.

- DEPARTMENTS**
- | | |
|------------------------------|---------------------------|
| 120 Advertising Index | 121 Free-Information Card |
| 14 Advertising Sales Offices | 16 Letters |
| 94 Books | 96 Market Center |
| 76 Computer Products | 85 New Products |
| 14 Editorial | 81 Radio Products |
| | 92 Stereo Products |

ON THE COVER

Even though it costs less than \$125 to build, the triggered oscilloscope contains some rather nifty features. For example, a reference display of the zero volt DC level. To find out more and to get started building your own, turn to page 39.



MULTI-LINGUAL VOICE SYSTEM from Votrax can talk to you in seven languages. To find out what other speech synthesizer equipment is available, turn to page 44.

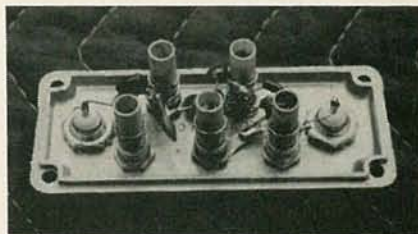

IF BANDPASS FILTER provides satellite TV receiver with the required selectivity. To find out the other missing components of the receiver, turn to page 47.

Radio-Electronics, (ISSN 0033-7862) Published monthly by Gernsback Publications, Inc., 200 Park Avenue South, New York, NY 10003. Phone: 212-777-6400. Controlled Circulation Postage Paid at Concord, NH. One-year subscription rate: U.S.A. and U.S. possessions, \$13.00, Canada, \$16.00, Other countries, \$18.00. Single copies \$1.25. © 1980 by Gernsback Publications, Inc. All rights reserved. Printed in U.S.A.

Subscription Service: Mail all subscription orders, changes, correspondence and Postmaster Notices of undelivered copies (Form 3579) to Radio-Electronics Subscription Service, Box 2520, Boulder, CO 80322.

A stamped self-addressed envelope must accompany all submitted manuscripts and/or artwork or photographs if their return is desired should they be rejected. We disclaim any responsibility for the loss or damage of manuscripts and/or artwork or photographs while in our possession or otherwise.

As a service to readers, Radio-Electronics publishes available plans or information relating to newsworthy products, techniques and scientific and technological developments. Because of possible variances in the quality and condition of materials and workmanship used by readers, Radio-Electronics disclaims any responsibility for the safe and proper functioning of reader-built projects based upon or from plans or information published in this magazine.

Sabtronics NEW Hand-held Digital Multimeters...

The only thing that beats their performance is their price.

Accurate performance you can rely on, time after time. That's what you expect from a quality DMM. But don't expect to pay as much for it any more. Because now Sabtronics brings you top quality DMMs with more features and better accuracy than other comparable units on the market today. And they cost surprisingly less!

We cut the price. Not the quality.

What you get is a precision crafted unit that features single-chip LSI logic, laser trimmed resistor network and a stable band-gap reference element for better long term accuracy. Basic DCV accuracy is 0.1%. The Model 2035A gives you 32 measurement ranges over 6 functions and the Model 2037A an additional two temperature ranges.

First in features. First in price.

Both models feature touch-and-hold capability with the optional probe — its so convenient, you'll wonder why the expensive models haven't got it yet! And two-terminal input for *all* measurement functions — this eliminates lead switching and makes your job easier. The Model 2037A even has a built-in temperature measuring circuit with a -50°C to $+150^{\circ}\text{C}$ range (-58°F to $+302^{\circ}\text{F}$) and is supplied complete with the sensor

probe. Of course, auto zero, auto polarity and overload protection are standard. And you get 200 hour operation from a single 9V transistor battery. A low battery indicator warns you of the last 20% of battery life. The large, crisp LCD readouts allow easy viewing even in bright sunlight.

Assembling either kit is simple with our easy-to-follow, step-by-step instructions. And the built-in calibration references allow you to calibrate the unit any time, any place. We've even eliminated difficult inter-connect wires. All parts mount on the PC board. The only wires you solder are the two battery-snap leads.

Biggest value in small DMMs

We are so sure that the Model 2035A and 2037A are the best values available that we offer a money-back guarantee. Examine either unit in your own home for 10 days, and if you are not convinced that it is the best value for your money, return it in its original condition for a prompt and courteous refund of the purchase price (less shipping and handling). Order yours today! Use the convenient order form or call

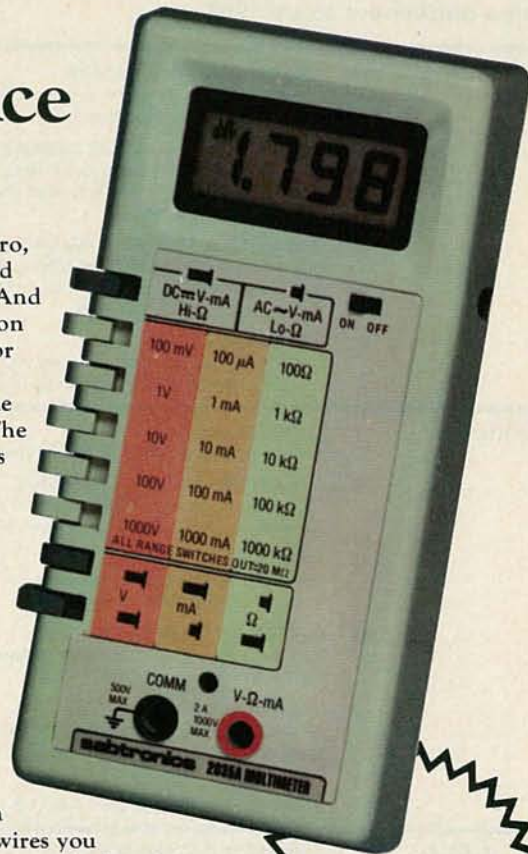

Model 2035A
\$74.95

F.O.B. Factory

us with your Master Charge or Visa number. To place orders only, call toll free 800-237-5567. For other information call (813) 623-2631

sabtronics INTERNATIONAL INC.

5709 N. 50th Street, M/S 35, Tampa, FL 33610

BRIEF SPECIFICATIONS:

DC VOLTS: 100 μ V - 1000V, 5 ranges
AC VOLTS: 100 μ V - 1000V, 5 ranges
DC CURRENT: 0.1 μ A - 2A, 5 ranges
AC CURRENT: 0.1 μ A - 2A, 5 ranges
HI-OHMS: 0.1 Ω - 20M Ω , 6 ranges
LO-OHMS: 0.1 Ω - 20M Ω , 6 ranges
TEMPERATURE: -50°C - $+150^{\circ}\text{C}$
(-58°F - $+302^{\circ}\text{F}$), 2 ranges
(Model 2037A only).

SIZE: 3.5"W. x 6.6"L. x 1.6"H.
WEIGHT: 11 oz. (excl. battery)

OVERLOAD PROTECTION: 1000V DC or ACpeak all voltage ranges; 250V DC or ACpeak all Ohms ranges; 2A/250V fuse all current ranges.

Mail to: Sabtronics International, Inc., 5709 N. 50th St., M/S 35, Tampa, FL 33610

Please send me...

_____ Model 2035A Hand-held Multimeter kit(s) @ \$74.95 each.....	\$
_____ Model 2035A Hand-held Multimeter assembled @ \$99.95 each.....	\$
_____ Model 2037A Hand-held Multimeter kit(s) @ \$89.95 each.....	\$
_____ Model 2037A Hand-held Multimeter assembled @ \$119.95 each.....	\$
_____ #THP-20 Touch-and-hold Probe(s) @ \$19.95.....	\$
_____ Shipping and Handling @ \$5.00 per instrument*.....	\$
For delivery in Florida, add 4% Sales Tax.....	\$
I enclose <input type="checkbox"/> check <input type="checkbox"/> money order <input type="checkbox"/> Master Charge <input type="checkbox"/> Visa	TOTAL.....\$
(Allow 2-3 weeks clearance time for personal checks). 10% deposit for C.O.D.	
Charge my credit card # _____ Expiry Date _____	

Name _____

Street _____

Apt. _____

City _____

State _____

Zip _____

*Continental U.S. only. AK, HI & PR: \$6.00. Canada: \$7.50. Foreign: \$19.00 Airmail.

looking ahead

Videodiscs heat up: A traditional rivalry has been buried in the interest of videodisc standardization. CBS and RCA, traditional rivals in the battles over color-TV systems, phonograph record speeds, and bitter competitors in broadcasting and records, have finally gotten together on something. CBS has taken out a license to press discs for the RCA *SelectaVision* grooved capacitance disc system, which is scheduled to go into nationwide marketing early in 1981 (See **Radio-Electronics**, March 1980). CBS's pressing operation is scheduled to be on stream in 1982. In the meantime, RCA will custom-press videodiscs for CBS.

And from Japan: Mighty Matsushita Electric finally got moving on videodiscs, too, after more than a year of indecision. Matsushita scrapped its own mechanical Visc-O-Pac system to officially embrace the grooveless capacitance VHD (video high density) system developed by its subsidiary Japan Victor Corporation. Matsushita said both companies would produce players and seek to have VHD established as the Japanese and world standard. Although both VHD and *SelectaVision* operate by reading variations in capacitance, they are incompatible. Not only is one grooveless and the other grooved, they use different modulation systems and RCA's revolves at 450 rpm while JVC's spins at 900 rpm.

Following the Philips-MCA optical system, now on the market, and RCA's announcement, VHD becomes the third "standard" to be announced for the consumer market. All three companies are wooing other TV receiver and record manufacturers as licensees for their respective systems. In the U.S., Zenith—the largest TV manufacturer—is getting the most attention. There's a feeling that if it opts for the RCA system, the battle is over. If it chooses either of the others, the consumer market will be saddled with multi-standards.

And another VCR: If you think that videodisc standards are muddled, how about those for videocassette recorders? In addition to fast-, medium- and slow-speed Beta and VHS formats, BASF is about to introduce its LVR (Linear Video Recorder), using 8-mm tape. Toshiba says it will market its own LVR (Longitudinal Video Recorder) using 1/2-inch endless-loop tape. Now along comes another—a neat-looking little seven-pound attache-case portable VCR that uses quarter-inch cassettes resembling audio cassettes. Playing time per cassette currently is 30 minutes, but is scheduled to be stepped up to a full hour. The unit is made in Japan by Funai Electric, and is expected to be imported into the U.S. by Technicolor as both a consumer and educational-institutional product. Price in the U.S. is targeted at "under \$1,000," double the prospective price of Toshiba's LVR.

Andean color: Nearly 20 years of lobbying effort by the U.S. Commerce Department and the American television industry have finally paid off in South America, as the NTSC color system makes a clean sweep of the six Andean countries. Colombia was the last country in the group to opt for the American-developed system, following Venezuela's choice of the system. Just before Venezuela's commitment, Ecuador chose the American system. The other countries

are Bolivia, Chile, and Peru. Some of them won't be color-casting for quite a while. But South America's two biggest countries are lost to NTSC. Brazil colorcasts in the German-developed PAL color on a 525-line television system. Argentina, which has not officially chosen a color system, probably will add PAL to its 625-line system, largely as a result of its extensive imports of German color equipment for last year's World Cup soccer matches. Argentina's neighbors Paraguay and Uruguay are still uncommitted.

Subscription TV: First it was pay cable. Now over-the-air subscription TV is beginning to make the kind of impact its proponents have forecast for 35 years. Although there are only six stations broadcasting the special no-commercial service, and they had a total of 400,000 subscribers at the start of this year (as compared with nearly 6,000,000 payable subscribers), rapid growth is seen, and manufacturers are hurrying to set up plants to build decoders. Some familiar names are getting into the act: Magnavox and Zenith are preparing to make the units, along with Canada's Electrohome, and CTS Knights, Oak, and Blonder-Tongue, the latter three already in production, as well as Consumer Technology. Up to a million decoders are expected to be installed this year, at \$125 and up. The simplest decoders merely unscramble the pay picture and are rented for a fixed monthly fee.

Dishes and captions: The old-line catalog and retail chain, Sears Roebuck, is gradually coming into the forefront of consumer-electronics technology. This month, Sears is scheduled to begin marketing captioning decoders for TV viewers with impaired hearing; they're manufactured by Sears affiliate Sanyo Manufacturing Co. ABC and NBC each is scheduled to offer five hours of programming with captions encoded in the vertical interval; PBS will provide 10 hours. Captioning will be handled by the new National Captioning Institute, which will get a royalty on each decoder and special TV decoding receiver sold. Decoders initially will be priced at \$250. The IC's for the decoders are being made by Texas Instruments. Sears, meanwhile, is holding talks with Comsat about possibly handling subscriptions and providing receiving installations for its proposed direct-to-home pay-TV system, which Comsat hopes to propose formally to the FCC this month.

Talking IC's: What's the hottest thing on the drawing boards in the semiconductor industry? Probably voice-synthesis and voice-recognition IC's. Everybody's working on special IC's to recognize and answer commands. One of the most interesting—and probably one of the first in the consumer field—is expected to be the talking automobile dashboard, considered a potential safety device. An imaginary conversation between driver and dashboard: "How's the gasoline?" "You've got about two gallons, enough to get 40 miles." "What about the oil pressure?" "It's OK." "Tune the radio to 96.2 and mute the commercials." "Yes, sir—and, by the way, you're exceeding the speed limit by five miles per hour."

DAVID LACHENBRUCH
CONTRIBUTING EDITOR

APRIL NEWS AROUND THE WORLD

FIBER SONICS

Warsaw—Polish scientists, following research designed to produce an inexpensive equivalent to fiber optics for use in the audio ranges, have announced the discovery of *fiber sonics*. They have discovered that certain tubular materials, consisting of interiors transparent to sound and skins opaque to sound, can actually transfer sound from one end to another over lengths of several dozen meters through a series of internal reflections. Research group head Tomski Edisinski completed his successful first trial using a garden hose and two funnels, following over 800 unsuccessful trials using such lavish materials as sausage casings stuffed with cheese, prune-whip filled soda straws, and 10-meter-long filter cigarettes.

FIBER PHONICS

Moscow—Russian scientists, claiming they had discovered "fiber sonics" years ago, but abandoned it due to a shortage of garden hose, today responded to the Polish announcement of fiber sonics with their own announcement of *fiber phonics*. Fiber phonics, instead of relying on the internal reflections of a carrier medium, takes advantage of the transmission capabilities of a suitably stressed elastic fiber. Initial tests involving two tin cans and a string were expanded to four tin cans and two strings for stereo; work on six tin cans and three strings has been delayed pending advances by Soviet medical technologists in grafting together the heads of one-and-a-half dogs.

NOPE SCOPE

Eugene—Oregon oscilloscope manufacturer Whobet-Packers today announced a major breakthrough in low-price oscilloscopes. Their surprising new no-trace oscilloscope offers response and bandwidth specifications reaching into the several Gigahertz region. Offering a 5-inch undergraduated display with illuminated ridicule, this new scope is slated to sell in the "under-\$100" area (just outside Enid, Oklahoma). Compared to single-trace, dual trace and multiple-trace scope, a company spokesman described this new no-trace scope as the ultimate in simplicity. "There's not a trace of confusion" sez he.

SOLDERLESS CAKE

No Haven—Solderless breadboard manufacturer Condimental Special Tease has again denied rumors of the development of solderless raisin, rye, and whole-wheat breadboards, while announcing plans to create an international breadboard shortage, resulting in a breadboard crisis, mandatory rationing, and wholesale price increases to an unaffordable level. Warned that price increases might dampen sales because of inflationary influences on available discretionary dollars, a company spokeswoman said "The peasants have no bread? Let them eat cake!" This announcement was quickly followed by the firing of the spokeswoman, abandonment of the planned price increases, new contracts for workers at the company's Bastille plant, and the announcement of a new line of inexpensive solderless cake boards.

PICO COMPUTERS

Austin—Taxless Instruments has announced a new level of miniaturization resulting in an under-three-hundred-dollar home computer, complete with keyboard and voice synthesis capabilities, small enough to fit on the head of a pin. Company miniaturization director V. Pryss, wearing a cloth over his head, explained to newsmen that only two problems remain before the new computer can be introduced to the public. First, keyboard entry seems to be a problem with the tiny, quarter-pinhead size keyboard. Second, they can't remember which pinhead they left it on. Meanwhile, several newsmen in the garden reported hearing a small voice crying "Help me! Help me!"

BUS STRUCTURES

Rainyvale—The California District Federal Court has ruled on the level of integration in integrated circuits, found it inadequate, and will enforce mandatory bussing beginning immediately. The judge in the case denied taking payoffs from wealthy IEEE Bus Company executive Carmen Getitt, claiming they were campaign contributions only.

ONE-CHANNEL STEREO

Parma—Ohio inventor Emma R. T. Sullivan has announced *stereo for one ear*. The new advance is said to require only one amplifier, one speaker, and is compatible with everything from current television audio to old 78-RPM records. Called *Emma Naural* after its inventor, the new advance is not expected to be commercially available in Parma until sometime in the next millenium.

CALCULATOR POCKET

Salerno—Fashion-designer Coochy has attacked what he finds as a major disadvantage to the pocket calculator. "Putta the dumma thing inna yor pocketta anna you no see what she says," complains Coochy. The answer is in his new line of shirts with transparent calculator pockets, including cutouts for keyboard access. The fashion world has acknowledged this as another Coochy coup.

MARTIN BRADLEY WEINSTEIN

Facts from Fluke on low-cost DMM's

Is this any way to treat a \$139 multimeter?

In the rough world of industrial electronics, even a precision test instrument can get treated like dirt. You need all the ruggedness and dependability you can get in a DMM for field use.

You'll find these qualities and more in the Fluke line of low-cost DMM's. Our DMM's have been dropped from towers, stepped on, and run over by construction equipment. And they've survived because we never cut corners on quality, even on our lowest-priced, six-function Model 8022A Troubleshooter at \$139 U.S.

Take a close look at a low-cost DMM from Fluke and you'll notice tough, lightweight construction that stands up to the hard knocks of life.

Sturdy internal design and high-impact, flame-retardant shells make these units practically indestructible. Right off the shelf, they meet or exceed severe military shock/vibration tests.

Even our LCD's are protected by cast-tempered plastic shields. We use rugged CMOS LSI circuitry for integrity and endurance, and devote a large number of

components to protection against overloading, accidental inputs and operator errors.

We go to these lengths with all our low-cost DMM's to make sure they are genuine price/performance values. You can count on that. Because, that's what leadership is all about.

For more facts on DMM reliability and where to find it, call toll free **800-426-0361**; use the coupon below; or contact your Fluke stocking distributor, sales office or representative.



8022A
Multimeter

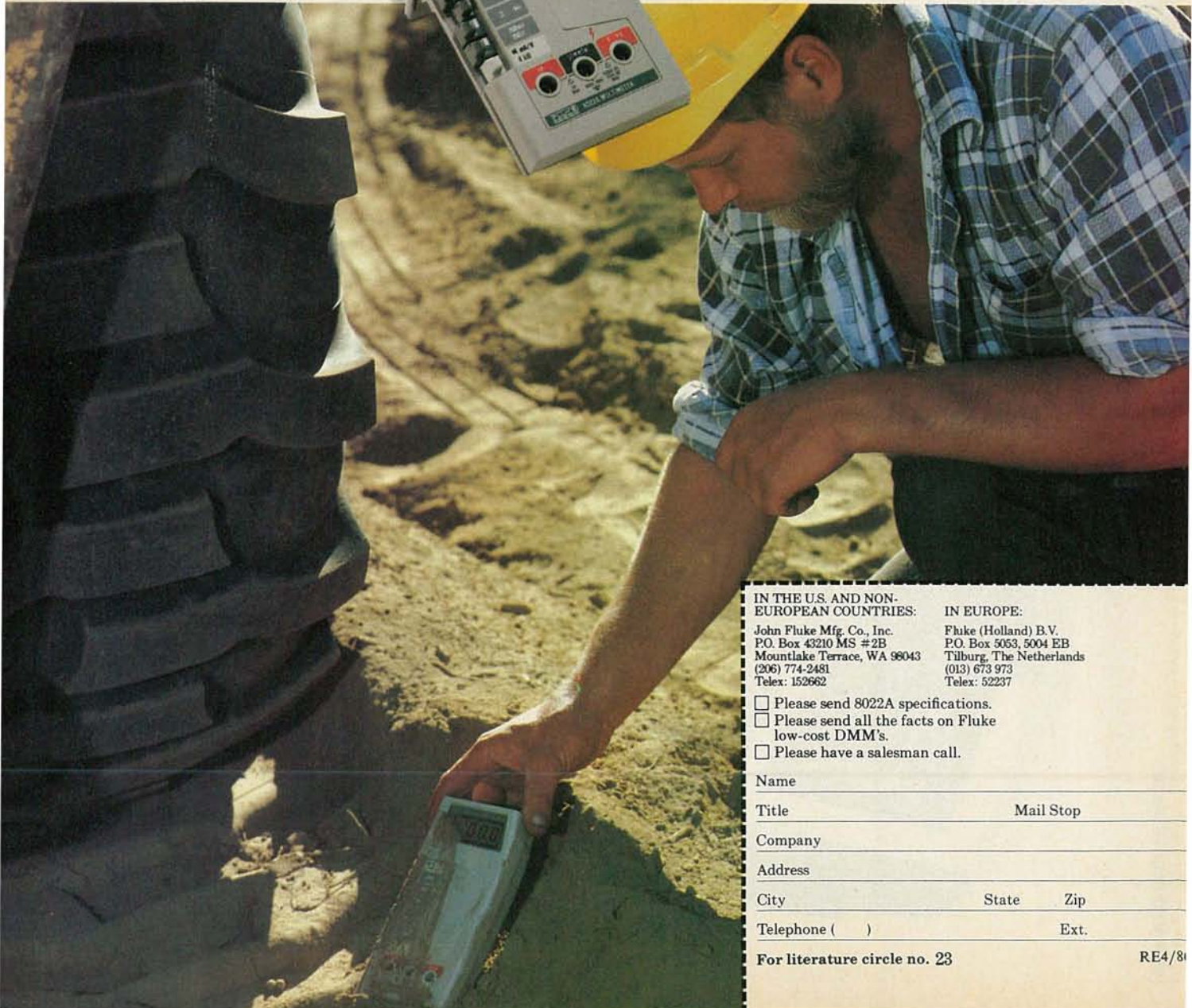

IN THE U.S. AND NON-EUROPEAN COUNTRIES:

John Fluke Mfg. Co., Inc.
P.O. Box 43210 MS #2B
Mountlake Terrace, WA 98043
(206) 774-2481
Telex: 152662

IN EUROPE:

Fluke (Holland) B.V.
P.O. Box 5053, 5004 EB
Tilburg, The Netherlands
(013) 673 973
Telex: 52237

- Please send 8022A specifications.
- Please send all the facts on Fluke low-cost DMM's.
- Please have a salesman call.

Name _____

Title _____ Mail Stop _____

Company _____

Address _____

City _____ State _____ Zip _____

Telephone () _____ Ext. _____

For literature circle no. 23

RE4/81

Everybody's making money selling microcomputers. Somebody's going to make money servicing them.

New NRI Home Study Course Shows You How to Make Money Servicing, Repairing,
and Programming Personal and Small Business Computers



Seems like every time you turn around, somebody comes along with a new computer for home or business use. And what's made it all possible is the amazing microprocessor, the tiny little chip that's a computer in itself.

Using this new technology, the industry is offering compact, affordable computers that will handle things like payrolls, billing, inventory, and other jobs for businesses of every size...perform household functions including budgeting, environmental systems control, indexing recipes, and more. And thousands of hobbyists are already owners, experimenting and developing their own programs.

Growing Demand for Computer Technicians

This is only one of the growth factors influencing the increasing opportunities for qualified computer technicians. The U.S. Department of Labor projects over a 100% increase in job openings for the decade through 1985. Most of them *new* jobs created by the expanding world of the computer.

Learn at Home in Your Spare Time

NRI can train you for this exciting, rewarding field. Train you at home to service not only microcomputers, but their larger brothers, too. Train you at your convenience, with clearly written "bite-size" lessons that you do evenings or weekends, without going to classes or quitting your present job.

Assemble Your Own Microcomputer

NRI training goes far beyond theory. It includes practical experience, too. As you progress, you perform meaningful experiments building and studying electronic circuits on the NRI Discovery Lab.[®] You assemble test instruments that include a transistorized volt-ohm meter and a CMOS digital frequency counter...instruments you learn on, use later in your work.



And you build your own microcomputer. Each step of construction advances your knowledge, gives you deeper insights into this amazing world that's upon us.

This is the only microcomputer designed for learning. It looks, operates, and performs just like the finest of its kind... actually does more than many commercial units. But NRI engineers have designed components and planned the assembly procedure so it demonstrates important principles, gives you working experience in detecting and correcting problems.

And that's what NRI training is all about.

Other Opportunities in Electronics

Since 1914, before commercial radio was even on the air, NRI has been the way to learn new electronics skills. Today's modern offerings include, in addition to three different computer courses, TV/Audio/Video Systems Servicing, with training on the only designed-for-learning 25" diagonal color TV, with state-of-the-art computer programming. Or, check out our Complete Communications Course, preparing you to enter this booming field servicing, installing, and repairing equipment like microwave, broadcast, CB, shortwave radio, paging, radar, and more.

Mail Postage-Paid Card for Free Catalog No Salesman Will Call

Send today for your free copy of our 100-page, full-color catalog. It describes all of our electronics courses in detail, showing kits, equipment, and lesson plans. Look it over at your convenience, then decide how NRI can help you make the most of your talents. There's no obligation and no salesman will ever call or bother you. With more than a million students and unmatched experience in home training, NRI gives you the most in training for new opportunity! If card has been removed, write to:



NRI Schools
McGraw-Hill Continuing
Education Center
3939 Wisconsin Avenue
Washington, D.C. 20016

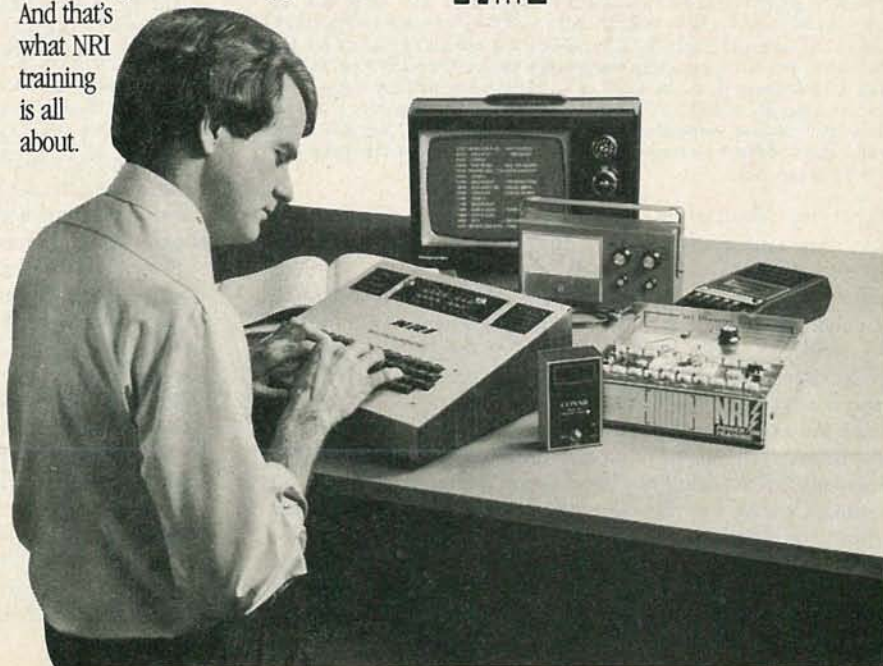

satellite tv news

International bird watching

A high percentage of the mail generated by the current series of articles on satellite TV in **Radio-Electronics** asks about receiving direct satellite-relayed reception from Europe, South America, and so on. It is possible. It is no more difficult than receiving the U.S. or Canadian domestic satellites, provided that you make a few minor adjustments to your equipment, and are ready to accept slightly inferior pictures.

One of the most interesting targets is the Russian Statsionar-4 satellite positioned over the Atlantic at 14° west (longitude). Statsionar-4 has at least six operating transponders: 3,695 MHz, 3,745 MHz, 3,795 MHz, 3,845 MHz, 3,895 MHz, and 3,945 MHz. The polarization is horizontal and audio is carried on a 7.5 MHz subcarrier. The apparent footprint-signal level is in the 19 dBw region on a global beam, which means that this satellite is receiveable throughout all of Europe and Africa and west to an imaginary line drawn north by south from Chicago to New Orleans. All of South America is included in that coverage.



RUSSIA'S STATIONAR-4 SATELLITE located at 14° west can be received well even on an 8-foot dish with a 150° Kelvin LNA as this photo shows. The edge of visibility (i.e., where the horizon cuts off for the satellite) in the U.S. is roughly along a line drawn from Chicago to New Orleans. Statsionar 8, to be located at 25 degrees west, will push the western edge of visibility to the eastern slope of the Rockies. If you go fishing for this one, remember the time-zone difference; Moscow signs off at around 10 PM their time most nights (although test patterns continue to be broadcast).

Within that coverage region a ten-foot dish, 150° Kelvin LNA and a tuneable receiver with a 11-13 dB noise figure should insure high-quality reception. It won't be in color however, because Russia employs the SECAM color system. That satellite is but one of approximately ten the Russians expect to have operational before this year is out, so that they can relay television worldwide by the start of 1981 using their own network of geostationary satellites.

Can American (or Canadian) DOMSAT's (domestic satellites) be received outside of North America? Yes, in some cases. Canadian ANIK satellites have sculptured antenna patterns favoring Canada; but reception south of the Mason-Dixon line without big antennas (20 feet in diameter or bigger) is poor. U.S. DOMSAT's have a bigger area to cover (Alaska to Puerto Rico, Maine to Hawaii) so there is more spillover than with ANIK birds. Bermuda, the central and western Caribbean, virtually all of Central America, and the shoreline regions of South America bordering on the Caribbean are all capable of receiving

U.S. DOMSAT's. But along with those coverage edges big antennas (20 to 30 feet in size) are required and with bigger antennas comes added expense.

The same people who refuse to grant private terminals permission to view their signals are quick to point out that, under international law, the U.S. (and Canadian) DOMSAT's are only licensed to serve their respective countries and that legally you are not supposed to set up a terminal in Caracas or Bogota in order to pirate U.S. satellite signals outside U.S. borders.

ROBERT B. COOPER, JR.

Cable TV companies selling homesat

Scientific-Atlanta has shifted its marketing strategy for the Homesat subsidiary it created last year. Now cable-TV companies will be selling the small TVRO earth stations to individual families within certain geographical regions. Originally, Homesat sold directly out of Scientific-Atlanta's home office. The first major cable-TV firm to hook into the deal is Tele-Communications Inc., which will sell Homesat equipment in the western states area, where that company operates many cable-TV systems. Meanwhile the increasing number of competing firms that sell earth-station equipment to families (such as Gardiner Communications' StarScan, Avcomm, Channel One) continue to work out their own distribution means.

Satellite news notes

KRON-TV, an NBC-TV affiliate in San Francisco, is the first Bay Area TV station to set up its own Washington D.C. news bureau. The staff there beams news reports affecting Californians back home each evening via satellite, thus giving the newscast a Washington report with a local touch. **WOR-TV** New York Channel 9—with its hefty line-up of sporting events and movies—is now a round-the-clock superstation via Eastern Microwave which sends the signal around the country aboard RCA Satcom on Transponder 17.

C-SPAN (Cable-Satellite Public Affairs Network), which carries live coverage of debates from the House of Representatives, is adding other Capitol Hill and political features. C-SPAN recently transmitted highlights of a Republican political caucus in Texas; and starting this year, there's an arrangement with Close-Up Foundation that will involve the presentation of high-schoolers interviewing Washington figures during the traditional school excursions to the Nation's Capitol. Those interviews will be beamed to schools around the country to be used as supplements in social studies, government, and civics classes.

Sony, which makes equipment for the Japanese direct-to-home-satellite experiment, is looking at the U.S. and could introduce components or entire systems when direct-broadcasting satellites arrive here. Currently the 12-GHz experiment in Japan involves earth terminals costing about \$350 each.

Political commercials via satellite! It's a possibility for this fall's campaign if a plan by John Blair & Co. materializes. Blair, a leading media company, has been experimenting with sending commercials directly to local TV stations via satellite links and hopes to have a system in place nationwide by this Autumn so that quickly up-dated commercials could be sent out. One obvious kind of commercials are the paid political announcements that are now usually air-freighted to TV stations; the satellite process could speed up their timeliness by a day or more.

GARY H. ARLEN

Not Just Another Limited Area Motion Detector!

guardex™

Protects Every Square Inch Of Your Building

Turns On Lights Automatically

Powerful Electronic Siren

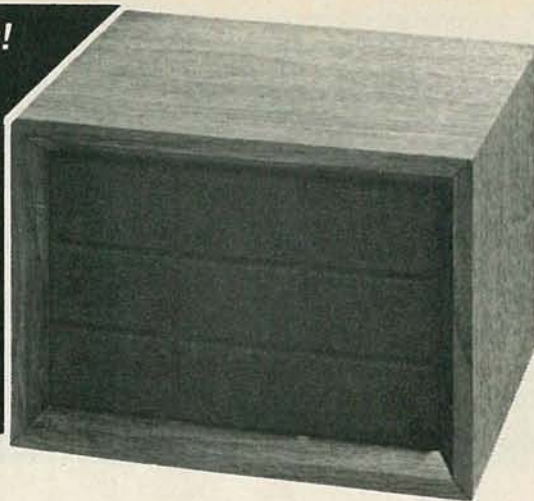

Low Cost Computerized Burglar Alarm System Home - Office - Business

The Guardex 8000 Alarm System is walnut grained and disguised to look like a small stereo speaker (6 3/4" x 9 3/4" x 8") and weighs less than 6 1/2 pounds.

NO INSTALLATION

Just plug the Guardex 8000 alarm system in, make several simple control adjustments to suit your particular building and it works! There are no other wires to run. This totally self-contained burglar alarm can completely seal off every square inch of the surface of your building. It protects doors, windows, and what most alarms miss... your roof, walls and floors.

HOW CAN ONE SMALL COMPUTER PROTECT MY WHOLE BUILDING?

Guardex 8000 Alarm System works on the principle of audio discrimination. This, put simply, is the process of electronically separating normal everyday sounds, such as voices, telephones, etc. from break-in type noises such as breaking glass, prying metal, or forcing a door open. The Guardex 8000 protects one story homes and offices up to 2000 square feet and open commercial buildings up to 10,000 square feet. The Guardex 9300 with wireless remote sensor capability is available for multi-story homes and offices or single story with more than 2000 square feet. Call the factory for more detailed information.

TURNS ON LIGHTS AUTOMATICALLY

When the first break-in type sound is detected, the system will instantly turn on lights, radio, or other electronic equipment that you have plugged into the back of the alarm. These lights or other equipment will remain on for a period of five minutes, then automatically turn off.

POWERFUL ELECTRONIC SIREN

The Guardex 8000 alarm is equipped with a loud built-in siren. If during the five minute period the lights or other electronic equipment has been activated, a second break-in sound is detected, (it can be only a second or two after the first break-in sound) the built-in siren will start blasting for 90 seconds. At the end of approximately 90 seconds the siren will shut off and the alarm listens again. If another break-in sound is heard, the siren will come on for another 90 seconds. If no other break-in sound is detected, the siren will stay off and at the end of the five minute period the lights will shut off and the alarm instantly resets.

EXIT AND ENTRY DELAY

The Guardex 8000 alarm has a built-in exit delay allowing you approximately one minute to lock up and leave the building before the alarm is armed. When you enter your building you may find that just your normal entering sounds activate the siren. You may delay it from starting for up to 30 seconds by turning up the siren entry delay control.

BATTERY BACK-UP

Burglars rarely cut power. However, to give you total protection from a burglar and possible power failure, our alarm has provisions for a battery back-up. (Batteries not included). 12 volt lantern batteries are available at most hardware stores.

THE BURGLARY PROBLEM

The F.B.I. statistics show that at the present rate, one out of every four Americans are going to be burglarized. That is not a very pleasant fact, but it is true. You have a greater chance of being burglarized than being a victim of a fire or automobile accident. The time is now to help protect yourself and your valuables with a Guardex 8000 alarm system.

OUTSIDE SIREN

The Guardex 8000 alarm is equipped with a loud, built-in siren, but if you desire an additional siren to mount outside or in an area away from the main alarm, they are available with 50 feet of wire for \$24.95. (Connecting terminals are provided on the back of the alarm).

30 DAY NO RISK TRIAL

This is your opportunity to purchase an alarm system directly from the factory for only \$199.95. Try it in your home or business for thirty days without risking one cent. Put our Guardex 8000 alarm to your own test. See for yourself! It will protect every window and door from break-in. If you are not completely satisfied, return the alarm within 30 days for a complete refund. To order your Guardex 8000 alarm, CALL TOLL FREE to charge your credit card or send your check to Guardian Electronics, Inc. in the amount of \$199.95. If you want the optional outside siren, add \$24.94. (California residents add 6% sales tax.)

(If you require more information, call during California business hours, Monday - Friday)



Dealer Inquiries Invited

CALL TOLL FREE
(800) 423-5499

California residents:
(213) 889-1414 collect.

GE GUARDIAN ELECTRONICS, INC.

31133 Via Colinas, Dept. B. Westlake Village, Calif. 91361

The rear control panel contains two standard AC plug receptacles for a table lamp, spot lights, radio, etc.; terminals for connecting optional outside siren and back-up battery (not included); entry delay time control and sensitivity control.



CIRCLE 48 ON FREE INFORMATION CARD

APRIL 1980 13

editorial

The BIG show

It was electronics time in Las Vegas. The 1980 Winter Consumer Electronics show had arrived and more than 65,000 retailers and distributors jammed the convention center to capacity, while previewing the products that will soon be available to us. Much of what was shown was conventional—those everyday products that are the staples of the consumer electronics industry. But here and there, the spotlight shone on the exceptional.

I'd like to take just a few moments of your time for a look at these exciting products.

A flat-screen TV prototype from Sinclair. It will not be available this year, but the unit demonstrated was a working model. It fortells a whole new world of television. I believe the prototype unit I saw may finally introduce those large-screen, hang-on-the-wall color sets that have been so consistently predicted over the years and have, to date, not appeared.

"The Source" is the name of a time-shared computer service. Connect your home computer to your phone via a modem and with a local phone call you can now dial up all kinds of advanced programs, daily news, and wire-service features that you can select with key words of your choice. It makes your terminal a part of a nationwide communications network that will permit you to talk or send mail to any other terminal for as little as \$2.75 per hour. It provides a buying service that lets you order merchandise, charge it to your credit card, and have it delivered to your door. It's an information service with endless possibilities. And there's much, much more; but that will be the subject of a complete article in a future issue.

Quasar presented a talking microwave oven. Again it's a prototype, but obviously represents the start of a whole wave of talking appliances, from wrist-watches and calculators to you name it.

And then there are the TV's you talk to—actually command. "Tell" it to switch on and it will. Tell it to change channel and it will. And it's custom-tailored to your voice—no one else can operate the remote. Panasonic and Toshiba showed these.

How about a Sharp TV that lets you watch nine channels at the same time on a single 25-inch color screen. Oh, you can snatch frames too. And Toshiba showed a four-channel-on-one-screen set too. Of course, it will probably be less expensive to buy multiple individual sets, but what a beautiful example of technology.

Satellite TV? Out in the parking lot, and not officially a part of the show, was a \$7500 earth station for satellite TV reception. In a truck with the antenna on the tailgate it was available for sale. The owner got his idea from the satellite-TV series currently running in **Radio-Electronics**.

Last, but not least, was Kenwood's FM stereo receiver. It has a CRT display that shows you every station on the air in your area; displays call signs and frequencies; measures signal strength, multipath distortion, and just about everything else you could possibly want. It is several years away from production, but if there had been one piece of equipment that I would have been allowed to cart out of the show, that FM tuner would have been my choice.

The next CES show is in Chicago in June and I just can't wait to get a look at that one.

Larry Steckler
LARRY STECKLER
PUBLISHER

Radio- Electronics®

Hugo Gernsback (1884-1967) founder

M. Harvey Gernsback, editor-in-chief

Larry Steckler, CET, publisher

Arthur Kleiman, managing editor

Robert F. Scott, CET, W2PWG,
technical editor

Jack Darr, CET service editor

Leonard Feldman

contributing high-fidelity editor

Karl Savon, semiconductor editor

Herb Freidman, communications editor

David Lachenbruch, contributing editor

Earl "Doc" Savage, K4SDS, hobby editor

Ruby Yee, production manager

Robert A. W. Lowndes, production
associate

Marie J. Stolfi, production assistant

Gabriele Margules, circulation director

Arline R. Fishman,
advertising coordinator

Cover design by Louis G. Rubsamen

Cover photo by Robert Lewis

Radio Electronics is indexed in *Applied Science & Technology Index* and *Readers Guide to Periodical Literature*.

Gernsback Publications, Inc.
200 Park Ave. S., New York, NY 10003
(212) 777-6400
President: M. Harvey Gernsback
Vice President: Larry Steckler
Secretary/Treasurer: Carol A. Gernsback

ADVERTISING SALES

Larry Steckler
Publisher
Paul McGinnis
Director of Marketing

EAST

Stanley Levitan
Radio-Electronics
200 Park Ave. South
New York, NY 10003
(212) 777-6400

MIDWEST/Texas/Arkansas/Okla.

Ralph Bergen
The Ralph Bergen Co.
540 Frontage Road—Suite 361-A
Northfield, Illinois 60093
(312) 446-1444

PACIFIC COAST Mountain States

Jay Eisenberg
J.E. Publishers Representative Co.,
8732 Sunset Blvd.,
4th Floor,
Los Angeles, CA 90069
(213) 659-3810
Sales Mart Building
1485 Bayshore Blvd., Box 140
San Francisco, CA 94124
(415) 467-0125

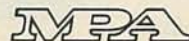



The most automatic DMM you can buy

- Automatically selects correct range for faster, more accurate measurements of voltage, current and resistance.
- Automatically places decimal point for correct readings.
- Automatically indicates polarity.

It's loaded with automatic features that save you time and make it so much easier to get accurate measurements.

The Heathkit IM-2212 Digital Multimeter automatically puts you in the correct range for the measurements you're making. And it gives you accuracy you can count on: $\pm 0.2\%$ on DC and $\pm 0.4\%$ on AC. That's precision.

The IM-2212 is super-fast, too. Response time on DC is less than 3 seconds, so you're not standing around waiting for a reading. You get a large, clear digital readout of your measurement with decimal point automatically placed at the correct digit.

Ranges include:

- AC & DC voltage from 200mV to 1000V.
- Resistance from 200 ohms to 20 megohm.
- AC & DC current from 200 μ A to 2.000 A.

A special hold switch lets you lock into the range you're using for added convenience.

The quality design of the IM-2212 includes complete input protection on all functions to prevent damaging overloads. An optional battery is even available for work in the field.



FREE CATALOG

Complete details and price on the Heathkit IM-2212 Digital Multimeter are in the new Heathkit Catalog, which describes more than 400 electronic kits for your home, work or pleasure. Send for your free Heathkit Catalog today or pick one up at your nearest Heathkit Electronic Center.

Heathkit®

Heath Company, Dept. 020-644, Benton Harbor, MI 49022

Heathkit Products are also sold and serviced at Heathkit Electronic Centers (Units of Veritechnology Electronics Corporation) in major cities throughout the U.S. See your white pages.

GX-376

letters

AC OUTLET CHECKER

The AC outlet checker described by William D. Kraengel, Jr., in the August 1979 issue has a serious shortcoming which may lull its users into a false sense of security. All neon-lamp outlet testers of that type will indicate whether the neutral and grounding conductors are at the same potential, but none of them will measure the actual *quality* of the ground.

It is imperative that the grounding (green or bare wire) conductor be able to carry the full fault current, which would be 15 or 20 amperes in a residential receptacle. To do that, the resistance to ground must be less than 8 ohms on a 15-ampere circuit, or 6 ohms on a 20-ampere circuit. Mr. Kraengel's tester will indicate a satisfactory ground connection even if the ground resistance is up on the kilohm range.

I recommend that all users of the simple neon-lamp receptacle testers perform a simple added check: De-energize the circuit, and measure the resistance between the grounded (wider slot) terminal and the grounding (round hole) terminal on a receptacle that has passed the neon-lamp test.

That resistance should be less than 10 ohms. It would be a good idea to measure the resistance between the grounding terminal on the receptacle and a known good ground, such as a water pipe or a ground rod; that resistance should be a few ohms at most.

One last word about ground quality: Some ground clamps that are sold in handyman and department stores are of inferior quality, being made of aluminum with a copper or brass plating. Don't use them! The safest, most durable grounding system uses copper ground rods (or a buried copper water-pipe network) with copper ground clamps and copper wire. I have discovered many faulty grounding systems where the clamp used to connect the load center's ground wire to the ground rod was made of aluminum, and had been eaten away completely by galvanic corrosion.

ERIC LEMMON
Lompoc, CA

updates and letters from other readers. I myself have managed to order a Magnavision optical system machine through the aid of a friend.

My concern is that a potentially beneficial invention, such as this, may be totally lost in the shuffle, or be greatly delayed in production, because of the useless haggling over different and entirely incompatible systems.

Many articles have stated: "Let the public decide." I would certainly agree with that. The problem is that the various companies are stacking the decks so that the public's decision will not be based upon the merits of a particular system but on the software available. Magnavision/MCA has Paramount, Universal, and Warner Brothers films, for example, while RCA has MGM and 20th Century Fox. Isn't that familiar—or have we forgotten about the quad situation when Columbia and RCA were incompatible? Everyone lost, including the consumer—perhaps especially the consumer!

Perhaps we could learn a better lesson from the videocassette "war" now going

continued on page 22

NEW 1980 DIGITAL MULTIMETERS FROM **FLUKE**

8010A
\$249

\$289
w/rechargeable
batteries
(OPTION - 01)



8010A and 8012A

- Large 3½-Digit LCD's - view in any light
- Conductance function - resistance to 10,000 MO
- AC measurements to 50 kHz and higher
- True RMS for ac accuracy
- Touch-Hold probe for tricky places (Y8008)
- Diode test and low power ohms
- AC or dc current to 10 amps with 8010A
- Resistance resolution to 0.001Ω with 8012A
- Built-in batteries and charger (Option -01)

8012A
\$299

\$339
w/rechargeable
batteries
(OPTION - 01)



NEW

8050A
\$329

\$379
w/rechargeable
batteries
(OPTION - 01)



8050A 4½-digit multimeter microprocessor technology

- dB: That's right, direct readings in dBm, referenced to any of 16 impedances that you select from the 8050A's scrolling reference memory.
- REL: This stands for relative reference in the dB mode or offset measurements in other functions.

- Conductance function - resistance to 10,000 MO
- AC measurements to 50 kHz and higher
- True RMS for ac accuracy
- Touch-Hold probe for tricky places (Y8008)
- Diode test and low power ohms
- Built-in batteries and charger (Option -01)

NEW

8024A
\$219

Model 8024A: The Investigator

- Nine functions: dc voltage, ac voltage, dc current, ac current, resistance, diode test, conductance (1/R), logic level and continuity detect, temperature (K-type thermocouple)
- Peak hold on voltage and current functions
- Selectable audible indicator for continuity or level detection
- 3½-digit resolution
- 0.1% basic dc accuracy
- LCD display
- Overload protection



Model 8022A: The Troubleshooter

- Six functions: dc voltage, ac voltage, dc current, ac current, resistance, diode test
- 3½-digit resolution
- 0.25% basic dc accuracy
- LCD display
- Overload protection



8022A
\$139

Model 8020A: The Analyst

- 0.1% basic dc accuracy
- LCD display
- Seven functions: dc voltage, ac voltage, dc current, ac current, resistance, diode test, conductance (1/R)
- 3½-digit resolution
- Overload protection
- Free Case
- Two year parts and labor warranty

8020A
\$179

TOLL FREE HOTLINE 800-223-0474

54 WEST 45TH STREET, NEW YORK, N.Y. 10036 212-687-2224

**ADVANCE
ELECTRONICS**

If you don't see your kind of
electronic pliers here,

look again,

Xcelite[®] makes them all.

Xcelite, long acknowledged as the world's first family of electronic hand tools, now includes a greatly expanded line of solid joint pliers and cutters. All the pliers you'll ever need, and more. Because new designs are continually added as new electronic products are born.

The present range extends through 38 patterns and sizes including 13 new models for miniature electronics. Made in U.S.A. by the latest technology and quality controls, in one of the world's most modern electronic hand tools plants, Xcelite pliers set the standards for the industry. Yet the same advanced production techniques make them competitively priced.

Typical of the features that single out Xcelite quality are coil spring openers, polished heads, cleanly milled and perfectly aligned jaws, hand-honed and mated cutting edges, exceptional strength and performance provided by forged alloy steel construction, precision machining and scientific proportioning. Handles are designed for maximum leverage and convenience, with plastic coated "Cushion-Grip" for added comfort.

Styles? What else could you possibly need: standard, midjet, and taper nose diagonals; standard, very fine and extra thin needle nose; long and short nose; long, short and midjet chain nose, with and without side cutters; side cutting; short flat nose; round nose; tip cutter wiring; cutting and looping; short nose tip cutting; thin bent nose; midjet semi and full flush cutting; diagonal full flush cutting; and stainless diagonal cutting.

You don't know what you can do with pliers until you know what Xcelite pliers can do for you. See your distributor and let him update you.



The Cooper Group
Electronics Division

WELLER[®] • WISS[®] • XCELITE[®]

P.O. BOX 728, APEX, NORTH CAROLINA 27502, 919/362-7511

CIRCLE 70 ON FREE INFORMATION CARD

**Learning
electronics
is no picnic.**

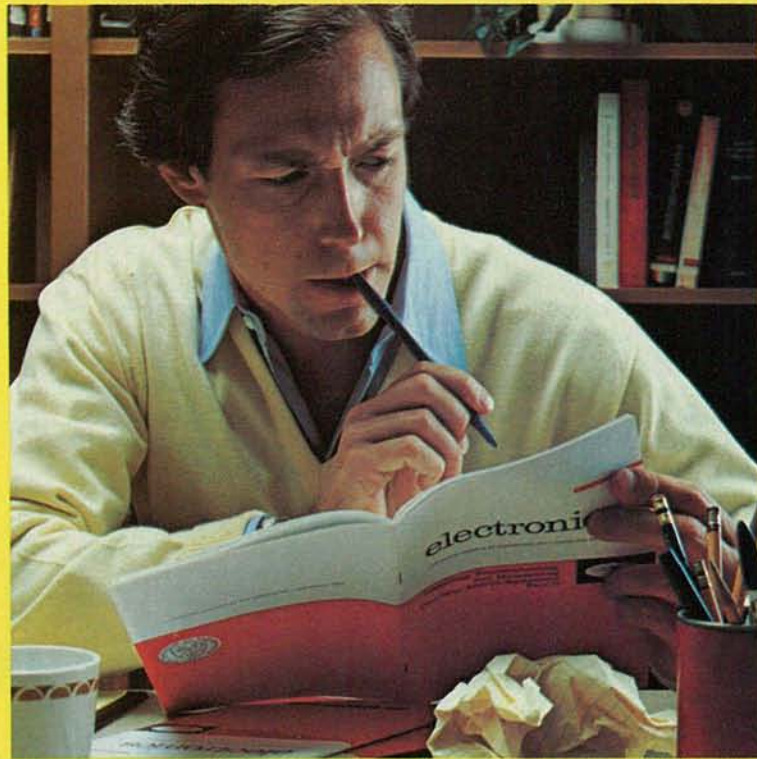

**At any level it
takes work and
a few sacrifices.
But with CIE,
it's worth it.**

Whoever said, "The best things in life are free," was writing a song, not living a life. Life is not just a bowl of cherries, and we all know it.

You fight for what you get. You get what you fight for. If you want a thorough, practical, working knowledge of electronics, come to CIE.

You can learn electronics at home by spending just 12 hard-working hours a week, two hours a day. Or, would you rather go bowling? Your success is up to you.

At CIE, you *earn* your diploma. It is not handed to you simply for putting in hours. But the hours you do put in will be on your schedule, not ours. You don't have to go to a classroom. The classroom comes to you.

Why electronics training?

Today the world depends on technology. And the "brain" of technology is electronics. Every year, companies the world over are finding new ways to apply the wonders of electronics to control and program manufacturing, processing...even to create new leisure-time products and services. And the more electronics applications there are, the greater the need will be for trained technicians to keep sophisticated equipment finely tuned and operating efficiently. That means career opportunities in the eighties and beyond.

Which CIE training fits you?

Beginner? Intermediate? Advanced? CIE home study courses are designed for ambitious people at all entry levels. People who may have:

1. No previous electronics knowledge, but do have an interest in it;
2. Some basic knowledge or experience in electronics;
3. In-depth working experience or prior training in electronics.

You can start where you fit and fit where you start, then go on from there to your Diploma, FCC License and career.

Many people can be taught electronics.

There is no mystery to learning electronics. At CIE you simply start with what you know and build on it to develop the knowledge and techniques that make you a specialist. Thousands of CIE graduates have learned to master the simple principles of electronics and operate or maintain even the most sophisticated electronics equipment.

CIE specializes exclusively in electronics.

Why CIE? CIE is the largest independent home study school that specializes exclusively in electronics. Nothing else. CIE has the electronics course that's right for you.

Learning electronics is a lot more than memorizing a laundry list of

facts about circuits and transistors. Electronics is interesting! It is based on recent developments in the industry. It's built on ideas. So, look for a program that starts with ideas and builds on them. Look to CIE.

Programmed learning.

That's exactly what happens with CIE's Auto-Programmed® Lessons. Each lesson uses famous "programmed learning" methods to teach you important principles. You explore them, master them completely, before you start to apply them. You thoroughly understand each step before you go on to the next. You learn at your own pace.

And, beyond theory, some courses come fully equipped with electronics gear (the things you see in technical magazines) to actually let you perform hundreds of checking, testing, and analyzing projects.

Experienced specialists work closely with you.

Even though you study at home, you are not alone! Each time you return a completed lesson, you can be sure it will be reviewed, graded and returned with appropriate instructional help. When you need additional individual help, you get it fast and in writing from the faculty technical specialist best qualified to

answer your question in terms you can understand.

CIE prepares you for your FCC License.

For some jobs in electronics, you must have a Federal Communications Commission (FCC) License. For others, some employers tend to consider your license a mark in your favor. Either way, your license is government-certified proof of your knowledge and skills. It sets you apart from the crowd.

More than half of CIE's courses prepare you to pass the government-administered exam. In continuing surveys, nearly 4 out of 5 graduates who take the exam get their licenses! You can be among the winners.

Today is the day. Send now.

Fill in and return the postage-free card attached. If some other ambitious person has removed it, cut out and mail the coupon. You'll get a FREE school catalog plus complete information on independent home study. For your convenience, we'll try to have a CIE representative contact you to answer any questions you may have.

Mail the card or the coupon or write CIE (mentioning name and date of this magazine) at: 1776 East 17th Street, Cleveland, Ohio 44114.



Pattern shown on oscilloscope screen is simulated.



CIE **Cleveland Institute of Electronics, Inc.**
1776 East 17th Street, Cleveland, Ohio 44114
Accredited Member National Home Study Council

YES... I want to learn from the specialists in electronics—CIE. Send me my FREE CIE school catalog plus my FREE package of home study information. RE-85

Name _____

Address _____ Apt. _____

City _____

State _____ Zip _____

Age _____ Phone (area code) _____

Check box for G.I. Bill bulletin on Educational Benefits: Veteran Active Duty

MAIL TODAY!

LETTERS

continued from page 16

on. True—there are different systems, but when software is made available it's produced in both formats: Beta and VHS. That way, the buyer can select a recorder for its recording abilities rather than being penalized because of which pre-recorded material he wants.

Along those lines, I see no reason why the two videodisc systems can't exist side by side. Those who want only movies, and a less expensive machine, can buy an RCA system. Those who want (or need) the extra features that Magnavision/Philips provides (such as freeze frame, lectures, art gallery tours, etc.) can buy that format, and would be willing to pay extra for the extra features. But the movies and other entertainment items should be available for both systems. A buyer could then truly decide upon which system he needs. As things stack up now, I would have to buy one player to see *Jaws* and a different one to see *Star Wars*.

Should this become a software war, rather than a hardware one, the public has shown, in the way it has ignored quad, that it will throw up its hands and bypass the whole thing. And that would be a shame. WILLIAM RADFORD-BENNETT
Washington, D.C.

TEXTRONIC TEST EQUIPMENT

Off and on in your magazine, I have noticed requests for technical data for Textronic and related test equipment. I have located the Air Force technical order numbers for some of the more common oscilloscopes and preamps on the surplus market, and have listed them below. To obtain those, individuals should write to the Government Printing Office, Washington, D.C. for information on price and availability.

Oscilloscopes:

Tex. RM35 T.O. No. 33A1-13-76
Tex. RM35A.. T.O. No. 33A1-13-177
Tex. 535..... T.O. No. 33A1-13-76
Tex. 535A T.O. No. 33A1-13-241
Tex. 545..... T.O. No. 33A1-13-73
Tex. 545A T.O. No. 33A1-13-247
Tex. 585..... T.O. No. 33A1-13-173
Hickock 1805,
1805A..... No. 33A1-13-66

Preamps:

Tex. type B ... T.O. No. 33A1-13-115
Tex. type CA..... No. 33A1-13-116
Tex. type K ... T.O. No. 33A1-13-113
Tex. type 53/54A.. No. 33A1-13-114
Tex. type 53/54B.. No. 33A1-13-115
Tex. type 53/54C.. No. 33A1-13-409
Tex. type 53/54CA No. 33A1-13-116
Tex. type 53/54G. No. 33A1-13-118
Tex. type 53/54K.. No. 33A1-13-113

CHARLES BROWN

EINSTEINIAN IMPOSSIBILITIES

Having made a list of extensive impossibilities in Einstein's special theory of relativity, I notice that Dr. Howard Mark's letter (October 1979 issue) mentioned an Einsteinian notion that is one of my evidences: relativity of simultaneity.

Mark states: "... events simultaneous to one observer cannot be simultaneous to (a moving) observer." By "events" he means, for instance, flash-emissions of

light at two spots (A' and B') in the moving reference system and equidistant from the "moving" and "rest" observers (M' and M respectively).

Resulting flash-beams are received simultaneously by M but non-simultaneously by M' because M' moves closer to one (from B') and farther from the other (from A'). Einstein could not explain how the beams could be received nonsimultaneously by M' in his reference system (say a train) because that would mean the beams had unequal or variable velocities coming from each direction along the train. So he assumed that the emissions occurred "nonsimultaneously" in the train. Purporting that one flash (at A') occurred later than the other (at B') he could insist that the beams had equal or constant velocities.

Inspect Einstein's logic closely: As M and M' coincide, M judges that the flash at A' occurs (with the flash at B'). It did not yet occur according to M' but occurs later, after M' moves farther to the right of M. Meanwhile, according to M, the beam has already passed A', having traveled along the train to some spot to the right of A'; observers in the same train with M', stationed between A' and that spot cannot have helped notice! Einstein's logic proves to be a physically impossible self-contradiction. Relativity of simultaneity is physically impossible.

ANTHONY HANS KLOTZ
Long Island, NY

OUTBOARD CONVERTERS

Can you tell me something about the availability of "outboard converters" as mentioned in the review of the Electra BC-220 scanner on page 35 of the September 1979 *Radio Electronics*? Any information about the purchase or construction of such converters would be greatly appreciated. Also, any information about improving reception on the Aircraft Band (118-136 MHz) would also be very helpful.

Your magazine is the finest in its field. Keep up the good work!
J. P. MAGUIRE
Wappingers Falls, NY

Converters are available both as kits and factory-wired units from several domestic manufacturers:

Hamtronics, Inc., 65 Moul Rd., Hilton, NY 14468;
Vanguard Electronic Labs, 196-23 Jamaica Ave., Hollis, NY 11423;
VHF Engineering, 320 Water St., Binghamton, NY 13901;
Hermes Research and Development Co., 3997 Elkcam Blvd SE., St. Petersburg, FL 33705;
Janel Laboratories, 33890 Eastgate Circle, Corvallis, OR 97330;
Advanced Receiver Research, Box 1212, Burlington, CT 06013.

We have been advised by the Electra Company (Cumberland, IN 46229) that the BC-220 aircraft performance has been improved since our evaluation sample was tested. They assure us that customers should find no trouble receiving stations in the 118-136 MHz frequency range. In any case, sensitivity on weak signal reception may be improved with the addition of a pre-amplifier available from virtually all of the converter manufacturers above.—Robert B. Grove

DMMs from Keithley. Call your nearest distributor.

ALABAMA

Huntsville
PIONEER 205/837-9300

ARIZONA

Phoenix
METERMASTER 602/243-4111
Tempe
JENSEN TOOLS, INC. 602/968-6231

CALIFORNIA

Los Angeles
METERMASTER 213/685-4340
Palo Alto
METERMASTER 415/968-0313
San Diego
METERMASTER 714/560-4841

CONNECTICUT

Middletown
EIL/MANCIB DIVISION 203/346-6646

FLORIDA

Orlando
PIONEER 305/859-3600
Palm Bay
EIL INSTRUMENTS, INC. 305/725-8300

ILLINOIS

Chicago
METERMASTER 312/593-8650
PIONEER 312/437-9680

INDIANA

Indianapolis
PIONEER 317/849-7300

MAINE

Burlington
EIL/MANCIB DIVISION 617/272-9450

MARYLAND

Baltimore
PIONEER 301/792-7500
Gaithersburg
PIONEER 301/948-0710

MINNESOTA

Timonium
EIL INSTRUMENTS, INC. 301/252-1260

MICHIGAN

Ann Arbor
PIONEER 313/455-9090
Livonia
PIONEER 313/525-1800

MINNESOTA

Minnetonka
PIONEER 612/935-5444

NEW JERSEY

Fairfield
AMPOWER 201/227-7720

NEW YORK

Great Neck
INSTRUMENT MART 516/487-7430
Long Island
EIL INSTRUMENTS, INC. 516/231-6333
New York
ADVANCE 212/687-2224

ROCHESTER

AMPOWER 716/377-1020

NORTH CAROLINA

Greensboro
PIONEER 916/273-4441

OHIO

Cleveland
PIONEER 216/587-3600
Dayton
PIONEER 513/898-7166

OREGON

Portland
WESTCON, INC. 503/283-0132

PENNSYLVANIA

Philadelphia
PIONEER 215/674-4000
EIL INSTRUMENTS INC. 215/357-7733
Pittsburgh
PIONEER 412/782-2300

TEXAS

Dallas
PIONEER 214/386-7300
Garland
METERMASTER 214/271-5671

HOUSTON

METERMASTER 713/988-5555
QUALITY INSTRUMENT LABS, INC.
713/524-0528

VIRGINIA

Alexandria
EIL INSTRUMENTS, INC. 703/354-4330
Virginia Beach
EIL INSTRUMENTS, INC. 804/449-3746

U.S.A.

ADVANCE ELECTRONICS 800/223-0474
(except New York)
AMPOWER 800/526-2514
(except New Jersey)

KEITHLEY

Our 130 DMM gives you 0.5% DCV accuracy, a 10A range, a bigger display, easier controls, and lighter weight.

With all the hand-held DMMs around these days, it can be tough to pick the one that's best for you. Some are just too basic; others have a lot of high-priced frills that you may not want. Our Model 130 Digital Multimeter makes that choice a lot easier because it was designed with your needs in mind.

Accurate. The 130 is five times more accurate than many comparably priced analog VOMs, and it also compares favorably with other, more expensive hand-held DMMs. Its basic 0.5% DCV accuracy is probably as much as you'll need outside of lab situations, so you don't have to pay for more than you want. That's long term accuracy—only one calibration adjustment is required, once a year.

Rugged. We built the 130 to be tough enough to take it in real-world situations. The case is 2.5mm (.100") thick and made of high strength, impact resistant plastic. The LCD window is tough, scratch-resistant polycarbonate. The handsome faceplate is designed for maximum legibility and ease of use—all ranges and functions are color-coded and clearly marked.

And all components are on a single PC board that's mounted to the faceplate, permitting the vital electronics to "float" free of the backing and protecting them from jolts. Yet the whole unit weighs a mere 283g (10 oz.)—one of the lightest units around.

Easy to use. Our 15mm (0.6") LCD display is 60% larger than that of many other pocket DMMs. Both range and function are easily selected with one hand—no complicated pushbuttons. And a rear panel mounting screw lets you use the 130 while it's mounted to a stand or special holder, even without taking it out of its optional carrying case.

And that's no fluke.

Keithley quality. Like all Keithley products, precision components and user-oriented design are built right in to the 130. Full overload protection, a 10A current range, auto zero and auto polarity round out the list of standard features. And a full line of accessories expands its capabilities to 40kV, 200A and 700MHz. But the real measure of Keithley value is how we give you all this performance at a sensible price.

KEITHLEY

Keithley Instruments, Inc.
28775 Aurora Road
Cleveland, Ohio 44139
(216) 248-0400

Now available through your local distributor.



\$99
(CASE EXTRA)

U.S.A. price. Prices and specifications subject to change without notice.

equipment reports

Beckman Instruments Models Tech 300 and 310 Digital Multimeters

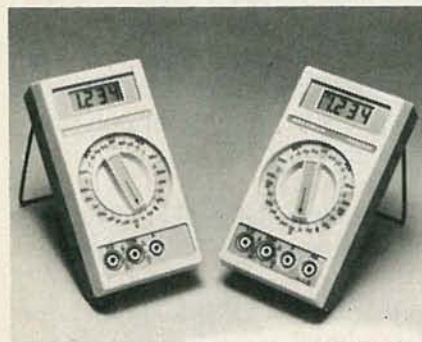

CIRCLE 101 ON FREE INFORMATION CARD

BECKMAN INSTRUMENTS, INC. (2500 HARBOR Blvd, Fullerton CA 92634) has been making test instruments and precision components of many kinds for a long time. They're now making a complete line of digital multimeters. One pair of almost twin meters are designed and priced especially for electronic technicians and hobbyists in all fields. These are the models *Tech-300* and *Tech-310*. A 10-ampere current range and a built-in continuity function are provided on the 310, but otherwise they're almost identical. The readout is a highly legible 3.5 digit liquid crystal display.

The *Tech-300* has a total of 27 ranges for seven functions, while the *Tech-310* has 27 ranges, plus an additional 10-ampere current range. The functions and ranges are selected using the function/range switch. (You can't say "controls" because there is only one.)

Each function and range is very plainly marked, and the knob is recessed to avoid accidental damage. So are the special banana jacks along the bottom. Those are of the protected type, so that no bare metal is exposed when the test-leads are plugged in. The test leads, by the way, are very rugged-looking and the probes have protective collars on the end to keep fingers out of things.

Both meters measure DC volts on 5 ranges from 200 mV up to 1500 V with an accuracy of 0.25% for the *Tech-310* and 0.5% for the *Tech-300*. AC volts are measured on the same ranges except for the top one which is 1,000 volts RMS. The accuracy of the AC voltage measurements is 0.75% for the *Tech-310* and 1.5% for the *Tech-300*. Alternating and direct current are measured in 5 ranges (6 ranges on the *Tech-310*) from 200 microamps to 2 amps with the *Tech-300* and 10 amps with the *Tech-310*. There are 5 resistance ranges, from 200 ohms to 20 megohms. All are low-power ohms with a maximum in-range voltage of 250 mV.

For diode/transistor testing, a special range is used, marked with a diode symbol. That applies up to 2.0 volts across the junction. If the junction is reverse-biased, OL appears on the display indicating circuit condition. Re-

verse the test leads and if the junction is good, you'll read the actual voltage drop across the junction on the 2-volt scale with a resolution of 0.1 mV. The current flowing is limited to 5 mA by a constant-current source. That protects transistors from damage. Junctions may be tested in-circuit with as little as 200 ohms shunt resistance.

A special continuity test that Beckman calls *Insta-Ohms* is used in the *Tech-310* on all ohms ranges. Continuity tests have been difficult on conventional DMM's. With this new feature, if you touch the test leads to a circuit and the resistance is anything less than twice the range chosen, an ohms (omega) symbol will appear instantly in the upper left corner of the display. It tells you that the circuit does have continuity. A fraction of a second later ($\frac{1}{4}$ second to be exact) the circuit resistance will appear. (If you're on the 200-ohm scale, you'll see the reading if there's anything below 400 ohms.) If it's more than range, OL appears and you switch to a higher range. The OL is also overrange readout for all other ranges and functions.

Another feature that should also be popular is the battery life. The meters use only a single 9-volt rectangular battery and an average life of 1600 hours or 2 years is claimed for a common zinc-carbon battery (with an alkaline battery, up to 2,000 hours). The low battery indication is a blinking decimal point. When that appears, there is approximately 200 hours of battery life left.

Practically all of the circuitry is contained on a custom-CMOS LSI IC. The CMOS technology accounts for the long battery life. By using the LSI IC, the total count of electronic parts is reduced to less than 40. Each instrument is given a 100-hour burn-in test and complete calibration tests. A one-year warranty is given, which includes calibration.

The high accuracy of these two meters is obtained by the use of special thin-film IC-type voltage divider networks. They are used on all functions. All of the inputs are protected against overload including the resistance ranges, which can withstand up to 300 VDC or RMS AC. The current inputs are protected against overload by a 2-ampere fuse, except for the 10-ampere range on the *Tech-310*. That input will withstand up to 20 amps for 30 seconds (which should give you plenty of time to "get out of there!")

Accessory probes are available for reading up to 50 kV DC, 200 MHz AC currents up to 1000 amps, with a current-clamp-type probe. Also available are a set of deluxe test leads and two carrying cases. The meter case itself is a tough plastic that is claimed to withstand a drop of 6 feet to a hard surface. It has a retractable bail that is used for a bench-rest, or can be flipped around to make a carrying handle.

The price is quite reasonable for instruments of this quality: \$110.00 for the *Tech-300* and \$140.00 for the *Tech-310*. The Beckman company has a wide reputation for making quality instruments and precision components and

their technology has been put to good use in designing and building these two meters.

We checked our meters out on TV sets and assorted semiconductors, and found them very easy to use and to read in dark places with no problems. Quite a pair of instruments! R-E

JVC HR-6700U Video Cassette Recorder



CIRCLE 102 ON FREE INFORMATION CARD

THE FIRST BLOW TO THE MOTION PICTURE INDUSTRY was the widespread proliferation of home television: Box-office receipts plummeted. Then Hollywood discovered that, rather than a threat, TV was a logical medium to exploit with the made-for-television movies. Now, a new threat appears to have emerged: the home video recorder.

The home video machines are available in two hotly-contested formats: Beta and VHS. At the present time, there seems to be an indication that VHS is winning. We decided to have a look at one of the better VHS machines, the 6700U video cassette recorder from JVC. In addition, JVC offers a matching *Vidstar* color camera that can turn the video cassette recorder into an instant home movie camera. . . . but more about that later.

The *HR-6700U* VCR weighs in at 31 pounds, and is a videophile's delight! Handsome in appearance and flexible in performance, the recorder touts a variety of features, many controlled by six microprocessor memories.

Selectable tape speeds provide up to six hours of recording from a standard two-hour T-120 video cassette. Slow motion at $\frac{1}{15}$ to $\frac{1}{3}$ normal speed shows no degradation or noise on the signal; and even still playback is available for "freeze-frame" fans!

The secret behind the quality of slow-speed video recording is the recording-head complement. Most competitive recorders use the same heads for recording a variety of speeds. Because of that tradeoff, non-standard speeds suffer distortion. The *HR-6700U* features six separate recording heads, providing a much higher density of information. Both picture and sound are enhanced using that technique at both slow and normal speeds.

Crosstalk distortion is also minimized by an advanced H-aligned format that allows noiseless double-speed playback in the normal (two-

continued on page 32

10 to 30 MHz oscilloscopes with more performance and reliability than you ever thought possible.

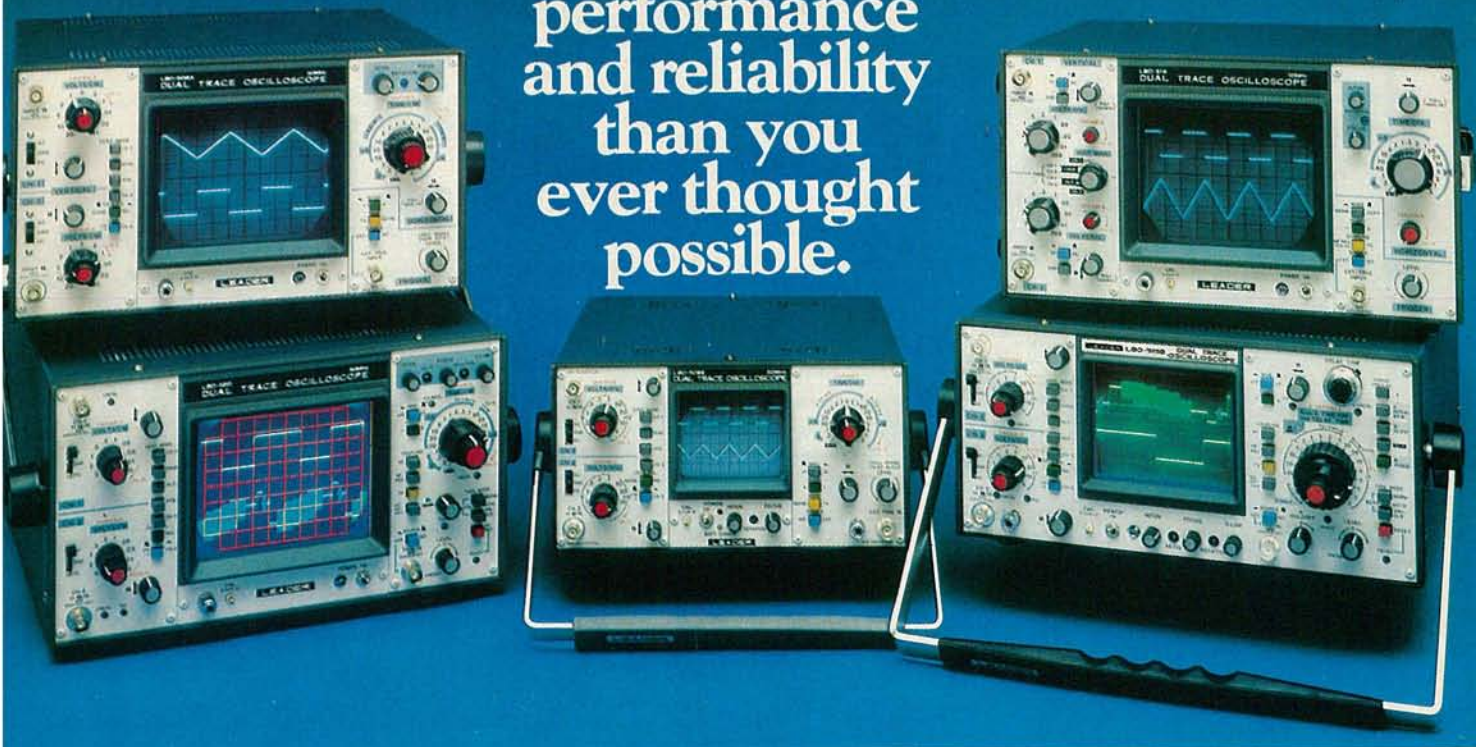

It's easy to see why LEADER oscilloscopes are now specified more than ever. More performance and quality for less cost... with immediate deliveries from over 100 stocking distributors. They also come with the best two-year warranty in the industry... backed by efficient factory service depots on the East and West Coasts.

A full-range of reliable, medium bandwidth oscilloscopes.

LEADER's oscilloscope line includes 11 models, single and dual trace versions, for bench or field use. All models offer comprehensive triggering controls, TTL compatible Z-axis modulation, front panel trace alignment control and convenient, color-keyed front panel layout. Probes are furnished with every oscilloscope and options include probe pouches, carrying cases, front panel covers and rack mounting adapters.

30 MHz delayed sweep - \$1,530.

LBO-515B is a compact, precision oscilloscope at a moderate price. Using a PDA 4-inch CRT with parallax-free internal graticule, it features 5 mV sensitivity and delayed sweep for viewing and measuring complex waveforms. Also has 120 ns signal delay, trigger hold-off and x-y operation at full sensitivity.

30 MHz with signal delay - \$1,100.

LBO-520 combines a 11.7 ns rise time with 5 mV sensitivity and 120 ns signal

The surprising leader.

delay lines. Has single shot triggering, X10 sweep magnifier and bright, sharp PDA CRT. Triggers to 50 MHz.

20 MHz dual and single trace - \$835., \$610.

LBO-508A and LBO-507A give you versatility at low cost. Rise time is 17.5 ns with 1 M Ω (35 pFd) input impedance. Automatic or external triggering, X5 sweep magnifier, 10 mV/cm sensitivity and add/subtract modes.

10 MHz with 1 mV sensitivity - \$645.

LBO-514 has both vertical and horizontal X5 magnifiers. Sensitivity is from 1 mV/cm to 10 V/cm. Sweep speeds from 0.2 s/cm to 0.1 μ s/cm. Auto or normal triggering. Z-axis modulation. (Single trace version, LBO-513, \$495.)

20 MHz battery/ac portable - \$950.

LBO-308S provides lab performance and high reliability in field service applications. Sensitivity is 2 mV with a complete set of triggering controls and 18 sweep ranges to 0.1 μ s/div. with X5 magnifier. Compact, lightweight with 3-inch rectangular, internal graticule CRT. (Optional 2 hour internal battery pack is recharged during ac operation, \$75.00.)

Two-year warranty. Evaluation units.

A history of high reliability permits LEADER to provide a generous 2-year warranty... backed by factory service depots on the East and West Coasts. A free, trial use of LEADER instruments

is available to all qualified companies.

Call toll-free (800) 645-5104 to request:

- an evaluation unit
- our 40-page catalog
- the name of your nearest "Select" distributor
- additional information

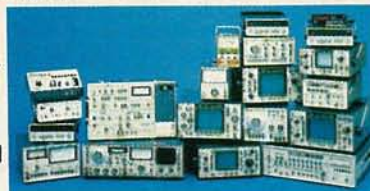

Oscilloscopes, frequency counters, function generators, video and audio instruments... a LEADER instrument for almost every need.

When Quality Counts
LEADER
Instruments Corporation

380 Oser Avenue
Hauppauge, N.Y. 11787 (516) 231-6900
Regional Offices:
Chicago, Los Angeles, Dallas.

CIRCLE 43 TO BE CONTACTED
BY LOCAL DISTRIBUTOR

JUST WRAP™ WIRE WRAPPING TOOL

WHY CUT? WHY STRIP? WHY SLIT?
WHY NOT JUST WRAP?

JW-1-B	BLUE WIRE	\$14.95
JW-1-W	WHITE WIRE	\$14.95
JW-1-Y	YELLOW WIRE	\$14.95
JW-1-R	RED WIRE	\$14.95



JUST WRAP REPLACEMENT ROLLS

R-JW-B	BLUE WIRE	50 ft. Roll	\$2.98
R-JW-W	WHITE WIRE	50 ft. Roll	\$2.98
R-JW-Y	YELLOW WIRE	50 ft. Roll	\$2.98
R-JW-R	RED WIRE	50 ft. Roll	\$2.98

UNWRAP TOOL FOR JUST WRAP

JW-1	UNWRAPPING TOOL	\$3.49
------	-----------------	--------

JUST WRAP KIT

JWK-6	JUST WRAP KIT	\$24.95
-------	---------------	---------

"HOBBY" WIRE WRAPPING TOOL BATTERY POWERED

BW-2630	FOR AWG 26-30	\$19.95
---------	---------------	---------

Use "C" size NICAD Batteries, not included. Bits not included.

BT-30	BIT FOR AWG 30	\$3.95
BT-2628	BIT FOR AWG 26-28	\$7.95

HOBBY WRAP TOOLS



WSU-30	REGULAR WRAP	\$6.95
WSU-30M	MODIFIED WRAP	\$7.95

30-B-50-010	30 AWG Blue Wire, 1" Long	\$.99
30-Y-50-010	30 AWG Yellow Wire, 1" Long	\$.99
30-W-50-010	30 AWG White Wire, 1" Long	\$.99
30-R-50-010	30 AWG Red Wire, 1" Long	\$.99
30-B-50-020	30 AWG Blue Wire, 2" Long	\$ 1.07
30-Y-50-020	30 AWG Yellow Wire, 2" Long	\$ 1.07
30-W-50-020	30 AWG White Wire, 2" Long	\$ 1.07
30-R-50-020	30 AWG Red Wire, 2" Long	\$ 1.07
30-B-50-030	30 AWG Blue Wire, 3" Long	\$ 1.16
30-Y-50-030	30 AWG Yellow Wire, 3" Long	\$ 1.16
30-W-50-030	30 AWG White Wire, 3" Long	\$ 1.16
30-R-50-030	30 AWG Red Wire, 3" Long	\$ 1.16
30-B-50-040	30 AWG Blue Wire, 4" Long	\$ 1.23
30-Y-50-040	30 AWG Yellow Wire, 4" Long	\$ 1.23
30-W-50-040	30 AWG White Wire, 4" Long	\$ 1.23
30-R-50-040	30 AWG Red Wire, 4" Long	\$ 1.23
30-B-50-050	30 AWG Blue Wire, 5" Long	\$ 1.30
30-Y-50-050	30 AWG Yellow Wire, 5" Long	\$ 1.30
30-W-50-050	30 AWG White Wire, 5" Long	\$ 1.30
30-R-50-050	30 AWG Red Wire, 5" Long	\$ 1.30
30-B-50-060	30 AWG Blue Wire, 6" Long	\$ 1.38
30-Y-50-060	30 AWG Yellow Wire, 6" Long	\$ 1.38
30-W-50-060	30 AWG White Wire, 6" Long	\$ 1.38
30-R-50-060	30 AWG Red Wire, 6" Long	\$ 1.38



STRIP WRAP UNWRAP

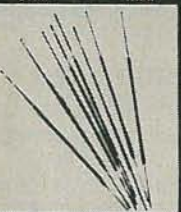

PRE-STRIPPED WIRE WRAPPING WIRE

Wire for wire-wrapping, AWG-30 (0.25mm) KYNAR® wire, 50 wires per package stripped 1" both ends.

© KYNAR PENNVALT

TRI-COLOR DISPENSER

WD-30-TRI	TRI-COLOR DISPENSER	\$5.95
R-30-TRI	REPLACEMENT ROLLS	\$3.95

WIRE DISPENSER

WD-30-B	BLUE WIRE	\$3.95
WD-30-Y	YELLOW WIRE	\$3.95
WD-30-W	WHITE WIRE	\$3.95
WD-30-R	RED WIRE	\$3.95

DISPENSER REPLACEMENT ROLLS

R-30B-0050	30-AWG BLUE 50 FT. ROLL	\$1.98
R-30Y-0050	30-AWG YELLOW 50 FT. ROLL	\$1.98
R-30W-0050	30-AWG WHITE 50 FT. ROLL	\$1.98
R-30R-0050	30-AWG RED 50 FT. ROLL	\$1.98

HOOK-UP WIRE

HK-18	18 AWG	25 FT.	SOLID CONDUCTOR	\$1.20
HK-20	20 AWG	25 FT.	SOLID CONDUCTOR	\$.98
HK-22	22 AWG	50 FT.	SOLID CONDUCTOR	\$1.35
HK-24	24 AWG	50 FT.	SOLID CONDUCTOR	\$1.35
HK-26	26 AWG	50 FT.	SOLID CONDUCTOR	\$1.35
SHK-18	18 AWG	25 FT.	STRANDED CONDUCTOR	\$1.20
SHK-20	20 AWG	25 FT.	STRANDED CONDUCTOR	\$.98
SHK-22	22 AWG	50 FT.	STRANDED CONDUCTOR	\$1.35
SHK-24	24 AWG	50 FT.	STRANDED CONDUCTOR	\$1.35
SHK-26	26 AWG	50 FT.	STRANDED CONDUCTOR	\$1.35

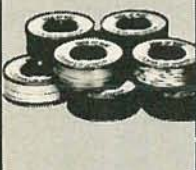

RIBBON CABLE ASSEMBLY SINGLE END

26 AWG Rainbow Coded flat cable.

SE 14-24	WITH 14 PIN DIP PLUG 24" LONG (609MM)	\$3.55
SE 14-48	WITH 14 PIN DIP PLUG 48" LONG (1218MM)	\$4.25
SE 16-24	WITH 16 PIN LONG DIP PLUG 24" LONG (609MM)	\$3.75
SE 16-48	WITH 16 PIN LONG DIP PLUG 48" LONG (1218MM)	\$4.45

DIP PLUG WITH COVER FOR USE WITH RIBBON CABLE

14-PLG	14 PIN PLUG & COVER	\$1.45
16-PLG	16 PIN PLUG & COVER	\$1.59

QUANTITY: 2 PLUGS, 2 COVERS

RIBBON CABLE ASSEMBLY DOUBLE END

DE 14-2	WITH 14 PIN DIP PLUG - 2"	\$3.75
DE 14-4	WITH 14 PIN DIP PLUG - 4"	\$3.85
DE 14-8	WITH 14 PIN DIP PLUG - 8"	\$3.95
DE 14-12	WITH 14 PIN DIP PLUG - 12"	\$4.07
DE 14-16	WITH 14 PIN DIP PLUG - 16"	\$4.12
DE 14-24	WITH 14 PIN DIP PLUG - 24"	\$4.15
DE 16-2	WITH 16 PIN DIP PLUG - 2"	\$4.15
DE 16-4	WITH 16 PIN DIP PLUG - 4"	\$4.25
DE 16-8	WITH 16 PIN DIP PLUG - 8"	\$4.35
DE 16-12	WITH 16 PIN DIP PLUG - 12"	\$4.47
DE 16-16	WITH 16 PIN DIP PLUG - 16"	\$4.52
DE 16-24	WITH 16 PIN DIP PLUG - 24"	\$4.55
DE 24-6	WITH 24 PIN DIP PLUG - 6"	\$6.05
DE 24-8	WITH 24 PIN DIP PLUG - 8"	\$6.50
DE 24-12	WITH 24 PIN DIP PLUG - 12"	\$6.90
DE 24-16	WITH 24 PIN DIP PLUG - 16"	\$7.10
DE 24-24	WITH 24 PIN DIP PLUG - 24"	\$7.70

DIP SOCKETS

14 DIP	14 PIN DIP SOCKET	\$0.79
16 DIP	16 PIN DIP SOCKET	\$0.89
24 DIP	24 PIN DIP SOCKET	\$1.49
36 DIP	36 PIN DIP SOCKET	\$2.49
40 DIP	40 PIN DIP SOCKET	\$2.99

DIP IC INSERTION TOOLS WITH PIN STRAIGHTENER

Narrow profile. Pin straightener built into tool. Automatic ejector.

INS-1416	14-16 PIN DIP/IC INSERTER	\$3.49
----------	------------------------------	--------

MOS, CMOS-SAFE

GROUND STRAP NOT INCLUDED

MOS-1416	14-16 PIN, MOS CMOS SAFE INSERTER	\$7.95
MOS-2428	24-28 PIN, MOS CMOS SAFE INSERTER	\$7.95

36-40 PIN CMOS-SAFE IC INSERTION TOOL

Aligns bent out pins. Includes terminal lug for attachment of ground strap.

GROUND STRAP NOT INCLUDED

MOS-40	36-40 PIN CMOS SAFE INSERTION TOOL	\$7.95
--------	---------------------------------------	--------

DIP IC EXTRACTOR TOOL

Extracts all LSI, MSI and SSI devices of from 8 to 24 pins.

EX-1	EXTRACTOR TOOL	\$1.49
------	----------------	--------

24-40 CMOS-SAFE EXTRACTOR TOOL

Removes 24-40 pin IC's, .600" centers. C-MOS safe. Includes terminal lug for attachment of ground strap.

GROUND STRAP NOT INCLUDED

EX-2	CMOS SAFE EXTRACTOR TOOL	\$7.95
------	--------------------------	--------

MINIMUM ORDER \$25.00. SHIPPING CHARGE \$2.00. N.Y. CITY AND STATE RESIDENTS ADD TAX

OK MACHINE & TOOL CORPORATION

3455 Conner St. Bronx, N.Y. 10475 (212) 994-6600 Telex 125091



PRB-1 DIGITAL LOGIC PROBE

- DC to > 50 MHz
- 10 Nsec. pulse response
- 120 K Ω impedance
- Automatic pulse stretching to 50 Msec.
- Automatic resetting memory
- Open circuit detection
- Automatic threshold resetting
- Compatible with all logic families 4-15 VDC
- Range extended to 15-25 VDC with optional PA-1 adapter
- Supply O.V.P. to \pm 70 VDC
- No switches/no calibration

PRB-1	DIGITAL LOGIC PROBE	\$36.95
-------	---------------------	---------



PROTOTYPE BOARD CM-100

TERMINALS: 1,020 TEST POINTS. 188 separate 5 point terminals, plus 2 horizontal bus lines of 40 common test points each.
 SIZE: 6 1/2" Wide, 5" Long.

CM-100	MODULAR PROTOTYPE BOARD	\$25.95
--------	-------------------------	---------



PROTOTYPE BOARD CM-200

TERMINALS: 630 TEST POINTS. 94 separate 5 point terminals, plus 4 bus lines of 40 common test points each. SIZE: 6" Wide, 3 1/2" Long.

CM-200	MODULAR PROTOTYPE BOARD	\$16.45
--------	-------------------------	---------



PROTOTYPE BOARD CM-300, CM-400

CM-300 and CM-400 have two separated rows of five interconnected contacts each. Each pin of a DIP inserted in the strip will have four additional tie-points per pin to insert connecting wires. They accept leads and components up to .032 in. diameter. Interconnections are readily made with RW-50 Jumper Wire. All contact sockets are on a .100 in. square grid (1 1/4 in. wide).

CM-300	MODULAR PROTOTYPE BOARD	\$9.95
CM-400	MODULAR PROTOTYPE BOARD	\$2.45

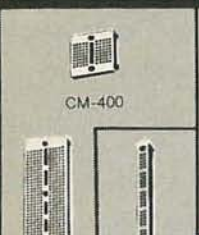

MODULAR BUS STRIP

CM-500 is a bus strip to be used in conjunction with CM-300 and CM-400 for distribution of power and common signed lines. Two separate rows of common terminals, grouped into clusters of five. All contact sockets are on a .100 in. square grid.

CM-500	MODULAR BUS STRIP	\$1.95
--------	-------------------	--------

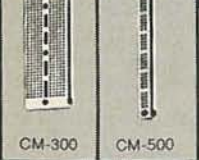

JUMPER WIRES

50 Preformed wires, from 1 1/2 to 4 inches, 20 AWG solid wire, white insulation.

RW-50	JUMPER WIRES	\$2.98
-------	--------------	--------



"CLIP AND STRIP" TOOL

For cutting and stripping 1 in. insulation from 30 AWG wire.

CAS-130	CLIP AND STRIP	\$1.98
---------	----------------	--------

THE ABOVE CUT AND STRIP TOOL IS NOT APPLICABLE FOR MYLENE OR TEFLON INSULATION



MINI SHEAR

MS-10	MINI-SHEAR	\$4.95
-------	------------	--------

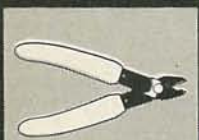

MINI SHEAR WITH SAFETY CLIP

MS-20	MINI-SHEAR WITH CLIP	\$5.95
-------	----------------------	--------



VACUUM VISE

ABS construction, 1 1/2 in. wide jaws.

VV-1	VACUUM VISE	\$3.49
------	-------------	--------



WIRE WRAPPING KITS WK-2, WK-3, WK-4

WK-2-B	WIRE-WRAPPING KIT (BLUE)	\$12.95
WK-2-Y	WIRE-WRAPPING KIT (YELLOW)	\$12.95
WK-2-W	WIRE-WRAPPING KIT (WHITE)	\$12.95
WK-2-R	WIRE-WRAPPING KIT (RED)	\$12.95
WK-3B (BLUE)	WIRE-WRAPPING KIT	\$16.95
WK-4B (BLUE)	WIRE-WRAPPING KIT	\$25.99



WIRE WRAPPING KIT WK-5

BW-630, WSU-30M, CON-1, EX-1, INS-1416, TRS-2, MS-20, 14, 16, 24 and 40 DIP sockets, WWT-1, WD-30-TR1, H-PCB-1.

WK-5	WIRE-WRAPPING KIT	\$74.95
------	-------------------	---------



PC BOARD

4 x 4.5 x 1/4 in. board, glass coated EPOXY laminate, solder coated 1 oz. copper pads. The board has provision for a 22/44 two sided edge connector. .156 in. spacing. Edge contacts are non-dedicated for maximum flexibility.

The board contains a matrix of .040 in. diameter holes on .100 in. centers. Component side contains 76 two-hole pads.

Two independent bus systems are provided for voltage and ground on both sides of the board.

H-PCB-1	HOBBY BOARD	\$4.99
---------	-------------	--------



TERMINAL BOARD

.062 thick glass coated epoxy laminate. Outside dimensions 6.3 in. x 3.94 in. Not plated.

A-PC-01	TERMINAL BOARD	\$3.45
---------	----------------	--------



PC BOARD

Same specifications as A-PC-01 except matrix pattern is copper plated and solder coated on one side.

A-PC-02	PRINTED CIRCUIT BOARD	\$5.95
---------	-----------------------	--------



PC BOARD

Same specifications as A-PC-01. Each line of holes is connected with copper plated and solder coated parallel strips on one side.

A-PC-03	PRINTED CIRCUIT BOARD	\$5.95
---------	-----------------------	--------

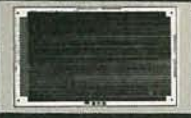

PC BOARD

Same specifications as A-PC-01. One side has horizontal copper strips, solder coated. Second side has vertical parallel bars.

A-PC-04	PRINTED CIRCUIT BOARD	\$7.95
---------	-----------------------	--------

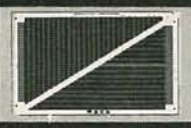

PC BOARD

The A-PC-05 features numbered contacts for easy reference along with a numbered matrix for easy hole locations. Made of .062 in. thick epoxy laminate. 4.5 in. x 5 in. Edge Connector Board.

A-PC-05	PRINTED CIRCUIT BOARD	\$5.45
---------	-----------------------	--------

Same as A-PC-05 except outside dimensions are 4.5 in. x 6.5 in. Edge Connector Board.

A-PC-06	PRINTED CIRCUIT BOARD	\$6.95
---------	-----------------------	--------

Same as A-PC-05 except outside dimensions are 4.5 in. x 7 in. Edge Connector Board.

A-PC-07	PRINTED CIRCUIT BOARD	\$8.95
---------	-----------------------	--------

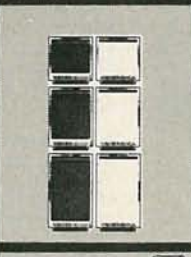

TERMINALS

WWT-1	SLOTTED TERMINAL	\$4.98
WWT-2	SINGLE SIDED TERMINAL	\$2.98
WWT-3	IC SOCKET TERMINAL	\$4.98
WWT-4	DOUBLE SIDED TERMINAL	\$1.98

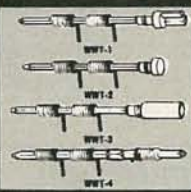

TERMINAL INSERTING TOOL

For inserting WWT-1, -2, -3 and -4 terminals.

INS-1	INSERTING TOOL	\$2.49
-------	----------------	--------

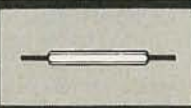

P.C.B. TERMINAL STRIPS

TS-4	4-POLE	\$1.39
TS-8	8-POLE	\$2.19
TS-12	12-POLE	\$2.99

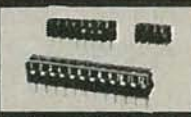

MODULAR TERMINAL STRIPS

TS-6MD	2-POLE	\$1.79
--------	--------	--------

(3 per Package)

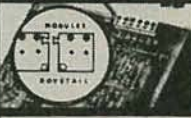

PC CARD GUIDES

TR-1	CARD GUIDES	\$1.89
------	-------------	--------

QUANTITY — ONE PAIR (2 PCS.)



PC CARD GUIDES & BRACKETS

TRS-2	GUIDES & BRACKETS	\$3.79
-------	-------------------	--------

QUANTITY — ONE SET (4 PCS.)



PC EDGE CONNECTOR

44 pin, dual read-out, .156 in. spacing, wire-wrapping.

CON-1	P.C. EDGE CONNECTOR	\$3.49
-------	---------------------	--------



MINIMUM ORDER \$25.00, SHIPPING CHARGE \$2.00, N.Y. CITY AND STATE RESIDENTS ADD TAX

OK MACHINE & TOOL CORPORATION
 3455 Conner St. Bronx, N.Y. 10475 (212) 994-6600 Telex 125091



An introductory Electronics

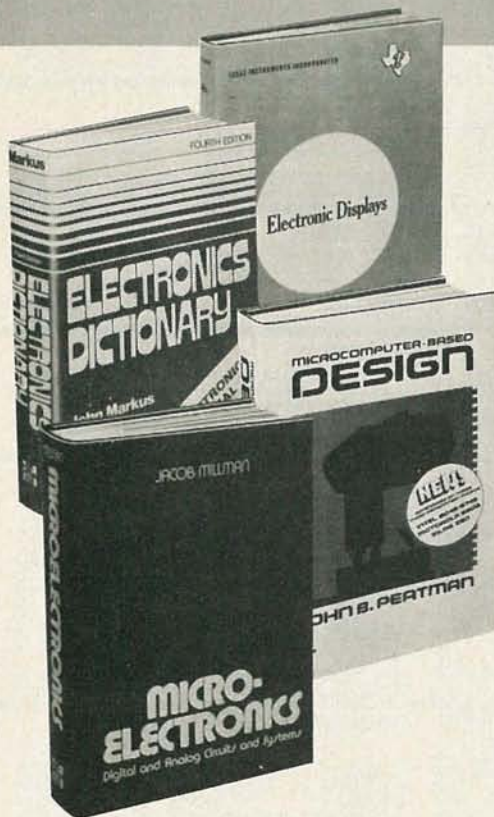

ELECTRONICS DESIGNERS' HANDBOOK. Edited by L. J. Giacoletto. 2nd Ed. 2,344 pp., 1,686 illus. Now doubled in size and with 90% of its material new, this famous classic (first edition by Landee, Davis, Albrecht) has been thoroughly revised and updated to give you not only the *how* and the *why* of all your design work but also the *how much* of every design step you take!
231/494 Pub. Pr., \$56.50 Club Pr., \$41.50

STANDARD HANDBOOK FOR ELECTRICAL ENGINEERS, 11/e. By D. G. Fink and H. W. Beaty. 448 pp., 1,414 illus. A giant in every sense of the word, today's most widely used source of electrical engineering information and data serves you as no other single work available anywhere when you need detailed, accurate, timely, and reliable facts and how-to on the generation, transmission, distribution, control, conversion, and application of electric power.
209/74X Pub. Pr., \$49.50 Club Pr., \$38.00

THE DESIGN AND DRAFTING OF PRINTED CIRCUITS. By D. Lindsey. 196 pp., 100 illus. For everything you need to know and understand about design phases that PC artworks go through, from schematics to the finished PC, your best all-around guide is this fully illustrated new teaching tool.
054/304 Pub. Pr., \$26.95 Club Pr., \$21.00

ELECTRONICS DICTIONARY. Edited by J. Markus. 4th Ed., 768 pp., 1,173 illus., 17,090 terms. With the new edition of this world-renowned dictionary you'll be able to quickly find the meaning and correct usage of any electronics term, no matter how obscure!
404/313 Pub. Pr., \$24.50 Club Pr., \$19.50

HANDBOOK OF OPERATIONAL AMPLIFIER CIRCUIT DESIGN. By D. F. Stout. Edited by M. Kaufman. 434 pp., 223 illus. Compact, concise, highly concentrated, and containing a storehouse of information, this one-stop volume will help you solve any op amp circuit problem!
617/97X Pub. Pr., \$29.65 Club Pr., \$17.50

ELECTRONIC DISPLAYS. By E. G. Bylander, Texas Instruments Incorporated. 172 pp., illus. The book describes current electronic displays by family types, discussing all aspects of their operation, application, and circuit requirements. You cover photometry and contrast enhancement, together with the fundamentals of such critical components as mounts and drives, interface requirements, and other necessary engineering information.
095/108 Pub. Pr., \$19.50 Club Pr., \$15.95

DIGITAL FILTERS. By A. Antoniou. 524 pp., illus. This all-inclusive, up-to-date treatment guarantees your thorough understanding of today's digital filters and the theories, techniques, and procedures you'll be using in their analysis, design, and implementation. The book gives you many design examples, together with the numerous possible approaches and engineering tradeoffs relating to their hardware implementation.
021/171 Pub. Pr., \$23.95 Club Pr., \$18.50

BUCHSBAUM'S COMPLETE HANDBOOK OF PRACTICAL ELECTRONIC REFERENCE DATA. By W. H. Buchsbaum. 2nd Ed., 645 pp., 371 illus., 70 tables: It gives you all the technical electronic information you need—from the factual foundations of electronics to the latest technical advances in optoelectronics, large scale integrated circuits, digital logic, microprocessors, and computers. Hundreds of formulas, graphs, charts, and tables.
786/550 Pub. Pr., \$19.95 Club Pr., \$16.95

BE SURE TO CONSIDER THESE IMPORTANT TITLES AS WELL:

LOGIC DESIGNERS' MANUAL. By J. D. Lenk. 784/671 Pub. Pr., \$18.95 Club Pr., \$15.75

CRYSTAL OSCILLATOR DESIGN AND TEMPERATURE COMPENSATION. By M. E. Frerking. 784/973 Pub. Pr., \$16.95 Club Pr., \$13.50

MINICOMPUTER SYSTEMS, 2/e. By R. H. Eckhouse, Jr. 787/026 Pub. Pr., \$21.95 Club Pr., \$17.75

UNDERSTANDING OSCILLOSCOPES AND DISPLAY WAVEFORMS. By K. W. Sessions & W. A. Fischer. 787/786 Pub. Pr., \$17.95 Club Pr., \$14.50

THE SEMICONDUCTOR MEMORY BOOK. By Intel Marketing Communications. 788/391 Pub. Pr., \$14.95 Club Pr., \$12.70

MICROPROCESSOR APPLICATIONS MANUAL. By Motorola Semiconductor Products, Inc. 435/278 Pub. Pr., \$38.00 Club Pr., \$26.50

NATIONAL ELECTRICAL CODE HANDBOOK, 16/e. By J. F. McPartland. 456/909 Pub. Pr., \$19.95 Club Pr., \$14.50

SOURCEBOOK OF PROGRAMMABLE CALCULATORS. By Texas Instruments, Inc. 637/466 Pub. Pr., \$16.50 Club Pr., \$12.50

OSCILLOSCOPES. By R. Van Erk. 670/501 Pub. Pr., \$19.50 Club Pr., \$14.50

NOISE REDUCTION TECHNIQUES IN ELECTRONIC SYSTEMS. By H. Ott. 769/63X Pub. Pr., \$21.25 Club Pr., \$15.50

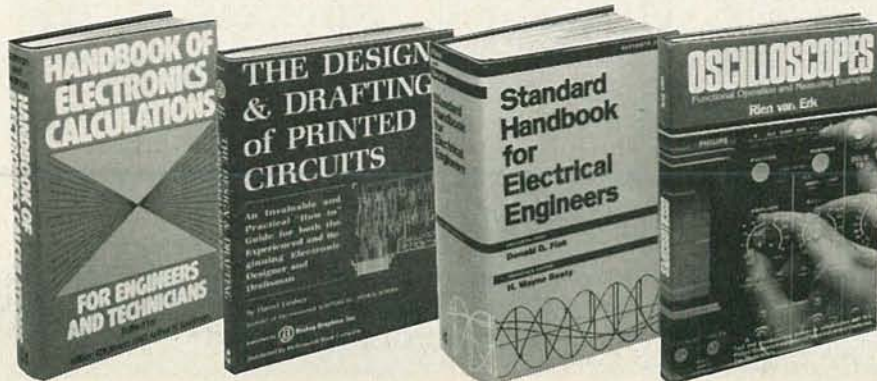

RADIO HANDBOOK. By W. I. Orr. 21st Ed., 1,135 pp., 1,364 illus. Now completely updated, expanded, and more deserving than ever this profusely illustrated reference gives you everything you need to know to understand, design, use, and experiment with every circuit and piece of equipment. (All recent technological breakthroughs are covered).
772/630 Pub. Pr., \$21.50 Club Pr., \$16.60

TRANSFORMER AND INDUCTOR DESIGN HANDBOOK. By W. T. McLyman. 428 pp., illus. User-oriented throughout, it covers everything from transformer design and inductor design with dc, power inductor design, designing for regulation, inductor design without dc, constant voltage transformer, current and three-phase transformer, to application of magnetic components in power electronics.
786/755 Pub. Pr., \$35.00 Club Pr., \$26.50

Offer to new members of the and Control Engineers' Book Club

HANDBOOK OF ELECTRONICS CALCULATIONS FOR ENGINEERS AND TECHNICIANS. Edited by M. Kaufman and A. H. Seidman. 653 pp., 725 illus. This first comprehensive tool of its kind includes hundreds of worked-out problems in analog and digital circuits. Includes more than 700 diagrams, curves, tables, and graphs.
333/920 Pub. Pr., \$24.50 Club Pr., \$18.95

MICROCOMPUTER-BASED DESIGN By J. B. Peatman. Expanded 4th printing, 604 pp., over 400 photos and other illustrations Do all your best day-to-day designs, as well as your supercreative and special designs, around the new microcomputers and the specific "how-to" help you get here!
491/380 Pub. Pr., \$26.95 Club Pr., \$18.95

MICROELECTRONICS Digital and Analog Circuits and Systems By J. Millman. 881 pp., 700 illus. This giant book takes you step by step from a qualitative knowledge of a semi-conductor, to an understanding of the operation of devices, and finally, to an appreciation of how these are combined to form micro-electronic chips.
423/27X Pub. Pr., \$24.50 Club Pr., \$19.50

MINI/MICROCOMPUTER HARDWARE DESIGN. By G. D. Kraft and W. N. Toy. 514 pp., 250 photos, diagrams, figures. The swing is more to designing and using small-scale computers as computing components, this is your guide to doing just that! With what you already know, plus the skills you'll gain here, you'll be way ahead as the whole field of computing moves towards distributed processing element systems!
788/26X Pub. Pr., \$19.95 Club Pr., \$16.95

DIGITAL INTEGRATED CIRCUITS AND OPERATIONAL AMPLIFIER AND OPTOELECTRONIC CIRCUIT DESIGN. Edited by B. Norris. 206 pp., 400 illus. Having this vast amount of case-tested data, proven shortcuts, worked-out circuit designs, and circuit diagrams handy saves you valuable time for your other, more vital, areas of creative design—and cuts down costs in all areas!
637/539 Pub. Pr., \$21.50 Club Pr., \$15.95

INTRODUCTION TO RADAR SYSTEMS, 2/e. By M. I. Skolnik. 698 pp., 244 illus. This new edition of a widely used text on radar from the systems engineer's point of view brings you full discussions of the many major changes that have occurred in the field recently.
579/091 Pub. Pr., \$34.95 Club Pr., \$27.95

ENGINEERING MATHEMATICS HANDBOOK Definitions, Theorems, Formulas, Tables. By J. J. Tuma. 2nd Ed., 394 pp., 226 illus. Now you can use even the most difficult formulas on your pocket calculator for input and/or storage! Literally thousands of formulas were remodeled to facilitate their application to today's pocket calculator operations.
654/298 Pub. Pr., \$21.95 Club Pr., \$17.50

ELECTRONICS ENGINEER'S HANDBOOK. Editor-in-Chief, D. G. Fink. 2,104 pp., 2,026 illus. Huge in every sense, this instant-reference volume gives you every latest essential in the field, 2,100 formulas and equations, a 2,500-item bibliography, and every illustration you need to clarify all of modern electronics!
209/804 Pub. Pr., \$52.50 Club Pr., \$37.50

PRINTED CIRCUITS HANDBOOK, 2/e. By C. F. Coombs, Jr. 256 pp., 327 illus. Blueprints every important phase of printed circuitry. Provides the information you need to establish a production facility and control the processes. A virtual encyclopedia in the field, five major sections cover engineering, fabrication, assembly, soldering, and testing.
126/089 Pub. Pr., \$32.50 Club Pr., \$24.50

ENGINEERING FUNDAMENTALS FOR PROFESSIONAL ENGINEERS' EXAMINATIONS, Second Edition. By L. M. Polentz. 416 pp., 326 illus. Here—in this single volume—you'll find all the latest, most essential material you need to prepare for and pass your state's engineering registration exam. Hundreds of examples and practice problems are all drawn from actual P.E. exams, and were selected because they are representative of the problems that will appear on your exam.
503/80X Pub. Pr., \$23.50 Club Pr., \$16.95

any one
of these great
professional books
for only **\$1.89**
values up
to \$56.50

Special \$1.89 premium
book comes to you
with your first
club selection

Why YOU should join now!

- **BEST BOOKS IN YOUR FIELD**—Books are selected from a wide range of publishers by expert editors and consultants to give you continuing access to the latest books in your field.
- **BIG SAVINGS**—Build your library and save money too! We guarantee savings of at least 15% off publishers' list prices on every book. Usually 20%, 25% or even higher!
- **BONUS BOOKS**—You will *immediately* begin to participate in our Bonus Book Plan that allows you savings between 70-80% off the publisher's price of many books.
- **CONVENIENCE**—14 times a year you receive the Club Bulletin FREE, fully describing the Main Selection and alternate selections, together with a dated reply card. If you want the Main Selection, you simply do nothing—it will be shipped automatically. If you want an alternate selection—or no book at all—you simply indicate it on the regular reply card and return it by the date specified. You will have at least 10 days to decide. If, because of late mail delivery of the Bulletin you should receive a book you do not want, just return it at the Club's expense.

As a member, you agree only to the purchase of four books (including your first selection) over a two-year period.

MAIL THIS COUPON TODAY

Electronics and Control Engineers' Book Club
PO. Box 582, Hightstown, New Jersey 08520

Please enroll me as a member and send me the two books indicated, billing me for my first selection only at the discounted member's price, plus local tax, postage and handling. If not satisfied, I may return the books within 10 days and my membership will be canceled. I agree to purchase a minimum of 3 additional books during the next 2 years as outlined under the club plan described in this ad. Membership in the club is continuous but cancelable by me at any time after the four book purchase requirement has been fulfilled.

Write Code # of PREMIUM selection here Write Code # of FIRST selection here

Orders from outside the U.S. must be prepaid with international money orders in U.S. dollars.

Signature _____
Name _____
Address _____
City _____
State _____ Zip _____

This order subject to acceptance by McGraw-Hill. All prices subject to change without notice. Offer good only to new members. A postage and handling charge is added to all shipments. E33421

This is easy- anyone can solder- WITH KESTER SOLDER

**KESTER
SOLDER**



Handymen! Hobbyists! DO-IT-YOURSELFERS!

Let Kester Solder aid you in your home repairs or hobbies. For that household item that needs repairing — a radio, TV, model train, jewelry, appliances, minor electrical repairs, plumbing, etc. — Save money — repair it yourself. Soldering with Kester is a simple, inexpensive way to permanently join two metals.

When you Solder go "First Class" — use Kester Solder.

For valuable soldering information send self-addressed stamped envelope to Kester for a FREE Copy of "Soldering Simplified".



KESTER SOLDER

Litton 4201 WRIGHTWOOD AVENUE/CHICAGO, ILLINOIS 60639

CIRCLE 36 ON FREE INFORMATION CARD

HOLD IT! Anywhere you want it.

PanaVise tilts, turns, rotates. One quick turn of the control knob and you securely position your work exactly where you want it. Holds firmly but gently the most delicate electronic parts and P. C. boards.

Whether you're into building home electronics, trouble shooting, or professional servicing . . . you'll wonder how you got along without this modestly priced 'extra hand.'

Model 396 Wide Opening PanaVise shown. An ingenious variety of other interchangeable bases, holders and accessories also available. See your electronics distributor, or write for FREE brochure.

PANA VISE® Dept. CE2
2850 29th St., Long Beach, CA 90806



CIRCLE 66 ON FREE INFORMATION CARD

EQUIPMENT REPORTS

continued from page 24

hour) mode as well as triple-speed playback in the six-hour mode.

Picture stability has always been a problem in video recording; as speed fluctuates, so does the synchronization signal. The new JVC recorder incorporates a microcomputer-controlled timer that works in conjunction with a fast-response capstan servomechanism to lock on to those synchronizing signals; that prevents the annoying flopover so frequently associated with home recorders.

For recording off the air, a built-in VHF/UHF solid-state tuner is operated manually or by microprocessor memories. Unattended, the machine will record six programs on different channels up to a week in advance; or at the same time every day—or at different times on different days! Now that's flexibility!

A dual-mode auto-search counter allows the user to program the recorder to stop at "0000" in rewind, or to stop where the recording began—whether in fast forward or rewind.

A remote-control accessory allows the operator to shift speeds from the comfort of his viewing position. But to use the convenience of the many automatic features, he may allow the machine to do his speed thinking for him. The HR-6700U senses the speed format of the tape that has been loaded and automatically switches to the correct speed.

When the owner desires to watch TV, he merely switches off his recorder; the antenna will be automatically connected to the television receiver. The tuner portion of the recorder is a presettable 12-channel VHF/UHF tuner with channel-lock provision. Input impedance is nominally 75 ohms on VHF, and 200 ohms on UHF.

Video signal-to-noise ratio is better than 45 dB, and horizontal resolution is at least 240 lines; the audio-frequency response is 50-10,000 Hz.

The optional matching color camera is compact and lightweight, slightly over three pounds, depending upon zoom lens.

The original engineering philosophy was to provide a camera that is as small and lightweight as a standard 8 mm home movie camera—and as easy to operate. A tall order, but JVC seems to have done it! In our test, the video camera came through with flying colors. Focus was sharp; persistence was fast (very little smear from rapid movement), and the camera was not fatiguing to hold and operate.

The operation of the camera couldn't have been simpler: Point and shoot! Zoom and focus are no more awkward than on a quality photographic camera. For the home-movie addict who wants to move up into the electronic age, this is the way to go.

The camera is built around a 0.66-inch vidicon with either a 3× or 6× zoom lens available. It features automatic iris control and through-the-lens viewfinder. Color correction (temperature or white balance) is accomplished electronically without the need of optical filters. Exposure indicators in the viewfinder alert the user whenever there are improper lighting conditions.

A built-in high-sensitivity condenser microphone features a wind screen. While a ten-foot cable is provided, extensions up to 60 feet from the recorder are allowable.

A pistol-trigger switch activates the camera and recorder. A tripod and spotlight accessory may be purchased separately if desired, to be used with the camera.

The specifications for the camera show it to be a 3.6-MHz single-carrier frequency multiplex system with 525 lines, 2:1 interlaced. Color temperatures are switch selectable among 3000, 4800, or 6000° K. Video output is 1 volt P-P with 250 line resolution.

We found the new JVC video cassette system with matching camera an impressive performer. It is full-featured, innovatively-engineered, and realistically-priced.

The suggested retail list price for the *GX-66U* Color Video Camera is \$850 and the *HR-6700U* Vidstar Color Video Cassette Recorder is \$1350. For more information, write to: JVC, 58-75 Queens Midtown Expressway, Maspeth, NY 11378. **R-E**

Hitachi Model V-302 Dual-Trace Scope



CIRCLE 103 ON FREE INFORMATION CARD

JUST A FEW YEARS AGO A 10-MHz OSCILLOSCOPE would have sufficed for all but the most critical applications. Today's sophisticated technology is rapidly making the 10-MHz scope as obsolete as the older 5-MHz units. Even the well-equipped TV service bench of today is required to have a scope capable of at least 30 MHz, especially if that service center is expecting to become a VCR service agency for most of the popular brands of units on the market.

With the above facts in mind, Hitachi Den-shi, Ltd., Tokyo, Japan, has introduced a unit that seems to fill the requirements of the TV service industry and at the same time is perfectly at home in the other fields of industry such as the computer field.

The Hitachi model *V-302* dual-trace scope is very neat-appearing and professional-looking with a brushed-metal rim surrounding the entire front panel. The panel itself is composed of three colors, and the colors are arranged to indicate to the user the location of all controls that are related to each other. For instance, the silver area contains the power switch, INTENSITY control, FOCUS control, and the LED pilot light.

The inputs and controls that are related to the horizontal (X) and vertical (Y) display functions will be found in the gray-colored sections. The third color is brown and it contains the trigger MODE and SOURCE switches, trigger LEVEL, and external TRIG INPUT. That multi-colored panel adds a quality look to the overall appearance as well as serving a very useful purpose for the operator. When shipped, the panel has a protective plastic film covering its entire surface. The protective shield may be removed or allowed to remain to prevent the front panel from becoming soiled from fingerprints, etc.

The unit supplied came equipped with two test probes, each containing a convenient built-in thumb hook that adds to the ease of handling the probe, especially when hooking onto a circuit point. The probe itself is of a convenient size for the state-of-the-art units the

present-day technician is required to troubleshoot. The "clip-on" hook portion may be removed and a miniature-sized needle-tipped test probe is available for point-to-point testing. The normal probes (as supplied) are $\times 10$ low-capacitance types.

The gray-shaded portion of the panel contains the horizontal-display controls. The TIME/DIV rotary switch dominates that section with 19 positions that select sweep speeds ranging from 0.2 μ s-per-division to 0.2 seconds-per-division in a 1-2-5 sequence. When this switch is placed in the fully clockwise position, the scope is set to operate in the X-Y mode. In that case, the input signal to Channel 1 is displayed on the X axis and Channel 2 signals are presented on the Y axis. To the right of the TIME/DIV switch is the variable sweep control for the timebase settings that are not covered by the preset times on the main switch. When the control is adjusted to the extreme clockwise position, the unit is in the calibrated mode. The horizontal-positioning (centering) control is also in this section. In addition, if the control is pulled outward, the scope is set for a $\times 10$ magnification of the horizontal trace.

The vertical sensitivity is selectable in ten steps over the range of 5mV-per-division to 5 volts-per-division. These ranges are also continuously variable when the vertical gain control is turned from the calibrated position. In addition, by pulling the vertical position knob to the outward position, the gain of the vertical (Y) amplifier is multiplied by a factor of 5. Of course, being a dual-trace unit, there are duplicate controls for the second channel. The vertical input has an impedance of 1 megohm

continued on page 34

**IF YOU'RE AN
ADVERTISER
WHO NEEDS
JUST A LITTLE
SPACE LIKE
THIS 1/6 PAGE,
CALL YOUR
NEAREST
RADIO-ELECTRONICS
SALES OFFICE
RIGHT NOW.
YOU'LL DISCOVER
YOU DON'T
HAVE TO SPEND
A LOT OF \$\$\$
TO REACH THE
PEOPLE WHO
DO SPEND A LOT.**

NEW YORK
212-777-6400

CHICAGO
312-446-1444

LOS ANGELES
213-659-3810

**Radio-
Electronics**



WHAT'S NEW IN HOME ELECTRONICS?



Find out in the latest Heathkit Catalog. It's filled with exciting kits in every price range, all easy to assemble, all at build-it-yourself savings.

Discover the fun you and your family can have building your own home computer, stereo system, color TV. Discover the pride of saying, "I built it myself." It's easier than you think.

Send today for your FREE Heathkit Catalog.



Heathkit®

If coupon is missing, write
Heath Co., Dept. 020-642,
Benton Harbor, MI 49022

Send For FREE Catalog Today!

Send to: Heath Co. Dept. 020-642,
Benton Harbor, MI 49022

Send my free Heathkit Catalog now.
I am not currently receiving your
catalog.

Name _____

Address _____

City _____ State _____

CL-724B Zip _____

CIRCLE 7 ON FREE INFORMATION CARD

shunted by 30 pF. A switch selects AC or DC input, as well as acting as a grounding switch for the input circuitry.

Other features are located in the brown-shaded area at the upper right hand corner and the extreme bottom center. The latter is the MODE switch that determines which input signals will be displayed. Aside from the normal Channel-1 or Channel-2 signals being displayed alone or simultaneously, the switch will also algebraically add or subtract the input signals. That feature is particularly useful when comparing phase and voltage relationships of the two input signals, among many other important tests.

The center right-hand portion of the front panel is related to the triggering of the timebase. In that section will be found the LEVEL control; the MODE switch, which selects wheth-

er the scope will be triggered automatically, in the normal manner, or if it is to be used with composite signals such as a TV signal. In fact, like most better scopes today, the MODE switch has positions for TV(+) and TV(-) signals. There is also a SOURCE switch that obtains the trigger pulse from the Channel-1 or Channel-2 inputs, the 60 Hz line, or the external TRIG INPUT jack. The latter is a BNC type.

For calibration purposes there is a 0.5V P-P squarewave signal available on the front panel. It is located at the upper right-hand side of the unit. The amplitude is accurate to within 3% and the frequency is 1 kHz \pm 10%.

Another control that is often not found on many scopes is a TRACE ROTATION control. It is useful in eliminating the effects of external magnetic fields and could be called a tilt control as that is the effect of misadjustment.

SPECIFICATIONS

Bandwidth	DC to 30 MHz DC to 5 MHz (using \times 5 gain)
Rise time	12 nanoseconds
Max input voltage	600 volts P-P, 300V (DC + AC peak)
Timebase	0.2 μ s to 0.2 s-per-div . . . 19 steps, 1-2-5 sequence
Magnification ...	\times 10 (max speed, 100 ns-per-div.)
Sensitivity	Y Axis: 5 mV to 5 V-per-div.) X Axis: same as above
Bandwidth	X Axis: DC to 500 kHz
X-Y phase	Less than 3-degrees at 10kHz
Trigger sensitivity	20 Hz to 5 MHz; 0.5 div internal, 200 mV external 5 MHz to 30 MHz 1.5 div internal 800 mV external

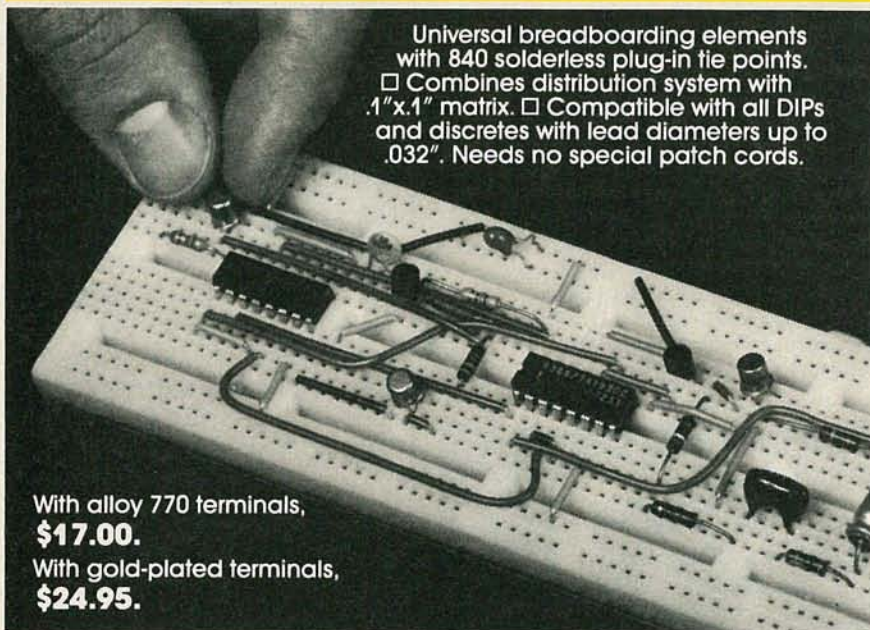

Universal breadboarding elements with 840 solderless plug-in tie points.
 Combines distribution system with 1"x1" matrix. Compatible with all DIPs and discretes with lead diameters up to .032". Needs no special patch cords.

With alloy 770 terminals,
\$17.00.

With gold-plated terminals,
\$24.95.

Your breadboarding is a super-snap with a solderless A P Super-Strip.

Build a circuit almost as fast as you dream it up. Pull it apart and do another—everything's as good as new.

Our versatile Super-Strip mini-breadboards give you the same top-quality contacts you get in our full-scale ACE All-Circuit Evaluators. Not so "mini," either. You can build circuits with

as many as nine 14-pin DIPs.

Instant-mount backing and quick-removal screws make stacking and racking a snap, too.

Where to buy? Phone (toll-free) 800-321-9668 for the name of your local A P distributor. And ask for our complete A P catalog, The Faster and Easier Book.



"Faster and Easier is what we're all about."



A P PRODUCTS INCORPORATED
 1359 W. Jackson St.
 Painesville, Ohio 44077
 Tel. 216/354-2101
 TWX: 810-425-2250

The rear panel contains an external blanking input jack, a 2-amp fuse (for 90-132V operation) and the AC line cord.

All input connectors with the exception of a common ground jack on the front panel are of the BNC type that allows for quick connection and disconnection of cables and probes. The ground jack is the banana-plug type.

Using this Hitachi scope on the bench is enjoyable. After the short period of time that is needed to become familiar with the location and function of the various controls, the ease of operation was quite noticeable. The patterns displayed were steady, sharp, and showed no signs of blooming. A composite video waveform was used to test the usefulness of the scope. The V-302 came through with flying colors. If your use for an oscilloscope is in the TV and video industry, then you are sure to appreciate the V-302's ability to display a composite waveform.

The operating manual supplied with the scope tested was complete and contained all the material necessary to help you become adept at the operation of the V-302. All controls, input jacks, and adjustments are outlined within the three dozen pages in the manual. In addition, there is a wealth of information and theories that outline the manner-in which the scope can be used to its fullest extent—including the measurement of frequency and time, amplitude, and voltage. Other uses include phase measurements and delays. Some internal operator-adjusted adjustments are also outlined in the manual.

Although many owners of such exotic equipment may be in the habit of making most of their own repairs, one thing lacking from the manual is almost anything relating to service. There is no schematic or any internal layout charts to assist in even minor servicing. While we do not doubt that such information is available, we feel that such equipment should be shipped with a simple service manual at the very least. There is, however, a list of Hitachi Denshi Ltd. offices throughout the world and

continued on page 36



THE ROADRUNNER ADMM™

Audio Digital Multimeter
FROM **WESTON**

ONLY
\$139

ARE YOU CONFUSED BY ALL THOSE HAND-HELD DIGITAL MULTI-METERS ON THE MARKET? COMPARE PRICE AGAINST FUNCTIONAL FLEXIBILITY AND YOU WILL BE CONVINCED THAT THE WESTON MODEL 6100 ROADRUNNER IS YOUR BEST BUY!

CHECK THESE FEATURES

- 29 Ranges
- .1mV to 1000VDC
- .1mV to 750VAC
- .001 to 2000mADC
- .001 to 2000mAAC
- .1ohm to 20Mohms
- 300VAC protection in ohms and audio
- Automatic polarity
- 200 hours battery life
- 10% "lo-batt" indication
- 3½ digit LCD .5" display
- 1, 10, 100mV and 1, 2V threshold pulse detect*
- 1, 10, 100 Ohm threshold continuity testing*
- Diode tests*
- Transistor tests*
- Capacitor tests*
- Stuffed PCB tests*
- RFI shielded
- X5 analog VOM accuracy
- Self Calibration
- Overrange indication
- Rugged case. Built-in stand.

*DENOTES AUDIO RESPONSE™ FUNCTION

FULL LINE OF ACCESSORIES

AC Clamp-on Probe	\$57.75	Carrying case	\$15.00
Battery Eliminator	15.00	RF Probe	29.00
Light Meter attachment	262.00	VHF RF Probe	63.00
Temperature Probe (avail. soon)		HV Probe	38.75

MODEL	FLUKE 8020A		DATA PRECISION 935			SABTRONICS 2037	
	FLUKE 8024A		BECKMAN 3010			B & K 2815	
	WESTON 6100		FLUKE 8022A				
DC VOLTS	D	D	D	D	D	D	D
AC VOLTS	D	D	D	D	D	D	D
DC CURRENT	D	D	D	D	D	D	D
AC CURRENT	D	D	D	D	D	D	D
RESISTANCE	D	D	D	D	D	D	D
CONDUCTANCE							
DIODE TEST	A	A	D	D	D	D	D
LOGIC LEVEL	A	A					
CAPACITANCE	A						
CONTINUITY	A	A		D			
TOTAL FUNCTIONS	9	9	7	6	7	6	6
PRICE (\$)	139	199	169	129	139	150	120

(A) Denotes AUDIBLE function

(D) Denotes DISPLAY function

INSTRUMENTATION, INC.

1554 ELMIRA, AURORA, COLORADO 80010



(303) 340-8728 364-8325

CALL COLLECT

BUY NOW

SPECIALIZING IN DIGITAL & ANALOG METERS AND MULTIMETERS

CIRCLE 77 ON FREE INFORMATION CARD

INTRODUCING... THE

ROAD RUNNER ADMM™

FROM WESTON



AUDIO RESPONSE™ PLUS DIGITAL DISPLAY

- 5 RANGE AUDIBLE SIGNALING FUNCTION
- RUGGED FIELD SERVICE DESIGN
- 0.5" LCD DISPLAY
- 6 FUNCTIONS
- 29 RANGES

WESTON INSTRUMENTS
THE MEASUREMENT PEOPLE®
614 Frelinghuysen Ave.,
Newark, NJ 07114

SANGAMO WESTON
Schlumberger

CIRCLE 4 ON FREE INFORMATION CARD

APRIL 1980

35

Start Computing For Just \$129.95 With An 8085-Based Professional Computer Kit—

Explorer/85

100% compatible with all 8080A and 8085 software & development tools!

No matter what your future computing plans may be, Level "A"—at \$129.95—is your starting point.

Starting at just \$129.95 for a Level "A" operating system, you can now build the exact computer you want. Explorer/85 can be your beginner's system, OEM controller, or IBM-formatted 8" disk small business system...yet you're never forced to spend a penny for a component or feature you don't want and you can expand in small, affordable steps!

Now, for just \$129.95, you can own the first level of a fully expandable computer with professional capabilities—a computer which features the advanced Intel 8085 cpu, thereby giving you immediate access to all software and development tools that exist for both the 8085 and its 8080A predecessor (they are 100% software compatible)—a computer which features onboard S-100 bus expansion—plus instant conversion to mass storage disk memory with either 5-1/4" diskettes or standard IBM-formatted 8" disks.

For just \$129.95 (plus the cost of a power supply, keyboard/terminal and RF modulator, if you don't have them already), Explorer/85 lets you begin computing on a significant level... applying the principles discussed in leading computer magazines... developing "state of the art" computer solutions for both the industrial and leisure environment.

Level "A" Specifications

Explorer/85's Level "A" system features the advanced Intel 8085 cpu, an 8355 ROM with 2k deluxe monitor/operating system, and an 8155 ROM-I/O—all on a single motherboard with room for RAM/ROM/PROM/EPROM and S-100 expansion, plus generous prototyping space.

(Level "A" makes a perfect OEM controller for industrial applications and is available in a special Hex Version which can be programmed using the Netronics Hex Keypad/Display.)



Level "A" at \$129.95 is a complete operating system, perfect for beginners, hobbiests, or industrial controller use.

PC Board: glass epoxy, plated through holes with solder mask

- I/O: provisions for 25-pin (DB25) connector for terminal serial I/O, which can also support a paper tape reader
- provision for 24-pin DIP socket for hex keypad/display... cassette tape recorder output... cassette tape control output... speaker output... LED output indicator on SOD (serial output) line... printer interface (less drivers)... total of four 8-bit plus one 6-bit I/O ports • Crystal Frequency: 6.144 MHz • Control Switches: reset and user (RST 7.5) interrupt... additional provisions for RST 5.5, 6.5 and TRAP interrupts onboard • Counter/Timer: programmable, 14-bit binary • System RAM: 256 bytes located at F800, ideal for smaller systems and for use as an isolated stack area in expanded systems... RAM expandable to 64k via S-100 bus or 4K on motherboard.

System Monitor (Terminal Version): 2k bytes of deluxe system monitor ROM located at F000 leaving 0000 free for user RAM/ROM. Features include tape load with labeling... tape dump with labeling... examine/change contents of memory... insert data... warm start... examine and change all registers... single step with register display at each break point, a debugging/training feature... go to execution address... move blocks of memory from one location to another... fill blocks of memory with a constant... display blocks of memory... automatic baud rate selection... variable display line length control (1-255 characters/line)... channelized I/O monitor routine with 8-bit parallel output for high speed printer... serial console in and console out channel so that monitor can communicate with I/O ports.

System Monitor (Hex Version): Tape load with labeling... tape dump with labeling... examine/change contents of memory... insert data... warm start... examine and change all



registers... single step with register display at each break point... go to execution address. Level "A" in the Hex Version makes a perfect controller for industrial applications and can be programmed using the Netronics Hex Keypad/Display.



Hex Keypad/Display.

Level "B" Specifications

Level "B" provides the S-100 signals plus buffers/drivers to support up to six S-100 bus boards and includes: address decoding for onboard 4k RAM expansion select-able in 4k blocks... address decoding for onboard 8k EPROM expansion select-able in 8k blocks... address and data bus drivers for onboard expansion... wait state generator (jumper select-able), to allow the use of slower memories... two separate 5 volt regulators.



Explorer/85 with Level "C" card cage.

Level "C" includes a sheet metal superstructure, a 5-card gold plated S-100 extension PC board which plugs into the motherboard. Just add required number of S-100 connectors

Level "D" Specifications

Level "D" provides 4k or RAM, power supply regulation, filtering decoupling components and sockets to expand your Explorer/85 memory to 4k (plus the original 256 bytes located in the 8155A). The static RAM can be located anywhere from 0000 to EFFF in 4k blocks.

Level "E" Specifications

Level "E" adds sockets for 8k of EPROM to use the popular Intel 2716 or the TI 2516. It includes all sockets, power supply regulator, heat sink, filtering and decoupling components. Sockets may also be used for soon to be available RAM IC's (allowing for up to 12k of onboard RAM).

Order A Coordinated Explorer/85 Applications Pak!

Experimenter's Pak (SAVE \$12.50)—Buy Level "A" and Hex Keypad/Display for \$199.90 and get FREE Intel 8085 user's manual plus FREE postage & handling!

Student Pak (SAVE \$24.45)—Buy Level "A", ASCII Keyboard/Computer Terminal, and Power Supply for \$319.85 and get FREE RF Modulator plus FREE Intel 8085 user's manual plus FREE postage & handling!

Engineering Pak (SAVE \$41.00)—Buy Levels "A," "B," "C," "D," and "E" with Power-Supply, ASCII Keyboard/Computer Terminal, and six S-100 Bus Connectors for \$514.75 and get 10 FREE computer grade cassette tapes plus FREE 8085 user's manual plus FREE postage & handling!

Business Pak (SAVE \$89.95)—Buy Explorer/85 Levels "A," "B," and "C" (with cabinet), Power Supply, ASCII Keyboard/Computer Terminal (with cabinet), 16k RAM, 12" Video Monitor, North Star 5-1/4" Disk Drive (includes North Star BASIC) with power supply and cabinet, all for just \$1599.40 and get 10 FREE 5-1/4" mindiskettes (\$49.95 value) plus FREE 8085 user's manual plus FREE postage & handling!

Continental U.S.A. Credit Card Buyers Outside Connecticut

CALL TOLL FREE 800-243-7428

To Order From Connecticut Or For Technical Assistance, Etc. Call (203) 354-9375

Netronics R&D Ltd., Dept. RE-4

333 Litchfield Road, New Milford, CT 06776

Please send the items checked below—

- Explorer/85 Level "A" Kit (ASCII Version), \$129.95 plus \$3 p&h.
- Explorer/85 Level "A" Kit (Hex Version), \$129.95 plus \$3 p&h.
- 8k Microsoft BASIC on cassette tape, \$64.95 postpaid.
- 8k Microsoft BASIC in ROM Kit (requires Levels "B," "D," and "E"), \$99.95 plus \$2 p&h.
- Level "B" (S-100) Kit, \$49.95 plus \$2 p&h.
- Level "C" (S-100 6-card expander) Kit, \$39.95 plus \$2 p&h.
- Level "D" (4k RAM) Kit, \$69.95 plus \$2 p&h.
- Level "E" (EPROM/ROM) Kit, \$5.95 plus 50¢ p&h.
- Deluxe Steel Cabinet for Explorer/85, \$49.95 plus \$3 p&h.
- ASCII Keyboard/Computer Terminal Kit (features a full 128 character set, upper & lower case, full cursor control, 75 ohm video output convertible to baudot output, selectable baud rate, RS232-C or 20 ma. I/O, 32 or 64 character by 16 line formats, and can be used with either a CRT monitor or a TV set (if you have an RF modulator), \$149.95 plus \$2.50 p&h.
- Hex Keypad/Display Kit, \$69.95 plus \$2 p&h.
- Deluxe Steel Cabinet for ASCII Keyboard/Terminal, \$19.95 plus \$2.50 p&h.
- Power Supply Kit (±8V @ 5 amps) in deluxe steel cabinet, \$39.95 plus \$2 p&h.
- Gold Plated S-100 Bus Connectors, \$4.85 each, postpaid.
- RF Modulator Kit (allows you to use your TV set as a monitor), \$8.95 postpaid.
- 16k RAM Kit (S-100 Board expands to 64k), \$199.95 plus \$2 p&h.
- 32k RAM Kit, \$329.95 plus \$2 p&h.
- 48k RAM Kit, \$459.95 plus \$2 p&h.
- 64k RAM Kit, \$589.95 plus \$2 p&h.
- 16k RAM Expansion Kit (to expand any of the above up to 64k), \$139.95 plus \$2 p&h each.
- Intel 8085 cpu User's Manual, \$7.50 postpaid.
- Special Computer Grade Cassette Tapes, \$1.90 each or 3 for \$5, postpaid.
- 12" Video Monitor (10 MHz bandwidth), \$139.95 plus \$5 p&h.
- North Star Double Density Floppy Disk Kit (One Drive) for Explorer/85 (includes 3 drive S-100 controller, DOS, and extended BASIC with per-

sonalized disk operating system—just plug it in and you're up and running!), \$69.95 plus \$5 p&h.

Power Supply Kit for North Star Disk Drive, \$39.95 plus \$2 p&h.

Deluxe Case for North Star Disk Drive, \$39.95 plus \$2 p&h.

Experimenter's Pak (see above), \$199.90 postpaid.

Student Pak (see above), \$319.85 postpaid.

Engineering Pak (see above), \$514.75 postpaid.

Business Pak (see above), \$1599.40 postpaid.

Total Enclosed \$ _____

(Conn. res. add sales tax) By—

Personal Check M.O./Cashier's Check Visa Master Charge

(Bank # _____)

Acct. # _____ Exp. Date _____

Signature _____ Print Name _____

Address _____

City _____ State _____ Zip _____

Send Me Information

EQUIPMENT REPORTS

continued from page 34

assistance would most likely be available from one of them. The V-302 is also covered by a 2 year warranty.

The lack of storage space for the line cord hampers the portability of the unit somewhat. Although not a serious problem, it could be solved easily by extending the length of the four bumpers on the rear of the cabinet and winding the cord around them.

In addition, the unit (supplied) had a handle on the top of the cabinet that is centered well and provides a well-balanced grip. One minor problem was noticeable on the bench... one that could be solved by the use of a bail-type handle. When the unit sat flat on the test bench, it was difficult to view the screen because of the low-profile of the Hitachi V-302. By tilting the scope upward, the visibility and ease of operation improved dramatically. A bail-type handle could be added, which would also serve as a prop or stand to elevate the front of the unit and therefore add to the operating comfort.

Even though the graticule was not illuminated, the divisions were found to be easy to read and as pointed out earlier, the ease of operation was outstanding.

The V-302 is designed to operate from an AC supply of 100/120/220/240V. The size is listed as 190 × 275 × 400mm (7.5 × 10.8 × 15.7 inches) and weights 8.5 kg (18.7 lbs.) Standard equipment supplied include two probes and the operation manual. Price \$945.

One final observation: the miniature-sized probes are extremely handy and do add to the ease of servicing on printed-circuit boards and IC's. There's no doubt that these probes are becoming standard equipment as they make more sense than the older large-sized units.

R-E

The BASIC Programmer's Toolkit for PET Computers

CIRCLE 104 ON FREE INFORMATION CARD

OWNERS OF PET PERSONAL COMPUTERS HAVE been known to collect software from numerous sources. Among this software are utility programs that assist the programmer in writing BASIC language programs. The best utility programs are written in machine language to minimize conflict with the user's program and to execute rapidly. Normally stored on tape, utility programs must be loaded each time they are used. If your computer system goes down for any reason, you must reload the utility program and usually carry out an inconvenient initialization procedure. To have two or more tape-resident utility programs in memory at the same time, you may have to relocate one or more so they don't overwrite each other. The BASIC Programmer's Toolkit is a firmware system that provides a real solution to the PET utility muddle.

The Toolkit is a collection of the most useful utilities programmed into a read-only memory that is always ready to use. The complete set of programs are initialized with a simple SYS command after the PET computer is turned on. The command must be given only once for each time the power is applied. If your system bombs out, or the power goes out temporarily, the Toolkit utilities can be called back into service in seconds. A very handy feature to incorporate into your computer.

The Toolkit has a ten-command repertoire.

Its unique design adds the *Toolkit* commands to the PET's own BASIC-command list. Once the system is initialized, you can't tell where the PET leaves off and the *Toolkit* takes over, except that the added commands cannot be written into program statements. The command list consists of: AUTO, DELETE, RENUMBER, APPEND, DUMP, TRACE, STEP, OFF, FIND, and HELP.

The AUTO command automatically prints statement-line numbers, starting at any legal number and increasing by any increment. DELETE erases a specified line or block of lines. RENUMBER spreads your line numbers apart after you have inserted too many lines to allow further additions. RENUMBER updates all jump destinations in GOTO statements etc.

The APPEND command combines two programs without the gyrations required by most other methods. You load the first program conventionally and then append the second. The only requirement is that the line numbers be in proper sequence. Of course, you can use the RENUMBER command to prepare programs for the append operation.

The DUMP command lists all the variables except arrays, following program execution. As a program runs, the TRACE facility displays the line numbers of the last six statements executed. STEP is a variation of TRACE that executes one statement at a time. OFF disables the TRACE and STEP functions.

The FIND command searches all program lines or a group of lines for a specified character sequence. It is very useful when you want to find a particular line that has been moved because of renumbering. It also helps determine if a particular variable name has already been used. FIND displays all lines that include the specified reference.

Finally, The HELP command makes short work of careless program errors. When the PET displays an error message, typing HELP will cause the computer to display the line in which the error occurred, and, in addition, display the end of the last completed statement in reverse-video.

A well-written instruction manual includes a section that contains a more detailed explanation of how the system and its commands work. All the programs function extremely well and the examples in the instruction manual demonstrate how seemingly strange things can crop up.

The *Toolkit* is available in several versions that match the various PET configurations. All involve the connection of a ROM into the "B" (11x4096) block of memory. Early PET's were not wired with empty ROM sockets, so the corresponding *Toolkit* version consists of a board that interfaces to the memory-expansion connector and to the second cassette port. Newer PET's have the extra sockets, so the applicable kits consists only of a ROM—no additional memory decoding is required. There are also versions for Expandamem and Skyles memory boards, so the *Toolkit* can be added without hooking into the memory connector already used to interface with the memory-expansion board.

The BASIC Programmer's Toolkit is a product of Palo Alto IC's and is available only at local PET dealers. Chip-only versions sell for \$49.95, and the completely-assembled versions for 8K Pets, Skyles or Expandamem boards are \$79.95. The Toolkit is an exceptional, professionally designed PET add-on. Any PET owner who is serious about BASIC programming would do well to put it at the top of his shopping list.

R-E

BE SWITCHED

EXCLUSIVE SHELDAHL FLEXSWITCH® KIT

Yours for only \$10.00

Put your imagination and a scissors to work to make the switch you want. Modify the .030 thick, non-tactile panel into a water/dust resistant switching module. Kit includes design guidelines, instructions, membrane switching panel, flexcircuit connector, press-on nomenclature and RFQ checklist.

© 1980 Sheldahl, Inc.

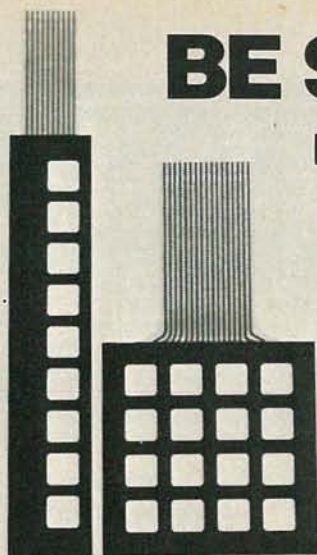

See your local distributor, or order by mail.

Please send me 16 key kit(s) short to ground crosspoint
 9 key kit(s) short to ground crosspoint

I enclose \$10 in check or money order for each kit order.

NAME _____

ADDRESS _____

CITY _____ STATE _____ ZIP _____



Sheldahl

Mail to:
Sheldahl Inc.
Electrical Products Division
P.O. Box 170
Northfield, MN 55057

BUILD A MASTERPIECE OF SOUND

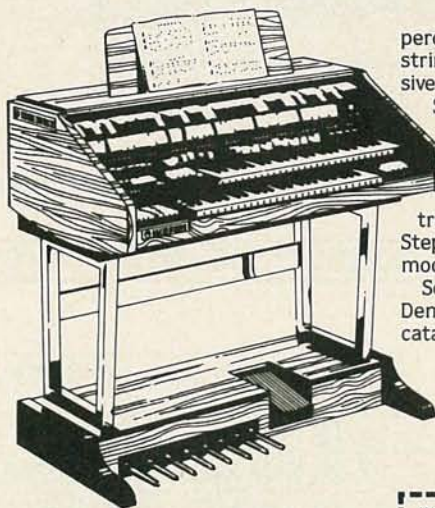

percussion and sustain. Wersi's famous string orchestra and bass guitar. Exclusive Sound Computer for 32-128 "One Stop Sounds" (total organ presets). Transposer. And lots more.

Build your own masterpiece of sound. No technical knowledge required. Just follow the clearly illustrated, easy to understand instructions. Step by step. Choose from at least 10 models. (Also factory assembled.)

Send \$6.00 with coupon for your Wersi Demo-Package (LP with 104-page color catalog).

WERSI

Wersi has combined select features of the electronic music field, added its own creations and years of research by top engineers and musicians, to produce an incomparable line of organs.

Space-age technology. True-to-life voicing with full drawbar system. Polyphonic

Wersi Electronics, Inc. Dept. 21
1720 Hempstead Road
Lancaster, PA 17601

Wersi Organs & Kits
Dept. 21
14104 E. Firestone Blvd.
Santa Fe Springs, CA 90670

Enclosed is \$6.00 for my Demo-Package (LP with 104-page color catalog.)

Name _____

Address _____

City _____ State _____ Zip _____

CIRCLE 29 ON FREE INFORMATION CARD

APRIL 1980

37

ITEM NO.
WK-7

CMOS SAFE

IC INSERTION/EXTRACTION KIT

- KIT INCLUDES**
- MOS-1416 14-16 CMOS SAFE INSERTER
 - EX-1 14-16 EXTRACTOR
 - MOS-2428 24-28 CMOS SAFE INSERTER
 - EX-2 24-40 CMOS SAFE EXTRACTOR
 - MOS-40 36-40 CMOS SAFE INSERTER



OK MACHINE & TOOL CORPORATION
3455 CONNER ST., BRONX, N.Y. 10475 U.S.A.
PHONE (212) 994 6600 TELEX NO 125091



PRINTED IN U.S.A.

PATENT PENDING

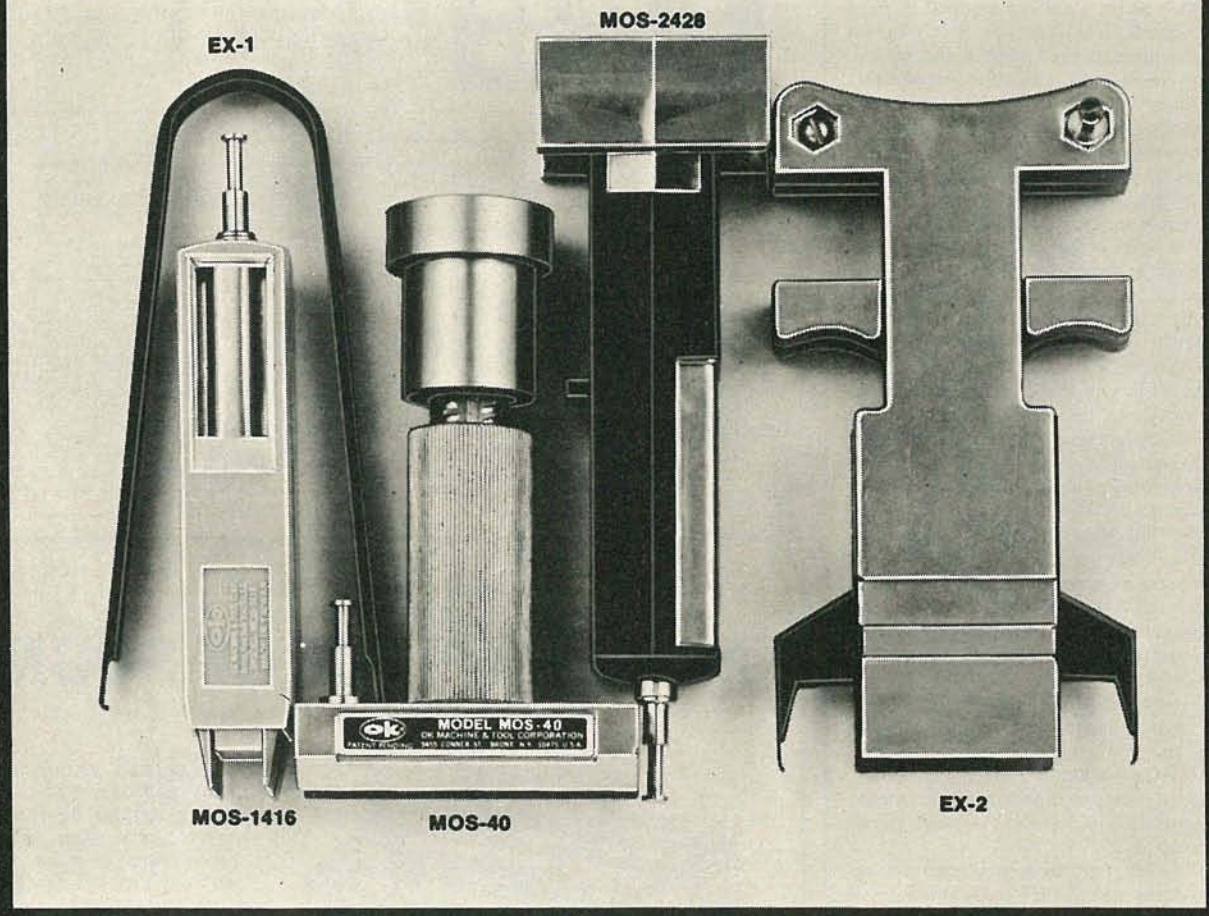

WK-7	COMPLETE IC INSERTER/EXTRACTOR KIT	\$29.95
------	------------------------------------	---------

INDIVIDUAL COMPONENTS

MOS-1416	14-16 PIN MOS CMOS SAFE INSERTER	\$ 7.95
MOS-2428	24-28 PIN MOS CMOS SAFE INSERTER	\$ 7.95
MOS-40	36-40 PIN MOS CMOS SAFE INSERTER	\$ 7.95
EX-1	14-16 PIN EXTRACTOR TOOL	\$ 1.49
EX-2	24-40 PIN CMOS SAFE EXTRACTOR TOOL	\$ 7.95

MINIMUM BILLING \$25.00. ADD SHIPPING CHARGE \$2.00. NEW YORK RESIDENTS ADD APPLICABLE TAX.

OK MACHINE & TOOL CORPORATION 3455 CONNER ST., BRONX, N.Y. 10475 (212) 994-6600/TELEX 125091

BUILD THIS

TRIGGERED OSCILLOSCOPE

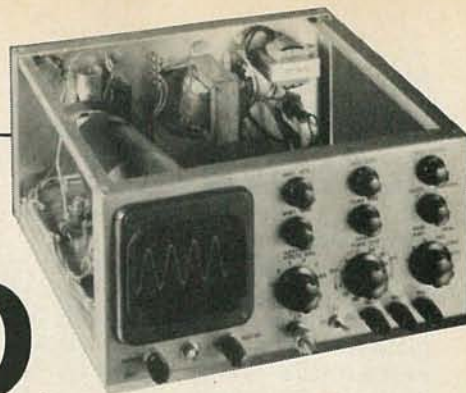

This easy-to-follow design lets you keep cost low by using a CRT of your choice. Its operational feature is a continuous zero baseline.

DANIEL METZGER and DENNIS PERRY

ONCE A TECHNICIAN HAS EXPERIENCED troubleshooting with a calibrated DC lab scope, he'll probably want to keep that scope probe close at hand most of the time he's at the service bench. Transistor base-emitter voltages, collector saturation voltages, and IC logic levels can be checked as easily as power-supply lines while the operating signals are present. No other instrument provides that simultaneous readout of bias and signal conditions.

Two factors have conspired to keep that scope probe out of the hands of most experimenters. The first is cost, which approaches \$200—even for a kit. That problem is easily solved by simplified design. The scope described here can be built from standard parts for \$100, and considerably less if the junk box is well stocked. Yet it boasts a 2-MHz bandwidth and 10 mV-per-division vertical sensitivity.

The second factor is the annoyingly frequent need to lay down the probe, reach over to the scope, throw the input switch from DC to GROUND, check the position of the zero-volt baseline, and throw the switch back to DC. That problem is handled by incorporating a circuit that provides a continuous display of the DC ground level at a brightness level lower than that of the signal display.

How it works

The operation of the scope as a whole is best understood from the block diagram, Fig. 1. The vertical attenuator and amplifier provide a replica of the input signal, both AC and DC, at the approximately 100-volt level needed at the deflection plates of the CRT. The electronic baseline switch interrupts the signal and grounds the amplifier input for ap-

proximately 3 ms each 15 ms, thus providing a 1/5 duty-cycle baseline display at a rate of about 60 Hz—too fast for the eye to perceive the flicker.

A separate trigger amplifier is fed from a point ahead of the electronic baseline switch to preserve continuity of sweep

triggering. A Schmitt trigger produces squarewaves in sync with the input signal, and a differentiator produces sharp spikes from the edges of the squarewaves. The negative spikes initiate a linear ramp that always starts at the same selected point on the input AC wave-

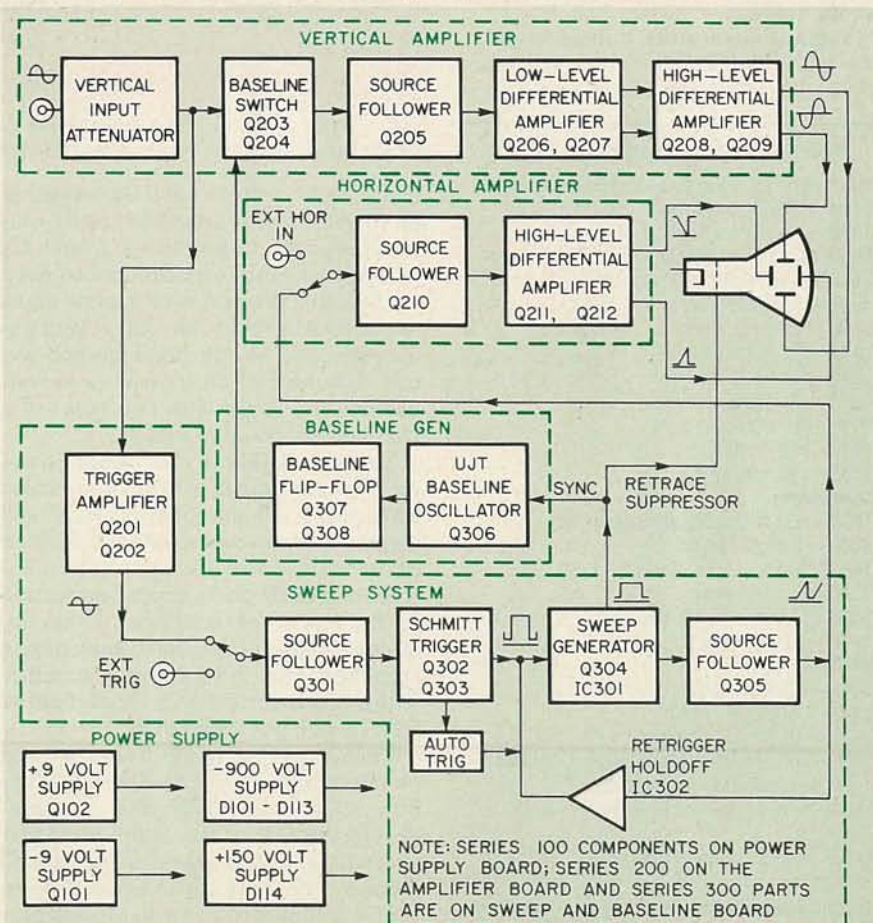

FIG. 1—BLOCK DIAGRAM of the zero-baseline scope. Operation is somewhat similar to a dual-trace scope with the baseline considered as the second trace.

form. That ramp is applied to the horizontal amplifier to produce the calibrated time sweep. A source-follower provides a low output impedance for the ramp, and an op-amp comparator holds off further triggering signals until the ramp voltage returns to zero.

An auto-trigger circuit senses when the Schmitt trigger is not switching and immediately applies a voltage to the ramp generator commanding continuous ramps, thus providing sweeps for the display of DC voltages.

A UJT baseline oscillator running at approximately 60 Hz is synchronized to the sweep generator to insure that the switching from signal to baseline will always occur during a retrace of the sweep. The baseline flip-flop drives the baseline-switching FET's at the input of the vertical amplifier.

The CRT cathode is operated at -900 volts to accelerate the electron beam toward the CRT face. Deflection sensitivity and hence calibration depend upon that voltage, so it is regulated by a string of 180-volt Zener diodes. Vertical and horizontal position and sweep time depend upon the 9-volt supplies, so they are transistor-regulated. The +150-volt supply serves only differential amplifiers, and their inherent common-mode rejection makes regulation of that supply unnecessary. We shall now proceed to a detailed description of each functional block.

Vertical attenuator: Voltage dividers R_A and R_B (Fig. 2) reduce the input signal to a maximum of 0.32 volt (8 divi-

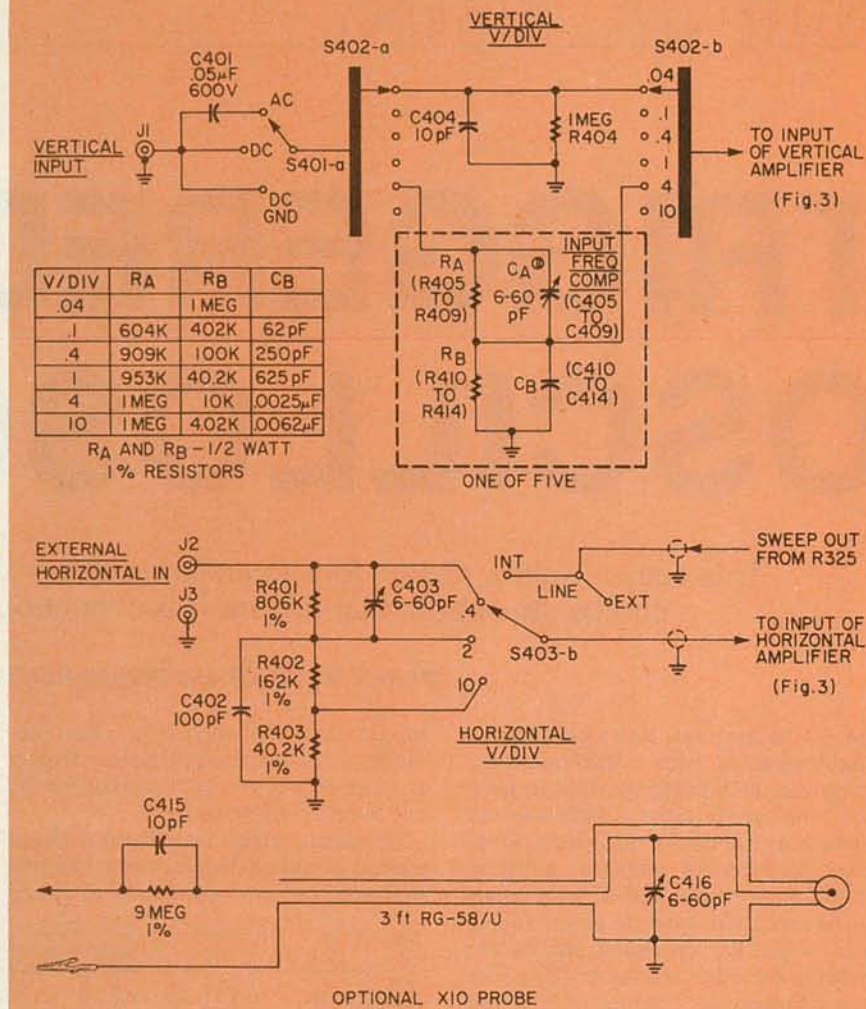
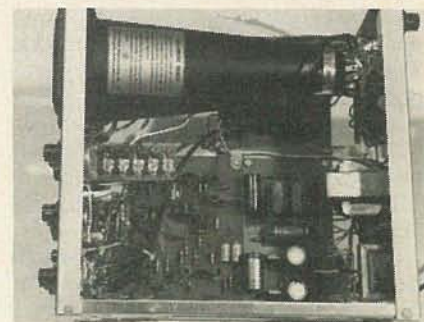

FIG. 2.—THE ATTENUATORS. Components for the vertical attenuator are mounted on a special circuit board. Also shown in the diagram of the optional multiplier probe.

sions at 0.04 volt-per-division) or a minimum of 0.01 volt (1 division at 0.01 volt-per-division). Capacitors C_A and C_B swamp out stray capacitances to keep the reactive division ratio exactly equal to the resistive division ratio at high frequencies. A1-4-10 step-sequence permits coverage of the 10-mV to 10-volt-per-division range with two poles of a standard six-position switch.

Vertical amplifier: The overall gain of the vertical amplifier (Fig. 3) is about 2000 in the full-gain ($\times 4$) position, and about 500 in the calibrated ($\times 1$) position of the vertical variable control. Resistor R201 and D201 provide input protection in the event of accidental overload. Source-follower Q201 and common-base amplifier Q202 form a trigger amplifier with a non-inverting AC gain of about 40 and a high input impedance.

Transistors Q203 and Q204 are switched on alternately by the zero-baseline flip-flop (Q307 and Q308, Fig. 4), connecting the base of source-follower Q205 alternately to the signal input and to ground. The stray capacitance of these FET's amounts to about 10 pF, and produces switching transients of about 10 μS duration on the 1-megohm input line.



TOP VIEW of the scope. The amplifier board is beneath the CRT. The power-supply board is at the rear near the transformers mounted on the back panel. The sweep board is up front near the controls. The attenuator board, with its five trimmers, is on a bracket held by the vertical-sensitivity control. Astigmatism control is on rear panel near base of the CRT.

The switching frequency must therefore be held below a few hundred hertz to prevent those transients from being frequent enough to be seen on the CRT display.

Transistors Q206 and Q207 are wired as a variable-gain differential amplifier. Potentiometer R213 is the 10-mV calibrator and sets the gain to four times the indicated vertical sensitivity with R214

PARTS LIST (Attenuators, Fig. 2)

Resistors 1% tolerance or better, 1/2 watt

R401—806,000 ohms
R402—162,000 ohms
R403, R412—40,200 ohms
R404, R408, R409—1 megohm
R405—604,000 ohms
R406—909,000 ohms
R407—953,000 ohms
R410—402,000 ohms
R411—100,000 ohms
R413—10,000 ohms
R414—4,020 ohms
R415*—9 megohms

Capacitors

C401—.05 μF, 600 volts, ceramic
C402—100 pF, Mylar
C403, C405—C414, C416*—6-60 pF ceramic trimmer
C404, C415*—10 pF, ceramic
C410—62 pF, mica
C411—250 pF, mica
C412—620 pF, mica
C413—.0022 μF, Mylar
C414—.0062 μF, Mylar

S401—miniature double-pole 3-position toggle switch (Alco MST205T)

S402—3-pole, 6-position rotary wafer switch

R403—2-pole, 6-position rotary wafer switch

Miscellaneous: printed circuit board

*Note: Components required for optional $\times 10$ probe

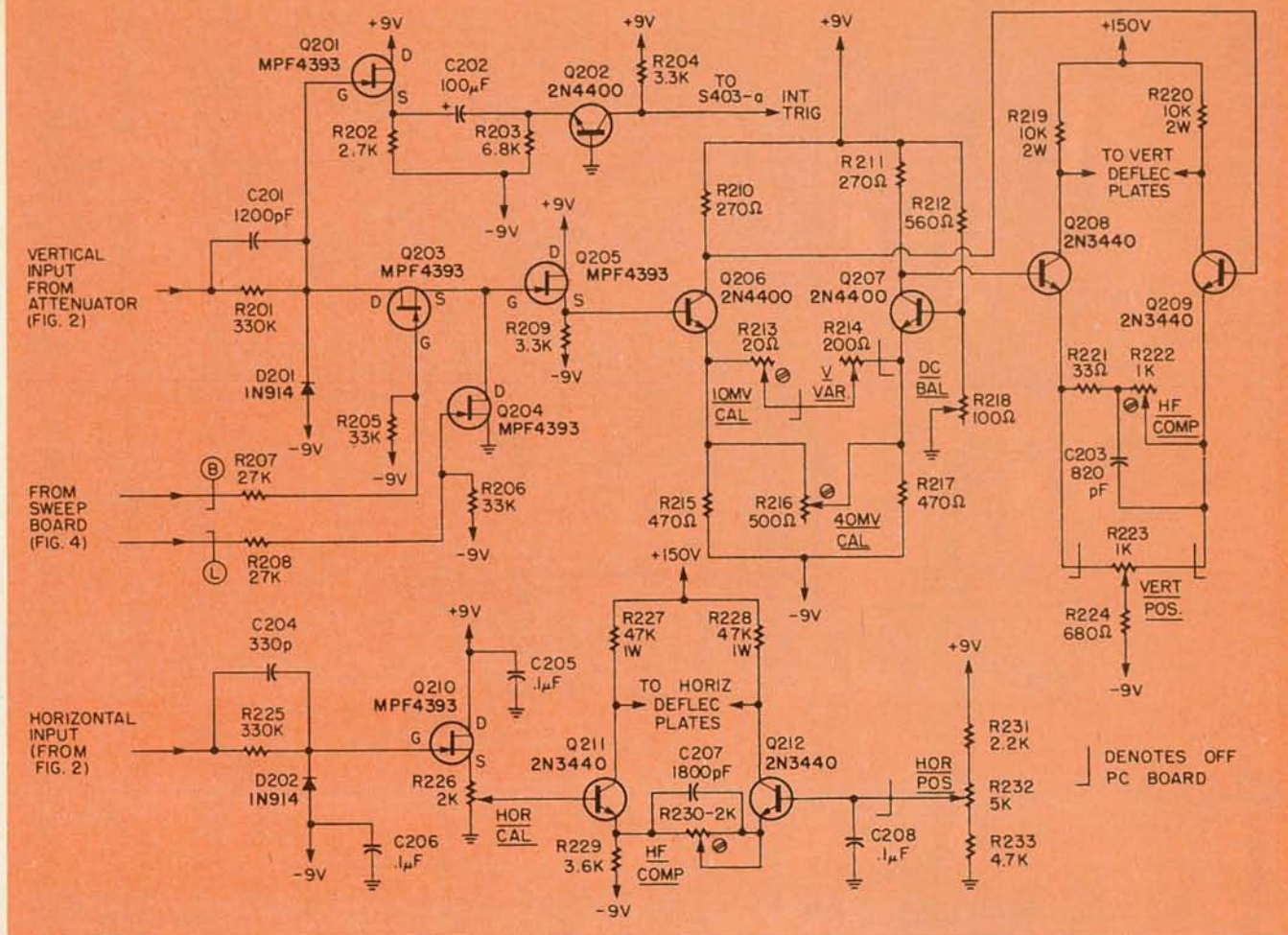

FIG. 3—SCHEMATIC DIAGRAMS of the vertical and horizontal deflection amplifiers. The latter is comparatively simple because its response is limited to the sweep frequencies.

at minimum resistance. Pot R216 is the 40-mV calibrator. It adjusts the indicated sensitivity with R214 at maximum resistance. Pot R218 is the DC balance control; it sets zero voltage between the two emitters at zero input in order that the gain control will not shift the vertical position.

Transistors Q208 and Q209 provide a

second stage of amplification, producing a maximum differential output of about 180 volts P-P. Capacitor C203 lowers the impedance between the emitters to track the decrease in impedance between the collectors caused by CRT plate capacitance at high frequencies. Since gain is essentially the ratio of those impedances, C203 tends to preserve

PARTS LIST (Amplifiers, Fig. 3)

Resistors ½ watt, 10%, carbon composition, unless otherwise noted

R201, R225—330,000 ohms
 R202—2700 ohms
 R203—6800 ohms
 R204, R209—3300 ohms
 R205, R206—33,000 ohms
 R207, R208—27,000 ohms
 R210, R211—270 ohms
 R212—560 ohms
 R213—20 ohms, trimmer, vertical mount
 R214—200 ohms, potentiometer
 R215, R217—470 ohms
 R216—500 ohms, trimmer, vertical mount
 R218—100 ohms, trimmer, vertical mount
 R219, R220—10,000 ohms, 2 watts
 R221—33 ohms
 R222—1000 ohms, trimmer, vertical mount
 R223—1000 ohms, potentiometer
 R224—680 ohms
 R226, R230—2000 ohms, trimmer, vertical mount
 R227, R228—47,000 ohms, 1 watt

R229—3600 ohms
 R231—2200 ohms
 R232—5000 ohms, potentiometer
 R233—4700 ohms
Capacitors
 C201—1200 pF, Mylar
 C202—100 μF, 15 volts, radial-lead electrolytic
 C203—820 pF, mica
 C204—330 pF, mica
 C205, C206, C208—0.1 μF, ceramic disc
 C207, 1800 pF, Mylar
Semiconductors
 D201, D202—1N914 or similar silicon diode
 Q201, Q203, Q204, Q205, Q210—MPF4393 or similar N-channel FET (Motorola)
 Q202—2N4402 or similar
 Q206, Q207—2N4400 or similar
 Q208, Q209, Q211, Q212—2N3440 or similar
Miscellaneous: PC or perforated circuit board, hookup wire, mounting hardware, transistor sockets, etc.

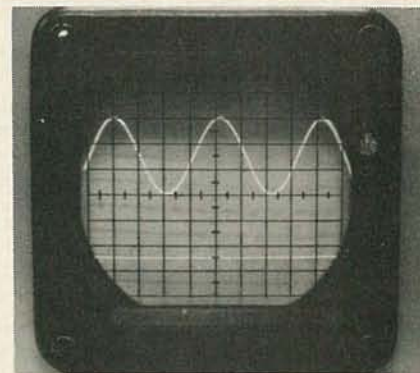

ZERO-BASELINE DISPLAY permits reading the DC component of this waveform. Scale factor is 1 V/div and the sinewave is 3 volts peak-to-peak riding on a 4-volt DC level.

a constant gain as frequency increases. Because an 820-pF trimmer would be large and unstable, we adjust the associated resistor (R202) to suit the capacitor, instead of vice-versa. Capacitor C203 thus determines the stage gain, and should be altered if necessary to produce a stage gain of about 50.

Horizontal amplifier: This amplifier (Fig. 3) is similar to the vertical amplifier except that the low-voltage differential stage is omitted and the entire gain (about 70) is achieved in the high-voltage stage. The differential output voltage required is about 250 volts P-P because the second (less sensitive) set of CRT deflection plates is used. Bandwidth is about 500 kHz.

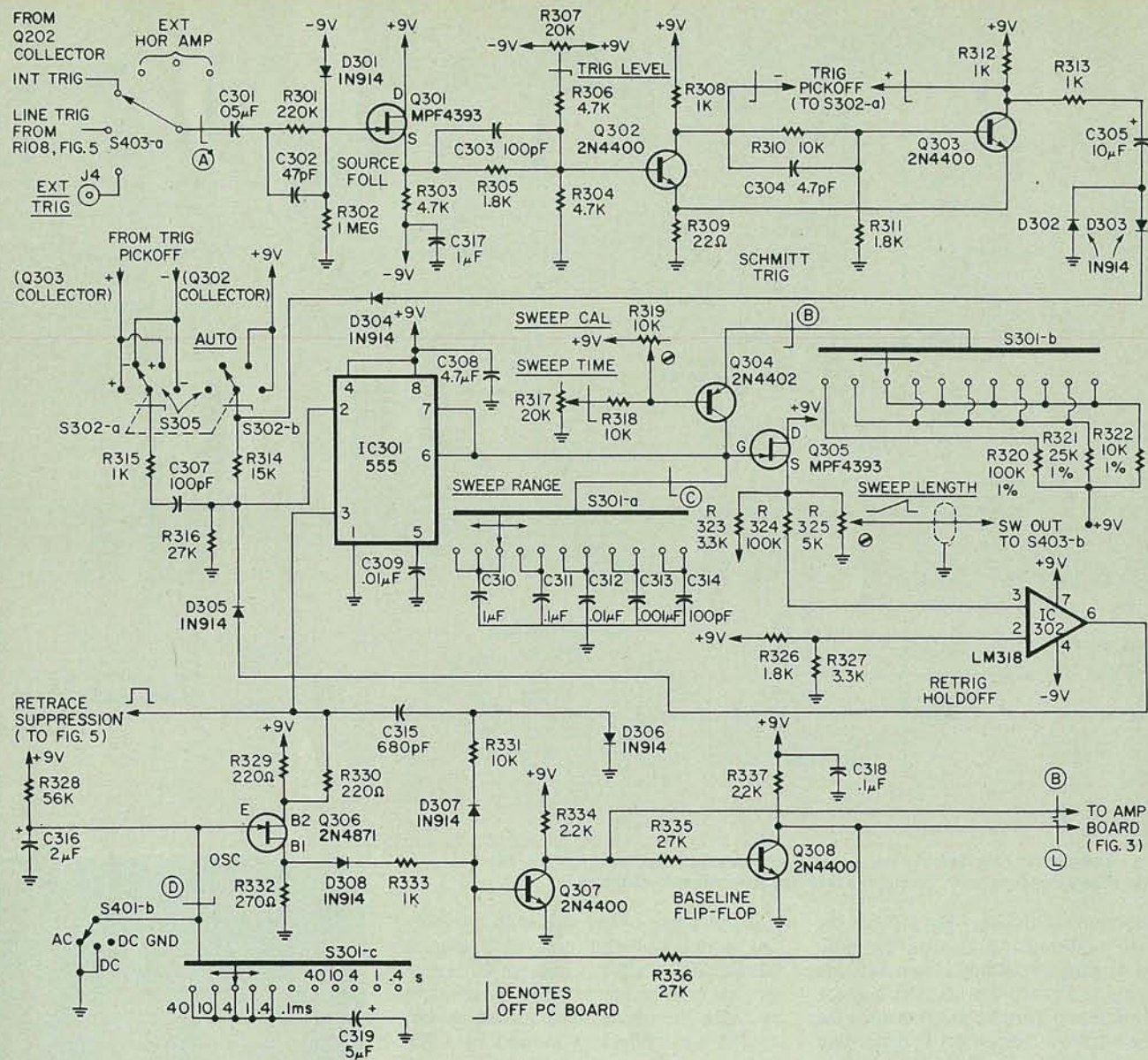

FIG. 4—THE SWEEP and zero-baseline generator circuits comprise the most complex sections of the instrument.

PARTS LIST (Sweep and zero-baseline generators, Fig. 4)

Resistors ½ watt, 10% unless otherwise noted

R301—220,000 ohms
 R302—1 megohm
 R303, R304, R306—4700 ohms
 R305, R311—1800 ohms
 R307, R317—20,000 ohms, potentiometer
 R308, R312, R313, R315, R333—1000 ohms
 R309—22 ohms
 R310, R318, R331—10,000 ohms
 R314—15,000 ohms
 R316, R335, R336—27,000 ohms
 R319—10,000 ohms, trimmer, vertical mount
 R320—100,000 ohms, 1%
 R321—25,000 ohms, 1%
 R322—10,000 ohms, 1%
 R323, R327—3300 ohms
 R324—100,000 ohms
 R325—5000 ohms, trimmer, vertical mount
 R326—18,000 ohms
 R328—56,000 ohms

R329, R330—220 ohms
 R332—270 ohms
 R334, R337—2000 ohms

Capacitors

C301—.05 μ F, 600 volts, ceramic disc
 C302, C304—47 pF, ceramic disc
 C303, C307—100 pF, ceramic disc
 C305, C306—10 μ F, 25 volts, axial-lead electrolytic
 C308—4.7 μ F, 25 volts, axial-lead electrolytic
 C309—.01 μ F, ceramic disc
 C310*—1 μ F, Mylar
 C311*—0.1 μ F, Mylar
 C312*—.01 μ F, Mylar
 C313*—.001 μ F, Mylar
 C314**—100 pF, ceramic trimmer
 C315—680 pF, ceramic disc
 C316—2 μ F, 25 volts, axial-lead electrolytic
 C317, C318—0.1 μ F, ceramic disc
 C319—5 μ F, 25 volts, axial-lead electrolytic

*Note: select to keep ratios within $\pm 1\%$

**Note: In prototype, C314 was made by connecting a 47-pF disc in parallel with a 6–60-pF ceramic trimmer

Semiconductors

D301—D308—1N914 or similar silicon diode
 IC301—555 timer
 IC302—LM318 op-amp (National)
 Q301, Q305—MPF4393 or similar N-channel FET (Motorola)
 Q302, Q303, Q307, Q308—2N4400 or similar
 Q304—2N4402 or similar
 Q306—2N4871 or similar unijunction transistor
 S401, S403—see attenuator parts list
 S301—3-pole, 11-position rotary wafer switch (Centralab PA-10009 or equal)
 S302—2-pole, 4-position rotary switch
Miscellaneous: PC or perforated circuit board, shielded cable, transistor and IC sockets, mounting hardware, knobs, etc.

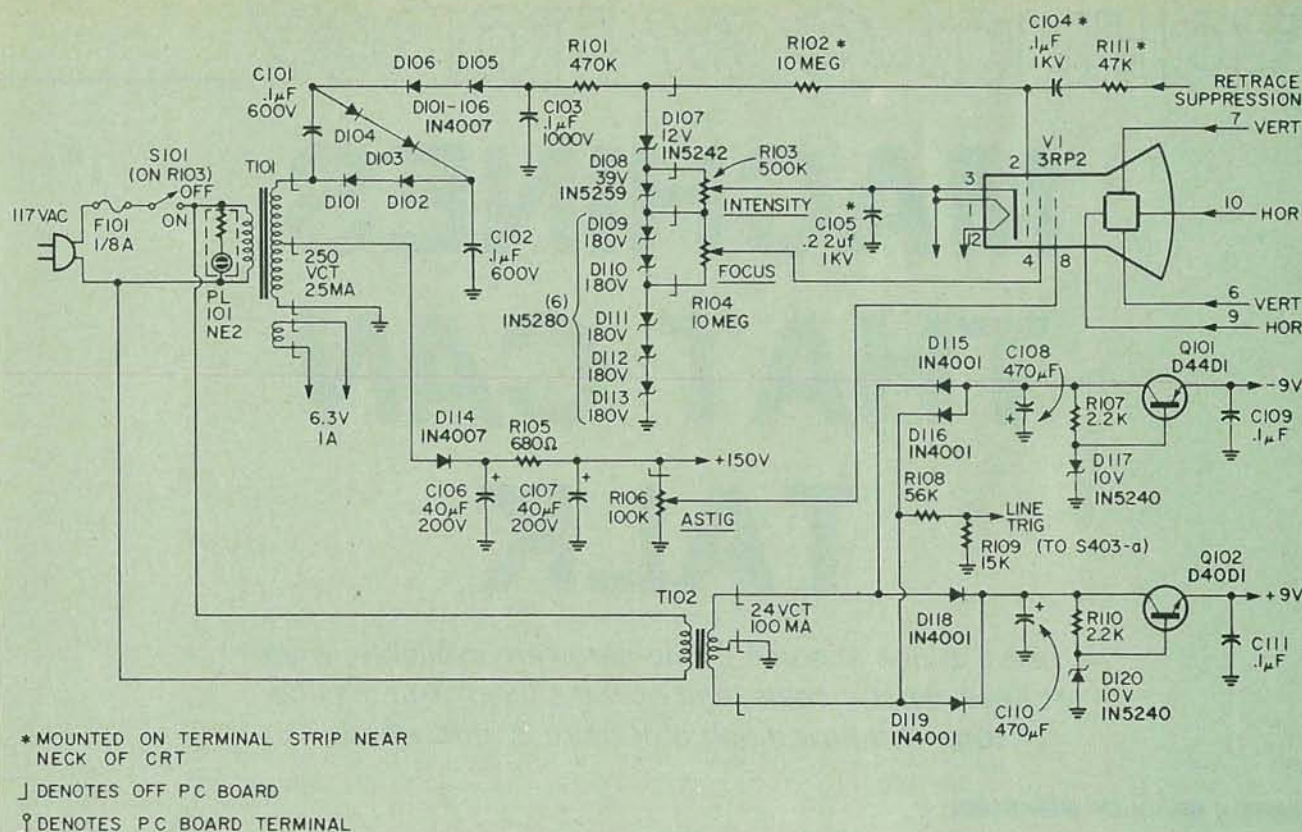

FIG. 5—THE POWER SUPPLY is simple and inexpensive to build. The voltage-tripler replaces the expensive and dangerous high-voltage power transformer used in many scopes. The string of Zener diodes replaces a high-resistance voltage-divider string.

Trigger circuits: Source-follower Q301 (Fig. 4) provides the high input impedance required during external triggering, and the low driving impedance necessary for good sensitivity of the Schmitt trigger, Q302 and Q303. The trigger will operate with 0.1 volt P-P input, and trigger up to 5 MHz with 0.3-volt P-P input. The edges of the Schmitt-trigger

output (inverted or non-inverted) are coupled through switch S302-a capacitor and C307 to the trigger input of the NE555, IC 301; that is where the negative edges are used to initiate the sweep ramps.

In the DRIVEN mode, the trigger input is held high by the +9-volt supply through R314 and triggering occurs only by nega-

PARTS LIST (Power supplies, Fig. 5)

Resistors ½ watt, 10% carbon composition unless otherwise noted

R101—470,000 ohms
R102—10 megohms
R103—500,000 ohms potentiometer with SPST switch
R104—10 megohms, potentiometer
R105—680 ohms
R106—100,000 ohms, potentiometer
R107, R110—2200 ohms
R108—56,000 ohms
R109—22,000 ohms
R111—47,000 ohms

Capacitors

C101, C102—0.1 uF, 600 volts, tubular
C103, C104—0.1 uF, 1000 volts, tubular
C105—.22 uF, 1000 volts, tubular
C106, C107—40 uF, 200 volts, axial-lead electrolytic
C108, C110—470 uF, 25 volts, radial-lead electrolytic
C109, C111—0.1 uF ceramic disc
V1—CRT, 3RP2 was used in prototype. 3EP1, 3RP1, 3BP1 and 3ACP11 can be used. See text.

Semiconductors

D101—D106, D114—1N4007

D107—1N5242 Zener diode, 12 volts, 500 mW

D108—1N5259 Zener diode, 39 volts, 500 mW

D109—D113—1N5280 Zener diode, 180 volts, 500 mW

D115, D116, D118, D119—1N4001

D117, D120—1N5240 Zener diode, 10 volts, 500 mW

Q101—D41D1 (GE) or similar PNP silicon transistor

Q102—D40D1 (GE) or similar NPN silicon transistor

F101—1/8-amp fuse

PL101—neon pilot-light assembly (NE-2 lamp with 68K resistor)

S101—SPST switch (part of R103)

T101—power transformer, 250 volts center-tapped, 25 mA; 6.3 volts, 1 amp. (Stancor PS-8416 or equivalent)

T102—power transformer, 24 volts center-tapped, 100 mA (Stancor P-8395 or equivalent)

Miscellaneous: Fuse holder, line cord, PC or perforated circuit board, hookup wire, terminal strip, MuMetal shield for CRT, CRT socket, transistor sockets, etc.

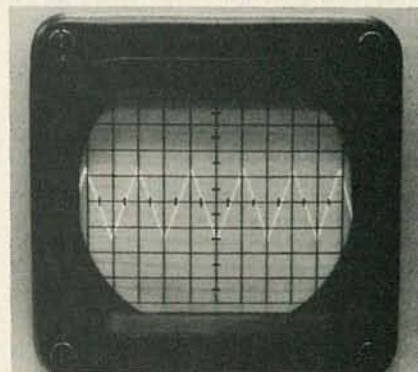

SWEEP LINEARITY is evident in this photo of a 500-kHz triangle waveform at 1 mV/div.

tive pulses from C307. In the AUTO mode, AC detectors D302, D303, and C306 furnish the positive supply as long as the Schmitt trigger is switching. However, if the trigger remains inoperative for longer than about 150 ms, C306 discharges and R316 pulls the trigger input low, resulting in automatic triggering with no input signal.

Sweep circuit: Transistor Q304 is a variable-current source that charges the selected timing capacitor (C310 through C314) at a linear rate depending on the sweep variable control and the selected timing resistor (R320 through R322). Pin 7 of the NE555 automatically discharges the capacitor whenever pin 6 rises to +6 volts. A source-follower Q305 buffers the ramp since any current drawn from it would destroy its linearity. Pot R325 reduces the ramp to 4.4 volts, thus providing 11 divisions of sweep to the 0.4 volt-per-division horizontal amplifier.

continued on page 80

MACHINES THAT CAN TALK

Here's a look at some of the hardware available; what it does, what it costs, and how it's used. You may be surprised how much of it there is, and where.

MARTIN BRADLEY WEINSTEIN

LAST TIME WE LOOKED AT THE PROBLEM of how a human voice might be synthesized, from the simplest digitized recording media to the sleeker new equipment (**Radio-Electronics**, March 1980).

The block diagram (Fig. 1) boils it all down into the most common areas of circuitry (by function) found in the more sophisticated general vocabulary synthesizers. How each function is handled varies widely from manufacturer to manufacturer, and often from product to product. But in some form or another, those elements almost always occur.

Somehow, having actual equipment to look at and talk about (eventually, to listen to) tends to make things easier to understand. So here's a brief review of the equipment available today, plus a peek at early tomorrow.

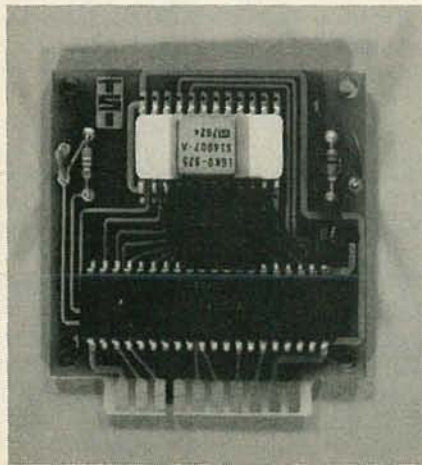

A TALKING CALCULATOR, the TSI Speech + is a most-handly device.

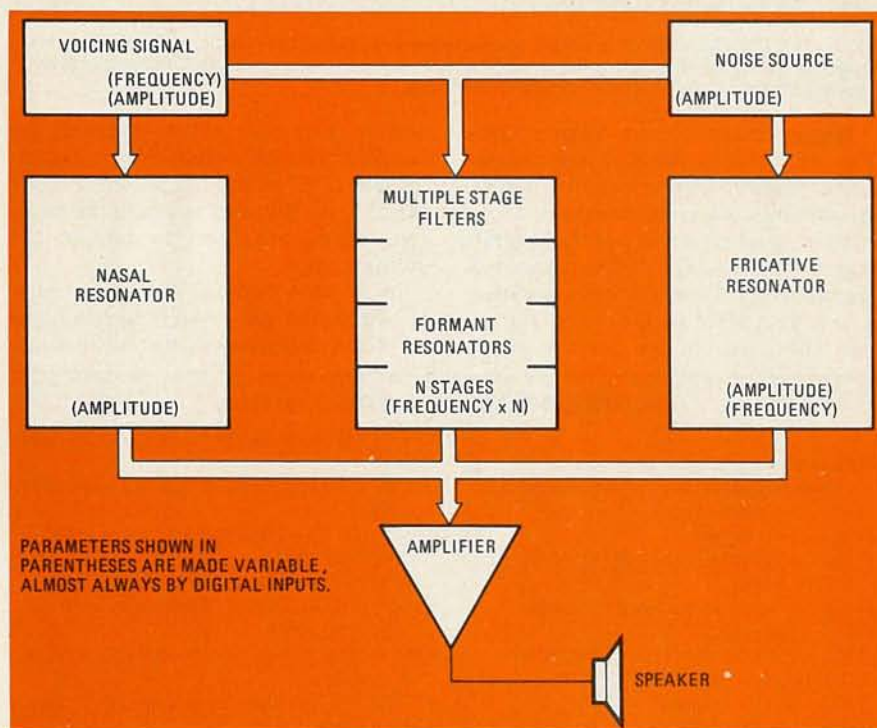

FIG. 1—BLOCK DIAGRAM OUTLINES MOST COMMON CIRCUITRY (by function) found in the more sophisticated general-vocabulary speech synthesizers.

Telesensory Systems, Inc.

Speech +[™] is a talking calculator designed for the blind and vision-impaired. In addition to operating as any normal calculator might, it offers the option of having its calculations announced by a built-in, 24-word-vocabulary speech synthesizer.

Telesensory Systems, Inc. (TSI, 3408 Hillview Avenue, P.O. Box 10099, Palo Alto, CA 94304), the manufacturer of

Speech +, offers the board—in English—for \$150. The same vocabulary is available in a small printed-circuit board module (less filters, amplifier, speaker)—in English, French or German—for \$95. And for \$179, two 64-word modules are available: one designed for announcing key hits on typewriter-style keyboards, the other for announcing electronic instrumentation readings.

Those modules contain little more than a custom MOS microprocessor



TELESENSORY SYSTEMS
model Speech +

built for TSI by General Instruments, and a ROM or two. Custom vocabularies are available to OEM's interested in large-volume purchases, and to those of us willing to invest \$200 per word for custom coding.

TSI has also announced a two-chip set of custom LSI IC's that can be applied to speech synthesis, as well as other tasks, but details are still a few months away.

Just now out from TSI is a special \$1500 speech synthesizer designed for elevators. ("Penthouse, going up.") The Elevator Voice Module includes circuitry that interfaces with the elevator controls, a speech synthesizer with custom elevator vocabulary, and the audio amplifier and speaker.

Votrax Division

Votrax Division of Federal Screw Works, (500 Stephenson Highway, Troy, MI 48084) manufactures what may be the broadest line of voice synthesizers available today.

Starting at the top of the pile, the LVM-70 Business Communicator is a fixed-vocabulary computer peripheral designed to tie into from 4 to 64 telephone lines. It offers up to 128 seconds of speech, translatable into as many as 256 individually-addressable variable-

length messages. Voice quality is excellent. That is the kind of voice/speech synthesizer often used with banks, telephone services, and "talking" computer services. Prices vary from under \$10,000 to over \$50,000, depending upon capabilities.

Working our way down the price stream, we find a generalized-vocabulary phonetic (phoneme-based) speech synthesizer capable of speaking English, German, Spanish, Italian, Japanese, French, and Farci. The key to that flexibility is an un-minimized phoneme set, including 122 selectable phonemes; in addition, each 12-bit command word permits 8 levels of inflection, or *pitch*, and 4 phoneme rates, or *duration*... yes, you can program it to speak with a



BUSINESS COMMUNICATOR model LVM-70 is a fixed vocabulary computer peripheral from Votrax.

drawl. The ML-1 Multi-Lingual Voice System doesn't come cheap (except, perhaps, comparatively, in terms of value received), with prices between roughly \$6000 and \$8000, depending on configuration, plus \$1500 for the companion keyboard and more for every



MULTI-LINGUAL VOICE SYSTEM, model ML-1, also from Votrax, speaks in seven languages, including Farci.

language after English (standard). It's well worth it, though, where multilingual capabilities are needed in conjunction with a computer, as evidenced by the success of the ML-1 in schools.

In the \$3500 to \$5000 range, the Votrax VS-6 Electronic Voice System uses 8-bit command words to select 61 phonemes and four levels of inflection; one VS-6 user has reportedly developed a vocabulary of over 300,000 words for it. While priced well beyond most hobby budgets, the VS-6 performs admirably in a number of fascinating applications, including military flight simulators,



AS MANY AS 300,000 WORDS have been developed by one user of the Votrax VS-6 Electronic Voice System.

talking instrumentation, handicapped aids, and talking OCR (optical character recognition) printed copy readers.

Votrax also manufactures the Radio Shack TRS-80 Voice Synthesizer, and includes with it software for a talking blackjack game. The user hears cards shuffling and the banter of a "wise guy" dealer.



RADIO-SHACK SPEECH SYNTHESIZER is a part of their TRS-80 personal computer system and is available as an option.

HC Electronics, Inc.

That division of American Hospital Supply Corporation (HC Electronics, Inc., 250 Camino Alto, Mill Valley, CA 94941) manufactures and distributes products for language and speech therapy. Their two speech synthesizers, *Phonic Mirror*[®] *HandiVoice*[™] models *HC110* and *HC120*, are actually manufactured for them by Votrax.

The *HC110* is a lap-size, flat device designed for young children, the handicapped, or developmentally disabled persons with speech impairments or disabilities. Most of its surface is covered by its 128-key keyboard, itself covered with one of three overlays—words, graphics, or symbols. It is pre-



HANDIVOICE HC120 is a portable device for language and speech-therapy applications.

programmed with 373 words, 45 phonemes, 26 letters (the English alphabet), 13 morphemes (standard word prefixes and suffixes), and 16 short phrases like "My name is...", "How are you?", "Would you come here?".

The *HC120*, by comparison, is a physically smaller unit that offers all the capabilities of the *HC110*, plus an additional 520 words, accessed by a 4x4 keyboard and a 3-digit control code.

Computalker Consultants

One of the least expensive, though highly capable, speech synthesizers available that is based on phonemes, yet capable of direct parameter control, is the *CT-1 Speech Synthesizer* by Computalker Consultants (P.O. Box 1951, Santa Monica, CA 90406).

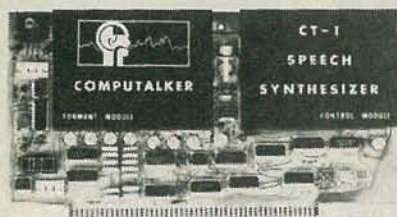

HIGH-CAPABILITY CT-1 SPEECH SYNTHESIZER from Computalker is available for the TRS-80, Apple II and S-100 computer systems.

The *CT-1* is in the \$425 to \$550 range, depending on software options, and plugs into the S-100 bus. Pre-packaged AC-powered versions for Apple II (*CT-1A*) and the TRS-80 (*CT-1T*) are available for \$595.

In the *Direct Parameter Control Mode*, signals modeled after previously-decoded words are used to recreate them. That is obviously a limited-vocabulary approach, but the naturalness of speech is especially high; even the mannerisms of the original speaker are preserved.

The *Phonetic Mode*, by comparison, is phoneme-based, but with a twist. Target values for each phoneme parameter are first located, then a smoothing-calculation performed to calculate parabolic trajectories between them. The result is less mechanical-sounding speech.

The computer hobbyist interested in experimenting with speech synthesis is strongly urged to investigate Computalker.

Also, about a year from now, expect news from Computalker about a totally digital system, replacing their current analog approach. Much of the cost of their current hardware is attributable to precision tuning and calibration of the many analog-circuit sections, a cost that the all-digital approach promises to all but eliminate.

Texas Instruments

While the TI approach to speech syn-

thesis leads inevitably to fixed vocabulary products (for the time being, at least), their expertise with high-density memories and the economies of high-volume production has yielded a group of products affordable and useful at a general-consumer level.

Speak & Spell[™] (mine cost about \$55), was introduced a couple of years ago. It conducts spelling bees and plays word games, primarily for children. (My wife and I both get a kick out of ours, though we have no children.)

New ROM modules to expand the vocabulary of *Speak & Spell* have now been introduced. *Vowel Power*[™] (recommended resale \$15) adds 140 words to help children master vowel sounds in four categories. Two new *Super Stumpers* modules (also \$15 each) for grades 4-6 and 7-8 add word lists to cover such problems as silent letters, irregular spellings, double consonants, and homonymous spellings.



TEXAS INSTRUMENTS' NEW HOME COMPUTER has a speech-synthesizer accessory available. They also use synthesizers in other products.

The heart of the Texas Instruments approach to speech synthesis is multiple-stage digital filtering and Linear Predictive Coding—a mathematical approach to modeling, analyzing, and synthesizing the human voice. While TI is producing 40,000 to 60,000 synthesizers-on-a-chip each month, their entire production output is currently going into TI products.

Two of those products are their talking *Language Translator* (about \$300, with \$60 modules to translate English, French, Spanish, German, Chinese, and Japanese) and their new *Home Computer*. The *Solid State Speech TM* peripheral (suggested resale \$150) synthesizes a 200-word vocabulary.

Who else?

Lexicon, Craig, Matsushita, and others have all admitted to "looking at" talking products. National Semiconductor has announced a one-chip synthesizer, about which little has reached us. Ohio Scientific offers a speech synthesizer of some description for their *Challenger* computers, but repeated calls to the company have resulted in no information to date.

Stay tuned. There's no telling who will speak up next. R-E

BACKYARD SATELLITE TV RECEIVER

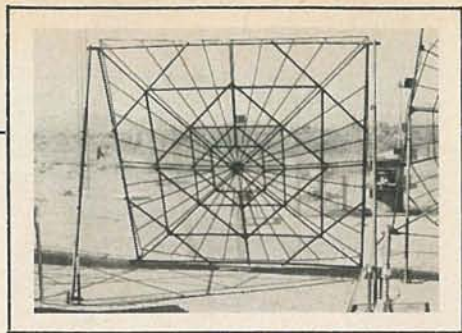

Conclusion of Bob Cooper's series on operational satellites that are relaying television programs and how we can receive their signals. This story describes receiver-system hardware and how it goes together.

ROBERT B. COOPER, JR.

IN THE PREVIOUS SIX PARTS OF THIS ARTICLE series, appearing in the August through October 1979 issues and the January through March 1980 issues, we have developed the background for the presently operational domestic and INTELSAT satellite systems that are transmitting television via satellite relay to virtually every portion of the globe. In the January and February issues, we have looked closely at the construction that is required to build your own low-cost home satellite television receiving terminal using a special spherical antenna design (February 1980 issue of **Radio-Electronics**), a single conversion 4-GHz-to-70-MHz GAAS-FET LNS plus active mixer package (March 1980 issue of **Radio-Electronics**) with an accompanying 24-channel frequency-agile tuning system.

In this seventh and final part, we will describe the 70-MHz IF-to-baseband system, and show you how to reconvert the baseband video and audio signals back to a standard NTSC-format RF carrier that can then be tuned in on your standard television receiver.

Gain at 70 MHz

In part six of this series we determined the amount of gain required between the 4-GHz feedhorn antenna receiving energy from the spherical reflector surface, and the baseband demodulator operating at 70 MHz. We determined that between 70 and 90 dB of voltage gain is required and that around 20 to 25 dB of that gain should be provided by the GAAS-FET LNA

(two stages). The amplified signal from the LNA should then drive a similar GAAS-FET active mixer converting our 4-GHz signal down to a more manageable (and comfortable!) 70-MHz IF. The balance of the gain should then be provided by the 70-MHz circuitry.

Getting gain at 70 MHz is so simple that it almost becomes a waste of space here to tell you how to get it. Here are several suggestions:

1. You need 50 dB of gain here.
2. How you get it is relatively unimportant although if you can keep the noise figure of the IF amplifier at or below 8 dB you will be much better off. (Too high a noise figure here will degrade the carefully created low noise figure from the 4-GHz to 70-MHz mixer.)
3. You may *not* need to build this IF amplifier: it may be lying over in the corner of your shop or down the street.

Virtually all of the pre-1970 era microwave equipment employed a 70-MHz IF strip, usually made up of six to ten tubes operated in cascade or cascode. Typical IF strings have 50 to 90 dB of gain (much more than you need and you'll have to cut it back) and such gear is around in surplus outlets (usually without power supply) for around \$10 an IF strip. Another source for 70-MHz IF gain is a CATV or MATV line amplifier. Typical line amps (the boards are available at local CATV firms, where they are taken out and discarded or sold as junk) have 25 to 30 dB of gain maximum and it will take a pair to get the gain you require.

However, the easiest—and perhaps for the most cheapest—way to get 50 or so dB of IF gain at 70 MHz is to investigate the Motorola AWT-120, a three-lead device that operates from near DC to around 300 MHz with 14 dB of gain with an acceptable noise figure. Four of those in series will give you 56 dB of voltage gain at 70 MHz. The AWT-120 is easy to make operate. Of the three leads, there is a ground pin, an input pin, and an output pin. The operating voltage (12 volts regulated) feeds into the output pin through a 330-ohm resistor. You couple into and out of the device through a .01 disc capacitor. Just pop four in a row on a piece of G-10 *double sided* board and you are in business. The AWT-120 costs around \$6 per device; for \$30 or so you have the full 50+ dB-gain IF strip.

Note however that our gain is spread from near DC to 300 MHz. And all we really want is the 30-MHz-wide spectrum between 55 MHz and 85MHz, centered on 70 MHz. Obviously we need some bandpass filtering in here someplace.

There are sound arguments for placing the 70-MHz bandpass filter *ahead* of the IF strip, and for placing it *after* the IF gain string. Some builders compromise and place it in the center of the string, or between the first and second AWT-120 devices. Briefly, if you place the bandpass filter ahead of the IF gain string, you run the risk of permitting a mistuned (or improperly built) 70-MHz bandpass filter to degrade the noise figure of the system. The bandpass filter will have some loss and that loss be-

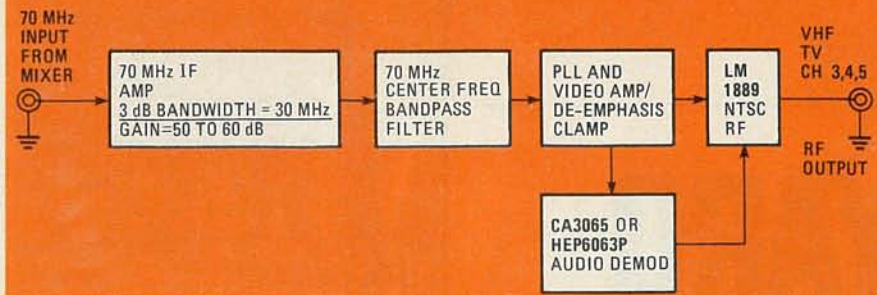

FIG. 1—BLOCK DIAGRAM shows how the 70-MHz signal from the mixer is converted to an NTSC RF output suitable for connection to the antenna terminals of your TV receiver.

comes part of the total system signal-to-noise equation. We'll describe a nearly foolproof 70-MHz bandpass filter for you shortly.

If you place the bandpass filter after the IF gain string, you run the risk of amplifying in the IF string undesirable heterodyne-produced products that may sum the desired signals coming out of the 4-GHz-to-70-MHz IF port on the mixer and causing the AWT-120 (or whatever) IF string to go into saturation. One solution is to run the AWT-120 first stage immediately after the 70-MHz IF output from the mixer, then stick in your bandpass filter, and proceed thereafter to amplify the 70-MHz signal in another three stages. We'll leave the final decision to you, noting only that we have placed the 70-MHz bandpass filter at the end of the IF string in the block diagram shown in Fig. 1.

Bandpass filter construction

There is no way we can suggest in good conscience that you will be able to construct and tune up this bandpass filter by eye or meter. You will need to run down a good CATV-type sweep generator and marker system to show you where in the spectrum you are tuning, and a detector and display. The sweep system should span the 50-to-100-MHz region as a minimum to align the bandpass filter properly.

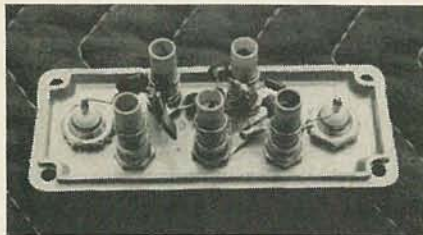

70-MHz IF BANDPASS FILTER is designed to pass a 30-MHz-wide spectrum centered on 70 MHz to provide the satellite-TV receiver with the selectivity required to separate adjacent satellite transponders.

Building the bandpass filter, shown in Figs. 2-a and 2-b, is not complicated, and if you follow the layout shown and mount the device in the Bud box recommended you won't have any problems. The coil forms, wire size, and capacitors (all are 5% dipped micas; don't substitute!) are important. If you change anything in the parts called for, you

have just entered the R and D business and you'll have to recompensate other part valves accordingly. Properly constructed, and aligned, the passband of the IF filter will be from 55 to 85 MHz, ± 3 dB at the very edges, with less than 1.5-dB insertion loss and a passband ripple of less than ± 0.5 dB from 60 through 80 MHz.

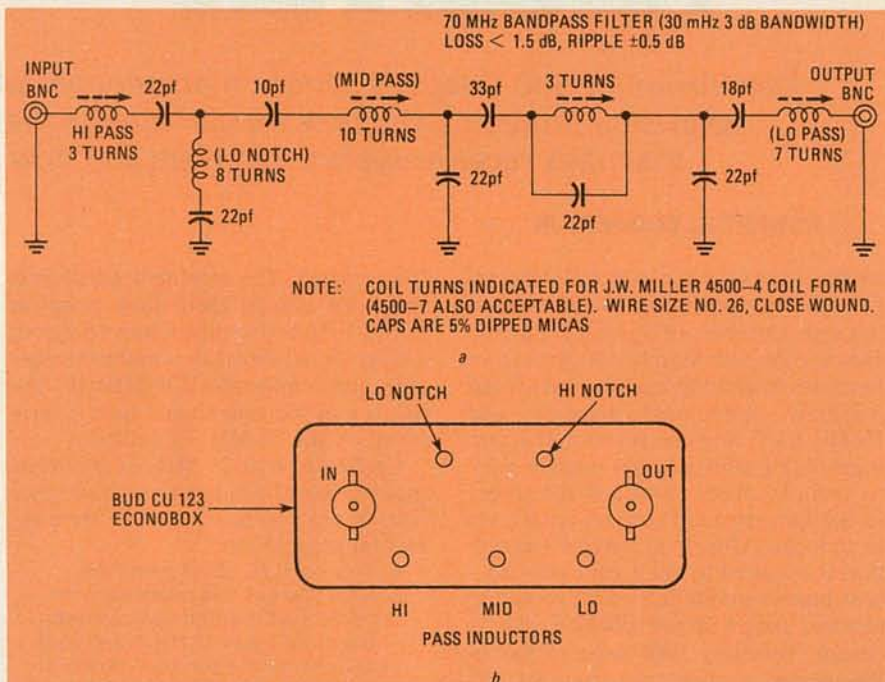

FIG. 2—70-MHz BANDPASS FILTER is relatively easy to build and is housed in a standard Bud enclosure.

PARTS LIST (70 MHz to baseband, video/audio)

Resistors $\frac{1}{4}$ watt, 10% unless otherwise specified

- R1—2200 ohms
- R2—27,000 ohms
- R3, R7; R27—1000 ohms
- R4—200 ohms
- R5, R17, R23, R28, R29—10,000 ohms
- R6—3900 ohms
- R8—R10, R12—147 ohms
- R11—41 ohms
- R13; R19—22,000 ohms
- R14—470 ohms
- R15, R16, R18—560 ohms
- R20, R21—10,000 ohms, potentiometer
- R22—270 ohms
- R24—R26—100,000 ohms
- R30—510 ohms

Capacitors

- C1, C4, C6, C15, C19—.01 μ F ceramic disc
- C2—1 μ F, 15 volts, electrolytic
- C3—100 μ F, 20 volts, electrolytic
- C5—.001 μ F ceramic disc

70 MHz to baseband

The utter simplicity of recovering good quality satellite TV video and audio becomes apparent as you study Fig. 3 (for the video) and Fig. 4 (for the audio). The secret is that you are coming into the field "late;" all of the dozen-transistor circuits worked out initially, some three or more years ago, have fallen by the wayside since clever design people such as Taylor Howard of Stanford tackled the project with an eye to reducing every section of the system to its basic required parts.

The 70-MHz IF input, following the 70-MHz IF gain-string, plugs into the input side (left hand side) of Fig. 3. The NE564 phase-locked loop makes a dandy video demodulator for this application, although note that there is this 5% warning:

The 564 is operating at the upper end

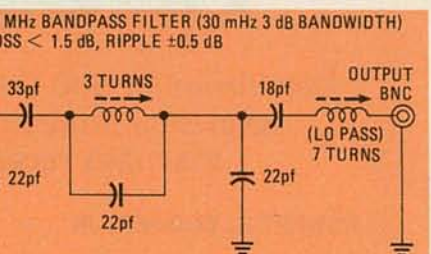

NOTE: COIL TURNS INDICATED FOR J.W. MILLER 4500-4 COIL FORM (4500-7 ALSO ACCEPTABLE). WIRE SIZE NO. 26, CLOSE WOUND. CAPS ARE 5% DIPPED MICAS

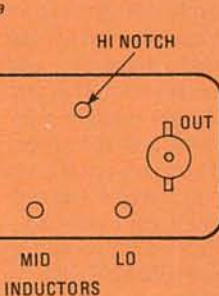

FIG. 2—70-MHz BANDPASS FILTER is relatively easy to build and is housed in a standard Bud enclosure.

PARTS LIST (70 MHz to baseband, video/audio)

Resistors $\frac{1}{4}$ watt, 10% unless otherwise specified

- R1—2200 ohms
- R2—27,000 ohms
- R3, R7; R27—1000 ohms
- R4—200 ohms
- R5, R17, R23, R28, R29—10,000 ohms
- R6—3900 ohms
- R8—R10, R12—147 ohms
- R11—41 ohms
- R13; R19—22,000 ohms
- R14—470 ohms
- R15, R16, R18—560 ohms
- R20, R21—10,000 ohms, potentiometer
- R22—270 ohms
- R24—R26—100,000 ohms
- R30—510 ohms

Capacitors

- C1, C4, C6, C15, C19—.01 μ F ceramic disc
- C2—1 μ F, 15 volts, electrolytic
- C3—100 μ F, 20 volts, electrolytic
- C5—.001 μ F ceramic disc

- C7—1.5 to 8 pF trimmer
- C8, C9—3 pF dipped silver mica
- C10—330 pF
- C11—4400 pF
- C12—91 pF
- C13—300 pF
- C14—100 μ F, 10 volts, electrolytic
- C16—1 μ F, 20 volts, electrolytic
- C17—15 μ F, 15 volts, electrolytic
- C18—300 μ F, 16 volts, electrolytic
- C20—22 μ F, 6 volts, electrolytic
- IC1—7812 voltage regulator, +12 volts
- IC2—NE564 phase-locked loop
- IC3—NE592 video amplifier
- Q1—Q3—2N2222
- D1—HP5082/2800 Schottky diode (Hewlett-Packard)
- D2—1N5248 Zener diode, 12 volts
- RFC1—100 μ H
- RFC2—2.7 μ H
- RFC3—4.7 μ H

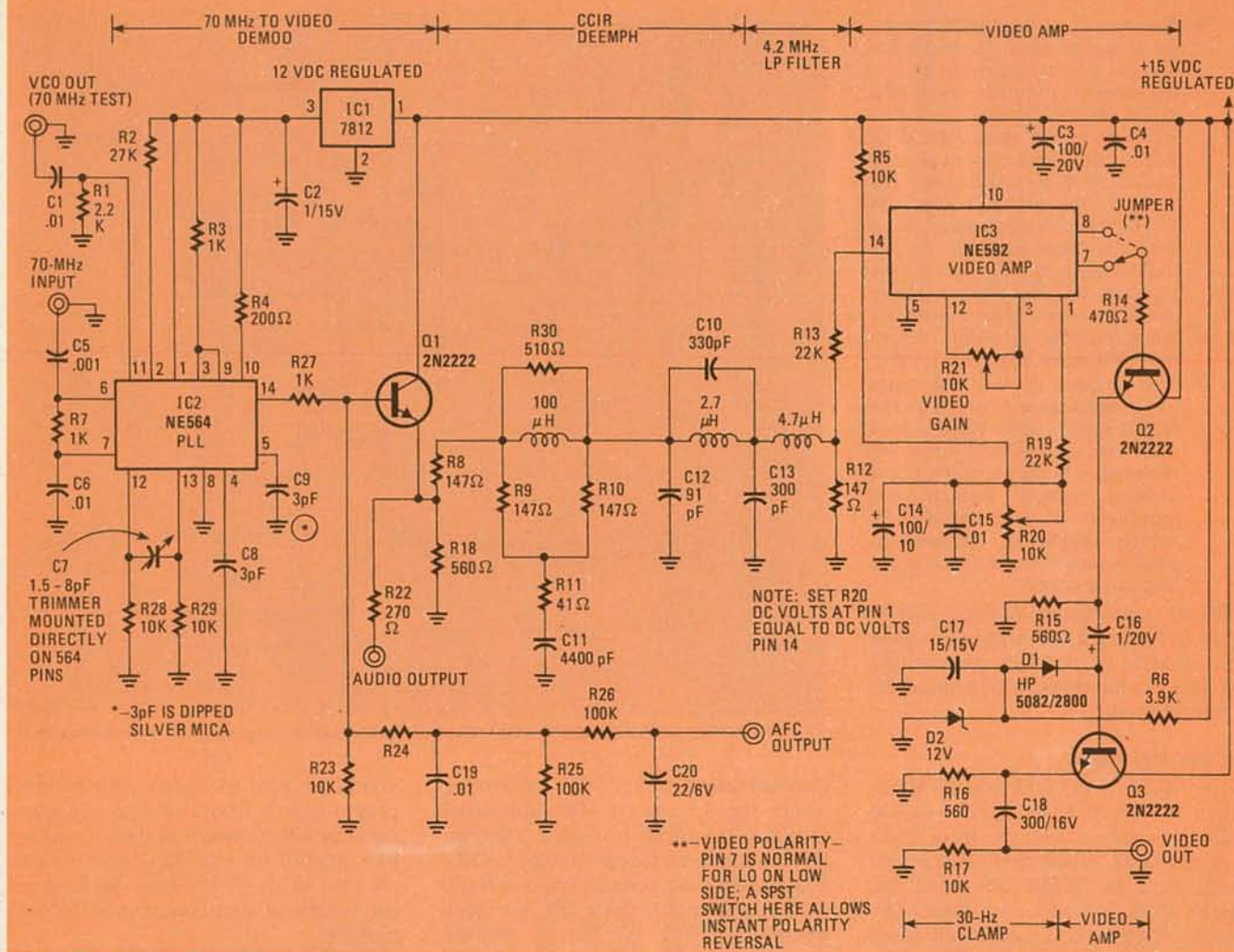

FIG. 3—BASEBAND VIDEO/AUDIO SYSTEM recovers video and audio signals from the 70-MHz output of the IF strip.

of its frequency range in this application, and you may find that some small percentage of the 564's around will not demodulate properly the video from the 70-MHz carrier. On the other hand (here's the good news), some 564's function to nearly 100 MHz. They are not touchy; several of the newer commercial receivers use the same device for this purpose and thousands of home-brewed receivers have been built using this approach.

The 564 provides video input that is amplified by a garden-variety 2N2222. Note that the audio-subcarrier comes off the emitter of the 2N2222 through a 270-ohm resistor. We'll talk about recovering the audio shortly.

Following the 2N2222 is a CCIR de-emphasis network. That's a collection of passive devices designed to establish the proper video baseband curve that matches the pre-emphasis networks used by the satellite TV transmitter on the uplink end. Without that network in place you'll get something less than true colors and will experience other video problems. Following the CCIR de-emphasis network is a 4.2-MHz low-pass filter network. This is in place to insure that the 6.2-, 6.8-, or 7.4-MHz

audio subcarrier does not get on into the balance of the video circuits. Frequencies above 4.2 MHz in the baseband region do not contribute to the video quality and in fact, if left in, will create high-frequency video noise on your baseband video signal.

Between the second 2N2222 (following the NE592) and the third such stage is a harmless-looking Schottky diode—the HP 5082/2800. That is a clamp diode. You may recall from previous sections that the uplink signals transmitted to the satellites are "frequency dithered" at a 30-Hz rate as a means of dispersing the energy waveform over a relatively wide band (36 MHz if you follow out to the 1% energy levels). That dispersal action was motivated by designers of early INTELSAT systems, who feared they might cause interference to terrestrial microwave circuits operating in the same 3.7-to-4.2-GHz region. Spreading the waveform energy out with the 30-Hz waveform reduces the probability that any appreciable amount of satellite TV downlink energy will get into any terrestrial system. To get rid of the 30-Hz waveform we shove the video into a hard clamp. The Schottky diode is fast and it clamps the 30-Hz waveform to

ground by as much as 40 dB or more. That either eliminates the 30-Hz flicker in the picture or reduces it to the point where it cannot be seen.

There are these caveats and cautions about this portion of the system:

1. Use only double-sided board; good quality G-10 board will do.
2. Mount the finished board in a container, grounding all the way around on both sides of the board. Place the 15 VDC regulated line on the backside of the board along with power supply bypasses and the 7812 regulator.
3. The 70-MHz VCO output test jack is for setting the operating frequency of the PLL to 70 MHz. Adjust the 1.5-to-8 pF trimmer (C7) for 70 MHz (a counter is handy but you could do it with the TV monitor tuning for best picture).
4. Adjust pot R20 off pin 1 of the NE592 for the same voltage on pin 1 as you have on pin 14 of the same device.
5. The AFC output shown is not totally applicable to the system you are presently building. As you get more sophisticated in using your home terminal you may wish to add an AFC system later on (as many have) and that brings it out so it is available when you wish to add the feature.

6. The output of the NE592 (pins 7 or 8) is selectable for good reason. As long as your local oscillator is driving the 4-GHz-to-70-MHz mixer on the low side (i.e. 4 GHz input frequency minus the VTO-8360 local-oscillator source equals 70 MHz) you will find the video in the proper polarity on pin 8. If you mistune and end up with the local oscillator on the high-frequency side, you'll have to swap the video output lead to pin 7 to re-establish the proper video polarity. A simple switch here will make changing simple.
7. The purpose of 10K video-gain pot between pins 12 and 3 on the NE592 is to set your video output level into your NTSC format RF modulator. Simply tune it for best looking picture, through the modulator, on your standard TV set (typically in the 1 volt peak-to-peak region if you can look at the level on a scope.)

There is absolutely nothing else to adjust or fiddle with! You have just gone from 70 MHz to relatively complicated FM video to baseband with a minimum of harrassment.

Recovering Audio

The RCA SATCOM and Western Union WESTAR birds carry their FM audio on either 6.2 or the more common 6.8-MHz subcarriers. When you demodulate the 70-MHz IF signal, the NE564 PLL recovers that higher-frequency baseband component right along with the video. We take it off after the first 2N2222 baseband amplifier and send it on to a second demodulator which is L-C tuned to the 6.2- or 6.8-MHz subcarrier frequency.

Two methods of recovering the audio are presented here. In Fig. 4 we have the basic (Taylor Howard developed) audio demodulator that uses a 2N3565 amplifier, a tuned network designed for either 6.8- or 6.2-MHz, a second 2N3565 amplifier, a (Motorola) HEP6063P demodulator (or RCA CA3065), and finally an audio amplifier. That system has seen thousands of duplications by home builders and it works just fine.

Simply tune L1 and L2 for the desired frequency (6.8- or 6.2-MHz) and then tune L3 for recovery of the audio on that frequency by simply listening on some suitable audio-display system. There is a 50K volume-control pot and those are the only adjustments that are in the system.

Figure 5 shows how to do the same thing for about \$12 for each audio subcarrier desired and perhaps 15 minutes of your time. Several satellite TV enthusiasts in the Indianapolis area, where RCA has a production facility, discovered that the RCA XL-100 audio demodulator (model PM-200) can be field-modified with a pair of capacitors to tune not the usual 4.5-MHz subcarrier

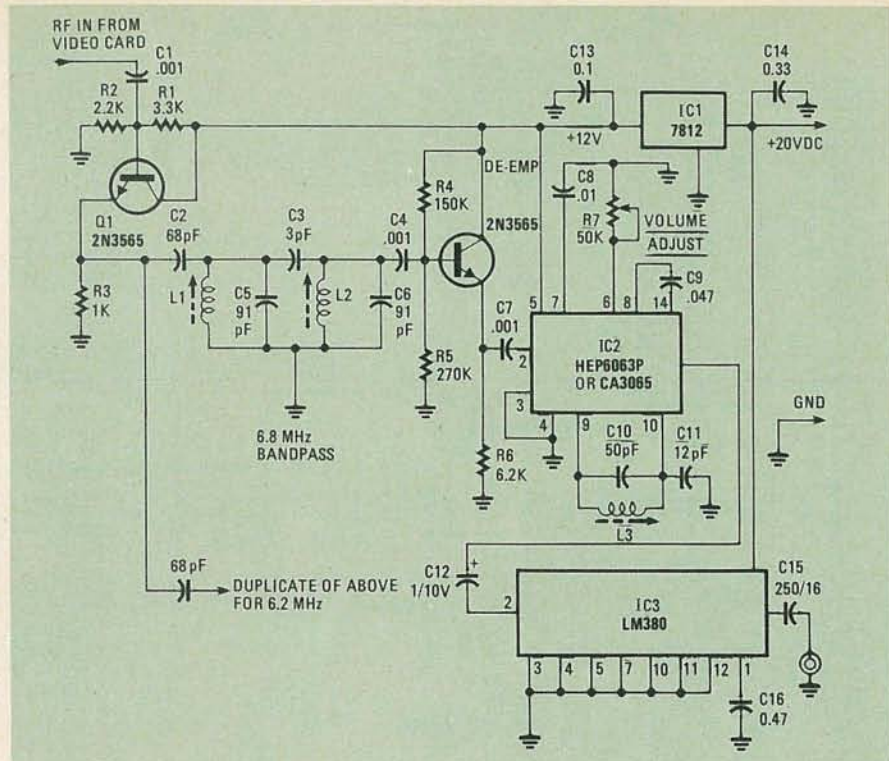

FIG. 4—6.8-MHZ AUDIO DEMODULATOR. Circuit is duplicated for recovering 6.2-MHz audio signal.

channel found in the NTSC system but rather the 6.2- or 6.8-MHz subcarrier found in the satellite system. The PM-200 is a stock replacement item for XL-100 chassis: it is a complete module ready to hook up and operate (RCA's stock number is 130-753). You go into the module and add capacitors C1 and C2 (both 33 pF to hit 6.8-MHz) as shown. Input is through pin 3. As noted, the cost of this module (new, through an RCA parts house) is in the \$12 range.

Once again, recovering the satellite audio is not much of a trick.

Modulating to NTSC

Now that you have the baseband video and audio displayed on a color-video monitor and audio system, it

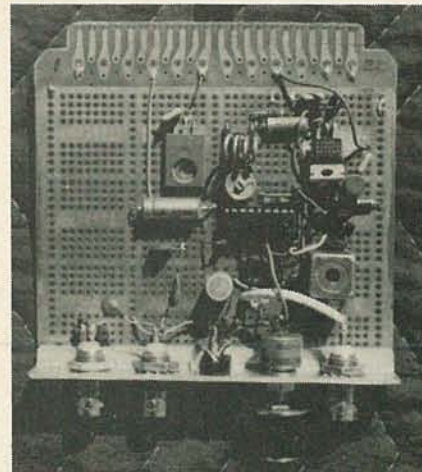

RF MODULATOR construction followed by do-it-yourself satellite-TV enthusiasts. This module is the RF modulator described in the text using the LM1889 IC device.

would be nice to watch your favorite programming from satellite programs on your TV receiver. In fact, if you are like most of us, you don't own a video monitor in the first place. So let's get the baseband signal back to NTSC format RF.

PARTS LIST (Audio demodulator, Fig. 4)

Resistors ¼ watt, 10% unless otherwise noted

- R1—3300 ohms
- R2—2200 ohms
- R3—1000 ohms
- R4—150,000 ohms
- R5—270,000 ohms
- R6—6200 ohms
- R7—50,000 ohms potentiometer

Capacitors

- C1, C4, C7—.001 μ F
- C2—68 pF dipped mica
- C3—3 pF dipped mica
- C5, C6—91 pF dipped mica
- C8—.01 μ F
- C9—.047 μ F
- C10—50 pF dipped mica
- C11—12 pF dipped mica
- C12—1 μ F 10 volts, electrolytic
- C13—0.1 μ F
- C14—.33 μ F
- C15—250 μ F, 16 volts, electrolytic
- C16—.47 μ F

Q1, Q2—2N3565

IC1—7812 voltage regulator, +12 volts

IC2*—HEP6063P or CA3065

IC3*—LM380

L1, L2—adjustable RF coil, 3—7 μ H (J.W. Miller No. 9051)

L3—adjustable RF coil, 7—14 μ H (J.W. Miller No. 9052)

*Note: The RCA CA3134GM can replace the CA3065/LM380 combination

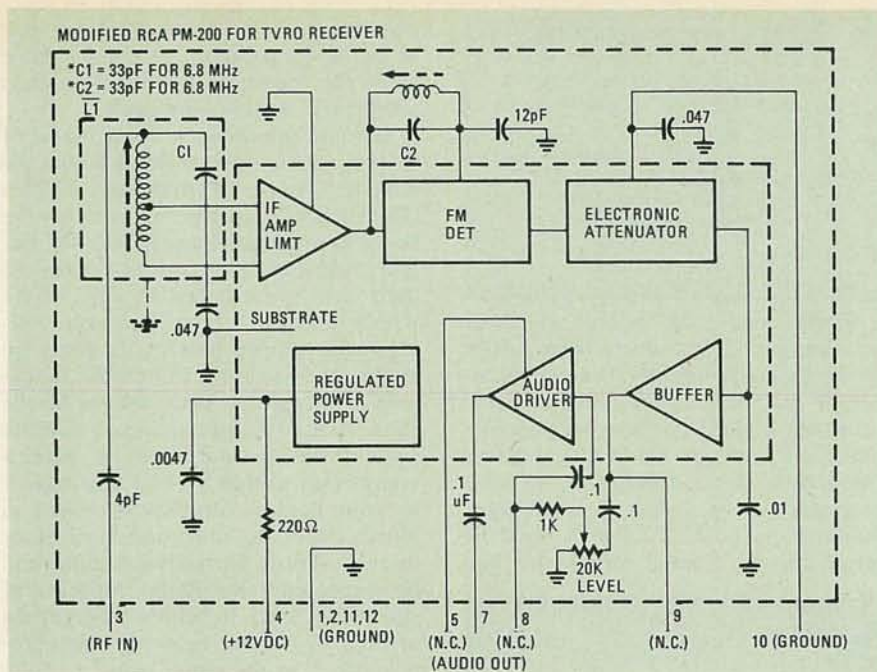

FIG. 5—ALTERNATE APPROACH to subcarrier audio detection uses a standard module from an RC TV receiver.

If you own a video-tape recorder, you already have a modulator. Simply connect the video output of the satellite receiver to the video input jack on the VCR, the AUDIO OUT to the AUDIO IN, and switch the VCR to CAMERA INPUT.

Now run a piece of RG-59/U coaxial cable from the output of the VCR to your TV receiver(s). And the satellite signals will appear on the modulated channel determined by the VCR modulator switch (typically Channel 3 or 4).

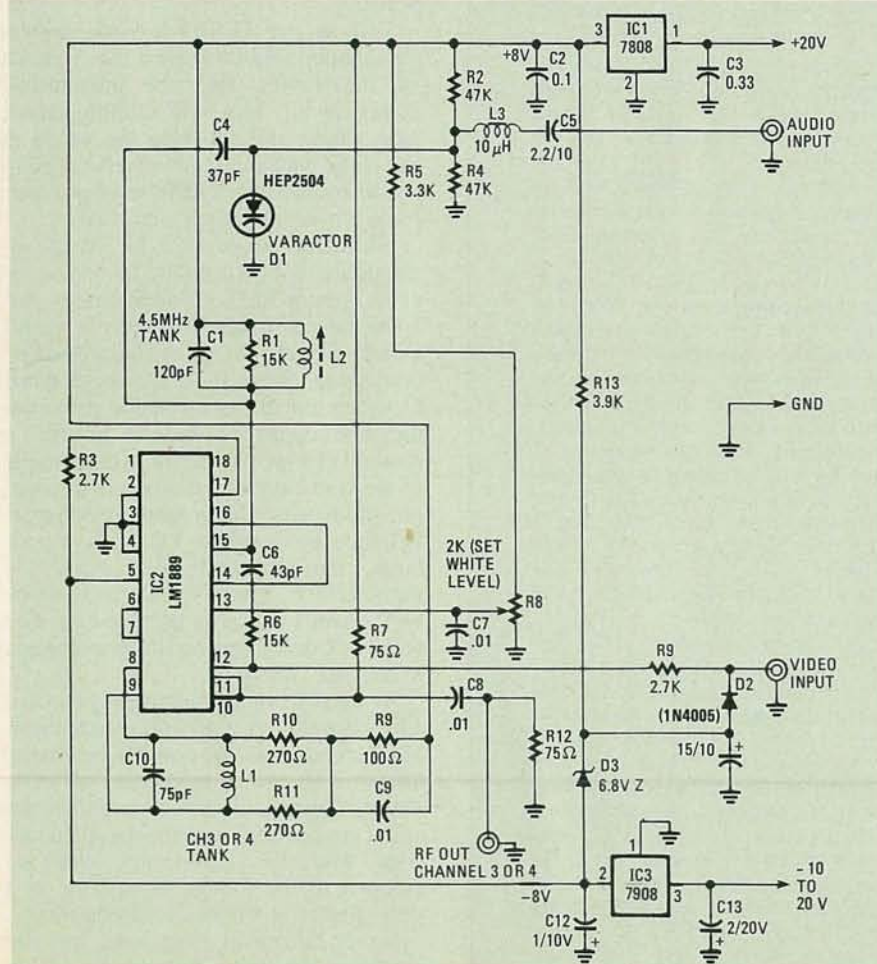

FIG. 6—NTSC RF MODULATOR for Channel 3, 4, or 5.

If you don't have a VCR, you'll need to build, or buy, your own video RF modulator. The most common RF modulator used by satellite TV enthusiasts is shown in Fig. 6. This system uses the LM1889 IC that is really a miniature TV transmitter disguised as an IC. The LM1889 device (or something very similar) is found in dozens of TV games, VCR modulators, computer modulators, and so on. The 1889 is available from firms such as Poly-Pak, usually for under \$5.00. A complete modulator kit, using the LM1889 is available (model PXP-4500) for around \$25 (ATV Research, 13-B Boardway, Dakota City, NB 68731).

The schematic in Fig. 6 shows what is involved. Coil L2 establishes the 4.5-MHz sub-carrier for the audio in a tuned network and a 2K pot connected to pin two of the 1889 establishes the saturated white level for the video. Although the schematic establishes tuning procedures (off pins 8 and 9 of the 1889) for Channel 3 or 4, many people have also found that the system will function on VHF TV Channel 5 as well, by adjusting the tank circuit accordingly.

A modulator such as this is capable of putting out around 10,000 microvolts of maximum signal (3,000 is more typical). That is more than enough RF voltage to drive through several hundred feet of RG-59/U coaxial cable into, perhaps, as many as a half dozen TV receivers con-

PARTS LIST (RF-modulator, Fig. 6)

Resistors 1/4-watt, 10% unless otherwise specified.

- R1, R6—15,000 ohms
- R2, R4—47,000 ohms
- R3, R9—2700 ohms
- R5—3300 ohms
- R7, R12—75 ohms
- R8—2000 ohms potentiometer
- R9—100 ohms
- R10, R11—270 ohms
- R13—3000 ohms

Capacitors

- C1—120 pF dipped mica
- C2—0.1 μ F ceramic disc
- C3—33 μ F ceramic disc
- C4—37 pF dipped mica
- C5—2.2 μ F, 10 volts, electrolytic
- C6—43 pF dipped mica
- C7—C9—.01 μ F ceramic disc
- C10—75 pF dipped mica
- C11—15 μ F, 10 volts, electrolytic
- C12—1 μ F, 10 volts, electrolytic
- C13—20 μ F, 20 volts, electrolytic
- IC1—7808 voltage regulator, +8 volts
- IC2—LM1889 TV video modulator
- IC3—7908 voltage regulator, -8 volts
- D1—HEP2504 varactor diode (Motorola)
- D2—1N4005 diode
- D3—Zener diode, 6.3 volts
- L1—tank coil, .08 μ H (3 turns No. 16 wire air-wound 1/4" ID, 3/8" long)
- L2—adjustable RF coil, 7—14 μ H (J. W. Miller type 9052)
- L3—10 μ H molded RF choke

nected to the system through appropriate 75-ohm splitters and taps.

Power supply

There is little to be said about the system powering that is not obvious in the schematics. The total power drain will be in the 1/2-ampere range at the master supply level of 20 volts. Regulation, where noted, is very important. Pure DC, well filtered, is very important. Protection of the satellite TV receiver, from line glitches is also very important. If you live in an area where you have erratic AC line service, invest a few dollars in some fast-acting devices so that AC line spikes and surges don't eat up your relatively delicate 4-GHz parts. Saving \$10 on the master power supply may cost you a \$100 GAAS-FET, so use a good, stiff, regulated supply.

SATELLITE TV REPRINTS

A booklet containing reprints of all seven articles in the series on Backyard Satellite TV Receivers by Robert B. Cooper, Jr. is available by sending \$5.50, including first-class postage, to:

Satellite TV Reprints
Radio-Electronics
45 East 17th St.
New York, NY 10003

New York State residents must include 8% State Sales Tax.

Satellite television has been called the new frontier of electronics. There is little doubt that a proliferation of communication satellites in the geostationary orbit will change the way we perceive ourselves and our world neighbors in the decade ahead. Heretofore we have been able to keep control of our individual nationalistic goals through a flood of programming created largely by our

own countrymen. What we have seen of Brazil, for example, or Zambia, have been the views of our own program producers, writers, and actors.

Satellite television is changing all of that: a trickle now, a flood within the next ten years. International satellites (INTELSAT) already in operation are beaming programs from Brazil, Zambia, and dozens of other nations not only to their own citizens but to 40% of the whole globe at a time. Regional satellites with shaped antenna patterns are spilling the programs from India, for example, throughout Africa and the Middle East. A Russian geostationary satellite system called Stasionar is nearing completion so that by 1981 you may sit in your home—virtually any place in North America—and tune in Moscow directly. Those Stasionar satellites can be expected, like Radio Moscow of shortwave fame, to become instruments of their operators, beaming video propaganda over the entire globe.

Satellite receiving hardware is a new, business still struggling between the first \$50,000 INTELSAT receivers and what will become ultimately (perhaps soon) \$1,000 receivers sold through electronic emporiums. By 1990, satellite television will be a household word and \$250 receiving systems will proliferate into every book corner of the world.

Just as our U.S. television system has shaped and re-shaped the America of the 1940's into the present-day America, so, too, will satellite television shape and re-shape the world of the early 1980's into an entirely different world by the year 2,000; some say perhaps ten years sooner than that.

Until October of 1979, for private individuals to own satellite television receivers here in the United States was something of a misdemeanor. It wasn't clearly illegal, but wasn't approved by law either. Since the FCC decided last October that private satellite terminals did not require a federal license, a marked change has begun in the attitude of electronic hardware suppliers throughout the world. Suddenly there is a marketplace for satellite TV gear—a very large, national and even worldwide marketplace. That FCC decision alone will result in dozens of receiving-system packages entering the marketplace in the year ahead.

As an electronics enthusiast you have a leg up on the rest of your countrymen. You have a head start on this new technology and, for a few years at least, your expertise in that area will make you a special person with special knowledge—and the opportunity either to enjoy it to the fullest, or cash in on a very attractive business opportunity.

Never before in electronics has the sky been the limit. Never before have we had satellite television available. R-E

LEARNING MORE ABOUT SATELLITE TV

If you are fascinated by the rapid development of satellite television as a worldwide video communications system, some of the following reference materials may be of interest to you:

Satellite Study Package—A thorough study of how the satellite system works, what the individual elements of a successful satellite TV receiving system are, how they work, and what they do. Includes a 72-page book written by Bob Cooper that explains in lay terms just what the satellite TV revolution is all about. Includes reference section with dozens of other study materials sourced. Also includes 22 × 35-inch four-color, two-sided wall chart depicting the presently operating international network of geostationary communication satellites, where they are, and what their operational parameters are. Price is \$15 for first class mail delivery in U.S. and Canada, \$20 (in U.S. funds) elsewhere from: Satellite Television Technology, P.O. Box 2476, Napa, CA 94558.

Satellite Seminar—The third in a series of *Satellite Private Terminal Seminars*; scheduled for mid-June in the San Francisco Bay Area of California. Three days of lectures; classroom instruction taught by leading designers of low-cost satellite TV systems. A combination of "how to do it yourself" featuring the latest state-of-the-art technology and "entering the satellite TV business" sessions. Two early seminars (Oklahoma in August, 1979, Miami, Florida this past February) were total sell outs, so advance registration is a must. For complete details contact: SPTS '80/California, P.O. Box G, Arcadia, Oklahoma 73007.

Construction Manuals—A series of three manuals describing the construction of (1) the *Swan spherical TVRO* multi-satellite antenna, (2)

Coleman TD-2 conversion Satellite TV Terminal, and (3) *Howard Terminal Receiver*. Swan's manual takes you into the satellite TV antenna world for less than \$300—cost for a very effective 10 × 10 foot antenna that features the unique ability to receive up to 9 separate satellites with one antenna in a fixed position. The *Coleman TD-2* manual covers conversion of surplus (inexpensive) microwave equipment to satellite TV reception, plus illustrates new low-cost microwave technology for home builders. The *Howard Terminal Receiver* manual describes 24-channel frequency-agile, double conversion receiver, LNA and feed antenna system that can be duplicated for under \$800. Price per manual is \$30, all three for \$80 (U.S. funds) from Satellite Television Technology, P.O. Box G, Arcadia, Ok. 73007.

Monthly Publication—A "nuts and bolts" monthly publication aimed squarely at explaining the construction of low-cost terminals, satellite operations, and the business of selling and installing private satellite TV terminals. Price for *Coop's Satellite Digest* is \$50 per year in U.S. and Canada, \$75 (in U.S. funds) elsewhere via first class mail from: Coop's Satellite Digest, P.O. Box G, Arcadia, Ok. 73007.

Circuit Boards—A series of circuit boards are available for virtually all portions of the satellite TV receiver described in this series. Circuit board *IF-70A* provides the circuit necessary to create your own 70-MHz IF strip as described here, using the Motorola ART-120 device. Circuit board *DEM0D-TVRO* provides the layout for the 70-MHz-to-baseboard demodulator circuits described in this issue. For price and delivery contact: Robert M. Coleman, RFD 3, Box 58-A, Travelers Rest, SC 29690.

PORTABLE ELECTRONIC ORGAN

If you don't play a keyboard instrument but would like to learn, you might consider starting out on one of the two simple easy-to-build organs described here. One plays melody; the other also plays chords.

I. QUEEN

MUSIC IS A POPULAR AND SATISFYING HOBBY, judging by the continuing sales of hi-fi equipment, FM receivers, tapes and discs. Listening to music is a pleasure, but playing your own instrument can be doubly satisfying and challenging. After experimenting with several types of audio oscillators and construction plans, I completed a simple organ that measures $14 \times 4\frac{1}{2} \times 1\frac{1}{2}$ inches and plays $2\frac{1}{2}$ octaves. It uses a single oscillator and can play any melody. This instrument was so successful that I then constructed a more sophisticated model that can play *chords* as well as the melody. This one covers 3 octaves. We'll take a look at how to build both models.

Playing an organ

It is amazing how quickly one can learn to play an organ, especially with the help of books written for piano beginners. First, we will give some simple music theory for those readers who are not familiar with it.

The human ear is a sensitive detector of frequency ratios. For example, it easily recognizes a ratio of 2:1. The higher frequency is said to be one *octave* above the other. Since piano and organ keyboards cover an extensive range of frequencies, let's use an octave as a convenient interval of sound. Each octave is divided into 12 equal geometric steps, each step representing a change of about 6%.

The keyboard is arranged so that a musician can distinguish and identify a particular key out of the 12 in each octave. The keys are arranged in 2 rows:

one with seven white keys, the other with five black keys forming a pair and a trio (See Fig. 1). A letter of the alphabet, from A to G, is assigned to each of the seven white keys. The word "sharp" (written as #) may be applied to a black key to indicate one step *higher*. For example, F# is one step above F. Sometimes it is more convenient to use the word "flat" (shown as b) to indicate a black key that is one step *lower*. For example, Bb is one step below B. Obviously, A# and Bb refer to the same black key.

keys. Key caps are sold that mate with the key switches.

Radio Shack has sold individual calculator keys, and some stores may still stock them. They are fairly good and can be cemented down on any flat surface.

(Neither of the switches we used are currently available from Poly-Paks or Radio Shack but you are sure to find suitable substitutes if you keep an eye on ads and catalogs from surplus parts dealers. Any SPST pushbutton switch can be used provided it is large enough to be comfortably used in a keyboard. Simply

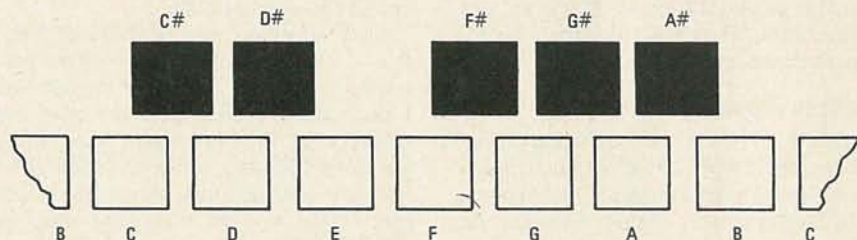

FIG. 1—HOW KEYS ARE ARRANGED on the home-built organ. You can salvage individual keys from an old electronic calculator or purchase them from a surplus parts dealer.

An inexpensive keyboard can be constructed with individual calculator keys, approximately $\frac{3}{4}$ -inch square, that you can take from an old calculator, or purchase from a surplus parts dealer.

Poly Paks for instance has carried switches that are easy to operate, and have low resistance. They come in sets of 4 switches, one of which is a dummy switch without leads. You can remove the inoperative switch and substitute a good one from another set. A set of 4 switches can also be sawed apart to make a group of 2 or 3, which are needed for the black

modify the switch mountings and organ housing to match the switches you use.—*Editor*)

Building the organ

The top and bottom of the organ are made of three-ply wood, held in place by aluminum supports at the front and rear, as shown in Fig. 2. Two L-shaped lengths of aluminum that are held together with machine screws form each U-shaped support. The aluminum comes in 6-foot lengths and measures 1 inch on each side. It is readily available in hardware stores.

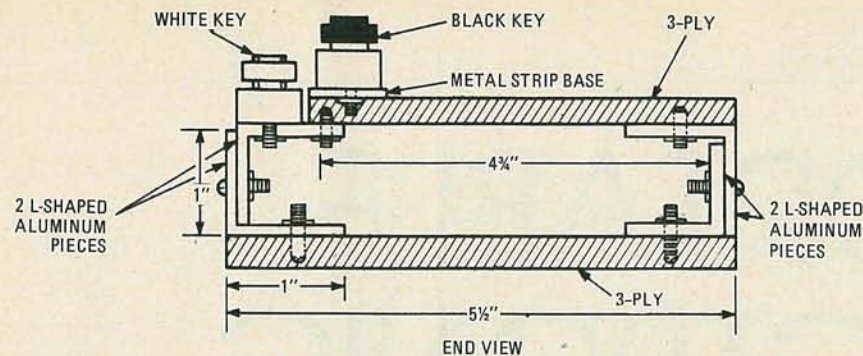

FIG. 2—PUTTING THE ORGAN TOGETHER. Drawing shows mechanical cross-section. Keys are mounted so the black ones are higher and farther back than the white ones; as on a piano keyboard.

For a 3-octave range, the length of the organ should be about 18 inches.

Note that the top of the organ is narrower than the bottom. This allows you to use a convenient metal base to the white keys right in front. The black keys should be slightly behind and somewhat higher than the white ones. Some types of keys have a flat bottom and are made to be cemented onto any flat surface. The Poly Paks key sets came with No. 2-56 screws extending from the bottom. With No. 2-56 hex nuts, I mounted the sets on a metal strip, since the screws are not long enough to pass through the plywood. Then, the metal strip was mounted on the plywood, with the aid of machine screws. Use a strip about three inches long to hold 3 black keys, and another strip about 2 1/4 inches long for 2 black keys.

Below each key, drill holes for the leads to pass through to the terminals.

Mount the power and the output jacks, as well as the volume control, on the rear metal panel.

To build either organ model, you must have a frequency meter that can measure to about 100 Hz. It is suggested that you construct the simpler organ first to get the feel of playing music. If you are still enthusiastic about playing, then go for the more difficult organ.

Melody organ

In Fig. 3, IC1 is a VCO (Voltage-Controlled Oscillator) whose output frequency varies with the voltage applied to pin 8. The frequency is minimum when the pin is connected *directly* to the positive (+) terminal of the power supply. As R2 increases, so does the frequency. With a 9-volt supply, the minimum frequency is about 130 Hz.

Oscillator IC1 generates three output waveforms: a sine wave (pin 2), a square wave (pin 9) and a triangular wave (pin 3). (The latter waveform is not used.) The squarewave output is sufficient to drive a 45-ohm speaker directly at J1. The sine wave has a pleasing tone, and can drive a high-impedance earphone at J2 or drive an external amplifier. An internal amplifier, IC2, is provided however. The output at J3 is greatly attenuated for a tape-recorder.

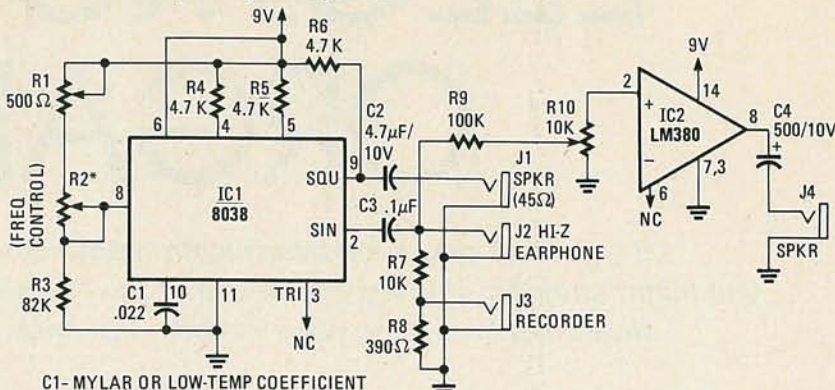

FIG. 3—SIMPLE MONOPHONIC ORGAN plays melodies—one note at a time. Circuit is based on IC1, a voltage-controlled oscillator tuned by the value of resistor R2.

Actually, R2 must be varied in steps for organ music, as shown in Fig. 4. Each resistor is selected to tune to the required frequency when the corresponding switch is closed.

To calibrate the organ, let IC1 warm up and connect a frequency meter at J2. Set R_A for the lowest tone to be played when S_A is closed. In the instrument I built, it is the key of F (175 Hz). Now, select R_B to play the next higher tone when S_B is closed, and so on up the scale. Table 1 lists the frequencies at the low end of the musical scale.

Each resistance in the series, R_B, R_C, R_D, . . . increases gradually over the preceding resistance. The first four resistors I used are 82 ohms each, the next five resistors are 100 ohms each. Then, there are three 120-ohm resistors, followed by four 150-ohm resistors, etc. At the upper end of the musical scale, the resistors should be about 300 ohms each. Try for a frequency accuracy of about 0.5% or better. If your resistors are in smaller increments—such as 82, 91, 100, 110, etc.—you can achieve higher accuracy. To reach a desired value, you can connect two resistors in series. Use terminal strips to hold resistors, or solder them directly to each other and to the keys. Hook the ends of resistors to hold them more securely.

Oscillator IC1 is very sensitive to changes in voltage. You must use either a regulated power supply or batteries. If required, R_A can be used to retune the organ to some extent. The socket of IC1 can easily be mounted on a socket adapter

TABLE 1

C _♯	139 Hz	G	196 Hz
D	147 Hz	G _♯	208 Hz
D _♯	156 Hz	A	220 Hz
E	165 Hz	A _♯	233 Hz
F	175 Hz	B	247 Hz
F _♯	185 Hz	C	262 Hz

See Fig. 6 for higher tones. Frequencies in Hz.

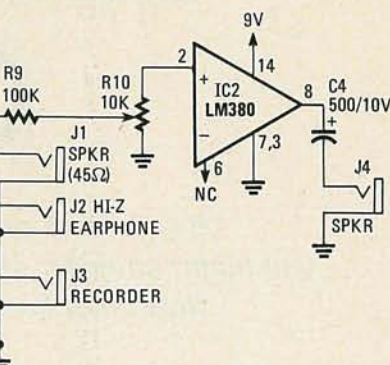

FIG. 4—HOW KEYS ARE WIRED to switch in different resistors to tune the VCO.

PARTS LIST FOR MELODY ORGAN

Resistors are 1/4 watt, 5%
 R1—500 ohms, potentiometer
 R2—calibrating resistors (see text and Fig. 4)
 R3—82,000 ohms
 R4—R6—4700 ohms
 R7—10,000 ohms
 R8—390 ohms
 R9—100,000 ohms
 R10—10,000-ohm potentiometer
 C1—.022 μF, Mylar or low-temperature coefficient
 C2—4.7 μF, 10 volts, electrolytic
 C3—0.1 μF, disc
 C4—500 μF, 10 volts, electrolytic
 IC1—8038, voltage-controlled oscillator
 IC2—LM380 audio amplifier
 J1—J4—miniature jacks
 Misc.—sockets for audio amplifier, keys (12 per octave), plywood, aluminum supports, hardware (see Fig. 2).

Table 2
(Frequency mHz)

		Oscillator					
		1	2	3	4	5	6
1st octave	B	247	C± 277	D± 311	F 349	G 392	A 440
	C	262	D 294	E 330	F± 370	G± 415	A± 466
2nd octave	B	494	C± 554	D± 622	F 698	G 784	A 880
	C	523	D 588	E 660	F± 740	G± 830	A± 932
3rd octave	B	988	C± 1108	D± 1244	F 1397	G 1568	A 1760
	C	1046	D 1176	E 1320	F± 1480	G± 1661	A± 1865

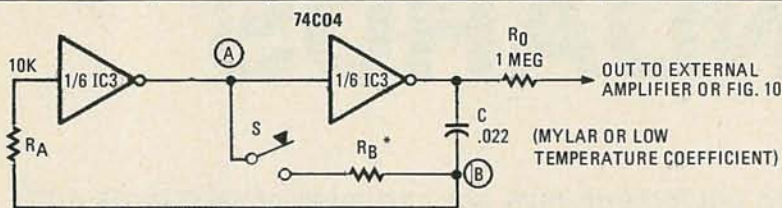

*R_B IS SHOWN IN MORE DETAIL IN FIG. 6 AS A SERIES OF 6 FIXED RESISTORS.

FIG. 5—ONE OF SIX OSCILLATORS based on a pair of CMOS inverters. The instantaneous frequency is determined by the value of resistor R_B.

WHAT IS A CHORD?
It is a combination of 3 or more simultaneous tones that harmonize and enhance the playing of a melody. The ear is a sensitive frequency ratio detector. The octave (2:1) was mentioned earlier. If you call any note of an organ, 1, and count half-steps upwards, you can show that the pair, 1 and 3, bear the ratio 9:8. Other pairs (and ratios) are: 1 and 4 (6:5), 1 and 5 (5:4), 1 and 6 (4:3), 1 and 8 (3:2). If the 4 notes; 1, 4, 6, 10, are played, it is called a "seventh chord" and combines the following pairs: 1 and 4, 1 and 6, 1 and 3, 1 and 5. The pair, 4 and 6, plays the same frequency ratio as, 1 and 3, since both have the same interval of 2 half-steps. A "major chord" is played, 1, 6, 10. Many other chords, and variations of them, are played in organ and piano music.

ent values of R_B, each with its own switch (See Fig. 6).

PARTS LIST FOR MELODY AND CHORD ORGAN

- Resistors are 1/4 watt, 5%
- R_A—10K (6 resistors, 1 for each oscillator)
- R_B—Calibrating resistors, selected by trial (see Fig. 6 and text)
- R₀—1 MEG (6 resistors, 1 for each oscillator)
- C—.022 μF Mylar (6 capacitors, 1 for each oscillator)
- Misc.—pair of 74C04 CMOS hex inverters (for building 6 oscillators as in Fig. 5); sockets for inverters; terminal strips for resistors; and plywood, aluminum, hardware, keys, as for organ 1.

(Radio Shack 276-024). I used a small piece of PC board to hold the socket of IC2.

Chord and melody organ

This organ is superior in several ways: It not only plays the melody but also plays chords and contains 3 octaves. It is more stable with respect to frequency and voltage. The IC's consume less power and are less expensive. A disadvantage is that the calibrating resistors vary over a wide range of values, and so are more difficult to select. You may need two or three resistors in series to achieve a desired value. An accurate calibration is desirable since errors are more noticeable when you play chords.

To play chords and melody over three octaves, it at first would appear that we need 36 oscillators, and this thought is unbearable! However, we can simplify. Each oscillator is responsible for two adjacent musical tones (called half-steps), as for example A and A±. Half-steps are seldom, if ever, played together. This cuts the required number of oscillators by half. Another simplification is to make each oscillator responsible for its own half-steps in all octaves. You cannot play the same note in more than one octave.

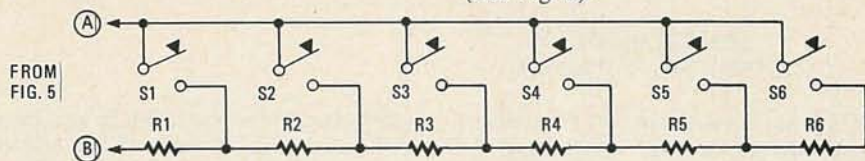

FIG. 6—THE CHORD ORGAN has six monophonic oscillators to cover three octaves. Each oscillator is tuned to six notes selected by the key arrangement shown.

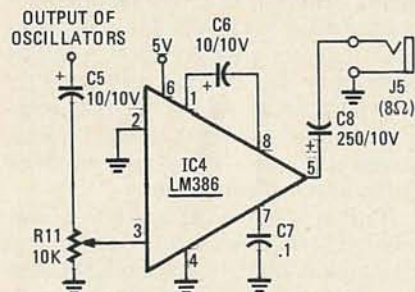

FIG. 7—SCHEMATIC DIAGRAM of the simple power amplifier used in the chord organ.

PARTS LIST FOR AMPLIFIER

- R11—10,000 ohms, potentiometer, 1/4 watt, 5%
- C5, C6—10 μF, 10 volts, electrolytic
- C7—0.1 μF, 10 volts, disc
- C8—250 μF, 10 volts, electrolytic
- J5—miniature jack
- IC4—LM386

Table 2 shows how six oscillators cover three octaves.

A typical oscillator is shown in Fig. 5. This oscillator is very stable with respect to voltage and temperature. It uses a pair of CMOS inverters operating at 5 volts. One hex inverter such as the 74C 04 can be used to make three oscillators. With R_A and C fixed, the frequency depends only on R_B. A larger R_B means a lower frequency. Of course, the voltage applied to the inverter must remain constant. This oscillator can generate only one frequency at a time. For six different frequencies, you must provide six differ-

Calibration

To calibrate the organ, begin with the oscillator 6. Referring to Table 2, select R1 for 1865 Hz when S1 is closed. Then, select a value for R2 to play 1760 Hz when S2 is closed. Next, select R3 to play 932 Hz when S3 is closed, and so on. Similarly, proceed with oscillator 5 and the remainder, observing the frequency meter for correct frequencies. Don't try for an exact frequency in each case, but accuracy should be well within 0.5%. You may need two or even three resistors in series to reach the desired value. Here are the approximate values for the resistors shown in Fig. 6:

Resistor R1 is about 10,000 ohms for oscillator 6; about 12,000 ohms for oscillator 5; 14,000 ohms for oscillator 4, etc. After selecting the value of R1 for any oscillator, the other values in the same series will be approximately as follows:

- R2 = .06 R1
- R3 = R1
- R4 = 2 R2
- R5 = 2 R3
- R6 = 2 R4

All the output leads (three leads from each oscillator) are tied together, and the signal is amplified. The simple output stage shown in Fig. 7 can be operated from the same power supply as the organ—either a regulated supply or batteries.

The more complex organ obviously requires more patience and time for proper calibration than does the simpler organ. However, it is well worth the extra effort.

CAR STEREO STANDARDS

Until now, makers of car stereo equipment have not had a set of standards and specifications that were meaningful to the consumer. Recently twenty-two manufacturers agreed on these new standards. Others are expected to follow.

LEN FELDMAN

CONTRIBUTING HI-FI EDITOR

IF YOU ARE A HIGH-FIDELITY ENTHUSIAST who has considered duplicating the good sound you enjoy at home in your car, truck, or van, you already know that until now there has been virtual chaos in the car stereo marketplace. Twenty watts of power in a car stereo amplifier or complete receiver is, in most instances, not even remotely related to 20 watts of audio power in a home hi-fi system. And a tuner sensitivity of $2.0\text{-}\mu\text{V}$ in a car radio (if quoted at all by the manufacturer) has usually meant sensitivity that is only one fourth as good as that of a home tuner boasting the same $2.0\text{-}\mu\text{V}$ sensitivity. As for tape-playing equipment in automobiles, frequency response, if quoted at all, has provided the prospective purchaser with little or no information as to the fidelity of the product being considered for installation in his or her vehicle.

We can now hope that the situation is about to change. As of this writing, 22 leading car stereo equipment manufacturers have agreed to publish specifications and measurements about their products that will be meaningful and helpful to consumers who want good sound on the road. What follows is some of the background that led to the creation of those new standards and a summary of the standard measurements themselves. Particular thanks are due to Marshall Mack Brown of Craig Corporation, who was in charge of the standards meetings that led to the creation of the new standards, along with Jim Twerdahl of Jensen Sound Laboratories and Don Coleman of Clarion Corporation.

It took more than 30 years for the home audio component industry to

reach its present level. But in less than five years annual sales of car stereo equipment have actually equalled or surpassed those of home audio equipment. Unfortunately, the rapid growth of car stereo has resulted in many practices that are contrary to high-fidelity philosophy and concepts. Perhaps the most flagrant abuse has been the artificially inflated "power ratings" of car stereo products. (We all remember that battle in home equipment.)

Back in 1974 the Federal Trade Commission formulated a rule that requires all manufacturers of home audio equipment to state the power output of audio amplifiers on the basis of continuous power, with extremes of frequencies at which the rated power can be delivered for a given level of harmonic distortion and into a specified load impedance. Note, however, that the FTC rule applies *only* to "home" audio equipment. In 1974, car-stereo equipment sales were not significant, and the FTC did not include that category in its rule. Given that loophole, many car-stereo manufacturers began to exaggerate power ratings, omit references to distortion levels, and so forth and so forth. Serious and conscientious audio-equipment makers were caught up in the specification race as well, and were often forced to publish unrealistic figures for their own products, if only to survive in a highly competitive marketplace.

Discouraged, but by no means defeated, those manufacturers (including many in the U.S., and several importers of equipment from abroad) did not give up. More than a year ago, they formed an Ad Hoc Committee of Car Stereo

Manufacturers and set about to write and publish their own measurement standards. Seventeen well-known manufacturers and importers participated in the deliberations. Their work has now been completed and, in a letter to all car-stereo manufacturers, they have invited all to endorse and use the specifications as presented. By endorsing the new standards, participating companies agree that by June 1, 1980, all of their printed catalogs, specifications sheets, advertisements, and other literature will present product specifications in accordance with the new standards.

Amplifier measurements standards

The new car-stereo standards are divided into three sections. Section I deals with audio power amplifiers (whether supplied as separate components or as part of a car radio) and parallels many of the standards developed for home audio amplifiers by the IHF (Institute of High Fidelity). Six specifications must be presented by a manufacturer in standard format. The format for specifying power output must read: "Power Output: ___ watts per channel minimum continuous average power into ___ ohms, both channels driven, from ___ Hz to ___ Hz with no more than ___% total harmonic distortion." While that method of presentation corresponds almost exactly to that required for home-audio equipment, the committee had to address itself to one important additional matter. The nominal 12-volt supply in most cars may vary from 11 to 16 volts under driving conditions. Figure 1 shows what happens to the power output of a nominally-rated 10-watt-per-channel amplifier over those



SHMEGG ELECTRONICS
MODEL 60A

extremes of supply voltage. With only 11 volts of supply voltage, clipping distortion is reached with only 8 watts delivered, while with 16 volts of battery supply, power output increases to more than 12 watts per channel. The new standards call for a standard DC voltage of 14.4 volts to be used when measuring power output of a car amplifier.

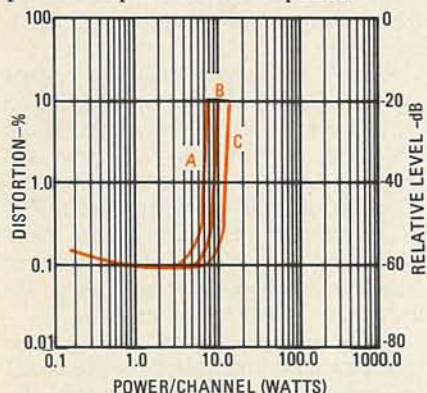

FIG. 1—HOW POWER OUTPUT VARIES with supply voltage. Curve A is for 11-volt supply, B is for 14.4 volts and C for 16.0 volts.

Frequency response for a car amplifier must be stated as follows: *Frequency Response: ___ Hz, to ___ Hz, \pm ___ dB.* Measurements must be made at a 1-watt output level with the amplifier terminated in its rated load impedance. For complete car radios (where the amplifier is inaccessible as a separate entity) the "input" maybe considered to be at the input of the volume control of the receiver.

For signal-to-noise measurements, an "A"-weighting network is to be used (that weighting is also called for in the IHF Amplifier Measurement Standards) and the S/N ratio must be quoted

with respect to 1-watt output, with an input voltage of 0.5 volts.

Input Sensitivity must be referenced to 1-watt of power output and should be expressed in volts. Here, an option is provided, wherein an additional sensitivity specification may be given for the input voltage required to produce rated output.

A minimum input-impedance specification is called for in the new standards, but that spec is applicable to separate component amplifiers only and is intended to establish compatibility of interfacing between models and brands. It would be stated, simply, in ohms.

The last required amplifier specification is Tone Control Action and the format will be: *Tone (Equalizer) Action: \pm ___ dB at ___ Hz and ___ Hz.* In the case of bass and treble controls, the recommended test frequencies are 100 Hz and 10,000 Hz. For multiband equalizers, the appropriate center fre-

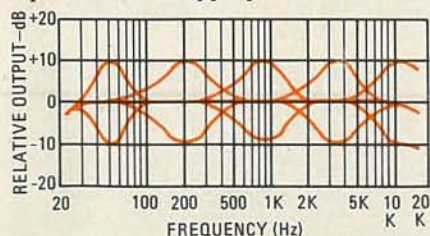

FIG. 2—TONE-CONTROL CURVES can be shown in specs. These curves are typical of those for a five-section equalizer.

quencies should be used in making the measurements. Curves, such as those shown in Fig. 2, may also be presented as an option, but those will most likely be used only for multiband equalizers.

Standards for FM tuners

The second section of the new standards is concerned with FM-tuner specifications, or the tuner section of a complete radio receiver. Nine separate disclosures are called for. The first of those is Monophonic Usable Sensitivity. It is to be stated in dBf. There has been wide variation in practice in measuring and stating the sensitivity of an FM receiver or tuner. Although it has been common practice to state sensitivity either in dB re: $1 \mu\text{V}$, or directly in volts (or microvolts), the modern practice of stating the sensitivity in terms of relative power level (expressed in dBf) eliminates ambiguity and enables the consumer to make direct comparisons between products. The ambiguities have been particularly prevalent when it comes to car stereo FM receivers, largely because their antenna input impedance is usually 75-ohms as opposed to the more common 300-ohm input impedance found on home FM equipment.

Figure 3 shows how $2 \mu\text{V}$, applied to a 75-ohm antenna input impedance, is

actually four times as much *power* delivered to the first stage of the receiver as the same $2\ \mu\text{V}$ would be if connected to a 300-ohm impedance. Looking at it another way, a tuner that boasts a $2\text{-}\mu\text{V}$

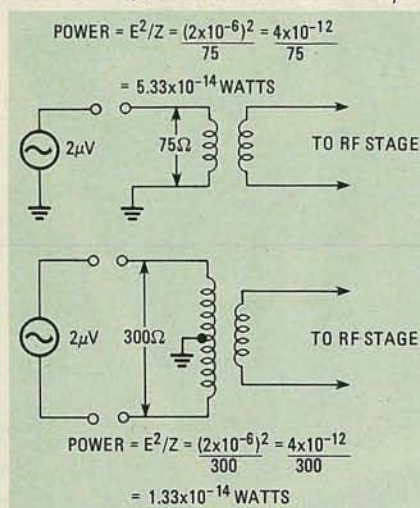

FIG. 2—RECEIVER SENSITIVITY depends on the input impedance of the first RF stage. Equations show relationships.

sensitivity (and fails to mention the fact that this figure applies to 75-ohm inputs) is really only one fourth as sensitive as one which has a $2\text{-}\mu\text{V}$ sensitivity but has a 300-ohm input.

Another indicator of tuner sensitivity that must be stated by manufacturers adhering to the new Car Stereo Standard is 50-dB Quieting Sensitivity, in mono. A signal-to-noise capability of 50 dB is generally considered to be the least amount of noise (with respect to signal peaks) that can be tolerated in high-fidelity equipment, whereas the 30-dB S/N figure, often used by car-stereo equipment manufacturers, really amounts to "barely usable" performance. The signal strength required for producing 50 dB of S/N is also to be quoted in terms of power, or dBf.

Frequency response of the tuner section is to be quoted over the range from 30 Hz to 15,000 Hz (the frequency limits of FM broadcasting) with a "plus and minus" dB tolerance required in the reporting format.

Such less familiar tuner characteristics as Capture Ratio (the ability of a tuner to zero in on the stronger of two stations broadcasting at the same frequency), Alternate Channel Selectivity (the ability of the tuner to reject signals that are removed in frequency from the desired station frequency by 400 kHz), Image Response Ratio (the ability of the tuner to reject incoming signals that are above 10.7 MHz the local oscillator frequency), and IF Response Ratio (ability of the tuner to reject incoming radio signals that are broadcast at the tuner's 10.7-MHz IF) are all called for in the new standard and are generally to be measured and reported in a manner consistent with the universally used

IHF/IEEE Tuner Measurement Standard which has been formalized since 1975 (IHF-T-200, 1975).

One additional tuner measurement standard called for in the new Car Stereo standards is actually borrowed from the IHF Amplifier Standard, and is called Maximum Output Voltage. It is to be reported in Volts, from ___ Hz to ___ Hz, with ___ ohms load. That specification is applicable to tuners, decks, and integrated units provided with line output terminals and is intended to establish compatibility of interfacing between models and brands. The minimum recommended load impedance must also be stated.

The third and final section of the new Car Stereo Standards deals with tape players. Since IHF standards for tape decks have not as yet been established, here the committee had to develop its own interim standards. Six required measurements and specifications are called for.

The first of those is playback frequency response. Tape playback frequency response has probably been one of the most flagrantly exaggerated specifications relating to car stereo tape equipment. As illustrated in Fig. 4, the frequency response shown in curve "A" for one typical tape deck and that shown in curve "B" for an inferior product could both be reported as extending from "30 Hz to 15,000 Hz"—providing that no tolerance in dB accompanies the published statement.

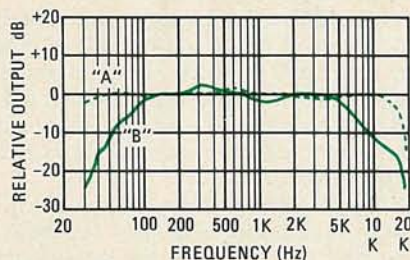

FIG. 4—PLAYBACK FREQUENCY RESPONSE curves for two tape recorders. The one producing curve A is clearly superior.

Clearly, the tape deck represented by the response curve of "B" is able to deliver some output at 30 Hz and some output at 15,000 Hz. That output, however, is some 15 dB lower than the reference level measured at 1 kHz and is therefore all but useless. For that reason, the format for stating tape playback frequency response must be: *Frequency Response: ___ Hz to ___ Hz,*



IN-DASH AM/FM/MPX CAR RADIO that includes an 8-track tape player. This model is the RCA AutoSound 12R711.

\pm dB. The specification must be referred to 1000 Hz as zero reference level and a ± 3 -dB tolerance is recommended (but not required) in the standard. Units having selectable equalization (e.g. for ferric oxide and chrome or chrome-equivalent tapes) should have frequency response stated for all conditions.

Wow-and-flutter performance of the tape equipment is to be measured using an rms-responding meter with weighted response. The meter is read for random 10-second periods at the beginning, middle, and end of the tape cassette or cartridge, noting the average of the peak readings, but excluding random peaks which do not occur more than twice in any 30-second period. Wow and flutter is reported as a percentage, followed by the notation "wrms" (weighted rms).

To measure stereo separation of car tape equipment, a reference level of 250 nWb/meter tone at 1 kHz is used, recorded on one channel. The opposite channel is played back through a narrow-band filter that includes 1 kHz, and the residual signal is measured. The purpose of the filter is to minimize the masking effect of tape noise, since interchannel leakage (crosstalk) may actually be lower in level than the noise and still be more objectionable.

"A"-weighted signal-to-noise ratio is also to be specified for tape playback devices intended for car use and is to be measured with respect to a 1-kHz recorded signal at a level of 250 nWb/meter, using a 20 Hz to 20,000-Hz band-pass filter.

Finally, the maximum output voltage of the tape deck is to be specified in volts, over the relevant frequency band and with a minimum recommended load also stated. Again, that specification is intended to establish compatibility of interfacing between models and brands, particularly where separate car stereo components (as opposed to all-in-one car stereo units) are used.

While there are certainly many more specifications which might be measured and published for mobile audio products in those three categories of amplifiers, tuner/receivers, and tape players (or combinations of them), it is significant that a group of audio-equipment manufacturers were able to get together, without any government prompting or pressure, to produce meaningful measurement standards. The result of their efforts can only benefit the audio consumer who wishes to have good high-fidelity sound while traveling in a vehicle.

The proposed standards have been printed, and readers wanting to learn more about them may write to Marshall Mack Brown, Chairman of the Ad Hoc Standards Committee of Car Stereo Manufacturers, at Craig Corporation, 921 West Artesia Blvd., Compton, California 90220. **R-E**

R.E.A.L. SOUND



1

CIRCLE 106 ON FREE INFORMATION CARD

Nikko Audio EQ-11 Graphic Equalizer

LEN FELDMAN
CONTRIBUTING HI-FI EDITOR

GRAPHIC EQUALIZERS HAVE BECOME ONE OF the most popular add-on products in a high-fidelity stereo system. By dividing the audio-frequency spectrum into several segments, a graphic equalizer permits the user to tailor tonal response of the entire system more precisely than would be possible using ordinary bass and treble controls or even bass, midrange and treble controls. Until now, most of the equalizers we have seen featured either five bands or ten bands per channel, with a few offering even more frequency segmentation.

Now Nikko has come up with a graphic equalizer, model *EQ-II* shown in Fig. 1, that offers six bands of frequency-per-channel, thereby providing a bit more flexibility than that offered by five-band units without increasing the retail price to that of most ten-band units.

The all-black front panel of the *EQ-II* features a POWER on/off switch at the left-hand side, above which is a small, red indicator light that turns on when power is applied to the unit. Nearby, along the lower edge of the panel, are

RADIO-ELECTRONICS AUDIO LAB

R.E.A.L. SOUND

RATES

NIKKO AUDIO EQ-II
GRAPHIC EQUALIZER

EXCELLENT

Copyright © Gernsback Publications Inc., 1979

a pair of pushbutton switches. One of these is used to bypass the equalizer when its functions are not required, or for making instant audible comparisons between equalized and unequalized sound. The other switch introduces a tape-monitor circuit that can be used to connect a tape deck, since the tape out/tape in jacks on any associated receiver or amplifier will have been used up by installation of the equalizer.

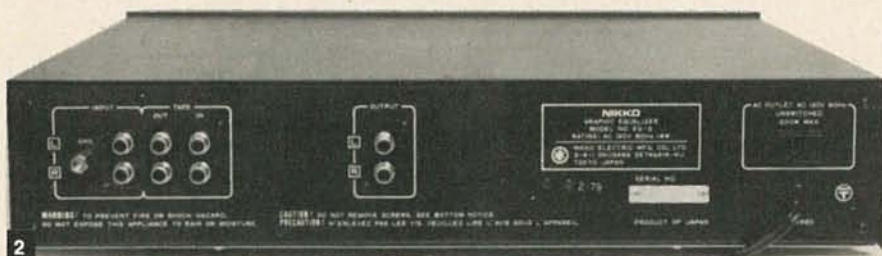

2

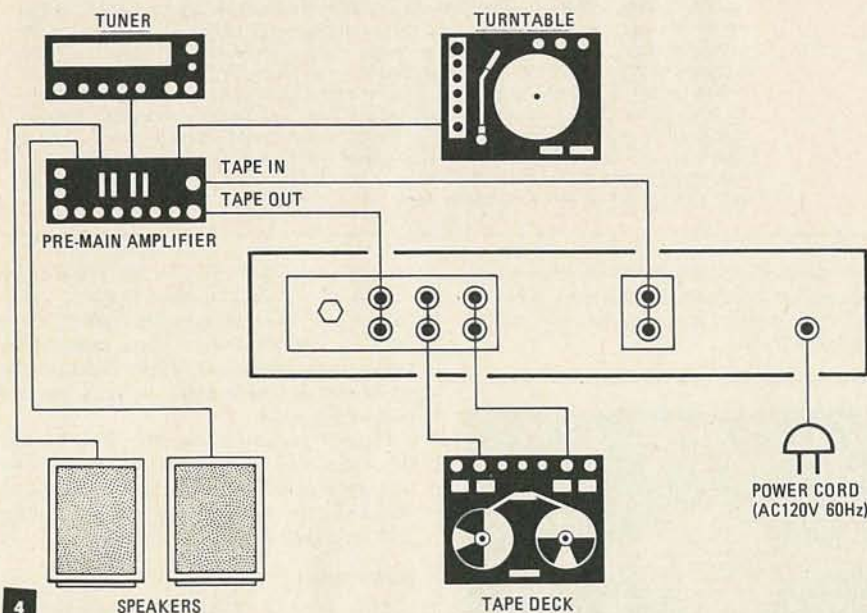

4

MANUFACTURER'S PUBLISHED SPECIFICATIONS:

Control Frequencies: 40 Hz, 125 Hz, 400 Hz, 1.25 kHz, 4 kHz, 12.5 kHz. **Control Range:** ± 12 dB at center frequencies. **Rated Output Level:** 1.0 volt. **Maximum Output Level:** 4.0 volts. **Total Harmonic Distortion:** 0.01%. **Signal-to-Noise Ratio:** IHF "A"-Weighted; 100 dB. **Frequency Response:** 10 Hz to 30 kHz, ± 1.0 dB. **Input Impedance:** 80K ohms. **Power Requirement:** 120 volts 60Hz, 14 Watts. **Dimensions:** 16½ W × 3¾ H × 13-inches D. **Net Weight:** 10.8 lbs. **Suggested Retail Price:** \$200.00

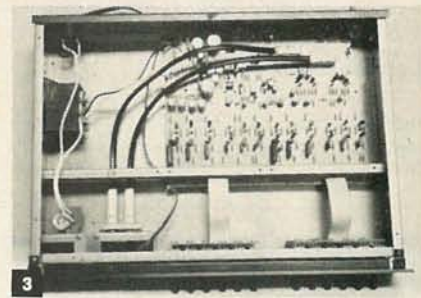

3

The wiring of the tape-monitor circuit is such that only preequalized signals can be fed to the line inputs of the connected tape deck. In other words, you cannot use the *EQ-II* to equalize signals being recorded; only to equalize signals being played back via the tape deck or your other program sources. Above the equalization in/out switch is a small green light that turns on when the *EQ-II* is "in circuit".

Nikko has chosen to separate the left and right channel slider controls that occupy the rest of the front panel into two separate groups. The alternative approach is to position left and right sliders that have the same center

frequencies in adjacent pairs. Each approach, of course, has its advantages and disadvantages. With all the controls of one channel grouped together, if the user finds that both channels require the same degree of equalization the arrangement on the *EQ-II* requires that each channel be adjusted separately. When similar center frequencies are paired together, (as on some other equalizers we have tested), the user can adjust left and right sliders with a single finger motion. On the other hand, in most practical situations, with speaker systems placed at different positions in the listening room, in non-identical environments, the likelihood is that the left-channel equalization requirements will differ from those of the right channel, and individual adjustment would be required in any case.

The center frequencies chosen by Nikko for this six-band equalizer are 40 Hz, 125 Hz, 400 Hz, 1.25 kHz, 4 kHz and 12.5 kHz. Spacing is therefore something more than one octave and less than two octaves. The slider controls used to adjust response at each of these center frequencies have well defined detents with approximately a 2-dB step per detent. Sliders are calibrated from 0 (center position) to 10 in both the boost and cut directions of the slider. Those calibration points have no direct correlation to dB of boost or cut, however, since maximum boost or cut is 12 dB.

The rear panel of the *EQ-II*, shown in Fig. 2, is equipped with a pair of INPUT jacks at the left, a pair of OUTPUT jacks at the center and the previously mentioned TAPE-OUT and TAPE-IN jacks in between. An unswitched AC convenience outlet, rated at 200 watts, is located at the extreme right of the rear panel above the power cord. There are no externally-replaceable fuses on the rear panel.

Figure 3 shows the inside of the chassis of the unit. Note that the single circuit board at the right rear contains no inductors, as such. Instead, gyrator circuits using op-amps with feedback networks are used to create the necessary individual filter circuits required. The entire circuit is well shielded from any induced hum via the front panel and from the small power transformer mounted at the extreme left of the chassis. That careful layout accounts in part for the excellent signal-to-noise ratio that we found. Figure 4 shows how to connect the *EQ-II* into a hi-fi system.

Lab measurements

Table I summarizes the laboratory measurements made on our sample unit. The exceedingly low distortion levels, measured at mid-frequencies as well as at the audio frequency

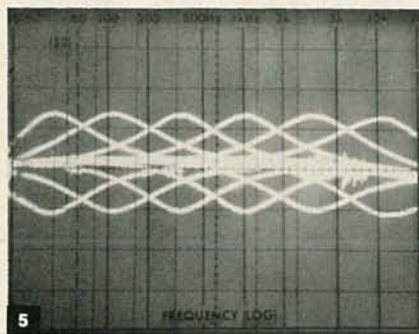

extremes, were measured with an input signal level of 1.0 volt, which corresponds to the rated output level of the unit (the *EQ-II* has 0 dB or

RADIO ELECTRONICS PRODUCT TEST REPORT		
TABLE 1		
Manufacturer: Nikko	Model: EQ-II Equalizer	
GRAPHIC EQUALIZER PERFORMANCE MEASUREMENTS		
Specification	R-E Measurement	R-E Evaluation
Control range (\pm dB)	12	Very Good
Center frequencies (Hz)	40, 125, 1.25K, 4K, 12.5K	Good
Maximum output level (V)	4.5	Very Good
Harmonic distortion, 1kHz (%)	0.003	Excellent
Harmonic distortion, 20 Hz (%)	0.008	Excellent
Harmonic distortion, 20kHz (%)	0.005	Excellent
S/N ratio, "A"-weighted (dB)	99	Very Good
Frequency response, Hz-kHz, \pm 1dB	10-25	Very Good
MATCHING CHARACTERISTICS		
Rated output (V)	1.0	
Input impedance (ohms)	80 K	
Power consumption (W)	12	

RADIO-ELECTRONICS PRODUCT TEST REPORT	
TABLE 2	
Manufacturer: Nikko Audio	Model: EQ-II Equalizer
OVERALL PRODUCT ANALYSIS	
Retail price	\$200.00
Price category	Medium
Price/performance ratio	Very good
Styling and appearance	Excellent
Sound quality	Excellent
Mechanical performance	Very good
<p>Comments: Many audio enthusiasts find that a 10-band (octave-by-octave) graphic equalizer is a bit too much to cope with while some of the low-cost 5-band equalizers don't offer as much control as they feel they need. Nikko Audio has apparently tried to solve that problem by coming up with a six-band graphic equalizer that provides just a bit more control flexibility than do the five-band models available. By resorting to gyrator circuitry, Nikko has managed to keep hum and noise levels as low as those found in much more expensive equalizers; distortion contributed by the device is almost at the vanishing level. The multi-detented settings of each slider control make preferred settings easily repeatable. The incorporation of a tape-monitor circuit means that those owning a receiver with only one tape circuit will not lose that function when connecting the <i>EQ-II</i>. It would have been nice (and not expensive) if Nikko had enabled the user to equalize signals <i>ahead</i> of the tape out circuit instead of only during playback. An overall level control would also have been useful, especially when extreme settings of the sliders are called for. But, all in all, the <i>EQ-II</i> offers good basic equalization facilities at a moderate price.</p>	

unity gain, as an equalizer should). Even as one approaches maximum output level, however, distortion remains almost as low until output exceeds 4.0 volts.

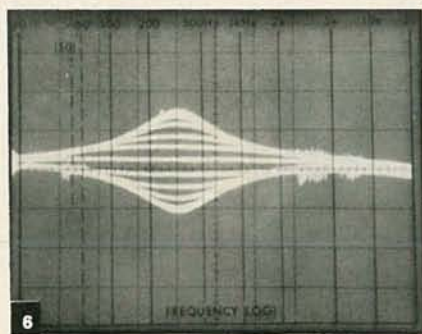

Figure 5 shows the response of the *EQ-II* with each of its frequency levers alternately moved to the maximum boost and cut posi-

tions. Vertical sensitivity for the presentation was 10 dB-per-division while frequency, plotted from left to right, extended from 20 Hz to 20 kHz, logarithmically. Thus, spacings between center frequencies of the various bands are almost precisely equal, between one and two octaves apart.

Figure 6 presents a sequential plot of one of the slider controls (the one having a center frequency of 400 Hz) for each of its eleven detented steps and while the boost and cut for each step, they are very nearly equal.

Summary

At its price, the Nikko *EQ-II* offers a good deal of tonal control flexibility. In listening tests, the unit introduced no noticeable sound coloration when the controls were set to their mid-positions and the EQ light was on. Neither was there any noticeable increase in distortion or noise level when the equalizer was switched into the rest of our test stereo component system. More detailed summary comments, together with our overall product evaluation, will be found in Table II.

R-E

BUILD THIS

3½ Digit DMM

Want to design and build your own DMM? If so, this developmental prototype is a good place to start. You can add features and select an enclosure and layout to meet your needs.

CARSON CHEN*

HERE'S HOW AN ACCURATE, INEXPENSIVE 3½ digit DMM can be built. The DMM is designed around a single 3½ digit DVM IC that performs the analog-to-digital conversion function. The specifications of the DMM are shown in Table 1.

Referring to the schematic in Fig. 1, (see page 62) the basic building block of the multimeter is the ADD3501 analog-to-digital converter using a pulse-modulation technique. A 2-volt reference voltage tapped off the LM336 2.5-volt precision reference diode allows for a 1mV resolution. Additional ADD3501 support circuitry consists of an NSB5388 LED display, a DS75492 digit driver, an RA08 resistor array and an LM340 to regulate the V_{CC} supply voltage.

DC voltage measurement: Depending upon the range selected, the positive or negative DC voltage to be measured is applied to the + and - meter probes and, where applicable, attenuated so that the maximum voltage per range equates to 2 volts full-scale and applied across the ADD3501 V_{IN+} and V_{IN-} pins (pins 13 and 12 respectively). The ADD3501 then performs a pulse-modulation analog-to-digital conversion and digitally displays the numerical equivalent of the analog input voltage.

DC current measurement: In the DC current mode, the meter probes are placed in series with the current to be measured. On any range, the DMM places a known resistance in series with the current to develop a 2-volt full-scale

voltage drop. (This voltage drop may be reduced to 200 mV; refer to the last section of this article). The equivalent drop across the current measuring resistor is then converted and displayed by the ADD3501.

Resistance Measurement: As in all multimeters, a current source develops a voltage drop across the unknown resistor being measured. In this case the resistor to be measured is placed across the + and - meter probes and, depending upon the range selected, a constant current is forced through the resistor developing, at maximum, 2 volts full-scale. This voltage is applied to the V_{IN+} and V_{IN-} pins of the ADD3501 and converted to its proper digital equivalent displayed as ohms. The current source is designed around two of the op-amps in the LM346 (IC2-a and IC2-b) and transistors Q1 and Q2.

Isolating the current source and analyzing the circuit in Fig. 2, we see that resistor R_X sets the desired current for a chosen resistance measurement range. It is essential to note that varying resistor



values placed at R_X must not alter the constant current through R_X . If this occurs, erroneous resistance readings will be displayed. To eliminate any non-constant current conditions, op-amp IC2-b and transistor Q2 function as follows:

To establish a constant-current source, a constant voltage drop must be maintained across load resistor, R_L . The closed-loop operation of IC2-b tries to maintain a zero differential input voltage. With V_A applied to the non-inverting input, point A is forced to $V_A + V_{BE}$ so that the voltage of point B would equal V_A . Thus a constant voltage potential is maintained across R_L . With V_A constant at point B, the current source remains constant, and varying R_X has no effect on the current source, provided that $R_X \times I_{SOURCE}$ is not greater than $V_A - V_{BE}$, so that transistor Q2 is saturated. This non-linear condition however will not be noticed since $R_X \times I_{SOURCE} \geq 2V$ will force the ADD3501 to display +OFL. (See Fig. 3.)

A change in the V_{CC} supply voltage is

TABLE 1—SPECIFICATIONS

DC Volts: Accuracy better than $\pm 1\%$ Ranges: 2 volts, 20 volts, 200 volts, 2 kV. Input impedance: greater than 10 megohms on 2-volt range; 10 megohms on 20-volt to 2-kV ranges.
AC RMS Volts: Accuracy better than $\pm 1\%$ Ranges: 2 volts, 20 volts, 200 volts, 2kV (40 Hz to 8 kHz, sinewave)
DC Amps: Accuracy better than $\pm 1\%$ Ranges: 200 μA , 2 mA, 20 mA, 2 amps
AC RMS Amps: Accuracy better than $\pm 1\%$ Ranges: 20 μA , 2 mA, 20 mA, 2 amps
Ohms: Accuracy better than $\pm 1\%$ Ranges: 200, 2000, 20,000, 200,000 ohms, 2 megohms

*Senior Applications Engineer, National Semiconductor

BATTERY TEST

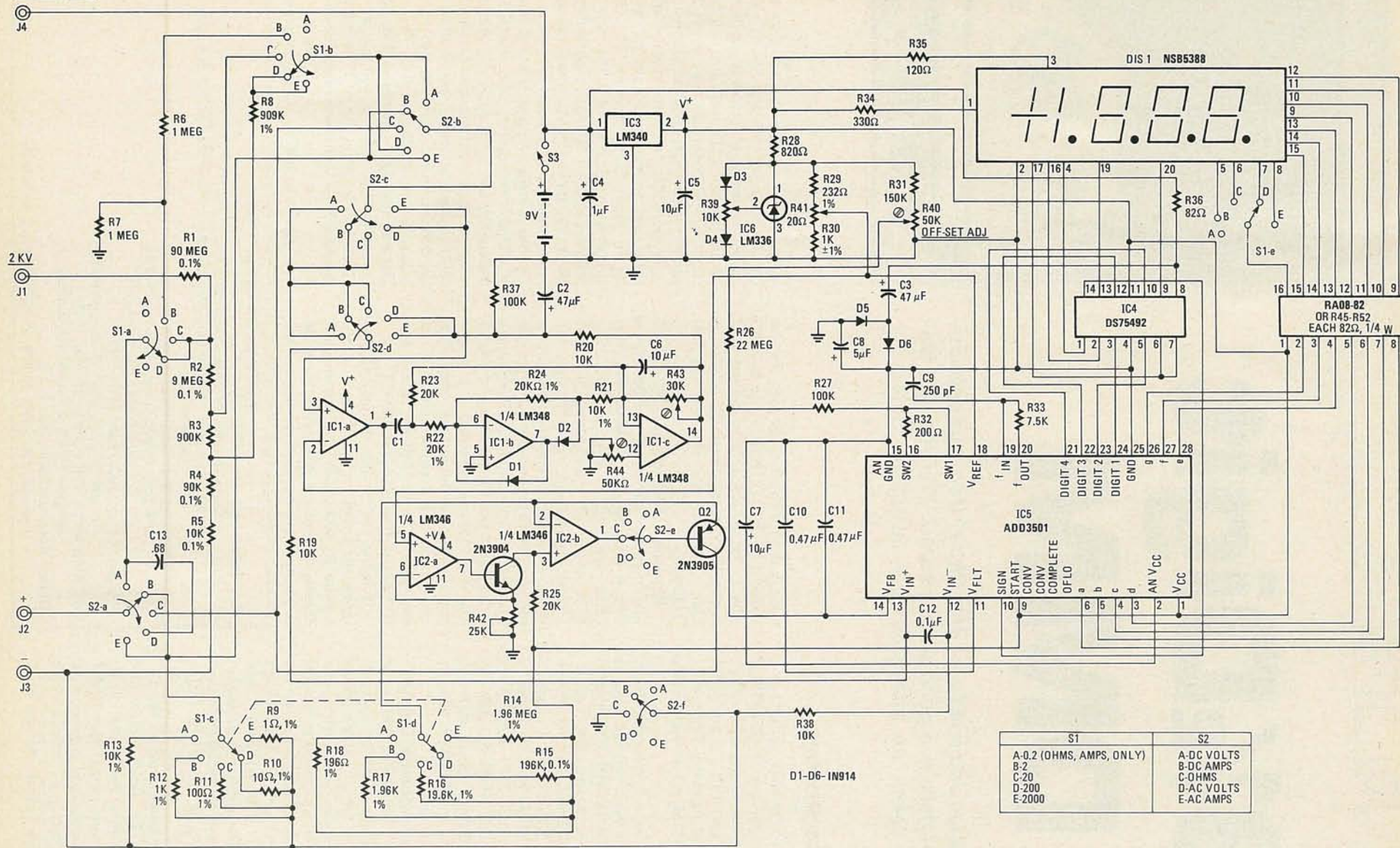

FIG. 1—SCHEMATIC of the low-cost digital multimeter. The component-count is low for an instrument of its versatility.

PARTS LIST

Resistors 1/4 watt, 5% unless otherwise specified

- R1—90 megohms, 0.1%
- R2—9 megohms, 0.1%
- R3—900,000 ohms, 0.1%
- R4—90,000 ohms, 0.1%
- R5—10,000 ohms, 0.1%
- R6, R7—1 megohms
- R8—909,000 ohms, 1%
- R9—1.0 ohms, 1%
- R10—10 ohms, 1%
- R11—100 ohms, 1%
- R12—1000 ohms, 1%
- R13—10,000 ohms, 1%
- R14—1.96 megohm, 1%
- R15, 196,000 ohms, 1%
- R16—19,600 ohms, 1%
- R17—1960 ohms, 1%
- R18—196 ohms, 1%
- R19, R20, R38—10,000 ohms
- R21—10,000 ohms, 1%
- R22, R23, R24—20,000 ohms, 1%
- R25—20,000 ohms
- R26—22 megohms,
- R27, R37—100,000 ohms
- R28—820 ohms
- R29—232 ohms, 1%
- R30—1000 ohms
- R31—150,000 ohms
- R32—200 ohms
- R33—7500 ohms
- R34—330 ohms
- R35—120 ohms
- R36—82 ohms
- R39—10,000 Ohms, 10-turn trimmer pot
- R40, R44—50,000 Ohms, 10-turn trimmer pot
- R41—20,000 ohms, 10-turn trimmer pot
- R42—25,000 ohms, 10-turn trimmer pot
- R43—30,000 ohms, 10-turn trimmer pot
- R45—R52—RA08-82 resistor array

Capacitors

- C1, C2, C3—47 μ F, 15 volts, electrolytic
- C4—1 μ F
- C5, C6, C6—10 μ F, 15 volts, electrolytic
- C8—5 μ F, 15 volts, electrolytic
- C9—250 pF
- C10, C11—0.47 μ F
- C12—0.1 μ F

Semiconductors

- D1—D6—1N914
 - Q1—2N3904
 - Q2—2N3905
 - DIS1—NSB5388 3 1/2-digit LED display
 - IC1—LM346 quad op-amp
 - IC2—LM348 quad op-amp
 - IC3—LM340 5-volt regulator
 - IC4—DS75492 (National) MOS to LED hex-digit driver
 - IC5—ADD3501 3 1/2-digit digital voltmeter
 - IC6—LM336 2.5-volt Zener reference source
 - S1—rotary switch, 5 circuits, 5 positions
 - S2—rotary switch, 6 circuits, 5 positions
 - S3—SPST miniature slide switch
- Miscellaneous hardware including case, stand-off bushings, hookup wire, IC sockets, etc.

another condition that may affect the constant-current source and must be corrected for within the circuit. A constant-current sink is established when amplifier IC2-a forces point C to the non-inverting input voltage V_{ref} . With V_{ref} held constant

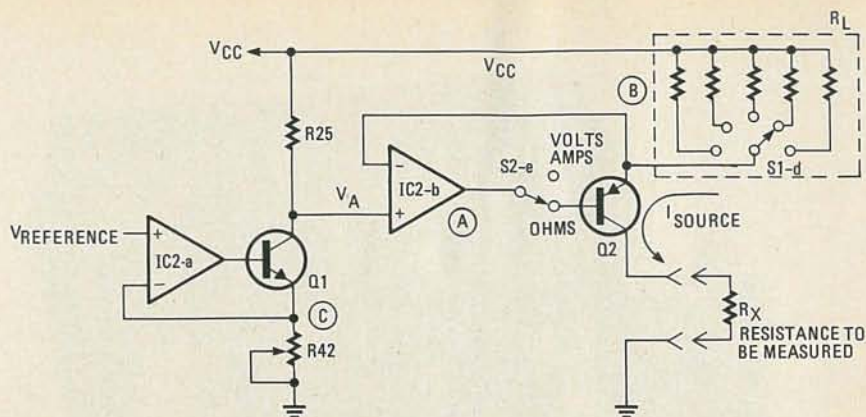

FIG. 2—FUNCTIONAL DIAGRAM of the constant-current source. The op-amps are part of a quad device.



FIG. 3—THIS DISPLAY on the readout can not be mistaken for anything other than overflow.

at point C, the current through R25 is roughly equal to the current through R42. (See equation 1.) This allows V_A to vary directly proportional to any fluctuations in supply voltage.

$$V_A = V_{CC} - [(V_{ref}/R42)\alpha]R25 \quad (1)$$

If V_{CC} drops by V_X , V_A drops by V_X and sustains the desired voltage across R_L . Reference voltage V_{ref} is taken from the LM336 and remains constant throughout the ADD3501 supply voltage range. Note that the base of Q2 must be left connect-

ed to IC2-b during the AC current or voltage measurements. In these modes the R_X terminals (and the collector-ground) are open circuited. This allows the Q2 emitterbase junction to act as a forward-biased diode pulling the V -supply to ground through IC2-b. This problem is eliminated by the opening switch (S2-e) connecting Q2 to IC2-b.

AC voltage measurement: The AC voltage is measured using the AC-to-DC converter shown in Fig. 4. The voltage attenuator has a source impedance on any range of 1 megohm. Amplifier IC1-a is connected as a voltage-follower lowering the source impedance driving IC1-b to a few hundred ohms. The small DC offset voltage is decoupled through C1.

The AC/DC converter, IC1-b and IC1-c, can best be understood by following the signal path for negative and then for positive inputs. For negative signals, the output of IC1-b is clamped to +0.7 volt by diode D1 and disconnected from the summing point of IC1-c by D2. Amplifier IC1-c then functions as a simple unity-gain inverter with input resistor R23 and feedback resistor R43 giving a positive-going output.

For positive inputs, IC1-b operates as a normal amplifier connected to the summing point of IC1-c through resistor R21. Amplifier IC1-b then acts as a simple unity gain inverter with input resistor R22 and feedback resistor R24. The gain accuracy of IC1-b is not affected by diode D2 since it is inside the feedback loop. Positive current enters the summing point of IC1-c through R23 and negative current is drawn from the summing point through R21. Since the voltage across R23 and R21 are equal and

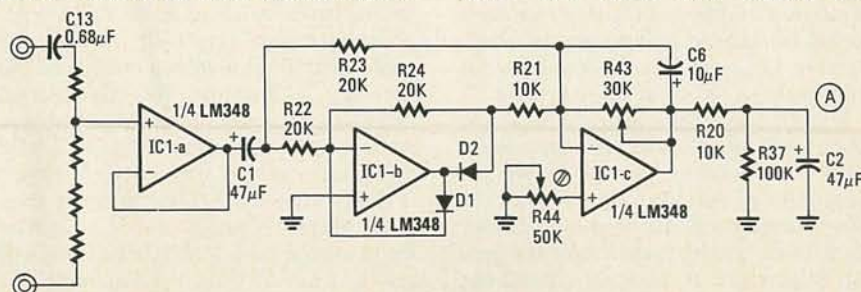

FIG. 4—THE AC/DC CONVERTER is designed around three op-amps and a few other components.

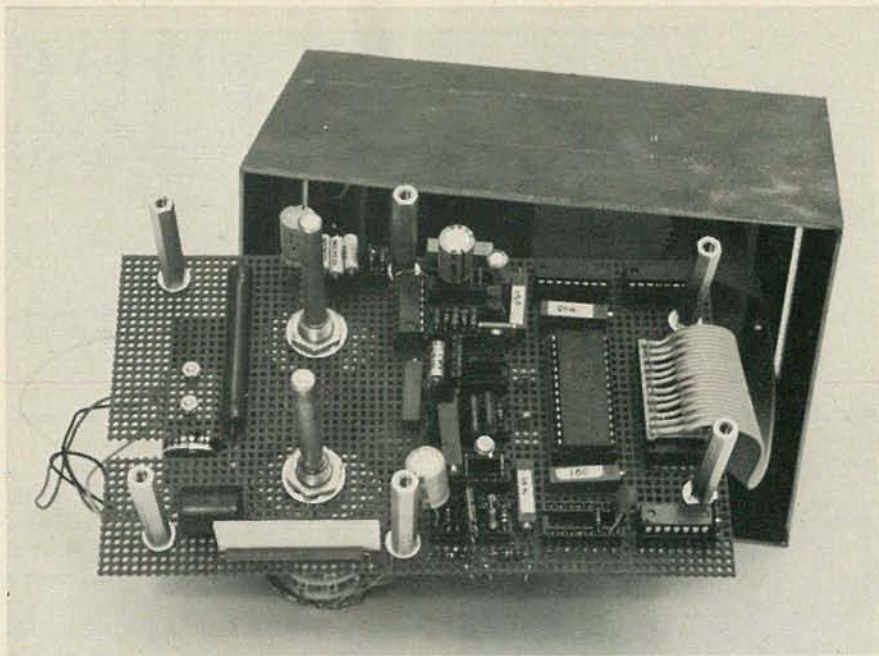

FIG. 5—INTERIOR VIEW of the DMM. Perforated board is used for the chassis. Wiring is point-to-point. Precision resistors in the voltage divider, current shunts and ohmmeter circuits are plugged into IC sockets.

opposite, and R21 is one-half the value of R23, the net input current at the summing point is equal to and opposite from the current through R23. Thus amplifier IC1-c operates as a summing inverter with unity gain, again giving a positive output. The circuit then becomes an averaging filter with C6 connected across R43. Trimmer resistor R44 is used to minimize output errors due to input offset currents.

AC current measurement: To measure AC current, the meter circuit is configured as in the DC current measurement setup. Again, IC1-a through IC1-c (see Fig. 4) performs the AC to DC conversion with the final DC voltage at point A being fed to and converted by the ADD3501.

Construction

The digital multimeter described here was developed as a prototype to prove the suitability of the ADD3501 for use in an inexpensive electronic test instrument. The circuit is simple and the component-count relatively low so point-to-point wiring or wirewrap on perforated board can be used. An interior view is in Fig. 5. Note that all V_{CC} connections should be made to a single point and all grounds should be made to a single ground point. Be sure to connect an $0.1\text{-}\mu\text{F}$ capacitor from each V_{CC} IC terminal to ground.

It cannot be overly stressed as to the importance of maintaining single-point ground connections for the amplifiers. Ground-loop resistances coupled with the offset currents and AC response can play absolute havoc with system linearity, gain and display flicker. Similarly, flickering occurs if precautions are not taken when considering the layout of analog, high-

switching-current and digital ground-loop paths of the ADD3501.

Calibration

Calibration of the digital multimeter is performed as follows:

1. Adjust R40 until the cathode of the precision zener reference diode (LM336) equals 2.49-volts. This adjusts the diode's temperature coefficient.
2. Set the meter to measure 2 volts DC. Short the + and - probe inputs of the meter and adjust R45 until the display reads 0000.
3. Now, apply 1.995 volts DC across the + and - probe inputs and adjust R41 until the display reads 1.995.
4. Set up the meter for resistance on the 2-megohm range. Select a precision resistor whose value is a little lower than 2 megohms and adjust R42 until the appropriate value is displayed.
5. Apply a known 1.995-volt RMS sinewave signal to the meter and adjust R43 until the display reads the same.

(Calibrating the DMM to three decimal places will be difficult for many readers. You can do it if you have access to a $4\frac{1}{2}$ -digit DMM. A friendly TV service technician or a lab technician in a local electronics plant may help you with the calibration. If, at first, you don't need the accuracy offered by this instrument, there are a couple of schemes that you can use to get all the precision you'll need for ordinary servicing and experiments.

Calibration on the DC range is relatively simple. A rough calibration can be made using a fresh flashlight cell that will give 1.54 to 1.55 volts. For a more precise reference, you can use a 1.35-volt mercury cell. Most of these supply 1.354 volts

± 2 mV. Note that 1.4 volt mercury cells are available but they are not suitable for use as voltage standards. Among the several 1.35-volt mercury cells that are available are Mallory RM12R, Burgess HG12R and Eveready E12N. The "N" and "R" suffixes indicate types suitable for instrument voltage references and high-temperature applications. If the type 12 is not available, try to get a 42, 400, 401 or 625 with the "N" or "R" suffix.

(If your scope has AC/DC coupling you can use it and your DC reference to arrive at a reasonably accurate AC reference source. Connect the DC reference cell across the vertical input and adjust the vertical attenuator for deflection to a convenient reference point above the zero reference line. Without changing the attenuator setting, switch the scope to AC and connect an adjustable AC source to the scope input. Adjust the applied voltage so its uppermost peak rests on the same reference line as the DC voltage.

(The effective or RMS value of the AC voltage equals 0.707 times the peak value indicated on the scope. For example, when a 1.35-volt cell is the DC reference, the equivalent RMS voltage giving the same deflection is 1.35×0.707 or 0.954 volt.—Editor).

Final note

The digital multimeter described here was specifically developed with accuracy and minimal cost in mind. For a more elaborate multimeter, improvements to the basic circuit of Fig. 1 can be made in the following areas.

1. Increase the volts mode to include a 200 mV full-scale range. (Refer to the ADD3501 data sheet).
2. Decrease the full-scale current measurement load voltage from 2 volts to 200 mV.
3. Provide true-RMS measurement capability.

The first two categories may be satisfied by dividing down the ADD3501 feedback loop by a ratio of 10 to 1, thus scaling down the full-scale 2-volt input requirement to 200 millivolts. This not only allows 200 mV impressed across the V_{IN+} and V_{IN-} inputs to display a full-scale reading but also implies that the maximum voltage dropped across the current-measuring resistance is also 200 millivolts.

Note, of course, that the values of the current-measurement resistor array must be scaled down by a factor of 10 to 1. Also note that a 200 mV full-scale input implies a resolution of $100\mu\text{V}$. At these low input levels, offset currents may effect linearity and gain of the AC/DC converter and some clever circuitry may be required to eliminate such problems. A true RMS meter can be made by replacing the AC to DC converter with LH0091, a true RMS-to-DC converter, and appropriate interface circuitry. **R-E**

TROUBLESHOOTING BETA TRANSPORT MECHANISMS

Threading video tape from a cassette into the transport mechanism blends a mixture of mechanics and electronics that seems simple—after you understand it.

FOREST BELT

IN MOST OF TODAY'S BETA-FORMAT home video recorders, one direct-current (DC) motor drives the entire tape-loading mechanism. (Sony, Toshiba and Zenith are the main Beta-system brands.) In one exception, a drive belt supplies the force from a main AC motor. Yet the mechanics of actual tape-threading remain the same whatever the driving force.

The DC motor drives a large *threading ring*. Running counterclockwise, the ring draws the video tape out of the cassette and wraps it in a giant semicircle around the video-head drum and assorted guides and sensors.

The DC motor reverses, too. Running clockwise, the threading ring unwraps the tape; the takeup reel in the cassette winds the tape slack back into the cassette.

Of course, that explanation oversimplifies. Yet, it describes the basic mechanical operation by which video tape from a Beta-format cassette is loaded or threaded into the recording/playing mechanism, and then withdrawn (unloaded or unthreaded). You can build from this fundamental view to a more detailed understanding of how a VCR works. The loading/unloading operation involves both mechanics and electronics. For best comprehension, the mechanics of a VCR may be the place for you to begin your study. That's where you generally should begin troubleshooting any Beta machine's loading/unloading faults.

Threading-ring drive

You can follow the action of tape-threading best with a video cassette recorder in front of you. To watch all that

happen, you need to remove the cover from the machine—an easy matter.

While you can derive a fair notion of the actions from the photo in this article, the better your familiarity with how specific operations proceed, the easier you can spot malfunctions.

To load a Beta cassette onto the machine, first depress the EJECT button. That raises a compartment called the *cassette-lift assembly*. Insert the video cassette, and then press the cassette compartment down until it clicks. The cassette fits down over the front edge

of the *threading ring* in such a way that a lead or No. 1 guidepost fits up behind the tape itself, more or less inside the cassette. Simultaneously, the downward motion lifts a cover on the front of the cassette, exposing the tape.

Proper switching takes place automatically when you push the cassette-lift compartment down until it latches. The cassette encounters a *cassette-in switch*. A DC motor (located inside the main chassis in the rear left corner) turns on. The motor's pulley-belt drives a worm gear that rotates a threading-



THREADING THE TAPE begins when the threading ring revolves counter clockwise.

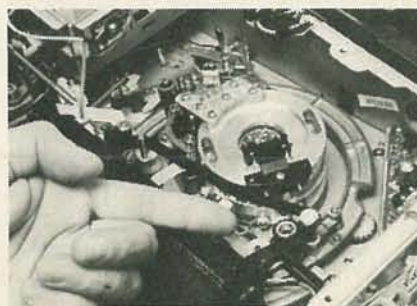

AS THE THREADING RING revolves, the lead guide post catches the tape.



THE THREADING RING continues to revolve wrapping the tape closely around the face of the video-head drum.

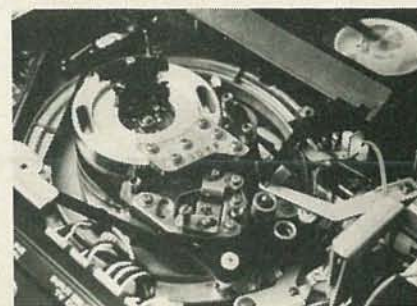

A STOPPER TAB ends threading ring travel when threading is completed.

drive shaft. On its upper end, the shaft has another gear that engages the large-diameter threading ring.

The threading ring revolves counter-clockwise (as you look down at it). The *lead guidepost* encounters the tape as the rotation brings the post outward and then begins pulling the tape out of the cassette.

The tape coming out of the cassette travels around the video-head drum. At first, the tape being pulled out by the lead post is doubled. But, at intervals, three additional guideposts on the circumference of the threading ring enter the tape loop. These posts hold the outer side of the tape loop away from the video-head drum. The inner side of the loop, however, wraps very closely around the face of the video-head drum. Behind the drum, two fixed guideposts also shape the outside dimensions of the tape loop.

Meanwhile, on the left-hand side of the cassette, a lever—with a guidepost that is also inside the cassette similar to the lead guidepost—has filled out a *tape-tension arm*. That post has also drawn some tape from the supply reel of the cassette.

Near the end of the threading-ring travel, a cam-follower lever moves the tape-tension arm solidly outward. That completes the tape-wrapping procedure around the video-head drum. As shown in the photo, this action also positions the tape so that it can pass the audio-control head properly.

A stopper tab ends the threading-ring travel. Microswitches open the circuit

to the DC threading motor. Toggle levers hold the ring firmly against the stopper. The tape is now in position for any of the RUN modes: PLAY, RECORD, FAST FORWARD, or REWIND.

Unthreading or unloading

When the EJECT button is down, the voltage at the DC motor reverses and starts the threading ring revolving clockwise. A few degrees of rotation toggles the cam-follower lever and loosens the tape-tension arm.

Tape comes suddenly go slack and create a "spill," but a lever lifts the brake from the takeup-reel turntable. The direction of the reel rotation winds up any slack in the tape as it occurs.

Continuing clockwise, the threading ring unwraps the tape from the video-head drum—exactly the reverse of how it operates in threading the machine. Finally, at the end of the unthreading operation, the cassette-lift mechanism raises the compartment. The cover at the front of the cassette closes, and the cassette can be removed.

Tape-loading electronics

Unless you know what happens electronically during the threading sequence, you cannot always determine for certain whether a defect is a mechanical or an electronic fault. Once you are familiar with both sides, troubleshooting can proceed directly.

Several electronic functions must be taken into account during tape loading. Many are safety interlocks that prevent damage to the machine. The basic

threading circuits are shown in Fig. 1.

A CASSETTE-IN microswitch operates from a plunger that is activated when the cassette is in the lift compartment and the assembly has been pushed down to latch it. The switch applies 12 volts of regulated DC to the loading-circuit board.

A LOADING-STOP microswitch connects as an interlock between pin 2 of connector CN4001 and pin 3 of CN4002. This switch is located beside the threading ring. It stays closed at all times except when the threading ring reaches its limit (when the tape is loaded). Thus, at the start of tape loading, the switch carries 12 volts from the CASSETTE-IN switch to the threading-control circuits.

With both microswitches closed, 12 volts goes to a *standby-lamp* stage (the circuits are not shown in Fig. 1). An illuminated standby lamp warns the operator to wait until loading is finished before pressing one of the RUN-mode buttons. Some Beta-format machines omit this warning light.

Forward-biased diode D4016 carries 12 volts DC to a charge-up circuit that consists of R4011, R4055 and C4009. This capacitor holds a 12-volt charge even after the voltage is removed; which is what happens when the threading-stop switch opens. The purpose is to keep the threading motor turning an extra moment or so until the threading ring reaches its mechanical-stop pin. That assures complete loading.

Diode D4015, which is also forward-biased, places 12 volts on pin 19 of the threading-logic IC. (In digital logic, that constitutes a logic high on pin 19.) As long as the other input of gate AND-2 sees a logic high, the output is a logic high. Two logic-high inputs to gate AND-3 gives another logic-high output, that inverts in the gate immediately following it.

The logic low from IC pin 21 cuts off transistor Q4003, placing a logic high on the base of Q4010. Because it is an emitter-follower (noninverting), Q4010 delivers a logic high through switch segment S4004-1 to one side of the DC threading motor. Switch-segment S4004-2 grounds the other side of the motor. The threading motor runs.

Now, let's review some of the ramifications of various circuit elements you have encountered along the way. Some of them can, for one reason or another, inhibit the operation of the threading motor.

First, let's start with gate AND-2. To deliver a logic-high output, both gate inputs must be high. However, if certain things malfunction elsewhere in the machine, an automatic-stop system switches a logic-low signal onto this line. A logic-low signal would inhibit gate AND-2, and this would force a logic high at IC pin 21, and, ultimately, a logic high at IC pin 21, and, ultimately,

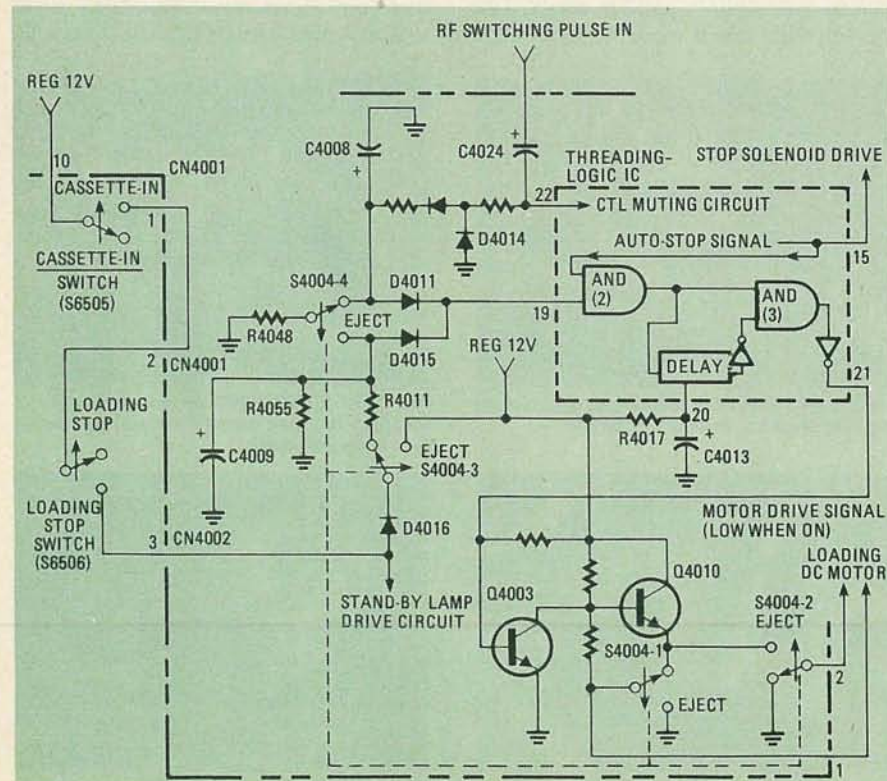

FIG. 1—BASIC THREADING CIRCUIT contains many safety interlocks that prevent damage to the machine during the tape loading process. A microswitch detects when the cassette is in place.

a logic low at the emitter of Q4010. Thus, the threading motor would stop.

Let's look at the delay-logic circuit block shown in Fig. 1. The delay circuit acts as a switch that keeps IC pin 20 normally grounded. This in turn sends a logic low to the delay gate and a normal logic high to gate AND-3.

However, when gate AND-2 applies a logic high to the delay input, it effectively lifts the ground from IC pin 20. Capacitor C4013 begins charging through R4017. If the threading finishes in the usual two or three seconds, the threading-stop switch opens, the output of gate AND-2 goes low and IC pin 20 reverts to ground or zero.

But if something goes wrong and threading has not been completed in ten seconds, capacitor C4013 attains nearly full charge. The delay gate inverts the developed logic-high output from the delay amplifier, sending a logic-low input signal to gate AND-3. A logic-high output thus appears on IC pin 21, which shuts off the threading motor, thus averting excessive tape stress or breakage.

Eject or unload

Eject mode is another term for unthreading the tape, returning it to the cassette and raising the cassette-lift mechanism to remove the cassette.

Basically, unthreading can proceed whenever the EJECT button is depressed. Figure 1 shows that Main Eject switch S4004 has four segments. Switch segments S4004-1 and S4004-2 reverse the DC voltage that is applied to the threading motor from Q4010. The motor runs in the opposite direction, and the gearing system now drives the threading ring back clockwise toward the tape-unloaded position.

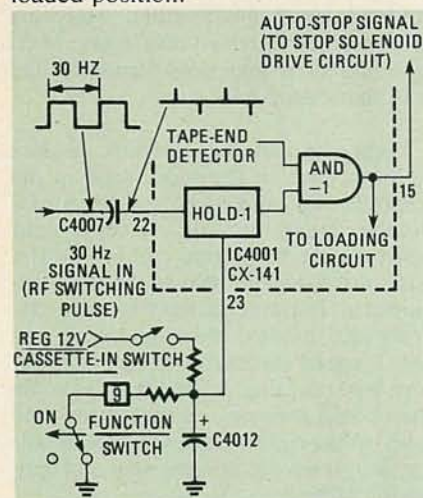

FIG. 2—THREADING LOGIC IC uses 30-Hz signal to verify that the video head drum is rotating.

Switch segment S4004-3 opens the voltage path from switches S6505 and S6506. Switch segment S4004-4 moves to its Eject position and discharges any voltage stored across capacitor C4009.

The turn-on logic for unthreading

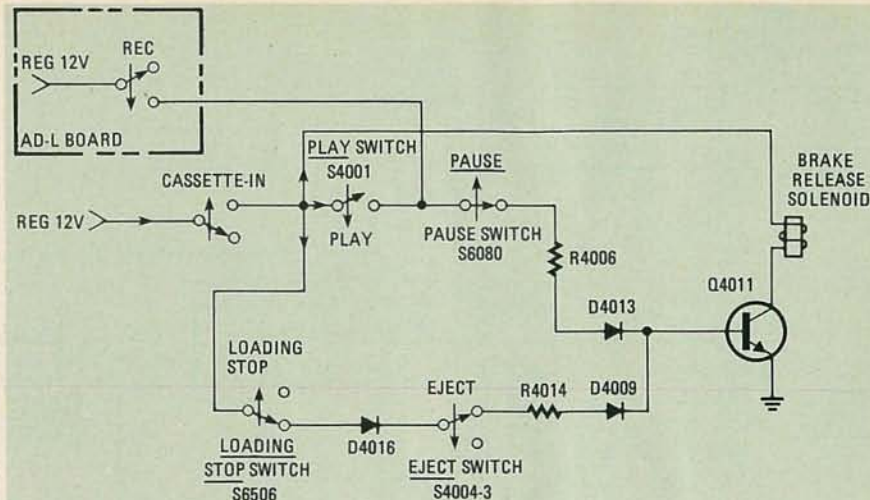

FIG. 3—BRAKE RELEASE ELECTRONICS control the brakes on both the take-up and supply reels. Brakes are released when solenoid is energized.

comes from a safety system. It is important that the take-up reel is operational when the threading ring begins unwinding tape from around the video-head drum. If not, the tape could wad up in the mechanism. Slack tape must be drawn back quickly into the cassette. The take-up turntable depends on the AC motor for its drive, so threading should not begin unless the AC motor is definitely running.

The turn-on voltage (logic) for the unthreading operation comes from this relation-sensing system. The head-switching pulse signal depends on the rotation of the head drum, which is belt-driven by the AC motor. Capacitor C4024, shown in Fig. 1, couples a sample of the switching signal into the threading-logic system.

Doubler diodes D4012 and D4014 rectify the signal. Positive DC develops across C4008, forward-biases D4011, and feeds a logic high to pin 19 of the IC. You have already traced through the remainder of the logic that activates the threading motor. Remember, though, that the motor is now turning backwards to unthread the tape.

One type of VCR uses circuits inside the threading-logic IC to verify the video-head drum rotation. See Fig. 2.

Capacitor C4007 couples a sample of the 30-Hz pulse-generator signal to a sample-and-hold stage in the IC. Capacitor C4012 is the charge-holding capacitor. As long as the signal is present, the logic output of the sample-and-hold stage stays high. When this logic-high output is fed to inhibit gate AND-1, it keeps the gate operative and feeding a logic high to gate AND-2 (Fig. 1) through threading IC pin 19.

When the signal ceases, indicating that the AC motor has stopped, C4012 discharges—leaving a logic low at pin 23. The sample-and-hold output goes low. Gate AND-1 inhibits gate AND-2, stopping any threading action. The same logic-low indication appears on the auto-stop signal line, and also trig-

gers a STOP solenoid into action.

Figure 2 shows that other safety shutoffs work through IC4001 and duplicate those shown in Fig. 1.

In Fig. 1, the delay system works for the unthreading operation just as for threading. If the unthreading is not finished in less than 10 seconds, the delay system shuts off the threading motor.

Brake-release electronics

During the loading or threading operations, the brakes on both the take-up and supply-reel turntables must be freed. In some VCR's a solenoid controls the brakes; in others, a mechanical link-up provides control. (In the rewind and unthreading modes, individual links manipulate the turntable brakes one at a time.)

Figure 3 shows the brake-release solenoid electronics. When the solenoid is at rest, the brakes are spring-applied to both take-up and supply-reel turntables. When activated, the solenoid releases both brakes. Inserting the cassette and dropping the lift compartment to its latched position turns on the cassette-in switch. This action applies 12-volts DC directly to the solenoid.

The bottom of the solenoid goes to ground through Q4011, but only when the transistor turns on. Figure 3 shows that there are two paths to the base of Q4011. One is via PLAY switch S4001, PAUSE switch S6080, R4006, and D4013. This path turns Q4011 on only when the PLAY pushbutton is down.

The other signal path goes through LOADING-STOP switch S6506, D4016, EJECT switch S4004-3, R4014 and D4009. Inserting a cassette applies DC to this *enable* path to Q4011. Therefore the transistor turns on and the brakes are released.

At the end of threading, switch S6506 opens and the brakes are set again. The same procedure occurs if the EJECT mode is selected; the mechanical link-ups control the take-up brake.

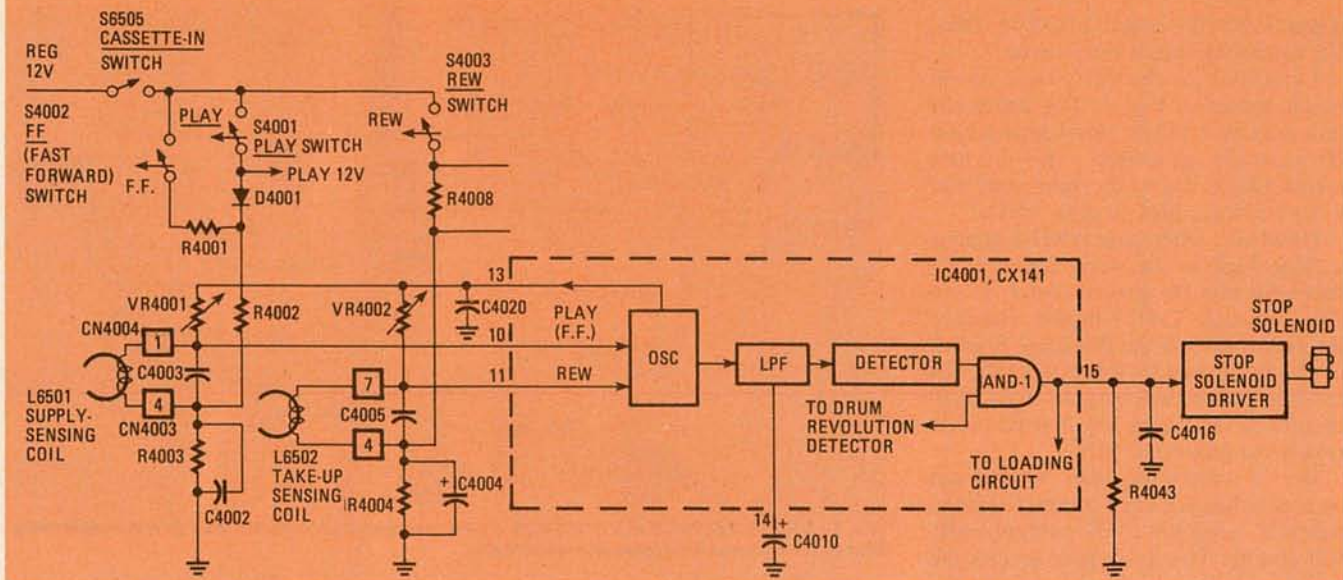

FIG. 4—END-OF-TAPE DETECTOR CIRCUIT uses sensing coils to detect the metallic leaders at both ends of the magnetic tape.

Once the tape has been threaded, both brakes can be released simultaneously by pressing either the RECORD or PLAY buttons (they're labelled FORWARD on some machines).

The braking system is simple, but you must remain aware of it. If a malfunction leaves the brakes set during the threading operation, the machine will shut down when the ten-second safety delay expires. That's because turntable brakes prevent the tape from being pulled out of the cassette.

Automatic stop signals

As you already know, due to the load-inhibit operation of gate AND-2 an automatic-stop signal from any stage in the machine can prevent loading or bring it to a halt. Hence, when you set out to troubleshoot a loading problem, you may track the fault to some far-away stage or section.

Now, refer again to Fig. 1. If you're

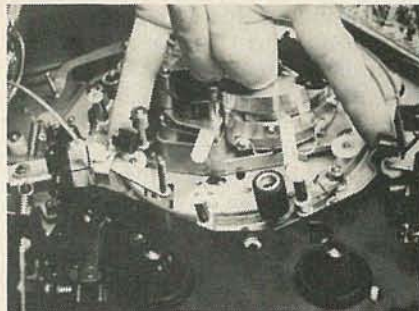

SENSING COILS detect metallic leaders at both ends of tape to provide an end-of-tape indication that is used to trigger automatic shutoff.

familiar with digital-logic diagnosis and tracing, you know there are two ways to check out inhibit operation of the AND-2 gate.

You can check the top input with a logic probe (or voltmeter). If the input measures logic low, the warning must be coming from elsewhere in the machine, and you troubleshoot there for the fault.

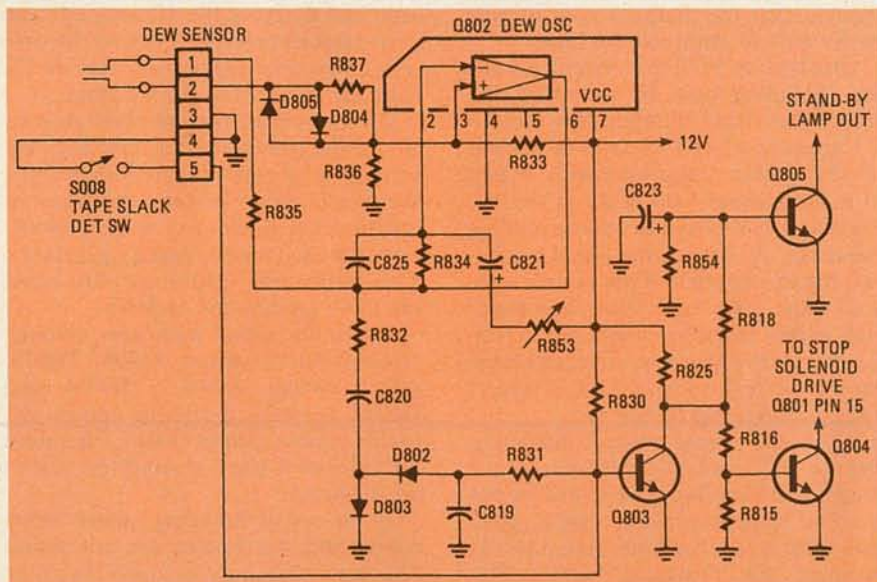

FIG. 5—DEW SENSOR CIRCUIT prevents operation if moisture condenses in the tape transport mechanism. Moisture can seriously damage tape.

If the inhibit input measures a logic high, the auto-stop signal line is OK, and the fault must lie inside the threading-logic system.

A less-desirable approach can be used: Disconnect the auto-stop line and feed a logic-high input to the inhibit side of gate AND-2. If all is well in the threading system, loading or unloading will start again. (Warning: Do not let the loading continue. The fault located "elsewhere" might cause damage, which is the reason for including the inhibit gate. Track down the trouble that is causing the auto-stop signal (a logic low).

Automatic-stop signals comprise part of the system control network. The threading/unthreading system you just studied is part of the system control, as are the brake release system and all mode pushbuttons. Here are other stages you must investigate when you detect a logic-low signal on the automatic-stop line.

Tape-end detector—Metallic leaders at both ends of the video tape in the cassette indicate end-of-tape. Two coils do the supply sensing. A supply-end sensing arm holds one coil beside the left-side tape path, next to the tape-tension arm. In the PLAY, RECORD, or FAST-FORWARD modes, this *supply-sensing coil* triggers automatic shutoff just before tape runs out. A fixed bracket holds the *takeup-sensing coil* next to the tape path on the right side beside the threading ring. It works the same way, but only during REWIND.

Figure 4 shows the switching that connects the sensing coils. DC from one of the forward-mode switches couples supply-sensing coil L6501 to the feedback loop of an oscillator. The signal from the oscillator is rectified and filtered in the detector, and then

continued on page 91

AFFORDABLE NTSC COLOR-BAR GENERATOR



A precision color-bar generator is desirable when servicing the color circuits of TV receivers and all types of video recorders. This new instrument brings TV-station accuracy to the shop at service-bench prices.

JACK DARR
SERVICE EDITOR

UP TO NOW, THERE HAVE BEEN TWO KINDS of TV test equipment: One kind is expensive, accurate and designed for use in TV stations and studios. The other kind is inexpensive, less accurate and made for TV service work. Now, the B&K-Precision Product Group of Dynascan Corp., 6460 W. Cortland St., Chicago, IL 60635 has come out with an instrument that is accurate enough for use in TV stations and studios and, at the same time, versatile and inexpensive enough to be valuable in the better TV service shops. In fact, the price is a real breakthrough at \$795.

Their new model 1250 NTSC (National Television Systems Committee) Color-Bar Generator will generate the same color-bar patterns used in TV stations with the same accuracy. It will also make four stock convergence patterns and all three color rasters (or any mix of the three). The RF output is on Channel 3 or Channel 4 and is crystal controlled. There is an IF output at 45.75 MHz, also crystal controlled. The sound subcarrier is at 4.5 MHz and may be frequency modulated with either a 1 kHz or 3 kHz audio signal that is generated internally. The audio signal is also available at a jack labelled *AUDIO OUT* for testing audio equipment, and there is a jack for an external audio input signal.

There is a composite video output that can be calibrated to the standard 1.0 volt P-P negative modulation, or can be varied up to 1.5 volts P-P. This is another standard signal for making many tests on video tape recorders, whether the big studio types or the home units. The video can be modulated by any of the standard patterns. A very accurate 3.579545-MHz

color subcarrier signal is available. All RF and video output impedances are 75 ohms and are equipped with BNC connectors. Audio inputs and outputs are phono jacks.

NTSC

Now, just what *is* an "NTSC color Signal?" Back in the early 1950's there was quite a hassle over two different color-TV systems. One was approved by the FCC and tried out: That was the CBS system which used a color wheel. The other, developed by RCA, was the all-electronic color system, with all of the matrixing done inside the picture tube. Eventually, that was the system chosen.

A national committee was appointed to study the RCA and other systems, and came up with a set of standards for transmitters and receivers. (That committee was the National Television Systems Committee.) In 1953, after some years of testing, deliberation and probably quite a bit of arguing, they selected what are now the NTSC Standards. The color TV systems now in use in Europe—PAL, and the French SECAM—were considered, tested and not chosen.

The NTSC system has worked very well so far; there have been no major alterations since its adoption. One of the headaches was coming up with a system that was fully compatible with black-and-white TV.

The NTSC Standards cover everything—the TV signal transmitted from the station, color modulation, and you name it. Thus, TV station engineers now had a set of standards to go by in setting up their equipment; and receiver

designers used those standards for making color TV receivers.

Now we come to the nitty-gritty: They also specified an NTSC Standard color-bar pattern that could be used in setting up TV cameras, monitors, and color TV receivers as well. There are several of these patterns, intended for use in checking the ability of TV equipment to reproduce the transmitted signal exactly.

At first, only TV stations had generators capable of producing the NTSC pattern. They were big and expensive, so only very few (if any) TV shops had them. Now, we have an NTSC generator that is not only accurate enough for a TV station but also can be afforded by a service shop. Somewhat simpler and less accurate types had been developed for the service shop, but they had some disadvantages, especially if you wanted precision.

The NTSC color bars

Let's go into the NTSC color-bar pattern a little more; there's more to it than meets the eye. Figure 1 shows the waveform of one line of the NTSC color-bar pattern. On the screen it looks like an ordinary color-bar pattern, with colors in a different place than we're used to. The first bar is pure white; next, in a logical progression comes yellow, which is nearest to a white. Then comes cyan (blue-green), green, magenta (blue-red), red, blue, and finally a black bar. It progresses from the brightest color, nearest to white, to the darkest, blue, which is nearest to black. The color signals are carefully controlled both in phase *and* in amplitude. Each of the colors is fully saturated; that is the difference between the NTSC sig-

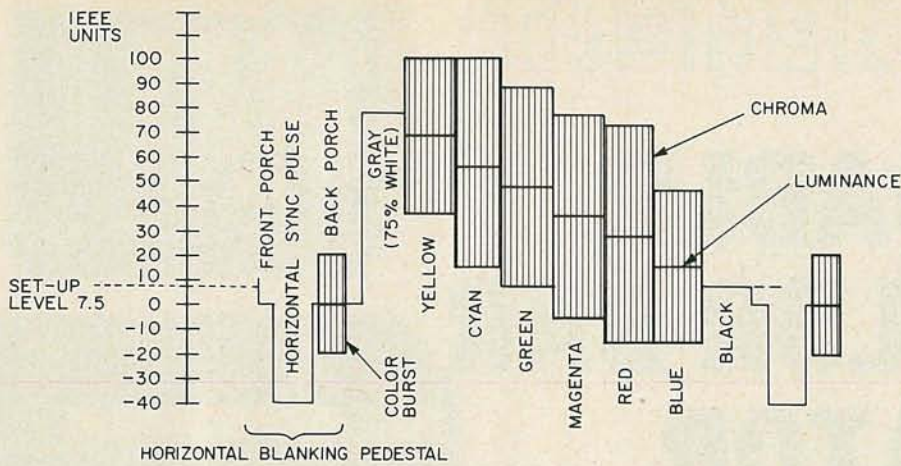

LUMINANCE	0	-40	0	77	69	56	48	36	28	15	7.5
CHROMA AMPLITUDE	-	-	40	-	62	88	82	82	88	62	-
VECTOR (FROM B-Y)	-	-	180°	-	167°	284°	241°	61°	104°	347°	-

Fig. 1—NTSC COLOR BAR waveform for one horizontal line. The waveform is 1 volt P-P and is divided into 140 IEEE units. Note the difference in luminance levels of the different colors and the staircase pattern.

nal and that of lower-priced generators. With lower-priced generators, the color bars are all at the same amplitude, and some are over-saturated.

The NTSC composite video signal is exactly 1.0 volt peak-to-peak. It is divided into 140 equal units, called "IEEE units." At first they were "IRE units" from Institute of Radio Engineers, but when this was changed to IEEE (Institute of Electrical and Electronic Engineers), the name of the units was also changed. Note, in Fig. 1, that the zero-reference for the composite video signal is the blanking level—the porches of the horizontal sync pulses are at -40 IEEE units; the sync pulse is approximately 0.3 volt. Note that the black level is at +7.5 units. That is called the setup level and is the black reference for the picture. Levels of luminance between 7.5 and 100 units produce various shades of gray. The brightest white is 100 units, or 100% and it is equivalent to zero modulation of the composite RF signal. The sync tips are at -40 units, which corresponds to maximum modulation of the RF carrier—hence the strongest signal. The advantage is that the weakest signal—where interference can cause snow—is in the white parts of the picture where snow isn't so easy to see.

Now, we come to the really different part: Note that each color is at a different luminance level. Note also that there is a difference between some colors. That was done so that each color will have precisely the right amplitude (of the chroma carrier) to give it full saturation—no more and no less. Note that the luminance has a "staircase" effect. That is a very important part of it. The staircase is another standard NTSC signal.

As previously mentioned, on the screen

it looks like a color-bar signal. On the scope it doesn't! Therein lies a major advantage. For example, when you feed the NTSC signal into the antenna you should see an exact duplicate at the video detector output. (Set the scope to display it at exactly 1.0 volt P-P). Feed in a video signal from the model 1250 to the upper channel of a dual-trace scope. (All RF, IF and video outputs may be used at the same time.) If there is any difference between the two waveforms, you have problems in the RF or IF circuits of the receiver. In fact, you can superimpose the two waveforms to make comparison easier. The model 1250 also provides scope trigger signals at vertical and horizontal frequencies, so that the patterns will be steady. Any distortion or poor frequency response, etc., will make the waveforms look different.

The -IWQ signal.

If you've ever seen a network color-bar signal (usually switched in by accident!) you've probably seen black and white bars across the bottom. That is another NTSC standard signal, called the "-IWQ." It's composed of equal parts of the signal

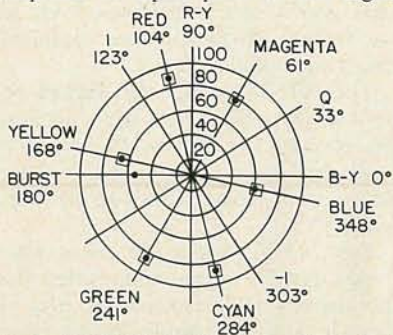

FIG. 2—NTSC VECTORSCOPE graticule. Each color phase produces a dot rather than the familiar "petal."

called -I (which is chroma at a phase angle of 303° from burst), a fully saturated 100 units white bar and the Q signal (which is chroma at 33° from burst). Both the I and Q signals are at a level of 40 units. The last bar you see at the right is a black signal at the 7.5 unit reference level.

The IWQ signal is used mainly in studio phase measurements, in video processors, amplifiers, and similar items. For an eyeball test, the first quarter of the pattern should be black, then you see pure white, then black again for the rest. Transitions between black and white should be sharp.

The NTSC color-bar pattern can also be used for vectorscope analysis. That is the method used in TV stations. The pattern is basically similar to the familiar "flower" pattern, but it has no petals; each color makes a single dot on a vectorscope. Fig. 2 shows a vectorscope ratio graticule for use with the NTSC color-bar pattern. Note the small boxes for each color or combination of colors; each color must fall within its box. If it isn't in the box, there's an incorrect phase.

One novel test is possible with this graticule and the model 1250. The model 1250 will make a pix raster of each primary color—red, blue, or green. You can also use two colors at once to make combinations such as cyan. On the vectorscope only the dots for the color in use will be seen. Very small phase shifts can be detected by this method. Note that the colors, burst, I, Q, etc., are all marked on the graticule.

The Staircase

Another NTSC standard pattern that is available with the model 1250 is the "staircase." The reason for the name should be obvious from the waveform. There are actually three different staircase patterns available, each with a different purpose. They are shown in Fig. 3. The pattern in Fig. 3-a is just 5 steps of video luminance without modulation. The screen will show a pattern of vertical bars, starting at left with black and going to white. The steps are 20 IEEE units each. These bars can be used to check for luminance response and linearity. It's the same procedure as with the color bars: Use a comparison pattern on one channel of the scope. All steps in the signal at the video detector must be exactly the same amplitude as the signal from the model 1250. Turn the CHROMA switch on the front panel of the model 1250 off to get this signal.

Figure 3-b shows one of the two modulated staircase patterns. Each step is modulated 20 IEEE units with chroma at burst phase. To get this signal, push the LOW STAIRCASE button. Figure 3-c shows the high staircase—identical but modulated at 40 IEEE units.

What can you do with these two unmodulated staircase signals? You can make

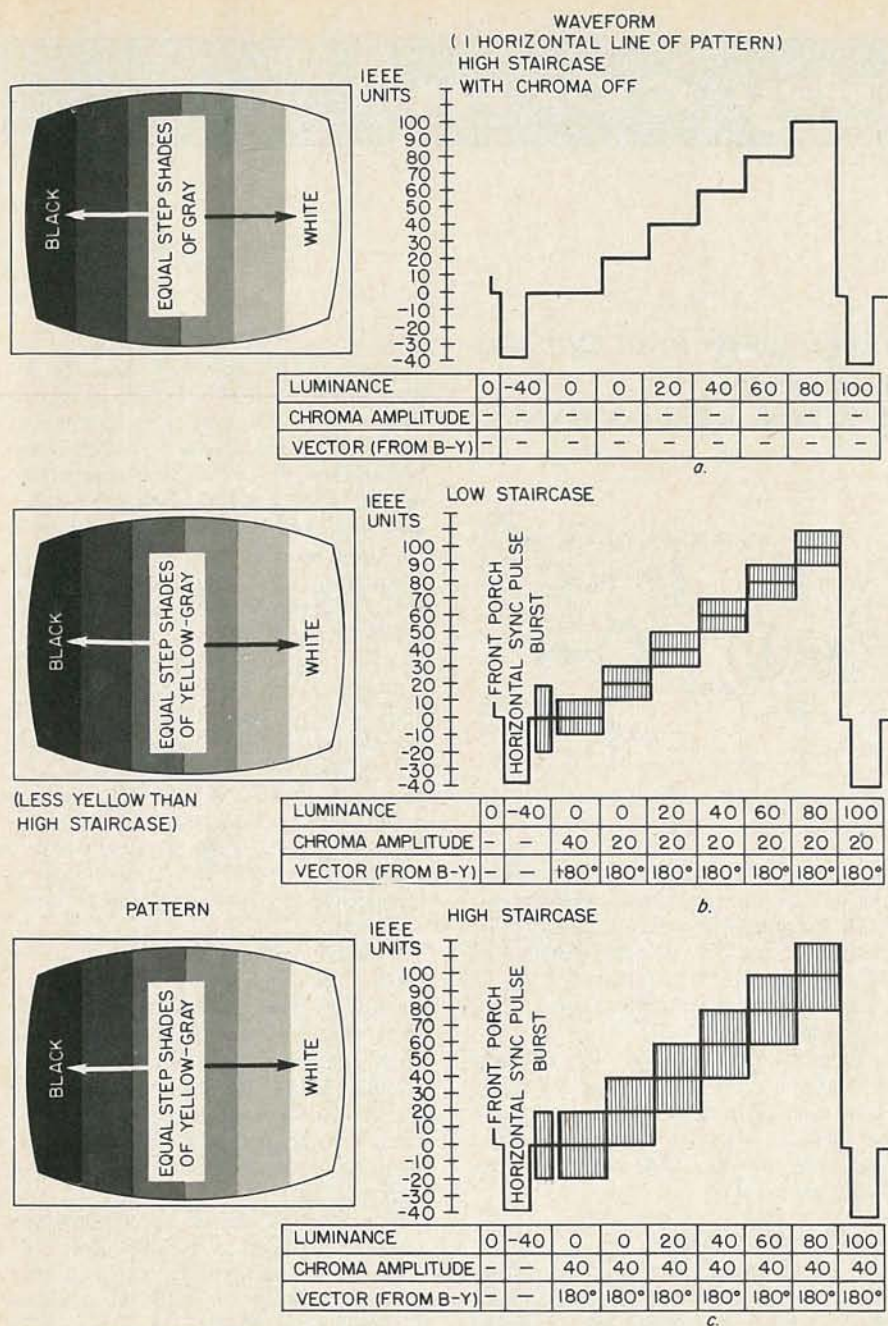

FIG. 3—NTSC STAIRCASE waveforms. The waveform shown in *a* contains only luminance and produces a series of bars on the picture screen from black to white. The low staircase waveform shown in *b* contains 20 IEEU unit chroma modulation. The high staircase waveform shown in *c* contains 40 IEEU unit chroma modulation. The waveforms shown in *b* and *c* are used to measure differential gain.

tests that up to now have been very difficult. They are for differential gain and differential phase. Either of these can cause color distortion. The TV studios use these two signals for checking video processing equipment of all kinds—video monitors, VTR's, etc. Now, with these two waveforms, you can check for these parameters.

Differential gain means that the chroma amplitude should not vary as the luminance is varied. That is done for you automatically; the staircase steps the luminance from zero to maximum; the amplitude of the chroma signal must remain the same as the input. Any variation means that something is wrong in the equipment. The two modulation levels let

you check so you can be sure there is no difference between low and high modulation levels.

The chroma phase must not shift as the luminance is varied from 0 to 100%. If it does, you have differential phase-shift problems. To check that, the staircase pattern is displayed on a vectorscope with chroma modulation. If there is any differential phase shift as the luminance steps up, it will show up as an angular shift of the dot on the graticule. Use both low and high modulation to make sure.

On the bench

The model 1250 can be a fast and accurate aid to any kind of service work: color TV sets, VTR's, VCR's, or you name it.

The front panel of the unit is laid out so that switching can be very easy. There are 15 pushbutton switches that are functionally divided into three groups. The NTSC patterns are all selected by the right-hand group, along with the FULL BURST, TOP BURST (that one turns off the burst for only the top fourth of the screen on the color bars and raster patterns: it's used to check the sync), CHROMA, -1WQ, LOW STAIRCASE and HIGH STAIRCASE pushbutton switches.

The next group, from right to left, are the four convergence pattern switches: DOTS, CROSSHATCH, DOT HATCH, and CENTER CROSS. Those are mechanically interlocked with the NTSC switches; if any of those is turned on the other patterns are turned off. Because of interlaced scanning, you may see a small vertical jitter in the convergence patterns. That is normal and won't affect convergence adjustments. It does *not* indicate any problems in vertical sync.

Last, but definitely not least, are the RASTER switches: one for each primary color and a raster ON-OFF switch. The raster ON-OFF switch is interlocked so that it turns off the NTSC or convergence switches that are on. There are three color raster buttons; you can make *eight* different color rasters with them. All switches off produces black at the 7.5 unit reference level. This is used for adjusting the receiver brightness control. Pure red, green, or blue rasters are for purity adjustments. Red was used in many older sets and some new ones. In some sets with in-line pix tubes, the green raster is for purity. By pushing any two at once you can get the combination of the two colors. Red and green give yellow, and so on. The three pure colors could be handy for checking the guns of a picture tube for equal emission. Pushing all three primaries at once gives you a pure white raster at a 75-unit level.

The IF output can be used for tuner substitution. It has a level of 10 mV with no load, which is ample.

If you use all possible combinations of switching, you can get a total of 28 different patterns! The manual lists them.

For TV and VTR testing, the composite video signal is available through a jack on the front panel. It has a gain control that will vary the level from 0 to 1.5 volts P-P. Turning the control fully counter clockwise until a click is heard sets the output at the standard level of 1.0 volt P-P with the sync negative going. That is the standard video input used for many VTR tests. Any of the patterns can be used to modulate the video signal. You can feed the NTSC color bar signal into a VTR, record it, then play it back to make sure it comes out the same as it went in. If you have sound problems in the VTR, you can feed an RF signal into its tuner, with either of the two audio frequencies as modulation.

continued on page 93

hobby corner

An inexpensive wide bandwidth preamplifier in kit form that has many applications on your workbench.

EARL "DOC" SAVAGE, K4SDS, HOBBY EDITOR

A WHILE BACK I WAS WORKING WITH SOME low-level RF circuits and discovered that my frequency counter would not pick up those feeble signals. Needing that information, I had two choices. One was to rebuild the counter-input stage to provide more gain. That seemed to be too much trouble so I chose to add a preamplifier.

International Crystal (10 North Lee St. Oklahoma City, OK 73102) has a little two-stage, broadband-amplifier kit that looked good for this application. The BAX-1 has 30 dB to 6 dB gain over a range of 20 Hz to 150 MHz—that was just what my counter needed. I put it together in about ten minutes and temporarily inserted it between the RF circuit and the counter.

The setup worked so well that I started taking the counter cabinet apart to stick the amplifier inside. Fortunately, I decided to try a few more things before wiring it in. Here is what happened.

With the BAX-1 in the input line, my AC voltmeter was much more sensitive. Of course, all measurements were relative instead of absolute but those really weak ones were in there.

The BAX on the output of a little crystal oscillator made an excellent low-power transmitter. Placed between the antenna and a shortwave receiver, it amplified the incoming signals and thus enabled the receiver to pick up weaker signals.

That's just for starters. There is no reason why the BAX can't be used to increase the sensitivity of a microphone. I want to try it on my TV antenna and on the FM in the car. The BAX is quite versatile and, in some applications, should be even better with a tuned circuit or filter before and/or after it. Needless to say, mine hasn't gotten into the counter cabinet yet and probably won't, at least for a good long while.

The BAX-1 (\$6.67 including postage in U.S.A.) contains a circuit board, all parts, and mounting hardware. You can get the kit or build your own from scratch. With International's permission, the circuit is shown in Fig. 1. There is nothing critical about its construction.

In a couple of applications I found that some method was needed to vary the gain (there was too much). Of course, that can

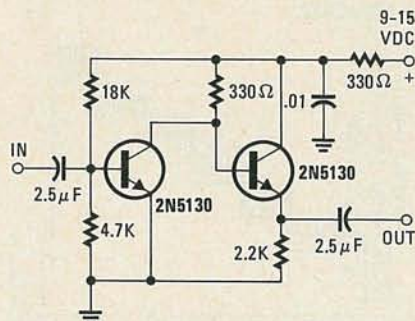

FIG. 1

be done in several ways; for example: a pot used as a voltage divider at the input, or by varying the bias on a transistor. The easiest way for me was to vary the applied voltage. The BAX-1 specifies 9 to 15 volts but it works fine at much lower voltages, too.

By the way, International has several other interesting little kits that I really want to investigate. If you have used any of them in unusual applications, how about sharing your experiences with me and other readers?

Technical training

In past columns I have mentioned from time to time the need for the serious hobbyist to learn more than just tinkering will provide. The real pleasure of electronics is found *beyond* the stage of following "cookbook" building plans (though that is a good place to begin). The satisfaction that comes from experimenting, modifying and, ultimately, designing is hard to beat.

Going beyond the simple matter of just following instructions requires a basic knowledge. Several suggestions have been made for acquiring that base. Among the suggestions was independent study—a method probably most suited to a majority of the hobbyists.

One of the problems with independent study has been finding the right materials. I have told you about study materials from the Heath Company and the American Radio Relay League, among others. Recently, I have discovered some excellent materials from the McGraw-Hill Book Company.

McGraw-Hill publishes textbooks on a

wide range of technical subjects. In the electricity and electronics area, the list goes on and on from servicing to applied mathematics. Of particular interest at this point are a couple of texts that I have had an opportunity to examine quite thoroughly. They are: *Electronics: Principles and Applications* by C. A. Schuler, with its Activities Manual (\$16.00 and \$7.50, respectively) and *Digital Electronics* by R. L. Tokheim, with its Activities Manual (\$8.50 and \$5.75).

As a professional educator, I have examined many textbooks over the years. Those two are near if not at the top in instructional quality. Both are unusually well-written and well-presented. Organization of content, clarity of circuit diagrams, and explanatory text are outstanding. Best of all, from our standpoint, is that those textbooks are as well suited to independent study as they are to classroom use.

I recommend either or both of those books, depending upon your interests and needs, for building that base of knowledge which will enable you to get the most from your hobby. If you choose to go that route, I also recommend that you get the corresponding Activities Manual(s). They are not necessary to an understanding of the texts but they will be an additional help.

The Manuals contain specific lab-type activities to illustrate and "nail down" the concepts in the texts. Components that may be needed to carry out the activities are readily available and inexpensive. (You probably have most of them in your junk box.)

It is unlikely that you can find those books and manuals locally. Exact prices and ordering information can be secured from Gordon Rockmaker, Editor in Chief, Electricity/Electronics, Gregg Division, McGraw-Hill Book Company, 1221 Avenue of the Americas, New York, NY 10020.

Again, I urge those of you who have not done so to do some studying and enjoy your "work" more!

Photo timer

J. D. Miner of Lima, OH has written about adapting a clock module for photographic use. Color processing, as you know, requires several sequential timed steps. Of course you can do that, J.D. It will start at zero and read elapsed minutes and seconds.

Most, if not all, modules have a *reset*

BIG 2 1/2" DISPLAY!



SOLID STATE CLOCK/CALENDAR KIT

0101 Displays time of day, date or alternate between both automatically. May be connected to 8 ohm speaker for alarm clock. Operates from 120 VAC 60 Hz.
\$49.95 Walnut case extra, **\$24.95**

AUTO CLOCK CALENDAR KIT



0106 Displays either hours and minutes, month and day, or seconds. Requires only 2 mA of current while ignition is off. Also operates on 9V battery. Mounts easily in compact two-inch enclosure (Not included)

\$29.95
 \$39.95 assembled

UNIVERSAL DESIGNER KIT

6100 Indispensable aid to digital IC design. 2 pushbuttons, 2 read-outs, 4 switch outputs, 8 LEDs, 2 generators, 2 counters, 5V supply pins. Shown with CSC QT47S Breadboard (not included)

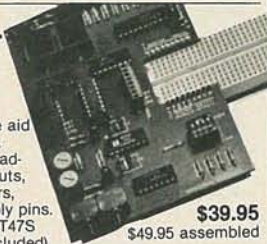

\$39.95
 \$49.95 assembled



SEND FOR **FREE** 8-PAGE CATALOG Add \$2.50 per order postage and handling.



PACCOM

14905 N.E. 40th Street, R-4
 Redmond, WA 98052 (206) 883-9200

CIRCLE 17 ON FREE INFORMATION CARD

capability. Take the National 5316 as an example: Activate the seconds display (pin 32) and then *both* the slow (pin 33) and fast (pin 34) set. The clock resets to midnight and the display, showing minutes and seconds, starts at zero.

As a matter of fact, the off-the-shelf commerial clocks that I have seen do exactly the same thing. You might make it a little more convenient as a timer by wiring the slow and fast pins to one double-pole switch.

But, J.D., let me pass along another way you may like. Some 25 years ago, when I was deep into photography, I ran across an article in one of the photography magazines about using a tape recorder to time color processing. What I did was to make a tape recording of some favorite music and, at appropriate times, faded to instructions; e.g., "in 30 seconds do thus-and-so. . . . now." Not only did the tape do the timing and free me from watching the clock, but it provided instructions and music to "agitate" by! R-E



American Heart Association

WE'RE FIGHTING FOR YOUR LIFE

The world of electronics gee-wizardry



-YOURS FREE.

32-pages of test instruments—from the latest digital multimeters to the famous EICO scopes. Security systems. Automotive and hobbyist products. Kits and assembled. EICO quality. EICO value. For FREE catalog, check reader service card or send 50¢ for first class mail.

EICO 108 New South Road
 Hicksville, N.Y. 11801

CIRCLE 40 ON FREE INFORMATION CARD

PTS 8001

Component Analyzer



Solid state component tester works in or out of circuit. Simple hook-up to any standard oscilloscope. High, medium and low range switch for matching the impedance of the component being tested.
 Dealer Net \$54.95

See the Yellow Pages for the Stocking Distributor or PTS Servicenter Nearest You.



PTS ELECTRONICS, INC.
 The Only Name You Need To Know

P.O. Box 272 Bloomington, IN 47402 812-824-9331

CIRCLE 59 ON FREE INFORMATION CARD

THE BIG PLUS + Graphic Equalizer

ASSEMBLED **\$200⁰⁰**
 KIT **\$110⁰⁰**



LOADED with Quality Features!

- Stereo . . . Eleven Bands Per Channel • Extremely Low Noise & Distortion • LED Peak Indicators • Center Detent ("flat") sliders • Built-in "record" Switching • Line and Microphone Level Inputs/Outputs • Regulated Power Supply • Fully Guaranteed • Horizontal or Vertical Cabinets • Kit or Fully Assembled • Plus Much, Much More!

Absolutely equals or exceeds overall performance and features of any graphic equalizer made today!

AARON-GAVIN INSTRUMENTS, INC.
 17231 Corla Avenue Tustin, California 92680

Yes! I've enclosed \$ _____; RUSH me: cabinet send brochure
 assembled equalizers at \$200.00, p.p.d. un-assembled equalizer kits at \$110.00, p.p.d. Horizontal (flat) Vertical (up-right)
 California residents include 6% sales tax Visa & Master Charge orders accepted

Name _____ Card No. _____
 Address _____ Exp. Date _____ Bank No. _____
 City _____ State _____ Zip _____

Dealer inquiries invited

CIRCLE 31 ON FREE INFORMATION CARD

APRIL 1980

73

displayed. This, of course, is due to the latches or the 8255 IC's in the interface. Thus, the microcomputer can output numeric information once and then go on to perform any other required operations.

Another interfacing method is digit *multiplexing*. Multiplexing reduces the display-interface electronics (number of parts) to a minimum; however, at the expense of longer and more complex display-driver software. Multiplexing a display consists of enabling or turning on one particular digit with a *digit-enable code* and providing the BCD numeric information for that digit to a multidigit display interface. In this way each digit is turned on, one at a time, as the actual BCD data for each digit is provided. Multiplexing is usually only used with multidigit displays.

As an example, let's suppose the number "237" is to be displayed on a 3-digit multiplexed display. To display this number the BCD value for the digit "7" would be output to the interface along with the digit-enable code for the right-hand display. After a short period (1 μ s to 10 μ s) the BCD value for number "3" would be output along with the digit-enable code for the middle digit. Again, after a short delay, the BCD value for the number "2" and the digit-enable code for the left-hand display would be output to the interface. By performing this sequence 50 or more times every second, each digit in the display *appears* to be on *all the time*. This display method is used in hand-held calculators. Even though the digits are being turned on and off, it happens too fast for the eye to see. The interface for a 10-digit multiplexed display is shown in Fig. 2.

When an OUT125 instruction is executed, bits D3-D0 of register A determines which one of the 10 digits in the display will be enabled (turned on). Therefore, these 4 bits constitute the digit-enable code. Bits D3-D0 are latched (7475) and are decoded with a one-of-10 decoder (7442). The decoded outputs of the 7442 are wired to the common cathodes of the individual digits in the display. Bits D7-D4 provide the BCD code of the value to be displayed (0-9). These bits are also latched (7475) and are decoded by a 7-segment decoder/driver (DS8857, manufactured by National Semiconductor, Santa Clara, CA):

An additional display method involves the use of an external display controller IC to control the multiplexed display. The Intel Corporation manufactures some of these IC's that are compatible with the 4004/4040, 8080 and 8085; these IC's are the 4269, 8279 and 8279-5. National Semiconductor Corporation also has developed two display controller IC's that can be used with 6-digit displays. One of the devices (the MM74C912) can be used to display 0-9 and the other (the MM74C917) can be used to display hexadecimal numbers. **R-E**

When will the Personal Computer Explosion touch YOU?

Are you prepared for the explosive transformation? Right in your own home? Electronic mail. Personalized investment analysis. Foreign language tutorial. Home energy management. Robots. Computer music. Secretarial service. Diet and menu planning. And more, more, more.

onComputing™, the new McGraw-Hill quarterly, prepares you for the enormous

changes coming during the 1980's (Some are already here). **onComputing™** explains in nontechnical language what personal computers are, how they work, and how you can use them at home, for fun and profit.

Don't let the personal computer explosion catch you off guard. Know what's happening and help make it happen! Prepare now for the exciting future with **onComputing™**!

Start your subscription today.
Call Toll Free 800-258-5485

onComputing™ Subscription Dept. P.O. Box 307, Martinsville, NJ 08836

DOMESTIC subscription rate:

U.S. 1 yr. (4 issues) @ \$8.50 Canada & Mexico, 1 yr. (4 issues) @ \$10.00

FOREIGN (to expedite service, please remit in U.S. funds drawn on a U.S. bank.)

Europe (and all other countries, except above), 1 yr. @ \$12.00 — surface delivery.

Bill Visa Bill Master Charge Bill me (North America only)

Card Number

Expiration

Signature

Name (please print)

Street/Apartment Number

City

State/Province/Country Code

7840

Please allow 6-8 weeks for processing.

CIRCLE 15 ON FREE INFORMATION CARD

© onComputing, Inc. 1980

APRIL 1980

75

The Clock of the 80's!

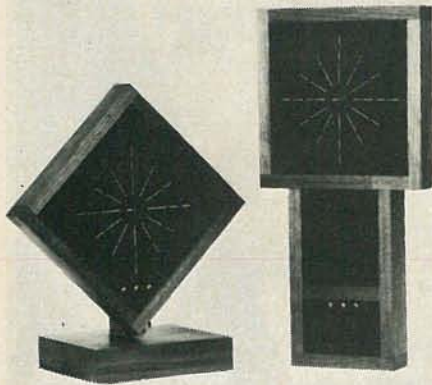

A truly digital movement with traditional analog display. The time is shown by three electronic eyes as they move within three concentric circles.

If you love contemporary design but want the more traditional, here is *the* clock for you. In creating our own version of the ever popular Grandfather Clock, we use the electronic eye to display each second, minute, and hour, and also the simulated pendulum motion.

The diagonal model which has no simulated pendulum is available for wall mounting or with base as a desk clock.

Our synthesized sounds composed of tic toc, modified Westminster Chimes and Bongs are available for any AMELECT clock. The chimes and bongs are composed of six frequencies, providing realistic bell sounds. They are totally within clock cabinet.

The AMELECT clocks, cabinets may be your choice of Cherry, Mahogany, Maple, or Walnut hardwoods.

SIZES

Diagonal Clock—14" tall on base
Grandpa Clock—19 1/2" tall

	Assembled	Kit	Base
CL7401A Diagonal	\$79.50	\$59.50	\$9.60
CL7402 Grandpa	\$99.50	\$75.50	
Chimes	\$45.00	\$39.00	

Indiana residents include 4% sales tax.
Shipping and Handling \$3.50
To order write or call 1-219-297-3320

Allow 4 to 6 weeks for delivery

AMELECT
INCORPORATED

Postoffice Box 367

GOODLAND, INDIANA 47948

Phone 219-297-3320

CIRCLE 69 ON FREE INFORMATION CARD

computer products

More information on computer products is available.
Use the Free Information Card inside the back cover.

PARALLEL INTERFACE, model VPI-1, is an SS-50 bus-compatible board providing four I/O ports to interface keyboard, printers, etc., with CPU's. Two MC6820 peripheral interface adapters, two MC6522 versatile interface adapters or a combination of both give a total of 40 I/O lines (36 of them for input/output, 4 for input only) to hookup to IC power drivers and buffers. The MC6522 has

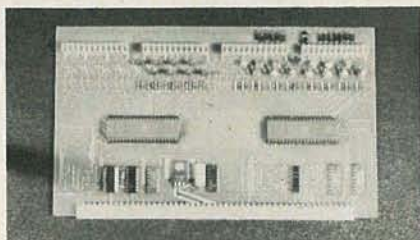

CIRCLE 121 ON FREE INFORMATION CARD

two programmable timers that provide for real-time interrupts and waveform generation. Address selection and port selection are DIP-switch or jumper-selectable. Prices: *model VPI-1* board, \$32.50, plus \$2.50 per order shipping and handling; documentation, \$5 ppd. Ohio residents add state and local taxes where applicable.—**F & D Associates**, 1210 Todd Rd., New Plymouth, OH 45654.

SINGLE-BOARD COMPUTER SYSTEM, Superboard II, is a complete personal computing system on one board. It provides 8K BASIC in ROM; 8K RAM; 6502 microprocessor; user-programmable 53-key keyboard; video display interface, audio cassette interface; machine-code monitor; and I/O ports. Video display provides upper/lower case, graphics and game characters for up to 156 X 256-point resolution. Available options include expander board with 24K RAM, dual mini-floppy disc; port adapter for printer or modem;

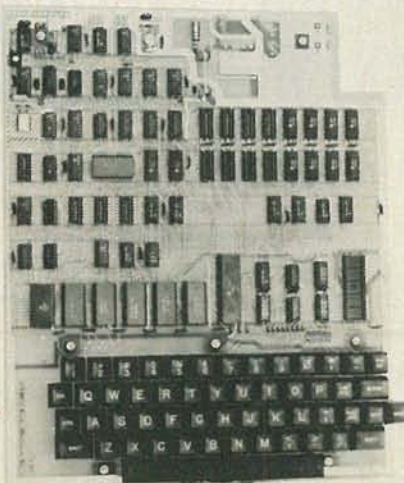

CIRCLE 122 ON FREE INFORMATION CARD

and 48-line expansion interface. Also available are an assembler/editor, extended machine-code monitor and complete software library. System is powered by +5-VDC 3-amp supply (not included), and is also available as *Challenger 1P* complete with case and on-board power supply. Suggested retail prices: *Superboard II*, \$279; *Challenger 1P*, \$349.—**Ohio Scientific, Inc.**, 1333 S. Chillicothe Rd., Aurora, OH 44202.

16K EPROM BOARD uses 2708 16K memories compatible with Digital Group 2708 systems. Features 8K or 16K selectability with each 8K memory block jumper to any 8K boundary and

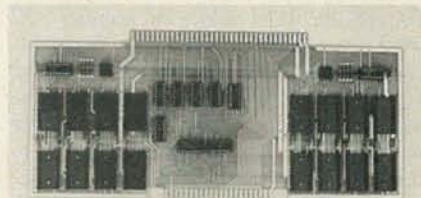

CIRCLE 123 ON FREE INFORMATION CARD

fully buffered address and data lines. The board comes assembled and ready for EPROM insertion. Price per board, \$99.50; 2708 EPROM's, \$12.50 each.—**PEC**, 21720 Alcazar Ave., Cupertino, CA 95014.

SS-50 BUS VIDEO BOARD has an 80 X 24 format with hardware scrolling, X-Y addressable cursor and multiple-character generators that allow user-programmable character sets. The board contains a 2716 EPROM with 128 upper

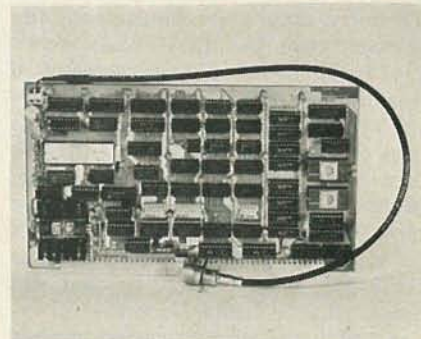

CIRCLE 124 ON FREE INFORMATION CARD

and lower case ASCII character set, plus a TMS 2716 socket for optional 128-character set; plus 2K RAM. User can create own graphics for storage on PROM, disc or tape. The board can be used to display up to 256 characters simultaneously, either in inverse or normal mode, at half or full intensity. The board is addressable to any 2K boundary; addressing allows multiple boards at the same address. Available software includes *GMXBUG* video-based 3K ROM monitor, separate driver routines and a program that lets you create your own characters. Price: \$458.76.—**Gimix, Inc.**, 1337 W. 37th Pl., Chicago, IL 60609.

R-E

RELAY MULTIVIBRATOR

AMONG THE EARLIER MULTIVIBRATORS, one of the simpler models was a device using two relays and one or more capacitors and resistors to control the timing cycle and operating frequency. When it comes to small size and speed, all is in favor of the solid-state electronic multivibrator.

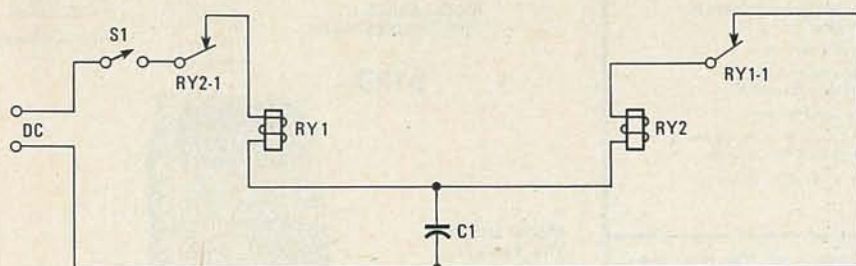

FIG. 1

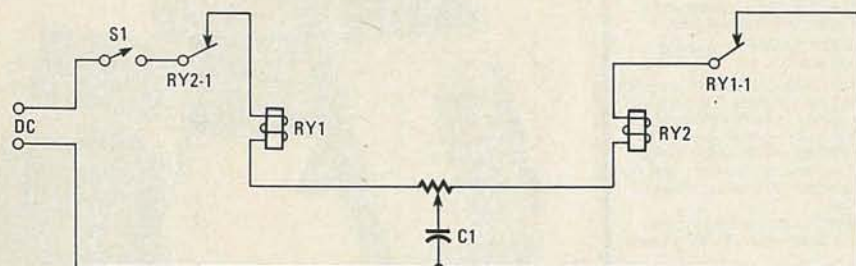

FIG. 2

However, from time to time we may need the simplicity of the relay multivibrator. Most circuits shown in literature use the charging of a capacitor to control the timing and one or more resistors to limit the discharge current so it won't damage the relay contacts. The circuit in Fig. 1 was developed around two relays and a single capacitor to perform the same tasks as the more elaborate circuits.

Circuit operation is as follows: When switch S1 is first closed, the C1 charging

current activates relay RY1 and causes its normally closed contacts (RY1-1) to open. When the C1 charging current falls below the hold-in rating of RY1, the relay releases and closes contact RY1-1.

At that moment, the coil of RY2 is connected across C1. The capacitor starts to discharge and the discharge current energizes RY2 and causes contact RY2-1 to open. When the discharge current drops below RY2's hold-in current rat-

ing, contact RY2-1 closes to start the cycle anew. The multivibrator will switch back and forth between the relays at a frequency governed by the capacitance of C1, the resistance of the relay coils, the applied voltage, and the hold-in current of the relays. As the relays cycle, switching operations can be carried out as needed by auxiliary contacts on either or both relays.

A potentiometer can be inserted between the relays as in Fig. 2 so you can vary the cycling.—*J. Ofer*

NEW IDEAS

This column is devoted to new ideas, circuits, device applications, construction techniques, helpful hints, etc.

All published entries, upon publication, will earn \$25 plus a Circuit Board Holder, Standard Base and Tray Base Mount from Panavise Products, Inc. (See photo below.) Selections will be made at the sole discretion of the editorial staff of **Radio-Electronics**.

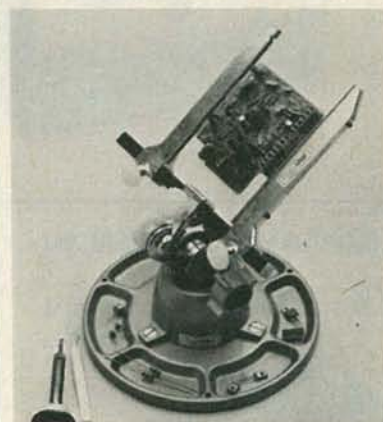

I agree to the above terms and grant **Radio-Electronics Magazine** the right to publish my idea. I declare that the attached idea is my own original material and that its publication does not violate any other copyright. I also declare that this material had not been previously published.

Title of Idea

Signature

Print Name

Date

Street

City

State

ZIP

Mail your idea along with this coupon to:

**New Ideas
Radio-Electronics
200 Park Ave. South
New York, NY 10003**

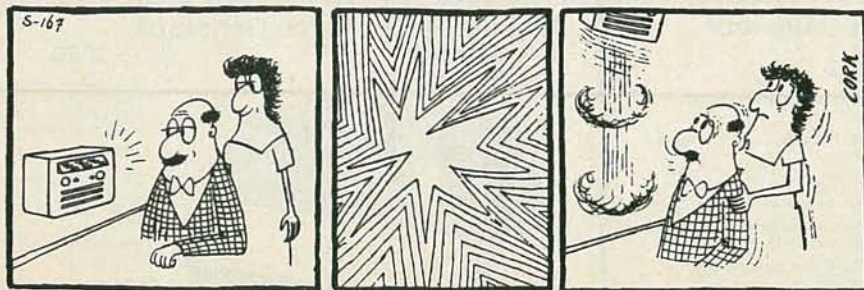

4.....3.....2.....1.....0.....LIFT OFF!!

HITACHI

VIZ formerly RCA

TRIPLETT



PHILIPS

HICKOK

FLUKE®

New Portable Digital Capacitance Meter

BK PRECISION



Call For Our Price

MODEL 820

- Measures capacitance from 0.1 pF to 1 Farad
- Resolves to 0.1 pF
- 10 ranges for accuracy and resolution
- 4 digit easy-to-read LED display
- 0.5% accuracy
- Special lead insertion jacks or banana jacks
- Fuse protected
- Uses either rechargeable or disposable batteries
- Overrange indication

FLUKE® **DIGITAL MULTIMETERS**

**Model 8022A:
The Troubleshooter**

\$139

- **Six functions**
 - dc voltage
 - ac voltage
 - dc current
 - ac current
 - resistance
 - diode test
- 3½-digit resolution
- 0.25% basic dc accuracy
- LCD display
- Overload protection



**Model 8020A:
The Analyst**

\$179

**Model 8024A:
The Investigator**

\$219



NEW

- **Seven functions**
 - dc voltage
 - ac voltage
 - dc current
 - ac current
 - resistance
 - diode test
 - conductance (1/R)
- 3½-digit resolution
- 0.1% basic dc accuracy
- LCD display
- Overload protection
- **Free case**
- Two year parts and labor warranty

- **Nine functions**
 - dc voltage
 - ac voltage
 - dc current
 - ac current
 - resistance
 - diode test
 - conductance (1/R)
 - logic level and continuity detect
 - temperature (K-type thermocouple)
- Peak hold on voltage and current function
- Selectable audible indicator for continuity or level detection
- 3½-digit resolution
- 0.1% basic dc accuracy
- LCD display
- Overload protection

**DATA PRECISION
Model 938**

0.1%, 3½-Digit, LCD DIGITAL CAPACITANCE METER



\$149

- **WIDE RANGING** — from 199.9 pF full scale (0.1 pF resolution) up to 1999 µF full scale, in eight ranges...virtually every capacitance you'll ever need to measure.
- **FAST AND EASY TO USE** — Direct reading, pushbutton ranges. Just plug in and read.
- **EXCEPTIONALLY ACCURATE** — provides ±0.1% basic accuracy.
- **TOUGH AND COMPACT** — Built to take rough usage without loss of calibration accuracy. Fits and goes anywhere; takes very little bench space; always handy for quick capacitance checkout, matching, calibration, and tracking.
- **PORTABLE** — Palm-sized, light-weight, operates up to approximately 200 hours on a single 9V alkaline battery.
- **EASY READING** — big, clear, high-contrast 3½-digit LCD display, a full 0.5" high, readable anywhere.
- **VALUE PACKED** — Outstanding measurement capability and dependability. Outperforms DC time-constant meters, and even bridges costing 2 to 5 times as much.
- **RELIABLE** — warranted for 2 full years.

HICKOK

LX304 DIGITAL MULTIMETER

**FAST, EASY,
ONE HAND
OPERATION**

NEW



AVAILABLE NOW
\$89⁹⁵

New Low Distortion Function Generator

BK PRECISION



Call For Our Price

MODEL 3010

- Generates sine, square and triangle waveforms
- Variable amplitude and fixed TTL square-wave outputs
- 0.1 Hz to 1MHz in six ranges
- Push button range and function selection
- Typical sine wave distortion under 0.5% from 0.1Hz to 100kHz
- Variable DC offset for engineering applications
- VCO external input for sweep-frequency tests

New Sweep/Function Generator

BK PRECISION



Call For Our Price

MODEL 3020

- Four instruments in one package—sweep generator, function generator, pulse generator, tone-burst generator.
- Covers 0.02Hz-2MHz
- 1000:1 tuning range
- Low-distortion high-accuracy outputs
- Three-step attenuator plus vernier control
- Internal linear and log sweeps
- Tone-burst output is front-panel externally programmable

Simpson

BK PRECISION

LEADER

DORIC



Non-Linear Systems



DATA PRECISION

**PORTABLE
OSCILLOSCOPES**
BATTERY OPERATED

NLS Non-Linear Systems

MS-15



Single Trace 15MHz
Reg. price \$349.
\$299⁹⁵

S-215



Dual Trace 15 MHz
Reg. price \$465.
\$399⁹⁵

MS-230



Dual Trace 30MHz
Regular price \$598.
\$499⁹⁵

**THESE 1980 B&K OSCILLOSCOPES
ARE IN STOCK AND AVAILABLE
FOR IMMEDIATE DELIVERY**



BK PRECISION

- 1479 Dual-Trace 30 MHz
- 1477 Dual-Trace 15 MHz
- 1432 Dual-Trace 15 MHz Portable
- 1476 Dual-Trace 10 MHz
- 1466 Single-Trace 10 MHz
- 1405 Single-Trace 5 MHz

**CALL FOR OUR
EARLY BIRD SPECIAL LOW PRICE**

**SUPER
SPECIAL**

**HICKOK 385X
500MHz COUNTER**
Reg 499⁹⁵

NOW 229⁹⁵

LIMITED QUANTITIES



Model LBO-520
**30 MHz Dual Trace
Scope with Delay Line**

List Price \$1100
\$879⁹⁵

**High Sensitivity.
Wide Bandwidth.**

Single Shot Trigger. P-D-A CRT.

- 5mV sensitivity facilities accurate signal viewing from low level sources.
- Built-in delay line makes it easy to view the leading edge of a pulse.
- Single shot trigger (CH-1, CH-2) captures transient phenomena — no guesswork, no "double-takes".



Automatic Transistor Checker

MODEL
LTC-906



**Lights Up. Sounds Off. Measures.
Identifies. Displays.**

- A multipurpose, portable, transistor checker automatically better for laboratory, shop and school.
- Checks transistors, FETs, diodes, good or bad & in or out of circuit.
- Automatically tests a broad range of parameters with simple, program on-off switches—no confusing buttons or lead changes.
- Automatically identifies Germanium or Silicon, plus emitter base and collector.
- LED display plus audible tone indicates defective or good performance.
- Absolute meter readout of DC parameters.

LEADER
Instruments Corp

Regular price \$189
\$159.⁹⁵



THE TEST EQUIPMENT SPECIALISTS
TOLL FREE HOT LINE
800-223-0474



54 WEST 45th STREET, NEW YORK, N.Y. 10036 212-687-2224

**ADVANCE
ELECTRONICS**

APRIL 1980

GET YOURS FREE

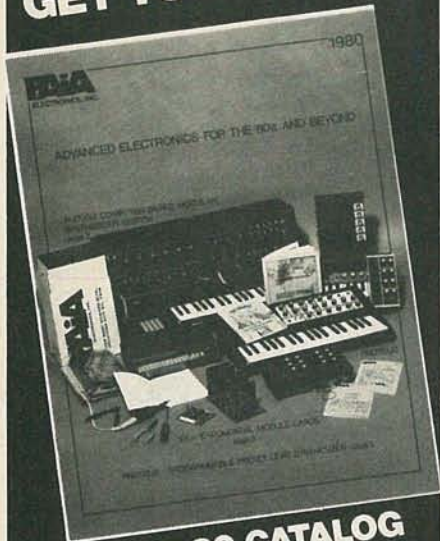

PMA's 1980 CATALOG
NEW IDEAS IN MUSICAL
ELECTRONICS

**PLEASE RUSH MY
FREE 1980 CATALOG**

name _____
address _____
city _____ state _____ zip _____

PMA ELECTRONICS, Dept. 4 R 1020 W. Wilshire, Oklahoma City, OK 73116

CIRCLE 44 ON FREE INFORMATION CARD

**Don't cut
yourself out
of a career as a
two-way radio
technician...**

MTI offers the only training for professional FM two-way radio available. Qualified technicians are employed in government, industry, and public service. But training is your key.

You could cut out a career as a two-way radio technician by cutting out this coupon. We'll send you information on how you can learn more about this specialized field, at home.

Name _____
Address _____
City _____
State/Zip _____

B3D



**Mobile Training
Institute**

Box 735, Camp Hill, PA 17011-U.S.A.

CIRCLE 2 ON FREE INFORMATION CARD

OSCILLOSCOPE

continued from page 43

The LM318 op-amp (IC302) is used as a voltage comparator, holding the trigger input of the 555 positive until the timing capacitor has completely discharged. Premature triggering during retrace is thus prevented. The 555 provides a squarewave output at pin 3 that goes to +9 volts while the ramp is rising and drops to ground during retrace and hold-off. That line is capacitively coupled to the CRT grid to suppress the beam except during the sweep.

Baseline generator: The retrace-suppression line is used via R330 to synchronize the zero-baseline oscillator Q306, insuring that the switch from baseline to signal display will always occur at the start of a retrace when the beam is suppressed. For the lower sweep speeds, synchronization requires a slower oscillator, and for that C319 is switched in.

Each time unijunction transistor Q306 fires, C316 discharges through R332, setting flip-flop Q307-Q308 through D308 and initiating a baseline sweep. After the baseline sweep (or several sweeps if C316 is not discharged after the first one) pin 3 of the 555 goes low, bringing the base of Q307 low through C315 and D307, thus resetting the flip-flop for a series of signal displays.

Power supplies: The power supplies (Fig. 5) are entirely conventional except for the -900-volt tripler. Diodes D105 and D106 charge C102 to the peak negative voltage of the transformer secondary on the negative half cycle. On the positive half-cycle, C102 and the secondary appear in series to charge C101 to twice the peak secondary voltage (negative on top), through D103 and D104. On the next negative half-cycle, C101 and the secondary appear in series to charge C103 to three times the peak secondary voltage through D101 and D102. The drain on that supply is about 200 μ A, so the 0.1 μ F Mylar filters are quite adequate. Some of those capacitors are used at 20% or so above their rated voltage, but many have been tested at four times rated voltage with no breakdowns. Any string of five to ten Zener diodes adding up to about 900 volts will do for D109 through D113 if 180-volt Zener diodes are hard to find. Capacitor C105 filters out the 60-Hz noise picked up from the power transformer by the CRT heater winding.

We must breakoff our discussion of the oscilloscope's power supplies now and will conclude it next month when we will also go into construction, checkout and calibration. **R-E**

**Now Build Professional
Quality Printed Circuit
Boards INSTANTLY With
E-Z CIRCUIT™**
by Bishop Graphics, Inc.
**PRESSURE-SENSITIVE COPPER
Design Products**



With E-Z CIRCUIT's revolutionary new pressure-sensitive Copper Design Products, you actually build "instant" professional caliber PC boards right in your own shop or home, *WITHOUT* chemicals, artwork, photography, screening or etching.

The exclusive new E-Z CIRCUIT Copper Design System contains everything you need to produce or repair a professional, printed circuit board with electrical and mechanical characteristics that simulate those of etched "production house" PC boards. Our unique Technical Manual, with easy-to-follow, illustrated "how to" tips and

techniques shows and tells you how.

E-Z CIRCUIT's pressure-sensitive copper products are only one dimension of the E-Z CIRCUIT family. The comprehensive E-Z CIRCUIT Technical Manual & Catalog 102 contains detailed information on the entire product line, including:

- PC Drafting Aids to help you create professional PC board artwork
- General Purpose PC Plug Boards, DIP & SIP Sockets, Terminal Pins, Wire and Accessories for building PC boards with today's fast, modern wire wrapping methods

E-Z CIRCUIT™
by Bishop Graphics, Inc.

5388 Sterling Center Drive • P.O. Box 5007 RE
Westlake Village, CA 91359 U.S.A.
(213) 991-2600 • Telex: 66-2400

CIRCLE 47 ON FREE INFORMATION CARD

For your copy of this value-packed E-Z CIRCUIT Technical Manual & Catalog 102, including information on the location of your nearest E-Z CIRCUIT Distributor, send \$1.00 — plus 50¢ for postage and handling — along with your name and address to:



Help light the candle of understanding.
Contact your local chapter of the
Epilepsy Foundation of America.
Or write: Epilepsy, Washington, D.C. 20036.
(Incorporating the former National Epilepsy League.)

radio products

More information on radio products is available. Use the Free Information Card inside the back cover.

AMPLIFIED MICROPHONE, model T²M, has integral touch-pad encoder, 12-key keyboard and LED display. Other features include preamplified electret element, digital integrated tone genera-



CIRCLE 111 ON FREE INFORMATION CARD

tor with 3.5795 crystal, and a mixer amplifier with up to 15-dB gain. Power is supplied by 6-0.16-volt DC sources. Mike is housed in rugged shielded plastic, and an 8-foot, 3-conductor cable is included. Suggested retail price; \$105—**The Astatic Corp.** Conneaut, OH 44030.

THREE-BAND ANTENNA, System Three, is a lightweight antenna designed for 10-15-20 meters, and features low SWR across the entire bandwidth, and a 14-foot x 4-inch boom length.

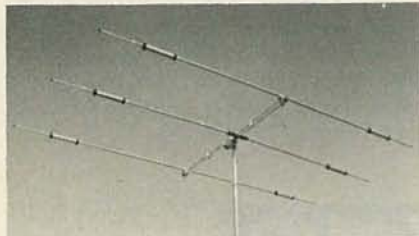

CIRCLE 112 ON FREE INFORMATION CARD

The antenna can survive up 100-mph winds. Direct feed with 52-ohm coax cable or a balun and has a power-handling capability of 2000 watts. Suggested retail price: \$179.95.—**Wilson Electronics**, P.O. Box 19000, Las Vegas, NV 89119.

CORDLESS REMOTE TELEPHONES, models CP-100S and CP-200S, contain full duplex circuitry and have an effective range of 300 feet. Features include pushbutton number entry, automatic redialing of the last number called, and rechargeable nickel cadmium batteries. Model

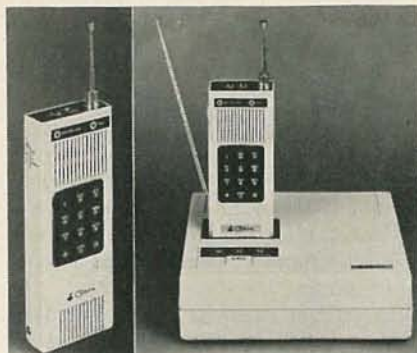

CIRCLE 113 ON FREE INFORMATION CARD
CP-100S is portable style and CP-200S is phone handset style. Suggested retail price \$269.95.—**Cobra Communications**, Dynascan Corp., 6460 W. Cortland St., Chicago, IL 60635.

MORSE CODE READER, Morse-A-Word, assembled or kit, is designed for SWL's and amateur radio operators. Accepts audio signals from communications receivers and displays 8 digital characters sequentially. Other features are a 5- to 35-



CIRCLE 114 ON FREE INFORMATION CARD

word-per-minute code speed, a built-in oscillator and monitor speaker for code practice. The unit measures 7.735 W x 5.75 D x 3.375 inches H, and weighs 4 lb. Suggested retail prices: kit, \$169.95; assembled, \$249.95.—**Microcraft Corp.**, Box 513, Theinsville, WI 53092.

CB RADIO, model PC-100, has a wide range of control functions including volume/squelch, RF microphone gain, clarifier, tone control and ANL. A panel switch provides instant shift to Channel 9.



CIRCLE 115 ON FREE INFORMATION CARD

Performance is monitored by a meter reading signal strength and power output, a TX modulation indicator and an RX lamp. Operation is from 13.8 VDC, positive or negative ground. Suggested retail price \$119.95.—**NDI**, 22125¹/₂ S. Vermont, Torrance, CA 90502.

Put Professional Knowledge and a COLLEGE DEGREE in your Electronics Career through HOME STUDY



Earn Your DEGREE

by correspondence, while continuing your present job. No commuting to class. Study at your own pace. Learn from complete and explicit lesson materials, with additional assistance from our home-study instructors. Advance as fast as you wish, but take all the time you need to master each topic.

The Grantham electronics degree program begins with basics, leads first to the A.S.E.T. degree, and then to the B.S.E.T. degree. Our free bulletin gives complete details of the program itself, the degrees awarded, the requirements for each degree, and how to enroll. (We are located at 2500 S. LaCienega Bl., Los Angeles, Calif.) Write to our mailing address shown below for *Bulletin R-80*

Grantham College of Engineering
P. O. Box 35499
Los Angeles, California 90035

Worldwide Career Training thru Home Study

9 reasons why the real pros prefer Endeco desoldering irons

1. Operates at 120v, 40w. Idles at 20w for longer tip life
2. Flexible, burn resistant Neoprene cord set
3. Cool, unbreakable polycarbonate handle
4. Exclusive bracket insures alignment, prevents damage
5. Safety light in handle tells when it's on
6. Stainless steel construction
7. Temperature control. Low, high or off.
8. Eight tip sizes. Comes with .063 I.D.
9. Converts to soldering iron with 1/4" shank type tip

See your distributor or write . . .

Enterprise Development Corp.

5127 E. 65th St. • Indianapolis IN 46220
PHONE (317) 251-1231

CIRCLE 58 ON FREE INFORMATION CARD

service clinic

How to locate faults in the all-electronic tuners

JACK DARR, SERVICE EDITOR

THE ALL-ELECTRONIC TUNER HAS BEEN with us for a while. Now they are beginning to show up on our service benches, too. As with all of the other innovations, we have to devise a method of attack for the problems that are showing up.

The problems are complicated. However, there is an old saying: "All complex circuits are nothing but a lot of simple circuits tied together."

If we look at the schematic of the electronic tuner *functionally* and rationally, we can get a much better idea of what is wrong and where. Most of the troubles will be the same as in the older mechanical tuners—snow, wrong channels, and so on. Translation: What does the thing do? It tunes in, converts and amplifies the RF TV signal, and makes the IF out of it.

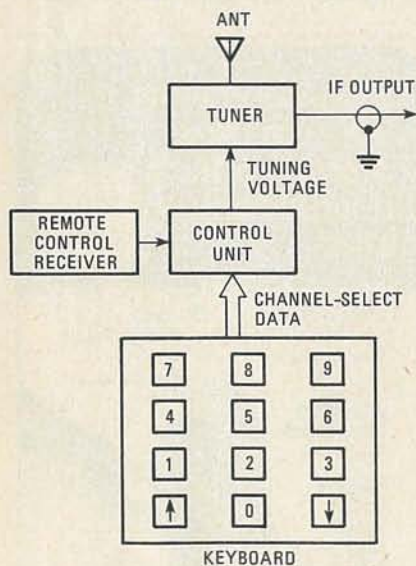

FIG. 1

The all-electronic tuners are composed of two major parts—the tuner itself and another unit that controls it. Figure 1 shows a block diagram. The tuner contains no moving parts. The only things that "move" when you change channels are *voltages*. The control circuit can be fairly simple, ranging from a couple of IC's to generate the voltages, all the way up to the frequency-synthesizer and microprocessor-controlled types. The purpose of the control circuit is to generate the tuning voltage in response to signals from the keyboard.

Understanding that gives us our first handle on the problem. Look at the TV set. What is it doing? If the answer is "nothing", providing just a plain or snowy white screen, then we may have a tuner problem. To make sure, use the old test: Feed the output of a tuner subber into the IF input and see if the rest of the set works. If so, the problem is definitely in the tuner and we've eliminated a whole lot of things.

The tuner will have the standard stages: an RF amplifier, usually a dual-gate FET, a mixer, another mixer, and the oscillator. All tuning will be done with varactor diodes that are controlled by the tuning voltage from the control unit. If the TV set tunes to a wrong channel, or refuses to change channels, the first thing you need to check is that tuning voltage.

Sams, and others, provide us with the other necessity: very complete service data and pinouts on the various circuits. Among that service data is a table of the tuning voltages you should get for the various channels. For example, let's look at the tuner in an RCA CTC-92A chassis. You should read +1.8 volts for Channel 2, +19 volts for Channel 6, +8.5 volts for Channel 7, and +14.6 volts for Channel 11. Punch in the various channels on the keyboard and make sure these voltages are correct; there is a small tolerance. If the tuning voltage is OK but the tuner still doesn't work, then the fault should be in the tuner itself and not in the control unit.

Bandswitching is also done by voltages and switching-diodes. Those voltages are also given in table form in the service data. If they prove not to be correct, you have a control-unit problem. Same principle goes for the tuning voltages. If the voltages are correct, the trouble lies in the tuner circuitry.

Since these *are* tuners, we can use signal-tracing tests to find out which stage is bad, just as we did with the mechanical tuners. Inject a signal into the mixer input. If that produces some kind of picture or at least a reaction, move to the RF input. Easy way: you do not have to make contact with the circuit. For safety's sake, connect a short piece of insulated wire to either lead of an antenna, or to the RF output of a bar-dot generator. Just hold-

ing the insulated end of the wire *near* the input of a stage should radiate enough signal into it to get some reaction.

Many of those units are modular. At first, you would probably be better off simply to replace the suspected module. However, when you're more familiar with them, you could try to locate and replace bad parts since the modules are pretty good-sized with "room to work" and make tests.

A lot of set-makers have come out with very detailed descriptions on how those circuits work, along with servicing hints and check-points—Magnavox, RCA, Sylvania and others among them. Get hold of those descriptions and read up on them. They provide a very valuable source of reference and familiarization material. Service data is absolutely necessary so that you'll know where the test points are for the voltages, etc.

So, I don't see why the new tuners should be any more difficult to service than some of the impossibly-crowded old ones. In many cases, they should be a lot easier! (For our sake let's hope so.) If you use a calm "functional approach:" Look at it and see what it's doing, then look at the service data and see what could make it do that, the new tuners should be much simpler than you'd think at first glance.

New service center

I've just gotten a notice that PTS Electronics, Inc., has opened a new service center at 1289 Madison Ave., P.O. Box 41043, Memphis, TN 38104. They rebuild tuners, modules, and quite a few other things. That should improve service for people in the Mid-America area. John Postlewaite, General Manager, invites all technicians to visit the new facility and get a first-hand look at the many things they can provide to help us out. **R-E**

service questions

VERTICAL RASTER LINES

I'm having a problem with a Zenith model 20X1C38. The set has bright vertical lines in the raster. So far nothing that I've checked or changed has had any effect! Any help would be appreciated—O.B.G., Albuquerque, NM.

continued on page 84

TRIONYX^{IND}

TR-1000 600 MHz FREQUENCY COUNTER

THE BEST VALUE IN FREQUENCY COUNTERS COMES TO YOU FROM TRIONYX INDUSTRIES . . .

THE NEW TRIONYX TR-1000 HAS BEEN DESIGNED TO SUCH STANDARDS THAT ONLY MODERN DAY TECHNOLOGY CAN GIVE YOU WITH FEATURES YOU'D EXPECT ONLY FROM FREQUENCY COUNTERS COSTING MANY TIMES MORE. THE TR-1000 FEATURES AN ATTRACTIVE HEAVY BLACK ANODIZED ALUMINUM CABINET. LARGE .4" LED DIGIT DISPLAYS, SELECTABLE GATE TIMES WITH GATE INDICATORS, DIRECT AND PRESCALED INPUTS FROM 10 Hz to 600 MHz, 50 OHM AND 1 MEG OHM INPUTS BOTH WITH AMPLIFIED SUPER SENSITIVE DIODE PROTECTED CIRCUITRY, AUTOMATIC DECIMAL POINT, FULLY SOCKETED IC'S, PORTABLE POWER PACK (4 AA NICADS), AND RAPID AND TRICKLE CHARGING CIRCUITRY.



SPECIFICATIONS

FREQUENCY RANGES: Direct • 10 Hz to 60 MHz
Prescaled • 10 MHz to 600 MHz

SENSITIVITY: <15 mv at 30 MHz typical
25 mv at 150 MHz typical
<50 mv at 450 MHz typical

TEMP. STABILITY: .09 PPM/C° (± 1 PPM
20° to 40° typ.)

GATE TIMES: Selectable — 1.0 second
0.1 second

RESOLUTION: 1 Hz - 10 Hz to 6 MHz
10 Hz - 10 MHz to 60 MHz
100 Hz - 10 MHz to 600 MHz (Prescaled)

INPUT IMPEDANCE: 60 MHz - 1 Meg shunted
by 20 pf
600 MHz - 50 ohm

INPUT PROTECTION: Direct input —
100 V up to 10 MHz
50 V up to 60 MHz
Prescaled input —
2 V max.

DECIMAL POINT: Automatic placement

POWER REQUIREMENTS: 9 to 15 V AC or DC 300 ma.

BATTERIES: 4 each AA Ni-Cad.

SIZE: 3 3/4" H x 5" W x 5 1/2" D.

WEIGHT: 1 Lb. 9 Oz. with batteries.

Look to TRIONYX Industries
for your best value in
Frequency Counters.

ORDER YOURS TODAY

Master Charge, VISA, Check,
Phone Orders Accepted

TRIONYX INDUSTRIES

6219 COFFMAN RD.

INDIANAPOLIS, IND. 46268

317-291-7280

Completely Assembled
with a
1-Year Warranty

PACKAGE INCLUDES:

TR-1000 freqcy. counter
telescoping antenna
AC power pack
4-AA nicad battery pack

ALL FOR **\$159.95**

FOB Indianapolis, Ind.
Indiana residents add 4% tax



ANTENNA PROBLEM?

DYMEK HAS THE SOLUTION WITH THE DA100D.

Need Full Frequency Coverage? The DA100D covers the entire frequency range of 50KHz - 30MHz.

Looking For Better Performance? Dymek users worldwide praise the DA100 and its ability to out-perform long wire antenna systems.

Worried About Impedance Problems? An output impedance attenuator switch prevents RF overload and matches varying receiver input requirements.

Want To Go Portable or Mobile? Selectable operation from either 115-230VAC or 12VDC allows both fixed and mobile or marine operation (DA100DM available for use on or near saltwater).

Money Back Guarantee.

Rent/Own Plan Available (U.S. Only). Specs and Details on Request. CALL TOLL FREE NOW.

800/854-7769

Calif 800/472-1783

Local 714-621-6711 ■ TWX 910-581-4990



McKAY DYMEK COMPANY
111 S. College Ave., P.O. Box 5000
Claremont, CA 91711

CIRCLE 67 ON FREE INFORMATION CARD

TUNER SUB \$19.95

Since all tuner subs that we know of are modified TV Tuners, we decided to market an excellent performing yet very low cost sub for the technician who has to get all he can for his money . . . a "Poor Boy's Sub" for only \$19.95.

This was not an easy task since cabinets, knobs and controls would push the price far above \$19.95 . . . We searched for a tuner that needed no cabinet and no controls . . . one that the tech could scrounge the knobs from most any old TV . . .

It took over two years but we finally found it. The gain is excellent . . . Battery drain is very low (only 18 mls). It's self biasing so there is no R.F. gain control to fiddle with . . . It works equally well on tube or transistor sets . . . b/w or color . . . and is as easy to use as starting a fight with your wife (well, almost). All you need do is hook the set's IF cable to the "Poor Boy" and view the picture . . . That's it . . . no set up controls to confuse you.

We compared the "Poor Boy" with other subs costing over twice the price and found it to work just as well on all the comparison tests we made . . . and often a lot easier to use . . . Even though instructions aren't needed . . . you get those too.

The "Poor Boy" is small enough to easily hold in one hand . . . no wires or controls dangling around it. It comes completely wired and tested including batteries and ready to use. Send a check for only \$19.95, plus \$1.50 shipping.

Master Charge and Visa accepted

Try it for 10 days . . . If not completely satisfied . . . return for full refund.

CALL TOLL FREE 1-800-433-7124

TEXAS TUNER SERVICE

4210 N.E. 28TH STREET,
FORT WORTH, TEXAS 76117

CIRCLE 68 ON FREE INFORMATION CARD

SERVICE QUESTIONS

continued from page 82

This one has a vaguely familiar look. Quite a while back, I had a similar problem, also in a Zenith of about this vintage. After "checking and changing everything we could think of," I noted that with a probe held near the high-voltage cage the stray pickup waveform showed something odd. If you turn the gain up until you can only see the horizontal part of the waveform (the spike is up and off-screen), note if there are small vertical spikes on it. This is the *scan* part of the waveform. After some nail-biting, we tried changing the flyback and that fixed it!

I've still got the original flyback in a box and to this day I have no idea at all what the defect is! My only guess is that it could be some kind of oddball ringing in one of the windings.

ARCING PROBLEM

When I turn the brightness up on this Admiral model 4H12 chassis, light and dark horizontal streaks show up in the picture. I've checked quite a few things with no luck. Any ideas?—S.L., Massapequa Park, NY.

(I suggested that he do a few things, and check the high-voltage rectifier tube, etc.) Later he wrote:

"I checked all the things you mentioned. While I was working, I happened to touch the degaussing coil socket and it bit me! I disconnected it, and the arcing disappeared. A new degaussing coil fixed it. Thanks!"

Glad to hear he found the trouble. Degaussing coils can do some fantastically funny things.

MYSTERY STEREO IDENTIFIED

I can't identify this AM/FM stereo that's labeled "2S2," and is made in Taiwan. One source told me it was an Admiral model ST-1000, but Admiral says no. Both the output transistors are shorted, and a diode in one transistor base has exploded. The PC board schematic shows a diode as being a "KB-162" and something else is shown as a 15-ohm resistor. The KB-162 in the working channel tests as a diode, but the 15-ohm resistor looks more like a glass diode. It checks out as a glass diode too, but if it is it's leaky! It has a low front-to-back ratio. Any help will be much appreciated.—J.P., Lewistown, MT.

Without much hope, I looked in my Admiral file and found a 2S2 listed that certainly looks like the minischematic you sent! (Sams Photofact Folder No. 1443-2 shows it.) The output transistors are a complementary-symmetry pair. An RCA SK-3083 replaces the 2SA699A(Q), PNP, and an SK-3054 replaces the 2SC1266A(Q). The bias diode is an SK-3087.

Both the Sams and Admiral schematics show *two* diodes in series in this stage. If the "something" you have checks as a

diode, I'd say that it is one. (Just to double-check on the leakage, lift one end of the transistor and repeat your tests.) Since it has 0.7 volt across it, it is probably a silicon diode. Perhaps an Si and a Ge diode were used in series to obtain the required bias voltage. I once had an amplifier that had one Si and one Ge transistor in the output stages. I replaced them with two Si's; this resulted in quite a lot of distortion. I finally checked and found out what was going on.

TRANSISTOR SUBS WANTED

I need replacement transistors for a Dynaco model 120 power amplifier. I can't seem to locate them, anywhere. I understand Dynaco is out of business. Can you help?—H.K., Akron, OH.

Yes, apparently Dynaco has gone out of business. Sams lists the name but not the address and no Photofacts schematics! However, the RCA SPG-202X *Transistor Guide* shows the 2N3053 as an SK-3024, NPN silicon, TO-39 case; the 2N4037 is an SK-3262, NPN silicon, TO-39 case. The voltage for each is about 90. That should do it.

TEXTBOOK ON PICTURE TUBES?

I'm looking for a textbook on picture tubes that tells how to test and handle them, what instruments to use, etc. Can you give me the name of such a book?—J.O., Richmond, IN.

I'm afraid not. This information is all available from set manufacturers (in their service data), and from picture tube manufacturers such as RCA, GE, Sylvania, etc. The "picture tube characteristics" books show a great deal of data on basing, voltage ratings, specs, etc. You should be able to obtain these books from your local radio-TV supplier.

In order to test picture tubes, you need a picture tube tester! These are manufactured by several companies. The instruction manuals give all the necessary data on how to use them. Suggestion: Try to obtain a Heathkit manual that describes one of this company's better picture tube testers. This manual will usually have a full circuit description and a very well-written explanation.

WORKS ON JIG, NOT IN SET

This RCA CTC-46 works on a test jig. Put it back in the cabinet and the vertical output transistors blew out! However, the yoke resistance checks out OK.—J.S., Lakewood, CO.

Well, the vertical output used here is a complementary-symmetry circuit, as used in audio amplifiers. It will withstand an open but a short will damage it. So, you have a short somewhere in the vertical yoke or in the pincushion circuitry. If the yoke resistance seems to be OK, check the pincushion corrector circuitry, looking for possible shorts to ground or to boost. It's bound to be in there somewhere!

R-E

new products

More information on new products is available. Use the Free Information Card inside the back cover.

VOLTAGE METER, the *Volt Sentry*, is designed to identify faulty outlets and circuits. It can be plugged into the common outlet to indicate the voltage level. The scale is divided into Normal,



CIRCLE 151 ON FREE INFORMATION CARD

Brown-Out and Surge. The meter also shows the actual voltage being fed to an appliance plugged into the same outlet. Measures 2½ × 2½ × 1½ inches. Price is \$14.95.—Whitesavers Co., 71 E. 13th St., Huntington Station, NY 11746.

SOLAR POWERED RADIO, 3 solar cells operate this 8 oz., 1.5 volt AM radio during daylight hours. By means of a selector switch, the radio can also



CIRCLE 152 ON FREE INFORMATION CARD

run during darkness from a battery contained in the case. Suggested retail price \$39.95.—Solec International, Inc., 12533 Chadron Ave., Hawthorne, CA 90250.

HEX KEYS AND WRENCHES, offers 4 new sizes of short-series standard right-angle hex keys, sizes ½", ⅜", ¼" and ⅜", and two new long-series, sizes 8mm and 10mm. Featured are pouched sets No. LM12 with 12 metric-sized keys and No. SLK17 with 17 short-series keys. The

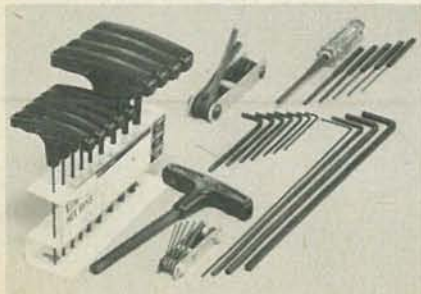

CIRCLE 153 ON FREE INFORMATION CARD

wrench line is available in short, long, extra and foot-long series, and includes a wrench that can drive at angles up to 40° with full torque. These products are made of steel, are corrosion resistant and are heat treated for added strength.—Vaco Products Co., 1510 Skokie Blvd., Northbrook, IL 60062.

LED SAMPLER KIT, model EK-2, contains samples of LED indicator lights that can be used in breadboarding or building working prototypes. The kit consists of 28 different LED's and assem-

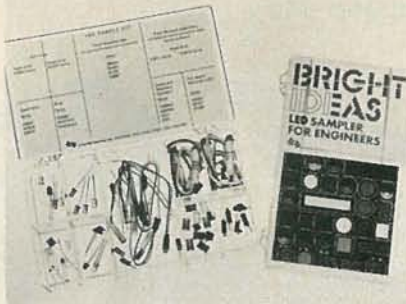

CIRCLE 154 ON FREE INFORMATION CARD

bles in 21 styles and 3 colors, including plain, panel-mounted, and PC-board-mounted LED's, and complete assemblies that include current-limiting resistors and protective diodes. Price is \$10 postpaid with check or money order.—Industrial Devices, Inc., 7 Hudson Ave., Edgewater, NJ 07020

AC VOLT/AMMETER, model 30, *The Grabber*, is a clamp-on handheld instrument designed for fast accurate service checks on electronic equipment. The unit has a one-inch jaw opening, a sin-



CIRCLE 155 ON FREE INFORMATION CARD

gle range switch, a lock switch for holding readings and an easy-to-read, large dial face. AC ranges are 0-300 amperes in six ranges and 0-

continued on page 90

Generate virtually any wave shape with famous B&K-PRECISION cost-effectiveness!

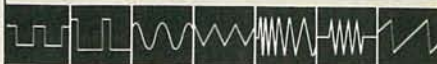

The B&K-PRECISION Model 3020 sweep/function generator is the most versatile signal source in its price range. This instrument alone can replace a function generator, sweep generator, pulse generator and toneburst generator. Frequency coverage spans 0.02Hz to 2MHz in seven ranges, each with linear 1000:1 frequency control.

A low-distortion, high-accuracy signal source, the 3020 can generate almost any waveform, including sine waves, square waves, TTL square waves, toneburst, pulses and ramps. All can be inverted. Internal linear and log sweep capability is also featured. Both modulation and carrier levels can be varied so even a double sideband suppressed carrier test signal can be generated.

For applications requiring standard signals, the Model 3010 low distortion function generator is offered. The 3010 generates sine, square, TTL square and triangle waveforms from 0.1Hz to 1MHz in six ranges. An external VCO input is provided for sweep frequency tests. Variable DC offset is included.

The 3020 and 3010 are available for immediate delivery at your local distributor. A ten day free trial is available at many locations.

BK PRECISION
DYNASCAN
CORPORATION

6460 West Cortland Street
Chicago, Illinois 60635 • 312/889-9087

Int'l. Sis., 6460 W. Cortland St., Chicago, IL 60635
Canadian Sales: Atlas Electronics, Ontario

CIRCLE 51 ON FREE INFORMATION CARD

APRIL 1980

85

EQUIPMENT AND TRAINING NO OTHER SCHOOL CAN MATCH.

**NTS HOME TRAINING INVITES YOU TO EXPLORE MICROCOMPUTERS,
DIGITAL SYSTEMS AND MORE, WITH STATE-OF-THE-ART EQUIPMENT
YOU ASSEMBLE AND KEEP.**

Without question, microcomputers are the state of the art in electronics. And NTS is the only home study school that enables you to train for this booming field by working with your own production-model microcomputer.

We'll explain the principles of troubleshooting and testing your microcomputer and, best of all, we'll show you how to program it to do what you want.

You'll use a digital multimeter, a digital logic probe and other sophisticated testing gear to learn how to localize problems and solve them.

Send for the full color catalog in the electronics area of your choice—discover *all* the advantages of home study with NTS!

NTS also offers courses in Auto Mechanics, Air Conditioning and Home Appliances. Check card for more information.

1.



2.

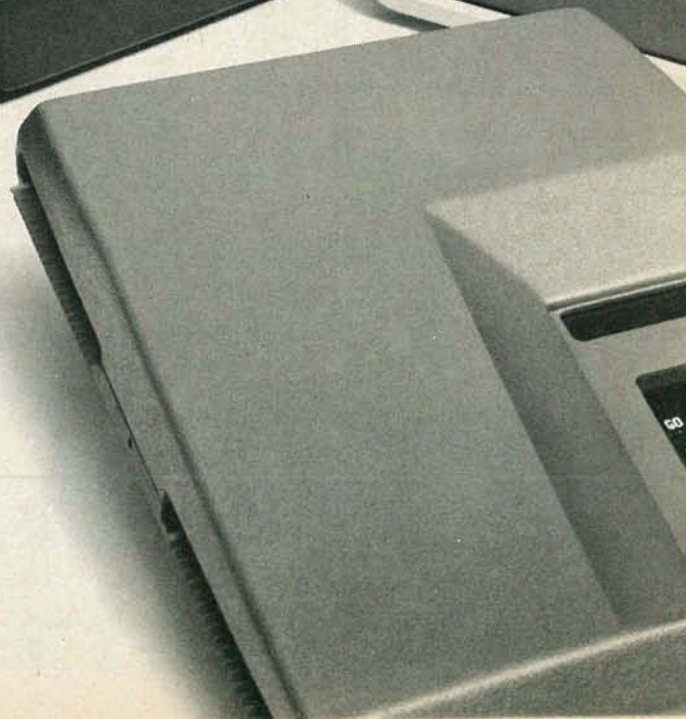

We believe that training on production-model equipment, rather than home-made learning devices, makes home study more exciting and relevant. That's why you'll find such gear in all 14 of NTS's electronics programs.

For instance, to learn Color TV Servicing, you'll build and keep the 25-inch (diagonal) NTS/HEATH digital color TV.

In Audio Electronics, you'll be able to assemble your own NTS/HEATH digital stereo receiver with 70 watts per channel.

But no matter which program you choose, NTS's Project Method of instruction helps you quickly acquire practical know-how.

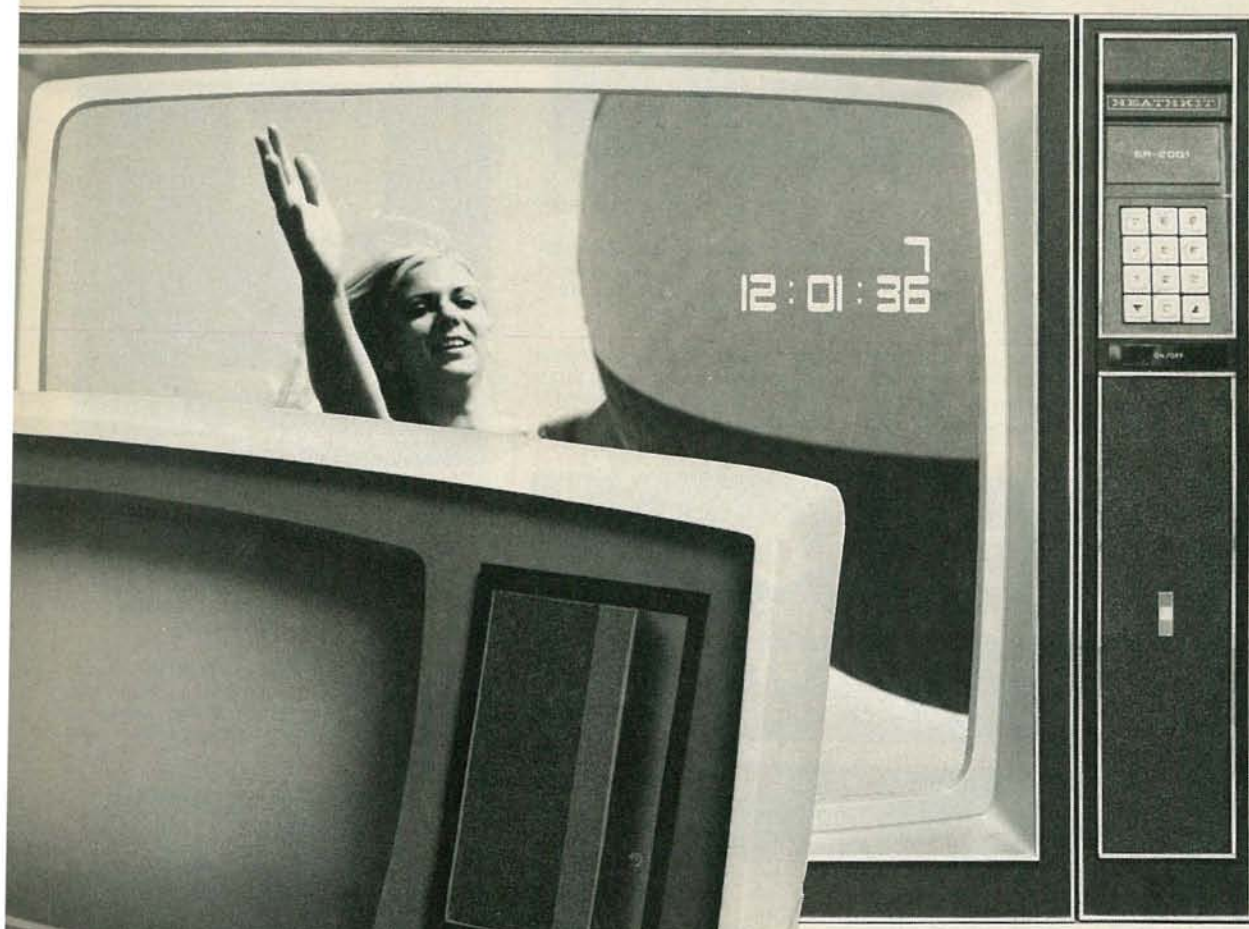

Simulated TV Reception

4.

3.

1. The NTS/Rockwell AIM 65

Microcomputer A single board unit with on-board 20 column alphanumeric printer and 20 character display. A 6502-based unit 4K RAM, expandable.

2. The NTS/KIM-1 Microcomputer A single board unit with 6 digit LED display and on-board 24 key hexadecimal calculator-type keyboard. A 6502 based microcomputer with 1K RAM, expandable.

3. The NTS/HEATH H-89 Microcomputer features floppy disk storage, "smart" video terminal, two Z80 micro-processors, 16K RAM memory, expandable to 48K. **4. The NTS/HEATH GR-2001 Digital Color TV (25" diagonal)** features specialized AGC-SYNC muting, filtered color and new solid-state high voltage tripler rectifier.

NATIONAL TECHNICAL SCHOOLS

TECHNICAL-TRADE TRAINING SINCE 1905
Resident and Home-Study Schools
4000 South Figueroa St., Los Angeles, Calif. 90037

**NO OBLIGATION. NO SALESMAN WILL CALL.
APPROVED FOR VETERAN TRAINING.**



NATIONAL TECHNICAL SCHOOLS

4000 South Figueroa Street, Dept. 206-040
Los Angeles, California 90037

Please rush FREE color catalog on course checked below

- | | |
|---|--|
| <input type="checkbox"/> MicroComputers/MicroProcessors | <input type="checkbox"/> Audio Electronics |
| <input type="checkbox"/> Communications Electronics | <input type="checkbox"/> Auto Mechanics |
| <input type="checkbox"/> Digital Electronics | <input type="checkbox"/> Air Conditioning |
| <input type="checkbox"/> Color TV Servicing | <input type="checkbox"/> Home Appliances |

Name _____ Age _____

Address _____

Apt. _____ City _____

State _____ Zip _____

- Check if interested in G.I. information.
 Check if interested ONLY in classroom training in Los Angeles.

NEW PRODUCTS

continued from page 85

600 volts in three ranges. Insulated test leads are disconnected when model 30 is set for AC current ranges. Optional accessories include a 0-1000 ohms plug-in adapter that is required for measuring resistance. The model can withstand momentary overloads and has an accuracy of 3% in all ranges. Frequency response of voltmeter is flat $\pm 1\%$ of full scale from 20 to 5000 Hz. Price is \$65.—**Triplet Corp.**, Dept. PR, 286 Harmon Rd., Bluffton, OH 45817.

TOOL KIT, model *JTK-24*, is a miniature and sub-miniature tool kit designed for servicing, repair and assembly of precision electronic equipment. It contains more than 120 tools including screwdrivers, nutdrivers, pliers, wrenches, drills, hex keys and many more. These tools are useful for repair of many types of equipment such optical,

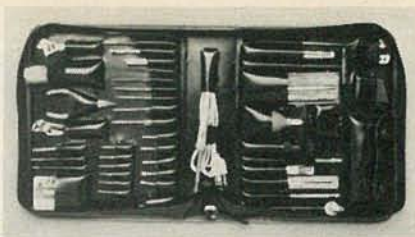

CIRCLE 156 ON FREE INFORMATION CARD

photographic, sound, broadcast and test equipment. Tools come in a $10\frac{1}{2} \times 12\frac{1}{2}$ -inch zippered case. Price is \$315.—**Jensen Tools, Inc.**, 1230 South Priest Dr., Tempe, AZ 85281.

COLOR PATTERN GENERATOR, model *1250*, is designed as a test signal source for station CATV as well as for maintenance and troubleshooting of

video equipment. It generates the NTSC bar pattern with a -IWQ signal plus a full-screen color bar pattern. Other patterns include a staircase with selectable chroma levels, plus dot, cross-hatch, center cross and color raster.



CIRCLE 157 ON FREE INFORMATION CARD

Model *1250* also produces a 4.5 MHz sound carrier or an external audio signal, and generates RF outputs on either Channel 3, 4, or the standard TV IF frequency. Operating manual is included. Price is \$795.—**B & K—Precision**, 6460 W. Cortland St., Chicago, IL 60635.

PICTURE TUBE MACHINE, the latest in research and development, enables anyone to rebuild any CRT—color, black and white, 20 mm, foreign or domestic picture tube, in approximately two

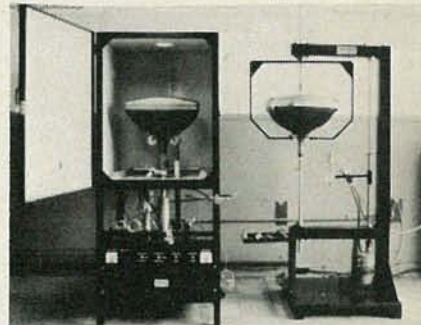

CIRCLE 158 ON FREE INFORMATION CARD

hours. Complete information and literature available.—**Lakeside Industries**, 4071 N. Elston Ave., Chicago, IL 60618.

DIGITAL PANEL METER, model *B500*, is a 3½-digit meter containing 13 parts—one IC, 7 passive components and a display. The unit is bipolar, differential and features auto-zero. The input



CIRCLE 159 ON FREE INFORMATION CARD

range is from 50mV to 1000V. Requires either a 5VDC source or a 115/230 VAC, 47-400 Hz source. It consumes 200-800 mW and its accuracy is $\pm 0.05\% \pm 1$ digit. The red LED display is 5 inches high. Price is \$49.00.—**International Microtronics Corp.**, 4016 E. Tennessee St., Tucson, AZ 85714. **R-E**

The DR22-C

Fully Synthesized General Coverage Receiver from McKay Dymek



FEATURES

- Shortwave, CB, ham radio, ships at sea, overseas phone calls, etc.
- High Impedance tuner output for Hi Fi System use.
- High level RF front end for excellent inter-modulation rejection and sensitivity.
- Crystal filters in first and second IF amplifiers, ceramic filter in third IF.
- Quartz crystal tuning accuracy at all frequencies, no crystals to buy.
- Built in power supply for 110-120 or 220-240 VAC switchable, 50-60 Hz.
- Low Phase Noise Synthesizer
- Solid state, phase locked, digital synthesis tuning.
- Extreme ease of tuning at all frequencies.
- No mechanical tuning dial error or backlash.
- Switch selectable 4 or 8 kHz RF bandwidth.
- Built in monitor speaker with external speaker connectors.
- Switchable impulse noise limiters for AM and SSB.

SPECIFICATIONS

■ Frequency coverage:	50 kHz to 29.7 MHz, continuous. Digital synthesis in 5 kHz steps, fine tune for ± 5 kHz.			
■ Reception modes:	AM, upper sideband, lower sideband, CW.			
■ Sensitivity for for 10 dB S + N/N:	100 kHz	200 kHz	400 kHz-20MHz	20MHz-29.7MHz
	CW, SSB 5 μ V AM 10 μ V	1.5 μ V 3.0 μ V	0.5 μ V 1.0 μ V	0.75 μ V 1.5 μ V
■ Selectivity:	-6dB @ ± 2 kHz or ± 4 kHz and -60dB @ ± 5 kHz or ± 14 kHz			
■ AM Harmonic distortion:	50% modulation = 0.6% T.H.D., 90% modulation = 1.5% T.H.D. (1kHz modulation)			
■ Frequency stability:	Within ± 40 Hz in any 8 hour period at a constant ambient of 25C, after 30 minute warm up.			
■ Circuitry:	43 integrated circuits, 18 transistors, 16 FETs and 54 diodes.			
■ Dimensions & Wt.:	(W x D x H) 17.5 x 14.5 x 5.1 inches. Shpg. Wt. 19 lbs. (8.7 Kg)			



McKay Dymek Company
111 South College Avenue
PO Box 5000
Claremont, CA 91711



For more information write or call today
Toll Free

800/854 7769

Calif. 800/472-1783

TXW 910 581 4990

Local Tel. 714/621-6711

CIRCLE 76 ON FREE INFORMATION CARD

TROUBLESHOOTING

continued from page 68

fed as a DC logic high to gate AND-1. (The other input of gate AND-1 is fed by the drum-rotation detector stage shown in Fig. 2.) A logic-high output goes to IC pin 15 when both detectors are working.

Near the end of the tape, the metallic strip severely loads down the Q of the supply-sensing coil. Oscillation stops, and the detector no longer sends a logic-high signal to the input of gate AND-1. A logic low goes to the auto-stop signal line and to gate AND-2 shown in Fig. 1.

Besides inhibiting any threading motion, the auto-stop signal triggers a driver stage that activates a STOP solenoid. The result is the same as you get from pressing the STOP pushbutton—tape transport ceases.

Rewind switching connects takeup-sensing coil L6502 into the oscillator-feedback loop. Again, as long as regular tape moves past the coil, the oscillator supplies a signal to the detector and (thus) a DC logic signal to gate AND-1. But when the metallic leader moves alongside the coil, the oscillation is loaded down and stops. A logic low at the input of gate AND-1 places a logic low on the auto-stop signal line.

You have already seen how the drum-rotation detector works. If the video-head drum stops spinning, the pulse generator that is a part of the drum immediately stops generating a signal. The sensing stages no longer produce logic high for gate AND-1. Again, a logic low on the auto-stop signal line triggers the STOP solenoid and also (through gate AND-2) inhibits any threading (or unthreading) activity.

Dew sensor—Not all Beta machines include this protective system. It keeps the mechanism from operating if moisture has condensed in the works (that could damage tape seriously). Figure 5 is the diagram of the dew-sensing stage used in one Toshiba model.

The sensor itself is a resistance that decreases in value (generally to below 500,000 ohms) when moisture forms on its probes. The sensor is part of the feedback circuit in a dew-oscillator stage. No oscillation takes place as long as the sensor resistance is high. As the resistance lowers, the feedback becomes sufficient to start the oscillator.

Network R832-C820 feeds the oscillator-output signal to rectifiers D802-D803. Filter capacitor C819 charges to a negative DC value (note the orientation of the diodes). This negative voltage "bucks" to zero the normal logic high that is fed to the base of Q803 through R830.

A logic low at the base of Q803 creates a logic high at the collector,

and then again a logic low at the collector of Q804. We know that a logic low on the auto-stop line to the STOP-solenoid driver causes the solenoid to activate. The same logic low from Q804 goes to gate AND-2 and inhibits the threading system.

In the Toshiba model, the reed switch on the tape-slack detector arm is also connected at the base of Q803. Any slack in the tape closes the switch and plunges the Q803 base to a logic low. Transistor Q803 generates a logic high and transistor Q804 generates a logic low. The STOP solenoid is activated, and threading is inhibited too.

Now that we've examined the electronics, we'll break off this issue in order to give you time to digest what you have learned. Next time we'll take a close look at the electromechanical systems. **R-E**



Your Toolbox Test Bench

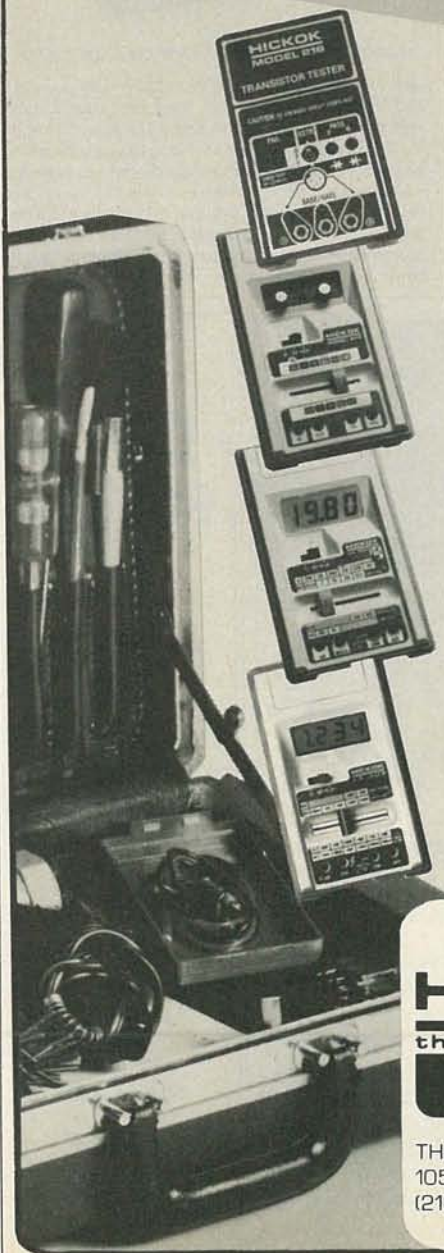

Model 216 Transistor Tester with fast, automatic switching for instant good-bad analysis of NPN's, PNP's, FET's, diodes and SCR's in or out of circuit. \$129.00

Model 240 Video Generator with 10 step gray scale staircase for VTR, CCTV monitor and TV applications. \$159.00

LX304 digital multimeter with automatic decimal point, built in low battery indicator and transistor testing capability. \$89.95

LX303 digital multimeter with easy-to-read LCD display. Only \$74.95

FOR THOSE ON THE GO FROM...

HICKOK
the value innovator

THE HICKOK ELECTRICAL INSTRUMENT CO.
10514 Dupont Avenue • Cleveland, Ohio 44108
(216) 541-8060 • TWX: 810-421-8286

stereo products

More information on stereo products is available. Use the Free Information Card inside the back cover.

PHONO CARTRIDGE, model M95HE, is a top-of-the-line phono cartridge incorporating a hyperelliptical nude diamond-tip stylus (model N95HE) that provides up to 25% reduction in distortion, and is also used with the model V15 Type



CIRCLE 131 ON FREE INFORMATION CARD

IV cartridge. The model M95HE features an ultra-flat frequency response, light trackability and tracks at between 3/4 and 1 1/2 grams. Suggested retail prices: M95HE, \$89.50; N95HE stylus, \$34.—Shure Brothers, Inc., 222 Hartrey Ave., Evanston, IL 60204.

GRAPHIC EQUALIZER, model GEM-1, is a five-band-per-channel instrument featuring center-



CIRCLE 132 ON FREE INFORMATION CARD

detented linear controls, three tape-deck switches for record equalization, playback equalization and tape monitor, and a separate power supply for low noise. Model GEM-1 also uses a system in which the user contours cards for a specific equalization setting. When a card is moved up the faceplate of the unit, all the frequency controls are automatically positioned. Another feature is narrow-bandwidth circuitry for minimum adjacent band interaction. All components are

mounted on a single glass epoxy PC board. Frequency response is 10 Hz to 150 KHz ± 0.5 dB. Suggested retail price is \$89.95.—Suporex Electronics Corp., 151 Ludlow St., Yonkers, NY 10705.

PERCUSSION SYNTHESIZER, the Drum 5700, is a versatile instrument that uses continuously variable controls for pitch modulation—up or down, oscillator waveform mix, noise filter frequency, and oscillator/noise mix. It features modular construction which allows it to configure any size drum set, and numerous rear panel patching and control points which allow multiple cards to be cascaded for a wide range of effects.

Other features include an encapsulated sensor that can be mounted permanently or temporarily to a drum set, and an optional cancel switch that

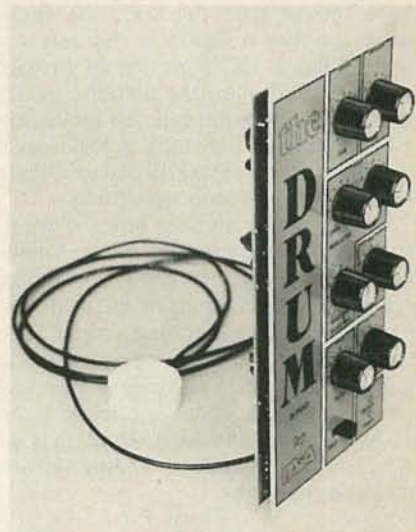

CIRCLE 133 ON FREE INFORMATION CARD

disables the synthesizer when not in use. Price is \$59.95 for a kit; assembled units are also available.—PAIA Electronics, Inc., 1020 Wilshire Blvd., Oklahoma City, OK 73116.

DIRECT-DRIVE TURNTABLE, model 650 RC, is an automatic single-play turntable that can be operated in automatic, semiautomatic and manual modes, and has remote-control capability (optional). The turntable features a high-torque DC motor, an ultra-low-mass (ULM) tonearm (with optional ULM cartridge), gimbal suspension, pitch control, cue control, antiskating control and



CIRCLE 134 ON FREE INFORMATION CARD

PRINTED CIRCUIT KITS MAKE CARDS QUICKLY



ONLY Vector kits contain:

- Positive photo-resist coated AND uncoated copper laminate—no messy photo-reversal—no spraying, dipping, or baking.
 - 4 types of art aids: rub transfers, ink, tape, cut and peel—use 1 or all.
 - 1:1 circuit art rub transfers—IC sets, pads, lines, connectors, symbols, letters, and numbers.
 - Everything included—just add water and sunlamp or bright sunshine.
 - Liquid etchant and developer—no dry chemical mixing problems.
- AND
- Process choices—make circuit on copper and etch for 1 card. Make circuit on film, expose, develop and etch for 1 or many cards.

ART AIDS	+	mylar film	+	sunlamp cards	+	developer & etchant	=	1 or many PC's
	+	card	+	etchant	=	1PC		

32XA-1 kit makes 7 PC cards. \$28.00. 32X-1 starter kit makes 2 cards. \$11.50 If not available locally factory order—include \$3.00 shipping, U.S. only. Vector Electronic Co., 12460 Gladstone Av., Sylmar, CA 91342 910177

CIRCLE 75 ON FREE INFORMATION CARD

DON'T FORGET



USE
YOUR
READER
SERVICE
CARD

an aluminum platter. The turntable comes complete with cover and base, and sells for a suggested retail price of under \$400. Optional cartridge, *model 55E*, \$110; and infra-red remote control, *model RC 152*, \$79.95.—**United Audio Products**, 120 So. Columbus Ave., Mt. Vernon, NY 10553.

SPEAKER SYSTEMS, a line of four speakers feature a unique total motor system that results in a higher than normal efficiency for acoustic suspension speakers. The 8-inch 2-way system, *model 94-1200*, is a lightweight compact speaker rated at 25 watts RMS with a frequency response of 45 to 20,000 Hz. The 10-inch 2-way system, *model 94-1300*, features a 10-inch woofer and



CIRCLE 135 ON FREE INFORMATION CARD

wide dispersion and is rated at 35 watts RMS. The 10-inch 3-way system, *model 94-1350* (shown), handles a power of 40 watts RMS; the 12-inch 3-way system, *model 94-1400*, has a 12-inch woofer, 4½-inch midrange, is rated at 45 watts RMS and has a frequency response of 35 to 20,000 Hz. Prices range from \$59.95 to \$99.95.—**GC Electronics**, 400 So. Wyman St., Rockford, IL 61101.

R-E

COLOR-BAR GENERATOR

continued from page 71

Even video cameras may be tested with the model 1250. You can switch to an external video input signal by just pulling out the center knob of the RF switch. Feed the camera output signal into the EXT VIDEO IN on the rear panel and you can see the results on a video monitor or color TV set.

Also on the rear panel is a BNC output jack for the 3.579545 subcarrier. A frequency counter can be connected there to check the frequency, or the signal can be used for synchronizing other circuits. The signal is at the 1.0 volt level with no load and is matched for a 75 ohm input impedance.

The model 1250 is an accurate and very versatile piece of electronic equipment for any serious video engineer, technician, or anyone else in the field. It can be used for many tests in CATV and MATV systems, and also for closed-circuit TV systems. Up to now, equipment of such accuracy has been far too expensive for the average TV shop, and also too big to fit comfortably on the service bench.

The model 1250 is only a bit more than 4 inches tall and 17.5 inches wide. The jacks that you will use most often are on the front panel. All of the controls are conveniently arranged, which makes the model 1250 a very easy instrument to operate quickly.

All of the RF and IF signals are crystal controlled for greater accuracy. Each one has its own crystal oscillator for maximum stability. The sync-generator circuitry uses the latest LSI circuit design. A single integrated circuit generates all of the sync signals, again to strict NTSC standards. Even the newer TV receivers, which use a count-down IC to develop the

sync signals will work here. Every one of the outputs of the model 1250 may be used at the same time. You could drive a video monitor with the video output and at the same time feed RF signals to a color TV set!

There's one other thing you can do with it, too. If you run into the hypercritical customer who insists that a problem is in his TV set (and you are almost sure that it is either a network goof or a local TV station goof!), you can show him that his set will indeed make the standard patterns and tell him that this is the kind of equipment that the TV station *ought* to be using!

R-E

Grab a handful of VIZ value!



More Magic from the Wizard of VIZ

NEW Tech DMM WD-747 \$89.95

More premium quality features per dollar than any other hand-held 3½ DMM! The *only* one with built-in test socket for transistor h_{FE} . Side switches for easy one-hand use. Auto polarity/zero. Large 0.5" LCD digits. Resolution down to 100 μ V. Accuracy

better than 0.8% DCV. 10M Ω input impedance. Full overload protection. All functions color coded. Complete with battery, deluxe test probes and spare fuse. HV probe, multiplier resistor and "LED head" continuity probe available.



0.1% Accurate DMM WD-759 \$159.95

Want top quality? Here's the *only* hand held 3½ DMM with full info LCD readout: Function (V, A or Ω), Amount (numeric value) and whether AC or DC. Also the *only* one with full range high and low power ohms. Features auto polarity/zero, RF shielding, recessed input jacks, high impact case with front guard rail that protects against damage if dropped face down. Supplied with battery, tilt stand, spare fuse (stored inside case). Deluxe test probes have dual banana plug, alligator clip and "no-short" probe tip. Full one-year warranty. AC adapter, "LED-head" continuity probe and carry case available.

Lab accuracy WD-758 with LED readout \$149.95

See your VIZ distributor
Ask about the 7 VIZ bench
DMMs with prices to \$359

VIZ

VIZ Mfg. Co., 335 E. Price St., Philadelphia, PA 19144
Over 70 test instruments in the line

books

RADIO OPERATOR'S LICENSE Q&A MANUAL (Revised Ninth Edition), by Milton Kaufman. Hayden Book Company, Inc., 50 Essex Street, Rochelle Park, NJ 07662. 646 pp. 5 1/4 x 8 1/4 in. Softcover \$8.95; cloth \$13.95.

The latest revision of this manual, which has been appearing regularly since 1949, is in complete accordance with the latest FCC Study Guides, the Supplements to the Study Guides, and the latest FCC Rules and Regulations. It's designed to prepare the student to take the radiotelephone examination for Third-Class, Second-Class, and First-Class licenses and for the Radar Endorsement. It contains all the information a student will need to take an examination for *any* class of radiotelephone operator's license.

The questions in each section are exactly the type of questions to be found in the official examinations, and at various stages sample FCC tests are printed. Questions are followed by clear, concise answers, and in many cases by a discussion of the matter at hand. It is the detailed discussions, accompanied by many diagrams, that make this single volume self-sufficient for the student.

In addition to the elements, there is an extensive section on troubleshooting, which will give the student practice in solving the kind of problems that will be posed in FCC examinations.

THE DESIGN & DRAFTING OF PRINTED CIRCUITS, By Darryl Lindsey. Bishop Graphics, Inc., 5388 Sterling Center Drive, PO Box 5007, Westlake Village, CA 91359. 196 pp. 8 1/4 x 11 in. Hardcover; \$24.95.

This sturdily-bound book is designed for use in the workshop as well as the library and will remain open at any page to which you turn. Bishop is the world's largest manufacturer of printed circuit design products, and the present volume is an answer to many requests received for a comprehensive single volume on understanding, designing, and creating PC artwork. Both those who are experienced and the beginning electronic designer and draftsman will find it a valuable "how to" guide.

The author, Darryl Lindsey, is the founder of the Masters PC Design

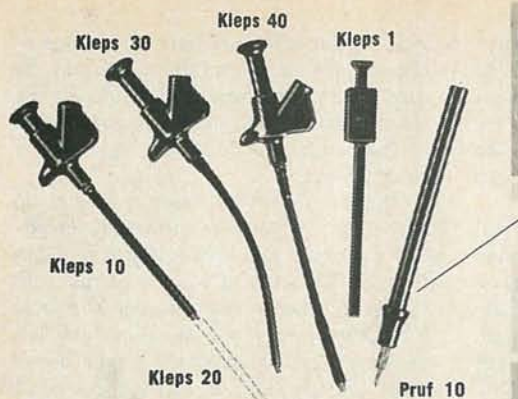

Clever Kleps

Test probes designed by your needs — Push to seize, push to release (all Kleps spring loaded).

Kleps 10. Boathook clamp grips wires, lugs, terminals. Accepts banana plug or bare wire lead. 4 3/4" long.

Kleps 20. Same, but 7" long.

Kleps 30. Completely flexible. Forked-tongue gripper. Accepts banana plug or bare lead. 6" long.

Kleps 40. Completely flexible. 3-segment automatic collet firmly grips wire ends, PC-board terminals, connector pins. Accepts banana plug or plain wire. 6 1/4" long.

Kleps 1. Economy Kleps for light line work (not lab quality). Meshing claws. 4 1/2" long.

Prof 10. Versatile test prod. Solder connection. Molded phenolic. Doubles as scribing tool. "Bunch" pin fits banana jack. Phone tip. 5 1/2" long.

Write for complete catalog of - test probes, plugs, sockets, connectors, earphones, headsets, miniature components.

Available through your local distributor, or write to:



RYE INDUSTRIES INC.

130 Spencer Place, Mamaroneck, N.Y. 10543

In Canada: Rye Industries (Canada) Ltd.

CIRCLE 35 ON FREE INFORMATION CARD

RCA Permacolor Outdoor TV Antennas.

They'll bring in a better sales and profit picture for you.

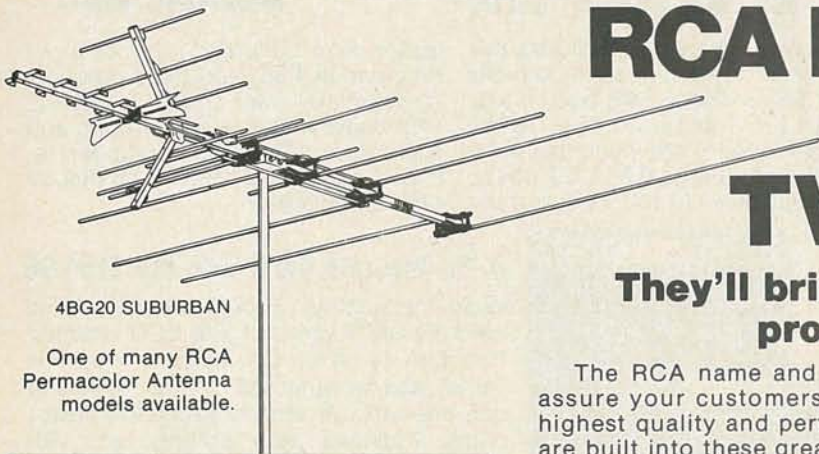

4BG20 SUBURBAN

One of many RCA Permacolor Antenna models available.

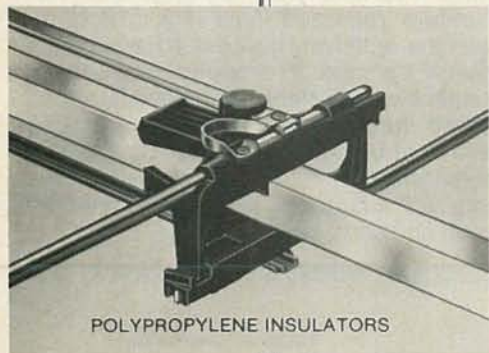

POLYPROPYLENE INSULATORS

Insulator design locks elements for top performance and long life.

The RCA name and tradition assure your customers that the highest quality and performance are built into these great Permacolor TV Antennas. And they're absolutely right.

RCA's Permacolor Outdoor TV Antennas have advanced engineering features that offer the best possible reception in almost any area — from deep fringe to metropolitan locations.

They're the first antennas with solid, permanent connections from elements to feed line. The first antennas with elements permanently riveted to pivoting polypropylene insulators. And, the first with a weather-resistant blue and gold vinyl finish.

RCA's Permacolor line is a complete line consisting of: 10 UHF-VHF/FM all band combo models, 7

VHF/FM models, 5 UHF models, an FM only model, and a selection of 75 ohm and 300 ohm antenna kits. Plus the amazing Mini-State — the first truly miniaturized rotating antenna system.

Once your customers get the picture with these advanced Permacolor Antennas, they'll never be satisfied with anything less.

For full information, see your RCA Distributor or write to: RCA Distributor and Special Products Division, Deptford, N.J. 08096, Attn: Sales Promotion Services.



School in San Francisco, and has spent over 17 years as a printed circuit draftsman, designer, and PC supervisor in the commercial and military electronics field.

The book includes chapters on schematics, PC board layout ground rules, discrete components layout, mounting components, IC grouping, digital layout, multi-layer PC boards, production considerations, artmaster tape-up, ground planes, familiarization with fabrication and assembly drawings, silk-screen drawings and artmasters, the manufacturing process of PC boards, and logic as it relates to PC design reference materials. There are over a hundred clear "how to" diagrams and charts.

OSCILLOSCOPE APPLICATIONS & EXPERIMENTS, by Edward M. Noll. Howard W. Sams & Co., Inc., 4300 West 62nd St., Indianapolis, IN 46268. 223pp. 5 1/4 x 8 1/4 in. Softcover. \$8.95.

For both the neophyte and the advanced technician, this book covers the entire range of oscilloscope application fundamentals and techniques. After a chapter on basics there are two chapters dealing with oscilloscope applications in audio, AM/FM receivers, and TV receivers. The fourth chapter emphasizes two-way radio applications, particularly in reference to modulation checks and waveform analysis. The last two chapters go into the dual-trace oscilloscope and applications in digital electronic circuits. Each chapter in the book includes suggested learning experiments. They will aid in developing new skills necessary to make the most effective use of the modern oscilloscope.

HANDBOOK OF ELECTRONICS CALCULATIONS FOR ENGINEERS AND TECHNICIANS, Edited by Milton Kaufman and Arthur H. Seidman. McGraw-Hill Book Company, 1221 Avenue of the Americas, New York, NY 10020. 668pp. 6 x 9 in. Hardcover; \$24.50.

Each of the 24 chapters in this handbook is written by an expert in its particular area, and the volume as a whole covers around 500 worked-out problems ranging from microprocessors to thick-film technology. There are over 700 illustrations.

The subjects covered are: Technical math review, DC circuit analysis, AC circuit analysis, Selecting *R*, *L*, and *C* components. Selecting semiconductor devices, audio amplifiers, tuned amplifiers, feedback, oscillators, power supplies, batteries and special skills, op amp applications, digital logic, computer-aided circuit design, analog-to-digital conversion, video amplifiers, microprocessors, transmission lines, filters, antennas, microwaves, communications systems, measurements, and thick-film technology. There are also 23 pages of appendices, and an index. The publishers state that the present volume is the first fully comprehensive electronics handbook that can help you solve the day-to-day problems of electronics engineers and technicians in a practical way.

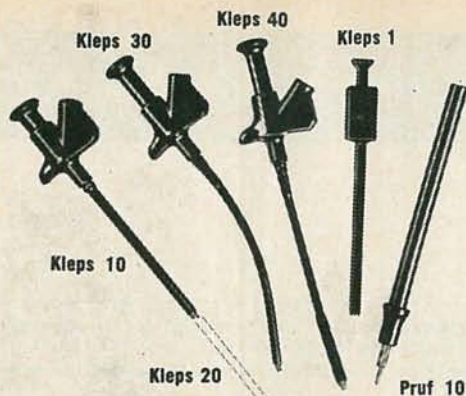

Clever Kleps

Test probes designed by your needs — Push to seize, push to release (all Kleps spring loaded).

Kleps 10. Boathook clamp-grips wires, lugs, terminals. Accepts banana plug or bare wire lead. 4 3/4" long.

Kleps 20. Same, but 7" long.

Kleps 30. Completely flexible. Forked-tongue gripper. Accepts banana plug or bare lead. 6" long.

Kleps 40. Completely flexible. 3-segment automatic collet firmly grips wire ends, PC-board terminals, connector pins. Accepts banana plug or plain wire. 6 1/4" long.

Kleps 1. Economy Kleps for light line work (not lab quality). Meshing claws. 4 1/2" long.

Prof 10. Versatile test prod. Solder connection. Molded phenolic. Doubles as scribing tool. "Bunch" pin fits banana jack. Phone tip. 5 1/2" long.

Write for complete catalog of - test probes, plugs, sockets, connectors, earphones, headsets, miniature components.

Available through your local distributor, or write to:



RYE INDUSTRIES INC.

130 Spencer Place, Mamaroneck, N.Y. 10543
In Canada: Rye Industries (Canada) Ltd.

CIRCLE 35 ON FREE INFORMATION CARD

Price Without Sacrifice.



HITACHI V-302 & V-152

Put a proven Hitachi dual-trace oscilloscope on your bench for as little as \$695. Our V-152 15MHz model includes unprecedented sensitivity (1 mV/div)...10X sweep magnification...front panel XY operation...trace rotation...Z-axis input...and more. Need greater bandwidth? Our V-302 model is the only 30MHz dual-trace scope with signal delay line priced under \$1000, with all the above features, to make your testing operations fast, easy, and accurate. Reliability is exceptional, too. (As you'd expect from a manufacturer with over 20 years of experience "outscoping" the competition.) So exceptional, in fact, that Hitachi quality is backed by a 2-year warranty...the longest in the industry. Whether you use it for teaching or repairs, for video, audio, or computer testing, you can't find more scope for your dollar than at Hitachi. Write for more details.

Hitachi...The measure of quality.

- V-152 15 MHz Dual Trace . . . \$695*
- V-302 30 MHz Dual Trace . . . \$945*

*Probes included.



HITACHI
Hitachi Denshi America, Ltd.
175 Crossways Park West
Woodbury, NY 11797
(516) 921-7200

CIRCLE 38 ON FREE INFORMATION CARD

market center

CLASSIFIED COMMERCIAL RATE (for firms or individuals offering commercial products or services). **\$1.50 per word (no charge for zip code)** . . . minimum 15 words.

NONCOMMERCIAL RATE (for individuals who want to buy or sell personal items) **85¢ per word** . . . no minimum.

ONLY FIRST WORD AND NAME set in bold caps. Additional bold face (not available as all caps) at 10¢ per word. Payment must accompany all ads except those placed by accredited advertising agencies. 5% discount for 6 issues, 10% for 12 issues within one year, if paid in advance. All copy subject to publisher's approval. **ADVERTISEMENTS USING P.O. BOX ADDRESS WILL NOT BE ACCEPTED UNTIL ADVERTISER SUPPLIES PUBLISHER WITH PERMANENT ADDRESS AND PHONE NUMBER.** Copy to be in our hands on the 26th of the third month preceding the date of the issue (i.e., August issue closes May 26). When normal closing date falls on Saturday, Sunday, or a holiday, issue closes on preceding working day.

EDUCATION & INSTRUCTION

UNIVERSITY degrees by mail! Bachelors, Masters, Ph.D's . . . Free revealing details. **COUNSELLING**, Box 317-RE4, Tustin, CA 92680

BROADCASTING! Start your own radio station at home, school, church! Become a DJ! Free information. "BROADCASTING", Box 130-F4, Paradise, CA 95969

MAKE Hydrogen fuel: Build Generators with material from Hardware stores. Illustrated Manual; \$10.95 ppd. **NEGEYE ENGINEERING**, Pennsboro, WV 26415

HOME study degree program in electronics engineering. 75 specialized courses also available. For information write: **CIEE**, P.O. Box 9196, Pittsburgh, PA 15224

AVIONICS Aircraft Electronics. Accredited School. Excellent employment opportunities. **AERO TECHNICIANS**, P.O. Box 7 RE, Rexburg, ID 83440

GRAPHIC EQUALIZER

TWELVE bands/channel \$100 kit. still available; see May 1978 R/E cover story or write: **SYMMETRIC SOUND SYSTEMS**, 912 Knobcone Place, Dept. R, Loveland, CO 80537

WANTED

MARCHANT mechanical calculator Model 10MR, \$100.00. **LEONARD WOODALL**, 3811 Dempster, Dallas, TX 75211

PASS FCC EXAMS

The Original FCC Tests-Answers exam manual that prepares you at home for FCC First and Second class Radiotelephone licenses. Newly revised multiple-choice exams cover all areas tested on the actual FCC exam. Plus "Self-Study" Ability Test. Proven! \$9.95 postpaid. Moneyback Guarantee.

COMMAND PRODUCTIONS
Radio Engineering Division

P.O. Box 26348 E
San Francisco, CA 94126



To run your own classified ad, put one word on each of the lines below and send this form along with your check for \$1.50 per word (minimum 15 words) to:

Radio-Electronics, 200 Park Avenue South, N.Y., N.Y. 10003

ORDER FORM

PLEASE INDICATE in which category of classified advertising you wish your ad to appear. For special headings, there is a surcharge of \$10.

() Plans/Kits () Business Opportunities () For Sale
() Education/Instruction () Wanted ()

Special Category: \$10

(PLEASE PRINT EACH WORD SEPARATELY, IN BLOCK LETTERS.)

1	2	3	4	5
6	7	8	9	10
11	12	13	14	15
16	17	18	19	20
21	22	23	24	25
26	27	28	29	30
31	32	33	34	35

PLEASE INCLUDE FOR OUR FILES YOUR PERMANENT ADDRESS AND PHONE NUMBER.

Telephone Listening Device

Record telephone conversations in your office or home. Connects between any cassette or tape recorder and your telephone or telephone LINE. Starts automatically when phone is answered. Records both sides of phone conversation. Stops recorder when phone is hung up. This device is not an answering service.



Each
\$18.95
Qty Disc Avail

Super Powerful Wireless Mic

10 times more powerful than other mics. Transmits up to 1/4 mile to any FM radio. Easy to assemble kit. 15V battery (not incl.)



Call (305) 725-1000 or send \$18.95 + \$1.00 shipping per item to **USI Corp.**, P.O. Box RE-2052, Melbourne, FL 32901. **COD's accept.** For catalog of transmitters, voice scramblers and other specialty items, enclose \$2.00 to **USI Corp.**

SATELLITE TELEVISION

SKYVISION—The monthly magazine of home satellite television reception. 12 monthly issues only \$12. Send to: **SKYVISION**, P.O. Box 10017, Chicago, IL 60610

GEOSTATIONARY satellites, present and future, found for your location. \$2.00 with longitude-latitude, \$3.00 without. For free sample, send self-addressed stamped envelope. **SAT-FIND**, Box 524, North Amherst, MA 01059

ELECTRONIC MUSIC

ELECTRONIC music and home recording in Polyphony magazine. Advanced applications, interviews, projects, computer music. Sample, \$1.50. Subscription (6 issues), \$8 US/\$10 foreign. **POLYPHONY**, Box R20305, Okla. City, OK 73156.

MICRO COMPUTERS

TRS-80 micro computers by Radio Shack at 15% discount. Also have software for business systems. **MICRO MANAGEMENT SYSTEMS**, Downtown Shopping Center Plaza, Cairo, GA 31728 (912) 377-7120

HIGHLY PROFITABLE

ELECTRONIC FACTORY

Investment unnecessary, knowledge not required, sales handled by professionals. Ideal home business. Write today for facts!

Postcard will do. Barta-RE-B, Box 248, Walnut Creek, CA 94597.

TELEPHONES

ELECTRONIC telephone ringer replaces harsh annoying bells, \$12.50. **Holdbutton** for single-line phones—at last! \$19.95. Catalog of other telephone items \$1.00. **CONSUMERS' TELEPHONE**, 69-A Smith St., Glen Head, NY 11545

INVENTIONS

INVENTORS: if you have an invention for sale or license, write for free booklet explaining how we can help you. **KESSLER SALES CORP.** C-314, Fremont, Ohio 43420.

BUSINESS OPPORTUNITIES

MECHANICALLY inclined individuals desiring ownership of Small Electronics Manufacturing Business—without investment. Write: **BUSINESS-ES**, 92-R, Brighton 11th, Brooklyn, NY 11235

NEW tax loopholes discovered. Everyone eligible. Unique ideas. Free facts. **ULC**, Box 359 BC, Clarkston, GA 30021

Special



**Horizontal Output
Transistor Equivalent to ECG 238**

(ECG is a registered trade mark of the Sylvania Corp.)

2.45

Minimum order of 10

**Stock up on these popular TV parts
while prices are low!**

**Sony Trinitron
Dual Antenna**

Sony AN16

(1-9) **\$7⁴⁰** (10-100) **\$6⁰⁰**

MAN-16



UHF/VHF/FM Splitters

300 OHM

(1-9) **\$1³⁰** (10-100) **\$1¹⁰**

SPL-701



75 Ohm

(1-9) **\$1⁴⁵** (10-100) **\$1³⁰**

SPL-702



TV Interference Filter

(1-9) **80c** (10-100) **65c**

TVI-1



**75 Ohm to 300 Ohm
Converter**

(1-9) **65c** (10-20) **55c**

TVT-1



**F-59 Connectors
with Ferule**

14c ea.



(on minimum order of 100)

**Universal Globar
Resistor Kit**

2 Universal Globars for color
TV automatic degauss
circuit. Contains a thermistor
and a varistor. Fits many
famous make color TV's

(1-9) **\$1⁰⁰** (10-100) **\$1⁰⁵**

KT-2



High Voltage Tripler

Equivalent to ECG-500A

(1-9) **\$12⁰⁰** (10-100) **\$11⁰⁰**

HVT-500A



There just isn't enough room . . .

Limited space prevents the listing of the many hundreds of TV & Stereo parts we stock. This page contains just a few of the low, low priced replacement parts we keep in our huge inventory, **at the lowest prices you'll ever find!** For our complete parts listing, call our toll-free number listed below, or write for our free 24-page catalog.

Tube Number	10-up	1-9	Tube Number	10-up	1-9	Tube Number	10-up	1-9
1V2	.95	1.10	6EL4	2.75	3.15	8AW8	2.45	2.65
2AV2	1.15	1.35	6FQ5	2.15	2.35	8FQ7	1.10	1.25
3A3	1.50	1.70	6FQ7/ECG7	1.15	1.30	8CG7	1.10	1.25
3AW3	1.50	1.70	6GF7A	1.95	2.25	12AU7A/ECC82	1.15	1.30
3CY3	1.60	1.85	6GH8A	1.15	1.35	12AV6	1.10	1.25
3DB3	1.60	1.85	6GM5	1.55	1.80	12AX7/ECC83	1.15	1.30
3HA5	1.40	1.60	6GU7	1.55	1.80	12GN7	2.10	2.35
3HM5	1.40	1.60	6HA5	1.45	1.60	12HG7	2.10	2.35
5GH8A	1.75	1.95	6HB7	1.45	1.60	13GF7A	1.95	2.20
5U4	1.20	1.40	6HM5	1.45	1.60	17BF11	2.85	3.10
6AQ5	1.20	1.40	6J10	2.30	2.60	17JZ8	1.60	1.85
6AU6	1.20	1.40	6JE6	3.10	3.50	24JE6	3.05	3.95
6AW8A	1.60	1.90	6JS6	2.80	3.10	24LQ6	3.05	3.45
6BA11	1.85	2.05	6KD6	3.20	3.60	31JS6	2.75	3.10
6BK4	2.75	3.15	6LG6C	2.30	2.60	33GY7	2.45	2.80
6BL8/ECF80	1.05	1.20	6LB6	3.00	3.45	38HE7	2.90	3.15
6CJ3	1.40	1.60	6LQ6	3.10	3.50	38HK7	2.75	3.10
6DW4	1.40	1.60	6MD8	2.20	2.50	40KD6/36KD6	3.15	3.55
6EJ7/EF184	1.40	1.60	6Z10	2.30	2.60	50C5	1.15	1.30

Call These Toll-Free 24 Hour Hot Lines

1-800-543-3528

(In Ohio call **1-800-762-3416**) TLX 288349

mem audio, inc.
Your original Japanese semiconductor supplier

639 Watervliet Avenue, Dayton, Ohio 45420

CIRCLE 20 ON FREE INFORMATION CARD

APRIL 1980

97

PICTURE TUBE MACHINE
We buy and sell NEW and USED CRT rebuilding machinery. COMPLETE TRAINING. Buy with CONFIDENCE from the ORIGINAL MFR.
For complete details send name, address, zip to:
LAKESIDE INDUSTRIES
4071 N. Elston Avenue
Chicago, Ill. 60618
Phone: 312-583-6565



PLANS & KITS

ELECTRONIC organ kits. The ultimate design. Sounds like a pipe organ. Build it to sell or build it to keep. Models for churches, homes, clubs, pizza parlors. Send \$1.00 for demo record and catalog. **DEVTRONIX**, Dept. 70, 6101 Warehouse Way, Sacramento, CA 95826

PRINTED circuit boards from sketch or artwork. Kit projects. Free details. **DANOCINTHS INC.**, Box 261, Westland, MI 48185

SPEAKERS. Save 50%. Build your own speaker system. "Free catalog" write: **MC GEE RADIO**, RE 1901, McGee Street, Kansas City, MO 64108

COPY Television Satellites! Parabolic screen mesh dish kits. Pre-cut ready to assemble. 8, 12, and 16 foot sizes available. Reasonable prices. Send SASE for details. **MARBLE COMPANY**, 32 Sea Street North, Weymouth, MA 02191

LASER plans using laser diode 1-1200 watts (specify) \$4.00. Catalog \$5.00. **LASERTRONICS (1)**, 12320 SW Spring, Portland, OR 97225

DIGITAL auto compass, eight LED direction indicators, three digit heading readout. Information \$1.00, complete plans \$3.50. **TS RESEARCH**, 2301 East Ball Road, c/o Office, Anaheim, CA 92806

NEGATIVE ion generator plans, \$4.00. Kits, other plans available, free list. **STARWIND**, Box 712, Goleta, CA 93017.

NEGATIVE ion generator plans. Build it yourself with easy-to-get parts, save up to 75%. Includes ozone check. \$5.00 to **LUNATRIX**, Box 891, Yucaipa, CA 92399

USE your talent, build burglar alarms, plans \$3.50. **DANNY MOWER**, Route 2, Box 460-D, Concord, NC 28025

SOUND effects. Greatly expand the use of your tape recorder and creativity. Echo, reverb, dubbing, time delay. Demo tape \$5.00, plans \$7.50. **SOUND EXPANSION**, Box 336, House Springs, MO 63051

SATELLITE TV FOR THE HOME

Our receiver lets you get over 75 channels of television directly from earth-orbiting cable TV satellites! HBO, Showtime, super stations, sports and movies from around the world.



Sick of Network TV? Buy Complete or Build our kit and save!

Our 24-channel receiver provides "studio quality" TV reception. Easy to install! Ultra low power consumption! Brilliant color! Works anywhere! FCC licensing no longer required. Order today! Complete details covered in our Home Earth Station manual. Send \$7.95 today (refundable against any purchase), or call:

24-hour C.O.D. Hotline
(305) 869-4283

SPACECOAST RESEARCH

Dept. T, P.O. Box 442, Altamonte Springs, FL 32701

INSTRUCTIONS and PC negatives, frequency counter 30MHz \$5.00, clock 4 digit \$2.50. **RCS ENTERPRISES**, Box 488, Sierra Vista, AZ 85635

SATELLITE TV antenna build for \$300. Detailed plans \$30. **NUMAN ENTERPRISES**, Rt. 1, Box 357, Jonesboro, TE 37659

MONITOR radiation, not a geiger counter, LED readout, complete plans and B/M. \$7.00, **RAD-TECH ENGINEERING**, P.O. Box 42804, Houston, TX 77042

BUGS. Build professional miniature FM transmitters. Plans \$5.00. Money-back guarantee. **PCEP ENTERPRISES**, Box 837-A, New York, NY 10004

EINSTEIN superCeded! Free! 408 Vermont, Daytona, FL 32018

WIRELESS control telephone tape recording device. Records conversations turning tape recorder on and off automatically. No connection to telephone. Information \$4.00. Send to: **MAHONE**, P.O. Box 2366, San Jose, CA 95109

AMAZING ELECTRONIC PROJECTS and PRODUCTS:

Lasers Super Powered, Burning, Cutting, Rifle, Pistol, Pocket. See in Dark—Shotgun Directional Mike—Unscramblers—Giant Tesla—Stunwand—TV Disrupter—Energy Producing, Surveillance, Detection, Electrifying, Ultrasonic, CB, Auto and Mech. Devices, Hundreds More—All New Plus INFO UNLTD PARTS SERVICE. Catalog \$1. Information Unlimited, Dept. R8 Box 716 Amherst, N.H. 03031.

FOR SALE

RADIO & TV tubes 49¢ each. One year guaranteed. Plus many unusual electronic bargains. Free catalog. **CORNELL**, 4217-E University, San Diego, Calif. 92105

SCANNER/monitor accessories—kits and factory assembled. Free catalog. **CAPRI ELECTRONICS**, Route 1R, Canon, GA 30520

FREE catalog, IC's, LED's, semi's, parts. **CORONET ELECTRONICS**, 649A Notre Dame W., Montreal, Que., Canada H3C 1H8. U.S. inquiries.

RECONDITIONED test equipment. \$1.00 for catalog. **JAMES WALTER TEST EQUIPMENT**, 2697 Nickel, San Pablo, CA 94806

SAVE up to 50% on name brand test equipment. Free catalog and price list. **SALEN ELECTRONICS**, Box 82-M, Skokie, IL 60077

GET IT ALL! Subscribe today, and don't miss a single issue.

When you subscribe to the best electronics magazine of all—Radio-Electronics—you're making sure that you'll get all the news of electronics you want, every month from now on. Issue after issue, you'll get equipment news, test reports, projects to build, computer technology, servicing tips and more, including regular columns on computers, solid state, hi-fi, hobbies and servicing. And every one is written by the experts, the outstanding authorities in the most exciting, fastest-growing field in the world today—electronics.



And...you save money, too, as much as \$5. off the newsstand price of Radio-Electronics when you select one of the subscription offers listed on the handy coupon. More important—you'll be assured of having your copy reserved, even if it runs out on the newsstands. You save money and time. Make sure you get all the excitement in every issue of Radio-Electronics, every month, by filling in and mailing the coupon, today.

GET THE BEST!—Radio-Electronics

40D0

(please print)

- 1 Year—12 issues ONLY \$13.00**
(You save \$2.00 off newsstand price.)
- 2 Years—24 issues ONLY \$25.00**
(Save More! \$5.00 off newsstand price.)
- Payment enclosed
- Bill me
- Extra Shipping: Canada \$3.00 per year, all other countries \$5.00 per year.

Name _____

Address _____

City _____

State _____ Zip Code _____

Mail to: **Radio Electronics** SUBSCRIPTION DEPT., P.O. BOX 2520, BOULDER, COLO. 80322

Active Electronic Sales Corp.

Zilog

Z8001 \$195.00 16 Bit CPU with segmented address space to 8 Megabytes.

Z8002 \$150.00 16 Bit CPU with non segmented address space to 64K bytes.

Z8000DB \$1500.00 A complete single board Z8000 microcomputer system. Contains the Z8002 microprocessor, 16K words of dynamic RAM, 2K word monitor PROM, dual serial interfaces, four counter/timers and 32 programmable parallel I/O lines.

**All Products Stocked in Depth
Largest Zilog Inventory**

Z80-CPU	2.5 MHz	\$ 9.95	Z80-DMA	2.5 MHz	\$26.85
Z80A-CPU	4.0 MHz	11.95	Z80A-DMA	4.0 MHz	33.60
Z80-PIO	2.5 MHz	7.20	Z80-SIO/O	2.5 MHz	36.00
Z80A-PIO	4.0 MHz	8.40	Z80A-SIO/O	4.0 MHz	39.50
Z80-CTC	2.5 MHz	7.20	Z80-SIO/1	2.5 MHz	36.00
Z80A-CTC	4.0 MHz	8.40	Z80A-SIO/1	4.0 MHz	39.50
			Z80-SIO/2	2.5 MHz	36.00
			Z80A-SIO/2	4.0 MHz	39.50

MICROPROCESSOR CHIP SETS

Part No.	Price	Part No.	Price	Part No.	Price
8080A	\$5.95	6800	\$6.95	6502	\$9.95
8085	12.95	6802	11.95	6504	9.95
				6505	9.95
8212	2.95	6810	3.95		
8214	3.95	6820	3.95	6520	6.95
8216	2.95	6821	3.95	6522	9.95
8224	3.45	6850	4.25	6532	13.95
8226	2.25	6852	3.95	6551	13.95
8228	4.98				
8238	4.98				
8251	6.95				
8253	14.95				
8255	5.75				
8257	10.95				
8259	14.95				

16K MOS DYNAMIC RAM's (16 PIN)

416-5 (300ns)	9.95
416-4 (250ns)	10.95
416-3 (200ns)	11.95

Over 200K pieces in stock

METAL POWER TRANSISTORS

Homotaxial — Best Quality

2N3054	.65	60V	NPN	TO-66
2N3055	.69	70V	NPN	TO-3
2N3442	1.50	160V	NPN	TO-3
2N3771	1.95	50V	NPN	TO-3
2N3772	1.95	100V	NPN	TO-3
2N3773	2.50	160V	NPN	TO-3

Universal SCR

C106D	.34	400V	5.0 AMP	TO-220
-------	-----	------	---------	--------

MOS MEMORIES

MOS Static RAM's

Part No.	Price
2101	\$1.95
1K (256 x 4) 350ns 22 PIN	
2102LFPC	1.19
1K (1K x 1) Low Power 350ns 16 PIN	
2102LHPC	1.29
1K (1K x 1) Low Power High Performance 250ns 16 PIN	
2102-1PC	0.94
1K (1K x 1) 450ns 16 PIN	
2102-2PC	0.89
1K (1K x 1) 650ns 16 PIN	
P2111-25	2.25
1K (256 x 4) 250ns 18 PIN	
P2112-35	2.25
1K (256 x 4) 350ns 18 PIN	
2114L	\$5.95
Low Power 4K (1024 x 4) 300 ns	

MOS Dynamic RAM's

TMS4060-30	2.95
4K (4K x 1) 300ns 22 PIN	
TMS4060-20	3.95
4K (4K x 1) 200ns 22 PIN	

UART's

AY5-1013A	4.50
0 to 40K BAUD 40 PIN	
AY3-1015	5.50
0 to 30K BAUD 40 PIN Single 5V supply	

1K CMOS RAM

5101	3.95
1K (256 x 4) 450ns 22 PIN Low Power	

4K CMOS RAM

P4315-45L	14.95
4K (4K x 1) 450ns 18 PIN	

SHIFT REGISTERS

3341PC	4.95
FIFO 700 KHz	
3341APC	5.50
FIFO 1 MHz	
3342PC	4.95
64 Bit Shift Register	
3347PC	4.95
80 Bit Shift Register	

ECL RAM

10410ADC/HM2106	Special 1.95
256 x 1 Bit Fully Decoded 15ns 16 PIN	

LINEAR I.C.'s

LM301N-8	.34	LM739CN-14	1.29
LM307N-8	.29	LM741CN-8	.49
LM308CH	.95	LM747CN-14	.59
LM311N-8	.59	LM748CN-8	.39
LM324N	.59	TBA810DAS	1.29
LM339N	.99	LM1458N-8	.49
LM348N-14	.55	LM1488N-14	.59
LM358N-8	.99	LM1489N-14	.69
LM555N-8	.59	LM3403N-14	.99
LM556N-14	.49	LM3900N	.59
LM723CN-14	.49	LM4136N-14	.99
LM725CN-8	1.25		

Special of the Month

EPROM

C2708-65/4708-6 \$6.90

1K (1K x 8) 650 ns



1980 IC MASTER

JUST RELEASED over 2700 PAGES

Complete integrated circuit data selector. Master guide to the latest I.C.'s including microprocessors and consumer circuits. 45,000 device types listed. 5,000 new device types added. Complete new section on MPU boards & Systems.

Free Quarterly Updates

Special \$59.95



SOUND & MUSIC GENERATOR I.C.

Creates almost any type of sound, from music to gunshots and explosions. High level on amp output. 28 pin DIP. Operates from one 9V battery. With data.

"Lowest Price Offered Anywhere"

SN76477N (.600" centers)	\$2.49
SN76477NF (.400" centers)	\$2.29

"New small package"

MICROCOMPUTER BOARDS

NEC MICROCOMPUTERS

TK80A \$299.00

Based on the 8080A the board has both 1K RAM and 1K electrically erasable PROM expandable to 4K x 8 and 8K x 8 on board. Complete with keypad with 25 real keys and 8 bright .500" digits for display.

Rockwell International

AIM65 \$375.00

As a learning aid AIM65 gives you an assembled, tested and warranted R6502 based microcomputer system with a full sized keyboard, an alphanumeric 20 character display and uniquely, an alphanumeric 20 column thermal printer. An on board Advanced Interface Monitor program provides extensive control and program development functions. 1K RAM.

L.E.D. LAMPS

LED209	T-1 3 mm Red	.09
LED211	T-1 3 mm Green	.18
LED212	T-1 3 mm Yellow	.14
LED220	T-1 5 mm Red	.11
LED222	T-1 5 mm Green	.24
LED224	T-1 5 mm Yellow	.16

DISPLAYS

FND357	.375" Common Cathode	1.09
FND367	.360" Common Cathode (high brightness)	1.29
FND500	.500" Common Cathode	1.09
FND507	.500" Common Anode	1.09
FND560	.500" Common Cathode (high brightness)	1.29
FND567	.500" Common Anode (high brightness)	1.29
DL704	.300" Common Cathode	1.29
DL707	.300" Common Anode	1.29
DL747	.630" Common Anode	2.29

ISOLATORS

ILD74	Dual Opto Isolator	1500V	1.29
ILD71	Quad Opto Isolator	1500V	3.95
MCT6	Dual Opto Isolator	1500V	1.29
TIL111	Opto Coupler	1500V	.69
4N26	Opto Isolator	2500V	.59
4N28	Opto Isolator	500V	.59
4N29	Opto Isolator	2500V	.69
4N32	Opto Isolator	2500V	.69

TEXAS INSTRUMENTS

Low Profile Sockets

Lowest prices anywhere for the highest quality, an unbeatable combination. Over one million pieces in stock.

Contacts	Price	Contacts	Price
8 PIN	.08	22 PIN	.22
14 PIN	.12	24 PIN	.24
16 PIN	.14	28 PIN	.28
18 PIN	.18	40 PIN	.40
20 PIN	.20		



Synertek® SYM-1 \$239.00

Fully assembled, tested, documented and expandable. Powerful 6502 8-bit microprocessor. 6-digit hex LED display. KIM-1 hardware compatibility. Single plus 5V power requirements.

Texas Instruments TM990/189 \$333.00

UNIVERSITY MODULE

A complete learning aid that in conjunction with the Tutorial Text offers hands on experience with microprocessors. I/O, memory and assembly language programming. Offers advanced features such as 45 key alphanumeric keyboard, a powerful instruction set, multiply and divide, vectored interrupts, single bit I/O manipulation parallel I/O and 7 addressing modes.

Active Electronic Sales Corp.

P.O. BOX 1035 FRAMINGHAM, MASSACHUSETTS 01701

Over-the-counter sales.
12 Mercer Rd., Natick, Mass 01760
Behind Zayres on Rte. 9
Telephone Orders & Enquiries (617) 879-0077

MINIMUM ORDER \$10.00 • ADD \$2.00 TO COVER POSTAGE & HANDLING

Foreign customers please remit payment on an international bank draft or international postal money order in American dollars.



IN CANADA

5651 FERRIER ST. MONTREAL, QUEBEC H4P 2K5 Tel.: (514) 731-7441	4800 DUFFERIN ST. DOWNSVIEW, ONTARIO M3H 5S9 Tel.: (416) 661-1115	BAXTER CENTRE 1050 BAXTER ROAD OTTAWA, ONTARIO K2C 3P2 Tel.: (613) 820-9471	3070 KINGSWAY VANCOUVER, B.C. V6R 5J7 Tel.: (604) 438-3321
---	--	---	---

CIRCLE 9 ON FREE INFORMATION CARD

Be sure to include sufficient postage.

AM-FM-STEREO

Convert Your Car Into A Concert Hall!

AM-FM-MONO



AUTOMATIC RADIO

MADE BY THE AUTO RADIO SPECIALISTS!!

Models May Vary

PUSH BUTTONS

AM-FM-MULTIPLEX

19⁹⁵ \$100 STEREO AUTO RADIO

\$2 for Shpg.

No. 5744W

UNBELIEVABLE

FACTORY CLOSEOUT! — One of America's largest independent manufacturers of automobile radios has given up which we announced in Nov. 1979 Radio Electronics & Popular Electronics magazines. We've been fortunate in acquiring more of the last auto radios in production. These are AM-FM-MPX-Stereo sets...designed for new cars. All are tested 100% operational and come with knobs & 5 push buttons. Ideal for installing in your auto, van, camper, boat or any other place 12 VDC is available.

NEWS ITEM! — Auto stereo has become as sophisticated as home hi-fi — and nearly as expensive. You can spend \$300 for simple components—which means stereo can be out of reach for many folks and 2nd cars. If you want a stereo sound system, you can start with the purchase of a \$100 radio for only a mere \$19.95 at Delta. The radios are designed for small interior of your car that has the combination of the hard plastic and soft upholstered surfaces. It is the perfect radio for a top-sounding stereo system.

14⁹⁵ AM-FM AUTOMATIC RADIO-FM

\$2 for Shpg.

BUY OF A LIFETIME!

No. 5745W

SAME RADIO as above except it is not stereo! Excellent FM reception; picks up stations with weak signals! Complete with metal top plate, push buttons and front bezels.

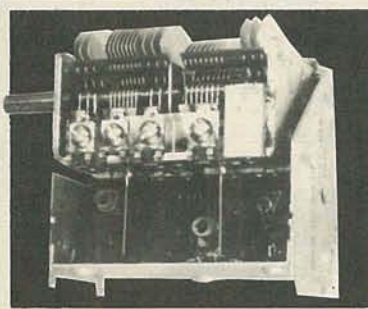

BUILD YOUR OWN STEREO RADIO.....

KLH FRONT END Tuner

Your Choice:

4.95

2 TYPES AVAILABLE

FM FM-AM

No. 60006R No. 60007R

"The Heart Of A Receiver!"...We have acquired a number of front end tuners.....made for KLH—one of the audio giants.....for use in its sophisticated receivers. These tuners contain the mechanical & electronic sections. The electronic section consists of an RF amplifier, oscillator and mixer. FM output from the tuner is 10.7 MHz, and the AM output is 455 KHZ. Both types operate on 12VDC, and draw approx. 12 ma. Tuning capacitor on FM models has a vernier for fine tuning. Entire unit is shielded.



PLASTIC

39" OVERALL

Wild West Goes "Electronic"

Electronic Rifle

Pump to cock! Pulling trigger fires it—giving an audible sound and making contact thru the 2-wire cable. Has compartment made to hold 9V battery & a couple of caps that charge up & then discharge thru the leads....lens in muzzle. We do not have specific info....but it's a terrific start for creating games; can be used by the kids....it's harmless. Limited Quantity!

3⁹⁵ EACH

No. 60104R

Send for free 1980 DELTA 120-pg. catalog

Delta Electronics, 176 Second Ave., Waltham, Ma. 02154



Resistor Assortment

Less Than Each 1/2¢ APPROX. 700 pcs. \$3

We have several million resistors—all cut and formed for P.C. boards. They are 5% 1/2-watt carbon film. Rather than count them, we are weighing 'em out by the 1/2-Lb....and find that they average about 700 pieces to the 1/2-Lb....making the price per resistor less than 1/2 cent each. This is a great way to build up an inventory for your work bench. Has large number of mixed values. No. 8926R

MAIL-ORDER ADDRESS:

DELTA ELECTRONICS

176 SECOND AVE. WALTHAM, MASS. 02154

Minimum Order \$8.00

TEL. (617) 388-4705

FOR SALE

HAMS, CBers, SWLs—eight character morse-A-word morse code reader; **RTTY reader**. Decodes signals off the air. Send for details. **MICROCRAFT CORPORATION**, Box 513R, Thiensville, WI 53092 1-414-241-8144.

"**SECRET** Registry of U.S. Government Radio Frequencies (25 to 470 MHz)." Book shows 3,800+ frequencies: FBI, FCC, Treasury, Border, Immigration, Secret Service, Customs, NASA, military, more. \$4.95 ppd., **CRB RESEARCH**, Box 56-RE, Commack, NY 11725

PARTS, IC's, LED's, keyboards. Free catalog. **R-E ELECTRONICS**, 1919 West Belt North 107, Houston, TX 77043.

PRINTED Circuit Boards: Your artwork, quick delivery, reasonable. Quantity discounts. **ATLAS CIRCUITS**, Box 974, Waynesville, NC 28786 (704) 456-3739

PORTABLE video recorders, special: Magnavox #8251; VHS; 2/4 hour; tuner-timer; only \$995. **AUDIO-VIDEO**, 2021 E. Markland, Kokomo, IN 46901 317-459-8511 9AM-2PM

SCANNERS, Bearcat, Regency, Fanon/Courier. Scanner crystals, antennas. **HARVEY PARK RADIO**, Box 19224, Denver, CO 80219

SURPLUS electronics. Monthly picture flyer. Low prices. U.S. only. **STAR-TRONICS**, Box 683, McMinnville, OR 97218

RAW speakers and finished systems for Hi-Fi and Sound Reinforcement. Also cabinet plans, hardware, grille cloth, crossovers, microphones, accessories, much more. Information-packed catalog, \$1.00. **UNIVERSAL DISCOUNT SOUND**, Dept. RE, 2243 Ringling Blvd, Sarasota, FL 33577

ALARM systems! Burglar, fire, car. Finest equipment! Save! Catalog, decal; 50¢, refundable! **AAS**, 186H Oxmoor Road, B'ham, AL 35209

ALL T.V. Tuners repaired \$11.95. Fast service quality work. **MIKE'S T.V. TUNER SERVICE**, Box 187, Bean Station, TN 37708 615-581-6393

SOUND EFFECTS GENERATOR BASIC KIT

Now Chaney Electronics makes it possible to build your own SOUND EFFECTS GENERATOR WITHOUT SPENDING A FORTUNE. WE SUPPLY YOU WITH THE 1176N77 SOUND CHIP PLUS AN ETCHED AND DRILLED GLASS EPOXY PCB BOARD WITH SCHEMATIC AND LAYOUT INSTRUCTIONS. THIS BOARD MAKES IT SIMPLE TO BUILD A GENERATOR CAPABLE OF PHASER SOUNDS, LOCOMOTIVE, SIRENS, AIRPLANES, CLOCKS, ETC. DOES NOT REQUIRE DIP SWITCHES OR OTHER EXPENSIVE/UNUSUAL COMPONENTS. YOU SUPPLY ONLY A FEW STANDARD RESISTORS, CAPACITORS, SWITCHES, POTS, SPEAKER, 2N2222 TRANSISTOR AND 9V BATTERY.

BASIC KIT CONTAINING: C23883 1176N77, PCB BOARD AND INSTRUCTIONS ONLY \$5.95.

2N2222 TRANSISTOR FOR ABOVE C23884 .39 EACH
IF YOU HAVE ALREADY PURCHASED THE 1176N77 CHIP YOU MAY BUY THE PCB BOARD AND INSTRUCTIONS ONLY C23885 \$4.50

LASER SLAVE TRIGGER KIT

WE SUPPLY ALL THE COMPONENTS PLUS SCHEMATIC TO MAKE A SENSITIVE SLAVE TRIGGER WHICH WILL FIRE YOUR SLAVE STROBE WHEN YOU TRIGGER YOUR MASTER STROBE. C23886 \$1.50

LED Flasher Kit

Simple to build kit uses the standard 555 timer IC to automatically flash a red and green LED. Comes complete with parts in etched PCB board. 9V battery is not included. C23887 \$2.49

6VDC Xenon Flasher Kit

Memory resistor. Flasher strobe. Mounts on light and approx. \$1 per month rate. Complete with all parts. PCB board, lead wire and instructions. C23888 \$8.00

Digital Counting Module

Made for use with a variety of digital counters. Includes all parts for assembly and testing. Operates on 9V battery. 100 pcs. C23889 \$1.79

120 VAC Xenon Strobe Kit

Complete variable rate strobe light kit. Contains all parts. PCB board, lead wire and instructions. C23911 \$7.50

Wheel of Fortune

Popular game device uses LED's, transistors & IC to give the effect of a single red ball spinning around numbers. Unit comes assembled with parts & fully etched PCB board. C23890 \$8.99

LED Panel Mounting Kit

12 sets for \$1.00

OPTO ISOLATORS

YOUR CHOICE 49¢ EACH

RO170 Rectifier

Popular 1000V @ 2.5 amp. Full charge type. Fast rev. with safe. C23916 \$5 for \$1.00 100 for \$15.00

GE Sub-C Nicad

1-30 PP MINIATURE ADJUSTABLE CAPACITOR C23898 50¢

Tube Specials

1A6T 12AU7 12AT7 Your choice 2 for \$1.00

Alco Knob

5/16" knobbed aluminum. With screw for 1/4" shaft. C23917 2 for \$1.00

Horse shoe Tube

Super slow wave tube. Made from 100% pure copper. C23918 \$3.95

• Minimum order \$5.00
• Please include \$1.00 for postage
• Visa, MC and COD accepted
• Phone orders are welcome

CHANEY electronics inc.
P.O. BOX 27038, DENVER, CO. 80227 (303) 781-5750

Send for our free giant catalog of unique items!!!

Low Cost...High Performance

DIGITAL MULTIMETER



\$99.95 WIRED

Low cost, high performance, that's the DM-700. Unlike some of the hobby grade DMMs available, the DM-700 offers professional quality performance and appearance at a hobbyist price. It features 26 different ranges and 5 functions, all arranged in a convenient, easy to use format. Measurements are displayed on a large 3 1/2 digit, 1/2 inch high LED display, with automatic decimal placement, automatic polarity, and overrange indication. You can depend upon the DM-700, state-of-the-art components such as a precision laser trimmed resistor array, semiconductor band gap reference, and reliable LSI circuitry insure lab quality performance for years to come. Basic DC volts and ohms accuracy is 0.1%, and you can measure voltage all the way from 100 μ V to 1000 volts, current from 0.1 μ A to 2.0 amps and resistance from 0.1 ohms to 20 megohms. Overload protection is inherent in the design of the DM-700, 1250 volts, AC or DC on all ranges, making it virtually goof proof. Power is supplied by four 'C' size cells, making the DM-700 portable, and, as options, a nicad battery pack and AC adapter are available. The DM-700 features a handsome, jet black, rugged ABS case with convenient retractable tilt bail. All factory wired units are covered by a one year limited warranty and kits have a 90 day parts warranty.

Order a DM-700, examine it for 10 days, and if you're not satisfied in every way, return it in original form for a prompt refund.

Specifications

DC and AC volts: 100 μ V to 1000 Volts, 5 ranges
 DC and AC current: 0.1 μ A to 2.0 Amps, 5 ranges
 Resistance: 0.1 Ω to 20 megohms, 6 ranges
 Input protection: 1250 volts AC/DC all ranges fuse protected for overcurrent
 Input impedance: 10 megohms, DC/AC volts
 Display: 3 1/2 digits, 0.5 inch LED
 Accuracy: 0.1% basic DC volts
 Power: 4 'C' cells, optional nicad pack, or AC adapter
 Size: 6"W x 3"H x 6"D
 Weight: 2 lbs with batteries

Prices

DM-700 wired + tested \$99.95
 DM-700 kit form 79.95
 AC adapter/charger 4.95
 Nicad battery pack 16.95
 Probe kit 3.95

TERMS: Satisfaction guaranteed or money refunded, COD, add \$1.50. Minimum order \$6.00. Orders under \$10.00, add \$.75. Add 5% for postage, insurance, handling. Overseas, add 15%. NY residents, add 7% tax.



600 mHz COUNTER



\$99.95 WIRED

The CT-70 breaks the price barrier on lab quality frequency counters. No longer do you have to settle for a kit, half-kit or poor performance, the CT-70 is completely wired and tested, features professional quality construction and specifications, plus is covered by a one year warranty. Power for the CT-70 is provided by four 'AA' size batteries or 12 volts, AC or DC, available as options are a nicad battery pack, and AC adapter. Three selectable frequency ranges, each with its own pre-amp, enable you to make accurate measurements from less than 10 Hz to greater than 600 mHz. All switches are conveniently located on the front panel for ease of operation, and a single input jack eliminates the need to change cables as different ranges are selected. Accurate readings are insured by the use of a large 0.4 inch seven digit LED display, a 1.0 ppm TCXO time base and a handy LED gate light indicator.

The CT-70 is the answer to all your measurement needs, in the field, in the lab, or in the ham shack. Order yours today, examine it for 10 days, if you're not completely satisfied, return the unit for a prompt and courteous refund.

Specifications

Frequency range: 10 Hz to over 600 mHz
 Sensitivity: less than 25 mv to 150 mHz
 less than 150 mv to 600 mHz
 Stability: 1.0 ppm, 20-40°C; 0.05 ppm/°C TCXO crystal time base
 Display: 7 digits, LED, 0.4 inch height
 Input protection: 50 VAC to 60 mHz, 10 VAC to 600 mHz
 Input impedance: 1 megohm, 6 and 60 mHz ranges 50 ohms, 600 mHz range
 Power: 4 'AA' cells, 12 V AC/DC
 Gate: 0.1 sec and 1.0 sec LED gate light
 Decimal point: Automatic, all ranges
 Size: 5"W x 1 1/2"H x 5 1/2"D
 Weight: 1 lb with batteries

Prices

CT-70 wired + tested \$99.95
 AC adapter 4.95
 Nicad pack with AC adapter/charger 9.95
 Telescopic whip antenna, BNC plug 7.95
 Tilt bail assembly 3.95
 CT-70 Kit Form 75.95

ramsey electronics

BOX 4072, ROCHESTER, N.Y. 14610
 PHONE ORDERS CALL
 (716) 271-6487

100W CLASS A POWER AMP KIT

Dynamic Bias Class "A" circuit design makes this unit unique in its class. Crystal clear, 100 watts power output will satisfy the most picky fans. A perfect combination with the TA-1020 low T.I.M. stereo pre-amp.

Specifications:

- Output power: 100W RMS into 8-ohm 125W RMS into 4-ohm
- Frequency response: 10Hz - 100 KHz
- T.H.D.: less than 0.008%
- S/N ratio: better than 80dB
- Input sensitivity: 1V max.
- Power supply: $\pm 40V @ 5 \text{ amp}$



TA-1000 KIT
\$51.95
Power transformer
\$15.00 each

PROFESSIONAL 10 OCTAVE STEREO GRAPHIC EQUALIZER!!



Graphic equalizer have been used for years in sound studios and concert arenas but were too expensive to be considered for home use. Now we offer you the facility at an affordable price. This unit can extend your control of your Hi-Fi system by minimizing the non-linearities of the combined speaker/room system. Fantastic features as follows:

- 10 double slide controls for two channels
- Cut out rumble, surface noise and hiss
- Minimizes speaker/room non-linearities
- Frequency response from 30Hz to 16KHz
- 10 tone controls plus defeat, monitor and tape selector.
- Control range $\pm 12\text{dB}$ in 10 octaves (30Hz, 60Hz, 120Hz, 240Hz, 500Hz, 1KHz, 2KHz, 4KHz, 8KHz, 16KHz.)
- Operating voltage 117V 50/60Hz.

FACTORY ASSEMBLED UNIT, NOT A KIT
SPECIAL PRICE \$117.00 ea

SUB MINI SIZE FET CONDENSER MICROPHONE

Specification:

Sensitivity: $-65\text{dB} \pm 3\text{db}$
FEO. Response: 50 Hz - 8 KHz
Output Impedance: 1K ohm max.
Polar Pattern: Omni-directional
Power Supply: 1.5V 10V D.C.
Sound Pressure Level: Max. 120dB
EMARP \$2.50 ea. or 2 for \$4.50



NEW MARK III 9 Steps 4 Colors LED VU

Stereo level indicator kit with arc-shape display panel!!!! This Mark III LED level indicator is a new design PC board with an arc-shape 4 colors LED display (change color from red, yellow, green and the peak output indicated by rose). The power range is very large, from -30dB to $+5\text{dB}$. The Mark III indicator is applicable to 1 watt - 200 watts amplifier operating voltage is 3V - 9V DC at max 400 MA. The circuit uses 10 LEDs per channel. It is very easy to connect to the amplifier. Just hook up with the speaker output!

IN KIT FORM \$18.50

MARK II SOUND ACTIVATED SWITCH KIT

A new designed circuit employed 2 I.C., a DPDT relay with a led indicator. A condenser microphone comes with the kit. The relay can handle up to 200 watts contact to allow to control most things. Just click the finger, the relay will close, the second click will release it. Sensitivity can be adjusted by an on board trim-pot. Operating voltage 9V D.C. TY-18
\$8.50 PER KIT



MARK IV 15 STEPS LED POWER LEVEL INDICATOR KIT

This new stereo level indicator kit consists of 36 4-color LED (15 per channel) to indicate the sound level output of your amplifier from -36dB to $+3\text{dB}$. Comes with a well-designed silk screen printed plastic panel and has a selector switch to allow floating or gradual output indicating. Power supply is 6V - 12V D.C. with THG on board input sensitivity controls. This unit can work with any amplifier from 1W to 200W!

Kit includes 70 pcs. driver transistors, 38 pcs. matched 4-color LED, all other electronic components, PC board and front panel.



MARK IV KIT \$31.50

30W + 30W STEREO HYBRID AMPLIFIER KIT

It works in 12V DC as well! Kit includes 1 PC SANYO STK-043 stereo power amp. IC LM 1458 as pre amp, all other electronic parts, PC Board, all control pots and special heat sink for hybrid. Power transformer not included. It produces ultra hi-fi output up to 60 watts (30 watts per channel) yet gives out less than 0.1% total harmonic distortion between 100MHz and 10KHz.



\$32.50 PER KIT

BATTERY POWERED FLUORESCENT LANTERN

MODEL 888 R

FEATURES

- Circuitry: designed for operation by high efficient, high power silicon transistor which enable illumination maintain in a standard level even the battery supply drops to a certain low voltage.
- 9" 6W cool/daylight miniature fluorescent tube.
- 8 x 1.5V UM-1 (size D) dry cell battery.
- Easy sliding door for changing batteries.
- Stainless reflector with wide angle increasing illumination of the lantern.

\$10.50 EA



STEREO AMPLIFIER

60 W
+
60 W



COMPLETED UNIT - NOT A KIT!

OCL pre amp. & power stereo amp. with bass, middle, treble 3-way tone control. Fully assembled and tested, ready to work. Total harmonic distortion less than 0.5% at full power. Output maximum is 60 watts per channel at 8 Ω . Power supply is 24 - 36V AC or DC. Complete unit. Assembled \$49.50 ea.
Power transformer \$ 8.50 ea.

5W AUDIO AMP KIT

2 LM 380 with Volume Control
Power Supply 6 18V DC
ONLY \$6.00 EACH



PROFESSIONAL PANEL METERS



A. 0-50UA 8.50 ea.
B. 0-30VDC 8.50 ea.
C. 0-50VDC 8.50 ea.
D. 0-3ADC 9.00 ea.
E. 0-100VDC 9.00 ea.

All meters white face with black scales. Plastic cover.

SPECIAL 0.5" LED SALE ALARM CLOCK MODULE

ASSEMBLED! NOT A KIT!

Features: • 4 digits 0.5" LED Displays • 12 hours real time format • 24 hours alarm audio output • 59 min. countdown timer • 10 min. snooze control.



ONLY \$7.00 EACH
SPECIAL TRANSFORMER FOR CLOCK
(FREE)

DIGITAL AUTO SECURITY SYSTEM

4 DIGITS PERSONAL CODE!!
SPECIAL \$19.95



- proximity triggered
- voltage triggered
- mechanically triggered

This alarm protects you and itself! Entering protected area will set it off, sounding your car horn or siren you add. Any change in voltage will also trigger the alarm into action. If cables within passenger compartment are cut, the unit protects itself by sounding the alarm.

3-WAY PROTECTION!

All units factory assembled and tested - Not a kit!

A NEW LED ARRAY AND DRIVER FOR LEVEL METERS

This series covers a wide range of level indication uses, output and input voltage, time related change, temperature, light measurement and sound level. The problem of uneven brilliance often encountered with LED arrangements as well as design problems caused by using several units of varying size are substantially reduced. 12 LEDs in one bar:

LED ARRAY

GL-112R3 Red, Red, Red \$5.50
GL-112N3 Green, Yellow, Red \$6.50
GL-112M2 Green, Green, Red \$6.50
GL-112G3 Green, Green, Green \$6.50

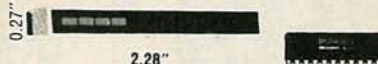

LED DRIVERS

1R 2406G is an I.C. specially designed to drive 12 LED. The number of LED is lineally illuminated according to the control voltage input terminal 21. Operating voltage is 9 - 12V D.C. \$5.35 EACH

PROFESSIONAL FM WIRELESS MICROPHONE

TCT model WEM-16 is a factory assembled FM wireless microphone powered by an AA size battery. Transmits in the range of 88-108MHz with 3 transistor circuits and an omni-directional electric condenser. Element built-in plastic tube type case; mike is 6 1/4" long. With a standard FM radio, can be heard anywhere on a one-acre lot; sound quality was judged very good.

\$16.50

FLASHER LED

Unique design combines a jumbo red LED with an IC flasher chip in one package. Operates directly from 5V-7V DC. No dropping resistor needed. Pulse rate 3Hz @ 5V 20mA.

2 for \$2.20

BIPOLAR LED RED/GREEN

2 colors in one LED, green and red, changes color when reverse voltage supply. Amazing!
2 FOR \$1.60

LCD CLOCK MODULE!

• 0.5" LCD 4 digits display • X'tal controlled circuits • D.C. powered (1.5V battery) • 12 hr. or 24 hr. display • 24 hr. alarm set • 60 min. countdown timer • On board dual back-up lights • Dual time zone display • Stop watch function.

NIC1200 (12 hr) \$24.50 EA.
NIC2400 (24 hr) \$26.50 EA.

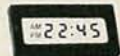

MINI-SIZED I.C. AM RADIO

Size smaller than a box of matches!
Receives all AM stations.
Batteries and ear phones included.

Only \$10.50



12 DC MINI RELAY

6V SPDT 2 AMP 1.30
12V SPDT 3 AMP 1.60
12V DPDT 2 AMP 2.50
12V 4PDT 3 AMP 3.50



LINEAR SLIDE POT

500R SINGLE
Metal Case 3" Long
2 FOR \$1.20



FLUORESCENT LIGHT DRIVER KIT



With Case Only
\$6.50 Per Kit

12V DC POWERED
Lights up 8 ~ 15 Watt Fluorescent Light Tubes. Ideal for camper, outdoor, auto or boat. Kit includes high voltage coil, power transistor, heat sink, all other electronic parts and PC Board, light tube not included!

SUPER FM WIRELESS MIC KIT — MARK III



FMC-105
\$11.50 PER KIT

This new designed circuit uses high FEQ. FET transistors with 2 stages pre amp. Transmits FM Range (88-120 MHz) up to 2 blocks away and with the ultra sensitive condenser microphone that comes with the kit, allows you to pick up any sound within 15 ft. away! Kit includes all electronic parts, OSC coils, and P.C. Board. Power supply 9V D.C.

PRESS-A-LIGHT SELF GENERATED FLASHLIGHT

EXCLUSIVE!! \$3.95 ea
Model F-179



Never worry about battery, because it has none! Easy to carry in pocket and handy to use. Ideal for emergency light. It generates its own electricity by squeezing grip lever. Put one in your car, boat, camper or home. You may need it some time!

ELECTRONIC DUAL SPEAKER PROTECTOR



Cut off when circuit is shorted or over load to protect your amplifier as well as your speakers. A must for OCL circuits.

KIT FORM
\$8.75 EA.

"FISHER" 30 WATT STEREO AMP



Super Buy
Only \$18.50

MAIN AMP (15W x 2)
Kit includes 2 pcs. Fisher PA 301 Hybrid IC all electronic parts with PC Board. Power supply ± 16V DC (not included). Power band with (KF 1% ± 3dB). Voltage gain 33dB. 20Hz - 20KHz.

SUPER 15 WATT AUDIO AMP KIT

Uses STK-015 Hybrid Power Amp
Kit includes: STK-015 Hybrid IC, power supply with power transformer, front Amp with tone control, all electronic parts as well as PC Board. Less than 0.5% harmonic distortion at full power 1/2dB response from 20-100,000 Hz. This amplifier has QUASI — Complementary class B output. Output max is watt (10 watt RMS) at 4Ω. ONLY \$23.50 each

HICKOK LX303 DIGITAL LCD MULTIMETER



• 3 1/2 digits display • 200 hours 9V battery life • Auto zero; polarity; overrange indication • 100MV DC F.S. sensitivity • 19 ranges and functions • D.C. volt: 0.1 MV to 1000V • A.C. volt: 0.1 V to 600 V • Resistance: 0.1Ω to 20 MΩ • D.C. current: 0.01 A to 100 MA

OUR PRICE \$71.45

PUSH-BUTTON SWITCH



N/Open Contact
Color: Red, White, Blue, Green, Black
3/\$1.00
N/Close also Available
50c each
LARGE QTY. AVAILABLE

HEAVY DUTY CLIP LEADS



10 pairs — 5 colors Alligator clips on a 22" long lead. Ideal for any testing.
\$2.20/pack

MANY SOUND DECISIONS!



\$3.60 EACH

Solid state sound indicator operating voltage 6V DC 30mA. Small size approximately 3/4"x1 1/4".
Model EB2116 (Continuous)
Model EB2126 (Slow Pulse)
Model EB2136 (Fast Pulse)



Continuous Slow pulse Fast pulse

"C" SIZE BATTERY PACK

10 C size ni-cd battery in dng pack, gives out 12.5V D.C. 1.8 amp per hour. All fresh code, pull-out from movie cameras. Can be disconnected to use as single c cells. Hard to find \$15.00 per pack of 10 batteries

ELECTRONIC ALARM SIRE COMPLETE UNIT



AU-999 \$7.50

Ideal for use as an Alarm Unit or hookup to your car back-up to make a reverse indicator. Light Output up to 130dB. Voltage supply 6 12V

SUB MINIATURE TOGGLE SWITCH



SPST 2 FOR 2.80 SPDT 2 FOR 3.20
6 AMP 125V AC CONTACT

TRANSFORMERS

ALL 117 VOLT INPUT		
30V	4 AMP	\$8.50 EA.
36V CT	3 AMP	\$10.50 EA.
48V CT	3 AMP	\$10.50 EA.
24V CT	3 AMP	\$10.50 EA.
24V CT	0.8 AMP	\$2.50 EA.
12V CT	0.5 AMP	\$2.50 EA.
12V CT	120 MA	\$1.80 EA.

AC POWER SUPPLY

Wall Type Transformer		
12V AC	Output 200 MA	\$2.75 EA.
16V CT AC	Output 100 MA	\$2.10 EA.
6V DC	Output 120 MA	\$1.90 EA.
12V DC	Output 100 MA	\$1.90 EA.

ULTRASONIC SWITCH KIT



Kit includes the Ultra Sonic Transducers, 2 PC Boards for transmitter and receiver. All electronic parts and instructions. Easy to build and a lot of uses such as remote control for TV, garage door, alarm system or counter. Unit operates by 9-12 DC. \$15.50

COMPLETE TIME MODULE

0.3" digits LCD Clock Module with month and date, hour, minute and seconds. As well as stop watch function!! Battery and back up light is with the module. Size of the module is 1" dia. Ideal for use in auto panel, computer, instrument and many others! \$8.95 EACH

SOUND ACTIVATED SWITCH



\$1.75 ea.

All parts completed on a PC Board SCR will turn on relay, buzzer or trigger other circuit for 2 - 10 sec. (adjustable). Ideal for use as door alarm, sound controlled toys and many other projects. Supply voltage 4.5V 9V D.C. 2 for \$3.00

FM WIRELESS MIC KIT



It is not a pack of cigarettes. It is a new FM wireless mic kit! New design PC board fits into a plastic cigarette box (case included). Uses a condenser microphone to allow you to have a better response in sound pick-up. Transmits up to 350 ft.! With an LED indicator to signal the unit is on #FMM2 KIT FORM \$7.95

REGULATED DUAL VOLTAGE SUPPLY KIT

±4 30V DC 800 MA adjustable, fully regulated by Fairchild 78MG and 79MG voltage regulator I.C. Kit includes all electronic parts, filter capacitors, I.C., heat sinks and P.C. board.

\$12.50 PER KIT

AA SIZE NI-CD SPECIAL SALE

RECHARGEABLE BATTERIES LIMITED QUANTITY AVAILABLE

BECKMAN FET LIQUID CRYSTAL DISPLAY

Overall size 2" x 1.2" 0-5" characters reflective type.
Model 737-01 — for clock 4 digits with PM, alarm, snooze, colon indicators.
Model 739-04 — for panel meter 4 digits.
Model 739-03 — for panel meter 3 1/2 digits with ± sign and over range indicator.
All displays include zeber connectors and front bezel. With data sheets. Your choice — any model \$7.50 EACH

POWER SUPPLY KIT

0-30V D.C. REGULATED
Uses UA723 and ZN3055 Power TR output can be adjusted from 0-30V, 2 AMP. Complete with PC board and all electronic parts.
Transformer for Power Supply, 0-30 Power Supply 2 AMP 24V x 2 \$8.50 \$10.50 each

I.C. TEST CLIPS

Same as the E-Z clips \$2.75
With 20" Long Leads
In Black and Red Colors per pair

SOUND GENERATOR I.C.

Creates almost any type of sound — gun shot, explosion, train, car crash, star war, birds, organ ext. A built-in audio amplifier provides high level output. Operates from one 9V battery, 28 pin dip; we supply the datas. \$2.90 EACH

ELECTRONIC SWITCH KIT

CONDENSER TYPE
Touch On Touch Off
uses 7473 I.C. and 12V relay
\$5.50 each

1 WATT AUDIO AMP

All parts are pre-assembled on a mini PC Board. Supply Voltage 6 9V D.C. SPECIAL PRICE \$1.95 ea.

LOW TIM DC STEREO PRE-AMP KIT TA-10 20

Incorporates brand-new D.C. design that gives a frequency response from 0Hz — 100KHz ± 0.5dB! Added features like tone defeat and loudness control let you tailor your own frequency supplies to eliminate power fluctuation!
Specifications: • T.H.D. less than .005% • T.I.M. less than .005% • Frequency response: DC to 100KHz ± 0.5dB • RIAA deviation: ± 0.2dB • S/N ratio: better than 70dB • Sensitivity: Phono 2MV 47K/Aux. 100MV 100K • Output level: 1.3V • Max. output: 15V • Tone control: bass ± 10dB @ 50Hz/treble ± 10dB @ 15Hz • Power supply: ± 24 D.C. @ 0.5A
Kit comes with regulated power supply, all you need is a 48V C.T. transformer @ 0.5A
ONLY \$44.50 X'tormer

SOLID STATE ELECTRONIC BUZZER

Mini size 1" x 3/4" x 3/4"
Supply voltage 1.5V - 12V
Ideal for Alarm or Tone Indicator
\$1.50 each

FORMULA INTERNATIONAL INC.

SHIPPING AND HANDLING CHARGES	
Under \$50.00 purchase	Over \$50.00 purchase
15%	10%
15%	10%
15%	10%

Outside California (includes Mexico & Canada)
Outside California (includes Mexico & Canada)
Outside California (includes Mexico & Canada)
Minimum Order \$10.00/Call. Residents Add 6% Sales Tax.
Phone Orders Accepted on Visa or MC ONLY, NO C.O.D./Store Hours 10-7 Mon. thru Sat.

12403 CRENSHAW BLVD., HAWTHORNE, CA 90250
PHONE: (213) 973-1921 • (213) 679-5162

Send \$1.00 For Detailed Catalogue



Buyers Worldwide Are Clamoring For Our 1¢ MORE GETS U 2

40-TWO WATT RESISTORS, carbo-films, carbons, some 5%ers, (#456)	1.29	80 for 1.30
50-TERMINAL STRIPS, ass'd solder and screw types, 2 lugs & up, (#334)	1.29	100 for 1.30
1-WATCH GUITS, LED, who knows how good, micro-digital bonanza, (#5115)	1.29	2 for 1.30
10-1000V 1A RECTIFIERS, 1N4007, epoxy case, axial leads, (#5926)	1.29	20 for 1.30
6-25 WATT PLASTIC POWER, 2N6100 series, TO-220, 200bvcbo, 3A, (#1786)	1.29	12 for 1.30
4-CALCULATOR AC JACKS, 3 terminals, takes mini plug, (#2316)	1.29	8 for 1.30
65-PRE-FORM 1/4 WATTERS, popular values, for PC appl., (#2444)	1.29	130 for 1.30
40-LOW NOISE RESISTORS, 1/8 & 1/2 W, oxide & magnetic film, (#220)	1.29	80 for 1.30
40PC-SEMI-CON SURPRISE, ass't. zeners, diodes, etc. untested, (#226)	1.29	80 for 1.30
20-TRANSISTOR ELECTROLYTICS, ass't. voltages from 5-100 mfd, (#453)	1.29	40 for 1.30
1-LASCR OPTO COUPLER, type H11C3, mini dip, (#5700)	1.29	2 for 1.30
10-UPRIGHT ELECTROS, 100% ass'd values and voltages, (#5900)	1.29	20 for 1.30
2-GE 3W AUDIO AMP, type PA-263 IC chip, mono, (#1522)	1.29	4 for 1.30
1-MERCURY TILT SWITCH, N.C. rated 24VDC @ .05A, w/leads, (#5686)	1.29	2 for 1.30
50-CAP SPECIAL, ass't. values in mylar, mica, ceramic, disc, etc. (#3775)	1.29	100 for 1.30
40-FEEDTHRU CAPACITORS, used for horns, RF, UHF circuitry, (#5668)	1.29	80 for 1.30
20-PLASTIC TRANSISTORS, ass't. untested and hobby, (#2604A)	1.29	80 for 1.30
4-6-CELL BATTERY HOLDER, 9V, for AA size cells, with 9V clip (#6365)	1.29	4 for 1.30
1-12 VOLT LAMPS, w/leads, popular voltage, 100's of uses, (#5942)	1.29	8 for 1.30
1-12 VDC SOLENOID, similar to Guardian 16-P, w/plunger, 1/4" stroke, (#6013)	1.29	2 for 1.30
10-AXIAL ELECTROS, assorted values and capacitance, (#5901)	1.29	20 for 1.30
10-POWER TAB TRANSISTORS, NPN, plastic, TO-220, (#5629)	1.29	20 for 1.30
6-PRECISION TRIM POTTS, ass'd singles and multi-turns, untested, (#3389)	1.29	12 for 1.30
2-1N4148, 4 NANO, SWITCHING DIODE, axial leads, 10mA, 100%, (#3000)	1.29	40 for 1.30
10-ASSORTED IC SOCKETS, 24, 28, & 40 pin sockets on G-10 board, (#6357)	1.29	20 for 1.30
4-PUSHBUTTON ALARM SWITCH, 125 VAC 1A SPST, NC, (#5289)	1.29	8 for 1.30
6-CABLE & PLUG SET, 2 cond. 2.5mm mini plug w/6 polarized cable; (#5737)	1.29	12 for 1.30
10-RESISTOR NETWORKS, assorted values in dips and singles, (#5699)	1.29	20 for 1.30
5-ASSORTED EDGE CONNECTORS, mixed 4 & 6 pin, double-sided, (#6362)	1.29	10 for 1.30



HY-GAIN ONE ARM BANDIT MIKES

Only
\$14.99
2 FOR \$15

Take one hand command of your mobile or base rig with Hy-Gain's One Arm Bandit Mike. ONOFF, VOLUME, SQUELCH, CHANNEL SELECTOR, SPEAKER, and DIGITAL DISPLAY are all conveniently located where your fingers do the talking. Comes with 6 ft. multi-conductor, color-coded, coiled cable, (separable) for easy integration into any type of rig. Size: 4 1/2" x 2 1/2" x 1 1/2". Wt. 9 oz. No. 92CU5886

2-DOUBLE-SIDED PC BOARDS, 3"x12" high quality G-10 glass, (#5694)	1.29	4 for 1.30
60-TUBULAR CAPACITORS, ass'd 100mfd to 1mfd to 600 WVDC, (#35A219)	1.29	120 for 1.30
6-MICRO MINI REED SWITCHES, 1" long, for alarms, relays, etc., (#1258)	1.29	12 for 1.30
10-TANTALUM ELECTROS, ass'd mini, axial, hermetically sealed, (#5848)	1.29	20 for 1.30
50-DISC TYPE CAPS, incl: NPO, hi-Q, mylar, ceramics, ass'd values, (#437)	1.29	100 for 1.30
60-COILS & CHOKES, ass'd RF, OSC, IF, parasitic types, (#35A297)	1.29	120 for 1.30
6-SWITCHCRAFT PHONO JACKS, hi-Q, chassis mount, teflon base, (#5119)	1.29	12 for 1.30
30-SUBMINI IF TRANSFORMERS, ass't. slug tuned, shielded, (#35A9)	1.29	60 for 1.30
40-ADJUSTABLE FERRITE CORES, center cut for hex adjust, (#5701)	1.29	80 for 1.30
10-PC TRIMPOTS, screwdriver adjust, assorted values, (#3346)	1.29	20 for 1.30
25-4" CABLE TIES, plastic, like Ty-wrap style, (#5217)	1.29	50 for 1.30
5-CRYSTALS, may include: CB, ham various shapes and sizes, (#5716)	1.29	10 for 1.30
3-MICRO SWITCHES, SPST, NO contacts, plunger style, solder tabs, (#5783)	1.29	6 for 1.30
65-MOLEX SOCKETS, "on-a-strip", for 8-40 pin ICs, (#1609)	1.29	130 for 1.30
6-PAIRS 9V BATTERY CLIPS, w/red & black color-coded leads, (#2852)	1.29	12 for 1.30
6-LM340T VOLTAGE REGULATORS, 5 to 24 volts, TO-220, (#5897)	1.29	12 for 1.30
40-POLYSTYRENE CAPACITORS, ass'd values and voltages, (#1052)	1.29	80 for 1.30
15-THERMISTORS, resistors that change with the temperature, (#2048)	1.29	30 for 1.30
65-1/4 WATT RESISTORS, ass'd values, metal film, marked, (#5797)	1.29	130 for 1.30
10-MODULAR SWITCHES, Centralab "push-on" type, up to 4PDT, (#3150)	1.29	20 for 1.30
5-"MOTORS MOTORS", small, high speed, ass'd sizes, 3-GVDC, (#2551)	1.29	10 for 1.30
50-MICAS ass't. sizes-n-shapes, incl "silvers" tool (#373)	1.29	100 for 1.30
10-TRANSISTOR SOCKETS, for npn and pnp types, (#3845)	1.29	20 for 1.30
4-HOBBY VOLTAGE REGULATORS, LM-309, 320, 340's, TO-3, (#3330A)	1.29	8 for 1.30
12-PANEL SWITCHES, assorted slides, rotaries, modulars, etc. (#295)	1.29	24 for 1.30
60-RESISTOR SPECIAL, 1/4 to 1 watt, carbons, carbo-films, etc. (#35896)	1.29	120 for 1.30
65-HALF WATT RESISTORS, ass'd values, carbo-films, various values, (#454)	1.29	130 for 1.30
15-HUMBUCKER CONTROLS, assorted values, manufacturer's dump, (#3807)	1.29	30 for 1.30
1-POWER TAB TRIAC, 100% orime, 400V 10A TO-220, (#6216)	1.29	2 for 1.30

'FLIP-OVER' DIGITAL CLOCK

\$6.99
each

- 115 VAC Operation
- Built-In Alarm Function With 24 Hour Dial Indicator
- 3/4" High White Numerals

2 for \$7
Cat. No. 92CU6336



50-PRECISION RESISTORS, 1/2, 1, & 2 watts, 1%, assorted types, (#363)	1.29	100 for 1.30
60-CERAMIC CAPS, ass'd val. & styles, incl: tubulars, NPO's, etc., (#590)	1.29	120 for 1.30
30-MOLEX CONNECTORS, nylon, ass'd styles, colors, & # of cond. (#5835)	1.29	60 for 1.30
4-ROCKER SWITCHES, DPDT, solder eyelet terminals, (#3302)	1.29	8 for 1.30
1-RELAY, BABCOCK 6VDC, SPST, plastic case (#5807)	1.29	2 for 1.30
4-THERMAL FUSES, epoxy sealed, metal clad, break at 257 F, axial (#6367)	1.29	8 for 1.30
50-1N4000 RECTIFIERS, epoxy, axial leads, untested, (#2594)	1.29	100 for 1.30
30pc-HEAT SHRINK, Thermo-fit, shrinks 50% (#5248)	1.29	60 for 1.30
10-SLIDE SWITCHES, SPST, SPDT, etc. all shapes and sizes, (#5927)	1.29	20 for 1.30
25-DTL's, 100% prime, ass'd flip flops, etc., marked, (#3709)	1.29	50 for 1.30
10-MAN-3's, 7 segment, w/bubble magnifier, 100% material, (#3842)	1.29	20 for 1.30
4-PL-259 COAX PLUG, mates to SO-239, Amphenol, (#5221)	1.29	8 for 1.30
1-LITE SENSITIVE UNIJUNCTION TRANSISTOR, programmable, (#5719)	1.29	2 for 1.30
100-PRE-FORMED 1/2 WATTERS, popular values, some 5 & 10 %ers, (#1060)	1.29	200 for 1.30
4-PHOTO ELECTRIC DARLINGTON TRANSISTORS, (#3276)	1.29	8 for 1.30
40-POWER RESISTORS, assorted types, includes 2 to 10 watters, (#228)	1.29	80 for 1.30
15-NE-2 LAMPS, neon red, for 110VAC, less resistor, (#1435)	1.29	30 for 1.30
30-"CRIMPALS", rings and spades, for # 12-20 wire, (#3955)	1.29	60 for 1.30
50-ONE-WATT RESISTORS, popular assort, some 5%ers, 100's of uses, (#3844)	1.29	100 for 1.30
30-FT. WIRE-WRAP WIRE, 30 ga. ge, insulated, continuous length, (#3803)	1.29	60 for 1.30
6-SPDT MICRO SLIDE SWITCH, incl 3/7" cube, for PC mount, (#3429)	1.29	12 for 1.30
10-PR-RCA PLUGS & JACKS, for audio, speakers, etc., (#402)	1.29	20 for 1.30
5-2N3055 HOBBY TRANSISTORS, TO-3, (#3771)	1.29	10 for 1.30
6-SINGLE PIN MICRO GREEN LEDS, 3V, 10 mils, "pin heads", 100%, (#6126)	1.29	12 for 1.30
6-JUMBO RED LEDS, 1.5-3 V @ 10 mA, 100% material, 100's of uses, (#6126)	1.29	12 for 1.30
6-MAGNETIC DISCS, shatter-resistant Plastalloy, 13/16" dia, (#6099)	1.29	12 for 1.30
5-PHOTO CELLS, 5-pin, disc type, R: 2K ohm (dark) w/leads, (#6135)	1.29	10 for 1.30
1-12VDC SPDT RELAY, 180 ohm coil, 25 mA, 1x1x1" sealed, (#5937)	1.29	2 for 1.30
10-VOLUME CONTROLS, ass't. values, audio, and switch too! (#592)	1.29	20 for 1.30
60-PREFORMED DISC CAPS, handy assortment of values, marked, (#1181)	1.29	120 for 1.30

SEND FOR FREE CATALOG

POLY PAKS®
P.O. BOX 942-R4
SO. LYNNFIELD, MA 01940

HOW TO ORDER
We honor MASTERCARD, VISA, check, and COD. (25% down). Order by phone or mail. Minimum order \$8. Please state Cat. No. & description, name & month of shipping. Postage: Continental, add \$5. Foreign: add \$10 (US funds). Excess will be returned. TERMS: add postage. RATED: Nat-30. Phone: (617) 245-3828

MICRO MART

552 Summit Ave.
Westfield, N.J. 07090
(201) 654-6008

MOTION DETECTOR
Completely assembled on circuit board with capacitors
Specs and application notes included—4.95
3 1/2" X 2 X 1 1/4" case with mtng tabs/3.00

CRYSTALS—3.579545 MHz 9%
6.0 MHz 2.95

JUMBO LED's
Green, 7/1.00-Yellow, 7/1.00-Red, 10/1.00
100/13.00 100/13.00 100/9.00
MOUNTING CLIPS—12/1.00

7 SEG Displays (comp. grade)
3"/95¢-6"/1.45 (specify ann. or cath.)

AM/FM RADIO CHIP—(#4408) 2.00 or 3/5.00
Complete AM/FM IC-external IF required

DIPPED TANTALUMS
47 µf 35V (1" leads) 10/1.00

SUPER SUB MINI LYTICS
(1" rad. leads, by Nichicon)
1000µf 50V (1 1/4" L X 1/4" W), 75¢ or 10/6.00
47 µf 25V (7/8" L X 1/4" W), 10/\$1.00
400µf 330V (photo flash or laser circuits)-2/1.00

COMPUTER GRADE TWIST LOCKS
3200µf 50V (ideal for power supplies) 1.00
1000µf 50V—1.00 1000µf 185V—2.00

DISCS—001 1KV 25/1.00, 1 50V 15/1.00

HEAT SENSITIVE SWITCH—4/1.00
self contained unit opens at 150 C

9 DIGIT FLOURESCENT DISPLAY by NEC
complete with driving circuitry-2.50

EXTRA LOUD 9V BUZZER—3/2.00

WALL PLUG ADAPTER—5VDC @ 160ma-1.50
6.3V 1.2 Amp Transformer—1.75

MINI AUDIO TRANSFORMERS—3/1.00

DIGITAL MOTION/UNIT COUNTER MODULE
(Fairchild) with large 4 digit display & specs-7.00

8035 Microprocessor, 17.00

INTERFACE CHIP-D8243
16 line I/O extender for all single chip µ Ps 5.75

Terms MICRO-MART accepts Visa, MC, and telephone COD'S. Foreign orders \$50.00 minimum plus shipping-US funds only. Orders under \$10.00 include \$2.00 for shipping/handling. All components guaranteed or money refunded. Immediate shipping. N.J. residents add 5% sales tax.

MICRO-MART • 552 SUMMIT AVE., WESTFIELD, N.J. 07090 • (201) 654-6008

**BRAND NEW ITEM
FREQUENCY COUNTER CHIP
ICM 7225 IPL**
(40 pin), with on board dividers, decoders/drivers. 18.95-specs included

A/D CONVERTER by Datal
ADC-MC88C-8 bit analog to digital converter, high speed-18.00

D/A CONVERTER-DAC-088C-8 bit-12.00
µa 741 OP AMPS (mini-dip) 4/1.00

ZENER DIODES—20V 1 amp 10/1.00

BRIDGES
1 1/2 amp/50.6 amp/2.00, 25 amp/1.00

LINEAR			
LM 323K	4.00	LM 1303	70
LM 300H	70	LM 1304	95
LM 301AN	30	LM 1305	1.15
LM 307H	50	LM 1307	60
LM 307	30	LM 1307E	90
LM 308H	85	LM 1310	1.75
LM 308	85	LM 1391	2.00
LM 310	80	LM 1414	1.50
LM 311H	80	LM 1800	70
LM 317K	2.75	LM 1808	2.50
LM 318H	1.10	LM 1820	2.50
LM 320K-15	1.10	LM 1828	2.00
LM 320K-12	1.10	LM 1830	2.25
LM 324	1.10	LM 1841	2.50
LM 325	1.35	LM 1848	2.00
LM 339J	1.00	LM 1889	2.50
LM 340K-12	1.00	LM 2111	1.15
LM 341P-12	80	LM 2113	1.75
LM 343H	3.50	LM 2907	2.00
LM 373	2.50	LM 2917	2.00
LM 377	2.00	LM 3046	60
LM 380	1.00	LM 3054	1.50
LM 381	1.25	LM 3064	2.00
LM 384	1.50	LM 3065	2.50
LM 386	1.20	LM 3067	2.50
LM 389	1.20	LM 3070	2.50
LM 390	1.65	LM 3071	2.00
LM 746	2.50	LM 3075	1.25
LM 748CN	30	LM 3089	1.25

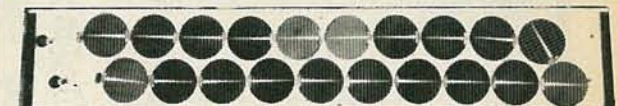

Electricity from the sun.
5 Volt panel 1/4 amp \$50 2.5 Volt panel 1/2 amp \$40
GIANT 3 1/2 inch cell, delivers 1 amp \$8.50
Above cell with special motor & prop, runs in sun \$10.25

Computer video monitor chassis 9 inch, 12 volt used \$50
Computer video monitor chassis 12 inch, new \$60
Hy Gain CB chassis, trunk mount \$9.00



Govt surplus walky talky, used cond.
47-55.4 mc range.
Ant. \$5 each extra.
With data.

\$25 ea 2 for \$45

AN/PRC-6

SEE IN THE DARKNESS

IR viewer, portable, new with choice of one lens...close up, telephoto or gen. purpose.
Requires 6 volt DC btry. \$250

PRINTER CENTRONICS # 101

Visually OK, with head.
Sold as is..... \$400.00

Shipping extra on all merchandise



Meshna Inc., PO Box 62, E. Lynn, Mass. 01904

ADVANCED COMPUTER PRODUCTS

1980 CATALOG AVAILABLE SOON

THE FIRST TO OFFER PRIME PRODUCTS TO THE HOBBYIST AT FAIR PRICES NOW LOWER PRICES EVEN FURTHER!

1. Proven Quality Factory tested products only, no re-tests or fallouts. Guaranteed money back. We stand behind our products.

1980 CATALOG AVAILABLE SOON.

Send \$1.00 to reserve your copy of the most complete catalog of computer products. A must for the serious computer user.

STATIC RAM BOARDS

S-100 32K (uses 2114) *Now, just more than 1/2¢ per bit!*

ASSEMBLED Kit
450ns. 599.00 450ns. 539.95
250ns. 699.95 250ns. 599.95
Bare Board 49.95
Bare Board w/all parts less mem. 99.95

RAM 65 (16K Static w/ Memory Management)
2 MHz \$299.00 4 MHz \$399.00
RAM 16 (16K Static w/Bank Select)
2 MHz \$249.00 4 MHz \$329.00
(16K Assembled & Tested Using Low Power 2114's)

LOGOS I 8K

ASSEMBLED
450 ns. 149.95 KIT 450ns. 125.95
250ns. 169.95 250ns. 149.95
Bare PC Board w/ Data \$21.95
*Special Offer Buy (4) 8K 450ns. Kits \$117.00

TRS-80 ADD-ON DISK

- VISTA V-80 MINIDISK
- 23% More Storage
- Capacity - 40 Tracks
- 40 track patch free
- New Double Density Expansion Module \$239.00
- 2 Drive Cable Add \$29.95
- 4 Drive Cable Add \$39.95

395.00

S-100 ADD-ON MINI-DISK

- VISTA V-200 Minifloppy System
- 204K Byte Capacity
- Double Density Drive
- CP/M & Basic "E"
- Double Density Controller
- Case and Power Supply
- Assembled & Tested Ready to Plug In
- EXIDY, HORIZON, SOL, etc. Compatible

V-200 699.00

S-100 ADD-ON DISK SUBSYSTEM

- VISTA V-1000 Floppy Disk Subsystem
- (2) Shugart B Disk Drives
- Case with Fan & Power Supply
- VISTA Floppy Disk Controller Card
- CP/M Disk Operating System
- Fully Factory Assembled & Tested

V-1000 1699.00

LOW-COST ADD-ON DISK SUBSYSTEM KIT

- (2) B Drives
- VISTA Floppy Controller Card
- Power Supply and Interface Cable
- CP/M Disk Operating System
- Box of 10 Diskettes

Low Cost Sys. 1299.00

IMS STATIC RAM BOARDS

- Memory Mapping
- Low Power
- Phantom
- Assembled & tested Recommended by Alphamicrosystems

250 ns. 450 ns.
8K Static \$209.00 \$189.00
16K Static \$449.00 \$399.00
32K Static \$799.00 \$699.00

ANADIX PRINTER

Model DP-8000 compact, impact, parallel or serial. Sprocket feed, 80 cols. 84 lines/min., bi-directional. New only...\$895.00

FLOPPY DISKETTES

- 5 1/4" Minidiskettes
- Softsector, 10 Sector, 16 Sector \$4.25 Each, 10/39.95
- 8" Standard Floppy Disks
- Soft Sector, Hard Sector \$4.50 Each, 10/41.95

*Add 4.95 for 10 Pack in Deluxe Disk Holder

MOTOROLA EXORCISER COMPATIBLE

9600 MPU Module w/8020 CPU...\$495.00
9601 16 Slot Mother Board...175.00
9602 Card Cage (19" Rack Mount)...75.00
9603 8 Slot Mother Board...100.00
9604 Switchmode System Power Supply...250.00
9610 Utility Prototyping Board...36.00
9616 Quad 8K Eprom Module...495.00
9620 16 Channel Parallel I/O Module...295.00
9622 Serial/Parallel I/O Combo...***
9626 8K Static RAM Module...295.00
9627 16K Static RAM Module...495.00
9630 Card Extender...68.00
9640 Multiple Programmable Timer (24 Timers)...395.00
9650 8 Channel Duplex Serial I/O...395.00
9650-0...45.00 96103...275.00
96702 32 Point Relay Module...350.00

6800 BARE BOARDS

9620-0...\$45.00 9603-0...27.00
9626-0...45.00 9600...55.00
9650-0...45.00 96103...55.00
9601-0...50.00 96702...55.00

Also AMI EVK System in Stock

APPLE/EXIDY/EXPANDO TRS 80 16K-UPGRADE KIT

- 16K with Jumpers & Instructions for either Level I or Level II...\$69.95
- 16K for Apple II Upgrade...\$69.95
- Special: TRS80 Schematic...\$ 4.95
- Expansion Interface Schematic...\$ 4.95
- Expansion Interface Connector...7.95

EXPANDOR II MEMORY KITS

- Bank Selectable * Uses 4116 200 ns.
- Write Protect * Power 8KVC, ±16VDC
- Phantom * Up to 4 MHz

Expando 64 Kit (4116)
16K \$248.95 48K \$439.00
32K \$358.00 64K \$519.00

FROM INTEGRAL DATA SYSTEMS

MODEL 440 "THE PAPER TIGER"
9.5" adjustable tractor feed, parallel & serial I/O, 132 columns, software selectable character size, 100, 300, 600, 1200 baud, to 198 cps. \$995.00
Graphics option w/2K buffer add...\$199.00

TASA touch activated solid state KEYBOARD

- Full 128 position 8-bit ASCII
- 3 color code, 55 positions
- Immune to static charge
- Low power

Optional stand...15.00

UV "Eprom" Eraser

Model UVs-11E \$69.95
Holds 4 Eprom's at a time. Backed by 45 years experience.
Model S-52T...\$265.00
Professional Industrial Model

TARELL FLOPPY INTERFACE

- Z80/8080 S 100 Compatible * Uses CPM
- Assembled for Shugart...SALE \$229.95
- Assembled Other Drives...\$269.95
- Kit...\$179.95
- Bare Board \$39.95 (Doc. Add \$10.00)

Note: For CPM Add \$70.00. Documentation Add \$20.00
Vista Double Density 5 1/4" Controller Assem...\$299.00
SD Versa Floppy Kit II...\$359.00
Tarell Cassette I/O Kit...\$115.00
Sale * 1771-01 Floppy Chip...\$27.95
VISTA Floppy Controller B (Shugart Comp.)...\$259.95

NEW CENTRONICS 730 PRINTER

Uses any paper roll, fanfold, single sheets, 96 character ASCII, 7 x 7 dot matrix, I/O CPS, RS232 or parallel I/O

WOW \$945.00

Z-80/Z-80A/8080 CPU BOARD

- On board 2708 * 2708 included (450ns.)
- Power on jump * completely socketed
- Z-80 Assembled and Tested...\$185.00
- Z-80 Kit...\$129.95
- Z-80 Bare PC Board...\$ 34.95
- For 4MHz Speed Add \$15.00
- 8080A Kit...\$ 99.95
- 8080A Assembled...\$149.95

S-100 MOTHERBOARD SPECIAL

8 slot expandable w/9 conn. **Now \$62.95**

SIEMENS FLOPPY SALE

- Special buy while supply lasts.
- 8" Drive with Double-Density
- 90 Day Warranty **\$449.00**

ACOUSTIC MODEM NOVATION CAT™

O-300 Baud
Bell 103
Answer, Originate \$189.00

ACOUSTIC COUPLER SPECIAL

AJ Model A30
SPECIAL PURCHASE OF SURPLUS UNITS
AVAILABILITY LIMITED \$29.95

DATA BOOKS • COMPUTER BOOKS

1678 IC Master...49.95 Intel MCS 80 Manual...1.95
NSC TTL Data...3.95 Intel MCS 40 Manual...4.95
NSC Linear...4.95 AMD 8080A Manual...5.95
NSC Linear App Notes II...3.95 AMD Schottky Diodes...5.95
NSC CMOS...3.95 AMI MCS/LSI Data...3.95
NSC Memory...3.95 GI MCS/LSI Data...4.95
Intel Databook...4.95 Harris Analog Databook...4.95
Intel MCS 85 Manual...7.50 TI Linear Control Data...3.95

SALE • OSBORNE BOOKS • SALE

Intro to Micros Vol. 0...\$40 7.75
Intro to Micros Vol. 1...\$40 7.75
6800A Programming...\$40 7.75
6800 Programming...\$40 7.75
Z80 Programming...\$40 7.75
Vol. II Some Real Microprocessors w/ Binder...\$40 27.50
Vol. III Some Real Support Devices w/ Binder...\$40 27.50
Intro to Micros Vol. III...\$40 7.75

SALE • DELPHUM COMPUTER BOOKS • SALE

Understanding Computers...\$7.95 9.95
8080 Microcomputer Experiments...\$7.95 9.95
Beginning BASIC...\$7.95 9.95
Beginning Glossary & Guide...\$7.95 9.95
Peanut Butter & Jelly Guide to Computers...\$7.95 9.95
8080 Machine Language Programming...\$7.95 9.95
Home Computers Vol. I Hardware...\$7.95 9.95
Home Computers Vol. II Software...\$7.95 9.95
Dianth Simulator...\$7.95 9.95

MICROPROCESSORS

Z8000	\$ CALL	21L02 450ns	1.24	25.99	100
Z80A	14.99	21L02 750ns	1.30	11.15	115
F-8 (3801)	16.95	2102	1.58	15.15	145
2801	18.95	2112	1.25	11.15	115
CD122	17.95	2110	1.75	3.65	355
8080A	9.95	2112-1	2.95	28.55	265
8080A-4MHz	19.95	2114-250ns	12.95	10.95	99.95
SALE 8085	12.95	2114-300ns	8.95	7.95	645
8088	14.95	2114E-450ns	7.50	6.75	4.75
290	19.95	4044/4041 300ns	9.95	8.75	7.95
9001A	19.95	4044/4041 450ns	7.50	6.75	4.75
1M5 9000UL	49.95	EMM4500A	9.75	7.15	6.25
CP1600	39.95	EMM4402	7.95	7.25	6.25
6502	11.50	EMM4804	12.50	11.50	9.95
6502A	11.95	uPM10 (4200)	10.95	10.25	9.25
6502B	24.95	AM09	10.95	10.25	9.25
6503	18.95	AM09 3031	12.95	11.95	10.25
8755	49.95	F5C 400 46416K CCD Only	11.95	9.95	11.25
8759	49.95	P2125-93425 (45 m)	7.95	7.35	7.25
8769	49.95	6508 1P x 1 CMOS	7.95	7.35	7.25
8085	\$ CALL	6518 1P x 1 CMOS	7.95	7.35	7.25
	\$ CALL	7451 83 64 bit Ram	3.95	3.25	2.50
	\$ CALL	8155 I/O w/ Buffer	21.95		
	\$ CALL	2147 Low Power 64 Bit Static	14.95		

SUPPORT DEVICES

AM851 1 Arch Processor \$195.00
AM851 1 300 mhz \$495.00
AM951 DMA Controller 71.95
AM951 Universal Interrupt 24.95
3811 (280 PIC) 9.85
3811 4 (AMHz) 14.95
3812 (2-32 CTC) 14.95
3812 4 (AMHz) 14.95
3883 8IO 20.95
3884 DMA 49.95
8205 7415 Decoder 2.50
8212 8 bit I/O 2.50
8216 Bus Driver 2.50
8224 (4MHz) 2.95
8228 Bus Driver 3.95
8228 Bus Driver 3.95
8228 Bus Driver 3.95
8238 32K Cont. 6.25
8251 Prog. I/O 6.95
8251 Prog. I/O 19.40
8251 Prog. I/O 5.95
8257 Prog. DMA 17.95
8259 Prog. I/O 8.25
8275 CRT Controller 49.95
8275 Prog. Keyboard 16.95
6810-1 128 x 8 RAM 4.75
6821 PIA 5.95
6821 PIA 5.95
6828 Priority Int. 8.95
6834 1512 x 8 Eprom 12.95
6850 NCA 1.95
6852 Serial Adapter 5.95
6854-1046505 CRT Cont. 39.95
6852 Modem 8.95
6852 Modem 11.95
6871A 1 CMOS OSC 25.95
6875 8257 1 CMOS OSC 8.25
8980 Bus Driver 2.38
8980 Bus Driver 2.38
1821 320 1K RAM 25.00
1822 320 356 x 4 RAM 16.95
1824 320 32 x 8 RAM 8.25
1852 CD 8 bit I/O 10.95
1854 Unit 10.95
1854 Unit 10.95
1857 CD I/O 8.95
8520 PIA 7.50
HP 6082 7400 Red Numeric 6.95
TIL 305 15.50
TIL 306 Numeric w/Logic 6.95
TIL 308 Numeric w/Logic 6.95
TIL 309 Numeric w/Logic 6.95
TIL 311 Hexadecimal 12.95
MAN 2A 320' Red Alpha Numeric 5.95
MAN 10A 270' Red Alpha Numeric 8.95

CHARGE COUPLED DEVICES

16K CCD - First time offered Fairchild 480 CCD
16K Memory new (you can experiment with CCD technology at a reasonable price. 17 page Application note supplied with each order. Quantity limited)
\$18.95 each (reg. 43.00)

CRYSTALS

Microprocessor Timexbas Tm Game

Frequency	Price	Frequency	Price
1.0MHz	55.85	8.0MHz	4.95
1.5MHz	81.44	4.95	4.95
2.0MHz	8.85	6.5536	4.95
2.01MHz	2.95	10.0MHz	4.95
2.09153MHz	1.95	13.0MHz	4.95
2.418MHz	5.85	14.31818	4.95
3.57954MHz	1.50	18.0MHz	4.95
4.0MHz	4.95	18.432MHz	4.95
4.19430MHz	5.95	20.0MHz	4.95
4.91520MHz	5.95	22.164MHz	5.95
5.0MHz	4.95	27.0MHz	5.95
5.0988	4.95	36.0MHz	5.95
5.1143MHz	5.95	48.0MHz	5.95
		100KC	1.95

DISPLAYS/OPTO/LED'S

- 7 SEGMENT + CALC + CLOCKS +
- DL 704 (CC) DL 707 (CA) 300' Red .99
- FND 357 (CC) 357' Red .99
- FND 607 (CA) 600' Red .99
- FND 507/510 (CA) 500' Red .99
- FND 600/603 (CC) 600' Red 1.75
- FND 607/610 (CA) 600' Red 1.75
- XAN 3062 500' Green 1.15
- HP5082-7731 (CA) 300' Red .99
- 9 Digit Bubble Hex Calc. Display .99
- 9 Digit Pinpoints Display .400
- MA1003 12V Auto Clock Module 15.99
- Bezel for MA1003 w/Red Filter 4.95
- MA1003 12V LED w/ Clock Module 10.95
- LED'S
- HEX DISPLAYS + ENCODED DISPLAYS
- HP 5082-7340 Red Hexadecimal 15.95
- HP 6082-7400 Red Numeric 6.95
- TIL 305 15.50
- TIL 306 Numeric w/Logic 6.95
- TIL 308 Numeric w/Logic 6.95
- TIL 309 Numeric w/Logic 6.95
- TIL 311 Hexadecimal 12.95
- MAN 2A 320' Red Alpha Numeric 5.95
- MAN 10A 270' Red Alpha Numeric 8.95

DYNAMIC RAMS

965 Set of 4 16K 16K (16 Pin) 89.95
4115 8K (16 Pin) 6.25
4050 4K x 1 (16 Pin) 4.95
4090 4K x 1 (22 Pin) 4.95
4096 4K x 1 (16 Pin) 3.75
2104 4K x 1 (16 Pin) 4.95
4027 4K x 1 (16 Pin) 4.95
5261 1.95 1103 1.95
5262 1.95 6008L 1.95
5270 7.95 6005 7.95
5280 4.95 6004 4.95
5290 1.45 6002 1.50

PROMS

2708 0.95
2708 6.50
1702A 2.50
2732 99.00
2716 34.95
2716-9V 12V 20.95
2738 5V 29.95
2738 12V 11.95
5204A2 9.95
6534 12.95
IM 5810 2.95
SALE 8223 32 x 8 2.99
825115 512 x 8 (TB) 16.95
825115 512 x 8 (TB) 2.50
825126 256 x 4 3.50
825127 256 x 4 (IO) 3.50
825130 512 x 4 (IO) 6.50
NSC DM7578 32 x 8 6.45
825131 14.95
825137 14.95

CHARACTER GEN

2513-005 (5V) Lower 9.95
2513-AD3 (5V) Lower 14.95
MCM6571 10.75
MCM6571 10.75
MCM6571 10.75
MCM6574 14.50
MCM6574 14.50

UARTS/USRTS

TR16028 (5V 12V) 3.95
AY51013 (5V 12V) 4.95
AY51014 (5V 12V) 4.95
AY51015A (863 (5V) 6.95
TMS 6011 (5V 12V) 7.95
IM640 9.95
IM640 9.95
2332 USRT 11.95
16718 Adrus 24.95
SALE TR1472B 2.99

BAUD RATE GEN

MC1441 11.95
WD1941 9.95
AY5-2378 13.75
AY5-3600 13.75
HD01 9.95
740922 9.95
740923 9.95

KEYBOARD ENCODERS

AY5-2378 13.75
AY5-3600 13.75
HD01 9.95
740922 9.95
740923 9.95

A/D CONVERTERS

8701 10 bit Binary 13.00
8703 8 bit TS 22.00
8704 10 bit Freq. Conv 7.25
8750 3 1/2 Digit BCD 13.95
1408L 6 bit 5.95
1408L 6 bit 5.95
DAC0 A/D 5.95

STATIC RAM HEADQUARTERS

21L02 450ns 1.24 25.99 100
21L02 750ns 1.30 11.15 115
2102 1.58 15.15 145
2112 1.25 11.15 115
2110 1.75 3.65 355
2112-1 2.95 28.55 265
2114-250ns 12.95 10.95 99.95
2114-300ns 8.95 7.95 645
2114E-450ns 7.50 6.75 4.75
4044/4041 300ns 9.95 8.75 7.95
4044/4041 450ns 7.50 6.75 4.75
EMM4500A 9.75 7.15 6.25
EMM4402 7.95 7.25 6.25
EMM4804 12.50 11.50 9.95
uPM10 (4200) 10.95 10.25 9.25
AM09 10.95 10.25 9.25
AM09 3031 12.95 11.95 10.25
F5C 400 46416K CCD Only \$18.95 Each
1101 9.75 7.15 6.25
P2125-93425 (45 m) 7.95 7.35 7.25
6508 1P x 1 CMOS 7.95 7.35 7.25
6518 1P x 1 CMOS 7.95 7.35 7.25
7451 83 64 bit Ram 3.95 3.25 2.50
8155 I/O w/ Buffer 21.95
2147 Low Power 64 Bit Static 14.95

SOCKETS

8 Pin WW 32 8 Pin S/T 17
14 Pin WW 37 14 Pin S/T 20
16 Pin WW 36 16 Pin S/T 23
18 Pin WW 60 18 Pin S/T 37
30 Pin WW 75 30 Pin S/T 54
34 Pin WW 83 34 Pin S/T 58
22 Pin WW 93 22 Pin S/T 35
24 Pin WW 85 24 Pin S/T 41
28 Pin WW 97 28 Pin S/T 48
40 Pin WW 149 40 Pin S/T 63

TEXTULO ZERO INSERTION FORCE SOCKETS

16 Pin S 510 24 Pin S 750
40 Pin S 250

TEST EQUIPMENT, TOOLS, TELEPHONE DEVICES, AUTO STEREO PRODUCTS

FREE 8 pc. Tool Set (value \$14.95) with \$200.00 purchase of merchandise from this ad

Logic Probe

- Compact circuit powered
- Detects pulses as short as 50 μ sec
- DTL/TTL/HTL/CMOS compatibility



Model LP-1

100 MHz 8-Digit Counter

- 20 Hz to 100 MHz range
- LED display
- Fully automatic

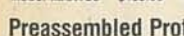

Model MAX100

Preassembled Proto Boards

- Fully assembled breadboard contains four OT-595 sockets, seven QT-598 bus strips and four 5-way binding posts

3 1/2-Digit 0.1% Digital Capacitance Meter

- 9 ranges from 1999 pF to 199.9 μ F
- 0.1% of reading accuracy
- Auto over and under range indication



Function Generator

- Model 2001
- Reg. \$185.95
- Sine-square-triangle and separate TTL square wave output



Proto Board with Built-in Power Supplies

- Regulated
- Short-proof



Model PB-203A
Reg. \$154.95
\$129.95



Model 3001
Reg. \$190.00
\$170

Portable Digital Capacitance Meter

- Measures capacitance from 0.1pF to 1 Farad
- Resolves to 0.1pF
- 10 ranges for accuracy and resolution
- 4 digit easy-to-read LED display
- 0.5% accuracy



Model 2815

Dual Trace 5" 30 MHz Triggered Scope

- Rise time 11.7 ns or less
- Built-in signal delay line
- Flat response with smooth rolloff past 30 MHz
- 5mV/cm vertical sensitivity
- Probes included

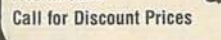

Model 1479P
Call for Discount Prices

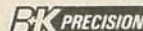

3 1/2-Digit DMM with LCD Readout

- 0.1% DC accuracy
- 0.5% LCD display for high readability
- 100 μ A current range
- 100 μ V, 100nA, 0.01 Ω resolution
- Battery life of over 100 hours
- Shielded to stay accurate in RF fields
- Low battery warning



Model 1479P

DIGITAL MULTIMETERS



Sinclair PDM 35
Reg. \$69.95
\$49.95



Hickok LX 303
\$69.50



Beckman TECH 310
22 M Ω input resistance
10 Amp AC/DC
1500V Overload
6KV Transient Protection
2 year battery life
\$130.



Simpson 461
Complete with nickel-cadmium batteries, AC charger adapter, test leads
\$149.95

LEADER



RF Wide Band Signal Generator Model LSG-16
Solid state FET oscillator circuitry
100 kHz to 100 MHz freq. range
300 MHz on harmonics

Transistorized LCR Bridge



Model LCR-740
Highly accurate 3 digit readout
Operates on one 9V battery or with AC adapter
Measures inductance, capacitance, resistance and loss factor.

25 MHz Dual Trace Time Base



with Calibrated Variable Delay
Model LBO-515A with probes
1 μ sec to 5 sec built-in delay



20 MHz Dual Trace Oscilloscope Model LBO-508A with probes
Call for Discount Prices

TECHNICIAN AIDS

Weller Xcelite

Attache Style

Model TC100-ST
Reg. \$471
\$279.95



Service Master

Model 99-SM
Reg. \$69.95
\$47.50



EDSYN SOLDAPULLT[®] Desoldering Tool

Model DS017
\$15.95



Cordless Soldering Iron

Model 7800
\$29.95



Thermal-Spot Circuit Tester

Model 5800
Finds faulty components quickly and easily
\$29.95



Weller Controlled Output Soldering Station

Model WTCPN
Reg. \$77.50
\$49.95

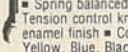

Econo-Lamp

Model XL-334A
Spring balanced arms
Tension control knobs
Baked enamel finish
Colors: Red, Yellow, Blue, Black, Oyster White
UL for 60W
\$16.95

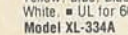

Magnifier Lamp

Model MG10A
Precision ground and polished magnification lens
\$49.95

CAR STEREO PRODUCTS

In-Dash Car Stereos



8-Track Tape Player with AM/FM/MPX Radio
Model C-777
\$52.50



Auto Reverse Cassette Tape Player with AM/FM/MPX Radio
Model CAS-999
\$79.95



Cassette Tape Player with AM/FM/MPX Radio
Model CAS-888
\$57.50

Stereo Power Booster

Model POW-40
40W stereo
20W per channel
Bass boost
\$24.95



6" x 9" 3-Way Speaker

Model BP2000-69TR
20 oz. ceramic magnet
\$14.95 ea.

Miniature High Fidelity 3-Way Stereo Speakers

MINI speakers
MAXI sound
Model HF-9
\$69.50 pr
Reg. \$149.95



BK PRECISION

30 MHz Portable Frequency Counter

Reg. \$130.00
\$65



HICKOK

Digital CB In-Line Tester

Model 388
\$169.95



SPECIALS

RCA-VIZ Super Chro-Bar

Model WR-538A
Reg. \$129.95
\$89.95



Portable VOM Multitester

Model VM520
20 K Ω VDC
10 K Ω VAC
\$19.95



RC Circuit Box

Model WC 412A
36 resistors (15 Ω to 10 M Ω)
18 capacitors (100 pF to 0.22 μ F)
Reg. \$49.95
\$42. includes test leads



Chess Challenger 7

7 levels of play
Model BBC
Reg. \$110.
\$79.95



CANON Calculator

Portable Printer with Adding Machine Tape
Model P10-D
\$69.98



Portable Oscilloscopes

15 MHz Dual Trace Triggered Miniscope
Model MS-15
Reg. \$435.00
\$369.95

15 MHz Triggered Miniscope
Model MS-15
Reg. \$319.00
\$269.95

30 MHz Dual Trace Triggered Miniscope
Model MS-230
Reg. \$559.00
\$479.95

TELEPHONE DEVICES

MURAPHONE Cordless Telephone System

Reg. \$89.95
\$74.95



CODE-A-PHONE Telephone Answering



Model 1550 Automatic Dialing
Reg. \$399.95
\$279.95

Model 1400 Call Control
Reg. \$349.95
\$199.95

Model 1500 Call Control
Reg. \$349.95
\$249.95

GTE Flip-Phone
\$37.95

BSR X-10 Remote Control for Lights & Appliances



4 Pc Standard Starter Kit
One (1) Standard Command Console
Two (2) Lamp Modules
One (1) Appliance Unit
Reg. \$87.95
\$79.50

5 Pc Ultrasonic Starter Kit
One (1) Deluxe Ultrasonic Command Console
One (1) Hand Held Remote Unit
Two (2) Lamp Modules
One (1) Appliance Unit
Reg. \$112.95
\$99.95

Lamp Modules \$14.50
Standard Command Console \$36.00
Appliance Modules \$14.50
Ultrasonic Command Console with Hand Held Remote \$59.95
Wall Switch Modules \$14.50

FORDHAM

855 Conklin St. Farmingdale, N.Y. 11735
Master Charge BankAmericard VISA
COD Check Money Order
CODs, shipping and insurance extra
N.Y. State residents add appropriate sales tax
TOLL FREE (800) 645-9518
in N.Y. State call (516) 752-0050

SPECIALS

Soldertail sockets: 14 pin 50/\$4.95; 16 pin 50/\$4.95; 18 pin 50/\$4.95; 20 pin 40/\$4.95; 24 pin 30/\$4.95; 28 pin 30/\$4.95; 40 pin 20/\$4.95. General purpose transistors; PNP, similar 2N3904 100/\$7.95. PNP, similar 2N3906 100/\$8.95.
Edge connectors: IMSAI spacing S-100 soldertail 2/\$5

EIGHT 16K DYNAMIC RAMS: \$87.20

Expand memory in TRS-80* -I and -II, Apple, other computers. Low power, 250 ns/4 MHz. Add \$3 for 2 dip shunts plus TRS-80* installation instructions.

*TRS-80 is a trademark of the Tandy Corporation.

MUSICIANS!

We have the knowledge you need to do-it-yourself and save, thanks to Craig Anderton's easy-to-read and informative books. **Electronic Projects for Musicians** (in its 3rd printing) shows you how to build preamps, tone controls, mixers, and more; **\$7.95** softcover. **Home Recording for Musicians** shows how to make quality recordings at home using equipment you can afford. **\$9.95** softcover.

WE ALSO SUPPLY PARTS KITS/BOARDS FOR CRAIG'S PROJECTS, FROM COMPRESSORS TO PHASE SIFTERS, AT A PRICE THAT'S MUSIC TO YOUR EARS.

SEND FOR OUR CATALOG TODAY!

TERMS: Cal res add tax. Allow 5% for shipping, excess refunded. VISA/Mastercharge* call (415) 562-0636, 24 hours. COD OK with street address for UPS. Special prices good through cover month of magazine while supplies last; other prices subject to change without notice. Add \$1 handling to orders under \$15.

GODBOUT

GODBOUT ELECTRONICS
 Bldg. 725, Oakland Airport, CA 94614

CIRCLE 61 ON FREE INFORMATION CARD

GFR Associates, Inc.

Newton, N.H. 03858

A MILESTONE PRINTER OFFER!!!

Used **DAISY WHEEL TERMINALS**
 Featuring **DIABLO 'HYTYPE' PRINTERS**



Features:

- KSR & Plot Modes
- ASCII RS-232 I/O
- 110, 115, 300 Baud Input
- Dual Pitch (10.12)
- 30 Day Guarantee
- Many More Exciting Features!

These used, cleaned and refurbished Daisy Wheel Terminals feature the FAMED DIABLO 'HYTYPE' Daisy Wheel Printer with its multitude of capabilities. Includes 1/60" horizontal & 1/48" vertical spacing in the 'PLOT' mode — LIMITED OFFER, SPECIAL PRICE! —

While They Last! Now From **\$1500!!**

We also offer many types of printers
 *Selectable** KSR, RO & More

I/O ELECTRIC Printer/Typewriter. Corresp code, 15" frame, hvy. duty 735-745 machine and solenoids, etc. Data and schematics included
 Removed Operational Condition. Only \$469.00 Call For Info!
 Processors (Price includes crating & shipping within the U.S.)

13" VIDEO MONITORS ONLY \$99.00
 115 VAC, 60 Hz, video input (BNC). Ready To Use!! Like New, Individ. Boxed Includes Controls.

9" (diag.), 12V VIDEO DISPLAYS ONLY \$89.00
 • Featuring 12VDC Operation!
 • Draws 800 mA @ 12 Volts DC
 • NEW in original boxes, ready to use!
 • LOW, LOW PRICE
 • Video Input
 • Mtg by Motorola

Write or Call for Our Exclusive
"USED PERIPHERAL FLYER"
(603)382-5179
 • Mastercharge & VISA Accepted
 • Phone Orders Are Welcome
 • Prices May Not Include Shipping & Handling
 • Quantities Are Limited • Prices Are Subject To Change

CIRCLE 55 ON FREE INFORMATION CARD



save on gas!

Enjoy the benefits of 20% better gas mileage, quicker starting, elimination of tune-ups, reduced pollution, and 50,000 miles on plugs and points.

Update your car with a TIGER solid state electronic ignition system. Easily installed in 30 minutes . . . even on new cars.

Tiger 500 CD Assembled \$49.95
Simplikit \$29.95

Postpaid U.S.A.

Master Charge & Bank America accepted.

Tri-Star Corporation

Phone (303) 243-5200
 P.O. Box 1727

Grand Junction, Colorado 81501
 CIRCLE 33 ON FREE INFORMATION CARD

PRINTED CIRCUIT BOARD

4" x 6" DOUBLE SIDED EPOXY BOARD 1/16" thick
 \$6.00 ea.

EPOXY glass vector board
 1/16" thick with 1/10" spacing \$1.95

CONTINENTAL SPECIALTIES
 # MAX 100 Freq. counter. #2001 1Hz — 100KHz
 An 8 digit 100 MHz count. Function Generator, sine, or AC or DC input. — square & triangle output. — \$159.00

7 WATT LD-65 LASER DIODE IR \$8.95
 25 watt Infra Red Pulse (SG 2006 equiv.)
 Laser Diode (Spec sheet included) \$24.95

MINIATURE MULTI-TURN TRIM POTS
 100, 2K, 5K, 10K, 20K, 250K, 1 Meg, .75 each \$2.00

2N3820 P FET \$.45
 2N5457 N FET \$.45
 2N2646 UJT \$.45
 ER 900 TRIGGER DIODES \$4.00/100
 2N 6028 PROG. UJT \$.65

FP 100 PHOTO TRANS. \$.50
 RED, YELLOW, GREEN LARGE LED'S, 2" \$6.00/100
 RED/GREEN BIPOLEAR LED'S, 2" \$.95
 TIL-118 OPTO-ISOLATOR \$.75
 MCT-6 OPTO-ISOLATOR \$.80
 1 WATT ZENERS: 3.3, 4.7, 5.1, 5.6, 6.1, 10
 12, 15, 18, or 22V \$6.00/100

Silicon Power Rectifiers

PRV	1A	3A	12A	50A	125A	240A
100	.06	.14	.35	.90	3.70	5.00
200	.07	.20	.40	1.30	4.25	6.50
400	.09	.25	.65	1.50	6.50	9.80
600	.11	.30	.80	2.00	8.50	12.50
800	.15	.35	1.00	2.50	10.50	16.50
1000	.20	.45	1.25	3.00	12.50	20.00

SAD 1024 a REDICON 1024 stage analog "Bucket Brigade" shift register. \$9.95

IN 4148 (IN914) 16¢/100
 1 or .01 of 25V ceramic disc. caps. 16¢/100, 100/\$50.00

RS232 CONNECTORS
 DB 25P male \$2.95
 DB 25S female \$3.50
 HOODS \$1.50

REGULATORS
 323K 5V 3A \$5.75
 309K \$1.60
 320T \$.50
 723 \$1.95
 340K-12, 15 or 24V \$1.50
 340T - 5, 6, 8, 12, 15, 18 or 24V \$1.30
 79MCG \$1.35
 79M05 \$.75

TRANSISTOR SPECIALS

2N823-NPN SWITCHING POWER \$1.95
 MRF-8004 a CB RF Transistor PNP \$.75
 2N3772 NPN Si TO-3 \$1.00
 2N4908 PNP Si TO-3 \$1.00
 2N4908 PNP Si TO-3 \$1.00
 2N5086 PNP Si TO-92 \$4.00
 2N3127 NPN Si RF \$1.50
 2N3919 NPN Si TO-18 \$1.50
 2N1420 NPN Si TO-5 \$3.00
 2N3767 NPN Si TO-6 \$.70
 2N2222 NPN Si TO-18 \$4.00
 2N3056 NPN Si TO-3 \$.60
 2N3904 NPN Si TO-92 \$4.00
 2N3298 NPN Si TO-20 \$4.00
 2N3638 PNP Si TO-5 \$4.00
 MPSA 13 NPN Si \$4.00
 2N1546 PNP GERM TO-3 \$.95

TTL IC SERIES

7400	-17	7450	-17	74155	-75
74101	-17	7472	-35	74157	-65
7402	-17	7473	-35	74160	-85
7403	-17	7474	-42	74161	-80
7404	-24	7475	-49	74162	-120
7405	-24	7476	-45	74163	-82
7406	-33	7480	-45	74164	-85
7407	-27	7483	-60	74165	-85
7409	-24	7485	-75	74170	-160
7410	-17	7486	-42	74173	-30
7411	-22	7489	-60	74174	-35
7412	-22	7490	-50	74175	-75
7413	-42	7491	-55	74176	-75
7414	-30	7492	-50	74177	-75
7416	-33	7493	-50	74180	-75
7417	-37	7494	-60	74181	-190
7420	-17	7495	-60	74190	-120
7425	-35	7496	-60	74191	-120
7426	-33	74107	-35	74192	-79
7427	-36	74121	-35	74193	-79
7430	-27	74122	-39	74194	-85
7432	-27	74123	-42	74195	-65
7437	-27	74125	-45	74196	-85
7438	-27	74126	-45	74197	-85
7440	-17	74145	-75	74279	-75
7441	-85	74148	-110	74368	-65
7442	-50	74150	-110	74325	-215
7445	-70	74151	-65	75491	-1.05
7447	-60	74153	-55	75492	-1.05
7448	-75	75154	-110	8797	-1.25
				8798	-1.10

14 pin headers \$3.00/100
 16 pin headers \$4.00 ea.

MM5387AA CLOCK CHIPS \$5.95
 MM5314 \$4.75

NO. 30 WIRE WRAP WIRE SINGLE STRAND
 100' \$1.40

ALCO MINIATURE TOGGLE SWITCHES
 MTA 100 SPDT \$1.95
 MTA 200 DPDT \$1.70
 MTA 206 P-DPDT CENTER OFF \$1.85
 MSD 206 P-DPDT CENTER OFF LEVER SWITCH \$1.85

PRV	2A	6A	25A	DIP SOCKETS
100			1.40	8 PIN .17
200	.80	1.30	2.20	14 PIN .20
400	1.00	1.65	3.30	16 PIN .22
600	1.30	1.90	4.40	24 PIN .40
				40 PIN .60

SANKEN AUDIO POWER AMPS
 Si 1010 G 10 WATTS \$ 6.75
 Si 1020 G 20 WATTS \$12.95
 Si 1050 G 50 WATTS \$25.90

TANTALUM CAPACITORS

22UF 35V	5¢/100	6.8 UF 35V	4¢/100
47UF 35V	5¢/100	10UF 10V	¢ .25
85UF 35V	5¢/100	22UF 25V	¢ .40
1UF 35V	5¢/100	15UF 35V	\$3.00/100
2.2UF 20V	5¢/100	30UF 6V	5¢/100
3.3UF 20V	4¢/100	100UF 15V	¢ .70
4.7UF 15V	5¢/100	150UF 15V	¢ .95

74LS SERIES			LINEAR CIRCUITS		
74LS00	-28	74LS123	-1.19	LM201	-75
74LS01	-28	74LS158	-1.19	LM301/748	-25
74LS02	-28	74LS166	-1.19	LM337	-30
74LS03	-28	74LS167	-1.19	LM339	-75
74LS04	-28	74LS168	-1.19	LM339	-75
74LS05	-36	74LS172	-1.19	LM339	-75
74LS06	-36	74LS173	-1.19	LM339	-75
74LS07	-36	74LS174	-1.19	LM339	-75
74LS08	-36	74LS175	-1.19	LM339	-75
74LS09	-36	74LS176	-1.19	LM339	-75
74LS10	-36	74LS177	-1.19	LM339	-75
74LS11	-36	74LS178	-1.19	LM339	-75
74LS12	-36	74LS179	-1.19	LM339	-75
74LS13	-36	74LS180	-1.19	LM339	-75
74LS14	-36	74LS181	-1.19	LM339	-75
74LS15	-36	74LS182	-1.19	LM339	-75
74LS16	-36	74LS183	-1.19	LM339	-75
74LS17	-36	74LS184	-1.19	LM339	-75
74LS18	-36	74LS185	-1.19	LM339	-75
74LS19	-36	74LS186	-1.19	LM339	-75
74LS20	-36	74LS187	-1.19	LM339	-75
74LS21	-36	74LS188	-1.19	LM339	-75
74LS22	-36	74LS189	-1.19	LM339	-75
74LS23	-36	74LS190	-1.19	LM339	-75
74LS24	-36	74LS191	-1.19	LM339	-75
74LS25	-36	74LS192	-1.19	LM339	-75
74LS26	-36	74LS193	-1.19	LM339	-75
74LS27	-36	74LS194	-1.19	LM339	-75
74LS28	-36	74LS195	-1.19	LM339	-75
74LS29	-36	74LS196	-1.19	LM339	-75
74LS30	-36	74LS197	-1.19	LM339	-75
74LS31	-36	74LS198	-1.19	LM339	-75
74LS32	-36	74LS199	-1.19	LM339	-75
74LS33	-36	74LS200	-1.19	LM339	-75
74LS34	-36	74LS201	-1.19	LM339	-75
74LS35	-36	74LS202	-1.19	LM339	-75
74LS36	-36	74LS203	-1.19	LM339	-75
74LS37	-36	74LS204	-1.19	LM339	-75
74LS38	-36	74LS205	-1.19	LM339	-75
74LS39	-36	74LS206	-1.19	LM339	-75
74LS40	-36	74LS207	-1.19	LM339	-75
74LS41	-36	74LS208	-1.19	LM339	-75
74LS42	-36	74LS209	-1.19	LM339	-75
74LS43	-36	74LS210	-1.19	LM339	-75
74LS44	-36	74LS211	-1.19	LM339	-75
74LS45	-36	74LS212	-1.19	LM339	-75
74LS46	-36	74LS213	-1.19	LM339	-75
74LS47	-36	74LS214	-1.19	LM339	-75
74LS48	-36	74LS215	-1.19	LM339	-75
74LS49	-36	74LS216	-1.19	LM339	-75
74LS50	-36	74LS217	-1.19	LM339	-75
74LS51	-36	74LS218	-1.19	LM339	-75
74LS52	-36	74LS219	-1.19	LM339	-75
74LS53	-36	74LS220	-1.19	LM339	-75
74LS54	-36	74LS221	-1.19	LM339	-75
74LS55	-36	74LS222	-1.19	LM339	-75
74LS56	-36	74LS223	-1.19	LM339	-75
74LS57	-36	74LS22			

BSR X-10 SUPER SPECIAL

DELUXE ULTRASONIC CONSOLE

REGULARLY \$49.95
NOW **\$29.95**



With the purchase of
three or more modules
Modules normally \$17.00 ea.
Modules of your choice
3 for \$47.95 6 for \$83.95
Ultrasonic Hand Unit
Normally \$24.95 Now \$18.95
Please add \$3.00 for shipping

TOLL FREE HOT LINE
800-223-0474

54 WEST 45TH STREET, NEW YORK, N.Y. 10036
212-687-2224

**ADVANCE
ELECTRONICS**

STEREO GRAPHIC EQUALIZER & PREAMP

Octave-Band 50 Hz to 12,800 18 CTS Slide controls



Assembled & tested \$109.15
No additional components necessary
for 12 VDC operation

- American made
- Glass epoxy Double sided p.t.h. circuit board
- ALLEN BRADLEY Type M conductive plastic volume control
- Adjustable input sensitivity: .3V to 3V RMS (Bourns MFT Dual trimmer)
- BIFET II Op amps: low noise, 13V/uS (TL074)
- Bourns 2% Resistor networks
- 1% Metal film resistors
- Instrument-type min. toggle switch (on-off-22 db mute)
- 2 accurate clipping lights: one on preamp stage, one on EQ stage
- All 3 LED's are Hi-brightness types (8mcd at 20mA DIFFUSED)
- Wiring & mtg. info included

80 WATT STEREO POWER AMPLIFIER

Assembled & tested circuit board.
American made \$67.89 (Class B \$61.90)
Ready to mount to heat sinks. Requires 27V split supply, 125W.

- 40W/ch 8 ohm Class AB • .08% THD at 20 khz, full power (2% Class B)
- Slew Rate 33V/uS, low TIM • VI limiting

POWER SUPPLY KIT FOR ABOVE

Includes 125W xfmr, filter caps, rect, schema \$33.00

- Transformer only \$27.00 Schema \$1.00
- NE541 80V Audio Power Driver \$3.80
- TIP 31A npn, TIP 32A pnp 60V compl. drivers \$5.1
- TIP 35A npn 25A 60V output \$1.65
- TIP 36A pnp compl to above \$1.73
- VARO 331X 100V 3A FAST RECOVERY rect \$5.3
- MR 751 6A 50V rect \$.83
- 4700uF/35V filter \$1.50
- The brightest LED! Stanley SBR 5531 8mcd@20mA diff \$.55
- ALLEN BRADLEY type M cond. plastic dual Aud. taper 100K, 1 cm cube 3mm (1/8") shaft w/mtg. hdw \$3.75
- ALL PARTS PRIME, NO SURPLUS. MANY OTHER PARTS AVAILABLE. SEND \$1.00 FOR FLYER (WE INCL. WITH ORDER). \$10.00 MIN. ORDER
- ONE DAY SHPMT 24 HOUR ORDER LINE (209) 577-4256 VISA/M.C. QB ELECTRONICS 2131 STONE MODESTO, CA 95351

CIRCLE 45 ON FREE INFORMATION CARD

NESDA

Provides Members
Low Bank Card Rate
On Mastercharge and
VISA/Bank Americard

From a high of only

1.67%

to as low as

1.10%

**ARE YOU
INTERESTED?**

NESDA Members:

Write for more information to:
NESDA BankCard Plan
2708 W. Berry, Fort Worth, Tx 76109

NOT A MEMBER?

WHY NOT?

Contact your NESDA-Affiliated
State Association or write NESDA
2708 W. Berry, Fort Worth, Tx 76109

CIRCLE 16 ON FREE INFORMATION CARD



Z-80

*

\$1250

MISCELLANEOUS CIRCUIT SPECIALS

7408	.20	CD4049B	.45
7416	.20	NC14520B	1.25
7474	.35	NC14520BCP	1.00
74181	1.55	NE555	.28
74393	1.85	NE556	.75
74LS03	.24	LM3900	.58
74LS08	.32	SN3083	1.25
74LS09	.35	C2416	3.99
74LS20	.30	N2431	1.99

80-COLUMN IMPACT PRINTER

LOWEST IN PRICE—HIGHEST IN PERFORMANCE

599.00
base2, inc.



4116

16Kx1 Static RAM
MEMORY ADD-ON FOR THE
TRS-80 OR APPLE II™
to 450ns
8 for \$59.95

8038C

VCO Waveform Gen w/sine \$265

78H05

\$595

video 100

12" BLACK & WHITE
LOW COST VIDEO
MONITOR \$129.00



LOGIC
PROBE
KIT

I.C. MASTER

NEW
"1980" \$59.95

2708

1024X8 EPROM

\$745
450ns AMD, SGS



SOROC
IQ120
\$749.00

8216 \$199
BUS DRIVER

T.I./M.M.I.
74LS240
74LS241
74LS243
74LS244
74LS373
74LS374
\$245
LIMIT 10 EACH

2716 16K EPROM
\$27.95
450ns single+5V
T.I., HIT., INT., SGS

8212
I/O PORT
3.95

ULN2001
High-current Drivers.
Darlingtons 69c

RESISTOR NETWORKS

values
270, 4.7K, & 15K
OHMS
1.5K & 10K
100/49c
\$.89 EA

EPROM ERASER

BY SPECTOLINE
UP TO 6 EPROMS IN 19 MINUTES
6000 HOUR BULB LIFE
\$49.95

MH0026CJ
DUAL CLOCK
DRIVER \$100

74S373
74S374
\$325

2114L
1024x4 Static RAMs
450 ns \$475

16K
STATIC
RAM
S-100 MEMORY ADD-ON

- FULLY STATIC OPERATION
- USES 2114 TYPE STATIC RAMS
- +3 VDC INPUT AT LESS THAN 2 AMPS
- BANK SELECT AVAILABLE BY BANK PORT AND BANK BYTE
- PHANTOM LINE CAPABILITY
- ADDRESSABLE IN 4K BLOCKS IN 4K INCREMENTS
- LED INDICATORS FOR BOARD/BANK
- SOLDER MASK ON BOTH SIDES OF BOARD

ASSEMBLED & TESTED \$269.00
California Computer Systems

CONCORD COMPUTER COMPONENTS

1971 SOUTH STATE COLLEGE - ANAHEIM, CA. 92806
VISA-MASTER CHARGE (714)937-0637
CHECK OR M.O. MINIMUM ORDER \$10.00
NO C.O.D. We stock and sell over 12,000 types of semi-conductors
ADD \$1.50 FOR FRT. CAL. RES. ADD 6%

CIRCLE 64 ON FREE INFORMATION CARD

We now have available a bunch of goodies too good to bypass. Items are limited so order today.

Call Your Phone Order in Today

MINI KITS - YOU HAVE SEEN THESE BEFORE NOW HERE ARE OLD FAVORITE AND NEW ONES TOO. GREAT FOR THAT AFTERNOON HOBBY.

FM MINI MIKE

A super high performance FM wireless mike kit! Transmits a stable signal up to 300 yards with exceptional audio quality by means of its built in electret mic. Kit includes case, mike, on-off switch, antenna, battery and super instructions. This is the finest unit available.

FM-3 Kit \$14.95
FM-3 Wired and Tested 19.95

Color Organ

See music come alive! 3 different lights flicker with music. One light each for, high, mid-range and lows. Each individually adjustable and drives up to 300 W. runs on 110 VAC.

Complete kit, ML-1 \$8.95

Video Modulator Kit
Converts any TV to video monitor. Super stable, tunable over ch. 4-6. Runs on 5-15V, accepts std. video signal. Best unit on the market! Complete kit, VD-1 \$7.95



Led Blinky Kit
A great attention getter which alternately flashes 2 jumbo LEDs. Use for name badges, buttons, warning panel lights, anything! Runs on 3 to 15 volts. Complete kit, BL-1 \$2.95

Super Sleuth
A super sensitive amplifier which will pick up a pin drop at 15 feet! Great for monitoring baby's room or as general purpose amplifier. Full 2 W rms output, runs on 6 to 15 volts, uses 8-45 ohm speaker. Complete kit, BN-9 \$5.95

CPO-1
Runs on 3-12 Vdc 1 wall out, 1 KHZ good for CPO. Alarm, Audio Oscillator. Complete kit \$2.95

CLOCK KITS

Your old favorites are here again. Over 7,000 Sold to Date. Be one of the gang and order yours today!

Try your hand at building the finest looking clock on the market. Its satin finish anodized aluminum case looks great anywhere, while six .4" LED digits provide a highly readable display. This is a complete kit, no extras needed, and it only takes 1-2 hours to assemble. Your choice of case colors: silver, gold, black (specify).
Clock kit, 12/24 hour, DC-5 \$24.95
Clock with 10 min. ID timer, 12/24 hour, DC-10 \$29.95
Alarm clock, 12 hour only, DC-8 \$29.95
12V DC car clock, DC-7 \$29.95

For wired and tested clocks add \$10.00 to kit price.

FM Wireless Mike Kit
Transmits up to 300' to any FM broadcast radio, uses any type of mike. Runs on 3 to 9V. Type FM-2 has added sensitive mike preamp stage.
FM-1 kit \$3.95 FM-2 kit \$4.95

Whisper Light Kit
An interesting kit, small mike picks up sounds and converts them to light. The louder the sound, the brighter the light. Includes mike, controls up to 300 W, runs on 110 VAC. Complete kit, WL-1 \$6.95

Tone Decoder
A complete tone decoder on a single PC board. Features: 400-5000 Hz adjustable range via 20 turn pot, voltage regulation, 567 IC. Useful for touch-tone burst detection, FSK, etc. Can also be used as a stable tone encoder. Runs on 5 to 12 volts. Complete kit, TD-1 \$5.95

Universal Timer Kit
Provides the basic parts and PC board required to provide a source of precision timing and pulse generation. Uses 555 timer IC and includes a range of parts for most timing needs.
UT-5 Kit \$5.95

Mad Blaster Kit
Produces LOUD ear shattering and attention getting siren like sound. Can supply up to 15 watts of obnoxious audio. Runs on 6-15 VDC.
MB-1 Kit \$4.95

Siren Kit
Produces upward and downward wail characteristic of a police siren. 5 W peak audio output, runs on 3-15 volts, uses 3-45 ohm speaker. Complete kit, SM-3 \$2.95

60 Hz Time Base
Runs on 5-15 VDC. Low current (2.5ma) 1 min/month accuracy TB-7 Kit \$5.95

Car Clock

The UN-KIT, only 5 solder connections

Here's a super looking, rugged and accurate auto clock, which is a snap to build and install. Clock movement is completely assembled - you only solder 3 wires and 2 switches. Takes about 15 minutes! Display is bright green with automatic brightness control photocell - assures you of a highly readable display, day or night. Comes in a satin finish anodized aluminum case which can be attached 5 different ways using 2 sided tape. Choice of silver, black or gold case (specify).
DC-3 kit, 12 hour format \$22.95
DC-3 wired and tested \$29.95

Calendar Alarm Clock
The clock that's got it all: 6-5" LEDs, 12/24 hour, snooze, 24 hour alarm, 4 year calendar, battery backup, and lots more. The super 7001 chip is used. Size: 5x4x2 inches. Complete kit, less case (not available) DC-9 \$34.95

Under Dash Car Clock
12/24 hour clock in a beautiful plastic case features: 6 jumbo RED LEDs high accuracy (.001%), easy 3 wire hookup, display blanks with ignition and super instructions. Optional dimmer automatically adjusts display to ambient light level. DC-11 clock with mtg bracket \$27.95 kit
DM-1 dimmer adapter \$2.50
Add \$10.00 Assy. and Test

PARTS PARADE

IC SPECIALS

LINEAR

301	\$.35
324	\$1.50
380	\$1.50
555	\$.45
556	\$1.00
565	\$1.00
566	\$1.00
567	\$1.25
571	\$2.00
1458	\$.50
3900	\$.50
3914	\$2.95
8038	\$2.95

TTL

74S00	\$.40
7447	\$.65
7475	\$.50
7490	\$.50
74196	\$1.35

SPECIAL

11C90	\$13.50
10116	\$1.25
7208	\$17.50
7207A	\$5.50
7216D	\$21.00
7107C	\$12.50
5314	\$2.95
5375AB/G	\$2.95
7001	\$6.50

Resistor Ass't
Assortment of Popular values - 1/4 watt. Cut lead for PC mounting, 1/2" center, 1/2" leads, bag of 300 or more. \$1.50

Switches
Mini toggle SPDT \$1.00
Red Pushbuttons N.O. 3/\$1.00

Earphones
3" leads, 8 ohm, good for small tone speakers, alarm clocks, etc. 10 for \$1.00

Mini 8 ohm Speaker
Approx. 2 1/2" diam. Round type for radios, mike etc. 3 for \$2.00

Slug Tuned Coils
Small 3/16" Hex Slugs turned coil. 3 turns. 15/\$1.00

Crystals

3.579545 MHZ	\$1.50
10.00000 MHZ	\$5.00
5.248800 MHZ	\$5.00

AC Adapters
Good for clocks, nicad chargers, all 110 VAC plug one end.
8.5 vdc @ 20 mA \$1.00
16 vdc @ 160mA \$2.50
12 vdc @ 250mA \$3.00

Solid State Buzzers
small buzzer 450 Hz, 86 dB, sound output on 5-12 vdc at 10-30 mA, TTL compatible. \$1.50

AC Outlet
Panel Mount with Leads 4/\$1.00

CMOS

4011	\$.20
4013	\$.25
4046	\$1.85
4049	\$.40
4059	\$9.00
4511	\$2.00
4518	\$1.35
5639	\$1.75

FERRITE BEADS
With info and specs 15/\$1.00
6 Hole Balun Beads 5/\$1.00

CAPACITORS

TANTALUM Dipped Epoxy	ALUMINUM Electrolytic	DISK CERAMIC
1.5 uF 25V \$/1.00	1000 uF 16V Radial \$.50	01 18V disk 20/\$1.00
1.8 uF 25V \$/1.00	500 uF 20V Axial \$.50	1 16V 15/\$1.00
25 uF 25V \$/1.00	150 uF 16V Axial 5/\$1.00	100 pf 20/\$1.00
	10 uF 15V Radial 10/\$1.00	047 16V 20/\$1.00

Ceramic IF Filters
Mini ceramic filters 7 KHz 8 W, very sharp \$1.50 ea.

Trimmer Caps
Sprague - 3-40 pf Stable Polypropylene .50 ea.

Coax Connector
Chassis mount BNC type \$1.00

9 Volt Battery Clips
Nice quality clips 5 for \$1.00
1/4" Rubber Grommets 10 for \$1.00

Connectors
6 pin type gold contacts for mA-1003 car clock module price .75 ea.

READOUTS

FND 359 4" C.C.	\$1.00
FND 507/510 5" C.A.	1.00
MAN 72/HP7730 33" C.A.	1.00
HP 7651 43" C.A.	2.00

Sockets

8 Pin	10/\$2.00
14 Pin	10/\$2.00
16 Pin	10/\$2.00
24 Pin	4/\$2.00
28 Pin	4/\$2.00
40 Pin	3/\$2.00

DC-DC Converter
+5 vdc input prod. -9 vdc @ 30ma
+8 vdc produces -15 vdc @ 35ma \$1.25

Crystal Microphone
Small 1" diameter 1/4" thick crystal mike cartridge \$.75

Parts Bag
Asst. of chokes, disc. caps, tant. resistors, transistors, diodes, MICA caps etc. sm. bag (100 pc) \$1.00 lg. bag (300 pc) \$2.50

Mini RG-174 Coax
10 ft. for \$1.00

25 AMP 100V Bridge
\$1.50 each

Mini-Bridge 50V 1 AMP
4 for \$1.00

Varactors
Motorola MV 2209 30 PF Nominal cap 20-80 PF - Tunable range - .50 each or 3/\$1.00

Audio Prescaler
Make high resolution audio measurements, great for musical instrument tuning, PL tones, etc. Multiplies audio UP in frequency, selectable x10 or x100, gives .01 Hz resolution with 1 sec. gate time! High sensitivity of 25 mv, 1 meg input z and built-in filtering gives great performance. Runs on 9V battery, all CMOS.
PS-2 kit \$29.95
PS-2 wired \$39.95

600 MHz PRESCALER

Extend the range of your counter to 600 MHz. Works with all counters. Less than 150 mv sensitivity. specify -10 or -100

Wired, tested, PS-1B \$59.95
Kit, PS-1B \$44.95

30 Watt 2 mtr PWR AMP

Simple Class C power amp features 8 times power gain. 1 W in for 8 out, 2 W in for 15 out, 4W in for 30 out. Max output of 35 W, incredible value, complete with all parts, less case and T-R relay. PA-1, 30 W pwr amp kit \$22.95
TR-1, RF sensed T-R relay kit 6.95

Power Supply Kit
Complete triple regulated power supply provides variable 6 to 18 volts at 200 ma and +5 at 1 Amp. Excellent load regulation, good filtering and small size. Less transformers, requires 6.3 V (a 1 A and 24 VCT). Complete kit, PS-3LT \$6.95

RF actuated relay senses RF (1W) and closes DPDT relay. For RF sensed T-R relay TR-1 Kit \$6.95

OP-AMP Special
BI-FET LF 13741 - Direct pin for pin 741 compatible, but 500,000 MEG input z, super low 50 pa input current, low power drain.
50 for only \$9.00 10 for \$2.00

TRANSISTORS

2N3904 NPN C-F	15/\$1.00
2N3906 PNP C-F	15/\$1.00
2N4403 PNP C-F	15/\$1.00
2N4410 NPN C-F	15/\$1.00
2N4916 FET C-F	4/\$1.00
2N5401 PNP C-F	5/\$1.00
2N6028 C-F	4/\$1.00
2N3771 NPN Silicon	\$1.50
2N5179 UHF NPN	3/\$2.00
Power Tab NPN 40W	3/\$1.00
Power Tab PNP 40W	3/\$1.00
MPF 102/2N5484	\$.50
NPN 3904 Type T-R	\$0.52/50
PNP 3906 Type T-R	\$0.52/50
2N3055	\$.80
2N2646 UJT	3/\$2.00

Diodes

5.1 V Zener	20/\$1.00
1N914 Type	50/\$1.00
1KV 2Amp	8/\$1.00
100V 1Amp	15/\$1.00

Regulators

7812	\$1.00
7815	\$1.00
7905	\$1.25
7912	\$1.25
7915	\$1.25

Shrink Tubing Nubs
Nice pre-cut pcs of shrink size: 1" x 1/4" shrink to 1/8". Great for splices. 50/\$1.00

Mini TO-92 Heat Sinks
Thermalloy Brand 5 for \$1.00
To-220 Heat Sinks 3 for \$1.00

Opto Isolators - 4N28 type
\$.50 ea.

Opto Reflectors - Photo diode + LED
\$1.00 ea.

Molex Pins
Molex already precut in length of 7. Perfect for 14 pin sockets. 20 strips for \$1.00

CDS Photocells
Resistance varies with light, 250 ohms to over 3 meg 3 for \$1.00

9 Volt Battery Clips
Nice quality clips 5 for \$1.00
1/4" Rubber Grommets 10 for \$1.00

Connectors
6 pin type gold contacts for mA-1003 car clock module price .75 ea.

INTERNATIONAL ELECTRONICS UNLIMITED

 <p>JUMBO RED LED 10/\$1.00 .20" diffused 25/\$2.00</p> <p>SUBMIN RED LED 100/\$7.50 .125" diffused</p> <p>JUMBO GREEN LED 7/\$1.00 .20" diffused 25/\$2.85</p> <p>SUBMIN GREEN LED 100/\$9.75 .125" diffused</p> <p>DIODES</p> <p>1N4148 400mw 15/\$1.00 100/\$5.00 1N4001 rectifier 12/\$1.00 100/\$7.00 1N4007 rectifier 10/\$1.00 100/\$9.00</p> <p>POLYESTER FILM CAPACITORS - 100V ± 10%</p> <table border="1" style="width: 100%; font-size: small;"> <tr> <th>EA.</th> <th>PK-10</th> <th>PK-100</th> <th>EA.</th> <th>PK-10</th> <th>PK-100</th> </tr> <tr> <td>.001uf</td> <td>.15</td> <td>.95</td> <td>6.50</td> <td>.033uf</td> <td>.20</td> <td>1.00</td> <td>10.00</td> </tr> <tr> <td>.0015uf</td> <td>.15</td> <td>.95</td> <td>7.50</td> <td>.047uf</td> <td>.20</td> <td>1.15</td> <td>10.50</td> </tr> <tr> <td>.0022uf</td> <td>.15</td> <td>.95</td> <td>7.50</td> <td>.068uf</td> <td>.25</td> <td>1.30</td> <td>12.00</td> </tr> <tr> <td>.0033uf</td> <td>.15</td> <td>.95</td> <td>7.50</td> <td>.1uf</td> <td>.30</td> <td>1.75</td> <td>13.50</td> </tr> <tr> <td>.0047uf</td> <td>.15</td> <td>.95</td> <td>7.50</td> <td>.15uf</td> <td>.35</td> <td>2.25</td> <td>14.00</td> </tr> <tr> <td>.0068uf</td> <td>.15</td> <td>.95</td> <td>7.50</td> <td>.22uf</td> <td>.40</td> <td>2.55</td> <td>20.00</td> </tr> <tr> <td>.01uf</td> <td>.15</td> <td>.95</td> <td>7.50</td> <td>.33uf</td> <td>.45</td> <td>2.75</td> <td>25.00</td> </tr> <tr> <td>.015uf</td> <td>.15</td> <td>.95</td> <td>7.50</td> <td>.47uf</td> <td>.50</td> <td>3.50</td> <td>30.00</td> </tr> <tr> <td>.022uf</td> <td>.15</td> <td>.95</td> <td>7.50</td> <td></td> <td></td> <td></td> <td></td> </tr> </table> <p>TOTAL QTY. 1000 pcs. -10%, 5000 pcs. -15%</p> <p>CERAMIC DISC CAPACITORS - 50V</p> <table border="1" style="width: 100%; font-size: small;"> <tr> <td>1pf</td> <td>22pf</td> <td>56pf</td> <td>120pf</td> <td>270pf</td> <td>820pf</td> <td>.0047uf</td> <td>.030uf</td> </tr> <tr> <td>5pf</td> <td>27pf</td> <td>68pf</td> <td>150pf</td> <td>390pf</td> <td>.001uf</td> <td>.01uf</td> <td>.050uf</td> </tr> <tr> <td>7pf</td> <td>33pf</td> <td>82pf</td> <td>180pf</td> <td>470pf</td> <td>.0015uf</td> <td>.015uf</td> <td>.1uf</td> </tr> <tr> <td>10pf</td> <td>47pf</td> <td>100pf</td> <td>220pf</td> <td>600pf</td> <td>.003uf</td> <td>.02uf</td> <td></td> </tr> </table> <p>TOTAL QTY. 1000 pcs. -10%, 5000 pcs. -15%</p> <p>QUART 1602B \$3.95ea 10/\$35.00 100/\$275.00</p> <p>CLOCK CHIP MM5375AA \$1.95 4-6 digit 60hz 12hr 10/\$17.50 alarm 24 pin 100/\$150.00</p> <p>VOLTAGE COMPARATOR \$.69ea LM311 8 pin DIP 10/\$5.90 100/\$47.50</p> <p>CLOCK CHIP MM5385N \$1.65ea 4 digit 50/60hz 12hr 10/\$12.50 alarm 40 pin 100/\$100.00</p> <p>QUAD PROGRAMMABLE OP AMP \$1.75 XR4202 16 pin DIP 10/\$15.00 100/\$125.00</p> <p>IC BREADBOARD \$1.15ea 10/\$10.00 100/\$75.00</p>	EA.	PK-10	PK-100	EA.	PK-10	PK-100	.001uf	.15	.95	6.50	.033uf	.20	1.00	10.00	.0015uf	.15	.95	7.50	.047uf	.20	1.15	10.50	.0022uf	.15	.95	7.50	.068uf	.25	1.30	12.00	.0033uf	.15	.95	7.50	.1uf	.30	1.75	13.50	.0047uf	.15	.95	7.50	.15uf	.35	2.25	14.00	.0068uf	.15	.95	7.50	.22uf	.40	2.55	20.00	.01uf	.15	.95	7.50	.33uf	.45	2.75	25.00	.015uf	.15	.95	7.50	.47uf	.50	3.50	30.00	.022uf	.15	.95	7.50					1pf	22pf	56pf	120pf	270pf	820pf	.0047uf	.030uf	5pf	27pf	68pf	150pf	390pf	.001uf	.01uf	.050uf	7pf	33pf	82pf	180pf	470pf	.0015uf	.015uf	.1uf	10pf	47pf	100pf	220pf	600pf	.003uf	.02uf		<p>.4" ORANGE LED DISPLAY \$1.19ea 7 segment RHD 10/\$7.95 MAN4610 - common anode 25/\$17.50 MAN4640 - common cathode 100/\$65.00</p> <p>.4" ORANGE overFlow ±1 \$.89ea MAN4630 - common anode 100/\$5.95</p> <p>.3" RED LED DISPLAY \$.99ea 7 segment RHD 10/\$7.95 XAN72(MAN72 equi) 25/\$17.50 common anode 100/\$65.00</p> <p>.3" RED LED DISPLAY \$.79ea 7 segment RHD 10/\$6.95 NSN74R common cathode 25/\$16.25 100/\$59.00</p> <p>.5" RED LED DISPLAY \$.89ea 7 segment RHD 10/\$7.75 FN5000 Common Cathode 25/\$17.00 100/\$62.00</p> <p>TIMER \$.65ea 555 8 pin DIP 10/\$5.50 100/\$47.50</p> <p>PLL TONE DECODER \$.99ea 567 8 pin DIP 10/\$8.55 100/\$80.00</p> <p>TRANSISTORS</p> <p>2N3904 NPN TO-92 10/\$1.50 2N3906 PNP TO-92 25/\$3.00 100/\$11.00</p> <p>METAL FILM RESISTORS ± 1% RN60 50 PPM/1/4w std. decade values 10 ohm - 475K, 1M ohm 1/8w only Total Qty. Each pk-10 pk-25 pk-100 1-999 \$.25 1.75 2.25 7.50 1000- .25 1.50 2.10 7.25</p> <p>CARBON FILM RESISTORS ± 5% 1/4w or 1/2w 1 ohm - 5.6M ohm 5.6M ohm - 15M ohm 1/2w only Total Qty. Each pk-10 pk-100 pk-1000 1-1000 \$.10 .45 3.00 1000- .10 .40 2.50 20.00</p> <p>Payment by check, M.O., UPS-COD, M/C or VISA. Add \$1.00 shipping/handling in US, Canada & Mexico. Other countries \$1.00 + 5% of order. California residents add sales tax. Minimum order \$10.00</p>
EA.	PK-10	PK-100	EA.	PK-10	PK-100																																																																																																										
.001uf	.15	.95	6.50	.033uf	.20	1.00	10.00																																																																																																								
.0015uf	.15	.95	7.50	.047uf	.20	1.15	10.50																																																																																																								
.0022uf	.15	.95	7.50	.068uf	.25	1.30	12.00																																																																																																								
.0033uf	.15	.95	7.50	.1uf	.30	1.75	13.50																																																																																																								
.0047uf	.15	.95	7.50	.15uf	.35	2.25	14.00																																																																																																								
.0068uf	.15	.95	7.50	.22uf	.40	2.55	20.00																																																																																																								
.01uf	.15	.95	7.50	.33uf	.45	2.75	25.00																																																																																																								
.015uf	.15	.95	7.50	.47uf	.50	3.50	30.00																																																																																																								
.022uf	.15	.95	7.50																																																																																																												
1pf	22pf	56pf	120pf	270pf	820pf	.0047uf	.030uf																																																																																																								
5pf	27pf	68pf	150pf	390pf	.001uf	.01uf	.050uf																																																																																																								
7pf	33pf	82pf	180pf	470pf	.0015uf	.015uf	.1uf																																																																																																								
10pf	47pf	100pf	220pf	600pf	.003uf	.02uf																																																																																																									

INTERNATIONAL ELECTRONICS UNLIMITED
225 Broadway Jackson Ca 95642
phone 209 223 3870

CIRCLE 27 ON FREE INFORMATION CARD

HOME of SURPLUS BARGAINS ELECTRONIC SUPERMARKET

P.O. BOX 619 — (DEPT R4) LYNNFIELD, MASS. 01940
Phone orders (617) 532-2323 — Use your Charge Card - Visa-MC-AE
TERMS: Add Postage; No. C.O.D.'s — \$10.00 Minimum Order

POWER SUPPLY KIT

INPUT 115 VOLTS 16 HZ.

We supply all electrical and electronic parts, you supply labor & mechanical parts, tools, & case.

Battery Charger 12VDC, 20A, 20 Lbs. 7C70005 (20A) . . . \$19.50
Battery Charger 12VDC, 15A, 15 Lbs. 9C0089 (15A) . . . \$14.50
Ni-Cad Battery Charger Kit, Super Buy! Up to 35VDC, 500Ma. Sh. Wt. 5 Lbs. 7C70243 . . . \$6.00
Loaic P.S. Kit. 5V, 1A, Reg'd. \$6.00 7C70267

5 TO 24VDC Reg'd & adjustable, 5 amps. Sh. Wt. 15 Lbs. 6M16030 \$14.88

AM/FM-MPX STEREO RECEIVER
*Close-out special @ watts (RMS)/channel *Tape inputs *Photo inputs *Fully wired & ready to install in cabinet or wall *Cabinet available *Just add speakers to operate *4 channel/quad outputs available *Complete jax panel & many other extras. L.P. was \$199.95. IC/FET. Sh. Wt. 7 lbs.
@ = 12 wts 9X0538 \$49.88
@ = 8 wts 9X0296 \$39.88



ELECTRONIC TIMER BOARD

Microwave oven timer board - req's 3 x 8 switch matrix. Make a 4 digit timer - runs on 115V 60Hz with data. Turn things on or off, up to 3.33 hrs. Sh. wt. 8 oz. D9CS0434 \$4.88
3 for \$12.88 D9CS0434 \$12.88/3

9" COMPUTER MONITOR (Conrac)

Must be modified for data used. L.P. \$200.00 (green-phosphor) Sh. wt. 25 lbs. QTY LTD - 913B0154 ONLY \$38.88!!!!

COMPUTER DESK (For above)

\$28.88...36" x 24" x 28" - 9220482 ONLY \$28.88!
KEYBOARD also- 9130159 - \$28.33



"AUTOMATIC RADIO" - SAVE \$51.07!

AM/FM CAR RADIOS

These pushbutton radios with front/rear speaker control & power antenna switch/burglar alarm control are completely built up in Japan, but to get a low custom rate the radio was assembled in Japan less dial & face plate & Pointer. We supply stuff to put together a complete radio - all in foam packed boxes from Japan. Made to sell for \$79.95 each -
Sh. Wt. 12 lbs. 9DS0376 \$38.88 ea.
Car Stereos - 9DS0402 \$49.88

Send for FREE cat'l. - visit our stores, 177 Washington St., Peabody, MA, or Towne Dumpe 777 So. Willow St., next to Woolco, Manchester, NH.

10% OFF ON ALL ORDERS of over \$10.00 from this ad!

CIRCLE 18 ON FREE INFORMATION CARD

ALARM CLOCK KITS: 4 Digit .5"

Here it is! The first of several quality kits we have been asked for: Here is what you get — unbelievable as it may sound...

- 1 National - 5375AA Clock Chip
- 1 Bowmar Clock Stick Readout (L.E.D.) 4 digit - 1/2"
- 13 Transistors
- 2 Push Buttons for time set
- 2 Toggle Switches for alarm
- 1 Filter cap
- 4 1N4000 series diodes
- 1 1N4148
- 2 Disc caps
- 29 Resistors
- 1 Transducer (Speaker) for Alarm Plug In
- 1 LED Lamp for alarm indicator Transformer \$1.50

NEW!
\$9.99

ORDER KIT CK-100AC P.C. Board \$2.25 Case - \$3.50

D.C. MODEL

Same as above except it includes 60 Hz timebase.

This Kit Includes:

- 1 National 5375AA Clock Chip
- 1 Bowmar Clock Stick Readout - (L.E.D.) 4 digit - 1/2"
- 12 Transistors
- 2 Push Buttons for time set
- 2 Disc caps
- 27 Resistors
- 1 MOV
- 1 60 Hz time base

NEW!
\$12.75

ORDER KIT CK-100DC P.C. Board \$2.25 Case - \$3.50

RADIO-ELECTRONICS

***** **CABLE TIES** *****

MAKE YOUR PROJECTS "NEAT & TIDY". 4" CABLE TIES AT A FANTASTIC PRICE. GET THIS BARGAIN AND "TIE" IT DOWN. **\$2.00 for 100 or better yet \$15.00 for 1000**

FACTORY PRIME
BI - Polar LED 59¢ ea. or 10 for \$5

LAB-BENCH VARIABLE POWER SUPPLY KIT

5 to 20 VDC at 1 AMP. Short circuit protected by current limit. Uses IC regulator and 10 AMP Power Darlington. Very good regulation and low ripple. Kit includes PC Board, all parts, large heatsink and shielded transformer. 50 MV. TYP. Regulation. **\$15.99 KIT**

5-14 V.D.C. BETTER BEEPER

Two audio oscillators - a low frequency pulse oscillator - either or both audio frequencies can be shifted (warbled) or pulsed on and off. Constant tone capability. Any combination of pulses and warbles or tones. 1 7/8" D X 1 3/4" ALARMS - TOYS - TESTING - ETC. Complete kit... **\$3.55 or 3 for \$9**

MICRO MINI TOGGLE SWITCHES

6 for \$5 with hardware.  **99¢ EACH**

16K DYNAMIC RAM CHIP

WORKS IN TRS-80 OR APPLE II
VERY LIMITED STOCK! "MAGAZINE SPECIAL" - **8/\$79.50**

Digital Research: Parts

(OF TEXAS)

P.O. BOX 401247B GARLAND, TEXAS 75040 • (214) 271-2461

TERMS: Add 50¢ postage, we pay balance. Orders under \$15 add 75¢ handling. No C.O.D. We accept Visa, MasterCard and American Express cards. Tex. Res. add 5% Tax. Foreign orders (except Canada) add 20% P&H. 90 Day Money Back Guarantee on all items. Write for our free catalog full of many useful bargains.

AVAILABLE NOW!

ONLY \$3.95
Add \$1.00 for shipping

JAPANESE TRANSISTOR SUBSTITUTION MANUAL



An invaluable Japanese to Japanese substitution guide for approximately 3000 transistors

- Covers the 2SA, 2SD, 2SC and 2SD series
- Introduction includes a guide to understanding Japanese transistors
- A 90 page 8 1/2" by 11" soft cover book

PARTS PROCUREMENT PROBLEMS

FUJI-SVEA Has the Largest Inventory of Original Japanese Parts Anywhere

Seeking Original Japanese Replacement Parts for CB, TV and Stereo Repair Use?

TYPE	25-UP	10-24	1-9	TYPE	25-UP	10-24	1-9	TYPE	25-UP	10-24	1-9	TYPE	25-UP	10-24	1-9	TYPE	25-UP	10-24	1-9
2SA 473	45	55	60	2SB 346	30	35	40	2SC 693F	20	27	30	2SC 1226A	50	55	60	2SD 234	60	70	80
2SA 483	2.00	2.20	2.50	2SB 367	1.10	1.25	1.40	2SC 696	1.00	1.20	1.30	2SC 1237	1.80	2.00	2.25	2SD 235	60	70	80
2SA 484	1.50	1.75	1.95	2SB 368B	1.80	2.00	2.25	2SC 698	1.30	1.45	1.60	2SC 1239	2.20	2.70	2.90	2SD 261	35	40	45
2SA 485	1.40	1.60	1.80	2SB 379	70	80	90	2SC 710	20	27	30	2SC 1279	50	55	60	2SD 287	2.50	2.70	2.90
2SA 488	1.10	1.25	1.40	2SB 381	30	35	40	2SC 712	20	27	30	2SC 1306	1.30	1.45	1.60	2SD 300	4.50	5.00	5.60
2SA 490	70	80	90	2SB 400	30	35	40	2SC 715	30	35	40	2SC 1307	1.90	2.10	2.40	2SD 313	60	70	80
2SA 493	45	53	59	2SB 405	30	35	40	2SC 725	30	35	40	2SC 1310	20	27	30	2SD 315	60	70	80
2SA 495	30	35	40	2SB 407	80	90	100	2SC 733	35	40	45	2SC 1312	20	27	30	2SD 325	60	70	80
2SA 496	50	64	70	2SB 415	30	35	40	2SC 727	1.00	1.20	1.30	2SC 1313G	20	27	30	2SD 330	60	70	80
2SA 497	1.00	1.20	1.30	2SB 434	80	90	100	2SC 730	3.00	3.20	3.40	2SC 1316	4.20	4.40	4.90	2SD 350	3.80	4.00	4.40
2SA 505	50	64	70	2SB 435	90	1.10	1.20	2SC 731	2.50	2.70	2.90	2SC 1317	20	27	30	2SD 380	5.20	5.40	5.95
2SA 509	30	35	40	2SB 440	40	53	59	2SC 732	20	27	30	2SC 1318	35	40	45	2SD 381	85	100	1.10
2SA 525	50	64	70	2SB 449	1.30	1.45	1.60	2SC 733	20	27	30	2SC 1325A	6.90	7.50	8.00	2SD 424	3.80	4.00	4.40
2SA 530	1.50	1.70	1.90	2SB 461	90	1.10	1.20	2SC 734	20	27	30	2SC 1327	20	27	30	2SD 426	3.10	3.30	3.60
2SA 537A	1.50	1.70	1.90	2SB 463	90	1.10	1.20	2SC 735	20	27	30	2SC 1330	50	55	60	2SD 427	1.80	2.00	2.25
2SA 539	40	45	50	2SB 471	1.10	1.25	1.40	2SC 738	20	27	30	2SC 1335	50	55	60	2SD 525	90	1.10	1.20
2SA 545	45	53	59	2SB 472	2.70	2.50	2.80	2SC 756	1.50	1.80	2.00	2SC 1344	45	53	59	2SD 526	60	70	80
2SA 561	30	35	40	2SB 473	80	90	1.00	2SC 764	3.00	3.20	3.40	2SC 1348	4.50	4.40	4.90	2SK 19BL	1.40	1.50	1.60
2SA 562	30	35	40	2SB 474	70	80	90	2SC 765	1.50	1.80	2.00	2SC 1358	4.20	4.40	4.90	3SK 9	90	1.10	1.20
2SA 564A	20	27	30	2SB 481	90	1.10	1.20	2SC 772	30	35	40	2SC 1359	30	35	40	3SK 40	90	1.10	1.20
2SA 565	70	80	90	2SB 492	60	70	80	2SC 773	35	40	45	2SC 1360	50	55	60	3SK 41	1.30	1.45	1.60
2SA 566	2.50	2.70	3.00	2SB 507	80	90	1.00	2SC 774	1.00	1.20	1.30	2SC 1362	35	40	45	3SK 45	1.30	1.45	1.60
2SA 606	1.00	1.20	1.30	2SB 509	1.10	1.20	1.30	2SC 775	1.40	1.60	1.80	2SC 1377	3.20	3.40	3.70	AN 203	1.40	1.60	1.80
2SA 607	1.10	1.25	1.40	2SB 511	70	80	90	2SC 776	1.20	1.30	1.40	2SC 1383	30	35	40	AN 214Q	1.50	1.70	1.90
2SA 624	70	80	90	2SB 514	70	80	90	2SC 777	3.00	3.25	3.50	2SC 1384	35	40	45	AN 239	4.20	4.40	4.90
2SA 627	3.10	3.30	3.60	2SB 523	70	80	90	2SC 778	2.90	3.20	3.40	2SC 1396	45	53	59	AN 247	2.50	2.70	3.00
2SA 628	30	35	40	2SB 526C	70	80	90	2SC 781	1.90	2.10	2.40	2SC 1398	70	80	90	AN 274	1.50	1.75	1.95
2SA 634	40	45	50	2SB 527	90	1.10	1.20	2SC 783	2.10	2.50	2.80	2SC 1400	35	40	45	AN 275	3.00	3.20	3.40
2SA 640	30	35	40	2SB 529	70	80	90	2SC 784	3.00	3.20	3.40	2SC 1403	3.00	3.20	3.40	AN 315	1.80	2.00	2.25
2SA 642	30	35	40	2SB 529	70	80	90	2SC 785	3.00	3.20	3.40	2SC 1407	50	55	60	BA 511A	1.80	2.00	2.25
2SA 643	30	40	45	2SB 530	3.20	3.40	3.70	2SC 789	80	90	1.00	2SC 1419	60	70	80	BA 521	1.90	2.10	2.40
2SA 653	1.90	2.10	2.40	2SB 531	1.80	2.00	2.25	2SC 790	80	90	1.00	2SC 1444	1.60	1.80	2.00	HA 1151	1.50	1.75	1.95
2SA 659	35	40	45	2SB 536	1.00	1.20	1.30	2SC 793	2.00	2.20	2.50	2SC 1445	2.50	2.70	2.90	HA 1365W	1.60	1.80	2.00
2SA 661	50	64	70	2SB 537	1.00	1.20	1.30	2SC 799	2.00	2.20	2.50	2SC 1447	6.90	7.50	8.00	HA 1306W	2.50	2.70	3.00
2SA 663	30	35	40	2SB 541	3.20	3.40	3.70	2SC 828	20	27	30	2SC 1448	4.50	4.40	4.90	HA 1339	2.50	2.70	3.00
2SA 666	35	40	45	2SB 544	5.00	6.00	6.60	2SC 830H	2.50	2.70	3.00	2SC 1449	60	70	80	HA 1339A	2.50	2.70	3.00
2SA 671	80	90	1.00	2SB 556	3.20	3.40	3.70	2SC 838	35	40	45	2SC 1451	1.00	1.10	1.20	HA 1342A	2.50	2.70	3.00
2SA 672	30	35	40	2SB 557	2.10	2.50	2.80	2SC 839	30	35	40	2SC 1454	3.20	3.40	3.70	HA 1366W	2.50	2.70	3.00
2SA 673	35	40	45	2SB 561B	35	40	45	2SC 853	70	80	90	2SC 1475	80	90	1.00	HA 1366WR	2.50	2.70	3.00
2SA 678	35	40	45	2SB 564	4.40	4.90	5.40	2SC 867	4.20	4.40	4.90	2SC 1478	60	70	80	LA 4031P	1.80	2.00	2.50
2SA 679	4.20	4.40	4.90	2SB 595	1.10	1.30	1.50	2SC 867A	4.20	4.40	4.90	2SC 1509	50	55	60	LA 4032P	1.80	2.00	2.25
2SA 680	4.20	4.40	4.90	2SB 596	1.10	1.40	1.50	2SC 870	35	40	45	2SC 1567	60	70	80	LA 4051P	1.80	2.00	2.25
2SA 682	80	90	1.00	2SB 600	5.00	6.00	6.60	2SC 871	35	40	45	2SC 1567A	60	70	80	LA 4400	1.90	2.10	2.40
2SA 683	30	35	40	2SC 183	40	53	59	2SC 895	4.20	4.40	4.90	2SC 1584	6.00	6.30	7.00	LA 4400Y	2.00	2.20	2.50
2SA 684	35	40	45	2SC 184	40	53	59	2SC 897	2.00	2.20	2.50	2SC 1586	6.30	6.90	7.60	LD 4001	2.00	2.20	2.50
2SA 695	40	53	59	2SC 283	40	53	59	2SC 900	2.50	2.70	3.00	2SC 1626	60	70	80	MS 1513L	2.00	2.20	2.50
2SA 697	45	53	59	2SC 284	80	90	1.00	2SC 923	20	27	30	2SC 1628	60	70	80	STK 011	3.80	4.00	4.40
2SA 699A	50	64	70	2SC 317	40	53	59	2SC 929	20	27	30	2SC 1647	70	80	90	STK 013	7.60	8.00	8.80
2SA 705	40	53	59	2SC 352A	2.00	2.20	2.50	2SC 930	20	27	30	2SC 1667	3.00	3.20	3.40	STK 015	4.20	4.40	4.90
2SA 706	85	1.00	1.10	2SC 353A	1.80	1.60	1.80	2SC 941	20	27	30	2SC 1674	30	35	40	STK 435	4.50	5.00	5.60
2SA 715	60	70	80	2SC 369	30	35	40	2SC 945	20	27	30	2SC 1678	1.10	1.25	1.40	STK 439	7.90	8.00	8.25
2SA 719	30	35	40	2SC 370	20	27	30	2SC 959	1.00	1.20	1.30	2SC 1678	1.10	1.25	1.40	TA 7045M	2.00	2.20	2.50
2SA 720	30	35	40	2SC 371	30	35	40	2SC 971	70	80	90	2SC 1687	3.00	3.20	3.40	TA 7055P	2.00	2.20	2.50
2SA 721	30	35	40	2SC 372	20	27	30	2SC 982	70	80	90	2SC 1687	3.00	3.20	3.40	TA 7061AP	90	1.10	1.20
2SA 723	30	35	40	2SC 373	20	27	30	2SC 983	50	64	70	2SC 1689	30	35	40	TA 7062P	1.10	1.25	1.40
2SA 725	30	35	40	2SC 374	30	35	40	2SC 984	35	40	45	2SC 1689	30	35	40	TA 7203P	2.50	2.70	2.90
2SA 726	30	35	40	2SC 375	30	35	40	2SC 985	1.00	1.40	1.50	2SC 1684	30	35	40	TA 7204P	2.00	2.20	2.50
2SA 730	20	27	30	2SC 376	30	35	40	2SC 1012	1.20	1.40	1.50	2SC 1687	40	45	50	TA 7205P	1.60	1.80	2.00
2SA 733	40	53	59	2SC 377	30	35	40	2SC 1013	50	64	70	2SC 1688	35	40	45	TA 7222P	3.40	3.55	3.90
2SA 734	4.20	4.40	4.90	2SC 380	20	27	30	2SC 1014	80	90	1.00	2SC 1708	30	35	40	TA 7310P	1.30	1.45	1.60
2SA 743A	85	1.00	1.10	2SC 381	35	40	45	2SC 1018	60	70	80	2SC 1728	70	80	90	TBA 8105H	1.90	2.10	2.40
2SA 744	4.20	4.40	4.90	2SC 382	35	40	45	2SC 1030	1.80	2.10	2.40	2SC 1730	45	53	59	TC 5080P	3.40	3.55	3.90
2SA 745R	3.80	4.00	4.40	2SC 383	35	40	45	2SC 1037	3.40	3.55	3.90	2SC 1756	50	55	60	TC 5081P	3.00	3.20	3.40
2SA 747	4.20	4.40	4.90	2SC 387A	35	40	45	2SC 1051	3.40	3.55	3.90	2SC 1760	70	80	90	UHC 001	4.20	4.40	4.90
2SA 748	70	80	90	2SC 388A	40	53	59	2SC											

LONG PLAY 10 HOUR TAPE RECORDER

Top quality AC-DC cassette recorder, modified to provide 5 continuous hours of recording and playback of true fidelity, distortion-free sound on each side of cassette for a total of 10 hours. Unit has many special built in features. TDK D-C180 cassette supplied. **NOW ONLY \$125.00***



PHONE RECORDING ADAPTER

Record incoming and outgoing calls automatically with this all solid state unit connected to your telephone jack and tape recorder. Starts recording when phone is lifted. Stops when you hang up, making a permanent record. Easily installed. No monthly charges. **FCC APPROVED \$24.50***



VOX VOICE ACTIVATED CONTROL SWITCH

Solid state. Self contained. Excellent adjustable sensitivity. Voices or other sounds activate recorder. Uses recorder mike or remote mike. 2 1/4 x 1 3/4 x 3/4" **\$24.95***



AMAZING ELECTRONIC MICRO MINI MIKE

Among world's smallest, solid state, self contained WIRELESS MIKE. Mercury Bat. furn. Picks up most sounds and transmits without wires up to 300 ft. thru FM Radio. Tuneable. Use as mike, amp., alarm & alert system, baby sitter, hot line, etc. 2-1/4 x 3/4 x 1/2" **\$24.95***



Phone Call Adapter, VOX, MIKE, (* plus \$1.00 ea. ship. & hdg.), 10 hr. Recorder (* plus \$4.00 ship. & hdg.), Calif. res. add tax. Mail Order, VISA, M/C, cod's o.k., quan. dis. avail. Money back guar. Free data.

**AMC SALES, Dept. 19, 9335 Lubec St., Box 928,
Downey, CA 90241 (213) 869-8519**

CIRCLE 28 ON FREE INFORMATION CARD

TECHNICAL ELECTRONICS CORPORATION

TERMS: Add Postage • SOME QUANTITIES LIMITED
MINIMUM ORDER: \$10.00 • MASTERCHARGE & VISA ACCEPTED

• CONDENSOR MIC Cat. No. 1086 Built-in FET Circuit	\$ 2.95		
• HI-CAP PACK Cat. No. 1647 12.5 Volts 500 mA new	\$12.87		
• LAMBDA DUAL VOLTAGE REGULATED POWER SUPPLY Cat. No. 1636 LXD-3-152 Input 115 Output ± 12 V @ 0.4 Amps	\$29.97		
• 6-12 VOLT WATER PUMP Cat. No. 1661 All Plastic Construction	\$ 3.69		
• QUAD JOYSTICK Cat. No. 1440 4-100 K Pots	\$ 4.49		
• BI-POLAR LEDS Cat. No. 1531 Green/Red	2 for \$ 1.15		
• LED ASSORTMENT Cat. No. 1501 25 Prime Assorted, All Styles	\$ 2.29		
• 12 VOLT 1 AMP POWER SUPPLY Cat. No. 1682 Less than 100mV ripple	\$14.88		
• COMPUTER GRADES CAPACITORS, FACTORY FRESH Cat. No. 1525			
330,000 uf @ 5VDC	\$ 2.00		
150,000 uf @ 6VDC	\$ 1.75		
89,000 uf @ 6VDC	\$ 1.00		
7,000 uf @ 6VDC	\$.35		
6,800 uf @ 25VDC	\$ 2.20		
• BATTERY CHARGERS ALL 110 VAC 50/60 Hz			
VOLTAGE	AMPERAGE	CAT. NO.	PRICE
2.9 VDC	125 mA	1181	\$ 1.35
3.0 VDC	800 mA	1639	\$ 1.49
4.5 VDC	150 mA	1180	\$ 1.95
6.0 VDC	30 mA	1574	\$ 1.29
6.5 VDC	20 mA	1610	\$ 1.09
7.8 VDC	30 mA	1527	\$ 1.79
9.0 VDC (regulated)	100 mA	1450	\$ 3.49
18.0 VAC	85 mA	1633	\$ 2.09

Please use Cat. No. & Voltage when ordering.

\$1750



2 for \$3000

TELEPHONE ANSWERING CONTROLLER

Another TEK-EL Exclusive, comes this unique 6 x 3" board, jam-packed with all the necessary components to build your own telephone answering machine! The unit features: On-board voltage regulation, Play and record electronics for tape and control signals (Record and Playback), all the switching circuitry for automatic answer, and a completely integrated circuit amplifier. Some of the obvious uses would be, Remote control device, Auto-answer for Acoustic Modems, Intercom, and even an application as diverse as a Vocal Doorbell. All units are brand new and guaranteed. Complete with schematic and specs. **Cat. No. 1857**

Wt. 12 oz.

STORE & WAREHOUSE OPEN MONDAY - FRIDAY 9-5, SATURDAY 9-1
TELEPHONE (617) 935-7328

CIRCLE 6 ON FREE INFORMATION CARD

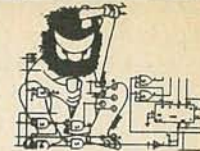

1. EMM 4200A, 4K Static RAMs, Ceramic A local memory boards manufacturer closed. We bought the new memory boards and took these 4200A static RAMs out. They are tested and 90-day guaranteed 100% good.

Prime tested 4200A 4K RAMs \$5.50 ea., 32/\$160.00, 300 pieces or more \$4.50 ea.

2. Motorola Triacs, 500 volt @ 15 amp MAC 20-7 10 for \$20.00

3. Power SCR's (GEC50A) 100 volts @ 110 amps..... \$6.95 ea.

4. Squirrel Cage Fans (Howard) .. \$7.00 ea.

5. Power Diode 1N1202A, 200 volt @ 12 amp..... 4 for \$1.00

6. LM 323 5 Volt 3 amps, voltage regulator 4.95 each or 10/\$45.00.

7. Super Saver. Micro PD411, Ceramic 4K x 1 dynamic RAMs..... 8 for \$10.00.



DELTRONIKS

5151 BUFORD HIGHWAY ✓ D28
ATLANTA, GA 30340
404-458-4690

CIRCLE 71 ON FREE INFORMATION CARD

Function Generator XR-2208KB
KIT \$19⁹⁵

8080A
MICRO-PROCESSOR **\$5⁹⁵**

PET 2001
Professional Computers
TRY THIS ONE!

• 16K Bytes • Large Keyboard
• Separate Numerics Pad
• Graphics
PET 2001-16N \$995.00

• **EPROM** •
5 Volt **\$29⁹⁰**
2716

OK JUST WRAP
WIRE WRAPPING TOOL KIT

• 50H: set, blue, white, red, yellow wire
• Unwrapping Tool
• JUST WRAP Tool
JWK-6 **\$24⁹⁵**

SYM-1
• KIM-1 Compatible • 4K ROM
Monitor • 1K Bytes 2114 RAM
• 65K Memory Expansion • User
2716 EPROM \$239.00

Test Clips
14-Pin Clip... \$ 4.50
16-Pin Clip... \$ 4.75
24-Pin Clip... \$10.00
40-Pin Clip... \$21.00

ATARI Personal Computer System

400 Includes: Computer Console, Basic Language Cartridge, Power Supply, TV Modulator, and all Operator and Programming Manuals \$600.00
800 Includes: Computer Console, Basic Language Cartridge, Education System Master Cartridge, Cassette Recorder, TV Modulator, 8K Memory (expandable to 48K), Power Supply and all Operation Manuals \$999.00

SD Systems	KITS
27001 ExpandoRAM Kit - Expandable RAM Board Kit (No RAMs)	\$220
27002 Versafloppy Flexible Disk Drive Controller Kit	250
27003 SSC-100 Single Board Computer Kit	295
27004 280 Starter Kit	340
27007 ExpandoPROM Kit	175
27010 Add-on RAM (16K Devices) 4116 (200ns) (package of eight devices)	165
27011 VDB-9024 Video Display Board Kit	370
27012 ExpandoRAM II Expandable RAM Board Kit (16K RAM)	460
27013 Versafloppy II Flexible Disk Drive Controller Kit	350
27014 PROM-100 PROM Programmer Board Kit	200
27015 MPB-100 280 Central Processing Unit Board Kit	250
27017 Add-on RAM (16K devices) 4116 (200ns)	250
27018 SSC-200 Single Board Computer Kit	320
27024 ExpandoRAM II Expandable RAM Board Kit (No RAMs)	230

SD Systems	ASSEMBLED
38001 ExpandoRAM (16K of on-board RAM)	\$ 480
38002 ExpandoRAM (32K of on-board RAM)	620
38003 ExpandoRAM (48K of on-board RAM)	760
38004 ExpandoRAM (64K of on-board RAM)	900
38005 Versafloppy Flexible Disk Drive Controller	335
38006 SSC-100 Single Board Computer	350
38007 280 Starter System	450
38010 ExpandoPROM	245
38011 Cable for 1" Disk Drives	80
38013 VDB-9024 Video Display Board	470
38016 Cable, 8ft., 28 Pin Edge Connector (one end)	50
38017 Cable for SD-100/SD-200 Interface to Texas Instruments 810 Printer	80
38018 Cable, same as above (Internal)	120
38019 Cable, same as above (External)	80
38020 ExpandoRAM II (16K Population)	610
38021 ExpandoRAM II (32K Population)	840
38022 ExpandoRAM II (48K Population)	1070
38023 ExpandoRAM II (64K Population)	1300
38024 Versafloppy II Double Density Flexible Disk Drive Controller	430
38025 PROM-100 PROM Programmer	265
38026 MPB-100 280 Microprocessor Board	325
38028 SSC-200 Single Board Computer	400

The Instructor 50
Desktop Computer
from SIGNETICS
Complete, Ready-To-Use
Microprocessor Learning Package
Includes everything you need to write, run and debug machine-language programs. Housed in one compact package.

\$35000

HICKOK
LX 303
DIGITAL MULTIMETER
Compact Accurate Dependable **\$74⁹⁵**

NON-LINEAR SYSTEMS
Portable Mini-Scopes
MS-15.....\$349
MS-215.....\$465
MS-230.....\$598

Light Emitting Diode ED95 Red-Orange and Green
Color mixing ONLY possible due to separate anode terminals. **\$1⁶⁰**

Flasher LED
Red LED and ONLY Flasher IC Chip **92¢ ea.**
in One Package

12 Segment LED Array
Excellent for use in level indication circuits.
GL-112R3 All Red **\$4⁸⁰**
GL-112M2 Green/Red **\$4⁸⁰** ea.

LED Driver
Designed to illuminate 12 segment LED Arrays according to an input control voltage. **\$4⁸⁰**
IR-2406

KX-33B Micro Computer
Easy-to-use 4-bit microcomputer intended to teach basic concepts of computer technology. Operates on 110VAC, 60Hz. **\$229⁰⁰**

★ 15% ★ DISCOUNT COUPON

Bring this COUPON into one of our stores or mail to our Mail Order address shown below and receive a **15% DISCOUNT** on purchases from this Ad of \$100.00 or more.

Offer EXPIRES on April 30, 1980

NAME.....
ADDRESS.....
CITY..... STATE.....
ZIP..... PHONE NO.....

Coupons accepted only with full name and address filled in.

ANCRONA
Send Check or Money Order to: P.O. Box 2208R, Culver City CA 90230
California residents add 6% sales tax. Minimum Order: \$10.00.
Add \$1.00 to cover postage and handling. Master Charge and Visa welcomed.
Please include your charge card number, interbank number and expiration date. **PHONE ORDERS: (213) 641-4064**

MAIL ORDER	PORTLAND	SANTA ANA	CULVER CITY
P.O. Box 2208R Culver City CA 90230 (213) 641-4064	1125 N.E. 82nd Ave Portland, OR 97220 (503) 254-5541	1300 E. Edinger Ave. Santa Ana, CA 92705 (714) 547-8424	11080 Jefferson Blvd. Culver City, CA 90230 (213) 390-3685
TUCSON	HOUSTON	ATLANTA	SUNNYVALE
4518 E. Broadway Tucson AZ 85711 (602) 881-2348	2648 Richmond Houston, TX 77098 (713) 529-3488	3330 Piedmont Rd. N.E. Atlanta, GA 30305 (404) 281-7100	1054 E. El Camino Real Sunnyvale, CA 94087 (408) 243-4121

CIRCLE 63 ON FREE INFORMATION CARD

NEW PRODUCTS!

Super Color S-100 Video Kit \$99.95
 Expandable to 256 x 192 high resolution color graphics. 6847 with all display modes computer controlled. Memory mapped. 1K RAM expandable to 6K. S-100 bus 1802, 8080, 8085, 280 etc.

Gremlin Color Video Kit \$59.95
 32 x 16 alpha/numerics and graphics; up to 8 colors with 6847 chip; 1K RAM at E000. Plugs into Super Elf 44 pin bus. Not expandable to high resolution Graphics.

Elf II Adapter Kit \$24.50
 Plugs into Elf II providing Super Elf 44 and 50 pin bus plus S-100 bus expansion (With Super Expansion). High and low address displays, state and mode LED's optional \$18.00.

1802 16K Dynamic RAM Kit \$149.00
 1802/S-100 expandable to 32K. Hidden refresh w/clocks up to 4 MHz w/no wait states Addl. 16K RAM \$79.00.

Quest Super Basic

Quest, the leader in inexpensive 1802 systems announces another first. Quest is the first company worldwide to ship a full size Basic for 1802 systems. A complete function Super Basic by Ron Cenko including floating point capability with scientific notation (number range $\pm 1.7E^{99}$), 32 bit integer ± 2 billion; Multi dim arrays; String arrays; String manipulation; Cassette I/O. Save and load, Basic, Data and machine language programs; and over 75 Statements, Functions and Operators.

programs. Cassette version in stock now. ROM versions coming soon with exchange privilege allowing some credit for cassette version.

- Super Basic on Cassette \$40.00**
- Tom Pittman's 1802 Tiny Basic Source listing now available. Find out how Tom Pittman wrote Tiny Basic and how to get the most out of it. Never offered before. \$19.00**
- S-100 4-Slot Expansion \$ 9.95**
- Super Monitor V.I. Source Listing \$15.00**
- Coming Soon: Assembler, Editor, Disassembler, DA/AD, Super Sound/Music, EPROM programmer, Stringy Floppy Disc System.**

Easily adaptable on most 1802 systems. Requires 12K RAM minimum for Basic and user

Same day shipment. First line parts only. Factory tested. Guaranteed money back Quality IC's and other components at factory prices.

INTEGRATED CIRCUITS

7400TTL	LM332K-5	3.95	CD4021	1.25
7400N	LM332N-5	1.50	CD4022	1.10
7400N	LM332N-5	1.50	CD4023	1.10
7400N	LM332N-5	1.50	CD4024	1.10
7400N	LM332N-5	1.50	CD4025	1.10
7400N	LM332N-5	1.50	CD4026	1.10
7400N	LM332N-5	1.50	CD4027	1.10
7400N	LM332N-5	1.50	CD4028	1.10
7400N	LM332N-5	1.50	CD4029	1.10
7400N	LM332N-5	1.50	CD4030	1.10
7400N	LM332N-5	1.50	CD4031	1.10
7400N	LM332N-5	1.50	CD4032	1.10
7400N	LM332N-5	1.50	CD4033	1.10
7400N	LM332N-5	1.50	CD4034	1.10
7400N	LM332N-5	1.50	CD4035	1.10
7400N	LM332N-5	1.50	CD4036	1.10
7400N	LM332N-5	1.50	CD4037	1.10
7400N	LM332N-5	1.50	CD4038	1.10
7400N	LM332N-5	1.50	CD4039	1.10
7400N	LM332N-5	1.50	CD4040	1.10
7400N	LM332N-5	1.50	CD4041	1.10
7400N	LM332N-5	1.50	CD4042	1.10
7400N	LM332N-5	1.50	CD4043	1.10
7400N	LM332N-5	1.50	CD4044	1.10
7400N	LM332N-5	1.50	CD4045	1.10
7400N	LM332N-5	1.50	CD4046	1.10
7400N	LM332N-5	1.50	CD4047	1.10
7400N	LM332N-5	1.50	CD4048	1.10
7400N	LM332N-5	1.50	CD4049	1.10
7400N	LM332N-5	1.50	CD4050	1.10
7400N	LM332N-5	1.50	CD4051	1.10
7400N	LM332N-5	1.50	CD4052	1.10
7400N	LM332N-5	1.50	CD4053	1.10
7400N	LM332N-5	1.50	CD4054	1.10
7400N	LM332N-5	1.50	CD4055	1.10
7400N	LM332N-5	1.50	CD4056	1.10
7400N	LM332N-5	1.50	CD4057	1.10
7400N	LM332N-5	1.50	CD4058	1.10
7400N	LM332N-5	1.50	CD4059	1.10
7400N	LM332N-5	1.50	CD4060	1.10
7400N	LM332N-5	1.50	CD4061	1.10
7400N	LM332N-5	1.50	CD4062	1.10
7400N	LM332N-5	1.50	CD4063	1.10
7400N	LM332N-5	1.50	CD4064	1.10
7400N	LM332N-5	1.50	CD4065	1.10
7400N	LM332N-5	1.50	CD4066	1.10
7400N	LM332N-5	1.50	CD4067	1.10
7400N	LM332N-5	1.50	CD4068	1.10
7400N	LM332N-5	1.50	CD4069	1.10
7400N	LM332N-5	1.50	CD4070	1.10
7400N	LM332N-5	1.50	CD4071	1.10
7400N	LM332N-5	1.50	CD4072	1.10
7400N	LM332N-5	1.50	CD4073	1.10
7400N	LM332N-5	1.50	CD4074	1.10
7400N	LM332N-5	1.50	CD4075	1.10
7400N	LM332N-5	1.50	CD4076	1.10
7400N	LM332N-5	1.50	CD4077	1.10
7400N	LM332N-5	1.50	CD4078	1.10
7400N	LM332N-5	1.50	CD4079	1.10
7400N	LM332N-5	1.50	CD4080	1.10
7400N	LM332N-5	1.50	CD4081	1.10
7400N	LM332N-5	1.50	CD4082	1.10
7400N	LM332N-5	1.50	CD4083	1.10
7400N	LM332N-5	1.50	CD4084	1.10
7400N	LM332N-5	1.50	CD4085	1.10
7400N	LM332N-5	1.50	CD4086	1.10
7400N	LM332N-5	1.50	CD4087	1.10
7400N	LM332N-5	1.50	CD4088	1.10
7400N	LM332N-5	1.50	CD4089	1.10
7400N	LM332N-5	1.50	CD4090	1.10
7400N	LM332N-5	1.50	CD4091	1.10
7400N	LM332N-5	1.50	CD4092	1.10
7400N	LM332N-5	1.50	CD4093	1.10
7400N	LM332N-5	1.50	CD4094	1.10
7400N	LM332N-5	1.50	CD4095	1.10
7400N	LM332N-5	1.50	CD4096	1.10
7400N	LM332N-5	1.50	CD4097	1.10
7400N	LM332N-5	1.50	CD4098	1.10
7400N	LM332N-5	1.50	CD4099	1.10
7400N	LM332N-5	1.50	CD4100	1.10

ELECTRONICS

RESISTORS 1/2 watt 5%	
10 per type 100 1000 per type 017	
25 per type 025 350 piece pack	
100 per type 015 350 per type 6 75	
1/2 watt 5% per type 05	
KEYBOARDS	
50 key ASCII keyboard kit \$67.50	
Fully assembled \$75.00	
80 key ASCII keyboard kit 60.00	
Fully assembled 70.00	
Enclosure 14.00	
Metall Enclosure 29.95	
LEDs	
Red T018 15	
Green, Yellow T018 20	
Yellow T018 20	
Green, Orange, Yellow, Amber, Red 20	
Clear LED Mounting Clips 851.25	
(specially red, amber, green, yellow, clear)	
CONTINENTAL SPECIALTIES in stock	
Complete line of breadboard test equip	
MAX 185 & digit Free. Cir. 3128.95	
DIK WIRE WRAP TOOLS in stock	
Portable Multimeter \$14.00	
SPECIAL PRODUCTS	
MM6018 Stopwatch/Timer 9.00	
with 18 tape spool 7.50	
PC Switch MM6018 Pushbutton 2.00	
3 pins wide 1.00	
Encoder HD0165-5 6.95	
Parallels 10GA LED \$224.00	
4 pin 4.50	
Modul 10 Trigger 4.25	
Expander Kit \$229.00	
Stimula IAC Bus CC 300 2.25	
10 MHz 3.90	
Grabber Kit \$369.00	
10 MHz 3.90	
Multi-meter \$59.95	
Close Counter Kit \$23.95	
2.5 MHz Frequency \$37.50	
30 MHz Frequency \$47.75	
Counter Kit	
2 MHz 4.50	
4 MHz 4.25	
6 MHz 4.25	
10 MHz 3.90	
18 MHz 3.90	
30 MHz 3.90	
45 MHz 3.90	
60 MHz 3.90	
75 MHz 3.90	
90 MHz 3.90	
108 MHz 3.90	
126 MHz 3.90	
150 MHz 3.90	
180 MHz 3.90	
216 MHz 3.90	
270 MHz 3.90	
324 MHz 3.90	
378 MHz 3.90	
450 MHz 3.90	
540 MHz 3.90	
630 MHz 3.90	
720 MHz 3.90	
810 MHz 3.90	
900 MHz 3.90	
1080 MHz 3.90	
1260 MHz 3.90	
1500 MHz 3.90	
1800 MHz 3.90	
2160 MHz 3.90	
2700 MHz 3.90	
3240 MHz 3.90	
3780 MHz 3.90	
4500 MHz 3.90	
5400 MHz 3.90	
6300 MHz 3.90	
7200 MHz 3.90	
8100 MHz 3.90	
9000 MHz 3.90	
10800 MHz 3.90	
12600 MHz 3.90	
15000 MHz 3.90	
18000 MHz 3.90	
21600 MHz 3.90	
27000 MHz 3.90	
32400 MHz 3.90	
37800 MHz 3.90	
45000 MHz 3.90	
54000 MHz 3.90	
63000 MHz 3.90	
72000 MHz 3.90	
81000 MHz 3.90	
90000 MHz 3.90	
108000 MHz 3.90	
126000 MHz 3.90	
150000 MHz 3.90	
180000 MHz 3.90	
216000 MHz 3.90	
270000 MHz 3.90	
324000 MHz 3.90	
378000 MHz 3.90	
450000 MHz 3.90	
540000 MHz 3.90	
630000 MHz 3.90	
720000 MHz 3.90	
810000 MHz 3.90	
900000 MHz 3.90	
1080000 MHz 3.90	
1260000 MHz 3.90	
1500000 MHz 3.90	
1800000 MHz 3.90	
2160000 MHz 3.90	
2700000 MHz 3.90	
3240000 MHz 3.90	
3780000 MHz 3.90	
4500000 MHz 3.90	
5400000 MHz 3.90	
6300000 MHz 3.90	
7200000 MHz 3.90	
8100000 MHz 3.90	
9000000 MHz 3.90	
10800000 MHz 3.90	
12600000 MHz 3.90	
15000000 MHz 3.90	
18000000 MHz 3.90	
21600000 MHz 3.90	
27000000 MHz 3.90	
32400000 MHz 3.90	
37800000 MHz 3.90	
45000000 MHz 3.90	
54000000 MHz 3.90	
63000000 MHz 3.90	
72000000 MHz 3.90	
81000000 MHz 3.90	
90000000 MHz 3.90	
108000000 MHz 3.90	
126000000 MHz 3.90	
150000000 MHz 3.90	
180000000 MHz 3.90	
216000000 MHz 3.90	
270000000 MHz 3.90	
324000000 MHz 3.90	
378000000 MHz 3.90	
450000000 MHz 3.90	
540000000 MHz 3.90	
630000000 MHz 3.90	
720000000 MHz 3.90	
810000000 MHz 3.90	
900000000 MHz 3.90	
1080000000 MHz 3.90	
1260000000 MHz 3.90	
1500000000 MHz 3.90	
1800000000 MHz 3.90	
2160000000 MHz 3.90	
2700000000 MHz 3.90	
3240000000 MHz 3.90	
3780000000 MHz 3.90	
4500000000 MHz 3.90	
5400000000 MHz 3.90	
6300000000 MHz 3.90	
7200000000 MHz 3.90	
8100000000 MHz 3.90	
9000000000 MHz 3.90	
10800000000 MHz 3.90	
12600000000 MHz 3.90	
15000000000 MHz 3.90	
18000000000 MHz 3.90	
21600000000 MHz 3.90	
27000000000 MHz 3.90	
32400000000 MHz 3.90	
37800000000 MHz 3.90	
45000000000 MHz 3.90	
54000000000 MHz 3.90	
63000000000 MHz 3.90	
72000000000 MHz 3.90	
81000000000 MHz 3.90	
90000000000 MHz 3.90	
108000000000 MHz 3.90	
126000000000 MHz 3.90	
150000000000 MHz 3.90	
180000000000 MHz 3.90	
216000000000 MHz 3.90	
270000000000 MHz 3.90	
324000000000 MHz 3.90	
378000000000 MHz 3.90	
450000000000 MHz 3.90	
540000000000 MHz 3.90	
630000000000 MHz 3.90	
720000000000 MHz 3.90	
810000000000 MHz 3.90	
900000000000 MHz 3.90	
1080000000000 MHz 3.90	
1260000000000 MHz 3.90	
1500000000000 MHz 3.90	
1800000000000 MHz 3.90	
2160000000000 MHz 3.90	
2700000000000 MHz 3.90	
3240000000000 MHz 3.90	
3780000000000 MHz 3.90	
4500000000000 MHz 3.90	
5400000000000 MHz 3.90	
6300000000000 MHz 3.90	
7200000000000 MHz 3.90	
8100000000000 MHz 3.90	
9000000000000 MHz 3.90	
10800000000000 MHz 3.90	
12600000000000 MHz 3.90	
15000000000000 MHz 3.90	
18000000000000 MHz 3.90	
21600000000000 MHz 3.90	
27000000000000 MHz 3.90	
32400000000000 MHz 3.90	
37800000000000 MHz 3.90	
45000000000000 MHz 3.90	
54000000000000 MHz 3.90	
63000000000000 MHz 3.90	
72000000000000 MHz 3.90	
81000000000000 MHz 3.90	
90000000000000 MHz 3.90	
108000000000000 MHz 3.90	
126000000000000 MHz 3.90	
150000000000000 MHz 3.90	
180000000000000 MHz 3.90	
216000000000000 MHz 3.90	
270000000000000 MHz 3.90	
324000000000000 MHz 3.90	
378000000000000 MHz 3.90	
450000000000000 MHz 3.90	
540000000000000 MHz 3.90	
630000000000000 MHz 3.90	
720000000000000 MHz 3.90	
810000000000000 MHz 3.90	
900000000000000 MHz 3.90	
1080000000000000 MHz 3.90	
1260000000000000 MHz 3.90	
1500000000000000 MHz 3.90	
1800000000000000 MHz 3.90	
2160000000000000 MHz 3.90	

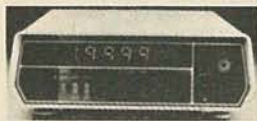

Model 178. A no-frills 4½-digit three-function DMM for production use. High accuracy and all the capability needed for most general purpose uses **\$235**



Model 179. Has all the features offered by the 178 plus TRMS AC, AC and DC current, 10µV sensitivity, and switch selectable HI-LO ohms **\$319**



Model 179-20A Has all the features of the Model 179 but also includes an additional 20A range, for applications beyond the 2A range of most DMMs **\$359**

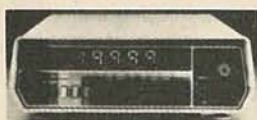

Model 177. This five-function, 4½-digit DMM has 1µV, 1mΩ, 1nA sensitivity, TRMS AC, 0.03% basic ac-accuracy and 1V analog output **\$429**

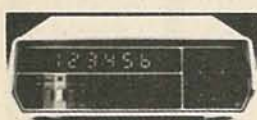

Model 191. Our top-of-the-line, 5½-digit DMM. Microprocessor control provides 0.007% basic DC accuracy. Also has pushbutton null **\$549**

Model 169. Our "macho meter" is a tough, 3½-digit bench DMM with 0.25% basic DC accuracy, large 0.6" LCD display, range and function annunciators on the display and 1-year battery life.

Model 130. Our rugged, handheld 3½-digit LCD DMM has five full functions, 0.5% basic DC accuracy, easy-to-use rotary switches, impact-resistant case, light (only 10 oz.) weight and a 10A current range.

\$149



\$99

KEITHLEY

SEND FOR OUR CATALOG

Call TOLL FREE:
NORTHEAST REGION (800) 526-2514
 N.J. CALL:
(201) 227-7720

AMPOWER INST., INC.

26 JUST ROAD, FAIRFIELD, N.J. 07006
 OUT OF NORTHEAST—CALL COLLECT

"WE SERVICE WHAT WE SELL"



Mastercharge
 BankAmericard
 and
 COD Accepted
 add \$10.00 to
 cover shipping
 handling insurance
 N.J. res. add
 5% tax.

FREE
 TEST LEADS
 WITH EVERY
 ORDER

CALL
 TODAY

**PRICES SUBJECT
 TO CHANGE**

CIRCLE 57 ON FREE INFORMATION CARD

GET IT ALL! Subscribe today, and don't miss a single issue.

When you subscribe to the best electronics magazine of all—Radio-Electronics—you're making sure that you'll get all the news of electronics you want, every month from now on. Issue after issue, you'll get equipment news, test reports, projects to build, computer technology, servicing tips and more, including regular columns on computers, solid state, hi-fi, hobbies and servicing. And every one is written by the experts, the outstanding authorities in the most exciting, fastest-growing field in the world today—electronics.



And...you save money, too, as much as \$5. off the newsstand price of Radio-Electronics when you select one of the subscription offers listed on the handy coupon. More important—you'll be assured of having your copy reserved, even if it runs out on the newsstands. You save money and time. Make sure you get all the excitement in every issue of Radio-Electronics, every month, by filling in and mailing the coupon, today.

GET THE BEST!—Radio-Electronics

40D0

(please print)

- 1 Year—12 issues ONLY \$13.00**
(You save \$2.00 off newsstand price.)
- 2 Years—24 issues ONLY \$25.00**
(Save More! \$5.00 off newsstand price.)
- Payment enclosed
- Bill me

Name _____

Address _____

City _____

State _____ Zip Code _____

Extra Shipping: Canada \$3.00 per year, all other countries \$5.00 per year.

Mail to: **Radio Electronics** SUBSCRIPTION DEPT., P.O. BOX 2520, BOULDER, COLO. 80322

Make The Shack[®] Your Parts Place!

Low Prices and New Items Every Day

100% Prime CMOS And TTL ICs



Low As **49¢** Each

Type	Cat. No.	ONLY
4001	276-2401	.69
4011	276-2411	.69
4012	276-2412	.79
4013	276-2413	.99
4017	276-2417	1.69
4020	276-2420	1.69
4021	276-2421	1.69
4023	276-2423	.69
4027	276-2427	.99
4028	276-2428	1.29
4046	276-2446	1.89
4049	276-2449	.79
4050	276-2450	.79
4066	276-2466	1.89
4070	276-2470	.79
4511	276-2447	1.69
4543	276-2491	1.99

TTL

Type	Cat. No.	ONLY
7400	276-1801	.49
7402	276-1811	.49
7404	276-1802	.49
7441	276-1804	.99
7447	276-1805	.99
7448	276-1816	.99
7473	276-1803	.49
7475	276-1806	.89
7476	276-1813	.59
7490	276-1808	.89
7492	276-1819	.89
74154	276-1834	1.39
74192	276-1831	1.19
74193	276-1820	1.19

Top Octave Synthesizer IC **6⁹⁹**

S50240. Ideal for electronic keyboard instruments! Generates 13 equally tempered notes, C₆ to C₈. CMOS-compatible square wave outputs. 11 to 16VDC, single supply. 16-pin DIP. With data. **276-1780** **6.99**

Rhythm Pattern Generator IC **5⁹⁹**

MM5871. Build your own rhythm box or drum synthesizer! 6 patterns can be used alone or in any combination. Trigger outputs for wood block, brushes, bongo, snare and bass drums. With data and applications circuits. 16-pin DIP. **276-1785** **5.99**

SALE! Resistor Packs

Save **30%** Reg. **9.95**
6⁹⁵ Each
 Pkg. of 350
Storage Box Included!

Less than 2¢ each! Precision-made resistors, popular values: 10Ω to 10 meg. Stock up!
 ½-Watt, 10% tol., 47 or more popular values. **271-601** Pkg. of 350 (Reg. 9.95) Sale **6.95**
 ¼-Watt, 5% tol., 56 or more popular values. **271-602** Pkg. of 350 (Reg. 9.95) Sale **6.95**

Why Solder? No-Strip Wire Wrapping Tool Speeds Up Wiring



12⁹⁵

For Fast, Pro-Quality Wiring

Quick-Wrap Tool.™ Ideal for daisy chain or point-to-point wiring. Cuts and strips wire. Easy to load. For 0.025" square posts. **276-1572** **12.95**

30-Gauge Kynar Wire. For above. 50' spool. Red, **278-501**. White, **278-502**. Blue, **278-503** Each **1.99**



2102L and 2114L Static RAMs
 Low As **2⁴⁹** Buy 8 2102Ls Save \$5

Type 2102L. 100% prime 1024x1 NMOS RAM. Single 5V supply. 16-pin DIP. Under 450ns. Buy 8 and save! **276-2501** **2.49** Each **8 for 14.95**

Type 2114L. 100% prime 1024x4 NMOS RAM. 18-pin DIP. Under 450ns. Single 5V supply. **276-2504** **10.95**

3½-Digit LCD Readout Multitester

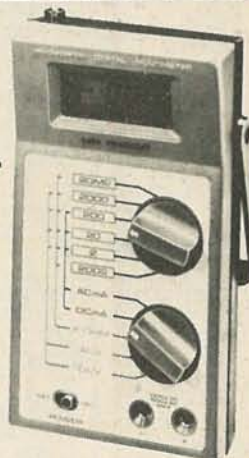

79⁹⁵

- 20 Ranges
- 10 Megohm Input
- Big 0.4" Display

Liquid crystal display is easy to read, even in sunlight. Automatic polarity and zero adjust. Over-range and low battery indicators. Voltage: 500V max. AC, 1000V max. DC. AC/DC Current: 2-20-200 mA. Resistance: 200-2k-20k-200k-2M-20MΩ. With test leads, instruction manual. 1½x3¼x6¾". Requires 9V battery or adapter. **22-198** **79.95**
AC Adapter for above. **273-1431** **4.95**



Engineer's Notebook of IC Circuits

1⁹⁹

Sold Only at Radio Shack

You'll constantly use this "must-have" source-book. Applications and circuit examples for most popular linear and digital ICs, truth tables, helpful tips, more. All circuits have been built and tested. 128 pages. **276-5001** Only **1.99**

Multipurpose, Digital and Op-Amp Edge-Card PC Boards

Save **20%** Reg. **4.99** **3⁹⁹** Each

Top quality! Low loss epoxy glass construction. All are 4½x4", with ½" grid and dual 22-contact edge. 1368 holes
Multipurpose. **276-155** Sale **3.99**
2-Voltage (Digital). **276-156** Sale **3.99**
3-Voltage (Op-Amp). **276-157** Sale **3.99**
22-Pin Dual-Edge Wire Wrapping Socket. For above. **276-1550** **3.49**

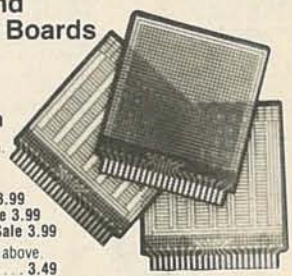

NEW! Project Case With Panel

- Flip Open Cover
- High Impact Plastic

2⁹⁹

This deluxe molded case is ideal for many projects. Easy-to-work reversible inner panel accepts switches, meter or readouts. Hinged lid has snap-lock closure. 5½x3¾x2". **270-290** **2.99**



Miniature Hobby Motors

99¢

Pkg. of 2

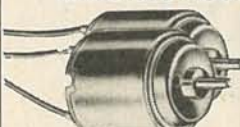

Ideal for model cars, boats and more! These PM-type motors operate with 1½ to 8VDC and deliver up to 10,000 RPM at no load. Motor: 1½x¾". Shaft: 3/16x¼". Long leads for easy hookup. Be creative at a sensible low price! **273-206** **2 for 99¢**

SALE! Resistor Packs

Save **30%** Reg. **9.95**
6⁹⁵ Each
 Pkg. of 350
Storage Box Included!

Less than 2¢ each! Precision-made resistors, popular values: 10Ω to 10 meg. Stock up!
 ½-Watt, 10% tol., 47 or more popular values. **271-601** Pkg. of 350 (Reg. 9.95) Sale **6.95**
 ¼-Watt, 5% tol., 56 or more popular values. **271-602** Pkg. of 350 (Reg. 9.95) Sale **6.95**

NEW! 12-Volt Lamp Assemblies

1⁸⁹ Pkg. of 2

Built-In Long Life Bulb
 One red, one green. Complements any project where high visibility is needed. Simple one-piece construction with snap-in mounting fits ½" diameter hole. 4" wire leads. **272-332** Pkg. of 2/1.89



SALE! Clock Cases & Bezel

Save Up to **33%**



A Digital Display Case. Ideal for clocks, counters, testers. Mounts up to four 0.6" or eight 0.3" readouts. **270-285**. Reg. 3.95 Sale **2.95**

B Auto Project Case. Mounts in or on dash. Companion enclosure to MA1003 Auto Clock Module. Accepts 3 push switches (not included). Blue lens. 3½x2½x2". **270-303**. Reg. 5.95 Sale **3.95**

C Bezel With Lens. High contrast lens, ideal for LED displays. 3¾x1" lens opening. With hardware. **270-301**. Reg. 3.95 Sale **2.95**

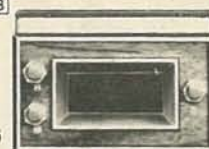

WHY WAIT FOR MAIL ORDER DELIVERY?
 IN STOCK NOW AT OUR STORE NEAR YOU!

Radio Shack[®]

A DIVISION OF TANDY CORPORATION • FORT WORTH, TEXAS 76102
 OVER 7000 LOCATIONS IN 40 COUNTRIES

Prices may vary at individual stores and dealers

CIRCLE 32 ON FREE INFORMATION CARD

APRIL 1980

119

Power Supplies

12 volts @ 13 amps

SURPLUS UNITS IN LIKE NEW CONDITION

INPUT: 115 vac 43-63 Hz
 OUTPUT: 12 vdc 0-13 amps
 REGULATION: 0.1% + 5 mV
 NL-FL, ± 0.1% ± 5mV for 10%
 Input change
 RIPPLE: 2mV RMS max., 20 mV
 P-P max.

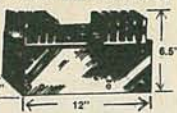

79.00 per unit

STABILITY: Typically 10 mV for eight hour period
 REMOTE SENSING, REMOTE VOLTAGE ADJUSTMENT,
 OVERLOAD PROTECTION and OVERVOLTAGE PROTECTION

ALSO AVAILABLE IN 5 VDC @ 25 AMPS \$79.00 per unit

10 MEG POTS
 • Standard 1/2 Watt Size
 • 1/4" Long Shaft
 • 1/4" Dia.
 25 For \$5.00 4 For \$1.00

22/44 EDGEBOARD CONNECTOR
 TIN SOLDER TAIL .156" x .200"

LARGE QUANTITIES AVAILABLE
 \$1.35 each 10 for \$12.50

50K AUDIO SLIDE POTS
 Knobs for Slide POTS 20¢ each
 75¢ Each
 • 3-1/2 inch long • 2-3/4 inch slide

C-H D.P.D.T. PRINTED
 CIRCUIT MINI TOGGLE
 \$1.50 each
 10 for \$12.50
 • 6 amps @ 125 vac
 • on-on

**POTTER BRUMFIELD
 4 PDT RELAYS**

• 14 pin style
 • 3 amp contacts
 • 24 volt d.c. or
 • 120 volt a.c. coil
 • Used but fully tested

\$1.25 each
 specify coil voltage
 LARGE QUANTITIES AVAILABLE

LINEAR SLIDE POTS

• approx. 1 1/4 inch long
 • 1 3/8 inch slide
 • 10K or 20K
 50¢ each SPECIFY VALUE

REED RELAYS
 9-15 VOLT D.C. LATCH
 NORMALLY OPENED
 CONTACTS: 1 amp max.
 switch — 2 amp max. carry
 BODY SIZE: approx. 1 inch
 long 1/4 inch high
 S.P.S.T. 1500 ohm coil
 \$1.15 each
 D.P.S.T. 1200 ohm coil
 \$1.30 each
 \$1.50 each
 3.P.S.T. 750 ohm coil

ALL ELECTRONICS CORP.

905 S. Vermont Ave. SEND FOR OUR FREE CATALOG
 Los Angeles, CA 90006
 (213) 380-8000
 Store & Warehouse Hours
 9 AM - 5 PM
 Monday thru Friday
 Saturday
 10 AM - 3 PM

TERMS
 • Quantities Limited
 • Min. Order \$10.00
 • Add \$2.00
 Shipping USA
 • Calif. Res. Add 6%
 • Prompt Shipping

CIRCLE 8 ON FREE INFORMATION CARD

ADVERTISING INDEX

RADIO-ELECTRONICS does not assume any responsibility for errors that may appear in the index below.

Free Information Number Page

28	AMC Sales	116
46	AP Products, Inc.	34
31	Aaron-Gavin Instruments	73
9	Active Electronics	99
—	Advance Electronics	16,78-79,110
60	Advanced Computer Products	105
8	All Electronics	120
69	Amelect, Inc.	76
13	American Antenna	Cov. 4
57	Ampower	118
63	Ancrona	116
51	B & K Precision Dynascan Corp.	85
—	Karel Barta	96
47	Bishop Graphics, Inc.	80
—	Bullet Electronics	106
55	CFR Associates	108
53	Chaney Electronics	100
—	CIE—Cleveland Institute of Electronics	18-21
—	Command Productions	96
64	Concord—Computer Components	110
26	Continental Specialties	Cov. 2
70	The Cooper Group—Electronics Div.	17
—	Dage Scientific	120
30	Delta Electronics	100
71	Deltroniks	116
49	Diamondback Electronics	106
34	Digi-Key	109
—	Digital Research Corporation	114
40	EICO	73
18	Electronic Supermarket	114
—	Electronics & Control Engineers' Book Club—McGraw Hill Book Div.	28-31
58	Enterprise Development Corp.	81
23	Fluke	7
—	Fordham Radio Supply	107
24-25	Formula International	102-103
62	Fuji-Svea	115
61	Godbout Electronics	108
—	Grantham College of Engineering	81
48	Guardian Electronics	13
100,7	Heath	15,33
52	Hickok Electrical Instruments	91
38	Hitachi-Denshi	95
—	Information Unlimited	98
27	International Electronics Unlimited	114
—	JS & A	1
11-12	Jameco Electronics	112-113
14	Jan Crystal	120
36	Kester Solder	32
—	Keithley Instruments	22-23
—	Lakeside Industries	98
3,43	Leader	25
20	MCM Audio	97
2	MTI—Mobile Training Institute	80
67,76	McKay Dymek	84,90
37	Meshna	104
56	Micro Mart	104
—	National Radio Institute (NRI)—Div. of McGraw Hill	8-11
—	National Technical Schools	86-89
16	Nesda	110
42	Netronics	36
21,22,54	O.K. Machine & Tool	26-27,38

15	onComputing (BYTE)	75
41	Optoelectronics	Cov. 3
44	PAIA	80
59	PTS Electronics	73
17	Pac-Com	73
66	Panavise	32
39	Poly Paks	104
45	QB Electronics	110
19	Quest	117
77	R & R Instrumentation	35
—	RCA	94
32	Radio Shack	119
5	Ramsey Electronics	101,111
35	Rye Industries	94,95
—	Sabtronics	2,4
—	Sheldahl	37
10	Solid State Sales	108
—	Spacecoast Research	98
6	Technical Electronics Corp.	116
68	Texas Tuner Service	84
33	Tri-Star Corp.	108
73	Trionyx	83
—	USI Corp.	96
75	Vector	92
—	VIZ Mfg. Co.	93
29	Wersi Electronics	37
4	Weston Instruments	35

FREE KIT Catalog

AUTORANGE DIGITAL CAP-METER contains KIT. Still the best for only \$74.95
Phone 415-447-3433
 Write or Phone for FREE CATALOG. Average 1 minute Saturday call is 21¢.
 TEST & EXPERIMENTER'S EQUIP.

DAGE SCIENTIFIC INSTRUMENTS
 BOX 1054R LIVERMORE CA 94550

MOVING?

Don't miss a single copy of **Radio-Electronics**. Give us:

Six weeks' notice

Your old address and zip code

Your new address and zip code

ATTACH LABEL HERE

name (please print)

address

city state zip code

Mail to: Radio-Electronics
 SUBSCRIPTION DEPT., P.O. BOX 2520,
 BOULDER, COLO. 80322

High stability crystals for frequency or time. Use the best.
 • CB
 • 2 meter
 • scanners
 • industry
 • Marine VHF
 • CB standard
 • Amateur Bands
 • General
 • Communication
 • Micro processor crystals

Send for our latest catalog. Write or phone for more details.
 Jan Crystals
 2400 Crystal Drive
 Ft. Myers, Florida 33907
 all phones (813) 956-2397

JAN CRYSTALS

When quality counts

Do not be fooled by the low prices, these brand new lab quality frequency counters have important advantages over instruments costing much more. The models 7010 and 8010 are not old counters repackaged but 100% new designs using the latest LSI state-of-the-art circuitry. With only 4 IC's, our new 7010 offers a host of features including 10 Hz to 600 MHz operation, 9 digit display, 3 gate times and more. This outperforms units using 10-15 IC's at several times the size and power consumption. The older designs using many more parts increase the possibility of failure and complexity of troubleshooting. Look closely at our impressive specifications and note you can buy these lab quality counters for similar or less money than hobby quality units with TV xtal time bases and plastic cases!

Both the new 7010 and 8010 have new amplifier circuits with amazingly flat frequency response and improved dynamic range. Sensitivity is excellent and charted below for all frequencies covered by the instruments.

Both counters use a modern, no warm up, 10 MHz TCXO [temperature compensated xtal oscillator] time base with external clock capability - no economical 3.579545 MHz TV xtal.

Quality metal cases with machine screws and heavy gauge black anodized aluminum provide RF shielding, light weight and are rugged and attractive - not economical plastic.

For improved resolution there are 3 gate times on the 7010 and 8 gate times on the 8010 with rapid display update. For example, the 10 second gate time on either model will update the continuous display every 10.2 seconds. Some competitive counters offering a 10 second gate time may require 20 seconds between display updates.

The 7010 and 8010 carry a 100% parts and labor guarantee for a full year. No "limited" guarantee here! Fast service when you need it too, 90% of all serviced instruments are on the way back to the user within two business days.

We have earned a reputation for state-of-the-art designs, quality products, fast service and honest advertising. All of our products are manufactured and shipped from our modern 13,000 square foot facility in Ft. Lauderdale, Florida.

When quality counts...count on Optoelectronics.

CIRCLE 41 ON FREE INFORMATION CARD

MODEL 7010 600 MHz



MODEL 8010 1 GHz



- 100% U.S.A. FACTORY ASSEMBLED
- 100% PARTS & LABOR YEAR GUARANTEE
- CERTIFIED NBS TRACEABLE CALIBRATION
- EXTERNAL CLOCK INPUT

- DISPLAY HOLD FUNCTION
- 9 RED LED DIGITS 4" HIGH
- 1 Hz RESOLUTION
- 0.1 PPM 10 MHz TCXO TIME BASE

- LAB/PORTABLE-AC ADAPTER INCLUDED
- 1 MEGOHM & 50 OHM INPUTS
- STATE-OF-THE-ART LSI DESIGNS
- COMPREHENSIVE USER MANUAL PROVIDED

• COMPACT SIZES—7010- 1-3/4" Hx4-1/4" Wx5-1/4"D 8010- 3" Hx7-1/2" Wx6-1/2"D

MODEL	\$ PRICE	RANGE 10Hz to	LED DIGITS	SENSITIVITY			HI-Z INPUT 10Hz - 60 MHz	GATE TIMES	RESOLUTION			TCXO TIME BASE		EXT CLOCK INPUT	NI-CAD BATT PACK
				25-250 MHz	250-450 MHz	450 MHz-1GHz			12 MHz	60 MHz	MAX. FREQ.	20°-40° C	FREQ.		
7010	145.00	600 MHz	9	5-20 mV	10-30 mV	20-40 mV to 600 MHz	1-10 mV	[3] .1, 1, 10 SEC	.1Hz	1 Hz	10 Hz 600 MHz	1 PPM 0.1 PPM	10 MHz	YES OPTION \$25.	YES OPTION \$15.
7010.1	225.00														
8010	325.00	1 GHz	9	1-10 mV	5-20 mV	10-25 mV	1-10 mV	[8] .01-20 SEC	.1 Hz	1 Hz	10 Hz 1 GHz	1 PPM 0.1 PPM	10 MHz	YES STD	YES OPTION \$39.
8010.1	405.00														

* Has precision 0.1 PPM TCXO time base.

MODEL 7010

- #7010 600 MHz Counter - 1 PPM TCXO \$145.00
- #7010.1 600 MHz Counter - 0.1 PPM TCXO \$225.00

OPTIONS

- #NI-Cad-701 Ni-Cad Battery Pack & charging circuitry
Installs inside unit \$ 15.00
- #EC-70 External Clock input, 10 MHz \$ 25.00
- #CC-70 Carry Case, Padded Black Vinyl \$ 8.95

MODEL 8010

- #8010 1 GHz Counter - 1 PPM TCXO \$325.00
- #8010.1 1 GHz Counter - 0.1 PPM TCXO \$405.00
- #8010.1-13 1.3 GHz Counter - 0.1 PPM TCXO \$495.00

OPTIONS

- #NI-Cad-801 Ni-Cad Battery Pack & charging circuitry
Installs inside unit \$ 39.00
- #CC-80 Carry Case, Padded Black Vinyl \$ 9.95

ACCESSORIES

- #TA-100 Telescope Ant with Right Angle BNC \$ 9.95
- #P-100 Probe, 50 ohm, 1x \$13.95
- #P-101 Probe, Lo-Pass, Audio Usage \$16.95
- #P-102 Probe, Hi-Z, General Purpose \$16.95



SELECTED PRICE INCREASES
EFFECTIVE APRIL 1, 1980
PLEASE CONSULT FACTORY



Optoelectronics inc

5821 N.E. 14th Avenue, Fort Lauderdale, Florida 33334

1-800-327-5912

FROM FLORIDA (305) 771-2051/2

TERMS: Orders to U.S. and Canada, add 5% for shipping, handling and insurance to a maximum of \$10.00. All other orders add 10%. D. collection fee \$1.00. Orders under \$15.00 add extra \$1.00 handling. Regular checks must clear before order is shipped. Florida residents add 4% sales tax.

In one year our **K40™** antenna has become the largest selling CB antenna in the world!

1. It's the most expensive ...

2. It's made better...

3. It's proven best!

\$42.50

suggested retail

And when you pay more, you expect more!

MORE PERFORMANCE:

The K40 is guaranteed to transmit further or receive clearer than any antenna it replaces. We know it will. We've tested it with 771 CB'ers just like you for one year.

MORE FLEXIBILITY:

You can fit your K40 to any mounting surface. It will fit any vehicle you'll ever own! That includes choppers, dune buggies, gutters, mirror mounts, luggage racks, trunks, hatchbacks, through roofs, semis, pick ups and RV's.

MORE QUALITY:

It's not imported. It's not made in Taiwan, Korea or Japan. It's American made in an American town. It's made with better materials that cost more and by professional people we pay more. And we designed it right here in the U.S.A.

*Including optional mounts at extra cost.

... This Antenna is so DYNAMITE you receive a ...

DOUBLE GUARANTEE

GUARANTEE I: The K-40 will transmit farther and receive more clearly than the antenna it replaces or the customer will receive a prompt and full refund from the Registered K-40 Dealer who installed and tuned it.

GUARANTEE II: Unconditionally guaranteed for 12 months. Guaranteed against cracking, chipping, or rusting. Guaranteed against mechanical failure. Guaranteed against electrical failure. Guaranteed against accidental breakage. No exclusions. No gimmicks. For a full 12 months.



...Here's what the leading CB publications said.

CB TIMES: "... it's not often that a product bursts onto the market scene, dominates and improves CB'ing for everyone. American Antenna and the K40 are doing it—repeated tests showed the K40 could out-perform the major competitive brands."

RADIO-ELECTRONICS: "The results of our tests showed that, in three different positions of the monitoring receiver, the model K40 equaled or out-performed the competitive antenna. Apparently, American Antenna's advertising is not merely Madison Avenue showmanship."

PERSONAL COMMUNICATIONS: "... an impressive 95% of the trials, the K40 out-performed the existing mobile antennas. We had to try one for ourselves. "... in every case, the K40 either equaled or out-performed its competitor.

"No ifs, ands, or buts! The K40 Antenna from American Antenna would have to be just about the best antenna around.

CB MAGAZINE: "Introduced in October, 1977, the K40 quickly became the top seller and in mid 1978, became the number one selling antenna in the nation."

...Here's what CB'ers all across the country said.

ANTENNA SPECIALISTS: "... truck driver and CB'er for 10 years ... 50% further than my M410 'Big Momma'."

—J.H. Collett, 207 McFee, Bastrop, LA

AVANTI: "I'm an electronic technician with a Second Class FCC license ... I was able to transmit 70% further and tune the SWR 75% lower than my Avanti."

—H.R. Castro, VRB, Monserrate D-67, Salinas, Puerto Rico

PAL: "... 20% better in transmission and reception than my 5/8 wave Pal Firestick."

—John A. Blum, Box 446, Zellenople, PA

SHAKESPEARE: "... I've been a CB'er for three years and the K40 is the best I've ever had. Better in reception and transmission than my Shakespeare."

—H. Bachert, Jr., 15 King Rd., Park Ridge, NJ

HUSTLER: "Compared to my Hustler XBLT-4, the K40 can consistently transmit 40% further and the reception was better. The K40 is the perfect way to complete a CB system."

—Jerome R. Brown, 7800 S. Linder, Burbank, IL



(SPECIAL NOTE) IF YOU'RE A BEGINNER:

Our K40 Dealers will be happy to sell you any of the older style and less expensive antennas that are great bargains for any beginning CB'er.

K40 POWER!

AMERICAN ANTENNA
ELGIN, IL 60120

© COPYRIGHT AMERICAN ANTENNA 1979

... Sold exclusively by 3500 American K40 Dealers throughout the U.S. & Canada.

CIRCLE 13 ON FREE INFORMATION CARD