

# POPULAR MECHANICS SHOP NOTES

For

1921

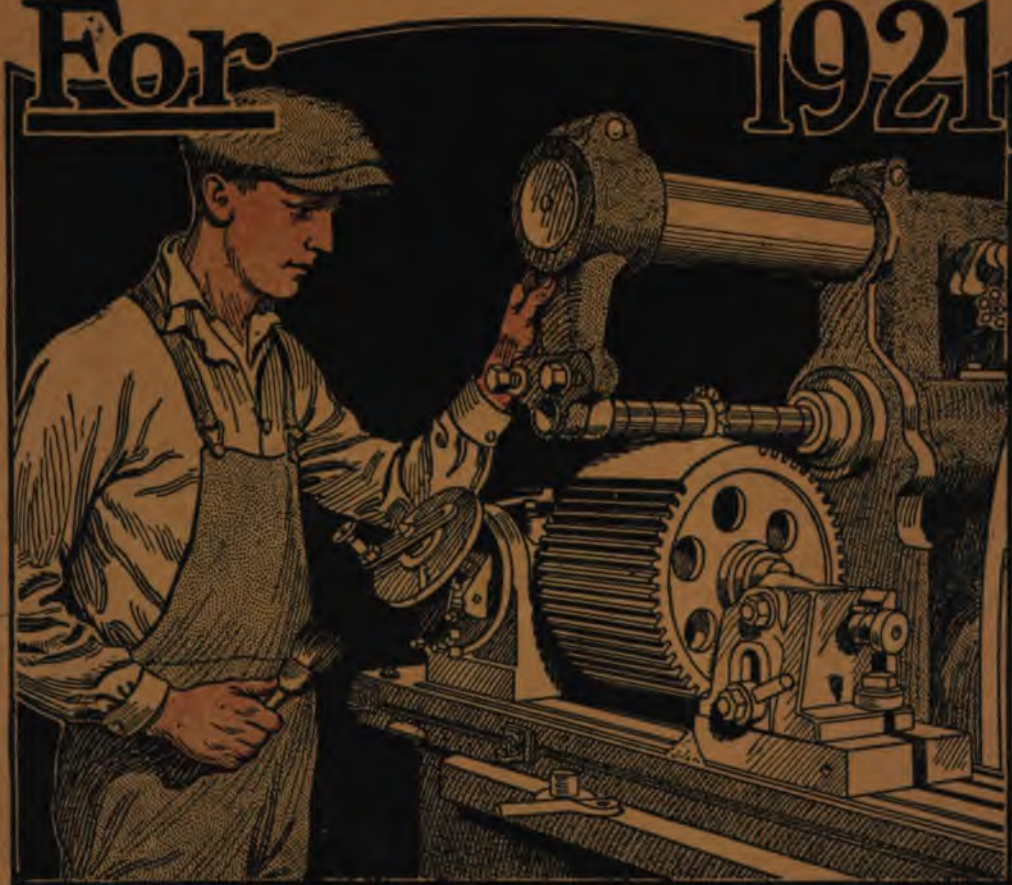

VOL. XVII

## EASY WAYS TO DO HARD THINGS

POPULAR MECHANICS

CHICAGO

POPULAR MECHANICS

# SHOP NOTES

FOR

1921

---

EASY WAYS TO DO HARD THINGS

---

OF DAILY USE  
TO EVERY MECHANIC

---

*Vol. XVII—Table of Contents, Pages 3511-3523*

---

POPULAR MECHANICS, CHICAGO

COPYRIGHT, 1920, BY H. H. WINDSOR

# Shop Notes

## A Half-Ton Traveling Crane

By J. V. ROMIG

THERE are many places where a small traveling crane can be used to advantage, such as small ice-making plants, shipping rooms, storage warehouses, etc., but where the cost of such an aid is a very big factor; to such places, the crane illustrated will prove a boon, as the various parts required in the assembly are usually to be found in the shop.

First, plan the exact location of the track; its length, width, and height from the floor; with these dimensions at hand, proceed to lay out the design of the various pieces. The dimensions shown in the drawing are suitable for a crane up to 6-ft. span. The channels which form the bridge are placed with their webs out, and the flanges about  $\frac{3}{4}$  in. apart. The end-pieces are of 4 by 2-in. angle iron, with 1-in. holes drilled in the 4-in. flange for the trolley-wheel pins. These endpieces are fastened to the channel irons by braces made from 6 by 6-in. angle iron, 3 in. wide, one leg of the brace being bolted to the channel iron, while the other is clamped to the endpiece by the nut of the trolley pin. The trolley wheels, car-

riage rolls, trolley pins, and roll pins are turned from cold-rolled steel to the dimensions shown, the roll pins having a small feather key in the center which fits a keyway in the carriage plate. The carriage plate is made of  $\frac{1}{2}$ -in. boiler plate, drilled for the roll pins and for the hoist hook.

When the crane has been assembled, measure the gauge of the trolley wheels, and put up stringers corresponding to this measurement, to carry the tracks. The track members are made up of  $\frac{3}{4}$ -in. square machine steel, bolted to pieces of 2-in. angle iron, which in turn are bolted to the  $\frac{1}{2}$  by 3-in. hangers. These hangers are fastened to the stringers by lag screws or bolts, and are braced as shown, by  $\frac{3}{8}$ -in. tie bolts; the hangers should be spaced about 3 ft. apart. The crane is completed by the addition of a  $\frac{1}{2}$ -ton hoist. By seeing that the track is level, and the trolley wheels and carriage rolls oiled at frequent intervals, a light-running crane will be the result, which will more than repay the labor of building it, by the saving effected in handling costs.

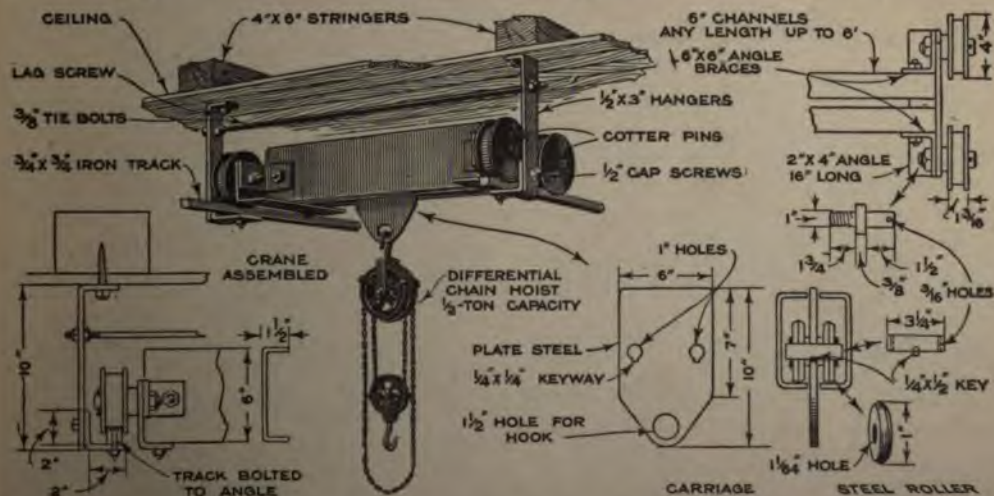

A Light-Running Crane, Which will Add Greatly to the Ease of Handling Materials in a Small Shop, is Easily Constructed of Available Materials



### A Lavatory for the Bench or Boat

The lack of space in a small shop or on a boat need not prevent having a permanent lavatory or folding washbasin, which

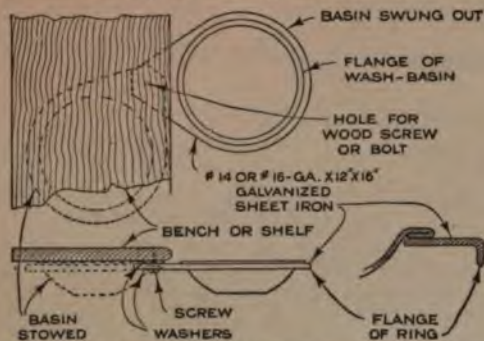

In a Small Shop or Boat a Permanent Mounting for a Washbasin will Provide at Least a Part of the Convenience to be Had in More Luxurious Quarters

can be built at small cost. It should be placed under some convenient shelf, locker, or bench, which is about as high as a common washbowl would be from the floor, and a little wider than a common enamel basin. A piece of galvanized sheet iron forms a ring which supports a common washbasin. The iron ring should have a flange bent downward all around the edge, for greater strength, and should have a hole drilled in the projecting portion at one side, through which a  $\frac{1}{4}$ -in. bolt or wood screw extends up into the bench or shelf. When not in use, the basin can thus be swung around out of sight. Such an arrangement has been found very satisfactory on small steam-boats.

### Indicator for Chucking Lathe Work

A tester, to determine whether a piece to be turned or machined in a lathe is chucked accurately, is shown in the drawing. An old lathe tool is drilled, and a center pin is driven into one end, as

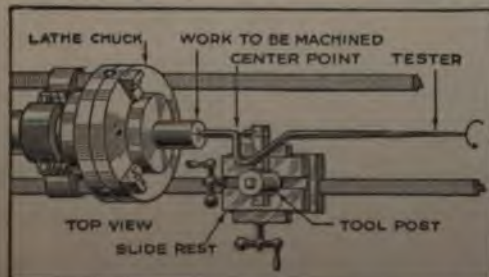

A Simple Testing Tool That Shows Whether Work Held in a Lathe Chuck has been Accurately Centered or Not

shown. A steel rod, about 15 in. long, is filed or turned to a tapering point at one end, the other end of the rod being provided with a point similar to that of a lathe center; a right-angle bend is made about 2 in. from the center-pointed end of the rod. A punch mark is made at the shoulder and a center hole is made to take the center point on the lathe tool; the rod is then bent as shown. To use this tester, the tool is set in the tool post, after the piece to be machined has been placed in the chuck. The point of the tester is set in the center hole of the work and the center in the tool post is placed in the center hole provided at the shoulder of the tester, as shown in the drawing. When the lathe spindle turns, the end of the tester will remain motionless if the work is properly chucked, but if the chucking is not true, it can be detected by the movement of the pointed end.—G. A. Luers, Washington, D. C.

### Tool Holder Saves High-Speed Steel

On account of the cost of high-speed steel, all possible means are resorted to to save it, and a single tool bit is employed until it is too small for further use. One of the most effective means of getting the utmost service from a tool bit is afforded by the holder shown in the drawing. This holder is made, according to the dimensions given, from cold-

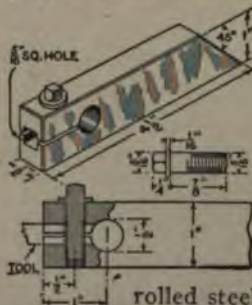

rolled steel, and is designed to take a  $\frac{1}{16}$ -in. bit. After the  $\frac{1}{2}$ -in. hole has been drilled, the square hole is formed by drilling, first with a  $\frac{3}{32}$ -in. drill and then filing; afterward, the tool is slitted, as shown, through the center of the square hole. A  $\frac{1}{4}$ -in. hole is drilled and tapped to take the setscrew which is made, to the dimensions given in the drawing, from cold-rolled steel, whereupon both the holder and setscrew should be casehardened. In use, the tool bit is inserted into the square hole where it is rigidly held by compression when the setscrew is drawn up. Tool bits as short as  $\frac{5}{8}$  in. can be satisfactorily used with this holder.

Hot valve handles wrapped with rope permit manipulation without burning the hands.



# Shop Notes

## A Half-Ton Traveling Crane

By J. V. ROMIG

THERE are many places where a small traveling crane can be used to advantage, such as small ice-making plants, shipping rooms, storage warehouses, etc., but where the cost of such an aid is a very big factor; to such places, the crane illustrated will prove a boon, as the various parts required in the assembly are usually to be found in the shop.

First, plan the exact location of the track; its length, width, and height from the floor; with these dimensions at hand, proceed to lay out the design of the various pieces. The dimensions shown in the drawing are suitable for a crane up to 6-ft. span. The channels which form the bridge are placed with their webs out, and the flanges about  $\frac{3}{4}$  in. apart. The end-pieces are of 4 by 2-in. angle iron, with 1-in. holes drilled in the 4-in. flange for the trolley-wheel pins. These endpieces are fastened to the channel irons by braces made from 6 by 6-in. angle iron, 3 in. wide, one leg of the brace being bolted to the channel iron, while the other is clamped to the endpiece by the nut of the trolley pin. The trolley wheels, car-

riage rolls, trolley pins, and roll pins are turned from cold-rolled steel to the dimensions shown, the roll pins having a small feather key in the center which fits a keyway in the carriage plate. The carriage plate is made of  $\frac{1}{2}$ -in. boiler plate, drilled for the roll pins and for the hoist hook.

When the crane has been assembled, measure the gauge of the trolley wheels, and put up stringers corresponding to this measurement, to carry the tracks. The track members are made up of  $\frac{3}{4}$ -in. square machine steel, bolted to pieces of 2-in. angle iron, which in turn are bolted to the  $\frac{1}{2}$  by 3-in. hangers. These hangers are fastened to the stringers by lag screws or bolts, and are braced as shown, by  $\frac{3}{8}$ -in. tie bolts; the hangers should be spaced about 3 ft. apart. The crane is completed by the addition of a  $\frac{1}{2}$ -ton hoist. By seeing that the track is level, and the trolley wheels and carriage rolls oiled at frequent intervals, a light-running crane will be the result, which will more than repay the labor of building it, by the saving effected in handling costs.

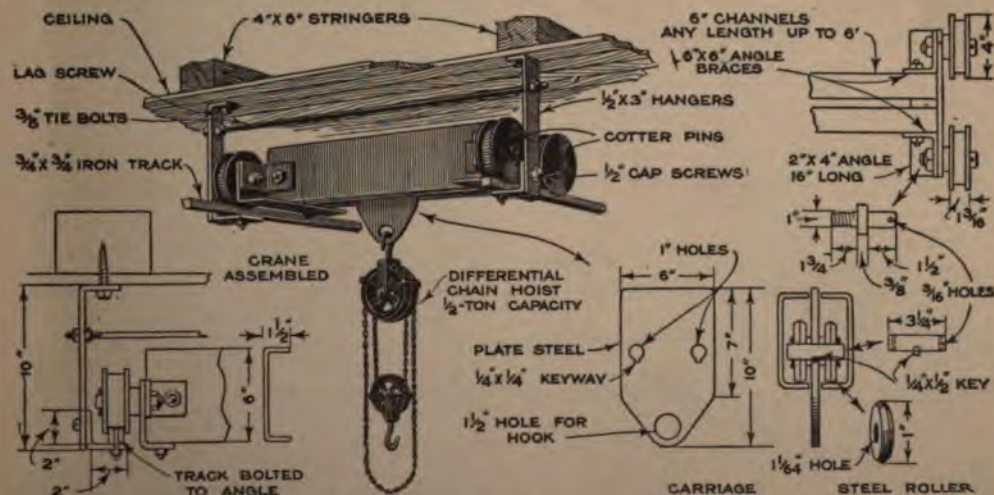

A Light-Running Crane, Which will Add Greatly to the Ease of Handling Materials in a Small Shop, is Easily Constructed of Available Materials



### Swinging Rule an Aid in Perspective Drawing

A time and labor-saving rule, or straight-edge, for projecting perspective drawings, is made from a strip of transparent celluloid,

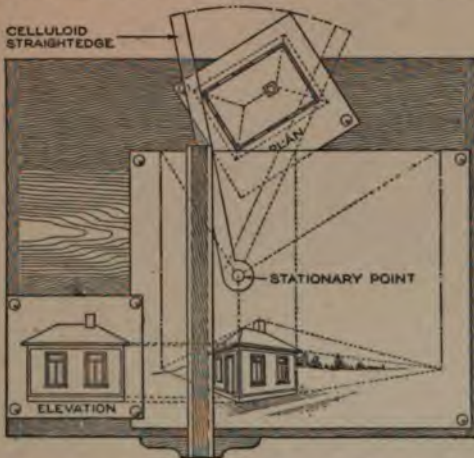

Draftsmen Who have Made Perspective Drawings by the Time-Honored but Tedious Method Commonly Used will Appreciate the Merit of a Swinging Perspective Rule

loid, or cardboard, as shown in the drawing. The stationary point is located as indicated, and on a line with the edge of the rule; the device is held to the drawing board, at the proper position, by a thumb-tack inserted at the stationary point.

To transfer any point on the plan onto the perspective, all that is necessary is to swing the rule until its working edge touches the desired point, and to hold it there while the T-square is moved until it intersects the working edge of the swinging rule, as indicated.—Henry Simon, Laguna Beach, Calif.

### Inserting a Tight Key or Feather

In some machines it is necessary to use a key that is inserted in the plain part of the shaft, away from the end, and to have the key, or feather, fixed in place. Such a key can be made by the following method:



same size and shape as the keyway, including the beveled ends. The key will, of course, be too long to insert. Bend

Cut the keyway as usual, but undercut the ends, as shown in the sketch. Make a soft-steel key of exactly the

it, as shown, until it can be dropped or tapped into the keyway, and straighten it out in place with a few sharp hammer blows. If properly made, the key will hold very firmly.

It is necessary to allow a little material for finishing up the key after it has been hammered home. Do not try this plan for a very short key, as the bend will not straighten out properly.—Howard Greene, New York, N. Y.

### Sweeping Chimney with a Small Tree

When a chimney or smokestack becomes so fouled with soot that its efficiency is impaired, it can be easily swept out with a small fir or spruce tree. If the chimney has a clean-out door at the bottom, a rope can be lowered from the top until the end can be drawn through the opening; the tree is tied to the middle of the rope and pulled up and down until the flue has been cleaned. In case there is no opening at the bottom, a stone, or other weight heavy enough to drag the tree to the bottom, can be tied to the tree. A good, strong rope should always be used, and the tree securely fastened so as to prevent its becoming caught in the chimney.—J. A. Stevens, East Boothbay, Me.

### To Prevent Iridescent Marks on Negatives

When using a broken negative that has been bound on a piece of glass with gummed tape, iridescent marks are often the cause of a lot of trouble, especially if the negative is used in the enlarging camera, when making a transparency for reproduction. It has been found that these marks can be easily eliminated by proper treatment. Scrape about  $\frac{1}{8}$  in. of the binding from the edge, and trim a match stick to a wedge; the thin edge is



inserted between the negative and the glass, to just the depth of the binding strip. Then trim the wood flush with the edge. This treatment allows air to enter between the negative and glass and disperses the iridescent marks. Sometimes it is necessary to do this on two or more sides, depending upon the size of the plate, and the number and position of the marks.—Wm. Underwood, Tunnel Hill, Ill.



### Blasting with Gasoline Vapor

That gasoline vapor can be used for dislodging an obstruction in an underground sewer pipe was discovered in an emergency that would otherwise have necessitated exploring underground in about 15 ft. of frozen earth. A single-cylinder, 5-hp. gasoline engine was connected to the rear wheel of a motor truck by a belt, both rear wheels being jacked off the ground. The exhaust from the engine was piped into a manhole, and the opening made air-tight by stuffing it with old burlap, cement, stones, and wood. The truck was then started and the gas engine was operated as a pump for some minutes, so that a mixture of gasoline and air was pumped into the sewer. The timer was arranged so that the engine would fire when the exhaust port was open. After pumping the inflammable vapor into the sewer for about 15 minutes the mixture was fired and the obstruction was blown out without damage to the sewer.

### Narrow Gate Useful on Farm

There are places, in fences and corrals, about every farm, where a gate would save much time and many steps. If two posts are set a little more than a foot apart, the average man can slip through sidewise easily, but cows and other stock cannot pass. These posts will not require other bracing than a piece of strap iron or timber spiked across the top. Such a gate is often most useful at the corner of a fence, or where a fence joins a building. If placed in the middle of a barbed-wire fence, the wire can be first stretched across the opening, and after it has been secured to the posts with staples, it can be cut in the center and the ends wrapped around the posts. Where small stock is kept, a single bar, placed diagonally across the opening and pivoted at the bottom, will keep the animals from passing; a strap-iron hook supports the upper end of the bar.

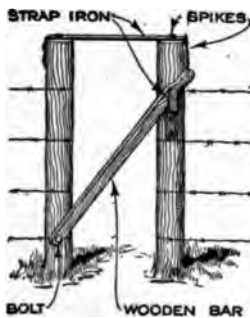

Hardened paint and varnish can be removed from paintbrushes with vinegar.

### Tool for Handling Wristpin Bushings

An easily made and effective tool for inserting or extracting piston wristpin bushings

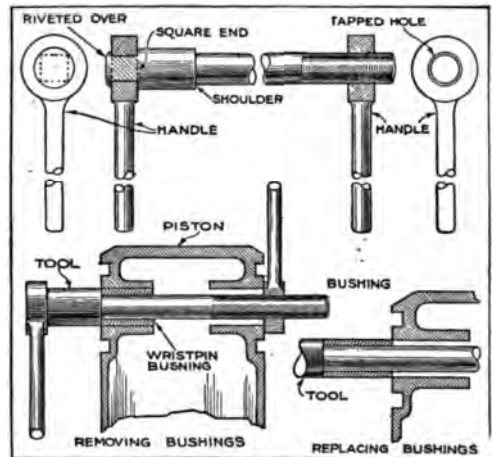

An Easily Made and Effective Tool for Inserting and Extracting Piston Wristpin Bushings: This Tool Does the Work of an Arbor Press without the Expense

bushings is shown in the drawing. This tool is made from a piece of steel rod which is turned to form a threaded shaft having a shoulder and a square end for a handle which is attached to the end of the tool by riveting the end after the handle has been put in place. The threaded end of the tool screws into a threaded collar which is welded to a handle, as indicated.

To remove a bushing, the tool is placed through the piston, and the collar is screwed up, forcing the bushing to the center of the piston and out of the boss. To insert a bushing, it is slipped over the tool, and the end is run through the piston; when the threaded collar is turned up, the new bushing is forced into the boss until it clears the outside of the piston.

### Tightening Wooden Spokes

Loose spokes and felloes of wooden wheels can be permanently tightened without shrinking the tires. Soak the entire wheel in water until the wood is swollen and the spokes and rims are tight. After this has been done, immerse the wheel, either wholly, or a section at a time, into boiling linseed oil. The oil will drive the water out of the pores and take its place, and, on drying, the oil will remain in the wood. This process will require about  $\frac{1}{2}$  gal. of oil for a set of small-size automobile wheels.

## Variable Electric Heater for Three-Wire Circuit

By ELMER A. CRANE

A CHARACTERISTIC feature of electric heaters is that they are highly efficient, that is, nearly all of the electrical

used to hold the slabs together. Each resistance coil is supported by passing its free ends through holes in the slabs, and connecting the ends together,

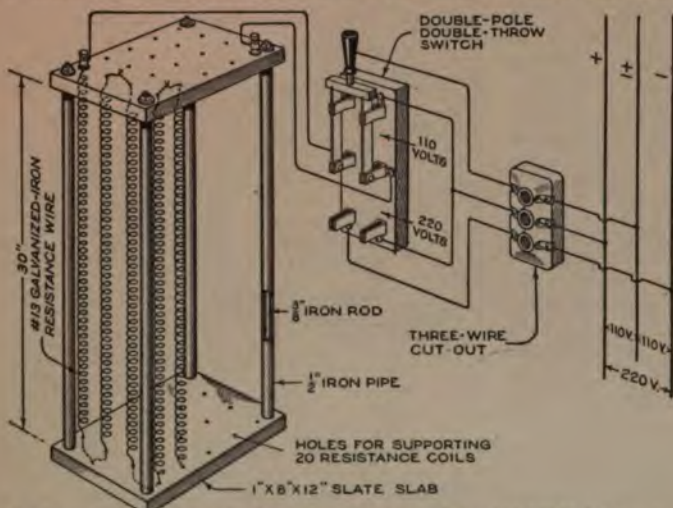

An Electric Heater Designed for Use on a Three-Wire 110-120-Volt Circuit: In Mild Weather It can be Connected into the 110-Volt Circuit, and in Severe Weather Twice the Heat is Developed by Switching It to the 220-Volt Circuit

energy which goes into the heater reappears as heat. A homemade heater, arranged for operation on a 110-220-volt, three-wire circuit, is described in this article.

The drawing shows the constructional details of this heater. The slate slabs are drilled as shown, for the accommodation of the resistance coils; iron tie-rods and pipe spacers at each corner of the slabs are

(Copyright, All Rights Reserved)

connecting the ends together, all of the coils being connected in series. Approximately 1,000 ft., or 25 lb., of No. 13 gauge galvanized-iron wire will be required for the resistance coils. The coils are connected to the source of current by suitable binding posts mounted on the upper slab, as shown.

In mild weather, the heater may be connected into the 110-volt circuit by throwing the double-pole, double-throw switch to the upper position, as in the drawing, and in severe weather, it can be connected into the 220-volt circuit by throwing the switch to the lower position; the heat developed in the latter case is twice that when connected with the 110-volt circuit. As suggested in the drawing, the apparatus is protected against overload by a three-wire cut out.

Such a heater was used with excellent results in a warehouse room 12 by 13 by 20 ft., having two windows and a glazed door, maintaining a comfortable temperature even during severe weather.

### Gauge for Setting Lathe Tool

A handy gauge to be used on the lathe tailstock for setting the tools, is shown in the drawing.

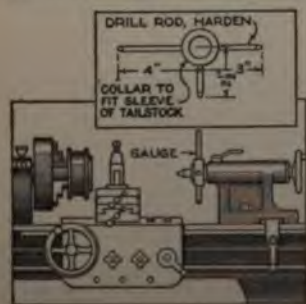

held to very close limits. As shown, it consists of a steel ring, ground to a fit on the tailstock sleeve, with holes drilled

radially around the circumference, into which are driven the rods used as gauges.

The length of these rods will, of course, depend upon the job; in use, the tool is run in until it just touches the rod for the particular size required, and the cut will reduce the piece to the proper size.

### Cutting Reinforcements in Concrete Structures

Reinforcing in concrete beams, walls, etc., should never be cut if it is possible to avoid it. The reinforcement is inserted in the concrete for the purpose of giving the concrete the necessary tensile strength, and, while there is usually an ample factor of safety used in computing the amount of reinforcing necessary, it is best, when it is necessary to cut through a beam or wall, to have the work super-



vised by a competent construction engineer, so that the structure may not be weakened beyond the safety mark. Of course, this does not apply to inserts set in the concrete for the purpose of bolting up hangers for line and countershafting, or where the concrete is used as a fire-proof coating for solid steel I-beams.

### Hangings Wallpaper over Grease Spot

Everyone who has tried it knows that wallpaper hung over an uncovered grease spot will absorb the grease and show an ugly stain, and paperhangers are often put to considerable trouble and expense by the necessity of sizing such spots before they can be papered. A simple dodge, in such cases, is to paste over the spot a piece of ordinary butcher's paper, at least twice the size of the spot to be covered.

### Power Feed for Drilling in Lathe

An attachment which does away with the necessity of feeding a drill by hand, when drilling in the lathe, is made from a

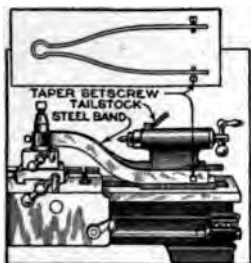

piece of 1 1/4 by 1/4-in. cold-rolled steel. The steel is bent as shown in the drawing, to fit around the toolpost, to which it is clamped by a setscrew; the two ends are brought down and fastened to

the tailstock setscrews.

In use, a tool holder is placed in the toolpost, and the toolpost tightened, the attachment is then secured in position, and the center run in to meet the drill; the carriage feed does the rest.

### Restoring Crossed Threads

After the crossed threads of an important part of a machine have been re-threaded to function properly, they are quite likely to turn hard and have a tendency to jump back and recross. Both of these handicaps can be overcome with a little valve-grinding compound. Apply the compound to the female threads and turn the threads into one another in the same fashion as in valve grinding: a back-and-forth turning, with a little gain on the forward motion at each turn. The compound should be thoroughly removed after the threads work properly.

### Rack Keeps Planer Bolts in Order

The rack shown in the drawing for holding the T-bolts used on planers, and

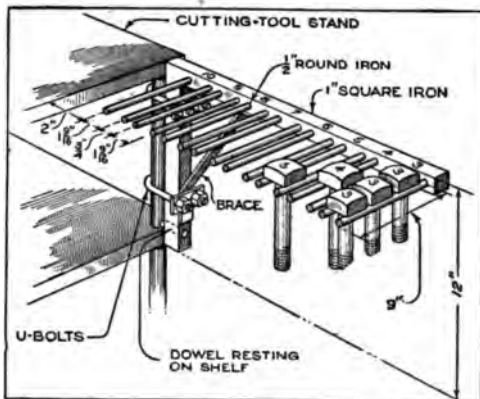

A Rack for Holding Planer Bolts Eliminates the Usual Search through a Box of Unsorted Bolts for One of the Proper Length

other metal-working machines, will meet with the approval of every operator who has fumbled around in a box of unsorted bolts in search for one of a certain length. Nearly all shops are now equipped with metal tool stands to which the rack in the drawing is attached with U-bolts, as shown; a small dowel at the lower end of the rack bears against the shelf of the tool stand and prevents slipping. The 1/2-in. holes, in the L-shaped rack arm, are carefully drilled; this will permit the round iron pegs, which are usually over-size, to be driven in tight. The size of each bolt is stamped on the head with a steel numbering die, and also on the rack, so that bolts of a certain length are easily located.—H. L. Ruark, Hillyard, Wash.

### Tool Lifter for Planer or Shaper

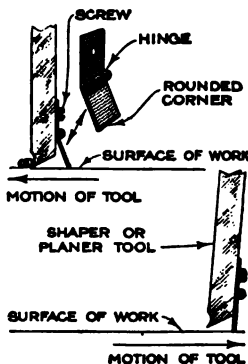

the tool as shown; the height is adjusted so that the tool will be raised about 1/4 in.—R. H. Kasper, Philadelphia, Pa.

An easily made attachment which will lift the shaper or planer tool on the back stroke, thus preventing undue wear on the cutting edge, is shown in the sketch. A common butt hinge, preferably a brass one, is attached to the back of

### How to Repair or Replace Sea Valve without Docking the Vessel

Often it is necessary to make repairs on the valve in the bottom of vessels, known as the sea valve, which is located

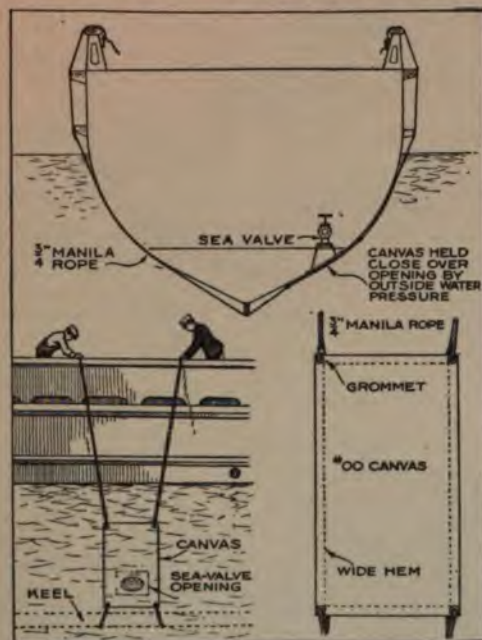

A Method of Blanking Off a Sea-Valve Opening to Obviate the Necessity of Docking the Vessel, is Shown in the Illustration

below the water line, and when a drydock or marine railway is not available, this is not easy to accomplish. The following article describes a method that has proved very successful in a number of emergencies.

The necessary materials to do the job are an 8 by 4-ft. piece of heavy canvas, No. 0, or better still 00, with a wide hem worked all around the edges and a large grommet in each corner. In each grommet is spliced a piece of about  $\frac{1}{4}$ -in. diameter Manila rope, long enough to suit the girth of the vessel with enough end to make fast on deck, as indicated in the top diagram. The sea valve in most cases is located in the fire or engine room of the vessel, usually amidships. Therefore it is necessary to get the canvas under the bottom, working aft from the bow, as there are less obstructions at this end. Four men should do this easily, two to each side of the vessel. Work the ropes under the keel to the location of the sea-chest opening, taking care that the opening in the hull is as near as possible to the center of the canvas.

When satisfied that the canvas is directly over the sea-chest opening, the valve can be tested, and if no more water comes in than what would naturally be in the body of the valve it will be safe to remove the valve, and make the necessary repairs; for safety's sake a blank flange can be placed on the opening while the valve is off.

Of course, the size of the ship and depth of draft will govern to a great extent the size of the canvas to be used, but in all cases be sure that the canvas is stout enough for the depth of water in which it is to be used.

For small vessels, such as tugs and inland steamers, it can be worked to quite good advantage, and has been successfully carried out at sea, on larger ships.

Should the keel and bottom be rough and cause difficulty in passing the canvas along the bottom, it is well to use some small weights on the canvas keeping it clear of the bottom until abreast of the sea-chest opening, when the form lines can be hauled tight and made fast at the rail.

### Turntable for Light Car

The illustration shows a readily made turntable for the private garage, which, although it cannot be recommended for the very heavy car, has proved a great convenience with the lighter vehicles.

In the center of the concrete floor of the garage a piece of 3-in. pipe is imbedded firmly in the concrete. A rectangular frame, of a size appropriate to the wheelbase of the car, is constructed as shown; two heavy casters are placed in each corner, directly under the wheels of the car.

It has been found that with a cement floor of ordinary smoothness, it is pos-

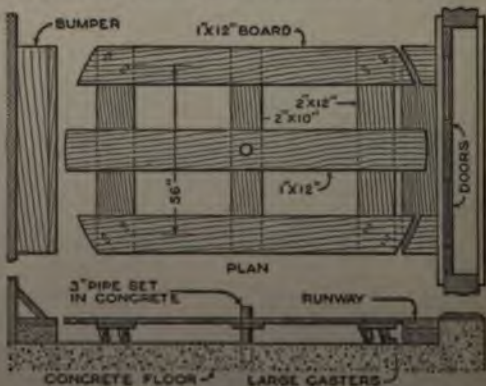

The Automobile Owner Who Tires of Backing His Car into the Garage may Find Relief in an Easily Constructed Turntable



sible for a woman of moderate strength to turn the car around without undue exertion. The floor under the frame can easily be cleaned by washing with a hose. If some scrap lumber and pipe is available, the only expense which need be incurred is that of purchasing the casters.—A. Svenson, Okmulgee, Okla.

**Tin-Can Key for Tire Repairs**

An efficient tool for repairing small punctures in single-tube bicycle tires is made from an ordinary tin-can key. The square end of the key is filed off as shown by the dotted lines, and a notch is filed in the top, as indicated. The slotted ends are filed to a long, sharp point. In use, several rubber bands are placed in the slot and stretched over the key, as shown; the rubber bands are coated with rubber cement and the tool is inserted into the puncture. After the bands have

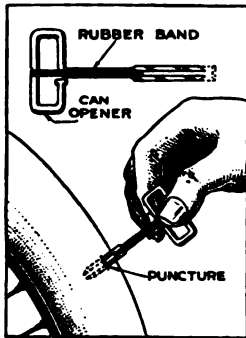

been released from the top of the tool, it is withdrawn, leaving the bands in the puncture; sufficient time is allowed for the rubber cement to harden and the projecting ends of the rubber bands are cut off flush with the outside of the tire.

—Paul M. Reidhaar, Connerville, Ind.

**Auxiliary Petcock Aids in Cleaning Gasoline-Feed Pipe**

To obtain gasoline for cleaning a tube to be patched, for cleaning the hands, or removing grease from the car or clothing, the usual practice is to dip something into the gas tank, generally a handkerchief or ball of waste. The result of this is frequently a mysterious stoppage of the motor caused by a bit of lint or dirt clogging the gasoline-feed pipe and cutting off the fuel supply. As a result considerable time is spent in locating the trouble and remedying it. An easy means of avoiding this is to substitute a tee for the usual ell underneath the tank, an auxiliary petcock being attached to one end, without drilling or tapping. This arrangement makes it possible to insert a wire into the feed pipe to dislodge obstructions without removing the pipe, by disconnecting the carburetor connection.

**Simple Rig Helps Overhead Drilling**

Having a large number of holes to drill in some gratings that were suspended at

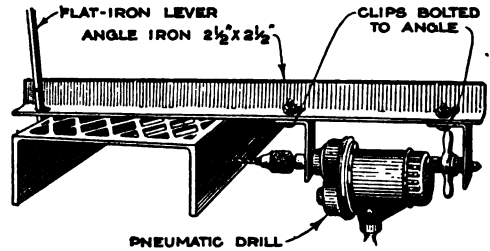

A Simple Rig, for Drilling Holes in Overhead Gratings, That Is Much More Effective than the Usual Type of Hook-and-Board "Old Man"

a distance above the floor, the workman on the job found that the regular hook-and-board "old man" method was too slow. The work was greatly facilitated by using the rig shown in the drawing, in which the pneumatic drill used was held in an angle-iron holder. A hole is provided at the outer end of the angle-iron arm through which a lever is inserted as shown, for exerting pressure on the drill point against the metal being drilled.—Edward N. Snowdon, Boothbay Harbor, Maine.

**A Nonspillable Oilcan**

Any oilcan of standard make can be made nonspillable by using materials to be found around the average shop.

As shown in the drawing, a piece of light sheet tin or brass is cut to fit inside the screwed end of the spout; five holes are drilled in this, the center hole being 3/32 in. in diameter. This is then soldered into place in the screw recess. A piece of 3/32-in. brass wire has a ball of solder attached to the end so that it will close up the opening in the spout, and the wire is cut so that it will just touch the bottom of the can when the ball rests on the opening. The wire is slipped through the spout and the center hole in the disk, a small coil spring placed on the wire as shown, and a washer soldered to the wire to keep a slight tension on the spring.

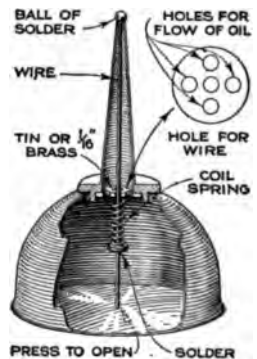

An oilcan of this description cannot spill its contents, and the bottom will never lose its spring.—Andrew Crowe, S. Manchester, Conn.

### Rig for Handling Heavy Crankshafts

When repairing heavy machinery in the field, far from the overhead crane of the

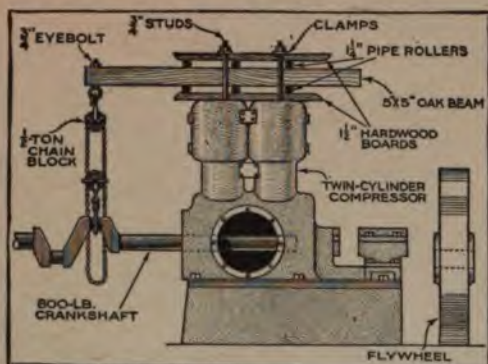

An Easy Method of Removing a Heavy Crankshaft, by Means of a Beam Running on Pipe Rollers

shop, the mechanic must depend upon his ingenuity to handle heavy parts, such as crankshafts and flywheels. The drawing shows a rigging that was used for overhauling a heavy vertical compressor in a refrigerating plant. Four long studs were screwed into stud holes on top of the compressor, as shown, and an oak timber, with an eyebolt at one end, was clamped between rollers in the manner indicated. While the beam is held down securely, the pipe rollers make lateral movement of the beam possible. Thus, when the shaft was lifted from its bearings, the beam was moved out, and the heavy forging lowered to the floor.

### "Hot-Spot" for Auto Intake

Intake manifolds on many automobile engines supply an inadequate amount of heat to make up for the cooling effect caused by the passage of the vaporized gasoline on its way to the engine cylin-

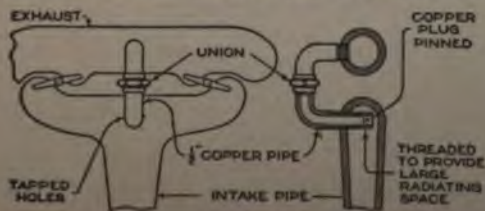

Automobile "Hot-Spot," Which Conducts Heat from the Exhaust to the Inlet Manifold, Improves Vaporization with Consequent Fuel Economy

ders. To offset this loss, one motorist used a short length of copper pipe to make a "hot-spot" inside the inlet manifold, as shown in the drawing. Holes, to take the copper pipe were drilled and tapped in both manifolds, the pipe being cut in half to take a union, as indicated. The inlet end of the copper pipe was plugged with a copper plug which was held in place with a pin; the threaded end of this piece was screwed well inside the inlet manifold, the threads providing additional radiation surface. The installation of this device provided better vaporization, with a resultant economy in fuel, and a smoother-running motor.

### Jig-Saw Attachment for the Lathe

The jig-saw attachment shown in the engraving was designed for use on a lathe of English manufacture having a flat-topped slide rest with several inverted T-slots. It is held in place on the lathe with a single T-head bolt.

The main casting is of brass, and the split bearings for the vertically actuated spindle consequently require no bushings; the casting that supports the table is iron. The table is 3-ply hardwood and is adjustable for height, so that more of the saw edge can be used than is ordinarily possible, thus making the blades give longer service. A jewelers' saw forms the saw frame; the wooden handle was removed and all but about  $\frac{3}{4}$  in. of the tang was cut off. This was filed flat and fitted into a slot of corresponding size at the upper end of the spindle and attached with rivets, as indicated in the illustration.



The attachment is driven by a small faceplate held in the chuck; this faceplate has a driving pin mounted  $\frac{1}{2}$  in. off center which engages the slotted cross-head attached to the spindle. Incidentally, this faceplate engages the flat-face surface of the cross-head, thus keeping the saw frame in alignment and obviating the necessity for other means of preserving alignment.

For cutting small shapes from sheet metal such a saw is very convenient and operates at fairly high speed without



breakage of blades. For sawing metal, use jewelers' saws, which may be had in various degrees of fineness; for wood, use regular scroll-saw blades, except for extremely fine work, in which case use the fine metal-cutting blades.—Harry F. Low Washington, D. C.

### A Stout Point for a Furrowing Pole

A substantial metal point for the useful furrowing pole can be made by inserting the end of the pole into an old knife-guard tooth from a mowing machine, and bolting it fast; this permits the pole to be easily thrust into any kind of soil.

### A Bolt to Fit Any Door

A variation of the many arrangements for preventing a lock from being picked or forced, is shown in the drawing. This device is made in two pieces, from  $\frac{1}{8}$ -in. flat iron. The bolt,  $3\frac{5}{8}$  in. long, is provided with a number of  $\frac{1}{16}$ -in. holes which are spaced  $\frac{7}{16}$  in. apart. At one end of the bolt, a metal block, or butt, is attached with rivets, as indicated. The saddle is cut from a piece of flat stock, and bent as shown, with a hole at the center which lines up with the holes in the bolt. In use, the butt is placed in the upper hole of the latch plate, and the door is closed; the saddle is then pushed up against the door and held in place by a pin, inserted through the saddle and the hole in the bolt nearest the door. The pin may be attached to the bolt with a short piece of chain for convenience.—Henri Marcelle, Honolulu, H. T.

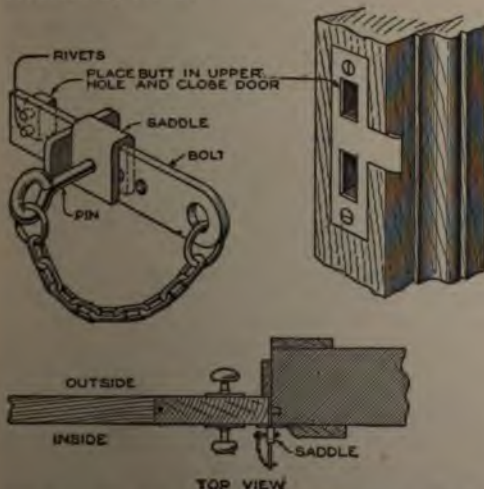

An Auxiliary to the Common Door Lock, Which Prevents the Door from being Opened without Its being Forced or Broken In

### Turning Brake Drums in the Drill Press

A small automobile shop, having a number of brake drums to be faced, and

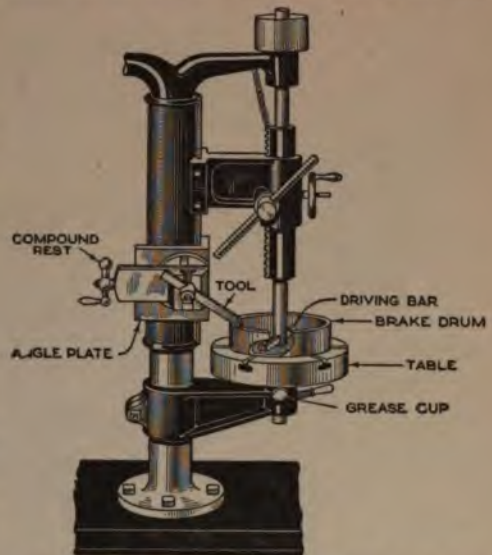

By Rigging the Drill Press as a Boring Mill, a Rush Job of Turning Brake Drums was Turned Out in a Very Satisfactory Manner

having no lathe large enough to swing them, solved the problem as shown in the drawing. A groove was cut in the arm supporting the drill-press table, and a grease cup fitted to provide for lubricating the table arbor. The clamp on the latter was loosened so that the arbor was an easy-running fit, and a brake drum clamped centrally on the table.

The drill spindle was run down to the drum, and a flat bar of steel slipped through the spindle slot, engaging with two of the bolts clamping the drum. On the vertical table slide, a small angle plate was fastened, and on the plate, a compound rest was mounted in the proper position to feed across the work. By feeding the tool across the work by hand, while running this drill press at its slowest speed, the job was turned out in very good time considering the handicap.

### Wire in Plastic Stove Lining

When putting a plastic lining in a stove, first insert a piece of poultry netting; this has the same effect as the reinforcing material used in reinforced concrete. The wire makes the insertion of the lining easier and also prolongs its life by preventing cracks.—Edward M. Brickett, Lynn, Mass.



### A Tapping Machine for Light Work

The drawing shows a small power-tapping machine built up of 4-in. channel iron, with cast-iron bearings and a shaft about  $\frac{5}{8}$  in. in diameter.

In order to obtain the forward and re-

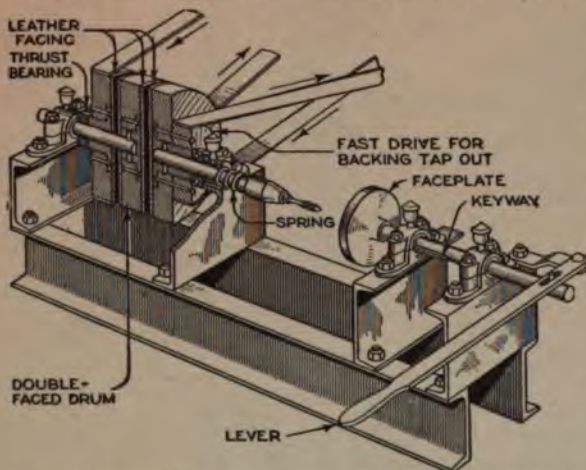

A Power-Operated Tapping Machine Which can be Built at Insignificant Expense, for Speeding Up the Tapping of Drilled Holes: It Is Practically Automatic

verse drive required for power tapping, a simple friction clutch is used; this consists of a double leather-faced pulley, or drum, rigidly attached to the center of the shaft. Loose, leather-faced pulleys on each side bear against the drum and, as pressure brings the faces of the separate pulleys against the faces of the drum, forward and reverse movements are obtained. Both pulleys are belted to the countershaft, one of the belts being crossed. The reverse pulley should be somewhat smaller than that on the countershaft so that the tap will be backed out

of the hole at high speed. The end of the shaft is tapered and provided with a chuck, behind which a fairly stiff spring is placed, as shown, to keep the faces of the reverse pulley and drum in contact and cause the machine to run backward when not actually engaged in tapping.

On the opposite end of the machine, a keyed shaft is supported on bearings in which it slides back and forth, the key preventing rotation; a lever, which is pivoted to the channel-iron support as indicated, is provided for moving the shaft. A faceplate, or fixture, for holding the work is attached to the inner end of this shaft.

The action of the machine is practically automatic. The work is placed in the fixture and by a movement of the lever is brought against the tap; the pressure against the tap brings the faces of the forward-drive pulley and drum together and the tap is fed into the hole so long as pressure against the tap is maintained. As soon as pressure on the lever is released the spring automatically

brings the faces of the reverse-drive pulley and drum together, and the tap is backed out at high speed. For lubricating the freely revolving forward and reverse-drive pulleys, a hole may be drilled through the center of the shaft with holes at right angles for each pulley; a grease cup screwed into the end of the shaft provides the lubricant. While not absolutely essential, the efficiency of the machine can be greatly increased by the installation of ball thrust bearings, as shown in the drawing.—H. H. Parker, Oakland, Calif.

### Airplane Protected from Tampering

In making airplane flights that cover a period of days, or even weeks, it is often necessary for the pilot to leave the craft unguarded and at the mercy of vandals or curio seekers, who remove anything portable, and often seriously damage or totally cripple it. Live stock rubbing against the control wires and directive surfaces may also do considerable damage. One airman, after a few experiences of this character, decided it was time to prevent unauthorized persons from tampering with his machine. He bought a small alarm clock, a 6-volt induction coil, three dry cells, a switch, and a few feet

of copper wire; a disk-contact switch was made and attached to the back of the clock in such a manner that when the clock was running, it would rotate the switch so that the circuit was opened and closed at one-minute intervals for 24 hours. The dry cells were wired to the coil, and the high-tension cable from the coil was grounded to some metal fitting of the plane. A small box attached inside the fuselage of the craft contained the apparatus and weighed about  $7\frac{1}{2}$  lb. complete. A secret, insulated switch, that could be turned on or off by the pilot, controlled the current. The results obtained with this arrangement were decidedly satisfactory, as anyone touching



any metal part of the machine—and it is almost impossible to avoid doing so—receives a severe but not dangerous shock.

**Covering Holes in Plaster**

For covering holes in the walls and ceilings of a room, such as stovepipe holes and spots from which the plaster has fallen, in preparation for paperhanging, it is not necessary to use plaster. A piece of muslin, or cheesecloth, is pasted over the hole, so that there is a margin of at least 6 in. on all sides; this is allowed to dry overnight, and the paper is applied over the patch in the usual manner. If the area to be patched is not too large, such spots can only be discerned on close inspection.

**Steadying the Water in a Locomotive Gauge Glass**

On a locomotive-type boiler with a sloping back head, where the bottom water-gauge "spud" is screwed in flush with the inside of the sheet, trouble is frequently experienced with the water jumping in the glass. One method of preventing this is shown in the sketch. A brass nipple was screwed into the "spud," as

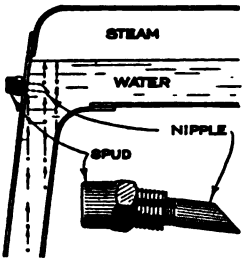

shown, having the end beveled, and extending 3 or 4 in. into the water space. The vapor bubbles rising through the water are not permitted to enter the gauge glass, and a steady water level is secured. —J. R. Minter, Washington, Ind.

**Testing Block for Spark Plugs**

It is necessary in auto-repair shops, and convenient in the home garage, to have some means whereby spark plugs may be tested. Most shops have means for testing, but in many cases they are unhandy and never ready for immediate use. The device described in this article will be found always at hand and ready for use, yet entirely out of the way. A block of dry, hard wood, or fiber, is used for the base, as shown in Fig. 1; this block is provided with a round hole at the center, which is flanked on each side by a square hole, cut out with a chisel. Underneath each of these square openings, sheet-brass tongues are fastened with washers

and screws, for the attachment of leads from an induction coil, in the manner

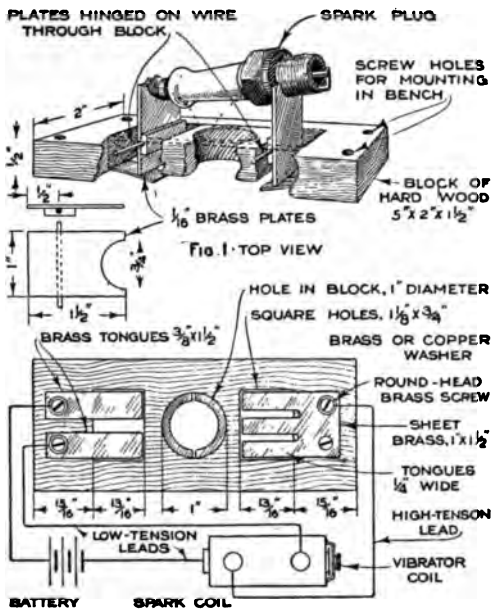

Fig. 2: BOTTOM VIEW, AND DIAGRAM OF CONNECTIONS  
A Convenient and Ever-Ready Testing Block for Spark Plugs, That Finds a Place of Usefulness in the Auto-Repair Shop as Well as in the Private Garage

shown in Fig. 2. Two brass plates, made according to the dimensions in Fig. 1, have a small piece of thicker metal attached to them, which is drilled so that a piece of wire can be passed through the block and form a hinge. When not in use, these plates are pushed over so that they are flush with the top of the block, as shown by the dotted lines in Fig. 1; when raised, the lower ends press against the brass tongues underneath the block, and form rests on which the metal parts of the plug to be tested are placed, as shown. As no circuit is formed until a spark plug is placed across the raised plates, no switch is necessary. A small depression is cut in the bench to permit movement of the brass tongues, when the plates are raised, and the completed testing block is attached with screws.

**An Emergency Typewriter Repair**

If the spring of a typewriter breaks, the machine can still be operated by attaching a stout rubber band to one end of the carriage, the other end of the band being attached to a thumbtack on the side of the desk, or wall. The operating speed will be reduced, but the machine can be used.—Harry H. Houck, Rochester, N. Y.

### Adjustable Table for Plant Breeders

The plant breeder often finds the flowers on a plant so small that it is difficult, or practically impossible, to work on them. As a result of his experiences in this respect, one breeder has evolved the shown. It consists of an ordinary saw-horse to which the adjustable table is attached; this

possible, to a result of his experiences in this respect, evolved the shown. It consists of an ordinary saw-horse to which the adjustable table is attached; this



Owing to the Difficulty of Bringing the Blossoms of a Plant to the Proper Elevation, a Plant Hybridizer Evolved This Adjustable Table

fastened a platform for holding the flowerpot. Thumbscrews make it possible to bring the blossoms to the proper height for ease in manipulation. The top of the horse is provided with a flat surface, for holding the notebook and other accessories of the hybridizer. As delicacy of touch and steadiness of hand are essential for successful work, the bench is equipped with arm supports on both sides.—J. L. Collins, Berkeley, Calif.

### Piping Plans Save Repairman's Time

The value of clear, well-drawn plans, or diagrams, of the lighting, gas, water, and sewerage systems of any completed building, or grounds, for reference after the actual construction has been completed,

can hardly be overestimated. Immediately upon the completion of any system of this nature, a clear, concise plan, preferably mounted in a frame, or otherwise protected, should be kept in some easily accessible location where it may be consulted at any time. This seems, at first glance, to be unnecessary precaution on the part of the contractor or builder, but, since men actually engaged in the construction seldom can be called upon for information regarding the location of any given part of the layout, it follows that this information should be available to those who are interested. Such plans should not only show all features of the original plan, but should also contain all changes, additions, and enlargements, together with necessary notes for locating them if any features of the layout are hidden from sight. If it is possible to obtain copies of the architect's plans covering these features, it will save much work and detail; if they are not available, a good working plan should be made in its stead. A suitable scale for this type of drawing is  $\frac{1}{2}$  in. to 1 ft., for inside work around houses and buildings, and 1 in. to 20 ft., for grounds, parks, and drives.

In order that the greatest good may be derived from these plans, they should be placed in the most likely or accessible place, at or near the control of the system; for example, the electric-wiring diagram should be placed on the inside of the door of the fuse or switch box; the gas plan near the gas meter, and so on. The time, labor, and expense involved in the preparation and execution of plans of this nature will be well repaid by the saving in these same items, as well as in patience and energy spent in useless searching, when repairs or alterations are to be made.—Roy H. Poston, St. Francois, Mo.

### Gasoline for Leaky Inner Tubes

A motorist, while touring, was annoyed at the inability of one of his tubes to hold air for any length of time. He was never able to detect any leaks, and deciding that the tube was "porous," was about to throw it away when he made a final effort at curing the defect. Being an observant individual, he had noted that rubber stoppers, when used in bottles containing gasoline, swelled to almost double their original diameter, when removed and exposed to the air for any length of time. He figured that, if the air in the tire contained some gasoline vapor, it would close



the small pores. He proceeded to apply his theory by injecting about a table-spoonful of gasoline, through the valve stem with a small oilcan. The effect was almost magical, the tube being used for months after without any trouble. While it is generally admitted that gasoline is not good for rubber, the small amount used was sufficient to close the invisible leaks without seriously affecting the tube itself.—E. Stetson, Okmulgee, Okla.

### Holder for Small, Round Lathe Tools

The accompanying sketch shows a useful tool holder. The V-grooves on opposite sides are of different depths, to



accommodate tools of different diameters. The clamp is set as close to the end as possible, and turns freely so that it can swing around the end to the opposite side. This tool may be used in the shaper or lathe, being especially useful in the latter, as very

small boring tools can be held firmly with it, thus permitting the use of short pieces of drill rod, or broken drills, as cutting tools. The holder also is useful for clamping round stock, for drilling it through the center.

### Rapidly Actuated Faceplate Screw

The time taken to screw the faceplate and chuck on a small lathe can be materially reduced if the form of screw shown in the drawing is used.

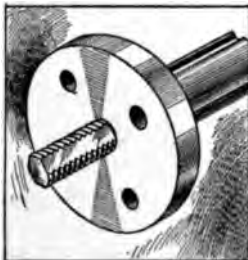

Three flats, 120° apart, are milled on the screw, and the female portion of the thread in the faceplate or chuck is also shaped out to fit the lands left on the screw. In use, the portions of the thread left on the screw are placed opposite the grooves in the faceplate. The faceplate is shoved home, and one-sixth of a turn will then lock it. To take it off, it is only necessary to reverse the operation.

### Quick Tightener for Clothesline

By the use of the very simple device illustrated it is possible to avoid having to tie and untie the clothesline. One end of the line, not shown, has an ordinary loop. At the other is a swivel pulley, around which the line is brought after catching through a piece of broomstick with holes cut in both ends. The end of the line is brought around and passed through the other hole, and then knotted to prevent its pulling through.

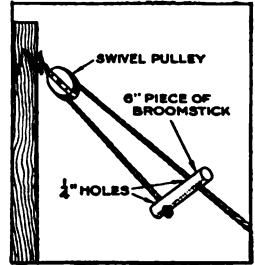

The line is tightened by pulling on the piece of broomstick. When the line begins to pull loose a kink is formed at the stick, which quickly stops the sagging. The line can be readily loosened, however, by gripping the broomstick and letting it slip back. The tightening device can be used at one end of a long line, which may pass over several hooks, through which it should move freely.

### Doing Close Work with a Hacksaw

There are many jobs where it is necessary to make hacksaw cuts as accurately as possible, and it is rather difficult to handle the tool so as to get good results.

A good way around the difficulty is to clamp a piece of a broken hacksaw blade, with fine teeth, between two pieces of brass or iron. This forms a convenient handle, and a trial of

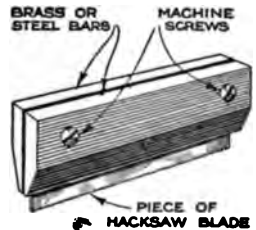

the plan will show that much better and more accurate results can be obtained, especially by the unskilled worker. If the cut is a deep one, it can be started with the clamped blade and then finished with the regular saw. Incidentally, this method eliminates most of the trouble from the tendency of the saw to slip out of a freshly started cut and mar the adjacent surfaces. If the saw makes too wide a cut, grind down the sides of the teeth somewhat on both sides of the blade, but do not grind too much, or all the "set" will be ground off, and the saw will stick in a deep cut.

### A Quick Method of Bending Small Tubing

Having a large number of small pieces of  $\frac{3}{8}$ -in. brass tubing, with  $\frac{1}{32}$ -in. wall, to bend as shown in the drawing, the job

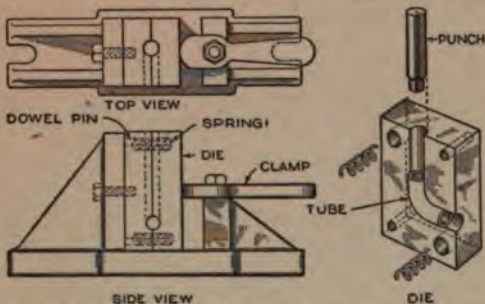

A Die for Bending Short Lengths of Metal Tubing in a Punch Press: The Curve is Produced without Wrinkles and Scratches by This Method

was quickly completed in a punch press, after a special die had been made, as indicated. The two half dies were sunk by using a ball-shaped end mill of the proper size. The work was strapped to the revolving table of the milling machine at the correct distance from the center, equal to the small radius of the bend required, plus one-half the diameter. The straight parts were cut by using the traverse feed, and the whole job of sinking one half of each die was accomplished at one setting.

When completed, the die was mounted on a specially designed bolster, as shown in the drawing. One half of the die was permanently attached to the vertical part of the casting, the other half of the die sliding on dowel pins held in the rigid part of the die. Compression springs, interposed between the halves of the die, normally hold them apart, to facilitate the insertion and removal of the tubes before and after bending. In the operating position, the dies are held together securely by an eccentric clamp, as shown.

In operation, a piece of tubing of the correct length is placed in the die, which is then clamped shut. The punch is merely a piece of hardened drill rod having a diameter equal to the outside diameter of the tubing and one end turned down to its inside diameter. The length of turned-down end must not be greater than the straight part of the tubing. When the punch descends against the end of the tubing, the latter is forced through the curve of the die.

This method works excellently for any form of tubing providing the walls are not too thin. The curve is produced without wrinkles or scratches, due partly to the

stretching and drawing effect produced on the outside of the curve.—S. B. Royal, Baltimore, Md.

### Calcium Carbide Routs Ants

The owner of a lawn, infested with ants, can get rid of them by the recently discovered calcium-carbide treatment. Several holes, about 6 in. deep, are dug into the ground, the number depending upon the size of the hill, or colony, and a handful of carbide is sprinkled into each one and covered with earth. The carbide is not moistened, the moisture of the earth sufficing to generate small quantities of acetylene gas for several days.

### Shop-Card Holder of Simple Construction

A shop-record or card holder of simple construction, like the one shown in the drawing, is in use in the machine shop of one of the naval gun factories. This holder consists of a square piece of tin, or other sheet metal, with a hole punched in one corner for hanging to a tack in the wall; the three remaining corners are turned over as indicated by the dotted lines to complete the holder. It will be observed that no soldering or riveting is required to make this holder, which is neat in appearance and serves its purpose admirably.



### Keeping Individual Poultry Records without Trap Nests

The advantages of trap nests for keeping an accurate record of hens, are obvious, but the great objection to the system is the labor involved in visiting the nests at frequent intervals to release the fowls.

A new system that has the approval of agricultural experiment stations is known as the "touch record" system, in which trap nests are not used, the hens being put through a daily "physical examination," to determine whether or not they will lay on that day. Each hen carries a numbered leg band. The method followed



in examining the hens, is to seize them, one at a time, as they emerge from the coop in the morning, and slightly pressing a finger against the side of the abdomen, over the pelvic bone, and near its end; if the hen is going to lay within the day, the presence of the egg will be detected by the finger.—John T. Bartlett, Boulder, Colo.

### Making a Punch Cut Easily

There are times when a punch can be used to better advantage than a drill for making a large number of holes in thin sheet metal. A trick worth knowing, and one that makes the punch more efficient, consists in grinding the end of the punch off at an angle of about  $1^\circ$ ; this gives one edge a chance to advance ahead of the opposite edge and the shearing effect produced makes it possible for the punch to be driven through the metal easier and quicker than if forced through with a square end. A block of hard wood or lead under the work to be punched is also an advantage.—L. B. Robbins, Harwich, Massachusetts.

### Repairing Broken Wagon Wheel

The delivery-wagon wheel shown in the illustration, was put out of commission in an accident, every spoke in the wheel



being fractured near the hub. The repair was made by using two paper friction clamps, common around sawmills. The shaft holes in the center were reamed out conically, on the inside, to fit snugly against the hub when placed in position. The wheel was removed from the axle, and one of the clamps was applied to each side, as shown; the bolt holes in the clamps were the right distance apart for a short bolt beside each spoke; these, when drawn up, reinforced the wheel to such an extent that it withstood several weeks of hard use before a new one was obtained.—L. M. Jordan, Wallace, Ala.

☛When no pencil is at hand, a substitute may be made by pointing a piece of wire solder and using it as a pencil.

### Attractive Outdoor Advertising Signboard

This suggestion, of happily wedded art and advertising, is one that may prove of value in ending the guerrilla warfare that

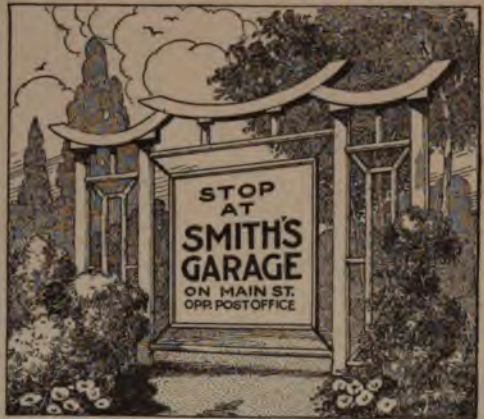

Art and Advertising are Happily Wedded in This Attractive Outdoor Advertising Sign in Japanese Effect

has long raged between artists and the artistic-minded public on the one hand, and outdoor-publicity men on the other.

The upright supports of this sign are made from old telegraph poles sunk into the ground; the smaller round pieces, which form the ornamental braces, are furnished by straight saplings. The curved top pieces are made by nailing planks to a framework of 2 by 4-in. material. The signboard proper, the part that contains the advertising announcement, is made by riveting together several sheets of galvanized iron. The corners are reinforced with heavier metal, so that the whole sign may be held by chains from each corner, as shown in the drawing. By exercising a little care as to location and with tasteful arrangement of inexpensive shrubbery about the base, the appearance of the whole will be decidedly pleasing and the Japanese effect of the signboard will be considerably heightened.

### Silencing Valve-Tappet Noises

Automobiles that are not provided with push-rod adjusting nuts can be silenced by drilling a hole in the top of the rod, about  $\frac{3}{8}$  in. in diameter and  $\frac{1}{4}$  in. deep; this cavity is filled with melted lead or babbitt. In the event that the filling should pound down after long use, the valve can be lifted and the deficiency built up with a drop or two of solder from the end of a soldering bit.



### Improvised Wheel Chair

When an invalid's wheel chair is needed for a convalescent patient, but the period of convalescence is judged



insufficient to justify the expense of a more elaborate chair, one may be quite easily made by fitting wheels to an ordinary chair, as shown in the drawing. The two back legs of the chair are clamped to a wooden axle, to which 8-in. wooden wheels are attached. At the center of the axle a piece of

wood is bolted at right angles, on the outer end of which a third wheel is mounted; an upright is fastened to this latter piece, in line with the front rungs of the chair, to which it is clamped. A light footrest is also provided, as shown in the drawing. By loosening the three or four bolts which clamp the chair to the wheeled truck, it can be removed, undamaged, in a few seconds.—Henry W. Buzzell, Outremont, Quebec.

### Engine Exhaust Carried through Furnace Pipe

When a gas engine for operating a pump was installed in the basement of a house, the disposal of the exhaust gases became a problem;

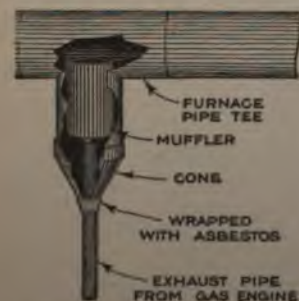

to exhaust in the basement would soon fill it with smoke, and to exhaust outdoors would mean disgruntled neighbors. The trouble was overcome by having a tinsmith make a special tee which was

placed in the furnace pipe between the furnace and chimney at a point far enough from the former to prevent the *James* from backing up into the registers.

The muffler was inserted inside the tee, as indicated, and the hole sealed up to prevent leakage. Not only was the sound of the exhaust well muffled, but the chimney draft drew the gases out into the open air.

### White Paint Improves Garage Light

Nowhere are the advantages of diffused light better demonstrated than when working about machinery. Try painting the walls and floor of the garage pit white and see how the light is reflected to every part of the machine above.—Earl Glass, Monrovia, Calif.

### Self-Lighting Gasoline Torch

A satisfactory and convenient arrangement for lighting a gasoline blowtorch, without the aid of matches, can be made from one of the so-called "flint and steel"



gas lighters. As shown in the drawing, the circular "file" part is attached above the gasoline cup with a machine screw; it must be so located that it will not become wet with gasoline from the cup, as this will prevent the "flint" from sparking. The

end of the lighter containing the sparking material is cut off and an eye is bent in it for attachment to the torch with a short length of chain, the end of which is soldered to the gasoline reservoir. When the sparker point is drawn across the "file," sparks will fall into the gasoline cup, igniting it. Such a lighter is always at hand when needed, a convenience which will be appreciated by all torch users.

### Storing and Running Rawhide Gears

Rawhide gears, when not in use, should be kept covered with shellac or hard grease, and should be stored in a place which is kept at a moderate temperature, in order to keep them from splitting or warping. In running such gears, do not use mineral oils, but lubricate with a mixture of light grease and graphite.—S. Guy Chicago, Ill.



**Lubricating Saws with Graphite**

When working with hardwood interior finish, the saw often gives trouble by sticking. Though it is inadvisable to use grease on the saw on account of soiling the wood, finely powdered graphite is not open to this objection. A small cloth bag filled with the graphite is rubbed over the saw as occasion may require, enough of the lubricant sifting out to make opening of the bag unnecessary.—G. E. Hendrickson, Argyle, Wis.

**A Reliable Ignition Auto Lock**

A simple ignition lock for a small automobile of a common type, that defies the efforts of unauthorized persons to start the car can be easily made as follows: Two brass clips are provided and bent to the form shown in the drawing; these are attached to the underside of the footboard, as shown. One of the clips is wired to the magneto terminal post and the other is grounded to the chassis with a short length of wire. A small hole is drilled in the footboard, between the two clips, in which a small nail is inserted in the manner shown, grounding the magneto; this will make it impossible to start the car until the nail is removed.

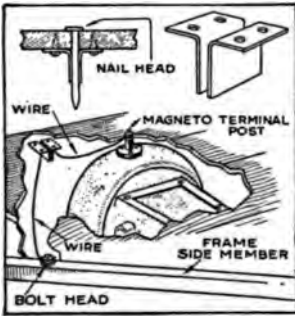

**Insulated Telephone Receiver Used on Power-Plant Line**

The operator at a telephone switchboard had experienced trouble with electric shocks transmitted along the line, these being due to the influence of a high-tension transmission line in the neighborhood. The difficulty was overcome by using, in connection with a breast transmitter, a receiver mounted as illustrated. An old transmitter bracket was fixed in place, and on its outer end was fastened half of a large toy rubber ball. Inside this rubber hemisphere a watchcase receiver was installed, and wired with ordinary cord, running along the bracket. The receiver was opposite the ear of the operator, coming about 1/4 in. from the

ear, when the rubber ball was fitted close to the side of the face. All other sounds

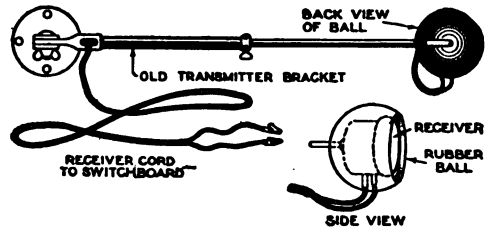

Higher Insulation for the Telephone Operator's Receiver was Provided by the Use of a Rubber Ball

were thus shut out, and the insulated receiver prevented any further trouble from electric shocks.—H. A. Barwick, Shawinigan Falls, Que.

**Homemade Saw Jointer**

In sharpening a handsaw, or any other kind, it is important that the points of the teeth are all the same height before the actual sharpening is begun; otherwise, with teeth of irregular height, imperfect results are obtained. An easily made saw jointer, for this purpose, can be made in a few minutes, from a hardwood block and a three-cornered file. A 3/8 or 1/2-in. hole, according to the size of the file used, is drilled through the block, and a slot is cut from the edge of the block into the hole. The file, preferably an old one, is fitted into the hole, as shown. After the teeth have been "set," this jointer is placed over the saw and passed back and forth until all the teeth have been brought to the same height, after which the saw is sharpened.—Washington S. Morton, Pasadena, Calif.

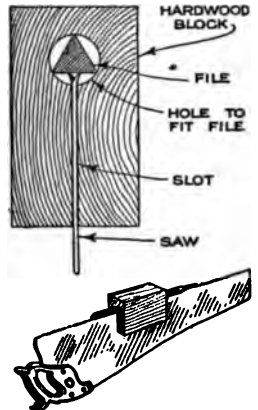

**Draft Shield for Bunsen Burner**

When a Bunsen burner is used in a draft, or near a fan that is in operation, the flame is likely to be blown out. A draft shield can be made of a can from which one end has been removed and in which is provided a notch to admit the gas tube. The opposite end may be removed, or a hole large enough for the flame may be made, as desired; the shield

is set over the burner and prevents the flame from being blown out.—G. H. Glitzke, Kansas City, Mo.

### Keyway Cutting with a Drill Press

The sketch illustrates a method by which a drill press was used to cut key-

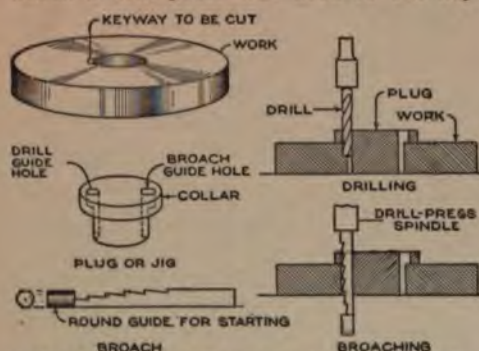

A Workman without Great Skill can Cut Good Keyways on a Drill Press, by the Use of a Special Jig as Illustrated

ways in a number of circular plates. The work was found to be quite accurate, although the operator was not a skilled machinist.

A jig is first made in the shape of a plug to fit the hole, having a collar or shoulder at its upper end. Through this shoulder two holes are cut, one round and one square, each being complete in the collar, and being continued as a slot down the body of the plug. The round hole is made to serve as a guide for a drill, and the square one for a broach. The work is first set up in the drill press, as shown at the upper right, and the drill is run through, resulting in a semicircular slot in the work. To square out this slot, the plug is turned so that the square hole comes directly over the slot, and the special broach illustrated is run through. The hand feed of the drill press is utilized for forcing the broach through, as suggested at the lower right. A single broach is found sufficient, as most of the metal is removed by the drill.

### Engraved Work Transferred by Chalk Impression

A quick, clean, and efficient process for transferring the design on an engraved article to another article, which is to be engraved with the same pattern or design, is the following: Fill the engraved lines with powdered chalk; then breathe on the left arm, just above the wrist, or moisten it slightly, and press the chalk-filled engraving against the flesh, using a

firm, hard pressure. This will leave the imprint of the article and a chalk impression of the design it is desired to reproduce on the arm. Now, take the next article to be engraved and breathe on it, or rub it with a dampened finger; this will leave a sticky film on the article, which is pressed firmly against the impression made by the pattern, and the chalk design on the arm will be transferred from the arm to the article in the exact location of the first one. From two to a half dozen impressions can be obtained, according to the depth of the engraving and the amount of chalk that adheres to the arm. Practice will enable the engraver to transfer the design to a half dozen spoons, forks, or other pieces in less time than is ordinarily required to coat the part with the various preparations used for laying out the design.

### A Simple Pipe Wrench

Where a heavy pipe wrench is only occasionally used, the small shop owner can make a very serviceable one from steel plate.

As shown in the sketch, the toothed jaw is made from plate steel,  $\frac{3}{8}$  to  $\frac{1}{2}$  in. thick and of any required length; the teeth are cut with a file, the working face being tapered. This face should be hardened before the tool is used. The U-shaped clip is of  $\frac{1}{4}$ -in. plate, bent and slotted to an easy fit for the jaw.

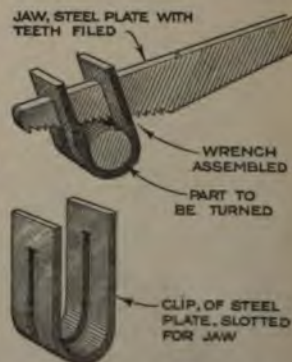

### Steel Ball Aids in Centering Work

Where no centers are available for centering work in the drill press, a steel ball of suitable diameter can be placed in a drill mark on the drill-press table and the work placed on it as shown. The drill should first be centered with the head along a long drill spot.







## Movable Table for Drill Press

BY ARTHUR F. COX

**I**N a shop which makes a specialty of drilling and assembling slate and marble switchboard panels, the drilling is done on a radial drill, the panel being supported on the special table shown in the drawing. This table permits one man to handle the largest panel with ease, and adds considerably to the efficiency of the drilling machine.

As shown, the table is built up of angle iron, the four legs being provided with flanged wheels, made to the dimensions shown in the detail drawing, and the whole table moves longitudinally on a track composed

of 1-in. square cold-rolled steel, fastened to the floor. These wheels also permit the table to be easily moved to any part of the shop. The table top is made of two layers of tongued-and-grooved hardwood flooring, the upper layer being laid at right angles to the bottom one. The table top runs on four rows of rollers, which are mounted on pins fastened by cotter pins through the angle-iron cross members. This table reduces the cost of the drilling operation considerably, as, by the combination of motions possible, the hole to be drilled is located much more quickly

and easily than by using the drill motion alone.

Further, the risk of breaking panels is greatly reduced by the use of the table, and it forms a substantial piece of equipment, in contrast to the usual flimsy wooden support used for this class of work,

which generally necessitates two men to handle the panels, and makes drilling a slow and inaccurate job, due to the weight and friction of the panels in moving them over a rough wooden surface. The pins on which the various rollers run should be casehardened, and should be

lubricated frequently to insure the utmost freedom in both movements of the table.

### Cutting In Sign Letters

The sign painter often experiences considerable difficulty, when painting on soft woods, on account of the paint's tendency to spread and follow the grain of the wood and so spoiling the clean-cut lines of his letters. Some attempt to overcome this by painting the board with a solid background and then painting the letters over this, but this method is not advised

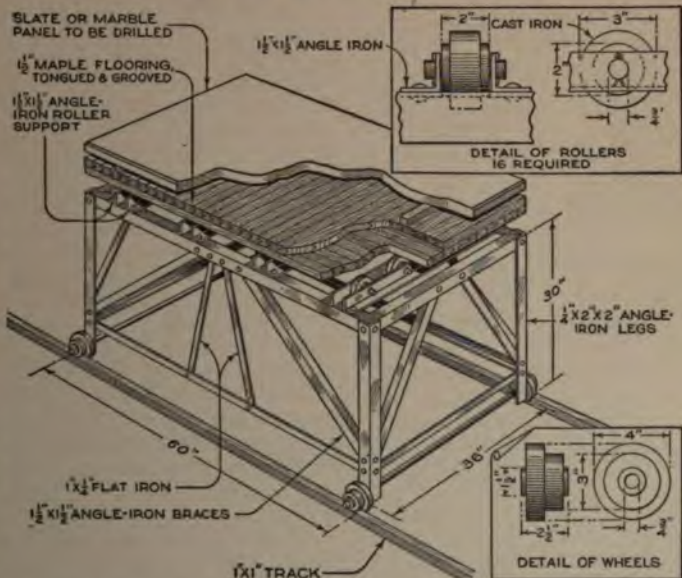

A Table That Is of Particular Convenience in Shops Where Large Slate or Marble Panels are Drilled: The Accuracy of the Work is Increased and the Output Augmented

is set over the burner and prevents the flame from being blown out.—G. H. Glitzke, Kansas City, Mo.

### Keyway Cutting with a Drill Press

The sketch illustrates a method by which a drill press was used to cut key-

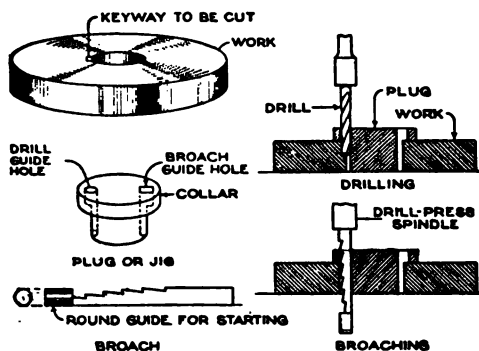

A Workman without Great Skill can Cut Good Keyways on a Drill Press, by the Use of a Special Jig as Illustrated

ways in a number of circular plates. The work was found to be quite accurate, although the operator was not a skilled machinist.

A jig is first made in the shape of a plug to fit the hole, having a collar or shoulder at its upper end. Through this shoulder two holes are cut, one round and one square, each being complete in the collar, and being continued as a slot down the body of the plug. The round hole is made to serve as a guide for a drill, and the square one for a broach. The work is first set up in the drill press, as shown at the upper right, and the drill is run through, resulting in a semicircular slot in the work. To square out this slot, the plug is turned so that the square hole comes directly over the slot, and the special broach illustrated is run through. The hand feed of the drill press is utilized for forcing the broach through, as suggested at the lower right. A single broach is found sufficient, as most of the metal is removed by the drill.

### Engraved Work Transferred by Chalk Impression

A quick, clean, and efficient process for transferring the design on an engraved article to another article, which is to be engraved with the same pattern or design, is the following: Fill the engraved lines with powdered chalk; then breathe on the left arm, just above the wrist, or moisten it slightly, and press the chalk-filled engraving against the flesh, using a

firm, hard pressure. This will leave the imprint of the article and a chalk impression of the design if it is desired to reproduce on the arm. Now, take the next article to be engraved and breathe on it, or rub it with a dampened finger; this will leave a sticky film on the article, which is pressed firmly against the impression made by the pattern, and the chalk design on the arm will be transferred from the arm to the article in the exact location of the first one. From two to a half dozen impressions can be obtained, according to the depth of the engraving and the amount of chalk that adheres to the arm. Practice will enable the engraver to transfer the design to a half dozen spoons, forks, or other pieces in less time than is ordinarily required to coat the part with the various preparations used for laying out the design.

### A Simple Pipe Wrench

Where a heavy pipe wrench is only occasionally used, the small shop owner can make a very serviceable one from steel plate.

As shown in the sketch, the toothed jaw is made from plate steel,  $\frac{3}{8}$  to  $\frac{1}{2}$  in. thick and of any required length; the teeth are cut with a file, the working face being tapered. This face should be hardened before the tool is used. The U-shaped clip is of  $\frac{1}{4}$ -in. plate, bent and slotted to an easy fit for the jaw.

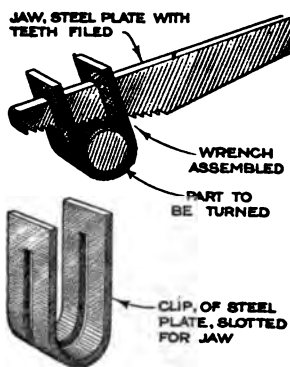

### Steel Ball Aids in Centering Work

Where no centers are available for centering work in the drill press, a steel ball of suitable diameter can be placed in a drill mark on the drill-press table and the work placed on it as shown. The drill mark should first be lined up with the head by running a long drill down into the spot.

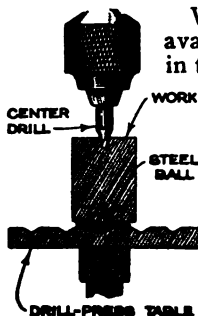



dish; then placing the glass, face down, over the tray and allowing it to remain until the etching has been carried to the proper depth.—Hugo J. Engel, New Braunfels, Tex.

### Hand-Operated Counterboring and Countersinking Tool

A hand-operated counterboring and countersinking tool, such as the one shown in the drawing, will find many uses around the shop. The countersinking tool is serviceable for obtaining accurate alinement of countersunk bolt heads in boiler and plate work.

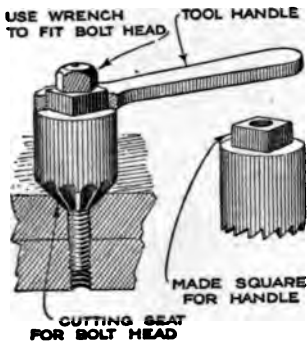

After drilling and tapping, an ordinary bolt is inserted through the tool and the desired amount of metal is removed by rotating the handle, the proper cutting pressure being obtained by screwing down the bolt

with a wrench, or a wing-headed bolt, for tightening with the fingers, can be used. Use of this countersinking tool causes the bolt to seat evenly, as the seat is cut concentric with the threaded hole. The counterboring tool is nearly the same as the countersink, but is used for spot facing the rough surface of a casting to provide a seat for cap screws or nuts.—G. A. Luers, Washington, D. C.

### An Emergency Gluing Clamp

A woodworker, having occasion to make a mortised frame, but having no clamps for holding the work together while the glue dried, devised the arrangement shown in the drawing, from two pieces of stout timber. A screweye was screwed into each end, and both pieces were connected together by wires and turnbuckles which were screwed up to give the desired compression against the glued joints.—Harry H. Houck, Rochester, N. Y.

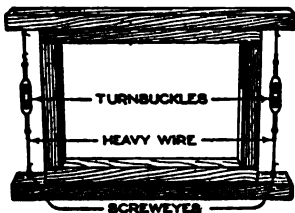

### House Moving by Steam Roller

A small house was moved nearly a quarter of a mile through the streets of a



A Small House being Dragged a Quarter of a Mile through the Streets of a Populous Town by a Steam Roller

populous town by a steam road roller. As the roller was not powerful enough to haul the building when connected directly to it, a block and tackle was used, one block being attached to the load and the other to trees and poles along the route; the free end of the rope was attached to the steam roller. The house rested on wooden rollers and the machine was able to haul it along about as fast as the men could take the rollers from the rear and replace them under the skids in front.—W. H. Sargent, Rutland, Vt.

### Lock for Fuel Tank on Truck

The owner of a truck that was stored in a public garage missed his gasoline, and to prevent further unauthorized removals attached the lock shown in the drawing to the tank. The lock consists of a piece of stiff sheet iron, formed as shown and drilled with three holes, one for fitting over a projection in the top of the filler cap; a suitable length of chain is attached to one of the other holes. The chain is passed around the tank and through the hole in the opposite edge of the plate; this chain is drawn up tight and locked in place by passing the bolt of a padlock through one of the links, as shown. The chain can be wrapped with canvas, or inserted into a piece of rubber tubing, to protect the finish, if desired.—D. B. Templeton, Bayonne, N. J.

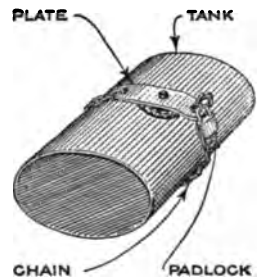

Old plane bits can be made into excellent scrapers for wood-finishing work.

as with but little exposure the background will show through the painted letters.

It will be found much easier and more effective to lay out the lettering on the bare board and then, with a sharp knife, cut deeply along the lines of the letters before painting. In this way the letters and background may be painted at the same time and in different colors without difficulty, and the job will stand exposure.

### Designing and Making a Speedster Body for the Old Automobile

The desire of most owners of old cars is to "cut it down" and make a "racer"

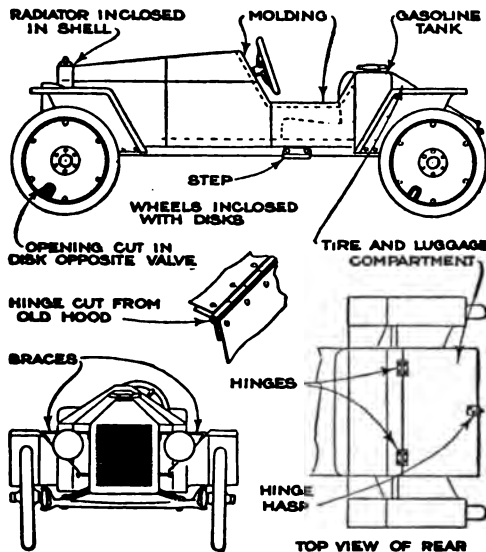

Rebuilding an Old Automobile Is Rather More Intricate than is Usually Considered, but by Using Care the Results will Amply Repay the Effort

out of it, or at any rate provide the old chassis with a body that will create the impression of power and speed. Many such attempts are foredoomed to failure, because the body is designed with no reference to drawings, patterns, or the tool equipment involved.

Preliminary to anything else, a scale drawing of the chassis and the new body should be made, and after the builder has established, to his own satisfaction, that the new body will fit the chassis, then only should the actual work be undertaken. However, a complete set of full-sized paper patterns should be made; with these the builder can determine whether the parts will fit together correctly, and at the same time rectify any errors of calculation, or judgment, that may have been made in the preliminary scale drawing.

The illustration shows a body that pos-

sesses straight lines throughout, as it is easier to work the sheet metal with sharp, angular lines than any other way, but the variety of design is infinite, and is only limited by the skill, cash, and facilities at the command of the builder.

The material most commonly used is No. 18 or 20 gauge sheet iron, although the lighter and more expensive aluminum can be used as well as a lighter-gauge iron, but the latter is inadvisable. For work of the kind shown in the drawing, the most essential tools will consist of a wooden mallet, tin shears, and riveting and soldering equipment. Most amateur builders fall into the error of trying to apply the component parts of the body to a wooden frame with nails, which invariably results in a botched and unsatisfactory job. The seams should at least be soldered or, preferably, brazed, and later these joints are finished off flush; thus a practically one-piece body is obtained.

Most speedster designs involve the necessity of more or less new framing under the cowl, and a new instrument board, the omission of which is another common blunder. Also, it is usually desirable to lower the steering post, and suitable means must be provided for supporting it; this is generally done by inserting wooden wedges between the dash and steering-post bracket, unless it is desired to make a special metal bracket.

Disk wheels are merely sheet-metal disks bolted to both sides of the wheels, with an opening for access to the tire valve. Such wheels, on the average light car, are not to be particularly commended, however, as they are not entirely satisfactory, and at the same time detract from that "low, rakish" appearance usually sought.

It should be remembered that the aim is to build a neat, individual automobile body and not a boiler, and that, therefore, the use of rivets and nails for closing seams should be shunned, since both give positive evidence of an amateur's handiwork.

### Etching Glass with Acid Fumes

To etch glass with various designs it is thoroughly cleaned, the parts that are not to be etched are covered with wax or Brunswick black, and the glass is exposed to the fumes arising from hydrofluoric acid (poison). If hydrofluoric acid cannot be had, the same effect is obtained by scattering an even layer of powdered fluorspar in a hard-rubber or earthenware tray, and pouring sulphuric acid into the



dish; then placing the glass, face down, over the tray and allowing it to remain until the etching has been carried to the proper depth.—Hugo J. Engel, New Braunfels, Tex.

### Hand-Operated Counterboring and Countersinking Tool

A hand-operated counterboring and countersinking tool, such as the one shown in the drawing, will find many uses around the shop. The countersinking tool is serviceable for obtaining accurate alinement of countersunk bolt heads in boiler and plate work. After drilling and tapping,

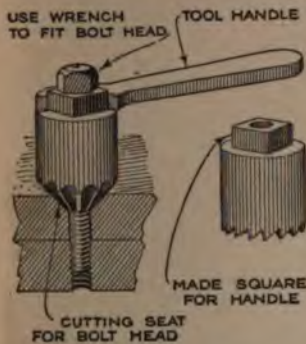

and tapping, an ordinary bolt is inserted through the tool and the desired amount of metal is removed by rotating the handle, the proper cutting pressure being obtained by screwing down the bolt with a wrench, or a wing-headed bolt, for tightening with the fingers, can be used. Use of this countersinking tool causes the bolt to seat evenly, as the seat is cut concentric with the threaded hole. The counterboring tool is nearly the same as the countersink, but is used for spot facing the rough surface of a casting to provide a seat for cap screws or nuts.—G. A. Luers, Washington, D. C.

### An Emergency Gluing Clamp

A woodworker, having occasion to make a mortised frame, but having no clamps for holding the work together while the glue dried, devised the arrangement shown in the drawing, from two pieces of stout timber. A screweye was screwed into each end, and both pieces were connected together by wires and turnbuckles which were screwed up to give the desired compression against the glued joints.—Harry H. Houck, Rochester, N. Y.



### House Moving by Steam Roller

A small house was moved nearly a quarter of a mile through the streets of a



A Small House being Dragged a Quarter of a Mile through the Streets of a Populous Town by a Steam Roller

populous town by a steam road roller. As the roller was not powerful enough to haul the building when connected directly to it, a block and tackle was used, one block being attached to the load and the other to trees and poles along the route; the free end of the rope was attached to the steam roller. The house rested on wooden rollers and the machine was able to haul it along about as fast as the men could take the rollers from the rear and replace them under the skids in front.—W. H. Sargent, Rutland, Vt.

### Lock for Fuel Tank on Truck

The owner of a truck that was stored in a public garage missed his gasoline, and to prevent further unauthorized removals attached the lock shown in the drawing to the tank. The lock consists of a piece of stiff sheet iron, formed as shown and drilled with three holes, one for fitting over a projection in the top of the filler cap; a suitable length of chain is attached to one of the other holes. The chain is passed around the tank and through the hole in the opposite edge of the plate; this chain is drawn up tight and locked in place by passing the bolt of a padlock through one of the links, as shown. The chain can be wrapped with canvas, or inserted into a piece of rubber tubing, to protect the finish, if desired.—D. B. Templeton, Bayonne, N. J.

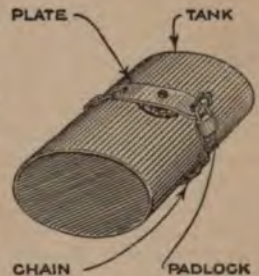

Old plane bits can be made into excellent scrapers for wood-finishing work.



### Homemade Knock Detector or Stethoscope

An improved and effective knock stethoscope, for detecting the location of

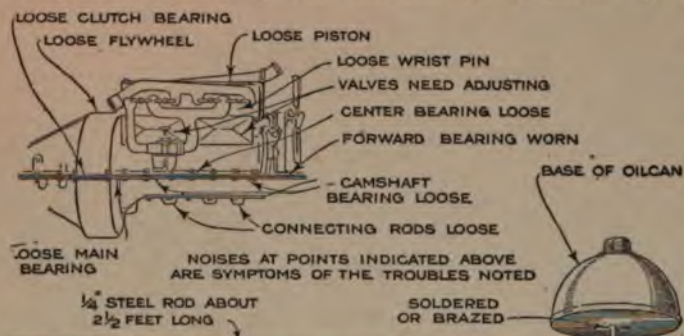

The Stethoscopic Principle of Magnifying Sound is Used for Detecting Knocks, and Other Irregularities, Common to Internal-Combustion Engines

knocks due to wear and looseness of bearings and moving parts of machinery, particularly of automobile engines, is made from an ordinary oilcan and a length of steel rod. As shown in the drawing, the steel rod is bent at one end and soldered, or brazed, to the bottom of the oilcan, and the spout of the can is removed. In use, the threaded collar of the oilcan is applied to the ear and the end of the rod is placed against the engine at the points indicated, to detect any of the various irregularities common to internal-combustion automobile engines.

### Preventing Water Stains on Wallboard

When applying wallboard panels, never allow them to reach completely to the floor, for they will be almost certain to absorb scrub water—sometimes to the height of 18 in. A better procedure in the application of such panels is to lay a narrow strip, about 2 in. wide, next to the floor, allowing an open space of about 1 in. between this and the panel proper, as shown in the drawing. The narrow strip will provide an even backing for the baseboard, the whole construction will be concealed, and the panels will be prevented from unsightly moisture stains.—Doncaster G. Hamm, Phoenix, Ariz.

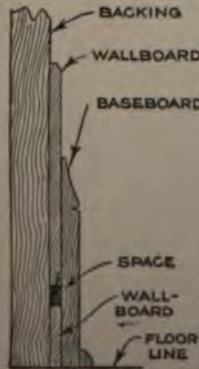

### An Auxiliary Draft for Slow-Steaming Boilers

When a steam boiler, such as used in factories, apartments, and other large installations, gets too old to steam rapidly, and when impaired draft and extreme weather cause trouble, a sure method of obtaining satisfactory results is to run an air line into the stack, above the smokepipe inlet; the pipe should point upward, inside the stack, this being accomplished by the use of an elbow and nipple. When the air pressure is turned on a forced draft is created which brings the steaming up to normal. Exhaust steam may also be used.—P. P. Avery, Garfield, N. J.

### Repairing Cracked Water Jacket

Hundreds of engine cylinders have been scrapped because of cracked water jackets, but the last journey of a casting for a 10-hp. stationary engine was indefinitely postponed by a simple method. Small holes were drilled at each end of the crack, to prevent it from extending farther. Three-quarters of an inch on each side of the crack, and 1 in. apart,  $\frac{1}{4}$ -in. holes were drilled through the jacket and counter-sunk; through these holes, a  $\frac{3}{16}$ -in. drill was inserted, and holes were drilled directly beneath them into the cylinder wall. Great care must be taken in drilling these holes, to avoid drilling through the cylinder wall. The smaller holes were tapped with a  $\frac{1}{4}$ -in. bottom tap. Iron studs,  $\frac{1}{4}$  in. in diameter, were threaded at one end and screwed in tightly. The studs were then sawed off on the outside, to within  $\frac{1}{4}$  in. of the casting; the projecting ends were upset, or riveted, and the crack was drawn together, making a water-tight joint which is unaffected by temperature changes.

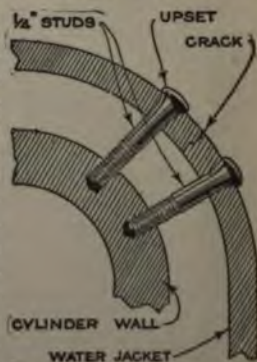



### Railroad-Car Repair Signal

Persons are familiar with the blue flags which repairmen place on the ends of cars undergoing repairs, in order to prevent other cars from being pushed past those on which men are working. It is sometimes difficult for brakemen riding in a car steps to see these flags, as they are often placed in the coupler and thus not in the center of the track. This is an unsafe practice, and to obviate danger, a railroad uses a square metal marker at the end of a metal rod. The rod is fitted at the lower end with a clamp which fits over the rail, and is bent at an angle so that the marker, which is painted with "safety" printed in large white letters, is held to one side of the track. When two such signals are used, one on each side of the track, they are plainly visible to switching crews at all times, no matter where they may be riding.

### Lathe Tool for Radius Cutting

The tool shown in the drawing is intended for radius cutting in the lathe. This tool permits cutting a radius of practically any size, and on account of the



light cut that it will take, chattering is overcome. The device consists of a support which is clamped in the toolpost; the end of this support is drilled to take the pivot pin of the tool holder, as indicated, the holder having a circular

face which is a snug rotating fit in the toolpost. A setscrew is used to hold the tool in the holder, and an extension handle is provided for moving the tool through the arc of the circular face to be cut. To cut a curve of any desired radius, the diameter of the holder being known, subtract half this diameter from the length of the radius to be cut; the distance is the distance that the tool should project from the holder, the tool being easily set with a scale.

Primary tarred roofing paper makes a good emergency substitute for a black-

### A Portable Countershaft

The drawing shows a portable countershaft that can be used to advantage under

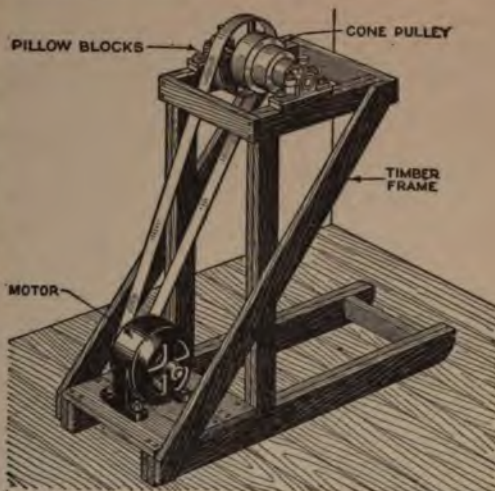

A Portable Countershaft for Emergency Purposes, That can be Transported to Various Parts of a Factory with Comparative Ease, Is a Time and Money Saver

many conditions. A heavy timber frame was made, and an electric motor was attached to the bottom platform; at the top of the frame, two pillow blocks were placed, to support a shaft and cone pulley, from which a belt ran to the motor. With such an arrangement, it is a comparatively simple matter to transport it to any part of the factory, to take the place of the regular motor that is out of commission, or for temporarily driving a single machine.—J. H. Moore, Toronto, Ontario.

### Tool for Marking Lettering Lines

In drafting rooms where there is a large amount of lettering to be done, the guideline marker shown in the drawing will

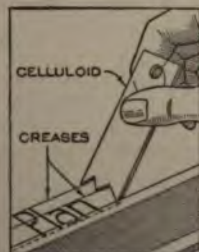

save considerable time in ruling, and later, in erasing lines. These markers are made in any desired size from pieces of old celluloid triangles. The notches are made the proper distance apart, and the tool is drawn along the edge of a square or angle with

sufficient pressure to make a light crease on the paper.—B. F. Dashiell, Dunkirk, Maryland.



# An Oil-Gas Generator

BY A. N. CAPRON

WITH the coming of cold weather and its usual concomitant of low gas pressure, every user of gas will be interested in the simple attachment

The separate turns of resistance wire should be from  $\frac{1}{2}$  to  $\frac{1}{16}$  in. apart. The ends of the heating element are solidly fastened and brazed with silver solder to

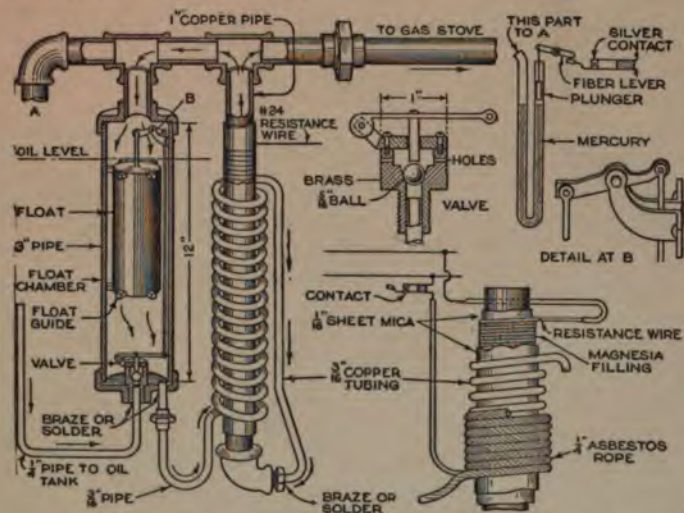

An Easily Constructed Generator of This Type will Be a Boon to Users of Gas Who are Confronted with Frozen Gas Pipes or Reduced Pressure. It is Adapted to Generating Kerosene Gas and Is Self-Regulating

shown in the drawing, by means of which the shop stove can be converted into an oil stove when the gaspipes freeze—or when there is insufficient gas to go around.

It is well known that the vapor of kerosene oil, commonly known as coal oil, flashes, or can be ignited, when the oil is heated to from  $120^{\circ}$  to  $140^{\circ}$  F., but the oil will not produce gas in abundance until a temperature of  $250^{\circ}$  is reached. This can be demonstrated by filling a metal tube, 1 in. in diameter by 16 in. long, half full of kerosene and attaching a gas jet over the open end. By heating the kerosene in the tube the jet can be lighted, and it is upon this principle that the generator described herein operates—the cold oil enters one end of the pipe and comes from the burner as a gas or vapor.

The first item that will be required is a piece of brass or copper pipe, threaded at both ends. One end of the pipe is fitted with a reducing elbow and plug, as indicated. For a distance of 12 in. from the elbow the pipe is wrapped with a  $\frac{1}{16}$ -in. layer of sheet mica, and over this is wound sufficient No. 24 resistance wire, or ribbon, to produce a temperature of approximately  $300^{\circ}$  F. inside the pipe when connected across the supply main.

12 in. of size 10 asbestos-covered lead. Rub some magnesia paste, made by mixing equal parts of powdered magnesia and plaster of Paris with water, or better still, the investment compound which can be obtained from dentists, between the turns to hold them in place. The whole coil is covered with a  $\frac{1}{16}$ -in. layer of mica. Twelve feet of  $\frac{3}{16}$ -in. annealed copper tubing will now be required. Keep 6 or 8 in. of one end free, and beginning  $1\frac{1}{2}$  in. above the reducing elbow, wind the tubing around the insulated heating element, as shown in the drawing. Clamp the last turn to hold it firmly,

and bring the loose end down to the plug in the reducing elbow. The brass plug is removed from the elbow and drilled through with a  $\frac{3}{16}$ -in. hole, counterboring,  $\frac{1}{8}$  in. deep, with a  $\frac{1}{4}$ -in. drill. Screw in the plug with powdered graphite, measure the tubing to fit the hole in the plug, cut to size, remove the burr, and braze the end in the plug, this being facilitated by the counterbore. This joint must be oil and gas-tight. The entire assembly is now tightly wrapped with  $\frac{1}{4}$ -in. asbestos rope to within 2 in. of the upper end.

A piece of 3-in. brass or iron pipe with  $\frac{3}{16}$  or  $\frac{1}{8}$ -in. walls, and caps to screw over the ends, are also needed for making the float chamber. The upper cap, as shown in the drawing, is drilled and tapped to take a 1-in. pipe, the lower cap being drilled and tapped with  $\frac{1}{2}$  and  $\frac{3}{16}$ -in. openings. A cylindrical float,  $2\frac{1}{4}$  in. in diameter by 6 in. long, is provided with 10 lugs or guides as shown in the drawing, to keep it centered in the float chamber without friction.

A valve is made, according to the detail drawing, from 1-in. round brass. The valve consists of two parts which are held together with screws, as indicated. The lower end of the valve is turned down to  $\frac{1}{2}$  in. and threaded to fit the



at the bottom cap of the float chamber. The valve is countersunk with a countersinking drill, or rose countersink, to provide a seat for a  $\frac{5}{16}$ -in. steel ball, which acts as a check valve in preventing the float from backing up into the supply.

The upper half of the valve is as shown in the drawing, and the lever is attached to the metal rod which presses down on the ball being fastened somewhat to the lever, to permit sideplay. A  $\frac{1}{2}$ -inch pipe is used to connect the float chamber with the valve, and the pipe is sweated to the former after assembly. The oil supply should be from 5 to 8 ft. above the valve. A short piece of  $\frac{5}{16}$ -in. tubing is soldered to the remaining hole in the bottom of the valve chamber, and a union is used for connecting the remaining end of the copper coil, in the manifold. The heating coil and the float chamber are connected together by the simple piping arrangement shown, and the automatic cut-out, to be de-

scribed, is not used, the end at A is plugged.

The automatic cut-out, which is connected to the end of the pipe at A, consists of a U-shaped metal or glass tube, half-filled with mercury, which acts on a fiber plunger inserted into the free end of the tube so that, when the pressure causes the mercury to rise, it will actuate the lever and open the heating circuit, automatically relieving the pressure, and as the pressure falls, the electrical contact is again established, the operation being automatic. The oil flows into the float chamber through the valve from the gravity tank. As the float chamber becomes filled, the float rises, which forces down the plunger and cuts off the supply. After sufficient pressure has been generated, the pressure forces the mercury in the U-tube up, and the current is cut off from the heating coil. At the very worst, if anything should fail, the mercury will be forced out of the tube which performs the function of a safety valve.

**Rubber Studs Make Instrument Feet**

When assembling a small model, some rubber feet were needed to insulate the machine. For the purpose some old wood supporters were used. The metal parts, with the rubber studs, were re-attached to the underside of the model.—Frank W. Bentley, Missouri, Ia.

**Pinning Sleeve to Shaft without Drilling**

When confronted with the task of pinning a small sleeve to a rod without having a drill at hand, one man did the job in the manner shown, with a hacksaw. Slots were cut in both shaft and sleeve, as indicated. When the two parts were slipped together, the slots lined up to form a hole where they joined. A pin, made from a finishing nail, was driven through and

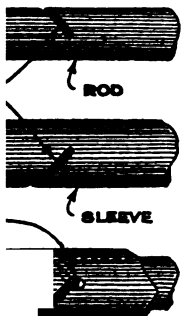

the ends were hammered down flush with the surface of the sleeve. Since there was little strain on the parts, this pin held perfectly.—Thos. W. Benson, Philadelphia, Pa.

**To Find Leaks in Gas Pipe**

Leaks in gas pipes can be detected with an ordinary dial-type air-pressure gauge.

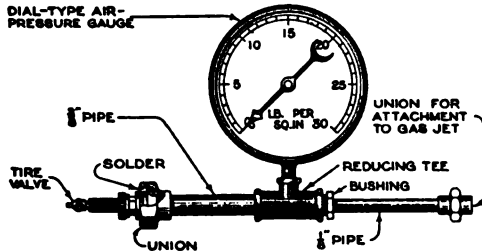

Dial-Type Air-Pressure Gauge, Equipped for Finding Leaks in Gas Pipes: A Tire Pump is Required to Operate the Device

The device is connected with two short pipes of different diameters by means of a reducing tee. A tire valve is installed in the end of the larger pipe, while the smaller is fitted with a union which can be screwed on a gas jet. When a test is to be made, the flow of gas is stopped by turning the meter valve, and the gauge is attached to a jet. A tire pump is connected with the tire valve, and pumped until the gauge shows a certain pressure. If this pressure falls after the pump has been removed, it indicates leaks in the gas pipes. In case a certain section of the latter is believed to be leaking, it should be disconnected from the other pipes and plugged before it is tested.—Ed. Borchik, Cleveland, Ohio.

### Root Cellar under Driveway

Farmers are more and more learning to utilize waste places. One farmer made a very satisfactory root cellar under the

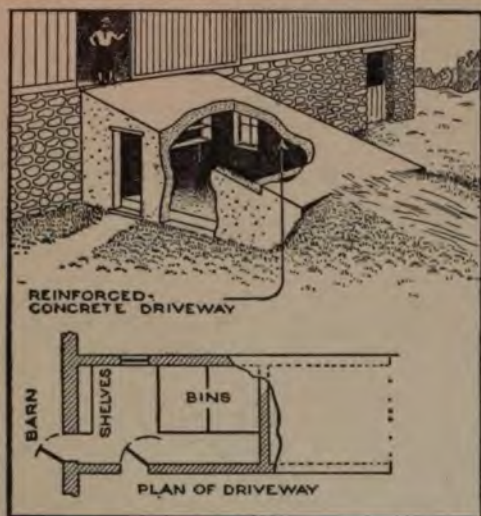

Instead of Filling Up the Space under the Driveway, This Farmer Uses It for Storing Roots

driveway to the second floor of his barn. Since the top must be reasonably thick, and the sides or walls were required for the drive, the only extra cost was that incurred by putting in a window and doorway, and making the roof slightly thicker, to stand up under the strain of the loaded wagons to be driven over it.—Dale R. Van Horn, Lincoln, Neb.

### Tapping in a Lathe

When tapping a job in the lathe, running the center against the end of the tap keeps the tap straight. In doing this, however, the mechanic cannot work very rapidly because he has three things to attend to



—power tap wrench, and tailstock wheel—and but two hands to do it with. This

disadvantage may be overcome; if a small pulley is made and tapped out to fit in place of the tailstock nut, the center can be fed

against the tap as fast as it advances into the work, leaving both hands free for the power and tap wrench; this is accomplished by attaching one end of a piece of stout twine to the pulley and wrapping it around several

times, and then fastening the end of the twine to the pulley arm. A weight is attached to the free end, and as the tap advances in the work the tension on the string turns the tailstock wheel and keeps the center against the tap.

### Tracing Wheel Rules Dotted Lines

Dotted lines may be made very rapidly with a tracing wheel, such as used by dressmakers and seamstresses, and a piece of carbon paper or typewriter ribbon. To make the dotted lines, place the ruler in position and slip a strip of carbon paper, or typewriter ribbon, under the edge. The dotted line is made by passing the toothed wheel over the paper or ribbon. If a whole sheet of paper is to be ruled with dotted lines, a sheet of carbon paper is placed, face up, under the page and the lines are ruled. The closeness of the dots may be varied by using wheels with different numbers of teeth. To prevent cutting holes in the paper, the points of the teeth are dulled with a file.

### Connecting-Rod Babbitting Fixture

The most difficult part of the job, in rebabbitting the crank bearing of a connecting rod, is to make sure that the bearing is exactly at right angles to the

center line of the piston. A very simple fixture has been found to insure this. A piece of 1-in. iron pipe, ground to size, is used as the arbor, and collars are mounted as in the usual practice. These are held on by the binding nuts, which fit onto threads cut at the ends of the arbor. At one side is the upright, which is merely a stiff bar of cast iron, with a V-groove cut in its lower end, in which the piston may fit. In this grooved part is cut a hole the same size as the wrist pin, and spaced the same distance from the center of the arbor and crank bearing. A short pin is inserted in this hole, and the piston is clamped against the groove, with the pin just entering the wrist-pin

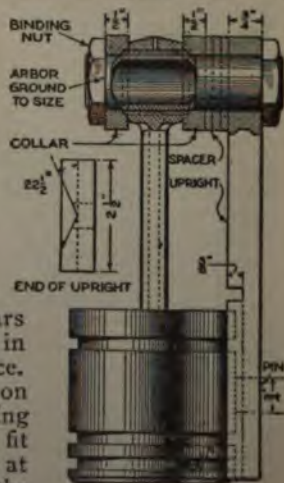

pin just entering the wrist-pin



ing. The larger bearing is then centered over the arbor, and a spacer, or collar, of proper thickness to bring the piston rod just perpendicular to the arbor. This thickness will of course vary with the diameter of the piston; it can be found either by calculation from the piston size, or by measurement. The oil is poured through the hole provided in the rough bearing, and should be removed afterward by scraping.

### A Folding Scaffolding Support

A folding scaffolding support, for the use of carpenters when applying siding to a building, is shown in the drawing. These



supports, or jacks, are made from two 2 by 4-in. pieces connected together at one end with a hinge, the free ends being provided with pivoted hooks in the manner shown. In use, the mechanic bores holes through the sheathing on the side of the building and inserts the hooks, as indicated, lays his boards

and proceeds with the application of the siding, working from the top to the bottom of the house. The location of the support is changed from time to time to accommodate the work as it progresses. See L. Blickenstaff, N. Manchester, Pa.

### Guide for Sawing Bottom of Door

When the amount to be trimmed from the bottom of a door is so small that difficulty is experienced in guiding the saw, the work will be facilitated by a simple device. If, for instance, a cut just the thickness of the saw is to be removed, the door is marked and a narrow strip of wood is nailed to the bottom. Only two nails are required, one at each end of the strip, and these are placed several inches from the end. The cut is then made, holding the saw against the strip, and continued until the first nail is reached; this is withdrawn and driven in with the heel of the saw, the operation being repeated when the second nail is reached. The guiding strip will be found more effective if made of hard wood.

### Trash Box for Garage or Shop

A trash box should form part of the equipment of every well-kept shop, as it provides against the accumulation of dirt

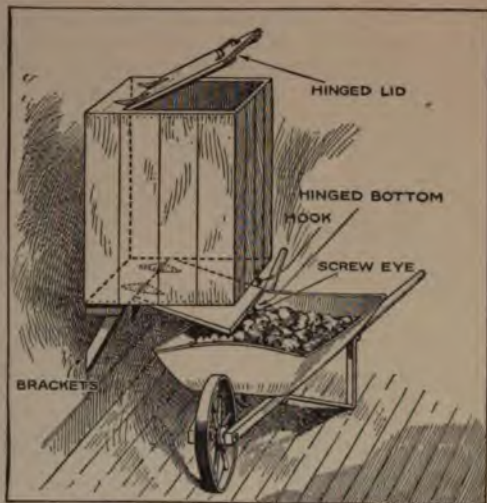

A Trash Box, for the Shop or Garage, That Discharges Its Contents into a Wheelbarrow Underneath

on the floors and in corners. The drawing shows an improved box for this purpose, which is readily made and easily emptied; it is mounted high enough to permit a wheelbarrow to be run under the box when it is to be emptied. A hinged bottom permits removal of the contents without the necessity of overturning the box. The box may be built of wood, but if it is to receive oily waste and rags, sheet metal would be preferable.

### Filing Small Screws

Filing the ends of small screws is usually rather awkward, on account of the difficulty of holding them firmly. This difficulty can be overcome by placing the screw in a pair of pliers, or nippers, and screwing the latter up tightly in a vise, as shown in the photograph.



Care should be taken to place the pliers, or nippers, in the vise as close to the fulcrum as possible to prevent possibility of cutting the screw.—F. R. M. Dunsmuir, Scranton, Pa.

## Ice-Cutting Machine Made from Automobile Parts

With very few exceptions, standard parts from an automobile were used in the construction of the ingenious ice-cutting machine shown in the drawing. The 40-in. circular saw is driven directly from the engine by means of the differential bevel gears. A substantial angle-iron frame, 13 ft. long, supports the engine, radiator, and other parts, and the whole is mounted on a set of runners, as shown,

spark-control rods, as well as the clutch-control lever, are within easy reach of the operator's hands. There is a gauge at either end of the machine by which the depth of cut is regulated, while adjustable gauges at each side engage in the previous cut and thus the cuts are uniformly spaced.

In operation, the engine is cranked in the ordinary way and the clutch thrown into engagement. For use with a saw of the diameter mentioned, about 500 r.p.m. will be found sufficient. As soon as the saw touches the ice it drops right into it, and the machine immediately begins to advance under its own power and must be held back by the operator, who otherwise would be forced to run to keep up with it. The top of the saw is covered with a sheet-metal guard.

In designing this machine, the object in view was to use the parts from the automobile without alteration, so that, at the end of the ice-cutting season, the machine could be disassembled and the parts again installed in the automobile.—Bayard D. Evans, Scranton, Pa.



Automobile Parts are Used to Make a Self-Propelled Ice-Cutting Machine. At the End of the Season the Machine is Dismantled and the Car is Reassembled

in such a manner that the saw can be lowered or raised as desired. Handles are attached to the rear of the frame for guiding the machine, and throttle and

end of the ice-cutting season, the machine could be disassembled and the parts again installed in the automobile.—Bayard D. Evans, Scranton, Pa.

## Adjustable Pipe Wrench

The pipe wrench shown in the drawing, which has a wide range of adjustment, is

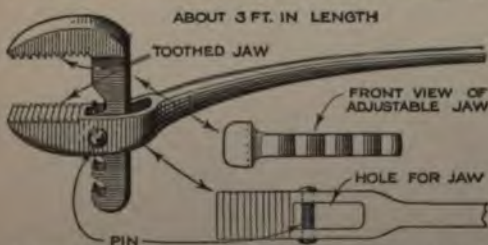

A Pipe Wrench with a Wide Range of Adjustability That Also Serves as a Pinch Bar When the Adjustable Lower Jaw is Removed: It is Made from Forged Steel

the product of a plumber's ingenuity. The main feature of this tool is the adjustable jaw, which permits it to be adjusted rapidly to handle any size of pipe within the wrench's capacity; the jaw may be removed entirely, and the handle

used as a small pinch bar. All parts are hand-forged from a good grade of steel, and the jaws are hardened after the teeth have been cut.

## Using Liquid Manure

Most gardeners do not use liquid manure because they do not know how to prepare it. This form of fertilizer has the advantage of being "quick," because the soluble plant-food elements are carried directly to the roots.

The first requisite in the preparation of liquid manure is a water-tight barrel. The fertilizer is made by filling the barrel half or three-fourths full of water and then suspending in it, from a stick across the top, a burlap bag filled with any available animal manure.

It is inevitable that the solution, thus prepared, will vary greatly in strength. No rules for dilution can be laid down, however, but it must be diluted with



water until it is about the color of weak tea, or some crops will be actually damaged by its application—"burnt," as the expression has it. The barrel containing the liquid manure can be transported from one point to another by using a simple wooden frame which consists of two long pieces forming handles joined together near the center by two cross-pieces. The opening thus formed should be slightly narrower than the widest diameter of the barrel. With this arrangement it is not necessary to attach the carrier to the barrel, and when not in use, it drops to the ground.—John T. Bartlett, Boulder, Colo.

### A Fixture for Cutting Wire Cable

The drawing shows a tool whose value can best be appreciated by loggers, seamen, and miners, as, with it, a wire cable of ordinary dimensions can be easily cut. The frame is made of tool steel and one side is provided with a cutting edge which acts as a shear blade; this cutting edge is beveled and tempered. The opposite frame member, which may be of mild steel, is provided with an opening to permit movement of the cable. The frame is assembled by placing spacers at each end and bolting, as shown; this will leave an opening in the center for the insertion of the sliding cutter and wedge. The cutter is made of tool steel with a beveled, semi-circular cutting edge, which is hardened and tempered. The dogs at the sides prevent the cable from bending while it is being cut. Both the wedge and the cutter should fit snugly, without sideplay, and plenty of oil should be used when making a cut. The cutter is operated by placing the cable between the two cutters and driving the wedge in behind the sliding cutter with a sledge hammer.—Chas. O. Olsen, Portland, Ore.

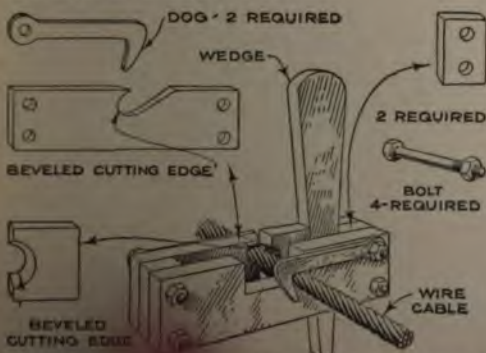

A Simple Tool for Cutting Wire Cable, the Value of Which is Appreciated by Seamen and Loggers

### A Wheel Puller for Full-Floating Rear Axles

To pull an automobile rear wheel from a full-floating axle is not quite so easy as



Pulling a Wheel from a Full-Floating Axle Is Easy When a Suitable Tool Is Applied; the Illustration Shows a Simple Tool for This Purpose

with the simpler types of rear axle, since the common wheel puller does not fit the job. Determined to make this work easy, once for all, one owner of a car of this type made a puller especially to fit his car, and the tool has since then relieved him of all difficulties in removing wheels. It consists of a screw, fitted with a handle working in a piece of heavy bar iron, which is drilled and tapped for the screw, and which also has two slotted holes near the ends. A hardwood cylinder, turned with a shoulder, completes the outfit; the cylinder is of a size to fit inside the wheel hub, and to bear directly against the axle shaft, as shown. Two of the screws around the hub of the wheel are removed, and replaced after passing them through the holes in the puller. Screwing up, as usual, removes the wheel, without danger of damage to any part of the hub.

### Protecting Painted Walls from Dirt

Means for protecting a coat of paint, in kitchens, and simplifying the task of cleaning, is afforded by the use of a thin solution of starch and water. The starch solution is applied over the paint, after it has dried; this will detract somewhat from the gloss of the paint, but all dirt, grease, and smoke will adhere to the starch instead of to the paint, and when cleaning time arrives, the starch coating can be washed off, removing the dirt along with it. By applying another coat of starch, the paint will be kept fresh for a long time.—Chas. Waller, Chicago, Ill.



## Ice-Cutting Machine Made from Automobile Parts

With very few exceptions, standard parts from an automobile were used in the construction of the ingenious ice-cutting machine shown in the drawing. The 40-in. circular saw is driven directly from the engine by means of the differential bevel gears. A substantial angle-iron frame, 13 ft. long, supports the engine, radiator, and other parts, and the whole is mounted on a set of runners, as shown,

spark-control rods, as well as the clutch-control lever, are within easy reach of the operator's hands. There is a gauge at either end of the machine by which the depth of cut is regulated, while adjustable gauges at each side engage in the previous cut and thus the cuts are uniformly spaced.

In operation, the engine is cranked in the ordinary way and the clutch thrown into engagement. For use with a saw of the diameter mentioned, about 500 r.p.m. will be found sufficient. As soon as the saw touches the ice it drops right into it, and the machine immediately begins to advance under its own power and must be held back by the operator, who otherwise would be forced to run to keep up with it. The top of the saw is covered with a sheet-metal guard.

In designing this machine, the object in view was to use the parts from the automobile without alteration, so that, at the end of the ice-cutting season, the machine could be disassembled and the parts again installed in the automobile.—Bayard D. Evans, Scranton, Pa.



Automobile Parts are Used to Make a Self-Propelled Ice-Cutting Machine. At the End of the Season the Machine is Dismantled and the Car is Reassembled

in such a manner that the saw can be lowered or raised as desired. Handles are attached to the rear of the frame for guiding the machine, and throttle and

## Adjustable Pipe Wrench

The pipe wrench shown in the drawing, which has a wide range of adjustment, is

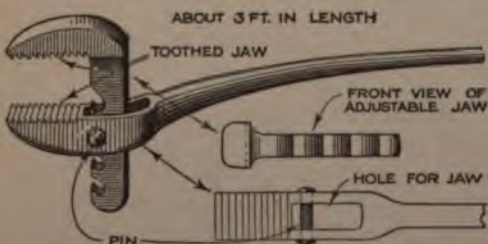

A Pipe Wrench with a Wide Range of Adjustability That Also Serves as a Pinch Bar When the Adjustable Lower Jaw is Removed; It is Made from Forged Steel

the product of a plumber's ingenuity. The main feature of this tool is the adjustable jaw, which permits it to be adjusted rapidly to handle any size of pipe within the wrench's capacity; the jaw may be removed entirely, and the handle

used as a small pinch bar. All parts are hand-forged from a good grade of steel, and the jaws are hardened after the teeth have been cut.

## Using Liquid Manure

Most gardeners do not use liquid manure because they do not know how to prepare it. This form of fertilizer has the advantage of being "quick," because the soluble plant-food elements are carried directly to the roots.

The first requisite in the preparation of liquid manure is a water-tight barrel. The fertilizer is made by filling the barrel half or three-fourths full of water and then suspending in it, from a stick across the top, a burlap bag filled with any available animal manure.

It is inevitable that the solution, thus prepared, will vary greatly in strength. No rules for dilution can be laid down, however, but it must be diluted with



nd at this temperature is a thin liquid, when heated to about 320° it becomes thick, making it hard to pour from ladle. Therefore, the sulphur should be heated until it is all melted, when it be quite thick. Remove the pot from fire and allow the sulphur to cool until it becomes thin enough to pour into hole into which the bolt has already placed.

to fasten bolts in a concrete ceiling, the sulphur cannot be used, a thick mass of litharge and glycerin is used.—Buck, San Francisco, Calif.

### Increasing the Height of a Chimney While in Use

A contractor undertook to add to the height of a brick smokestack without interfering with its daily use, and the job successfully accomplished in an original manner. A large opening was made on the side of the square stack, somewhat above the top; 5-in. spikes were driven into the masonry, 5 or 6 in. below the top of the stack, and several pieces of corrugated sheet iron, of the proper thickness, were supported by these spikes, completely closing the top of the stack and forcing the smoke out of the opening. After this preparatory work had been completed, the masons were brought on the job and the work of adding to the stack was completed. Afterward the pieces of sheet iron were removed through the opening underneath, and was then bricked up.

### Draining the Radiator Made Easy

A piece of iron rod properly applied to drain cock of an automobile radiator overcomes the contortions and inconvenience of draining the radiator, as it is normally done. As shown in the drawing, a hole is drilled in the handle of the drain cock and one end of a piece of iron rod is inserted and bent into an eye; this rod is carried out beyond the frame, from which it is supported by

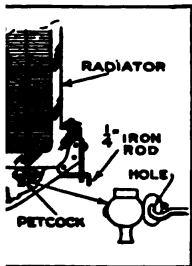

a length of flat iron bolted to the side, as indicated. A handle is formed on the outer end of the rod, and as this is in an exposed location, the drain cock can be opened without difficulty.

### Electrically Lighted Fixture Keeps Soldering Bit Hot

For the repairman who requires a hot soldering bit at intervals during the day,

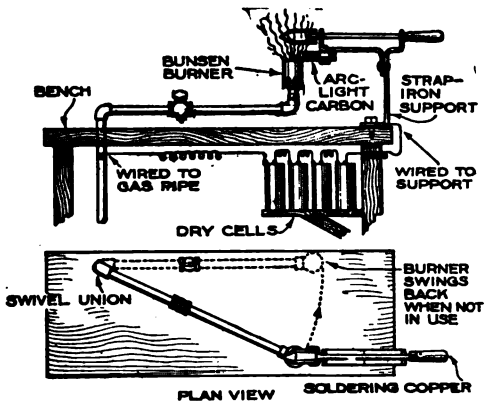

An Automatic Electric Lighter for a Gas Soldering-Bit Heater. The Burner Swings Back against the Wall and Leaves the Bench Clear for Other Work

the arrangement shown in the drawing will prove decidedly convenient. An ordinary Bunsen burner is attached to a swinging pipe which is connected to the gas supply by a swivel union, as shown. A support for the soldering bit is made from pieces of flat iron, and is bolted to the bench in such a position that the burner can be swung in under the point of the bit. A clamp on the underside of the support is provided to hold a piece of arc-light carbon.

To supply current, four to six dry cells are connected to the separate parts of the arrangement, as indicated, the wires being soldered to the metal parts. Swinging the burner, with the gas turned on, so that contact is made with the arc-lamp carbon, a spark is produced which lights the gas instantly. The burner should be so arranged that it will not be in steady contact with the carbon, to avoid discharging the battery. When the burner is swung back against the wall, the bench top is clear for other work, the stand not being much in the way.

### Coke as a Substitute for Sandpaper

A sandpaper substitute, that has special merit for removing rust from tools without scratching, is made from crushed coke. The coke is crushed to the required degree of fineness and sifted through a piece of cloth onto a piece of coarse paper which has been coated with glue. After the glue has dried, the paper is ready for use.

### Natural-Gas Flow Operates Improved Water Pump

A satisfactory pumping arrangement was devised in a West Virginia gas field

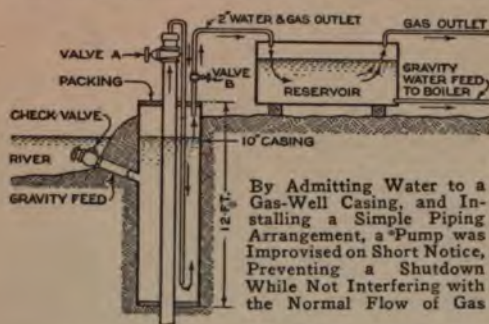

By Admitting Water to a Gas-Well Casing, and Installing a Simple Piping Arrangement, a "Pump" was Improvised on Short Notice, Preventing a Shutdown While Not Interfering with the Normal Flow of Gas

recently when a tie-up of local railroads deprived several drillers of the pump which was to have raised water from a near-by river to the boilers of their engines. They first laid a gravity-feed pipe from the river to the 10-in. air and water-tight casing, that surrounds one of the gas wells of the vicinity for 12 ft. before its emergence from the ground. From the main gas valve one pipe was sunk to the bottom of this casing; another was led from the top of the casing to the top of a water tank placed above the boilers. River water was then admitted to the casing through the gravity pipe. Now the gas valve was opened. Under high pressure, the gas passed down through the first pipe, and up through the water; out of the second pipe, into the water tank, and then out through a pipe in the top of the tank. As it traveled this route, the gas carried with it, as a fine spray, a steady flow of water. This fell into, and soon filled, the tank.

Had the main object been to pump the water, without at the same time allowing the gas to flow, the water-outlet pipe would have been run down to the lower position and the gas pipe cut off just inside the casing, to allow the gas pressure to act on the water.

### An Emergency Babbitt Ladle

For the infrequent pouring of babbitt bearings in the home garage, or shop, an old hub cap can be used, if the quantity of metal to be poured is not large. A hole is drilled through one side of the cap and a threaded rod is secured by nuts on both sides. For convenience in pouring, a lip can be formed with a hammer. A discarded piston can be similarly used by

passing a threaded rod through the piston-pin hole and using nuts and washers. A notch, filed or ground into the rim of the piston, serves as a pouring lip.

### Internal Friction Wheel Gives High Speed Reduction

A simple method of driving some slow-speed machine, such as a grindstone, by an engine without the use of belts or countershafts, is shown in the illustration.

Referring to the drawing it will be observed that the connecting shaft is attached to the center of the wooden wheel which has a round rubber tire, about  $\frac{1}{2}$  in. in diameter, fitted to its circumference. A hole is drilled in the center of the wheel, to engage with the pin on the end of the engine crankshaft, as indicated; this pin is set  $\frac{1}{2}$  in. off center, so that it will force the wheel against the edge of the circular opening in the upright board. The engine is set on the platform so that the center of the shaft lines up with the center of the opening. The board platform and upright are hinged together to permit their being folded together when not in use, and are fitted with angular braces, as shown. If the engine is once lined up, it can be easily removed and replaced without disturbing the alinement.

This arrangement gives a ratio of 13 to 1, or a reduction in speed from 550 r.p.m. to slightly more than 40. With a reduc-

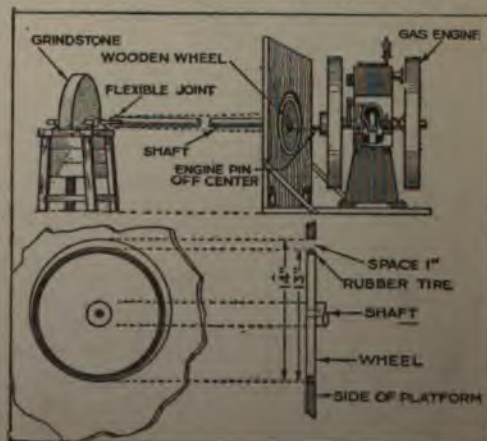

This Method of Obtaining Speed Reduction Employs No Shafts, Pulleys, or Belts. It Reduces Speed from 150 Revolutions to Slightly More than 40

tion gear of this character, the driven machine must be equipped with a flexible coupling, as shown, in order to offset the vibration of the shaft.—Philip G. Bernholz, E. Orange, N. J.



and at this temperature is a thin liquid, when heated to about 320° it becomes thick, making it hard to pour from ladle. Therefore, the sulphur should be heated until it is all melted, when it is quite thick. Remove the pot from fire and allow the sulphur to cool until it becomes thin enough to pour into hole into which the bolt has already been placed.

To fasten bolts in a concrete ceiling, the sulphur cannot be used, a thick mixture of litharge and glycerin is used.—Buck, San Francisco, Calif.

### Increasing the Height of a Chimney While in Use

A contractor undertook to add to the height of a brick smokestack without interfering with its daily use, and the job was successfully accomplished in an original manner. A large opening was made on the side of the square stack, somewhat above the top; 5-in. spikes were driven into the masonry, 5 or 6 in. below the top of the stack, and several pieces of corrugated sheet iron, of the proper length, were supported by these spikes, completely closing the top of the stack and forcing the smoke out of the opening. After this preparatory work had been completed, the masons were brought on the job and the work of adding to the stack was completed. Afterward the pieces of sheet iron were removed through the opening underneath, and was then bricked up.

### Draining the Radiator Made Easy

A piece of iron rod properly applied to drain cock of an automobile radiator eliminates the contortions and inconvenience of draining the radiator, as it is normally done. As shown in the drawing, a hole is drilled in the handle of the drain cock and one end of a piece of iron rod is inserted and bent into an eye; this rod is carried out beyond the frame, from which it is supported by

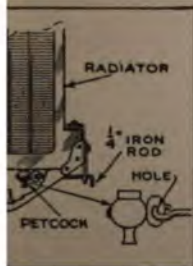

an equal length of flat iron bolted to the side, as indicated. A handle is formed on the outer end of the rod, and as this is in an exposed location, the drain cock can be opened without difficulty.

### Electrically Lighted Fixture Keeps Soldering Bit Hot

For the repairman who requires a hot soldering bit at intervals during the day,

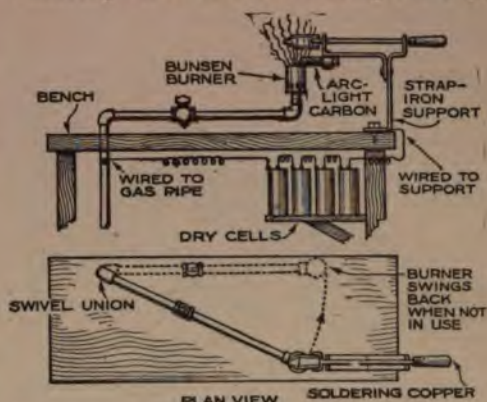

An Automatic Electric Lighter for a Gas Soldering-Bit Heater. The Burner Swings Back against the Wall and Leaves the Bench Clear for Other Work

the arrangement shown in the drawing will prove decidedly convenient. An ordinary Bunsen burner is attached to a swinging pipe which is connected to the gas supply by a swivel union, as shown. A support for the soldering bit is made from pieces of flat iron, and is bolted to the bench in such a position that the burner can be swung in under the point of the bit. A clamp on the underside of the support is provided to hold a piece of arc-light carbon.

To supply current, four to six dry cells are connected to the separate parts of the arrangement, as indicated, the wires being soldered to the metal parts. Swinging the burner, with the gas turned on, so that contact is made with the arc-clamp carbon, a spark is produced which lights the gas instantly. The burner should be so arranged that it will not be in steady contact with the carbon, to avoid discharging the battery. When the burner is swung back against the wall, the bench top is clear for other work, the stand not being much in the way.

### Coke as a Substitute for Sandpaper

A sandpaper substitute, that has special merit for removing rust from tools without scratching, is made from crushed coke. The coke is crushed to the required degree of fineness and sifted through a piece of cloth onto a piece of coarse paper which has been coated with glue. After the glue has dried, the paper is ready for use.



### A Simple Drill Vise

A very efficient, quick-opening and closing vise for the drill-press table, is

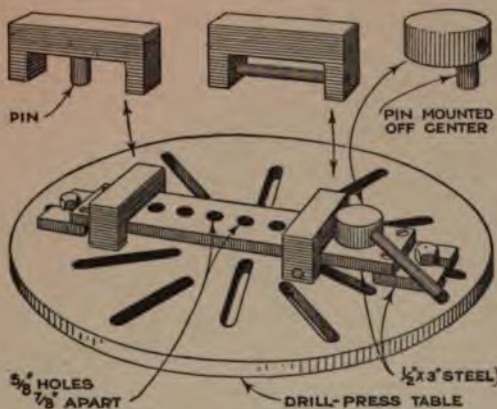

An Efficient and Easily Made Vise, Which can be Quickly Adjusted and Operated

shown in the drawing. The steel bar which forms the bed of the device is provided with holes at regular intervals and supported from the drill-press table, at the ends, by pieces of the same stock, provided with slots for bolting to the table. The jaws are movable on the bar, the fixed one having a pin driven into it which fits into the holes; the movable jaw is held in place by a horizontal pin riveted to the sides, as shown. The cam consists of a disk of steel shafting into one face of which a pin, to fit the holes in the bar, is driven eccentrically. At right angles to this pin a handle is inserted into a hole in the circumference of the cam.—C. H. Willey, Concord, N. H.

### A Handy Sanding Block

The accompanying drawing illustrates the construction of a sanding block of



unusual merit. As the fingers do not come into contact with the rough surface of the abrasive, sore fingers are eliminated. The device is constructed from a hardwood block, with slanting grooves cut on one side, as shown, to hold one edge of the paper, which is brought around underneath the block and held on the other side by the clamp;

this is hinged at one end, a latch at the opposite end serving to keep the clamp in place.—E. K. Wehry, Cedar Rapids, Ia.

### Making Compass Leads

By reducing the diameter of leads from common pencils, the draftsman can make his own compass leads. This is done by laying a pencil pointer on the table, holding another in one hand, and rolling the lead back and forth between the two sandpaper surfaces.—Earl Stevens, Niagara Falls, N. Y.

### A Neat Window Cooler

Instead of the usual full-length storm sash, the window shown in the illustration is in two sections. The upper half is attached with buttons in the usual manner, but the lower half is set out about 8 in. from the window sill and is boxed in tightly;

this forms a clean, cool, covered shelf, about 12 in. deep, to which the lower sash of the inner window forms a close-fitting glass door that may be raised or lowered as desired. With a sash curtain in place, the appearance of the window cooler is as neat as though it served only its usual purpose, and very little light is excluded by the arrangement. From early fall until the last spring frosts, this arrangement makes an excellent and satisfactory substitute for the refrigerator.—Rubie Franklin, Rochester, Minn.



### The Making of Amber Varnish

Amber gum is a well-known commercial product, and is used principally for the manufacture of pipe stems, cigar tubes, beads, etc.; also in the manufacture of very high-grade, hard, and durable varnish. Gum amber is a fossil resin and is the hardest, most resistant and beautiful of all gums.

To convert this gum into varnish it must first be made liquid, or melted, which requires a temperature of 500 or 600° F. To melt amber successfully a good



crucible holding about 1 qt. is required. The crucible should have a stiff wire holder for removing it from the fire, and a short steel rod driven into a wooden handle is also required for stirring the melting gum. Scrap amber is thrown into the crucible with no regard to color unless some particular result is sought. The best means of heating is to build a good coal fire in the kitchen range with the coals coming close to the top of the open hole. After the gum has been placed in the crucible, it is sunk well down into the hot coals. From the time the crucible is placed in the fire particular care must be exercised to prevent the melting mass from becoming hot enough to catch fire. If this should happen, the crucible may be lifted from the fire and the flame blown out, after which it is replaced over the fire. The melting mass should be stirred constantly. When the gum is entirely melted, it is removed from the fire and allowed to cool to the point where a drop of oil does not cause it to blaze up. Then add drop by drop enough of the best boiled linseed oil to reduce the mass to the proper consistency. Some charges of gum will require more oil than others, but by rubbing a drop of the varnish on a piece of polished wood and allowing it to cool, the proper fluidity can be observed, meanwhile keeping the crucible of varnish hot. When the varnish attains the proper consistency, it should be strained while hot through a very fine wire strainer, preferably more than once. Amber varnish may be almost white or it may be any shade between that and the rich wine color of costly pipe stems. The color will be varied somewhat by the degree of heat required to melt the gum, the length of time it is cooked after melting, and by the original color of the gum used.

### Skin Infections Caused by Oils and Grease

The practice of washing the hands in oil or grease, common among workmen in industrial establishments, is responsible for many mysterious epidemics of boils, eczema, and other skin diseases, according to the Department of Labor.

The grease or oils, as they come to the plant, do not contain any bacteria, but become contaminated after being handled by employes having pus infections on their hands or arms.

The use of gloves by workmen who handle grease is recommended, and frequent cleansing of the hands with warm water and good soap.

### Using the Protractor

A handier method of using the protractor than that usually employed is shown in the illustration.

The protractor and a triangle are placed

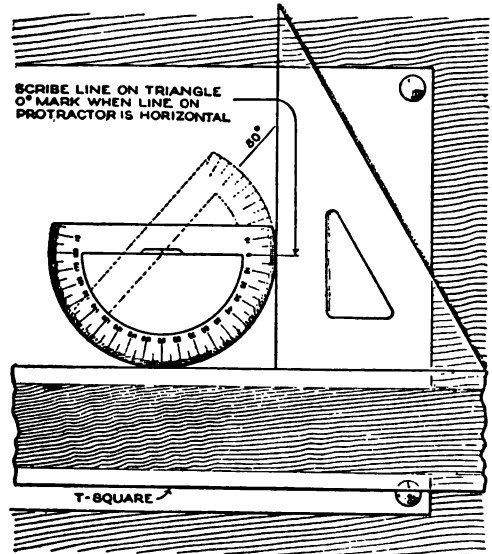

A Method of Using a Protractor, Which Is in Some Respects Handier than the Usual One

upon the T-square as shown, and a mark is made upon the triangle corresponding to the zero mark on the protractor, when the latter is in a perfectly horizontal position. Now, by keeping the T-square and triangle in the same relative position, lines may be drawn with the straight edge of the protractor, the angles being found by simply rotating the protractor until the proper graduation coincides with the mark on the triangle.—C. B. Smith, Indianapolis, Ind.

### Reducing Breakage of Small Drills

The breakage of small drills caused by too great downward pressure in drilling,

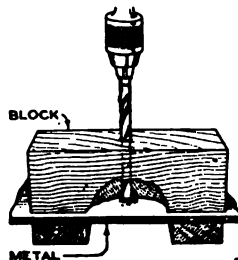

can be largely reduced. A wooden block, of sufficient thickness to allow the drill to extend through the underside, is drilled; this is then laid on the work, as shown in the drawing. The block will serve not only to absorb most of the side strain but also to steady the drill.

### Tire-Repair Stand

A tire stand that facilitates the handling of tires and tubes in the small tire-

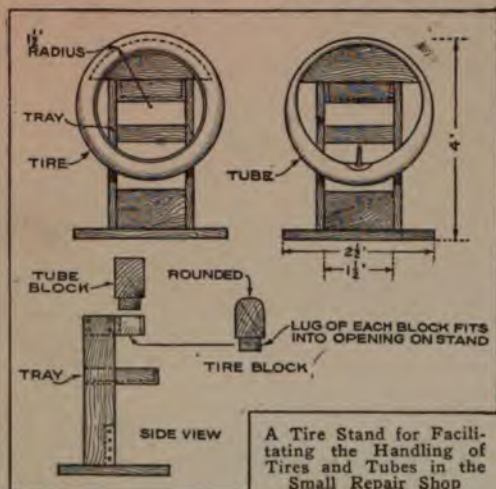

repair shop, is shown in the drawing. As the whole device is made from wood, it is easily built. The stand consists of a framed support and two semicircular blocks; one of the blocks has a flat face, for use in repairing tubes, and the face of the other is rounded to conform to the inside of a cover placed over it for repair. A lug on the bottom of each block fits into an opening provided in the top of the stand, so that they are readily interchangeable.

### A Homemade Pipe Wrench

A homemade pipe wrench that has some advantages over the purchased article is shown in the drawing.

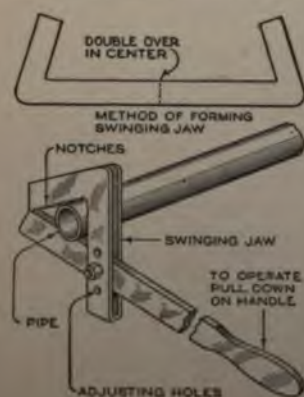

The upper jaw is free to swing and is provided with holes for adjustment, although a wide range of pipe sizes can be accommodated in each position of the jaw. With the exception of the bolt all parts are

made from flat steel. The jaw is made by bending over the ends, as shown, and then bending at the center; notches are

filed in the underside, and if possible, this part of the wrench is hardened to minimize wear.—R. H. Kasper, Philadelphia, Pennsylvania.

### Ruling Lines with Cross-Section Paper

Common cross-section paper can be made to help very materially in properly spacing lines that are to be drawn parallel with each other, regardless of the distance between lines. A strip of the paper is used as a guide on the edge of the area to be ruled. The distance between the lines can be varied by changing the angle of the line from which one works, either by moving the cross-section paper or by using different triangles.—Frank W. Roth, Joplin, Mo.

### Fixture for Splitting Round Rubber

Almost everyone knows the difficulty of attaching round rubber to a flat surface so as to make a neat job, and splitting the rubber

so that the cut surface will be even is also difficult. The simple fixture illustrated herewith shows how the latter can be done quickly and neatly. A hole to accommodate the rubber is drilled in a board, and an old razor blade is fastened securely into a groove provided for it on one side.



The operation is started by slitting the rubber for a few inches with a knife and then inserting it in the fixture and pulling it through from the back.—Frank Jablecnik, Chicago, Ill.

### Painting Screens with a Sponge

Wire screens can be painted more easily and with better results than by the ordinary method of painting with a brush, if the paint is thinned and applied to the screen with an old sponge.—Edward B. Zolle, Jersey City, N. J.

☛ A heat-resisting cement is made of equal parts of manganese peroxide and zinc white, mixed with water glass, or sodium silicate.



crucible holding about 1 qt. is required. The crucible should have a stiff wire holder for removing it from the fire, and a short steel rod driven into a wooden handle is also required for stirring the melting gum. Scrap amber is thrown into the crucible with no regard to color unless some particular result is sought. The best means of heating is to build a good coal fire in the kitchen range with the coals coming close to the top of the open hole. After the gum has been placed in the crucible, it is sunk well down into the hot coals. From the time the crucible is placed in the fire particular care must be exercised to prevent the melting mass from becoming hot enough to catch fire. If this should happen, the crucible may be lifted from the fire and the flame blown out, after which it is replaced over the fire. The melting mass should be stirred constantly. When the gum is entirely melted, it is removed from the fire and allowed to cool to the point where a drop of oil does not cause it to blaze up. Then add drop by drop enough of the best boiled linseed oil to reduce the mass to the proper consistency. Some charges of gum will require more oil than others, but by rubbing a drop of the varnish on a piece of polished wood and allowing it to cool, the proper fluidity can be observed, meanwhile keeping the crucible of varnish hot. When the varnish attains the proper consistency, it should be strained while hot through a very fine wire strainer, preferably more than once. Amber varnish may be almost white or it may be any shade between that and the rich wine color of costly pipe stems. The color will be varied somewhat by the degree of heat required to melt the gum, the length of time it is cooked after melting, and by the original color of the gum used.

### Skin Infections Caused by Oils and Grease

The practice of washing the hands in oil or grease, common among workmen in industrial establishments, is responsible for many mysterious epidemics of boils, eczema, and other skin diseases, according to the Department of Labor.

The grease or oils, as they come to the plant, do not contain any bacteria, but become contaminated after being handled by employes having pus infections on their hands or arms.

The use of gloves by workmen who handle grease is recommended, and frequent cleansing of the hands with warm water and good soap.

### Using the Protractor

A handier method of using the protractor than that usually employed is shown in the illustration.

The protractor and a triangle are placed

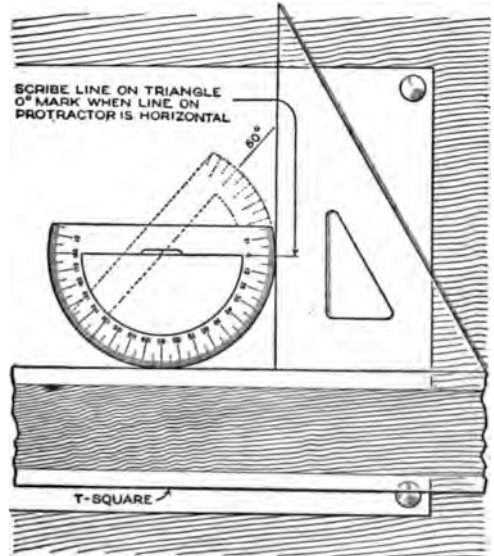

A Method of Using a Protractor, Which Is in Some Respects Handier than the Usual One

upon the T-square as shown, and a mark is made upon the triangle corresponding to the zero mark on the protractor, when the latter is in a perfectly horizontal position. Now, by keeping the T-square and triangle in the same relative position, lines may be drawn with the straight edge of the protractor, the angles being found by simply rotating the protractor until the proper graduation coincides with the mark on the triangle.—C. B. Smith, Indianapolis, Ind.

### Reducing Breakage of Small Drills

The breakage of small drills caused by too great downward pressure in drilling,

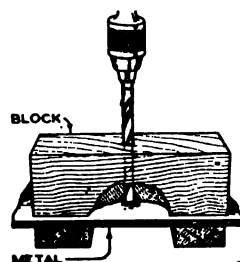

can be largely reduced. A wooden block, of sufficient thickness to allow the drill to extend through the underside, is drilled; this is then laid on the work, as shown in the drawing. The block will serve not only to absorb most of the side strain but also to steady the drill.

the commutator end in a steady rest, instead of carrying it on the center in the usual way. The steady rest can be set to hold the job with the commutator bars in precisely the correct position, at a considerable saving in time and trouble.—Howard Greene, Broadway, N. Y.

### Trouble Lamp Always Kept Handy

While trouble lamps on automobiles are practically indispensable where tire

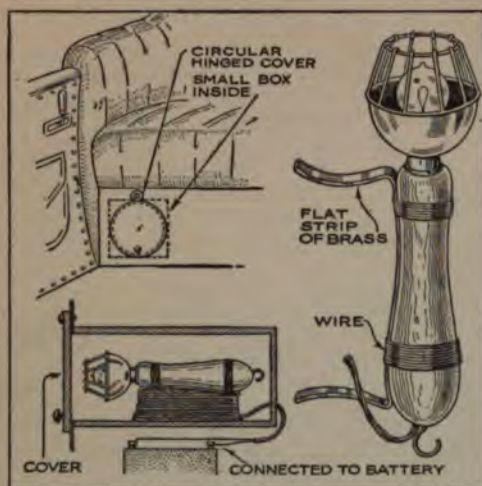

An Arrangement Which Makes the Trouble Lamp Easy of Access, and Which Keeps Lamp and Cord in Good Order

or engine trouble is met with at night, the length of cord required is somewhat bothersome, usually becoming entangled with everything in the tool box. A small box, large enough to contain lamp and cord, is built at one end of the tool compartment. A flat strip of brass is bent, as shown in the drawing, and securely wired to the lamp; this serves as a cleat to wind the cord around. A hinged cover, closing by its own weight, is provided, and the connection to the battery is taken out through the rear end of the box. This makes a very neat arrangement, finding and using the lamp being the work of but a moment.—G. A. Luers, Washington, D. C.

### Wire-Fence Frame for Snow Houses

Boys have a lot of fun building snow forts and houses, but generally the result is more or less unsatisfactory. However, by forming wire fencing into the shape of an Eskimo igloo and covering it with tightly packed snow, a first-class and last-

ing snow house is the result. After the snow has been packed around the wire form, it is watered slightly so that the whole mass will freeze into a solid piece.—Wm. E. King, Monessen, Pa.

### Preventing Bolts from Turning

When placed in wood, the square shank of a carriage bolt seldom prevents the bolt from turning when a rusted nut is to be removed. This movement of the bolt can be prevented by drilling a small hole through the head of the bolt and driving a nail through it into the wood, parallel with the bolt. If the bolt head is not accessible, the same plan can sometimes be followed by drilling through the wood and the bolt at right angles, and inserting the nail as described.

### Homemade Snowshoes

A serviceable set of snowshoes can be made from almost anything broad and light enough to be worn comfortably. Thus, two chair seats, trimmed off to the desired form, may have thongs attached to them for fastening to the feet, as indicated in the drawing. Another idea



is to join two barrel staves together at the ends with cleats, to make the individual shoe, thongs being provided for attaching to the feet. Barrel hoops can also be used, by stretching a piece of stout canvas across the hoops so tightly that the latter are bent to an oval shape. Also, as might be expected, tennis rackets that have seen better days may be utilized for the same purpose. The operation is simple and consists merely of attaching cleats to the underside of the racket, for the fastening of thongs, and a light board, 4 or 5 in. wide, under the handle, as shown.



# A Device for Rapid Multiplication and Division

BY H. HERTZBERG

**A**N easily made device for the rapid division or multiplication of whole or decimal numbers can be made from a piece of stiff Bristol board and two strips of transparent celluloid. A heavy piece of Bristol board, 7 by 9 in., is selected, and two centers are made 1 in. from the lower edge of the card and about 4 in. apart. From these points the entire chart is drawn and plotted as shown.

Two arms of transparent celluloid, about  $\frac{1}{8}$  in. thick, are made to the shape and dimensions shown, with a hole at the large end for riveting. The opposite end of each arm is drilled with four small holes for the insertion of a pencil point when drawing the scales; these arms are riveted to the card with round-head copper rivets and washers,

to permit free movement without lost motion, which would cause a loss of accuracy.

The two curved scales are first drawn by inserting the point of a pencil into the holes of the celluloid arms and these curved lines are divided into scales of 10 cardinal points to read from 0 to 10, as shown, and each cardinal division is subdivided into 10 equal parts. All radial lines of the scales are drawn with the upper edge of the celluloid arms, which must be perfectly straight and radiating from the center.

The two curved scales are used for multiplying and the product scale is plotted in the following manner: Draw straight radial lines from each cardinal point to the pivot centers as shown, using the arms as rulers. The triangle and horizontal lines are next drawn from the intersecting points; these points are the cardinal points of the product scale and should be drawn and inked heavily. The spaces between these cardinal points are subdivided into 10 equal parts and light subdivision lines are drawn and inked in parallel to the cardinal lines from 10 to 100; from 0 to 10 the lines forming the subdivisions are not parallel to the division lines, but must be located by performing two multiplications for each division, joining the intersections and continuing the lines to the center and sides of the

triangle; for example, to locate subdivision 4, multiply 2 by 2, mark the point of intersection, multiply 4 by 1, mark this

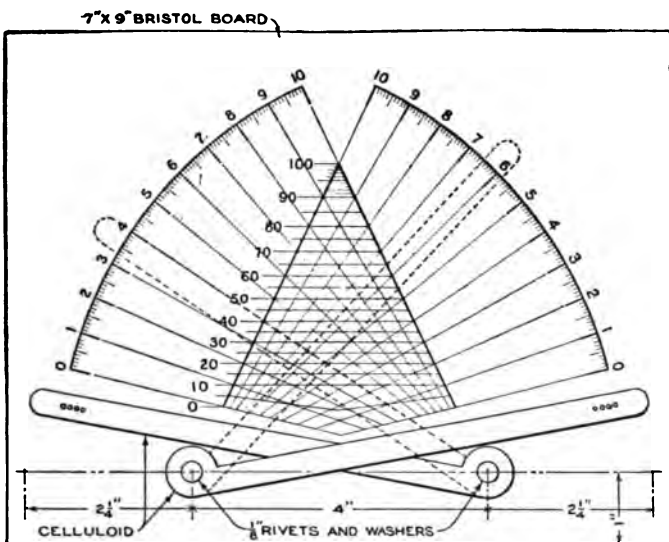

A Cardboard Device of Extreme Simplicity by Means of Which Problems of Multiplication and Division are Worked Out with Speed and Accuracy

point also, and join the points, continuing the line until it meets the center and sides as described. To avoid confusion, only one division is shown subdivided. The cardinal lines are numbered in the scale at the left of the triangle in multiples of 10, as shown, in order to make the device applicable to the decimal system, so that any whole or decimal number may be multiplied or divided by simply inserting the decimal point in the proper place or by adding the proper number of ciphers in multiplying large numbers.

In operation, for example, it is desired to multiply 400 by 650; place one arm on 4 and the other on 6.5 when the intersection will be at 26 on the center scale and as there are six numerals in the multiplier and multiplicand there will be four ciphers to add, making 260,000 the product. To divide the number 260,000 by 400, place the arm on 4 of the left-hand scale, and then bring up the other arm until the intersection is on 26 when the quotient will be 6.5 on the scale at the right, and by removing the decimal point two places to the right the answer will be 650. A little practice with this device will make it possible to formulate rules for placing the decimal point and to obtain results as quickly and accurately as with a slide rule, although its cost is but a fraction of the price of that instrument.

### A Wheelbarrow Ash Sifter

A revolving ash sifter inclosed in a wheeled container, similar to a wheelbarrow, will be found to be both a labor saver

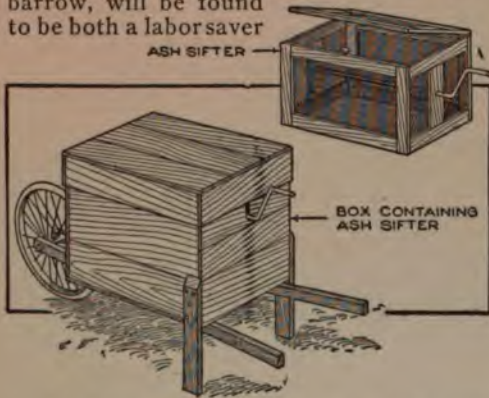

An Ash Sifter in a Dust-Tight Container is Mounted on a Homemade Wheelbarrow, and can be Moved In and Out of a Basement without Trouble

and an aid to domestic cleanliness, all that is necessary being a revolving sieve pivoted on a wheelbarrow. To make the sieve, cover a wooden frame with  $\frac{3}{8}$ -in. mesh wire screen, and fit it with a hinged cover and an iron rod, or shaft, with a crank at one end. The wheelbarrow is simply a wooden box with slots at both ends to form bearings for the shaft, and provided with wooden legs, handles, a wheel taken from an old bicycle, and a close-fitting cover which practically makes it dust-tight. With this arrangement it is possible to sift the ashes at the furnace, causing no more dust than is occasioned by the usual transfer to an ash can. A few turns of the crank completely separate the fine material, and the sifter may then be wheeled away to any convenient place and left covered. The next time it is used, the cinders may be removed without causing any dust, and when sufficient fine ash has accumulated in the box, the wheel makes it easy to dispose of it. There is no difficulty in getting the barrow out of the basement, as the diameter of the bicycle wheel makes it a simple matter to push the whole outfit up a flight of stairs.—R. L. Wales, Kingston, R. I.

### Air Chamber Prevents Tank from Bursting

Cracking, and possible ruin of concrete watering trough by freezing, was prevented on a ranch by the simple dodge of anchoring an empty 5-gal. can to the bottom of the tank. The can, which was

square, was made air-tight by screwing the cap down tightly against a rubber gasket, and was then anchored to the bottom by a rock. As the can was kept well below the surface of the water, the pressure of the freezing water against the sides of the tank was in a large measure prevented by the collapse of the sides of the can.—Dale R. Van Horn, Lincoln, Nebraska.

### A Water-Level Indicator for a Concealed Tank

A practical and trouble-proof gauge for indicating the water level of a concealed tank can be fitted to almost any tank, as shown in the drawing. The

float, in this instance a tightly stoppered varnish can, is attached to one end of a hinged wooden arm, as indicated. The opposite end of the arm is provided with a screw-eye, to which one end of a stout cord, or flexible wire, is attached. The indicator dial is made of wood or sheet metal and is supported on a pipe standard as shown, the lower end of the pipe being split and

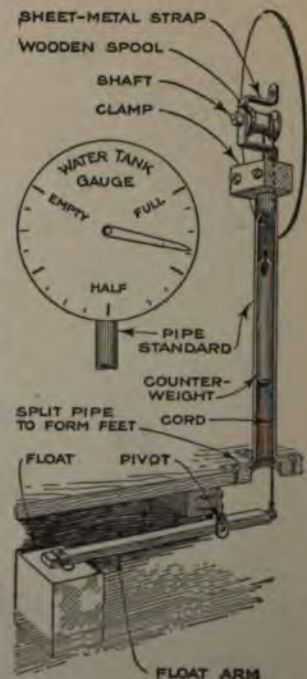

spread at right angles to form feet, which are bolted to the top of the tank. The pointer, or indicator, is made of polished tin or brass, and is attached to one end of a light shaft, to which a wooden spool or drum is secured, behind the dial, a sheet-metal strap supporting the rear end of the shaft, as shown. The cord or wire from the float arm is brought up through the pipe and is given two turns around the spool. The free end of the cord has a suitable counterweight attached to it which is concealed inside the pipe standard.



## Imitating White Tiling

A good way for anyone inexperienced in making imitation tiling in the soft plaster of a kitchen or bathroom, is to allow the plaster to dry hard and then apply a thin mold, or rail, 4 ft. from the floor. The plaster between the baseboard and the rail is given a coat of white paint. After this has thoroughly dried, the walls are marked out, 3 by 6 in. for the kitchen, and 2 by 8 in. for the bathroom, with a carpenter's pencil. Avoid the use of indelible pencils. Then apply a coat of oil varnish, and after this has dried, a second or even a third coat. Such a surface can be kept clean by washing with soap and water.—Matthew Hyndman, North Bend, B. C.

## Faceplate for Multiple-Thread Cutting

When cutting a thread, or worm, having more than one lead, the device shown in the drawing will be found very useful.

A small faceplate is mounted on the lathe, and a cut taken across the face and around the circumference, to make its running truly. A plate, of machine steel or cast iron, is then counter-bored to receive easily the faceplate, as shown; this plate carries the driving stud, and is bored with 12 distant holes, which must be accurately laid out and bored. A hole is drilled in the faceplate to correspond with each of the 12 holes, and a taper pin is fitted, as shown. The outer plate is held to the faceplate by three pieces of machine steel screwed to the counterbored edge.

The operation of the device is simplicity itself; if, for instance, a triple-leaded screw is to be cut, the first lead is made in the usual manner. Then, without moving the tool or carriage, remove the taper pin from the device, turn the faceplate through one-third of a revolution, that is, four holes, insert the pin in the next hole, and proceed to cut the second lead; the operation is repeated for the third lead. Twelve holes are used, as this will enable the operator to cut two, three, four, or six threads in much less time than the usual method.

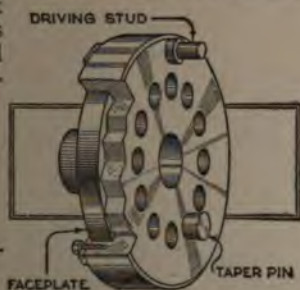

## Electric-Lamp Radiator Heater

The photograph shows an electric-lamp automobile heater that keeps the engine sufficiently warm so that there is little



An Electric Radiator Heater That Makes Starting Easy and Eliminates the Possibility of Freezing; The Heater is Made of Wood and Lined with Asbestos Paper

or no difficulty in starting and no danger of freezing. The heater is made of wood and lined with asbestos paper. Six 20-watt tungsten lamps are wired on three sides of the heater; by using carbon-filament lamps only three will be needed, but it is better to have six lamps, any number of which can be burned according to the temperature. The box fits snugly behind the headlights, which hold it against the radiator. Thick felt strips are tacked to the edge of the box to exclude cold air.

## Clamp Aids in Tapping Drilled Holes

While erecting some heavy machinery, I encountered some few holes which had not been tapped by the builders of the machine. These holes were in a flange, which ran around part of the body beneath an overhanging portion, so that a tap wrench could not be used. To turn in a  $\frac{3}{8}$ -in. tap with a monkey wrench and make the tap run straight was more than the builders had cared to do. The way I turned the trick was to bolt a muzzle clamp on the shank of the tap, as shown in the drawing, which served as a guide. The hole in the muzzle was drilled

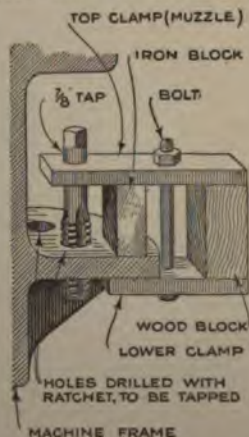

from the muzzle of an inch larger than the hole in the machine.

the diameter of the tap shank, and oil was used liberally on both the shank and the threaded part.—J. V. Romig, Allentown, Pa.

### Stovepipe Radiator Saves Coal

A room in which there is a long stovepipe can be warmed more economically, and more evenly, if the stovepipe is made into a radiator, as indicated in the drawing.

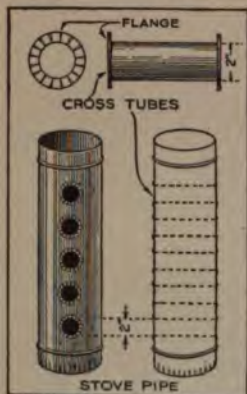

Holes, about 2 in. in diameter, are made in opposite sides of the pipe, short lengths of 2-in. pipe are inserted, and the ends flanged. The additional radiation area provided by the cross tubes makes it possible to effect a considerable fuel economy.—Neil D. Cameron, Athelstan, Que.

### A Simple and Effective Bench Dog

A bench dog that provides a firm grip on work of different thicknesses, from an inch to the thickness of a shingle, is made as shown in the drawing. A hardwood block is fixed to the bench and a circular button is mounted eccentrically with a single screw, as shown, so that when the wide part of the button is turned toward the block the two parts will almost touch. Both parts are slightly beveled under so that they may grip the work more tightly at their upper edges and prevent it from rising.—H. F. Grinstead, Columbia, Mo.

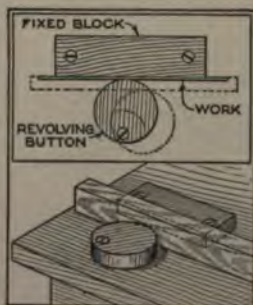

### Removing Yellow Stain from Rubber

It is well known that the exposed surfaces of fountain pens, and other articles of hard rubber, frequently change from a glossy black to a dirty yellowish-brown color. This unsightly color may be removed and the rubber restored to its pristine blackness by soaking it for several

hours in a warm solution of lye which dissolves the yellow coating. Rub this off with a rag, smear the surface with oil, and after wiping it off, polish the rubber with chamois skin. Care should be taken not to use the solution too warm, as hard rubber softens under the action of heat, and the article may be rendered useless or lose its shape.—Thos. R. Baker, Winter Park, Fla.

### Hose Clamp Limits Engine Cooling

In cold weather it is necessary to reduce the effect of the cooling system, if the best operating conditions are to be obtained. The drawing shows how too rapid cooling of the engine can be prevented. An ordinary strap hinge is fastened to the radiator hose with wire; a bolt and thumb-screw in the end screw holes providing an easy means of controlling the circulation.



In very cold weather the hose may be almost closed, thus cutting off most of the circulation and allowing the engine to run hotter, although the radiator will be cooler. As the weather moderates, the clamp is released, permitting better circulation.

### Repairing Drill-Press Feed Rack

While using a high-power radial drill press the heavy downward pressure was so great that the shoulder on the rack was broken, as indicated in the drawing, and the screws sheared off. Obviously, it was impractical to make a repair that would throw the entire strain on the feed-rack screws. After the sheared off screws had been drilled out and the holes tapped, keyways were cut in both rack and sleeve and the rack fastened with new screws, while keys, made from  $\frac{3}{8}$ -in. key steel, were driven into the keyways, as shown in the drawing, to take the end pressure.

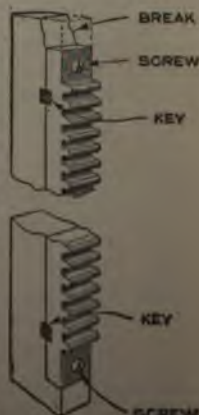

—A. A. Stafford, San Francisco, Calif.



## Reading Decimal-Equivalent Tables

Most decimal-equivalent tables are difficult, or at least confusing to read, on account of the close spacing of their large number of figures. A convenient little device that brings the equivalent sought to light without possibility of confusing with some other, may be easily made. Eighths, sixteenths, thirty-seconds, sixty-fourths are written in separate columns on a piece of heavy drawing paper, or thin, stiff cardboard. An envelope is made to hold the card, with slots at the top through which the column sought is shown separated from others as the card is pulled out of, or fed into the envelope.

## Neat and Strong Tree Support

The tree support shown in the illustration will be of interest to those who have difficulty in inducing young trees to grow right and in guarding them from knocks.

Eight sticks, about 4 ft. long, are driven into the ground to form a circle and the tops are at a distance of about 1 ft. The tops of these sticks should all be at the same height, and be tied together as shown in the drawing.

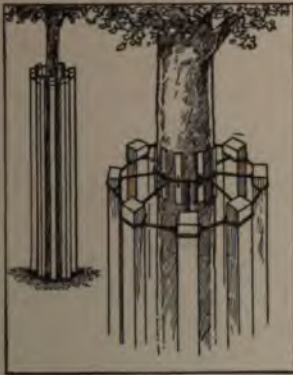

Eight small sticks, about  $1\frac{1}{2}$  by 2 in., are provided, and these are wired around the trunk of the tree in the manner shown. A small staple driven into each stick, over the wire, holds them in place. Attach short wires from the wire encircling the tree to the outer wire, being careful that the tree is in the center of the ring formed by the sticks. The distance about the tree trunk should not be made up so tightly as to constrict the growth of the tree, but sufficient space should be allowed for its free growth, and soon as this space has been occupied, the inner ring should be loosened.—Frank Matter, Portland, Ore.

Headlight lenses can be frosted by applying a saturated solution of Epsom salt to the back.

## Shelter Built on Lumber Sled

Men who haul lumber or freight often suffer from the biting cold of winter



For Preventing Chilblains and Frostbites a Teamster has Attached the Cozy Cab Shown in the Drawing to a Bobsled Used for Hauling Lumber and Freight

mornings, but the man who uses the arrangement shown in the drawing does not. A small cab, 5 ft. high and 4 ft. square, was built on the sled, as indicated. A door was located at one side, and a window was provided in each side, so that the driver can see in all directions. The roof is covered with roofing paper, and a section of stovepipe acts as a ventilator. The whole arrangement is so light that it can be removed and set aside when the sled is being loaded; it is then set back on top of the load. If there is any danger of its falling off, the driver simply throws a chain down from the eyes at each of the bottom corners and anchors it to the sled. A chair, and a lantern to keep the temperature comfortable, complete the equipment.

## Chain Attachment Helps in Plowing

By attaching a length of moderately heavy chain to the turning plow, in the manner shown in the drawing, the work of turning under weeds and trash is not only facilitated, but a much neater and more satisfactory job is obtained. Enough slack is allowed in the chain so that it will drag lightly on the earth in the bottom of the previously plowed furrow,



A Length of Chain Attached, as Shown, Aids in Plowing Under Undesirable Vegetation



which it will do automatically. This is almost indispensable when turning over land for sowing hay and forage crops, where undesirable vegetation has reached such a height that the bare plow will not completely cover it.

### A Feeder for Cattle

In some parts of the country, the easily constructed cattle feeder shown in the



A Cattle Feeder That Is Particularly Useful for Feeding Cattle during the Winter, on Chopped Forage, or Grains: It Holds Approximately 500 Bushels of Feed

drawing has been found to be a worthwhile addition to the stock raiser's equipment. In those localities where cattle are fed throughout the winter on chopped ear corn, ground corn, cob and cottonseed meal, this type of feeder is generally used. A common size is about 8 by 10 ft., with a capacity of approximately 500 bu. of feed. The feeder is best built 2 ft. above the ground, and, if a permanent location can be had, the foundation should be of concrete. A movable feeder, similar to the permanent one shown, can be made by mounting the structure on heavy timber skids, so that a team can haul it to any part of the feed lot.

If concrete piers are to be used, anchor bolts should be imbedded in the tops so that the double sills can be bolted securely to the foundation piers. The floor joists should extend 1 ft. beyond each side of the building, to form feeding troughs, as indicated; the joists are spaced 2 ft. apart and spiked to the wall studs. This makes a solid job and prevents spreading. A double plate is spiked to the tops of the studs, to provide a base for the rafters,

but before the roof is built, the studs on opposite sides are joined together with crossies.

When the structure is filled with feed there is considerable horizontal pressure against the walls, and consequently they should be well braced to prevent spreading and bulging. The triangular deflector, which takes the place of a floor, distributes the stored feed equally to the troughs. Adjustable slides may be arranged on the sides to control the amount of feed running into the troughs. The roof is built with wide eaves and covered with roofing paper, and the walls are covered with matched siding nailed to the studs. Doors are provided at one or both ends of the feeder for convenience in filling. All parts should be built with an eye to strength, as fat steers will speedily smash up a flimsy building around the feed lot. An approximate bill of material for such a feeder will consist of 2 bbl. cement, 6 sills, 11 joists, 22 studs, 4 wall plates, 6 crossies, 10 pieces for grain deflector, 12 rafters, 2 feed-trough fenders, and 700 ft. of matched siding.—W. E. Frudden, Charles City, Ia.

### A Novel Stockroom Display Rack

Making up stockroom display racks and arranging samples thereon, properly tagged and numbered, is in most factories a laborious and time-consuming task. A

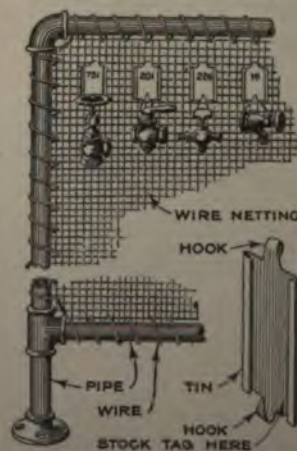

clerk in one establishment has improved on the usual practice by making a gas-pipe frame of the proper size and covering it with wire netting. This arrangement can be made to stand on the floor by providing it with suitable legs and floor flanges, or it can be suspended from hooks on the wall.

Combination hooks and tag holders, similar to those shown in the drawing, were made from sheet metal, and the edges were turned over to make grooves for the insertion of the stockroom tag. The parts are suspended from the hook at the bottom of the tag holder by wire



s. In this manner the samples can easily arranged, and any change in or model merely requires a change in the holder, while the discontinu- or addition of samples may be taken of without difficulty at a moment's ce.

**Kerosene as an Antifreeze Solution**

The use of kerosene in automobile cool- systems to prevent freezing, while tive, is open to numerous objections. oil vaporizes at a lower temperature water; consequently, if the temper- e rises, the cooling effect is reduced overheating of the engine follows. An- objection to the use of kerosene for purpose is the danger of fire from the mable gas that is generated when oil becomes heated. Besides, kerosene s off a disagreeable odor when heated, rapidly decomposes the rubber radi- connections. But if one is willing to e the objections enumerated he can nd upon kerosene not to freeze.

**Device for Rolling a Barrel**

Quantities of water are sometimes ed around the farm where there is e, and to carry amount re- ed in buckets d be a trou- me job. It for use in cases that



Empty Barrel Arranged to Transport Water to Distant Points on the Farm, Where Water is Needed, Instead of Carrying It in Buckets

The device shown herewith was made. As be readily seen, the construction is simple; a cross is nailed to each end of the barrel, in the center of which are fitted a pipe flange and a short length of pipe which fits into a hole in the rear of the shafts. Besides serving its original purpose as a water carrier, it also serves as an excellent roller when filled with water.

**Circuit Breaker Stops Motor When Belt Breaks**

A simple arrangement for stopping an electric motor, in the absence of a circuit

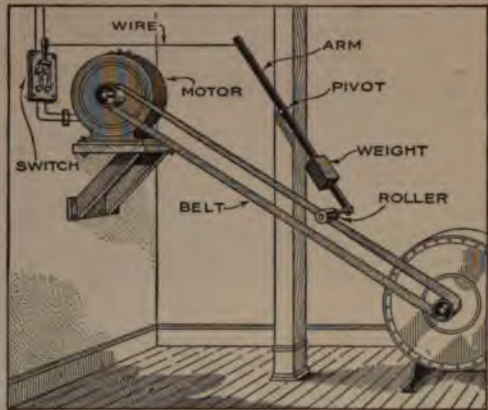

As Soon as the Belt Breaks or Slips from the Pulley the Weighted Arm Drops to a Vertical Position, Opening the Circuit and Stopping the Motor

breaker, when the belt breaks or slips off the pulley, is shown in the drawing. A pivoted arm, having a roller and weight at its lower end, is connected to the switch, as shown, by a wire. Normally, the roller rides on the surface of the belt, but, should the belt break or slip off, the weighted end of the arm will drop to a vertical position and open the circuit.—Roy H. Poston, St. Francois, Mo.

**Boring in the Drill Press**

When boring holes of large diameter with a boring bar in the drill press, greater rigidity may be secured by using the spindle itself as the boring bar.

The cutter is inserted in the spindle slot as shown, and a pilot, having a threaded end, and tapered to fit the spindle socket, is used to draw the cutter firmly to its seat, the pilot being provided with flats upon which a wrench may be used. The pilot may be as long as desired, of a diameter suited to the work in hand, of the diameter of the center hole, or a bushing in the drill-press platen. By this method the boring bar is made just as strong and rigid as the machine itself.

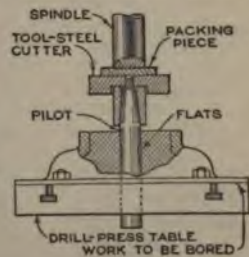



which it will do automatically. This is almost indispensable when turning over land for sowing hay and forage crops, where undesirable vegetation has reached such a height that the bare plow will not completely cover it.

### A Feeder for Cattle

In some parts of the country, the easily constructed cattle feeder shown in the

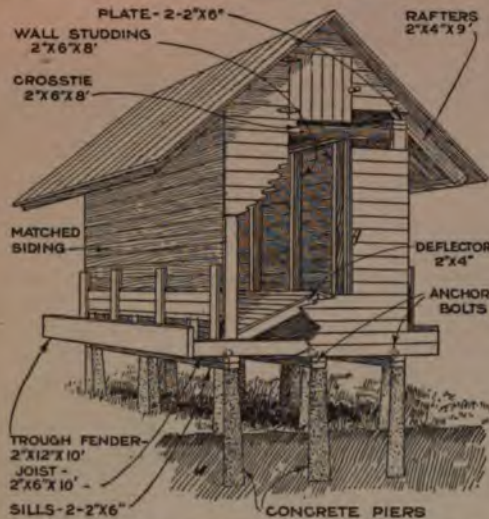

A Cattle Feeder That Is Particularly Useful for Feeding Cattle during the Winter, on Chopped Forage, or Grains: It Holds Approximately 500 Bushels of Feed

drawing has been found to be a worthwhile addition to the stock raiser's equipment. In those localities where cattle are fed throughout the winter on chopped ear corn, ground corn, cob and cottonseed meal, this type of feeder is generally used. A common size is about 8 by 10 ft., with a capacity of approximately 500 bu. of feed. The feeder is best built 2 ft. above the ground, and, if a permanent location can be had, the foundation should be of concrete. A movable feeder, similar to the permanent one shown, can be made by mounting the structure on heavy timber skids, so that a team can haul it to any part of the feed lot.

If concrete piers are to be used, anchor bolts should be imbedded in the tops so that the double sills can be bolted securely to the foundation piers. The floor joists should extend 1 ft. beyond each side of the building, to form feeding troughs, as indicated; the joists are spaced 2 ft. apart and spiked to the wall studs. This makes a solid job and prevents spreading. A double plate is spiked to the tops of the studs, to provide a base for the rafters,

but before the roof is built, the studs on opposite sides are joined together with cross-ties.

When the structure is filled with feed there is considerable horizontal pressure against the walls, and consequently they should be well braced to prevent spreading and bulging. The triangular deflector, which takes the place of a floor, distributes the stored feed equally to the troughs. Adjustable slides may be arranged on the sides to control the amount of feed running into the troughs. The roof is built with wide eaves and covered with roofing paper, and the walls are covered with matched siding nailed to the studs. Doors are provided at one or both ends of the feeder for convenience in filling. All parts should be built with an eye to strength, as fat steers will speedily smash up a flimsy building around the feed lot. An approximate bill of material for such a feeder will consist of 2 bbl. cement, 6 sills, 11 joists, 22 studs, 4 wall plates, 6 cross-ties, 10 pieces for grain deflector, 12 rafters, 2 feed-trough fenders, and 700 ft. of matched siding.—W. E. Frudden, Charles City, Ia.

### A Novel Stockroom Display Rack

Making up stockroom display racks and arranging samples thereon, properly tagged and numbered, is in most factories a laborious and time-consuming task. A

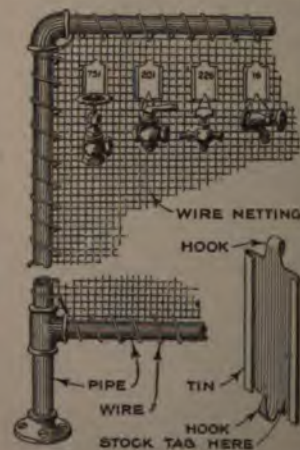

clerk in one establishment has improved on the usual practice by making a gas-pipe frame of the proper size and covering it with wire netting. This arrangement can be made to stand on the floor by providing it with suitable legs and floor flanges, or it can be sus-

ended from hooks on the wall. Combination hooks and tag holders, similar to those shown in the drawing, were made from sheet metal, and the edges were turned over to make grooves for the insertion of the stockroom tag. The parts are suspended from the hook at the bottom of the tag holder by wire



loops. In this manner the samples can be easily arranged, and any change in style or model merely requires a change of tags in the holder, while the discontinuance or addition of samples may be taken care of without difficulty at a moment's notice.

### Kerosene as an Antifreeze Solution

The use of kerosene in automobile cooling systems to prevent freezing, while effective, is open to numerous objections. The oil vaporizes at a lower temperature than water; consequently, if the temperature rises, the cooling effect is reduced and overheating of the engine follows. Another objection to the use of kerosene for this purpose is the danger of fire from the inflammable gas that is generated when the oil becomes heated. Besides, kerosene gives off a disagreeable odor when heated, and rapidly decomposes the rubber radiator connections. But if one is willing to waive the objections enumerated he can depend upon kerosene not to freeze.

### Device for Rolling a Barrel

Quantities of water are sometimes needed around the farm where there is none, and to carry the amount required in buckets would be a troublesome job. It was for use in such cases that



An Empty Barrel Arranged to Transport Water to Distant Points on the Farm, Where Water is Needed, Instead of Carrying It in Buckets

the device shown herewith was made. As will be readily seen, the construction is very simple; a cross is nailed to each end of the barrel, in the center of which are fastened a pipe flange and a short length of pipe which fits into a hole in the rear end of the shafts. Besides serving its original purpose as a water carrier, it also makes an excellent roller when filled with water.

### Circuit Breaker Stops Motor When Belt Breaks

A simple arrangement for stopping an electric motor, in the absence of a circuit

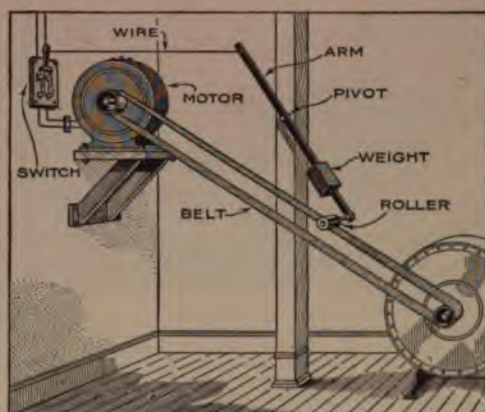

As Soon as the Belt Breaks or Slips off the Pulley the Weighted Arm Drops to a Vertical Position, Opening the Circuit and Stopping the Motor

breaker, when the belt breaks or slips off the pulley, is shown in the drawing. A pivoted arm, having a roller and weight at its lower end, is connected to the switch, as shown, by a wire. Normally, the roller rides on the surface of the belt, but, should the belt break or slip off, the weighted end of the arm will drop to a vertical position and open the circuit.—Roy H. Poston, St. Francois, Mo.

### Boring in the Drill Press

When boring holes of large diameter with a boring bar in the drill press, greater rigidity may be secured by using the spindle itself as the boring bar.

The cutter is inserted in the spindle slot as shown, and a pilot, having a threaded end, and tapered to fit the spindle socket, is used to draw the cutter firmly to its seat, the pilot being provided with flats upon which a wrench may be used. The pilot may be as long as desired, of a diameter suited to the work in hand, of the diameter of the center hole, or a bushing in the drill-press platen. By this method the boring bar is made just as strong and rigid as the machine itself.

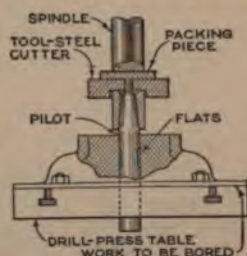

**Turning Two Tapers at One Setting**

Having a large number of crown pulleys to make, one mechanic cut the time of doing the job practically in two by

using two tools at one time. A small compound slide rest was taken from another lathe, and set on the back of the cross slide, upon an iron block to raise it to the proper height, slide rest and block being fastened to the cross slide by long cap screws.

The cross-slide nut was disengaged and the taper attachment set over the required amount; then the front tool was sunk into the center of the pulley to the proper depth, the rear tool was adjusted to take a corresponding cut on the edge of the pulley, and the cut started. Both angular faces are by this means finished at one pass.

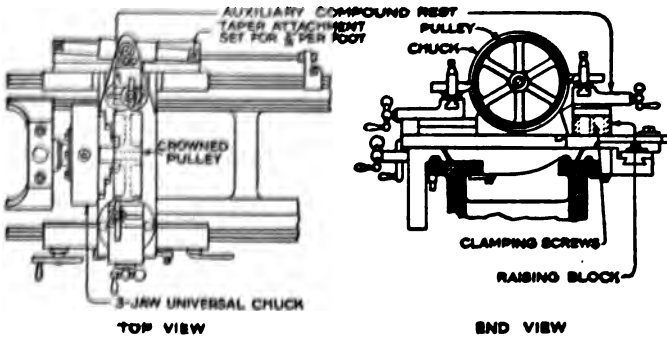

By Using Two Tools in Connection with the Taper Attachment, the Time Required for Turning Pulleys was Cut in Half

**Hooks Aid Lumber Handlers**

A lumber handler observed that sore backs and shoulders caused by carrying

lumber was a common complaint. He induced the yard blacksmith to make several hooks, such as the one shown in the drawing, from flat stock, 1/4 by 2 by 30 in. An eye was cut into the upper end to accommodate a



leather strap. In use, these hooks are worn over the shoulder of the workman, as indicated. Since they have been in use, the men have been able to carry heavier loads, walk faster, maintain better balance, all with greater convenience and less fatigue than formerly.

**Snow Track for Hauling Ice**

To make it possible to haul ice from the river where it was harvested to a place of storage on shore after the snow had melted, it was necessary to build and maintain a snow track. Bobsleds were, of course, the only thing on the ice, but no team could pull a loaded sled over the bare pavement. The track was formed

by spreading the snow scraped from the ice harvest and scraps of ice over the route to the ice house.—C. L. Meller, Fargo, N. D.

**A Fixture for Swaging Rawhide Pins**

In manufacturing some special machines, rawhide pins with flat heads were needed, and as these were not a commercial product, we were forced to make them ourselves. After some experimenting, the pins were made from the 1/8-in. rawhide pins used in connection with a certain kind of belt fastener, in this manner: An anvil piece arranged with a flange to be held in a vise, as indicated, was made from tough oil-hardened steel. The cap, of glass-hardened tool steel, slides over the upper part of the anvil, and the hole in the cap is made to conform to the final shape of the pin, the length of the latter before forming being indicated by the dotted lines. The pin is first cut to length with a pair of pliers, inserted into the opening in the cap. The projecting end is swaged down

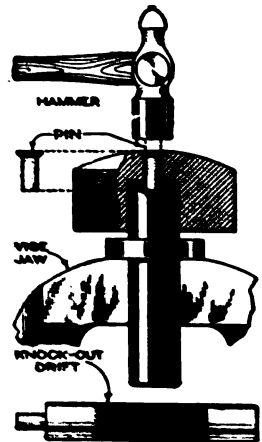



The cap is then lifted from the anvil, and the knock-out drift shown is used for removing the pin. A production of 180 pins an hour was obtained with this arrangement.—Burr Bennett, Honesdale, Pennsylvania.

### A Convenient Triangle for Draftsmen

The drawing shows a draftsman's triangle made from an ordinary 45° angle, so that a number of other angles are obtainable. One angle is cut away as shown by the dotted lines; a good way to do this being to mark off the 30° side, and then cut slightly outside the line, finishing to the line with a smooth file. The angles obtainable with such an instrument are 15, 30, 45, 60, 75, and 90°, which are produced by placing it against the T-square in different positions. The 15° angle is particularly convenient for designing 15° threads, which ordinarily requires the use of two triangles.—E. S. Brown, Hannibal, Mo.

### Clamping Connecting-Rod Bearings in Vise

Connecting-rod and main-bearing caps are frequently longer than the opening between the vise jaws, making it difficult, if not impossible, to grip them when filing the face for bearing adjustment. The adjustable holder shown in the drawing permits such bearings to be held securely when the face is being filed, so that a smooth, flat surface is obtained, and the rocking about in the vise jaws is overcome. The attachment also permits chamfering of the edges of the babbitt for oil channels with the one setting of the cap in the vise. The holder consists of three pieces of forged steel: the semi-circular clamp and the two Z-shaped pieces. Adjustment is obtained by the holes in the end of the horizontal clamp.



### Garage Door Closed by Passage of Car

Any easy-running garage or barn door may be arranged, as shown in the drawing,

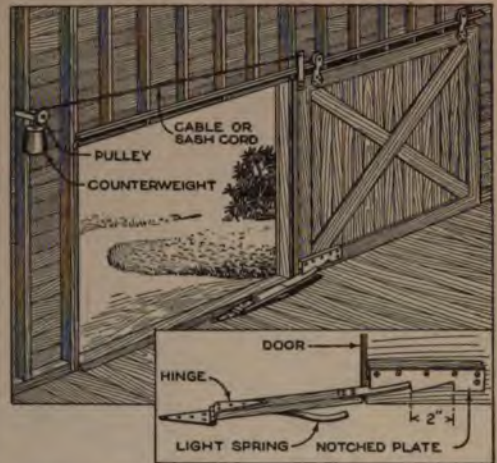

A Simple Device That Automatically Closes Sliding Garage Doors after the Passage of a Vehicle

ing, to close itself as soon as the rear wheels of a vehicle pass over the tripping device. The door is counterweighted so that, when the trip is released, the weight pulls the door shut. The trip, or release, consists of a hinged plank arranged, as indicated, to engage with the notched plate on the door; this plate has two notches, one of which engages with the plank in the extreme open position. A spring on the underside of the plank holds it in engagement with the notches. In operation, the front wheel of the vehicle pushes the trip down and the door is released until the catch engages in the second notch, which is about 2 in. back of the first. The rear wheel disengages the catch from the second notch and the door rolls shut. The door travel should be adjusted so that it will clear the car as it shuts.

### Fruit Trees Protected from Cold

A successful method of protecting fruit trees from being killed during the winter is to bind adjacent branches together. The branches are wrapped with a heavy layer of excelsior which is covered with burlap and sewed. The idea is to protect the fruit spurs as much as possible; the branches should not be crowded too closely. The "bedclothes" are removed in the spring, after danger of frost has passed, and the tree is then cared for in the usual manner.



### An Automatic Soldering-Iron Switch

A rack and automatic switch for an electric soldering iron that not only holds the iron when not in use and the current

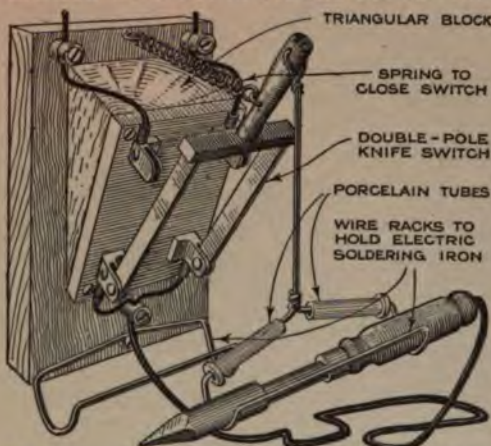

An Automatically Operated Switch for the Electric Soldering Iron That Makes for Convenience and Economy in Operation

is off, but provides a safe place to leave it while it is heating up, or while arranging the work to be soldered, can be used to advantage in the well-equipped shop.

A double-pole knife switch is attached to the underside of a triangular block, which is mounted on a base, as shown in the drawing. The switch handle is attached to one end of a coil spring, the opposite end of which is fastened to the switch mounting in such a manner that the tension of the spring always keeps the switch closed. A stiff-wire rest or rack, formed as indicated, is suspended from a hole drilled near the end of the switch handle. In forming this rack, two porcelain tubes are placed as shown, to protect against possible contact with the switch which would short-circuit the line and blow a fuse, if nothing more serious. A similar rack is also made and attached to the bottom of the block, to form a support for the iron while the current is on and the iron is heating, or while the work is being arranged. When the weight of the iron is resting on the rack attached to the switch handle, the switch is opened and the current cut off. The front of the block should be covered with sheet asbestos to prevent possibility of fire that might be caused by overheating of the iron while in the lower rest.

Run-over rubber heels can be straightened with an emery wheel or rasp,

### Muffled Hoofs for Horses' Safety

The muffling of horses' hoofs has long been associated with illegitimate aims and objects, as, in the past, muffling was part of the technique with which every shady individual interested in horses was acquainted. But wrapping liberal thicknesses of burlap around a horse's hoofs is also a resource used by the driver when an icy spell catches him without calks or chains.—John T. Bartlett, Boulder, Colo.

### Cutting Pins in the Shaper

Where a large number of wire pins are to be cut in standard lengths, there is no easier way of doing the job than on a shaper, if one is available. A cast-iron block is provided with a tool-steel bushing, a few thousandths of an inch larger than the wire to be cut, and an adjustable stop, as shown in the drawing. The block is fastened to the shaper table, and a regular cut-off tool is placed in the shaper head, in the manner shown. Different-sized bushings may be used to take various sizes of wire, the bushing being held in place by a setscrew.

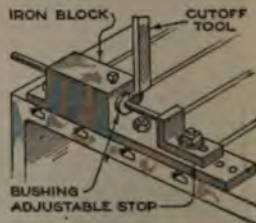

### An Emergency Pipe Joint

A water pipe was to be extended, and while there were plenty of fittings at hand, dies were not available for threading the pipes. Notwithstanding this, a water-tight joint was made, as shown in the drawing. The cap was replaced by a threaded sleeve, and the end of the new pipe, which was of slightly smaller diameter than the old, was flared slightly, and packing was wrapped around the outside of the flare, as indicated. The two pipes were arranged end to end, as shown, and a

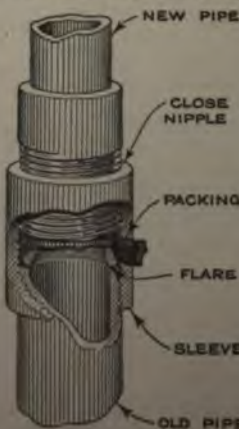



close-fitting nipple, with an internal thread to fit the smaller pipe, was screwed down tightly against the packing and the flared pipe. Plenty of white lead was used on both threads and packing.

### Breaking Out a Sled from the Ice

When unhitching a sled at night, do not leave the front runners in a line with the rear ones. Leaving both sets of runners in line with each other seems to be the natural way, but it does not anticipate the "morning after," when the runners will be frozen in. A twist is what does the loosening, not a straight pull. Leave the front runners at an angle with the rear ones and then, when the sled is hitched in the morning, the pull, combined with a twist, will pry the runners loose without difficulty.

### A Special Garage Anvil

The anvil shown in the drawing possesses peculiar usefulness for riveting drive-shaft and rear-axle housings of automobiles.

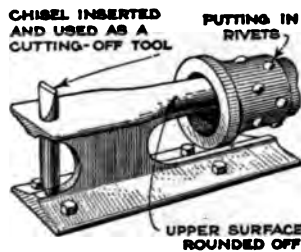
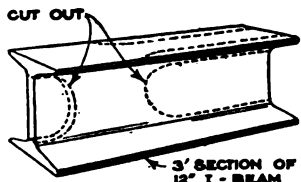

It is made from a 3-ft. length of 12-in. I-beam. The web of the beam is cut away, as shown, for about 18 in., and holes are drilled in the bottom flange for bolting to a bench or block. The upper surface of the anvil is ground, or machined,

round, to permit rivets to be inserted and supported in these comparatively small parts. The heel of the anvil has a hole drilled through it, in which a cold chisel can be inserted and used as a cutting-off tool.

### A Gas-Fired Forge

Recently a small shop had difficulty in melting babbitt metal in the soft-coal fire of a portable forge. The work had to be done on the main machine floor, and the smoke was very annoying; also, the babbitt was 85 per cent tin, and required a sustained temperature of 650° F., which

was difficult to maintain unless a man was kept turning the crank, and the temperature varied greatly when the fire

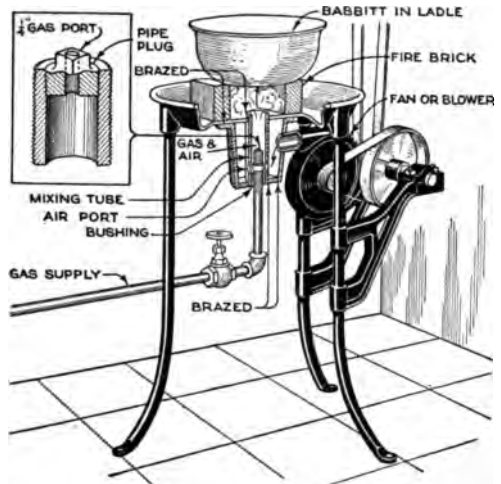

An Old Hand-Operated Forge Rebuilt to Burn Artificial Gas, for Melting Babbitt, Produces Exceptional Results and Holds the Heat within 10 Degrees

burned down and fresh fuel was added. It was decided to convert the forge into a gas-fired one, and this was successfully accomplished, in the manner shown in the drawing. First of all, the top and bottom of the tuyère box were closed by metal plates, brazed in position with an oxy-acetylene torch; then a mixing tube, with a reducing bushing threaded in the bottom plate, was permanently fastened by brazing. Around the bottom of this mixing tube, and just above the bushing, a circle of 1/2-in. air ports was drilled. The gas-supply line has a pipe plug threaded into the end and a 1/4-in. gas port is drilled through its center. The end of the gas-supply pipe was threaded for about 6 in., so that it could be adjusted up or down for obtaining the proper burner height. The legs of the forge were bolted down to the floor, and after the hand crank had been removed, a pulley was put in its place, and the blower belted to an overhead countershaft. After some experimenting to obtain the proper blower speed and the correct burner adjustment, the new arrangement was put into use with exceptionally satisfactory results. It has been found possible to hold the temperature of the metal to within 10° at all times, and to raise the temperature to as high as 1,000°. The labor of turning the crank was done away with, and there were no fumes to bother the men. Even with the high price of the artificial gas used, the operating cost was less than that of coal.

**An Automatic Soldering-Iron Switch**

A rack and automatic switch for an electric soldering iron that not only holds the iron when not in use and the current

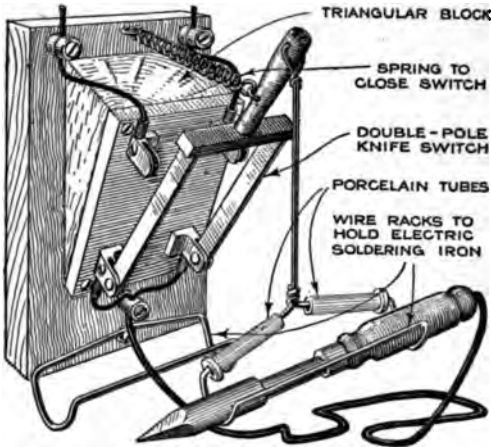

**An Automatically Operated Switch for the Electric Soldering Iron That Makes for Convenience and Economy in Operation**

is off, but provides a safe place to leave it while it is heating up, or while arranging the work to be soldered, can be used to advantage in the well-equipped shop.

A double-pole knife switch is attached to the underside of a triangular block, which is mounted on a base, as shown in the drawing. The switch handle is attached to one end of a coil spring, the opposite end of which is fastened to the switch mounting in such a manner that the tension of the spring always keeps the switch closed. A stiff-wire rest or rack, formed as indicated, is suspended from a hole drilled near the end of the switch handle. In forming this rack, two porcelain tubes are placed as shown, to protect against possible contact with the switch which would short-circuit the line and blow a fuse, if nothing more serious. A similar rack is also made and attached to the bottom of the block, to form a support for the iron while the current is on and the iron is heating, or while the work is being arranged. When the weight of the iron is resting on the rack attached to the switch handle, the switch is opened and the current cut off. The front of the block should be covered with sheet asbestos to prevent possibility of fire that might be caused by overheating of the iron while in the lower rest.

ⓄRun-over rubber heels can be straightened with an emery wheel or rasp.

**Muffled Hoofs for Horses' Safety**

The muffling of horses' hoofs has long been associated with illegitimate aims and objects, as, in the past, muffling was part of the technique with which every shady individual interested in horses was acquainted. But wrapping liberal thicknesses of burlap around a horse's hoofs is also a resource used by the driver when an icy spell catches him without calks or chains.—John T. Bartlett, Boulder, Colo.

**Cutting Pins in the Shaper**

Where a large number of wire pins are to be cut in standard lengths, there is no easier way of doing the job than on a shaper, if one is available. A cast-iron block is provided with a tool-steel bushing, a few thousandths of an inch larger than the wire to be cut, and an adjustable stop, as shown in the drawing. The block is fastened to the shaper table, and a regular cut-off tool is placed in the shaper head, in the manner shown. Different-sized bushings may be used to take various sizes of wire, the bushing being held in place by a setscrew.

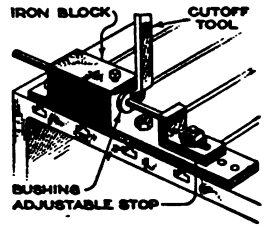

**An Emergency Pipe Joint**

A water pipe was to be extended, and while there were plenty of fittings at hand, dies were not available for threading the pipes. Notwithstanding this, a water-tight joint was made, as shown in the drawing. The cap was replaced by a threaded sleeve, and the end of the new pipe, which was of slightly smaller diameter than the old, was flared slightly, and packing was wrapped around the outside of the flare, as indicated. The two pipes were arranged end to end, as shown, and a

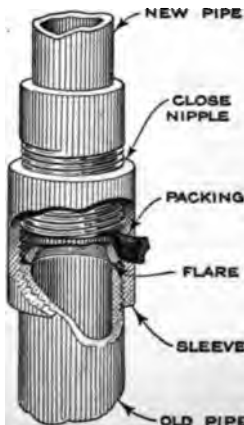



close-fitting nipple, with an internal thread to fit the smaller pipe, was screwed down tightly against the packing and the flared pipe. Plenty of white lead was used on both threads and packing.

### Breaking Out a Sled from the Ice

When unhitching a sled at night, do not leave the front runners in a line with the rear ones. Leaving both sets of runners in line with each other seems to be the natural way, but it does not anticipate the "morning after," when the runners will be frozen in. A twist is what does the loosening, not a straight pull. Leave the front runners at an angle with the rear ones and then, when the sled is hitched in the morning, the pull, combined with a twist, will pry the runners loose without difficulty.

### A Special Garage Anvil

The anvil shown in the drawing possesses peculiar usefulness for riveting drive-shaft and rear-axle

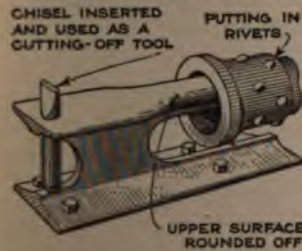
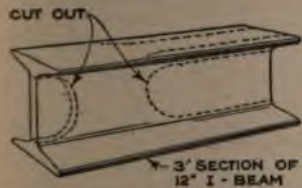

housing of automobiles. It is made from a 3-ft. length of 12-in. I-beam. The web of the beam is cut away, as shown, for about 18 in., and holes are drilled in the bottom flange for bolting to a bench or block. The upper surface of the anvil is ground, or machined, round, to permit rivets to be inserted and supported in these comparatively small parts. The heel of the anvil has a hole drilled through it, in which a cold chisel can be inserted and used as a cutting-off tool.

### A Gas-Fired Forge

Recently a small shop had difficulty in melting babbitt metal in the soft-coal fire of a portable forge. The work had to be done on the main machine floor, and the smoke was very annoying; also, the babbitt was 85 per cent tin, and required a sustained temperature of 650° F., which

was difficult to maintain unless a man was kept turning the crank, and the temperature varied greatly when the fire

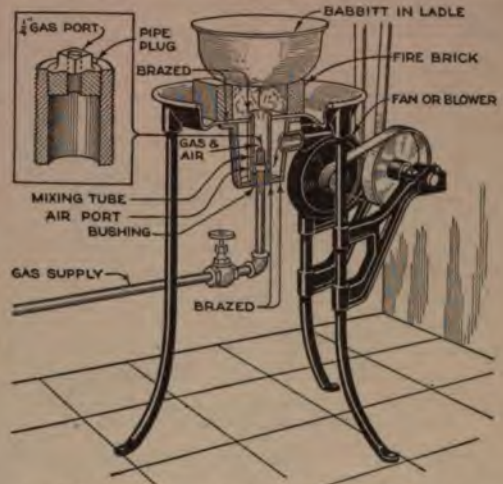

An Old Hand-Operated Forge Rebuilt to Burn Artificial Gas, for Melting Babbitt, Produces Exceptional Results and Holds the Heat within 10 Degrees

burned down and fresh fuel was added. It was decided to convert the forge into a gas-fired one, and this was successfully accomplished, in the manner shown in the drawing. First of all, the top and bottom of the tuyère box were closed by metal plates, brazed in position with an oxy-acetylene torch; then a mixing tube, with a reducing bushing threaded in the bottom plate, was permanently fastened by brazing. Around the bottom of this mixing tube, and just above the bushing, a circle of  $\frac{1}{2}$ -in. air ports was drilled. The gas-supply line has a pipe plug threaded into the end and a  $\frac{1}{4}$ -in. gas port is drilled through its center. The end of the gas-supply pipe was threaded for about 6 in., so that it could be adjusted up or down for obtaining the proper burner height. The legs of the forge were bolted down to the floor, and after the hand crank had been removed, a pulley was put in its place, and the blower belted to an overhead countershaft. After some experimenting to obtain the proper blower speed and the correct burner adjustment, the new arrangement was put into use with exceptionally satisfactory results. It has been found possible to hold the temperature of the metal to within 10° at all times, and to raise the temperature to as high as 1,000°. The labor of turning the crank was done away with, and there were no fumes to bother the men. Even with the high price of the artificial gas used, the operating cost was less than that of coal.

### Making Right-Angle Bends in Conduit

In making right-angle bends of standard radii in conduit work, one electrician has found the accompanying table

SIZE OF CONDUIT	OUTSIDE DIAMETER OF CONDUIT	STANDARD RADIUS OF $\frac{1}{4}$ OF BEND	- INCHES	+ INCHES
$\frac{1}{2}$	$\frac{5}{8}$	$4\frac{1}{2}$	5	2
$\frac{3}{4}$	$1\frac{1}{8}$	$5\frac{3}{8}$	6	$2\frac{1}{2}$
1	$1\frac{3}{8}$	$5\frac{3}{4}$	$6\frac{1}{2}$	$2\frac{1}{2}$
$1\frac{1}{4}$	$1\frac{7}{8}$	$7\frac{1}{4}$	8	$3\frac{1}{4}$
$1\frac{1}{2}$	$1\frac{7}{8}$	8 $\frac{1}{2}$	$9\frac{1}{2}$	3 $\frac{1}{2}$
2	$2\frac{1}{8}$	$9\frac{1}{2}$	$10\frac{1}{2}$	$4\frac{1}{2}$
$2\frac{1}{2}$	$2\frac{3}{8}$	$10\frac{1}{2}$	12	$4\frac{1}{2}$
3	$3\frac{1}{8}$	13	$14\frac{1}{2}$	$5\frac{1}{2}$
$3\frac{1}{2}$	4	15	17	$6\frac{1}{2}$
4	$4\frac{1}{2}$	16	$18\frac{1}{2}$	$6\frac{1}{2}$

A Table Which will Prove Useful to the Lineman in Locating Right-Angle Bends in Conduit

of great assistance in locating the bend at the proper point.

An example of the use of this table is shown in Figs. 1 and 2. Supposing that  $\frac{1}{2}$ -in. conduit is to be run from the ceiling outlet box A, across to the wall and down, as shown in Fig. 1. On a length of  $\frac{1}{2}$ -in. conduit, lay off the distance L, Fig. 2. Under column marked "—inches"

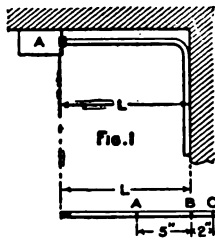

in the table and opposite  $\frac{1}{2}$ -in. conduit, find 5 inches; and under column "+ inches," find 2 inches. From point B lay off A, 5 in. to the left, as shown in Fig. 2, and lay off C, 2 in. to the right. Then

start the bend at A, and finish it at C. If the measurement L, Fig. 1, is made to the inner edge of the conduit, the diameter of the conduit must be added to the distance L, Fig. 2.

### Keeping Fuel Oil Liquid in Cold Weather

In a steel plant, trouble was experienced during the cold months of the year in keeping the fuel oil sufficiently liquid to pass through the fine strainer screens. To remove this difficulty, three 500-watt electric heating units, each about 2 ft. long, were arranged around the pipe, on a spider frame, to prevent contact of the heater elements with the pipe. A section of magnesia pipe covering was placed over the heaters as an insulation. Last winter

no trouble was experienced with this arrangement, and the fuel oil, though it stiffened at 40° F., passed through the piping at the rate of 30 gal. an hour, even when it entered the heater at a temperature as low as 5°.—George J. Kirkganer, Milwaukee, Wis.

### Grease Leaks Cured by Spring Washer

In certain makes of cars, the owner is often annoyed by grease leaking from the rear axle, smearing the wheel, and preventing the brakes from holding.

A felt washer, which will be automatically compensated for wear, and will maintain a tight joint between axle and housing, is shown in the drawing. Take a new washer and split it around the circumference, to within  $\frac{1}{4}$  in. of the center hole.

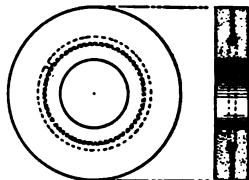

Coil a piece of spring wire around a shaft, about the same size as the axle, and cut off one coil for the washer. Spring the wire into the slot in the washer, and apply to the axle in the usual manner.

When fitting new washers, be sure that the axle is not rough, causing the washer hole to wear unduly; a heavy grease should be used, and care should be taken not to fill the housing above the prescribed level.—S. E. Gibbs, Urbana, Ill.

### An Improved Tap and Reamer Wrench

A navy-yard machinist uses a tap and reamer wrench of his own design which is a departure from the usual type, as shown in the drawing. The central portion of the wrench is made spherical in shape, to afford a convenient grip for the palm of the hand when starting a tap into the drilled hole, thus making it possible to hold the tap centrally and causing it to take hold readily without tearing out the

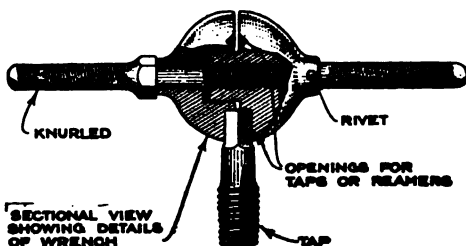

A Tap and Reamer Wrench Which Affords a Comfortable Grip for the Hand in Starting the Tool



same time, of keeping the glass ed against the sash, consists in using dinary pencil equipped with a rub-raser. The friction of the rubber st the glazing point makes it possi-) slide it to any point and hold it until driven into the sash.—C. J. sco, Washington, D. C.

### A Cheap and Accurate Level

water level is a very simple and l tool, and one which should be bet-nown. It consists of the desired 1 of rubber hose with a piece of -gauge glass inserted in each end. hose is then filled with water to 1 2 or 3 in. of each end. Such a is used for leveling floors and ceil-f of new buildings. One of the glasses eced on a given level mark on a or other vertical surface and the at the opposite end of the hose is d to the part to be leveled. When ater in the first glass is oppsite iven mark the water in the second is at the required level, and an priate mark is made. If a given is 4 ft. below the ceiling or above oor, measure 4 ft. from the second up or down, as the case may re-to get the location of the finished e. Such a level is particularly use-or leveling from one room to an-or any distance from a few inches 50 or 60 ft.—E. A. Weatherston, go, Ill.

### A Portable Stock Rack

stock rack that can be taken from ocation to another, but which is not too easily moved, is built as shown in the drawing. An ordinary stock rack may be converted to this purpose by adding a pair of iron wheels as indicated. The advantage of such a rack is appar-ent. If desired for holding work behind a machine, a stand of this type will not roll away as would one with four wheels, and yet, when it is desired to move the rack, but little ef-fort will be required.

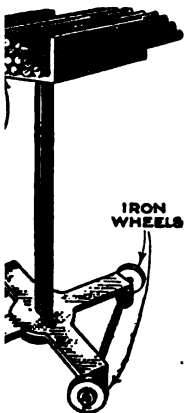

### Making a Small Deadbeat Scale

In processes where a large number of individual weighings of small quantities

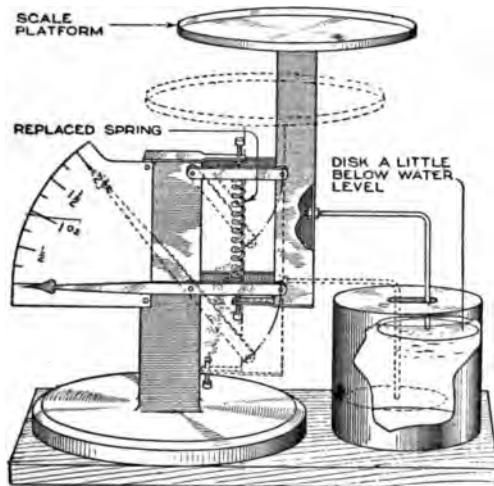

Where Accurate, Quick Readings Are Essential, This Deadbeat Scale will Prove of Considerable Value

of material is necessary, some form of deadbeat scale is essential, to combine speed with accuracy. The drawing shows how a small postal scale was converted into a low-reading deadbeat scale.

The original spring was replaced by a lighter one, and by testing with standard weights, a new scale of stiff Bristol board was carefully calibrated and placed over the original one. The readings were very accurate, but the scale was too lively and sensitive, and the pointer would vibrate for a considerable time before coming to rest and making a reading possible. This objectionable vibration was overcome by the deadbeat arrangement which brings the pointer to an instant standstill. A dashpot was arranged on the base, as indicated in the drawing. A disk of thin sheet aluminum was attached to the end of a bent piece of aluminum rod, which is fastened to the scale, as shown. The dashpot consists of a small covered can, filled with water, having a slot in the top large enough to clear the rod.—Harry Hertzberg, Brooklyn, N. Y.

### Coloring Brass for Laying Out

Brass can be colored with the ordinary copper-sulphate solution used for laying out iron and steel. Some fine cast-iron filings are placed on the brass at the points to be marked. The copper solution is applied to the filings, and a deposit of copper is produced.

### A Tool Grinder Attached to the Lathe

There are numerous cases where a tool grinder attached to the lathe, as shown, would result in economies of one sort or another.

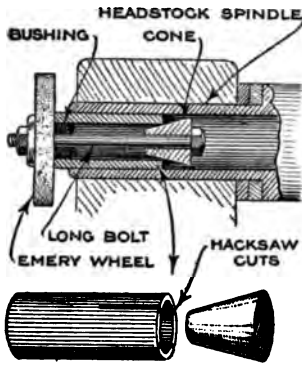

A section of tubing which makes a snug fit inside the headstock spindle is used for holding the grinding wheel to the lathe. One end of the pipe is split at right angles for about 4 in., and a

bushing is shrunk or threaded into the opposite end, as a bearing for the long bolt on which the grinding wheel is mounted. The wheel is held firmly in place when the cone is drawn inside the split end of the tube as the outside nut is tightened. A scratch brush or a polishing wheel may be substituted for the grinding wheel, if desired.—Harold E. Benson, Boulder, Colo.

### Making New Dictating-Machine Records from Old Records and Shavings

New dictating-machine records can be made from the shavings and from old records by melting the wax and pouring it into a mold, which can be made from the arbor of the shaving machine. This is removed from the machine and set up as shown in the drawing, a piece of writing paper being wrapped around it and held with a piece of cord. A piece of coarse cord may be wound spirally around the arbor if desired, to duplicate the internal grooves of the original cylinder. The outer portion of the mold is made from one of the cardboard record boxes which is held concentrically with the arbor by a hole cut in the center of the base. The fleece-lined lining of the box is removed and re-

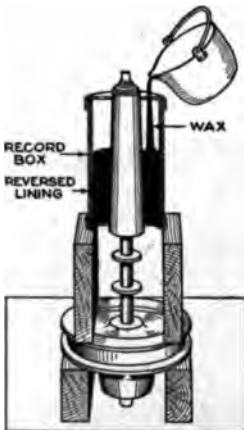

versed so that the plain back is exposed to the melted wax. The shavings and pieces of broken records are placed in a saucepan and melted over a gas jet. When sufficiently fluid, the wax is poured through small openings cut near the edge of the cover.—J. R. Henderson, Montreal, Can.

### Readjusting a Worn Feed Nut

To eliminate the lost motion caused by the wearing of the feed screw and feed nut in lathes, planers, milling machines, or wherever a cross-feed screw and nut may be used, the following method has been found satisfactory.

Remove the feed nut from the machine; lay out, drill, and tap holes for filister-head screws, as indicated in the drawing, using screws as large as possible without weakening the nut too much; then saw the nut in two, as near the center as possible, without coming too close to the anchor-screw hole. The sawed ends are faced off square; the gap created by the saw cut and subsequent facing is measured, and a piece of laminated shim stock of this thickness, drilled for the screws to pass through, is placed between the two halves, which are then screwed together tightly. After the exposed edges of the shim stock have been dressed down, the nut is again placed in the machine ready for service. When further wear develops all that is necessary to take up the lost motion is to remove the screws and peel off one or more of the shim laminations. This method not only produces an adjustable nut, but it is finished in less time than would be required for making a new one.

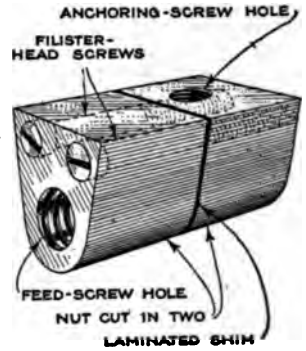

### Driving Glaziers' Points

Most mechanics and all amateur glaziers find it difficult to hold the little triangular glaziers' points tightly against the glass while driving them in, for they must be driven deep enough to be concealed by the line of putty. An effective way of holding the points while driving, and, at



me time, of keeping the glass against the sash, consists in using a rubber pencil equipped with a rubber tip. The friction of the rubber tip against the glazing point makes it possible to slide it to any point and hold it until driven into the sash.—C. J. O'Connell, Washington, D. C.

### Cheap and Accurate Level

A water level is a very simple and cheap tool, and one which should be kept in every toolbox. It consists of the desired length of rubber hose with a piece of gauge glass inserted in each end. The hose is then filled with water to a depth of 2 or 3 in. of each end. Such a level is used for leveling floors and ceilings in new buildings. One of the glasses is placed on a given level mark on a vertical surface and the other end of the hose is placed on the opposite end of the hose is placed on the part to be leveled. When the water in the first glass is opposite the mark in the second glass, the level is at the required level, and an accurate mark is made. If a given distance is 4 ft. below the ceiling or above the floor, measure 4 ft. from the second glass up or down, as the case may require, to get the location of the finished level.

Such a level is particularly useful for leveling from one room to another any distance from a few inches to 50 or 60 ft.—E. A. Weatherston, New York, Ill.

### A Portable Stock Rack

A stock rack that can be taken from one location to another, but which is not too easily moved, is built as shown in the drawing. An ordinary stock rack may be converted to this purpose by adding a pair of iron wheels as indicated. The advantage of such a rack is apparent. If desired for holding work behind a machine, a stand of this type will not roll away as would one with four wheels, and yet, when it is desired to move the rack, but little effort will be required.

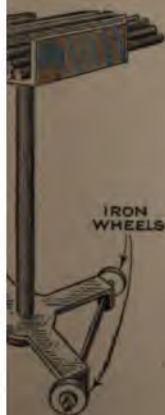

### Making a Small Deadbeat Scale

In processes where a large number of individual weighings of small quantities

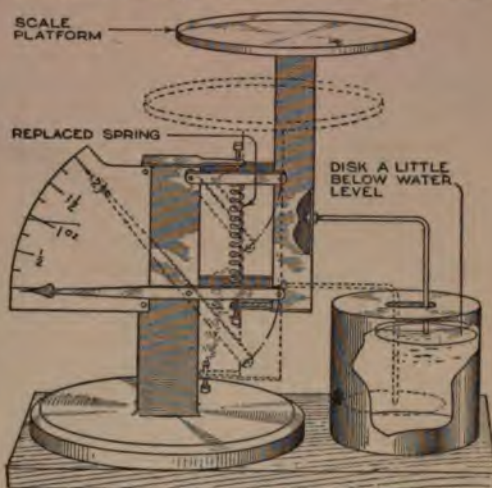

Where Accurate, Quick Readings Are Essential, This Deadbeat Scale will Prove of Considerable Value

of material is necessary, some form of deadbeat scale is essential, to combine speed with accuracy. The drawing shows how a small postal scale was converted into a low-reading deadbeat scale.

The original spring was replaced by a lighter one, and by testing with standard weights, a new scale of stiff Bristol board was carefully calibrated and placed over the original one. The readings were very accurate, but the scale was too lively and sensitive, and the pointer would vibrate for a considerable time before coming to rest and making a reading possible. This objectionable vibration was overcome by the deadbeat arrangement which brings the pointer to an instant standstill. A dashpot was arranged on the base, as indicated in the drawing. A disk of thin sheet aluminum was attached to the end of a bent piece of aluminum rod, which is fastened to the scale, as shown. The dashpot consists of a small covered can, filled with water, having a slot in the top large enough to clear the rod.—Harry Hertzberg, Brooklyn, N. Y.

### Coloring Brass for Laying Out

Brass can be colored with the ordinary copper-sulphate solution used for laying out iron and steel. Some fine cast-iron filings are placed on the brass at the points to be marked. The copper solution is applied to the filings, and a deposit of copper is produced.

### Hollow Columns Conceal Counterweights

It is frequently desirable to counterweight an air line, gasoline hose, or elec-

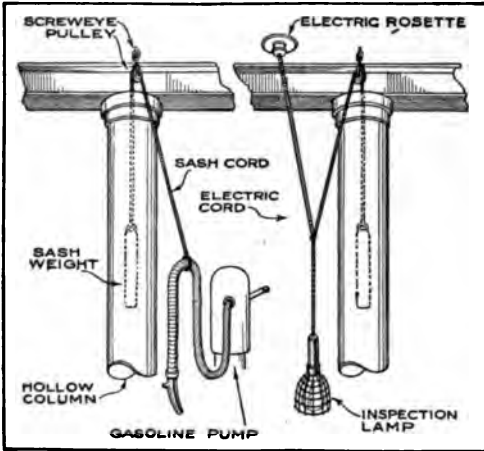

Counterweights Concealed inside Hollow Iron Columns Keep Hose and Electric Wires Out of Harm's Way

tric droplight cable, to lift it from the floor, and for clearance. The drawing shows a method of using counterweights which are concealed inside of hollow supporting pillars. In case the weight cannot be inserted at the top of the pillar, an opening can be made in the side large enough for the insertion of a sash weight, or lead-filled pipe, a pulley being attached over the opening with machine screws.

### Boring-Tool Holder

On jobs requiring the use of a long boring tool, it is important that the tool be very firmly held in the tool post, as the pressure on the cutting edge has a long leverage to force the tool back from the work. On such jobs it is also es-

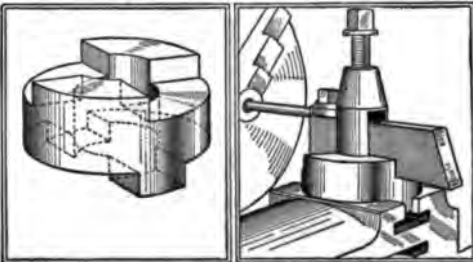

A Metal Block Cut to This Special Shape will Take Most of the Strain off the Tool-Post Screw When Using a Long Boring Tool

pecially important that the tool be held *exactly* parallel with the spindle.

The device, detailed at the left, and illustrated in use at the right, gives a positive grip on the tool so that even if the tool-post screw should become slightly loose, the tool will continue to cut. The piece is shaped from either cast iron or mild steel, and the recesses are milled in its top side, the bottom having a tongue to fit the T-slot.—M. L. Lowrey, Livermore, California.

### Spring Holds Apron

Considerable time is lost when one is in a hurry, in tying or untying the ordinary workshop apron, which is fastened about the waist with tapes. However, if the tape is removed and a piece of stiff clock spring, bent to conform to the waist, is inserted instead, all further troubles with the strings are removed. The spring is easily taken out when the article is to be laundered.—Forrest Benson, Boulder, Colorado.

### Tire-Pump Assembly Fixture

The rapid assembly of the cup leather on the piston rod of a hand tire pump was the problem that came up in a factory manufacturing pumps of this character, and anyone who has undertaken the insertion of such a leather into the barrel of a pump will testify to the difficulty of the operation. After some consideration, the assembly sleeve shown

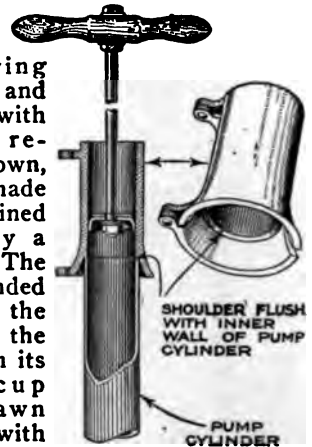

in the drawing was designed and put into use with satisfactory results. As shown, the fixture is made in two parts, joined together by a hinged joint. The device is intended to be held with the left hand while the piston rod with its attached cup leather is drawn into the fixture with the right hand, bringing the leather to the position indicated. Still holding the fixture together in the hand, it is placed over the end of the pump cylinder and up to the shoulder, which is flush with the inside walls of the barrel; then the piston is shoved down into the cylinder, placing the cup leather without a wrinkle.



line KM equal to JK; the point M then be at one point of the hexagon.

Other unknown angles may be laid in a similar manner.—R. C. Hard, Balboa Heights, C. Z.

### Iron Pipe as Gear Puller

One way to get a gear off a shaft is to take a piece of pipe a little larger than the shaft, file off the end to a very nearly true edge, and clamp it to the bench. Then turn the shaft in the pipe and let the gear strike the end of the pipe. If the gear is hard, it will not be damaged by the blow against the pipe, and if the pipe is faced off pretty frequently there will be little, if any, tendency to damage the shaft.

### Truing Up Gas-Engine Valves

Due to the hardness of the metal in general use for the valve heads of internal-combustion engines, about the most satisfactory method of truing them is by grinding on a universal or other grinding machine.

In removing the valves from the engine, the valve stem should first be trued if found necessary. These valves usually have a center hole in the head only, since a center hole in the stem would cause the stem to wear down locally under the continued striking of the valve tappet. It is, therefore, rather desirable to hold the valve between centers.

It is desirable to have such work supported between centers, a false center being made, which enabled better and faster work. If a false center is made, necessarily considerable care, from cold-rolled stock, and consists of a sleeve to fit over the valve stem. This sleeve is threaded on a standard pipe thread, and is then used to permit sufficient compression to hold the valve tightly when the nut is screwed up on the tapering thread. A center hole is drilled into the solid end of

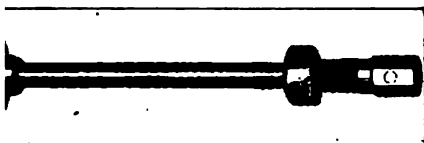

Lack of a Center Hole in the Valve Stem is Overcome by the Use of a False Center

sleeve, and the work is then taken to the grinding machine and the face ground, the valve revolving between centers during operation.—M. L. Lowrey, Livermore, Calif.

### Hinge for Heavy Doors and Gates

The drawing shows an extra-heavy hinge that was designed for use on all railroad and teaming gates, and heavy

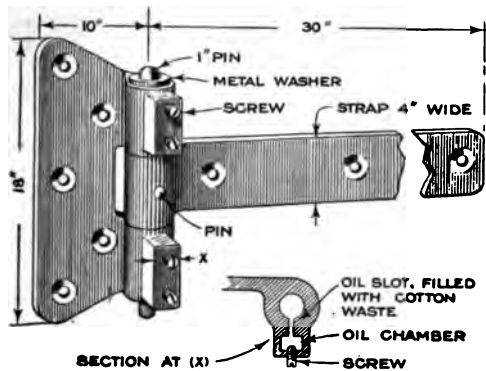

A Rusted Hinge on a Heavy and Expensive Gate Is Dangerous and Costly. This Specially Designed Hinge, for Heavy Gates, Is Proof against Sticking

doors of a large industrial establishment. The principal parts of the hinge are steel castings, provision being made for oil chambers in the butt, to keep the pin lubricated and prevent rusting; the pin fits loosely in the butt hub, but must be driven through the strap to which it is rigidly attached with a pin, as indicated. Dirt and water are prevented from entering the hinge bearing by a tight-fitting copper washer forced on over the projecting upper end of the hinge pin. The oil chamber is provided with two screws, for filling with lubricant, so that the hinges may be used for right and left-hand doors, the upper screw being removed for filling. The oil slot is packed with waste before the hinge pin is inserted, and after the installation has been made, the oil chamber is filled with heavy lubricating oil; this keeps the waste saturated with lubricant and prevents the pin from rusting and sticking.—M. E. Duggan, Kenosha, Wis.

### An Emergency Lap

In replacing a set of worn wristpins in a new set of automobile pistons, it was found that the new pins were a trifle oversize and would not enter the hole. No reamer of the right size was at hand, so one of the worn pins was placed in the chuck of an electric drill, and coated with valve-grinding compound. By holding the pistons on the pin and turning on the power for the drill, the holes were soon ground out to the desired size; this method was found to produce a perfect-fitting job.

### A Comfortable Crutch

The crutch shown in the drawing is the invention of a man who is compelled to

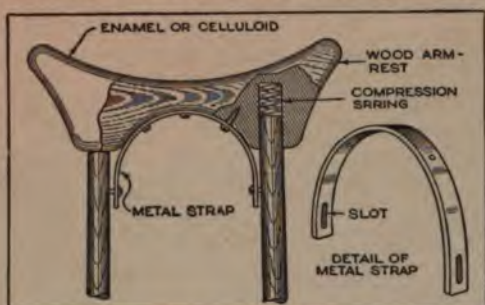

An Improved Crutch That does Not Heat or Chafe, and Provides Comfort to the Crutch User through a New Form of Spring Suspension for the Arm-piece

use crutches continually; he has obtained a patent on the manufacture of this crutch, but appreciating the discomforts of the usual crutch he has given permission to other crutch users to make a pair for their personal use.

This crutch has a specially designed armpiece which is devoid of angles, the entire surface being rounded and finished in special enamel, or celluloid, to prevent friction, wear of clothing, and chafing. In the underside of the armpiece, holes are bored to contain the compression springs shown in the drawing; these springs are suited to the weight of the user. The openings also serve to receive the ends of the crutch shafts which rest against the springs, the combination acting as a cushion, or shock absorber. A metal strap, which is attached underneath the armpiece, is held to the shafts in the manner shown in the drawing, and retains the parts in movable relation. The armpiece, being entirely independent of the crutch shafts, adjusts itself to the various movements of the body, and the curved surface does not change its form through pressure, which would be the case if it were padded or upholstered. The proper distance from the arm to handpiece and the correct length of the crutch are readily obtained by sawing off pieces from the ferrule and upper ends of the shafts to the required length.

### Ammonia as a Fire Extinguisher

Ammonia pistols are effective against either man or animal, and as weapons of defense are carried by many motorists. They are also quite effective, under certain conditions, for extinguishing small

gasoline fires. The ammonia fumes being heavier than air will quickly extinguish the flame, especially if it is confined. A quart bottle of ammonia, carried on the car, makes an effective fire extinguisher to carry on tours, and besides, it is good for cleaning glass or polished metals. Also, an "automatic" fire extinguisher, for the garage, may be made by suspending bottles of ammonia from the ceiling with inflammable strings, which are burned by the flames allowing the bottles to drop and break. The ammonia fumes in the confined garage would be of assistance in checking, if not entirely extinguishing, the blaze.—G. A. Luers, Washington, D. C.

### Constant Level for Filtering

In filtering liquids, such as oils that are to be recovered, or other liquids that run through the filter very slowly, the arrangement shown in the drawing will keep a constant level of the liquid in the filter.

A short piece of pipe is soldered over an opening made in the screw cap of a 5-gal. can. The oil, or liquid, to be filtered is placed in the can; the cap is screwed on, and the can inverted over the filter, as shown in the drawing. When the level of the liquid in the filter reaches the end of the pipe, the flow from the can stops until the level falls below it, when more of the liquid is released. This arrangement, in the case of oils, which filter slowly, is automatic and allows the filter to be changed.



### Adapting Saw Vise to Sharpening of Band Saw

When attempting to sharpen a band saw in the common saw vise, it is difficult to prevent the saw from slipping down too far in the vise while shifting it along.

By drilling a row of holes at each end of the vise, as shown, and putting two cotter pins in the proper holes, this trouble is avoided, and





the line KM equal to JK; the point M will then be at one point of the hexagon. Other unknown angles may be located in a similar manner.—R. C. Hardman, Balboa Heights, C. Z.

### Iron Pipe as Gear Puller

One way to get a gear off a shaft is to find a piece of pipe a little larger than the shaft, file off the end to a very nearly true surface, and clamp it to the bench. Then slam in the shaft and let the gear strike the end of the pipe. If the gear is hard, it will not be damaged by the blow against the pipe, and if the pipe is faced off pretty accurately there will be little, if any, tendency to damage the shaft.

### Truing Up Gas-Engine Valves

Owing to the hardness of the metal now in general use for the valve heads of internal-combustion engines, about the most satisfactory method of truing them up is by grinding on a universal or other grinding machine.

On removing the valves from the engine, the valve stem should first be trued up, if found necessary. These valves generally have a center hole in the head end only, since a center hole in the stem end would cause the stem to wear down rapidly under the continued striking of the valve tappet. It is, therefore, rather difficult to hold the valve between centers. As it is desirable to have such work suspended between centers, a false center was made, which enabled better and faster work.

This false center is made, necessarily with considerable care, from cold-rolled steel, and consists of a sleeve to fit over the valve stem. This sleeve is threaded with standard pipe thread, and is then slotted to permit sufficient compression to hold the valve tightly when the nut is turned up on the tapering thread. A center hole is drilled into the solid end of



The Lack of a Center Hole in the Valve Stem is Overcome by the Use of a False Center

the sleeve, and the work is then taken to the grinding machine and the face ground, the valve revolving between centers during the operation.—M. L. Lowrey, Livermore, Calif.

### Hinge for Heavy Doors and Gates

The drawing shows an extra-heavy hinge that was designed for use on all railroad and teaming gates, and heavy

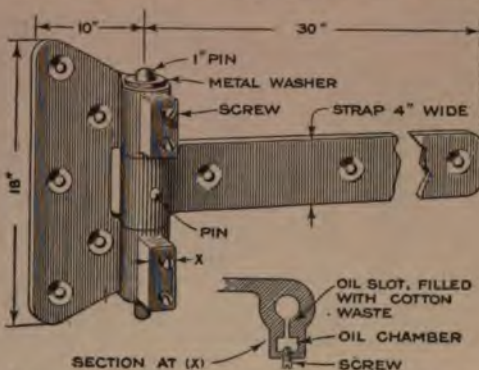

A Rusty Hinge on a Heavy and Expensive Gate Is Dangerous and Costly. This Specially Designed Hinge, for Heavy Gates, Is Proof against Sticking

doors of a large industrial establishment. The principal parts of the hinge are steel castings, provision being made for oil chambers in the butt, to keep the pin lubricated and prevent rusting; the pin fits loosely in the butt hub, but must be driven through the strap to which it is rigidly attached with a pin, as indicated. Dirt and water are prevented from entering the hinge bearing by a tight-fitting copper washer forced on over the projecting upper end of the hinge pin. The oil chamber is provided with two screws, for filling with lubricant, so that the hinges may be used for right and left-hand doors, the upper screw being removed for filling. The oil slot is packed with waste before the hinge pin is inserted, and after the installation has been made, the oil chamber is filled with heavy lubricating oil; this keeps the waste saturated with lubricant and prevents the pin from rusting and sticking.—M. E. Duggan, Kenosha, Wis.

### An Emergency Lap

In replacing a set of worn wristpins in a new set of automobile pistons, it was found that the new pins were a trifle oversize and would not enter the hole. No reamer of the right size was at hand, so one of the worn pins was placed in the chuck of an electric drill, and coated with valve-grinding compound. By holding the pistons on the pin and turning on the power for the drill, the holes were soon ground out to the desired size; this method was found to produce a perfect-fitting job.

### A Comfortable Crutch

The crutch shown in the drawing is the invention of a man who is compelled to

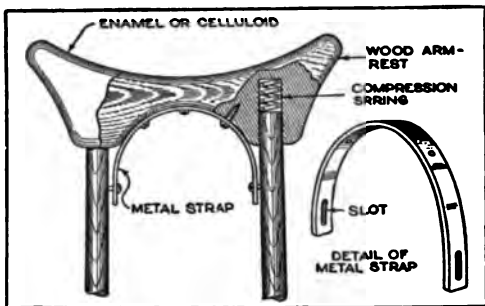

An Improved Crutch That does Not Heat or Chafe, and Provides Comfort to the Crutch User through a New Form of Spring Suspension for the Armpiece

use crutches continually; he has obtained a patent on the manufacture of this crutch, but appreciating the discomforts of the usual crutch he has given permission to other crutch users to make a pair for their personal use.

This crutch has a specially designed armpiece which is devoid of angles, the entire surface being rounded and finished in special enamel, or celluloid, to prevent friction, wear of clothing, and chafing. In the underside of the armpiece, holes are bored to contain the compression springs shown in the drawing; these springs are suited to the weight of the user. The openings also serve to receive the ends of the crutch shafts which rest against the springs, the combination acting as a cushion, or shock absorber. A metal strap, which is attached underneath the armpiece, is held to the shafts in the manner shown in the drawing, and retains the parts in movable relation. The armpiece, being entirely independent of the crutch shafts, adjusts itself to the various movements of the body, and the curved surface does not change its form through pressure, which would be the case if it were padded or upholstered. The proper distance from the arm to handpiece and the correct length of the crutch are readily obtained by sawing off pieces from the ferrule and upper ends of the shafts to the required length.

### Ammonia as a Fire Extinguisher

Ammonia pistols are effective against either man or animal, and as weapons of defense are carried by many motorists. They are also quite effective, under certain conditions, for extinguishing small

gasoline fires. The ammonia fumes being heavier than air will quickly extinguish the flame, especially if it is confined. A quart bottle of ammonia, carried on the car, makes an effective fire extinguisher to carry on tours, and besides, it is good for cleaning glass or polished metals. Also, an "automatic" fire extinguisher, for the garage, may be made by suspending bottles of ammonia from the ceiling with inflammable strings, which are burned by the flames allowing the bottles to drop and break. The ammonia fumes in the confined garage would be of assistance in checking, if not entirely extinguishing, the blaze.—G. A. Luers, Washington, D. C.

### Constant Level for Filtering

In filtering liquids, such as oils that are to be recovered, or other liquids that run through the filter very slowly, the arrangement shown in the drawing will keep a constant level of the liquid in the filter.

A short piece of pipe is soldered over an opening made in the screw cap of a 5-gal. can. The oil, or liquid, to be filtered is placed in the can; the cap is screwed on, and the can inverted, as shown in the drawing. When the level of the liquid in the filter reaches the end of the pipe, the flow from the can stops until the level falls below it, when more of the liquid is released. This arrangement, in the case of oils, which filter slowly, is automatic and allows the filter to be changed.



### Adapting Saw Vise to Sharpening of Band Saw

When attempting to sharpen a band saw in the common saw vise, it is difficult to prevent the saw from slipping down too far in the vise while shifting it along.

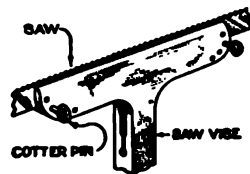

By drilling a row of holes at each end of the vise, as shown, and putting two cotter pins in the proper holes, this trouble is avoided, and



h, depending upon the size of the to be used. When cool, the babbitt ler is placed in the lathe, and light taken from it, until the stock be- s too small to work longer. These or ribbons should be about  $\frac{1}{8}$  in. and not more than .005 in. thick; are gathered in a box as they come the lathe, and need no further atten- until required for service. Usually or 4,000 ft. of babbitt ribbon should pt on hand, and the packing made ; required.

en ready to use these ribbons, h them over two nails, placed about 4 ft. apart, running the ribbon back forth about the nails until, when ed in the hand and squeezed tightly, urch has a diameter twice that of the red packing. The ends of any two ns are joined by twisting together, short as well as long pieces can be

The mass of ribbon is then removed the nails, and the two ends are ed in opposite directions, until the eter is reduced to packing size. Be- twisting, paint the ribbons with a ire of cylinder oil and graphite, for cating.

e rope of twisted babbitt ribbons is cut off in desired lengths, and ap- just like any high-pressure packing, being taken to allow for the expan- of metal at the joint, when the stuff- ox gland is taken up. A liberal int of oil is applied to the piston rod lve stem the first few days, until the itt works into place.

care is taken when placing this pack- it will last indefinitely; the rod or will soon take on a high polish, and aking will stop; the packing needs g up very seldom, and a new turn cking can be put in at any time. The r found it particularly good for high- ure feed pumps, and has used it on a pump with no attention, other an occasional tightening of a gland, 19 months.—L. E. Fetter, Ports- h, N. H.

### Fire Boot Made from Old Paper

motorist, unfortunate enough to find elf in the country with a blowout and atch on hand, was able to complete ip by using pages from an old maga-

Seventy-five or 80 of the pages were out and placed inside, over the hole e casing. When the tube was put in nflated, the patch was held firmly in , and the repair shop was reached ut trouble.

### Tool for Removing Woodruff Keys

A tool which will remove a Woodruff key from a shaft into which it is tightly fitted is shown in the drawing.

The tool is made from  $\frac{1}{2}$ -in. square machine steel, bent and formed as shown;

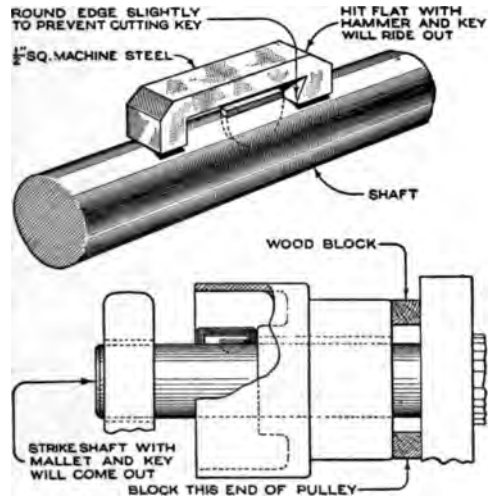

A Simple Tool That Makes the Task of Removing Woodruff Keys Easy

on an exposed key it is used as shown in the upper half of the sketch. The lower sketch shows the tool in use where the hammer cannot be used directly. Small blocks of wood, of the proper thickness, are placed behind the pulley, which is slipped back until the blocks come against a shoulder on the machine, leaving just enough space between the pulley and key to insert the tool. A few blows on the end of the shaft will then remove the key.

—F. K. Ladd, Bellows Falls, Vt.

### Spring Holds Pliers Open

A simple little fixture that expedites work with the pliers consists of a wire spring attached to the handles for holding the jaws apart, as shown in the drawing. The spring is made from a piece of spring wire and the coils are formed around the handles of the plier it is to be used with. Such an attachment

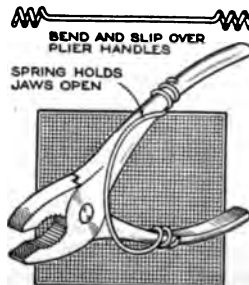

permits of easy manipulation and simpli- fies working in close quarters.

## Machine Bends Wire Mesh for Concrete-Column Reinforcement

Contractors and workers in reinforced concrete are aware of the difficulty involved in bending wire-mesh reinforcing for square columns. The machine shown in the drawing provides a convenient and

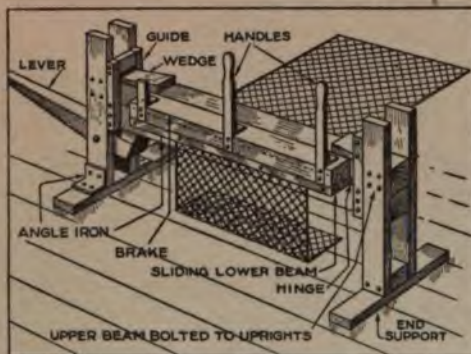

A Convenient and Economical Method of Bending Wire Mesh, for Reinforcing Square Columns, is Afforded by the Use of This Bending Machine

economical method of bending wire mesh into square or rectangular forms of any size. As shown, two wooden beams, about 6 in. square and of any convenient length, are supported between substantial uprights at the ends, the upper beam being permanently attached to the end supports with bolts. The lower beam slides up and down on guides, which are bolted to it at each end in the manner shown; the

height of this vertical movement is regulated by wedges inserted between the crosspieces at the top of the guides and the upper beam. A heavy lever is mounted between the left end support, with a long bolt, in such a manner that the end of the lever will bear against the lower beam and press it against the upper beam when the lever is pressed down. The brake consists of a smaller wood beam which is attached to the upper beam with hinges so that the lower edges of both are flush; handles are fitted to the brake, and the lower edge is faced with a strip of angle iron, to prevent wear.

In use, the wedges are inserted under the guides in such a manner that just enough space is left for the strip or reinforcing mesh to be inserted between the upper and lower beams, and when the lever is pulled down, the reinforcing material will be tightly gripped between the two beams. The wire mesh is pushed through the opening between the upper and lower beams from the back of the machine; when the proper length has been pushed through, the lever at the end is pressed down, gripping the reinforcing mesh between the beams; the brake is then pulled downward, and the material is bent at right angles to the strip.

This operation is repeated as desired, and the finished reinforcing form is cut from the strip with a bolt cutter.

## Steel-Ball Circular Level

A level for horizontal work, which is so simple that it does not have to be

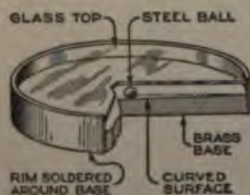

"made," consists of a piece of smooth plate glass, with a good steel ball placed on it. The rolling of the ball will indicate the low side instantly. A

better level can be made by accurately finishing a piece of sheet brass on a surface plate, soldering a brass rim around it, and putting on a glass cover. If a lathe is available, a still better job can be made by making a disk that is very slightly concave, so that the ball will tend to remain at the center if the surface tested is level, but will roll out otherwise. *The depression must be exceedingly slight, and should be of a spherical cur-*

vature, as nearly as possible. The best way to produce it is first to get the plate true, and then work down the center a little in the lathe, with fine emery cloth, taking care to make the deepest depression at the center, and taper off gradually to the edges, where the surface is left untouched.—Howard Greene, New York, New York.

## Testing Automobile Generators

It is often desirable to test automobile generators when removed from the car. In such cases, it is usually difficult to drive the generator from a motor or other source of power, on account of the gear, or sprocket, with which the generator is usually equipped, without removing the gear and substituting a pulley. However, the gear can be converted into a temporary pulley without difficulty.

Take ordinary friction tape and make small rolls of it, just large enough to go



length, depending upon the size of the lathe to be used. When cool, the babbitt cylinder is placed in the lathe, and light chips taken from it, until the stock becomes too small to work longer. These chips or ribbons should be about  $\frac{1}{8}$  in. deep, and not more than .005 in. thick; they are gathered in a box as they come from the lathe, and need no further attention until required for service. Usually 3,000 or 4,000 ft. of babbitt ribbon should be kept on hand, and the packing made up as required.

When ready to use these ribbons, stretch them over two nails, placed about 3 or 4 ft. apart, running the ribbon back and forth about the nails until, when grasped in the hand and squeezed tightly, the bunch has a diameter twice that of the required packing. The ends of any two ribbons are joined by twisting together, and short as well as long pieces can be used. The mass of ribbon is then removed from the nails, and the two ends are twisted in opposite directions, until the diameter is reduced to packing size. Before twisting, paint the ribbons with a mixture of cylinder oil and graphite, for lubricating.

The rope of twisted babbitt ribbons is then cut off in desired lengths, and applied just like any high-pressure packing, care being taken to allow for the expansion of metal at the joint, when the stuffing-box gland is taken up. A liberal amount of oil is applied to the piston rod or valve stem the first few days, until the babbitt works into place.

If care is taken when placing this packing, it will last indefinitely; the rod or stem will soon take on a high polish, and all leaking will stop; the packing needs taking up very seldom, and a new turn of packing can be put in at any time. The writer found it particularly good for high-pressure feed pumps, and has used it on such a pump with no attention, other than an occasional tightening of a gland, for 19 months.—L. E. Fetter, Portsmouth, N. H.

### Tire Boot Made from Old Paper

A motorist, unfortunate enough to find himself in the country with a blowout and no patch on hand, was able to complete his trip by using pages from an old magazine. Seventy-five or 80 of the pages were torn out and placed inside, over the hole in the casing. When the tube was put in and inflated, the patch was held firmly in place, and the repair shop was reached without trouble.

### Tool for Removing Woodruff Keys

A tool which will remove a Woodruff key from a shaft into which it is tightly fitted is shown in the drawing.

The tool is made from  $\frac{1}{2}$ -in. square machine steel, bent and formed as shown;

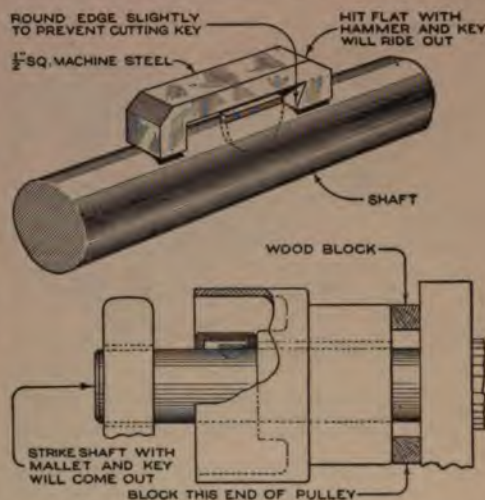

A Simple Tool That Makes the Task of Removing Woodruff Keys Easy

on an exposed key it is used as shown in the upper half of the sketch. The lower sketch shows the tool in use where the hammer cannot be used directly. Small blocks of wood, of the proper thickness, are placed behind the pulley, which is slipped back until the blocks come against a shoulder on the machine, leaving just enough space between the pulley and key to insert the tool. A few blows on the end of the shaft will then remove the key.—F. K. Ladd, Bellows Falls, Vt.

### Spring Holds Pliers Open

A simple little fixture that expedites work with the pliers consists of a wire spring attached to the handles for holding the jaws apart, as shown in the drawing. The spring is made from a piece of spring wire and the coils are formed around the handles of the plier it is to be used with. Such an attachment permits of easy manipulation and simplifies working in close quarters.



## Machine Bends Wire Mesh for Concrete-Column Reinforcement

Contractors and workers in reinforced concrete are aware of the difficulty involved in bending wire-mesh reinforcing for square columns. The machine shown in the drawing provides a convenient and

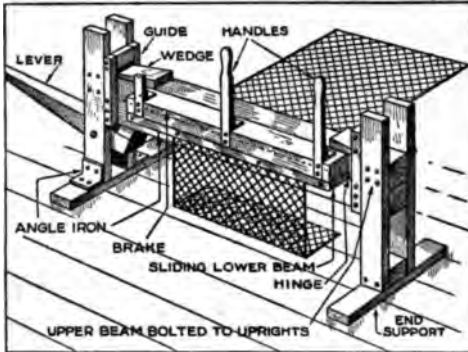

A Convenient and Economical Method of Bending Wire Mesh, for Reinforcing Square Columns, is Afforded by the Use of This Bending Machine

economical method of bending wire mesh into square or rectangular forms of any size. As shown, two wooden beams, about 6 in. square and of any convenient length, are supported between substantial uprights at the ends, the upper beam being permanently attached to the end supports with bolts. The lower beam slides up and down on guides, which are bolted to it at each end in the manner shown; the

height of this vertical movement is regulated by wedges inserted between the crosspieces at the top of the guides and the upper beam. A heavy lever is mounted between the left end support, with a long bolt, in such a manner that the end of the lever will bear against the lower beam and press it against the upper beam when the lever is pressed down. The brake consists of a smaller wood beam which is attached to the upper beam with hinges so that the lower edges of both are flush; handles are fitted to the brake, and the lower edge is faced with a strip of angle iron, to prevent wear.

In use, the wedges are inserted under the guides in such a manner that just enough space is left for the strip or reinforcing mesh to be inserted between the upper and lower beams, and when the lever is pulled down, the reinforcing material will be tightly gripped between the two beams. The wire mesh is pushed through the opening between the upper and lower beams from the back of the machine; when the proper length has been pushed through, the lever at the end is pressed down, gripping the reinforcing mesh between the beams; the brake is then pulled downward, and the material is bent at right angles to the strip.

This operation is repeated as desired, and the finished reinforcing form is cut from the strip with a bolt cutter.

## Steel-Ball Circular Level

A level for horizontal work, which is so simple that it does not have to be "made," consists of a piece of smooth plate glass, with a good steel ball placed on it. The rolling of the ball will indicate the low side instantly. A better level can be made by accurately finishing a piece of sheet brass on a surface plate, soldering a brass rim around it, and putting on a glass cover. If a lathe is available, a still better job can be made by making a disk that is very slightly concave, so that the ball will tend to remain at the center if the surface tested is level, but will roll out otherwise. The depression must be exceedingly slight, and should be of a spherical cur-

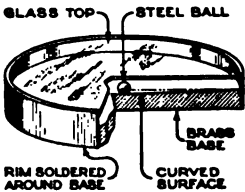

vature, as nearly as possible. The best way to produce it is first to get the plate true, and then work down the center a little in the lathe, with fine emery cloth, taking care to make the deepest depression at the center, and taper off gradually to the edges, where the surface is left untouched.—Howard Greene, New York, New York.

## Testing Automobile Generators

It is often desirable to test automobile generators when removed from the car. In such cases, it is usually difficult to drive the generator from a motor or other source of power, on account of the gear, or sprocket, with which the generator is usually equipped, without removing the gear and substituting a pulley. However, the gear can be converted into a temporary pulley without difficulty.

Take ordinary friction tape and make small rolls of it, just large enough to go



between two teeth; this is repeated until the spaces between all the teeth have been filled. Then wind the tape over the teeth in the direction the wheel is to be driven. Carry the tape around five or six times and then cover with a single layer of stiff paper, lapping the end and gluing it in the direction of rotation. Of course, with such a pulley, a narrow belt will be required.—B. B. Brackett, Brookings, South Dakota.

### A Combined Scale and Protractor for Topographical Draftsmen

The combined scale and protractor shown in the drawing is made from a piece of transparent celluloid, and will be found especially useful for plotting the topography for highway and railroad locations, as it does away with the use of two instruments. This instrument, it will be noted, is a simple protractor with a quadrant cut out, as shown,

the scale graduations being marked off along the edges from which the quadrant has been removed.

The drawing shows the plotting of a structure located at an angle of 55° to the left and 100 ft. distant from station 3+30. Place the center of the protractor at station 3+00, with the zero edge along the center line, and locate station 3+30 with a pencil. Holding the pencil at this point, slide the protractor along the center line until the pencil strikes the center, and turn the angle, then go out along the scale 100 ft. and locate the point of the structure; the protractor may then be used for drawing in the building.

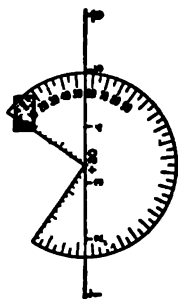

### Aid for Painting Window Sash

To prevent paint from getting on the window glass when painting the sash, a useful tool for the amateur painter is made from a strip of tin, about 1 ft. long and 4 in. wide. This strip is slightly curved, and is held against the glass underneath the sash, in the manner shown in the drawing.

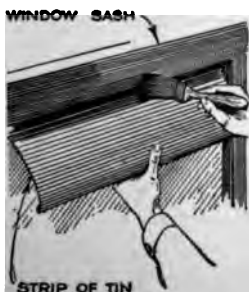

### Regulator for Steam Water Heater Operates by Mercury Expansion

A low-cost temperature regulator, for steam water-heating plants, which de-

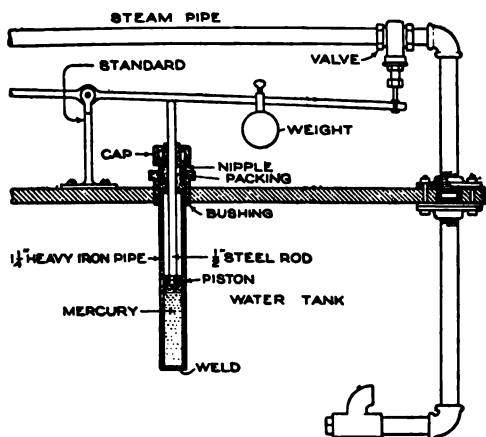

An Easily Attached Regulator, Made from Simple Materials, Controls the Flow of Steam to the Water Heater

pendes for its action upon the expansive force of heated mercury, can be easily installed on the average heater. As shown in the drawing, a piece of heavy iron pipe, about 18 in. long, is inserted inside the heater. An iron piston is made, as indicated, to fit inside this pipe, the latter being partly filled with mercury before the piston is fitted in place and the bushing and packing that guide the piston rod and prevent the mercury from overflowing are added. The outer end of the piston rod bears against an arm, that is attached at one end to a standard, bolted to the furnace, and at the other to a gate valve in the steam line; the position of a suitable weight on this arm determines the point at which the valve opens and closes. The operation of this regulating device requires no attention, aside from adjusting the weight on the regulator arm. As the mercury in the pipe becomes heated, it expands and forces the piston up, closing off the steam supply, and in cooling, it contracts and allows the piston to drop and open the valve.

### Substitute for Screen Door

In places where it is impossible to hang a screen door, its place can be taken by hanging a full curtain of mosquito netting over the door opening. A wide hem is provided at the bottom and small weights or a metal rod are sewed inside to keep the curtain taut.

### Burglar Alarm Designed to Confuse an Expert

The burglar-alarm circuit shown in the drawing is novel as a burglar alarm be-

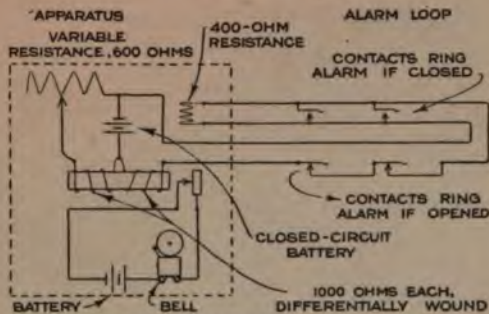

The Porch Climber and the Sneak Thief are Circumvented by the Ingenuity of This Burglar-Alarm Circuit; They cannot Cripple It by Cutting the Wires

cause of its certainty of operation, and because it cannot be put out of order without giving an alarm. It is an ideal circuit for installations which include out-buildings.

The main feature is the relay; this may be a reconstructed telegraph relay, and should have two windings consisting of the same number of ampere-turns and wound on the core in opposite directions. The two inside ends of the windings should be spliced together, and this middle lead from the relay is connected to one side of a closed-circuit battery. The outside of one winding is connected to one side of a variable resistance, and the other side of the battery is connected to the resistance in the manner indicated; this same side of the battery and the free end of the second relay winding compose the alarm loop. The alarm contacts can be arranged to either open or close this pair of wires, or both open and closed contacts may be installed on the same circuit; this pair can be run to any location desired, but must have a fixed resistance shunted across the end, as shown.

When the circuit is completely connected, the relay armature should be adjusted very closely to the core, and then the variable resistance adjusted to a point where the armature will not be attracted; this operation is explained by the fact that the resistance, battery, and one relay winding form one side of a bridge circuit. The fixed resistance, the contact loop, the battery, and the other relay winding form the other side of the bridge circuit. By adjusting the variable resistance, a point is reached where both relay coils receive *exactly the same amount of current from*

the battery, and because the armature is on the core in different directions, it will neutralize each other's effect. If one becomes in the least attracted, the other will receive the other, overcoming the other coil and causing the armature to be magnetized. When the armature is attracted, it completes the circuit which rings the bell. Crouch, Minneapolis.

### Taking Up Back

After considerable use, some gears wear away a certain amount of back teeth. If they are running under a very heavy load, a new gear is not economical. An excess play can be eliminated by the following method:

Remove the gear and split it in half with a machine saw. This must be done carefully, to insure that the parts are of equal thickness. File away the faces of the gear, grind off the faces of the gear, and place the halves together, offsetting them to bring them in line. The other worn gear holes through the points, and tap or drill the holes. Screw the gear is ready to be used.

If desired, the gear can be elongated to prevent further wearing of the teeth by unscrewing the gear and further offsetting the teeth. This method is of course, not a perfect use, but it is possible to run for quite a long time. Harwich, Mass.

### Hand Grinder can

When I took some of the gears to turn them down, I found the center and found it was not true. I inquired of the foreman of the center grinder he told me that one they had was not true and would have to shift the center. The center was not want to lose the



### Keeping Vermin from Seeds Hung on Wire

Where seeds are stored by hanging on a horizontal wire, it is often a problem to keep the rats and mice from getting to them, as these pests seem to be able to run along the wire as easily as anywhere else.

Secure several tin disks, such as ordinary sirup-can lids, about 4 or 5 inches in diameter; punch a hole in the center a little larger than the wire, and string one or three on each side of the seeds. Rats or mice cannot pass these, as, if they attempt to cross over them, the lids will revolve and throw them off.—S. Van Port Ewen, N. Y.

### Automatic Quick-Acting Lathe Dog

When a large number of shafts of the same size are to be turned in a lathe, the work can be increased by the use of an automatic, quick-acting lathe dog, such as the one shown in the drawing.



The body of the dog may be made from a steel casting, or worked up from the solid. The hole is made  $\frac{1}{16}$  in. larger than the shaft to be turned.

Dogs of different size will be required to accommodate shafts of various sizes. The gripping dog is made of hardened steel, and provided with teeth at the front end, which is made eccentric, so that the heavier the cut the greater will be the holding power.—R. F. Martlin, Dun-ont.

### Detecting Pinholes in Camera Bellows

A convenient method of detecting pinholes in a camera bellows, or a changing bag, is to place an electric lamp inside, examine the bellows, or bag, from the outside, in a dark room. The smallest amount of light issuing from a pinhole can easily be detected by moving the light around inside. The back of the bellows should be covered, to prevent the escape of light which would interfere with the detection of the pinholes.

### Wing Bolt is Used to Fasten Timbers to Hollow Tile

It is not possible to use expansion bolts or anchor bolts in hollow tile, as the pres-

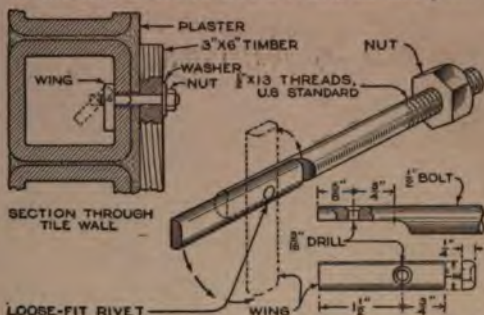

For Fastening Timbers to Hollow Tile the Wing Bolt Illustrated Is Better than Expansion or Anchor Bolts

sure necessary to tighten the bolts will crack the tile, but, by using the type of bolt shown in the drawing, studding and timbers, may be fastened to the wall without damage to the tile.

A hole is first drilled through the tile, about  $\frac{1}{8}$  in. larger than the diameter of the wing bolt used; the wing of the bolt is then set parallel with the body, and pushed through the hole, when the weight of the long end of the wing will cause it to fall, and span the hole, as shown.

Bolts of varying proportions should, of course, be used for different sizes of work, but the size shown in the drawings will be found suitable for general purposes.

The rivet connecting the wing and bolt must not bind too tightly.

### Joining Rawhide Belts

Rawhide belts have been found by one company to have a longer life than the endless cotton ones they had been using formerly, and their method of joining the ends is shown in the engraving. A slit is cut in one end of the belt, and two notches are cut out of the other end. The notched end is forced through the slit and pulled tight. This method eliminates dangerous rivets, and when the belt stretches, it is the work of a moment to pull the end through the slit, cut fresh notches, and pull the belt tight again.—S. Guy, Chicago, Ill.





## Auto Hub as Lathe and Drill Press

A number of tractors, sold by an agency, started to pump oil in the cylinders after the machines had been in use but a short

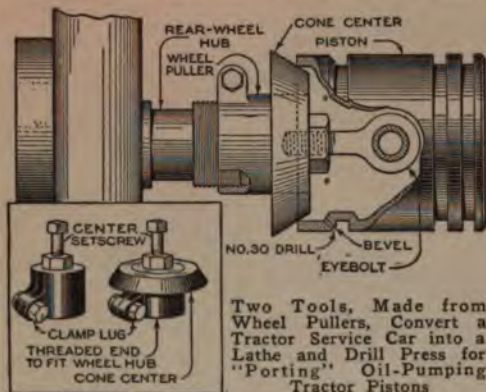

time, and in these cases "porting" the pistons was resorted to as the only effective remedy. This operation consisted in drilling from four to eight holes, with a No. 30 drill, in the previously beveled lower edge of the bottom piston-ring groove. Whenever possible, the tractors were brought into the shop and this work done on a lathe, but as most of the machines were from 5 to 25 miles from the shop, it was necessary to send a service man into the field to do much of the work. The agency's service car, a light automobile, was equipped with two special tools made from a common type of wheel puller. One of the wheel pullers was centered in a lathe and the outside smoothed down as far as the clamp lug.

A steel disk, about  $1\frac{1}{4}$  in. thick, was then bored to make a press fit over the top of the puller; this was pressed on and brazed to the puller, and a taper was turned on the outer circumference of the ring, as shown in the drawing. The center setscrew of the puller was removed, and its place was taken by an eyebolt, having an eye large enough for the tractor piston pins to be inserted. The second puller had its setscrew removed, and a drill chuck was firmly fixed in place, care being taken to have it accurately centered.

When the service man was called to a job, he jacked up one rear wheel of his car and removed the regular hub cap. The puller with the eyebolt was then screwed on the hub in place of the cap. The piston, with the piston pin through the eyebolt, was then placed over the puller and screwed on, holding the piston

tight and centered on the taper, as shown in the drawing.

By starting the engine and throwing the car into "high," the piston was revolved rapidly on the end of the hub, and the edge of the piston-ring groove was beveled by holding a file against it, as in a lathe. When all the pistons had been beveled, the puller was removed and the one with the drill chuck substituted. By running the engine as before, and holding the pistons against the drill with the hands, the service man was able to do a quick and satisfactory job.—Vernon Orr, Pomona, Calif.

## Sanitary Closet of Vitrified-Clay Sewer Pipe

The accompanying drawing represents an improved type of surface closet, especially designed for use in rural districts, where sanitary sewers are not available. This closet is suitable for either the home or the school. Any number of seats can be provided by using another sewer-pipe tee for each additional seat. The system should be used only where a satisfactory disposal field for tile drain is conveniently located. Existing surface-closet buildings can be used to house the system, which is installed in such cases in the same manner as in a new structure. The necessary material can be obtained from any dealer in drain tile and sewer pipe, as all the pieces are of standard size.

A box is built around the vertical pipe that projects into the building from the tee. On top of the box is placed a wooden seat, which is provided with a hinged

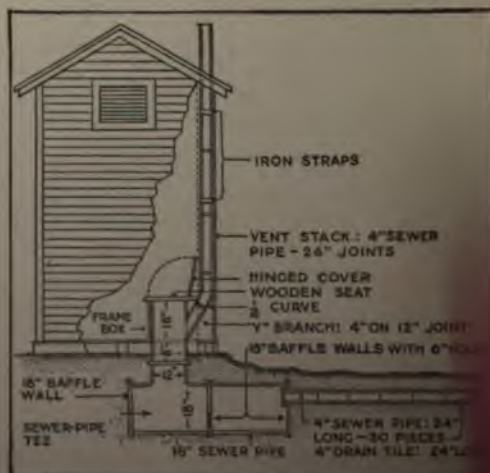

Surface Closet of Sewer Pipe and Drain Tile, Suitable for Homes and Schools in Outlying Districts Which Lack Sanitary Sewers



it annealed and turn it. On inquiring at the tool-room window, as a last resort, whether there was no other grinder available, I spied a small hand-operated grinder clamped to the vise bench. Taking this small grinder, I clamped it to the compound rest, which was set to the 30° angle, and by turning the grinder by hand and running the lathe, I was able to grind the center without trouble.—Joe W. Romig, Allentown, Pa.

### Tapping Holes in Sheet Metal

In order to obtain a firmer hold for machine screws, when used in threaded holes in sheet metal, drill the hole with a drill somewhat smaller than the tap to be used. Then use a drift of the proper diameter to enlarge the hole. If the tap is then used, it will be found that quite a few extra threads can be cut, on account of the drift raising a bur on the metal.

### Box for Holding Tape Reel

People who have frequent use for adhesive tape of paper or cloth will find the arrangement illustrated to be a great timesaver, as the end of the tape is always in sight and cannot be pulled back into the box which protects the tape from dirt and dust. It consists merely of a wooden box with a hinged lid, which may be mounted on a wooden base, if desired. The end of the tape is held between a fixed block and an eccentric, which permits the tape to be pulled out freely, but clamps it immediately when pulled or pushed backward. A light spring should be used to keep the eccentric in contact with the tape.

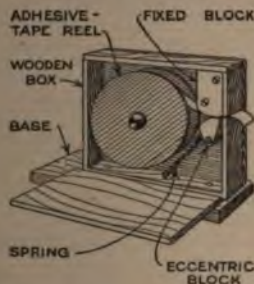

### Straightening Tubular Radiator Fins

A very handy tool to have around the garage and radiator-repair shop, for straightening the fins on water-tube, or tubular, radiators is made by welding two pieces of 4 by 1 by 1/8-in. steel at right angles to the nose of a pair of blacksmith's tongs, so that the faces of the steel pieces will be parallel. Such a tool will do a very nice job of straightening, no matter how badly the fins are bent.

### An Improved Cotter-Pin Puller

The tool shown in the drawing will save many minutes, and prevent many cuts and

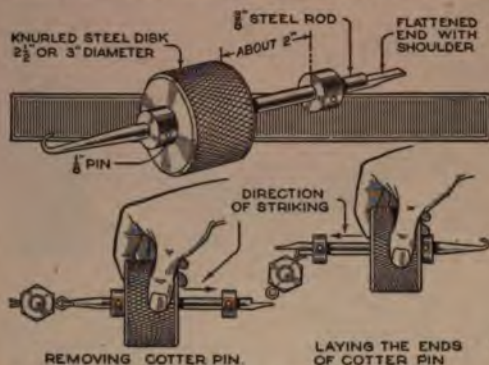

A Device for Pulling Cotter Pins, Which Combines Several Tools in One, Is a Useful Addition to the Mechanic's Tool Chest

bruises in removing cotter pins from places that are difficult to reach. A steel rod, of the diameter shown, has one end drawn to a taper, and a hook turned on it; the opposite end is filed flat for a short distance, leaving a shoulder for laying the ends of the pins. A knurled steel disk is drilled through the center so as to slide easily over the rod, and two small collars are pinned to the rod about 2 in. apart. The manner of using the tool, which comprises hammer, screwdriver, and puller, is obvious from the illustration.

### Jig for Bending Eyes in Wire

The simple jig shown in the drawing was designed to turn eyes at the ends of short lengths of wire. The wire is held securely by a toggle lever and prevented from bending during the formation of the eye by a series of staggered pegs set into the base. The bending lever is made from a piece of flat iron with a hole at one end to fit over a substantial peg, as shown. A bending pin is secured to the lever at a distance from the hole, this distance being governed by the thickness of the wire to be bent. In use, the wire is inserted into the jig and held tight, with the end against the gauge. The bending lever is then put in place and turned, on the pivot, forming the eye.—Chas. M. Greer, Buffalo, N. Y.





### Sensitive Relay Operates Alarm When Brushes Spark

Where storage batteries are used for operating telephone plants, the charging

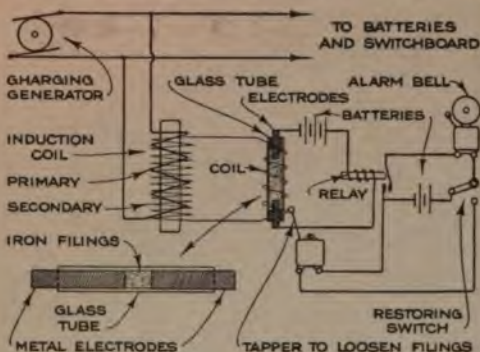

An Unusually Sensitive Relay is Provided, So That Small Variations of Current, Caused by Sparking at the Brushes, will Operate the Alarm

generators must be watched very carefully to eliminate noise. Any slight sparking of the brushes, or dirt on the commutator, will cause all the telephones to become noisy, and will impair the transmission or talking quality of the circuits. The sparking brush causes this by making slight variations in the current flowing from the generator to the batteries and telephone switchboard. When this happens, it is very important that an attendant be notified immediately. To do this automatically, the circuit and apparatus shown was devised.

The primary of an induction coil is connected across the generator terminals. As long as the generator is producing a steady flow of direct current, it is evident that there will be no current flow in the secondary of the coil; the magnetic field produced by the primary winding must be either interrupted or varied to produce this result. A current thus produced is, however, so weak that it is not capable of operating any ordinary piece of apparatus to notify the attendant that the trouble exists.

A sensitive relay that will operate on this small margin can be made in this manner: A small glass tube, about 2 in. long, is fitted with two electrodes, as shown in the drawing. The space between the electrodes, inside the tube, should be made adjustable, and filled with iron filings, or a mixture of iron and nickel filings, like the early wireless-telegraph coherer. Around the tube is wound a coil of many turns of fine wire. The two ends of this coil are connected to

the secondary of the induction coil. The two electrodes are connected to still another circuit, consisting of a battery and bell.

The operation is as follows: As long as no current is flowing through the coil wound on the glass tube, the relay will not operate, because of the high resistance of the loose iron filings between the electrodes. But if the magnetic field of the induction coil is varied in the least, the induced current in the secondary will flow through the coil on the tube, producing a field which will affect the iron filings within, causing them to become magnetized and to cohere closely. This reduces the resistance of the relay circuit, causing the relay to operate. The alarm circuit is thus closed and the bell rings. To reset the circuit after it has operated once, it is necessary to tap the glass tube containing the filings, in order to loosen them up. This can be done by mounting a bell so that the clapper will strike the tube gently when the restoring switch is operated.

### Flour Bin on Cupboard Door

The sketch shows a flour bin which was constructed in a recess in the wall, which originally contained a cupboard;



the shelves were removed, and the space was used to hold the bin, which entirely filled it,  $\frac{1}{4}$  in. clearance being allowed on all sides. A cleat nailed along the floor of the recess took the weight of the bin when it was pushed back into the wall. In this way there was no strain upon the hinges, except when the bin was swung outward. It had no top, so that the flour could be reached from above.

### Removing a "Frozen" Valve Stem

The removal of broken or "frozen" valve stems usually presents a problem to the repairman whose equipment is limited. In such cases try this "kink": Cut a heavy nail to the proper length, and insert



cover. The vent stack, of 4-in. sewer tile, is connected to the Y-branch of the vertical pipe by means of the 45° bend; this stack serves to ventilate the system.

The tee and the plain 18-in. sewer pipe are placed end to end, with a perforated baffle wall between. A plain baffle wall closes the opposite end of the tee, while the other perforated baffle wall is placed at the opposite end of the plain pipe, and serves to admit a 4-in. sewer pipe. To the latter are connected 30 pieces of drain tile, which are laid with open joints to permit any overflow from the system to seep into the ground. The chamber formed by the installation of baffle walls at the end of the tee temporarily holds floating matter. Liquid passes into the plain pipe through the hole in the baffle wall which separates the tee from the plain pipe.

To put the system into operation, dissolve 10 lb. of caustic soda in 20 gal. of water; each month 1 lb. of caustic soda should be poured into each closet. The contents of the closet should be agitated periodically with a rod inserted through the hole in the seat, and toilet paper only should be used. If necessary, the contents can be pumped out of the closet.—E. G. Eggert, Austin, Tex.

### Groove Plowed for Screw Heads Replaces Countersinking

It frequently happens that numerous screws must have their heads countersunk in cleats, strips, drawer slides, and other pieces that come in contact with moving parts or against which other parts are to be placed. In such cases a considerable saving of time and labor is effected if, instead of placing a separate countersink, a narrow, shallow groove, or when the screws are to be staggered, two such grooves are plowed in the stock. This saving is particularly pronounced where many such pieces are regularly used, because it is possible to have the stock run at the mill ready to be put on, leaving only the holes to be drilled. In addition, the screws are alined without the necessity of making further marks.



### Special Shears for Use on Anvil

A pair of heavy shears suitable for cutting bars, bolts, or plates is shown in the

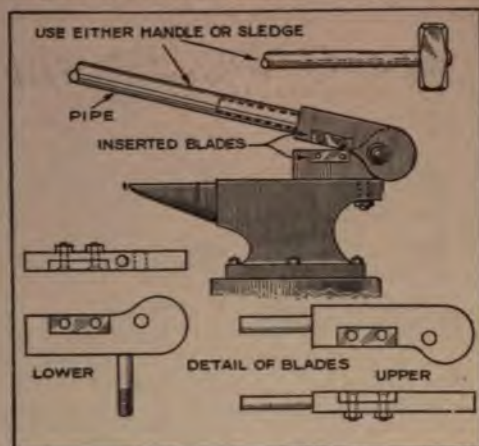

A Convenient Substitute for a Regular Shear is Made from Materials to be Found around Any Shop

illustration; it is used either with the handle or hammer, depending upon the material to be cut. The anvil is used as a base, and the stud attached to the fixed cutter is put through the hardy hole, and tightened by a nut.

The upper and lower members are forged steel; the inserted cutters are of tool steel, hardened and tempered. A piece of pipe, of such size that it can be slipped over the shank of the upper member, is used as a handle, and the pivot is an ordinary bolt and nut.

### Gas-Engine Exhaust Rids Building of Rats

The manager of a grain elevator was troubled by the constantly increasing horde of rats that made their homes underneath the floor of the building. Every effort to rid the building of its destructive tenants was a failure until he conceived the idea of "gassing" the rodents with the exhaust from the gas engine of the elevator. The exhaust pipe was run under the floor of the building and fitted with a muffler. A screen of fine wire was placed over the muffler outlet to prevent fire being blown through. After this installation was put to work, the rats speedily sought other and less odorous quarters.—Chester C. Cook, McMinnville, Tennessee.

⦿ A little wad of fine steel wool makes an excellent eraser for removing ink lines.

### Sensitive Relay Operates Alarm When Brushes Spark

Where storage batteries are used for operating telephone plants, the charging

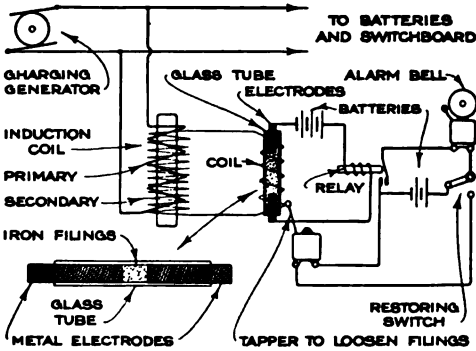

An Unusually Sensitive Relay is Provided, So That Small Variations of Current, Caused by Sparking at the Brushes, will Operate the Alarm

generators must be watched very carefully to eliminate noise. Any slight sparking of the brushes, or dirt on the commutator, will cause all the telephones to become noisy, and will impair the transmission or talking quality of the circuits. The sparking brush causes this by making slight variations in the current flowing from the generator to the batteries and telephone switchboard. When this happens, it is very important that an attendant be notified immediately. To do this automatically, the circuit and apparatus shown was devised.

The primary of an induction coil is connected across the generator terminals. As long as the generator is producing a steady flow of direct current, it is evident that there will be no current flow in the secondary of the coil; the magnetic field produced by the primary winding must be either interrupted or varied to produce this result. A current thus produced is, however, so weak that it is not capable of operating any ordinary piece of apparatus to notify the attendant that the trouble exists.

A sensitive relay that will operate on this small margin can be made in this manner: A small glass tube, about 2 in. long, is fitted with two electrodes, as shown in the drawing. The space between the electrodes, inside the tube, should be made adjustable, and filled with iron filings, or a mixture of iron and nickel filings, like the early wireless-telegraph coherer. Around the tube is wound a coil of many turns of fine wire. The two ends of this coil are connected to

the secondary of the induction coil. The two electrodes are connected to still another circuit, consisting of a battery and bell.

The operation is as follows: As long as no current is flowing through the coil wound on the glass tube, the relay will not operate, because of the high resistance of the loose iron filings between the electrodes. But if the magnetic field of the induction coil is varied in the least, the induced current in the secondary will flow through the coil on the tube, producing a field which will affect the iron filings within, causing them to become magnetized and to cohere closely. This reduces the resistance of the relay circuit, causing the relay to operate. The alarm circuit is thus closed and the bell rings. To reset the circuit after it has operated once, it is necessary to tap the glass tube containing the filings, in order to loosen them up. This can be done by mounting a bell so that the clapper will strike the tube gently when the restoring switch is operated.

### Flour Bin on Cupboard Door

The sketch shows a flour bin which was constructed in a recess in the wall, which originally contained a cupboard;

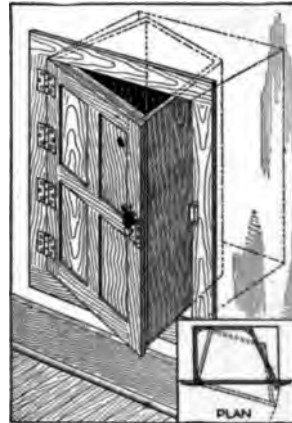

the shelves were removed, and the space was used to hold the bin, which entirely filled it,  $\frac{1}{4}$  in. clearance being allowed on all sides. A cleat nailed along the floor of the recess took the weight of the bin when it was pushed back into the wall. In this

way there was no strain upon the hinges, except when the bin was swung outward. It had no top, so that the flour could be reached from above.

### Removing a "Frozen" Valve Stem

The removal of broken or "frozen" valve stems usually presents a problem to the repairman whose equipment is limited. In such cases try this "kink": Cut a heavy nail to the proper length, and insert



it in the valve guide, with its head resting against the top of the push rod. As the engine is turned over by hand, the cam forces the nail up; this operation is repeated as necessary, and a chisel, or some other spacer, is placed underneath the nail to keep it against the end of the valve and exert pressure against it.

### Copper Wire Set in Piston Rings

The fact that copper, when heated, expands considerably more than cast iron, is used to increase compression in an engine cylinder, prevent oil pumping, and, at the same time, indirectly check the formation of carbon by keeping oil out of the combustion chamber.

As shown in the illustration, one or more rings on each piston are chamfered to a depth of about  $\frac{3}{4}$  in. and dovetailed a triple, so that a piece of copper wire, about No. 18 gauge, can be inserted and pushed into the groove to the other end of the split. The wire is then cut off and filed flush with the cast iron. This idea will also be found useful in cases where the cylinder has been scored or is out of round.

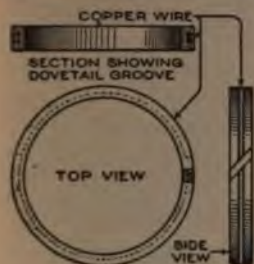

### Clamping Together a Split Pipe

The drawing shows an emergency repair for a burst pipe which makes a practically permanent job and provides means for further tightening, if necessary. This repair consists of a spiral clamp of iron rod, the ends of which are threaded previous to bending it around the pipe. A flat plate, drilled to receive the ends of the clamp, is provided

and screwed down tightly with nuts on the threaded projecting ends of the rod. By this means sufficient pressure can be exerted to close the split. Before applying the clamp, a patch, consisting of a piece of sheet rubber, or packing, and a metal plate bent to the contour of the pipe, is placed over the break as shown.

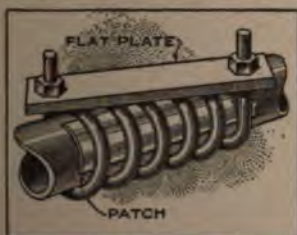

### Automatic Caliper Shows Oversize

The caliper illustrated will be very useful in the modern shop, especially where

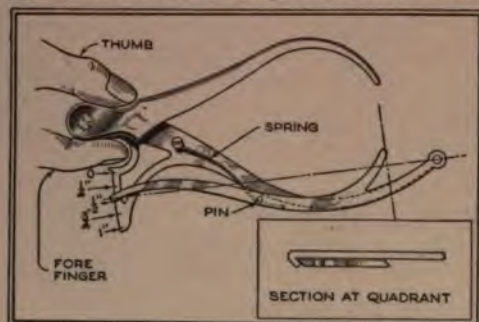

A Caliper Which will Show Any Variation from a Standard Size, can be Easily Made from a Common Caliper

there is a limit of tolerance on the work, for oversize or undersize. One leg of the caliper is made in the ordinary way. The other leg extends down beyond the ordinary one, and instead of a caliper point, has a hole in the end. A rivet through this hole acts as a pivot for the indicating arm, which is the feature of the tool. The indicating arm has a projection which forms the other caliper point, meeting the end of the other leg when the caliper is closed. The upper end of the indicator arm moves over a graduated quadrant, and indicates oversize or undersize.

To use the caliper, say, for gauging a shaft being turned or ground to a diameter of 1 in., set the caliper to a distance of exactly 1 in., using an inside micrometer or gauge block. During the setting keep the indicator arm at zero by holding it with the index finger. Now force the caliper over the shaft being turned; the indicator arm will swing out to a point which indicates the excess of the shaft diameter over 1 in. Noting this, it is readily possible to set in the tool the proper distance to get the required diameter.

In making the tool, several precautions must be observed; the spring used must be a light one, otherwise the friction joint of the caliper may be forced to work instead of the spring. The special caliper leg must be of fairly heavy metal, to avoid the possibility of springing. The amount by which the actual excess of the diameter will be magnified on the scale depends on the length of the indicator arm, and the length from its caliper point to the pivot. If the arm is 5 in. long, for instance, and the pivot center is 1 in. from the caliper

point, then a distance of  $\frac{1}{10}$  in. on the scale will indicate an excess diameter of  $\frac{1}{100}$  in. or .020 in. If it is desired to use the caliper for showing variation from a standard diameter, the zero of the scale can be placed at the center of it, and the arm should be held or clamped at the zero point while the caliper is being set. The use of the tool as described above will then indicate whether the work comes between the required limits.

**Steam Prevents Carbon in Gas Engines**

The benefits of admitting moisture, with the fuel mixture, into the cylinder

operation of the engine should be noted meanwhile, and the carburetor readjusted, if necessary. It is advisable to connect a valve in the water line so that the water can be shut off without disturbing the needle-valve adjustment.

Moisture so introduced into the fuel mixture has a decided effect on the engine at open throttle, but on closed throttle will cause it to miss, so due allowance must be made. It increases the power of the engine and makes it run cooler. The heat of combustion increases the temperature of the steam and increases the pressure on the piston. The moisture further prevents the accumulation of carbon.

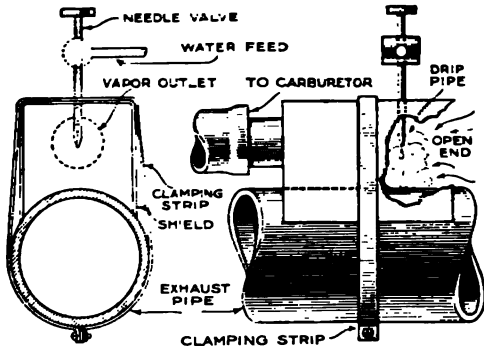

A Device for Generating Steam Which is Mixed with the Fuel and Admitted to the Cylinder of a Stationary Engine, Increases Operating Efficiency, and Also Prevents Accumulation of Carbon

of an internal-combustion engine are generally recognized but seldom taken advantage of in practice. These benefits are particularly noticeable in stationary engines using kerosene for fuel, and the device shown in the drawing can be readily constructed and fitted to the engine for introducing moisture.

A metal shield is made and attached to the exhaust manifold with a clamping strip, as indicated. One end of this shield is left open, and an opening is provided in the opposite end for the attachment of a flexible pipe to the air inlet of the carburetor. Another opening is provided in the top of the shield for the insertion of a needle valve, which is connected to an elevated tank or directly to the water pipes.

In service, the engine is started, and when the exhaust pipe has become hot, the water valve is opened, and drops of water begin falling on the heated pipe; the water vaporizes instantly and is sucked into the engine cylinder. It will be necessary to adjust the needle valve so that the water will be vaporized as fast as it is fed onto the exhaust manifold. The

**Screw Plate as Auger Handle**

In the absence of a handle for turning large wood-boring augers, a screw plate can be used for the purpose. A set of worn-out dies is inserted in the plate, to grip the auger shank; the handle of the screw plate is turned down tight. The teeth of the old dies prevent the plate from slipping on the auger shank.

**Charts Insure Correct Meter Readings**

Very often, through carelessness, incomplete training, or ignorance, important meters in and around power houses, pumping stations, etc., are incorrectly read, causing trouble and inconvenience in keeping complete records of operation.

To overcome this trouble in one Missouri plant, facsimiles of the dial faces were printed on a daily-report sheet, the upper part of which is shown in the illustration. The sheet measures 8½ by 11 in., and there is a separate division for day, evening, and night shifts. The operator in charge on each shift was required to

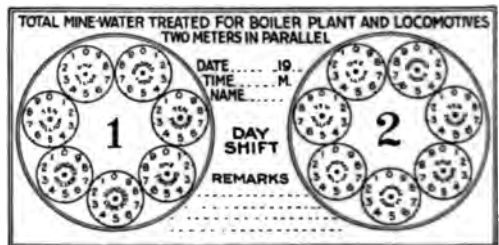

To Avoid Errors in Reading Meters, Operators are Required to Mark the Position of the Hands on These Charts

mark in pencil on the printed dials, the exact location of the meter hands, thus eliminating any possible source of error. —R. H. Poston, St. Francois, Mo.



### Bacon Rind for Pump Packing

After having much trouble with the packing in a pump head, used in connection with a gasoline engine for pumping water from a well, the owner hit upon the idea of using strips of bacon rind for the purpose. This novel packing proved entirely satisfactory and outlasted the commercial product that had been used.—S. G. Parks, De Leon, Tex.

### A General-Purpose Hod

A hod, slightly different from those used by hodcarriers, will find a variety of uses around the farm. It is made from  $\frac{1}{2}$ -in. material; as shown in the drawing, it has a handle near the center, and a cleat under the open end, so that when it is hung over a stake or wagon box it can be filled easily. A cover is provided for the open end, to prevent the contents from falling out.



This cover is made to fit the open end of the hod, and is held in place by four iron hooks, which are secured to the hod with screws in the manner shown. As the weight of the load comes where it is easy to carry, such a hod is very convenient when a load of loose material has to be carried on the shoulder for any little distance.

This cover is made to fit the open end of the hod,

and is held in place by four iron hooks, which are secured to the hod with screws in the manner shown. As the weight of the load comes where it is easy to carry, such a hod is very convenient when a load of loose material has to be carried on the shoulder for any little distance.

### Binding Post Adapted to Cord Tips

Electrical instruments that are fitted with ordinary binding posts afford an insecure connection when used with cords that have round metal tips for terminals, as they pull out easily. To overcome this condition, a piece of copper, or brass, is cut to the form and dimensions shown, with holes at the ends for fitting the adapter over the binding-post screw after it has been bent to the shape indicated in the drawing. In use, the adapter is slipped over the binding-post screw, underneath the thumbnut.—Thos. W. Benson, Philadelphia, Pa.



### Automatic Testing of Steel Balls

A factory received an order for a large quantity of hardened steel balls, the con-

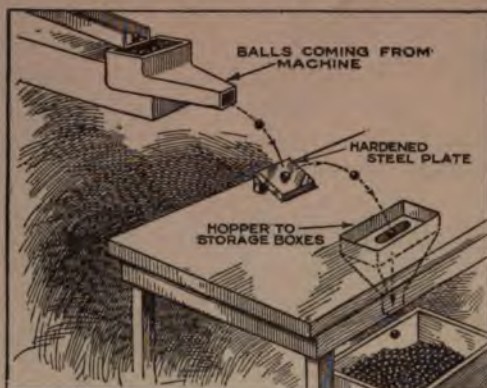

Correctly Hardened Balls Bounce into a Chute; Imperfect Balls Bounce Too Far or Fall Short of the Hopper

tract specifying a certain degree of hardness. As the time was limited, it would have been impossible to run each ball through a testing machine, but after a little testing and experimenting with perfectly hardened balls, the device shown in the drawing was rigged up, and the balls were tested automatically as they came from the machines. The finished balls ran from the machine to a funnel-shaped spout, the outlet of which was slightly elevated, and just large enough for one ball to come through at a time. The ball, on coming out, naturally described an arc in falling onto a hardened steel plate underneath the spout, as shown. On striking this plate the correctly hardened balls bounced off into a tray, sunk flush with the bench, but, if they were too soft, they would not bounce far enough to enter the tray and, if they were too hard they would bounce too far. Thus, only the perfect balls fell into the tray.—J. H. Moore, Toronto, Ont.

### Leaks in Automobile Intake Cause Cylinders to Miss

One source of automobile trouble, which is very difficult to locate, is the "missing" of one or more cylinders. When the explosions are noticed to be irregular, the driver usually examines the carburetor and the ignition system, but often fails to correct the fault. This trouble is sometimes occasioned by the faulty connection of the intake pipe. Leaks at either the carburetor or cylinder end will cause "missing." The trouble, however, is more



plied to a nozzle in the air duct, placed as directed above. The water tank is connected to this nozzle by a  $\frac{1}{8}$ -in. pipe, which enters the tee connection, and is flattened out slightly in the nozzle itself. When the air is turned on, it creates a vacuum in the water pipe, which draws water from the tank to the nozzle. It is then blown out in an exceedingly fine spray. This is in turn blown down the shaft by the current from an electric fan, placed about a foot from the nozzle. The air evaporates the water, and the current emitted at the outlet will be many degrees cooler than the air sucked in from the window, or other opening.

An ordinary 12 or 16-in. electric fan is

### Cool Water for Farm Workers

A jug that will keep water cool and fresh all day long in hot weather will be particularly appreciated by farm workers away from their usual water supply.

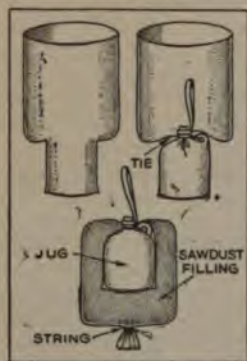

A leather carrying strap is first put through the jug handle. From burlap, or other coarse material, a bag such as shown in the drawing is made; the bottom is made to fit the jug, and the upper part is larger and longer. Slip the jug into the bottom part, and tie it tightly around the neck with a piece of stout cord, taking care that the strap is on the outside. The larger part of the bag is then turned down over the jug, and filled with tightly packed sawdust. After the sawdust filling has been put in, the bag is tied at the bottom of the jug. To use this outfit, the jug is filled with cold water, and enough cold water is poured over the sawdust to keep it wet.—Warner H. Ellis, Mt. Vernon, Illinois.

### Thumb Tacks Easily Removed

To remove an ordinary thumb tack with the finger nails is a painful process. Those draftsmen who prefer to use the finger nails, rather than keep handy a metal tool for the purpose, may avoid much of the discomfort by making two cuts toward the center on each side of the tack. The strips of metal between two pairs of cuts

sufficient for the small system described here. For a large shop, a regular ventilating fan should be used, and the size of the shaft increased.

Two screens of galvanized-wire netting, placed about 2 ft. apart in the air shaft, will aid in breaking up the spray, and thus in cooling the air current.

Whether the ordinary nozzle spray, or the compressed-air spray is used, the duct should slope slightly toward the air outlet, to allow the spray to collect, and to drain off. In the case of the compressed-air spray, the condensed water is returned to the tank for re-use. If water is used under pressure, the drain pipe should lead outside the building.

should be bent up slightly, and they will thus form tabs by which the thumb tack can easily be pulled out. If round-head thumb tacks are used, the tabs need not stand any higher from the paper than the center of the tack head, and will still give room for inserting the thumb nail underneath.—L. B. Robbins, Harwich, Mass.

### Restoring a Micrometer to Accuracy

Micrometers usually wear out at the face of the anvil and the spindle; that is, these parts lose their accuracy before the thread in the handle wears loose. All good micrometers are provided with an adjusting screw to take up wear on the faces, but without a true plane to start from, one can never be sure of having plane surfaces. To provide a true plane on

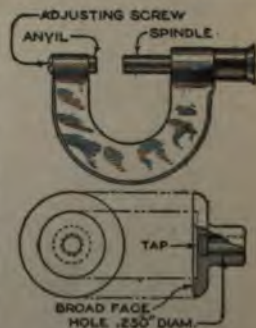

the end of the spindle, I made a fixture, as illustrated, to fit over the spindle. The broad face of the fixture should be faced off exactly perpendicular to the hole, which should be made a tight sliding fit on the spindle—ordinarily .250 in. The center of this circular broad face is undercut, and the hole is tapped for a short distance, so as to insert a plug. Then, mounting the fixture on the spindle as shown, a cast-iron lap is laid on the broad face, and used to true off the surface of the anvil. The lap may be about  $\frac{1}{4}$  by 1 by 4 in. in size, and should be charged with diamond dust or emery powder, on one





## Water-Spray Air Cooler for the Shop

By J. HORACE VAN NICE

**T**HE problem of keeping the temperature of a small shop at working level during the summer months is not difficult to solve with materials usually at hand. A little planning, and a few hours' work, will suffice to provide an air cooler that will make work pleasant and more efficient, even in an upper room under a tin roof. The expense should not be prohibitive, for the device is simple, and can be made right in the shop.

Evaporation of water, by passing a current of air through a fine spray, furnishes the cooling principle of the device. The air current is obtained by placing an electric fan in an air duct extending from an opening in the wall, or a window, to a point about midway of one wall, near the ceiling. This directs the cooled air to a point whence it circulates downward, and outward, thus changing the temperature of the whole shop.

For a small shop, an air shaft, 2 ft. square, will suffice. It should be made of galvanized iron, light-gauge sheet being satisfactory if the air duct is supported

properly. The length of the duct, and the position of the opening, will depend on the size and shape of the shop. In any case, direct the opening out into the room, and not downward. Support the air duct by bending strap-iron bands around it, screwing the ends of the bands to the ceiling.

Two types of water spray may be used, either of which is efficient. The simplest method is to place a hose nozzle about 1 ft. in front of the place provided for the fan. The nozzle must be regulated to give a very fine spray when the water is turned on full force. This nozzle is then connected to the shop water supply by either pipe or hose, with a valve for closing the line. The second method, illustrated in the detail drawing, is perhaps a little more efficient, especially for the larger cooling systems, and is almost necessary where a pressure water supply is not available. This second type of sprayer is really an atomizer, operated from a water tank and from the shop compressed-air supply. The air is sup-

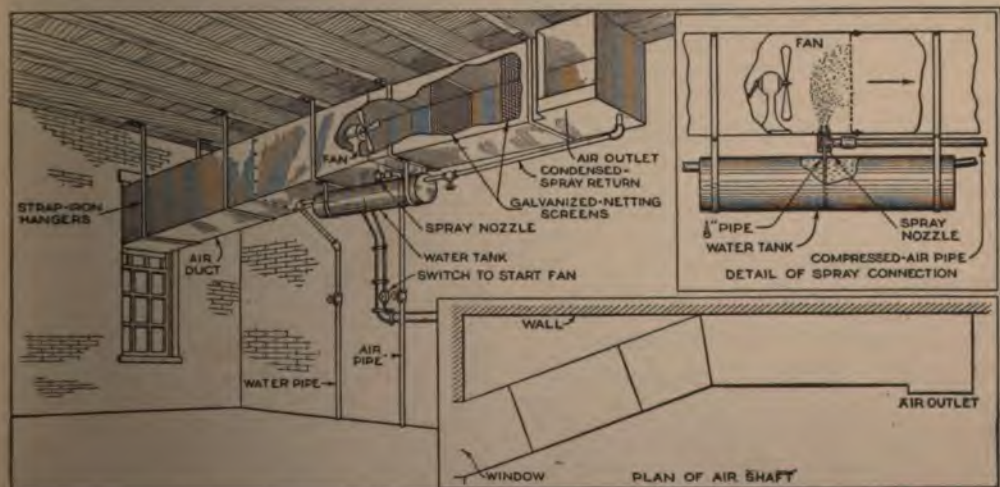

The Shop Which Has Electric Current need Not Be without Means of Providing Cool, Moist Air. In This Arrangement, the Cooling Power of the Fan is Supplemented by the Effect of Evaporation of Water, Resulting in a Supply, at Low Cost, of Comfortable Air for Hot-Weather Work

plied to a nozzle in the air duct, placed as directed above. The water tank is connected to this nozzle by a  $\frac{1}{8}$ -in. pipe, which enters the tee connection, and is flattened out slightly in the nozzle itself. When the air is turned on, it creates a vacuum in the water pipe, which draws water from the tank to the nozzle. It is then blown out in an exceedingly fine spray. This is in turn blown down the shaft by the current from an electric fan, placed about a foot from the nozzle. The air evaporates the water, and the current emitted at the outlet will be many degrees cooler than the air sucked in from the window, or other opening.

An ordinary 12 or 16-in. electric fan is

sufficient for the small system described here. For a large shop, a regular ventilating fan should be used, and the size of the shaft increased.

Two screens of galvanized-wire netting, placed about 2 ft. apart in the air shaft, will aid in breaking up the spray, and thus in cooling the air current.

Whether the ordinary nozzle spray, or the compressed-air spray is used, the duct should slope slightly toward the air outlet, to allow the spray to collect, and to drain off. In the case of the compressed-air spray, the condensed water is returned to the tank for re-use. If water is used under pressure, the drain pipe should lead outside the building.

### Cool Water for Farm Workers

A jug that will keep water cool and fresh all day long in hot weather will be particularly appreciated by farm workers away from their usual water supply.

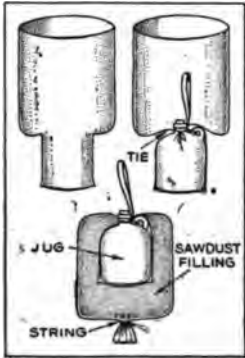

A leather carrying strap is first put through the jug handle. From burlap, or other coarse material, a bag such as shown in the drawing is made; the bottom is made to fit the jug, and the upper part is larger and longer. Slip the jug into the bot-

tom part, and tie it tightly around the neck with a piece of stout cord, taking care that the strap is on the outside. The larger part of the bag is then turned down over the jug, and filled with tightly packed sawdust. After the sawdust filling has been put in, the bag is tied at the bottom of the jug. To use this outfit, the jug is filled with cold water, and enough cold water is poured over the sawdust to keep it wet.—Warner H. Ellis, Mt. Vernon, Illinois.

### Thumb Tacks Easily Removed

To remove an ordinary thumb tack with the finger nails is a painful process. Those draftsmen who prefer to use the finger nails, rather than keep handy a metal tool for the purpose, may avoid much of the discomfort by making two cuts toward the center on each side of the tack. The strips of metal between two pairs of cuts

should be bent up slightly, and they will thus form tabs by which the thumb tack can easily be pulled out. If round-head thumb tacks are used, the tabs need not stand any higher from the paper than the center of the tack head, and will still give room for inserting the thumb nail underneath.—L. B. Robbins, Harwich, Mass.

### Restoring a Micrometer to Accuracy

Micrometers usually wear out at the face of the anvil and the spindle; that is, these parts lose their accuracy before the thread in the handle wears loose. All good micrometers are provided with an adjusting screw to take up wear on the faces, but without a true plane to start from, one can never be sure of having plane surfaces. To provide

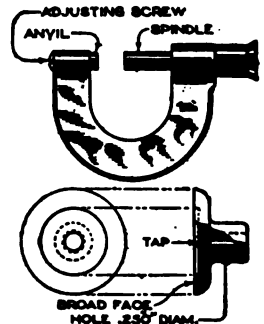

a true plane on the end of the spindle, I made a fixture, as illustrated, to fit over the spindle. The broad face of the fixture should be faced off exactly perpendicular to the hole, which should be made a tight sliding fit on the spindle—ordinarily .250 in. The center of this circular broad face is undercut, and the hole is tapped for a short distance, so as to insert a plug. Then, mounting the fixture on the spindle as shown, a cast-iron lap is laid on the broad face, and used to true off the surface of the anvil. The lap may be about  $\frac{1}{4}$  by 1 by 4 in. in size, and should be charged with diamond dust or emery powder, on one



side only. A drop of oil is placed on the other side to keep the broad face from wearing away, and to provide easy sliding. After the anvil is lapped true in this way, it is not difficult to lap the spindle true against the anvil. The adjusting screw is then taken up to provide a correct zero reading.—Carl H. Spatz, Nutley, N. J.

### Clip for Hanging Prints

A quick-acting clip for hanging up blueprints or photo prints is shown in the sketch.



These clips can be made up rapidly in patterns shaped by sawing a thick block on a band-saw to the proper outline, and then slicing off pieces about  $\frac{3}{4}$  in. thick. The main advantage of such a clip is that the paper can be very quickly removed; to insert it, merely

press up on the tongue between the prongs of the larger piece.—G. A. Luers, Washington, D. C.

### Fruit Press Made from a Jack

A lot of fruit was left on my hands, and could not be shipped, so I wished to press out the juice. I had no press, but found an old automobile jack, which I used to build a press, as follows:

I placed the jack on top of an old wooden box. The top was cut so as to move up and down inside of the box, and a heavy wood frame was built to take the pressure from the top of the jack. The press was then filled with fruit, the jack was operated as usual, and the juice caught as it flowed out of an opening at the bottom of the box into a pan prepared for it.—J. Nolan, Oakley, Calif.



### Reinforcing Boiler Tubes

The point where steam boiler tubes first begin to leak on account of rust and exposure is near the boiler head, where



Boiler Tubes Repaired by Driving In Short Pieces of Pipe have Given Service without Trouble for Over One Year

they are beaded over it. The illustration shows a repairman reinforcing the ends of several tubes that had begun to leak. A piece of steam pipe, 1 ft. long, the outside diameter of which was slightly greater than the inside diameter of the flues, was driven into the protruding end of each tube, and crimped over it. These pipe cuttings were tight enough to be a drive fit, and strengthened considerably the defective tube ends. A maximum pressure of steam has been held on the boiler ever since the repair was made, and no blow-outs have occurred.

### Trousers Holder for Stencil

To prevent slipping of stencils while being used, and daubing of ink on the fingers, clip the end of the stencil in an ordinary trousers holder, using the hook on the holder for a handle. If necessary, the holder can be made to grip more strongly by bending the wires slightly, or by gluing strips of pasteboard to the jaws.—Archie Klingbeil, Ashtabula, Ohio.

CA novel swing for the youngster is made by suspending an old automobile tire casing, by a rope, from a tree or other support. The child sits in the hanging tire, which affords a comfortable seat.

### Detachable Boom Converts Pile Driver into Derrick

The photographs show how a pile driver in a Pacific-coast city was fitted up to be used as a crane for moving piles, preparatory to driving them. In the large



When the Boom is Not in Use, It is Tied Fast to the Pile Driver, in Such a Manner That It Does Not Interfere with the Operation of the Hammer

photograph a pile is being lifted by a boom, merely set into the framework. This method of detaching it was found to be tedious, and the improved method afterward installed consisted, as shown in the small photograph, in attaching the bottom of the boom directly to the hammer, or ram, by a metal fitting. The fitting permits a rotating movement, so that the derrick is given a wider range of operation. When the lifting work is done, and piles are to be driven, the boom is removed from the hammer by detaching the nut from the heavy bolt, which fits into a heavy metal pin, fastened through the hammer. The boom, loosened from the hammer, is attached to the side of the runners by means of a rope, until it is again needed. The arrangement has greatly increased the usefulness of the pile driver to which it was applied.—C. W. Geiger, San Francisco, Calif.

### Safety First with a Scythe

The scythe, either of the grass or brush type, is a heavy unwieldy instrument and should be handled carefully if accidents from its long sharp blade are to be avoided.

There is no better way of carrying a scythe than that employed before the advent of the mowing machine and binder, when the scythe was the universal tool for harvesting crops. The handles

of a scythe snath which are grasped by the hands when cutting grass, are termed "nibs." To carry a scythe safely, the right arm is crooked around the second or lower nib, which rests in the crook of the elbow, the hand holding the snath several inches higher. The blade of the scythe is behind the man and to his right, with the sharp edge about parallel with the ground and facing to the front. Thus held the likelihood of accident is reduced.

Old-time farmers had one or two other scythe rules worth knowing. It was an unpardonable error to leave a scythe on the ground unless the blade was run under the grass and well covered. The proper thing to do, unless there was special reason for different practice, was to hang the scythe in a tree where it could be seen.—John T. Bartlett, Boulder, Colo.

### Powder Can for Draftsman's Use

Instead of sprinkling powder on tracing cloth, and rubbing it in afterward with a rag, it will save time to glue a large felt washer to the lid of the powder can; the powder is then spread around as it is sprinkled, thus saving some valuable time.



### Catching Telephone-Wire Thieves

Because of the high prices paid for junk copper, thieves found that they could make "easy money" by going into the country at night and cutting down miles of copper telephone wire. We were almost frantic; the cost of the copper was a small item compared with the labor.

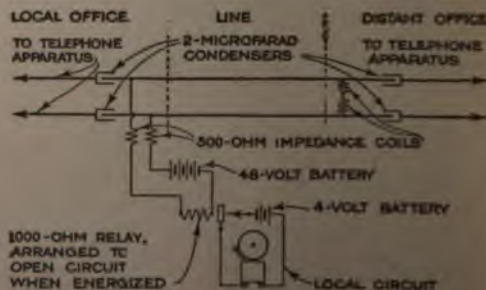

An Alarm Circuit Operates over Telephone Wires without Interfering with the High-Frequency, Sound-Producing Currents



forefinger of the right hand, and placed at the left-hand corner of the square, nearest the user. The rest of the knife should now be swung around like a compass on the point of the small blade as a center; the large blade will thus mark out an arc, distances along which are to represent areas. Make a pencil mark across this arc, for the starting point of the large blade. Place the point of the small blade again at its starting point, and set the large blade at the point on the arc. Trace with the point of the small blade around the edges of the square, thus outlining an area of exactly 1 or 4 sq. in., according to the size of the square, as it has been drawn. When the blade point has been brought back to the starting place, make a mark at the point on the arc where the large blade rests. The distance from this point to the first point on the arc represents 1 sq. in. of area, or 4 sq. in. if the 2-in. square is used, in which case the distance should be divided into four equal parts.

Having found in this way the distance along the arc to represent 1 sq. in., succeeding points, to mark off larger numbers of square inches, can be found by going around the square again and again. Then proceed to measure any irregular area of reasonable size, in the same way. Start at a corresponding point on the outline of this area, moving around it in the same direction. On arriving at the starting point, measure the distance on the arc, which the large blade has traveled, and compare it with the distance which has been found to represent 1 sq. in. This measures the irregular area in square inches. It is easy to construct on a card a scale which, when laid on the arc, will enable the operator to read directly the area in square inches. Such a scale will hold good for the same pocket-knife, whenever the small blade is opened to exactly the same point as in the test, or calibration.

While absolutely accurate results are not to be expected with this instrument, it is surprising how closely the measurements will agree with those made by an expensive planimeter.—Frank L. Brittin, Chicago, Ill.

### Handles for Carrying Saws

Very often, around lumber mills and in the bush, a man has to carry a circular saw or long saw, which is not only an awkward load, but one likely to inflict ugly cuts if not handled carefully. By making a handle, such as the one shown

in the drawing, any such saw may be carried with greater ease and safety. The

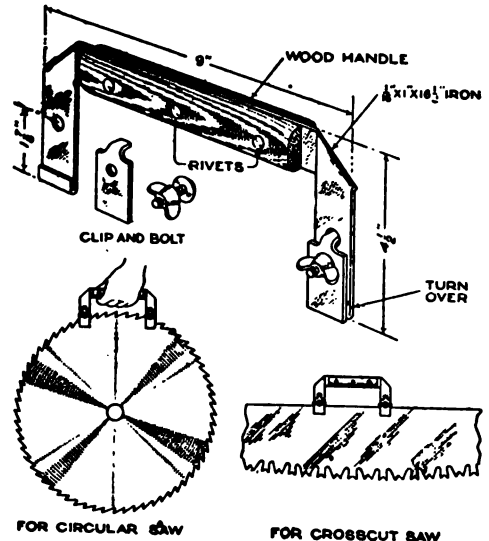

FOR CIRCULAR SAW      FOR CROSSCUT SAW  
A Simply Made Handle Diminishes the Danger of Torn Clothing and Injured Hands, Incident to Carrying Crosscut or Circular Saws

clamp is readily attached or detached by tightening or loosening the wing nuts. When the handle is clamped to the end of a one-man saw, the latter may be used by two men, like an ordinary two-man crosscut saw.—Neil D. Cameron, Athelstan, Quebec.

### Dust Protector for Burette

To prevent dust from entering a burette or other vertical tube in the laboratory, and at the same time permit the liquid within it to flow freely, uninfluenced by air pressure, the device illustrated is very practical, as it can be made in a few minutes

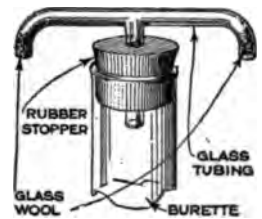

from common materials. A single-holed rubber stopper is fitted with a piece of glass tubing worked into the form of a "T." In the downward-curved ends of the "T," wads of glass wool are inserted, thus plugging the holes so that no air can enter except by filtering through the glass wool.

☐ A mirror, mounted at an angle on casters, allows the auto salesman to show his "prospect" the under part of the machine.

# An Electric Induction Water Heater

By ARTHMAN CAPRON

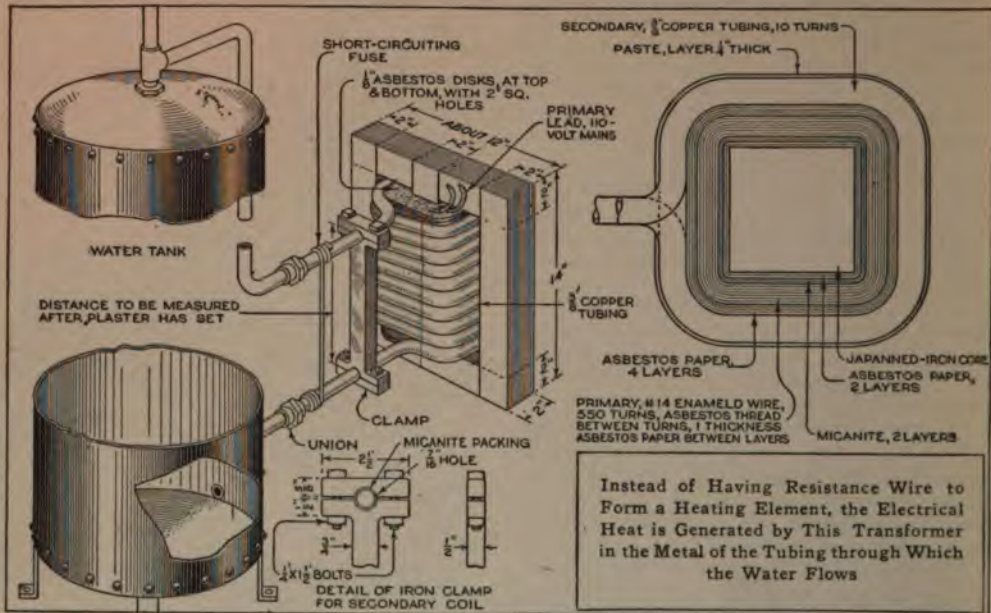

Instead of Having Resistance Wire to Form a Heating Element, the Electrical Heat is Generated by This Transformer in the Metal of the Tubing through Which the Water Flows

MY experience with ordinary electric water heaters of the resistance type was unsatisfactory, as the wire burned out frequently and had to be replaced. This difficulty was solved by the use of a heater, homemade like the ones I had previously used, but employing no high-resistance material, and having practically nothing to burn out. In short, it is built on the principle of a welding transformer: The coil of copper tubing through which the water circulates also carries the current which heats the tubing and the water inside. This current, flowing in a circuit of such low resistance, depends on the production of a low voltage by induction, as in any ordinary transformer.

The transformer core is of the shell type, having the windings around the central member. The instrument is mounted at the side of the water heater, and the water is piped from the bottom of the tank to the lower end of the coil of copper tubing. On emerging from the upper end of this coil it flows back into the tank, entering at the top, so that whatever water is heated ready for use will remain for some time at the top of the tank, not mixing with the cold water below.

The coil of copper tubing, besides conducting the water, forms the secondary, or low-voltage, coil of the step-down transformer, developing about two volts. This amount is sufficient to send only a

small current through the coil of tubing when the circuit includes the water tank and the iron piping to and from it. When, however, the two ends of the tubing coil are short-circuited by connecting across them a piece of heavy fuse wire, the resistance of the secondary coil becomes very low, and a heavy current flows through it, heating the tubing, and hence the water flowing through it. The short-circuiting conductor should be made of such a size of fuse wire that, should the system go dry or overheat, the fuse will blow, thus leaving only the circuit of higher resistance through the iron piping and tank.

While a transformer of this type cannot be expected to attain a very high electrical efficiency, still the heat is transferred very directly from the tubing in which it is developed to the water flowing through it. Hence, the heater wastes hardly more heat than one which is submerged in the water to be heated, and has the advantage of containing no resistance element which is likely to burn out.

The material required for building the induction heater is enumerated below, and the construction is shown in the drawing. The core may be made of any soft sheet iron, though best results can be expected with high-quality transformer iron of the thickness given. The vertical pieces may be cut to length at the beginning of the work, but the horizontal



forefinger of the right hand, and placed at the left-hand corner of the square, nearest the user. The rest of the knife should now be swung around like a compass on the point of the small blade as a center; the large blade will thus mark out an arc, distances along which are to represent areas. Make a pencil mark across this arc, for the starting point of the large blade. Place the point of the small blade again at its starting point, and set the large blade at the point on the arc. Trace with the point of the small blade around the edges of the square, thus outlining an area of exactly 1 or 4 sq. in., according to the size of the square, as it has been drawn. When the blade point has been brought back to the starting place, make a mark at the point on the arc where the large blade rests. The distance from this point to the first point on the arc represents 1 sq. in. of area, or 4 sq. in. if the 2-in. square is used, in which case the distance should be divided into four equal parts.

Having found in this way the distance along the arc to represent 1 sq. in., succeeding points, to mark off larger numbers of square inches, can be found by going around the square again and again. Then proceed to measure any irregular area of reasonable size, in the same way. Start at a corresponding point on the outline of this area, moving around it in the same direction. On arriving at the starting point, measure the distance on the arc, which the large blade has traveled, and compare it with the distance which has been found to represent 1 sq. in. This measures the irregular area in square inches. It is easy to construct on a card a scale which, when laid on the arc, will enable the operator to read directly the area in square inches. Such a scale will hold good for the same pocket-knife, whenever the small blade is opened to exactly the same point as in the test, or calibration.

While absolutely accurate results are not to be expected with this instrument, it is surprising how closely the measurements will agree with those made by an expensive planimeter.—Frank L. Brittin, Chicago, Ill.

### Handles for Carrying Saws

Very often, around lumber mills and in the bush, a man has to carry a circular saw or long saw, which is not only an awkward load, but one likely to inflict ugly cuts if not handled carefully. By making a handle, such as the one shown

in the drawing, any such saw may be carried with greater ease and safety. The

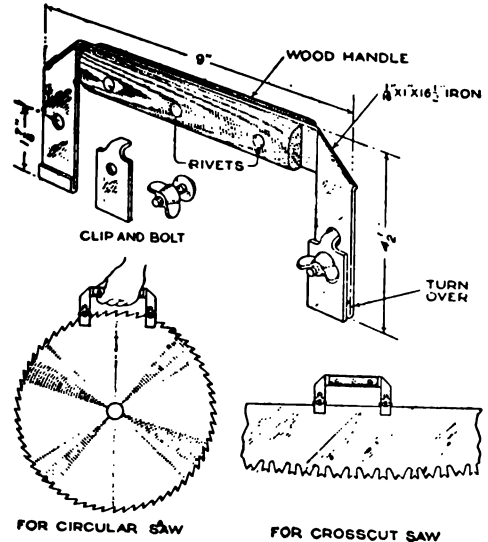

A Simply Made Handle Diminishes the Danger of Torn Clothing and Injured Hands, Incident to Carrying Crosscut or Circular Saws

clamp is readily attached or detached by tightening or loosening the wing nuts. When the handle is clamped to the end of a one-man saw, the latter may be used by two men, like an ordinary two-man crosscut saw.—Neil D. Cameron, Athelstan, Quebec.

### Dust Protector for Burette

To prevent dust from entering a burette or other vertical tube in the laboratory, and at the same time permit the liquid within it to flow freely, uninfluenced by air pressure, the device illustrated is very practical, as it can be made in a few minutes from common materials. A single-holed rubber stopper is fitted with a piece of glass tubing worked into the form of a "T." In the downward-curved ends of the "T," wads of glass wool are inserted, thus plugging the holes so that no air can enter except by filtering through the glass wool.

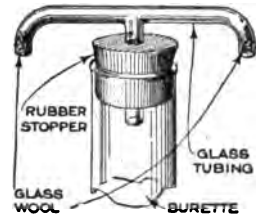

ⒸA mirror, mounted at an angle on casters, allows the auto salesman to show his "prospect" the under part of the machine.

# An Electric Induction Water Heater

By ARTHMAN CAPRON

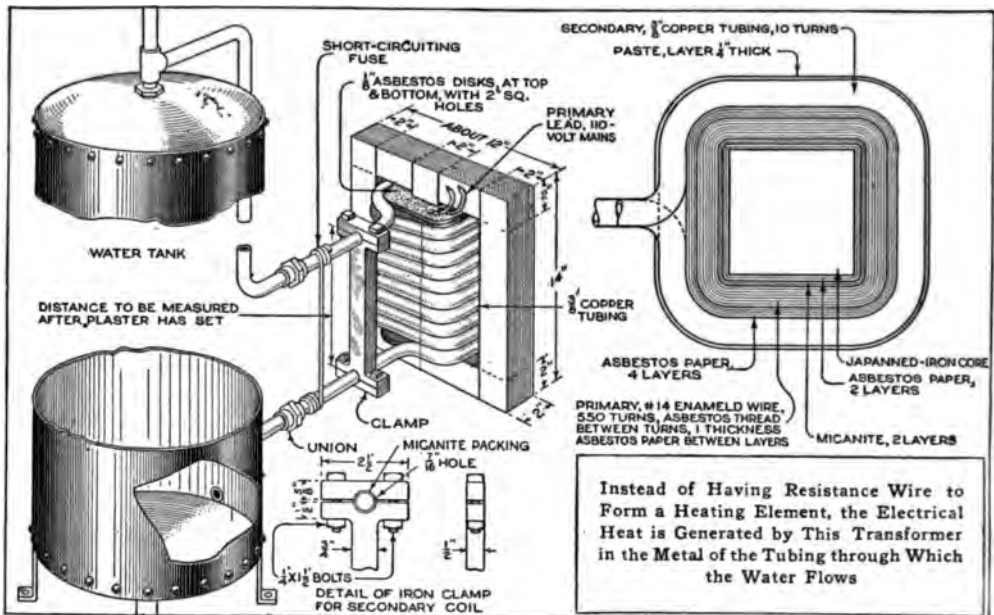

Instead of Having Resistance Wire to Form a Heating Element, the Electrical Heat is Generated by This Transformer in the Metal of the Tubing through Which the Water Flows

MY experience with ordinary electric water heaters of the resistance type was unsatisfactory, as the wire burned out frequently and had to be replaced. This difficulty was solved by the use of a heater, homemade like the ones I had previously used, but employing no high-resistance material, and having practically nothing to burn out. In short, it is built on the principle of a welding transformer: The coil of copper tubing through which the water circulates also carries the current which heats the tubing and the water inside. This current, flowing in a circuit of such low resistance, depends on the production of a low voltage by induction, as in any ordinary transformer.

The transformer core is of the shell type, having the windings around the central member. The instrument is mounted at the side of the water heater, and the water is piped from the bottom of the tank to the lower end of the coil of copper tubing. On emerging from the upper end of this coil it flows back into the tank, entering at the top, so that whatever water is heated ready for use will remain for some time at the top of the tank, not mixing with the cold water below.

The coil of copper tubing, besides conducting the water, forms the secondary, or low-voltage, coil of the step-down transformer, developing about two volts. This amount is sufficient to send only a

small current through the coil of tubing when the circuit includes the water tank and the iron piping to and from it. When, however, the two ends of the tubing coil are short-circuited by connecting across them a piece of heavy fuse wire, the resistance of the secondary coil becomes very low, and a heavy current flows through it, heating the tubing, and hence the water flowing through it. The short-circuiting conductor should be made of such a size of fuse wire that, should the system go dry or overheat, the fuse will blow, thus leaving only the circuit of higher resistance through the iron piping and tank.

While a transformer of this type cannot be expected to attain a very high electrical efficiency, still the heat is transferred very directly from the tubing in which it is developed to the water flowing through it. Hence, the heater wastes hardly more heat than one which is submerged in the water to be heated, and has the advantage of containing no resistance element which is likely to burn out.

The material required for building the induction heater is enumerated below, and the construction is shown in the drawing. The core may be made of any soft sheet iron, though best results can be expected with high-quality transformer iron of the thickness given. The vertical pieces may be cut to length at the beginning of the work, but the horizontal/



pieces should be cut to length only after the coil has been built up, so that the shell will be just long enough to go around the coil, but no longer. All the sheet iron should be given a coat of japan varnish to reduce eddy-current losses.

When the central member of the core has been built up of 14-in. sheets alternating with 10-in. ones, the insulation and primary winding are wound directly upon it. The four layers of asbestos paper outside of the primary winding may be replaced with two layers of micanite, if plenty of the latter material is available. When the core is ready for the layer of tubing, make a wooden mandrel of its exact shape, and just slightly larger; wind the coil of tubing upon this, and then transfer it to the core.

The spaces in and around the copper tubing are filled with a paste made of a mixture of magnesia and plaster of Paris. This is worked in between the turns, to keep them from touching each other, and also covers the entire coil to a thickness of  $\frac{1}{2}$  in. When the coil has been completed, the core on which it is wound is set up and fitted into the transformer, and the horizontal pieces are trimmed to a proper length so that the outer legs of the coil will fit around the coil without coming in contact with the plaster coating.

The primary is connected in the ordinary way to wires carrying 110-volt alternating current, using a suitable switch so that the heat can be turned on and off as desired. A piece of heavy fuse wire or sheet lead should be connected across,

as in the drawing, and care should be taken that this makes good contact with both ends of the tube, as these junctions must be able to carry a high current without developing much heat. Some extra fuse wire must be provided and kept handy, so that if the transformer overheats and blows the fuse, another can be mounted. This is not likely to happen, of course, unless the tank runs dry, or the heater is left on too long. A heavy clamp, as illustrated, will be necessary to provide against damage by expansion.

The heater described uses from 500 to 1,500 watts, depending chiefly on the resistance of the short-circuiting fuse. The tank is heated to the boiling point in about 15 minutes.

#### MATERIAL REQUIRED

- 210 pieces of No. 20 gauge, soft iron, 2 by 14 in.
- 210 pieces of No. 20 gauge, soft iron, 2 by 10 in.
- 140 pieces of No. 20 gauge, soft iron, 2 by about 12 in.
- 280 pieces of No. 20 gauge, soft iron, 2 by about 6 in.
- (The 6 and 12-in. strips to be cut after the coil is completed.)
- 7 lb. No. 14 gauge enameled copper wire (550 turns).
- 22 ft.,  $\frac{3}{8}$ -in. outside diameter by No. 14 gauge ( $\frac{3}{16}$ -in.) wall, annealed seamless brass or copper tubing (10 turns).
- 2 union couplings, to fit  $\frac{3}{8}$ -in. tubing and size of water pipe used.
- 1 piece of micanite, .020 by 10 by 18 in.
- 1,200 ft. asbestos thread.
- 1 can japan varnish.
- 20 sq. ft. asbestos paper.
- 2 pieces of asbestos,  $\frac{3}{8}$  by 8 by 8 in.
- $\frac{3}{4}$  lb. magnesia.
- 1 lb. plaster of Paris.
- 1 piece of iron,  $2\frac{1}{2}$  by  $\frac{1}{2}$  by about 9 in.
- 2 pieces of iron,  $\frac{1}{2}$  by  $\frac{3}{8}$  by  $2\frac{1}{2}$  in.
- 4 bolts,  $\frac{1}{4}$  by  $1\frac{1}{2}$  in.

#### A Finish for Plaster Casts

Plaster casts, plaster ornaments, and even designs worked into the plastering of a room, quickly become dirty and unsightly. A coat of shellac, then two coats or more of flat, white wall finish, and two of white enamel, renew their fine appearance at once. The great advantage is that the enamel can be washed.

#### Corrugated Board as Pencil Holder

A piece of ordinary single-faced corrugated board, such as used for packing, is very effective in a tray or desk drawer for keeping lead pencils in order and preventing them from rattling. The corrugated board is readily bent to conform to the curved tray or compartment, and is readily fastened with a little glue or mucilage.—Otto Kney, Chicago, Ill.

#### Pliers Made from Clothespin

A handy little pair of pliers, or tweezers, is easily made from an ordinary spring clothespin by reversing the spring. The spring is removed from the clothespin and reversed, so that its ends will bear against the opposite ends of the clothespin and hold them together, notches being cut into the wood to furnish a seat for the springs. Such a pair of pliers is quite a convenience for picking up small objects around the home or shop.

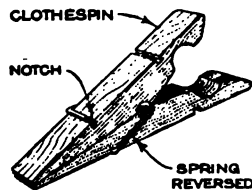

Old negatives are easily cleaned with warm water and sodium fluoride.

### Patternmaker's Spokeshave

The spokeshave illustrated is a tool which, although quite small, is found very useful in the daily work of a pattern-

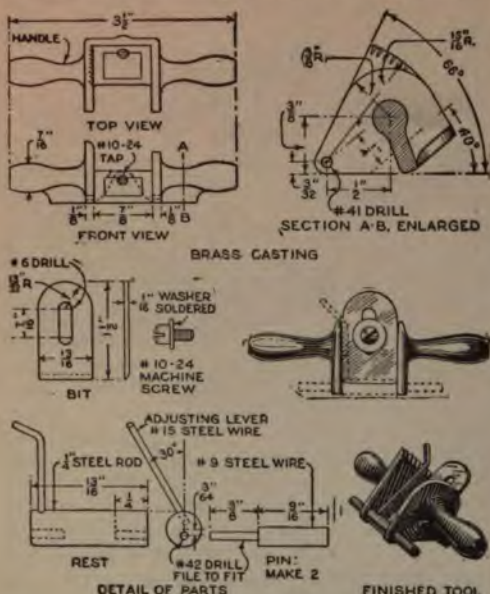

Full Working Drawings are Given for the Construction of a Small Spokeshave, Which a Skilled Patternmaker has Found to Be One of the Most Useful Tools in His Outfit

maker. It consists of a brass casting, the pattern for which may be made in the workman's spare time, and a few pieces of steel, made and assembled as shown. The tool is held in the usual manner, the thumbs engaging the two handles, and the forefingers resting on the pins which project from the rest. In this way the adjusting lever is between the thumb and forefinger of the right hand, and by moving it up and down, the thickness of shaving can be varied without stopping work. The lever rotates the circular rest through an angle of about  $30^\circ$ , and the rest can be ground after assembly, so that this adjustment gives the proper range of thickness for the shaving.

The great advantage of this little tool is its usefulness on irregular and curved work, where a larger spokeshave would not fit the job.—M. E. Duggan, Kenosha, Wisconsin.

☞ A good curbing for trees and plants is an old demountable automobile rim. Half buried in the ground, the rim holds enough water to prevent the trees from drying up.

### Emergency Stretcher

For carrying an injured person, a very good stretcher may be made out of a coat and two poles. Button up the coat and thrust the poles, one on either side, through the arms and lower part. If the coat is only a short one, and a longer stretcher is needed, two garments may be used in the manner described.

### Winding Telescope Springs

The winding of telescope or collapsible springs requires an arbor of great taper, with a spiral groove cut in it to guide the wire when being wound. Many improper rigs for doing this work are to be seen in steam plants, where these springs are used to hold down the valves in the water ends of steam pumps of a number of different makes.



The arbor illustrated is made of low-carbon steel, with a groove in it of the same general shape that the spring is to have. This groove is best cut by turning the tool upside down in the tool-post, and running the lathe backward. The tool can thus be made to cut a good groove by careful use of the cross-feed.

The arbor is fitted with a screw and pin, as shown, the latter having a small hole in which the end of the spring wire is clamped by tightening the screw. The diameter of the arbor must be somewhat smaller at all points than the desired diameter of the spring, as the latter will spring out somewhat when released.

### Burning Out Concrete Reinforcement

The writer, while running a 4-in. conduit through a reinforced-concrete floor, discovered several pieces of heavy steel reinforcement crossing a hole being bored for the conduit. It is very difficult to chisel out steel in a concrete base, and a weary job at best, so I finally decided to burn it out. As there was no

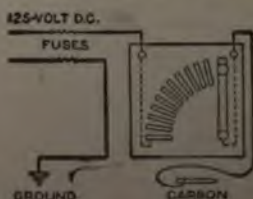



### Spokes Form Screen-Door Brace

Two spokes from an old bicycle wheel, properly attached to a screen door, will prevent it from sagging. A stout screw eye is inserted in the bottom of the door, and another in its side. Through these the spokes are thrust, the nipples catching in the screw eyes, and the hub ends of the spokes coming together across the lower angle of the door. These ends are twisted together securely; when the nipples are tightened with a screwdriver, the door is drawn up tight; it can be further tightened if it begins to sag.—J. P. Burbank, Boston, Mass.

### Stubborn Joints Made Steam-Tight

The sketch shows a method by which a leaky steam-pipe joint can be made absolutely tight. A dovetail groove is cut in the flanges as indicated, and in this is fitted a copper ring, which protrudes slightly. After the bolts have been tightened, the exposed copper is hammered until the soft metal completely fills the groove. Care should be exercised in hammering the copper, as there is danger of breaking the bolts if the blows are too heavy, or unevenly distributed.

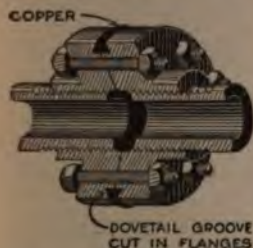

### Self-Locking Nut

A nut which turns freely on a bolt tends to work loose if subjected to vibration. This may be overcome by using a lock washer or castellated nut, but these are often troublesome. The accompanying sketch shows a nut which turns freely on the bolt, but which automatically tightens itself when it reaches the bearing surface.

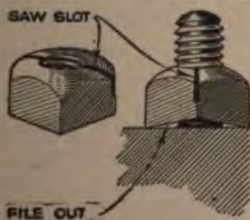

A slot is sawed through the center for about two-thirds the height of the nut. The underside is filed, as shown. On tightening, the nut grips the bolt very tightly, but if loosened a part of a turn with a wrench, it can be removed with the fingers.

### Laying the Porch Covering Smooth

Porch roofs, which must be waterproof, besides being flat and tough enough to

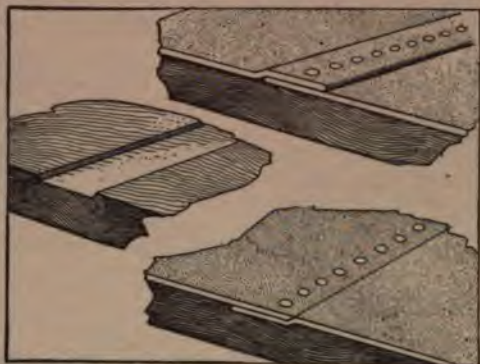

Porch Roofing, when Laid So as to Avoid Ridges Where the Strips Overlap, will Be Much More Durable

serve as a floor for an upper porch or balcony, are ordinarily made of composition material, which comes about 1 yd. or more wide. If the material is merely lapped, as shown at the upper right in the sketch, ridges are produced which are uncomfortable to walk on, hard to keep clean, and likely to collect water.

It involves only a little extra labor to mark the location of each lap on the porch floor before laying the material; then, with a rabbet plane, cut out a dado or shallow groove, corresponding in width to the desired lap, and in depth to the thickness of the roofing. Such grooves will be ordinarily about  $\frac{1}{8}$  in. deep and  $1\frac{1}{2}$  in. wide. The material is then laid as shown in the lower sketch, the lower edge being tacked lightly into the groove, and the edge of the upper piece being nailed as usual. The resulting floor is much more durable than one which has the ridges.

### Brake Does Work of Lost Tire Chain

A rural visitor to town lost one of the tire chains from his automobile, but all went well until he encountered a slippery, muddy hill on the homeward journey. The wheel wearing the remaining chain remained stationary in the mud, while the other spun around, sinking the car deeper. To overcome this, the driver loosened the emergency-brake rod on the wheel with the chain. When he drew up on the emergency brake the chainless wheel was prevented from spinning, but the other was allowed to turn, permitting the car to extricate itself.

**Patternmaker's Spokeshave**

The spokeshave illustrated is a tool which, although quite small, is found very useful in the daily work of a pattern-

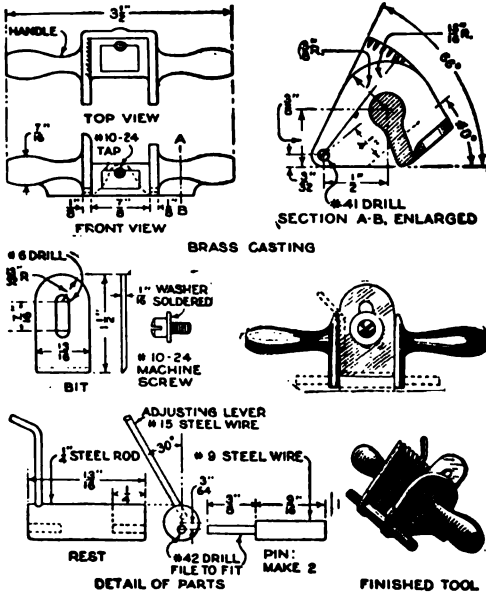

Full Working Drawings are Given for the Construction of a Small Spokeshave, Which a Skilled Patternmaker has Found to Be One of the Most Useful Tools in His Outfit

maker. It consists of a brass casting, the pattern for which may be made in the workman's spare time, and a few pieces of steel, made and assembled as shown. The tool is held in the usual manner, the thumbs engaging the two handles, and the forefingers resting on the pins which project from the rest. In this way the adjusting lever is between the thumb and forefinger of the right hand, and by moving it up and down, the thickness of shaving can be varied without stopping work. The lever rotates the circular rest through an angle of about 30°, and the rest can be ground after assembly, so that this adjustment gives the proper range of thickness for the shaving.

The great advantage of this little tool is its usefulness on irregular and curved work, where a larger spokeshave would not fit the job.—M. E. Duggan, Kenosha, Wisconsin.

CA good curbing for trees and plants is an old demountable automobile rim. Half buried in the ground, the rim holds enough water to prevent the trees from drying up.

**Emergency Stretcher**

For carrying an injured person, a very good stretcher may be made out of a coat and two poles. Button up the coat and thrust the poles, one on either side, through the arms and lower part. If the coat is only a short one, and a longer stretcher is needed, two garments may be used in the manner described.

**Winding Telescope Springs**

The winding of telescope or collapsible springs requires an arbor of great taper, with a spiral groove cut in it to guide the wire when being wound. Many improper rigs for doing this work are to be seen in steam plants, where these springs are used to hold down the valves in the water ends of steam pumps of a number of different makes.

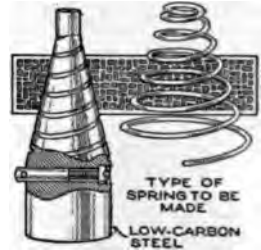

The arbor illustrated is made of low-carbon steel, with a groove in it of the same general shape that the spring is to have. This groove is best cut by turning the tool upside down in the tool-post, and running the lathe backward. The tool can thus be made to cut a good groove by careful use of the cross-feed.

The arbor is fitted with a screw and pin, as shown, the latter having a small hole in which the end of the spring wire is clamped by tightening the screw. The diameter of the arbor must be somewhat smaller at all points than the desired diameter of the spring, as the latter will spring out somewhat when released.

**Burning Out Concrete Reinforcement**

The writer, while running a 4-in. conduit through a reinforced-concrete floor, discovered several pieces of heavy steel reinforcement crossing a hole being bored for the conduit. It is very difficult to chisel out steel in a concrete base, and a weary job at best, so I finally decided to burn it out. As there was no

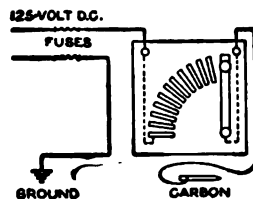



and found that there were five times as many teeth in the large gear as in the pinion. He then put a twist drill in the chuck, and inserted the end of the drill in the center of the shaft. With his watch in his left hand, and the handle of the drill in the right, in such a position that the handle on the gear would just touch his hand at every revolution, he counted the revolutions made by the handle in a minute. Multiplying this by five gave him the number of revolutions made by the shaft drill, this being therefore the speed of the shaft.

**Stove Damper for Grain-Bag Filler**

An ordinary stovepipe and damper may be used to make a grain-bag filler, if the hole in the center of the damper is closed up. The pipe is inserted in the bottom of the grain bin, extending through the ceiling of the floor below. Here it terminates in a sturdy grain-bag support, on which the bag is hung. The damper is turned on, allowing the grain to flow until the bag is full, when the damper is turned off.

**Grinding Attachment for Lathe**

A grinding head can be made in a little spare time for the shop which is not equipped with such a head, the materials consisting of a 1/2-in. pipe tee, two plugs, a pulley, and a few scraps of metal. The bearings are brass-pipe plugs screwed in at the opposite ends of the tee. In the branch end of the tee is screwed a plug, which is formed at the end to fit into the tool post of the lathe. The pulley and grinding wheel are mounted on a 1/2-in. spindle, and a belt can be run to the countershaft of the lathe.

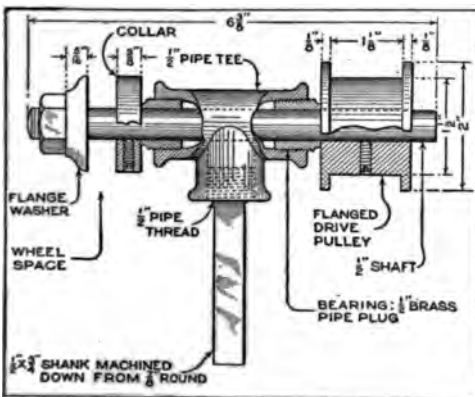

Many Jobs of Grinding can be Handled in the Lathe, if a Grinding Attachment is Made with a Pipe Tee as Its Basis

**Newspaper Bulletin Board**

Pasting bulletin sheets to a bulletin board, or window, with the consequent

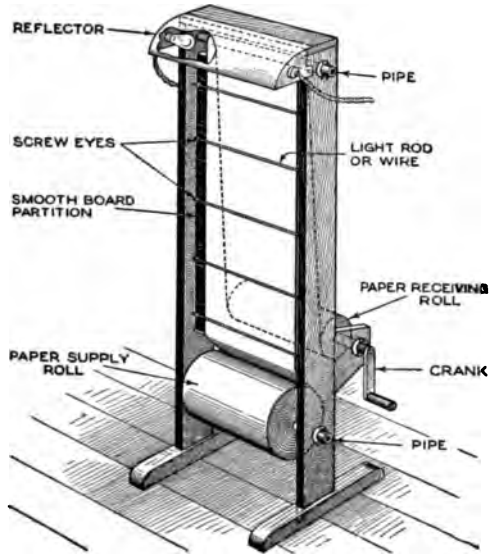

This Improved Newspaper Bulletin Board Has a Number of Advantages over the Old Method of Pasting Sheets to a Board or Window

loss of time and unnecessary work, is eliminated with the board shown in the drawing. The bulletins are painted on the paper strip, and a turn or two of the crank takes the oldest bulletins out of sight and brings the latest ones into view of the readers.

The board is simple, and consists merely of a suitable wooden support, the distance between the uprights being determined by the width of the paper roll used. While no definite dimensions are possible, the height should be from 8 to 10 ft., or more, according to requirements. It will be observed that a smooth board partition is built between the sides; this serves as a support for the strip of paper and is of great assistance when lettering. A piece of smooth pipe, or rod, is provided at the top, over which the paper passes to the receiving roll at the rear; this is merely a pipe shaft with a crank at one end, mounted on brackets as shown. Screw eyes are placed at intervals on both sides of the partition, and wires, or rods, are run from side to side, to prevent the paper from fluttering, or blowing loose. At night the bulletins are illuminated by two or three lights in a reflector across the top, as indicated. By reversing the paper roll, both sides can be used; a rather thick paper is therefore desirable.

### Winding Springs with Brace

A uniform coil spring, of a size governed by the size of the rod, can be wound

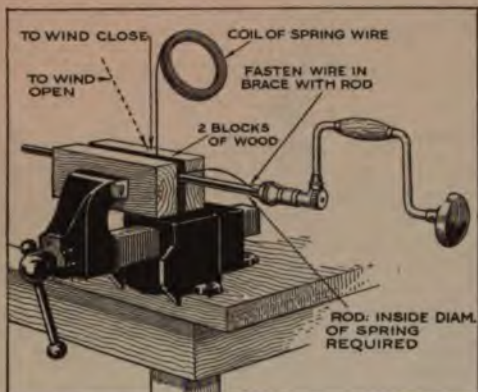

Good Coil Springs are Made by Clamping between Wooden Blocks in a Vise, No Lathe being Required

with the arrangement shown. If a tight, or expansion, spring is required, feed the wire in at right angles; for an open or compression spring, any pitch can be obtained by slanting the wire. I find a more uniform spring can be wound by this method than by the use of a lathe or other revolving machine.—John C. Smith, Tacoma, Wash.

### Growing Strawberries in a Barrel

This small strawberry garden is easily and cheaply made and kept, requiring no cultivation of the plants and but little attention other than an occasional watering of the plants after setting them. It is an ordinary 50-gal. coal-oil barrel, having a number of holes bored in its sides; it is filled with soil and compost, and the plants are set in the soil with their stems and foliage extending through the holes on the outside. A convenient means of



watering the roots of the plants is provided by making a square box of  $\frac{1}{2}$  by 3-in. strips, long enough to stand on the bottom of the barrel inside at the cen-

ter, and reach to the top. It is drilled with small auger holes all around, and through its entire length. This box stands in the soil in the center of the barrel, and the water is poured in its end protruding out of the soil at the top. The upper end of the barrel is left open. Several holes are bored in the bottom head, to drain off surplus water. The holes for the plants are bored in diagonal rows, 6 in. apart. In boring these holes, the auger is held in a diagonal position, which inclines the plants to a natural upward growth, and also helps prevent the soil from sifting out through the holes when dry.

A surprisingly large number of plants can be grown in a single barrel in this way, and one barrel of plants will supply the home needs of a moderate-sized family. The plants grow well, and bear fruit as heavily as when cultivated in open ground, and the fruit is free from grit and soil. The barrel shown in the illustration has 72 plants in its side, one in each hole, and 12 growing in the top of the soil around the watering tube.

### Miter Box for Cutting Tubing

The mechanic often finds that he must cut metal tubing at certain angles in order to make joints. This is difficult to do

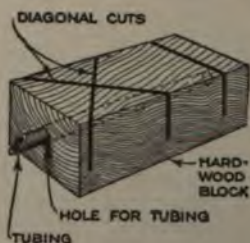

unless a guiding form is used. For this reason a miter block should be used, just as a miter box is used by carpenters in cutting wood. Choose a suitable block of hard wood, and drill a hole a little larger than the tubing through the center of the block. Then mark lines across the top surface at the required angles, and saw down vertically below the bottom of the hole. The tubing is then run through the hole, and the cut made with the hacksaw. Smaller tubing than that provided for can be sawed by wedging it in the hole with splinters of wood.

### Testing for Piston Leaks

When an automobile engine is turned over with the starting crank, and there is evidence of a lack of compression in one or more cylinders, the condition is usually attributed to leaky valves. This defect is, however, very frequently the result of too



and found that there were five times as many teeth in the large gear as in the pinion. He then put a twist drill in the chuck, and inserted the end of the drill in the center of the shaft. With his watch in his left hand, and the handle of the drill in the right, in such a position that the handle on the gear would just touch his hand at every revolution, he counted the revolutions made by the handle in a minute. Multiplying this by five gave him the number of revolutions made by the shaft drill, this being therefore the speed of the shaft.

### Stove Damper for Grain-Bag Filler

An ordinary stovepipe and damper may be used to make a grain-bag filler, if the hole in the center of the damper is closed up. The pipe is inserted in the bottom of the grain bin, extending through the ceiling of the floor below. Here it terminates in a sturdy grain-bag support, on which the bag is hung. The damper is turned on, allowing the grain to flow until the bag is full, when the damper is turned off.

### Grinding Attachment for Lathe

A grinding head can be made in a little spare time for the shop which is not equipped with such a head, the materials consisting of a  $\frac{1}{2}$ -in. pipe tee, two plugs, a pulley, and a few scraps of metal. The bearings are brass-pipe plugs screwed in at the opposite ends of the tee. In the branch end of the tee is screwed a plug, which is formed at the end to fit into the tool post of the lathe. The pulley and grinding wheel are mounted on a  $\frac{1}{2}$ -in. spindle, and a belt can be run to the countershaft of the lathe.

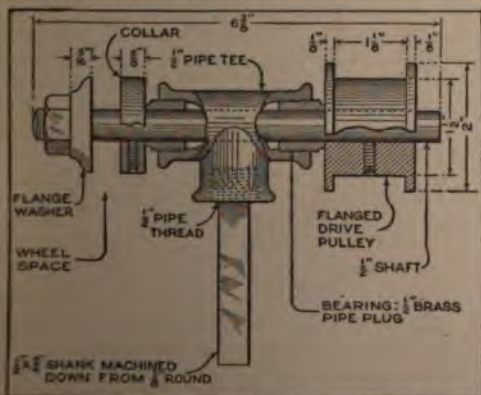

Many Jobs of Grinding can be Handled in the Lathe, if a Grinding Attachment is Made with a Pipe Tee as Its Basis

### Newspaper Bulletin Board

Pasting bulletin sheets to a bulletin board, or window, with the consequent

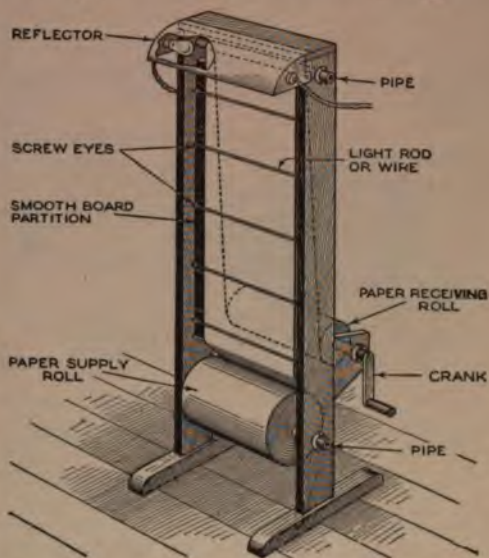

This Improved Newspaper Bulletin Board Has a Number of Advantages over the Old Method of Pasting Sheets to a Board or Window

loss of time and unnecessary work, is eliminated with the board shown in the drawing. The bulletins are painted on the paper strip, and a turn or two of the crank takes the oldest bulletins out of sight and brings the latest ones into view of the readers.

The board is simple, and consists merely of a suitable wooden support, the distance between the uprights being determined by the width of the paper roll used. While no definite dimensions are possible, the height should be from 8 to 10 ft., or more, according to requirements. It will be observed that a smooth board partition is built between the sides; this serves as a support for the strip of paper and is of great assistance when lettering. A piece of smooth pipe, or rod, is provided at the top, over which the paper passes to the receiving roll at the rear; this is merely a pipe shaft with a crank at one end, mounted on brackets as shown. Screw eyes are placed at intervals on both sides of the partition, and wires, or rods, are run from side to side, to prevent the paper from fluttering, or blowing loose. At night the bulletins are illuminated by two or three lights in a reflector across the top, as indicated. By reversing the paper roll, both sides can be used; a rather thick paper is therefore desirable.



### A Turret-Lathe Job Done on an Engine Lathe

The drawings illustrate how a job ordinarily handled on a turret lathe, or hand

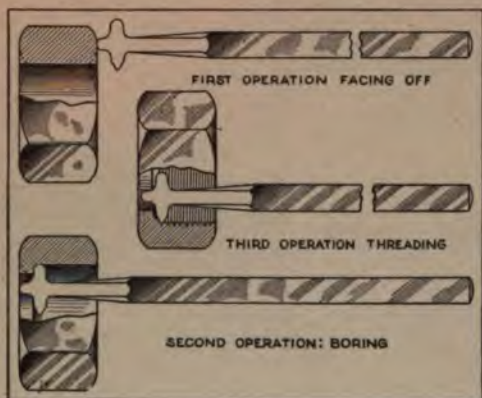

A Special Tool, Forged for the Job of Making Brass Packing Nuts, Completes at One Setting the Operations of Facing, Boring, Counterboring, and Threading

screw machine, was done on a common engine lathe in the absence of any turret machine. The work was that of making a number of hexagon packing nuts,  $1\frac{1}{8}$  in. in diameter. The material used was brass castings, the flats being afterward finished in the milling machine.

The device which made it possible to turn out these parts almost as rapidly as would have been possible with a turret lathe was a special tool forged to the shape illustrated. The rough brass casting was held in a universal chuck, and a drill slightly smaller than the hole, held in the tailstock spindle, was run through. The tailstock was then pulled back, and the special tool brought into action. The casting was first faced off with the front of the tool. Then, running the lathe backward, the small hole was bored to size by the upper part of the tool, which was ground to a round point. The casting was then counterbored with the same part of the tool to the size of the root of the thread. When this was done, the lathe was again reversed, and the thread cut in the usual manner with the lower side of the tool, ground to the ordinary  $60^\circ$  angle. All these operations were completed without changing the setting of the tool.

The first nut was made to calipers and gauges, noting the reading of the dial on the cross-feed screw when boring the small hole, and setting stops to give the proper depth and diameter to the counterbore; also for the threading operation. After this no calipering was done except

to try a part occasionally to see that the tool had not worn too much, or the adjustment changed.

After this operation the nuts were screwed onto an arbor, the other side faced, and the hexagon milled, according to the ordinary practice. The operations covered at one setting in the engine lathe comprise all of those which would be done at one chucking in a turret lathe, and the time required was not more than would have been required with the more expensive machine. There was no turret to swing three times for each nut. The only loss of time was in reversing the lathe for the boring operation.—M. L. Lowrey, Livermore, Calif.

### Vise Attachment for Filing Bevels

When filing beveled edges on work held in the common type of vise, it is necessary for the worker to assume an awkward position, as the file must be held at an angle.

The accompanying sketch shows an attachment which makes it possible to hold the file in a horizontal position, the bevel being produced by holding the work at an angle. The two parts of the attachment are cut from old pieces of shafting, the dotted lines showing the portions removed. The vise must of course be screwed up rather tighter than when holding the work in the jaws directly.—R. H. Kasper, Philadelphia, Pa.

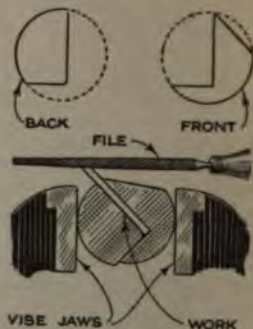

### Carpenter's Centering Gauge

A very useful tool to the carpenter is one which can be made from some scraps of wood in a few moments of spare time. A strip of hard wood, of about the dimensions shown in the drawing, is fitted

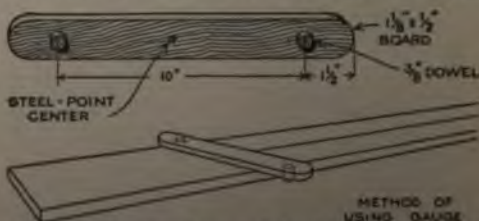

A Tool Made from Scraps of Hard Wood and Dowel Stock Makes Easy the Job of Scribing a Center Line



much clearance between the piston rings and cylinder walls. To detect leakage due to worn and loose or worn rings, a 3-ft. length of rubber hose is placed over the bellows pipe, or oil-filler tube. One end of the hose is placed against the ear of the tester and the leakage past the piston is clearly evidenced by a pronounced hiss when the engine is turned over slowly by hand. The piston at fault is located, and the obvious remedy applied, which is usually new piston rings or oversize pistons. In case the valves are the cause of the lost compression, the hiss is not heard.

**Spring Washer for Door Knobs**

The screw holes for fastening the knob to the shank of a common type of door lock do not always bring the knob into such position that endwise motion of the shank is taken up. Instead of using thin washers to fill up the space, an effective means of taking up the lost motion is to substitute for the washers two or three coils of wire spring, of suitable size to go over the shank of the knob. Music wire, about .025 in. in diameter, is preferable, wound in an open coil and cut off as needed. A washer should be used at one end of the spring, to prevent it from going through the hole in the plate.—Chas. F. Merrill, Hopedale, Mass.

**How to Drill a Curved Hole**

To drill a hole with a curve in it might not be considered possible with ordinary

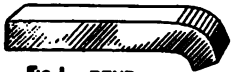

FIG. 1: BEND

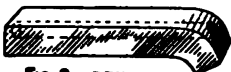

FIG. 2: DRILL



FIG. 3: STRAIGHTEN

tools and hand processes, yet, like many other things which appear difficult at first glance, it is easy to do. First make a bend in the piece in the opposite direction from the bend which is desired in the hole. This is shown in Fig. 1.

Then drill a hole straight through with an ordinary drill, as in Fig. 2. It remains only to heat the piece of metal again and bend it back to its original shape, as shown in Fig. 3, and the hole will then be curved. The metal, if finished nicely, will offer no evidence as to how the curved hole was made.

Small emery wheels may be dressed by using an old glass cutter of the type embodying a small hard-steel wheel.

**Pipe and Conduit Threads Cleaned by Guided Reamer**

Insulated wires which are run through metal conduits may often be injured by

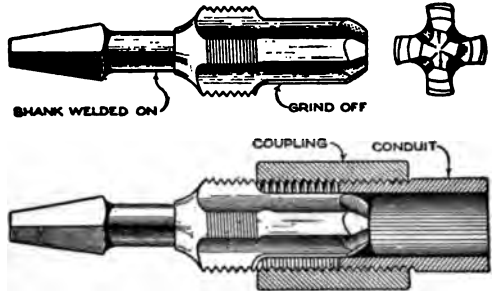

A Combination of Guided Reamer and Thread Chaser, All in One Tool, Adds to the Convenience of the Conduit Layer and Plumber

burrs remaining on the ends of the conduit. To prevent this, it is good practice to ream out the end of the conduit in order to remove any burr which may exist. A combination tool which does this, and at the same time cleans out the threads of the coupling, is illustrated in the drawing. The tool can be made by grinding down a standard tap, and forming, by means of the grinding wheel, the cutting edges at the end of the tap and at the forward end of the threaded portion.

The tool is held in an ordinary bit brace by means of a shank, which can be welded onto the tap. As the reamer is fed in, the bur-removing edge at the end first does its work. The ground-down portion then runs on into the conduit, forming a guide, while the thread-cutting portion runs through the threads in the coupling, cleaning them out and straightening them, ready to take the next section of conduit. One size of reamer handles only one size of conduit and coupling, but it will pay the electrical worker to make and keep on hand tools of this type for whatever size of conduit he uses.—Eugene F. Gardner, Chicago, Ill.

**Waterproofing Dry Batteries**

Remove the cardboard casing and dip the cell into melted pitch, or asphalt. Coal tar may be used, either by dipping the cells or applying with a brush, and replacing the cell in the casings. Melted paraffin will also serve for this purpose. The coating, besides protecting the batteries from moisture, prevents the zinc from becoming oxidized, thus reducing deterioration.—A. A. Lobrovick, Brooklyn, N. Y.

### Opening in Fence Prevents Accidents

At a corner where a high fence around an industrial plant created danger of traffic collisions, the owner of the fence



The Possibility of Accidents at a Street Crossing was Greatly Reduced by Substituting Wire Screening for Wood in the Upper Part of the Fence

was prevailed upon to install an open section in it, covered with heavy screen wire. This enabled motorists to look through, and see the approaching vehicles on the crossing street. Moreover, the peculiar appearance of the fence acted to call the attention of drivers to the crossing, and the necessity for caution.

### Drawing Centerless Circle Arcs

A problem which is fairly frequent in the draftsman's daily work is to draw a circular arc through three given points. When the points are such that the center

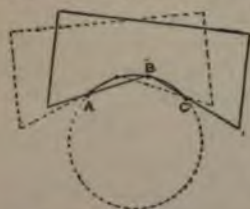

Fig. 1. JOINING POINTS BY AN ARC



Fig. 2. CONTINUING THE ARC

of the arc falls outside the board or table, it is inconvenient to draw the mark with compass or string, and the irregular curve is often resorted to as an approximate method. Such an arc can be drawn as here described; the solution is geometrically correct, or, in other words, the accuracy to be attained depends solely on the care with which the work is done.

Assuming A, B, and C, in Fig. 1, to be the three points through which a circular arc is to be drawn, the lines AB and BC are drawn, and are prolonged as shown. A piece of stiff cardboard is employed; a broad notch is cut in one side, the angle of which is equal to the angle ABC. Each side of this angle in the card is

shifted along, its angle B traveling from A to C on the paper, while the card remains in contact with pins inserted at A and C. The pencil held at the corner B in the card will then trace a circular arc, passing through all three points. The process is merely a practical application of the geometrical principle that "all angles inscribed in the same arc are equal."

If it is necessary to continue the arc on past the points A and C, this can be done by cutting a notch in a card with the angle equal to the angle BCA, as in Fig. 2, and another notch with the angle BAC. The first of the two cards is employed for extending the arc beyond C, as illustrated, and the other may be employed for extending it beyond A, though it is often possible to get just as accurate results by using the first card alone.

If it is desired to determine the length in degrees of the arc ABC, measure the angle ABC with protractor. Double this angle and subtract from  $360^\circ$ ; the remainder will be the angular length of the arc.

To strike an arc a certain number of degrees in length between two points, subtract the desired number of degrees from  $360^\circ$ , divide the remainder by two, and cut the notch in the card to the number of degrees given. Using it as in Fig. 1, draw the arc required.

### A Common Refrigerator Trouble

Many good refrigerators are condemned and discarded every year for their deficiency in keeping cold, regardless of how much ice is kept in them. A frequent cause of this deficiency is that explained here, and its cure is very simple.

The ice rack in the bottom of the ice chamber rests on brackets of various construction, just over the cold-air down vent, this rack being a sheet of galvanized steel. Even if it is corrugated, which it usually is, it will in course of time be bent down until it rests on the flange surrounding the vent hole, thereby preventing the cold air from sinking into the food chambers. There should never be less than 1 in. of space between this rack and the top of the flange around the vent hole. When the rack becomes bent, take it out and straighten it, even making it a little convex if necessary to get required space. If the supporting brackets under the rack are broken or damaged, a small piece of wood may be used to keep it properly elevated.



with two hardwood dowels. At a point exactly central between the two dowels, a pointed pin is fitted, similar to the scratch pins commonly used in marking gauges.

To mark a line down the center of a board, it is only necessary to place the gauge on the work, spring it until the dowels are in contact with the edges, and slide it along, the sharp pin scribing the center line.

The gauge, as dimensioned, will handle anything up to 6-in. stock. It can, however, readily be made long enough to handle boards 12 in. or more wide. A long gauge is applicable to narrow boards, except when they are curved, or a center mark is wanted near the end of the board, in which case it will be advisable to use a shorter centering gauge.

### How to Keep Air Dry

For keeping the air dry in rooms where fruit is stored, calcium chloride is placed in a slightly slanting metal tray, resting on a table or stand. The tray is provided with a lip at the lowest point so that any liquid will flow into a vessel placed underneath. When a sufficient quantity of the salt has liquefied, the moisture may be removed by heating, which restores it to its original condition, so that it may be used repeatedly. Calcium chloride will absorb about double its own weight of moisture.

### Tool for Putting on Belts

Putting a belt on a high pulley is sometimes a dangerous job, and often a nuisance, because

some one has to get a ladder and do a good deal of fussing about it. The appliance illustrated has been used in machine shops for years, and deserves to be better known than it seems to be. A disk of heavy sheet metal is mounted so that it turns easily at the end of the belt pole, and a tapered horn projects from its center. The horn is used to lift the belt into place, and is kept inside the pulley rim while the belt is running on. If it is allowed to get between the belt and the pulley it may cause trouble, but its conical form makes this unlikely.

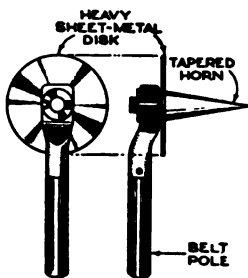

### Garage Floor as Trouble Guide

The car owner will find it a good plan to watch the garage floor for evidence of

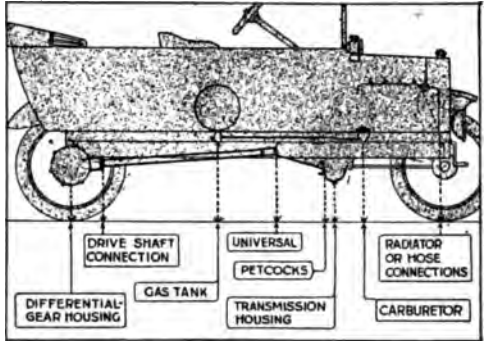

Stains on a Garage Floor Where a Car has been Standing Overnight Provide a Reliable Method of Locating Leaks

leakage, whether of grease, oil, gasoline, or water. A small puddle of water found on the floor in the morning, after the car has been standing overnight, may indicate a leak in the pump packing, radiator hose, or some other part of the cooling system; but the loss is not likely to be of much consequence, unless an anti-freezing solution is used. A leak in the carburetor or fuel pipe is of more importance, and can generally be located by inspecting the floor before moving the car. Oil leakage from a loose petcock, defective gasket, or felt washer can generally be detected in the same way, and the cause remedied. Grease beneath the transmission, differential housing, or a universal joint, is often caused by loosened bolts in these parts. When the evidence is observed on the floor, the loose bolts can be tightened before they get a chance to come out entirely and cause serious trouble.

### Removing Tight Bottle Stoppers

The stoppers of bottles holding certain chemicals often become tightly fixed, and it is not always an easy matter to get them loose. Application of heat to the neck is not always effective, but by applying a freezing mixture to the stopper, it usually loosens without difficulty. Make a mixture of crushed ice and calcium chloride, and put the stopper in this, taking care that the freezing mixture does not touch the neck of the bottle. After a few minutes of this treatment, the stopper will come out easily, owing to contraction of the stopper.—S. Leonard Bastin, Bournemouth, England.

### Opening in Fence Prevents Accidents

At a corner where a high fence around an industrial plant created danger of traffic collisions, the owner of the fence

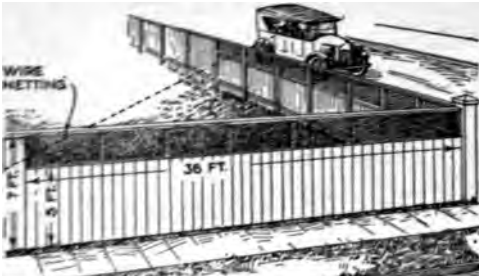

The Possibility of Accidents at a Street Crossing was Greatly Reduced by Substituting Wire Screening for Wood in the Upper Part of the Fence

was prevailed upon to install an open section in it, covered with heavy screen wire. This enabled motorists to look through, and see the approaching vehicles on the crossing street. Moreover, the peculiar appearance of the fence acted to call the attention of drivers to the crossing, and the necessity for caution.

### Drawing Centerless Circle Arcs

A problem which is fairly frequent in the draftsman's daily work is to draw a circular arc through three given points. When the points are such that the center

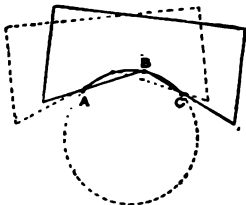

Fig. 1. JOINING POINTS BY AN ARC

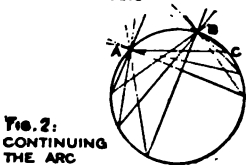

Fig. 2. CONTINUING THE ARC

of the arc falls outside the board or table, it is inconvenient to draw the mark with compass or string, and the irregular curve is often resorted to as an approximate method. Such an arc can be drawn as here described; the solution is geometrically correct, or, in other words, the accuracy to be attained depends solely on the care with which the work is done.

Assuming A, B, and C, in Fig. 1, to be the three points through which a circular arc is to be drawn, the lines AB and BC are drawn, and are prolonged as shown. A piece of stiff cardboard is employed; a broad notch is cut in one side, the angle of which is equal to the angle ABC. Each side of this angle in the card is

shifted along, its angle B traveling from A to C on the paper, while the card remains in contact with pins inserted at A and C. The pencil held at the corner B in the card will then trace a circular arc, passing through all three points. The process is merely a practical application of the geometrical principle that "all angles inscribed in the same arc are equal."

If it is necessary to continue the arc on past the points A and C, this can be done by cutting a notch in a card with the angle equal to the angle BCA, as in Fig. 2, and another notch with the angle BAC. The first of the two cards is employed for extending the arc beyond C, as illustrated, and the other may be employed for extending it beyond A, though it is often possible to get just as accurate results by using the first card alone.

If it is desired to determine the length in degrees of the arc ABC, measure the angle ABC with protractor. Double this angle and subtract from  $360^\circ$ ; the remainder will be the angular length of the arc.

To strike an arc a certain number of degrees in length between two points, subtract the desired number of degrees from  $360^\circ$ , divide the remainder by two, and cut the notch in the card to the number of degrees given. Using it as in Fig. 1, draw the arc required.

### A Common Refrigerator Trouble

Many good refrigerators are condemned and discarded every year for their deficiency in keeping cold, regardless of how much ice is kept in them. A frequent cause of this deficiency is that explained here, and its cure is very simple.

The ice rack in the bottom of the ice chamber rests on brackets of various construction, just over the cold-air down vent, this rack being a sheet of galvanized steel. Even if it is corrugated, which it usually is, it will in course of time be bent down until it rests on the flange surrounding the vent hole, thereby preventing the cold air from sinking into the food chambers. There should never be less than 1 in. of space between this rack and the top of the flange around the vent hole. When the rack becomes bent, take it out and straighten it, even making it a little convex if necessary to get required space. If the supporting brackets under the rack are broken or damaged, a small piece of wood may be used to keep it properly elevated.



### Remedy for Slipping Cone Clutch

A hacksaw and a little ingenuity helped an autoist to get his heavily laden car through woods and over sandy roads, miles away from a garage, when the clutch slipped and failed to provide the necessary pulling power. The blade of the saw was broken into pieces as long as the width of the leather belt, and these were then driven, at equal intervals, between the clutch and the leather. The latter was thus raised, and, when engaged, the clutch held firmly, remaining in good condition for a long time. The plan is an easy one, but care must be used to place the pieces of saw so as not to shear off the copper rivets.—Loyal F. Garris, Jackson, Mich.

### Support for Stock being Cut on Power Hacksaw

Cutting long material in a power hacksaw is a difficult task unless some means is used for supporting the stock on a level with the bed of the machine. For this purpose a tripod can be made from iron or steel bars, which are shaped and assembled as shown by the drawing. The construction of the joint at the top of the three legs permits alterations in height by simply adjusting the spread of the legs. This feature makes it possible



Stock Support for Power Hacksaw: The Height of the Tripod can be Varied by Changing the Spread of the Three Legs

to use the support on an uneven floor, or on the ground.—Frank W. Roth, Joplin, Missouri.

ⒸA nonheating knob for a pot cover may be made from an old fuse plug. The rivet in the end of the plug is removed, and the cover is attached by a small stove bolt.

### Baggage Rack over Car Hood

The baggage rack shown in the accompanying photograph is in daily use for carrying grips and suitcases of guests



A Metal Rack, Placed over the Hood as a Baggage Carrier, Is Both a Convenience and an Advertisement for the Proprietor of the Hotel

from the railway station to an Ohio hotel. The rack is made of  $\frac{3}{8}$ -in. pipe, mounted on two  $\frac{1}{2}$ -in. rods fixed to the cross member of the automobile frame. The floor is a lattice of iron strips  $\frac{3}{16}$  by 1 in. in size, placed about 4 in. apart. The rear end of the rack is supported on brackets which project from the cowl. The rack is 24 by 30 in. in size, and carries several heavy suitcases quite easily. Those on the driver's side are laid flat in the rack in order to give a clear view of the road.

### Potatoes Sprayed by Exhaust

The exhaust of an automobile engine operates the potato-plant sprayer shown in the illustration. A length of pipe is brazed to the exhaust pipe of a touring car, or truck, and on the end of this is screwed a tee, with its lateral opening turned upward. A short length of pipe connects the tee with a wye, into which are screwed two pipes, bent slightly upward, and equipped at their opposite ends with elbows. The openings of the latter are turned downward. The spraying-liquid container is placed near the back of the vehicle, and connected with the pipes by means of a rubber hose, which is attached to the lateral opening of the tee. A stop cock at the upper end of the hose controls the flow of liquid. To operate the device, the valve is opened, and the machine driven so that the ends of the



branching pipes pass over two rows of plants. The exhaust converts the liquid into spray, which is applied to the plants by the branching pipes. The contrivance

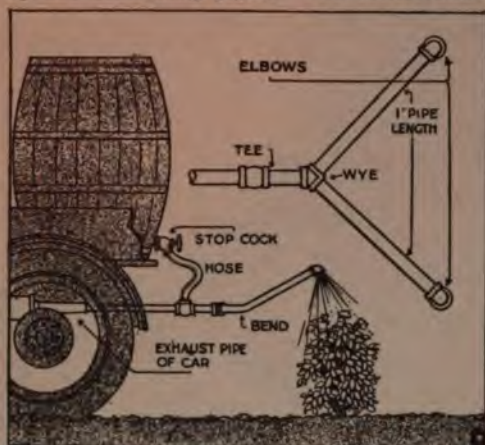

Potato-Plant Sprayer; Two Rows are Treated at One Time by the Device, Which is Operated by the Exhaust of an Automobile Engine

can be utilized for spraying various other vegetables. It is especially adapted for use with a mixture of paris green and water.—Paul L. Fetherston, Ottawa, Ill.

### Pneumatic Clamp or Vise

Railroad repair shops are probably the greatest users of compressed air in the mechanical field, and devices such as the little vise, or clamp, in the accompanying sketch are very common. It consists of a cylinder, a piston with a triangular head on end of the piston rod, two clamping jaws, and the necessary frame for at-

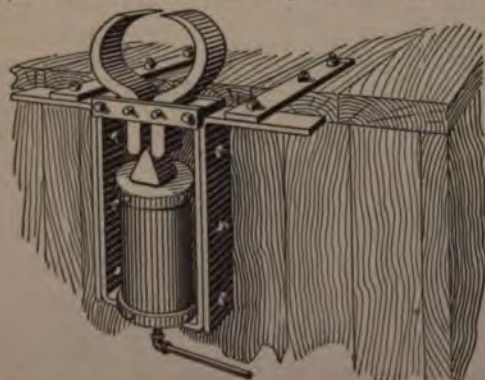

Where Compressed Air Is Available, a Useful Vise may be Operated by a Foot-Controlled Air Valve

taching to a workbench. As made, the cylinder was a piece of ordinary wrought-iron pipe, while the piston, frame, and

jaws were forged from scrap. The jaws shown were those used for clamping hose to pipe nipples, but other styles of jaws made the vise suitable for holding work for chipping, filing, or other operations. With garages using compressed air in more and more ways, devices such as this soon pay for their cost in labor and material.

### Manifold Heated by Concrete

A motorist who experienced difficulty in starting his automobile engine, after letting it stand in a cold garage overnight, constructed a concrete block, molding it to the exact shape of the intake pipe. Two hooks for supporting it were imbedded on the side of the motor.

The scheme involves no danger, as from fire in heating the manifold with an open flame, or troublesome disorders such as are likely to ensue when hot water is poured around the carburetor. The concrete form is heated by simply placing it inside the furnace door a few minutes prior to using the car; then it is taken

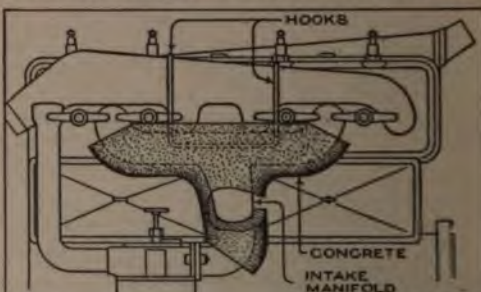

A Cement Block is Heated in the Furnace and Afterward Hung on the Intake Manifold, Heating It Quickly for an Easy Start

to the garage and hung on the side of the intake manifold. By the time the motorist is ready to "crank up," the manifold is hot enough to vaporize the incoming gasoline, giving an immediate start. The block is carried under the hood at other times; if trouble occurs during the day, the owner can use the block again by reheating it in some convenient furnace or fire.—G. A. Luers, Washington, D. C.

### Fine Points of Valve Grinding

The better the finish on valves and valve seats, the longer they will wear. When grinding valves, use only fine grinding paste, unless the valves are in very bad condition. This avoids a good deal of scratching and scoring, which is likely to occur with coarse com-



ound, unless the grinder is an expert. When the job is nearly finished, wipe all the abrasive off the valve only; put a little more oil on the seat with the remainder of the compound that sticks to it, and continue grinding. Wipe the seat off perfectly clean, leaving the paste on the valve. Repeat this a few times until the abrasive is "dead." Then put a little graphite and oil on, together with the remainder of the compound, and give a finishing rub. By this time the valve and seat will be very smooth and polished, and the surface will be in fine working condition.—Howard Greene, New York, New York.

### Handle for Rotating Shafts

The shop mechanic often finds it necessary to rotate the shaft of a motor, engine, or other machinery upon which he is making repairs. This operation may be accomplished with ease with the aid of a detachable lever or crank. For shafts under 1 in. in diameter, it is suggested that the lever arm be made of mild steel  $\frac{3}{16}$  by 1 by 12 in. At one end is made, its axis being perpendicular to the 1 in. surface. At the other end, the steel strip is given a half twist, and the 1-in. width is formed around the shaft, as shown, the extreme tip of the strip being bent in to catch in the keyway of the shaft. To turn the shaft it is only necessary to slip the curved hook of the handle over the end of the shaft so the tip will engage with the keyway, and turn as if cranking an automobile. This is an excellent tool for inspectors; they can thus easily rotate the movable parts so as to make a thorough examination.



### Gummed Paper in Machine Shop

There are many cases when small machine parts must be held together temporarily, for example while screws are being put in, or while adjustments are being made. In one shop, several widths of gummed paper, in rolls, are kept for just this purpose. The sticky tape is quickly and conveniently bound around any part and holds against moderately severe strains.

### Electric Lighter on the Bench for Gasoline Torches

(Copyright, All Rights Reserved.)

An electric lighter for gasoline torches, suitable for the shop, is shown in the

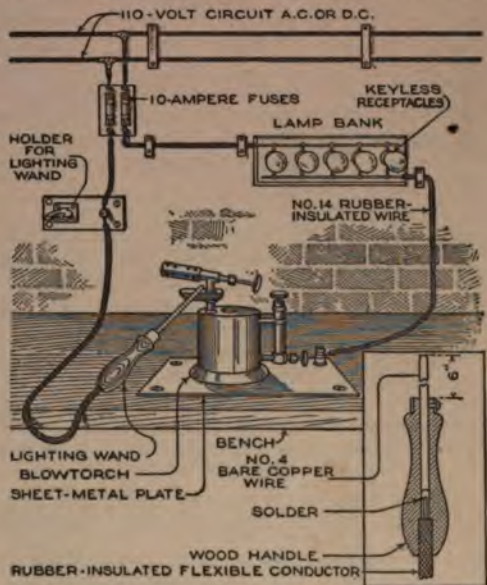

Electric Lighter for Gasoline Torches. Installed on a Bench: The Device Obtains Current from an Ordinary Lighting Circuit

drawing. Electricity is obtained from an ordinary lighting circuit, and either direct or alternating current can be used. A bank of multiple-connected incandescent lamps limits the current by resistance. One wire from the bank is attached to a metal plate, fastened on a bench, while the other terminates in the lighting wand, detailed in the illustration. When a torch is set on the plate, and the wand applied to the filled gasoline cup, the fluid is ignited by the resulting spark. If the number of lamps is increased, a better spark will be obtained. Fuses are installed as indicated. The holder for the wand is not essential, but is convenient. When the device is fed by a circuit which has one of its side conductors grounded, the lead to the bank and plate should be connected to the grounded wire. In the case of a grounded neutral conductor in a three-wire system, the same lead should be connected to the neutral wire.—Alfred H. Hayes, St. Louis, Missouri.

☞ An efficient foot scraper is made from a discarded currycomb attached at some convenient point on porch or steps.

# HOW TO MAKE A FIRELESS COOKER

By KENNETH COGGESHALL

**A FIRELESS** cooker is a device so constructed that, through the agency of insulating materials, accumulated heat may be retained. Just as the walls of a refrigerator insulate ice from any heat outside the box, so a fireless cooker prevents heat radiation from its interior compartments to the relatively cooler surrounding air. Food, therefore, may be brought to cooking temperature, removed from the source of heat supply, and placed in a fireless cooker, where the process of cooking will continue.

The construction of such a cooker is not complicated; no special tools, skill, or materials are required. And, because of its many advantages over stove cooking, every kitchen should contain a cooker as a part of its necessary equipment. Its use will accomplish a material saving in fuel, decrease the time and labor of cooking, and eliminate heat and odors from the kitchen, and besides provide thoroughly cooked, fully flavored foods.

The requisite parts for such a device

are a box; a bucket or kettle for holding the food; a container, or other metal nest lining, for the bucket, and a quantity of good nonconducting or heat-insulating material.

While the outside container may be made from any tightly constructed box, half barrel, or small trunk, a chest box for the purpose will not only present a more pleasing appearance, but will be more economical of space. One-inch cypress boards, free from all knots and other defects, should be used. Cypress, if properly finished, will give beautiful grain effects, and is less expensive than hard woods. Lighter lumber should not be considered unless well braced; the pressure exerted in tamping in the insulating material is likely to bend out of shape the boards of the box, if they are thinner than the weight specified.

The general appearance of the chest is shown in Fig. 1. The front and back are matched and fastened to cleats or cross-pieces, as indicated in Fig. 2. Two end sections, seen in Fig. 3, are constructed

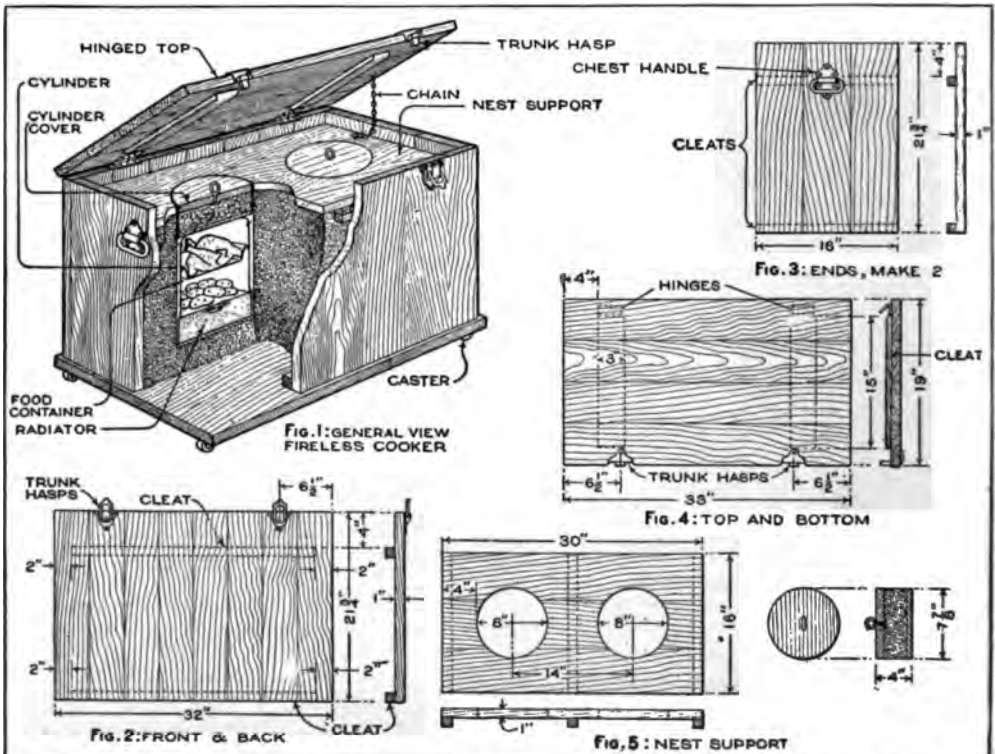

In Figs. 1 to 5 are Shown an Assembly View of the Fireless Cooker, and Details of the Various Parts of the Chest. This is Made Quite Solid, and Mounted on Casters for Easy Moving



similarly. Cross cleats are also utilized here, at both top and bottom, to hold the boards in position.

While the top and bottom sections, shown in Fig. 4, are identical as to dimensions, they may be different as to finish. It is permissible to use rough, unfinished lumber for the bottom; the top should be constructed of selected cypress to match the sides and front of the chest. Moreover, since both sides of the top are presented to view, the workmanship should be of the best.

The sides, front, and back should be first assembled, leaving the cover and bottom until later. Two inches from the top edge of the chest, a wooden nest support should be fastened in position. This support is constructed as shown in Fig. 5. Using a keyhole or band saw, cut two 8-in. holes, at the positions indicated.

The metal cylinder lining, illustrated in Fig. 6, is cut from sheet zinc or galvanized iron; it is rolled into a cylinder, and the seam soldered. For a cylinder of this size, the developed dimensions of the flat metal will be as given in the pattern. It may be found possible to use heavy cardboard instead of sheet iron, but the latter is more durable and far more sanitary. Two such cylinders are required.

Prepare two wooden disks, detailed in Fig. 7, to serve as bottoms for the cylinders. Fasten them in place, as shown in Fig. 6, with small nails. The free ends of the cylinders are then fitted in the 8-in. holes in the wooden support, and fastened with screws or nails. The nests being thus prepared, the insulation may be packed in place.

Practically any material which will not conduct heat may be used as a packing. Mineral wool is perhaps the best, since it is fireproof, sanitary, and odorless. It is recommended for the cooker here described. Asbestos is also fireproof, and may be used with success. Ground cork, such as is used in packing grapes, is excellent, and can probably be obtained from a fruit dealer. Other suitable insulators are Spanish moss, excelsior, wool, cotton, crumpled paper, hay, and

even hard-coal cinders. If fireproof insulation cannot be obtained, a sheet of as-

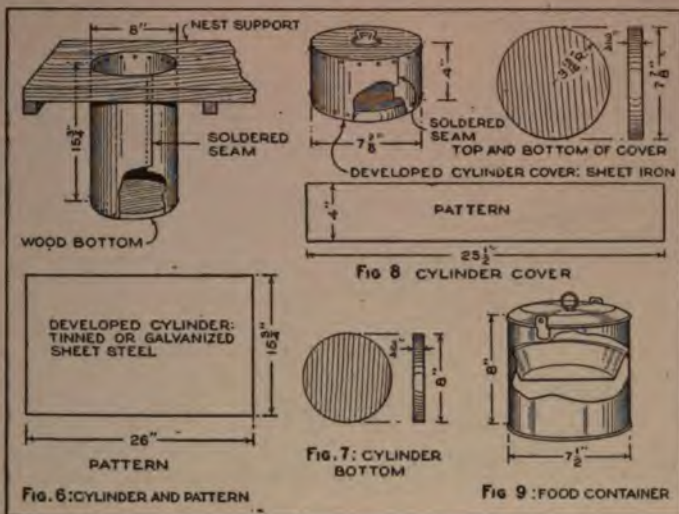

Figs. 6 to 9 Illustrate Parts of the Two Cylinders Which Hold the Food Containers; Also a Suggestion as to the Container Itself

bestos should be wrapped around the outside of each metal cylinder.

With the chest upside down and the bottom removed, carefully pack in the insulating material. Every crevice, especially near the metal cylinders, must be tightly tamped full of the packing. Fill up, as far as possible, all air spaces which might cause heat convection. When the insulation fills the chest to the level of the edges, screw or nail the bottom section in place.

The top should now be attached, the hinges being placed at the back. A light chain may be used to prevent the top from falling backward. Two chest fasteners, secured at the points indicated in Fig. 2, may be utilized to hold the top tightly closed when the cooker is in use. A handle on each end of the chest will improve its appearance as well as aid in moving the cooker about. Easy-running casters should be provided, one at each of the bottom corners. Stain, oil, or varnish may be used to complete the finished surface of the chest.

The construction of the insulating cover, seen in Fig. 8, requires some degree of skill in matching the 8-in. holes in the nest support. Two metal cylinders are formed, of dimensions given. Two wooden disks, as detailed, are required for each cushion. Fasten one of these disks in place as a bottom to the cylinder, fill the container thus formed with the insu-

lating substance, and attach the top wooden disk. After an addition of a wire handle, or a knob, in the upper disk, the assembled cushion appears as in the first view, Fig. 8.

Needless to say, the kettles or containers for cooking should be durable, and as free as possible from seams. Perpendicu-

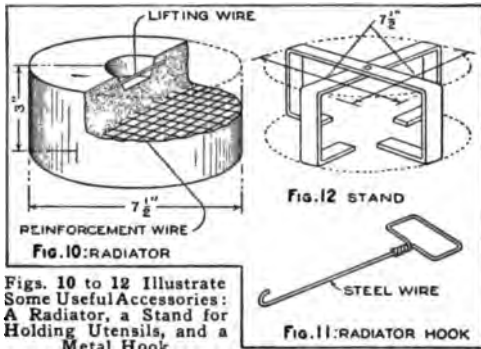

Figs. 10 to 12 Illustrate Some Useful Accessories: A Radiator, a Stand for Holding Utensils, and a Metal Hook

lar sides are necessary to insure a tight fit in the nest. Obviously the container covers should also fit closely, to prevent the escape of steam. While it is possible to purchase utensils for use in fireless cookers, a bucket serves the purpose just as well. The cooker here described is designed to use two standard 6-qt. buckets. Larger containers may, of course, be substituted, provided at least 4 in. of insulating packing surrounds them. While tinned ware can be used, experience shows it will rust after but short use. Enamelware, or better still, aluminum, insures longer service; a suitable container is illustrated in Fig. 9. If the handle is in the way, remove it, and provide two metal hooks for lifting the bucket out of the nest, similar to the one mentioned below for lifting the radiator.

It is not always necessary, as experience will prove, to furnish additional heat to assist the process of cooking. A much wider range of cooking, however, is provided if an extra source of heat supply is available. Soapstone radiators may be purchased for fireless-cooker use, but a brick, or iron disk, such as a stove lid, proves just as efficient. A radiator to match the dimensions of each cooker is easily made of cement. Molds, similar to the cover cushions, should be provided. It is not necessary that the radiator be larger than 7 1/2 in. in diameter, and 3 in. in height. For reinforcement, a disk cut from heavy wire mesh, such as in Fig. 10, is employed. After the cement is poured in the mold, it must be placed in some lo-

cation where it will dry slowly to avoid cracking. Besides the reinforcement, it is best to provide a lifting wire by forming a depression, exposing the middle part of a heavy wire imbedded in the cement. The radiator can then be lifted by gripping this wire with the hook shown in Fig. 11. The initial warming of the radiators should not be accomplished in haste. This caution also applies to the use of purchased soapstones. Unless these stone radiators are stored in a warm, dry place, they will crack when heated on the stove. Two iron stove lids of the correct size, bolted together, make a much more durable radiator and one that may be heated to a high degree.

Other accessories may be provided as required. A stand, for instance, such as is shown in Fig. 12, is convenient when two pies or cakes are being baked in one compartment. This stand is made of light strap iron, formed as indicated. Pans can be placed both inside and on top of it. Figs. 1 and 9 also present a method of placing a pan inside one of the buckets. Food may thus be cooked in the bottom space while its retained heat assists in the cooking of the contents in the pan above. Three angle lugs are riveted to the side of the bucket to form the pan support.

By referring to the sectional view of Fig. 1, the method of placing the various parts in the nest may be seen. A small dead-air space is permissible between the vessel and the cylinder walls, as circulation of air inside the cylinder cannot carry heat to the outside.

A fireless cooker can be utilized to greatest advantage in preparing foods which require long boiling, stewing, or steaming. Such foods are soups, cereals, meats, steamed bread or pudding, and vegetables. Obviously, large quantities of food, because the accumulated heat is greater, will cook faster and more thoroughly. If it is necessary to prepare a comparatively small quantity of food, good results are obtained by putting it in some container similar to a baking-powder can or a 1-qt. bucket, which should then be placed in the 6-qt. bucket, after pouring into the latter a suitable quantity of boiling water. The radiators, previously heated to a high degree on the stove, will assist in preserving a cooking temperature in the nest compartment.

Empty thread spools, attached to the wall by long screws or nails, make satisfactory clothes hangers.



## Plate on Stove Distributes Heat

Everyone is familiar with the so-called cannon stove used to heat small depots, railroad repair shanties, and the like. The top of one of these stoves was recently fitted with a loose plate, made from an old piece of boiler steel.

To fit the plate to the stove top required only the cutting of a hole in the plate, for the stove-pipe connection on top of the stove; after this had been done, the pipe was lifted and the plate slipped up over it.

Primarily, the plate was to be used for holding cooking utensils, but it was found that the heat radiating upward along the sides of the stove was deflected downward and outward by the plate, so that a much larger area in the room was warmed than formerly.

## Novel Method of Placing Valve Springs

Secure two strips of  $\frac{1}{16}$ -in. band iron of a length equal to the height of the spring when fully compressed, plus an allowance for a  $\frac{1}{4}$ -in. bend-over at each end. While the valve spring is fully compressed in the bench vise, set one of these pieces on each side of the spring

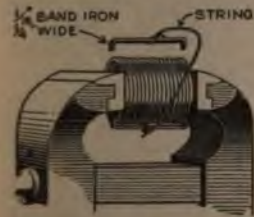

to hold it in compression. To both of them tie the ends of a piece of string, about 3 in. long. Now remove the spring, thus held, from the vise, and place on valve stem. After inserting the spring seat and key, take hold of the string loop and jerk the iron pieces from the spring, which will snap into proper position. For time and labor saving, this method is very efficient.—C. Nye, New York, N. Y.

☛ To remove stains from the hands, rub them well with a mixture of cornmeal and vinegar before washing in the usual way with soap and water. Laundry soap placed under the finger nails will prevent discoloration.

## Gluing Press Made of Strap Iron and Pipe

The photo shows a simple and effective clamp which was made for gluing the sides and tops of cedar chests. Its ad-

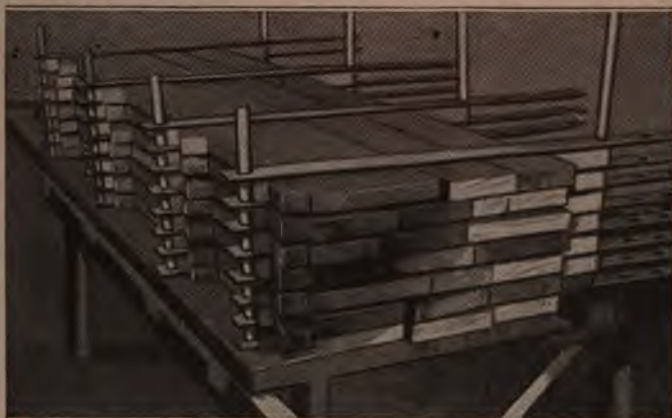

Where a Number of Large Panels are to be Glued Together, a Clamping Arrangement of This Type will be Found Handy

vantage over the usual type of clamp is that it holds the strips in line securely, so that the glued surface is perfectly flat and true, while, with the common type of clamp, it is often necessary to plane off nearly half of the two surfaces in order to bring out warps and twists.

This clamp consists of a solid table, having a top made of 2-in. material with a series of holes bored for each iron rod; eight round iron rods, and four pieces of strap iron drilled for the rods. Four straps are required for each set to be glued; they are piled up as high as desired.

On the back side, blocks of wood are inserted between each rod and the built-up top; on the front side, wedge-shaped pieces of hard wood are driven in. The clamp shown will glue eight tops or sides at a time; it cost about \$3 for material.—Dale R. Van Horn, Lincoln, Neb.

## Irregular Ripsaw Filing

The results of filing a crosscut saw can be observed quite well by looking down the channel between the points of the teeth, but with a ripsaw this cannot be done. A good way of inspecting the teeth of the latter kind is to bend and straighten it alternately at various points in its length; in this way the teeth can be observed with considerable accuracy. The reflection of light from the various teeth will also aid in telling whether they have been given the correct shape and set.

### Improvised Hand Pile Driver

The fact that there was no regular pile driver at hand did not retard the progress of certain bridge builders very



long when they came to a pond. They simply took 10 of the timbers which were to go into the bridge, and covered them crosswise with 3-in. plank for a pontoon. They nailed 2 by 2-in. strips on two 4 by 4-in. pieces, 16 ft. long, and raised them as guides for the hammer, which was made from a log of maple, 14 in. square and 5 ft.

long. Then, with a rope and block, as shown in the photograph, three men were able to drive eight piles in a day in solid blue clay.

No trip was necessary; when the hammer was hoisted to the top the men let go the rope. A shorter hammer much larger in diameter was used at first, but would not stand the jar; that of smaller diameter and greater length proved much more effective.—W. S. Richards, Albany, Oregon.

### Adapter for Telephone Cords

In using a pair of telephones of the kind employed in receiving radio messages and for testing purposes, it is often desirable to have some means of connecting them to ordinary battery binding

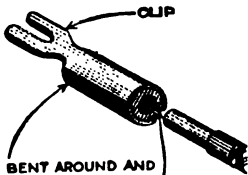

posts, which are not provided with holes for the insertion of the plugs on the end of the receiver cord. The easily made device shown in the sketch can be

utilized for this purpose. A common terminal lug and a piece of brass tubing are the parts needed. The ferrule of the lug is bent around the tubing, which has first been split with a fine saw. The diameter of the tubing is such that the cord plug will fit in it tightly. Solder is used to

fasten the tubing to the lug. When it is desired to connect the instruments to an ordinary battery, the plug is pushed into the tubing, and the lug attached to the binding post in the usual manner. The lug can be removed from the plug when a hole for the latter is available.—Frank Sahlmann, Manhattan, Kan.

### Engine Exhaust Heats Tank

A farmer, who keeps his gasoline engine running almost continuously for operating a cream separator, grinding feed, pumping water, and other tasks, has devised a simple way to heat the contents of a stock-watering tank with the exhaust. The exhaust pot, or muffler, is placed in the tank on a brick foundation, which allows water to circulate around it. The exhaust gases pass through the pot, and are released by an outlet that extends above the surface of the water. The contrivance keeps the water at a moderate temperature.—Chester C. Cook, McMinnville, Tenn.

### Gauge for Gear Setting

A firm which sends out machinery to be erected, experienced much annoyance from the fact that gears were often set up with improper clearance, thus increasing wear and tear. The difficulty was overcome by an idea obtained from a draftsman; his suggestion was to send out with each gear a small hardwood block whose thickness represented exactly the clearance to be allowed between the tip of the tooth on one gear and the root of the other gear. By the use of this block a workman without great skill in millwrighting was enabled to space the gears so as to have the clearance exactly right.

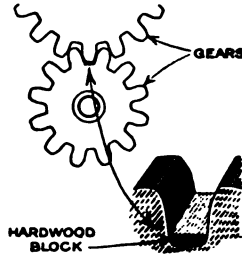

### Benzine for Wringer Rolls

The rubber rolls in clothes wringers become badly stained each time they are used. Even careful cleaning with soap and water will not prevent this. When they become almost black they leave streaks on delicate clothes. A little benzine, or gasoline, on a rag will cut the



stain off at once, leaving the rolls white and clean. By turning the rolls, they are quickly cleaned. The benzine should be allowed to evaporate before the wringer is used.—J. Horace Van Nice, Chicago, Illinois.

### Tool for Straightening Steel Bars

In a shop which uses much bright, drawn-steel bar, from which are turned small shafts, the usual method of straightening with a bar, after mounting the shaft between centers, is not found very successful. Moreover, it is bad for the lathe and lathe centers.

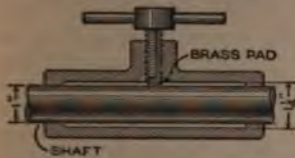

To overcome this was the purpose of devising the bar straightener shown in the drawing. It is cheap, and can be quickly made, complete, by the lathe hand. This one is for a 1-in. bar, and was turned and bored from a 2 $\frac{3}{4}$ -in. bar; the large diameter was used to provide ample thread distance for the straightening screw.

### Crane Helps in Unbolting Timbers

Some scaffold uprights, that were discarded by the big shipbuilding company for which I worked, were being unbolting to obtain lumber for other purposes.

The short lengths of timber which held the uprights in alignment had 10 or 12 bolts through them, and were difficult to remove. A crane being handy, I passed a cable around them, as shown in the sketch, and when the nuts had been removed from the bolts, signaled for "slow hoist" until the cable was pulled taut. Then I signaled "hoist," and the pieces came off with little trouble. By the same method I have removed angle clips bolted to ways decking. A chain was used to get the angle clips off, as a cable cannot be made into a small enough loop. To get a chain taut on an angle clip requires a very slow hoist. The workman should stand to one side while the hoisting is in progress.

—R. W. Goodwin, Philadelphia, Pa.



### Clips Hold Bearing Liners

Automobile mechanics who experience trouble in keeping bearing liners in place when refitting connecting-rod bearings will find the clip illustrated a convenience. Brass spring wire is used to make the device. The material is bent into shape with a pair of pliers. A set of clips can be attached to the bearings in a few seconds, and will hold the liners securely in place.—Charles H. Willey, Concord, New Hampshire.



### Dishpan Makes Concrete Manhole Form

An easy way to form the manhole for a concrete cistern top, or septic tank, is to use an old dishpan of the desired size. This is set in the regular form, and the outside shape gives the shape to the opening. The cover is then made by pouring concrete inside the pan up to the level of that outside, thus giving the proper bevel and insuring a fit.

Twisted wire, or a round piece of woven-wire fencing, can be used for reinforcing the cover or lid. A rod, or ring, should be put in and tied to the reinforcing for a handle.—M. W. Lowry, Athens, Ga.



### Saving Alcohol from Auto Radiator

Alcohol placed in an automobile radiator to prevent the cooling system from freezing is lost rapidly by evaporation when the engine runs, as many motorists have learned from experience. To save the alcohol, a 1-gal. tin can is placed under the hood, and a hose, connected with the overflow pipe, is inserted in it. Alcohol vapor escaping from the overflow pipe will be condensed in the can.—Harlan J. Lindsley, Constantine, Mich.



### Funnel with Breather Tubes

The inefficiency of a common funnel is due to the fact that while the liquid is being poured into the receptacle to be filled, the air is compressed within and a resultant back pressure occurs.

The funnel illustrated has vent pipes leading from the bottom to the top of the funnel. These pipes carry off the air in the receptacle as the liquid is being poured in, and hence permits rapid pouring. Larger funnels may be equipped with larger vent pipes.

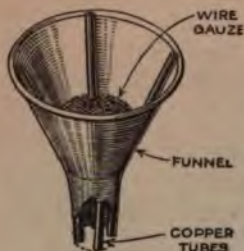

### Service Button Fastened on Coat



To prevent the loss of a military-service badge, use an ordinary pin on the back of the coat lapel. Insert the pin at right angles to the buttonhole, close to the shank of the badge.

### Recovering Tools from a Deep Well

Small tools accidentally dropped into a deep drilled well can be recovered easily with the simple device shown in the illustration. An old buggy spring is cut in half, and the two sections are inserted into one end of a 3-ft. length of iron pipe,

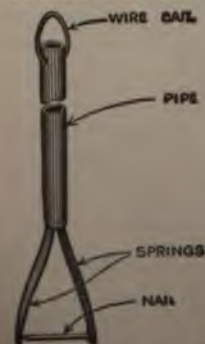

with their concave curved sides facing each other. The end of the pipe is flattened slightly to permit the pieces to be fitted, and wooden wedges are driven in to hold them firmly in place. To retrieve a hammer, auger, wrench, or other similar implement, the ends of the springs are separated, and a nail or stick is placed

between them. The contrivance is then lowered into the well by means of a rope, attached to a wire bail at the opposite

end of the pipe, and alternately raised a few inches from the bottom and dropped again. When the springs come astride the object sought, the latter dislodges the stick or nail, and the springs grasp the object itself, holding it firmly so that it can be brought to the surface.—L. M. Jordan, Wallace, Ala.

### Notches Take Place of Cigar Cutting



Try cutting two notches near the end of a cigar, instead of cutting off the tip. The smoke will be drawn around the side of the tongue, and the teeth, fitting in the notches, will hold the cigar firmly in the mouth.

### Timesaving Elevator Sign

In a building where there are two elevators, only one of which is required at certain times to carry the traffic, signs have been installed on the elevator-shaft doors, which enable the operator very quickly to notify persons on all floors which elevator is running. The sign placed on each door consists of two parts, the lower one being attached



solidly to the door, while the upper swings on hinges, as illustrated. When the upper half is swung up, the sign reads "Please take the other elevator;" when it is swung down, the sign is entirely hidden. A spring holds this upper half in either position. When one of the elevators is to be stopped, the operator has only to step out at each floor, and swing up the upper half of the sign.

¶ An ordinary cork, of sufficient size, should be attached to the boat key by means of a cord. The idea is that, should the key be accidentally dropped into the water, it would not sink to the bottom and become lost.



### Electric Toaster for Starting Auto

An old electric toaster is used by a middle-western motorist to assist in starting the engine of his automobile in cold weather. The toaster is placed under the hood, connected to a socket, and allowed to remain in operation for about 30 minutes. Enough heat is then given off to make it easy to start the machine.—Ralph C. Busbey, Columbus, Ohio.

### Chicken Coop Made from Trunk

A good two-compartment coop for sitting hens, or hens with chicks, can be quickly made out of an old trunk, the straps on the ends enabling the owner to transport it conveniently. The hinged cover permits examination of the occupants from above, and the walls are not likely to admit drafts.

The trunk is divided across the middle by a partition which reaches nearly to the top, and which, for general purposes, should be made of boards, as there will then be no trouble between sitting hens. For fowls brooding chicks, however, a poultry-wire partition, chicken-size, is adequate.

The coop entrances are rectangular holes, 6 in. wide and 8 in. high. For one of the two compartments the entrance is made in the trunk front at the bottom, midway between the partition and the end; and for the other one it is in a corresponding position at the back. The purpose of making entrances on opposite sides is partly to prevent trouble between broods, and partly to enable each brood to get in and out without crowding.

Each of these entrances is furnished with two light wooden doors, hinged at the side, one above the other. The upper door is 5½ in. high, and the lower one 2½ in., the latter being used when it is desired to confine the hen, but release the chicks.

For ventilation, an opening is cut in each end of the trunk lid, about 8 in. long and 2 in. wide, and wire mosquito netting is stretched across it. There should also be a row of air holes about ½ in. in diameter, along the trunk wall, eight or ten being allowed to each compartment.

If the trunk has a rounded top, all that is needed to make the roof rainproof is some oilcloth, roofing paper, or other waterproof material. This is tacked on tightly, and the edges are allowed to extend an inch or so beyond the front and back, so as to protect the walls. If the

top is flat, the necessary pitch can be given to the roof by cutting a 2-in. piece of wood the same length as the trunk, and nailing it along the top in the middle.



A Few Changes Turn an Old Trunk into a Two-Compartment Chicken Coop Which Lasts for Years

It is good policy to make these changes in such a way that the job will be permanent, as the coop, if stored away carefully after each brooding season, will last indefinitely.—J. T. Bartlett, Boulder, Colo.

### Jack Made from an Old Monkey Wrench

With a little labor, an old monkey wrench can be converted into a small jack, which can be used in places where it is impossible to employ an ordinary jack, because of its size. The movable jaw of the wrench is cut with a hacksaw, as indicated, to form the base of the device. Two holes are made in the knurled head, and in these are inserted small rods, which serve as levers to turn the screw. The cap is shaped on a lathe, after which a hole is bored in it to receive the end

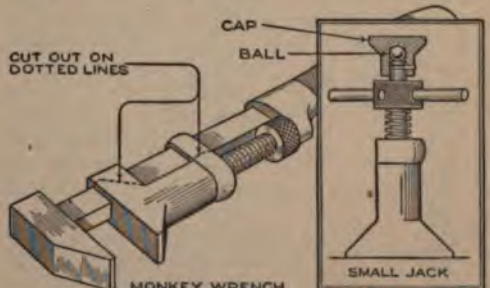

A Handy Small Jack, Which can be Used When an Ordinary Jack Is Too Large, is Made from an Old Monkey Wrench

of the screw. A small pin, inserted in the side of the cap, fits in a groove around the screw, and holds the two parts together. A steel ball serves as a bearing.—S. E. Gibbs, Ames, Ia.



### Underground Water Reservoir Aids Growth of Trees

Trees growing along the sidewalks of city streets are likely to wither unless special precautions are taken to supply the roots with moisture. A concrete pavement prevents the necessary quantity of surface drainage from reaching them, so

that the needed nourishment must be col-



Barrels, 20 to 30 Feet Apart, are Buried beneath the Concrete Sidewalk to Act as Cisterns and Provide Artificial Irrigation

lected by artificial means. Dig a pit in the sidewalk on each side of the tree, sufficiently far from the trunk to leave room for the roots. A distance of 10 or 15 ft. will be about right, as the roots extend underground for a considerable distance. Bore a number of 1-in. holes through the staves of two old paint barrels, and bury one of them in each pit, with the open end down, and the upper end just below the level of the pavement. Connect each barrel by a pipe with the gutter, and provide it with some sort of strainer to keep the dirt out while letting water run into the barrels. These will then act as a cisterns, and the water accumulated in them will percolate through the holes in the staves and nourish the roots of the tree.—T. B. Lambert, Chicago, Ill.

### Improving Flame of Small Torch



Small gasoline torches that produce red, sputtering flames will give better service if the burner and supply pipe are connected by heat-conducting strips. The torch will then burn with a very hot blue flame.

### Automobile Painting Easily and Rapidly Done

Automobile owners who contemplate refinishing their machines should give consideration to the method used in painting army motor cars and trucks. These vehicles are painted at frequent intervals, but nevertheless are kept in constant service. This is made possible by the use of a paint, which is made by mixing white lead and coloring pigment with linseed oil, and adding a relatively large quantity of drier. It requires about an hour to apply a coat of this paint to an ordinary car, which is less than the time required for waxing and polishing—a temporary remedy. The paint dries in eight or ten hours, so if the car is painted at night, it can be driven the following morning. Before the actual painting is done, the car is carefully washed with soap and water, and rough spots are smoothed with steel wool. As no varnish is used, dust does not spoil the appearance of the coat, and the work can be done in any garage.

### Drawing Water from Lake Far Below

A farmer whose home is situated on high ground adjacent to a small lake raises water from the latter for his stock and household use by means of a simple home-made device which cost little to construct. A  $\frac{1}{2}$ -in. wire cable is stretched between a standard erected on an elevation, near the lake, and a heavy anchor about 15 ft. from shore. On this is a traveling block, equipped with a hauling line. The latter is attached to a rough wooden drum located at the base of the standard. Suspended from the block is a 4-gal. tin can, so weighted that it tilts and fills when it reaches the surface of the water. When filled, the can is pulled up the slanting cable by rotating the drum with a crank provided for that purpose. Its contents are then emptied into a bucket or other container, for carrying to the house.





## Electrolytic Rectifier for Charging Storage Batteries

By THOS. W. BENSON

THE automobilist or experimenter will find the rectifier to be described cheap to construct and quite efficient. It is of the single-cell type, but by using three electrodes and a special lamp bank it utilizes both sides of the cycle. This construction is much cheaper than the use of an auto transformer, and but little less efficient.

The lamp bank and switches are mounted on a board, 1 ft. wide and 2 ft. long. Eight lamp sockets are mounted in two rows, with two double-pole switches at the bottom. These should be 10-ampere indicating snap switches, wired as shown in the diagram. The terminals for connecting to the storage cell to be charged are located at the lower edge of the board. The board is mounted on the wall convenient to a source of alternating current, a shelf to hold the rectifier cell being placed above it.

For the cell container, any large glass, or porcelain, jar will serve. The jar from a 300-amp.-hr. Edison-Lalande primary battery is ideal, the cover forming an excellent support for the electrodes. If one of these cells is not available, any jar 7 in. in diameter and 12 in. high may be used. Make a cover of wood, and impregnate it with paraffin. Three holes are drilled in the cover, to support the plates.

The plates measure 3 in. wide, 11 in. long, and  $\frac{1}{8}$  in. thick, two being of aluminum, the other of iron. Holes are drilled in the ends of the plates before bending, and then they can be mounted in the wood cover by bolts that form terminals. Connections are to be made to these terminals by flexible leads.

The solution put in the jar is made up in the following manner: To every 2 qt. of water add two tablespoonfuls of carbonate of soda and three tablespoonfuls of alum. Stir well and dissolve thoroughly before inserting the plates.

The apparatus is then ready for use. Screw eight 32-cp. carbon lamps into the sockets, and turn the left-hand snap switch. The lamps should light up to half brilliancy. The storage battery to be charged is connected to charging terminals by flexible leads, taking care that the positive post on the board is connected to the positive terminal of the battery. Turning the right-hand switch will start the battery charging.

This outfit is quite practical and serviceable. The maximum direct current ob-

tainable is four amperes; this can be exceeded for short runs by using more lamps, but the jar will heat badly and will boil if the overload is continued too long. The outfit as described should give four

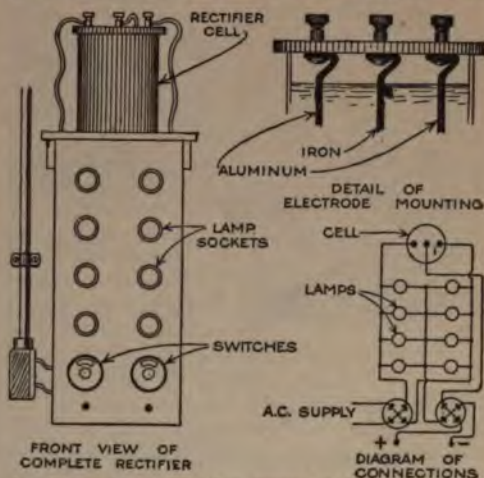

An Electrolytic Rectifier Provides an Inexpensive Means of Charging Batteries

amperes continuously without overheating. A number of storage batteries may be charged in series, and for high efficiency this is the preferable method of operating the device.

### Grindstone Frame Made from Part of an Old Bicycle

By using part of a discarded bicycle, a Georgia farmer fashioned the convenient foot-power grindstone shown in the accompanying illustration. The rear section of the frame was mounted on a wooden standard, and the circular stone substituted for the rear wheel of the machine. The value of the idea will be quickly seen by anyone who has attempted to use an ordinary hand-power grindstone without the help of an assistant. The arrangement supplies a ball-bearing device which is very easily operated.—Searle Hendee, Winnipeg, Can.



attempted to use an ordinary hand-power grindstone without the help of an assistant. The arrangement supplies a ball-bearing device which is very easily operated.—Searle Hendee, Winnipeg, Can.



### Oil-Well Casing as Air Tank

At a western oil company's shops, an oil-well casing, closed by welding at both top and bottom,



serves as a compressed-air tank. The air is maintained at very great pressure in this shop, and the casing makes a safe receptacle for storing the air. Besides, being placed in a corner of the shop, it does not take up valuable room. It is supported on a wooden base about 1 ft. above the floor. The

idea may be interesting to many small shops in the oil districts.—C. W. Geiger, San Francisco, Calif.

### Stand Attached to Tobacco Pipe

A device that will prevent a tobacco pipe from tipping over is made by bending a piece of wire to fit on the stem and extend under the bowl.



### Repairing Auto Tire on Rim

Cuts and holes in tires can be repaired very satisfactorily with cement and tire



putty. It is quite a job, however, to get the cut cleaned out so the cement will stick, especially when the tire is on the rim; but it can be done very easily if the tire is deflated and an ordinary wood screw clamp is placed on the tire, as shown. By tightening the screw, the cut will be spread out, and can then be easily cleaned with a stick and a rag soaked with gasoline. Apply cement and putty before removing the clamp. This makes an extra good repair.

—Chas. Albert, Chicago, Ill.

### Testing Tool Steel at the Forge

Good steel may be easily distinguished from poor-grade stock by the following simple means. Heat the steel to a good cherry red, then hammer the surface well at the forge with a flat-faced hammer, as though the piece were being drawn out. It is again returned to the fire and heated to a cherry red, then plunged into water to quench it. The piece is struck with a hammer to make the scales come off. The surface left after this treatment is the index to the quality of the steel.

If the entire piece scales off clean, leaving a white surface, the steel is of the best grade and about 100 points carbon; that is, one per cent.

If the scales come off in patches, leaving a speckled surface, and the scales partly attached to the metal are very thin, the steel is of a good grade and about 75 to 80 points carbon.

If the scales come off in patches and the remaining scales are thick and heavy, the steel is a medium-grade of 40 to 50 points carbon.

If the piece does not scale off at all, it is very poor grade and low in carbon.

If the fire in which the work is heated is smoky, the degree of whiteness under the scales will be less pronounced, but the scaling process will be no different.

By these simple tests, the mistake of making a good tool from a piece of poor steel is avoided, as a piece of low grade sometimes gets in the rack with the good-grade steel. It is only necessary to test a small end. This may be done by cutting off a piece, or by leaving it on the bar, which will save the waste of any material.

### To Renovate Typewriter Ribbons

Typewriter ribbons that have become dry, causing the letter impressions to be faint, can be restored to good condition by putting a few drops of any light machine oil on their edges as they are wound. After the oil has permeated all parts of the fabric, which requires only a little time, the writing will be improved.

### Paraffin Repairs Leak in Float

To repair small leaks in a hollow-metal float, the device should be placed in melted paraffin, and rotated until the surface is completely covered with the wax. This treatment fills the holes, and serves also to protect the float from corrosion.



## Electrolytic Rectifier for Charging Storage Batteries

By THOS. W. BENSON

THE automobilist or experimenter will find the rectifier to be described cheap to construct and quite efficient. It is of the single-cell type, but by using three electrodes and a special lamp bank it utilizes both sides of the cycle. This construction is much cheaper than the use of an auto transformer, and but little less efficient.

The lamp bank and switches are mounted on a board, 1 ft. wide and 2 ft. long. Eight lamp sockets are mounted in two rows, with two double-pole switches at the bottom. These should be 10-ampere indicating snap switches, wired as shown in the diagram. The terminals for connecting to the storage cell to be charged are located at the lower edge of the board. The board is mounted on the wall convenient to a source of alternating current, a shelf to hold the rectifier cell being placed above it.

For the cell container, any large glass, or porcelain, jar will serve. The jar from a 300-amp.-hr. Edison-Lalande primary battery is ideal, the cover forming an excellent support for the electrodes. If one of these cells is not available, any jar 7 in. in diameter and 12 in. high may be used. Make a cover of wood, and impregnate it with paraffin. Three holes are drilled in the cover, to support the plates.

The plates measure 3 in. wide, 11 in. long, and  $\frac{1}{8}$  in. thick, two being of aluminum, the other of iron. Holes are drilled in the ends of the plates before bending, and then they can be mounted in the wood cover by bolts that form terminals. Connections are to be made to these terminals by flexible leads.

The solution put in the jar is made up in the following manner: To every 2 qt. of water add two tablespoonfuls of carbonate of soda and three tablespoonfuls of alum. Stir well and dissolve thoroughly before inserting the plates.

The apparatus is then ready for use. Screw eight 32-cp. carbon lamps into the sockets, and turn the left-hand snap switch. The lamps should light up to half brilliancy. The storage battery to be charged is connected to charging terminals by flexible leads, taking care that the positive post on the board is connected to the positive terminal of the battery. Turning the right-hand switch will start the battery charging.

This outfit is quite practical and serviceable. The maximum direct current ob-

tainable is four amperes; this can be exceeded for short runs by using more lamps, but the jar will heat badly and will boil if the overload is continued too long. The outfit as described should give four

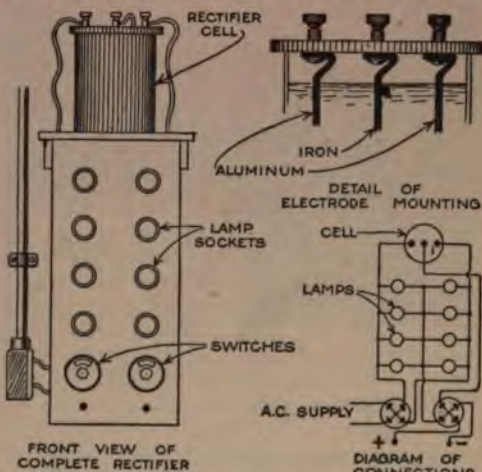

An Electrolytic Rectifier Provides an Inexpensive Means of Charging Batteries

amperes continuously without overheating. A number of storage batteries may be charged in series, and for high efficiency this is the preferable method of operating the device.

## Grindstone Frame Made from Part of an Old Bicycle

By using part of a discarded bicycle, a Georgia farmer fashioned the conven-

ient foot-power grindstone shown in the accompanying illustration. The rear section of the frame was mounted on a wooden standard, and the circular stone substituted for the rear wheel of the machine. The value of the idea will be quickly seen by anyone who has attempted to use an ordinary hand-power grindstone without the help of an assistant. The arrangement supplies a ball-bearing device which is very easily operated.—Searle Hendee, Winnipeg, Can.



### Oil-Well Casing as Air Tank

At a western oil company's shops, an oil-well casing, closed by welding at both top and bottom, serves as a compressed-air tank. The air is maintained at very great pressure in this shop, and the casing makes a safe receptacle for storing the air. Besides, being placed in the corner of the shop, it does not take up valuable room. It is supported on a wooden base about 1 ft. above the floor. The idea may be interesting to many small shops in the oil districts.—C. W. Geiger, San Francisco, Calif.



### Stand Attached to Tobacco Pipe

A device that will prevent a tobacco pipe from tipping over is made by bending a piece of wire to fit on the stem and extend under the bowl.

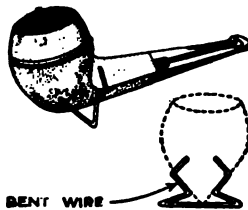

### Repairing Auto Tire on Rim

Cuts and holes in tires can be repaired very satisfactorily with cement and tire putty. It is quite a job, however, to get the cut cleaned out so the cement will stick, especially when the tire is on the rim; but it can be done very easily if the tire is deflated and an ordinary wood screw clamp is placed on the tire, as shown. By tightening the screw, the cut will be spread out, and can then be easily cleaned with a stick and a rag soaked with gasoline. Apply cement and putty before removing the clamp. This makes an extra good repair.—Chas. Albert, Chicago, Ill.

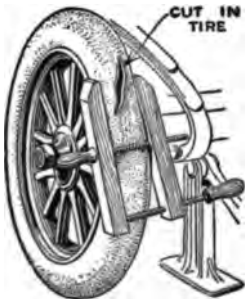

### Testing Tool Steel at the Forge

Good steel may be easily distinguished from poor-grade stock by the following simple means. Heat the steel to a good cherry red, then hammer the surface well at the forge with a flat-faced hammer, as though the piece were being drawn out. It is again returned to the fire and heated to a cherry red, then plunged into water to quench it. The piece is struck with a hammer to make the scales come off. The surface left after this treatment is the index to the quality of the steel.

If the entire piece scales off clean, leaving a white surface, the steel is of the best grade and about 100 points carbon; that is, one per cent.

If the scales come off in patches, leaving a speckled surface, and the scales partly attached to the metal are very thin, the steel is of a good grade and about 75 to 80 points carbon.

If the scales come off in patches and the remaining scales are thick and heavy, the steel is a medium-grade of 40 to 50 points carbon.

If the piece does not scale off at all, it is very poor grade and low in carbon.

If the fire in which the work is heated is smoky, the degree of whiteness under the scales will be less pronounced, but the scaling process will be no different.

By these simple tests, the mistake of making a good tool from a piece of poor steel is avoided, as a piece of low grade sometimes gets in the rack with the good-grade steel. It is only necessary to test a small end. This may be done by cutting off a piece, or by leaving it on the bar, which will save the waste of any material.

### To Renovate Typewriter Ribbons

Typewriter ribbons that have become dry, causing the letter impressions to be faint, can be restored to good condition by putting a few drops of any light machine oil on their edges as they are wound. After the oil has permeated all parts of the fabric, which requires only a little time, the writing will be improved.

### Paraffin Repairs Leak in Float

To repair small leaks in a hollow-metal float, the device should be placed in melted paraffin, and rotated until the surface is completely covered with the wax. This treatment fills the holes, and serves also to protect the float from corrosion.



### Signs Made of Gummed Paper

Price signs for retail stores can be made by combining ordinary wrapping paper and gummed paper tape such as used instead of string to tie parcels. Suitable lengths of the tape are stuck on a piece of wrapping paper to form letters. If differently colored strips of tape are used, the attractiveness of the signs is increased.

### Protection for Film While Scraping

Motion-picture machine operators who splice many films will find constant use for a device which protects the film while it is being scraped to remove the emulsion. Although the emulsion must be removed before the two surfaces can be cemented together, great care must be taken to avoid scratching the next picture. A 2 by 4-in. piece of sheet brass, riveted at one end to a 3 by 4-in. piece, provides the necessary protection. The film to be scraped is slipped between the two pieces with the edge of the picture nearest the break held just under the edge of the smaller brass piece. The projecting portion of the film is easily scraped with a knife, while the whole film is kept from slipping by pressing down on the upper piece of brass.

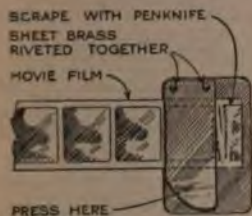

### Adjustable Countersink on Drill

The tool illustrated drills a countersink in one operation. It is adjustable so that any depth of hole can be drilled. The attachment fitted to an ordinary twist drill consists of a collar containing a set-screw and a plate made of hardened and ground tool steel. The plate, or cutting tool, fits into a flute of the drill, and is attached to the collar with a screw.

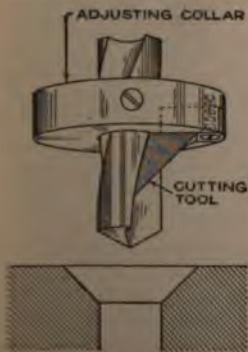

Separate tools are required for each size drill.—W. R. Calver, Brooklyn, N. Y.

### Numbered Parking Spaces for Autos

The method of numbering motor-parking spaces illustrated by the accompanying photograph has been found highly advantageous at a western naval base.



By Numbering the Parking Spaces about a Naval Reservation, the Various Motor Vehicles are Easily Found

The idea might well be employed about large industrial plants, or other places where numerous motor vehicles are in use.

Thus, the officer who instructs an enlisted man to report to headquarters with a certain machine has only to say that it is in parking space No. 15, for instance, and the man knows exactly which machine is meant. With the usual system it is necessary to designate machines by make, description, and even license numbers, which causes considerable waste of time.

### Funnel Spout for Oilcan



The spout-equipped oilcan illustrated is made by soldering together a 1-gal. tin sirup can and an ordinary funnel. An elliptical hole in the lid receives the funnel, which is cut diagonally across the flare, and fitted to the can.

### Spraying Removes Old Wall Paper

Old wall paper should always be removed in order to insure a smooth surface for the new paper. To do this easily, fill any common hand sprayer with clean water, preferably quite warm, and spray the walls and ceiling thoroughly. In a few minutes the paper will soften and can be quickly removed with the aid of a large knife, or spatula.—Milton P. Matthews, Chagrin Falls, Ohio.



often be held merely by driving nails into a heavy board in such position as to hold the steamed piece to the proper shape when it is placed between them. In the case of heavier boards, it is necessary to resort to specially built forms, such as the one illustrated in Fig. 3. Whatever type of form is used, the wood should be allowed to remain on it for two or three days, if the best results are to be obtained.

### Wheelbarrow from Hot-Water Tank

An efficient means for the transportation of refuse, ashes, and other bulk materials from one place to another can

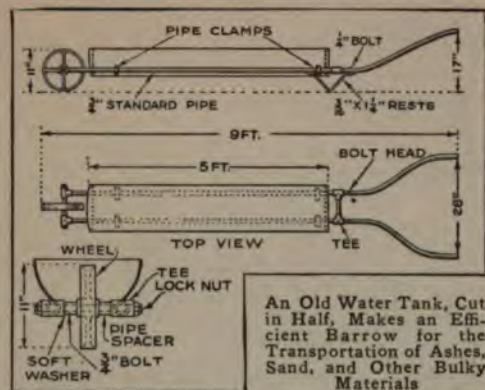

easily be made from an old water tank. The tank is cut in half with a cold chisel, or with an oxyacetylene torch. The wheel turns on a long bolt, which passes through the tees at the outer end of the barrow, as shown in the detail drawing. The pipe frame is attached to the boiler with ordinary pipe clamps. The rests are made from ordinary flat-bar stock, and bolted to the handles and frame as indicated in the side view.—P. P. Avery, Garfield, N. J.

### Making Oval or Flat Coil Springs

The making of an oval or flat spring is a job which may prove troublesome, from the fact that such a spring, wound on a flat mandrel without proper precaution, will be difficult to remove from the mandrel. This can be obviated by first winding the mandrel with paper, then winding the spring over the paper, and afterward heating the mandrel and spring sufficiently to char the paper. To avoid overheating, melt onto the spring and paper some tallow or beeswax, and heat the mandrel till the tallow is just burned off. *Before and after heating, hammer gently*

It will be found that the steaming has a tendency to open up the pores of the wood, causing it to gain or lose moisture rapidly, according to the humidity of the surrounding atmosphere. These rapid changes will cause cracking or distortion, if not guarded against. It is therefore advisable to protect the wood, by varnishing or painting, immediately after its removal from the bending forms.

the flat side of the spring, on the mandrel. After hammering the second time, it is well to apply heat again, with some more tallow to prevent overheating. If the heat applied is not excessive, it will be found that the quality of the spring is improved by it, as certain internal strains in the metal are removed.

The main benefit, however, is the ease with which the spring is removed from the mandrel after the paper has been completely burned away.—James H. Beebe, Rochester, N. Y.

### A Round File That will Not Stick

In using a round file to enlarge a hole drilled in metal, there is always an annoying tendency of the file to stick. Besides being troublesome to pull out, the file may under such circumstances distort the hole. Where much of this work has to be done, it is a good thing to provide files with various portions smoothed down, like the one in the cut. Such a file is adapted for enlarging a hole to a diameter slightly greater than that at the point marked "diameter" on the drawing. The smooth portion provides a clearance space, to prevent the file from getting caught.



### Lawn Laid like Carpet

A lawn can be grown and trimmed to any desired shape or design, somewhat after the fashion in which one lays a carpet. Grass seed is sown on thick canvas or burlap bagging, although any other cheap material will answer. This is kept moistened, and is speedily covered with a mass of verdure. The location for the lawn is carefully prepared, giving special attention to getting the surface level and





## Wood Bending and Forming

By F. D. BURKE

**I**N many lines of woodwork, such as the building of boats or canoes, it is necessary to use wood which is bent to shape. This is done by steaming the wood, or soaking it in boiling water, to render it more pliable. Steaming is the better process, and methods of applying it to long pieces of wood will be described in this article.

The bending of a piece of wood consists actually in stretching one side of it and compressing the opposite side. This is illustrated in Fig. 1. When a straight piece is bent to form a circular ring, the inner diameter of this ring will be less

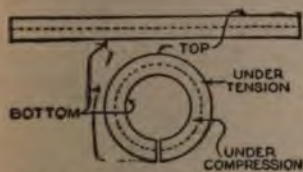

FIG. 1: PRINCIPLE OF BENDING

than the outer diameter, the inner surface having been compressed and the outer stretched. If the wood is green, it usually bends without difficulty, and if it is held to shape while being dried out, the shape will be permanent. When, however, the wood is well dried out, and it is to be bent, it must be restored to a condition similar to that of green wood. It is this effect which is accomplished by steam or boiling water.

The necessary materials for building a box for steaming long pieces can often be found around the home or shop. Such a box is shown in Fig. 2. Four boards of suitable length and width are nailed together to form a long box, and one end is permanently closed. An old varnish can is fitted to the lower side of the box, as illustrated. The box is set on horses, and a hole is drilled in the bottom, just large enough to fit the neck of the varnish can tightly. The can may be held firmly to the box by wire supports. Water is placed in the varnish can, and a gas burner, an oilstove, or a blowtorch, furnishes the heat which converts it into steam. The wood to be steamed is placed

in the box, and the open end is closed by stuffing a piece of burlap into it. The joint must not, of course, be steam-tight,

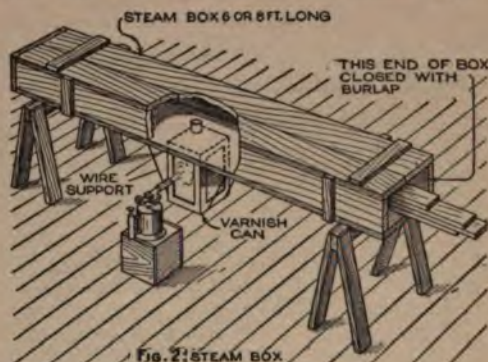

FIG. 2: STEAM BOX

The wood is placed in a steam box, which is supplied with steam from a tin can below it, heated by an oil burner or blowtorch

but it must be tight enough so that steam or air will escape from it very slowly. The time required for thoroughly steaming a piece of wood depends not only on its size, but on its kind and condition.

When the wood is thoroughly steamed, the next problem is to hold it to shape until it is dry. Small light pieces can



FIG. 3: BENDING FORM

When heavy pieces are being bent, it is advisable to construct a form, which may hold several pieces to shape at the same time

often be held merely by driving nails into a heavy board in such position as to hold the steamed piece to the proper shape when it is placed between them. In the case of heavier boards, it is necessary to resort to specially built forms, such as the one illustrated in Fig. 3. Whatever type of form is used, the wood should be allowed to remain on it for two or three days, if the best results are to be obtained.

**Wheelbarrow from Hot-Water Tank**

An efficient means for the transportation of refuse, ashes, and other bulk materials from one place to another can

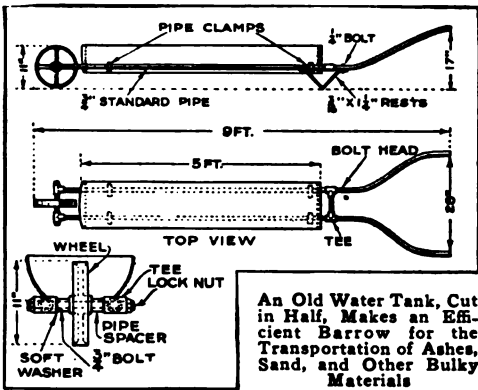

easily be made from an old water tank. The tank is cut in half with a cold chisel, or with an oxyacetylene torch. The wheel turns on a long bolt, which passes through the tees at the outer end of the barrow, as shown in the detail drawing. The pipe frame is attached to the boiler with ordinary pipe clamps. The rests are made from ordinary flat-bar stock, and bolted to the handles and frame as indicated in the side view.—P. P. Avery, Garfield, N. J.

**Making Oval or Flat Coil Springs**

The making of an oval or flat spring is a job which may prove troublesome, from the fact that such a spring, wound on a flat mandrel without proper precaution, will be difficult to remove from the mandrel. This can be obviated by first winding the mandrel with paper, then winding the spring over the paper, and afterward heating the mandrel and spring sufficiently to char the paper. To avoid overheating, melt onto the spring and paper some tallow or beeswax, and heat the mandrel till the tallow is just burned off. Before and after heating, hammer gently

It will be found that the steaming has a tendency to open up the pores of the wood, causing it to gain or lose moisture rapidly, according to the humidity of the surrounding atmosphere. These rapid changes will cause cracking or distortion, if not guarded against. It is therefore advisable to protect the wood, by varnishing or painting, immediately after its removal from the bending forms.

the flat side of the spring, on the mandrel. After hammering the second time, it is well to apply heat again, with some more tallow to prevent overheating. If the heat applied is not excessive, it will be found that the quality of the spring is improved by it, as certain internal strains in the metal are removed.

The main benefit, however, is the ease with which the spring is removed from the mandrel after the paper has been completely burned away.—James H. Beebe, Rochester, N. Y.

**A Round File That will Not Stick**

In using a round file to enlarge a hole drilled in metal, there is always an annoying tendency of the file to stick. Besides being troublesome to pull out, the file may under such circumstances distort the hole. Where much of this work has to be done, it is a good thing to provide files with various portions smoothed down, like the one in the cut. Such a file is adapted for enlarging a hole to a diameter slightly greater than that at the point marked "diameter" on the drawing. The smooth portion provides a clearance space, to prevent the file from getting caught.

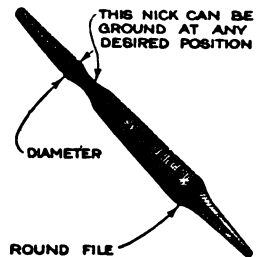

**Lawn Laid like Carpet**

A lawn can be grown and trimmed to any desired shape or design, somewhat after the fashion in which one lays a carpet. Grass seed is sown on thick canvas or burlap bagging, although any other cheap material will answer. This is kept moistened, and is speedily covered with a mass of verdure. The location for the lawn is carefully prepared, giving special attention to getting the surface level and



well fertilized. Then the grass mats are laid down in sections, with their edges touching, and lightly rolled to insure contact with the earth. The mats are kept well moistened for several days, until the roots penetrate through the fabric into the soil, which they readily do. Eventually the fabric disintegrates and the lawn becomes a permanent feature.—S. Leonard Bastin, Bournemouth, Eng.

### Lock for Pulley Pin

When a pulley of the type shown is provided with a pin for keying it to the shaft, and holes through the rim for driving out the pin are necessary, it is possible, by the method illustrated, to provide against danger of the pin working out. A long pin is used, and a piece of clock spring is formed to fit inside the rim. Two small lugs are soldered to

the clock-spring, so as to fit into the holes in the rim. The pin cannot then work out, no matter how loose it is, until the spring is removed.



### Bit for Boring Large Holes

An accessory merchant, making a specialty of installing various new devices, made the brace bit illustrated for boring out different-size circular holes in the dash or cowl of automobiles to take clocks, speedometers, oil gauges, primers, and the like.

The tool consisted of a square rod, with the end fashioned to fit into the brace. The point end was ground round. A piece of flat saw steel was fashioned as



A Tool Made from a Few Scraps of Steel is Useful for Fitting Instruments to the Dashboard

shown, with a pivot hole, an elongated slot, and a cutting edge. Holes of any diameter within the range of the tool are cut in either wood or light sheet metal.—G. A. Luers, Washington, D. C.

### Filter Clarifies Ditch Water

In irrigated sections, many farmers use water from the ditches for household purposes. This water, however, is usually

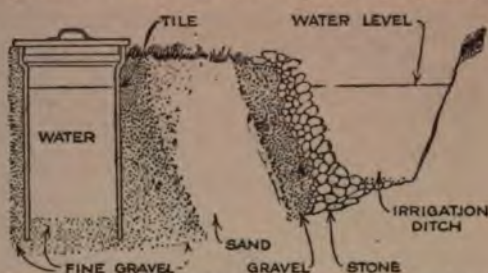

Muddy Water, from the Irrigation Ditch, Percolates through Sand and Gravel Filter Layers into the Well, from Which It is Drawn, Clear and Cool

more or less muddy, but with a simple filter, such as the one described, it may be satisfactorily clarified. At right angles to the irrigation ditch, and connected with it, another ditch, from 4 to 10 ft. in length is dug. It is made a little deeper than the ditch carrying the water, and at the end, a large-sized joint of vitrified tile is set. Coarse gravel is tamped around the tile, and a layer placed in the bottom; a layer of finer gravel is put on this. A section of the short lateral ditch is packed with coarse sand. This is faced with a layer of gravel, and lastly, with large stones at the water's edge.

In operation, the water percolates through the sand and gravel, rising in the tile, from which it may be dipped or pumped. Most of the impurities will be removed by the process and the water will be clear and cool. A concrete curb, or even a barrel, may be substituted for the joint of tile.

### Fiber for Hammer Handles

A very substantial hammer handle can be made from common black or red fiber, which is often found in the scrap heap around electrical plants. Fiber handles never split and seldom warp, if a well-seasoned piece is used. It is also found that the elasticity of the material is such as to minimize the sting which is felt when a blow is struck not exactly square. For riveting hammers the fiber handle is ideal; it is not well adapted for heavy hammers. For the ordinary small riveting hammer, a piece of fiber 1 by 1½ by 11 in. forms good raw material. It is roughed out on an emery wheel and finished with a file.—Harry B. Stillman, Plainville, Conn.



### A Modern Back-Yard Swimming Pool

Including the fence and a small bathhouse, the 36 by 13-ft. reinforced-concrete swimming pool, shown in the photo-



Including the Fence and a Small Bathhouse This Modern Reinforced-Concrete Swimming Pool was Built for Less than \$500

graph, was built at a cost of less than \$500. The tank is from 3 to 6 ft. deep and holds 12,000 gal. of water, 24 hours

being required for filling with an ordinary garden hose. A "scum trough" around the edges of the pool slopes toward one end, where any overflow is carried off by the sewer. This trough also serves as a handhold for the bathers, and as one can never be more than 6½ ft. from the edge, the possibility of accidents is greatly reduced. Fresh water is run into the tank each day to make up for what is lost. The tank is completely drained every three weeks, by opening the 4-in. drain provided at the lowest point; the bottom is then scrubbed, the inside walls given a thin coating of whitewash, and the tank is refilled.

On alternate days about ½ lb. of chloride of lime is mixed into the tank for the purpose of sterilizing the water.

### Hiding the Fireplace in Summer

During the summer months, when there is no need for a fire, an empty fireplace is apt to be an eyesore. To do away



with this unsightliness, one architect equipped the opening with doors.

These were made of heavy wood, covered, on the side exposed to the fire in winter, with sheet asbestos, which was fastened on by means of brass-head tacks. Both sides of the doors were given a coat of fire-resistant paint, or lacquer. In summer the doors are closed, shutting in the fireplace completely, so that it resembles a cupboard set in the wall.—R. T. Townsend, New York, N. Y.

### Maul Made from Auto Piston

The piston from an old automobile engine may be easily converted into a maul for driving stakes and similar purposes. The wristpin is removed, and a handle inserted in the pin holes. The piston is filled with a concrete mixture composed of 3 parts cement and 1 part sand, which

should be allowed to set for several days. If available, melted lead may be used for filling the piston, and the delay of waiting for the cement to set will be avoided. —Chas. H. Peterson, Fulton, Wyo.

### Container for Brazing Flux

In brazing joints, work which is rough and full of blowholes is often caused by the presence of moisture in the brazing flux. The flux, which consists mainly of borax, absorbs moisture very readily when exposed to the air; it is possible to keep it dry by using the container shown in the cut.



The cover has a wire basket attached to fit inside the vessel. The basket is filled with unslaked lime, calcium chloride, or other material which absorbs water more readily than the borax. With this cover on, any water which is present in the air of the container or the borax will be absorbed by the more absorbent substance, thus keeping the borax itself dry. If it is found that any great amount of moisture is absorbed by the drying



agent, a pan may be placed on the bottom of the basket to keep water from falling into the borax.

### Boring and Calipering Segments

It frequently happens that a mechanic is confronted with the problem of boring, in the lathe, a segment of a circle which is less than  $180^\circ$ . As a means of calipering the work for close limits, it is possible to clamp a piece of scrap on the opposite side of the faceplate, but this method is unsatisfactory, because it is often necessary to place a counterbalance in that position. Another way is to place an arbor between the centers, and caliper from its largest diameter to the arc being bored. This distance, plus half the diameter of the arbor, will be the radius of the arc.—Geo. Lewis, Boston, Mass.

### Old Watch as Speed Counter

Desiring to count the revolutions of a shaft, and not having a speed indicator handy, I struck upon the following idea, which answered very nicely. Having on



hand an old dollar watch, which was minus the minute hand, I fitted a piece, as shown in the sketch, over the winding knob of the watch. This piece is drilled slightly smaller than the knob, and is slotted with a hacksaw, so as to make a tight fit over the knob. The other end is filed so as to present three sharp edges, which take hold in the center hole of the shaft. With the piece pushed over the winding knob, the point is placed in the shaft center. By pushing the watch against the shaft, the gears which revolve the hands are brought into mesh, and the number of revolutions of the hour hand are counted. The second hand on some watches can be used to show how much time elapsed. On the watch used by the writer, it required six revolutions of the winding knob to make a complete revolution of the hour hand. The number of revolutions per minute of the hour hand, multiplied by six, thus gave the number of revolutions of the shaft. Although not adaptable to very high speeds, this method answers very well on speeds up to 1,000 revolutions per minute.—R. H. Kasper, Philadelphia, Pa.

### How to Make Brass Tubing Smaller

Several brass bushings were required, to be afterward reamed out to 1 in. diam-

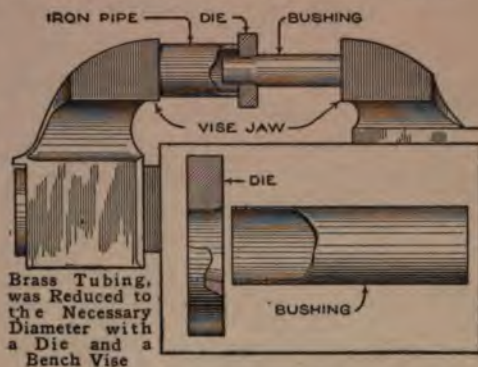

eter. Brass tubing with  $\frac{1}{32}$ -in. wall was to be used, but the only stock obtainable had an inside diameter of 1.007 in. So a large cast-iron washer, about  $\frac{5}{8}$  in. thick, was bored out, and one side flared enough to admit the bushings. Then the brass tubing, cut to length, was squeezed through the cast-iron die in a large vise, using a piece of pipe as a distance piece, and was reduced in inside diameter to 0.997 in., allowing .003 in. to be removed with a 1-in. hand reamer. The bushings were lubricated while being pressed through the die.—H. H. Parker, Oakland, California.

### Shovel Harvests Cabbage

A cabbage harvester that will do away with a great deal of stooping and bending is made



from an ordinary steel shovel, as shown in the drawing. A triangular piece is cut from the center of the shovel, and the edges are sharpened. The cutting edges are pushed against the stalk, and a slight pressure severs the head. The cabbages may be cut and tossed directly into the wagon. Equipped with such a tool, one man is able to increase greatly the amount of work and to perform it with less fatigue than by the ordinary method.—Violet Johnson, Rockford, Ill.

### Removing Carbon with Wire Brush

The ordinary carbon scraper is a more or less unsatisfactory tool, especially where the only access to the piston and

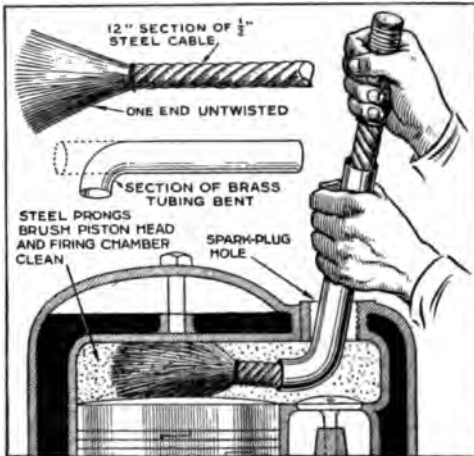

A Carbon Remover Which Has a Very Direct and Positive Action is Made from Stranded Steel Cable

cylinders is through the spark-plug hole. A special tool for the purpose consists of some stranded-wire cable and a piece of brass tubing. One end of the tube is bent slightly, as indicated in the sketch, the wire cable is placed through the pipe, and the end frayed or untwisted. The opposite end of the cable is taped and wound with twine, to afford a convenient handle.

The tool is used as illustrated; gripping the pipe with the left hand, the right hand is used to move the cable back and forth in pump fashion. The projecting prongs scour the piston head and cylinder walls.

After the carbon is pulverized, the motor is run for a few minutes with the spark plug left out, when the suction and compression of the piston blows most of the loose carbon out of the exhaust port and the plug opening. A piece of steel-wire cable should be used in making this tool; soft-iron wire is not stiff enough to be effective.

### Electric Tire-Theft Protector

The automobile driver who has just experienced the loss of a spare tire by theft may be interested in the possibility of an alarm to sound a warning whenever the spare tire is detached by an unauthorized person. Such an alarm can easily be rigged up by building a small contact spring onto the tire holder, in such a way that when the tire is in position, the

spring is held out of contact, but when the tire is removed, the contact is closed. The device should be connected in parallel with the horn button, so that when both the switch and contact are closed, current will be supplied to the horn, which will thus blow continuously. The switch should, of course, be placed in some concealed position, and the contacts should be installed in such a way that they will not be conspicuous.—C. S. Cierpiak, Chicago, Ill.

### Rotating-Disk Reamer

A drill or reamer, which was found useful for rough-boring cored holes, was made from a piece of shafting, slotted

across its end. Two hardened steel disks were inserted so as to revolve freely on a pin which passes through their centers. These disks are ground to a bevel all around, and are inserted so that the sharp edges are away from each other. The drill is used in the same manner as a twist drill, though it cannot be used to start

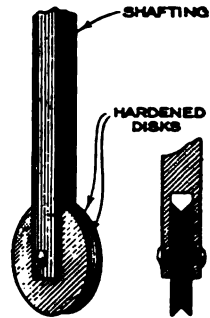

a hole, but only for enlarging. It is found to stand up better than a twist drill on scaly cast iron, as the cutting is done by longer edges. A hole produced by such a drill will be almost as smooth as that left by a reamer, though it will not, of course, be as straight.

### Eccentric Wrench for Stud Removal

The wrench illustrated will remove studs of various diameters in the minimum of time. It is simple to construct,

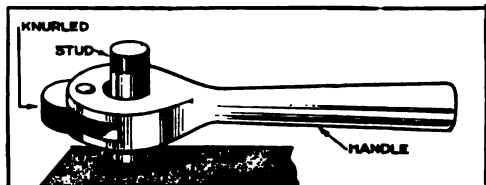

A Reversible Wrench, Which Grips by Means of an Eccentric, Is Effective in Handling Studs

consisting mainly of a steel circular-ended handle. This is drilled to accommodate the largest size of stud which it is desired to remove. A hole is also drilled for the insertion of a pivot pin, for an eccentric clamp.



The clamp roller is of steel, knurled and hardened, and is fitted to revolve freely in a sawed slot. The eccentric clamp permits either the insertion or removal of the studs, as is desired. In work on gas and steam-engine cylinder heads, a wrench of this type saves considerable time; also for turning pipe and rods, this tool can be used to advantage.

### Vacuum Lamp for Acetylene Work

It is well known that when working with explosive gases, as is necessary in acetylene welding, an open light must never be used. Not only is it advisable to use an electric lamp, but it should be well protected. It has been found, moreover, that it is a distinct advantage to use a vacuum bulb rather than one of the modern gas-filled type, because in case of the breakage of the bulb, the filament of the vacuum lamp will be consumed instantly. In the gas-filled lamp on the other hand, the filament may retain its incandescence long enough, after the breakage of the glass, to ignite an explosive gas.

### Windmill Sign Made from Bicycle

This windmill sign was constructed for a bicycle shop, but it could be used to



attract attention in many lines of trade, as it is the moving object that always catches the eye. The material can be obtained for a few dollars, as a "wheel" that has outlived its usefulness will sell for very little, and the other parts of

the sign are two short pieces of lumber, 2 by 4 in. and 4 by 4 in. Blades, which cause the wheels to revolve, are cut out of tin and fastened firmly to the spokes and the rims at a slight angle, to catch the wind. The windmill is made to face the wind by a blade, shaped like the feather end of an arrow, which may be cut from thin wood or sheet metal. The upright timber must be solidly set on the roof, and well braced; the crosspiece that carries the bicycle is pivoted to this by a large bolt so that the device will turn easily in a light breeze. Such a sign can be made in spare hours, and will show up effectively against the sky.

### Agitator for Mixing Liquids

A bacteriologist in a western agricultural college, confronted by the necessity of having a solution in 600 flasks agitated for two hours, constructed the machine illustrated to do the work, thus saving a vast amount of labor for his laboratory staff. Ordinary horizontal shaking would not do, because it allowed the heavier constituents of the solution to go to the bottom of the flask and



A Machine Built by a Bacteriologist Agitates a Solution with a Motion Approximating That of the Hand in Shaking It

remain there, the lighter elements simply washing back and forth over them; the downward thrust such as is given to a bottle shaken by hand, as well as the horizontal motion, had to be imitated. This was accomplished by setting two of the hinged legs nearer the center, as shown in the cut. Varying thrusts of the connecting rod were obtained by boring holes in the driving wheels at different distances from the center. Cone pulleys gave variable speeds. A small electric motor furnished the power.

Wrapped in a towel, a flask was placed in the rocking box as shown in the cut, the switch was turned, and the machine did the rest, agitating the contents of the flask just as effectively as by hand.

CA restaurant owner, annoyed by the supply of drinking water in his cooler giving out during a rush, placed in his cooler a float valve, which automatically refilled the tank whenever the water got below a certain predetermined level.



# A Stereotyping Outfit for the Small Newspaper Shop

By H. W. SMITH

THE allurements of molten linotype metal has caused many printers in country-newspaper shops to experiment with stereotyping. Few who have been in the game eight or ten years have not tried it. Some results have been good, considering the crudity of means available.

The first essential is a casting box. In case of necessity, it may be made from two old mounted electrotypes, three strips of wood, and two to four clamps. This is not an outfit that will stand continued service, because of the warping of the wood, necessitating frequent replacing of parts. If metal parts are substituted, the difficulty is overcome.

With this in view, two flat cast-iron plates, as illustrated in Fig. 1, may be picked from the scrap pile of the local junk dealer. A convenient size for the making of small castings is 8 in. by 15 in.; this size will accommodate a three-column, 10-in. casting. It is sometimes possible to make a heading six or seven columns wide, in a box of this size, by casting in two parts and carefully joining the ends. The cast-iron plates should be at least  $\frac{1}{2}$  in. thick. Each should be finished smooth on one side, and polished. Attach a handle to the upper plate, consisting of an iron rod welded to it, and covered with a wooden jacket. Bevel a wide slot in one end of the same plate, this to be the "pouring" end.

The casting box is completed by the three metal strips, shown in Fig. 2, which

will hold the plates apart and give thickness to the casting. At this stage it must be decided whether the castings are to be type-high or thin, in the latter case necessitating wooden mountings. The thin plate is more easily trimmed, and moreover it "ties up" less linotype metal, but it is more difficult to cast. The metal is more likely to chill while being poured, because the volume is small and the contact surfaces are close together. With such an outfit as this, therefore, it is better to make the castings type-high. For this purpose, procure three strips of scrap iron. Dress and polish them to a width of about  $\frac{3}{4}$  in. and a depth of .917 in., or .001 in. less than type-height. Weld the short strip to one of the long ones, at an angle of  $90^\circ$ , thus making two strip units.

A stand or base for the casting box may be made from a stout wooden box, sawing through the box at an oblique angle, indicated in Fig. 3. Remove the sides; nail a board to the sawed ends, and brace well inside. Nail a wooden cleat across the top surface near the sawed end. Lay the lower casting plate on the top surface, with one end resting against the cleat. Procure four stout C-clamps from a hardware store; for a casting box of this size only two will be needed at a time, but it is well to have two in reserve.

The stereotype, as is well known, is a casting made by pouring type metal into a paper mold, which is known as a matrix

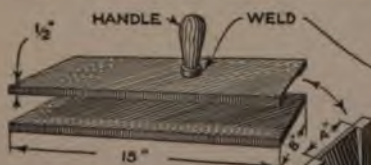

Fig. 1: CAST-IRON PLATES

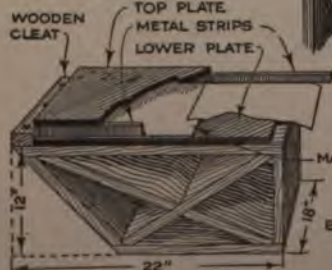

Fig. 3: ARRANGEMENT OF MATS

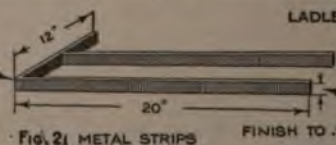

Fig. 2: METAL STRIPS

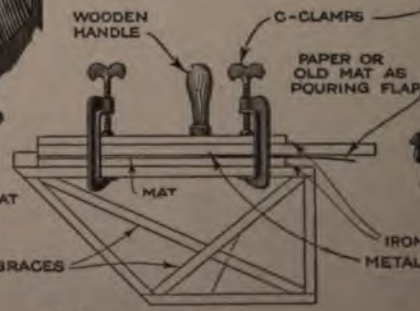

Fig. 4: CLAMPED FOR POURING

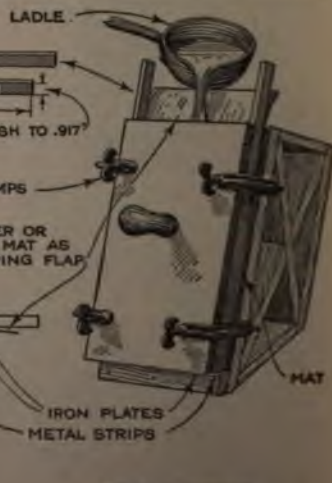

Fig. 5: POURING

The Owner of a Small Print Shop Need Not Be without Means for Making Stereotypes from the "Mats" Which Many National Advertisers Furnish to Their Local Representatives



or "mat." The process is used on newspapers of large circulation, all the printing being done from stereotype plates, rather than from actual type. The purpose for which the outfit here described is intended, consists rather in the making of small stereotypes from mats that are commonly supplied by national advertisers to their local representatives. The print shop which is equipped with the stereotyping apparatus here illustrated, will be able to make use of these advertising mats, thus getting advertising business that might otherwise have to be refused on account of inability to make the necessary stereotypes.

Cut from the sheet the desired portion of the matrix or mat, taking care to divide equally the flat depressed space surrounding the image. Cut out a piece of thin, stiff paper, having the same width as the mat to be cast. Paste it to the mat, lapping over as shown in Fig. 3. See that the paste is thoroughly dry, and then lay this mat unit on the lower plate; the paper is to serve as a pouring flap. Place the two metal strips on the depressed edges of the mat, taking care that the strips are in proper alinement with the lines of the mat image, and also that the strips do not cover any lines to be cast. See that the ends of the metal-strip units join closely, to prevent leakage of metal. Lay the upper plate on the strips, and clamp the casting box together, as in Fig. 4. Tip the mounting box over on the oblique end, carefully skim the metal, and ladle it quickly, as illustrated in Fig. 5, into the open end. Good results can

also be obtained by using a piece of old mat lapped over the good one instead of thin paper, except that the pressman is then more likely to have to correct uneven thickness of the casting, by pasting paper to the back of it.

After two or three minutes the metal will have "set;" then remove the clamps, the top plate, and the two metal strips.

To insure success with the first cast, the casting box should be heated. This may be done by leaving out the mat and filling the box with molten metal. The mat should also be warmed in advance, to prevent blisters on its surface.

If an inside mortise is desired, saw an old wooden electrotype mounting to the required shape, and lay it on the surface of the mat in the proper place. Fasten with two brads, inserted from the back of the mat. After such a casting has been made, care should be exercised in loosening the mat from the wood, which is now gripped solidly by the metal. The wood may be removed with a chisel.

The most laborious part of the process—unless the shop is equipped with that very useful machine, the saw trimmer—is sawing and trimming the castings. A vise and a carpenter's handsaw will answer that purpose, as linotype metal will not dull a wood saw as quickly as one would expect. A coarse flat file or rasp will smooth the edges. It is not easy to trim the plates square unless a "shoot board," or squaring plane for wood or soft metal is provided. This may be bought from a photoengraving supply shop for \$50, or thereabout.

### Cooling Tank for Water Systems

The occupants of a western farmhouse, finding the supply of drinking water in the summer unpleasantly warm, sought a remedy for the inconvenience. The water came from an elevated supply tank, which became heated quite easily by the sun's rays. The length of underground pipe line between the tank and the house was not sufficient to cool the water, so an old hot-water boiler was procured, and was laid in a pit at the lowest point of the pipe line. The pipe was connected so as to lead through this tank, and the arrangement had the desired result of keeping the drinking-water supply cool.

☛ Before putting the razor away draw the blade across the hair several times. The oil in the hair leaves a film on the razor and prevents its becoming rusty.

### Valve Grinder Made from Auger

An old auger bit of the proper size is readily made into a valve-grinding tool which will fit into any ordinary bit brace. The bit can be sawed through at about the point indicated by the dotted line in the drawing, being first annealed for easy cutting. The remaining stub of the bit is filed out, so that the legs at the two opposite sides fit the holes in the valve. In a garage where various kinds of valves are encountered, it is convenient to have several tools of this type made in assorted sizes.





### Scuffle Hoe Made from Saw

It is the scuffle hoe that gets the weeds below the ground. Such a hoe is easily made. A short section of a worn-out



A Scuffle Hoe, for Getting at the Weeds under the Surface, is Made from a Piece of Saw Steel

crosscut saw, a piece of heavy band iron, and a discarded broom handle, together with a few stove bolts of proper size, are all the parts required. The section of the saw should be about 6 in. long, and the piece of band iron about 18 in., of which a foot is to be bolted onto the handle, while the remaining 6 in. is to be bent at an acute angle, so that when the saw section is bolted onto the band iron, it will tend to work into the soil, or "scuffle" when the hoe is drawn toward the worker. All necessary holes should be drilled before attempting to assemble the hoe, but the band iron can be bent after the hoe has been put together, and thus the best working angle can be found by actual trial. Keeping several sections on hand, sharpened ready for use, is a great convenience.

Such a tool can be made either to be drawn toward the worker or pushed away from him, as seems easiest for the individual worker. This is done simply by bending the band iron either more or less than a right angle. Setting the saw section at an acute angle to the width of the iron gives the hoe more of a cutting action in its work on the roots of the weeds.—C. L. Meller, Fargo, N. D.

### Quick Method of Curing Hams

A quick method of curing hams for home consumption consists in burying them in hot salt for 10 to 15 minutes. The hams are first covered with sirup, so as to give them a sweet flavor. An iron kettle is about half filled with salt and then heated until the salt is hot enough

to snap. The salt should be continually stirred to prevent its scorching. A small ham or shoulder will be done in 10 minutes, a large one in 15 to 20 minutes. After taking the hams from the salt, they should be placed in a cool, dry place for a few days, when they are ready for consumption.

The action of the hot salt on the juices of the meat makes a solution that is strong enough to check bacterial development. The hot-salting method has the advantage that it can be used in mild weather when there is danger of meat spoiling with the usual method.—C. T. Conklin, Columbus, Ohio.

### Hand Horn Operated by Foot

A hand horn for automobile or truck is easily operated by the heel of the foot, if set on an angle iron under the floor board, as shown in section in the drawing.



### Clamp for Drying Straw Hat

The life of a straw hat is brief at best, and water is one of its worst enemies, as the brim usually warps out of shape in drying, and the appearance of the hat is spoiled. One

remedy for this is to place the hat on a table and weight the brim down with several books or other heavy articles, but if the hat has to

be hung up in a crowded office this can hardly be done. A simple homemade clamp can be made from two pieces of thin board for holding the wet brim straight while drying, which will preserve the appearance and life of the hat. A hole is cut in the upper piece sufficiently large to admit the hat crown, and both boards are hinged together, as shown. A button fastener on the bottom board holds the hat tightly between the clamp. A number of holes are drilled in both top and bottom of the clamp to allow the air to circulate and expedite drying.

CA  $\frac{1}{8}$ -in. hole drilled in the pipe, just above the pump cylinder, permits the pump to drain, and prevents freezing.

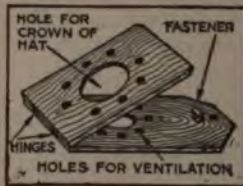



### How to Keep Artist's Brushes

Every user of small oil-paint brushes, or artist's brushes used in oil, has been annoyed by the problem of keeping them clean after use. It is hardly possible to wash them, in kerosene, so clean that they will not harden on exposure to the air. Instead of attempting to do this, a good way is to cover the hairs with a thick coat of vaseline before putting them away. Vaseline does not dry out easily, and it is found that the brushes treated in this way show a better condition and a longer life.—Carl Busch, Paso Robles, Calif.

### Hand Cutter for Thin Washers

For cutting thin washers out of paper, rubber, or soft leather, it is convenient to have a tool which can be manipulated with one hand, while the other is employed in holding the work. For such thin material, a tool with a handle is often more useful than the ordinary one intended to fit into a bit brace.

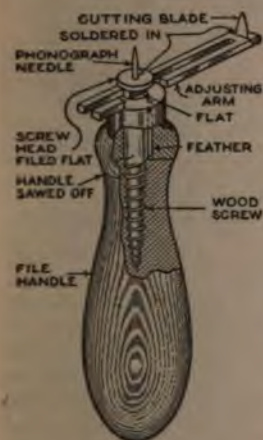

The tool illustrated is adjustable within the limits determined by the length of the adjusting arm. The adjustment is made by unscrewing the bottom part of the handle, which

permits the upper part to slide down enough to loosen the adjusting arm. After the arm has been set for the radius desired, the handle is again screwed up, clamping the arm under the screw head. The feather prevents the upper piece of the handle from turning with the lower piece, and a grip can thus be obtained for tightening up the tool.

An old file handle is good raw material for the handle of the tool. A phonograph needle should be soldered into the end of the screw as a center pin. The adjusting arm is cut out with the hacksaw from a piece of thin sheet steel, and a blade may be ground out from an old hacksaw blade. A piece of steel wire, soldered into a groove in the side of the screw to act as a feather, completes the materials required.—Chas. S. Rice, Washington, D. C.

### Auto Wheel Operates Tire Pump

The illustrations show how a common tire pump can be attached to the rear hub

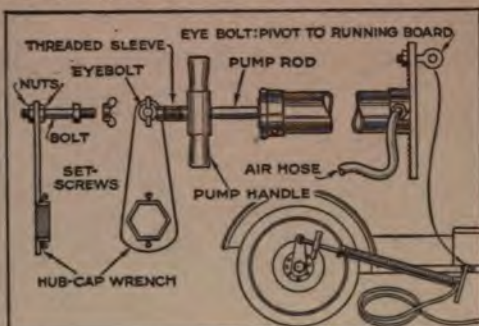

An Ordinary Hand Pump may be Converted by the Ingenious Motorist into a Power-Driven Pump

of an auto wheel, and be driven by the engine.

First, drill a hole in the free end of the hub-cap wrench, and fit it with a strong bolt, as shown. Two nuts hold the bolt solidly against the wrench, while a third nut acts as a stop for the pump rod, and the wing nut holds it on the bolt. Arrange two set screws on the wrench, so it will stay in position on the cap. Make a threaded sleeve and put it on the end of the pump rod, in place of the nut that holds the wooden handle. Then fit an eyebolt in the open end of the sleeve, to slip over the bolt in the hub-cap wrench.

Arrange a second eyebolt in the foot plate of the pump, and fasten a bolt or pivot to the edge of the running board of the car, around which this eyebolt can oscillate. Set the bolt at such a distance from the hub that when the pump rod is drawn somewhat less than halfway out, the hub-cap wrench will be in a perpendicular position.

Then, by jacking up one rear wheel, blocking the other, and starting the motor, the pump will be made to operate, and the tires will be rapidly pumped up through a hose, which should preferably be made long enough to reach all four of the tires.

### Felt Hat for Filtering Oil

A simple oil filter is made by suspending an old felt hat inside the rim of a can or other container. The brim of the hat is bent over and tied with cord to the outside of the vessel. The inverted crown is filled with oil, which filters through the felt, any dirt or other foreign matter contained in it thus being effectively removed.



### A Gas-Burning Instantaneous Water Heater

With a little labor, a very satisfactory water heater for the home can be made

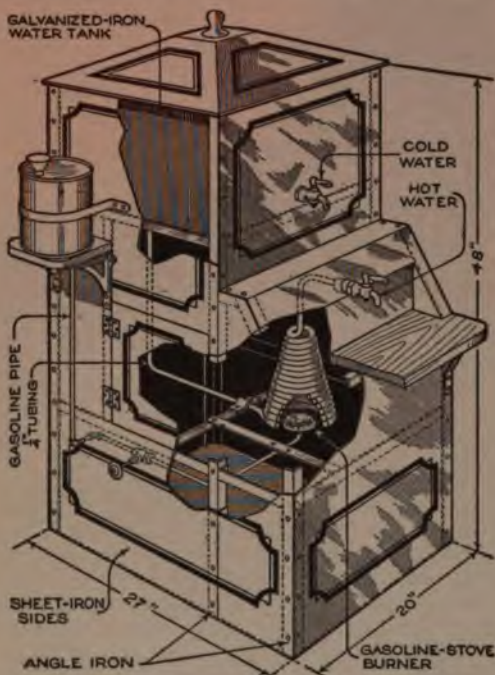

Parts of an Old Gasoline Stove are Used in Making a Heater, for the Home Not Provided with Piped Water

with parts taken from a dismantled gasoline stove. It will heat water almost instantaneously.

Four pieces of light angle iron form the framework, and serve as legs; they may be placed any convenient distance apart. They should be tied together at intervals by cross angles riveted in place, the upper four serving as a support for the water tank, which is made of sheet iron, just large enough to fit snugly between the posts.

Near one corner of the tank bottom, provision should be made for a length of  $\frac{1}{4}$ -in. brass or copper tubing, which is to be firmly held in place by lock nuts and leather washers. About 15 ft. of this tubing will be required. The end connecting to the water tank should be threaded for a nut, and the other end for a water faucet. About 10 ft. of the tubing, nearest the faucet, should be formed into a spiral coil, the turns decreasing in diameter as they near the outlet.

At the lower end of the coil is mounted

a burner taken from the stove, the connecting pipe leading out through the side of the heater and thence up to a small supply tank secured to the framework near the top. At any convenient point on this supply line, a valve is placed for regulating the flow of gas. The framework is covered with squares of sheet iron, cut from the stove. These should be riveted to the angle-iron legs, or held in place by small stove bolts.

For lighting the burner, and for access to the coil, a door should be left in the side. This may also be of sheet iron taken from the stove, hinged along the back edge and reinforced with angles or strap iron. When completed, the heater should be given a coat or two of black enamel.

### Soft Heads on Piston Pin

One of the most vital of gas-engine troubles is caused by the piston pin working loose so that it cuts grooves in the cylinder walls. The only remedy is to re-bore the cylinders and put in new oversize pistons, or get new cylinders. However, the piston pin shown in the sketch will not injure the cylinder if it comes loose. In fact, several such sets have been in service over a year. The ends are protected by soft-brass pieces, as shown. The tip should be made to a close fit, and pressed on.—S. E. Gibbs, Ames, Ia.



### Sandpaper Pencil Pointer

A very convenient pencil pointer is made from a block of wood, about 1 by 2 by 5 in., and a strip of fine sandpaper. A V-shaped groove is cut along the block; the sandpaper is pressed into the groove, and tacked at the side. The disadvantage of the common pointer, in general use among draftsmen, is that it is hard to give pencils a long enough point; this is overcome in the device illustrated, as it has plenty of clearance for the pencil, back of the point to be sharpened.—Forrest Benson, Boulder, Colorado.



The disadvantage of the common pointer, in general use among draftsmen, is that it is hard to give pencils a long enough point; this is overcome in the device illustrated, as it has plenty of clearance for the pencil, back of the point to be sharpened.—Forrest Benson, Boulder, Colorado.



### Rubber Bands for Head Lettuce

In order to produce the best head lettuce, each head should be tied up so that it cannot spread out to become tough and green. This can be done with twine, but a more convenient way, by which good results have been obtained, is to use rubber bands, made from an old inner tube.

### Pincushion on the Sewing Machine



A very useful thing on a sewing machine is a pincushion, made of a piece of flannel wound around the machine as shown in the drawing.

### Installing Strainer in Hand Pump

An ordinary hand pump had been giving me a good deal of trouble from small stones and other such dirt being drawn up through the pipe, and then becoming lodged in the lower washer or valve. Whenever this occurred, the pump ceased to deliver water, and it was necessary to dismantle it to remove the stones.

To overcome this, I have installed the strainer illustrated in the drawing. It consists of a piece of ordinary wire window screening, preferably coppered or galvanized, rolled into a tube, and soldered at each end to a collar made from the metal top of a vaseline bottle. One of the tops should have a hole made in its center, large enough for water to pass through. The strainer, thus completed, is placed in a pipe tee, connected as shown. All water drawn up by the pump is thus strained through the screen wire, and no stones or large particles of dirt can pass through. After the screen is placed in the tee, an ordinary pipe plug is screwed in, not too tightly to prevent the escape of the water, or the entry of the air. To clean this, the pipe plug is removed, giving access to the screen.—Chas. H. McMahon, Miami, Fla.

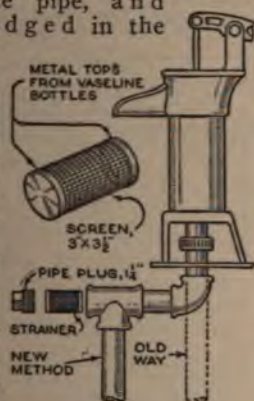

### Table for Use in Automobile

A woman, under a physician's orders to remain most of the time out of doors,



A Small Coupé, Equipped with a Table of Simple Construction, Provides a Comfortable Outdoor Workroom. Resting on the Car Door and the Steering Column, It Is Easily Detachable

solved the problem of an outdoor workroom in this manner:

The small coupé she owned was equipped with a table, compact enough to be stowed in the back of the car when not in use, and strong enough to support a typewriter. This table was nothing more than a straight board, 27 in. long by 11 in. wide, fitting in between the closed door of the car and the steering post. The right end of the board rested on the metal rod on the door, and was kept from slipping forward by a stay piece on the underside. The left end of the table, shown in the photo to the right, had a large notch cut in it, to fit around the steering post. Two cleats were nailed on the underside; the one under the outer edge a triangular-shaped block, placed so that the hypotenuse face rested against the steering post; the other projecting backward underneath the board for 4 or 5 in., so as to rest upon the steering wheel. A strip of adhesive plaster, wrapped around this inner cleat, protected the wheel from injury. A button, about 5 in. long and rounded at the end where it came against the steering post, was screwed down above the inner cleat; when in position, this button projected out over the notch, and prevented the table from slipping down the post.—Ethel Van Cise, San Diego, Calif.

### Opera Glasses Enlarge Drawings

To enlarge small printed plates or drawings for studying lines and details, which is especially desirable in pen-and-ink work before redrawing to larger scale, use a pair of cheap opera glasses. After redrawing, reverse the glasses, and the work is shown properly reduced.

### Frame for Painting Rowboats

To lighten the labor of painting rowboats and canoes, particularly if a number are to be painted, the frame described

end horses in line with the run. Large pointed screws, with wing nuts attached, are provided at the inner ends of the bases for regulating the distance between the supporting horses. The points of these screws should project through the bottom of the base when screwed down, and pierce the surface of the run, so as to hold the horses tight. By releasing the clamp screw, the horses may be slid along the run freely.

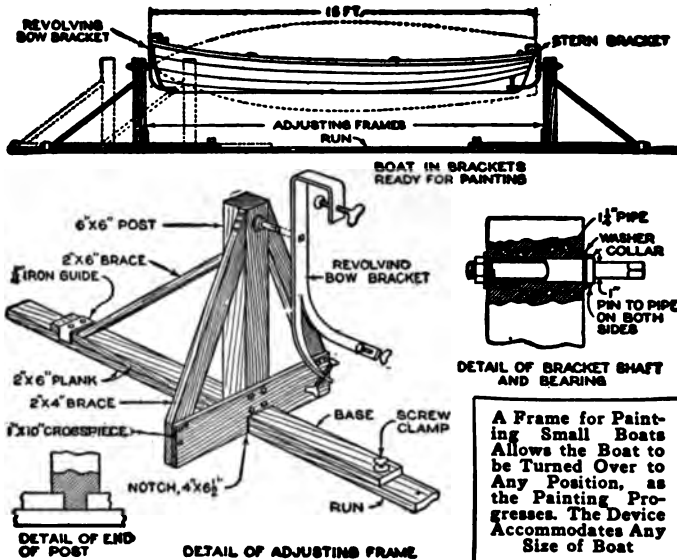

herewith will prove its value, as it allows the boat to be turned as the work progresses, and makes the job fast, clean, and systematic. In addition, it is adjustable to various sizes of boats.

The run, or foundation for the frame, should be made considerably longer than the largest boat to be painted, so the end horses may be pulled away from the boats without pulling them off the run. If one plank is not long enough for the run, two or more of the same width may be lined up and fastened, flat side down.

No definite measurements can be given for the end horses, on account of the variations in size of boats. However, for the average boat the base should be at least 4 ft. wide, and the upright support about 3 ft. high. Material for the base should be of the same size as that used for the run. The end post is mortised to the base; mortised joints should be used wherever possible, as additional strength is thus obtained. The bottom crosspieces of the end horses are bolted to the braces and uprights. A piece will have to be removed from the center of these bottom crosspieces, to accommodate the run and base. When assembled, the bottom edge of the crosspieces should just clear the floor, without scraping. A metal guide, as shown in the drawing, is attached to the outer end of the bases, to keep the

Near the top of each upright a hole is bored, as shown, so that a piece of 1/4-in. pipe will make a tight fit in it. These are the bearings for the bracket shafts; be sure that the holes are equidistant from the base.

The size and shape of the iron brackets will depend largely on the style of the boat, although those shown will accommodate the average flat-bottomed boat. For round-bottomed boats, let the horizontal legs twist a trifle upward at the outer corners, to grip the round bilge at a better angle. Make the bottom screws quite long, to allow freedom of adjustment. The top clamps may be short—just long enough to grip the top of the stern or fit over the transom. A square hole is cut about the center of each bracket, into which is riveted the square end of the steel shaft. As mentioned above, the shaft revolves on pipe bearings. A collar is pinned on the bracket end of the shaft, and a nut and washer on the other end can be tightened, so as to hold the boat in almost any position.

**A Frame for Painting Small Boats Allows the Boat to be Turned Over to Any Position, as the Painting Progresses. The Device Accommodates Any Size of Boat**

### Music Kept on Back of Piano

One user of a piano manages to avoid the untidy appearance of sheet music scattered over the top of the piano, without the expense of providing a cabinet for it. The piano was set at a 45° angle across the corner of a room, and on the back of it were attached six pockets, made from ordinary canvas, each large enough to take sheet music. Each pocket was held in place by seven small wood screws, with washers under the heads, to prevent tearing the canvas.—**Jas. E. Noble, Portsmouth, Ont.**



sheathing were cut out at various points; the sections were cleated, and when replaced were hinged, forming doors which were fitted with snap locks or latches.

As the timbers of the railing were 2 by 6 in. in size, there was a space 6 in. wide between the walls of the railing, into which could be stowed rugs, hammocks, short lengths of garden hose, etc. In case of a sudden rainstorm, this is a quick way of disposing of the small things about a veranda which might otherwise become wet.

### Incubator for Raising Bread

It is difficult in cold weather to maintain the proper temperature for bread dough during the raising process. Some housewives have found an incubator suitable for this purpose. The thermostat is adjusted to hold the temperature in the machine between 85 and 90° F., after which the lamp is lighted and the dough placed in the egg chamber, with a shallow pan of water to supply moisture by evaporation.

### Reinforced Bottom for Copper Wash Boilers

The copper bottom of a wash boiler often wears out before the rest of the vessel, due to wear from the bottom side. This can be largely prevented by installing a sheet of coarse wire mesh, as indicated in the cut, and soldering it around the edge. When the wire mesh wears out or gets broken, it can be removed by melting out the solder, and substituting a new mesh bottom, thus greatly prolonging the usefulness of the boiler.



### Straightening New Rope

New rope is often hard to use on account of kinks and bends. A neat device for straightening it is made by bolting some large spools in a straight row, so that each one turns freely; the rope is then threaded in and out among the spools, and is drawn through, which removes the kinks and makes the rope more pliable.

### Rubber Shock Absorber for Auto

An effective shock absorber for a light automobile was made from an old inner tube. The tube was first straightened

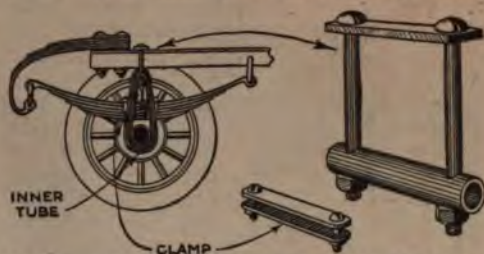

An Inner Tube, Cut into Two Strips of Rubber, Forms a Shock Absorber Which will Better the Riding Qualities of a Light Car

out, cut through, and split twice lengthwise, thus forming it into two long ribbons of rubber, one for each end of the rear axle. These were wound around the axle, and around a hanger, which was made from some scraps of metal and bolts, as illustrated. The two ends of each ribbon were clamped by the use of simple metal clips, to keep them from slipping around. For the best effect, such a shock absorber should be mounted while the car is loaded with a normal weight of passengers, or an equivalent weight. This is in order that in operation the rubber will begin to stretch, just as soon as the frame begins its travel above its normal position. That is, the rubber should exert no force while the springs are being depressed, or while they are returning to normal, but the action should begin immediately when the car begins to be thrown upward by the rebound of the spring.—Chas. Walte, Louisville, Ky.

### Simple Method of Adjusting Droplights

When there is no ball or other device for holding the light cord at the desired height, the method shown in the sketch may be utilized. Place two pulleys in the ceiling, in line with the rosette. Tie a stout cord to the electric-light cord, about halfway down, and run it through the two pulleys, attaching a weight to the other end which will just balance the lamp.





### A Sewage-Disposal System for the Summer Cottage

One of the drawbacks of summer-cottage life is the lack of an adequate method for getting rid of sewage. Sewer lines are usually impractical, because of the



expense, and the water level is often so near the surface that it is impossible to secure sufficient drainage to permit the installation of a standard type of septic tank, or cesspool. As a result, waste is sometimes allowed to accumulate at the rear of the cottage in an unsightly, disease-breeding puddle.

This condition can be obviated by the use of the little septic tank described and illustrated herewith. The actual cost is but small; an empty barrel (preferably an old oil barrel), a sack of Portland cement, three short lengths of 2-in. tile or galvanized gas pipe, and an elbow, are about all one need purchase, for the rock and gravel are usually to be found in the hole, or near by.

This system can be installed in a single day. First, a hole about twice the diameter of the barrel is dug to the desired depth. If the water level permits, it should be dug deep enough to provide good drainage in gravel or rock.

Next, two holes are drilled in the barrel, as shown in the cut, and the inlet and outlet pipes are inserted. This being done, a few large rocks are thrown into the hole, and the barrel is put in place; the space between the outside of the barrel and the hole is filled with rocks, care being taken to place them in such a way as to provide the greatest possible amount of open space between them. The pipes

then sealed into the openings in the barrel with mortar; the top is covered with heavy paper, to prevent water from running down and settling in the rock, and a reinforcement is put in place, covering the top and the stone. The system is completed, and is ready to be connected with the kitchen

effective septic tank or

system; the barrel forms the air-tight compartment, and the stones about the barrel take the place of a porous tank. If properly installed, with the pipes ending below the surface of the liquid, as indicated in the cut, the sewage will be completely decomposed in the two compartments, and will seep away in the form of a fluid.

When the hoops about the barrel rust away, the staves will be held in position by the rocks. The barrel itself will resist decay as long as it is constantly saturated with water, and the tank will continue to serve its purpose, with no item of maintenance, for a long period of years.—Paul Llewellyn, Milwaukee, Wis.

### Holding Tapered Work in Shaper



By mounting a piece of metal in a sort of ball-socket joint in a shaper vise, as illustrated, it is possible to hold for machining a piece of work having any taper within the capacity of the device.—Louis Barber, Worcester, Mass.

### Tile Gate for Small Dam

Much trouble is often caused by a leaking gate in a dam. A square gate may stick just at the time when it is to be raised. Such difficulties can be avoided by using a simple gate made of a piece of tile pipe. Put the tile through the dam with the collar end inside the dam. Bolt a pole or narrow plank to a round wooden disk, which will just fit the collar of the tile; have the pole long enough to project above the water level. The gate thus formed is placed in position as shown, and some dirt is thrown against it, to hold it in place. This closes the outlet through the dam. When it is to be opened, remove the cover from the end of the tile by using the long pole



as a lever.



### How to Make Whitewash

A good whitewash, which is widely used for lighthouses, is made as follows: Slack one bushel of lime in boiling water, keeping the mixture covered during this process. Then strain the lime, and add a quantity of brine, made by dissolving one peck of salt in warm water. Next, put 3 lb. of ground rice in boiling water, and cook until the mixture becomes pasty. Add this paste to the lime and brine. Other ingredients are  $\frac{1}{2}$  lb. of Spanish whiting, and 1 lb. of clear glue, dissolved in warm water. After all these are well mixed, the whitewash should stand for a week or more, and then should be kept in a kettle, or portable furnace, as it must be heated white-hot for use.

### Gauge for Composition Shingles

In laying composition shingles, the eaves are usually started with a single course of wood shingles, followed by a double course of the composition shingles. The first of these is usually reversed, that is, turned with the bottom edge upward, and the second is placed in normal position.



To make an even projection, a straight piece of flooring plank, turned with the groove toward the eave, serves a double purpose as a straightedge. The wood shingles are butted against the edge of the groove, while the composition shingles are put to the bottom of the groove. This insures a straight line at the lower edge of the shingles, and gives the composition shingles a projection of  $\frac{1}{4}$  in. over the wooden ones, which forms a drip line that protects all the wood portion of the roof from wetting.—M. W. Lowry, Athens, Georgia.

### Rigging for Grinding Plowshares

In grinding plowshares at a small machine shop, a swinging, counterbalanced frame is suspended from the ceiling, as shown. The frame is composed of two ordinary plow handles connected by cross-pieces which have slots, so that the

share to be ground may be fitted in them. The handles are joined at the end farthest from the operator; a round bar which

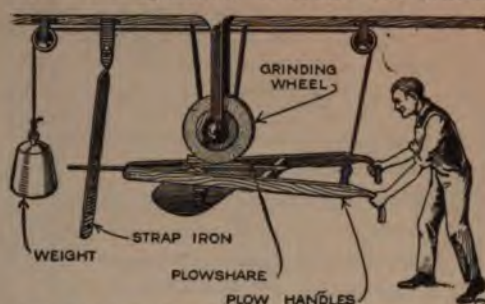

Two Old Plow Handles, Fitted with Slotted Cross-pieces for Holding a Share to be Ground, Permit It to be Held at any Angle

projects forward from the joint is inserted in one of the holes in a suspended piece of strap iron. The bar forms a pivot, so that the whole face of the share may be subjected to grinding, whatever the angle at which it must be held.—Frank W. Roth, Neosho, Mo.

### A Farm-Tank Heater

A heater for preventing the contents of a water trough from freezing in cold weather is illustrated. The body of the device is a water-tight can, made of sheet iron or other similar material. This is placed in the trough, with its top a few inches above the surface of the water. A length of water pipe, admitted through a hole in the cover of the can, and extending nearly to the bottom, provides draft. The flue is made from two pieces



Water-Trough Heater: This Simple Device will Prevent the Water from Freezing in Cold Weather. Wood or Coal may be Used as Fuel

of pipe, joined with an elbow. The grate is attached to the draft pipe, and can easily be removed when it is necessary to clean the heater. Wood or coal can be used as fuel.

### A Sewage-Disposal System for the Summer Cottage

One of the drawbacks of summer-cottage life is the lack of an adequate method for getting rid of sewage. Sewer lines are usually impractical, because of the

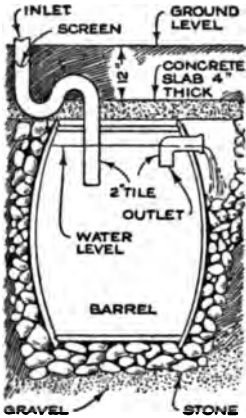

expense, and the water level is often so near the surface that it is impossible to secure sufficient drainage to permit the installation of a standard type of septic tank, or cesspool. As a result, waste is sometimes allowed to accumulate at the rear of the cottage in an unsightly, disease-breeding puddle.

This condition can be obviated by the use of the little septic tank described and illustrated herewith. The actual cost is but small; an empty barrel (preferably an old oil barrel), a sack of Portland cement, three short lengths of 2-in. tile or galvanized gas pipe, and an elbow, are about all one need purchase, for the rock and gravel are usually to be found in the hole, or near by.

This system can be installed in a single day. First, a hole about twice the diameter of the barrel is dug to the desired depth. If the water level permits, it should be dug deep enough to provide good drainage in gravel or rock.

Next, two holes are drilled in the barrel, as shown in the cut, and the inlet and outlet pipes are inserted. This being done, a few large rocks are thrown into the hole, and the barrel is put in place; the space between the outside of the barrel and the hole is filled with rocks, care being taken to place them in such a way as to provide the greatest possible amount of open space between them. The pipes are then sealed into the openings in the barrel with mortar; the top is covered with boards or heavy paper, to prevent the wet concrete from running down and filling the voids in the rock, and a reinforced-concrete slab is put in place, covering the barrel and the stone. The structure is now completed, and is ready for use when connected with the kitchen drain.

This gives an effective septic tank or

system; the barrel forms the air-tight compartment, and the stones about the barrel take the place of a porous tank. If properly installed, with the pipes ending below the surface of the liquid, as indicated in the cut, the sewage will be completely decomposed in the two compartments, and will seep away in the form of a fluid.

When the hoops about the barrel rust away, the staves will be held in position by the rocks. The barrel itself will resist decay as long as it is constantly saturated with water, and the tank will continue to serve its purpose, with no item of maintenance, for a long period of years.—Paul Llewellyn, Milwaukee, Wis.

### Holding Tapered Work in Shaper

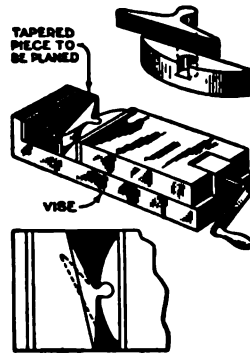

By mounting a piece of metal in a sort of ball-socket joint in a shaper vise, as illustrated, it is possible to hold for machining a piece of work having any taper within the capacity of the device.—Louis Barber, Worcester, Mass.

### Tile Gate for Small Dam

Much trouble is often caused by a leaking gate in a dam. A square gate may stick just at the time when it is to be raised. Such difficulties can be avoided by using a simple gate made of a piece of tile pipe. Put the tile through the dam with the collar end inside the dam. Bolt a pole or narrow plank to a round wooden disk, which will just fit the collar of the tile; have the pole long enough to project above the water level. The gate thus formed is placed in position as shown, and some dirt is thrown against it, to hold it in place. This closes the outlet through the dam. When it is to be opened, remove the cover from the end of the tile by using the long pole as a lever.





### How to Make Whitewash

A good whitewash, which is widely used for lighthouses, is made as follows: Slack one bushel of lime in boiling water, keeping the mixture covered during this process. Then strain the lime, and add a quantity of brine, made by dissolving one peck of salt in warm water. Next, put 3 lb. of ground rice in boiling water, and cook until the mixture becomes pasty. Add this paste to the lime and brine. Other ingredients are  $\frac{1}{2}$  lb. of Spanish whiting, and 1 lb. of clear glue, dissolved in warm water. After all these are well mixed, the whitewash should stand for a week or more, and then should be kept in a kettle, or portable furnace, as it must be heated white-hot for use.

### Gauge for Composition Shingles

In laying composition shingles, the eaves are usually started with a single course of wood shingles, followed by a double course of the composition shingles. The first of these is usually reversed, that is, turned with the bottom edge upward, and the second is placed in normal position.



To make an even projection, a straight piece of flooring plank, turned with the groove toward the eave, serves a double purpose as a straightedge. The wood shingles are butted against the edge of the groove, while the composition shingles are put to the bottom of the groove. This insures a straight line at the lower edge of the shingles, and gives the composition shingles a projection of  $\frac{1}{4}$  in. over the wooden ones, which forms a drip line that protects all the wood portion of the roof from wetting.—M. W. Lowry, Athens, Georgia.

### Rigging for Grinding Plowshares

In grinding plowshares at a small machine shop, a swinging, counterbalanced frame is suspended from the ceiling, as shown. The frame is composed of two ordinary plow handles connected by cross-pieces which have slots, so that the

share to be ground may be fitted in them. The handles are joined at the end farthest from the operator; a round bar which

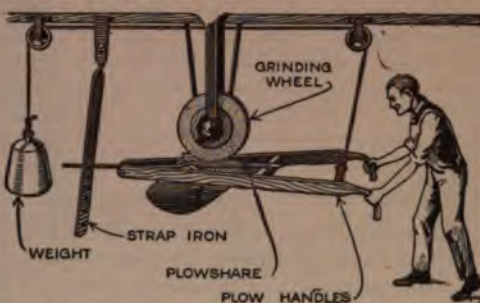

Two Old Plow Handles, Fitted with Slotted Cross-pieces for Holding a Share to be Ground, Permit It to be Held at any Angle

projects forward from the joint is inserted in one of the holes in a suspended piece of strap iron. The bar forms a pivot, so that the whole face of the share may be subjected to grinding, whatever the angle at which it must be held.—Frank W. Roth, Neosho, Mo.

### A Farm-Tank Heater

A heater for preventing the contents of a water trough from freezing in cold weather is illustrated. The body of the device is a water-tight can, made of sheet iron or other similar material. This is placed in the trough, with its top a few inches above the surface of the water. A length of water pipe, admitted through a hole in the cover of the can, and extending nearly to the bottom, provides draft. The flue is made from two pieces



Water-Trough Heater: This Simple Device will Prevent the Water from Freezing in Cold Weather. Wood or Coal may be Used as Fuel

of pipe, joined with an elbow. The grate is attached to the draft pipe, and can easily be removed when it is necessary to clean the heater. Wood or coal can be used as fuel.

# POPULAR MECHANICS

## Concrete Work in Freezing Weather

Construction of a concrete dam and in the northern Adirondacks winter was attended by many

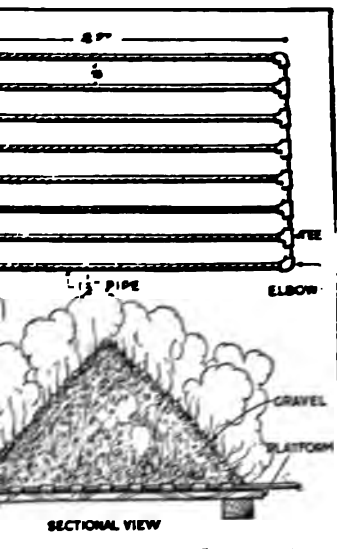

Method for Heating Gravel Used in Concrete: Made It Possible to Mix and Pour Material in Freezing Weather

The thermometer frequently as low as 35° F. below zero. this, it was difficult to prevent the concrete from freezing in the molds, to obtain a good bond between fresh concrete and that previously placed. The material was often covered with a layer of ice, caused by the freezing of the concrete in a near-by waterfall. It was necessary to remove the ice to obtain satisfactory results. Gravel was obtained from a quarry located near the scene of operation and hauled to the mixer on flatbed cars.

To overcome the difficulties, a lumber building was built near the mixer, and a radiator shown in the sketch was placed on it. The cars were dumped on the platform, and the gravel thor- oughly heated before it was placed in the mixer. Water used in mixing the concrete was heated by discharging a jet of steam from a small pipe inserted in the side of the tank. A small quantity of cement was added to the mixture to raise the freezing point. The surface of the concrete was warmed by the application of steam before new concrete was laid on it. Stones that were imbedded in the concrete were warmed with

steam. Fresh concrete was prevented from freezing by covering it with tarpaulins. A space of about 1 ft. was left between the tarpaulins and the surface of the concrete, and this space was kept filled with steam.

In spite of the severe weather which prevailed while the work was being done, an examination of the structures the following spring failed to disclose any flaws in the concrete.—T. S. Burns, New York City.

## Tool Cuts Out Round Wooden Plugs

One day when I was in need of some short wooden plugs, 1/2 in. in diameter, I made them by means of a tool formed from an old 3/4-in., tapered drill shank. The drill had been broken, so that the shank was merely scrap metal. After annealing it in lime, I centered it in a lathe, and turned out the cutter illustrated, afterward filing the teeth on the end, and drilling a 3/16-in. hole for chips to escape. Wooden plugs were cut out by running this tool part way into the end of a board, and then sawing off the board at the end of the drilled portion. The plugs were thus separated from the wood around them. In this way the plugs were made quite quickly, and the method was found so successful that larger tools have since been made from reamers of the type

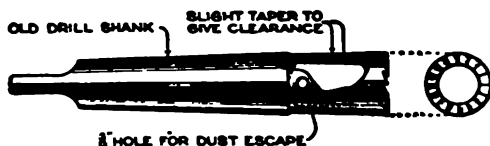

A Tool Made from the Shank of a Broken Twist Drill Provides a Ready Means of Cutting Out Small Wooden Plugs of a Given Diameter

which have a heavy band of hard steel sweated on.—D. T. Draper, U. S. S. "Bridgeport."

## Flood Lighting for Skaters

Experiments with flood lights have shown them to be more suitable for illuminating ice-skating rinks than arc or incandescent lamps. Their use eliminates deep shadows to a large extent, as well as reflections which are likely to blind the skaters. In one case two flood lights were employed to light a large rink. They were mounted on the roof of a near-by building and focused on the surface of the ice. One served to illuminate an area about 900 ft. long and from 75 to 150 ft. wide, while the other lighted a space 150



by 200 ft. It was found, also, that these lights could be operated at less expense than arc or incandescent lamps.—C. L. Meller, Fargo, N. D.

### To Save Pieces of Shaving Soap

Shaving-soap remnants should not be thrown away when a fresh cake is put in the mug. The pieces can be melted by placing the mug in hot water. When they have melted, the new cake sinks to the bottom, causing the softened soap to come up around the edges of the cake, and to fill the space between it and the mug. By this means water is prevented from getting under the new cake and rendering it mushy, while all of the old soap will be used with the new supply.—W. H. Kruse, Fort Wayne, Ind.

### Drip Belt Prevents Chimney Leaks

Nearly every roof leaks a little around the chimney, through cracks between the roofing and the brick. A simple way to prevent this nuisance is to place a concrete drip belt about the chimney, as shown in the cut. The material will not exceed \$2 in cost, and if applied according to directions, the leak will be permanently stopped.

First fasten the roofing well against the chimney on all sides. Then fashion a wooden form for a drip belt, as illustrated, and place it around the chimney. It is very important that the outer edge of the belt should be lower than the inner edge. Otherwise the water will



A Concrete Belt Placed around the Chimney will, Except in Very Stormy Weather, Keep Water from Leaking through the Roof along the Chimney

simply run around the belt and on down the outside of the chimney.

The concrete should be reinforced with a little chicken wire, and well tamped into place so as to form a water-tight joint between it and the brick. The mixture must be quite rich—three parts of sand to one of cement is the best proportion to use.—Paul L. Fetherston, Ottawa, Ill.

### Pipe Connections on Range Boilers

When pipe connections on a range boiler are as shown on the left of the sketch, the circulation system has two disadvantages. One is the distribution of rust and sediment through the system, and the other is the difficulty of obtain-

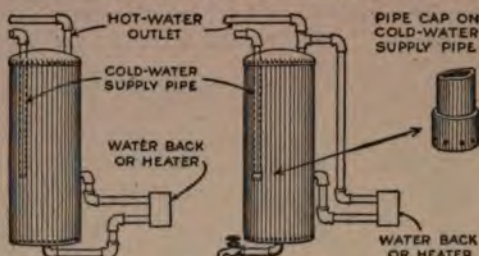

By Changing the Circulation System on a Range Boiler, the Water is Kept Free from Rust

ing hot water before the total contents of the boiler have reached a high temperature.

The circulation of sediment is due to the fact that water reaches the water back through a pipe which connects with the bottom of the boiler, where the sediment has settled, and passes from the water back into the center of the boiler. This is prevented in more modern practice, by making connections as shown on the right of the sketch, so that the water is supplied to the water back from the center of the boiler. Here it is free from sediment, and passes upward to the hot-water outlet. As an added precaution, a pipe cap is placed on the lower end of the cold-water supply pipe, with small holes drilled around the edge. From these the water flows radially in a horizontal direction, whereas by the old method it flowed downward with considerable force, and stirred up the sediment.

A drain valve fitted at the bottom of the boiler makes it a simple matter to remove sediment. When this is being done, the cold-water supply must be shut off, and the nearest hot-water spigot should be opened. This will admit air to the pipes and to the inside of the boiler, thus reducing the pressure so that the water can flow freely.

The second defect is also remedied by this arrangement. The right-hand view shows how heated water can be made to pass immediately to the hot-water outlet, instead of circulating as shown on the left, and mixing again with cooler water in the boiler.—James W. Cottrell, Hammon, N. J.



.0002 in.—equal to what the ordinary workman does with a micrometer. For it must be understood, to grasp the importance of this work, that the ability of the eye to estimate decimal parts is entirely independent of the size of the whole. The length of the printed scale, for example, is 10 centimeters, but once the decimal parts are fixed in the mind, it is as easy to read hundredths of a .01-in. space (ten-thousandths of an inch)

as to read hundredths of 10 cm. (millimeters). This is, of course, limited by the fineness of the vision, or—which amounts to the same thing—by the power of the magnifier available. But the man with the tenth-reading eye has such an enormous advantage, in these days of ten-thousandth-inch dimensions, that a little practice to gain this ability in accurate scale reading is well worth while.

### Radiator Heater for Garage

A heater that will prevent an automobile radiator from freezing while the machine stands in a garage is shown in the drawing. The bottom of an old milk can is cut off, as indicated, and that end of the container flattened. A strap-iron stand supports the can, which is held in position by an iron rod that connects the upper ends of the short legs of the stand. The flattened end rests on a wire, strung between the long legs. Heat is furnished by an ordinary lamp, the chimney of which fits in a hole in the can. The lamp is placed on a shelf attached to the short legs. Cold air drawn into the mouth of

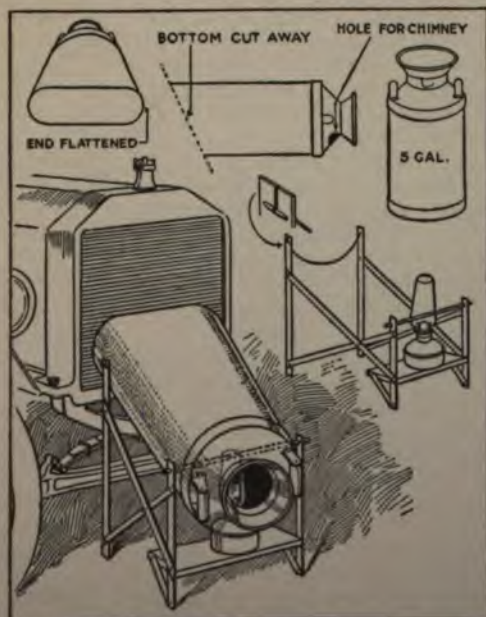

Made from an Old Milk Can, the Device is Used in a Garage to Prevent Freezing

the can is heated by the lamp, and directed against the radiator by the can, which serves as a flue.

### Adjustable Milling Cutter

The sketch shows, at the right, a type of milling cutter that is especially valu-



A Set of Two Milling Cutters, Ground to an Angle and Shimmed Apart, will Produce Finished Slots, of Variable Width

able in milling slots, as it may be adjusted for width, and at the same time leaves no fin between the cutters, as is the case if two ordinary cutters are used and shimmed apart, as shown at the left. To produce the cutter described, two ordinary cutters of the same diameter are used, and one side of each is ground on an angle of 10° or more. They are fitted with a key to hold them in alignment, and clamped together on the spindle of the milling machine, with the proper thickness of shim between them to produce the width of slot required in one cut. It is evident that no fin will be left between the cutters, on account of the slant of the opening between them.—S. B. Royal, Philadelphia, Pa.

### Wire Baskets Separate Chickens in Incubator

Wire baskets taken from corn poppers are used by many poultrymen to separate chickens hatched in incubators according to pedigree. The eggs are numbered to indicate the different hens from which



# Learn to Read Any Scale by Tenths

By H. KURTZ RANDALL

ONE of the most widely useful things to learn for any mechanic who does precision work, and one which comparatively few take the trouble to master, is to read tenths of a division on a scale. The electrical worker usually learns it, so that he can look at a voltmeter, say, with scale marks for every volt, and "take a reading" of 37.3 volts, or 153.7 volts—where the novice, looking at the same meter, would read merely 37 or 154. The machinist who must lay off a dimension of .97 in. usually considers that he requires a scale graduated in hundredths; but the electrical draftsman who can read tenths may lay off the same dimension just as accurately with a tenth-inch scale—the work involving much less strain on the eyes than using the finer scale. To measure a distance of 1.678 in., and be sure that it is not 1.677 or 1.679, the ordinary workman needs a micrometer. But if the eye is trained to estimate tenths, a hundredth-inch scale and a good magnifying glass are all that is necessary.

A little instrument made of paper, as illustrated, will be of great assistance in training the eye for this purpose. A strip of pasteboard is cut, 1 in. wide and 9 in. long. Beginning  $\frac{1}{2}$  in. from the left end, a scale of 100 parts should be laid out and numbered, like the one here shown; or the printed scale can be cut out and pasted to the strip. On the other side of the strip, exactly opposite the 100 mark of the scale, rule a line across the strip.

Now obtain a card, about 3 by 5 in., of a different color from the 1-in. strip. Make two slits in it, exactly as far apart as the length of the scale. Lay the narrow strip, scale-side down, upon the card and pass the ends through the slits. The instrument is now complete.

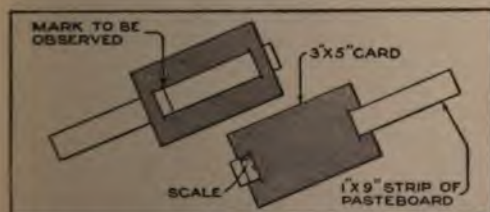

Two Pieces of Cardboard Are the Only Necessary Materials for Making an Instrument to Train the Eye in Reading Tenths of Divisions on a Scale

For the first lesson, set the strip so that the "10" mark just coincides with the slit in the card, as in the picture. Then turn the instrument over, right to

left—not top to bottom—and observe very closely the position of the cross mark with reference to the two slits. Identify this position in the mind with .1 (one-tenth). Then shift the strip to "20" on the scale, and again note the position of the cross mark on the reverse side, remembering it as .2. Proceed in this way until familiar with the appearance of a line placed at .1, .2, or any such part, up to 9, of the distance from the left side of a space to the right side.

Then test the estimating ability thus acquired, as follows: Set the cross mark at any point between the slits, at random, doing this preferably with the eyes closed. Try to estimate which tenth mark is most nearly represented by this position of the cross mark. After a little practice, the correct figure should be named in almost every case. Perfection is not to be expected; the eye training may be considered good if the nearest figure is named correctly in all cases where the actual distance, as read on the scale, is within .03 of the whole. That is, if the setting is actually .77, or .825, the eye should be able to name positively the nearest tenth (.8)—but if the actual setting is .747, or .768, some uncertainty may be expected as to whether the nearest tenth is .7 or .8. It should be remarked in this connection that when the measurements are used afterward in calculation, the error resulting from reading .747 as .8 instead of .7, is a very slight one, while if the actual distance is .727, the use of .8 instead of .7 would introduce a considerably greater error.

After some experience is acquired through these methods, it will be interesting to try setting the instrument at random, as before, and estimating hundredths instead of tenths, turning the card each time to test the accuracy of the estimate. After some practice at this, it may be possible to estimate in nearly all cases within an error of .02 of the whole distance.

This means that with a steel scale graduated in hundredths, and a magnifying glass, one may measure the length of a piece of metal with an error of less than

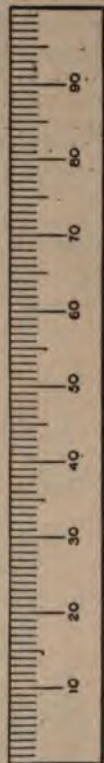



### Serving Table Made from Bookrack

A resourceful western woman saves herself many steps by using a serving



An Old Bookcase was Used to Make This Convenient Three-Shelf Serving Table, Which is Mounted on Casters

table made from an old bookcase that had been relegated to the attic as worthless. The case comprised three shelves, and was mounted on short wooden legs. The latter were removed, and casters substituted for them, whereupon the whole was refinished. When food is ready to be served, it is set on the two top shelves, and the improvised table is wheeled into the dining room, where it is placed beside the chair of the housewife, with its open side toward her. The bottom shelf is reserved for dishes soiled during the meal, and after it is finished, the left-overs are put on the other shelves and the contrivance is wheeled back into the kitchen.

### An Electric-Lighting System for the Garage

The convenience of electric lights in the garage is best appreciated by those who have had to do without them. But even if there is no commercial circuit available, any car equipped with a storage battery can furnish plenty of light for a reasonable time.

Detachable trouble lamps, while very useful, are hardly enough for the garage. A better plan is a system of overhead wiring, connected to the car battery through a removable plug. (The same socket will serve for a trouble lamp, when on the road.) With this system there is no groping about in the dark, for a switch can be provided at the door, and lights arranged in any convenient way.

The plug, on a flexible cord, hangs near the car, and can be connected and removed in an instant.

The permanent wiring should conform to the usual standards for lighting circuits of small capacity, but must not be extensive. Wire should be rubber-covered, No. 14 gauge or larger, on porcelain insulators or in moldings; fuses, same as used on headlight circuit in the car; all fixtures standard, except fuse blocks and lamp sockets, which will have to be of automobile type, since low-voltage lamps are hard to get in standard screw bases. Short circuits are not harmless even on 12-volt storage-battery circuits; and, besides, this same wiring can be used in case commercial current becomes available.

The connection to the car can be made through any kind of socket and removable plug. If the car is already fitted with a dash trouble lamp, the problem is solved. Otherwise, a socket can be fitted on the footboard, or dash, where connection is easily made to the ammeter terminal at the back of the instrument board. Unless the owner thoroughly understands his car wiring, a reliable electrician or service station should be consulted.

Of course, the system must not be overloaded, or used for an unreasonable

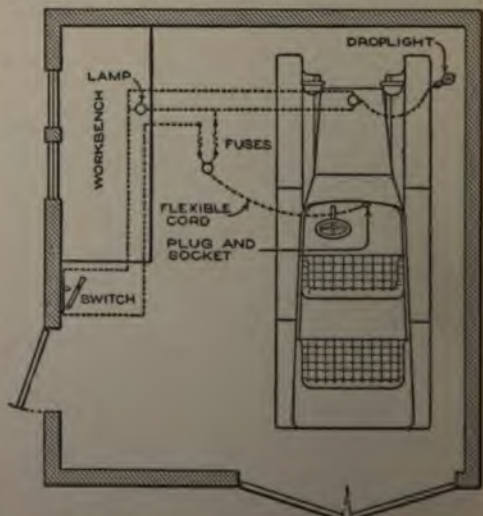

For the Car Owner Who Drives Chiefly in the Day-time, and Whose Storage Battery Therefore Has an Excess of Capacity, a Low-Voltage Garage-Lighting System Is Entirely Practicable

length of time. One or two lamps of not more than 15 cp., a droplight, and possibly a small light at the door, all fitted with suitable reflectors, are ample.



they came. On the eighteenth day of incubation they are sorted, and those bearing the same number are placed together in a basket. The baskets are tagged to identify their contents, and put in the incubator. When the eggs hatch, the chickens are banded before those in different baskets are allowed to mingle.—J. T. Bartlett, Boulder, Colo.

### Wells Several Hundred Feet Apart Operated by One Windmill

A western farmer has one good windmill, and two wells, about 600 ft. apart. The method by which he used the one windmill for pumping from both wells is indicated in the diagram. The two triangular disks are connected by stout steel wires, which run through holes in a number of posts along the route in order to prevent excessive sag and consequent strain on the bearings of the disks. The latter themselves are made of two thicknesses of 1-in. hard wood, with the grain crossed. The disk which does the driving is located above the pump on the windmill tower, and is connected and disconnected with the windmill shaft, at will, by means of a bolt.

This method of power transmission has also been used in other instances for carrying power from an engine, located in a shop, to a water pump, located under a

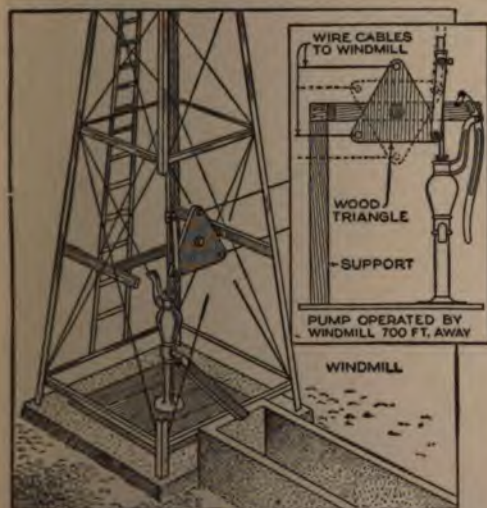

Two Rotating Triangular Disks, Connected by Two Long Stout Wires, Form a Practical Method of Power Transmission

windmill some distance away. The engine was then used for operating the pump when the wind was not blowing.

### Lathe Attachment for Grinding or Turning Pistons

When grinding or turning down new pistons to suit gas-engine cylinders that have had to be re-bored, difficulty is often encountered because the walls of the piston are so thin that they

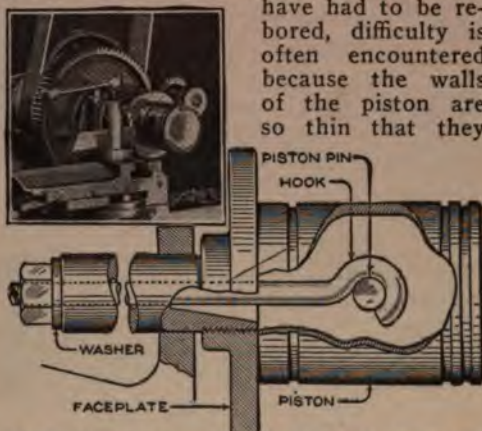

In Machining a Piston in the Lathe, It Is Well to Employ a Device for Holding the Work without Distorting the Piston Walls

spring out of round when gripped in the chuck.

This may be overcome by the use of the clamping bar shown in the cut. After putting the piston in a universal chuck and facing off the lower rim, it is placed with this trued surface against the chuck and clamped there by means of the bar. This hook over the piston pin, passes through the headstock spindle, and is secured in place by a nut and washer on its threaded end. Tightening the nut draws the piston firmly against the faceplate.

Should grinding be necessary, a special faceplate, slightly smaller in diameter than the cylinder bore, is used. This permits the grinding wheel to pass entirely across the face of the piston without striking.—M. L. Lowrey, Livermore, Calif.

### Soldering-Flux Spreader

A convenient soldering-flux spreader can be made from a 1/4-in. glass tube of sufficient length to reach the bottom of the acid bottle. One end of the tube is heated and flattened until it is nearly closed. To use the device, the flattened end is dipped in the flux bottle, and a finger placed over the other end when it is withdrawn. The acid is released when the finger is removed. A brass tube can be used instead of the glass, if the latter cannot be obtained.—Fred W. Page, Winfield, Kan.

### Serving Table Made from Bookrack

A resourceful western woman saves herself many steps by using a serving



An Old Bookcase was Used to Make This Convenient Three-Shelfed Serving Table, Which is Mounted on Casters

table made from an old bookcase that had been relegated to the attic as worthless. The case comprised three shelves, and was mounted on short wooden legs. The latter were removed, and casters substituted for them, whereupon the whole was refinished. When food is ready to be served, it is set on the two top shelves, and the improvised table is wheeled into the dining room, where it is placed beside the chair of the housewife, with its open side toward her. The bottom shelf is reserved for dishes soiled during the meal, and after it is finished, the left-overs are put on the other shelves and the contrivance is wheeled back into the kitchen.

### An Electric-Lighting System for the Garage

The convenience of electric lights in the garage is best appreciated by those who have had to do without them. But even if there is no commercial circuit available, any car equipped with a storage battery can furnish plenty of light for a reasonable time.

Detachable trouble lamps, while very useful, are hardly enough for the garage. A better plan is a system of overhead wiring, connected to the car battery through a removable plug. (The same socket will serve for a trouble lamp, when on the road.) With this system there is no groping about in the dark, for a switch can be provided at the door, and lights arranged in any convenient way.

The plug, on a flexible cord, hangs near the car, and can be connected and removed in an instant.

The permanent wiring should conform to the usual standards for lighting circuits of small capacity, but must not be extensive. Wire should be rubber-covered, No. 14 gauge or larger, on porcelain insulators or in moldings; fuses, same as used on headlight circuit in the car; all fixtures standard, except fuse blocks and lamp sockets, which will have to be of automobile type, since low-voltage lamps are hard to get in standard screw bases. Short circuits are not harmless even on 12-volt storage-battery circuits; and, besides, this same wiring can be used in case commercial current becomes available.

The connection to the car can be made through any kind of socket and removable plug. If the car is already fitted with a dash trouble lamp, the problem is solved. Otherwise, a socket can be fitted on the footboard, or dash, where connection is easily made to the ammeter terminal at the back of the instrument board. Unless the owner thoroughly understands his car wiring, a reliable electrician or service station should be consulted.

Of course, the system must not be overloaded, or used for an unreasonable

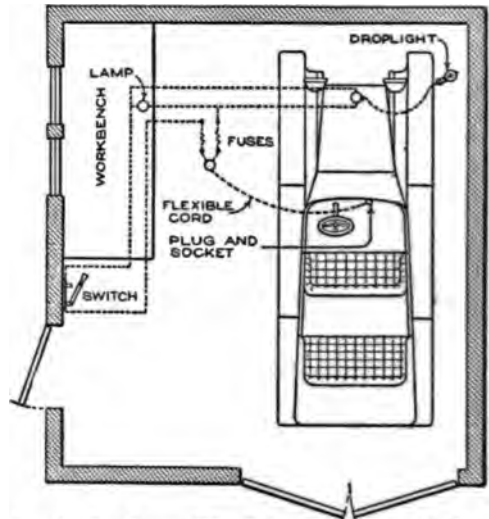

For the Car Owner Who Drives Chiefly in the Day-time, and Whose Storage Battery Therefore Has an Excess of Capacity, a Low-Voltage Garage-Lighting System Is Entirely Practicable

length of time. One or two lamps of not more than 15 cp., a droplight, and possibly a small light at the door, all fitted with suitable reflectors, are ample.



# Sled Runners with Plow Attachment for Light Cars

By P. P. AVERY

**I**N traveling through deep snow with an ordinary automobile, the tendency of the front wheels to pack up the snow in front of them often makes it difficult for the rear wheels to get traction, without slipping until the snow is thrown away by the chains. By providing the front axle with sled runners instead of with wheels, this effect can be eliminated. The runners are purposely designed with a narrow surface so that they will sink through soft snow, and will find or make a hard snow surface near the ground. At the rear of the runners, sheet-iron sides flare out to make a path for the rear wheels on which they can get good traction, it being understood that both are provided with chains.

heavy steel washers, wide enough to bear against the iron strap, so that the bending stress will not have to be taken by the hickory bearing. The two runners should be tied together by a bar across the front, and should, of course, be lined up parallel with each other as is done with wheels.

The flare formed on the heavy galvanized-iron sides of the runners acts as a small snowplow. Two iron braces should be fitted across from one side of the lining to the other, as indicated in the detail sketch.

Among the precautions to be observed in constructing the outfit are these: The bearing on the spindle must be a good fit, and all the washers must be held

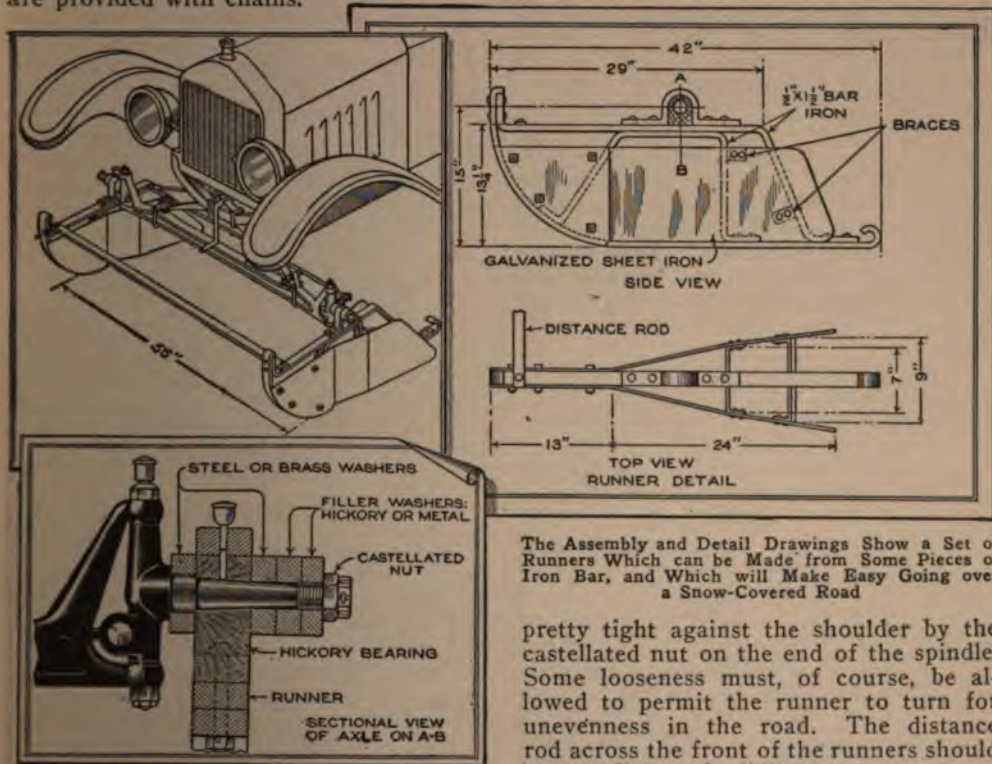

The Assembly and Detail Drawings Show a Set of Runners Which can be Made from Some Pieces of Iron Bar, and Which will Make Easy Going over a Snow-Covered Road

The runners themselves are formed from heavy iron bar stock, bolted together, and provided with a bearing at the top which fits onto the spindles, from which the front wheels of the car have been removed. This bearing can well be formed of a block of hickory with a taper hole reamed in it to take the spindle, surrounded by a heavy iron strap bolted to the body of the runner. At both inner and outer sides of the bearing should be

pretty tight against the shoulder by the castellated nut on the end of the spindle. Some looseness must, of course, be allowed to permit the runner to turn for unevenness in the road. The distance rod across the front of the runners should have sufficient flexibility, or looseness at the bolts, to permit one runner to turn a little on the spindle without the other's doing so.

A coat of paint on the iron will help to prevent rust. The wheels can be replaced on the axles in a few minutes, and the runners can be stored in a small space until needed again. Not the least of the advantages of a machine of this type is that the track which it leaves forms a path through the snow for other automobiles.

### Removing Moisture from Air Blast

Any person familiar with compressed air knows that water is always present, to a greater or less extent, in the air, and is a great nuisance, especially when the air is used to furnish blast for an oil or gas furnace.

The accompanying illustration shows a device that can be made from standard fittings, and connected on the line in series just ahead of the furnace. It will remove nearly all water without the use of any other trap. However, a common trap may be employed in addition, if desired.

Using a piece of pipe, four to six times the diameter of the supply line, and 1 to 2 ft. long, attach a pipe cap or a blank flange to each end; tap out two holes in the upper cap, as shown, for inlet and outlet, and provide a drain pipe with globe valve at the lower end.—W. H. Steele, Pittsburgh, Pa.

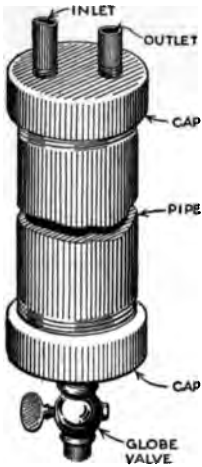

num was used to make the cylinder that fastens over the manifold. The material was cut to conform to a paper pattern which was fitted in advance. A short length of copper tubing conducts heated gas from the exhaust pipe to the cylinder. The tubing is held in position by a clip attached to the cylinder with a screw bolt. The contrivance is said to lower the gasoline consumption of the car, mileage considered, and to allow the engine to be throttled to a slower speed than is possible otherwise.

### Shoe for Lame Mule

One of a team of large mules was severely cut by barbed wire just over the hoof of its left hind leg. As a result the foot was drawn backward so that it could not be set on the ground properly; the mule had to walk on the edge of the toe. A blacksmith fashioned the device



shown out of a piece of 1/2 by 1 1/4-in. steel. It was welded to the mule's shoe where the front calk would have been, and the shoe was then nailed on in the usual way.

The mule now walks without difficulty, and with only the slightest trace of a limp.

### Automobile Manifold Heater

An intake-manifold heater for an automobile engine was made by an eastern motorist from odds and ends found in the

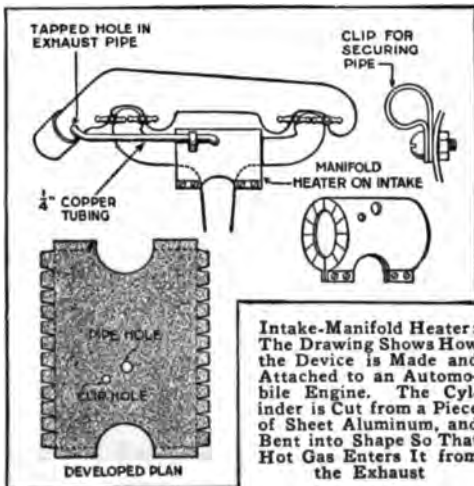

Intake-Manifold Heater: The Drawing Shows How the Device is Made and Attached to an Automobile Engine. The Cylinder is Cut from a Piece of Sheet Aluminum, and Bent into Shape So That Hot Gas Enters It from the Exhaust

### Removing Boiler Scale with Steam

Boiler scale may be quickly removed by the use of steam. When the boiler is cool, wash the loose mud out, then put the manhole heads loosely in place, and admit sufficient steam into the boiler to heat the scale. Remove the heads, and wash out. The scale will come off in sheets as soon as the water strikes it, due to the fact that while the boiler is steaming, the hottest side of the metal is the fire side, but while cool, the fire side is the cool side—the expansion and contraction being thus reversed, which causes the scale to come loose. Cold water also has a tendency to crack the hot scale.

Care must be taken to remove all the loose scale from the boiler, or it may either form a dangerous bank in the bottom of the boiler, or clog the blow-off.—Jack Solon, Natchez, Miss.

garage. The illustration indicates how the device was fashioned. Sheet alumi-



### Old Cot Made into Creeper

The frame and springs of an old iron cot can be transformed into a comfortable creeper for use by automobile mechanics while working underneath cars. After the legs are removed, a 2 by 4-in. scantling, as long as the cot is wide, is screwed, or bolted, under each end of the frame. Holes bored near the ends of these wooden pieces accommodate the casters taken from the legs. A canvas cover, and a padded headrest at one end of the frame, complete the contrivance.

### Washer Cutter Made from Tubing

When a small number of felt, or paper, washers is needed, and the expense of a die is not warranted, the work can be done with the shop-made device illustrated. A circular shoulder is cut in the end of a piece of hard wood. Around this is placed a collar, made from a short section of steel tubing, sharpened on one edge. Another collar of the same description and length, but smaller in diameter, is fitted inside the shoulder. The material to be cut is placed on the end of a wooden block, and the cutter is then driven through it.—Arthur A. Richardson, Quincy, Mass.

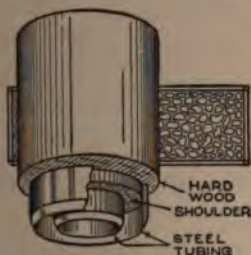

### Old Man and Ratchet

A compact and adaptable old man for use with a ratchet drill is shown in the cut. It is especially useful as being attachable to almost any part of a machine where a ratchet and drill is required to be used. The ratchet may be set at any point under the arm, as shown. This arm

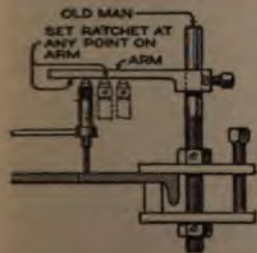

may also revolve on the old man, so that the hole may be drilled at any point within a circle of a radius equal to the length of the arm. The arm is also adjustable up or down, to accommodate the length of the drill.

### Hook Pulls Snow from Roof

With the easily made device shown in the illustration, snow can be removed



Device for Removing Snow from Roofs: As the Pole is Pulled Downward, the Boards Extend and a Large Area is Cleaned

from a roof without dangerous climbing. Two boards are hinged together and fastened to the end of a long pole. The "hook" is pushed into the snow with the boards folded against the pole. When the contrivance is pulled downward by the operator, who stands on the ground, the boards extend, and a mass of snow is shoved in front of them. A length of rope prevents their spreading too far.

### Holding Rough Work in Vise

Our shop had a job of planing 30 small steel blocks, about 2 in. long, and we had no jig suitable for holding them on the shaper. We could not hold more than one at a time in the vise, as they were forged to different sizes; the vise would tighten up on one or two, and the rest would be loose. In order to hold several of the blocks in the vise at once, we placed against each one of them a 1/2-in. cap screw, with a nut which rested against the vise jaw. Each nut was tightened until the block was held thoroughly tight, an effort being made to get each screw just as tight as the others. The vise was then tightened, clamping each block very tightly. In this way, five blocks at once were handled.—Joseph F. Convery, Worcester, Mass.

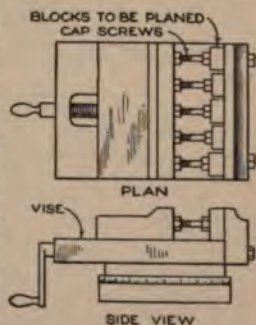



### Farm Gate Works on Wheel

Using a wheel taken from an old cultivator a farmer built a gate that requires little effort to open or close. The wheel



A Wheel from a Discarded Cultivator, Attached to a Farm Gate as Shown, Makes It Easy to Open and Close the Latter

is mounted near the free end of the gate between two vertical scantlings, which are mortised to receive the axle. Iron straps nailed across the openings hold the axle in position. The wheel supports one end of the gate, and acts as a roller when the latter is swung on its hinges, besides preventing it from sagging. The improvement cost little, and was made with only a small amount of labor.—Thomas A. Leadley, Lincoln, Neb.

### Leveling Work to be Drilled at an Angle

When a piece of flat metal work must be held at an angle on the drill-press table, so that an oblique hole can be drilled, it is not always an easy matter to obtain this angle accurately. A common carpenter's level, fitted with a steel pin as illustrated, will simplify this problem. A piece of  $\frac{1}{2}$ -in. steel rod is run through one end of the level, and provided with a set-screw to tighten it in any position. The distance from the center of this pin to

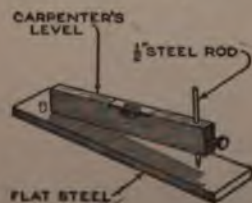

the farther end of the level should be some round number of inches, such as 10, 15, or 20. The lower end of the pin is filed or turned down to a fairly sharp point, which should be exactly centered.

If the work is to be drilled at an angle, for instance, of  $10^\circ$ , and the distance from steel point to farthest end of level is 20 in., the level is set as follows: From a handbook, the tangent of  $10^\circ$  is found to be .1763. Twenty inches multiplied by the .1763 gives 3.526 in., which is the distance the point of the pin must come below the bottom of the level. When the pin is fastened in this position, and the work clamped to the drill-press table the level can be placed on the work, and will show immediately whether the angle at which the work is set is the correct one. If not, adjustments are readily made.

### Lock and Protector for Switches

The electrical worker who has on his bench a row of knife switches, controlling various test circuits, may desire a simple method of locking these switches so that each one remains as set, open or

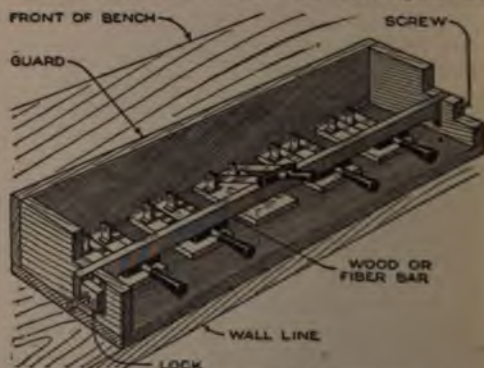

By Means of a Long Bar and a Cabinet-Door Lock, It Is Possible to Prevent Meddlers from Interfering with the Row of Knife Switches

closed, until thrown by the person carrying the key.

The arrangement illustrated involves the use of a bar of hard wood, or fiber, slightly longer than the length of the row of switches. One end of this bar is hinged on a screw so that it can be swung up to a vertical position. The other end falls into a slot provided with a small lock of the type used for cabinet doors. This lock is mounted so that the bolt projects into the hole in the long bar, thus preventing its being raised until the device is unlocked.

The bar must be located so that, when



the switches are closed, it will be in contact, or nearly in contact, with the bars of the knife switches, to keep them from being raised. The horizontal position of the bar should be determined so that it will be equally effective in preventing the closing of any switch which is left open when the bar is locked. It is well to set up a board between the switches and the rest of the bench to serve as a guard.

### Quick-Operating Jacks

The most common suggestion, for jacking up a car in the absence of the regular type of ratchet or screw jack, is to obtain a fence rail. Many motorists, however, do not even understand the proper use of fence rails for this purpose. As an explanation of the use of such a piece of planking, for jacking out of holes or for tire removal, the upper sketch shows how the work is accomplished with the least manual labor. Two large stones, or chunks of wood, are used with the rail. One stone or block is placed beyond the axle; this is the fulcrum for obtaining the desired leverage. The second

block, or stone, is placed under the other end of the rail, after the car axle is lifted to the desired height.

A modification of the idea, which is used by a busy farmer, consists in using a long beam with a block of wood nailed at one end. At the middle of the length

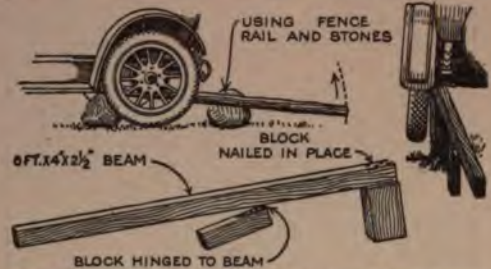

As a Quick-Acting Jack, for the Motorist Not Averse to a Little Muscular Effort, the Simple Device in the Lower Sketch Is a Great Success

of the bar is a strap hinge with a short piece of beam arranged to swing flat against the long piece. By merely pushing the lever under the axle, and giving a direct lift on the extreme end, the hinged member is swung out, and the job is done.

### Portable Pot for Bearing Metal

A manufacturer of machinery has found a way of saving time by converting a stationary type of electrically heated metal-melting pot into a portable, tilting outfit. The pot, which is about 10 in. high and 15 in. in diameter, is supported by means of bands on a shaft, the whole in turn being supported on a small hand-power truck. This can be taken to any part of the shop, and a considerable radius may be covered by the provision of a long, heavy, flexible cable, arranged for connection to the electric circuit at various points.

Bearing metal is heated in this outfit, and is applied directly at the location where it is required by simply tilting the pot. Two time-consuming features are overcome—the walking back and forth to a stationary melting pot, and the dipping of the

metal from it, and lifting it over the top. The pot used is of the immersion type, the electric heater units being housed in a cylindrical seamless-steel casing which is immersed in the metal to be melted.



One-Hundred-Pound Standard Bench-Type Electric Pot Used for Melting Bearing Metal: The User Mounted This on the Small Truck So That the Metal in the Pot could be Carried Directly to the Work

The current required for a pot of this kind and size is equivalent to that required for fifteen 100-watt lamps, or a 2-hp. motor.

### Gas Water Heater as Auxiliary to Furnace

By attaching a gas water heater to the principal radiator lines of a residence hot-water heating system, the latter can

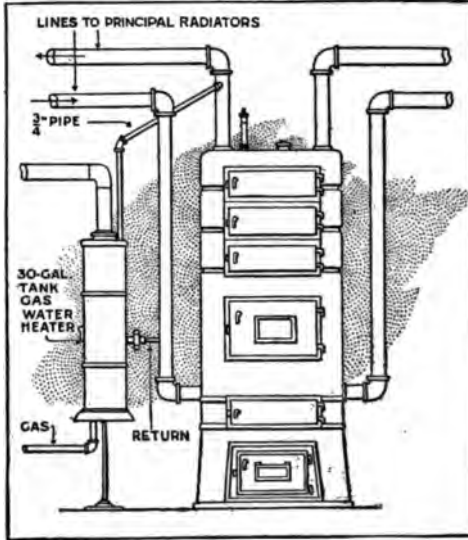

An Ordinary Gas Water Heater, Used Instead of the Boiler, Operates a Hot-Water Heating System

be operated without using the boiler. The outlet pipe of the heater is connected to the radiator supply pipe at any point between the boiler and the first radiator, while the heater inlet is connected to the radiator return pipe. Only the water in the lines and radiators to which they lead will be circulated by the heater. The contents of the boiler will remain stationary. Since the amount of water used is small, the gas consumption will not be large. This method can be used all winter, if desired, though it is especially suitable for supplying a small amount of heat during the spring and fall, on days when the weather is not cold enough to warrant a fire under the boiler. It is possible to use the heater to heat water for household purposes, while it is connected with the radiator lines, but this is not advisable, because of the dirt in the latter.

### Pure Aluminum Readily Worked with Carpenters' Tools

Tools suitable for working other metals are not adapted for use on pure aluminum, as many have discovered. However, excellent results can be obtained with ordinary carpenters' tools, set and

sharpened for use on hardwood. Planes will work satisfactorily on aluminum, provided the piece is not over 1 in. wide. The material removed resembles hardwood shavings, and the tool leaves a bright, smooth surface. While files do not give good results, a coarse rasp is an excellent instrument for use on rounded ends, or irregularly shaped pieces. Wood chisels may be employed for making mortises, though it is not advisable to use one over 3/4 in. wide. Parts that cannot be reached with a plane can be finished with a scraper, adjusted for hardwood, while fine sandpaper quickly produces a desirable semidull finish. In some respects aluminum is more easily worked than hardwood (because there is no grain in the metal), and unless the metal is impure, tools retain their sharp edges as long as, and sometimes longer than, when used on wood.

### Using Rubber Stamp on Curved Surfaces

It is difficult to use an ordinary rubber stamp on a cylindrical surface because the ends of the stamp will nearly always slip and blur, or print too heavily or not heavily enough. The illustration shows how a stamp may be mounted for use, especially on cylindrical work, such as broomsticks or round pasteboard boxes. A piece of sheet brass, or plated steel, is bent to cover loosely the top and sides of the stamp. The edges of the metal are rolled back so that the fold is in line with the face of the rubber type, or slightly above it. The straight handle is provided with a coil spring, which keeps the metal form down against the stamp mounting. The metal form is

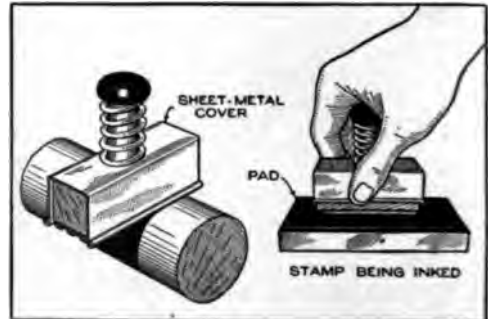

A Sheet-Metal Cover for a Rubber Stamp, Together with a Coil Spring on the Handle, Provides Means of Making Uniform Impressions on Cylindrical Surfaces

grasped by the thumb and finger, while the handle engages the palm of the hand. To ink the stamp, pull back the metal form and ink as usual; to imprint upon



the round surface, hold the stamp by the metal form only, not touching the handle. The spring should be strong enough to insure approximately equal pressure on all parts of the stamp, thus producing an even impression.—Harry E. Gifford, Medford, Mass.

### Engine Exhaust Provides Sand Blast

The exhaust pipe of a gasoline engine, if brought out to a horizontal position, can be converted into a sand blast by inserting in it a tube that is connected with an elevated sand box. A small quantity of sand collects in the pipe between exhausts, and is expelled with considerable force when the gases are released.—Chester Cook, McMinnville, Tennessee.

### Lathe Center for Small Work

The sketch shows a lathe center made for use in turning small rods, where the regular center would be in the way when the cutting tool reaches the end of the work.



A piece of steel is turned and tapered to fit the lathe-center holes, and drilled to take a length of drill rod, which should be a drive fit. A smaller drill is run entirely through, to provide an opening for driving out the small center when replacement is necessary. The center should be pointed while in place on the live spindle, and then hardened; if a center-grinder attachment is at hand, it may be accurately ground after hardening.—H. H. Parker, Oakland, Calif.

### Two Ways of Spoiling Taps

Taps are rather delicate tools, as every metal worker knows to his sorrow. There are two ways, among many others, in which taps are often rendered useless. One is to turn them with a monkey wrench instead of the regular tap wrench. This results in applying pressure at one side, and brings a bending strain on the tap, which very easily breaks it. The other is to use taps in cored holes in castings without first cleaning out the holes with a flat drill to take off the hard, gritty scale. This scale or skin is exceedingly hard on cutting tools of all kinds.

### Truck Skids for Use on Stairways

Two runners nailed to the sides of a two-wheeled hand truck make it possible to slide the truck, with a load, up or



Difficulty in Moving a Hand Truck up or down a Stairway is Considerably Reduced by Providing Runners Back of the Wheels

down an ordinary stairway. The runners, made from two boards rounded at the ends, should be wide enough to prevent the truck wheels from dragging on the steps. The device is especially useful in moving furniture and packing cases from the street into the first floor of a residence.

### Buggy-Top Brace Wire Stretcher

A convenient and serviceable wire stretcher was made from an old buggy-top brace and two pieces of angle iron. The brace was cut about 6 in. from the joint, and this end bent and sharpened as shown, leaving the other end long enough to provide good leverage. Small pieces of angle iron were then riveted at each side of the joint.

To use the stretcher, grip the wire between the angle irons, set the sharpened point against the post, and pull. The wire is held taut with one hand while the staple is driven with the other.





vice is simply a heavy wooden crosspiece, bolted underneath the inner end of the runway, and separated from it by two short pipe spacers, to compensate for the thickness of the turntable. As the crosspiece is underneath the turntable, as indicated, the weight of the runway presses it against the under surface of the turntable, and prevents slippage.

The fruit is picked into a bag by the picker, who empties it into boxes carried on the end of the turntable. When the boxes are filled, they are slid down

the chute, which also serves to brace the platform. For revolving the turntable, the runway is pulled back by means of the rope shown, which is attached at its inner end to a stout upright bolted to the turntable.

With an arrangement of this character, it is possible to pick the fruit from four trees at one stand, without changing the location of the machine, merely by revolving the turntable after the runway has been pulled back. One horse is used to draw the machine between the rows.

### Plane Adapted for Curved Surfaces

A very serviceable plane for smoothing curved wood surfaces can be easily made from an ordinary jackplane, as

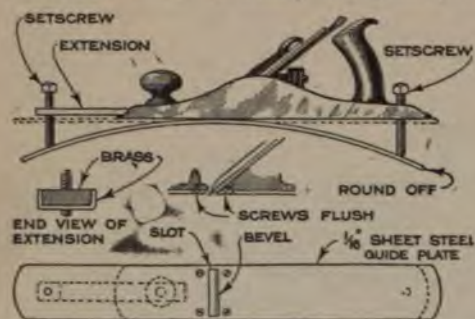

A Very Serviceable Plane for Smoothing Curved Surfaces can be Easily Made from an Ordinary Jackplane, by Adding a Guide Plate

shown in the drawing; such a plane can be adjusted to various arcs, within certain limits, and will be found fairly accurate.

The guiding surface is made of sheet steel the exact width of the plane; the slot for the plane iron can be quickly cut by drilling holes and finishing with a file, and the bevel should be on the same angle as the slot in the plane. The guide plate is held in place by four flat-head machine screws, located close to the slot as shown; the holes for the screws can best be located by clamping the guide plate in position and then drilling and tapping at one operation. The heads of the screws should be exactly flush, or, better, a trifle below the surface of the guide plate, so that no part of the screws will protrude and tear a planed wood surface. The adjusting screws, of which there are two, must be located as shown in the drawing; drill and tap for a  $\frac{1}{4}$ -in. setscrew. The forward adjusting screw has an extension provided for it. The distance from the forward ad-

justing screw to the cutting edge of the plane iron must be exactly the same as the distance from the iron to the rear adjusting screw; this is absolutely essential, so that the arc to which the plane is adjusted will always be part of a perfect circle. The extension is made of sheet brass, shaped as shown; one end is drilled and fitted underneath the wooden grip. A piece of brass is soldered inside the outer end of this channel section, as indicated, and drilled and tapped for a  $\frac{1}{4}$ -in. setscrew. The plane will slide easier if the guide plate is rounded off at each end.—Frank W. Harth, New York.

### Wind-Propelled Farm Sign

A simple revolving sign, which may be used to advantage along highways by farmers having produce for sale, is made from a few readily obtainable materials. The sign itself may have only two sides, but if preferred, may be made into a cube or cylinder.

The vertical shaft has a nail driven into its lower end; the head is cut off and the nail sharpened to fit into a depression

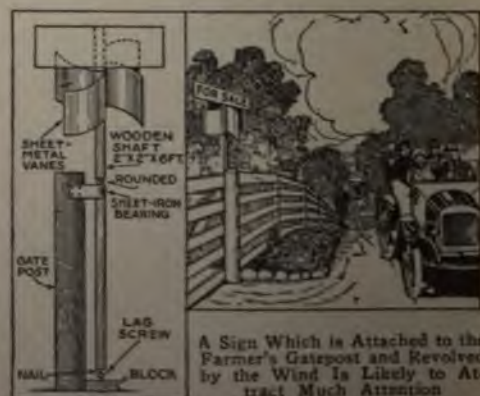

A Sign Which is Attached to the Farmer's Gatepost and Revolved by the Wind is Likely to Attract Much Attention

which is drilled in the head of the screw that is screwed into





### Bumper Protects File Drawers

Drawers in filing cases are often split, and sometimes the case itself, by being slammed shut. The easiest method of preventing this, where the construction of the drawer will admit its use, is to secure a piece of springy felt to the rear end of the drawer. Long pieces of spring brass or clock spring, secured to the sides of the drawer guides will retard the closing of the drawer sufficiently to prevent many accidents, while a combination of both springs and bumper will preserve all except very carelessly handled equipment.—J. H. Van Nice, Chicago, Ill.

### Moving a Garage by Tractor

When a man recently changed his residence, he resorted to a novel method to move his garage. Finding the cost of moving it by the usual method to be too high, he engaged the services of a truck and its driver for two hours. When the outfit arrived, he had the windows removed, and all was in readiness. The truck was backed into the garage, and two timbers made ready. The garage was then jacked up about 20 in., the timbers were run through the windows across the top of the truck body, and the jacks removed. This left about 16-in. clearance between the ground and the sill of the garage. It was then an easy matter to carry the garage to its new site.—Dale R. Van Horn, Lincoln, Neb.



Moving Expenses for the Garage Illustrated were Greatly Reduced by Motorizing the Process

### Fruit-Picking Ladder Wagon

The machine shown in the drawing was designed to supplement ladder-picking methods in a large apple orchard. A



DETAIL OF RUNWAY LOCKING ARRANGEMENT  
With This Machine Two Men Are Able to Do the Work of Eight. Fruit may be Picked from Four Trees without Changing Its Location

substantial wooden platform, of the desired height, was bolted to an ordinary box-bed wagon. At the top of this platform a turntable, of suitable length, was pivoted with a heavy bolt, an L-shaped section being obtained by bolting together two pieces of wood of different sizes, as shown in the detail drawing. Straight-grained material should be used for the extension runway on which the picker stands, as indicated by the drawing. This runway travels over a roller across the outer end of the turntable; wheels are provided at the inner end of the runway, for ease in extending or withdrawing it. As the runway is extended beyond the turntable, it is locked in place by its own weight, by means of the device shown in the detail drawing. This locking de-



### Two Farm Footbridges

The usual procedure in building a foot-bridge across a small ravine or stream is to select two heavy timbers for the string-

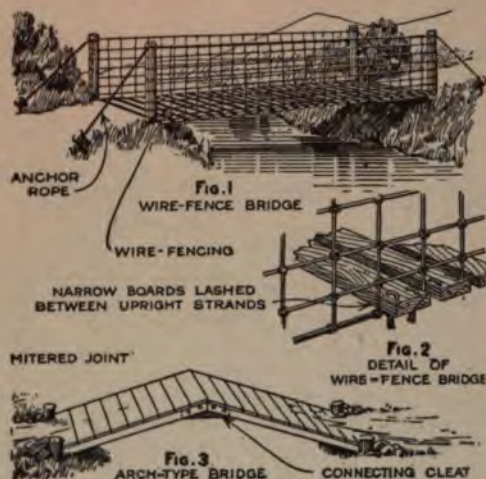

Two Simple Footbridges for Spanning a Small Ravine or Stream That can be Made from Readily Available and Inexpensive Materials

ers, or foundation, but, as these are not always available, the two bridges shown in the drawing are designed to be built from materials usually found on the average farm.

The bridge shown in Fig. 1 is made of heavy galvanized-wire fencing and narrow boards. Four posts, two at each end of the bridge site, are set into the ground at the desired distance apart, usually about 3 ft.; these posts should be perpendicular and be securely anchored to the anchor posts, a few feet to the rear. Wire fencing is stretched across the space to be bridged and made fast to the posts on opposite sides, care being taken to have the bottom strand of each strip parallel with the other. One-inch boards are used for the floor; these are drilled at each end and secured to the bottom strands of the fencing with wire, as shown in detail in Fig. 2.

In Fig. 3 is shown a bridge that is a simple adaptation of the arch; this bridge is constructed in two sections of equal length which are made by nailing 3-ft. lengths of 1-in. board to two pieces of 2 by 6-in. plank. The total length of the two sections, when laid end to end, should exceed the width of the place to be bridged by several feet. Two posts are solidly planted at each end of the bridge so that the distance between them be from 1 to 1½ ft. less than the width

of the sections. When the shore ends of the sections are made to butt against the two pairs of posts, the ends at the center will be somewhat higher, as shown; heavy cleats, behind the planks, are used for securing the sections together at the center. Such a bridge supports itself, because its total length, when straightened out, is greater than the space it occupies, and will bear a remarkable amount of weight without danger of buckling.—L. B. Robbins, Harwich, Mass.

### Cup for Leaking Oil at Valve Rod

On several types of automobile engines it is often found that oil will leak out through and around the valve tappet. This may be prevented by building around the valve-tappet opening a cup to catch the oil, so that it will flow back into the crankcase. A piece of brass tubing, faced off smooth and fitted over the boss or lug through which the tappet moves, will serve this purpose, and will thus prevent an excess loss of oil.—Hobart M. Kraner, Columbus, Ohio.

### Drawing Board for Office Desk

A shop foreman or superintendent often finds himself in need of a small board for sketching, sometimes wishing to use regular drawing instruments. A handy method of mounting such a board on a roll-top desk is shown in the picture. The board is merely the slide removed from the right of the desk; when not in use as a drawing board it is inserted again in its place. The board will have to be altered so that it can be removed freely from the desk, and will have to be provided with one or two staples or screweyes, to hang from hooks inserted in the base of the desk. When used as a drawing board, the slide should be turned bottom side up, so that thumb-tack holes will not mar its appearance as a desk slide. If the board originally used in the desk is of a wood too hard to take thumb





shown. Above the center of the shaft, a length of about 2 in. is rounded so that it will revolve easily in a bearing, made of a strip of tin or sheet iron with its ends secured to the fence post. To make the vanes, the bottom of an old metal bushel measure is cut out, and the curved metal is cut into four equal parts; these are nailed to the sides of the shaft, as shown in the drawing.

### Shelf for Shaper Tools

A machinist frequently has work to do on a shaper, which requires that his scales, calipers, and other tools that are frequently used, be kept within easy reach. The usual practice is to lay the

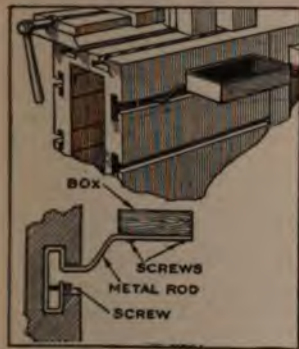

tools on the top of the vise, which is open to the objection that they are soon covered with chips, and small tools are sometimes lost by being brushed off with the chips. The drawing

### Simple Grindstone Water Can

There is a very good reason for using a drip can for keeping the grindstone wet, instead of a trough of water under the stone. The water in a trough washes off the loose grit, which has a marked effect in the grinding, so that not only does the stone wear down faster, but it does not grind so well. An easy way to make a drip can that will regulate the flow of water perfectly is to use a round can of any sort, and punch a hole in the side about  $\frac{1}{4}$  in. from the bottom. Put a good stout rubber band around the can. When the band covers the hole completely, no water will flow, of course, and the more the band is raised the more water will flow. Another plan is to insert a splinter of wood, such as a toothpick, under the band near the hole. The opening is regulated by moving the wood.

### Stops for the Washboard

When a washboard is used in a tub there is nearly always trouble because it

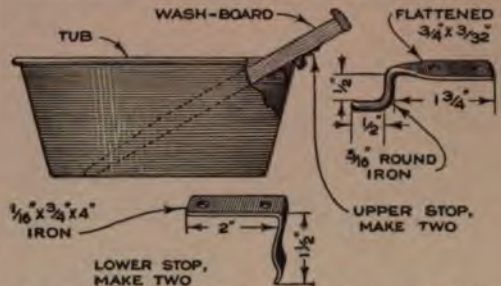

A Washboard Which does Not Move around the Tub as It is Used will Ease the Labor of Washing

has the tendency to slide around. This can be prevented by fitting the board with some stops to prevent it from moving up and down; nearly all the sidewise movement will also be prevented by this means.

Two lower stops and two upper ones are required; these are forged of iron, to the shape and dimensions given in the drawing. The two lower stops are not exactly alike, as they have to be twisted in opposite directions, to fit the curvature of the tub. When the stops are finished, attach them by screws or bolts underneath the sidepieces of the washboard, being careful to get the lower stops on the proper sides. The positions for all the stops should be marked while the board is actually set in the tub; it is then removed, and the stops are made fast. The lower stops should come in contact with the tub, and the upper ones should hook onto the rim. To detach the board from the tub, simply raise it to a horizontal position and slide it outward.

### Oil-Hole Covers Made of Corks

Dirt in the machine shop ruins many a machine by getting into the bearings, or plugging up some oil hole, with the result that the bearing soon burns out. The difficulty was overcome in one shop, as illustrated. An ordinary cork was dressed down, to make a snug fit for the pocket, and glued to an ordinary steel washer. This arrangement gave protection to the oil hole, yet it was but the work of a moment to remove the washer and cork.





### Auto Windshield as Dining Table

When one is picnicking or traveling in an automobile, and meal time comes around, a simple table can be improvised



The Windshield of the Car, Especially if Built Double, Forms a Convenient Picnic Table

from the windshield, within a few minutes.

Open the lower part of the windshield, to a horizontal position, so as to make a shelf; treat the upper part in the same way, thus making two tables, or counters. The lunch can be placed upon them in an appetizing manner.—Oden Liljegren Fern, S. Pasadena, Calif.

### Quickly Made Hand Level

A detail of men was sent out to locate some source of water supply, "somewhere in France," and it became necessary to run levels between a proposed camp site

and a lake. As no instruments of any kind were at hand, a novel hand level was improvised. A triangular framework, about 3 ft. long on each side, was made from boards; a stone that weighed about 3 lb. was firmly lashed to one corner, as shown, while a small, triangular-shaped hole, with one point up, was cut in the center of the side opposite the stone. The device was then supported on a nail driven into a piece of board, just below eye level, so that the upper side of the triangle swung approximately level, with the stone down. A nail was driven into each end of the upper side, in the manner indicated, the height being adjusted so that the nail heads were in a horizontal line when the triangle was permitted to swing free. By holding the de-



vice upright with one hand and sighting along the nail heads, it was possible to run the desired levels.

### Sparks as a Guide for Grinding

When grinding out a hole, on a machine with an adjustable table, precautions must be taken if the hole is to be ground absolutely without taper; unless the adjustment is quite exact, a slight taper will be cut in a hole which is intended to be cylindrical. One way of avoiding this is by gauging with an inside micrometer, but this is tedious and difficult. A method which is just as accurate, and easier to carry out, is to take a light cut on one side of the hole, along its full length, noting the amount of spark produced by the abrasive wheel. If the spark is uniform at all points along that side of the hole, move the wheel over to the other side of the hole and see whether the spark is uniform for all points along its length. If so, the hole will be ground true; if not, the table will require a more careful adjustment.—H. A. James, Jr., Wilmington, Delaware.

### Parallel Wedges for Accurate Settings

A parallel-wedge arrangement that is extremely useful, when it is desired to set work accurately, is made as shown in the drawing. The wedges may be made of steel, cast iron, or bronze, either cast and finished, or cut out from solid metal; the latter does not involve any considerable labor where small sets are required. Both wedges are grooved in the center, as shown, and a guide, made from a piece of round rod, is secured to the lower wedge; the wedges are grooved by filing, or by clamping them together and drilling. Spacing blocks are used to eliminate the need of a long adjusting screw.



### Blow-Out Patches Made from Garden Hose

One objection to the ordinary fabric or leather blow-out patch is that it is too short. When a tire is old enough or weak enough to blow out, it needs more protection than the short patch gives, for, while the hole in the tire is covered the weakened fibers farther back



tacks, a small drawing board can be obtained; it should be dressed down to fit the desk, and the edges and one side may be finished to conform to the rest of the desk. The other side is then available for use as a drawing board. Two hooks and eyes are better than one pair, but one is sufficient for small boards.

### Cleaning a Drain with a Stick

A practical method of clearing out a clogged sink pipe is to get a smooth stick of timber, of a diameter about two-thirds that of the pipe, and a length of about 18 in. Fill the sink half full of water, and wrap around one end of the stick a piece of cloth a little longer than the stick. Hold the stick in the right hand and the cloth in the left. Place the stick in the pipe and give several up-and-down strokes, holding the cloth tight. This will act like a force pump, and will clear the pipe.

### Asbestos Soldering Pad

The mechanic who has occasion to solder small articles will find an asbestos pad a great saver of time and patience. The pad is made by cutting sheet asbestos, of any thickness, into strips  $\frac{3}{4}$  in. wide; these strips are rolled into a spiral to form a pad of any desired size. The pad can be bound with wire or, better still, by making it fit inside the lid of a hand-soap

can. In use, the articles to be soldered are held together by pins, or short wires, pushed into the asbestos pad. Such a pad will facilitate the sweating together of small articles and will last indefinitely.

### To Keep Auto Hood Looking Bright

It may often be noticed that the hood and radiator of an automobile become dull and shabby-looking, while the paint on the remainder of the car is still neat. The ordinary cause of this is found in the practice of washing and polishing the car while the engine and surrounding parts are hot. The drying of soap and polish, owing to the effect of the heat, will injure the finish in a short time if continued. It is therefore much better to wait until the engine has cooled before washing the car.

### Toolmaker's Apron as a Tool Case

An excellent tool case for the small tools used by the mechanic can be easily made from an ordinary toolmaker's

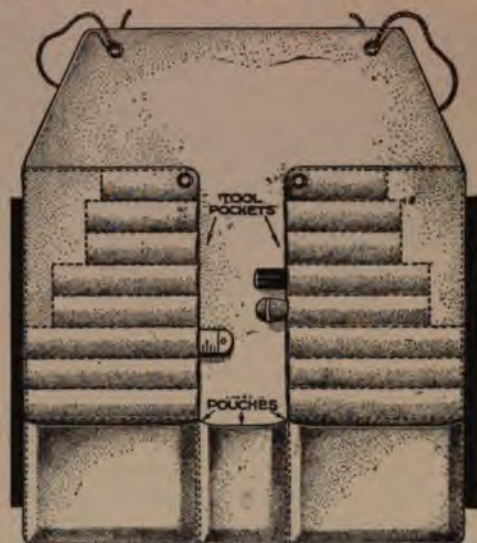

A Toolmaker's Canvas Apron Makes an Excellent Tool Case for Carrying the Mechanic's Small Tools Instead of Piling Them Indiscriminately into a Box or Bag

apron, by lapping over the sides and stitching the flaps to the apron to form pockets for the various tools, as shown by the drawing. Pouches may be formed at the bottom for holding small parts and miscellaneous supplies. When the case is rolled up, the bib portion forms a flap; cords or tapes, through the eyelets of the bib, are used for tying the roll and prevents it from unrolling.—W. F. Hollis, Chicago, Ill.

### Handy Soldering-Iron Rest

It is often very hard to find a convenient and available rest for a hot soldering iron. However, if two nails, about 3 in. long, are available, various unsatisfactory makeshifts can be discarded. The nails are driven at an angle to each other in the bench, as shown in the drawing; this forms a rest for the iron and leaves space for the fingers to grasp the handle quickly.—P. P. Avery, Garfield, N. J.





### Auto Windshield as Dining Table

When one is picnicking or traveling in an automobile, and meal time comes around, a simple table can be improvised



The Windshield of the Car, Especially if Built Double, Forms a Convenient Picnic Table

from the windshield, within a few minutes.

Open the lower part of the windshield, to a horizontal position, so as to make a shelf; treat the upper part in the same way, thus making two tables, or counters. The lunch can be placed upon them in an appetizing manner.—Oden Liljegren Fern, S. Pasadena, Calif.

### Quickly Made Hand Level

A detail of men was sent out to locate some source of water supply, "somewhere in France," and it became necessary to run levels between a proposed camp site



and a lake. As no instruments of any kind were at hand, a novel hand level was improvised. A triangular framework, about 3 ft. long on each side, was made from boards; a stone that weighed about 3 lb. was firmly lashed to one corner, as shown, while a small, triangular-shaped hole, with one point up, was cut in the center of the side opposite the stone. The device was then supported on a nail driven into a piece of board, just below eye level, so that the upper side of the triangle swung approximately level, with the stone down. A nail was driven into each end of the upper side, in the manner indicated, the height being adjusted so that the nail heads were in a horizontal line when the triangle was permitted to swing free. By holding the de-

vice upright with one hand and sighting along the nail heads, it was possible to run the desired levels.

### Sparks as a Guide for Grinding

When grinding out a hole, on a machine with an adjustable table, precautions must be taken if the hole is to be ground absolutely without taper; unless the adjustment is quite exact, a slight taper will be cut in a hole which is intended to be cylindrical. One way of avoiding this is by gauging with an inside micrometer, but this is tedious and difficult. A method which is just as accurate, and easier to carry out, is to take a light cut on one side of the hole, along its full length, noting the amount of spark produced by the abrasive wheel. If the spark is uniform at all points along that side of the hole, move the wheel over to the other side of the hole and see whether the spark is uniform for all points along its length. If so, the hole will be ground true; if not, the table will require a more careful adjustment.—H. A. James, Jr., Wilmington, Delaware.

### Parallel Wedges for Accurate Settings

A parallel-wedge arrangement that is extremely useful, when it is desired to set work accurately, is made as shown in the drawing. The wedges may be made of steel, cast iron, or bronze, either cast and finished, or cut out from solid metal; the latter does not involve any considerable labor where small sets are required. Both wedges are grooved in the center, as shown, and a guide, made from a piece of round rod, is secured to the lower wedge; the wedges are grooved by filing, or by clamping them together and drilling. Spacing blocks are used to eliminate the need of a long adjusting screw.



### Blow-Out Patches Made from Garden Hose

One objection to the ordinary fabric or leather blow-out patch is that it is too short. When a tire is old enough or weak enough to blow out, it needs more protection than the short patch gives, for, while the hole in the tire is covered, the weakened fibers farther back are not suffi-



tast gaining in popularity, is the binder engine illustrated in the other illustration. It is detachable from the binder frame, and may be used for a variety of other purposes around the farm, but is of peculiar value on the binder, as it reduces the number of horses needed to draw the machine. Traction is then independent of operation, and the chain is removed from the bull-wheel sprocket, the function of that wheel becoming merely that of carrying the load.

### Making Solder Stick to Cast Iron

Soldering cast iron is greatly facilitated if, after the iron is thoroughly scraped and cleaned, it is rubbed with a piece of soft brass. The brass must be soft enough so that some of it will stick to the iron; this can be readily observed. Thereafter, use the solder in the usual way.

### Adjustable Horse for the Wood Shop

The wooden horse shown in the drawing has some valuable features, inasmuch as one side can be elevated above the other. The purpose of this horse is to support long sticks as they pass in and out of woodworking machines, and it is especially intended for supporting long lumber that is being cut on a bevel, as indicated by the position of the roller in the dotted lines. The roller can be instantly raised and automatically locked at any angle by means of the pawl-and-ratchet arrangement shown. Pressure on the foot release disengages the pawls and lets the vertical posts drop. Flat springs, attached to the underside of the horse, press against the pawls and keep them in engagement with the ratchets.—M. E. Duggan, Kenosha, Wis.

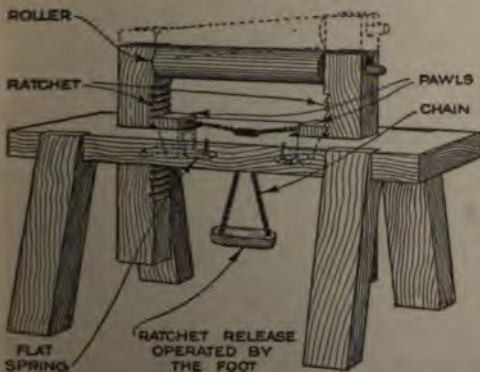

A Wooden Horse for Wood Shops That Has Some Valuable Features: The Height and Position of the Roller Are Instantly Adjustable

### Cold Drinking-Water Tank for Shop

A garage which has an old radiator lying around can make it, with very little

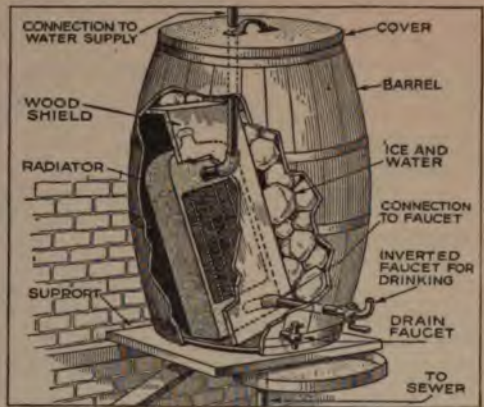

An Old Oil Barrel and a Discarded Radiator can be Combined to Furnish Cool Drinking Water

labor, into a drinking-water cooler for the shop. A water-tight wooden barrel is mounted on a bench or shelf. The radiator is thoroughly cleaned with soda, and is then placed inside of the barrel. Connections are made as illustrated. The drinking water flows down into the radiator, where it is cooled by the melting of ice which is dumped into the barrel. An inverted faucet, connected to the bottom of the radiator, will form a sanitary drinking fountain, and a drain faucet should be provided at the bottom of the barrel for removing the water formed by the melting of the ice. A wooden shield should be built up around the radiator to prevent it from being damaged by ice falling upon it.—G. A. Luers, Washington, D. C.

### Dividing a Small Circle Accurately

When it is desired to lay out divisions on a small circle with accuracy, it is difficult to do the work with dividers. The best way is to lay out a circle as large as possible, concentric with the one to be divided; divide the large circle as accurately as possible, and then transfer the divisions to the small circle by drawing straight lines to the center with a straight-edge. The advantage of this method is, first, that it is easier to work on a large scale, and second, that whatever errors there may be in the large divisions will be reduced in the small circle, though, of course, the proportions will remain the same. Much the same plan can be used in dividing a straight line or an arc.—Howard Greene, New York, N. Y.





# Aids for the Binder Working in Wet Soil

By Thomas A. Leadley

**D**URING recent years a large number of farmers in the wheat belt have been using very practical methods of meeting the difficulties which arise when a binder is operated in a wet harvest season. In various ways they have succeeded in preventing the bull wheel from breaking through the top crust of soil and sinking into soil that is wetter still. On binders of most types, the mechanism that is operated by the bull wheel is sufficiently heavy to act as a brake, so that a comparatively slight obstruction may prevent its turning. This is exactly what occurs under the conditions described: The bull wheel drags along without turning, the machinery stops, and the cutter plows its way through the standing grain without cutting it.

It is therefore necessary to keep the bull wheel from sinking. A common way of accomplishing this is to provide the binder frame with some additional support, so that the weight of the machine will be distributed. The roller, or keg float, shown in one illustration, is probably the most familiar. It is made by passing a piece of 1½-in. pipe, about 3 ft. long, through holes bored in the center of the heads; this axle is then attached to the binder frame with iron brackets, so as to be carried behind the bull

wheel, and about 3 in. above the surface, when the binder is set. By using the tilting lever, a part of the machine's weight may be thrown on the keg at any time.



A Keg Float Attached to the Binder Frame is Shown at the Left. The Style Shown at the Right Is of Simpler Construction

The type of keg float shown in the same illustration, on the right, consists of a keg with two planks bolted to it by clamps around the axle, the planks being attached to the front of the binder frame. With a float of this type, the keg rolls on the ground at all times, but when the bull wheel sinks into wet soil, part of the machine's weight is thrown on the planks. This float is a little easier to make than the former and does not place any additional weight on the binder, whereas in the first style the keg is supported by the frame.

The plank float, which is not shown, is even simpler than the keg float, and operates merely as a skid. It consists of a piece of 2 by 12-in. plank, about 6 ft. long, one end of which is fastened to the front of the binder frame with a short piece of chain. The plank slides along on the stubble, carrying no weight except where the ground is so soft that the bull wheel sinks several inches. Wood blocks are fastened above the plank at the rear end of the frame, so as to determine the condition under which it shall take a part of the machine's weight.



To Make the Operation of a Binder Independent of the Bull Wheel, a Gasoline Motor is Bolted to the Frame. Its Power Drives the Binding Mechanism, Relieving the Bull Wheel of This Duty

An alternative to the float, which is



fast gaining in popularity, is the binder engine illustrated in the other illustration. It is detachable from the binder frame, and may be used for a variety of other purposes around the farm, but is of peculiar value on the binder, as it reduces the number of horses needed to draw the machine. Traction is then independent of operation, and the chain is removed from the bull-wheel sprocket, the function of that wheel becoming merely that of carrying the load.

### Making Solder Stick to Cast Iron

Soldering cast iron is greatly facilitated if, after the iron is thoroughly scraped and cleaned, it is rubbed with a piece of soft brass. The brass must be soft enough so that some of it will stick to the iron; this can be readily observed. Thereafter, use the solder in the usual way.

### Adjustable Horse for the Wood Shop

The wooden horse shown in the drawing has some valuable features, inasmuch as one side can be elevated above the other. The purpose of this horse is to support long sticks as they pass in and out of woodworking machines, and it is especially intended for supporting long lumber that is being cut on a bevel, as indicated by the position of the roller in the dotted lines. The roller can be instantly raised and automatically locked at any angle by means of the pawl-and-ratchet arrangement shown. Pressure on the foot release disengages the pawls and lets the vertical posts drop. Flat springs, attached to the underside of the horse, press against the pawls and keep them in engagement with the ratchets.—M. E. Duggan, Kenosha, Wis.



A Wooden Horse for Wood Shops That Has Some Valuable Features: The Height and Position of the Roller Are Instantly Adjustable

### Cold Drinking-Water Tank for Shop

A garage which has an old radiator lying around can make it, with very little



An Old Oil Barrel and a Discarded Radiator can be Combined to Furnish Cool Drinking Water

labor, into a drinking-water cooler for the shop. A water-tight wooden barrel is mounted on a bench or shelf. The radiator is thoroughly cleaned with soda, and is then placed inside of the barrel. Connections are made as illustrated. The drinking water flows down into the radiator, where it is cooled by the melting of ice which is dumped into the barrel. An inverted radiator, connected to the bottom of the radiator, will form a sanitary drinking fountain, and a drain faucet should be provided at the bottom of the barrel for removing the water formed by the melting of the ice. A wooden shield should be built up around the radiator to prevent it from being damaged by ice falling upon it.—G. A. Luers, Washington, D. C.

### Dividing a Small Circle Accurately

When it is desired to lay out divisions on a small circle with accuracy, it is difficult to do the work with dividers. The best way is to lay out a circle as large as possible, concentric with the one to be divided; divide the large circle as accurately as possible, and then transfer the divisions to the small circle by drawing straight lines to the center with a straight-edge. The advantage of this method is, first, that it is easier to work on a large scale, and second, that whatever errors there may be in the large divisions will be reduced in the small circle, though, of course, the proportions will remain the same. Much the same plan can be used in dividing a straight line or an arc.—Howard Greene, New York, N. Y.

### Damper Governor Maintains Constant Draft in Chimney

The drawing illustrates a damper governor which has been found very successful in preserving a uniform draft in a

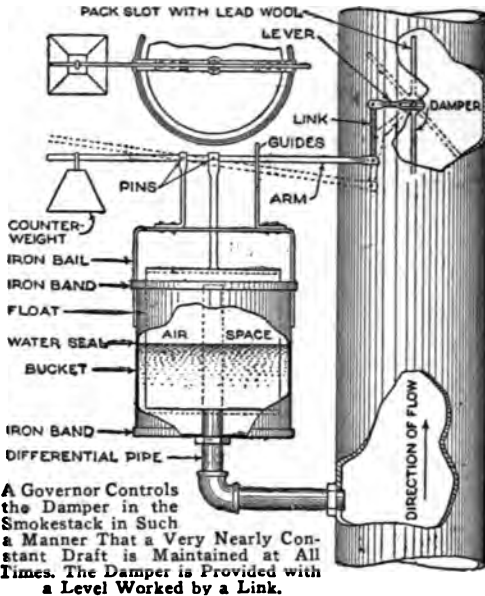

chimney or smokestack. The amount of draft which will be maintained by the governor is adjustable, within limits, by changing the size of the counterweight and float.

The damper, of ordinary type, is mounted in the chimney, but is provided with a lever worked by a link, as shown. The lower end of the link is attached to an arm which rocks on a pin. Beyond this the counterweight is hung. Some distance below, in the chimney, a communicating pipe leads to the bucket and float. The bucket is a galvanized-iron cylinder, open at the upper end, and having a water-tight bottom through which runs the differential pipe from the chimney. This pipe should extend nearly, or quite, even with the open top of the bucket. The float is another galvanized-iron cylinder, but is closed at the upper end instead of the lower one. It is inverted in the bucket, and some water is introduced, forming a sealed air space, which communicates only with the chimney through the differential pipe. Changes in the draft, or pressure, below the damper will cause varying amounts of gas to pass over into the float, which will cause the float to rise or fall, thus moving the damper to correct the variation in draft.

It has been found possible to control the draft in this manner within very narrow limits, but the dimensions of various parts must be a matter of experiment in each case, as conditions vary widely.

Iron bands are riveted around the top and bottom of the bucket to straighten its shell; this passes around the outside of the iron bail, straightening the adjustment of the latter to the bucket. It is necessary that the differential pipe come nearly even with the top of the bucket, to prevent danger of water being thrown down the pipe in times of high wind. All parts, and especially joints and bearings, should be designed to withstand moisture. —F. J. Lillis, Indianapolis, Ind.

### Exhaust Keeps Truck Chains Clean

In some parts of the country, where the soil is sandy, the chains of motor trucks must be run dry—without lubricant of any kind. Otherwise, the sand would become mixed with the grease on the chains and form a grinding compound which would make short work of chains and sprockets, but, by directing the exhaust from the engine against the chains, the evil effects of running without lubricant are minimized, and the chains are, at the same time, kept free of sand and dirt. Ordinary pipe and fittings are used for conducting the waste gases from the muffler to nozzles under the chains. The nozzles are formed by flattening the end of a short piece of pipe which is screwed into the ells. The long axes of the nozzles should be parallel with the chains and a little below them. Also, to prevent

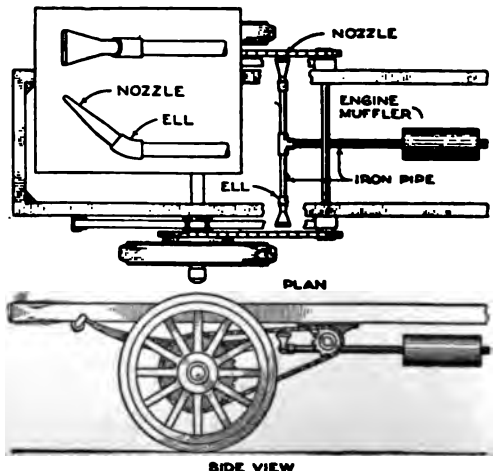

Directing the Exhaust Gases against the Chains of a Motor Truck by a Simple Arrangement, the Chains are Kept Free of Sand and Dirt, and Also Lubricated



back pressure, the nozzle openings should not be made too small. Some or all of the muffler baffle plates are removed, and the pipe is attached to the muffler instead of the exhaust pipe; the piping will reduce the noise of the exhaust, and it is desirable that the exhaust will come from the nozzles with considerable force. The exhaust gas will blow sand and dirt off the chain, also lubricating it to some extent, and, as the exhaust will be slightly cooled by the time it reaches the nozzles, it will not overheat the chains.—J. A. Birdsall, Hammonton, N. J.

### Making Logarithmic-Ruled Paper

In some parts of the country it is hard to obtain paper ruled for charts and tables, and the draftsman or student of design is obliged to make his own. A sliderule shortens the labor considerably, if it is laid along the sheet and the intervals marked from the graduations on the rule.—U. S. Lattner, Urbana, Ill.

### Mirror for Examining Boat Propeller

When the underwater mechanism of a motorboat is damaged, the usual procedure is to hoist the boat out of the water so as to determine the extent of the damage. The necessity of lifting the boat can be avoided by the following method:

Attach a section of stovepipe to a stout stick, 6 or 8 ft. long; to one end of the stick fasten a mirror by a hinge, and tie two strings, as shown, to the edges of the mirror farthest from the stick. The section of stovepipe should be of such a height that when the mirror is lowered to the correct point for getting a view of the propeller or rudder, the surface of the water will come somewhere near the middle of the stovepipe section. The purpose of the pipe, of course, is to provide a smooth water surface which will not obstruct the view in the mirror. In the case of smaller boats, it is often possible to see the propeller merely by holding a mirror under the water in the hand. Unless the water is very smooth, however, some such device as the stovepipe will be necessary.



### Horizontal Brace for Wire Fence

The constant strain of a wire fence soon pulls the posts over. This is especially annoying when the fence is built on a curve. Here is a rail brace that presents great resistance to the destructive force of the wires. It is placed 18 in. above the surface of the ground, and is mortised into the posts about  $\frac{1}{4}$  in. at



If the Posts are Braced against Each Other by Timbers Firmly Mortised In, the Fence is Strengthened against the Pull of the Wire

each end. The posts are set a rod apart, and are 6 or 7 in. in diameter, so that a timber 4 by 4 in. by 16 ft. will just fit in between the posts. The posts and rail should be creosoted, and the posts should be firmly set in holes 3 ft. deep. The woodwork will then outlast the wire.

### Lock for Wagon Tailboard

A quick-acting lock for a wagon tailboard, that prevents any possibility of the tailboard

working loose, and has no handscrews to fuss with, is shown in the drawing. An eyebolt is screwed into each side of the wagon box, near the top, to take the iron rods, as shown; these rods are both of the same length. An eye is turned

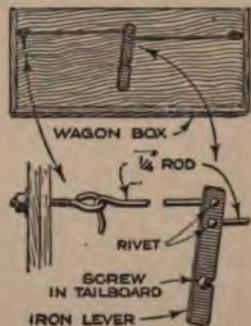

on the end of one rod and a hook is formed on one end of the other, the opposite ends of each being bent at right angles to fit into the holes of the iron lever, to which they are riveted. A screw in the tailboard engages with a notch in the lever, and thus any possibility of the tailboard working loose is eliminated.—E. K. Wehry, Cedar Rapids, Ia.

### Revolving Tool Holder for Lathe

For use chiefly in experimental work, the multiple tool holder illustrated was made so as to fit onto the cross slide of a lathe and to hold as many as six differ-

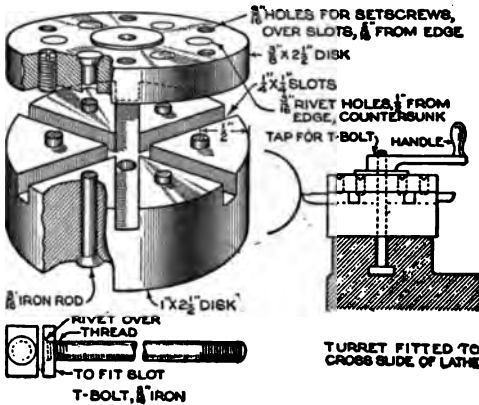

A Turret, to Hold Up to Six Cutting Tools, Is a Timesaving Accessory for the Model Maker's Lathe

ent cutting tools, or as many as are required for the job at hand. An example of the work for which the device was used is the turning of terminals and binding posts, in electrical construction.

The built-up turret is held to the cross slide by a T-bolt, and when the bolt is loosened by turning the handle, the whole turret can be revolved to the proper point for use of the next tool. Another turn of the handle tightens it ready for use. No attempt is made to place the tool automatically in exact cutting position, as the work done is chiefly by hand feed, and without close limits as to diameter.

The two cylindrical pieces of metal forming the turret are cut from 2½-in. cold-rolled steel shafting. They may be cut ½ in. and 1⅛ in. thick respectively, at first, being afterward dressed to size. First face off the larger piece, and lay out the six slots illustrated, by drawing six diameters, each 60° apart, and then drawing a line on both sides of each diameter, at a distance of ⅛ in. Cut out the slots by sawing on the outside lines, and cutting the metal away with a ¼-in. cold chisel. When the slots have been finished smooth, face off the thinner of the two cylinders to the thickness of ⅜ in., leaving a central boss, as illustrated. Now drill a central hole through both cylinders, to take a T-bolt, whose size will be determined by the key slot in the cross slide.

Next, the six rivet holes should be

drilled; it is convenient, while doing this, to have the two cylinders clamped together, by a bolt through the center hole. The rivet holes are countersunk, as shown, so that after the two cylinders are firmly riveted together, the burs can be ground off roughly, the whole turret chucked in the lathe, and the excess metal faced off, leaving the rivet heads flush. The setscrew holes are then drilled and tapped, one over each slot, so that the cutting tools can be clamped in the slots. Cut out a simple metal handle from some iron-bar stock, and tap the center hole to the handle, to take T-bolt thread. The T-bolt itself is made by attaching a steel block, machined to fit the slot, to a stud bolt, and then riveting, as shown in the detail. Finally, the bottom of the turret should be faced off to such a height that the center of the lathe comes level with the joint between the upper and lower cylinders of the turret.

The device was made in five hours, and has saved its cost many times over in speeding up many small lathe jobs.—A. N. Capron, Montreal, Can.

### Ventilator Used with Window Shade

Proper ventilation in a sleeping room is made difficult when a window shade is drawn down its entire length, and the draft through an open sash will often cause the shade to flap in an annoying fashion.

A simple remedy for these inconveniences is to make a stiff wire frame, about 5 in. wide and 2 in. longer than the width of the curtain. Insert two screweyes into the window frame, about 1 ft. below the curtain roller; bend open the eyes to receive the lower corners of the frame; then close them again. The ends of the wire are fastened together by a sleeve, or by soldering. The curtain is drawn down in front of the upper cross wire, and back of the lower cross wire. Attach a cord to one end of the wire, to draw it down and forward. This gives a triangular opening at each side of the curtain. To hold the curtain in this position, tie the cord to a cleat in the window frame.

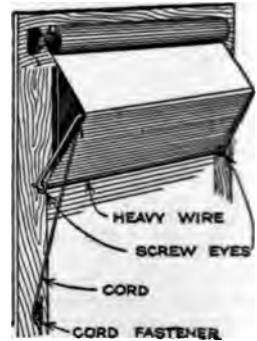



## A Level and Straightedge Tool for Ditching and Grading

FOR ditching, grading, and road work, a long straightedge, provided with an adjustable level, is in some cases more convenient than even a surveyor's leveling instrument. A convenient and effective way to mount a cheap carpenter's level in a long straight plank, for this purpose, is illustrated in the drawing.

A long mortise is cut in the center of the plank, large enough for the carpenter's level to fit in, with about  $\frac{1}{8}$ -in. clearance at the ends. The level is fitted in, and a bolt is run through one end as a pivot. Near the other end of the level, graduation marks are made on its side, as illustrated, and a series of holes are drilled through the level, one corresponding to each graduation.

By means of these, the instrument can be adjusted so that when the bubble comes to the center of the tube, the straight-edge will be at an inclination of  $\frac{1}{16}$  in. to the foot,  $\frac{1}{8}$  in., or any other desired grade, up to the end of the scale, which may represent 1 in. to the foot.

It will be convenient to use a piece of steel wire as a key, to hold the level in the proper position, and to drill holes through the level in a staggered position along two arcs, as shown, with two holes of the same size drilled through the plank to correspond to these two series of holes in the level. The two holes in the plank should be drilled first, say,  $\frac{1}{4}$  in. apart. The level should then be clamped tight with wedges, and adjusted so that it reads level when the bottom of the straightedge is actually level. The correctness of this adjustment may be tested as usual, by reversing the ends of the straightedge. When the adjustment is secured, drill a hole, at A,

through the plank, and clear through the level, taking care that the drill is at right angles to the surface. Unless the top edge of the level is perfectly flush with the top surface of the plank, the latter should be trued off flush with the level, or else a zero mark should be made along the level, even with the top of the plank. Now loosen the level, and pull the loose end out from the mortise; strike an arc from the pivot bolt as a center, using a known radius, such as 24 in. On this arc lay off, with a rule, graduations representing various grades; if the radius is 24 in., these will be easy to lay off, as  $\frac{1}{8}$  in. on the arc will represent a grade of  $\frac{1}{16}$  in. to the foot, etc. When the marks have all

been made, swing the level back into the mortise, and again clamp it by the wedges, but this time so that the first graduation is even with the top. Then drill a hole through plank and level, at B. Move the level to the next graduation, and drill another hole through the level, using the

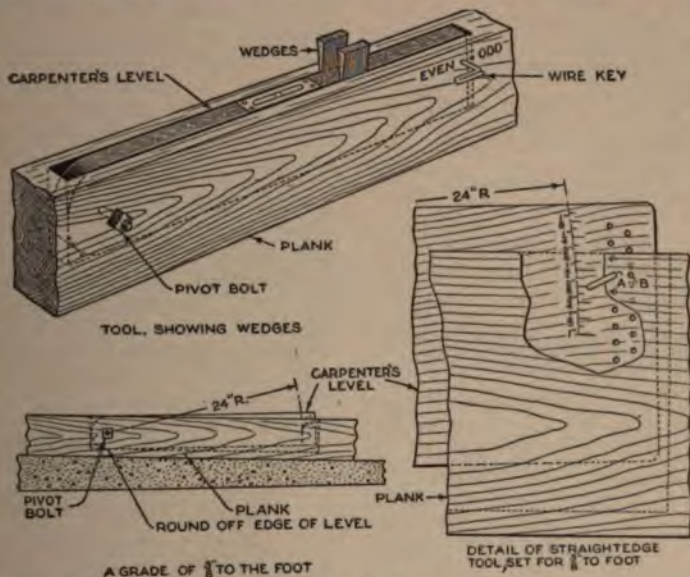

The Farmer or Contractor Who Has Grading to Do in Earth or Concrete can Do His Leveling with an Instrument Made from a Cheap Carpenter's Level

hole A in the plank as a guide. In doing this, it will be of the greatest importance to hold the drill perpendicular to the surface. Otherwise the hole on the farther side of the plank will be enlarged. On account of this necessity for true drilling, it is advisable to use a small drill press.

The purpose of drilling the holes along two arcs is simply to prevent their running together. It will be necessary in using the instrument to remember that for eighths, or for even sixteenths, the key should be thrust through hole A. For odd sixteenths the key fits into hole B.

When this work has been done, the level is ready for use. If a certain piece of



### Circular Saw Gummed on Grinder

The illustration shows how one shop solved the problem of gumming circular



saws in the absence of a regular machine. An ordinary trace chain with a swivel link about the center of its length, was fastened to an overhead support in such a position that, when the bottom link was pushed through the hole in the center of the saw, and a pin inserted in the link, the saw was held at the proper height for grinding.

The chain supports the saw, and relieves the workman of its weight, while the swivel link keeps the chain from twisting, and thus raising the saw from the proper height in relation to the emery wheel.

The teeth being gummed are supported by the tool rest, swung around to the face of the wheel.

### To Prevent Peeling of Bark from Rustic Timbers

For preventing the bark from flaking off logs used in rustic structures, the Forest Products Laboratory recommends the most effective methods of seasoning and preparing the timbers. First, the timber should be cut late in the summer. Score it on two sides; that is, cut off two narrow strips of the bark, for the entire length. Pile the timber in the shade, in an open pile, to allow thorough circulation of air. Allow the timbers to season until the following spring or summer before using.

A second method requires that the tim-

bers be cut and seasoned as described, and, in addition, the ends, stripped portions, and knots be coated with coal-tar creosote, using one coat a few days after the timbers have been cut, and another just before using them.

The third method also requires the timber to be cut in late summer, and to be seasoned until the following spring or summer, but the bark is not scored. When the timbers are in place, the bark is tacked on with large-headed nails, placing one to each square foot of surface. Paint the nail heads to resemble the color of the bark.

The fourth method is perhaps the simplest, in that the bark is tacked or nailed on without particular attention to the time of cutting or other treatment.

The nailing method has been successfully used by one western company which maintains numerous rustic hotels, and also on a large rustic building erected for exposition purposes.

### Turning Flanges on Thin Tubes

To turn a flange on a thin tube, such as a motorcycle exhaust pipe, which has broken off, cut a piece of flat steel about  $\frac{1}{2}$  in. thick,  $\frac{3}{4}$  in. wider, and 3 in. longer than the diameter of the tube to be flanged. Drill a hole in the center of the plate, to be a tight sliding fit for the tube; insert the tube so as to project above the plate a distance equal to the width of flange desired. Drive into the end of the tube a plug of round steel, about  $\frac{3}{4}$  in. thick, slightly tapered for driving, and dressed to the necessary diameter for a drive fit. Drill and tap a hole in the center of the round piece, so that a bolt can be inserted, to remove the plug after the flange has been completed; this is not necessary if the plug can be driven out from the other end of the tube.



Heat the assembly to a dull red, and hammer the tube down to form the flange. To remove the outside plate, slide it back  $\frac{1}{2}$  in. or more from the flange, and saw it in two, on both sides, at the narrowest place.—Edward N. Snowdon, Bath, Me.



strument is determined by placing it on a perfectly level surface and adjusting until both levels check up.

**A Makeshift Potentiometer**

An electrician who had broken his potentiometer, made another one by using graphite instead of the usual length of wire. He carefully split a long pencil and removed the graphite, after which he cut a thin board, about 10 in. long and 2 in. wide, and made a groove down the center deep enough to hold the graphite, but not deep enough to let its surface sink to the level of the board at any point. He then marked graduations along the groove, and mounted a rod over it which carried a contact slide, so that contact could be made whenever desired. The instrument was completed by attaching the usual terminals and connections.—James Motter, Washington, D. C.

**Tool for Drilling Centers in Rods**

The tool illustrated is for the purpose of drilling center holes correctly in small and medium-sized round rods, to prepare

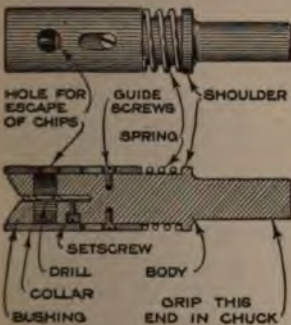

them for turning in the lathe. The body of the tool is turned on the lathe, with a shoulder as illustrated, forming a stop for a spring. Two holes are drilled and tapped on the opposite sides of the body to take two small fillister-head machine screws, forming the guide screws marked on the drawing. A set screw is set in against the drill, and held tight in the body. The collar, which slips back and forth against the spring, is prevented from turning by the guide screws in the two slots. A countersunk bushing is fitted around the point of the drill, and is a drive fit in the collar. The collar is therefore held from rotating on the drill, but is permitted to slide back, compressing the spring against the shoulder as the rod to be centered is forced against the bushing. One or more holes are drilled in the collar, as illustrated, to form a means of escape for any drill chips which may collect back of the bushing.—E. S. Goodell, Elkhorn, Wis.

**Blacksmith's Tire Shrinker**

In most blacksmith shops, the tire shrinker is mounted on a bench, or sup-

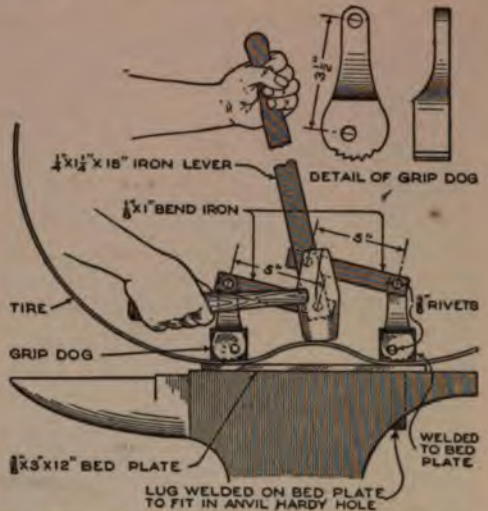

By Fitting the Tire Shrinker on the Anvil, a Tire can be Removed from the Forge Fire, Placed in the Machine, and Shrunken Before It Cools

port of its own, and is usually inconveniently located with reference to the forge, where the tire is heated. The drawing shows a shrinker mounted directly on the anvil, to which it is held by a square lug fitting into the hardy hole. All parts for this shrinker may be made in the shop or taken from a machine already on hand. The bedplate has a square lug, which fits into the hardy hole, welded to it at one end, and suitable projections, to which the grip dogs are attached, are welded on one side, as indicated. When the grip dogs have been riveted in place, the tool is completed by adding the hand lever and bend irons. With the use of a tire shrinker of this character it is possible to remove the heated tire from the forge and insert it directly into the machine, instead of carrying it to the shrinker in some other part of the shop.

**A Convenient Bolt-Hole Gauge**

A gauge made by boring a hole with every size drill bit in a piece of 3/4-in. board is often a timesaver when looking for a drill to fit a certain bolt. The bolt is tried in the holes until the proper size is found and the drill selected at once. The drill size is stamped above the corresponding hole, and a small hole drilled for hanging the gauge.—S. Vanaken, Port Ewen, N. Y.



# A Small Toggle Press for the Bench

By JOE V. ROMIG

THE small toggle press here described was originally built by the writer for use on press fits in light machine assembling, such as pressing spindles into gears and wheels, pressing in pins and bushings, etc. After seeing its strength and power and appreciating its further possibilities, I rigged it up for light punching on thin-gauge metal on lever arms, bell cranks, small wrenches, and holes of all sizes up to  $\frac{3}{8}$  inches.

The power is obtained by using the principle of the toggle lever; most of the work being done when the toggles are approaching the vertical position, great force can be secured in this manner.

The base is a simple iron casting of T-form, machined to shape, and drilled to the workbench with two  $\frac{1}{2}$ -in. bolts. The top of it, forming the table, is planed off so as to have an accurate surface to lay the work on, and the front face is shaped to allow the lower cross

member to bear against it, thus taking the side thrust of the lower toggle off the two columns. The columns are threaded for half their length, and fitted with two nuts, as shown. They are made stiff and rigid enough for punch work.

The cross members are made of cold-rolled flat steel, and are drilled and reamed to a nice sliding fit on the two standards. The upper cross member is drilled to receive the anvil, for press-fit work, or the punch. The lower cross member is slotted in its center, to receive the lower toggle, and is drilled for the toggle pin and for the two  $\frac{3}{8}$ -in. pins which hold it fast to the two columns. Care should be taken to keep all center distances alike, in the base and the two cross members, so as to allow an easy sliding fit. The toggle pins are made of

hard steel, which will better stand the shearing stress if they are hardened and drawn to a blue color.

When ready to assemble, place the lower toggle lever into the slot in the lower cross member, and insert the pin. Next, fasten the two upper lug toggles to the frame on the toggle lug. Slip the two columns down through the base, and through the lower cross member, and insert the pins. The top cross member is

then placed in position, and held so by the two nuts on each standard. Fasten the press to the workbench, and the press is ready for business. When setting it up for any certain height, care should be taken to have the upper cross member parallel with the base; this can be tested by measuring up from the base.

For pressing in small spindles and shafts, I use a cup-shaped anvil above, as illustrated, and a collapsing centering-anvil below.

This arrangement brings both shaft and hole in perfect vertical relation to each other. For small punchings, I insert the punch in the upper cross member, and clamp the die directly over the 1-in. hole drilled in the base. Below this hole is fastened a thin sheet-metal chute, which throws out all the punchings and scale, and also protects the toggles from all the scale and grit.

When setting up for a punching operation, care should be taken to line up both punch and die correctly, and to fasten them tightly. The operation of the press is quite simple; pulling the toggle handle upward lowers the columns and the upper cross member, and exerts a powerful pressure downward on the table. Since most of the work is done with toggles in their position of greatest leverage, very little effort on the p

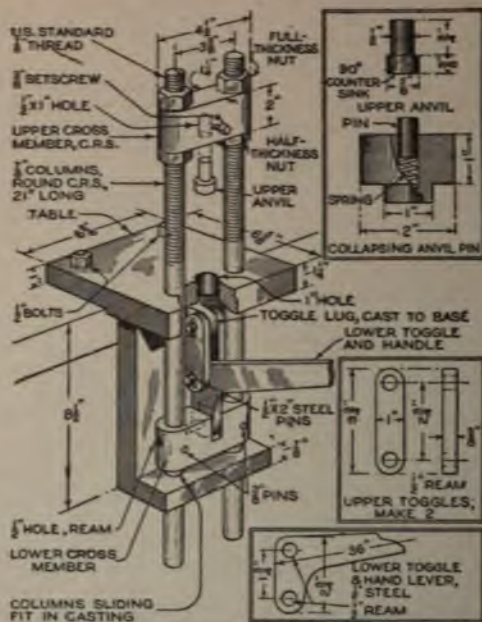

A Bench Press, Operated by a Lever through a Toggle Joint, Makes Possible Light Punching at a Very Small Expense



### Knife Blade Makes Ignition Key

One blade of a pocketknife will afford the owner of an automobile an emergency switch key for starting his car, or one for regular use if desired.

Simply shape the blade to correspond to the automobile switch key with a triangular file. If the blade is too hard to file, the steel can be softened by holding it in the flame of a torch or stove until it gets red, and then allowing it to cool slowly. This emergency key is less likely to be lost than the regular one, on account of its size.

### Filing Out Holes in Rubber

In filing cut-out work on hard rubber or dark-colored fiber, where the layout lines do not show up plainly, it is possible to obtain better results, on

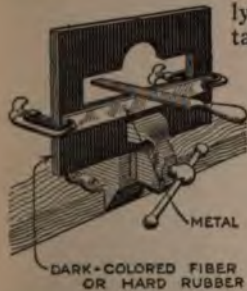

straight filing, by using a strip of metal as a filing gauge, in the manner shown. Clamping the straight edge of the metal even with the line will mean a better and quicker job, with no risk of filing below the line. Copper and other metals may be filed in the same way, by using an old hacksaw blade as the filing gauge.

### Easily Lubricated Lathe Center

Where heavy work is done on the lathe, there is often abnormal wear on the dead center. This can be largely avoided by making a center with an oil passage, as shown in the illustration. The point of the center is cut away, and a small hole drilled to a point just back of the shoulder, where it intersects a second hole drilled radially. A small groove at the point allows the oil to flow to the bearing surface. Oil is inserted in the radial hole with a squirt can.



Ⓢ A broken twist drill, ground to a blunt point, makes an excellent center punch.

### A Powerful Bolt Clipper

The illustration shows a powerful clipper, fashioned from easily obtained, in-

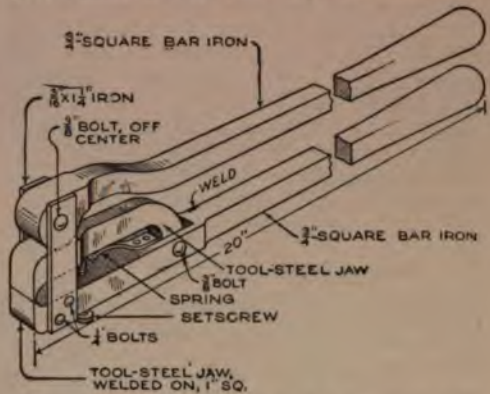

An Efficient Bolt Clipper, Made from Iron and Tool Steel, will Save Much Tedious Labor with a Hacksaw or Chisel

expensive materials, and suitable for cutting small bolts, rivets, and metal bars, or heavy wire. The tool-steel jaw, which is welded to one of the iron handles, is tempered between the weld and the point where the spring is attached, in order to give it sufficient strength. The spring forces the cutting edges of the jaws apart when the handles are separated, so that material to be cut can be inserted between the former. By removing a few bolts, the device can be taken apart. It is then possible to sharpen the cutting edges on a grindstone or an emery wheel.

### Shoes Enable Crutches to be Used in Soft Dirt

Many people who are forced to use crutches will welcome an idea, which will enable them to use their crutches in the garden, a pleasure which is usually denied them, on account of the difficulty of using crutches in soft soil.

Secure two ordinary sirup tins, punch four holes around the upper edge of each tin, run heavy rubber bands through the holes, then put the crutches down into the tins, and cut a notch in the crutch legs several inches above the top of the tins. Draw the rubber bands taut and securely bind them in the notches, and the shoes are finished.

The cans provide a large surface which will not easily sink in soft soil, while the rubber bands allow the crutches to rock slightly when walking, thus keeping the bottom of the cans flat.—E. Van Valkenburg, Moline, Ill.



### Stock-Proof Farm Gate

A short-cut path across a field to an electric car line was blocked by the owner, who fenced it with wire and



To Enable Pedestrians to Pass through a Field without Danger of Cattle Escaping, a Gate was Built of Three Posts

turned cattle in to graze. Since the path saved a great many steps, he received many protests. The owner gave permission to the pedestrians to put in a gate at each end of the path that would permit them to pass, but prevent the escape of cattle. This was done in the manner illustrated.

An opening was cut in the fence,  $1\frac{1}{2}$  ft. wide, a post placed on each side, and a third post midway between them, about  $1\frac{1}{2}$  ft. from the fence line. The arrangement proved to be quite satisfactory.—Werner W. Baumeister, Walla Walla, Washington.

### Collapsible Show-Card Desk

The show-card bench described will prove of great value in the sign shop where space is not very plentiful. It can be folded up against the wall, out of the way, when not in use. Another good feature is that when lettering a large oilcloth on a large sign, the bench can be lowered for working on the top line, then gradually raised until the last line is reached.

It will be easier to put the bench together before attaching it to the wall. Make it any length desired, putting battens on the underside. Then fasten the

2 by 1-in. stringer with screws, and attach the 2 by 2-in. piece to it by means of hinges placed every 3 ft. The width of the bench should be 3 ft. The legs must be 4 in. shorter than the width of bench. They are to be hinged to the bench itself, far enough away from the battens so as to fold up compactly. A hole, or notch, should be made in the 2 by 2-in. piece, to pass the rope through. If the bench is to be attached to a plastered wall, find the uprights back of the plaster, and fasten the 2 by 2-in. strip to the wall with 4-in. bolts, or screws, using washers. At the bottom of the legs, drive 1-in. wire nails, permitting  $\frac{1}{4}$  in. to extend. Cut off the heads; this prevents the legs from slipping on the floor. Before setting the bench in place, close it and place it against the wall, letting its outer edge touch the floor. Make a pencil mark on the wall above the strip, so that the bench will not be fastened too low to fold against the wall.

To raise the bench, simply lift it with the hand. To lower, or fold it away,

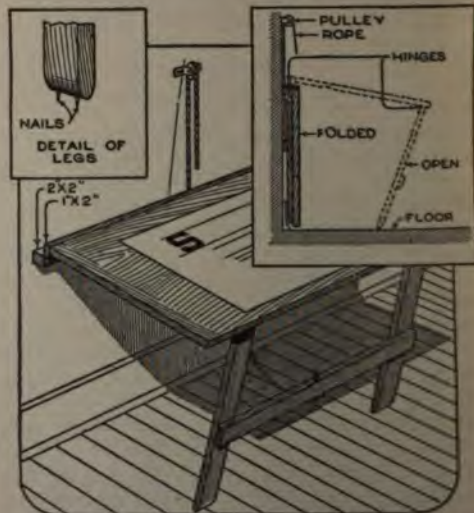

A Bench Made in This Way Takes Up Scarcely Any Room at All When Not Required, but Is Instantly Available When Lifted Up with the Hand

raise it slightly, pull on the rope that has been passed through the pulley above the bench, and let the bench down gently.—Arthur J. Kelly, Brooklyn, N. Y.

Auto tops which are left down most of the time soon have holes worn in them. They may be easily repaired by the use of the ordinary cementless rubber patches used to repair inner tubes.



ator is needed. No safety appliances are necessary on this press, as the weight of the toggle handle, in its lowered position, is more than enough to hold up the columns and cross members.

### Spring Makes Graduations Easily Read

When chasing threads on a lathe which is not provided with a cross-feed stop, it is very easy to forget what graduation on the cross-feed dial was last used, with the consequence that sometimes the tool is fed in too far, and the thread spoiled.

This danger is done away with by bending a piece of clock spring, or other light spring steel, into a ring which will spring over the cross-feed dial, leaving only a few graduations visible. By setting one edge of the spring on the dial to the zero mark on the apron, taking a cut, running the tool in again until the edge of the spring coincides with the mark again, then moving the spring two or three more graduations, and once more feeding in to the zero mark, the tool is positively returned each time to its previous position.—H. A. James, Wilmington, Delaware.

### A Quickly Made Awning

The sketch shows a quickly made, convenient, and cheap awning, to be used on windows. The frame is merely a length of heavy-gauge wire, bent to the shape and size required by the particular window. The ends of the wire are bent into loops, which fit into screw-eyes, thus making a hinge. This frame is covered with

duck, drill, or canvas. To raise and lower the awning easily, two pulleys or screw-eyes are attached to the window frame, one near the top, the other near the bottom of the frame. A light rope is carried through both pulleys, and the ends tied to the outer edge of the awning frame. This rope should have loops tied in it, for catching over a hook to hold the awning in any desired position.

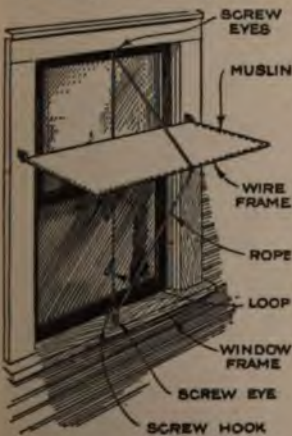

### Eaves Trough Repaired with Roofing

Eaves troughs that are beginning to rust through in places, can be satisfactorily re-



Eaves Troughs That are Beginning to Rust and Leak can be Satisfactorily Repaired by Lining Them with a Strip of Roofing Paper

paired by lining them with a strip of roofing paper. The cost is negligible, and if the repair is properly done, the trough will last several years longer. Cut off a strip of roofing paper the length of the gutter, and just wide enough to fit exactly inside, and so that the edges will just come under the hangers, as shown in the drawing. If the repair is made without taking the trough from the eaves, begin at the outlet end and unfasten the outer ends of one or two of the hangers; then insert as much of the strip of paper as possible, refasten the hangers and repeat the operation until the job is completed. If a good quality of paper is used and it is cut to an exact fit, the hangers will hold it in place and no other fastening will be necessary.—Chas. Albert, Chicago, Ill.

### Handles for Lifting Cylinder Heads

Detachable cylinder heads are usually heavy and difficult to handle when removing or replacing them. Handles to insure a firm and positive grip, to place the head squarely on the motor without damaging either gasket or fingers, are so readily made up of short pieces of pipe and pipe fittings that they are worth adding to the shop equipment.

Obtain several pieces of pipe, either one-half or three-quarters, and corresponding-size pipe tees. Thread the ends, screw the tees on, and the handles are ready to handle even the most stubborn cylinder head.

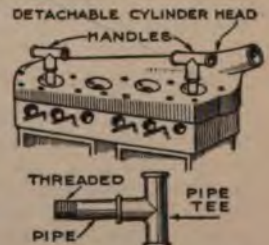





PHOTO COURTESY GEDNER HOOVER  
 The Side View Shows the Narrow Weather Boards of the New Structure being Built a Few Inches Away from the Old One. The View of the Front Door Also Indicates the Small Space between the Two Walls, and the Necessity of Having the New Doors Correspond in Position to the Old Ones

## Building a New House around the Old

THE pictures show how a western man accomplished the rather unusual feat of building a new house on the same ground as the old one without first tearing down the latter. The new house was built all around the old one.

The owner, who was of course a professional builder of long experience, first proceeded to dig a trench close about all four sides of the foundation of the old bungalow. These were then filled with concrete, forming a complete new concrete foundation. The only part of the old house which was torn away before the outward portion of the new one was completed was the front porch. The builder then proceeded with the frame walls for the new structure, these being in some places as close as 3 in. to the old walls. As the walls neared the top, the main difficulty was encountered, for the new bungalow had been planned to have a gable roof built at a different direction

from that of the old structure. To overcome this difficulty, holes were cut through the old roof for the new rafters, the holes being temporarily patched against the weather with tar paper. Then, as the new roof took form, the old one was gradually cut away. During this work the family occupied the old home as usual. When the outward structure of the new building was completed, two rooms were finished in the rear, which extended 20 ft. back from the old bungalow, and these served to house the occupants while the old house was torn down.

It may seem that a great amount of labor was wasted in working under such difficulties, but when it is considered that the amount saved in the labor of moving, and in keeping the floor coverings, carpets, and other articles intact, was estimated at over \$1,500, it may be well understood that the owner looked upon the job as a great financial success.

### Graduated Jaws for Milling Machines

It often occurs that the vise is used on the milling machine to mill a flat of a certain width, as shown in the sketch herewith.



By graduating one of the vise jaws in inches, the operator can immediately tell when he is right

or wrong. Such a method does not spoil the vise jaw for use on other jobs.

### Old License Plates Save Car Floor

It is a common thing to see two holes or ragged depressions in a car floor where the heels rest, just behind the clutch and brake pedals. Old license plates tacked over these places will reduce the wear on the floor, and yet provide adequate support. The rubber mat used on the floor may have a rectangular portion cut out just over this metal floor covering, thus protecting the mat from further wear in that spot, while still covering the rest of the floor.



## Prevention of Frost on Show Windows

By G. E. SAMPSON

WHAT would otherwise be a good window display is often rendered ineffective by frost. This happens when the temperature inside the window is higher than outside. When this is true, the moisture of the inside air condenses



When the Window Glass is Set in a Wooden Frame Which Extends above the Window Floor, All the Holes Required may be Made in This Frame

on the panes, and forms a thin film of ice. Frosting of this kind can be eliminated easily. One way is to place an electric fan inside the window to throw a current of air against the glass. However, with this method, certain areas of the glass surface, not touched by the air current, are covered with frost, giving the window a spotted appearance.

The method described here is cheap and satisfactory. The underlying principle is to ventilate so that the inside and outside temperatures are nearly the same. With it, an inclosed background must be used. That is, the show window must be so modified that it is shut off from the remainder of the store by practically air-tight partitions. Thus the background must be built entirely to the ceiling, as shown in Figs. 1 and 2. In the upper part of the background, window glass can be placed so that light will be permitted to enter the store. Over the lower part of the background, which is built of matched tongue-and-groove stock, a layer of white muslin is pasted, and, for decorative purposes, this may be covered with colored crêpe paper, wall paper, or cloth. It may also be desirable to divide the background into panels with strips of wood. Then the panels may be tinted any color with a flat oil or water paint. The means which should be employed

for providing ventilation will vary with the construction of the show window. Two general types may be encountered. In windows of the older designs (Fig. 1), the glass is set in a wooden frame. With the more modern buildings (Fig. 2), the glass frame does not extend above the floor of the window.

Where the window construction is that of Fig. 1, a number of ventilating holes, about  $\frac{3}{4}$  in. or 1 in. in diameter, are bored, equidistantly spaced in the window frame, as illustrated. A corresponding number of holes is also cut through the upper frame. Thereby, ventilation will be established, as suggested in the diagram. Fine-mesh screen, similar to that used in the windows of sleeping cars, should be tacked over the holes inside of the window, to prevent the entrance of dust. During warm weather, battens should be nailed over the holes so as to stop them entirely.

Where the window construction is similar to that suggested in Fig. 2, ventilating ducts opening to the outside are provided. Through the top window frame ventilat-



When the Lower Frame of the Window Does Not Extend above the Floor, Recourse must be Had to Two or Three Large Openings, Covered with Gratings

ing holes are bored. The ducts can be assembled from stovepipe or hot-air furnace fittings. On the outside, the openings should be covered with gratings. Hot-air-furnace register gratings will answer nicely. The openings in the window floor can be covered with fine-mesh netting or cheesecloth. In dressing the window, these openings should not be totally obstructed, because if they are, the window will frost in cold weather.





PHOTO COURTESY BISHOP MOVIER  
 The Side View Shows the Narrow Weather Boards of the New Structure being Built a Few Inches Away from the Old One. The View of the Front Door Also Indicates the Small Space between the Two Walls, and the Necessity of Having the New Doors Correspond in Position to the Old Ones

## Building a New House around the Old

**T**HE pictures show how a western man accomplished the rather unusual feat of building a new house on the same ground as the old one without first tearing down the latter. The new house was built all around the old one.

The owner, who was of course a professional builder of long experience, first proceeded to dig a trench close about all four sides of the foundation of the old bungalow. These were then filled with concrete, forming a complete new concrete foundation. The only part of the old house which was torn away before the outward portion of the new one was completed was the front porch. The builder then proceeded with the frame walls for the new structure, these being in some places as close as 3 in. to the old walls. As the walls neared the top, the main difficulty was encountered, for the new bungalow had been planned to have a gable roof built at a different direction

from that of the old structure. To overcome this difficulty, holes were cut through the old roof for the new rafters, the holes being temporarily patched against the weather with tar paper. Then, as the new roof took form, the old one was gradually cut away. During this work the family occupied the old home as usual. When the outward structure of the new building was completed, two rooms were finished in the rear, which extended 20 ft. back from the old bungalow, and these served to house the occupants while the old house was torn down.

It may seem that a great amount of labor was wasted in working under such difficulties, but when it is considered that the amount saved in the labor of moving, and in keeping the floor coverings, carpets, and other articles intact, was estimated at over \$1,500, it may be well understood that the owner looked upon the job as a great financial success.

### Graduated Jaws for Milling Machines

It often occurs that the vise is used on the milling machine to mill a flat of a certain width, as shown in the sketch herewith.



By graduating one of the vise jaws in inches, the operator can immediately tell when he is right

or wrong. Such a method does not spoil the vise jaw for use on other jobs.

### Old License Plates Save Car Floor

It is a common thing to see two holes or ragged depressions in a car floor where the heels rest, just behind the clutch and brake pedals. Old license plates tacked over these places will reduce the wear on the floor, and yet provide adequate support. The rubber mat used on the floor may have a rectangular portion cut out just over this metal floor covering, thus protecting the mat from further wear in that spot, while still covering the rest of the floor.



### Steel Wool for Cleaning Glass

Lettering or paint on glass of a rough or curved surface is a difficult thing to clean off with either scraper or paint remover. A simple method is to shave off as much of the paint as possible with a razor blade, and then go over the remaining paint with the finest grade of steel wool. This will remove every trace of paint. There need be no fear of injuring the glass, as the steel wool can be used for glass polishing. Glass in skylights, that has become weather-stained through neglect for years, can be made as clean as new glass by rubbing with coarse steel wool, and then polishing with the finest wool.—Arthur J. Kelly, Brooklyn, New York.

### Breast Drill Hung on Coat Hooks

The amateur mechanic generally hangs his tools on the wall by screw eyes, nails, etc., but when he tries the method with a breast drill, he finds that none of these will hold it. If two coat hooks are set in the wall, about 2 in. apart, the drill will hang straight and secure on them.

### Burning Garbage in the Stove

Garbage which collects in the household, consisting sometimes of vegetables, potato peelings, etc., when thrown in a



stove has a tendency to put the fire out, or at least to interfere with its heat. A better method is to build a receptacle in the roof of the stove, in which the garbage may be placed. It will then be dried out by the heat

of the fire without damaging the fire in the least, and will afterward catch fire and burn itself.

An old pan is first secured, and holes of ample size cut all over it. By means of small flanges it is bolted to the outer rim of the lid. In this way the damp rubbish can be placed in the pan by lifting off the small center lid. When the garbage has been consumed, the ashes filter through the openings and are removed with the coal ashes.—J. H. Rodgers, Montreal, Can.

### Cattle Holder for Dehorning

A lock gate for catching and holding cattle while they are being dehorned and marked, is simple in construction.



A Gate, Rigged Up So as to Leave Only an Opening Big Enough for a Steer's Head. Is Useful When the Animal is to be Marked or Dehorned

First make a gateway in the lot fence, using not less than 4-in. material for the gateposts. Now nail a 6-in. board on each side of these posts, across the gate at the ground, and also two others across at the top of the posts. Close up half of the opening by nailing boards diagonally to the boards at top and bottom of the posts, as illustrated. Get a strong pole, about 4 in. in diameter and 12 ft. long. Bore a hole through its large end with a 1-in. auger; also bore through the bottom boards, about 8 or 10 in. from the post at the open side of the gate. Let the pole down between the top boards and the bottom ones, and insert a 1-in. rod through the bottom boards and the pole. Then tie a 1-in. rope to the top end of the pole.

When ready to dehorn or mark a large strong animal, drive him toward the gate. Just as he passes his head by the pole, pull it over against his neck, and he is easily held. There is no danger of his doing damage with his horns, for he cannot move his head.



## A Practical Radio Arc-and-Spark Receiving Cabinet

By FRANK L. BRITTIN

**T**HE question of buying or making a wireless receiving set is uppermost in the minds of thousands of amateurs today, since the government has removed war-time restrictions on receiving radio messages.

The war has broadened the radio field to a really remarkable degree. The amateur now wants a receiving cabinet that will enable him to receive from the powerful arc stations of Europe, as well as from both arc and spark stations of this country. Receiving apparatus that has to be scattered all over a large table is obsolete; the modern receiving cabinet is a thing of beauty, an ornament to the home. The one here described meets the desire of the most advanced amateur. Set up in Illinois, it is sensitive to the long-wave or arc signals from IDO (Rome, Italy), POZ (Nauen, Germany), YN (Lyons, France), and other European stations, as well as the large stations of America. The aerial used is a single 160-ft. wire, on the roof of a three-story building.

The cabinet is constructed of  $\frac{1}{2}$ -in. birch, or mahogany, and is  $14\frac{1}{2}$  in. high,  $41\frac{1}{2}$  in. long, and 9 in. deep. It is divided into three sections. The front of the cabinet is of  $\frac{1}{4}$ -in. polished hard rubber, in three separate panels.

Before drilling these panels, a template of heavy cardboard should be made for each, and the scales for the condensers and rheostats scribed on the polished hard rubber, which is then marked for drilling. Fig. 1 shows the middle, or control, panel; and on this are mounted the battery controls for the "A" and "B" batteries, so-called. (The "A" battery is the storage battery which furnishes the filament current, while the "B" battery furnishes potential to the plate circuit.) The mounting for the bulbs may also be fitted to receive any type of audion bulb.

At C1, C2, C3, and C4 are shown the positions of the variable condensers for the arc circuit. R1 is the rheostat for the arc-receiver bulb, the bulb being placed directly above it. Double binding posts are used for the phones, so that more than one pair of phones can be connected when desired. The "A" battery, which is a six-volt, 40 to 80-amp.-hr., automobile-type storage battery, is used to provide the filament lighting for both bulbs.

At R2 is shown the rheostat for the spark-receiving circuit, and the bulb for it is placed above. The "B" battery controls

are shown at B1, for the arc side, and at B2, for the spark. Ten three-cell flashlight batteries provide the plate voltage for the arc circuit, and ten for the spark. The "B" batteries are placed in two banks of 10, each bank connected in series. A lead is taken from the negative side of each of the first nine batteries



Taking Up Only a Small Amount of Space in the Corner of the Room, the Cabinet Is an Inconspicuous Article of Furniture, and If Properly Finished, may Be a Real Ornament

to the upper control rheostat, and the last tap is left dead, as an "off" point.

The tenth battery of each bank must be opened, the sealing wax carefully removed, a lead taken from each cell and brought to one of the points of the lower four-point switch, for the fine adjustment; thus any number of cells up to 30 can be connected in, as needed. All leads from "B" batteries to taps should be placed in the proper position, as shown in the photo, and a thin strip of wood should be screwed to the top of the cabinet to hold them in place. This allows for the renewing of the "B" batteries without disturbing the arrangement of the leads. The "B" batteries for both arc and spark are connected in the same manner. All connections are carefully soldered. Two telephone-jack switches of the three-way type are used to throw the receiving circuit from the arc to the spark, and vice versa; if such jacks are not readily procured, or-



dinary double-pole, double-throw knife switches can be substituted.

At each side of the central panel is a smaller one. The one at the left carries the control for the long-wave primary; below it are the two binding posts for connecting the "A" battery. The right panel carries the short-wave primary control; the posts below it are to provide for an additional variable condenser, to be placed across the secondary of the short-wave coupler, if so desired. These panels are mounted flush with the face of the cabinet, a 1/4-in. rabbet being cut to permit this construction. The joining edges of the panels are covered with a thin narrow strip of nicked brass, screwed into the dividing partitions of the cabinet. The back of the cabinet is of beaver board, in three sections, like the front panel, allowing easy access to the circuits.

The "A" battery rheostats, R1 and R2, are of the back-mounted type, and are screwed to the back of the control panel. The condensers are mounted in the same manner.

Condensers C1 and C2 are 23-plate variables, and condenser C3 is a small-capacity five-plate variable, placed across the long-wave secondary. C4 is connected across the phones and consists of 43 plates. This comprises all the condensers in the long-wave receiving circuit in the electrical diagram, Fig. 2.

These condensers must be carefully constructed and mounted in correct

alignment, with a calibrated scale on the front of the panel. The scales are scribed

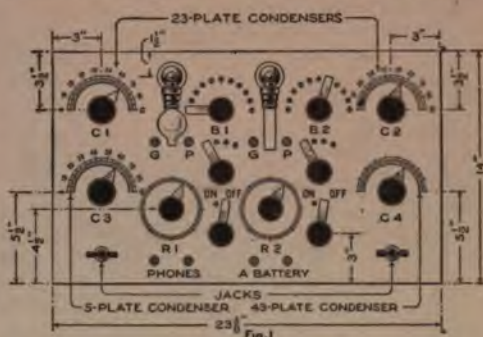

The Face of the Central Panel is Here Represented, with the Symbols and Dimensions Marked upon It

into the panel with an engraving tool, and jeweler's wax is rubbed into them, giving a clear, sharp detail.

The primary of the long-wave coupler is 7 1/2 by 13 in., and is wound with No. 30 double cotton-covered wire. The secondary is 6 3/4 by 12 in., and is wound with No. 32 double silk-covered wire. Both the primary and secondary are wound on heavy cardboard tubing, and are tapped off in the usual manner.

The primary of the short-wave coupler is 5 by 10 in., and is wound with No. 22 double cotton-covered wire; the secondary is 4 1/4 by 8 1/2 in., and wound with No. 28 double silk-covered wire. The primary tube is 13 in. long, but only wound for 10 in. of its length, as this provides

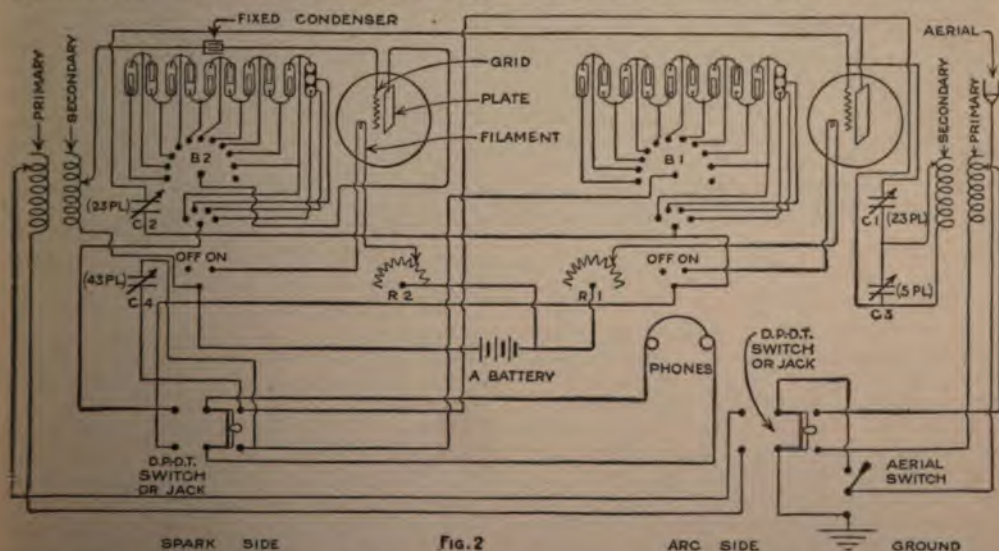

Fig. 2

The Complete Diagram of Electrical Circuits: The Spark Circuits are Grouped at the Left, and the Arc Circuits at the Right. The Two Circuits Interlock, However, at a Number of Different Points.



## Cyclometer Measures Mountain Trails

Information regarding the length of certain mountain trails was required for



By Pushing a Bicycle Wheel with a Cyclometer before Him, a Pedestrian Measures the Exact Length of a Mountain Trail

a guidebook. The paths were difficult to measure by the use of a pedometer, because of the rough ground and the winding of the paths.

A measuring instrument was made by mounting a bicycle wheel and cyclometer in a discarded front fork. This was fitted with a long shank and a handle. When pushed along the trail, the turning of the wheel is registered by the cyclometer, thus recording the exact distance covered by the pedestrian.

## A Simple Wire Snap

A quick-action snap is appreciated by those who work around horses, or who often have ropes to fasten quickly. The sketch shows a snap made from heavy spring-steel wire. It is easily formed, and fastens over a ring or staple with only one motion of the hand. The size can be made to meet requirements, and the work be sily and efficiently done on the farm, or the home.



## Low Wagon for Silo Filling

For filling silos, or other work about the farm, a low wagon is often convenient. To convert the ordinary high wagon into one of this type the reach is removed, and two 2 by 6-in. oak planks, about 16 ft. long, are fastened edge-wise to the underside of the rear axle, about 4 ft. apart. They should be held in place with U-bolts or wire. The forward ends are next brought together, and a 2 by 6-in. plank, about 10 in. long, nailed between them. This shorter plank should have a hole drilled through it so that it can be secured to the underside of the front axle by the kingbolt.

This V-shaped frame, which will easily carry a one-ton load, takes the place of the reach. On it, and far enough back so that the front wheels will not interfere while turning, a platform, about 7 ft. wide, is constructed of planks.

A wagon of this type is so low that, when in use, the fodder may be loaded or unloaded directly from the ground, and without an extra man on top being necessary.—John T. Bartlett, Boulder, Colorado.

## Clothespin Used as Vise

When it is necessary to do delicate work on small articles of jewelry, a clothespin makes a very dependable vise. Pass a small screw through the lips of the pin, secure it with a wing nut, and fasten the head of the pin with screws, or nails, to a table or window sill. The wing nut makes it possible to make very delicate adjustments, so that the lips of the pin hold the article steady, while the softness of the wood prevents it from being crushed.—Abel Green, New York, N. Y.



## Oil Limits Evaporation of Alcohol

Alcohol, which is considered by some to be the only thoroughly satisfactory antifreezing agent for automobile radiators, has the one fault of evaporating rapidly. This tendency may be largely overcome by pouring 1 or 2 oz. of very thin lubricating oil into the radiator. The amount depends upon the size of the car.—Paul A. Johnson, Rockford, Ill.



materials used. All the weights are covered with chamois, so as to make the coupling operation noiseless; and the square hole in the base of the secondary coil, through which the tube passes, is lined with leather to eliminate all friction noise.

The circuits are all shown in the diagram, Fig. 2; little need be said as to the connections for the short-wave side, as they are the ordinary "straight audion hook-up."

To change from arc to spark, and vice versa, it is only necessary to reverse both of the double-pole switches or jacks. The switch at the left controls the phones, and the one at the right the aerial and ground connections. Current is supplied to either filament by closing the two-point switch in series with it.

It will also be noted in the diagram that the permanent connection of the aerial is to a single-blade, double-throw knife switch. The connection is made to the blade of the switch; the latter is thrown upward when messages are to be received, and downward at other times, so that the aerial is grounded for protection against lightning.

The cost of a set such as described will

of course depend on how many of the necessary parts are made and how many

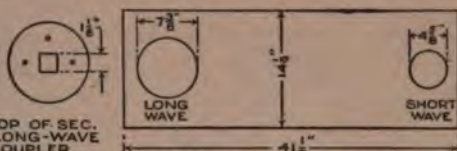

Fig. 3: TOP OF CABINET

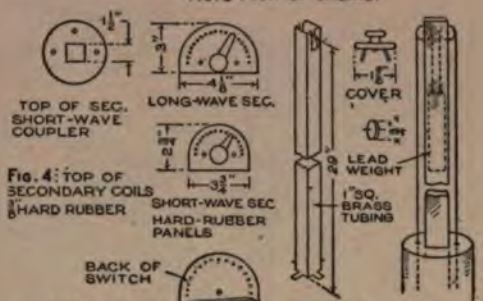

Fig. 4: TOP OF SECONDARY COILS

Fig. 5: SECONDARY CONTROLS

Fig. 6: DETAIL OF COIL COUPLING

Details of Construction: In Figures 3-6 Are Shown the Shape and Dimensions of the Secondary Mountings, and Their Controls

are purchased. With a reasonable effort to save money, it should not be over 75 dollars at the very most.

#### MATERIALS NECESSARY

- 2 back-mounted rheostats (battery).
- 2 23-plate back-mounted variable condensers.
- 1 5-plate back-mounted variable condenser.
- 1 43-plate back-mounted variable condenser.
- 2 3-way telephone jacks, or D.P.-D.T. switches.
- 2 double binding posts for phones.
- 10 small binding posts.
- 18 switch knobs complete.
- 164 switch points.
- 2 pieces  $\frac{3}{4}$ -in. hard rubber, 8 $\frac{1}{2}$  by 14 in.
- 1 piece  $\frac{1}{4}$ -in. hard rubber, 14 by 23 $\frac{1}{2}$  in.
- 2 pieces  $\frac{3}{8}$ -in. birch, or mahogany, 9 by 14 $\frac{1}{2}$  in.
- 2 pieces  $\frac{1}{2}$ -in. birch, or mahogany, 9 by 41 $\frac{1}{2}$  in.
- 2 1-in. square brass tubes, 29 in. long.
- 4  $\frac{3}{4}$ -in. pulleys.
- 1 8-in. square piece hard rubber,  $\frac{3}{4}$  in. thick.

- 1 5 $\frac{1}{2}$ -in. square piece hard rubber,  $\frac{1}{4}$  in. thick.
- 1 3 by 4 $\frac{1}{2}$ -in. piece hard rubber,  $\frac{1}{4}$  in. thick.
- 1 3 by 4-in. piece hard rubber,  $\frac{1}{4}$  in. thick.
- 16 1-in. machine screws (nickel).
- 19 1-in. wood screws.
- 2  $\frac{3}{4}$  by 14-in. thin brass strips (nickel).
- 20 3-cell flashlight batteries.
- 2 bulb sockets.
- 1 seamless cardboard tube, 7 $\frac{1}{2}$  by 13 in.
- 1 seamless cardboard tube, 6 $\frac{3}{4}$  by 12 in.
- 1 seamless cardboard tube, 5 by 13 in.
- 1 seamless cardboard tube, 4 $\frac{1}{4}$  by 8 $\frac{1}{2}$  in.
- No. 22 double cotton-covered wire.
- No. 28 double silk-covered wire.
- No. 30 double silk-covered wire.
- No. 32 double silk-covered wire.

#### Protecting Auto Engine from Cold

Unless measures are taken to protect an automobile engine during the winter, a great deal of trouble may be experienced as a result of excessive cooling. Spark-plug porcelains often crack when subjected to a cold blast of air while heated by the explosions in the cylinders; the carburetor fails to function properly, and the spark plugs are likely to become fouled with oil if the motor is not kept warm. Tin or sheet-iron shields will go far toward eliminating these difficulties. One of these should be installed on the intake manifold, and shaped so that it

protects not only that part of the manifold supplying the forward cylinder, but the carburetor as well. Another shield should be attached to the top of the forward cylinder, and extended upward and backward to deflect cold air from the spark plugs. In making these shields, a pattern of cardboard should be fitted before the material is cut. Further protection may be obtained by bolting sheets of tin or iron to the inside of the hood in such positions as to close the ventilating slits along the sides. If the entire hood is lined with sheet asbestos, the engine will run efficiently in the cold-weather likely to be encountered.



## Cyclometer Measures Mountain Trails

Information regarding the length of certain mountain trails was required for



By Pushing a Bicycle Wheel with a Cyclometer before Him, a Pedestrian Measures the Exact Length of a Mountain Trail

a guidebook. The paths were difficult to measure by the use of a pedometer, because of the rough ground and the winding of the paths.

A measuring instrument was made by mounting a bicycle wheel and cyclometer in a discarded front fork. This was fitted with a long shank and a handle. When pushed along the trail, the turning of the wheel is registered by the cyclometer, thus recording the exact distance covered by the pedestrian.

## A Simple Wire Snap

A quick-action snap is appreciated by those who work around horses, or who often have ropes to fasten quickly. The sketch shows a snap made from heavy spring-steel wire. It is easily formed, and fastens over a ring or staple with only one motion of the hand. The size can be made to meet requirements, and the work be easily and efficiently done on the farm, or in the home.



## Low Wagon for Silo Filling

For filling silos, or other work about the farm, a low wagon is often convenient. To convert the ordinary high wagon into one of this type the reach is removed, and two 2 by 6-in. oak planks, about 16 ft. long, are fastened edgewise to the underside of the rear axle, about 4 ft. apart. They should be held in place with U-bolts or wire. The forward ends are next brought together, and a 2 by 6-in. plank, about 10 in. long, nailed between them. This shorter plank should have a hole drilled through it so that it can be secured to the underside of the front axle by the kingbolt.

This V-shaped frame, which will easily carry a one-ton load, takes the place of the reach. On it, and far enough back so that the front wheels will not interfere while turning, a platform, about 7 ft. wide, is constructed of planks.

A wagon of this type is so low that, when in use, the fodder may be loaded or unloaded directly from the ground, and without an extra man on top being necessary.—John T. Bartlett, Boulder, Colorado.

## Clothespin Used as Vise

When it is necessary to do delicate work on small articles of jewelry, a clothespin makes a very dependable vise. Pass a small screw through the lips of the pin, secure it with a wing nut, and fasten the head of the pin with screws, or nails, to a table or window sill. The wing nut makes it possible to make very delicate adjustments, so that the lips of the pin hold the article steady, while the softness of the wood prevents it from being crushed.—Abel Green, New York, N. Y.



## Oil Limits Evaporation of Alcohol

Alcohol, which is considered by some to be the only thoroughly satisfactory antifreezing agent for automobile radiators, has the one fault of evaporating rapidly. This tendency may be largely overcome by pouring 1 or 2 oz. of very thin lubricating oil into the radiator. The amount depends upon the size of the car.—Paul A. Johnson, Rockford, Ill.



### Coaster Wagons Driven by Auto-Starting Motor

The photograph illustrates a vehicle used by a Pennsylvania battery expert in carrying automobile storage batteries from one place to another. It is made of two toy wagons, and is propelled by an automobile-starting motor of the single-unit type. The motor draws current from a six-volt, 80-amp.-hr. storage battery, which is carried in the rear end of the trailer. The motor carries a 19-tooth sprocket, and a 37-tooth sprocket is mounted on the rear axle of the front wagon, so that the speed is reduced in ratio of 1.95 to 1. A silent chain, 30 in. long, transmits the power, and the current is carried from the battery through 8 ft. of No. 4 copper wire. A two-point switch, having plenty of current capacity, is used, one point being connected directly to the motor, and the other point to a resistance, used for starting. With the six-volt battery a speed of from 8 to 15 miles is attained with the usual load. A 12-volt battery has been found to give from 17 to 22 m. p. h. Great care must be exer-

cised, however, in applying the higher voltage to a motor built for six volts



Two Solidly Built Toy Wagons, an Automobile-Starting Motor, and a Common Automobile Storage Battery, Are the Component Parts of an Outfit for Delivering Storage Batteries and Other Heavy Objects

only. It is also very important that the wagon used be one which is strongly constructed, as a cheap toy wagon can readily be broken down by the weight of one or more storage batteries and the wear and tear due to the operation of the motor. The outfit illustrated is in daily use in the delivering of storage batteries, after recharging and repairing, and it is found quite satisfactory for its purpose.

### Mounting for Auto-Horn Button

The bracket illustrated, for mounting the horn button of an automobile in a convenient place directly under the steering wheel, is readily made from a piece of steel or brass tubing. This is perhaps the most convenient place for the horn button, unless it is placed on the steering wheel itself, which causes continual twisting of the wires, and is, therefore, not to be preferred. The tubing may be  $\frac{1}{2}$  in. in diameter, and is slotted for a suitable distance from each end. The end to go around the steering column will probably be slotted about 4 in., and the other end, to fold out for attaching the button, about 1 in. The two wires leading to the button may be twisted around the steering post or, better, led through a piece of conduit down to the dash.

A button so mounted is always within reach of the driver's finger except when turning very sharp curves, and even then it is quite easy to find in emergencies.

The tube may be bent slightly upward to bring the button nearer to the rim of

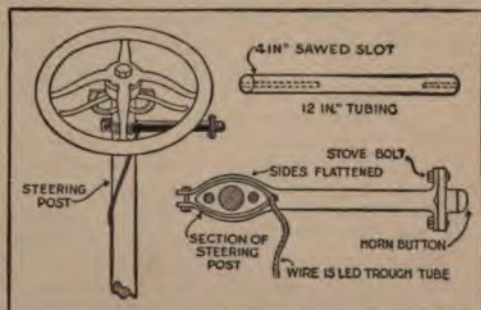

The Horn Button may be Mounted in a Very Convenient Position under the Rim of the Steering Wheel by the Use of a Piece of Tubing

the steering wheel, if this is found to result in added convenience.

☞ Corks which have been used a long time, and do not fit the neck of the bottle, can be renewed by putting them in boiling water and leaving it to cool.

**A Collapsible Window Ventilator**

A very great aid to health in cold weather is an efficient type of window

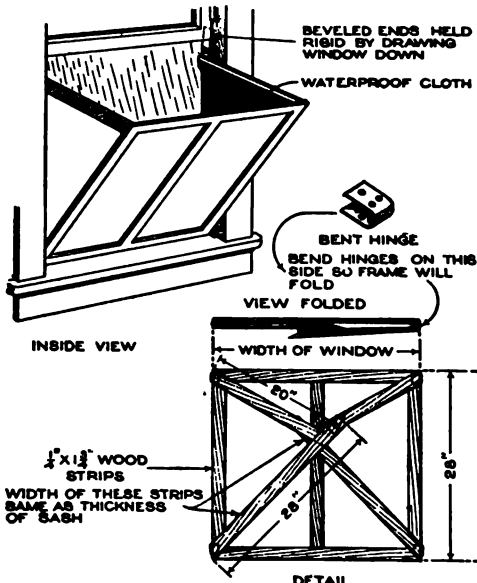

A Ventilator Made of Wooden Frames Covered with Oilcloth is Readily Detached and Folded Up

ventilator. To leave windows open in cold weather without some device to distribute the air properly merely causes the incoming cold air to settle at the floor of the room, while the warm air rises to the ceiling, where its heat is largely wasted. The incoming air should, therefore, be deflected upward so that it will be warmed by mixing with the warm air in the room. Another objection to leaving windows open in winter without a ventilator is that rain and snow are quite sure to blow in.

The device illustrated is no more efficient as a ventilator than some other types, but it has the advantage of being readily taken off and folded up, so that it can be put away in fine weather. The ventilator consists of three members, hinged so as to fold together. The rectangular member is as long as the width of the window, and may be 28 in. high, or less if preferred. It and the two triangular pieces are both light frames of wood, covered with oilcloth or some other water-resisting material. At the vertical edges of the triangular pieces are two strips which project above them, and are beveled off at the top to a sharp edge. These strips fit into the groove in which the lower sash works, and the sash, when

brought down, clamps them firmly in position, thus holding the ventilator securely in place. If the hinges on one side of the ventilator are bent somewhat as shown, the device can be folded up. —F. E. Leitch, Brooklyn, N. Y.

**Spacing Nails on Boxes**

Observations of packages which have failed in service and tests on packing boxes by the U. S. Forest Products Laboratory have shown that the most common defect in box construction is inadequate nailing. Attempts to strengthen boxes by the use of thicker lumber, without regard for nailing, very often only wastes material. The extra wood may not be needed so much as a few more nails.

Nails holding boards to the end grain of the box end should be spaced  $1\frac{3}{4}$  in. apart, and nails holding boards to the side grain of the end, 2 in. apart, when nails are 6-penny, or less. Increase the spacing  $\frac{1}{4}$  in. for each penny over six. No board should have less than two nails at each nailing end. Space the nails holding the top and bottom to the sides 6 in. or more apart, when the nails are 6-penny or less, increasing the spacing 1 in. for each penny over six.

While such spacing may appear to be too close, it actually calls for only about two-thirds of the number required to balance the strength of the nailed joints with the strength of the box in other respects. With the spacing given above, the nailing is still the weakest point of the ordinary box.

**Convenient Drawer Lock**

To prevent young children from upsetting the drawers of sewing machines and desks, a bent rod



can be mounted as illustrated. The rod, or stiff wire, is bent to a right angle at the top, and kinks are made in it which project into holes cut in the sides of the drawers. A shallow groove on the top of the desk allows the level end of the

rod to sink into it, preventing it from turning except when lifted.



### A Stain for Glass Windows

Window staining, for privacy or other purposes, can be quickly and cheaply done at home without calling in a professional workman. The only materials required are white shellac, dye of the desired color, and waterproof varnish.

For a white window, which admits light, but which is not transparent, coat the glass carefully with white shellac, dissolved in alcohol. After the shellac is dry, apply another coat, if necessary; then, after drying again, cover with the waterproof varnish. Such a window can be washed indefinitely without removing the stain.

Colored windows are made by mixing ordinary cloth dyes into the shellac until the desired shade is attained. For instance, for photographic dark-room use, mix orange and crimson dyes into the shellac until it is very dark. Cover with varnish when dry, as with the white coat. This forms a durable coating which can be washed, and which is not difficult to remove with alcohol. It serves the purpose, and costs much less than stained glass.—J. Horace Van Nice, Chicago, Ill.

### Double-Mesh Screens for Durability

Ordinary window screen must be replaced in from one to four seasons, depending upon conditions. Changing them spring and fall always damages them more or less. By covering the regular wire mesh with another piece of screening having a larger mesh, such as  $\frac{1}{4}$  in., the screens will stand much more abuse, and often last as long as 15 seasons. This more than pays for the additional cost.

### Chalk Holder Made from Cartridge

A large-caliber cartridge is readily made into a handy chalk holder in the manner illustrated. The small end of the cartridge shell is split in three places, and a knurled ring with a tapered hole is made to fit onto it, so that when it is pushed on, the chalk is held. A coil spring inside the shell pushes the chalk out when the ring is loosened.



### Arbor, Bushing, and Gear Press

A useful and easily constructed bushing and gear press, for use around the

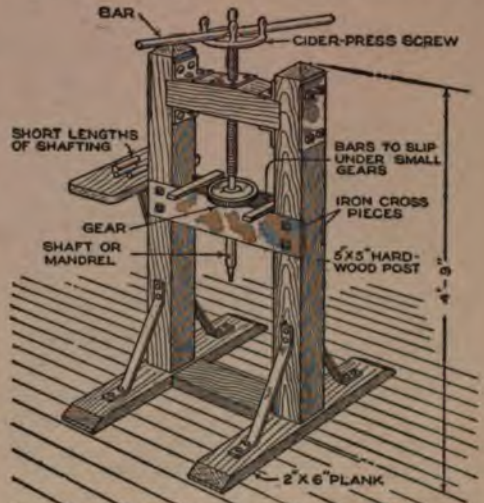

A Substantial Press for the Small Shop, Not Unpleasant in Appearance, can be Built Around Parts of an Old Cider Press

small-town garage and on the farm, may be made in the manner here described. An old cider-press screw, complete with its handwheel and crossarm, is obtained at a junk yard. Next, two hardwood posts, about 5 in. square, are secured, and the crossarm is mortised into these and firmly bolted; this should be about 5 in. from the top of the posts. Now screw down the handwheel, as far as the threads will allow. Mortise two heavy iron bars into the posts, one on each side; the top edge of these should be about flush with the lower end of the screw. These bars are to hold the work to be pressed. Short bars may be placed at right angles to the long ones, to accommodate small work. Short lengths of shafting of different sizes should be kept handy, for pressing out shafts from gears. When pressing in new bushings, the new one should be placed on the old one; the new bushing thus pushes the old out as it takes its place.—Fred W. Page, Winfield, Kan.

For giving a white coating to work that is to be laid out for drilling, used carbide makes an excellent substitute for chalk. Before using, draw off the water so that it will be about the consistency of paint, then apply evenly with a fine brush. When dry, the surface is ready for marking.



### A Mechanical Mystery with Tubes

Two tubes are first shown to be empty, by passing one through the other and



A Simple Device Is the Hook over the Tube, Yet One Which can be Made Very Mysterious

then exhibiting each in turn to the audience, who can see right through the tubes. Yet, at command, various articles are removed from the interior of the tubes, such as potatoes, handkerchiefs, dishes, fruit, or anything the performer desires to produce.

The trick is very simple, as the "load" is merely hidden in one of the tubes, while the other is exhibited. The articles to be produced, such as an assortment of fruit, are put in a handkerchief or tied together with string, and suspended inside one of the tubes by means of a hook that protrudes over the top as in the illustration. Both tubes are the same in height, but one is a little bit narrower than the other so that it can pass through it. The articles are suspended in the smaller tube which stands on the left side of the other. First the larger tube—the empty one—is picked up and shown to be empty, by holding it up so that anyone can see right through it. Then pick up the smaller tube, being careful not to let anyone see the inside of it, and lower this tube down through the larger one. As the extending hook reaches the tube, it will catch on so that the suspended load is lifted from one tube to the other. Now the smaller tube can be shown empty.

Then produce the articles; as each tube was in turn shown empty, the production of fruit will be mystifying. The small hook cannot be observed unless the audience is too near, and at the end of

the trick, this hook should be removed under cover of some of the articles produced. Then the audience can examine the whole affair.—Clarence T. Hubbard, Hartford, Conn.

### Auxiliary Cells beneath Floor Boards

When occasion arises to add four or five dry cells to the equipment of an automobile, for the purpose of auxiliary ignition, it is not always easy to find a convenient location for them. To stow them under a seat frequently means to encroach on space that already is very limited, and a satisfactory alternative is to place them under one of the floor boards. This can be done by removing the board and nailing a small box to the lower surface, to be used as a container for the cells. The wire leads can be brought out through one small hole in the board. When the cells are to be renewed, the board is removed from the car, and the container is opened by raising one of its sides, which is fastened to a hinge, and so forms a lid. This construction makes it unnecessary to cut a hole in the floor board to provide access to the container, so that the strength of the floor is in no way impaired.

### Cooking Bracket on Gas Jet

Where it is desired to keep water or food on a gas jet, great assistance can be furnished by a wire frame which fits into the shade holder, as illustrated. The frame should be made of stiff steel wire, and the lower ends of the two U-shaped pieces may be soldered to a ring of the same wire, which is formed to the same size as the base of the shade. It is then firmly gripped by the same setscrews which hold the shade.—F. W. Runge, Elmira, New York.



Long-necked vases can be cleaned by filling them with hot water in which small bits of paper have been mixed, then shaking vigorously. The wet paper removes the grime and sediment.



### Tomato Foliage as Insect Killer

It has been proved that there are properties in tomato foliage which have a destructive effect upon blight of various kinds, especially plant lice. There is generally an abundance of this foliage in kitchen gardens, and good results can be obtained by doing no more than placing some of the leaves upon blight-infested plants; but it is, of course, more practical to make a solution for spraying. Bruise some of the foliage in a pan, pour on boiling water, and add more leaves until the solution is of a deep-green color. Let it become tepid—not cold—and spray the plants abundantly. The preparation may be used without restriction as to quantity, since it is harmless to vegetables, though very effective in destroying blight. It loses its power in a few days, but fresh supplies can be very easily prepared.—S. Leonard Bastin, Bournemouth, England.

### Chains Pull Tire from Rims

An easily constructed and easily carried tool for the removal of split rims from automobile tires is made from two 15-in. pieces of chain, and a short piece of gas pipe. After the latch holding the ends of the rim together is knocked loose, the two hooks on the ends of the chain are attached to opposite edges of the rim. A pull, in the direction indicated, on the end of the pipe quickly loosens the rim from the tire. Adjustments for the various sizes of rims can be made by providing hooks on the pipe, to which any length of the chain can be attached. The removal of a rim from the casing is not an easy job in any case, but a tool of this type makes it much easier than when it is attempted with ordinary tire tools.—G. A. Luers, Washington, D. C.



☛Copper ash trays may be made by pounding the edges of the copper plates upon which announcements and invitations have been engraved. Besides having interest as souvenirs, they are very durable.

### Wagon Axle Used as Gate Hinge

On almost every farm can be found an old wagon or implement wheel with its

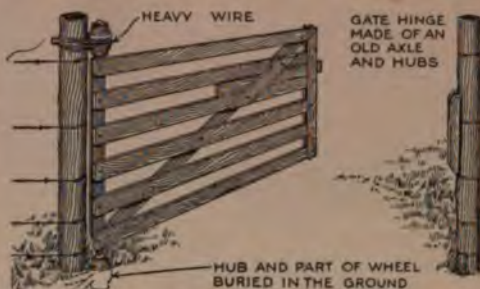

An Old Axle, with Parts of the Two Wheels Remaining upon It, Forms an Essential Part of This Easy-Working Farm Gate

axle. The illustration shows how it can be made to form one side and a very effective hinge for the farm gate. The axle is set upright with the slats of the gate bolted to it. The lower end of the axle should be fitted with an old hub to serve as a bearing. The hub on the upper end should have at least one spoke remaining in it, so that the latter can be thrust through a hole bored in the gatepost. Some stout wire, or iron strips, will be necessary to hold the hub up against the post.—H. F. Grinstead, Columbia, Mo.

### Rail for Coat Hangers

A very convenient method of hanging wearing apparel in a clothes closet is here described. Make two wood blocks of the dimensions shown, and drill a hole through one end of each, the size of an eight-penny wire nail. Push a nail through each hole and drive it into the square-cut end of a broomstick, or other similar round stick. Fasten the rack so formed to the outer edge of the closet shelf by driving two nails through each block, as shown; it is best to sink the blocks flush with the edge of the shelf. Clothes hangers can be hung and freely moved on this rod, and the method is more convenient and economical of space than the practice of hanging on wardrobe hooks, besides being a time-saver at moments when one is usually in haste.—W. H. Wilcox, Los Angeles, Calif.





### Blueprint-Paper Sensitizing Device

The writer had occasion to use a large number of quite small sheets of blue-

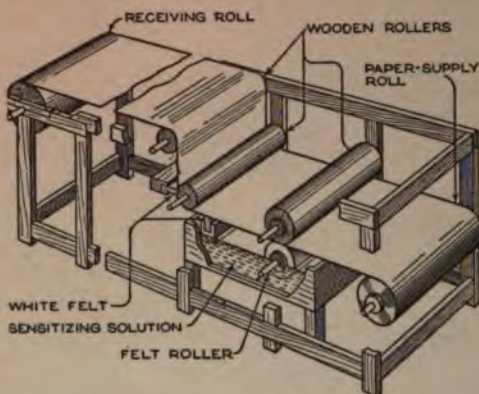

A Small Apparatus Like This Enables One to Prepare Blueprint Paper in Narrow Rolls, as Required for Special Purposes

print paper, and constructed the apparatus illustrated, so as to sensitize his own paper at a fraction of the cost of the commercial product.

The paper used was the kind sold in rolls, for use in adding machines. This paper is about 2 in. wide, and can be bought for a few cents a roll.

As shown in the drawing, a felt roller makes contact with the sensitizing solution, and carries it to the paper. This roller is made by compressing a large number of white-felt washers between metal disks at the ends of a threaded rod. The roll is then set between centers in a lathe or grinder, and finished off smooth with sandpaper, or an abrasive wheel. Above the felt roller is a plain wooden roller, which is adjustable, so as to hold the paper firmly against the felt roller. The smaller rollers are also made of wood; near the lower one, two strips of heavy white felt are mounted, so as to brush the surplus solution from the paper. Of these, the one farther to the left is made adjustable, so that it will leave just the right amount of solution on the paper. The paper-supply roll, at the right end of the drawing, runs free on its axle; the receiving roll, at the left, may be driven by a hand crank, or by a small motor through a worm drive.

Between the rest of the machine and the receiving roll, the writer installed a 5-ft. tin box, open at the ends, through which the paper was drawn, while a current of warm air was blown through it by a small motor blower. This insured

thorough drying before the paper was wound up.

The fluid used for sensitizing consists of two solutions, made separately and mixed together only for immediate use. The first is a solution of 10 drams of potassium ferricyanide in 4 oz. of distilled water; the second is 15 drams of ammonium citrate, similarly dissolved in 4 oz. of distilled water. The addition of  $\frac{1}{2}$  grain of potassium bichromate to each ounce of the mixed solution will improve the keeping qualities of the paper.

The complete process should be conducted in a dark room, or one with very little light, and the apparatus should be thoroughly washed after use. Metal parts which come in contact with the solution should be coated with shellac or asphaltum varnish, to prevent chemical action which might ruin the solution.—Henry B. Graves, Jr., Rochester, N. Y.

### Chair Seats of Paper

Nearly every household possesses a few chairs of the cheaper type, with seats made of light veneer, or with papier-mâché, or fiber substituted for leather. Such material is a little fragile, but is easily replaced when broken. For instance, the heavy cardboard of which many shipping boxes are made is quite strong enough for the purpose. Cut a seat of the same size and shape as the broken one, and fasten it in position with round-headed tacks.—Jack Solon, Vicksburg, Miss.

### Reflector and Protector for Lamp

An automobile owner, who had occasion to use an electric light on an extension cord, for repair work at night on his car, constructed the illustrated device in a few minutes. A bright tin funnel was placed over the wire, after this had been

disconnected from the socket. The funnel opening was secured to the light wire with tape, and several pieces of wire extended over the outer end of the bulb for protection at this place. One end of this wire was bent up to form a hook, by means of which the light was hung. Such a light concentrates the rays on the work being carried on under the car.





### Extension Handles on Petcocks

To overcome the inconvenience of opening automobile valves and petcocks, short extension handles made of  $\frac{1}{2}$ -in. gas pipe are valuable. For the shut-off valve on the gasoline tank, the radiator drain, and the oil-level petcock, such handles are fastened to the valves by slotting the ends of the pipe, drilling holes in the valve handles and the pipes, and then securing the pipes to the valve handles by the use of small cotter pins. The extension pipe handles are carried to convenient places in the dash and floor, and, in the case of the radiator drain, through the side of the engine pan. These extensions permit opening or closing the valves without reaching under the car.

### A Simple Steam-Jet Pump

A steam pumping jet, while not very efficient compared with a reciprocating pump, is nevertheless useful in many places where a pump is not available. The illustration shows how to make one,

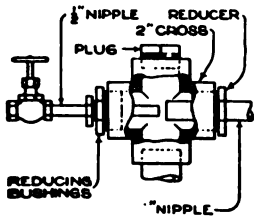

at a very small cost, which should handle about 120 gal. per minute. In the ends of the 2-in. cross tee, place reducing fittings so as to take  $\frac{1}{2}$ -in. and 1-in. pipes, respectively. Cut

a long thread on a  $\frac{1}{2}$ -in. nipple, and screw it into the  $\frac{1}{2}$ -in. reducer, until it almost reaches the center of the cross tee. Screw a 1-in. nipple into the opposite side until the ends of the nipples are not over  $\frac{1}{2}$  in. apart. Connect a 2-in. suction pipe to the bottom of the tee, and place a plug in the top.

Such a steam jet will give good satisfaction on various temporary pumping jobs, and will handle mud and sand, which would soon wear out the valves of the reciprocating pump.

### Heating the Soldering Copper without a Torch

The soldering copper is a useful addition to the tool equipment of the automobilist, but without means of heating the iron it may as well be left out. Leaking tanks, pipes, radiators, and many other defects may be quickly repaired by means of solder and a hot iron, and

there are various ways of heating the tool, whether the work is done in a

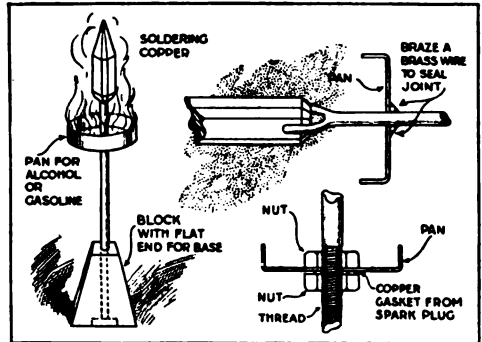

A Soldering Copper with Its Own Heater Attached will be Found a Useful Article in the Tourist's Tool Box

garage or on the road. A vulcanizer, if one is carried, will serve in an emergency, it being merely necessary to pour in an ounce or so of gasoline, ignite it, and prop up the iron in such a position that the flame will envelop the copper. If, however, no vulcanizer is carried, the cup or lid of a can may be used for the gasoline or alcohol.

But a still better scheme is to carry a soldering iron with a fuel holder permanently attached. The problem in attaching such a holder is to make it leak and heat-proof, up to the temperature which will be produced in it by the burning gasoline. This temperature is too high to allow of soldering; the holder should therefore either be brazed on, as shown at the upper right in the sketch, or attached with nuts, as shown below. The latter method has the disadvantage of requiring a long thread to be cut, thus weakening the stem, but it may be an admissible method where no brazing machine is available. A large wooden base, with a flat bottom, will enable the soldering copper to stand upright while being heated.

### Heater for Hydraulic Test Basin

On a job where a trough of cold water was required for testing purposes, trouble was experienced during cold weather from the freezing of the water. The trouble was remedied by installing an ordinary soft-coal stove near by, with a coil of pipe built into it, and two pipes leading from the ends of the coil to the upper and lower parts of the trough, respectively. The water thus circulated through the stove and the trough.

## Swinging Tool Racks or Shelves

Where shop space is at a premium, a great deal can be saved by hanging

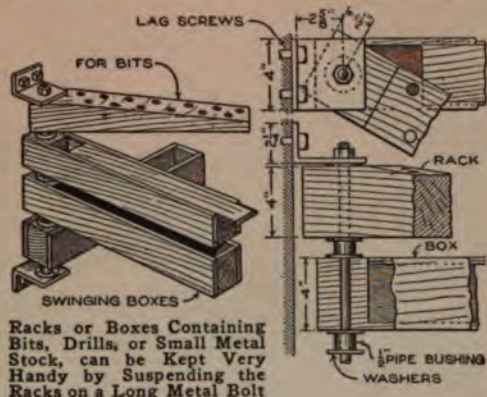

Racks or Boxes Containing Bits, Drills, or Small Metal Stock, can be Kept Very Handy by Suspending the Racks on a Long Metal Bolt

things on the wall in compact racks. The drawing shows how a large number of bits, screws, or other small parts, can be kept in boxes, or racks, hung on a long vertical bolt, attached to the wall or to a post. A few iron angle pieces will be required—also some washers and  $\frac{1}{2}$ -in. lengths of pipe to separate the various boxes or racks. Boxes used for this purpose must have a block in one end, through which the bolt passes.

## Cords Keep Drawings in Place



Unless drawings are firmly secured to the drafting board, they are in danger of tearing loose, or being blown away by a current of air from an open window, during the draftsman's absence. The sketch shows a method of holding the drawings or board cover in place. Three or more strong hemp cords are fastened at equal intervals at the top of the board. They should be of sufficient length to pass across the board, and hang over the edge several inches. A little cloth bag, filled with lead shot, or other heavy material, is tied to the end of each cord. These weights serve to draw the cords taut; they are thrown aside when the board is in use.—Kenneth Coggeshall, Webster Groves, Mo.

## Tin Chloride Removes Rust

A rusty metal rule may be made silvery white in color by allowing it to remain overnight in a saturated solution of tin chloride in water. Rinse the tin solution off the rule by holding it in running water. Dry with a chamois, and keep it in this improved condition by the use of oil. The solution may be kept for future use.—W. S. Standiford, Youngstown, Ohio.

## Reaching Device Made of Clothespin

The handy pick-up device shown in the illustration is one that can be easily and quickly made, and such a tool is valuable to the motorist for reaching into the depths of his splash pan, and about the parts of the engine, for a lost screw, nut, or cotter pin. It is also handy for storekeepers, for reaching for small articles in the show window, and is useful in many other lines.

A spring clothespin is secured to a stick of hard wood, by means of two screws through one leg, and is operated by means of a stout cord, or piece of piano wire, passed down one side of the stick, and worked through a hole, the cord being connected to the outer leg of the clothespin. A handle for pulling the cord is made from a piece of sheet  $\frac{1}{16}$ -in. iron, as shown in the detail.



## Slotted Nail as Polishing Reamer

A very handy polishing reamer for use on small work can be made by sawing a slot in a nail a little smaller than the hole to be polished, setting a small piece of fine emery cloth in the slot and bending it around the nail. Such a reamer is useful in places such as the bearing of the rocker arm in a magneto timer; with it the bearing can be easily polished.—J. Magis-Frankart, Ouffet, Belgium.

Food-chopper clamps will not work loose if a piece of coarse sandpaper is placed, rough side up, under the upper side of the clamp.



### Electric Fan Displays Sign

A striking window display advertisement may be arranged with an electric fan, four pieces of sewing thread, 3 ft. long, and a piece of cardboard, 3 by 6 in. in size. The advertisement is printed on the cardboard, and a string is then tied to each corner of the card, and to the wire guard of the fan at equal distances around its circumference. Hold the cardboard at the ends of the strings, and turn on the fan. When the motor attains its maximum speed, release the card. It will move about with erratic jumps and twists, but the advertisement will always be readable.—H. E. Pilkington, Chester, Pennsylvania.

### Bracket for Draftsman's Lamp

The photograph shows a convenient method by which a draftsman adjusted the position of a lamp and shade over a drawing board. An ordinary folding telephone bracket was mounted on the wall, near the left-hand edge of the board, and a small block of wood, about  $1\frac{1}{2}$  in. square and 2 in. long, was fastened with wood screws to the end of the bracket. A hole was then bored in the front



face of the block, to admit the central arm of a pipe tee; and a reducer was screwed into the lower arm of the tee, so that it hung in a vertical position and connected the tee with an ordinary key socket, the wider member of the reducer entering the tee, while the narrower one passed into the socket. The lamp cord was led through the loops in the bracket and down into the tee, from which it passed through the adapter into the socket. This arrangement made it possible to illuminate any part of the board at will, or to fold the bracket back out of the way when not needed.—E. L. Durgin, Auburn, Me.

### Chute Hooks Supported on Springs

In nearly all mines and quarries where coarse ore and rock is sent through chutes to the crushers, it falls to the lot of several workmen to be stationed along the chutes to keep the stuff moving.

These workmen are usually supplied with long steel hooks, with which they dislodge the rocks when they jam.

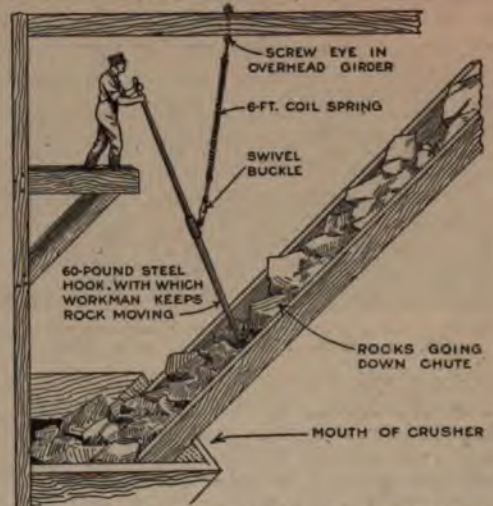

Where Rocks have to be Kept Moving down a Chute, the Hook Required may be Improved by Adding a Support

The hooks used in this work usually weigh about 60 lb. Thus the work of lifting this load all day is even greater than the amount of energy expended in moving the rocks. All this has been eliminated, in one quarry, by the use of spring-supported hooks, as shown in the accompanying sketch.

With the spring-supported hooks, the men are not only able to work faster, but they accomplish the same amount of work with far less effort. The spring-supporting method is primarily a man saver. Workers in other mines and quarries would do well to adopt the idea, which is decidedly a profit-maker for both the employer and his workmen.

### Strap Hinge Used as Hasp

When a hinge hasp for a barn door was badly needed, and was not at hand, a very good substitute was made from an ordinary strap hinge. One half of the hinge was attached by screws, as usual, to the door casing, and the free half was cut out by means of a drill and cold chisel, to take the staple. The free end of the hinge was turned back slightly for a grip.





### Auto Operates Tank Pump

It is becoming quite common to use automobiles as a source of power, but it is not always possible to do this



Without the Use of Pulley or Belt, the Automobile is Used to Drive a Water Pump on a Farm

without the use of a transmission belt. The photograph shows how a connecting rod was bolted directly to one of the rear wheels of the car, jacked up off the ground for the occasion. The rod was a 2 by 4-in. timber, and the other end was connected to the plunger arm of the cylinder water pump. As the pump requires a slow operating speed, and not a great deal of power, the automobile engine handled it successfully.—T. A. Leadley, Lincoln, Neb.

### Veneering Large Round Columns

Our shop had an order for three wooden columns, 8 in. in diameter and 8 ft. long, to be covered with  $\frac{1}{8}$ -in. quarter-sawed, red-oak veneer, after being built up and turned. Having no special equipment for this job, nor any round-cut veneer, I cut six pieces of  $\frac{1}{8}$ -in. flat veneer, wide enough so that two pieces would nearly cover the surface of one column, leaving a space of  $\frac{1}{8}$  in., or

a little more, between the two pieces. These wide pieces were softened in hot water, and tied around the columns with small cords. The columns were then put into a kiln for 10 hours. At the end of this time the veneer was pretty well formed to shape, and ready to be glued. Each column was swung on centers, so it could be turned with a crank. The veneer was glued to it, and while one man turned the column, cheap sash cord was



wound over it like thread on a spool. When the veneer was all covered, the cord was wet with hot water. This caused it to shrink, and hold the veneer very tightly to the column. After another 24 hours in the kiln, the columns came out perfectly hard and solid. Narrow strips of the same veneer were cut to fit the cracks between the wide pieces, and glued in. The columns were then finished with sandpaper on the lathe, and a beautiful job was the result.—E. K. Wehry, Cedar Rapids, Ia.

### Rack for Lathe Tools

When lathe tools are thrown into a box or tray indiscriminately, the cutting edges are frequently damaged, so that regrinding is necessary. Also, where a variety of tools are used, valuable time is lost in hunting up the right one. The drawing shows a simple and effective arrangement, by which each cutter is kept separately, and in a place where it may be found without loss of time.—J. H. Moore, Toronto, Ont.

TOOL RACK



### Secret Ignition Switch for Car

If an automobile thief knows just where to look for a locked break in the ignition circuit, he will quickly accomplish his end and get away with the car. If there is a break that cannot be located, however, he will be delayed, and the more difficult the finding of the break, the greater the delay. The following is a scheme that is very hard to detect. Make a little cleat of wood or fiber, or use an ordinary ready-made cleat such as is used to hold wiring in position. Instead of running the wire straight through, however, as is usual, cut the wire and bare the ends. Drill small holes so that the ends of the wire can be run to the screws used for holding down the cleat, putting cop-





per washers under the screws. Do this work so that there is nothing to indicate how the wire is run. Use flat-head screws with heads large enough to project above the copper washers. When the cleat is screwed down there will be nothing whatever to indicate that it is anything but the ordinary arrangement. There will be a perfect break in the circuit, however. To complete the circuit, use a little piece of spring brass or copper with the ends notched out, a little longer than the distance between the two screw heads. Spring the brass until the notched ends will catch under the projecting screw heads, and the circuit is completed. Remove the strip, and it is broken, though nothing shows it. Such a lock is so easily made that it is very little trouble to put two or three in the circuit in different places, and it will take a clever thief to untangle the puzzle.—Howard Greene, New York, N. Y.

### Round Holes Made with Cold Chisel

Having a number of round holes to cut in a thin sheet-iron box, I tried to cut them out with the chisels we had—cape, square-point, etc.,—but could not make a clean-cut round hole. Finally, by taking a square-edge cold chisel, and grinding a round cutting edge on it, I was able to cut a round hole nearly as clean as one which had been punched. The chisel must, of course, be held at an angle to the work, but in the case of very thin metal this is no great objection.—R. B. Miller, San Pedro, Calif.



### Potato for Keeping Metal Cool

Broken tools, such as scissors, plane irons, and chisels, will not lose their temper when being repaired by brazing, if inserted in a potato. A dovetail notch is cut in each part, and a piece of steel, cut to fit, is driven tightly into the notches. The tool is then thrust into a potato, until the smallest possible portion protrudes. The moisture in the potato keeps the metal cool during the brazing process, and prevents it from losing its temper.—Réné J. Rousseau, Suresnes, France.

### Sign Printing without a Press

Fence posters, sidewalk signs, and other forms of printed announcements, may be made without a printing press and at

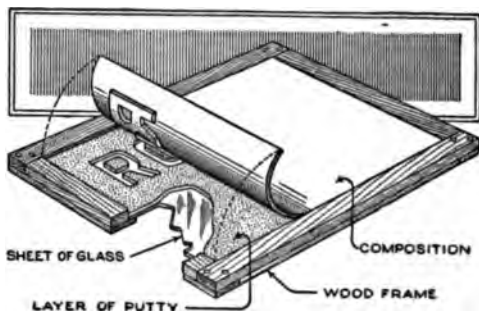

By Cutting Letters in Putty, and Making a Rotary Stamp with Printers' Roller Compound, the Printing of Signs is Easily Accomplished

slight expense, as follows: Obtain a piece of glass and lay it on a flat surface. Moisten the face of the glass with water; before it dries, cover with a ¼-in. layer of putty and smooth off level. With a sharp-pointed knife, cut the letters through the entire thickness of putty. Moistening the glass before laying on the putty makes it possible to remove the body of the letters without their sticking to the glass. A wooden frame, ½ in. high, exactly fitting the glass, is applied, as shown in the drawing, and filled level with printers' roller compound. To make this substance, soak 8 lb. of glue in about 4 pt. of water, and heat gently until dissolved. To the glue solution add 3 lb. of brown sugar; when both glue and sugar have been thoroughly dissolved, pour in ½ pt. of glycerin. Allow this compound to stand on the mold from 12 to 24 hours. Care should be taken that the composition is not torn in removing it from the mold.

The cast thus obtained is glued to a wooden cylinder, making a rotary stamp. A nail is driven into the center of each end of the wooden cylinder, and a strong wire handle is attached.

Printers' ink, or thick paint, is then distributed over a piece of glass or slate, and the rotary stamp passed over it until the raised letters are thoroughly inked. After inking the stamp, it is rolled over the surface to be printed, and a clear-cut impression of the letters results.—J. G. Allshouse, Vandergrift, Pa.

Bits of uncured rubber, dissolved in gasoline, make a good rubber cement.

**Auto Operates Tank Pump**

It is becoming quite common to use automobiles as a source of power, but it is not always possible to do this



Without the Use of Pulley or Belt, the Automobile is Used to Drive a Water Pump on a Farm

without the use of a transmission belt. The photograph shows how a connecting rod was bolted directly to one of the rear wheels of the car, jacked up off the ground for the occasion. The rod was a 2 by 4-in. timber, and the other end was connected to the plunger arm of the cylinder water pump. As the pump requires a slow operating speed, and not a great deal of power, the automobile engine handled it successfully.—T. A. Leadley, Lincoln, Neb.

**Veneering Large Round Columns**

Our shop had an order for three wooden columns, 8 in. in diameter and 8 ft. long, to be covered with 1/8-in. quarter-sawn, red-oak veneer, after being built up and turned.

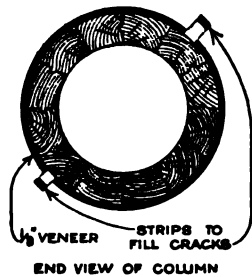

a little more, between the two pieces. These wide pieces were softened in hot water, and tied around the columns with small cords. The columns were then put into a kiln for 10 hours. At the end of this time the veneer was pretty well formed to shape, and ready to be glued. Each column was swung on centers, so it could be turned with a crank. The veneer was glued to it, and while one man turned the column, cheap sash cord was

wound over it like thread on a spool. When the veneer was all covered, the cord was wet with hot water. This caused it to shrink, and hold the veneer very tightly to the column. After another 24 hours in the kiln, the columns came out perfectly hard and solid. Narrow strips of the same veneer were cut to fit the cracks between the wide pieces, and glued in. The columns were then finished with sandpaper on the lathe, and a beautiful job was the result.—E. K. Wehry, Cedar Rapids, Ia.

**Rack for Lathe Tools**

When lathe tools are thrown into a box or tray indiscriminately, the cutting edges are frequently damaged, so that regrinding is necessary. Also, where a variety of tools are used, valuable time is lost in hunting up the right one. The drawing shows a simple and effective arrangement, by which each cutter is kept separately, and in a place where it may be found without loss of time.—J. H. Moore, Toronto, Ont.

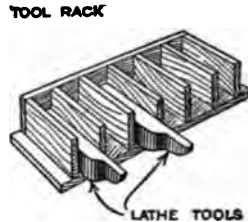

**Secret Ignition Switch for Car**

If an automobile thief knows just where to look for a locked break in the ignition circuit, he will quickly accomplish his end and get away with the car. If there is a break that cannot be located, however, he will be delayed, and the more difficult the finding of the break, the greater the delay. The following is a scheme that is very hard to detect. Make a little cleat of wood or fiber, or use an ordinary ready-made cleat such as is used to hold wiring in position. Instead of running the wire straight through, however, as is usual, cut the wire and bare the ends. Drill small holes so that the ends of the wire can be run to the screws used for holding down the cleat, putting cop-

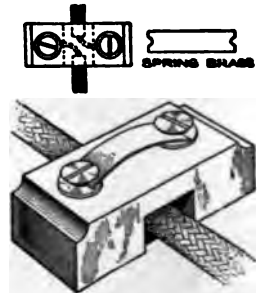



**Chimney Cleaner Made from Wire Netting and Broom Handle**

To make a useful device for cleaning chimneys and flues, get a broom handle and a piece of wire netting, 2 by 3 ft. in size. With staples, fasten this netting in a roll around the broom handle. The soft wire may be bent around in any desired shape, so that it will enter into narrow openings. The tool has been found to be more effective than ordinary brushes, in getting rid of hard incrustations.

**Providing Water for Bees**

Bees require an abundance of moisture during the honey season. If pure water is not available, they will drink from sewers, or other foul places. When bees are compelled to depend on the farm watering trough, they become a menace to stock, and, besides, large numbers fall in and drown.

A safe and sanitary drinking place is easily made, by covering a shallow pan with wire screening. If the pan is kept filled with water, the bees will be able to drink without difficulty, and with no danger of drowning.—Bessie L. Putnam, Conneaut Lake, Pa.

**Replacing Auto Engine Manifolds**

In making engine repairs on a popular make of light automobile, it is often necessary to remove both intake and exhaust manifolds, the replacement of which usually calls for an additional pair of hands. However, it is possible for one man to replace both manifolds, without difficulty by proceeding as directed below.

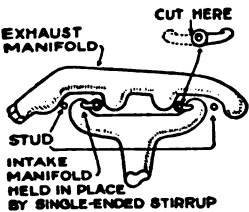

Two of the regular manifold-retaining stirrups are obtained, and one end, or arm, is removed from each, as shown. The intake manifold is put in place and tightened up, using the single-armed stirrups, or clamps, which are put on the two inside studs. The exhaust manifold is now applied, using the regular stirrups, which are tightened up on the two end studs. The one-armed stirrups are removed one at a time and replaced with the regular parts.—Graeme B. Baker, Deer Lodge, Mont.

**Fender Turns Under Weeds While Plowing**

A rainy spell at plowing time gives the weeds a good start and prevents the

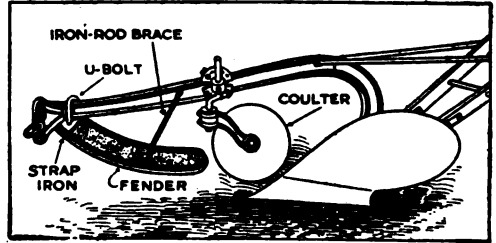

When Weeds Get a Good Start, Plowing Them Under Is Difficult. Part of an Old Auto Fender Turns the Weeds under the Coulters, Where They Are Cut and Turned under the Soil

farmer from plowing. By the time the work can begin, the weeds, in consequence, are usually more or less difficult to plow under.

A simple arrangement, such as shown, solved the problem for one farmer. Part of an old automobile fender was bolted to the beam of the plow, just ahead of the rolling coulters, with a long U-bolt. A piece of strap iron, riveted to the end of the fender and drilled for the U-bolt, as shown, takes up the strain when the bolt is tightened about one-third of the way back, a brace of stiff iron rod, from the plow beam to the fender, was provided. The rest of the fender was left free, and was springy enough to allow for unevenness of the surface and yet force under all the weeds. When the weeds were green and tender, no difficulty was experienced in turning them under in a very satisfactory manner.—Dale R. Van Horn, Lincoln, Neb.

**An Effective Line Guard**

Any farmer who has been annoyed by the tangling of his lines with the draft rigging, while plowing, will appreciate a simple preventive. A piece of 3/8-in. iron rod is bent, as shown, and provided with an eye at each end. The rod is bolted to the double-tree with short bolts. Care should be taken to have the rod long enough to allow ample clearance for the singletrees.—H. F. Grinstead, Columbia, Mo.

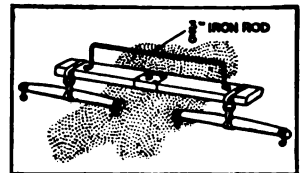

# A Boring Machine for Crankshaft Bearings

By EDGAR GARDNER

**M**ODERN high-class automobile engines are for the most part designed to use the pressure oil-feed system. Oil is conducted to each point which requires lubrication by means of pipe leads and oil passages, under pressure from a pump. The splash system is thus eliminated, and the amount of oil supplied to meet the requirements of varying engine speeds is automatically controlled, resulting in increased efficiency and economy.

The main crankshaft and connecting-rod bearings in engines of this type must be fitted practically oil-tight. Any oil that can leak through the bearings will

follow the crankshaft to the crank throw, and will be thrown up into the cylinders. The necessity of having oil-tight bearings presents a condition very difficult to meet with bearings designed to use shims. To prevent leaks, it is necessary that the two parts of the bearing be fitted solidly, metal to metal, and the caps bolted down solid, making an oil-tight joint where the halves of the bearing meet. Besides preventing oil leaks, this construction makes a more solid and rigid unit than is possible where shims are used, and, in connection with the oil-pressure

system, helps produce a very durable engine. The oil being under pressure, the crankshaft is practically floated in the bearings.

The approved practice in high-class engines is to make the bearing of bronze, bored large enough to allow facing with babbitt metal to form the bearing surface. The main and connecting-rod bearings must be fitted with an equal clearance around the entire circumference. The old practice of relieving them at the sides, so successfully followed with the splash system, cannot be followed with the pressure feed, as it would allow the oil to

leak out of the sides of the bearing, causing an excess supply of oil at points that have been specially provided with oil leads to furnish the required amount. On bearings designed for the pressure system, the oil pocket is formed with a special tool, making a series of narrow grooves, with a strip of metal between each groove. These strips retain the bearing fit, forming a serrated oil pocket.

The factory, with special tools and jigs, meets the requirements of the system without difficulty. To the repair shop, however, the rebuilding and overhauling of this type of engine presents quite a

problem, as more different sizes are encountered. The hand-scraping method of fitting bearings is a tedious job, and is seldom successful where the pressure system is used, since the scraper marks, extending through the end of the bearing, are apt to form a passage for oil to leak through.

The boring bar illustrated was built for repair-shop service, and is in constant use on a leading make of six-cylinder engine, having a seven-bearing crankshaft. It is found to produce work which meets the exacting requirements of the pressure system,

retaining the original high efficiency of the engine. It works on the old boring-bar principle, so familiar to mechanics, and can be operated either by hand or by power.

One cutting tool is provided for each bearing. The method of adjusting the tools to bore out the bearing to exactly the proper size is illustrated in the insert of the second photograph. The tools are fitted into round holes made in the bar; these should be blind, so that an exact measurement can be made with a micrometer from the cutting edge of the tool to the opposite side of the bar. From

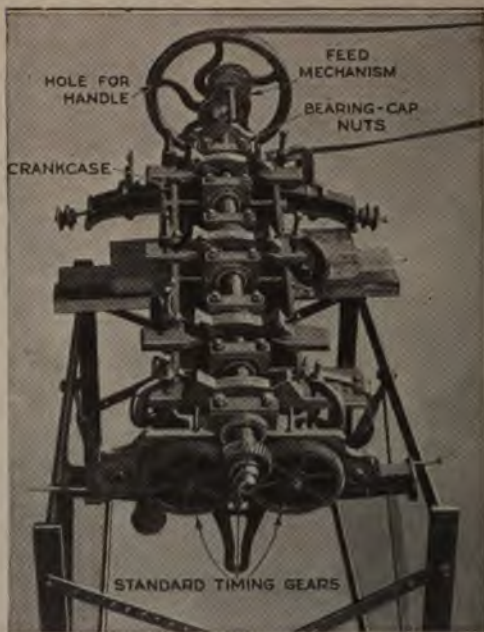

Assembly View of the Boring Apparatus: The Bar, Working in Steady Rests, and Fed by a Lead Screw, Bores Out Each Bearing with a Tool Adjusted to Give It a Proper Finish Diameter



### Chimney Cleaner Made from Wire Netting and Broom Handle

To make a useful device for cleaning chimneys and flues, get a broom handle and a piece of wire netting, 2 by 3 ft. in size. With staples, fasten this netting in a roll around the broom handle. The soft wire may be bent around in any desired shape, so that it will enter into narrow openings. The tool has been found to be more effective than ordinary brushes, in getting rid of hard incrustations.

### Providing Water for Bees

Bees require an abundance of moisture during the honey season. If pure water is not available, they will drink from sewers, or other foul places. When bees are compelled to depend on the farm watering trough, they become a menace to stock, and, besides, large numbers fall in and drown.

A safe and sanitary drinking place is easily made, by covering a shallow pan with wire screening. If the pan is kept filled with water, the bees will be able to drink without difficulty, and with no danger of drowning.—Bessie L. Putnam, Conneaut Lake, Pa.

### Replacing Auto Engine Manifolds

In making engine repairs on a popular make of light automobile, it is often necessary to remove both intake and exhaust manifolds, the replacement of which usually calls for an additional pair of hands. However, it is possible for one man to replace both manifolds, without difficulty by proceeding as directed below.

Two of the regular manifold-retaining stirrups are obtained, and one end, or arm, is removed from each, as shown. The intake manifold is put in place and tightened up, using the single-armed stirrups, or clamps, which are put on the two inside studs. The exhaust manifold is now applied, using the regular stirrups, which are tightened up on the two end studs. The one-armed stirrups are removed one at a time and replaced with the regular parts.—Graeme B. Baker, Deer Lodge, Mont.

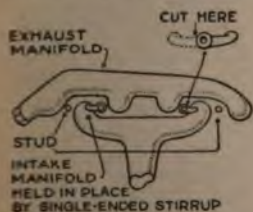

### Fender Turns Under Weeds While Plowing

A rainy spell at plowing time gives the weeds a good start and prevents the

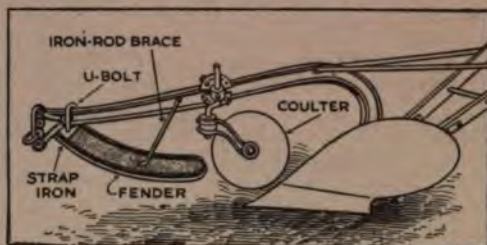

When Weeds Get a Good Start, Plowing Them Under Is Difficult. Part of an Old Auto Fender Turns the Weeds under the Coulters, Where They Are Cut and Turned under the Soil

farmer from plowing. By the time the work can begin, the weeds, in consequence, are usually more or less difficult to plow under.

A simple arrangement, such as shown, solved the problem for one farmer. Part of an old automobile fender was bolted to the beam of the plow, just ahead of the rolling coulters, with a long U-bolt. A piece of strap iron, riveted to the end of the fender and drilled for the U-bolt, as shown, takes up the strain when the bolt is tightened about one-third of the way back, a brace of stiff iron rod, from the plow beam to the fender, was provided. The rest of the fender was left free, and was springy enough to allow for unevenness of the surface and yet force under all the weeds. When the weeds were green and tender, no difficulty was experienced in turning them under in a very satisfactory manner.—Dale R. Van Horn, Lincoln, Neb.

### An Effective Line Guard

Any farmer who has been annoyed by the tangling of his lines with the draft rigging, while plowing, will appreciate a simple preventive. A piece of  $\frac{3}{8}$ -in. iron rod is bent, as shown, and provided with an eye at each end. The rod is bolted to the double-tree with short bolts. Care should be taken to have the rod long enough to allow ample clearance for the singletrees.—H. F. Grinstead, Columbia, Mo.





# A Boring Machine for Crankshaft Bearings

By EDGAR GARDNER

MODERN high-class automobile engines are for the most part designed to use the pressure oil-feed system. Oil is conducted to each point which requires lubrication by means of pipe leads and oil passages, under pressure from a pump. The splash system is thus eliminated, and the amount of oil supplied to meet the requirements of varying engine speeds is automatically controlled, resulting in increased efficiency and economy.

The main crankshaft and connecting-rod bearings in engines of this type must be fitted practically oil-tight. Any oil that can leak through the bearings will follow the crankshaft to the crank throw, and will be thrown up into the cylinders. The necessity of having oil-tight bearings presents a condition very difficult to meet with bearings designed to use shims. To prevent leaks, it is necessary that the two parts of the bearing be fitted solidly, metal to metal, and the caps bolted down solid, making an oil-tight joint where the halves of the bearing meet. Besides preventing oil leaks, this construction makes a more solid and rigid unit than is possible where shims are used, and, in connection with the oil-pressure system, helps produce a very durable engine. The oil being under pressure, the crankshaft is practically floated in the bearings.

The approved practice in high-class engines is to make the bearing of bronze, bored large enough to allow facing with babbitt metal to form the bearing surface. The main and connecting-rod bearings must be fitted with an equal clearance around the entire circumference. The old practice of relieving them at the sides, so successfully followed with the splash system, cannot be followed with the pressure feed, as it would allow the oil to

leak out of the sides of the bearing, causing an excess supply of oil at points that have been specially provided with oil leads to furnish the required amount. On bearings designed for the pressure system, the oil pocket is formed with a special tool, making a series of narrow grooves, with a strip of metal between each groove. These strips retain the bearing fit, forming a serrated oil pocket.

The factory, with special tools and jigs, meets the requirements of the system without difficulty. To the repair shop, however, the rebuilding and overhauling of this type of engine presents quite a

problem, as more different sizes are encountered. The hand-scraping method of fitting bearings is a tedious job, and is seldom successful where the pressure system is used, since the scraper marks, extending through the end of the bearing, are apt to form a passage for oil to leak through.

The boring bar illustrated was built for repair-shop service, and is in constant use on a leading make of six-cylinder engine, having a seven-bearing crankshaft. It is found to produce work which meets the exacting requirements of the pressure system,

retaining the original high efficiency of the engine. It works on the old boring-bar principle, so familiar to mechanics, and can be operated either by hand or by power.

One cutting tool is provided for each bearing. The method of adjusting the tools to bore out the bearing to exactly the proper size is illustrated in the insert of the second photograph. The tools are fitted into round holes made in the bar; these should be blind, so that an exact measurement can be made with a micrometer from the cutting edge of the tool to the opposite side of the bar. From

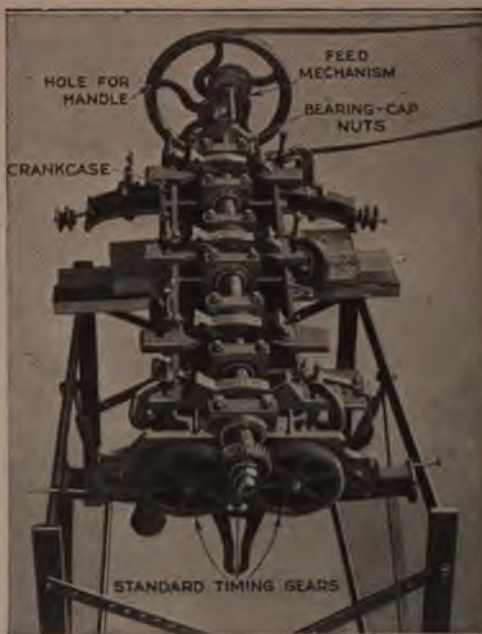

Assembly View of the Boring Apparatus: The Bar, Working in Steady Rests, and Fed by a Lead Screw, Bores Out Each Bearing with a Tool Adjusted to Give It a Proper Finish Diameter



serious body burns in the process. In such an emergency one quick-witted person thought of a large, empty ash can in the cellar, and fetching it with all possible speed, turned it, upside down, over the stove. A few puffs of black smoke issued from under the can, but the blaze was effectually choked. The stove was permitted to cool before removing the ash can.—L. Halmer, Walton, N. Y.

### How to Make Abrasive Stones

A mixture of cement and emery, carborundum, or other abrasive, is easily molded into sharpening stones of any desired shape. By varying the proportions of the ingredients and using abrasive material of different fineness, almost any grade of sharpening stone is produced.

### Nonspilling Acid Container

A container for soldering acid, or other liquids, that will not break or spill its contents when upset, will be found a decidedly convenient addition to the shop. Such a container is made from a short piece of  $1\frac{1}{4}$  or  $1\frac{1}{2}$ -in. lead pipe, which is expanded broadly at one end, as shown by the dotted lines. The bottom is then drawn together, and the openings filled with solder. A piece of  $\frac{1}{2}$ -in. lead pipe is similarly expanded at one end, and soldered into the top of the larger pipe, as shown. Small ears for a bail, or handle, are soldered to the side, which completes the container. Such a container is unaffected by acids, and can be turned or upset at any angle without its contents spilling.

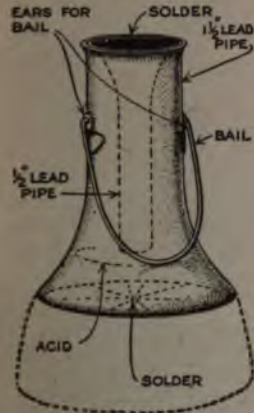

### Worn Rubber Converted into Foothold

It is usually the case that a woman's rubber wears through at the heel while the rest of it is still in good condition. By cutting off the heel, so that a strap is formed to fit over the back of the shoe, the overshoe can be converted into toe rubbers, or footholds.—R. H. Metzfeld, Milwaukee, Wis.

### A Band and Wire Stretcher for Packers

In tightening up the steel plates around packing boxes, much hard labor can be

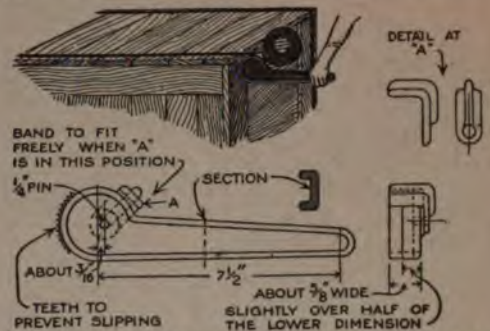

The Hard Hand Work of Stretching Steel Bands around Packing Boxes is Eliminated by the Use of This Tool

saved by using a tool such as illustrated. The band is wedged between the handle and the part A. This piece is pivoted on the main piece or lever, at a point to the right of the center, and has such a curvature that when the lever is brought down, the band is tightly clamped. Pressing the lever still farther down tightens the band around the box, and it can be nailed while held in this position. Teeth may be formed on the end of the lever, as shown, to prevent slipping, but if the surface of the lever is fairly rough, they are not really necessary.—Henry G. Appleblad, West Haven, Conn.

### Tool for Cleaning T-Slots

The time wasted in cleaning out T-slots of a planing or milling machine will be saved by the use of the tool illustrated, which can be made from a scrap of iron in a few minutes. The end that fits into the slot should be made about  $\frac{1}{2}$  in. smaller than the dimensions of the slot, so that it can be pulled freely along the table of the machine. By turning the tool at right angles, it can be removed or inserted at any point in the slot.—Harvey Mead, Scranton, Pa.



When filing solder, a little machine oil will prevent the teeth from clogging.

bearing-cap nuts to the proper tightness, and to mark them so that they can be brought back to the same point in the final assembly. It has been found that drawing up the bearing-cap nut the small distance of one cotter-pin notch, after the bearing has been finished, may spring the case and throw the bearing out of true.

As seen in the first photograph, the boring bar is supported on brackets having adjustable steady rests, as in ordinary lathe practice. The front end of the bar is fitted with a standard timing gear, similar to the one on the end of the crankshaft. The boring bar is located, by means of the steady-rest adjustment, so that this gear meshes, with just the right amount of play, with the two large timing gears on the crankcase. The rear end of the bar is located by means of a slip ring, or sleeve, bored out to a sliding fit on the bar. The outside diameter of the sleeve is to fit the bearing, as rough-bored in the lathe; in practice, this end bearing will be roughed out to fit the sleeve which is to be used. The bearing is centered for rough-boring by reference to the bronze shell; this is located by the factory with sufficient accuracy to enable it to be used to find the correct center. Before starting the finish-boring, however, measurements should be taken with a depth gauge from the boring bar to the faces of the crankcase to which the cylinders are bolted. If

the boring bar is found to be parallel with these faces, then it is correctly placed. The tools have already been set to produce the correct diameter, and the bar is now fed through, giving the finished bearing surface to the babbitt. After this boring operation has been completed, the only hand work necessary in fitting the crankshaft into place is that of relieving the ends of the bearings to fit the fillets of the crankshaft.

After the crankshaft has been finally assembled, the connecting-rod bearings, which have been accurately bored out in the lathe, are fitted to the shaft. An oil-pressure test, running up to a pressure of 50 lb. per square inch, is then applied. This figure is selected as compared with 35 lb., which represents the usual maximum working pressure. If no leak appears at the test pressure, the engine is ready for final assembly.

Besides the great advantage of eliminating the tedious process of hand scraping, the boring process has the advantage of aligning all of the bearings very accurately with each other, resulting in a remarkably free-running engine. The boring method is found in practice to give a surface not inferior to that produced by reaming, and the equipment required is within the reach of any shop which does any considerable quantity of engine overhauling.

### Nut Which will Not Come Loose

The sketch shows a simple means of producing a good free-acting tension on a knurled or other type of nut. It will stay put, and yet not be too tight to be removed without the use of a wrench.

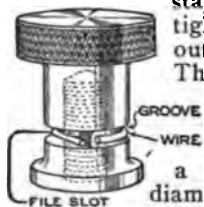

The wire has a spring temper, and fits into a groove in the nut. The groove must be a little wider than the diameter of the wire, to allow it freedom of action to locate itself in the groove of the thread. With such a wire, almost any tension desired may be had, by bending the wire before springing it into place.



CA preventive of carbon troubles, which has been found successful, is to insert in each cylinder of the engine, about once a week, one tablespoonful of so-called solidified alcohol, while the motor is hot.

### Restoring Lost Compression

When the thread in a cylinder head, into which the spark plug screws, is so badly worn that the plug can no longer be held gas-tight, the proper method of repair is by electric or oxyacetylene welding. When such facilities are not at hand, a practical repair can often be made by wrapping a piece of "paper brass," about .003 in. thick, about the spark plugs, and then screwing each in place. The brass should be cut accurately, so that the ends just touch but do not overlap, and should be coated with graphite and grease before screwing in. This repair has been known to give months of service.

### Ash Can as Fire Extinguisher

The average individual is decidedly at a loss how to dispose of an oil stove when the oil becomes ignited. It is a question whether to risk a serious fire in the house, or to pick up the stove and throw it out of the house, perhaps getting



### Triangle with Irregular Curves

The artist, or draftsman, who is handy with a jackknife or a file can turn an ordinary solid triangle into one which is useful also for drawing irregular curves. If a scroll saw is available, the work can be simplified, but a jackknife for the wooden triangle, or a drill and file for a transparent composition triangle, will make the work possible without the scroll saw. The form of the outlines to be cut in the triangle should be governed by the nature of the curves which the workman ordinarily encounters.

### Driver for Small Lathe Dogs

In doing small lathe work held on the centers, the tail of the dog is often too short to reach the slot in the driving blade. In such a case it is possible to put a stud in the driving plate, or to put another dog on the lathe center, but both these methods are objectionable as being likely to throw the lathe out of

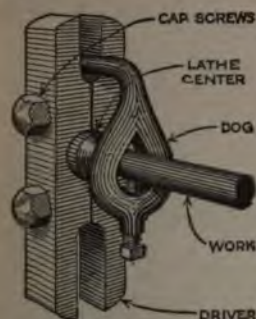

balance at high speeds. Also, there is lost motion amounting to one complete revolution whenever the lathe is reversed—unless the tail of the dog is fastened to the stud, or tail, of the other dog. This can be done with a piece of string, or wire, but considerable

time may be lost by such methods. The driver, shown clamped on the lathe center in the illustration, was designed to handle a big job of this kind of work. It is made of two pieces of mild steel put together with screws, and bored through the joint to a diameter .005 in. smaller than the center, so that it can be clamped on tightly by turning the screws. The two slots in the end, which should preferably be of different sizes to accommodate various dogs, are milled, after drilling out part of the steel.

The driver does not mar the lathe center as would the setscrew of a dog. It is neater and more satisfactory in every way.

☛ A mixture of four parts sodium fluoride and one part pulverized sugar is very effective in destroying ants.

### Aluminum Castings Tested by Weight

A difficulty in the use of small aluminum castings is that air bubbles, which may have formed on the inside, greatly



Perfect Aluminum Castings are Distinguished from Those Having Air Holes by Testing for Weight with a Special Balance

reduce the strength of the finished part. A factory which uses a great many such castings employs the balance illustrated for determining whether a casting is free from air bubbles or not. The balance is first adjusted so that the weight of a perfect casting is just sufficient to tip the beam, while a defective casting containing an air hole is too light to do so. The method is quite rapid, and sufficiently accurate to give reliable results.—John Edwin Hogg, Los Angeles, Calif.

### Tight Rivets in Blind Holes

The riveting of a plate to a body is often a tedious job. The sketch shows how a rivet can be fastened securely in a blind hole. Before the rivet is inserted, a hole is bored in its end, and a steel ball dropped into the blind hole. When the rivet head is hammered, the ball is forced into the hole in the rivet, expanding the latter and seating it firmly.



### Compressed Air Cleans Tobacco Pipe

An easy way to clean a pipe is to hold the end of the pipe stem against the valve of a compressed-air tube, such as is to be found in nearly every garage. When one is on the road in a car, the valve of one of the tires may be used for the same purpose.—Robert C. Knox, Rogers, Ark.

### Repair for Auto Low Gear

When the low-gear friction band, on a popular light automobile, burns out after a long pull, it will be found prac-

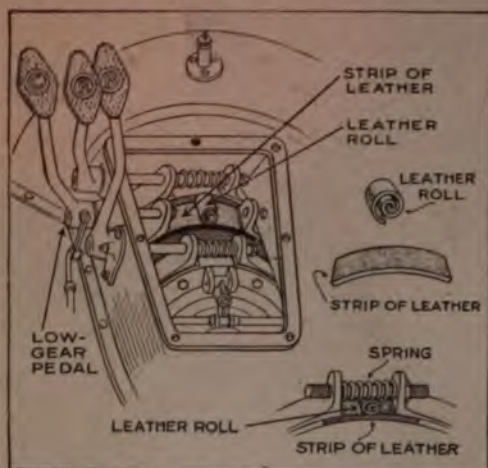

Strips of Leather, or Heavy Canvas, Makes It Possible to Get the Light Automobile into "High" When the Low-Gear Friction Band Burns Out

tically impossible to get the clutch into high gear. When such an emergency occurs, a temporary repair, that will hold for several days, or until permanent repairs can be made, is easily effected.

The cover of the transmission case is removed with care, so that the gasket will not be broken. The band-adjusting screw, on the outside of the transmission case, is unscrewed until the low-gear friction band is released from friction. A strip of leather, from a heavy shoe, or a piece of thick, tough canvas, is inserted between the low-gear band and the drum, as shown in the drawing. Another strip of leather, or heavy cloth, 2 or 3 in. long, is rolled up and inserted between the coil spring and the flat leather band, in the manner indicated. Tightening the adjusting screw, until the low-gear friction band is nearly tight, and replacing the transmission cover completes the repair.—Leo C. Shinn, Portland, Ore.

### Mixture for Cleaning Windshield

Equal parts of alcohol and glycerin form a fairly well-known compound to keep the windshield and glass of an automobile free from moisture and water during rainy weather. However, few take the trouble to purchase and mix the ingredients in preparation for rain.

Small tins of "solidified alcohol" afford

a very satisfactory means of combating the blurred windshield. Simply apply it with a piece of rag over the surface of the glass. The material contains a little paraffin or waxy oil, perfectly transparent, that sheds the water as well as the above-mentioned alcohol and glycerin.—G. A. Luers, Washington, D. C.

### Splicing Heavy Wire Smoothly

In splicing a stiff wire with the type of splice illustrated, difficulty is often experienced in getting the ends of the coils to lie tight against the straight wire, thus making a smooth splice. One method of getting such a splice is to leave the ends of the wire long, notching them, as illustrated, at a point which represents the proper length for splicing. The wire is then wrapped a half turn past the notches, and when the extra ends are broken off at the notches, the rest of the wire will not be disturbed.—Thos. L. Parker, Wibus, Mont.

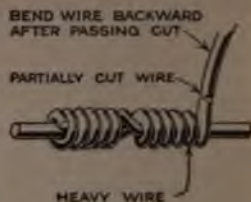

### Show-Card Drying Rack

Freshly lettered show cards can be dried in a rack made from a few clothespins and a small board. Slanting holes are

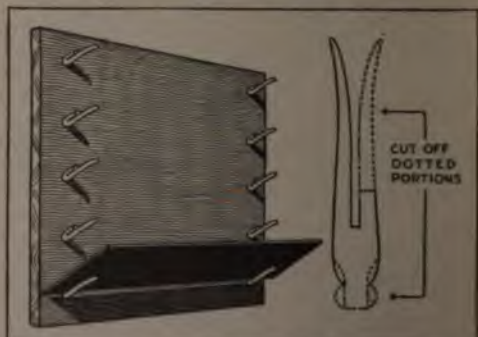

Rack for Drying Show Cards: Clothespins, Cut as Indicated, are Inserted in Slanting Holes in a Board

bored near the ends of the latter at regular intervals. One prong of each pin is cut off at a point  $\frac{1}{2}$  in. from its attached end, and the heads are trimmed with a sharp knife. The pins are inserted in the board as shown in the drawing. Two of them serve to hold a card.—Arthur J. Kelly, Brooklyn, N. Y.



# Some Modern Methods in Live-Stock Corral Construction

By H. A. SHEARER

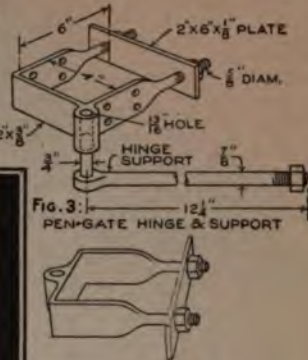
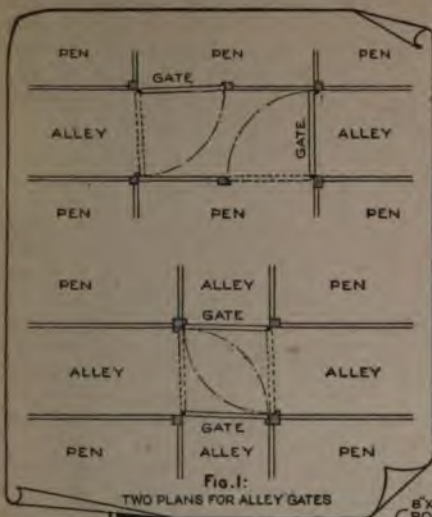
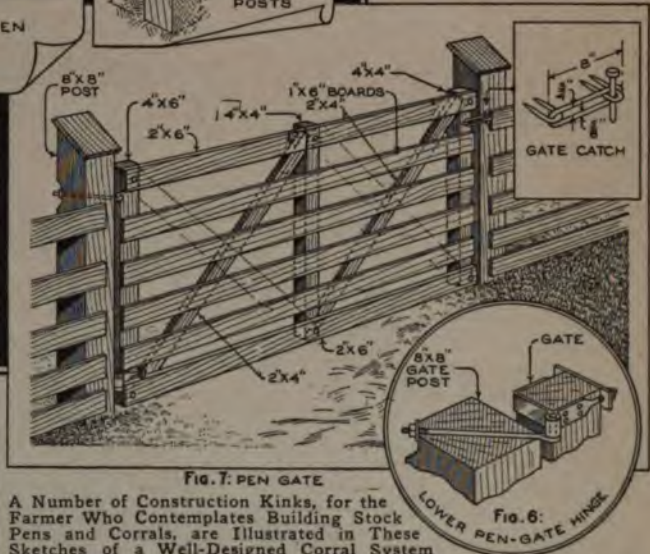
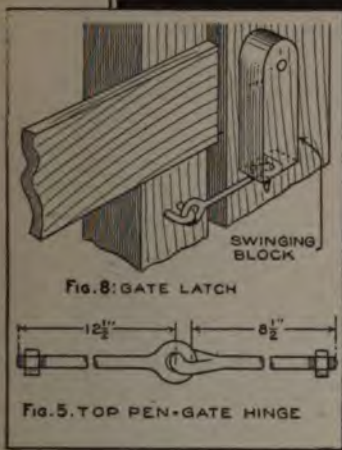

Fig. 4: ALLEY-GATE HINGE.



A Number of Construction Kinks, for the Farmer Who Contemplates Building Stock Pens and Corrals, are Illustrated in These Sketches of a Well-Designed Corral System

**PENS** and lanes to control hogs, cattle, and horses must conform to the old specifications, "hog-tight, horse-high, and bull-strong." Modern requirements also demand convenience and labor-saving features as well as safety for man and beast.

The drawing shows some of the latest and most approved methods of laying out the corrals, lanes, and cross lanes; also methods of constructing the fences and gates to hold the animals in their respective pens, and to facilitate their removal to or from the loading chutes, or other places of transfer.

Valuable animals must be securely controlled, but they must also be gently handled. The present high value of domestic animals fully warrants the necessary outlay, and a satisfactory profit is

almost certain if the construction cost is proportional to the amount of business transacted.

Referring to the illustrations, Fig. 1 gives suggestions in regard to layout of the pens and alleys, together with the system whereby one pair of gates is made to control the animals both in the pens and in the alleys. The detail drawing, Fig. 2, shows how the corral fences are built of heavy posts with boards running horizontally.

Figure 3 shows a heel-strap hinge, with the eye at the corner. This hinge is used on lane gates that open back against the fence. Fig. 4 is the same kind of box-strap hinge, except that the eye is made opposite the center line so the gate will swing both ways, to open or close either a pen or lane as illustrated in Fig. 1. Figs.

### Worn Shirts Made "Good as New"

Many a fine shirt is discarded when the usual method of careful patching has failed to mend the holes worn by the edges of the collar, without



plainly. To avoid this waste, lay the shirt out flat on a board, bosom up, and smooth out the front. Using a rule, mark a line with a pencil, or marking chalk, thus:

Starting from the shoulder strap, mark straight down the front of the shirt, about 1 in. in from the armhole seam, on both sides of the shirt, following the stripe of the cloth, if any. If the cloth is plain, follow the weave. Then make a mark on the bosom, on both sides, parallel with the front of the collar band and the front edge of the shoulder strap; this mark should be about  $\frac{1}{4}$  in. below the worn places in the bosom, to allow for hemming.

Next rip the front seam of the shoulder strap and the front seam of the collar band. Cut along the lines made on both sides of the shirt front, from the lower end of the shirt up to the shoulder strap. Also cut across the bosom, about  $\frac{1}{4}$  in. above the mark, leaving this  $\frac{1}{4}$  in. for seaming in. The torn part of the garment has now been entirely removed. Move up the whole front of the garment, until the lines across the front come to the collar band and the shoulder straps; with the sewing machine run up the long seams on either side of the garment, taking care that the button holes match the buttons down the front. Then baste the upper ends of the bosom into the collar band and shoulder straps. If desired for the sake of appearance, the lower ends of the garment may be evened off, so that

there will be no difference in the length of the front and sides. The long seams at the sides, being under the vest, do not show, and the garment has all the appearance of being new.—M. V. Tessier, Nyack, N. Y.

### Pail Forms Chimney-Pipe Hole

A metal-lined stovepipe inlet for a brick chimney is provided by placing an ordinary straight-sided tin pail of the proper diameter in the flue wall at a convenient point. After the bottom and bail have been removed, the pail is set in the chimney with its top flush with the outside surface of the wall. When the inlet is not occupied by a stovepipe, as often is the case in warm weather, it can be closed with the lid of the pail.—L. M. Jordan, Wallace, Ala.

### Splice for Surveyors' Tape

To repair temporarily a surveyor's chain, or a tape broken during the progress of work in the field, cut from a soft-wood sapling, a piece about 6 in. long and  $\frac{5}{8}$  in. in diameter. Split this piece on a diameter, place the two broken ends in the split, and wrap the whole tightly in tough, small cord. Then place the splice in water for about 15 minutes. It will take much more than the usual pull on a chain to cause the broken ends to part.—Richard F. Lufkin, Charleston, W. Va.

### Homemade Buggy-Tire Puller

A tire puller, useful for removing steel tires from buggy wheels, can be made from an old buggy axle. Cut the axle off 16 in. square the end

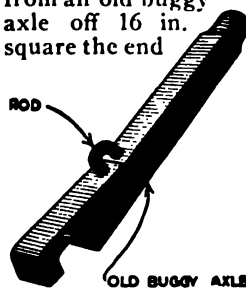

and split with a hacksaw for 5 in. Cut off part of one of the sides thus formed; forge the other one over, and cut it entirely off as shown. Drill holes and run in a staple made of stout iron rod; rivet the ends on the opposite side. The tool will work well on either buggy or wagon tires. The tire is of course gripped between the forged tip and the sawed-off end, and the other end of the tool forms a lever for working off the tire.



### Delivery by Toy Wagon

Discovering that patrons were buying bulky articles, such as potatoes and flour, from stores having delivery systems, the proprietor of a "cash-and-carry" grocery purchased a number of toy wagons, and placed them at the disposal of his customers, who use them in taking home heavy and unwieldy packages. The wagons are placed near the door of the store, and on each is painted this information: "Use me when you need me, but bring me back." A small charge is made when the vehicles are not returned promptly, but none under other circumstances. The plan has proved quite popular with customers.

### Canvas Shoes for the Farmer

In wet weather, when a farmer, or any other outside worker, finds it necessary to make a short visit into the house—for instance, to answer the telephone—a pair of canvas sacks will be found very convenient. These can be made to go easily over the shoes, with rubber bands at the top to prevent their slipping down.

The sacks can be kept clean, outside the house, and will prevent dirt from being left in the house.

### Jig Makes Drill Self-Oiling

Having a number of pieces to be drilled, similar to the one illustrated, I made a



jig of such design that the point of the drill, on lubricating one piece of work, takes up oil, to be used in drilling the next piece, from a cup built in the jig. It takes no longer to remove and insert the work than when using an ordinary jig of this type, and the work of oiling the drill is saved, besides insuring that the drill will always be lubricated as long as the cup holds oil.

### Spring Lock Used on Sliding Door

Usually applied only to swinging doors, a spring lock may be fitted to rolling or sliding doors, such as used on barns and



Sliding Doors Fitted with This Spring-Type Lock Provide Additional Security to Either Garage or Barn



garages. This is accomplished by means of a lever, somewhat like a common latch. In locking, the latch is operated from the outside by a wing nut, on a pivot bolt at about the center of the lever. When the latch end is lowered so as to catch, the other end rises, permitting the bolt of the lock to engage in the notch provided for it, and locking the door. A coil spring pulls the lock end of the lever down the instant the key turns back the bolt of the lock, thus freeing the latch and permitting the door to be opened.—Alva H. Pulver, Sodus, N. Y.

### Holding Square Wire in Chuck

When a small square shank, or piece of square wire, is to be gripped in a lathe chuck for turning, and it is necessary to use a three-jaw universal chuck, a very handy kink is to wind some copper or brass wire around the square metal. The three-jaw chuck will take a grip around the wire which, although it may not hold the square section absolutely concentric, will center it with sufficient accuracy for most purposes.—J. F. Brennan, Kingston, Jamaica.

5 and 6 show the upper and lower gate hinges, the former made of two heavy eyebolts linked together. Fig. 7 shows the construction of the heavy gates, and the way they are hung and fastened—also a very satisfactory type of fastener. Fig. 8 is a safety button that prevents

snoopy cattle or mischievous colts from lifting the hook with their noses or tongues. The button hangs from a bolt directly over the staple, as shown. It is easily pushed aside when the attendant wants to open the gate, but cannot be operated by the animals.

### Front-Axle Stand for Automobiles



The front axle of a car may often be supported more satisfactorily than on an ordinary jack, by the use of a prop made from a section of an old rear-axle housing, cut off to include half of the enlarged, or central, part.

### To Drop Medicine into the Eye

When it is necessary to drop medicine into the eyes unaided, this method has been found satisfactory: Slipping a cord through the supporting prop of a stand mirror, fasten the cord from one end of the bedstead to the other, so that the mirror hangs face down over the bed. By lying on the bed underneath the mirror, it is possible to drop the medicine into the eyes without difficulty.

### Keeping Electric Soldering Irons Ready for Use

To prevent an electric soldering iron from overheating while not in use, and at the same time keep it at the right temperature for work whenever needed, a resistance coil and a switch should be installed, as indicated in the sketch. When the iron is being used, the switch is closed, cutting out the coil, and permitting a full supply of current to reach the tool.

As the irons vary considerably in size and current consumption, no fixed rule can be



given as to the amount of resistance necessary, but this can be easily ascertained by experiment. Iron or nickel-silver wire is suitable for the coil.—Van Allen Lyman, Balboa, C. Z.

### Combined Gauge and Safety Valve

The sketch shows a combined pressure indicator and safety valve, suitable for installation on steam boilers, air tanks, and water systems. Strong metal should be used for the cylinder, but the upper shell can be made from wood, iron, or any other material that is available. The interior of the cylinder should be smoothed in a lathe, so that the piston will fit perfectly in all positions. If the area of the lower end of the piston is 1 sq. in., and if the rod and its attached weight have a combined weight of 75 lb., it will require a pressure of 75 lb.

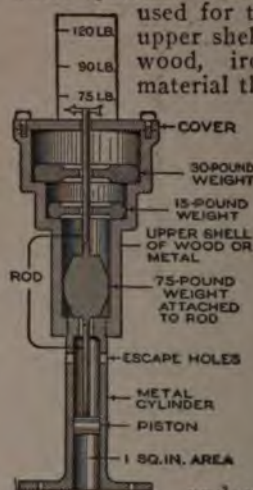

under the piston to raise the rod to a point where the arrow will rest on the 75-lb. mark of the scale. When the pressure reaches 90-lb., the 15-lb. weight will be lifted by the rod, while the 30-lb. weight will be added to the load when the pressure reaches 120 lb. In case the pressure exceeds 120 lb., the piston will be forced past the escape holes, and held there until the pressure falls below that point. If the area of the end of the piston is doubled, the weights should be twice as heavy to indicate the same pressure.

The device can be constructed to show larger or smaller increases in pressure by varying the size of the piston and weights. The cover should hold the rod firmly in an upright position, as otherwise the piston may stick in the cylinder.—James E. Noble, Portsmouth, Ont., Can.



makes heat, but the size of its heating chamber.

If your purse is slim, remember that every cubic foot you build costs just so much to build, clean, and heat.

The cost of a servant's wage and keep for one year will buy many labor-saving devices for the home.

Figure out what the spare room costs to build, heat, and clean—to furnish, to insure, and to pay taxes on; then figure how often it will be used—you may build it!

Keep something in hand for the grounds around the house; the setting has a lot to do with the appearance of a house.—H. E. Lloyd Owen, Port Arthur, Ontario.

### Paper Plate under Paint Can

A paper plate, of the sort used for picnics and for holding small pies, can be put under a paint can to prevent the drippings from soiling the floor. What paint does escape down the sides of the can, serves to keep the plate in place when the can is picked up. This use of paper plates has been found especially handy with paint pots used for "touching up" automobile bodies.—Jas. W. Cottrell, Hammonton, N. J.

### Bellows for Cleaning Furnace

To clean out the furnace, between the inside walls, I used a 3-ft. piece of garden hose, placing it on the end of a small bellows. The hose can be pushed into all the nooks and corners while an assistant operates the bellows. The idea may help the many who know no other way of doing this work than with wires and brushes.—Geo. Veldman, Grand Rapids, Mich.



### Enforcing Careful Driving at Corners

To discourage fast automobile driving around dangerous curves in the vicinity of country towns, the following method may be found effective: Pile cinders, about 1 ft. high, all the way across the road. This pile should be about 15 ft. from the curve, so that in slowing down for the bumps the driver slackens the speed at which he takes the turn.—Edwin Dick, Ocean Springs, Miss.

### Telephone Generator for Electrical Testing on Automobiles

In locating grounds, shorts, and open circuits, I have found the instrument

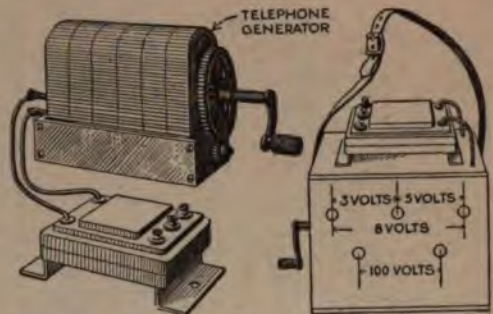

A Small Testing Set, Made Up of a Bell-Ringing Transformer and a Telephone Generator, Is Useful to the Mechanic

shown very cheap and useful. It consists of a telephone generator, or magneto, which develops alternating current at about 100 volts, connected to a bell-ringing transformer, which transforms the 100-volt current to three, five, and eight volts. I have thus four different tensions which can be used when required. For testing insulation and locating short circuits, I use the 100 volts direct, completing the circuit with the fingers. That is, instead of connecting both wires to the leads of the instrument, I hold one wire in the hand and press the finger on the lead; a very slight current can thus be felt. For testing bells, low-tension coils, etc., either the three, five, or eight-volt current is used.

The magneto is fastened inside of a wooden box, and the transformer on the cover. Connections between the magneto and transformer are made on the inside, all terminals having a lead outside for connection. A leather strap is fastened to the box for carrying.—Jos. Magis, Ouffet, Belgium.

### Sawdust for Plugging Holes

When it is found desirable to use an old board, the following method may be employed to fill up nail holes in its surface: Saw a small piece off the end to get a supply of sawdust from the same board. Mix the sawdust with a little glue, and fill in the holes with the mixture. When dry, sandpaper the board down even, and it will be almost impossible to find where the holes were.—John Madlena, Standard, Ill.



### Movable Pen Makes Available Fresh Feeding Ground for Young Stock

By providing a light runway with an axle and two wheels from a discarded



By Lifting on the Handles and Pushing the Pen Ahead Slowly, the Pigs are Moved to a Fresh Feeding Ground

buggy or wagon, fresh portions of pasture ground may be utilized for pigs, or other animals, with little inconvenience. The top members of the runway frame are extended at one end to form handles, by which that end may be easily lifted. They are shaped to fit the hands comfortably. Straps of light-gauge iron may be used to hold the axle to the opposite end of the frame, it being fastened just high enough to keep the bottom of the frame off the ground. The runway itself may be covered with wire netting, or may be made in any way to suit the owner. It is a matter of only a few minutes to lift the runway by the handles and push it ahead to some fresh place, without disturbing the animals while the move is being made.

### Invisible House Chimney



The drawing shows how a chimney may be placed in a house, so that it does not protrude in any of the rooms, thus eliminating objectionable extra corners.

### To Test a Job of Door Hanging

A good test to apply to a door after it is hung is to close all doors and windows in the room on the other side, and then try to slam shut the door to be tested. If the door refuses to close with a bang, owing to the cushion of air, but can then be closed easily by a slow, gentle pres-

sure of the hand, it is a fairly sure indication that it has been hung in a skillful manner.—Willis E. Berg, Berkeley, Calif.

### Carbon Tetrachloride Cleans Goggles

Machinists, mechanics, airmen, and others who wear goggles, are often bothered by grease collecting on the lenses. Gasoline does not clean it off perfectly, because this liquid itself has a tendency to leave a greasy residue on glass. Carbon tetrachloride, a grease solvent, removes every trace instantly.

### Clothespin as Insulating Pliers

An ordinary wooden clothespin will serve as insulating pliers when automobile spark plugs are tested. A detached spark-plug wire is pushed into the slot in the pin. The end of the wire can then be held close to the spark-plug binding post without danger of shock.—A. D. Bonfils, New York City.

### Broken-Tap Extractor

A simple device for removing taps from material in which they have been broken off is made by bending a piece of drill rod into a "U." The ends of the rod are placed in opposite flutes of the tap, and a monkey wrench, fitted on the projecting portion of the "U," is employed to turn the imbedded tool. To facilitate the operation, small cuttings should be removed with an air blast or a magnetized rod, and oil should be squirted around the tap.



### Hints for Home Builders

The following pointers are offered to enthusiastic but uninitiated home builders by an architect of many years' experience:

Warm walls save coal.

A bungalow costs more than a house of the same cubic contents.

It isn't the nickel on the plumbing that denotes good fixtures.

A cold house is not a matter of chance, but of bad building.

It isn't the size of the furnace that



# INDEX TO VOLUME XVII

# SHOP NOTES FOR 1921

Abrasive Stones, Making.....	3501
Accidents, Opening in Fence Prevents...	3402
Accuracy, Restoring a Micrometer to...	3384
Acetylene Work, Vacuum Lamp for.....	3427
Acid Container, Nonspilling.....	3501
Acid Fumes, Etching Glass with.....	3324
Adapter for Telephone Cords.....	3410
Adapting Saw Vise to Sharpening of Band Saw .....	3366
Adjustable Auto Trouble Lamp.....	3510
Adjustable Electric-Lamp Shade.....	3253
Adjustable Horse for the Wood Shop....	3463
Adjustable Pipe Wrench.....	3334
Adjustable Stock Guide for the Punch Press .....	3339
Adjustable V-Block .....	3353
Advertising Sign, Windmill, made from Bicycle .....	3427
Advertising Signboard, Attractive Out- door .....	3319
Advertising Signs Made of Gummed Paper .....	3419
Agitator for Mixing Liquids.....	3427
Aid for Painting Window Sash.....	3371
Aid in Perspective Drawing, Swinging Rule an .....	3306
Aids for Binders Working in Wet Soil..	3462
Air Blast, Removing Moisture from.....	3448
Air Chamber Prevents Tank from Burst- ing .....	3346
Air, Compressed, for Cleaning Tobacco Pipe .....	3503
Air Cooler, Water-Spray, for the Shop..	3383
Air Filter for Tractors.....	3488
Air, How to Keep Dry.....	3401
Air Tank Made from Oil-Well Casing....	3418
Airplane Protected from Tampering....	3314
Alarm, Burglar, Designed to Confuse an Expert .....	3374
Alarm, Electric Tire-Theft Protector....	3426
Alarm, Sensitive Relay Operates, When Brushes Spark .....	3378
Alcohol, Saving, from Auto Radiator....	3411
Alcohol, Oil Limits Evaporation of.....	3482
Alignment, Wobbler Test Lathe.....	3295
Aluminum Castings Tested by Weight..	3503
Aluminum, Pure, Readily Worked with Carpenter's Tools .....	3452
Amber Varnish, Making of.....	3340
Ammonia as a Fire Extinguisher.....	3366
Angle Iron, Shop Trestle Made of.....	3461
Angular Work, Drilling.....	3450
Antifreeze Solution, Kerosene as.....	3351
Ants, Calcium Carbide Routs.....	3318
Ants, Destroying, Powder for.....	3503
Ants, Poison Sirup for.....	3372
Anvil Made from Steel Rail.....	3496
Anvil, Special Garage.....	3357
Anvil, Special Shears for Use on.....	3377
Aphis, Tomato Follage for Killing.....	3487
Apples, Stored, Keeping Rats from.....	3364
Apron, Spring Holds.....	3262
Apron, Toolmaker's, as Tool Case.....	3459
Arbor, Bushing and Gear Press.....	3485
Arc and Spark Radio Receiving Cabinet..	3478
Arcs, Centerless, Drawing.....	3402
Artists Brushes, How to Keep.....	3431
Asbestos Soldering Pad.....	3459
Ash Can as Fire Extinguisher.....	3500
Ash Sifter Prepares Potting Soil.....	3436
Ash Sifters, Wheelbarrow.....	3246
Ash Trays, Copper, Making.....	3487
Assembly Fixture, Tire-Pump.....	3262
Auger Handle, Screw Plate as.....	3280
Automatic Quick-Acting Lathe Dog.....	3373
Automatic Soldering-Iron Switch.....	3556
Auto, Atomizer Injects Carbon Remover in Cylinders .....	3435
Auto, Baggage Rack over Car Hood.....	3403
Automobile Battery, Auxiliary.....	3486
Automobile Becomes Locomotive for Narrow-Gauge Railway .....	3435
Auto, Brake Does Work of Lost Tire Chain .....	3393
Automobile Circuits, Telephone Genera- tor for Testing.....	3509
Automobile Crankshaft Bearings, Bor- ing Machine for.....	3498
Auto, Creeper Made from Old Cot.....	3449
Automobile Cylinder Heads, Handles for Lifting .....	3473
Auto, Electric Toaster for Starting....	3413
Automobile Engine, Cooling with Ex- haust .....	3496
Automobile Engine Hood, Varnishing....	3339
Automobile Engine Manifolds, Replacing Auto Engine, Protecting from Cold....	3497
Automobile Engine, Restoring Compre- sion .....	3481
Automobile Floor Saved by Old License Plates .....	3500
Automobile Generators, Testing.....	3476
Automobile Hood, To Keep Bright.....	3370
Automobile Horn Button, Mounting for, Auto Hub as Lathe and Drill Press....	3459
Automobile Ignition Key, Knife Blade Makes .....	3483
Automobile Ignition Switch, Secret....	3471
Auto Intake, "Hot-Spot" for.....	3494
Automobile Intake, Leaks in, Cause Cyl- inders to Miss.....	3312
Auto, Jacks, Quick-Operating.....	3381
Auto Lock, Reliable Ignition.....	3451
Automobile, Low Gear, Repair for.....	3321
Auto Manifold Heated by Concrete....	3502
Automobile Manifold Heater.....	3404
Automobile, Old, Designing and Making a Speedster Body for.....	3448
Automobile Operates Tank Pump.....	3324
Auto Painting Easily and Rapidly Done	3494
Automobile Parts, Ice-Cutting Machine Made from .....	3416
Auto Parts, Scrap, Revolving Table from Auto, Rear of Covered, Forms Bed for Camping .....	3334
Auto, Removing Carbon with Wire Brush	3326
Auto, Rubber Shock Absorber.....	3388
Auto, Saving Alcohol from Auto Radiator	3426
Auto, Sled Runners with Plow Attach- ments for Light Cars.....	3437
Automobile Split Rims, Removing Tire..	3447
Auto Springs, Compressed Air for Oiling	3487
Auto, Starting in Cold Weather.....	3420
Auto Starting Motor Drives Coaster Wagon .....	3415
Auto, Steel Wool Heats Intake Mani- fold .....	3483
Automobile Generators, Testing.....	3442
Automobile Thieves, Discouraging.....	3370
Auto, Tire Gauge Attached to Hose Con- nection .....	3489
Auto Tire, Repairing on Rim.....	3436
Automobile Tops, Repairing Holes in...	3418
Automobile Trouble Lamp, Adjustable..	3474
Auto Wheel Operates Tire Pump.....	3510
Automobile Windshield as Dining Table..	3431
Automobile Windshield, Mixture for Cleaning .....	3460
Automobiles, Front Axle Stand for.....	3502
Autos, Numbered Parking Spaces for...	3506
Automobiles, Reckless Driving Prevented by Cinders .....	3419
Auxiliary Battery under Floorboard of Auto .....	3509
Awning, A Quickly Made.....	3486
Axle Stand, Front, for Autos.....	3473
Axle, Wagon, Used as Gate Hinge.....	3506
Axles, Full-Floating Rear, Wheel Puller for .....	3487
	3335

### Homemade Garden Tools

From odds and ends readily available to almost anyone, substantial and satisfactory garden tools are easily made. A

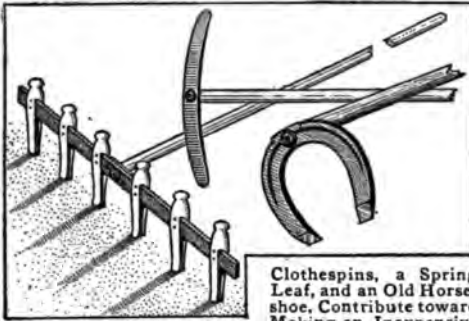

Clothespins, a Spring Leaf, and an Old Horseshoe. Contribute toward Making an Inexpensive Set of Garden Tools That Answer Their Purpose Admirably When Regular Tools Are Unobtainable

leaf from an old spring, attached to a handle, as shown, makes a good grub hoe or a pickax, when the ends have been sharpened by filing or grinding. An old horseshoe, sharpened at the heels and attached to a handle, makes a good cultivator. The row marker illustrated is made from a lath, nailed to a broom handle, and a few clothespins.—C. A. Black, Jr., Hightstown, N. J.

### Adjustable Auto Trouble Lamp

A handy detachable trouble lamp for automobiles can be made from a discarded electric headlight and a clamp of

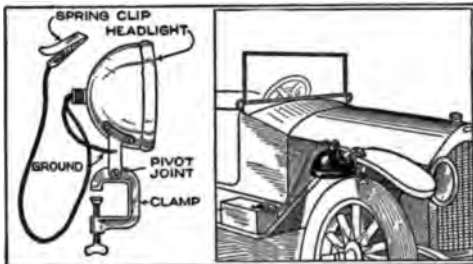

By Combining an Old Electric Headlight and a Clamp, as Shown Here, a Handy Trouble Lamp for Automobiles can be Made

the type illustrated. The headlight bracket is attached to the clamp by a small bolt that is passed through holes of suitable size in both pieces. This provides a joint which permits the position of the lamp to be changed when the device is fastened to a fender, or some other part of a car. If the car has a grounded electric system, one of the wires leading to the light bulb is grounded on the lamp, while the second is fitted with a metal clip for attach-

ing it to a "live" point on the wiring system. With a double-wire system, clips should be fastened to the ends of both wires. This lamp is very convenient when it is necessary to make repairs at night, as it can be attached in an instant wherever it is needed.

### Driving Nails in Cement

Cement would be used in many places, were it not for the difficulty of driving nails into it so that they will hold. If clean cinders are mixed with the sand and cement, the surface will hold a nail almost as solidly as wood. It is suitable for fence posts and places for driving nails in basements.—A. Handelman, Montreal, Que., Can.

### Grain-Bag Holder Protects Bag

A means for attaching a grain bag to a chute without the use of hooks, which tear the bag, is shown in the accompanying drawing. A channel, 1 in. wide and  $\frac{1}{2}$  in. deep, is cut near the bottom of the chute. When the bag is bound to the chute with a heavy strap, which fits in the channel and is buckled tightly, it can be filled. To remove the bag, simply unbuckle the strap. If it is desired to use a stand holder, a section of a chute, provided with a channel, can be mounted on legs.



### Street Signs Cheaply Obtained

Street signs made from old automobile-license tags, donated by local car owners, are serving satisfactorily in a small middle-western town. The reverse sides of the tags are painted white, and lettered in black. The inexpensive guides are nailed to telephone poles at street intersections.—Mrs. George Katzenmeyer, Bowling Green, Ohio.

ⒸA large spring cotter may be converted into a serviceable pair of tweezers by grinding the open end to a point. Before grinding, wrap the cotter with a string near the eye, tight enough to close the open end.



Cartridge, Chalk Holder Made from.....	3485	Closet, Sanitary, of Vitrified-Clay Sewer	
Case, Tool, Toolmaker's Apron as.....	3459	Pipe.....	3376
Cases, Shipping, Band and Wire Stretcher		Cloth, Wire Screen, Backing for.....	3485
for.....	3501	Clothes Hangers Made from Spools.....	3408
Cast Iron, Soldering.....	3463	Clothes Hangers, Rail for.....	3487
Castings, Aluminum, Testing by Weight	3503	Clothesline, Quick Tightener for.....	3317
Casts, Plaster, A Finish for.....	3391	Clothespin as Insulating Pliers.....	3508
Cattle, Feeder for.....	3350	Clothespin Makes Reaching Device.....	3492
Cattle, Holder for Dehorning.....	3477	Clothespin, Pliers Made from.....	3391
Celluloid Straightedge, Truing a.....	3327	Clothespin Used as Vise.....	3482
Cement Blocks, Imitating in Form Work	3352	Clothespins, Making a Show-Card Dry-	
Cement, Driving Nails in.....	3510	ing Rack of.....	3502
Cement, Rubber, Making.....	3495	Clutch, A Remedy for Slipping Cone....	3403
Center, Lathe, for Small Work.....	3453	Coal, Stovepipe Radiator Saves.....	3348
Center, Lathe, Lubricated.....	3471	Coaster Wagon Driven by Auto-Starting	
Centering Gauge, Carpenter's.....	3400	Motor.....	3483
Centering Work, Steel Ball Aids in.....	3322	Coat Hangers, Rail for.....	3487
Centers in Rods, Tool for Drilling.....	3469	Coll Springs, Making Oval or Flat.....	3422
Chain Attachment Helps in Plowing....	3349	Coke as a Substitute for Sandpaper....	3337
Chain Paddle, Water, Motor.....	3496	Cold Chisel, Making Round Holes with...	3495
Chain, Surveyor's, Splice for.....	3504	Cold Drinking-Water Tank for Shop....	3463
Chains Pull Tires from Rims.....	3487	Cold, Fruit Trees Protected from.....	3355
Chains, Truck, Exhaust Keeps Clean....	3464	Cold, Protecting Auto Engine from.....	3481
Chair Seats of Paper.....	3490	Cold Weather, Keeping Fuel Oil Liquid	
Chalk Holder Made from Cartridge.....	3485	in.....	3358
Chalk Impression, Engraved Work Trans-		Collapsible Showcard Desk.....	3474
ferred by.....	3322	Collapsible Window Ventilator.....	3484
Charging Storage Batteries, Electrolytic		Coloring Brass for Laying Out.....	3361
Rectifier for.....	3417	Columns, Hollow, Conceal Counterweights	
Charts Insure Correct Meter Readings..	3380	Columns, Round, Veneering Large.....	3494
Chassis Frames, Straightening Bent....	3352	Comb Foundation, Economy in Using....	3327
Cheap and Accurate Level.....	3361	Comb, To Rule Paper with.....	3435
Cheaply Made Street Corner Signs.....	3510	Combination Sawhorse, Desk, Table, and	
Check, Typewriter Prevents Raising		Easel.....	3363
Bank.....	3496	Combined Gauge and Safety Valve.....	3506
Chicken Coop Made from Trunk.....	3413	Comfortable Crutch.....	3366
Chickens, Wire Baskets Separate, from		Commutator Strips, Mica, Undercutting...	3343
Incubator.....	3444	Commutators, Cleaning.....	3392
Chimney, Cleaner for.....	3497	Compass Lead, Making.....	3340
Chimney, Draft in, Damper Governor		Compressed Air for Cleaning Tobacco	
Maintains Constant.....	3464	Pipe.....	3503
Chimney, Increasing Height of While in		Compression, Restoring Lost.....	3500
Use.....	3337	Concrete - Column Reinforcement, Ma-	
Chimney, Invisible House.....	3507	chine Bends Wire Mesh for.....	3370
Chimney Leaks, Drip Belt Prevents.....	3441	Concrete, Doing Concrete Work in Freez-	
Chimney, Light Globe for Cleaning....	3496	ing Weather.....	3440
Chimney Pipe Hole Made from Pall....	3504	Concrete, Driving Nails in.....	3510
Chimney, Sweeping with a Small Tree..	3308	Concrete, Manhole Form, Dishpan Makes	
Chisel, Cold, Making Round Holes with		Concrete, Manifold Heated by.....	3404
Chloride, Tin, Removes Rust.....	3492	Concrete Reinforcement, Burning Out....	3394
Chuck, Holding Square Wire in.....	3507	Concrete Structures, Cutting Reinforce-	
Chuckling Lathe Work, Indicator for....	3304	ments in.....	3308
Chute Hooks Supported on Springs.....	3493	Concrete Trough That will Not Burst	
Cigar, Notches Take Place of Cigar Cut-		When Frozen.....	3336
ting.....	3414	Conduit, Making Right-Angle Bends in...	3358
Cinder Pile Slows Down Speeders at		Connecting-Rod Babbitting Fixture....	3332
Corners.....	3509	Connecting-Rod Bearings, Clamping in	
Cinders Prevent Reckless Driving at		Vise.....	3355
Corners.....	3509	Connections, Electric, Proper Care of...	3442
Circle, Dividing Accurately.....	3463	Connector, Binding Post Adapted to Cord	
Circuit Breaker Stops Motor When Belt		Tips.....	3381
Breaks.....	3351	Constant Level for Filtering.....	3366
Circular Saw Gummed in Grinder.....	3470	Cooker, Fireless, How to Make.....	3406
Circular Work, Double Level for.....	3468	Cooking Bracket on Gas Jet.....	3486
Clamp Aids in Tapping Drilled Holes..	3347	Cool, Potato Keeps Metal.....	3495
Clamp—Clamping Together a Split Pipe.	3379	Cool Water for Farm Workers.....	3384
Clamp, Emergency Gluing.....	3325	Cooler, Air, Water Spray, for the Shop..	3383
Clamp, Pneumatic.....	3404	Cooler, Neat Window.....	3340
Clamping Connecting-Rod Bearings in		Cooling Auto Engines with Exhaust....	3496
Vise.....	3355	Cooling House in Summer.....	3396
Clamps, Sandpaper Prevents Shifting of		Coop, Chicken, Made from Trunk.....	3413
Cleaner, Air, for Tractors.....	3488	Copper Ash Trays, Making.....	3487
Cleaner for Chimneys.....	3497	Copper, Soldering, Heated without a	
Cleaning a Drain with a Stick.....	3459	Torch.....	3491
Cleaning Furnace with a Bellows.....	3509	Copper, Soldering, Rest for.....	3459
Cleaning Glass, Steel Wool for.....	3477	Coppers, Soldering, Electric, Keeping	
Cleaning Goggles with Carbon Tetra-		Ready for Use.....	3506
chloride.....	3508	Cord Tips, Binding Post Adapted to....	3381
Cleaning Long-Necked Vases.....	3486	Cords, Electric, Proper Care of.....	3442
Cleaning Metal for Soldering, Wire Brush		Cords Keep Drawings in Place.....	3492
for.....	3489	Cords, Telephone, Adapter for.....	3410
Cleaning Motor Truck Chains with Ex-		Corks, Oil Hole Covers Made from.....	3457
haust.....	3464	Corks, Using Old.....	3483
Cleaning Old Negatives.....	3391	Corner Signs, Street.....	3510
Cleaning Stack, Light Globe for.....	3496	Corral, Livestock, Building.....	3505
Cleaning T-Slots, Tool for.....	3501	Cot, Old, Made into Creeper.....	3449
Cleaning Tobacco Pipe with Compressed		Cotter Pin Makes Tweezers.....	3510
Air.....	3502	Cotter-Pin Puller, An Improved.....	3375
Cleaning Windshield, Mixture for.....	3502	Counter, Speed, Old Watch as.....	3425
Clip for Hanging Prints.....	3385	Counterboring and Countersinking Tool,	
Cipper, Bolt.....	3471	Hand-Operated.....	3325
Close-Quarters Screwdriver.....	3461	Countershaft, Portable.....	3325

Babbitt Bearings, Good, How to Pour...	3327	Boilers, Slow-Steaming, Auxiliary Draft for	3328
Babbitt Ladle, Emergency	3338	Bolt Clipper	3471
Babbitt Packing for Steam Joints	3368	Bolt-Hole Gauge	3469
Babbitt, Portable Pot for	3451	Bolt to Fit Any Door	3313
Babbitting Fixture, Connecting-Rod	3332	Bolt, Wing, is Used to Fasten Timbers to Hollow Tile	3373
Babbitting Steam Engine Bearings	3468	Bolts, Planer, Rack Keeps in Order	3309
Backing for Wire Screen Cloth	3485	Bolts, Preventing from Turning	3344
Backlash, Taking Up, in a Gear	3374	Bolts, Setting in Rock and Concrete	3336
Bag Filler, Grain, Stove Damper as	3397	Boring and Callipering Segments	3425
Baggage Rack over Car Hood	3403	Boring Bit for Large Holes	3423
Baking-Incubator Raises Bread	3437	Boring in the Drill Press	3351
Ball, Steel, Aids in Centering Work	3322	Boring Machine for Crankshaft Bearings	3498
Balls, Automatic Testing of Steel	3381	Boring-Tool Holder	3362
Band and Wire Stretcher for Shipping Cases	3501	Boring Tools, Small, Holder for	3339
Band Saw, Adapting Saw Vise to Sharp- ening of	3366	Bottle Stoppers, Removing Tight	3401
Bank Checks, Typewriter Prevents Rais- ing	3496	Bottom of Door, Guide for Sawing	3333
Bark, Peeling of, on Rustic Timbers, To Prevent	3470	Box for Holding Tape Reel	3375
Barrel, Device for Rolling a	3351	Boxes, Spacing Nails in	3484
Barrel Support, Shelf-Bracket	3435	Brace, Horizontal, for Wire Fence	3465
Bars, Steel, Tool for Straightening	3411	Brace, Screen-Door, Spokes Form	3393
Basin, Test, Heater for Hydraulic	3491	Bracket, Cooking, on Gas Jet	3486
Batteries, Storage, Electrolytic Rectifier for Charging	3417	Bracket for Draftsman's Lamp	3493
Batteries, Waterproofing Dry	3399	Brake Does Work of Lost Tire Chain	3393
Battery Under Floor of Auto	3486	Brake Drums, Turning in the Drill Press	3313
Bearing Liners, Clips Hold	3411	Brass, Coloring for Laying Out	3361
Bearing Metal, Portable Pot for	3451	Brass Tubing, How to Make Smaller	3425
Bearings, Automatic Testing of Steel Balls	3381	Brazing, Asbestos Pad	3459
Bearings, Connecting-Rod, Clamping in Vise	3355	Brazing Flux, Container for	3424
Bearings, Crankshaft, Boring Machine for	3498	Brazing, Potato Keeps Metal Cool	3495
Bearings, Steam Engine, Babbitting	3468	Bread Board, Sanitary Waxed-Paper	3454
Bed for Camping, Rear of Covered Auto Forms	3388	Bread, Incubator Raises	3437
Bed from Pipe and Fittings	3395	Breakage of Small Drills, Reducing	3341
Bees, Drinking Water for	3497	Breaking Out a Sled from the Ice	3357
Bellows, Detecting Pinholes in Camera	3373	Brickwork, Circular, Double Level for	3468
Bellows for Cleaning Furnace	3509	Bridges, Farm Foot	3458
Belt Breaks, Circuit Breaker Stops Motor When	3351	Bright Automobile Hood, To Keep	3459
Belts, Joining Rawhide	3373	Broken Tap Extractor	3508
Belts, Tool for Putting on	3401	Brush, Wire, Cleans Metal for Soldering	3489
Bench Dog, Simple and Effective	3348	Brush, Wire, for Removing Carbon	3426
Bench or Boat, Lavatory for	3304	Brushes, Artists, How to Keep	3431
Bench, Toggle Press for Bench	3473	Bucket Makes Chimney-Pipe Hole	3504
Bending and Forming, Wood	3421	Buggy Converted into Sleigh	3412
Bending Small Tubing, Quick Method of	3318	Buggy Tire Puller	3504
Bends in Conduit, Making Right-Angle	3358	Building a Home, Hints for	3508
Bevels, Vise Attachment for Filing	3400	Building a Livestock Corral	3505
Bicycle, Grindstone Frame, Made from Part of an Old	3417	Building a New House Around the Old	3376
Bicycle Motor for Grinding	3382	Bulletin Board, Newspaper	3397
Bin, Flour, on Cupboard Door	3378	Bumper, Filling Case	3455
Binders Working in Wet Soil, Aids for	3462	Bunsen Burner, Draft Shield for	3321
Binding Post Adapted to Cord Taps	3381	Bunsen Burner, Hot Flame	3392
Bit for Boring Large Holes	3423	Burette, Dust Protector for	3389
Bit, Soldering, Heated without a Torch	3491	Burglar Alarm Designed to Confuse an Expert	3374
Bit, Soldering, Rest for	3459	Burning Garbage in the Stove	3477
Bitbrace Handle, Repair for	3336	Burst When Frozen, Concrete Trough That Will Not	3336
Bits, Electric Soldering, Keeping Ready for Use	3506	Bursting, Air Chamber Prevents Tank from	3346
Blacksmith's Tire Shrinker	3469	Bushing, Arbor and Gear Press	3485
Blade, Knife, Makes Ignition Key	3471	Bushings, Wristpin, Tool for Handling	3307
Blad, Sand, Engine Exhaust Provides	3453	Button, Automobile Horn, Mounting for	3483
Blasting with Gasoline Vapor	3307	Button, Service, Fastened on Coat	3414
Blind Holes, Tight Rivets in	3503	Cabbage, Shovel Harvests	3425
Blind, Window, Ventilator Used with	3466	Cabinet, Receiving, Radio Arc and Spark	3478
Blow-Off Valve and Gauge Combined	3506	Calcium Carbide Routs Ants	3318
Blowout Patches Made from Garden Hose	3460	Calliper, Automatic, Shows Oversize	3379
Blueprint Paper Sensitizing Machine	3490	Callipering and Boring Segments	3425
Blueprinting Part of a Tracing	3367	Calks, Horseshoe Toe, Repairing Broken Gears with	3339
Board, Drafting, Drawings Kept on by Cords	3492	Calclimine, How to Make Whitewash	3439
Board, Drawing, for Office Desk	3458	Camera Bellows, Detecting Pinholes in	3373
Board, Newspaper Bulletin	3397	Can, Ash, as Fire Extinguisher	3500
Boat, Lavatory for Bench or	3304	Can, Paint, Paper Plate under	3509
Boat Propeller, Examining with Mirror	3465	Can, Water, Grindstone	3457
Boats—Frame for Painting Rowboats	3434	Candle Lighted Electrically	3488
Boiler, Range, Pipe Connections on	3441	Canvas Shoes for the Farmer	3507
Boiler Scale Removed by Steam	3448	Cap for Deflating Inner Tubes	3359
Boiler Tubes Measured While Hot	3412	Car, Garage Door Closed by Passage of Car, Light, Turntable for	3355
Boiler Tubes, Reinforcing	3385	Car, Sliding Garage Door opened by	3310
Boiler, Wash, Reinforcing Bottom	3437	Carbon Remover, Atomizer Injects in Cylinders	3435
Boiler Water, Ship Provided with, While at Sea	3388	Carbon, Removing, with Wire Brush	3426
		Carbon, Steam Prevents, in Gas Engines	3380
		Carbon Tetrachloride Cleans Goggles	3508
		Card Holder, Shop, of Simple Construc- tion	3318
		Card, Show Drying Rack	3502
		Carpenter's Square, Laying Out a Regu- lar Hexagon with	3364



Engine Exhaust Heats Mill.....	3454	Flour Bin on Cupboard Door.....	3378
Engine Exhaust Heats Tank.....	3410	Flux, Brazing, Container for.....	3424
Engine Exhaust Provides Sand Blast...	3453	Flux, Soldering, Spreader.....	3445
Engine Manifolds, Auto, Replacing.....	3497	Folding Scaffolding Support.....	3333
Engine, Removing a "Frozen" Valve Stem.....	3373	Foliage, Tomato, as Insect Killer.....	3487
Engine, Restoring Compression in Auto	3500	Food Chopper Clamps, Preventing Slip- ping of.....	3492
Engine, Soft Heads on Piston Pin.....	3432	Foot-Power Shaper, Homemade.....	3364
Engines, Steam Prevents Carbon in Gas.	3380	Footbridges, Farm.....	3458
Engraved Work Transferred by Chalk Impression.....	3322	Forge, Gas-Fired.....	3357
Entering Small Screws in Awkward Places.....	3327	Forge Made from Old Sink.....	3326
Envelopes, Examining for Inclosures...	3461	Form, Concrete Manhole Dishpan Makes	3411
Eraser, Steel Wool, for Ink Lines.....	3377	Form Work, Imitating Cement Blocks in	3352
Etching Glass with Acid Fumes.....	3324	Forming and Bending, Wood.....	3421
Evaporation of Alcohol Limited by Oil...	3482	Fountain, Drinking, for Bees.....	3497
Examining Boat Propeller with Mirror...	3465	Frame, Wire-Fence, for Snow Houses...	3344
Examining Envelopes for Inclosures...	3461	Freezing, Preventing Pump from.....	3430
Exhaust Cools Auto Engine.....	3496	Friction Wheel, Internal, Gives High Speed Reduction.....	3338
Exhaust, Engine, Carried through Fur- nace Pipe.....	3320	Front Axle Stand for Autos.....	3506
Exhaust, Gas-Engine, Rids Building of Rats.....	3377	Frost on Show Windows, Preventing.....	3475
Exhaust Gas Heats Mill.....	3454	Frozen, Concrete Trough That will Not Burst When.....	3336
Exhaust Keeps Truck Chains Clean.....	3464	Fruit, Growing Strawberries in Barrel..	3398
Extension Handles on Petcocks.....	3491	Fruit-Picking Ladder Wagon.....	3455
Extension Lamp, Guard and Reflector for.....	3490	Fruit Press Made from a Jack.....	3385
Extinguisher, Ash Can as Fire.....	3500	Fruit Trees Protected from Cold.....	3355
Extractor, Broken Tap.....	3508	Fuel Oil, Keeping Liquid in Cold Weather	3358
Eyes, Dropping Medicine into.....	3506	Fuel Tank on Truck, Lock for.....	3325
Eyes, Jig for Bending, in Wire.....	3375	Full-Floating Rear Axles, Wheel Puller for.....	3335
Faceplate for Multiple-Thread Cutting...	3347	Funnel Spout for Oilcan.....	3419
Faceplate Screw, Rapidly Actuated.....	3317	Funnel With Breather Tubes.....	3414
Fan, Electric, Displays Sign.....	3493	Furnace, Cleaning with a Bellows.....	3509
Farm Footbridges.....	3458	Furnace, Gas Water Heater as Auxiliary to.....	3452
Farm Gate, Stock-Proof.....	3474	Furnace Keeps House Cool in Summer...	3396
Farm, Narrow Gate Useful on.....	3307	Furnace Pipe, Engine Exhaust Carried through.....	3320
Farm Sign, Wind-Propelled.....	3456	Furrowing Pole, Stout Point for.....	3313
Farmer, Canvas Shoes for the.....	3507	Garage Anvil, Special.....	3357
Faucet, Protecting, on Gasoline Pump...	3338	Garage Door Closed by Passage of Car..	3355
Feather, Inserting Tight Key or.....	3306	Garage Door, Sliding, Opened by Car...	3372
Feed Nut, Readjusting a Worn.....	3360	Garage, Electric-Lighting System for...	3446
Feed Rack, Repairing Drill Press.....	3348	Garage Floor as Trouble Guide.....	3401
Feeder for Cattle.....	3350	Garage, Folding Runway.....	3387
Fence, Opening in, Prevents Accidents...	3402	Garage Light, White Paint Improves...	3320
Fence, Poultry, Low-Cost.....	3305	Garage, Moving with Tractor.....	3455
Fence, Wire, Horizontal Brace for.....	3465	Garage or Shop, Trash Box for.....	3333
Fender for Plow Turns Under Trash...	3497	Garage, Radiator Heater for.....	3444
Fiber, Drill for.....	3435	Garbage, Burning in the Stove.....	3477
Fiber Handles for Hammers.....	3423	Garbage Incinerator for Stove.....	3477
Fiber Pliers for Electricians.....	3387	Garden Hose, Blowout Patches Made from.....	3460
Filing a Round File That will Not Stick	3422	Garden Tools, Homemade.....	3510
Filing Bevels, Vise Attachment for.....	3400	Garment Hangers, Rail for.....	3487
Filing Case Bumper.....	3455	Garter Studs Make Instrument Feet...	3331
Filing Holes in Rubber.....	3471	Gas-Engine Valves, Truing Up.....	3365
Filing Metal Pieces Thinner.....	3392	Gas-Fired Forge.....	3357
Filing, Ripsaw, Irregular.....	3409	Gas Jet, Cooking Bracket on.....	3486
Filing Small Screws.....	3333	Gas Pipe, To Find Leaks in.....	3331
Filing Solder.....	3501	Gases, Exhaust, Clean Motor Truck Chains.....	3464
Filler, Grain-Bag, Stove Damper as.....	3397	Gasoline—Feed Pipe, Auxiliary Petcock Aids in Cleaning.....	3311
Filling Silo, Lowe Wagon for.....	3432	Gasoline for Leaky Inne. Tubes.....	3316
Film, Protection for, While Scraping...	3419	Gasoline Torch, Self-Lighting.....	3320
Films, Box for Developing Motion-Pic- ture.....	3382	Gasoline Vapor, Blasting with.....	3501
Filter, Air, for Tractors.....	3438	Gate, Farm, Works on Wheel.....	3450
Filter, Clarifies Ditch Water.....	3423	Gate Hinge, Wagon Axle Used as.....	3487
Filtering, Constant Level for.....	3366	Gate Latch, Iron Ring.....	3336
Filtering Oil, Felt Hat for.....	3431	Gate, Narrow, Useful on Farm.....	3307
Fire Extinguisher, Ammonia as.....	3366	Gate, Stock-Proof Farm.....	3474
Fire Extinguisher, Ash Can as.....	3500	Gate, Tile, for Small Dam.....	3438
Fireless Cooker, How to Make.....	3406	Gate, Wagon End, Lock for.....	3465
Fireplace, Hiding, in Summer.....	3424	Gates, Heavy Doors and Hinge for...	3365
Fixture, Electrically Lighted, Keeps Sol- dering Bit Hot.....	3337	Gauge and Safety Valve, Combined.....	3506
Fixture for Cutting Wire Cable.....	3335	Gauge, Bolt-Hole.....	3469
Fixture for Holding Rough Work in Vise.....	3449	Gauge, Carpenter's Centering.....	3400
Fixture for Holding Tapered Work in Shaper.....	3438	Gauge for Composition Shingles.....	3439
Fixture for Splitting Round Rubber...	3342	Gauge for Gear Setting.....	3410
Fixture for Swaging Rawhide Pins.....	3354	Gauge for Setting Lathe Tool.....	3308
Flame, Hot, Without Air Blast.....	3392	Gauge Glass, Locomotive, Steadying the Water in.....	3315
Flame, Improving, of Small Torch.....	3416	Gauge, Spring, for Lathe Screw Cutting...	3473
Flanges on Thin Tubes, Turning.....	3470	Gauge, Tire, Attached to Hose Connec- tion.....	3436
Float, Paraffin Repairs Leaks in.....	3418	Gear, Bushing and Arbor Press.....	3485
loor, Automobile, Auxiliary Battery Under.....	3486	Gear, Low, Auto, Repair for.....	3502
loor, Automobile, Saved by Old License Plates.....	3476	Gear Puller, Iron Pipe as.....	3345
		Gear Setting, Gauge for.....	3435

Countersink, Adjustable, on Drill.....	3419	Draft Shield for Bunsen Burner.....	3321
Counterweights, Hollow Columns Con- ceal.....	3362	Drafting Board, Cords Keep Drawings on.....	3492
Covers, Oil Hole, Made from Corks.....	3457	Drafting Board for Office Desk.....	3458
Cracked Water Jacket, Repairing.....	3328	Draftsman's Lamp Bracket.....	3493
Cracks in Tools, To Find.....	3412	Draftsman's Triangle with Irregular Curves.....	3503
Crane, Half-Ton Traveling.....	3303	Draftsmen, Convenient Triangle for.....	3355
Crane Helps in Unbolting Timbers.....	3411	Drain, Cleaning with a Stick.....	3459
Crankshaft Bearings, Boring Machine for.....	3498	Draining the Radiator Made Easy.....	3337
Crankshafts, Heavy, Rig for Handling.....	3312	Drawer, Filing Case, Bumper for.....	3455
Creeper Made from Old Cot.....	3449	Drawer Lock, Desk.....	3484
Cross-Section Paper, Ruling Lines with.....	3342	Drawing Board for Office Desk.....	3458
Crossed Threads, Restoring.....	3309	Drawing Brass Tubing.....	3425
Crutch, Comfortable.....	3366	Drawing Centerless Circle Arcs.....	3402
Crutch Shoe for Soft Soil.....	3471	Drawing Ellipse with Steel Square.....	3468
Cup for Leaking Oil at Valve Rod.....	3458	Drawing, Perspective, Swinging Rule an Aid in.....	3306
Curbing for Trees from Auto Rim.....	3394	Drawings and Tracings, Waterproofing.....	3326
Curing Hams, Quick Method of.....	3430	Drawings Kept in Place with Cords.....	3492
Current Motor, Water.....	3496	Drawings, Opera Glasses Reduce or En- large.....	3433
Curved Surfaces, Plane Adapted for.....	3456	Drill, Adjustable Countersink on.....	3419
Curves, Irregular, Triangle with.....	3503	Drill for Fiber and Soft Metals.....	3435
Cut Easily, Making a Punch.....	3319	Drill, Hand, as Speed Counter.....	3396
Cutter, Bolt.....	3471	Drill Press, Boring in.....	3351
Cutter, Hand, for Thin Washers.....	3431	Drill-Press Feed Rack, Repairing.....	3348
Cutter, Milling, Adjustable.....	3444	Drill Press, Keyway Cutting with.....	3322
Cutter, Washer, Made from Tubing.....	3449	Drill Press, Movable Table for.....	3323
Cutting Aluminum.....	3452	Drill Press, Turning Brake Drums in.....	3313
Cutting Pins in the Shaper.....	3356	Drill, Ratchet, and Old Man.....	3449
Cutting Wire Cable, Fixture for.....	3335	Drill Vise, Simple.....	3340
Cyclometer Measures Mountain Trails.....	3482	Drilled Holes, Clamp Aids in Tapping.....	3347
Cylinder Heads, Handles for Lifting.....	3473	Drilling a Curved Hole.....	3399
Dam, Small, Tile Gate for.....	3438	Drilling Angular Work.....	3450
Damper Governor Maintains Constant Draft in Chimney.....	3464	Drilling Centers in Rods, Tool for.....	3469
Damper, Stove, as Grain-Bag Filler.....	3397	Drilling in Lathe, Power Feed for.....	3309
Deadboat Scale, Small, Making a.....	3361	Drilling, Overhead, Simple Rig Helps.....	3311
Decimal-Equivalent Tables, Reading.....	3349	Drilling, Pinning Sleeve to Shaft with- out.....	3321
Decorating, Spraying Removes Old Wall Paper.....	3419	Drilling, Rock, Pump for Cleaning Out Holes.....	3442
Deflating Inner Tubes, Cap for.....	3359	Drills, Small, Reducing Breakage of.....	3341
Dehorning Cattle, Holder for.....	3477	Drinking Fountain for Bees.....	3497
Delivery by Toy Wagon.....	3507	Drinking Water for Bees.....	3497
Derrick, Detachable Boom Converts Pile Driver Into.....	3386	Drinking Water Tank, Cold, for Shop.....	3463
Designing and Making a Speedster Body for the Old Automobile.....	3324	Driver for Small Lathe Dogs.....	3503
Desk, Collapsible Show-Card.....	3174	Driver, Pile, Improvised Hand.....	3410
Desk Drawer Lock.....	3484	Driveway, Root Cellar under.....	3332
Desk, Office, Drawing Board for.....	3458	Driving Glaziers' Points.....	3360
Desk, Table, Easel, and Sawhorse Com- bination.....	3363	Driving Nails in Cement.....	3510
Detector, Ground, for Light and Power Circuits.....	3367	Droplights, Simple Method of Adjusting.....	3437
Developing, Box for, Motion - Picture Films.....	3382	Dropping Medicine Into the Eye.....	3506
Device for Rapid Multiplication and Di- vision.....	3345	Drying Rack, Show-Card.....	3502
Device for Rolling a Barrel.....	3351	Drying Straw Hat, Clamp for.....	3430
Dictating-Machine Records, New, Mak- ing from Old Records and Shavings.....	3360	Dust Protector for Burette.....	3389
Dining Table, Automobile Windshield as Dirt, Protecting Painted Walls from.....	3460	Earth, Wet, Aids for Working Binders in Easel, Desk, Table and Sawhorse, Com- bination.....	3462
Discouraging Automobile Thieves.....	3335	Eases Trough Repaired with Roofing Paper.....	3363
Disk Reamer, Rotating.....	3489	Economy in Using Comb Foundation.....	3473
Display Rack, Novel Stockroom.....	3426	Egg Beater, Mixing Paints with an.....	3327
Display, Tire Hung on Chains for.....	3350	Electric, An, Induction Water Heater.....	3387
Display Windows, Preventing Frost on.....	3442	Electric Appliances, Proper Care of.....	3390
Ditching and Grading, Level and Straightedge Tool for.....	3475	Electric Fan Displays Sign.....	3442
Dividing a Small Circle Accurately.....	3467	Electric Heater, Variable, for Three- Wire Circuit.....	3493
Dog, Lathe, Automatic Quick-Acting.....	3463	Electric-Lamp Radiator Heater.....	3308
Dogs, Lathe, Driver for Small.....	3373	Electric Lamp, Reflector and Guard for.....	3347
Door, Bolt to Fit Any.....	3313	Electric-Lamp Shade, Adjustable.....	3490
Door, Flour Bin on Cupboard.....	3503	Electric-Soldering Irons, Keeping Ready for Use.....	3353
Door, Garage, Closed by Passage of Car.....	3313	Electrically Lighted Fixture Keeps Sol- dering Bit Hot.....	3506
Door, Guide for Sawing Bottom of.....	3378	Electricity for Lighting a Candle.....	3337
Door, Hanging, To Test.....	3355	Elevator Sign, Timesaving.....	3438
Door Knobs, Spring Washer for.....	3333	Ellipse, Drawing, with Steel Square.....	3414
Door, Screen, Spokes Form Brace.....	3508	Emergency Babbitt Ladle.....	3468
Door, Screen, Substitute for.....	3399	Emergency Lap, An.....	3338
Door, Sliding Garage, Opened by Car.....	3393	Emergency Pipe Joint.....	3365
Door, Sliding, Spring Lock for.....	3371	Emergency Typewriter Repair.....	3356
Doors and Gates, Hinge for Heavy.....	3372	Emery Wheels, Dressing.....	3315
Doors, Template Aids in Hanging.....	3507	End Gate, Wagon, Lock for.....	3399
Dotted Lines, Tracing Wheel Rules.....	3365	Engine, Auto, Cooling with Exhaust.....	3465
Double Level for Circular Work.....	3305	Engine, Automobile, Protecting from Cold.....	3496
Draft, Auxiliary, for Slow-Steaming Boilers.....	3332	Engine Bearings, Babbiting Steam.....	3431
Draft in Chimney, Damper Governor Maintains Constant.....	3468	Engine Cooling, Hose Clamp Limits.....	3468
		Engine Exhaust Carried through Fur- nace Pipe.....	3345



Intake, Leaks in Automobile, Cause Cyl- inders to Miss .....	3381	Lettuce, Head, Rubber Bands for.....	3433
Internal Friction Wheel Gives High Speed Reduction .....	3338	Level and Straightedge Tool for Ditch- ing and Grading .....	3467
Invisible House Chimney.....	3508	Level, Cheap and Accurate.....	3361
Iridescent Marks on Negatives, To Pre- vent .....	3306	Level, Constant, for Filtering.....	3366
Iron, Angle, Shop Trestle Made of.....	3461	Level, Double, for Circular Work.....	3468
Iron, Cast, Soldering .....	3463	Level, Hand, Quickly Made.....	3460
Iron Pipe as Gear Puller .....	3365	Level, Steel-Ball Circular.....	3370
Iron-Ring Gate Latch.....	3336	Leveling Work to be Drilled at an Angle	3450
Iron, Soldering, A Gas.....	3392	Lice, Plant, Tomato Leaves for Killing..	3487
Iron, Soldering, Heated without a Torch	3491	License Plates Save Car Floor.....	3476
Iron, Soldering, Rest for.....	3459	Lid, Steam Valve in Pot.....	3387
Irons, Soldering, Electric, Keeping Ready for Use .....	3506	Lifting Cylinder Heads, Handles for....	3473
Irregular Curves, Triangle with.....	3503	Light and Power Circuits, Ground De- tector for .....	3367
Jack Made from Old Monkey Wrench... 3413		Light, Garage, White Paint Improves... 3320	
Jacks, Quick-Operating .....	3451	Light Globe for Cleaning Stack.....	3496
Jaws, Graduated, for Milling Machines.. 3476		Lighter, Electric, on the Bench for Gaso- line Torches .....	3405
Jet, Gas, Cooking Bracket on.....	3486	Lighting a Candle Electrically.....	3488
Jig, for Bending Eyes in Wire.....	3375	Lighting, Flood, for Skaters.....	3440
Jig-Saw Attachment for the Lathe.....	3312	Lighting System, Electric, for Garage.. 3446	
Jointer, Homemade Saw .....	3321	Lights, Drop, Simple Method of Adjust- ing .....	3437
Joints, Mitered, Square for Use on.....	3489	Line Guard, Draft Rigging.....	3497
Joints, Stubborn, Made Steam Tight.... 3393		Line, Power-Plant, Insulated Telephone Receiver Used on .....	3321
Keeping Electric Soldering Irons Ready for Use .....	3506	Lines, Bearing, Clips Hold.....	3411
Keg, Shop Tray Made from.....	3488	Lines, Lettering, Tool for Marking.....	3329
Kerosene as an Antifreeze Solution.... 3351		Lines, Ruling with Cross-Section Paper Liquid, Keeping Fuel Oil in Cold Weather .....	3342
Key—Cork Prevents Boat Key from Sink- ing .....	3414	Liquid Manure, Using .....	3358
Key, Cotter, Makes Tweezers.....	3510	Liquids, Agitator for Mixing.....	3324
Key, Ignition, Knife Blade Makes.. 3471		Livestock Corral, Building.....	3427
Key, Tight, or Feather, Inserting.....	3306	Livestock, Movable Pens for Young.... 3505	
Key, Tin-Can, for Tire Repairs.....	3311	Lock, Desk Drawer .....	3508
Keyway Cutting with a Drill Press.....	3322	Lock for Fuel Tank on Truck.....	3484
Killing Insects, Tomato Foliage for.. 3487		Lock for Wagon Tailboard.....	3325
Kink for Laying Shingles.....	3359	Lock Nut .....	3465
Knife Blade Makes Ignition Key.... 3471		Lock Nut, Self-Locking Nut.....	3500
Knee Detector or Stethoscope, Home- made .....	3328	Lock, Reliable Ignition Auto.....	3393
Ladder, Inaccessible to Children.....	3412	Lock, Spring, for Sliding Door.....	3321
Ladder Wagon, Fruit-Picking.....	3455	Lock, Switch.....	3507
Ladle for Babbitt .....	3395	Locomotive, Auto Becomes, for Gauge Railway .....	3450
Lake, Drawing Water from.....	3416	Locomotive Gauge Glass, Stead- y Water in .....	3435
Lamp, Automobile Trouble.....	3510	Logarithmic Ruled Paper, Making.....	3315
Lamp Bracket for Draftsman's Lamp.....	3493	Long-Necked Vases, Cleaning.....	3465
Lamp, Electric, Reflector and Guard for 3490		Low-Cost Poultry Fence.....	3486
Lamp, Trouble, Always Kept Handy.....	3344	Low Gear, Repair for Auto.....	3305
Lamp, Vacuum, for Acetylene Work.....	3427	Low Wagon for Silo Filling.....	3502
Lap, An Emergency .....	3365	Lubricant Leaking at Valve Rod, Cup for Lubricated Lathe Center .....	3482
Lathe Attachment for Grinding or Turn- ing Pistons .....	3445	Lubricating Saws with Graphite.....	3458
Lathe Center for Small Work.....	3453	Lumber Handlers, Hooks Aid.....	3471
Lathe Center, Lubricated.....	3471	Lumber Sled, Shelter Built on.....	3321
Lathe, Chip Guard for Brass Turning... 3420		Machine Bends Wire Mesh for Concrete Column .....	3354
Lathe, Dog, Automatic Quick-Acting... 3373		Machine, Boring, for Crankshaft Bear- ings .....	3349
Lathe Dogs, Driver for Small.....	3503	Machine for Sensitizing Blueprint Paper 3480	
Lathe, Engine, Turret Lathe Job done on 3400		Machine, Ice-Cutting, Made from Auto- mobile Parts .....	3334
Lathe, Grinding Attachment for.....	3397	Machines, Milling, Graduated Jaws for.. 3476	
Lathe, Hand Grinder can be Used in... 3374		Machining Profiles on the Planer.....	3343
Lathe, Improved Thread Tool for.....	3415	Magic with Tubes, Mechanical.....	3486
Lathe, Jig-Saw Attachment for.....	3312	Mahogany Stain, Cheap.....	3372
Lathe, Power Feed for Drilling in.....	3309	Makeshift Potentiometer .....	3469
Lathe, Revolving Tool Holder for.....	3466	Making Solder Stick to Cast Iron... 3463	
Lathe, Spring Gauge for Screw Cutting 3332		Mallet, Maul Made from Auto Piston... 3424	
Lathe, Tapping in a.....	3329	Manifold Heated by Concrete.....	3404
Lathe Tool for Radius Cutting.....	3308	Manifold, Intake, Steel Wool Heats... 3442	
Lathe Tool, Gauge for Setting.....	3360	Manifolds, Replacing Automobile Engine 3497	
Lathe Tools, Rack for.....	3494	Manure Scraper, One-Horse.....	3339
Lathe Tools, Small, Round, Holder for.. 3317		Manure, Using Liquid .....	3354
Lathe, Wobbler Tests Alinement.....	3395	Marking Lettering Lines, Tool for... 3329	
Lathe Work, Indicator for Chucking... 3304		Marks, Iridescent, on Negatives, To Pre- vent .....	3306
Lavatory for Bench or Boat.....	3304	Masonry, Double Level for Circular... 3488	
Lawn Laid like Carpet.....	3422	Matches, Eliminating from the Shop... 3488	
Lawn Mower and Roller, Motor.....	3363	Maul Made from Auto Piston.....	3424
Laying Out a Regular Hexagon with a Carpenter's Square .....	3364	Measuring Chain, Splice for Surveyor's.. 3504	
Laying Out, Coloring Brass for.....	3361	Measuring Mountain Trails with Cyclom- eter .....	3482
Laying Out Solution, White.....	3485	Measuring Tape, Pointed Ring for.... 3461	
Lead Container, Nonspilling Acid.....	3501	Mechanical Mystery with Tubes.....	3486
Leads, Making Compass .....	3340	Medicine, Dropping into Eyes.....	3506
Laying Oil at Valve Rod, Cup for.....	3458	Meter Readings, Charts Insure Correct.. 3380	
Leaks, Chimney, Drip Belt Prevents... 3441		Mica Commutator Strips, Undercutting.. 3444	
Leaks in Gas Pipe, To Find.....	3331		
Leaks, Piston, Testing for.....	3398		
Leaves, Tomato, as Insect Killer.....	3487		
Lettering Lines, Tool for Marking.....	3329		

Gear, Taking Up Backlash in a.....	3374	Heating Soldering Copper without a Torch.....	3491
Gears, Broken, Repairing with Horse-shoe Toe Calks.....	3339	Height of a Chimney, Increasing While in Use.....	3337
Gears, Rawhide, Storing and Running..	3320	Hexagon, Regular, Laying Out with a Carpenter's Square.....	3364
Generator, An Oil-Gas.....	3330	High-Speed Steel, Tool Holder Saves..	3304
Generator, Telephone, for Automobile Testing.....	3509	Hinge for Heavy Doors and Gates.....	3365
Glass, Cleaning, Steel Wool for.....	3477	Hinge, Gate, Wagon Axle Used as.....	3487
Glass, Etching with Acid Fumes.....	3324	Hinge, Strap, Used as Hasp.....	3493
Glass Windows, Stain for.....	3485	Hints for Home Builders.....	3508
Glasses, Opera, Reduce or Enlarge Draw-ings.....	3433	Hod, A General-Purpose.....	3381
Glaziers' Points, Driving.....	3360	Hoe, Scuffle, Made from Saw.....	3430
Globe, Light, for Cleaning Stack.....	3496	Holder, Boring-Tool.....	3362
Gluing Clamp, Emergency.....	3325	Holder, Chalk, Made from Cartridge.....	3485
Gluing Press, Made of Strap Iron and Pipe.....	3409	Holder Economizes Use of Sandpaper..	3353
Goggles, Cleaning with Carbon Tetra-chloride.....	3508	Holder for Dehorning Cattle.....	3477
Governor Damper Maintains Constant Draft in Chimney.....	3464	Holder for Small Boring Tools.....	3339
Grading and Ditching, Level and Straightedge Tool for.....	3467	Holder for Small, Round Lathe Tools..	3317
Graduated Jaws for Milling Machines..	3476	Holder, Grain Sack.....	3510
Grain Binders, Working in Wet Soil, Aids for.....	3462	Holding Square Wire in Chuck.....	3507
Grain Sack Holder.....	3510	Hole, Chimney-Pipe, Made from Pall..	3504
Graphite, Lubricating Saws with.....	3321	Hole Gauge Bolt.....	3469
Grass, Lawn, Laid like Carpet.....	3422	Hole, Jagged, in Ship's Bottom, Wooden Patch for.....	3359
Grate, Hiding, in Summer.....	3424	Holes, Blind, Tight Rivets in.....	3503
Grease Leaks Cured by Spring Washer..	3358	Holes, Drilled, Clamp Aids in Tapping..	3347
Grease Spot, Hanging Wallpaper over..	3309	Holes, Drilling Curved.....	3399
Grinder, Gumming Circular Saws in.....	3470	Holes in Auto Tops, Tube Patches for..	3474
Grinder, Hand, Can be Used in Lathe..	3374	Holes in Plaster, Covering.....	3315
Grinder, Valve, Made from Auger.....	3429	Holes in Rubber, Filling.....	3471
Grinding Attachment for Lathe.....	3397	Holes, Plugging with Sawdust.....	3509
Grinding, Bicycle Motor for.....	3382	Holes, Round, Made with Cold Chisel..	3495
Grinding Edge Tools, Table for.....	3305	Hollow Columns Conceal Counterweights	3362
Grinding Plowshares, Rigging for.....	3439	Home Builders, Hints for.....	3508
Grinding, Sparks as Guide in.....	3460	Homemade Garden Tools.....	3510
Grinding, Valve, Fine Points of.....	3404	Hones, Sharpening, Making.....	3501
Grindstone Frame Made from Part of an Old Bicycle.....	3417	Hood, Automobile Engine, Varnishing..	3339
Grindstone Water Can.....	3457	Hood, Automobile, To Keep Bright.....	3459
Groove Plowed for Screw Heads Replaces Countersinking.....	3377	Hoofs, Muffled, for Horses' Safety.....	3356
Ground Detector for Light and Power Circuits.....	3367	Hook, Wire Snap.....	3482
Guard and Reflector for Lamp.....	3490	Hooks Aid Lumber Handlers.....	3354
Guard, Chip, for Brass Turning.....	3420	Hooks, Chute, Supported on Springs....	3493
Guard, Line, Draft Rigging.....	3497	Horizontal Brace for Wire Fence.....	3465
Guard, Rein, Draft Rigging.....	3497	Horn Button, Mounting for Automobile	3483
Guide for Sawing Bottom of Door.....	3333	Horn, Hand, Operated by Foot.....	3430
Guide, Grinding, Sparks as.....	3460	Horse, Adjustable, for the Wood Shop..	3463
Gummed Paper in Machine Shop.....	3405	Horse, Angle Iron.....	3461
Gumming Circular Saws in Grinder.....	3470	Horses' Safety, Muffled Hoofs for.....	3356
Gumming Saws with Reamer.....	3436	Horseshoe for Lame Mule.....	3448
Hacksaw, A Support for Stock being Cut in Power.....	3403	Hose Clamp Limits Engine Cooling.....	3348
Hacksaw, Doing Close Work with.....	3317	Hose, Garden, Blowout Patches Made from.....	3460
Half-Ton Traveling Crane.....	3303	Hot, Electrically Lighted Fixture Keeps Soldering Bit.....	3337
Hammer Handles, Fiber.....	3423	"Hot-Spot" for Auto Intake.....	3312
Hams, Curling, Quick Method of.....	3430	House, Building a New One Around Old	3476
Hand Level, Quickly Made.....	3460	House Chimney, Invisible.....	3506
Hand-Operated Counterboring and Countersinking Tool.....	3325	House Moving by Steam Roller.....	3325
Handles, Extension, on Petcocks.....	3491	Hub, Auto, as Lathe and Drill Press..	3376
Handles, Fiber, for Hammers.....	3423	Hydraulic Test Basin, Heater for.....	3491
Handles for Lifting Cylinder Heads.....	3473	Ice, Breaking Out a Sled from.....	3357
Handy Soldering Iron Rest.....	3459	Ice-Cutting Machine Made from Auto-mobile Parts.....	3334
Hangers, Clothes, Made from Spools..	3408	Ice, Snow Track for Hauling.....	3354
Hangers, Rail for Coat.....	3487	Ice Tongs, Old, for Tire Work.....	3415
Hanging a Door, To Test.....	3508	Icebox—A Common Refrigerator Trouble	3402
Hanging Doors, Template Aids in.....	3305	Ignition Auto Lock, Reliable.....	3321
Hard Rubber, Filing Holes in.....	3471	Ignition Battery, Auxiliary, Automobile	3486
Hasp, Strap Hinge Used as.....	3493	Ignition Key, Knife Blade Makes.....	3471
Hat, Straw, Clamp for Drying.....	3430	Ignition Switch, Secret Automobile.....	3494
Heads, Cylinder, Handles for Lifting..	3473	Imitating Cement Blocks in Form Work	3352
Heat, Plate on Stove Distributes.....	3409	Imitating White Tiling.....	3347
Heater, An Electric Induction Water..	3390	Inclinator, Garbage, for Stove.....	3477
Heater, Auto Manifold.....	3448	Inclosures, Examining Envelopes for..	3461
Heater for Hydraulic Test Basin.....	3491	Incubator, Chickens Separated from, by Wire Baskets.....	3444
Heater, Gas Water, as Auxiliary to Furnace.....	3452	Incubator for Raising Bread.....	3437
Heater, Radiator, for Garage.....	3444	Indicator for Chucking Lathe Work....	3304
Heater, Regulator for Steam Water, Operates by Mercury Expansion.....	3371	Indicator, Water-Level, for a Concealed Tank.....	3346
Heater, Tank, A Farm.....	3439	Infections, Skin, Caused by Oils and Grease.....	3341
Heater, Water, A Gas-Burning Instantaneous.....	3432	Ink, Fountain-Pen, A Test for.....	3372
Heating Mill by Exhaust Gas.....	3454	Inner Tubes, Cap for Deflating.....	3359
		Inner Tubes, Gasoline for Leaky.....	3316
		Insect Killer, Tomato Foliage as.....	3487
		Inserting a Tight Key or Feather.....	3306
		Instrument Feet, Garter Studs Make..	3332
		Insulated Pliers, Clothespin as.....	350
		Insulators Made from Broken Phono-graph Records.....	331



Intake, Leaks in Automobile, Cause Cylinders to Miss .....	3381	Lettuce, Head, Rubber Bands for.....	3433
Internal Friction Wheel Gives High Speed Reduction .....	3338	Level and Straightedge Tool for Ditching and Grading .....	3467
Invisible House Chimney.....	3508	Level, Cheap and Accurate.....	3361
Iridescent Marks on Negatives, To Prevent .....	3306	Level, Constant, for Filtering.....	3366
Iron, Angle, Shop Trestle Made of.....	3461	Level, Double, for Circular Work.....	3468
Iron, Cast, Soldering .....	3463	Level, Hand, Quickly Made.....	3460
Iron Pipe as Gear Puller .....	3365	Level, Steel-Ball Circular.....	3370
Iron-Ring Gate Latch .....	3336	Leveling Work to be Drilled at an Angle	3450
Iron, Soldering, A Gas.....	3392	Lice, Plant, Tomato Leaves for Killing..	3487
Iron, Soldering, Heated without a Torch	3491	License Plates Save Car Floor.....	3476
Iron, Soldering, Rest for.....	3459	Lid, Steam Valve in Pot.....	3387
Irons, Soldering, Electric, Keeping Ready for Use .....	3506	Lifting Cylinder Heads, Handles for....	3473
Irregular Curves, Triangle with.....	3503	Light and Power Circuits, Ground Detector for .....	3367
Jack Made from Old Monkey Wrench... 3413		Light, Garage, White Paint Improves..	3320
Jacks, Quick-Operating .....	3451	Light Globe for Cleaning Stack.....	3496
Jaws, Graduated, for Milling Machines..	3476	Lighter, Electric, on the Bench for Gasoline Torches .....	3405
Jet, Gas, Cooking Bracket on.....	3486	Lighting a Candle Electrically.....	3488
Jig, for Bending Eyes in Wire.....	3375	Lighting, Flood, for Skaters.....	3440
Jig-Saw Attachment for the Lathe.....	3312	Lighting System, Electric, for Garage..	3446
Jointer, Homemade Saw .....	3321	Lights, Drop, Simple Method of Adjusting .....	3437
Joints, Mitered, Square for Use on.....	3489	Line Guard, Draft Rigging .....	3497
Joints, Stubborn, Made Steam Tight....	3393	Line, Power-Plant, Insulated Telephone Receiver Used on.....	3321
Keeping Electric Soldering Irons Ready for Use .....	3506	Liners, Bearing, Clips Hold.....	3411
Keg, Shop Tray Made from.....	3488	Lines, Lettering, Tool for Marking.....	3329
Kerosene as an Antifreeze Solution.....	3351	Lines, Ruling with Cross-Section Paper	3342
Key—Cork Prevents Boat Key from Sinking .....	3414	Liquid, Keeping Fuel Oil in Cold Weather .....	3358
Key, Cotter, Makes Tweezers.....	3510	Liquid Manure, Using .....	3334
Key, Ignition, Knife Blade Makes.....	3471	Liquids, Agitator for Mixing.....	3427
Key, Tight, or Feather, Inserting.....	3306	Livestock Corral, Building .....	3505
Key, Tin-Can, for Tire Repairs.....	3311	Livestock, Movable Pens for Young....	3508
Keyway Cutting with a Drill Press.....	3322	Lock, Desk Drawer .....	3484
Killing Insects, Tomato Foliage for....	3487	Lock for Fuel Tank on Truck.....	3325
Kink for Laying Shingles.....	3359	Lock for Wagon Tailboard.....	3465
Knife Blade Makes Ignition Key.....	3471	Lock Nut .....	3500
Knife Detector or Stethoscope, Home-Use .....	3328	Lock Nut, Self-Locking Nut.....	3393
Ladder, Inaccessible to Children.....	3412	Lock, Reliable Ignition Auto.....	3321
Ladder Wagon, Fruit-Picking.....	3455	Lock, Spring, for Sliding Door.....	3507
Ladle for Babbitt .....	3395	Lock, Switch, .....	3450
Lake, Drawing Water from.....	3418	Locomotive, Auto Becomes, for Narrow-Gauge Railway .....	3435
Lamp, Automobile Trouble .....	3510	Locomotive Gauge Glass, Steadying the Water in .....	3315
Lamp Bracket for Draftsman's Lamp.....	3493	Logarithmic Ruled Paper, Making.....	3465
Lamp, Electric, Reflector and Guard for	3490	Long-Necked Vases, Cleaning.....	3486
Lamp, Trouble, Always Kept Handy.....	3344	Low-Cost Poultry Fence .....	3305
Lamp, Vacuum, for Acetylene Work.....	3427	Low Gear, Repair for Auto.....	3502
Lap, An Emergency .....	3365	Low Wagon for Silo Filling .....	3482
Lathe Attachment for Grinding or Turning Pistons .....	3445	Lubricant Leaking at Valve Rod, Cup for	3468
Lathe Center for Small Work.....	3453	Lubricated Lathe Center .....	3471
Lathe Center, Lubricated.....	3471	Lubricating Saws with Graphite.....	3321
Lathe, Chip Guard for Brass Turning....	3420	Lumber Handlers, Hooks Aid.....	3554
Lathe Dog, Automatic Quick-Acting.....	3373	Lumber Sled, Shelter Built on.....	3549
Lathe Dogs, Driver for Small.....	3503	Machine Bends Wire Mesh for Concrete Column .....	3370
Lathe, Engine, Turret Lathe Job done on	3400	Machine, Boring, for Crankshaft Bearings .....	3498
Lathe, Grinding Attachment for.....	3397	Machine for Sensitizing Blueprint Paper	3490
Lathe, Hand Grinder can be Used In.....	3374	Machine, Ice-Cutting, Made from Automobile Parts .....	3334
Lathe, Improved Thread Tool for.....	3415	Machines, Milling, Graduated Jaws for..	3476
Lathe, Jig-Saw Attachment for.....	3312	Machining Profiles on the Planer.....	3343
Lathe, Power Feed for Drilling in.....	3309	Magic with Tubes, Mechanical.....	3486
Lathe, Revolving Tool Holder for.....	3466	Mahogany Stain, Cheap.....	3372
Lathe, Spring Gauge for Screw Cutting	3473	Makeshift Potentiometer .....	3469
Lathe, Tapping in a.....	3332	Making Solder Stick to Cast Iron.....	3463
Lathe Tool for Radius Cutting.....	3329	Mallet, Maul Made from Auto Piston....	3424
Lathe Tool, Gauge for Setting.....	3308	Manifold Heated by Concrete.....	3404
Lathe, Tool Grinder Attached to.....	3360	Manifold, Intake, Steel Wool Heats....	3442
Lathe Tools, Rack for.....	3494	Manifolds, Replacing Automobile Engine	3497
Lathe Tools, Small, Round, Holder for..	3317	Manure Scraper, One-Horse.....	3339
Lathe, Wobbler Tests Alinement.....	3395	Manure, Using Liquid .....	3334
Lathe Work, Indicator for Chucking....	3304	Marking Lettering Lines, Tool for.....	3329
Lavatory for Bench or Boat.....	3422	Marks, Iridescent, on Negatives, To Prevent .....	3306
Lawn Laid like Carpet.....	3422	Masonry, Double Level for Circular....	3468
Lawn Mower and Roller, Motor.....	3365	Matches, Eliminating from the Shop....	3488
Laying Out a Regular Hexagon with a Carpenter's Square .....	3364	Maul Made from Auto Piston.....	3424
Laying Out, Coloring Brass for.....	3361	Measuring Chain, Splice for Surveyor's	3504
Laying Out Solution, White.....	3485	Measuring Mountain Trails with Cyclometer .....	3482
Lead Container, Nonspilling Acid.....	3501	Measuring Tape, Pointed Ring for.....	3461
Leads, Making Compass .....	3340	Mechanical Mystery with Tubes.....	3486
Leaking Oil at Valve Rod, Cup for.....	3453	Medicine, Dropping into Eyes.....	3506
Leaks, Chimney, Drip Belt Prevents.....	3441	Meter Readings, Charts Insure Correct..	3380
Leaks in Gas Pipe, To Find.....	3331	Mica Commutator Strips, Undercutting..	3343
Leaks, Piston, Testing for.....	3398		
Leaves, Tomato, as Insect Killer.....	3487		
Lettering Lines, Tool for Marking.....	3329		



Rule, Swinging, An Aid in Perspective Drawing .....	3306	Shelves, Swinging Tool Racks on .....	3493
Ruled Paper, Logarithmic, Making .....	3465	Shield, Draft, for Bunsen Burner .....	3321
Ruling Lines with Cross Section Paper ..	3342	Shingles, Composition, Gauge for .....	3439
Ruling Paper with a Comb .....	3435	Shingles, Kink for Laying .....	3359
Runway, Folding Automobile .....	3387	Ship's Bottom, Wooden Patch for a Jagged Hole in .....	3359
Rust Remover, Tin Chloride as .....	3492	Shirts, Renewing Worn .....	3504
Rustic Timbers, To Prevent Bark from Peeling from .....	3470	Shock Absorber, Rubber, for Auto .....	3437
Sack Holder, Grain .....	3510	Shoe, Crutch, for Soft Soil .....	3471
Safety Setscrew Used as Socket Wrench	3353	Shoe for Lame Mule .....	3448
Safety Switch Lock .....	3450	Shoes, Canvas, for the Farmer .....	3507
Safety Valve and Gauge Combined .....	3506	Shop-Card Holder of Simple Construction .....	3318
Sand Blast, Engine Exhaust Provides .....	3453	Shop, Cold Drinking-Water Tank for .....	3463
Sanding Block, Handy .....	3340	Shop, Eliminating Matches from the .....	3488
Sandpaper, Coke as a Substitute for .....	3337	Shop, Trash Box for Garage or .....	3333
Sandpaper, Holder Economizes Use of .....	3353	Shop Tray Made from Nail Keg .....	3458
Sandpaper Prevents Clamps from Shifting .....	3492	Shop Trestle Made of Angle Iron .....	3461
Saw, Circular, Gipped in Grinder .....	3470	Shop, Woodworking, Adjustable Horse for .....	3463
Saw, Irregular Rip Saw Filing .....	3409	Show-Card Desk, Collapsible .....	3474
Saw Jointer, Homemade .....	3321	Show-Card Drying Rack .....	3502
Saw Vise, Adapting to Sharpening of Band Saw .....	3366	Show Windows, Preventing Frost on Shrinker, Tire, Blacksmith's .....	3475
Sawdust for Plugging Holes .....	3509	Sign Displayed by Electric Fan .....	3493
Sawhorse, Desk, Table, and Easel, Combination .....	3363	Sign Printing without a Press .....	3495
Sawing Bottom of Door, Guide for .....	3333	Sign, Timesaving Elevator .....	3414
Saws, Gumming with Reamer .....	3436	Sign, Wind-Propelled Farm .....	3456
Saws, Handles for Carrying .....	3389	Sign, Windmill, Made from Bicycle .....	3427
Saws, Lubricating with Graphite .....	3321	Signal, Hand, Operated by Foot .....	3430
Scaffold, Crane Helps in Unbolting .....	3411	Signal, Railroad-Car Repair .....	3329
Scaffolding Support, Folding .....	3333	Signboard, Advertising, Attractive Outdoor .....	3319
Scale and Protractor for Topographical Draftsmen, Combined .....	3371	Signs Made of Gummed Paper .....	3419
Scale, Boiler, Removed by Steam .....	3448	Signs, Street Corner .....	3510
Scale, Making a Small Deadbeat .....	3361	Silencer for Noisy Waste Pipe .....	3454
Scales, Learn to Read Any, by Tenths ..	3443	Silencing Valve-Tappet Noises .....	3319
Scrap Auto Parts, Revolving Table from Scraper, Foot, from Currycomb .....	3405	Silo Filling, Low Wagon for .....	3482
Screen Door, Substitute for .....	3371	Silver Polish, Cigar Ash for .....	3420
Screens, Backing Wire Cloth in .....	3485	Simple Grindstone Water Can .....	3457
Screens, Painting with a Sponge .....	3342	Sink, Old, Forge Made from .....	3326
Screw Cutting, Improved Tool for .....	3415	Sink, Silencer for Noisy Waste Pipe .....	3454
Screw Cutting on Lathe, Spring Gauge for .....	3473	Sirup, Poison, for Ants .....	3372
Screw Heads, Groove Plowed for, Replaces Countersinking .....	3377	Skaters, Flood Lighting for .....	3440
Screw Plate as Auger Handle .....	3380	Skids, Truck, for Use on Stairway .....	3453
Screw, Rapidly Actuated Faceplate .....	3317	Skin Infections Caused by Oils and Grease .....	3341
Screwdriver, Close-Quarters .....	3461	Sled, Breaking Out from the Ice .....	3357
Screws, Filing Small .....	3333	Sled Runners with Plow Attachment for Light Cars .....	3447
Screws, Small, Entering in Awkward Places .....	3327	Sleeve, Pinning to Shaft without Drilling .....	3331
Scuffle Hoe Made from Saw .....	3430	Sleigh, Buggy, Converted into .....	3412
Scythe, Safety First with a .....	3386	Sliding Door, Spring Lock for .....	3507
Sea Valve, How to Repair or Replace without Docking the Vessel .....	3310	Slipping Cone Clutch, A Remedy for .....	3403
Seats, Chair, Made of Paper .....	3490	Slots, T, Tool for Cleaning .....	3501
Seeds, Keeping Vermin from, Hung on Wire .....	3373	Slotted Nail as Polishing Reamer .....	3492
Segments, Boring and Calipering .....	3425	Smokstack, Light Globe for Cleaning ..	3496
Self-Lighting Gasoline Torch .....	3320	Snap Hook, Wire .....	3482
Sensitizing Blueprint Paper, Machine for .....	3490	Snow Houses, Wire-Fence Frame for .....	3344
Serving Table Made from Bookrack .....	3446	Snow Pulled from Roof by Hook .....	3449
Setscrew, Safety, Used as Socket Wrench	3353	Snow Track for Hauling Ice .....	3354
Setting Bolts in Rock and Concrete .....	3336	Snowshoes, Homemade .....	3344
Setting, Turning Two Tapers at One .....	3354	Soap, Shaving, To Save Pieces .....	3441
Sewage-Disposal System for Summer Cottage .....	3438	Socket Wrench, Safety Setscrew Used as .....	3353
Sewing Machine, Pincushion .....	3433	Soft Soil, Crutch Shoe for .....	3471
Shade, Adjustable Electric-Lamp .....	3353	Soil, Potting, Ash Sifter Prepares .....	3436
Shade, Window, Ventilator Used with ..	3466	Soil, Wet, Aids for Binders working in ..	3462
Shaft, Pinning Sleeve to without Drilling	3331	Solder, Filing .....	3501
Shaft Repair, Temporary .....	3353	Solder, Sticking to Cast Iron .....	3463
Shafts, Handle for Rotating .....	3405	Soldering Bit, Electrically Lighted Fixture Keeps Hot .....	3337
Shaper, Cutting Pins in .....	3356	Soldering Cast Iron .....	3463
Shaper, Holding Tapered Work .....	3438	Soldering Copper Heated without a torch	3491
Shaper, Homemade Foot-Power .....	3364	Soldering-Flux Spreader .....	3446
Shaper, Tool Lifter for Planer or .....	3309	Soldering Iron, A Gas .....	3399
Shaper Tools, Shelf for .....	3457	Soldering Iron Rest .....	3459
Sharpening of Band Saw, Adapting Saw Vise to .....	3366	Soldering-Iron Switch, Automatic .....	3354
Sharpening Stones, Abrasive, Making .....	3501	Soldering Irons, Electric, Keeping Ready for Use .....	3500
Shaving Soap, To Save Pieces .....	3441	Soldering, Ladle for Soldering Wire Joints .....	342
Shears, Special, for Use on Anvil .....	3377	Soldering Pad, Asbestos .....	345
Sheet Metal, Tapping Holes in .....	3375	Soldering, Wire Brush Cleans Metal for ..	34
Shelf for Shaper Tools .....	3457	Spacing Nails on Boxes .....	34
Shelter Built on Lumber Sled .....	3349	Spark and Arc, Radio Receiving Cabinet ..	34
Shelves Built in Porch Railing .....	3436	Spark Plugs, Testing Block for .....	351
		Sparks as Guide in Grinding .....	346
		Speed Counter, Hand Drill as .....	339
		Speed Counter, Old Watch as .....	342
		Speed Reduction, High, Internal Friction Wheel Gives .....	333



Polish, Silver, Cigar Ash for.....	3420	Rawhide Belts, Joining.....	3373
Polishing Reamer, Slotted Nail as.....	3492	Rawhide Gears, Storing and Running...	3320
Pool, Swimming, A Back-Yard.....	3424	Rawhide Pins, Fixture for Swaging.....	3354
Porch—Laying the Porch Covering		Razors, To Keep from Rusting.....	3429
Smooth.....	3393	Reaching Device Made of Clothespin.....	3492
Porch, Shelves Built in Railing.....	3436	Reading Decimal-Equivalent Tables.....	3349
Portable Countershaft.....	3329	Reading Scales by Tenths.....	3443
Portable Stock Rack.....	3361	Readings, Meter, Charts Insure Correct.....	3380
Pot, Portable, for Bearing Metal.....	3451	Readjusting a Worn Feed Nut.....	3360
Potato Keeps Metal Cool when Brazing	3495	Reamer, Pipe and Conduit Threads	
Potatoes Sprayed by Exhaust.....	3403	Cleaned by.....	3399
Potentiometer, A Makeshift.....	3469	Reamer, Polishing, Slotted Nail as.....	3492
Poultry Fence, Low-Cost.....	3305	Reamer, Rotating-Disk.....	3426
Poultry Records, Individual, Keeping		Receiving Cabinet, Radio Arc and Spark	3478
without Trap Nests.....	3318	Records, New Dictating-Machine, Making	
Poultry, Wire Baskets Separate Chickens		from Old Records and Shavings.....	3360
from Incubator.....	3444	Records, Phonograph, Insulators Made	
Pour Good Babbitt Bearings, How to....	3327	from.....	3382
Powder Can for Draftsman's Use.....	3386	Rectifier, Electrolytic, for Charging	
Powder for Destroying Ants.....	3503	Storage Batteries.....	3417
Power Circuits, Light and, Ground De-		Reducing Breakage of Small Drills.....	3341
tector for.....	3367	Reel, Tape, Box for Holding.....	3375
Power Feed for Drilling in Lathe.....	3309	Reflector and Protector for Lamp.....	3490
Power-Plant Line, Insulated Telephone		Refrigerator, a Common Trouble.....	3402
Receiver Used on.....	3321	Regrinding Monkey Wrenches.....	3372
Press, Fruit, Made from a Jack.....	3385	Regulator for Steam Water Heater	
Press, Gear, Bushing and Arbor.....	3485	Operates by Mercury Expansion.....	3371
Press, Gluing, Made of Scrap Iron and		Rein Guard, Draft Rigging.....	3497
Pipe.....	3409	Reinforcement, Concrete, Burning Out...	3394
Press, Printing Signs without a.....	3495	Reinforcements in Concrete Structures,	
Press, Small Toggle, for the Bench.....	3472	Cutting.....	3308
Prevention of Frost on Show Windows..	3475	Relay, Sensitive, Operates Alarm when	
Printing Signs without a Press.....	3495	Brushes Spark.....	3378
Printing, Stereotyping Outfit for the		Reliable Ignition Auto Lock.....	3321
Small Shop.....	3428	Removing Broken Tap.....	3420
Prints, Clip for Hanging.....	3385	Removing Rust with Tin Chloride.....	3492
Prints, Photographic, Mounting Roller,		Removing Spring from Valve Cage.....	3305
Pencil as.....	3489	Removing Yellow Stain from Rubber...	3348
Profiles, Machining on the Planer.....	3343	Renewing Old Overshoes.....	3501
Propeller, Boat, Examining with Mirror	3465	Renewing Worn Shirts.....	3504
Protecting Auto Engine from Cold.....	3481	Repair, Emergency Typewriter.....	3315
Protecting Painted Walls from Dirt....	3335	Repair for Auto Low Gear.....	3502
Protector and Reflector for Lamp.....	3490	Repair for Bitbrace Handle.....	3336
Protractor, Combined Scale and, for Topo-		Repair or Replace Sea Valve without	
graphical Draftsmen.....	3371	Docking the Vessel, How to.....	3310
Protractor, Using the.....	3341	Repair Signal, Railroad-Car.....	3329
Puller, Cotter-Pin, An Improved.....	3375	Repairing Auto Tire on Rim.....	3418
Puller for Removing Tires from Split		Repairing Broken Wagon Wheel.....	3319
Rims.....	3487	Replacing Auto Engine Manifolds.....	3497
Pulley, Lock for Pin.....	3423	Reservoir, Underground, Aids Growth of	
Pump for Cleaning Out Holes Drilled in		Trees.....	3416
Rock.....	3442	Rest, Soldering Iron.....	3459
Pump, Gasoline, Protecting Faucet on..	3388	Restoring Crossed Threads.....	3309
Pump, Improved Water, Natural-Gas		Restoring Lost Compression.....	3500
Flow Operates.....	3338	Revolution Counter, Hand Drill as.....	3396
Pump, Installing Strainer.....	3433	Revolution Counter, Old Watch as.....	3425
Pump Packing, Bacon Rind for.....	3381	Revolving Table from Scrap Auto Parts	3326
Pump, Preventing from Freezing.....	3430	Revolving Tool Holder for Lathe.....	3466
Pump, Steam-Jet.....	3491	Ribbons, Typewriter, Renovating.....	3418
Pump, Tank, Operated by Automobile..	3494	Rifle Cartridge, Chalk Holder Made from	3485
Pump, Tire, Auto Wheel Operates.....	3431	Rig for Handling Heavy Crankshafts...	3312
Punch, Making Cut Easily.....	3319	Rig, Simple, Helps Overhead Drilling...	3311
Punch Press, Adjustable Stock Guide for	3329	Right-Angle Bends in Conduit, Making	3358
		Rims, Split, Removing Tires from.....	3487
Quick Method of Bending Small Tubing	3318	Ring, Pointed, for Measuring Tape....	3461
Quickly Made Hand Level.....	3460	Ring, Stovepipe, Made of Pall.....	3504
		Rings, Piston, Copper Wire Set in....	3379
Rack, Baggage, over Car Hood.....	3403	Rivets, Tight, in Blind Holes.....	3503
Rack for Lathe Tools.....	3494	Rock and Concrete, Setting Bolts in...	3336
Rack Keeps Planer Bolts in Order.....	3309	Rod, Valve, Cup for Oil Leaking at....	3458
Rack, Portable Stock.....	3361	Rods, Tool for Drilling Centers in....	3469
Rack, Show-Card Drying.....	3502	Roller, Motor Lawn Mower and.....	3368
Racks, Swinging Tool, on Shelves.....	3492	Roller, Mounting Pencil as.....	3489
Radiator, Draining Made Easy.....	3337	Rolling a Barrel, Device for.....	3351
Radiator, Fins, Straightening Tubular..	3375	Rolls, Wringer, Benzine for.....	3410
Radiator Heater, Electric-Lamp.....	3347	Roof Cleared of Snow by Hook.....	3449
Radiator Heater for Garage.....	3444	Roof, Gauge for Composition Shingles..	3439
Radiator, Stovepipe, Saves Coal.....	3348	Roof, Laying the Porch Covering Smooth	3393
Radio Arc and Spark Receiving Cabinet	3478	Roofing Paper, Repairing Eaves Trough	
Radius Cutting, Lathe Tool for.....	3329	with.....	3473
Rail for Coat Hangers.....	3487	Root Cellar under Driveway.....	3332
Rail, Steel, Anvil Made from.....	3496	Rope, Straightening.....	3437
Railroad-Car Repair Signal.....	3329	Rotating Shafts, Handle for.....	3405
Railway, Auto Becomes Locomotive for		Round Columns, Veneering Large.....	3494
Narrow-Gauge.....	3435	Round Holes Made with Cold Chisel...	3495
Range Boiler, Pipe Connections on.....	3441	Rubber Cement, Making.....	3495
Rapid Multiplication and Division, De-		Rubber, Hard, Filling Holes in.....	3471
vice for.....	3345	Rubber, Removing Yellow Stain from...	3348
Ratchet Wrench for Tight Places.....	3367	Rubber, Round, Fixture for Splitting...	3342
Rats, Gas-Engine Exhaust Rids Building		Rubber Stamp, Using on Curved Sur-	
of.....	3377	faces.....	3452
Rats, Keeping from Stored Apples.....	3364	Rubbers, Renewing Old.....	3501

<b>Rule, Swinging, An Aid in Perspective</b>		<b>Shelves, Swinging Tool Racks on</b>	<b>3492</b>
Drawing	3306	Shield, Draft, for Bunsen Burner	3321
Ruled Paper, Logarithmic, Making	3465	Shingles, Composition, Gauge for	3439
Ruling Lines with Cross Section Paper	3342	Shingles, Kink for Laying	3359
Ruling Paper with a Comb	3435	Ship's Bottom, Wooden Patch for a Jagged Hole in	3359
Runway, Folding Automobile	3387	Shirts, Renewing Worn	3504
Rust Remover Tin Chloride as	3492	Shock Absorber, Rubber, for Auto	3437
Rustic Timbers, To Prevent Bark from Peeling from	3470	Shoe, Crutch, for Soft Soil	3471
		Shoe for Lame Mule	3448
<b>Sack Holder, Grain</b>	<b>3510</b>	Shoes, Canvas, for the Farmer	3507
<b>Safety Setscrew Used as Socket Wrench</b>	<b>3353</b>	Shop-Card Holder of Simple Construction	3318
<b>Safety Switch Lock</b>	<b>3450</b>	Shop, Cold Drinking-Water Tank for	3463
<b>Safety Valve and Gauge Combined</b>	<b>3506</b>	Shop, Eliminating Matches from the	3488
<b>Sand Blast, Engine Exhaust Provides</b>	<b>3453</b>	Shop, Trash Box for Garage or	3333
<b>Sanding Block, Handy</b>	<b>3340</b>	Shop Tray Made from Nail Keg	3488
<b>Sandpaper, Coke as a Substitute for</b>	<b>3337</b>	Shop Trestle Made of Angle Iron	3461
<b>Sandpaper, Holder Economizes Use of</b>	<b>3353</b>	Shop, Woodworking, Adjustable Horse for	3463
<b>Sandpaper Prevents Clamps from Shifting</b>	<b>3492</b>	Show-Card Desk, Collapsible	3474
<b>Saw, Circular, Gummed in Grinder</b>	<b>3470</b>	Show-Card Drying Rack	3502
<b>Saw, Irregular Ripsaw Filing</b>	<b>3409</b>	Show Windows, Preventing Frost on	3475
<b>Saw Jointer, Homemade</b>	<b>3321</b>	Shrinker, Tire, Blacksmith's	3469
<b>Saw Vise, Adapting to Sharpening of Band Saw</b>	<b>3366</b>	Sign Displayed by Electric Fan	3493
<b>Sawdust for Plugging Holes</b>	<b>3509</b>	Sign Printing without a Press	3495
<b>Sawhorse, Desk, Table, and Easel, Combination</b>	<b>3363</b>	Sign, Timesaving Elevator	3414
<b>Sawing Bottom of Door, Guide for</b>	<b>3333</b>	Sign, Wind-Propelled Farm	3456
<b>Saws, Gumming with Reamer</b>	<b>3436</b>	Sign, Windmill, Made from Bicycle	3427
<b>Saws, Handles for Carrying</b>	<b>3389</b>	Signal, Hand, Operated by Foot	3430
<b>Saws, Lubricating with Graphite</b>	<b>3321</b>	Signal, Railroad-Car Repair	3329
<b>Scaffold, Crane Helps in Unbolting</b>	<b>3411</b>	Signboard, Advertising, Attractive Outdoor	3319
<b>Scaffolding Support, Folding</b>	<b>3333</b>	Signs Made of Gummed Paper	3419
<b>Scale and Protractor for Topographical Draftsmen, Combined</b>	<b>3371</b>	Signs, Street Corner	3510
<b>Scale, Boiler, Removed by Steam</b>	<b>3448</b>	Silencer for Noisy Waste Pipe	3454
<b>Scale, Making a Small Deadbeat</b>	<b>3361</b>	Silencing Valve-Tappet Noises	3319
<b>Scales, Learn to Read Any, by Tenths</b>	<b>3443</b>	Silo Filling, Low Wagon for	3482
<b>Scrap Auto Parts, Revolving Table from Scraper, Foot, from Currycomb</b>	<b>3405</b>	Silver Polish, Cigar Ash for	3420
<b>Screen Door, Substitute for</b>	<b>3371</b>	Simple Grindstone Water Can	3457
<b>Screens, Backing Wire Cloth in</b>	<b>3485</b>	Sink, Old, Forge Made from	3326
<b>Screens, Painting with a Sponge</b>	<b>3342</b>	Sink, Silencer for Noisy Waste Pipe	3454
<b>Screw Cutting, Improved Tool for</b>	<b>3415</b>	Sirup, Poison, for Ants	3372
<b>Screw Cutting on Lathe, Spring Gauge for</b>	<b>3473</b>	Skaters, Flood Lighting for	3440
<b>Screw Heads, Groove Plowed for, Replaces Countersinking</b>	<b>3377</b>	Skids, Truck, for Use on Stairway	3453
<b>Screw Plate as Auger Handle</b>	<b>3380</b>	Skin Infections Caused by Oils and Grease	3341
<b>Screw, Rapidly Actuated Faceplate</b>	<b>3317</b>	Sled, Breaking Out from the Ice	3357
<b>Screwdriver, Close-Quarters</b>	<b>3461</b>	Sled Runners with Plow Attachment for Light Cars	3447
<b>Screws, Filing Small</b>	<b>3333</b>	Sleeve, Pinning to Shaft without Drilling	3331
<b>Screws, Small, Entering in Awkward Places</b>	<b>3327</b>	Sleigh, Buggy Converted into	3412
<b>Scuffie Hoe Made from Saw</b>	<b>3430</b>	Sliding Door, Spring Lock for	3507
<b>Scythe, Safety First with a</b>	<b>3386</b>	Slipping Cone Clutch, A Remedy for	3403
<b>Sea Valve, How to Repair or Replace without Docking the Vessel</b>	<b>3310</b>	Slots, T, Tool for Cleaning	3501
<b>Seats, Char., Made of Paper</b>	<b>3490</b>	Slotted Nail as Polishing Reamer	3492
<b>Seeds, Keeping Vermin from, Hung on Wire</b>	<b>3373</b>	Smokestack, Light Globe for Cleaning	3486
<b>Segments, Boring and Calipering</b>	<b>3425</b>	Snap Hook, Wire	3482
<b>Self-Lighting Gasoline Torch</b>	<b>3320</b>	Snow Houses, Wire-Fence Frame for	3344
<b>Sensitizing Blueprint Paper, Machine for</b>	<b>3490</b>	Snow Pulled from Roof by Hook	3449
<b>Serving Table Made from Bookrack</b>	<b>3446</b>	Snow Track for Hauling Ice	3354
<b>Setscrew, Safety, Used as Socket Wrench</b>	<b>3353</b>	Snowshoes, Homemade	3344
<b>Setting Bolts in Rock and Concrete</b>	<b>3336</b>	Soap, Shaving, To Save Pieces	3441
<b>Setting, Turning Two Tapers at One</b>	<b>3354</b>	Socket Wrench, Safety Setscrew Used as	3353
<b>Sewage-Disposal System for Summer Cottage</b>	<b>3438</b>	Soft Soil, Crutch Shoe for	3471
<b>Sewing Machine, Pincushion</b>	<b>3433</b>	Soil, Potting, Ash Sifter Prepares	3436
<b>Shade, Adjustable Electric-Lamp</b>	<b>3353</b>	Soil, Wet, Aids for Binders working in	3462
<b>Shade, Window, Ventilator Used with</b>	<b>3486</b>	Solder, Filing	3501
<b>Shaft, Pinning Sleeve to without Drilling</b>	<b>3331</b>	Solder, Sticking to Cast Iron	3463
<b>Shaft Repair, Temporary</b>	<b>3353</b>	Soldering Bit, Electrically Lighted Fixture Keeps Hot	3337
<b>Shafts, Handle for Rotating</b>	<b>3405</b>	Soldering Cast Iron	3463
<b>Shaper, Cutting Pins n</b>	<b>3356</b>	Soldering Copper Heated without a torch	3491
<b>Shaper, Holding Tapered Work</b>	<b>3438</b>	Soldering-Flux Spreader	3445
<b>Shaper, Homemade Foot-Power</b>	<b>3364</b>	Soldering Iron, A Gas	3392
<b>Shaper, Tool Lifter for Planer or</b>	<b>3309</b>	Soldering Iron Rest	3459
<b>Shaper Tools, Shelf for</b>	<b>3457</b>	Soldering-Iron Switch, Automatic	3356
<b>Sharpening of Band Saw, Adapting Saw Vise to</b>	<b>3366</b>	Soldering Irons, Electric, Keeping Ready for Use	3506
<b>Sharpening Stones, Abrasive, Making</b>	<b>3501</b>	Soldering, Ladle for Soldering Wire Joints	3420
<b>Shaving Soap, To Save Pieces</b>	<b>3441</b>	Soldering Pad, Asbestos	3459
<b>Shears, Special, for Use on Anvil</b>	<b>3377</b>	Soldering, Wire Brush Cleans Metal for	3489
<b>Sheet Metal, Tapping Holes in</b>	<b>3375</b>	Spacing Nails on Boxes	348
<b>Shelf for Shaper Tools</b>	<b>3457</b>	Spark and Arc Radio Receiving Cabinet	347
<b>Shelter Built on Lumber Sled</b>	<b>3349</b>	Spark Plugs, Testing Block for	331
<b>Shelves Built in Porch Railing</b>	<b>3436</b>	Sparks as Guide in Grinding	346
		Speed Counter, Hand Drill as	339
		Speed Counter, Old Watch as	342
		Speed Reduction, High, Internal Friction Wheel Gives	333



Speedster Body for the Old Automobile, Designing and Making.....	3324	Stud Wrench, Eccentric.....	3426
Splice for Surveyor's Tape.....	3504	Substitute for Sandpaper, Coke as.....	3337
Splicing Heavy Wire Smoothly.....	3502	Support, Folding Scaffolding.....	3333
Split Rims, Removing Tires from.....	3487	Support, Gate Made from Wheel.....	3450
Splitting Round Rubber, Fixture for.....	3342	Surveyor's Tape, Splice for.....	3504
Spokes, Wooden, Tightening.....	3307	Swaging Rawhide Pins, Fixture for.....	3354
Spoke Shave, Patternmaker's.....	3394	Sweeping Chimney with a Small Tree.....	3306
Sponge, Painting Screens with.....	3342	Swimming Pool, A Back-Yard.....	3424
Sprayer, Potato, Operates by Exhaust.....	3403	Swing, Circle, Amuses Many Children.....	3395
Spring Gauge for Lathe Thread Cutting.....	3473	Swing Made from Tire Casing.....	3385
Spring Holds Apron.....	3362	Swinging Rule an Aid in Perspective Drawing.....	3306
Spring Holds Pliers Open.....	3369	Swinging Tool Racks on Shelves.....	3492
Spring Lock for Sliding Door.....	3507	Switch, Automatic Soldering-Iron.....	3356
Spring, Removing from Valve Cage.....	3305	Switch, Ignition, Secret Automobile.....	3494
Spring Washer, Grease Leaks Cured by.....	3358	Switch Lock and Protector.....	3450
Springs, Auto, Compressed Air for Oiling.....	3420	Table, Adjustable, for Plant Breeders... ..	3316
Springs, Chute Hooks Supported on.....	3493	Table, Dining, Automobile Windshield as.....	3460
Springs, Making Oval or Flat.....	3422	Table, Easel, Desk and Sawhorse, Com- bination.....	3363
Springs, Valve, Novel Method of Placing.....	3409	Table for Grinding Edge Tools.....	3305
Springs, Volute, Winding.....	3394	Table for Use in Automobile.....	3433
Springs, Winding, with Brace.....	3393	Table, Movable, for Drill Press.....	3323
Square for Use on Mitered Joints.....	3489	Table, Revolving, from Scrap Auto Parts.....	3326
Square, Steel, for Drawing Ellipse.....	3468	Table, Serving, Made from Bookrack.....	3446
Square Wire, Holding in Chuck.....	3507	Tables, Reading Decimal-Equivalent.....	3349
Stack, Cleaning, Light Globe for.....	3496	Tailboard, Wagon, Lock for.....	3465
Stain, Cheap Mahogany.....	3372	Tampering, Airplane Protected from.....	3314
Stain for Glass Windows.....	3485	Tank, Air Chamber Prevents from Burst- ing.....	3346
Stain, Yellow, Removing from Rubber.....	3348	Tank, Air, Made from Oil-Well Casing.....	3413
Stains, Removing from Hands.....	3409	Tank, Cold Drinking-Water, for Shop.....	3463
Stains, Water, on Wallboard, Preventing.....	3323	Tank, Concealed, Water-Level Indicator for.....	3346
Stairway, Truck Skids for Use on.....	3453	Tank, Cooling, for Water System.....	3429
Stamp, Rubber, Using on Curved Sur- faces.....	3452	Tank, Engine Exhaust Heats.....	3410
Stand Attached to Tobacco Pipe.....	3418	Tank Heater, A Farm.....	3439
Stand, Front Axle, for Autos.....	3506	Tank, Hot-Water, Wheelbarrow from.....	3422
Stand, Tire-Repair.....	3342	Tank, Paraffin Repairs Leaks in Float.....	3418
Starting Auto in Cold Weather.....	3415	Tank Pump Operated by Automobile.....	3494
Starting Motor, Auto, Drives Coaster Wagon.....	3483	Tank, Water-Cooler, Refilled Automatic- ally.....	3427
Steam Engine Bearings, Babbiting.....	3468	Tap and Reamer Wrench, Improved.....	3358
Steam-Jet Pump.....	3491	Tap, Broken, Removing.....	3420
Steam Joints, Babbitt Packing for.....	3368	Tap Extractor, Broken.....	3508
Steam Joints, Made Tight.....	3393	Tape, Measuring, Pointed Ring for.....	3461
Steam Roller, House Moving by.....	3325	Tape Reel, Box for Holding.....	3375
Steel Ball Aids in Centering Work.....	3322	Tapers, Turning Two at One Setting.....	3354
Steel-Ball Circular Level.....	3370	Tapping Drilled Holes, Clamp Aids in.....	3347
Steel Hawser, Unwinding the Outer Strands of.....	3352	Tapping Holes in Sheet Metal.....	3375
Steel, High-Speed, Tool Holder Saves.....	3304	Tapping in a Lathe.....	3332
Steel Rail, Anvil Made from.....	3496	Tapping Machine for Light Work.....	3314
Steel Square for Drawing Ellipse.....	3468	Taps, Two Ways of Spoiling.....	3453
Steel, Tool, Testing at the Forge.....	3418	Telephone Generator for Automobile Testing.....	3509
Steel Wool for Cleaning Glass.....	3477	Telephone Receiver, Insulated, Used on Power-Plant Line.....	3321
Stencil, Trousers Holder for.....	3385	Temper, Preventing Loss of in Brazing.....	3495
Stereotyping, Outfit for the Small New- paper Shop.....	3428	Template Aids in Hanging Doors.....	3305
Stethoscope, Homemade Knock Detector or.....	3328	Temporary Shaft Repair.....	3353
Stick, Cleaning a Drain with a.....	3459	Tenths, Reading Scales by.....	3443
Stock Guide for the Punch Press, Ad- justable.....	3339	Test, A, for Fountain-Pen Ink.....	3372
Stock-Proof Farm Gate.....	3474	Test Basin, Hydraulic, Heater for.....	3491
Stock Rack, Portable.....	3361	Testing Aluminum Castings by Weight.....	3503
Stock Support for Power Hacksaw.....	3403	Testing, Automatic, of Steel Balls.....	3381
Stockroom Display Rack, Novel.....	3350	Testing Automobile Generators.....	3370
Stones, Abrasive Sharpening, Making.....	3501	Testing Block for Spark Plugs.....	3315
Stoppers, Cork, Using Old.....	3483	Testing Door Hanging.....	3508
Stoppers, Tight Bottle, Removing.....	3401	Testing Tool Steel at the Forge.....	3418
Stops for Washboard.....	3457	Tetrachloride of Carbon Cleans Goggles.....	3508
Storing and Running Rawhide Gears.....	3320	Thieves, Automobile, Discouraging.....	3489
Stove, Burning Garbage in the.....	3477	Thieves, Catching Telephone-Wire.....	3386
Stove Lining, Plastic, Wire in.....	3313	Thread Cutting, Multiple, Faceplate for Thread Cutting on Lathe, Spring Gauge for.....	3347
Stove, Plate on, Distributes Heat.....	3408	Thread Tool, Improved, for Lathe.....	3415
Stovepipe Radiator Saves Coal.....	3348	Threads, Crossed, Restoring.....	3309
Straightedge and Level Tool for Ditch- ing and Grading.....	3467	Threads, Cutting, in Wood.....	3396
Straightedge, Celluloid, Truing a.....	3327	Threads, Pipe and Conduit, Cleaned by Guided Reamer.....	3399
Straightening Bent Chassis Frames.....	3352	Three-Wire Circuit, Variable Electric Heater for.....	3308
Straightening New Rope.....	3437	Tight Places, Ratchet Wrench for.....	3367
Straightening Steel Bars, Tool for.....	3411	Tight Rivets in Blind Holes.....	3503
Straightening Tubular Radiator Fins.....	3375	Tightener, Quick, for Clotheshline.....	3317
Strainer, Installing in Hand Pump.....	3433	Tightening Wooden Spokes.....	3307
Strands of a Steel Hawser, Outer, Un- winding.....	3352	Tile, Hollow, Wing Bolt Is Used to Fasten Timbers to.....	3373
trap Hinge Used as Hasp.....	3493	Tiling, White, Imitating.....	3347
strawberries, Growing, in Barrel.....	3398	Timbers, Rustic, Preventing Peeling of Bark.....	3470
street Corner Signs.....	3510		
tretcher, Band and Wire, for Shipping Cases.....	3501		
tretcher, Emergency.....	3394		
tretcher, Wire, Buggy-Top Brace.....	3453		

Timbers, Wing Bolt is Used to Fasten, to Hollow Tile.....	3373	Truck Chains, Clean, Exhaust Keeps....	3464
Time, Piping Plans Save Repairman's..	3316	Truck, for Turning in Small Space.....	3454
Tin-Can Key for Tire Repairs.....	3311	Truck, Lock for Fuel Tank on.....	3325
Tin Chloride Removes Rust.....	3492	Truck Made of Pipe.....	3326
Tire, Auto, Repairing on Rim.....	3418	Truing a Celluloid Straightedge.....	3327
Tire Boot Made from Old Paper.....	3369	Truing Up Gas-Engine Valves.....	3365
Tire, Electric Theft Protector.....	3426	Tube Patches for Holes in Auto Tops...	3474
Tire Gauge Attached to Hose Connection	3436	Tubes, Boiler, Measured While Hot....	3412
Tire Patches for Holes in Auto Tops...	3474	Tubes, Boiler, Reinforcing.....	3385
Tire Puller, Buggy.....	3504	Tubes, Breather, Funnel with.....	3414
Tire-Pump Assembly Fixture.....	3362	Tubes, Mechanical Trick with.....	3486
Tire Pump, Auto Wheel Operates.....	3431	Tubes, Thin, Turning Flanges on.....	3470
Tire-Repair Stand.....	3342	Tubing, Brass, How to Make Smaller....	3425
Tire Repairs, Tin-Can Key for.....	3311	Tubing, Miter Box for Cutting.....	3398
Tire Shrinker, Blacksmith's.....	3469	Tubing, Small, Quick Method of Bending	3318
Tire Work, Old Ice Tongs for.....	3415	Turning Brake Drums in the Drill Press	3313
Tires Hung on Chains for Display.....	3442	Turning Flanges on Thin Tubes.....	3470
Tires, Removing from Split Rims.....	3487	Turning, Preventing Bolts from.....	3344
To Keep Auto Hood Looking Bright.....	3459	Turning Two Tapers at One Setting....	3353
Toaster, Electric, for Starting Auto....	3413	Turntable for Light Car.....	3310
Toe Calks, Horseshoe, Repairing Broken		Turret Lathe Job Done on Engine Lathe	3400
Gears with.....	3339	Tweezers Made of Cotter Pin.....	3510
Toggle Press for the Bench.....	3472	Typewriter Prevents Check Raising....	3496
Toilet, Sewage-Disposal System for		Typewriter Repair, Emergency.....	3315
Summer Cottage.....	3438	Typewriter Ribbons, Renovating.....	3418
Tomato Foliage as Insect Killer.....	3487	Undercutting Mica Commutator Strips..	3343
Tongs, Ice, for Tire Work.....	3415	Unwinding the Outer Strands of a Steel	
Tool Case, Toolmaker's Apron as.....	3459	Hawser.....	3352
Tool for Cleaning T-Slots.....	3501	V-Block, Adjustable.....	3353
Tool for Ditching and Grading, Level		Valve Cage, Removing Spring from.....	3305
and Straightedge.....	3467	Valve, Float, Refills Water-Cooler Tank	3427
Tool for Drilling Centers in Rods.....	3469	Valve Grinding, Fine Points of.....	3404
Tool for Handling Wristpin Bushings...	3307	Valve Rod, Oil Leaking at, Cup for....	3458
Tool for Marking Lettering Lines.....	3329	Valve, Safety, and Gauge Combined....	3506
Tool for Removing Woodruff Keys.....	3369	Valve Springs, Novel Method of Placing	3409
Tool Grinder Attached to the Lathe....	3360	Valve, Steam, in Pot Lid.....	3387
Tool, Hand-Operated Counterboring and		Valve Stem, Removing a "Frozen".....	3378
Countersinking.....	3325	Valve-Tappet Noises, Silencing.....	3319
Tool Holder for Lathe, Revolving.....	3466	Valves, Gas-Engine, Truing Up.....	3365
Tool Holder Saves High-Speed Steel....	3304	Variable Electric Heater for Three-Wire	
Tool, Lathe, Gauge for Setting.....	3308	Circuit.....	3308
Tool Lifter for Planer or Shaper.....	3309	Varnish, Amber, Making of.....	3340
Tool Racks on Shelves, Swinging.....	3492	Varnishing the Automobile Engine Hood	3339
Tool Steel, Testing at the Forge.....	3418	Vases, Cleaning, Long Necked.....	3486
Toolmaker's Apron as Tool Case.....	3459	Vegetables, Rubber Bands for Head Let- tuce.....	3433
Tools, Edge, Table for Grinding.....	3305	Vegetables, Shovel Harvests Cabbage...	3425
Tools, Garden, Homemade.....	3510	Veneering Large Round Columns.....	3494
Tools, Rack for Lathe.....	3494	Ventilator, Collapsible Window.....	3484
Tools, Recovering, from Deep Well....	3414	Ventilator Used with Window Shade...	3466
Tools, Shaper, Shelf for.....	3457	Vermin, Keeping, from Seeds Hung on	
Tools, Small Boring, Holder for.....	3339	Wire.....	3373
Tools, Small, Care of Taps.....	3453	Vessel, How to Repair or Replace Sea	
Tools, To Find Small Cracks in.....	3412	Valve without Docking.....	3310
Topographical Draftsmen, Combined		Vise Attachment for Filing Bevels....	3400
Scale and Protractor for.....	3371	Vise, Clamping Connecting-Rod Bear- ings in.....	3355
Torch, Improving Flame of.....	3416	Vise, Clothespin Used as.....	3482
Torches, Gasoline, Electric Lighter on		Vise, Holding Rough Work in.....	3449
Bench for.....	3405	Vise, Pneumatic.....	3404
Toy Wagon, Delivery by.....	3507	Vise, Simple Drill.....	3340
Tracing, Blueprinting Part of a.....	3367	Volute Springs, Winding.....	3394
Tracing, Powder Can for Draftsman's		Wagon Axle Used as Gate Hinge.....	3487
Use.....	3386	Wagon, Coaster, Driven by Auto Start- ing Motor.....	3482
Tracing Wheel Rules Dotted Lines....	3332	Wagon, Ladder, Fruit-Picking.....	3455
Tracings, Waterproofing Drawings and.		Wagon, Low, for Silo Filling.....	3482
Tractor, Moving Garage with.....	3455	Wagon Tailboard, Lock for.....	3465
Tractors, Air Filter for.....	3488	Wagon, Toy, Delivery by.....	3507
Trails, Mountain, Measuring with a		Wagon Wheel, Repairing Broken.....	3319
Cyclometer.....	3482	Wall Paper, Hanging over Grease Spot..	3309
Trap Nests, Keeping Individual Poultry		Wall Paper, Spraying Removes.....	3419
Records without.....	3318	Wallboard, Preventing Water Stains on	3323
Trash Box for Garage or Shop.....	3333	Walls, Painted, Protecting from Dirt..	3335
Traveling Crane, Half-Ton.....	3303	Wash Boiler, Copper, Reinforcing Bot- tom.....	3437
Tray, Shop, Made from Keg.....	3488	Washboard, Stops for.....	3457
Trays, Copper Ash.....	3487	Washer Cutter Made from Tubing.....	3445
Tree, Small, Sweeping Chimney with...	3306	Washer, Spring, for Door Knobs.....	3399
Tree Support, Neat and Strong.....	3349	Washers, Thin, Hand Cutter for.....	3431
Trees, Fruit, Protected from Cold.....	3355	Waste Pipe, Noisy, Silencer for.....	3464
Trees, Underground Water Reservoir		Water, Boiler, Ship Provided with,	
Aids Growth of.....	3416	While at Sea.....	3398
Trestle, Shop, Made of Angle Iron....	3461	Water Can, Grindstone.....	3452
Triangle for Draftsmen, Convenient....	3355	Water, Cool, for Farm Workers.....	3384
Triangle with Irregular Curves.....	3503	Water, Ditch, Filter Clarifies.....	343
Trick with Tubes, Mechanical.....	3486	Water, Drawing, from Lake Far Below	341
Trouble Guide, Garage Floor as.....	3401	Water for Bees.....	349
Trouble Lamp Always Kept Handy.....	3344	Water Heater, A Farm.....	343
Trouble Lamp, Auto.....	3510		
Trough, Concrete, That will Not Burst			
When Frozen.....	3336		
Trough, Eaves, Repaired with Roofing			
Paper.....	3473		
Trousers Holder for Stencil.....	3355		



Water Heater, A Gas-Burning Instantaneous .....	3432	Window Ventilator, Collapsible .....	3484
Water Heater, An Electric Induction...	3390	Windows, Glass, Stain for .....	3485
Water Heater, Regulator for Steam, Operates by Mercury Expansion.....	3371	Windows, Show, Preventing Frost on...	3475
Water in a Locomotive Gauge Glass, Steadying .....	3315	Windshield, Automobile, as Dining Table	3460
Water Jacket, Repairing Cracked.....	3328	Windshield, Mixture for Cleaning.....	3502
Water-Level Indicator for a Concealed Tank .....	3346	Wire and Band Stretcher for Shipping Cases .....	3501
Water Motor, Paddle-Chain.....	3496	Wire Brush Cleans Metal for Soldering	3489
Water Pump, Improved, Natural-Gas Flow Operates .....	3328	Wire Cable, Fixture for Cutting.....	3335
Water Stains on Wallboard, Preventing	3429	Wire-Fence Frame for Snow Houses...	3344
Water System, Cooling Tank.....	3428	Wire Fence, Horizontal Brace for.....	3465
Water Tank, Cold-Water, for Shop.....	3463	Wire, Heavy, Splicing Smoothly.....	3502
Waterproofing Drawings and Tracings..	3326	Wire in Plastic Stove Lining.....	3313
Waterproofing Dry Batteries.....	3399	Wire, Jig for Bending Eyes in.....	3375
Waxed Paper Bread Board.....	3454	Wire Joints, Ladle for Soldering.....	3420
Wedges, Parallel, for Accurate Settings	3460	Wire Mesh, Machine Bends for Concrete-Column Reinforcement .....	3370
Weeds Turned Under by Plow Fender..	3497	Wire Screen Cloth, Backing for.....	3485
Weighing Aluminum Castings for Testing .....	3503	Wire Snap Hook .....	3482
Weight, Aluminum Castings Tested by..	3503	Wire, Square, Holding in Chuck.....	3507
Well, Recovering Tools from.....	3414	Wire Stretcher, Buggy-Top Brace.....	3453
Wells Several Hundred Feet Apart Operated by One Windmill.....	3445	Wire Thieves, Telephone, Catching....	3386
Wet Soil, Aids for Binders Working in Wheel Chair, Improved .....	3462	Wiring, Auto, Testing with Telephone Generator .....	3509
Wheel Puller for Full-Floating Rear Axles .....	3320	Wood Bending and Forming .....	3421
Wheel, Wagon, Repairing Broken.....	3319	Wood Box under Window Seat.....	3336
Wheelbarrow Ash Sifter .....	3346	Wooden Patch for a Jagged Hole in a Ship's Bottom .....	3359
Wheelbarrow from Hot-Water Tank.....	3422	Wooden Plugs, Tool Cuts Out.....	3440
Wheels, Truck, Arranged to Turn in Small Space .....	3454	Wooden Spokes, Tightening .....	3307
White Solution for Laying Out Metal...	3485	Wooden Threads, Cutting .....	3396
Whitewash, How to Make .....	3439	Woodruff Keys, Tool for Removing....	3269
Wind-Propelled Farm Sign.....	3456	Woodworking Shop, Adjustable Horse for .....	3463
Winding Springs with Brace .....	3398	Wool, Steel, for Cleaning Glass.....	3477
Winding Telescope Springs.....	3394	Work, Close, Doing with a Hacksaw...	3317
Windmill Operates Wells Several Hundred Feet Apart .....	3445	Work, Light, Tapping Machine for...	3314
Window Awning, A Quickly Made.....	3473	Work, Steel Ball Aids in Centering...	3322
Window Cooler, Neat .....	3340	Worn Feed Nut, Readjusting.....	3360
Window Sash, Aid for Painting.....	3371	Wrench, Improved Tap and Reamer.....	3358
Window Seat, Wood Box under.....	3336	Wrench, Monkey, Jack Made from.....	3413
Window Shade, Ventilator Used with...	3466	Wrench, Stud, Eccentric.....	3426
		Wrenches, Monkey, Regrinding .....	3372
		Wringer Rolls, Benzine for .....	3410
		Wristpin Bushings, Tool for Handling..	3307
		Young Stock, Movable Pens for.....	3508



