

# POPULAR MECHANICS SHOP NOTES

For

1920



Vol. XVI

50¢

## EASY WAYS TO DO HARD THINGS

POPULAR MECHANICS  
CHICAGO

Copyright 1920  
by  
H. H. WINDSOR



# Shop Notes

## Vertical-Drum Windlass Made of Old Barrel

By C. S. GREEN

A PRACTICAL windlass was made to haul a small sailboat from the water, and the method of construction is so simple that many other uses can be found for this type of rigging. The boat was arranged on skids with the usual rollers, and the hauling rope was fastened to the bow, as shown. By steadily winding the rope on the barrel drum, the craft was drawn from the water without danger of damage, and then moved to the desired position on land. In this instance, the heavy iron pipe, on which the drum pivots, was set into the ground. This is a handy method in many cases, but where the windlass is to be shifted from place to place frequently, it is best to set it on a substantial foundation of timber.

A strong barrel was used, and the bands were set tightly after both heads had been put into place. A cross arm slipped over the iron pipe serves as a bearing at the bottom, and the top of the barrel is reinforced with 2 by 4-in. pieces, as shown. An iron plate caps the upper end of the pipe. The push

bar is made to be removed handily, and can be set shorter for use in limited space. When heavy loads are to be handled, an additional push bar on the opposite side can be used.



A Powerful Windlass can be Rigged Up Quickly with a Barrel as the Drum, and by Providing a Suitable Frame, the Outfit can be Made Suitable for Moving from Job to Job

### Accurate Method of Setting Thread Tool in Lathe

A thread tool may be set accurately in a lathe by the following method: Set the lathe centers carefully in their usual position. Turn a cold-rolled steel plug, 1 in. in diameter and the length of the piece to be threaded. Cut a deep groove, the shape of the thread groove to be cut, in the plug, using the tool in the ordinary manner. Then reverse the plug, end for end, and fit the thread tool in the groove. The extent to which the tool is out of alignment is thus shown. The tool is then adjusted about one-half the extreme extent of the error indicated. The groove is next cut slightly deeper with the tool in the new setting, and the plug again reversed on centers. The tool is then fitted into the groove, and the process repeated, if necessary.—F. Shrier, Derby, Conn.



### Device for Lifting Barrels to be Emptied

It is found cumbersome to handle heavy barrels of liquid to be poured

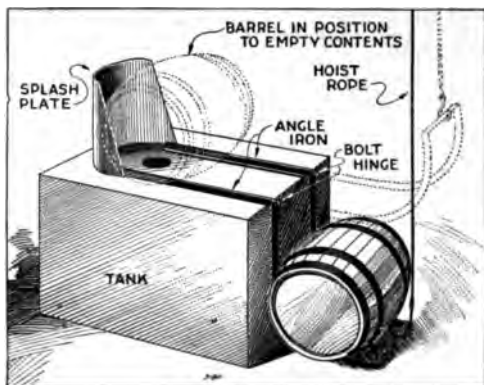

Heavy Barrels of Liquid are Handled Easily by One Man with This Arrangement

into an overground tank, and the device shown in the sketch was built so that one man can easily handle the barrels. The barrel is rolled onto the cradle of strap iron and hoisted by means of the tackle. It rolls along the angle-iron ways to the splash plate, where it is emptied. This plate causes the liquid that is splashed around the tank opening to flow back.—Otto Kraft, Chicago, Ill.

### Adjustable Leg for Table or Bench

For use on floors that are not level, or which have depressions, a table or bench leg that is adjustable is a convenience. One of this type can be made out of pipe fittings, as detailed. A flange is fastened to a suitable length of pipe and the upper flange is set on to give room for adjustment. By

the use of a pipe wrench, or other means, the leg is set to the proper height and fastened in place.

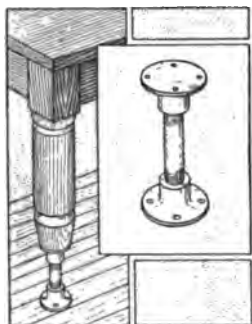

### Tin Foil Winding on Bulb Intensifies Electric Light

A handy way of increasing the power of an incandescent lamp which is to be used over a small area is to cover the upper portion of it with a winding of tin foil, held in place with tape. The tin foil acts as a reflector, concentrating the light at the lower end of the bulb and making a shade of the ordinary type unnecessary. This method, resorted to as an emergency kink, proved so successful that its use was continued.—Ernest Schwartz, Brooklyn, N. Y.

### Tool for Packing Wires in Slots of Motor Fields

In winding or repairing motors of the type known as "semi-inclosed slot motors," it is necessary to use a special tool to pack the wires tightly. Such a tool must have a thin shank, so that it may be operated through the slit between the teeth, and yet have a flat end to act as a tamper, as shown in

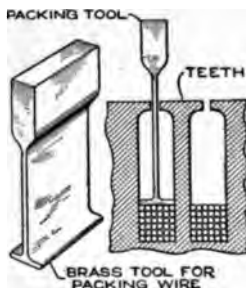

the sketch. This tool, nicknamed by most motor-field winders "doodlehoppers," can be made from a brass rod of rectangular cross section, all the work being done with a file. The general shape of the tool is as shown, but the dimensions should be adapted to the work in hand.

### Check-Out Board Helps Locate Mechanics in Shop

Shop or office business often takes an employe to another department than his own for a short time. While he is away the foreman, or other official, may want to communicate with him without delay. As an aid in locating absent men, a check-out board



is used with success in a large plant. Each man in the department has a hook on the board, his name being placed under it. When he leaves the room for another department, he writes the fact on a blank shipping tag and hangs it on his hook. If an employe is absent from business entirely, the cause of his absence and date last at work are written on a card and placed on the board by the shop clerk. Thus by referring to the check-out board a record of the absentees is at hand.

### Bushing Fitted Snugly by Knurling or Roughening Surface

Not infrequently bushings become loose, or are machined slightly under-size, and some mechanics use a cold chisel or prick punch to roughen the exterior surface, causing projections which make the bushing stay in place.

A better method is to replace the bushing in the lathe, and increase the diameter by using a knurling tool on the exterior surface. This increases the diameter sufficiently, even when the bushing is  $\frac{1}{32}$  in. under-size. It makes a better job than the first-mentioned method.—G. A. Luers, Washington, D. C.

### Old Gaskets Sawed Out from between Flanges

Often when a leaky gasket is encountered in a flange-joint pipe line, the pipes are so firm that the flanges cannot be pried apart to permit the ready removal of the old gasket. In such instances the latter can, after the bolts have been removed, be cut out with a saw, preferably one which has been discarded as unfit for regular use. It is essential that the adjacent faces of the flanges be clean before the new

gasket is inserted, otherwise the joint is likely to leak. Where possible, the flanges should be forced apart, so that

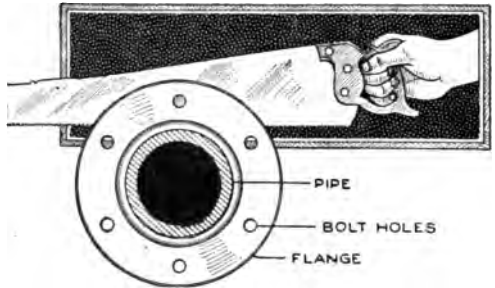

The Old Gasket is Removed Handily by Sawing It Out with an Old Saw

they can be scraped with a chisel. Where this cannot be done, the saw can be used as a scraping tool. In setting the bolts, all should be tightened to approximately the same tension. Otherwise, unequal strains may result, causing the joint to leak, or the gasket to blow out.—C. C. Williams, Des Moines, Ia.

### Rattling of Automobile Doors Overcome by Setting Hinges

The doors of many automobile bodies, particularly the light cars, loosen up after considerable running, and cause a disagreeable rattle. Rubber-head nails, or strips of rubber cut from inner tubes, are frequently used to take up the play between the door and frame. A method that is more effective and requires a minimum of work is that of bending the hinge, as shown, using a wrench with a pad between the jaws to prevent marring the paint. The hinge so bent also assists

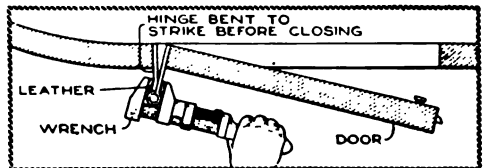

A Simple Remedy for the Rattling of Automobile Doors Is to Bend the Hinges Slightly

in opening the door, the springlike action swinging the door partly open when the catch is released.

# Making Dentil Moldings for Cabinet Trim

By CHARLES A. KING

**C**ORNICES and similar effects in cabinetwork often require dentil moldings, and a quick method of making them is a valuable bit of knowledge for the woodworker and craftsman. A



Fig. 1



Fig. 2



Fig. 3

Fig. 4

The Dentils are Made Accurately and Quickly by Cutting Properly Spaced Grooves across a Board, and Then Ripping This into Moldings

circular-saw table can be easily fitted to cut several moldings economically and accurately. The resulting strips may be handled and fastened in place like moldings. Figs. 1 and 2 show the two types of dentils commonly used, applied to furniture, and interior or exterior finish.

In fitting the saw for cutting dentils, as shown in Fig. 5, a piece of straight hard wood, A,  $1\frac{1}{4}$  by  $2\frac{1}{2}$  in., is fastened to the two cutting-off gauges B, to make them move as one, and a saw cut is made, at C, with the saw which is to be used in cutting the dentils. The saw is adjusted to cut the desired depth and the board, properly trued up, is passed over it, making the first cut E. To gauge the second cut F, and succeeding cuts G, etc., a nail, D, is set through the piece A, as detailed in Fig. 5, at the left. The distance H, between the saw cuts, is marked carefully on piece A, and the nail, of a size to fit easily but snugly into the saw cut, is driven through, so

that its point projects an inch or more. The board is drawn back with the rest, in the usual manner. The board is then shifted so that cut E fits over the nail, thus gauging the next cut. Each succeeding groove serves in turn as a gauge stop for the nail, in locating the next saw cut.

When the crosscuts have been made, the board is ripped into strips, as at J, Fig. 5, of the desired widths, as at K, Figs. 3 and 4. The two kinds of dentils are provided by making the cuts of suitable depth and ripping the board to the proper-size moldings. The face of each strip of dentils is held against the face of the ripping gauge, or fence, and the strip is sawed to the desired thickness and height of dentil. If small dentils are desired, the cuts across the surface of the board may be made upon both sides of a board of sufficient thickness, and the resulting strips each ripped into two dentil moldings. In making saw cuts for dentils of the type shown in Fig. 4, a saw must be used which will make the bottom of the cut straight, as shown at L; an ordinary cutting-off saw makes the cut as shown at M.

Large dentils suitable for use on cornices may be made by the same general method. A grooving head must be used in making the cuts between the dentils. Instead of the nail

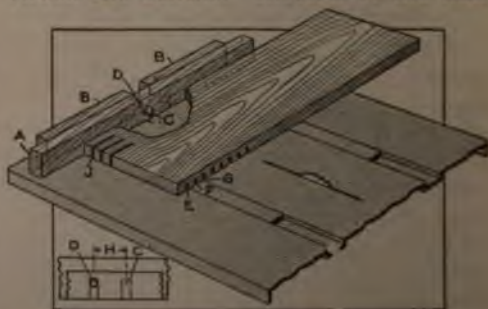

Fig. 5

An Ordinary Circular-Saw Table is Used for Cutting the Dentil Moldings, by Fitting a Gauge Device on the Usual Guides

D, Fig. 5, a piece of wood to fit the groove between the dentils is fastened securely to piece A, as a gauge stop.



is used with success in a large plant. Each man in the department has a hook on the board, his name being placed under it. When he leaves the room for another department, he writes the fact on a blank shipping tag and hangs it on his hook. If an employe is absent from business entirely, the cause of his absence and date last at work are written on a card and placed on the board by the shop clerk. Thus by referring to the check-out board a record of the absentees is at hand.

### Bushing Fitted Snugly by Knurling or Roughening Surface

Not infrequently bushings become loose, or are machined slightly under-size, and some mechanics use a cold chisel or prick punch to roughen the exterior surface, causing projections which make the bushing stay in place.

A better method is to replace the bushing in the lathe, and increase the diameter by using a knurling tool on the exterior surface. This increases the diameter sufficiently, even when the bushing is  $\frac{1}{32}$  in. under-size. It makes a better job than the first-mentioned method.—G. A. Luers, Washington, D. C.

### Old Gaskets Sawed Out from between Flanges

Often when a leaky gasket is encountered in a flange-joint pipe line, the pipes are so firm that the flanges cannot be pried apart to permit the ready removal of the old gasket. In such instances the latter can, after the bolts have been removed, be cut out with a saw, preferably one which has been discarded as unfit for regular use. It is essential that the adjacent faces of the flanges be clean before the new

gasket is inserted, otherwise the joint is likely to leak. Where possible, the flanges should be forced apart, so that

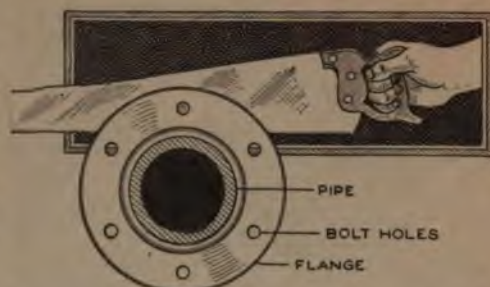

The Old Gasket is Removed Handily by Sawing It Out with an Old Saw

they can be scraped with a chisel. Where this cannot be done, the saw can be used as a scraping tool. In setting the bolts, all should be tightened to approximately the same tension. Otherwise, unequal strains may result, causing the joint to leak, or the gasket to blow out.—C. C. Williams, Des Moines, Ia.

### Rattling of Automobile Doors Overcome by Setting Hinges

The doors of many automobile bodies, particularly the light cars, loosen up after considerable running, and cause a disagreeable rattle. Rubber-head nails, or strips of rubber cut from inner tubes, are frequently used to take up the play between the door and frame. A method that is more effective and requires a minimum of work is that of bending the hinge, as shown, using a wrench with a pad between the jaws to prevent marring the paint. The hinge so bent also assists



A Simple Remedy for the Rattling of Automobile Doors Is to Bend the Hinges Slightly

in opening the door, the springlike action swinging the door partly open when the catch is released.



# Making Dentil Moldings for Cabinet Trim

By CHARLES A. KING

CORNICES and similar effects in cabinetwork often require dentil moldings, and a quick method of making them is a valuable bit of knowledge for the woodworker and craftsman. A

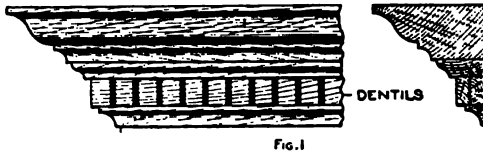

Fig. 1

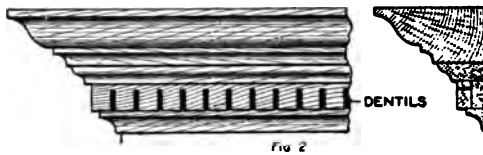

Fig. 2

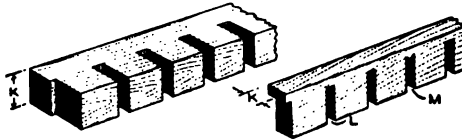

Fig. 3

Fig. 4

The Dentils are Made Accurately and Quickly by Cutting Properly Spaced Grooves across a Board, and Then Ripping This into Moldings

circular-saw table can be easily fitted to cut several moldings economically and accurately. The resulting strips may be handled and fastened in place like moldings. Figs. 1 and 2 show the two types of dentils commonly used, applied to furniture, and interior or exterior finish.

In fitting the saw for cutting dentils, as shown in Fig. 5, a piece of straight hard wood, A,  $1\frac{1}{4}$  by  $2\frac{1}{2}$  in., is fastened to the two cutting-off gauges B, to make them move as one, and a saw cut is made, at C, with the saw which is to be used in cutting the dentils. The saw is adjusted to cut the desired depth and the board, properly trued up, is passed over it, making the first cut E. To gauge the second cut F, and succeeding cuts G, etc., a nail, D, is set through the piece A, as detailed in Fig. 5, at the left. The distance H, between the saw cuts, is marked carefully on the board, and a nail, of a size to fit between the saw cut, is set through the board at the

that its point projects an inch or more. The board is drawn back with the rest, in the usual manner. The board is then shifted so that cut E fits over the nail, thus gauging the next cut. Each succeeding groove serves in turn as a gauge stop for the nail, in locating the next saw cut.

When the crosscuts have been made, the board is ripped into strips, as at J, Fig. 5, of the desired widths, as at K, Figs. 3 and 4. The two kinds of dentils are provided by making the cuts of suitable depth and ripping the board to the proper-size moldings. The face of each strip of dentils is held against the face of the ripping gauge, or fence, and the strip is sawed to the desired thickness and height of dentil. If small dentils are desired, the cuts across the surface of the board may be made upon both sides of a board of sufficient thickness, and the resulting strips each ripped into two dentil moldings. In making saw cuts for dentils of the type shown in Fig. 4, a saw must be used which will make the bottom of the cut straight, as shown at L; an ordinary cutting-off saw makes the cut as shown at M.

Large dentils suitable for use on cornices may be made by the same general method. A grooving head must be used in making the cuts between the dentils. Instead of the nail

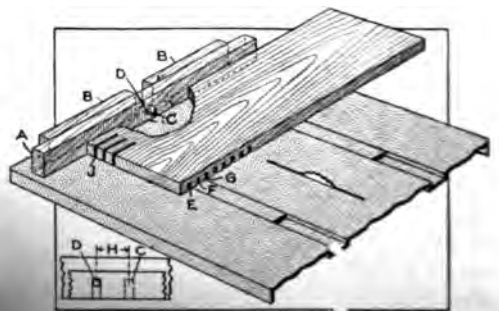

Fig. 5

An Ordinary Circular-Saw Table is Used for Cutting the Dentil Moldings, by Fitting a Gauge Device on the Usual Guides

In Fig. 5, a piece of wood to fit the space between the dentils is fastened to the board at the left, as a gauge stop.

### Fitting Metal Gaskets Securely in Bolted Flanges

Where a metal gasket is used in the flange joint between two pipe lengths, it should be of relatively small diameter, and should be placed within the bolts, as shown, as against the incorrect method. The practice suggested is preferable because, where the gasket is of small area, the pressure to the square inch, imposed on it when the bolts are tightened, is much greater than if it has a large area, and a small-diameter gasket is squeezed tighter in the joint, relatively. Where rubber, or some similar yielding material is used for the gasket, it should be made by the method indicated as incorrect for metal. The bolts hold the gasket in

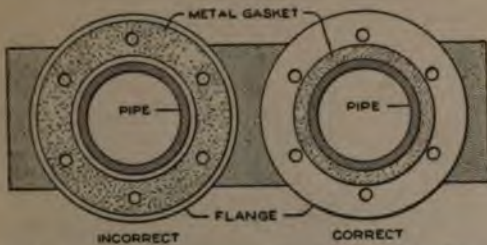

The Metal Gasket is Cut to Fit Inside of the Ring of Bolts and the Rubber One is Fitted to Surround Them

place, and the usual pressure is sufficient to insure a tight joint.

### Device Regulates Windmill to Maintain Water Supply

A busy farmer who depends on wind power to pump water for his stock rigged up an automatic device, as shown in the sketch, to regulate the windmill. By this means the pump is automatically brought into action, or shut off, when the water tank is in need of filling, or filled. A 5-gal. can with a small hole in the bottom was hung on the end of a 4-ft. horizontal lever, which is attached to the wire controlling the fan of the windmill. The overflow pipe of the storage tank was lengthened with garden hose so that its outlet was above the can. When the tank is full, the overflow fills the can

and this weight turns off the windmill, stopping the pump. In 15 or 20 minutes a portion of the water leaks out



This Device for Regulating a Windmill Does Its Work Automatically

of the can, and the weight being reduced, the mill again comes into operation. However, if the cattle have meanwhile lowered the water level in the trough, which is automatically refilled from the storage tank, the mill continues to pump until the tank is full.—F. E. Tuck, Nevada City, Calif.

### Tap Wrench Fits Various Sizes of Shanks

This tap wrench was made to take the place of different-sized wrenches. The sketch shows it assembled for small taps, less than  $\frac{3}{8}$  in. The other notches are used on taps larger than  $\frac{3}{8}$  in. The wrench gives more leverage with the larger taps, by shifting the handles to the proper notch positions. Both ends are the same. To match the large notches, holes A and C in the upper piece are matched

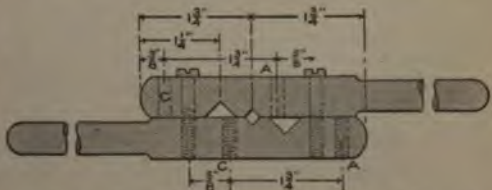

A Single Tap Wrench Does the Work of Several by Reason of the Double Notches

against holes A and C in the lower piece.—Clarence H. Anderson, Worcester, Mass.

closing the switch electric waves will

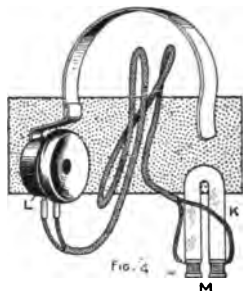

G. A series of pass through the loop formed by the crossed wires. The extreme end of the loop is at the point where the wires are crossed. The waves will travel to this point and back to the instrument at the cable terminal.

By transforming these waves into sound, the end of the loop—the place of trouble—can be located within 1 in. For this purpose two telephone receivers are used, as shown in Fig. 4. A head strap permits use of both hands.

The magnet and coils K are removed from a receiver of the type used on desk telephones, and connected by a cord with a small receiver, L, which

has a head band. To detect the waves passing through the cable, the receiver L is placed to the ear, and the magnet, with coils K, is held with the ends M touching the lead cover of the cable. If the listener is between the cable terminal and the place of trouble, a buzzing sound will be heard. By moving away from the terminal, a span at a time, the trouble will soon be located between two poles, as the sound will not be heard when the listener is beyond the end of the loop where the trouble is.

By the use of a cable car, the listener can travel slowly over the span and locate the exact spot where the wires are crossed. The cable can then be opened and repairs made. If testing over a long stretch of cable, it may be necessary to use more than three cells with the induction coil to make up for the additional resistance in a long loop. A small storage cell will also meet this requirement.

### Rim Reinforces Cooling Fan

A kink that was used on an automobile cooling fan of the familiar design, in which the blades are riveted to small projections cast integral with the fan hub proper, will be of interest to autoists and others who repair cars. The blades continually became loose and bent because they were not held firmly

enough. A ring of cold-drawn rod,  $\frac{3}{8}$  by  $\frac{1}{8}$  in. in cross section, was made, the diameter being sufficient to clear the fan blades by at least  $\frac{3}{8}$  in., as indicated. The ring was riveted to the six blades by

means of strips of metal,  $\frac{1}{16}$  by  $\frac{3}{8}$  in. in cross section, and  $\frac{1}{8}$ -in. round-head rivets. This made the fan rigid, and no further trouble was experienced with it.

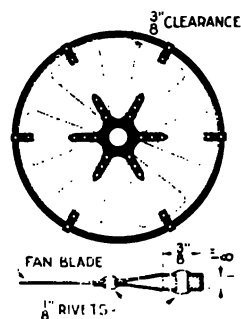

### A Self-Chalking Chalk Line and Reel

A tin box with a tightly fitting cover was made into a useful reel case and automatic chalking device for a chalk line, as shown in the illustration. The box used was 4 in. in diameter and 2 in. deep. The line is wound on a rod. B, which is provided with two side disks as

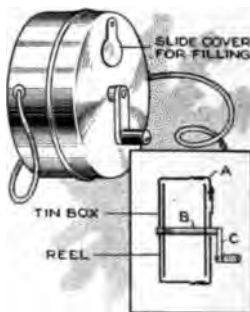

guides for the line. The shaft is set in the bottom and the cover of the box, and provided with a handle, C, as shown. An eyelet is set in the can where the line is drawn out. If the cover is very tight-fitting, it may be used to get at the interior of the box. Otherwise, a small slide cover of spring brass may be fitted over a hole in the top, and the cover soldered at the joint A. The spring cover should



be made with a slight dish effect so as to fit the hole snugly.—R. B. Hayward, Keene, N. H.

### Tool for Holding Polished Metal Parts in Machine Operations

It is sometimes necessary to drill holes in highly polished metal parts, or those having threads on the outside surface. To hold such parts in a vise, a wooden holder should be made, as shown, suitable for several sizes. The holder consists of two strips of wood, shaped, and hinged together.



The free ends have a bolt through them tightened with a wing nut. The holder may be held tight by pressure of the handles on light work, and the grooves shaped to suit special jobs.

### Overhanging Edge on Roofing Found Superior

In putting on roofing, of the sheet or prepared kind, I have found that better wear is given and as good protection also, by setting the roofing so that it has an overhang at the edges of the roof instead of being nailed solidly along the edges. When the roofing material is folded over, as indicated, the nails are usually driven into the edges of the board. This allows



OLD WAY



NEW WAY

water to creep in around the nails and affects their holding qualities, as well as deteriorates the roofing material. The overhang causes the water to be thrown clear of the edge.—T. J. Hubbard, Mendota, Ill.

### Hook Fitted to Hand Truck Holds Boxes

By fitting an ordinary hand truck, of the two-wheel type, with a hook which grasps the box or other load, preventing it from falling forward, the trucker may not only save time but also prevent damage to the load or to fellow workmen. The hook is shaped of wrought iron and slides on a rod, as shown.



The rod is flattened at the end and fastened to the crossbars of the truck with screws. The hook is thus adjustable to boxes of various sizes.—R. B. Glenn, Atlanta, Ga.

### Detachable Handle Convenient for Paint Buckets

By the use of a simple handle fitting, which can be attached to an ordinary can or bucket, a convenient receptacle for paint, white-wash, or other materials, can be provided. The clamping device, to which the bail is attached, consists of two pieces of strap iron, shaped as shown, and bolt-



ed together with a stove bolt and wing nut. The inner piece is bent to grasp the edge of the can, and the grip is made firm by tightening the wing nut. The handle can be sprung sufficiently to accommodate it to cans within a reasonable range. A good kink is to provide several sizes of handles, if sufficient use is found for the device.—Bert Waychoff, Fort Collins, Colorado.

closing the switch electric waves will

G. A series of pass through the loop formed by the crossed wires. The extreme end of the loop is at the point where the wires are crossed. The waves will travel to this point and back to the instrument at the cable terminal.

has a head band. To detect the waves passing through the cable, the receiver L is placed to the ear, and the magnet, with coils K, is held with the ends M touching the lead cover of the cable. If the listener is between the cable terminal and the place of trouble, a buzzing sound will be heard. By moving away from the terminal, a span at a time, the trouble will soon be located between two poles, as the sound will not be heard when the listener is beyond the end of the loop where the trouble is.

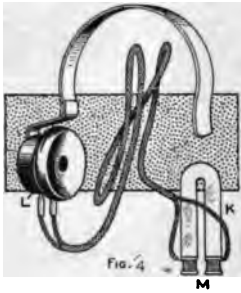

Fig. 4

By transforming these waves into sound, the end of the loop—the place of trouble—can be located within 1 in. For this purpose two telephone receivers are used, as shown in Fig. 4. A head strap permits use of both hands. The magnet and coils K are removed from a receiver of the type used on desk telephones, and connected by a cord with a small receiver, L, which

By the use of a cable car, the listener can travel slowly over the span and locate the exact spot where the wires are crossed. The cable can then be opened and repairs made. If testing over a long stretch of cable, it may be necessary to use more than three cells with the induction coil to make up for the additional resistance in a long loop. A small storage cell will also meet this requirement.

Rim Reinforces Cooling Fan

A Self-Chalking Chalk Line and Reel

A kink that was used on an automobile cooling fan of the familiar design, in which the blades are riveted to small projections cast integral with the fan hub proper, will be of interest to auto-ists and others who repair cars. The blades continually became loose and bent because they were not held firmly

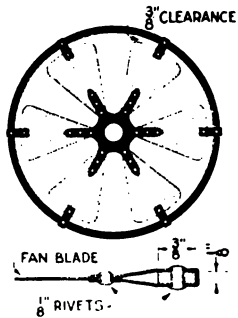

enough. A ring of cold-drawn rod, 3/8 by 1/8 in. in cross section, was made, the diameter being sufficient to clear the fan blades by at least 3/8 in., as indicated. The ring was riveted to the six blades by

means of strips of metal, 1/16 by 3/8 in. in cross section, and 1/8-in. round-head rivets. This made the fan rigid, and no further trouble was experienced with it.

A tin box with a tightly fitting cover was made into a useful reel case and automatic chalking device for a chalk line, as shown in the illustration. The box used was 4 in. in diameter and 2 in. deep. The line is wound on a rod, B, which is provided with two side disks as

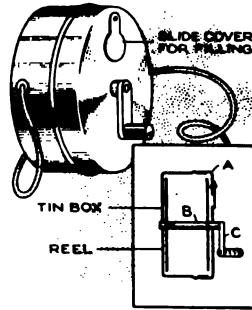

guides for the line. The shaft is set in the bottom and the cover of the box, and provided with a handle, C, as shown. An eyelet is set in the can where the line is drawn out. If the cover is very tight-fitting, it may be used to get at the interior of the box. Otherwise, a small slide cover of spring brass may be fitted in the top, and the cover the joint A. The spr

the joint A. The spr



be made with a slight dish effect so as to fit the hole snugly.—R. B. Hayward, Keene, N. H.

### Tool for Holding Polished Metal Parts in Machine Operations

It is sometimes necessary to drill holes in highly polished metal parts, or those having threads on the outside surface. To hold such parts in a vise, a wooden holder should be made, as shown, suitable for several sizes. The holder consists of two strips of wood, shaped, and hinged together. The free ends have a bolt through them tightened with a wing nut. The holder may be held tight by pressure of the handles on light work, and the grooves shaped to suit special jobs.



### Overhanging Edge on Roofing Found Superior

In putting on roofing, of the sheet or prepared kind, I have found that better wear is given and as good protection also, by setting the roofing so that it has an overhang at the edges of the roof instead of being nailed solidly along the edges. When the roofing material is folded over, as indicated, the nails are usually driven into the edges of the board. This allows



OLD WAY



NEW WAY

allows water to creep in around the nails and affects their holding qualities, as well as deteriorates the roofing material. The overhang causes the water to be thrown clear of the edge.—T. J. Hubbard, Mendota, Ill.

### Hook Fitted to Hand Truck Holds Boxes

By fitting an ordinary hand truck, of the two-wheel type, with a hook which grasps the box or other load, preventing it from falling forward, the trucker may not only save time but also prevent damage to the load or to fellow workmen. The hook is shaped of wrought iron and slides on a rod, as shown.



The rod is flattened at the end and fastened to the crossbars of the truck with screws. The hook is thus adjustable to boxes of various sizes.—R. B. Glenn, Atlanta, Ga.

### Detachable Handle Convenient for Paint Buckets

By the use of a simple handle fitting, which can be attached to an ordinary can or bucket, a convenient receptacle for paint, white-wash, or other materials, can be provided. The clamping device, to which the bail is attached, consists of two pieces of strap iron, shaped as shown, and bolted together with a stove bolt and wing nut. The inner piece is bent to grasp the edge of the can, and the grip is made firm by tightening the wing nut. The handle can be sprung sufficiently to accommodate it to cans within a reasonable range. A good kink is to provide several sizes of handles, if sufficient use is found for the device.—Bert Waychoff, Fort Collins, Colorado.





form the arc. In this cavity are placed the materials through which the arc plays. The seams where the surfaces of the bricks meet may be cemented, if necessary, but the adjustment of the carbons in their grooves must be loose to permit the gases generated to escape. As these gases are not always nonpoisonous, the usual precautions against inhaling them should be taken. A hole through the upper brick can be cut to allow the operator to view the action within the cavity. This opening is covered with a mica sheet. The cover can be removed, and the materials within adjusted, if desired. This type of furnace produces a much greater heat than type A.

The third type of furnace, C, is an arrangement where the cathode, or negative pole, is made up of a graphite crucible in which the material in work, reduced to a powder, is packed. The

wire carrying the current is attached to the outside of the crucible, as shown, and the usual resistance provided.

A few suggestions as to possible uses of these furnaces are valuable: The less volatile and refractory metals and compounds, such as lead, zinc, etc., quickly melt, oxidize, and volatilize in the heat of these furnaces. Copper, iron, gold, and even platinum soon melt and come to a boiling point. Their vapors then pass off and upon examination, when the furnace is cooled off, their crystals will be found on the surfaces of the oven. Some of these are beautiful, especially those of gold. Quicklime may be produced easily in the furnace by permitting the arc to play on a piece of marble. The quicklime may be then tested by adding water to it, and the heat given off will show its nature.

### Soldering Electrically without an Iron

Electrical soldering, based on the principle of spot welding, is both

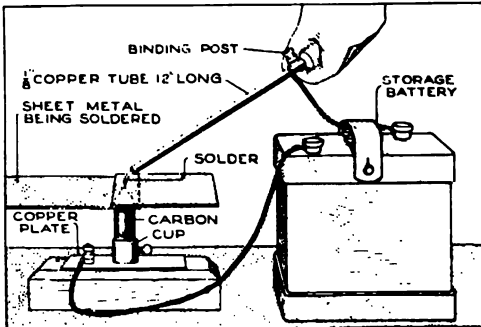

The Solder Point is Heated When a Contact is Made, Completing the Electrical Circuit

economical and efficient. Electric energy is used only during the interval of soldering, thus insuring low cost; and the device is also ready for instant use. A simple outfit, as shown, consists first of a short length of arc-light carbon, tapered at one end, while the other end is fitted into a copper cup, in which it is tightly held by a set screw. The copper cup can easily be formed by hand from a short strip,

1 in. wide and  $\frac{3}{8}$  in. thick, made into a ring. The ring is soldered to a copper plate which forms the bottom of the cup, and serves also as a support. The plate is fastened with screws to a wooden base. Next procure a copper tube, 12 in. long, and  $\frac{1}{8}$  in. inside diameter. Fit one end of the tube into a wooden handle. Binding posts, as shown, are set on the copper plate and on the tube, and these posts connected to a six or eight-volt storage battery. The outfit is then complete.

Before starting work, a 6-in. length of string solder is placed in the tube, leaving an inch or so projecting from the end. Place the metal sheets to be soldered on the carbon tip, as shown. Then touch the end of the solder to the sheets directly above the carbon electrode at the point to receive the solder. Immediately the carbon will glow, heating the metal sheets, which in turn melt the solder, permitting it to flow on smoothly, and in the desired quantity. The instant the solder string is removed from the sheets, the electrical contact is broken and the carbon point cools.—K. M. Coggeshall, Webster Groves, Mo.

**Hanging Oilcan Handy  
for Overhead Work**

When oiling machinery that can be reached only by standing on a ladder, it will be found more convenient to hang up the oilcan than to set it down where it is in danger of tipping over. It is only necessary to solder a brass ring to the oilcan stem near its end. The ring can then be hung over a hook on the ladder, or on the machinery.

**Tool Block for Making  
Small Pins on Lathe**

Having some small pins to turn and no turret lathe I made the tool block shown in the sketch. The stock of which the pins were made was cold-rolled machine steel. It was held in the draw chuck of one of our engine lathes. A block of cast iron was shaped up and drilled, and the tools mounted upon it, as indicated, the tools being held by clamps and cap screws. The graduated dial was run to zero, and the tools were set from a previously turned model, each set of tools taking the same amount of cut, the finishers taking as much as the roughers. When a cut was finished the carriage was run in a few thousandths of an inch and run back. The cutting-off tool was

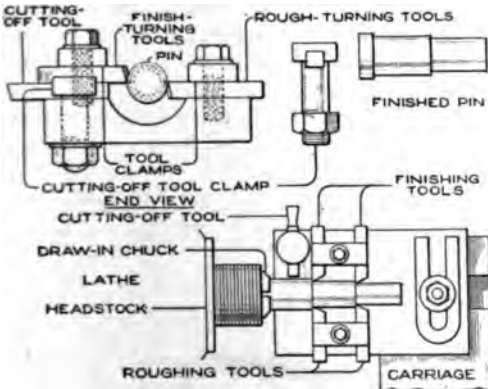

TOP VIEW

**A Turret Lathe Not Being Available, the Pins were Quickly Made by the Use of This Special Lathe Fixture**

then brought into play, cutting off the stock and facing off the end.—Joe V. Romig, Allentown, Pa.

**Old Auto Radiator Converted  
into Shop Water Heater**

By reversing the work done by an automobile radiator, which was no longer fit for service as such, a blacksmith provided himself with a hot-

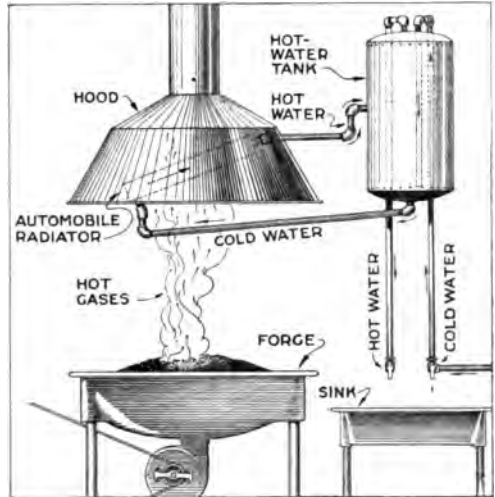

**An Old Auto Radiator was Utilized to Provide a Water Heater for the Workshop by Conserving the Heat Above the Forge**

water supply, which he appreciated especially in washing up after a hard day's work. In the arrangement which he devised, as shown in the illustration, the water circulating within the radiator is heated by the hot gases and air above the forge. The hot water is piped to a conveniently located storage tank. The method of arranging the pipe to provide for a cold-water supply and a hot-water delivery system is shown, the arrows indicating the direction of flow. The radiator is supported at an angle in the hood of the forge. The vent in the radiator is soldered, and the filler opening provided with a wiped joint, to which the 1½-in. iron pipe, used to make the connection to the halfway point on the side of the 6-gal. tank, is attached. The heated water is taken from the top of the tank, and the cold water enters by means of a pipe extending through the top and down inside the tank to the bottom. Heat otherwise lost is thus conserved.—E. F. Hallock, Brooklyn, N. Y.

### Wagon Wheels Provide Forms for Concrete Culverts

In constructing a concrete culvert several old wagon wheels, of uniform size, were put to good use as supports for the form over which the concrete



By the Use of Old Wagon Wheels Wired to the Planks Which Supported the Concrete for a Culvert, They are Easily Recovered for Further Use

was laid. The wagon wheels were set on logs, or planks, which could easily be removed, thus dropping the wheels from their position under the forms. The planking, of 2 by 6-in. stuff, was wired to the wheels, by passing the wire around the planks and the hubs, as shown. The wires were easily cut in removing the wheels, and the planking was likewise easily withdrawn. Both the wheels and the planking could be used again.—Robert C. Knox, Arcadia, Fla.

### Square-Point Center Punch Handy for Revising Marks

In laying out work in the machine shop, or other metal-working shops, it is customary to indicate centers and other points by means of center-punch marks. The punch is usually ground to a conical point, and it is difficult to distinguish various groups of markings, and especially revisions. A practical kink in this connection is to use a special punch for making revisions, or for indicating certain kinds of marks, the punch being ground to a square

pyramid at the point. Triangular or other points may also be used if several different marks are desirable.—Edward M. Davis, Philadelphia, Pa.

### Auto Radiator Water Gasket Altered for Winter Operation

Motorists realize the necessity of covering the radiator and hood of an automobile in the winter months, because the rapid radiation of the heat results in inefficient operation. A thermostatic valve set in the outflow pipe of the water system is used in many motors for cold weather. A simple change in the gasket at the outflow pipe, connecting the water jackets to the radiator, is nearly as effective as the thermostatic valve. It has an advantage in saving the nonfreezing solution, commonly employed, from rapidly boiling away, as often happens where the radiator is covered and maintained in a heated condition. The change in the gasket is merely in the substitution of one having a smaller opening. A gasket of one-half the normal area was used on a 22-hp. motor with excellent results. The proper size for the engine on which it is to be used can be best determined by experimenting, a gasket with a small opening being first set into the outlet water connection. A thermometer of the type used for vulcanizing rubber is placed on the cylinder head. If this records over 180° with the engine running rapidly, the gasket should be removed and the opening enlarged.



By Providing a Gasket with a Smaller Opening, the Radiator System is Operated Economically in Cold Weather

When the proper-size opening is secured, the radiator is relatively cool.



### Hanging Oilcan Handy for Overhead Work

When oiling machinery that can be reached only by standing on a ladder, it will be found more convenient to hang up the oilcan than to set it down where it is in danger of tipping over. It is only necessary to solder a brass ring to the oilcan stem near its end. The ring can then be hung over a hook on the ladder, or on the machinery.

### Tool Block for Making Small Pins on Lathe

Having some small pins to turn and no turret lathe I made the tool block shown in the sketch. The stock of which the pins were made was cold-rolled machine steel. It was held in the draw chuck of one of our engine lathes. A block of cast iron was shaped up and drilled, and the tools mounted upon it, as indicated, the tools being held by clamps and cap screws. The graduated dial was run to zero, and the tools were set from a previously turned model, each set of tools taking the same amount of cut, the finishers taking as much as the roughers. When a cut was finished the carriage was run in a few thousandths of an inch and run back. The cutting-off tool was

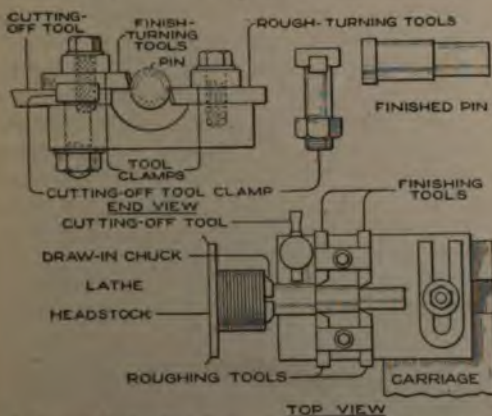

A Turret Lathe Not Being Available, the Pins were Quickly Made by the Use of This Special Lathe Fixture

then brought into play, cutting off the stock and facing off the end.—Joe V. Romig, Allentown, Pa.

### Old Auto Radiator Converted into Shop Water Heater

By reversing the work done by an automobile radiator, which was no longer fit for service as such, a blacksmith provided himself with a hot-

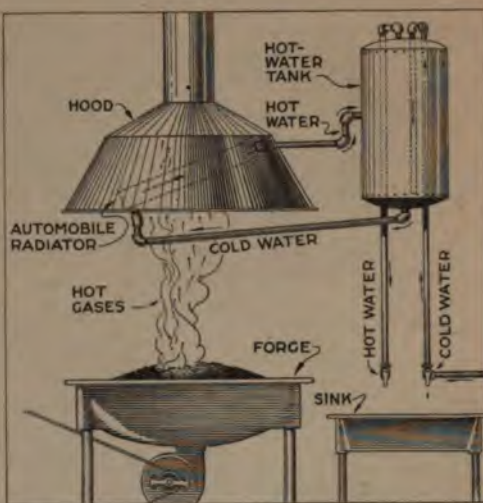

An Old Auto Radiator was Utilized to Provide a Water Heater for the Workshop by Conserving the Heat Above the Forge

water supply, which he appreciated especially in washing up after a hard day's work. In the arrangement which he devised, as shown in the illustration, the water circulating within the radiator is heated by the hot gases and air above the forge. The hot water is piped to a conveniently located storage tank. The method of arranging the pipe to provide for a cold-water supply and a hot-water delivery system is shown, the arrows indicating the direction of flow. The radiator is supported at an angle in the hood of the forge. The vent in the radiator is soldered, and the filler opening provided with a wiped joint, to which the  $\frac{1}{2}$ -in. iron pipe, used to make the connection to the halfway point on the side of the 6-gal. tank, is attached. The heated water is taken from the top of the tank, and the cold water enters by means of a pipe extending through the top and down inside the tank to the bottom. Heat otherwise lost is thus conserved.—E. F. Hallock, Brooklyn, N. Y.

**A Substantial Float Mooring  
for Small Boats**

It is often worth while in making a permanent mooring and anchor for small boats to make a float mooring. A float mooring is a small float or boat which carries the mooring vessel and serves as a permanent mooring station in the harbor. The keel was fitted with a mooring eye, which is a small shaped iron plate, which is bolted to the keel and the float was mounted. The float is made of a large block and the mooring cable fastened to a heavy iron ring, which is bolted through

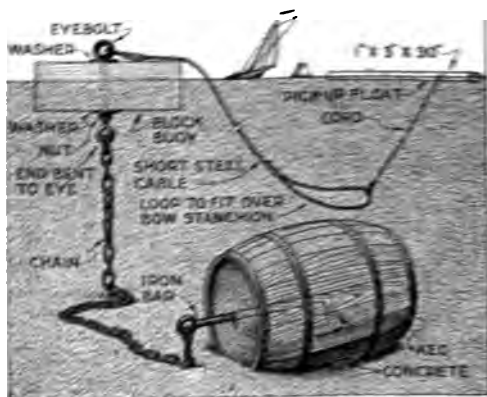

This Mooring for a Small Boat Anchored by Means of a Keel Filled with Concrete is Desirable Where Waves Are Choppy

it before the lower eye was shaped. A short steel cable, having a loop to fit over the bow stanchion of the craft, was fastened to the surface eyebolt of the float. A small pick-up float was attached to the loop of the cable, as shown, for convenience in running up to the buoy. B. Francis Dashiell, Dandurk, Md.

**Testing Compression in Cylinders  
of Automobile Motor**

Automobile engines usually lose compression after considerable wear, and the charge in the cylinders is retained with more or less leakage. The causes are, in the common order of their occurrence: leakages through the spark plug and valve-cap joints; leakage through exhaust valves, and

leakage past the piston rings. If each cylinder lost compression in equal degree, the results would be only loss of power and increased gasoline consumption, but this is seldom the case. In any engine in which there is loss of compression, some one cylinder will be found to lose its charge more rapidly than the others. Because of the resulting unequal pressure exerted by the pistons upon the rotating members, the engine vibrates, pounds under a heavy load, and develops noisiness in the valve motion. These conditions should be remedied promptly.

The usual method of testing compression is to turn the engine over, against compression, by means of the cranking handle, noting the resistance offered by each cylinder. A much better method is to run the machine part way up a moderately steep, smooth-surfaced grade, stop the car and engine, set the engine into reverse, engage the clutch, and, releasing the brakes, allow the car to back down until stopped by the cylinder compression. If the compression in the cylinder taking the load is approximately perfect, the car will remain motionless for several minutes; if not, the car will settle back against the compression stroke in the next cylinder more quickly, relative to the leakage.

The identity of the cylinder under compression can be determined by testing with the priming cocks, and once the order of compression is found, a continuance of the backing experiment will determine very accurately the relative compression in each cylinder. Cylinder oil squirted around spark-plug and valve-cap joints betrays leakage by foaming. The condition of the exhaust valves can be discovered by inspection. When the joints and valves are tight, continued loss of compression indicates leakage past the piston rings, possibly resulting from lack of lubrication, sticking, or distortion of the rings caused by deposits of carbon. Excessive heating of the motor base also indicates leakage past the piston rings.—Hayes Bigelow, Brattleboro, Vt.



**Worn Loose Pulleys Replaced  
by Adjoining Set Pulleys**

Much noise was caused in a small machine and pattern shop by the pounding of loose pulleys on the countershaft, the bore in the hubs being worn slightly oval. The set pulleys were removed and put in place of the worn loose pulleys. The latter were then set on the shafts in place of the old set pulleys. The noise and undue wear on the shafting was thus overcome.—J. C. Hansen, Chicago, Ill.

**Jaws for Holding Hexagonal  
Stock in Chuck**

In machining hexagonal stock in a four-jaw chuck, trouble is usually experienced in centering the work. Under these conditions, special jaws like those shown in the sketch were made, and proved effective.



By use, it was necessary to get the stock into place and to adjust it in the usual manner. The jaws are held against the chuck means of headless set screws.—G. W. Brews, Boston, Mass.

**Using Paper as Packing  
in Pumps and Fittings**

It is a common practice to use packing union joints, pipe pumps, and similar fittings. On account of the scarcity and high price of packing, it makes a substitute especially desirable. It has been found that a layer of three-ply felt roofing paper is an excellent substitute for packing, and lasts a considerable time. The holes in the packing should be cut a trifle large, as the paper has a tendency to swell.

**Stock Bins Built Up from Boxes  
as Units**

Boxes of various sizes may be joined into series of stock bins, if the boxes



The Boxes are Arranged in Tiers to Form Handy Stock Bins. More Rows may be Added as Desired

are sorted and those of the same dimensions joined together as shown. The boxes are nailed together in tiers, with short nails through the bottoms, where the edges overlap. The end tiers are supported by strips nailed at the corners. A convenient method is to build up the boxes into standard sections, of about the size indicated, and then to place these sections as required.

**A Siphon That is Easily  
Kept Primed**

A ready-primed siphon can be made by bending a piece of pipe into the shape shown in the illustration. After being once filled, the water, or other liquid, remains in the pipe as long as the outlets are level. It is preferable to balance the pipe by means of a chain, as shown,

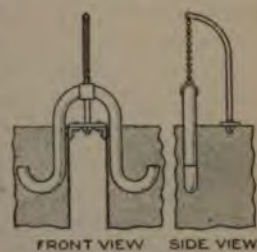

and connect it with a collar on the pipe, for adjustment. This method of siphoning provides a temporary means of connecting two adjacent tanks, and is useful for many other purposes where the flow is irregular and personal attention unavailable.—A. W. Allen, New York, N. Y.



the truck and guiding it, as shown. The bearing above the large caster is heavily reinforced with a plate of iron, bent to the shape shown in the side view, and riveted to the lower truck frame. The main upright frame is riveted to the lower truck frame, and may be suitably braced to it, if the boxes to be lifted are quite heavy.

The winch drum and crank arrangement is shown in the front and side views, and is of the usual geared type. A single gear with a pawl may be used for handling comparatively light loads, or a train of gears may be used for heavier loads with a stronger framework. The pulley arrangement for conducting the cable to the load is clearly shown, the pulleys being carried between angle supports.

The truck carriage, which supports the load, is shown slightly raised from the lower frame. It is strongly built of iron bars, into the upper edges of which 2-in. pipe rollers are set, as shown. These rollers are handy in placing the boxes on the carriage, or in removing them. The carriage is braced to its upper framework by upright braces, made as detailed, and riveted into place. These braces carry the brace rollers, which are guided in the channel irons of the main frame. The method of fastening the other parts of the carriage is shown in the front view. The metal parts, other than the bearings, should be given a coat of red lead when the work is assembled, and later suitably painted. The working parts should be properly greased.

### Large Minnow Net Made of Branches and Netting

The fisherman who does not care to take extensive equipment with him on

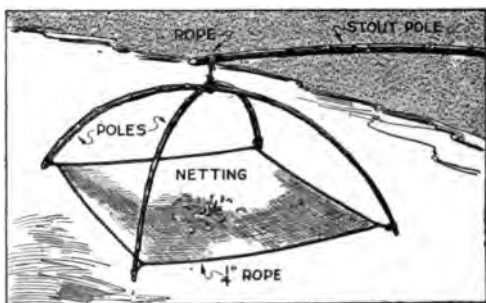

The Rigging for This Homemade Minnow Net is Quickly Arranged at the Fishing Spot

a trip often has need of an efficient means of catching minnows, especially in places where it is difficult to wade and make use of an ordinary minnow net. A handy way to arrange the net is to attach it to branches, cut on the spot, the poles being lashed together, as shown in the sketch. The net is reinforced at the edges with rope, and fitted with ropes for tying it at the corners. The net rigging is supported from a stout pole, making it convenient to use the outfit even from a high bank.

### Scraping Babbitt Bearings to a Nice Fit

After a babbitt-metal bearing has been poured in the box, using the shaft as a core or mold, it should be scraped so that it will accurately fit the shaft. A good tool for this purpose is one homemade of triangular cross section, like a three-cornered file without the teeth. If such a tool is not available, one may be improvised by grinding the teeth from such an old file with an emery wheel. The ground faces should be honed smooth. The scraping is done with the edges, which must be sharp.

In use, the portion of the shaft which is to rotate in the babbitted bearing is given a thin coat of lamp-black, or Prussian-blue oil paint. The painted shaft is placed in the bearing and turned by hand a few rotations and removed. At the points where the shaft contacts with the bearing metal, paint from the shaft will be left on the babbitt. These spots are scraped with the tool. The shaft is again painted and rotated, and the high spots scraped off. The process is continued until the paint is found to be evenly distributed over the entire surface of the bearing. The shaft should have

a good "running fit" but without sufficient play to permit knocking.—Frank R. Cameron, Chicago, Ill.

### Ankle Strains in Driving Auto Relieved by Heel Block

Leg and ankle strains, attending the operation of a foot throttle in driving an automobile, may be effectively reduced by the installation of an angular block to serve as a foot rest. The block is bolted to the floor, with the bolt heads countersunk, and notched to form a socket for the heel. The angle of slope up toward the throttle should be such that the sole of the shoe rests flat on the block, when the accelerator is completely depressed.—A. L. Payne, Garfield, N. J.

### Large Jigs and Templates Painted Red for Identification

The annoyance of having large jigs and templates mistaken for commercial machine parts and being carted out of the shop was avoided, in a large plant, by giving them a coat of red paint. Because of their unyieldiness, these parts are ordinarily kept near the mechanics using them. The conspicuous red coloring identifies these special parts, and laborers are less likely to truck them away by error.—Joseph Plogmann, Cincinnati, Ohio.

### Pedal-Control Wire-Stripping Bench Tool

A tool that will be found useful, in a shop where electrical wiring is done, is a wire stripper which can be set to remove uniform lengths of the covering from the wire. The outfit is fitted on the bench, or table, near the edge, as shown, and the wire is fed in between the cutters, against an adjustable gauge. The operator presses on the pedal and gives the wire a slight turn, so as to cut the covering all around. It may then be removed easily. The set-screw adjustment provides for cutting various sizes of wire.

The detail construction of the cutters and gauge is shown at the right. The main frame is shaped from a strip of iron, and the cutters are of tool steel.

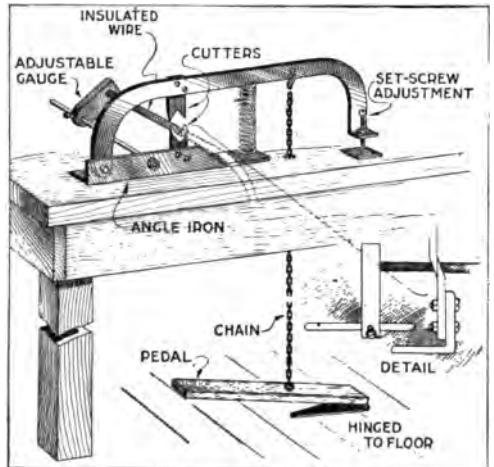

The Gauge is Set as Desired and the Ends of the Wire Thrust between the Cutters, Pressure being Applied on the Pedal

A coiled spring raises the cutter and frame, releasing the wire.—C. C. Spreen, Flint, Mich.

### Blowtorch with Flexible Tube for Work in Close Spaces

In various kinds of repair work, especially on automobiles, brazing and soldering must be done in places where it is difficult to use a blowtorch of the ordinary type, unless it is adapted especially for the job. Under these circumstances, a blowtorch of the usual type was fitted with a flexible tube, as

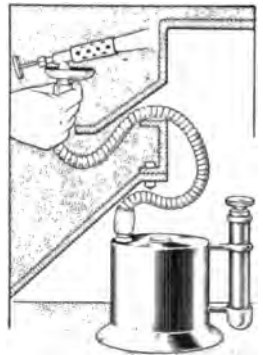

shown, the burner being fastened at one end of it. By this means the flame could be directed on spots which it would otherwise not reach. The tube is quickly disconnected and kept with the torch for convenient use.—Earl Botten, Boscobel, Wis.

### Homemade Pistol Grip for Surveyors' Tape

The tape commonly used by surveyors is hard to hold, especially when the hands are cold. The sketch shows a pistol grip that was cut from a tree branch.



It measures about  $\frac{3}{4}$  in. in diameter and is attached to the reel case by means of two strips of sheet metal,  $\frac{5}{8}$  in. wide. The strips are attached to the case by rivets, which pass through the rim of the case, so that they are not in the way of the tape. Two rivets secure the strips to the handle. The grip is especially handy in unwinding or rolling the tape.—F. H. Linthicum, Annapolis, Md.

to the case by rivets, which pass through the rim of the case, so that they are not in the way of the tape. Two rivets secure the strips to the handle. The grip is especially handy in unwinding or rolling the tape.—F. H. Linthicum, Annapolis, Md.

### Homemade Built-Up Liners for Linotype Machines

Having to set different bodies of type on the linotype machine, and being supplied with only one liner of the desired length, I made some liners which can be built up to various thicknesses, as required. I took a piece of brass rule of the desired thickness and length,



and ground it down to the height of the mold. Two slight projections were then made in the surface of the strip to fit into two holes, bored in the liner as shown in the sketch. By building up with several strips of suitable length, various thicknesses are provided, saving the expense of buying special liners for each size of type desired.—Frank B. Waltrip, Hopkinsville, Ky.

and ground it down to the height of the mold. Two slight projections were then made in the surface of the strip to fit into two holes, bored in the liner as shown in the sketch. By building up with several strips of suitable length, various thicknesses are provided, saving the expense of buying special liners for each size of type desired.—Frank B. Waltrip, Hopkinsville, Ky.

### Support for Garage "Free-Air" Hose at Curbing

A convenient support for the "free-air" hose of a garage was fashioned from a piece of pipe, and set into the concrete of the street curbing. The main standard is a pipe set vertically, with two horizontal hooks fixed near the upper end, on the sides of the pipe, to hold the hose. The support prevents the hose from falling in the gutter, where it may be damaged by vehicles, and also attracts attention to the garage and its "free-air" service. The cost of this device is trivial when compared with the advertising it gives.—Jos. Thalheimer, Jr., Phoenix, Ariz.

### Device for Making Bell Ends on Tubing

In making joints in brass and copper tubing, commonly used in oil and air-

pipe lines, the sections are usually connected in a screw joint, or union, and one of the tube ends is formed into a "bell end." A tool for forming these bell ends uniformly and

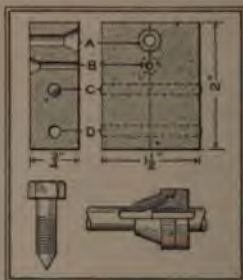

quickly is shown in the sketch. It consists of a metal plate,  $\frac{3}{4}$  by  $1\frac{1}{2}$  by 2 in. in size, and provided with countersunk holes for two or more standard sizes of tubing. The tube is inserted in the die A or B, depending on the size, and clamped in place, with the end to be shaped just flush with the surface on the side which is countersunk. A machine bolt, ground to the proper point, is used to spread the tube end in the countersunk hole. Pins, C and D, hold the two sections of the die in place while it is being clamped. The plain end of the tubing is fitted into the bell end, as detailed. The bell end is removed from the die by releasing the pins C and D.—D. C. Goff, Kenosha, Wisconsin.





## A Machine That Executes Military-Drill Movements

By LIEUT. FRANK SHORT

THE squad-right and right-turn machine described and illustrated herewith is designed to be of service to the man who has difficulty in grasping the details of these two fundamental military-drill movements. Any company commander can have such a machine constructed, and it will illustrate the movement in a way that cannot be equaled by any verbal or graphic description.

Construction of the machine requires no elaborate equipment, and all necessary dimensions are given to permit

the proper shaping of the cam surfaces. The scale of the whole may be changed at discretion.

In operation, for "squad right," the cam A is placed on the table, as in Fig. 1, with the long guide rail K, and with the square corner in line with the division point 0. The front-rank men, being linked together as indicated by H and S, in Figs. 7 and 8, are lined up touching the right-hand outside edge of the cam, as in Fig. 1, the bolt R of the pivot man passing through the slot M,

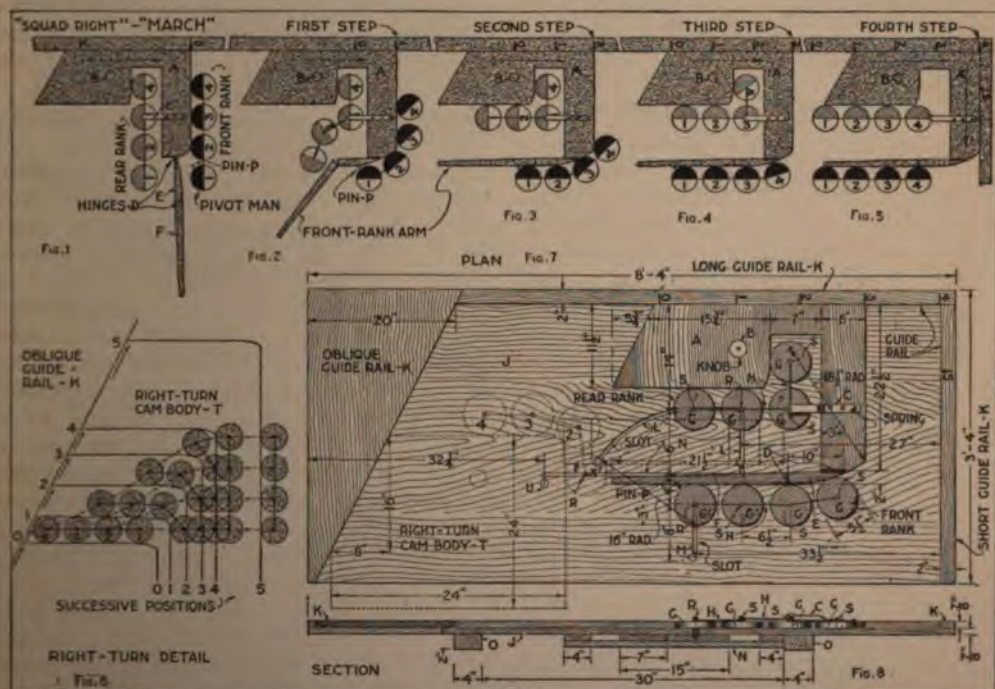

Fundamental Military-Drill Movements are Executed on the Machine in a Manner Which Points Out to the New Recruit the Exact Position He should Occupy during Each Successive Movement. After Learning the Movements by Watching the Mechanical "Men" He Has Little Difficulty in Taking Up the March

washers and nuts preventing its being pulled off the table J. Parts N and O indicate structural details. The front-rank arm joints, E and F, extend parallel with the short cam surface and to the right of the front rank, thus avoiding the rear rank. In the latter, No. 2's pin passes through the curved guide slot L, at its extremity, X, while No. 3's pivot pin, S, which is longer than the others, is held in the cup of the holding spring C. No. 4 rests against the inner surface of the cam in the same relative position as in the illustration, and No. 1 is in prolongation of the line of the other three.

When the knob B is pushed toward the short guide rail, keeping the long side of the cam in contact with the long guide rail, the successive changes in the movement are executed, as shown in Figs. 2, 3, 4, and 5. The squad is in line in the new direction when the cam reaches the short guide rail, and is caused to step off in the new direction by a movement of the cam in that sense.

To make a right turn, the pin P, shown in Fig. 7, is removed from the table, and the movement is executed for one rank only by the cam T. The front rank of the squad is used, No. 1 being placed with its bolt R in the opening of the slot L, at U. The rank is placed in the extension of the long slot, and the cam T is placed with the oblique edge parallel with the oblique guide rail K, and with the adjacent

edge in contact with the line of men, as shown in position 0, Fig. 6.

Movement of the cam parallel with the oblique guide rail until the long guide rail is reached completes the turn, as indicated by the successive movements in Fig. 6. The rank is caused to take up the full step by moving the cam along the long guide rail.

The execution of squad right by the machine is nearly perfect. By changing the number and spacing of the division points on the guide rails, the machine will satisfy a "six-count" advocate as well as the "four-count" faction, for which it is marked out. Right turn is not so accurate. No. 1 and No. 2 are approximately correct in their action, but Nos. 3 and 4 oblique are at too steep an angle and make the second oblique just before coming into the line, which is advancing at somewhat less than a half step. The movement, however, is sufficiently accurate to give a clear idea of the proper execution, and is an excellent illustration.

In both movements the machine may be operated fast or slow, or may be stopped in any position. Each man of a squad may watch the path of his corresponding "man" on the machine and is presented with a clearer idea of where he belongs at each instant than is obtainable from talks or sketches. In addition, the machine itself is interesting to the men, and aids to incite interest in the performance of the movement.

### Theft of Shovels Prevented by Chain and Padlock

On a large construction job requiring the use of many hand shovels, considerable annoyance was experienced in the repeated thefts of one or two shovels overnight. This was stopped by assembling all the shovels in one place at night, and running a strong chain through the D-handles, fastening the two ends of the chain with a reliable padlock, and attaching the entire lot to a heavy tool box.—Roy H. Poston, Flat River, Mo.

### Respirator Made of Cotton and Muslin

An excellent respirator may be made of a thick sheet of carded cotton wool placed between two pieces of muslin. For emergency use the material can be pieced or tied together suitably. Where a more substantial article is desired, for use in shops, buffing rooms, by janitors in sweeping dusty floors, etc., the cotton can be covered neatly in a strongly sewed mask, with tie ribbons at the back.—William A. Lorence, Richmond Hill, N. Y.



### Drawings Superseded by Others Plainly and Promptly Marked

When a drawing for shop or construction use is superseded by another, the original should be plainly marked "Superseded," and the title, serial number, and other designations of the later drawing should also be marked on the first one. This safeguard takes only a few minutes' time, and may save costly errors by the issuance of the wrong drawing.—C. H. Post, Denver, Colo.

### Patching Teeth into Broken Gears

Costly gears, having one or several teeth stripped, may be repaired to render indefinite service by fitting new teeth as illustrated. A slot is first cut

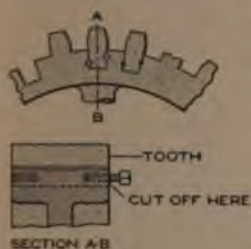

into the gear flange to remove all traces of the broken tooth, and a new tooth is fitted as indicated at AB. A cap screw, threaded in on either side of the new tooth and cut off flush with the gear flange, precludes all possibility of the insert working out.

### Small Water-Supply Reservoir Built in Mountain Stream

Securing a supply of clean water from a stream at all times is satisfactorily accomplished by the following method: A part of the stream is chosen where there is a fall of at least 1 ft. in a distance of 30 ft. The water is then temporarily diverted, and a dam built across the channel. A clear-water delivery pipe is then installed as near the bottom as possible. A spillway should be provided large enough to take care of maximum overflow. The supply pipe should terminate several feet inside the wall, being plugged at the end. The water enters through a series of  $\frac{1}{4}$ -in. perforations along the pipe. A wooden framework covered

with coarse wire netting surrounds the intake end of the pipe. Over the framework and the bottom of the chan-



A Steady Flow of Water Free from Surface Dirt is Obtained through the Pipe

nel a layer of large stones is placed. The stones are covered with gravel or chippings, and then with a layer of sand. Clarification will depend upon the thickness of the uppermost surface.

### Door Knobs Make Convenient Handles for Bits

An excellent handle for boring bits, screwdrivers, and similar tools, for use in cramped places, is a discarded doorknob. For occasional use it will be found satisfactory to use the knob without any alteration, simply inserting the bit into the socket and tightening with the screw. The bit has a tendency to wobble slightly, but otherwise is held securely. By beveling off the end of the hole in conformity with the shape of the bit shanks, or by filing off the shanks to an even thickness, a perfect fit is obtained.





the truck and guiding it, as shown. The bearing above the large caster is heavily reinforced with a plate of iron, bent to the shape shown in the side view, and riveted to the lower truck frame. The main upright frame is riveted to the lower truck frame, and may be suitably braced to it, if the boxes to be lifted are quite heavy.

The winch drum and crank arrangement is shown in the front and side views, and is of the usual geared type. A single gear with a pawl may be used for handling comparatively light loads, or a train of gears may be used for heavier loads with a stronger framework. The pulley arrangement for conducting the cable to the load is clearly shown, the pulleys being carried between angle supports.

The truck carriage, which supports the load, is shown slightly raised from the lower frame. It is strongly built of iron bars, into the upper edges of which 2-in. pipe rollers are set, as shown. These rollers are handy in placing the boxes on the carriage, or in removing them. The carriage is braced to its upper framework by upright braces, made as detailed, and riveted into place. These braces carry the brace rollers, which are guided in the channel irons of the main frame. The method of fastening the other parts of the carriage is shown in the front view. The metal parts, other than the bearings, should be given a coat of red lead when the work is assembled, and later suitably painted. The working parts should be properly greased.

### Large Minnow Net Made of Branches and Netting

The fisherman who does not care to take extensive equipment with him on

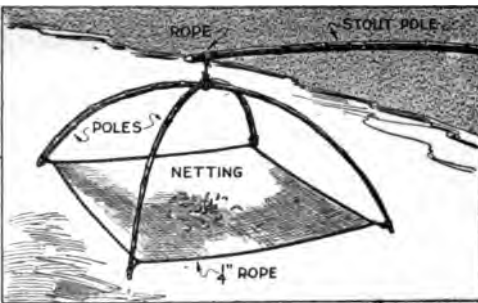

The Rigging for This Homemade Minnow Net is Quickly Arranged at the Fishing Spot

a trip often has need of an efficient means of catching minnows, especially in places where it is difficult to wade and make use of an ordinary minnow net. A handy way to arrange the net is to attach it to branches, cut on the spot, the poles being lashed together, as shown in the sketch. The net is reinforced at the edges with rope, and fitted with ropes for tying it at the corners. The net rigging is supported from a stout pole, making it convenient to use the outfit even from a high bank.

### Scraping Babbitt Bearings to a Nice Fit

After a babbitt-metal bearing has been poured in the box, using the shaft as a core or mold, it should be scraped so that it will accurately fit the shaft. A good tool for this purpose is one homemade of triangular cross section, like a three-cornered file without the teeth. If such a tool is not available, one may be improvised by grinding the teeth from such an old file with an emery wheel. The ground faces should be honed smooth. The scraping is done with the edges, which must be sharp.

In use, the portion of the shaft which is to rotate in the babbitted bearing is given a thin coat of lamp-black, or Prussian-blue oil paint. The painted shaft is placed in the bearing and turned by hand a few rotations and removed. At the points where the shaft contacts with the bearing metal, paint from the shaft will be left on the babbitt. These spots are scraped with the tool. The shaft is again painted and rotated, and the high spots scraped off. The process is continued until the paint is found to be evenly distributed over the entire surface of the bearing. The shaft :

### File Handles Convenient on Large Tee Wrenches

File handles, bored out and fitted to the handles of a large T-wrench, provide a firm hold, minimizing the danger of injury by the slipping of the tool, especially when the hands of the workman are greasy. With a handle of this type, it is easier, also, to exert greater power on the wrench, without bruising the palms.

### An Oil Filter and Tank for the Shop

An oil filter which may be constructed from two old casks in any small machine shop or garage will save many times its original cost in the reduction of oil bills. A 25-gal. cask and one of 15-gal. capacity are placed, as indicated, and connected by a pipe having a valve near the lower barrel. A  $\frac{3}{4}$ -in. water-supply pipe is led in near the bottom of the larger barrel, and a glass gauge is installed to determine the water level. A 2-in. vertical pipe, connected with a horizontal pipe at the bottom, is put through the head of the large barrel. The horizontal pipe is capped at both ends and has two rows of  $\frac{1}{8}$ -in. holes drilled in it. A large funnel—an oilcan, as shown, may be used—is soldered to the vertical pipe and properly braced to the head of the cask. Two screens, one 70-mesh and the other 90-mesh, are soldered inside the body of the funnel, as shown in the illustration.

Water is let into the large cask to a depth of 18 in. and the perforated horizontal pipe is secured within 5 in. of the bottom. Used oil is poured into the funnel and is washed by rising through the water as it emerges from the perforations in the horizontal pipe. Sediment is deposited at the bottom, while the clean oil floats on top of the water until its level gets above that of the overflow pipe. When the valve in the overflow pipe is opened the washed oil runs into the clean-oil reservoir through a filtering layer of cheesecloth, and three layers of felt. This disposes of any foreign matter

that may not have been removed in the washing. The filtering material should be removed and washed in kerosene

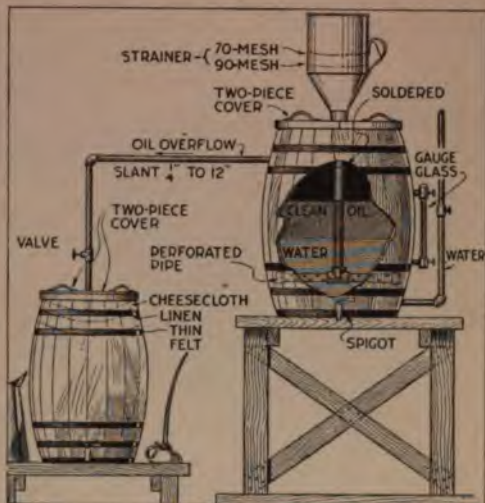

This Simple Filter Permits Old Oil to be Used Many Times

whenever sediment is apparent.—John E. Cahill, Jr., New York, N. Y.

### Depth Gauge for Hacksaw

Cutting to a designated depth with a hacksaw is accurately accomplished by fitting the blade with a depth gauge as indicated by the sketch. Most of the parts essential for the making of such a gauge can be picked up about the shop so that very little machining or fitting is necessary. The finished

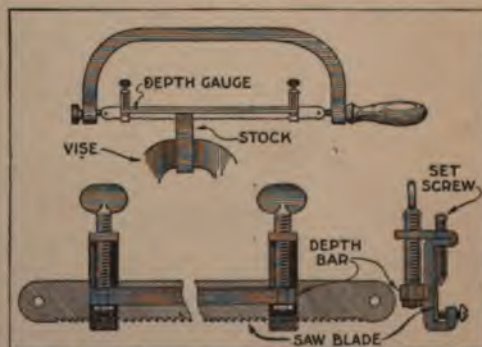

The Depth Gauge Eliminates Cutting Deeper than the Desired Distance

tool not only aids in accurate work but saves many broken saw blades as well.



### Adjustability of Big Blackboard Makes Stepladder Needless

By mounting a large blackboard, or drafting board, in a sash and counter-



Either the Top or Bottom of the Board may be Brought to a Convenient Working Height by Lowering or Raising It

balancing it with weights, so that it may be raised or lower l like a window, the necessity of using a stepladder when working near the top, or of bending in an uncomfortable position to reach the bottom, is obviated. The convenience of the arrangement is made apparent and the plan of construction indicated clearly by the accompanying illustration.—Kingston Forbes, Flint, Mich.

### Loosening Rusted Engine Pistons with Hot Water

Engine repairmen are often confronted with the job of getting into shape an old gasoline motor, or similar engine, that has been rusted badly. The pistons in such an old engine were rusted fast and after trying various methods of soaking them in oil, they were loosened by the following method:

The oil was permitted to soak thoroughly. Boiling water was poured into the hopper of the engine, and allowed to circulate around the cylinders only long enough to heat the cylinder walls but not to affect the pistons. The pistons were then driven loose with a wooden block and a hammer. It was necessary to drain the water out and to refill the jacket with hot water in order to loosen a particularly tight piston. This method freed the pistons after a half hour's work, where soaking them in kerosene for three days failed to do so. If the pistons are made of cast iron, the boiling water should be applied gradually.—Earl L. Botten, Bos-cobel, Wis.

### Wood Inserts in Pulley Bushing Conduct Oil

Cutting and heating of shafts and pulley bushings is impossible if the parts, while in motion, are supplied with an abundance of good cool oil. An unfailing supply of oil may be secured to any large bushing by inserting hardwood pins, as illustrated. The pins allow the oil to ooze out as fast as it is consumed and deliver it over the

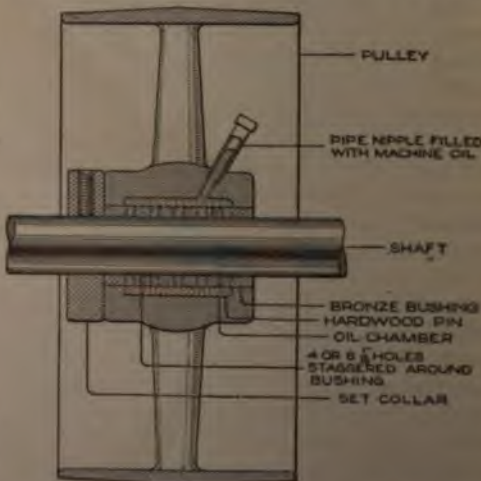

The Wooden Pins Distribute Oil Evenly over the Entire Bearing Surface

shaft in such a way that the entire surface is thoroughly lubricated.



a good "running fit" but without sufficient play to permit knocking.—Frank R. Cameron, Chicago, Ill.

### Ankle Strains in Driving Auto Relieved by Heel Block

Leg and ankle strains, attending the operation of a foot throttle in driving an automobile, may be effectively reduced by the installation of an angular block to serve as a foot rest. The block is bolted to the floor, with the bolt heads countersunk, and notched to form a socket for the heel. The angle of slope up toward the throttle should be such that the sole of the shoe rests flat on the block, when the accelerator is completely depressed.—A. L. Payne, Garfield, N. J.

### Large Jigs and Templates Painted Red for Identification

The annoyance of having large jigs and templates mistaken for commercial machine parts and being carted out of the shop was avoided, in a large plant, by giving them a coat of red paint. Because of their unwieldiness, these parts are ordinarily kept near the mechanics using them. The conspicuous red coloring identifies these special parts, and laborers are less likely to truck them away by error.—Joseph Plogmann, Cincinnati, Ohio.

### Pedal-Control Wire-Stripping Bench Tool

A tool that will be found useful, in a shop where electrical wiring is done, is a wire stripper which can be set to remove uniform lengths of the covering from the wire. The outfit is fitted on the bench, or table, near the edge, as shown, and the wire is fed in between the cutters, against an adjustable gauge. The operator presses on the pedal and gives the wire a slight turn, so as to cut the covering all around. It may then be removed easily. The set-screw adjustment provides for cutting various sizes of wire.

The detail construction of the cutters and gauge is shown at the right. The main frame is shaped from a strip of iron, and the cutters are of tool steel.

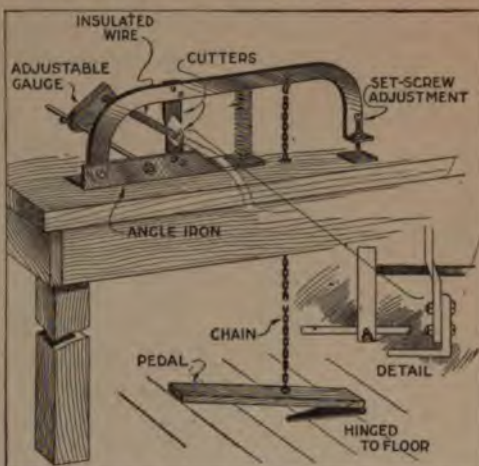

The Gauge is Set as Desired and the Ends of the Wire Thrust between the Cutters, Pressure being Applied on the Pedal

A coiled spring raises the cutter and frame, releasing the wire.—C. C. Spreen, Flint, Mich.

### Blowtorch with Flexible Tube for Work in Close Spaces

In various kinds of repair work, especially on automobiles, brazing and soldering must be done in places where it is difficult to use a blowtorch of the ordinary type, unless it is adapted especially for the job. Under these circumstances, a blowtorch of the usual type was fitted with a flexible tube, as shown, the burner being fastened at one end of it. By this means the flame could be directed on spots which it would otherwise not reach. The tube is quickly disconnected and kept with the torch for convenient use.—Earl Botten, Boscobel, Wis.



### Homemade Pistol Grip for Surveyors' Tape

The tape commonly used by surveyors is hard to hold, especially when the hands are cold. The sketch shows a pistol grip that was cut from a tree branch. It measures about  $\frac{3}{4}$  in. in diameter and is attached to the reel case by means of two strips of sheet metal,  $\frac{5}{8}$  in. wide. The strips are attached to

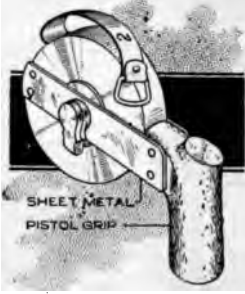

the case by rivets, which pass through the rim of the case, so that they are not in the way of the tape. Two rivets secure the strips to the handle. The grip is especially handy in unwinding or rolling the tape.—F. H. Linthicum, Annapolis, Md.

### Homemade Built-Up Liners for Linotype Machines

Having to set different bodies of type on the linotype machine, and being supplied with only one liner of the desired length, I made some liners which can be built up to various thicknesses, as required. I took a piece of brass rule of the desired thickness and length,



and ground it down to the height of the mold. Two slight projections were then made in the surface of the strip to fit into two holes, bored in the liner as shown in the sketch. By building up with several strips of suitable length, various thicknesses are provided, saving the expense of buying special liners for each size of type desired.—Frank B. Waltrip, Hopkinsville, Ky.

### Support for Garage "Free-Air" Hose at Curbing

A convenient support for the "free-air" hose of a garage was fashioned from a piece of pipe, and set into the concrete of the street curbing. The main standard is a pipe set vertically, with two horizontal hooks fixed near the upper end, on the sides of the pipe, to hold the hose. The support prevents the hose from falling in the gutter, where it may be damaged by vehicles, and also attracts attention to the garage and its "free-air" service. The cost of this device is trivial when compared with the advertising it gives.—Jos. Thalheimer, Jr., Phoenix, Ariz.

### Device for Making Bell Ends on Tubing

In making joints in brass and copper pipe lines, commonly used in oil and air-pipe lines, the sections are usually connected in a screw joint, or union, and one of the tube ends is formed into a "bell end." A tool for forming these bell ends uniformly and

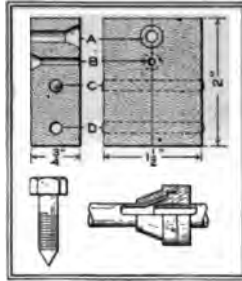

quickly is shown in the sketch. It consists of a metal plate,  $\frac{3}{4}$  by  $1\frac{1}{2}$  by 2 in. in size, and provided with countersunk holes for two or more standard sizes of tubing. The tube is inserted in the die A or B, depending on the size, and clamped in place, with the end to be shaped just flush with the surface on the side which is countersunk. A machine bolt, ground to the proper point, is used to spread the tube end in the countersunk hole. Pins, C and D, hold the two sections of the die in place while it is being clamped. The plain end of the tubing is fitted into the bell end, as detailed. The bell end is removed from the die by releasing the pins C and D.—D. C. Goff, Kenosha, Wisconsin.



of steel, soft enough to be easily worked, is most suitable for its construction.

### Old Cistern Remodeled as Storage Space

In one corner of a basement was a large cemented cistern, and as it was not used for its original purpose, the owner decided to make some other use of it. The cistern was cleaned out thoroughly, and a door opening was cut into it. A frame and door was fitted into the opening, and an electric light installed. The space was used as a storage for fuel, and proved quite practical.

### Sorting Hopper for Berries and Small Vegetables

Berries and small vegetables bring highest market prices when sorted according to quality and size. Ordinarily this is done by hand. A sorting hopper of the design illustrated saves much tedious work and sorts the product satisfactorily. The frame is built the same as an ordinary screen, the back and sides being of 8-in. boards. It should be about 3 ft. wide at the large end, and tapered to 15 in. This forms

a frame somewhat the shape of a crude rowboat. The joggle cam should be



Work That would Keep Several Persons Busy for Hours is Accomplished in a Few Minutes by the Machine

made of hard wood, while the slatted bottom may be of any material available. The distance between the slats is determined by the product to be sifted. Turning the crank rapidly vibrates the slatted section up and down, separating the large and small fruits and running them into different barrels.—L. B. Robbins, Harwich, Massachusetts.

### Forge of Concrete for Single or Multiple Use

One of the most recent uses of concrete is in the making of blacksmiths' forges. The multiple arrangement pictured has been in service for more than a year and has proved entirely satisfactory. A mixture of four parts gravel, two parts cement, and two of sand was



The Shop Equipped with Multiple Forges of Concrete Presents an Appearance of Neatness Heretofore Unobtainable

used. The forms for the legs and hearth were built first. That for the hearth was built onto the leg forms, and the form for the hood was built onto the hearth form. The top of the forms of the hood and hearth was left open in each case to permit pouring and troweling. The



washers and nuts preventing its being pulled off the table J. Parts N and O indicate structural details. The front-rank arm joints, E and F, extend parallel with the short cam surface and to the right of the front rank, thus avoiding the rear rank. In the latter, No. 2's pin passes through the curved guide slot L, at its extremity, X, while No. 3's pivot pin, S, which is longer than the others, is held in the cup of the holding spring C. No. 4 rests against the inner surface of the cam in the same relative position as in the illustration, and No. 1 is in prolongation of the line of the other three.

When the knob B is pushed toward the short guide rail, keeping the long side of the cam in contact with the long guide rail, the successive changes in the movement are executed, as shown in Figs. 2, 3, 4, and 5. The squad is in line in the new direction when the cam reaches the short guide rail, and is caused to step off in the new direction by a movement of the cam in that sense.

To make a right turn, the pin P, shown in Fig. 7, is removed from the table, and the movement is executed for one rank only by the cam T. The front rank of the squad is used, No. 1 being placed with its bolt R in the opening of the slot L, at U. The rank is placed in the extension of the long slot, and the cam T is placed with the oblique edge parallel with the oblique guide rail K, and with the adjacent

edge in contact with the line of men, as shown in position O, Fig. 6.

Movement of the cam parallel with the oblique guide rail until the long guide rail is reached completes the turn, as indicated by the successive movements in Fig. 6. The rank is caused to take up the full step by moving the cam along the long guide rail.

The execution of squad right by the machine is nearly perfect. By changing the number and spacing of the division points on the guide rails, the machine will satisfy a "six-count" advocate as well as the "four-count" faction, for which it is marked out. Right turn is not so accurate. No. 1 and No. 2 are approximately correct in their action, but Nos. 3 and 4 oblique are at too steep an angle and make the second oblique just before coming into the line, which is advancing at somewhat less than a half step. The movement, however, is sufficiently accurate to give a clear idea of the proper execution, and is an excellent illustration.

In both movements the machine may be operated fast or slow, or may be stopped in any position. Each man of a squad may watch the path of his corresponding "man" on the machine and is presented with a clearer idea of where he belongs at each instant than is obtainable from talks or sketches. In addition, the machine itself is interesting to the men, and aids to incite interest in the performance of the movement.

### Theft of Shovels Prevented by Chain and Padlock

On a large construction job requiring the use of many hand shovels, considerable annoyance was experienced in the repeated thefts of one or two shovels overnight. This was stopped by assembling all the shovels in one place at night, and running a strong chain through the D-handles, fastening the two ends of the chain with a reliable padlock, and attaching the entire lot to a heavy tool box.—Roy H. Poston, Flat River, Mo.

### Respirator Made of Cotton and Muslin

An excellent respirator may be made of a thick sheet of carded cotton wool placed between two pieces of muslin. For emergency use the material can be pieced or tied together suitably. Where a more substantial article is desired, for use in shops, buffing rooms, by janitors in sweeping dusty floors, etc., the cotton can be covered neatly in a strongly sewed mask, with tie ribbons at the back.—William A. Richmond Hill, N. Y.

### Drawings Superseded by Others Plainly and Promptly Marked

When a drawing for shop or construction use is superseded by another, the original should be plainly marked "Superseded," and the title, serial number, and other designations of the later drawing should also be marked on the first one. This safeguard takes only a few minutes' time, and may save costly errors by the issuance of the wrong drawing.—C. H. Post, Denver, Colo.

### Patching Teeth into Broken Gears

Costly gears, having one or several teeth stripped, may be repaired to render indefinite service by fitting new teeth as illustrated. A slot is first cut

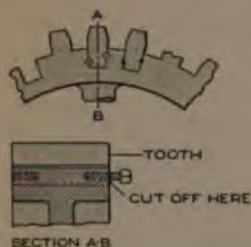

into the gear flange to remove all traces of the broken tooth, and a new tooth is fitted as indicated at AB. A cap screw, threaded in on either side of the new tooth and

cut off flush with the gear flange, precludes all possibility of the insert working out.

### Small Water-Supply Reservoir Built in Mountain Stream

Securing a supply of clean water from a stream at all times is satisfactorily accomplished by the following method: A part of the stream is chosen where there is a fall of at least 1 ft. in a distance of 30 ft. The water is then temporarily diverted, and a dam built across the channel. A clear-water delivery pipe is then installed as near the bottom as possible. A spillway should be provided large enough to take care of maximum overflow. The supply pipe should terminate several feet inside the wall, being plugged at the end. The water enters through a series of  $\frac{1}{4}$ -in. perforations along the pipe. A wooden framework covered

with coarse wire netting surrounds the intake end of the pipe. Over the framework and the bottom of the chan-



A Steady Flow of Water Free from Surface Dirt is Obtained through the Pipe

nel a layer of large stones is placed. The stones are covered with gravel or chippings, and then with a layer of sand. Clarification will depend upon the thickness of the uppermost surface.

### Door Knobs Make Convenient Handles for Bits

An excellent handle for boring bits, screwdrivers, and similar tools, for use in cramped places, is a discarded door knob. For occasional use it will be found satisfactory to use the knob without any alteration, simply inserting the bit into the socket and tightening with the screw. The bit has a tendency to wobble slightly, but otherwise is held securely. By beveling off the end of the hole in conformity with the shape of the bit shanks, or by filing off the shanks to an even thickness, a perfect fit is obtained.



after arriving at the neutral point. Electrical connection should be made from the scale and standard, through batteries, to the electromagnet.

The operation of the weighing machine is quite simple. For instance, if it is desired to weigh up a number of 10-lb. sacks of sugar, a 10-lb. weight

would be put on one scale pan. The other pan being directly below the bin door, the latter is opened until the catches engage. The instant the sugar balances the weight, the index pointer will make connection with the wire on the standard, and the door will drop, shutting off the supply of sugar.

### Signs on Idle Machinery Give Reasons for Delay in Production

Where there are a large number of machines in a department it is not an easy matter for the foreman to keep in



mind the exact reason why any one machine is idle. An idle machine means a decrease in production and a consequent lowering of efficiency of that department. A factory has adopted the

method indicated by the drawing, of placarding all machines, whenever shut down, with the reason for the delay in production. The signs are of metal, 8 in. long and 4 in. wide. If the material has been used up a "Stock" sign is placed on the machine. Other signs read, "Repairs," "Tools," "Operator," or as the circumstances may be. The superintendent, walking through the department, notes the signs and immediately takes the necessary action to put the machine bearing such a sign in operation.

### Protecting the Hands from Dirt and Grease on Engine Work

By applying soap to the hands before beginning work on an automobile, or other piece of machinery, the dirt and grease are easily removed. Work up a good soap lather on the hands and as far up on the arms as thought necessary. Allow the soap suds to dry. Then scratch the cake of soap with the finger nails, so that the soap is packed

tightly under the ends of the nails, and allow it to dry. The hands are protected by a film of soap that will not be removed easily unless they come in contact with water. When the work is finished the dirt can be washed off with very little scrubbing. This method is particularly good for those who do not care to wear gloves when working on machinery.

### Welding Mask Made from a Metal Bucket

A serviceable welding mask may be made in a few minutes from an ordinary metal bucket. One of 3-gal. capacity is the best size. A rectangular hole, 6 in. by 4 in. is cut in its side, as shown. Over the hole two pieces of colored glass, each 3½ in. by 4½ in., are placed, so



that the long edges will meet at the vertical center line of the hole. The two pieces should form an obtuse angle with each other so as to conform as nearly as possible to the curvature of the pail. The glasses are held in place by metal clips soldered inside the bucket. Several holes should be drilled in the bottom for ventilation. A hat, or cap, is worn to act as a pad for the head, the bucket being worn inverted and in such a position that the operator looks through the colored glass while welding.

Ⓒ In washing photographic prints, care should be taken that they are not creased, or the surface may be cracked.



### Novel Repair for Cracked Water Jacket on Engine

A cracked water jacket may be repaired satisfactorily as follows: Drill and tap a small hole at the end of the crack. Thread in a copper wire, or rod, and cut it off flush. Next drill another hole beside the first one, and close enough to it, so that the threads of the plug, screwed into it, will lap into the first plug. This process is repeated until the crack is filled. The heads of the plugs are then riveted, to close the small intervening spaces. With careful workmanship, this method will provide a water-tight repair that will give indefinite service.—Anthony Ottis, Bloomington, Ill.

### Cements for Pipe Joints

Cement for making screw joints in pipes steam-tight may be made from graphite and heavy cylinder oil. Just enough oil is mixed with the graphite to form a thick paste. A good cement for both water and steam pipes has this composition: Whiting, 4 lb.; fine yellow ocher, 10 lb.; ground litharge, 4 lb., and 1/2 lb. of hemp cut into fine particles. These ingredients are mixed thoroughly with linseed oil to form a paste, which is applied on the threads of the pipes and fittings. For ammonia piping, a cement made of litharge and glycerin is used. Sufficient glycerin is added to the litharge to form a putty. Only enough of this cement should be mixed to serve immediate needs, as it sets quickly. After having once set, it should not be disturbed.

### Cooling Large Bearings with Grounded Copper Wires

Large bronze, or babbitt, bearings are effectively reduced in temperature, and static electricity is abolished, by connecting a large copper wire from the bearing to the ground. The heat is radiated over the wire and much of it is lost in the air. That which reaches the ground is absorbed. If the ground

wire is placed in moist earth, cooling is all the more effective. The larger

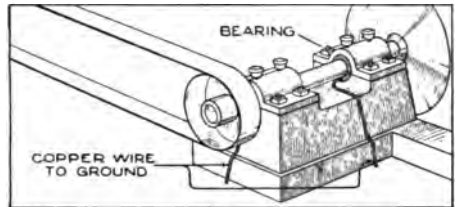
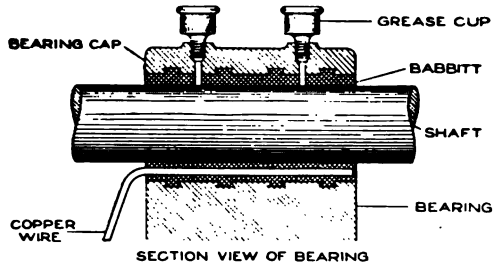

Heat Created by Friction and Static Electricity is Radiated from the Bearing by a Large Copper Wire

the diameter of the ground wire used, the faster will be the radiation of heat.

### Attachment Adapts Tachometer for Shafts without End Centers

Ascertaining the correct speed of a shaft that has no end center to accommodate the speed indicator is almost impossible without registering more or less slippage. To overcome this difficulty I turned a piece of pure gum rubber to the shape of a cone, 2 3/4 in. in diameter at the larger end and 4 in. long. I then hollowed out the latter end and fastened the small end to the shaft of the speed indicator with a tin clamp and wing nut. To determine the speed of a shaft the cone is pressed

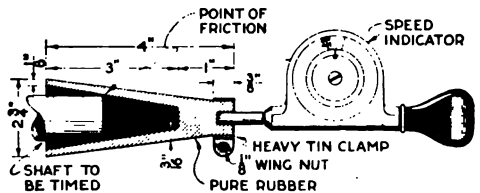

The Rubber Cone Grips the Shaft Securely and Eliminates Slippage

over the end until it holds without slipping. The cone will fit any shaft from 1/2 in. to 2 1/2 in.—P. P. Avery, Garfield, New Jersey.

### Rubber Tube Protects Ignition Distributor of Auto Engine

When motoring in heavy rains, or where streams must be forded, the

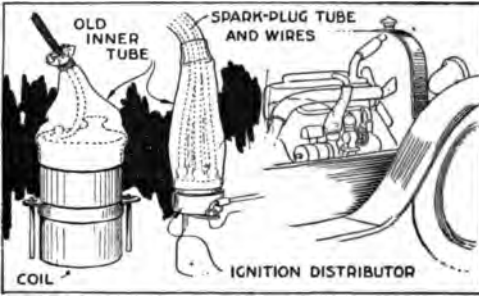

The Distributor and Terminal Wires are Protected against Moisture by a Section of an Old Inner Tube

ignition of a car is frequently put out of commission by water getting under the engine bonnet and drenching the distributor. This difficulty may be avoided and the motor fully protected against short-circuiting, from anything short of an actual immersion in water, by capping the distributor with a piece of old inner tube, as indicated. The wires are removed while the rubber is stretched over the distributor and the end of the ignition manifold. Once in place and tied securely, all moisture is excluded.

### Machine Nuts Set on Rods with Belting as Wrench

A large stock of iron rods, with threaded sections at each end, were to be fitted with two nuts at each threaded part. The nuts were to be turned down firmly preparatory to shipping the rods. To save time, I started the nuts on the threads by hand, and then set them quickly by the use of an old piece of belting, 3 ft. long. The rod was gripped in a vise, and the belting looped over the nuts near one end of it. By drawing the belting quickly around the nuts they were turned up snugly with a single motion of the belting. To have done this work with a wrench would have taken much more time.—H. G. Corbin, St. Paul, Minn.

### Micrometer Used as Indicator on Work in Chuck

A micrometer can often be used to true up finished work in the lathe chuck when an indicator is not at hand. Open the jaws of the micrometer part way and clamp the frame to the tool rest with blocks of wood. Run the carriage in until the end of the micrometer handle is near the work. Slowly revolve the chuck by hand, frequently setting the handle against the work, and observe the reading to determine the eccentricity of the piece. When the reading is the same at various points on the circumference of the piece, it is centered. This method can also be used in setting up work in a milling machine or shaper.—H. H. Raymond, Newburyport, Mass.

### Disk-Bearing Stand for Balancing Rotary Machine Parts

Balancing flywheels, pulleys, and similar parts, is simplified by the use of a disk-bearing stand, as illustrated. The disk-bearing surface allows the part to rotate with so little friction that the heavy portion to be trued

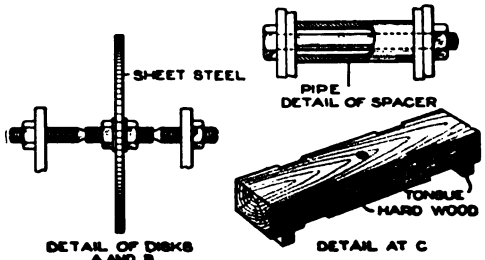
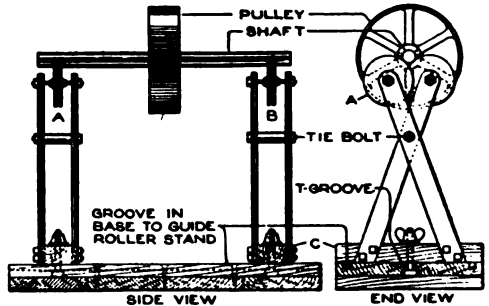

The Parts to be Balanced Rotate without Friction, Sending the Heaviest Portion to the Bottom

immediately goes to the bottom. Material is then removed from the heavy side until an accurate balance is obtained. The disk rollers are carried on conical bearings, supported by a steel framework mounted on a base of well-seasoned hard wood. The distance between the disk rollers is adjustable for accommodation to various lengths of shafts.

**Revolving Cone for Sharpening All Sizes of Gouges**

Cone-shaped emery wheels are not always provided, even in pattern or cabinet shops, and frequently I have been at a loss for a means of sharpening various sizes of gouges. Accordingly

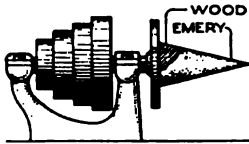

I have improvised a satisfactory cone-grinding tool from wood, glue, and emery. I screwed

a piece of maple to a small faceplate and turned it down to a cone, 3 in. in diameter at the large end, and 6½ in. long. A coat of cold glue was then applied to the cone, and after being allowed to dry for a few minutes, it was sprinkled with medium emery. Once the glue was dry the device worked quite as well as a cone-shaped emery wheel. Several such cones were made up and sprinkled with different grades of emery to suit various grinding jobs. When the cutting surface is worn out, it is only necessary to resurface the cone by the application of more glue and emery. The size of the cone may be altered to suit requirements.—R. L. Martine, Shelton, Connecticut.

**Counterweight Returns Block and Tackle to Loading Point**

Where loads are carried one way on an incline track with a block and tackle on a carriage, the entire mechanism may be returned to the loading point automatically by a cable and counterweight, connected as shown in the illustration. The weight should be

just heavy enough to return the empty carriage. The brake is provided to

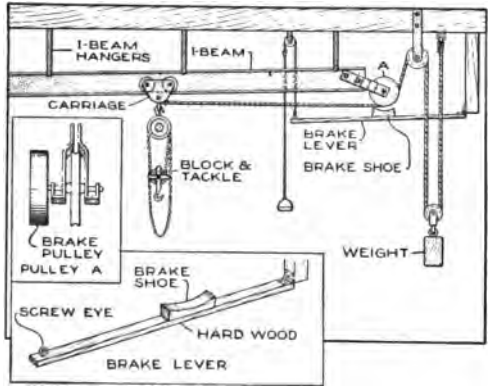

With the Tackle and Carriage Returning Automatically When Unloaded, Work is Accomplished Rapidly

check the speed of the loaded tackle and carriage as may be desired.

**Device for Tightening Bolts Quickly with Brace**

In assembling stoves and many other varieties of work where large numbers of small bolts are used a brace-attachment tool as indicated in the sketch is a great saver of time and labor. It is only necessary to start the bolts with the fingers, after which they are held and tightened practically by a single operation of the tool. A hexagon

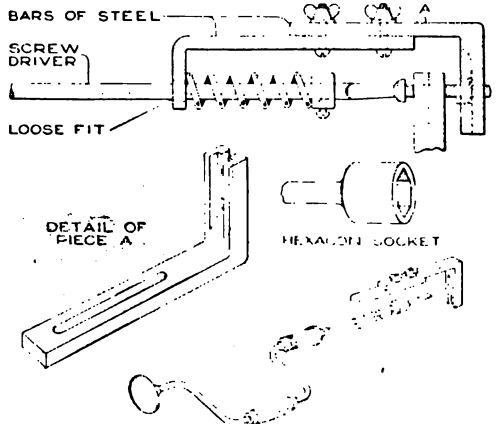

The End of the Tool Holds the Nut While the Bolt is Sent Home with a Few Turns of the Brace

socket to be inserted in the brace permits the same application with head-cap screws.



### Tool for Machining Bosses and Hubs on Drill Press

Bosses and hubs for all manner of light machinery may be machined on a

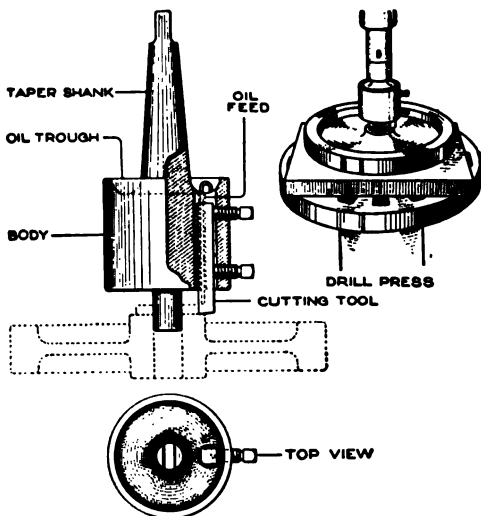

Equipped with This Tool, the Drill Press Machines Bosses and Hubs Accurately

drill press by the adoption of a taper-shank cutting tool as shown in the illustration. Best results are accomplished in this work if the press is operated at its lowest speed. For machining bronze, aluminum, or soft castings, no oil is needed, but for any work harder than the best grades of gray iron a continuous oil bath through the top of the tool is essential to retaining a keen edge.

### Carpet Pad for Wood Planes Saves Frequent Sharpening

The home woodworker, who has not trained himself to be especially careful of his edge tools, finds his planes nick quickly. This is often caused by laying the plane hurriedly on the bench among other tools. A plan that will save much resharpening, and will keep the edge on the plane, is to provide a  $\frac{7}{8}$ -in. board, about 10 in. wide and 14 in. long, covered with a carpet pad, on which the plane can be set. This pad may be on the bench top, or arranged as a shelf.—S. C. Lange, Detroit, Mich.

### Removing Old Babbitt Metal from Bearing Boxes

Usually most of the babbitt metal can be removed from a bearing box with a cold chisel and hammer. If this procedure is not feasible, the box may be placed in a forge fire, and the babbitt melted out. The melting method is undesirable because of the probability of losing part of the metal. Where the bearing box is small the metal may sometimes be melted by the use of a blowtorch, and permitted to drop from the box into a suitable tray arranged underneath.—L. S. Sherman, Chicago, Ill.

### Device for Plugging Ends of Pipes under Pressure Tests

In testing pipes, or tubing, for leaks with either water or air pressure, an end plug that may be applied or removed almost instantly is desirable. Such a plug, with a piece of steam hose as the stoppage member, may be fashioned by using the threaded combination indicated in the sketch. After being inserted in the pipe the hose is expanded with a few turns of the handle.

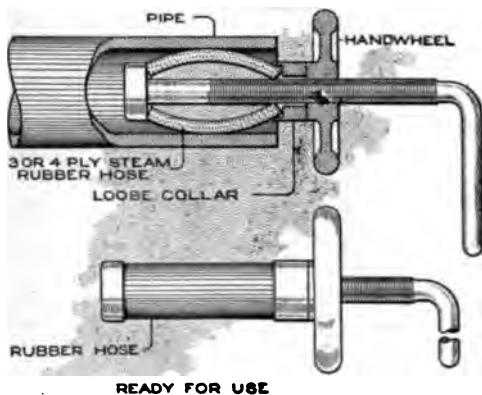

A Couple of Turns of the Lever and Handwheel Plugs the Pipe Securely

Once placed, it forms a contact sufficiently tight for normal test pressures.

Interior corners of patterns are rounded off with fillets because a sharp interior corner in a casting weakens it.

### Serial-Number Identifications on Working Drawings Save Time

When there are several drawings on separate sheets made in connection with a drafting job, every sheet should bear the serial number, title, date, and index, or filing, number. The best method is to place this information on the sheet as soon as the work is begun. This simplifies checking up the drawings, and makes it possible to file them so that persons unfamiliar with the drawings or subject can easily locate the sketches of the various features covered by the design, or working drawing.—William B. Johnson, Baltimore, Md.

### Simple Belt Shifter with Spring Lock

An ordinary belt shifter can be provided with a locking device, to prevent the belt from working back on the loose pulley and stopping the machine, by fitting the shifter with the arrangement shown. The method can be applied to shifters in various positions. The original shift lever is shown with the belt hook attached to it. The handle C is pivoted, with a screw, on the old shifter. An upright is fitted with a block, B, and a key, A. The key fits into notches, about 1 in. wide and  $\frac{1}{2}$  in. deep, cut at points slightly farther apart than the width of the belt. A section of clock spring on block B holds the handle against the key A. A spiral spring aids in keeping the belt hook in position over the loose pulley when the lock is not being used, temporarily. The shifting of the belt, and locking it securely is easily accomplished.—Robert B. Binns, Boston, Massachusetts.

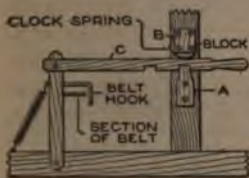

Polishes intended for brass, or other metal, should not be used on lacquered work, unless the lacquer, which is removed, is replaced by a new coating.

### Truck with Lifting Platform and Cradle for Auto Motors

The truck illustrated is designed for use in handling automobile motors in

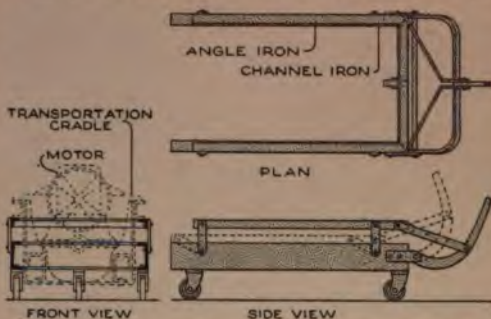

The Dotted Lines Indicate the Functioning of the Lifting Platform. The Plan View Shows Structural Details

garages and assembling plants. It consists of a main body of channel iron bent into the shape of a large "U." Three casters are set on it, one at the base of the U, and the others at each of the ends. A U-shaped bar is set on four small toggle levers that are fastened to this bar and the main frame. The bar is operated by a long lever attached at one end to the main frame and connected by a free-working lever to the small bar.

To operate the truck it is slid under the engine-cradle side channels. Then by pulling down on the long lever the small U-bar is raised on the toggle and lifts the cradle. The linkage is so arranged that it holds the weight up while the truck is wheeled about by the same handle that raised it. In the sketch the truck is shown with the

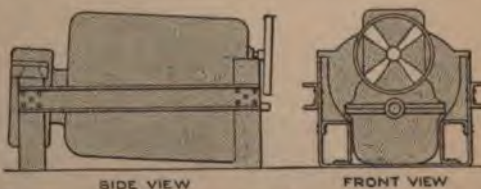

With This Truck Automobile Motors are Installed or Removed with a Minimum of Effort

U-bar raised. The dotted lines in the two upper sketches indicate the position the platform takes when raised and lowered.

### Using the Drill Press as a Wood-Turning Lathe

In shops unprovided with facilities for turning wood, there is frequently demand for work requiring a fairly accurate cylindrical outline. Such work may be turned out on a drill press. Two stout pins are driven in the ends as nearly in the center as possible. One of the pins is secured in the

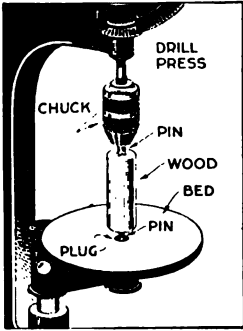

chuck while the lower one is given a bearing in one of the holes of the drill table. A suitable tool rest is provided by an ordinary machine clamp, while an old bastard file, ground off, sharpened, and provided with a handle, makes a satisfactory cutting tool. The size of work that may be turned out in this manner is limited only by the size and adjustments of the drill press. —J. S. Hagans, Toledo, Ohio.

### Method of Making Copper Rivets from Annealed Wire

After finding it impossible to make good copper rivets in a vise, I contrived the method illustrated in the sketch. In a piece of steel, about  $\frac{1}{4}$  in. thick, a hole is drilled, the size of the stock from which the rivets are to be made. A single cut should then be made with a hacksaw from

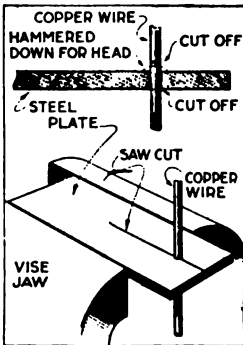

the end of the piece of steel to a point an inch or more beyond the hole. When the steel is put in a vise it tightens up on the stock inserted in the hole,

holding it firmly while the top of the rivet is headed down and the other end cut off. Rivets of uniform size and of any desired length may be made by making a form of the required dimensions.—Melvin Snyder, Duluth, Minnesota.

### Adjustable Valve-Spring Tension Adapts Motorcycle for High Speed

Powerful exhaust-valve springs are essential when high speed is demanded of a motorcycle, but such springs make the motor difficult to start and unsatisfactory when throttled down.

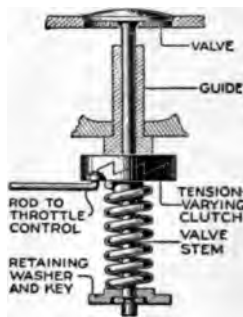

By providing his machine with a ratchet tension-varying clutch, as illustrated, a motorcyclist has secured a compromise between the touring and high-speed types of mount. The

ratchet is connected with the throttle control so that, as the speed of the motor is increased, the tension of the exhaust-valve springs is increased by compressing them slightly.—E. F. Hallock, Brooklyn, N. Y.

### Cement Mixture for Patching Dents in Boat Hulls

Red lead and Portland cement mixed, half and half, with oil to a putty consistency, form an excellent patching material for holes, up to the size of a silver dollar, in boat bottoms. The edge of the hole should be dry, rough, and pegged with small galvanized nails projecting slightly to reinforce the cement. The patch hardens slowly, hence it is best to do this work in winter, or while the boat is out of commission. For a quick repair, cement and water is fairly satisfactory. It is then unnecessary to have the wood dry and the boat can be used, without danger to the patch, in about two days.—Hayes Bigelow, Brattleboro, Vt.



# An Automatic Weighing Machine Electrically Operated

By K. M. COGGESHALL

**A**N automatic weighing machine has a large range of usefulness, and anyone of fair mechanical ability may construct such an apparatus to meet his particular requirements. The device illustrated is suited to every need and capacity, since the principle of operation remains the same. Grain dealers will find in it a rapid method of measuring grain; on a smaller scale the retail store can easily weigh out a hundred sacks of sugar or coffee for the stock supply in a few minutes, while even shops and factories will find in it many applications.

The mechanism consists of an electrically controlled drop trap and an electric switch operated by a scale balance. Two vertical runways for the door, as shown in the sketch, should be built at the mouth of the chute from the supply bin. These runways must be absolutely parallel so that the door will slide up and down them with minimum friction. A catch, B, should be cut from a strip of  $\frac{1}{4}$ -in. sheet iron and then screwed to the top of the door in the position shown. A knob, K, may be fastened to the door if desired, to aid in lifting it.

The pivoted lever A should be made of soft sheet iron, at least  $\frac{1}{4}$  in. thick. The layout of this part is shown in the detail sketch. It may be cut out with a hacksaw, or cold chisel, and finished with a file. The square end is then bent on the dotted line, as shown, so that the flap may act as an armature for the

magnet. A hole is drilled in the middle of the lower half of the lever A for a

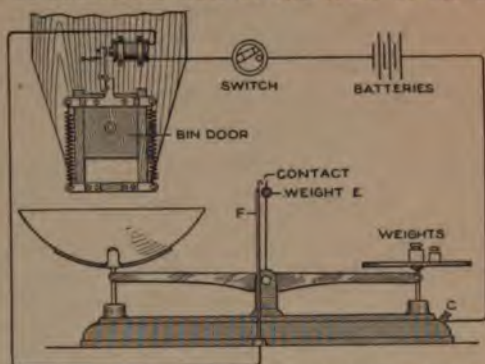

The Supply of Material is Checked Automatically Whenever the Balance Exceeds the Specified Weight for Which the Scale is Set. The Springs Close the Door When the Electrical Contact Releases the Latch

pivot. The armature should then be placed in such a position on the bin that the catch on the door C will engage the catch on the lever. A spring helps hold the armature in position.

An electromagnet should be wound with No. 18 gauge magnet wire. The size of this magnet will, of course, depend on the conditions and weight of the door drop, but after a few trials the correct number of turns of wire will be easily ascertained. The magnet should be secured in such a position that its core will be opposite, and within  $\frac{3}{32}$  in. of, the armature, as shown in the sketch. It will then be seen that, if a current of electricity passes through the coil on the magnet, the armature will be attracted, releasing the catch B so that the springs D pull the door shut.

The electric current is controlled by a scale switch. For small weighing machines, a balance scale may be used, as shown in the sketch. A lead ball, or other heavy weight, should be fastened to the upright index finger E, so that the balance action will be snappy. Next, a metal standard, F, should be fastened to a wooden base insulated from the scale. A wire should project from near the top of the standard and across the path of the index pointer. It must be adjusted so that the index pointer will touch the wire immediately

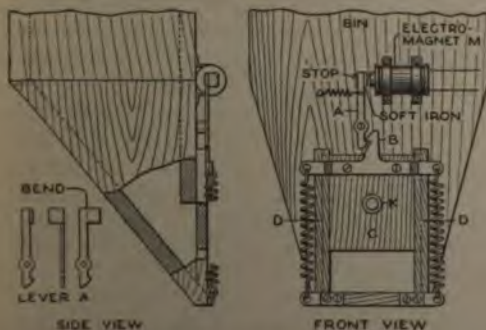

Diagram Showing Wiring and Details of Construction of the Electrically Operated Weighing Machine; The Point of Electrical Contact may be Adjusted to Any Designated Weight

after arriving at the neutral point. Electrical connection should be made from the scale and standard, through batteries, to the electromagnet.

The operation of the weighing machine is quite simple. For instance, if it is desired to weigh up a number of 10-lb. sacks of sugar, a 10-lb. weight

would be put on one scale pan. The other pan being directly below the bin door, the latter is opened until the catches engage. The instant the sugar balances the weight, the index pointer will make connection with the wire on the standard, and the door will drop, shutting off the supply of sugar.

### Signs on Idle Machinery Give Reasons for Delay in Production

Where there are a large number of machines in a department it is not an easy matter for the foreman to keep in mind the exact reason why any one machine is idle. An idle machine means a decrease in production and a consequent lowering of efficiency of that department. A factory has adopted the



method indicated by the drawing, of placarding all machines, whenever shut down, with the reason for the delay in production. The signs are of metal, 8 in. long and 4 in. wide. If the material has been used up a "Stock" sign is placed on the machine. Other signs read, "Repairs," "Tools," "Operator," or as the circumstances may be. The superintendent, walking through the department, notes the signs and immediately takes the necessary action to put the machine bearing such a sign in operation.

### Protecting the Hands from Dirt and Grease on Engine Work

By applying soap to the hands before beginning work on an automobile, or other piece of machinery, the dirt and grease are easily removed. Work up a good soap lather on the hands and as far up on the arms as thought necessary. Allow the soap suds to dry. Then scratch the cake of soap with the finger nails, so that the soap is packed

tightly under the ends of the nails, and allow it to dry. The hands are protected by a film of soap that will not be removed easily unless they come in contact with water. When the work is finished the dirt can be washed off with very little scrubbing. This method is particularly good for those who do not care to wear gloves when working on machinery.

### Welding Mask Made from a Metal Bucket

A serviceable welding mask may be made in a few minutes from an ordinary metal bucket. One of 3-gal. capacity is the best size. A rectangular hole, 6 in. by 4 in. is cut in its side, as shown. Over the hole two pieces of colored glass, each 3½ in. by 4½ in., are placed, so



that the long edges will meet at the vertical center line of the hole. The two pieces should form an obtuse angle with each other so as to conform as nearly as possible to the curvature of the pail. The glasses are held in place by metal clips soldered inside the bucket. Several holes should be drilled in the bottom for ventilation. A hat, or cap, is worn to act as a pad for the head, the bucket being worn inverted and in such a position that the operator looks through the colored glass while welding.

(In washing photographic prints, care should be taken that they are not creased, or the surface may be



### Novel Repair for Cracked Water Jacket on Engine

A cracked water jacket may be repaired satisfactorily as follows: Drill and tap a small hole at the end of the crack. Thread in a copper wire, or rod, and cut it off flush. Next drill another hole beside the first one, and close enough to it, so that the threads of the plug, screwed into it, will lap into the first plug. This process is repeated until the crack is filled. The heads of the plugs are then riveted, to close the small intervening spaces. With careful workmanship, this method will provide a water-tight repair that will give indefinite service.—Anthony Ottis, Bloomington, Ill.

### Cements for Pipe Joints

Cement for making screw joints in pipes steam-tight may be made from graphite and heavy cylinder oil. Just enough oil is mixed with the graphite to form a thick paste. A good cement for both water and steam pipes has this composition: Whiting, 4 lb.; fine yellow ocher, 10 lb.; ground litharge, 4 lb., and  $\frac{1}{2}$  lb. of hemp cut into fine particles. These ingredients are mixed thoroughly with linseed oil to form a paste, which is applied on the threads of the pipes and fittings. For ammonia piping, a cement made of litharge and glycerin is used. Sufficient glycerin is added to the litharge to form a putty. Only enough of this cement should be mixed to serve immediate needs, as it sets quickly. After having once set, it should not be disturbed.

### Cooling Large Bearings with Grounded Copper Wires

Large bronze, or babbitt, bearings are effectively reduced in temperature, and static electricity is abolished, by connecting a large copper wire from the bearing to the ground. The heat is radiated over the wire and much of it is lost in the air. That which reaches the ground is absorbed. If the ground

wire is placed in moist earth, cooling is all the more effective. The larger

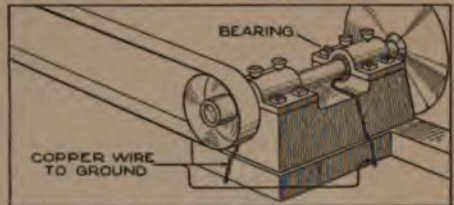
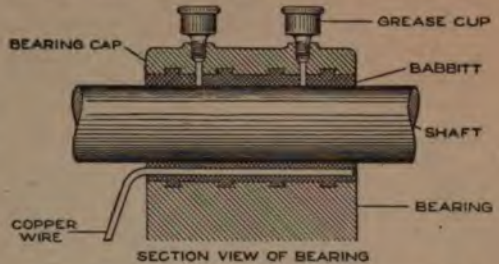

Heat Created by Friction and Static Electricity is Radiated from the Bearing by a Large Copper Wire

the diameter of the ground wire used, the faster will be the radiation of heat.

### Attachment Adapts Tachometer for Shafts without End Centers

Ascertaining the correct speed of a shaft that has no end center to accommodate the speed indicator is almost impossible without registering more or less slippage. To overcome this difficulty I turned a piece of pure gum rubber to the shape of a cone,  $2\frac{3}{4}$  in. in diameter at the larger end and 4 in. long. I then hollowed out the latter end and fastened the small end to the shaft of the speed indicator with a tin clamp and wing nut. To determine the speed of a shaft the cone is pressed

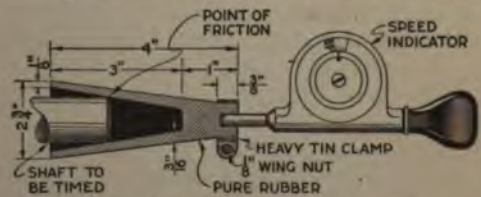

The Rubber Cone Grips the Shaft Securely and Eliminates Slippage

over the end until it holds without slipping. The cone will fit any shaft from  $\frac{1}{2}$  in. to  $2\frac{1}{2}$  in.—P. P. Avery, Garfield, New Jersey.



or if great power is demanded, the size of the paddles should be increased according to requirements. The crank

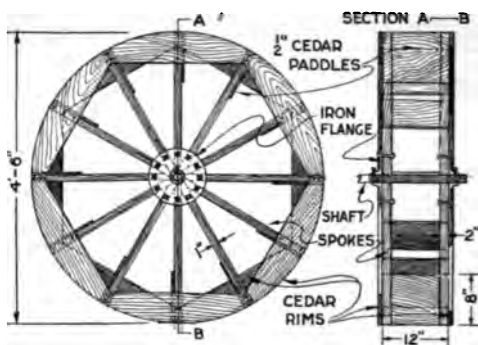

Construction Details of the Paddle Wheels: The Metal Fittings Are Few and Simple. They may be Made in the Home Workshop or Purchased at Any Machinery Supply House

in the center of the shaft will, of course, be half the stroke of the pump piston in length. By elevating the shaft bearings the necessary clearance is provided for the crank without the necessity of making a depression in an otherwise solid and level deck.

There are a number of pumps that might be adapted to this use, but the most satisfactory one, and the one that will meet most requirements, is the usual tank pump which is ordinarily operated by means of a vertical lever. Such a pump is obtainable at any well-stocked supply house. The pump illustrated has a capacity of 1,000 gal., that is, it will throw 1,000 gal. of water an hour to a height of 20 ft., with the paddle wheels turning 100 revolutions a minute. Details of the pump, and the paddles that will be needed to operate it, are, of course, decided by the conditions under which the system is to be used.

The supply hose should be supported by a stake or stakes driven in the bed of the stream, or by slings from any convenient overhanging limbs. Careful attention should also be given to the barge moorings. There should be plenty of line to allow for fluctuations of the water level, and the stability of the barge will be increased if the line is attached as shown in the illustration.

Once well placed, the system will require little attention. If there is any doubt as to the tightness of the hull, an excellent precaution is to fit an auxiliary intake of gas pipe leading to the floor of the hull. This should be provided with a shut-off valve, which is opened if it becomes necessary to bail out the boat.

### An Economical Type Gauge

Printers not possessing a standard type-high gauge will find a convenient and accurate substitute in an old screw composing stick. By setting the knee of the stick to a large type the gauge may be used as a gauge, the etching entering far enough into the jaws to insure accuracy. A mark should be made at the point where the type sticks fast to the jaws, and this mark used to gauge the cut. The stick may also be used as a caliper.—George Parke, Mount Morris, Ill.

### Blocks for Starting Taps Squarely

Cutting female threads is often difficult because of the tendency of the tap to take a bad start. By the use of a steel tap guide, as illustrated, faulty starting of the threading tool is impossible. The tap is held in correct

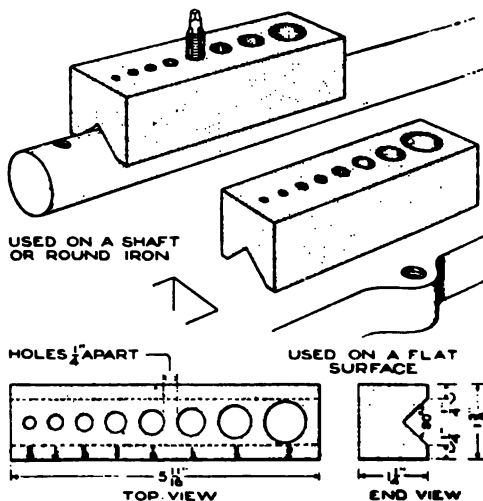

If the First Few Threads are Cut Properly the Others Follow Their Lead

alinement until the first three or four threads are cut, after which the guide may be removed. This tool is especially useful in tapping threads in shafting, or any other round surfaced stock.

### Tin Guards for Edges of Chisels

When wood chisels are properly guarded, much time can be saved in resharpener because the edges are not nicked from contact with other tools, on the bench or in the tool box. Metal guards, as shown in the sketch, were found superior to leather ones. They can be made easily from light tin, or sheet metal, cut to the shape indicated and folded on the dotted lines.

BEND ON DOTTED LINE



upper portion of the guard must clamp the chisel closely, so that the cutting edge cannot be forced against the guard under ordinary conditions.—H. A. Trester, Milwaukee, Wis.

### Air-Bellows Device Protects Sand-Blast Operators

One of the most effective as well as easily contrived devices for protecting sand-blast workers from breathing sand-laden air, is the hoop and bellows combination illustrated. It is very light, being made of heavy muslin, or other close-woven cloth. The hoops are made of light reeds, and the first eight of them are hung by means of rings to an overhead bar so that they can be drawn back and forth. There should be sufficient slack to enable the workman to move freely. A glass window is fitted into a light steel frame through which the operator is able to observe his work. The lower section is provided with a draw string which is pulled up until the cloth fits snugly about the neck. Thus equipped one is

fully protected against the sand, and breathes only the air that is brought

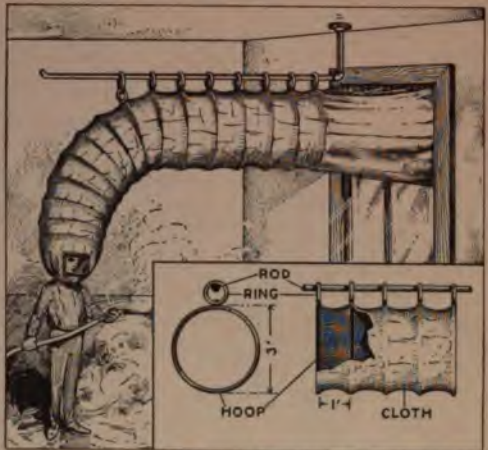

The Cloth Bellows Protects the Sand-Blast Operator and Gives Him Ample Freedom of Movement

in from the outside.—Alfred J. Bell, Detroit, Mich.

### Towel-Rack Improvement Keeps Articles in Place

An ordinary metal towel rack is usually a source of annoyance because the towels slip off onto the floor unless carefully hung or the ends balanced. This difficulty may be overcome by soldering a row of copper studs along the top of the rail, as illustrated. A piece of heavy wire should be used. It is first soldered to the rail and then snipped off to  $\frac{1}{4}$ -in. lengths. A file is used to dress the points off slightly. If the studs are placed about 1 in. apart over the length of the rail, every towel will remain in the exact position in

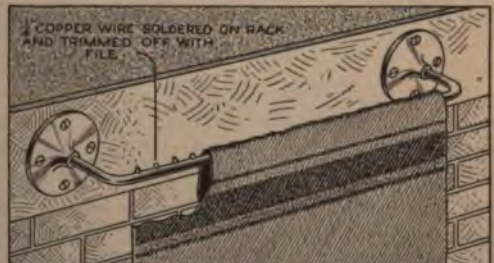

A Row of Studs Soldered along the Top of the Rack Prevents the Towels from Slipping Off

which it is hung. A coat of nickel-plate will improve its appearance.

### Hook Supports for Threading and Fitting Long Pipes

Plumbers and steamfitters frequently experience difficulty when working on long lengths of pipe because of the

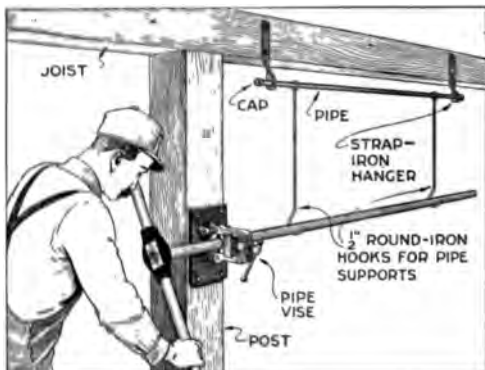

The End of a Long Pipe is Supported by the Hooks When the Other End is Placed in the Pipe Vise for Threading or Fitting

tendency of the long end to sag and strain the pipe vise. By providing a set of hooks, as shown in the illustration, the longest pipe may be held in the vise in an absolutely horizontal position. It will be noted that these hooks are swung on a length of pipe which is held in two straps of iron bolted overhead. Ordinary pipe caps are fitted to the ends of the supporting pipe to retain it in its fastenings. This device is invaluable for shop use, and it is not so bulky but that it may be thrown into the truck or wagon and moved from job to job.—Ross A. Williamson, Memphis, Tenn.

### Preventing Casehardening in Dressing Circular Saws

In a small establishment, when hand-filed woodworking saws were sent out to be gummed on an emery wheel, they came back so casehardened as to be very difficult to file at first. Finally a saw sharpener was found, who gummed them without the casehardening. His method was to go around the saw in the usual manner, then go around again once or twice, just touching each tooth enough to remove the

outer surface, but not enough to leave a heated surface. In finishing, he imitated the action of high-class automatic filing machines, and no casehardened surface remained on the finished saw.—J. E. McCormack, Haliburton, Ont., Canada.

### Lubricating Bolt of a Ball Thrust on a Torque Rod

The bolt carrying the ball thrust of the torque rod on my automobile had no lubricating means provided, so the thrust housing was continually jammed, and consequently could not move when the rod gave under the load. I decided to make this bolt self-lubricating and did so in the following manner:

The head of the bolt was first cut off, after which a deep  $\frac{1}{4}$ -in. hole was drilled into the bolt, as shown. Two small  $\frac{1}{16}$ -in. holes were next drilled at right angles to the large hole. The grease-cup head of an old spring-shackle bolt was fastened to the headless bolt, and a  $\frac{1}{16}$ -in. steel washer placed next to it. Ordinary white lead was smeared over the threaded projection of the grease cup to insure a permanent fit. A constant flow of grease

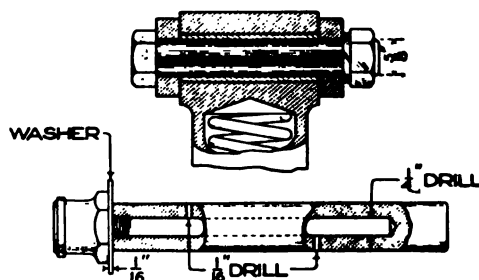
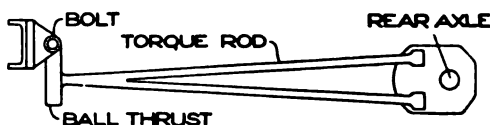

Applying a Grease Cup to a Bolt on the Torque-Rod Ball Thrust of an Automobile

was provided to the bearing and all the trouble eliminated. The resulting decrease in wear was also appreciable.—L. Kline, Chicago, Ill.



### Etching a Hole through Hardened Steel

When it is desired to cut a hole through hardened steel, which turns the edge of ordinary tools, a good substitute is to etch the hole through. Cover the steel with melted beeswax; when thoroughly coated and cold, make a hole in the wax with a fine-pointed needle, or other tool, the size of the hole required. Put strong nitric acid upon it; after an hour rinse it and apply more acid, repeating the process until the hole is cut as desired.—William A. Lorence, Richmond Hill, N. Y.

### Method of Protecting Terminals from Moisture

Where electric wires are exposed to the weather and run downward to a transformer, or other instrument, trouble is frequently experienced, because the water that runs down the wire seeps in at the terminals, causing short circuits and other damage.



This may be prevented by making a loop in the wires as shown in the sketch. The moisture will then run down the wire and drip off at the base of the loop. Motorists whose cars are in use in all weather will find this a useful kink if applied to spark-plug wires that are in the habit of giving trouble.

### Ink-Bottle Stopper Lifter Saves Draftsman's Time

India ink dries so rapidly that, if the bottle is not kept corked between dip-pings, the ink quickly becomes cloudy and useless. I have overcome this difficulty and am saved the annoyance of removing the stopper for every inking of the pen by contriving an inkwell, as indicated in the illustration. The

device is made almost entirely of hard wood, and the few metal fittings it contains are obtainable in any shop scrap heap. With it the ink is protected from the air at all times, and one hand



A Slight Pressure of the Hand Brings the Inking Quill into Position

only is required for inking the pen.—George A. Luers, Washington, D. C.

### Conical Points for Engine Bolts Simplify Motorcycle Repairs

After a motorcycle engine has been removed from the frame there is difficulty in replacing it because the crank-case bolt holes do not line up with the holes in the lugs of the frame. This is avoided and much valuable time saved by fitting the engine bolts with a removable conical head, as illustrated. A hole is drilled in the end of each bolt to a depth of  $\frac{1}{4}$  in., and is threaded with a female thread. The conical head is then turned on the lathe and provided with a male thread to fit into the socket of the threaded end of the bolt. The base of the conical head, being exactly the same size as the body of the bolt, is attached and driven through the parts without the slightest danger of the external threads of the bolt being injured. When the bolt is pounded through as far as it



The Conical Steel Head Attached to the Engine Bolts Enables the Motorcycle Repairman to Fasten a Motor in the Frame Regardless of the Alignment of the Bolt Holes

will go the head is removed and attached to the next bolt.—J. A., London, England.

### Using the Drill Press as a Wood-Turning Lathe

In shops unprovided with facilities for turning wood, there is frequently demand for work requiring a fairly accurate cylindrical outline. Such work may be turned out on a drill press. Two stout pins are driven in the ends as nearly in the center as possible. One of the pins is secured in the

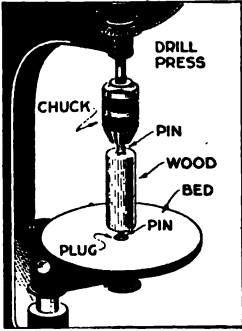

chuck while the lower one is given a bearing in one of the holes of the drill table. A suitable tool rest is provided by an ordinary machine clamp, while an old bastard file, ground off, sharpened, and provided with a handle, makes a satisfactory cutting tool. The size of work that may be turned out in this manner is limited only by the size and adjustments of the drill press. —J. S. Hagans, Toledo, Ohio.

### Method of Making Copper Rivets from Annealed Wire

After finding it impossible to make good copper rivets in a vise, I contrived the method illustrated in the sketch. In a piece of steel, about  $\frac{1}{4}$  in. thick, a hole is drilled, the size of the stock from which the rivets are to be made. A single cut should then be made with a hacksaw from

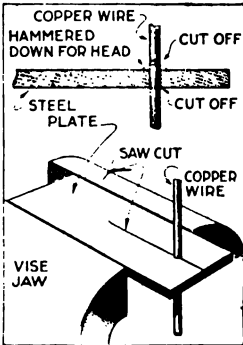

the end of the piece of steel to a point an inch or more beyond the hole. When the steel is put in a vise it tightens up on the stock inserted in the hole,

holding it firmly while the top of the rivet is headed down and the other end cut off. Rivets of uniform size and of any desired length may be made by making a form of the required dimensions.—Melvin Snyder, Duluth, Minnesota.

### Adjustable Valve-Spring Tension Adapts Motorcycle for High Speed

Powerful exhaust-valve springs are essential when high speed is demanded of a motorcycle, but such springs make the motor difficult to start and unsatisfactory when throttled down. By providing his machine with a ratchet tension-varying clutch, as illustrated, a motorcyclist has secured a compromise between the touring and high-speed types of mount. The

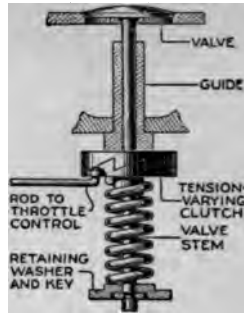

ratchet is connected with the throttle control so that, as the speed of the motor is increased, the tension of the exhaust-valve springs is increased by compressing them slightly.—E. F. Hallock, Brooklyn, N. Y.

### Cement Mixture for Patching Dents in Boat Hulls

Red lead and Portland cement mixed, half and half, with oil to a putty consistency, form an excellent patching material for holes, up to the size of a silver dollar, in boat bottoms. The edge of the hole should be dry, rough, and pegged with small galvanized nails projecting slightly to reinforce the cement. The patch hardens slowly, hence it is best to do this work in winter, or while the boat is out of commission. For a quick repair, cement and water is fairly satisfactory. It is then unnecessary to have the wood dry and the boat can be used, without danger to the patch, in about two days.—Hayes Bigelow, Brattleboro



taken to have the circle as near perfect as possible; otherwise the wheel will not run true. The mixture used should be one part Portland cement to five parts of clean, fine sand.

The wheel should be cast around the shaft upon which it is to be used, and great care must be used to have the shaft exactly in the center when the concrete is poured. Two holes are drilled in the shaft about a quarter of an inch apart and at right angles with each other, into which are driven steel rods, about 8 in. in length. These rods will be gripped by the concrete and hold the wheel and shaft together as if they were one piece. This is important, inasmuch as there is a heavy strain on the wheel, and a breaking fly-wheel is as dangerous as an exploding gun barrel.

Care must also be used to set the shaft square with the face of the wheel so that it will run true. A square with a long blade should be applied all around the shaft, and the shaft shifted until it is as accurately placed as possible. No matter how carefully the mold has been set for the outer edge, it should be gauged as to its distance from the shaft when the latter has been set. If the shaft is out of center, the wheel will wobble, causing violent vibration. After being completed and set in place, the surface of the wheel can be greatly improved by the application of a coat of good belt dressing, rubbed well into the pores and the surplus removed.—Kinsley Greene, Cliffside, N. J.

### Locomotive-Apron Holder Aids Quick Coupling

Delays and inconvenience are frequently caused in coupling and uncoupling locomotives to and from the tender because the apron drops down below its horizontal position. This may be prevented by the installation of the holding device shown in the sketch. It consists of two clamps of the size and shape illustrated. Each clamp has a setscrew for tightening it on the apron for safety. Attached to

the clamps are  $16\frac{1}{4}$ -in. lengths of  $\frac{5}{32}$ -in. chain, which hook at the other end to the cab handholds. The parts are

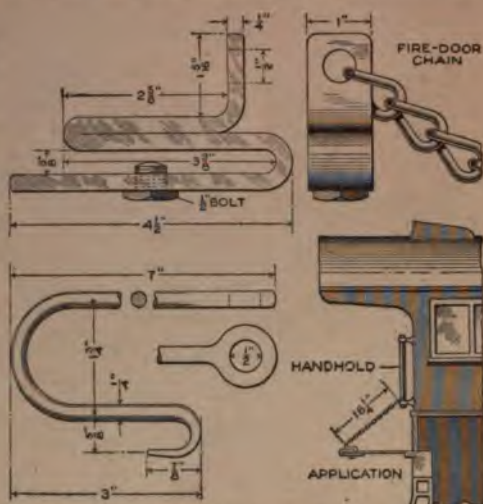

Details of the Locomotive-Apron Holder with Sketch Showing the Manner in Which It Supports the Heavy Part While the Engine is being Coupled or Uncoupled

inexpensive to make, and besides saving much time and aggravation, will prevent many injuries to fingers.

### Wooden Miter Box with Many Uses

Handling a considerable amount of mitered work, with double angles and odd joints, made necessary a miter box in which these various cuts could be made readily. In working out this problem the result was a homemade wooden miter box, which does every service of an ordinary, expensive metal and wood machine, and much other



View of the Miter Box in Use, Showing the Adjustable Guide and the Slotted Uprights

work not possible on the usual type of miter box. It was built largely of wood, as shown in the photographs, and detailed in the working drawing. The base was made of 1-in. hard wood, sup-



ported on cleats. At the back of the base are mounted two vertical supports, slotted to receive the sliding pieces which are hinged to the piece that covers the work being sawed. The

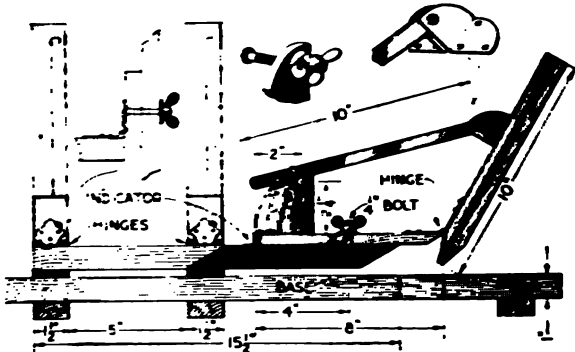

Details of the Construction, Showing the Clamping and Pivotal Features of the Saw Guide and Gauge

work is placed on the base, back against the uprights, and the cover piece, which supports the adjustable gauge and guide, is placed over it, the proper adjustment being made at the wing nuts on the uprights.

Adjustment for the various angles on the horizontal surface is made by pivoting the saw guide around its center, and clamping it at the wing nut. The adjustment for angles of cut from the vertical is made by means of the hinged saw guide and the clamping bar at the back of the guide. This bar is made of a strip of iron, pivoted at its upper end between two galvanized-iron angles. Its lower end rests on a washer cut to receive it, as detailed, and is clamped firmly by means of the wing nut. The range of adjust-



Under View of the Cover Piece and the Guide, and Specimen Cuts

ment, as is evident from the detailed drawing, covers a wide angle, and can even be extended by enlarging some of the parts.

## Testing Knife-Switch Contact Blades

It is important that knife-switch blades, especially the large ones, should make good contact in the jaws. A poor contact will cause the switch to heat and produce corrosion that will eventually destroy the blade. Any thin, hard material may be used for making a "feeler," by the use of which one may determine the condition of a contact. A piece of mica,  $\frac{3}{8}$  in. wide and .003 in. thick, or a piece of sheet steel of the same dimensions, is satisfactory. To use this tool it is inserted between the jaw and switch blade at different points. If it can be

pushed in readily the contact is poor. This may be corrected by light hammer blows on the sides of the jaws. This repair is only temporary. To make a perfect contact, the switch should be ground in with vaseline and fine pumice.—R. L. Berge, St. Louis, Missouri.

## Balancing Rotating Machine Parts by Drilling

In spite of careful machine work, rotors made in a shop where there was no machine for balancing machine parts precisely were found to be slightly out of balance. This was remedied by mounting the rotors on a pair of parallels, having knife-edges. After the light side had been determined, a small hole was drilled in it, and a pin inserted. Washers were put on the pins until a balance resulted. The amount of metal to be removed from the opposite side by drilling small holes was thus determined accurately, and the exact point at which this could be done handily was also found.—Clarence Anderson, Worcester, Mass.

Where numerous nuts are used on a machine, it is desirable to have them fitted by a single wrench, or at least that they are of standard sizes.

### Lead Mallet Head Cast Securely on Pipe Handle

Most machine shops have use for a babbitt, or lead, mallet, which may be used on polished metal parts. A good form of such a mallet is that having the head cast around a pipe handle, the end of the pipe being spread to lock it in the lead. A pattern for the head is made of wood, on a lathe. A suitable length of 1-in. diameter gas pipe serves as a handle. A mold for the head is made in sand, in the usual manner, and the pipe placed in position, in the mold. The metal is then poured in, imbedding the handle firmly.

### A Vise and Breast Drill Used as a Substitute Drill Press

Having to drill a number of holes in pieces of  $\frac{1}{2}$ -in. steel with no drill

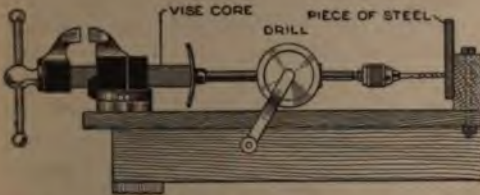

By Combining the Vise and Breast Drill, the Action of a Horizontal Boring Machine was Secured

press available, the work was tedious. The necessity of bearing heavily against the brace of a breast drill made frequent rests unavoidable. To overcome the difficulty, a block of wood was bolted to the bench, 18 in. from the vise, which happened to be of the swivel type. The piece of steel to be drilled was then brought into place in front of this. The point of the drill was properly centered and its arm brace at the other end was placed against the moving core of the vise, as shown in the sketch. By turning the drill with the right hand and tightening the vise with the left as the drill penetrated the steel, a constant pressure was easily maintained. The holes were drilled rapidly and with comparatively little labor.—Russell Wilson, Detroit, Mich.

### Loud-Sounding Air Whistle for Camp or Motorboat

At slight expense and with little work a portable air whistle, suitable

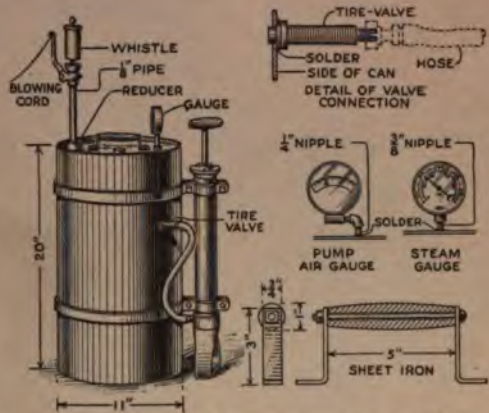

Showing Details of Construction of Siren Made of Kerosene Drum, Tire Pump and Gauge, and Brass Whistle

for installation in a motorboat, and for various other purposes, may be made by using a kerosene drum as a pressure tank. An ordinary foot pump is clamped to the cylinder with iron straps, and a tire valve soldered in a hole drilled near by. A pressure gauge of some kind and a brass whistle, 3 in. long, are soldered in the top of the can.—P. P. Avery, Garfield, N. J.

### Old Hacksaw Blades Converted into Electricians' Knives

Knives of a type suitable for many uses in electrical work, and especially for trimming core cells, may be made by grinding old hacksaw blades and providing them with a handle, as illustrated. Blades of 1-in. width prove the most practical. A file holder makes the best handle, but a corncob will

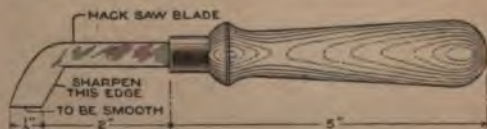

For Scraping Insulation, and for Many Other Electrical Uses, Hacksaw-Blade Knives Are Useful

serve the purpose quite well.—R. R. Dilenschneider, Fremont, Ohio.

or if great power is demanded, the size of the paddles should be increased according to requirements. The crank

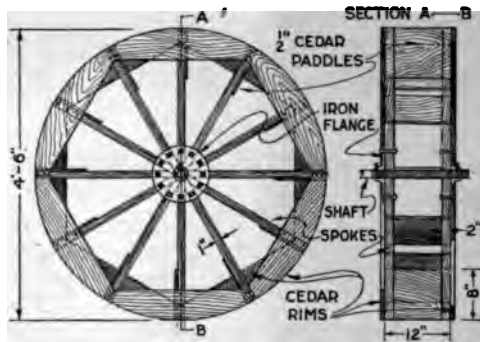

Construction Details of the Paddle Wheels: The Metal Fittings Are Few and Simple. They may be Made in the Home Workshop or Purchased at Any Machinery Supply House

in the center of the shaft will, of course, be half the stroke of the pump piston in length. By elevating the shaft bearings the necessary clearance is provided for the crank without the necessity of making a depression in an otherwise solid and level deck.

There are a number of pumps that might be adapted to this use, but the most satisfactory one, and the one that will meet most requirements, is the usual tank pump which is ordinarily operated by means of a vertical lever. Such a pump is obtainable at any well-stocked supply house. The pump illustrated has a capacity of 1,000 gal., that is, it will throw 1,000 gal. of water an hour to a height of 20 ft., with the paddle wheels turning 100 revolutions a minute. Details of the pump, and the paddles that will be needed to operate it, are, of course, decided by the conditions under which the system is to be used.

The supply hose should be supported by a stake or stakes driven in the bed of the stream, or by slings from any convenient overhanging limbs. Careful attention should also be given to the barge moorings. There should be plenty of line to allow for fluctuations of the water level, and the stability of the barge will be increased if the line is attached as shown in the illustration.

Once well placed, the system will require little attention. If there is any doubt as to the tightness of the hull, an excellent precaution is to fit an auxiliary intake of gas pipe leading to the floor of the hull. This should be provided with a shut-off valve, which is opened if it becomes necessary to bail out the boat.

### An Economical Type Gauge

Printers not possessing a standard type-high gauge will find a convenient and accurate substitute in an old screw composing stick. By setting the knee of the stick to a large type the stick may be used as a gauge, the etching entering far enough into the jaws to insure accuracy. A mark should be made at the point where the type sticks fast to the jaws, and this mark used to gauge the cut. The stick may also be used as a caliper.—George Parke, Mount Morris, Ill.

### Blocks for Starting Taps Squarely

Cutting female threads is often difficult because of the tendency of the tap to take a bad start. By the use of a steel tap guide, as illustrated, faulty starting of the threading tool is impossible. The tap is held in correc-

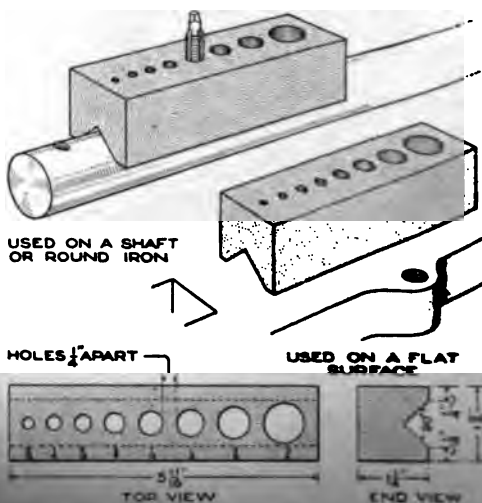

If the First Few Threads are Cut Properly the Others Follow Their Lead



**Washing Off Pencil Tracings after Blueprinting Saves Cloth**

A goodly saving in drafting supplies may be effected by making drawings of a temporary nature, such as foundation plans, bills of material, preliminary surveys, etc., on tracing cloth with a soft pencil. After the required number of blueprints have been made, the drawing is washed off the cloth entirely with gasoline, and as soon as it is dry, this taking only a few minutes, the cloth is ready for the next drawing. A piece of tracing cloth used in this manner, if carefully handled, is good for 15 or 20 drawings. Use a soft rag or piece of cotton waste to apply the gasoline.—Roy H. Poston, Flat River, Mo.

**Center Punches Made from Old Rat-Tail Files**

Serviceable center punches may be made from worn-out and discarded rat-tail files by grinding off the ends and shaping them on an emery wheel. After being ground, the upper end should be softened slightly by heating to a dull red and allowing it to cool slowly. The intermediate file surface should not be removed, inasmuch as it aids the workman in holding the punch.

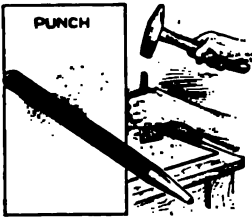

**Half-Round Blocks Aid in Clamping Beveled-End Work**

A few short pieces of half-round hard wood of various sizes are useful for beveled-end clamping operations, as indicated in the sketch. They may be used in connection with all work where the bevel is slight. These blocks are also useful in cases where wide work has to be clamped under heavy pressure and the bar is sprung. The half-round blocks automatically adjust

themselves to the deviation and transmit the pressure uniformly. Where a

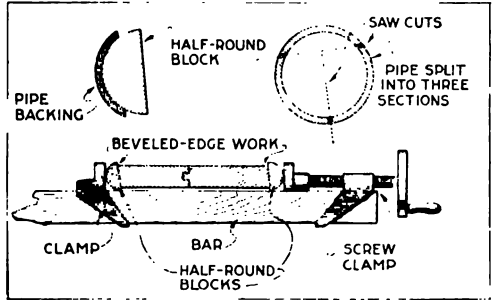

The Blocks of Half-Round Hard Wood Make Beveled-End Work Easy to Clamp

great deal of such clamping is done, or the work is heavy, it is often desirable to make half-round blocks with a steel back. These may be formed by splitting a short piece of pipe into three sections and gluing a piece of half-round block into each section. Convenient lengths for these blocks are 3, 4, and 6 in. The pipe backs should be about an inch shorter than these lengths.

**Pulley Arrangement Is Helpful in Operating Double Doors**

To keep the sliding double doors of a garage, or barn, tightly closed and also to enable a person to open both of them simultaneously, the pulley-and-weight system explained by the drawing has been found satisfactory. When wishing to enter or leave the building without opening both doors, the one at the right should be used, for it slides easily and does not

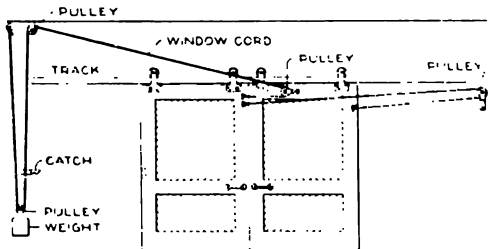

By the Use of Pulleys and Weights Both Doors are Opened or Closed Simultaneously and with Little Effort

actuate its companion.—Robert L. Cook, Madisonville, Ky.

**How to Repair Broken Slate Instrument Panel**

By using an angle iron

In the case of a slate instrument panel which has been broken into several pieces, the following method may be used to repair it.

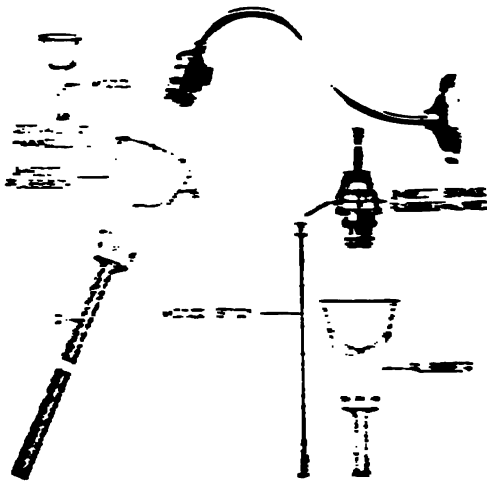

The angle iron shown in the drawing is a 1/2 in. wide by 1/2 in. thick. The hole in the slate is 1/2 in. in diameter. The hook is made of 1/2 in. diameter wire. The hole in the slate is 1/2 in. in diameter. The hook is made of 1/2 in. diameter wire. The hole in the slate is 1/2 in. in diameter. The hook is made of 1/2 in. diameter wire.

When a slate instrument panel is broken into several pieces, it is in the way of the instruments and the danger of the instruments being damaged is increased. The following method of repair is simple and does not require much of the original cost. The handle may be made from any piece of wood and of the length desired. It is shaped at one end as shown in the detail sketch. The handle is made to engage the globe when the instrument is in operation. It is made from any heavy sheet rubber. With these tools, the globe may be raised up, or on a drop cord, may be removed or replaced with little effort, and with the usual danger of such work wholly lacking.—I. C. McDonnell, Toronto, Ontario, Canada.

**Broken Slate Instrument Panel Repaired with Angle Iron**

After an expensive slate instrument panel had been drilled for a large number of instruments, thus adding to its original cost, the panel was accidentally thrown to the floor, breaking

After the inside. A satisfactory repair was made by bolting angle irons to the ends of the panel and across the break. This made the panel as strong and secure as if unbroken. After the work was finished and polished, the break was hardly noticeable.

**Magnetic Tack Hammer Is Electrically Operated**

Increasing difficulty in driving small nails with an ordinary magnetic hammer because it would allow of several ticks when tacks being driven. I constructed the electrically operated hammer illustrated. I first procured a piece of soft steel and turned it as shown in the diagram. The ends were drilled in the shape of rings enough to admit a 1/2 in. gauge magnet wire, and the magnet was then wound. Two slots were cut in the handle to accommodate the wire leading from the binding back part to the end of the handle, to the magnet coil. I used a 2-in. length of brass spring stock to form the switch. This was attached to the handle by small screws. The handle and magnet coil of the finished hammer were wound with insulating tape and given a coat of shellac. Two dry cells and a length of flexible cord supply the current, which may be ap-

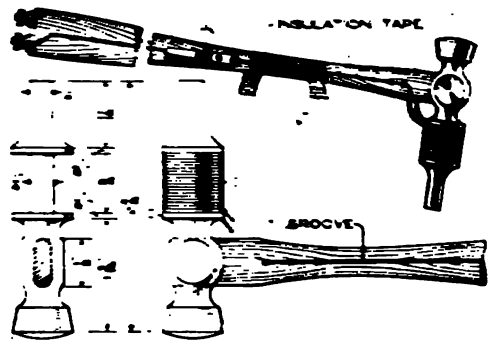

The Electric Tack Hammer Is Invaluable for Many Uses Because It may be Instantly Magnetized or Demagnetized as Desired

plied or broken as desired by the use of the switch.—Marion J. Teachout, Martville, N. Y.

### Etching a Hole through Hardened Steel

When it is desired to cut a hole through hardened steel, which turns the edge of ordinary tools, a good substitute is to etch the hole through. Cover the steel with melted beeswax; when thoroughly coated and cold, make a hole in the wax with a fine-pointed needle, or other tool, the size of the hole required. Put strong nitric acid upon it; after an hour rinse it and apply more acid, repeating the process until the hole is cut as desired.—William A. Lorence, Richmond Hill, N. Y.

### Method of Protecting Terminals from Moisture

Where electric wires are exposed to the weather and run downward to a transformer, or other instrument, trouble is frequently experienced, because the water that runs down the wire seeps in at the terminals, causing short circuits and other damage.



This may be prevented by making a loop in the wires as shown in the sketch. The moisture will then run down the wire and drip off at the base of the loop. Motorists whose cars are in use in all weather will find this a useful kink if applied to spark-plug wires that are in the habit of giving trouble.

### Ink-Bottle Stopper Lifter Saves Draftsman's Time

India ink dries so rapidly that, if the bottle is not kept corked between dip-pings, the ink quickly becomes cloudy and useless. I have overcome this difficulty and am saved the annoyance of removing the stopper for every inking of the pen by contriving an inkwell, as indicated in the illustration. The

device is made almost entirely of hard wood, and the few metal fittings it contains are obtainable in any shop scrap heap. With it the ink is protected from the air at all times, and one hand



A Slight Pressure of the Hand Brings the Inking Quill into Position

only is required for inking the pen.—George A. Luers, Washington, D. C.

### Conical Points for Engine Bolts Simplify Motorcycle Repairs

After a motorcycle engine has been removed from the frame there is difficulty in replacing it because the crank-case bolt holes do not line up with the holes in the lugs of the frame. This is avoided and much valuable time saved by fitting the engine bolts with a removable conical head, as illustrated. A hole is drilled in the end of each bolt to a depth of  $\frac{1}{4}$  in., and is threaded with a female thread. The conical head is then turned on the lathe and provided with a male thread to fit into the socket of the threaded end of the bolt. The base of the conical head, being exactly the same size as the body of the bolt, is attached and driven through the parts without the slightest danger of the external threads of the bolt being injured. When the bolt is pounded through as far as it



The Conical Steel Head Attached to the Engine Bolts Enables the Motorcycle Repairman to Fasten a Motor in the Frame Regardless of the Alignment of the Bolt Holes

will go the head is removed and attached to the next bolt.—J. A., London, England.



ing the end of the shaft. The diameter of the opening in the end of the driving block should be large enough to insert the hand if parts are dropped inside.

### Shield on Creeper Protects Face When Working under Auto

To protect one's face when working beneath a motor car, a transparent

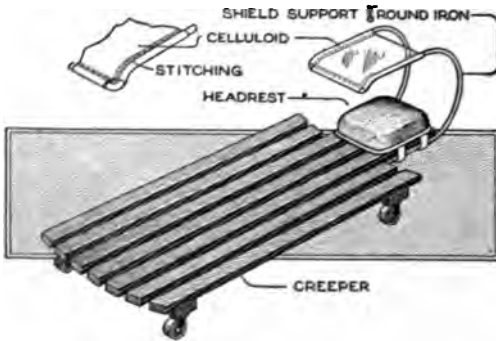

The Frame, Made by Bending an Iron Rod, Supports a Celluloid Shield above the Headrest of the Creeper

shield may be provided above the headrest of a creeper by attaching a sheet of celluloid to an iron frame. The support is made by bending a rod and clamping its free ends to extended slats. The celluloid should be sewed to strips of canvas bound around the rod.

### Pattern Maker's Boring Tool for Small, Deep Work

When a pattern maker has small, accurate pieces of work calling for the boring of deep holes of small diameter, it is usually more or less difficult because the necessary tools are not at

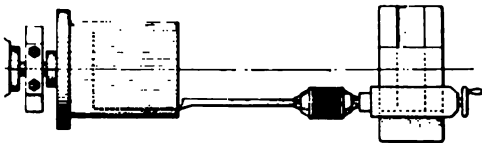

For Deep, Accurate Work in Pattern Making This Lathe Cutting Tool in Many Instances Fulfills All Requirements

hand. Most pattern shops are provided with a lathe having a tailstock that may be shifted to the right or left

of the lathe bed. By providing a tool as illustrated, and placing it in the drill stock, small, deep, and accurate work may be accomplished. The tool is made from a piece of  $\frac{3}{8}$ -in. tool steel. It is heated and hammered flat, then ground and retempered. When held in the tailstock it will cut a  $\frac{1}{4}$ -in. hole, which may be enlarged to any desired size by shifting the position of the tool. Several such tools when made up in different sizes will enable one to meet almost every requirement of deep cutting work.

### Gas Pipe Guides Nails Driven in Close Quarters

In millwrighting, as in general building-repair work, it is sometimes necessary to drive nails in cramped places where they cannot readily be held with the hand to insure their being driven straight. In

such cases, take a short piece of gas piping, a  $\frac{3}{8}$ -in. size, for example, and get a slightly longer length of steel, or iron, rod that will slip loosely into the piping. Then drop the nail into the pipe, sliding the rod behind it, and use the pipe to guide the nail while hammering on the end of the rod, as shown.

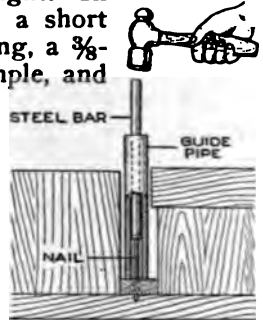

### Mending Torn Tracings

Tracings that have become worn, frayed by use, or torn, may be mended, without destroying their usefulness in making legible prints, by pasting a piece of unused tracing cloth, or tracing paper, at the damaged place. The patch should be pasted on the dull side of the tracing cloth, with library paste. The weave of the tracing-cloth patch should be set to correspond with the weave of the tracing, or serious buckling may result at the patched part of the drawing.



## A Sanitary Hog House of Saw-Tooth Design

By HERBERT A. SHEARER

**A**BUNDANCE of fresh air and sunshine is one of the most important requisites in the care of little pigs

and brood sows, and in recent years many excellent types of hog houses have been designed with this consideration in view. Some of these are of very expensive construction, with windows carefully placed and at scientifically correct angles to admit the direct rays of sunlight into the nests during March and April and again in September and October, the usual farrowing months in the latitude of central United States.

One of the most practical of these hog houses is the saw-tooth design illustrated. It is cheaper to build than most of the others, and with its three rows of windows, placed just above the nests, the desired results are obtained most effectively. The rows of windows are so arranged that through

the greater portion of the day the house is flooded with sunlight, yet it will be noticed that the structure of

the roof is such that the heat stored within during the day is not rapidly radiated at night. This is a desirable feature, since extremes of temperature should be avoided wherever possible.

The perspective illustration shows, in a general way, the exterior construction of the building. In the floor plan it will be noticed that the center alley is made to serve as a feeding

room, transfer alley, and place for the drainage gutters. It also forms a passage through the structure from end to end.

The concrete floors in the pens slope slightly from the sides of the house to the alley, to aid cleaning. Overflow from the running water in the troughs is kept out of the nests by reason of the gutters in the alley being lower.

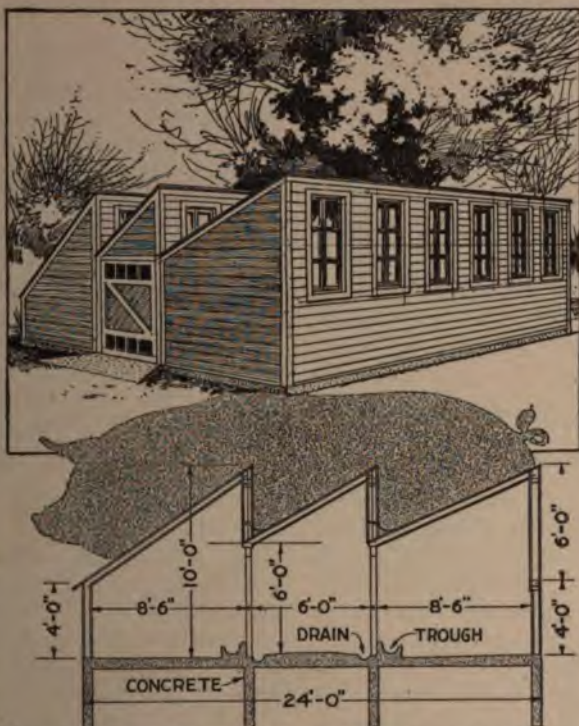

General View and Cross Section of the Saw-Tooth Hog House, Showing Its Exterior Construction and the Provisions for Sanitation That are Made in the Interior: The Dimensions are Given as Details for Building



ported on cleats. At the back of the base are mounted two vertical supports, slotted to receive the sliding pieces which are hinged to the piece that covers the work being sawed. The

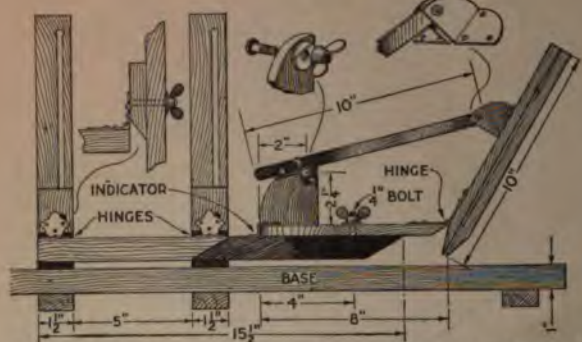

Details of the Construction, Showing the Clamping and Pivotal Features of the Saw Guide and Gauge

work is placed on the base, back against the uprights, and the cover piece, which supports the adjustable gauge and guide, is placed over it, the proper adjustment being made at the wing nuts on the uprights.

Adjustment for the various angles on the horizontal surface is made by pivoting the saw guide around its center, and clamping it at the wing nut. The adjustment for angles of cut from the vertical is made by means of the hinged saw guide and the clamping bar at the back of the guide. This bar is made of a strip of iron, pivoted at its upper end between two galvanized-iron angles. Its lower end rests on a washer cut to receive it, as detailed, and is clamped firmly by means of the wing nut. The range of adjust-



Under View of the Cover Piece and the Guide, and Specimen Cuts

ment, as is evident from the detailed drawing, covers a wide angle, and can even be extended by enlarging some of the parts.

### Testing Knife-Switch Contact Blades

It is important that knife-switch blades, especially the large ones, should make good contact in the jaws. A poor contact will cause the switch to heat and produce corrosion that will eventually destroy the blade. Any thin, hard material may be used for making a "feeler," by the use of which one may determine the condition of a contact. A piece of mica,  $\frac{3}{8}$  in. wide and .003 in. thick, or a piece of sheet steel of the same dimensions, is satisfactory. To use this tool it is inserted between the jaw and switch blade at different points. If it can be pushed in readily the contact is poor. This may be corrected by light hammer blows on the sides of the jaws. This repair is only temporary. To make a perfect contact, the switch should be ground in with vaseline and fine pumice.—R. L. Berge, St. Louis, Missouri.

### Balancing Rotating Machine Parts by Drilling

In spite of careful machine work, rotors made in a shop where there was no machine for balancing machine parts precisely were found to be slightly out of balance. This was remedied by mounting the rotors on a pair of parallels, having knife-edges. After the light side had been determined, a small hole was drilled in it, and a pin inserted. Washers were put on the pins until a balance resulted. The amount of metal to be removed from the opposite side by drilling small holes was thus determined accurately, and the exact point at which this could be done handily was also found.—Clarence Anderson, Worcester, Mass.

Where numerous nuts are used on a machine, it is desirable to have them fitted by a single wrench, or at least that they are of standard sizes.



### Lead Mallet Head Cast Securely on Pipe Handle

Most machine shops have use for a babbitt, or lead, mallet, which may be used on polished metal parts. A good form of such a mallet is that having the head cast around a pipe handle, the end of the pipe being spread to lock it in the lead. A pattern for the head is made of wood, on a lathe. A suitable length of 1-in. diameter gas pipe serves as a handle. A mold for the head is made in sand, in the usual manner, and the pipe placed in position, in the mold. The metal is then poured in, imbedding the handle firmly.

### A Vise and Breast Drill Used as a Substitute Drill Press

Having to drill a number of holes in pieces of  $\frac{1}{2}$ -in. steel with no drill

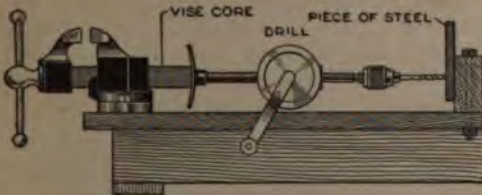

By Combining the Vise and Breast Drill, the Action of a Horizontal Boring Machine was Secured

press available, the work was tedious. The necessity of bearing heavily against the brace of a breast drill made frequent rests unavoidable. To overcome the difficulty, a block of wood was bolted to the bench, 18 in. from the vise, which happened to be of the swivel type. The piece of steel to be drilled was then brought into place in front of this. The point of the drill was properly centered and its arm brace at the other end was placed against the moving core of the vise, as shown in the sketch. By turning the drill with the right hand and tightening the vise with the left as the drill penetrated the steel, a constant pressure was easily maintained. The holes were drilled rapidly and with comparatively little labor.—Russell Wilson, Detroit, Mich.

### Loud-Sounding Air Whistle for Camp or Motorboat

At slight expense and with little work a portable air whistle, suitable

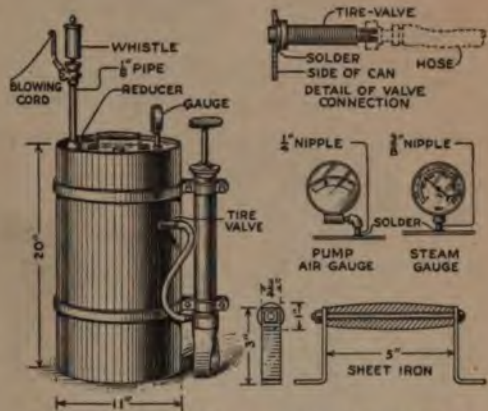

Showing Details of Construction of Siren Made of Kerosene Drum, Tire Pump and Gauge, and Brass Whistle

for installation in a motorboat, and for various other purposes, may be made by using a kerosene drum as a pressure tank. An ordinary foot pump is clamped to the cylinder with iron straps, and a tire valve soldered in a hole drilled near by. A pressure gauge of some kind and a brass whistle, 3 in. long, are soldered in the top of the can.—P. P. Avery, Garfield, N. J.

### Old Hacksaw Blades Converted into Electricians' Knives

Knives of a type suitable for many uses in electrical work, and especially for trimming core cells, may be made by grinding old hacksaw blades and providing them with a handle, as illustrated. Blades of 1-in. width prove the most practical. A file holder makes the best handle, but a corncob will



For Scraping Insulation, and for Many Other Electrical Uses, Hacksaw-Blade Knives Are Useful

serve the purpose quite well.—R. R. Dilenschneider, Fremont, Ohio.

## Head-Fitting and Bar-Fastening Repair for Motorcycle

While nearing the finish of an otherwise successful record-breaking trial, the handlebars were torn from my ma-



This Improved Fastening for a Pair of Motorcycle Handlebars was Made in Less Than an Hour. It Proved to Be Stronger Than the Original

chine in a spill. Inspection showed that the expander bolt was broken, and that there was apparently no way to fasten the bars on again without securing new parts. To obtain these from the nearest agency would have occasioned a disastrous delay. I rolled the machine to a blacksmith shop that happened to be near, and there effected the temporary repair illustrated. A steel plate, of the size and shape illustrated, was made and fitted over the fork stem and the end of the fork-reinforcement stem. This plate was locked in place between the head-cup fittings and the fork-stem reinforcement

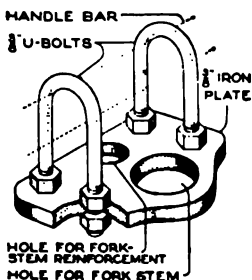

nuts. Two  $\frac{3}{8}$ -in. U-bolts were fitted into the steel plate and tightened up after the handlebars had been passed through them, the handlebar headpost having been previously driven down into the fork stem as far as it would go. The improvised repair was

completed in less than an hour. It was stronger than the original construction, and not only saved my record but gave satisfactory service for several thousand miles afterward.—E. G. (Cannonball) Baker, Indianapolis, Ind.

## Oiling Motor Timer and Magneto Properly

The timer and magneto of an automobile require little lubrication, but it should be of the best. Pure castor oil is very effective in these places, but should be used sparingly on the magneto bearings. Several drops, two or three times a season, is all that is required.—G. A. Luers, Washington, District of Columbia.

## Electroplating the Inside of a Tube or Casting

The usual method of suspending parts in an electroplating bath will not result in a uniform deposit over the inside surfaces of tubes or castings. Successful plating of inside surfaces is not difficult, however, with the use of a special, yet easily constructed, device, as shown in the sketch. A wooden frame is made, with clips, to hold the tube in position, as illustrated. A hole

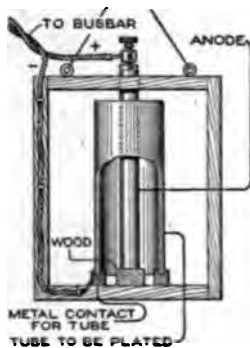

is provided in the top crosspiece of the frame so that the rod of the metal used in plating, zinc for instance, may be passed through and down into the center space of the tube. A flexible copper cord is attached to the rod, and this in turn is connected with the positive busbar when plating. The tube, of course, is connected with the negative bar. This application of the current causes the metal from the central rod to be deposited evenly over the inside of the tube.—K. M. Coggeshall, Webster Groves, Mo.



## A Motor-Starting and Regulating Switch

The motor-starting, speed-regulating switch illustrated is for use with small electric motors, taking about 10 volts. But by making slight changes, the switch may be used on 110-volt circuits. The blade is of copper,  $\frac{1}{2}$  in. wide by  $\frac{1}{16}$  in. thick, and  $5\frac{1}{2}$  in. long. The contact jaws are also of copper,  $\frac{3}{8}$  in. wide and  $\frac{1}{32}$  in. thick. Four of these will be needed. A strip of the copper is bent to the shape shown, to form the jaws. The lengths of the jaws vary by  $\frac{1}{4}$  in., and are made in the following lengths:  $1\frac{1}{4}$  in., 1 in.,  $\frac{3}{4}$  in., and  $\frac{1}{2}$  in., one of each length. Mount them upon a piece of hard rubber, fiber, or hard wood, separating them by  $\frac{1}{2}$  in. The base of the switch may be the top of the box or containing case which holds the resistance coils. This box should be 6 in. long, 3 in. wide, and 2 in. deep, and lined with sheet asbestos.

On a pencil wind some No. 28 gauge German-silver wire for a distance of 2 in. Make three of these resistance coils. Connect the jaws A and B together with one coil, stretching it down until it touches the bottom of the box, and fasten down with a tack or let it remain loose. Then connect jaws B to C, and C to D. Connect D to a binding post and the blade bearing E to the other binding post.

When using the switch, connect in series with the motor. To start the motor, throw the blade into contact with jaw A: all the resistance is on;

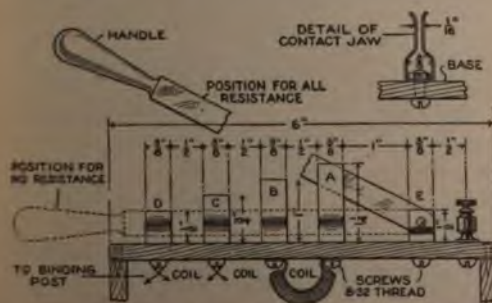

his Serviceable Motor-Starting and Regulating Switch was Made from Waste Materials Picked Up about the Shop

then push down to B; this cuts out one coil; then to C, and lastly to D, when all the resistance is cut out.—Francis B. Dashiell, Dunkirk, Md.

## Creepers for Use under Vehicles is Provided with Tool Trays

Probably the greatest annoyance of working under an automobile, or other



The Trays Incorporated as a Part of the Creeper Enable One to Keep All His Tools within Reach as He Moves About under a Motor Vehicle

vehicle, with a shop creeper is that of laying one's tools on the floor and then moving out of reach of them. This is eliminated, and much valuable time is saved, by providing one's creeper with tool trays, as illustrated. The trays are fastened by means of two horizontal bands of iron bolted under the framework of the creeper. Separate compartments for different tools may be built into the trays, if desired. With this addition, which may be quickly made to any creeper, one is able to work with all his tools at his fingers' ends regardless of how much moving about under the machine may be necessary.—Charles C. Springer, Grand Rapids, Mich.

## Exploiting Old Photographic Negative Glass

Stocks of old plates that have accumulated in photographers' shops during the past years have attained considerable value and are now being purchased for recoating by the manufacturers of photographic supplies. This has been occasioned by a shortage of high-grade glass resulting from the closing by the war of the factories in northern France. These plants were heretofore the sole source of supply of such glass.—Leon A. Haloin, Denver, Colorado.



### Oil Discharged by Pressure Eliminates Lifting Barrel

In garages and shops where oil of any kind is used by the barrel, a great deal of back-breaking labor is elimi-

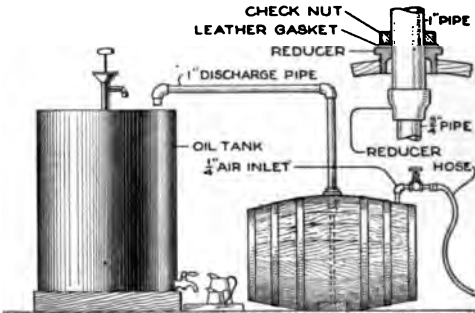

With This Simple Pressure Device a Barrel of Oil is Transferred to a Reservoir with No Other Effort Than Rolling the Barrel

nated by providing a pressure-discharging device, as shown in the sketch. The discharge-pipe reducing bushing is screwed into the bung-hole of the barrel to insure an air-tight fit. The air-inlet pipe is also screwed in, as shown. With 50-lb. air pressure in the hose, a 50-gal. barrel is emptied in a few minutes. If the outlet pipe is fitted to within  $\frac{1}{4}$  in. of the bottom of the barrel the last drop of oil will be forced out.—Samuel C. Carter, Detroit, Mich.

### Blasting Soot from Factory Smokestacks

Smokestacks that are clogged with soot are wasteful of fuel. A quick and economical method of cleaning them is by exploding a charge of blasting powder within the stack, thereby creating a concussion which jars loose and brings down all soot deposits on the walls. For this purpose a gun is used. It is made from a piece of pipe shafting, 4 in. in diameter and 16 in. in length. A hole,  $1\frac{3}{4}$  in. in diameter, is bored in one end to a depth of 10 in., converting it into a small cannon. A  $\frac{1}{4}$ -in. hole is bored in the side near the base of the longitudinal hole to accommodate a fuse. The cannon is loaded with an 8-in. charge of blasting

powder, wadded securely with paper and clay, and is fired after being placed with its muzzle upward in the base of the flue. This charge is usually sufficient to loosen the soot in a chimney 100 ft. high and 4 ft. in diameter. A larger flue, or one that is badly sooted, may require several shots, or the size of the cannon and the charge of explosive used may be increased to meet the requirements. Much time is saved by this method of cleaning. With careful handling there should be no occasion for an accident and no danger whatever of injuring the stack.

### A Dowel Cutter for the Home Workshop

In woodworking, wooden dowels frequently must be of a special size. The homemade cutter illustrated is thoroughly useful, both for making dowels and cutting down those which happen to be oversize. A hardwood block, about 2 by 2 by 3 in., has, near the center of one end, a hole bored the size of the dowel. On the other end a hole is bored large enough to permit the uncut part of the stick to pass through freely. On the middle of one side of the block a slot is cut, as indicated. This slot is large enough to permit a ground gouge to fit into it. The cutting edge of the gouge must center with the dowel to be cut. Over this slot is fastened a metal plate with a wood screw passing through it, to hold the gouge in proper adjustment. A strip

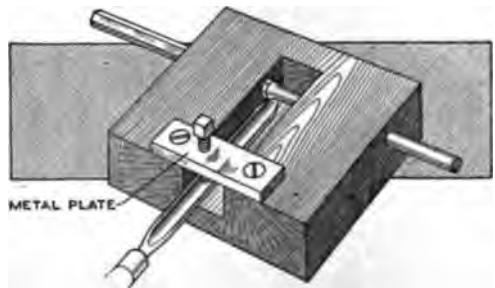

Dowels may be Quickly Made or Trimmed Down in the Home Workshop with the Aid of This Simple Cutter

of maple, or other hard wood, is sawed to a hexagon slightly larger than the

dowel wanted. One end is then placed in the headstock of the lathe, and while revolving, the cutter is held by hand and started at the other end. By feeding the cutter slowly a smooth, accurate dowel is made.—Arthur A. Richardson, Center Barnstead, N. H.

### Convenient Bench for Use at Drafting Table

Many draftsmen find the ordinary high stool uncomfortable and inconvenient, especially when working on a long sheet. After considerable experimenting in a large drafting room, benches of the type shown in the illustration were found to overcome both objections to the high stool. It is strongly constructed, as shown, the joints being bolted wherever possible.

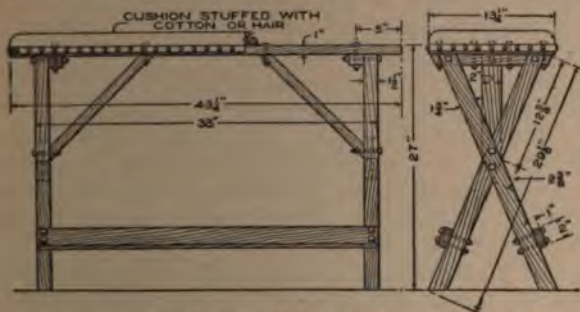

This Strongly Made Draftsman's Bench was Found More Convenient Than the High Stools Commonly Used

The padded cushion, of strong, smooth cloth, is an especially good feature, and the foot rests also provide stout braces. Oak and maple are good woods from which to make the bench, and can be finished easily to match other furniture.

### Drill for Enlarging the Bottom of Threaded Holes

The drill illustrated is ground from a piece of tool steel to the shape and size required for the work in hand. After this type of drill has been used, bottoming taps will be found unnecessary. It also permits enlarging the bottom of the hole without the slightest danger to the threaded walls. In a hole thus bottomed, the stud may

be screwed in firmly, as there is vacant space all around its end, and once



Threaded Holes are Easily and Efficiently Enlarged at the Bottom by the Use of This Simple Tool

sent home it will have little tendency to back out.—M. L. Lowrey, Livermore, Calif.

### Paraffin for Woodworking Tools

Paraffin is a desirable lubricant for tools used on woodwork, because it is clean, leaves no stains or marks on the wood, and stays on the tools longer than oil or grease. It is easier to apply, being simply rubbed on, can be carried unwrapped and unprotected in the pocket, and is more economical than oil. One-third of the tablet commonly sold fits the hand and the pocket. For rabbet and plow work, paraffin is especially handy. It sticks to the wooden surfaces of tools used in such work, and if a little is rubbed occasionally along the sides of the rabbet or plow, the plane works easier.

### Quick-Releasing Tapeline Holder does Not Snag Readily

By bending a piece of No. 10 gauge wire to the form shown, a helpful hook-and-pin tapeline anchor is provided for single-handed work. It may be made fast almost anywhere and released by simply whipping the line. When the tape is reeled in, the hook does not snag in weeds or grass.

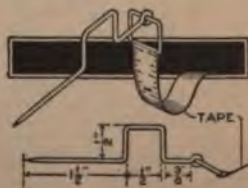

ing the end of the shaft. The diameter of the opening in the end of the driving block should be large enough to insert the hand if parts are dropped inside.

### Shield on Creeper Protects Face When Working under Auto

To protect one's face when working beneath a motor car, a transparent



The Frame, Made by Bending an Iron Rod, Supports a Celluloid Shield above the Headrest of the Creeper

shield may be provided above the headrest of a creeper by attaching a sheet of celluloid to an iron frame. The support is made by bending a rod and clamping its free ends to extended slats. The celluloid should be sewed to strips of canvas bound around the rod.

### Pattern Maker's Boring Tool for Small, Deep Work

When a pattern maker has small, accurate pieces of work calling for the boring of deep holes of small diameter, it is usually more or less difficult because the necessary tools are not at

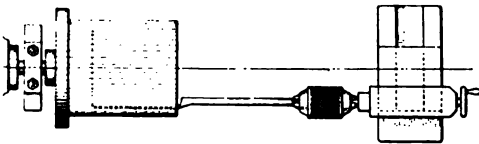

For Deep, Accurate Work in Pattern Making This Lathe Cutting Tool in Many Instances Fulfills All Requirements

hand. Most pattern shops are provided with a lathe having a tailstock that may be shifted to the right or left

of the lathe bed. By providing a tool as illustrated, and placing it in the drill stock, small, deep, and accurate work may be accomplished. The tool is made from a piece of  $\frac{3}{8}$ -in. tool steel. It is heated and hammered flat, then ground and retempered. When held in the tailstock it will cut a  $\frac{1}{4}$ -in. hole, which may be enlarged to any desired size by shifting the position of the tool. Several such tools when made up in different sizes will enable one to meet almost every requirement of deep cutting work.

### Gas Pipe Guides Nails Driven in Close Quarters

In millwrighting, as in general building-repair work, it is sometimes necessary to drive nails in cramped places where they cannot readily be held with the hand to insure their being driven straight. In such cases, take a short piece of gas piping, a  $\frac{3}{8}$ -in. size, for example, and get a slightly longer length of steel, or iron, rod that will slip loosely into the piping. Then drop the nail into the pipe, sliding the rod behind it, and use the pipe to guide the nail while hammering on the end of the rod, as shown.

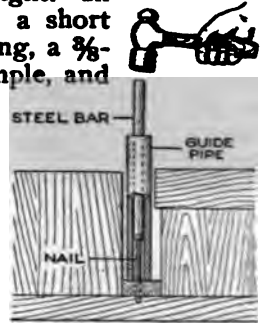

### Mending Torn Tracings

Tracings that have become worn, frayed by use, or torn, may be mended, without destroying their usefulness in making legible prints, by pasting a piece of unused tracing cloth, or tracing paper, at the damaged place. The patch should be pasted on the dull side of the tracing cloth, with library paste. The weave of the tracing-cloth patch should be set to correspond with the weave of the tracing, or serious buckling may be patched part of the draw



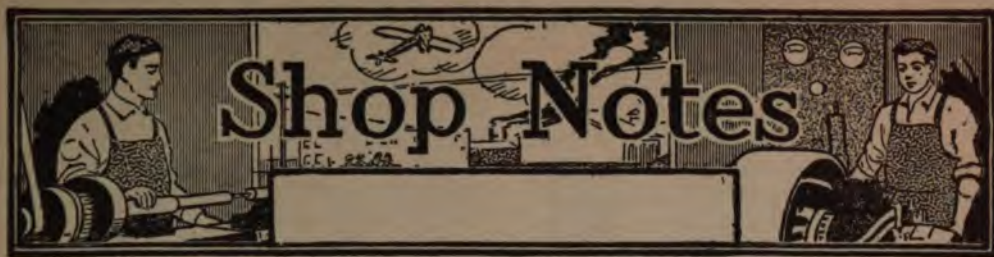

## A Sanitary Hog House of Saw-Tooth Design

By HERBERT A. SHEARER

**A**BUNDANCE of fresh air and sunshine is one of the most important requisites in the care of little pigs

and brood sows, and in recent years many excellent types of hog houses have been designed with this consideration in view. Some of these are of very expensive construction, with windows carefully placed and at scientifically correct angles to admit the direct rays of sunlight into the nests during March and April and again in September and October, the usual farrowing months in the latitude of central United States.

One of the most practical of these hog houses is the saw-tooth design illustrated. It is cheaper to build than most of the others, and with its three rows of windows, placed just above the nests, the desired results are obtained most effectively. The rows of windows are so arranged that through

the greater portion of the day the house is flooded with sunlight, yet it will be noticed that the structure of

the roof is such that the heat stored within during the day is not rapidly radiated at night. This is a desirable feature, since extremes of temperature should be avoided wherever possible.

The perspective illustration shows, in a general way, the exterior construction of the building. In the floor plan it will be noticed that the center alley is made to serve as a feeding room, transfer

alley, and place for the drainage gutters. It also forms a passage through the structure from end to end.

The concrete floors in the pens slope slightly from the sides of the house to the alley, to aid cleaning. Overflow from the running water in the troughs is kept out of the nests by reason of the gutters in the alley being lower.

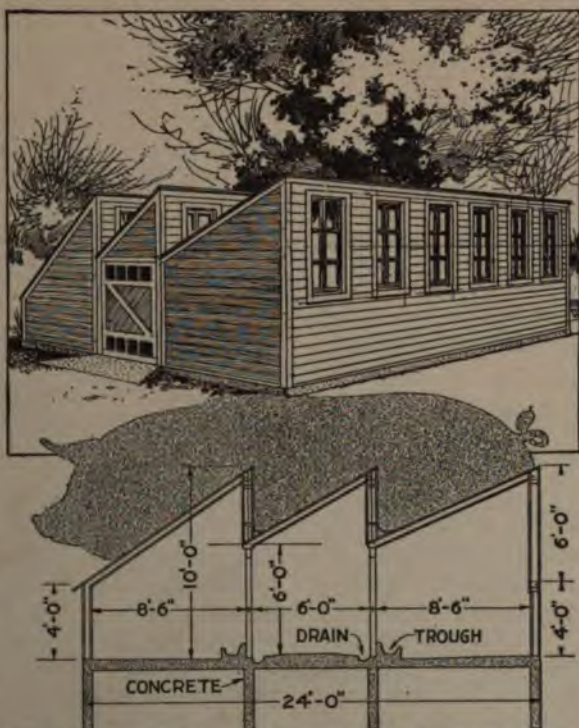

General View and Cross Section of the Saw-Tooth Hog House, Showing Its Exterior Construction and the Provisions for Sanitation That are Made in the Interior. The Dimensions are Given as Details for Building

The gutters also have a lengthwise slope of about 1 in. in 10 feet.

The center saw-tooth roof is sup-



Floor Plan of the Sanitary Hog House, Showing the Arrangement of the Interior, Nests, Concrete Feeding Troughs, and Other Features: Gates may be Added to the Pens, or in the Alley, as Desired

ported on 4 by 4-in. posts. These posts also form the alley partitions for the pens. The alleys are 6 ft. wide. This width ordinarily will be found adequate, as it will permit the use of a two-wheeled feed cart, and a wheelbarrow may be brought in for purposes of cleaning. Galvanized-iron gutters, as shown in the cross section, carry rain water accumulated between the saw teeth to the ends of the building.

### Emergency Repair for a Broken Motorcycle Piston

A broken valve in a motor always results in a broken piston head, if the head of the valve falls inside the cylinder. It was my misfortune to have this experience while many miles from any railroad and several hundred miles from the nearest agency where spare parts could be obtained. In a ranchman's workshop inspection showed that the valve



head had gone through the piston edge-wise, making a clean-cut hole. After removing the broken parts, I effected the repair shown in the sketch. A sheet-iron plate,  $\frac{1}{8}$  in. thick, was cut

exactly the same size as the top of the piston and fastened down with eight copper rivets. To compensate for the increased compression resulting from the plate, a heavy fiber gasket was placed under the cylinder. When assembled, the motor held compression well enough to get started, and after being run for a time with an abundance of oil, it held perfectly. The repair not only got the machine home under its own power, but is still in service after more than a thousand miles of use.—Edwin Edgerton, Alhambra, Calif.

### Paper-Ornament Making Machine for Restaurant Use

Restaurant owners who endeavor to please the eye as well as the palate of their customers have long made a practice of adorning the unsightly shank bones of fowls, steaks, and chops with fancy tissue-paper ornaments. But such frills are an expense which counts, especially in these war times. One restaurant owner has built a simple machine and is now making his own



paper ornaments during the slack hours that most restaurant people experience between meals. The machine consists of two iron braces, bent and attached on a wooden base. Between the braces five safety-razor blades of two-hole type, attached to the braces with leather spacers between them, are placed as shown in the sketch. Strips of tissue paper are fed between the blades and the board with the paper between the machine is run. The paper is pressed down along the blades and the ornaments are then shrunk to the desired length. The machine is simple to require no special tools or ington,



do. The finished caps should be lined with leather to prevent splitting of the wood, and to provide the slight resiliency necessary.

### Acid-Proof Cement for Pipe Fittings

An excellent cement for packing the joints of piping or vessels containing strong acid solutions is made by mixing equal parts of asbestos fiber, linseed oil, and white lead. For weak acids the cement may be cheapened by the addition of clay.—J. J. O'Brien, Buffalo, N. Y.

### Handy Twine Cutter Made from a Wood Screw

By heating and flattening the head of a large wood screw, driving it into a block of wood of a convenient size to serve as a handle, and filing the head as illustrated, an excellent twine-cutting tool is produced. Such a device may be contrived in



about five minutes, and for use about a shipping room or other place where twine is used it is invaluable. Any twine, from ordinary wrapping cord to a carpenter's chalk line, is instantly severed by jerking it against the cutting edge.—George W. Smith, Chicago, Illinois.

### Emergency Corrugated Fasteners for Use in Woodwork

Splendid corrugated fasteners for locking boards together may be made by running strips of heavy-gauge tin, copper, or other sheet metal, through a pair of meshed gears and cutting the wrinkled strips into the desired lengths. Upon the size of the gears will depend the size of the fasteners. This operation will in no way injure the gears.—H. W. Offins, Grants Pass, Ore.

### Wooden Roller Aids Construction of Concrete Highways

A concrete-road roller of the type illustrated is easily made and is of



The Roller Tapers to a Smaller Diameter near the Middle, and Thus Automatically Rolls a Concrete Road to the Correct Pitch for Drainage

inestimable value because it gives the desired drainage pitch to the center of the highway with a single rolling operation. The roller shown was used in the construction of a cantonment highway, 18 ft. wide. It was turned from a piece of yellow pine, 8 in. square and 20 ft. in length. A dowel, 1 ft. long, was turned on each end, and over each an iron handle was fitted, for convenience in handling the roller while molding the highway.—Frank Yocum, Reading, Pa.

### Blowtorch Made of an Oilcan and a Bicycle Pump

A handy blowtorch for light soldering and heating may be made by combining parts of an oilcan and a bicycle pump, as indicated in the sketch. The spout of the oilcan is cut off and soldered to the body to form an air nozzle directed just above a wick inserted in the neck. A piece of air hose is used to connect the pump with the air spout, after which the whole is mounted on a 4 by 12-in. wooden base, by means of screws passing through an extension soldered to the bottom of the oilcan.





### Head-Fitting and Bar-Fastening Repair for Motorcycle

While nearing the finish of an otherwise successful record-breaking trial, the handlebars were torn from my ma-



This Improved Fastening for a Pair of Motorcycle Handlebars was Made in Less Than an Hour. It Proved to Be Stronger Than the Original

chine in a spill. Inspection showed that the expander bolt was broken, and that there was apparently no way to fasten the bars on again without securing new parts. To obtain these from the nearest agency would have occasioned a disastrous delay. I rolled the machine to a blacksmith shop that happened to be near, and there effected the temporary repair illustrated. A steel plate, of the size and shape illustrated, was made and fitted over the fork stem and the end of the fork-reinforcement stem. This plate was locked in place between the head-cup fittings and the fork-stem reinforcement nuts. Two

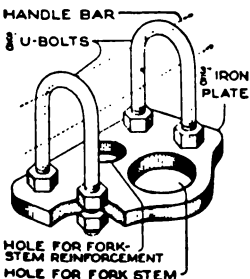

$\frac{3}{8}$ -in. U-bolts were fitted into the steel plate and tightened up after the handlebars had been passed through them, the handlebar headpost having been previously driven

down into the fork stem as far as it would go. The improvised repair was

completed in less than an hour. It was stronger than the original construction, and not only saved my record but gave satisfactory service for several thousand miles afterward.—E. G. (Cannonball) Baker, Indianapolis, Ind.

### Oiling Motor Timer and Magneto Properly

The timer and magneto of an automobile require little lubrication, but it should be of the best. Pure castor oil is very effective in these places, but should be used sparingly on the magneto bearings. Several drops, two or three times a season, is all that is required.—G. A. Luers, Washington, District of Columbia.

### Electroplating the Inside of a Tube or Casting

The usual method of suspending parts in an electroplating bath will not result in a uniform deposit over the inside surfaces of tubes or castings.

Successful plating of inside surfaces is not difficult, however, with the use of a special, yet easily constructed, device, as shown in the sketch. A wooden frame is made, with clips, to hold the tube in position, as illustrated. A hole

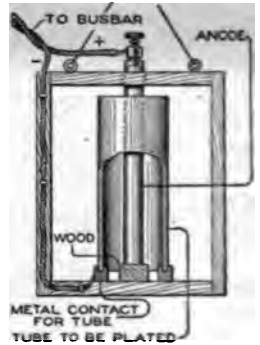

is provided in the top crosspiece of the frame so that the rod of the metal used in plating, zinc for instance, may be passed through and down into the center space of the tube. A flexible copper cord is attached to the rod, and this in turn is connected with the positive busbar when plating. The tube, of course, is connected with the negative bar. This application of the current causes the metal from the central rod to be deposited evenly over the inside of the tube.—K. M. Webster Groves, Mo.

are tapped lightly with a soft hammer. Drift pins are also used to aid in pulling the courses together.—W. H. Thomas, Davenport, Ia.

### A Convenient Homemade Scraper Handle

Scraping is always hard work when carried on in the usual fashion of grasping the bare, sharp-cornered blade.

There are numerous commercial scraper handles, but most of them have the objection of hampering nicety of control. The scraper handle illustrated, while giving a comfortable handhold, also reduces the effort of scraping. It is made from two pieces of  $\frac{1}{2}$ -in. hard wood, preferably apple or rosewood. The outline is first cut with a coping saw. Then the curves are worked with a rasp and file. Holes are drilled through the blade to accommodate the two screws, which are countersunk and hold the halves of the handle.



### Worn-Out Piston Used as Blowtorch Furnace

When small parts must be heated for tempering, some sort of a heat-retaining furnace is essential if the heat is to be properly distributed and the temper uniformly applied. A simple furnace for such use is made by mounting an old cast-iron piston, as shown in the sketch, and using a blowtorch to direct the heat into the open end. With this arrangement thoroughly efficient heating and tempering is easily accomplished.

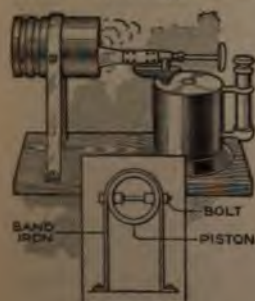

### Weighted Rulers Keep Drawings from Rolling When in Use

To a large extent the trouble encountered by draftsmen in keeping drawings, that have once been rolled, from curling when spread on tables, may be overcome by using weighted rulers. Made of hard wood in the manner illustrated, and covered on the bottom with dark felt, they serve satisfactorily. If the rulers are placed on drawings in filing cabinets, they enable crowded drawers to be opened without disturbing the contents.



### Stethoscope for Telephone and Automobile Use

Difficulty of hearing over a telephone may be eliminated and loose bearings in internal-combustion motors are quickly located by the use of a physician's stethoscope. Many such instruments of slightly antiquated models are obtainable for a nominal sum, and for mechanical service are quite as good as new ones. For the telephone, the diaphragm is fitted to the receiver. This enables one to hear perfectly, regardless of noises in the immediate vicinity. In locating mechanical irregularities about machinery, the diaphragm is placed against the machine and by listening through the ear tubes the position of the trouble is quickly determined.—F. Ball Pinkus, La Crescenta, Calif.



### Oil Discharged by Pressure Eliminates Lifting Barrel

In garages and shops where oil of any kind is used by the barrel, a great deal of back-breaking labor is elimi-

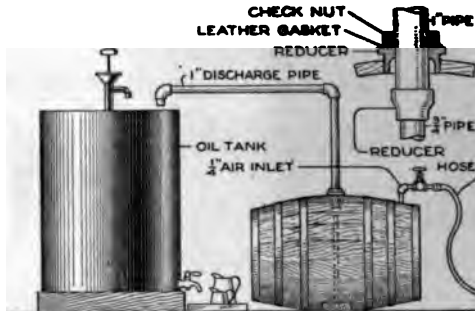

With This Simple Pressure Device a Barrel of Oil is Transferred to a Reservoir with No Other Effort Than Rolling the Barrel

nated by providing a pressure-discharging device, as shown in the sketch. The discharge-pipe reducing bushing is screwed into the bunghole of the barrel to insure an air-tight fit. The air-inlet pipe is also screwed in, as shown. With 50-lb. air pressure in the hose, a 50-gal. barrel is emptied in a few minutes. If the outlet pipe is fitted to within  $\frac{1}{4}$  in. of the bottom of the barrel the last drop of oil will be forced out.—Samuel C. Carter, Detroit, Mich.

### Blasting Soot from Factory Smokestacks

Smokestacks that are clogged with soot are wasteful of fuel. A quick and economical method of cleaning them is by exploding a charge of blasting powder within the stack, thereby creating a concussion which jars loose and brings down all soot deposits on the walls. For this purpose a gun is used. It is made from a piece of pipe shafting, 4 in. in diameter and 16 in. in length. A hole,  $1\frac{3}{4}$  in. in diameter, is bored in one end to a depth of 10 in., converting it into a small cannon. A  $\frac{1}{4}$ -in. hole is bored in the side near the base of the longitudinal hole to accommodate a fuse. The cannon is loaded with an 8-in. charge of blasting

powder, wadded securely with paper and clay, and is fired after being placed with its muzzle upward in the base of the flue. This charge is usually sufficient to loosen the soot in a chimney 100 ft. high and 4 ft. in diameter. A larger flue, or one that is badly sooted, may require several shots, or the size of the cannon and the charge of explosive used may be increased to meet the requirements. Much time is saved by this method of cleaning. With careful handling there should be no occasion for an accident and no danger whatever of injuring the stack.

### A Dowel Cutter for the Home Workshop

In woodworking, wooden dowels frequently must be of a special size. The homemade cutter illustrated is thoroughly useful, both for making dowels and cutting down those which happen to be oversize. A hardwood block, about 2 by 2 by 3 in., has, near the center of one end, a hole bored the size of the dowel. On the other end a hole is bored large enough to permit the uncut part of the stick to pass through freely. On the middle of one side of the block a slot is cut, as indicated. This slot is large enough to permit a ground gouge to fit into it. The cutting edge of the gouge must center with the dowel to be cut. Over this slot is fastened a metal plate with a wood screw passing through it, to hold the gouge in proper adjustment. A strip

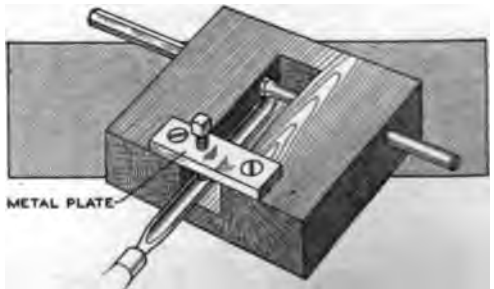

Dowels may be Quickly Made or Trimmed Down in the Home Workshop with the Aid of This Simple Cutter

of maple, or other hard r sawed to a hexagon slightly



dowel wanted. One end is then placed in the headstock of the lathe, and while revolving, the cutter is held by hand and started at the other end. By feeding the cutter slowly a smooth, accurate dowel is made.—Arthur A. Richardson, Center Barnstead, N. H.

**Convenient Bench for Use at Drafting Table**

Many draftsmen find the ordinary high stool uncomfortable and inconvenient, especially when working on a long sheet. After considerable experimenting in a large drafting room, benches of the type shown in the illustration were found to overcome both objections to the high stool. It is strongly constructed, as shown, the joints being bolted wherever possible.

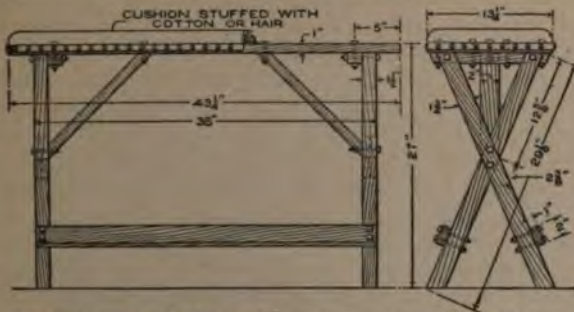

This Strongly Made Draftsman's Bench was Found More Convenient Than the High Stools Commonly Used

The padded cushion, of strong, smooth cloth, is an especially good feature, and the foot rests also provide stout braces. Oak and maple are good woods from which to make the bench, and can be finished easily to match other furniture.

**Drill for Enlarging the Bottom of Threaded Holes**

The drill illustrated is ground from a piece of tool steel to the shape and size required for the work in hand. After this type of drill has been used, bottoming taps will be found unnecessary. It also permits enlarging the bottom of the hole without the slightest danger to the threaded walls. In a hole thus bottomed, the stud may

be screwed in firmly, as there is vacant space all around its end, and once



Threaded Holes are Easily and Efficiently Enlarged at the Bottom by the Use of This Simple Tool

sent home it will have little tendency to back out.—M. L. Lowrey, Livermore, Calif.

**Paraffin for Woodworking Tools**

Paraffin is a desirable lubricant for tools used on woodwork, because it is clean, leaves no stains or marks on the wood, and stays on the tools longer than oil or grease. It is easier to apply, being simply rubbed on, can be carried unwrapped and unprotected in the pocket, and is more economical than oil. One-third of the tablet commonly sold fits the hand and the pocket. For rabbet and plow work, paraffin is especially handy. It sticks to the wooden surfaces of tools used in such work, and if a little is rubbed occasionally along the sides of the rabbet or plow, the plane works easier.

**Quick-Releasing Tapeline Holder does Not Snag Readily**

By bending a piece of No. 10 gauge wire to the form shown, a helpful hook-and-pin tapeline anchor is provided for single-handed work. It may be made fast almost anywhere and released by simply whipping the line. When the tape is reeled in, the hook does not snag in weeds or grass.

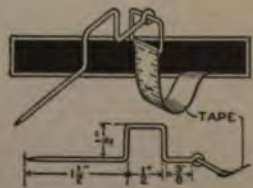

### Handy Tool Drives Small Nails into Hard Wood

Driving small nails in hard wood is difficult because, if the utmost care is

### Easy Method of Removing Foreign Particles from the Eye

The removal of foreign substances from the eye is difficult when the hands are smeared with grease or other stains of shop work. Under such circumstances the desired result is frequently accomplished by immersing the eye in a basin of clean, warm water and then blinking rapidly half a dozen times. Unless the particle has actually been imbedded in the eyeball or lids this procedure will usually wash it out or into the

corner of the eye, where its removal becomes easy.—T. J. Grogan, Atlanta, Georgia.

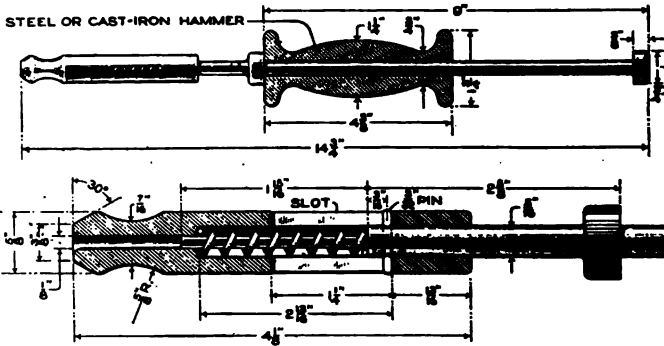

Small Finishing Nails are Quickly Driven into Hard Wood without Danger of Bending, with the Aid of This Simple Homemade Tool

not used, they will bend rather than enter the wood. The homemade tool illustrated overcomes this difficulty by holding the nail so that it cannot bend while driving it home or into the wood at an angle. There are but four principal parts to the tool, and these are of the shapes and dimensions indicated in the sketch. All are made of shaft steel, with the exception of the sliding hammer, which may be of cast iron. The end of the driving rod is hardened and magnetized for picking up the nails. The upper end of the rod is threaded, and the cap is screwed on and pinned in place after the hammer has been mounted. The nail tube is hollowed out, as shown, and provided with a coil

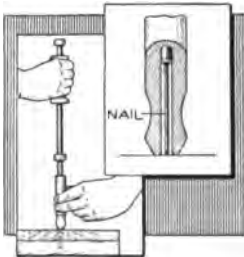

spring to accomplish the rebounding of the driving rod after each blow is struck. The nails are placed, one at a time, in the nail tube, which is then set over the spot where the nail is to be driven. A few blows with the hammer finishes the task. Even the most slender nails may be driven into the hardest wood without danger of bending.

corner of the eye, where its removal becomes easy.—T. J. Grogan, Atlanta, Georgia.

### Round Recesses Easily Cut with Homemade Tool

The legs of furniture fitted with casters are less liable to split if the caster stems are fitted into short lengths of gas pipe of the proper diameter and recessed into the wood. To make the pipes fit, recesses should be



cut in the ends of the legs with a cutter made from a piece of the same pipe. The tool should be 6 in. in length and provided with a row of teeth on one end. After sharpening the teeth, which may be done with a file, that end should be tempered slightly. A hole is then drilled through the other end for the insertion of a rod to serve as a cross handle. Quick and thoroughly accurate work is accomplished with this tool, and the holes thus made are the correct size to take the pipe, insuring a perfect driven fit.—Frank L. Matter, Portland, Ore.



### Simple Test to Distinguish Wood Alcohol from Denatured Alcohol

It is often difficult to tell the difference between refined poisonous wood alcohol and denatured alcohol. A thin piece of celluloid, if put in a vial of the alcohol in question, will quickly reveal its nature. Wood alcohol will dissolve the celluloid, while denatured alcohol will have no other effect in 12 hours than to remove the polish. In handling these chemicals it should be borne in mind that wood alcohol is not only a deadly poison if taken internally, but that one may be poisoned by breathing its fumes, or by absorption through the skin.

### Old Files Made Serviceable by Treating with Acid

Files that have been worn until they are no longer fit for use may be made to render additional service by soaking them for 48 hours in a weak solution of sulphuric acid. The worn teeth are corroded so that numerous sharp cutting edges remain. When using sulphuric acid it should be remembered that it is poisonous and corrosive, and should be handled with great care.

### Gauge Stick Useful for Alining Automobile Wheels

In alining automobile wheels, either in assembling or in making repairs, a gauge stick, as illustrated, is of mate-

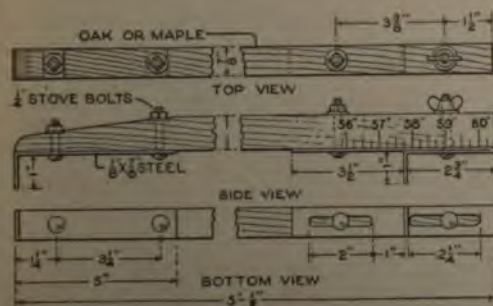

Construction Details of the Automobile Wheel Alining Gauge Stick

rial aid in procuring the accuracy essential to obtain maximum tire mile-

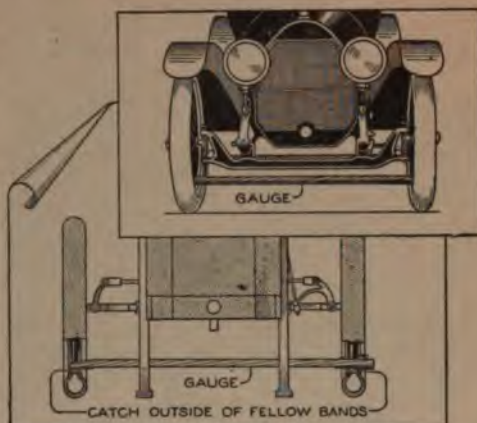

In Use, One End of the Gauge Stick is Hooked over One of the Rims While the Measurements are Taken on the Opposite Wheel

age. Guesswork wheel alinements are usually costly experiments. The stick is best constructed from a piece of maple or other good, clear wood. It should be  $5\frac{1}{2}$  ft. long, 1 in. wide, and  $\frac{7}{8}$  in. in thickness. The end fitments are made from  $\frac{1}{8}$ -in. band-iron stock.

### Method of Planing Chair Cane

When recaning a worn-out chair seat it often happens that one wishes to reduce the size of one or more of the strands of cane. This may be satisfactorily accomplished by guiding the cane against a plane bit with a large darning needle. The plane is placed, bottom side up, in a vise. The eye of the needle is then thrust upward through the throat of the plane and the cane threaded into it. By pulling the cane through the eye and across the cutting edge with one hand and pressing it squarely against the plane bottom by means of the needle with the other hand, a fine uniform shaving may be removed. Besides reducing the size, this treatment eliminates rough edges and splinters and corrects variations in width. Smoother, neater work is thus obtained.—T. A. Reynolds, Monroe, Wis.



### Labor-Saving Method of Excavating under a Building

By the use of a conveyor-belt and dump-bin system, as illustrated, a base-

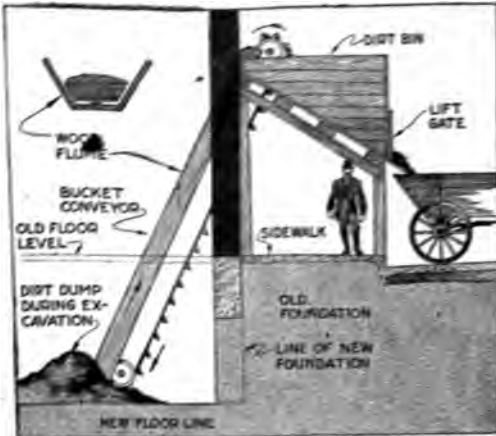

Without Disturbing the Occupants of the Building or Obstructing Street Traffic, a Basement was Dug under an Apartment House by the Use of an Endless Conveyor Belt and an Overhead Bin

ment has been dug under a large reinforced-concrete building with a minimum of labor and without obstructing the sidewalk. An opening was made in the front wall of the building and a hole dug to the depth of the basement and large enough to install the conveyor. The conveyor was operated by a small motor and dumped the dirt taken from the excavation into a bin built high enough above the sidewalk to provide headroom underneath. A lift gate was built in the end of the bin and served to regulate the loading of the wagons.

### Drawers under Bench Vise to Catch Filings

When working on costly metals a convenient method of preserving the filings is to have a tier of shallow drawers directly beneath the vise in which the work is being done. If it is lead upon which one is working, the top drawer is pulled out. The other drawers are used for copper, brass, aluminum, or bronze, as the case may be. Each drawer should be labeled and used exclusively for one kind of metal.

It is then easy to collect and redeem the filings when a drawer becomes filled.

### Garage Air Compressor Made from Discarded Cycle Motor

By making a few simple alterations on an old motorcycle engine that had outlived its usefulness as such, a garage man has provided his place with an excellent and economical air compressor. The motor was first rebored and a new piston fitted, to insure good compression. A steel plate, with a gasket under it, was bolted over the exhaust port, to close it. The original automatic inlet valve was left intact, to supply air to the cylinder when being used as a pump. A ball-valve hose connection was substituted for the priming cock on top of the cylinder, and the hose from it connected with the air tank. A longer main shaft was fitted to the engine, and on its end an ordinary shaft pulley was keyed and mounted, as illustrated. The old motorcycle flywheel, originally outside the crank case, was left in place to supply the necessary momentum. Steel lugs were made and bolted to the floor, and into these the motor base was fastened

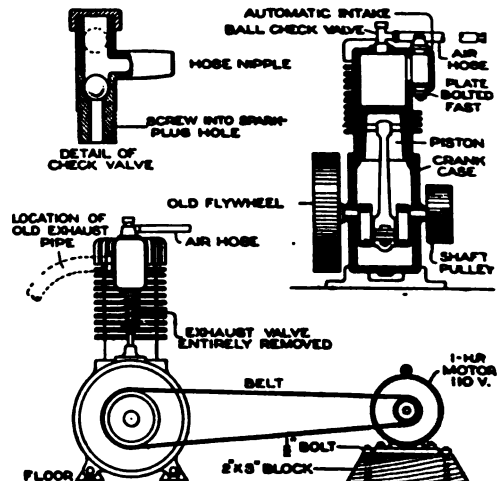

With a Nominal Outlay and Slight Mechanical Alteration a Discarded Motorcycle Engine may be Converted into a Serviceable Air Compressor for Garage Use

in the same manner as it would naturally be held in the frame of the cycle.

The completed compressor was belted to a 1-hp., 110-volt motor. Lubrication was provided by splash system, the oil being placed in the motor base. The completed outfit cost but a fraction of a new commercial article, but proved thoroughly satisfactory in its operation.—P. P. Avery, Garfield, N. J.

### Efficient Method of Cleaning Small Pinion Gears

Small gears such as those of watches, clocks, and other light machinery, are quickly and thoroughly cleaned by being stamped into the pithy center of a piece of elderberry or burdock. All grease and residue are instantly wiped from between the teeth. The wheel is then shaken out, and the piece of wood



prepared for the next one by being cut off beyond the used portion.

### Device for Stretching Fly Screen over the Frames

By the use of the screen-stretching device illustrated, work is speeded up as well as accomplished with greater efficiency. Two wooden brackets are secured on the left-hand end of the workbench. These should be slightly lower than the top and provided with rollers, as indicated. An axle or shaft is then provided, and on this the screen is rolled. About 12 in. from the end of the bench, a stop is screwed to hold the screen frame while working upon it. A wooden hand lever is then pivoted to the farther side of the bench, and at the other end is provided with a metal clamp for locking it in position. The screen is unrolled from the stock, tacked to one end of the frame, and then stretched by pressing down

the hand lever. The lever is clamped in position, and holds the screen taut

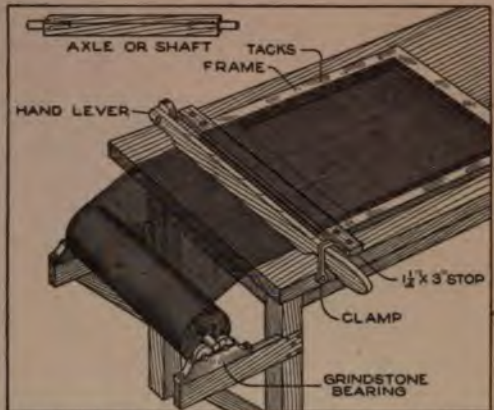

Tacking Screens to Their Frames is Simplified and Better Work is Accomplished with the Aid of This Bench Device for Stretching the Wire

while the tacks are being applied to the frame.—Herman F. Zimmerman, Los Angeles, Calif.

### Tray for Moving Small Threaded Parts without Injury

To truck small machine parts which are threaded both inside and out, without danger of damaging them, a carrying tray as illustrated is invaluable. The parts are slipped over soft wooden pegs which are so spaced over the surface of the tray as to prevent the parts from coming in contact with each other. Pegs should be of suitable length to

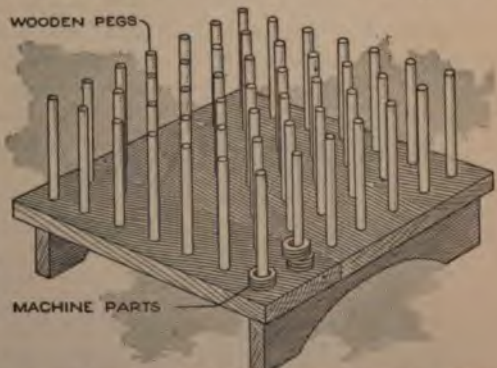

By the Use of a Tray with Rows of Wooden Pegs, Small Threaded Machine Parts are Handled without Danger of Injury and may be Counted at a Glance

hold 10 parts on each. This is a great aid in counting.

**Sandpaper Block for Use on Curved Surfaces**

A sandpaper block for use on curved surfaces is made by attaching

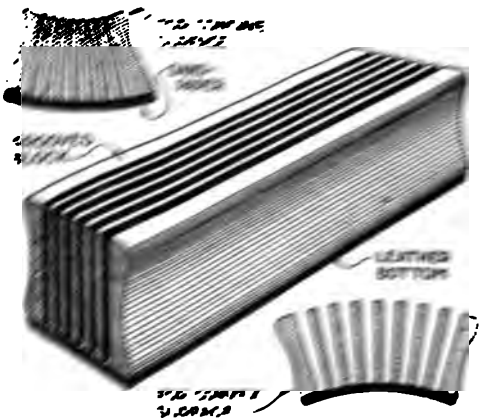

A sandpaper block. Made by fastening a piece of wood and covering top with leather. Which permits adjustment for use on curved surfaces.

ing a piece of heavy leather to a split block, as shown in the sketch. The block is first grooved and finished, as indicated. The leather is then glued to the lower surfaces. The sandpaper is cut to the proper size and glued to the leather. For sandpapering concave surfaces the upper side of the serrated block is squeezed together. For convex work it is spread apart. Robert M. Thomas, Cheyenne, Wyo.

**Adjustable Counterboring Tool Has Many Applications**

Mechanics whose work calls upon them for a variety of counterboring

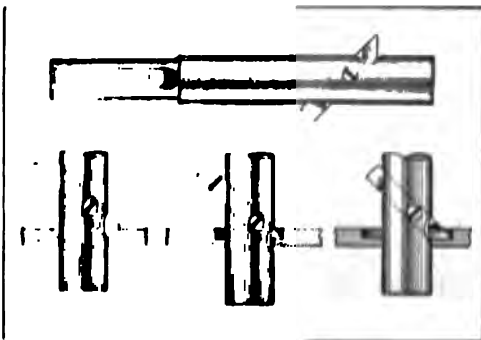

The sketches illustrate various types of counterbore jobs to which the tool is applicable. As will be noted, it is adjustable for shapes as well as sizes of counterbores.

jobs will instantly recognize a wide range of applications for the adjustable tool illustrated. Any desired size or shape of counterbore may be made with the one tool, depending upon the setting that is given the cutting member, or the angle to which it may be ground. The cutters are of high-speed steel, and if the hole in the bar is to be made exactly 90° the cutting edge is measured with a protractor and ground accordingly. The bar is made of milled steel and should be case-hardened.—M. J. Conway, Lawrence, Calif.

**Sphere Attachment for Dividers When Measuring from Holes**

It is sometimes necessary to mark castings a given distance from drilled holes. For such work a sphere attachment for the dividers, as illustrated, is useful.

A smooth cast-iron or steel sphere having a tapered hole to take the divider point is secured, and is used as shown in the sketch. This attachment per-

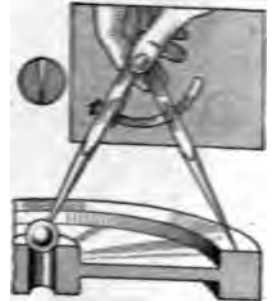

mits much greater accuracy than is obtainable by the use of a center-marked rivet or bolt.—W. H. Thomas, Davenport, Ia.

**Formula for Making Strong Asbestos Plaster**

Asbestos, or magnesium, plaster, as ordinarily applied to large tanks and hot-well pipe joints, is sometimes lacking in mechanical strength although satisfactory as a heat insulator. By mixing in the plaster 100 parts of asbestos fiber, 8 to 10 parts Portland cement, and 6 parts of common salt, a material is produced which has both strength and weather-resisting properties.—Maurice St. Johns, Montreal, Quebec, Canada.



are tapped lightly with a soft hammer. Drift pins are also used to aid in pulling the courses together.—W. H. Thomas, Davenport, Ia.

### A Convenient Homemade Scraper Handle

Scraping is always hard work when carried on in the usual fashion of grasping the bare, sharp-cornered blade. There are numerous commercial scraper handles, but most of them have the objection of hampering nicety of control. The scraper handle illustrated, while giving a comfortable handhold, also reduces the effort of scraping. It is made from two pieces of  $\frac{1}{2}$ -in. hard wood, preferably apple or rosewood. The outline is first cut with a coping saw. Then the curves are worked with a rasp and file. Holes are drilled through the blade to accommodate the two screws, which are countersunk and hold the halves of the handle.



### Worn-Out Piston Used as Blowtorch Furnace

When small parts must be heated for tempering, some sort of a heat-retaining furnace is essential if the heat is to be properly distributed and the temper uniformly applied. A simple furnace for such use is made by mounting an old cast-iron piston, as shown in the sketch, and using a blowtorch to direct the heat into the open end. With this arrangement thoroughly efficient heating and tempering is easily accomplished.

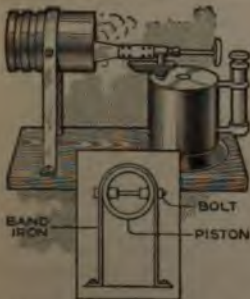

### Weighted Rulers Keep Drawings from Rolling When in Use

To a large extent the trouble encountered by draftsmen in keeping drawings, that have once been rolled, from curling when spread on tables, may be overcome by using weighted rulers. Made of hard wood in the manner illustrated, and covered on the bottom with dark felt, they serve satisfactorily. If the rulers are placed on drawings in filing cabinets, they enable crowded drawers to be opened without disturbing the contents.

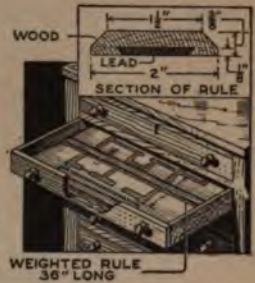

### Stethoscope for Telephone and Automobile Use

Difficulty of hearing over a telephone may be eliminated and loose bearings in internal-combustion motors are quickly located by the use of a physician's stethoscope. Many such instruments of slightly antiquated models are obtainable for a nominal sum, and for mechanical service are quite as good as new ones. For the telephone, the diaphragm is fitted to the receiver. This enables one to hear perfectly, regardless of noises in the immediate vicinity. In locating mechanical irregularities about machinery, the diaphragm is placed against the machine and by listening through the ear tubes the position of the trouble is quickly determined.—F. Ball Pinkus, La Crescenta, Calif.



**Pivot Stand Aids in Handling of Rough Lumber**

Wherever quantities of rough lumber must be loaded, unloaded, or piled, a

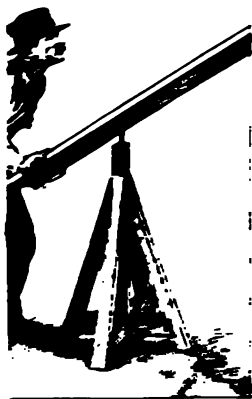

pivot stand as shown in the illustration of great assistance in the work of handling such a stand consists of a central upright erected on two crossed bottom pieces, the ends of which are mortised into four slanting legs which grip the upper part of the central piece. Into the end of

the upright is set a stout steel pin having a rather blunt point. The stand is placed alongside the wagon or lumber pile and is used as a pivot where leverage accomplishes much of the work ordinarily done by actually lifting each board.—Henry Simon, Laguna Beach, California.

**Rapid and Accurate Method of Making Tenons**

The following manner of making tenons gives better results than the usual method, and takes less time than the ordinary way. After making the saw cuts determining the length of the tenons on the pieces, roughly shape the tenons

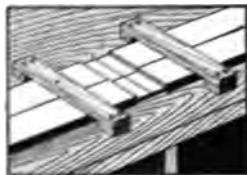

to within  $\frac{1}{16}$  in. of the desired thickness. Then place the pieces in pairs opposite each other, as shown. Clamp them down, placing a piece of sandpaper, folded double so as to present two sanded sides, between the clamping strips and the pieces to be worked. This prevents slipping. With a router

plane level off the depressions; reverse the work and level off the opposite sides. A set of tenons of unvarying accuracy will result.

**Boring Small Machine Parts after Grinding**

Where a large number of small machine parts must be ground and drilled, much time and labor is avoided if the

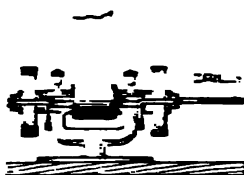

emery wheel is provided with the proper size of drill, as illustrated. This is best accomplished by boring the drill socket in the center of the wheel shaft, and locking the drill in position with a countersunk setscrew. Thus equipped, the operator is able to complete the two operations without changing his position.

**Handy Writing Board for Shop Material-Checking Work**

For inventory or the checking in of shop materials, a writing board made of light wood, and of the dimensions illustrated, is a great convenience. The cut-out portion near the corner should be about 4 in. in width and 1 in. deep. The board should be sandpapered smooth and given two coats of spar varnish. In use, the board rests on the left forearm, the curved portion fitting into the angle formed by the elbow. It is easy to hold the

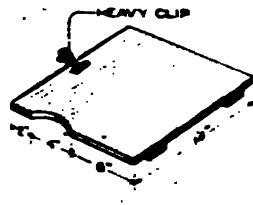

board in this position, which will be found convenient for writing. A spring clip mounted near the upper edge keeps one's papers from blowing away or being misplaced when the board is tilted or set down. Stockroom clerks and shop foremen will find such a board useful in their work.



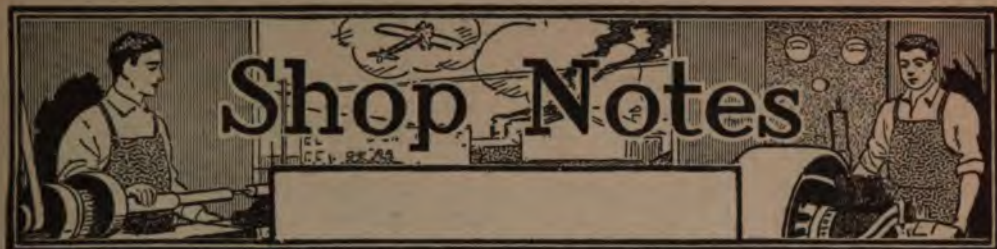

## War-Time Efficiency Methods Applied to the Dairy Barn

By H. V. STANLEY

A FARMER who conducted a dairy farm found himself seriously handicapped when his two sons enlisted in the army and he was left to attend alone a herd of 32 milch cows which formerly required the services of the three. At first it appeared as if he must dispose of at least part of the herd, as competent farm help was unobtainable. To have sold the stock would have meant the sacrificing of an estate that had taken years of toil to build up.

The problem was solved by rearranging the barn, as illustrated in the sketch, and laying it out on the plan shown in Fig. 2. With the remodeled barn the herd was not only retained but increased by eight head, while the

farmer unassisted now accomplishes in less time the work which formerly demanded the entire attention of himself and his two sons.

Figure 1 illustrates the plan of the barn before the young men entered the army. In this form, the stable housed 32 milch cows. A bull and the calves were kept in separate pens and shelters adjoining. The cows were then milked by hand. Grain, hay, and ensilage were hauled about with pushcarts, while wheelbarrows were used for cleaning the place. The bull and calves also demanded separate attention. The amount of work entailed by this plan occupied the entire time of the three men.

In the remodeling, the entire interior

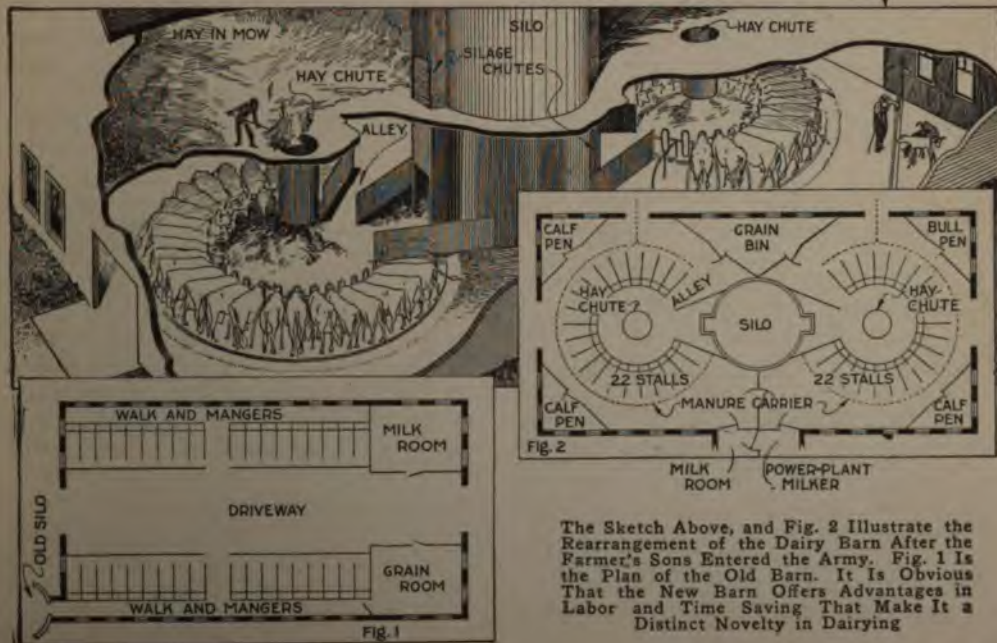

The Sketch Above, and Fig. 2 Illustrate the Rearrangement of the Dairy Barn After the Farmer's Sons Entered the Army. Fig. 1 Is the Plan of the Old Barn. It Is Obvious That the New Barn Offers Advantages in Labor and Time Saving That Make It a Distinct Novelty in Dairying



structure of the old barn was removed. The old insanitary wooden floor was replaced with cement. The old silo was torn down and replaced with a new one of concrete, in the position indicated in Fig. 2. The old rows of stalls and stanchions were rearranged as shown, with provision for 22 milch cows in each circle.

A power-plant milker, operated by one man, now does in 30 minutes the work that formerly took three men two hours. Feeding is also accomplished with a similar saving of time and labor by the new arrangement. Hay is thrown down from the mow, and from the chutes drops into the center of the

stall circles, from which position it is pitched to the stock with little effort. When hay is thrown from the mow ensilage is also thrown down and is accessible for feeding. The ensilage chutes extend through the roof and serve as ventilators for the stable. Mucking out is accomplished in less than an hour by the use of a wheeled carrier behind the rings of stalls, as indicated in Fig. 2. A small truck is used to carry grain from the bin and place it before the cows. The bull and calves, of course, are attended separately, but nevertheless at a great saving of time and energy over the old arrangement of the barn.

### Swivel Jaw for Holding Wedge-Shaped Articles in Vise

Wedge-shaped or beveled-edge articles are usually difficult to clamp in a

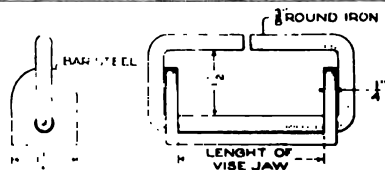
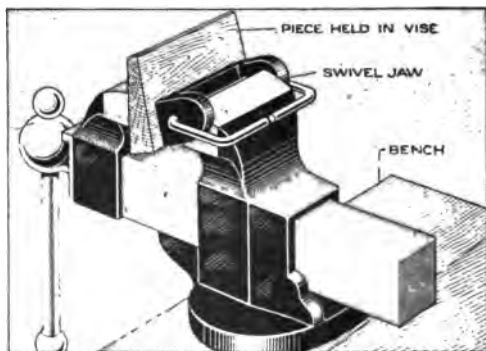

With the Swivel-Jaw Attachment for a Vise a Wedge-Shaped Article may be Clamped as Securely in an Ordinary Vise as If the Surfaces Were Parallel

vise for the reason that one side of the vise jaws will not rest squarely upon the surface. Absolute security may be had in the clamping of such articles with the aid of a swivel-jaw attachment, as illustrated.

The attachment is made to the shape indicated in the diagram of bar steel and is hooked

to the main body of the vise with a  $\frac{3}{8}$ -in. iron link, as shown. The dimensions of the swivel jaw are of course determined by the size of vise in connection with which it is to be used. It may be knurled on the clamping surface or left smooth as requirements demand—C. C. Spreen, Flint, Mich.

### Auto Air Intake Guarded for Crossing Streams

Having frequent occasion to cross a small stream that was just deep enough to kill my automobile engine, I devised a scheme to obviate this nuisance. I disconnected the air intake at the carburetor, and placed one end of a piece of rubber hose, about 3 ft. long, over the nipple on the carburetor, fitting the joint air-tight, and bent the hose upward into the engine hood. The hose permits the air for the carburetor to be taken in above the water level, and the water therefore cannot drown it. The electrical timer is coated with grease and oil, and requires no protection for the minute or two consumed in fording.—P. R. Miller, Indianapolis, Ind.

Old dry cells may be stimulated for temporary use by removing the wax from the top and moistening the interior with a solution of common salt and

tractor was clear of the hole, but the work was quickly done and with little difficulty. For this odd application of power, the cylinder cocks of the engine were opened to relieve compression.—Carl William Thies, Cedar Falls, Ia.

**Reamer for Accurate Work in Wood**

It frequently happens that holes in wood must be bored to give a very accurate fit, such as a light wedging fit, or a snug sliding fit for a pin. For such work a beveled-end reamer, as illustrated, is of great service. The reamer is made by beveling off the end of a piece of cold-rolled steel of the required size and slotting it with a hacksaw and file, as indicated.



The faces of the cut should be smoothed with a fine file, using care to keep the cutting edges intact. The knife-edges of the reamer will cut out all projecting material and the notch will collect the shavings.

**Efficient Method of Testing Motor Journal Bearings**

In plants provided with an air compressor a practical method of testing journal bearings for possible leakage is shown in the illustration. This consists of a cast-iron frame, large enough to accommodate the bearing. The side A, in addition to being equipped with air-compressor connections, contains a rubber pad, B, through the center of which a hole has been drilled to permit the passage of air. The other side, C, contains an adjusting screw and handle D. The end of the screw is fitted with a loose cast-iron cylindrical plate, E, to which is also bolted the rubber pad F. The ball-pointed screw G, passing through the top, is used in conjunction with the block and pad H. The journal box to be tested is placed

in this rigging and held in position by the screw D. The block H is placed

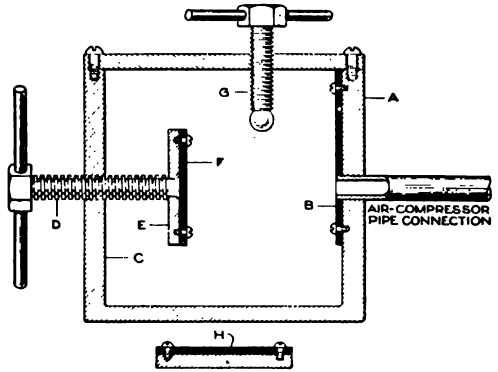

Motor Bearings are Held in This Frame While Flaws are being Located by the Use of Compressed Air

over the cover opening and clamped down by the ball-pointed screw G. This renders the bearing entirely airtight, and by turning on the inlet valve forming part of the air compressor it is a simple matter to detect any flaw, which is then remedied by plugging the holes with lead. This method of testing reduces to a minimum any motor-bearing trouble arising after the finished product has left the factory.—Frank H. Rapp, Atlanta, Ga.

**Spacing Gauge for Power-Punching or Drilling Sheet Metal**

When a number of pieces of material are being punched, or drilled, simultaneously, a spacing gauge, as indi-

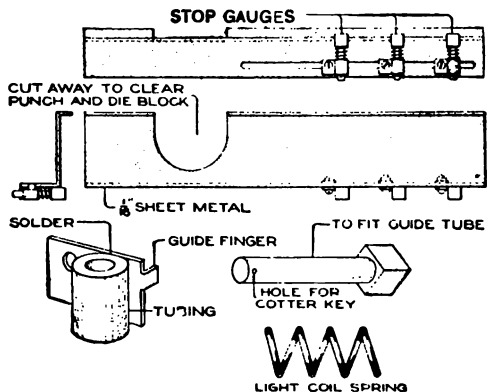

Component Parts of the Punching and Drilling Gauge Showing the Details of Construction Essential for Constructing It

### Labor-Saving Method of Excavating under a Building

By the use of a conveyor-belt and dump-bin system, as illustrated, a base-

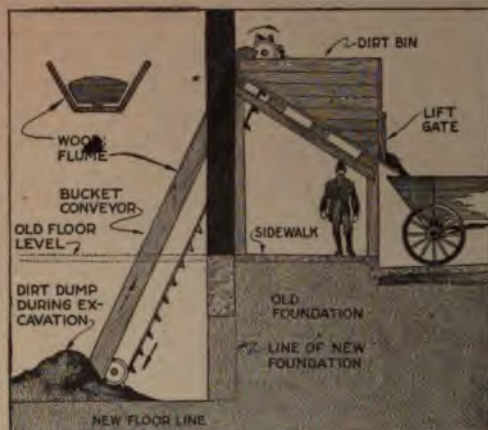

Without Disturbing the Occupants of the Building or Obstructing Street Traffic, a Basement was Dug under an Apartment House by the Use of an Endless Conveyor Belt and an Overhead Bin

ment has been dug under a large reinforced-concrete building with a minimum of labor and without obstructing the sidewalk. An opening was made in the front wall of the building and a hole dug to the depth of the basement and large enough to install the conveyor. The conveyor was operated by a small motor and dumped the dirt taken from the excavation into a bin built high enough above the sidewalk to provide headroom underneath. A lift gate was built in the end of the bin and served to regulate the loading of the wagons.

### Drawers under Bench Vise to Catch Filings

When working on costly metals a convenient method of preserving the filings is to have a tier of shallow drawers directly beneath the vise in which the work is being done. If it is lead upon which one is working, the top drawer is pulled out. The other drawers are used for copper, brass, aluminum, or bronze, as the case may be. Each drawer should be labeled and used exclusively for one kind of metal.

It is then easy to collect and redeem the filings when a drawer becomes filled.

### Garage Air Compressor Made from Discarded Cycle Motor

By making a few simple alterations on an old motorcycle engine that had outlived its usefulness as such, a garage man has provided his place with an excellent and economical air compressor. The motor was first rebored and a new piston fitted, to insure good compression. A steel plate, with a gasket under it, was bolted over the exhaust port, to close it. The original automatic inlet valve was left intact, to supply air to the cylinder when being used as a pump. A ball-valve hose connection was substituted for the priming cock on top of the cylinder, and the hose from it connected with the air tank. A longer main shaft was fitted to the engine, and on its end an ordinary shaft pulley was keyed and mounted, as illustrated. The old motorcycle flywheel, originally outside the crank case, was left in place to supply the necessary momentum. Steel lugs were made and bolted to the floor, and into these the motor base was fastened

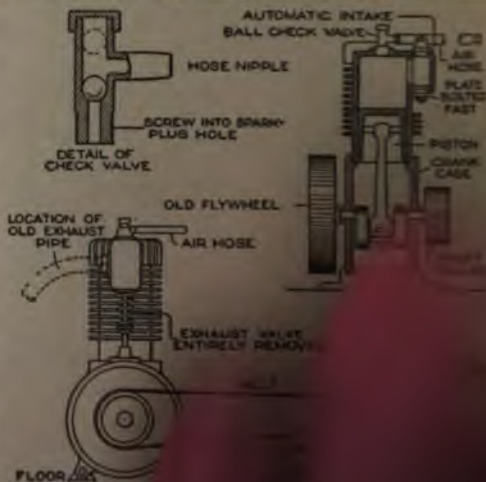

With a New Alteration a Discarded Motorcycle Engine is Converted into

in the same way as a garage air compressor.



measured. The lower jaw is moved until it is in firm contact with the lower surface, and is locked in that position by tightening the wing nut controlling the clamp mechanism on the handle. The size of the object calipered is then determined by measuring the distance between the caliper jaws with a ruler.

### Efficient Method of Recovering Pump-Jack Rods

When connecting a pump-jack rod with a windmill, great difficulty is often experienced because of the rod dropping down so the connecting pin cannot be passed through. Such

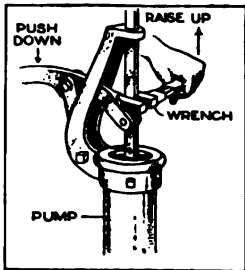

fallen rods may be easily pulled back by gripping them with a monkey wrench as shown in the sketch. After being applied, the handle of the wrench is pulled

upward until the jaws take a firm hold on the rod. The handle of the pump is then used as a lever to pull the jack rod into place.—Will F. Benzel, Rockford, Ia.

### Extension Control for Tractor Aids in Work of Plowing

When pulling a riding plow with a tractor, more efficient work is accomplished if one is on the plow. To accomplish this I have fitted my tractor with an auxiliary control, as illustrated. An old automobile steering wheel was purchased in a junk yard, and a little blacksmithing in the farm workshop completed the control system. Two ½-in. rods, connected, just above the drawbar, with a universal joint and fastened to the tractor steering wheel and to the second wheel, furnished the extension guide. The rod was fastened to the tractor by making a "U" on the end and running the ends through the spokes of the steering wheel and on

through an iron bar which was bolted in place. Supporting rods were also attached to the tractor and to the plow.



The Auxiliary Tractor Control Enables the Operator to be on the Riding Plow and to Handle Both Machines with Maximum Efficiency and Ease

Two lines, one from the clutch lever, and one from the speed and reverse lever, were used to control the tractor. These were attached to the plow with the aid of two old binder levers, which serve as controls. With this method excellent results are obtained. I often work the tractor for two or three hours at a time without the necessity of stopping for anything.—Charles N. Garber, North Manchester, Ind.

### An Improved Electric-Light Socket

Needing an extra electric-light socket and having none available, I contrived one from a piece of spring wire as indicated in the sketch. Two stove bolts were set in a block of wood. These protruded into a groove on the underside of the block and were used for the wire connections.

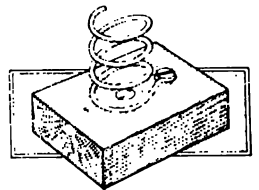

The spring was wound to fit the threads of the outside electrode of the globe and contact was made with the central electrode by turning the globe down against the bolt in the center of the coil. The makeshift gave thoroughly satisfactory service.—George Perkins, Millburn, New Jersey.

### Tool for Conserving Small Pieces of High-Speed Steel

With the present scarcity of high-speed steel, the necessity for conserving

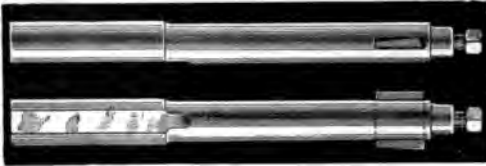

This Tool, Which may be Used for a Variety of Boring Jobs, Has Cutting Members Made from Small Scraps of High-Speed Steel That Usually are Wasted

this material has been brought home to both large shops and small. The tool illustrated permits a wide range of boring operations, utilizing the small scraps of high-speed steel that ordinarily go to waste. The shaft is of milled steel, hence is inexpensive and easy to make. The cutters, being held by a setscrew in the end of the tool, are readily removable for grinding.—L. M. Rowley, Livermore, Calif.

### A Holdfast Leather-Belting Cement

Scraps of waste celluloid, such as old film, combs, and similar articles, dissolved by agitation in methyl acetone to produce a thick sirupy solution, make an excellent leather-belting cement. Belting thus cemented is both flexible and waterproof. It should be borne in mind that the ingredients of this cement are highly inflammable and should not be mixed or used in the vicinity of any open flame.—Leon A. Haloin, Denver, Colo.

### Emergency Bearing for Tractor Made from Oil-Soaked Maple

While being operated in a section of country remote from any repair shop, or source of machine supplies, a tractor engine burned out a main-shaft bearing. Without some sort of an emergency repair the machine could not be driven, and to have fitted a new bearing without having the machine in a repair shop would have been prac-

tically impossible. As an experiment a bearing was made from a piece of hard maple. It was boiled in cylinder oil for several hours to impregnate the wood thoroughly and was then placed in the machine. With the wooden bearing the machine was run slowly and with an abundance of oil until it became apparent that the wood was developing no signs of heating. The tractor was put to work with this makeshift repair and gave satisfactory service until it could be taken to a shop for a more permanent job.—C. C. Cook, McMinnville, Tenn.

### Hoisting Hook Has Instantaneous Positive Grip

An exceptionally handy hoisting hook for use in basements, warehouses, and other places where there are overhead rafters, is made as indicated in the sketch. Such a hook may be instantly attached for use wherever needed. Up to the limits of its capacity and that of the supporting beam, the prongs take a more positive grip the greater the strain imposed upon it. The dimensions given in the sketch are designed for comparatively light

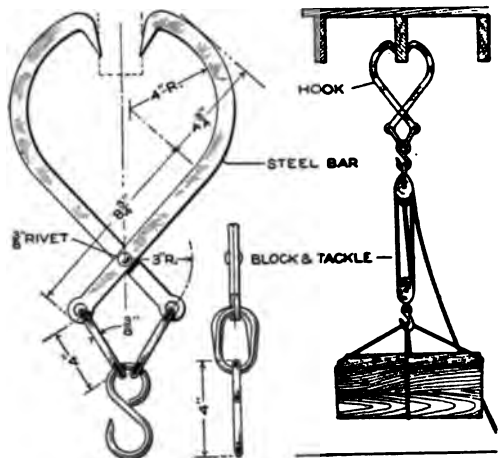

In Shops, or Other Places Where There Are Overhead Beams or Rafters, This Portable Hoisting Hook may be Instantly Applied

work. For heavier lifting, they should be increased according to requirements.

### An Emergency Spark-Plug Repair

The writer was caught in a rain-storm. Water struck the spark plug of his motorcycle and cracked the porcelain insulation. This short-circuited the plug, as the spark jumped through the crack. Temporary repairs were made by removing the upper broken porcelain, and placing  $\frac{1}{8}$ -in. dry-paper washers in the break. Then the plug was reassembled and fastened in place. The plug worked satisfactorily until home was reached.—Bernard Bergman, Belleville, Ill.

### Jig for Drilling Small Sheet-Metal Pieces

Where a large number of small, thin, square or rectangular pieces of sheet metal or brass, having in them one or more holes, are to be drilled, an effective jig can be constructed with little work from a block of steel, as shown in the illustration. In using this jig the pieces to be drilled are piled in the groove of the block.

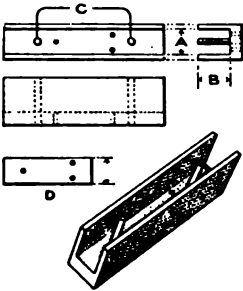

A finished piece, D, which serves as a template to locate the holes accurately, is placed on the top of the others when the contrivance is being used. In width the block should be equal to the dimension A plus  $\frac{1}{4}$  in. Its length should be such that it can, when in use, be held securely and safely by the hand. The slot is milled of such a width that the pieces which are to be drilled can be placed in or taken out of it easily. However, it should not be too wide because this would impair its accuracy. The depth, B, should be such that several pieces can be accommodated and drilled simultaneously. Two guide pins, C, driven in drilled holes, prevent longitudinal motion of the pieces.

### Device for Bending Conduit Elbows

When bending conduit elbows for ceiling outlets, it is often desirable to arrange a form, as illustrated. The

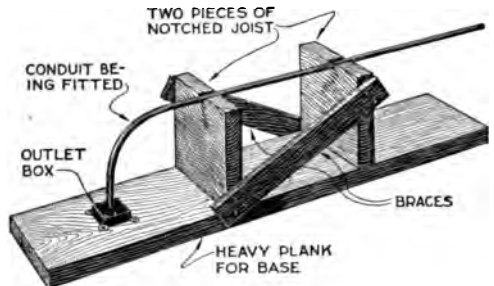

With This Simple Device Electrical Conduits are Quickly Bent to Fit in the Location in Which They are to be Installed

heavy end pieces are sections cut from a joist, of the same depth as those used in the building in which the installation is to be made. The plank for the base should be at least 5 ft. long and 2 in. thick. An outlet box of the type being used is mounted on the plank, as shown. After each bend is formed, it is tried in this template as it lies on the floor. The correctness of fit is thus determined without the necessity of taking the conduit to the location in which it is to be installed.—G. G. Hartman, St. Louis, Mo.

### Safety Washer for Fastening Emery Wheels

The safety washer for fastening emery wheels, shown in the sketch, was adopted recently by the safety commission of a great manufacturing state. It is turned from a single piece of steel, which serves as a box into which the nut is set deep enough to avoid all possibility of one's clothing becoming entangled. A socket wrench is, of course, used in the application and removal of wheels with this type of fastening.—Rollin C. Woodford, Meadville, Pa.

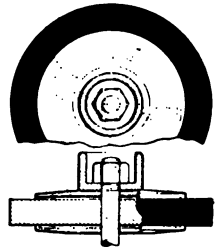



### Pivot Stand Aids in Handling of Rough Lumber

Wherever quantities of rough lumber must be loaded, unloaded, or piled, a



pivot stand, as shown in the sketch, is of great assistance in the work of handling. Such a stand consists of a central upright erected on two crossed bottom pieces, the ends of which are mortised into four slanting legs which grip the upper part of the central piece.

Into the end of the upright is set a stout steel pin having a rather blunt point. The stand is placed alongside the wagon or lumber pile and is used as a pivot where leverage accomplishes much of the work ordinarily done by actually lifting each board.—Henry Simon, Laguna Beach, California.

### Rapid and Accurate Method of Making Tenons

The following manner of making tenons gives better results than the usual method, and takes less time than



the ordinary way. After making the saw cuts determining the length of the tenons on the pieces, roughly shape the tenons to within  $\frac{1}{16}$  in. of the desired thickness. Then place the pieces in pairs opposite each other, as shown. Clamp them down, placing a piece of sandpaper, folded double so as to present two sanded sides, between the clamping strips and the pieces to be worked. This prevents slipping. With a rou

plane, level off the depressions; reverse the work, and level off the opposite sides. A set of tenons of unvarying accuracy will result.

### Boring Small Machine Parts after Grinding

Where a large number of small machine parts must be ground and drilled, much time and labor is avoided if the

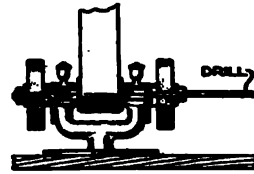

emery wheel is provided with the proper size of drill, as illustrated. This is best accomplished by boring the drill

socket in the center of the wheel shaft, and locking the drill in position with a countersunk setscrew. Thus equipped, the operator is able to complete the two operations without changing his position:

### Handy Writing Board for Shop Material-Checking Work

For inventory or the checking in of shop materials, a writing board made of light wood, and of the dimensions illustrated, is a great convenience. The cut-out portion near the corner should be about 4 in. in width and 1 in. deep. The board should be sandpapered smooth and given two coats of

spar varnish. In use, the board rests on the left forearm, the curved portion fitting into the angle formed by the elbow. It is easy to hold the



board in this position, which will be found convenient for writing. A spring clip mounted near the upper edge keeps one's papers from blowing away or being misplaced when the board is tilted or set down. *Stockroom clerks*

## A Handy Clamp Made from Waste Materials

There are numerous clamping operations about the average small shop where a clamp of the type illustrated is useful, but if purchased ready-made, such clamps are almost prohibitive in price. A very serviceable article is made from an iron bar and an 8-in. machine bolt, as shown in the sketch. A threaded block is provided for the bolt and attached by means of a keystone notch to one end of the bar. The other end of the bar is provided with a hardwood block, as shown. This block is made adjustable by being fastened with a steel pin, which may be set in various holes along the body of the bar. The finished clamp is very powerful as well as almost instantly adjust-

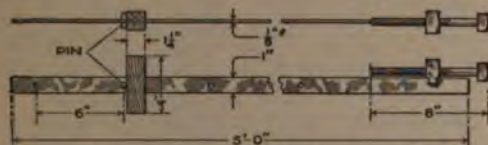

A Powerful Clamp, Having a Wide Range of Application, Which may be Made from Waste Materials Usually to be Found about the Small Shop

able for any variety of work.—Norman Harris, Toronto, Ont., Canada.

## Method of Preventing Binder Canvas from Ripping

To prevent grain-binder canvas from ripping, rivet a leather strap along the underside outer edge. A rivet should be placed near the end of each slat to allow for stretching in the canvas. Ordinarily the canvas wears through first at the end of the slats. The leather strap will prevent this.—Stanley Dougan, Pawnee, Okla.

## Device for Vulcanizing Tires on Steam-Engine Cylinder

Wishing to retread a motorcycle tire and not having a vulcanizer, I improvised an outfit which did the work satisfactorily. A mold to fit the tire was cast from babbitt metal and propped against the engine cylinder until thor-

oughly hot. The tire was then placed in position and clamped by means of a

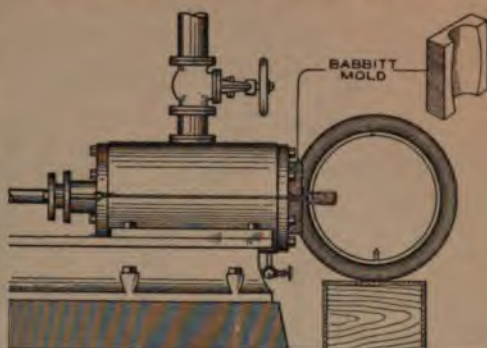

By Utilizing the Heat of a Steam-Engine Cylinder Satisfactory Vulcanizing may be Accomplished with the Aid of an Improved Babbitt Mold

stick put through it and wired to a bolt on each side of the cylinder, as illustrated. With 80 lb. of steam it took about an hour to thoroughly vulcanize a section of a 3-in. casing. A larger tire would of course take more time.—M. C. Metzger, Silver Creek, Neb.

## Mandrel for Truing the Faces of Nuts

The most unevenly faced nut may be quickly trued with the aid of the rocking-washer mandrel illustrated. Regardless of how uneven the face of the nut may be, it may be turned down securely on the threads of the mandrel. The mandrel is then placed in the lathe and the surface of the nut is marked and faced off. The mandrel is made from tool steel, or milled steel thoroughly casehardened.



☐ In tinkering on automobile engines, searching in the mud pan for dropped tools and parts may be avoided by stuffing sacking into the space between the engine and chassis frame.

### Cold-Water System with Cooling Coil in Supply Pipe

Any shop can have a continuous supply of cold drinking water by installing

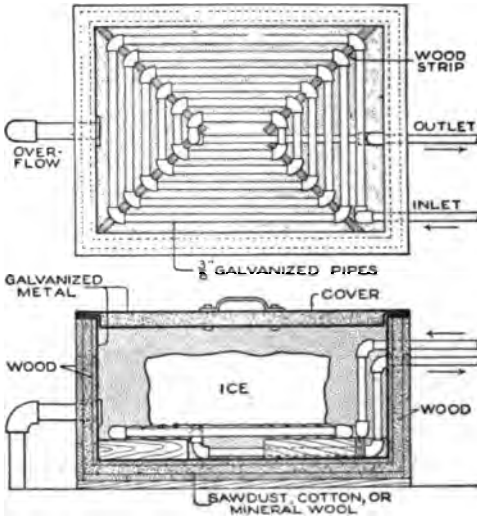

A Simple System for Providing a Continuous Supply of Cold Drinking Water in a Shop

an equipment such as that shown in the accompanying diagrams. The cooling coil, which is inserted in the water-supply pipe to the drinking fountain, is assembled from malleable-iron elbows and pipe nipples. To prevent excessive radiation, heat-insulating materials are incorporated in the sides and cover of the box. Ice is packed on top of the cooling coil. Water which flows to the fountain is thereby cooled. An overflow pipe from the cooler leads to the sewer, to carry away excessive water from the melting ice. This cooler may be installed at any convenient location, but preferably should be near the fountain so that the temperature of the water will not be raised ap-

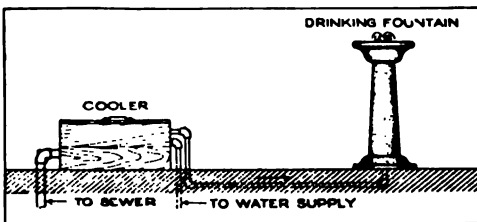

Diagrammatic View of Pipe Connections between Cooler and Drinking Fountain, Water Supply, and Drainage System

preciably in flowing from the cooler to the fountain. It is desirable to inclose the pipe between the cooler and the fountain in a magnesia or similar heat-insulating covering.—C. C. Spreen, Flint, Mich.

### Buggy Hub Used for Repairing Worn Threads of a Pump Cylinder

A farmer whose crops were threatened with injury because of the failure of an irrigation pump, effected the temporary repair illustrated. The threads of the cylinder caps had stripped, allowing the cylinder to pull apart and rendering the pump useless. An old buggy hub was cut in two, and the halves were passed over the jack rod, as indicated. Through holes previously drilled in the spoke flanges, two steel rods were inserted. The ends of these rods were threaded and nuts applied for pulling the entire mechanism together. This makeshift repair produced a water-tight cylinder, which

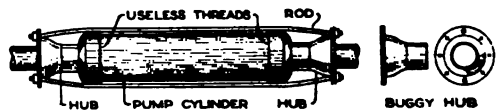

The Halves of a Buggy Hub were Used to Secure a Connection for Threaded Steel Rods Which Held Together the Caps of a Pump Cylinder from Which the Threads had been Stripped

gave satisfactory service until a new one could be procured.—C. C. Jackson, Roanoke, Ind.

### Chalking a Tap to Get a Perfect Fit

It is always desirable to get a perfect fit for steam, air, or water-tight work on studs, plugs, patch bolts, and similar jobs where tapered taps are used. A simple method of determining the exact size of a tapped hole is to chalk the tap with ordinary white chalk, and then run it into the hole. When the tap is screwed into the hole the chalk is removed due to the friction of the metal against the tap. After the tap has been run in as far as it will go, it is taken out. The chalk will not show on the tap up to the



tractor was clear of the hole, but the work was quickly done and with little difficulty. For this odd application of power, the cylinder cocks of the engine were opened to relieve compression.—Carl William Thies, Cedar Falls, Ia.

**Reamer for Accurate Work in Wood**

It frequently happens that holes in wood must be bored to give a very accurate fit, such as a light wedging fit, or a snug sliding fit for a pin. For such work a beveled-end reamer, as illustrated, is of great service. The reamer is made by beveling off the end of a piece of cold-rolled steel of the required size and slotting it with a hacksaw and file, as indicated.

The faces of the cut should be smoothed with a fine file, using care to keep the cutting edges intact. The knife-edges of the reamer will cut out all projecting material and the notch will collect the shavings.



**Efficient Method of Testing Motor Journal Bearings**

In plants provided with an air compressor a practical method of testing journal bearings for possible leakage is shown in the illustration. This consists of a cast-iron frame, large enough to accommodate the bearing. The side A, in addition to being equipped with air-compressor connections, contains a rubber pad, B, through the center of which a hole has been drilled to permit the passage of air. The other side, C, contains an adjusting screw and handle D. The end of the screw is with a loose cast-iron cylindrical pad F. The ball-pointed screw through the top, is used in connection with the block and pad H. The bearing box to be tested is placed

in this rigging and held in position by the screw D. The block H is placed

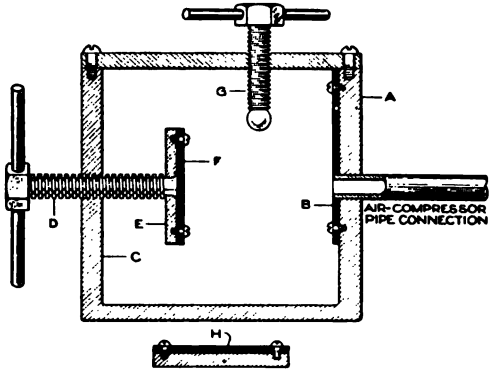

Motor Bearings are Held in This Frame While Flaws are being Located by the Use of Compressed Air

over the cover opening and clamped down by the ball-pointed screw G. This renders the bearing entirely airtight, and by turning on the inlet valve forming part of the air compressor it is a simple matter to detect any flaw, which is then remedied by plugging the holes with lead. This method of testing reduces to a minimum any motor-bearing trouble arising after the finished product has left the factory.—Frank H. Rapp, Atlanta, Ga.

**Spacing Gauge for Power-Punching or Drilling Sheet Metal**

When a number of pieces of material are being punched, or drilled, simultaneously, a spacing gauge, as indi-

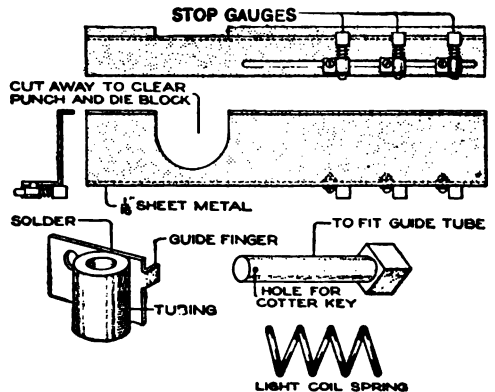

Component Parts of the Punching and Drilling Gauge Showing the Details of Construction Essential for Constructing It

### Effective Emergency Repair - for Automobile Wheel

In the photographic reproduction is shown how a broken automobile wheel



The Right Rear Wheel of This Automobile is Made from Three Wooden Disks Fitted to the Old Hub and Felloe. After the Spokes had Broken. The Car was Driven 250 Miles with It

was quickly and effectively repaired on the Valdez Trail, Alaska, 150 miles from any automobile-supply station. After the repair, the machine was driven without failure over bad roads for 250 miles. In constructing the improvised wheel, six pieces of board, each  $1\frac{1}{4}$  in. thick, and the old felloe were used. The only tools employed were a brace and bit, a saw, and a hammer. The six boards were assembled and sawed into three disks giving a total thickness of  $3\frac{3}{4}$  in. The boards were so placed that the grain of the wood crossed in adjacent layers. Two of the wooden disks were of the same diameter as that of the outside of the felloe. The inner disk was sawed to fit tightly inside of the felloe. Six bolts passing through the felloe and two outer disks clamped the parts together. A hole was bored through the center of the three disks for the hub. The old hub was used, with spoke flanges on the outside. A notch was cut in the outside and center disks to permit access to the tire valve. Then the wheel was ready for use. It required only two hours to build it. A small piece of board with a nail driven in each end was used as a compass for striking the circles.—John S. Griswold, Fairbanks, Alaska.

### Iron Cement Made from Old Dry-Cell Filler

The black filler material from old dry cells, when combined with powdered iron and Portland cement, makes an excellent iron cement which is suitable for a variety of purposes. The proportions are: cement, 15 oz.; powdered iron, 20 oz.; battery filler, 5 oz. All this material must be perfectly dry when mixed and as fine as possible. Any moisture will set up a chemical action that will set the mixture. Cement powder will keep indefinitely if stored in a dry place. When desired for use, it is only necessary to add water to make a thick paste and apply.

### Mole Plow Makes Subsurface Drain without Use of Tile

The mole plow shown in the sketch has been used successfully for draining the ground about several American army cantonments and by farmers in the cultivation of low, marshy land. The mole, which is made of hardened steel, makes a 4-in. hole 15 in. to 18 in. underground as fast as the plow can be drawn along by horses or machinery. Its construction presents no difficulty that cannot be overcome in the average shop. The handles are taken from an old walking plow,

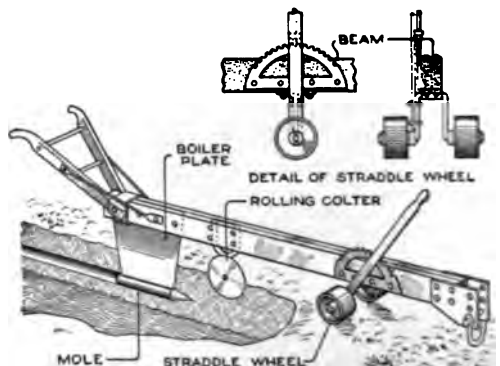

Boggy Ground is Quickly Drained through the Underground Hole Left by the Passage of the Steel Mole

while the straddle wheels and lever for controlling same are from a grain

measured. The lower jaw is moved until it is in firm contact with the lower surface, and is locked in that position by tightening the wing nut controlling the clamp mechanism on the handle. The size of the object calipered is then determined by measuring the distance between the caliper jaws with a ruler.

### Efficient Method of Recovering Pump-Jack Rods

When connecting a pump-jack rod with a windmill, great difficulty is often experienced because of the rod dropping down so the connecting pin cannot be passed through. Such fallen rods may be easily pulled back by gripping them with a monkey wrench as shown in the sketch. After being applied, the handle of the pump is pulled

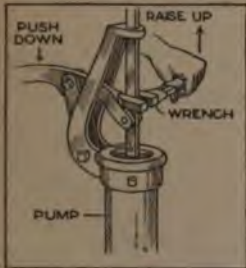

upward until the jaws take a firm hold on the rod. The handle of the pump is then used as a lever to pull the jack rod into place.—Will F. Benzell, Rockford, Ia.

### Extension Control for Tractor Aids in Work of Plowing

When pulling a riding plow with a tractor, more efficient work is accomplished if one is on the plow. To accomplish this I have fitted my tractor with an auxiliary control, as illustrated. An old automobile steering wheel was purchased in a junk yard, and a little blacksmithing in the farm workshop completed the control system. Two  $\frac{1}{2}$ -in. rods, connected, just above the drawbar, with a universal joint and fastened to the tractor steering wheel and to the second wheel, furnished the extension guide. The rod was fastened to the tractor by making a "U" on the end and running the ends through the spokes of the steering wheel and on

through an iron bar which was bolted in place. Supporting rods were also attached to the tractor and to the plow.



The Auxiliary Tractor Control Enables the Operator to be on the Riding Plow and to Handle Both Machines with Maximum Efficiency and Ease

Two lines, one from the clutch lever, and one from the speed and reverse lever, were used to control the tractor. These were attached to the plow with the aid of two old binder levers, which serve as controls. With this method excellent results are obtained. I often work the tractor for two or three hours at a time without the necessity of stopping for anything.—Charles N. Garber, North Manchester, Ind.

### An Improved Electric-Light Socket

Needing an extra electric-light socket and having none available, I contrived one from a piece of spring wire as indicated in the sketch. Two stove bolts were set in a block of wood. These protruded into a groove on the underside of the block and were used for the wire connections.



The spring was wound to fit the threads of the outside electrode of the globe and contact was made with the central electrode by turning the globe down against the bolt in the center of the coil. The makeshift gave thoroughly satisfactory service.—George Perkins, Millburn, New Jersey.



### Tool for Conserving Small Pieces of High-Speed Steel

With the present scarcity of high-speed steel, the necessity for conserving



This Tool, Which may be Used for a Variety of Boring Jobs, Has Cutting Members Made from Small Scraps of High-Speed Steel That Usually are Wasted

this material has been brought home to both large shops and small. The tool illustrated permits a wide range of boring operations, utilizing the small scraps of high-speed steel that ordinarily go to waste. The shaft is of milled steel, hence is inexpensive and easy to make. The cutters, being held by a setscrew in the end of the tool, are readily removable for grinding.—L. M. Rowley, Livermore, Calif.

### A Holdfast Leather-Belting Cement

Scraps of waste celluloid, such as old film, combs, and similar articles, dissolved by agitation in methyl acetone to produce a thick sirupy solution, make an excellent leather-belting cement. Belting thus cemented is both flexible and waterproof. It should be borne in mind that the ingredients of this cement are highly inflammable and should not be mixed or used in the vicinity of any open flame.—Leon A. Haloin, Denver, Colo.

### Emergency Bearing for Tractor Made from Oil-Soaked Maple

While being operated in a section of country remote from any repair shop, or source of machine supplies, a tractor engine burned out a main-shaft bearing. Without some sort of an emergency repair the machine could not be driven, and to have fitted a new bearing without having the machine in a repair shop would have been prac-

tically impossible. As an experiment a bearing was made from a piece of hard maple. It was boiled in cylinder oil for several hours to impregnate the wood thoroughly and was then placed in the machine. With the wooden bearing the machine was run slowly and with an abundance of oil until it became apparent that the wood was developing no signs of heating. The tractor was put to work with this makeshift repair and gave satisfactory service until it could be taken to a shop for a more permanent job.—C. C. Cook, McMinnville, Tenn.

### Hoisting Hook Has Instantaneous Positive Grip

An exceptionally handy hoisting hook for use in basements, warehouses, and other places where there are overhead rafters, is made as indicated in the sketch. Such a hook may be instantly attached for use wherever needed. Up to the limits of its capacity and that of the supporting beam, the prongs take a more positive grip the greater the strain imposed upon it. The dimensions given in the sketch are designed for comparatively light

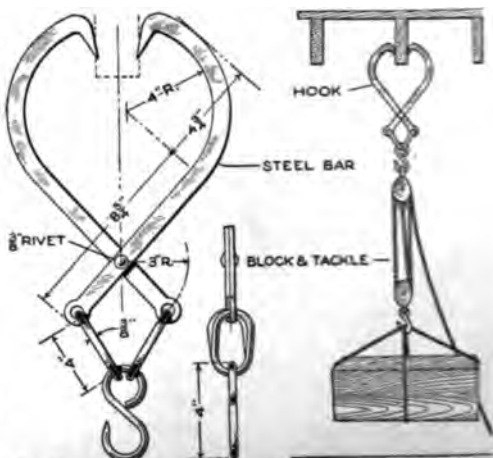

In Shops, or Other Places Where There Are Overhead Beams or Rafters, This Portable Hoisting Hook may be Instantly Applied

work. For heavier lifting, they should be increased according to requirements.

### An Emergency Spark-Plug Repair

The writer was caught in a rain-storm. Water struck the spark plug of his motorcycle and cracked the porcelain insulation. This short-circuited the plug, as the spark jumped through the crack. Temporary repairs were made by removing the upper broken porcelain, and placing  $\frac{1}{8}$ -in. dry-paper washers in the break. Then the plug was reassembled and fastened in place. The plug worked satisfactorily until home was reached.—Bernard Bergman, Belleville, Ill.

### Jig for Drilling Small Sheet-Metal Pieces

Where a large number of small, thin, square or rectangular pieces of sheet metal or brass, having in them one or more holes, are to be drilled, an effective jig can be constructed with little work from a block of steel, as shown in the illustration. In using this jig the pieces to be drilled are piled in the groove of the block. A finished piece, D, which serves as a template to

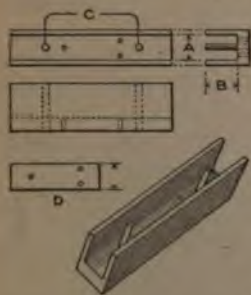

locate the holes accurately, is placed on the top of the others when the contrivance is being used. In width the block should be equal to the dimension A plus  $\frac{1}{4}$  in. Its length should be such that it can, when in use, be held securely and safely by the hand. The slot is milled of such a width that the pieces which are to be drilled can be placed in or taken out of it easily. However, it should not be too wide because this would impair its accuracy. The depth, B, should be such that several pieces can be accommodated and drilled simultaneously. Two guide pins, C, driven in drilled holes, prevent longitudinal motion of the pieces.

locate the holes accurately, is placed on the top of the others when the contrivance is being used. In width the block should be equal to the dimension A plus  $\frac{1}{4}$  in. Its length should be such that it can, when in use, be held securely and safely by the hand. The slot is milled of such a width that the pieces which are to be drilled can be placed in or taken out of it easily. However, it should not be too wide because this would impair its accuracy. The depth, B, should be such that several pieces can be accommodated and drilled simultaneously. Two guide pins, C, driven in drilled holes, prevent longitudinal motion of the pieces.

### Device for Bending Conduit Elbows

When bending conduit elbows for ceiling outlets, it is often desirable to arrange a form, as illustrated. The

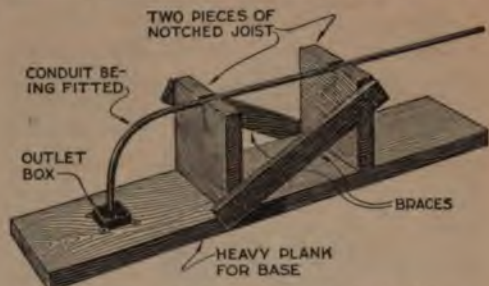

With This Simple Device Electrical Conduits are Quickly Bent to Fit in the Location in Which They are to be Installed

heavy end pieces are sections cut from a joist, of the same depth as those used in the building in which the installation is to be made. The plank for the base should be at least 5 ft. long and 2 in. thick. An outlet box of the type being used is mounted on the plank, as shown. After each bend is formed, it is tried in this template as it lies on the floor. The correctness of fit is thus determined without the necessity of taking the conduit to the location in which it is to be installed.—G. G. Hartman, St. Louis, Mo.

### Safety Washer for Fastening Emery Wheels

The safety washer for fastening emery wheels, shown in the sketch, was adopted recently by the safety commission of a great manufacturing state. It is turned from a single piece of steel, which serves as a box into which the nut is set deep enough to avoid all possibility of one's clothing becoming entangled. A socket wrench is, of course, used in the application and removal of wheels with this type of fastening.—Rollin C. Woodford, Meadville, Pa.



**Automatic Signaling Device  
for Projecting Machines**

Modern motion-picture projecting machines are provided with mechanism for automatically notifying the operator

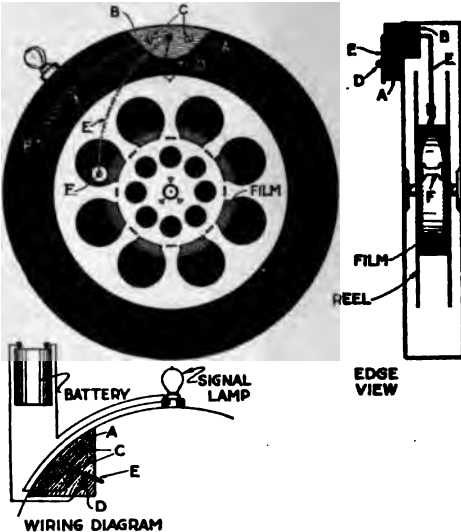

**WIRING DIAGRAM**  
Construction Details of a Simple Electrical Signal for Old-Type Motion-Picture Projecting Machines; By Its Use the Operator is Notified When the End of the Reel is Being Approached

when the end of a reel is being approached. The lack of any such mechanism on many old types of machines, still in use, is frequently a source of annoyance to operators, exhibitors, and audience alike. These old-style machines may be modernized in this respect by the installation of the automatic signaling device illustrated. It consists of a simple form of electrical contact by which a globe is lighted to notify the operator whenever the reel nears its end. This is accomplished by means of a contact spring, E, with a small roller on the end F, which presses against the film, descending as the film is unwound, and closing the circuit when all but a small portion of the film has been shown. Referring to the drawing it will be noted that the spring is mounted in the machine upon two wooden blocks, A and B, which are fastened by means of a screw, C. The other end of the roller, rides on the reel is star

contact segment away from the circuit point D, until the reel is nearly finished. As the film passes through the machine during the exhibition, the roller F gradually sinks toward the axle of the reel. Eventually the opposite end comes against the contact screw D, forming the circuit to the light, and signaling the operator.—A. F. Andrews, Chicago, Ill.

**Adjustable Supporting Stand  
Substitute for Jackscrew**

An adjustable stand, the construction of which is disclosed in the illustration, has been found very useful in the shop for supporting frames of machines, or similar objects, which are being assembled or repaired. It may be substituted effectively for the usual jack. It is safer than the latter and its first cost is lower. The base is a standard floor flange. The vertical column is a length of wrought-iron pipe, threaded at the end which screws into the flange. The movable shaft is another piece of pipe, its diameter being such that it will slide easily within the pipe column. A 3/8-in. pin, cut from cold-rolled steel, constitutes a key whereby the shaft may be held at any desired height. Equidistantly spaced holes, 7/16 in. in diameter, are drilled in the shaft and column for the key. The

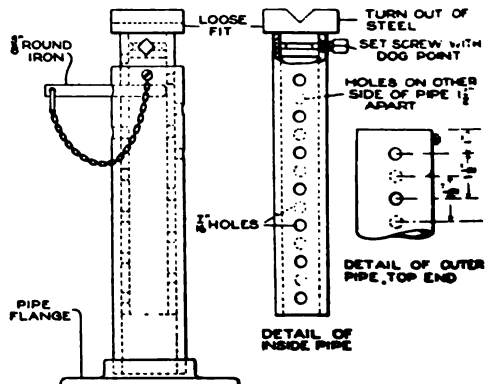

The Stand Is Useful on the Assembly Floor. The Lock Is Positive and cannot be Released by Accident

It should be chained to will not be



V-notch machined across its upper face. An annular groove is turned in its lower extension. Into this groove a setscrew with a dog point engages. The point of this setscrew should fit loosely in the groove so that the V-notch may be rotated to any desired position.

### Electric Ignition System Wired to Counteract Loose Connections

Electrical ignition systems are frequently operated upon low voltages from primary batteries, storage batteries, or low-pressure generators. The power required is very small, and on this account batteries are much used. The primary voltage is generally about six volts and the series-multiple con-

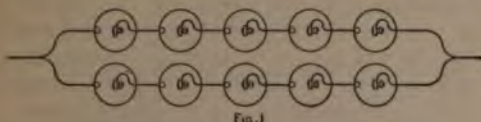

Fig. 1

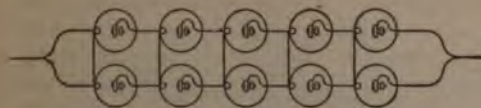

Fig. 2

By Providing Cross Connections, the Entire Series is Not Rendered Useless Because of a Loose Contact

nection, shown in Fig. 1, is usually employed. If additional cross connections are made, as shown in Fig. 2, a loose connection in one series of batteries will not render the entire series useless.—Peter J. M. Clute, Schenectady, N. Y.

### Fixing Compass-Point Centers on Drawing Sheets

When a large number of circles are drawn from the same compass center a hole is ordinarily worn in the paper. It thus becomes impossible to draw circles or arcs concentric with each other. To remedy this, glue a small piece of celluloid over the center to take the point of the compass. Such compass-point centers may be removed from the drawing, when completed, with a knife.

### Holes Drilled through Brick and Mortar

In wiring an old house for electricity, the workmen had to drill a vertical hole through several layers of wood, brick, and plaster. The only tool that could do the work was a drill bit with a short auger section and a long shank. After the hole had been drilled a few inches it began to clog, as the fine dust would not lift out. It packed hard at the bottom of the hole and hampered progress. Then a short piece of tubing was thrust into the hole. When the workman blew into the tube, the dust came out in a jiffy. A shield of paper around the tubing protected the workman's face. The operation was repeated as often as necessary.—Dale R. Van Horn, North Loup, Neb.



### Guideboards Are Great Aid for Correct Saw Filing

The difficult job of filing a saw properly is rendered much easier by the use of an angle guide board, as shown in the drawing. Such a guide board is readily made from three pieces of wood. After being fitted over the saw blade the correct angles for filing are located with a ruler and pencil and made permanent with saw cuts. When filing the saw the file is kept in line with the guide marks, thus eliminating all guesswork as to the correctness of the angle of filing.



### A Serviceable Homemade Tool for Trimming Belts

Many old belts may be trimmed down, or split, and made to give in-

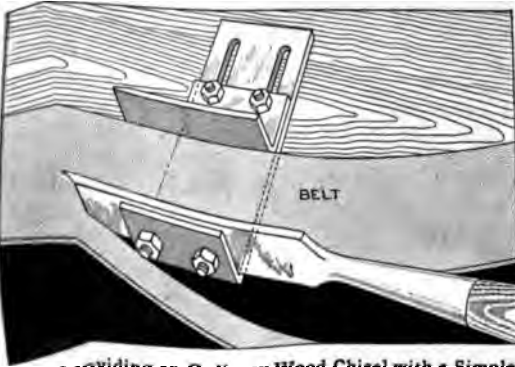

By Providing an Ordinary Wood Chisel with a Simple Metal Guide It may be Used as a Tool for Trimming Leather Belting and Similar Stock

definite service on smaller machinery. An excellent tool for trimming such belting is made from an old chisel, as illustrated. Two holes are drilled through the blade and through these holes bolts are passed to fasten a piece of steel, bent at right angles and slotted as shown. A second piece of steel, bent at right angles, is bolted through these slots, and when tightened in place, serves as a guide for governing the depth of the split to be made.—Charles H. Wiley, Concord, N. H.

### Utilizing Sun's Rays for Truing a Straightedge

I had occasion to use a long straight-edge, but no means for truing it was

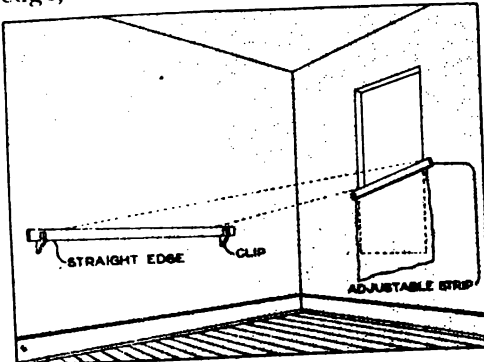

The Sun Shining through the Window at the Left Defined a Straight Line on the Side Wall, along Which the Straightedge was Trued

available. Finally, I thought of the rays of the sun, shining through the window, to define a long straight line. Accordingly I mounted an adjustable strip on a window as shown in the illustration, just so that the rays over its edge cut the top of the location where I mounted the straightedge. Thereby a straight line was indicated and the straightedge was trued.—H. A. ter, Milwaukee, Wis.

### Making a Sprung Shaft Self-Alining

Because too much load was placed in the middle of some shafts sprung and bound in the bearing crowning the journals, a good bearing surface was had at any load. A spring of the shaft is indicated in the picture, and even with this amount of deflection, the shaft revolved. Of course, a shaft turning at high

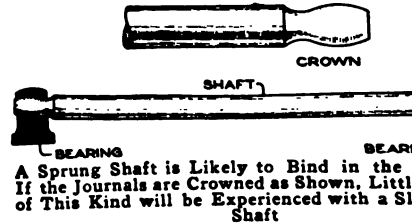

A Sprung Shaft is Likely to Bind in the Bearing. If the Journals are Crowned as Shown, Little or No Binding will be Experienced with a Sprung Shaft

or under a heavy load could not be expected to give satisfactory results under such conditions. In the case of the shaft illustrated the speed was only a few revolutions per minute.

### Reducing Waste in Breaking Tool Steel

As high-speed steel is very expensive and scarce, the following method is helpful in preventing waste. In some cases the machinist cuts off a piece from the bar, and shapes the end. Usually he grinds the bar on a lathe wheel, and makes two cuts, one on each side, so the cross section of the bar is like an "X." This is wasteful. The right way is to make a single V-cut from one side to the other.—Danyard, Detroit, Mich.

## Water-Jacketing an Air-Cooled Motor

By E. E. STEVENSON

An air-cooled, two-cylinder, four-cylinder automobile motor of conventional design was installed in a small speed boat. Its service was satisfactory except that it heated excessively after a half hour's operation. The heating was due to impaired air circulation. A water-cooling jacket, arranged as will be described, corrected the difficulty satisfactorily. All of the air flanges on each cylinder except the three nearest the flywheel were turned off in a lathe. Then these three, together with the inlet and exhaust-manifold bosses, were machined to a common true diameter, which was also the exact inside diameter of the sheet-copper water jackets which had been provided. Each jacket comprised a cylinder of sheet copper,  $\frac{1}{16}$  in. thick, with a disk of the same material brazed into one end. The spaces between the three remaining flanges on each cylinder were packed with asbestos cordage and red lead. Then the copper jackets were gently pressed onto the cylinders. Steel bands were shrunk on over them at the flywheel ends, clamping them snugly to the remaining flanges. Holes were cut in the jackets for the valve cages, and the intake and exhaust

manifolds, and also for their respective tap bolts. These parts being securely

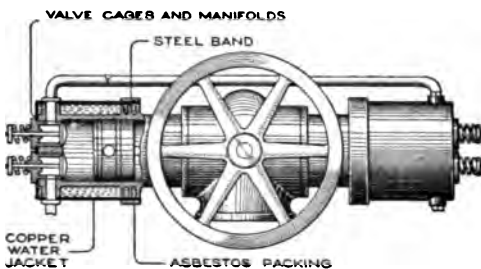

By Removing Some of the Flanges on the Cylinder of an Air-Cooled Motor, Fitting Sheet-Copper Water Jackets in Place of the Removed Flanges, as Shown, and Providing a Pump and Proper Connections, the Engine was Converted into a Water-Cooled One for Use in a Speed Boat

clamped to the cylinders, water-tight joints were thereby provided between the cylinder walls and the copper water jackets. To circulate the cooling water, a geared pump, not shown in the illustration, was fitted to the end of the cam shaft. A supply pipe was arranged from the pump to each jacket and a discharge pipe was installed from each jacket through the side of the boat. Operation of the pump forced cool water through the jackets, thereby maintaining the cylinders at a reasonably low temperature.

### Tool for Holding Tape Lines in Corners

In measuring interiors unassisted, it is often difficult to hold the end of a

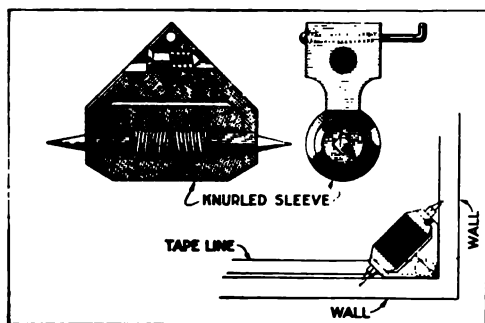

This Tool may be Instantly Hooked in Any Corner to Provide a Fastening for Tape-Line Measurements

tape line in a corner. This difficulty is quickly overcome with the fastening tool illustrated. The tool is made up from any grade of steel that is soft enough to be easily worked. It is provided with a hook for affixing the tape line to it. A knurled cylinder turns on an axle composed of two hardened steel pins, pointed at the ends and operating an interior two-way thread. The angle end of the tool is placed in the corner from which the measurements are to be taken. A turn or two on the knurled cylinder expands the pins, driving their points into the woodwork. The end of the tape line is then attached to the hook on the tool as in the sketch.—John R. Wiggins, Baltimore, Md.



**Follow Mill in Making Wooden Knitting Needles and Lumber Pins**

The mill is used in the lathe to make wooden knitting needles and lumber pins. The mill is held in the tool post and the wood is fed into it from the headstock.

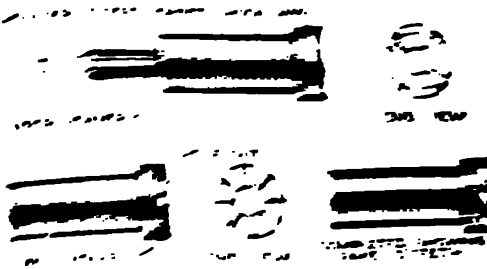

Figure 1. The mill in the lathe barrel for making wooden knitting needles and lumber pins. The mill is held in the tool post.

The mill is used in the lathe to make wooden knitting needles and lumber pins. The mill is held in the tool post and the wood is fed into it from the headstock.

The mill is used in the lathe to make wooden knitting needles and lumber pins. The mill is held in the tool post and the wood is fed into it from the headstock. The mill is used in the lathe to make wooden knitting needles and lumber pins. The mill is held in the tool post and the wood is fed into it from the headstock. The mill is used in the lathe to make wooden knitting needles and lumber pins. The mill is held in the tool post and the wood is fed into it from the headstock.

The mill can be used in a variety of ways. If the lathe has a hollow headstock, the mill is placed in the tool post and the wood is placed against the end of the tool rest. It is necessary, of course, to plane down the end of the tick so it can be fed into the mill. If the headstock is not hollow, the wood can be held in the chuck and the mill clamped on the tool post. The mill can even be clamped in a vise, and the

wood secured in the jaws of a breast drill and turned round.—E. E. Torres, Barbersport, Pa., U.S.A.

**Softening Hard Iron and Brass Castings**

**Castings**

It is a well known fact that castings were found to be extremely hard and it was impossible to find tools that would stand up to them. We put a tank into a furnace and when they were cooled and at their best. Then they were machined with ease.

A similar treatment was adopted for these castings for pipe fittings. They were hard and brittle and would break under slight pressure. We put the castings in a furnace and burned out the excess iron. Machining was just afterward.—R. Thomas, Theyerne, Wis.

**A Self-Lighting Gas Soldering Torch**

**Soldering Torch**

How a gas soldering-torch torch, which requires no matches for its lighting, can be made is described graphically in the illustration. When the carbon is swung over the tip of the gas burner it contacts momentarily there-with, and when the current is broken, as the carbon is swung on around, a spark results. This, if the gas valve is open, ignites the gas. The carbon is

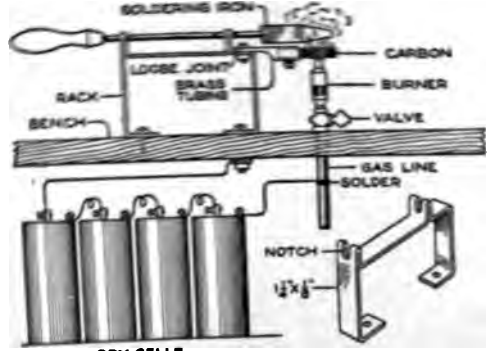

By Connecting a Battery of Dry Cells to the Torch as Shown and Swinging the Carbon Away from the Gas Burner, a Spark is Created, Igniting the Gas

connected electrically through the rack to one terminal of a battery of dry cells.

binder. This mechanism serves to regulate the depth at which the plow is to travel. The rolling colter, like the plow blade, is made from a piece of boiler plate. Its function is to cut all roots and sod in the path of the plow blade.  
—E. R. McIntyre, Madison, Wis.

### Triple-Bladed Pocket Screwdriver

A pocket screwdriver like that here illustrated costs practically nothing to make, weighs little, and occupies a minimum of space in the tool chest or pocket. On the other hand, with it, most of the operations possible with larger screwdrivers can be effected. It offers instantly



the proper-sized blade for each ordinary size of screw and provides a leverage entirely out of proportion to its size. A triangular piece of tempered steel, about  $\frac{1}{8}$  in. thick, is the only material needed. It can be shaped hot—or cold with a hacksaw. If a hacksaw is used, the  $\frac{1}{8}$ -in. steel plate should be first annealed. Round off the edges between the blades and temper the blade points. A length between base and apex of about 3 in. will be found most convenient. If the tool is made of these proportions, it is possible to grasp it firmly without the points interfering; they will be entirely clear of the hand.

### Locomotive Steam Used to Clean and Sterilize Well

Steam generated by a locomotive was, after other methods failed, used successfully for cleaning and sterilizing a well located on the line of a western railroad. A steam ejector was screwed on the lower end of a pipe, as detailed in the accompanying drawing. Then this pipe was lowered into the well casing and held with ropes so that its lower end came within about 4 in. from the bottom of the well. A flexible hose,

as shown in the photograph, fed the steam supply from the boiler to the



By Connecting a Flexible Hose from the Locomotive to an Injector Immersed in a Well, the Latter was Effectively Cleaned of Sand and Mud

ejector. As the steam was permitted to flow through the apparatus discharging the water, workmen stirred the bottom of the well with poles. Thereby the sand and mud which had accumulated was caused to rise and, together with considerable water, was ejected through the discharge pipe. The water was heated almost to a boiling temperature. After the discharge had been operating for three hours, the water which flowed out became clear and clean, indicating that the job had been completed.

A previous attempt made to clean the well with steam from a pile driver was unsuccessful because of the rela-

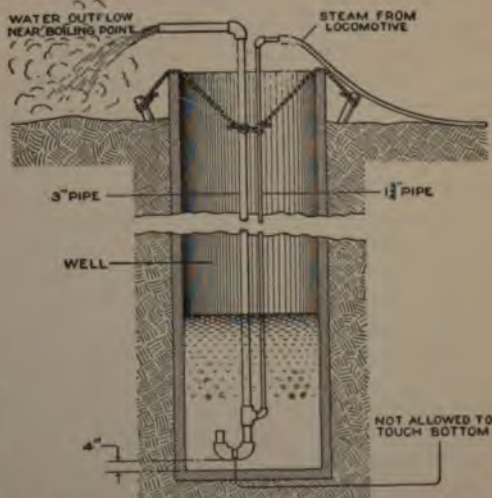
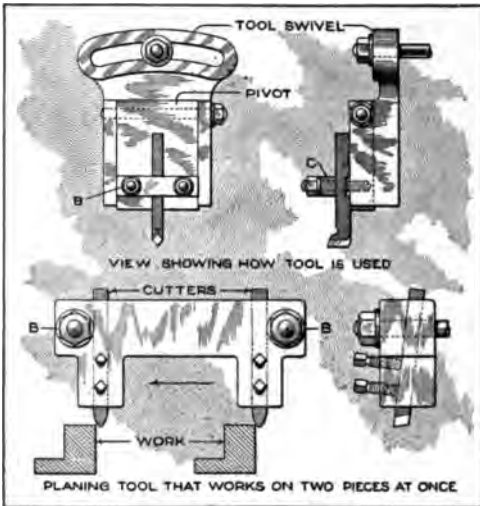

Diagram of the Steam Injector and Outflow Pipe, and the Manner of Its Suspension in the Well

tively low steam pressure which its boiler developed.—H. H. Isard, Caliente, Nev.

### Planing Tool for Machining Two Parts at Once

It is often profitable, on work that will permit it, to plane two parts at



Two Pieces of Work are Planed Simultaneously by the Use of This Simple Two-Cutter Planing Tool

once. This may be done very cheaply by equipping the planer as shown in the sketch. The tool holder is made by removing the strap C and the nuts B, which is followed by putting the tool holder containing the two cutters over the studs. These two tools now plane two parts in the usual manner by being fed across the work in the direction indicated by the arrow. Placing the tool holder over the studs in this manner does not interfere with the clapper-box feature of planing, as the tool holder is mounted directly on the pivot block, thereby permitting the tools to swing clear of the work on the return stroke.—J. Smith Higgins, Pawtucket, R. I.

### Quick Methods of Converting Metric Measures

In working with metric measurements I have found the following methods practical in changing metric and other standards to their approximate equivalents in English standards.

To bring centigrade degrees to Fah-

renheit, double the figure, deduct 10 per cent, and add 32. Example: 30° C. doubled is 60; less 10 per cent is 54; adding 32, gives 86. Another example: 100° C. doubled is 200; less 10 per cent is 180; adding 32 is 212°, the boiling point in the Fahrenheit scale.

To bring millimeters to inches, accurately enough for general purposes, multiply each 100 millimeters by 4, drop off the required number of ciphers, and the result will be in inches. Example: 150 millimeters multiplied by 4 is 600; dropping the ciphers gives 6 in., which is approximately correct.

To bring meters to feet multiply by 3 and add 10 per cent. To bring kilograms to pounds multiply by 2 and add 10 per cent.—Victor A. Rettich, New York, N. Y.

### Old Automobile Brake Adapted for Use on Windlass

The handle of a windlass that is unprovided with a brake is usually as treacherous as a bucking broncho when heavy loads are being lowered. Such a windlass may be made as docile as a kitten by fitting it with an old automobile brake as illustrated. The brake-control lever should be placed within convenient reach of the operator, so that once the load is lifted it may be locked in any position. If the loads to be lifted are sufficiently heavy to neces-

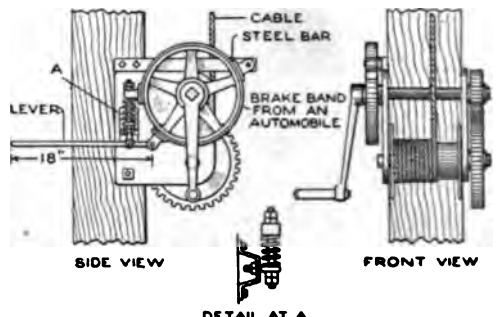

With the Brake, the Load Handled by the Windlass is Held Securely in Any Position

sitate the use of both hands, a foot control on the brake will be found convenient.—Samuel J. Knox, Portland, Oregon.



### Swinging Door in Sliding Door Saves Employes' Time

Heavy sliding fire doors are extensively used as factory exits, and in fire walls. These doors are generally kept closed to eliminate drafts and economize heat. An employe must open these heavy doors in passing from department to department, thus wasting time. The remedy is to fit a small door in the sliding one. The small door is closed with a spring, easy to operate, and does not interfere with the automatic operation of the heavy sliding fire door.

### Tool for Laying Out Keyways

A tool useful for laying out keyways, or centers, on cylindrical pieces can be made by mounting a small level on a V-block, as shown, and adding a



locating prick punch which extends through a hole drilled in the apex of the V-groove. The punch is not held rigidly

by the screw, but is restrained by the friction of a spiral spring. With the tool level on the shaft, a tap with a hammer on the punch will form a prick hole at the vertical position in the shaft. To verify the accuracy of the tool, it may be reversed and another prick mark made, which can be compared with the first.—J. H. Rouse, San Francisco, Calif.

### Reinforced-Concrete Cistern Cap

A cap for a cistern can be made easily of reinforced concrete, as will be described. A cover of this material has the advantage that it will withstand the effects of the elements indefinitely and that it will not foul the water. The procedure is this: Fit planks over the opening of the cistern. Then lay a sheet of heavy paper over these boards. This prevents the concrete from sticking to the wall or leaking through the cracks. Arrange the form

boards, which should be 4 or 5 in. high around the outside, as shown in

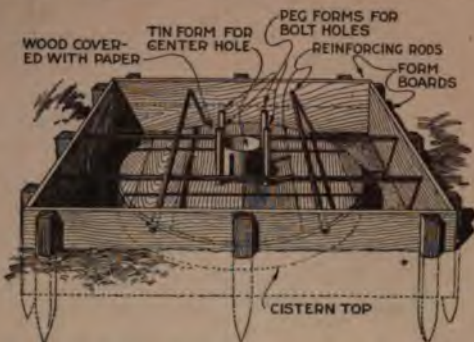

Form for Casting Reinforced-Concrete Cap over the Top of the Cistern on Which It is to be Used

the drawing, and support them in position with stakes. Then bend a strip of sheet iron into a hollow cylinder of sufficient diameter to admit the pump cylinder. Set this form in the center to provide an opening for the pump. Place heavy iron rods for reinforcing, in the form, as shown, and fill the form with concrete. Before the concrete has set push into it vertically, down to the wooden cover, four cylindrical sticks of wood. These should be located to correspond with the bolt holes in the pump base. After the concrete has set remove the form boards and bore out the cylindrical wooden rods.—Stanley Dougan, Pawnee, Okla.

### Self-Centering Nonslipping Screwdriver Head

If the point of a screwdriver which is used for driving screws of only one diameter is fitted with a bell, as shown in the sketch, the slipping of the edge of the driver from the slot will be prevented. Furthermore, the bell automatically centers the blade in the slot, promoting rapid work. The

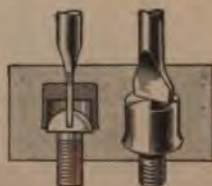

bell may be formed from sheet metal, but for continuous use one turned from bar stock will prove more economical.—P. J. Backus, Delphos, Ohio.

**Handy Rubber-Stamp Ink Pad  
for the Shop Office**

A block of wood forms the major portion of an ink pad that will not permit a large



quantity of ink to adhere to the rubber stamp, thus insuring an even, unblurred reproduction. Secure a block of some soft wood, the cross section of which is 2 by 4 in. Saw a section of this across the grain so that the piece secured will be 1/2 in. thick. This piece is then placed in the tin lid from a wood can with a layer of felt under it, as shown in the sketch. The ink is placed in the felt and is carried through the grain of the wood by capillary attraction. It will be found that just the right amount of ink comes through the wood to ink the rubber stamps properly.

**Band Saw Cuts Out Paper Labels  
of Irregular Outline**

A printer who produces many labels of irregular outline employs a band saw for cutting out a thousand of them



simultaneously. Thereby the cost of and the delay in obtaining a die is obviated. This is a decided improvement over the method of cutting a few at a time. Here is the procedure: Assume that a consignment of approximately round labels is to be produced. Print all of the labels on square pieces of paper of uniform size. Cut two blocks of soft wood, as illustrated, of the same size as the labels. Place one wooden block at the bottom

and the other on the top of the pile. Pad the blocks and the labels together with strong glue. Paste on the top block one printed label which will serve as a guide when cutting. Now cut with a fine hand saw around the outline of the label. About one thousand may be cut with the saw at one time. Heart-shaped, octagonal, or any other irregular contours can be cut as readily as can the approximately round label reproduced in the illustration. With a suitable saw the finished product is perfect and the cost is very low.

**Collar for Flue-Cutter  
Slip-Joint Shaft**

It was necessary to provide a collar on a flue-cutter shaft to prevent longitudinal movement of the shaft, because without the collar the shaft would work over so far that the belt slipped from the pulley

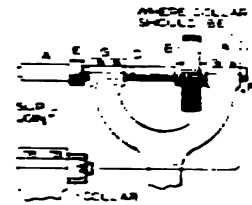

B. The machine could not be taken apart to place a set collar at D where it should, under ordinary conditions, be located.

A clamp collar might have been used, but this would involve the installation of a guard for it. When the shoulder E was close to the box G there was not enough shaft exposed at F to accommodate a set collar. The small detail at the left shows how the problem was solved. A cap of 2-in. outside diameter was made. It was counterbored 3/8 in. to fit over the shaft and was held in place by a screw turning into a tapped hole in the end of the shaft, as shown. This screw has a round head to prevent its catching on objects and is pinned to prevent it from turning out. Thus an effective "end collar" was provided.—A. G. Corssen, Centralia, Ill.

To learn sign and show-card painting, one of the best books to get is a type catalog.





## Making a Punch-and-Die Attachment for a Bench Vise

By L. A. CROZIER

AN ordinary bench vise may often do the work of a punch press costing several hundred dollars, if rigged up as shown in the illustration. Of course, the speed of operation will be much slower, and it will be difficult to secure any great accuracy, but these are often not of much importance when only a small number of parts are to be made — say from 20 up to 1,000.

The method of construction described here can, of course, be varied to suit different conditions; the size of hole that can be punched depends on the size of the vise, and on the thickness and hardness of the material. In the case here described, a  $\frac{3}{8}$ -in. hole was to be punched in a number of phosphor-bronze lugs. A punch, B, made of  $\frac{3}{8}$ -in. drill rod, hardened at the cutting end, was fitted into a piece of  $\frac{1}{2}$ -in. flat, mild steel, A, shaped to cover the movable jaw, and a setscrew, C, was placed so as to keep it from working loose. The soft end of the punch should seat firmly against the vise jaw. The punch holder A was made fast to the vise jaw by two thin pieces, D, with small machine screws. This completes the punch, or moving

member. The fixed member, or die, is similarly fastened to the stationary jaw of the vise. It consists of the die block E, the stripper K, the plate F, and the two thin pieces D, fastened together with screws as shown. The die block should be made of tool steel, at least  $\frac{1}{2}$  in. thick, and should be drilled out the size of the punch; or if a cleaner-looking hole in the work is desired, the die block may be drilled small and reamed to size in a lathe. A notch or groove, shown at J, should be cut, large enough

to permit the punching to drop out. The hole in the die block should be enlarged slightly, up to about  $\frac{1}{4}$  in. from the cutting surface L, as indicated at H; this may be done with a

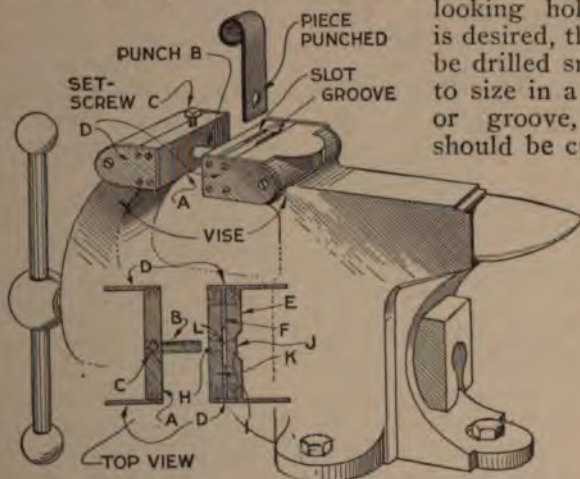

By Mounting a Simple Punch and Die in the Jaws of a Bench Vise, It may be Made to Do the Work of a Punch Press

larger drill or with a taper reamer.

The stripper for such a die should be made quite thick, this one being made of the same thickness as the punch holder; it should be drilled and countersunk as shown, or reamed with a taper reamer, depending on the amount of "wobble" in the vise, so as to guide the punch accurately into the die and prevent shearing the punch.

The plate F is a little thicker than the work to be punched, and is shaped so as to locate it properly.

A good way to match the punch with



the die hole is to complete the punch first, and assemble the parts of the die before the hole is drilled in the die block and stripper. With the two members mounted in the vise, the punch can be screwed up against the stripper and a mark scribed around it

to locate the hole, which may then be drilled clear through the die. The die block should of course be hardened before use.

Various types of simple dies for use in vise jaws will suggest themselves when required.

### Convenient Ladder Bucket Jack for Roof Workers

An ingenious painter has built this jack or shelf to hold his paint bucket

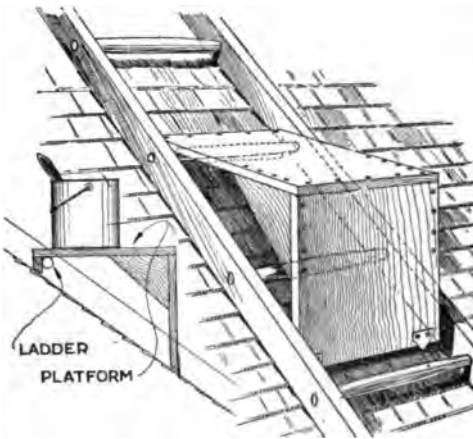

A Bucket Jack for Roof Painting, Which can be Quickly Moved as the Work Progresses

while at work on a roof. The construction is shown clearly in the sketch. The upper end hangs over a rung of the ladder, while the lower end has two steel plates with sharp points which take hold in the shingles; the points may be left off if the corner braces are firmly fastened with screws. The rack can be moved from one rung to another in a second or two.—T. B. Paul, Dermott, Ark.

### Burrs inside Tubing and Castings Removed by File in Chuck

Tubing and metal castings having an inside surface frequently require burring. The burrs on the inside surface, caused by drilling holes from the outside or from milling operations, are often difficult to remove by hand. In the burring department of a large fac-

tory it is the practice to insert a rat-tail file in the chuck of a lathe. This permits the revolving of the file at high speed, and if the product to be burred is held so that the file operates against the inside surface, the burr is quickly and neatly removed.

### Surveyor's Tripod Level Made Quickly from Carpenter's Level

A good substitute for an architect's or surveyor's level for general purposes, such as leveling house foundations, building roadways, and similar work not requiring minute accuracy, is shown in the sketch. It consists of an ordinary carpenter's level placed upon a simple tripod. A small finishing nail on each end of the level is convenient in sighting. The method of leveling is, of course, the same as that employed

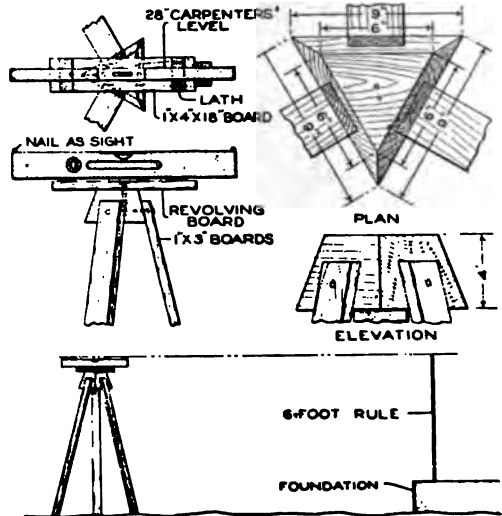

Sufficiently Accurate Results for Ordinary Work may be Obtained Up to a Distance of 500 Feet on a Clear Day with This Homemade Level

when using the surveyor's level.—Roy H. Poston, Flat River, Mo.

### A Simple Depth Gauge for Blind Holes in Wood

When a number of holes are to be drilled in wood, of the same depth, and no collar is handy to make into a depth gauge, a cork may be used. A hole is drilled through it somewhat smaller than the drill, and it is forced on. It has been found that as many as 100 holes can be drilled to an accurate depth without readjusting the cork.—H. S. Hart, Shreveport, La.

the strip, the strip is turned back, and the sidewalk center tool run across the

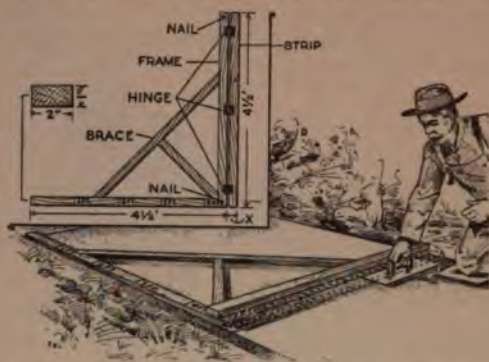

The Folding Square Divides Cement Sidewalks into Even Squares That Are Accurate

block, keeping one edge of the tool against the frame. The square has been found to be convenient and rapid.—J. W. Muncey, Jesup, Iowa.

### An Electric Cigar-Case Humidifier

A proper degree of humidity may be maintained in a cigar-display case and the case illuminated, at the same time, by arranging a n incandescent lamp so that its lower end dips in water contained in a glass fixture bowl. The globe is supported from the lamp socket by an ordinary shade holder. When the lamp is lighted, the heat developed vaporizes the water, which keeps the cigars moist.



### Colored-Light Electrical Shop-Call System

A visual call system for an office, shop, store, or other institution, which will make it unnecessary to send a messenger about the plant to locate an individual who is wanted in the office, can be arranged as indicated in the illustration. Where such a system is used, a combination of lights can be assigned as a signal to each person who is frequently called. The switches operate similar lights in every department, so that wherever the man called

### Folding Square for Dividing Concrete Sidewalks

The sketch shows a square for rapidly cutting cement sidewalks into blocks, 4 ft. long, or any other dimension. It is designed as an improvement on the method of pencil marks made on the forms, which are obscured by the concrete and are seen with difficulty. The frame may be made of 1 by 2-in. material and each arm should be about 4 1/2 ft. long. Drive nails through as indicated, projecting about 1/4 in. to prevent slipping of the square. The strip at the right swings on hinges. The distance X should be the same as the distance from one edge to the center of the sidewalk center tool, which varies from 1 1/4 to 1 7/16 in. As soon as the block is cut at the edge of

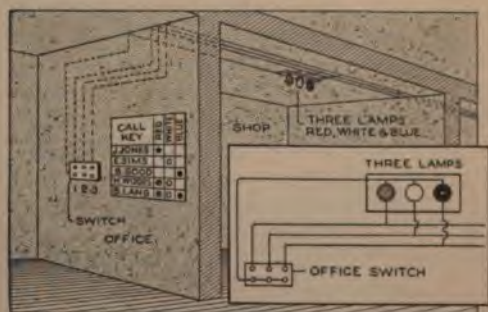

Schematic Representation, with Wiring Diagram, of a Colored-Light Electric Shop-Call System

happens to be, he will see his signal, and will call the office on the nearest telephone.

**Hollow Mill for Making Wooden Knitting Needles and Dowel Pins**

Often it is desired to turn pins that are too light to run on centers. The tool described below handles such

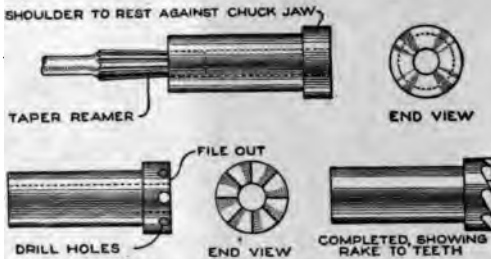

Hollow Mill, Made from an Old Rifle Barrel, for Turning Pins and Other Objects Too Light to be Held on Centers in the Lathe

work well, and gives a good finish on hard wood.

A piece of an old .22-caliber rifle barrel is very adaptable material. Cut off about 1½ in. of the barrel or other suitable material. Ream out all traces of the rifling. Then face the piece in a lathe, and turn a collar at one end, to hold the tool in the chuck. At this end lay out and drill a series of holes at right angle to the bore. These holes form the throat of the teeth, which are completed by filing away the wall of metal between the holes and the end. When the teeth have been formed, a taper should be run in from the back, to give clearance and remove the burr left in drilling the holes. I have made these hollow mills from ¼ in. to ½ in. for use on brass and mild steel. The method of forming the teeth gives a good rake which makes them cut quickly. The holes at the root of the teeth aid in clearing out the chips or cuttings.

The hollow mill can be used in a variety of ways. If the lathe has a hollow headstock, the mill is placed in the chuck, and the wood is placed against a tool in the tool rest. It is necessary, of course, to plane down the end of the stick so it can be fed into the mill. If the headstock is not hollow, the wood can be held in the chuck and the mill clamped on the tool post. The mill can even be clamped in a vise, and the

wood secured in the jaws of a brace drill, and rotated rapidly.—B. E. Bree, Battleford, Sask., Canada.

**Softening Hard Iron and Brass Castings**

A lot of iron castings to be machined were found to be extra-hard, and it was impossible to find tools that would stand up on them. We put a piece into a furnace until they were hot, and let them cool. Then they were machined with ease.

A similar treatment was adopted for brass castings for valve rings. These were hard and brittle, and would not work under slight pressure. We put the castings in a furnace and burned off the excess tin. Machining was easy after that.—R. Thomas, Cheyenne, Wyo.

**A Self-Lighting Gas Soldering Torch**

How a gas soldering-iron torch which requires no matches for its lighting, can be made is described graphically in the illustration. When the burner is swung over the top of the burner, it contacts momentarily the carbon tip with, and when the circuit is broken, as the carbon is swung on around, a spark results. This, if the gas valve is open, ignites the gas. The carbon

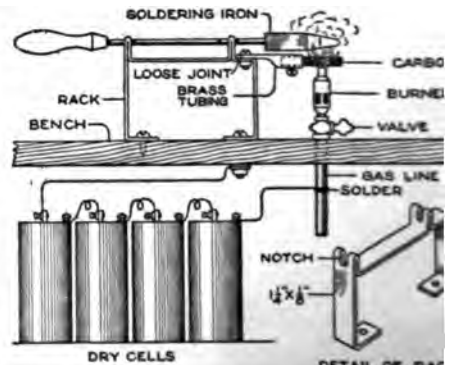

By Connecting a Battery of Dry Cells to the Top Shown and Swinging the Carbon Away from the Burner, a Spark is Created, Igniting the Gas

connected electrically through the top to one terminal of a battery of dry cells



The opposite terminal is grounded on the gas pipe. Although not always necessary, a spark coil connected in series with the batteries will increase the effectiveness of the arrangement. The carbon is supported in a piece of brass tubing which is flattened on one end to provide for the insertion of the screw on which this holder is pivoted. The rack, shown in detail in the drawing, is bent from  $1\frac{1}{4}$  by  $\frac{1}{8}$ -in. strap iron.

### Alining Hold-Down Bolts in Concrete Foundations

When concrete bases are designed for machine foundations and column footings, hold-down bolts must be cast into the concrete. It is frequently difficult to place the bolts accurately

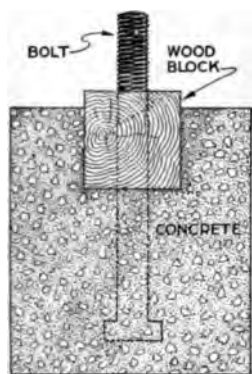

enough to fit the foundations. If the holes in the foundations are not slotted to allow for slight inaccuracies in placing the bolts, the following simple expedient will be found practical.

Set the bolts into the concrete, and provide a drilled wooden block for each bolt, several inches thick and large enough to suit. The concrete is poured with the blocks so placed on the bolts as to make a shallow, narrow pit in the concrete. Remove the blocks before the concrete sets. The purpose of the pit is to permit the bolt to be bent slightly in any direction. In this way the bolts can be set to fit the holes in the machine foundation or column base. The pit made by the block is filled with concrete when the bolts have been fitted to the base. The block must not be left too long in the concrete, or the wood is apt to swell, making it difficult to remove.—S. B. Royal, Baltimore, Md.

### Flexible Scraper Makes Difficult Jobs Easy

Scraping corners is difficult where glue is used, as where the sides of a table are butted against the legs. The glue squeezes out, and there is danger of marring the wood and tearing out splinters when a common scraper is used.



A flexible scraper made of saw steel can be pressed flat against the work, while the hand has a good grip on the free end.

It is impossible to cut deeper than the rolled edge, or to enter the joint. Use a piece of No. 26 gauge saw-blade steel, cut 2 in. wide by 6 in. long, which can be bought at any large hardware store. It can be cut with tinner's snips.

### Useful Kink for Valve- Grinding Jobs

In case it is impossible to use a bit and brace to rotate the valve, motion may be given by a bow drill. Arrange a screwdriver

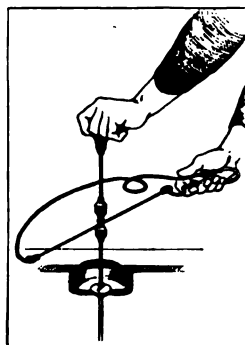

a screwdriver with a pulley in the center, and a handle that will permit the shank to rotate. Make the bow by looping a piece of heavy iron wire. Then connect the ends of the bow with heavy cord, making a full turn on the pulley with the cord. This plan makes it possible to keep an even pressure on the valve and an even movement in both directions.

**Planing Tool for Machining  
Two Parts at Once**

It is often profitable, on work that will permit it, to plane two parts at

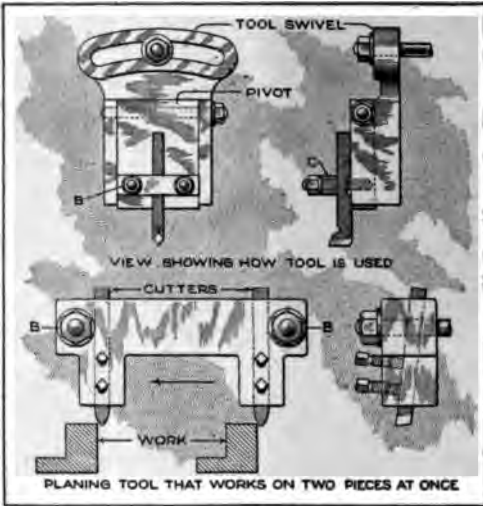

Two Pieces of Work are Planed Simultaneously by the Use of This Simple Two-Cutter Planing Tool

once. This may be done very cheaply by equipping the planer as shown in the sketch. The tool holder is made by removing the strap C and the nuts B, which is followed by putting the tool holder containing the two cutters over the studs. These two tools now plane two parts in the usual manner by being fed across the work in the direction indicated by the arrow. Placing the tool holder over the studs in this manner does not interfere with the clapper-box feature of planing, as the tool holder is mounted directly on the pivot block, thereby permitting the tools to swing clear of the work on the return stroke.—J. Smith Higgins, Pawtucket, R. I.

**Quick Methods of Converting Metric Measures**

In working with metric measurements I have found the following methods practical in changing metric and other standards to their approximate equivalents in English standards.

To bring centigrade degrees to Fah-

renheit, double the figure, deduct 10 per cent, and add 32. Example: 30° C. doubled is 60; less 10 per cent is 54; adding 32, gives 86. Another example: 100° C. doubled is 200; less 10 per cent is 180; adding 32 is 212°, the boiling point in the Fahrenheit scale.

To bring millimeters to inches, accurately enough for general purposes, multiply each 100 millimeters by 4, drop off the required number of ciphers, and the result will be in inches. Example: 150 millimeters multiplied by 4 is 600; dropping the ciphers gives 6 in., which is approximately correct.

To bring meters to feet multiply by 3 and add 10 per cent. To bring kilograms to pounds multiply by 2 and add 10 per cent.—Victor A. Rettich, New York, N. Y.

**Old Automobile Brake Adapted  
for Use on Windlass**

The handle of a windlass that is unprovided with a brake is usually as treacherous as a bucking broncho when heavy loads are being lowered. Such a windlass may be made as docile as a kitten by fitting it with an old automobile brake as illustrated. The brake-control lever should be placed within convenient reach of the operator, so that once the load is lifted it may be locked in any position. If the loads to be lifted are sufficiently heavy to neces-

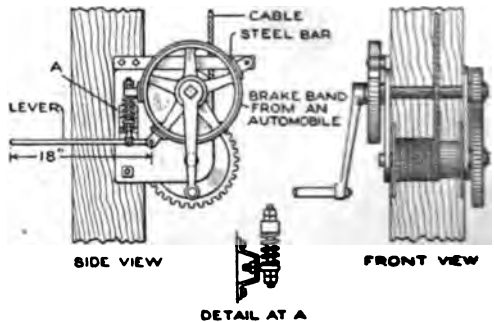

With the Brake, the Load Handled by the Windlass is Held Securely in Any Position

sitate the use of both hands, a foot control on the brake will be found convenient.—Samuel J. Knox, Post, Oregon.

### Swinging Door in Sliding Door Saves Employes' Time

Heavy sliding fire doors are extensively used as factory exits, and in fire walls. These doors are generally kept closed to eliminate drafts and economize heat. An employe must open these heavy doors in passing from department to department, thus wasting time. The remedy is to fit a small door in the sliding one. The small door is closed with a spring, easy to operate, and does not interfere with the automatic operation of the heavy sliding fire door.

### Tool for Laying Out Keyways

A tool useful for laying out keyways, or centers, on cylindrical pieces can be made by mounting a small level on a V-block, as shown, and adding a



locating prick punch which extends through a hole drilled in the apex of the V-groove. The punch is not held rigidly

by the screw, but is restrained by the friction of a spiral spring. With the tool level on the shaft, a tap with a hammer on the punch will form a prick hole at the vertical position in the shaft. To verify the accuracy of the tool, it may be reversed and another prick mark made, which can be compared with the first.—J. H. Rouse, San Francisco, Calif.

### Reinforced-Concrete Cistern Cap

A cap for a cistern can be made easily of reinforced concrete, as will be described. A cover of this material has the advantage that it will withstand the effects of the elements indefinitely and that it will not foul the water. The procedure is this: Fit planks over the opening of the cistern. Then lay a sheet of heavy paper over these boards. This prevents the concrete from sticking to the wall or leaking through the cracks. Arrange the form

boards, which should be 4 or 5 in. high around the outside, as shown in

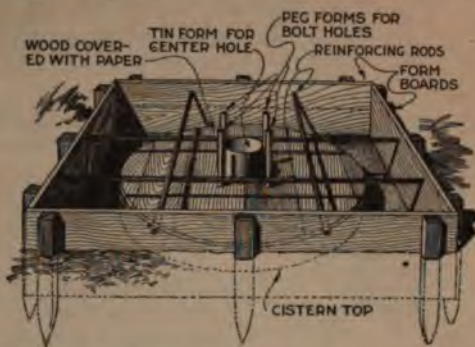

Form for Casting Reinforced-Concrete Cap over the Top of the Cistern on Which It is to be Used

the drawing, and support them in position with stakes. Then bend a strip of sheet iron into a hollow cylinder of sufficient diameter to admit the pump cylinder. Set this form in the center to provide an opening for the pump. Place heavy iron rods for reinforcing, in the form, as shown, and fill the form with concrete. Before the concrete has set push into it vertically, down to the wooden cover, four cylindrical sticks of wood. These should be located to correspond with the bolt holes in the pump base. After the concrete has set remove the form boards and bore out the cylindrical wooden rods.—Stanley Dougan, Pawnee, Okla.

### Self-Centering Nonslipping Screwdriver Head

If the point of a screwdriver which is used for driving screws of only one diameter is fitted with a bell, as shown in the sketch, the slipping of the edge of the driver from the slot will be prevented. Furthermore, the bell automatically centers the blade in the slot, promoting rapid work. The bell may be formed from sheet metal, but for continuous use one turned from bar stock will prove more economical.—P. J. Backus, Delphos, Ohio.

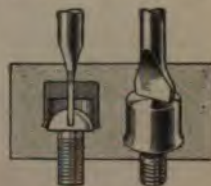



### Handy Rubber-Stamp Ink Pad for the Shop Office

A block of wood forms the major portion of an ink pad that will not permit a large quantity of ink to adhere to the rubber stamp, thus insuring an even, unblurred reproduction. Secure a block of some soft wood, the cross section of which is 2 by 4 in. Saw a section of this across the grain so that the piece secured will be  $\frac{1}{4}$  in. thick. This piece is then placed in the tin lid from a cocoa can with a layer of felt under it, as shown in the sketch. The ink is placed in the felt and is carried through the grain of the wood by capillary attraction. It will be found that just the right amount of ink comes through the wood to ink the rubber stamps properly.

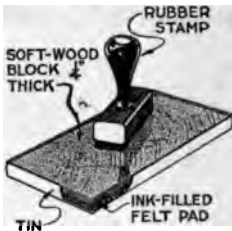

4 in. Saw a section of this across the grain so that the piece secured will be  $\frac{1}{4}$  in. thick. This piece is then placed in the tin lid from a cocoa can with a layer of felt under it, as shown in the sketch. The ink is placed in the felt and is carried through the grain of the wood by capillary attraction. It will be found that just the right amount of ink comes through the wood to ink the rubber stamps properly.

### Band Saw Cuts Out Paper Labels of Irregular Outline

A printer who produces many labels of irregular outline employs a band saw for cutting out a thousand of them simultaneously. Thereby the cost of and the delay in obtaining a die is obviated. This is a decided improvement over the method of cutting a few at a time. Here is the procedure: Assume that a consignment of approximately round labels is to be produced. Print all of the labels on square pieces of paper of uniform size. Cut two blocks of soft wood, as illustrated, of the same size as the labels. Place one wooden block at the bottom

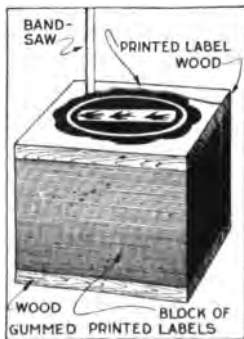

and the other on the top of the pit. Pad the blocks and the labels together with strong glue. Paste on the top block one printed label which will serve as a guide when cutting. Now cut with a fine band saw around the outline of the label. About one thousand may be cut with the saw at one time. Heart-shaped, octagonal, or any other irregular contours can be cut as readily as can the approximately round label reproduced in the illustration. With a suitable saw the finished product is perfect and the cost is very low.

### Collar for Flue-Cutter Slip-Joint Shaft

It was necessary to provide a collar on a flue-cutter shaft to prevent longitudinal movement of the shaft, because without the collar the shaft would work over so far that the belt slipped from the pulley B. The machine could not be taken apart to place a set collar at D where it should, under ordinary conditions, be located.

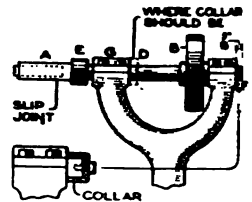

A clamp collar might have been used, but this would involve the installation of a guard for it. When the shoulder E was close to the box G there was not enough shaft exposed at F to accommodate a set collar. The small detail at the left shows how the problem was solved. A cap of 2-in. outside diameter was made. It was counterbored  $\frac{5}{16}$  in. to fit over the shaft and was held in place by a screw turning into a tapped hole in the end of the shaft, as shown. This screw has a round head to prevent its catching on objects and is pinned to prevent it from turning out. Thus an effective "end collar" was provided. — A. G. Corssen, Centralia, Ill.

To learn sign and show-card painting, one of the best books to get is a type catalog.

of the same width, such as are used on most office typewriters. Ribbons of the portable typewriter are usually 10 yd. in length. For such a ribbon one pays 75 cents or \$1, the same as for the longer ribbon that is used on office machines.

By buying the 20-yd. ribbon and cutting it in two, one has two ribbons for the little machine at the same price ordinarily paid for one. If the portable typewriter is provided with a two-color adjustment and one is able to get along with one color, the service of four ordinary ribbons may be obtained from the one 20-yd. ribbon. After being cut to form two ribbons, each ribbon is used on both edges by manipulating the two-color shifting adjustment.—John Edwin Hogg, Alhambra, Calif.

### Handy Square Attachment for Laying Out Stairs

After the riser and tread have been decided, this device is handy in scribing the stair stringers. It consists of a carpenter's square, and a wooden bar with clamps which hold the bar and square snugly together. When set, there can be no slipping, and thus all marks are regular and the finished job uniform.

The illustration shows how the wooden bar is drilled to take the bolts. The clamps are formed

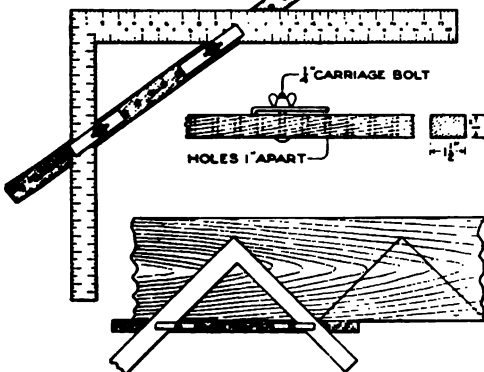

With This Device Attached to an Ordinary Carpenter's Square, the Laying Out of Steps is Made Easy

of strips of  $\frac{3}{16}$  by  $1\frac{1}{4}$ -in. steel.—C. C. Spreen, Flint, Michigan.

### Novel Method for Lifting Large Objects

A short time ago a neighbor undertook to enlarge a barn from a one-story affair to two stories. The way in which he hoisted the roof in one piece was so simple, and did the work so well that it might be of

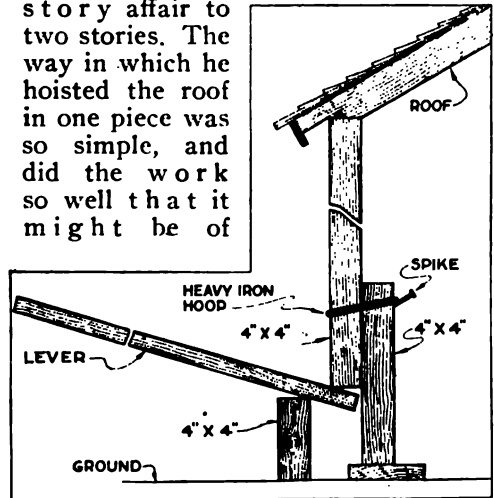

The Entire Roof of the Barn was Raised by Prying Up Each of the 4 by 4-Inch Timbers a Little at a Time. The Iron Hoops Kept Them from Slipping Back

value to others. The roof was severed from the sides, resting upon temporary supports, and several boards were removed from the sides. Then six or eight hoops were made at the blacksmith shop, a little over 4 by 8 in., inside dimensions. These being made ready, a number of timbers, 4 by 4 in. in size, were secured and arranged as shown. One was set in the wall where a board had been removed, to help support the roof. A shorter one was placed against the first, and the hoop slipped over both. A spike was driven into the shorter one to support the hoop. All the timbers and hoops were arranged in this manner, and when ready, it was but a simple matter to go around from one to the next, lifting each one a little in its turn.

The action of the hoop is obvious. As the roof is raised, the hoop allows a movement of the timber up, but when released, automatically clamps and holds it against an opposite movement. The whole cost for material was \$4, and the roof was raised in an hour.—Dale R. Van Horn, North Loup, Neb.

the die hole is to complete the punch first, and assemble the parts of the die before the hole is drilled in the die block and stripper. With the two members mounted in the vise, the punch can be screwed up against the stripper and a mark scribed around it

to locate the hole, which may then be drilled clear through the die. The die block should of course be hardened before use.

Various types of simple dies for use in vise jaws will suggest themselves when required.

### Convenient Ladder Bucket Jack for Roof Workers

An ingenious painter has built this jack or shelf to hold his paint bucket

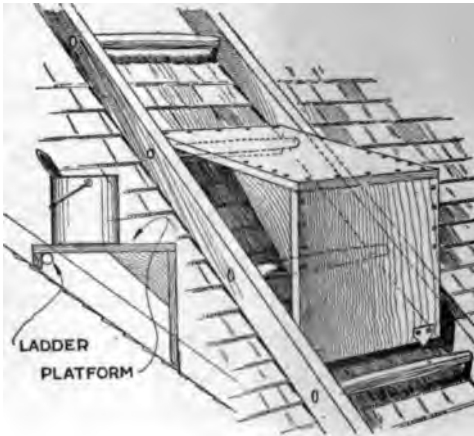

A Bucket Jack for Roof Painting, Which can be Quickly Moved as the Work Progresses

while at work on a roof. The construction is shown clearly in the sketch. The upper end hangs over a rung of the ladder, while the lower end has two steel plates with sharp points which take hold in the shingles; the points may be left off if the corner braces are firmly fastened with screws. The rack can be moved from one rung to another in a second or two.—T. B. Paul, Dermott, Ark.

### Burrs inside Tubing and Castings Removed by File in Chuck

Tubing and metal castings having an inside surface frequently require burring. The burrs on the inside surface, caused by drilling holes from the outside or from milling operations, are often difficult to remove by hand. In the burring department of a

tory it is the practice to insert a rat-tail file in the chuck of a lathe. This permits the revolving of the file at high speed, and if the product to be burred is held so that the file operates against the inside surface, the burr is quickly and neatly removed.

### Surveyor's Tripod Level Made Quickly from Carpenter's Level

A good substitute for an architect's or surveyor's level for general purposes, such as leveling house foundations, building roadways, and similar work not requiring minute accuracy, is shown in the sketch. It consists of an ordinary carpenter's level placed upon a simple tripod. A small finishing nail on each end of the level is convenient in sighting. The method of leveling is, of course, the same as that employed

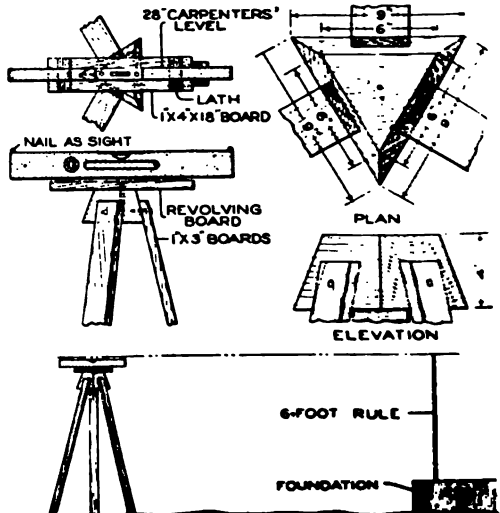

Sufficiently Accurate Results for Ordinary Work may be Obtained Up to a Distance of 500 Feet on a Clear Day with This Homemade Level

when using the surveyor's  
Poston, Flat River



bit can then be used in the handle, whether there is a hole to take the key or not.—Henry Getaz, Pittsfield, Mass.

### Simple Method of Making and Attaching a Metal Ferrule

Take copper or brass wire and wrap it around the place desired—as on a file or chisel handle. Solder as fast as wound, for the heat of the iron will expand the wire, and when it cools the ferrule will be as sound as though it were solid metal, forced on. Use about No. 20 gauge wire for small ferrules; No. 14 or 12 can be used for very large sizes.—J. Garrett Kemp, Stillwater, Oklahoma.

### A Durable Solderless Repair for Boiler Leaks

When a leak is discovered in a small tank, or boiler, such as the reservoirs on many kitchen ranges, the problem of repair is often difficult, because solder does not stick well to the corroded

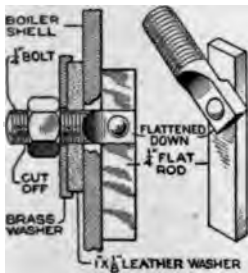

surface, and only one side of the tank wall can be reached for a mechanical repair. Materials required for this device are a  $\frac{1}{4}$ -in. bolt and nut; a small piece of rod, or sheet

steel, about  $\frac{1}{8}$  by  $\frac{1}{4}$  by  $1\frac{1}{4}$  in.; a  $\frac{1}{8}$  by 1-in. brass washer; a  $\frac{1}{4}$  by 1-in. leather washer, and a small rivet, or piece of soft steel wire. The bolt, after the head is removed, is flattened out, as shown, a hole is drilled in it, and the flat rod is riveted to it. While riveting, a slotted shim should be placed between the two pieces, so that it can be removed afterward, leaving a loose joint. The leak in the tank is enlarged if necessary, and the flat rod is pushed through the hole, long end first. When it has completely entered, it will drop to the perpendicular position, and the washers and nut are put on the bolt.

### Angle Pieces Shaped in V-Block with Arbor Press

An order came in for a large number of angle pieces of odd size. To do the work quickly, and with some degree of accuracy, it was necessary to bend the pieces in some form of die in a press. Neither press nor die were available, but an arbor press and a V-block were among the shop equipment. The sketch shows how the pieces were made by the use of the

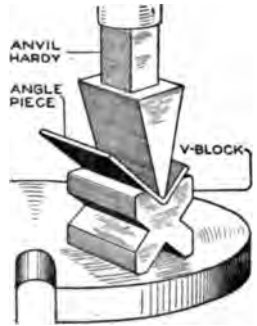

arbor press, the V-block, and an anvil hardy. By bringing the plunger of the press down on the hardy the angle was formed in the V-block. The hardy should be blunt, otherwise there is danger of breaking the stock at the bend.—Harvey Mead, Scranton, Pa.

### Wire Used to String Rings as They Come from Lathe

When a large number of brass, bronze, or cast-iron rings are turned from a single piece of stock, a heavy wire arranged for catching them as they come from the lathe will be found useful. The wire may be secured to any convenient point at the right-hand end of the machine. The other

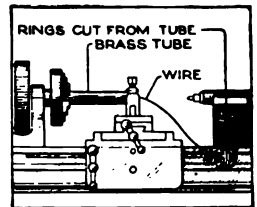

end is permitted to ride free inside the stock from which the rings are being cut. It is obvious that with this arrangement the rings are automatically strung on the wire as they are cut, and may be removed with a single operation when the stock becomes exhausted.—George L. Furse, St. Louis, Missouri.

### How to Make a Fireproof Concrete Safe

The chief features of this safe are simplicity in construction and cheap-

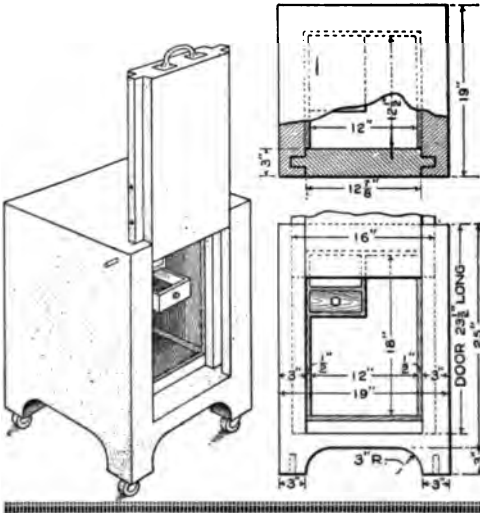

Fireproof Safe Made of Concrete can be Built at Home at Very Low Cost

ness. About two sacks of cement are needed. If desired, the safe can be given a good black finish by mixing about  $1\frac{1}{2}$  lb. of lampblack into the cement.

It will be noted that the door slides up to open. The door can be latched open by means of a rod spanning the opening, moving freely in holes cored into the concrete. The end of such a rod is shown in the view of the completed safe, projecting from the side, near the top of the opening. For convenience in handling, the safe should be set on casters. Mold sockets for the casters when pouring the concrete.

### An Improved Furnace for Small Casehardening Jobs

A good substitute for a casehardening furnace for small work may be had by capping one end of a length of iron pipe and plugging the other end with fire clay, after the material to be hardened has been placed inside. The pipe is then placed in the usual casehardening

ing furnace or heated in the brazing machine.—Abel Greenstein, New York, New York.

### Doors Have Removable Panels for Summer and Winter Use

Doors of permanent construction having a large removable panel are fitted with glass sashes for winter use and with screens in summer. This eliminates changing an entire door for seasonal variations.—J. S. Hagans, Toledo, Ohio.

### Bevel Square for Door and Window Fitting

Openings for doors and windows are seldom square and true. Due to this condition much extra work is required when they are being fitted unless suitable methods are used. With windows particularly, a poor job is a frequent occurrence, since they have to be fitted both at the top and bottom. No correction can be made if too much wood is taken off. Trying-in doors also is arduous work. Such difficulties are greatly minimized if a large bevel square, such as that shown in the sketch, is employed. Its construction is obvious from a study of the details. The only materials needed for the construction of this tool are three hardwood sticks,  $\frac{1}{4}$  by 2 by 30 in., one  $\frac{1}{4}$  by  $1\frac{1}{4}$ -in. stove bolt, one  $\frac{1}{4}$ -in. punched washer, one  $\frac{1}{4}$ -in. wing nut, and several  $\frac{5}{8}$ -in. flat-head wood screws. The size of the square is such

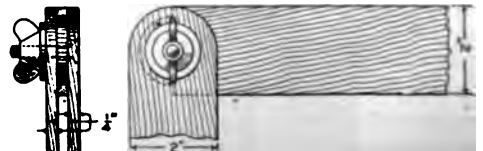
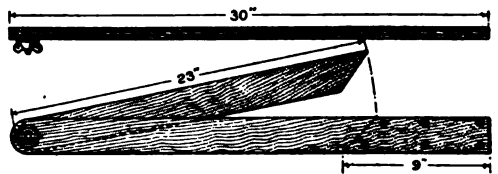

Detail of Homemade Bevel Square to be Used in Fitting Doors and Windows

that it will disclose any appreciable variation from the true in a large door or window opening and thereby permit the door or window to be cut accordingly. Yet the tongue, being 23 in. long, is sufficiently short to be used in openings only 2 ft. wide.—Henry Simon, Laguna Beach, Calif.

### Snap Bow Aids in Making Chalk Lines

The chalk line is often much quicker to use for marking than a straightedge and pencil, but fastening the far end, or having some one to hold it, makes it inconvenient. A snap bow will enable one to use the simple and accurate chalk-line method without trouble. The fishline may be rubbed with white or colored chalk, laid against the surface to be marked, and picked with the



The Snap Bow Provides a One-Man Way to Use a Chalkline

finger. The device has been found useful in scenic painting.

### A Quick and Convenient Blueprint Washer

There are a great many methods of washing blueprints, but a spray washer, constructed as shown in the illustration, will prove as economical and satisfactory as any in a shop where a large number of prints are made. A wooden tray of suitable size is made and covered with zinc. The water is admitted to the tray through two spray pipes which are drilled with holes through about 45° of their lower surfaces. When a print is to be washed, the water is turned on and permitted to wet the zinc thoroughly. Then it is shut off, and the blueprint, with its sensitized side out, placed on the zinc in the back of the tray, so that the top edge of the print is high enough

to prevent the water from spraying above it. With the print in position, the water is again turned on and will

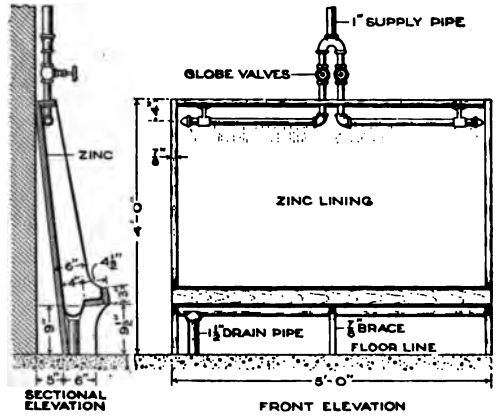

Blueprints are Quickly Washed in Running Water with This Device. For Small Prints, Only One of the Valves need be Turned On

quickly wash off the sensitizing chemicals. Experience has shown that the prints will dry quicker when washed in this manner than when washed by soaking them in a large tray, and the prints are not so likely to become torn.—W. J. Carol, St. Louis, Mo.

### A One-Man Wrench for Automobile Crank-Case Bolts

The socket wrench shown in the drawing was devised by an ingenious repair man who had felt the shortage of workmen. It is made by combining two socket wrenches so that one holds the bolt head while the other is used in the ordinary way. The construction may also be adapted, though not so readily, to the type of wrench which uses only one handle with a head for each size of nut. The device will be quite useful in many other cases where two men would otherwise be required.

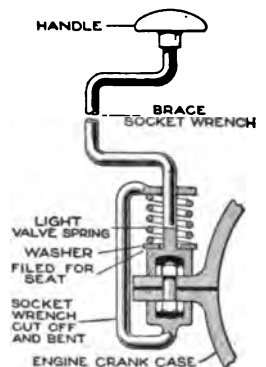



### Sprayer or Air Brush Easily Made from Common Materials

Secure an ordinary preserving jar, either quart or pint size; also about 18 in. of  $\frac{1}{8}$ -in. pipe, a small pet cock,

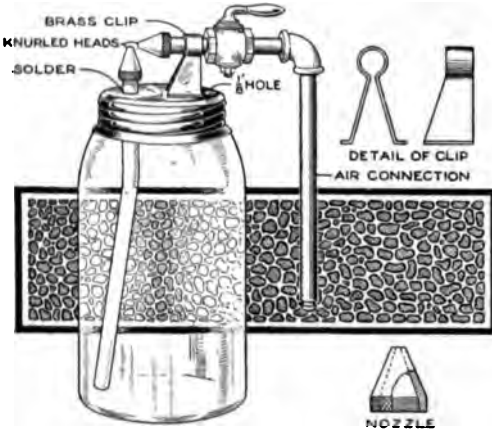

Sprayer, or Air Brush, Made from Mason Jar, for Finishing Small Parts, Such as Plaster Casts, and for Stenciling

an ell, and a piece of sheet brass, 2 by 5 in. Drill a hole in the fruit-jar cap to fit the pipe; also another,  $\frac{1}{8}$  in. diameter, about  $\frac{1}{4}$  in. from the edge of the cap, to act as an air vent. Thread one end of the pipe, and bend as shown in the sketch. Allow 1 in. of the threaded end of the pipe to project beyond the cap, and solder the pipe to the cap.

Cut three additional pieces of pipe, as follows: one 6 in. long, and two 2 in. long. Thread both ends of the smaller pieces and one end of the 6-in. pipe. The other end of the 6-in. pipe is grooved to take the air hose. The sheet of brass is shaped into a clip, and bent so as to fit the pipe and form a support for the 6-in. pipe. Two caps, or nozzles, are turned on a lathe. The nozzles are threaded to fit the pipes, tapered, and drilled  $\frac{3}{64}$  in. at the smallest end. One nozzle is screwed to the piece of pipe on the jar cap, the other on a 2-in. piece of pipe. Assemble the parts as indicated in the sketch. The clip is soldered to the jar top and the nozzles centered.

The sprayer is now ready for work. Color is placed in the jar, and the air

hose connected with the inlet of the sprayer, at the end of the 6-in. pipe. Adjustment is secured by turning the two nozzles. By having different jars with similar threads, various colors can be used without cleaning the jars. Liquid carbon dioxide is the most convenient source of pressure. Compressed air from any source is also effective. A regulator is required to vary the pressure, as heavy color mixtures require greater pressure than water colors or dyes. By having two or three outfits, different-size sprays can be obtained. Heavy colors require from 40 to 50 lb. pressure, while water colors, or dyes, require only 20 to 30 lb. Japan colors, oil, and varnish can be used. A great saving of time can be effected in painting or tinting plaster casts, artificial foliage, metal castings, papier-mâché forms, and in stenciling and similar work.—H. H. Marshall, Los Angeles, Calif.

### Convenient Electroplating Rack for Small Pieces

Where a large number of small pieces are to be electroplated, time can be saved if, instead of wiring individually each piece, they are strung on the arms of a metal rack.

Such a rack may be made quickly by inserting several 12-in. lengths of heavy copper or brass wire through equidistantly spaced holes drilled in a section of brass or copper rod. The wires should be soldered in place. Before the insertion of the wires, the upper end of the rod should be bent into a hook so that it can be suspended from the negative bus bar of the plating tank. Both ends of each horizontal wire should be bent upward to prevent the falling off of pieces hung on it.—K. M. Coggeshall, Webster Groves, Missouri.

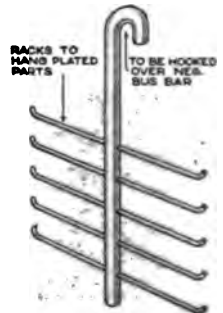

## Cigarette Box Deals Out One at a Time

WHEN the cover or top is raised this cigarette box delivers one cigarette each time the process is repeated.

A wood base is fashioned of hard wood, in the manner shown in section in Fig. 1,  $4\frac{1}{2}$  in. square, to which is fastened an upright with a grooved top, large enough to hold a cigarette. The base is cut out  $\frac{1}{8}$  in. in depth to admit the upright, which is screwed fast from the bottom, as in the sectional view. Two sidepieces, of  $\frac{1}{8}$ -in. material, are nailed to the sides of the upright to make it firm, and also to act as a slide for the cover, as shown in Fig. 2. The top, or outside box, is also made of  $\frac{1}{8}$ -in. material. The sides are cut so as to fit loosely over the two sidepieces of the upright. In the top a slot is cut,  $\frac{5}{8}$  in. wide and the length of the top, to admit the upright. The sides and top of the cover together are  $3\frac{3}{16}$  in. in height, so that the upright is flush with the top. Two pieces of  $\frac{1}{8}$ -in. stuff are cut 3 in. wide and as long as the inside of the cover, and glued to it, as shown, forming a triangular hopper for the cigarettes. Sufficient space at either end is allowed for the cover to be let down over the lower part until it rests on the base. A small slot is also cut in each end of the cover,

put into the upright on either side, through the slot at the top, to prevent

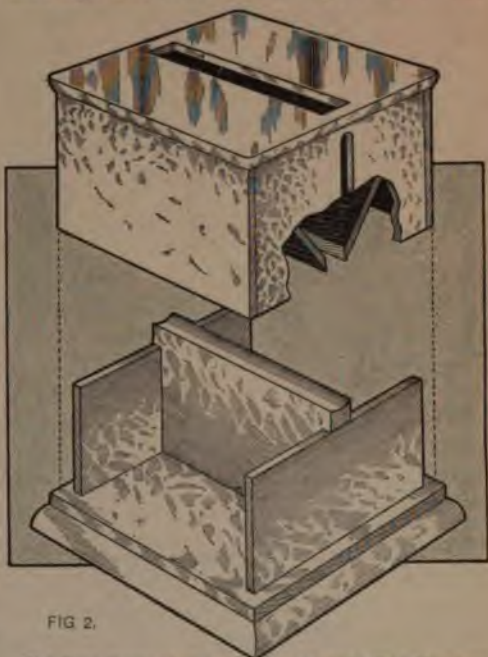
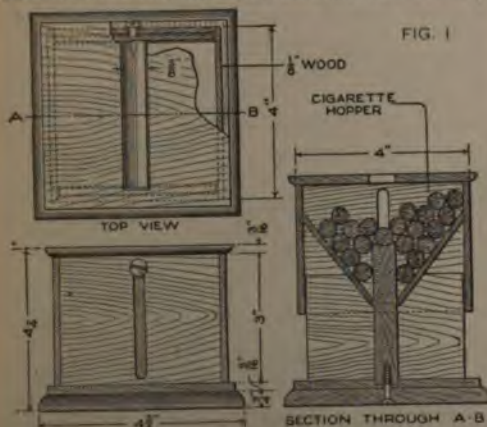

FIG. 2.

The Two Parts of the Box Completed: The Hopper under the Top Has Space for About 40 Cigarettes

the top from coming off when it is raised. The box is then polished or shellacked, and a piece of felt glued to the underside of the base to prevent it from scratching. The filling is accomplished by raising the cover and putting the cigarettes into the hopper through the opening in the top. The box will contain about 40 cigarettes when filled. The sectional view in Fig. 1 clearly shows what happens when the cover is raised and lowered.



Dimensions and Details of a Box Which Delivers One Cigarette Every Time the Cover is Raised and Lowered

as shown. The cover is then put into place, and a small round-head screw

## Filling Cracks in Concrete with Putty

To repair temporarily cracks in concrete work around brick flues on houses, where they project from the roof, putty has been used with good results. The putty for this work should be mixed until it is thoroughly elastic, but not thin, and then worked well into the crevices.—H. K. Capps, Stahl, Mo.

### A Chair Shelf That Folds Out of the Way

A shelf like the one illustrated may be made to look well, besides being

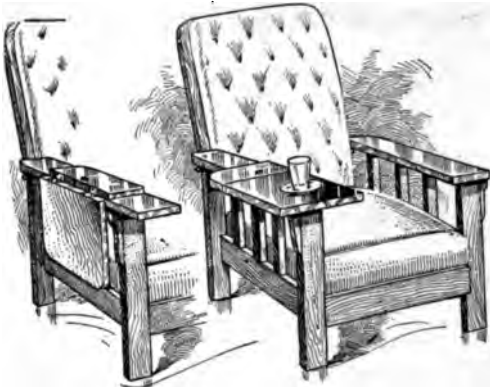

A Folding Shelf for the Arm Chair Which may be Made Both Slightly and Strong

very useful for writing or for holding dishes or drinking glasses. The folding member should be attached to the smaller board by hinges which are set into the wood; the small board is fastened to the arm of the chair by a single bolt on which it revolves. This bolt should be set well forward toward the hinge line, and there should be at least 5 or 6 in. of length behind it, for leverage against the weight on the shelf.—W. H. Sargent, Rutland, Vt.

### Tapping a Hole without a Tap

After removing a stay bolt, it was found that a tap of the proper size was not at hand. To retap the hole a stay bolt was used. Its end was pointed with a file, and grooves were filed running longitudinally as in a tap. The bolt was then casehardened, and the retapping of the hole was done in the ordinary manner.

### Size for Holding Aluminum Bronze Letters

To do a job of lettering with aluminum bronze on glass, make a size as follows: Mix together 3 parts of good quick-drying varnish, 1 part of chrome in oil, medium shade, and 1 part

of turpentine. This size should be fit to take the bronze in an hour after application, when it ought to have the proper tackiness. In warm weather it will be fit in much less time. But try it with the tip of a finger to ascertain when it gets tacky.—Charles Richard, Cleveland, Ohio.

### An Automatic Electric Backing-Up Automobile Light

With this auxiliary lighting system, when the gear-shifting lever is thrown to the reverse position, the backing-up light and also the tail light will be illuminated and the entire road in the rear of the car brightly lighted. As shown in the upper part of the diagram, the backing-up light is wired on a separate circuit so that closing the automatic switch permits current to pass through it. The switch, as detailed in the lower part of the drawing, consists of two strips bent from spring brass. These are mounted on a wooden block which provides insulation. The block is bolted under the floor of the car. The contact lug, whereby the switch is caused to close, comprises two pieces, bent from strap iron, which

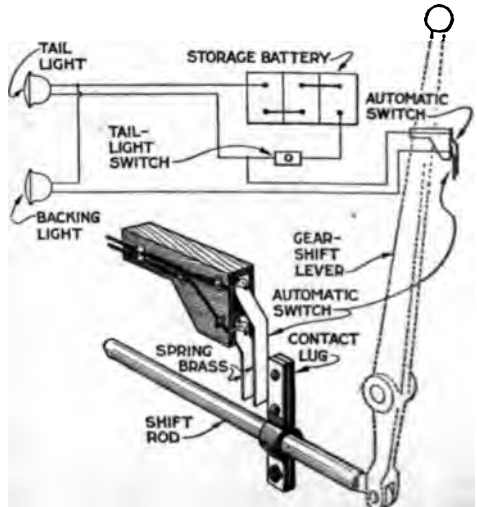

As the Gear Lever is Thrown into Reverse Position, It Switches on a Light at the Rear of the Car

are faced with fiber or rubber. Throwing the gear-shift lever to the re-



of the same width, such as are used on most office typewriters. Ribbons of the portable typewriter are usually 10 yd. in length. For such a ribbon one pays 75 cents or \$1, the same as for the longer ribbon that is used on office machines.

By buying the 20-yd. ribbon and cutting it in two, one has two ribbons for the little machine at the same price ordinarily paid for one. If the portable typewriter is provided with a two-color adjustment and one is able to get along with one color, the service of four ordinary ribbons may be obtained from the one 20-yd. ribbon. After being cut to form two ribbons, each ribbon is used on both edges by manipulating the two-color shifting adjustment.—John Edwin Hogg, Alhambra, Calif.

### Handy Square Attachment for Laying Out Stairs

After the riser and tread have been decided, this device is handy in scribing the stair stringers. It consists of a carpenter's square, and a wooden bar with clamps which hold the bar and square snugly together. When set, there can be no slipping, and thus all marks are regular and the finished job uniform.

The illustration shows how the wooden bar is drilled to take the bolts. The clamps are formed

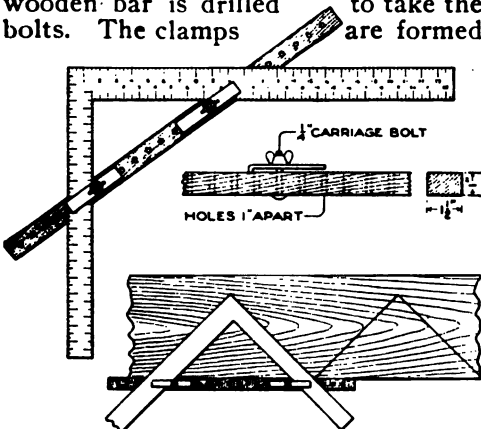

With This Device Attached to an Ordinary Carpenter's Square, the Laying Out of Steps is Made Easy

of strips of  $\frac{3}{16}$  by  $1\frac{1}{4}$ -in. steel.—C. C. Spreen, Flint, Michigan.

### Novel Method for Lifting Large Objects

A short time ago a neighbor undertook to enlarge a barn from a one-story affair to two stories. The way in which he hoisted the roof in one piece was so simple, and did the work so well that it might be of

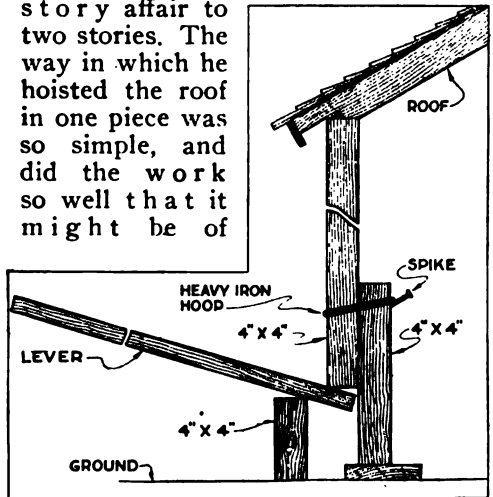

The Entire Roof of the Barn was Raised by Prying Up Each of the 4 by 4-Inch Timbers a Little at a Time. The Iron Hoops Kept Them from Slipping Back

value to others. The roof was severed from the sides, resting upon temporary supports, and several boards were removed from the sides. Then six or eight hoops were made at the blacksmith shop, a little over 4 by 8 in., inside dimensions. These being made ready, a number of timbers, 4 by 4 in. in size, were secured and arranged as shown. One was set in the wall where a board had been removed, to help support the roof. A shorter one was placed against the first, and the hoop slipped over both. A spike was driven into the shorter one to support the hoop. All the timbers and hoops were arranged in this manner, and when ready, it was but a simple matter to go around from one to the next, lifting each one a little in its turn.

The action of the hoop is obvious. As the roof is raised, the hoop allows a movement of the timber up, but when released, automatically clamps and holds it against an opposite movement. The whole cost for material was \$4, and the roof was raised in an hour.—Dale R. Van Horn, North Loup, Neb.

### Wrench for Small Polished Pipes

A sure-grip wrench which can be used on highly polished nickel or brass pipe, without marring or crushing the

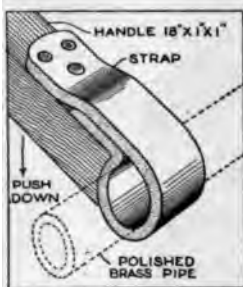

tube, may be made in the following manner: Nail to one end of an 18 by 1 by 1-in. hardwood stick a strong leather, or canvas, strap of suitable length, as shown. Rub powdered rosin on the strap. Wrap it around the pipe in the manner shown. Use the wooden-stick lever as a handle. To turn the pipe in the opposite direction, reverse the tool.—Walter B. Raynor, Patchogue, N. Y.

### Automobile Radiator as a Heating Unit

Having need of an additional steam radiator for one side of his show window, the depth of which was very scant, an automobile repair man solved the problem of fitting the additional heater by making use of a discarded automobile radiator, instead of the regular cast-iron or pipe kind.

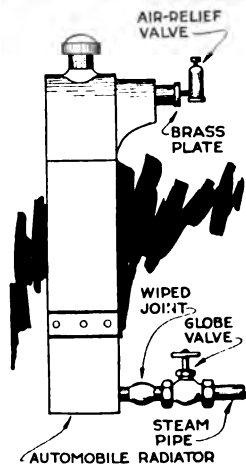

For the purpose, a brass flange, to take the 1½-in. steam-pipe union, was wiped on the lower, or outlet, pipe of the radiator. The upper, or inlet, pipe was permanently closed with a brass plate soldered in place, making a tight fit. The plate was drilled and tapped with a ⅛-in. pipe tap, to receive the air-relief

valve. A copper-asbestos gasket was fitted to the filler cap, which was screwed down hard in place. The precaution had been taken, of course, to solder up the small overflow pipe.

### Gear Puller Cheaply Made from an Old Metal Screw Clip

This is a handy tool for emergencies. The difficulty of removing gears from their shafts is familiar to all motorists.

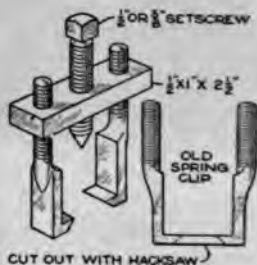

CUT OUT WITH HACKSAW

This device has the merit of simplicity, cheapness, and compactness. An old spring clip is sawed apart, and two claws for gripping the gear are finished with a file. A steel bar is then drilled

and tapped in three places, as shown. Into the center hole is screwed a pointed setscrew. The two claws are set on the gear hub or rim. The depth may be varied to meet the circumstances. By turning the pointed setscrew with a wrench, the claws start the gear or pinion, and pull it from the shaft smoothly and surely, even from a tight fit.

### Handle for Bits for Close Work

When holes must be bored, or screws driven, and there is not much space in front of the hole, the handle shown in the sketch will be useful. The shank of the bit should be adapted for it by drilling a small hole, as shown. The handle is made of a piece of steel tubing, with two holes drilled and filed out square, of the proper size as determined by fitting in the bits. A key of steel wire holds the bits in place. In case of necessity, any square-shank

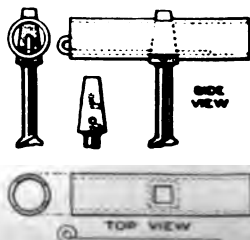

# A Spark-Plug Atomizer Starter for Automobile Engines

By GEORGE A. LUERS

A TYPE of automobile starter which can be installed with great satisfaction, on cars which were built for hand cranking only, is the one here described, consisting of an apparatus for placing an explosive mixture directly at the point of ignition. The mixture is ignited by whatever means is provided for "starting on the spark"; this varies with the type of ignition, and is not ordinarily available in engines ignited by magneto only. On others, however, means are usually provided for producing a spark when the engine is at rest.

The complete outfit is shown in outline in Fig. 1, as arranged for a car with vibrator ignition, using a battery of dry cells. A pressure pump located on the dash is connected to the gasoline line, and its discharge end is connected to a tube leading to a row of tees with an elbow at the end, which lead into the spark plugs. A plug, as fitted with this nozzle, is shown in detail in Fig. 1; almost any plug can be used, of the type where the porcelain can be removed for cleaning. With the plugs screwed in tightly, make a mark on each one to locate

$\frac{3}{16}$ -in. outside diameter, being careful to strike the interior of the plug at a point below the porcelain. The

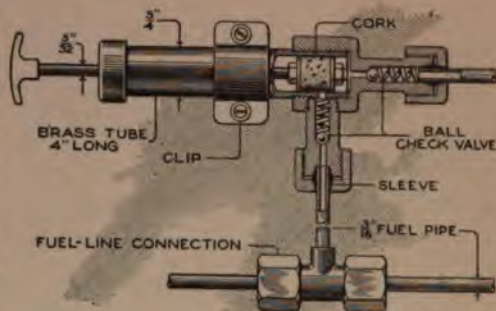

Fig. 2

The Pump Which Forces Gasoline into the Plugs can be Made in the Home Shop from Scrap Metal or from an Old Pressure Pump

short piece of tubing which extends from the tee into the plug should be peened down at the extreme end to an opening not exceeding about  $\frac{1}{64}$  or  $.02$  in. in diameter, so as to form a nozzle.

The pressure pump may be made from pieces of pipe and scraps, but an old oil pump or gasoline pressure-feed pump may be readily modified for this use. On the upstroke the pump sucks gasoline from the fuel line, and on the downstroke delivers it to the spark plugs, this action being forced by the two ball check valves shown in Fig. 2.

To operate the starter, simply push the pump handle up and down once or twice, and produce the spark by the means provided. A start should result, even in the coldest weather. It might be thought that the small opening in the spark plugs would cause loss of power; this is practically negligible if the nozzles are small enough, but can be prevented if desired by placing a ball valve in each of the tubes to the spark plugs. The expense of operating such a starter is almost nothing, and its simplicity has much to recommend it.

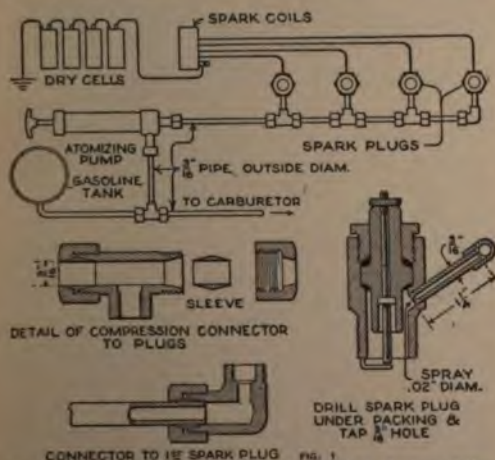

FIG. 1

General Arrangement of the Atomizing Automobile Starter, Showing Tubes Leading to Spark Plugs

accurately the point which will be toward the tee; remove the plugs, and drill and tap holes into them of proper size to take gasoline-line tubing of

Wet shoes dry more quickly, and are held in shape better, if stuffed with newspaper.



**Pedal Extension on Auto-Jack  
Lever Saves Labor**

When a mechanic wants to relieve himself of some of the back-breaking

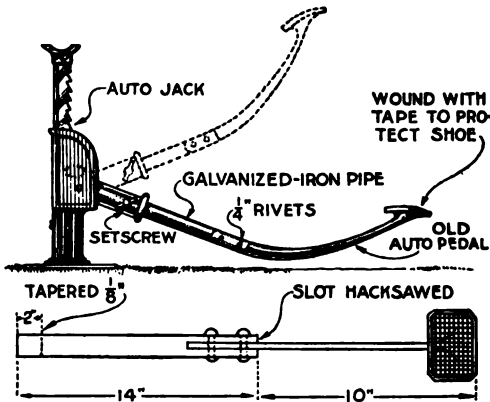

Auto Jacks can be Made to Work Easily by Lengthening the Leverage

While saws made for this purpose can be obtained, it is often more satisfactory to have a gauge which can be attached to any ordinary saw. The illustration shows how such a gauge can be made from a few sticks of wood, having the added advantage that it is adjustable for depth, so that much blocking up of work can be avoided. The gauge is fastened on the saw by tightening the two wing nuts. If it is desired to saw a number of slots to a distance of  $\frac{1}{4}$  in. from the bottom, for example, a good way to set the gauge is to put a piece of  $\frac{1}{4}$ -in. wood in the miter box, place the saw in the box resting on the piece of wood, set the gauge, and remove the piece of wood.

work of jacking up a heavy load, he lengthens the leverage with a bar or a piece of pipe. Here is a plan to lengthen the leverage of an auto jack. The extension of the lever by adding an old pedal saves much work and soiling of clothes. The cost is nominal, as an old auto pedal is easily procured. The sketch shows how the work is done.—P. P. Avery, Garfield, New Jersey.

**Dot and Dash Ruler  
Easily Made**

A timesaving tool for the draftsman is a dot and dash ruler. For pencil work, the one illustrated is very convenient, and can be made with a little careful work. It consists of an ordinary straightedge with a thin strip of steel, celluloid, or hard paper, glued under it, which has a line of small holes, the proper distance away from the edge of the ruler so that a pencil point of average sharpness will just strike the holes or slots. The holes may be marked in the



**Depth Gauge for Wooden  
Miter Boxes**

When one is making saw cuts in a miter box to a certain depth, it is almost impossible to do good work without a gauge, or stop, on the saw.

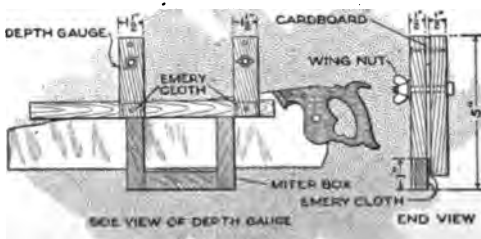

Homemade Gauge Converts Any Saw into an Adjustable Miter-Box Saw

strip with a needle point and drilled with a small drill, or a machine-perforated piece of paper may be used, cutting out and joining together with a knife every two or three holes, for a dash ruler. If it is desired to make a complete set of rulers of celluloid, or of thin steel, for dots, dashes, and combinations of dots and dashes for center lines, etc., a good plan is to make a template of thicker metal with the round holes only. The various strips can be drilled through it, and

that it will disclose any appreciable variation from the true in a large door or window opening and thereby permit the door or window to be cut accordingly. Yet the tongue, being 23 in. long, is sufficiently short to be used in openings only 2 ft. wide.—Henry Simon, Laguna Beach, Calif.

### Snap Bow Aids in Making Chalk Lines

The chalk line is often much quicker to use for marking than a straightedge and pencil, but fastening the far end, or having some one to hold it, makes it inconvenient. A snap bow will enable one to use the simple and accurate chalk-line method without trouble. The fishline may be rubbed with white or colored chalk, laid against the surface to be marked, and picked with the



The Snap Bow Provides a One-Man Way to Use a Chalkline

finger. The device has been found useful in scenic painting.

### A Quick and Convenient Blueprint Washer

There are a great many methods of washing blueprints, but a spray washer, constructed as shown in the illustration, will prove as economical and satisfactory as any in a shop where a large number of prints are made. A wooden tray of suitable size is made and covered with zinc. The water is admitted to the tray through two spray pipes which are drilled with holes through about 45° of their lower surfaces. When a print is to be washed, the water is turned on and permitted to wet the zinc thoroughly. Then it is shut off, and the blueprint, with its sensitized side out, placed on the zinc in the back of the tray, so that the top edge of the print is high enough

to prevent the water from spraying above it. With the print in position, the water is again turned on and will

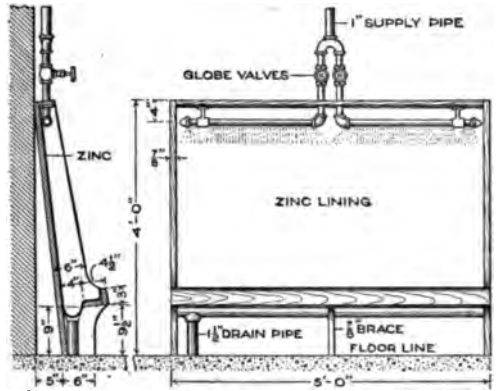

Blueprints are Quickly Washed in Running Water with This Device. For Small Prints, Only One of the Valves need be Turned On

quickly wash off the sensitizing chemicals. Experience has shown that the prints will dry quicker when washed in this manner than when washed by soaking them in a large tray, and the prints are not so likely to become torn.—W. J. Carol, St. Louis, Mo.

### A One-Man Wrench for Automobile Crank-Case Bolts

The socket wrench shown in the drawing was devised by an ingenious repair man who had felt the shortage of workmen. It is made by combining two socket wrenches so that one holds the bolt head while the other is used in the ordinary way. The construction may also be adapted, though not so readily, to the type of wrench which uses only one handle with a head for each size of nut. The device will be quite useful in many other cases where two men would otherwise be required.

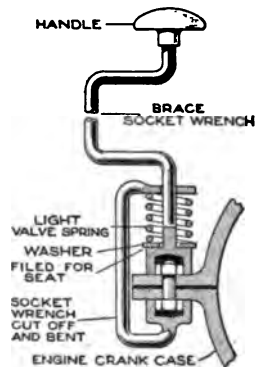

### Drill-Press Attachment for Bench Lathe

In the small shop a drill-press attachment for a bench lathe, such as

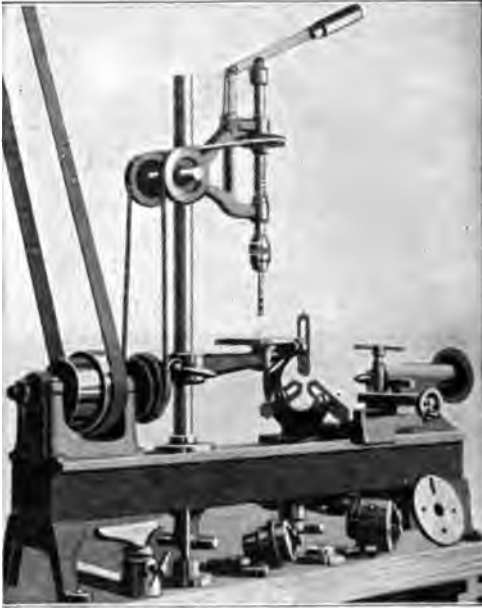

The Drill Press Takes Its Power from the Lathe, and can be Readily Mounted and Detached

the one here shown, is often useful. The standard is a piece of 1-in. cold-rolled shafting, while the spindle is a piece of 1/2-in. drill rod. The drill-press belt is tightened by raising the head; all the clamping is done by tangent screws. The pulleys on the head run on steel pins. A lever feed forces the drill down into the work; it is returned by a spring.—James H. Beebee, Rochester, N. Y.

### Shellac Gives Protection against Wear

A coat of brown shellac on an automobile tire, which is to be stored or carried as a spare, will assist in preventing oxidation and deterioration.

White shellac can be used on a great many articles to form a transparent waterproof coating. Drawings, photographs, printed or written documents, or any other papers which

must be frequently handled or exposed to dirt, will be the better for such a coating.

### Increasing the Power of an Auto Engine

The device illustrated was designed to admit additional air to the manifold, and thus completely vaporize the gasoline. At a convenient point on the intake manifold, drill three holes, 1/4 in. in diameter, and one, 1/8 in. in diameter. The holes must be located within a radius of 1/2 in. A disk of iron, 1 1/4 in. in diameter, is fitted with a 1/8-in. rod, 1 1/2 in. long. The upper end of the rod is threaded for 1/2 in. with an 8-32 die. The parts are assembled as shown in the sketch. The stem is riveted in the 1/8-in. hole in the center. The three 1/4-in. holes are covered on the inside of the manifold with the disk. A spring is slipped over the rod, followed by a washer and two lock nuts. Use sufficient tension to hold the disk firmly in place.

Start the engine and advance the throttle about one-quarter. Release the lower nut gradually. A point will be reached where the engine gains in speed, as the vacuum formed in the intake draws down the disk covering the holes. Do not loosen the tension too much, or the engine will not throttle down to low speeds.

A roadster equipped with this device, driven by a 22-hp. engine, showed

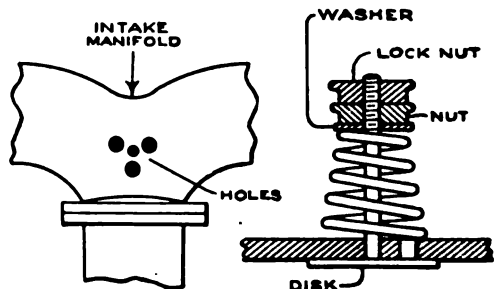

Air Valve in Automobile Manifold Increases Power and Speed of Car

a remarkable increase in power. The results as applied to a motor truck were also satisfactory.



### Paraffin Grease for Auto and Wagon Springs

An excellent grease for inserting between the leaves of auto and wagon springs can be made by melting several candles, and adding a small quantity of flake graphite. When this is placed between the blades of springs, its replenishment is very seldom needed, as it resists the effect of water and heat better than lighter lubricants. Rust formation is prevented, and besides adding to the life of the spring, it makes the vehicle ride easier.

### The Proper Shape to Cut a Shim or Filler

Shimming bolts and flues after they have been placed is a task which requires much patience. It has been found that to make the shim enter the space in the hole around the bolt or flue, without difficulty, the shim should be cut triangular. An

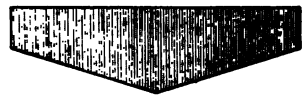

equalateral triangle is not necessary; merely enough angle to give the shim a good starting point when rolled up. After the shim has been cut and rolled, the point is inserted into the space to be shimmed, and the shim is tapped lightly with the hammer. Due to the pointed end, the shim will conform to the space more readily than if it is cut rectangular.

### Relieve Compression of Cylinder Which is Not Firing

When it is necessary to drive an automobile or motorcycle with one or more cylinders missing fire, the compression should be relieved in the missing cylinders by opening the petcocks or removing the spark plug. This will often make a big difference in the ability of the remaining cylinders to pull the machine.—Henry Priebe, Kent, Ohio.

### Small Wheels Aid Handling of Wheelbarrow

The wheelbarrow is a peculiarly useful vehicle where a load must be transported along a plank or narrow path, but where plenty of space is available it often seems foolish to carry so much of the weight in the hands instead of on wheels.



Wheels can be placed on the legs of the ordinary wheelbarrow to very good advantage; they should have wide treads, and if necessary such treads can be cut from sheet iron and riveted around the wheels used. The extra wheels will prove particularly useful in going over curbstones and such elevations.—Herault A. Trester, Milwaukee, Wis.

### Soldering Iron for Attachment to Blowtorch

For many purposes, a soldering copper which is permanently attached to the blowtorch will do as good work as an electric soldering iron, and at a much lower cost. To make the one illustrated, cut down a short piece of 1-in. pipe to the shape shown, and fit the block of copper into the end. The copper should be forged or turned to a cone or pyramid shape, and may be fastened into the pipe by peening its inside face. A hole drilled in the copper, as shown, will cause it to heat up more quickly. The other end of the pipe frame is then fastened to the blowtorch by a setscrew. A handle may be made to fit in the same place when it is desired to use the soldering iron in the ordinary way.

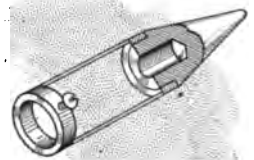

### A Chair Shelf That Folds Out of the Way

A shelf like the one illustrated may be made to look well, besides being

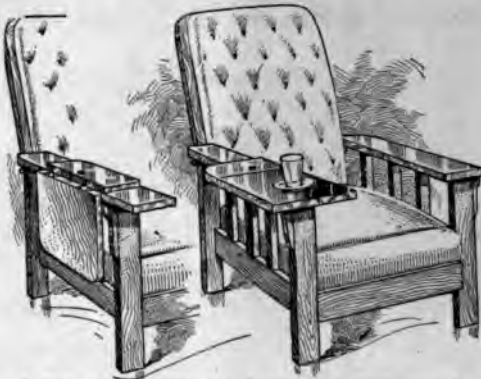

A Folding Shelf for the Armchair Which may be Made Both Sightly and Strong

very useful for writing or for holding dishes or drinking glasses. The folding member should be attached to the smaller board by hinges which are set into the wood; the small board is fastened to the arm of the chair by a single bolt on which it revolves. This bolt should be set well forward toward the hinge line, and there should be at least 5 or 6 in. of length behind it, for leverage against the weight on the shelf.—W. H. Sargent, Rutland, Vt.

### Tapping a Hole without a Tap

After removing a stay bolt, it was found that a tap of the proper size was not at hand. To retap the hole a stay bolt was used. Its end was pointed with a file, and grooves were filed running longitudinally as in a tap. The bolt was then casehardened, and the retapping of the hole was done in the ordinary manner.

### Size for Holding Aluminum Bronze Letters

To do a job of lettering with aluminum bronze on glass, make a size as follows: Mix together 3 parts of good quick-drying varnish, 1 part of chrome yellow in oil, medium shade, and 1 part

of turpentine. This size should be left to take the bronze in an hour after application, when it ought to have the proper tackiness. In warm weather it will be fit in much less time. But test it with the tip of a finger to ascertain when it gets tacky.—Charles Richard Cleveland, Ohio.

### An Automatic Electric Backing-Up Automobile Light

With this auxiliary lighting system when the gear-shifting lever is thrown to the reverse position, the backing-up light and also the tail light will be illuminated and the entire road in the rear of the car brightly lighted. As shown in the upper part of the diagram, the backing-up light is wired to a separate circuit so that closing the automatic switch permits current to pass through it. The switch, as detailed in the lower part of the drawing, consists of two strips bent from spring brass. These are mounted on a wood block which provides insulation. The block is bolted under the floor of the car. The contact lug, whereby the switch is caused to close, comprises two pieces, bent from strap iron, which

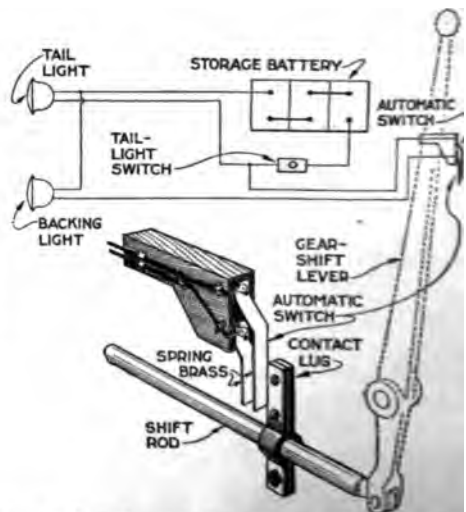

As the Gear Lever is Thrown into Reverse Position It Switches on a Light at the Rear of the Car

are faced with fiber or rubber. Throwing the gear-shift lever to the r

be readily seen that a considerable amount of money is involved.

A concern which markets a preparation to be used for this purpose has prepared a chart which shows readily the cost per year of belt slip to any plant, over and above the minimum which cannot be avoided. To read the chart, draw a line through the appropriate points on scales A and B, and from the point where this line intersects line C, draw another line to the proper point on scale E. The intersection with scale D will show the result. For example, when 1,000 tons per year of \$4 coal are used and the belt slippage is six per cent, then the annual loss is \$160.

### Removing Tailstock Centers Easily by Means of Drift Pin

Lathe tailstocks are built so that the center may be removed by working it back to the end of its travel, when it will be pressed out from the end. This often takes considerable time and trouble, which may be avoided by fitting the centers with holes, or slots, so that they can



be driven out with a few light blows on a drift pin, as is done in the drill press. The pin should be fastened with a chain, and may be carried in the oil well on the tailstock and used also for dropping oil on the dead center.—Charles R. Elliott, Los Angeles, California.

### Cupola Made from an Old Boiler

A practical cupola, melting from 100 to 150 lb. at a charge, can be made from an old hot-water tank, some piping, and a blacksmith's motor-driven blower. The tank is cut off at the top for charging. The sketch shows the details of construction.

The cupola is lined with thin fire

brick from the pouring spout to the top of the melting zone. The remain-

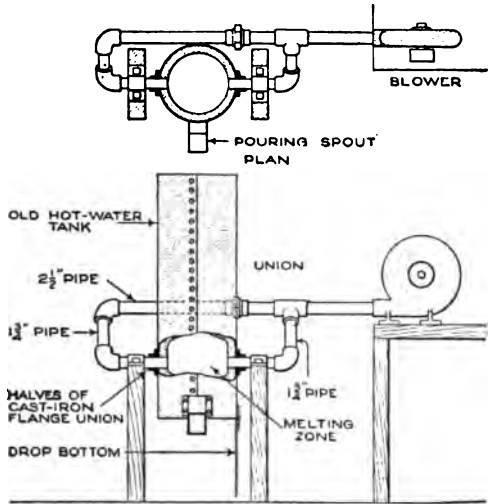

Cupola in Plan and Elevation: The Blower Discharges through the Pipes and Tuyeres into the Melting Zone

der of the cupola can be lined with a mixture of fire clay and sharp sand. Stove coke is used as fuel. The iron to be melted must be broken up in small pieces.—A. Gemmell, Ansonia, Connecticut.

### Mold for Solder Easily Made of Plaster of Paris

Scraps of solder should always be saved, melted up, and poured into bar or wire form. A convenient mold can be made of plaster of Paris. The wooden patterns for the mold should first be made; their proportions being selected to suit the user's convenience. Pour-

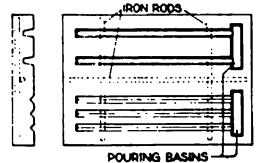

ing basins should be molded at the end of the grooves, and at least 1/4 in. deeper, so that the solder may run out evenly into the grooves. The plaster may be molded in a rectangular wooden frame, laid upon a glass or other smooth surface. Iron rods should be molded into the plaster in order to strengthen it.—William B. Jones, Medford, Mass.



### Shop Truck That may be Picked Up by Crane

The use of a truck that can be picked up by an overhead crane, as illustrated,

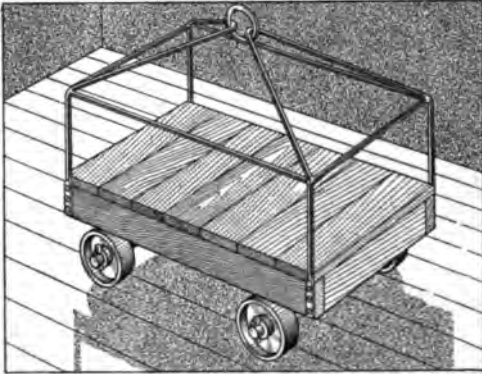

The Truck can be Carried by a Crane without Extra Ropes or Cables

will save much time in handling materials. For instance, a heavy piece of machinery may be carried on such a truck to a bench; the truck can then be picked up by a crane, raised to the level of the bench, and easily transferred to it. Again, if the progress of the truck is blocked by obstacles in its path, it may be lifted over them by a crane. To convert an ordinary truck so that it may be so handled, secure two steel rods of a length depending on the size of the truck. Flatten the ends, and drill three-bolt holes in each. One end of a rod is bolted to each corner. Horizontal brace rods may be welded in place, and a ring at the top is provided for the crane hook. The load should be balanced on the truck when lifted, so that it will not slide off.—Kenneth Coggeshall, Webster Groves, Mo.

### Boring Large Holes in Glass

Take a piece of brass tube, about 11½ in. long, and the diameter of the hole to be made, and file small teeth in one end. Make a shank which will fit a drill-press chuck, or use a discarded drill shank. Taper one end slightly to fit into the brass tube about ¼ in. Small holes may be bored in the tube just be-

low the end of the shank for the purpose of lubrication. Use a mixture of gum camphor and turpentine for a lubricant, to which is added a little emery flour to make a thin paste. The speed and feed of the drill must not be sufficient to develop heat, as this may crack the glass. This is a process of wearing rather than of cutting. When the upper hard skin of the glass is cut, the drilling will progress rather easily until the lower glass skin is reached. To prevent cracking when the drill goes through, drill a small hole through the lower skin, and then ream out to size. The same method may be used to cut glass along straight lines, by using a copper or brass disk with small teeth on the outer edge, and rotating in a lathe or milling machine.—J. Garrett Kemp, Stillwater, Minn.

### Testing Oil Level in Automobile Crank Cases

On some light automobiles the only method provided for testing the level of oil in the crank case is to open petcocks, which are hard to get at without crawling under the car. By the method shown it is possible to avoid this trouble without the danger of

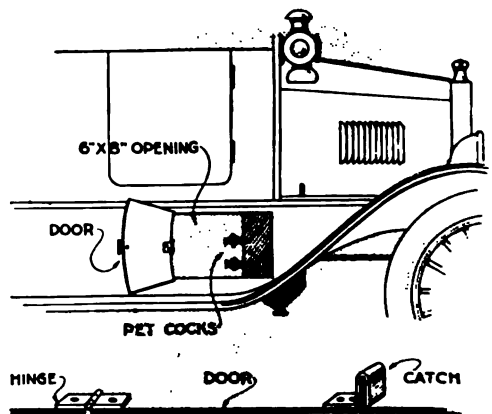

A Small Door in the Running-Board Shield Overcomes Troublesome Methods of Oil-Level Testing

breakage which is present when a gauge glass is used. A rectangular

opening is cut in the running-board shield, and is provided with a hinged door. The door will not rattle if a spring catch is used, and it will be no detriment to the looks of the car if painted the same color.—George A. Brown, Des Moines, Ia.

**Garden Hose Protects Dishes against Chipping and Breaking**

An inch of old garden hose, put on the tip of the faucet, will save many dishes from being chipped or broken while rinsing the dishes under the faucet.—Charles H. Crossman, Brooklyn, New York.

**Converting Broken Drills into Lathe Tools**

Broken twist-drill shanks make excellent lathe tools, particularly if the drill happens to be of high-speed steel. A holder for such pieces of broken drill is made as illustrated. A set-screw is placed in the underside of the cutter to be used as an adjustment. This permits using up all but a very small scrap of the steel. Of course the drill shank must be thoroughly hardened for this use.



**A Lathe Bell Center for Turning Tubing**

A cone-shaped tailstock center, or "dead center," which is very useful for turning tubing in a lathe can be made as shown in the sketch. The spindle is made of machine steel, or cold-rolled shafting; the cone, which revolves with the tubing, may be made of cast iron. The shank should be turned to the proper taper to fit the tailstock; the cylindrical portion may be slightly smaller, for most work. For durability, a phosphor-bronze washer may be provided to take the thrust, and a bushing of the same material, or of babbitt, may be used. The conical

surface should then be turned down with an inclined angle of about 90°,

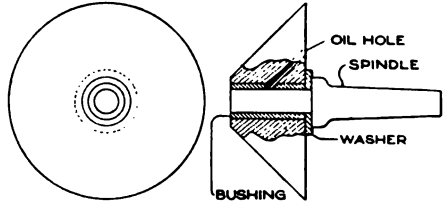
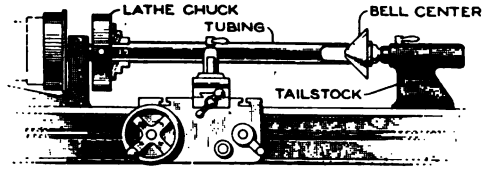

The Cone on the Bell Center Rotates with the Tubing, Holding It Firmly Centered

as shown. The finishing cut, at least, should be taken with the cone revolving upon the spindle as it would when in use. The bushing and washer may, of course, be omitted in a center which is intended for temporary use only. In using the center, plenty of oil should be provided, both in the oil hole and on the thrust washer, which may have an oil groove cut across its face.

**Paper Shim Makes Worn Taper Grip Tightly**

When tapers in friction grips, and similar machinery, are so badly worn that they strike at the end instead of gripping, they may be used by inserting a paper shim. The paper may be cut from any at hand, and the general shape will be as illustrated. Cutting the shim to the exact shape is a not difficult geometrical problem, but takes more time than is necessary; the shape can be guessed at close enough after a few trials.—Joe W. Romig, Allentown, Pa.

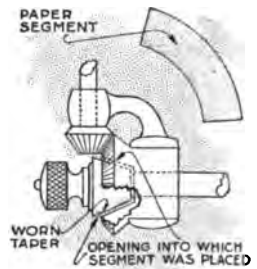

### An Ironing Board with Novel Features

Most of the portable ironing boards are insecure. This renders working on

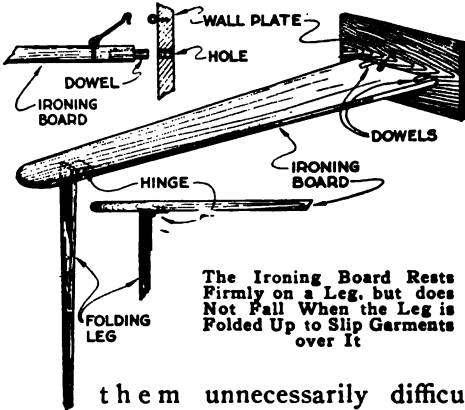

them unnecessarily difficult and tiresome. The design detailed in the accompanying illustration shows a convenient board and furthermore incorporates features of portability and adaptability. It can be taken down and stored away in a small space. When a waist or skirt is being ironed the hinged leg may be folded up along the ironing board until the garment is drawn on the board, when the leg falls back automatically to its normal location. The dimensions may vary, but experience has shown the following to be good proportions: Make the ironing board from a 2 by 12-in. plank, 4 ft. long. Taper it down to a width of 6 in. at one end. Any convenient 2 by 4-in. stick will serve as a leg. Fasten the leg about 6 in. from the small end of the ironing board with a metal hinge or a piece of leather. For a wall plate a piece of 1 by 8 by 24-in. stock is employed. To accommodate the dowels, bore two 1/2-in. holes through the wall plate and into the end of the ironing board. Into each of the holes in the end of the board drive a 1/2 by 4-in. round iron pin. Ream the holes in the wall plate so that these dowel pins will slip into them readily. Provide a screw hook and eye to prevent the board from falling when garments are being drawn over the end, and to keep the

board solidly against the wall. The wall plate should be fastened, with flat-head wood screws, to the wall of the room at the location where the board is used.—James Reid, Lumsden, Canada.

### How to Make Good Signs without Special Skill

By means of three patterns cut from pasteboard, almost anyone can make good-looking signs. The height of the letters must first be decided upon, and patterns made to suit. The first is a strip, a little longer than the height of the letters, and having a width about 1/8 of this height. The other two patterns are made from a circular ring, whose outside diameter is one-half of the height of letters, and whose width is the same as the width of the strip. The circle is cut into three pieces as shown.

How these patterns are combined to form letters is shown in the illustration. The outline is drawn around the pattern in pencil, and may be filled in afterward with a brush and ink. On a few letters, such as R, short strokes may well be made freehand; this will soon come easy. With the exception of "I," "M," and "W," all letters may be made of equal width, and if desired,

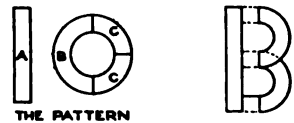

Letters for Signs are Readily Formed from Three Patterns Cut Out of Pasteboard

the spaces between all letters may be made equal. Much better appearance



dash holes cut out with a small cold chisel as required.—Reginald R. Wayt, Pittsburgh, Pa.

### Pneumatic Riveter Useful in Wood Shop

The compressed-air riveting machine is found to be extremely useful in woodworking establishments handling large work. It is made adaptable by fitting, instead of the hammer tool, heavy wood-cutting chisels and gouges with shanks shaped to fit in the machine. Mortise and tenon joints can be chipped out quickly and easily with the chisel tool. In the shop where large built-up work has to be shaped by hand, the gouge will be found convenient for roughing off. I have used this means several times to shape large, irregular wood patterns, such as hawser pipes and struts.—Arthur A. Richardson, Center Barnstead, N. H.

### Reliable Oiling Systems for Chain-Driven Trucks

The difficulty and uncertainty of keeping the chains oiled is one of the main objections to the old reliable chain drive. Two methods of overcoming this are shown in the illustrations.

The gravity oiler is the simpler one. It consists of two oil cups, mounted on brackets, so as to be directly over the small sprockets on the jackshaft, with two tubes or spouts, A, hanging down from each so as to place the oil on the sides of the sprocket, whence it is thrown out into the chain by centrifugal force. The construction is evident from Fig. 2; the bracket is bolted to the frame, and the 1/4-in. spouts are bolted to the oil cup. Enough oil is thrown onto the chain once thoroughly to last for several days, and the cups just before starting to run, and it drains out by gravity.

The pressure system, shown at the top of Fig. 1, is more expensive, but it is more reliable and more convenient. It is arranged as in the gravity oiler, but the spouts are soldered to a pipe

extending across the frame, which has a tee in the middle. From the tee an

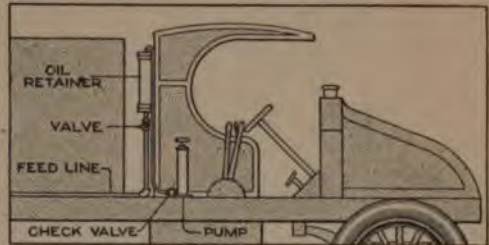
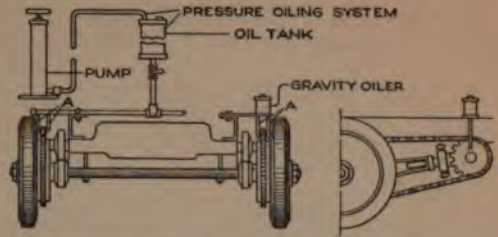

Fig. 1 The Oil is Thrown onto the Side of the Small Sprocket, and Works into the Chain

other pipe runs back, through a stopcock, placed handy to the driver's seat, to an oil tank. Air pressure is provided in the tank by a tube leading to a bicycle pump, and a screw plug is provided in the tank, for filling with oil. The tank should be filled with oil while the stopcock is closed; then, while running, the stopcock can be opened whenever desired, the pressure raised to 10 or 20 lb. by means of the

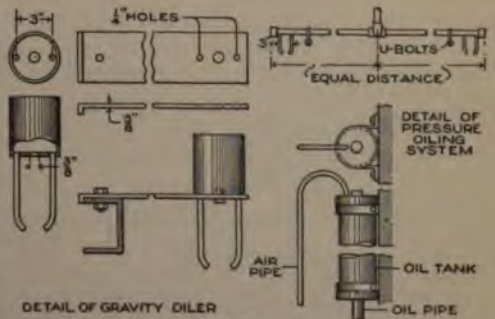

Fig. 2 Details of the Two Systems, Showing How the Apparatus is Attached to the Frame

pump, and sufficient oil run onto the chain to lubricate it.

A heavy oil should be used that will stick to the chain.—Ed. H. Samen, Chicago, Ill.

### Gauge Tells Height of Water in Elevated Tank

A pressure gauge forms a very convenient height gauge for a water tank, if properly arranged.

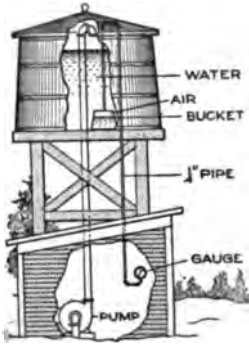

When the tank is elevated, and the gauge is to be located some distance below it, care must be taken that the gauge does not show the pressure due to the height of the tank above the gauge, in addition to the pressure due to the

actual height of water in the tank.

Whenever there is a pipe full of water leading down from the tank, its weight will read on the gauge, which must be of sufficient capacity to indicate the increased pressure, and the actual height of water in the tank does not, in such a case, show with sufficient clearness.

The method shown enables one to use a low-reading gauge, which will read zero when the tank is empty, and indicate pressures which are exactly proportional to the height of water in the tank.

A water-tight pail is inverted in the tank, with a small pipe leading upward from it, over the edge of the tank, and down to the pressure gauge. The pail is nailed down, but a small hole should be made in it near the rim, so as to allow the water to flow in and out.

The gauge thus connected will indicate the air pressure in the pail, or .4327 lb. for each foot of water height in the tank, above the level in the bucket—which is so near the bottom of the tank that it may be considered as being at the bottom. The gauge dial may be marked to read in feet, or the marks for pounds of pressure will each indicate .4327 times as many feet as the number of pounds.—Henry R. Helander, Nesconset, N. Y.

### An Emergency Handle for the Screwdriver

Needing a long, thin screwdriver handle on a holiday when it was impossible to procure one, I took a piece of drill rod of the required length, and hardened and ground the end. I then cut 3 or 4 in. of thread on the upper end and screwed down a nut until it was firm. Tapping enough copper rivets to fill  $\frac{1}{2}$  in. of the shaft, I used faucet washers for the balance of the handle. These were screwed on with a little glue and finished off with a nut and washer, after which the end was burred slightly to hold them tight. After tapping off the faucet washers I had a strong, neat, and serviceable screwdriver that had taken but a few minutes to make.—Charles H. Crawford, New York, N. Y.

### A Small Bevel Square Made from Sheet Steel

Try-squares are made down to very small sizes, but small bevels are hard to obtain, though they are often badly needed. The narrow square-edged work can usually be simply laid down on the bench, and need only be held by a stop in front. In bevel work, however, it is often necessary to clamp, or tack, the stock down firmly to the bench if it is too long and narrow to

be held in the vise. In such work it is particularly inconvenient to remove the work to try it with an ordinary T-bevel.

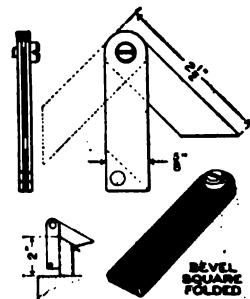

The little tool illustrated here will be found useful to every carpenter, as in addition to being a valuable help on the bench, it will also do work in corners, narrow openings, and other places where the ordinary bevel cannot be used. The tool is made f

### Paraffin Grease for Auto and Wagon Springs

An excellent grease for inserting between the leaves of auto and wagon springs can be made by melting several candles, and adding a small quantity of flake graphite. When this is placed between the blades of springs, its replenishment is very seldom needed, as it resists the effect of water and heat better than lighter lubricants. Rust formation is prevented, and besides adding to the life of the spring, it makes the vehicle ride easier.

### The Proper Shape to Cut a Shim or Filler

Shimming bolts and flues after they have been placed is a task which requires much patience. It has been found that to make the shim enter the space in the hole around the bolt or flue, without difficulty, the shim should be cut triangular. An

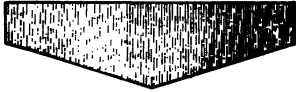

equilateral triangle is not necessary; merely enough angle to give the shim a good starting point when rolled up. After the shim has been cut and rolled, the point is inserted into the space to be shimmed, and the shim is tapped lightly with the hammer. Due to the pointed end, the shim will conform to the space more readily than if it is cut rectangular.

### Relieve Compression of Cylinder Which is Not Firing

When it is necessary to drive an automobile or motorcycle with one or more cylinders missing fire, the compression should be relieved in the missing cylinders by opening the petcocks or removing the spark plug. This will often make a big difference in the ability of the remaining cylinders to pull the machine.—Henry Priebe, Kent, Ohio.

### Small Wheels Aid Handling of Wheelbarrow

The wheelbarrow is a peculiarly useful vehicle where a load must be transported along a plank or narrow path, but where plenty of space is available it often seems foolish to carry so much of the weight in the hands instead of on wheels.



Wheels can be placed on the legs of the ordinary wheelbarrow to very good advantage; they should have wide treads, and if necessary such treads can be cut from sheet iron and riveted around the wheels used. The extra wheels will prove particularly useful in going over curbstones and such elevations.—Herauld A. Trester, Milwaukee, Wis.

### Soldering Iron for Attachment to Blowtorch

For many purposes, a soldering copper which is permanently attached to the blowtorch will do as good work as an electric soldering iron, and at a much lower cost. To make the one illustrated, cut down a short piece of 1-in. pipe to the shape shown, and fit the block of copper into the end. The copper should be forged or turned to a cone or pyramid shape, and may be fastened into the pipe by peening its inside face. A hole drilled in the copper, as shown, will cause it to heat up more quickly. The other end of the pipe frame is then fastened to the blowtorch by a setscrew. A handle may be made to fit in the same place when it is desired to use the soldering iron in the ordinary way.

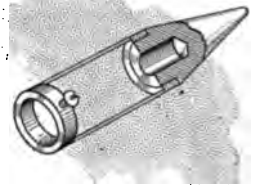



### Drill Jig for Formed Flat Pieces

A number of thin flat pieces, shown in detail at A, were to be drilled. At the left of the diagram is reproduced the drilling jig whereby the holes were

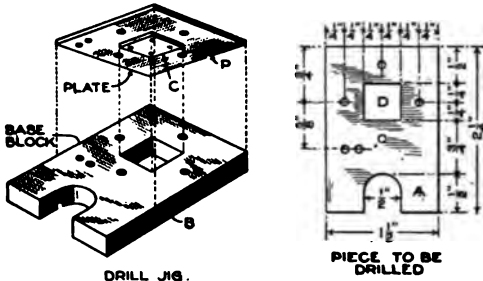

Parts and Dimensions of Jig Constructed for Drilling Thin, Flat Pieces

drilled accurately in the locations specified. The drilling was done as follows: The piece A was laid on the base block B which rested on the table of a drill press. The plate P was placed over them. The square boss C, riveted to the lower surface of the plate, served to center the piece accurately between the plate and the base block. The drill was forced successively through each of the template holes in the plate. For the plate P, a flat piece of machine steel,  $\frac{3}{16}$  in. thick by  $1\frac{1}{2}$  in. square, was utilized. The boss C was finished to make a good fit in the square opening machined in the base block to receive it. After the drill holes had been laid out and drilled in the jig it was casehardened, which tends to prevent enlargement of the holes due to wear. When drilling the pieces, one drill is first used to locate all the holes. Then such holes as are to be of a greater diameter can be drilled out to the larger size in a subsequent operation.

### Bending Conduit Easily at the Workbench

Bore holes in the top of the workbench to accommodate conduit of the sizes handled. About  $\frac{1}{16}$ -in. diametrical clearance should be allowed. To bend the tube, insert it in the proper hole to the point where the bend is to come,

and pull on the free end. Pipes up to and including  $1\frac{1}{2}$ -in. diameter can be bent cold. Larger conduits should be heated before bending.

### Mechanic's Tool Case Made from a Suitcase

If the mechanic happens to have an old suitcase, he can convert it into a tool case that will answer as well as a case bought at from \$7 to \$10. A drawer frame, or insert, is made of  $\frac{3}{16}$ -in. white wood, divided and joined as shown in the sketch. The frame is fastened in the suitcase by four small screws and flat nuts, or by copper rivets. The drawers are made of XX heavy sheet tin, soldered. A light ring is clamped and riveted to the front center of each container. The top compartment is for plans, data, delicate instruments, etc. The heavy tools are placed in the bottom compartment, and those above are for miscellaneous tools, nuts, bolts, small parts, etc. One of the compartments might be reserved for lunch. This case is very handily laid out, and should prove very serviceable to mechanics who have to travel to emergency re-

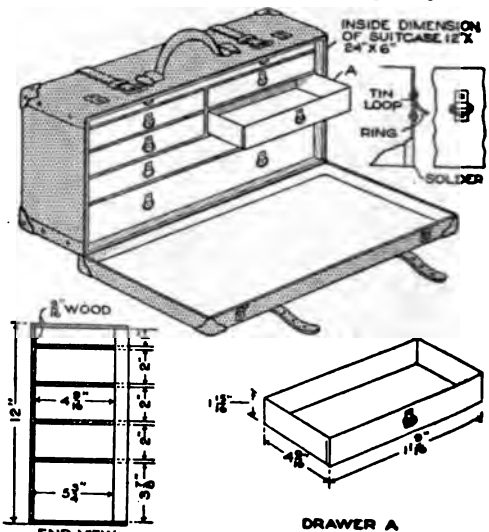

This Tool Case, Made from an Old Suitcase, Provides a "Place for Everything and Everything in Its Place"

pair jobs, and other work.—P. P. Avery, Garfield, N. J.



## How to Make a Sanitary Kitchen Cabinet

By S. R. WINTERS

THE modern discovery that saving of steps can result in a vast increase in human efficiency has found its way into the kitchen chiefly in the form of the modern kitchen cabinets. These are built with the idea of making it possible for the housewife to have nearly all the materials and tools which she needs kept together in one place, systematically arranged, so that they can be found without loss of time, and used without being carried across the kitchen. The cabinet should therefore be placed very close to the range, a good position being that shown in the lower photograph.

The construction of the cabinet is evident from the two photographs and the working drawings on the next page. Almost any kind of wood will do, if it is well-seasoned and reasonably clear. The cabinet is 6 ft. 5½ in. high, from the casters to the top of the closet, and 31 in. to the top of the table; it is 21 in. deep and 50½ in. wide. The part below the table contains the flour bin, a large drawer, rack, and dough, or pastry, board. The bin is fastened to the frame with loose-pin hinges, so that by removing the pins the bin can be taken out, cleaned, and replaced. The

bin can be lined with tin to make it free from moisture, insects, and rats. The bread board is made of wood that is tasteless and odorless, and fitted in the opening just below the

table. A batten is tongued and grooved on each side of the board to prevent it from warping. The roomy drawer can be used for small utensils. The open space below the drawer is a good place to keep the kitchen stool, or the fireless cooker, when not in use. Pie pans, lids, and covers have a convenient place in the

rack below the drawer. A drop leaf, or folding shelf, 21 in. wide and 19 in. long, increases the table surface; it is supported by inexpensive folding brackets.

The upper part of the cabinet consists of a closed compartment, three drawers, three open shelves, a knife rack, and a row of screw hooks for hanging kitchen utensils. The closed compartment is for package goods and large utensils; the drawers are inviting for depositing kitchen linen, package goods, and other things needed in daily use. The lower shelf is 5 in. in depth,



A Homemade Kitchen Cabinet, Placed near the Range, Saves the Housewife Much Time and Many Steps

while the upper shelves are 7½ in. On these shelves are kept coffee, tea, sugar, and spice jars, and canned goods. Three

measuring cup, and other small conveniences.

To make the cabinet attractive and

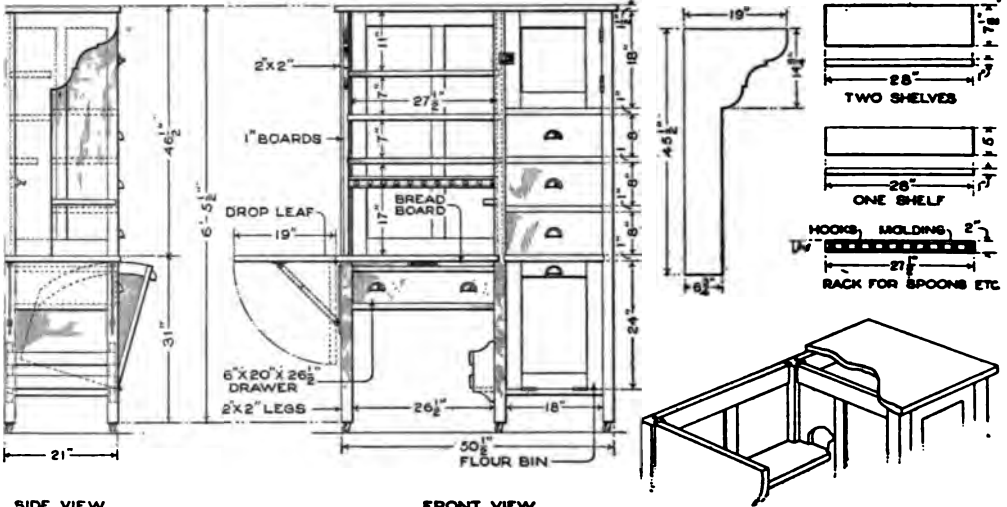

Construction of the Cabinet: Shelves, Hooks, Drawers, and Compartments are Provided for Almost Everything Required in the Kitchen

inches below the lower shelf there is a strip, 1½ in. wide, which holds screw hooks on which are hung strainer,

easily cleaned, it should be finished with two coats of white paint and one coat of white enamel.

### Four Men Use Two Padlocks on One Door

Four men wished to lock a door in such a way that any one of them could unlock it; they had two locks, each having two keys. The illustration shows how the two locks were

he has finished, he closes his own lock on the staple; if one of the men carrying the other kind of key is using the locker at the same time, the door is left open until he has finished, when he closes his lock through the other one. — Ernest Schwartz, Brooklyn, New York.

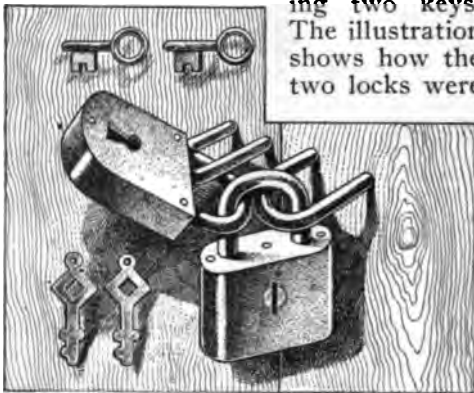

By Closing the Two Locks into Each Other, Four Men, Although Carrying Different Keys, Have Access to the Same Locker

combined to serve the purpose. Each man unlocks whichever lock his key fits, and the door can be opened. When

### Counterweights on Portable Drills and Other Heavy Tools

In a factory where a careless operator had allowed an expensive electric portable drill to roll off the bench and become ruined, similar drills were suspended by sash cord from 2½-in. iron pulleys held up with 1-in. screw eyes. The other end of the cord carried a counterweight, which just balanced the drill at any height. A knot was tied in the cord above the drill to prevent its getting out of reach when raised. The cord was attached to a band, bolted around the drill at its center of gravity, so that it remained suspended horizontally.



**Using Hacksaw Blades  
with Broken Teeth**

When a hacksaw blade loses some of its teeth, grind away the teeth at each side of the damaged portion, in a slanting direction, so that the stubs of the broken teeth can slide over the work without breaking, and the remaining good teeth can do the cutting. This process will often enable the workman to finish a job which might otherwise be held up.

**Cone Container Conserves  
Powdered Emery**

Those who use emery dust for grinding valves and joints, and for similar purposes, will find the container shown in the sketch a useful tool. It is made by soldering a 1½-in. screw can top to a cone formed of tinned sheet iron. Emery may be sprinkled out through a small hole at the apex of the cone. The diameter of this hole should be proportioned in accordance with the fineness of the emery powder used. Thus the exact amount of dust required can be applied to the surface which is to be ground.—J. R. Minter, Washington, Ind.

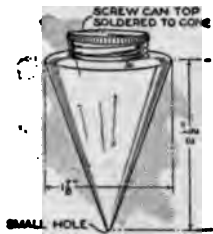

**Outside Coal Bin Provides  
Convenient Storage**

Many householders are prevented from laying in an early coal supply by the smallness of their coal-storage capacity. When space in the basement is scarce, a coal bin built just outside the foundation wall becomes desirable. The one illustrated was built of cement blocks, with a cement roof just above ground level, supported by wooden rafters. A heavy stone cover, which need only be removed for receiving coal in the bin, provides considerable security against theft of coal, and if greater security is desired, it is only necessary

to attach a chain to the bottom of the cover and fasten it through a hole in

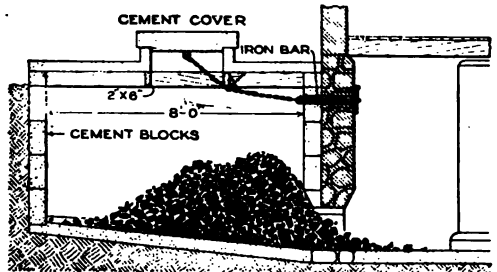

Building the Coal Bin Outside the Foundation Wall Keeps the Coal Safe and Handy and Saves Cellar Space

the basement wall. The floor of the bin should slope toward the opening, from all directions, so that the last shovelful of coal will come into position when needed. From 40 to 45 cu. ft. of space should be provided for each ton of coal to be stored.—Richard Chambers, Lynbrook, L. I.

**Flash Light on Automobile  
Steering Column**

To keep the flash light handy where it will not get lost, and at the same time have a dash, or speedometer, light, it is only necessary to fasten the flash light on the steering column, as shown in the illustration. The light can be removed instantly from the spring clamps, which are made of pieces of an old clock mainspring, or any other pieces of thin spring steel. The screw holes may be punched

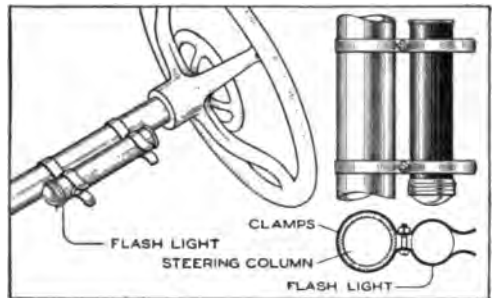

A Flash Light Attached to the Steering Column Provides a Dash Light and Trouble Light in One

through the spring steel, or it may be annealed and retempered after drilling the holes.

**Door Latch Controlled from Kitchen  
Saves Many Steps**

In many city apartments there is a long private hall with the entrance door at one end, and rooms all along

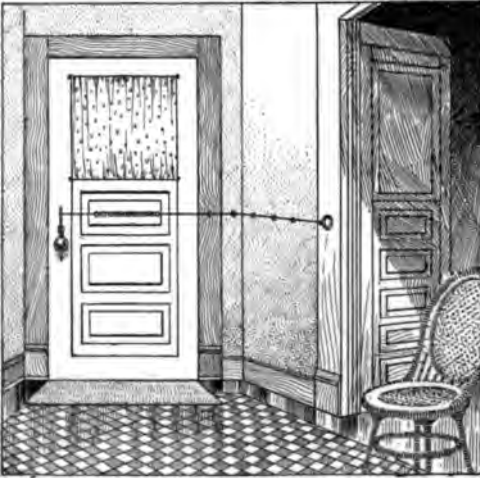

A Cord Attached to a Lever on the Door Knob will Save Much Time in Many City Flats

it. Usually the kitchen is at the end of the hall. Many tedious steps to answer doorbells can be saved by means of a steel wire attached to the door knob, running through screw eyes placed in position for the purpose, to the outside of the kitchen door. A handle is then attached to the wire, by pulling on which the door knob may be turned and the door opened when the bell is rung. The door is best provided with spring hinges to close it, and a weak spring may be placed around a section of the cord to take up the slack, the ends of the spring being attached at the proper places on the cord to insure doing this. The cord is drawn taut when in use.

**Fitting Bearing Adjustments  
Accurately**

Refitting main bearings and connecting rods sometimes brings the slots in the castelled nut out of line with the cotter-pin hole in the bolt. The *safe and sure way is to fit the nut to the new position, rather than to use*

"dutchmen" in the form of liners. Note how far the slot on the nut comes out from the hole in the bolt, and dress down the flat side of the nut with a file. A few rubs with a good file will make the nut fit in a workmanlike manner.—W. H. Thomas, Cedar Rapids, Ia.

**Wedge-Clamp Jig Helps  
Speed Up Production**

Holes in small, thick pieces must be drilled rather than punched for accuracy, even when produced in large numbers. Much of the cost of drilling is represented by the time necessary to clamp the part securely in the jig, so that the holes will be accurately placed. The jig illustrated enables the piece to be inserted as rapidly as in a punch-press die. In the piece to be drilled, the dimension to be made accurate was that between the two small holes, the center hole being left rough. Instead of having an ordinary jig, where the part must be laid between gauge pins and lifted out vertically when it is finished, the piece is merely shoved in on a flat surface against stop pins, and is clamped down by a lever operating a wedge-shaped plug which fits the center hole. The lever

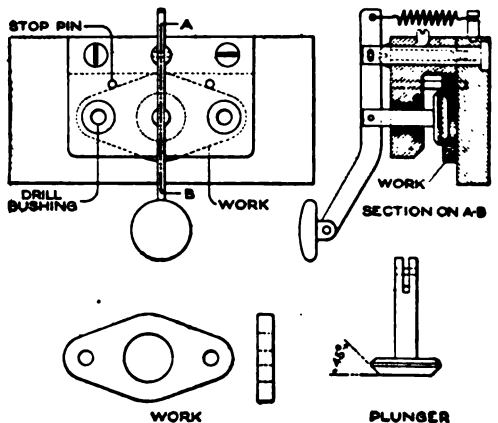

The Method of Clamping Employed Enables the Operator to Insert and Remove the Piece Much More Rapidly Than in the Conventional Jig

can be operated by the left hand as the drill-press lever is worked with the right.—John Havekost, New York, New York.

# Automatic Shut-Off for Filling Cans or Buckets

By J. C. WINTERBURN

**M**ANY gallons of gasoline and oil are wasted because cans are filled too full, and overflow. It is not difficult to make a link motion to operate the valve, which will save both the liquid sometimes wasted and the time and care constantly required to keep from wasting more.

The valve is an ordinary globe, or pressure, valve, the stem of which has had its threads filed down smooth, handle removed, and packing renewed. In place of the handle is

fastened an adjustable link, which consists of a bolt with flat head, screwed into a threaded tube which is also flattened and drilled at the other end. The other link is made of a stiff scrap of sheet steel, shaped as shown; one end is fastened to a coil spring, and from the other a cord or wire extends down to the hinged platform, on which the can to be filled is placed. Any number of hooks or nails may be provided on which to hang the springs, each one corresponding to a certain number of gallons of the liquid to be drawn. The position of these hooks can best be found by experiment, pouring a measured amount of liquid into the can, and then finding the point where the spring must be attached to make the valve close as soon as that amount of liquid is in the can.

The action is as follows: Place the empty can in position, and attach the spring to the proper hook, thus opening the valve. No more attention is then required; whenever the proper amount of liquid has flowed out, its

weight pulling on the cord overcomes the pull of the spring, straightens out the toggle joint formed by the links, and thus closes the valve. Before removing the filled can, the spring must of course be detached from the hook; the weight of the platform is then sufficient to hold the valve closed.

Several points must be borne in mind when proportioning the various parts:

The lower end of the cord should be attached much farther from the

hinge on the platform than the upper end is from the link pivot, so as to reduce the amount of motion of the platform; otherwise too large a funnel will be required, or the liquid may spill.

The lever to which the spring is attached should be made long, as shown, and a long spring should be used, but weak and flexible enough so that it will have to be stretched in at-

taching it to any of the hooks. If this suggestion is followed, and the link is shaped so that the end to which the cord is attached makes an angle of about  $45^\circ$  with the cord, then the valve will close suddenly as soon as the proper weight is reached by the liquid in the can. Otherwise, as the platform swings down, the increase of the lever arm A, tending to close the valve suddenly, will be overcome by the increased pull of the spring, and the valve will close only partly until sufficient liquid flows in to close it entirely.

The length of the adjustable link must be made such that the valve will be closed tight as the end of the long link strikes the stop block.

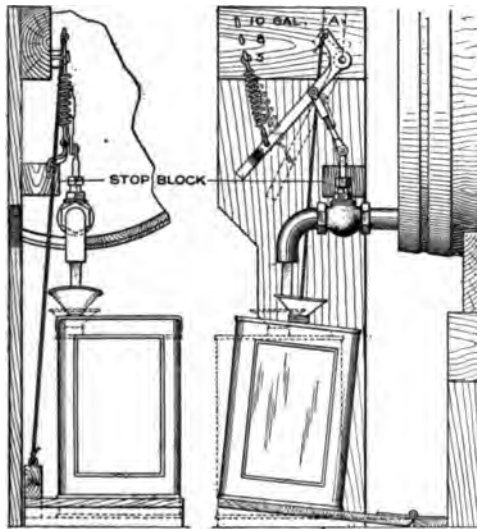

When the Liquid in the Can Reaches the Proper Height, Its Weight Works the Toggle-Joint Linkage, Closing the Valve



### Timesaving Device to Open and Close Cellar Windows

When the coal bin in the cellar is well filled with coal, it is often troublesome to get at the cellar window above



A Very Simple Arrangement for Opening and Closing the Window over the Coal Bin

in order to close it. A number of devices for controlling such a window from a distance have been made and described, but most of them have the disadvantage of being either too complicated or too inconvenient in use.

The one here illustrated is made from three pulleys, a cord with a handle on its end, and an old piece of strap iron. The cord is fastened, as shown, to the spring latch usually found on cellar windows, and extends at an angle toward the place from which the window is to be controlled. As will be seen, a pull on the handle first unlatches the window, then pulls it open, and holds it so by means of the catch and the knot in the string. When the window is to be closed, the cord is released, and the window slams shut. If the hinges work hard, or the window is too light to latch itself without pressure, a weight may be attached to the inner side of the window.

### Clogged Spout Readily Cleaned with Hose

If the spout leading down from the caves trough becomes clogged with leaves, and a water hose is handy with sufficient pressure, the pipe may be easily cleaned out thus: Remove the

nozzle from the hose, and insert the hose at the top of the clogged pipe spout. Turn on the water, and as the dirt is driven out at the top or bottom, work the hose down until the pipe is clean.—James H. Beebe, Rochester, New York.

### Car Leaving Garage Automatically Gives Warning

The plan of having an electric automobile horn placed in the entrance of a garage to notify pedestrians that a car is about to cross the sidewalk is not a new one, but the operation of the horn usually depends on the memory of an employe. Link motions for doing this automatically can, of course, be built in many different ways, but are likely to give trouble from being too complicated, from failure to work at the right time, or a possibility of working at the wrong time.

In the illustration, a long lever is set into the cement floor across the garage exit, having underneath it a strong spring, so that it cannot be depressed by the weight of a man anywhere upon it, or by the weight of a car, except as a wheel crosses its outer end. The end near the hinge is sunk flush with the floor. A simple link motion pushes a button which connects the horn either

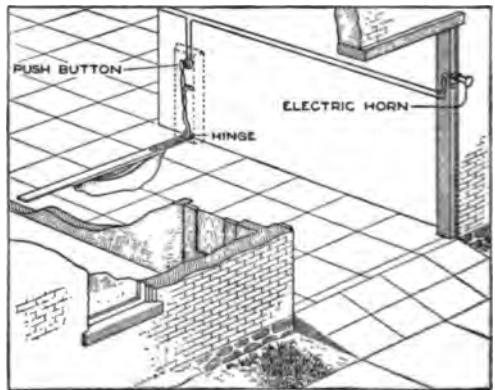

A Well-Arranged and Strongly Supported Floor Lever Makes Practicable an Automatic Arrangement for the Garage Entrance

to a battery of dry cells, or to the 6-volt testing mains, which are available in many garages.

### Old Piston Used to Polish Rebored Cylinders

When an old automobile or gas-engine cylinder has been rebored for the use of new pistons, the old pistons may be made use of to lap out the cylinder before fitting in the new ones. Split the old pistons in half, and place expanding wire springs on the wrist pin, so as to force the halves of the piston apart; then work them through the cylinder with oil and fine emery, finishing with pumice.—H. G. McQueen, Dow City, Iowa.

### Removable Heavy Edge for the Bench

The weak part of a carpenter's workbench is the upper edge of the working side, particularly where the vise works against the side, and the upper part, if the bench must also serve as vise jaw.

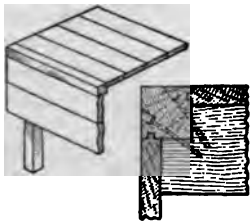

The edge wears a way rapidly, and to renew it means considerable trouble, without the satisfaction of permanent relief.

This condition is entirely remedied by the solid edge here illustrated. A solid piece, made from 4 by 4-in. surfaced stock, forms the edge, the side and top being either matched into it, which is preferable, or simply joined onto it. The cleats, or joists, are cut off at the corner and mortised into the edge, as shown at the right, and the edge is fastened to them by spikes, having their heads sunk well below the surface. The heavy edge stays straight and true indefinitely, and does not work loose, because of its heaviness and the fact that the spikes are set into the wood at an angle to the direction of all strains thrown upon it.

A workbench made of soft wood can by this method be provided with a hardwood edge, in which case the edge piece need be of only 3 by 3-in. stock.—Henry Simmons, San Diego, Calif.

### Safety Radial Tether for Animals

To tether a horse or cow so as to admit of its having a large feeding range, and yet so as to be perfectly secure and require no attention, a pole, 20 or 30 ft. in length, is pivoted at one end and fitted with an iron ring large enough to slip along from end to end. The small end of the pole is supported by a light metal wheel from some old farm implement, or a wooden one cut from a piece of plank. The animal is fastened with a halter chain, too short to get tangled up with the animal's legs.—Joseph G. Allshouse, Vandergrift, Pennsylvania.



### To Keep Animals from Molesting the Garbage Can

The refuse pail in the back yard is attractive to cats and dogs, and sometimes to rats. Often the pail is thus tipped and the refuse spread on the ground. The contrivance illustrated remedies this condition. The pail is placed near a clothes post or fence; a narrow strip is hinged to the post, level with the top of the pail. A second strip is hinged above the first at about the angle shown.

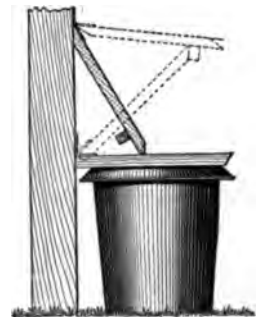

When both strips are down, the upper one falls and rests on the lower, checking it from being raised unless the upper one is first raised. To release the pail, raise the upper strip; then raise the lower strip to engage the cleat on the upper one.

### Self-Raising Box Bottom Aids in Obtaining Contents

Many people are now using wood to save coal. One family eliminated the back-breaking job of picking sticks out

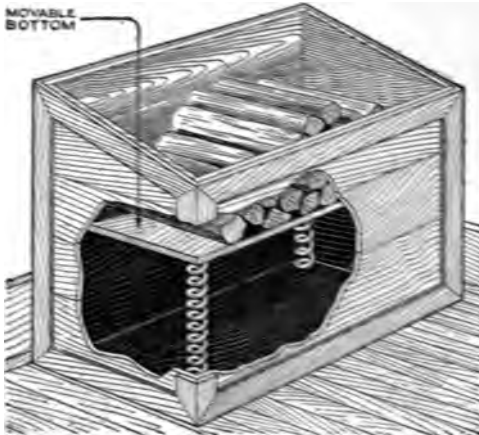

By Mounting a False Bottom on Springs in the Fire-Wood Box, the Wood is Always Kept near the Top of the Box

of the bottom of the wood box by putting in a self-raising bottom for the box. Four springs were found and fitted one in each corner, holding up the movable bottom to a height of 12 in. When wood is placed in the box, its weight forces down the movable bottom. When the wood is nearly used, the springs raise the last sticks up so that they can be obtained without great effort. The same arrangement could be used on any chest or box where supplies, such as grain, tools, or coal, are kept in a deep box, thus making it easy to get at the contents.

### Draining Pipes in an Unoccupied House for the Winter

When a house stands unoccupied during the winter, it is necessary to see that the water is drained from the pipes as much as possible, to prevent freezing and causing cracks in the pipes and fittings. Any house owner can do this for himself, and save the plumber's bill, if he understands the piping system. First turn the shut-off valve on the supply pipe where it enters the house; sometimes there are

two or more of these on branches of the supply pipe. This shuts off all water from entering the house, and allows the water in the pipes to drain out entirely except for a few sections. Flush the toilet and open the sink faucets, and there then remains only the water in the water traps, or U-shaped sections of pipe which prevent sewer gas from entering the house. With rags soak up all the water in the toilet bowl, and pour into it 1 qt. of kerosene, which forms a seal for sewer gas. The water in the sink, washbowl, and bathtub traps cannot be so easily removed, but by pouring 3 qt. of kerosene down the sink drains, the water is carried off and the oil left in the trap. For complete security, have the water company or the city water department turn off the water at the curb.

### Moving a Crippled Automobile Single-Handed

A piece of timber, fastened with ropes to the rear hubs of an automobile, is a great help when it must be moved by hand, and by one man only. If the transmission mechanism is not injured, the easiest way to propel the car is often by the use of the starting crank. Put the car in low gear, and relieve the compression by opening pet cocks or removing spark plugs. With the timber behind, to keep the car from

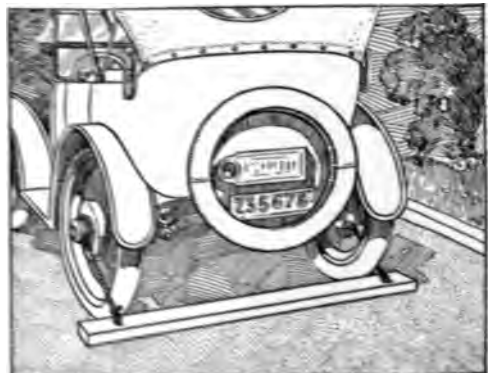

The Use of the Starting Crank and a Self-Adjusting Stop Block Makes Hand-Propelling Easy

slipping back, the job will then lose most of its difficulty.—Bonar W. Balfour, St. Catharines, Ont.



# Inexpensive Belt Sander Made from a Lathe

By HARLIE GARVER

**A** SERVICEABLE belt machine for sanding wood surfaces can be very easily rigged up from material about the shop, in connection with a woodworking or high-speed lathe. Build up four solid wood pulleys with 8-in. faces and 10-in. diameters, turn them in the lathe and give them a very slight crown to make the belt run smoother; too much crown will be injurious to the belt. Rig up the pulleys somewhat as shown in the drawing, centering one in the lathe on a firmly held arbor, and mounting the other three on shafts which may be made of iron pipe. Turn and file a true journal surface on the pipe, and pour a babbitt bushing in the pulleys; provide grooves in either the pipe or the babbitt to carry oil. If the shafts are supported as shown, the belt can be removed without taking the shafts out; if this feature is not desired, however, greater strength will be secured by supporting the shaft on both sides of the pulley.

The garnet-paper belt used for such a machine comes in 50-yd. rolls, and costs about \$5 for the 6-in. width, which is the best for the purpose. Grade No. 11½ is best for general work. To prepare the belt, cut it to the proper length, so that the ends just meet when stretched over the pulleys. Then spread glue over the paper on the smooth side, near the joint; first splice it with a piece of cloth about 1 in. wide, and then with one about 3 in. wide. Lay a piece of paper over each side to prevent the glue from sticking, and clamp, placing a small board on each side next to the paper. With a sander of this kind it has been found that the best speed is about 2,500 ft. per minute. The cone pulley of the lathe will usually allow for proper speed.

In operating the sander, the work is adjusted at such a height as to leave about 1 in. between the surface to be

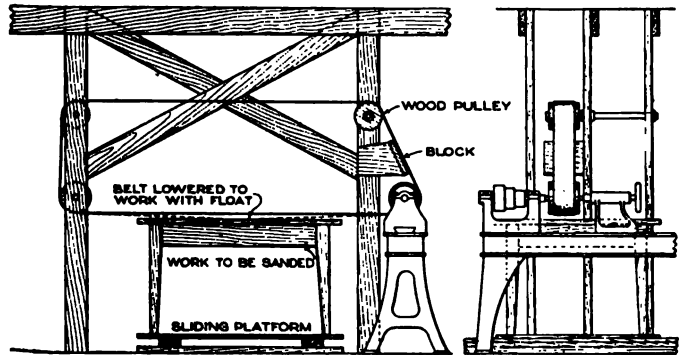

Wood Surfaces can be Quickly Dressed Smooth with a Belt Sander Operated from the Lathe

sanded and the belt. The machine is then started and the belt pressed down to the surface with a float, similar in size and appearance to an ordinary blackboard eraser, or with a roller, which can be made to suit the operator and the class of work to be done. In factory-made machines the adjustment for height is made by an easily adjusted platform, upon which the work rests. A sliding arrangement also allows the work to be moved to and from the operator as it is being sanded. It is quite troublesome to rig up such a device, however, and a table will usually serve for flat pieces, especially if it is set upon a low platform as illustrated. The sliding mechanism consists simply of two sets of tongue-and-groove joints, fastened at right angles to the belt. In case table tops are to be sanded, the assembled table can be placed upon the sliding platform. For irregular work the operator can usually place some kind of support to serve the particular case. Small work can be handled on a block which may be mounted just above the lathe, the block being detachable if desired, so as not to interfere with the use of the lathe.

The upper pulleys may, of course, be omitted, but the added conven-

ience and safety, which they provide by getting the returning belt up out of the way, amply justify the trouble of providing them.

### Outside Cistern Pump Operated from the Kitchen

In using this peculiarly arranged pump, the housewife turns a handle in



This Outside Pump is Used with All the Convenience of an Inside Pump

the kitchen, and the water is delivered into the sink, although the pump is entirely outside the house. A chain pump is used, with the shaft lengthened to extend through the house wall, and a pipe from the pump spout also runs into the house, being set to slope slightly so that the water will flow freely.—Allen P. DeLong, Tarkio, Mo.

### Emergency Fuse Repair

Often a fuse of the ordinary tubular kind, on either house-lighting circuits or automobile wiring, will be found to have blown out, when no new fuse of the proper size is at hand to replace it. In order to avoid interruption of service, or putting the car out of commission, many persons simply twist a piece of copper wire around the terminals on the fuse block, thus leaving the circuit without protection. This might do for an emergency, but is a dangerous practice, chiefly because it tempts one to forget to obtain a new fuse as soon as possible. A better way is to wrap the blown-out fuse with tin foil, such as is used for wrapping chewing gum and tobacco, and insert the fuse as be-

fore. If no more tin foil is used than is necessary to fit tightly around the fuse, its electrical conductivity will be low enough to give some degree of protection to the circuit until a new fuse can be obtained.

### Using Fountain-Pen Filler to Fill Ruling Pens

A cleaner and quicker method of filling ruling pens than the usual one is as follows: Remove the usual ink-bottle stopper; get a cork to fit the bottle and bore a hole through it, large enough to hold tightly a fountain-pen filler or eye dropper. When necessary to fill the instruments, the ink is drawn up in the filler and applied.

### Motorcycle Back Rest to Carry Camera

When carrying on a motorcycle some object, such as a camera, which may be injured by an excessive jar, it will be found useful to have some arrangement by which the vibration due to the engine can be minimized. One motorcyclist did this by building a hollow back rest, as shown in the illustration, thus making the one device serve two purposes. The material used was wood, with some simple upholstery in front, shaped to fit the rider's back.

The wooden box is mounted on spring rods, and attached to the saddle,



The Camera Carrier is Built in Such a Position as to Form a Back Rest for the Rider

which of course should receive less vibration than any other part of the machine.—John Kakerbeck, New York, New York.

**Using Hacksaw Blades  
with Broken Teeth**

When a hacksaw blade loses some of its teeth, grind away the teeth at each side of the damaged portion, in a slanting direction, so that the stubs of the broken teeth can slide over the work without breaking, and the remaining good teeth can do the cutting. This process will often enable the workman to finish a job which might otherwise be held up.

**Cone Container Conserves  
Powdered Emery**

Those who use emery dust for grinding valves and joints, and for similar purposes, will find the container shown in the sketch a useful tool. It is made by soldering a 1½-in. screw can top to a cone formed of tinned sheet iron. Emery may be sprinkled out through a small hole at the apex of the cone. The diameter of this hole should be proportioned in accordance with the fineness of the emery powder used. Thus the exact amount of dust required can be applied to the surface which is to be ground.—J. R. Minter, Washington, Ind.

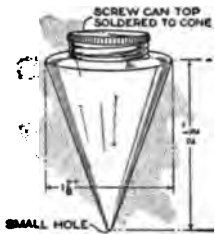

**Outside Coal Bin Provides  
Convenient Storage**

Many householders are prevented from laying in an early coal supply by the smallness of their coal-storage capacity. When space in the basement is scarce, a coal bin built just outside the foundation wall becomes desirable. The one illustrated was built of cement blocks, with a cement roof just above ground level, supported by wooden rafters. A heavy stone cover, which need only be removed for receiving coal in the bin, provides considerable security against theft of coal, and if greater security is desired, it is only necessary

to attach a chain to the bottom of the cover and fasten it through a hole in

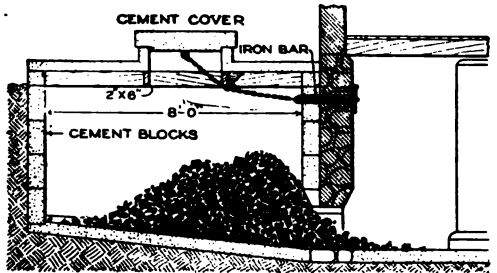

Building the Coal Bin Outside the Foundation Wall Keeps the Coal Safe and Handy and Saves Cellar Space

the basement wall. The floor of the bin should slope toward the opening, from all directions, so that the last shovelful of coal will come into position when needed. From 40 to 45 cu. ft. of space should be provided for each ton of coal to be stored.—Richard Chambers, Lynbrook, L. I.

**Flash Light on Automobile  
Steering Column**

To keep the flash light handy where it will not get lost, and at the same time have a dash, or speedometer, light, it is only necessary to fasten the flash light on the steering column, as shown in the illustration. The light can be removed instantly from the spring clamps, which are made of pieces of an old clock mainspring, or any other pieces of thin spring steel. The screw holes may be punched

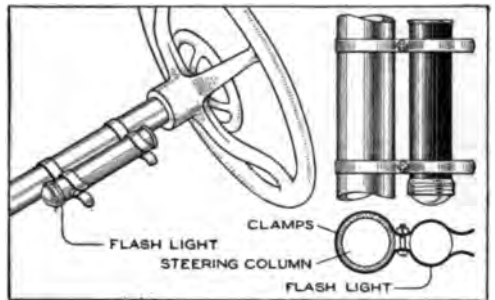

A Flash Light Attached to the Steering Column Provides a Dash Light and Trouble Light in One

through the spring steel, or it may be annealed and retempered after drilling the holes.



## Gas Water Heater Controlled by Electricity

The control system for a hot-water heater, shown in Fig. 1, can be made

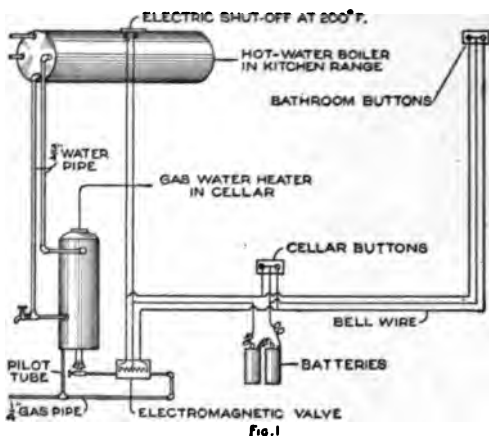

The Water Heater can be Turned On or Off by Pressing a Button in Any Part of House

by anyone having a fair knowledge of electrical experimenting, and will save much annoyance. The system makes use of a hot-water tank such as is often built into kitchen ranges, and an ordinary gas water heater. The electrical apparatus consists of four push buttons, two dry cells, a small thermostat, and a gas valve opened and closed by electromagnets. The operation of the valve is shown in detail in Fig. 2. When current flows through the coil at the right, the valve is pulled open. Just before the downward motion of the core inside this coil is completed, however, the circuit through it is broken by the cessation of contact between the long lever and the brass contact spring, so that no current is used except during the

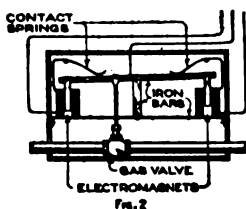

The two circuits, or three wires, leading from the valve, are connected

as shown, to buttons, batteries, and thermostat. The buttons may be placed anywhere about the house; any number of pairs of them may be connected in parallel, and the valve operated from any of these points. Pressing the white button opens the valve, and pressing the black one closes it. The thermostat should be set so that it will close the valve-closing circuit automatically if the temperature of the tank is allowed to rise to a dangerous point. A pilot light is kept burning at all times in the heater, just high enough so that the gas from the main pipe will ignite when turned on.

There must be sufficient friction in the valve mechanism to hold the valve closed, or gas may leak into the burners.

## Quickly Made Gas Burner for Kitchen Range

Select a piece of 1½-in. pipe, as long as the fire box of the range, bore and tap a hole for ⅝-in. pipe at the center, as shown in the diagram, and close the ends with caps or by shrinking disks into them. Drill three rows of holes, about ⅜-in. in diameter and about ½ in. apart, in the top side of the 1½-in. pipe. Let the ⅝-in.

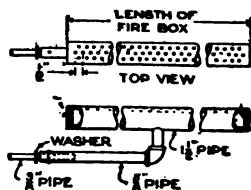

pipe be long enough to extend from the center of the fire box to the outside of the back of the stove. This burner is to be hung from the grate, while the ⅝-in. feed pipe is to pass through a hole drilled through the back of the ash pit. The small ⅜-in. or ¼-in. pipe is to be inserted into the feed pipe about 2 in.; about 1 in. from the end of each pipe drill a ⅛-in. hole for a pin to hold them together. In the end of the small feed pipe a plug must be inserted, with a hole of proper size, which will be from ⅜ in. to ⅝ in., depending on the quality and pressure of the gas to be used. The mixer is completed by slipping a metal washer over the small feed pipe, to be plac

# Automatic Shut-Off for Filling Cans or Buckets

By J. C. WINTERBURN

**M**ANY gallons of gasoline and oil are wasted because cans are filled too full, and overflow. It is not difficult to make a link motion to operate the valve, which will save both the liquid sometimes wasted and the time and care constantly required to keep from wasting more.

The valve is an ordinary globe, or pressure, valve, the stem of which has had its threads filed down smooth, handle removed, and packing renewed. In place of the handle is

fastened an adjustable link, which consists of a bolt with flat head, screwed into a threaded tube which is also flattened and drilled at the other end. The other link is made of a stiff scrap of sheet steel, shaped as shown; one end is fastened to a coil spring, and from the other a cord or wire extends down to the hinged platform, on which the can to be filled is

placed. Any number of hooks or nails may be provided on which to hang the springs, each one corresponding to a certain number of gallons of the liquid to be drawn. The position of these hooks can best be found by experiment, pouring a measured amount of liquid into the can, and then finding the point where the spring must be attached to make the valve close as soon as that amount of liquid is in the can.

The action is as follows: Place the empty can in position, and attach the spring to the proper hook, thus opening the valve. No more attention is then required; whenever the proper amount of liquid has flowed out, its

weight pulling on the cord overcomes the pull of the spring, straightens out the toggle joint formed by the links, and thus closes the valve. Before removing the filled can, the spring must of course be detached from the hook; the weight of the platform is then sufficient to hold the valve closed.

Several points must be borne in mind when proportioning the various parts:

The lower end of the cord should be attached much farther from the

hinge on the platform than the upper end is from the link pivot, so as to reduce the amount of motion of the platform; otherwise too large a funnel will be required, or the liquid may spill.

The lever to which the spring is attached should be made long, as shown, and a long spring should be used, but weak and flexible enough so that it will have to be stretched in at-

taching it to any of the hooks. If this suggestion is followed, and the link is shaped so that the end to which the cord is attached makes an angle of about  $45^\circ$  with the cord, then the valve will close suddenly as soon as the proper weight is reached by the liquid in the can. Otherwise, as the platform swings down, the increase of the lever arm A, tending to close the valve suddenly, will be overcome by the increased pull of the spring, and the valve will close only partly until sufficient liquid flows in to close it entirely.

The length of the adjustable link must be made such that the valve will be closed tight as the end of the long link strikes the stop block.

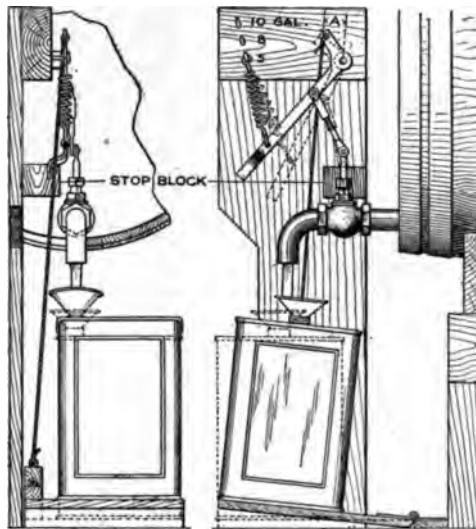

When the Liquid in the Can Reaches the Proper Height, Its Weight Works the Toggle-Joint Linkage, Closing the Valve

### Making Use of Old Rectangular Oilcans

Many handy articles can be easily and quickly made from empty 5-gal.

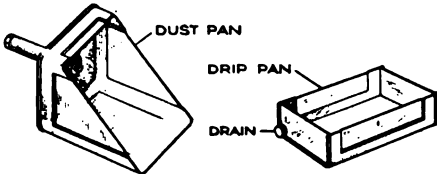
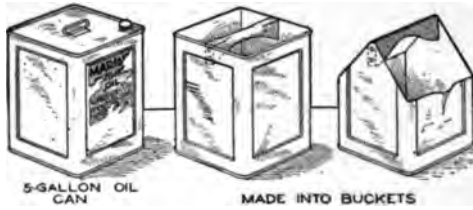

Cans in Which Lubricating Oil is Shipped can be Made Use of in Various Ways

oil tins, as shown herewith. Edges at cuts may be bent over double where desired, to give round edges of greater strength. In drip pans, the screw cap of the can forms a convenient drain.

### Railing Protects Young Pigs from being Crushed

Every farrowing pen should have a rail near the wall to prevent the sow from crushing the new-born pigs when she lies down. Planks are often used for this purpose, but a rail is better for the reason that the attendant can help the little fellows out when they get trapped behind the sow. The il-

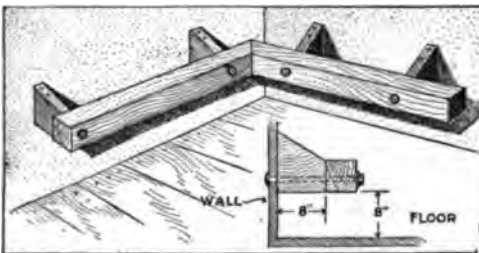

A Stout Rail about the Hog Pen Protects Young Pigs from being Crushed by the Sow

lustration shows how the rail is held out 8 in. from the wall and 8 in. up from the floor, by brackets. Bolts pass

through both the rail, the bracket and the wall. Like all fittings about a hog pen, the rail should be made very strong.—Charles L. Beckwith, New London, Conn.

### Steam Jet to Thaw Frozen Water Pipes

A cold snap which caught New York last winter without sufficient coal to keep warm, played havoc with the plumbing fixtures in all parts of the city. The plumbers were kept busy day and night repairing the burst pipes and thawing out those which had managed to withstand the pressure from within. One plumber in the Brooklyn section speeded up his work by the use of steam from the heating systems for thawing out the frozen pipes. In many instances, it was found that, in order to conserve coal, tenants had shut off the steam on the top floors, leaving them without sufficient heat to keep the plumbing from freezing.

When this was the case, and other conditions permitted, operations were begun by shutting off all the steam radiators in the house except the one in the room where the fixtures were frozen. From this, the air valve was removed, and a short piece of  $\frac{1}{8}$ -in. pipe screwed in its place. A rubber hose of sufficient length to reach to the bathtub and other fixtures was slipped over the iron nipple. Steam, at about 5-lb. pressure, was then turned on all the exposed plumbing fixtures, warming them up sufficiently to melt what ice they contained. Drain traps were thawed by means of the steam, and drained of water. Then the jet was turned into the drain pipe, provision against its return into the room being made by holding wet rags over all openings.

The result was that the whole length of drain pipe extending through the pipe gallery became heated and acted as a radiator, warming up the water pipes within a comparatively short space of time. Usually the cold-water pipe would thaw first, the hot-water pipe giving the greatest trouble



such cases, the cold water was often turned off in the cellar, the pipes drained and the steam jet attached to the cold-water faucet in the bathroom. On opening the cold-water faucet in the laundry in the cellar, the steam would soon make its way to this outlet. Again a section of rubber tubing was used, this time to connect the cold-water faucet with the hot-water faucet in the laundry tubs, and so turn the jet of steam in under the ice. The steam was gradually forced to work its way back upstairs by opening the hot-water faucets on the successive floors, closing them as soon as the water was all blown out and steam began to come. It was only in rare cases that the ice resisted this treatment for more than 10 to 15 minutes.—E. F. Hallock, Brooklyn, N. Y.

### Using High-Speed Steel for Hand Punches

It was found in a machine shop that certain hand punches, broaches, and drifts gave much better service if made of high-speed steel. The objection to this was that they could not be struck

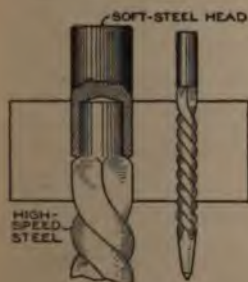

with a steel hammer, being so hard that they soon ruined the hammer. Worse yet, particles of the hard steel were continually breaking off, flying with great force, and frequently imbed-

ding themselves in the workman's hands or face. Consequently, copper or brass hammers were used, until the expedient was discovered of grinding the upper end of these tools round, and shrinking on a soft steel cap or head. The cap being of soft steel, an ordinary steel hammer can be used without danger. These tools give long service, and for many classes of work are found to be more economical than the ordinary carbon-steel tools.—M. L. Lawrence, Los Angeles, Calif.

### Concrete Ventilating System for Stable

Fresh air may be carried into a cow stable and delivered directly in front of the cows' noses through a concrete con-



A Conduit Running the Full Length of the Dairy Barn Provides the Cattle with Fresh Air

duit under the center feed alley. It must be constructed so as to be easily cleaned, and it must be kept dry.

The air flue, shown in the illustration, is 30 in. wide and 30 in. deep, with a curved surface. It is covered with a board walk that extends the whole length of the feed alley. The boards are supported by crosspieces of 2 by 4-in. timber, placed 2 ft. apart, with the ends resting on the edges of the concrete conduit. This leaves an opening for the intake of fresh air, 4 in. high, on each side of the board walk, thus providing about 160 sq. in. of ventilation opening for each cow. Small wooden blocks, nailed to the undersides of the 2 by 4-in. crosspieces, prevent the board walk from slipping down into the air duct. The walk is made in sections, 12 ft. long, and may be laid over against the mangers to give easy access to the conduit at cleaning time.

The amount of air admitted into the conduit is regulated by round wooden dampers that may be operated to close or partly close either end of the conduit, according to the strength or direction of the wind.—H. A. Shearer, Chicago, Ill.

⌈Steel running in steel should be hardened; cast iron running in cast iron, or mild steel in mild steel, is bad mechanical practice.

### Ratchet Brace Remodeled for Work in Cramped Spaces

The plan illustrated has been devised to handle the job of boring holes in

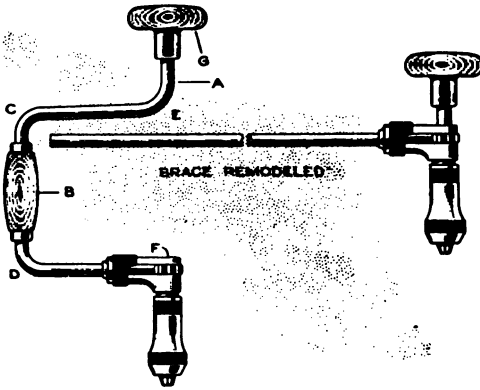

By a Few Simple Changes, an Ordinary Ratchet Brace is Converted into One Suitable for Work in "Tight Places"

close quarters, such as between two beams. Any ordinary brace with a ratchet can be adapted as described. The frame is cut with a hacksaw, at A. The wooden grip B is removed, and the corners at C, D, and E are straightened. Next bore a hole at F, in which to fit the short stem GA which was cut off. In operation, pressure is applied at F. On the forward stroke the lever revolves the drill bit, and on the backward stroke it slides with the ratchet.—Frank Barretta, Tenafly, N. J.

### Holder and Pick-Up Tool for Cotter Pins

In automobile and tractor work, it is often necessary to insert cotter pins in places where there is scarcely room for a man's hand. The small instru-

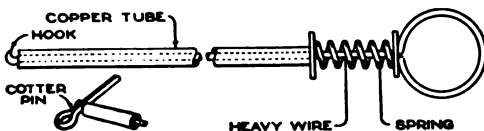

A Short Piece of Gasoline-Line Tubing and Some Wire Form a Handy Cotter-Pin Holder

ment illustrated has been found very useful for this purpose, as it holds the

cotter pins firmly, and can be made long enough to reach into the most difficult place. It can also be used to pick up cotter pins or other small objects that have accidentally fallen into the crank case or pan. In using this instrument, place the handle end in the palm of the hand, and take the copper tube between the thumb and first finger. By pulling back on the tube, the instrument is opened to admit the cotter; by releasing it, the cotter is gripped tightly.—M. D. Lawrence, Oakland, California.

### Switch Reversed by Tilting Mercury Cups

Finish a hardwood block, about  $2\frac{1}{2}$  by  $3\frac{1}{2}$  by 5 in., and bevel the ends as shown in the sketch. The angle of the bevels should allow the switch to rest securely upon either bevel when tilted. Secure binding posts at A, B, C, D, E, and F, and bore two  $\frac{3}{4}$ -in. holes, as shown at M, about  $1\frac{1}{2}$  in. deep. Pour melted paraffin into the holes M until filled. When cool, trim the paraffin out with a knife, so that the sides and bottoms of the holes are coated with a thin shell of paraffin. This closes the pores of the wood.

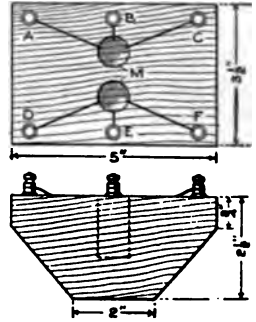

Run iron wires from the binding posts to the holes M, as shown in the sketch. The wires from B and E should reach the bottom of the holes M. The wires from A, C, D, and F should be cut off about  $\frac{3}{4}$  in. from the bottom of the holes M. When the block is placed upon a table in the position shown in the sketch, pour sufficient mercury into the holes M so that the ends of the wires from A, C, D, and F are about  $\frac{1}{8}$  in. from the surface of the mercury. Pour about  $\frac{1}{4}$  in. of kerosene or machine oil upon the mercury. Now plug up each hole



# Inexpensive Belt Sander Made from a Lathe

By HARLIE GARVER

A SERVICEABLE belt machine for sanding wood surfaces can be very easily rigged up from material about the shop, in connection with a woodworking or high-speed lathe. Build up four solid wood pulleys with 8-in. faces and 10-in. diameters, turn them in the lathe and give them a very slight crown to make the belt run smoother; too much crown will be injurious to the belt. Rig up the pulleys somewhat as shown in the drawing, center-

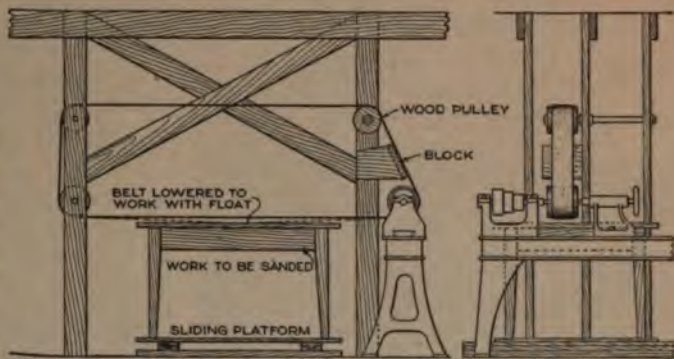

Wood Surfaces can be Quickly Dressed Smooth with a Belt Sander Operated from the Lathe

ing one in the lathe on a firmly held arbor, and mounting the other three on shafts which may be made of iron pipe. Turn and file a true journal surface on the pipe, and pour a babbitt bushing in the pulleys; provide grooves in either the pipe or the babbitt to carry oil. If the shafts are supported as shown, the belt can be removed without taking the shafts out; if this feature is not desired, however, greater strength will be secured by supporting the shaft on both sides of the pulley.

The garnet-paper belt used for such a machine comes in 50-yd. rolls, and costs about \$5 for the 6-in. width, which is the best for the purpose. Grade No. 11½ is best for general work. To prepare the belt, cut it to the proper length, so that the ends just meet when stretched over the pulleys. Then spread glue over the paper on the smooth side, near the joint; first splice it with a piece of cloth about 1 in. wide, and then with one about 3 in. wide. Lay a piece of paper over each side to prevent the glue from sticking, and clamp, placing a small board on each side next to the paper. With a sander of this kind it has been found that the best speed is about 2,500 ft. per minute. The cone pulley of the lathe will usually allow for proper speed.

In operating the sander, the work is adjusted at such a height as to leave about 1 in. between the surface to be

sanded and the belt. The machine is then started and the belt pressed down to the surface with a float, similar in size and appearance to an ordinary blackboard eraser, or with a roller, which can be made to suit the operator and the class of work to be done. In factory-made machines the adjustment for height is made by an easily adjusted platform, upon which the work rests. A sliding arrangement also allows the work to be moved to and from the operator as it is being sanded. It is quite troublesome to rig up such a device, however, and a table will usually serve for flat pieces, especially if it is set upon a low platform as illustrated. The sliding mechanism consists simply of two sets of tongue-and-groove joints, fastened at right angles to the belt. In case table tops are to be sanded, the assembled table can be placed upon the sliding platform. For irregular work the operator can usually place some kind of support to serve the particular case. Small work can be handled on a block which may be mounted just above the lathe, the block being detachable if desired, so as not to interfere with the use of the lathe.

The upper pulleys may, of course, be omitted, but the added conven-

### Removal of the Wax

#### and the Wax

... ..



... ..

... ..

### Removal of the Wax

#### and the Wax

... ..

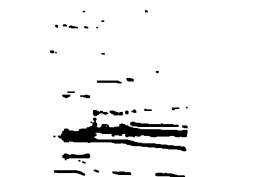

... ..

... ..

### Removal of the Wax

#### and the Wax

... ..

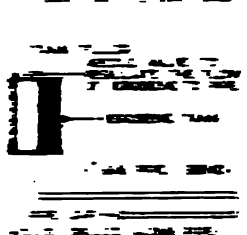

... ..

... ..

### Removal of the Wax

#### and the Wax

... ..

... ..

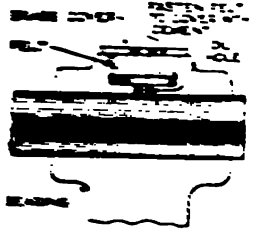

... ..



tion of it with a lighted match, and thereby burning out some of the alcohol. A cement thus prepared is impervious to oil and ordinary alkalis. The oiler is filled by running oil from the can into the hole in the cover disk, without removing the cover. The oil seeps down through the felt and lubricates the bearing, but dust and grit are excluded. The bearings of a polishing lathe, on which an abrasive dust was used, were equipped as above described, and their operation has been altogether satisfactory.—O. C. Richards, St. Louis, Mo.

### Locating Bolt Holes Where Scriber cannot be Used

Where a bolt must pass through two pieces of metal separated by an air space, it is often difficult to mark the location of one hole from the other. In the case illustrated, where the base of a motor was to be bolted down, the mechanic, finding it impossible to use a scriber or a center punch in the ordinary way, turned up a bushing and used a small center punch made of drill rod to locate the center of the hole.—Joe W. Romig, Allentown, Pa.

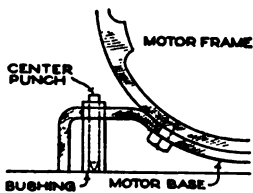

### Calculating Belt Lengths for Splicing

When changing machine speeds it becomes necessary to change the length of the belt. To figure how much belting to cut out or add, subtract the diameter of the smaller pulley from that of the larger one, divide by two, and multiply the result by three. This gives the length of the piece to be cut out, or to be added. Stated another way, multiply half the difference in diameters by three. If both pulleys are changed, the rule is applied twice, once for each change. This rule is for open belts, though it is also fairly close for crossed belts.

### Cotter-Pin Extractor Has Hammer Built In

This simple tool is a welcome addition to the average mechanic's tool kit.

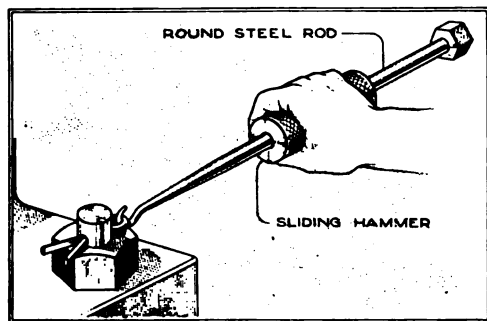

This Cotter-Pin Puller has Its Hammer and Hook Built Permanently Together

It is made from good machine-steel rod, and the hook end is thoroughly case-hardened and tempered. If the range of work done is wide, two or three sizes can be made.—Chas. H. Willey, Concord, N. H.

### Moving a Lathe Easily with Hand Trucks

The usual way of moving an engine lathe around the shop is to place planks and pipe rollers under it and shift it

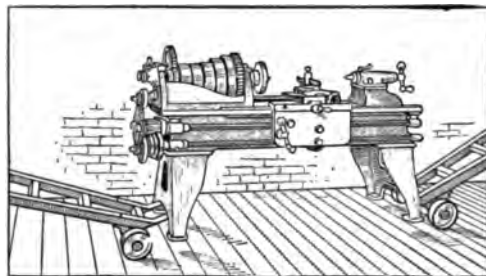

By the Use of Two Hand Trucks and a Few Minutes of Three or Four Men's Time, the Lathe can be Quickly Moved

along, but an easier and quicker method is to use a two-wheeled hand truck under each end, and lift the lathe just enough to clear the floor. While one or two helpers steady it because of its being top-heavy, it can be wheeled along the floor with scarcely any stops. Progress will be considerably more rapid than when using rollers.—H. S. Rich, Cromwell, Conn.

## Gas Water Heater Controlled by Electricity

The control system for a hot-water heater, shown in Fig. 1, can be made

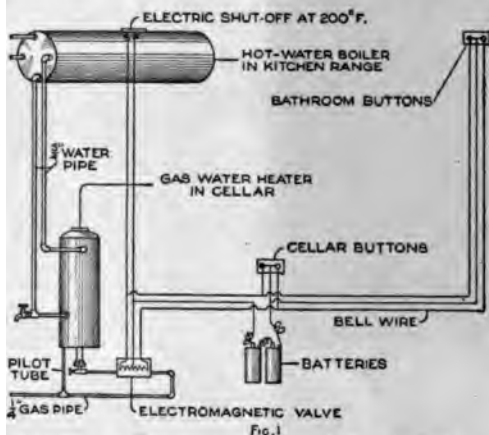

The Water Heater can be Turned On or Off by Pressing a Button in Any Part of House

by anyone having a fair knowledge of electrical experimenting, and will save much annoyance. The system makes use of a hot-water tank such as is often built into kitchen ranges, and an ordinary gas water heater. The electrical apparatus consists of four push buttons, two dry cells, a small thermostat, and a gas valve opened and closed by electromagnets. The operation of the valve is shown in detail in Fig. 2. When current flows through the coil at the right, the valve is pulled open. Just before the downward motion of the core inside this coil is completed, however, the circuit through it is broken by the cessation of contact between the long lever and the brass contact spring, so that no current is used except during the actual opening of the valve. The electromagnet at the left in the same way closes the valve whenever current flows through it.

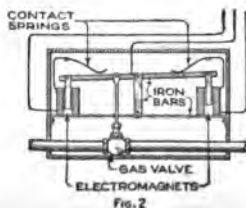

The two circuits, or three wires, leading from the valve, are connected

as shown, to buttons, batteries, and thermostat. The buttons may be placed anywhere about the house; any number of pairs of them may be connected in parallel, and the valve operated from any of these points. Pressing the white button opens the valve, and pressing the black one closes it. The thermostat should be set so that it will close the valve-closing circuit automatically if the temperature of the tank is allowed to rise to a dangerous point. A pilot light is kept burning at all times in the heater, just high enough so that the gas from the main pipe will ignite when turned on.

There must be sufficient friction in the valve mechanism to hold the valve closed, or gas may leak into the burners.

## Quickly Made Gas Burner for Kitchen Range

Select a piece of  $1\frac{1}{2}$ -in. pipe, as long as the fire box of the range, bore and tap a hole for  $\frac{5}{8}$ -in. pipe at the center, as shown in the diagram, and close the ends with caps or by shrinking disks into them. Drill three rows of holes, about  $\frac{3}{32}$ -in. in diameter and about  $\frac{1}{2}$  in. apart, in the top side of the  $1\frac{1}{2}$ -in. pipe. Let the  $\frac{5}{8}$ -in.

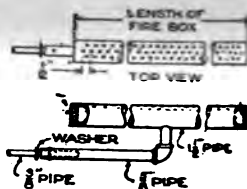

pipe be long enough to extend from the center of the fire box to the outside of the back of the stove. This burner is to be hung from the grate, while the  $\frac{5}{8}$ -in. feed pipe is to pass through a hole drilled through the back of the ash pit. The small  $\frac{3}{8}$ -in. or  $\frac{1}{4}$ -in. pipe is to be inserted into the feed pipe about 2 in.; about 1 in. from the end of each pipe drill a  $\frac{1}{16}$ -in. hole for a pin to hold them together. In the end of the small feed pipe a plug must be inserted, with a hole of proper size, which will be from  $\frac{1}{32}$  in. to  $\frac{3}{32}$  in., depending on the quality and pressure of the gas to be used. The mixer is completed by slipping a metal washer over the small feed pipe, to be placed a

short distance from the end of the large pipe so as to adjust the flow of air drawn into it. A rubber hose connects the other end of the small feed pipe to the gas cock. This burner has been found to be quite satisfactory. If the fire box is filled with porous fire bricks, a very efficient heating arrangement is the result. Whenever desired, coal or wood may be burned without disturbing the burner, and gas may be used at the same time.

### Renewing Valve Guides in Auto Engines

When the valve-guide bushing in the cylinder becomes badly worn and has to be replaced, it is not always desirable to put the car or truck into the repair shop or to tear down the engine to replace it. A handy device for taking out and replacing the worn guide bushing can be made by using a rod threaded at one end to fit the spark-plug thread in the valve cap, and long enough to force the guide out. As the spark-plug thread is standard, the same size rod will do for different engines. To force the worn guide out, screw the rod down by the use of the two lock nuts. To insert the new guide, a bolt is made which will pass down through the guide. The lower end of the bolt is threaded up far enough so that the guide may be forced in place by turning a nut. The head of the

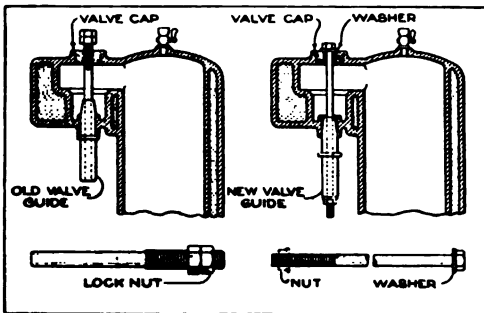

The Valve Guide is Pressed into or Out of the Cylinder by Turning a Nut

bolt, with a flat washer underneath, takes the pressure which is required to force the guide into place.

### Safety Tool Extracts Particles from the Eye

Mechanics, particularly ironworkers, are continually getting small particles of steel, sawdust, or other substance

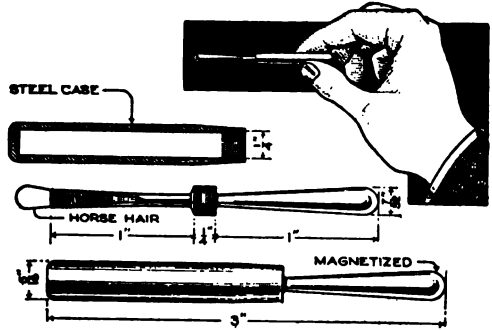

This Easily Made Tool Extracts Particles from the Eye Quickly and Safely

in their eyes. These foreign bodies are usually removed with a toothpick or match that has been sharpened to a point—a very dangerous instrument in unskilled hands. The illustration shows a safe and convenient instrument for this purpose. It is made of tool steel; the handle end is hardened and magnetized. On the other end a horsehair is securely fastened with a silk thread, which is then given a coat of shellac to prevent the knot from untying. For convenience and protection, the instrument is screwed into a case made of mild steel.

If the particle in the eye is iron or steel, the magnetized end will often remove it. If not, it can be loosened with the horsehair without danger of injuring the eyeball. If, however, the particle is so deeply imbedded that it does not readily respond to either treatment, a surgeon or eye specialist should be consulted immediately; indeed it is best to have medical attention if the wound is at all serious.—M. L. Lowrey, Livermore, Calif.

For tables of sufficient size, white porcelain door knobs can be used for sliding casters, by boring out the leg, inserting the stem of the knob, and fastening with a screw through the side.





small cylinders, which tends to increase the difficulty of proper lubrication.

This trouble has been overcome, in one of the famous foreign aeroplane engines, in a very simple manner. The same method has since been used on several automobile engines with entire success. A groove is cut from bearing to bearing on the top side of the piston, as shown in the illustration. The oil collects in the groove, and drains into the piston-pin bearings. The depth of the groove in the piston depends upon the thickness of the piston at that point, and care must be taken that the wall is not weakened too much.—S. E. Gibbs, Urbana, Ill.

### Bench Grinder or Polishing Head Made from Old Piston

A badly worn piston from an old gas or automobile engine can easily be made into a bench grinder or polisher. The piston-pin bearings are best fitted with a brass or bronze bushing, or a bearing can be poured with babbit around the shaft. The belt pulley, being placed inside the piston, is surrounded by the piston wall, forming a splendid belt guard. The grease cup, mounted as shown, furnishes lubrication, and the oil or grease should be distributed by means of grooves cut in the shaft. Emery or polishing wheels may be mounted on one or both ends of the shaft, which is held in place by collars with set-screws. The piston may be bolted either to the bench, or to a special stand made for it. The stand should, however, be very stiff to withstand the high speeds at which these tools are run.

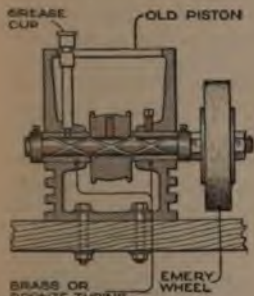

### Keep the Coal Wet

One way of saving coal, which is widely known but not so widely practiced, is by keeping it wet. It is found by tests, that coal which is kept exposed to the air, loses a considerable percentage of its fuel value by gradual oxidation. This can be eliminated by keeping the coal under water, or it can be reduced very largely by keeping the coal wet.—John J. Spaulding, Zanesville, Ohio.

### Moving Heavy Stones into Place on a Wall

In moving heavy stones to the top of a wall, a low truck or barrow was used on a broad plank, which formed an incline and had at its upper end a groove, in which the upper wheels could rest. The truck, carrying a heavy stone, was pushed up the plank, until the wheels fell into the groove; the handles could then be lifted so as to slide the stone off onto the wall, without danger of sliding back down the incline, and without the necessity of placing any blocks back of the truck wheel. As the placing of such blocks would require the labor of an extra man or boy, considerable expense was saved by this arrangement.—J. G. Allshouse, Vandergrift, Pa.



### Wood Box Built into Wall of Kitchen

Carrying wood into the kitchen for use in the range is one of the chores which nearly every farmer's boy dislikes. It is troublesome because doors must be opened and closed while the arms are full, and because it is difficult to keep the wood from striking against objects in the kitchen. A better and cleaner way is shown in the sketch. The wood box is built into the wall; the wood is thrown in from the outside, and can be lifted out by opening another door on the inside. The outer door should be fitted quite closely, and may be packed with felt, or several thicknesses of cloth, in order to keep out the cold air. The "dead air" in the wood box will then form a good heat insulator.—P. T. Hines, Raleigh, N. C.



### Ratchet Brace Remodeled for Work in Cramped Spaces

The plan illustrated has been devised to handle the job of boring holes in

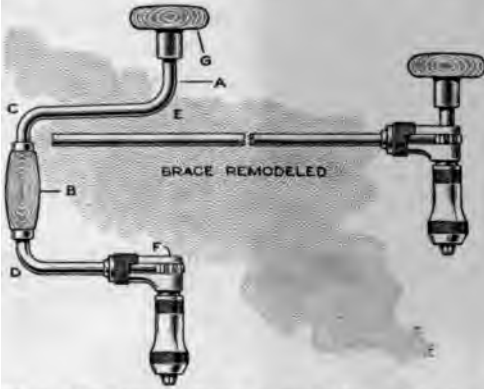

By a Few Simple Changes, an Ordinary Ratchet Brace is Converted into One Suitable for Work in "Tight Places"

close quarters, such as between two beams. Any ordinary brace with a ratchet can be adapted as described. The frame is cut with a hacksaw, at A. The wooden grip B is removed, and the corners at C, D, and E are straightened. Next bore a hole at F, in which to fit the short stem GA which was cut off. In operation, pressure is applied at F. On the forward stroke the lever revolves the drill bit, and on the backward stroke it slides with the ratchet.—Frank Barretta, Tenafly, N. J.

### Holder and Pick-Up Tool for Cotter Pins

In automobile and tractor work, it is often necessary to insert cotter pins in places where there is scarcely room for a man's hand. The small instru-

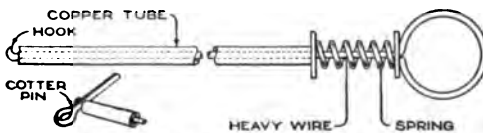

A Short Piece of Gasoline-Line Tubing and Some Wire Form a Handy Cotter-Pin Holder

ment illustrated has been found very useful for this purpose, as it holds the

cotter pins firmly, and can be made long enough to reach into the most difficult place. It can also be used to pick up cotter pins or other small objects that have accidentally fallen into the crank case or pan. In using this instrument, place the handle end in the palm of the hand, and take the copper tube between the thumb and first finger. By pulling back on the tube, the instrument is opened to admit the cotter; by releasing it, the cotter is gripped tightly.—M. D. Lawrence, Oakland, California.

### Switch Reversed by Tilting Mercury Cups

Finish a hardwood block, about  $3\frac{1}{2}$  by  $3\frac{1}{2}$  by 5 in., and bevel the ends as shown in the sketch. The angle of the bevels should allow the switch to rest securely upon either bevel when tilted. Secure binding posts at A, B, C, D, E, and F, and bore

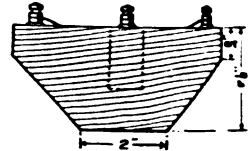
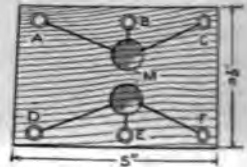

two  $\frac{3}{4}$ -in. holes, as shown at M, about  $1\frac{1}{2}$  in. deep. Pour melted paraffin into the holes M until filled. When cool, trim the paraffin out with a knife, so that the sides and bottoms of the holes are coated with a thin shell of paraffin. This closes the pores of the wood.

Run iron wires from the binding posts to the holes M, as shown in the sketch. The wires from B and E should reach the bottom of the holes M. The wires from A, C, D, and F should be cut off about  $\frac{3}{4}$  in. from the bottom of the holes M. When the block is placed upon a table in the position shown in the sketch, pour sufficient mercury into the holes M so that the ends of the wires from B, C, D, and F are about  $\frac{1}{8}$  in. from the surface of the mercury. Pour about  $\frac{1}{4}$  in. of kerosene or machine oil upon the mercury. Now plug up each hole M



with tightly fitting stoppers to prevent spilling the oil or mercury, should the block be upset by accident. The oil will prevent dangerous sparking if a large amount of current is flowing in the circuit when the switch is opened.

When the switch is tilted to the right, contact's will be made between B and C and E and F. When tilted to the left, A and B and D and E will make contact. When the binding posts A and F are connected to one wire, and C and D to the other, a double-pole reversing switch results. In an emergency the mercury may be replaced by salt water. However, for a permanent switch, mercury is much better.—J. Garrett Kemp, Stillwater, Oklahoma.

### One-Piece Pipe Wrench Made from Bar Steel

A pipe wrench which will grip firmly a piece of heavy pipe can be made in an emergency from a single bar of tool steel. Simply anneal the bar, file notches in it with a three-cornered file to form teeth, bend it to an angle about like the one shown, harden the bar, and temper it so that a smooth file will cut the steel just slightly. The length of the toothed portion will depend on

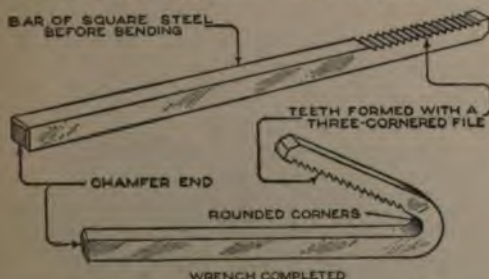

This Pipe Wrench is Quickly Made, and Quite Effective Where Tooth Marks on the Pipe Are Not Objectionable

what range of pipe sizes is to be handled.—L. M. Hinrichs, St. Louis, Missouri.

ⒸPowdered graphite, shaken up in a squirt can with kerosene, is useful in lubricating the springs of an automobile. The mixture is squirted along the edges of the springs.

### Bit Brace Makes Excellent Handle for Tool Box

Every mechanic's tool chest contains a bit brace, and it can readily be kept

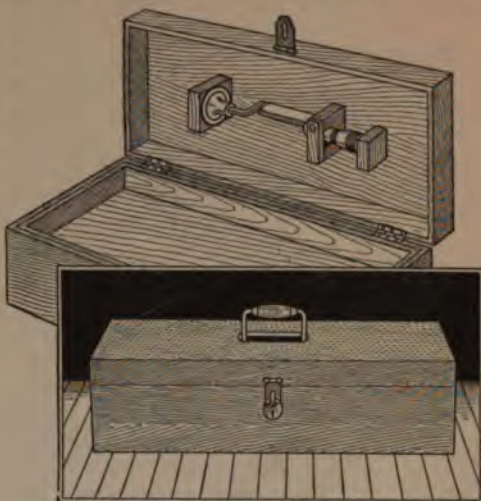

The Bit Brace Which Is Part of Every Mechanic's Equipment Makes a Good Handle for His Tool Chest

in the chest in such a way as to form a convenient handle for the chest, which will not wear out or come off. The illustration shows a suggested arrangement. When the brace is to be used, it is withdrawn from the chest by turning the button which holds the chuck in place; the other end of the brace then pulls out of the hollowed-out block of wood in which it rests.—Everett Black, New York, N. Y.

### Digging Holes in Dry Ground with a Hose

When a small hole must be sunk deeply into dry, sun-baked ground, as for chicken-yard posts, or for goal posts, or backstops, for athletic fields, the best tool is a hose with water at 50-lb. pressure, or more, such as is available in most cities. With a nozzle  $\frac{1}{4}$  in. in diameter, a hole, 6 ft. deep, was dug in three minutes, and only 9 gal. of water were used. For deep holes, the nozzle may be wired to a stick so as to be sure it points straight downward.

### Temporary Pole Step Made from Two Spikes

Cheap but safe pole steps can be made with 5-in. spikes. One spike is driven in at an angle of 45°; another is then driven horizontally so that it rests on the head of the first one. Campers, surveyors, and others, will find this an easy way to ascend trees and poles quickly. Instead of bending under weight, the horizontal spike has a tendency to press the 45° spike farther into the hole or tree. If the head of the lower spike is curved slightly, as shown, the safety of the device will be increased.—Wm. Warnicke, Jr., New York, N. Y.

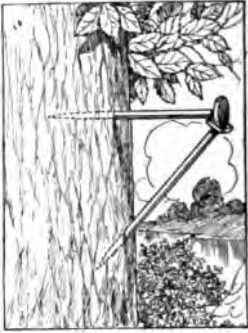

### Removing Automobile Wheels with the Hub Cap

Many automobile rear wheels are fastened to the rear axle by a key in a tapered shaft, and unless a special wheel pulley is at hand, the job of removing the wheel is a puzzling one. A quick and effective method is as follows: Remove the hub cap, take out the cotter pin, and unscrew the castellated nut. Place a piece of iron or steel, of suitable thickness, in the end of the hub cap, and screw the cap onto the wheel, with the inserted piece bearing against the end of the tapered shaft. The force exerted by the cap threads is usually sufficient to pull or start the wheel, but a blow on the end of the cap with a wood or lead mallet will help when the wheel is very tight.

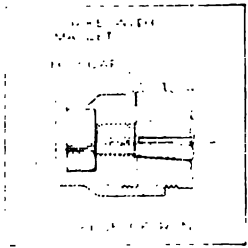

### Kerosene Burner or Stove Readily Made

Due to the great scarcity of coal-wood, it is advantageous to use kerosene instead when a large fire is required. This may be done by means of the burner illustrated. The tank may be made from an ordinary kerosene can; a tube bent down from the top and a pipe valve regulate the flow of the liquid. The bottom of the burner end of the tube is bent and drilled as shown, so that the flame at the holes in the tube heats the liquid of tube above it, thereby vaporizing kerosene before it reaches the burner. To start the burner, simply let kerosene run out until it can be lighted at the burner; as soon as it heats, the hot blue flame will appear.—C. Spreen, Flint, Mich.

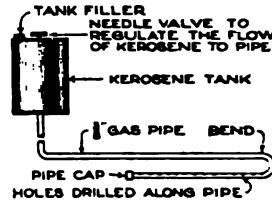

### Cover for Oil Holes in Dirty Places

When oil holes on small shaftings are located in places where dirt or dirt prevails, some sort of an oil device should be used which will prevent the dirt from entering the bearing and scoring the shaft. Oil caps may be applied in some cases, but they are expensive and troublesome. In such instances an oiling arrangement similar to that here shown may be used. It consists merely of a cover of sheet metal for the oil hole, to which is attached a pad of felt. The felt can be cemented to the metal disk, which constitutes the cover, with thick white shellac. If the shellac is too thin, it can be readily thickened by igniting a small

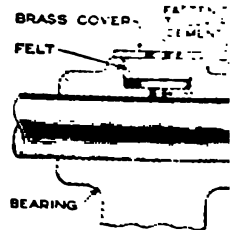



tion of it with a lighted match, and thereby burning out some of the alcohol. A cement thus prepared is impervious to oil and ordinary alkalis. The oiler is filled by running oil from the can into the hole in the cover disk, without removing the cover. The oil seeps down through the felt and lubricates the bearing, but dust and grit are excluded. The bearings of a polishing lathe, on which an abrasive dust was used, were equipped as above described, and their operation has been altogether satisfactory.—O. C. Richards, St. Louis, Mo.

### Locating Bolt Holes Where Scriber cannot be Used

Where a bolt must pass through two pieces of metal separated by an air space, it is often difficult to mark the location of one hole from the other.

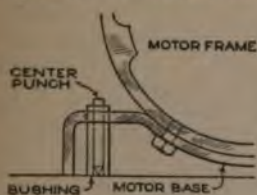

In the case illustrated, where the base of a motor was to be bolted down, the mechanic, finding it impossible to use a scriber or a center punch in the ordinary way, turned up a bushing and used a small center punch made of drill rod to locate the center of the hole.—

Joe W. Romig, Allentown, Pa.

### Calculating Belt Lengths for Splicing

When changing machine speeds it becomes necessary to change the length of the belt. To figure how much belting to cut out or add, subtract the diameter of the smaller pulley from that of the larger one, divide by two, and multiply the result by three. This gives the length of the piece to be cut out, or to be added. Stated another way, multiply half the difference in diameters by three. If both pulleys are changed, the rule is applied twice, once for each change. This rule is for open belts, though it is also fairly close for crossed belts.

### Cotter-Pin Extractor Has Hammer Built In

This simple tool is a welcome addition to the average mechanic's tool kit.

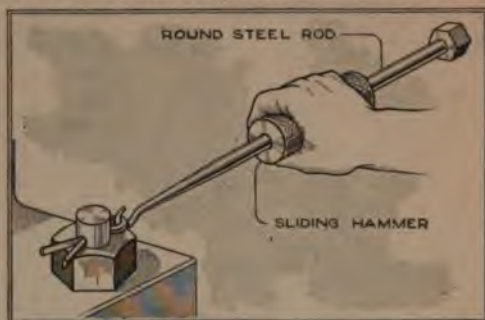

This Cotter-Pin Puller has Its Hammer and Hook Built Permanently Together

It is made from good machine-steel rod, and the hook end is thoroughly case-hardened and tempered. If the range of work done is wide, two or three sizes can be made.—Chas. H. Willey, Concord, N. H.

### Moving a Lathe Easily with Hand Trucks

The usual way of moving an engine lathe around the shop is to place planks and pipe rollers under it and shift it



By the Use of Two Hand Trucks and a Few Minutes of Three or Four Men's Time, the Lathe can be Quickly Moved

along, but an easier and quicker method is to use a two-wheeled hand truck under each end, and lift the lathe just enough to clear the floor. While one or two helpers steady it because of its being top-heavy, it can be wheeled along the floor with scarcely any stops. Progress will be considerably more rapid than when using rollers.—H. S. Rich, Cromwell, Conn.

### Clamp Holds Work Down on Top of Bench

This simple type of bench clamp, or holdfast, is constructed from stock that

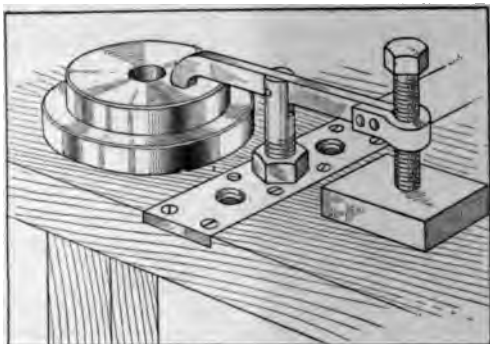

This Type of Bench Clamp Is Very Useful for Holding Irregular Objects

can be found around the shop. A  $\frac{7}{8}$ -in. bolt has its head cut off and a slot cut in the body to take the clamping bar, which is made of  $\frac{3}{4}$  by  $\frac{3}{8}$ -in. stock. One end of the bar is bent around a small rod and riveted; the rod is then removed, and the hole tapped out for a  $\frac{5}{8}$ -in. bolt. A long strip of  $\frac{1}{2}$  by  $1\frac{1}{2}$ -in. bar stock, set into the bench and fastened with screws, has holes drilled and tapped at convenient intervals to receive the bench clamp. The long bar may also be placed underneath the bench top, so that screws will not be necessary to take the pull.

### Headrest for Auto Creeper Made from Inner Tube

Creepers with solid cushions usually become covered with dirt and oil that falls down on them when in use under cars. This dirt gets into the worker's

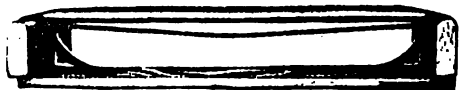

An Old Inner Tube Forms a Cushion for a Creeper Which is Easily Cleaned of Grease and Dirt

hair and scalp, and can only be removed with great difficulty. Old inner tubes are plentiful, and one can be

put to good use in making a headrest which is easily cleaned. Two blocks 4 in. high, form the sides, and a steel bracket acts as a brace. Stretch tin tubes around the frame, and reinforce, if found desirable, by placing a screen-door spring under it.—J. H. Shadel, Oradell, N. J.

### Running Board on Automobile Strengthened by Brace

Many drivers of light cars load down their running boards with boxes, storage batteries, camping equipment, etc., without much thought of the fact that the running board is not built to take this extra load. It may be readily strengthened, however, by the addition of a brace such as illustrated. The dimensions given are suitable for many light-weight cars, but can be modified when necessary. The brace is hung from the frame of the car, and will help

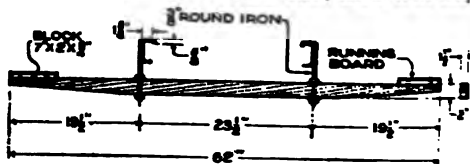

A Wooden Brace Suspended from the Frame Strengthens the Running Board

materially where extra loads are carried.—S. J. Forsyth, Syracuse, N. Y.

### Threading Die Made from a Nut

A nut which has a well-cut thread can be transformed into a die by filing four or five notches in the threads of the nut with a round or three-cornered file, backing off the cutting edges with a larger round file, and then hardening the improvised die. The notches can be cut more effectively with a drill press if one is available; first screw a threaded stud into the nut, and then drill small holes around the circumference of the stud, half in the stud and half in the nut. Remove the stud and touch up the holes with a file. If the stud sticks in the nut, it can be loosened by drilling a hole through its center.—T. T. Smith, St. Lo.

# Save Coal by Burning Ashes

By P. P. AVERY

It is quite well known that when fresh coal exclusively is burned in a large stove or furnace, the ashes which are shaken down nearly always contain a considerable proportion of unburned coal or coke. Anyone who is careful of the amount of coal he uses must take some means of recovering the good coal from the ashes, and burning it over again. To do this, it must be mixed with fresh coal, and mixing it in the proper proportion with a shovel, or with several coal hods, is sometimes a job which is so tedious as to be frequently neglected, sometimes to the extent of even wasting the partly burned coal.

With this in view, a mixing hopper was constructed in an old wooden box. The bottom of the hopper is made to come about 13 in. from the floor, so that a coal hod can be set under it; this bottom consists of a valve, or slide, made of heavy galvanized iron. In it are two rectangular holes, one for each of the two halves into which the hopper is divided by a wooden partition. One of these openings is made 50 per cent larger than the other one, because it is necessary for best results to have a rather greater volume of fresh coal than of the partly burned coke. The back end of the iron slide is bent down slightly, in order to prevent it from slipping out from the two guides which support it at the sides, and the front end is shaped to form a handle, either by bending it over, as shown, or by cutting out a hole to fit the hand. Underneath this part, the front side of the box is cut out large enough to permit the coal hod to be pushed in. It is better not to have any more of the box open than just what is necessary in order to insert the coal hod, because the sides of the box are effective in keeping the dust confined.

In using the hopper, the coal is dumped or shoveled into one side, and the ashes, thoroughly sifted and cleared of clinkers, are thrown into the other side. With the empty coal hod standing underneath, the valve is pulled out and pushed back several times, or until the coal hod is full. The fuel will be thoroughly mixed, in the

proportion which is fixed approximately by the relative size of the two openings in the slide. The exact size of these openings will, of course, depend somewhat on the kind of fuel burned. It will therefore be advisable at first to cut the larger of these openings slightly smaller than the half of the hopper bottom, so that

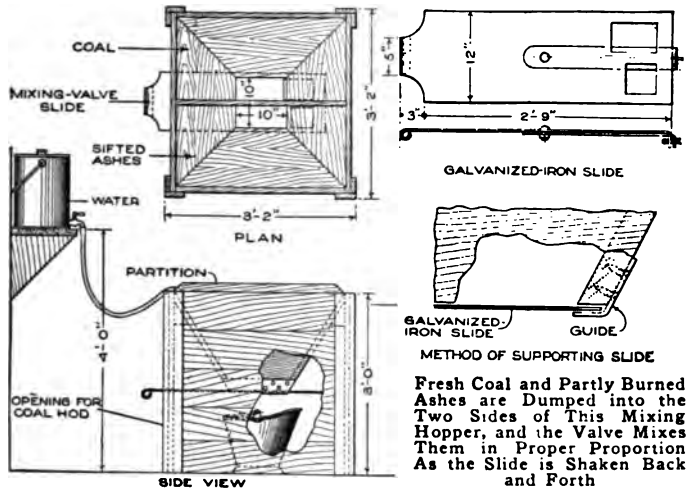

Method of Supporting Slide  
Fresh Coal and Partly Burned Ashes are Dumped into the Two Sides of This Mixing Hopper, and the Valve Mixes Them in Proper Proportion As the Slide is Shaken Back and Forth

either opening can be enlarged if the mixture is not just right. If still more accurate results are wanted, it is entirely possible to attach to the bottom of the slide a strip of iron which swings on a pin, as shown in the detail, so that a slight change in its position increases the size of one opening and decreases the size of the other.

A good deal will depend, of course, on the skill developed in using the mixing hopper, as, for instance, the handling of the slide. The mixing will be much more thorough if the slide is kept in motion, by shaking it back and forth while the fuel is falling through. Better results will often be obtained by sprinkling the ashes with water; a 5-gal. oil or gasoline can filled with water can be mounted on a shelf near the hopper, and a rubber hose then makes this sprinkling very easy. The partition should be built a few inches higher than the sides of the box, so as to make it less likely that stray lumps of fuel will fall into the wrong side of the hopper. By this thorough mixing, in the proper proportion, of fresh coal and partly burned ashes, the weekly coal consumption of an ordinary kitchen range, carefully measured, was reduced from 14½ hods a week to 10 hods, the amount of cooking and heating being the same.

The mixture is especially useful for banked fires in cold weather, which need not be very hot, but must last through the night.

### Swivel Chair Made from Wagon-Wheel Fellys

A useful and not ungraceful swivel chair was made by removing the broken

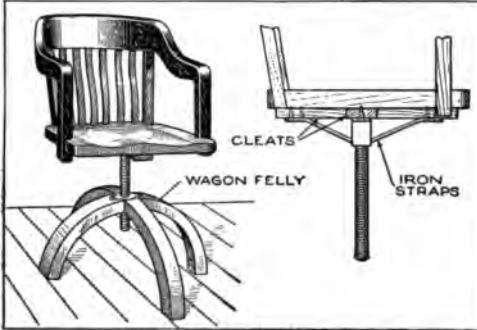

After Having a Leg Broken, This Chair was Converted into a Swivel Chair by Mounting It on Two Pieces of the Felly of a Wagon Wheel

legs of an old chair and mounting the good portion on a base made from two pieces of wagon-wheel fellys. An iron bar, 1 in. in diameter, was threaded and made to work easily through a threaded hole in the fellys, strengthened by the addition of a metal blade on top. On the bottom of the chair seat, two wooden strips were fastened with screws, at right angles to each other, crossing in the center. The end of the iron rod, sharpened to a square point, was driven into a tapered hole in this center, and was braced by two iron strips, tapped out to take the thread on the bar, screwed into position as shown, and fastened with screws.—Charles Black, Jr., Hightstown, N. J.

### Lever-and-Fulcrum Snow Shovel Makes Heavy Shoveling Easy

For heavy snowfalls a hand-derrick shovel gives the user a great advantage

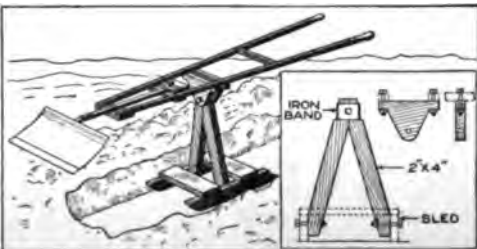

The Lifting of Heavy Shovelfuls of Snow is Avoided by Mounting the Shovel on a Fulcrum

over the old-style shovel. Simply mount on a sled an upright frame made of 2 by 4-in. lumber; upon this as a pivot, a pair of handles is bolted, to which is attached an ordinary shovel. The upright frame is 24 in. high, and it also swings, on the two bolts at the bottom. The width of the sled is 12 in. The sled is made of two pieces of 2 by 4-in. timber, with lighter pieces nailed across. The handles are 5 ft. long, or more; three braces hold them secure for heavy lifting. Large screws fasten the handles to the triangular-shaped pieces, and bolts hold the shovel to the handles. At the rear the handles are 2 ft. apart and taper to 3 in. apart in front.—F. E. Brimmer, Dalton, New York.

### Push Button Locked against Interference by Children

Many small boys take pleasure in unscrewing covers from electric push buttons, often losing or disconnecting parts of them. The illustration shows how they may be protected against interference by anyone who does

not understand the method of opening them. Unscrew the cover or cap, and determine the thickness of the base, which carries the thread; then replace the cap and bore a hole, just large enough to

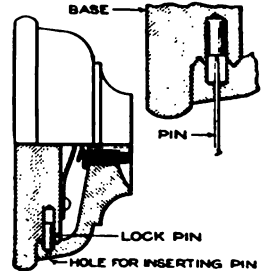

take an ordinary brass pin, through the cover and the base. Unscrew the cover, and enlarge the inner part of the hole, in both base and cover, so as to take a lock pin made of wire, about  $\frac{1}{8}$  in. in diameter. The lock pin should work quite freely in this hole. Now insert the lock pin in the base and hold it in place with a piece of paper or a key, until the cover is screwed on. After the cover is screwed clear into place, the lock pin will drop, preventing the cover from again being removed until the lock pin is released by upward pressure of a common pin through the small hole.

### Renewing Old Electricians' Tape

Electricians' tape which has been used, or has dried, can have its stickiness restored by immersing in strong hot soap-suds, and leaving until the solution has penetrated. It is then taken out and



hung up to dry, being rolled up as soon as it reaches the required stage of "stickiness."—Fred C. David, St. Joseph, Mo.

### Using Soft-Coal Screenings with Anthracite

The following idea may be of benefit to many householders who have only a small amount of anthracite on hand:

First, secure a load or two of soft-coal screenings, No. 1 grade if possible. Second, sift all the refuse from cooking stove and furnace, and after picking out the slate and clinkers, mix an equal amount of the screenings with the sifted cinders (not the fine ash), and use the mixture in the furnace. If the soft coal is a noncaking fuel, it will neither harden over nor clinker, and practically all the anthracite as well as the screenings will be consumed; furthermore it will give a lasting fire.

Using cinders alone with anthracite makes a dirty fire with lots of clinkers, and I have found from experience that when cinders are used with anthracite alone, it requires quite a few siftings to consume even the first cinders used. No doubt this is the reason for the great waste of cinders in private houses. The mixture of cinders and screenings makes a great deal less smoke than the best grade of soft-coal lump. This is no doubt due to the fact that the anthracite cinders are of practically the same composition as coke; that is to say, nearly pure carbon.—James E. Noble, Portsmouth, Ont.

### Breastplate for Brace and Bit

When using a brace and bit, or a hand drill, on a job which requires consider-



able pressure, a large surface by which the pressure can be applied will make the job much easier. The end of a common tin can, nailed to a round wooden disk about 10 in. in diameter, forms a handy device

for this purpose. By placing the end of the brace inside of the can and the disk against the operator's body, considerable pressure is applied quite easily.—A. M. Fairfield, St. Marys, Kan.

### Sandpaper Held Firmly on Block by Its Tapered Shape

A neat form of sandpaper block has its two sides slightly out of parallel, one of them having a slot into which the edges of the piece of sandpaper are folded. The paper will be clamped quite tightly by pushing it toward the larger end of the block, or instantly released by pulling it toward the small end.

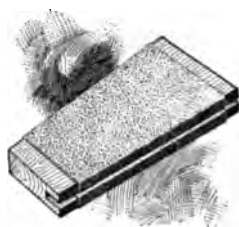

In using the block, if it is held with the small end toward the workman, the index finger resting on the large end, there will be no tendency of the paper to slip out of place. Blocks embodying this principle can, of course, be made of various shapes, and with corners curved off to any radius to fit fillets in the wood to be sanded.—Henry Wedde, Chicago, Illinois.

### Using a Barrel as a Mouse Trap

When difficulty is encountered in ridding a place of mice by the ordinary methods, try this one: Get a fairly tight barrel and bore a hole near the bottom to serve as an entrance. Throw into the barrel a quantity of shavings, or any material that would be useful to the mice in forming nests. Add some grain to serve as an additional attraction, and then cover with a piece of wood. Let the barrel remain in a place infested with mice for a week or ten days. At the end of this time numbers of the creatures will have taken up their abode in the barrel, and be busy nest making. Then stop up the hole in the bottom with a cork or wood plug of proper size, lift up the cover of the barrel a little, and pour in water until there is sufficient to drown the occupants. The trap may be emptied and, after drying, set up again. In this way a locality is soon cleared of mice.—S. Leonard Bastin, Bournemouth, Eng.

### Pinch Bar Made from Buggy Axle

When an old buggy is thrown on the scrap heap, its axle can be made by any blacksmith into a handy and durable pinch bar or crowbar. The size and weight of the axle make it well adapted to this purpose.

### Convenient Rack for Rubber Gum and Fabric

Vulcanizers will find this rack convenient and practical. It keeps the repair stock clean, and permits several men to

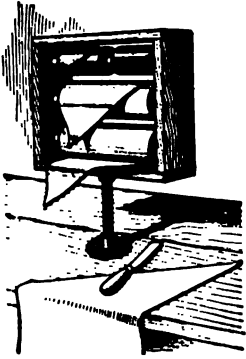

work at the same table without interfering with each other. The wooden frame, made to hold several rolls of gum and fabric, revolves on a stand fastened to the table. It can be turned in any direction, to accommodate workmen at the opposite ends of the table.

The frame is of lumber, 4 in. wide, with holes bored through the sides to hold the rolls. The rack revolves on a piece of half-inch pipe, threaded on one end to fit a flange, which is screwed to the center of the table. On the bottom of the rack another flange is screwed, in which the pipe should turn easily.

On the ends of the rack may be hung knives, rollers, stitchers, scissors, etc., thus keeping the table clear of working tools and allowing more table space. The entire contrivance is so simple that any vulcanizer can easily construct one.

### Screwdriver Handle Made of Dust Cap from Tire Valve

An ideal screwdriver handle is made from an old dust cap, such as used on automobile tire valves. A piece of hard wood is driven into the cap as tightly as possible, a rivet is then driven through,

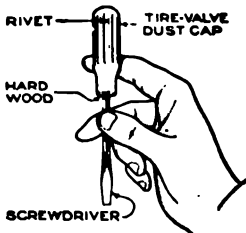

near the upper end, to prevent the wood from turning in the cap, and a hole is drilled in the wood at the open end, somewhat smaller than the round rod which forms the

blade. The latter, which may be a piece of drill rod  $\frac{1}{8}$  to  $\frac{3}{16}$  in. in diameter, should be beveled off to a chisel edge, driven into the handle, and then ground to the proper shape for use as

a screwdriver. The dust cap forms a durable handle and ferrule in one piece, and has the additional advantage that it is of distinctive appearance, and is so made that a very firm grip can be taken upon it with the hand.

### Partitioning Off a Room to Save Heat and Coal

In very cold weather, it may help greatly to save coal if the expedient is adopted of hanging curtains across a large room, so as to confine the heat of the stove or radiator to the part of the room actually required for use. The curtains may consist of blankets hung on a wire. A space of, say, two feet may be left between them and the ceiling for ventilation, without impairing greatly the efficiency as a coal saver.—Eric Warren, Corpus Christi, Tex.

### Clamping Block for Filing Scraper Blades

Scraper blades are awkward to file, unless a special vise adapted for such work is at hand. If merely put into the ordinary vise it is necessary to let the blade stick out so far, in order to permit the file to be worked at the proper angle, that the blade bends at every stroke. This is not much bettered even by supporting it by one or two pieces of board, for though the blade then does not bend, the operation of clamping is made awkward, and the blade is still in a vertical position, which lends itself badly to the filing of a bevel.



The filing block shown in the illustration, made in a few minutes from scraps, grasps the blade firmly just back of the cutting edge and holds it in an inclined position which makes it possible to hold the file level. It is made by simply ripping diagonally a block of 3 by 4-in. stock, beveling off the upper portion of the front piece, as shown, and connecting the two by countersunk screws, placed near the bottom end, which are screwed in tight enough to hold the scraper blade while filing.—Henry Simon, Laguna Beach, Calif.

### Keeping Collapsible Tubes Inverted Prevents Contents Drying Out

Paint, tooth paste, or other materials kept in collapsible tubes, will sometimes separate, and the oil will squeeze from the tube first, leaving the remaining substance dry. After each time of using, it will be more dry than before, and the last of it may be too dry to be squeezed from the tube. This occurs because the solid matter sinks to the bottom, and may be remedied by keeping the tube in an inverted position. To facilitate this, make a small hole in a wooden block, into which the cap of the tube can be pressed, the block serving as a base or holder for the tube. If the cap is sufficiently tight in the block, the latter will also be of use in unscrewing the cap.

### Making Special Angles and Curves for Drafting Jobs

Draftsmen who often have occasion to draw certain curves or angles will save time and work by cutting their own irregular curves and angles out of sheet celluloid, fiber, or hard rubber, using a pattern of heavy paper pasted to the material as a guide, cutting with a scroll saw, and smoothing the edges with a fine file. Often a standard angle or curve can be altered very easily to the required pattern.—J. Horace Van Nice, Chicago, Ill.

### A Handy Wire Hook for Carrying Window Panes

Carrying a pane of glass is a job which, although apparently easy, causes much loss of temper. If the pane is wrapped



with paper, there is often danger that it will slip out of the hand and fall. If it is not wrapped, the edges are likely to cut the hand. One who provides himself with an old glove, and a piece of stiff wire inside of a long, heavy cloth-

covered rubber tubing, will find the difficulty practically solved. The wire is used as shown in the illustration, and the glass is held from tipping out by a slight pressure of the thumb.—Henry W. Kingston, Milwaukee, Wis.

### Signboard Shows Where Workman is to be Found

An electrician in a large mill installed on the door of his shop a signboard which saved much time for his fellow employes.

When out working in the mill, his shop door was always left closed, and when electric trouble developed in a distant part of the mill, much time was often wasted in finding him.

The device consisted simply of a wide board attached outside the shop door, having painted upon it the names of the various departments in the mill where electrical work frequently had to be done. In front of each was drilled a small hole in which could be inserted a plug hanging by a string from a nail in the door casing. When the electrician left his shop, he simply inserted the plug in the proper hole, which notified callers immediately of his whereabouts. Parties calling him by telephone and receiving no answer could call the department opposite his shop and inquire where the electrician was, the question being answered by a glance at the board on the door.

A small piece of slate was inserted in the board below the painted letters, and a plug hole was also made beside this slate. When going to a place not covered by the painted signs, the electrician noted this on the slate with a piece of chalk, and inserted the plug opposite it. The plug was provided with a conspicuous white head made of an old porcelain insulator, and was hung by a cord from a nail in the casing, near the door knob. Thus the door could not be opened without removing the plug from the hole, and there was no danger of the electrician returning without indicating it by removing the plug. This idea could be made use of by many tradesmen.—Frederic Doremus, Passaic, N. J.



### Base Knobs or Door Bumpers Put to Various Uses

Base knobs, which may be purchased for from 2 to 10 cents each, may be used for many purposes besides acting as door



Base Knobs, Such as are Placed behind Doors to Keep Them from Marring Woodwork, Are Useful for Purposes Such as These

stops. An ordinary chair may be made higher for a child's use by simply screwing a knob into the leg of each chair. A novel footrest may be made from the top of a discarded organ stool by screwing four of these knobs into the underside. Small tables may also be made higher by this means.—Mrs. Grace E. Willey, Concord, N. H.

### Unloading a Heavy Machine from a Truck

A man who had the job of unloading heavy machines from a truck was confronted by the shortage of labor, and employed a method which made use of the power of the truck for moving machines. On backing the truck up against the loading platform, the machine was moved by means of levers, so that the base of it projected about 10 in. from the rear end of the truck. It was raised slightly, so



By Moving a Truck Forward and Back under Its Own Power, Heavy Machines are Unloaded from It on Rollers, and Pushed onto Flat Cars

that a roller could be placed under it. While a rope and hook then held the

machine from moving, the truck was moved forward a short distance, under its own power. It was then gently backed against the platform again, the machine thus moving farther onto the platform, and enabling more rollers to be placed under it. With the rope shortened, the operation was repeated, until the machine rested entirely on rollers on the platform. By means of a pole, the machine was then pushed, a short distance at a time, onto the flat car beyond the loading platform. The process should be attempted only by a truck driver who is thoroughly familiar with the clutch action of his truck, as too great a movement of the truck might easily prove disastrous to the load.

### Lumber-Saving Kink for Making Split Patterns

To make a circular, split pattern, it was necessary to cut two semicircular pieces of wood. A piece of material was found

which was suitable, except that it was not quite twice as long as the diameter of the circle. The diagram shows how this stick was nevertheless used, by sawing it at an angle. The dotted line shows how much too short

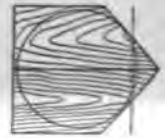

the stick would have been if it had been cut at right angles.—C. W. Thunen, Benicia, Calif.

### Extinguishing Spontaneous Fire in a Coal Pile

A large pile of coal was found to be on fire, due to spontaneous combustion. A hose and water pressure were available, but it was found difficult to make the water penetrate deeply into the burning coal. The difficulty was overcome by attaching to the end of the hose a 10-ft. length of 1-in. iron pipe. The other end of the pipe was thrust into the pile as far as possible, and the water turned on. As the coal directly in front of the pipe was gradually forced away by the water pressure, the pipe was thrust farther in. Occasionally a large lump was encountered, which would have to be broken by blows of the pipe itself acting as a hammer, or of a heavy hammer applied to it. After driving several holes into the interior of



the coal pile in this way, the fire was found to be extinguished.—Maury Robinson, Paris, Tex.

### Sheet-Metal Backing Helps When Sawing Softer Materials

When attempting to cut a very brittle piece of hard rubber, fiber, or asbestos sheeting with a hacksaw, especially if only a small vise is available for holding the work, it is well to clamp the material between two sheets of tin or other thin material. The resulting cut will be true, smooth, and firm-edged. This is particularly helpful in the case of cutting materials such as asbestos.

### Dissolving Boiler Scale Saves Fuel and Provides More Heat

One means of saving coal, which is applicable to any hot-water heater or steam boiler where hard water is used, is that of keeping the boiler clear of scale so that the heat can reach the water, instead of being wasted to a large extent in the chimney gases. When starting a fire, if a small can of potash, dissolved in about a gallon of water, is poured into the boiler, it will help greatly to loosen the scale as the fire starts to burn. After the system has become thoroughly heated up, the fire should be allowed to die out and the boiler to cool down. The water is then drawn off, carrying with it the scale which has been removed, and the boiler is filled with fresh water and is then ready for service. It should be remembered, however, that there are many kinds of boiler scale, depending on the composition of the water used, so that the efficacy of this method in any particular boiler can only be ascertained by trial.

Other kinks which should be remembered are to keep the flues clean by frequent attention to them, and not to shake the fire too hard, as this often causes coals which are only partly burned to fall through into the ashes.—F. H. Sidney, Wakefield, Mass.

### Snow Scraper Made from Rake

A rake in wintertime is almost as useless as a snow scraper in summer; therefore a device which enables the rake to be converted into a snow scraper will practically make two tools out of one. This is easily done by getting a 1-in. board, about 9 by 18 in. in size, and fastening it onto

the rake by some such means as is shown in the photograph. Strips should be nailed



Converting the Rake into a Snow Scraper Enables the Same Tool to be Used the Year Round for Two Widely Different Purposes

across the ends of the board to strengthen it. For light snowfalls especially, the tool will be found even more useful than the ordinary snow shovel.—J. H. Shadek, Oradell, N. J.

### Wrench for Setscrews in Dogs Attached to Lathe

A simple addition to the bed of a lathe will save time for workers who have frequent use for dogs of various sizes. In using this form of wrench, instead of holding the work in one hand with the dog attached, and tightening or loosening the screws with a wrench held in the other hand, the work itself forms the wrench, and the setscrew head is inserted in the tapered slot which grips it like a vise.

The advantages of this form of wrench are, of course, that it is always handy and never gets lost, that it takes all ordinary sizes of setscrew heads used on lathe

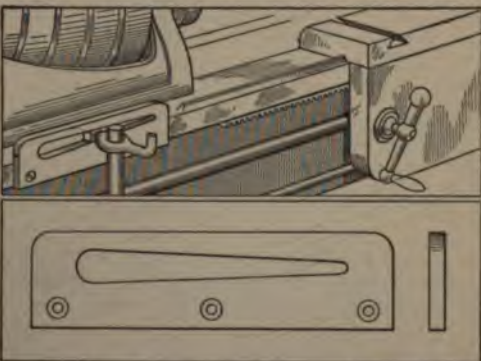

A Sheet-Iron Wrench Attached to the Lathe Bed Saves Time in Loosening and Tightening Setscrews in Lathe Dogs

dogs, and that the operation of tightening or loosening the dog requires fewer operations, and therefore less time when this form of wrench is provided.

### Handy Rack Holds Draftsman's Tools

A rack, which will keep most of the draftsman's tools safe from being pushed off the table, is easily made from a single



The Draftsman Who Keeps His Tools in a Rack will Have Less Trouble in Finding Them and More Room on His Table

block of wood. The work will, however, be much easier if a buzz saw and some large auger bits, or an expansion bit, are available. The size of the block can be varied to take different combinations of triangles, ink bottles, etc. In the rack shown, the three circular holes are suitable either for a bottle of ink, or for holding such small objects as erasers, extra leads, or thumb tacks. Small holes beside these are made to hold the ink-bottle stoppers. Any number of semi-circular grooves can be made in front; if red and black ink, for instance, are both used, one groove may be painted black and the black penholder used in black ink may be kept in it, another groove being similarly painted red for the red pen. —D. D. Symmes, West Haven, Conn.

### Building Heavy Doors in Place Saves Trouble of Hanging

When heavy barn or outbuilding doors are to be hung, many farmers build the doors complete and then hang them. It is thus often difficult to prevent sagging while mounting the hinges. A better way is to nail in place the frame for the door, the nails being driven in only part way. The door planks are then cut and fitted in place, as though they were to be a stationary part of the structure. Sufficient space must, of course, be left around the door openings so that they will swing freely. When the door planks are in place, the hinges are attached, and the door is hung

the frame in place are drawn out, allowing the door to swing free. Double doors may be built in one piece, and sawed in two in the middle after the whole door is completed.

### Small Piece of Glass Is Useful in Tool Grinding

When grinding a tool to a master gauge or template, or to cut a standard thread, lay on the tool a small piece of window glass, and place the gauge fit against the other side of the glass. A piece of glass, 1 by 2 in., is a great convenience in a mechanic's tool box. To prevent cutting of the fingers, the edges may be smoothed down with a whetstone.

### Repairing a Pillar with Cement

A wooden porch pillar, which has rotted out at one point, may be repaired at a very slight cost, as shown in the sketch. First cut out the rotted portion, leaving projections on both ends at the center of the pillar, as shown. Cut a piece of iron pipe, just long enough to drive in between the two pieces, and wind some stout wire around to act as reinforcement. Then bind a piece of sheet iron around the lower segment, extending up to within about 2 in. of the upper segment, leaving enough space for pouring cement. Line up the top of the sheet iron with the surface of the upper part of the pillar, and pour full of cement. After the cement has dried for about three days, remove the sheet iron.

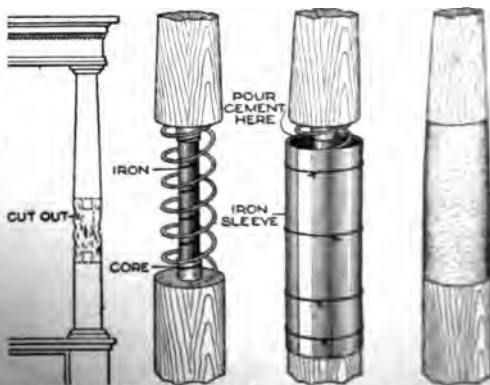

A Wooden Pillar Which has Begun to Rot can be Repaired Quite Satisfactorily by Means of a Piece of Pipe, Covered with Cement

gap with cement, and trim up defects. If the repaired post is repainted, the joints will be scarcely noticeable. —E. Stumpf, Jersey City, N. J.



# Save Coal by Burning Ashes

By P. P. AVERY

It is quite well known that when fresh coal exclusively is burned in a large stove or furnace, the ashes which are shaken down nearly always contain a considerable proportion of unburned coal or coke. Anyone who is careful of the amount of coal he uses must take some means of recovering the good coal from the ashes, and burning it over again. To do this, it must be mixed with fresh coal, and mixing it in the proper proportion with a shovel, or with several coal hods, is sometimes a job which is so tedious as to be frequently neglected, sometimes to the extent of even wasting the partly burned coal.

With this in view, a mixing hopper was constructed in an old wooden box. The bottom of the hopper is made to come about 13 in. from the floor, so that a coal hod can be set under it; this bottom consists of a valve, or slide, made of heavy galvanized iron. In it are two rectangular holes, one for each of the two halves into which the hopper is divided by a wooden partition. One of these openings is made 50 per cent larger than the other one, because it is necessary for best results to have a rather greater volume of fresh coal than of the partly burned coke. The back end of the iron slide is bent down slightly, in order to prevent it from slipping out from the two guides which support it at the sides, and the front end is shaped to form a handle, either by bending it over, as shown, or by cutting out a hole to fit the hand. Underneath this part, the front side of the box is cut out large enough to permit the coal hod to be pushed in. It is better not to have any more of the box open than just what is necessary in order to insert the coal hod, because the sides of the box are effective in keeping the dust confined.

In using the hopper, the coal is dumped or shoveled into one side, and the ashes, thoroughly sifted and cleared of clinkers, are thrown into the other side. With the empty coal hod standing underneath, the valve is pulled out and pushed back several times, or until the coal hod is full. The fuel will be thoroughly mixed, in the

proportion which is fixed approximately by the relative size of the two openings in the slide. The exact size of these openings will, of course, depend somewhat on the kind of fuel burned. It will therefore be advisable at first to cut the larger of these openings slightly smaller than the half of the hopper bottom, so that

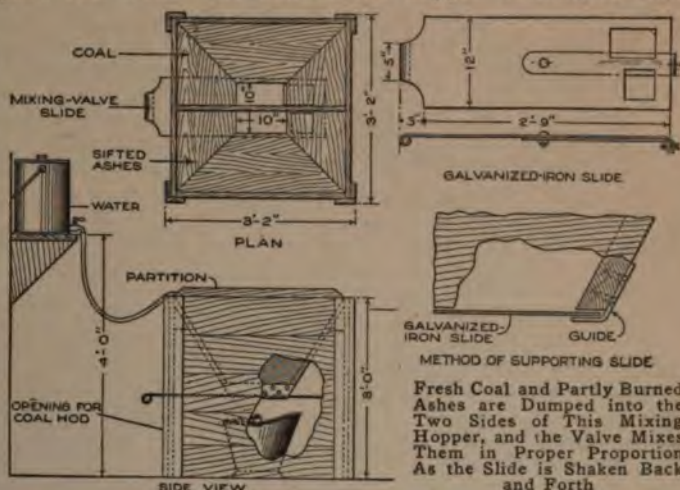

either opening can be enlarged if the mixture is not just right. If still more accurate results are wanted, it is entirely possible to attach to the bottom of the slide a strip of iron which swings on a pin, as shown in the detail, so that a slight change in its position increases the size of one opening and decreases the size of the other.

A good deal will depend, of course, on the skill developed in using the mixing hopper, as, for instance, the handling of the slide. The mixing will be much more thorough if the slide is kept in motion, by shaking it back and forth while the fuel is falling through. Better results will often be obtained by sprinkling the ashes with water; a 5-gal. oil or gasoline can filled with water can be mounted on a shelf near the hopper, and a rubber hose then makes this sprinkling very easy. The partition should be built a few inches higher than the sides of the box, so as to make it less likely that stray lumps of fuel will fall into the wrong side of the hopper. By this thorough mixing, in the proper proportion, of fresh coal and partly burned ashes, the weekly coal consumption of an ordinary kitchen range, carefully measured, was reduced from 14½ hods a week to 10 hods, the amount of cooking and heating being the same.

### Compressing Stiff Clutch Springs with Woodworkers' Clamp

A woodworking clamp is a good tool for removing and replacing the clutch springs on automobiles. The clamp jaws

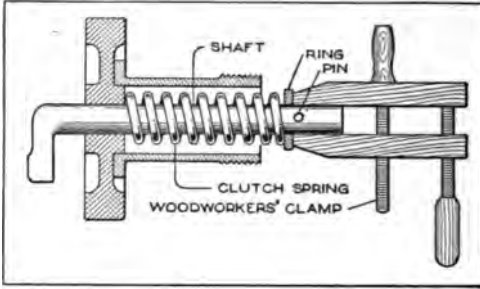

**A Woodworkers' Clamp, Driven On with a Hammer, Compresses the Clutch Spring, So as to Extract or Replace the Pin**

are simply tightened on the shaft, with the ends bearing against the ring, or collar, which retains the spring in position. The clamp is driven on with a hammer, compressing the spring until the retaining pin can be removed or replaced, as desired. The advantage of the clamp method is its adaptability to different sizes of shafts. Often, too, awkward places, in which springs are difficult to compress, can be easily reached by the protruding ends of the clamp jaws.—G. A. Luers, Washington, D. C.

### Fuel-Saving Kinks Valuable in the Home

If the fire box of the stove is partly filled with bricks or stone, leaving the center for the coal, a fire can be made with less coal, which will have more heating ability than it would have without the bricks or stone to absorb the heat.

Too much heat in a home, that is to say, any temperature above 68°, the point which has been set by the Fuel Administration as a proper room temperature, tends to produce something which dangerously approaches laziness. This is felt plainly when the temperature runs up to 75 or 80°, but is present even at 72 degrees.

Fires in bedrooms are unnecessary. A bed can be warmed before retiring, if absolutely necessary, by hot water in a bottle or jug, or by an electric-light bed warmer, and this will be found after use to be even more luxurious than a heated bedroom, and decidedly more sanitary and economical.

*When the fire has died out and the*

room is beginning to get chilly, if one must still sit in it, place a kerosene lamp under the chair and it will save the necessity of firing up again.—B. W. Rice, Caldwell, Idaho.

### Pedal Switch for Emery- Wheel Motors

Emery wheels do not take a great deal of power, but when it is considered that they often run all day, while the total time during which they are actually used does not amount to more than perhaps half an hour, it will be seen that a considerable waste of energy is involved. One way to reduce this is to install a pedal control for the switch or belt shifter, together with a spring, so that the switch will be opened or the band shifted back to the loose pulley by the action of the spring, as soon as the tension on the pedal is released. It may, of course, be objected that a workman would have to wait a few seconds while the wheel was reaching its full speed, thus losing time, but in many cases, this time can be fully occupied in examining the tool to be ground, and determining the exact angle at which it is to be held.

### Foot Control Handy for Faucets in Washbowls

Foot control for the wash basin is recognized as the most convenient and sanitary method, and its adoption would be much wider than

it is, if its advantages were better known. It will contribute wonderfully to the cleanliness and convenience of the shop wash-bowl, if a pedal is installed so that pressure, applied to it with the



foot, turns on the water, it being turned off by a spring, when the foot is removed. In this way, the convenience of a steady stream of water is secured, while at the same time all danger of the water being left turned on by a careless person is eliminated.

Time can be saved in photographic work by making a mark on the bottle, to indicate the amount of hypo, or other material, usually weighed out in making solutions.



hung up to dry, being rolled up as soon as it reaches the required stage of "stickiness."—Fred C. David, St. Joseph, Mo.

### Using Soft-Coal Screenings with Anthracite

The following idea may be of benefit to many householders who have only a small amount of anthracite on hand:

First, secure a load or two of soft-coal screenings, No. 1 grade if possible. Second, sift all the refuse from cooking stove and furnace, and after picking out the slate and clinkers, mix an equal amount of the screenings with the sifted cinders (not the fine ash), and use the mixture in the furnace. If the soft coal is a noncaking fuel, it will neither harden over nor clinker, and practically all the anthracite as well as the screenings will be consumed; furthermore it will give a lasting fire.

Using cinders alone with anthracite makes a dirty fire with lots of clinkers, and I have found from experience that when cinders are used with anthracite alone, it requires quite a few siftings to consume even the first cinders used. No doubt this is the reason for the great waste of cinders in private houses. The mixture of cinders and screenings makes a great deal less smoke than the best grade of soft-coal lump. This is no doubt due to the fact that the anthracite cinders are of practically the same composition as coke; that is to say, nearly pure carbon.—James E. Noble, Portsmouth, Ont.

### Breastplate for Brace and Bit

When using a brace and bit, or a hand drill, on a job which

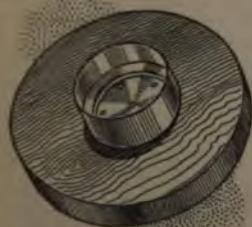

requires considerable pressure, a large surface by which the pressure can be applied will make the job much easier. The end of a common tin can, nailed to a round wooden disk about 10 in. in diameter, forms a handy device

for this purpose. By placing the end of the brace inside of the can and the disk against the operator's body, considerable pressure is applied quite easily.—A. M. Fairfield, St. Marys, Kan.

### Sandpaper Held Firmly on Block by Its Tapered Shape

A neat form of sandpaper block has its two sides slightly out of parallel, one of them having a slot into which the edges of the piece of sandpaper are folded. The paper will be clamped quite tightly by pushing it toward the larger end of the block, or instantly released by pulling it toward the small end.



In using the block, if it is held with the small end toward the workman, the index finger resting on the large end, there will be no tendency of the paper to slip out of place. Blocks embodying this principle can, of course, be made of various shapes, and with corners curved off to any radius to fit fillets in the wood to be sanded.—Henry Wedde, Chicago, Illinois.

### Using a Barrel as a Mouse Trap

When difficulty is encountered in ridding a place of mice by the ordinary methods, try this one: Get a fairly tight barrel and bore a hole near the bottom to serve as an entrance. Throw into the barrel a quantity of shavings, or any material that would be useful to the mice in forming nests. Add some grain to serve as an additional attraction, and then cover with a piece of wood. Let the barrel remain in a place infested with mice for a week or ten days. At the end of this time numbers of the creatures will have taken up their abode in the barrel, and be busy nest making. Then stop up the hole in the bottom with a cork or wood plug of proper size, lift up the cover of the barrel a little, and pour in water until there is sufficient to drown the occupants. The trap may be emptied and, after drying, set up again. In this way a locality is soon cleared of mice.—S. Leonard Bastin, Bournemouth, Eng.

### Pinch Bar Made from Buggy Axle

When an old buggy is thrown on the scrap heap, its axle can be made by any blacksmith into a handy and durable pinch bar or crowbar. The size and weight of the axle make it well adapted to this purpose.

proper speed is reached; some resistance wire, large enough to carry several amperes of current, and some pieces of wood and spring brass to make the seat switch. As will be noted in the circuit diagram, when the concealed switch is closed and the seat switch is afterward closed, the circuit through the bell is established, and, at the same time, the current flowing through the circuit breaker closes a circuit which connects around the seat switch so that, even though the latter is open, the bell continues to ring. The resistance coil would not be necessary if the circuit through the bell was continuous. Since, however, it is interrupted at each tap of the bell, the coil is necessary, in order to maintain a sufficient current through the circuit breaker to keep it from permitting the shunt circuit across the seat switch to open, thus stopping the alarm. The only way in which the alarm can be stopped is by breaking the main circuit, either at the concealed switch or at some other point. If properly wired, this cannot be done by a stranger without spending considerable time, which, under the circumstances, is out of the question for a thief, at least in a city or town.

The making of the seat switch will not be difficult for any electrical experimenter, and its successful working must, of course, be tested by experiment. The sketch may give a suggestion. It will be advisable to carry the two wires from the seat switch directly down below the car, where the circuit breaker, bell, and resistance coil can readily be mounted in one removable unit. As the current first comes through the seat switch, it will close the contact points; as the seat switch is opened, the current flows through the shunt circuit, including the contact points, and keeps the points closed until the main circuit is broken.

The unit under the car, consisting of the bell, circuit breaker, and resistance coil, will have two wires leading from it: one to the seat switch and one to the concealed switch. If the car is wired on the double-wire system, there will also have to be a return wire to the battery. With the grounded-battery system, there is simply a connection from the unit under the car to some screw or nut on the frame of the car.

The concealed switch may be located in a pocket on the door, just behind the dash board, under a corner of the floor mat, or any other place where it will be out of sight; or it may be built into a combination, or key, lock. Ignition locks designed

for use with magnetos, which have a closed circuit when locked, are readily used for this purpose. One advantage to be gained by the concealed-switch idea, however, is that there is no visible indication that the car is locked, thus encouraging the thief to get himself trapped. Car owners who regard this as a disadvantage, preferring to notify the thief in advance that the car is protected, may use a lock switch. If the thief then connects across the two wires leading to it before taking his seat at the wheel, he will not have prevented the gong from giving the alarm. Using two or more concealed switches presents an additional advantage, as closing any one of them throws on the alarm, and all must be open to throw it off.

### Etching on Glass and Metal with a Sandblast

A sandblast may be made use of in many novel ways. Any part of an electric-light bulb may be frosted by covering the other part of the glass with a piece of heavy paper, and exposing to the sandblast. A similar process will serve to etch any lettering or design on any glass or polished-metal article, and a finish may be given to soft wood which gives it the appearance of being hand-engraved.

### Weight and Pulleys Keep Air Hose Convenient and Reduce Wear

The usual air-hose arrangement about garages and service stations is frequently



a source of annoyance to both motorists and attendants alike, and when the hose is dragged about on the ground, it is very short-lived. The weight-and-pulley mounting, illustrated in the accompanying photograph, keeps the hose up out of the dirt at all times. Its position is convenient for getting at all four wheels of a car; it is in the shade, and is not needlessly worn by being dragged out over the



### Keeping Collapsible Tubes Inverted Prevents Contents Drying Out

Paint, tooth paste, or other materials kept in collapsible tubes, will sometimes separate, and the oil will squeeze from the tube first, leaving the remaining substance dry. After each time of using, it will be more dry than before, and the last of it may be too dry to be squeezed from the tube. This occurs because the solid matter sinks to the bottom, and may be remedied by keeping the tube in an inverted position. To facilitate this, make a small hole in a wooden block, into which the cap of the tube can be pressed, the block serving as a base or holder for the tube. If the cap is sufficiently tight in the block, the latter will also be of use in unscrewing the cap.

### Making Special Angles and Curves for Drafting Jobs

Draftsmen who often have occasion to draw certain curves or angles will save time and work by cutting their own irregular curves and angles out of sheet celluloid, fiber, or hard rubber, using a pattern of heavy paper pasted to the material as a guide, cutting with a scroll saw, and smoothing the edges with a fine file. Often a standard angle or curve can be altered very easily to the required pattern. —J. Horace Van Nice, Chicago, Ill.

### A Handy Wire Hook for Carrying Window Panes

Carrying a pane of glass is a job which, although apparently easy, causes much loss of temper. If the pane is wrapped with paper, there is often danger that it will slip out of the hand and fall. If it is not wrapped, the edges are likely to cut the hand. One who provides himself with an old glove, and a piece of stiff wire inside of a long, heavy cloth-covered rubber tubing, will find the difficulty practically solved. The wire is used as shown in the illustration, and the glass is held from tipping out by a slight pressure of the thumb. —Henry W. Kingston, Milwaukee, Wis.



### Signboard Shows Where Workman is to be Found

An electrician in a large mill installed on the door of his shop a signboard

which saved much time for his fellow employees. When out working in the mill, his shop door was always left closed, and when electric trouble developed in a distant part of the mill, much time was often wasted in finding him. The device consisted simply of a wide board



attached outside the shop door, having painted upon it the names of the various departments in the mill where electrical work frequently had to be done. In front of each was drilled a small hole in which could be inserted a plug hanging by a string from a nail in the door casing. When the electrician left his shop, he simply inserted the plug in the proper hole, which notified callers immediately of his whereabouts. Parties calling him by telephone and receiving no answer could call the department opposite his shop and inquire where the electrician was, the question being answered by a glance at the board on the door.

A small piece of slate was inserted in the board below the painted letters, and a plug hole was also made beside this slate. When going to a place not covered by the painted signs, the electrician noted this on the slate with a piece of chalk, and inserted the plug opposite it. The plug was provided with a conspicuous white head made of an old porcelain insulator, and was hung by a cord from a nail in the casing, near the door knob. Thus the door could not be opened without removing the plug from the hole, and there was no danger of the electrician returning without indicating it by removing the plug. This idea could be made use of by many tradesmen. —Frederic Doremus, Passaic, N. J.

## Scaffolding without Nails

On a repair job where the scaffolding could not be attached to the side of the



Brackets for Scaffolding Supported by Long Braces Reaching to the Ground are Found Useful on Repair Jobs

house, and it was not desired to build up a whole structure from the ground, a contractor designed a number of brackets, which enabled him to get at the work conveniently and safely after very little preparation. The brackets were made of 2 by 4-in. scantlings, each brace consisting of two pieces nailed together so that the central portion, where the greatest stiffness is required, is full 4 by 4 in. The braces fit snugly into the brackets, and the whole scaffolding can be removed in a few minutes and carried to another job.—W. K. Crosson, Detroit, Mich.

## Keeping Brushes Soft with Paraffin

Keeping paintbrushes soft by placing them under alcohol, turpentine, or other such liquids, is a somewhat expensive method, especially when the brushes are to be out of use for long periods. If a brush which is still moist with paint or shellac is dipped in melted paraffin several times, so that a heavy coat of the paraffin adheres to it, the brush will retain its softness indefinitely, the paraffin preventing any evaporation. To remove the paraffin, merely pull it off; it will come easily, leaving the brush as fresh as when the paraffin was applied to it.

## Keep the Lamps Clean

A simple explanation of a gradually failing light in many stoves is to be found in the lamp glasses and shades are not kept clean and, therefore, do not transmit or reflect the light properly. A little attention to keeping the lamps clean will often enable a stove to avoid the necessity of installing more lights or to have much better illumination with those already installed.—William Philip, Bloomfield, N. J.

## Small Truck Aids in Moving Stove

Here is a device that is cheap and easily made, and will enable one grown person with the help of a child, to move quite a large stove. The frame, of strips, 1 by 3 in., is bolted at three corners with  $\frac{1}{2}$ -in. stove bolts, and casters are fastened beneath with screws. In the fourth corner the bolt is first put through the upper board only, and the nut put on to hold it firmly in place. The platform should be made the proper size so that the stove legs may rest on the corners right over, or slightly to the inside of, the bolts. If this is not done there will be some trouble in putting the stove in place.

To use, have the loose corner open, and place the frame near the stove legs. Tip the stove forward so that the strip A may be put into place beneath the back legs. Then, lifting the front, draw the frame together and into position. The bolt in the top strip should drop into the hole in the lower one, and be fastened with a nut. Now the stove may be wheeled into the exact position desired, and by reversing the directions given above may be quickly unloaded. It is better to load the heavy end first and unload it last. Through the summer it will do no harm to let the stove

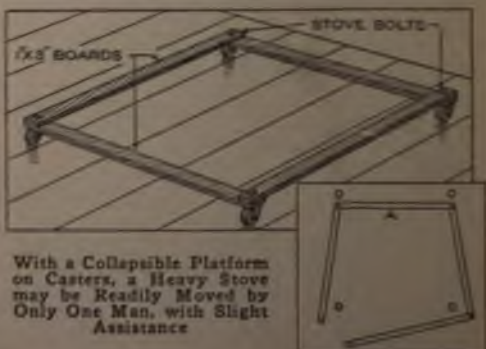

With a Collapsible Platform on Casters, a Heavy Stove may be Readily Moved by Only One Man, with Slight Assistance

stand on this truck. The casters should turn readily in any direction. Good ones can be purchased at five cents each.



# A Homemade Die-Casting Machine

By C. M. MAHOOD

ONE of the interesting processes which has been introduced recently in quantity-production factories is that of making quite accurate finished castings without machining, by the process known as die-casting. In this process, the melted metal is forced into dies under pressure, and after it has cooled, the dies are opened and the finished castings removed. It is thus possible to cast parts which have the "particular" dimensions accurate to the thousandth of an inch, or even less. The metals used are alloys of fairly low melting points, as it has not been found practicable to make dies which would stand up under the temperatures necessary for casting iron or steel.

While die-casting is more particularly a factory process, yet, for certain jobs, it is entirely possible to use to advantage some methods of die-casting in the small shop. Whenever a considerable number of small parts have to be made which do not have to be of great strength, but should be accurate, the method of casting the parts directly to the finished shape should at least be carefully considered.

The apparatus herewith illustrated, which is almost entirely homemade, enables anyone to apply, in a somewhat crude way, the die-casting process. An ordinary iron kettle forms the pot in which the metal is melted, while two pieces of  $\frac{3}{4}$ -in. iron pipe, with two caps and two floor flanges, form the uprights which support it. These are set up and given a coat of stovepipe enamel. If the metal used is one having a fairly high melting point, so that the pot becomes excessively hot, a sheet-iron jacket may be placed around it, extending to the floor and inclosing the gas burner, gasoline torch, or other means of heating.

To the bottom of the pot is riveted a steel cylinder, which has an inner surface

quite accurately machined. An old automobile cylinder, if not too badly worn, will serve, and the plunger may be made from the automobile piston, or machined from a very simple iron casting. The plunger is suspended by a wire loop tapped into it just beside the stem, and a cord runs from this loop to a lever, at the other end of which is a spring for the purpose of counterbalancing the plunger and automatically raising it, so as to clear the upper porthole. This hole, or slot, is about  $1\frac{1}{2}$  in. wide and  $\frac{1}{4}$  in. high, and forms the main entrance for the metal from the surrounding pot. The level of the metal should be kept just above this porthole. A small porthole, about  $\frac{1}{8}$  in. in diameter, is also made near the bottom

of the cylinder. Up through the stem of the plunger runs a  $\frac{1}{4}$ -in. hole, and the top of the stem is turned off to fit any standard countersink, which will be used in countersinking the sprue hole in the dies.

The dies are made in any of several ways. If one wishes to go to the expense of getting a high-quality die for long service, it can be ordered

from a commercial die sinker. For certain types of parts, the die can be made by pouring out two pieces of cast iron and fitting them with dowels and wooden handles, and finishing the die inside with plaster of Paris. Such a die is readily made and is useful for short rough runs.

The operation of such an apparatus is as follows: Fill the pot with metal to a height slightly above the upper porthole, and heat the metal to  $100^{\circ}$  or  $200^{\circ}$  F. above its melting point, in order to offset cooling in the stem of the plunger. Heat the die with a blowpipe flame before making the first casting; after the run is started, the die will be sufficiently heated by the hot metal, and in the case of large parts may even have to be cooled somewhat between operations. Lubricate the

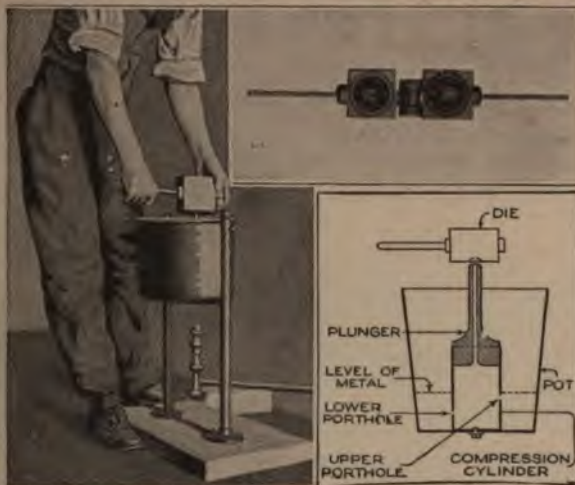

A Die-Casting Apparatus for the Home Shop: To the Left is Shown the Method of Making the Castings. The Smaller Photograph Shows a Type of Die for Casting Disks, and the Sketch Shows the Construction of the Apparatus





## Groove Plane Made from Rip Saw

It will often be found on an old rip saw that the teeth near the handle remain quite sharp, although the teeth near the center of the saw are entirely worn out. If the saw is cut or broken off 8 or 10 in. from the handle, the short saw thus formed can readily be mounted with a few wooden blocks to form a groove plane. By giving the teeth a pronounced set, the groove cut may be made somewhat wider, if desirable.

## A Bench Stop Which Clamps the Work

Ideas without number have been brought forth for bench stops and similar devices to hold work on the bench while planing or chiseling. All of them have their own virtues, but few have the property of clamping the work tightly when it is pushed into or against them.

A stop which has this property to an excellent degree and yet is simple of construction, is here illustrated. It consists of a sliding block, A, with one edge cut to a bevel, as shown; a fixed block, B, which also has one edge cut to a similar bevel, so that the edge of A fits against it and the straight block C. Blocks B and C can be fastened to the bench directly, or to a block on top of the bench. The notch opposite the bevel edge of block A is made of such size that it will take a certain range of jobs. Any number of blocks A can be made, each having a different shape and notch, and each taking a certain range of work. The work is inserted in the bench stop by simply laying the end of it in the notch in the block A and pushing it forward, so that the work is

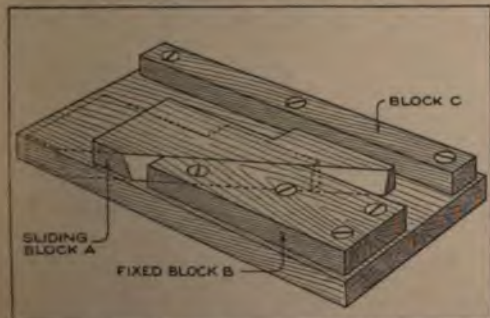

A Simple but Efficient Bench Stop: As the Work is Pushed Forward into the Stop, the End of It is Firmly Clamped without Marring

wedged in between A and C. It is loosened by merely striking a blow on the small end of block A.—E. K. Wehry, Cedar Rapids, Ia.

## Bench Snips or Shears

Very handy and cheap bench shears for cutting tin, or other sheet metal, which



A Handy Shearing Machine for the Bench is Made from a File and a Piece of Scrap Iron



is too heavy for the hand snips, can be made for the home-shop workbench, as indicated in the drawing.

A 14-in. flat file, with one side ground smooth, and a portion of the tip and one edge sharpened, makes the movable shear knife. The fixed cutter can be forged from a part of an old plowshare, or other suitable scrap steel. The bolt hole in the file is punched while the file is at a cherry-red heat. A locknut must be used on the bolt, or else the end must be riveted.—Chas. H. Willey, Concord, N. H.

## Drilling Holes through Heavy Metal with a Bit Brace

When holes of a diameter greater than about  $\frac{1}{4}$  in. must be drilled through iron of considerable thickness with a bit brace, the big part of the job is to maintain the proper pressure on the drill. It will be much easier if a small hole is first drilled by means of a hand drill, of, say,  $\frac{1}{8}$  in. diameter, the hole being reamed to size with the large drill in the brace, which will then require much less pressure than without the small hole.—Chas. A. Black, Jr., Hightstown, N. J.

## Universal Lathe Chuck Used as a Vice

A universal chuck mounted face up on a heavy wooden block is a useful type of vise for many purposes in the shop. Any job that would be held in the chuck for lathe work can be held similarly in this vise, and is then ready for any handwork, such as laying out, filing, or scraping.—H. S. Hart, Shreveport, La.

### Compressing Stiff Clutch Springs with Woodworkers' Clamp

A woodworking clamp is a good tool for removing and replacing the clutch springs on automobiles. The clamp jaws

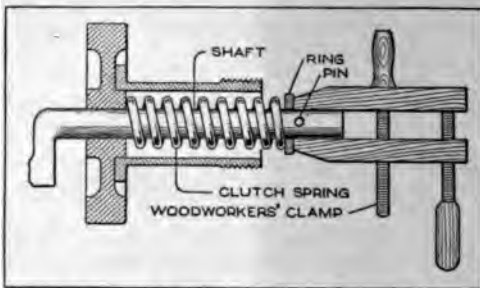

A Woodworkers' Clamp, Driven On with a Hammer, Compresses the Clutch Spring, So as to Extract or Replace the Pin

are simply tightened on the shaft, with the ends bearing against the ring, or collar, which retains the spring in position. The clamp is driven on with a hammer, compressing the spring until the retaining pin can be removed or replaced, as desired. The advantage of the clamp method is its adaptability to different sizes of shafts. Often, too, awkward places, in which springs are difficult to compress, can be easily reached by the protruding ends of the clamp jaws.—G. A. Luers, Washington, D. C.

### Fuel-Saving Kinks Valuable in the Home

If the fire box of the stove is partly filled with bricks or stone, leaving the center for the coal, a fire can be made with less coal, which will have more heating ability than it would have without the bricks or stone to absorb the heat.

Too much heat in a home, that is to say, any temperature above 68°, the point which has been set by the Fuel Administration as a proper room temperature, tends to produce something which dangerously approaches laziness. This is felt plainly when the temperature runs up to 75 or 80°, but is present even at 72 degrees.

Fires in bedrooms are unnecessary. A bed can be warmed before retiring, if absolutely necessary, by hot water in a bottle or jug, or by an electric-light bed warmer, and this will be found after use to be even more luxurious than a heated bedroom, and decidedly more sanitary and economical.

When the fire has died out and the

room is beginning to get chilly, it *one* must still sit in it, place a kerosene lamp under the chair and it will save the necessity of firing up again.—B. W. Rice, Caldwell, Idaho.

### Pedal Switch for Emery- Wheel Motors

Emery wheels do not take a great deal of power, but when it is considered that they often run all day, while the total time during which they are actually used does not amount to more than perhaps half an hour, it will be seen that a considerable waste of energy is involved. One way to reduce this is to install a pedal control for the switch or belt shifter, together with a spring, so that the switch will be opened or the band shifted back to the loose pulley by the action of the spring, as soon as the tension on the pedal is released. It may, of course, be objected that a workman would have to wait a few seconds while the wheel was reaching its full speed, thus losing time, but in many cases, this time can be fully occupied in examining the tool to be ground, and determining the exact angle at which it is to be held.

### Foot Control Handy for Faucets in Washbowls

Foot control for the wash basin is recognized as the most convenient and sanitary method, and its adoption would be much wider than it is, if its advantages were better known. It will contribute wonderfully to the cleanliness and convenience of the shop wash-bowl, if a pedal is installed so that pressure, applied to it with the



foot, turns on the water, it being turned off by a spring, when the foot is removed. In this way, the convenience of a steady stream of water is secured, while at the same time all danger of the water being left turned on by a careless person is eliminated.

Time can be saved in photographic work by making a mark on the bottle, to indicate the amount of hypo, or other material, usually weighed out in making solutions.



wrapped with friction tape for convenience and safety in laying the tongs down; it is not necessary for protecting the hands, if the rheostat is wound noninductively.—Kenneth Coggeshall, Webster Groves, Mo.

### Soldering Paste Carried on Torch

A handy way to carry soldering paste, when working on poles or ladders, is to solder a piece of 1½-in. square brass tubing, about 3 in. long, with a bottom soldered in it, to the side of the blowtorch. Fill it with paste, and it will always be handy when wanted.—E. C. Galbreath, Denver Colo.

### Making Wood Screws Hold When Parallel to Grain

Wood screws inserted into the end of the grain, especially of soft wood, do not



take a very strong hold. The hold may be improved by backing out the screw after it is inserted, placing a small amount of glue in the hole and then reinserting the screw. When screws are to be taken

out repeatedly and reinserted into the end of the grain, as is often necessary where work is required to be taken apart in the foundry, simply screwing them into the end of the grain should not be depended upon. In such cases, insert at right angles a hardwood plug, as shown, and allow the screw to pass through it. When the screw will no longer hold in consequence of its repeated withdrawals, the worn-out plug may be taken out and a new plug inserted.—Ernest Schwartz, Brooklyn, New York.

### Improving an Old Ladle

Small ladles for pouring babbitt or lead can often be improved as shown in the sketch. A piece of tubing, about 5 in. long and flared out at both ends, is slipped over the handle. A piece of steel, bent to a right angle, is then riveted onto the handle, back of the tube, serving the double purpose of holding the tube on and of forming a leg so that the ladle can be set down, if required, without tipping over. In order to serve its purpose well as a leg, this piece of steel should be at least 1 or 2 in. wide. By gripping the

tube handle with the left hand and tilting the ladle by gripping the end of the long handle, with the right hand, the metal

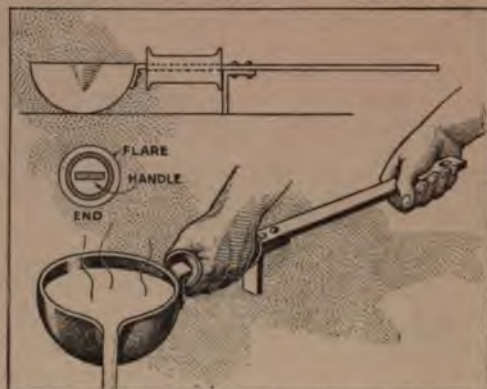

A Steel Leg, and a Grip of Metal Tubing over the Handle, Make the Old Ladle More Convenient in Use

can be poured quite readily. Hold a piece of folded cloth, or soft asbestos, under the left hand around the grip, so as to protect the hand from the hot metal surface.

### Neat Chest under Lathe Holds Tools and Gears

The chuck and faceplates of a lathe in many shops will be found either on the floor or hanging somewhere about the legs of the lathe. The drawing suggests a means of keeping the chuck, faceplates, dogs, and gears neatly where they can always be found, and of having the drip pan in a proper position at the same time. The tray may be removed from the box

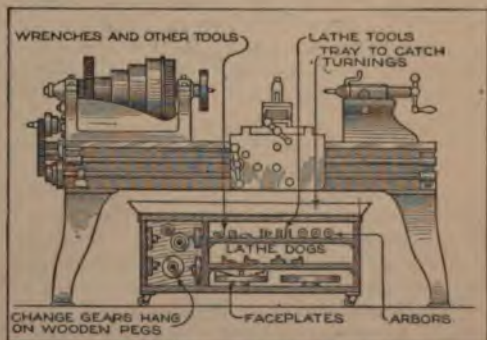

A Chest Placed under the Lathe Carries the Drip Pan on Top, and Has Shelves and Hooks for the Lathe Tools and Accessories

to dump out the oil and chips from the lathe, and the entire box can be rolled out on its casters when sweeping the floor.

**Vessel for Cooking Potatoes for Hogs on the Farm**

It is not necessary to feed raw cull potatoes to hogs just because there is no

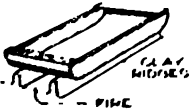
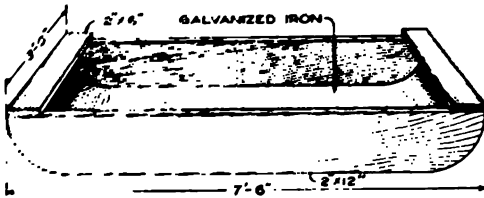

A Large Cooking Pan for Use on the Farm may Consist Partly of Wood. It is Used in Such a Way That the Wood is Protected from the Fire

cooker on the farm. One 16-ft. plank and a sheet of galvanized iron, together with a few nails, will make a good, serviceable cooking pan that will last all winter if it is used carefully.

The plank should be 2 by 12 in., and long enough to be cut in two pieces, 7 ft. 6 in. long. The two pieces are rounded at both ends, sled-runner fashion, and made square and smooth on the edges with the plane and drawshave.

The galvanized iron should be No. 24 gauge, or thicker. It should be 3 ft. wide and 8 ft. long. It is thoroughly nailed to the edges of the planks with eight-penny wire nails. The cooker is finished at the ends by crosspieces of wood to protect the edges of the galvanized iron and stiffen the frame.

To use the cooker, it should be placed on two ridges of clay, made level and plastic with water so the cooker fits down tight all along both sides. The fire is made near the windward end, so the draft will carry the heat under the whole length of the cooker to get the full benefit of the fuel.

There should be enough water in the cooker to boil the potatoes soft without burning. Just before the cooking is finished, let the fire die down, and dip all surplus water out so the mass of potatoes will steam dry, just as in cooking potatoes for household use.

This heating pan may also be used to heat water for scalding pigs at killing time.

**Cleaning Out Clogged Drains with Fluid Pressure**

In many cases the handiest way to clean out drain pipes which have become clogged with dirt, is by means of water or air pressure. It is, of course, quite common to use the nozzle of a hose, thrusting it down through the drain and turning on the water under high pressure, this method being used often in cleaning out sewer outlets in city streets. The objection to such procedure is that the water backs up into the sink or washbowl. This can be prevented by making a taper plug of wood, as shown in Fig. 1, which can be fastened on the hose nozzle and thrust into the drain inlet so as to prevent the possibility of the water backing up.

Another way to prevent the backing up of water, which is useful in places where the above method would not be practicable, is to make, on the end of a piece of 3/4-in. pipe, a piston of proper size, as in Fig. 2, to be pushed into a large drain pipe which has become clogged. To the other end of the piece of pipe the hose is attached, and water is then forced in without danger of backing up.

Where water pressure is not available, it is possible to use air pressure as furnished by an automobile-tire pump, as shown and detailed in Fig. 3. One way to do this is to unscrew the plug at the bottom of the water trap below the washbowl, and solder into this plug an automobile or bicycle-tire valve. Then, if the

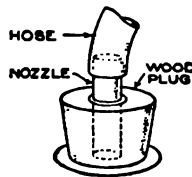

Fig. 1

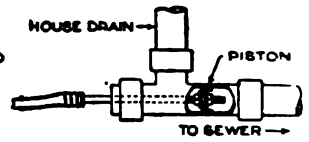

Fig. 2

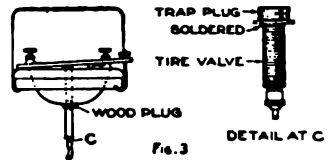
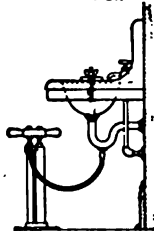

Fig. 3

One of These Devices for Forcing Fluid Pressure into Stopped-Up Drain Pipes may Often Save Much Time and Expense

(Rubber cement is good for patching clothing. Use according to directions given for rubber; pressure with a hot iron will vulcanize the job if desired.

bowl outlet is tightly plugged, air can be forced in at a pressure high enough to dislodge the dirt which causes the congestion.



ground or left in a position to be run over by machines. This type of hose support costs little to install, and will pay for itself many times by the convenient service it renders and the reduced wear on the hose.—John Edwin Hogg, Alhambra, California.

### Moving "Rusted-In" Screws

Steel screws which have rusted into place are difficult to remove. They can often be loosened by tapping the screwdriver with a hammer, or by heating, but a better way is to treat them before setting them in place with a rust preventive. Common oil will do this to a slight extent, but a mixture of graphite and tallow rubbed onto the screw, will be effective for a much longer time.—S. Leonard Bastin, Bournemouth, Eng.

### Holding Screws While Threading or Turning Them

When small screws must be turned or threaded in the lathe, time is often lost because no chuck is at hand which fits the screw. A collet, to be held in the chuck, and to hold securely the size of

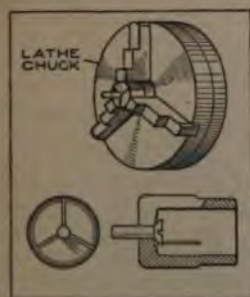

screw for which it is designed, is made from a piece of round steel. It should be about  $1\frac{1}{8}$  in. in diameter, and its length should be somewhat greater. Drill a hole clear through it, the size of the screw to be held; then, from one end, ream this with a  $\frac{3}{4}$ -in. drill, to within  $\frac{1}{4}$  in. of the other end. Turn down slightly the half of the piece from which the  $\frac{3}{4}$ -in. hole was started, so as to provide clearance. With a hacksaw, saw three or four slots, as shown, so as to form a spring collet. The number of slots should be the same as the number of jaws in the lathe chuck. The collet may be hardened, or casehardened if convenient, and its life will then be much longer. If the collet is accurately made, a universal chuck will be satisfactory to use with it; for extreme accuracy, however, which is often necessary in small work, the chuck with independent jaws is to be preferred.—E. L. Howard, Springfield, Ohio.

### Large Kettle Inverted over Soft-Coal Fire Saves Heat

On putting fresh soft coal into a stove, an intense smoke is given off, which fouls the pipes and spreads soot over the room, besides wasting coal. A means for diminishing this was found in a large iron pot. The pot was provided with a ring on the bottom, by means of which it could be carried on the end of the poker. Immediately after putting on fresh coal, the inverted pot was set on top of the fire and was found to have the effect of causing the smoke and coal dust either to collect inside the pot or to escape around the edge, where the gas would burst into a ring of flame, consuming much of the coal dust, which would otherwise be wasted. The kettle is left on until the fresh coal becomes hot and is reduced to coke by having the gas roasted out of it; the pot is then removed, leaving a coke fire, which burns and lasts very well.—A. S. Thomas, Amherstburg, Ontario, Can.



### Carry Tool Checks on a Safety Pin

In shops where each workman has a number of tool checks bearing a number, one of which he deposits in the tool room as a receipt for a tool taken out, the loss of these checks may sometimes involve unpleasantness. A safer way of carrying them than in the pocket is to sew a large, strong safety pin to the overalls or shop clothes and hang the checks upon it. The checks can be removed or replaced with either hand, so that the other one is left free for carrying the tools.—C. C. Spreen, Detroit, Mich.





the sides in place temporarily and marking with a straightedge. The width of the steps should be such that the sides will fit fairly snugly down on to the ways, yet not so tight as to bind in the least. Then a groove should be cut along the outside of the sides, into which will slide the edge of the iron straps, or guards. These prevent the stairs from being pulled away from the ways. Set in the treads, parallel with the floor, and the same distance apart all the way up. It is well to mortise them into the sides about  $\frac{1}{4}$  in. to stiffen the structure. Angle irons at the top and bottom steps will further prevent it from pulling out of shape. A little paraffin on the ways will improve the sliding qualities.

The stairway disappears by sliding it up the ways until the bottom is some distance above the lower end of the panel. Somewhat more than half of the stairway should project into the air and should be slightly more than sufficient to counterbalance the weight of the panel

and bottom of the steps. To fasten the stairway when it is pushed to the proper height, and keep it from falling, a spring hook is provided, as shown in the detail. It works automatically when the stairway is being put away, but must be released by hand when the stairs are being lowered for use. When they are fastened by this hook, the panel tends to rise, being pulled upward by the weight of the upper end of the stairs. By means of the chain, which should have some sort of knob at its end, the panel is held as it moves into place. No catch or fastening is necessary to hold it there, as the counterbalancing weight of the stairs accomplishes this purpose.

Being a stairway which is as easy to ascend as an ordinary one, and yet taking up no more space than the trapdoor and ladder so frequently found, the construction may be very useful for reaching almost any upper story if access is not necessary in the daytime, but only at night for sleeping purposes.

### Shoe Shining at Home Made Easy by Handy Outfit

One of the needless luxuries for which Americans spend enormous sums of



money is that of having their shoes shined at a public shoe-shining parlor. It is well to remember that shining one's own shoes means no loss of time, but rather a saving of time, as there is no waiting and no delay if everything is handy. A rack, such as illustrated, makes

this surprisingly easy. Either foot is placed on the outer rail and all brushes and material are then within handy reach. The posture can be shifted as found convenient, to give access to the rack, and clearance for the polishing cloth.

### Improved Electromagnet Picks Wrench from Crankcase

A wrench which had been accidentally dropped into the transmission case of a car, seemed to be almost impossible to recover without tearing down part of the transmission. It was recovered quite

easily in this way: A  $\frac{1}{2}$ -in. bolt, 15 in. long, was wound with about 15 ft. of insulated copper wire, and four dry cells, in multiple, were connected to this coil. At the cost of a few seconds of ruinous service on the cells, an electromagnet was formed, so powerful that it lifted the wrench from the transmission case and saved a big job of tearing down and re-assembling.—John H. Thies, Cedar Falls, Iowa.

### Keeping Small Punchings from Sticking to the Perforator

In perforating, on the punch press, holes in very thin stock or of very small diameter, one important source of trouble is that the punchings have a tendency to stick to the end of the perforator, and be carried along the stock to the next hole to be punched, where they do much damage. The trouble can be obviated by the use of the compound type of punch and die, but these are expensive. A cheaper method is to ream out the hole in the die to a slight taper at the top, so that it is about .002 in. oversize at the cutting edge. The perforator is made just long enough

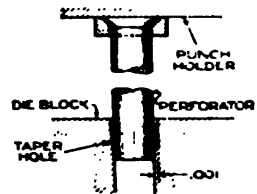

to be used. A cheaper method is to ream out the hole in the die to a slight taper at the top, so that it is about .002 in. oversize at the cutting edge. The perforator is made just long enough

to reach down beyond the end of the taper. The punching will then be wedged tightly in the die hole, and will not adhere to the perforator. There will, of course, be a slight burr turned up around the punched hole, but this will be removed in the tumbling operation commonly performed on this class of parts.—S. B. Royal, Reading, Pa.

### Useful Kinks for Improving the Draftsman's Triangle

The ingenious draftsman can make on his triangle many little improvements which will facilitate his particular line of

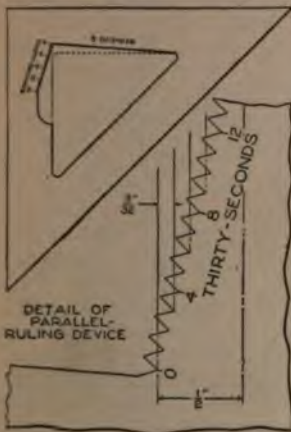

work. Two such kinks are shown in the illustration. Each shop usually has its own rule as to draft angles in castings, these being usually from  $5$  to  $10^\circ$ . One of the inside edges of the triangle may be dressed off with a knife, chisel or file to this angle;

and by turning the triangle to a suitable position, one can then readily draw these lines with the proper slant.

Another useful kink is to dress off another of the interior edges to a somewhat steeper angle, and file notches of uniform depth at equal intervals along the edge. These are quite useful in section-lining and in drawing lines for lettering, as the lines are easily spaced the same distance apart. In determining the position of the notches, the triangle should be placed over two lines, which are drawn  $\frac{1}{4}$  or  $\frac{1}{2}$  in. apart, and the part of the slanted edge which comes between the two lines should then be divided into 8, 16, 25 or 50 equal spaces, as preferred. If notches of equal depth are made at these points, then, by setting the pencil in the notches and sliding the triangle along, lines can be readily drawn at a distance from each other of any desired number of thirty-seconds or hundredths. Figures can be scratched onto the triangle, making an enlarged scale along this edge of the triangle.

### Shafting Hangers Converted into Neat Bench Buffer

Many shops where the position of overhead shafting has been changed, can find use for a pair of shaft hangers, which may have been left over, to fit up a bench buffer. A short piece of shafting is mounted, as illustrated, with collars and setscrews to keep it in place lengthwise, and buffing or polishing wheels are mounted on the two ends. It is not desirable to run a heavy emery wheel at high speed on ordinary shaft hangers, as they are not built for such service, but for buffing and polishing of various kinds the arrangement does very well. The cost of construction is practically nothing, as no material need be purchased.—Ernest Schwartz, Brooklyn, N. Y.



### Boiling Potatoes to Loosen Boiler Scale

A 40-hp. steam boiler was kept clear of scale for over 20 years by the simple process of placing in it at intervals a bushel of potatoes. It was found that after these were boiled for a time, the scale loosened and collected in the bottom of the boiler, where it could be easily removed.—T. J. Hubbard, Mendota, Ill.

### Sawing through Plaster Walls

When cutting an opening for a doorway through a plastered wall, the usual result is a number of cracks in the plaster, some of them projecting beyond the part to be covered by the door casing. Owing to the hair used in the plaster to make it stick together, the saw mutilates it badly, sometimes tearing out large pieces. This can be diminished by nailing two stiff boards to the plaster, with room between them for the saw, and working the saw between these two boards.—W. K. Sargent, Rutland, Vt.





die with beeswax; then close it, place it on top of the stem, with the end of the stem in the sprue hole, and press down upon the handles of the die. The metal will be forced into the die by pressure sufficient to form it for fairly accurate work. Remove the die at once, and as soon as the metal has had time to cool, open the die, throw out the part and proceed to make the next one in the same way. For small, thin parts, the time required for solidifying the castings will be found almost negligible, and the parts can be made as fast as the die can be closed, opened, and pressed down on the stem of the plunger.

As the plunger comes down, it at first forces metal out through the upper porthole; when the lower end of this is reached, the metal is forced upward through the stem. To prevent too great a shock when the main porthole is suddenly closed, the  $\frac{1}{8}$ -in. hole is drilled

farther down, which has the effect of diminishing the suddenness of closing the main porthole. The slight amount of metal which will flow out through the lower porthole will not prevent the flow to the die, as the action must be rapid.

Metals for this process are of various composition. Tables of alloys, having various properties, can be found in mechanical handbooks; the cheaper metals are those having a lead base, and have very little strength, though they are entirely practical for some purposes. The metal known as stereotyper's metal, composed of lead, tin, and antimony, melts at about 550° F., and is a useful metal for this class of castings. Where a harder product is desired, alloys with a zinc base and from 10 to 30 per cent each of copper and tin may be used. Shrinkage also varies for these different metals; that of the alloy used should be carefully ascertained before making any accurate die.

### Pumps of Centrifugal and Screw Type Work Together

Tests of a well showed that it would furnish a large amount of water, but that



The Screw Pump Raises the Water to the Surface, and the Centrifugal Pump Then Takes Hold and Throws it Up to the Storage Tank

a heavy lift would have to be overcome to get the water to the surface, when it would have to be lifted an additional 50 ft. into a large storage tank.

It was clear that for such a heavy head, a centrifugal pump would be best. On account of the limited suction capacity of such pumps, however, it was also evident that a deep and expensive pit would have had to be built.

On the other hand, one of the new type of screw pumps, made to fit the casing of the well and sunk below the suction limit,

would plainly have been indicated but for the fact that the efficiency of such pumps is greatly decreased by a heavy head of water. The expense of the pit, with all its attendant troubles and annoyances, would have been avoided, but the cost of pumping would have been greatly increased.

The owner finally solved the difficulty by installing the screw pump in the well and directly connecting it at the surface with a horizontal centrifugal pump, placing the two side by side and running both off the two pulleys of his engine.

The outcome proved him right. The load on the screw pump is relieved, before the water reaches the surface, by the centrifugal pump, which lifts it from there on the additional 50 ft. into the tank, and the centrifugal pump does not have to exert its limit of suction to take in the water.—Henry Simon, Laguna Beach, California.

### Staining Wood a Dark Color with Roofing Cement

When a dark-walnut flat finish is desired on woodwork, one may use the cement which is furnished with rolls of composition-roofing material. To use this cement for a stain, work it sparingly into the wood with a lintless cloth, or small varnish brush; if any surplus cement remains, take it off with the cloth. The results obtained with this novel staining material are declared to be very satisfactory.—H. K. Capps, Stahl, Mo.



### Used Oil from Auto Engines Makes Good Fuel

When the lubricating oil in the automobile engine is changed, the old oil, although it has lost its usefulness as a lubricant, still makes an excellent fuel. A good way to utilize it is by soaking it up into paper or shavings, and pressing these, if possible, into compact shapes. Care must be taken to guard against spontaneous combustion, and to protect the oil-soaked material in every way possible from fire danger.—Parke L. Shee, Oak Park, Ill.

### Steam Whistle Made from Pipe Fittings

A small shop, which does not require the daily use of a steam whistle, may nevertheless desire it greatly on special occasions, such as for celebration purposes. Even though steam pressure may not be available, compressed air, as maintained for inflating tires, is equally useful. A whistle can be made almost entirely from pipe fittings and scraps of iron. Only one part need be turned in the lathe, namely, the irregular part contained within the reducing coupling. It should be turned to allow an opening

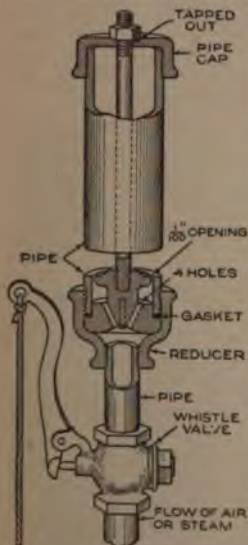

of not much more than .01 in. between it and the short piece of pipe by which it is surrounded. The tone of the whistle depends on the length of the upper pipe, and 3 or 4 in. will be found a useful length. The whistle valve may be purchased, or, for occasional use, some other form of valve may take its place.—Charles Springer, Detroit, Mich.

### Mechanic's Clothes Laundered by Exhaust Steam

In a shop where exhaust steam was plentiful, a mechanic built a box, with a lid for closing it tightly, connected to a pipe which led through a valve to the exhaust-steam line. Soiled overalls or shop

clothes are thrown into the box, and the steam is turned on. A small pipe was pro-

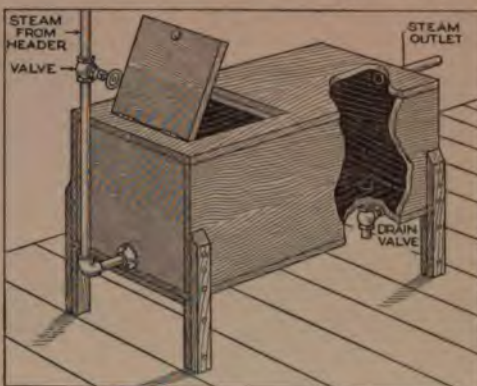

A Mechanic Built His Own Steam Laundry for Cleaning His Overalls, Making Use of the Exhaust Steam from the Shop Engines

vided as a steam outlet, and another to carry off the condensed steam from the bottom. It was found that, after remaining in the box for a few minutes, the overalls were quite well cleaned. After removal from the box, they were rinsed in cold water, and the box was ready for the next batch.—Roy H. Poston, St. Francois, Mo.

### Replacing Incandescent Lamps in Lofty Ceiling Fixtures

A useful tool, for removing blown-out electric lamps from high ceiling fixtures and replacing them with new ones, was made from a long pole with wire loops firmly attached to the end.

The loops of spring wire were so shaped as to slip over the end of a lamp of the size used and hold it firmly. Each loop was wrapped, at the point where the lamp diameter was largest, with insulating tape, which created friction between the tool and the glass, so that the lamps could be loosened even if screwed in quite tightly. A tool of this character can readily be made jointed, to reach fixtures of various heights, and will save a great deal of the time otherwise spent in bringing ladders and climbing upon them to reach the lamps.—Dale R. Van Horn, North Loup, Neb.

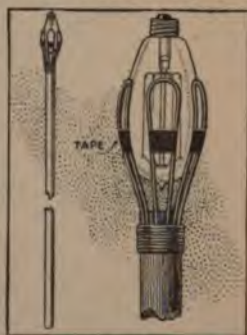

### A Rack for Washers

Workmen who have frequent use for plain washers of various sizes, and who

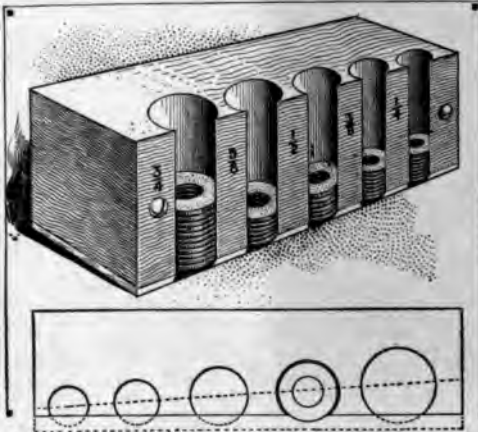

The Washers Are Always in Sight, and cannot Rattle Loose. The Rack is Easily Filled, and One or More Washers are Easily Removed with the Fingers

like to keep them handy so that they can be picked up and put into place as quickly as possible, may find it convenient to make a rack like the one shown in the sketch. It is made from a single block of wood, by boring holes slightly larger than the respective diameters of the washer to be used. The line on which the center for these holes is laid out should be slightly out of parallel with the edge of the block, and should be located so that the largest hole to be made will not meet either edge of the block. Then, after all the holes are drilled and a piece of cigar-box, or other thin, wood is attached to form a bottom, plane off the block, so as to expose the holes from the side. The washers can be stacked in the rack by simply dumping them in and shaking the rack about.

### Enlarging Pistons by Peening to Eliminate Slap

When an automobile piston is found to be "slapping," due to the skirt being too small, one way to remedy the trouble is to remove the piston from the connecting rod, lay it upon its side on an anvil, and strike a succession of blows with a ball-peen hammer on the inside of the skirt. The blows should be light and very even, and uniformly distributed. The piston should be accurately calipered to see that the enlargement is proceeding properly and that the peening is not bending the skirt slightly out of round. A piston thus treated, fitted with good-quality piston

rings, will often give satisfactory service where oversize pistons would otherwise have to be fitted.

### Electric-Soldering Tongs

Simple soldering jobs, such as splicing wires, fastening cable leads to terminal clips, or sweating metal plates together, may be quickly and neatly done with electric-soldering tongs. The parts to be soldered are brought almost instantly to the correct heat, which is not possible with the ordinary soldering copper.

Two spring-brass strips, 10 in. long, 1½ in. wide, and at least ⅜ in. thick, are used to carry the electric current to the carbon electrodes as well as to form the tong handles. Form two brass clips of such dimensions that they will each hold a piece of carbon, 1 by 1 in., by ½ in. thick. Rivet them to the end of the brass strips; a good job of riveting must be done, and the clips must seat snugly against the strips so that a good electrical connection is assured. Saw a block of fiber 1½ by 2 in., by 1½ in. thick. Drill small holes in the free ends of the strips so that the latter may be screwed to the fiber block, parallel and insulated from each other. Provide electric wire connections to the brass strips.

The tongs must be operated from a low-voltage circuit, and for most shops the storage battery will best meet this requirement. For temperature regulation during soldering, a variable resistance or rheostat should be used to decrease or increase the flow of current. To solder, it is only necessary to grasp the piece or pieces to be worked on between the carbon electrodes by using the device like a pair of tongs. The instant an electric circuit is established between the carbons the latter

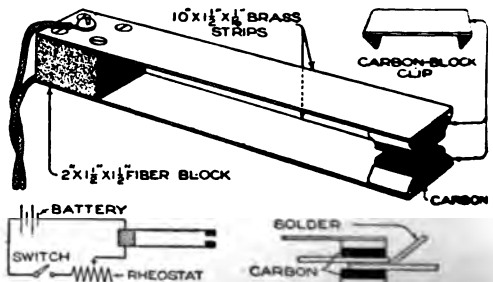

The Electric-Soldering Tongs Operate on a Principle Similar to That of Electric Welding, the Heat being Due to Passage of Heavy Current through the Work

should come to a red heat, and soldering is the work of but a few moments.

If desired, the brass strips may be



## Punch for Laying Out Drill Holes

When laying out a row of holes for cutting out a piece of metal, as in die work, it often requires a great deal of practice to be able to space the holes accurately. A special punch which makes this work much easier can be made from a piece of drill rod the size of the drill to be used. Shape the end, as shown in the illustration; then harden and temper the piece for use as a punch. The manner of using it is evident from the illustration; the small center marks can be deepened with an ordinary center punch before drilling, if found convenient.

—J. H. Beebe, Rochester, N. Y.



## THE THOUSANDTH OF AN INCH

By Thos. A. McMahon

At night I sit and ponder  
On the thousandth of an inch;  
I knit my brow, and scratch my head,  
And then my fists I clinch.  
O show to me the man, sez I—  
If Irish, Dutch, or Frinch—  
The man who first invented  
The thousandth of an inch!

When finally I crawl in bed,  
So thankful for a snooze,  
I drive my sorrows all away  
Without the aid of booze—  
I dream that they have caught the man,  
And him they now will lynch,  
By jinks! The man who did invent  
The thousandth of an inch!

## Glass Plate over Buzz Saw Protects Eyes

When a buzz saw begins to get dull, it usually throws sawdust quite badly into the face of the operator. One user of a



buzz saw found it convenient to have handy a pane of glass mounted on a frame, as illustrated, so that the glass could be placed directly over the saw, to shield the operator's face.

The utmost care must, of course, be taken to make the frame solid and steady, so as to prevent the glass from coming into contact with the saw.—Frederic Doremus, Passaic, N. J.

## Homemade Concrete Tombstone

The photograph shows the splendid results obtained in making a tombstone of concrete with no special equipment. A mold was made out of 7/8-in. lumber, in four parts, for the four sections of the tombstone. The letters were cut from cardboard, and fastened to the side of the mold, reading in reverse so that they would be in the correct order on the stone. The concrete was mixed, using one part cement and three of sand, and was poured in from the top. It takes about three weeks for such a stone to dry, but if well made, it is scarcely less durable than a marble stone, and makes an appearance which is not at all unpleasing.—James F. Wellner, Danville, Pa.



## A Handle for Scraper Blades

Scrapers for wood are widely used without handles, the blade being held directly in the hands. While this is hard on the fingers, especially of an inexperienced man, it is necessary, chiefly in order to get into corners where a handle would be in the way, or would interfere with holding the scraper at the proper angle. A carpenter, who uses on his scrapers the handle here illustrated, finds that it gives very little trouble in this respect, and saves soreness of the fingers when there is much of this kind of work to do. The handle is cut from hard wood, 7/8 in. thick, and the backing block is rounded off smooth at the top to allow a firm hold by the left hand, giving plenty of pressure against the work.—Benj. W. Bush, Keyport, N. J.

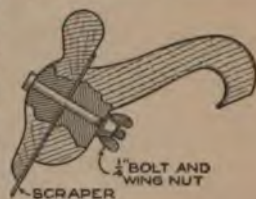

ⒸAll bearing surfaces in machinery should be as large as is practicable, insuring against undue wear. Compensation for wear should also be provided for.



**Vessel for Cooking Potatoes for Hogs on the Farm**

It is not necessary to feed raw cull potatoes to hogs just because there is no



cooker on the farm. One 16-ft. plank and a sheet of galvanized iron, together with a few nails, will make a good, serviceable cooking pan that will last all winter if it is used carefully.

The plank should be 2 by 12 in., and long enough to be cut in two pieces, 7 ft. 6 in. long. The two pieces are rounded at both ends, sled-runner fashion, and made square and smooth on the edges with the plane and drawshave.

The galvanized iron should be No. 24 gauge, or thicker. It should be 3 ft. wide and 8 ft. long. It is thoroughly nailed to the edges of the planks with eight-penny wire nails. The cooker is finished at the ends by crosspieces of wood to protect the edges of the galvanized iron and stiffen the frame.

To use the cooker, it should be placed on two ridges of clay, made level and plastic with water so the cooker fits down tight all along both sides. The fire is made near the windward end, so the draft will carry the heat under the whole length of the cooker to get the full benefit of the fuel.

There should be enough water in the cooker to boil the potatoes soft without burning. Just before the cooking is finished, let the fire die down, and dip all surplus water out so the mass of potatoes will steam dry, just as in cooking potatoes for household use.

This heating pan may also be used to heat water for scalding pigs at killing time.

☞ Rubber cement is good for patching clothing. Use according to directions given for rubber; pressure with a hot iron will vulcanize the job if desired.

**Cleaning Out Clogged Drains with Fluid Pressure**

In many cases the handiest way to clean out drain pipes which have become clogged with dirt, is by means of water or air pressure. It is, of course, quite common to use the nozzle of a hose, thrusting it down through the drain and turning on the water under high pressure, this method being used often in cleaning out sewer outlets in city streets. The objection to such procedure is that the water backs up into the sink or washbowl. This can be prevented by making a taper plug of wood, as shown in Fig. 1, which can be fastened on the hose nozzle and thrust into the drain inlet so as to prevent the possibility of the water backing up.

Another way to prevent the backing up of water, which is useful in places where the above method would not be practicable, is to make, on the end of a piece of 3/4-in. pipe, a piston of proper size, as in Fig. 2, to be pushed into a large drain pipe which has become clogged. To the other end of the piece of pipe the hose is attached, and water is then forced in without danger of backing up.

Where water pressure is not available, it is possible to use air pressure as furnished by an automobile-tire pump, as shown and detailed in Fig. 3. One way to do this is to unscrew the plug at the bottom of the water trap below the washbowl, and solder into this plug an automobile or bicycle-tire valve.

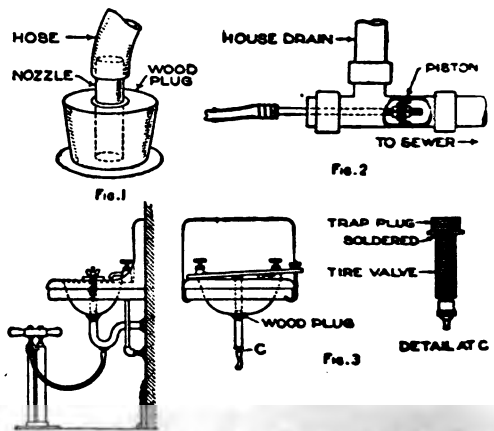

One of These Devices for Forcing Fluid Pressure into Stopped-Up Drain Pipes may Often Save Much Time and Expense

bowl outlet is tightly plugged, air can be forced in at a pressure high enough to dislodge the dirt which causes the congestion.

# A Disappearing Stairway

By L. B. ROBBINS

A STAIRWAY which can be quickly and easily disposed of so as to give needed floor space in the bungalow, or small cottage, is a thing generally much desired. Such stairs are not at all difficult to construct.

As will be seen in the sketches at the left, the stairs are hung in an opening, or well. This should be cut 6 ft. long, between two adjacent rafters. It is then boarded in on the sides and ends, the boards coming flush with the ceiling of the room. A casing of 6-in. boards should be laid around the edge of the well, so that the edges of these boards will just

with inclined ways, as illustrated to the right. Cut two boards to the shape shown for the guard rails, of  $\frac{7}{8}$ -in. stock, 9 in. high at one end, and 3 in. high at the other. Then make another pair for the ways, 8 in. high at one end and 2 in. at the other. Match each pair and screw them solidly to each other, the ways inside of the guard rails. Along the top edge of the latter, screw strips of band iron,  $1\frac{1}{2}$  in. wide. See that this iron has straight and parallel edges, and that the outside edges are flush with the guard rails. The ends of these boards should come at least 2 in. from each end of the

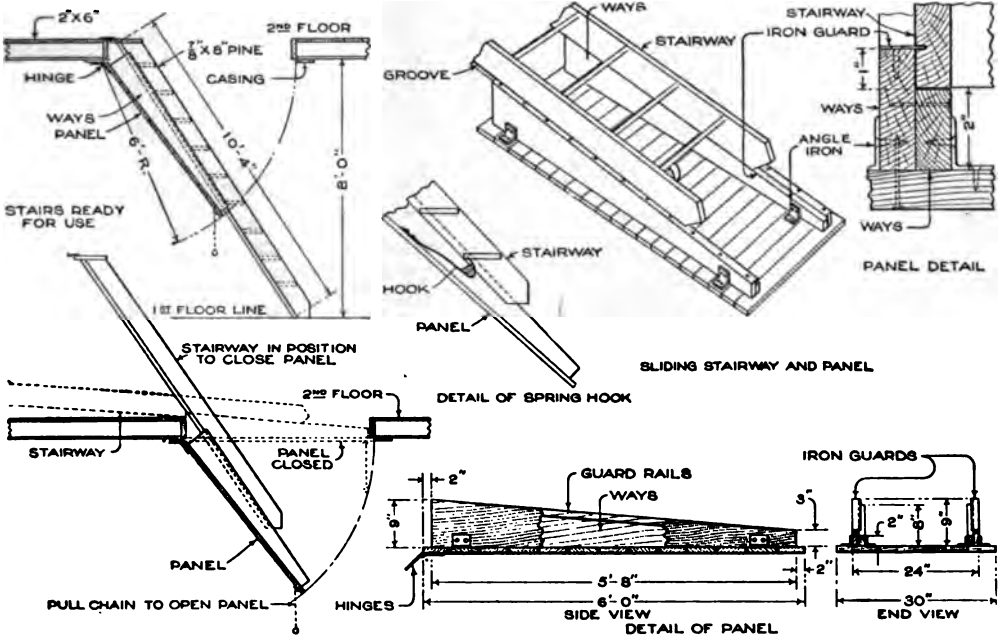

A Stairway Which is Lifted Out of the Way in a Few Seconds: It is Only Necessary to Slide the Stairs Upward on the Ways Until They Catch on the Spring Hook, and Let the Panel Rise Flush with the Ceiling. A Corresponding Operation Brings the Stairway Down, Ready for Use

meet the edges of those inside the well. The swinging panel is constructed in such a way as to make a presentable appearance to the occupants of the room when it is swung up in place. It is 6 ft. long and 2 ft. 6 in. wide, supposing the rafters to be 30 in. apart. If the ceiling timbers are spaced any other distance between centers, make the panel of a width to correspond, so it will lap over the edge of the sides of the opening about 1 in. When the well is ready for the panel it should measure 5 ft. 10 in. by 2 ft. 4 in.; the panel then sets into, and flush with, the casing.

panel. Fasten the guard rails to the panel with angle irons. Hinge the panel at the heavy end to the casing of the well with solid hinges, and provide the free end with a chain by which it can be pulled down to put the stairs in service.

The stairs illustrated are for a room 8 ft. high; the length can be easily varied to suit the height of any room more or less than 8 ft. Cut the sides from two 8-in. pine boards of  $\frac{7}{8}$ -in. stock. The longest edge, as indicated, should be 10 ft. 4 in. long to obtain a good angle for such a stairway. The bevel at the lower end is 6 in. wide, and the top bevel can be cut parallel with the upper floor by setting

The upper face of the panel is provided

### Movable Posts Made of Pipe Useful in Stock Rooms

The sacks in the picture are held between movable posts, each made of two

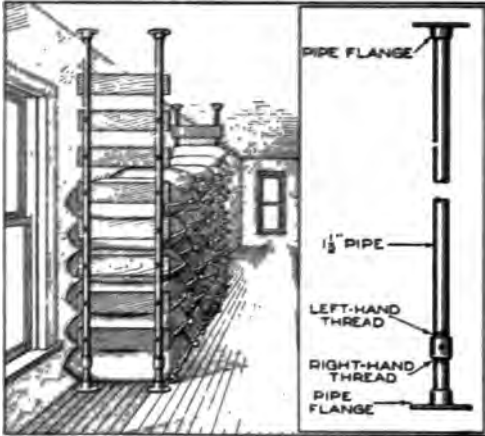

Movable Steel Posts, between Which Stock can be Piled Up, will be Found Useful in Many Factory Stock Rooms

pieces of pipe, two flanges, and a coupling. At the coupling, both pieces of pipe are threaded with a straight thread, not a pipe thread, one being right-hand and the other left-hand. The coupling is threaded internally, to correspond with these, and is adjusted like a turnbuckle, a hole being drilled through the center of it, to take an iron rod, as a wrench. To move the posts from one place to another, it is only necessary to loosen this coupling, move the posts, and again tighten it up.

### Repairing a Cracked Water Jacket with Cement

A 10-hp. gasoline engine suddenly developed a crack in the water jacket, and was put out of commission. As the location was far from a repair shop, an emergency repair was attempted with cement. It was found that by having a rough boxing built around the cylinder and a few inches above it, and pouring in a mixture of 1 part Portland cement and 3 parts sand, with a few iron bars laid across it to prevent cracking, the crack was plugged so that no water leaked. After the cement had dried, the engine ran as well as ever.—H. S. Rich, Cromwell, Conn.

Where rubber gaskets might be objectionable, as on cooking utensils, tin foil is very useful for the purpose.

### Lighting a Fire at the Top Saves Fuel

Although a coal fire always burns better, especially at the start, when lighted from the bottom, it has been found to be much more economical of coal if the paper and kindling wood are placed above the coal. A few small coals and cinders are spread over the top of the kindling wood to enable a coal fire to be started. After the top layer begins to burn properly, the fire will spread slowly downward, if the air draft is right. This method secures the most complete combustion, because the gases from the unburned coal at the bottom must pass through the burning layer at the top, and thus become completely burned. It is admittedly harder to build and control this kind of a fire, but the saving in fuel often justifies the extra trouble.

### Handy Twine Holder and Cutter

To make a very convenient holder and cutter for twine, place the ball of twine in a wooden box, with the end coming out through a hole in the lid, over which a flat spring is fastened so as to hold it from slipping back into the box. From this spring the twine comes out under the knife, which may be made from a piece of a saw or a safety-razor blade. The knife is mounted on a block which works on a hinge, as shown. Another flat spring is mounted under the block, to keep it away from the twine while it is being drawn out. To cut off the twine, simply strike the knob on top with the

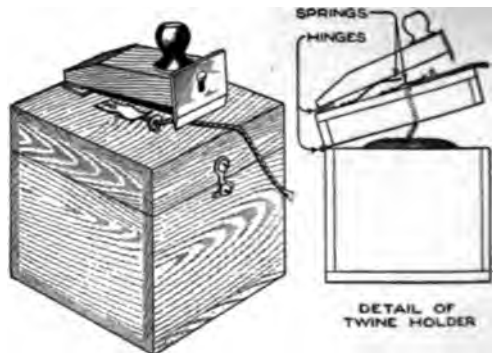

A Great Convenience in Tying Up Packages Is a Twine Cutter, Which Never Gets Lost and can be Operated by Striking the Hand against a Knob

hand, bringing the knife down on the twine. The knife should be removed and sharpened when necessary.—Chandler H. Montgomery, Piqua, Ohio.



reach down beyond the end of the er. The punching will then be wedged tightly in the die hole, and will not adhere to the perforator. There will, of course, be a slight burr turned up around the punched hole, but this will be removed in the tumbling operation commonly performed on this class of parts.—B. Royal, Reading, Pa.

### Useful Kinks for Improving the Draftsman's Triangle

The ingenious draftsman can make on his triangle many little improvements which will facilitate his particular line of

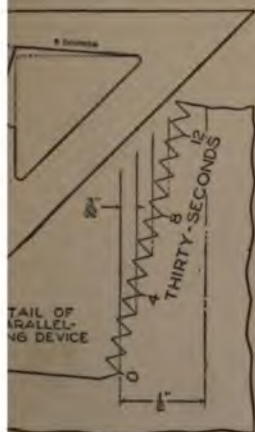

work. Two such kinks are shown in the illustration. Each shop usually has its own rule as to draft angles in castings, these being usually from 5 to 10°. One of the inside edges of the triangle may be dressed off with a knife, chisel or file to this angle;

by turning the triangle to a suitable position, one can then readily draw these lines with the proper slant.

Another useful kink is to dress off one of the interior edges to a somewhat steeper angle, and file notches of uniform depth at equal intervals along the edge. These are quite useful in sectioning and in drawing lines for lettering, as the lines are easily spaced the desired distance apart. In determining the position of the notches, the triangle should be placed over two lines, which are drawn  $\frac{1}{4}$  or  $\frac{1}{2}$  in. apart, and the part of the slanted edge which comes between the two lines should then be divided into 6, 25 or 50 equal spaces, as preferred. Notches of equal depth are made at these points, then, by setting the pencil on the notches and sliding the triangle along, lines can be readily drawn at a distance from each other of any desired number of thirty-seconds or hundredths. Figures can be scratched onto the triangle, making an enlarged scale along this edge of the triangle.

### Shafting Hangers Converted into Neat Bench Buffer

Many shops where the position of overhead shafting has been changed, can find use for a pair of shaft hangers, which may have been left over, to fit up a bench buffer. A short piece of shafting is mounted, as illustrated, with collars and setscrews to keep it in place lengthwise, and buffing or polishing wheels are mounted on the two ends. It is not desirable to run a heavy emery wheel at high speed on ordinary shaft hangers, as they are not built for such service, but for buffing and polishing of various kinds the arrangement does very well. The cost of construction is practically nothing, as no material need be purchased.—Ernest Schwartz, Brooklyn, N. Y.



### Boiling Potatoes to Loosen Boiler Scale

A 40-hp. steam boiler was kept clear of scale for over 20 years by the simple process of placing in it at intervals a bushel of potatoes. It was found that after these were boiled for a time, the scale loosened and collected in the bottom of the boiler, where it could be easily removed.—T. J. Hubbard, Mendota, Ill.

### Sawing through Plaster Walls

When cutting an opening for a doorway through a plastered wall, the usual result is a number of cracks in the plaster, some of them projecting beyond the part to be covered by the door casing. Owing to the hair used in the plaster to make it stick together, the saw mutilates it badly, sometimes tearing out large pieces. This can be diminished by nailing two stiff boards to the plaster, with room between them for the saw, and working the saw between these two boards.—W. H. Sargent, Rutland, Vt.



hot enough to crack the casting. While this is being done, the special soldering copper should be heated. Get it hot enough to melt the solder, but not so hot as to spatter it. As soon as the copper and cylinder are ready, apply the solution to the scored surface, making sure that every portion of it is moistened with the liquid. When dry, fill the score with melted solder by inserting the stick of solder into the cylinder and putting the hot copper against it. After the score is entirely filled with solder, allow the whole thing to cool; then reheat the copper and smooth out the solder. Work the copper back and forth or sideways like a trowel, until every crevice is full of solder. Allow the cylinder casting to cool again, and then employ the hand borer, as shown in Fig. 2. The boring tool should fit the cylinder quite snugly; if it is too loose, it may be possible topeen the inside of the piston surface with a ball-peen hammer even all around, so as to expand it.

The reliability of this method depends upon the thoroughness with which the solder is applied to the scored portion. Sometimes it is necessary to reheat the soldering copper several times during the process. Either a welding torch or a common tinner's blowtorch, will do, or even a common gas burner, though the work will then be slower. After the cylinder is bored out, it is sometimes necessary to polish the solder with waste or with a scraping tool. The soldering method is not recommended as equal to the welding process, but it is particularly valuable on rush jobs where the customer cannot wait for welding, or where there is no welding shop which is equipped to do the work. When welding cylinders, it is sometimes necessary to put in new pistons, as the cylinder has to be bored oversize; with the soldered cylinder, the old pistons can be used.

The question which will occur to the mechanic is whether a soft solder can be relied upon to remain solid under the temperatures prevailing in an engine cylinder. This is unquestionably the weak point of the method, but it should be remembered that the lower part of the cylinder, where the worst scores often occur, does not get so hot as the combustion chamber above, and that in any case the inner surface of the cylinder does not reach anything like the temperature found at the center of the piston head, unless the cooling system is allowed to run dry. But in deciding whether to apply the soldering method, the location of the scores should

be considered, as well as the probability of the engine being used under conditions which would cause it to heat up greatly.

Figure 3 shows another application of the soldering method, namely, repairing a crack in the water jacket of a cylinder casting. This is not recommended for great reliability, but it is often useful in a pinch. The process is very similar to that described above, except that the common soldering copper is used. The line of the crack is cut out to a V-shaped groove, as for welding. This groove is made with a cold chisel, almost to the full depth of the metal's thickness, and about  $\frac{1}{4}$  in. wide at the top. The groove is painted with the acid solution; it is then filled with melted solder and smoothed down with the soldering copper. Again, the chief requirement is to see that the soldering powder is thoroughly stuck to the iron. The appearance of such jobs is very neat, but although they have been known to give satisfaction for months, the repairing should not be regarded as permanent. The upright casting in Fig. 1 shows such a repair to the water jacket. Along the right and lower edges of this casting can be seen the white marks which are the only visible indication that the soldering process has been applied.

### Sharpening a Worn-Down Saw

Many carpenters, especially those who have been at the trade for some time, number among their tools a saw or two which, through many filings, are worn to half their former width. The handle is thus in the way of the saw-filing clamp and must be removed for filing, or at least three or four screws must be removed to

permit the handle to be turned back. This consumes time, and, since each screw consists of two parts, often results in the loss of a needed and not easily replaced screw. An easy way out of the difficulty, and one which does not harm the



saw in any way, consists in enlarging the holes of all except the uppermost screw to notches leading to the edge of the saw blade, these notches being shaped in conformity with the circle traced by each



when the handle is pivoted on the top. This is easily done by moving all but the pivot screw and turning the handle about on it, while a file is held against first one, and then the opposite side of each screw hole, marking the path of each over the center. The slots can then be cut out, following these marks. To get a saw thus prepared ready for filing, it is only necessary to give each screw a half turn and to swing back the handle.—Henry Simmons, Angeles, Calif.

### Making Gasoline-Torch Piston Leathers

Piston leathers for gasoline torches can be made as indicated in the illustration, by using a short length of  $\frac{7}{8}$ -in. thin brass tubing as a form, and then driving a piece of oil-soaked leather into it with a section of  $\frac{3}{4}$ -in. brass tubing, used as a punch. Place the piece of  $\frac{7}{8}$ -in. tubing, which should be about  $\frac{1}{4}$  in. high, on the top of the bench. Lay a piece of leather, the same thickness as the old one, over the top

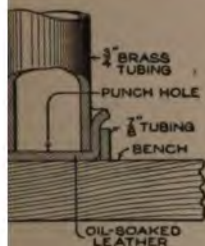

of the  $\frac{7}{8}$ -in. tube. By forcing the  $\frac{3}{4}$ -in. tube down, as shown in the picture, the leather will be molded into the form required. It can then be trimmed off evenly around the top of the  $\frac{7}{8}$ -in. tubing ring. The leather should be permitted to remain in the form for a few hours, or, if possible, after which it will be in the required shape. A hole should be punched in the middle of the piston leather to accommodate the screw which fits it to the piston head. If, after using, the piston leaks, soapsuds should be run around it rather than gasoline. If kerosene is used, it will dissolve the oil on the piston leather and spoil it.—L. M. Moore, St. Louis, Mo.

### Old Linen Collars Make Good Marking Tags

From discarded linen collars, excellent labels, or tags, can be made. The end surface which comes about with repeated starching makes an excellent surface to write upon. A hole is punched at one end, through which a short length of string is twisted. Labels made in this way are very durable, and do not pull away or tear.

### Saving Gas in Heating Water

A vessel which will heat water on a gas stove more quickly than will an ordinary pan or kettle, and which will for this reason save gas, can be made by soldering an inverted funnel into the bottom of the tin pan. Nearly the whole portion of the bottom of the pan that is covered by the funnel should be cut away, so that the hot gases from the flame can go up through the funnel as well as around the sides of the pan. It is this double heating that makes the vessel efficient.—Harvey Mead, Scranton, Pa.



### Salt in Whitewash

Where it is customary in the summer months to whitewash hothouse or greenhouse windows to keep off some of the hot rays, it is necessary to clean the windows in the winter time, and it is usually hard to remove the old covering. By putting one gallon of common salt in a barrel of whitewash, a mixture will be made which can be removed easily.

### Screw Eyes Carry Padlock

In applying a padlock to a door, the main requirement for the hasp is that it should be fastened in such a way that no screws are exposed when the lock is on; otherwise the lock can be removed by taking out the screws with a screwdriver. An equally effective method of applying a padlock, which does not require the use of a regular hasp, is to insert two



screw eyes in the position shown; one in the door, and the other in the door jamb, so that they come close to each other when the door is closed. When the padlock is attached as shown, the screw eyes cannot be unscrewed.—J. H. Norrell, Augusta, Ga.



# Testing Seed Corn for Germination

By H. A. FRANKLIN

THE average yield of corn throughout the United States is not far from 28 bu. per acre. There are 4,800 hills of corn to the acre, planted 3 ft. apart each

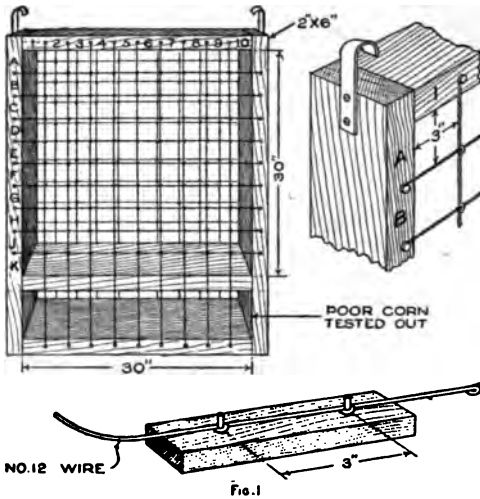

Seed-Corn Ears are Kept in Racks, Each Numbered and Tagged, While the Kernels from It are being Tested for Germination

way. Three stalks to the hill and one ear on each stalk would yield 14,400 ears, which, at half a pound to the ear, would make 7,200 lb. or 130 bu. of shelled corn per acre. This is not all theory, for corn-club boys have produced such yields in a dozen different states. The difference between this and the average yield corresponds to the difference between the old-fashioned way of planting by the rule of thumb, and the new way of applying scientific knowledge to the growing of crops.

The first step in the production of large yields of corn is the selection of seed with strong vitality from the best-producing stalks in one year's field for next year's crop. The best-looking kernels may be dead. Some grains of corn that germinate fairly well show weak roots or sprouts. Stalks grown from such seeds fail to have ears. Leaving out the question of poor soil and a badly prepared seed bed, the two principal causes of low yields of corn are vacant hills and barren stalks, both of which may be prevented by thorough ripening, careful curing, and the final process of elimination by testing the germinating qualities of each seed ear in the incubator. Growing three productive stalks to the hill without any skips, or *the same ratio* when planted in drills, is *too near perfection* to expect, but intel-

ligent effort, with the assistance of modern machinery and laboratory appliances, will always increase the yield.

The seed-curing rack, here shown, will hold 100 ears of seed corn, each ear in a separate compartment, from the day the ears are selected in the field, through the final ripening and curing processes and the testing of each individual ear for germination, to the final selection for planting; and each of the 100 ears will retain its identity throughout the test.

Each ear should have a card fastened to the butt end of the cob, preferably by a thin, blind staple. On the card is marked the number corresponding with the wire pigeonhole that the ear occupies. These numbers will read A1, A2, etc., using the first 10 letters of the alphabet with the exception of letter "I," as shown in Fig. 1. The same system of letters and figures will identify the five grains from any ear while they are being tested for germination.

The incubator cabinet, Fig. 2, completes the equipment for the scientific handling of seed corn, which includes also a permanent record such as modern farming demands for the registration of pure-bred seed. This record is made by marking the date and result of each germination test on the card that is attached

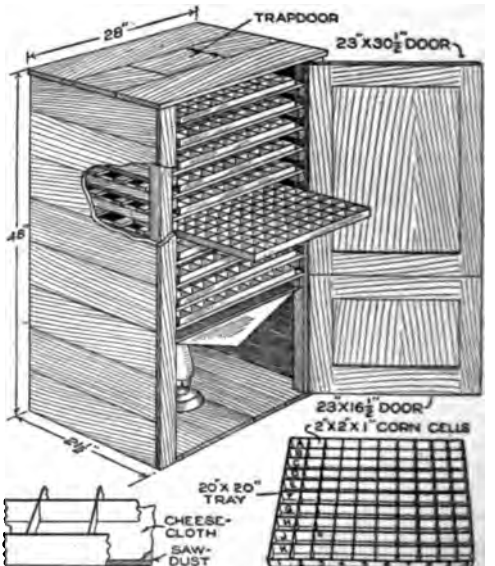

Fig. 2

The Testing is Done in an Incubating Cabinet Where Five Kernels from Each Ear are Kept Warm and Moist by Steam Generated Below

to the cob. The cabinet is used in connection with the curing racks, to test the

fitness of the different ears for seed. Its capacity is 1,000 ears, or equal to 10 seed-corn racks as represented in Fig. 1. The racks and drawers may be numbered correspondingly from 1 to 10, so that, for instance, 9-J-8 will indicate the eighth compartment in row J of the ninth drawer, containing grains from ear No. 9-J-8, which is placed in the ninth rack, row J, eighth space.

This testing cabinet is 48 in. high, 28 in. wide, and 21½ in. deep. The four corner posts are 2 by 2-in. strips. The cabinet is boxed in with sound ½-in. ceiling lumber of the matched variety. The top is also of ceiling lumber, with a trapdoor in the center. The bottom pair of cleats, on the corner posts, are nailed on 15 in. from the floor. The other cleats are 3 in. apart, as shown in the drawing. These cleats support the shelves, and should be of sound material, 1½ in. wide by 7/8 in. thick. The shelves are made of slats so that the temperature will be more uniform, but they must be level, straight, and true.

The tin deflector is filled with water to supply moisture. It also prevents excessive heating of the lowest pan; it distributes the heat in equal amounts on either side of the lamp, and starts it up at the sides of the cabinet to circulate around each pan alike. The heating arrangement is more or less automatic in that each pan receives an average amount of heat, and the temperatures at various heights are as nearly uniform as is easily obtainable. The temperature should be maintained between 72 and 80° F. The trapdoor ventilator in the top lets out the superheated air when necessary. A good lamp of the incubator style furnishes heat, and is not easily put out of service.

The pans should be of No. 24 gauge galvanized iron. They should be made accurately to size, 20 by 20 in., fitted with nine tin partition strips running each way, thus dividing the pan into 100 divisions, or compartments, each 2 in. square and 1 in. deep. The tin partitions are 1 in. high, and the tin strips are 20 in. long. They are cut to the center at intervals of 2 in., and pushed together like the paper strips in an egg carton, and may be touched with solder at the joints to make the racks hold together. They can then be lifted out of the pans and cleaned with boiling water or live steam, after each test, to kill spores.

The sides of the various cells are marked on the left with letters and on the front with figures, with a waterproof

crayon, the letters and figures corresponding with those on the corn-curing rack. This system positively identifies the five grains in the tester with the ear in the rack.

The front is closed with two doors of the same material as the sides and back; the upper one incloses the pans, while the lower one covers the lamp.

To operate, put warm water in each pan, about ¼ in. deep, and put in five kernels from every ear to be tested in their proper cell. Seeds must have air as well as moisture, so it is better to sift a layer of fine sawdust over the pans, then cover the sawdust with a square of cheesecloth, place the racks in position, and put the kernels of corn on top of the cheesecloth. This cabinet, without the tin racks, may also be used as a sprouter for grain in the winter months, when grain feed is so greatly desired in the poultry yard.

#### Hardware Store Has Special Drawer for Carpenters' Squares

One of the problems of the retail hardware store is to arrange the stock of car-

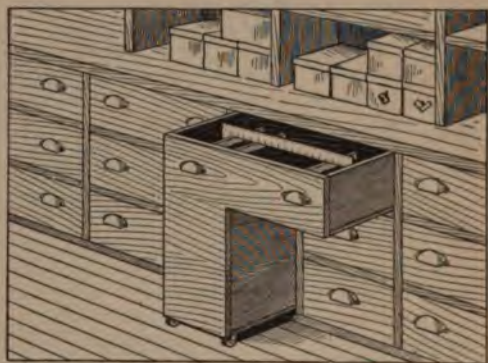

A Drawer Especially Built to Accommodate Carpenters' Squares Is a Neat Device in Any Hardware Store

penters' squares so they may be easily displayed, and yet take up as little room as possible. They are awkward articles to arrange, and no little trouble to the clerks. One store overcame the difficulty in the following manner: A drawer was built to conform to the shape of the squares, and was so constructed that it could be easily rolled out of its pocket in the wall case, displaying the entire line of squares at once. The drawing shows how the drawer was built and how the otherwise dead space below the horizontal section of the drawer was used to house a number of small drawers, thus utilizing the entire space.—L. B. Robbins, Harwich, Mass.



### How a Big Tree Is Moved

It has been known for a long time that even large trees can be moved from one place to another without injury. This



By Digging Out the Ground Properly and Providing Runways of Lumber It Is Possible to Remove Large Trees Successfully

must be carried out during the natural resting time of the tree, that is, in the winter. The remover of big trees strives at all cost to avoid injuring the roots more than is absolutely necessary, and to this end a square of soil is cut out all around the tree. On one side, an opening, or slipway, is made, as can be seen in the photograph.

The most difficult part of all is to cut under the tree so as to sever the roots that may have penetrated to some depth in the soil. Several small tunnels are opened up, and from these the separation of the tree from the subsoil is carried out. Planks of wood are slipped under the tree to act as runners on a track which is prepared. The tree is then hauled by horses or, in the case of a very large specimen, by mechanical power. The ropes are placed round the square of earth, as it is dangerous to pull on any part of the tree itself. Before the removal of the tree is attempted, the new position must be ready. Down toward the excavation, a track is cut out so that the tree will travel easily into the new location.—S. Leonard Bastin, Bournemouth, England.

### Starting Auto in Deep Sand

A farmer, located in a very sandy country, was sometimes embarrassed because friends who came to see him found that, upon leaving, they encountered a great deal of trouble in getting their cars loos-

ened from the deep sand. After the experience of furnishing to one of his guests a pair of mules and a quantity of heavy planks, he devised a much less troublesome method for the next case. He got from his barn an old horse blanket and spread it on the ground in front of the drivewheels. The difficulty, of course, is the tendency of a heavy machine to bury itself in the sand, by constant efforts to start. As soon as the wheels climb onto the horse blanket, even if they drag it part way down into the sand with them, the burying tendency is checked.—Samuel C. Appleby, Baltimore, Md.

### A Stove That Burns Sawdust

A simple stove made of sheet iron, using only sawdust for fuel, will burn a long while on one charge, giving sufficient heat to cook a meal. The stove itself is an iron can, from 6 to 8 in. in diameter, and about the same height. The bottom must be riveted to the sides. A 1-in. hole is cut on one side, 1 in. from the bottom. Around the top of the can, a number of notches are cut,  $\frac{1}{2}$  in. deep and  $\frac{1}{2}$  in. wide. To start the fire, sprinkle sawdust in the bottom of the can up to the 1-in. opening. In this hole place a round piece of wood long enough to reach a little past the center of the can, and to leave a grasping length outside. Rest a similar piece vertically upon the first one, in the center of the can. Then pack sawdust tightly to the level of the notches in the top. After carefully removing both sticks so as not to jar sawdust into the holes left, stuff a bit of crumpled paper into the 1-in. opening.

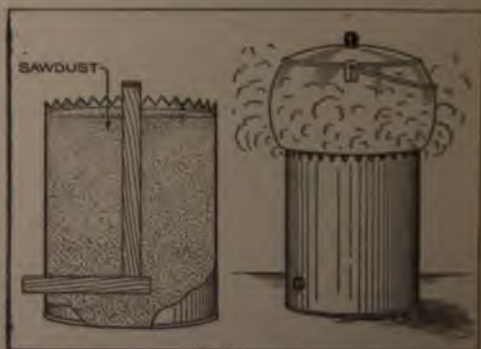

A Simple Sheet-Iron Stove, Which Burns Sawdust, Furnishes Heat Enough to Cook a Meal

and light. In a few minutes the whole mass of sawdust will glow with a red heat which will last for a long time.



### Removing Wall Paper with Steam

Stripping wall paper from the walls of a room is a tedious and unpleasant task. The following method has been found to do this work satisfactorily: Remove all furniture from the room and take up the floor covering; place, in the middle of the room, some kind of a portable stove with a big pan of water on top. Light the stove and close all the windows and doors; when the room becomes full of steam, it will soften the paste which has been used for sticking the paper on the wall. After an hour or more of the steaming, it will be easy to remove the paper.

### Small Drafting Work Easily Done without a T-Square

Small mechanical drawings, which consist mostly of horizontal and vertical lines, are made most quickly by using, instead of a T-square, a straightedge and the 45° triangle. Clamp the straightedge to the table, diagonally, so that it is below and to the right of the space where the drawing is to be made. Lay the triangle with the long side against the straightedge; the triangle should be large

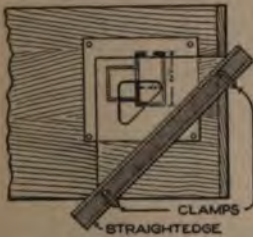

enough so that, as it slides along the straightedge, it will pass over the whole space to be covered by the drawing; that is, the drawing will lie between the straightedge and the line of motion of the vertex of the triangle. If these conditions are fulfilled, all vertical and horizontal lines can be made with the two sides of the triangle; for lines at 45°, 60°, or other angles, other triangles or a protractor will be required, as usual.

### Adjustable Chute for Coal Wagon

The ordinary chute used by coal dealers does not always make it possible to fill the customer's bin without carrying. It is often supported by boxes and barrels, but this is not satisfactory. The chute can be made to fit a greater number of cases, and to give better service where used, by making an adjustable support for it on the back of the wagon. This support is really a part of the wagon box, but

it allows the chute to be used in a number of positions, and gives it a firmer hold

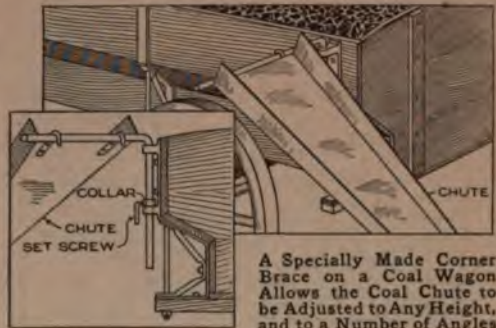

than is obtained by the usual method of hanging it over the edge of the box.

Changing the corner brace of the wagon box to meet the requirements may not be possible; a new brace is more practical. It should be made of heavy iron, the dimensions depending on the wagon and the chute. Two lugs, or ears, on the brace support a heavy iron rod which turns, hinge-fashion, on the lugs. A collar on the rod is provided with a set-screw so that the height of the chute with reference to the wagon box may be regulated. Heavy hooks on the chute fit over the rod, making a steady, firm support. If both back-corner braces are changed in this manner such a variety of positions is possible that the chute nearly always can be used successfully.—M. E. Duggan, Kenosha, Wis.

### Stop on Faucet Avoids Oil Leakage

Quite frequently the faucet on an oil supply can, such as is used around a machine shop for storing lard and machine oil, is not provided with a stop, with the result that in closing the cock it is pushed too far, and leakage and waste of oil result. A simple and easily applied stop, which is a successful cure for this difficulty, consists of a strip of metal, bent to the shape shown, and soldered in place so that the end of the handle strikes it, and is thus prevented from moving beyond the closed position.



**A Barrel Tumbler for Punch Shop or Foundry**

The usual method of removing burs from punched parts or sharp edges, and molding sand from fresh castings, is to

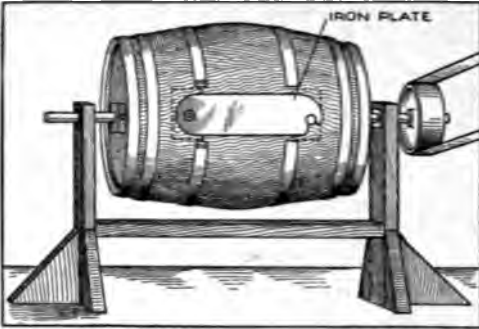

**A Tumbler Made from an Ordinary Barrel will Do Good Work in the Small Shop**

tumble them about in a rotating container. Broken pieces of carborundum wheels, emery sand, or some other abrasive, are usually placed in the container to hasten the burring process. The small foundry or punch shop cannot well afford to be without such a tumbler, particularly when one may be easily constructed from a stout barrel. If the parts to be tumbled are light in weight, a drive shaft, 1 in. in diameter, may be used. This rod should be long enough to pass through the barrel and allow about 1 ft. to project from each head, as shown in the sketch. A heavy block of hard wood strengthens the heads where the shaft passes through. A steel pin is driven through the wooden block, and into a hole drilled in the rod, so that the barrel will turn with the shaft. Suitable standards with bearings are provided to support the tumbler, and a pulley is placed on the shaft so the device may be driven from some outside source. Bearings may be made by wrapping the shaft with paper, and casting babbitt around it.

A hole should be cut in the side of the barrel, approximately 2 ft. long and 1 ft. wide. It will be necessary to sever the steel hoops at the point where the hole is cut, but before doing so, nail or screw the hoops to the barrel, near the cut-off point. Thus these hoops will remain to help strengthen the barrel. The cover placed over the hole is made of sheet steel, and arranged so it can be quickly placed in position or removed at will. A good method is to let one end swing on a heavy bolt, while the other end is

shaped so it will hook over another bolt, which, when tightened, will hold the cover rigid.—Kenneth Coggeshall, Webster Groves, Mo.

**Asbestos Hood for a Soldering Iron**

An ordinary soldering iron may be carried some distance from the source of heat, and be kept at working temperature for 15 or 20 minutes, if the point is covered with a thick asbestos hood, made from several layers of sheet asbestos.—K. M. Anderson, Temple, Texas.

**A Substantial Flagpole**

A neat, substantial flagstaff is made of 12 ft. of 2-in. galvanized-iron pipe, a 2-in. to 1 1/4-in. reducer, 8 ft. of 1 1/4-in. pipe, a 1 1/4-in. to 3/4-in. reducer, 6 ft. of 3/4-in. pipe, and a 3/4-in. cap, put together in the order named. Through the center of the cap a 3/4-in. hole is drilled for the bolt which holds the small galvanized pulley to the top of the pole. A galvanized hook for the rope is clamped to the pole, 6 ft. from the lower end, with a strap of galvanized iron. A 3/8-in. rope of the best quality should be threaded through the pulley. The staff is set upon a rock in the bottom of a hole, 2 1/2 ft. deep and 2 ft. in diameter, and is braced temporarily. Around it is poured a rather wet mixture of 1 part cement, 2 parts clean river sand, and 3 parts crushed rock. This should

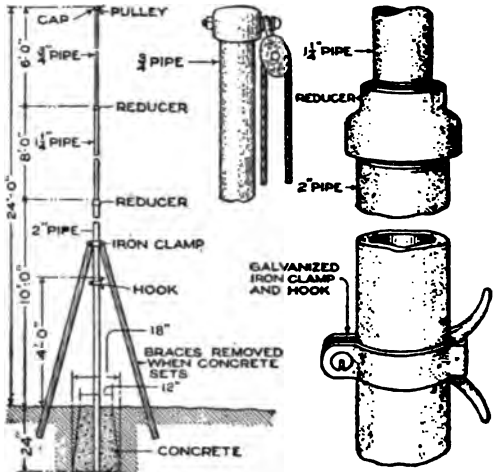

**A Flagpole Made of Iron Pipe and Fittings, and Set in Concrete, Is Durable in Construction and Graceful in Appearance**

be rounded up above the surface of the ground. When the base has set firmly, the braces may be removed.



## A Swinging Elevator for Trunks and Light Freight

A peculiar form of hand-power elevator, consisting of a hinged platform used in connection with a rope and tackle, will be found useful in homes where trunks are stored in the attic, and in many small shops where freight has to be moved by hand from one story to another.

The elevator is best built in connection with a stairway, although this is not a necessary feature. The platform proper is made of 2-in. material, or lengths of 1-in. lumber very strongly braced. At one end, it is attached with good strong hinges, as shown, while at the other end an end board is placed, large enough so that, when it is swung down into the lower position, a trunk or box may be raised onto it and will rest there securely. If this end board is braced on both sides, as shown, it will be necessary to detach the pulley block when loading on the freight. This is the preferable method, as it is very little trouble to detach the block, and the braces on both sides add much to the strength of the elevator. It may be desirable to leave off one of the braces, since the freight can then be loaded from the side without detaching the pulley block. The upper pulley may be fastened to the ceiling joists, or rafters, of the floor above. If sufficient power is not obtained by pulling the rope with the hands, it is, of course, possible to provide a windlass, or other means of increasing the pull, but this will not be necessary for trunks and like objects.

If the elevator is only to be used occasionally, it is entirely possible to leave



Trunks are Lifted to the Upper Floor by Placing Them on the Swinging Platform and Pulling on the Rope

it in the upper position so that its floor forms a part of the second-story floor. The rope end can also be carried up the stairway and fastened on a hook above, so that no part of the elevator is in evidence on the lower floor. For places where the elevator would be in more frequent use, it would be well to provide a hook, such as the one shown, on the wall, where the end-pulley block can be hung, out of the way but easily attached to the elevator in a few seconds.

This type of elevator is not adapted for freight which must be kept standing upright, but this will not be found to interfere seriously with its usefulness.—C. H. Patterson, Portland, Ore.

## Countersinking Center Drills Held in Special Chucks

Combination countersink and center drills are in general use in machine shops, but many shops have inadequate means of holding them. The sketch shows two forms of chuck which are readily made for this purpose. The lower one is turned from a bar of machine steel, and has merely a hole in the end, with a setscrew for holding the drill. The taper of the chuck is made to fit the tailstock of the lathe. The upper sketch shows a chuck made from a worn-out  $\frac{3}{4}$ -in. twist drill. The end is turned down and threaded with a taper thread. A  $\frac{1}{4}$ -in. pipe thread was used on this chuck, and a nut was then tapped out with a standard  $\frac{1}{4}$ -in. pipe tap. Slots were sawed in the threaded portion, making spring jaws, a hole being

drilled in the end, of the right size for the center drills used. The piece of twist drill should be retempered after it is cut

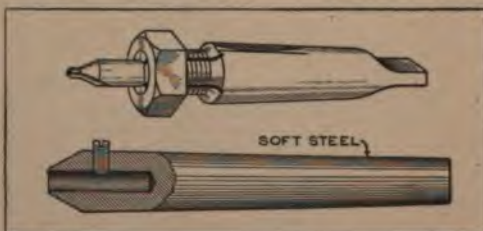

Two Handy Forms of Chuck, Readily Made, to Take the Combination Countersink and Center Drills Which have Proved So Popular

to this shape, and the nut should be case-hardened, or, if convenient, a nut may be made from carbon steel and tempered.—M. L. Lowrey, Livermore, Calif.



### Load of Lumber Hauled by Light Car and Hand Truck

A load of 20-ft. lumber was to be removed, and no wagon or truck of the necessary length was available. The illus-

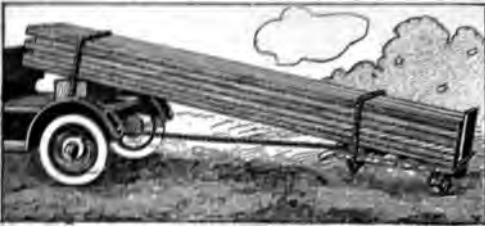

How a Light Automobile and a Hand Truck were Made to Do the Work of a Long Wagon in Hauling a Load of Lumber

tration shows how the job was done with a light automobile and a hand truck borrowed from a grocery. The rope from the rear axle of the car to the hand truck pulled the load, while the rope around the rear end of the lumber held the truck off the ground.—Edwin L. Camp, Huntington Park, Calif.

### Emergency Call-Bell System Has Permanent Wiring

When a person is taken sick in one room of a house, and must have means of calling for assistance from a person in another room, an electric-bell signaling system always is desirable. In time of sickness, however, there is likely to be small opportunity to rig up such a system,

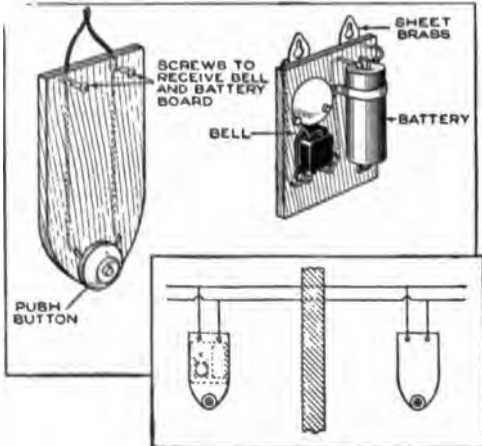

A Call-Bell System Which Meets Emergencies without Delay: Each Room Has a Push Button Permanently Installed, and the Bell can be Carried to Any Room Desired and at Once Placed in Service

and its absence may cause real distress.

An effective way to be prepared for this

condition, at no great expense, is to install in each bedroom, within easy access of the bed, a push button, mounted on a block, as shown in the sketch. These buttons are connected, in parallel, to a pair of wires which connect all the different rooms. At the top of the block are two screws, each of which is connected to one side of the wiring system. One or more bell boards, such as shown in the upper right-hand corner, are then made, so that they can be hung on the two screws in any room where the bell may be desired. The bell is mounted in series with one or two dry cells on this board, and the wires run underneath the board to the two sheet-brass lugs, which serve the double purpose of supporting the board on the screws and of conducting current into the wires. The weight of the bell board will be sufficient to give a firm contact, if the two lugs are set a good distance apart, and the weight on the board is fairly well balanced.

Should sickness occur in any room, it is then only necessary to see that the patient is within reach of the push button, and to hang the bell board in whatever room the nurse or attendant will be. Two or more boards can be used, the same push button then sounding the bells wherever they are placed. If the attendant's work calls her to another room, she can lift the bell board from the screws, take it with her to the other room, and hang it above the push button there. In rooms where use may at some time be found for one of the bells, but which are never used as bedrooms, it is not necessary to install buttons, but merely the two screws the proper distance apart, connected to the two wires which run from room to room.

In an ordinary call-bell system, the addition of extra bells to be sounded simultaneously means extra strain on the batteries, which they may not be able to stand. With this system of wiring, each bell has its own battery, so that any number of them can be hung up in different places and operated by any one of the push buttons without any extra load on the batteries. The bell board may be rigged as shown, or, if a louder alarm is wanted, two cells may be used, one on each side of the bell, in order to balance the weight properly. In times when there is no sickness, the call system may be put to various other uses, and in any case, at least one bell board should at all times be kept on hand, with a battery mounted on it, which is in serviceable condition.—H. E. Gifford, Medford, Mass.

### Lighter for the Gas Torch Made from a Spark Plug

It is the practice in some shops to leave a welding torch burning with a small flame when it is not in use, owing to the time required for lighting it. Aside from the danger of fire caused by this custom, it always wastes more or less gas, which is not necessary if some apparatus such as that shown in the sketch is provided. Underneath the bench, in a box mounted for the purpose, are placed four or five dry cells, connected in the usual way to a jump-spark coil, such as used on automobiles or stationary gas engines. The high-tension terminals of the spark coil are connected to a spark plug, mounted as shown in the detail, so that the points are flush with the bench. In the primary circuit is connected a push button, which may be located on the floor, preferably sunk into it, so as to project no farther than the necessary distance for pushing the button with the foot. The torch is lighted by turning on the gas and bringing the nozzle near the spark plug, at the same time pressing the button with the foot. The time required for this operation is practically none, after the workman has become familiar with the location of the button and spark plug. In the upper right-hand corner of the sketch is shown a simple method of making a stand or rack for the torch, which will be handy in connection with the lighting apparatus.

While the gas saved is perhaps a small item, the element of safety is more im-

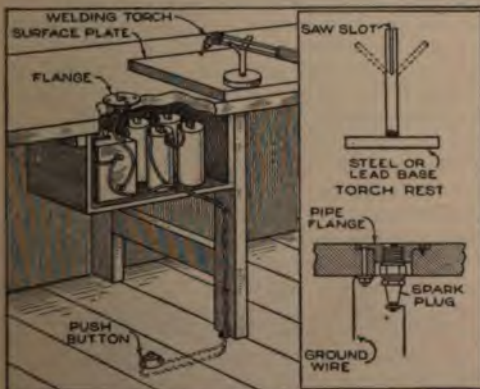

A Spark Plug, Sunk in the Bench, and Connected to a Coil and Battery of Dry Cells, Eliminates the Necessity of Leaving the Torch Burning

all-around usefulness of a welding torch is appreciated.—C. C. Spreen, Detroit, Michigan.

### Portable Fence Formed of Easily Detached Sections

Modern methods of raising live stock on the cafeteria plan require the use of



Universal Panel with Interlocking Ends Builds Portable Fence to Confine Stock to Small Feed Areas

a succession of pasture crops, planted in rotation to mature at just the time when they give the greatest food value, and in the amounts best calculated to furnish the necessary feed without waste. To use the plan with the greatest success it is necessary to confine the stock to the feeding ground ready at the time, so that they will not injure or waste the growing crops. Since it is not practical to cut a farm permanently into small fields, some system of portable fences must be used.

Such a fence is set up very quickly by using a universal panel which may be put together in either of two ways, and which may be made of any size desired. The panels are built of boards, 6 in. wide and 1 in. thick. At one end of each panel a space is left into which an interlocking end of a similar panel will fit. The panels are made rigid with an inverted-V brace. The fence may be set up with the interlocking members forming a sort of zigzag, in which case the fence needs no other support; or, if so desired, the panels may be placed in a straight line, when it will be necessary to drive stakes on each side of the interlocking joints.—Herbert A. Shearer, Chicago, Ill.

### Rubber Cement for Repairing Tire Valve

A bicycle rider found himself 15 miles from the nearest village, with a fast-leaking tire valve, due to the rubber washer being worn out. Remembering that he had some rubber cement in a tube, he applied a small quantity of it to the worn washer, and after letting it dry, inserted it again in the valve stem. It served the purpose perfectly until a new valve stem could be obtained.—Raymond Lister, Winnipeg, Manitoba, Can.

portant, and since the amount of current used is very small, the apparatus will be advantageous in many shops where the

**Headrest for Auto Mechanic Strapped to His Head**

An automobile mechanic who had experimented with various devices to rest his head upon, while working underneath a car, found that they were all liable to the objection that, when moving around, it was difficult to move them and get them in the right place without losing considerable time. He then made a pad consisting of a block of wood lined with felt, to



fit the back of his head, and provided it with a piece of tape which was tied around his forehead. He could thus move around under the car without worry as to whether his head would come down in a puddle of grease on the floor. Should the headrest come in contact with such a puddle, no other precaution is necessary than to slip it off the head before standing erect.—Glenn Bron, Salt Lake City, Utah.

**The Auto Stop Block Reduced to Efficiency**

To keep cars in place on the floor of the garage, the usual method is to set a block of wood against the tire, kicking it into place with the foot, which is a very easy and effective process. The trouble comes in removing the block, if it is tightly wedged in. To overcome this difficulty, a large east-ern garage uses specially shaped blocks, fitted with pieces of gas pipe for handles. The blocks can thus be removed in less

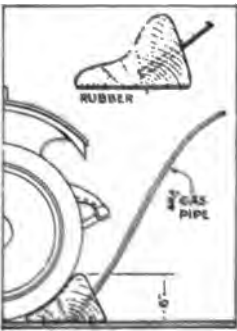

time, and quite easily.—P. P. Avery, Garfield, N. J.

Repair gums and tire fabrics received in cold weather sometimes appear lifeless when they are merely frozen. Thaw out the material in a warm room before using it.

**Spring-Opening Lock Fitted on Ruling Pen**

A small, stiff piece of spring steel, drilled to fit under the thumbscrew on an ordinary ruling pen, converts it into a spring-lock instrument. A curve on one end holds the blades together when the metal is turned the long way of the blade, while the other end is made long, to serve as a lever for unlocking. This is done by swinging the lever to one side, thus releasing the spring of the pen, and allowing the blades to open for inking; swinging it back brings the blades together again. Pens thus equipped give service equal to that of high-priced instruments.—Elmer O. Tetzlaff, Cicero, Ill.

**An Adjustable Bushing Puller**

Removing tight bushings is a subject which has engaged the ingenuity of many a mechanic. The device here illustrated may often enable one to extract, without damage, a bushing which would otherwise have to be cut in two in order to remove it. The materials necessary are a short piece of pipe, a steel bar, or disk, across the top, two pieces of steel rod, and two nuts. Both pieces of rod should be forged at the lower end to the shape shown; at the upper end one piece is threaded and the other is left smooth. They are riveted or bolted together, somewhat like a pair of heavy inside calipers. The piece of pipe should be cut out at one side to give access to the cone nut with the fingers. After it is tightened, the bushing is pulled up by turning the upper nut with a wrench.

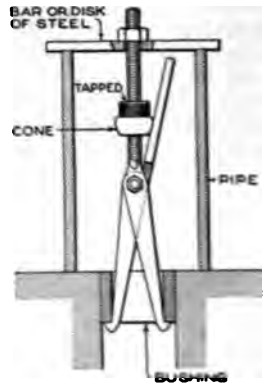

**Draftsman's Triangle with Raised Points or Feet**

A draftsman's triangle, of wood or composition material, may be fitted with three brass plugs, or rivets, located near the three corners of the triangle, riveted over to form similar heads on both sides. These will give two advantages in use. The tendency of the ruling pen to blur the line



when the ink comes in contact with the triangle will be eliminated, and the triangle will be much easier to lift from the table, as there will be sufficient space under it to insert the finger nail. Triangles fitted up in this way will save much time for the draftsman and tracer.—G. A. Luers, Washington, D. C.

### Inspector's Stamp Built into Hammer

Stamping of wood, or soft-metal, parts, such as might be required after inspection, is most quickly accomplished by constructing a stamping hammer, as shown in the sketch. A wooden head and handle are formed out of pieces of fairly hard, heavy wood, and a socket is cut in the head so that the metal stamp can be driven in securely. To stamp an article, simply strike a blow with the tool, instead of using the stamp with a hammer. Such a device is of use in stamping either inspection marks, figures, or letters required in processes of manufacture.



### Valve Grinder Made from Washer

A valve-grinding tool such as this will be found very handy for valves which are provided with two holes for gripping them while grinding, rather than with a slot. The shank may be held in a bit brace, or it may be made longer and bent to the shape indicated, so as to be used like a bit brace itself. A heavy iron washer of the proper size is cut in half and filed so as to



leave the two lugs projecting the proper distance apart to fit the holes in the valve. The shank is then pinned to the center of this semicircular piece, and the tool is ready for use. It will be seen that the tool has the advantage of equalizing the pressure on all sides of the valve, which greatly assists the formation of a good fit all around the valve seat.—J. E. Barkley, Detroit, Mich.

### Footstool Made from Harness Hooks

A novel and pretty footstool may be made from a board, about 12 in. square; four harness hooks, 6 in. long or over, and a piece of brocaded velvet, or leather, for covering. Saw off the corners of the board, being sure to get the sides of equal length, thus making an octagon. Screw the four harness hooks under the stool where the corners were cut off. Pad the top of the stool, and cover it with the brocaded velvet or leather. Turn the edges of the covering material under at the lower edge, and fasten with tacks, completing the stool.—Mrs. Grace E. Willey, Concord, N. H.



### Wires across Barrel Heads Give Protection

A concern which every year ships many tons of iron castings in barrels had trouble from the heads of the barrels being knocked out. It was found to help a great deal in preventing this to fix across the end of the edge of the barrel heads stout steel wires, twisted together, as shown in the sketch. Four holes were drilled under the first hoop; the wire was passed from one hole to the opposite one, doubled back, firmly twisted, and spliced. The crossing wire was put in in the same way. The barrels held together during long trips and much rough handling.—Irl R. Hicks, Centralia, Mo.



### Reaming Large Holes with an Ordinary Twist Drill

Large holes that must be still further enlarged can easily be reamed with a twist drill, when the desired size of reamer cannot be had. By procuring round oak plugs, turned to a driving fit, and driving these plugs into the hole to be reamed, the drill will be less likely to bind and wobble, and therefore less liable to breakage than when trying to drill the holes without the plugs.

### An All-Metal Coat Rack

A clothes rack for the shop, which is very strong and durable and free from dirt-catching corners, is made as shown

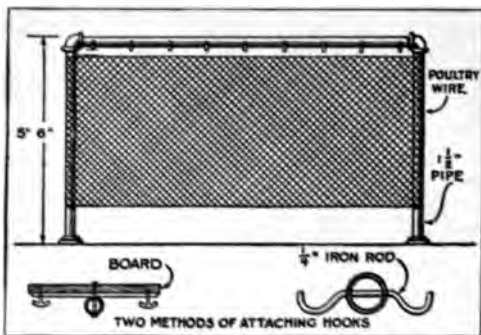

A Stout Sanitary Coat Rack is Readily Made in a Few Minutes from Three Pieces of Pipe, Some Wire Netting, and Scraps of Iron Rod

in the sketch. On a frame, consisting of three pieces of  $1\frac{1}{2}$ -in. pipe screwed into flanges on the floor, is hung a length of poultry-wire netting to separate the garments hung on one side of the rack from those hung on the other. To the horizontal pipe are attached the hooks, which may be arranged in any of several different ways. The arrangement in the lower right-hand corner is simple, the hook consisting merely of a piece of  $\frac{1}{4}$ -in. iron rod, driven through a hole drilled in the pipe, and bent into shape with a hammer and round anvil. The hook arrangement in the left-hand corner gives greater capacity to the rack, but is slightly more expensive. With either of these types of hooks, it is advisable to put a pin through the elbow at one end of the horizontal pipe, so as to keep it from turning, in case one side should be overloaded with heavy clothes.

### Crane at Rear of Truck Helps Load and Unload

For a truck man, or anyone engaged in general hauling, the idea of a crane built onto the back end of a truck presents great possibilities in the way of cutting down the time and number of men required for heavy jobs of loading and unloading. The frame of the crane may consist of two pieces of channel steel, long enough to reach from the ground up over the top of any load which may be expected to be carried on the truck; a shorter channel across the top of the two uprights, and a piece of flat sheet steel for

the bottom. The first use of the crane, shown in the upper left-hand corner of the sketch, is to raise the rear end of the truck from the ground up to the height of the loading platform, whenever this is necessary. For this purpose, the pulley blocks, two at each side, are arranged as shown, and turning the crank at the right raises the truck to any height desired. Before this is attempted, the front wheels must be securely blocked, front and rear, since, with the rear wheels off the ground, the brakes on an ordinary truck are of no use.

After the truck is in position, it may be held there either by the rope, and the pawl acting against the ratchet, or by putting a pin across through the crane and the frame members. If it is held in the latter way, the upper pulley blocks can then be detached from the top of the crane, and the same tackle can be used to pull the load on or off of the truck, as shown in the lower sketch. Finally, after the job of loading or unloading is done, the upper pulley block may be shifted down to a hook on the bottom plate of the crane, and it can then be raised by turning the crank high enough so that the pin can be placed through the frame members, thus attaching the crane firmly to the truck for carrying. It is then swung down to the position shown dotted in the upper sketch, where it rests

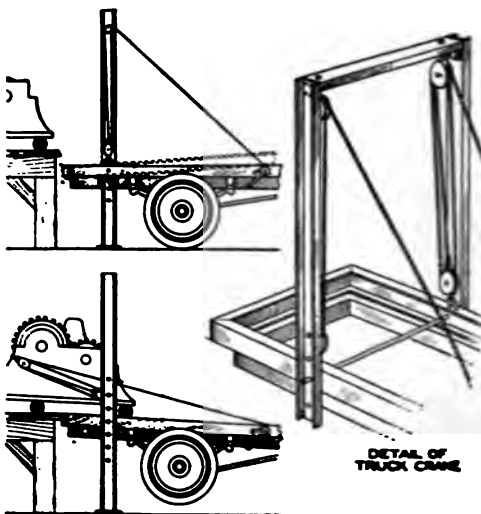

A Crane Attached to the Rear of the Truck Often Enables Two Men to Do with Ease What might Otherwise Be Slow and Difficult for Three or Four

securely during the haul, or until it is next required. At the right, the crane is shown in greater detail, and suggested



means of attachment are indicated; these will, of course, vary for different types of trucks. If the U-bolt illustrated is used for attaching the lower pulley blocks to the crane, it will be advisable to attach a similar U-bolt to the middle of the bottom plate of the crane, in order that the frame members may not interfere with the pulley blocks when the tackle is arranged for raising the crane to the carrying position. Dimensions and strengths of the various parts will have to be worked out for each case separately, as they depend on the size, weight, and character of the truck, and the nature of the loads expected.—F. F. Burnstead, Long Beach, Calif.

### Emergency Nut Cast of Babbitt

When a nut, especially a large one of a certain size, must be had for repair work, and is not to be found, a good way is to make one from babbitt. In the case illustrated, a portion of a tin can was bent up



to a shape approximating that of the nut desired. A hole was made to fit the thread of the axle, and the can was set in place to form a mold. After greasing the

threads and the mold with an oily rag, babbitt metal was poured into the mold. When cool, the tin is torn away and a nut remains, which, if it has not the strength of a steel nut, will often give good service. The process is especially useful when a nut with a left-hand thread is required, as left-hand taps of the required size are less likely to be found handy than right-hand taps, while the babbitt nut can be used in either case.—W. J. Mahnke, Coeur d'Alene, Idaho.

### Invalid's Table Rests on Bed

For the invalid who is able to sit up in bed, a great convenience is a table, or tray, made somewhat shorter than the width of the bed, with supports, 8 or 10 in. high, at either end, so that it can be set upon the bed directly over and in front of the patient. Three sides of the top are furnished with a narrow molding, and small brass handles attached at the ends. The wood may be stained and ornamental pockets made on its ends. These end pieces can be fastened to the top with nails

or screws directly, and some form of blocks or braces should be used under-



A Tray of This Type, Which Extends across the Patient's Knees, will Often be Found Handier Than Those Ordinarily Used in Hospitals

neath to strengthen the joints.—Mrs. G. E. Wilson, Boston, Mass.

### A Scarecrow with Moving Hands

A scarecrow which, if not very lifelike, proved effective in frightening away the birds, was provided with "arms" to be revolved by the wind. On the ends of the crossbar were mounted two sticks of pine, 1 in. square. To one end of these sticks were fastened disks of bright tin, 7 in. in diameter; the other end was rounded off, and a piece of iron or lead pipe was driven on as a weight. The holes through these arms were placed at the points found by balancing the arms after the disks and pipe weights were applied; thus the slightest breeze would cause them to re-

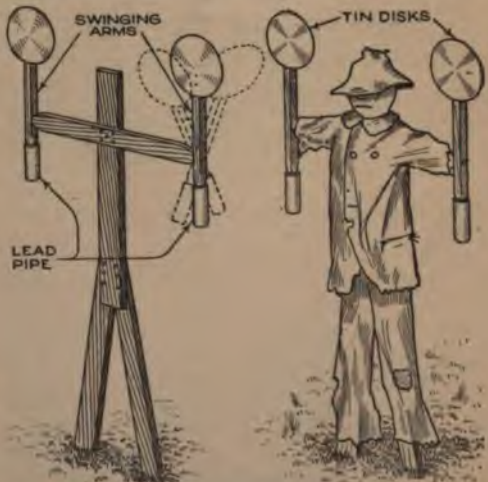

The Scarecrow Waves Its Arms with Great Rapidity Whenever a Slight Wind Blows, and Is Very Efficient in Keeping Away the Predatory Birds

volve. They will move somewhat more freely if washers are placed between them and the crossbar.—Sylvanus Van Allen, Port Ewen, N. Y.



### An Asparagus Buncher

A handy rack for bunching and tying up asparagus, rhubarb, and similar garden produce, is made from two horseshoes,

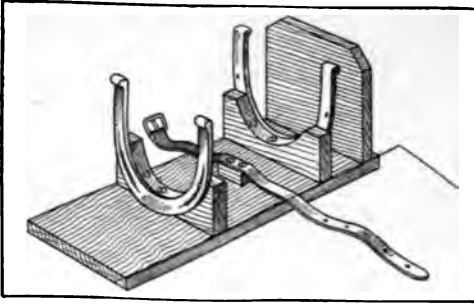

Vegetables, Such as Asparagus, are Laid in This Rack, Made from Horseshoes, and are Held with a Leather Strap While being Tied for Market

mounted on blocks of wood. The base should be about 8 in. wide and 13 in. long. A block, about as high as the horseshoe, should be used as a headboard. The horseshoes are nailed to two blocks, sawed out as shown, and a leather strap, tacked to the baseboard, will serve to hold the bunch while it is being tied. The ends of the horseshoes should be set out somewhat with a hammer before mounting, so as not to bend inward at the top. String cut to the right length is placed on the board before starting work.

### Hardening Long, Thin Pieces without Warping

It is difficult to harden a long, thin piece of steel without considerable warping. This is due to the cooling of different

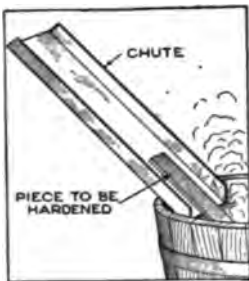

parts at different times, producing internal strains. If the red-hot piece is allowed to slide into the liquid on a chute held at an angle of about 45°, it will strike the water, end foremost, and cut into it at once. This gives better

results than dropping it directly from the tongs, as the latter allows it to tilt, which will keep it from cutting in sharply and delay the contact of the liquid with some parts of the surface, thus causing warping. The chute may be a piece of scrap iron or tin, about 2 ft. long, bent up on two sides as shown.

### A Milk-Bottle Cover

The thin tin boxes in which some kinds of fancy crackers are packed may be easily cut by scissors to make an excellent milk-bottle cover. Cut a strip a little wider than the top of the bottle, so that both sides may be bent down to engage the neck of the bottle, the tin being bent inward on an angle a little less than that of the wall of the lip. In cutting the ends of the tin, leave a lip or point on one end, to be bent down, and make an inward curve on the other end, to permit an opening to be made without removing the cover from the bottle.

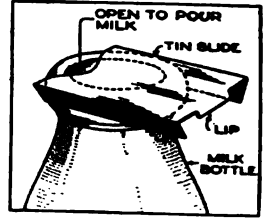

### Magnetic Locator Useful in Wiring Finished Houses

A simple method of locating positions for openings in wiring old houses is that of using an ordinary magnetic compass, and a large, magnetized file. The file, which should be strongly magnetized, is driven into the ceiling at the point where it is desired to bore the hole. By moving the magnetic needle over the flooring above, it is possible to locate the desired position by the agitation of the compass needle.—Peter J. M. Clute, Schenectady, New York.

### Good and Bad Scraper Edges

A great many carpenters have constant trouble in putting a good working edge on a scraper. This difficulty is almost always due to the curling of the honed edge while

"turning" it, or, to use an inappropriate though widely employed term, "rolling" it. While it is quite difficult to learn to turn the edge of a scraper, anyone can easily rectify a poorly turned edge by straightening out the portion that has curled.

This is easily accomplished by running the sharp edge of a chisel along the inside

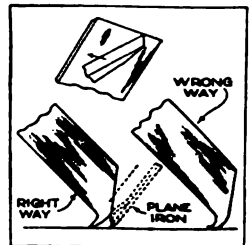

of the turned edge of the scraper. To do this, the chisel must be held at a very acute angle to the surface of the scraper blade, and at an angle of about  $45^\circ$  to the turned edge, holding the under, or flat, side of the chisel up and going along the edge lightly and without the use of any force. The sharp, honed, and perfectly straight edge of the chisel takes hold of the finest curled scraper edge. The angle used in the operation is very similar to that at which a plane iron is honed and set in the plane. The same scraper edge can be brought back to good working condition repeatedly by employing this process, which not only rectifies the edge, but also removes from it particles of wood, dust, and glue.—Henry Simon, Laguna Beach, Calif.

### Measuring Gauge for Power Hacksaw

The ordinary forms of power hacksaw are not provided with gauges for determining the length of the pieces to be sawed, and the usual method is to measure the length required with a scale, and set the piece in the vise so that the saw comes at the proper point. In order that the hacksaw may be provided with its own measuring scale, a gauge like the one illustrated can be



readily built onto almost any power hacksaw. A piece of thick tubing is held in metal strips, screwed under the frame of the machine, and a setscrew, of a form easily turned with the fingers, is threaded into this tube. For strength and durability, it is well to reinforce the tube at the point where the setscrew comes by driving on it, or soldering around it, a piece of larger tubing, or an iron strap, so that the screw will have a longer thread to work against. Inside of this tube slides a piece of round iron rod, which is bent to a U-shape, as shown. Upon it may be marked graduations to indicate directly the length of the pieces to be sawed off from the stock. It will also be found useful in many shops to add a spring and some notches in the rod, at a distance from each other of 1 or  $\frac{1}{2}$  in., so that the gauge may be easily set to these frequently used points.—C. Anderson, Worcester, Mass.

### Door Latch Operated by Sign Reading "No Admittance"

A factory made use of a novel device on one of its doors, which was intended for the use of employes only, although open-

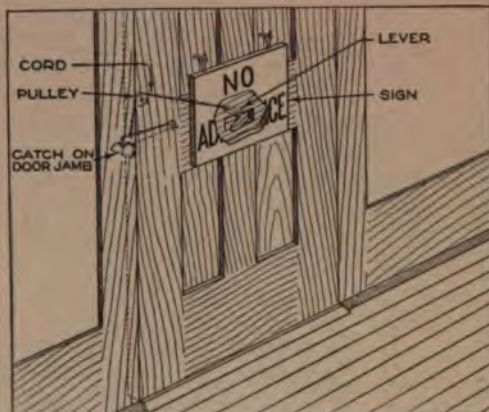

The Door is Provided with a Latch Opened by Pressure on the "No Admittance" Sign, and the Stranger, Seeing No Means of Entrance, is Forced to Obey the Sign

ing on a semipublic thoroughfare. There was on the outside of the door no knob or latch, and no other visible indication of how to open the door. The latch behind the door was, in fact, worked by a lever and cord, which was operated by pressure at the proper spot on the "No Admittance" sign. This was known to employes, and the secret can readily be discovered by anyone after gaining access, but the method by which the employes opened the door was far from being apparent to bystanders, and did good service in keeping out intruders.—H. F. Blanchard, Portland, Me.

### Making a Screwdriver Magnetic

Magnetized screwdrivers are useful for many classes of work, the carbon steel of which screwdrivers are made being capable of retaining considerable magnetism. A screwdriver which will retain a considerably stronger magnetism than an ordinary one, may be made from a round piece of tool steel, or preferably of tungsten steel, by simply grinding the end of a bar into the form of a very short screwdriver blade.—Maurice Clement, Youngstown, Ohio.



### Long Lever Eases Action of Force Pump

A vertical force pump of the common kitchen variety was too hard-working

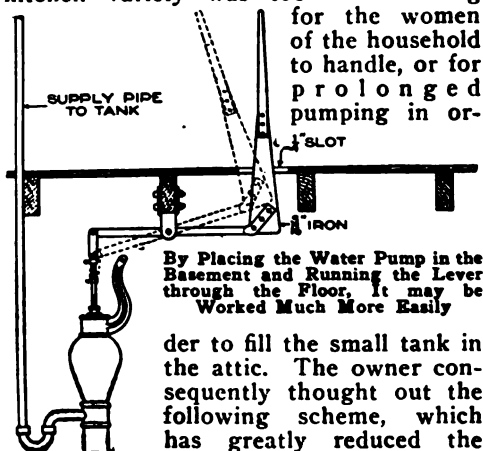

der to fill the small tank in the attic. The owner consequently thought out the following scheme, which has greatly reduced the labor.

The pump was placed under the kitchen floor, as shown, and the blacksmith made a lever from an old axle, somewhat of the shape illustrated. At the left end was placed a link, as in common pump jacks, and to it was fastened the upper end of the pump rod. The other end of the lever was riveted to a piece of sheet iron, and the handle was fastened to it. The lever was pivoted to the underside of a joist by means of an eyeplate and bolt. A slot in the floor allowed the handle to be swung back and forth. This slot was too narrow to permit mice to pass through, or much cold air to enter. Where 50 strokes of the pump was formerly quite tiresome, the operator can now take 500 without undue exertion.

### Handy Kitchen Chopping Board

A handy chopping board may be quickly and easily made from a piece of hard wood, a pointed kitchen knife, and a



large staple. The staple is driven into the edge of the chopping board far enough to set it firmly and at the same time to allow the point of the knife to fit into it. To operate, the knife is raised and lowered with one hand, while the food is passed under the blade with

the other. Use of this device makes it easy to chop, slice, or mince, and there is little danger of the knife slipping, even though great pressure is applied.

### Nail Makes Satisfactory Plow-Plane Bit

When cutters of a special size are required for plow planes, a quick and efficient way to make them is to dress down a large nail or spike to the required shape. Although the adjustment of such a cutter will present somewhat greater difficulty than one of the ordinary type, its performance, if it is carefully made and sharpened, will be quite satisfactory for many purposes. Cutters up to  $\frac{3}{4}$  in. wide can be made from 16, 20, and 30-penny spikes.

### Staple Prevents Manipulation of Lock

Many doors which have been long in use have shrunk to such an extent that

there is quite a space between the door and frame when the door is closed. Manipulation of the locks through this space is quite possible, especially where spring locks are used. An effective method of preventing this is to make a staple of sheet iron, long

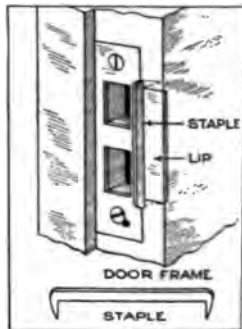

enough to take, between the two pointed ends, the lip of the striking plate. If this staple is then firmly driven in the position shown, it will be impossible to get at the lock to manipulate it.

### Carrying Piano Made Easy by Handles

When a heavy piano is carried upstairs and down and from one place to another, injuries to the instrument and to steps and doorways will usually result. The difficult thing in the transportation of a piano is not in the weight but in the placement of the weight. A carrier which will reduce this difficulty is made easily from two 10-ft. pieces of 2 by 4-in. lumber. These are placed, one at the front of the piano, between the legs, and



# INDEX TO VOLUME XVI

# SHOP NOTES FOR 1920

Accurate Method of Setting Thread Tool in Lathe	3095	Auto and Wagon Springs, Paraffin Grease for	3217
Acetylene Manifold Heater Starts Cold	3225	Auto, Ankle Strains in Driving Relieved by Heel Block	3113
Acid, Old Files Made Serviceable by Treating with	3157	Auto-Body Panels, and in Tanks, Removing Dents in	3140
Acid-Proof Cement for Pipe Fittings	3159	Auto Chassis, Loading Truck Facilitates Handling of	3263
Action of Force Pump, Long Lever Bases	3302	Auto Creeper, Headrest for, Made from Inner Tube	3246
Adjustable Bushing Puller	3296	Auto Drive Shaft, Spring End Bearings Overcome Play in	3134
Adjustable Chute for Coal Wagon	3291	Auto Engines, Cold, Acetylene Manifold Heater Starts	3225
Adjustable Leg for Table or Bench	3096	Auto Engine, Increasing the Power of	3216
Adjustment of Light, Fine, Divided Window Shades Permit	3261	Auto Engines, Renewing Valve Guides in	3239
Air-Bellows Device Protects Sand-Blast Operators	3137	Auto Engine, Rubber Tube Protects Ignition Distributor of	3128
Air Brush, Sprayer or, Easily Made from Common Materials	3208	Auto Engines, Used Oil from Makes Good Fuel	3279
Air Compressor, Garage, Made from Discarded Cycle Motor	3166	Auto-Jack Lever, Pedal Extension on, Saves Labor	3214
Air-Cooled Motor, Water-Jacketing An	3189	Automatic Electric Backing-Up Automobile Light	3210
Air Hammers, Storing in Oil Improves Working Quality	3212	Automatic Shut-Off for Filling Cans or Buckets	3231
Air Hose, Weight and Pulleys Keep Convenient and Reduce Wear	3266	Automatic Signaling Device for Projecting Machines	3178
Air Intake, Auto, Guarded for Crossing Streams	3164	Automatic Weighing Machine Electrically Operated	3125
Air Whistle, Loud-Sounding, for Camp Alarm, Automobile-Thief	3143	Auto Mechanic, Headrest for, Strapped to His Head	3296
Alcohol, Wood, Simple Test to Distinguish from Denatured Alcohol	3265	Automobile Brake, Old, Adapted for Use on Windlass	3192
Aligning Automobile Wheels, Gauge Stick Useful for	3157	Automobile Crank-Case Bolts, One-Man Wrench for	3207
Aligning Hold-Down Bolts in Concrete Foundations	3191	Automobile Crank Cases, Testing Oil Level in	3220
Alteration Adapts Twist Drill for Soft Metals	3225	Automobile Engines, Spark-Plug Atomizer Starter for	3213
Aluminum Bronze Letters, Size for Holding	3210	Automobile, Crippled, Moving Single-Handed	3234
Angle Iron, Broken Slate Instrument Panel Repaired with	3146	Automobile Doors, Rattling of, Overcome by Setting Hinges	3097
Angle Pieces Shaped in V-Block with Arbor Press	3205	Automobile-Exhaust Heater Mounted in Floor Register	3251
Angles and Curves for Drafting Jobs, Making Special	3259	Automobile Gasoline Gauges, Calibrating	3212
Animals, Safety Radial Tether for	3233	Automobile, Handy Chemical for Use about	3200
Animals, To Keep from Molesting the Garbage Can	3233	Automobile Hood, Rubber Hose Stops Rattling of	3147
Ankle Strains in Driving Auto Relieved by Heel Block	3113	Automobile Light, Automatic Electric Backing-Up	3210
Annealed Wire, Method of Making Copper Rivets from	3132	Automobile Motor, Testing Compression in Cylinders of	3110
Anthracite, Using Soft-Coal Screenings with	3257	Automobile, Passenger, Converting into Delivery Car	3297
Apparatus for Locating Trouble in Aerial Telephone Cables	3101	Automobile Radiator as a Heating Unit	3204
Apparatus of Simple Construction for Bending Heavy Pipe	3185	Automobile Steering Wheel, Electric Hand Warmer for	3282
Applications, Adjustable Counterboring Tool Has Many	3168	Automobile, Running Board on Strengthened by Brace	3246
Arbor Press, Angle Pieces Shaped in V-Block with	3205	Automobile Steering Column, Flash Light on	3229
Armature of Motor, Pipe Aids in Removing	3124	Automobile-Thief Alarm	3265
Articles in Place, Towel-Rack Improvement Keeps	3137	Automobile Use, Telephone and, Stethoscope for	3161
Asbestos Hood for a Soldering Iron	3292	Automobile Wheels, Device for Removing from Axle	3158
Asbestos Plaster, Strong, Formula for Making	3168	Automobile Wheels, Gauge Stick Useful for Aligning	3157
Ashes, Save Coal by Burning	3255	Automobile Wheel, Effective Emergency Repair for	3182
Asparagus Buncher	3300	Automobile Wheels, Removing with the Hub Cap	3244
Atomizer Starter, Spark-Plug, for Automobile Engines	3213	Automobiles, Exhaust Deflectors Keep Fumes Out of	3223
Attachment Adapts Tachometer for Shafts without End Centers	3127	Auto Motors, Truck with Lifting Platform and Cradle for	3131
Attachment for Use as Square, Hand-saw Fitted with	3251		
Attachment to Blowtorch, Soldering Iron for	3217		
Auto Air Intake Guarded for Crossing Streams	3164		





Bolts, Device for Tightening Quickly with Brace .....	3129	Car, Light, and Hand Truck, Load of Lumber Hauled by .....	3294
Bolts, Hold-Down, Alining in Concrete Foundations .....	3191	Carburetor Troubles, Chamois-Skin Gasoline Filter Avoids .....	3260
Bolts, Serviceable Tool for Cleaning Threads on .....	3200	Carpenters' Squares, Hardware Store Has Special Drawer for .....	3289
Bolts, Small, Locked Quickly by Cutting with Chisel .....	3104	Carpet Pad for Wood Planes Saves Frequent Sharpening .....	3130
Boring Bars, Lathe, Methods of Holding Tools in .....	3200	Carry Tool Checks on a Safety Pin .....	3267
Boring Large Holes in Glass .....	3220	Carrying Piano Made Easy by Handles .....	3302
Boring Small Machine Parts after Grinding .....	3170	Carrying Window Panes, Handy Wire Hook for .....	3259
Boring Tool, Pattern Maker's, for Small, Deep Work .....	3148	Cars Equipped with Split Rims, Serviceable Tire Remover for .....	3172
Bosses and Hubs on Drill Press, Tool for Machining .....	3130	Casehardening Jobs, Improvised Furnace for Small .....	3206
Bow, Snap, Aids in Making Chalk Lines Box Bottom, Self-Raising, Aids in Obtaining Contents .....	3207	Casehardening, Preventing in Dressing Circular Saws .....	3138
Boxes as Units, Stock Bins Built Up from .....	3109	Caster for Heavy Blueprint Frame, Detachable .....	3100
Boxes, Hook Fitted to Hand Truck Holds .....	3103	Casting, Hard, Novel Method of Machining Slot in .....	3144
Boxes, Winch Truck for Piling and Loading .....	3111	Casting, Tube or, Electroplating the Inside of .....	3152
Brace and Bit, Breastplate for .....	3257	Castings, Softening Hard Iron and Brass Cellar Windows, Timesaving Device to Open and Close .....	3232
Brace, Device for Tightening Bolts Quickly with .....	3129	Cement, Acid-Proof, for Pipe Fittings .....	3159
Brace, Ratchet, Remodeled for Work in Cramped Spaces .....	3242	Cement, Holdfast Leather-Belting .....	3176
Brace, Running Board on Automobile Strengthened by .....	3246	Cement, Making Drill Jigs of .....	3237
Brake, Old Automobile, Adapted for Use on Windlass .....	3192	Cement Mixture for Patching Dents in Boat Hull .....	3132
Branches and Netting, Large Minnow Net Made of .....	3112	Cement, Repairing a Cracked Water Jacket with .....	3284
Brass Scraper for Cleaning Tools .....	3212	Cement, Repairing a Pillar with .....	3254
Brass Washers, Thin, Tool for Cutting .....	3198	Cement, Roofing, Staining Wood a Dark Color with .....	3270
Bread Pans, Desk Drawers Made of .....	3261	Cements for Pipe Joints .....	3127
Breaking Porcelain Tubes Squarely .....	3100	Center Drills, Countersinking, Held in Special Chucks .....	3293
Breast Drill, Vise and, Used as a Substitute Drill Press .....	3143	Center Punch, Square-Point, Handy for Revising Marks .....	3108
Breastplate for Brace and Bit .....	3257	Center Punches Made from Old Rat-Tail Files .....	3145
Brick and Mortar, Holes Drilled through Broken Point, Setting a Lag Screw in a Hole Containing .....	3179	Centrifugal and Screw Type Pumps Work Together .....	3270
Broken Slate Instrument Panel Repaired with Angle Iron .....	3146	Chain and Padlock, Theft of Shovels Prevented by .....	3116
Brushes, Keeping Soft with Paraffin .....	3268	Chain-Driven Trucks, Reliable Oiling Systems for .....	3215
Bucket Jack, Convenient Ladder, for Roof Workers .....	3196	Chair Cane, Method of Planing .....	3157
Buggy Axle, Pinch Bar Made from .....	3257	Chair Shelf That Folds Out of the Way .....	3210
Buggy Hub Used for Repairing Worn Threads of a Pump Cylinder .....	3180	Chair Swivel, Made from Wagon-Wheel Felloes .....	3256
Building, Labor-Saving Method of Excavating under a .....	3166	Chalk Line and Reel, Self-Chalking .....	3102
Bulb, Tin Foil Winding on, Intensifies Electric Light .....	3096	Chalk Lines, Snap Bow Aids in Making .....	3207
Buncher, Asparagus .....	3300	Chalking a Tap to Get a Perfect Fit .....	3180
Burner, Renewing Enlarged Orifice in .....	3261	Chamois-Skin Gasoline Filter Avoids Carburetor Troubles .....	3260
Burrs inside Tubing and Castings Removed by File in Chuck .....	3196	Check-Out Board Helps Locate Mechanics in Shop .....	3096
Bushing Fitted snugly by Knurling or Roughening Surface .....	3097	Chemical, Handy, for Use about the Automobile .....	3200
Bushing Fuller, Adjustable .....	3296	Chest, Neat, under Lathe Holds Tools and Gears .....	3273
Buzz Saw, Glass Plate over, Protects Eyes .....	3281	Chicks, Food for, Poultry Feeder Places Out of Hens' Reach .....	3250
Cabinet Trim, Making Dentil Moldings for .....	3098	Children, Push Button Locked against Interference by .....	3256
Cable, Heavy Covered, Pipe Cutter Used to Strip .....	3134	Chipping and Breaking, Garden Hose Protects Dishes against .....	3221
Calculating Belt Lengths for Splicing .....	3245	Chisel, Small Bolts Locked Quickly by Cutting with .....	3104
Caldron Pours Molten Metal with One Hand .....	3133	Chisels, Tin Guards for Edges of .....	3137
Calibrating Automobile Gasoline Gauges Callipers for Overhead Work Eliminate Use of Ladder .....	3174	Chopping Board, Handy Kitchen .....	3302
Call-Bell System, Emergency, Has Permanent Wiring .....	3294	Chuck Holds Auto Timers for Refinishing .....	3262
Camera, Motorcycle Back Rest to Carry Camp or Motorboat, Loud-Sounding Air Whistle for .....	3236	Chuck, Jaws for Holding Hexagonal Stock in .....	3109
Can or Container, Clips for Holding Straining Cloth over .....	3124	Chuck, Micrometer Used as Indicator on Work in .....	3128
Cans or Buckets, Automatic Shut-Off for Filling .....	3231	Chuck Which Centers and Drives Pistons being Machined in Lathe .....	3181
Canvas, Binder, Method of Preventing from Ripping .....	3171	Chucks, Special, Countersinking Center Drills Held in .....	3293
Caps, Wooden, Convert Machinists' Vise into Bench Clamp .....	3158	Chute for Coal Wagon, Adjustable .....	3291
Car Leaving Garage Automatically Gives Warning .....	3232	Cigar-Case Humidifier, Electric .....	3197
		Cigarette Box Deals Out One at a Time .....	3201
		Circuits, Experimental, Timesaving Magazine Fuse Box .....	3218
		Circular Saw, Discarded, Forms Loud Bell for Use in Shop .....	3250
		Circular Saws, Preventing Casehardening in Dressing .....	3128



Cistern Cap, Reinforced-Concrete.....	3193	Concrete Culverts, Wagon Wheels Provide Forms for.....	3108
Cistern, Old, Remodeled as Storage Space.....	3123	Concrete Flywheels for Light Foot-Power Machinery.....	3140
Cistern Pump, Outside, Operated from the Kitchen.....	3236	Concrete, Forge of, for Single or Multiple Use.....	3123
Clamp, Handy, Made from Waste Materials.....	3171	Concrete Foundations, Alining Hold-Down Bolts in.....	3191
Clamp Holds Work Down on Top of Bench.....	3246	Concrete Highways, Wooden Roller Aids Construction of.....	3159
Clamp, Three-Way Hand, Has Many Uses.....	3144	Concrete Safe, How to Make Fireproof.....	3206
Clamp, Woodworkers, Compressing Stiff Clutch Springs with.....	3264	Concrete Sidewalks, Folding Square for Dividing.....	3197
Clamping Beveled-End Work, Half-Round Blocks Aid in.....	3145	Concrete, Small Drains in, Made with Pipes.....	3100
Clamping Block for Filling Scraper Blades.....	3258	Concrete Tombstone, Homemade.....	3281
Clamping Device, Adjustable, for the Machine Shop.....	3158	Concrete Ventilating System for Stable.....	3241
Clamps the Work, Bench Stop Which.....	3271	Conduit, Bending Easily at Workbench.....	3226
Clean, Keep Lamps.....	3268	Conduit Elbows, Device for Bending.....	3177
Cleaning a Clock Quickly and Thoroughly.....	3199	Cone Container Conserves Powdered Emery.....	3229
Cleaning Files with Block of Wood.....	3147	Connecting Sections of Pipe, Easy Method of.....	3160
Cleaning Out Clogged Drains with Fluid Pressure.....	3274	Connections, Loose, Electric Ignition System Wired to Counteract.....	3179
Cleaning Screw-Machine Products, Tank for.....	3174	Conical Points for Engine Bolts Simplify Motorcycle Repairs.....	3139
Cleaning Small Pinion Gears, Efficient Method of.....	3167	Conserving Small Pieces of High-Speed Steel, Tool for.....	3176
Cleaning Threads on Bolts, Serviceable Tool for.....	3200	Construction of Concrete Highways, Wooden Roller Aids in.....	3159
Cleaning Tools, Brass Scraper for.....	3212	Contact Blades, Knife-Switch, Testing, Control, Extension, for Tractor Aids in Work of Plowing.....	3176
Clips for Holding Straining Cloth over Can or Container.....	3124	Converting a Passenger Automobile into Delivery Car.....	3237
Clock, Cleaning Quickly and Thoroughly.....	3199	Converting Broken Drills into Lathe Tools.....	3221
Clogged Spout Readily Cleaned with Hose.....	3233	Converting Metric Measures, Quick Methods of.....	3192
Close of Workday, Machines Oiled at, Start Easily in Cold.....	3134	Cooling Coil in Supply Pipe, Cold-Water System with.....	3180
Close Work, Handle for Bits for.....	3204	Cooling Fan, Rim Reinforces.....	3102
Closing Cast-Iron Pipe Ends without a Plug.....	3260	Cooling Large Bearings with Grounded Copper Wires.....	3127
Clothes, Mechanic's, Laundered by Exhaust Steam.....	3279	Copper Rivets, Method of Making from Annealed Wire.....	3122
Clutch, Holding a Loose Grease Cup on.....	3133	Copper Tubes, Small, Cutting with Side-Cutting Pliers.....	3165
Clutch Springs, Stiff, Compressing with Woodworkers' Clamp.....	3264	Copper Wires, Grounded, Cooling Large Bearings with.....	3127
Coal Bin, Outside, Provides Convenient Storage.....	3229	Corn, Seed, Testing for Germination.....	3258
Coal, Heat and, Partitioning Off a Room to Save.....	3258	Cotter-Pin Extractor Has Hammer Built In.....	3245
Coal, Keep Wet.....	3249	Cotter Pins, Holder and Pick-Up Tool for.....	3242
Coal Pipe, Extinguishing Spontaneous Fire in.....	3252	Cotton and Muslin, Respirator Made of.....	3116
Coal, Sand Furnace for House Heating Conserves.....	3209	Counterboring Tool, Adjustable, Has Many Applications.....	3168
Coal, Save by Burning Ashes.....	3255	Countersinking Center Drills Held in Special Chucks.....	3293
Coal, Thermometers Save in Small Plant.....	3250	Counterweight Returns Block and Tackle to Loading Point.....	3129
Coal Wagon, Adjustable Chute for.....	3291	Counterweights on Portable Drills and Other Heavy Tools.....	3228
Coal Rack, An All-Metal.....	3298	Coupling, Locomotive-Apron Holder Aids Quick.....	3141
Coal Is Handy Gauge for Spark-Plug Gap.....	3118	Coupling, Removing a Broken Nipple from.....	3212
Cold, Machines Oiled at Close of Workday Start Easily in.....	3134	Cover for Oil Holes in Dirty Places.....	3244
Cold-Water System with Cooling Coil in Supply Pipe.....	3180	Cover, Milk-Bottle.....	3260
Collapsible Tubes, Keeping Inverted Prevents Contents Drying Out.....	3259	Cracks in Concrete, Filling with Putty.....	3201
Collar for Flue-Cutter Slip-Joint Shaft.....	3194	Cramped Spaces, Work in, Ratchet Brace Remodeled for.....	3242
Collars, Old Linen, Make Good Marking Tapes.....	3287	Crane at Rear of Truck Helps Load and Unload.....	3298
Color, Dark, Staining Wood with Roofing Cement.....	3270	Crane Shop Truck That may be Picked Up by.....	3220
Color-Light Electrical Shop-Call System.....	3197	Crank-Case Bolts, Automobile, One-Man Wrench for.....	3267
Comb for Gooseberry Picking Saves Time and Fingers.....	3225	Crank Cases, Testing Oil Level in Automobile.....	3229
Combination Stepladder and Portable Elevator.....	3181	Crankcase, Improved Electromagnet Picks Wrench from.....	3276
Comfort to Workmen, Fans Belted from Mill Shaft Give.....	3151	Crankshaft with a Cracked Web, Emergency Repair for.....	3263
Compass-Point Centers, Fixing on Drawing Sheets.....	3179	Creeper for Use under Vehicles is Provided with Tool Trays.....	3153
Compression in Cylinders of Automobile Motor, Testing.....	3110	Creeper, Shield on, Protects Face When Working under Auto.....	3148
Compression of Cylinder Which is Not Firing, Relieve.....	3217	Crushed, Railing Protects Young Pigs from being.....	3260
Compressing Spring Wire While Bending Preserves Strength.....	3260	Culverts, Concrete, Wagon Wheels Provide Forms for.....	3108
Compressing Stiff Clutch Springs with Woodworkers' Clamp.....	3264		
Compression of Old Gas Engines, Improving.....	3211		
Concrete, Cracks in, Filling with Putty.....	3201		

Cupola Made from an Old Boiler.....	3219	Drafting, Fingers for Holding Spline Weights in.....	3211
Curved Surfaces, Sandpaper Block for Use on.....	3168	Drafting Jobs, Making Special Angles and Curves for.....	3259
Curves, Irregular, Homemade Gauge for Cutter, Handy Twine Holder and.....	3284	Drafting Table, Convenient Bench for Use at.....	3155
Cutting Disks or Rings Accurately from Sheet Metal.....	3162	Drafting Work, Small, Easily Done without a T-Square.....	3291
Cutting Small Copper Tubes with Side-Cutting Pliers.....	3165	Draftsman's Time, Ink-Bottle Stopper Lifter Saves.....	3139
Cutting Thin Brass Washers, Tool for.....	3198	Draftsman's Tools, Handy Rack Holds.....	3254
Cutting Washers and Packings, Homemade Machine for.....	3144	Draftsman's Triangle, Useful Kinks for Improving the.....	3277
Cutting with Chisel, Small Bolts Locked Quickly by.....	3104	Draftsman's Triangle with Raised Points or Feet.....	3296
Cycle Motor, Discarded, Garage Air Compressor Made from.....	3166	Draftsmen, Pen Wiper for.....	3283
Cylinder, Steam-Engine, Device for Vulcanizing Tires on.....	3171	Drain, Subsurface, Mole Plow Makes without Use of Tile.....	3182
Cylinder Which is Not Firing, Relieve Compression of.....	3217	Draining Pipes in an Unoccupied House for the Winter.....	3234
Cylinders, Guide for Inserting Piston Rings in.....	3133	Drains, Clogged, Cleaning Out with Fluid Pressure.....	3274
Cylinders of Automobile Motor, Testing Compression in.....	3110	Drains, Small, in Concrete, Made with Pipes.....	3100
Cylinders, Rebored, Old Piston Used to Polish.....	3233	Drawer, Portable Tool.....	3282
Cylinders, Scored, Repaired by Soldering.....	3285	Drawer, Special, for Carpenters' Squares, Hardware Store Has.....	3289
Dairy Barn, War-time Efficiency Methods Applied to.....	3163	Drawers, Desk, Made of Bread Pans.....	3261
Dance Floor, How to Make Wax for.....	3202	Drawers, Sliding, Lubricated Varnish Eliminates Trouble with.....	3260
Dehydrating Denatured Alcohol.....	3181	Drawers under Bench, Vise to Catch Fillings.....	3166
Delivery Car, Converting a Passenger Automobile into.....	3237	Drawing Paper, Fastening Tightly to the Board.....	3278
Denatured Alcohol, Dehydrating.....	3181	Drawing Sheets, Fixing Compass-Point Centers on.....	3179
Denatured Alcohol, Simple Test to Distinguish Wood Alcohol from.....	3157	Drawings Superseded by Others Plainly and Promptly Marked.....	3117
Dentil Moldings for Cabinet Trim, Making.....	3098	Drawings, Weighted Rulers Keep from Rolling When in Use.....	3161
Dents in Auto-Body Panels and in Tanks, Removing.....	3140	Dressing Circular Saws, Preventing Casehardening in.....	3138
Depth Gauge for Hacksaw.....	3119	Drift Pin, Removing Tailstock Centers Easily by Means of.....	3219
Depth Gauge for Wooden Miter Boxes.....	3214	Drift Tool for Easy Removal of Taper-Shank Drills.....	3184
Depth Gauge, Simple, for Blind Holes in Wood.....	3197	Drill for Enlarging the Bottom of Threaded Holes.....	3155
Desk Drawers Made of Bread Pans.....	3261	Drill Holes, Punch for Laying Out.....	3281
Desk, Strong and Inexpensive, Made for Shop Use.....	3104	Drill Jig for Formed Flat Pieces.....	3226
Device for Lifting Barrels to be Emptied Die-Casting Machine, Homemade.....	3096	Drill Jigs of Cement, Making.....	3237
Digging Holes in Dry Ground with a Hose.....	3243	Drill-Press Attachment for Bench Lathe Drill Press, Substitute, Vise and Breast Drill Used as.....	3143
Dirt and Grease on Engine Work, Protecting the Hands from.....	3126	Drill, Twist, Alteration Adapts for Soft Metals.....	3225
Dirty Places, Cover for Oil Holes in.....	3244	Drill Press, Tool for Machining Bosses and Hubs on.....	3130
Disappearing Stairway, A.....	3275	Drill Press, Using as a Wood-Turning Lathe.....	3132
Dishes, Garden Hose Protects against Chipping and Breaking.....	3221	Drilling, Balancing Rotating Machine Parts by.....	3142
Disk-Bearing Stand for Balancing Rotary Machine Parts.....	3128	Drilling, Handle for Holding Polished Round Stock for.....	3187
Disks or Rings, Cutting Accurately from Sheet Metal.....	3162	Drilling Holes in Steel Plates, Rigging Lessens Work of.....	3134
Dissolving Boiler Scale Saves Fuel and Provides More Heat.....	3253	Drilling Holes through Heavy Metal with a Bit Brace.....	3271
Divided Window Shades Permit Fine Adjustment of Light.....	3261	Drilling Sheet Metal, Power-Punching or Spacing Gauge for.....	3173
Dividers, Sphere Attachment for, When Measuring from Holes.....	3168	Drilling Small Sheet-Metal Pieces, Jig for.....	3177
Dividing Concrete Sidewalks, Folding Square for.....	3197	Drills, Broken, Converting into Lathe Tools.....	3221
Door and Window Fitting, Bevel Square for.....	3206	Drills, Drift Tool for Easy Removal of Taper-Shank.....	3184
Door Bumpers, Base Knobs or, Put to Various Uses.....	3252	Drills, Portable, and Other Heavy Tools, Counterweights on.....	3228
Door, Four Men Use Two Padlocks on One.....	3228	Dry-Cell Filler, Iron Cement Made from Old.....	3182
Door Knobs Make Convenient Handles for Bits.....	3117	Drying a Lens Properly.....	3280
Door Latch Controlled from Kitchen Saves Many Steps.....	3230	Drying Out, Keeping Collapsible Tubes Inverted Prevents Contents from.....	3259
Door Latch Operated by Sign Reading "No Admittance".....	3301	Durable Hingeless Field Gate.....	3262
Door, Proper Placing of Three Hinges on Doors, Double, Pulley Arrangement is Helpful in Operating.....	3145	Dust Cap from Tire Valve, Screwdriver Handle Made of.....	3258
Doors Have Removable Panels for Summer and Winter Use.....	3206	Easy-Running T-Square for Vertical Boards.....	3223
Doors, Heavy, Building in Place Saves Trouble of Hanging.....	3254	Ebony Finish, Selecting Wood to Take.....	3174
Dot and Dash Ruler Easily Made.....	3214	Edge, Removable Heavy, for the Bench.....	3233
Dowel Cutter for the Home Workshop.....	3154	Efficiency, Auto Stop Block Reduced to.....	3296
Dowel Pins, Wooden, Knitting Needles and, Hollow Mill for Making.....	3190	Efficiency Methods, War-Time, Applied to the Dairy Barn.....	3283
Draft-Proof Window for Small-Shop Ventilation.....	3169		

Efficient Method of Cleaning Small Pinion Gears .....	3167	Eyes, Glass Plate over Buzz Saw Protects .....	3231
Elbows, Conduit, Device for Bending .....	3177	Fabric, Rubber Gum and, Convenient Back for .....	3253
Electric Backing-Up Automobile Light, Automatic .....	3219	Face, Shield on Creeper Protects, When Working under Auto .....	3148
Electric Bells Having Small Transformers, Improvement for .....	3122	Factory Smokestacks, Blasting Soot from .....	3154
Electric Cigar-Case Humidifier .....	3197	Fan, Cooling, Rim Reinforces .....	3102
Electric Furnaces, Small, for Shop or Laboratory .....	3145	Fans Belted from Mill Shaft Give Comfort to Workmen .....	3151
Electric Globes, Tools for Handling without a Ladder .....	3146	Farm, Vessel for Cooking Potatoes for Hogs on .....	3274
Electric Ignition System Wired to Counteract Loose Connection .....	3179	Fasteners, Emergency Corrugated, for Use in Woodwork .....	3159
Electric Hand Warmer for Automobile Steering Wheel .....	3282	Fastening Drawing Paper Tightly to the Board .....	3278
Electric Light Socket, Improved .....	3175	Faucet, Stop on, Avoids Oil Leakage .....	3291
Electric Light, Tin Foil Winding on Bulb Intensifies .....	3095	Faucets in Washbowl, Foot Control Handy for .....	3264
Electric-Soldering Tongs .....	3272	Fellies, Wagon-Wheel, Swivel Chair Made from .....	3256
Electrical Shop-Call System, Colored-Light .....	3197	Fence, Portable, Formed of Easily Detached Sections .....	3296
Electricians' Knives, Old Hack Saw Blades Converted into .....	3142	Ferrule, Metal, Simple Method of Making and Attaching a .....	3205
Electricians' Tape, Renewing Old .....	3256	Field Gate, Durable Hingeless .....	3262
Electricians' Tools, Handy, Made from Old Hack Saw Blades .....	3165	File Handles Convenient on Large Tee Wrenches .....	3119
Electricity, Gas Water Heater Controlled by .....	3238	File in Chuck, Burrs inside Tubing and Castings Removed by .....	3196
Electromagnet, In-provised, Picks Wrench from Crankcase .....	3276	Files, Cleaning with Block of Wood .....	3147
Electroplating Rack for Small Pieces, Convenient .....	3208	Files Made of Sandpaper Handy in Woodwork .....	3151
Electroplating the Inside of a Tube or Casting .....	3152	Files, Old, Made Serviceable by Treating with Acid .....	3157
Elevator, Portable, Combination Step-ladder and .....	3181	Files, Old Rat-Tail, Center Punches Made from .....	3146
Elevator, Swinging, for Trunks and Light Freight .....	3293	Filing Scraper Blades, Clamping Block for .....	3253
Elimination of Belt Slippage Conserves Fuel .....	3218	Fillings, Drawers under Bench Vise to Catch .....	3168
Emergency Call-Bell System Has Permanent Wiring .....	3294	Filler, Shim or, Proper Shape to Cut .....	3217
Emergency Fuse Repair .....	3236	Filling Cans or Buckets, Automatic Shut-Off for .....	3231
Emergency Nut Cast of Babbitt .....	3299	Filling Cracks in Concrete with Putty .....	3201
Emery, Powdered, Cone Container Conserves .....	3229	Filter, Oil, and Tank for the Shop .....	3119
Emery-Wheel Motors, Pedal Switch for .....	3244	Fingers for Holding Spline Weights in Drafting .....	3211
Emery Wheels, Safety Washer for Fastening .....	3177	Fingers, Friction Lock Keeps Vise Ball Point from Injuring .....	3118
End Cap of Roofing Rolls, Soap Dish Made from .....	3237	Finish, Ebony, Selecting Wood to Take .....	3174
Engine Bolts, Conical Points for, Simplify Motorcycle Repairs .....	3139	Fire, Lighting at Top Saves Fuel .....	3284
End Centers, Attachment Adapts Tachometer for Shafts without .....	3127	Fire, Spontaneous, in a Coal Pile, Extinguishing .....	3252
Engine Exhaust, Hot Water for Boat from .....	3121	Fireproof Concrete Safe, How to Make .....	3206
Engine, Novel Repair for Cracked Water Jacket on .....	3127	Firing, Relieve Compression of Cylinder Which is Not .....	3217
Engine Pistons, Rusted, Loosening with Hot Water .....	3120	Fish, Harpoon Gun for Spearing, Made from Old Rifle .....	3151
Engine Work, Protecting the Hands from Dirt and Grease on .....	3126	Fit, Nice, Scraping Babbitt Bearings to .....	3112
Engines, Overhead-Valve, Tool for Lifting Rocker Arms on .....	3260	Fit, Perfect, Chalking a Tap to Get .....	3180
Engines, V-Type, Lubricating Piston Pins on .....	3248	Fitting Bearing Adjustments Accurately .....	3230
Enlarging Pistons by Peening to Eliminate Slap .....	3272	Fitting Metal Gaskets Securely in Bolted Flanges .....	3099
Enlarging the Bottom of Threaded Holes, Drill for .....	3155	Fitting Pins Tightly in Oversize Holes .....	3223
Etching a Hole through Hardened Steel .....	3139	Fixtures, Lofly Ceiling, Replacing Incandescent Lamps in .....	3279
Etching on Glass and Metal with a Sandblast .....	3266	Flagpole, Substantial .....	3292
Excavating under a Building, Labor-Saving Method of .....	3166	Flanges, Bolted, Fitting Metal Gaskets Securely in .....	3099
Exhaust Collectors Keep Fumes Out of Automobiles .....	3223	Flanges, Old Gaskets Sawed Out from between .....	3097
Exploiting Old Photographic Negative Glass .....	3153	Flash Light on Automobile Steering Column .....	3229
Extension Control for Tractor Aids in Work of Plowing .....	3175	Flat Pieces, Formed, Drill Jig for .....	3226
Extinguishing Spontaneous Fire in a Coal Pile .....	3252	Float Mooring, Substantial, for Small Boats .....	3110
Extractor, Cotter-Pin, Has Hammer Built In .....	3245	Flue-Cutter Slip-Joint Shaft, Collar for Fluid Pressure, Cleaning Out Clogged Drains with .....	3194
Eye, Easy Method of Removing Foreign Particles from .....	3156	Flutes, Method of Milling in Taps and Reamers .....	3186
Eye, Safety Tool Extracts Particles from Eyelets Handy in Lacing Holes of Light Belts .....	3239	Fluxing, Difficult, Solder Paste for .....	3184
	3104	Fly Screen, Device for Stretching over Frames .....	3167
		Fly Screens, Fastening in Sashes with Stove Bolts .....	3158
		Flywheels, Concrete, for Light Foot-Power Machinery .....	3140
		Folds Out of the Way, Chair Shelf .....	3210



Force Pump, Long Lever Eases Action of Foreign Particles, Easy Method of Removing from the Eye.....	3156	Gasoline-Torch Piston Leathers, Making Gate, Durable Hingeless Field.....	3287
Forge Fire, Handy Method of Heating Rivets in.....	3100	Gate Hinge, Springless Self-Closing....	3283
Forge of Concrete for Single or Multiple Use.....	3123	Gauge, Handy, Coin Is for Spark-Plug Gap.....	3118
Forms for Concrete Culverts, Wagon Wheels Provide.....	3108	Gauge, Homemade, for Irregular Curves.....	3122
Formula for Making Strong Asbestos Plaster.....	3168	Gauge, Measuring, for Power Hacksaw.....	3301
Food for Chicks, Poultry Feeder Places Out of Hens' Reach.....	3250	Gauge, Spacing, for Power-Punching or Drilling Sheet Metal.....	3173
Foot Control Handy for Faucets in Washbowls.....	3264	Gauge Stick Useful for Alining Automobile Wheels.....	3157
Foot-Power Hammer for Use in Small Shops.....	3165	Gauge Tells Height of Water in Elevated Tank.....	3224
Footstool Made from Harness Hooks....	3297	Gauges, Calibrating Automobile Gasoline.....	3212
Foundry, Barrel Tumbler for Punch Shop or.....	3292	Gear Patterns, Making Emergency.....	3184
Fountain-Pen Filler, Using to Fill Ruling Pens.....	3236	Gear Puller Cheaply Made from an Old Metal Screw Clip.....	3204
Four Men Use Two Padlocks on One Door.....	3228	Gears, Broken, Patching Teeth into....	3117
Frame Holds Oilcan and Tilts for Pouring.....	3261	Gears, Small Pinion, Efficient Method of Cleaning.....	3167
Frames, Device for Stretching Ply Screen over.....	3167	"German Soldiers," Lead, Used as Targets.....	3282
Freezing, Keeping Water Trough from Friction, Lock Keeps Vise Ball Points from Injuring Fingers.....	3248	Germination, Testing Seed Corn for.....	3288
Frozen Water Pipes, Steam Jet to Thaw Fruit Trees, Heavily Laden, Braced with Wires.....	3172	Glass and Metal, Etching on with a Sandblast.....	3266
Fuel, Dissolving Boiler Scale Saves, and Provides More Heat.....	3253	Glass, Boring Large Holes in.....	3220
Fuel, Elimination of Belt Slippage Conserves.....	3218	Glass, Exploiting Old Photographic Negative.....	3153
Fuel, Good, Used Oil from Auto Engines Makes.....	3279	Glass Plate over Buzz Saw Protects Eyes.....	3281
Fuel, Lighting a Fire at Top Saves.....	3284	Glass, Small Piece of, Useful in Tool Grinding.....	3254
Fuel, Saving in Plant Which Burns Oil.....	3248	Good and Bad Scraper Edges.....	3300
Fuel-Saving Kinks Valuable in the Home.....	3264	Gooseberry Picking, Comb for, Saves Time and Fingers.....	3225
Fuel, Saving on the Gas Range.....	3282	Gauges, Revolving Cone for Sharpening All Sizes of.....	3129
Fumes, Exhaust Deflectors Keep Out of Automobiles.....	3223	Grain, Making Wood Screws Hold When Parallel to.....	3273
Fuse Block, Rack near Holds Fuses for Emergency.....	3162	Grain, Making Wood Screws Hold When Parallel to.....	3133
Fuse Blocks, Tool for Removing and Applying Safely.....	3140	Grease Cup, Loose, Holding on a Clutch Grease Cup to Contain Ink for Proof Press.....	3211
Fuse Box, Timesaving Magazine, for Experimental Circuits.....	3218	Grinding, Boring Small Machine Parts after.....	3170
Fuse Repair, Emergency.....	3236	Grip, Hoisting Hook Has Instantaneous Positive.....	3176
Fuses, Rack near Fuse Block Holds for Emergency.....	3162	Groove Plane Made from Rip Saw.....	3271
Furnace, Hot-Air, Auxiliary Oil Burners in.....	3247	Grooved Pulley Made of Barrel Heads.....	3262
Furnace, Improvised, for Small Case-hardening Jobs.....	3206	Ground, Dry, Digging Holes in, with a Hose.....	3243
Furnace, Sand, for House Heating Conserves Coal.....	3209	Guards, Tin, for Edges of Chisels.....	3137
Garage Air Compressor Made from Discarded Cycle Motor.....	3166	Guide for Inserting Piston Rings in Cylinders.....	3133
Garage, Car Leaving Automatically Gives Warning.....	3232	Guideboards Are Great Aid for Correct Saw Filing.....	3179
Garage "Free-Air" Hose at Curbing, Support for.....	3114	Hacksaw Blades, Handy Electrician's Tools Made from.....	3165
Garbage Can, To Keep Animals from Molesting.....	3233	Hacksaw Blades, Old, Converted into Electrician's Knives.....	3143
Garden Hose, Protects Dishes against Chipping and Breaking.....	3221	Hacksaw Blades with Broken Teeth, Using.....	3229
Gas Burner for Kitchen Range, Quickly Made.....	3238	Hacksaw, Depth Gauge for.....	3119
Gas Engines, Old, Improving Compression of.....	3211	Hacksaw, Power, Measuring Gauge for Hammer Built In, Cotter-Pin Extractor Has.....	3245
Gas Pipe Guides Nails Driven in Close Quarters.....	3148	Hammer, Foot-Power, for Use in Small Shops.....	3165
Gas Range, Saving Fuel on.....	3282	Hammer Handles, Prolonging the Life of.....	3162
Gas, Saving, in Heating Water.....	3287	Hammer-Head Holds Fast.....	3185
Gas Soldering Torch, Self-Lighting....	3190	Hammer Inspectors' Stamp Built into.....	3297
Gas Torch Lighter for, Made from a Spark Plug.....	3295	Hand Clamp, Three-Way, Has Many Uses.....	3144
Gas Water Heater Controlled by Electricity.....	3238	Hand One, Caldron Pours Molten Metal with.....	3133
Gaskets, Metal, Fitting Securely in Bolted Flanges.....	3099	Hand Plow Rigged in Bicycle Frame....	3100
Gaskets, Old, Sawed Out from between Flanges.....	3097	Hand Punches, Using High-Speed Steel for.....	3241
Gasoline Filter, Chamolis-Skin, Avoids Carburetor Troubles.....	3260	Hand, Soldering-Iron Shield Protects from Dripping Solder.....	3160
Gasoline Gauges, Calibrating Automobile.....	3212	Hand Trucks, Moving Lathe Easily with Hand Warmer, Electric, for Automobile Steering Wheel.....	3282
		Handle, Convenient Homemade Scraper Handle, Detachable, Convenient for Paint Buckets.....	3161
		Handle for Bits for Close Work.....	3103
		Handle for Holding Polished Round Stock for Drilling.....	3187
		Handle for Scraper Blades.....	3281
		Handle for Tool Box, Excellent, Box Brace Makes.....	3220

- Handles, Carrying Piano Made Easy by 3302  
 Handle, Emergency, for Screwdriver... 3224  
 Handles for Bits, Convenient, Door  
 Knobs Make 3117  
 Handles for Pliers and Other Tools,  
 Insulating 3283  
 Handling of Auto Chassis, Loading  
 Truck Facilitates 3263  
 Handling of Rough Lumber, Pivot Stand  
 Aids in 3170  
 Hands, Moving, Scar-crow with... 3239  
 Hands, Protecting from Dirt and Grease  
 on Engine Work 3126  
 Handsaw Fitted with Attachment for  
 Use as Square 3251  
 Handy Outfit, Shoe Shining at Home  
 Made Easy by 3276  
 Hanging, Building Heavy Doors in  
 Place Saves Trouble of 3254  
 Hanging Oilcan Handy for Overhead  
 Work 3107  
 Hard Wood, Handy Tool Drives Small  
 Nails into 3156  
 Hardening Long, Thin Pieces without  
 Warping 3300  
 Harness Hooks, Footstool Made from... 3297  
 Harpoon Gun for Spearling Fish Made  
 from Old Rifle 3151  
 Hardware Store Has Special Drawer for  
 Carpenters' Squares 3289  
 Head-Fitting and Bar-Fastening Repair  
 for Motorcycle 3152  
 Head, Headrest for Auto Mechanic  
 Strapped to His 3296  
 Headrest for Auto Creeper Made from  
 Inner Tube 3246  
 Headrest for Auto Mechanic Strapped to  
 His Head 3296  
 Heat and Coal, Partitioning Off a Room  
 to Save 3258  
 Heat, Dissolving Boiler Scale Saves Fuel  
 and Provides More 3253  
 Heat, Large Kettle Inverted over Soft-  
 Coal Fire Saves 3267  
 Heater, Automobile-Exhaust, Mounted  
 in Floor Register 3251  
 Heating Device, Suspension, for Small  
 Utensils 3147  
 Heating, House, Sand Furnace for, Con-  
 serves Coal 3209  
 Heating Rivets in Forge Fire, Handy  
 Method of 3100  
 Heating Unit, Automobile Radiator as a  
 Heating Water, Saving Gas in 3204  
 Heel Block, Ankle Strains in Driving  
 Relieved by 3113  
 Height of Water in Elevated Tank,  
 Gauge Tells 3224  
 Hens' Reach, Poultry Feeder Places Food  
 for Chicks Out of 3250  
 Hexagonal Stock, Jaws for Holding in  
 Chuck 3109  
 High-Speed Steel for Hand Punches,  
 Using 3241  
 Highways, Concrete, Wooden Roller Aids  
 Construction of 3159  
 Hinge, Springless Self-Closing Gate... 3283  
 Hingeless Field Gate, Durable 3262  
 Hinges, Rattling of Automobile Doors  
 Overcome by Settling 3097  
 Hinges, Three, Proper Placing of, on a  
 Door 3282  
 Hog House of Saw-Tooth Design, Sanitary  
 3149  
 Hogs on the Farm, Vessel for Cooking  
 Potatoes for 3274  
 Hogs, Snout Snare Makes It Easy to  
 Ring 3225  
 Hoisting Hook Has Instantaneous Posi-  
 tive Grip 3176  
 Holder and Pick-Up Tool for Cotter  
 Pins 3242  
 Holder, Locomotive-Apron, Aids Quick  
 Coupling 3141  
 Holdfast, Hammer-Head 3185  
 Holding Split Patterns in the Lathe... 3280  
 Hole, Etching through Hardened Steel... 3139  
 Hole, Tapping without a Tap 3210  
 Holes Drilled through Brick and Mortar  
 3179  
 Holes, Drilling through Heavy Metal  
 with a Bit Brace 3271  
 Holes in Dry Ground, Digging with a  
 Hose 3243  
 Holes in Steel Plates, Rigging Lessens  
 Work of Drilling 3134  
 Holes, Large, Boring in Glass 3220  
 Holes, Large, Reaming with an Ordinary  
 Twist Drill 3297  
 Holes of Light Belts, Eyelets Handy in  
 Lacing 3104  
 Holes, Oversize, Fitting Pins Tightly in  
 Holes, Sphere Attachment for Dividers  
 When Measuring from 3168  
 Home, Fuel-Saving Kinks Valuable in... 3264  
 Home or Shop Use, Simple Pipe Bender  
 for 3169  
 Hood for a Soldering Iron, Asbestos... 3292  
 Hook Fitted to Hand Truck Holds Boxes  
 3103  
 Hook Supports for Threading and Fit-  
 ting Long Pipes 3135  
 Hopper, Sorting, for Berries and Small  
 Vegetables 3123  
 Hose, Clogged Spout Readily Cleared  
 with 3232  
 Hose, Digging Holes in Dry Ground with  
 Hose, Garage "Free-Air" Support for,  
 at Curbing 3243  
 Hot-Air Furnace, Auxiliary Oil Burners  
 in 3247  
 Hot Water for the Boat from Engine  
 Exhaust 3121  
 Hot Water, Loosening Rusted Engine  
 Pistons with 3120  
 House Heating, Sand Furnace for, Con-  
 serves Coal 3209  
 House, Unoccupied, Draining Pipes in,  
 for the Winter 3234  
 Houses, Finished, Magnetic Locator Use-  
 ful in Wiring 3300  
 Hub Cap, R-moving Automobile Wheels  
 with 3244  
 Humidifier, Electric Cigar-Case... 3197  
 Hydraulic Pump Is Independent of  
 Water Levels 3135  
 Identification, Large Jigs and Templates  
 Painted for 3113  
 Identifications, Serial-Number, on Work-  
 ing Drawings Save Time 3131  
 Ignition Distributor of Auto Engine,  
 Rubber Tube Protects 3128  
 Ignition System, Electric, Wired to  
 Counteract Loose Connections 3179  
 Improving an Old Ladle 3273  
 Improving the Draftsman's Triangle,  
 Useful Kinks for 3277  
 Incandescent Lamps in Lofty Ceiling  
 Fixtures, Replacing 3279  
 Inch, The Thousandth of 3281  
 Indicator on Work in Chuck, Micrometer  
 Used as 3128  
 Inexpensive Belt-Sander Made from a  
 Lathe 3235  
 Inflating Tires with Air by Use of City  
 Water Pressure 3169  
 Injury, Tray for Moving Small Threaded  
 Parts without 3167  
 Ink-Bottle Stopper Lifter Saves Drafts-  
 man's Time 3139  
 Ink for Proof Press, Grease Cup to Con-  
 tain 3211  
 Ink Pad, Handy Rubber-Stamp, for the  
 Shop Office 3194  
 Inner Tube, Headrest for Auto Creeper  
 Made from 3246  
 Inspectors' Stamp Built into Hammer... 3297  
 Insulating Handles for Pliers and Other  
 Tools 3283  
 Interference by Children, Push Button  
 Locked against 3256  
 Invalids' Table Rests on Bed 3298  
 Iron and Brass Castings, Softening Hard  
 Iron Cement Made from Old Dry-Cell  
 Filler 3188  
 Iron, Soldering Electrically without... 3100  
 Ironing Board with Novel Features... 3222  
 Irregular Outline, Band Saw Cuts Out  
 Paper Labels of 3191  
 Jackscrew, Adjustable Supporting Stand  
 Substitute for 317  
 Jaws for Holding Hexagonal Stock in  
 Chuck 3109  
 Jig for Drilling Small Sheet-Metal Pieces  
 3177  
 Jig for Holding a Round Rod to be  
 Drilled 3196



Jig, Segment-Joining, for the Home Workshop	3202	Lid Is Opened, Tool-Chest Tray Rises When	3278
Jig, Wedge-Clamp, Helps Speed Up Production	3230	Lifter, Ink-Bottle Stopper, Saves Draftsman's Time	3139
Jigs and Templates, Large, Painted Red for Identification	3113	Lifting Barrels to be Emptied, Device for	3096
Jobs, Difficult, Flexible Scraper Makes Easy	3191	Lifting Large Objects, Novel Method for	3203
Kerosene Burner or Stove Readily Made	3244	Lifting Platform and Cradle for Auto Motors Truck with	3131
Kettle, Large, Inverted over Soft-Coal Fire Saves Heat	3267	Light, Automatic Electric Backing-Up Automobile	3210
Keyways, Tool for Laying Out	3193	Light, Divided Window Shades Permit Fine Adjustment of	3261
Kink, Useful, for Valve-Grinding Jobs	3191	Lighter for Gas Torch Made from a Spark Plug	3295
Kitchen Cabinet, Sanitary, How to Make	3227	Lighting a Fire at the Top Saves Fuel	3284
Kitchen Chopping Board, Handy	3302	Linen Collars, Old, Make Good Marking Tags	3287
Kitchen, Door Latch Controlled from, Saves Many Steps	3230	Liners for Linotype Machines, Homemade Built-Up	3114
Kitchen, Outside Cistern Pump Operated from	3236	Linotype Machines, Homemade Built-Up Liners for	3114
Kitchen Range, Quickly Made Gas Burner for	3238	Load of Lumber Hauled by Light Car and Hand Truck	3294
Kitchen, Wood Box Built into Wall of	3249	Loading Boxes, Piling and, Winch Truck for	3111
Knife-Switch Contact Blades, Testing	3142	Loading Point, Counterweight Returns Block and Tackle to	3129
Knitting Needles and Dowel Pins, Wooden, Hollow Mill for Making	3190	Loading Truck Facilitates Handling of Auto Chassis	3263
Labor, Pedal Extension on Auto-Jack Lever Saves	3214	Locating Bolt Holes Where Scriber Cannot be Used	3245
Labor-Saving Method of Excavating under a Building	3166	Locator, Magnetic, Useful in Wiring Finished Houses	3300
Ladder Bucket Jack for Roof Workers, Convenient	3196	Lock, Friction, Keep Vise Ball Points from Injuring Fingers	3118
Ladder, Callipers for Overhead Work Eliminate Use of	3174	Lock, Spring-Opening, Fitted on Ruling Pen	3296
Ladder, Tools for Handling Electric Globes without	3146	Lock, Staple Prevents Manipulation of	3302
Ladle, Old, Improving	3273	Lock Washers, Easily Made	3263
Lamps, Incandescent, Replacing in Lofty Ceiling Fixtures	3279	Locomotive-Apron Holder Aids Quick Coupling	3141
Lamps, Keep Clean	3268	Locomotive Steam Used to Clean and Sterilize Well	3183
Large Objects, Novel Method for Lifting	3203	Loosening Rusty Wood Screws	3185
Lease, Accurate Method of Setting Thread Tool in	3095	Loud-Sounding Air Whistle for Camp or Motorboat	3143
Lathe Bell Center for Turning Tubing	3221	Lubricated Varnish Eliminates Trouble with Sliding Drawers	3260
Lathe, Bench, Drill-Press Attachment for	3216	Lubricating Bolt of a Ball Thrust on a Torque Rod	3138
Lathe Boring Bars, Methods of Holding Tools in	3200	Lubricating Piston Pins on V-Type Engines	3248
Lathe Chuck, Universal, Used as a Vise	3271	Lumber, Load of, Hauled by Light Car and Hand Truck	3294
Lathe, Chuck Which Centers and Drives Pistons being Machined in	3181	Lumber, Rough, Pivot Stand Aids in Handling of	3170
Lathe, Device for Winding Spiral Springs on	3198	Lumber-Saving Kink for Making Split Patterns	3252
Lathe, Holding Split Patterns in	3280	Machine, Heavy, Unloading from a Truck	3252
Lathe, Inexpensive Belt Sander Made from	3235	Machine, Homemade Die-Casting	3269
Lathe, Moving Easily with Hand Trucks	3245	Machine, Homemade, for Cutting Washers and Packings	3144
Lathe, Neat Chest under Holds Tools and Gears	3273	Machine Nuts Set on Rods with Belting as Wrench	3128
Lathe, Nineteen-Inch, Turning a Fifty-Four-Inch Wheel on	3160	Machine Operations, Tool for Holding Polished Metal Parts in	3103
Lathe, Tool Block for Making Small Pins on	3107	Machine, Paper-Ornament Making, for Restaurant Use	3150
Lathe Tools, Converting Broken Drills into	3221	Machine Parts, Mandrels and Similar, Block for Driving	3147
Lathe, Wire Used to String Rings as They Come from	3205	Machine Parts, Rotating, Balancing by Drilling	3142
Lathe, Wood-Turning, Using the Drill Press as	3132	Machine Parts, Small, Boring after Grinding	3170
Lathe, Wrench for Setscrews in Dogs Attached to	3253	Machine Parts, Small, Painted by Use of Novel Device	3118
Laying Out Drill Holes, Punch for	3281	Machine Shop, Adjustable Clamping Device for	3158
Laying Out Keyways, Tool for	3193	Machine That Executes Military-Drill Movements	3115
Laying Out Stairs, Handy Square Attachment for	3203	Machinery, Light Foot-Power, Concrete Flywheels for	3140
Lead "German Soldiers" Used as Targets	3282	Machinery, Signs on Idle, Give Reasons for Delay in Production	3126
Lead Mallet Head Cast Securely on Pipe Handle	3143	Machines Oiled at Close of Workday Start Easily in Cold	3134
Leakage, Oil, Stop on Faucet Avoids	3291	Machining Two Parts at Once, Planing Tool for	3192
Leaks, Boiler, Durable Solderless Repair for	3205	Machinist's Vise, Wooden Caps Convert into Bench Clamp	3155
Leather, Belting Cement, Holdfast	3176		
Leg, Adjustable, for Table or Bench	3096		
Lens, To Dry Properly	3280		
Letters, Aluminum Bronze, Size for Holding	3210		
Level, Carpenters', Surveyors' Tripod Level Made Quickly from	3196		
Lever-and-Fulcrum Snow Shovel Makes Heavy Shoveling Easy	3256		
Lever, Long, Eases Action of Force Pump	3302		



- Magazine Fuse Box, Timesaving, for Experimental Circuits . . . . . 3218
- Magnetic Locator Useful in Wiring Finished Houses . . . . . 3300
- Magnetic, Making Screwdriver . . . . . 3301
- Magnetic Tack Hammer Is Electrically Operated . . . . . 3146
- Magneto, Motor Timer and, Oiling Properly . . . . . 3152
- Mallet Head, Lead, Cast Securely on Pipe Handle . . . . . 3143
- Mandrel for Truing the Faces of Nuts. . . . . 3171
- Mandrels and Similar Machine Parts, Block for Driving . . . . . 3147
- Manifold Heater, Acetylene, Starts Cold Auto Engines . . . . . 3225
- Manipulation of Lock, Staple Prevents. . . . . 3302
- Maple, Oil-Soaked, Emergency Bearing for Tractor Made from . . . . . 3176
- Mapping Surveyor's Data, Device for . . . . . 3104
- Marking Tags, Good, Old Linen Collars Make . . . . . 3287
- Marks, Square-Point Center Punch Handy for Revising. . . . . 3108
- Materials, Common, Sprayer or Air Brush Easily Made from . . . . . 3208
- Measuring from Holes, Sphere Attachment for Dividers When . . . . . 3168
- Measuring Gauge for Power Hacksaw . . . . . 3301
- Mechanic, Auto, Headrest for Strapped to His Head . . . . . 3296
- Mechanic's Clothes Laundered by Exhaust Steam . . . . . 3279
- Mechanics in Shop, Check-Out Board Helps Locate . . . . . 3096
- Mechanic's Tool Case Made from a Suitcase . . . . . 3226
- Mending Torn Tracings . . . . . 3148
- Mercury Cups, Switch Reversed by Tilting . . . . . 3242
- Metal Bucket, Welding Mask Made from Metal Ferrule, Simple Method of Making and Attaching a . . . . . 3206
- Metal, Heavy, Drilling Holes through with a Bit Brace . . . . . 3271
- Metal, Molten, Caldron Pours with One Hand . . . . . 3133
- Metal Parts, Polished, Tool for Holding in Machine Operations . . . . . 3103
- Metals, Soft, Alteration Adapts Twist Drill for . . . . . 3225
- Method, Accurate, of Setting Thread Tool in Lathe . . . . . 3095
- Metric Measures, Quick Methods of Converting . . . . . 3192
- Micrometer Used as Indicator on Work in Chuck . . . . . 3128
- Military-Drill Movements, Machine That Executes . . . . . 3115
- Milk-Bottle Cover . . . . . 3300
- Mill, Hollow, for Making Wooden Knitting Needles and Dowel Pins. . . . . 3189
- Mill Shaft, Fans Belted from, Give Comfort to Workmen . . . . . 3151
- Milling Flutes in Taps and Reamers, Method of . . . . . 3186
- Minnow Net, Large, Made of Branches and Netting . . . . . 3112
- Mirror, Pocket, Useful in the Shop. . . . . 3278
- Miter Box, How to Do Miter-Box Work without . . . . . 3237
- Miter Box, Sandpaper Prevents Slipping of Work in . . . . . 3118
- Miter Box, Wooden, with Many Uses. . . . . 3141
- Miter-Box Work, How to Do without a Miter Box . . . . . 3237
- Miter Boxes, Wooden, Depth Gauge for Mold for Solder Easily Made of Plaster of Paris . . . . . 3219
- Moldings, Dentil, for Cabinet Trim, Making . . . . . 3098
- Mole Plow Makes Subsurface Drain without Use of Tile. . . . . 3182
- Moisture, Method of Protecting Terminals from . . . . . 3139
- Mooring, Substantial Float, for Small Boats . . . . . 3110
- Motor, Air-Cooled, Water-Jacketing an Motor Car, Thermometer for Water-Cooling System of . . . . . 3160
- Motor, Discarded Cycle, Garage Air Compressor Made from . . . . . 3166
- Motor Fields, Tool for Packing Wires in Slots of . . . . . 3096
- Motor Journal Bearings, Efficient Method of Testing . . . . . 3173
- Motor, Pipe Aids in Removing Armature of . . . . . 3124
- Motor-Starting and Regulating Switch. . . . . 3153
- Motor Timer and Magneto, Oiling Properly . . . . . 3152
- Motorboat, Loud-Sounding Air Whistle for Camp or . . . . . 3143
- Motorcycle, Adjustable Valve-Spring Tension Adapts for High Speed. . . . . 3132
- Motorcycle Back Rest to Carry Camera. . . . . 3236
- Motorcycle, Head-Fitting and Bar-Fastening Repair for . . . . . 3153
- Motorcycle Piston, Broken, Emergency Repair for . . . . . 3150
- Motorcycle Repairs, Conical Points for Engine Bolts Simplify . . . . . 3139
- Motors, Emery-Wheel, Pedal Switch for Mountain Stream, Small Water-Supply Reservoir Built in . . . . . 3117
- Mouse Trap, Using a Barrel as . . . . . 3257
- Movable Posts Made of Pipe Useful in Stock Rooms . . . . . 3284
- Moved, How Big Tree is . . . . . 3290
- Moving a Crippled Automobile Single-Handed . . . . . 3234
- Moving a Lathe Easily with Hand Trucks . . . . . 3245
- Moving Hands, Scarecrow with . . . . . 3299
- Moving Heavy Stones into Place on a Wall . . . . . 3249
- Moving "Rusted-In" Screws. . . . . 3267
- Moving Stove, Small Truck Aids in . . . . . 3268
- Mud Hole, Novel Method of Getting Tractor Out of . . . . . 3172
- Nail Makes Satisfactory Plow-Plane Bit Nails Driven in Close Quarters, Gas Pipe Gouges . . . . . 3148
- Nails, Preventing from Spitting Wood. . . . . 3261
- Nails, Scaffolding without . . . . . 3268
- Nails, Small, Handy Tool Drives into Hard Wood . . . . . 3166
- Net, Large Minnow, Made of Branches and Netting . . . . . 3112
- Nipple, Broken, Removing from a Coupling . . . . . 3212
- Novel Device, Small Machine Parts Painted by Use of . . . . . 3118
- Novel Features, Ironing Board with. . . . . 3222
- Nut, Emergency, Cast of Babbitt. . . . . 3299
- Nut, Threading Die Made from . . . . . 3246
- Nuts, Faces of, Mandrel for Truing. . . . . 3171
- Oil Burners, Auxillary, in a Hot-Air Furnace . . . . . 3247
- Oil Conserved by Using Soapy Water. . . . . 3169
- Oil Discharged by Pressure Eliminates Lifting Barrel . . . . . 3154
- Oil Filter and Tank for the Shop. . . . . 3119
- Oil Holes in Dirty Places, Cover for. . . . . 3244
- Oil Leakage, Stop on Faucet Avoids. . . . . 3291
- Oil Level in Automobile Crank Cases, Testing . . . . . 3220
- Oil, Saving Fuel in Plant Which Burns Oil, Storing Air Hammers in Improves Working Quality . . . . . 3212
- Oil, Used from Auto Engines Makes Good Fuel . . . . . 3279
- Oil, Wood Inserts in Pulley Bushing Conduct . . . . . 3120
- Oilcan and Bicycle Pump, Blowtorch Made of . . . . . 3159
- Oilcan, Frame Holds and Tilts for Pouring . . . . . 3261
- Oilcan, Hanging Handy for Overhead Work . . . . . 3107
- Oilcans, Old Rectangular, Making Use of Oiling Motor Timer and Magneto Properly . . . . . 3240
- Oiling Systems, Reliable, for Chain-Driven Trucks . . . . . 3215
- One at a Time, Cigarette Box Deals Out One-Piece Pipe Wrench Made from Bar Steel . . . . . 3243
- Open and Close Cellar Windows, Timesaving Device to . . . . . 3223
- Orifice, Enlarged, Renewing in Burner. . . . . 3263
- Outside Cistern Pump Operated from the Kitchen . . . . . 3296

Overhanging Edge on Roofing Found Superior	3103	der Pressure Tests	3130
Overhead-Valve Engines, Tool for Lifting Rocker Arms on	3260	Pipes in an Unoccupied House, Draining for the Winter	3234
Overhead Work, Callipers for, Eliminate Use of Ladder	3174	Pipes, Long, Hook Supports for Threading and Fitting	3138
Overhead Work, Hanging Oilcan Handy for	3107	Pipes, Small Drains in Concrete Made with	3100
Packing for Pumps and Fittings, Roofing Paper as	3109	Pipes, Small Polished, Wrench for	3204
Padlock, Screw Eyes Carry	3287	Pistol Grip, Homemade, for Surveyors' Tape	3114
Padlocks, Two, Four Men Use on One Door	3228	Piston, Broken Motorcycle, Emergency Repair for	3150
Pail, Wire Soldered over Mouth of Saves Paint	3147	Piston Leathers, Gasoline-Torch, Making	3287
Paint Buckets, Detachable Handle Convenient for	3103	Piston, Old, Bench Grinder or Polishing Head Made from	3249
Paint, Solution for Removal of	3186	Pipe, Movable Posts Made of, Useful in Piston, Old, Used to Polish Rebored Cylinders	3233
Paint, Wire Soldered over Mouth of Pail Saves	3147	Piston Pins on V-Type Engines, Lubricating	3248
Paper Labels of Irregular Outline, Band Saw Cuts Out	3194	Piston Rings, Guide for Inserting in Cylinders	3133
Paper-Ornament Making Machine for Restaurant Use	3150	Piston Rings, Tool for Removing Step-Cut	3140
Paper Shim Makes Worn Taper Grip Tightly	3221	Piston, Worn-Out, Used as Blowtorch Furnace	3161
Panels, Removable, for Summer and Winter Use, Doors Have	3206	Pistons being Machined in Lathe, Chuck Which Centers and Drives	3181
Pans, Bread, Desk Drawers Made of	3261	Pistons, Enlarging by Peening to Eliminate Slap	3272
Paraffin for Woodworking Tools	3155	Pistons, Rusted Engine, Loosening with Hot Water	3120
Paraffin Grease for Auto and Wagon Springs	3217	Pivot Stand Aids in Handling of Rough Lumber	3170
Paraffin, Keeping Brushes Soft with	3268	Placing of Three Hinges on a Door, Proper	3282
Particles, Safety Tool Extracts from the Eye	3239	Plane, Groove, Made from Rip Saw	3271
Partitioning Off a Room to Save Heat and Coal	3258	Planing Chair Cane, Method of	3157
Patching Dents in Boat Hulls, Cement Mixture for	3132	Planing Tool for Machining Two Parts at Once	3192
Pattern Maker's Boring Tool for Small, Deep Work	3148	Plant, Small, Thermometers Save Coal in	3250
Patterns, Split, Holding in the Lathe	3280	Plant Which Burns Oil, Saving Fuel in Plaster of Paris, Mold for Solder Easily Made of	3219
Patterns, Split, Lumber-Saving Kink for Making	3252	Plaster, Strong Asbestos, Formula for Making	3168
Pedal-Control Wire-Stripping Bench Tool	3113	Plaster Walls, Sawing through	3277
Pedal Extension on Auto-Jack Lever Saves Labor	3214	Platform, Useful for Weighing Sacks on Steelyard Scales	3187
Pedal Switch for Emery-Wheel Motors	3264	Play in Auto Drive Shaft, Spring End Bearings Overcome	3134
Peening, Enlarging Pistons by to Eliminate Slap	3272	Pliers and Other Tools, Insulating Handles for	3283
Pencil Tracings, Washing Off after Blueprinting Saves Cloth	3145	Pliers, Side-Cutting, Cutting Small Copper Tubes with	3165
Pen Wiper for Draftsmen	3283	Plow, Hand, Rugged in Bicycle Frame	3100
Perforator, Keeping Small Punchings from Sticking to	3276	Plow-Plane Bit, Satisfactory, Nail Makes	3302
Photographic Negative Glass, Exploiting Old	3153	Plowing, Extension Control for Tractor Aids in Work of	3175
Piano, Carrying Made Easy by Handles	3302	Plug, Closing Cast-Iron Pipe Ends without	3260
Picture Hook, Safety Pin Makes Good	3212	Plugging Ends of Pipes under Pressure Tests, Device for	3130
Pieces, Long, Thin, Hardening without Warping	3300	Pneumatic Riveter Useful in Wood Shop Points or Feet, Raised, Draftsman's Triangle with	3215
Pigs, Young, Railing Protects from being Crushed	3240	Pole Step, Temporary, Made from Two Spikes	3296
Piling and Loading Boxes, Winch Truck for	3111	Polish Rebored Cylinders, Old Piston Used to	3233
Pillar, Repairing with Cement	3254	Polishing Head, Bench Grinder or, Made from Old Piston	3249
Pinch Bar Made from Buggy Axle	3257	Polishing, Rod for Holding Scissors Blades While	3185
Pins, Fitting Tightly in Oversize Holes	3223	Porcelain Tubes, Breaking Squarely	3100
Pins, Small, Tool Block for Making on Lathe	3107	Portable Fence Formed of Easily Detached Sections	3295
Pipe Aids in Removing Armature of Motor	3124	Portable Tool Drawer	3282
Pipe Bender, Simple, for Home or Shop Use	3169	Portable Water-Heater Outfit Made from a Barrel	3199
Pipe Cutter Used to Strip Heavy Covered Cable	3134	Posts, Movable, Made of Pipe Useful in Stock Rooms	3284
Pipe, Easy Method of Connecting Sections of	3160	Potatoes, Boiling to Loosen Boiler Scale	3277
Pipe Ends, Cast-Iron, Closing without a Plug	3260	Potatoes, Vessel for Cooking for Hogs on the Farm	3274
Pipe Fittings, Acid-Proof Cement for	3159	Poultry Feeder Places Food for Chickens Out of Hens' Reach	3250
Pipe Fittings, Steam Whistle Made from Pipe Handle, Lead Mallet Head Cast Securely on	3143	Pouring, Frame Holds Oilcan and Tilts for	3261
Pipe, Heavy, Apparatus of Simple Construction for Bending	3185	Power Hacksaw, Measuring Gauge for	3281
Pipe Joints, Cements for	3127	Power of an Auto Engine, Increasing	3218
Stock Rooms	3284		
Pipe Wrench, One-Piece, Made from Bar Steel	3243		
Pipes, Ends of, Device for Plugging un-			

Power-Punching or Drilling Sheet Metal, Spacing Gauge for	3173	Refinishing, Chuck Holds Auto Timers for	3262
Pressure for a Soldering Torch, Tire Used to Furnish	3133	Register, Floor, Automobile-Exhaust Heater Mounted in	3261
Pressure, Oil Discharged by, Eliminates Lifting Barrel	3154	Reinforced-Concrete Cistern Cap	3193
Pressure Tests, Device for Plugging Ends of Pipes under	3130	Removable Heavy Edge for the Bench	3233
Primed, Siphon That is Easily Kept	3109	Removal of Paint, Solution for	3186
Production, Signs on Idle Machinery Give Reasons for Delay in	3126	Removal of Taper-Shank Drills, Easy, Drift Tool for	3184
Production, Wedge-Clamp Jig Helps Speed Up	3230	Removing a Boiler Flue, Easy Method of	3199
Projecting Machines, Automatic Signaling Device for	3178	Removing a Broken Nipple from a Coupling	3212
Proof Press, Grease Cup to Contain Ink for	3211	Removing Automobile Wheels from Axle, Device for	3158
Protecting Terminals from Moisture, Method of	3139	Removing Automobile Wheels with the Hub Cap	3244
Protecting the Hands from Dirt and Grease on Engine Work	3126	Removing Foreign Particles from the Eye, Easy Method of	3156
Protection against Wear, Shellac Gives Protection, Wires across Barrel Heads Give	3297	Removing Old Babbitt Metal from Bearing Boxes	3130
Pulley Arrangement is Helpful in Operating Double Doors	3145	Removing Tailstock Centers Easily by Means of Drift Pin	3219
Pulley Bushing, Wood Inserts in, Conduct Oil	3120	Removing Wall Paper with Steam	3291
Pulley, Grooved, Made of Barrel Heads Pulleys, Worn Loose, Replaced by Adjoining Set Pulleys	3109	Renewing Enlarged Orifice in Burner	3261
Pump Cylinder, Buggy Hub Used for Repairing Worn Threads of	3180	Renewing Old Electricians' Tape	3256
Pump, Force, Long Lever Eases Action of	3302	Renewing Valve Guides in Auto Engines	3239
Pump, Hydraulic, is Independent of Water Levels	3135	Repair Effective Emergency, for Automobile Wheel	3182
Pump-Jack Rods, Efficient Method of Recovering	3175	Repair, Emergency, for a Broken Motorcycle Piston	3150
Pumps and Fittings, Roofing Paper as Packing for	3109	Repair, Emergency, for a Crankshaft with a Cracked Web	3263
Pumps of Centrifugal and Screw Type Work Together	3270	Repair, Emergency Fuse	3236
Punch-and-Die Attachment for a Bench Vice, Making	3195	Repair, Emergency Spark-Plug	3177
Punch for Laying Out Drill Holes	3281	Repair for Boiler Leaks, Durable, Solderless	3205
Punch Shop or Foundry, Barrel Tumbler for	3292	Repair for Motorcycle, Head-Fitting and Bar-Fastening	3152
Punchings, Small, Keeping from Sticking to the Perforator	3276	Repair, Novel, for Cracked Water Jacket on Engine	3127
Punches, Center, Made from Old Rat-Tail Files	3145	Repairing a Cracked Water Jacket with Cement	3284
Push Button Locked against Interference by Children	3256	Repairing a Pillar with Cement	3254
Putty, Filling Cracks in Concrete with	3201	Replacing Incandescent Lamps in Lofty Ceiling Fixtures	3279
Quick-Releasing Tapeline Holder does Not Snag Readily	3155	Reservoir, Small Water-Supply, Built in Mountain Stream	3117
Rack, Convenient Electroplating, for Small Pieces	3208	Respirator Made of Cotton and Muslin	3116
Rack for Flat Tools	3118	Restaurant Use, Paper-Ornament Making Machine for	3150
Rack for Rubber Gum and Fabric, Convenient	3258	Revolving Cone for Sharpening All Sizes of Gouges	3129
Rack for Washers	3272	Rifle, Old, Harpoon Gun for Spearing Fish Made from	3151
Rack, Handy, Holds Draftsman's Tools	3254	Rigging Lessens Work of Drilling Holes in Steel Plates	3134
Rack near Fuse Block Holds Fuses for Emergency	3162	Rim Reinforces Cooling Fan	3192
Radiator, Automobile, as a Heating Unit	3204	Rims, Split, Serviceable, Tire Remover for Cars Equipped with	3172
Radiator, Old Auto, Converted into Shop Water Heater	3107	Rings, Wire Used to String, as They Come from Lathe	3295
Railing Protects Young Pigs from being Crushed	3240	Rip Saw, Groove Plane Made from	3271
Rake, Snow Scraper Made from	3253	Ripping, Method of Preventing Binder Canvas from	3171
Rat-Tail Files, Old, Center Punches Made from	3145	Riveter, Pneumatic, Useful in Wood Shop	3215
Ratchet Brace Remodeled for Work in Cramped Spaces	3242	Rivets, Handy Method of Heating in Forge Fire	3190
Rattling of Automobile Doors Overcome by Setting Hinges	3097	Rocker Arms on Overhead-Valve Engines, Tool for Lifting	3264
Rattling of Automobile Hood, Rubber Hose Stops	3147	Rod for Holding Scissors Blades While Polishing	3185
Reamer for Accurate Work in Wood	3173	Rod, Round, to be Drilled, Jig for Holding	3198
Reaming Large Holes with an Ordinary Twist Drill	3297	Rods, Machine Nuts Set on, with Belting as Wrench	3129
Rear of Truck, Crane at, Helps Load and Unload	3298	Rods, Pump-Jack, Efficient Method of Recovering	3173
Recesses, Round, Easily Cut with Home-made Tool	3156	Roller, Wooden, Aids Construction of Concrete Highways	3159
Rectangular Oilcans, Making Use of Old	3240	Roof Workers, Convenient Ladder	3194
Red, Large Jigs and Templates Painted or Identification	3113	Roofing Cement, Staining Wood a Dark Color	3270
		Roofing, Overhanging Edge on Foundation Superior	3288
		Roofing Paper as Packing for Pumps and Fittings	3280
		Roofing Rolls, Soap Dish Made from End Cap of	31
		Room, Partitioning Off to Save Heat and Coal	31



Rotary Machine Parts, Disk-Bearing Stand for Balancing	3128	Screwdriver, Emergency Handle for	3224
Round Recesses Easily Cut with Home-made Tool	3156	Screwdriver Handle Made of Dust Cap from Tire Valve	3258
Rubber Cement for Repairing Tire Valve	3295	Screwdriver Head, Self-Centering Non-slipping	3193
Rubber Gum and Fabric, Convenient Rack for	3258	Screwdriver, Making Magnetic	3201
Rubber Hose Stops Rattling of Automobile Hood	3147	Screwdriver, Triple-Bladed Pocket	3183
Rubber-Stamp Ink Pad, Handy, for the Shop Office	3194	Screws, Holding While Threading or Turning Them	3267
Rubber Tube Protects Ignition Distributor of Auto Engine	3128	Screws, Loosening Rusty Wood	3185
Ruler, Dot and Dash, Easily Made	3214	Screws, Moving "Rusted-In"	3267
Rulers, Weighted, Keep Drawings from Rolling When in Use	3161	Screws, Wood, Making Hold When Parallel to Grain	3273
Ruling Pen, Spring-Opening Lock Fitted on	3296	Scriber, Locating Bolt Holes Where Same Cannot be Used	3245
Ruling Pens, Using Fountain-Pen Filler to Fill	3236	Sections, Easily Detached, Portable Fence Formed of	3295
Running Board on Automobile Strengthened by Brace	3246	Seed Corn, Testing for Germination	3288
Rusted Engine Pistons, Loosening with Hot Water	3120	Segment-Joining Jig for the Home Workshop	3202
"Rusted-In" Screws, Moving	3267	Self-Alining, Making a Sprung Shaft	3188
Safe, Fireproof Concrete, How to Make	3206	Self-Centering Nonslipping Screwdriver Head	3193
Safety Pin, Carry Tool Checks on	3267	Self-Chalking Line and Reel	3102
Safety Pin Makes Good Picture Hook	3212	Self-Closing Gate Hinge, Springless	3283
Safety Tool Extracts Particles from the Eye	3239	Self-Lighting Gas-Soldering Torch	3190
Safety Washer for Fastening Emery Wheels	3177	Self-Raising Box Bottom Aids in Obtaining Contents	3234
Salt in Whitewash	3287	Serial-Number Identifications on Working Drawings Save Time	3131
Sand, Deep, Starting Auto in	3290	Set Pulleys, Worn Loose Pulleys Replaced by Adjoining	3109
Sand Furnace for House Heating Conserves Coal	3209	Setscrew Loosening, Overcoming	3202
Sand-Elast Operators, Air-Bellows Device Protects	3137	Setscrews in Dogs Attached to Lathe, Wrench for	3253
Sandblast, Etching on Glass and Metal with	3266	Setting a Lag Screw in a Hole Containing a Broken Point	3187
Sandpaper Block for Use on Curved Surfaces	3168	Shaft, Collar for Flue-Cutter Slip-Joint	3194
Sandpaper, Files Made of, Handy in Woodwork	3151	Shaft, Sprung, Making Self-Alining	3188
Sandpaper Held Firmly on Block by Its Tapered Shape	3257	Shafting Hangers Converted into Neat Bench Buffer	3277
Sandpaper Prevents Slipping of Work in Miter Box	3118	Shafts without End Centers, Attachment Adapts Tachometer for	3127
Sawdust, Stove That Burns	3290	Shanks, Tap Wrench Fits Various Sizes of	3099
Sawing Softer Materials Sheet-Metal Backing Helps When	3253	Shape, Proper, to Cut a Shim or Filler	3217
Sawing through Plaster Walls	3277	Sharpening a Worn-Down Saw	3286
Scaffolding without Nails	3268	Sharpening All Sizes of Gouges, Revolving Cone for	3129
Scarecrow with Moving Hands	3299	Sharpening, Carpet Pad for Wood Planes Saves Frequent	3130
Scissors Blades, Rod for Holding While Polishing	3185	Shears, Bench Snips or	3271
Scored Cylinder Repaired by Soldering	3285	Sheet-Metal Backing Helps When Sawing Softer Materials	3253
Scraper Blades, Clamping Block for Filing	3258	Sheet Metal, Cutting Disks or Rings Accurately from	3162
Scraper Blades, Handle for	3281	Sheet-Metal Pieces, Small, Jig for Drilling	3177
Scraper Edges, Good and Bad	3300	Sheet Metal, Power-Punching or Drilling, Spacing Gauge for	3173
Scraper, Flexible, Makes Difficult Jobs Easy	3191	Shield, Chair, That Folds Out of the Way	3210
Scraper Handle, Convenient Homemade	3161	Shellac Gives Protection against Wear	3216
Scraping Babbitt Bearings to a Nice Fit	3112	Shield on Creeper Protects Face When Working under Auto	3148
Screenings, Soft-Coal, Using with Anthracite	3257	Shield, Soldering-Iron, Protects Hand from Drizzling Solder	3160
Screw and Centrifugal Type Pumps Work Together	3270	Shim or Filler, Proper Shape to Cut	3217
Screw Clip, Old Metal, Gear Puller Cheaply Made from	3204	Shim, Paper, Makes Worn Taper Grip Tightly	3221
Screw Eyes Carry Padlock	3287	Shoe Shining at Home Made Easy by Handy Outfit	3276
Screw, Lag, Setting in a Hole Containing a Broken Point	3187	Shop-Call System, Colored-Light Electrical	3197
Screw-Machine Products, Tank for Cleaning	3174	Shop, Check-Out Board Helps Locate Mechanics in	3096
		Shop, Discarded Circular Saw Forms Loud Bell for Use in	3250
		Shop Material-Checking Work, Handy Writing Board for	3170
		Shop Office, Handy Rubber-Stamp Ink Pad for	3194
		Shop, Oil Filter and Tank for	3119
		Shop or Laboratory, Small Electric Furnaces for	3105
		Shop, Pocket Mirror Useful in	3278
		Shop, Portable Tool Chest and Workbench is Easily Moved about	3186
		Shop Truck That may be Picked Up by Crane	3220
		Shop Use, Home or, Simple Pipe Bender for	3183
		Shop Use, Strong and Inexpensive Desk Made for	3104

Shop Ventilation, Small, Draft-Proof Window for	3169	Spark-Plug Repair, Emergency	3177
Shop Water Heater, Old Auto Radiator Converted Into	3107	Speed, High, Adjustable Valve-Spring Tension Adapts Motorcycle for	3132
Shops, Small, Foot-Power Hammer for Use in	3165	Speed Up Production, Wedge-Clamp Jig Helps	3230
Shoveling Heavy, Lever-and-Fulcrum Snow Shovel Makes Easy	3256	Sphere Attachment for Dividers When Measuring from Holes	3168
Shovels, Theft of Prevented by Chain and Padlock	3116	Spikes, Two, Temporary Pole Step Made from	3244
Shut-Off, Automatic, for Filling Cans or Buckets	3231	Splicing, Calculating Belt Lengths for	3245
Sidewalks, Concrete, Folding Square for Dividing	3197	Splicing Stranded Wire	3280
Sign Reading "No Admittance," Door Latch Operated by	3801	Spline Weights, Fingers for Holding in Drafting	3211
Signaling Device, Automatic, for Projecting Machines	3178	Splitting Wood, Preventing Nails from Spout, Clogged, Readily Cleaned with Hose	3261
Signboard Shows Where Workman is to be Found	3259	Sprayer or Air Brush Easily Made from Common Materials	3208
Signs, Good, How to Make without Special Skill	3222	Spring End Bearings Overcome Play in Auto Drive Shaft	3134
Signs on Idle Machinery Give Reasons for Delay in Production	3125	Spring Lock, Simple Belt Shifter with	3131
Siphon That is Easily Kept Primed	3109	Spring-Opening Lock Fitted on Ruling Pen	3296
Size for Holding Aluminum Bronze Letters	3210	Spring Wire, Compressing While Bending Preserves Strength	3260
Skill, Special, How to Make Good Signs without	3222	Springless Self-Closing Gate Hinge	3283
Slap, Enlarging Pistons by Peening to Eliminate	3272	Springs, Auto and Wagon, Paraffin Grease for	3217
Slate Instrument Panel, Broken, Repaired with Angle Iron	3146	Springs, Spiral, Device for Winding on a Lathe	3198
Sliding Door, Swinging Door in Saves Employees' Time	3193	Square Attachment, Handy, for Laying Out Stairs	3202
Sliding Drawers, Lubricated Varnish Eliminates Trouble with	3260	Square, Bevel, for Door and Window Fitting	3206
Slipping of Work in Miter Box, Sandpaper Prevents	3118	Square, Folding, for Dividing Concrete Sidewalks	3197
Slot in Hard Casting, Novel Method of Machining	3144	Square, Handsaw Fitted with Attachment for Use as	3251
Small Drafting Work Easily Done without a T-Square	3291	Square-Point Center Punch Handy for Revising Marks	3108
Small Pieces, Convenient Electroplating Rack for	3208	Stable, Concrete Ventilating System for Staining Wood a Dark Color with Roofing Cement	3241
Smokestacks, Factory, Blasting Soot from	3154	Stairs, Handy Square Attachment for Laying Out	3202
Snap Bow Aids in Making Chalk Lines	3207	Stairway, Disappearing	3275
Snout Snare Makes It Easy to Ring Hogs	3225	Stamp, Inspector's, Built into Hammer	3297
Snow Scraper Made from Rake	3253	Stand, Disk Bearing, for Balancing Rotary Machine Parts	3128
Snow Shovel, Lever-and-Fulcrum, Makes Heavy Shoveling Easy	3256	Staple Prevents Manipulation of Lock	3302
Soap Dish Made from End Cap of Roofing Rolls	3237	Starter, Spark-Plug Atomizer, for Automobile Engines	3213
Soapy Water, Oil Conserved by Using	3169	Starting Auto in Deep Sand	3290
Socket, Improvised Electric-Light	3175	Steam-Engine Cylinder, Device for Vulcanizing Tires on	3171
Soft-Coal Fire, Large Kettle Inverted over Saves Heat	3267	Steam, Exhaust, Mechanic's Clothes Laundered by	3279
Soft-Coal Screenings, Using with Anthracite	3251	Steam Jet to Thaw Frozen Water Pipes	3240
Softening Hard Iron and Brass Castings	3190	Steam, Locomotive, Used to Clean and Sterilize Well	3183
Softening Materials, Sheet-Metal Backing Help When Sawing	3253	Steam, Removing Wall Paper with	3291
Solder, Dripping, Soldering-Iron Shield Protects Hand from	3160	Steam Whistle Made from Pipe Fittings	3279
Solder, Mold for, Easily Made of Plaster of Paris	3219	Steel, Bar, One-Piece Pipe Wrench Made from	3243
Solder Paste for Difficult Fluxing	3184	Steel, Hardened, Etching a Hole through	3133
Soldering Electrically without an Iron	3106	Steel, High-Speed, Tool for Conserving Small Pieces of	3176
Soldering Iron, Asbestos Hood for	3292	Steel Lever and Wheel Handles, Tin-Coating	3187
Soldering Iron for Attachment to Blow-torch	3217	Steel Plates, Rigging Lessens Work of Drilling Holes in	3134
Soldering-Iron Shield Protects Hand from Dripping Solder	3160	Steel, Sheet, Small Bevel Square Made from	3224
Soldering Paste Carried on Torch	3273	Steel, Using High-Speed for Hand Punches	3241
Soldering, Scored Cylinders Repaired by Soldering Torch, Self-Lighting Gas	3190	Steelyard Scales, Useful Platform for Weighing Sacks on	3187
Soldering Torch, Tire Used to Furnish Pressure for	3133	Steering Column, Automobile, Flash Light on	3229
Solution for the Removal of Paint	3186	Steering Wheel, Automobile, Electric Hand Warmer for	3282
Soot, Blasting from Factory Smokestacks	3154	Stopladder and Portable Elevator, Combination	3181
Sorting Hopper for Berries and Small Vegetables	3123	Stopladder, Adjustability of Big Blackboard Makes Needless	3120
Spacing Gauge for Power-Punching or Drilling Sheet Metal	3173	Steps, Door Latch Controlled from Kitchen Saves Many	3230
Spark-Plug Atomizer Starter for Automobile Engines	3213	Sterilize Well, Locomotive Steam Used to Clean and	3183
Spark-Plug Gap, Coin is Handy Gauge for	3118	Stethoscope for Telephone and Automobile Use	3161
Spark Plug, Lighter for Gas Torch Made from	3295	Sticking to Perforator, Keeping Small Punchings from	327



Stock Bins Built Up from Boxes as Units	3109	Taper, Worn, Paper Shim Makes Grip Tightly	3221
Stock, Polished Round, Handle for Holding for Drilling	3187	Tapered Shape, Sandpaper Held Firmly on Block by Its	3257
Stock Rooms, Movable Posts Made of Pipe Useful in	3284	Tapping a Hole without a Tap	3210
Stones, Heavy, Moving into Place on a Wall	3249	Taps and Reamers, Method of Milling Flutes in	3186
Stop Block, Auto, Reduced to Efficiency	3296	Taps, Blocks for Starting Squarely	3136
Stop on Faucet Avoids Oil Leakage	3291	Targets, Lead "German Soldiers" Used as	3282
Storage, Convenient, Outside Coal Bin Provides	3229	Tee Wrenches, Large, File Handles Convenient on	3119
Storage Space, Old Cistern Remodeled as Storing Air Hammers in Oil Improves Working Quality	3212	Teeth, Broken, Using Hacksaw Blades with	3229
Stove Bolts, Fastening Fly Screens in Sashes with	3158	Teeth, Patching into Broken Gears	3117
Stove, Kerosene Burner or, Readily Made	3244	Telephone and Automobile Use, Stethoscope for	3161
Stove, Small Truck Aids in Moving	3268	Telephone Cables, Aerial, Apparatus for Locating Trouble in	3101
Stove That Burns Sawdust	3290	Templates, Large Jigs and, Painted Red for Identification	3113
Straightedge, Utilizing Sun's Rays for Truing	3188	Tenons, Rapid and Accurate Method of Making	3170
Straining Cloth, Clips for Holding over Can or Container	3124	Tension, Adjustable Valve-Spring, Adapts Motorcycle for High Speed	3132
Stranded Wire, Splicing	3280	Terminals, Method of Protecting from Moisture	3139
Streams, Crossing, Auto Air Intake Guarded for	3164	Temporary Pole Step Made from Two Spikes	3244
Strength, Compressing Spring Wire While Bending, Preserves	3260	Test, Simple, to Distinguish Wood Alcohol from Denatured Alcohol	3157
Substantial Flagpole	3292	Testing Compression in Cylinders of Automobile Motor	3110
Substitute for Jackscrew, Adjustable Supporting Stand is	3178	Testing Knife-Switch Contact Blades	3142
Suitcase, Mechanic's Tool Case Made from	3226	Testing Motor Journal Bearings, Efficient Method of	3173
Summer and Winter Use, Doors Have Removable Panels for	3206	Testing Oil Level in Automobile Crank Cases	3220
Sun's Rays, Utilizing for Truing a Straightedge	3188	Testing Seed Corn for Germination	3288
Supply Pipe, Cold-Water System with Cooling Coil in	3180	Tether, Safety Radial, for Animals	3233
Support for Garage "Free-Air" Hose at Curbing	3114	Thaw Frozen Water Pipes, Steam Jet to Theft of Shovels Prevented by Chain and Padlock	3116
Supporting Stand, Adjustable, Substitute for Jackscrew	3178	Thermometer for Water-Cooling System of Motor Car	3160
Surveyor's Data, Device for Mapping	3104	Thermometers Save Coal in Small Plant Thousandth of an Inch, The	3250
Surveyors' Tape, Homemade Pistol Grip for	3114	Thread Tool, Accurate Method of Setting in Lathe	3281
Surveyor's Tripod Level Made Quickly from Carpenter's Level	3196	Threaded Holes, Drill for Enlarging the Bottom of	3095
Suspension Heating Device for Small Utensils	3147	Threaded Parts, Small, Tray for Moving without Injury	3155
Swinging Door in Sliding Door Saves Employees' Time	3193	Threading and Fitting Long Pipes, Hook Supports for	3138
Swinging Elevator for Trunks and Light Freight	3293	Threading Die Made from a Nut	3246
Switch, Motor-Starting and Regulating	3153	Threading or Turning Screws, Holding While	3267
Switch, Pedal, for Emery-Wheel Motors	3264	Threads of a Pump Cylinder, Buggy Hub Used for Repairing Worn	3180
Switch Reversed by Tilting Mercury Cups	3242	Threads on Bolts, Serviceable Tool for Cleaning	3200
Swivel Chair Made from Wagon-Wheel Felloes	3255	Three-Way Hand Clamp Has Many Uses	3144
Swivel Jaw for Holding Wedge-Shaped Articles in Vise	3164	Tightening Bolts Quickly with Brace, Device for	3129
T-Square for Vertical Boards, Easy-Running	3223	Tile, Mole Plow Makes Subsurface Drain without Use of	3182
T-Square, Small Drafting Work Easily Done without	3291	Time, Employees', Swinging Door in Sliding Door Saves	3193
Table, Invalid's, Rests on Bed	3299	Time, Serial-Number Identifications on Working Drawings Save	3131
Table or Bench, Adjustable Leg for	3096	Timesaving Device to Open and Close Cellar Windows	3232
Tachometer for Shafts without End Centers, Attachment Adapts	3127	Timesaving Magazine Fuse Box for Experimental Circuits	3218
Tack Hammer, Magnetic, Is Electrically Operated	3146	Tin-Coating Steel Lever and Wheel Handles	3187
Tags, Good Marking, Old Linen Collars Make	3287	Tin Foil Winding on Bulb Intensifies Electric Light	3096
Tailstock Centers, Removing Easily by Means of Drift Pin	3219	Tin Guards for Edges of Chisels	3137
Tank, Elevated, Gauge Tells Height of Water in	3224	Tire Remover, Serviceable, for Cars Equipped with Split Rims	3172
Tank for Cleaning Screw-Machine Products	3174	Tire Used to Furnish Pressure for a Soldering Torch	3133
Tanks, Auto-Body Panels and, Removing Dents in	3140	Tire Valve, Rubber Cement for Repairing	3295
Tap, Chalking to Get a Perfect Fit	3180	Tire Valve, Screwdriver Handle Made of Dust Cap from	3253
Tap, Tapping a Hole without	3210	Tires, Device for Vulcanizing on Steam-Engine Cylinder	3171
Tap, Wrench Fits Various Sizes of Shanks	3099	Tires, Inflating with Air by Use of City Water Pressure	3180
Tape, Electricians', Renewing Old	3256	Tombstone, Homemade Concrete	3281
Tape Lines, Tool for Holding in Corners	3189		
Tapeline Holder, Quick-Releasing, does not Snag Readily	3155		



Handles, Carrying Piano Made Easy by	3302	Holes in Steel Plates, Rigging Lessens	
Handle, Emergency, for Screwdriver...	3224	Work of Drilling	3134
Handles for Bits, Convenient, Door		Holes, Large, Boring in Glass	3125
Knobs Make	3117	Holes, Large, Reaming with an Ordinary	
Handles for Pliers and Other Tools,		Twist Drill	3237
Insulating	3283	Holes of Light Belts, Eyelets Handy in	
Handling of Auto Chassis, Loading		Lacing	3164
Truck Facilitates	3263	Holes, Oversize, Fitting Pins Tightly in	3123
Handling of Rough Lumber, Pivot Stand		Holes, Sphere Attachment for Dividers	
Aids in	3170	When Measuring from	3140
Hands, Moving, Scarecrow with	3299	Home, Fuel-Saving Kinks Valuable in	3284
Hands, Protecting from Dirt and Grease		Home or Shop Use, Simple Pipe Bender	
on Engine Work	3126	for	3140
Handsaw Fitted with Attachment for		Hood for a Soldering Iron, Asbestos	3230
Use as Square	3251	Hook Fitted to Hand Truck Holds Boxes	3130
Handy Outfit, Shoe Shining at Home		Hook Supports for Threading and Fitting	
Made Easy by	3276	Long Pipes	3120
Hanging, Building Heavy Doors in		Hopper, Sorting, for Berries and Small	
Place Saves Trouble of	3254	Vegetables	3123
Hanging Oilcan Handy for Overhead		Hose, Clogged Spout Readily Cleaned	
Work	3107	with	3221
Hard Wood, Handy Tool Drives Small		Hose, Digging Holes in Dry Ground with	3243
Nails into	3156	Hose, Garage "Free-Air," Support for,	
Hardening Long, Thin Pieces without		at Curbing	3114
Warping	3300	Hot-Air Furnace, Auxillary Oil Burners	
Harness Hooks, Footstool Made from	3297	in	3267
Harpoon Gun for Spear		Water for the Boat from Engine	
from Old Rifle		Water, Loosening Rusted Engine	3121
Hardware Store Has Spec		Water, with	3126
Carpenters' Squares		Heating, Sand Furnace for, Con-	
Head-Fitting and Bar-Pas		Coal	3290
for Motorcycle		Unoccupied, Draining Pipes in,	
Head, Headrest for Auto Mechan		Winter	3234
Strapped to His	3296	Finished, Magnetic Locator Use-	
Headrest for Auto Creeper Made from		Wiring	3240
Inner Tube	3246	Removing Automobile Wheels	
Headrest for Auto Mechanic Strapped to		Electric Cigar-Case	3244
His Head	3296	Electric Pump Is Independent of	3137
Heat and Coal, Partitioning Off a Room		Levels	3128
to Save	3258	ation, Large Jigs and Templates	
Heat, Dissolving Boiler Scale Saves Fuel		ed for	3113
and Provides More	3253	ations, Serial-Number, on Work-	
Heat, Large Kettle Inverted over Soft-		drawings Save Time.	3131
Coal Fire Saves	3267	Distributor of Auto Engine,	
Heater, Automobile-Exhaust, Mounted		Tube Protects	3128
in Floor Register	3251	System, Electric, Wired to	
Heating Device, Suspension, for Small		Contract Loose Connections	3173
Utensils	3147	Improving an Old Ladle	3273
Heating, House, Sand Furnace for, Con-		Improving the Draftsman's Triangle,	
serves Coal	3209	Useful Kinks for	3277
Heating Rivets in Forge Fire, Handy		Incandescent Lamps in Lofty Ceiling	
Method of	3100	Fixtures, Replacing	3279
Heating Unit, Automobile Radiator as a	3204	Inch, The Thousandth of	3281
Heating Water, Saving Gas in	3287	Indicator on Work in Chuck, Micrometer	
Heel Block, Ankle Strains in Driving		Used as	3128
Relieved by	3113	Inexpensive Belt-Sander Made from a	
Height of Water in Elevated Tank,		Lathe	3235
Gauge Tells	3224	Inflating Tires with Air by Use of City	
Hens' Reach, Poultry Feeder Places Food		Water Pressure	3169
for Chicks Out of	3250	Injury, Tray for Moving Small Threaded	
Hexagonal Stock, Jaws for Holding in		Parts without	3167
Chuck	3109	Ink-Bottle Stopper Lifter Saves Drafts-	
High-Speed Steel for Hand Punches,		man's Time	3139
Using	3241	Ink for Proof Press, Grease Cup to Con-	
Highways, Concrete, Wooden Roller Aids		tain	3211
Construction of	3159	Ink Pad, Handy Rubber-Stamp, for the	
Hinge, Springless Self-Closing Gate...	3283	Shop Office	3194
Hingeless Field Gate, Durable	3262	Inner Tube, Headrest for Auto Creeper	
Hinges, Rattling of Automobile Doors		Made from	3246
Overcome by Setting	3097	Inspectors' Stamp Built into Hammer...	3297
Hinges, Three, Proper Placing of, on a		Insulating Handles for Pliers and Other	
Door	3282	Tools	3283
Hog House of Saw-Tooth Design, Sanitary		Interference by Children, Push Button	
Hogs on the Farm, Vessel for Cooking	3149	Locked against	3256
Potatoes for	3274	Invalids' Table Rests on Bed	3255
Hogs, Snout Snare Makes It Easy to		Iron and Brass Castings, Softening Hard	3190
Ring	3225	Iron Cement Made from Old Dry-Cell	
Hoisting Hook Has Instantaneous Positive		Filler	3183
Grip	3176	Iron, Soldering Electrically without	3166
Holder and Pick-Up Tool for Cotter		Ironing Board with Novel Features	3222
Pins	3242	Irregular Outline, Band Saw	
Holder, Locomotive-Apron, Aids Quick		Paper Labels of	
Coupling	3141	Jackscrew, Adjustable S	
Holdfast, Hammer-Head	3185	Substitute for	
Holding Split Patterns in the Lathe	3280	Jaws for Holding H	
Hole, Etching through Hardened Steel	3139	Chuck	
Hole, Tapping without a Tap	3210	Jig for Drilling S	
Holes Drilled through Brick and Mortar	3179	Jig for Holding	
Holes, Drilling through Heavy Metal		Drilled	
with a Bit Brace	3271		
Holes in Dry Ground, Digging with a			
Hose	3243		

Jig, Segment-Joining, for the Home Workshop	3202	Lid is Opened, Tool-Chest Tray Rises When	3278
Jig, Wedge-Clamp, Helps Speed Up Production	3230	Lifter, Ink-Bottle Stopper, Saves Draftsman's Time	3139
Jigs and Templates, Large, Painted Red for Identification	3113	Lifting Barrels to be Emptied, Device for	3096
Jobs, Difficult, Flexible Scraper Makes Easy	3191	Lifting Large Objects, Novel Method for Lifting Platform and Cradle for Auto Motors Truck with	3203
Kerosene Burner or Stove Readily Made	3244	Light, Automatic Electric Backing-Up Automobile	3131
Kettle, Large, Inverted over Soft-Coal Fire Saves Heat	3267	Light, Divided Window Shades Permit Fine Adjustment of	3210
Keyways, Tool for Laying Out	3193	Lighter for Gas Torch Made from a Spark Plug	3261
Kink, Useful, for Valve-Grinding Jobs	3191	Lighting a Fire at the Top Saves Fuel	3295
Kitchen Cabinet, Sanitary, How to Make	3227	Linen Collars, Old, Make Good Marking Tags	3284
Kitchen Chopping Board, Handy	3302	Liners for Linotype Machines, Homemade Built-Up	3287
Kitchen, Door Latch Controlled from, Saves Many Steps	3230	Linotype Machines, Homemade Built-Up Liners for	3114
Kitchen, Outside Cistern Pump Operated from	3236	Load of Lumber Hauled by Light Car and Hand Truck	3114
Kitchen Range, Quickly Made Gas Burner for	3238	Loading Boxes, Piling and, Winch Truck for	3294
Kitchen, Wood Box Built into Wall of	3249	Loading Point, Counterweight Returns Block and Tackle to	3111
Knife-Switch Contact Blades, Testing	3142	Loading Truck Facilitates Handling of Auto Chassis	3129
Knitting Needles and Dowel Pins, Wooden, Hollow Mill for Making	3190	Locating Bolt Holes Where Scriber Cannot be Used	3263
Labor, Pedal Extension on Auto-Jack Lever Saves	3214	Locator, Magnetic, Useful in Wiring Finished Houses	3245
Labor-Saving Method of Excavating under a Building	3166	Lock, Friction, Keep Vise Ball Points from Injuring Fingers	3300
Ladder Bucket Jack for Roof Workers, Convenient	3196	Lock, Spring-Opening, Fitted on Ruling Pen	3118
Ladder, Callipers for Overhead Work Eliminate Use of	3174	Lock, Staple Prevents Manipulation of	3296
Ladder, Tools for Handling Electric Globes without	3146	Lock Washers, Easily Made	3302
Ladle, Old, Improving	3273	Locomotive-Apron Holder Aids Quick Coupling	3263
Lamps, Incandescent, Replacing in Lofty Ceiling Fixtures	3279	Locomotive Steam Used to Clean and Sterilize Well	3141
Lamps, Keep Clean	3268	Loosening Rusty Wood Screws	3183
Large Objects, Novel Method for Lifting	3203	Loud-Sounding Air Whistle for Camp or Motorboat	3185
Lathe, Accurate Method of Setting Thread Tool in	3095	Lubricated Varnish Eliminates Trouble with Sliding Drawers	3143
Lathe Bell Center for Turning Tubing	3221	Lubricating Bolt of a Ball Thrust on a Torque Rod	3260
Lathe, Bench, Drill-Press Attachment for	3216	Lubricating Piston Pins on V-Type Engines	3138
Lathe Boring Bars, Methods of Holding Tools in	3200	Lumber, Load of, Hauled by Light Car and Hand Truck	3248
Lathe Chuck, Universal, Used as a Vise	3271	Lumber, Rough, Pivot Stand Aids in Handling of	3294
Lathe, Chuck Which Centers and Drives Pistons being Machined in	3181	Lumber-Saving Kink for Making Split Patterns	3170
Lathe, Device for Winding Spiral Springs on	3198	Machine, Heavy, Unloading from a Truck	3252
Lathe, Holding Split Patterns in	3280	Machine, Homemade Die-Casting	3269
Lathe, Inexpensive Belt Sander Made from	3235	Machine, Homemade, for Cutting Washers and Packings	3144
Lathe, Moving Easily with Hand Trucks	3245	Machine Nuts Set on Rods with Belting as Wrench	3128
Lathe, Neat Chest under Holds Tools and Gears	3273	Machine Operations, Tool for Holding Polished Metal Parts in	3103
Lathe, Nineteen-Inch, Turning a Fifty-Four-Inch Wheel on	3160	Machine, Paper-Ornament Making, for Restaurant Use	3150
Lathe, Tool Block for Making Small Pins on	3107	Machine Parts, Mandrels and Similar, Block for Driving	3147
Lathe Tools, Converting Broken Drills into	3221	Machine Parts, Rotating, Balancing by Drilling	3142
Lathe, Wire Used to String Rings as They Come from	3205	Machine Parts, Small, Boring after Grinding	3170
Lathe, Wood-Turning, Using the Drill Press as	3132	Machine Parts, Small, Painted by Use of Novel Device	3118
Lathe, Wrench for Setscrews in Dogs Attached to	3253	Machine Shop, Adjustable Clamping Device for	3158
Laying Out Drill Holes, Punch for	3281	Machine That Executes Military-Drill Movements	3115
Laying Out Keyways, Tool for	3193	Machinery, Light Foot-Power, Concrete Flywheels for	3140
Laying Out Stairs, Handy Square Attachment for	3203	Machinery, Signs on Idle, Give Reasons for Delay in Production	3126
Lead "German Soldiers" Used as Targets	3282	Machines Oiled at Close of Workday Start Easily in Cold	3134
Lead Mallet Head Cast Securely on Pipe Handle	3143	Machining Two Parts at Once, Planing Tool for	3192
Leakage, Oil, Stop on Faucet Avoids	3291	Machinist's Vise, Wooden Caps Convert into Bench Clamp	3155
Leaks, Boiler, Durable Solderless Repair for	3205		
Leather-Belting Cement, Holdfast	3176		
Leg, Adjustable, for Table or Bench	3096		
Lens, To Dry Properly	3280		
Letters, Aluminum Bronze, Size for Holding	3210		
Level, Carpenters' Surveyors' Tripod Level Made Quickly from	3196		
Lever-and-Fulcrum Snow Shovel Makes Heavy Shoveling Easy	3256		
Lever, Long, Eases Action of Force Pump	3302		

<b>Workbench, Bending Conduit Easily at.</b>	<b>3226</b>	<b>Worn-Down Saw, Sharpening</b>	<b>3286</b>
<b>Workbench, Portable Tool Chest and, is Easily Moved about the Shop.</b>	<b>3186</b>	<b>Wrench, Improvised Electromagnet Picks from Crankcase.</b>	<b>3276</b>
<b>Working Drawings, Serial-Number Identifications on Save Time.</b>	<b>3131</b>	<b>Wrench Tool, Handy Vise or, for Bench Use</b>	<b>3162</b>
<b>Working Quality, Storing Air Hammers in Oil Improves</b>	<b>3212</b>	<b>Writing Board, Handy, for Shop Machine for Setscrews in Dogs Attached to Lathe</b>	<b>3253</b>
<b>Workman, Signboard Shows Where He is to be Found.</b>	<b>3259</b>	<b>Wrench for Small Polished Pipes.</b>	<b>3204</b>
<b>Workshop, Home, Dowel Cutter for</b>	<b>3154</b>	<b>Wrench, One-Man, for Automobile Crank-Case Bolts</b>	<b>3207</b>
<b>Workshop, Home, Segment-Joining Jig for</b>	<b>3202</b>	<b>terial-Checking Work</b>	<b>3170</b>





POPULAR MECHANICS

# Shop Notes Series

## OF YEAR BOOKS

One of these books is issued the first of each year, and is a reprint of all the articles which have been published during the year past in our "Shop Notes Department"

200 Pages	Vol. I,	"Shop Notes for 1905"	385 Illustrations
228 Pages	Vol. II,	"Shop Notes for 1906"	555 Illustrations
228 Pages	Vol. III,	"Shop Notes for 1907"	580 Illustrations
212 Pages	Vol. IV,	"Shop Notes for 1908"	536 Illustrations
224 Pages	Vol. V,	"Shop Notes for 1909"	461 Illustrations
224 Pages	Vol. VI,	"Shop Notes for 1910"	451 Illustrations
224 Pages	Vol. VII,	"Shop Notes for 1911"	468 Illustrations
224 Pages	Vol. VIII,	"Shop Notes for 1912"	510 Illustrations
224 Pages	Vol. IX,	"Shop Notes for 1913"	503 Illustrations
224 Pages	Vol. X,	"Shop Notes for 1914"	462 Illustrations
224 Pages	Vol. XI,	"Shop Notes for 1915"	517 Illustrations
224 Pages	Vol. XII,	"Shop Notes for 1916"	469 Illustrations
224 Pages	Vol. XIII,	"Shop Notes for 1917"	422 Illustrations
224 Pages	Vol. XIV,	"Shop Notes for 1918"	344 Illustrations
224 Pages	Vol. XV,	"Shop Notes for 1919"	464 Illustrations
224 Pages	Vol. XVI,	"Shop Notes for 1920"	485 Illustrations
224 Pages	Vol. XVII,	"Shop Notes for 1921"	495 Illustrations
224 Pages	Vol. XVIII,	"Shop Notes for 1922"	465 Illustrations
224 Pages	Vol. XIX,	"Shop Notes for 1923"	436 Illustrations

These books are a perfect gold mine of information for every one interested in mechanics, or who uses tools for pleasure or as an occupation. Of equal value and help to the professional mechanic and the amateur. These articles are the cream of the experience of years of hundreds of the most successful mechanics in the country. There is nothing on the market equal to these books at five times their price. The Popular Mechanics Shop Notes Series tells easy ways to do hard things, and like Popular Mechanics, is "Written so you can understand it." These books are indexed very fully and with great care.

The subjects treated cover every department of mechanics, with useful time saving "kinks" for engineers, firemen, carpenters, machinists, plumbers, painters, iron and wood workers, electricians of all kinds, masons and in fact all the trades.

"Worth Its Weight in Gold" is a frequent expression from our readers, and one young mechanic in the far west who started a repair shop for himself, says he owes his success to "Popular Mechanics Shop Notes." Many a time when a customer brought in a job new to him, he consulted his "Shop Notes," which told him how to do it.

Each volume contains entirely different matter from that published in the others. A set of these books covering several years will make an encyclopedia of priceless value to the owner.

*\*Price (Heavy Bristol Cover) 50 Cents Per Volume, Postpaid*

## Shop Notes Series of 19 Volumes

*Contain 10,000 articles, 4228 pages and 9062 illustrations*

Order through your dealer or direct from the publishers

**POPULAR MECHANICS BOOK DEPT.**

**200 E. Ontario St., CHICAGO**

*\*Vol. XI, Shop Notes for 1915 is also bound in cloth at \$1.00 postpaid.*

