

# Popular Mechanics

**KILLER  
ROLLER  
COASTERS**



Is Design Safety Taking A Back Seat To Thrills?

**TOUGHEST AND PLUSHIEST**

## 4x4s FOR TOWN AND COUNTRY

- Complete Buyer's Guide With Prices
- Torture-Testing The Unstoppable Range Rover
- Exotic Lamborghini-Mercedes 4x4s

### BATTLE OF THE BEHEMOTHS

Cadillac Brougham vs. Lincoln Town Car

### GARDEN TRACTOR PERFORMANCE TEST

5-Way Comparison Picks The Best Of The Bunch

### PROBING THE UNIVERSE

New Technology Allows Us To See Deeper Than Ever

### SPORTS

Laps, Dep... On Your Whise



Chevrolet's XT-1: Blazer of the future







Come to  
**Marlboro Country.**



Marlboro Red or Longhorn 100's—  
you get a lot to like.

**SURGEON GENERAL'S WARNING: Smoking  
By Pregnant Women May Result in Fetal  
Injury, Premature Birth, And Low Birth Weight.**

16 mg "tar," 1.0 mg nicotine  
av. per cigarette, FTC Report Feb. '85





This One



PDX2-9EG-FQK5

© Philip Morris Inc. 1987

См. также на упаковке, защищенный авторским правом



# HAVOLINE SUPREME IS COOL UNDER FIRE!

When the heat's on, motor  
oil viscosity can break down.  
You need the oil that's cool  
under fire:

Havoline Supreme! Its viscosity  
booster helps protect engines  
against wear under extreme  
heat and stress.

When the heat's on, protect  
your car's engine with Texaco's  
Havoline Supreme motor  
oil. It's cool under fire!

**SAVE \$3** on 12 quarts or  
**\$1.25** on 5 quarts.  
Look for rebate coupons  
at your local store or  
retailers.  
**Hurry! Offer ends  
November 1, 1987.**







### 79 COVER STORY

Today, companies are marketing sport/utility vehicles with more options than a Coupe deVille. This month's special report, '88 Sport/Utility, covers the 4x4s of today and tomorrow, offers a complete buyer's guide, introduces some off-beat off-roaders, and takes you on a first-hand drive test of the Range Rover.

—PM photo by Bill Ashe

Although no accident has ever occurred on the Python in Busch Gardens, Tampa, Florida (shown on our cover), there has been a rash of fatal accidents on other amusement park rides. Our exclusive report (page 56) is guaranteed to make you think twice the next time you get the urge to board a thrill ride.



60 Big eye on the sky



74 Tractors for all reasons



70 Power base



56 Killer coasters

## DEPARTMENTS

4 Editor's Notes	44 Audio
6 Letters	48 New/Home
10 Science	50 New/Workshop
14 Electronics	51 Hints
20 Freewheeling	113 Worth
24 Car Clinic	Writing For
28 Inside Detroit	117 The Better Home
32 Workbench Basics	123 Homeowners' Clinic
37 Outdoors	124 Appliance Clinic
40 Photography	140 Next Month
42 New/Auto	

## SPECIAL REPORT: '88 SPORT/UTILITY

- 79 COVER**
- 81 CONTENTS**
- 82 4x4s Move Uptown**  
Utes move upscale and upmarket from their humble beginnings.
- 84 Buyer's Guide**  
By the end of 1988, you'll have 25 or more 4x4s to choose from. Here's an advance look at them.
- 90 Off-Beat Off-Roaders**  
If you're in the market for something completely different, look to Europe. The home of the exotic sports car breeds some pretty outrageous 4x4s.
- 94 It's Not A 4x4. It's A 4x4.**  
We tame the boondocks in the Rolls Royce of sport/utility vehicles, the Range Rover.



## AUTOMOBILES

- 53 Battle Of The Behemoths**  
We pit the Cadillac Brougham against the Lincoln Town Car.

## SCIENCE/TECHNOLOGY

- 56 Killer Coasters**  
New loop-the-loop roller coasters have transformed our nation's amusement parks. But recent mishaps pose the question: Will you survive your next ride?
- 107 Technology Update**  
The latest innovations in environmental, military, sports, energy, electronics, aviation, space and automotive technology.

## ASTRONOMY

- 60 Big Eye On The Sky**  
Advances in photographic emulsion and telescope lens technology are giving astronomers at Cal Tech's Palomar Observatory a new tool.

## MILITARY

- 67 Fire Power**  
New Squad Automatic Weapon packs enough punch to serve our ground forces into the next century.

## HOME/SHOP

- 70 Power Base**  
Turn your stable of hand power tools into accurate stationary machinery.
- 74 Tractors For All Reasons**  
We comparison test big-ticket garden tractors.

## OUTDOORS

- 64 Best Of Times**  
Sport-tech designs and functions emerge in aerospace-light and military-tough watches.



# EDITOR'S NOTES

# Popular Mechanics

**T**he Range Rover I was driving slammed over another 4-ft.-deep, mud-filled hole and careened over a fallen log in the dense Tuxedo, New York, forest. And I finally understood. No wonder there has been a 407-percent growth in the sport/utility vehicle market segment since 1982. No wonder unit sales in that period have grown from under 152,000 to nearly 769,000. These things are fun! Not only are they fun to bash around in the boonies, they're also one of the most versatile types of vehicles sold. You can use them as passenger cars, station wagons, pickup trucks, even snow plows, as well as for just sport driving. Because of this popularity and versatility, our special section this month on sport/utility vehicles focuses on what's new and available in this exciting area and how much they cost. . . . In recent months, Cadillac has taken a lot of flak from the press, from its competition and from the buying public. Sales are way off. Critics will tell you that Cadillacs have lost the distinctive styling they once had. And they'll point to Cadillac's lackluster performance compared to European luxury sedans. All these woes crossed my mind as we prepared the Cadillac Brougham versus Lincoln Town Car comparison test for this issue. One of our testers summed it up best: "Where are the antilock brake systems? Where are the fuel-injected, advanced-design engines? Where are the high-tech suspension systems?" Where indeed? Why can't Cadillac, the carmaker once called the Standard of the World, build cars that lead, not follow, the engineering trends in automotive design? The Allante is Cadillac's newest, most advanced car. Yet, even that design is merely a clone of a 15-year-old Mercedes-Benz model. One answer to Cadillac's problems might be found in a statement made by Cadillac

General Manager John O. Grettenberger at an Allante press conference. He spoke of the possibility of selling the Allante in Europe, and said: "We would probably re-tune the car in terms of its suspension and we would give its powertrain more low-end torque, giving up fuel economy to get it. The European version of the Allante should be stiffer and give us more acceleration than we would need in this country." I think it's unfortunate that Cadillac's general manager thinks we Americans want slow, mushy-handling cars. The European cars that Cadillac competes with—like Mercedes-Benz, BMW, Jaguar and others—are all fast, tight-handling



automobiles. Today, Americans equate an upscale, luxury, status car with outstanding performance, extraordinary handling and advanced engineering. As the owner of two Cadillacs, I hope that the management of that once-proud marque gets the word. . . . Turning to another kind of vehicle, this issue carries the first ever (that we know of) head-to-head comparison test of garden tractors. To conduct the test, Home & Shop Editor Steve Willson and a crew of hundreds had to spend weeks out of the office in the sun-drenched countryside to wring out every last drop of performance from these machines. I think you'll find the end result worth all the effort. . . . Frankly, our article on roller coasters is not the type of feature I like to run. But with recent tragedies involving some of these "amusement" rides, questions have to be asked and issues have to be raised. The task fell to our Science/Technology Editor, Tim Cole. I'm sure you'll find his report provocative and even a little scary. 'Til next time.

  
Joe Oldham

## Editor-in-Chief

Joe Oldham

## Managing Editor

Bill Hartford

## Graphics Director

Bryan Canniff

## Automotive

Wade A. Hoyt, SAE, editor  
Jim Dunne, Detroit editor  
Mike Allen, assistant editor  
Michael Lamm, Norman S. Mayersohn,  
Mort Schultz, Rich Taylor,  
contributing editors

## Home And Shop

Steven Willson, editor  
Joseph Truini, shop and tools editor  
Thomas Klenc, associate editor  
Norman Becker, Rosario Capotosto,  
Steve Toth, Bob Vila,  
contributing editors

## Electronics/Photography

Stephen A. Booth, editor  
James B. Meigs, Frank Vizard,  
contributing editors

## Science/Technology/Aerospace

Timothy H. Cole, editor  
Fred Mackerodt, contributing editor

## Boating/Outdoors

Joe Skorupa, editor

## West Coast

Steve Parker, editor

## Editorial Production

John Bostonian Jr., art editor  
Deborah Frank, production editor  
Nancy Coggins, art assistant  
Jodi Tashman, production assistant

## Art

Alan Andresen, Ann Bennett,  
associate art directors  
Larry Sullivan, assistant art director

## Editorial Administration

Josephine Caronia, administrative assistant  
Barbara A. Novak, executive assistant

## Editorial Offices

224 West 57th St., New York, NY 10019

We cannot be responsible for loss of unsolicited queries, manuscripts, or photos. For return, they must be accompanied by adequate postage.

**SUBSCRIPTION SERVICE:** Popular Mechanics Magazine will, upon receipt from its reader of a complete new or renewal subscription order, undertake fulfillment of that order so as to provide the first-copy delivery either to the Postal Service or alternate carriers within six to twelve weeks. If for some reason this cannot be done, you will be promptly notified of the issue date that will begin your subscription, with a request for any further instructions you may have concerning your order. Please address all such orders to us at Popular Mechanics, P.O. Box 10064, Des Moines, IA 50350. • Should you have any problem with your subscription, please write Joan Harris, Customer Service Department, Popular Mechanics, P.O. Box 10064, Des Moines, IA 50350 or call toll-free 1-800-333-4948. Please enclose your mailing label when writing to us or renewing your subscription • Renewal orders must be received at least eight weeks prior to expiration to assure continued service.

Use this address for subscription orders & inquiries. POPULAR MECHANICS, P.O. Box 10064 Des Moines, Iowa 50350.



# A TRADITION OF HORSEPOWER

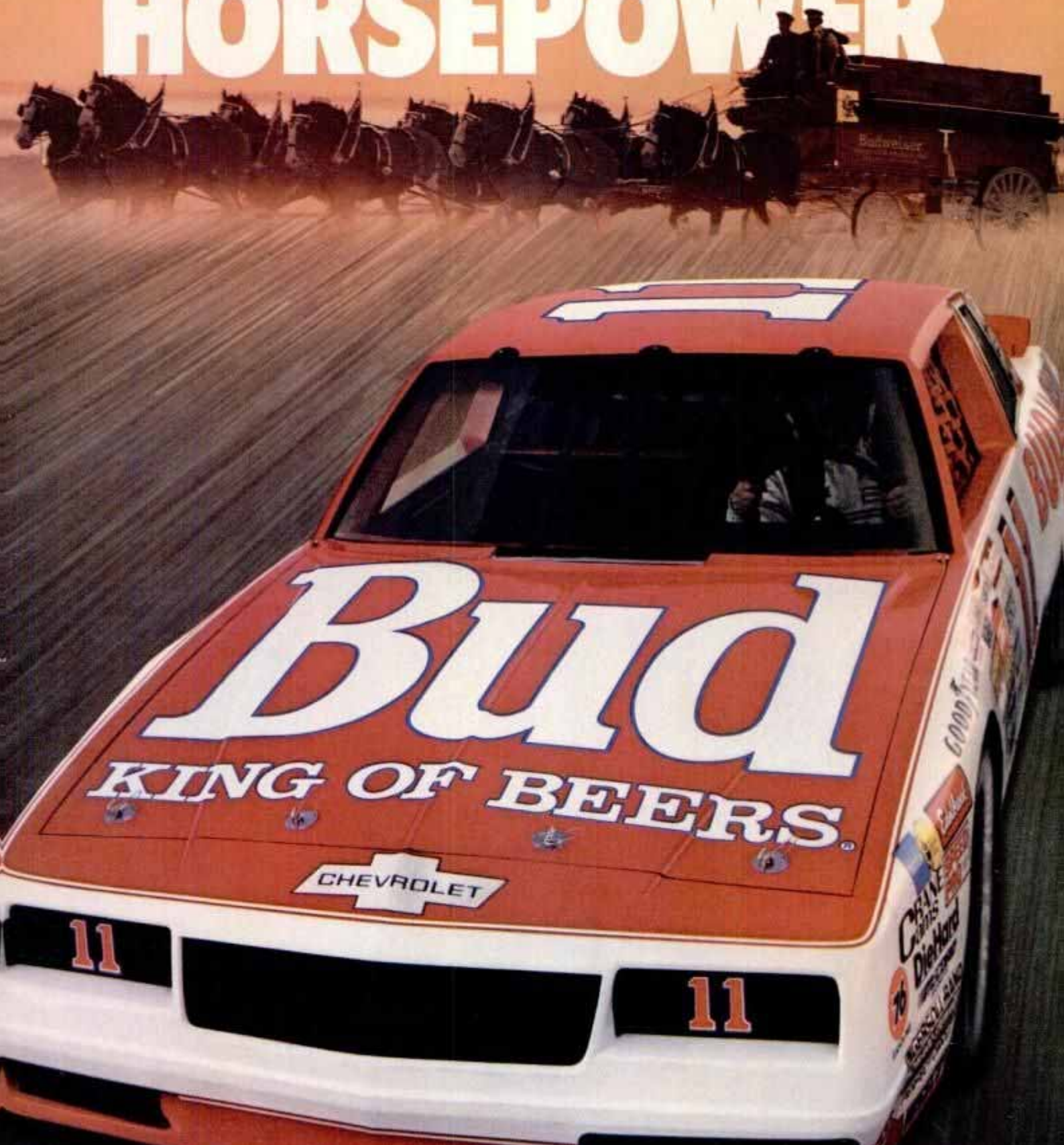

Junior Johnson and Terry Labonte. The 1987 Budweiser<sup>®</sup> NASCAR team.

PLEASE RECYCLE OUR ALUMINUM CANS. BUDWEISER<sup>®</sup> KING OF BEERS<sup>®</sup> ©1987 ANHEUSER-BUSCH, INC. ST. LOUIS, MO



# LETTERS

## How Many Woodies?



Woody was built by the Harrovers from PM plans.

You can add our Woody to the list of those completed from your plans (*Build PM's Woody Wagon*, page 137, July '83). I saw the Woody that Calvin West built pictured in your July '86 issue (*Letters*, page 10). We located our VW from an ad run by a college student. When we pulled up in the '84 300ZX sports car we were driving at the time, she couldn't understand why in the world we would want her old Beetle. Now we can show her!

DEBORAH HARROVER  
TEMPE, AZ

## Upstaged

I read with interest the recent letters from readers who built the Fisher Body coach and Overland Stage (*Letters*, page 8, May '87). Here's a look at a stage I made using plans in the 1955 *PM Do-It-Yourself Encyclopedia*. Mine is handmade in sterling silver with a touch of gold trim!

GEORGE M. KLEIN  
(ADDRESS WITHHELD  
BY REQUEST)



Stage is from PM's plans, but it's in silver and gold!

## Hands On Deck

When I built my deck with the combination planter/bench from your June '85 issue (*Two-Level Deck*, page 90), I had no idea of the reactions I would get from my friends. The one modification I made to the plans was



Reader George Whittaker's built-in bench/planter graces his deck.

to eliminate the backrest to open up our view of the backyard.

GEORGE WHITTAKER  
ATCO, NJ

## Cancel That Tip!

Your tip in the May issue made my hair stand on end! (*Car Clinic*, page 24) Using freon to cool off sparkplugs before removing them from a hot head is irresponsible. The Earth's ozone layer has taken enough abuse already. We must stop the indiscriminate release of fluorocarbons into the Earth's atmosphere. I'm also against the procedure of "sweep charging" air conditioning and refrigerant systems: Use a vacuum pump.

RICHARD HELLER  
HONOLULU, HI

## Say No To Drugs!

I'm a regular reader of Steve Booth's *Electronics* column and enjoy his style very much. But, with all the drug abuse problems our society is facing today, he tells people the only way to relieve pain is to take drugs! In *Computer Maladies* (page 34, April '87) he says, "Short of buying special computer furniture, there isn't much you can do about the table height and neckache problem except take painkillers." There are alternatives that do not involve invasive practice. One of the most effective is CHIROPRACTIC!

ROBERT L. DUBIN  
CHIROPRACTOR  
PETALUMA, CA



Charles Fiero's dining room chair shows fine scroll saw work.

*man Toolbox*, page 108, April '83): My wife says it's too nice for tools and wants it for a jewelry box! I just may have to make another. This one is modified from the plans you published. I customized mine by making a raised panel door instead of the plain front-panel assembly. I'm a long-time subscriber and look forward to every issue.

CHARLES SCHEFFEL  
LYONS, IL

## Choice Seating!

I've built several of your woodworking projects and enjoyed them all, but never as much as building and using this chair (*Choice Seating*, page 84, Aug. '86).

The project was certainly challenging, but the instructions and hints were easy to follow. Everyone who sees our Chippendale-inspired dining room chair is amazed! Thanks for another very fine project.

CHARLES FIERO  
BROOKLYN, NY

## For Tools—Or Jewels?

Here's a warning to other readers who might contemplate building the cherry toolbox from your plans (*Build Our Master Crafts-*



Charles Scheffel's toolbox may never be used for tools.

*Reprints of Choice Seating and Overland Coach are \$2.50; of Two-Level Deck are \$3.00; and readers who want to build PM's classic toolbox/jewelbox can request plan PM-1826 and send \$4.95 to Popular Mechanics, Box 1014, Radio City Station, New York, NY 10101. The Woody, \$14.95, is from Stevenson Projects, Drawer K, Del Mar, CA 92104.*



**For 7 years running...**  
**1987, 1986, '85, '84, '83, '82, '81,**  
**Ford Motor Company**  
**has designed and built**  
**the highest quality**  
**American cars and trucks.**

**No other company can**  
**make this statement.**

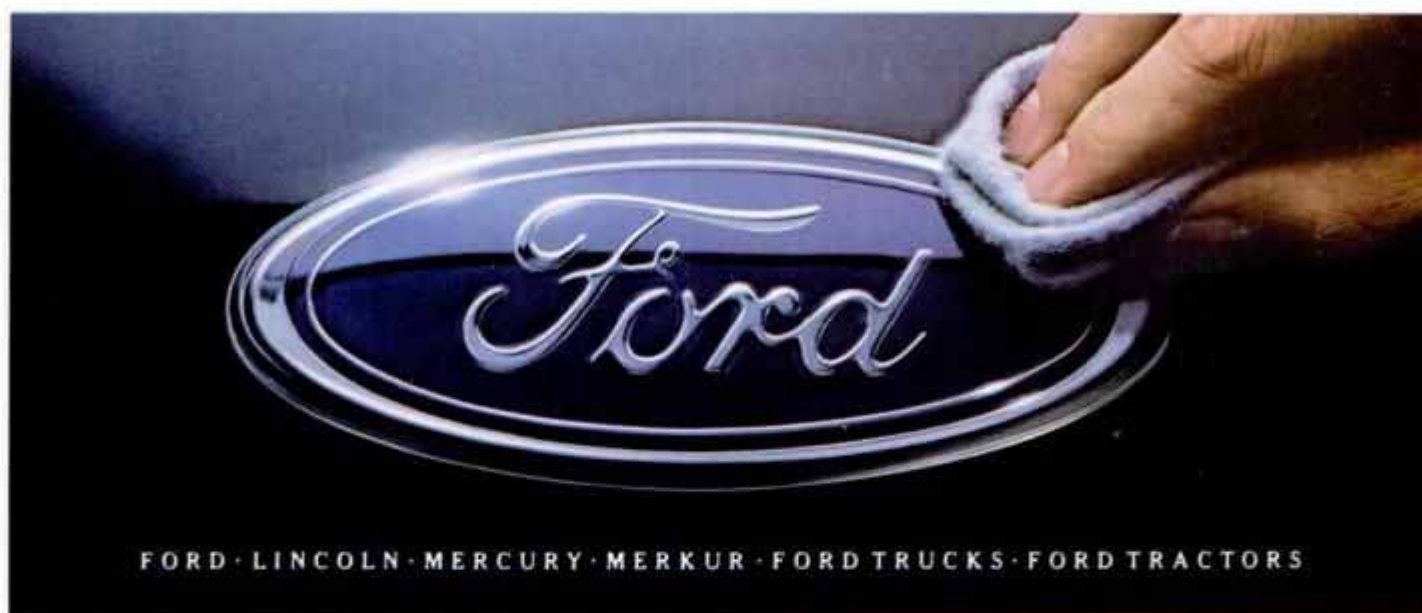

FORD · LINCOLN · MERCURY · MERKUR · FORD TRUCKS · FORD TRACTORS

Based on an average of owner-reported problems in a series of surveys  
of '81-'87 models designed and built in North America.

**Quality is Job 1.**



Buckle up—Together we can save lives.

Материал защищен авторским правом



# NOW YOU CAN CONQUER RUST!



## New NEUTRA RUST Gets Rid of Rust For Good!

**NOT A PAINT, NOT A COVER-UP**, but an entirely new and revolutionary process for eliminating rust. Neutra Rust was originally developed to control the incredible rust on oil rigs in the North Sea and on ships of the Royal Navy. Think of the rust problems they have! Naturally they use vast quantities of Neutra Rust and buy it in huge 50 gallon drums. For a long time that was the only way you could buy it. But at last Neutra Rust is available in smaller sizes for home and shop.

Now you can get rid of rust for good just the way they do at industrial and military installations all over the world!

### WHAT NEUTRA RUST DOES

Neutra Rust is like nothing you've ever used

before. It's amazing! No tiresome scraping, wire brushing and sanding to get down to bare metal. Neutra Rust works best applied right over rust! It penetrates the rust. Gets right down there and chemically changes the rust into an entirely new substance—a hard, black, paintable compound called ferrous ferric. The rust is gone—not just covered up—GONE! For good. It no longer even exists.

### NEUTRA RUST IS EASY TO USE

First knock off the loose or scaly rust, but leave the rest of the rust there. (Remember Neutra Rust works with rust.) Then just brush Neutra Rust on. Within minutes that rust will be gone and the new surface will be there. That's all there is to it. Clean up is easy, too. Just soap and water.

## YOU CAN ACTUALLY SEE NEUTRA RUST WORK!



When you first brush on Neutra Rust it is white. Then, as you watch, it turns pale green, then darker green, then finally a deep, wrought-iron

black. What you have seen is the rust being chemically converted. The hard new surface can be painted any color you want, or left as is.

**USE NEUTRA RUST ON:** Automobiles • Boats  
Outdoor Furniture • Drain Pipes • Gutters  
Mailboxes • Swing Sets • Tools • Lawnmowers  
Appliances • Toys • Bikes • Wagons • Hinges  
Railings • *Anywhere There's Rust!*

For Mail Orders Call:  
1-800-221-6545

For further information  
about Neutra Rust  
write to:

Jeff Morrison, VP Marketing  
New York Bronze Powder Co., Inc.  
777 Dowd Avenue, Elizabeth, New Jersey 07201



© COPYRIGHT NYBCO, INC. 1986

# Popular Mechanics

**Publisher**  
Daniel J. Coleman

**Advertising Director**  
Floyd Sembler

**National Sales Manager**  
Bud Gilbert

### Advertising Offices

**New York**  
224 West 57th St.  
New York, NY 10019  
(212) 262-8824

**Chicago**  
1 South Wacker Dr.  
Chicago, IL 60606  
(312) 984-5190

**Detroit**  
377 Fisher Rd.  
Grosse Pointe, MI 48230  
(313) 881-3520

**Los Angeles**  
3000 Ocean Park Blvd.  
Santa Monica, CA 90405  
(213) 450-8881

### Direct Response Advertising

Al Cohen  
224 West 57th St.  
New York, NY 10019  
(212) 262-4279

Daniel Kellner  
1 South Wacker Dr.  
Chicago, IL 60606  
(312) 984-5190

**Business Manager**  
Agnes P. Maillaro

**Marketing Director**  
Edward Vaquero

**Production Manager**  
Lori Ellwood

**Advertising Production**  
Patricia Tanner  
(212) 262-4800

**Classified Sales Manager**  
Sophie Gronowicz  
(212) 262-4825

**Reader Service Department**  
Gary Frederick, supervisor  
224 West 57th St., New York, NY 10019  
(212) 262-4292

Published by The Hearst Corporation:  
Frank A. Bennack Jr., President  
Randolph A. Hearst, Chairman  
Gilbert C. Maurer, President, Magazines Division  
Richard E. Deems, Publishing Consultant

POPULAR MECHANICS is published monthly by the Hearst Corporation, 959 Eighth Avenue, New York, NY 10019, U.S.A. Frank A. Bennack Jr., President; Randolph A. Hearst, Chairman; Harvey L. Lipton, Vice-President and Secretary; Edwin A. Lewis, Vice-President and Treasurer. Hearst Magazines Division: Gilbert C. Maurer, President; K. Robert Brink, Executive Vice-President; George J. Green, Executive Vice-President; Mark F. Miller, Executive Vice-President, General Manager; Raymond J. Petersen, Executive Vice-President; Thomas J. Hughes, Vice-President & Resident Controller; Daniel J. Coleman, Vice-President for Popular Mechanics.

INTERNATIONAL EDITIONS: CARIBBEAN, MEXICO, SOUTHERN HEMISPHERE

AS A SERVICE TO READERS, Popular Mechanics publishes newsworthy products, techniques and scientific and technological developments. Due to possible variance in the quality and condition of materials and workmanship, Popular Mechanics cannot assume responsibility for proper application of techniques or proper and safe functioning of manufactured products or reader-built projects resulting from plans published in this magazine.

POPULAR MECHANICS • SEPTEMBER 1987

Материал защищен авторским правом



# uniden

The **PRO 520e**  
When the End of the Road is just the Beginning.



## High Performance Communications, The Pro Series by Uniden.

From the company that leads the world in radio communications technology comes the next logical step in the evolution of the CB radio, the Pro Series by Uniden.

The Uniden line of Citizens Band Radio Transceivers is the most extensive in the industry today. Melding today's lifestyle with the latest audio features, precise engineering and contemporary styling.

Styled to compliment other mobile audio equipment, the Pro series renders all other CB's obsolete. From the feature packed PRO 540e to the 310e handheld there is no better Citizens Band Radio on the market today.

Uniden Pro Series, a new generation of radio transceivers to ensure that when you're out, you're never out of touch.

For more information about Uniden CB Radios or any other Uniden product, fill out the coupon and mail it today.

Uniden Corp. of America  
Consumer Products Division  
6345 Castleway Ct.  
Indianapolis, IN 46250

Name \_\_\_\_\_  
Address \_\_\_\_\_  
City \_\_\_\_\_ State \_\_\_\_\_ Zip \_\_\_\_\_  
 Scanners  CB Radios  
 Home Satellite Receivers  Radar Detectors  
 Telephones  Marine Electronics

The Choice of Professional  
Golfer Jack Nicklaus  
Winner of 20 Major Championships  
© 1987 Uniden Corporation of America



**uniden**<sup>®</sup>  
A New Generation of Communications



BY TIM COLE

## New War Against Pests



The pesky bee mite: Small enough to clog a bee's breathing passage, yet big enough to deplete a whole hive's honey production.

The grisly creature pictured in the microscopic view above is called a bee mite, and it's so small that it lives, feeds and reproduces within the breathing tube of a honey bee. The mites block oxygen flow to the bee's flight muscles. And if a bee can't fly, it can't collect the nectar it needs to produce honey. What to do?

Researchers at the U.S. Department of Agriculture Subtropical Research Laboratory in Weslaco, Texas, have come up with a solution that also highlights the many new ways we're learning how to control pest populations without harming the environment.

The problem of the bee mite is an interesting one: A chemical insecticide would eliminate the bee mite, but not without eliminating the bee. So scientists like Dr. William T. Wilson are introducing simple, environmentally safe menthol fumes to the bee's environment.

"Menthol fumes hurt the mites, but don't hurt the honey bees. It only irritates them enough so they fan their wings," says Wilson, "and the fanning spreads

the menthol fumes around the hive."

Elsewhere, scientists are learning how to use nature to eradicate or reduce the impact of unwanted insects. Spraying often kills insects beneficial to the ecosystem or agriculture as well as the pests.

And insects eventually mutate a resistance to most chemical applications. That says nothing for the harm chemicals impose on natural resources.

The first technique in-

volves introducing laboratory-reared insects sterilized by irradiation into an insect population. Wild insects mate with sterile insects—a union incapable of producing any progeny because of this involuntary form of birth control.

One example of a successful introduction of sterile flies into an insect population is in Hawaii, where scientists began incubating 20 to 30 million Mediterranean fruit flies weekly beginning in 1974. The flies are sterilized with a Cobalt-60 irradiator and dropped over a test site by airplane. The object is to sexually overwhelm the wild fly group with flies that are incapable of reproducing.

In the second, environmentally benign procedure, the sex pheromone produced by the male insect is extracted and used to attract the female insect. The females are then easily trapped and eliminated.

### Altering Atomic Structures

Trekies are familiar with the scenario: Captain Kirk commands Scottie to "beam me up" and his body is instantly atomized. Transported to the orbiting *USS Enterprise*, he is then con-

veniently reassembled.

Actually, this fantastic manipulation of molecules may not be too far off at Bell Labs, where researchers have discovered that a scanning-tunneling microscope has the ability to physically lift and move atoms. Using the microscope to study a germanium crystal, researchers recently picked up an atom from its structural position and put it in a new spot. Germanium is a carbon element that can be used as a semiconductor and is often used in making transistors. The scanning-tunneling microscope consists of an exceedingly fine tungsten tip that skims above a sample at a distance equal to a few diameters of a single atom. When a weak electrical current is applied to the tungsten tip, a current flows across the tip-to-sample gap. The slightest variations in the gap's width will alter the current. So, by monitoring the flow of current as the tip scans the sample's surface, researchers can map its microscopic hills and valleys, down to bumps on individual atoms.

After scanning the germanium a second time, they discovered it had changed. Instead of a perfect crystal, some of the atoms protruded slightly.

In essence, the Bell scientists had discovered a method of picking up a single atom and physically displacing it.

Bell Labs researcher Russell Becker speculates that the tungsten tip somehow attracted a few stray atoms, or that the electrical field created by the microscope rearranged the crystal's structure. Already, scientists are theorizing new ways to etch the tiniest possible circuitry—no wider than an atom—on a computer chip for smaller, more powerful computers.

PM

Bell Labs scientist and the scanning-tunneling microscope. Atom displacement is visible (inset).

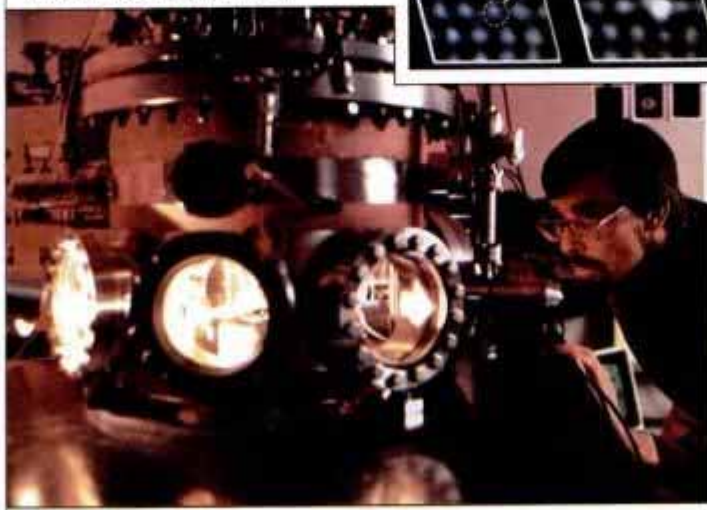



# CAMEL LIGHTS

Share a new adventure.



9 mg. "tar", 0.6 mg. nicotine av. per cigarette by FTC method

**SURGEON GENERAL'S WARNING: Smoking Causes Lung Cancer, Heart Disease, Emphysema, And May Complicate Pregnancy.**



# THE QUIET REVOLUTION CONTINUES.

Introducing the new  
Wrangler LT rib radial.  
Engineered to bring you  
the sounds of silence.

Treadwear is important in a light truck or van rib radial.

So is handling. And wet and dry traction.

But one feature that is often overlooked is the feature that can have the biggest effect on you as a driver.

And that feature is noise. The noise your tires make as they travel down the highway.

Now, with the addition of the Wrangler LT rib radial to the new Wrangler radial line, Goodyear is continuing a quiet revolution.



And, as you'll discover, noise reduction isn't the only improvement to be found in these remarkable new rib radials.

## *Noise: the final frontier.*

People who buy rib radials tend to drive more in a year than people who buy other types of van or light truck tires.

So we made treadwear a prime consideration when we designed the new Wrangler LT.

Since we knew that you wanted a strong tire, we also insisted that it should be a true steel-belted radial.

We set design parameters for handling and for wet and dry traction.

We gave it a new shoulder rib to improve wear capabilities. And we gave it a continuous center rib, which contributes







to overall quietness. Finally, but just as importantly, we set a goal for noise reduction.

The result: The new Wrangler LT, a strong, rib-designed radial that offers long mileage, good handling and traction, plus a smooth, quiet ride.

It is a tire that goes a long way towards pushing back the final frontier.

***Underneath is the strength of our on- and off-road tire.***

At the heart of the Wrangler LT is the same strong carcass that's used in our on- and off-road Wrangler AT.

You will find a minimum of two high-tensile steel belts.

And beneath the steel belts, you will also find two plies of chemically stabilized polyester cord for long tire carcass life.

You will also find that the sidewalls have been reinforced and have a cut-resistant compound.



For long life, we also added a cool running sub-tread compound.

For good air retention, we added a butyl liner.

And for better stability in the bead area, we added a new lower sidewall design.

This improved sidewall design, together with the reinforced sidewalls, gives you responsive steering.

Although the new Wrangler LT rib radial is designed for use on any axle position, it can be used in pairs

capacity of 3,042 lbs. per tire.

But no matter which size you choose, you'll get the benefits of a strong, smooth-riding radial that has been engineered to bring you the sounds of silence.

***The best surprises are quiet surprises.***

Out on the highway, and over the long haul, the new Wrangler LT will come as a very pleasant, quiet surprise.

We also believe that you'll be pleasantly surprised by the traction



just on the steer axle. It can also be used on all of the axle positions of the vehicles you may tow.

The Wrangler LT is available in a wide variety of widths, sizes, and load capacities, up to a maximum load

the Wrangler LT gives you.

You can see the new Wrangler LT radial at your Goodyear dealer. Where you will discover that some of the best surprises are quiet surprises.



*Take me home.*

*The quiet way.*





# ELECTRONICS

BY STEPHEN A. BOOTH

## The Lava Light Returns

**W**e have much to thank Nikola Tesla for—not the least of which is our system of delivering electricity, known as alternating current. The inventor and engineer who lived from 1856 to 1943 also proposed the idea of wireless transmission of electrical power, and it's likely that someday the juice will flow via beams of electromagnetic energy.

One little-known invention of Tesla's was his Chamber of Living Lightning. It's the basis for a new type of living room conversation piece called Eye Of The Storm, from Santa Monica, California-based Rabbit Systems.

Sealed within the 8-in.-dia. glass globe is an electrode and a combination of rare but harmless gases.

They interact to stage a lightshow of blue and magenta rays, whose movement and intensity varies according to the type of external stimuli and the amount of electrical discharge you select.

By adjusting the frequency control on the unit's 6-in.-tall black base, you can generate a subtle shower of colored light or a turbulent lightning storm. The forces within the globe respond to touch, voices or music. Place your hand on the chamber and streams of illumination rise up and follow your movements. As you speak, lightning vibrates and trembles within the chamber. Play music in the room and the lights undulate and dance in sync with the sound.

Eye Of The Storm (\$180)

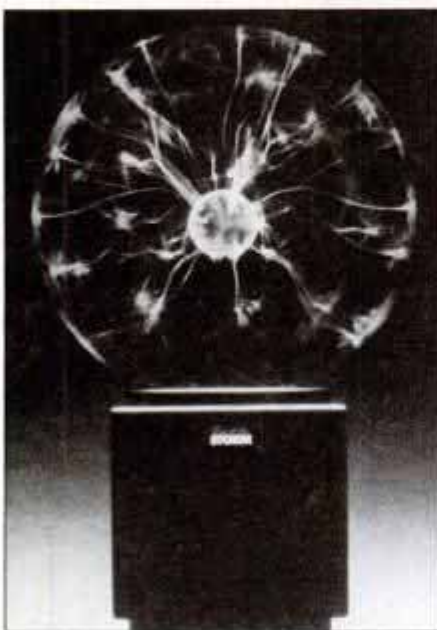

Eye Of The Storm, by Rabbit Systems, responds to sound and touch with lightshows.

is a lot more dynamic than the lethargic "lava light" of the 1960s—and certainly more interactive with its owners. It's sure to break the ice at parties, but since it depends on AC current, keep candles and a whoopee cushion handy.

### Heavyweight Contender

What's heavier than Jerry Cooney, shorter than Mike Tyson, and has the reach of Boncrusher Smith? No, it's not a Kenyan mountain ape, but you'll need a gorilla or two to carry Mitsubishi's new 37-in., high-resolution TV home from the store. If you could buy it, that is.

Combined with its pedestal stand, Mitsubishi's XC-3710C tips the scales at 309 pounds and stands 5 ft., 3 in. More impressive is the display quality of the 37-in. diagonal cathode-ray tube. It packs 640 lines of horizontal resolution and 480 vertically.

Thanks to its 110° deflection angle, the cabinet is only 29 in. deep. That's not a lot deeper than a 25-in. di-

agonal set—but the 37-in. screen provides 80 percent more viewing area.

Mitsubishi's new heavy-weight contender is yours for \$10,000. That purse might lead you to suspect that the XC-3710C is not really intended for watching the Friday night prize-fights in your brother-in-law's rec room—or even down at the local bar. Actually, the monitor was developed for industrial and commercial use, especially those applications which involve a computer, such as in computer-aided design. For this reason, the monitor automatically operates at any vertical scanning frequency from 40 Hz to 75 Hz (TV and video run at 60 Hz in the U.S.).

Though the XC-3710C does more than most of us now need or can ever afford, some of its attributes will trickle down to home sets in the years to come. Large tube sizes will become more widely available, and horizontal resolu-



Mitsubishi's \$10,000 TV has a 37-in. superhi-res screen.

tion in the neighborhood of 450 lines will be a must once the new Super VHS camcorders and VCRs (*Home Video*, page 21, June '87) go on sale here.

### Featherweight Class

As nice as it might be to dream of a 37-in. tube TV, something smaller and



You can build Heath's featherweight 9-in. color TV from a kit.

more affordable is Heathkit's 9-in. color set. You can even build it yourself—in three nights, according to Benton Harbor, Michigan-based Heath.

The featherweight GR-9009 runs on AC or DC power, so it can go where you go. Its quartz-controlled electronic tuning locks onto the exact VHF or UHF frequency you choose, and eliminates moving parts. You can select a channel directly via pushbutton, or scan up and down.

Other features include a built-in whip antenna, a retractable carrying handle, earphone and glarehood for outdoor use.

Internal components of the GR-9009 include large-scale integrated circuits—and most boards are preassembled. A built-in crosshatch generator for aligning the TV gets you up and running all the faster. The kit costs \$250 and can be ordered by phone: (800) 253-0570, or (616) 982-3411 if you live in Alaska or Michigan.

### DAT Update

In our nation's capital, the air is still hot from the battle of words over Digital Audio Tape (DAT). As reported in our exclusive hands-on evaluation (*Digital Audio Cassettes*, page 106, July '87), the music industry is lobbying for an

(Please turn to page 16)



# The World's First Truck Stereo Kicks Bass.

Introducing Pioneer's  
Truck Riders™. The first  
audio systems designed  
exclusively for trucks.

Understand, this isn't a car  
stereo attached to a pair of car  
speakers. This is a complete  
truck sound system designed  
to work as one.

It all starts in the dash  
with a tough, 50-watt, impact-  
resistant AM/FM cassette deck.  
And it comes out of specially  
designed behind-the-seat  
speakers that pound the sound  
right into your spine. Yet before  
it even reaches your brain,  
it's been fine tuned by Pioneer  
innovations like Super Bass,  
Stereo Wide, and Front/Rear  
Blend Control. The result: Your  
cab literally explodes with  
crystal clear sound.

Pioneer's tough new  
Truck Riders™. Go ahead.  
Kick some bass.



TS-TRXS Truck Speakers



KEH-8282TR AM/FM Cassette Deck

 **PIONEER**



# SAVE UP TO 20% IN LAWN-BOY'S FALL CLEAN SWEEP SALE.

Now through October 31st, Lawn-Boy® lawn mowers are up to 20% off the regular price.\* Powered by the famous Lawn-Boy two-cycle engine, these machines are built to last. But these prices won't. Pick up a Lawn-Boy 1400CL trimmer on sale, too. With optional vacuum and blower attachments, it's the most powerful way to clean up this fall.



## LAWN-BOY

*America's long-running tradition.*

\*Subject to local dealer participation. ©1987 Outboard Marine Corporation, A Division of Outboard Marine Corporation, Memphis, TN 38113.

## ELECTRONICS

*(Continued from page 14)*

import ban on DAT decks that do not have a circuit to prevent the recording of compact discs and other copy-protected programming.

Until Congress decides what it does or doesn't want to do—something not likely to happen this year—most Japan-based audio companies remain equally indecisive about selling DAT recorders here. An American company, however, has decided to take the bull by the horns and be the first to make the technology available to American hi-fi buffs.

That company is the venerable Marantz, always one of hi-fi's pioneers. The Chatsworth, California-based firm is celebrating its 30th anniversary by introducing its DT-84 in October, by which time it should have Underwriters Labs' blessing on the DAT recorder.

"In our partisan way we believe that the recording industry may be naive and shortsighted in its view of taping," said Marantz President Jim Twerdahl, in a statement delivered at this summer's Consumer Electronics Show.

"Not only have the courts consistently sided with the public's right to

record for its own personal use, but it can be argued that the ability to copy and disseminate information has greatly broadened everyone's markets," he said.

Although it is likely that other hi-fi makers will follow Marantz's lead, Twerdahl said the company is prepared to go it alone.

"Even if there is no prerecorded software, and even if there are legislative barriers, we will proceed with our marketing plans. If need be, we will litigate ours and our customers' rights to present this new technology without restrictions."

Way to go, Jim. If the electronics companies had been afraid of their own shadows back when the "Beta-max Case" litigation sought to prevent home video recording, we wouldn't have VCRs and camcorders today.

The position established by Marantz has already prompted activity on the DAT front.

As we go to press, sources tell me that four other manufacturers have submitted DAT decks to UL for testing, as a prelude to sale.

## Needlecraft

One of the most critical components of a hi-fi system, and one of the smallest,

is the stylus or "needle" that exhumes music from its resting place in the grooves of a record. Inevitably the day comes when that needle needs to be replaced—and then you learn how big a pain in the neck that tiny splinter can be.

Often, locating the right replacement stylus (or even the entire phono-cartridge) can be difficult—especially so if you bought your stereo in a department store or appliance shop, which isn't likely to stock the range of replacement parts you'd find in a full-service specialty hi-fi retailer.

Help is on the way, in the form of a national franchise called Needle In A Haystack.

The Washington, D.C.-based chain stocks more than 1200 replacement needles and cartridges for record players, plus numerous accessories. Additionally, the company performs repairs on audio and video components of all kinds and brands.

That's a useful service, especially when your equipment is no longer under the manufacturer's warranty—or if the manufacturer has moved on to oblivion.

To find the Needle In A Haystack franchise nearest to you, or to purchase directly, call toll-free (800) 368-3506. **PM**



# Train with NRI for a high paying career servicing computers.



**DIGITAL MULTIMETER**—Professional test instrument for quick and easy measurements.

**LESSONS**—Clear, well illustrated texts build your understanding of computers step-by-step.

**DISK SOFTWARE**—including MS-DOS, GW BASIC, WordStar, and CalcStar.

**SANYO COMPUTER**—8085 CPU double-sided disk drive, 256K RAM, 4.77 MHz and 8 MHz turbo speed.

**MONITOR**—High resolution, green screen displays, crisp text and graphics.

**TECHNICAL MANUALS**—with complete specs on Sanyo computer and professional programs.

**DISCOVERY LAB**—Using it, you construct and test circuits like those used with computers.

**DIGITAL LOGIC PROBE**—Simplifies analyzing digital circuit operation.

## Get started now by building this fully IBM PC compatible computer

Now you get it all... training for America's fastest growing career opportunity... training to service all computers... training on the newest total computer system, the Sanyo 880. Only NRI can give you the well-rounded training you need, because only NRI gives you a complete computer system... computer, monitor, disk drive, software, even test instruments like a digital multimeter and logic probe to work with and keep. It all adds up to training that builds the knowledge, competence, and ability you need to succeed as a computer service specialist.

### Get inside the newest, fully IBM PC compatible Sanyo Microcomputer

As an NRI student, you'll get total hands-on training as you actually build your own latest model Sanyo 880 Series computer from the keyboard up. It's fully IBM PC compatible and, best of all, it runs programs almost twice as fast as an IBM PC. As you assemble the Sanyo 880, you'll perform demonstrations and

experiments that will give you a total mastery of computer operation and servicing techniques. You'll do programming in BASIC language—even run and interpret essential diagnostic software.

### Understanding you get only through experience

You need no previous knowledge to succeed with NRI. You start with the basics, rapidly building on the fundamentals of electronics with bite-size lessons. You perform hands-on experiments with your NRI Discovery Lab and then move on to master advanced concepts like digital logic, microprocessors, and computer memories.

### Learn at home in your spare time

You train in your own home at your own convenience, backed at all times by your own NRI instructor and the entire NRI staff of educators and student service support people. They're always ready to give you guidance, follow your progress,

and help you over the rough spots to keep you moving toward your goal.

### 100 page free catalog tells more... send today

Send the postage-paid reply card today for NRI's 100 page catalog that gives all the facts about computer training plus career training in robotics, data communications, TV/audio/video servicing, and many other fields. If the card is missing, write to NRI at the address below.

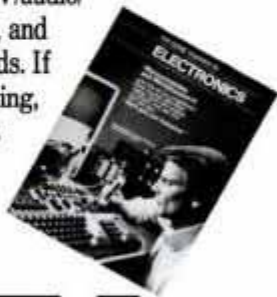

# NRI

 SCHOOLS

McGraw-Hill Continuing Education Center  
3939 Wisconsin Avenue  
Washington, DC 20016

We'll give you tomorrow





# FREEWHEELING

BY WADE HOYT

## 4ws: Will It Stick?

The long-awaited introduction of 4-wheel steering is upon us with the 1988 Honda Prelude. At low speeds, the rear wheels steer in the opposite direction from the front wheels, making the car more maneuverable and cutting its

You'll still know it's a Prelude. But it's longer and smoother than the '87 model. The front end looks very much like a miniature Ferrari 308GT, though you'll wonder where the engine went (it's midship in the Ferrari). By leaning the en-



Rear wheels of '88 Honda Prelude countersteer 5.3°.

turning circle from 34.8 ft. to 31.4 ft. At highway speeds, the rear wheels steer in the same direction as the fronts, giving added stability to cornering, lane changes and other high-speed maneuvers.

Even without 4ws, the '88 Prelude is very impressive. The new car's styling won't cause any confusion.

gine backward 18°—as opposed to a 15° forward tilt on the '87—and using Honda's unique double-wishbone front suspension instead of the towering MacPherson struts, Honda's designers have been able to achieve what they proudly call an "engineless" look. The rear roofline has BMW overtones.

A longer wheelbase gives rear-seat passengers an extra inch of legroom, although most adults could use a 4- to 6-in. stretch.

Two engines are offered, both with identical 2-liter blocks. The base S model has dual carburetors, a single overhead cam, three valves per cylinder and 104 hp. The Si version has dual overhead cams, four valves per cylinder, fuel injection and 135 hp.

Si performance is right up in sports car country with 0 to 60 times of 8.5 seconds, the ¼-mile in 16.5 seconds, cornering forces of .83 G and a top speed just over 125 mph.

The most striking feature, however, is the 4-wheel steering, which is available only in a \$1500 package that includes alloy wheels, power door locks and bronzed-tinted window glass. Compared to some other carmakers, Honda's all-mechanical 4ws system is elegantly simple and devilishly clever.

A shaft runs from the front steering rack to a second steering gearbox between the rear wheels (see drawings below). This center shaft is driven by the rack and terminates in an eccentric (or offset) shaft

that forces a planetary gear around inside an internal-tooth gear.

As the planetary gear climbs the side of the internal-tooth gear, a stub shaft operates a stroke rod, which is attached to the tie rods for the rear wheels.

The motion of the stub shaft is the sum of the motions of the eccentric shaft and the planetary gear. When the steering wheel is first turned, the planetary gear rotates in the opposite direction and the stroke rod moves to one side.

But as the planetary gear continues to climb up its toothed ladder, the stroke rod begins to move in the opposite direction.

Thus, when the steering wheel is turned a little bit, as it is at high speeds, the rear wheels turn in the same direction as the front wheels. However, they cannot turn more than 1.5°, which is quite enough at high speed. As the steering wheel continues to turn, the rear wheels first come back to the straight-ahead position, then steer in the opposite direction to a maximum of 5.3°.

The system is not actually speed sensitive. The theory is that, at high speeds,

*(Please turn to page 22)*

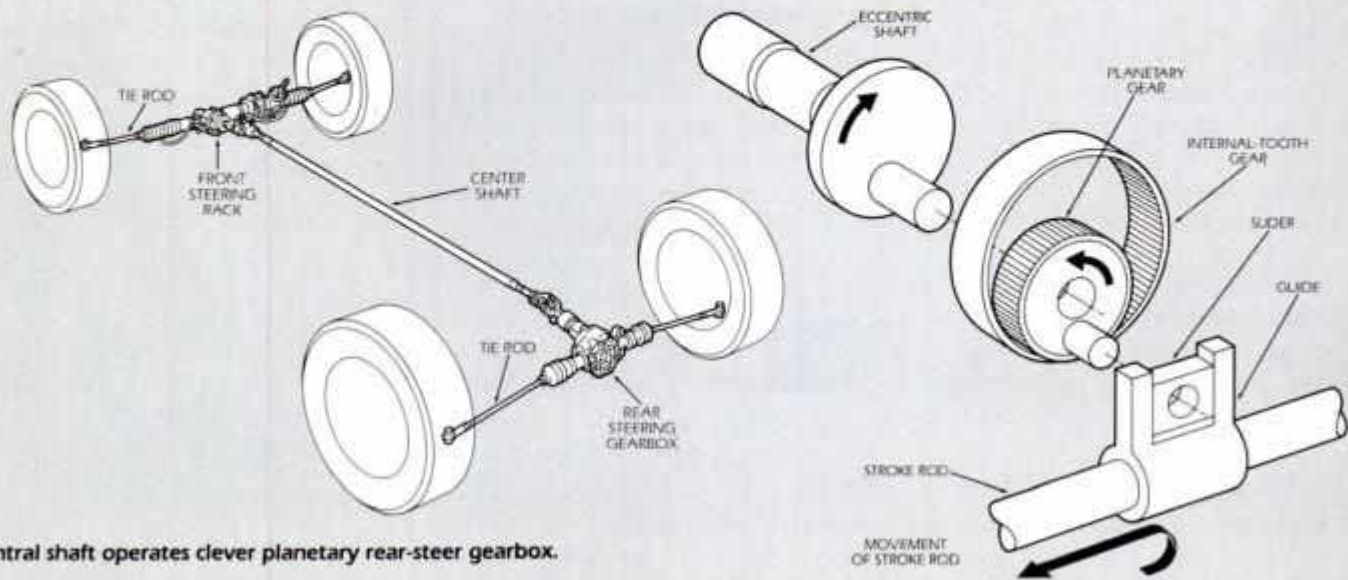

Central shaft operates clever planetary rear-steer gearbox.



Buckle up — for life!



## AT \$6399,\* YOU'LL HAVE PLENTY OF MONEY LEFT OVER TO FILL IT UP.

At a price of only \$6399,<sup>\*</sup> the Isuzu P'UP is the lowest priced import truck in America.<sup>†</sup>

But about the only place we made compromises was the price.

We certainly didn't cave in when it came to the payload. It's capable of carrying over 1,100 pounds, more than enough to handle anything from a load of bricks to a loaded motorcycle.

And when it came time to make it rugged, our standards got tougher. For more than 73 years, our trucks have conquered Mexican deserts, African jungles, Arctic

blizzards and Moroccan sand and we don't intend to let them start slipping now.

Nor did we sit back when it came to the cab. That's why its interior appointments seem to be "almost custom installed" according to the editors at *Road and Track*.<sup>\*\*</sup>

So while you're getting America's lowest priced import truck when you buy a P'UP, you should always keep one thing in mind. It didn't come cheap.



\*Manufacturer's suggested retail price P.O.E. excluding tax, license and transportation fee. Price as of 5/1/87 and is subject to change. †Except Hawaii. \*\**Road and Truck Truck Buyer's Guide*, 1987.

*The First Car Builders of Japan.*

# ISUZU



# Have Snips Will Travel.



## Free carry pouch with purchase.

Look for genuine Wiss® snips in the specially marked pack and get a genuine leather carry pouch worth \$3. Absolutely free. Now at participating hardware stores and home centers.



**CooperTools**

The difference between work and workmanship.

BREWER-TITCHENER® CAMPBELL® COVERT® CRESCENT® LUFKIN® MERRILL® NICHOLSON® PLUMB® H.K. PORTER TURNER® WELLER® WIRE-WRAP® WISS® XCELITE®

## FREEWHEELING

(Continued from page 20)

you don't turn the wheel very much, while at low speeds you do. Since you've got to turn the steering wheel 246° before the system switches over from one direction to the other, there isn't much chance of that happening at high speed. But there is a possibility that a driver, all crossed up in a skid, will turn the wheel more than 246° trying to recover, and find the rear wheels working against him.

Driving the 4ws Prelude is different enough to make a sensitive driver uneasy at first. You can feel the back wheels doing something you're not used to, and even though they're doing something good, it takes a while to gain confidence in the car.

At low speeds, the extra maneuverability allows you to make U-turns where normal Preludes require a K-turn. You can worm your way in and out of impossible parking spots with ease, once you remember to allow for the extra-short turning radius.

Snaking through an obstacle course, the quick-steering Prelude gives you the eerie impression that you're driving a fork lift. In high-speed corners and lane changes, the 4ws car is definitely more stable.

Off the test track and out on the open road, however, the differences between the 2ws and 4ws becomes more subtle. The standard Prelude chassis is so good that it's hard for even a professional test driver to tell the difference between the two versions. The average driver will wonder why he spent the extra money. That's not to say that the extra money was ill-spent. Four-wheel steer gives you about a 10 percent increase in cornering ability and, therefore, safety. An inexperienced driver will get the most benefit from it, being able to improve his time through a slalom much more dramatically than a pro.

We're going to see a lot of 4ws cars over the next few years. Mazda's new 626 has it, and Mitsubishi is next in line. Nissan and Toyota have prototypes running around. It's certainly going to top the goody list for a while, right up there with 4wd, turbos and digital instruments. Whether 4ws will be a lasting benefit, like disc brakes, or just this year's talking dashboards, remains to be seen. **FM**



Mazda 626 4ws is speed sensitive.



# Save Gas, Save Engine with "POLY"

The following introduces one of the most fully tested and proven gas saving, friction-reducing engine treatments ever to reach the market!

## The Secret is "Poly"

"Poly" is short for polytetrafluoroethylene (TFE), the slipperiest substance known to man. (1981 Guinness Book of World Records). Petrolon Corporation, makers of Slick 50, invented a way to permanently bind this slippery chemical to your engine with one treatment. Just one quart of Slick 50 can reduce engine friction, increase gas mileage and horsepower and reduce engine operating temperature, causing your oil and engine to last longer. . . plus it reduces metal wear, defraying costly overhauls.

## Years of Testing and Use Have Proved It True!

Slick 50 has been thoroughly tested in independent laboratories and out on the road:

The March/April 1982, p. 35 issue of "Consumer Digest" magazine stated, "Slick 50 does reduce engine heat and ordinary wear, and our informal tests indicate that it will improve gas mileage by about 2 or 3 miles per gallon."

One of the country's most respected research institutes reported applying a powerful ultrasonic cleaning process to a Slick 50 treated engine and were surprised at its permanence. "We actually expected the Petrolon Slick 50 TFE Resin coating to also be removed, but later found it was still there."

"Dune Buggies & Hot VWs" magazine April 1983 issue records the results of their one year testing of Slick 50. "We can indeed say scientifically that Slick 50 does work, and that it does reduce engine wear! . . . for the price of one treatment when compared to engine rebuild, we feel that you'd be money ahead using Slick 50."

The Federal Aviation Administration has fully accepted a similar product for aircraft—Slick 50 Aircraft Piston Engine Treatment (F.A.R. #33.49). This FAA endurance test simulated 1400 hours of engine use.

The power technology laboratory at a leading southwestern university stated, "Slick 50 does increase horsepower and decreases fuel consumption in tests done at the university."

The Space Shuttle Columbia uses the chemical "poly" in its gears and bearings because it is the only chemical lubricant which can withstand the heat and corrosive elements of space.

Perhaps most dramatic of all is a torture test overseen by the Automotive Services Council for Pennsylvania and shown on WTVE television. Three cars with 75,000 to 129,000 miles on them were treated with Slick 50. Six months later the oil was drained from each vehicle, and the cars driven without the oil plugs for about a half hour. The water temperature never rose and the engines sustained no apparent damage.

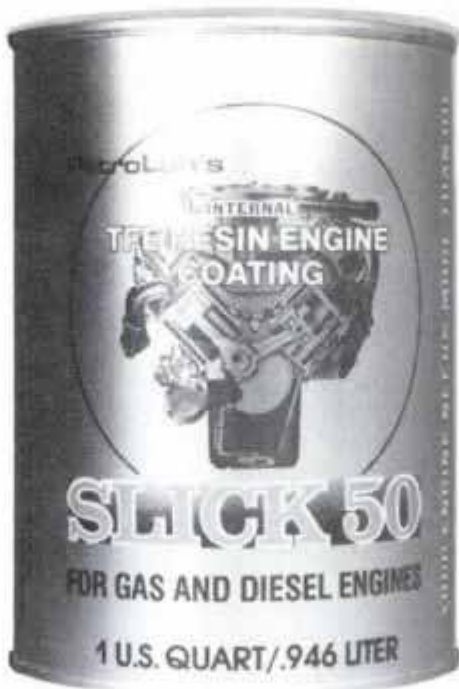

There isn't room here to tell you about the dozens of other tests proving that Slick 50 is everything we say. However, if you're still skeptical, send \$2.00 to cover printing and postage costs, and we'll send you detailed test results plus actual letters from users who report how Slick 50 saved their engines and saved them money!

## It's Easy to Treat Your Engine

A few minutes before oil and filter change, add the engine flush you get free with each order to clean out the engine. Let the engine idle for 5 minutes. Then drain the oil, change the filter and add the proper amount of oil, less one quart. Add one quart of Slick 50, drive for 30 minutes, and leave it in the crankcase for at least 3,000 miles. As the engine operates, the oil carries the "poly" between the parts where it is burnished into the pores of the metal.

## Only One Treatment Necessary

It's permanent, so you do it only once, not each time you change oil. One quart of Slick 50 will treat all standard 4, 6 and 8-cylinder gasoline and diesel engines.

## Works with Most Oils

Slick 50 will work with all petroleum-based oils and all synthetics compatible with petroleum-based oils with the exception of graphite oils. However, once an engine is treated, you can go back to a graphite type if desired.

## 4 Ways Slick 50 Saves You Money

Your actual percentages may vary depending on your driving, vehicle condition, weather and geographic location, but no matter what your conditions, Slick 50 can:

1. Increase mileage
2. Increase horsepower (small economy cars and large RV's really need this)

3. Reduce operating temperatures, thus increasing the lubrication and life of the oil and engine

4. Minimize or eliminate costly overhauls by reducing engine wear

Up to 90% of the engine wear on a car can be caused by lubrication starvation cars experience when first started before the oil begins to circulate. Slick 50 can eliminate this problem for less than the cost of two tanks of gas.

## Slick 50 Will Not Affect Your Warranty

Slick 50 is suspended in an excellent grade of petroleum oil which meets or exceeds every manufacturer's engine warranty requirements. In addition, this oil carries an American Petroleum Institute service classification SF-CC-CD.

## There's No Risk with Our Money Back Guarantee

Use Slick 50 for 3000 miles. If you don't notice an improvement in engine performance, return your invoice with a short note telling why, for a prompt full refund — no questions asked.

## Profit from Selling Slick 50 Yourself

Here's an opportunity to make handsome profits. Having such solid test results from major institutions make Slick 50 easier to sell than many other products. Free dealership information is sent upon request.

For purchase or further information call toll-free 1-800-525-8624, ext 9 (in California 1-800-233-9559) or send to: Progressive Energy Corporation, 255 South Bent Avenue, #B-1, Dept. PM987, San Marcos, California 92069.

Yes, I want to improve my car's performance and save my engine — rush me risk free

One Slick 50 at \$39.95 + \$4.00 shipping and handling. Calif. Residents add 6% Sales Tax

Give me free shipping and handling for my order of 2 or more at \$39.95 each.

Check  C.O.D.  Visa/MasterCard

Card # \_\_\_\_\_

Exp. Date \_\_\_\_\_

Name \_\_\_\_\_

Address \_\_\_\_\_  
(Give street address if possible for UPS delivery)

City \_\_\_\_\_ State \_\_\_\_\_ Zip \_\_\_\_\_

**PEC**

Progressive Energy Corporation

255 South Bent Avenue, #B-1, Dept. PM987  
San Marcos, California 92069  
CALL NOW, TOLL FREE 1-800-525-8624.  
IN CALIFORNIA, TOLL FREE 1-800-233-9559.  
©1987 Progressive Energy Corp.



# CAR CLINIC

BY MORT SCHULTZ

## Don't Be A Whiner

I purchased a new 1986 Nissan Maxima, but it wasn't until the day after I took delivery that I heard a whine coming from the automatic transaxle, especially noticeable between 43 and 47 mph.

The dealer replaced the speedometer cable, which hasn't helped. Now a factory representative tells me he can do nothing, because the noise is "commercially acceptable." Do I, or do I not have trouble?

FRANCIS J. BALOY  
TAMARAC, FL

*Of course you understand I'm taking a shot at this with the car 1300 miles to the south of me. But if that transaxle whine is like others I've come across in Maximas and also Stanzas, nah, you don't have trouble. But neither is what you do have "commercially acceptable," whatever that means. If your Maxima is like others, the noise is being made by mismatched transaxle output and idler gears.*

*The factory rep may have*

*known this, but tried to get off the hook, because at the time he drove the car, there was no solution.*

*There is now. It's in the form of a new matched output and idler gear set available under part No. 31493-21X55. In making the switch, the dealer will need new idler-gear taper and output-shaft outer bearings (part No. 31491-21X00), an output-shaft inner bearing (part No. 31488-21X01) and preload adjusting shims (part No. 31499-21X00-21X22).*

*Before he proceeds to tear down the transaxle, there's a less drastic procedure that should be tried. Maybe it will help the Maxima avoid major surgery. Mind you, it's only a possibility. But the dealer should see to it that the speedometer cable is properly adjusted. Attached to the cable is a hunk called a mass damper. It should be loosened and slid up or down until its edges fall on the two lines, called the middle lines, scribed on the cable.*

## Out, Out Damn Spots

The Pontiac dealer can't offer a solution for stopping spots the size of quarters from forming on the outside of the windshield of my 1986 Parisienne. They develop when the air conditioner is on and get so bad I have to use the windshield wipers to remove them. Must I put up with this?

PEGGY HARRISON  
VIDOR, TX

*What you describe is not really that odd. The same thing happened to me a few years ago in Florida when driving a rental. Large-size water spots developed on the outside of the windshield when I had the air conditioner on, because the ambient temperature and humidity were oppressive. Being curious, I checked and found that the car's defrost doors weren't closing tight. This allowed cold air to blow on the hot windshield and condense. The sun's rays refracting through the moisture was visible to me as spots. If you have your dealer readjust*

*the defrost doors in your Pontiac, I'll bet the spots won't appear.*

## Ford's Warranty Commitment

*In last month's Car Clinic, I began a discussion of the new long-term warranties with a rundown of GM's position. It's now Ford's turn. The Ford warranty which began with the 1987 models is split into basic coverage, powertrain coverage, emissions control system coverage, and corrosion coverage. Here are the highlights:*

•Basic coverage, umbrellas all parts of a car or light truck for 12 months or 12,000 miles, whichever occurs first. Excluded are tires (covered by the tire manufacturer), parts and labor needed for maintenance under the maintenance program outlined in the owner guide, and parts subject to normal wear and tear (for example, windshield wiper blades, brake linings and pads, and clutch linings). There are several factory-installed systems covered for a full 12 months regardless of mileage. They are the radio or radio/tape deck, air conditioner, heater, rear-window defroster, heated outside rearview mirror, and electrically heated windshield.

•Powertrain coverage lasts for six years or 60,000 miles, but don't get confused about this. The powertrain comes under the provisions of the basic warranty for the first 12 months or 12,000 miles. When the basic warranty runs out, the powertrain warranty takes over for an additional 60 months or 48,000 miles.

*The second owner can have the remaining portion transferred to his or her name by sending a filled-out "Request to Transfer Powertrain Coverage" form and \$100 to Warranty*

*(Please turn to page 26)*



PM CAR CARE

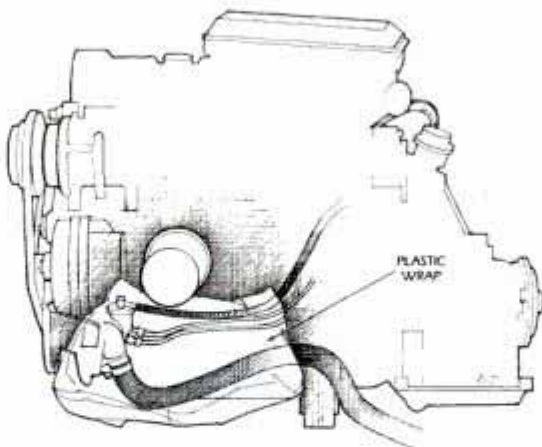

## It's A Clean Machine

Changing the oil filter always leaves a big mess because the oil filter dribbles oil onto the side of the engine block and anything else in the vicinity, no matter how careful you are. To avoid having oil drip on hoses and wires laying beneath the oil filter as you replace the filter, drape plastic over exposed parts like

electrical wires and hoses. Unlike a rag that will get saturated, slick plastic wrap won't hold oil. It will slide off into the drain pan you have on the ground under the filter. Who says things have to be complicated to work? Thanks for the tip go to reader T. E. Stevenson of Sophia, North Carolina.





# After 9 years of advancing the science of radar warning, we have quite a following

If imitation is the sincerest form of flattery, then Escort and Passport are easily the world's most admired radar detectors.

And if imitation were the same as duplication, then there would be other equally capable detectors. Occasionally you hear of imitations "just as good as" Escort and Passport, usually from someone trying to sell you something cheaper.

#### The experts are unanimous

No matter what anybody says, there is, in fact, no detector on the market that's "just as good as" Escort and Passport. And you needn't take our word for it. In 1987, three respected magazines have published comparison tests of radar detectors.

#### What Car and Driver says

In April, *Car and Driver* rated Passport highest of nine miniature models, saying, "At \$295 direct from the factory, it's the most expensive piece of electronic protection in the group, but it's worth every nickel in roadgoing peace of mind."

#### What Roundel says

In June, *Roundel* ranked Passport and Escort first and second respectively in a comparison of 14 detectors. About Passport the author said, "It remains the State of the Art, a true quality product, American ingenuity at its best." Regarding Escort, "It is an excellent detector in its own right and continues as a pacesetter in the detector market."

#### What Popular Mechanics says

In July, *Popular Mechanics* rated Escort first and Passport second in a group of 11 brands. The magazine concluded, "Clearly, the Escort is the best radar detector around. The best of the minis was the Passport..."



#### Expert Testimony, It's FREE:

In every 1987 magazine test of radar detectors, Escort and Passport have been rated highest. See for yourself. For complete copies of the tests (not excerpts or selected quotes), showing ranking of all brands, just call us toll free.

**99 THINGS THAT AMERICANS MAKE BEST**

“All of these widely available U.S.-made goods...are clearly superior to their overseas competitors, overwhelmingly dominate their markets or are so outstanding or novel that they have no well-known international counterpart.”

Escort and Passport are the only radar detectors to make the list.

#### What we say

Escort and Passport stay at the top of the experts' ratings year after year because, by definition, the imitators are always behind. Our engineers work constantly to lengthen detection range, and when they make a breakthrough, we rush that improvement into production.

Still, early warning means nothing if the warning is false. That's why—a year ago—we added Alternating Frequency Rejection (AFR™) circuitry, designed specifically to ignore the Rashid VRSS collision warning system.

Said *Car and Driver*, "While other makers have spent their energy on funny features or zooty styling, CM has found a way to improve function in a quiet and systematic way. Such innovation is the mark of a leader, and we applaud Cincinnati Microwave for its eagerness to head off problems before they become problems."

Our anti-Rashid circuitry demonstrates our commitment to the highest radar warning technology. We think the fact that the imitators don't have it demonstrates their commitment too.

#### Right here in Cincinnati

Our attitude is unique in another way. We keep all of our engineering, assembly, sales, and service in one location so that we can respond quickly to our customers. If you have questions, need service, or want to order, just call toll free.

We sell direct to our customers only. Orders in by 3:00 pm eastern time go out the same day by UPS, and we pay for shipping. Overnight delivery is guaranteed by Federal Express for only \$10 extra.

#### Satisfaction guaranteed

If you're not entirely satisfied within 30 days, return your purchase. We'll refund all of your money and your shipping costs.

For the only radar detectors "just as good as" Escort and Passport, please call toll free.

#### Order Today

**TOLL FREE... 800-543-1608**  
(Mon-Fri 8am-11pm, Sat-Sun 9:30-6 EST)



By mail send to address below. All orders processed immediately. Prices slightly higher for Canadian shipments.

**PASSPORT**  
RADAR RECEIVER

**Pocket-Size Radar Protection \$295**  
(Ohio res. add \$16.23 tax)

**ESCORT**  
RADAR WARNING RECEIVER

**The Classic of Radar Warning \$245**  
(Ohio Res. add \$13.48 tax)

Cincinnati Microwave  
Department 66897  
One Microwave Plaza  
Cincinnati, Ohio 45249-9502



## Essential Tools For Your Garage.

The right tools for the job are within reach when you include Berryman products in your blueprint for preventative maintenance.

Berryman's NEW IMPROVED GAS BLAST OCTANE BOOSTER stops knocks and pings, prevents rough idling and stops stalling. Increases octane number 2 to 5 points in leaded or unleaded fuel.

For maximum performance, Berryman products are the answer.



Guaranteed Quality Since 1918  
3800 E. Randol Mill Rd.  
Arlington, Texas 76011



## CAR CLINIC

(Continued from page 24)

Transfer Headquarters, FoMoCo, P.O. Box 27130, Detroit, MI 48227. The form is available from this agency if you can't get it from a dealer. Third and subsequent owners don't have this option. However, if they buy the vehicle within two years or 24,000 miles of its manufacture, the powertrain will be covered.

Engine parts covered by the powertrain warranty are the cylinder block, heads and all internal parts, manifolds, valve-train parts and valve covers, engine seals and gaskets, turbocharger and associated parts, flywheel, oil pump and oil pan, water pump, camshaft timing-drive components and cover, and diesel engine fuel-injection pump and lines. Transmission/transaxle parts covered are the case, all internal parts and seals and gaskets, clutch cover and housing, and torque converter and housing.

Axle and drive parts covered are front and/or rear-drive axles and all internal parts, driveshaft and universal joints, transfer case and all internal parts of 4-wheel-drive vehicles.

Note: Be aware that when you take your vehicle to a dealer for repair under the powertrain warranty, you are



### Easy Enough

Our "Car Care Tips" usually advise you to do something. This one recommends that you do nothing.

If an investigation of a hard-to-start engine reveals that sparkplugs are fouled and gasoline has mixed with oil, you don't have to change the oil and replace the filter despite what you may be told. A higher authority says, "Gasoline in oil boils off at relatively low temperatures and will have no detrimental effect on engine performance. Changing oil and oil filter as a result of fouled



sparkplugs is not necessary." Who is the higher authority? Chevrolet! Just be sure that you've corrected the original problem, and that when you start driving the car, you drive around long enough to warm the engine up fully and boil off the excess fuel.

responsible for paying the first \$100 of cost unless the part that's being repaired is covered by the emissions control system warranty.

●Emissions control system coverage is divided into two warranties: the emissions defect warranty and the emissions performance warranty. The



emissions defect warranty assures that your vehicle meets the emissions regulations of the EPA for a period of five years or 50,000 miles. The parts and systems covered under this are the air/fuel feedback control system and sensors, heating element for an electric choke, altitude compensation system, deceleration controls, certain spark control components, fuel-vapor storage canister, liquid separator and associated controls, fuel-filler neck restrictor and filler cap, PCV valve and oil-filler cap, EGR valve, spacer plate and associated components, Thermoactor air pump and associated components, pulse-air valve and associated components, catalytic converter, electronic engine controls, sensors and switches, and emissions-related hoses, clamps, brackets, tubes, gaskets, seals, belts and connectors used by the systems I have just listed.

The emissions performance warranty covers vehicles that are registered in states where the state or your local government has an inspection and maintenance program that meets EPA requirements. This part of the coverage does not cover vehicles that are tested at a high altitude, but are certified to meet emissions standards only at sea level.

The term of this warranty is two

years or 24,000 miles. Parts covered in addition to those listed above include components of the carburetor or fuel-injection system, components of the cold-start enrichment system, distributor components and ignition-control components.

●Corrosion coverage applies to body sheetmetal panels. If corrosion does not cause holes, the damage will be repaired under the terms of the warranty for 12 months or 12,000 miles. If corrosion causes holes, damage will be repaired for a period of six years or 100,000 miles.

Let me warn you about something concerning not only the Ford warranty, but also GM's (see Car Clinic, page 24, Aug. '87) and Chrysler/AMC's (look out for it in next month's Car Clinic). I can hit only their highlights, not every provision. So read the document carefully. If you don't, you may find that you aren't covered for something you think you're covered for, because you did something or failed to do something in violation of the terms of the agreement.

#### DO YOU HAVE A CAR PROBLEM?

Just ask Mort about it. Send your question to the Car Clinic, Popular Mechanics, 224 West 57th St., New York, NY 10019. While letters cannot be answered individually, problems that are of general interest will be discussed in the column.

#### SERVICE TIPS

- There's a recall on 1984-85 Ford/Mercury cars (not light truck) equipped with a 1.6- or 2.3-liter engine. Your engine may have a thick-film ignition (TFI) module that's causing hard starting, poor performance or die-out while running. See a dealer. As long as the car hasn't surpassed 50,000 miles, a new module will be installed at no cost. You've got until '89 with an '84—until '90 with an '85.
- Do you have a 1985-87 Chevy Malibu with a 2.5- or 4.3-liter engine and throttle-body injection that suddenly stalls and won't start? Save yourself needless diagnostic costs by directing your dealer to technical service bulletin (TSB) 87-T-53.
- Are you upset with the way your imported 1987 Dodge Raider or Power Ram 50, both with 4-wheel drive, shifts gears? Refer your dealer to TSB 21-10-87 on how to modify the input gear.
- Don't take as normal a slow-returning or not-returning-all-the-way brake pedal in a 1982-87 Pontiac 6000. Simply add a new washer (part No. 10087739) between the eyelet end of the brake booster pushrod and brake pedal, and lubing the pushrod as described in TSB 87-5-4.

Make life miserable  
for burglars.

And brighter for you.



Protect your home with Kwikset's new Superior Duty Deadlock...and make your home safer with a free Automatic Night Light!



Kwikset introduces two new deadlock models that give your home and family solid security at an affordable price.

Our new Superior Duty Deadlocks provide a variety of extra protection features including a 1" deadbolt with steel insert that resists sawing. Installation is simple and easy and they can be keyed alike to any Kwikset entry lock for one key convenience.

#### FREE Automatic Night Light for added home safety.

With every specially tagged Superior Duty Deadlock you buy, you can send for a free Automatic Night Light (suggested retail value \$6.25). It goes on at dusk, off at dawn.

Greater security with our new Superior Duty Deadlock, greater safety with the free Automatic Night Light.

Look for this special 2-for-1 Kwikset offer wherever you buy fine hardware.



(No. 870)

EMHART

**kwikset**



# INSIDE DETROIT

BY JIM DUNNE

## Mazstang In Disguise?



Mazda-Ford sportster still under wraps.

Ford will probably not call this Mazda sports car the Mustang, but up to now that's the way it has been identified. The front-drive, 4-seat fastback was designed by Mazda, but will be built for sale by Ford in the U.S. Mazda plans to produce the car at a new assembly plant in Flat Rock, Michigan, just 20 miles from Ford's headquarters in Dearborn. Ford owns a big chunk of Mazda, so the hookup between the two companies is a natural. While the body and chassis are based on Mazda's 626, Ford will supply the 2.3-liter 4-cylinder engine.

Anyway, the word going around Detroit is that the new car could carry the Mustang nameplate. But that seems less likely as time passes, since Mustang is a revered name at Ford, and many officials within the company want to reserve it for an all-Ford product.

Don't be deceived by the pizza delivery truck shape. The spy photo shows false panels on the hood, front fenders and the rear that disguise the sleek lines of this fastback coupe—a common practice at foreign car companies.

## Fiero Limo

It comes as no surprise to find that Pontiac is searching for ways to attract more Fiero buyers. Since the 2-seat sports car was introduced three years ago, sales have fallen off dramatically—down from a high of about 100,000 in 1984 to an expected 50,000 this year.

There is no reason for Pontiac to panic at these numbers since a successful low-priced sports car *should* sell in the 40-to-50,000-per-year range.

Still, Pontiac wants to make certain that Fiero sales fall no further. That's why you see design proposals like this

one for a 4-place model. Building a stretch Fiero is no problem. The unique body construction—steel understructure capped with plastic body panels—and midship engine placement are ideally suited to easy body changes.

But building an attractive shape in a 4-place layout may be more difficult, as you can see from this spy photo. If the proposed design is given the green light by GM management, the Fiero 4-place will be one of the most unusual cars on the road. In recent times—since WWII—no 4-seat midship-engine car has been sold in North America.

Stretch Fiero 4-seater is no joke at GM.



PHOTO BY THOM CANNELL

## Not For Lee

You might think that Lee Iacocca, chairman of Chrysler Corp., couldn't wait to drive the Countach, the superhot Italian sports car that came to Chrysler as part of the purchase of Lamborghini. Just for the thrill, if nothing else. But you'd be wrong. Iacocca told me that the low-slung 2-seater is "too tough to get in and out of . . . it is not a runabout that you take down to *Great Scott!* (supermarket) to pick up groceries."



Lamborghini Countach needs more room in the seat for Lee.

## No Wire Wheels

At least, not on Mercedes. "They don't look strong enough for our cars" says Bruno Sacco, styling chief of the German luxury cars. "That doesn't mean they're not strong enough. They just don't have the look of strength that I want to see under the Mercedes." Other styling no-nos that Sacco won't allow:

- Unmatched wheel-opening shapes, like fender skirts on the rear, none on the front.

- Whitewall tires, unless the tires become bigger, need the white stripe to "lighten up their appearance."

- Hidden headlights that would make Mercedes look like a number of other cars. ("Headlights are an essential part of Mercedes design, and will remain uncovered.")

- Digital-instrument panels. At least for now Mercedes will stick with the analog instruments that use moving needles on circular gauges.

In the future though, Mercedes probably will go to electronic gauges that either imitate analog types, or to television-screen readouts that deliver lots more information to the driver.

Bruno Sacco likes the design of these non-Mercedes cars: Fiat Uno, Ferrari BB, Ford Taurus. Those that Sacco says do not measure up: Jaguar XJ6 (too much like the old design) and Cadillac Allante ("Too close to the 16-year-old design of our SL. That's not the fault of Pininfarina, but of GM's management who wanted Allante that way").

## Ford Barchetta

Ford is preparing another small sports car for the U.S., this one code-named SA-30 or Barchetta. To be built in Australia by Mazda, the car is a 4-place convertible that uses Mazda's 323 drive line and chassis.

Styling is all new, and borrows more from the Ford tradition than Mazda. The overall shape is a boxy wedge, something like the TR-7. In appearance, the Barchetta looks smaller than either the Mustang or the new Mazda-Mustang, and word is that it will sell at a price well below those two. Ford plans to introduce that car in the U.S. as a 1989 model sometime next summer.

## Break In

Car theft is a problem in Europe too. And the car companies are trying to make locks more secure. To make the new Scorpio's locks more secure from theft, Ford uses plates rather than tumblers. As a test, according to Jackie Stewart, Ford of Europe managed to get the services

(Please turn to page 30)



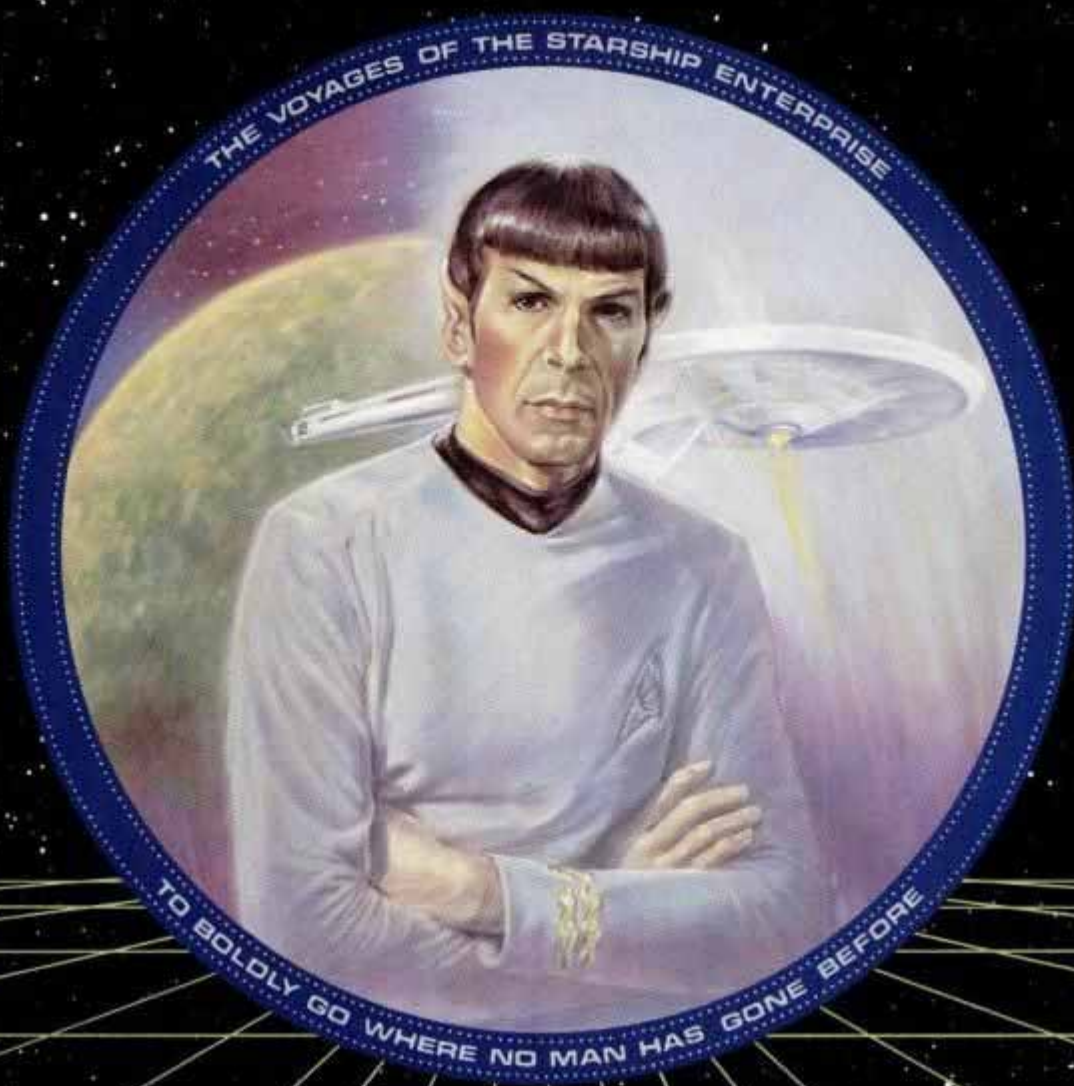

The Hamilton Collection Presents

# MR. SPOCK

**The First-Ever Star Trek®  
Collector Plate — Issued in a  
Limited Edition**

The powerful science-fiction drama of *Star Trek* has entranced millions for nearly two decades. And from the very beginning, the Science Officer of the Starship Enterprise, Mr. Spock, earned the admiration of millions with his superior intellect, cool demeanor, and intriguing Vulcan appearance.

Now the legendary *Star Trek* series and the popularity of Mr. Spock have inspired the **first-ever Star Trek limited-edition collector plate**. Susie Morton, well-known portraitist of celebrities, has been commissioned to create this important new first issue for The Hamilton Collection, in association with Ernst Enterprises.

"Ms. Morton has captured the very essence of Spock in this colorful true-to-life portrayal," said Bjo Trimble, a *Star Trek* expert. And "Mr. Spock" will endure for generations, because this portrait is fused to a gleaming, 8½" fine porcelain plate.

The coveted limited-edition status is assured for "Mr. Spock," since it will be limited to 90 firing days. To document the issue for future generations, each plate will be hand-numbered and accompanied by a same-numbered Certificate of Authenticity.

"Mr. Spock" premieres a collection of eight fine porcelain plates portraying the main characters of *Star Trek*. You will have the guaranteed right to own all subsequent issues at the original issue price of \$29.50 each. **But you will never be under any obligation** to acquire any further plates.

Furthermore, you may order "Mr. Spock" with absolutely **no risk**. Under The Hamilton Collection **100% Buy-Back Guarantee**, you may return any plate within 30 days of receipt, for a full refund.

Because of the millions of *Star Trek* fans and plate collectors who want "Mr. Spock," **demand has been quite strong**. So please return your application **today** to The Hamilton Collection, 9550 Regency Square Blvd., P.O. Box 44051, Jacksonville, FL 32231.

**RESPOND BY: September 30, 1987**

*Limit: Two plates per collector*

Please accept my application for "Mr. Spock." I wish to purchase \_\_\_\_\_ (1 or 2) plate(s) at \$29.50 (plus \$2.14 shipping and handling) each, for a total of \$\_\_\_\_\_ (\$31.64\* or \$63.28\*). **Please check one:**

I enclose payment by check or money order.  
 Charge my credit card:  Visa  
 American Express  MasterCard

Acct. No. \_\_\_\_\_

Exp. Date \_\_\_\_\_ 25171 BA

Name \_\_\_\_\_

Address \_\_\_\_\_

City \_\_\_\_\_

State \_\_\_\_\_ Zip \_\_\_\_\_

Signature \_\_\_\_\_

**\*FL residents add \$1.59 and IL residents add \$2.22 per plate for tax.** Please allow 6-8 weeks from date of application for shipment. All applications must be signed and are subject to acceptance. Produced by R.J. Ernst Enterprises Inc. under exclusive license from Paramount Pictures Corporation. *Star Trek* is a Registered Trademark of Paramount Pictures Corporation. © 1987. 1987 Paramount Pictures Corporation. All rights reserved.

**The Hamilton Collection**  
 9550 Regency Square Blvd., P.O. Box 44051, Jacksonville, FL 32231



This is the  
end of the line  
for rust.

And the  
finish line for  
wood.



Protect your wood and metal possessions with new Rustmaster® primers and paints, and Woodmaster™ stains and varnishes. New formulations make them the best metal and wood protection you can buy. Look for them at leading retailers.

Glidden

Your enamels, stains and finishes should be this good.

©1987, The Glidden Company

## INSIDE DETROIT

(Continued from page 28)

of an out-of-work, in-custody expert (jailbird) to try to break into a new Scorpio. "It took him 1½ hours to solve the new locks," says Stewart.

"But," he added, "we're not as enterprising as Americans. We haven't discovered the quick way—a brick through the car window."

## Overcharge

Ford's work on the supercharged V6 engine for the 1989 Thunderbird ran into some unexpected problems. Seems the supercharger develops too much power for the engine to handle easily. One major problem occurred when the crankshaft journals cracked as the engine was run under full power. The cast-iron parts were beefed up with more metal, and that seems to be all that was needed.

"We get as much power as the 5-liter HO V8 puts out [about 225 horsepower]," reports one Ford insider. "Our new V6 was not designed for all that. But it was not a major change. We still use only two bolts, instead of going to four bolts, per bearing."

Biggest difference between the new 3.8-liter V6 supercharged engine and the current turbocharged 2.3-liter type is low-end torque, report Ford insiders.

The new engine has the power of a V8 even at low speeds.

## Runs Like A Rotary

John Deere is jumping into the rotary-engine business in a big way. The farm-equipment manufacturer just introduced 14 rotaries of different displacements ranging from a tiny 0.7 liter (40 cu. in.) to mammoth 34.7 liters (2100 cu. in.). Designed primarily for military use, the engines offer the traditional rotary advantages of small-package size and few moving parts, plus the ability to run on a number of different fuels including gasoline, diesel, alcohol and kerosene. Deere hopes to install the rotaries in light aircraft to start with, then would expand to seagoing and land vehicles like assault ships, tanks and APCs.

## Two-Stroke Comeback?

There is a chance that a car of the mid-1990s will use a 2-stroke engine if developments by Orbital Engine Co. of Australia work out for production. Orbital is the company that has introduced what it calls a pneumatic fuel-injection system that allows 2-strokers to run with as clean exhaust as 4-stroke types.

Presently, aside from the unique rotary engine used by Mazda, all automobile engines use the 4-stroke design. Advantages of the proposed 2-stroke are

lighter weight and less cost per horsepower output. Two-strokers are said to be smoother running as well, because each cylinder fires twice as often per engine revolution as a 4-stroke type. In a 3-cylinder engine, for example, firings per revolution would be as frequent as those in a 6-cylinder design.

Key to the clean exhaust of the Orbital technique is a fuel injector that mixes air and fuel together in the injector, in a 3-to-1 ratio, before the mixture is delivered into the combustion chamber.

The premixed charge tends to keep droplets of fuel separate for a longer time, so that they burn more completely, and are not exhausted from the engine as raw fuel.

## Russians Coming

A new freedom from central industrial planning in the U.S.S.R. has encouraged the Lenin Komosomol Motor Works in Moscow to consider exporting the new Moskvich 5-door hatchback to the U.S. in 1991. First, they'll have to come up with a new engine that meets American emissions specs. Talks have been going on with Volkswagen to design 1.8- to 2-liter gasoline and diesel engines. But hold your deposits: Plans to introduce an export version of the new front-drive Moskvich in the European market this fall have already been put off until January. **PM**



**Now you can  
have Lifetime  
Security in a  
CASH business  
where you can  
easily make up  
to \$200.00 per  
day and more**

**Find out how ...**

**... send NOW for your**



**... send NOW for your  
FREE Lifetime Security Fact Kit**

Your FREE Lifetime Security Fact Kit tells you how to make \$18.00 to \$30.00 an hour in your own Foley-Belsaw Full-Service Saw and Tool Sharpening Business. Your FREE Fact Kit explains how you can:

- be your own BOSS!
- work full time or part time, right at home.
- do work you enjoy and take pride in.
- operate a CASH business where 90¢ of every dollar you take in is clear cash profit.

And it is *so easy* to learn. Foley-Belsaw gives you all the facts and instructions. No previous experience or special training is necessary. All you need is the desire and ambition to be your own boss. Foley-Belsaw tells you everything you need to know to be successful.

There's plenty of business where you live to keep you busy. It doesn't matter whether you live in a big city, small town or a small farm community.

You'll quickly be able to develop the skills necessary to earn a steady income. You'll be able to sharpen all types of saws, garden and shop tools for home, farm and industry.

Profits from your Foley-Belsaw Full-Service Sharpening Business can provide...

- ... CASH for future security or supplemental income
- ... CASH for travel, vacations, fishing trips
- ... CASH for the things you've always wanted!

And you'll be able to set your own hours and not

have to worry about layoffs and strikes. There are no franchise fees. Best of all—age or physical condition is no barrier—any age person can succeed.

You can be like Steve Taylor of Brookville, Ohio, who told us:

*"... the first year I grossed \$21,000.00."*

Or James B. Jones, of Albuquerque, NM who reported:

*"This past summer my sales and service amounted to almost \$6,000.00 a month."*

But you've got to get the FACTS before you can get started. So WRITE NOW for your FREE Lifetime Security Fact Kit. It's yours to keep with NO OBLIGATION.

The Foley-Belsaw Company  
6301 Equitable Rd., Dept. 20524  
Kansas City, Mo. 64120



**FREE  
LIFETIME  
SECURITY  
FACT KIT**



Foley-Belsaw Co.  
6301 Equitable Rd., Dept. 20524  
Kansas City, Mo. 64120

- YES, I want to know more! Please rush my FREE Lifetime Security Fact Kit. No obligation

Name \_\_\_\_\_

Address \_\_\_\_\_

City \_\_\_\_\_

State \_\_\_\_\_

Zip \_\_\_\_\_

(Area Code) Phone \_\_\_\_\_



# WORKBENCH BASICS

BY ROSARIO CAPOTOSTO

## Sharpening Cutlery

**K**itchen knives are arguably the most used and abused tools in the home. Therefore, they become dull quickly. Household scissors fare no better in the struggle to stay sharp. However, a few properly executed strokes over a sharpening stone will keep your knives and scissors on the cutting edge.

There are various sharpening stones available. I prefer an aluminum-oxide stone that's coarse on one side, fine on the other.



Push the knife across a well-oiled sharpening stone while holding the blade at the same angle as the original cutting-edge bevel.

Lubricant is important when sharpening to float away metal and abrasive particles. I use special honing oil, but you can get by with mineral oil or 3-in-1 machine oil.

If a blade has lost its cutting edge completely, reform the edge on a coarse stone. Then, hone the cutting-edge bevels on a fine stone. Most knives, however, will just need honing. To

start, apply oil to a fine stone and hold the blade flat on the surface. Now tilt the blade until the cutting-edge bevel meets the stone. While holding this angle, slide the knife forward across the stone. Also, slide it sideways to hone the entire blade length. Flip over the blade and draw it across the stone in the opposite direction. Continue alternate stroking until it's sharp. Knife blades that are serrated on one edge can be sharpened, as shown. Touch up the serrations with a needle file and then remove any burrs with the stone. **PM**



Slide the blade, cutting edge first, simultaneously across the stone and sideways in order to hone the entire length of the blade.



Flip over the knife and repeat the stroke in the opposite direction. Be sure to maintain the same angle throughout the process.



To sharpen knives serrated on one side only, first touch up the serrations with a needle file. Hold the file at the proper angle.



Then, lay the blade flat on its back on the stone. Draw the blade lightly across the stone to remove any burrs made by filing.



When sharpening scissors, place the stone on a large wood block or at the edge of a workbench in order to provide clearance.



Hold the cutting edge flat on the stone and draw the scissors across at a slight angle. Repeat several times for each scissor blade.



**This is your brain,**



**this is drugs,**



**this is your brain on drugs.**

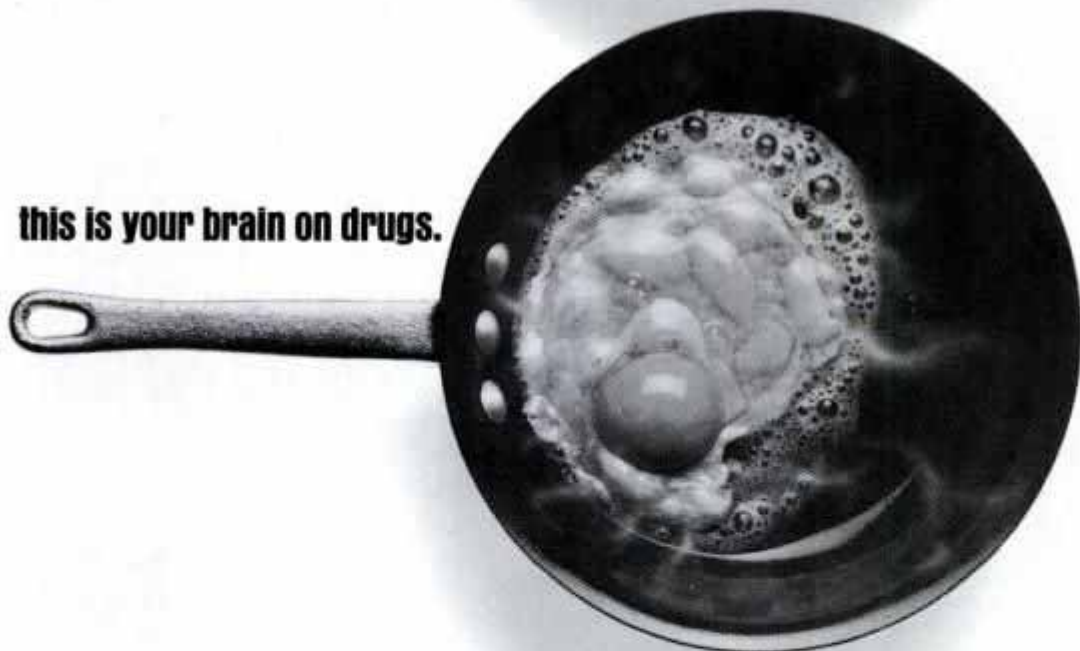

**Partnership For A Drug-Free America**



**N.Y., NY 10017**

© 1999 Partnership For A Drug-Free America. All rights reserved.



# 41 Ways to help you qualify for the job you want

## Get Your Associate in Specialized Business or Technology Degree or Career Diploma at Home in Your Spare Time

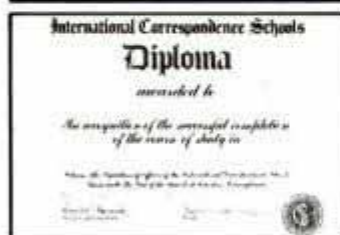

The decision to invest your time, energy and money preparing for a new career is not a simple one. Yet it may well be the most important decision you will ever make. It can offer you the opportunity to qualify for the job you want... more money, more security and a better way of life.

At ICS we've spent close to a hundred years training people for exciting and profitable careers in a wide variety of fields. From our beginnings in 1891, we have expanded our curriculum to include hundreds of different courses. Over the years we have become a world leader in training for business, industry, science and technology. In fact, the ICS training method has proven so successful that over 9,000,000 students have enrolled and close to 2,000 American corporations have chosen ICS training for their own employees including Bethlehem Steel, Union Carbide, Mack Truck and International Paper.

### Mail Post-Paid Card for Free Facts

**Self-Paced, Individualized Studies**  
Choose either an Associate in Specialized Business or Specialized Technology Degree Program or get career-specific training leading to a Career Diploma. Train for an entry-level job or continue your studies and develop supervisory skills. With ICS you learn at home—no time wasted traveling to class or waiting in lines. Study when and where you choose... go at your own pace. You're in a "class of one," so

you don't wait for the next semester to start—you can start anytime!

**Learn from Specialists! Home Study makes it easy to get the career training you really want!**

Our staff guides you throughout your program. Whether you're preparing for an entry level job or management career, whatever you need to complete your training is included with your course at no extra cost!

If card is missing, write directly to:

- \* Business Management \* Accounting
- \* Business Management with Option in Marketing \* Business Management with Option in Finance \* Mechanical Engineering Technology \* Civil Engineering Technology \* Electrical Engineering Technology \* Electronics Technology \* Computer Programming \* High School \* Catering/Gourmet Cooking \* Medical/Dental Office Assistant \* Microcomputer Repair \* Auto Mechanics \* Bookkeeping \* Hotel/Restaurant Management \* Drafting \* Veterinary Assistant \* Travel Agent \* Air Conditioning & Refrigeration \* Electronics \* Secretary \* Electrician \* Police Sciences \* Art \* Small Business Management \* Interior Decorating \* Wildlife/Forestry Conservation \* Legal Secretary \* Diesel Mechanics \* Fashion Merchandising \* Gun Repair \* Motorcycle Repair \* Surveying & Mapping \* Fitness & Nutrition \* TV/VCR Repair \* Child Day Care \* Legal Assistant \* Photography \* Dressmaking & Design \* Journalism/Short Story Writing

\* These are 4-Semester Programs Leading to a Specialized Associate Degree in Business or Technology.

**Many programs can be completed in less than 18 months!**



**International Correspondence Schools**  
Scranton, Pennsylvania 18515 Dept. PBS97  
A Subsidiary of National Education Corporation



# OUTDOORS

BY JOE SKORUPA

## Tour De FourTrax

It was hot enough to become welded to the padded seats of our new Honda Foreman FourTrax 4x4s, and we were exhausted. The reason was that we had just spent two days wringing out these off-road workhorses, clawing slick rock, and crawling near-vertical obstacles on one of the most grueling trails in Utah's Canyonland desert.

Now it was time to cut loose. About 5 miles from camp, three of us decided to push back the thumb throttles. We took the steepest obstacles in Second gear, boulder-strewn stretches in Third, and red-sand flats wide open in Fourth.

We didn't win any trophies, but we found out how easily these ATV 4x4s can eat up pieces of forbidding Southwestern moonscape.

And it was legal fun.

Honda's 600-pound Foreman FourTrax is designed to be a versatile workhorse vehicle. Its torquey single-cylinder, 4-stroke, 350-cc engine pushes out 25 hp and can tow 850 pounds. Large front and back carrier racks tote as much as 200 pounds. This load capacity makes it ideal for farmers, ranchers, hunters and fishermen. Still, when all is said and done, a lot of Foreman owners are going to use them exactly the way we did—roaring off into the outback. We took our 4x4s to Hole-in-the-Rock Trail, near Bluff, Utah. Pioneers carved this torturous trail in 1879, pushing 1.7 miles per day through the harsh but beautiful landscape. We were there two and a half days and covered more than 80 miles, guided by Dale Lemmon of the Searchers, an adventure/video company from Cortez, Colorado.

We were able to do this because of the Foreman's out-

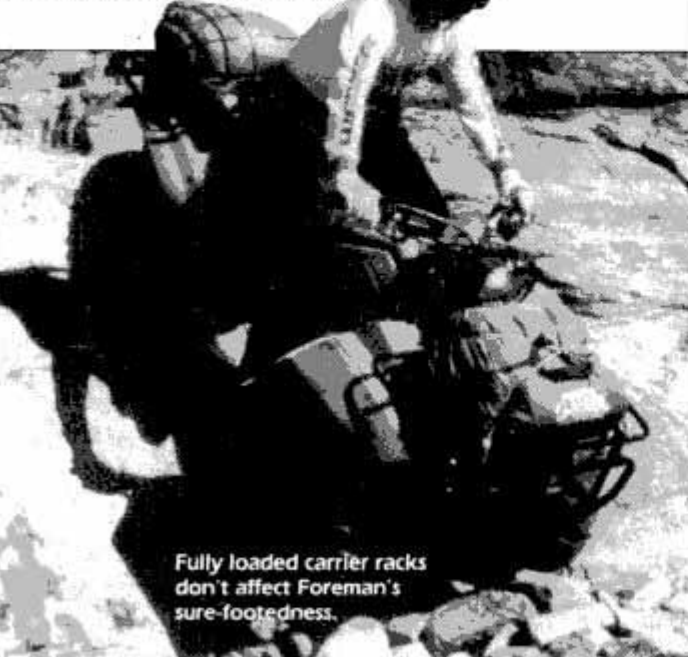

Fully loaded carrier racks don't affect Foreman's sure-footedness.

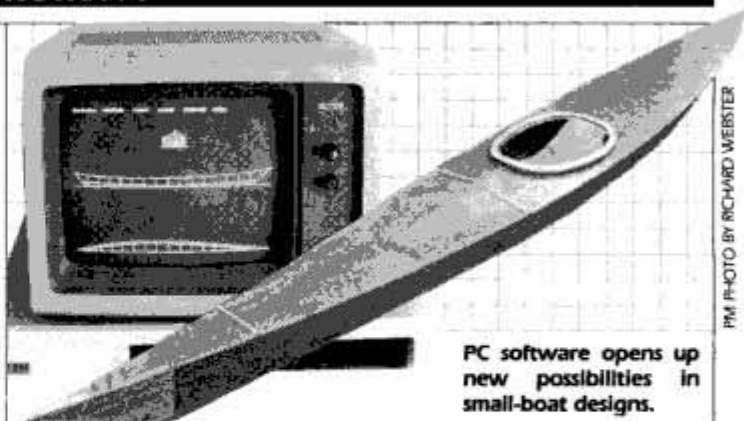

PC software opens up new possibilities in small-boat designs.

PHOTO BY RICHARD WEBSTER

standing stability and traction. Its full-time 4-wheel drive with limited-slip front differential, front and rear drum brakes, and fat, deep-lug tires make it as sure-footed as a mountain goat. Its automatic clutch and 5-speed transmission (with super low and reverse) make it easy to operate in any conditions.

The only complaint, and a small one, is that the choke lever gave everyone a silver-dollar-size bruise on their left thigh. The choke lever should be moved above the handlebar.

The Foreman FourTrax costs \$3800. This may seem like a lot for an ATV, but the Foreman is one off-road machine that eats up tough terrain that would normally slow down or stop most larger 4x4 vehicles.

Performance by ATVs is not the issue on most people's minds, however. The issue here is safety. Foreman FourTrax 4x4s are large, powerful machines that take considerable skill to use. If riders obtain proper instruction and follow certain rules, they can be safe. Remember to always wear a helmet, eye protection, sturdy boots and gloves, never drive on paved roads, adjust weight in turns and on uneven terrain, never carry passengers, and never put your feet down in turns (the rear tires will run them over). This isn't a kid's toy, but adults can have a blast.

## Building PC Boats

It's not news that some PM readers design and build boats. Few, however, do it on home computers like Enrique Enriquez, of Medley, Florida, and John Lockwood, of Port Townsend, Washington.

Enriquez is currently building a self-designed, 31-ft. water scorcher that incorporates hull and power breakthroughs that may push his boat up to 200 mph.

Lockwood is presently marketing a self-designed, plywood-kit boat called the *Queen Charlotte*, a Greenland-style sea kayak.

Both men did their designing on home PCs. Computer programs with similar capabilities have been around for years, but they were run on main-frame computers, putting them out of reach of most home designers. Now, thanks to new software starting to appear on the market, this technology is becoming available to anyone.

It took Lockwood only about an hour to design his hard-chined kayak. He did it by entering nine critical points of reference on his PC. His program, called AutoEXPAND, which Lockwood designed, is used in conjunction with AutoYACHT, by Coast Yacht Design, of Surrey, British Columbia, in Canada. It visually tells him whether or not his hull is developable. Once he designs a developable hull, the program produces full-scale, unsprung

(Please turn to page 39)





*The Duke - inspired by the 1939 Jaguar SS-100.*



*The V-8 powered Sebring 5000 - rally Austin-Healey reproduction.*



*The Saxon - 1962 Austin-Healey reproduction.*



*The Duchess, inspired by the 1952 MG-TD.*

# Why Is Building Your Own Classic Roadster So Much Fun?

**I**f you're looking for an exciting project for the whole family, you can't beat the satisfaction that comes from building your own Classic Roadster. Our kits provide tremendous learning experiences as well as beautifully finished automobiles. Your friends and neighbors will be amazed at your handiwork.

## Easiest To Build Kit Cars On The Market

We put a lot of effort into our kits, so you won't have to. We've spent more on research and development than anyone else in the industry. Our design staff has over 100 years cumulative experience.

With our kits, you'll do no fibreglassing or painting. It's all done for you before your kit leaves our factory. And it's done so well that Classic Roadsters

offers a ten-day money back quality guarantee.

## One Of The Most Respected Names In The Business

Don't take our word about our

quality, listen to the experts:

*"The Sebring's construction and fit are typical of Classic Roadsters' standards. In a word — great."*

*Petersen's Kit Car. "Its combination of big car comfort, elegant styling and solid engineering may make the Duke a new industry standard for medium-priced replicas." The Supercatalog of Kit Cars.*

*"... part of a handful of manufacturers who are changing the face of the kit car industry." Hi Performance Cars.*

## Give Us A Call

Thousands have already discovered the satisfaction that comes from building your own automobile. You can too! To get started, or for more information, call us toll-free today. If you prefer to write, use the convenient coupon.

For details, call toll-free  
**1-800-437-4342**

Please send me complete details on the Classic Collection. Enclosed is \$3. I am most interested in:

- Easy-to-assemble Kit     Factory-Built Auto  
 Profit opportunity information (\$2 additional)

Name \_\_\_\_\_

Address \_\_\_\_\_

City \_\_\_\_\_ State \_\_\_\_\_ Zip \_\_\_\_\_

Day Phone ( ) \_\_\_\_\_

Evening Phone ( ) \_\_\_\_\_

(Coupon must be completed to process information request)



**Classic Roadsters, Ltd.**

1617 Main Ave., Fargo, ND 58103

PM-887-1310



## OUTDOORS

(Continued from page 37)

panel shapes that can be used to make templates of the pattern.

Readers interested in producing a PC boat design first need a PC with a minimum of 640K worth of memory. Then a graphics board and a pen-plotter. And finally, you need AutoYACHT (\$1850) and AutoEXPAND (\$2000).

Though it may seem pricey, this advancement in design technology represents an exciting breakthrough that is likely to have a dramatic effect on the future of small-boat designs.

## Dive Data Console

Handheld computer-data units are about to arrive on the scuba-dive scene, but for now, current technology provides affordable, electronic units that perform multiple and highly accurate functions.

Case in point is Dacor's Electronic Dive Console, which has a depth indicator, bottom timer and compass in a convenient handheld unit.



Time, depth and direction are packed in diver's handheld electronic console.

The digital depth indicator is accurate to plus or minus 6 in. at any depth up to 200 ft. The surface interval timer begins counting when the diver surfaces and continues for 12 hours after the last dive. The bottom timer starts counting when the diver descends and stops when he ascends to 5 ft.

Other functions of Dacor's Dive Console include maximum depth indicator, current depth indicator, dive counter, battery indicator, thermometer, analog pressure gauge and 360° swivel. Price is around \$400.

## Sharp Fishing Tool

After a few hours of angling, your boat usually more resembles a messy basement than a lean-and-mean fishing machine. Rods, tackle, hooks, lures, food

and tools get scattered around and, more often than not, there comes a time when you need something and can't find it.

The Line Sickle, which is a multifunctional tool that attaches to a fishing rod, can help reduce the severity of this recurrent problem. It cuts lines, sharpens hooks and hones knives, and it can only be misplaced if you lose your favorite rod. Because it weighs 1/3 ounce and flexes, it won't interfere with rod balance or action.

The Line Sickle, which can also be mounted on a boat seat, gunwale or rod holder, is a convenient, space-saving fishing tool that costs about \$9.95. **PM**



A blade and sharpening stone are combined in this cleverly mounted fishing tool.

# ARROW

Makers of the World Famous T-50 Staple Gun

## Now Brings You A Full Selection Of Professional Quality Fastening Tools For All Your Fix-It Fastening Needs!

**ARROW**  
ELECTRO-MATIC

Model ETN-50  
Electro-Matic  
Professional  
Quality

**ELECTRIC  
STAPLE  
GUN**

**FLUSH  
FRONT  
EXTENDED NOSE**

Permits easy fastening in recessed areas, close corners, and other hard-to-get-at places with pin-point accuracy!



**ARROW**  
**XPANDO**

Model T-50XP  
XPANDO  
FASTENING SYSTEM

Attachment & Fasteners  
Instantly converts the Arrow T-50, T-50M, or T-55 Staple Gun into a multi-purpose fastening tool!

Easily slips on front of Staple Gun!

Wood Plastering Metal Hollow Dunes Sheetrock

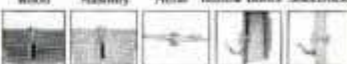

Replaces screws, nails, rivets, anchors



**HOT MELT GLUE GUNS**

Model TR-550  
Professional  
Automatic Lever Feed  
**HOT MELT GLUE GUNS**

Electronic Solid State  
Ni-Impact/Ni-Temp Housing

- 4 Types of Glue Stix available
- Uses 2" or 4" Glue Stix
- Cool contoured handle
- Interchangeable nozzle
- Re-usable storage box
- Light weight
- Uses 4 types of Glue Stix
- Built-in Drip Tray/Stand



**ARROW**  
**EZ-Pull™**  
**Rivet Tool**

Model RH-200  
Professional  
**E-Z Pull RIVET TOOLS**

- Extended nose for hard-to-get-at places
- Uses 4 rivet sizes: 3/32", 1/8", 5/32", and 3/16"
- Spring-loaded handle for easy rivet loading and ejection
- All steel construction
- Comfortable vinyl grip
- 4 nose pieces with wrench
- Handle locks when not in use



**ARROW FASTENER COMPANY, INC.**

271 Mayhill Street, Saddle Brook, NJ 07662

In Canada: Jardel Distributors, Inc., 6505 Metropolitan Blvd. East, Montreal H1P 1X9 Quebec  
Available at all leading Hardware, Home Center, and Discount Department Stores everywhere.



# PHOTOGRAPHY

BY STEPHEN A. BOOTH

## Seeing-Eye Cameras

The point-and-shoot, autofocus rangefinder camera owes its success and popularity to its simplicity. Line up your subject, release the shutter and presto—you've got your picture. The camera has fo-

SLR could offer all the magic of a compact 35—and then some. The latest autofocus SLRs, the Pentax SF-1 and Nikon N4004,



Pentax SF-1 is the first autofocus SLR with built-in flash and spot-beam for accurate autofocus in low-light conditions.

ocused for you, determined the correct shutter speed and aperture, and even fired the flash if needed. The 35mm film automatically advances, too.

This doesn't leave much for you to do. You can't exert any creative control, such as select between a deep field of focus or a blurred background. You can't even change lenses. If you want those creative options, you've got to go to a 35mm SLR (single lens reflex) camera. To make these more attractive to beginning photographers, camera manufacturers have made the SLR easier to use. The point-and-shoot automatic-exposure feature is built in, in case you don't want to set shutter speed and aperture manually. When Minolta's Maxxum added automatic focusing to the package, the

even have a built-in flash.

Pentax, in fact, calls its SF-1 the "first full-time" autofocus SLR, because the inclusion of the flash enables you to use the autofocus feature when ambient lighting is too low for the

autofocus sensor to function on its own (the SF-1 can autofocus in light as low as EV-2—an exposure equal to 1 second at  $f/2$  using ISO-100 film). In case you're wondering how the SF-1 can focus in darkness before the flash is fired, the answer pops right out of the camera's pentaprism along with the flash. Just to the left of the flash head there's an oval-shaped spotbeam, whose job it is to project a light pattern (invisible to the naked eye) on the subject so the SF-1's sensor can take a fix. Once it does, the sensor transmits the distance information to the SF-1's microcomputer. The microcomputer, in turn, tells the focusing motor just how far to move the lens elements for proper focus.

In the field—and even in dimly lighted interiors—the Pentax SF-1 (body \$522) focused quickly and accurately, even with long focal-length lenses (there are nine new autofocus lenses for the system, including five zooms). A 1.7x teleconverter (\$140) lets you adapt 19 earlier Pentax lenses for autofocus operation. It will also indicate correct focus (by flash-



N4004 adds sophisticated autoexposure to autofocus SLRs.

ing lights in the viewfinder) when you manually focus an additional 37 lenses already in the Pentax line.

The built-in flash and spotbeam on the SF-1 is a truly welcome convenience in an SLR. To get the added versatility they provide, most other autofocus SLRs require you to carry and mount a bulky flash unit. Another nice touch on the SF-1 is the nonslip rubber finish on the parts of the body you'll grip, and on the lens focusing rings.

Speaking of convenience, the SF-1's top-mounted information panel uses pictures to give you pertinent exposure and film-drive data. For example, the picture of a running figure tells you you've selected the high shutter speed program for action photos. A



## Tips For Better Pictures

### Wide-Angle Lenses

One of the most frequent uses for wide-angle lenses is to squeeze in more left-to-right subject area when you're shooting in tight spaces, such as indoors. The other common application is for landscapes, where the wider angle of view enhances the sweeping, panoramic illusion.

Wide angles, whether they're fixed focal-length lenses (35, 28, 24, 18mm) or part of a zoom, produce much greater depth of field than a normal (50mm) lens set on the same aperture ( $f$ /stop). Because you have more subject area in focus, you can get closer to the foreground subject and still keep the background sharp. They also distort the size relationship between close and distant subjects, giving the close ones a bigger-than-life look.—Armand Ensanian





figure posed against a mountain tells you the autoexposure program is biased for small apertures (high *f*/stop numbers) to get greater depth of field. A single black box means you've set the built-in motor drive to advance a single frame with each press of the shutter release. A series of boxes indicates continuous-fire operation at two frames per second. The only thing the display doesn't tell you is whether you've set the camera for manual focusing, single-shot autofocus (the shutter won't release until the subject is in focus) or servo-autofocus (the lens continues focusing on a moving subject, and the shutter can be released even if the subject is out of focus). Though it would be nice to see the focus status in the display, you can probably check the 3-position sliding switch just as easily.

### Nikon's New AF

Nikon's got a second autofocus SLR to keep its existing N2020 company (*Photography*, page 58, Aug. '86). It's called the N4004 (\$504 with 50mm-f/1.8 lens) and, like the Pentax SF-1, it boasts a built-in flash.

We haven't had the chance to give the N4004 a full, in-the-field workout. But based on a quick examination, it can be said that the camera's Decision Master System is one of the most sophisticated autoexposure programs available today. Basically, the camera's light-metering system will analyze a composition and determine whether it would benefit from some fill-flash—and just how much. Should you decide against using the flash, the N4004 will revert to an *f*/stop and shutter-speed combo that gives the best-balanced exposure for the subject at the center of the viewfinder.

Nikon also makes some claims for the N4004's autofocus sensor. Specifically, the company says that because the sensor has more CCDs (charge-coupled devices) than others, and because they're arranged diagonally, autofocus should be faster and more accurate—especially under conditions (such as parallel lines) that make autofocusing difficult. This sounds plausible, and we'll find out in the field. Unlike the earlier N2020, there's no teleconverter that will give older Nikon lenses autofocusing ability when used with the N4004. You can use the existing, non-AF Nikon lenses, but only manually, and you'll sacrifice some of the N4004's autoexposure tricks.

### Contests

There's still time to get World Series tickets through Fuji's Home Run Game. Score a homer with a specially marked package of Fuji color print film and you'll qualify for four ducats. Base hits also earn you a rebate check with Mickey Mantle's autograph and photo. **PM**



We took this picture on Mule Appreciation Day right here in Lynchburg, Tennessee.

A TENNESSEE MULE is a lot like a Tennessee whiskey-maker: Good, and stubborn.

For seven generations in Jack Daniel's Hollow we've refused to budge from a whiskey-making method called charcoal mellowing. That's where every drop of just-made Jack Daniel's is seeped through tightly packed charcoal before aging. And nothing (not even aging) makes it more mellow. So when folks call us ornery and mule-like, we're quick to agree. You see, if we hadn't been so stubborn all these years, our whiskey wouldn't be so smooth.



SMOOTH SIPPIN'  
TENNESSEE WHISKEY

Tennessee Whiskey • 80-90 Proof • Distilled and Bottled by Jack Daniel Distillery  
Lem Motlow, Proprietor, Route 1, Lynchburg (Pop. 361), Tennessee 37352



## Easy Rider For Pick-ups

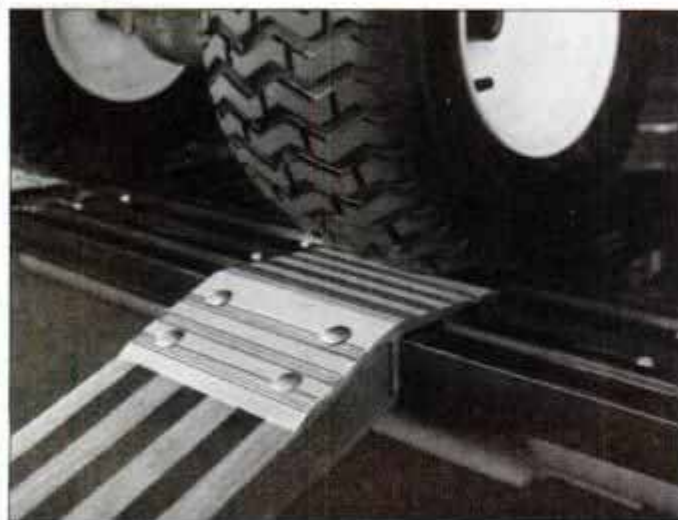

Ramparts keep your lawn tractor from pushing the ramps out from under its wheels while being loaded onto your truck.

These aluminum extrusions bolt to the end of your planks to make loading operations simple, safe and easy. The safety ramp parts kit permits easy on-and-off loading of wheeled power equipment from your pickup bed. They eliminated the bump where the plank is propped over the tailgate of the truck, and keep the planks from squirting out from under the wheels of your tractor or dolly. A chart included in

the instructions tells how long a plank you need to maintain the correct 15° slope for various heights of tailgate or dock. Also adaptable as a temporary wheel chair ramp, the \$39.95 (plus \$2 shipping) extruded aluminum ramp ends easily bolt to any 2 x 8-in. plank with simple hardware included in the kit. Order direct from Ramparts, Inc., 53 Belcher Rd., Blairstown, NJ 07825, (201) 362-9137.

## Down Boy, Down

Safe Dog will keep your pet in the bed of a pickup, while allowing it to move around safely. The unit consists of two specially designed clamps and 7 ft. of 1-in. nylon strap. The clamps are of universal design to fit the

side rails of nearly every domestic and imported pickup. The strap stretches from one clamp to the other, and has a centrally located leash that attaches to the pet's collar or harness. This provides a 4-ft. safety radius in the center of

the pickup bed, allowing the pet to move about the truck. It's \$29.95 plus \$2 shipping from Mother & Son Manufacturing, P.O. Box 261175, San Diego, CA 92126, (619) 549-4235, or call your Humane Society.



Safe Pet keeps your pet from falling into traffic during a sudden maneuver while driving.

## Elbow Grease

This complete car polishing and washing system utilizes a powerful electric motor to drive the scrubbing brush and polishing pad that are included. By attaching a garden hose, water is applied to the brush. Separate valves for water and the built-in soap dispenser permit any desired combination of soap and water. For rinsing, the motor will give the water a pulsating action to really scrub out the bugs and salt. Great for floor mats and wheels, too. After washing, snap on the polishing pad, and Dyna Shine's 12-volt motor will help you apply



The 12-volt Scrubber/Polisher takes the work out of wax jobs.

and buff a coat of wax. It's about \$35 from your Amway distributor, Wards, Sears, JC Penney, True Value and auto parts stores, or call Winland Electronics (507) 625-7231 for information.



Gas Alert tells you how much alcohol is in your gas.

## How Dry Am I?

Has your car been drinking while driving? Now you can test not only for the presence but for the concentration of alcohol in pump gasoline with Gas Alert from DCS. Even if your car runs well on Gasohol, which is 10 percent ethanol, it probably will run poorly or even be damaged by higher proportions of alcohol. Check it in just seconds at the pump. Available at auto parts stores or direct from DCS, Inc., 2832 Horsetooth Rd., Fort Collins, CO 80526, (303) 226-3378. It's \$6.95 (plus \$1.50 shipping).

## How Full Am I?

High-performance cars and their high-performance tires deserve accurate tire pressures. Neotech's \$39.95 (plus \$3 shipping) digital gauge is accurate to 0.2 psi, and beeps when the measurement is displayed. It reads from 0-to-50 psi, is not affected by altitude, pressure or shock and vibration, and has unique changeable adapters rather than a fixed chuck. The display flashes a warning to alert the user when it's time to change the battery. In Texas call (214) 539-1094, or if you live outside Texas

(800) 622-6776. Neotech, P.O. Box 610669, Dallas/Fort Worth Airport, TX 75261. **PM**

Precision tire gauge, accurate to 0.2 psi readout, fits in shirt pocket.





# I found a way to **SELL PART-TIME... MAKE FULL-TIME INCOME!**



**earned \$7,700 from  
my first Pace order... plus financial  
security in my own business.**

1st person story by Tedd Mainwaring

**I** worked on an oil drilling crew out west. We drilled 11 wells one year, every one a gusher! But did I strike it rich? Not on your life—I was paid by the hour and struggled to feed a growing family. That started me to thinking, 'Why should I do all the work while someone else gets all the gravy.'

"About that time I got injured and ended up having to move my family to a different area to take a job as a maintenance mechanic. That idea of controlling my own destiny kept gnawing at me. By now I had five children with extra expense of about \$2,400 a year sending the oldest one to a speech and hearing center.

"How could a guy like me save up enough money to start my own business? To get into most businesses you have to own a corner of Fort Knox. If I could only ease into a business without giving up the regular salary I had to count on to put food on the table. And without making any investment. As long as I was dreaming, wouldn't it be great to find something where every single spare time order could bring in *really big* extra money.

"Sound like the impossible dream? Well, I had seen a Pace Products story about a man who earned \$4,154.65 on just one Seamless Spray order. And he didn't have to invest a penny. I sent for the free information. Believe me, when I received their literature and saw how easy their field-tested sales kit made everything—I knew it could all be more than just a dream. I decided to become a Pace distributor. And it was the best decision I ever made.

## **YOU NEED ABSOLUTELY NO EXPERIENCE**

"Now I haven't mentioned anything about Pace—I've saved the best for last. As you know, it costs a fortune these days for schools, hospitals, plants and other commercial buildings to have roof contractors repair or re-do their roofs. Pace *saves* them that fortune—by-passing the contractor. The building owner uses Pace's Seamless Spray process to apply Pace Roof Renewal Sealant right over the old roof. The cost is so low, the proven results so satisfactory for such well-known firms as General Motors, American Airlines, Holiday Inns and hundreds more, that there is little if any sales resistance.

"Pace ships the Pace Seamless Spray equipment on Free Loan. The customer pays only for the roofing products from Pace. His own men apply it. And the clincher—I would get my big commissions up front. Paid in advance. Weekly.

"With my mechanic's job, I was able to start out with Pace in my spare time. I didn't know a thing about roofs, but Pace told me everything I had to know. They showed me how easy

it is to set up a business and keep it running profitably. So all I had to do was go out and find somebody with a leaky roof, and tell him about Pace products.

"Quite frankly, my first prospect didn't buy. But I made a call for a school building with a roof the size of a football field. They called it the "Bucket Leaker," because every time it rained they had to put out buckets—in classrooms, hallways, even the cafeteria—to catch the water. I got the job and made \$7,700 on it.

"That school building is now leak-free for the first time in 25 years, so they had me do five other roofs with Pace's Seamless Spray. I was on my way. Today my family and I are enjoying a life we never thought possible before—all thanks to my accepting Pace's invitation to return that little coupon in the ad I read."

*Tedd Mainwaring*

## **MAIL COUPON TODAY FOR FREE FACTS—NO OBLIGATION**

Would you like to earn big money, starting out in your spare time, like Tedd Mainwaring? Would you like the freedom and independence of your own business? It can be yours. Let us mail you the facts. Simply send in the coupon below and we'll rush you all the details. There's no obligation. No salesman will call.

Our field-tested sales kit gives you all the know-how you need to get into the Pace business. There's no waiting, no training needed. And no investment required. You can get into the Pace business that offers a way to make \$1,550 or more on one sale—even up to \$7,700 like Tedd Mainwaring—and more!

This is your once-in-a-lifetime opportunity. Get all the facts. Study them in the privacy of your own home and then decide for yourself. But don't delay. Mail the coupon now.

**PACE PRODUCTS, INC., Dept. PM-987  
Quality Plaza, 112th & College Blvd.  
P.O. Box 10925, Overland Park, Ks. 66210**

**WITHOUT OBLIGATION** send free material that tells how I can have my own Pace business. No salesman will call.

PLEASE PRINT

Name \_\_\_\_\_

Address \_\_\_\_\_

City \_\_\_\_\_

State \_\_\_\_\_ Zip \_\_\_\_\_



# AUDIO

BY FRANK VIZARD

## Electronic Musical Chairs



Visit different acoustic environments with the Yamaha Digital Soundfield Processor.

Somewhere, someone must have asked the question: "How can we re-create the varying acoustic signatures of different listening environments?"

Yamaha decided to answer the question. The result is the Digital Soundfield Processor, a machine that can re-create 48 different acoustical environments. The DSP-1 is an amazing technical achievement but it is not a simple answer to the question.

To begin with, full appreciation of the DSP-1 requires three pairs of speakers and an extra 4-channel amplifier. One pair of speakers is designated the "main" set while the 4-channel amplifier powers the second set of front speakers and the rear-speaker pair. The DSP-1 lists for \$850. When you add the cost of an extra amplifier and two sets of speakers, the investment can become sizable.

Once I had a 6-speaker system in place, I could begin my examination of the DSP-1. At first glance, the component is unassuming. Front panel controls are few. In addition to the power button, there are input jacks and level controls that let you play instruments such as an electronic keyboard through the DSP-1. There's also a playback level dial for tapes as well as a tape selector switch with three settings—one for normal playback, a second for recording the acoustic effects of the DSP-1, and a

third "monitor" setting for use with a 3-head cassette deck. The DSP-1's display panel is to the far right and is a little too small for viewing from any distance.

The rear panel, as you might expect, offers a variety of input and output jacks for connecting various types of audio equipment. More unusual is the placement of the balance control for the left and right channels, on the rear panel. There's also a switch that enables the DSP-1 to be used in a 4-speaker system. Sound level to the main stereo speakers can also be cut 10 dB via a rear-channel switch if necessary.

What is impressive about the DSP-1 is the new Very Large Scale Integrated (VLSI) circuit Yamaha designed for the unit. This new VLSI chip is able to reproduce the digitally stored reflection data Yamaha gathered from numerous

locations around the world. (The Alte Oper in Frankfurt and the Münster in Freiberg, West Germany, were two of the locations sampled. Yamaha won't reveal any of the remaining locations.) The DSP-1 uses three of these chips to properly re-create the 48 different acoustic environments offered by the machine.

The different acoustic environments or "soundfields" recorded by Yamaha are accessed through the DSP-1's remote control. The potential listening environments are incredibly varied, ranging from the re-creation of intimate jazz clubs and medium-sized halls to churches and outdoor stadiums. The DSP-1 also offers three surround-sound settings suitable for video applications.

The parameters governing the acoustic settings can also be altered by adjusting eight different "pro-

gram composition factors." Effects as subtle as the difference in starting time between the original sound and the reflection can be adjusted to your specification. Some of the acoustic settings have preset variations as well.

The "jazz club" setting, for example, can be altered to feature a live, mellow or spacious sound.

The DSP-1 also offers a "sound effector" mode. This mode can produce 16 different audio effects. Echoes, delays, pitch changes, stereo phasing and other effects can be introduced into the audio signal. You can also move the sound anywhere you'd like around the room in a circular or front/back pattern.

Lastly, there is a user program allowing you to store your own acoustic environmental data.

In sum, it's all too much. Less, perhaps, would have meant more. The sound effector program is initially amusing but contributes little to the enjoyment of the music. Operating this system with one less pair of speakers would also be nice. The various acoustic settings and the variations within each are too numerous and, I suspect, of interest to only the most serious audiophile. The acoustic difference, for example, between the "Church" and "Münster" setting, while apparent, borders on splitting hairs.

The DSP-1 is a remarkable technical achievement but in this instance there is some overachieving at work. A product like the DSP-1 has a place in the audio component chain, I'd like to see a product with a third fewer acoustic settings but which included

(Please turn to 46)

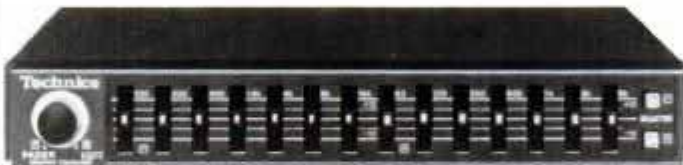

New Technics autosound graphic equalizer, CY-EQ77, has separate and different settings for front and rear loudspeakers.

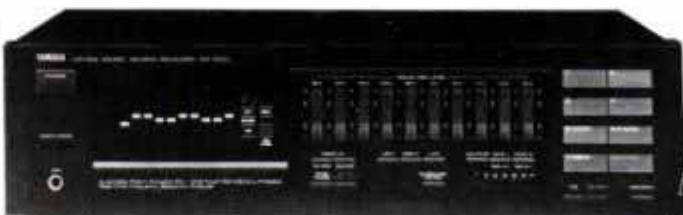

Yamaha's EQ-1100U equalizes room automatically by using microphone to measure signal emitted through loudspeakers.



WARNING:

THIS PRODUCT  
IS NOT A SAFE  
ALTERNATIVE TO  
CIGARETTES

**RED MAN**



Chewing

Tobacco

LARGE  
SIZE

NET WT.  
3 OZ.

**GOLDEN BLEND**

New Golden Blend strikes the perfect blend of  
taste and tradition. With the kind of tobacco satisfaction  
that could only come from Red Man Land!

**THE DAWN OF GOLDEN BLEND™**

© The Prinehart Tobacco Co., 1987



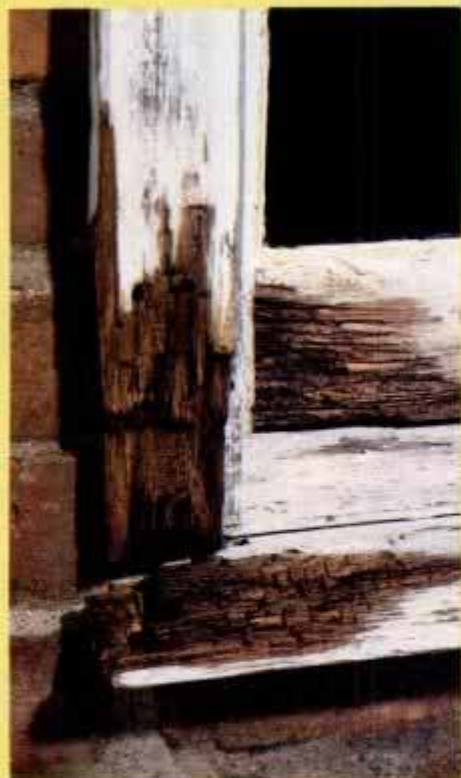

## \$300 to replace. \$10 to repair.

Now there's a wood filler for the big jobs, indoors or out. High Performance Wood Filler by Minwax. It won't shrink, crack or fall out. It hardens in 15 minutes and can be sanded, planed, drilled, painted or stained.

If the wood is soft because of rot, prepare a rock-solid base with High Performance Wood Hardener.

Send today for our free 30-page booklet, *Tips on Wood Finishing*. Minwax Company, Inc., Dept. PM-097 P.O. Box 426, Little Falls, NJ 07424.



### High Performance Wood Filler



All the hard work and continual adjusting is eliminated, however, by a new crop of graphic equalizers with enough built-in brains to do the work for you. Among the latest is Yamaha's EQ-1100U. This unit, like others of its kind, uses a pink-noise generator operating in conjunction with a microphone to precisely measure the audio response of a room. Once the response is sampled, the EQ-1100U's "Auto Room EQ" takes over, adjusting each of the unit's 10 left and right channel bands accordingly.

The equalization will vary according to the type of music being played. The EQ-1100U is preprogrammed for vocal, jazz fusion and disco music, and there are four additional presets for programming additional choices. The EQ-1100U also has a remote control so that you can change equalization settings at the touch of a button. List price is \$599.

Perhaps the most unusual of all these smart equalizers is the Technics SH-8066. Instead of the adjustable sliders common to most other graphic equalizers, the SH-8066 allows you to plot an equalization curve simply by running your finger along a touch-sensitive panel. The SH-8066 can store four original equalization curves in addition to the three factory presets for jazz, rock and vocal music. And unlike other models, you can stack any two preset curves—say "vocals" on top of "rock"—for even more accurate equalization. List price for the SH-8066 is \$450.

For those of you who like to fine tune your autosound system, you might try a new equalizer from Technics. Unlike most other equalizers, the CY-EQ77 allows you to separately balance the front and rear speakers of your system.

The CY-EQ77 is essentially two equalizers in one, offering seven bands of equalization for the front and another seven for the rear. The usefulness of this approach is indicated by the disparity between the equalization settings for the front and rear. The front seven bands can be adjusted at 100 Hz, 200 Hz, 400 Hz, 1.6kHz, 4kHz, 8kHz and 16kHz. By contrast, the rear equalization settings are placed at 63 Hz, 125 Hz, 500 Hz, 1kHz, 2kHz and 5kHz.

Why the difference? In most autosound systems, the speakers reproducing the midrange and treble frequencies are installed in the front of the car, either in the dashboard or the doors. Space limitations generally mandate that the larger, bass-producing speakers be installed in the rear deck. Each of the CY-EQ77's equalizers, therefore, is optimized for each assignment.

The CY-EQ77 offers plus or minus 12 dB of adjustment, and measures just 1 in. in height. Independent front/rear defeat switches allow you to isolate each equalizer, making the CY-EQ77 a good learning tool. List price is \$250. **PM**

### AUDIO

*(Continued from page 44)*

Dolby surround sound for video. It should also be optimally designed for a 4-speaker system. Then the price would be more realistic.

### High IQ For EQ

Yamaha's DSP-1 might be the smartest signal processor ever developed, but some other signal processors, most notably graphic equalizers, are coming equipped with lots of smarts.

Graphic equalizers are essentially elaborate tone controls that allow you to

compensate for the acoustics of an individual room. Drapes and upholstered furniture, for example, tend to absorb treble sounds so you might compensate for this tendency by boosting the high frequencies on the graphic equalizer. Conversely, a lack of sound-absorbing material in a room might cause a boomy sound, alleviated by cutting the lower bass frequencies.

A keen ear and a deft touch, however, are required to operate graphic equalizers effectively. Furthermore, you might want to adjust the equalization according to the signal source, especially when shifting from audio to audio/video.



**NEW!**  
Introducing  
the first new  
leveling tool in  
100 years.

For every professional and do-it-yourselfer.  
So versatile, it belongs in every craftsman's toolbox.  
So rugged, your great-grandchild will be using it.

Replaces  
all these tools.



Total retail value \$77.90.  
You save \$27.95

—Pivoting arm  
locks at any  
angle between  
0° and 180°

—Inch  
markings are  
recessed and  
painted for long  
wear and  
visibility

**24-MONTH GUARANTEE**  
against materials and workmanship.

©1987, G. Rawlings, Inc.

The rawlings™  
**COMBINATION  
LEVEL.**

Made in U.S.A.  
U.S. Patent #4,144,850



—Protractor  
indicates both  
true and  
complementary  
angles

**It's 5-tools-in-1**

—Fully-calibrated in inch, angle, plumbing and  
roof-pitch markings (metric optional)



1. It's a 2ft. level



2. It's a 4ft. level



3. It's a square (and miter)



4. It's an angle-finder



5. It's a rule and straightedge

- Available in 2 sizes, 12"/2ft. & 2ft./4ft.
- Saves buying and carrying several tools
- Rugged I-beam design

There's hardly a job you can't use this revolutionary tool on.

The new rawlings™ COMBINATION LEVEL is packed with handy features that make it the friend of carpenters, bricklayers, boatbuilders, sheet-metal workers, glaziers, plumbers, siding & roofing workers, aluminum installers, wrought-iron and ironworkers, and other skilled craftsmen. To say nothing of the home handyman.

Just look at its features: a recessed locking lever that operates from either side. It frees up the pivoting arm to form a 90° square, 45° miter or any angle between 0° and 180°. At the hinge is a protractor with true and complementary angle indicators. It lets you read off any angle for any job, from roofing pitch to plumbing pipe slope; odd-shaped kitchen cabinets to angled carpet cutting.

The rawlings™ COMBINATION LEVEL is a rugged, precision tool. It's made from Borg-Warner's Cylolac®. The same miracle material used extensively in the aerospace industry.

Inch markings are recessed and painted for easy-to-read, lifetime wear. Cut-outs on all sides allow you to read bubble levels from any angle.

If you work with metal a lot, or just occasionally, get the optional, B.F. Goodrich magnetic insert.

The ingenious new rawlings™ COMBINATION LEVEL is so versatile it belongs in every craftsmen's tool box.

Just a few of the hundreds of jobs the rawlings™ COMBINATION LEVEL will handle:



Dormer siding and sheeting

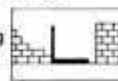

Standing-square for brick and blocklaying



Countertops, cabinets, flooring, tile, carpeting

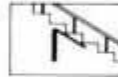

Building stairways, laying up paneling, drywall

**Use the revolutionary new rawlings™ COMBINATION LEVEL AT OUR RISK for 20 days.** Use it. Abuse it! If not 100% satisfied, return it for a full refund.

G. Rawlings, Inc., 13161 McGregor Blvd., Ft. Myers, FL 33907

P2



For credit card orders, call toll-free

**1-800-367-9623**

(In Fla. 1-813-433-7767)

Payment in  check  money order  
 Visa  Mastercard

Signature \_\_\_\_\_ Account No. \_\_\_\_\_ Exp. Date \_\_\_\_\_

Name \_\_\_\_\_ Address \_\_\_\_\_

City \_\_\_\_\_ State \_\_\_\_\_ Zip \_\_\_\_\_ This purchase is for  professional  home use

Qty \_\_\_\_\_ 2ft./4ft. rawlings™ COMBINATION LEVEL(S) @ \$49.95

Include B.F. Goodrich magnetic inserts @ \$6.99

Qty \_\_\_\_\_ 12"/2ft. rawlings™ COMBINATION LEVEL(S) @ \$39.95

Include B.F. Goodrich magnetic inserts @ \$5.99

Add \$2.50 shipping & handling. Fla. residents add 5% sales tax.

Send free brochure

Total enclosed \$ \_\_\_\_\_



# NEW/HOME

## Breakthrough Chain Saw

Until recently, a powerful chain saw was a heavy, fatigue-producing tool. But the new line of Solo chain saws are engineered for superior cutting power at reduced weights.

The Model 647 (shown) is a semiprofessional chain saw that offers the serious wood cutter a powerful, easy-to-handle saw that is lighter and less expensive than comparable professional-duty chain saws. The saw's 2-cycle, 47-cc engine produces

about 3 hp. With a 16-in. bar and chain, it weighs approximately 14 pounds. The saw has a direct-drive oiler that lubricates the bar and chain automatically when the chain is moving.

Safety features include a chain brake, front and rear hand guards, throttle interlock and vibration-absorbing handle mounts. An electronic ignition ensures easy starting and it's equipped with an oversized muffler to greatly reduce engine noise.



The saw's excellent power-to-weight ratio means higher torque at reduced weight. Model 647 accepts a 14-, 16- or 18-in.-long bar.

The Model 647 with a 16-in. bar costs about \$340 at Solo dealers. The saw model with an 18-in. bar and chain

costs about \$350. For information, contact Solo, Inc., Box 5030, Newport News, VA 23605.

## Convertible Handtruck Kit



Lightweight handtruck is made of 1 1/4-in.-dia. PVC pipe.

The next time you're lugging garbage cans down to the street, think how much easier your task would be with the aid of this versatile, lightweight handtruck. Constructed of 1 1/4-in.-dia. PVC pipe, it's available in kit form. The 14 1/2-in.-wide x 39-in.-tall handtruck comes partially assembled in three parts: upper crossbar and handle, middle crossbar section, and lower crossbar with wheel and axle assembly.

The kit comes with instructions and a can of PVC cement. Apply cement to pipe ends and

tap the parts together with a mallet. The kit also includes two 24-in.-long extension bars that form a cradle for carrying firewood, newspapers and other stackable loads. The handtruck's removable extension bars are installed with bolts and wingnuts.

The handtruck kit is available for \$59.95 from Pipe Dreams, Mr. Pida, 10225 Bevis Ave., Mission Hills, CA 91345.



Carry a load of firewood easily by adding the extension bars.

## Handheld Leaf Chaser

Blow away leaves, litter and grass clippings from walks, decks, patios and driveways with the Stihl handheld, gas-powered blower (Model BG-61AVE). The 9-pound unit features an adjustable throttle

that enables you to choose the most efficient airflow for the job at hand. It's sold at Stihl dealers for about \$179. For more information, contact Stihl, 536 Viking Dr., Virginia Beach, VA 23452. **PM**

## Skin-Deep Beauty Of Oak



Colonial casing (above) has oak veneer applied to pine molding. Ten profiles are available in 7-ft. and 8-ft. lengths including inside corner and base (right).



Solid oak moldings can add a touch of class to any room. Installing oak moldings, however, is not an easy chore. Warped, twisted stock, knots and planer marks all add to installation headaches. Also, you must bore nail pilot-holes to avoid splitting the stock.

But now you can enjoy the look of solid oak with easy-to-install Oakmate veneer moldings. Oakmate is made of long-grain red oak veneer applied to ponderosa pine molding. This creates a molding that is 50 percent lighter than oak, uni-

form in quality, easy to nail and presanded and ready to use for finishing.

Oakmate comes in 10 profiles: casing, base (both in Ranch or Colonial style), crown, chair rail, stop, inside and outside corner and flat jamb stock. Oakmate is comparable in price to solid oak moldings. For example, a 7-ft. piece of Colonial casing costs about \$7. An 8-ft. Colonial base is about \$10.75.

Contact Gossen Corp., 2030 W. Bender Rd., Milwaukee, WI 53209; or call toll-free: (800) 558-8985.



Lightweight, compact leaf blower produces strong, broad airstream.



**Start your own money making business!**

**Make up to \$26<sup>00</sup> an hour—  
even while learning!**

*Train FAST  
at home!*

*Get into this booming high-profit business that's  
Easy to learn—Easy to do—Easy on You!*

**Be  
Your  
Own  
Boss!**

Never before have money-making opportunities been so great for qualified Locksmiths. Now lucrative regular lock and key business has multiplied a thousandfold as millions seek more protection against zooming crime. Yet there's only one Locksmith for every 17,000 people!

**Start Collecting CASH PROFITS Right Away**

You're in "business" ready to earn \$10 to \$26.00 an hour a few days after you begin Foley-Belsaw's shortcut training. Take advantage of today's unprecedented opportunities in locksmithing for year-round EXTRA INCOME in spare time—or fulltime in a high-profit business of your own. Hundreds we've trained have done it. So can YOU! All tools plus professional Key Machine given you with course. These plus practice materials and equipment plus simple, illustrated lessons, plus expert supervision, plus business building guidance will enable you the KEEP THE MONEY COMING IN! Ideal for retirement—good jobs, too.

**SEND FOR EXCITING FACTS—No Obligation**

Discover what's in Locksmithing for you—how Foley-Belsaw's Master Locksmith-approved training can give you the skill you can depend on to EARN MORE—ENJOY LIFE MORE.

**No Extra  
Cost!**



**Included With Your  
Locksmith Training**

**BURGLAR  
ALARM  
and SECURITY  
SYSTEMS**

training. Covers all phases of Burglar, Hold-Up and Fire Alarm servicing and installation. This valuable and timely instruction includes all special tools and supplies. ONLY Foley-Belsaw offers such extensive training in this rapidly expanding field as a part of your Locksmith training.

**ADVANCED Locksmithing!**  
How to change combinations, install and service Safe, Vault and Bank Safe-Deposit Box locks. You'll find it fascinating and highly profitable work.



# BE A LOCKSMITH!

**Hundreds of Foley-Belsaw trained men  
have succeeded in this fascinating  
and highly profitable field...**

*"Before enrolling I checked  
other courses and also asked  
for advice from several  
locksmiths in my area. They  
all said yours was tops  
and has the most  
versatile Key  
Machine.*

*"I always  
wanted to be in  
business for myself  
and now I am...  
thanks to  
Foley-Belsaw  
Institute.*



**David Fairbrother—Dave's Locksmith Service  
Milwaukee, Wisconsin 53209**



*"I opened my own business, spare  
time, seven months after I enrolled and  
made a profit of \$329 for the first week."*  
**B. A. Deberry Littleton, Colorado**

*"No more hard, nasty work for me.  
Now I have my own business and with  
hardly any effort I average around \$50  
a day. Thanks for my new start in life."*  
**Sam Walker Prichard, Alabama**



**30-DAY  
NO RISK  
TRIAL!**  
Send for  
details!

**THIS PRO KEY  
MACHINE IS  
YOURS TO KEEP!**



**FREE**

*This Pro Key  
Machine can alone  
add up to \$200 a  
month to your income...  
and it won't cost you a penny  
extra with your training.*

**Find out all about it! Send for FREE Facts TODAY!**

Just fill in and mail coupon below (or  
send postcard) to receive full information  
and details by return mail. **DO IT TODAY!**

**RUSH  
COUPON!**

**ALL SPECIAL TOOLS  
AND EQUIPMENT INCLUDED!**



**FOLEY-BELSAW INSTITUTE**  
5301 Equitable Rd., Dept. 11234  
Kansas City, Mo. 64120

**There is NO OBLIGATION and NO SALESMAN Will Call—ever!**

**RUSH COUPON TODAY  
FOR THIS FACT-FILLED**

**FREE  
BOOKLET!**

Tells how you quickly  
train to be your own boss  
in a profitable Sparetime  
or Fulltime business of  
your own PLUS complete  
details on our 30-Day  
NO RISK Trial Offer!



**Send for your  
copy today!**

**FOLEY-BELSAW INSTITUTE**  
5301 Equitable Rd., Dept. 11234  
Kansas City, Mo. 64120



**YES**, please send me the FREE booklet that  
gives full details about starting my own business in  
Locksmithing. I understand there is no obligation  
and that no salesman will call.

Name \_\_\_\_\_

Address \_\_\_\_\_

City \_\_\_\_\_

State \_\_\_\_\_ Zip \_\_\_\_\_

**... YOU Can Do It Too!**



# NEW/WORKSHOP

## Carry-About Saw

If you've ever lugged around a radial-arm saw, then you'll appreciate Black & Decker's new *folding* radial-arm saw (model No. 1712). A unique swivel fitting at the base of the column permits the saw to fold flat. This allows you to carry the saw comfortably under one arm and store it flat against a wall or under a workbench. The saw weighs about 66 pounds and measures only 10 $\frac{1}{4}$  in. high when folded.

The 10-in. saw has a depth-of-cut capacity of 2 $\frac{1}{4}$  in. at 90° and 2 in. at 45° (bevel cut). It can crosscut a 12-in.-wide board and rip to 19 in. wide. Maximum blade-to-table clearance is 4 $\frac{1}{4}$  in. Power is provided by a 2-hp induction motor that produces a no-load speed of 3550 rpm.

The saw comes with a 10-in., high-speed steel blade and 21-in.-wide  $\times$  34-in.-long particleboard worktable. An optional steel leg stand (\$63) is available, too. Other features include ball-bearing construction, blade guard and die-cast aluminum arm with steel track inserts. The model No. 1712 radial-arm saw costs about \$365. For details contact Black & Decker, Stationary Tools, Dept. 1712-PM, 325 E. Oliver St., Baltimore, MD 21202.



Compact 10-in. radial-arm saw is a good choice for home workshops. It's shown here with its optional steel legstand.



Saw folds flat so that one person can transport it and store it easily. Saw weighs about 66 pounds.

## Lube Job

This may look like just another can of spray lubricant, but Tri-Flow is specially formulated with Teflon to provide superior protection against wear and friction. It can withstand up to 3750 pounds of pressure and temperature ranges of -65° F to 475° F. That's five times more effective than other leading aerosol lubricants, according to Tri-Flow.

Use the light-viscosity oil to protect outdoor power equipment, tools, locks, marine and automotive hardware, motorcycles, bicycles, guns and fishing gear. It comes in 3-oz. (\$3), 6-oz. (\$5) and 12-oz. (\$8) spray cans at bicycle shops, hardware stores and sporting goods stores. For more information, contact Tri-Flow, 825 Crossover La., Memphis, TN 38117.



Spray lubricant contains Teflon to protect moving parts from wear and friction.

## Plugs Prevent Popout

Peg-Board, or wall-mounted perforated hardboard, is a popular way to store and organize hand tools. The major drawback to this system is that the metal hooks have an annoying tendency to pop out of the Peg-Board holes when you remove a tool. Well, now there's a simple, inexpensive solution to this problem. Peg-Lox is a rubber grommet that fits in the hole and grasps the hook securely. It fits  $\frac{1}{8}$ -in.-dia. hooks and all  $\frac{1}{4}$ -in.-thick Peg-

Board. Peg-Lox are adaptable for use in  $\frac{1}{8}$ -in. Peg-Board, too. Ten Peg-Lox costs \$1.25, plus \$1 shipping. Steiner Specialty, Box 884 PM, Lancaster, OH 43130.



Prevent hook-popout with easy-to-install Peg-Lox. The soft rubber grommets fit in the holes to hold hooks securely.

## Good News For Knees

Kneeling is an uncomfortable and painful part of many jobs and recreational activities. The Craftseat, a combination knee pad and seat, relieves knee and back pain caused by prolonged kneeling. The strap-on aluminum frame has two polyurethane-foam pads—one for your knee and one for your buttocks. The walk-through design allows you to move freely without adjusting the two straps. One Craftseat

is sufficient for most jobs, although you can wear two for added comfort. Typical users include carpenters, plumbers, tile layers, mechanics, welders and hunters. They cost about \$35 each at hardware stores and building suppliers. Amcraft, Box 3335, Idaho Springs, CO 80452. **PM**



In kneeling position, one pad protects the knee while the other acts as seat cushion. It's designed to relieve knee and back pain.



Clever walk-through design allows you to move freely without adjusting the straps.



# HINTS FROM READERS

## Quick Applicator



For applying paint, stain or glue on small work, use a strip of felt, leather or cardboard as a convenient disposable brush. To hold these "brushes," make this simple handle. Cut two bars of wood  $\frac{3}{8}$  in. square x  $5\frac{1}{2}$  in. long and taper one end of each similar to plier jaws. Fasten the other ends together with a small box nail that passes through a bored hole in one bar and is driven into the other. This nail acts as a hinge, so don't drive the nail too tight. Then wind a rubber band about 1 in. in from the tapered end. Use a screwdriver to open the jaws when installing or removing the applicator strips.—Walter E. Burton

## Drafting Tool Tray

This tool tray can be clamped to your sloped drafting board to keep pens, pencils and other drafting needs close at hand. The tray is constructed using finish nails and glue to fasten the parts. To determine the angle of the pine end pieces, hold a level against the sloping edge of the drafting board and then use a sliding bevel gauge to copy the angle onto your stock. Sand and varnish the tray and clamp it to your drafting board with a small C-clamp.

—Victor LaMoy

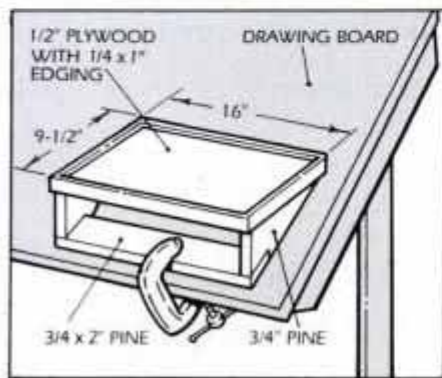

# Attack the paint. Defend the wood.

Removing layers of paint from wood is difficult. Removing the paint *without harming the wood* may be one of the world's *toughest* tasks.

Homer Formby has the solution: Formby's® Wood Formula Paint Remover.

Independent tests show Formby's Wood

Formula Paint Remover is better at removing layers of paint than the most commonly used brands. And it won't raise wood grain or discolor the wood.

Formby's Wood Formula Paint Remover is the one to use on wood.

Homer has done it again.



## PAINT REMOVER

©1987 Thompson & Formby Inc.

## For QUIETER SMOOTHER RUNNING ENGINES

RISLONE and RISLONE CONCENTRATE eliminate the varnish, gum and sludge which cause noisy valves and lifters, lost compression and power, and rough, sluggish engine performance.

A quart of RISLONE... use at oil change time or when you're down a quart.

15 oz. RISLONE CONCENTRATE... add it anytime... even to a full crankcase.



For free Lube Tips booklet send a stamped self-addressed envelope



THE SHALER COMPANY • BOX 471 • WAUPUN, WI 53963



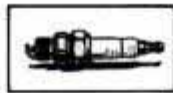

**We have only 14 technical service vans. Our competition, however, has none.**



Somewhere out there, a mechanic is installing a spark plug. And doing it wrong. Chances are, though, the plug isn't a Champion.

That's because at Champion, we establish an ongoing, working relationship with the people who sell and install our plugs—to make sure they know how to do it right.

And we do it the hard way—by sending our instructors to garages and service stations around the country. Where, using mobile laboratories called Technical Service Vans, they turn everyday mechanics into experts on spark plugs and the entire ignition process.

Of course, you might wonder why other spark plugs manufacturers fail to perform such a vital service.

But when you consider that Champion's superior quality is recognized by the vast majority of car makers—38 of whom choose Champions as original equipment—it's perfectly understandable:

**Our competition just doesn't have as much at stake as we do.**

MORE PEOPLE RELY ON CHAMPION THAN ANY OTHER SPARK PLUG IN THE WORLD.





# BATTLE OF THE BEHEMOTHS

Who's got the biggest, baddest luxury car?  
We pit the Cadillac Brougham against the Lincoln Town Car.



**Y**ou've seen the TV ads. A bunch of stuffy executive types are standing around the country club valet parking station when a thinly veneered dispute erupts. These bozos, whose annual salaries are a couple thousand times their IQs, can't tell GM's front-drive luxury cars apart. Then comes the clincher when the owner of the Lincoln Town Car has no trouble identifying his car.

After a while someone at Cadillac remem-

bered that they, too, still made a rear-drive behemoth, and the Caddy riposte has a pair of snobs in pinstripes waiting for their cars. The Town Car pulls up and its owner says: "Too bad Cadillac doesn't make a really big car any more." Then the Cadillac Brougham steams up and its owner smugly announces something to the effect: "They do. And my Caddy is bigger than your Town Car."

Well, we can't resist an opening like that, so





## LINCOLN TOWN CAR

we decided to test these 4-wheeled giants to see how much quality and substance they offered along with their obvious quantity. We ordered up the most lavish versions of each car: the Cartier signature edition Lincoln Town Car and the Brougham d'Elegance—\$55,000 worth of wretched excess on wheels.

The major differences between your entry-level \$23,650 Town Car and the Cartier version are that the Cartier edition includes a power deck lid pulldown which closes the trunk that last inch for you, Headlamp Convenience System which turns the lights on and off auto-

matically, keyless entry system with its keypad on the driver's door, special Crystal Clearcoat paint, Turbine Spoke aluminum wheels, leather upholstery, leather-wrapped steering wheel, dual illuminated vanity mirrors, power passenger seat, assorted pinstripe and trim subtleties, and a Half Coach Roof with Wrap-over Moulding and French Backlite (a padded half-vinyl roof with teensy rear window).

Likewise, the Brougham d'Elegance is separated from your ordinary Brougham by the addition of tufted, button seats, dual armrests, three as-

sist handles, 6-way power passenger seat, rear reading lamps, intermittent wiper system, power trunk release and various trim tweaks.

Then we did something that would make Louis Cartier and Antoine de la Mothe Cadillac blanch. We took them to Raceway Park in Englishtown, New Jersey, and put them through our usual battery of track tests.

The next day, our team of seven test drivers took each car around a 12-mile loop of roads that contained everything from a divided highway to bumpy rural routes. Each car was rated in 22 areas, and the road-test results reflect the opinions of the entire crew.

## Cadillac Brougham

The ground rules for all our comparison car tests state that, when cars are tied for overall rating, the tie is broken in favor of the road-test ranking. In most areas, the Lincoln Town Car is a much better automobile than the Caddy. But the Lincoln's impossibly vague steering (see below) caused it to be ranked behind the Brougham in the road rankings. And since we had only a 2-car comparison, that tied them up. So the Caddy technically comes in first. This is not to say that the Brougham d'Elegance was the better car. It just snuck through a loophole.

The build quality of our test car won't do much to revive Cadillac's long-held "Standard of the World" image. The me-



Handling of the two cars was flaccid with lots of body roll and plowing. The numbers generated on the test track were about the worst we've ever recorded.





## CADILLAC BROUGHAM

tallic paint on the trunk lid had spots. The paint on the hood was actually granular. The fit and finish of the bodywork was terrible. The hood was visibly wavy, and there were no less than seven shims (totaling about  $\frac{3}{4}$  in.) between the front fender and its mounting surface, all visible when the door was open. These things would make the buyer of an \$8000 car see red. But at \$28,000, there is absolutely no excuse for such shoddy assembly.

On the road, the Caddy was also a disappointment. Its 140-hp 307-cu.-in. Oldsmobile V8 simply doesn't have enough power to move this 2-ton car with any authority, much less elegance. Yet, this relatively small motor has somehow managed to cram the engine compartment. There's a loud intake roar from the antiquated 4-barrel carburetor intake system on full-throttle acceleration that's out of place on a luxury car. Quarter-mile performance is in the Chevy Nova class.

Handling is strictly in the marshmallow category. The car rolled excessively in hard corners as the tires plowed and squealed. We also thought the brakes were inadequate for a car this heavy. At 28 grand, where's the advanced technology antilock brake system? In a light rain, the Brougham was a skidmobile. Part of the problem lies with the low-performance Uniroyal Tiger Paw all-weather tires fitted to our test car. In 1988, antilock brakes will be available

on other Cadillacs but the Brougham and the Cimarron. The "tufted-pillow seating area" drew a lot of criticism. Although some testers found the seats more comfortable than they looked, taller drivers had a problem with the upper edge of the quilted cushions poking them across the shoulder blades.

Traditionally, Cadillacs have always been big, fast, road-worthy cars capable of transporting a reasonable number of people in luxury at high speeds over the highway. Today's flagship Cadillac is neither fast nor road-worthy. Is it any wonder that European marques such as

Mercedes-Benz have overshadowed them in recent years as the leaders in the luxury car segment?

## Lincoln Town Car

Our Town Car was much better built than the Cadillac. Fit and finish was several cuts above the Caddy, although some gaps and sloppy seams were detected. The Town Car's seats, however, were terrible leather marshmallows with no discernable means of support. The Lincoln also blew the Caddy away at the track, with 0-to-60 times that

*(Please turn to page 98)*



Injected Lincoln was much faster than 4-barrel Caddy at the drag strip despite only a 10-hp difference in their official horsepower ratings.







# KILLER COASTERS

New loop-the-loop roller coasters have transformed our nation's amusement parks. But recent mishaps pose the question: Will you survive your next ride?

BY TIM COLE, Science/Technology Editor

It was 4 p.m. on a sun-filled afternoon in June, and the young people standing in line for the twin Lightnin' Loops roller coasters at Great Adventure amusement park were excited, eager, maybe a little nervous. Lightnin' Loops is the latest generation thrill machine, with separate interlocking roller coasters that loop inside each other. Like many of America's hot new attractions, Lightnin' Loops is guaranteed to dispense the proper mixture of terror and sensory stimulation.

Nineteen-year-old Karen Brown of Chester, Pennsylvania, advanced to the head of the line with her fiancée Rick DePrince, also 19, and boarded one of the cars. But as the safety restraints came down on the other passengers, Rick and Karen knew something was wrong—dead wrong—and a day of enjoyment and expectation was replaced by tragedy. Karen's safety bar snapped shut behind her instead of in front, as required. Lightnin' Loops computer sensors indicated that all passengers were securely buckled in—just as Rick and Karen screamed to the operators to halt the ride. Later, it was learned that Lightnin' Loops couldn't be stopped once launched on its 30-second, 41-mph circuit.

Numbed by panic, Karen Brown reached the 85-ft. inverted apex of Lightnin' Loops before she was tossed between the cars. Lightnin' Loops ran her over before pitching her mangled body 75 ft. to the concrete below.

It was the 11th fatality at the New Jersey amusement park since 1977. Eight teenagers died in a haunted house fire in 1984. In 1977, two people—an employee and a

visitor—were killed within three days of one another in separate roller coaster accidents.

The public places enormous faith in amusement park attractions, and when that trust is sundered by an accident, the suffering seems more palpable. Fun and gait—emotions that roller coasters naturally engender—are replaced in a flash by anguish. And through the pain, we ask once again: Just how safe are roller coasters? And what can be done to make them safer?

It's a question the people of Edmonton, Alberta, Canada, have been asking ever since a roller coaster failure claimed three lives one night a little more than a year ago. David Sager, 24, of Calgary, along with Tony Mandrusiak, 24, and Cindy Sims, 21, both of Edmonton, were killed when the Mindbender, a radical, triple-loop roller coaster inside the gigantic West Edmonton Mall, derailed and hurled their bodies up to 100 ft. Sims was partially decapitated when she struck a concrete

ledge. Investigators say two of the victims were riding in the rear car when it left the track at more than 60 mph. A wheel assembly sheared away from the car and slammed it into a support pillar. The rest of the cars stalled vertically inside the loop. The third death occurred seconds after the derailment when one of the victims plunged from his seat to the floor of the Mall.

Blame for the Mindbender crash is alternately placed on Mindbender's owner, Triple Five Corp., for a lapse in maintenance, and on Mindbender's builder, Schwarzkopf GmbH of West Germany, for design and manufacturing flaws.

Ironically, Schwarzkopf is also credited with making a major contribution to the current renaissance in steel roller coasters and is widely acknowledged as the builder that perfected the vertical loop. Indeed, despite infrequent deaths and injuries, the Schwarzkopf loop has made roller coasters a significant feature on America's recreational landscape.

Sixty-three-year-old former cartwright Anton Schwarzkopf holds nearly 60 patents in the field of roller coaster design and manufacturing, and has produced more than 55 roller coaster systems around the world. His loop is the result of rigorous research and development conducted in the early '70s at his Bavarian test track. Other roller coaster makers had designed loops, but their "geometry" had imposed too many Gs on passengers, resulting in whiplash, broken collar bones, bruises and other bodily strains. Schwarzkopf determined that a safe loop consisted of a spiral in



The twin Lightnin' Loops roller coasters at Great Adventure in New Jersey stand empty following the death of 19-year-old Karen Brown. Her safety bar somehow closed behind her and her body was pitched from the top of the highest loop. Could an overreliance on computer safety checks have led to operator complacency? Opposite: A roller coaster's vast potential for fun is revealed aboard the Tidal Wave at Great America in Chicago.



## KILLER COASTERS

which the radius of curvature decreased at a constant rate. Thus, most modern loops are tear drop or oval-shaped, which means riders are subjected to slightly less than 6 Gs as the roller coaster's cars enter and leave the loop.

The loop is only one example of the complexity of the modern roller coaster. Systems today must achieve a subtle but dramatic confluence of high speed and gravitational braking through the use of vertical sections and turns. Newtonian physics are at the heart of roller coaster propulsion, and initial inclines rarely exceed 55°. A first drop of under 120-ft. provides sufficient come-back-for-more excitement, with speeds somewhere between 60 and 65 mph. Actually, speed becomes an expensive proposition for roller coaster developers. Velocity equals the square root of two times gravity, times height. In other words, gravity diminishes speed as a square root of a roller coaster's vertical dimension. Thus, adding 20 ft. to a 120-ft. roller coaster only increases top speed by 5 mph, assuming an initial incline of 55°. To achieve a top speed of 100

mph, an operator would have to build a roller coaster 400 ft. high.

Since Schwarzkopf's early achievements (the firm declared bankruptcy following the Edmonton tragedy), other firms have designed looping roller coasters, notably Arrow Dynamics, Inc., of Clearfield, Utah, which designed and built Lightnin' Loops, the Vortex at Kings Island Amusement Park in Cincinnati, and the hot new suspended Iron Dragon roller coaster in Sandusky, Ohio, among many others.

There are striking differences between the Arrow Dynamics roller coaster and the Schwarzkopf. Arrow Dynamics uses welded pipe for tracks and the entire roller coaster expands and contracts as a unit when subjected to temperature extremes. The Schwarzkopf tracks are bolted together with slip joints that accommodate expansion. The Schwarzkopf cars use wheels made of a top secret concoction of nylon and other materials. Arrow Dynamics wheels are made of polyurethane. Both use metal-to-metal caliper brakes and bearings lubricated with molybdenum disulfide.

Since Schwarzkopf and Arrow Dynamics began constructing looping roller coasters made of steel, variations on the theme have entered the lexicon of roller coaster enthusiasts. The launch loop (Lightnin' Loops is an example), propels passengers toward a tear-drop loop from a standing position in the loading station. A corkscrew has a 90° turn just prior to the loop and a 90° turn just afterward. A boomerang sends passengers on two loops—they enter and exit



PHOTO BY SAMP GANDY

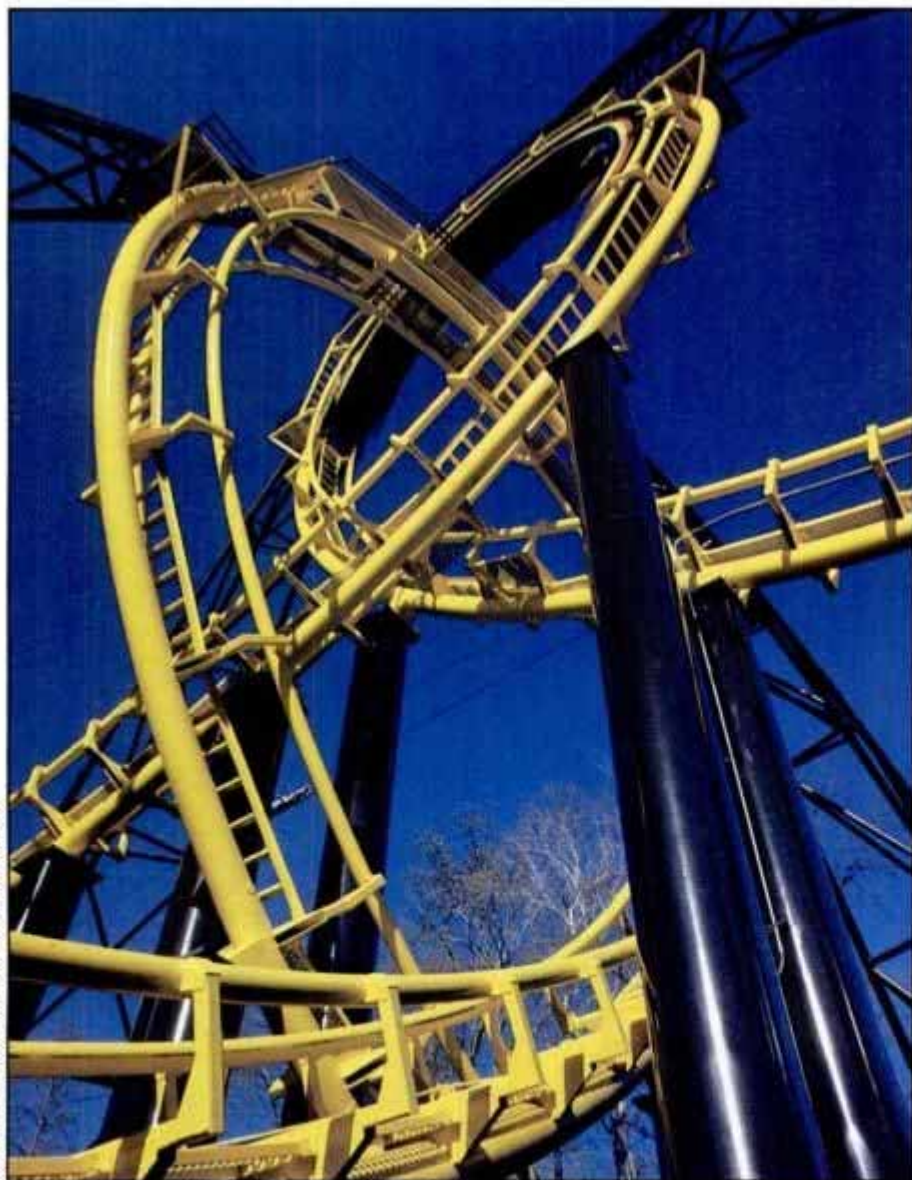
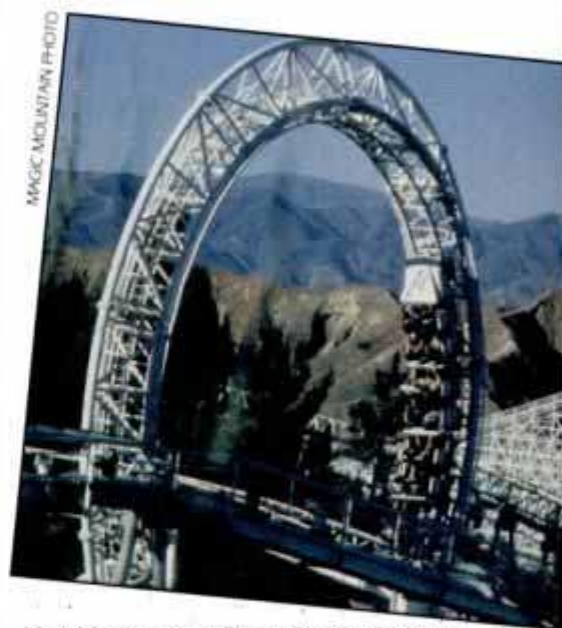

PHOTO BY DAVE DRISCOLL/PHOTO RESEARCHERS



MAGIC MOUNTAIN PHOTO

**Variable geometry:** The corkscrew Python at Busch Gardens in Tampa, Florida, above left, has never had an accident. The Loch Ness Monster at Busch Gardens in Williamsburg, Virginia, left, reveals the intricate possibilities of steel. Revolution, above, co-exists at Magic Mountain in Valencia, California, with the venerable woody Colossus.



the same loop twice when they leave from and return to the loading point.

Amusement park operators constantly seek a new genus of the species to satisfy the growing number of roller coaster devotees. The love affair began in Coney Island in 1884 when La Marcus A. Thompson unveiled his Switchback Gravity Pleasure Railway. Patrons flocked by the thousands for the thrill of speeding up to 6 mph along 450 ft. of track. As engineering skills grew, so did the roller coaster trade.

By 1927, the state of the art brought us the Coney Island Cyclone, designed by Vernon Keenan and built by Harry C. Baker. An amazingly sharp, 60° first drop took riders on an 85-ft. plunge. Its earliest top speed has been lost to history, but today's Cyclone, with the help of bimetal rails and computers, averages 60 mph.

The amusement park was heading for oblivion in the 1950s when Walt Disney began building Disneyland. Slowly, thrill rides entered a rebirth with the second Disney park, Walt Disney World in Orlando, Florida. Then, thrill rides took off with the building of Six Flags theme parks across the nation.

One hub of roller coaster design and construction these days is at the Kings Island amusement park in Cincinnati, home of The Beast and The Vortex. The Beast hurtles down an initial drop of 135 ft. into an underground tunnel, then runs up and down a 72-ft. drop into a tree-lined ravine, around a 300° banked turn through two more tunnels.

It screeches to a halt before chugging up another steep hill via another chain lift to a 141-ft. drop, and, finally, spins into a 540° banked helix tunnel at 60 mph. The Vortex, a huge, new roller coaster that went on line at Kings Island this year, combines two loops, a corkscrew and a boomerang on a ride that last 175 seconds. In fact, The Vortex turns riders upside down six times, a world record.

Opinions vary widely among roller coaster connoisseurs as to what constitutes the best ride in North America. Included in most lists are: The Riverside Cyclone in Agawam, Massachusetts, which accelerates from zero to 60 mph in 3 seconds; the venerable Coney Island Cyclone, still sufficiently terrifying after almost 60 years; the Texas Cyclone in Houston, Texas, a near copy of the Coney Island granddaddy; Le Monstre in Montreal, Quebec, Canada, a huge, woody capable of wicked surprises; Big Bad Wolf at Busch Gardens in Williamsburg, Virginia, a suspended roller coaster with cars that resemble free-swinging gondolas; the Twister at Elych Gardens in Denver, Colorado, combining a breathtaking vista—and a pitch black tunnel; the Gemini in San-

*(Please turn to page 102)*

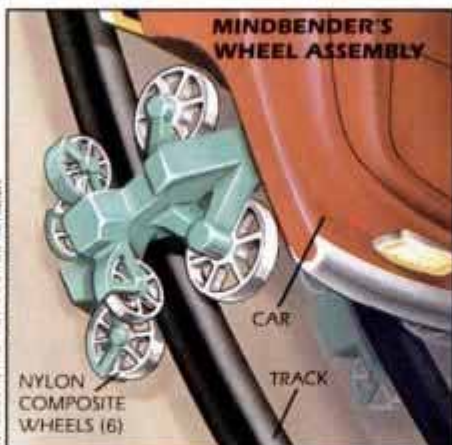

The Schwarzkopf-designed Mindbender, above and right, killed three young people on the night of June 14, 1986 in Edmonton, Alberta, Canada. Investigators say an exterior wheel assembly similar to the one illustrated sheared away from the rear car. The failure caused a sudden derailment. Investigators can't decide if a maintenance lapse was at fault, or poor design.









# BIG EYE ON THE SKY

Advances in photographic emulsion and telescope lens technology are giving astronomers at Cal Tech's Palomar Observatory a new tool for charting the heavens.

BY TERENCE DICKINSON



**A**t Palomar Mountain Observatory near San Diego, California, a recently upgraded telescopic camera, capable of photographing words on a freeway interchange sign 20 miles away, is being used to record more of the night sky than ever before. From now until 1992, the Palomar Sky Survey, as it is called, will be photographing stars and galaxies several million times fainter than the dimmest stars visible to the unaided eye. When the new sky-mapping project is completed with similar telescopes in the Southern Hemisphere, the resulting sky atlas will contain the images of nearly a billion individual stars in our galaxy as well as millions of other galaxies beyond. Astronomers will be using the new Palomar

Sky Survey as a cosmic road-map and research tool well into the 21st century. In the 1990s, it will provide guide-star positions for pointing the most powerful astronomical instruments on—and off—the Earth.



The Palomar Sky Survey using the venerable Schmidt 48-in. telescope, left, will yield new information about the cosmos, including the mighty Andromeda Galaxy (opposite page). The telescope produces star images on glass plates, like the one being studied by researcher Bob Thicksten, above.





They are the shuttle-launched Hubble Space Telescope and the 400-in. Keck reflector now under construction on Mauna Kea, Hawaii's highest peak.

The survey is being conducted by scientists using the Schmidt 48. Advances in lens design, instrument building and photographic emulsion technology have increased the telescope's effective power by a factor of 10 compared to its performance in the 1950s, when it was employed for a similar all-sky photo atlas. Although officially known as the Palomar Schmidt Telescope, the instrument has no eyepiece and has never been used visually. In effect, it is a 3000mm f/2.5 telephoto lens used exclusively for photographing faint celestial objects. Starlight entering the instrument first passes through a shallow, bowl-shaped, 2-element lens at the front. Rather than focusing the light, the 48-in.-wide lens actually spreads the beam.

At the rear of the 30-ft.-long telescopic camera, a concave mirror 72-in. across reflects the light into a tight cone focused on a photographic plate holder halfway up the tube. The front lens corrects optical aberrations imparted by the big mirror. Together they yield pinpoint images right to the corners of 14-



in.-sq. glass photographic plates. Closeup examination of one of these plates after a 1-hour sky exposure reveals an ocean of stars, here and there wreathed in misty clouds of cosmic gas. A magnifying glass shows even more: Tiny images of faint stars that could be brighter than the sun but 10,000 light-years from Earth, oval smudges that



are in reality vast galaxies of billions of stars, and starlike quasars, whose light has been traveling across space so long it is older than the Earth when it reaches the photographic plate.

Each plate takes in as much sky as that covered by a block of four postage stamps held at arm's length. The entire sky requires 1788 plates—the northern

PM PHOTOS TOP AND CENTER BY RICH COX; CAL TECH PHOTO AT RIGHT

POPULAR MECHANICS • SEPTEMBER 1987



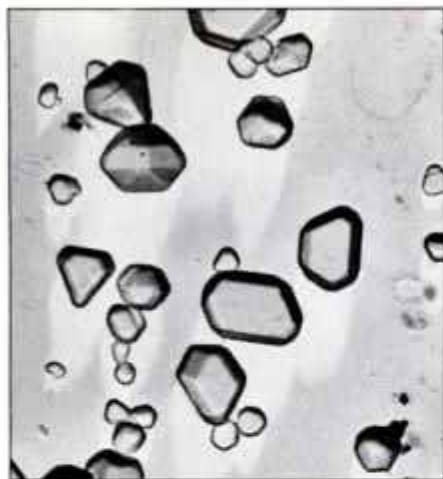

Key to the latest Palomar Sky Survey is improvement in silver halide photographic emulsion. Coarse grain of emulsion on old

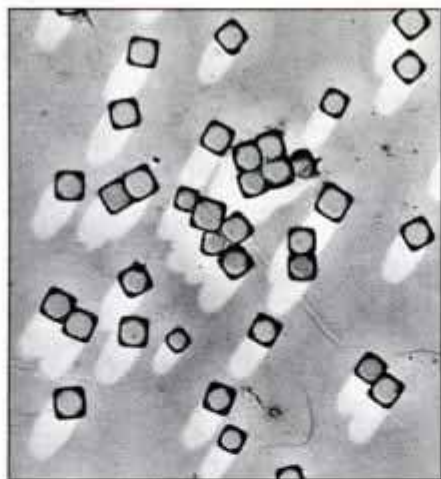

plates, left, contrasts with extreme fine grain, right. Hypersensitization prior to exposure vastly improves image-making.

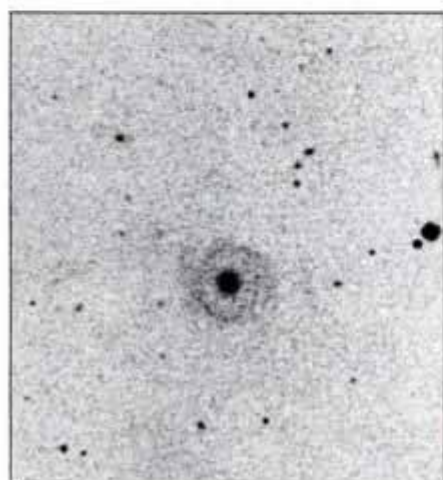

The results of Kodak's improved film technology are evident in these two views of a single far-off galaxy. In the old survey, the gal-

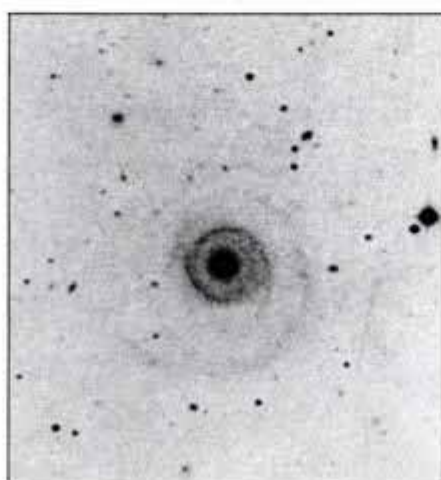

axy is an ill-defined smudge. In the new view, the galaxy is sharpened into a pinwheel of circulating stars.

half to be taken at Palomar, the southern half with an identical Schmidt at Siding Spring Observatory in New South Wales, Australia, and a somewhat smaller one at the European Southern Observatory in Chile.

"Sometime in the early 1990s, we'll drive the photographic equivalent of the golden spike at the celestial equator," says Palomar's Assistant Director Robert Brucato.

But there is more to the Palomar Sky Survey than 894 plates for the Northern Hemisphere. "Each field is photographed three times, using emulsions sensitive to blue, red and infrared light," explains Brucato.

That's a total of 2682 plates. The survey's high standards mean rejecting plates with scratches, telescope focus errors, tracking flaws, bright meteor and satellite trails, aircraft lights or thumb prints. So as many as 5000 plates are needed to get 2682 perfect atlas-grade portraits of the cosmos.

Why not use color film? Monochrome is preferred over color due to its greater sensitivity to light and easier applica-

tion to scientific research. Astronomers need reliable data on the wavelength of light that produce the images. Filters placed in front of the plate holder in the Schmidt Telescope ensure that a known range of wavelengths are received by each plate.

Built in California in the 1940s, the Palomar Schmidt was for many years the largest instrument of its type in the world. Today, only a 53-in. Schmidt, manufactured by Zeiss Jena, located in East Germany, is bigger. By the end of the century, Schmidt telescopes will still be in wide use as celestial cameras. But they will stand alone in the astronomer's arsenal as the only type of telescope using film.

"Photography is fast becoming obsolete as a way of recording telescopic images," says University of Toronto astronomer Barry Madore, who has used many of the world's largest telescopes. "Electronic imaging, which is up to 20 times as sensitive as photographic emulsion, is now used exclusively on many big scopes, like the Palomar 200-in.," explains Madore. However, the

most sensitive electronic imagers, called charge-coupled devices, or CCDs, have detector surface areas about the size of a postage stamp. That's not a problem when focusing on the compact image of a remote quasar or galaxy, which are the frequent targets of telescopes like the 200-in. But the giant Schmidt plates just can't be duplicated by an array of CCDs the size of a record album. Someday, maybe. Right now, cost puts it out of the question.

A typical night of shooting on the Palomar Sky Survey begins when astronomers place the first 2-mm-thick glass plate onto an aluminum or magnesium plate holder. Clamps on the plate holder grasp and physically warp the plate into a concave curvature an inch higher at the center than the edges. The curvature matches that of the big mirror at the rear of the telescope and allows all the starlight falling on the plate to be exactly in focus.

The plate holder is then placed in a pulley system that transports it from the side of the tube to the focus point where it is locked in position. Precise focus tweaking is usually necessary to account for the particular filter being used. To aim the camera, the operator at the control-console keyboard punches in the target area's correct ascension and declination, the celestial equivalent of longitude and latitude. The 3-speed motors swing the 12-ton instrument to the exact position. A 10-in. refractor telescope mounted on the side of the big Schmidt acts as a guiding scope. Looking through the guide scope, the astronomer selects a moderately bright star, fixes the crosshairs on it, and switches on a Cal Tech-designed electronic autoguider. The autoguider detects any drifting of the star image caused by anything from a cell of warm air passing between the scope and the image—or a layer of grease in a driving gear—commanding the telescope control system to re-center.

Sky Survey II includes near-infrared plates which were not available back in the 1950s. They couldn't have been taken anyway. The original 48-in. corrector lens was good for its day, but it was a single piece of glass that introduced unwanted aberrations, especially in red and near-infrared wavelengths. A new, cemented twin-element lens yields perfect images across the visible spectrum and into the infrared.

Each Schmidt plate contains more surface area of photographic emulsion than four rolls of 36-exposure 35mm film. Yet the emulsion's grain size is finer than that of the best modern 100-speed 35mm films. The survey plates could be blown up to wall-sized prints without noticeable graininess.

"The new photographic emulsions are

*(Please turn to page 114)*





# BEST *of* TIMES

Sport-tech designs and functions emerge in aerospace-light and military-tough performance watches. And they tell time, too!

BY JOE SKORUPA; PM photos by Brian Kosoff

**B**odies take a pounding today. Triathletes blast through land-and-water endurance tests. Divers descend to crushing depths. Explorers penetrate the Earth's most hostile environments. And wherever these hard-driving bodies go, so go their watches.

Demands for super durability and other sport-specific functions, by sportsmen, scientists and the military, have spawned a new generation of highly specialized, performance watches. These new watches are marvels of *sport-tech*—features and functions designed for specific athletic pursuits.





Today's performance watches are minimarvels of ultrarugged and sport-specific designs. Shown from left: Porsche Design Compass Watch, with flip-up face concealing a removable compass; Citizen Wind Surfer, water-resistant and handy for converting meters per second into knots; Porsche Design's Ocean Titanium Diver's Watch, made of a space-age metal; Casio Time and Direction, with a liquid-filled compass; Timex Ironman, for hard-charging triathletes; Casio 30-Lap, with a multifunction memory; Seiko Training Timer, with remote cable switch; and Heuer Super Professional, with an easy-gripping, time-lapse bezel.



## BEST OF TIMES

Watches can now withstand nearly a G-force of shock or 160 atmospheres of undersea water pressure, and perform dozens of minicomputer functions.

Scuba diving is a major beneficiary of recent sport-tech developments. The Rolex Sea-Dweller, for example, is water resistant to 4000 ft. below the sea. And, due to an innovative 1-way helium escape valve and special case closures, it is also pressure proof. To prove it, Rolex strapped a Sea-Dweller with a reinforced crystal to the outside of a bathyscaph that descended 35,000 ft. into the Marianas Trench in the Pacific Ocean. Both the bathyscaph and the watch emerged in working order.

Though water can't penetrate the Sea-Dweller's 1-piece steel case, helium atoms under thousands of feet of pressure can. This happens when divers work for long periods of time in artificial, helium-rich atmospheres. Under great pressure, the watches are unaffected by the helium penetration. During rapid, but safe, decompression, as the gases expand, the escape valve allows excess helium to bleed off. Without the valve, the watch would explode.

Another rugged design feature, integrated metal shoulders, surrounds the time-setting stem. These shoulders protect the most vulnerable point on the watch, what Rolex calls the Triplock Crown, from banging or shock.

The Triplock Crown, another ingenious sport-tech design, operates like a submarine hatch by screwing in and out. It gets its "Triplock" name from three rubber O-ring gaskets used on the stem for added water resistance.

Like the Sea-Dweller, Heuer's Super Professional diver's watch has a synthetic sapphire crystal, automatic self-winding (batteries can fail at low temperatures) and a 1-way rotating bezel



New sport-tech features include Citizen Professional Diver's depth sensor, left, Timex Marathon 50's ergonomic shape and controls, and the liquid-battery power of the Water Watch.

with dive duration markings, among many other sport-tech features.

The outline of Heuer's bezel, however, differs from the Rolex by having six large claws for easy gripping when wearing gloves. The revolving bezel incorporates ratchets so that it can only be turned in one direction. Accidental movement while under water will only result in a shorter dive. It is warranted for water resistance to 3300 ft.

While Porsche Design's Ocean Titanium Diver's Watch has many sport-tech features similar to Rolex and Heuer, it has one important difference. It is made of the same space-age metal used as the skin of the world's fastest plane, the military's SR-71 Blackbird.

Titanium possesses a unique combination of strength, lightness and corrosion resistance that makes it ideal for aerospace and submarine applications. The Space Shuttle, F-15 fighters, B1-B bombers, Boeing 747s and submarines make extensive use of titanium. It is expensive and difficult to work with, but

among its many special qualities for watchmaking are antimagnetism and a tendency for its outer-oxide layer to "heal" surface scratches.

The Ocean Titanium Diver's Watch, which takes full advantage of titanium's super strength and beauty, is water resistant to an awesome 6600 ft.

Marvels of sport-tech design, such as deep-diving watches, don't come cheaply. The Rolex Sea-Dweller has a suggested retail price of \$1700. Heuer's Super Professional is \$1450. And Porsche Design's Ocean Titanium Diver's Watch is around \$2200.

For less extravagant budgets, and fewer sport-tech features, the Citizen Professional Diver is a practical alternative. This good-looking and rugged watch is water resistant to 660 ft. and its digital-display depth sensor is accurate to 260 ft., more than enough for nonprofessional divers. It costs about \$325.

Besides divers, runners have also been a major beneficiary of recent

*(Please turn to page 104)*

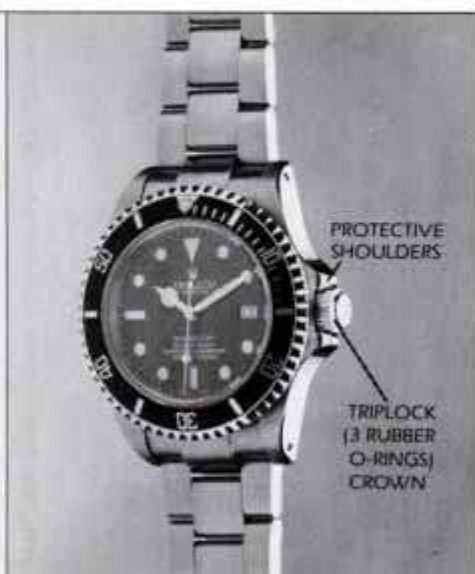

Crushing depths can't squeeze the Rolex Sea-Dweller, which incorporates sport-tech elements that allow it to survive 35,000-ft. descents.



# FIRE POWER

Lighter, stronger, faster, the new Squad Automatic Weapon packs enough punch to serve our ground forces into the next century.

BY JIM BASHLINE



Casings from the M-249's link-belt 5.56-mm ammunition spew from the weapon's shell ejection port during a live-fire exercise.

**N**uclear capabilities, Star Wars concepts and laser-guided missiles receive far more attention from the press and public than hand-carried battle weapons. But what's new? It's logical to suppose that catapults hurling huge rocks generated more coverage during the Middle Ages than the bow and arrow. Yet, it remains the individual foot soldier, gaining and occupying real estate, who ultimately decides victory or defeat. With full understanding of this truism, the U.S. military has selected a new Squad Automatic Weapon (SAW) that is destined for long service. Officially, it's

called "Machinegun, 5.56-mm, M-249."

In current U.S. Army-Marine battlefield strategy, each combat platoon consists of three squads carrying a full complement of 11 men each. Within each squad, one soldier is designated as the AR (automatic rifle) man. In the days of the heavy, but effective, Browning Automatic Rifle, it was an AR team that provided the full automatic fire for each squad. Two men were needed to lug the big gun and extra ammunition, which weighed over twice as much as today's 5.56-mm ammo (in civilian terms, the 5.56 is the equivalent of the Remington .223

PM PHOTOS BY BRIAN R. WOLFF



## Browning Automatic Rifle



Heavy but effective, this nation's first squad machinegun served in two world wars.

## M-14 A1



The '50s-era BAR replacement was lighter, but relied on shoulder-bruising 7.62-mm ammo.

## M-60



Belt-fed 7.62-mm rounds increased firepower dramatically in this Vietnam-era workhorse.

## M-249 5.56-mm Squad Automatic

Latest U.S. military machinegun uses 5.56-mm rounds with bullet weight of 60 grains. Muzzle velocity is 3000 ft. per second and automatic firing rate is 800 to 850 rounds per minute.



sporting cartridge). The old BAR was a good functioning workhorse, but at 19.4 pounds, and with ammo boxes that weighed twice as much, it wasn't a weapon one enjoyed carrying all day.

The equally effective M-14 A1 weighed much less, about 10 pounds, but firing the 7.62-NATO round was punishing to the user's shoulder on full automatic. The same thing goes for the later M-60. Following these imperfect but effective machineguns is the M-249, and trained users say it will "write your name on a newspaper with bullet holes." That's user friendly!

So what are the basic characteristics of our military's newest machinegun? Its standard NATO-5.56-mm round has a bullet weight of 60 grains, which leaves the muzzle at 3000 ft. per second. The action is a gas-operated, unlocked breech capable of a fully automatic rate of fire of 800 to 850 rounds per minute.

The SAW combines two modes of feeding ammunition to the chamber—a box or magazine. A structural nylon box containing 200 rounds of link-belt ammunition can be attached to a sliding dove-tail joint on the bottom of the piece. The disposable links disassemble as rounds are cycled into the chamber. In addition, a standard 5.56 magazine for the M-16 A2 can be attached to the SAW for emergencies.

Weight, minus the primary 200-round magazine, is 14.3 pounds. Overall length is 41 in., which includes 18.35 in.



for the flash suppressor-equipped barrel. Glass-filled nylon forms the stock which may be retrofitted with a new full stock in later versions.

Sighting arrangement on the new M-249 consists of two concentric circles with a vertical post in the front circle. The aperture is 2 mm with front and rear sights being a half meter apart. The outer ring not only helps align the sights but also serves as a front sight protector. This sight picture is not unlike that of a sporting rifle equipped with so-called peep sights.

According to current plans, all of the armed forces will be receiving regular supplies of M-249s during early 1988 and the full transition will be accomplished by 1990. The Army's order for 200-million rounds of 5.56-mm ammunition per year for an indefinite period indicates that it's serious about this. Lake City Ordnance and the Olin Corp. will manufacture the first lots of ammunition, which will be loaded in the M-249's 200-round box magazine at a bullet to tracer ratio of 4-to-1.

Some military observers wonder about the switch to the smaller caliber 5.56-mm round. The small projectile, weighing a mere 60 grains versus 150 grains for the older .30 M1 and 7.62 cartridges (both .308 dia.), seems diminutive indeed. The .30 M1 (.30-06) is just about dead in the U.S. services, and the 7.62-mm cartridge sees service mostly as fodder for the M-60.

Will the 5.56-mm round prove to be as effective in battle as the older and larger cartridges? From a pragmatic point of view, the scale clearly tips in favor of the old timers. They both fired larger bullets with more energy. But, there are a number of ifs. The velocity of the 5.56 round is greater than the 7.62 by about 300 fps. With much less energy (about 1000 ft.-lbs. less), it would appear that this added bullet speed doesn't amount to all that much. But there is much more to the rationale. Because of its extremely mild recoil, soldiers learn to shoot the smaller cartridge with more accuracy and more frequency, making multiple hits more likely. And, with ammunition weighing approximately half of what was formerly used, twice as many back up rounds can be carried.

The designing of automatic weapons is not, and has never been, a casual undertaking. A number of mechanical and chemical interactions have to take place at precise intervals in order to make a firearm shoot again and again. Basically, there are two types of automatic fire mechanisms. The first is blow-back. With this system, the rearward recoil created by the bullet as it travels down the muzzle kicks back to unlock the breech and cycle the round. The gas-operated system depends on a portion of trapped gas behind the fired bullet squirting into a small hole in the barrel to drive the breech bolt back to chamber a fresh bullet.

In both methods of operation, there is a lot of clanking and banging of metal and heating of barrels and other parts. A high tolerance to mud, snow, sand, twigs, leaves and water must be built in. Being dropped on rocks, kicked, pounded and generally mistreated is expected to be tolerated by a weapon of war. Of course, these are extremes, but the bare truth is, your life or someone else's can be lengthened or shortened depending on how the weapon functions—or doesn't function.

Functioning under the most adverse conditions is something the new SAW M-249 seems to thrive on. Mud, water and sand must be literally poured over it, according to some who have purposefully abused the piece, before it refuses to fire. Even then, a quick wipe with a rag or a gloved hand will usually solve the problem.

Now that the M-249 is being integrated into the Department of Defense system, what new designs are on the drawing boards for soldiers of the next century? Actually, small-arms technology is on the verge of bursting onto a totally new plateau.

Our sources prefer not to be individually identified, but the Armament Research Development Engineering Center is currently testing a device that powers a small, bullet-sized projectile via electromagnetic force at a velocity in the 15,000-fps range. Compared with smokeless powder as a propellant, this new power source beats current limits of velocity by 200 percent.

No one knows just what size projectile is being tested, or what the weapon's capabilities might be. It is not difficult, however, to make an educated guess. Moving at 4000 fps, a 50-grain bullet (that's about the size of a pencil eraser) would penetrate a half inch of steel plate. Simple arithmetic would indicate that at over three times that speed, the same bullet would slice through far more armor at close range and pierce current aircraft at low altitudes with relative ease. Such velocity would put anti-aircraft weaponry into the hands of the foot soldier—a dream of many who have seen low-flying aircraft wreak havoc in tactical encounters.

It is not the purpose of this article to debate the merits of the instruments of war in a broad sense. Any civilized person with a modicum of concern for his fellow human must agree that fighting wars and killing each other is not a good way to live and die. Unfortunately, and proven all too many times, some among us choose to think differently. Since we don't live in a perfect world, as a nation we must take steps to defend ourselves. That being the case, I will sleep a bit better for the next 20 years knowing that the SAW 5.56, M-249 is ours and not somebody else's.

FM







# POWER BASE





Ready for work, the power table (above) is a self-contained work center with ample shelf space below for storage. In addition to the router and circular saw, we'll show you how to mount the sabre saw and belt sander. The drill can be used vertically as a drum sander, or horizontally for boring operations.

Turn your stable of hand power tools into accurate stationary machinery with our power table.

TEXT AND PHOTOS BY ROSARIO CAPOTOSTO, Contributing Editor

In the July issue of POPULAR MECHANICS (*One For All*, page 124), we showed you how to construct three innovative shop fixtures that can make your home workshop more efficient and productive. Among these was our unique power-tool table—a versatile work center that utilizes your hand power tools for stationary machine performance.

If you've started construction of your power table, keep reading. We're going to show you a few ways to maximize the utility of this versatile tool. If you haven't started yet, let us give you a little more motivation. Once you get an idea of the power-tool table's potential, you may just forget those dreams of a home workshop equipped with expensive industrial machinery.

Central to the power-table system are the octagonal plates on which you can mount virtually all your hand power tools. Dove-tailed sliding plates, secured permanently in the table, permit quick tool changes and accurate alignment. Tools are installed by backing off the sliding-plate clamp screws and pulling back the sliding plate to insert the tool. Then, tighten the plate clamp. Two tools can be installed at the same time to speed multiple machining operations. And, as if that weren't enough, we'll show you how to use your power table as a clamping table for holding flat or irregular stock. As with all machinery, keep safety foremost in your mind. Always unplug the tool before removing it from the table and making adjustments. Keep the table surface uncluttered and wear suitable eye protection.

The power tools that are natural first choices for installation are the circular saw and router. The July issue describes how to construct the mounting plates for these tools. Installing the router and circular saw first allows you to use the power table to make the other inserts and accessories. For ripping, slide the bridge fence in the tracks to the desired distance from the blade and clamp in place with two 6-in. bar clamps. Two clamp access holes are provided for positioning the fence near the center.

For normal ripping, keep the fold-down fence in the upright position. The extra width of this fence is an advantage when holding stock on edge. For ripping narrower strips, fold the fence down and gain extra room for holding the stock as you pass it by the blade. To cut bevels, unplug the tool and remove the plate to make adjustments to blade angle and cutting depth.

Because of the way hand circular saws pivot, you'll need a selection of blade inserts for the most common bev-



## POWER BASE

els. After adjusting, simply reinsert the tool, adjust the fence and make your cut. Alignment is automatic.

The fence can be used in conjunction with many other power tools including the router. Here, grooves, rabbets and dadoes can be cut with consistent results. Of course, the router can be used without the fence by using router bits with pilots.

We call our fence a bridge fence because it provides an additional function unlike anything we've seen. When folding down the fence, you'll notice it lifts up and down allowing stock to be passed underneath. Use this feature when crosscutting long stock with a handheld circular saw. Slide the wood under the fence and hold it firmly against the rail stop on the far side. Then let the fence edge guide your saw for square cuts every time. Make sure the fence is clamped in position so the blade runs in the center track. You can also rout straight, square-to-the-edge dadoes in boards of any length up to 20 in. wide.

The miter gauge is adjusted by backing off the wingnut and pivoting the arm to the desired location. It's a good idea to mark the most commonly used angles on the miter gauge rail for quick setup. Sawing a miter is only the beginning, though. Now you can trim the cut at the exact angle and length by using the miter gauge to guide the work past the router and straight bit or drum sander. For mitering picture frames or molding corners, use the sliding-table miter jig. This permits cutting both sides of the miter joint without turning the stock upside down.

If you've ever had to make a very wide crosscut or miter you'll appreciate this next feature. Because the power table is equipped with two long tracks as well as the center cross track, you can slide the miter gauge along the length of the table on either side. Set the circular saw in place so the blade is parallel to the length of the table. Now, use the miter gauge to guide the stock for crosscutting up to 20 in.

In addition to the circular saw and router, the electric drill, sabre saw and

## USING THE BRIDGE FENCE

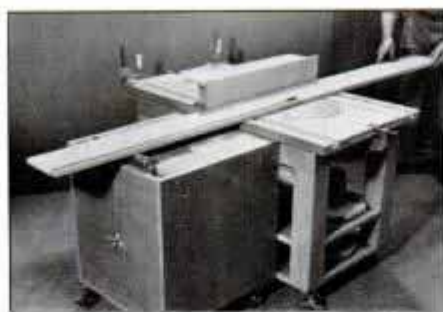

**1** To rip, clamp the fence at the desired position. Adjustable outfeed roller on the small-parts cabinet supports stock.

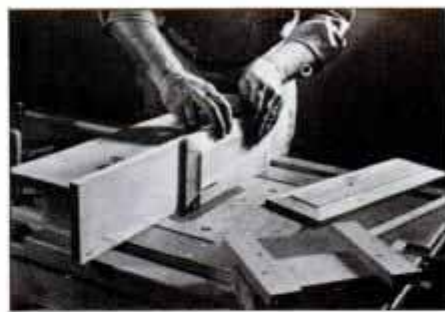

**2** The extra-wide fence helps when passing the stock on edge. Tilt the saw blade for making these beveled panel edges.



**3** Crosscuts on long unwieldy stock are easy when the stock is held under the bridge fence and cut with a handheld saw.



**4** Use the bridge fence to guide your router when cutting dadoes square to the panel edge, as in shelf construction.

## CUTTING MITERS

### SLIDING MITER JIG

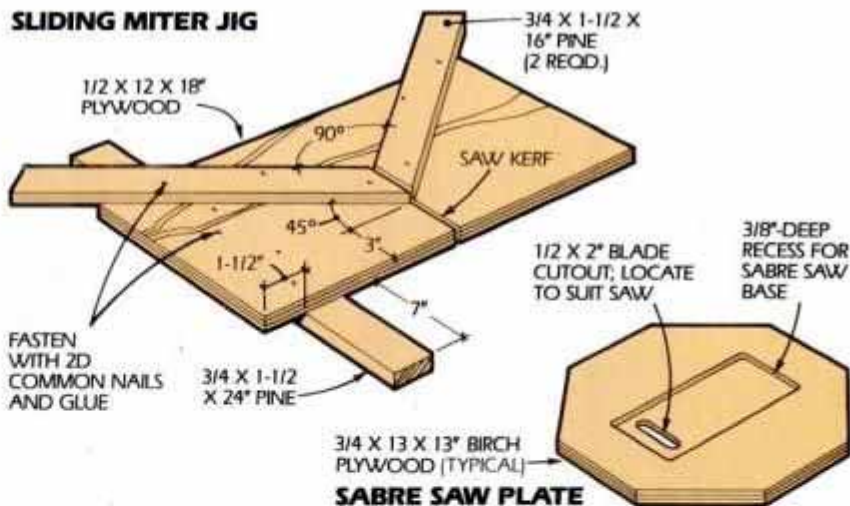

**5** Clamp a stop block to the miter gauge for repetitive cutting. For longer pieces, clamp the block to the table surface.



**6** Cut compound angles by adjusting the miter gauge and bevel the angle on the saw. Use backup stock to cut small pieces.



**7** Picture frames require that stock be held molding side up for smooth cuts. Use this miter jig for accurate, clean corners.







PM COMPARISON TEST

# TRACTORS FOR ALL REASONS

These big-ticket garden tractors are a gentleman farmer's dream.

BY STEVEN WILLSON, Home And Shop Editor





**W**hen I was young, growing up in dairy farm country, I knew what a tractor was—everybody did. It was that huge, stripped farm machine that fought daily battles with hilly terrain, rocky soil and harsh elements. It pushed things, pulled things and even drove, by means of a power take off (PTO), any number of stationary implements from forage blowers to bucking saws. It was a practical no-nonsense machine. But one of the few things it couldn't do—and no one ever thought it should do—was mow a suburban lawn neatly.

Now all this has changed and the term tractor applies to any number of downsized/upscale machines, some of which *can* mow your lawn neatly and still drive a host of specialized attachments. These garden tractors have so many claimed capabilities and, in some cases, such astounding price tags, we decided to try out a few and see just how much real tractor was in each of them.

For this test, we obtained five popular models, all in the 16- to 18-hp range, with attachments for snow blowing, soil tilling and lawn mowing included. We used this equipment for



Garden tractors occupy the high end of the lawn and garden power equipment market. They are designed to serve as powerplants for many different ground-contact attachments. They boast high-horsepower engines, power take offs and, in most cases, heavy-duty construction. If you just want to mow your lawn, don't even consider this expensive machinery. Look at smaller lawn tractors or riding mowers instead. But if you also want to blow snow, till soil and pursue other more arcane capabilities—all with power to spare—then this equipment is your logical choice. To get a better idea of what to expect from these machines, we put a Snapper LT 16, Cub Cadet 1811, Ariens GT 18, Deere 318 and Sears YT 16 Automatic through their paces. Here are the results.

PHOTO BY HUMPHREY SUTTON





## TRACTORS

four months, from late winter to early summer, on a 30-acre spread in upstate New York.

Because these units with attachments vary in price from almost \$4000 to more than \$9500, we thought it was unfair to rank them as if they were direct competitors. In most cases, however, the old adage was true: You get what you pay for. But if there ever was a product category where you can easily pay for more than you need, this group is a shoe-in for membership.

The most important thing to keep in mind is: The whole menu is a la carte. Except for the Snapper model, which included a mowing deck, when you buy one of these tractors that's exactly what you are buying, a tractor. All the attachments are add-ons. So, you have to make some pretty specific decisions up front about the work you want to do.

### Snow Blowing

There are many good walk-behind snow blowers, either self-propelled or push models, that can handle a modest sidewalk and short driveway. But when your needs are more substantial, the additional power and comfort offered by a

tractor-mounted blower become attractive. One of the great advantages of using the same powerplant for mowing and snow blowing is that you won't have two engines to service and maintain.

As expected, in our tests the 2-stage blowers out-performed the single-stage versions. The difference involved both how fast the tractors moved through the snow and how far the snow was blown. The width of cut, however, seemed much less important.

Finally, the lift mechanism, the means by which the blower—or any attachment—is raised and lowered, is a real comfort consideration. The mechanical systems require some muscle while the hydraulic lifts are effortless. Two more required add-ons are wheel weights and chains for the rear wheels. Without them, getting up even a modest incline is almost impossible.

### Soil Tilling

You've got to be quite a gardener to want—or to afford—one of these attachments. But their great advantage is that the tractor absorbs almost all of the vibration, the walk-behinds cannot. Also, if you choose a tractor with a hydraulic lift, you gain a great deal of control over consistent tilling depth.

As with the snow blowers, operating width seems less important than other factors. First is quality of construction because these machines take a real beating. Heavy-duty steel plate is preferable to stamped sheet steel.

Second is the drive mechanism. Over the long haul, hydraulic-drive and the shaft-drive models are preferable to the belt-drive systems.

One drawback to the tractor-mounted design is the sheer space required to operate the equipment. Tight spots are a real problem because of the size and turning radius of the tractors. Also, the ground clearance under these tractors is surprisingly scant which makes tilling raised planting beds quite a challenge. Finally, to mount most tillers you must buy another attachment, namely a 3-point hitch for the back of the tractor.

### Mowing And Collecting

With the exception of the relatively narrow Snapper single-blade deck, all the tested mowers featured more than 40-in. mowing widths. Unlike the blowers and tillers, cutting width is a serious convenience issue. On larger lawns, especially over the duration of a mowing season, working time can be reduced significantly by these out-sized decks.

### Test Procedures

We obtained these tractors for a 4-month period from late winter to early summer of this year. Each came with attachments for mowing grass, blowing snow and tilling soil. The Snapper, Ariens and Deere also had grass-collection systems. Test conditions featured flat lawn and rough meadows for mowing; soft, previously tilled soil and very rocky, virgin soil for the tillers; and wet and dry snow for the blowers. Each manufacturer offers many other attachments besides the ones we tested. Write to them, at the addresses below, for full-line catalogs.



TRACTORS	SEARS CRAFTSMAN	SNAPPER
Manufacturer Model/Price	YT 16 Automatic/\$2549 (incl. mowing deck)	LT-16/\$2535
Engine Type/Fuel Capacity/Oil Filter	2-cyl. 16-hp Craftsman/3.5 gal./No	2-cyl. 16-hp Briggs & Stratton/5 qt./No
Transmission	Hydrostatic	Dual range, 6 forward, one reverse speeds
PTO/Lift Mechanism	Center/Mechanical	Front/Mechanical
Length/Width	65"/54"	66"/34"
Wheelbase/Weight	44"/656 lbs.	48"/450 lbs.
Tire size: Front/Rear	15 x 6.00-6/20 x 10.00-10	15 x 6.00-6/21 x 7.00-10
Turning Radius (Tested at inside of rear wheel)	27"	39"
<b>ATTACHMENTS</b>		
Mowing Deck: Type/Cutting Width/Price	3 blades/44"/included with mower	1 blade/33"/\$253
Collection System: Type/Capacity/Price	Not available for tested deck	Twin Bag/6.5 bu./\$250
Snowblower: Type/Removal Width/Price	Single stage/40"/\$750	2-stage/36"/\$760
Tiller: Type/Tilling Width/Price	Belt driven/21"/\$500	Separate engine/20"/\$757
Miscellaneous Attachments/Price	None	3-pt. hitch/included in tiller price; Rear wheel weights/\$45; Chains/\$70
<b>TOTAL EQUIPMENT COST AS TESTED</b>	<b>\$3799</b>	<b>\$4670</b>
<b>MANUFACTURER'S ADDRESSES</b> For information on other attachments	Sears Roebuck, Sears Tower, Dept. 703, Chicago, IL 60684	Snapper Power Equipment, PO Box 777, McDonough, GA 30253



An added bonus is how close these wider decks can cut around yard plantings, because the blades extend beyond the tractor wheels on both sides.

The hydraulic lift, however, is not as important here. Most people simply set the deck at a specific height and have no need to raise or lower it frequently. Also, cutting performance is more dependent on the sharpness of the blades than any individual deck geometry.

There are a few shortcomings to these tractor-mounted decks. First, the weight of the tractor and size of the front tires tend to flatten the grass. This prevents the vacuum action of the rotary blades from standing up the grass completely before it's cut. Second, these tractors simply cannot tolerate mowing across an incline. Of course, all the manufacturers point this out—with safety stickers plastered on the equipment and bold-faced warnings throughout the product literature.

But, if your property does not conform to these litigious guidelines, steer clear of this product category. In tests we conducted mowing across inclines, we found the tractors feeling faint at just 9° and positively unstable at 12°. However, when it came to mowing up and down an incline, all the tractors in

the group handled the steepest one available which was about 20°.

Your selection process gets more difficult if you want a grass-collection option. On some wide decks, the manufacturers offer no collection system, reasoning that folks with so much area to mow don't want to be bothered with collection. If you do want to collect clippings, however, you must buy into an auxiliary blower.

The rotary blades cannot throw the clippings with enough force to reach the collection bags. This system works well, but can be unbearably noisy.

One final concern is serviceability. You can't drop off this equipment at a gas station on your way to work. Routine owner maintenance is crucial and a reliable local dealer is almost a necessity. Be sure to review all the product literature and warranty fine print before making your decision.

### Sears Craftsman YT 16 Automatic

It's not surprising that the Sears tractor is the least expensive model in this group. From the lightweight stampings used for the front axle to the insubstantial U-bolts that hold the rear axle, you can see cost cutting everywhere. The

stamped frame also features unitized construction rather than a twin-rail design. This makes service much more difficult because the parts above the center horizontal plate cannot be reached from below. Furthermore, the multitude of pulley axles attached to this plate are simply bolted in place. If one works loose and enlarges the mounting hole, the repair can be made only by welding over the hole and redrilling it.

Another look under the tractor reveals why the steering is so poor. Instead of using the straightest linkage possible, the tie rod and drag link have no less than six separate bends. This makes steering sloppy and fatiguing.

Like the Snapper that comes next, the Sears engine has no spin-on oil filter which could affect engine longevity. And its seat is incredibly uncomfortable. Add to this the noise level which requires hearing protection at full throttle and you end up with a tractor that is a real disappointment.

That's the bad news, but there's some not-so-bad news, too. The instrument panel is logical and convenient and features an exclusive height-adjustment knob that controls the mechanical lift system for the attachments. Another good feature is an accessible coast-con-



#### CUB CADET

1811/\$4649

2-cyl. 18-hp Kohler/4 gal./Yes

Hydrostatic

Front/Hydraulic

72"/38"

44"/800 lbs.

16 × 6.50-8/23 × 10.50-12

34"

3 blades/44"/\$579

Not available for tested deck

2-stage/45"/\$904

Belt driven/38"/\$1227 (with adapter)

3-pt. hitch/\$249; rear wheel weights/\$125; Chains/\$50.75

\$7783.75

Cub Cadet Corp., PO Box 36930, Cleveland, OH 44136

#### ARIENS

GT 18/\$4689

2-cyl. 18-hp Kohler/4.5 gal./Yes

Hydrostatic

Front, Middle, Rear/Hydraulic

74.75"/43"

48"/925 lbs.

16 × 6.50-8/23 × 10.50-12

37"

3 blades/48"/\$799

Single Bag, auxiliary blower/12 bu. \$679

2-stage/48"/\$1079

Shaft drive/48"/\$1559

3-pt. hitch/\$148; Rear wheel weights/\$99.50; Chains/\$89.50; Weight box/\$79.50

\$9221.50

Ariens Co., 655 West Ryan St., Brillion, WI 54110

#### JOHN DEERE

318/\$5229

2-cyl. 18-hp Onan/4.5 gal./Yes

Hydrostatic

Front, Rear/Hydraulic

68.5"/44"

46"/836 lbs.

16 × 6.50-8/23 × 10.50-12

25"

3 blades/46"/\$634

Twin Bag, auxiliary blower/6.5 bu./\$486

Single-stage, hydraulic/46"/\$1058

Hydraulic/30"/\$1503

3-pt. hitch/\$248; Rear wheel weights/\$87.72; Chains/\$54; Weight bar with 6 weights/\$298

\$9597.72

Consumer Products Advertising Dept., Deere & Co., John Deere Rd., Moline, IL 61265



## TRACTORS

trol knob that can override the transmission. This allows you to push the tractor easily when it's not running, something that makes attaching the implements more convenient.

The ignition switch broke after one day's use. This also nullifies the safety interlock switch which shuts off the engine if the operator gets off the tractor seat. Of course, small things can go wrong with any piece of equipment and often these are caught during dealer prep. The Sears tractor, however, is delivered in a cardboard box. Sears informed us that local representatives will come to service the tractor.

### Sears Attachments

The no-dealer-prep arrangement became a real irritation when it took more than 7 hours to assemble and attach the snow-blower unit. Once in place, however, the single-stage blower did work well in light snow and even crawled through heavy wet snow, though it was our poorest performer.

The tiller was a good bit easier to install, but its performance was deplorable. It's difficult to understand what type of soil the Sears folks had in mind for this machine. It bucked, bounced and started to *burn* the drive belts when confronted with virgin, rocky soil. The machine worked only slightly better in previously tilled soil.

Despite the problems with the blower and tiller, the mowing deck operated very well. But, unlike the other wide decks in our test, this unit had only one steel runner to function as an antiscaling device. The others had rollers or wheels to prevent the blades from gouging your lawn. Sears does not offer a collection system for this deck.

### Snapper LT 16

Our Snapper tractor had several things in common with the Sears model. Both feature 16-hp engines and occupy the low end of the price range. Also, both have very uncomfortable seats. But here, the similarities end. On almost every front, the people at Snapper have opted for honest, common-sense design.

The LT 16 was the only tractor that did not feature hydrostatic drive. Instead, it employs a simple friction-drive system that allows you to change between the six forward speeds without clutching. You must, however, use the clutch to move into Neutral or Reverse. Even though the rubber-faced friction component seems prone to wear, replacing it only involves removing three very accessible nuts. The transmission also features high range for mowing and a low range for snow blowing and tilling.

The twin U-channel frame represents durable construction and allows for easy

servicing. And while the front axle is stamped, like the Sears tractor, the steel is much heavier. The Snapper steering is responsive and predictable with only one bend in its linkage and the steering wheel is adjustable—the only one in this test. Finally, the narrow tires on this tractor may not look as substantial as the others. But they offered an edge in friction because of their higher load per square inch of contact area. This is a plus for snow blowing and tilling and a minus on a soggy lawn.

### Snapper Attachments

The Snapper 2-stage snow blower may not be the easiest model to attach—it took well over an hour the first time—but it was the best performer. It sent wet and dry snow alike flying more than 40 ft. away. At one point, we stacked it against a 16-in.-deep stretch of soaking wet snow and the tractor just crawled along its merry way.

The blower is belt driven off a front PTO and the additional weight on the front wheels does make steering stiff. But the same was true of every tractor in the group, except the Deere which has power steering. It should be noted that in 0° temperatures the Snapper started better than all the others.

The Snapper tiller, on the other hand, was the smallest and next to least expensive model we tested. And the only one that was not driven off the tractor. It was powered by its own 5-hp Briggs & Stratton engine. There is some wisdom to this arrangement, especially on a tractor that has only one front-mounted PTO. To transfer the power back to a tiller requires a very long expanse of exposed V-belt. When going over rocky soil, the belt can hit obstructions. Surprisingly, our worries about the noise level of this additional engine were unfounded, and the unit was easy to start while sitting on the tractor. Its one drawback was that it tended to churn up the soil in clumps which required three or four passes to smooth out.

The Snapper single-blade mowing deck was smaller than the others. But it's worth serious consideration because it cuts very well and doesn't require an auxiliary blower to move the clipping into the double rear bags. Not only is noise reduced, but there is also one less obstruction in the chute to clog with clippings. In light of how well the collection system worked, it seems strange that Snapper would join the bag support brackets with brittle hardware. Two of the bushing nuts broke when the system was being installed.

### Cub Cadet 1811

By moving up to the Cub Cadet, you enter a higher-priced neighborhood and a better-built machine. Its fit and finish is superior and it possesses, along with

the John Deere, the best ride we tested. It also shares the quietest performance and a very similar, sensible dashboard. Though the machine does have an ammeter, oil-pressure light and an engine-hour meter, it lacks a light to indicate when the PTO is engaged. This is a convenience and safety feature we think should be thrown in for the price.

The Cub has the best front end in the group. It's the only design with a kingpin separate from the front-wheel spindles, which is both durable and easy to service. The quality theme is carried over to the steering linkage where both the tie rod and drag link are straight heavy-gauge steel rods. Combine these features with a substantial axle casting and you end up with the best manual steering in the group.

The hydraulic-lift mechanism functioned well in all our attachment tests, and the seat is very comfortable. Also, the Cub was the fastest tractor in our test, though this is a somewhat dubious distinction. All the attachments function best at slower ground speeds. The biggest drawback to the Cub is its single, front-mounted PTO. As mentioned earlier, to transfer the power all the way back to a tiller requires a very long, unshielded expanse of V-belt.

Despite the obvious quality construction of this machine, two distressing breakdowns occurred. The first was the failure of the seat's safety-interlock switch. The second concerned a broken weld on the linkage between the speed-control knob and the transmission. Both are covered by the warranty, but they end up undermining an otherwise favorable impression of quality control.

### Cub Cadet Attachments

The Cub's 2-stage blower was a breeze to install and worked well in both powder and wet snow. Its hydraulic lift and superior manual steering made operating the blower almost effortless.

The tiller attachment was somewhat more difficult to install. A separate gearbox and adapter kit had to be added to the 3-point hitch to receive the belt-drive assembly. This gearbox does, however, accomplish the change in belt direction internally. This reduces belt wear and makes fine-tuning the belt tension easier. Still, on several occasions, the belt did jump its pulleys. In virgin, rocky soil the machine sought its depth with ease, yielding a relatively smooth planting bed in just one pass.

Rounding out the Cub attachments was a first-class mowing deck. Not only was it easy to install, it also featured antiscalp wheels on both sides of the deck and a totally enclosed belt-drive system that powered its three rotary blades. The manufacturer does not offer a collection system with this wide deck.

*(Please turn to page 99)*



SPECIAL REPORT

# '88 SPORT UTILITY

- 4x4s TODAY AND TOMORROW
- COMPLETE BUYER'S GUIDE
- OFF-BEAT OFF-ROADERS
- RANGE ROVER DRIVE REPORT





# TOYOTA 4RUNNER

## UTILITY PLUS

In-town shopping to boulder hopping, 4Runner makes life easier. When you need big cargo space, fold down the rear seats and pile in the load.



## COMFORT IN ACTION!

Fully reclining front bucket seats and power rear window are standard. Also available is an optional ECT automatic overdrive transmission.\*\*



## IT DRIVES PEOPLE HAPPY.

Happy owners have named Toyota's four-wheel drive, family-size 4Runner number one in customer satisfaction for the second straight year.\* In an independent nationwide survey, 4Runner's owners came through loud and clear; no other compact sport utility vehicle was liked so much. That's Toyota: looking out for you with quality that makes people happy.

**RATED #1 IN CUSTOMER SATISFACTION.**



WHO COULD ASK  
TOYOTA  
FOR ANYTHING  
MORE!

Get More From Life... Buckle Up!

\*J.D. Power & Associates Compact Truck CSI, 1986 and 1987.

\*\*Standard on 4Runner Turbo.

© 1987 Toyota Motor Sales, U.S.A., Inc.



# '88 SPORT UTILITY

## CONTENTS



Experimental Blazer XT-1



Ford Bronco II



Pinzgauer Turbo D



Home of the Range Rover: Our Outdoors Editor Joe Skorupa gets a driving lesson.

### 4x4s MOVE UPTOWN

**82** Not to mention upscale, up-market and high-tech. Here's a quick look at where the sport/utility market is today, how it got there, and where it's going in the years ahead.

### BUYER'S GUIDE

**84** First look at the '88s, featuring 25 models from 13 manufacturers including an upscale Suzuki for Chevy dealers, a CJ-5 clone from India, and an Italian luxu cruiser.

### OFF-BEAT OFF-ROADERS

**90** Okay trivia fans, here's how to tell a Pinzgauer from an Afri-car. Would you believe 4x4s from Mercedes-Benz and Lamborghini? Or a 6x6 Range Rover? They're all here.

### FIRSTHAND DRIVE REPORT: RANGE ROVER

**94** Our Outdoors Editor samples the Rolls Royce of utility vehicles on the factory's torturous course in England—the world's only off-road driving school.

Range Rover photography by John Mason; Blazer XT-1 studio photography by Bill Ashe; XT-1 steering demonstration photos by Mike Allen; 1988 Chevy Tracker, GMC S-15 Jimmy and Rayton-Fissore Magnum photos by Jim Dunne; Bronco II photo (this page) from Studio 10.



## STIX-ALL GLUES ALMOST EVERYTHING. EXCEPT YOUR FINGERS.

Elmer's® Stix-All glues it all. With a bond that stands up to heat, cold, rain, impact and vibration. That's something no super glue can do. So use Stix-All for saving just about anything that breaks or tears. And save your skin at the same time.



© Borden Inc 1986



'88 SPORT  
UTILITY



# 4x4s MOVE UPTOWN

Utes move upscale and upmarket from their humble beginnings.

BY WADE A. HOYT, Automotive Editor



Back in the Dark Ages of trucking, they were simply called utility vehicles because that's just what they were—roofed-over pickup trucks used by utility companies, construction firms and the like. Then some sports started to use these "utes" on the weekend, just for fun.

These recreational users wanted a bit more than a stripped tin box: a better radio, maybe, air conditioning, or more comfortable seats.

And pretty soon, companies were marketing sport/utility vehicles with more options than a Coupe deVille. Right now, 11 firms offer 20 different models, with at least another eight about to be unleashed.

What sparked the market was the introduction of the compact Blazer and Bronco in the early '80s. They were a runaway success, followed by similar models from Japan. Last year, came mini utes—like the Suzuki Samurai—opening up a whole new market niche.

Total ute sales are expected to reach more than a million a year by 1991. Why? Listen to Chrysler president Hal





Computer power to work the animated 3-D CRT instrument panel (center) and complex drive system is housed under two lockers in the cargo bay (above), but will eventually be miniaturized to fit underhood. The CRT not only tells you what's wrong with the truck, but shows you how to fix it!



Experimental Blazer XT-1 falls midway in size between the S-10 and full-size utes. Steer-by-wire system employs electric motors at each wheel that can actuate two different programs: lane-change "crabbing" (left) or front/rear countersteer (right) for maneuverability.

Sperlich rhapsodize about the Jeep: "It's awesome. I mean, Jeep won the war. It's Ike. It's America. It's all about personal freedom and fun." Chrysler sees the ute and minivan blurring the distinction between cars and trucks. As utes get more civilized and car-like without losing their practicality, they will appeal to more car owners.

What will the ute of 1991 be like? Pos-

sibly very much like Chevrolet's Blazer XT-1, which features 4-wheel steering, ABS brakes, traction control and 3-dimensional CRT instruments. The driver can set the suspension height and handling to suit the terrain. He can also choose the 4-wheel-steering program: All four wheels turning in the same direction for effortless lane changes, or front-rear countersteering for phenom-

enal maneuverability. The 202-hp 4.3-liter V6 is adapted from the Astro minivan. A computer-controlled transfer case shifts into 4wd when sensors detect any wheel slippage. While the XT-1 is in 4wd, the computer can shift torque fore or aft by up to 30 percent whenever slip is detected. The 3-D dash has all the usual information, plus service and repair data with animated illustrations. **PM**



# BUYER'S GUIDE

By the end of 1988, you'll have 25 or more 4x4s to choose from. Here's an advance look at them.

BY JIM DUNNE, Detroit Editor



Today, sport/utility buyers can choose from models that range in image and price from the tiny \$6895 Suzuki Samurai to the luxurious \$30,000-plus Range Rover. In between are 18 other makes—if you count GMC and Chevy separately—that include such well-known names as Jeep, Blazer and Bronco, along with relative newcomers from Japan like 4Runner and Pathfinder. More are on the way, according to insider reports. Chances are you will soon see a Daihatsu Rocky, Chevrolet Tracker, Mazda and Yugo utes, military Jeep-clones made in India, Spain and Portugal, plus a luxury 4x4 from Italy.

Sales are on a strong upturn. In 1980, about 200,000 sport/utility vehicles were sold in the U.S. That figure skyrocketed to almost 900,000 in 1986, and is expected to jump to over 1 million within the next four years.

In many home driveways, utility vehicles are taking the place of the traditional station wagon. Utes offer similar cargo capacity, look great at the country club

and can easily pull a trailer. The rise in popularity of utility vehicles almost matches the fall in sales of full-size, rear-drive station wagons.

Trailer towers know the value of utility vehicles. Because they have chassis and powertrain systems that are based on commercial trucks, the muscle is there to pull some of the biggest recreational trailers. Big V8s and diesel engines furnish the most power. Ford has a 351-cu.-in. V8 as its top Bronco engine, while GMC and Chevy offer up to 454 cu. in., depending on the model. Even the small utes can tow trailers.

Think you might like to buy a 4x4? Surveys of shoppers, as quoted by Nissan, show that the typical buyer of a compact utility vehicle uses the vehicle primarily for commuting to work, and wants attractive exterior styling to go along with lots of room inside.

Take the base prices listed on page 89 with a grain of salt. The numbers look attractive, but they can be deceiving. Many lower-priced models rise dramatically in cost when you add up the options that you'll want.



## CHEVROLET BLAZER

Full-size Blazers use full-size engines, both of them V8s. The base engine has 5-liters displacement (305 cu. in.). Horsepower on this smaller engine is up to 170 from 160 last year, thanks to the replacement of the carburetor with a throttle-body fuel injector. Optional engine is GM's 6.2-liter diesel V8, which is a *real* die-

sel, not a converted gasoline engine. It produces 148 hp and bags of torque.

Cousin to the GMC Jimmy you will note that the Blazer cab and front end have not yet changed in appearance, even though the Chevy full-size pickup has been redesigned. Blazer's turn for restyling comes in 1989.



## CHEVROLET S-10 BLAZER

Chevy boasts that the S-10 Blazer is the "top selling sport/utility vehicle in America." An improved 98-hp 2.5-liter 4-cylinder engine, with power up 7 percent from last year, is the base powerplant, while the 120-hp 2.8-liter V6 is the option. Both engines now use a single serpentine belt to run accessories. Two

transmissions are offered on the 4-wheel-drive models—a 4-speed manual and a 4-speed automatic with overdrive. The 2-wheel-drive S-10 has a 3-speed automatic as another option. Except for a slightly lower price, the S-10 Blazer is identical to the S-15 GMC Jimmy. A front-end restyle is in the works.





### CHEVROLET SUBURBAN

If you are looking for the true do-everything vehicle, the Chevy Suburban—and its cousin from GMC—may fill your bill. Throttle-body fuel injection on all the gasoline engines, the 5-, 5.7-, and 7.4-liter V8s, plus other improvements in the intake and exhaust system, have raised horsepower by 5 to 17 percent. The TBI

systems also make cold starts easier, quicker and smooth out driveability.

The optional 6.2-liter V8 truck diesel may be the best answer to serious, long-distance drivers who want to save money on fuel. On the road, the ride of this 4x4 is about as smooth as that of some of the biggest passenger sedans.



### CHEVROLET TRACKER 4x4

You'll have to wait a year or so before this model hits the showrooms. Suzuki will build the Tracker in Canada starting early next year. Both Suzuki and Chevrolet will offer the car for sale in the U.S.

Though details of the chassis and engine are closely held secrets at the two companies, it is known

that Tracker is bigger than the Samurai, has a more powerful engine and has a car-like appearance inside. Its price will be a level higher too, probably in the \$8500 range. Like most Japanese products built in North America, Tracker will have a Japanese-built engine, transmission and 4-wheel-drive system.



### DODGE RAIDER

One of the smaller compacts in the sport/utility field, the Raider is still not as small as the mini-class Suzuki Samurai. Made by Mitsubishi, the Raider is a clone of that company's Montero in most respects.

Small does not mean spartan, however. The Raider uses an oversized 109-hp 2.6-liter 4-cylinder

engine that drives through either a 5-speed manual or 4-speed automatic overdrive transmission.

Standard features include automatic locking hubs, power steering, adjustable steering column and 15-in. tires. And an inclinometer tells you how far you are tilting side to side or front to rear.



### DODGE RAMCHARGER

Unique among full-size utilities, Ramchargers come in both 2- and 4-wheel drive. The 2-wheel drive is designed for traditional station wagon buyers or for trailer towers who need a husky chassis and powerful engine. The 4-wheel drive offers off-road capability.

Standard engine is a 145-hp 5.2-liter V8, while the

power option is a 5.9-liter V8. The 4x4 models can be shifted in and out of 4-wheel drive at speeds up to 55 mph when the driver pulls a lever on the instrument panel. Big, sturdy and reasonably priced, the Ramcharger is built at Chrysler plants in Warren, Michigan, and Lago Alberto, Mexico.

### FORD BRONCO

Ford's full-size heavy-weight hauler has a new face for 1987, but still keeps its look of strength and power. Flush-mounted headlights outside and a new instrument panel inside are the major changes from last year. Three engines are available—a 4.9-liter inline Six, a 5-liter V8 and a 5.8-liter V8.

Insiders say the 4.9-liter Six, which runs as smoothly as a V8, is better in delivering low-speed torque, while the V8 runs with more authority at high speeds. Fuel injection will be standard on all engines in 1988, and ABS rear brakes optional. Transmission choices are a manual 4-speed, and automatic 3- or 4-speed.







## FORD BRONCO II

Ford's compact has the same type of Twin-I-Beam front suspension as its big brother Bronco. That's one reason the Bronco II appears to have a taller body. It's suspension needs more vertical room to flex. So the engine is set higher off ground level. From that, all other parts of the vehicle rise, along with the center

of gravity. Ford offers the smaller Bronco with 2- or 4-wheel drive. A 140-hp 2.9-liter V6 is the only engine, but you can order either a 5-speed manual or 4-speed automatic overdrive transmission. All the car-like power options that give compact utes their wide appeal are available on the Bronco II.



## GMC JIMMY

The full-size cousin to Chevy's Blazer has identical equipment to the Blazer, but the price for the Jimmy is about \$50 more, as is GM's custom in selling these two utility trucks. For your extra money, GMC dealers offer "Commitment Plus," a delivery service that gives the buyer extras like a full tank of gas,

a free 3000-mile checkup, one oil and filter change, and other perks.

GMC's "Commitment Plus" plan is in effect with the S-15 Jimmy and the GMC Suburban as well.

Like the other full-size utes, the Jimmy is very tall and wide. Make sure you're comfortable with a test drive before you buy it.



## GMC S-15 JIMMY

A modest facelift is in store for this GMC version of the Chevrolet S-10 Blazer.

Individual headlights give way to aero-shaped, flush lenses and the grille will have a slightly different appearance. Virtually all dimensions and equipment will be carryover, including the choice of 2-wheel or 4-wheel drive. The

long-promised 4-door model is still on the horizon. There will be changes in the power lineup of both the S-10 and S-15 in '88.

Look for the premium 2.8-liter V6 engine to get more horsepower, so GM will be able to match the performance of Jeep's powerful 173-hp 6-cylinder Cherokee and Wagoneer.



## GMC SUBURBAN

You're talking big when you talk Suburban, an exclusive of GMC and Chevy that is big enough to pull just about any travel trailer. Husky 5-, 5.7-, and 7.4-liter gasoline engines and a 6.2-liter truck diesel furnish the muscle. Both smaller engines have a fuel injection system this year, a feature that aids starting

in any temperature, and controls idle speed after cold startups. You can order the Suburban in either 2- or 4-wheel-drive versions and equipped with just about any comfort or convenience option of a passenger car. It can haul a gross weight of 16,000 pounds including vehicle, passengers, cargo and trailer.

PHOTO BY JIM DUNNE

## ISUZU TROOPER II

Rugged looks are the theme for most sport/utility models, and that was one reason Isuzu put wider axles and a simpler grille on the Trooper II model for 1987. Big 15-in. wheels and tires add to the ground clearance, and contribute to the huskier overall appearance. You can order the Trooper II in either 2-

or 4-door body styles this year in both the Deluxe and higher priced LS versions. The Japanese built utility/wagon uses either a 96-hp 2.3-liter overhead-cam 4-cylinder gasoline engine or 2.2-liter turbo diesel. They are matched up to a 5-speed manual transmission. For a compact, there's lots of interior room.







## JEEP CHEROKEE/WAGONEER

The keys to the success of Cherokee/Wagoneer include an attractive appearance, good power, both 2- and 4-door body styles, and the reputation of Jeep ruggedness. The base engine is AMC's own 121-hp 2.5-liter fuel-injected Four. The optional 4.2-liter inline Six is the most powerful in the compact class. It develops

173 hp, and makes the Cherokee/Wagoneer one of the best small rigs when it comes to hauling trailers. It is rated to pull up to 5000 pounds. Cherokee/Wagoneer is available in both 2- and 4-wheel drive. Buyers have the choice of 4- and 5-speed manual transmission, and a new 4-speed overdrive automatic.



## JEEP GRAND WAGONEER

AMC's biggest sport/utility truck is the company's best model for pulling big trailers, or for providing room inside. Compared to the Cherokee/Wagoneer line, the Grand Wagoneer is 20 in. longer, rides on a 7-in.-longer wheelbase, and uses a 144-hp 5.9-liter V8 with bags of torque and a 3-speed automatic.

Fully equipped models are the standard, and that is reflected in the price, a hefty \$23,000-plus. Included are leather seats, power steering and air conditioning plus a new self-sealing Michelin tire. The body design has remained unchanged for almost a decade, and there are no plans to change it.



## JEEP WRANGLER

The Wrangler is the successor to the Jeep CJ-7 and direct descendant of the WWII military vehicle. Passenger comfort is emphasized in the Wrangler because surveys of buyers of the CJ-7 showed that more buyers used them for personal transportation. The base Wrangler has a fabric top but the top-of-

the-line Laredo is available only with a fiberglass hard-top roof and roll-up windows. Engines are both AMC designs—a 2.5-liter Four as the base engine, and a 4.2-liter Six as the performance option.

Although the Six makes 5 hp less than the Four, it produces a hefty 75 lb.-ft. more torque.



## MITSUBISHI MONTERO

Montero is the vehicle that the Dodge Raider is based on. All significant features are identical, including dimensions, engines and transmissions. A 109-hp 2.6-liter inline 4-cylinder engine is the only powerplant offering. You can hook that up to a 5-speed manual or 4-speed automatic overdrive transmission.

Two models are available, the base Montero and the Sport. Both use 15-in. tires and wheels. The move to oversize wheels on this subcompact is part of a trend toward both a more muscular appearance and a higher ground clearance for the chassis. The 1/2-in. extra ground clearance does make a difference.

## NISSAN PATHFINDER

A recent entry into the sport/utility field, the Pathfinder is loaded with technical features that competitors may have sometime in the future. They include a more powerful optional 3-liter V6 engine rated at 140 hp, vent windows for rear-seat passengers, 2-way opening tailgate, and coil spring rear suspension.

Base engine is a 106-hp 2.4-liter Four. Two transmissions are offered—a 5-speed manual and a 3-speed automatic. Fuel economy ranges between 15 and 19 mpg in city and highway driving. Pathfinder's modern good looks aren't reminiscent of paramilitary hardware, but still have an air of athletic competence.







## RANGE ROVER

Drive this British-built import in rough country for a few miles and you will quickly agree that the Range Rover is the luxury off-roader. Lockable differential lets all wheels pull in concert. The high price of the Range Rover makes it an "ideal second car for owners of luxury marques like Mercedes, Porsche and

BMW," according to Charles Hughes, president of Range Rover of North America.

Typical buyer of the vehicle earns \$100,000 a year or more, according to RRNA surveys, and owners of the 150-hp 3.5-liter aluminum V8-powered 4x4 use it more like a station wagon than an off-road scrambler.



## RAYTON-FISSORE MAGNUM

This luxury 4-wheel-drive vehicle will compete with Range Rover and the plushest Suburbans in the \$30,000 price class. The 4-door vehicles will be partially assembled in Italy, then shipped to the U.S. for installation of Ford 5.0-liter V8 engines, transmissions, transfer cases and emissions equipment. The only

transmission will be a Ford 4-speed automatic. The transfer case is a shift-on-the-fly Chrysler New Process type.

A big vehicle, the Rayton-Fissore weighs over 5000 pounds and comes fully equipped with air conditioning, leather seats, power locks and a trailer towing package.



## SUZUKI SAMURAI

The Samurai is the first of the smaller 4-wheelers of the future. Its tidy dimensions, good fuel economy and low price of \$6995 make it the model that other manufacturers will try to imitate.

Hardtop or softtop versions are available. The softtop turns the vehicle into an open air convert-

ible, a feature that makes the Samurai especially appealing to younger buyers. The 64-hp 1.3-liter engine seems small compared with the monster V8s that you get on full-size 4x4s. But the Samurai's 2100-pound curb weight gives it a favorable power-to-weight ratio that rivals most other utility vehicles in its class.



## TOYOTA 4RUNNER

The 4Runner is basically a simple adaptation of Toyota's top selling pickup truck, with its manual locking front hubs. Drive this Toyota with the top on or off, since the rear portion of the roof and windows can be removed for open-air riding. With the top off, you don't get a true pickup truck. The cab remains

open at the back and rear seats are exposed. But you can carry passengers in the rear with convertible-like openness. A 116-hp 2.4-liter 4-cylinder inline engine with 5-speed manual transmission is standard.

Options include a 135-hp turbo engine and a 4-speed automatic overdrive transmission.

## TOYOTA LAND CRUISER WAGON

Call this a station wagon if you want, but the Land Cruiser has all the features of a sport/utility vehicle, including 4-wheel drive and rear passenger quarters that convert into a spacious load-carrying enclosure. Land Cruisers have been steady sellers for 15 years. Fairly dated in its mechanical details, the Land Cruis-

er is offered only with manual 4-speed transmission. Its engine is a 4.2-liter In-line Six with the nostalgia of a manual choke. Suspension consists of leaf springs on rigid axles front and rear. Sturdy and simple, the Land Cruiser is a favorite of rugged individualists in the Rockies and Pacific Northwest.







### UNIVERSAL INDIAN

Universal Motors of North America is the rather grand name of a small company in New York City that plans to import several 4x4s over the next few years. The Indian was originally developed for Portuguese military use and is now helping several NATO armies over the rough stuff. Redesigned for the civilian mar-

ket in 1984, the U.S. version will feature a fuel-injected V6 engine, a 5-speed manual transmission, disc/drum brakes, limited-slip differential and gas shock absorbers. Options will include power steering, automatic transmission and air conditioning. Expect \$14,000 to \$17,000 prices in '88.



### UNIVERSAL LIGERO

This paramilitary delight is made in Spain for various military applications in more than 27 model configurations with long or short wheelbases. The model selected for the U.S. market will have a 2.3-liter U.S.-built 4-cylinder engine (probably a Ford) so parts and service should be easy to come by. The Ligero has

an all-aluminum body and a 5-speed manual transmission. A 2.4-liter gasoline Four and a 3.4-liter diesel Six, available in Spain, will probably not be imported. Universal hopes to sell the Ligero in the United States next year in the \$12,000 to \$15,000 range, which should make it popular if it's as rugged as it looks.

### UNIVERSAL MAHINDRA

And you thought the CJ5 was dead? It's been reincarnated in India by a major manufacturing conglomerate that's been building Jeeps under license since 1954. Now being sold in 15 countries, the Mahindra is powered by the popular 2.6-liter Mitsubishi Four, found in thousands of Chrysler products. Auto-

matic or 5-speed manual transmissions are available. Brakes are disc front, drum rear, with leaf springs all around. Tires are hefty 235/75R15s on 6½-in. rims. Wheelbase is 95.5 in.

Universal Motors plans to introduce this Jeep clone to Canada and the U.S. in 1988 for \$8000 to \$9000. **PM**



## Sport/Utility Prices

<b>Chevy Blazer</b> 2-Wheel Drive NA 4-Wheel Drive \$13,066	<b>Ford Bronco</b> 2-Wheel Drive NA 4-Wheel Drive \$14,686	<b>Jeep Wrangler</b> 2-Wheel Drive NA 4-Wheel Drive \$10,295	<b>Suzuki Samurai</b> 2-Wheel Drive NA 4-Wheel Drive \$6895
<b>Chevy S-10 Blazer</b> 2-Wheel Drive \$10,124 4-Wheel Drive 11,586	<b>Ford Bronco II</b> 2-Wheel Drive \$12,512 4-Wheel Drive 13,203	<b>Jeep Cherokee</b> 2-Wheel Drive \$10,741 4-Wheel Drive 12,053	<b>Toyota Land Cruiser</b> 2-Wheel Drive NA 4-Wheel Drive \$17,198
<b>Chevy Suburban</b> 2-Wheel Drive \$12,435 4-Wheel Drive 13,512	<b>GMC Jimmy</b> 2-Wheel Drive NA 4-Wheel Drive \$13,117	<b>Jeep Grand Wagoneer</b> 2-Wheel Drive NA 4-Wheel Drive \$23,906	<b>Toyota 4Runner</b> 2-Wheel Drive NA 4-Wheel Drive \$12,998
<b>Chevy Tracker 4x4</b> 2-Wheel Drive NA 4-Wheel Drive \$8500*	<b>GMC S-15 Jimmy</b> 2-Wheel Drive \$10,171 4-Wheel Drive 11,635	<b>Mitsubishi Montero</b> 2-Wheel Drive NA 4-Wheel Drive \$9889	<b>Universal Indian</b> 2-Wheel Drive NA 4-Wheel Drive \$14,000*
<b>Dodge Raider</b> 2-Wheel Drive NA 4-Wheel Drive \$10,317	<b>GMC Suburban</b> 2-Wheel Drive \$12,487 4-Wheel Drive 13,564	<b>Nissan Pathfinder</b> 2-Wheel Drive \$6599 4-Wheel Drive 9549	<b>Universal Ligero</b> 2-Wheel Drive NA 4-Wheel Drive \$12,000*
<b>Dodge Ramcharger</b> 2-Wheel Drive \$12,820 4-Wheel Drive 13,866	<b>Isuzu Trooper II</b> 2-Wheel Drive NA 4-Wheel Drive \$10,809	<b>Range Rover</b> 2-Wheel Drive NA 4-Wheel Drive \$30,900	<b>Universal Mahindra</b> 2-Wheel Drive NA 4-Wheel Drive \$8000*
		<b>Rayton-Fissore Magnum</b> 2-Wheel Drive NA 4-Wheel Drive \$30,000*	

\*Estimate; NA=Not Available



**88 SPORT  
UTILITY**

# OFF-BEAT OFF-ROADERS

May we show you something in a Lamborghini or Mercedes 4x4, or would his lordship prefer the plywood 6x6?

BY WADE A. HOYT  
Automotive Editor



ou say you're bored with the same old Chevys, Dodges and Fords? If you see another Jeep you'll urp? And all the Japanese utes look alike? If you're in the market for something completely different, look to Europe. The home of the exotic sports car breeds some pretty outrageous 4x4s.

Leading the outrage list is the Monster G by Swiss wild man Franco Sbarro, who builds some of the most outlandish vehicles on the European auto show circuit and makes his living by selling road-going duplicates.

For only \$65,000 down and \$65,000 on delivery, Franco will be happy to knock off a Monster that makes even Big Foot look mild. Powered by a modified Mercedes-Benz V8 of 6.3 or 6.9 liters, the 2-seat 4x4 measures 15 ft. long, 6½ ft. wide and over 7½ ft. high. With more than 350 hp to move its 3300 pounds, this Monster can really fly.

The special Goodyear tires and wheels are patterned after those on the Boeing 747. If the Monster G bogs down, an electrically operated crutch can be extended to lift the front, rear or all four wheels clear, giving the striking vehicle an extra dimension of mobility in rough terrain. If even the crutch fails, the Monster packs a small motor scooter in the rear, where most utes stow the spare tire.

## Arabian Delight

If you'd prefer something slightly closer to the mainstream, consider the Lamborghini LM002, a desert fox designed



Pinzgauer (top) looks like the box the other utes came in. This civilian version of a military vehicle has exceptional off-road performance. It's named after a strong, good-natured breed of Austrian work horse. Plywood-bodied Africar in 4x4 and 6x6 configurations (center) completed an Arctic-to-Equator test run in 1984. Truly exotic off-roader is the Lamborghini LM002 (left), powered by a 450-hp V12. It will do 120 mph in the desert.





# Get in on the PROFITS in SMALL ENGINE service and repair Start your own money



## BEAT INFLATION!

Cash in on the huge demand for small engine repair.

Work part time, full time right at home - we help you every step of the way.

## making business!

In just a short time, you can be ready to join one of the fastest growing industries in America... an industry where qualified men are making from \$25.00 to \$30.00 per hour... and that's just for labor. Parts, engines and accessories add even more to the profits.



Because the small engine industry has grown so quickly, an acute shortage of qualified Small Engine Professionals exists throughout the country. In fact, it's not unusual for a good small engine man to be three to four weeks behind in the summer and at least a week behind in the winter. When you see how many small engines are in use today, it's easy to understand why qualified men command such high prices — as much as \$49.95 for a simple tune-up that takes less than an hour!

## 65-million small engines are in service today!

That's right — there are over sixty-five million 2-cycle and 4-cycle small engines in service across the U.S.A. That's the official count from the Engine Service Assn., and new engines are being built at a rate of one-million per month! With fully accredited and approved Foley-Belsaw training, you can soon have the skill and knowledge to make top money servicing these engines. Home-owners and businessmen will seek you out and pay you well to service and repair their lawnmowers, tillers, edgers, power rakes, garden tractors, chain saws, mini-bikes, go-carts, snowmobiles, generators, snowblowers, paint sprayers... the list is almost endless.

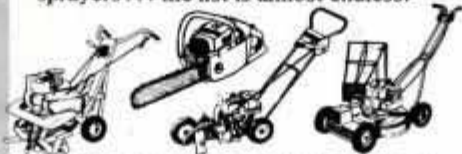

## No experience necessary.

You don't need to be a 'born mechanic' or have prior experience. If you can read, you can master this profitable trade right at home, in your sparetime, without missing a single paycheck. Lessons are fully illustrated — so clear you can't go wrong.

## You receive trade secrets and business plans.

We guide you every step of the way, including tested and proven instructions on how to get business, what to charge, how to get free advertising, where to get supplies wholesale... all the "tricks of the trade"... all the inside facts you need to assure success right from the start.

### Increased Income

"I've had about 8 years experience repairing small engines... but repairs were only minor... until I started the Foley-Belsaw Course."



Walter H. Strick Campbell, California

With our famous 'learn-by-doing' training method, you get practical 'hands-on' experience with specialized tools and equipment that you'll receive with your training plus a brand-new 4 HP engine — all yours to keep!

## SEND FOR FREE FACTS!

You risk nothing by accepting this offer to find out how Foley-Belsaw training can give you the skills you need to increase your income in a high-profit, recession-proof business of your own.

Just fill in and mail coupon below (or send postcard) to receive full information and details by return mail. **DO IT TODAY!**

You get all this Professional equipment with your course, PLUS 4 H.P. Engine... ALL YOURS TO KEEP... All at NO EXTRA COST.

Send TODAY for this fact-filled FREE BOOKLET!



### FOLEY-BELSAW INSTITUTE

6301 Equitable Rd., Dept. 51246  
Kansas City, Mo. 64120

There is NO OBLIGATION and NO SALESMAN Will Call—ever!

### FOLEY-BELSAW INSTITUTE

6301 Equitable Rd., Dept. 51246  
Kansas City, Mo. 64120



YES, please send me the FREE booklet that gives full details about starting my own business in Small Engine Repair. I understand there is no obligation and that no salesman will call.

Name \_\_\_\_\_

Address \_\_\_\_\_

City \_\_\_\_\_

State \_\_\_\_\_ Zip \_\_\_\_\_



Tells how you quickly train to be your own boss in a profitable Sparetime or Fulltime business of your own PLUS complete details on our 30-Day NO RISK Trial Offer!





with the oil-rich Arab nations in mind, who are Europe's best customers for exotic vehicles of all kinds.

Like the space-age Countach supercar, the 002 is powered by a 450-hp V12—enough to get it across the sand dunes despite its sturdy 5940-pound weight. Zero-to-60 mph takes only 8.5 seconds with a top speed of 120 mph.

Power is routed through a ZF 5-speed manual transmission and a dual-range transfer case with variable front/rear torque split to special Pirelli 325/65-VR17 low-pressure, high-speed desert/highway tires. The unusual aluminum and fiberglass bodywork includes an open back porch, complete with railing, presumably for falconry.

Now that Chrysler owns Lamborghini, we might get to see a 002 now and again. But at \$135,000 a pop, don't look for them in the K-Mart lot.

## Splinter Group

At the other end of the performance and price spectrum is the Africar, a wooden 4x4 (or 6x6, or 8x8) designed for cheap and easy assembly in Third World nations. The body is made of plywood covered with epoxy resin that is easy to make and to repair.

The engine is an unusual air-cooled, twin-crankshaft, opposed-piston 2-stroke with two or three cylinders (which means four to six pistons) that can run on gasoline or diesel fuel. Front and rear suspensions are coupled hydraulically, like early Citroëns, for a better ride on rough ground.

More than 50 variations of 4-, 6- and 8-wheel cars, buses, trucks and ambulances are proposed. All of them can ford water 30 in. deep, climb a 100-per-

cent grade, and have short overhangs for a 52° angle of attack and departure.

## Austrian Workhorse

The Pinzgauer doesn't look like much—its styling resembles a corrugated aluminum brick. But it's one of the most highly regarded 4x4s among off-road aficionados. Built in Austria by Steyr-Daimler-Puch, the Pinzgauer is the civilian version of the all-terrain vehicle used by the Swiss Army.

Reduction gears at each wheel raise the axles for 12 in. of ground clearance. Its 6-cylinder turbo diesel engine and



Not officially imported in the U.S., Mercedes G-Wagon is a familiar sight elsewhere in the world.

lockable differentials can pull it up any slope where the tires retain traction. A 6x6 version will climb a 45° slope with a payload of 4400 pounds. A sophisticated load-leveling system keeps the center of gravity low at all times.

Plans to sell the Pinzgauer in the U.S. for \$50,000—equipped like a luxury car—were scuttled over a year ago when the dollar started its nosedive. We can only hope the greenback gets well soon.

## Long Rovers

A stretch limo may suit Ronald Reagan, but Indonesia's president and Saudi Arabia's king prefer stretch Range Rovers. Even the famous Popemobile is a customized Range Rover.

A number of Britain's custom coachwork houses specialize in 6-wheeled Rovers for royalty in faraway places. The Glenfrome conversion in our photo has a 10-in. center stretch and a 36-in. rear extension to house the extra axle. It's available with 6x4 or 6x6-wheel drive, extra seats and a host of luxury interior appointments.

## At Home In The Alps

If Range Rover is the Rolls Royce of utility vehicles, the G-wagon is clearly the Mercedes, because it's sold by Mercedes-Benz dealers throughout the world. It has a bulletproof reputation and is sold in long- and short-wheelbase versions as a wagon, van or convertible pickup with two to nine seats.

Four-, 5- and 6-cylinder diesel and gasoline engines with 72 to 150 hp haul payloads ranging up to 1850 pounds, putting it more into the Cherokee class than the Pinzgauer's. Shift-on-the-fly 4wd, a dual-range transfer case and locking differentials front and rear keep the G-wagon going as long as one wheel has traction. And it's got one thing no other ute can boast—that 3-pointed star on the grille.

Where can you get one of these beauties? You can order Sbarro's specials through Unicorn Automobiles of North America, 4400 MacArthur Blvd., Newport Beach, CA 92660. Lamborghini's importer is Chrysler Italian Imports, Inc., 501 Tonnelle Ave., N. Bergen, NJ 07047.

FM



You, too, could be at home in a Range Rover that's been stretched nearly 4 ft. Extra axle at the rear supports added weight of luxury appointments that are literally fit for a king.

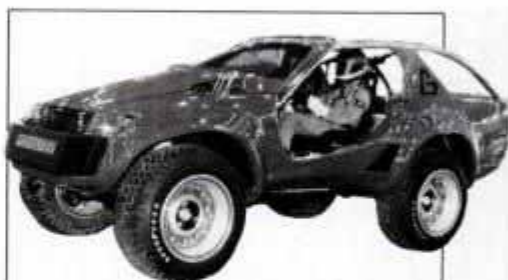

Sbarro's Monster, perfect for off-road warriors, packs a small 2-wheeler.



# FALL ROUND SALE - UP



**Northern  
Hydraulics  
INC.**

Call Toll Free  
**1-800-533-5545**  
24 Hours a day,  
7 days a week!

**Save 20-50%**  
off list prices on name brands!



Sale Ends  
Sept. 30, 87  
For Your Free Catalog,  
Send in the Coupon Below!



**22" Working Height**

**16 Ton Log Splitter**  
24" stroke, 5 HP, detent valve, 4" x 24" cylinder. A \$1,300.00 Value. Item #1134

**Sale.....\$699.95**



**20 Ton Vertical/Horizontal Log Splitter**  
24" stroke, splits wood in vertical and horizontal position. 6x6 H-beam, 5 HP, 4 x 24 Cylinder. Detent valve. \$1,400.00 Value.

**Sale.....\$799.95**



**SAVE**

**Deluxe Garden Cart**  
Carries lawn and garden tools, clippings, branches and more. Includes a **FREE** swingout Dumpster Door. **Big 20" wheels.** Size 48"x27"x24"H. Item #14512 List \$198.95

**Sale.....\$64.95**



**Two Stage Hydraulic Pumps**

11 GPM.....	<b>Sale \$79.95</b>
13.6 GPM.....	<b>Sale \$109.95</b>
16 GPM.....	<b>Sale \$115.95</b>

**Hydraulic Cylinders**

3 1/2"x24"x1 1/2".....	<b>Sale \$92.95</b>
4"x24"x1 3/4".....	<b>Sale \$109.95</b>
5" x 30" x 2".....	<b>Sale \$209.95</b>

**Detent Valve**  
Automatic return. Adjustable from 600 to 25000 PSI.

**Sale.....\$48.50**

**THOUSANDS IN STOCK**

**SAVE!!! GAS ENGINES!**  
Wide variety of horizontal and vertical gas engines, 3 to 23HP. Famous brands like Tecumseh, Briggs, Honda, Wisconsin Robin and Kohler.

5 HP.....	<b>\$129.95</b>
8 HP.....	<b>\$187.95</b>
10HP.....	<b>\$219.95</b>

**5000 Watts (Surge)**

**4000 Watt Continuous Rated Generators**  
Ideal for homeowners, farmers, contractors and vacationers. **8-HP Tecumseh engine has cast iron sleeve for long life durability!** Item #16425

**Sale.....\$379.95**

**Electric Start Model**  
Item # 16426.....**\$459.95**



**Barrel Stove Kit**  
100% cast iron kit converts any 30 or 55 gal. drum into an efficient wood burning heater. List \$49.95

**Sale.....\$18.95**

**Double Barrel Adaptor Kit**  
Adapts above barrel stove kit into a double barrel heater, creating greater heating efficiency. List \$22.95

**Sale.....\$11.95**

**Our Tarps Are Tougher!**  
Our hefty (approx.) 12 mil. woven poly tarps with rustproof grommets.

Item#	Cut Size	Sale Price
1770	6' x 8'	\$2.42
1771	8' x 10'	\$4.46
1772	10' x 12'	\$5.35
1773	12' x 16'	\$8.95
1774	12' x 20'	\$11.65
1775	16' x 20'	\$17.95
1776	20' x 30'	\$35.95
1777	30' x 40'	\$62.95
1778	30' x 50'	\$80.95
1779	30' x 60'	\$89.95



**100 Amp Mig Welder**  
Includes welding gun, CO2 tank, linear gas regulator, 6' ground lead with clamp, spare tips for gun, 2 lb. spool of wire and mask. List \$699.95 Item #155442

**Sale.....\$299.95**



**McCulloch Pro-Mac 605**  
Features a big 3.4 cu. in. engine. 16" laminated sprocket tip, bar and chain. Item #19090

**Sale...\$239.95**  
**Less Mfr. Mail In Rebate...\$50.00**  
**Your Final Cost \$189.95**

**Oregon Semi Chisel Loop**  
This standard chain is available in 3/8" pitch, with .050 and .058 gauge.

**Sale.....\$8.55**



**Workbench Legs and Tool Organizer**  
Make your own workbench, worktable, hobby bench or laundry table with these long lasting steel legs. **FREE** tool Organizer. Item #15038

**Sale.....\$11.95**

**Milwaukee** **DELTA**

**"We Carry A Full Line At The Lowest Prices"**

**NH Northern Hydraulics INC.** Dept. #69405

Call Toll Free  
**1-800-533-5545**  
24 hours a day, 7 days a week!

Send for a **FREE** 128 page catalog!  
NORTHERN HYDRAULICS, INC.  
Dept. #69405  
P.O. Box 1499  
Burnsville, MN 55337-0499

Name \_\_\_\_\_  
Address \_\_\_\_\_  
City \_\_\_\_\_  
State \_\_\_\_\_ Zip \_\_\_\_\_



# '88 SPORT UTILITY

## DRIVE REPORT: RANGE ROVER

# IT'S NOT A 4x4.

# *It's a 4x4.*

We tame the boondocks in the Rolls Royce  
of sport/utility vehicles.

BY JOE SKORUPA, Outdoors Editor; PM photos by John Mason



Few off-road adventures begin like this. An old English castle in the Malvern Hills. Ivy-covered walls. Manicured lawns. And a Range Rover 4x4. Sitting in the castle courtyard, the Range Rover, with its subdued styling and plush interior, looked more like the refined vehicle of an English country gentleman than a jungle-taming 4x4. But appearances can be deceiving.

A few moments after climbing into the graceful vehicle, Roger Craithorn, demonstrations and presentations manager of Land Rover, Ltd., and I were crashing through dense underbrush, plunging into water up to our door handles, and bouncing over jagged rocks and bumpy logs.

In a period of three days, Craithorn, who's driven Range Rovers through some of the planet's most vicious terrain, guided me through an off-road testing course that pushed our gutsy 4x4 to its limits. With the gas pedal floored, we blasted through belt-high water, climbed 45° slopes, and clawed through hip-deep mud using the sidewalls of the tires for extra traction.

We drove hundreds of miles in the Range Rover, over roads as smooth as the M1 Motorway and as harsh as the advanced testing course at Eastnor Castle. Throughout the trip, I was constantly amazed that the same vehicle that transported us in such comfort to

hotels and pubs could so easily tame the brutal outback. The Range Rover proved itself to be, one might say, an off-roader *and* a gentleman.

The heart of this luxury sport/utility vehicle is a torquey 3.5-liter, fuel-injected, aluminum-alloy V8 that delivers 150 hp. It is capable of cruising at 100 mph on the highway and effortlessly towing a 4-ton load at more than 70 mph.

Its dual-rate, coil-spring suspension (with Boge-Hydromat self-leveling rear unit) was stable and sure-footed, performing all manner of off-road gymnastics. And its 4-speed ZF automatic transmission, wedded to a center differential that can be locked to send equal power to the front and rear axles, proved itself to be a powerhouse, in both high and low range.

Matching the strength of the engine and transmission are a tough, boxed steel frame and chassis, rust-free aluminum body panels, permanently engaged 4-wheel-drive system and strong disc brakes. Add to this, cruise control, air conditioning, a Clarion sound system and power accessories (seats, windows, steering, brakes, mirrors, door locks, rear defogger with washer/wiper), and it's easy to see why Range Rover has a reputation for being king of the off-road.

Our Range Rover torture test began at the company's headquarters in Solihull, near Coventry in the English Midlands. After a factory tour, we headed for Solihull's infamous Land and Jungle Track, the only one of its kind in the

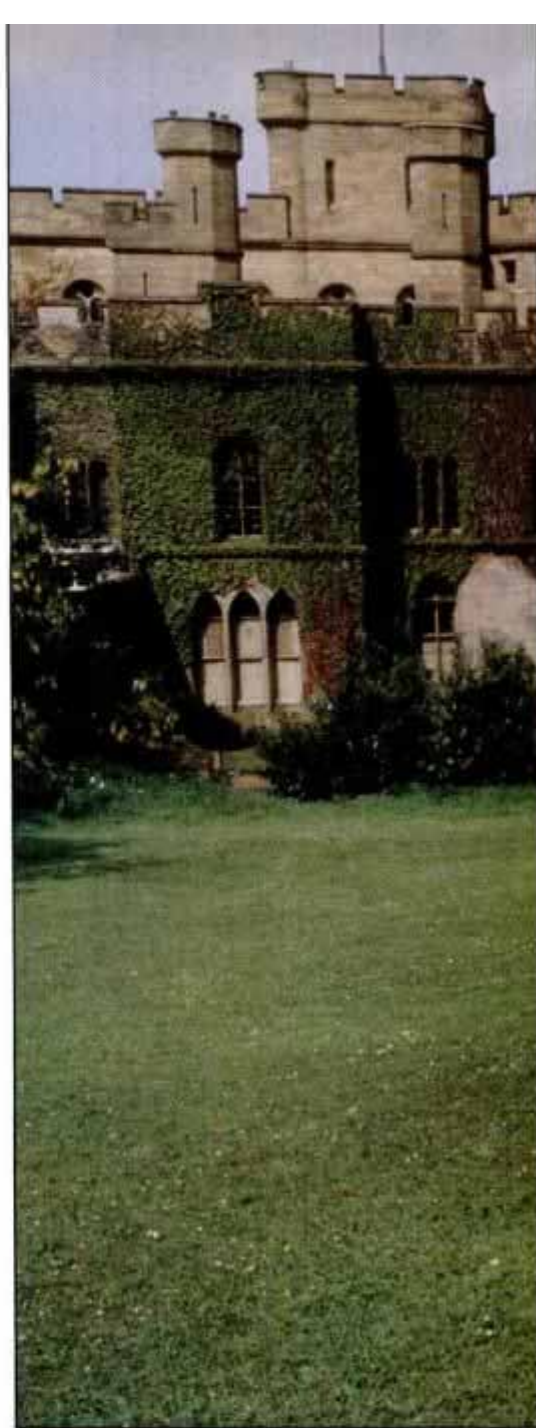

The Range Rover is equally at home posing and looking pretty in front of Eastnor Castle as it is climbing 45° slopes and blasting through belt-high water hazards. And it did all three during our 3-day torture test. Is it worth \$31,900? Like its more luxurious cousin, Rolls Royce, Range Rover is a one-of-a-kind vehicle that is handmade to custom specs and exacting standards. Also like a Rolls, if you have to ask the price, you can't afford it.





Go-anywhere capability is tested on concrete steps (left and far left), part of a Land and Jungle Track that assaults 4x4s with an array of torturous obstacles. Compared to the track, crashing through dense vegetation, above, seems civilized.



# FREE CLOCKMAKING CATALOG

Discover the world of clockmaking, and find out how satisfying this popular hobby can be.

This KLOCKIT Catalog contains thousands of clockmaking products to fit any skill level.

Choose from:

- Quartz and Mechanical Clock Movements
- Dials • Bezels • Kits • Hardware
- Woodworking Tools • Music Movements and Boxes • and much more!

Join the thousands of people who have discovered the enjoyment of clockmaking. The satisfaction of making that first clock will make you want to come back for more. And KLOCKIT makes coming back easy with the lowest prices on top quality products.



Fill out the coupon below for your FREE KLOCKIT Catalog.

## KLOCKIT

Dept. PM97 P.O. Box 542  
Lake Geneva, WI 53147

Name \_\_\_\_\_  
Address \_\_\_\_\_  
City \_\_\_\_\_ State \_\_\_\_\_ Zip \_\_\_\_\_

# '88 SPORT

world. It's here that Craithorn terrifies novice off-road drivers.

The first half of the 3-mile track is a simulated jungle of thick vegetation, swampy mudholes, deep water, pitted ruts and submerged obstacles. The second half is a jungle-gym course of steep hills, side tilts, railroad tracks, concrete steps, axle-twisting steel risers and a near-vertical humpback bridge.

The track was designed by Craithorn to demonstrate Range Rover's off-road capabilities to new owners. Hills are graded to maximum pitch. Articulation humps are spaced for extreme axle twist. Mud and muck are plentiful.

Policemen and armed services personnel from around the world, as well as private individuals, receive a special Range Rover baptism by fire on this 200-acre course.

But as challenging as the Solihull track is, it is as smooth as a putting green compared to the advanced-testing course at Eastnor.

Here, thanks to a special arrangement with the castle's owner, Major Ben Hervey-Bathurst, Craithorn was given 6000 undulating acres to sculpt into an automotive purgatory.

Recalling terrain he's driven in Central and South America, India and Africa, Craithorn has created a labyrinth of axle-busting obstacles. While I eventually conquered the entire course, on my first time around I bottomed out in slippery, clay-rich mud and stalled out in murky, belt-high water. But on the second try, using advice offered by Craithorn, we sailed right through.

Craithorn, a trim athletic figure of medium height in his 40s, is an adept teacher. In addition to the testing he does for research and development, he has driven the world's most grueling roads during his 24 years with Land Rover, Ltd. He is an engineer by training, but also a bit of an adventurer.

In 1972, he was a team member for the successful Range Rover Americas expedition—which went from Anchorage, Alaska, to the southernmost tip of Argentina. This record-breaking trek included crossing a stretch of roadless, swamp-infested wilderness between Medellin, Columbia and Panama City, known as the Darien Gap. Though only 250 miles long, this ultimate test for man and machine took the team 95 days to cross. It had never been done before in motorized vehicles.

The many off-road tips Craithorn demonstrated included upshifting when climbing steep hills, especially if they're slick. Although high gears and hills seem like oil and water, power surges in low gear caused destabilizing wheel-spin. In Third gear (out of four in the low range), the vehicle had good traction

POPULAR MECHANICS • SEPTEMBER 1987

DATSUN • SAAB • MERCEDES BENZ

## FACTORY REPLACEMENT TURBOCHARGERS



UP TO 55% BELOW FACTORY LIST  
(Exchange)

NEW OR REBUILT

### ALSO AVAILABLE: REPLACEMENT CARTRIDGES

Bearing Housing • Bearings  
Seals and Rotation Parts

### REBUILD KITS

Bearing • Seals • Gaskets

### HOP UP KITS

Boost Regulator • Water Injection  
Boost Gauge

### INTERCOOLER KITS

Intercooler • Four Silicone Turbo Hoses

### DEALER INQUIRIES WELCOMED

Not legal for sale or use on any pollution-controlled motor vehicle in California. CATALOG AVAILABLE, SEND \$3.00 TO:

## TURBO CITY INC.

1201 W. Katella Dept. PM  
P.O. Box 6010 • Orange, CA 92667

(714) 639-4933

## EARN UP TO \$20.00 AN HOUR

### BE YOUR OWN BOSS AS A... PROFESSIONAL UPHOLSTERER!

Over \$65 billion a year are spent by U.S. Consumers on Home Furnishings. Of the 86 million households, estimates indicate an average of over five pieces of furniture per household... that's 430 million pieces of furniture. And for a fraction of the cost of new furniture, the average American can have their old furniture restored to like-new condition by a Professional Upholsterer... someone like YOU!

Yes, you can learn all the short-cuts of professional upholstery and refinishing techniques in the comfort of your own home. The Foley-Belsaw system of "hands-on" training provides clear, step-by-step instructions in the use of tools and materials on actual furniture "kits"... all included with the course... so you can earn as you learn. Turn your spare-time into Extra CASH restoring old cast-offs picked up for a few dollars, into beautiful furniture worth hundreds of dollars anyone would be proud to own. For friends, relatives, neighbors... even community businesses, you'll find your skills as a Professional Upholsterer in demand. Your spare-time projects can easily lead to a profitable full-time business of your own.

Go ahead! Send for our FREE Book Today! We'll rush you all the details at no cost or obligation. Get the facts on our 30 Day FREE Trial Offer and find out how YOU can get started for as little as \$25.00. Write to:

FOLEY-BELSAW INSTITUTE OF UPHOLSTERY  
6301 Equitable Rd., Dept. 80517, Kansas City, Mo. 64120  
**NO OBLIGATION! NO SALESMAN WILL CALL!**

FOLEY-BELSAW INSTITUTE OF UPHOLSTERY  
6301 Equitable Rd., Dept. 80517 Kansas City, Mo. 64120

NAME \_\_\_\_\_ AGE \_\_\_\_\_

ADDRESS \_\_\_\_\_

CITY \_\_\_\_\_

STATE \_\_\_\_\_ ZIP \_\_\_\_\_



# 88 SPORT UTILITY

and more than enough punch to climb the steepest slopes.

In deep water, Craithorn demonstrated two interesting techniques. One was to move fast enough to form a bow wave in front of the hood. This pushes water ahead of the vehicle and prevents water from flowing over the hood and drowning the engine.

The second technique was demonstrated unintentionally. Our photographer left the rear door open a crack, allowing water to pour into the normally watertight cab. When we failed to climb out on the first try, water flooded inside. The added weight allowed our wheels to dig in and pull us out of the ditch. By the way, the plush rugs are removable to avoid mishaps such as this, or the effects of muddy boots, and allow the interior to be flushed out with clean water.

When the vehicle later bottomed out and the wheels lost traction in the mud, Craithorn showed me that quick back-and-forth steering movements forced the tires into the sides of the ruts and allowed the sidewalls to grab for extra traction. This technique came in handy in a particularly nasty section where I had the gas pedal floored and the front wheels turned directly into the side of the rutted track.

As we pulled out of the rut's deepest section, I had to call on two other Craithorn rules—avoid oversteering in rutted tracks, and never circle your thumbs around the steering wheel. The reason? As the tires suddenly regain traction, they want to do one of two things: either lurch dangerously in the direction of the oversteer, or straighten themselves out in a hurry, causing the steering wheel to spin with force enough to break your thumbs.

Despite the vehicle's awesome off-road abilities, Craithorn admits that 90 percent of the Range Rovers sold never leave pavement. While driving through London, we spotted a number of these civilized Range Rovers, some well-customized. Among its owners you can count Queen Elizabeth II.

Part of the reason for Range Rover's appeal is upscale status. With a price tag of \$31,900, it is the highest priced vehicle in the sport/utility market. Leather upholstery is the only option.

Range Rovers are now being offered in the U.S. for the first time. By the end of the year, the company is hoping to sell 3000, which is the Solihull factory's current capacity for U.S.-spec vehicles. Whether these new owners take their Range Rovers on a torture test or to the country club, they're going to be as impressed with its unique sense of brute elegance—a winning combination of off-road capability and on-road comfort. **PM**

## EVERY TRUCK NEEDS A **STOW-AWAY™**

PATENT PENDING

**NEW** STORE MORE IN YOUR **4X4**  
A STORAGE BOX FOR THAT  
WASTED SPACE BEHIND THE WHEEL WELL.

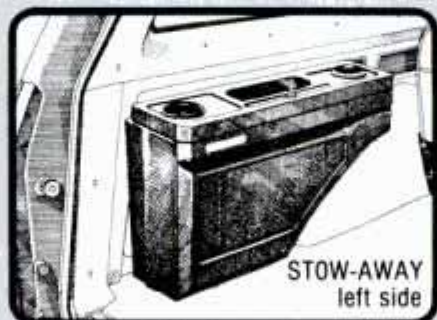

STOW-AWAY  
left side

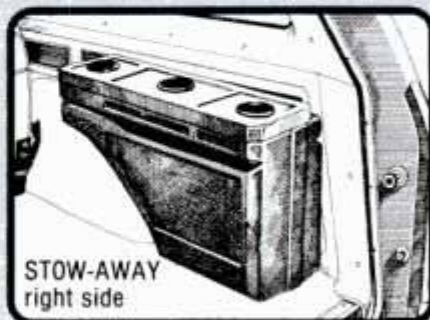

STOW-AWAY  
right side

Your sport/utility vehicle has wasted space and the STOW-AWAY™ cleans it up, and locks it up! STOW-AWAY™ tools, toys, tackle, jumper cables, emergency gear, snow chains, towing ball.

Every sport/utility vehicle has a STOW-AWAY™ custom engineered to fit behind the wheel well.

**ONLY \$89<sup>00</sup>** EACH

Average size  
27 x 14 x 8 1/2

FOR INFORMATION, CALL TOLL FREE 1-800-533-5436,  
IN TEXAS (512) 655-5443

PLEASE CHECK BOX FOR VEHICLE STYLE AND CIRCLE WHETHER RIGHT SIDE, LEFT OR BOTH				MAKE CHECK OR MONEY ORDER PAYABLE TO:						
<input type="checkbox"/> BIG BLAZER/GMC	(W/ SPEAKER MOUNT IN LID)	L	R	<b>LIDO</b>	13615 TOPPER CIRCLE #2					
<input type="checkbox"/> S-10 BLAZER/S-15 JIMMY			R		INCORPORATED	SAN ANTONIO, TX 78233-4031				
<input type="checkbox"/> BIG BRONCO	(ALLOWS ACCESS TO EXISTING POCKET)	L	R		NAME _____					
<input type="checkbox"/> BRONCO II		L	R		PLEASE PRINT ADDRESS _____					
<input type="checkbox"/> ISUZU TROOPER		L	R		CITY _____	USE STREET ADDRESS FOR SHIPPING UPS				
<input type="checkbox"/> JEEP CHEROKEE		L	R		STATE _____	ZIP _____				
<input type="checkbox"/> JEEP CJ-8		L	R		VEHICLE YEAR _____	DAY PHONE ( ) _____				
<input type="checkbox"/> MONTERO/RAIDER		L	R		PAYMENT BY:	<input type="checkbox"/> Check <input type="checkbox"/> Money Order <input type="checkbox"/> <input type="checkbox"/>				
<input type="checkbox"/> PATH FINDER			R		CARD NO. _____	EXP. DATE _____				
<input type="checkbox"/> RAM CHARGER		L	R		PRICE	QTY	SHIPP	SUBTOT	TAX	TOTAL
<input type="checkbox"/> SUBURBAN		L	R		\$89	x	+	=	+	=
<input type="checkbox"/> TOYOTA LANDCRUISER		L	R	*Texas Residents add \$5 per STOW-AWAY. Shipping/handling Add \$5 per STOW-AWAY.						
<input type="checkbox"/> WAGONEER		L	R	SIGNATURE AS ON CARD _____						
OTHER		L	R							

**A SINGER'S DREAM!**

**REMOVES VOCALS FROM RECORDS!**  
Now You can sing with the world's best bands!  
The Thompson Vocal Eliminator can remove most or virtually all of a lead vocal from a standard stereo record and leave the background!  
Write or call for a free brochure and demo record.  
**LT Sound, Dept. P.M., P.O. Box 338,**  
Stone Mountain, GA 30086 (404) 493-1258

## SOLVE YOUR MESSY STORAGE PROBLEMS

Make efficient use of air space with suspended rafter shelving. Made of 14 gauge steel. Hangs on standard stud centers. Full one year warranty. Prompt delivery.



Style	W	H	L	Price
16" Centers	14 1/2"	25"	36"	\$49.75
18" Centers	16"	25"	36"	\$51.75
24" Centers	22 1/2"	25"	36"	\$53.75

Send check or money order plus \$3.50 per item, shipping & handling to:  
**Milwaukee Steel Fabricating, Inc.**  
1624 S. West Ave., Waukesha, WI 53186  
Attn: Dept. SGS PM  
\*Wisconsin Resident Include 5% Sales Tax.  
Sorry No C.O.D.'s



## BATTLE OF THE BEHEMOTHS

(continued from page 55)

were 2.5 seconds better and with stopping distances 20 ft. shorter. The Town Car was also slightly better in most other categories, including the slalom, where both cars recorded dismal figures below .7 G.

This is not only worse than the Yugo GV, worse than the Hyundai Excel, and worse than the Chevy Nova, but worse than most of the pickup trucks we tested in this issue (except when they were loaded with half a ton of railroad ties. And even then, an overloaded Jeep Comanche could out-corner either one of these cars).

While we don't expect anyone who buys a Lincoln or a Caddy to go racing, many of these performance figures are a measure of the ability of a car to perform an evasive maneuver to avoid an accident. If you can stop short, turn nimbly or accelerate out of danger, you're less of a sitting duck on the highway.

The worst criticism was reserved for the Lincoln's vague steering. The problem went beyond having absolutely no road feel or feedback through the wheel. It was so overboosted that, if we took our eyes off the road for even a moment, say to change radio stations (forget about playing with the inscrutable trip computer), we'd find ourselves 3 ft. into the next lane.

We used to think that many drivers of these cars were simply poor drivers. But it turns out that even professional drivers had trouble keeping the Town Car in its lane. This trait made the car uncomfortable to drive at highway speeds, which does not coincide with our definition of luxury.

There were a few other anomalies on a car costing this much. Yes, it had a power antenna, but you have to run it up

and down with a separate switch on the dash. It doesn't work automatically with the radio's ON/OFF knob like on other cars with an electric antenna.

The parking brake can only be released by shifting into Drive, even though people back out of most parking spaces nowadays.

Despite wallowy handling, there's a disturbing ride jiggle on rough roads. And the optional Headlight Convenience System seemed to turn the lights and high-beams on and off at random, until we figured out how to shut it off.

This is convenience?



Not as good as they look: Plush leather seats in Town Car had no support.



Brougham's tufted, button cushions caught tall drivers across the shoulder blades.

## Conclusion

There are probably worse things you can do with \$28,000 than to buy one of these cars, but offhand we can't think of any. For 28 grand, we expect a luxury car to have such advanced features as 4-wheel disc brakes with ABS, power seats and mirrors with a memory setting, full independent suspension, heated seats and outside mirrors, strong acceleration, and stable, confidence-inspiring handling. These two cars had none of these features. Both cars had manual seatback adjusters. The Caddy doesn't even have fuel injection.

When you look at the actual hardware in these cars, there's no reason for them to cost so much.

Except for one thing. These are the two biggest cars made in America. If space and size are your priorities for buying a car, then there is nothing that does the job as well as these two cars.

In fact, you have to go all the way up to a Mercedes-Benz 560SEL to find a 4-door sedan that compares in size and interior spaciousness—and, of course, the Mercedes is more than double the price of either the Cadillac Brougham or Lincoln Town Car.

To many American car buyers, the Cadillac and Lincoln marques still represent prestige and status. To these buyers, the Brougham and Town Car still represent cars to aspire to as financial success is attained. They want a *big* car so that there is no mistaking the fact that they've made it financially. For these buyers, taut handling, strong acceleration and advanced technological features are not concerns.

It's no wonder that both these cars are enjoying a sales renaissance. The bottom line seems to be that some Americans just love big cars—the bigger the better. As mama used to say, there's no accounting for taste. **PM**

## SPECIFICATIONS AND DIMENSIONS

MANUFACTURER/MODEL	BASE PRICE	PRICE AS TESTED	ENGINE	TRANSMISSION	WHEEL-BASE (in.)	LENGTH (in.)	WEIGHT (lb.)
Cadillac Brougham d'Elegance	\$22,637	\$27,814	140-hp OHV 5.0-liter V-8	4-speed automatic	121.5	221.0	4200
Lincoln Town Car Cartier Edition	23,650	27,797	150-hp OHV 5.0-liter V-8	4-speed automatic	117.3	219.0	4100

## TEST RESULTS

GAS MILEAGE (EPA city/PM test)	¼-MILE (sec. @ mph)	ACCELERATION 0-60 mph (sec.)	BRAKING (ft.) (60-0 mph)	SLALOM <sup>1</sup> (mph)	SKIDPAD <sup>2</sup> (cw/ccw)	TRUNK SPACE <sup>3</sup>	INTERIOR SPACE INDEX <sup>4</sup>	TEST TRACK RANKING <sup>5</sup>	ROAD TEST RANKING <sup>6</sup>	OVERALL RATING <sup>7</sup>
18/13.51	19.080 @ 70.25	13.53	156	51.80	.67/.68	19	152.32	2	1	1
18/14.02	17.735 @ 76.33	10.99	137	51.40	.69/.69	18	159.35	1	2	2

\* Estimate

- Best speed while weaving through seven cones placed 100 ft. apart; the higher the speed, the better the transient handling.
- G-forces generated during steady-state cornering around a 200-ft.-dia. circle; cw=clockwise, ccw=counterclockwise.
- The number of standard-size 7" x 12" x 17" grocery bags that will stand upright (1-in. crush space permitted) in trunk.
- Front-seat width x headroom x legroom + rear-seat width x headroom x legroom + 1000.
- Points are awarded from best (1) to worst (12) in each category. Fewest total points ranks first, and so on.
- Subjective ranking on the road by a team of testers; cars are graded by "feel," independent of test track results.
- Average of Test Track and Road Test ratings. Road Test score breaks ties. Bold numbers show best performance.



## TRACTORS

(Continued from page 78)

### Ariens GT 18

The Ariens is a big piece of machinery. It stands higher and has a longer wheel base, and overall length, than any other tractor in the group. It also has the biggest seat, an advantage that is negated by a lack of support springs. Long hours over rough terrain are uncomfortable. The folks at Ariens certainly didn't spare the steel in this tractor. From the frame to the foot supports, you see heavy-gauge material. Even the front grille is made of a huge casting. But simple weight does not make a great machine. The twin, U-beam frame is certainly strong and durable, but a welded cross panel makes under-tractor engine servicing impossible. Fortunately, the engine is almost completely accessible from both sides. Another complaint is an exposed rubber, hydraulic line that could easily snag on a rock or stump. The metal line featured on the Cub is a better approach while the protected line on the Deere is even better.

On the other hand, one of the best features of the Ariens is the user friendliness of its important controls. Instead of mounting the drive and lift levers on the dash, Ariens placed them on the right, rear-wheel fender. This location is immediately comfortable, and improves reaction time in emergencies.

Other controls are less convenient, particularly the lift selector that engages the hydraulic lift mechanism for either front or rear attachments. Not only was it difficult to operate, but also, it seemed like an afterthought. To engage the front lift, you had to pull it back. For the rear lift, you pulled it forward. Because you don't make this change often, this is not a serious complaint. But it did add to the overall feeling that things were cobbled together, as if this capable machine still had a few years before it could match the standards of the Cub or Deere.

### Ariens Attachments

Simplicity and elegance of design may not apply to all the Ariens attachments, but all three certainly *worked* well. With a 48-in. blowing width, the Ariens 2-stage blower is practically a monster. It performed very well in both wet and dry snow. But a strangely restricted chute opening above the second-stage impeller prevented it from outpointing the Snapper. The responsiveness of its hydraulic-lift mechanism was, however, the best in the group.

Big capacity was also the calling card for 48-in.-wide Ariens tiller. We ran this behemoth in virgin soil filled with 8- and 10-in.-dia. rocks and the machine crawled through it all. In fact, the only shortcoming of this unit may be its size.

It occupies a lot of space in operation and storage.

The Ariens mowing deck was another standout performer especially with its powerful collection system attached. This deck is so big you have to drive the tractor *over* it to get it positioned properly, an operation that was more complicated than the brochure made it sound. More troublesome is the construction of the deck. The heavy-gauge steel is admirable, but most of the assembly employs nuts and bolts instead of welds. Over time, these will vibrate loose and cause maintenance headaches.

One notable Ariens innovation is a large, single-bag collection system. It's powered by an auxiliary blower driven off the rear PTO, and has the best vacuum characteristics we tested. It was, however, unacceptably loud. Hearing protection is required. The single bag also has a huge, zippered back flap. Once open, clippings can be pushed out easily without the back strain associated with lifting smaller bags off their supports. Unfortunately, this zipper was incredibly difficult, even after being sprayed with Teflon lubricant. Similar fit and finish problems were seen on the vacuum chute. It rubbed against the rear wheel, which is sloppy and damaging. In this price range, you should expect both performance *and* durability.

### John Deere 318

The folks at John Deere have good reason to be proud of this piece of equipment. It is the most solid and substantial tractor in our test, and as such, represents a clear investment in long-term durability. Farm tractor expertise is evident in a number of places. Substantial castings appear on the rear-axle housing and front-axle assembly. Hydraulic fittings are mounted on the tractor front for operating a wide range of implements. A split brake pedal allows you to actuate one rear-wheel brake at a time, providing a very tight turning circle. And the power steering provides great low-speed control and operator comfort for long work sessions.

The seat—the same one used on the Cub Cadet—was comfortable and all the controls were neatly labeled and easy to use. The 318's dash includes warning lights, in a compact cluster, for oil pressure, battery charge and engagement of front or rear PTO. The fuel system also sports a reserve gas tank, like the old Volkswagens, that holds enough gas to get back home when the main tank is empty. The hydraulic lift system, however, tended toward jerky operation instead of smooth movement of the Cub or Ariens.

One big plus for Deere owners is the extensive, clearly illustrated product literature. This made attaching the var-

(Please turn to page 100)



### AMERICAN HEIRLOOM

Solid oak mantel clock kit featuring hand-screened glass and dial, and polished brass hardware. Kit is easy to assemble and comes complete with quartz pendulum movement and instructions.

C7661 Pre-Cut Kit \$79.95

(Include \$5.00 for shipping and handling.  
Mass. residents add 5% sales tax)

Send \$2 to receive a one year subscription to our 56-page clock building supply catalog. Includes clock kits, dials, movements, weather instruments, hardware, tools, hooks and accessories.

NAME \_\_\_\_\_  
ADDRESS \_\_\_\_\_  
CITY \_\_\_\_\_ STATE \_\_\_\_\_ ZIP \_\_\_\_\_

**Mason & Sullivan**

Dept. 1227, 586 Higgins Crowell Road  
W. Yarmouth, Massachusetts 02673

## WOODWORKING MACHINES 5 in 1 Combination

WITH ELECTRIC MOTOR WHICH  
DEVELOPS 3 HP.

- 34" LATHE
- 10" TABLE SAW
- 11 1/2" DISC SANDER
- 16 1/2" VERTICAL DRILL PRESS
- HORIZONTAL DRILL PRESS

As long as stocks last!  
**\$699.00**



### VERY IMPORTANT

The only machine built with:  
A. ALL CAST IRON TABLES  
B. HEAVY DUTY DESIGN  
C. DEVELOPS 3 HP MOTOR  
D. BUILT AS AN INDUSTRIAL MACHINE

ONE PLACE FOR ALL YOUR NEEDS...

Toll Free (1-800) 421-2467

IN CALIFORNIA CALL COLLECT (213) 549-0761

VISA  MASTERCARD  MONEY ORDER

### MASTER WOODCRAFT MACHINE CO.

DEPT. PM, P.O. BOX 669  
HARBOR CITY, CA 90710  
(A Republic-Lagun Group)



# The Weed Eater Blower/Vacs.

## Two reasons why you'll never touch a rake again.

Every fall, it's the same old story. You spend hours raking, sweeping and bagging. Well, it doesn't have to be that way anymore.

With a Weed Eater Blower/Vac, you can do all of your yard work in much less time. And, with much less effort. Collect leaves, sweep driveways, clean rain gutters, and clean up after one of our trimmers—all with a single tool.

Weed Eater gives you six different blowers and blower/vacs to choose from, in gas-powered and electric models. All lightweight and easy to use. And all built with Weed Eater dependability and durability. Just check with your Weed Eater dealer to see which one's right for you. And kiss your rake goodbye.

\*Vacuum and gutter attachments optional.

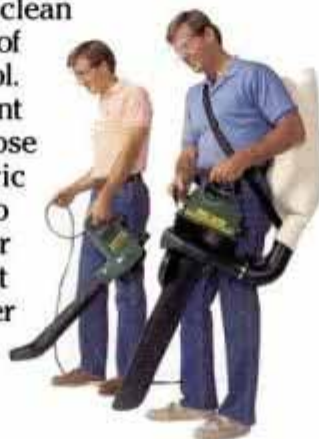

## WEED EATER®

Poulan/Weed Eater, Div. White Consolidated Ind., Inc. 5020 Flournoy-Lucas Rd., Shreveport, LA 71129 318/687-0100  
© 1987 White Consolidated Industries, Inc.

### TRACTORS

(Continued from page 99)

ious implements much easier and gives the less-than-expert mechanic some real help. Not one thing went wrong with this tractor in four months.

#### Deere Attachments

These attachments were the easiest to mount of the whole group. Simple hanging hardware on the front and rear of the tractor revealed careful engineering and a real understanding that people don't want to struggle with an expensive piece of machinery. The performance of the attachments, as a whole, was also excellent.

We did, however, have some reservations about the snow blower. Most concerned its single-stage design which simply can't compete with 2-stage models. The fit and finish on the blower also seemed substandard compared to the rest of the Deere equipment. But it is tempting to ignore these complaints because the blower was hydraulically driven off the tractor. This not only made for much quieter operation, but also suggested long-term durability.

The Deere tiller is another piece of hydraulic equipment, but unlike the blower, its reservoir and pump are part of the tilling unit. This tiller does have an outstanding feature that none of the others have. You can change the rotation of the tines depending on whether you are tilling soft or rocky soil. Two passes made in rocky soil yielded smooth, uniform planting beds. One pass over soft soil turned the surface into velvet.

The 318's mowing deck and collection system were excellent. The deck was easy to install, as was the double-bag support system. Also, by locating the auxiliary blower just above the deck, sound levels were greatly decreased. But in high, wet grass, its chute opening tended to clog, something that was never a problem with the Ariens.

One final grace note: The bag hood had acrylic windows on the top and front. This allows you to see at a glance how full the bags are.

#### Conclusion

After four months of hard use, we are convinced that these downsized models do have a good deal of real tractor in them. The John Deere 318 is a great machine, as is the Snapper LT 16 in its price range. But over the months, we could never quite come to grips with the dollars involved. It's hard to see where all the money goes, especially when you can still buy a decent car for what some of this equipment costs. If money is no problem, that's fine. But if it is, make sure you really want the capabilities you'll be paying for so dearly. **FM**





## “Sure it’s selfish not to share my Lancaster.<sup>®</sup> But I can live with the guilt.”

When you go to a lot of trouble to get what you want, it’s only natural to want to keep it to yourself. And, Lancaster isn’t an easy chew to find. Because it’s made in only limited quantity, it isn’t available everywhere. It isn’t exactly cheap, either.

Reason is, Lancaster’s basically a hand made chew. Hand picked and hand cleaned.

And it’s guaranteed to have less sticks and stems than the brand you’re using, or you’ll get your money back.

But it’s so moist, so rich, so full of flavor, you soon forget about the extra money and extra time it takes to find. You forget about the idea of sharing it, too.

And as for the guilt? Guilt? What guilt?

WARNING:

THIS PRODUCT  
IS NOT A SAFE  
ALTERNATIVE TO  
CIGARETTES



**Hard to find.  
Even harder to share.**

Материал: защищенный авторским правом



**Our 15th year**  
**CUT FUEL bills**  
 Modernize your fireplace with  
**HEARTH AID II**  
 America's favorite fireplace heat exchanger

**Increases Heat Output by 500%**

- ★ Custom Built to fit any Fireplace
- ★ Easy to install.
- ★ Thermostatically controlled, works automatically.
- ★ Super Efficient titanium stainless Heat Exchanger.
- ★ No extras to buy.
- ★ No dangerous Creosote Buildup

And best of all you can enjoy your fireplace while saving on your heating bills because with **Hearth-Aid II®** you don't need to sacrifice your fireplace's appearance or the delight of an open fire to be energy efficient. Works with: Wood, Coal, or Gas Logs.

For Free Information, Write or Call:  
 The Heat Exchange, Inc., P.O. Box 1027  
 Brentwood, TN 37027 Dept. SPM  
 Nationwide Toll Free: 1-800-742-HEAT  
 1-615-794-8425

**WE SPECIALIZE IN ARCHES, CORNERS & PREFABS.**

## WOODWORKER'S CATALOG

There are over 3,000 money saving reasons why woodworkers rely on Constantine.

3,000 woodwork items—to help you Build-Restore-Repair-Refinish! Over 200 different woods... 150 veneers... 500 plans... cabinet hardware... 96 How-To Books... 118 carving tools and chisels... 76 inlay designs... and lots more for One-Stop, Right-Price Shopping without leaving home!

116 Page Catalog—Only \$1.00

**CONSTANTINE** Est. 1812  
 2051 S Eastchester Road, Bronx, NY 10461

**SMALL ENGINES**  
 Generators, Troy-Built tillers, and more.

**FREE CATALOG DISCOUNT PRICES**

**SMALL ENGINE CITY**  
 2612 Lyndale So. Dept. PM-3  
 Minneapolis, MN 55408  
 612-872-4298

## KILLER COASTERS

(Continued from page 59)

dusky, Ohio, one of the highest, fastest twin roller coasters in the midwest at 125 ft. tall; the Wild One in Largo, Maryland, a 98-ft. wooden classic; and the Revolution at Six Flags Magic Mountain in Valencia, California, one of the first looping steel roller coasters.

New roller coasters on an increasingly crowded scene include the Iron Dragon in Sandusky, Ohio, a suspended coaster that takes riders on a "pretzel knot" placed over a lagoon. The Shock Wave is also located at Magic Mountain in Valencia, and passengers stand in padded compartments rather than sit. King Cobra at Kings Island and Sky Rider in Toronto are similarly configured.

Increasingly, electronics plays a major role in roller coaster safety. Despite the Karen Brown death, Great Adventure's Lightnin' Loops is an interesting example of the promise—and perhaps the compromise—of modern computerized safety mechanisms.

Harold Hudson, vice president in charge of engineering for Great Adventure, says coasters like Arrow Dynamics' Lightnin' Loops are festooned with sensors that tell operators the status of the attraction. The track is divided into blocks at lifts, drops, loops or elsewhere, and computers tell the operators what's happening in any particular block. No two trains are allowed in the same block at the same time, a procedure called interval control. Sensors also indicate train speed, switch location in the case of roller coasters equipped with movable tracks, and yes, whether or not safety bars are down and latched. The computer receives these status reports from the roller coaster's various components and the computer decides whether or not the ride is operational from a safety standpoint.

Indeed, the computer operates the ride itself. And because the duration of some rides like Lightnin' Loops might be only 30 seconds, the ride can't be stopped once started. Steve Okamoto, project engineer for Arrow Dynamics, says halting a roller coaster that has a ride duration of only 30 seconds would risk stopping the cars in the loop, a highly dangerous condition.

Okamoto indicates that roller coaster safety is only as good as the last accident, and mishaps spark design changes. "We try to design out any odd circumstances. This was a circumstance (Karen Brown's death at Great Adventure) that was kind of unusual. As the facts come out in the investigation, if there are shortcomings, we'll try to make improvements.

"Right now we're in the conceptual stage of thinking about different ways we might be able to do things so we can

sense when a person is in his seat. A cutoff switch would be a possibility, but there are some obvious roadblocks. What do you do when you have an empty seat, for instance? You can get into a situation where you're asking a lot of sensors to do a lot of work. Do you want to make the coaster smart enough to figure out the problem, or do you want to have a person do it?"

Indeed, could all the backups, redundancies and controls lead to operator complacency, a "let-the-computer-do-it" mentality that lulls personnel into abandoning a final visual check on passenger safety? Has faith in technology supplanted common sense?

Despite some misgivings, and to answer our initial question, riding roller coasters is remarkably safe if you consider the statistics. Harold Hudson asserts: "Between 1973 and 1985, one person out of every million and a half users was injured on an amusement park attraction, not necessarily a roller coaster, to the point where the injured had to go to an emergency room."

There are numerous statistics to back him up. The last comparison between roller coasters and other dangerous activities was conducted by the American Consumer Product Safety Commission in 1985. Though the commission no longer gathers these particular figures, it determined two years ago that riding roller coasters is near the bottom of the ladder when compared to other activities, at three accidents per 100,000 uses. Stairs and landings accounted for 531 accidents per 100,000 uses, bicycles 253, baseballs 224, knives and scissors 158 and doors 135.

A further reading of the statistics is revealing. The safety commission says that between 1973 and 1985, the last complete year for which they have a record, 7770 people were treated in a hospital emergency room after an amusement park ride accident. More than 4500 mishaps occurred on carnival type rides. More than 3000 were related to fixed-site amusement parks. Of the 71 deaths that occurred in the United States at carnivals and fixed-site parks between '73 and '85, only 20 were roller coaster related. Pat Duricka, spokeswoman for the International Association of Amusement Parks and Attractions in Alexandria, Virginia, cites a 1986 survey that estimates between 215 and 220 million total visits to North America's 580 theme parks between March and September of last year. IAAPA says theme park guests took more than a billion rides on amusement park attractions in that time period. Obviously, the ratio of rides to mishaps is almost infinitesimal. Statistics can be comforting. But don't try to convince the family of Karen Brown there's no danger in riding roller coasters. **PM**



# Why Are We Giving Away Famous Nationally Advertised CYCLONE 600™ Commando Knives for only \$10?

Same original commando warfare design—now available to hunters, fishermen, divers and outdoorsmen who seek the *ultimate survival knife*. Thousands already sold!

**8½ inches long and r-r-r-r-r-razor sharp!**

This is a big knife. Each CYCLONE 600™ is a whopping 8½ inches long—yet so perfectly balanced it cuts and thrusts like an extension of your own hand. Heft this beauty just once; you'll never want to put it down.

Each CYCLONE 600 double-edged blade is entirely crafted from a single seamless shaft of *420 molecular stainless steel*™! Thick as a silver dollar at the spine, it's tough enough to split wood or shatter bone. Serrations at blade base give extra cutting power.

CYCLONE 600's unique finger holes give you a grip of iron even with wet and greasy hands. From cleaning a fish...to dressing a deer...to fighting off sharks...to hacking down a small tree.

#### Instant "quick-release" mechanism built into sheath

*Click, click—that quick!* Thumb button on sheath instantly quick-releases blade into palm of hand. Blade resheaths itself—and locks—automatically. Special speed straps (included) fasten sheath to arm, leg or boot for hands-free operation.

These CYCLONE 600 Commando Knives will *not* be sold at this or any other price by the company in any store. There is a limit of two (2) per address at this price, but if your request is mailed early enough (before Oct. 31) you may order up to five. Every knife is covered by the company's full one-year money-back guarantee.

To order, mail this *original* printed announcement (no copies or photostats) together with your name and address and \$10 for each knife. Add only \$2 shipping per knife ordered. (New York residents add sales tax.) Allow up to 6-8 weeks for shipment. *Make check payable to RBM Ltd.* Mail to: **RBM, CYCLONE 600 Knife, Dept. 114-116, Box 1710, Hicksville, New York 11802. (R44770)**

NO CANADIAN ORDERS ACCEPTED.

© 1987 RBM Ltd., 1200 Shames Drive, Westbury, N.Y. 11590

## FREE GIFT For Prompt Action

### Free "Trigger Blade" Sportsman's Knife

if you order your CYCLONE 600 Knife before October 31.

Razor sharp blade of fine stainless steel locks open automatically, can't close by accident. Over half-a-foot long when open; folds to



pocket size when you press the trigger. Respond before Oct. 31—and it's yours to keep—FREE—even if you return your CYCLONE 600 Knife for a refund.

### QUICK-RELEASE SPEED SHEATH



Thumb controlled, Quick-Release Sheath straps to arm, leg or boot. Click, click—that quick! Simply press thumb button to activate.





**Increase Tire Shop Safety and We Will Give You This Solid Bronze Buckle.**

Heavy truck wheel/rim servicing can be dangerous.

Motor Wheel Rim Safety Training kit has material and instructions to help you teach safe wheel/rim servicing and help avoid needless accidents.

Send for free kit.

Post the safety material. Present the program to your service people. Return validation certificate. And we'll send you a Motor Wheel Think Safety belt buckle.

**Write: Dept. 91074,  
Motor Wheel Corp.,  
Lansing, MI 48910**



**MOTOR WHEEL**

**ALL NEW!** The Homebuilt **JET HELICOPTER**  
LOW-COST DESIGN — SIMPLIFIED ASSEMBLY  
• Uses low-cost fuel • No license needed  
E-x-p-o-s-e-d CONSTRUCTION MANUAL Fully illustrated. Only \$12.95\*  
THE Helicopter Experimenters' HANDBOOK  
• photos • designs • data  
Only \$10.95\*  
Plus/kit information: \$3.00 or free with your order!  
CREDIT CARD ORDER LINE: 1-801-863-6344  
P.O. Box 30  
Riderwood, MD 21139

**Get your HIGH SCHOOL DIPLOMA**

...at home in spare time. No need to attend class or quit your job. Get your Diploma in as little as 4 months for each year you need. Previous high school, military and work experience count toward graduation. Dozens of interesting electives. Write for free facts. No obligation. No salesman will visit you.

**ICS Newport/Pacific High School, Dept. PB097**  
Scranton, PA 18515

**200 FULL-SIZE PROFESSIONAL PLANS**  
CATALOG — \$2.00 • SEND TODAY  
Build chairs, tables, desks, cabinets, buffets, cradles, beds and more. Make your own reproductions of Early American, English, Spanish and Modern furniture styles using full-size fine quality plans.  
**FURNITURE DESIGNS, INC. Dept. PF-97**  
1827 Elmdale Ave., Glenview, IL 60025

**BEST OF TIMES**

(Continued from page 66)

sport-tech developments. Casio's 30-Lap Memory watch, for example, has nearly as many functions as a lap-top computer. It can record net time, lap time and split time. It can count up to 99 laps, signal 10 target-time settings, countdown to the start of a race, and store data for later recall of up to 30 lap/split times. All this for about \$35.

Timex's Marathon 50 is a unique combination of high-tech and ergonomics—the science of adapting men to machines. The case has an off-center shape to allow the wrist freedom of movement. The mode and set buttons are located on the left where they cannot be accidentally activated. And the chronograph control buttons are top-mounted on the right for easy accessibility while running.

Beyond ergonomics, the Marathon 50 has a 13-hour, multimode chronograph, countdown timer, and memory recall. Price is around \$30.

For serious runners, Seiko's LC Digital Quartz Training Timer uses a remote-cable release switch to record highly accurate split times. The detachable remote cable connects the watch to a ring worn on the index finger. In mid-stride, a runner can activate the button without having to reach across his body.

The Training Timer also sounds alarms for preset target times and stores finish times of up to eight races for future recall. It can be found for about \$95.

To most runners, even marathoners, triathletes approach the lunatic fringe of sports achievement.

They race through three consecutive torture tests without pausing—a 2.5-mile ocean swim, a 112-mile bike ride and a 26.2-mile marathon. These competitors are tough.

Timex's Ironman watch, named after the celebrated triathlon event in Hawaii, meets the special requirements of these superhuman performers. It is a unique combination of shock and water resistance with large top-mounted controls for easy access. The strap and case are made of tough fiber-reinforced resins, while its multimode chronograph has an 8-lap memory, lap counter with memory recall, and countdown timer. Price is about \$35.

Two watches that perform similar functions, the Porsche Design Compass Watch and the Casio Time and Direction, are a study in sport-tech contrast. Both are well-suited for campers and outdoorsmen, because they tell direction as well as time, but all similarity ends here.

The Porsche Design Compass Watch combines a highly accurate timepiece that flips up to reveal a detachable com-

pass. Both instruments are slim and durable. In this superimposed configuration, however, replacement of steel with antimagnetic materials was required to eliminate any magnetic influence on the compass. The precision automatic-winding mechanism uses ruby micro ballbearings, for example, and the band is made of non-oxidizing durox aluminum. Other features include sapphire crystals on both instruments and water resistance to 90 ft. Cost? A mere \$1800.

Casio approaches the same problem differently. Its solution is to mount the instruments side-by-side, so that magnetic interference is avoided rather than overcome. High-tech it's not, but the purchase price is only about \$35.

As popular as scuba diving may be, far more people play on the water than under it. For boardsailors, Citizen has a Wind Surfer watch that has a highly accurate quartz-crystal stopwatch with a countdown timer to signal the start of a race. On the watch's rubber strap, for serious racers, is a wind-velocity chart that is a quick reference for changing meters per second into knots.

The movable bezel can be used for noting wind direction. Cost for this rugged watch is \$145.

After meters per second have been converted into a first-place finish, it's time for the winning sailor's traditional ritual of champagne shower and tossing off the dock. What watch is best suited for this kind of treatment? Something new called the Water Watch.

The first thing a new owner does with a Water Watch is to submerge it from 10 to 15 minutes, after which its voltaic cell, or water battery, begins to work. The watch's manufacturer, VentuResearch, from El Paso, Texas, recommends tap water for best performance, but concedes the watch will run on beer, wine, soft drinks or champagne.

Sailors need to win a race only about every 10 days to get a dousing and a battery charge.

The watch's battery is made of alternating plates of zinc and copper, separated by pads soaked in a liquid. Though the high-tech application is new, the basic water battery was discovered nearly 200 years ago, by Alessandro Volta. Improvements have been made primarily in miniaturization. It produces a charge that's slight, but more than enough to meet the microchip power demands of an LCD watch. Water Watches cost about \$30.

The world of sport-tech watches is a wide one, from high-performance, high-cost Rolexes and Porsches to miniature miracles from Casio and Seiko. As sport-specific designs and functions continue to be developed, sportsmen will be able to count on their watches for much more than a good time. **PM**



## POWER BASE

(Continued from page 73)

sawn edge quickly and accurately without changing machines.

You can also make open mortise and tenon joints with these tools. First, cut the open mortises on the circular saw with the fence in the upright position. Then mill the tenons by using the miter gauge to guide the stock over a straight bit mounted in the router.

The sabre saw and drum sander combination is ideal for cutting and dressing curved profiles. Straight, smooth ribs can also be made. Use the fence to rip and set up an auxiliary guide strip next to the sander to dress the edge. For profiles with beveled edges, use the sabre saw in conjunction with the belt sander.

Although you may have thought your workbench was the only place to clamp your work for sanding, handheld routing or carving, the two end clamps permit the table to be used for holding stock up to 33 in. wide.

You'll need to construct special clamping plates as shown in the drawing. Each of these has a series of 3/4-in.-dia. holes for the insertion of clamping pins. The auxiliary clamping blocks are especially useful for holding irregular shapes and two can be used with the split plate for holding thin stock.

Horizontal boring machines are a luxury even in well-equipped shops. Mount your drill horizontally in the drill mounting plate and use the stock-support jig with wood or cardboard shims to hold workpiece at proper height. The stock support is held in place by a clamping plate and pins and the drill guide allows you to advance the drill uniformly.

These are only a few of the many possibilities for using the power table. We're sure that, with a little experimentation, you'll discover other innovative ways to utilize this versatile tool. **PM**

## ADDITIONAL FEATURES

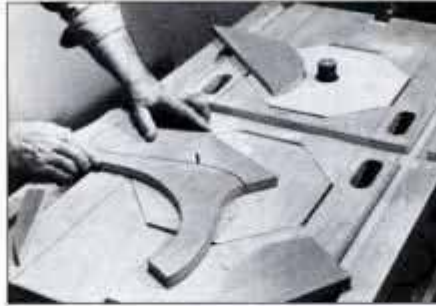

**11** Scrolling is easier when you move the work instead of the tool. Keep the drum sander mounted for dressing the edges.



**12** After cutting the profile, move to the drum sander. It's powered by the drill mounted in a drill guide under the plate.

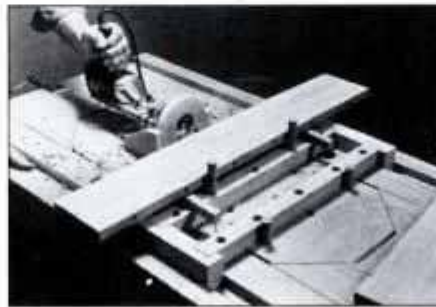

**13** Flip over the drill-mounting plate and remount the drill and guide parallel to the table for horizontal-boring operations.



**14** The top-mounted drill also powers a disc sander or disc rasp. Install a buffing wheel for polishing chores.

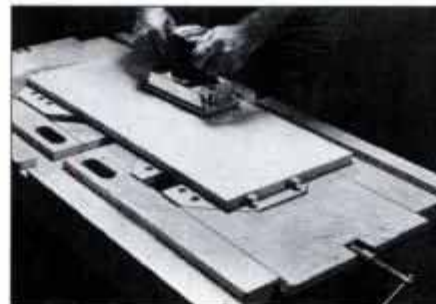

**15** Use the clamping plates to secure flat stock. Open the sliding plates, place the pins in position. Then tighten clamps.



**16** Auxiliary clamping blocks permit gripping work with small contact surfaces. Use them with a split clamping plate.

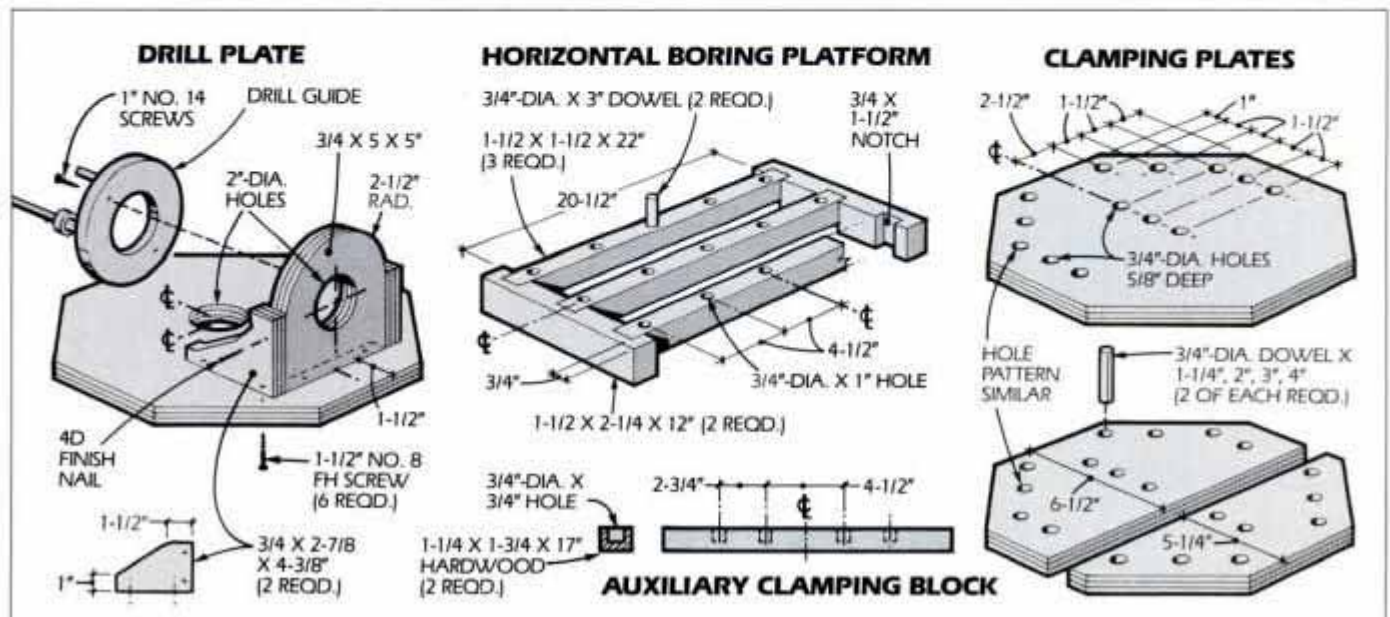



**START YOUR OWN  
PROFITABLE CASH BUSINESS  
EVEN WHILE LEARNING!**



# BE YOUR OWN BOSS... BE A LOCKSMITH

**There is a difference  
in locksmithing  
training and  
the difference  
is NRI**

Only NRI gives you such complete training, so much real bench experience, and the confidence and all the tools you will need to earn cash money fast.

A well-trained locksmith earns money in many different ways—installing locks in apartments, homes, businesses, and automobiles, fixing broken locks, cutting new keys, and more. And this huge market is just begging for new qualified locksmiths. Today there is only one locksmith for every 18,000 people!

## The Newest, Most Advanced Course of Its Kind

Thorough step-by-step lessons and professional locksmithing equipment such as the Taylor KD5 Key Machine give you hands-on experience in this exciting growth field. You'll start earning huge cash profits of 800% to 900% duplicating keys. And only NRI offers you an Electronic Security Alarm training system.

Compare! NRI offers the only course that is nationally approved by the accrediting commission of the National Home Study Council.

Compare! NRI's course training has been broken down into 10 learning modules, each with the right number of lessons to keep your



training at an easy-to-follow pace. All the lessons, hands-on training, and experiments have been developed to ensure that you begin practicing from the very first day... and can begin making cash as soon as you like. All the money-making secrets of a locksmithing trade will become yours with your NRI training.

Plus, only NRI gives you training in both locksmithing and electronics security systems in one complete course.

## Start Your Own Business, Full or Part-Time, Even From Your Home

Add to your income with part-time work with established locksmiths... start your own part-time or retirement business in your own home... make locksmithing and security a full-time career as a skilled technician in your own growing business. There is opportunity everywhere!

NRI's free 4-color booklet will show you how quickly you can train to be your own boss in a profitable locksmithing business and gain the respect you deserve as a trained technician like other professionals in your community.

**Make \$25 to \$100 per hour**

with  
**Badge-A-Minit**

Yes, it's really possible by making and selling bright, colorful Badge-A-Minit buttons. Buttons are proven money-makers at fairs, flea markets, conventions, or anywhere people congregate. They're fast and easy to make with Badge-A-Minit and inexpensive!

Send for a FREE full color catalog and idea book, or send for a Starter Kit, only \$25.95 plus \$1.75 shipping. (IL residents add \$1.50 tax)

Badge-A-Minit, Dept. PM-987  
346 North 30th Rd., Box 800, LaSalle, IL 61301, Phone (815) 224-2096



★★★★ PRESENTING ★★★★★  
**CABLE TV  
EQUIPMENT**  
★★★★ STARRING ★★★★★  
**JERROLD, HAMLIN, OAK**  
AND OTHER FAMOUS MANUFACTURERS

- FINEST WARRANTY PROGRAM AVAILABLE
- LOWEST RETAIL/WHOLESALE PRICES IN U.S.
- ORDERS SHIPPED FROM STOCK WITHIN 24 HOURS

FOR FREE CATALOG ONLY 1-800-345-8927  
FOR ALL INFORMATION 1-818-716-5914

**PACIFIC CABLE CO., INC.**  
7325H RESEDA BLVD., DEPT. 1710  
RESEDA, CA 91335

## What Is He Doing?

He's making a concrete flower pot... and so can YOU!

Make and sell your own ornamental concrete items. Order your book with over 425 aluminum molds, prices and production trade secrets from world's largest mold manufacturer.



Only \$700

**CONCRETE MACHINERY CO., INC.**

P.O. Box A-99 Hickory, NC 28603

## LEARN CLOCK REPAIR

★ EARN BIG MONEY ★  
WORK AT HOME • NO VOUCHER/COUPON BOOKS  
FOR DETAILS SEND \$1.00 TO:

**NATIONAL  
CLOCKMAKERS  
INSTITUTE**



**SEND FOR FULL INFORMATION BOOKLET TODAY! COMPARE.  
THERE'S NO OBLIGATION AND NO SALESMAN WILL CALL!**

**NRI** SCHOOLS

McGraw-Hill Continuing Education Center  
3939 Wisconsin Avenue, Washington, DC 20016



We'll give you tomorrow.

- CHECK ONE FREE CATALOG ONLY
- Locksmithing & Electronic Security
- Data Communications
- Robotics & Industrial Controls
- Color TV, Audio, and Video System Servicing
- Electronics Design Technology

- Digital Electronics
- Communications Electronics
- Industrial Electronics
- Basic Electronics
- Telephone Servicing
- Small Engine Servicing

- Appliance Servicing
- Automotive Servicing
- Air Conditioning, Heating, Refrigeration, & Solar Technology
- Building Construction
- Computer Electronics with Microcomputers

For Career courses approved under GI bill

check for details.

Name (Please Print)

Age

Street

City/State/Zip

Accredited by the National Home Study Council

1701-097

**REPLICA  
MODELS**

**HISTORIC  
NON-FIRING MODEL GUNS...**

Safe! Full size. Zinc alloy. Realistic.  
Over 30 parts. Cannot chamber or fire  
real ammo. Assembled. FREE Catalog.

**COLLECTOR'S ARMOURY** Credit

800 States Lane  
Box 59, Dept. PM  
Alexandria, VA 22313

Card Orders:

(800) 638-3000  
Tot. Free 24 Hrs.

U.S. M1911  
45 AUTO.  
\$79 PPD.  
Length: 8.5"  
Weight: 41 oz.



## BASEMENT TOILET

**FLUSHES UP To Sewer or Sump Tank**

No Digging Up Floors  
Install It Yourself - Anywhere  
Write McPherson, Inc., Dept. 16  
Box 15133 Tampa, Florida 33684





# P M TECH UPDATE

SEPTEMBER 1987

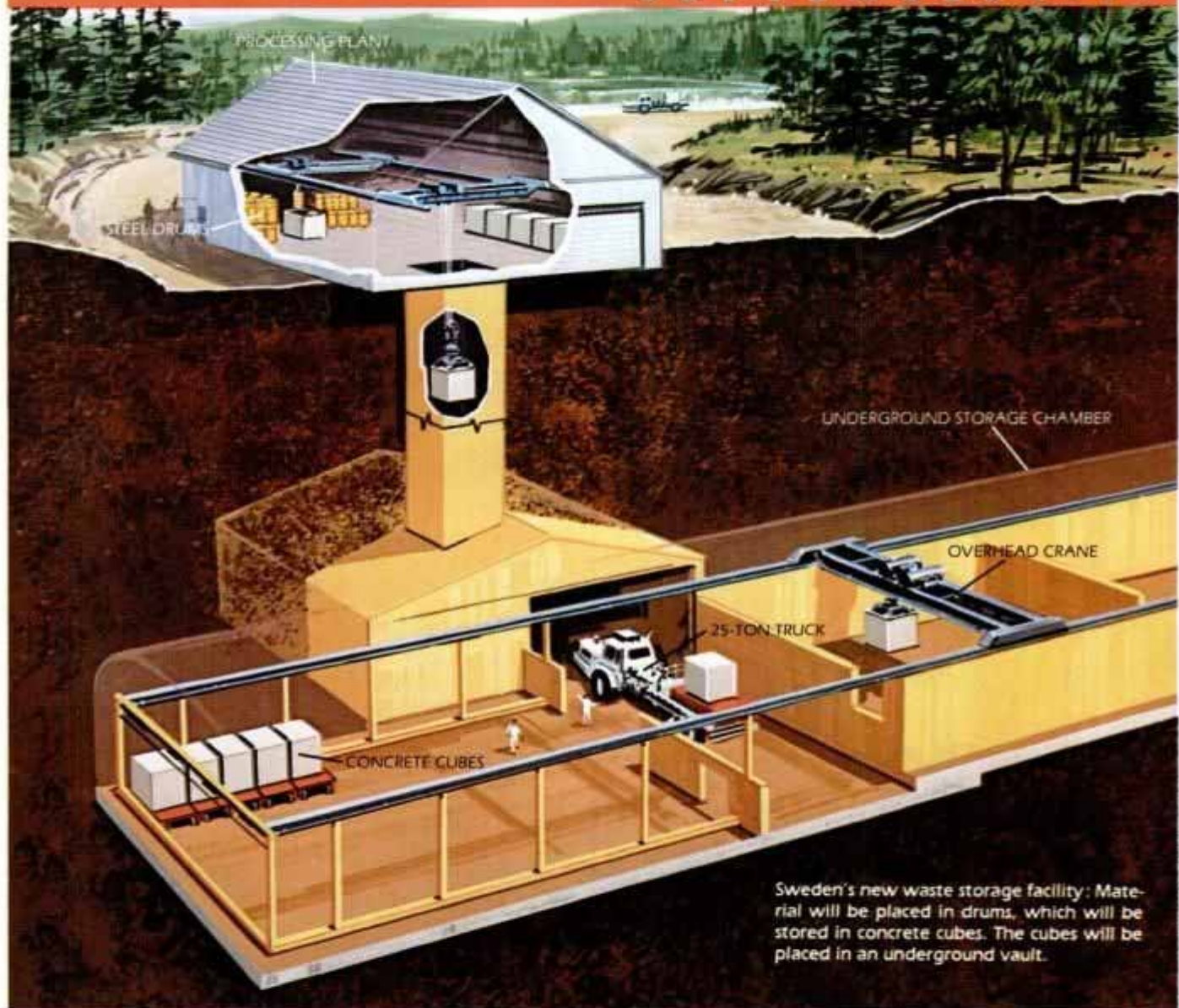

Sweden's new waste storage facility: Material will be placed in drums, which will be stored in concrete cubes. The cubes will be placed in an underground vault.

PM ILLUSTRATION BY ED VALIGURSKY

## The Swedish Model For Handling Dangerous Waste

**P**rotecting the environment from toxic and radioactive byproducts is a global priority.

But a waste treatment and storage concept soon to become operational in Studsvik, Sweden, may show the world how to tackle one of mankind's most pressing problems.

The Swedish government has commissioned the firm

Studsvik Energiteknik to create AMOS, a waste handling facility that includes a solid and liquid waste processing plant, underground-interim storage and a harbor where material will be ultimately loaded on special boats for the trip to Sweden's permanent underground-storage facility being built near Forsmark.

Under AMOS, the waste is

sorted, cut and compacted into drums, which are then placed in concrete cubes, five drums to a cube. The cubes are placed in transport casks and moved by 25-ton trucks to AMOS' underground caverns which have been modified to include overhead cranes.

Plans for safe, permanent-waste storage are gaining momentum in the United

States. The U.S. Department of Energy has proposed a \$3 billion Monitored Retrievable Storage facility to Congress, and Department of Energy officials will conduct a conference next month to focus on modern waste handling and waste storage facilities.

Editor: Tim Cole  
Contributors: Ed Valigursky,  
Berk Wheeler, Mort Schultz.



## Loitering Missile

The Air Force calls it Tacit Rainbow and it's designed to knock out enemy radar emitters during air strikes. The air-launched, 8-ft., 4-in. weapon is equipped with a small jet engine, short wings and ventral/dorsal stabilizers in the tail. Chief feature of the weapon, built by Northrop Corp. in Perry, Geor-

Tacit Rainbow antiradar missile being released by an A-7 Corsair. The new missile waits for enemy radar to activate.

gia, is the ability to fly for long periods over enemy positions and wait until anti-aircraft radar-targeting systems are activated. As soon as Tacit Rainbow detects radar, it homes in on the beam and destroys the radar site.



NORTHROP PHOTO

## World's Fastest Chip?

IBM engineers say the tiny opto-electrical device can "read" 40 encyclopedia volumes every second, transforming light into electrical signals that a computer can

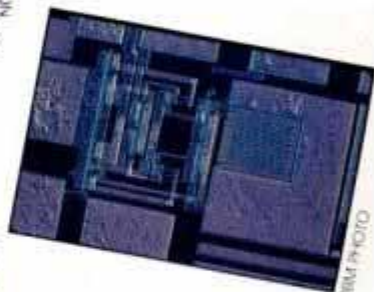

IBM PHOTO

IBM's new chip moves signals faster than traditional silicon.

understand. A breakthrough gallium-arsenide semiconductor is at the heart of this IBM achievement, which could mean smaller, more powerful computers.

## NOTAR Civilian Choppers?

A NOTAR (no tail rotor) test bed from McDonnell Douglas currently touring the U.S. is demonstrating the feasibility of the system. Directional control in a NOTAR helicopter is derived from a fan-driven air-circulation system in the tail boom.

McDonnell Douglas says NOTAR technology is more reliable, improves handling, reduces pilot workload, requires less maintenance and increases safety for both ground and air crews. NOTAR's noise-reducing features may increase the use of helicopters in urban areas for medical and police work.

## Pressurized Nuclear Plant Model



SANDIA PHOTO

The reactor model will be pressurized to 115 percent of designed capacity.

The 37-ft.-tall reinforced-concrete structure is  $\frac{1}{6}$  the size of a conventional nuclear containment building. Researchers at Sandia National Labs will subject the model to extreme internal pressures to study structural integrity—it'll be pressurized to 115 percent of its capacity—crack mapping and leak rates. Finally, the structure will be "blown up" until it fails. The exercise will teach engineers how to build safer nuclear plant structures.



MCDONNELL DOUGLAS ILLUSTRATION

Will tail rotor soon disappear from multi-task civilian helicopters?

## Livelier Baseballs

It's bad news for hitters. Cooper Union Engineering Professor Joel Hollenberg recently used a wind tunnel and computer to predict the exact trajectory of the knuckleball, which performs erratically because of low spin and stitching drag. Hollenberg's research can show a knuckleball pitcher like Phil Niekro how varying his angle of release can change a knuckleball's flight path. And for fastball artists, Mattel, Inc., of Hawthorne, California, has recently introduced Speed Tracker, the baseball that actually times your pitch. A battery-powered device displays time on a tiny LCD window. Depress the orange dye to zero the timer, which starts on release. Catching the ball stops the timer. Speed is determined by conversion charts. Batter up!



Joel Hollenberg, left, and the wind tunnel used in knuckleball tests. Below, Mattel's Speed Tracker uses LCD timer.

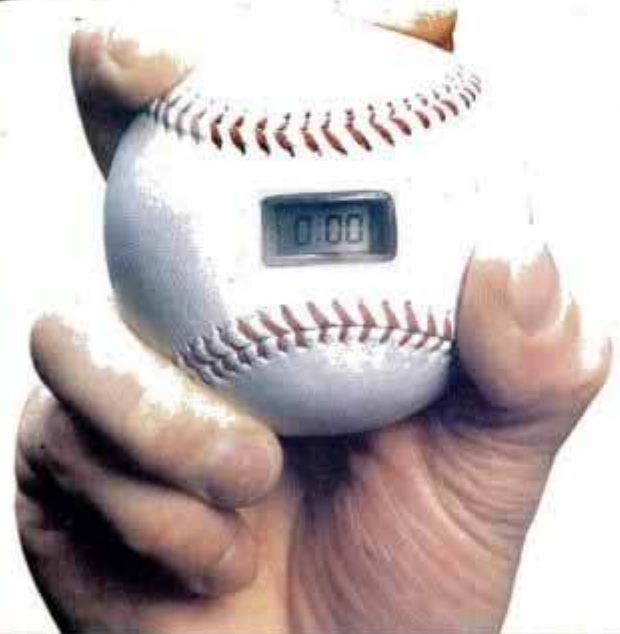

PMA PHOTO BY JEFF WEIR, (INSET) COOPER UNION PHOTO



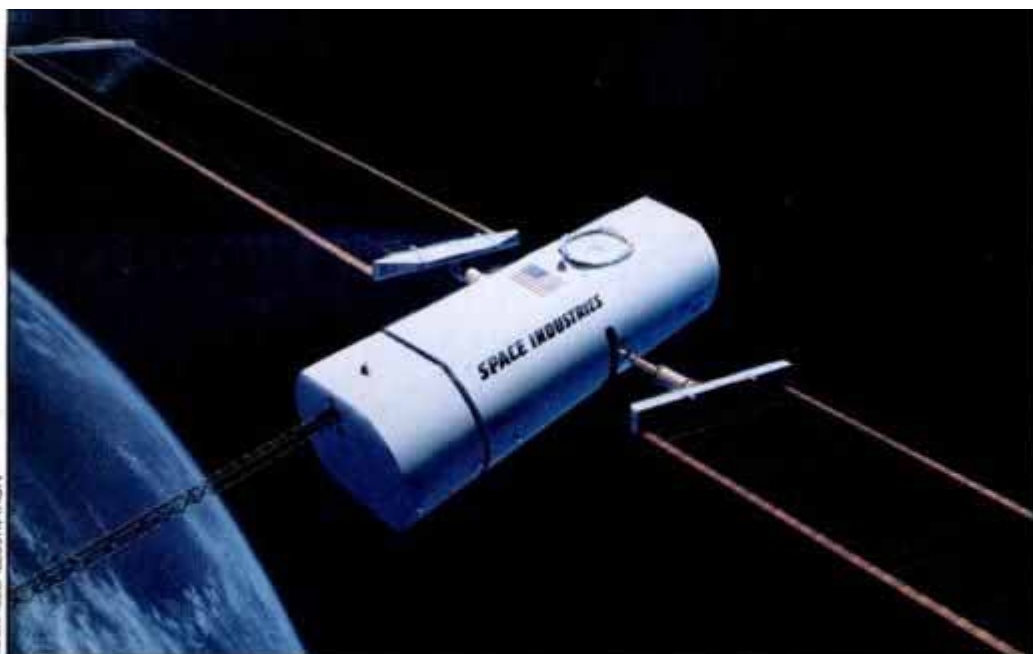

The Industrial Space Facility will produce materials in microgravity using a 28-kilowatt solar powerplant.

## Space Power

The problem: How to provide electricity to the orbiting Industrial Space Facility, scheduled for shuttle launch in the mid-1990s. The Lockheed solution is a 28-kilowatt power module that will use twin 105-ft. solar arrays to convert sunlight into energy. The flexible solar wings have nearly 30,000 silicon solar cells welded to a printed circuit, sandwiched between two layers of flexible Kapton plastic. The Industrial Space Facility, designed to free-fly or dock with either shuttle or space station, will be used for materials research in a microgravity environment.

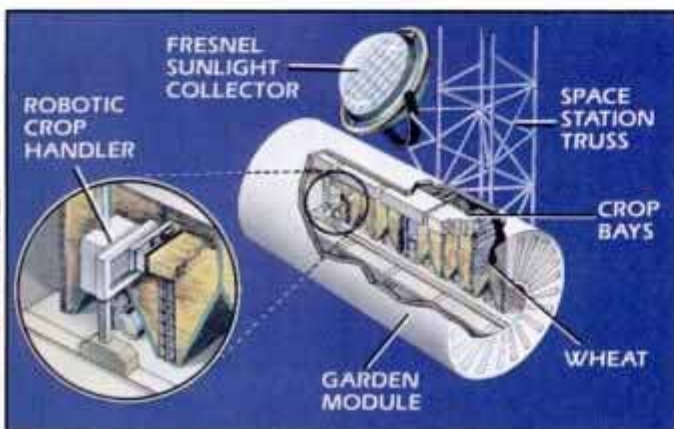

A 45-ft.-long, 14-ft.-wide gardening module from Boeing would incorporate "aeroponic" nutrient delivery and piped sunlight.

## Gardening In Space

The year is 2020 and NASA has just docked Boeing's garden module to the space station. Seeds implanted in accordian-style racks allow virtually any crop to grow in

microgravity. A misty aeroponic medium transports nutrients and needed moisture. An external solar collector channels light needed for photosynthesis. Such a garden module will provide food for crewmembers and help purify station atmosphere.

## Sub Rides The Wind

Scientists at NASA's Langley Research Center can duplicate fluid dynamics encountered by a submarine by subjecting a 20-ft. sub model to high atmospheric pressure at 230° below 0° F. Introducing liquid nitrogen into this environment achieves realistic fluid flow when the nitrogen vaporizes into a gas much denser than air. Researchers are currently studying the flow in a sub's stern area, which is complicated by propeller vortices.



Technician checks inverted sub model in Langley wind tunnel.

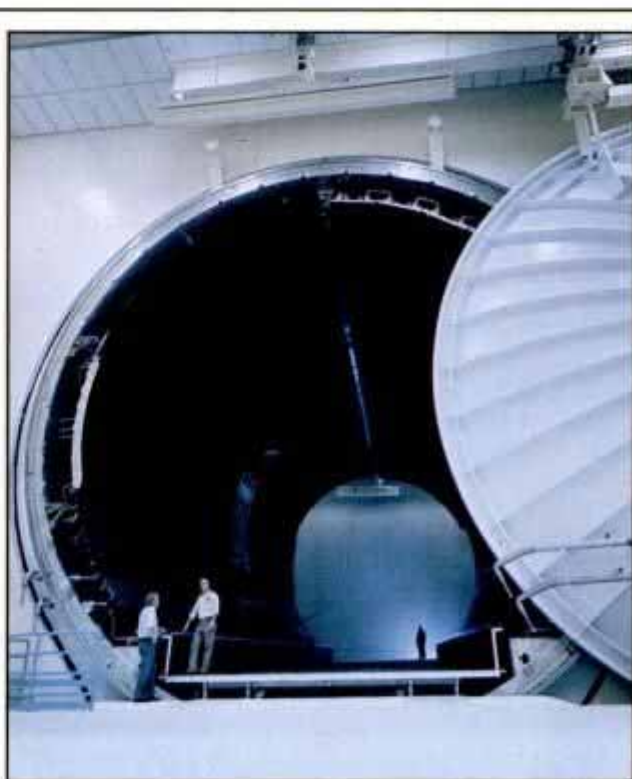

Lockheed's huge Dual-Entry Large Thermal Altitude chamber.

## Chamber Duplicates Space

Spacecraft and other systems intended for launch into space can be pre-tested in a huge chamber developed by Lockheed. The spacecraft is rolled into the 80-ft. x 40-ft. cylinder and subjected to extremely cold temperatures. Atmosphere is then withdrawn in three stages—first when mechanized pumps evacuate most of the air, second when helium cryopumps supplemented by turbomolecular pumps remove residual air, and third when residual gas is reduced by internal-cryopumping panels. Interior temperatures can sink to -280°F and chamber pressure can be reduced to  $\frac{1}{130}$  billionth of an atmosphere. The thermal-vacuum chamber weighs 350 tons, and the circular sliding doors weigh 30 tons apiece. The space test bed will be used to evaluate Milstar, the military communications satellite system of the 1990s.



## Lights For Future Cars

New aerodynamic-car designs have had an impact on headlight configurations. One proposal recently submitted to the Department of Transportation would reduce the size of individual headlights to a bare 2 in. x 3 in. to conform to contoured front ends, but would increase the number of headlights to eight—four on a side. Polyellipsoid-halogen lamps and homofocal reflectors would allow headlight to emit the same amount of light currently available. Spare lamps would fit in your glove box.

## Assault On Battery Design

It's been the dream of automobile designers for generations—a practical electric vehicle that can travel up to 300 miles at highway speeds. Scientists at Argonne National Laboratory in Chicago may have placed us one step closer with the recent introduction of a large lithium-iron-sulfide battery intended for installation in a van. The 216-volt battery (illustration) is equipped with air-coolant lines and a unique heat exchanger that moderates internal temperatures.

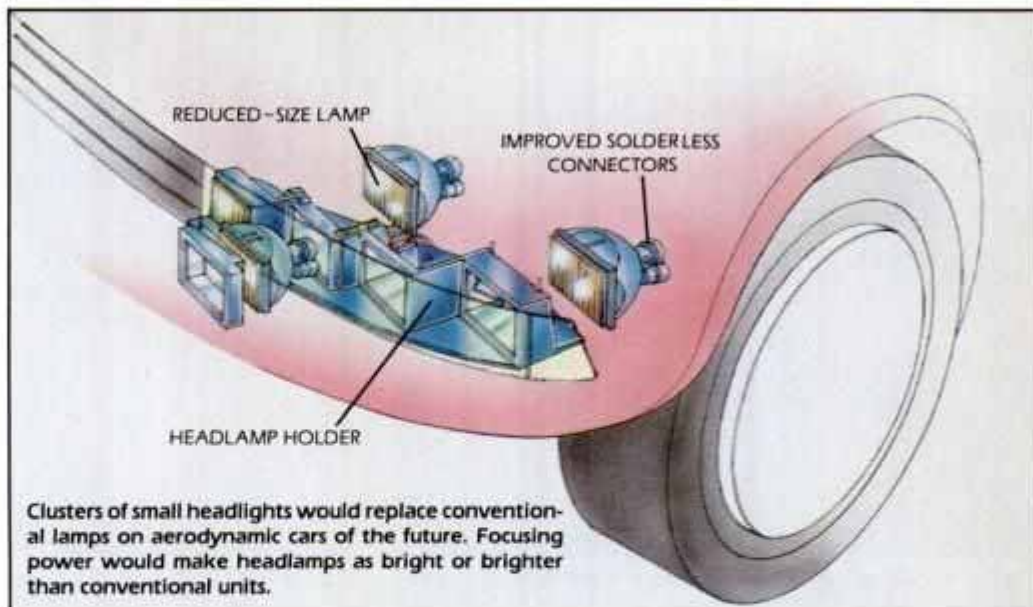

Clusters of small headlights would replace conventional lamps on aerodynamic cars of the future. Focusing power would make headlamps as bright or brighter than conventional units.

PM ILLUSTRATION BY LYNDA RICHARDS



UNIROYAL GOODRICH PHOTO

Steel wheel drilled for standard bolt holes is surrounded by spare's polyurethane vanes.



SENSOR DEVELOPMENTS PHOTO

The clamp-on transducer tells engineers how much force it takes to turn front-wheel-drive steering wheel.

## A Plastic Spare Tire?

The Uniroyal/Goodrich Tire Co. innovation was recently tested on a Chevrolet Cavalier Z-24. The non-pneumatic tire is made of an elastomeric-polyurethane ring that has been bonded to a center steel wheel drilled for standard

bolt holes. Polyurethane baffles comprise the space between the steel wheel and the tire tread. The baffles are patterned like the vanes of a turbine wheel. The unit weighs less than 6 pounds. Tread life is from 2000 to 3000 miles. Designers call it completely flatproof, and it may appear in the next decade.

## Measuring Steering Effort

The front wheels of a front-wheel-drive car tend to stay put when coming out of a turn unless the driver rotates the steering wheel hard enough to overcome forces acting against the steering system. It's a characteristic which has led to oversteering by some drivers more familiar with rear-wheel drive. To study this phenomenon and develop more driver-responsive steering, engineers rely on the Steering Effort Transducer, designed by Sensor Developments, Inc.

The clamp-on steering transducer helps carmakers measure precisely all forces reacting against a steering system, including tires, steering linkages, suspension, road-paving materials and steering-system geometry. It's also helping tire manufacturers gauge the effects of new tread design. 

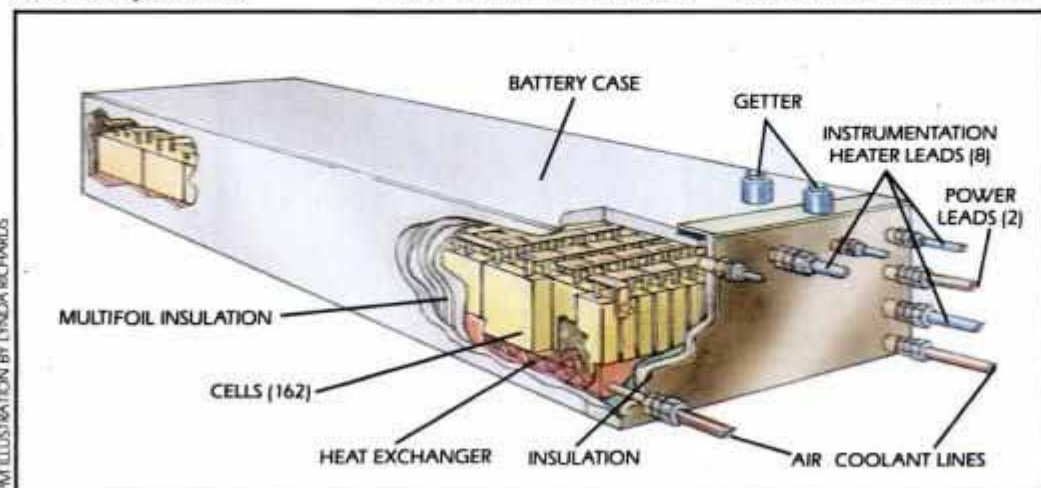

PM ILLUSTRATION BY LYNDA RICHARDS

Sophisticated cooling is at the heart of Argonne's lithium-iron-sulfide battery.



**Easy!**



# Water from your own backyard well!

With this reliable, convenient source of water you can supply your home, your garden, and with a water well heat pump you can even heat and cool your home for a fraction of the cost of conventional systems!

In the past, the cost of drilling a well made it uneconomical for anyone who could hook on to city water mains. However, as city water becomes much more expensive, backyard wells have become more and more popular. To hold the cost of drilling a well to an affordable level, an easy-to-use, low-cost machine has been developed for the homeowner who wants to drill his own. Called the *HYDRA-DRILL*, it is already in use around the world, and an estimated 100,000 *HYDRA-DRILL* wells have been drilled to date.

The *HYDRA-DRILL* can drill to depths of 200 feet, which puts you within reach of most of all the good, fresh ground water in the world. The typical *HYDRA-DRILL* well can produce over 4,000 gallons of water each day—just compare that with

the average U.S. family consumption of 500 gallons of water per day!

The *HYDRA-DRILL* is remarkably simple to operate. It is completely portable, and can be operated anywhere...even in places a truck-mounted drilling rig can't get. Yet it can drill most anything the big, truck-mounted rigs can drill, and drilling speeds range up to 40 feet per hour.

For free information concerning the *HYDRA-DRILL* and how you can drill your own water well, call or write TODAY!

DeepRock Mfg. Co., Opelika, AL 36802

**CALL TOLL-FREE**

**1-800-633-8774**

(Ask for Operator 5324)

AL, AK, & Outside U.S.A.: Call (205) 749-3377

Or clip coupon and Mail TODAY!

**DeepRock** 5324 Anderson Road  
Opelika, Alabama 36802  
Please mail your FREE Brochure.

Print Name \_\_\_\_\_  
Address \_\_\_\_\_  
City State Zip \_\_\_\_\_  
Phone \_\_\_\_\_ © 1987 DeepRock Mfg. Co.

Opelika, Alabama—What can you buy for a nickel and still get some change back? 500 gallons of water, that's what! As a matter of fact, the electricity to pump 500 gallons from your own backyard well costs only 3 or 4 cents.

## Exhaust-Away™

**Automobile Exhaust Removal System for the Home Mechanic**



**The safe, comfortable way to work on your car.**

- Takes exhaust fumes outside.
- Lets you work inside your garage.
- Also used by professional mechanics for more than 35 years.
- Withstands 600°F exhaust temperatures.

### Exhaust-Away Features

- 5-foot crush-proof 3" flexible rubber hose
- Tailpipe adapter with security chain
- Exclusive Safety Port™ vent

**Single Exhaust: \$49.50**

(Plus \$3.50 UPS shipping & handling)

**Dual Exhaust: \$98.50**

(Plus \$5.50 UPS shipping & handling)

**1-800-227-1817, ext. 10**

Visa or MasterCard

Patent Pending

Satisfaction guaranteed. Return in 30 days for full refund if not satisfied.

## FACTORY DIRECT GRANDFATHER CLOCKS

**Do-It-Yourself Case Kits**

Prices Starting At **\$159.50**

(movement and dial extra)

**OR Completely Assembled and Finished**

- Solid 3/4" hardwoods: black walnut, cherry, oak
- Heirloom quality
- Solid brass West German chiming movements and dials
- Easy to assemble kits or completely assembled and finished
- Money back guarantee



**SEND \$1 FOR 32-PAGE FULL COLOR CATALOG**



**EMPEROR CLOCK COMPANY**

WORLD'S LARGEST MANUFACTURER OF GRANDFATHER CLOCKS

Dept. 2425, Emperor Industrial Park  
Fairhope, Alabama 36532 • Phone 1-205-928-2318

I am interested in  Do-It-Yourself Kits  
 Finished Clocks

Name \_\_\_\_\_  
Street \_\_\_\_\_  
City \_\_\_\_\_  
State \_\_\_\_\_ Zip \_\_\_\_\_  
(please print)





*Bill Koch*  
8 time Nat'l X-C  
Ski Champion  
Olympic Silver Medalist  
World Cup Winner

## Scientific Study Ranks NordicTrack #1

In tests of exercise efficiency at a major university, NordicTrack burned more calories and provided greater aerobic workouts.

### Rank of Exercise Efficiency

1. NordicTrack X-C Ski Exerciser
2. An Exercise Bike
3. A Rowing Machine
4. A Shuffle-Type Ski Exerciser

NordicTrack's higher oxygen usage test scores show that more muscle mass is involved in the exercise and more calories are being burned.

### It's Only Logical that NordicTrack Would Get the Highest Scores

- because NordicTrack is more complete than an Exercise Bike.

Adds important upper body exercise. Provides more uniform leg muscle usage.

- because NordicTrack is more thorough than a Rowing Machine.

NordicTrack's resistance is proportioned according to the individual muscle strength—no major muscles are over-stressed or under-worked.

- because NordicTrack has inertial resistance not available on a Shuffle-Type Ski Exerciser.

Other ski exercisers use less efficient frictional resistance with a resulting calisthenics-like feeling. NordicTrack's unique flywheel resistance for a life-like feeling of smoothness and continuity is matched only by real skiing.

### Burns Up To 600 Calories per 20 Minute Workout

Free Brochure, and New Video!

800-328-5888

Minnesota 612-448-6987

**NordicTrack**  
© PSI 1986

141PM Jonathan Blvd. N., Chaska, MN 55318

# Bolt On Edelbrock



## Bolt On Performance

You probably notice poor engine performance most when your engine is operating mid-range under load. Passing, towing or loaded with cargo, the vehicle feels sluggish and unresponsive. It downshifts often and when you press the pedal, not much happens.

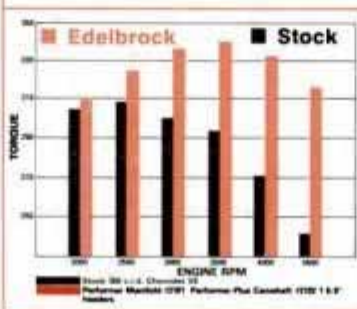

Edelbrock's Performer manifold is the 1st step to crisper throttle response, quicker acceleration and better fuel economy. The graph shows the significant gain in torque typical of an Edelbrock-equipped engine. Performer manifolds (available for emissions & non-emissions engines) team up perfectly with Performer-Plus camshafts, the dyno-matched cam ground specifically to work with the manifold.

This Performer/Performer-Plus combination is great for passenger cars, trucks, 4x4's, towing and RV's (any vehicle operating primarily off-idle to 5500 rpm). Performer-Plus camshafts come complete with lifter and lube. Compatible valve springs and timing chains for Edelbrock cams sold separately. Edelbrock parts available for most domestic engines.

Edelbrock is the official manifold of the IROC Camaros.



Products here sold by mail. \$154.95 plus shipping, handling & tax. Send \$2 for catalog and price list: Edelbrock Corp., 411 Coral Circle, Dept. PM987, El Segundo, CA 90245. Not legal for sale or use in CA on pollution controlled motor vehicles.

**Edelbrock**

## Wood-Mizer®

The World's Largest Mfr. of Quality Portable Bandsaw Mills

Now with Hydraulic Log Handling

- One Man Loads, Turns, Clamps
- Capacities up to 32" Dia. X 33' Long
- Safe—Precise—Efficient
- More Lumber per Log

FIVE MODELS AVAILABLE



BUY DIRECT—3 FACTORY SALES LOCATIONS. For our 44-Page Catalog, Send \$1.00 to: Wood-Mizer®, Dept. 032, 8180 W. 10th Street, Indianapolis, IN 46214 or Call (317) 271-1542

## MEN PAST 40

Troubled With Getting Up Nights  
Pains in Back, Hips, Legs  
Nervousness, Tiredness

If you are disturbed by these symptoms, your troubles may be caused by glandular inflammation of your prostate. Methods that merely give temporary relief for this condition cannot be expected to remove the cause of your trouble.

The Excelsior Institute Clinic, devoted to the **NON-SURGICAL** methods of treatment for diseases peculiar to older men, has a new **FREE BOOK** that tells how these troubles may be corrected. The **NON-SURGICAL** treatments described in this book require no surgery, hospitalization or long period of convalescence. Treatments take but a short time and the cost is reasonable.

Write today. This book may prove of utmost importance to you. No obligation.

Excelsior Institute Clinic, Dept. 129B  
110 E. Broadway, Excelsior Springs, Mo. 64024



# WORTH WRITING FOR

**361 HOW TO BEAT COLD FEET**

Color booklet from Red Wing explores how to keep your feet comfortable in cold, wet weather. Discussion centers around how your body reacts to cold and how to best insulate and keep feet dry in harsh conditions. Free

**362 GET WIRED**

On-Wall™ Wiring brings electrical power where needed without breaking through walls or ceilings. Color pamphlet gives basic information on installing outlets, switches and fixtures. From The Wiremold Company. Free.

**363 TRAVEL RIGHT**

ZIPLOC® Brand Storage Bags 8-page brochure on how advanced preparation is the key for making business or personal travel rewarding and enjoyable. Includes tips on how to get organized, including a don't forget check list. Free

**364 HOLD THAT AIR!**

Mortell's 16-page pocket-sized guide will show you how to check your home for energy waste and will provide solutions for problem areas by using weather-stripping. Free

**365 ACTIVE TRACTOR**

Massey-Ferguson's 12-page, full-color brochure illustrates their full line of home tractors from 16 to 35hp. Available in 2 or 4-wheel drive, the many attachments make them suitable for mowing, tilling, snowblowing and more. Free

**366 LEATHERCRAFTER'S DELIGHT**

The 48-page Stamped Leathercraft Supply catalog offers quality leathers, tools, stamps, hardware, finishes and kits. \$1.00 (Refundable)

**367 CULTURED DECOR**

Cultured marble and onyx are man-made molded products reproducing the beauty of these natural substances at a much lower cost. The Cultured Marble Institutes' 4-color brochure describes advantages, uses for bath, kitchen, wall panels and more. Free

**368 PORTABLE POWER**

Coleman Powermate™ offers a full line of generators, ranging from 500-7000 watts for DIY projects, recreation and home standby. Color brochures provides specifications and uses. 50¢

**369 WOODWORKING PLANS**

Popular Mechanics' new catalog of plans shows how you can build everything from a bookcase wall to a hovercraft. Hundreds of plans listed, plus a complete selection of how-to books and videotapes. \$1.95

**370 SATELLITE SENSE**

Winegard's "All You Need To Know About Satellite TV" answers the most-asked questions about home satellite television. Includes valuable illustrations and a glossary of technical terms. Free

**371 GO BLOW YOUR SNOW**

Ariens' new 30-page, color catalog features their full line of Sno-Thros™. Includes specifications and photographs of attachments, accessories for both walk-behind and tractor snow blowers. Free

**372 3-STEP PAINT REMOVAL**

Klean-Strips' 8-page color booklet assists the DIYer in choosing the right paint remover. Detailed instructions illustrate how to remove paint from furniture and the refinishing touches to restore its original beauty. Free

**373 TV TIPS**

A comprehensive 32-page brochure from Winegard includes tips on improving your TV reception and how to install your own TV antenna. Plus a glossary of technical terms and do's and don'ts of rooftop antenna erection. Free

**374 HELPFUL HORSE**

Color literature from Cosco details how the Buck-horse™ functions as a total work support system. Photos show how it serves as a sawhorse, sawbuck and a self-stabilizing work surface. Free

**375 CONTEMPORARY HOME PLANS**

Home Planners Inc. offers new dimensions in living that are refreshingly different, yet practical and economical. Floor plans from 1200 to 3000 sq. ft.; one, 1½, two-story and multi-levels. 112 pages. Blueprints available. \$3.95

**376 THE INFORMANT**

Regency's color brochure gives in-depth details about their Model INF-1. A radio that can seek out and scan all standard police and weather frequencies. Free

**377 STOW, STOW, STOW AWAY**

Gold Eagle's booklet explains the problems that can arise when lawn mowers, boats and RVs are stored for over 60 days. Tips on how to store properly and eliminate storage woes. Free

**378 REVIEWED YOUR INSURANCE NEEDS LATELY?**

Growing family? New home? Changed jobs? Recently retired? Chances are you'll find it's time to update your insurance protection. Union Fidelity Insurance would like to show you how to meet your changing insurance needs. Free

**379 SAVE MONEY WHILE YOU CONSERVE ENERGY**

Catalog offers new line of energy-saving fluorescent safety and security flood lights, porch and post lamps, decorative lights. Add beauty, safety and security to your home and business. \$2.00

**380 BOOKCASE WALL**

Make your living or family room appear larger and classier with POPULAR MECHANICS' floor-to-ceiling bookcase wall. Detailed, easy-to-follow plans make it simple to build. With cabinets on the bottom and bookshelves on top, you'll be amazed at all the storage space it provides. \$5.95

**381 WHERE'S THE FISH**

Furnuo's 14-page color catalog presents new compact high-performance fish finders that seek down to 640 feet. Features include full-size 6" display screen, high resolution LCD and microprocessor controls. Free

**382 LIGHTING YOUR LIFE**

A 24-page guide to home lighting from the American Home Lighting Institute. Everything you need to know about determining your lighting needs, options available and energy saving tips for every room and outdoors. Free

**383 SPAGE-AGE LUBES**

Progressive Energy's brochure features automobile lubricants that reduce engine temperature and friction, thereby increasing HP and performance. Also, works in differentials, transmissions and gear boxes. Free

**384 HOLIDAY GIFT CATALOG**

The Swiss Colony-Gifts of perfect taste. More than 1,000 gift ideas. Zesty cheeses, hearty sausages, delicious pastries, candies, fruit and more. 200-page catalog. Free

**385 DO-IT-YOURSELF VINYL FLOORS**

It is easier than you think to install vinyl flooring in your home. Armstrong Trim and Fit™ floors are made especially for DIYers. Folder contains complete shopping selection tips, information, photos and a copy of the warranty. Free

Popular Mechanics 9/87  
Box 1718, Sandusky, Ohio 44870

Please see that I receive the items checked below

- |                              |                                     |                              |                                     |                                     |                              |
|------------------------------|-------------------------------------|------------------------------|-------------------------------------|-------------------------------------|------------------------------|
| <input type="checkbox"/> 361 | <input type="checkbox"/> 366 \$1.00 | <input type="checkbox"/> 370 | <input type="checkbox"/> 374        | <input type="checkbox"/> 378        | <input type="checkbox"/> 382 |
| <input type="checkbox"/> 362 | <input type="checkbox"/> 367        | <input type="checkbox"/> 371 | <input type="checkbox"/> 375 \$3.95 | <input type="checkbox"/> 379 \$2.00 | <input type="checkbox"/> 383 |
| <input type="checkbox"/> 363 | <input type="checkbox"/> 368 50¢    | <input type="checkbox"/> 372 | <input type="checkbox"/> 376        | <input type="checkbox"/> 380 \$5.95 | <input type="checkbox"/> 384 |
| <input type="checkbox"/> 364 | <input type="checkbox"/> 369 \$1.95 | <input type="checkbox"/> 373 | <input type="checkbox"/> 377        | <input type="checkbox"/> 381        | <input type="checkbox"/> 385 |
| <input type="checkbox"/> 365 |                                     |                              |                                     |                                     |                              |

This Coupon Expires November 30, 1987

Total money for priced items \$ \_\_\_\_\_

Service Charge \$ \_\_\_\_\_ .50

Total money enclosed \$ \_\_\_\_\_

Total items requested \_\_\_\_\_

Name (Please Print) \_\_\_\_\_

Address \_\_\_\_\_

Town \_\_\_\_\_ State \_\_\_\_\_ Zip Code \_\_\_\_\_

(Please send cash, check or money order made out to POPULAR MECHANICS. No stamps, please)

**Note: Popular Mechanics processes your requests for the above information and forwards these inquiries to the organization making the offer. Each company mails the material directly. Your order will be on its way to you within 90 days.**





## ONE-MAN Sawmill

The Only  
ONE-MAN  
PORTABLE

### SAWMILL Of Its Kind In The World!

If you need good, high-quality lumber, don't let inflated lumber prices stop your important building projects. The Foley-Belsaw goes right to the trees and turns out smooth, true-cut lumber... even beginners get excellent results. Just one man (no crew needed) can easily cut enough on weekends to save hundreds of dollars over high lumberyard prices. For power use tractor PTO or other low HP diesel or electric unit. Factory-direct selling keeps price low, and convenient time payments may be arranged.

Send for **FREE BOOK!** Just mail coupon below for "How To Saw Lumber" booklet and complete facts on the One-Man Sawmill. There is **NO Obligation** and **NO Salesman Will Call on you. Do It TODAY!**

**FREE BOOK**

Foley-Belsaw Co.  
6301 Equitable Rd., Dept. 30783  
Kansas City, Mo. 64120

**FOLEY BELSAW**

Please send all facts and details in your **FREE BOOK "How To Saw Lumber"**. I understand there is **No Obligation** and that **No Salesman** will call on me.

Name \_\_\_\_\_

Address \_\_\_\_\_

City-State \_\_\_\_\_ Zip \_\_\_\_\_

## Magnifying Reading Glasses



Send for your **FREE Catalog** today. Our 16-page catalog features 40 styles of magnifiers priced from \$9.98, plus many other helpful vision aids and useful products, such as our new magnified sunglasses and fisherman glasses.

NAME \_\_\_\_\_

ADDRESS \_\_\_\_\_

CITY STATE ZIP

PRECISION OPTICAL Dept 132-R, Rochelle, IL 61068

# ban the flush!



**Envirolet.**  
The Ecological Toilet System

- NO WATER
- NO CHEMICALS
- NO SEPTIC TANK

Sancor Industries Ltd.

140 - 30 Milner Ave., Scarborough, Ont. M1S 3R3  
(CDA 416-299-6586)  
in U.S.A. TOLL FREE 1-800-387-5126

## BIG EYE ON THE SKY

(Continued from page 63)

the most important advance over the original survey," notes Brucato. "They have far better signal-to-noise ratio which means darker backgrounds, higher contrast and the ability to detect fainter objects."

Alan G. Millikan of Eastman Kodak's research labs in Rochester, New York, invented the new emulsions 15 years ago. The three fine-grain monochrome (black and white) emulsions, "tuned" in sensitivity to blue, red and near-infrared light, also have extremely low reciprocity failure. Reciprocity failure is the tendency of most photographic emulsions to rapidly become less sensitive to light after the first few minutes of exposure.

Kodak's scientific products marketing planner, Gordon P. Brown, says a key to the new film's effectiveness is a technique called preprocessing hypersensitization, which greatly reduces reciprocity failure and effectively increases film speed.

A few weeks prior to exposure, the plates are placed in a vacuum chamber that is filled with nitrogen. Before the film is used, the chamber is filled with hydrogen, which purges moisture and oxygen from the emulsion.

"This cuts the exposure time in half,"

says Brown. "It adds up when you consider that a modern observatory can cost \$5000 a night to operate."

What will the Palomar Sky Survey ultimately yield? Simple reference for one thing. The rotation of the Milky Way Galaxy has changed the position of thousands of stars in the past 30 years.

"Modern computers and machine vision techniques can accurately measure the position and brightness of stars right from the plates and compare them to the old survey," says astronomer David Monet of the U.S. Naval Observatory in Flagstaff, Arizona. "With this 30-year baseline, the motions of many nearby stars can be measured."

Mapping the wholesale flow of stars in our galaxy will allow an accurate measure of the gravitational forces acting on them. Astronomers particularly keep getting their hands on such data because preliminary analysis by less detailed methods suggests that invisible matter amounting to up to half the mass of our galaxy is influencing star motions. Many astronomers suspect the real treasure of the sky atlas will be the millions of galaxies that were missed in the old survey.

"Mapping these galaxies may show how galaxies are clustered and where there are voids," muses Schombert. "It could give us a picture of the structure of the universe." **PM**

## The Supernova's Twin

It exploded into the heavens over the Southern Hemisphere last February 23, producing the energy output of an entire galaxy of billions of stars. And even though the supernovas like the one observed by scientists at Chile's Cerro Tololo Observatory are extremely infrequent and unpredictable, it has already yielded a mother lode of astronomical information. According to Dr. Robert W. Noyes of the Harvard-Smithsonian Center for Astrophysics, the exploding star may actually be two pinpoints of light very close together, with one pinpoint about 10 times brighter than its companion. To Dr. Noyes and his colleagues, "very close together" means 3000 astronomical units, or 3000 times the

distance between the Earth and sun—about 279,000,000,000 miles. Scientists speculate the two points of light may be the result of gravitational lensing, a phenomenon that occurs when an extremely massive object bends light passing near it.

The last supernova seen in our sector of the universe occurred in 1604. The supernova drought during the next 383 years ended when one appeared as a medium bright star in the Large Magellanic Cloud, the nearest galaxy to the Milky Way. The stellar cataclysm actually occurred 170,000 years ago, but it took that long for the light to traverse the 170,000 light-years between it and us.

—Terence Dickinson

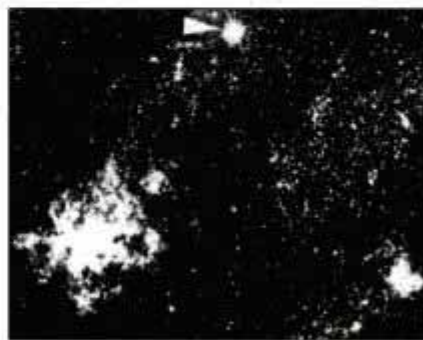
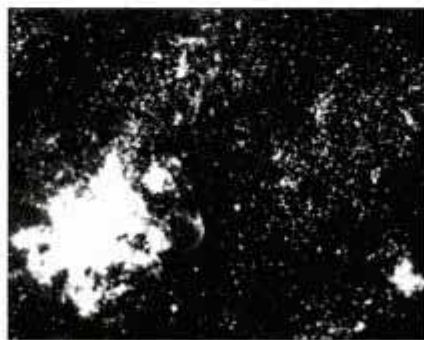

The astronomical event of the decade: The 1987 Supernova is nowhere to be seen in view of the Large Magellanic Cloud, left. But it flares into view in the photo at right (arrow).



# \$25,000,000,000

## The Government Holds For You

Would you like to stake a share of the \$25,000,000,000 the government holds for just making a few phone calls and looking in some phone books? That is all you have to do to enjoy thousands of dollars. If you can read English and can speak on the phone, you can make thousands of dollars overnight—and you don't have to do any selling at all.

This ad will explain every detail of an exciting new business that has never been advertised or attempted before—what's more, you can enter with absolutely no money.

Life was not always rosy for me. I got involved in a bad business investment a few years ago and lost about \$11,000. Everything I owned was taken away from me. I needed money desperately to feed my family, so I was forced to toil as a waiter at the Sheraton Harbor Island Hotel in San Diego by night, and I was a filing clerk during the day. It was so exhausting, that as soon as I got home, I would sleep for just a few hours, wake up in a stupor, drink four cups of coffee, and then scramble to my next job. I had no choice. It was the only thing I could do to stop disappointing my loved ones. I remember coming home on Mother's Day really eager to call my mother, only to find that my phone had been disconnected. I went through the mail praying for some good news, only to find an envelope with no return address—it contained an eviction notice. At this point I thought we would have to live in our beat-up Fiat. We were fortunate to have relatives that were kind enough to let us stay with them. I never knew life could be so miserable. I sat down on the sidewalk just realizing how much being in debt could hurt. With tears in my eyes, I prayed for a way out.

My friend Gary, who was in the same financial boat as I was told me a story that changed my life forever. He told me very excitedly, "I received a funny-looking letter. When I first saw it, I thought it was another creditor making a claim on me. The letter told me about money that was rightfully mine—it said that if I signed the enclosed form, I would receive \$2,592.59. Things were so bad that I had nothing to lose, so I signed the form neatly and returned it to the company.

"Ten days later I received a check for \$2,592.59 with an explanation. A distant aunt had died and left \$4,320.98 in her savings account. The company that found me collected \$1,728.39. The firm had no trouble finding out that I was related to her. Just for matching up people with the same last names, that agency was making millions every year."

It was just then that an amazing idea popped into my mind. I was overcome with excitement; this revolutionary system was so simple, yet I knew it would take me out of my rut. I was compelled to find out more about it. I had lost everything I owned; what else could

I lose? I found out everything I could and began to work on a plan. I put it into effect. My prayers were heard. To my relief I started to make more money than I have ever seen in my life for doing practically nothing. In fact, my income for just last month was \$50,076.78.

### Testimonials

*I have been able to locate and notify 421 claimants (worth \$20,197,323.97 in claims). I was even contacted by a Texas ranger that thought I was running a scam. Later when the ranger understood what I was doing he told me I could use him for a reference. I have made over \$300,000 since I last wrote you Dave.*

**Herb H., TX**

*Due to the methods in your book I was able to secure \$16,212 with the help of my brother. I had to get my 16 year old brother to help me because I am under age. I am 15 years old and have been traveling to Miami, Jamaica, St. Croix, New York. I'll be going to England very soon and L.A. Thank you for helping me make money with your system.*

**Andre I., CT**

*I've spent at least \$7,000 on money-making books and seminars. The difference between them and your method is that yours works! In less than three weeks (part time) I was able to secure \$52,614.21. Thanks for a business that will easily make me \$100,000 this year. If I can ever be of service just call.*

**Steve S., CO**

*Having read your book, I have recently launched into the fascinating endeavor of locating people. As a result, I have succeeded in finding an individual with a fairly large sum of money.*

**Ben S., CA**

*Thank you so much for the methods outlined in your book. I was able to secure \$24,685 in just six hours of work. I have read just about all the other "get rich" books but yours has to be the best.*

**Terrie, T., MI**

I had a C-minus average in high school—one year, I received an F in English. By no means was I ever considered to have the smarts. But I did it. All you have to do to make large amounts of money is thumb through phone books and make a few phone calls.

Last summer we moved into a gorgeous home. My wife told me it was her life long dream to own a brand new car. You should have seen her tears of joy when I surprised her with her own new \$20,000 car. Later I bought a 1986 Mercedes 560SL that cost me \$56,000.

The amount of money I was making was incredible. Just as a hedge against taxes, I bought two three bedroom houses valued at \$200,000.

Twenty-five billion is just sitting there waiting for someone to recover it. One out of ten Americans have forgotten or lost money in bank accounts, stocks, insurance premiums, etc. I will disclose a plan to you that will show you how to get your hands on this money.

Only 10 percent of the rightful owners claim their share of the \$25 billion. The states make no strong effort to contact the rightful owners. Why should they, when unclaimed property is their biggest source of revenue, second only to taxes? The states are required by law to make a list of unclaimed owners. These lists are hard to find but I will show you how to get every one that the states publish. And in some cases, they're free.

Let me give you a random sample list from the state of Wisconsin. (Addresses are included in lists.)

Owner's Name	Property	Amount
Drinka, Teresa, A	Savings	\$10,891.47
Lavelle, Samuel	Stock Proceeds	\$21,529.61
McDonnell, Martha	Savings	\$12,843.78
Meyer, Thusneida	Savings	\$18,489.18
Patterson, Arthur	Savings	\$14,629.24
Stien, George	Savings	\$57,525.83

This listing is only a minor portion of the \$25 billion in unclaimed property that is waiting for you.

To make thousands of dollars, all you need are telephone books and a phone. The proven system in this book can be learned in a half hour. After that, you are all set. If you can read English and can speak on the phone, you're in business. It's as easy as that.

### Sample Proof

Bonnie Goldstein, a well-known syndicated newspaper writer who doesn't know anything about finding people, located the owners of \$4,100 in two and a half hours with two telephone directories—she said so in the *San Francisco Sunday Examiner & Chronicle*.

### My Guarantee

Send for my complete guide to recovering unclaimed money. Read the simple formula that has been tailored for each individual state. Sit down and make the required few phone calls and directory searches. After following the simple formula, you must be able to recover \$10,000 in one day or your complete payment will be returned to you.

This opportunity can give you a new home, car and all of the luxuries money has to offer. There is a definite flaw in our revenue system, and you can profit from it.

David Bendah (619) 265-8777  
6602 El Cajon Blvd., Suite B, Dept. 513H  
San Diego, CA 92115

Dear Dave:

Send me your complete guide to recovering \$25,000,000,000 in unclaimed money on the condition that I must be able to locate \$10,000 easily in one day with your book or you will return my entire payment.

On that basis, here is my \$10.

Name \_\_\_\_\_

Address \_\_\_\_\_

City \_\_\_\_\_ State \_\_\_\_\_ Zip \_\_\_\_\_

Please add \$1 dollar to cover part of the shipping costs. All checks must be accepted by TeleCheck; payments not accepted will be returned in full.



**Homeowners!**

# Rid Your Property of Unsightly Brush Piles!

Turn a mess like this...



into beautiful **FREE** mulch in less than one hour!



**NEW**  
3 1/2 HP MODEL available

© 1987 Garden Way Inc.

...with the Amazing New **SUPER TOMAHAWK® Chipper/Shredder... exclusively from Garden Way!**

- It's a powerful Chipper... handles big branches up to 3" in diameter with ease!
- It's an efficient Shredder... turns almost any organic matter into perfect mulch and compost instantly!
- Revolutionary New Compact Design... 7 ways better than bulky "old-style" chipper/shredders!
- Professional Quality... designed, sized and priced for the homeowner!

Send for **FREE** details today!

FROM THE MAKERS OF  
**TROY-BILT**  
- Roto Tillers -

Garden Way Mfg. Co., Dept. A613  
102nd St. & 9th Ave., Troy, N.Y. 12180 3 13

**YES!** I want to know more about the amazing SUPER TOMAHAWK Chipper/Shredder! Please send me complete details including prices, models and SPECIAL SAVINGS OFFER right away!

Name \_\_\_\_\_  
Address \_\_\_\_\_  
City \_\_\_\_\_  
State \_\_\_\_\_ Zip \_\_\_\_\_

## Big on Quality - Low on Cost!

**PowerPro**  
5 HP/60 Gallon  
Air Compressor

- ASME rated, 60 gal. tank. • 5 HP motor. • 230V, 15 amp. • 932 RPM. • 125 lbs. max. pressure. • ACFM of 40/90 PSI - 11.8/9.4. Service centers nationwide. • Overall: 28 1/2" L x 23 1/2" W x 71 1/2" H. • Wt.: 340 lbs. • 1 year limited warranty from mfg. • Made in the U.S.

Compare at \$1200.00  
Order No. P6207-2094  
Ship. Frt. Col., . . .  
Ship. Wt.: 340 lbs.

**\$466**

**Folding Universal Aluminum Ladder**

Great for reaching second-story windows and bathroom tree branches! Can be used as a 12' ladder, 2-man scaffold, also fold & secure at 90° to work in stairwells. Six specially designed hinges rotate to any of 3 positions and lock! Features: • Made of heavy gauge aluminum. • Built to industrial standards. • Folded size: 23 1/2" L x 9" W x 40 1/2" H. • Weight: 30 lbs.

Compare at \$130.00  
Order No. P6247-1310  
S. & H.: \$14.00

**\$89**

**19,400 BTU Kerosene Heater**

Perfect for the home, cottage, or cabin!

- 1.9 gallon tank. • 18 hour continuous heat.
- Pushbutton ignition-battery powered (2-D size batt. - not incl.).
- Auto shut-off. • Fiber glass wick.
- 23" H x 18 1/2" dia. • 1 yr. ltd. wty.!
- **FREE PUMP!** to first 500 orders!

Mfg. Retail: \$149.00  
Order No. P6357-2250  
S./H.: \$10.50 . . . . .

**\$99**

Wt. 35 lbs.

**6000 Watt Power Generators**

Auxiliary power during outages, in the field, or at the cabin! Both models feature: • 8 HP Briggs & Stratton engine. • Magnetron® solid-state ignition. • 1-120V duplex & 1-240V duplex receptacles, 36.7/18.3 amps. • 6000 watts surge, 4400 watts continuous power. • Rotary field design. • Circuit breakers. • 1 year limited warranty.

Compare at \$1200.00  
Order No. P6240-1034

**\$499**

Compare at \$1000.00  
Order No. P6240-1018

**\$399**

Both Models: Shipped Freight Collect

**A. Recoil & Electric Start** - 29 1/2" L x 20 1/2" W x 19 1/2" H. Shipping Wt.: 152 lbs.

**B. Recoil Start** - 25" L x 17 1/2" W x 17 1/2" H. Shipping Wt.: 129 lbs.

60 Hz

### Wholesale America, Inc.

4777 Menard Drive, Eau Claire, WI 54703

For Mail-in Order - type/print on clean paper product name(s) & order no.(s) along with your name & address. Send check/money order payable to Wholesale America, Inc. (note: add ship./hand. chgs.). To charge to MasterCard, VISA or DISCOVER, give acct. #, exp. date and sign name. Allow 7 days for UPS delivery. Add 3-4 wks. for check orders & freight collect items. Residents of AK, HI, Canada, Puerto Rico, and Virgin Islands, add 50% to ship./hand. WI residents - add 5% sales tax.

Send \$1 for the latest Money-Saving Catalog from Wholesale America! Includes Huge Savings on Power Tools, Hardware & Housewares!

**10 DAY No Hassle Guarantee!**

For credit card orders: **1-715-874-5000** or **1-800-826-3403**

ORDER TODAY!!

**DON'T BUY! BEFORE YOU TRY!**

**TEST PIPE**

Be Sure Your **CATALYTIC CONVERTER** Needs To Be Replaced

**SAVE \$\$\$**

from \$5.95 to \$17.95  
AIR TUBE \$10.00

**MSA Mfg. Co., Inc.**  
MUFFLER SYSTEM ADAPTOR MFG. CO.  
PO-138 New Bedford, Ma. 02745  
Telephone 800-225-8142 or 617-994-9620

**BUILD YOUR OWN ROCKET MOTORS!**

- 40 POUNDS THRUST!
- FIFTY CENTS EACH!
- BUILD A DOZEN IN AN EVENING!

Write for our catalog and we'll send you a WORKING SAMPLE of an electric igniter that YOU CAN MAKE YOURSELF from materials you'll find around the house.

Send \$2.00 to: **THE TELEFLITE CORPORATION**, Dept. PM9, 11620 Kitching St., Sunnymead, Calif. 92388

**TELEPHONE LISTENING DEVICE**

Record telephone conversations in your office or home. Connects between any cassette or tape recorder and your telephone line. Starts automatically when phone is answered. Records both sides of conversation. Stops recorder when phone is hung up.

1 1/2" Dia. 10" in.

**\$19.95 EACH** (In the U.S.)

**Super Powerful FM TRANSMITTER**

Many times more powerful than other transmitters. Transmits up to 1/2 mile in any FM radio - Easy to Assemble Kit - up to 9V battery (not incl.) For catalog of Transmitters, Voice Scrapers and other specialty items, enclose \$2.00 to USI Corp.

Call 309-729-1000 or write \$19.95 + \$1.00 shipping to: USI Corp., Dept. PM9, P.O. Box 205, Moline, Ill. 61201, COO'S OK.

**At Least a New Amazingly Simple GAS TURBINE JET ENGINE**

Build from easy to follow plans. Length 15", Dia. 8 1/2", Wt. 15 lbs. Fuel: Gasoline or Kerosene. Screaming Demon™ develops 20 H.P. Ideal project for serious-minded hobbyists, students, scientific and industrial arts classes. Make an 8" metal cutting lathe with milling attachment. For use on small racing boats, model cars, etc. Full size assembly drawings with critical dimensions, bill of materials and photos. Price \$100.00 No. C.O.D. SAVOY SCIENTIFIC 1510 28th St. P.O. Box 1398 SANTA MONICA, CALIF. 90406

**Pay For Your Hobby!**

With White's NEW Series 3 Metal Detectors

Sensitive detectors locate the rare and valuable for fun and profit. \$99.95 & up!

Call Toll Free: 1-800-547-6911  
**WHITE'S ELECTRONICS**  
Dept. PA-6 Sweet Home, OR 97386

**MUSCLES**

HOW TO BUILD A MORE POWERFUL BODY!

Free Booklet

New Muscle Pumping Methods gives you wider shoulders + trimmer waist + Powerful chest + Bigger arms + Gain weight and strength. Write today!

**UNIVERSAL BODYBUILDING**  
Dept. 04, BOX 6864, DETROIT, MI 48240

**LOSE FAT!**



# THE BETTER HOME

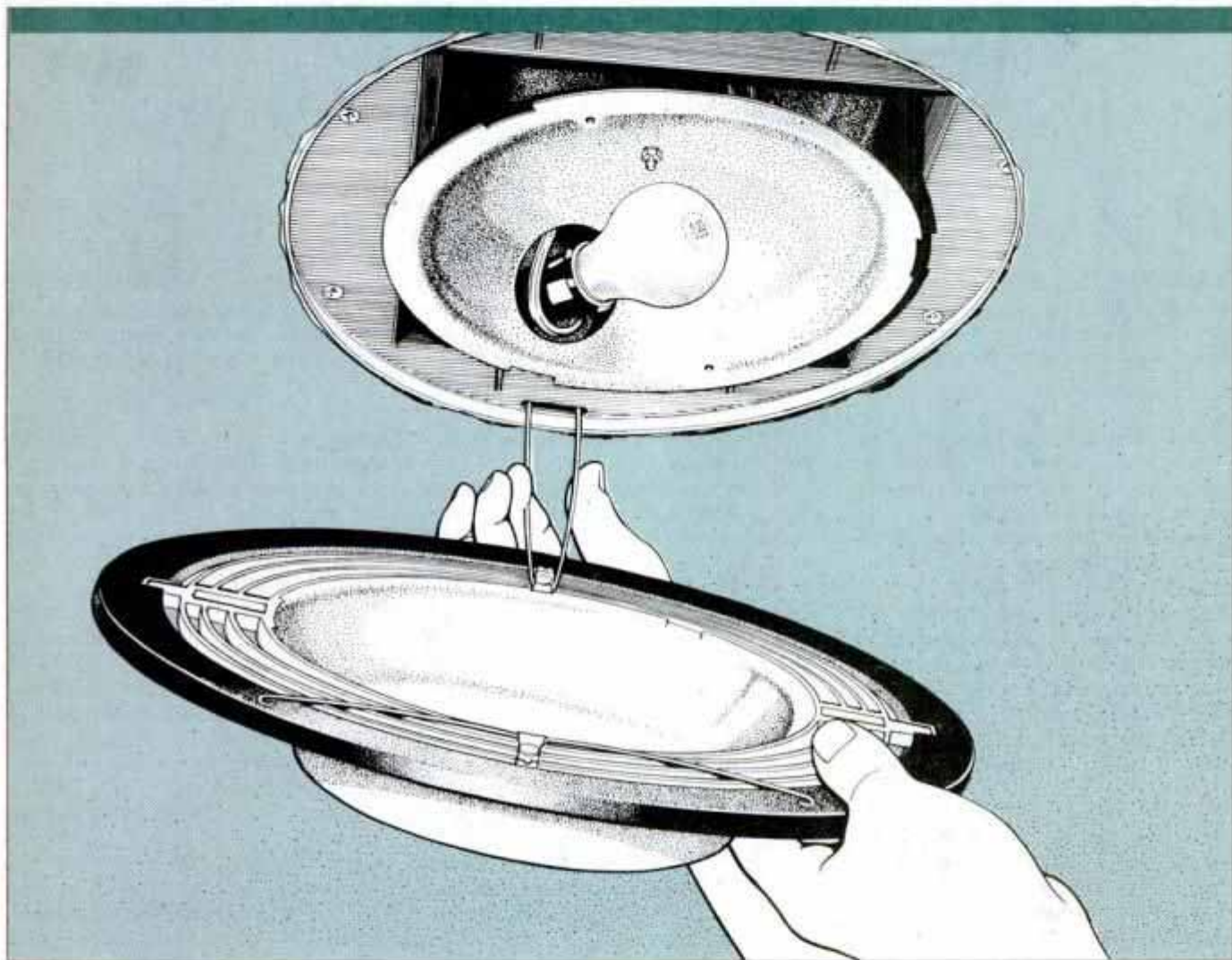

## How To Install A BATHROOM VENTILATOR

**E**ver since the energy crunch of the mid-1970s, homeowners have been busy sealing drafts and adding insulation to combat energy loss—both heating and cooling. However, while these conservation measures are effective in saving energy, in many cases they create a new problem: inadequate ventilation. Many good-intentioned homeowners have buttoned up their houses so tight that stale room air and moisture have no way to escape. Proper ventilation is especially important in the bathroom where excessive

BY PAUL BARRETT  
Illustrations by George Retseck

moisture can ruin paint, wallpaper and, eventually, the wall itself and the insulation behind it.

Most bathrooms have a window for ventilation. But, it's inconvenient to open and close the window every time someone uses the bathroom, showers or shaves. And in the winter months, the window is seldom, if ever, opened.

An effective way to end moisture problems in any bathroom—with or

without a window—is to install a ventilator unit. A ventilator is simply a ceiling-mounted exhaust fan that draws out moist, stale room air and vents it through a duct to the outdoors. If your bathroom is located on the top floor, it is easiest to vent the unit through the roof. For bathrooms situated below another floor, you'll need to vent it through the house wall. We show how to handle both types of installations here.

Ventilators are available in a wide variety of styles and sizes to suit your needs and decor. They're sold at home



# THE BETTER HOME

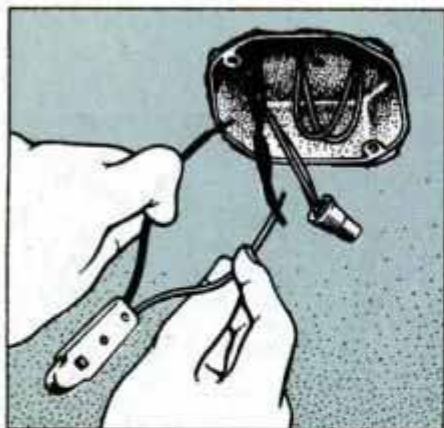

**1** Hold probe of tester on hot lead (black wires) and touch other probe to metal box. Power is off if the tester doesn't light up.

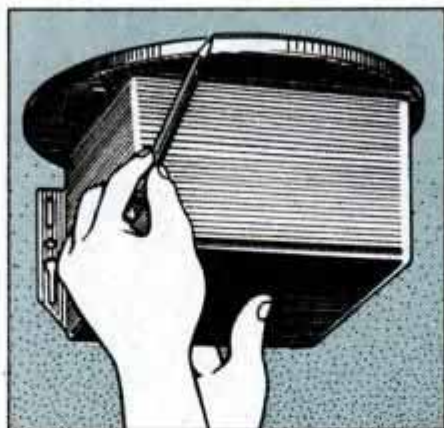

**2** Hold the ventilator housing upside down against the ceiling and trace around its flange with a pencil to mark the cutout.

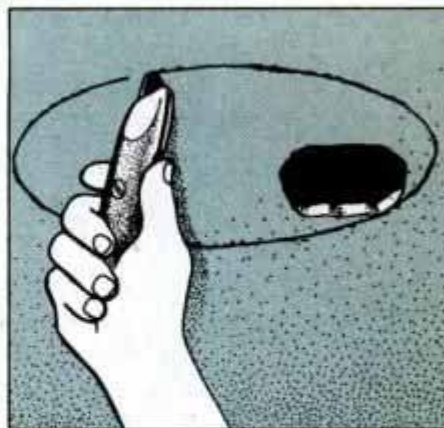

**3** Cut away ceiling with a utility knife. Off-center cutout positions electrical box on ventilator nearest to the power cable.

centers and kitchen and bath showrooms. We installed a NuTone ventilator (model No. 8663-DG) that is a combination exhaust fan and light.

For more information, contact NuTone, Inc., Madison and Red Bank Rds., Cincinnati, OH 45227.

Ventilators are rated according to the cubic feet of air they exhaust per minute (cfm) and by their operating noise level, which is measured in sones.

One sone, for example, is equivalent to the sound made by a modern refrigerator. A typical ventilator operates at about 3 to 4 sones.

To determine the volume of your bathroom, multiply: length  $\times$  width  $\times$  height. An 8  $\times$  10-ft. room with an 8-ft.-high ceiling contains 640 cu. ft. Therefore, a 100-cfm ventilator will exchange the room air in about 6½ minutes and more than nine times per hour. When selecting your ventilator, keep in mind that the minimum recommended air exchange rate for bathrooms is eight changes per hour. Also, some ventilators can be placed directly over a tub or shower stall. For this type of installation, though, you must use a ground-fault circuit-interrupter (GFCI) as an added safety precaution against electrical shock.

In addition to the ventilator, you'll also need a length of round duct, either flexible or metal, a vent cap for mounting to the roof or sidewall, and, if any rewiring is necessary, some nonmetallic sheathed electrical cable.

## Installation Procedures

The installation shown is the most common and easiest: replacing an existing ceiling-mounted light fixture with a fan-light ventilator. For other installations, you'll have to tap into a nearby circuit

and run an electrical cable to the ventilator's location.

Begin by shutting off the power to the light fixture at the fuse box or circuit breaker panel. Remove the light fixture to expose the electrical box. Next, use an electrical circuit tester to check that power to the circuit is indeed off. Place one probe of the tester on the hot lead (black wires) and hold the other probe on the metal box (Fig. 1). Just to be safe, check the other lead, too.

When the tester verifies that the power is off, then it's safe to proceed. The box will be wired either at the end of an electrical run or, more likely, in the middle of a circuit. In either case, remove the existing electrical box. All the electrical connections will be made later in the junction box on the ventilator unit itself.

Notice that the box on the ventilator is usually positioned off to one side—it isn't mounted in the center of the unit. Therefore, it's important to position the ventilator so that its box is closest to the

wires in the ceiling. Otherwise, the wires may not reach into the box and it would be impossible to make the necessary connections.

Next, hold the ventilator upside down against the ceiling and trace around its housing with a pencil (Fig. 2). Using the pencil line as a guide, cut out the ceiling with a compass saw or utility knife (Fig. 3).

Notice that the hole from the old electrical box is located off-center, near the edge of the cutout. This will position the electrical box on the ventilator nearest to the existing wires.

Then, nail or screw wood blocks to the joists to provide solid support for mounting the ventilator (Fig. 4). You may need to double-up the blocks in order to center the ventilator in the ceiling cutout. Test-fit the ventilator in the cutout to be sure that it sits flush with the finished ceiling. This is important since the grille and lens assembly won't fit properly if the housing isn't installed correctly. Now decide where to run the



**7** Fasten vent cap with roofing nails fitted with rubber washers. Nail through flashing and apply roof cement to nailheads.

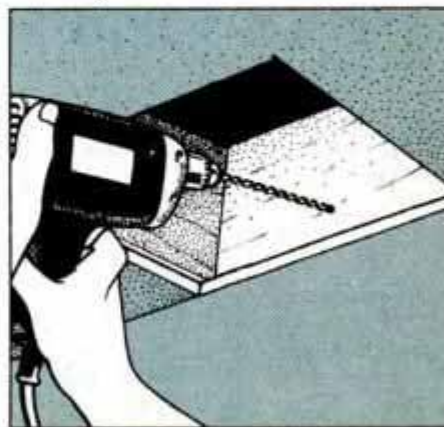

**8** To install a wall-mounted vent cap, first cut away the ceiling and bore a pilot hole through the header joist to the outside.



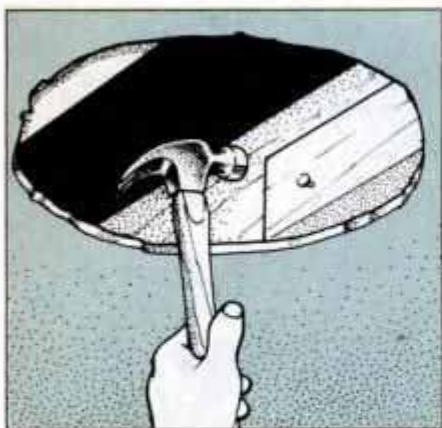

**4** Nail wood-block supports to joists for mounting the ventilator. If possible, work from above in the attic or crawl space.

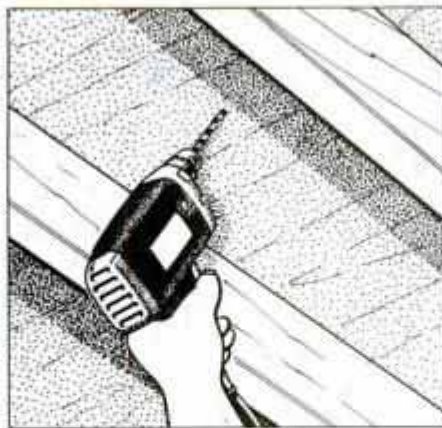

**5** Bore a  $\frac{3}{8}$ -in.-dia. pilot hole through the roof, between two rafters, to establish the center of the roof-mounted vent cap.

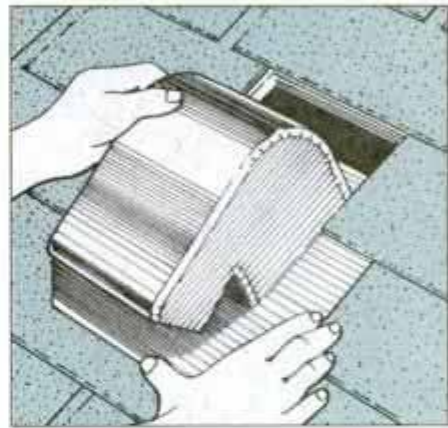

**6** After sawing the vent-cap hole, apply roof cement to cap's bottom surface and slide it under the upper course of shingles.

duct—either through the roof or out the side of the house.

## Roof-Mounted Vent

From inside of the attic, mark the desired vent-cap location on the roof between two rafters. Choose a spot near the ventilator to avoid a long duct-run with lots of bends. The straighter the duct-run is, the more efficiently the ventilator will work. Bore a  $\frac{3}{8}$ -in.-dia. hole through the roof to establish the center of the vent cap (Fig. 5). Push a brightly colored wire through the hole to make it easy to spot from outside.

Now, working from the outside, use the  $\frac{3}{8}$ -in.-dia. center hole as a reference point to lay out and cut the vent-cap hole. Make the cutout in the roof with a sabre saw or compass saw.

Next, carefully pull out the nails from the shingles directly above the cutout. Then, slide the vent cap into place so that its flashing is *under* the upper course of shingles and *over* the lower course (Fig. 6). Trim the shingles, if

necessary, to cover the maximum amount of flashing. Remove the vent cap and spread roofing cement on the underside of the flashing.

Slide the vent cap back into place and nail through the shingles and flashing using aluminum roofing nails with rubber washers (Fig. 7). Cover each exposed nailhead with roofing cement. Now go inside and attach the duct to the vent cap and run it to the ventilator location. Save the final connections until the ventilator has been installed.

## Wall-Mounted Vent

When it isn't possible to vent through the roof, you'll have to run the duct above the ceiling and vent it out the side of the house.

Start by peeking up into the ceiling cutout to determine which direction the joists run. The duct will run between the joists and out the wall. It's easiest to vent out the nearest wall.

However, if the nearest wall is the front of the house, you may want to vent

the duct in the opposite direction out the back where the vent cap will be less noticeable. Running perpendicular to the ceiling joists, at the outside wall, is the header joist. Note that it's necessary to bore a pilot hole through the header joist to the outside to indicate the center of the vent cap.

In the best of situations, you'll be able to reach the header from the ventilator cutout in the ceiling. But more than likely, the wall will be too far away to reach. In this case, it's necessary to cut an access hole in the ceiling, where it meets the wall, to expose the header. Measure about 12 in. from the wall and cut out a section of ceiling from the *center* of one joist to the *center* of the next. If you remove the ceiling section carefully, it can be replaced and patched later.

Now, with the access hole cut, bore a  $\frac{3}{8}$ -in.-dia. pilot hole through the header, sheathing and siding (Fig. 8). Then, move outside and, using the pilot hole as a guide, lay out the wall vent-cap hole.

Next, cut the vent-cap hole with a sabre saw (Fig. 9). Slide the vent cap into the hole and hold it against the siding. Scribe a pencil line around the cap's flange onto the siding.

Then, pull away the vent cap, apply caulk inside of the lines (Fig. 10), and slide the cap back in place. Secure the vent cap by screwing through its flange with aluminum or stainless-steel pan-head wood screws (Fig. 11).

From the inside, slip the stabilizer ring over the vent-cap pipe (Fig. 12) and nail it to the header joist with 1-in. roofing nails. Next, attach the duct end to the vent-cap pipe with duct tape. Then, feed the duct between the joists until the free end has reached the ceiling cutout for the ventilator.

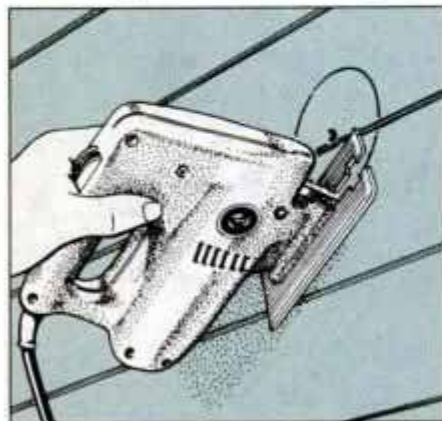

**9** Using the pilot hole as a guide, cut out the vent-cap hole with a sabre saw. Most vent caps accept 3-in. or 4-in.-dia. ducting.

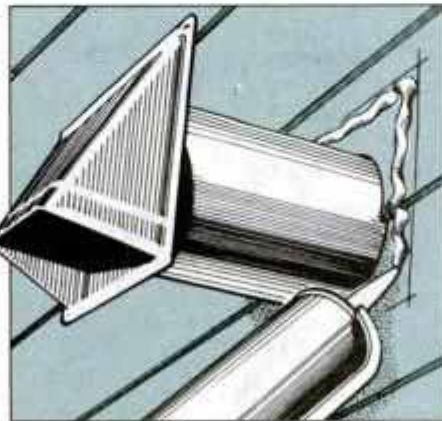

**10** Hold vent cap against siding and mark its outline. Then, apply caulk inside of the pencil lines all around the vent-cap cutout.



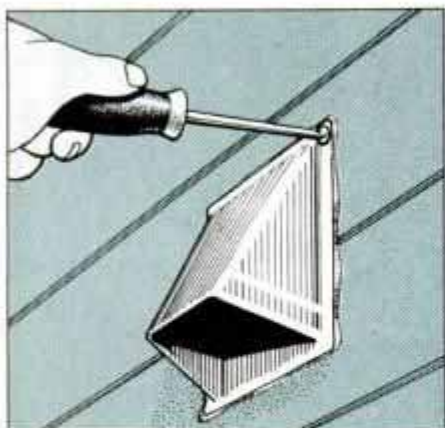

**11** Push the vent cap tight against siding and fasten with panhead wood screws. Clean off any caulking that squeezes out.

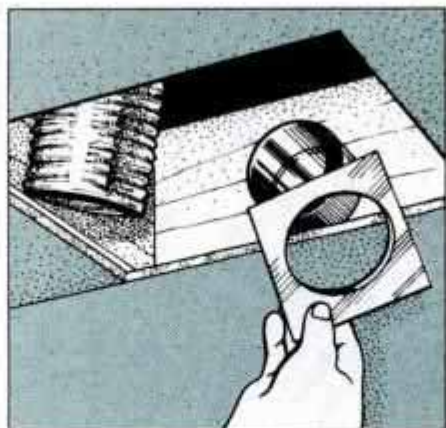

**12** From the inside, slip the stabilizer ring over the end of vent-cap pipe. Attach ring to the header with 1-in. roofing nails.

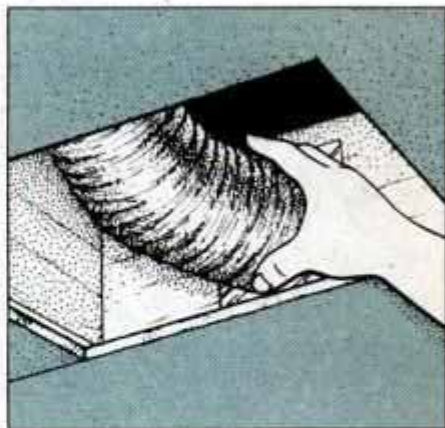

**13** Attach the duct to vent-cap pipe with duct tape or use a nylon cable tie. Use flexible duct, as shown, or round metal duct.

## Wiring Procedures

The easiest way to make the electrical connections is from above in an attic. However, you can also fish the wires through the ventilator's box and make the connections from below, if you are working on the first floor.

First, attach a cable connector to the electrical cable. Be sure that the threaded, male portion of the connector is facing toward the end of the cable. Secure a 12-in. length of scrap wire to the cable end. This scrap-wire leader makes it easy to fish the cable into the box from below. Next, remove a circular knockout plug from the side of the box. Then, while holding the ventilator near the ceiling, make the final connections to attach the duct to the housing. Secure the duct with duct tape. Also, fish the scrap-wire leader through the knockout hole. Pull the leader and cable into the box from below as you push the ventilator up into the ceiling. Fasten the ventilator to the ceiling with 1-in. No. 6 panhead screws. Slip the locknut of the cable con-

necting over the end of the leader wire and cable and thread it onto the connector. Tighten the nut to secure the connector and cable to the box. Cable connectors are required by code. Check your local electrical code for other requirements. Now remove the scrap-wire leader from the cable end.

The ventilator is wired with two separate sets of leads so that the light and exhaust fan can be controlled by separate switches.

To operate them individually, you'll need to run a separate switch leg to the ventilator to handle the second switch. To operate the light and fan with one switch, simply connect the black wires in the housing to the black, hot lead of the cable. Then, connect the white wires to the white, neutral cable lead. Secure the connections with wire nuts. Fasten the ground lead to the grounding screw in the box.

With the wiring completed and the housing secured to the ceiling, the next step is to install the light fixture and the

fan assembly. The housing's two receptacles provide easy, plug-in installation. First, install the fan by inserting its two tabs into the housing and securing it with a single sheetmetal screw (Fig. 15). Plug the fan into the receptacle. Next, plug the light fixture into the remaining receptacle and fasten it to the fan assembly with a wingnut (Fig. 16). Although this is a typical installation, be sure to read the detailed instructions that come with your particular ventilator before starting the installation.

Now, install the grille and lens assembly. The assembly attaches to the housing with two spring-wire clips. Squeeze the clips together and insert them into slots cut in the housing. This system makes it easy to lower the lens to change the light bulb.

Install a light bulb and push the grille up to the ceiling to be sure that the clips hold it securely. Finally, turn on the power and flip the wall switch. Congratulations! You've just ended your bathroom moisture problems. **PM**

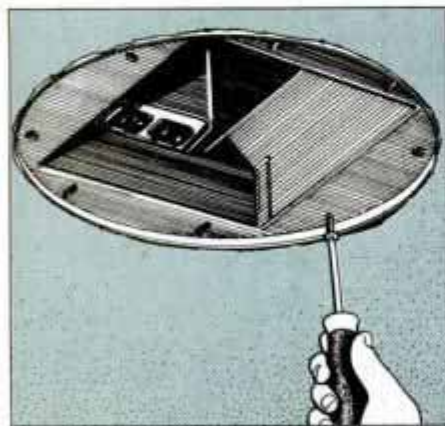

**14** After making electrical and duct connections, fasten the ventilator's housing to the wood-block supports with screws.

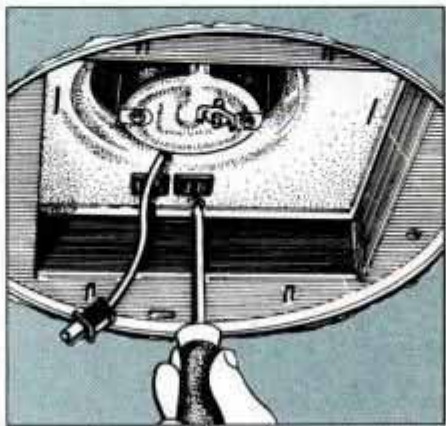

**15** Install the prewired exhaust fan in the housing and secure it with a sheetmetal screw. Plug the fan into the receptacle.

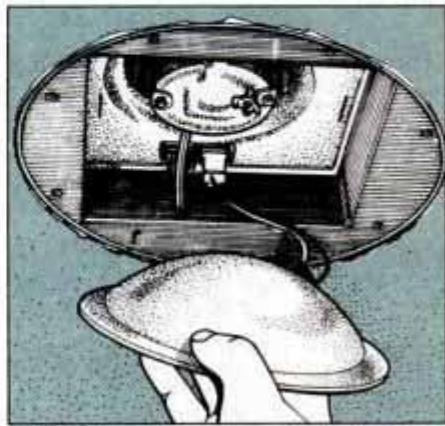

**16** Then, plug the light fixture into the remaining receptacle and fasten it to the fan assembly with the provided wingnut.



## THE BETTER HOME

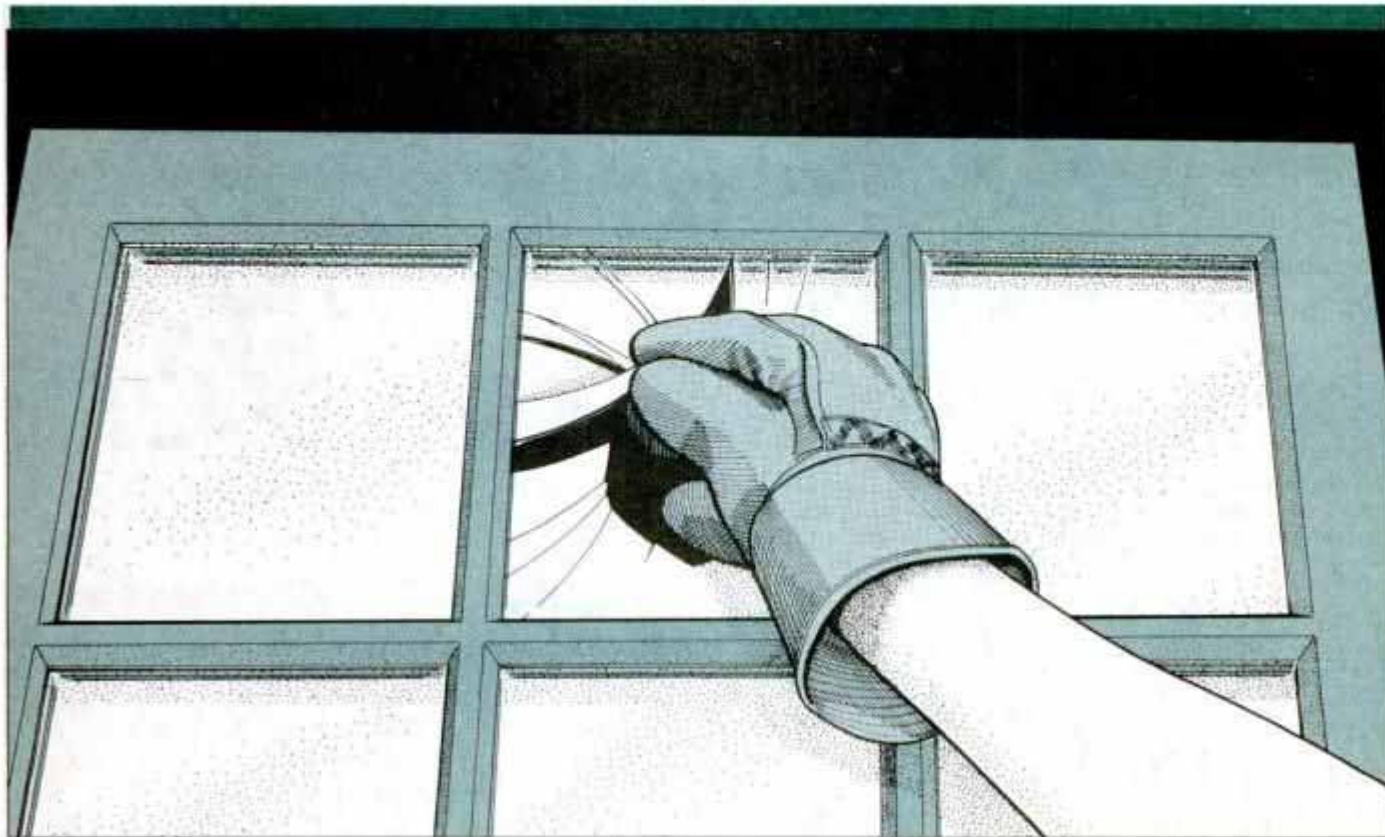

# How To REGLAZE WINDOWS

**R**eplacing a broken pane of window glass is a relatively simple task and, for most homeowners, an inevitable one. However, if it's performed carelessly, it can result in serious injury. Follow the shop-tested, step-by-step instructions presented here to repair shattered windows like a pro—safely and easily.

To make the job easier, it's advisable to remove the window sash from the frame and repair it on a workbench. Lay the sash on the bench with the exterior side of the window facing up. While wearing heavy-duty leather work gloves and safety goggles, pull free any loose shards of glass from the shattered windowpane.

Next, remove the old putty from around the pane. If the putty hasn't become too hard, you can pry it off with an old chisel or rigid-blade putty knife. Otherwise, you'll have to first soften the putty with a heat gun (Fig. 1) and then scrape it off.

Also, remove the glazier's points that you'll find under the old putty stuck into the wood sash and muntins. The small

BY ROSARIO CAPOTOSTO  
Illustrations by George Retseck

metal points secure the window glass to the sash.

After removing the old putty, pull free all of the remaining glass from the broken pane. Now scrape down the sash and muntin rabbets to the bare wood using a chisel held perpendicular to the surface (Fig. 2). Try to avoid digging into and gouging the wood.

Next, apply a liberal coat of linseed oil to the clean rabbets with a small brush. The linseed oil will prevent the bare wood from absorbing any oil out of the new glazing putty. Oil in the glazing putty helps to keep the putty flexible and crack-free longer.

### Installing A New Pane

While the linseed oil is soaking into the wood, cut the replacement glass pane. Cut the pane from single-strength glass with a standard glass cutter. Measure the opening and subtract  $\frac{1}{8}$  in. from the overall width and length.

Next, nail a straightedged board to

the workbench and butt the replacement glass against it. Lubricate the cut line with kerosene and, while using a framing square as a guide, score the glass with the cutter (Fig. 4).

While wearing gloves and goggles, hold the glass with the cut line on the edge of the bench. Push down firmly and the glass will break cleanly on the line. Although glass cutting is very easy, if you'd rather, you can custom-order pre-cut glass from most hardware stores and glass shops.

Next, apply a  $\frac{1}{8}$ -in.-thick bead of glazing compound (not putty) in the rabbets around the opening (Fig. 5). Compound is preferred over putty since it doesn't dry brittle and it resists cracking and shrinking.

While wearing gloves, position the glass pane in the opening and press down gently to eliminate any air pockets that may appear in the compound.

Then, using a rigid-blade putty knife, push glazier's points in the rabbets to secure the glass (Fig. 7). Space the points about 4 in. apart.

Note that there are two basic types of



# THE BETTER HOME



**1** Use a flameless heat gun to soften old, brittle putty. Heat the putty (be careful not to char the wood) and then scrape it off.



**2** Scrape clean sash and muntin rabbets with a sharp chisel. Hold chisel perpendicular and scrape down to bare wood.



**3** Apply a coat of linseed oil to the clean rabbets. This prevents bare wood from absorbing oil out of the new compound.

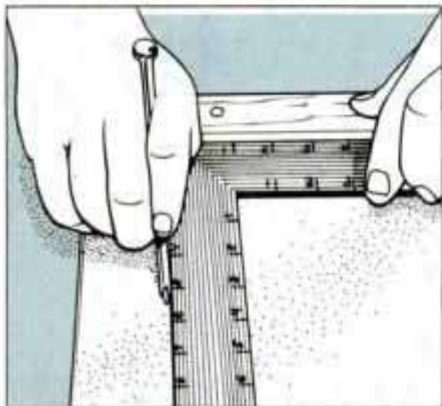

**4** Hold glass cutter between index and middle fingers and score glass. Use square and board, nailed to bench, as guides.

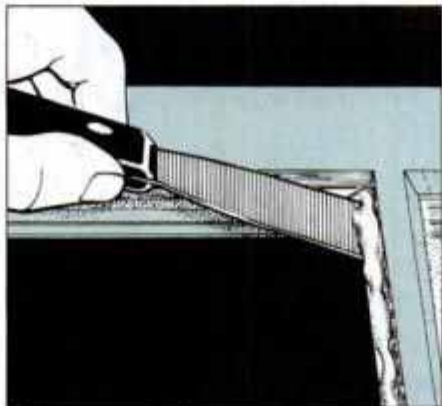

**5** Use a flexible-blade putty knife to apply a 1/2-in.-thick bead of glazing compound in the four rabbets around the opening.

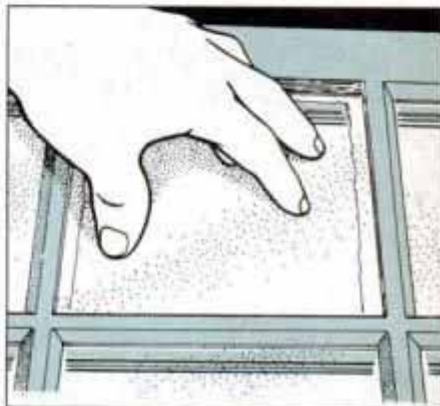

**6** Place new pane into the opening and press down gently. Squeeze out air pockets trapped in compound for a good seal.

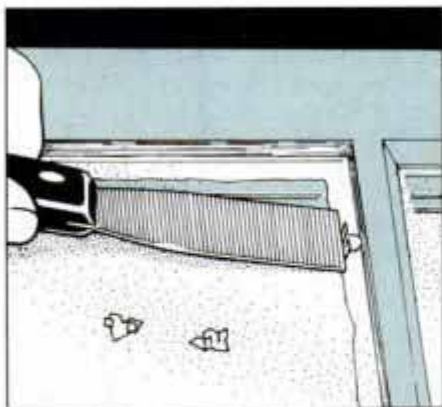

**7** Install push-point glazier's points with a rigid-blade putty knife. Force the points into the wood to hold the glass securely.

glazier's points: there's the flat, triangular style, and there are the push points. Push points, as shown in Fig. 7, have two turned-up tabs that make them much easier to install than the flat, triangular points.

Roll glazing compound between your hands to form 3/16-in.-dia. ropes. Lay the

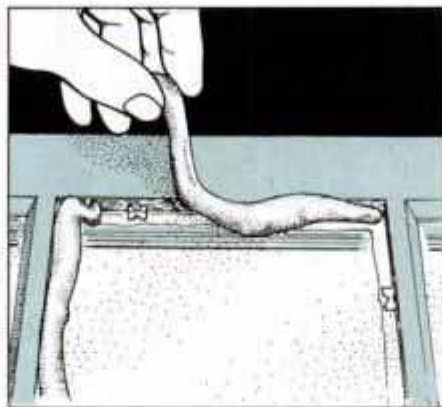

**8** Roll glazing compound between your palms to form 3/16-in.-dia. ropes. Lay these ropes around the perimeter of the glass.

ropes around the edges of the pane (Fig. 8) and press them into place with your fingers. Be sure to conceal all of the glazier's points.

Now, using a flexible-blade putty knife, compress the compound to form a smooth, triangular-shaped bead (Fig. 9). Clean off the excess compound from

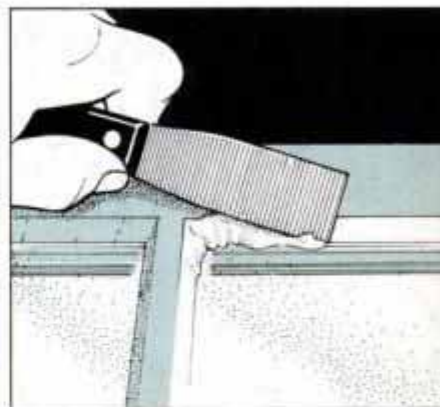

**9** Hold the putty knife at an angle and press the compound into the rabbets to form a smooth, triangular-shaped bead.

both sides of the glass.

Allow the compound to dry for about a week before painting it. Then, apply the paint so that it extends about 1/16 in. onto the glass to form a moisture seal. This little trick will help to protect the compound and seal the glass from excessive moisture. **FM**



# Homeowners' Clinic

BY NORMAN BECKER, P.E.

## Hydrostatic Headache

In the February '86 issue, you described a system to collect basement water seepage without having to dig around the foundation. However, you noted that where water is forced through the floor by hydrostatic pressure, as it is in my house, such a system won't work. During exceptionally heavy rains, the groundwater level rises above the cellar floor and seeps in through cracks in the floor and the door to the outside. The finished grade around the foundation is 3 to 4 ft. above the floor. There is a drain around the foundation footing, but it doesn't have an outlet.

I cut a hole through the concrete landing outside the door, removed a piece of the footing drain, and installed a sump pump that discharges the water on the ground about 50 ft. away. The water still accumulates in the cellar, sometimes 8 in. above the floor.

RONALD RUDOLPH  
POUGHKEEPSIE, NY

*It looks like your pump can't remove the water at the rate it's accumulating. I recommend replacing the existing pump with one that has greater capacity. First, estimate the number of gallons that must be pumped per minute by using this formula: Multiply the floor area in sq. ft. by the inches of water seepage per hour and multiply this number by .01. If, for example, your cellar is 40 ft. long x 22 ft. wide, and fills at a rate of 4 in. per hour, then your pump needs to discharge at a rate of 35.2 gallons per minute.*

*When you buy a sump pump you'll receive a sheet showing its performance curve. Pumps are rated by their capacity to discharge water at varying heads. The head reflects the height that the discharging water must be raised. As the total head decreases, pump capacity increases.*

*If an appropriately sized pump drains the sump pit but water still collects in the basement, it means your foundation footing drain is not very effective. In this case, you'll have to either replace the footing drain or install perforated pipes under the slab which discharge into the sump pit.*

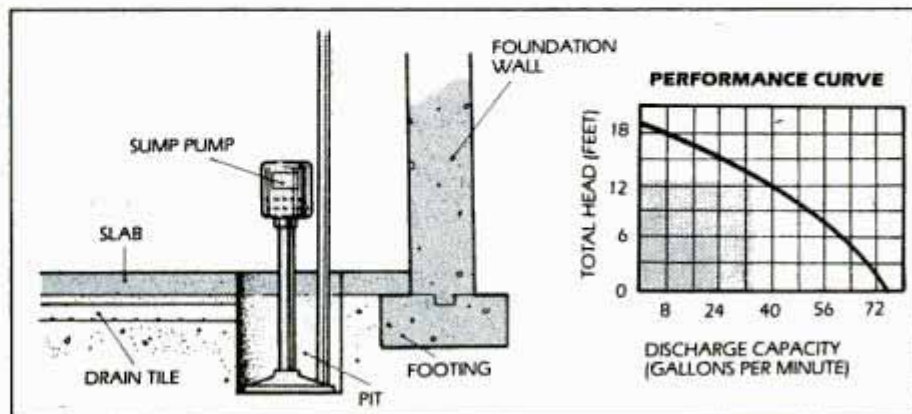

Determine your sump pump's capacity by examining its performance curve. Discharge capacity varies with the height (total head) the water must be lifted. In extreme cases, install drain tile under the basement slab to route water to the pump.

## Sweating Tank

I renovated my bathroom and want to avoid the dripping condensation that ruined the original floor. I tried toilet-tank liners, but they're not the answer. Can you help?

C. PARK  
ISLIP, NY

Insulation liners available in home supply stores are not always effective in eliminating such problems.

There are two sure ways to stop condensation from forming on your toilet tank: Reduce the relative humidity in the room by using a dehumidifier, exhaust fan or air conditioner, or install a tempering valve (mixing valve) on the pipe that supplies water to the tank to introduce a small amount of warm water. By raising the temperature of the tank water about 5° to 7°, the tank surface should be warm enough to avoid condensation.

## Strip Fireplace Paint

We have a brick fireplace which has had several coats of paint applied to it over the years. Is there a way to remove the paint and restore the brick to its original condition?

BYRON LEWIS  
CHATHAM, NJ

When working inside a house, you can't use a high-pressure water spray to wash down the brick that you'd nor-

mally use outdoors. But you can remove the layers of paint by using a chemical stripper. This is a messy and labor-intensive job. Intensive scrubbing with a stiff bristle scrub brush is necessary to remove the paint residue from the cracks and crevices.

ProSoCo, Inc., has a product that will do the job. Sure Klean Heavy-Duty Paint Stripper is a gel-type solvent-alkaline remover that was specially formulated to remove paint from masonry surfaces.

A gallon of Sure Klean costs about \$20 and covers about 70 sq. ft. Write ProSoCo, Inc., Box 1578, Kansas City, KS 66117.

Observe the manufacturer's precautions when using it. Protect yourself by wearing rubber gloves, goggles and a face mask. The room should be well ventilated and the floor in the fireplace area should be covered. Use a heavy tarpaulin covered with straw to absorb the droppings.

Remember that the waste is toxic and should not be flushed down the sewer. Contact a waste hauler and pay him to have it disposed of properly. PM

*Do you have a home-maintenance or repair problem? Send it to Homeowners' Clinic, Popular Mechanics, 224 West 57th St., New York, NY 10019. Letters cannot be answered individually, but problems of wide interest will be discussed in the column. For more home-repair and maintenance help, get PM's Home Care Guide, \$2.45 postpaid. Send your order(s) to Popular Mechanics, Box 1014, Radio City Station, New York, NY 10101.*



# Appliance Clinic

BY STEVE TOTH

## 50 Degrees Off

The oven temperature dial on my Whirlpool electric range with model No. RGE6700N-1 and serial No. MK00373857 is off by about 50°. How can I reset it?  
WAYNE MITZNER  
BALTIMORE, MD

*The thermostat in your range is unlike the conventional type which has an adjustment screw in the center of the thermostat shaft. To recalibrate your unit, you need to lock the cam inside the thermostat and then force the thermostat shaft and knob to the desired temperature.*

*To lock the cam, you'll need a special tool that you can make out of  $\frac{3}{32}$ -in. wire or a good quality coat hanger. Cut the wire about 5 in. long and bend it at 90° so that one leg is 1 $\frac{3}{8}$  in. Clean off any burrs on the short end.*

*First check the degree to which the actual temperature varies from the dial setting. Place a good mercury thermometer in the middle of the center rack. Then, close the door and adjust the thermostat knob to 350°. Let the oven cycle on and off and note the temperatures at which the heating element turns on and off. Jot down two cut-in and two cut-out temperatures. Add these together. Divide by four to get the average temperature for that dial setting. If the thermostat dial is more than 70° away from the actual oven temperature, replace it.*

*To reset the calibration, first disconnect the range power supply. Rotate the thermostat knob to 450° and pull the knob off the shaft. You'll see a small hole about  $\frac{1}{4}$  in. below the center of the shaft. Insert the short end of the L-shaped tool into this hole and align it through the adjusting spline slot and into the cam. Then replace the knob. Turn the knob the number of degrees the thermostat dial is offset. Turn counterclockwise if the oven temperature was higher than the thermostat setting, and clockwise if the oven temperature was lower.*

*After adjusting the thermostat, take off the knob, remove the tool and replace the knob. Reconnect the power and check the recalibration. It may require a second adjustment.*

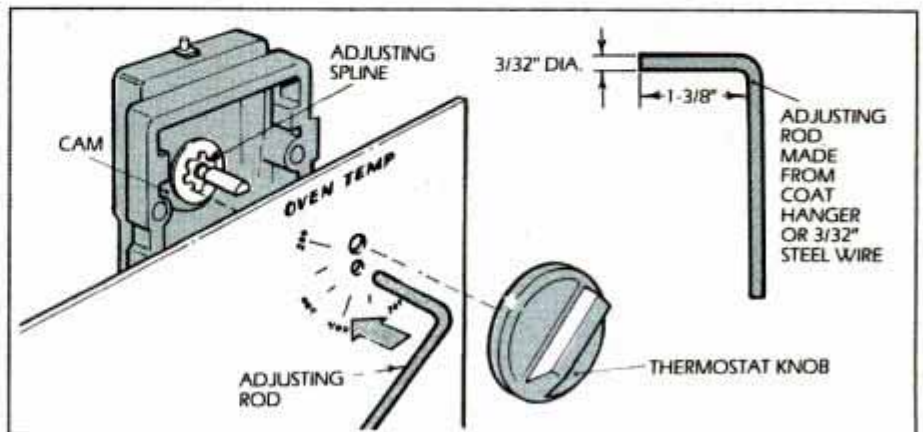

Reset the temperature dial relative to actual oven temperature by removing the dial and inserting the adjusting rod. Replace the dial and turn to correct the setting.

## Waltzing Washer

I have a new washing machine that I'm about ready to bolt to the floor. During the spin cycle, the machine vibrates excessively regardless of the load. It actually begins to walk across the floor. The washer is a Hotpoint model No. WLW3700B.  
JOSEPH SANTAMARIA JR.  
VIENNA, VA

*First adjust the leveling legs so the washer is level and sits as close to the floor as possible. If this doesn't help, get two leveling pads available from any General Electric parts distributor. Ask for GE part No. WL1X165. Each 3-in.-dia. pad (\$9) is steel reinforced and has adhesive backing and a recess that fits the front legs.*

## Darkening With Age

We have a Frigidaire electric range with a ceramic top, model No. RCDE3-37CW, serial No. 41CE3430. The top gets stained each time it's used. We've tried different cooking utensils, but the problem remains.  
JOE STIRSMAN  
BREMEN, KY

*If the top is exceptionally dirty, first try cleaning the affected area with a product called Barkeepers Friend, Delete or Zud, all of which are available at local food stores. Be sure it's fresh. Apply the product and remove as much of the stain as possible. Rinse with water and dry. Next, apply a thick layer of the cleaner to the affected area and add*

*a little water to make a paste. Then place a glass pie plate upside-down over the area and let it sit overnight. The pie plate will keep the water from evaporating. Be sure to keep the paste from coming into contact with the stainless-steel rim as it can discolor the metal. The next morning, remove the paste and wipe the top off thoroughly. Then, clean again in the normal way.*

## Reader Writes

*Do you have an older Norge dryer that suffers from mysterious stopping and starting problems? Ray Schumacher of Battle Lake, Minnesota, may have just the answer. He explains that the older dryers have open frame motors which allow lint to collect inside the motor and around the windings. Excessive lint accumulation can restrict the airflow through the motor, causing it to heat up. Then the overload protector will open the circuit and stop the motor. After the motor cools, the overload protector will reset and the dryer will start again, in most cases finishing the cycle. Periodic cleaning will help prevent this problem. Unplug the dryer and remove the motor access cover. Use a vacuum to remove lint around the motor.*

*If you have a problem with any appliance, send your question, along with the model and serial numbers, to Appliance Clinic, Popular Mechanics, 224 West 57th St., New York, NY 10019. Sorry, but letters cannot be answered individually. Problems of wide interest will be discussed in this column.*



# Popular Mechanics

## How-To Books

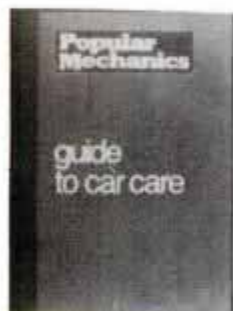

**Guide to Car Care** A collection of the best from *Popular Mechanics*' "Saturday Mechanic"

articles and "Car Care Guides." All fix-it procedures are explained by repair experts and are illustrated with detailed diagrams. Learn it all, from troubleshooting your engine to repairing the electrical system. (BF-1915—\$9.95)

**TO ORDER:** Send your name and address with check or money order to **Popular Mechanics**, Box 1014, Radio City Station, New York, NY 10101. Please specify the proper "BF" number.

Popular Mechanics is a publication of Hearst Magazines, a Division of the Hearst Corporation. © 1986 The Hearst Corporation. All rights reserved.



**Auto Repair Manual '81-'87** A valuable reference for the do-it-yourselfer. Covers more than 1,900 domestic models, with over 55,000 essential service specs and repair facts and 2,500 diagrams, cutaways and quick-check spec charts.

Updated sections on fuel and ignition systems for at-home repair. (BF-1914—\$21.50)

**How Do They Do That?** The modern trivia book that explains mysteries of today's world. Among the 150 puzzles: How are underwater tunnels dug? How do magicians saw a woman in half? How does truth serum work? How do sword swallows swallow swords? A book for those with inquisitive minds. (BF-1923—\$8.95)

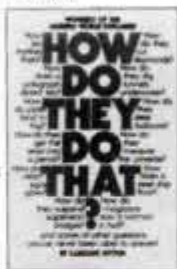

**Guide to Do-It-Yourself Materials** This best-selling *Popular Mechanics*' guide is back, with advice on choosing and buying the materials you'll need for home repair and remodeling. Learn about lumber, fasteners, plumbing and electrical products, roofing, even garden supplies. Make your work easier with the right materials. (BF-1916—\$8.95)

# NEW RAMPARTS



## RAMP PARTS KIT

Need to load a riding mower, tiller, snow blower, motorcycle or ATV? The Ramparts Kit is the answer! You make sturdy loading ramps that fit snugly against tailgates, loading surfaces or steps. They can be easily assembled from two common 2 x 8's and a Ramparts Kit.

No more problems with shifting planks. The ramp end allows equipment to roll smoothly to or from the loading surface. Moving equipment and materials is faster and safer with Ramparts.

The ramps are very versatile: use them for a temporary wheelchair ramp or with appliance dollies leaving the center of the steps open for foot traffic. Ramparts ramps are also great on the job. They smooth the way for wheelbarrows and hand trucks or carrying heavy materials from one level to another.

Ramparts Kits are manufactured from sturdy high tensile strength extruded aluminum. The ramp ends are designed to bolt easily to your planks and the hardware is supplied.

**Payment Method** **\$39<sup>95</sup>**  
Add \$2.00 per order for shipping and handling.

No. of kits desired: \_\_\_\_\_      
 Check or Money Order (Payable to Ramparts, Inc.)

Mastercard or VISA Number \_\_\_\_\_

Signature \_\_\_\_\_

Expiration Date \_\_\_\_\_

Name \_\_\_\_\_

Address \_\_\_\_\_

City \_\_\_\_\_

State \_\_\_\_\_

Zip \_\_\_\_\_

**RAMPARTS, INC.**  
53 Belcher Road, Blairstown, **DEALER**  
New Jersey 07825 **INQUIRES**  
(201) 362-9137 **INVITED**

## BE A PROFESSIONAL LOCKSMITH

**Earn money in your spare time or even run your own locksmith shop!**

Train at home with the original Locksmithing Institute. In as little as 6 months you can take care of the demand in your community for professional locksmiths.

**Earn while learning, too!** In a few weeks, you'll have the know-how to make money changing locks, making keys, simple installations.

**Learn by doing** Locksmithing Institute's tested and proven method makes it easy for you to learn. Each lesson is fully illustrated and you work with professional tools and materials sent to you with the course... even an electric key machine... equipment that you will be using in your own locksmith shop.

**Cash in on the growing need for locksmiths** You'll find locksmithing work all around you. And, with your Diploma as a skilled Master Locksmith, you'll start cashing in on your money making skills. **Get the exciting profit facts by mail... no salesman will ever call. Mail the coupon today.**

IF COUPON IS MISSING, WRITE:  
**LOCKSMITHING INSTITUTE**

1500 Cardinal Drive, Little Falls, N.J. 07424

**LOCKSMITHING INSTITUTE** PLEASE CHECK ONE ONLY  
1500 Cardinal Drive, Little Falls, NJ 07424 Dept 110-097  
PLEASE RUSH FREE CAREER BROCHURE

- LOCKSMITHING**  
**OTHER CAREER COURSES AVAILABLE**
- Upholstery
  - Legal Investigation
  - Color TV Electronics
  - Small Engine Mechanics
  - Insurance Adjusting
  - Interior Design
  - Fundamental Electronics
  - Burglar and Fire Alarm Systems
  - Airc conditioning / Refrigeration / Heating
  - Conservation
  - Drafting
  - Automotive Mechanics
  - Bookkeeping & General Accounting

NAME \_\_\_\_\_  
ADDRESS \_\_\_\_\_  
CITY \_\_\_\_\_ STATE \_\_\_\_\_ ZIP \_\_\_\_\_  
PHONE \_\_\_\_\_



## Geodesic Home Kits. Beautiful, Efficient, Affordable.

Monterey Domes sells home kits for less than many new home down payments. Completely affordable...remarkably beautiful...our homes are designed for a lifetime of savings.

The most energy efficient homes on earth...up to 50% more than everyday homes. In addition, construction costs are cut dramatically using our patented building system... (our 1813 sq. ft. house package is just \$15,660!)

Discover Monterey Domes living with our 100 page Color Catalog and Plans Book. ORDER TODAY for just \$7.00. Unconditionally Guaranteed or your Money Back!

- Please rush my 100 page copy of Monterey Domes Catalog and Plans Book. Enclosed is \$7.00.  
 Also please send me the Monterey Domes Basic Dome Assembly Manual for an additional \$5.00.  
**Order by Credit Card. Call 800-634-2255 (In Calif. 800-847-4663)**

Name \_\_\_\_\_  
Address \_\_\_\_\_  
City/State/Zip \_\_\_\_\_

Send to: **MONTEREY DOMES**  
Dept. AQ-9  
1760 Chicago Ave.  
Riverside, Calif. 92517





# Authorized Liquidation

NATIONALLY FAMOUS  HOME SHOPPING CLUB

Medical Research and Space Age Technology Prove You Can

## RID YOUR PET OF FLEAS & TICKS

### STARTING IN 15 SECONDS!

Two years of testing by Scientists, Veterinarians and Kennels has proven that Pet Shield works to rid your pet of fleas and ticks starting in just 15 seconds after securing the collar, and surrounds your pet with a blanket of protection from head to tail.

Pet Shield emits intense ultrasound waves that drive fleas and ticks from your pet without harming or disturbing him. No smelly, dangerous chemicals or powders. It is waterproof and inaudible to humans and all breeds of dogs or cats. Space age electronic technology and a custom microcircuit all make this the most effective pest eliminator your pet could possibly have and it won't damage his skin as other collars might.

RETAIL  
~~\$49.95~~



NOW ONLY  
**\$19.75**

- 100% Safe and Effective
- Full 1 Year Warranty
- Veterinarian Tested
- Completely Waterproof
- No Poisons or Chemicals
- A Blanket of Protection For Your Pet



**HOME SHOPPING CLUB**  
An American Stock Exchange Company  
Symbol HSN

Dept. 316  
115 Brand Road  
Salem, VA 24156

YES! Please rush me \_\_\_\_\_ (qty.) PET SHIELD(S) #105 at only \$19.75 each plus \$2.75 postage & handling. Enclosed is \$ \_\_\_\_\_ FL, VA res. add sales tax.

Charge it:  VISA  MASTERCARD  AMEX  DISCOVER

Card # \_\_\_\_\_ Exp. Date \_\_\_\_\_

Signature \_\_\_\_\_

Name \_\_\_\_\_

Address \_\_\_\_\_

City \_\_\_\_\_ State \_\_\_\_\_ Zip \_\_\_\_\_

**CALL TOLL-FREE 1-800-848-2929** © 1987 HSN Inc.

## MESSY SHELVES?

Magazines all over the place! What you need are Popular Mechanics FILE BOXES to help you keep those bookshelves neat and orderly. Each box stands alone with all twelve issues intact. With every order you receive FREE self-adhesive labels covering the years 1975 through 1990. Peel off the year required and place on appropriate box.

1 File Box,  
\$2.95

2 File Boxes,  
\$2.75 ea.



3 File Boxes  
or  
more,  
\$2.50 ea.

Send order to Popular Mechanics, Dept. FL, Box 1014  
Radio City Station, New York, NY 10101.

For more on interesting projects send for PM's Plans and Ideas catalog, \$1.95

## Build this Utility Shed, from Popular Mechanics.

Create a big 12' x 16' shed, with storage loft, built-in workbench, bay window and room for garden equipment. Plans complete with materials list, blueprints and 8-page instruction booklet.



To order, send \$17.50 to Popular Mechanics,  
Dept. MART, PO Box 1014, Radio City  
Station, New York, NY 10101.

Popular Mechanics is a publication of Hearst Magazines, a division of The Hearst Corporation. © 1987 The Hearst Corporation.

FREE 112 Page Catalog  
for Lovers of

# SHIPS and the SEA



You could shop for months and never find the hundreds of decorative nautical ideas illustrated in Preston's new catalog: 112 pages teeming with ship models, marine paintings, nautical lamps and clocks, ships' wheels, figureheads and scores of other nautical ideas for the Home.

**PRESTON'S**

179-B Main Street Wharf, Greenport, NY 11944



A bi-monthly magazine with plans/instructions for metal-working projects you can build. \$18.50 per year (Check/M.O.). With charge card - call toll-free.

THE HOME SHOP  
**Machinist**

1-800-447-7367 or write  
The Home Shop Machinist, Box 1810-C5  
Traverse City, MI 49685

MONEY BACK GUARANTEE

## THERE IS MONEY TO BE MADE SELLING KNAPP SHOES



Start earning extra cash instantly... plus receive a 30% discount on a pair of cushion comfort Knapp shoes for yourself from the largest direct selling shoe company in the entire country. Over 20,000 sales people like yourself are making money every day selling from our full color catalog featuring over 250 attractive styles for men and women including dress, casual, work, safety, and outdoor styles. Knapp will send you a complete FREE SELLING KIT, including everything you need to get started earning extra money immediately. There is no risk when you sell Knapp shoes. We support our sales people with free training and back our shoes with an unconditional money back guarantee. No cost! No obligation! *Send coupon today!!*

Thomas McCaffrey, KNAPP SHOES, One Knapp Centre  
Dept. 5916 Brockton, MA 02401

Name: \_\_\_\_\_  
Address: \_\_\_\_\_  
City: \_\_\_\_\_ State: \_\_\_\_\_ Zip: \_\_\_\_\_  
Tel. No.: \_\_\_\_\_

**KNAPP** America works in Knapp shoes

## USE ZIP CODES WHEN ANSWERING ADS



# Do-It-Yourself Videotapes

## This Old House

Make home repairs easily with this tape by hosts Bob Vila and Norm Abram. Among the topics: repairing a screen door, fixing a faucet, installing track lighting and trimming a door. With the cost of home repairs these days, you'll save money by doing them yourself. **\$27.45** (includes shipping)



To order, send a check or money order to Popular Mechanics, Dept. MART, Box 1014, Radio City Station, New York, NY 10101.

Please specify VHS or Beta.

Popular Mechanics is a publication of Hearst Magazines, a division of The Hearst Corporation. ©1987 The Hearst Corporation.

## Last Chance Garage



Learn to do basic auto repairs and spare yourself costly trips to the mechanic. See how easy it is to change your oil and filter, flush the radiator and lubricate the suspension. 20 topics in all! Buy it for yourself or as a great

gift for someone else. **\$27.45** (includes shipping)

## Furniture Refinishing

Take that old piece of furniture and make it look brand new. By following the three main steps outlined in this tape (stripping away the old finish, preparing the wood for the new finish and applying the new stain or varnish), you will expertly restore your furniture to its original beauty. **\$32.45** (includes shipping)

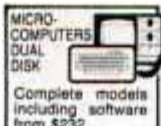

**MICRO-COMPUTERS DUAL DISK**  
Complete models including software from \$232.



**DOLLS**  
Stuffed, porcelain, 1,000's designs.



**LOCK BLADE KNIFE** 100's models  
71¢

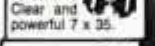

**FIELD GLASSES**  
Clear and powerful 7 x 35.

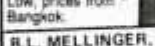

**DIAMONDS SAPPHIRES**  
Low prices from Bangkok.

**B.L. MELLINGER**, Famous World Trader, Internationally-known Mail Order Expert, President, Mellinger Co. "I started only a few years ago, part time, in my garage with less than \$100. Today my business empire spans the globe. I will help you succeed using my personal experience. Mail coupon for **FREE REPORT**."

## START WITH 24,221 PRODUCTS!

Many you can buy one at a time or order in quantity. Example: one 35 mm camera with hot shoe and carry case \$13.00 ppd or 12 for \$7.41 ppd. Price drops to only \$5.80 in larger quantities. New government ruling makes thousands of imports free of any duty whatsoever. You deal direct my International Traders way. Cut out greedy U.S. specialty merchandise middlemen. Really deal direct.



**35 mm CAMERA** with hot shoe and carrying case. **\$5.80**

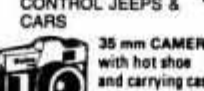

**SONIC REMOTE CONTROL JEEPS & CARS**

**1000's more dazzling products you can buy DIRECT!**

## PERSONAL GUIDANCE!

I believe in giving you my personal help! Regularly I meet I.T. Members at regional closed door Seminars across the country. You will be invited to these meetings.

**THE MELLINGER CO.**, 6100 Variel Ave., Dept. W2259, Woodland Hills, CA 91367-3779.

# SAMPLE IMPORT FREE!

...and I'll tell you exactly how to turn it into big money!

CLIP COUPON, MAIL TODAY PUT AD IN WALLET AS REMINDER OF BIG PROFITS AHEAD!



## How to start your own big profit HOME IMPORT BUSINESS

MY PLAN STARTS YOU FAST... Shows you how to **Buy Below Wholesale**

**24,221 IMPORTS** MEN-WOMEN... Turn Spare Hours or Full Time into INCOME!

**DISCOVER PROFITS OF IMPORT!** My Home Mail Order Import Business Plan guides your every step... it is based totally on my personal success. Shows how to deal direct and cut out costly middlemen... so you keep all the profits! I do the "hard work" for you... by traveling the world to find dazzling "first time offered" new imports. The actual sample I will send you Free is typical of my import discoveries. You can pick and choose from more than 24,000 products. Deal in one product or 1000's. Buy below wholesale.

**YOU CAN START IMMEDIATELY.** I arrange free membership in exclusive International Traders organization... instantly puts you in direct contact with suppliers abroad. I show how to operate anywhere. Age no barrier. Ideal for spare time husband/wife or retirement business. My report, "How to Import and Export" tells how to do it. No obligation. No salesman will call. Certificate brings your free gift sample import and everything else.

- SATELLITE ANTENNA** Dish and all accessories only \$82.
- BENCH DRILLS** Power tools all types. Buy top quality below wholesale. Make big profits.
- MINK COATS** Many styles below wholesale.
- RECONDITIONED CARS AND TRUCKS** Toyota, Nissan, Isuzu, Mitsubishi. Reconditioned to perform like new. Make giant profits shipping to Africa states, Caribbean Islands, England etc.
- CORDLESS DRILL** Superior quality below wholesale.
- GENUINE JADE NECKLACE** ONLY \$4.60
- KITES & WINDSOCKS** Hundreds designs from 32¢ ea.

## This Certificate Good for ONE SAMPLE IMPORT - FREE!

**B. L. Mellinger/The Mellinger Co.**  
6100 Variel Ave., Dept. W2259  
Woodland Hills, CA 91367-3779

Send **FREE REPORT**, "How to Import and Export"... also actual Free Sample Import. Everything you send me is mine to keep without obligation. Show me how I can start a profitable home business of my own.

Name \_\_\_\_\_ Age \_\_\_\_\_  
Address \_\_\_\_\_  
City \_\_\_\_\_  
State \_\_\_\_\_ Zip \_\_\_\_\_

**IMPORTANT!**  
Your initials must appear below to qualify for Free Sample Import. Because of high cost and limited supply, I hereby agree to limit my request to one, and one ONLY. Free Sample Import. I have not previously requested this Free sample. I am over 18 years of age.  
Initial here \_\_\_\_\_

## LIVE STEAM

A monthly magazine with plans/instructions for steam-powered machining projects, including locomotives you can ride!

\$26 per year (Check/M.O.)  
\$48 for 2 years  
Charge card, call toll-free

**1-800-447-7367** or write  
**Live Steam, P.O. Box 629-C5**  
**Traverse City, MI 49685**



**MONEY-BACK GUARANTEE**

## CABLE T.V. CONVERTERS WHY PAY A HIGH MONTHLY FEE?

All Jerrold, Oak, Hamlin, Zenith, Scientific Atlanta, Maganavox and all specialized cable equipment available for shipment with 24 hours. For fast service MC/VISA or C.O.D. telephone orders accepted (312) 658-5320 60 Day Warranty (Quantity Discounts) 9 A.M. to 6 P.M. Monday through Friday Central Time. Stamp Envelope (60¢ postage) for **FREE Catalog**.

**Midwest Electronics Inc.**  
5143 W. Diversey • Chicago, IL 60639  
No Illinois Orders Accepted



# RETIRE IN MEXICO ON \$10 A DAY

(Special) Publisher Ross Paron announced release of the new book *Paradise Found: How to Live in North America's Best Climate for Under \$300 a Month*. The book reveals how over 25,000 Americans live the good life on a beautiful, 60-mile long lake nestled in the mountains of Mexico. Please read this exclusive interview.

**Question: Where is this paradise located?**

**Answer:** It's simple to get there. You can drive there in a few days from anywhere in the U.S. or Canada. By air, it's just a few hours away.

**Question: Why do so many Americans live there?**

**Answer:** The climate is near perfect year round. You're never too cold or too hot. Prices are ridiculously low. You can get a nice hotel room for \$7 a night...Full course meals less than \$2. Many people live comfortably on social security or small pensions.

**Question: Besides the near perfect climate and low cost of living, what else draws Americans there?**

**Answer:** The sheer beauty of the place. You're on a magnificent lake 60 miles long, nestled in the mountains. You'll breathe fresh, clean, unpolluted air. You'll see stunning colors. Blue water, green mountains, red and yellow flowers.

I have travelled throughout Europe, the Carribean and Hawaii and never have I seen such an enchanting place. That's why I call the book *Paradise Found*, it's the closest thing to Paradise you'll ever find.

**Question: How do the local people treat Americans there?**

**Answer:** You'll be treated with warmth and kindness. They love Americans. We provide most of the jobs for the townspeople. You can have a maid, gardener or cook for about 52¢ an hour. And you'll be paying more than the going wage rates.

**Question: Do Americans get homesick?**

**Answer:** Not at all. You have an American library there, medical care, American style shopping facilities, clubs and many social activities. Best of all, you'll be living in one of the world's best climates for a fraction of your present living costs.

**Question: What else does the book cover about this Paradise?**

**Answer:** The book explains everything you need to know. How to get there, where to stay, where to eat, what to do. You'll discover how to buy a home at ridiculous prices. How to earn extra money. Most important, you'll discover how to turn away from stress and tension and start enjoying life to the fullest.

Whether you're looking for a place to retire, a low-cost vacation spot or somewhere to get away from it all, this place has something for you.

**Question: Sounds like you've really hit on something here. How can readers get a copy of *Paradise Found: How To Live In North America's Best Climate For Under \$300 a Month*?**

**Answer:** You can order direct from the publisher and save. Send only \$12.95 plus \$1 postage and handling to: United Research Publishers, 249 South Highway 101, Dept. MP-1, Solana Beach, CA 92075. You can return the book within 30 days and receive a full refund if not 100% satisfied.

# BANKS POWER

QUALITY PRODUCTS FOR 30 YEARS

## BANKS DIESEL TURBOS

The "No. 1 Asked For" System

80% FASTER HILL CLIMBING  
52% QUICKER PASSING  
45% BETTER ACCELERATION  
- TRAILER LIFE Magazine 1/85



FORD 6.9L TURBO SYSTEM  
GM 6.2L TURBO ALSO AVAILABLE

- 40-50% Greater Towing Power with 10% Better Mileage
- Emissions Legal In All 50 States\*
- 12 Month/Unlimited Mileage Warranty On Turbo System
- Excellent HIGH ALTITUDE Performance And Dealers Nationwide

\*C.A.R.B. EXEC. ORD. #D-161-2, #D-161-3

Drop in for a demonstration ride or call for the name of your Banks authorized dealer.

**banks**™ WHEN COMPROMISE IS OUT OF THE QUESTION™

FOR FREE INFORMATION:

Gale Banks Engineering, 546 Duggan Ave., Dept. 650, Azusa, CA 91702 (818) 969-9605

© 1987, GALE BANKS ENGINEERING

## Golden Opportunity

Join the Industry Leader

Builder? Do-it-yourselfer?  
This is your opportunity to start your own business! Become a distributor for Tri-Steel— America's largest manufacturer of strong, energy efficient (R-30), low maintenance steel frame homes.

Investment opportunities start at only \$2,950 and are backed by

Tri-Steel training and support.

For a FREE BROCHURE and more facts on how you can become an independent distributor of steel frame homes, please call Tri-Steel today, toll free at:

**1-800-433-5555**  
or 1-800-433-5553 TX 1-800-772-5909

Changing the way America builds.





# Popular Mechanics PLANS

## FURNITURE AND CRAFTS



**Barn/Garden Shed** Our well-designed yard building provides handsome storage for yard tools, hand tools, power equipment, gardening supplies and a gardening center for the whole family. It also has an upstairs loft! Dim.: 12 x 16 ft. Plans, instruction manual & material list. (1 plan: PL-1278—\$10.50) (2 plans: PL-1278A—\$17.50)



**For Nostalgia Buffs: A Roll Top Desk You Can Build** Back in the era of the trolley car and Model-T, the roll top desk was popular in both home and office. Today it's a cherished antique. Build one yourself in fine cherry and you can own and take great pride in this charming heirloom. You build it as two separate units, a base and a roll top. Plans and material list are included. (PL-1736—\$5.95)

Send your name and address with check or money order payable to **POPULAR MECHANICS**. Mail to: Popular Mechanics, Box 1014 Radio City Station, New York, N.Y. 10101

# Your home workshop can PAY OFF BIG!

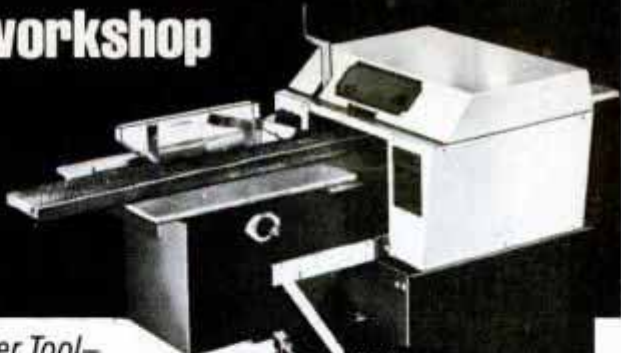

This One Low-Cost Power Tool—  
**SAWS** to desired Width...  
**PLANES** to desired Thickness...  
**MOLDS** all popular Patterns...

All at once or separately... All By Power Feed!

TRY THE FOLEY-BELSAW  
IN YOUR OWN SHOP  
**30 DAY FREE  
TRIAL OFFER**

Only 3-in-1-Workshop Tool Of Its Kind!

**From the Day It Arrives**... Your Planer will make and save you money. With shortages and inflation driving lumber prices sky-high, this versatile power tool easily pays for itself by quickly converting low-cost rough lumber into high value finished stock. In just one pass turn out your own quarter-round, door and window stop, casing, tongue-and-groove... all popular patterns. Other Foley-Belsaw operators are making cases for grandfather clocks, furniture, picture frames, fencing, bee hives, bed slats, surveying stakes... all kinds of millwork.

Built For Pros... Priced For the Home Craftsmen

... it is engineered and built to industrial standards, but factory-direct selling keeps the price low. Handles tough oak and walnut as easily as pine, and so simple to operate even beginners with no experience can use it.

## Start Your Own Business Earn Extra Income Right at Home

With just this one low cost power-feed machine in a corner of your garage or basement, you can set up a profitable business by supplying lumberyards, cabinetmakers, carpenters, remodelers, contractors and hobbyists in your area with custom-planed lumber, trim, molding... ALL of their millwork requirements. Supply picture molding to art shops, hardware and department stores, or sell direct to framing shops. All standard patterns in stock... custom knives ground to your design or sample.



**FREE BOOKLET!**

Get FREE Book with facts and full details... **RUSH COUPON TODAY!**

If coupon has been removed, just send postcard with name and address to:

Foley-Belsaw Co.  
6301 Equitable Rd., Dept. 91144  
Kansas City, Mo. 64120

**NO RISK 100%**

### Guarantee of Satisfaction

"Try the Foley-Belsaw in your own shop for a full 30-Days and put it to work for you. Give it a thorough test and make it prove that it can do everything we say it will... use it as much as you want. Then if you are not completely satisfied, just send it back and we'll return every penny sent with your order. And YOU are the sole judge. There are no questions asked... there are no fine print 'use' charges. Our flat guarantee is that YOU must be 100% satisfied or you get your money back!"

## Does The Foley-Belsaw Pay? YOU BET!

### READ WHAT OTHER FOLEY-BELSAW OWNERS SAY:

**A Good Investment:** "I believe that the Planer is the best investment I ever made. I've been a planer man for years and am now retired. The Foley-Belsaw has earned me over \$60,000 extra income in the past eleven years."

Robert Sawyer, Roseburg, Oregon

**Pays For Itself:** "I bought a batch of walnut in the rough, and after planing it on the Foley-Belsaw I figured up the money I had saved. It was enough to pay for two-thirds the cost of the Planer. It really does a good job."

R.S. Clark, Springfield, Ohio

**More Than Expected:** "This machine pays for itself by making money out of scrap boards. It is a very well built machine and I confess it is more than I expected for the price. It does everything you say it will."

Stephen Schultz, Orangeville, Penna.

... And Foley-Belsaw Is The Choice Of Professionals: "I recommend Foley-Belsaw's Planer-Molder-Saw as the most useful shop tool that any craftsman could own. We use ours every day in the WORKBENCH model shop, and couldn't get along without it."

JAY HEDDEN — Editor of WORKBENCH Magazine

**NO OBLIGATION and NO SALESMAN Calls!**

SEND FOR FREE BOOKLET



Foley-Belsaw Co.  
6301 Equitable Rd.  
Dept. 91144  
Kansas City, Mo. 64120

YES, please send me the FREE Booklet that gives me complete facts about your Planer-Molder-Saw and full details on how I can qualify for a 30-Day Free Trial right in my own shop. I understand there is No Obligation and that No Salesman will call.

NAME \_\_\_\_\_

ADDRESS \_\_\_\_\_

CITY \_\_\_\_\_

STATE \_\_\_\_\_

ZIP \_\_\_\_\_





The comfortable Microtech® Flea and Tick Collar, the alternative to poisons & powders for flea control.

**NO MORE POISONS**

**Lowest Price Ever!**

**STARTS TO WORK IN SECONDS!**

# Fleas gone or your money back.

*"Introducing the Microtech® Flea Collar, the revolutionary new breakthrough in flea control."*

**P**ut the Microtech® Flea Collar on your dog or cat and throw away your poisons. 72 hours later you will forget your pet ever had fleas.

It's that easy. Once every 6 months you change the battery. That's it!

## HOW DOES IT WORK?

The Microtech® Flea Collar uses PMBC™ (Pulsed Modulated Burst Circuit), fancy words, but one of the Microtech® engineers explained it this way.

Have you ever found yourself near a loud siren or alarm? Didn't you want to get away from the noise? Now multiply this effect several times and you'll have an idea of what is happening to the fleas **FLEAS CAN'T STAND IT! THEY'VE GOT TO GET OUT!** And they do.

## WHO TESTED ITS EFFECTIVENESS?

Hundreds of tests were conducted under various weather conditions, and the results were consistent and dramatic. Veterinarians conducted extensive tests and the units worked to their satisfaction.

### From a Veterinarian Report on Microtech®

*"Microtech® has demonstrated its effectiveness in significantly reducing, or totally eliminating fleas from pets."*

R.P.K., DVM

## IS IT SAFE?

In over 1 year of testing, no adverse reactions were reported. The frequency of waves put out are tuned to the perception of fleas and are fully out of the range of human and dog hearing. Yet it is as loud as standing next to a jackhammer for pests, and there is no shock hazard when wet or dry.

Compare this to the poisons and chemicals in conventional flea collars, shampoos and sprays, or to the side effects that certain drugs for flea treatment can have on your dog (not to mention the effects these poisons may have on you and your children).

## IS IT EASY?

Unless you enjoy:

- chasing your pet for hours every week to bathe him
- seeing him roll around in the dirt after every bath
- hassling with chemicals and powders

Then the Microtech® Flea Collar is for you.

## IS THERE ANYTHING ELSE TO BUY?

No. Microtech® is supplied complete with a durable nylon collar, long life Duracell lithium batteries and a 1 year limited warranty.

## TRY ONE FOR 30 DAYS.

The Microtech® Flea Collar is very sturdy, made for and tested on active pets. If you are not completely satisfied with the reduction in fleas, you may return the unit within 30 days for a full refund.

### What Satisfied Users Say

*We tell everyone we can about your product — our vet was impressed too! It's so nice not to have fleas in the house since our cat doesn't bring them in!*

A.W., Pt. Arthur, TX

*Last year our beloved Irish Setter Kerry was so flea prone, even with all the veterinary help offered allergy pills, etc. she had to wear a huge Elizabethan collar around the clock to keep her from ripping out her fur. The flea situation with Kerry was hopeless. NO MORE -she is never without her collar, and not a trace of fleas...Thanks from Kerry, and from us.*

P.B., Knoxville, TN

*We now have two contented beagles, each with one of your collars. The flea and tick problem at our house is nonexistent.*

G.R., Key West, FL

PRICE \$19.75 Plus \$2.75 shipping

**CALL TOLL FREE**  
**1-800-634-5463**

In Iowa 1-800-542-7981  
Mon.-Fri., 8 am - 8 pm Eastern Time

**VANGUARD**  
**MAIL ORDER**

Dept. EG  
1865 Miner St./Des Plaines, IL 60016

©1987 Vanguard Mail Order



# CLASSIFIED ADVERTISEMENTS

Sophie Gronowicz, Classified Sales Manager Dorothy Nolan, Classified Service Manager  
Rate: \$7.00 per word payable in advance each insertion. Minimum insertion ten words.

Bold face capitalized words—\$1.00 per word additional (First word set in Bold Face at no extra charge, Zip Code Free.) Centered Headlines in All Bold-Face Letters—\$45.00.

The next available issue to place an advertisement in America's No. 1 Classified Section is **NOVEMBER**. The closing is **SEPTEMBER 4th**.

Send remittance payable and order to Popular Mechanics, Classified Department, 224 West 57th Street, New York, New York 10019.

Please indicate Heading under which ad is to appear. As a consumer service and in cooperation with our mail-order advertisers

who use post office box addresses for their convenience in handling your order, Popular Mechanics

maintains a register of such mail-order advertisers containing their complete names and street addresses.

Advertisers using P.O. Box number must furnish complete name and street address for our records.

To avoid delay in the publication of your ad, please send samples and descriptive materials with your request if your ad does not state clearly what is being offered.

**PLEASE NOTE: WE HAVE 142 CLASSIFICATIONS TO CHOOSE FROM.  
FOR OUR LIST WRITE TO ADDRESS ABOVE AND REQUEST OUR ORDER FORM.**

## PUBLISHER'S MART BOOKS & PUBLICATIONS

**125,000** Science Fiction, Mystery And Other Paperbacks, Hardcover And Magazines in Stock. Free Catalogs. Pandora's Books, Box PP-54, Neche, ND 58265.

**FINANCIAL RECORD BOOKLET**, Before Travel, Etc., Helps Surviving Spouse. \$3.00. ENTERPRISES, Box 244, Pine Mountain, GA 31822.

**CLEAN** your VCR. Easy step-by-step instructions. \$3.00. Kleenit, 617 25th Street, Sacramento, CA 95816

**PUBLISH** Your Book! Join our successful authors. All subjects invited. Publicity, advertising, beautiful books. Send for fact-filled booklet and free manuscript report. Carlton Press, Dept. PM, 11 West 32 Street, New York 10001

**UNDERSTAND INCOME TAX BRACKETS**. Reduce taxes. Written by CPA. Free Details. InformTexts, 602 North Sycamore, Los Angeles, Ca. 90036

**UNIQUE BOOK CATALOG** Moneymaking, Business, Health, Love. Rush \$1. Midwest, Box 8147, Green Bay, WI 54306-8147

**"NO MORE EXCUSES, I'M GOING TO BE RICH!"** Unlimited Success and Riches guaranteed through **HOW GOALS CAN PRODUCE GOLD** Or your money back. Valuable information sections included. \$10.00 + \$2.00 PH: Transformers (Transmindology), P.O. Box 30473, Memphis, TN 38130.

**THE THREE DIFFERENT JESUS CHRISTS** in the New Testament Gospels and all contradictions. Send Eight Dollars plus Two Dollars for Postage and handling for Booklet, giving Chapter and Verse to: P.L. Atkinson, 272 East Orange, San Bernardino, Calif. 92410

**POPULAR MECHANICS "PLANS AND IDEAS" CATALOG #1700** — Hundreds of ideas on workshop projects, plans for shop tools, storage houses, boats, furniture, toys — just about everything! Send \$1.50 to: **POPULAR MECHANICS P.O. BOX 1014, RADIO CITY STA., NEW YORK, N.Y. 10101**

## CATALOGS

**DOLLHOUSE** Plans, construction, electrification supplies. Discounts. \$2.00 refundable. Jacqueline's, P.O. Box 23464PM, Oakland, CA 94623-0464.

**JEEP® REPLACEMENT FIBERGLASS STEEL REINFORCED BODYS AND PARTS JEEP® FIBERGLASS FULL AND HALF HARDTOPS PICKUP TRUCK SLEEPERS. SEND \$2.00 FOR CATALOG. A J'S 4WD MFG., R.D. #3, BOX 284 APM, JERSEY SHORE, PA 17740. 717-396-7520**

**2,955** Tools, Electronics, Games, More. Wholesale! Giant Catalog and Price Book. \$5.00 Refundable. Quality, Box 372, Northfield, N.J. 08225

**LEATHERCRAFT CATALOG**. Over 2000 items. Largest selection available of genuine leathers, tools, kits, books, supplies. Fine upholstery, utility garment leathers, suedes, exotics. Belt, wallet, moccasin kits and more! Send \$1.00 post/hd to: Tandy Leather Company, Dept. PM987C, P.O. Box 2934, Fort Worth, TX 76113.

## PORTER'S FREE PHOTO/VIDEO CATALOG BEST IN THE INDUSTRY

**OVER 4,000** products — Brand names, many unique and unusual items, discount prices and Fast service. For your Free copy write: Porter's Camera Store, Inc., Box 628, Dept. PM, Cedar Falls, Iowa 50613 or phone **1-800-553-2001**.

**FLAGS! FLAGS! FLAGS!** American, State, Religious, Foreign. Home and business **FLAGPOLES**. **FREE CATALOG!** Write: **LIBERTY FLAG**, P.O. Box 424/PM, Reedsburg, WI 53959 or **CALL 608-524-2834**.

**DISTINCTIVE MERCHANDISE BELOW WHOLESALE**. Items Appealing To All Interests. For Catalog Rush \$2.00 To: Ross, Box 35065, Tulsa, OK 74153

**BUY KNIVES, CUTLERY ITEMS** at Wholesale. Save up to 60%. Huge Selection, Satisfaction Guaranteed, Fast Service. Send for **FREE** Catalog. Smoky Mountain Knife Works, Box 714PM, Sevierville, TN 37862.

## AUTOMOBILES

**CAR COLLECTORS AND RESTORERS** - find your dream car plus all the parts you need in **HEMMINGS MOTOR NEWS**, world's largest old-auto marketplace since 1954. Over 600 pages each month listing thousands of old cars, parts, services, supplies and more. Your best chance to buy, sell or swap. Subscribe today and save 62% off the newsstand price only \$17.95 for 12 giant issues. Satisfaction guaranteed. P.O. Box 100, Dept 7918, Bennington, VT 05201.

**FALL** Carlisle '87 Collector Car Flea Market. 7500 Vendor Spaces of Cars and Parts for Sale. October 1-4, Carlisle, Pennsylvania Fairgrounds. Info: The Flea Marketeers, 1000 Bryn Mawr Rd., Carlisle, PA 17013. Phone: (717) 243-7855 (Weekdays).

**IS IT True** You Can Buy Jeeps for \$44 through the U.S. government? Get the facts today! Call 1-312-742-1142 Ext. 7133.

**HOW To Get TROUBLE FREE DELIVERY** On Your New Car. Send \$10.00 for Consumer News Letter P.O. Box 371, Hobe Sound, Fla. 33475

**CAR BUYING?** Save 15% or more, free details plus Bonus. JTG, 7027 Cooper Ave., Merchantville, NJ 08109

**SUPER Mileage Carburetors! Do They Work? FREE DETAILS.** TDC, Dept. 967A, 304 San Miguel, St. Charles, MO 63303

**VAPOR** Carburetor Triples MPG, Free information. H&A, R2 PV, Bowling Green, MO 63334

**SELLING YOUR CAR? MAXIMUM DOLLAR RETURN!** Detailed guide \$4. Research Specialties, Box 18033, Salem, OR 97305.

**'76 - '85 JEEP CJ & DJ** Windshield glass: \$55 plus \$10 shipping. Specify year, model, tint or clear. CGI Glass, P.O. Box 52018, Minneapolis, MN 55402

**METRIC**—Nuts, bolts, screws assortment for all foreign cars. \$4.95pp. WREC, Box 12912, Arlington, VA 22209

**USED** Car Buyers' Guide helps you save big bucks. \$2. McCollum, Box 244, Huntington Beach, CA 92648.

**"ELIMINATE DANGEROUS BLINDSPOT"** Brochure describes how to make you a safer driver. Nothing else to buy. Send \$2.00 to: "Eliminate Blindspot", P.O. Box 40908/PM-9, Fayetteville, N.C. 28304

## AUTO SUPPLIES & EQUIPMENT

**SAVE** gas, improve performance. **GUARANTEED**—\$14.50. Postpaid-Refunded If Not Satisfied—**FREE** Gift. CTD Box 478, McAfee, NJ 07428

**ALTERNATOR** Generator Rebuilding Book. Price: Hedelund Engineering, Box 26024, Las Vegas, NV 89126.

**PARTS:** Army Jeep and truck parts. Spare Parts & Equipment Co., P.O. Box 751, Lexington, Kentucky 40587-0751

**ENGINE OVERHAUL KITS: WHOLESALE CATALOG** \$2.00. ESG, Dept. PM, Box 13053, Lansing, MI 48901

**AUTOMOTIVE** air conditioning parts discount prices: Catalog \$2.00. Auto Air Supply, 166 Placid Heights, Seguin, Texas 78155.

**MONITOR** All Exterior Lights On Your Vehicle. Installation Kit \$10.00. Lightwatch, 762 Olive, Denver, Colorado 80220

**CHEVELLE**, Camaro, Chevy II, and Impala Parts, 56 Page Catalog Free. Discount Parts And Pieces, P.O. Box 1120B, Hillsborough, N.C. 27278

**"SYSTEM 48"** Friction Modifier, \$16.50/lifetime treatment, Postpaid. **SATISFACTION GUARANTEED**, 545 Second, Carbondale, CO 81623-2113.

**STOP CONFUSION! AVOID ACCIDENTS!** Motorists-Install a New Volume Control **BUZZER** unit on your Turn Signal system that you can really hear. Free details. Unitherm Industries, 6932 N. Table Mountain, Tucson, AZ 85718

**MOTALOY** ring valve job while driving. Guaranteed. \$10.00, two \$18.00. Postpaid. Andris, Box 34061, San Francisco, CA 94134. Dept. A

**AUTO CLOCK RESTORATION**, upgrading to quartz. Repair kits available. Instruments Services, 433 S. Arch, Janesville, WI 53545. 1-800-558-2674

**CAR WINDOW AND SURFACE SPRAY CLEANER** All in one. Container, sponge, squeegee. \$4.49 to: Inter-Am Enterprises, 420 E. 73rd St., New York, NY 10021

## MOTORCYCLES, MOTORSCOOTERS & SUPPLIES

**MINI-BIKE** Kit—\$49.00. Go-Karts, 2, 3 And 4-Wheel ATV's, Engines, Wheels, Tires, Clutches and Accessories. 1987 40 Page Wholesale Catalog—\$2.00. Go-Karts & Kits, P.O. Box 755, Closter, NJ 07624-0755.

**GO KARTS**, Minibikes, Atv's. Kits, Parts, Engines. Lowest Prices. Largest Selection. 80 Page Catalog \$3.00. Refundable. Kart World, Dept. C., 1488 Mentor Ave., Painesville, Ohio 44077

## AVIATION, HANG GLIDING

**GYROCAR** a practical, roadable aircraft. Brochure \$5.00. Rotary Flight, Inc., P.O. Box 577, Cedar Crest, NM 87008

(Continued on next page)



## AVIATION, HANG GLIDING

(Continued from preceding page)

### NEW WAY TO FLY

**AMAZING** 179Lb flying machine **CLIMBS** to 10,000 Feet. **NO LICENSE** Required. **NO WINGS** or Helicopter Blades. **FOLDS** to Fit in Trunk of Car. **SAFEST**, Easiest, Cheapest Way to Fly. Buy One Be a Dealer (if open). For Complete information & **FREE** Demo flight send \$5.95 to: Freedom Flyers, P.O. Box 135M, West-Pittston, PA 18643.

**DESIGN**-Build Airplanes, Hang Gliders. Simplified publications brochure 25c. McCoy Aircraft, Suite 243, Box J, Manhattan Beach, CA 90266

**VOLKSWAGEN** Airboat Plans, \$19.00. Airboats-Hovercraft, 15 to 250 Horsepower. Completed Models, Plans, Kits, Propellers, Engines, Supplies. Catalog \$3.00. Sportscraft, Box PM, Meeker, Oklahoma 74855

**HOBBY HELICOPTER**. "Choppy" Ultralight Single-Seat Helicopter. Simplified Construction—Motorcycle Engine. Brochure \$3.00. Polynova, Box 670M, St. Remi, Quebec, Canada J0L 2L0

### PROPELLERS

**PROPELLERS** - for Hovercraft, Ultralights, Homebuilts, Wind Generators. Information \$1.00. Aerotec, Rt. 1 Box 1025, Quinlan, TX 75474. 214-447-2010

### SPACE & ASTRONAUTS

**NASA** emblems, toys, gifts, collectibles. Catalog \$2.00. Refundable. Collector Trends, Box 361, Dayton, Ohio 45409

**BOOMERANGS ... HI-TECH RETURNS!** Polycarbonate, Paxolin, Wood Constructed. World's Best! Collectible. 11th Annual Catalog. **FREE!** BoomerangMan, 1806-1 N. 3rd., Monroe, LA 71201-4222

### HOVERCRAFT

**HOVERCRAFT** Plans All Sizes. Catalog \$1.00. Universal Hovercraft, Box 281, Cordova, Illinois 61242

**AERO-CAR** Amazing Hovercraft built easily with ordinary tools. Lawnmower engine power. Carries one man plus. Hovers, flies forward, backward. Sideways over land/snow/water. Complete construction plans and brochure. \$10.95. Aero-Projects, Box 5118PM, Clinton, New Jersey 08809.

**VW HOVERCRAFT** Information \$10, Plans \$25. Neoteric, Box 2438, Melbourne, Australia, 3001

**BARTLETT** Flying Saucer Ultra-Light Hovercraft Featured in Documentary Film, "Force Beyond." Powered By Ordinary Lawn Mower Engine. Complete Plans \$10.00 Send To: Herb Bartlett, P.O. Box 156M, Silverdale, WA 98383

**HOVERCRAFT PLANS & PUBLICATIONS** Catalog, \$1.00. Lansing Aero-Marine, P.O. Box 27855, Lansing, Michigan 48909

### CB'S, RADIO & HAM EQUIPMENT

**POLICE** Scanners, Bearcat, Regency, HPR, Box 19224PM, Denver, CO 80219.

### ELECTRONICS

**BUGGED? WIREAPPED?** Find out fast! Countermeasures equipment catalog \$1. Capri Electronics, Box 589P, Bayfield, CO 81122

**MAKE** To \$48/Hour In Mobile TV Repair Business! Immediate Full/Part Time Opportunity! Small Investment! We Teach You! Send For **FREE REPORT**: Dowdell TV, Box 8057, Temple Hills, MD 20735

**NIGHT VISION SCOPES**. Reconditioned Military units. Both Starlight (Passive) and Infrared (Active). Catalogs \$4.00. STANO Components, P.O. Box 6274, San Bernardino, CA 92412, (714) 883-2728.

**ELECTRONICS FOR SECURITY, COUNTERSURVEILLANCE AND PERSONAL PROTECTION CATALOG.** \$1. **HUNTEREX**, BOX 12922, WINSTON-SALEM, NC 27117

### COMPUTERS & SOFTWARE

**Ti-99/4A** Software/Hardware bargains. Hard to find items. Huge selection. Fast Service. Free Catalog. Dynamic, Box 690, Hicksville, N.Y. 11801

**COMPUTER FACT BOOK** Learn about Computers the Easy Way, for **FREE** Information write: Computer & Arts, 5580 La Jolla Blvd., Suite 472-H, La Jolla, CA 92037

**THE CONSTRUCTION ESTIMATOR**-House Additions Garages Apple II IBM \$95. 175 Marshall Ave., Guilford, CT 06437. (203) 453-4809

**COMMODORE** - Largest US Repair Center (eg. C64-\$39.95). 72 hour service. Send for chips/parts catalog. Kasara Inc., 33 Murray Hill, Springvalley, NY 10977. 800-642-7634

### STEREO, CASSETTE TAPES, ETC.

**THOUSANDS OF OLDIES!** Hard-to-find 45 rpm hit records from the last 40 years including pop, country, rock and soul. Send \$2.00 for catalog to: American Pie, P.O. Box 66455, Dept. PM, Los Angeles, CA 90066

### TV & VIDEO EQUIPMENT

NOTICE: USE OF CERTAIN ITEMS IN THIS CLASSIFICATION REQUIRES STATION AUTHORIZATION.

**VCR Owners** Don't Damage Video Heads Using Abrasive Cassette Cleaners. Clean Heads Same As Professionals. Copyrighted Instructions and Free Cleaning Wand. \$6.00. Tunco, P.O. Box 3147 E, Shelby, NC 28150

**CABLE TV CONVERTERS**. Scientific Atlanta, Jerrold, Oak, Zenith, Hamlin. Many others. "New" **VIDEO HOPPER** "The Copy Killer". Visa, M/C & Amex Accepted. Toll Free **1-800-626-7623**. B&B Inc., 10517 Upton Circle, Bloomington, Mn. 55431

**SATELLITE TV SYSTEMS**, Upgrade Electronics, Buyers Guide, Discount Prices. \$3.00. NECS Inc., Box 22808-MI, Little Rock, AR 72221

**CABLE TV** Converters, quality merchandise, we ship C.O.D., low prices. Send \$2.00 for catalog. Cabletronics Unlimited, P.O. Box 286PM, S. Weymouth, MA 02190. (617) 843-5191

**SUPER** High Grade Video Cassette, VHS6hrs, satisfaction guaranteed. 5/\$14.95, \$2.95 P&H, 10/\$29.95, \$3.95. Tape Deal, 410W. Center, Springville, Ut. 84663

### CAMPERS & TRAILERS—KITS, PLANS

**BUILD YOUR OWN** - Travel Trailer - Fifth Wheeler - Motorhome - Camper - Pickup Cover - Plans - Patterns - Kits - Catalog \$1 - Glen-L R-V's, 9152PM Rosecrans, Box 1804, Bellflower, CA 90706.

### TRAILER PARTS

**TRAILER PARTS** for personal or commercial use. Complete catalog \$3.00. Croft Trailer Supply, 4935 Truman Road, Kansas City, MO 64127

### BOATS, OUTBOARDS, TRAILERS, & KITS

**BOAT KITS-PLANS-PATTERNS**-Plywood-Wood/Epoxy-Fiberglass-Steel-Aluminum-**WORLD'S LARGEST COMPLETE LINE-8/70'** Sailboats-Powerboats-Cruisers-Sportboats - Houseboats - Hydroplanes - Tunnelhulls - Runabouts-Duckboats - Canoes - Kayaks - Dories - Prams - Multihulls - **CATALOG \$3.00** (Airmail \$5.00) includes International Catalog and Supplies Catalog (Epoxy Fiberglass-Flotation Foam)-**BOOK** "Amateur Boatbuilding", \$6.00-**CLARKCRAFT**, 16-P Aqualane, Tonawanda, NY 14150

**EVINRUDES - NEW 1986 BARGAINS - TOP BRANDS ...** all sizes ... \$2.00 handling ... Scott McCulloch parts ... Electra Marine, 610 Merrick Road, Lynbrook, New York 11563

**BOAT** Plans - Patterns - Kits - Hundreds of designs - 7'/55' - Sailboats - Powerboats - Sportfishers - Houseboats - Rowboats - Duckboats - Bassboats - Canoes - Kayaks - Hydroplanes - Dories - Boattrailers - Simple construction - Proven instructions - Tremendous savings! Gigantic 160-page catalog \$3.00 (\$4.00 Airmail) - Includes Free "Boatbuilding Supplies" catalog - Fiberglass - Fastenings - Glues - Books. Revolutionary "Poxygrip/Poxyshield" manual \$2.00. Glen-L, 9152 Rosecrans, Box 1804MP, Bellflower, CA 90706

**BOAT KITS - SAIL 16'-30'**. **FIBERGLASS**. Save half. Anyone can assemble. **FREE** 40 page catalog. **LUGER**, Dept. BC-97, P.O. Box 1398, St. Joseph, MO 64502. 1-800-BOAT KIT in MO: (816) 233-5116.

**FIBERGLASS** Boat Building Materials Call or Write for **FREE** Catalog 1-800-237-9511 or Fl. residents 1-800-282-9498. Suncoast Fiberglass, 2880 Palm Beach Blvd., Fort Myers, FL 33901

**EXTENSION** Handle for Steering Electric or Gasoline Outboards. \$10. Alysse, Box 1306, Lady Lake, FL 32659-1306

### CAMPING EQUIPMENT & TENTS

**MRE'S**, Freeze Dried & Storage Foods. **FREE CATALOG!** Survival Supply, DPM, 15010 Keswick, Van Nuys, CA 91405

### ATHLETIC EQUIPMENT AND BODY BUILDING COURSES

**BURN** Fat. Build Muscle! New Incredibly Effective Method. \$9.95. Braycraft, #18-5305 47A Avenue, Red Deer, Alberta, Canada T4N 3R6

**BIGGER**, More Powerful Muscles - faster! Free Booklet! Universal, Box 8694A, Detroit, Michigan 48240

**KUNG-FU** Free Lessons. Send \$1.00 for Postage. McLisa, Box 1755, Dept. PM87J, Honolulu, Hawaii 96806

### FISHING, TACKLE, LURES

**FREE** Sinkers Mold Catalog over 100 molds 25 shapes. Carmen's, Box 220PM, West Newton, PA 15089

### GUNS, DECOYS, HUNTING

**BEEMAN HIGH POWER ADULT AIRGUNS**, Fine Firearms, Magnum Slingshot. Guaranteed best prices for the very finest. Unexcelled power yes, but more importantly: unequal accuracy, trigger action, durability, ownership pride. \$1 Lifetime Repair Policy. Mention code PMC for **FREE** Airgun Catalog/Firearm information. Add \$1 for fast mail. Beeman, 3440-PMC Airway Dr., Santa Rosa, CA 95401-2040.

### BATTERY REBUILDING SCHOOL

**TECHNICAL** breakthrough in battery chargers-uses 1/2 the electricity compared to old type. Technical breakthrough in carbon pile testers-no burnout! Moore Tool & Cover Company, 10415 US 98, Sebring, FL 33870. 813-655-1616

### ENGINES, MOTORS

**SMALL ENGINES** Galore! Free Discount Catalog. Engines, Box 166P, Ashland, MO 65010.

**GENERATOR KIT** 5 H.P.-2400 Watt, Assemble in minutes. Save hundreds. Send \$5.00 (refundable) to: Gen-Kit, PM8705, P.O. Box 180, Rockford, MN 55373. Dealers Specify.

**VIDEO** how to overhaul small two and four stroke engines, \$30.00 US no C.O.D. Engtech, Box 493, Pelly S0A-220

**BUILD** 1-hp versatile **AIR COMPRESSOR**. Maximum pressure 125 PSI. Send for Plan PC-1717 + \$6.95 to: **POPULAR MECHANICS**, Box 1014, Radio City Sta., New York, N.Y. 10101

**BUY WHOLESALE!** Parts for Lawn, Garden Equipment, Small Engines, Chainsaws, Minibikes, Karts, More. Includes repair manuals, specialty tools. Send \$4.00 for 184 page catalog. Sav-On-Parts, P.O. Box 45231, Dept P., Somerville, MA 02145

### TOOLS FOR SALE

**BOLTS, SCREWS, TOOLS, WHOLESALE, DIRECT.** Guaranteed. Catalog \$1.00 (Refundable). Camelot, Dept. 44, Box 65, Bristol, Wisconsin 53104

(Continued on next page)



## TOOLS FOR SALE

(Continued from preceding page)

**POWER TOOLS AT WHOLESALE. SHIPPED FREE, FAST. FREE CATALOG. BEAVER TOOLS. CALL FREE 1-800-992-2877.**

**REPLACEMENT HARDWOOD TOOL HANDLES** High quality, low cost! Send \$2.00 (refundable) now: Ozark Handle Catalog, Box 390M, Eureka Springs, AR 72632

## UPHOLSTERY SEWING MACHINES

**UPHOLSTERY** Sewing Machines with Walking Feet. Complete ready to use-only \$510.00. Thompson Model PW201-AVAILABLE FROM YOUR LOCAL DEALER, or order direct (Master Charge-Visa). Datho Mfg. Inc., P.O. Box 12110, Lubbock, Texas 79452-Phone: (806) 744-6774

## MACHINERY, TOOLS & SUPPLIES

**LATHE OWNERS.** Quick Change Tool Post. Starting at \$58.00. Plans \$15.00. KRF, Box 783A, St. Joseph, MI 49085. 616-429-7050.

**BEST Prices.** Woodworkers Machinery Catalog, Free. McKilligan, PMC87, Johnson City, N.Y. 13790

**SMALL FOUNDRY Furnaces, Supplies.** Free literature. Pyramid Products, 3736 South 7th Avenue, Phoenix, Arizona 85041

**"SHARPENERS REPORT"** Monthly Newsletter, Sharpening Guidebook, Angle Wall Chart, Free details. Skog Company, Dept. PM9, P.O. 22559, Minneapolis, MN 55422

**BANDSAW BLADES,** Any Size, Free literature. King Saw, 6541 Tidewater Drive, Norfolk, Virginia 23509

**LATHES, Mills, Tools.** New catalogs \$1.00. Blue Ridge, Box 536V, Hurricane, WV 25526. 304-562-3538.

**LATHES - INDUSTRIAL/HOBBY FROM \$295.00, METALS, SUPPLIES. LARGE CATALOG \$2.00. CAMPBELL TOOLS 32nd YEAR. 2100-D SELMA RD., SPRINGFIELD, OHIO 45505. 1-613-322-8562.**

**STEEL, Aluminum, Brass—Sheet, Bar, Shop Supplies.** Plans. Write: CEI, RR1, Box 163, Cameron, IL 61423.

**4" METAL Cutting Lathe \$104.50.** Taig, 15048 Proctor, Industry, CA 91746

**MITER Fence For Radial Arm Saw.** Free Details. RH Products, 3212 Skycroft, Minneapolis, MN 55418

## ENERGY SAVING

**SAVE ON AIR CONDITIONING ELECTRICAL CONSUMPTION.** Professional Repairman's Video Shows How. \$25.00. Rick's, Route 4, Elberton, GA 30635

**SAVE Money On Gas Bill.** Install Gas Saver On Water Heater. Send \$1 For Brochure. Refundable. Walker, P.O. Box 12029, Omaha, Neb. 68112

## SOLAR & ALTERNATE ENERGY

**SOLAR, HYDRO-ELECTRIC, WIND POWER equipment CATALOG.** U.S. addresses send \$3.00, all others send \$6.00 in U.S. funds to: WESCO, Box 936, Redway, CA 95560

**VIDEO chimney cleaning, inspecting.** Fireplace Woodstove 2 hr. tape (VHS) by certified professional. \$39.95 + \$2.00 shipping. Chimney Sweep, Rte. 1 Box 37A, Grove City, MN 56243

## HOME CRAFTSMAN

**OVER 500 WOODWORKING DESIGNS!** Create profitable toys, gifts, folk art, whirligigs, household accessories... more! Brochure Plus Sample Pattern only \$2.00. Accents (BP-97), Box 7387, Gonic, NH 03867

**MAKE WOODEN TOYS,** whirligigs, classic autos, swing sets, doll houses, crafts, furniture with our plans, parts, kits, supplies. Color catalog subscription \$1. (614) 464-4363. Cherry Tree Toys, Belmont, Ohio 43718-0369

**WOODCRAFT PATTERNS,** Windmills, Wishing Wells, Bird Houses, Feeders, Flying Duck, Pheasant, Outdoor Planters, Catalog \$1.00. Crafters, 11840 US 27 North, DeWitt, Michigan 48820

**FAVORITE WOOD TOYS,** Patterns, Parts, Wheels, Catalog \$1.00. Toys and Joys, Box 628M, Lynden, Wash. 98264

**PVC PIPE FURNITURE** Plans, Kits And Supplies. Free Brochure. Casual, Box 208, Tewksbury, MA 01876

**WOODWORKING** Plans, Sofa beds, Futon convertible beds, Platform beds. Complete details. Set of 4 plans, \$12. Lachimia Designs, Box 27173 Market Square, Philadelphia, PA 19118.

**"QUARTZ** chime clock movements and kits." Catalog and sales plan \$1.00. NEWPORT, 2313 Burbank Blvd, Burbank, CA 91506

**ELECTROPLATING!!!** It's different! For pleasure/profit—Handbook just published! Details free. Corbin, 3380 Sheridan, Suite 143-P, Amherst, NY 14226-1439.

**HOBBY MONEY** - Report tells how to turn your hobby into cash. \$3.00. Monarch, 500 N. Montour, Gibsonsia, PA 15044

**PROFITABLE WOODEN "COUNTRY CRAFTS"** Made \$2,000 one weekend. 100 full size patterns and details only \$6.00. Hartville Woodcrafts-P97, 12355 Market, Hartville, OH 44632

**FULL-SIZE PROFESSIONAL PLANS** - Catalog \$2.00. Over 200 professionally designed plans for building furniture. Traditional, Early American. Furniture Designs, Inc., CP-87 1827 Elmdale Ave., Glenview, IL 60025.

**STEAM ENGINE KITS** Power models at savings to you! Send \$1.00 for literature. P.M. Research Inc., Dept. 7 RD #2 Box 29, Wellsville, NY 14895

**DOLL CRADLE** — is a reproduction of an 18th century cradle. Ours is handcrafted of mellow pine with varnish finish. Any little girl will enjoy playing with this beautiful cradle. (10 3/4" x 22 1/2") plans and material list. (PC-1820-\$4.95). Send order to: Popular Mechanics, P.O. Box 1014, Radio City Station, New York, NY 10101

## WOOD, WOODWORKING

**STRATO A NEW** oil finish, hand rubbed look, nothing else compares information and price. 108 Old McCloud Rd., Mt. Shasta, CA 96067. (916) 926-4990

**SQUARE DEAL!** Fisher's Combination Square, Centerfinder, Protractor And More! \$18.95 Delivered! **WAVERLY WOODWORKS**, Route 5, Box 1204, Forest, VA 24551. Orders: 1-800-237-9328. Send for **FREE WOODWORKER'S CATALOG.**

**WOODWORKERS!** 1001 handtools, thin hardwoods, veneers, woodturning/carving stock, patterns, dowels. Catalog \$1.00. Morgan, P01M40, 1123 Bardstown, Louisville, Kentucky 40204.

**WOOD IDEAS** Craftplans, Gazebos, Lawn Furniture, etc. Catalog \$1.00. H&E Design, Box 38, Richmond, MI 48062

**CHERRY OAK, WALNUT, MAPLE** Boards. Small Orders Our Specialty. Send \$1.00 for Listing (Refundable). Park Timber, P.O. Box 558P, Orchard Park, N.Y. 14127

**BUILD ROCKING HORSES!** Size 25" x 36", Plan #245 for \$8.00. Size 35" x 58", Plan #400 for \$10.50, postpaid. NY residents add tax. Armor Products, Box 445AC, East Northport, NY 11731.

## PLANS, BLUEPRINTS, PROJECTS

**25 FURNITURE PLANS.** Full Instructions \$18. **HITCHEN**, RR #3, Bracebridge, Ontario, Canada P0B 1C0

**TRAILER PLANS:** Build Yourself, Save \$, Have Fun. Specify, Utility Or Garden Model. \$3.00. Roann, 7153 Maple, Sebastopol, CA 95472

**DOLLHOUSE FOR 12" FASHION DOLLS** detailed plans for a simple two story dollhouse. Send \$5.00 for a 5 in 1 dollhouse, toybox, and desk, seat and garage **PROFITABLE** at Flea Markets. Send \$7.00 to: ABC Engineering, 1731 Bluebird Ct., Melbourne, FL 32935

**PLANS** for Caboose Type Structure for domestic use. Excellent utility and illusion. Usable Space. Twelve pages. Send Bank Check or M.O. for \$48.95 plus \$1.23 P&H, or Add \$3.00 for Blueprints, to: **BEN JOHANSON**, P.O. Box 3422, Lacey, Wa 98503.

**172 TRAILER PLANS** Motorcycle, Utility, Car, Construction - Strong, Streamlined, good looking, easily built. Catalog \$4.00 (Refundable). Tag-Along, Box 15107, Salem, OR 97309

**UTILITY WORKBENCH** - Sturdy construction, 7 drawers, 2 cabinets. \$6.95 for Professional Blue-Prints and instructions. Steve Gable, Box 5400, Incline Village, NV 89450

## FOR THE HOME

**"THE RADON REPORT"** provides basic information about Radon Gas in the home, using a simple question - and-answer format. \$3.00 from the Parker Village Press, Box 2067, Westford, MA 01886-5067

**WASH WINDOWS** like the professionals. Easy instructions. Send \$5.00. Windows, P.O. Box 51532, New Berlin, WI 53151

**NEW BOOK REDUCES YOUR HOME REPAIR COSTS!** Easy, fast way to learn about your apartment, house or condominium. **CONCISE** and **CLEARLY WRITTEN** book covers many topics including appliances, security, yards, wiring, and plumbing. \$7/\$1 P&H, satisfaction guaranteed. AdSoft Enterprises, Box 253-PM1, Newton, MA 02159.

**ANTS!** Solve your Ant problems forever. Send \$3.00 to: Victory, 201 Tenth Street, Pittsburgh, PA 15215

**STRIP** and finish furniture for profit. Professional reveals secrets. Booklet \$4.00. Shearer Refinishing, 14 East State Street, Marshalltown, Iowa 50158

**WIRELESS DOORBELL SYSTEM** 5 Minutes Installation \$59.95 Toll Free 1-800-553-3070.

## PLASTICS

**CASTOLITE** Liquid Resins and Molding Supplies to cast, embed, coat, fiberglass, repair and reproduce; in industry, laboratories, craft work. Catalog \$2.00. **CASTOLITE**, Dept. 87L/PM, Box 391, Woodstock, IL 60098.

## AIR CONDITIONING & HEATING

**SAVE MONEY, VERY SIMPLE TEST** tells how **EFFICIENTLY** your Air Conditioner Operates, anyone can do it. Money Saving Tips \$7.00. Brigs, Box 1708, Merritt Island, FL 32952

**SAVE Money.** Make Money Repairing Home And Automobile Air Conditioning. Valuable Free Report. Easy. 215 Postoffice #1205 N., Galveston, TX 77550.

## DO IT YOURSELF

**APPLIANCE REPAIR HANDBOOKS**—\$2.65 to \$6.90 each. Free brochure. ASN, Box 789D, Lombard, IL 60148

**MAJOR Appliance Parts Supply Model & Brand.** Appliance Parts, 2516 Whitney Ave., Hamden, Ct. 06518

**BELT BUCKLES** for coins or stones, specialty buckles, jewelry mountings, cut stones, clock works. Wholesale catalog 25¢. Eloxite Corp., 806 1/2 10th Street, Wheatland, Wyoming 82201

**ELECTROPLATING.** Complete Textbook. Electroplate Metallics/Nonmetallics. \$11.95. Details Free. Tropix, Palm Bay, FL 32906-0095

**INSTALL YOUR OWN IN GROUND SWIMMING POOL** for as low as \$1,695.00. Cheswick Pools, Rt. #28, Cheswick, PA 15024. 412-274-6400

**ARROWHEAD MAKING!!!** Inexpensive Fun Hobby. Free Information. Commons Crafts, P.O. Box 5012-M, Central Point, Oregon 97502

**LIGHT BULB SAVERS** Don't change another light bulb in 10 year's. Set's of 6, \$9.95. Free gift catalog. Satisfaction Guaranteed. JW Ltd., 229 South Juniper, Escondido, California 92025

**PROJECTION TV** ... Convert your TV to project 7 Foot picture ... Results comparable to \$2,500 projectors ... Total Cost less than \$30 ... **PLANS AND 8" LENS \$21.95** ... Illustrated information. **FREE.** Macrocoma-BA, Washington Crossing, Pennsylvania 18977. Creditcard Orders 24HRS. (215) 736-3979.

**COMPLETE** in-ground swimming pool kits from \$1595.00. Free Brochure & Price Lists. Burnett, 341 Hillard Road, North Little Rock, Arkansas 72118.

**SAVE MONEY!** Stop Water Heater Replacement! Details \$1.00 (Refundable). Enterprises, 1331 Missouri, Longmont, CO 80501.

**4,321 Catalogs Listed.** Sources for Anything! \$5.00. Directory, Box, 92452N, Atlanta, Georgia 30314

(Continued on next page)



## DO IT YOURSELF

(Continued from preceding page)

**HOW** to clean and service your VCR. Step by step video tape. 90 minutes. Specify VHS/Beta \$21.95. Visa/M/C, Amex accepted. Salco, 318 Mesa Verde Ave., Palmdale, CA 93550

**EQUITY PROTECTION** - Buying, selling, renting, building. New **PROPERTY INSPECTION/EVALUATION KIT**. Details SASE: CDC, Suite 58-14 Dept PM, Andreas, PA 18211

## ARTS, CRAFTS, SUPPLIES

**CLOCK WORKS**. Wood clock blanks, rockhound supplies, belt buckles, cut stones, etc. Wholesale catalog 25¢. Eloixite Corp., 806 1/2 10th Street, Wheatland, Wyoming 82201

**STAINED GLASS SUPPLIES: EXCITING SUPER CATALOG-PM \$3.00. CORAN-SHOLES INDUSTRIES, 509 E. SECOND, BOSTON, MA 02127.**

**QUARTZ CLOCK MOVEMENTS**—digitals \$1.50, epoxy resin \$16.00 gallon, foil prints .95¢, music movements \$1.40, complete clock kits \$6.50, components, plans—much more! 52pg. wholesale catalog \$3.00 (credited). Steebar, P.O. Box 463P, Andover, NJ 07821-0463.

**STAINED GLASS SUPPLIES**. Complete catalog \$2.00. Sunshine Glassworks, 3690 Harlem, Buffalo, NY 14215

"GETTING Started in Stained Glass." \$1.00. Whittemore, Box 2065T, Hanover, Mass. 02339

## CARTOONING, COMMERCIAL ARTS, SIGN PAINTING

**CARTOON** for Fun and Money!!! Free Booklet!!! Cartoons, Box 40614A, Detroit, Michigan 48240

**LEARN** Sign Painting, Pin Stripping. Free Catalog. Kaufmann Company, Centertown, Missouri 65023

**NEW!** "CARTOONING FOR BEGINNERS INSTRUCTION." Catalogue! Samples! \$2.00. Harris, Box 1567-S, Portland, Oregon 97207

## MODELS, MODEL SUPPLIES

**FIRING CANNON** Model Plans CATALOG \$2.00. GREEN-PM97, Box 892, Shalimar, FL 32579-0892

**RADIO CONTROL** Airplanes, Boats, Helicopters, Supplies. Big Discount Catalog \$5.00 (Refundable). Modelers Supply, Box 310P, Eclectic, AL 36024

## TOYS, GAMES, KITES, PUZZLES, NOVELTIES

**WOOD TOYS, FURNITURE** Plans, Kits Catalog \$1.00. Birite Wood Treasures, P.O. Box 15356, Milwaukee, WI 53215-0356

## MAGIC TRICKS, JOKES, VENTRILOQUISM

**FREE!** World's Leading Novelty Catalog. 1600 Jokes, Tricks, Science, Sports, Hobbies. Johnson-Smith, F-01, Bradenton, Fla. 34203-3796

**LEARN VENTRILOQUISM!** Guaranteed Instruction, Supplies, DUMMIES. Information Free! Maher, Box 420-PM, Littleton, Colorado 80160.

**FREE!** Insider Magic Report. **MAGICIANS INTELLIGENCE**, 3380 Sheridan, Amherst, NY 14226

**FREE** Magic Catalog. Enclose 50¢ Postage. Winkler's Warehouse Of Wonders, 24 J Doyle Road, Oakdale, CT 06370

## HOBBIES & COLLECTIONS

**NAZI** & Historical Military Collectibles. **FREE** catalog. HMA, Box 1806PS, Lafayette, CA 94549.

**MILITARY** Medals Catalogue \$1.00. Subscription Yearly \$6.00. Vernon, Box 1387PM, N. Baldwin, NY 11510.

**ANTIQUE** Plastic Airplane Kits. Send for list \$1.00. G&C, 3529 West Boynton Beach Blvd., Boynton Beach, Fla. 33436

## DECALS, EMBLEMS, PATCHES

**CUSTOM EMBROIDERED EMBLEMS, PINS, DECALS.** Free Catalog/Quotes. Rush Sketch. Stadri, 61P Jane, N.Y.C. 10014. (212) 929-2293

## 134 POPULAR MECHANICS

## ANTIQUES, RELICS, INDIAN GOODS & CURIOS

**FREE** List to Serious Collectors. 30,000 Indian Artifacts, Pots, Spears, Axes, Slate, Beadwork. Caddo Trading, Box 669, Murfreesboro, AR 71958

**INDIAN** Relics List 50¢. Identification Guide Book \$11.44. Arrowhead Samples \$20.00. Secrist's, Deerfield, MO 64741

## MILITARY INSIGNIA, ETC.

**U.S. MILITARY INSIGNIA** Large Catalog. \$2.00. Saunders, Box 3133PM, Naples, FL 33939-3133

## STAMP COLLECTING

**50 YEARS** Old fifteen different United States, over fifty years old-25¢ with approvals. Jaxon, Box C11-P, New Rochelle, New York 10804

**350 DIFFERENT COUNTRIES!** Free Packet Pricelist. King, Box 101, Smithfield, Pennsylvania. 15478

**FREE** Packet. Request Worldwide Approvals. Carmel Stamps, 124 Gale Place, Riverdale, NY 10463

**FREE** Catalog Free! Big Bargain Catalog - New edition listing thousands of bargains including U.S. and B.N.A. stamps, packets albums, accessories and supplies. Also fine stamps from our approval service. Buy only what you like. Return balance promptly! Thank you. Jamestown Stamp Company, Dept. E97PM, Jamestown, NY 14701.

**FREE** 25 World Wide Stamps Plus Free Catalogue With Over 2,000,000 Stamps. No Approvals. Jefferies, 3480 Middlebelt, West Bloomfield, MI 48033

**50 DIFFERENT** Old U.S. between 1861 and 1939 - \$1.00. Ed Roush, 423 Shepard, Mansfield, Ohio 44907.

**FREE** Gift With First Purchase. U.S. Approvals And Want List Service. 20¢ for Handling. The Stamp Boutique, P.O. Box 456, Madison, N.J. 07940

**OLD** U.S. stamps on approval. Sherman, Box 15355E, Philadelphia, PA 19111

"**INVERTED ERROR**" + 100 Different United States, 50¢ with approvals. Luray, P.O. Box 7088, Silver Spring, MD 20907

**200 DIFFERENT** Canada \$1.00. Worldwide approvals. Quebephil, Box 68, St-Jerome, Canada J7Z 5T7.

**WORLD** Wide Stamps mounted in books on approval 2¢ and up. **TRUST STAMP COMPANY**, P.O. Box 100-P, Jamaica, N.Y. 11435

**FREE!** Surprise Collection with approvals. Gould, Box 750128, Petaluma, CA 94975

**ONE!** Two! Three! Cent Stamp Approvals, Regardless Catalog. Kloster, 4164 52nd St., San Diego, CA 92105

**FREE** Worldwide Packet. Penny approvals. Froehlich, Box 177DA, Pine River, WI 54965

**BARGAIN** 100 World-wide Stamps 25¢. Quality Approvals. R. Parker, Box 143, West Brookfield, MA 01585

**100** Different U.S. 25¢. Approvals. Bradley, Box 425P, Midlothian, VA 23113

**COLLECTIBLES**, Bird, Duck & Wildlife Stamps & Prints. Free Catalog. Depot, Dept. 005, Sullivan, IL 61951

**U.S.** 6 commemorative plate blocks or 30 mint Commemoratives \$1.00! Approvals. Gordon Davison, Contoocook, N.H. 03229

**FREE** Worldwide Packet Approvals. REVA Sales, Box 11780, Phoenix, AZ 85061

**1000** Stamps \$2.95 - Guaranteed Worth Over \$30 at Standard Catalog Prices! Money Back If Not Delighted. Approvals. Kenmore, OT-106, Milford, N.H. 03055

**AUSTRALIA 50 DIFFERENT BEAUTIFUL COMMEMORATIVES 10¢.** Approvals. Pence, POB 3041, Winchester, Virginia 22601

**ISRAEL** 15 Different 10¢ Approvals. Sam Chazen, Box 666, Delray Beach, Florida 33444

**FREE.** U.S. Mint pictorial set complete. Mint approvals included. Hildebrand, Box 4857, Santa Clara, California 95054

**FREE** 50 Canadian stamps with approval request. Briner's, P.O. Box 5607, San Mateo, California 94402

**CANADA.** 100 Different 25¢. Approvals. Oroszky, Box 1-C, Sarnia, Ontario, Canada N7T-7H8.

**OUR** approval customers say: **GREAT SELECTION, GOOD PRICES, SEND MORE.** Isham McConnell, Box 95, Nutting Lake, MA 01865

**WOW!** All Different Germany -25¢. Super collection of genuine German Commemoratives, Definitives, Airmails, High Values. Free Big Catalog. Also fine stamps from our approval service. Buy what you like. Return balance promptly! Send 25¢ today! Thank you. Jamestown Stamp Co., Dept. A97PM, Jamestown, NY 14701

## COINS, TOKENS, CURRENCY

**CLAY POKER CHIPS**, Casino quality, weigh 9 grams, all colors. Specify quantity and color(s). \$25.00 per 100. K & K Enterprises, Dept. A, P.O. Box 8336, Hemet, CA 92343

## BINOCULARS, TELESCOPES, MICROSCOPES, MAGNIFIERS

**DISCOUNT OPTICS** Bushnell, Steiner, Nikon, many others. U.S.A. Warranties. **FREE** Catalog! Optical Advantage, Box 32791P, Pikesville, MD 21208. (301) 653-3306.

**NEW MULTIFUNCTION BINOCULAR!** See and hear your favorite sport. Rush SASE to: S&J Enterprises, Box 187P, Hamersville, Oh. 45130.

## PHOTOS & PHOTO SUPPLIES

**PERSONALIZED MAGNETIC** Calendars. Details Mini Mags<sup>TM</sup>, Dept.C, Box 2733, Lynnwood, WA 98037-0805

## PLAYS, SONGS, MANUSCRIPTS

**POEMS**, Songs Wanted. Free Recording/Publishing. Broadway Music Productions, Box 7438PM, Sarasota, FL 33578

**FREE SONGWRITING SUCCESS BOOK!** Top Records, Box 23505PM, Nashville, TN 37202

## MUSIC INSTRUCTIONS & INSTRUMENTS

**ACCORDIONS, NEW, USED.** Electric, electronic. Cordovox, concertinas. Button Boxes. Hohners We Buy. Sell. Trade. Exchange. Repair. Tunes. 50 Years Experience If Dealers unavailable. Call or Write for Brochures. Mastercard, Visa And AMEX Accepted. **CASTIGLIONE ACCORDION**, 12644 E 7 Mile, Detroit, MI 48205. 313-527-1595/1-800-325-1832.

**PIANOS, PLAYERS, PUMP ORGANS.** Rebuild and repair. Catalog of "How-To" books, \$2.00 (refundable). Vestal Press, Vestal 11, New York 13850.

**INTERNATIONAL VIOLIN COMPANY**, Catalog for instrument makers, repairers. Imported tonewood, tools, varnishes, parts, accessories, strings, cases. European instruments, bows. Assemble yourself violin and guitar kits. Catalog \$1.00 includes 10% discount certificate. Dept. HV, 4026 W. Belvedere Ave., Baltimore, Md. 21215.

**VIOLIN, GUITAR**, etc., making materials, accessories, books. Catalog, \$1.00. International Luthiers Supply, Box 580397, Tulsa, OK 74158

**ACCORDION** Top Brands, Cordovox, Buy Direct. Tremendous Discounts. Trades accepted. Free brochure. PM, Accordion-O-Rama, 16 West 19th Street, New York, NY 10011. Phone 212-675-9089.

**LEARN** music instantly! Teach yourself courses. Amaze your friends! Catalog. Davidsons, 6727PMM Metcalf, Shawnee Mission, Kansas 66204.

**INSTRUMENT** Kits! Build Appalachian and hammered dulcimers, banjos, mandolins; even harps, harpsichords. Free Catalog. PM Hughes, 4419 West Colfax, Denver, CO 80204

## SELF IMPROVEMENT

**YOU** Can Quit! How- To Quit Smoking! \$3. May Enterprises, Box 706-PM, Grandville, Mich 49418-0706

**ENHANCE IDENTITY, SUCCESS, SKILLS, CHARISMA.** Details free. Graham, David, William Associates, P.O. Box 7342, Bloomfield, Conn. 06002

(Continued on next page)



## SELF IMPROVEMENT

(Continued from preceding page)

**CONTROL YOUR PHOBIAS.** Don't let fear cause you to panic. Informative booklet. Details. Phobia, Box 388184, Chicago, IL 60638

## EDUCATION & INSTRUCTIONS

**RADIESTHESIA,** Radionics, Dowsing E.S.P. Courses and Equipment Illustrated Catalog \$1.00 (refundable) Established 27 years. Dept. PM/R, Bruce Copen, Highfield, Danehill, Sussex, England RH17 7EX.

**EASY-CAD,** Learn about computer-aided-drafting. Free information. CADTECH INC., Dept. PM967, 31 Oneida Street, Pawtucket, Rhode Island 02860

**BRAIN BOOSTER TABLETS!** New! Powerful! Genius 1-2-3! Free information. Advanced Learning Institute, Drawer 12810-LAB2, Jackson, MS 39236

**SUPER-INTELLIGENCE!** Amazing results guaranteed! Info. EDEMP, Box 1462, Glendora, CA 91740

**HANDLE YOUR OWN LEGAL AFFAIRS.** Be a Paralegal Accredited Attorney Instruction. Home Study. FREE CATALOG. Southern Career Institute, Drawer 97PM-2158, Boca Raton, FL 33427. (305) 368-2522

**OBEY Jesus.** Include Acts 2:21-47. Tracts For Printing \$1.00. 1127 N.E. Fifth St., Ocala, Fla. 32670

**EXTENSION** And Post-Graduate Awards in Philosophy, Art, Science, Botanic, Medicine, Homeopathy, Radionics, and others. 30 subjects Curricular free (airmail \$1.00 refundable). Registrar, Sussex College of Technology, Highfield, Danehill, Sussex, England.

**PIANO TUNING PAYS** - Piano tuning - Electronic organ servicing. Learned easily at home. Free booklet. Niles Bryant School, P.O. Box 20153, Sacramento, CA 95820

**L-EARN** Clock Repair, Enjoyable, lucrative. Free Details. School of Clock Repair, 8313 ComeAbout Way, Rm. M, Awendaw, SC 29429

**AUTOSUGGESTION.** Sleep-learning headquarters! Tapes, records, books. Gigantic catalog free. Research Association, Box 24PM, Olympia, Washington 98501.

**UNIVERSITY DEGREES** By Mail. Accredited Bachelors, Masters, PhD's. Free Facts Revealed. Careers-PM9, Box 470886, Tulsa, OK 74147

**LEARN** Auctioneering - Free Catalog, Nashville Auction School, Box 2026, D-4, Columbia, Tennessee 38402-2026

**EARN MORE IN 90 DAYS.** Free 1987 catalogue describes 200 success proven correspondence Diploma courses. Granton Institute, 263A Adelaide Street West, Toronto, Canada M5H 1Y3

**PARALEGAL GRADED CURRICULUM.** Approved in-depth training by correspondence. **BLACKSTONE SCHOOL OF LAW:** 100 years of legal training. Write for free catalog. P.O. Box 790906, Dept. PM, Dallas, Texas 75379

**DO YOU ENJOY WORKING WITH CARS?** You Can Have A Secure, Good Paying Future in Automotive Electronics. Financial Aid is Available. Call VT1. (713) 956-0010 NOW!

**BECOME** an Electronic Or Video Technician in only 14 months. Financial Aid, Placement Assistance and an Associate's Degree. Call Now! (214) 263-2613 Dallas, (213) 595-1660 Long Beach, or (713) 956-0010 Houston. VT1

**LOCKSMITHING,** Universal School of Master, Correspondence and Shop Training. Box 214652PM, Sacramento, CA 95821

**COLLEGE SCHOLARSHIPS** Available! Everyone Eligible. Guaranteed. Free Info Packet. Shelton Associates, Box 9016-PM, Newark, NJ 07104.

**LEARN** Landscaping At Home. Free booklet. Lifetime Career Schools, Dept. A-285, 2251 Barry Avenue, Los Angeles, California 90064.

**MOONSHINE** Past and Present Send \$5. Polygon G., 54 Arnold Ave., W. Babylon, N.Y. 11704

**LEARN** Facts to Live Better! 100's of reports on How To, Money, Health etc. Send \$1 for catalog. Ocean Publishing, 4021 Alhambra, Coral Gables, FL 33146.

**MONEY MAKING CAREER IN REAL ESTATE APPRAISAL** In-Home Study Course Pacific State College, 3755 Avocado Blvd. Div. 414, La Mesa, CA 92041. (619) 447-6607.

**DETECTIVE** Profession. Easy Home Study. Free Lapel pin, certificate, future. Professional Investigator Training School, Dept. CP, P.O. Box 41256, Los Angeles, CA 90041

**HIGH SCHOOL AT HOME, NO CLASSES.** Low monthly payments. Information free. Our 90th year. Call 1-800-228-5600 or write American School, Dept. #345, 850 E. 58th St., Chicago, IL 60637

**EARN YOUR COLLEGE DEGREE AT HOME.** Free revealing details. **KENSAM,** Box 1383PM9, Far Rockaway, New York, 11691

**CONSTRUCTION WORKERS** Learn Painting Estimating \$5.00. Duncan, 101 Lasondas, Santa Barbara, Calif. 93109

**EARN \$45. OR MORE PER HOUR** after learning Piano Tuning at home. Accredited member N.H.S.C. Aubrey Willis School, 301 W. Indian School #111, Phoenix, AZ 85013 - (602) 266-1640.

**BECOME A PROFESSIONAL REAL ESTATE APPRAISER.** Certification From American Society Of Professional Appraisers. Home Study Or Classes, Atlanta, Los Angeles. Instruction By Professionals. Free Information. National College Of Appraisal. 800-223-4542.

## SCHOOLS

**WORLD WIDE COLLEGE OF AUCTIONEERING, INC.** Since 1933. Term Soon. Free Catalog. **COL. GORDON E. TAYLOR,** Box 949, Dept. 19, Mason City, IA 50401. 515/423-5242.

**MERCHANT-Seaman School** World Travel, Room Board Tuition Paid. Free Information. 116 14 St. #C, Manhattan Beach, CA 90268

## EMPLOYMENT INFORMATION

**JOBS, CRUISESHIPS, TUGS, SHIPS, RIVERBOATS, OIL-RIGS:** Women-Men. Work month-Home month. USA + Overseas. Information \$3.00. Marine Employment, Box 207, Central, IN 47110

**WORK IN AUSTRALIA** Excellent Pay and Conditions, Australians are Warm and Friendly. State Age-Skills Send \$22.50 Australian Funds R/Postage-Processing Bell Housing Group, P.O. Box 78, Mooloolaba 4557 Qld., Australia

**ALASKA** Employment Bulletin: Send \$3.85 to: AIMS, Inc., 2212 Arcadia Drive, Anchorage, AK 99517

## HELP WANTED

**GOVERNMENT JOBS \$16,040 - \$58,230/YR. NOW HIRING.** CALL 805-667-6000 EXT. R-20024 FOR CURRENT FEDERAL LIST.

**OVERSEAS** ... \$25,000 - \$75,000+. Free Report! Employment, Box 19760-AW, Indianapolis, IN 46219.

**AUSTRALIA WANTS YOU!** Big Pay! Transportation! Newest Employment Handbook—\$2.00. International, Box 19107-AW, Washington, DC 20036.

**GOVERNMENT** Jobs - Thousands of vacancies must be filled immediately. \$17,634 to \$50,112. Call 216-453-3000, Ext. J6050.

## FOR INVENTORS

**PATENT AND DEVELOP** Your Invention. Registered Patent Agent and Licensed Professional Engineer. Send for FREE PATENT INFORMATION Every Invention Should Have. Richard L. Miller, 12 Parkside Drive, Suite M, Dix Hills, NY 11746 (516) 499-4343

**SELL YOUR OWN IDEAS.** We tell you how. Send \$5.00 to: SEI, P.O. Box 20, Imperial, PA 15128

**REGISTERED PATENT ATTORNEY** Reasonable rates. Edwin D. Schindler, 1523 East 4 Street, Brooklyn, NY 11230.

**INVENTIONS Wanted! PATENT INVESTMENTS INTERNATIONAL,** 1050 Connecticut #300, Washington, DC 20036

**REGISTERED PATENT ATTORNEY** Washington, D.C. Suburb. Donald A. Kettlestrings, 414 Hungerford Drive, Rockville, Maryland 20850

**INVENTORS:** Learn how to submit your ideas to industry. Call free 1-800-528-6050. Canada, 1-800-528-6060. X631.

**PATENT IT ECONOMICALLY!** Free details. Licensed since 1958. Raner Associates, 2008 Fondulac, Richmond, VA 23229.

**INVENTORS!!! DEVELOP! PROTECT! MARKET!** Your invention—Handbook just published—Details free!! Corbin, 3380 Sheridan, Suite 143-P, Amherst, NY 14226-1439

**FREE** help for Inventors! No charge for recording forms and evaluation. Affiliated Inventors Foundation, 501-B Iowa, Colorado Springs, CO 80909, or Toll Free 1-800-525-5885.

**INVENTORS:** Free information on offering your invention for sale. Kessler Sales Corporation, C-5-F1, Fremont, Ohio 43420

**JOIN** National Institute For Inventors. Details - P.D. Distributors, Inc., Seneca, S.C. 29679-1465

**INVENTORS!** Can you patent and profit from your idea? Call or write for your free information package. Over a decade of service. **AMERICAN INVENTORS CORPORATION,** 82 Broad Street, Dept. PM, Westfield, Massachusetts 01086. 1-800-338-5656. In Massachusetts or Canada call (413) 568-3753.

**\$250,000 INVENTION LICENSING** Expert's techniques, super **CONTRACT. MILLIONAIRE** inventors' secrets. Free details. **INTECH,** 859 Box 34069, Seattle, Washington 98124

**UNIQUE POSTER** shows pathways to success. 17" X 22", full color. Free Details. Innmark, PM1, 1330 E82d, Minneapolis, MN 55420

## INVENTIONS WANTED

**INVENTORS! HAVE AN IDEA?** Don't know what to do? Call **AIM** for free information kit. Toll Free 1-800-225-5800

**INVENTION MARKETING. FREE INFORMATION. REPRESENTING MANUFACTURERS.** Patmart, 77 Fulton, 26D, Financial District, New York, NY 10038

**INVENTORS!** If you have an invention for sale or license, write for free booklet explaining how we can help you. Kessler Sales Corp., C-5-1W, Fremont, Ohio 43420

## REAL ESTATE & FARMS

**LAND** Can Make You RICH! Report Shows How To Begin Buying And Selling. Satisfaction Guaranteed. Order Now! Send \$3.00 Plus 50c Shipping. Creative Links, 1202 Lone Oak, P.O. 1322, Paris, TN 38242

**CANADIAN COUNTRY PROPERTIES.** Acreages for recreation, development, farming, fishing, hunting, investment, minerals, etc. **OUR 72ND YEAR.** Terms available. Titles guaranteed. Catalog airmailed \$1.00. **DIGNAM CORPORATION,** Dept. 496, 370 Dunlop St. West, Unit 807, Barrie, Ontario L4N 5R7, Canada.

**UNITED NATIONAL REAL ESTATE** ... New FREE Catalog! Top real estate values coast to coast. Full Color Premier Properties section. **UNITED** ... For every type of real estate! **UNITED NATIONAL REAL ESTATE,** 4700-PM Bellevue, Kansas City, MO 64112.

**CALIFORNIA.** Lots. Acreage. \$40 Down. \$40 Monthly. Box 35291, Los Angeles, 90035.

**GOVERNMENT HOMES.** Delinquent tax property. Repossessions. Call 805-667-6000 Ext. T-20024 for current repo list.

## YOUR OWN FISH AND HUNT LAND

**LOW AS \$39/ ACRE \$50 DOWN!**

**BEST** areas for fish and game. Government report more fish and game per square mile. **TITLE GUARANTEE. BUY-BACK GUARANTEE.** Bought thru **ESTATE LIQUIDATIONS** across Canada. **EASY PAYMENTS.** Get your **FREE** catalog **NOW!** **CANADIAN ESTATE LAND,** Dept. PM9, 3089 Bathurst Street, Suite 303, Toronto, Ontario M6A 2A4. Phone anytime 1-416-783-3357

**FREE CATALOGS - FLORIDA, GEORGIA.** Homes, Land, Businesses. Please Specify State & Property Preferred. **COUNTRY NETWORK,** Box 368PM, Gainesville, MO 65655-4632. (417) 679-4632

## BUY IT WHOLESALE

**EARN MONEY** selling Gold and costume jewelry, rings, watches-Buy Direct. 130% Below Retail. Catalog \$1.00. Anka-PM, 90 Greenwich Ave., Warwick, RI 02885

**FREE** 16 page **PRINTING PRICE LIST,** 1 to 5 colors, sheets to catalogs. Copen Press, 100 (PM) Berriman St., Brooklyn, N.Y. 11208.

**BELTS,** Buckles, Key Tags, Hat Tacs, Jewelry. More. Complete line fast sellers. Big Profits. Complete dealer set up. Color catalog \$1.00 (refundable). Anchor, Box 3958-PMR, North Providence, RI 02911

(Continued on next page)



## BUY IT WHOLESALE

(Continued from preceding page)

**WORLDWIDE BARGAINS**... Imports - Dropship - Closeout - Surplus - Freebies - (Stamped Envelope). Marnees, Box 1717PM, Highland, Ind. 46322

**400,000 BARGAINS** Below Wholesale: Many Free! Liquidations... Closeouts... Job Lots... Single Samples. Free Details. Bargainhunters Opportunities, Box 1409-A, Holland, Michigan 49422.

**VACUUM CLEANERS** "Discount Prices" New Rainbow \$499.95, Kirby, Filter Queen, Panasonic, Royal, Oreck. Details: ABC Vacuum Warehouse, 6720 Burnet-PM, Austin, TX 78757

**FREE BELOW WHOLESALE CATALOGS**—500,000 Amazing Bargains Photographed!! Exciting information: Intercontinental, Box 1852B, San Antonio, Texas 78218-0626.

**CLOSEOUT** Jewelry & Craft Supplies. (Catalog 25c). Rousseis, 107-1631 Dow, Arlington, MA 02174-7199

**WHOLESALE** 232 page colorful catalog includes telephones, answer machines, porcelain, toys, silver, housewares, brass leathers, 2600 items. Send \$3.00 (refundable).

**NORTHSTAR WESTERN**, 1822 1/2 Newport, Suite 127, Costa Mesa, CA 92627

**CLOSEOUTS!** Discounts! Below Wholesale! Freebies! Information/stamp: DDN, Box 20152K, Ferndale, Michigan 48220

**PHILIPPINE DIRECTORY**, 6,294 Items. Details. Ludlum Enterprises, 295 Broadway, Orcutt, CA 93455

**IMPORT DIRECT!** Easy! Some Samples! Write: Samco, Box 3635, Clarksville, TN 37043

**VCR'S, TV'S, CD'S, STEREO'S MUCH MORE WHOLESALE AND BELOW.** Catalog \$2.00. CC Wholesale, P.O. Box 516, Bayonne, N.J. 07002

**SINGAPORE, HONG KONG, TAIWAN DIRECTORIES.** Listing 11,000 suppliers, 20,000 products. Buy direct. Information \$1.00. Merrick Distributing, Box 274M, Merrick, NY 11566

## ADVERTISING AGENCIES, ADV. SER. MAILING LISTS

**CASH PAYING OPPORTUNITY SEEKERS!** FREE Information Fast! Gregg Lühring, 5666 La Jolla Blvd #317A, La Jolla, CA 92037

**FREE** Brochure, Lowest Priced Buyer Lists. Zip Coded, Peel/Stick, Many Categories. Delivery Guaranteed. Eva Lists, Dept. 203, Box 6061, Torrance, CA 90504

**FREE** sample of mailing lists that get results! McCann, 32 Maine, Carteret, NJ 07008

**NEW NAMES MONTHLY! MIXED STATES AVAILABLE!** IMMEDIATE SHIPMENT! Adhesive Labels. Computerized - Guaranteed Opportunity Seekers 200/\$15; 500/\$25; 1000/\$40. Others. ADVON, Drawer B2, Shelley, ID 83274. Visa/MC/AmEx 1-800-992-3866.

**FREE** Mailing List Consultation. Details. GOC-42P, Box 1107, Stuart, FL 33494. (305) 334-5205. 1-800-554-5478

**HOT** list - many categories. Credit card orders 1-800-843-0755/1-515-232-6789. List, Box 1033, Ames, IA 50010

**NAMES! FRESH, HOTLINE, DELIVERABLE LABELS!** GUARANTEED! QUALITY PRICES! 1-(800)-992-9405.

**FRESH HOT NAMES!! OPPORTUNITY SEEKERS.** Peel/Stick Labels. Zip Coded. **GUARANTEED DELIVERABLE!** 500/\$20; 1000/\$35; 2000/\$60. JR Enterprises, 809 Briarwood-PM9, Victoria, Texas 77904

**HIGH QUALITY** Mailing Lists, guaranteed deliverable, send for **FREE** details. Marshall Gilbert Co., P.O. Box 12925, Seattle, WA 98111

**PROFITABLE** Computerized Mailing Lists. Guaranteed. JIMCO, Box 215, Brimfield, IL 61517

**OPPORTUNITY SEEKERS/MLM NAMES. FREE SAMPLE.** Venture-LP, Box 336, Riviera, AZ 86442

## BUSINESS SERVICES

**INCORPORATE** without legal fees! Free booklet tells how, includes forms. Call Harvard Business Services, now 800-345-CORP.

## RUBBER STAMPS

**RUBBER** Stamps Catalog \$2.00 Refundable. Crispin's Stamp Shop, Box 2533, Davenport, Iowa 52809-2533

## PRINTING PRESSES, RUBBER STAMP OUTFITS

**TYPE** Fonts, Hand Printing Presses, Hot Stampers, Supplies. 120 Pages. \$2.00 Deductible first order. Acme Type, 1720 N. Marshfield, Chicago, 60622

**MAKE** rubber stamps—big profits. Complete supply and equipment catalog with instructions. \$1 deductible with order. Star Stamp Supply, 1720 N. Marshfield, Chicago 60622

**TYPE** for printing. Catalog \$1.00/deductible 1st order. Quaker City Type, R.D. 3, Box 134, Honeybrook, PA 19344

**BARCO** Type Founders. Type and Rubber Stamps catalogue. Mail \$2.00 refundable on first order. P.O. Box 1011, Bensenville, 60106

**YOUR** address printed on gummed and self-stick labels. Send SASE for circular. Barbara's Mailbox, Dept. PM, 1200 Robert Hardeman Rd. #2A, Winterville, GA 30683

**PRINTING** Presses, new and used supplies. List 50c: Turnbull Printers Supply, Mechanicsburg, Penna. 17055

## PRINTING SUPPLIES

**QUICK** Copy Printing. Low Prices. Write: Nationwide, 614 North Main, Bloomington, Illinois 61701

## GIFT SHOPPING

**DISTINCTIVE** gifts. Free catalog. Nannette Hall's Nook, 13775 Guerne Hill, Guerneville, CA 95446

**CLASSIC CAR SET** 1907 Peugeot, 1912 Simplex, 1906 Rolls Royce, 1910 Model-T-Ford, 1901 Fiat, 1914 Prince Henry. 2 1/2" long, handpainted, cast metal, high-impact Plastic. \$8.95. plus \$2.40 Handling. "FREE" gift catalog. JIM HAMMOCK INTERNATIONAL, 121 South "E." Street, Yale, Oklahoma, 74085

## CLOCKS, WATCHES, OLD GOLD, JEWELRY

**HIGHEST CASH** for Gold, Jewelry, Gold Teeth, Rings, Diamonds, Watches, Silver, Platinum. Mail Articles Today. Free gift with information. Chicago Gold & Precious Metals, 10 South Wabash, Dept. 158, Chicago, 60603.

**SWISS WATCH REPLICAS!** Wholesaler! Exact Details! Warranty! "LABOR DAY SPECIAL!" (404) 963-3USA.

**TAKE NO CHANCES.** Deal with oldest, most reliable firm in old gold business. Established in 1934. We buy Gold, Silver, Platinum, Diamonds, Highest Cash. Free Information: Rose Industries, 29-A East Madison, Chicago 60602

**CLOCKWORKS**, wood clock blanks, rockhound supplies, belt buckles, cut stones, etc. Wholesale catalog 25c. Eloxite Corp., 806 1/2 10th Street, Wheatland, Wyoming 82201

**CLOCKS, MOVEMENTS, ACCESSORIES** (German). Free catalog. 1-800-558-2674. Instruments Services, Dept. PM, 433 So. Arch, Janesville, WI 53545.

**REPLICA** Watches, Free! High Quality. Low Prices. JJ's, Box 73027, Dept. PM9, Houston, TX 77273

**COLOMBIAN EMERALDS**, Marvelous Personalized Gift, Fabulous Investment. Free Information: GREENSTAR, A. A. 85394, Bogotá-Colombia.

## TREASURE FINDERS

**TREASURE**—Locate quarter mile away with ultra sensitive locator—brochure free. Research Products, Box 270270-AMC, Tampa, Florida 33688

**GOLD** Panning Guaranteed; Map, Details, \$4.00. Qualitron Network, Box 46044, Denver, Colo. 80202

## PROFITABLE OCCUPATIONS

**FREE** Information Starter & Alternator Rebuilding. Box 422, Seymour, TN 37865

**PLASTERCRAFT**... Profitable Home Business 3000 Molds Available. Details. Lynnette, 6251C Mentpark, Mentor, Ohio 44060.

**FREE** Brochures. Repair air conditioning, Refrigeration. Tools, Supplies, full instructions. Doolco, Inc., 11252 Goodnight, Dallas, TX 75229.

**FT. SMITH** Auction School, Ft. Smith, Ark. 72903. Resident & Home study. Veteran Approved.

**LEARN** The Auctioneers Chant For Fun or Profit. Easy Method Audio Tape & Literature. Send \$14.95 To: Pioneer Auctioneers Ent., P.O. Box 915426, Longwood, Fla 32791-5426

**BECOME A CONSULTANT OR EXPAND YOUR CURRENT CONSULTING BUSINESS!** Hazardous chemical safety training and consulting has unlimited potential, no previous experience necessary. Our software package and video tapes provides all you need. Call CMS, Inc. 312-779-1700.

**REPAIR** lawnmowers thousands of parts and tools wholesale list 50c Ellwanger's, PM, P.O. Box V, Port Jervis, NY 12771

**LOCKSMITH** will guide you into business with new book. Send stamp. Lockraft, 206 Hamilton, Winona, MN 55987

## SALESMEN-DIST.

**MAKE EXTRA MONEY DURING YOUR SPARE TIME!** Earn weekly commissions showing our exciting line of Calendars, Pens and other popular Advertising Gifts. Prompt, personal service from AAA-1 firm. Our 78th year. No experience necessary. No investment or collections. Set your own hours. Full Time Potential! Write to Kevin Peska, NEWTON MANUFACTURING COMPANY, Dept. EPMC9, Newton, Iowa 50208

**EARN + \$50,000/year**, full or part time selling **MINIPRINT** world's smallest silkscreen printer for logos size half of 3" circle on flat surface, every business a potential. Contact: Fairwater Ltd., 87 Marie-Victorin, Candiac, Quebec, J5R 1C3

## AGENTS WANTED

**WITH** Mason Shoes, pay day is when you want it! Take orders from friends and neighbors. Watch your business build, without risk or investment. Call Toll Free 1-800-826-7030. Ask for Ext. K-436. In WI 1-800-472-7003. Ask for Ext. K-436, or write Mason Shoes, K-435, Chippewa Falls, WI 54774.

## BUSINESS OPPORTUNITIES

**IMPORT-Export** opportunity, profitable world-wide, mail order business from home, without capital. We ship plan for no risk examination. Experience unnecessary. Free Report. Mellinger, Dept. A2709, Woodland Hills, California 91367

**ARAB BUSINESSMEN** have money to buy & invest. Top finders fees paid. IMEA, 737PM1 Box 3574, Newport Beach, CA 92663

**GUARANTEED!** \$1.00 Pound from "Junked" tires! (Send Stamp). LeValleys, Fountain, FL 32438.

**FREE DEALERSHIP-SELL MAILING LISTS!** Complete program free! PCW, Box 1302-PM9, Valley Stream NY 11582

**UNLIMITED INCOME POTENTIAL** Sponsoring Multilevel Distributors by Mail. **FREE** Tape. Hotline Recording (414) - 764-6448 Dickinson-PM987, Box 37775, Milwaukee, WI 53237-0775

**HARD WORK** Yes, Earn \$50,000 Plus. **FREE** information On New Construction Interior Cleaning. Home Based, Family Business. Book And Video Available. Dr. Doo, Route 2 Box 480, Queen Creek, AZ 85242

**\$50,000.00 NOW!** We will show you how to make \$50,000.00 for two hours work. Send \$1.99 shipping/handling: International Marketing, 4325-PM N. Northgate Dr., Oak Harbor, WA 98277.

**FINALLY!!** Complete. Comprehensive information on many spectacular home business opportunities! **WE WILL GET YOU STARTED! WRITE TODAY!** Share Data Publishing, 5311 Wasena Ave., Dept. A, Baltimore, MD 21225

**UNLIMITED EARNINGS!** Mail Our Burglar Alarm Advertisements From Your Home! RTM Merchandising, Box 527, Tylertown, MS 39667

**START MONEYMAKING WOODCRAFT BUSINESS** making "Easy - Quick" toys, gifts, novelties. Free details. Williams, 3600 L San Sebastian, Tucson, AZ 85715

**FREE** Starters Kit! Increase Your Income. No Purchase/Inventory Required. Home Businesses, 1484 Iverson, Atlanta, GA 30307

**NEW** exciting ways to start your own business. Make money and become independent. Rush stamped envelope to: A&L World Trade Company, Box 9315 Dept. 29, Carolina, P.R. 00628.

**STOP** Thinking About Your Own Business. Start It Now! Bookworm Publications, P.O. Box 2249, Florence, AL 35630

(Continued on next page)



## BUSINESS OPPORTUNITIES

(Continued from preceding page)

**INCREASE Your Income!** Arrange loans, leases, other financial services through nationwide lender network. Prestigious money business, full/part-time. Top Commissions, complete training, continuous support. Free details by electronic mail! PFA, Box 697-P, Dana Point, CA 92629. (714) 240-0405 X100-P

**EARN WHILE YOU LEARN.** Repair Hydraulic Jacks. Free Details. Hydraulic Jack Inc., Dept PMCA, P.O. Box 18, Accord, NY 12404

**PIANO** Tuning quickly learned with home study courses. Diploma granted. American Tuning School, 17050 Telfer Drive, Morgan Hill, Calif. 95037.

**TAKE** Catalog Orders. We drop-ship 2955 best selling specialty products. Lowest below wholesale prices. Immediate delivery. Spectacular home business opportunity. Free Book. SMC, 9401 De Soto Avenue, Dept. 20-81, Chatsworth, CA 91311-4991.

**EASIEST 7 BUSINESSES STARTED WITHOUT MONEY!!** Free information: Havisham, Box 5089-M, Poland, OH 44514

**BATH TUB REGLAZING**, product sales, service and training. Call Unique Coatings Corp. (404) 945-0072.

**EARNINGS** Unlimited! Mail our burglar alarm advertisements from home! RBM Merchandising, Box 59314, Chicago, Illinois 60659

**MAKE HOMEMADE BOOKLETS.** I've earned \$187,000 with mine. Free information. Falcon, P.O. Box 1039, Gatlinburg, TN 37738

**\$40,000 ON 1/2 ACRE!** New Hydroponics - inexpensive, pleasant, practical! Free information. Robin's, Box 1214, Franklin, TN 37065-1214

**VINYL'S** Where the money is! Professionally repair, refinish, recolor furniture, car tops. Quick, easy. Two small \$20 jobs a day earn you \$1,000 a month. Homes, cars, offices, restaurants, unlimited customers. Start earning after a few days practice. Details free. VIP, 2007 Montrose, Chicago, 60618.

**RECYCLE METALS. NO, NOT BEER CANS!** Easy \$458 weekly! Free information. Recycler, Box 1214, Franklin, TN 37065-1214

**MAKE BIG MONEY REPAIRING WINDSHIELDS & Plate Glass!** Up to \$60,000 yearly! Call TOLL-FREE for Valuable FREE report. 1-800-321-2597. Glas-Weld Systems, Box 5755D9, Bend, OR 97708.

**\$1,000 weekly mailorder.** Immediate opportunity. No obligation. Enterprise, 210 Welch-PM, Ames, IA 50010

**REPAIR HYDRAULIC JACKS—DETAILS FREE. WRITE: HYDRAULIC PARTS SUPPLY, BOX 4157, BROWNSVILLE, TEXAS 77820.**

**VENDING MACHINES.** No selling. Routes earn amazing profits. "Big Catalogue FREE." Parkway Corporation, 1930 PMB Greenspring Drive, Timonium, Maryland 21093

**LEARN** Sewing Machine Repairing. Men, Women. Lucrative Profits. Gresslin Correspondence School, Box 5104, Spencer, Iowa 51301.

**PREPARE** Tax Returns. Earn high fees, dignified work. Train at home. Accredited Program. National Tax Training School, Monsey, 2JU, New York 10952.

**\$1,000 Weekly.** Home Business Directory, Box 2019-PM, New York, New York 10163.

**ASSEMBLE** wooden novelties at home. We pay \$232.88 weekly. No experience. SASE. Walpine, Box 660M, Pinellas Park, FL 34664-0660

**ALUMINUM SCRAP — Recycle Yourself — MAKE \$25.00/ POUND!** Free information: Industrial-PM79, Box 127, Alexandria Bay, New York 13607

**EXTRA INCOME.** Assemble products at home. No experience. Details. 1-813-545-8421. Ext. 898.

**MULT-Level Mailorder, Two Opportunities.** O'Neil-M, 10 Oak Lane, Suisun, CA 94585

**LEARN MIRROR RESILVERING** free information. Silvercraft, Box 127, Lansdowne, PA 19050.

**BUMPERSTICKER PRINTER.** Cheap, Simple, Portable. Free Details. Bumper, POB 22791 (GC), Tampa, FL 33622.

**MAKE** Rubber Stamps. Highly Profitable. Free Details. STAMPER, P.O. Box 22809 (GC), Tampa, FL 33622

**SCREEN PRINT T-SHIRTS.** Inexpensive kits. Free Details. T-Printer, P.O. Box 23991 (GC), Tampa, FL 33623

**MAKE BALLOON ANIMALS.** \$400 Weekends! FREE SAMPLES/INSTRUCTIONS: Funnyman's - PM79, Box 250, Alexandria Bay, New York 13607

**ASSEMBLE PRODUCTS AT HOME.** Many opportunities paying High Weekly Profits presently available without investment. Write: Businesses, 92B Brighton 11th, Brooklyn, New York 11235

**\$10,000 MONTHLY** Taking Photographs at Home! Call recorded message: (303) 674-8155

**ASSEMBLE** Electronic parts. We supply components and instructions. No experience, no selling, guaranteed payment. Write: SouthTech Electronics, Box 28217P, Kenneth City, FL 33709

**MAKE YOUR DREAM COME TRUE. EARN \$60,000 YEARLY REPAIRING SMALL CRACKS IN WINDSHIELDS NOT REPLACING THEM. CALL TOLL FREE 1-800-826-8523 OR WRITE: THE GLASS MECHANIX INC., BOX 17693, PLANTATION, FLA 33318**

**14,947 HONG KONG-TAIWAN** Products Cheap. Small lots. Some samples free. Harbor, Box 1719PM9, Yuba City, CA 95992

**\$1,000'S WEEKLY!! MAILING FROM HOME!** Immediate opportunity! Century Publishing Company, Box 2659PM, Danbury, CT 06813

**RECONDITION BATTERIES!** Easily Earn Hundreds Weekly. Untold Secrets. Free Information. Battery Outlet, Box 3300M, Hickory, N.C. 28603.

**\$40 - \$106/HOUR.** Amazing breakthrough process restores Burned/Cut/Damaged Countertops WITHOUT REPLACEMENT. 2 hours/day earn \$30,000/year. Millions of apartments, homes pay profits immediately! Free Information. RENEW, Box 9900-PC, Vancouver, WA 98664

**MAKE MILLIONS MANUFACTURING BATTERIES!!!** Supplies available. Everlast, Box 365, Bogota, NJ 07603

**FULL/Part Time \$180 Per Roll Guaranteed** Taking Photographs. Experience Unnecessary 35mm Camera And Film Supplied Free. 1-416-482-2100 X907A Days/Evenings/Weekends

**TRIAL** subscription absolutely free. Send name, address, zip to: Spare Time Money Making Opportunities magazine, Dept. C-97, 5810 W. Oklahoma Ave., Milwaukee, WI 53219.

**"MORTGAGE Brokerage."** Lucrative! (Particulars \$2.00). Sources-P9, Box 291332, Davie, FL 33329

**105** easy homework moneymaking ideas. Booklet \$2.00. Sunshine Sales, Box 511-B, Byron, IL 61010.

**\$588** from \$10 wood. Details \$3. Aircraft, Box 208, Belleville, Ontario, Canada K8N 5A2

**START** your own business! Write now for free details. Nancy's Gifts, 497 Sease Dr., Peru, IN 46970

**BE FIRST.** Sell all-new self-help moneymaking manual. HURRY! DEALERS WANTED NOW! Free information. August Publications, Box 792, Novi, Mich 48050

**SEIZED IN GOVERNMENT NARCOTICS RAID!!** Automobiles ... Vans ... Boats ... Furniture ... Thousands other items. Buy Dirt Cheap—Resell for Big Profits! Free information. Marcel, Box 7557-M, Monroe, LA 71211

**BIG MONEY IN SHARPENING, GET MY BOOK "HOW TO BUILD A SUCCESSFUL SHARPENING BUSINESS" PLUS HOW TO SHARPEN DOZENS OF TOOLS. FACTS GAINED FROM MY OWN SHOP. \$14.95 FOR BOOK AND 200 ITEM SHARPENERS SUPPLY CATALOG OR SEND \$3.50 FOR MORE DETAILS. R & S SHARPENERS SUPPLY, 604 PHYLLIS, CONROE, TX 77303**

**UNTAPPED POTENTIAL** in aerial advertising. EARN while you FLY! Free information: FLYER, 91 Longbeach, Montgomery, Ill. 60538

**EXCEPTIONAL Opportunity.** Earn \$50,000/\$100,000 annually. + Save 30%/50% on present or future mortgage costs. Details. American Fidelity, Drawer 9185-P9, Charleston, SC 29410-9185

**WRITE SIMPLE REPORTS.** Earn \$3,000 monthly! Details: Hartwick, Box 348, Port Orford, OR 97465

**A LICENSE TO STEAL!** Unique program exposes secrets on buying/selling government confiscated property! New - widely profitable! Free details: WMC, Box 30169-C, San Bernardino, CA 92413.

**LEARN AN EASY - WEALTH PRODUCING BUSINESS FREE** Details. Tadd And Company, 3278 Curry Rd., Mahopac, N.Y. 10541

**\$1,000 WEEKLY FREE BOOK** Home Mailorder business. H&A, R2-E35P, Bowling Green, MO 63334

**UNLIMITED INCOME GUARANTEED!** Profitable Home Businesses! Easy To Start, Low Investment! Free information: Pollard Enterprises, 2581-PM-6 Countrywood, Greenville, Ms. 38701

**WRITE** a song - SELL it! Details free. Graham, David, William Associates, P.O. Box 7342, Bloomfield, Conn. 06002

**PROFITABLE GOLD FOIL PRINTER,** Personalize business cards, pencils, matches. Free details. Gold, P.O. Box 24986 (GC), Tampa, FL 33623

**STAY HOME AND MAKE MONEY!** Hundreds of profitable plans. Free information. Hill Marketing, 105-M Station Rd., Westmoreland, N.Y. 13490

**IMPORT!** Pamphlet with Hundreds of Products and over 160 Addresses of Companies from the Orient. Send \$5 To: Dedman, P.O. Box 843, Pearland, Texas 77588

**MAKE MONEY WITH YOUR CAR!** Start your own business. Complete details - \$3.00. Ideal Gifts Company, Box 410A, Janesville, MN 56048

**PROJECTION TV ... Make \$\$\$'s** assembling Projectors ... Easy ... Results comparable to \$2,500 projectors ... Total Cost Less Than \$30.00 ... PLANS, 6" LENS & Dealers information \$20.50 ... Illustrated information FREE ... Macrocoma-BAX, Washington Crossing, Pennsylvania 18977, Creditcard orders 24HRS. (215) 736-2880.

**RIGHT PRODUCT** costs 25¢ to produce! Sells like hot cakes for \$10!! Free information. SNP, Suite 18-270K, 12416 North 28th Drive, Phoenix, Arizona 85029.

**\$1,000'S WEEKLY MAILING.** Stamped envelope: Progress, Box 93248, Los Angeles, CA 90093.

**PRO'S CLOSELY GUARDED SECRETS!** Mailorder Book-selling. 1000% Profit. Free Report. Premium, Box 1621-A9, Spring, Texas 77383

**KEEP** Your Job Until Success Is Certain: 99 profitable businesses you can start part-time. Free information: Empire Publishing, 5515 North 7th Str. #5-149M, Phoenix, Arizona 85014

**YOUR FORTUNE** from product you can get FREE. Katz Enterprises, 1019D Merchant, Effingham, IL 62401

**\$5000/Month-Free** information - No Obligation - Longs, Box 1465, Garden Grove, CA 92642 - 714/638-2167.

**NEW** discovery in battery reconditioning. Eighteen months guarantee means "Big Profits Fast"! Electone, 7415 Gable Dr., Little Rock, AR 72205

**PIANO** Tuning learned quickly at home. Free information. Empire School, Box 1014PM, Jupiter, FL 33468.

**GET** Rich selling simple information by mail, FREE Details. Barham, 647 Greenfield Dr., El Cajon, CA 92021

**LOW COST,** own your own manufacturing business using space age polymers. Send \$4.95 for literature and sample. Cynwood, Box 6291, Crestline, California 92325

**NEW PRODUCTS NEWSLETTER.** Exclusive opportunities. Free information. International, Box 636PM, Newark, NJ 07101

**START A Mailorder Business!** Free Subscription to Newsletter Shows How. Write: Image, 2458 Lomita #112-PM9, Lomita, CA 90717

**TOLL-FREE** Recording describes many profitable networking businesses. Lines open after 11PM and weekends. (800) 237-8656

**CONCRETE** Block Machines: Catalog \$1.00. Route One, Box 3740, Rapid City, South Dakota 57702-3740

**LOCATE HEIRS** and make big money. Complete course: \$14.50 plus \$1.50 postage and handling: Haley, P.O. Box 1573, Gardnerville, Nevada 89410

**\$1,000 weekly.** Air Tool Repairing Instructions. Parts and Tools Wholesale. Free Details. Box 534, Wichita Falls, TX 76307.

**MAKE \$15,000 MONTHLY!** Easy! No investment. McDowell, Box 5529-A, Diamond Bar, CA 91785.

(Continued on next page)



## BUSINESS OPPORTUNITIES

(Continued from preceding page)

**UNBELIEVEABLE** profits operating from home. Free details-SASE. J&A Distributors, 38-724 Jefferson, Bermuda Dunes, CA 92201

**MAILORDER** Books, 1,000% Profit Report. Selective, Box 1140, Clearwater, FL 33517

**TIRED** of moneymaking ideas that don't work? This one does! Free information. Brant Consulting, Box 8027, Williamsport, PA 17701

**2000+% profit possible.** Home mail order business. Start without capital. Clark, Box 39720J, Lacey, Washington 98503

**GET** into the most unique printing business in the world. Start from your home on a full or part time basis. Print in full color on paper, fabrics, metals, acrylics, mylars, etc. Call toll free: 1-800-223-1596. Case Equipment Inc., Rt. 4, Turner, Maine 04282. Ask John Sullivan about our free Maine Trip.

**RAISE \$200,000** in 24 Hrs. Get Any Credit Card. Become Debt-Free. **FREE** Details. **ACT NOW!** Red-Cap/PM1, 721 W. Belmont, Chicago, IL 60657.

**EASY BUSINESS!** Earn \$1,000's Weekly. Free Details. Write or send stamped addressed envelope. Toddco, Dept. PM, 4219 West Olive Ave., Burbank, CA 91505.

**INCREDIBLE** book of the 80's. How to Start profitable business at home. **FREE** information. J. Abbagnano, 4490 Carr St., Wheatridge, CO 80033

**SELL** Books By Mail - 500% Profit - Details - Sel-Don, Box 199, Lebanon, Oregon 97355

**REPAIR VIDEO TAPES!** Easy, Profitable. Write: Save-a-Tape!, Box AA2, Philmont, N.Y. 12565

**CASH POOR?** Make up to \$30,000 a year guaranteed. Free details. Kirksey Enterprises, Dept. PM9, 118 Robinwood, Hot Springs, Ark. 71901

**RICHES** now. Easy plan to start. Free details. Fortune House, 7507 S. Tamiami Trail, Suite 215-M9, Sarasota, FL 34231

**\$20,000 YEARLY POSSIBLE.** Prepare at home for Postal Clerk-Carrier employment examinations. Free Details. Write: Delta (1), Box 230, Indianola, MS 38751

**BIG** Money Wholesaling! Free Details: Crowded, Box 6671, Dothan, AL 36302

**FOLLOW ME TO THE MONEY TREE.** Free information. Milam Merchandise, 10655 S.W. Pueblo Court, Tualatin, Ore. 97062

**THE LONG LINE DOWNLINE** does it all! Free, no recruiting, co-op advertising. Send LSASE. LLD-9, Drawer 31, Patchogue, NY 11772.

**BE YOUR** own boss. Own your own business. Free details. R&J Enterprises, Box 1869, Lake Havasu City, AZ 86403. Not a get rich quick scheme.

**WE'LL HELP FINANCE YOU** in mailorder business. Free plan. Hall Inc., Dept. PM, 300 Duncan, Clearwater, FL 33515

**SUCCESS!** Money! Power! You can have it all. Free literature. B D Enterprises, 251 Atlantic City Ave., Grover City, Calif. 93433

**PLANNING** New Business? CPA Tells How! \$9.95 For Cassette Plus \$1 Handling, GM, P.O. Box 1140, Long Beach, WA 98631

**\$1,000'S WEEKLY** Mailorder. **FREE** Report. Loan Enterprises, Box 1028-M9, Williams Bay, WI 53191

**MAKE THOUSANDS** guaranteed! Part-time with home based businesses. Free details. Dynamic Publishing, 8 Rosser Drive PM9, Hampton, Virginia 23669

**OUT OF WORK? NEED MONEY?** \$1.00 booklet shows you how to start your own business through classified advertising. Popular Mechanics, Dept. KC, 224 W. 57th St., New York, NY 10019.

**\$192.00** From Square Foot Plywood. (Huge Demand) Revealing Proof 50c. (Refundable). Woodwin, Bridgewater, Mass. 02324

### EARN \$75,000 + PER YEAR

**REPAIRING** damaged windshields, not replacing them! For **FREE** information package call **TOLL FREE** 1-800-STAR5 44 or write: Orion, 3375 Park Avenue, 2000A, Wantagh, NY 11793.

## MONEYMAKING OPPORTUNITIES

**FAMOUS CLAM BAKE LEARN HOW** Expert From East Fish - Vegetable 5-500 Can, Be Served, Natural Taste \$6.00 You Love or Money Back. "Clam" P.O. Box 518, Sand Dimas, CA 91773. Grateful Thanks

**SUCCESS** Within Six Months in your Home Based Business-All Ages. Ralddap, Box 13880, St. Paul, MN 55113

**MAKE** To \$15/Hour - Work At Home! All Ages! Low Investment! Free Details. Guaranteed. Morin Products, 1816 Laliberte Avenue, Beauval, Saskatchewan, Canada S0M-0G0

**HIGHLY PROFITABLE** home-based business requiring no inventory or major investment. SASE: Wilco, Dept. P, 1643 Frank St., Scotch Plains, NJ 07076.

**HIGH** Profits T-Shirts And Caps. Inexpensive, professional transfer machines, supplies. Press Magic, P.O. Box 22809-(GG), Tampa, FL 33623.

**FANTASTIC** earnings mailing from home!! Offer: Rush Stamped Addressed Envelope. Imperial, P-8 X17410, Fort Lauderdale, FL 33318

**MAKE** Rubber Stamps. Highly Profitable. Free Details. **STAMPER**, P.O. Box 22809 (GG), Tampa, FL 33622

**MONEYMAKING** Opportunities write: C.L. Graham & Assoc., Rm 202, 8434 S. Vernon, Chicago, IL 60619

**BUMPERSTICKER PRINTER.** Cheap, Simple, Portable. Free Details. Bumper, POB 22791 (GG), Tampa, FL 33622.

**THE EASIEST BUSINESS ON EARTH** Can Earn You Millions. Free Details. Beacon, Box 50066, Albany, Georgia 31705

**MONEY** From discarded tires! Details. Brownie, Box 53, Fishers, Indiana 46038

**ADVERTISE** Free in 507 Magazines. \$5.00. Directory, Box 11N, Atlanta, Georgia 30301

**MAKE MONEY** investing in Real Estate \$1.00 To: Gregg Rieley, 5840 Pinedale Dr., Harrison, TN 37341

**MONEY** for referrals. Details \$1.00. Enterprises, 1331 Missouri, Longmont, CO 80501.

**GET** Rich, Zero Investment, No Borrowing. Free Details. Kathy Vance, 500 Vine St., Suite 2, Connerville, IN 47331

**"100% RETURN GUARANTEED!"** Advantage Publications, 18861-A1 Gregory, Huntington Beach, California 92646.

**MEGABUCKS** now. Easy steps to wealth. Free details. Fortune House, 7507 S. Tamiami Trail, Suite 215-M90, Sarasota, FL 34231

**GET MORE MONEY!** New scientific method reveals how to get more Anything! I made **MILLIONS!** (S.E.C. files). Interactive Tape/Workbook Program. Satisfaction Guaranteed! \$19.95. InnerScience, Box 585/PM9, Safety Harbor, FL 34695

**CASH** in on Booming Business. Free Information. EVP, 24843 Del Prado, Ste. 439, Dana Point, CA 92629

**MAKE MONEY IN SPARE TIME.** Earn generous commissions as a subscription representative for leading magazines. For free details, send this ad with your name and address to: **POPULAR MECHANICS**, Dept. AB-S, 250 W. 55th St., New York, NY 10019

**CASH** in on Booming Business. Free Information. EVP, 24843 Del Prado, Ste. 439, Dana Point, CA 92629

**MAKE MONEY IN SPARE TIME.** Earn generous commissions as a subscription representative for leading magazines. For free details, send this ad with your name and address to: **POPULAR MECHANICS**, Dept. AB-S, 250 W. 55th St., New York, NY 10019

**MAKE MONEY IN SPARE TIME.** Earn generous commissions as a subscription representative for leading magazines. For free details, send this ad with your name and address to: **POPULAR MECHANICS**, Dept. AB-S, 250 W. 55th St., New York, NY 10019

**MAKE MONEY IN SPARE TIME.** Earn generous commissions as a subscription representative for leading magazines. For free details, send this ad with your name and address to: **POPULAR MECHANICS**, Dept. AB-S, 250 W. 55th St., New York, NY 10019

**MAKE MONEY IN SPARE TIME.** Earn generous commissions as a subscription representative for leading magazines. For free details, send this ad with your name and address to: **POPULAR MECHANICS**, Dept. AB-S, 250 W. 55th St., New York, NY 10019

**MAKE MONEY IN SPARE TIME.** Earn generous commissions as a subscription representative for leading magazines. For free details, send this ad with your name and address to: **POPULAR MECHANICS**, Dept. AB-S, 250 W. 55th St., New York, NY 10019

**MAKE MONEY IN SPARE TIME.** Earn generous commissions as a subscription representative for leading magazines. For free details, send this ad with your name and address to: **POPULAR MECHANICS**, Dept. AB-S, 250 W. 55th St., New York, NY 10019

**MAKE MONEY IN SPARE TIME.** Earn generous commissions as a subscription representative for leading magazines. For free details, send this ad with your name and address to: **POPULAR MECHANICS**, Dept. AB-S, 250 W. 55th St., New York, NY 10019

**MAKE MONEY IN SPARE TIME.** Earn generous commissions as a subscription representative for leading magazines. For free details, send this ad with your name and address to: **POPULAR MECHANICS**, Dept. AB-S, 250 W. 55th St., New York, NY 10019

**MAKE MONEY IN SPARE TIME.** Earn generous commissions as a subscription representative for leading magazines. For free details, send this ad with your name and address to: **POPULAR MECHANICS**, Dept. AB-S, 250 W. 55th St., New York, NY 10019

**MAKE MONEY IN SPARE TIME.** Earn generous commissions as a subscription representative for leading magazines. For free details, send this ad with your name and address to: **POPULAR MECHANICS**, Dept. AB-S, 250 W. 55th St., New York, NY 10019

**MAKE MONEY IN SPARE TIME.** Earn generous commissions as a subscription representative for leading magazines. For free details, send this ad with your name and address to: **POPULAR MECHANICS**, Dept. AB-S, 250 W. 55th St., New York, NY 10019

**MAKE MONEY IN SPARE TIME.** Earn generous commissions as a subscription representative for leading magazines. For free details, send this ad with your name and address to: **POPULAR MECHANICS**, Dept. AB-S, 250 W. 55th St., New York, NY 10019

**MAKE MONEY IN SPARE TIME.** Earn generous commissions as a subscription representative for leading magazines. For free details, send this ad with your name and address to: **POPULAR MECHANICS**, Dept. AB-S, 250 W. 55th St., New York, NY 10019

**MAKE MONEY IN SPARE TIME.** Earn generous commissions as a subscription representative for leading magazines. For free details, send this ad with your name and address to: **POPULAR MECHANICS**, Dept. AB-S, 250 W. 55th St., New York, NY 10019

**MAKE MONEY IN SPARE TIME.** Earn generous commissions as a subscription representative for leading magazines. For free details, send this ad with your name and address to: **POPULAR MECHANICS**, Dept. AB-S, 250 W. 55th St., New York, NY 10019

**FREE** Promotional Albums, Concert Tickets, Stereos, etc. Information: Barry Publications, 477 82nd Street, Brooklyn, NY 11209

**STOP GETTING SPEEDING TICKETS.** Order my 8 page booklet, packed with little known secrets. Send \$4.90 to: **STOP TICKETS**, 211 Condor Ave., Ben Lomond, CA 95005

**SUBLIMINAL TAPES/PRODUCTS**, professionally endorsed. Catalog \$1.00. Success Educational Institute, Box 9606P, San Diego, CA 92109. Dealerships Available.

**IMPROVE** knowledge - **INCREASE** your **ODDS** in games, races. Details free. Graham, David, William Associates, P.O. Box 7342, Bloomfield, Conn. 06002

**HOW** I found a religion that makes **SENSE**. \$1. to: Swedenborg Information, Cairncrest, Bryn Athyn, PA 19009.

**CREDIT REPORTS.** Booklet explains credit reports, maintaining clean credit. Joe Powell, 472E Turnberry, Newport News, VA 23602.

**50% DISCOUNT** - 3,000 general merchandise items. \$10.00 deposit (refundable) brings giant catalogue, information, and discount privileges. R&J Distributors, P.O. Box 181, Bristol, CT 06010-0181.

**50% DISCOUNT** - 3,000 general merchandise items. \$10.00 deposit (refundable) brings giant catalogue, information, and discount privileges. R&J Distributors, P.O. Box 181, Bristol, CT 06010-0181.

**50% DISCOUNT** - 3,000 general merchandise items. \$10.00 deposit (refundable) brings giant catalogue, information, and discount privileges. R&J Distributors, P.O. Box 181, Bristol, CT 06010-0181.

**50% DISCOUNT** - 3,000 general merchandise items. \$10.00 deposit (refundable) brings giant catalogue, information, and discount privileges. R&J Distributors, P.O. Box 181, Bristol, CT 06010-0181.

**50% DISCOUNT** - 3,000 general merchandise items. \$10.00 deposit (refundable) brings giant catalogue, information, and discount privileges. R&J Distributors, P.O. Box 181, Bristol, CT 06010-0181.

**50% DISCOUNT** - 3,000 general merchandise items. \$10.00 deposit (refundable) brings giant catalogue, information, and discount privileges. R&J Distributors, P.O. Box 181, Bristol, CT 06010-0181.

**50% DISCOUNT** - 3,000 general merchandise items. \$10.00 deposit (refundable) brings giant catalogue, information, and discount privileges. R&J Distributors, P.O. Box 181, Bristol, CT 06010-0181.

**50% DISCOUNT** - 3,000 general merchandise items. \$10.00 deposit (refundable) brings giant catalogue, information, and discount privileges. R&J Distributors, P.O. Box 181, Bristol, CT 06010-0181.

**50% DISCOUNT** - 3,000 general merchandise items. \$10.00 deposit (refundable) brings giant catalogue, information, and discount privileges. R&J Distributors, P.O. Box 181, Bristol, CT 06010-0181.

**50% DISCOUNT** - 3,000 general merchandise items. \$10.00 deposit (refundable) brings giant catalogue, information, and discount privileges. R&J Distributors, P.O. Box 181, Bristol, CT 06010-0181.

**50% DISCOUNT** - 3,000 general merchandise items. \$10.00 deposit (refundable) brings giant catalogue, information, and discount privileges. R&J Distributors, P.O. Box 181, Bristol, CT 06010-0181.

**50% DISCOUNT** - 3,000 general merchandise items. \$10.00 deposit (refundable) brings giant catalogue, information, and discount privileges. R&J Distributors, P.O. Box 181, Bristol, CT 06010-0181.

**50% DISCOUNT** - 3,000 general merchandise items. \$10.00 deposit (refundable) brings giant catalogue, information, and discount privileges. R&J Distributors, P.O. Box 181, Bristol, CT 06010-0181.

**50% DISCOUNT** - 3,000 general merchandise items. \$10.00 deposit (refundable) brings giant catalogue, information, and discount privileges. R&J Distributors, P.O. Box 181, Bristol, CT 06010-0181.

**50% DISCOUNT** - 3,000 general merchandise items. \$10.00 deposit (refundable) brings giant catalogue, information, and discount privileges. R&J Distributors, P.O. Box 181, Bristol, CT 06010-0181.

**50% DISCOUNT** - 3,000 general merchandise items. \$10.00 deposit (refundable) brings giant catalogue, information, and discount privileges. R&J Distributors, P.O. Box 181, Bristol, CT 06010-0181.

**50% DISCOUNT** - 3,000 general merchandise items. \$10.00 deposit (refundable) brings giant catalogue, information, and discount privileges. R&J Distributors, P.O. Box 181, Bristol, CT 06010-0181.

**50% DISCOUNT** - 3,000 general merchandise items. \$10.00 deposit (refundable) brings giant catalogue, information, and discount privileges. R&J Distributors, P.O. Box 181, Bristol, CT 06010-0181.

**50% DISCOUNT** - 3,000 general merchandise items. \$10.00 deposit (refundable) brings giant catalogue, information, and discount privileges. R&J Distributors, P.O. Box 181, Bristol, CT 06010-0181.

**50% DISCOUNT** - 3,000 general merchandise items. \$10.00 deposit (refundable) brings giant catalogue, information, and discount privileges. R&J Distributors, P.O. Box 181, Bristol, CT 06010-0181.

**50% DISCOUNT** - 3,000 general merchandise items. \$10.00 deposit (refundable) brings giant catalogue, information, and discount privileges. R&J Distributors, P.O. Box 181, Bristol, CT 06010-0181.

**50% DISCOUNT** - 3,000 general merchandise items. \$10.00 deposit (refundable) brings giant catalogue, information, and discount privileges. R&J Distributors, P.O. Box 181, Bristol, CT 06010-0181.

**50% DISCOUNT** - 3,000 general merchandise items. \$10.00 deposit (refundable) brings giant catalogue, information, and discount privileges. R&J Distributors, P.O. Box 181, Bristol, CT 06010-0181.

**50% DISCOUNT** - 3,000 general merchandise items. \$10.00 deposit (refundable) brings giant catalogue, information, and discount privileges. R&J Distributors, P.O. Box 181, Bristol, CT 06010-0181.

## GOVERNMENT SURPLUS

**JEEPS**, \$60. Typewriters, \$4. **BOATS, GUNS**, Cars at Unbelievable Prices. Send \$3 for Government Surplus Directory. Imagination Station, 136 West Pacemont Road, Columbus, Ohio 43202

**NARCOTICS RAID SEIZURES**... Autos... Vans... Boats... Airplanes... Millions Surplus Bargains... many 1% original cost! "Nationwide Sales Directory"—\$3.00. Disposal, Box 19107-AW, Washington, DC 20036.

**"GOVERNMENT SURPLUS" JEEPS \$30.00!** 5,000,000 items! Complete Information Your Area. **1988 OFFICIAL DIRECTORY**. \$3.00 (Guaranteed). **SURPLUS**, (B242), Box 90048, WASHINGTON, D.C. 20066

**GOVERNMENT SURPLUS.** How to purchase Jeeps, Trucks, Tools, Furniture, Electronics in your area. Information 24 hours, 602-964-3231

**GOVERNMENT SURPLUS.** How to purchase Jeeps, Trucks, Tools, Furniture, Electronics in your area. Information 24 hours, 602-964-3231

**GOVERNMENT SURPLUS.** How to purchase Jeeps, Trucks, Tools, Furniture, Electronics in your area. Information 24 hours, 602-964-3231

**GOVERNMENT SURPLUS.** How to purchase Jeeps, Trucks, Tools, Furniture, Electronics in your area. Information 24 hours, 602-964-3231

**GOVERNMENT SURPLUS.** How to purchase Jeeps, Trucks, Tools, Furniture, Electronics in your area. Information 24 hours, 602-964-3231

**GOVERNMENT SURPLUS.** How to purchase Jeeps, Trucks, Tools, Furniture, Electronics in your area. Information 24 hours, 602-964-3231

**GOVERNMENT SURPLUS.** How to purchase Jeeps, Trucks, Tools, Furniture, Electronics in your area. Information 24 hours, 602-964-3231

**GOVERNMENT SURPLUS.** How to purchase Jeeps, Trucks, Tools, Furniture, Electronics in your area. Information 24 hours, 602-964-3231

**GOVERNMENT SURPLUS.** How to purchase Jeeps, Trucks, Tools, Furniture, Electronics in your area. Information 24 hours, 602-964-3231

**GOVERNMENT SURPLUS.** How to purchase Jeeps, Trucks, Tools, Furniture, Electronics in your area. Information 24 hours, 602-964-3231

**GOVERNMENT SURPLUS.** How to purchase Jeeps, Trucks, Tools, Furniture, Electronics in your area. Information 24 hours, 602-964-3231

**GOVERNMENT SURPLUS.** How to purchase Jeeps, Trucks, Tools, Furniture, Electronics in your area. Information 24 hours, 602-964-3231

**GOVERNMENT SURPLUS.** How to purchase Jeeps, Trucks, Tools, Furniture, Electronics in your area. Information 24 hours, 602-964-3231

**GOVERNMENT SURPLUS.** How to purchase Jeeps, Trucks, Tools, Furniture, Electronics in your area. Information 24 hours, 602-964-3231

**GOVERNMENT SURPLUS.** How to purchase Jeeps, Trucks, Tools, Furniture, Electronics in your area. Information 24 hours, 602-964-3231

**GOVERNMENT SURPLUS.** How to purchase Jeeps, Trucks, Tools, Furniture, Electronics in your area. Information 24 hours, 602-964-3231

**GOVERNMENT SURPLUS.** How to purchase Jeeps, Trucks, Tools, Furniture, Electronics in your area. Information 24 hours, 602-964-3231

(Continued on next page)

Материал, защищенный авторским правом



## LOANS BY MAIL

(Continued from preceding page)

**BORROW \$500-\$40,000!** "Overnight." On Signature. Keep indefinitely! Action, Box 5499-A, Diamond Bar, CA 91765.

**WANT CREDIT CARDS?** Apply by phone for instant Preliminary Approval! Get your MoneyCard, VISA® and MasterCard® credit cards, regardless of credit experience! Toll Free- 24 Hours, 1-800-554-8472

**"LOANS By Mail"** Need Cash? Government Grants - No Investigations - Loans Available To Everyone: Credit Bank, Box 4039 NCP, Parkside Sta., Forest Hills, N.Y. 11375

**\$100,000** Line Credit Without Investigation! Private Swiss Bank Account! Other Financial Benefits! Free Valuable Report! NACC-PM9, Box 5399, Torrance, CA 90503

## DIVORCE

**WINNING INFORMATION \$2.00 MEN'S RIGHTS ASSOCIATION**, 17854 (Lyons), Forest Lake, MN 55025

**FATHERS CAN WIN.** Free Information. The Father's Forum, 500 W. Santa Ana Blvd. Suite 200, Santa Ana, CA 92701. (714) 542-1555

## PERSONAL

**LEGAL WILL FORM SETS** Instructions. Fill in Blanks. Guaranteed. 2/\$10.00. Legalaide, 640 Bob White St., Johnstown, PA 15904

## REMAILING SERVICE

**TRUSTWORTHY** forwarding. Stamped remails \$1.00. Diamond-H, Box 129A, Caddo, Texas 76029.

**FREE** Remailers List. Agents Needed. PS, Box 29656, San Antonio, Texas 78229

**UNLISTED ADDRESS** Discreet and confidential. Remail \$1.00 Single. Mail Forwarding Service, 8050 S. Main, Houston, Texas 77025

**CONFIDENTIAL** Mail Receiving/Forwarding. Mail Drop, Box 608039PM, Orlando, FL 32860

**FREE** Details! Postal Shoppe, 369 East 900 South, Salt Lake City, UT 84111

**SECURITY**, Confidentially. Details: Consumer Warehouse, 6333 Pacific #508, Stockton, CA 95207

**PROMPT**, dependable remails. \$100. Mark-pm, Box 822323, Dallas, Texas 75231-9998

**GUARANTEED** forwarding stamped remails \$1.00. CR, Box 4847, Kailua-Kona, Hawaii 96745

**CONFIDENTIAL**, Unlisted Forwarding Address. Remails \$1.00. MS, Box 31511, Phoenix, AZ 85046

**CONFIDENTIAL** Receiving/Forwarding Sensitive Foreign Mail. Details \$2.00, reply air mail. IMS, Box 3553, Monrovia, Liberia/West Africa.

## WANTED MISCELLANEOUS

**BUYING** Tungsten Carbide, Tungsten, Molybdenum, Silver Solder, Silver Contacts, Gold, Platinum. 800-321-6914 Ohio 216-531-8333 collect.

**GOLD**, Silver, Platinum, Mercury, Tantalum. Samples Evaluated Free. Ore Assaying Service. Call Wholesale Terminal Toll Free: 1-800-932-1010.

**SCRAP SILVER CONTACTS, FORKLIFT CONTACTS**, Silver Solder, Sterling, Gold Plated. Robert Leszczak, 652 Myrtle St., Elizabeth, NJ 07202

## FOR SALE MISCELLANEOUS

**BUSINESS CARDS** \$11.95/M Postpaid w/Logo \$13.95/M Brochure Available. Lance Sales, Box 29285PM, St. Louis, MO 63126

**SENSATIONAL** new patented CRAFTSEAT provides comfortable support for kneeling position activities. Free brochure. FVTC, Box 1391, Vancouver, WA 98660.

## PERFECT KNOWLEDGE

**SURVIVE** under Universal Law into Millennium as Godated by CREATOR'S original MEASURES, embracing TOTAL Knowledge for unlimited free ENERGY; monadic gravity; friction-free, work/Travel VEHICLES; instant MANNA. Cancels experimental research! No mail. Test in person. ATA Base, 1500 North Texas, Westaco, Texas 78596

## HEARING AIDS

**HUGE SAVINGS** Eliminate Dealer Markups. Free Trial. Batteries Wholesale. Terms Arranged. Call Toll Free 1-800-323-1212. Or Write: Lloyds-PMC, Rockford, IL 61110

**FREE HEARING AID CATALOG-** Save 1/2 by mail! Write: "MoneySavers", 9530PM-9 Langdon, Sepulveda, California 91343.

## TOBACCO

**ROLL** Your Own Cigarette Tobacco. Free Catalog. Green River Tobacco, Box 1313 PM, Owensboro, KY 42302

**SMOKE A PIPE?** Try BOURBON VANILLA tobacco. \$1.00 for sample and catalog. PIPE 'N TOBAC, Broadway Square Mall, Tyler, Texas 75703

## SCIENCE & CHEMISTRY

**ANATOMICAL CHARTS, MODELS, SKELETONS**, \$1.00 Catalog. CHARTS, 7124 North Clark, Chicago, IL 60626

**FREE SCIENTIFIC SUPPLIES AND CHEMICAL CATALOGS.** R.J.M. Laboratories, Inc. presents its latest catalogs containing scientific laboratory equipment, supplies, chemicals and a complete line of specialty laboratory glassware. Write today for your FREE catalogs: R.J.M. Laboratories (II), Box 699, Santee, CA 92071

**HERCULES** - The World's Strongest Magnet. FREE Astonishing Details. ADLAB, P.O. Box 76400, St. Petersburg, FL 33734

**"SURPLUS SOLAR CELLS, PANELS**, magnets, lab chemicals, glassware, robots, lasers. Catalog \$1. Applied Photovoltaics, Box 2773, Staunton, VA 24401

**LABORATORY CHEMICALS, GLASSWARE - APPARATUS.** Established 1953 - Catalog \$1.00. HAGENOW LABORATORIES, 1302 Washington, MAINTOWOC, WISCONSIN 54220

## FORMULAS, PLANS, ETC.

**BEST MONEYMAKING** Formulas. Free lists. Research-P9, Box 291332, Davie, FL 33329

**MONEYMAKING CHEMICAL PRODUCT FORMULAS!** CATALOG LISTING THOUSANDS ONLY \$5.00 (REFUNDABLE!) GWA3, Box 193, Brookfield, WI 53008-0193

## TRAVEL AND RESORTS

**TRAVEL** Free anywhere in the world. Two methods described. Factual report. Its true. \$2.00 and self-addressed stamped envelope. Irma Wilson, P.O. Box 2895-G, NYC 10027

## TELEPHONE & SERVICE

**TELEPHONES** Sales-Service (American Made) Write: Telephones, Box 6M, Simpson, PA 18407

## SPECIAL SERVICES

**INFORMATION** On anything. Ferguson Research Specialists, 60-15 Woodside, Woodside, New York 11377.

**MICRODOT** Identification custom made for you. Protect anything. Almost invisible. Write for info. I-Dot, Inc., P.O. Box 6738, Lake Charles, LA 70606

## HEALTH, VITAMINS

**PSORIASIS** Sufferers: Discouraged? Write for Free Important information that is helping thousands. Pixacol, P.O. Box 28117PM, Dallas, TX 75228

**HOW TO SAVE 30% ON ALL VITAMINS AND MINERALS** Free brochure. I.E. Harris - Son, Dept. 5, 13003 Clarion Rd., Ft. Washington, MD 20744

## WORK CLOTHING

**OSHKOSH** B'Gosh Work Clothes (Railroadiana). Free Catalog. Depot, Dept. RR, Sullivan, IL 61951

## WEARING APPAREL

**EMBROIDERED** caps any name foam fits all. Red, navy, white, green, script or block letters \$9.95 state color and letter. Monogram Embroidering, P.O. Box 9521, Coral Spring, FL 33065

## REPAIRS & SERVICES

**APPLIANCE REPAIR HANDBOOKS**—\$2.65 to \$6.90 each. Free brochure. ASN, Box 789R, Lombard, IL 60148

## GREENHOUSES

**GREENHOUSE** - Redwood/fiberglass kits. Free Brochure. Gothic Arch Greenhouses, P. O. Box 1584-PM, Mobile, AL 36633. Toll Free 1-800-255-0284 after tone 1059

## GARDENING & LAWN CARE

**SOW** now, Tree & Shrub Seeds, e.g., 25 Magnolia or 200 Blue Spruce plus instructions- only \$4.75. Send \$1.00 for price list. G.L. Landscaping, 701 Howard, Evanston, IL 60202.

## FLOWERS, PLANTS & NURSERY SUPPLIES

**ORCHIDS** Dendrobiums, Cattleyas, Phalaenopsis, Plants \$15.00 Each! Full Catalog. Seeds, Cuttings, Bulbs, Various Plants, \$5.00. Bri-Co, Box 5158, Kailua-Kona, Hawaii 96745.

## RECIPES, COOKING, ETC.

**LATIN AMERICAN 10 COLLECTION RECIPES** \$3.95. Alvaro Raul, 2407 SW 101 Court, Miami, Florida 33165

**NEW ORLEANS** Creole cookbook for children!—Free Details—Dart Specialties, Box 30708, New Orleans, LA 70190

**EASY** mouthwatering lasagna. \$2.00. Kasey's Kitchen, 3109-PM9 Lemon, Dubuque, IA 52001

**TURTLE** 5 Recipes Plus How To Catch and Clean \$2.50. Wade, 18644 14th Ave., Orlando, Florida 32833

**COOK'IE** for Breakfast Lunch Dinner Snacks \$1.25. Cahill, 452 Verona Avenue, Danville, CA 94526

**DELICIOUS** Meatballs Like My Mother Makes Them For Recipe \$2.00. Thomas's Gift Gallery, 4 Lancelot Court #4, Salem, NH 03079

**CAJUN CLASSICS-GREAT RECIPES** \$3.00. Mr. Russell, Box 73464, Metairie, LA 70033

**HOLIDAY** Cookbook, 30 Tempting recipes. \$4.95. Kasey's Kitchen, 3109-PM9 Lemon, Dubuque, IA 52001

**AUSTRALIAN** Cooking, 25 Unique Recipes. \$4. AUSCAN, P.O. Box 8014, Blaine, WA 98230

**SOUTHERN HASH, DAD'S CHICKEN STEW** Send \$3.00 SASE. Recipes, 101 Simpsonville Plaza, Simpsonville, S.C. 29681

**AUTHENTIC HAWAIIAN RECIPES.** \$3.95 SASE. 1645 Dole Street 403, Honolulu, Hawaii 96822

**SINGLE FATHERS COOK BOOK** \$3.00. Kaldveer, 249 W. Gobbi N, Ukiah, CA 95482

**DOTTIES** 50 best recipes over 50 years. Send \$5 to: P.O. Box 72, Abingdom, Maryland 21009.

**BEER BREAD** - Easy, delicious! \$2.00 - Beecher, 117 Pine Dr., Ocean Springs, MS 39564.

**EXQUISITE**, Rich, Mouth-Watering European Family Treasures: Chocolate Nut Cake, Nut Pie, AI's Incredible Salad. Each One A Sure Hit At Any Occasion Or Double Your Money Back. \$6.00. Exclusive-PM, Box 1442, Station "A", London, Ontario, Canada, N6A 5M2.

**OLD ENGLISH** Recipes. \$4.00. Hitcher, RR #1, Bracebridge, Ontario, POB 1C0 Canada

**ALASKAN RECIPES!** \$5.00 SASE to: Lifeline, POB 32919, Juneau, AK 99803

**TASTY CHILJ & Partners** \$2.00 SASE. Nitza, POB 150, NYC 10101

**MOUTH-watering** Polish Hunter's Stew and coffee liqueur recipes. Send \$1.25. T. Zawadzki, P.O. Box 7504, Chicago, IL 60659-7504

## WINEMAKING, BEERMaking, ETC.

**FREE CATALOG** Winemaking, Beermaking supplies. Continental, Box 1227-C9, Daytona Beach, Florida 32015.

**BEERMakers ONLY!** FREE Catalog/Newsletter. William's, Box 2195-M9, San Leandro, CA 94577

**MAKE QUALITY BEER**, wine. Free catalog. Root & Vine, Box 3051PM, Westport, MA 02790.

**WINEMAKERS—BEERMakers: FREE ILLUSTRATED CATALOG OF SUPPLIES. SEMPLEX, BOX 11476R, MINNEAPOLIS, MINNESOTA 55411**

**WINEMAKERS—BEERMakers** - Free Catalog - Fast Service - Large Selection: Kraus, Box 7650-L, Independence, Missouri 64053

**WINE/BEER MAKING** Catalog: B&J Enterprises, 1845 South 19th, Springfield, Illinois 62703

**BEERMaking - WINEMaking** Catalog Lowest Prices. BEERGear, Box 25093N, Lansing, Michigan 48909

**WINEMAKERS—Beermakers** Free Catalog. Low Prices. Free Recipes. Cellar-M, Box 33525, Seattle, WA 98133



# COMING NEXT MONTH

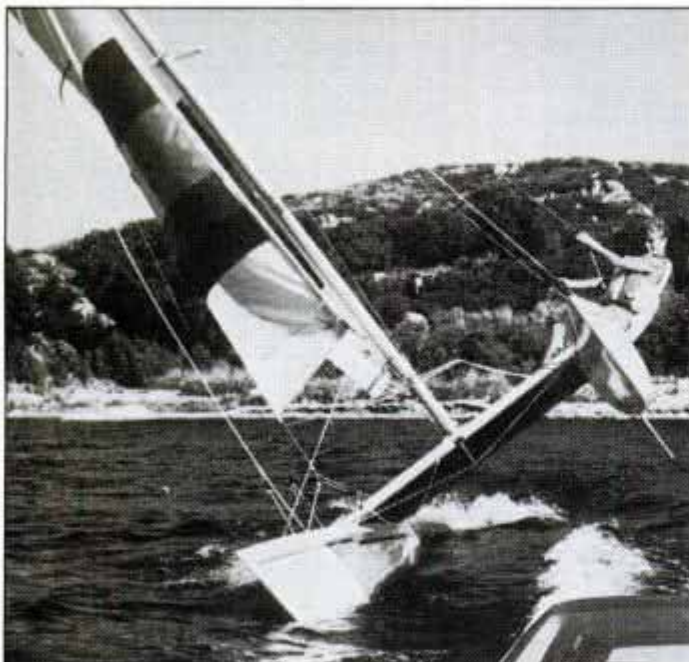

Sailors go airborne: We test a handful of high-flying hulls, two of them seen here on Prindle's catamaran.



Where were you when Sputnik went into orbit 30 years ago?



The man: Aerobat Leo Laudenslager. The machine: Laser 200, an extension of his body that he knows just how to stand on its head.



A graceful spindle bed appears to be beyond the skills of a home woodworker, but we show how it's done.



We drive and look under the skin of the all-new Lincoln Continental that's coming at you for '88.

## Detroit's Hot New '88s

Ride the future now with Lincoln's active suspension. Plus an in-depth look at Pontiac's 4wd STE, the GM-10s and more.

## Wave Of The Future

We put five small sailboats to the test: the flaired-hull, hot-performance Super Ray 17; and a Zuma, Holder, Hobie and Prindle.

## Ace Of The Aerobats

Fly the upside-down world of Leo Laudenslager as we study his self-built Laser 200 and daring flying style.

## Sputnik: 30 Years Later

The untold, behind-the-scenes story of the first man-made satellite and its effect on the American way of life.

## Wood Dream Project

Build our English-American-influence spindle bed. You'll marvel at the "headboard," but this project is easier than it looks.

## Rethink Your Kitchen

Here's how to redo your kitchen yourself—from wallpaper to appliances—and save thousands of dollars.

POPULAR MECHANICS (ISSN 0022-4558) is published monthly by The Hearst Corporation, 224 West 57th Street, New York, NY 10019, U.S.A. Subscription prices: United States and possessions, \$13.97 for one year; \$23.97 for two years. Canada and all other countries, add \$16.00 for each year. Second-class postage paid at New York, NY, and additional mailing offices. Authorized second-class mailing in Canada privileges by Canada Post, Windsor, Ont. Registered as second-class matter at the Post Office at Mexico D.F., Mexico, June 20, 1960. © 1987 by The Hearst Corporation. All rights reserved. Printed in U.S.A. POSTMASTER: Please send address changes to Popular Mechanics, P.O. Box 10064, Des Moines, IA 50350.





**Motorcraft  
oil filters.**  
**THE WAY TO  
STAY IN  
SHAPE.**

**Motorcraft**  
**FL-1A**  
**LONG LIFE  
OIL FILTER**

The new shape of the American car. Sophisticated. Advanced. And reflecting a total dedication to quality. Today's high-quality automobiles deserve equally superior replacement parts. Like Motorcraft FL-1A long-life oil filters, original equipment in advanced cars like Mercury Sable. FL-1A's state-of-the-art design traps more dirt and lasts longer than other major brands. There's a Motorcraft oil filter, and a full line of Motorcraft quality parts—batteries, oil, air filters and spark plugs—to help your car stay in shape.

**Motorcraft from Ford**  
**EXCEEDS THE NEED**



# Real Friends



**Real people  
want real taste.  
Winston**

SURGEON GENERAL'S WARNING: Cigarette  
Smoke Contains Carbon Monoxide.

