

JUNE 1987 \$1.50

Popular Mechanics

**STUNNING
NEW LOOK
FOR YOUR
HOME**



Easy-To-Build Fence That Beautifies And Protects

NEW FROM THE GROUND UP

HIGH-PERFORMANCE MOTOR HOMES

- Faster • Quieter
- Better Handling
- More Luxury

SPYING ON DETROIT

Sneak
Photos
Of Next
Year's
Cars

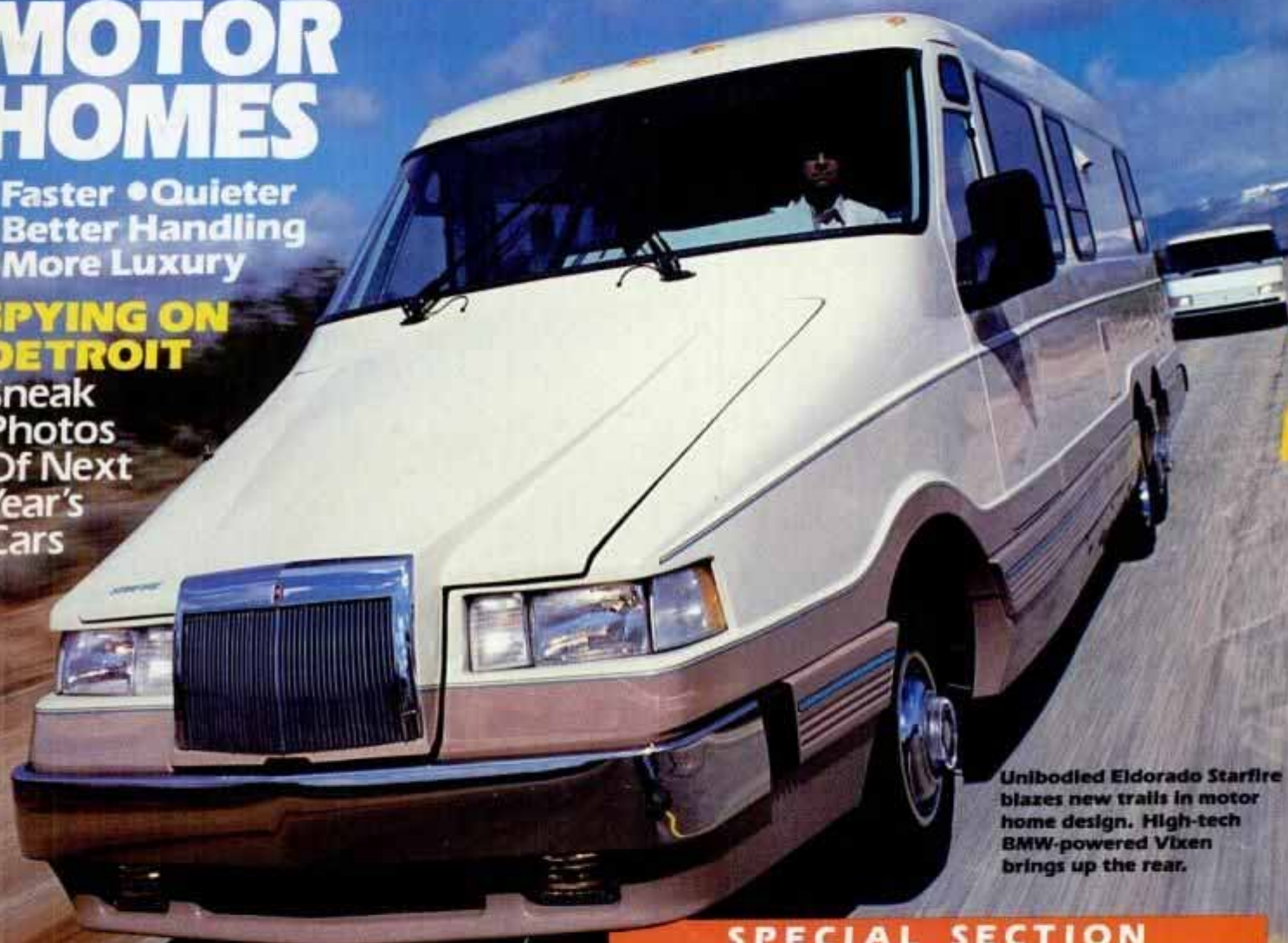

Unibodied Eldorado Starfire blazes new trails in motor home design. High-tech BMW-powered Vixen brings up the rear.

HOT NEW DECK BOATS

Party Boat Comfort,
Speed Boat Thrills

RAGTOP FEVER We Test
8 Cool New Convertibles



THE ART OF MOTORCYCLE TOURING

By Malcolm Forbes

SPECIAL SECTION

CAR STEREO

Sensational Sound For Any Car Or Truck



- Newest State-Of-The-Art Equipment
 - How To Upgrade Your Present System
 - Installation Tips For Vans, Wagons, 4x4s
 - Hottest Accessories
- Plus Much Much More*

Now, Two Ford Bronco II's ...4-wheel and 2-wheel drive models.

Choose a Ford Bronco II to suit your active lifestyle—with traditional four-wheel drive, or a two-wheel drive only model.

For those who love their town and country driving, Bronco II gives you more ways to have fun with style: either tooling around the out-back or threading city streets. That's because there's now a two-wheel drive model available... great for people who like the kick of a Bronco II but don't need 4WD.

Rear antilock brake system.

Both Bronco II's feature a first in their class—rear antilock brakes. They're designed to help you make straight stops when you're traveling in 2-wheel drive. Only Ford has them, and they're standard!



Unbeaten V-6 power.

For '87 Bronco II turns loose the juice with an electronically fuel-injected 2.9L multi-port V-6. This powerplant is unbeaten by any standard engine in its class! On the freeways or in the mountains you have 140 hp* at your command.

The Ford Bronco II is versatile and fun to drive. Its "command seating" puts you in charge of the road. On or off road, it's the way to go first class in pure comfort!

Touch and go.

Just push a button on the 4WD Bronco II and Ford's electric "Touch-Drive" option automatically kicks from two-wheel drive into 4WD high at any speed. The traction you want in all-weather driving is there instantly. You don't have to stop, get out, or shift.

Eddie Bauer

Eddie Bauer Bronco II features unique two-tone paint and special trim, high-style interior with dual Captain's Chairs for extra comfort. And it comes with "Ford Care" extended service plan** protection too—24 months or 24,000 miles, whichever comes first. Plus an Eddie Bauer garment bag and 6-pocket gear bag.

6-Year/60,000-Mile Powertrain Warranty.

New Ford limited warranty covers powertrains for 6 years/60,000 miles and provides protection against body-panel rust-through for 6 years/100,000 miles, whichever comes first. Restrictions and deductible apply. Ask to see a copy of this limited warranty when you visit your Ford Dealer.

Best-Built American Trucks six years running.

"Quality is Job 1." In fact, for the past six consecutive years, Ford quality has led all other American automotive companies. This is based on an average of owner-reported problems in the first three months of service on '86 models and in a six-month period on '81-'85 models designed and built in North America.

Buckle up— together we can save lives.

*Based on SAE Standard J1349.
**Limited warranty. Ask to see a copy at your dealer.



Bronco II
BUILT FUN TOUGH

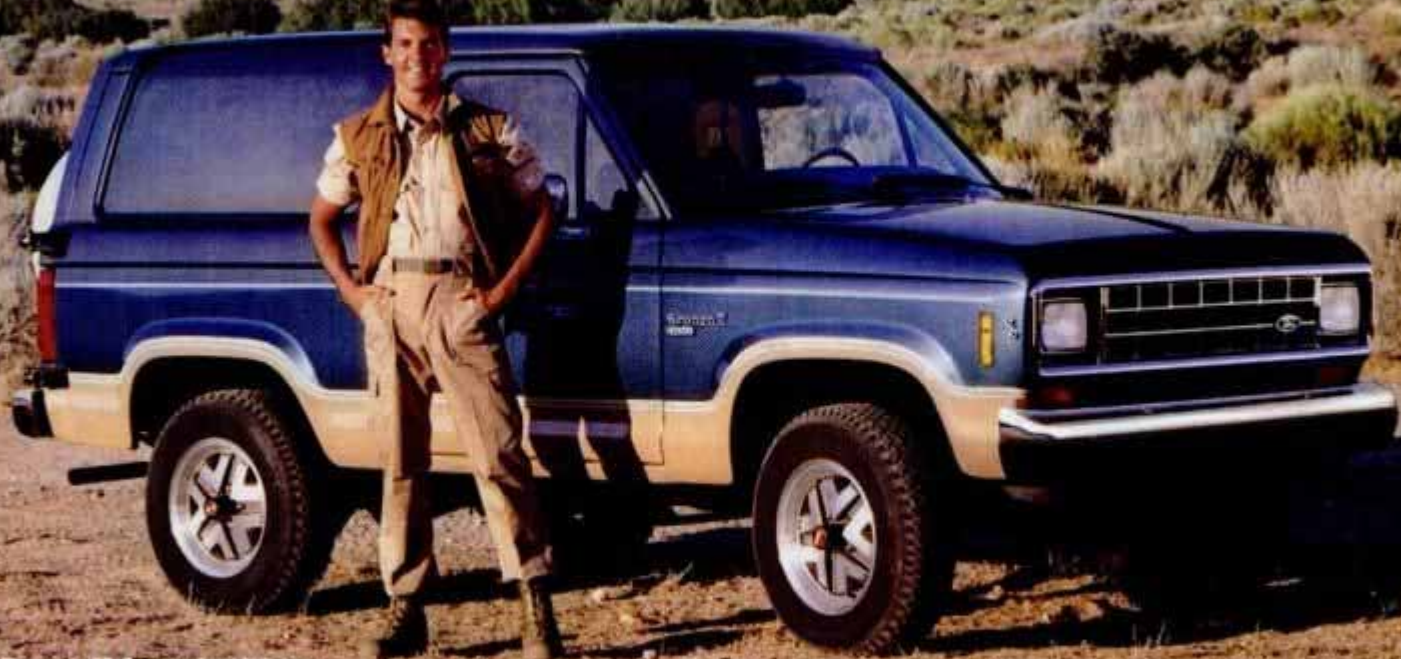

Bronco II four-wheel drive

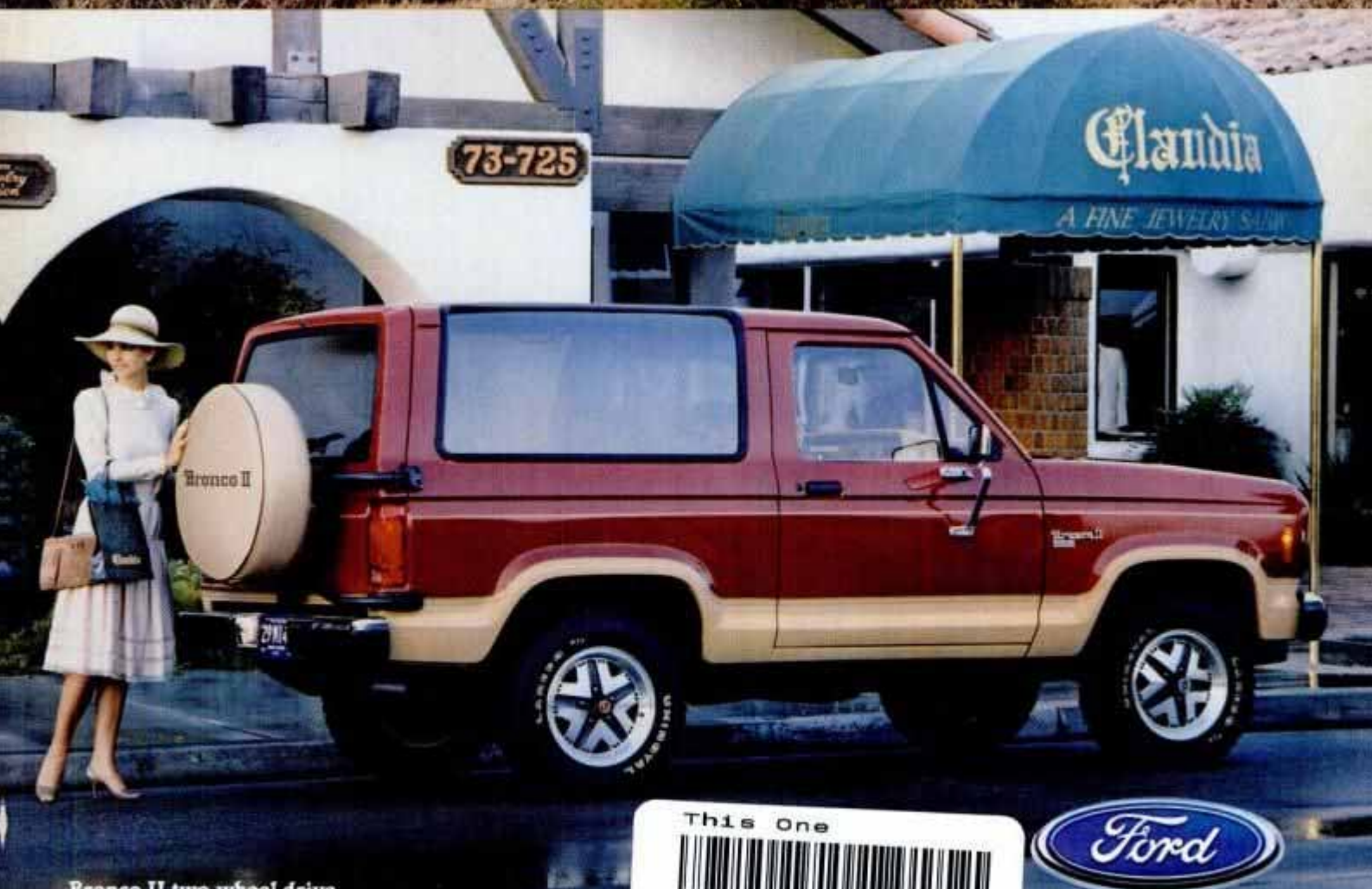

Bronco II two-wheel drive

This One
L5RX-Y1X-PSKH



THE WIDE STICK



**Speed Stick[®]
Anti-Perspirant.
The Wide Stick.[™]**

*Fights wetness
and odor
better than ever and
gives you the edge.*

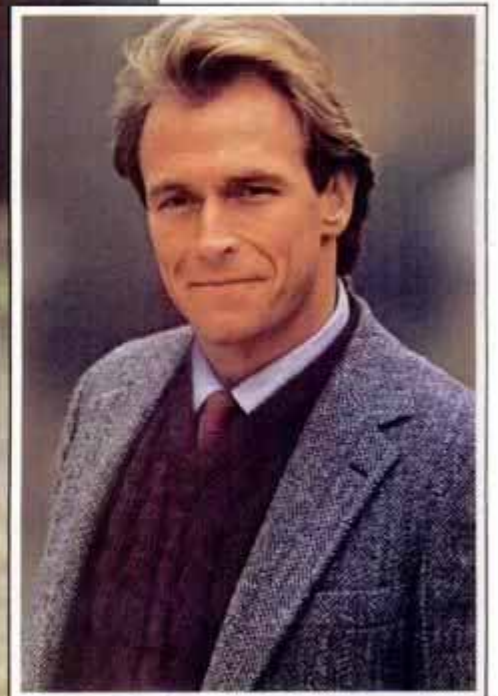

by **MENNEN**
© 1986 THE MENNEN CO.

Материал, предназначенный для розничной продажи



ON THE COVER

Traditionally, motorhomes have never been fancied by car buffs who want real driving machines. But today, the more sophisticated motorhomes feature computer-generated aerodynamic styling, molded construction and more efficient chassis design. Read about the future of motorhome design and function on page 86.

—PM photo by Rich Cox



98 First-class fence



82 Stacked decks



90 Motorcycle touring



71 Ragtop fever

SPECIAL REPORT: AUTOSOUND

103 Cover

104 Highway Hi-Fi

Today's car stereo rivals the sophistication of home hi-fi with a variety of gear.

106 Sound Sources

Digital stereo is mobile and accelerating. The newest in electronics and speakers can match the pace.

112 Changing Gear

Highway hi-fi comes plain or fancy. Here's how to upgrade your equipment to match your budget and aspirations.

116 Rockin' And Rollin'

Wagons, hatchbacks and sport/utility rigs pose acoustical challenges. Some gear can make the grade.



AUTOMOBILES

71 Ragtop Fever

Born-again convertibles bring back driving fun. We test eight new soft tops on the U.S. market.

76 Detroit Sneak Preview

Our intelligence agent in Motown spies the future.

78 Blast From The Past

We race Stirling Moss at 160 mph in 30-year-old race cars as vintage racing sweeps the nation.

146 Yugo GV

Owners rate this Yugoslav car a real bargain.

OUTDOORS

82 Stacked Decks

Performance and conviviality converge in a 5-way deck boat showdown.

86 New Age RVs

Today's motorhomes have shed the clunker image.

90 The art of Motorcycle Touring

Malcolm Forbes tells us what he's learned from motorcycle touring around the world.

HOME AND SHOP

95 Levels

Simple hand tools that establish dead-on accuracy.

98 First-Class Fence

Build our board-and-lattice fence that's really three fences in one.

135 The Better Home

Use our guide to repair a patio screen door and to find out which air conditioners cool the best.

TECHNOLOGY

65 PM Tech Update

Read about the latest innovations in entertainment, space, automotive, aviation, marine and military.

DEPARTMENTS

- 4 Editor's Notes**
- 7 Letters**
- 10 Imports**
- 12 Outdoors**
- 16 Home Video**
- 24 Car Clinic**
- 30 Electronics**
- 39 Aviation**
- 42 Inside Detroit**
- 47 Freewheeling**
- 48 Tool Test**
- 50 Science**
- 57, 155 Hints**
- 58 New/Home**
- 62 New/Auto**
- 141 Homeowners' Clinic**
- 142 Appliance Clinic**
- 156 New/Workshop**
- 158 Next Month**
- 170 Time Machine**

151 Sat. Mech. Exhaust

Editor's Notes



I met Malcom Forbes, the man they call the Capitalist Prince, in 1970. He was just getting into the sport of motorcycling, and he was doing it the way he does everything—almost overboard. He had already purchased an interest in a motorcycle dealership and was the owner of 12 bikes. He decided he'd like to meet the motorcycle press. As the editor then of a magazine called *Supercycle*, I was among a group of invitees to a fabulous weekend at his compound in Far Hills, New Jersey, and aboard his yacht *Highlander* berthed on the Hudson River. A great weekend and an unforgettable introduction to a man who lives life the way all of us would like to—maxed out to the limit. Even after all these years, Forbes, the publisher of *Forbes* and *American Heritage* magazines, is still the man I remember from that night 17 years ago—a super-enthusiast and a down-to-earth human being. Happily for us, he channeled some of that enthusiasm into an article starting on page 90 on what he's learned about motorcycle touring, something he's done all over the world. . . . One of the things I've always thought made our magazine stand out has been the consistent high quality of our illustrations, especially the technical illustrations that accompany our Home and Shop how-to articles. One of the people who produces those top-quality technical illustrations is Gene Thompson, an artist who has been at the top of his craft for about 30 years. He's worked for POPULAR MECHANICS for 12 of those years, adding his innovative artwork to a package of construction articles that is unsurpassed in the publishing field. Thompson has the skill to add new dimensions to the field of technical illustration not only on the drawing board, but in the classroom as well. Naturally, Thompson did the technical illustrations for our fence article starting on page 98. What's more, he also designed the fence and, with wife, Beth, built it at their home in Glen Cove, New York. That's what I call being the complete artist. . . . Speaking of articles that come out of our Home and Shop Department, you may have noticed our expanded *Better Home* section that began last month. The *Better Home* has proved to be so popular with you readers that we've gone from four to eight pages every month. One of the things we've done is move the popular *Appliance Clinic* and *Homeowners' Clinic* monthly columns into the *Better Home*, where they're more at home. . . . We were



Framed in their gate: Beth, Gene Thompson.

very proud to learn recently that staff member Tim Cole has been voted the Magazine Feature Writer of the Year by the Unlimited Racing Commission, the governing body that sanctions hydroplane racing in this country. Tim's winning article on the *Miss Budweiser* unlimited hydroplane appeared in our October '86 issue.

"Til next time.



Miss Bud's owner, Bernie Little, and Cole.

Joe Oldham

Popular Mechanics

Editor-in-Chief
Joe Oldham

Managing Editor
Bill Hartford

Graphics Director
Bryan Canniff

Science/Technology/Aerospace
Dennis Eskow, editor
Fred Mackerodt, contributing editor

Automotive
Wade A. Hoyt, SAE, editor
Jim Dunne, Detroit editor
Mike Allen, assistant editor
Michael Lamm, Norman S. Mayersohn,
Mort Schultz, Rich Taylor,
contributing editors

Home And Shop
Steven Willson, editor
Joseph Truini, shop and tools editor
Thomas Klenc, associate editor
Norman Becker, Rosario Capotosto,
Steve Toth, Bob Vila,
contributing editors

Electronics/Photography
Stephen A. Booth, editor
James B. Meigs, Frank Vizard,
contributing editors

Boating/Outdoors
Timothy H. Cole, editor

West Coast
Steve Parker, editor

Editorial Production
John Bostonian Jr., art editor
Deborah Frank, production editor
Nancy Coggins, art assistant

Art
John Johaneck, art director
Alan Andresen, Ann Bennett,
Diane DePasque, associate art directors

Editorial Administration
Josephine Caronia, administrative assistant
Barbara A. Novak, executive assistant

Editorial Offices
224 West 57th St., New York, NY 10019
We cannot be responsible for loss of unsolicited queries, manuscripts, or photos. For return, they must be accompanied by adequate postage.

SUBSCRIPTION SERVICE: Popular Mechanics Magazine will, upon receipt from its reader of a complete new or renewal subscription order, undertake fulfillment of that order so as to provide the first-copy delivery either to the Postal Service or alternate carriers within six to twelve weeks. If for some reason this cannot be done, you will be promptly notified of the issue date that will begin your subscription, with a request for any further instructions you may have concerning your order. Please address all such orders to us at Popular Mechanics, P.O. Box 10064, Des Moines, IA 50350. • Should you have any problem with your subscription, please write Joan Harris, Customer Service Department, Popular Mechanics, P.O. Box 10064, Des Moines, IA 50350 or call toll-free 1-800-247-5470; IA residents call 1-800-532-1272. Please enclose your mailing label when writing to us or renewing your subscription. • Renewal orders must be received at least eight weeks prior to expiration to assure continued service.

Use this address for subscription orders & inquiries. POPULAR MECHANICS, P.O. Box 10064 Des Moines, Iowa 50350.



This is the famous Budweiser beer. We know of no brand produced by any other brewer which costs so much to brew and age. Our exclusive Beechwood Aging produces a taste, a smoothness and a drinkability you will find in no other beer at any price.



Budweiser®

KING OF BEERS®

*Brewed by our original process from the
Choicest Hops, Rice and Best Barley Malt*
Anheuser-Busch, Inc. St. Louis, Mo.

Genuine.

NOW YOU CAN CONQUER RUST!



New NEUTRA RUST Gets Rid of Rust For Good!

NOT A PAINT, NOT A COVER-UP, but an entirely new and revolutionary process for eliminating rust. Neutra Rust was originally developed to control the incredible rust on oil rigs in the North Sea and on ships of the Royal Navy. Think of the rust problems they have! Naturally they use vast quantities of Neutra Rust and buy it in huge 50 gallon drums. For a long time that was the only way you could buy it. But at last Neutra Rust is available in smaller sizes for home and shop.

Now you can get rid of rust for good just the way they do at industrial and military installations all over the world!

WHAT NEUTRA RUST DOES

Neutra Rust is like nothing you've ever used

before. It's amazing! No tiresome scraping, wire brushing and sanding to get down to bare metal. Neutra Rust works best applied right over rust! It penetrates the rust. Gets right down there and chemically changes the rust into an entirely new substance—a hard, black, paintable compound called feroferic. The rust is gone—**not just covered up—GONE!** For good. It no longer even exists.

NEUTRA RUST IS EASY TO USE

First knock off the loose or scaly rust, but leave the rest of the rust there. (Remember Neutra Rust works with rust.) Then just brush Neutra Rust on. Within minutes that rust will be gone and the new surface will be there. That's all there is to it. Clean up is easy, too. Just soap and water.

YOU CAN ACTUALLY SEE NEUTRA RUST WORK!



When you first brush on Neutra Rust it is white. Then, as you watch, it turns pale green, then darker green, then finally a deep, wrought-iron

black. What you have seen is the rust being chemically converted. The hard new surface can be painted any color you want, or left as is.

USE NEUTRA RUST ON: Automobiles • Boats
Outdoor Furniture • Drain Pipes • Gutters
Mailboxes • Swing Sets • Tools • Lawnmowers
Appliances • Toys • Bikes • Wagons • Hinges
Railings • *Anywhere There's Rust!*

For Mail Orders Call:
1-800-221-6545

For further information
about Neutra Rust
write to:

Jeff Morrison, VP Marketing
New York Bronze Powder Co., Inc.
777 Dowd Avenue, Elizabeth, New Jersey 07201

nybco

© COPYRIGHT NYBCO, INC. 1986



Popular Mechanics

Publisher

Daniel J. Coleman

Advertising Director

Floyd Sembler

National Sales Manager

Bud Gilbert

Advertising Offices

New York

224 West 57th St.
New York, NY 10019
(212) 262-8824

Chicago

1 South Wacker Dr.
Chicago, IL 60606
(312) 984-5190

Detroit

377 Fisher Rd.
Grosse Pointe, MI 48230
(313) 881-3520

Los Angeles

3000 Ocean Park Blvd.
Santa Monica, CA 90405
(213) 450-8881

Direct Response Advertising

Al Cohen

224 West 57th St.
New York, NY 10019
(212) 262-4279

Daniel Kellner

1 South Wacker Dr.
Chicago, IL 60606
(312) 984-5190

Business Manager

Agnes P. Maillaro

Marketing Director

Edward Vaquero

Production Manager

Lori Ellwood

Advertising Production

Patricia Woods
(212) 262-4800

Classified Sales Manager

Sophie Gronowicz
(212) 262-4825

Reader Service Department

Gary Frederick, supervisor
224 West 57th St., New York, NY 10019
(212) 262-4292

Published by The Hearst Corporation:

Frank A. Benaick Jr., President
Randolph A. Hearst, Chairman
Gilbert C. Maurer, President, Magazines Division
Richard E. Deems, Publishing Consultant

POPULAR MECHANICS is published monthly by the Hearst Corporation, 959 Eighth Avenue, New York, NY 10019, U.S.A. Frank A. Benaick Jr., President; Randolph A. Hearst, Chairman; Harvey L. Lipton, Vice-President and Secretary; Edwin A. Lewis, Vice-President and Treasurer. Hearst Magazines Division: Gilbert C. Maurer, President; K. Robert Brink, Executive Vice-President; George J. Green, Executive Vice-President; Mark F. Müller, Executive Vice-President, General Manager; Raymond J. Petersen, Executive Vice-President; Thomas J. Hughes, Vice-President & Resident Controller; Daniel J. Coleman, Vice-President for Popular Mechanics.

INTERNATIONAL EDITIONS: CARIBBEAN, MEXICO, SOUTHERN HEMISPHERE

AS A SERVICE TO READERS, Popular Mechanics publishes newsworthy products, techniques and scientific and technological developments. Due to possible variance in the quality and condition of materials and workmanship, Popular Mechanics cannot assume responsibility for proper application of techniques or proper and safe functioning of manufactured products or reader-built projects resulting from plans published in this magazine.

POPULAR MECHANICS • JUNE 1987

Материал, защищенный авторским правом

Letters



Upscale Model



Reader Jedd's SS United States is scaled up from PM plans.

Your article and plans for building a model of the superliner SS United States (page 182, Dec. '82) launched me on quite a voyage. It was a 12-year sign-on, in fact, that took me to the U.S. Lines and the Smithsonian. I was so impressed with the 990-ft.-long United States (1,200,000 blueprints were used in her construction!) that I wasn't happy to build my model 36 in. as per your plans; I built her 54 in. long. I'm now constructing a 5-ft. model of the Normandy.

MICHAEL G. JEDD
WATERDOWN, CT

United States plans are \$9.95 from Popular Mechanics, Radio City Station, New York, NY 10101.

Chopper Flak

As a helicopter pilot with some 20-years experience in various types of helicopters from lightweight trainers to heavy transports, I want to read even more about the Voljet *Hot-Air Chopper* (page 82, Feb. '87). Also, you say the collective is on the right side of the pilot. This would be a first for me!

EUGENE L. OSMONDSON
COL. (RET.) USMC
MILTON, FL

We got up on the wrong side of the collective that day; it's on the left side of the pilot, of course. As for more about the chopper, Terry Jones of Voljet International says there are significant weight savings in eliminating the transmission, shafts, couplings, gearboxes, tail rotor and long tail boom associated with the mechanical drivetrain of the conventional helicopter. A portion of these savings, however, are offset by the need for the larger engine required to produce equal propulsive power to the rotor—more in the Voljet 585 because it's designed to meet hot and high mission requirements. Still, the 585's ratio of useful load to gross weight is far better than any of its conventional competition. Regarding limits, the only readily measurable ones are those of fuel consumption and speed. The greater fuel consumption is directly related to the increased power requirements referred to above.

Doubling Up

Since I have two girls, ages 6 and 9, I had to build two of the jewelry boxes you showed in your Bonus Woodworking Section last year (*Miniature Chest*, page 160, March '86). I made them of laminated oak and walnut strips with birch drawers lined with red velvet. I made the boxes 1 in. deeper than your plans show so I could build in a small music box.

FRED UECKERT
VERNON, BC
CANADA



Miniature jewelry chest is one of two made by Fred Ueckert.

Fast...Drivers

Maybe it's time you referred to American *drivers* who love the feel of a fast car under them. Keep in mind that there are women—like me!—who know a few things about "speed thrills" (*Speed Thrills*, page 63, March '87). I bought a Buick Regal GN and find that it's more of a driver's car. With automatic transmission, it takes more skill to tap the GN's horses.

KATHY GROLD
MALIBU, CA



The power to merge.

Do you trust your car to perform well on the on-ramp? Does it accelerate smoothly? Hit cruising speed quickly?

If it doesn't, dirty fuel injectors could be robbing your engine of power.

But one bottle of STP® Super Concentrated Fuel Injector Cleaner quickly dissolves deposits and unclogs grimy injectors. It helps restore lost power and improve acceleration. Helps eliminate tough starts and rough idling, too.

And when your car performs better, you feel better about driving. Now that's a nice balance of power.



Simply stated: Ford Thunderbird.

You'll notice that its glass and headlamps fit flush with the body. And that its hood is sleek and low to the ground.

These refinements not only give Thunderbird its distinctive new look, but are functional as well. Its design reduces interior wind noise and allows air moving over its surface to actually contribute to road stability.

The principles of flight.

A fuel-injected 3.8 liter V-6 and MacPherson strut suspension gives Thunderbird the kind of performance you would expect from a true driver's car.

And the driver is the focus of attention inside as well. The seats have been designed to position

the driver comfortably behind the wheel. And the controls have been placed where they can be easily found and operated. All of which allows the driver to perform as well as the automobile.

The new Ford Thunderbird.

It's a unique expression of advanced design.

New 6-Year/60,000-Mile Powertrain Warranty.

Ford now covers all new 1987 cars with a 6-year/60,000-mile warranty on major powertrain components. Restrictions and deductible apply. New, longer corrosion warranty coverage for body panel rust-through is 6 years/100,000 miles. Also, participating Ford Dealers stand behind their customer paid work with a free Lifetime Service

THE LAWS OF AERODYNAMICS EXPRESSED IN AUTOMOTIVE TERMS

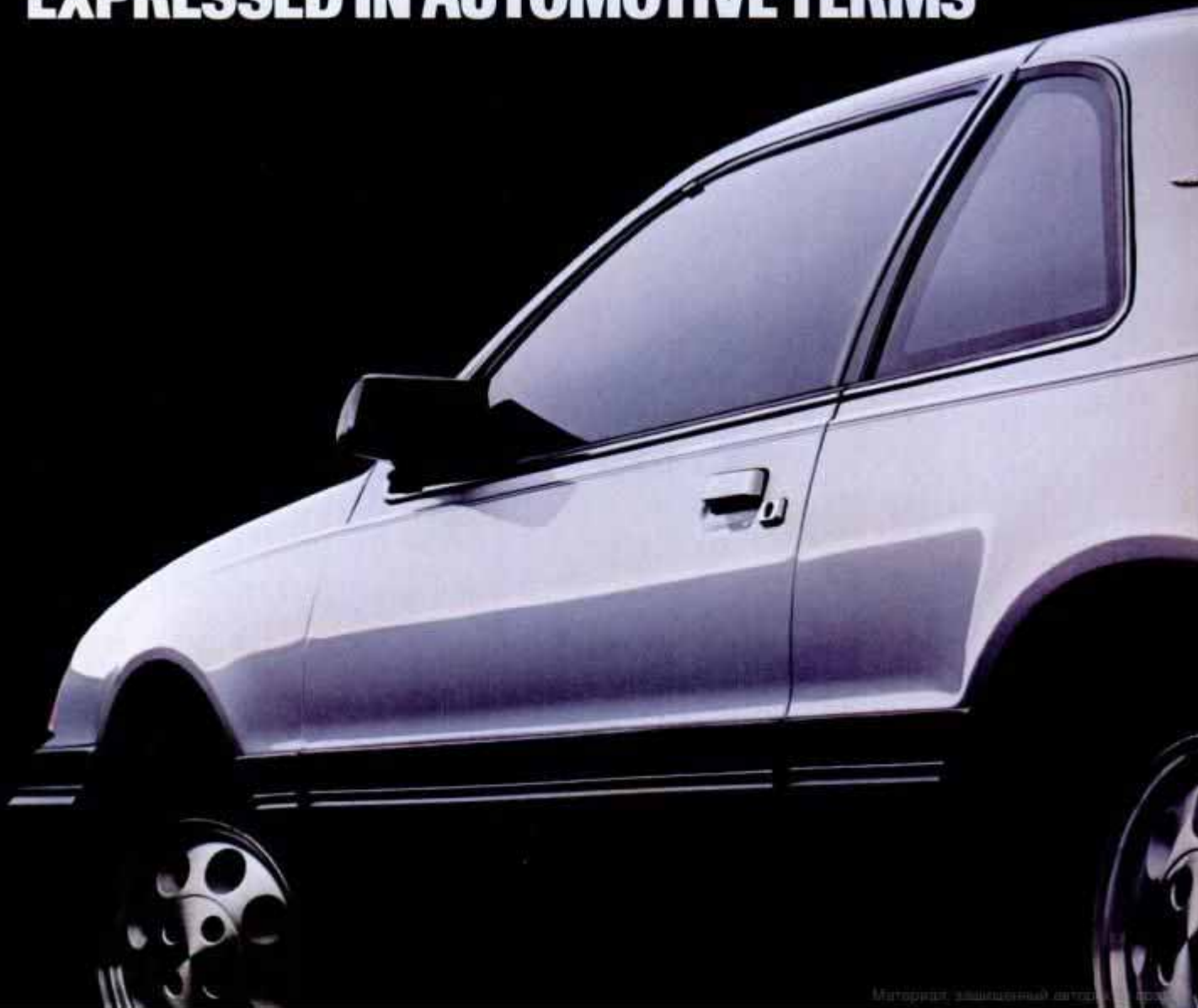

Guarantee. It's good for as long as you own your Ford car. Ask to see the limited warranty and the service guarantee when you visit your Ford Dealer.

**Ford. Best-built American cars...
six years running.**

For the past six consecutive years, Ford quality has led all other American car companies. This is based on an average of owner-reported

FORD THUNDERBIRD

problems in the first three months of service on '86 models, and in a six-month period on '81-'85 models designed and built in North America.

Have you driven a Ford...lately?



Buckle up—Together we can save lives.

Imports



BY BILL HARTFORD

Volley Of Volkswagens



Quantum jump: Finally, a totally integrated design.

There's a passionate sense of tradition in Germany—a commitment to the long term. Some years ago, it led VW to wonder why the Beetle, which became a classic of this century, should ever have to be changed. After all, who would dare update Bach, or Beethoven, or Brahms? But if you're in the business of selling cars today, you have to be on the popular charts. Volkswagen did get on the bandwagon with up-tempo models, and more are on the way. The venerable van, for example, will go to fwd, abandoning the Boxer rear-engine rear drive. It will, however, maintain its

very clean profile. VW does know about good taste in design: How else could this vehicle, also known as the Type 2 or VW Bus, pass the 6-million mark in 36 years of



Polo concept is sports car-like coupe.

production? The new van will offer a choice of VW's in-line engines, to be mounted transversely in the longer nose, and a 4wd option, too.

A stunning design for a new coupe in the European Polo line shows a 2-seater that looks like a sports car. It will likely get one of VW's small-displacement but high-horsepower engines for very impressive performance. And, the Quantum—which has been technically, but never stylistically, up to date—will finally arrive as a perfect package.



It's the Van again, but now with fwd.

Way Off Road

Now that the Range Rover has blazed the 4x4 trail from England to the United States, can the Africar be far behind? This new off-roader offers a selection of chassis sizes and modular construction that lets you choose from among several body styles. The body panels are constructed of a plastic-reinforced plywood. The production start-up of this very simple—and inexpensive—"Third World" concept is imminent. Africar International is a Brit-

ish enterprise that's located at Caton Rd., Lancaster LA1 3NG, England.



Africar prototype made arctic-to-equator shakedown run.

Rolls Warranty

The advantages of buying a brand-new car and keeping it "forever" are well known to PM do-it-yourselfers. But here's news that might make you consider buying used—maybe even 10-years used. What if an oldie came with a warranty covering engine,

transmission, drivetrain, suspension, a/c and more? Well, that's exactly the deal you get on Rolls-Royces and Bentleys up to 10 years old with up to 80,000 miles on the odometer. Now just ask your dealer to let you know when that little old lady's '77 Silver Shadow comes in.

Proton And Yugo

Be glad that when Tan Sri Dato Jamil Jan, chairman of the Board of Perusahaan Otomobil Nasional SDN. BHD., signed an agreement in Kuala Lumpur, Malaysia, to export cars here, that it was for the Proton Saga. That's one of the easiest pronounced new-car names of all the imports coming from those far-away places with strange-sounding names. There's no way anyone can mess up the name of this Malaysian subcompact

hatchbacks which will start under \$5000. The Proton Saga is a Malaysian National Car Project involving the Heavy Industries Corp. of



The \$10,000 Yugo: Convertible version is due next spring.



Proton Saga, \$5000 subcompact from Malaysia, arrives Feb. '88.

(but then I thought there was no mispronouncing Yugo until I heard "Hugo!"). February is the due date for the fwd 4-door sedans and 5-door

Malaysia (HICOM) and Mitsubishi, with 70/30-percent equity, respectively. The arrangement accounts for Mitsubishi's 1.5-liter Four powering the 94-in.-wheelbase automobile. If you've followed the story so far, you should also know that Proton America, Inc., and Yugo America, Inc., are both subsidiaries of Global Motors, Inc., which will operate dealerships. A new Yugo model to be available soon after is a convertible, the GVC, which will have a powered top and unique tailgate design for luggage access. **PM**

WARNING:

THIS PRODUCT
MAY CAUSE GUM
DISEASE AND
TOOTH LOSS



Good Company.

Copenhagen® satisfies.
And it's been doing that
since 1822.



Outdoors



BY TIM COLE

Itasca's "Little Brother"

As you can see from the feature in this issue called "New-Age RVs," motorhome design has come a long way from the corrugated crackerboxes that once lumbered along America's roadways. Except for Airstream,

homes, however, still clung to that severe, blunt-nosed rectangle we tend to associate with motorhomes generally. Refinements in lightweight, high-strength materials, the once (and future?) fuel crunch, power-



Updated Itasca Phasar 220I—leading the RV "aero" wave.

which adopted its distinctive aerodynamic trademark way back in the '40s, contemporary coach builders are slowly embracing a cleaner, more fuel-efficient profile.

Our article, written by *Motorhome* magazine editor Bill Livingston, points out that the motorhome industry has matured, adopting automotive manufacturing techniques and styling ideas from the often converging spheres of aviation and marine technology.

One might say that all this fuss about aerodynamics is pretty old news. R. Buckminster Fuller enflamed a generation of automotive aerodynamicists in 1933 with his 3-engine, omnidirectional Dymaxion. Prompted by this vision of the future, post-War automakers crafted cars using complex shapes and sensuous contours. Motor-

train developments and, perhaps most important, public styling demands, all contributed to the lean, clean look of motorhomes in the '80s.

Call it quaint (and therefore irrelevant), but we're prone to establish benchmarks for developments such as these, and we can make a case that the leader of the new wave in aerodynamic RV design rolled off the Winnebago assembly line two years ago. Its LeSharo and identical Itasca Phasar "garageable" motorhome has taken the RV world by storm, accounting for a sizable portion of Winnebago production. The latest styling package is a Phasar 220I with an updated "Euro" nose job. Recent Phasar/LeSharo innovations also include a sculpted rear cap, zippy accent stripes and upscale wool/velvet upholstery.

Not the kind of package

that can easily assault the Rockies, but definitely a superior highway cruiser. And the motorhome that has changed an industry.

Putt-putts Are Forever

We admit to an inordinate fascination with large, complicated, swift, expensive marine powerplants. That's why we concentrated on large outboard technology in our March boating guide, and why our most recent comparison tests have involved sterndrives. We haven't forgotten the ubiquitous kicker, however, and that brings us around to the new Mercury 4-hp., a well-engineered entry in the micro-outboard field. Mercury has sensibly downsized various features found on much larger outboards for this unit—like the twist-grip throttle and F-N-R gearshift. These features keep hands away from the powerhead—thereby putting all eyes front during dockside maneuvering.

The Merc 4 differs from its OMC rivals in that it has no detachable fuel reservoir, which some outdoorsmen may actually prefer. For more information, contact Mercury Marine at 1939 Pioneer Rd., Fond du Lac, WI 54935.

Econocamper

With all this talk of motor-



Propulsion solution for small boats on ponds, lakes, rivers.

homing this issue, it's easy to lose sight of what some may consider the best way to see the outdoors—attaching a lightweight, pop-up tent camper to the hitch of a compact truck or auto and heading for the nearest trout stream. The 575-pound Coleman Colorado is one of the smallest models in the genre, and offers a compelling blend of comfort and simplicity.

The unit has a low profile on the road for enhanced fuel economy, and converts at the campsite to a roomy tent with 6 ft., 7 in. headroom. A unique canopy over the rear door provides protection from sun and rain.

The whole rig is the answer for campers on a budget. At the very least it's a camper for those who find comfort in the bare necessities.

For more information, contact The Coleman Co., Inc., Camping Trailer Division, R.D. 2, Somerset, PA 15501. **PM**



It's back to basics with the Coleman Colorado mini-camper.



A RIDING MOWER THAT COULD BE THE CAR-OF-THE-YEAR.

If that seems a bit far-fetched, consider: Our automobiles have earned the title twice in the last six years alone. So, why not our riding mower?

After all, both feature powerplants that evolved from innovative Honda engineering. Mid-mounted for optimum maneuverability, the advanced Overhead Valve

engines that drive our riding mowers set the industry standard for fuel and oil efficiency. Like our automobiles, our riding mowers are easy to handle. With Honda's exclusive Mechanical Autoclutch Transmission (MAT™), there's no clutch pedal to operate. You just shift gears and mow. Of course, all Honda products share an impressive reputa-

tion for reliability.

Admittedly, a top speed of 5 mph is slow for a Car-of-the-Year, but a beautifully manicured lawn may help you overlook that. Indeed, you may be inclined to overlook our competition, once you realize that for the price of a riding mower, you can own a Honda.

IT'S A HONDA

HONDA
Power
Equipment

For optimum performance and safety, we recommend you read the owner's manual before operating your Honda Power Equipment. ©1986 American Honda Motor Co., Inc.

ANNOUNCING: A VERY QUIET

The new Goodyear Wrangler AT and ST radials. Engineered for year-round peace and quiet.

The biggest drawback of most tires made for light trucks, vans and RVs isn't the way they look.

It isn't even the way they perform.

It's the way they sound.

The noise they make. As they drone, whine, or rumble down the highway.

Now, with the introduction of the new Wrangler AT and ST radials, Goodyear has started a very quiet revolution.

And, as you'll discover, noise reduction isn't the only improvement to be found in these remarkable new tires.

The strong but silent type.

The characteristics demanded by our development engineers for the new Wrangler AT and ST radials were strategically very simple:

They had to be the strong but silent type.

And strong they are.

Both the Wrangler AT and ST are true steel-belted radials, with a minimum of two high-strength steel belts.

Beneath the steel belts, you'll find two plies of chemically stabilized polyester cord for long tire carcass life.

For additional strength, the sidewalls are reinforced and have a cut-resistant compound.

One more benefit of the

reinforced sidewalls; they provide responsive steering.

We also added a cool running sub-tread compound.

And a butyl liner for good air pressure retention.

And a new lower sidewall design for better stability in the bead area.

And those are just a few of the design features of the new Wrangler AT and ST radials.

So, as you can tell, we didn't take any shortcuts on our road to stronger, quieter tires.

Radials that aren't afraid of the weather.

Because you cannot always choose when or where you drive,



both the Wrangler AT and ST were designed for quiet, year-round performance.

In all weather. In all seasons.

On dry roads, they run cool, quiet and easy.

In the wet, they both channel away water to maintain contact and control.

And in snow, the deep traction biting edges dig in deep to get you through.

The concept is the same. The execution is different.

Although the Wrangler AT and ST radials share many of the same strong construction features, their final execution is different. Most noticeably in the tread design.

The Wrangler ST radial was designed for light trucks, vans, and RVs that operate primarily on the street and highway. And it has been tuned for quiet, smooth operation in that particular environment.



THE START OF REVOLUTION.



The Wrangler AT, on the other hand, was designed for light trucks and RVs that need both an on-road and off-road capability.

The open shoulders of the new Wrangler AT radial let it reach down deep for a solid grip in dirt, mud and wet grass.

The broad, open tread face of the Wrangler AT also gives it excellent traction in soft soil.

And while the tread of the new Wrangler AT gives outstanding off-road performance, it has been tuned to a low noise pitch sequence to help maintain a quiet highway ride.

Additionally, the Wrangler AT comes in a wide variety of widths and sizes, with a maximum load capacity of up to 3,042 lbs. per tire.

But no matter which Wrangler you choose, both offer you low rolling resistance to aid fuel economy.

When the road ends, the performance doesn't.

In everyday use, the new Wrangler ST radial will come as a very pleasant, quiet surprise.

It is a strong, year-round, all-weather tire that has been designed to give you long wear, better handling and excellent traction.

Ditto for the Wrangler AT radial.

Except that the new Wrangler AT has another pleasant surprise.

Because when the road ends, its true performance begins.

See the Wrangler ST and AT radials at your Goodyear dealer. And witness the start of a very quiet revolution.

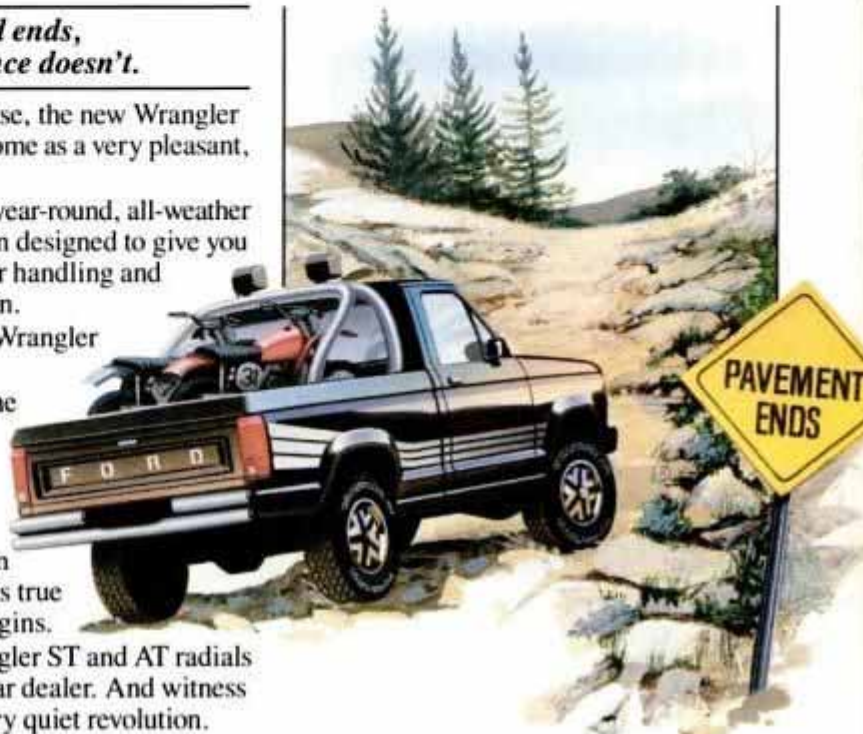

GOODYEAR

Take me home. The quiet way.



Home Video



BY JAMES B. MEIGS

Putting Heads Together

Making sense of the "head games" VCR salespeople sometimes play can be the toughest thing about buying a VCR. Walk into almost any electronics store and you'll hear people touting the advantages of their 3-, 4-, 5- and even 6-head VCRs.

Yet, while the video head count can be confusing, it's also an important indicator of a VCR's capabilities. Video heads are critical to VCR performance; they actually write the signal on the videotape during recording, and then read it back for playback. Here's a brief guide to how they work.

In essence, a video head is like a tiny horseshoe magnet. It consists of two magnetic poles separated by a fraction-of-an-inch gap. During recording, a tiny electric current (in this case, a video signal) is fed to the head, and an electromagnetic flux develops in the head gap. If you slide the head across a strip of magnetic tape, the head will magnetize the tape in a pattern that matches whatever signal you've been feeding it.

During playback, the same head sliding across the tape will create a tiny signal based on the magnetic information on the tape. That signal, when amplified, becomes the video picture.

But video pictures contain a

huge amount of information, far too much to record by simply dragging the tape across a single head. Instead

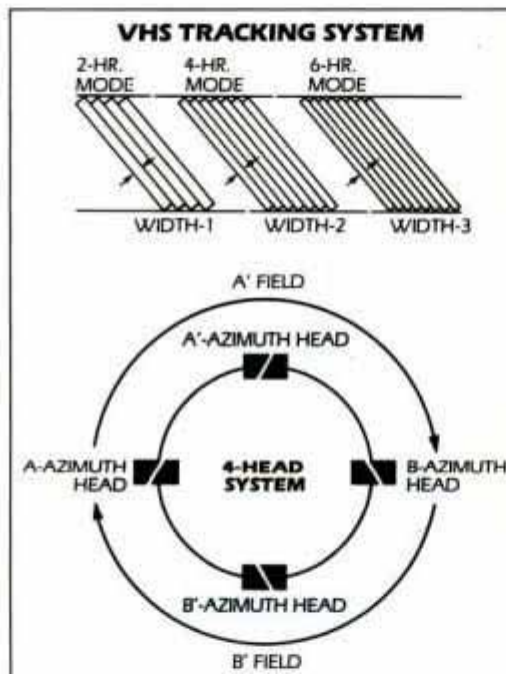

Four heads improve long play and special effects.

the video heads are mounted on the outer edge of a small drum (shaped like a small hockey puck) which spins rapidly, moving the heads past the tape at high speed. The tape wraps around the drum in a diagonal pattern, so that the heads cross the tape in a series of narrow diagonal stripes, or "tracks," each as wide as the head gap that makes it.

The least expensive VCRs use two video heads, one for each of the two video "fields" that make up a complete TV frame. There are a couple of limitations to this approach.

For one thing, in order to record or play back at the 6-hour—or extended play (EP)—speed, the video tracks have to be much narrower (as shown in the accompanying diagram). But the wide head gap appropriate to the standard play (SP) speed can't record or play back those narrow tracks without producing a scrambled picture. Most 2-head VCRs get around this problem by using a compromise head gap, one that does an adequate—but not great—job in either speed. A better solution is to add a second set of heads (the A' and B' heads on the accompanying diagram) designed specifically for slow-speed recording. This is the reason salespeople are likely to suggest buying a 4-head VCR.

Another problem with 2-head decks comes during slow-motion or freeze-frame playback. Because the heads track across the tape at a different angle during those special effects, it's difficult for a 2-head VCR to yield acceptable pictures with special effects, especially in the SP mode. One solution is to optimize the second set of heads on a 4-head deck to get special effects playback—and, in fact, most 4-head VCRs will provide much better special effects than 2-head models. VCRs manufactured by Hitachi (including RCA's models) often include a single, extra head for special effects, thus turning what would be a 2-head model

into a 3-head deck and 4-head models into 5-head decks. All offer very good special effects.

One word of warning: Don't let a fast-talking salesperson include nonvideo heads when he gives you a deck's head count. Many decks have additional heads that aren't involved in video recording and playback (although they do provide important functions). VHS Hi-Fi machines have two heads just for audio, for example, and some 8mm and Beta home decks offer "flying erase heads" that help give cleaner transitions between scenes during editing. If a salesperson describes a 4-head VCR that also has two Hi-Fi audio heads as a "6-head VCR," he may be taking you for a ride.

Video To Go

Did you ever wish your video gear were a little more portable? Citizen has just introduced a compact video cassette player (VCP), with a built-in color monitor, that can go wherever you go—the bedroom, RV or summer house. While the VCP-5MU's 5-in. monitor may be too small to entertain a roomful of people, it's fine for up-close viewing and small groups. The \$599 player is only slightly bigger than a briefcase, and weighs in at 22 pounds. It can operate on either AC or DC power.

Aside from the player's value as a portable movie machine, it has obvious advantages for business and salespeople. It could make many presentations as simple as inserting a cassette.

In fact, the VCP-5MU is sold through Citizen's Business Products division in Los Angeles, California.

(Please turn to page 21)



Citizen video cassette player has a built-in, 5-in. color TV.



**INTRODUCING
A VEHICLE TO MEET YOUR
HIGHEST EXPECTATIONS ...**



... AND EXCEED THEM. SIERRA: THE ULTIMATE PICKUP FROM GMC TRUCK.

You demand a lot of your possessions.

To fit your life, a vehicle must do more than simply fit in your driveway. It must offer a sense of adventure that complements your own personal style. It must suggest endless possibilities — and then fulfill them. What you drive must be as comfortable as a broken-in pair

of jeans, and yet as contemporary as anything on the road today.

In short, you expect a lot. But you are easy to satisfy — because you only want the best. It is for individuals like you that we proudly introduce Sierra. The ultimate pickup from GMC Truck.

Sierra is clearly a new concept in full-size pickup design. Designed to

be the last word in pickups, from the first name in trucks: GMC Truck.

But don't just take our word for it. We invite you to refer to the last page of this section for a detailed explanation of Sierra.

And don't forget to bring your expectations.



SIERRA. SOPHISTICATION YOU NEVER EXPECTED IN A PICKUP. ALL THE ROOM, POWER AND PERFORMANCE YOU EXPECT FROM A GMC TRUCK.

Your expectations are high. Sierra will fulfill them. And then some.

Advanced aerodynamic lines give Sierra a fresh contemporary shape, with a rakish windshield and flush-fitting side glass for a quiet, comfortable ride. With its sophisticated styling, Sierra is ready to go everywhere. Select a four-wheel-drive model (with the Insta-Trac system that lets you shift conveniently from two-wheel to four-wheel drive without stopping) and "everywhere" can be almost anywhere!



Full-size inside.

Sierra's interior features more shoulder and leg room than previous full-size pickups from GMC Truck. So there's plenty of stretch-out space for three adults. Standard power steering and power brakes ease your driving.



And you can add almost every conceivable driving amenity, from electronic cruise control to power windows and power door locks.

Full-size outside.

In today's world of "mid-size,"

"small-size," and "downsized" pickup trucks, Sierra is a full-size pickup that still delivers the goods. Select from 6½' short-bed or 8' long-bed models. The long-bed can still accommodate the proverbial 4' x 8' sheet of plywood between the wheelhousings.

Full-size power.

The amazing 4.3-liter Vortec V-6 engine is standard (except on 3500 models which feature a standard 5.7-liter V-8). And with the available five-speed manual overdrive transmission and Vortec engine, a two-wheel-drive Sierra is rated at an impressive EPA estimated MPG city 17 and highway 23. Or you can select from a big choice of V-8s: 5.0-liter (305 cu in), 5.7-liter (350 cu in), 7.4-liter (454 cu in), or the 6.2-liter (379 cu in) diesel. Standard electronic fuel injection on all gas engines gives instant starting response and outstanding over-the-road performance. When properly equipped, Sierra is ready to move up to 19,000 lbs, including itself, passengers, trailer, equipment and cargo.

Built to be driven.

Sierra gives a whole new meaning to the phrase, "drives like a truck," thanks to a new fully independent torsion bar front suspension on 4 x 4 models or its newly improved two-wheel-drive front suspension.

The standard rear-wheel anti-lock brake system (operable only in the two-wheel-drive mode on four-wheel-drive models) is designed to prevent rear-wheel lockup and helps control skidding on sudden stops, on wet or dry pavement, loaded or unloaded.

The fuel tank is mounted between the frame rails. There's a new box-section front frame with impressive strength. And the side glass has been increased by 33% over our 1987 Full-Size Pickup, for greater visibility.

Built to last — in the GMC Truck tradition.

The majority of all exposed metal surfaces are galvanized steel, protected by deep-luster basecoat/clearcoat acrylic enamel — the same advanced

painting technique that protects some of the world's finest automobiles. An uncluttered underhood area offers impressive service access, and a new aluminum radiator reduces weight and helps prevent corrosion.

It's not just a truck. It's a new idea.

At GMC Truck, we've been saying, "It's not just a truck anymore," when we speak of our entire product lineup. And no product better exemplifies that phrase than our new Sierra.

It's not just a new pickup. It's a whole new way of thinking that says the traditional American full-size pickup can be just as advanced as any automobile on the road today, while still accomplishing all the truck-like things you usually buy a pickup for.

And every new Sierra is backed by a 6-year/60,000-mile warranty on the



powertrain and a 6-year/100,000-mile warranty on outer-body rust-through. Buckle up and visit your GMC Truck dealer for the terms and conditions of this limited warranty. (Check the Yellow Pages under "Truck" or "Automobile.")



Then, take a look at Sierra. It's like nothing you've ever expected in a full-size pickup. And everything you've come to expect from a GMC truck.

GMC TRUCK
IT'S NOT JUST A TRUCK
ANYMORE.

HOME VIDEO

(Continued from page 16)

Get Ready For S-VHS

We've been hearing rumors about an ultrahigh-quality version of the VHS home video format for years. And just recently, JVC, inventor of the VHS format, shook up the video world by announcing that it will be unveiling what it's calling S-VHS—for Super VHS—any day (see *Electronics*, page 34, April '87).

According to JVC, the new format will boast the most remarkable performance in the history of home video: pictures with more than 400 lines of horizontal resolution. That's better than live broadcasts! How do they do it? The latest specifications have just come in from Tokyo. Here's what we know so far.

S-VHS decks will be able to play and record both S-VHS tapes and today's VHS cassettes. That means you won't have to worry about your current library of VHS cassettes being incompatible with the new VCRs. But in order to produce an S-VHS picture, S-VHS VCRs use a new type of videotape. The new S-VHS cassettes—which look almost exactly like ordinary VHS—will contain a high-density, oxide-tape formulation that lets them handle the higher frequency signals of S-VHS. TDK, Maxell, Fuji and 3M have all announced that they will offer S-VHS cassettes.

The new super cassettes include a special identification hole that enables S-VHS VCRs distinguish them from ordinary cassettes. If you were to record with an S-VHS cassette in a conventional VHS VCR, you would get an ordinary VHS picture—and you can play it back in an S-VHS deck. On the other hand, a recorded S-VHS cassette won't play at all in an ordinary VHS deck.

In most respects, S-VHS VCRs will work exactly like their conventional cousins. S-VHS tape runs at the same speeds. Audio recording—whether conventional or Hi-Fi—is performed as it is today. Video recording will use essentially the same "color-under" process used today. The difference will be in the frequency used to record the picture's luminance (or brightness) information. S-VHS machines move the entire luminance signal into a higher frequency range. Instead of recording the signal in the range between 3.4 and 4.4 MHz (MegaHertz) like conventional VHS, S-VHS uses the range between 5.4 and 7.0 MHz. Why is that important? Because the new luminance signal is not only higher in frequency, it also occupies a much broader frequency band: 1.6 MHz compared to 1.0 MHz. This increase in bandwidth should mean a dramatic improvement in picture quality.



NEC uses digital circuit to reduce noise, improve picture.

S-VHS decks will also have another unique quality. According to JVC, S-VHS VCRs will offer special outputs that keep the luminance and chrominance (color) signals separate. Keeping the two components of the video signal separate, instead of combining them in a conventional—or "composite"—TV signal, eliminates the picture degradation otherwise caused by interference between them. This is an approach used in some professional video equipment, and should help S-VHS VCRs maintain an impeccable level of picture quality when sending signals to other components (S-VHS decks will also have composite outputs).

What sorts of products might have the special luminance/chrominance inputs to accept these signals? There are reports from Tokyo that the leading VHS manufacturers will be introducing new TV monitors along with S-VHS VCRs. Featuring luminance/chrominance inputs, the new sets should be able to take advantage of every bit of picture quality this remarkable new format has to offer.

Though it's not definite which companies will have the first S-VHS VCRs available in stores, it appears that JVC, Sharp, Matsushita (parent company to Panasonic and Quasar), Mitsubishi and Hitachi will all have S-VHS models on display soon. We'll keep you posted.

Beta Bites Back

Yes, you guessed it: Sony's looked at Super VHS and contends Beta's still better. Not Superbeta—that exists already. But ED Beta, meaning extended definition. Sony says the new improved Beta will emerge this fall with 500 lines of horizontal definition. The system uses cassettes housing metal particle tape—which can't be played or recorded in older Beta VCRs. Conventional Beta cassettes can be recorded in the ED Beta machine, but only at the Hi-Band Superbeta level—not ED. At press time, it was not known whether older Beta recordings will play on the ED system. Stay tuned.

Digital Dilemma

While super VCR systems are in the making, conventional VCRs with picture-improving digital circuitry are here.

From NEC Home Electronics come two digital effects VCRs, the DX-1000U (\$699) and DX-2000U (\$819). Both use their digital memory capacity to remove unwanted noise from the video image, and

(Please turn to page 22)



Bill Koch
8 time Nat'l X-C
Ski Champion
Olympic Silver Medalist
World Cup Winner

Scientific Study Ranks NordicTrack #1

In tests of exercise efficiency at a major university, NordicTrack burned more calories and provided greater aerobic workouts.

Rank of Exercise Efficiency

1. NordicTrack X-C Ski Exerciser
2. An Exercise Bike
3. A Rowing Machine
4. A Shuffle-Type Ski Exerciser

NordicTrack's higher oxygen usage test scores show that more muscle mass is involved in the exercise and more calories are being burned.

It's Only Logical that NordicTrack Would Get the Highest Scores

- because NordicTrack is more complete than an Exercise Bike. Adds important upper body exercise. Provides more uniform leg muscle usage.
- because NordicTrack is more thorough than a Rowing Machine. NordicTrack's resistance is proportioned according to the individual muscle strength—no major muscles are overstressed or under-worked.
- because NordicTrack has inertial resistance not available on a Shuffle-Type Ski Exerciser. Other ski exercisers use less efficient frictional resistance with a resulting calisthenics-like feeling. NordicTrack's unique flywheel resistance for a life-like feeling of smoothness and continuity is matched only by real skiing.

Burns Up To 600 Calories per 20 Minute Workout

Free Brochure, and New Video!

800-328-5888

Minnesota 612-448-6987

NordicTrack
© PSI 1986

141PM Jonathan Blvd. N., Chaska, MN 55318

Any metal worth painting, is worth protecting.

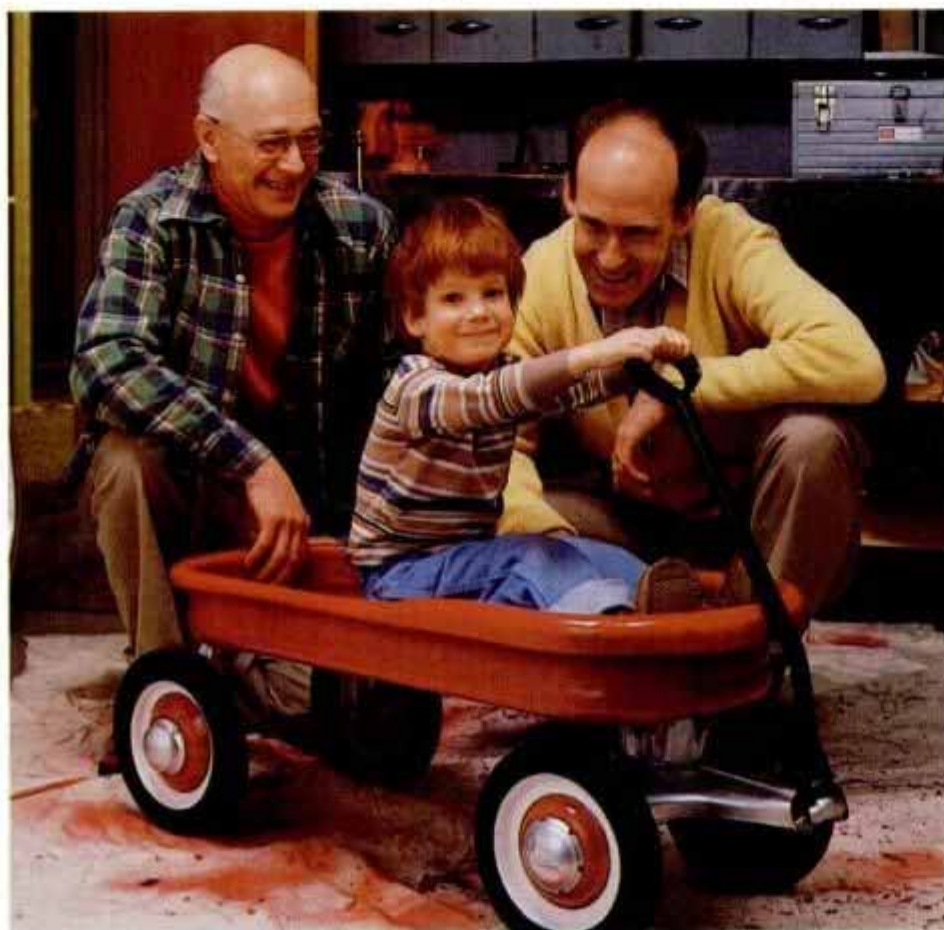

Your father gave you that wagon for your fifth birthday. Now it's your turn to pass it on.

Any spray paint could make it red again. If that's all you wanted.

But Rust-Oleum, with an average of 50% more protective ingredients than its nearest competitor, can do more.

Its protective formula not only prevents rust, it also gives metal better protection from chipping, peeling and fading than other spray paints.



RUST-OLEUM
CORPORATION

© 1987 Rust-Oleum Corporation USA

HOME VIDEO

(Continued from page 21)

to provide clean special effects (such as freeze frame) with two heads instead of four. Other so-called digital VCRs use their memory to provide secondary picture-in-picture viewing, but do nothing to improve picture quality.

NEC's two machines improve the picture's video signal-to-noise ratio by an impressive and visible 9 dB. Compared to conventional VHS machines (whose S/N ratio is about 43 dB) this yields a 50-dB rating on par with the signal transmitted by broadcasters and the reproduction capability of most TVs.

In practical terms, this means that noisy, poor-quality tapes (from any sources) will look dramatically better when played back on NEC's digital VCRs. Tapes recorded on the DX-1000U and DX-2000U can be played back in other machines, but won't benefit since the digital noise reduction operates only in playback on the NEC machines.

The DX-1000U is a monaural audio machine that includes picture-enhancing HQ circuitry. The DX-2000U adds hi-fi stereo, and MTS broadcast stereo reception. By the way, each machine does perform a neat trick. They'll freeze a live TV frame on your screen on those occasions when you want to scribble down a toll-free phone number.

Maxxum Of Camcorders

Possibly the neatest VHS-C camcorder introduced to date is Minolta's new Master Series C3300. Within its compact body are several tricks Minolta learned in the film-camera business. We'll have a full hands-on report in a future issue.

Video CD Is Coming

You read it here first, nearly a year ago (*Audio*, page 14, July '86). Digital audio Compact Discs with 5 minutes of motion video are coming. In addition to the video's soundtrack, there's another 20 minutes of music on the discs. The first combo player (also for playing 8- and 12-in. videodiscs) will hail from Magnavox, later this summer. **PM**



Forthcoming Magnavox unit plays CDs, video CDs, and regular laser video discs.

WINNER!

Top-rated radar detector beats Passport.
Costs \$115 less!

"It produced the earliest warning in our [road] tests."

Road & Track,
September, 1986



Only 1 1/4" tall,
3 1/4" wide, and 4 1/2" long.
Fits in your pocket.
Travels where you travel.

Shown actual size.

No doubt who won.

Road & Track magazine recently tested eight popular radar detectors. SNOOPER D-4000 won big. In actual road tests where it counts. Around the corner and over the hill radar ambushes. What about current best-seller Passport? "... second only to the SNOOPER D-4000." Sorry guys.

Fact: The SNOOPER D-4000 beats Passport on performance. Fact: It costs \$115 less! No doubt who won.

"The SNOOPER D-4000 produced the earliest warning in our around-the-corner and over-the-hill tests."

Road & Track, September 1986

Sold on new high performance cars.

The SNOOPER D-4000 is made in Garland, Texas by Microwave Systems, Inc. — the inventor of solid-state radar detection for cars. The first to use superheterodyne



All accessories are included.



circuitry. The pioneer in remote devices. Maybe that's why SNOOPER came in first. Innovation and experience!

Until now, the SNOOPER D-4000 has been sold mainly through new car dealers. So you could wait and buy one with your next Porsche, BMW or Corvette. Or you can pick up the phone now and have one in your hands tomorrow. The SNOOPER D-4000 is NOT sold in catalogs, parts stores or discount chains.

Only \$180!
If you can afford one of theirs...

... why not buy TWO of ours? ONE Passport costs \$295. For another \$65, you can have TWO of ours. Protect other drivers in your family against radar surveillance, too. SNOOPER D-4000 is the top-performer, and at \$180, it's the runaway winner for top value.

All the features you want.

The SNOOPER D-4000 is a triple superhet advanced radar detection device. Sniffs

out both X- and K-bands radar, alerts you with a loud audible signal and simultaneous warning light.

Filters out false alarms, and "dirty" signals from other radar detectors. Comes with visor clip and dashtop mount. Plugs into car cigarette lighter. On/off and highway/city switches. Simple. No complicated dials or bar graphs to slow your reaction time.

Order today.

Order yours at no risk. Call toll-free to order. Drive with your SNOOPER D-4000 for 30 days. If not satisfied, return it and we'll refund your purchase and your shipping costs. Comes with one-year factory warranty. And, remember, it's the winner. The most for less. You can't go wrong!

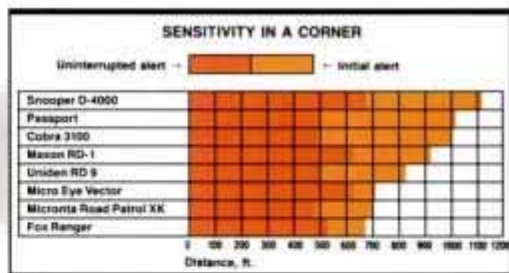

SOURCE: ROAD & TRACK

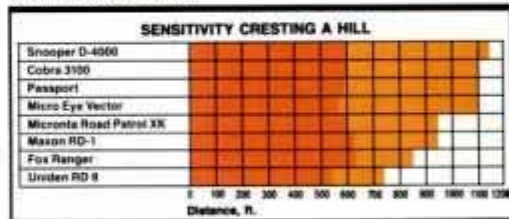

SNOOPER D-4000
TRIPLE SUPERHETERODYNE XK

SNOOPER DIRECT
47 RICHARDS AVENUE
NORWALK, CONN. 06857

\$180 (plus \$5 S&H)
(Conn. res. add \$13.88 tax)
Want it tomorrow? We'll ship
Federal Express overnight,
just \$10 extra.



TOLL-FREE 1-800-367-4534

Extension 231

in Connecticut 855-8717
(Phone M-F 8:30-10, Sat. 9-5 EST)
By mail send to address at left.
Orders processed immediately.

Car Clinic



BY MORT SCHULTZ

Overdrive Options

I have received conflicting instructions regarding the operation of my 1986 Oldsmobile 98 overdrive automatic transmission. The owner's manual says to operate the unit in Overdrive at all times, except in hilly areas. The dealer says to disregard the owner's manual and operate the transmission in Drive at all times, except on freeways and level rural roads—then, shift to Overdrive. Could you straighten this out so I can operate the unit properly?

JOHN GRAY
STOCKTON, CA

Sure, John. Do what's comfortable. Either way, you won't harm the transmission. The owner's manual recommendation allows for maximum fuel efficiency, which full-time Overdrive operation gets you. Your dealer may be hedging, because he doesn't want you parked on his doorstep complaining about transmission hunt. Operating in Overdrive all the time will result in the transmission shifting between gears as you vary your driving speed. On freeways, where you operate pretty much at a constant speed, this won't happen. It's all up to you. If transmission hunting doesn't bother you, use Overdrive; but if hunting is annoying, use Drive for all except freeway driving.

Yellow Flag

I think you should alert your readers to a recent experience I had, since the warning

may save someone's life. The vehicle that's involved is a 1987 Ford Ranger with a 2.9-liter V6 fuel-injected engine. Soon after I took delivery, I filled the gas tank and made a 60-mile round trip. On the return leg, I was surprised to find the fuel gauge needle laying on the $\frac{1}{4}$ mark. When I reached home and opened the door of the vehicle, a strong odor of gasoline whacked me in the nose, causing me to suspect a leak. I checked and was amazed to find that plastic fuel lines possessing push-on connectors are being used instead of metal lines and fittings. The area of leakage was at the pressure-relief line from the fuel-injection pump. It was

resting against the exhaust manifold, and the hot manifold had melted a hole in the side of the line; consequently, gas was leaking onto the manifold. I was lucky there was no fire. Neither the dealer nor Ford's Customer Service organization seems concerned. They should be.

ALFRED KAVALAR
TRAVERSE CITY, MI

Your warning shouldn't fall on deaf ears. If plastic fuel lines aren't retained securely with brackets, they can constitute a hazard. Therefore, because of your experience, other drivers may want to check or have their dealers check those plastic fuel lines. They should be at least 2 in. from hot engine parts and retained securely with brackets, as they were meant to be.

Just at press time the National Highway Traffic Safety Administration (NHTSA) announced additions to an ongoing investigation of engine compartment fires in Ford trucks and other vehicles by several manufacturers. Ford products included '84-'86 pickups, Ranger, Escort, Tempo and EXP, as well as Mercury versions of the same vehicles, Lynx and Topaz.

Beating Tenacity

I've tried to find out how to remove vinyl siding from a car, but no one knows. You're my last hope. Help!

HELEN BEATZ
JAMESTOWN, TN

I figure you're asking about the simulated wood grain panels on a station wagon. You have two ways to go. You've had good luck removing vinyl overlays with an ordinary hair dryer. This works pretty well on bumper stickers as well. Get a corner started with your fingernail and then, with a blast of heat right along the parting line, slowly peel back the vinyl. The secret is not to try and rush things, because the metal and glue have to heat up as you go along. The heat isn't intense enough to damage the paint because your hands are right there in the hot-air blast. This method tends to remove most of the glue, so try it first. But if the vinyl is old and brittle, it tends to tear, no matter how careful you are.

If that's the case, get some 3M Woodgrain and Stripe Remover (3M part No. 051135-08907). Try an auto parts outfit that caters to body shops. Following in-

(Please turn to page 26)



Keeping Kids On Board

"Terror is driving along with three small kids in the rear of the car and having a back door opened by an 18-month-old child who reached over and operated the lock and door handle although he was securely belted into a car seat," writes Diana Hilliard of Newton, Manitoba, Canada.

After this experience, Diana and her husband, Joe, attempted to find a safety device for the rocker-style locks on the doors of their 1984 Reliant station wagon. They weren't successful, so they

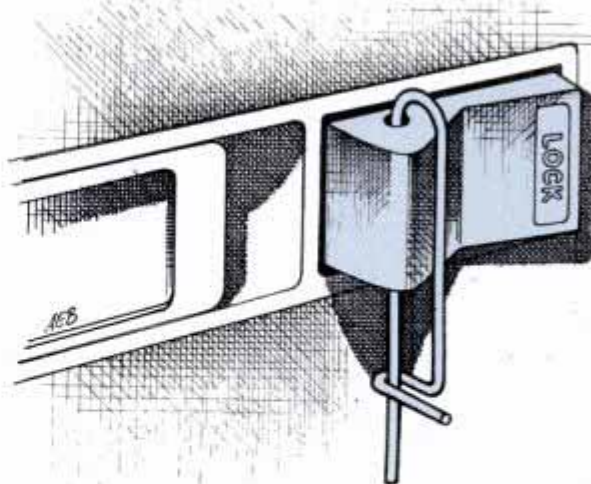

made their own from wire coat hangers they fashioned into safety pins.

"With the lock in locked position," Diana says, "we drilled a hole in the protruding part of the hollow rocker mechanism and

stuck the safety pin through it. For a child to unlock the latch and open the door now, he or she would have to open and withdraw the safety pin. This is a task most preschool children would find difficult."



**Motorcraft
oil filters.
THE WAY TO
STAY IN
SHAPE.**

**Motorcraft
FL-1A
LONG LIFE
OIL FILTER**

The new shape of the American car. Sophisticated. Advanced. And reflecting a total dedication to quality. Today's high-quality automobiles deserve equally superior replacement parts. Like Motorcraft FL-1A long-life oil filters, original equipment in advanced cars like Mercury Sable. FL-1A's state-of-the-art design traps more dirt and lasts longer than other major brands. There's a Motorcraft oil filter, and a full line of Motorcraft quality parts—batteries, oil, air filters and spark plugs—to help your car stay in shape.

Motorcraft from Ford
EXCEEDS THE NEED

CAR CLINIC

(Continued from page 24)

structions, spray the siding and let the chemical soak in. Then, peel off the vinyl. The tough job is to remove the glue adhering to the metal. Use 3M Woodgrain and Stripe Adhesive Remover (3M part No. 051135-08908)—it won't damage the paint. You're going to need lots of patience.

Batch Of Scratches

How can I remove scratches in a windshield, which are especially hazardous when driving at night? The windshield disperses light because of the scratches, which were caused by long-time scraping by the wipers. Is there a chemical I can use?

ROBERTO C. LOZADA
CEBU CITY, PHILIPPINES

Jeweler's rouge, which resembles a bar of soap, may be a remedy for very light scratches. It can be bought from a jeweler or a glass shop. Rub some on a buffer pad you've attached to a 1/4- or 3/8-in. drill and go at it—gently. If this doesn't work, the only alternative is to get a new windshield. There are some commercial products for polishing windshields as well, and



This Caps It

If the gas filler in your car is behind the license plate, as it is on GM models, you'll be interested in this bit of ingenuity, courtesy of Chuck Lewis of Zeniople, Pennsylvania. Chuck says that pulling on the corner of the plate can cause the plate to bend. That's true. It's especially a nuisance in winter when wearing gloves makes it difficult to get your fingers behind the plate. You often have to take the glove off and touch cold metal—not a jolly state of affairs when the ambient temperature is below freezing. What Chuck did was to drill a hole in the center of the plate and install a



small brass drawer pull (see illustration).

Also add the following to your bag of tricks about flapped plates: After pulling the license plate down and removing the cap, lay the cap across the right-hand hinge. By doing this, you'll accomplish two things: First, the cap will keep the license plate flap down so you can insert the nozzle without having to hold the plate; and, second, since it's in view, you won't drive off without screwing the cap back on.

you may want to talk to a glass shop about doing the polishing. In the U.S., the labor might be prohibitive when weighed against the cost of replacing the windshield. But that may not be true in the Philippines, where finding replacement parts could be tough.

False Economy

I have a 1982 Ford Bronco with a 302-cu.-in. engine and 2-barrel Motorcraft carburetor, and I'm going broke replacing the carb's economizer valve. So far, this has been done six times, the carburetor has been rebuilt once, and a rebuilt

Get the flavor of these leading brands, but less tar.



Breakaway to Merit.

Kings: 8 mg "tar," 0.5 mg nicotine av. per cigarette, FTC Report Feb. '85.

SURGEON GENERAL'S WARNING: Smoking By Pregnant Women May Result in Fetal Injury, Premature Birth, And Low Birth Weight.

© Philip Morris Inc. 1987

Comparisons based on king-size version of products shown and "tar" levels from Feb. '85 FTC Report or by FTC method.

carburetor has been installed once. Each time, the vehicle runs great for a few days; then, gas mileage goes way down because the economizer valve ruptures. The condition is verified by the presence of gas in the economizer valve cover. The Bronco presently has 64,000 miles on it and has given no trouble until this started a short time ago. Ironically, a friend of mine drives a Ford van with a 351-cu.-in. engine and a 2-barrel carburetor. His truck, which has 68,000 miles, is now doing the same thing. Help me and you'll be helping him at the same time.

JOHN LANG
BASTROP, LA

Just because you're finding gas in the power valve cover—the economizer valve is also called the power valve—it doesn't mean the valve keeps going bad. What should have been done the first time your economizer valve became suspect was test it using a hand-vacuum pump and vacuum-cup adapter. If you have a hand-vacuum pump but no adapter, you can get one from a tool company, such as Borroughs or Kent-Moore. To make the test, the vacuum-cup adapter is put over the diaphragm side of the power valve with the hand-vacuum pump attached to the adapter. Vacuum is

then applied. If the gauge on the hand-vacuum pump shows that the valve retains vacuum for 2.5 seconds or longer, the valve is in great shape and should not be replaced. There's gas in the power valve cover because it's normal for it to be there. It's the result of fuel vapor condensing in the cover. The presence of fuel in the power valve cover does not indicate leakage past the power valve, nor does it mean the valve is bad. So why do you get such a sharp drop in fuel economy a few days after replacing the power valve? I suggest you look at other possibilities.

To begin with, I would test the EGR system. The problems a malfunctioning EGR causes—poor fuel economy, rough idling and shoddy low-speed performance—are the same as those a bad economizer valve causes. Check the EGR valve for sticking and for the presence of the proper vacuum signal. If the EGR system checks out okay, look for plugged or restricted carburetor booster air bleeds. They will cause the carburetor to run rich, which would kill your gas mileage.

PM

DO YOU HAVE A CAR PROBLEM?

Just ask Mort about it. Send your question to the Car Clinic, Popular Mechanics, 221 West 57th St., New York, NY 10019. While letters cannot be answered individually, problems that are of general interest will be discussed in the column.

SERVICE TIPS

- Owners of 1987 Chrysler-built Ram Raiders having power steering take note: You may be losing fluid from around the steering-gear side-cover adjusting bolt. Have a dealer install a new seal (part No. MB553220) as instructed by technical service bulletin (TSB) 19-01-87.
- If a rear strut of your 1985-87 GM car that's equipped with Electronic Level Control pops a bladder and starts to leak air, don't replace the strut. Instead, order a Rear Strut Electronic Level Control Air Bladder Service Kit (part No. 220625061).
- A low-coolant warning light that comes on when the coolant level is up to snuff may simply mean that your 1985-86 Merkur XR4Ti needs a newer-design low-coolant warning sensor. The new sensor carries part No. E6RY-10D968-A. Its use is sanctioned by TSB 87-1-6.
- Many 1986-87 Nissan models have automatic transaxles or transmissions that shift sluggishly in cold weather. It's because of the fluid installed at the factory. Have the factory-fill replaced with Dexron automatic transmission fluid. Have dealer check the lineup in TSB TS87-010 to see if your car fits the description.

Breakaway to flavor.



INTRODUCING A FULL-SIZE

**The 1988 full-size Chevy.
Built new from the inside out
to be a whole new animal.**

By every measure, the 1988 Chevy is an entirely new truck. Leaner outside for better performance. Tougher, roomier, more aerodynamic.

It gives you the heaviest base payload of any 1/2-ton pickup,* the most standard power in 1/2-ton pickups.

Outside, there's two-sided galvanized steel protection to help make it last longer. Inside, there's more cab room than Ford. More shoulder room than Ford or Dodge.

Check out the new full-size Chevy Pickup today at your Chevy dealer's. And find out what it's like to drive a whole new animal.

*Excludes other GM products.

Let's get it
together...
buckle up.



QUALITY COMMITMENT PLAN

See your Chevrolet dealer for terms and conditions of the new limited powertrain warranty.

**Massive new frame
that's bigger and
heavier than before.**

**Most standard power
in half-ton pickups:
the fuel-injected 160-
HP Vortec V6.**

**Most V8 power and
torque available in
pickups under
8,500 lbs. GVWR: the
fuel-injected 350 V8.**

**Standard rear-wheel
anti-lock brake
system for stable,
smooth stops empty
or loaded, on slick or
dry pavement. A
remarkable achieve-
ment in control. System
operates in 2WD only.**

**Fully independent
front suspension.
Standard on 2WD
and 4WD.**

Material, a... ..

LEANER, MEANER CHEVY.

More total cab room
than Ford or Dodge.

Two-tier loading.
Indentations in cargo-
box sides let you
build a platform of
2x6s across top of
wheelhousings.

Heaviest base pay-
load rating of any
half-ton pickup.*

Highest highway gas
mileage of any full-
size pickup*: EPA
est. 23 highway MPG.

Two-sided galvanized
steel on all exterior
body panels except
the cab roof.

New rear suspension
with longer leaf springs
for a smooth ride.

THE
Heartbeat
OF AMERICA



TODAY'S
CHEVY TRUCKS

Electronics



BY STEPHEN A. BOOTH

Apple's New Mac



New Apple crop: Macintosh II (left) and SE upgrade core machines.

Draw up a wish list for Macintosh fanciers, and you'll come close to the spec sheet for Apple's new top-of-the-line Macintosh II. The computer keeps the Mac's essence but offers both a new look and, more importantly, a new level of power and utility that rivals the Intel 80386-based muscle cars of the MS-DOS world. Gone from the Macintosh II is the one box configuration of the original Mac. Instead, the new machine adopts the "system"-look of the IBM PC and its clones: a main module housing CPU and storage units, a separate monitor and a separate keyboard.

For starters, the new Mac II offers a faster microprocessor, the fully 32-bit, 16-megahertz MC68020. According to Apple, the chip promises at least a 4-fold improvement in program execution speed over the former top-of-the-line Macintosh Plus, along with, as standard equipment, a powerful coprocessor for math and engineering applications. What's

more, one megabyte of RAM is standard, with expansion up to 8 megabytes possible on the logic board. For RAM dreamers a lot more memory—up to 2 billion bytes—is accessible via the computer's NuBus slots.

Color, at long last, is the next major addition that the Macintosh II brings. At its best, the Mac II's video adapter offers an on-screen display of 256 colors out of a palette of more than 16 million, plus a new, higher resolution of 640 x 480 pixels. Apple offers two new, larger monitors to couple with the Mac II's superior video output, a 13-in. color CRT and a 12-in. monochrome model. On the sonic side, the new computer now features 4-voice stereo sound using an Apple digital-sound chip.

Massive data storage is available too: Apple offers three sizes of hard disks for the Mac II, including a fast (30-millisecond access time) 40-megabyte internal drive, and an 80-meg external unit.

Like its decade-old prede-

cessor the Apple II, the Macintosh II is highly expandable. Six expansion slots are available. That means there's space for Apple's respectful nod to the MS-DOS universe, an optional Intel 80286-based add-in board that gives the new Apple micro IBM PC/AT-grade compatibility and power. Adding to the machine's flexibility are two serial ports, a SCSI parallel port, and two Apple Desktop Bus ports.

The new micro comes with a hefty 230-watt power supply that automatically configures itself to the voltage needs of whatever country it finds itself in. Additionally—and a first for Apple—there's a variable-speed fan to keep the system cool.

All this wish fulfillment doesn't come cheaply. The Macintosh II, in basic dress, starts at about \$3900. Tricked out with hard disk, count on spending between \$5500 and \$7000 on this "Maserati for your mind."

More affordable is Apple's other new entrant in the micro-

computer marketplace, the new SE.

The SE is basically an enhanced version of the Macintosh Plus that keeps the original Mac's compact chassis on the outside, but reworks the Mac's innards to provide some agreeable amenities to the Mac formula.

Like the Macintosh II the new Macintosh SE includes a fan and a stronger power supply (75 watts). The SE retains the Mac's 9-in. monochrome display and MC68000 microprocessor, but adds a couple of major new wrinkles along with a host of other improvements.

For one thing, Apple is bowing to practicality by offering the SE only as a 2-drive machine. You get a choice of either two 800KB micro-floppy units or one floppy drive with a 20-megabyte internal Winchester fixed disk.

Secondly, the SE includes one expansion slot that could house, among other things, an accelerator card or a coprocessor card for MS-DOS

(Please turn to page 34)

Electronic Transparencies

Hitachi is bringing yet a newer twist to the new field of filmless, electronic still photography. Its Compton, CA-based industrial division introduced two video color printers that yield transparencies as well as prints. Other still-video printers yield opaque prints only.

Hitachi's transparencies are intended primarily for overhead projectors used in audio-visual presentations. They measure the same 3 x 4 in. as the company's electronic prints, and take the

same 80 seconds to produce. Color quality's good, thanks to the VY-100A printer's thermal dye-transfer process and 64-tone color scale.

The VY-1000A, at \$4000, isn't cheap. Nor is its 32-tone little brother, the VY-50A (\$2500). Both print from any type of video source.



Hitachi's new video color printers for filmless photos make 64-tone transparencies (left) or hard-copy prints (above).



**We've put the oil that protects
Bobby Allison's race car
in a very unusual place.**



Bobby Allison

Your favorite store shelf.

For this kind of torture, Bobby Allison, Bobby Hillin, Jr., and the Miller American / Stavola Brothers Race Team need one specially-formulated motor oil. So it's no surprise they use Pennzoil P•Z•L* Turbo 10W-30.

What is surprising, is the tough oil you'll find on this team, is the *same* tough oil you'll find on your favorite store shelf.

And that makes P•Z•L* Turbo 10W-30 a welcome surprise. For owners of *all turbo and non-turbocharged cars.*

It exceeds the toughest automotive engine oil requirements in the world. And it's been rated as superior by a leading national consumer testing group.

It's the oil that protects in *any* temperature, even the extreme temperatures found in today's turbocharged engines. Plus, it fights against engine oil thickening, corrosion, and wear.

So the next time you reach for turbo protection on your store shelf, reach for the oil that protects at NASCAR. World Class P•Z•L* Turbo 10W-30 Motor Oil.



*The Standard of Protection
Since 1889™*

Everybody makes mistakes.

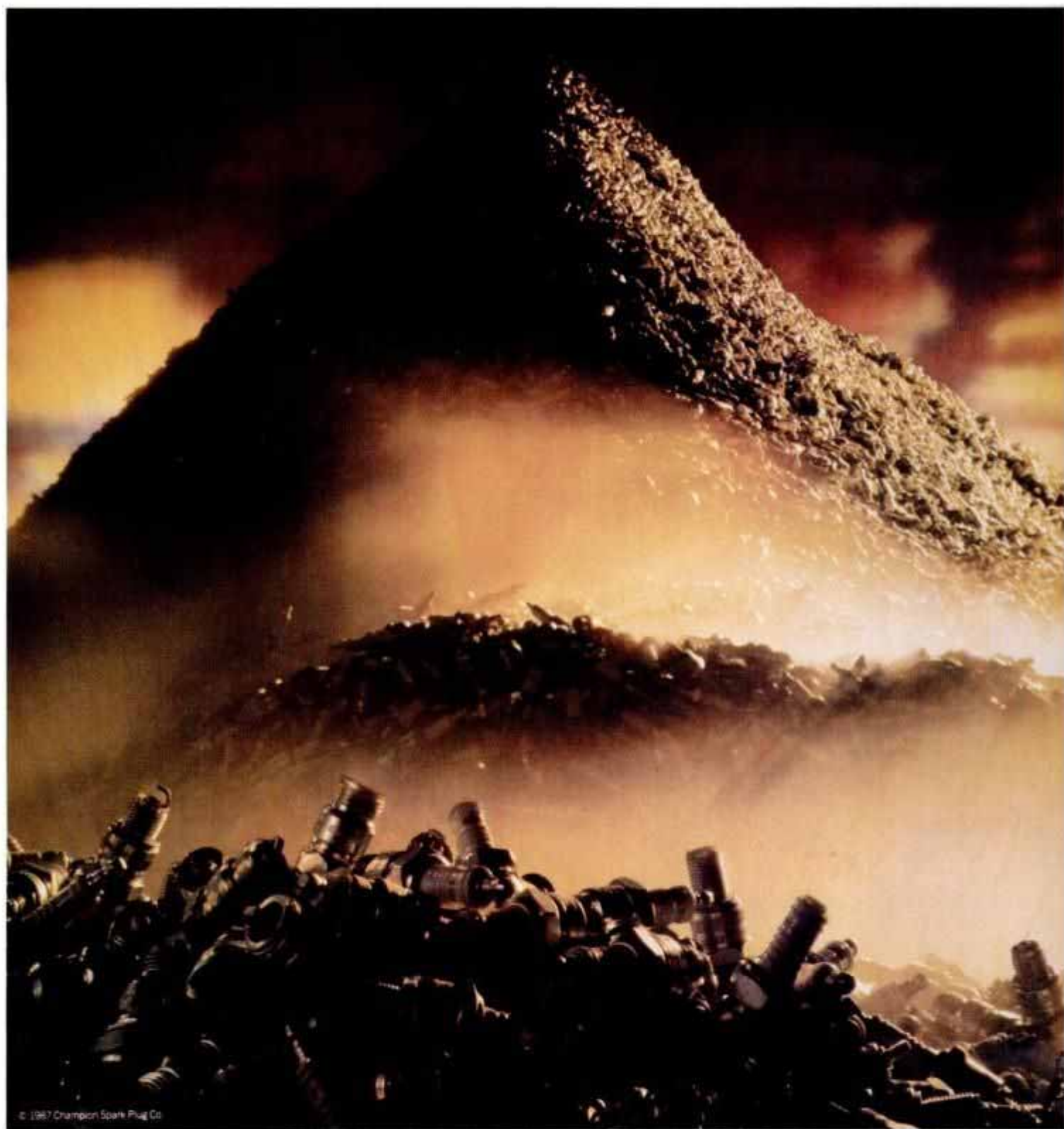

MORE PEOPLE RELY ON CHAMPION THAN

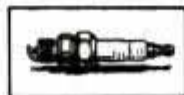

Материал, защищенный авторским правом

Ours never leave the factory.

Champion spark plugs have to pass 154 quality controls during production before we pass them on to you.

Each one has to measure up to tolerances that can be as high as 1/200,000th of an inch. And meet or exceed some of the toughest standards in the automobile industry.

Standards laid down by Chrysler and Ferrari to name but two of the 38 auto makers who choose Champion spark plugs as original equipment in their cars.

Each spark plug is checked for complete zinc anti-corrosion coverage. (Most spark plugs don't even have a zinc coating to check.)

Finally, each Champion spark plug is approved (or rejected) by hand.

At the bottom of this page it says, "More people rely on Champion than any other spark plug in the world."

Now you know a few of the reasons why.



The perfect spark plug.

ANY OTHER SPARK PLUG IN THE WORLD.



ELECTRONICS

(Continued from page 30)



SharpWriter, by Sharp Electronics, combines full-fledged PC-clone capabilities with flexibility of regular typewriter.

software compatibility. The SE includes a new logic-board design that Apple claims will yield from 15 to 20 percent better performance than the Macintosh Plus, with noticeably faster screen updates.

The 2-floppy SE is priced at \$2900, the hard-disk model at \$3700. Both earlier Macintoshes now in the Mac family, the 512K Model E and the Macintosh Plus, will remain in the expanded line and keep their current suggested retail prices of \$1699 and \$2199, respectively.—Ron Scibilia

Typewriter Or Computer?

Cross a computer with a typewriter and you'll get a SharpWriter model ZY-1000S by Sharp. The Mahwah, New Jersey-based electronics company has cloned its ZX-420 electronic typewriter to an IBM-compatible PC to produce a \$3400 system that works either way. If the price appears steep compared to the latest econoclones, bear in mind that the typewriter portion performs double-duty as a multifunction letter-quality computer printer. As a computer, the SharpWriter is no slouch. It comes with dual 5¼-in. floppy drives, 448KB-RAM (expandable to 704KB), 80 character/25 line screen, a full complement of ports (including telecommunications ability),

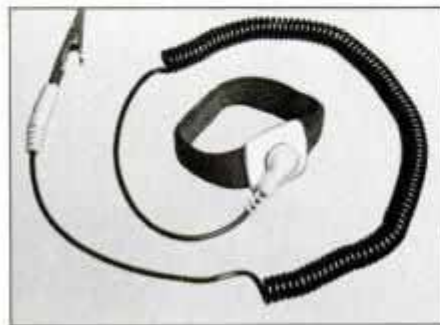

Wristex conductive bracelet sends static to ground, instead of to your computer, to avoid risk of chips getting amnesia.

and the ability to run thousands of IBM-compatible software programs.

It's a practical machine, too. At the flip of a switch, it reverts to being a typewriter—for quick jobs that don't require computer word-processing.

Antistatic Cling

Here's yet another handful of help in man's battle to protect the computer from static.

It's called Wristex and you wear it—guess where?—to conduct harmful static to ground, instead of to your computer. Unlike similar conductive bracelets, this one's flexible and comfortable, with a coiled cord that stretches to 6 ft. It costs \$14.50 and is available from Solder Absorbing Technology, Springfield, MA.



The latest satellite receivers have built-in descramblers. Experimental Zenith system packages receiver, descrambler and antenna-positioner into 27-in. stereo TV.

Blue Chips Drop Price

In previous columns, we've commented on the influx of bargain-priced IBM PC-compatible computers. The first to break the \$1000 line was the Blue Chip PC, built by Korea's Hyundai of econo-car fame.

That XT-compatible machine entered the market late last year at \$699—though monitor and accouterments brought the final ticket near to \$1000. Now, Chandler, AZ-based Blue Chip Electronics has lowered the base-price sticker to \$599—and throws in the DOS (disk operating system) free. This item formerly cost \$99.

We've worked with the Blue Chip PC, and found it a good clone for the money. The unit comes with 512 kilobytes of RAM standard, expandable to 640K. Power supply is rated at 130 watts,

sufficient to drive peripherals such as a 20- or 40-megabyte hard disk. Though the IBM-AT-style keyboard is less responsive than you might like, it's certainly adequate, and you can always upgrade. Likewise, the single 5¼-in.



Cheyenne IR/D from Chaparral integrates satellite TV receiver with descrambler.

floppy disk drive can be supplemented by a second unit. A cutout in the PC's dashboard makes this retrofit possible.

Satellite Sightings

The skies didn't exactly go dark when major TV programmers began scrambling their shows. But the practice did require you to pay for the programming—and to buy a separate, outboard descrambler to make it viewable.

Well, as we forecast in our October '86 issue (*Down To Earth*, page 138), the manufacturers of satellite receivers have begun to incorporate the descrambler into the receiver chassis. This consolidation saves you money as well as space.

The latest manufacturers to take this tack include Zenith, Chaparral and General Instrument (whose VideoCipher II system is used for scrambling in the first place). Zenith's combo is the most interesting—though it's not for sale.

The veteran TV company packages a satellite receiver, descrambler and an antenna-positioning actuator into the same chassis with one of its top-shelf 27-in. stereo TV sets.

An infrared remote controls everything, even a VCR. At this writing, we're waiting for Zenith's space commander to radio a launch date.

Two enterprising electronics companies are even selling the scrambled programming with their receiver/descrambler combo units—at a discount too, until June 30. It's Houston Tracker Systems and Echosphere, dba Discount Satellite Programming. Ask your satellite-TV dealer, or call (404) 827-2500 for more information. **PM**



Scrambler-owner General Instruments also builds descrambler into its remote-control VideoCipher II 2400R satellite TV receiver.

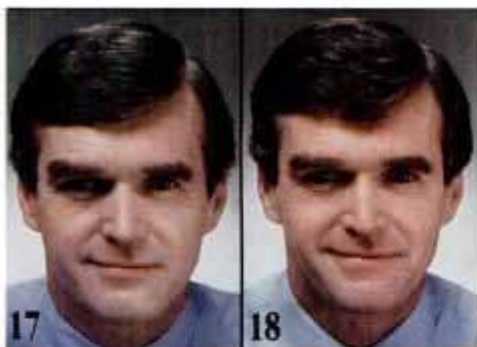

PICTURE YOURSELF

with a little less gray, a lot less, or none at all.

All over the country, there's a group of men—actually millions of them—who have a secret they don't share with anyone. Not even with each other.

Their secret? That nobody knows they're using Grecian® Formula 16® to gradually take away as much gray—or as little as they want to lose, without anybody knowing. That's their secret.

They do it with a clear liquid, as easy to use as a hair tonic. Here on this page you can see the undoctored photographs of the hair taken day-by-day as one of these Grecian users gradually took care of that older look.

Note in the photos around the page how the change each day seems like no change at all. But compare #1 (when he began) with #18. The nearly invisible day-to-day changes have eliminated the gray and created a younger looking man.

You can do it too. Not necessarily the way this Grecian user did. You may have more or less gray to start with. And you may want to end up with more—or less. You're in control. A lot of Grecian users leave a little gray on the sides.

The important thing is that you look perfectly natural all the time. The return of your own natural looking color each day over a period of weeks is so imperceptible, not even your friends can tell you're using Grecian. Unless, of course, you tell them yourself.

You'll be glad to know you won't have trouble finding Grecian. It's available wherever men's toiletries are sold. That's because millions of men quietly demand it.

Free trial offer. For a trial package send \$1.00 for postage and handling to Grecian, P.O. Box 9936, Maple Plain, MN 55348. Specify liquid or cream. Limit one per family. Offer ends 8/31/87.

GRECIAN® FORMULA 16®

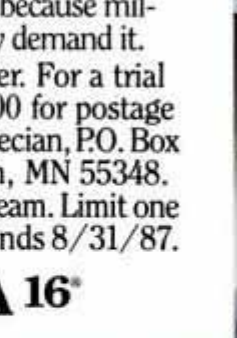
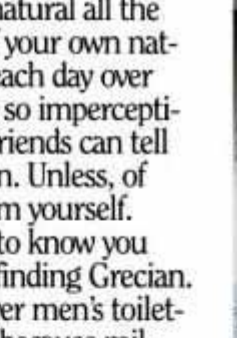
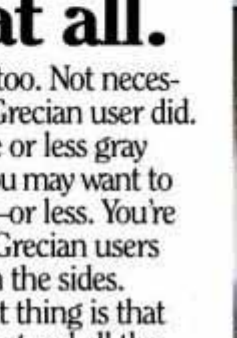
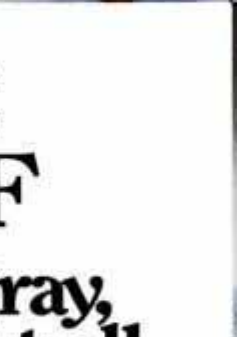
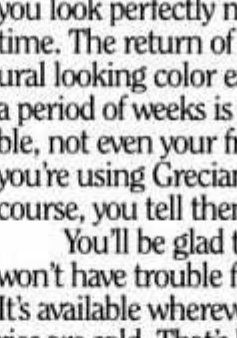
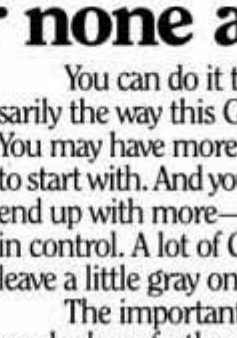
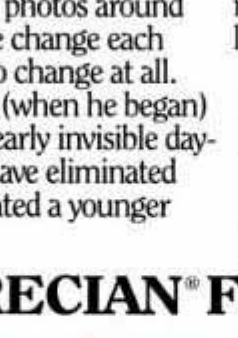
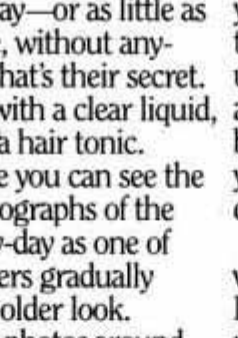
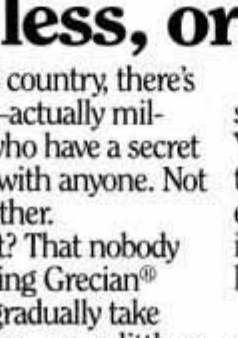
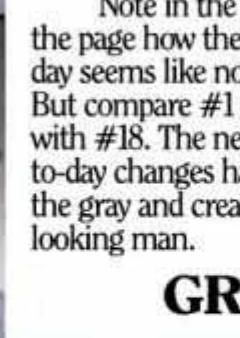
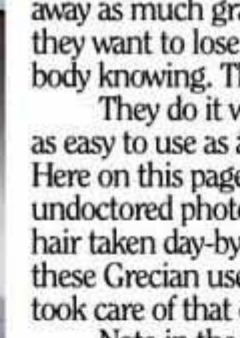
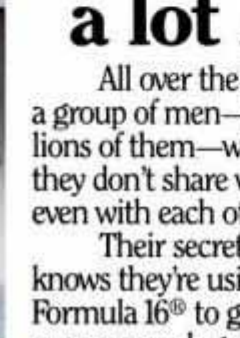

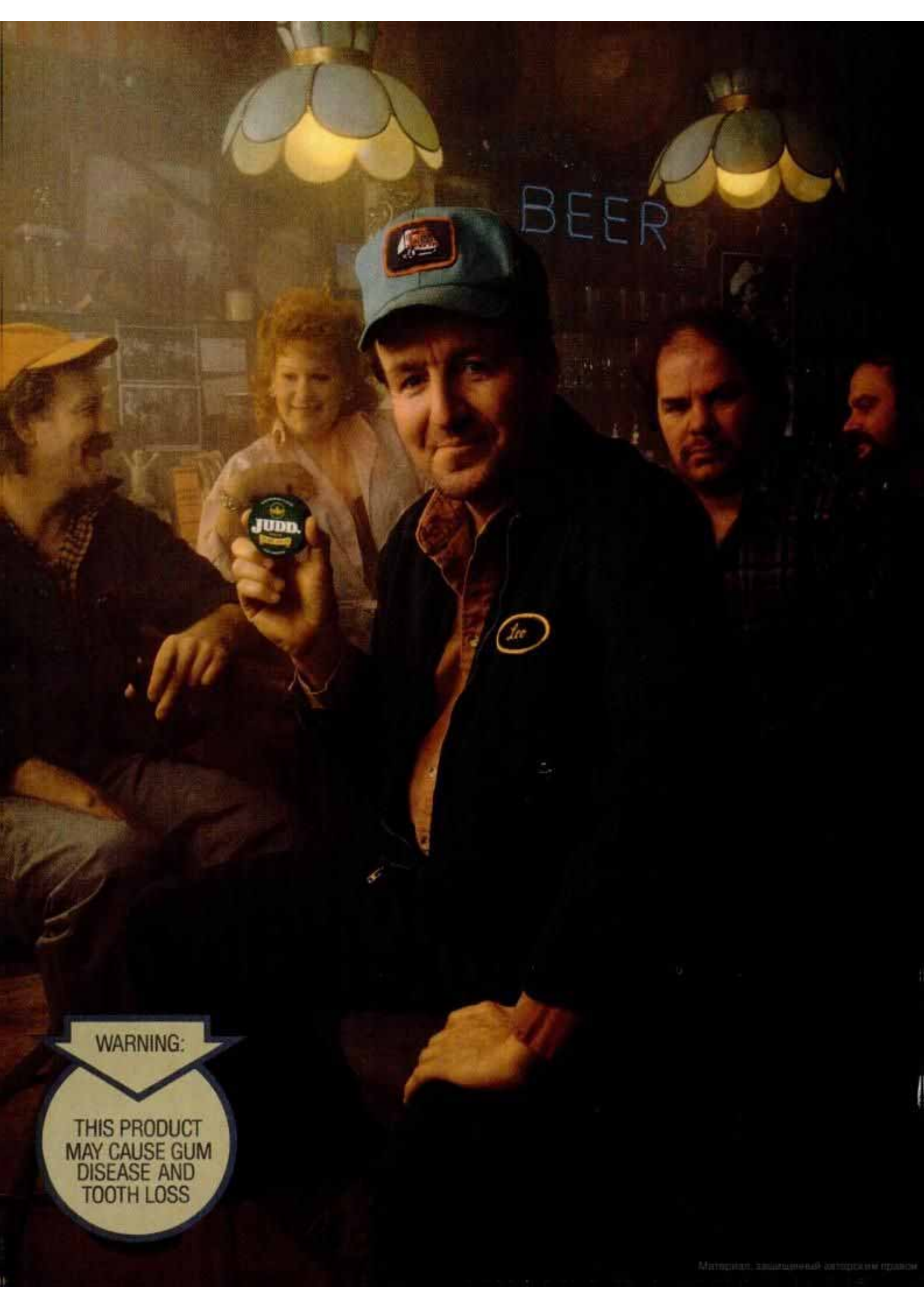

BEER

Judd's

Lee

WARNING:

THIS PRODUCT
MAY CAUSE GUM
DISEASE AND
TOOTH LOSS

Introducing Judd LightTM

You don't pour it, drink it,
gulp it, chug it, swig it or sip it.
You dip it.

New Judd Light is the first and original moist smokeless tobacco with less nicotine. But it has a taste that really satisfies.

Because it's made from our finest Dark Fired tobacco that has a rich, full-bodied flavor.

Judd Light is available in natural or winter-green flavors. And its freshness comes protected in a plastic can.

Sounds too good to be true? Wait until you've tasted it. Then you may find it even harder to believe.



If we didn't tell you, you'd never know it has less nicotine.

Buckle up — for life!



AT \$6299,* YOU'LL HAVE PLENTY OF MONEY LEFT OVER TO FILL IT UP.

At a price of only \$6299,* the Isuzu P'UP is the lowest priced import truck in America.†

But about the only place we made compromises was the price.

We certainly didn't cave in when it came to the payload. It's capable of carrying over 1,100 pounds, more than enough to handle anything from a load of bricks to a loaded motorcycle.

And when it came time to make it rugged, our standards got tougher. For more than 73 years, our trucks have conquered Mexican deserts, African jungles, Arctic

blizzards and Moroccan sand and we don't intend to let them start slipping now.

Nor did we sit back when it came to the cab. That's why its interior appointments seem to be "almost custom installed" according to the editors at *Road and Track*.‡

So while you're getting America's lowest priced import truck when you buy a P'UP, you should always keep one thing in mind. It didn't come cheap.



*Manufacturer's suggested retail price P.O.E. excluding tax, license and transportation fee. Price as of 1/1/87 and is subject to change. †Except Hawaii. ‡*Road and Track Truck Buyer's Guide*, 1987.

The First Car Builders of Japan.

ISUZU

Матрица — защищенный авторским правом.

Aviation



BY FRED MACKERODT

Aviation Heaven



Mojave Airport's Dan Sabovich and a bit of fighter history.

Like most aviation addicts, I love to visit airports. Strange airports mean airplanes I haven't seen before, and even the most mundane Cessna 152 might have something that makes it worth looking at.

I recently visited Mojave Airport, 100 miles northeast of Los Angeles, as a member of a panel of aviation industry leaders convened by **POPULAR MECHANICS** to come up with ideas for an entry-level plane of the future.

Our meetings were held at Scaled Composites, Inc.,—Burt Rutan's operation at one end of the airport. Between sessions, Rutan took us inside a hangar where his Beech Starship prototype hangs from the ceiling like a giant model airplane. It actually is a model, since it's only 85 percent of the size the production aircraft will be. Still, it goes on record as one of the world's largest com-

posite aircraft. To get to see Starship, Rutan hustled us past yellow-screened areas, apologizing all the way for not being able to let us see behind the screens and get a view into aviation's future.

Mojave Airport is a study in contrasts. Straight across from the Scaled Composites hangar at one end of the 2885-acre Mojave facility rests what is probably the largest fleet of Convair jet transports in the world.



GE's unducted fan engine goes through R&D at Mojave.

About six years ago, Allen Paulson assembled the 22 Convair 880 and 990 4-engine jets, which he planned to convert into freighters and resell to cargo operators. Unlike another one of Paulson's projects—his fabulously successful Gulfstream executive jets—buyers for the converted airlines never materialized. Now Charlotte Aerospace is trying to sell the Convairs overseas. The engines are too dirty and noisy for operation in the U.S.

As we walked down the ramp, we passed a Hawker Hunter, a Gloster Meteor and two Swedish Saab Lansen fighters. These privately owned '40s and '50s fighters are only a few of the pristine vintage aircraft on the field.

At the other end of the flight line is the future. General Electric recently completed testing one of its unducted fan engines on a Boeing 727. The 727, from its right side, looks like a giant Cuisinart. The next airplane to be tested will be the McDonnell Douglas MD-80 which is right now being fitted with a UDF engine. It should be flying this August. The company is also working on the CFM56-5 engine for Airbus Industrie.

Next to GE's hangar is the display housing Rutan's historic around-the-world Voyager. Temporarily housed here until the Smithsonian is ready to accept it, the Voyager is on view for all to see. According to Mojave Airport manager and chief booster Dan Sabovich, the Voyager has made the facility a real tourist attraction. One Sunday afternoon, 324 private aircraft landed to pay homage

at the Rutan hangar. There is no charge to see it.

In the middle of the flight line is Flight Systems, Inc. Two McDonnell Douglas F-4 Phantoms with civilian tail-numbers sit outside next to four North American F-86 Sabrejets and a pair of F-100s. Flight Systems operates a flight test, systems development and aircraft modification center at Mojave. The F-86s, F-4s and F-100s are used for specialized testing. The company is in the process of converting 209 of the pristine F-100s—first flown in 1953 and this country's first production supersonic fighter—into target drones. As they are completed by Flight Systems, the shiny F-100s are delivered to Tyndall AFB in Florida where they are flown 15 to 20 times before being ingloriously shot right out of the sky—unpiloted of course. Four General Dynamics F-106s are also on the Flight Systems line. When the Air Force finishes pop-shooting the last of the F-100s, the company hopes to convert 200 of the F-106s—first flown in 1956—into more fodder for the service's aerial turkey shoot. It's enough to make a grown man cry.

If you're anywhere near Los Angeles, take time out to visit Mojave Airport. The Voyager is worth the price of the trip, and the rest is aviation gravy.

Best Book

When it comes to understanding the current crop of Continental and Lycoming aircraft engines, the absolute best book to read is the *Aircraft Engine Operating Guide*. This 200-page book by Kas Thomas, editor of the newsletter *Light Plane Maintenance*, is the most thorough, informative and readable tome ever written on aircraft powerplants. Would you believe a whole chapter on mixture management? The book is available for \$19.95 postpaid directly from Belvoir Publications, 1111 East Putnam Ave., Riverside, CT 06878.

(Please turn to page 40)

Aviation's Twin Meccas

We just flew in from the annual week-long Sun 'n' Fun extravaganza put on by the Experimental Aircraft Assn. in Lakeland, Florida. Held in mid-March this year, and scheduled for mid-April next year, highlights of the show included a slew of fine antique restorations, a number of which had just been completed, and a very strong Warbird contingent, led off by a rare Hawker Hurricane down from Canada. Allison turbine-powered airplanes in attendance included a Bonanza, a 206 Cessna on floats, and a brand-new Maule.

Sun 'n' Fun was a great show, but it pales in comparison with Oshkosh. In fact, everything pales in comparison with EAA's really big bash in Oshkosh, Wisconsin. The granddaddy of aircraft events is going to be held over eight days this year, from July 31 to Aug. 7, and the size of the event is best expressed by last year's statistics.

Start with 800,000 people, 15,000 private planes and 1741 showplanes. There were 252 vintage warbirds ranging from P-51s to B-17s. And every variety of homebuilt and ultralight.

Add to this the best aerobatic airplanes and pilots in the world. What you have is the biggest collection of aircraft ever assembled.

And there's lots of activity in the air, too. The FAA recorded 64,000 operations during show week last year, more than 12,000 of which occurred in one 18-hour period. That made Wittman Field four times busier than Chicago's O'Hare, which is reputed to be the world's busiest airport.

Despite the crush, the FAA people and the dedicated throng of EAA volunteers manage to get everybody in safely with little or no hassle.

Each afternoon there's a spectacular world-class air show, but John Burton, head of EAA's public relations department, is quick to point out that Oshkosh is more than just an air show.

The gates open at 8 every morning and the activity begins at 8:45 a.m. when the total of 500 separate forums covering every aspect of flying begin. Topics for the week-long sessions include sheetmetal working, fabric handling, woodworking, composite construction and just plain airplane building. The forums run well into the night. And then there's the fantastic EAA museum, which is on the field and takes the good part of a day to fully appreciate.

A friend of ours has flown to Oshkosh every year for the past four years. As many others do, he camps next to his plane—Seneca N4327N—and spends every waking hour at Wittman Field. He expresses one concern about Oshkosh.

"I never get to see everything," he says. "There just isn't enough time."

For more information on Oshkosh, contact the EAA at (414) 426-4800 or write Oshkosh '87, Wittman Field, Oshkosh, WI 54903-3086.

New Tricks For An Old Friend

When we originally plopped the Apollo 612 loran in the panel of our old Cessna 182 back in 1984, we thought we had died and gone to heaven. Here was a little black box that, with a little practice, could be made to tell almost exactly where we were, in what direction we should head to get to our destination, how many miles distant it was, and how fast we were getting there, among other neat tidbits of information.

Now the 182 is history, but that loran is in the panel of Aztec 87A, and with a number of software updates, is doing a lot of other things.

Readers of this column will know that it's been coupled with a Shadin Digi-Flo fuel-metering device that monitors fuel burn down to a fraction of a gallon, and, with the ground speed information it gets from the loran, tells us not only how much fuel it will take to get to our destination, but how much we'll have left when we arrive.

The manufacturer of the 612, II Morrow, had the unit certified for enroute IFR last summer and we just recently had it wired and approved by the avionics experts at Braden Piper in Easton, Pennsylvania, to fly in the air-traffic control system. Now we can legally file an instrument flight plan "Pittsburgh direct Miami" if the controllers are creative enough to approve that routing. And coupled with the Aztec's autopilot, the 612 holds rock-solid headings. Anyone who has watched an autopilot try to track a VOR signal, especially close in to the station, will appreciate this little feature. But no sooner are we getting used to the 612 in the IFR enroute environment, than we find out that II

Morrow is working on loran C approaches. The company has now begun collecting data for utilizing the 612 for non-precision approaches in what the FAA calls a "limited implementation program." The ultimate objective of this program is to develop stand-alone loran C approaches to airports which now are limited to VFR operations only. This eventually will keep a lot of fields open when the ceilings go down.

Fifty airplanes will participate in the program using the few airports in this country which now have published loran approaches. We are proud to say that POPULAR MECHANICS has been chosen to participate in the program and that Aztec 87A will soon be getting the experimental software to do the job.

Now, if we can only get a loran approach at our home drome in Caldwell, New Jersey . . .

Nostalgia Now Costs Less

With the P51 Mustang now approaching \$500,000 a copy, there has to be room on the market for something a little cheaper. How about \$5000?

For the price of one wingtip of the original, a 3/4-scale Mustang is now being sold by Loehle Aviation. Dubbed the "5151," for its \$5151 kit price, the Mustang replica has just finished its first 100 hours of testing, and, according to manufacturer and chief test pilot Mike Loehle, the little fighter performed "even better than expected." Admittedly conceived to appeal to the Walter Mitty in all of us, the plane is powered by a 50-hp. Rotax 503 which provides very adequate performance considering the plane's 400-pound weight.

Several options are available including retractable gear and a 10- or 15-gallon fuel capacity to replace the stock 5-gallon tank. Brakes, electric start and a 4-bladed propeller are also available.

Prospective Smilin' Jacks should call Mike Loehle or Sandy Burgess in Wartrace, Tennessee, at 615-857-3419. **PM**



The "5151" repliplane, a 3/4-scale Mustang replica, passes its first 100-hour test.

Because You Know What it Takes...

You don't have to race to know what real performance takes. Or to drive some of the most race proven street tires on the road today. Firestone Firehawk performance radials. Street tires we've raced at America's toughest tracks, pushing them to the limit to prove and improve their performance in our own Firestone Firehawk Endurance Championship series. The same ones you can buy now at your Firestone retailer. Our V-speed rated Firehawk SV.** Our H-speed rated Firehawk GT.** Proven in endurance racing like no other street tires made. Because, like you, we're driven to win.

FIRESTONE FIREHAWK PERFORMANCE RADIALS

Driven to Win.

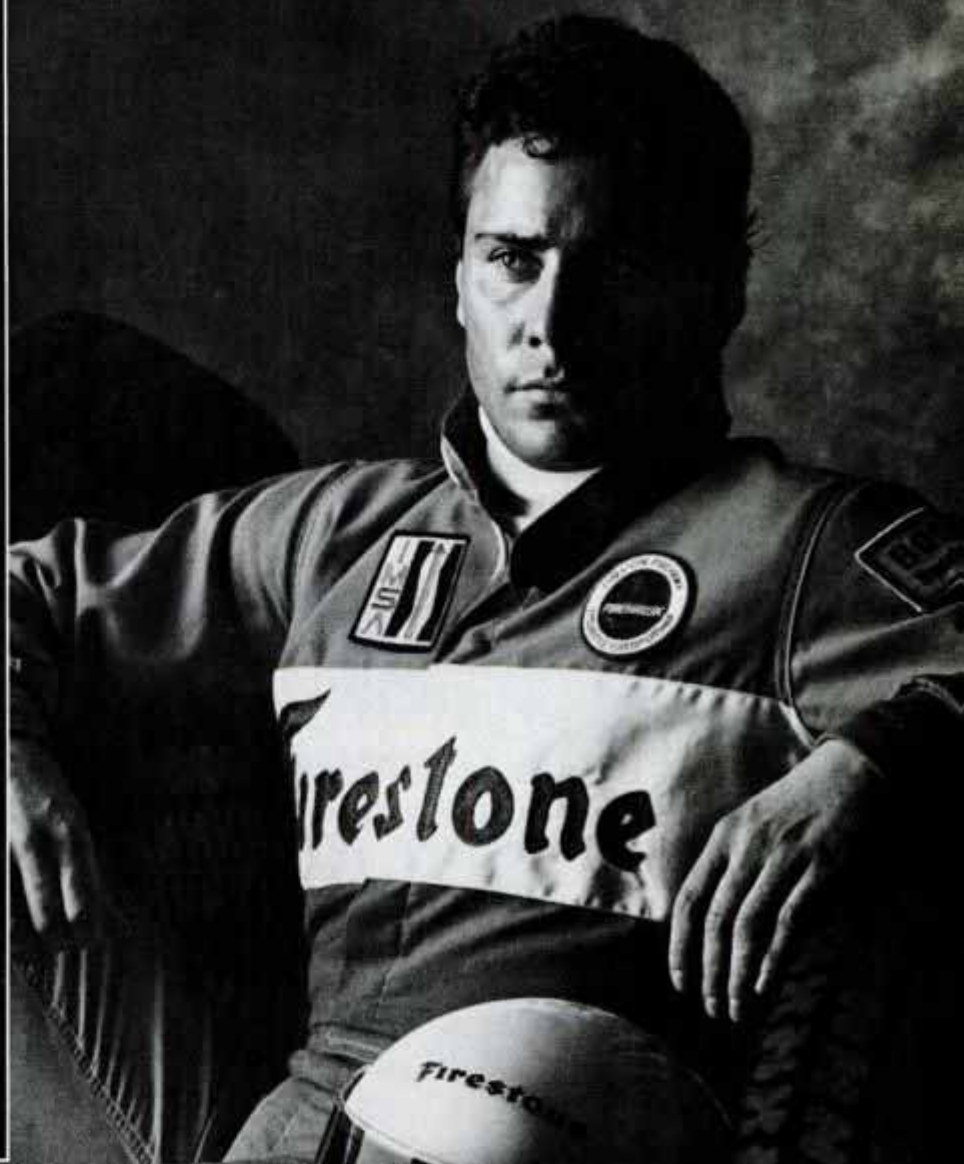

FIREHAWK GT

*In competition, Firehawk performance radials are modified by shaving their treads to racing depth. See your Firestone retailer for written speed rating and tire safety information.

Материал защищен авторским правом

Inside Detroit



BY JIM DUNNE

'89 Cougar Captured



The 1989 Mercury Cougar will retain its V8 engine and rear-drive, with a more conventional formal roofline.

Longer wheelbase, a lower hood, but with the distinctive, upright rear window are key styling cues of the 1989 Mercury personal coupe. That swoopy rear-side window treatment that has graced the most recent Cougars is gone, with a more formal look taking its place.

Ford is sticking with rear-wheel drive and V8 engines in this car, defying the competition's—GM, Chrysler, imports—Fours and Sixes with turbochargers. The squeezed-down grille still has a distinctive Cougar look with a rectangular opening in the center, vertical bars and the Cougar crest prominent. Independent rear suspension, with the possibility of a supercharger on a V6, are among major mechanical plans.

Eldorado '88

Most folks, me included, can't understand why it takes so long to make minor changes in a car. The '88 Eldorado is a



case in point. Almost from the time it was introduced in 1986. Cadillac officials knew the current Eldo's styling was a dud. Among other things, the car was afflicted with GM's epidemic "look-alike" disease—too many high-priced GM models look like other GM offerings that sell for \$10,000 to \$15,000 less.

The Eldo also went against the grain of customers who purchase their cars "by the foot." Bigger is better for a lot of high-ticket customers, and if you were measuring Eldorado in a Sears catalog, the car wouldn't even rate a "Good." GM's remedy: make the car 4 in. longer by extending the rear fenders, elongating the taillights and pulling out the bumper to protect it all. That minor change will have taken two years to get into produc-

tion. You'll see the results next fall when the 1988 Eldo hits the showrooms. Small as the changes seem on paper, the new 1988 does appear much larger.

Cool Out

A new technique for cooling your engine may lead to smaller radiators and more efficient engines. Corvettes modified by Calloway have a new coolant that boils at a higher temperature than normal coolants—370°F versus 230°F—allowing engines to run at higher temperatures. Developed by National Technologies, the system can run at 300°F with no after-boil, works in a nonpressurized system and can increase heavy-load fuel economy by 5 to 7 percent because the spark setting need not be retarded to offset preignition detonation. The coolant is anhydrous propylene glycol.

"We were looking for ways to increase horsepower," recalls Jack Evans of National Technologies. "We found that propylene glycol vaporizes at hot spots just like all coolants, but the vapor collapses quickly, so fresh coolant can get next to the hot spot. With normal coolants, the vapor pushes liquid away, keeps it away from the metal. That's when the engine overheats."

The higher cost of the new coolant may be offset by the smaller quantity of coolant needed for the system and the smaller cooling radiator it uses. Insiders look for regular production Corvettes to have the system within two years.

Mazda's Mustang

Yes, a 1989 Mustang will be built by Mazda. At the same time, another 1989 Mustang

will be built by Ford. The Mazda "Mustang III" version will be a 3-door hatchback that uses the Mazda 626 chassis as its platform. That means front-wheel drive and 4-cylinder engines for power.

The outside appearance is described by insiders as "very slippery," with glass that covers the roof pillars "from A-post to A-post—all around." Other details include unique exterior door handles made of fiberglass and pop-up headlights. This car will be built at Mazda's new assembly plant in Flat Rock, Michigan.

Just a few miles away, Ford will continue to build an updated version of the current Mustang GT. With modest exterior changes, the Ford Mustang will continue with V8 engine power and rear-wheel drive.

Not A Fire Sale

AMC is a valuable property, a prize acquisition for any company, and a real coup for Chrysler if its offer to buy passes the usual obstacles. The Jeep line is the most precious jewel in AMC's crown, but a new assembly plant in Canada and the Medallion and Premier sedans are solid assets that Chrysler can profit from.

"Our dealers today can't get enough Jeeps," says Joe Cappy, AMC president. "They are selling that well." But Cappy is not resting on his successes. A replacement for the Cherokee is already being prepared for 1989. Code-named ZJ, the new Jeep will have more modern styling, and more powerful engines than the present model.

BMW: No Fwd

You won't see front-wheel drive on any BMW in the next 10 years, if ever. The compli-

(Please turn to page 45)

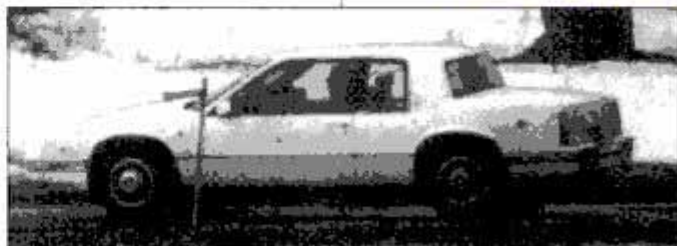

Minor stretch marks '88 Eldorado's attempt at big-car cachet.

YOU'VE SEEN "BUG-AWAY"™ ON TV FOR \$29.95

HOW CAN WE SELL
THE SAME PRODUCT
FOR JUST... \$9.87?

COMPLETE WITH AC ADAPTOR
& FREQUENCY CONTROL

Unbelievable, but true!

As part of an enormous publicity campaign to prove that our collective buying method can guarantee you the lowest possible price in the nation, this gigantic marketing firm, will give away one million (1,000,000) of its most expensive Ultrasonic Soundwave Control Devices — the TemPest EL130 — for the unbelievable publicity price of only \$9.87 each only to those who write to the company address (below) before Midnight, June 30, 1987.

*"EVEN HOME SHOPPING on
TV is still double the price!"*

These Ultrasonic Soundwave Control Devices are not copies. These are the famous TemPest EL130 Ultrasonic devices that have been publicized in some of this country's most prestigious magazines and newspapers. They are identical to those that you have seen nationally advertised on television under various brand names and selling for many times the price. Even Home Shopping, which is known to have the absolute lowest prices available, is still double the price of ours. Other similar devices that have the EXACT same function and utility have sold in this country's most prestigious catalogs for up to ten times the price!

The TemPest EL130 is the latest in Ultrasonic Soundwave technology. These electronic units put out an incredible 130 decibels of ultrasonic sound pressure — using the UL listed AC adaptor (included) that means NO EXPENSIVE BATTERIES TO BUY! Don't worry — these high intensity sound waves are out of the range of hearing of humans and most household pets such as dogs, cats, fish, birds, and farm animals. These remarkable units have been proven to cause absolutely no interference to televisions, radios, pacemakers, hearing aids or other electronic equipment. We cannot go into further details here,



but we can tell you that this product does EXACTLY what the others do! And it costs you less than half the price of our closest competitor.

Yes, it's true. Nobody can beat the incredible buying power of large volume buying. As the old saying goes "cheaper by the dozen." Throughout history it's been a widely known fact — the more quantity you buy, the cheaper the price. Just imagine the buying power we have when we tell the factory we want to buy ONE MILLION UNITS. It's truly incredible and everybody benefits. The factory is happy to get all that business, we get the lowest possible price, and you get the savings passed on to you. All thanks to this nationwide collective buying effort and individuals like yourself.

*"Just imagine our buying power
when we purchase...1 million...
and pass the savings on to you!"*

Each unit is covered by the company's standard money-back guarantee and has a full 2 year consumer warranty. There is a limit of two units per address at this price, but if your order is mailed early enough (before June 25) you may request up to five. These Famous TemPest EL130 Ultrasonic Devices will not be sold at this price by the company in any store.

To join in this collective buying effort, simply mail your name and address and \$9.87 for each unit you are requesting. Add just \$3 FIRST PRIORITY shipping and handling no matter how many units you are requesting. Allow up to 60 days for shipment. Sorry, not available in Colorado. Mail to:

**The Smart Shoppers Club, Dept. 6157A,
937 Rt. 23, Pompton Plains, NJ 07444.**



**INEXPENSIVE HOME SECURITY SYSTEM PROTECTS
YOU AGAINST UNINVITED GUESTS.**

Let's call burglars, second-story-men, and sneak thieves by their right name: ghouls. Who but such foul things would invade the sanctity of your home, often under the cloak of darkness, when you're asleep, vulnerable, defenseless?

That's why we made the Schlage Keepsafer™ security system positively ghoul-proof.

Equipped with virtually every feature found in the most sophisticated systems, the Keepsafer can be operated at the touch of a button, and offers an optional emergency dialer which automatically alerts authorities the instant your home is entered by any one or any *thing*.

In fact, the only sophisticated feature you won't find in our system is a monstrous price.

What's more, the Keepsafer is wireless. By the mere turn of a screwdriver you can do the job yourself, protecting your budget against an even bigger bite.

Rest assured, with the Schlage Keepsafer, your money and your life are safeguarded, because ghouls won't rush in where wise men fear to tread.

 **SCHLAGE**

Keepsafer Security System. It won't cost you an arm and a neck.

Available at home centers, hardware stores, locksmiths and finer electronics stores. For a dealer near you, call 1-800-331-6060 ext. 134.



INSIDE DETROIT

(Continued from page 42)

cated power system is not as much fun to operate as rear-wheel drive.

"Driving experience enhancement is not made by front-wheel drive," says Gunter Kramer, chairman of BMW of North America.

That same measurement will be made on active suspensions, when BMW has enough test experience in that field. If the car is less fun to drive, active suspensions will not be offered.

Evidently, Mercedes is in full agreement with BMW on front-drive since that company does not offer front-drive on any of its cars. However, it is a good bet that both of Germany's premier luxury car-makers will have active suspensions on some models by 1990.

BMW 2-Seater

The Z1, a 2-seat convertible coupe, will be offered by BMW "sometime after 1988," according to Gunter Kramer, BMW of North America chairman. The small convertible will use the 3-series platform and its 6-cylinder engine and transmissions. The price should be at the \$30,000-plus level, according to company officials. But production will be limited to a few thousand per year, making it a high-demand item in BMW's U.S. showrooms.

Call It Anything

But don't call it Saturn. That's the attitude at GM nowadays when its completely new car project is mentioned. Saturn Corp. was set up to develop a car that would compete against the imports, but the program, of late, is having problems sorting out its own personality. Its \$5-billion investment in a new assembly plant has been pared back to about half that amount. And the idea of a subcompact-size car has given way to a car "targeted right at the heart of the imports," wherever that means.

Latest shift in the program is the announcement that the Saturn name itself could be changed. Surveys conducted by GM show that Saturn is not an exciting moniker with car buyers. Some folks even think that there is something satanic about the name. Others connect it with the ill-fated Space Shuttle.

Plastic Blob

More than 10 million cars and trucks are junked each year. That poses a problem for salvage people that could be compounded in the near future. Most of the metals from junked cars can be recycled fairly easily. But with the growing use of plastic body parts, the process becomes more complicated. You can't just crush plastic and use it again. So, for the time being, plastic is primarily dumped into landfills or burned. But, at the rate that new cars are using plastic, we'll soon run

out of landfills. GE, a major supplier of plastic to the auto industry, has one solution. It is offering a line of body plastics that can be recycled. Just grind down the body panel, and the granules can be used again to make a different kind of plastic part. GE suggests one procedure: Recycle plastic bottles that were made for soft drinks; make car body parts from the recycled plastic; then recycle the body parts to make rough plastic containers like bins or boxes.

Mix And Match

Plastic suppliers like GE think that within a few years you'll be able to put your

choice of body style together right in the new car dealer's service stall. The idea is to ship partially finished cars to the dealer—say the rear part of the body or the roof panels are missing.

When a customer wants a hatchback body style, for example, the dealer adds a hatch to the rear of the car instead of a trunk. You want a sunroof? The dealer selects that kind of roof and installs it in place of a solid panel.

Bolt-on plastic panels are the key to this type of system. But first, drastic changes in the shape of cars will have to be made. Look at the Pulsar NX as the forerunner of this trend. **PM**

For Big Cleaning Jobs... Shop-Vac Power.

The Shop-Vac® wet/dry vac is built to tackle your toughest cleaning problems: basement leakage, workshop sawdust, standing water in clogged sinks, family room spills, garage dirt, car interiors, patio debris and carpets. Cleaning chores are a breeze with the Shop-Vac® wet/dry vac because it's powerful enough to handle cleaning jobs that could choke an ordinary vacuum cleaner. Count on the heavy-duty Shop-Vac® pick-up power ... when a regular vacuum cleaner just isn't enough.

shop·vac®

Picks up where the others leave off.

Shop-Vac® is a registered trademark of Shop-Vac Corporation, Williamsport, PA. Available only in stores in the U.S.A. 600-01

America's Favorite Store

mart

N I S S A N H A R D B O D Y

BIGGEST. WIDEST. STRONGEST.

AND FIRST! Here's the first truck ever to win the prestigious Industrial Design Excellence Award (IDEA). It's loaded with power. Loaded with performance. And all at our lowest sticker-price.

BIGGEST CARGO SPACE. Pack it up! With the most cargo volume of all leading compact trucks, it'll take all you can dish out. Double-wall bed construction means twin layers of steel insulate the sleek outside from whatever you throw inside. And there's more between-wheel-well space than any other pickup in its class. A full 3.4 feet for those wide loads.

WIDEST CAB. Size it up. Sit three across with the most hip room of all leading standard compact trucks. Nissan's roomiest cab ever was



designed around you. The enormous windshield and side glass give you a commanding view. And there's more leg, shoulder, and head room than you ever thought possible.

STRONGEST ENGINE. Turn it on, it's made to perform. A 2.4-liter, fuel-injected engine sees to that. Twin-spark plugs and a hemi-head help crank out the most horsepower and torque of all the leading standard compact trucks. The 5-speed is standard.

Independent front suspension, steel-belted radials, and rear leaf springs combine to provide a smooth, easy ride without sacrificing payload. The rear brake's proportioning valve automatically adjusts to payload for improved braking under load. The Hardbody 4X2. Works tough. Plays rough. See your Nissan Dealer today.

FOR TOUGHNESS AND VALUE
THE NAME IS NISSAN



 **NISSAN**

©1988 Nissan North America, Inc. All rights reserved.

Freewheeling

BY WADE HOYT



Power To The Fore!



Who says you can't put 250 hp through the front wheels?

There's been a lot of worry lately that, as GM converts nearly all of its cars to front-drive, some of its best engines may be thrown out with the bath water. Front-drive chassis have a lot of trouble handling more than about 180 hp. Some can't even cope with 145.

One of the main problems is torque steer. As power is applied, the drive axles wind up, or twist. If one axle is longer than the other (which is usually the case with the off-center differentials used on transverse engines) one axle winds up more than the other. Then, one wheel turns more than the other and the car steers when you don't want it to. The more power, the more twist. There are some fwd turbo models

that head for the weeds whenever you stand on the gas in low gear (where torque and windup are greatest).

One of GM's most powerful motors is Buick's 245-hp, 3.8-liter turbo V6. And next year, the last of Buick's rear-drive chassis goes away when the Regal switches to front-drive.

Larry Baker, manager of Buick's Vehicle Activity Dept., wanted to do a front-drive feasibility study, so he and his crew took a stock Riviera, pulled the engine and bolted on all the hot-rod parts from the turbo Grand National engine. The result was the awesome Riv you see here. With turbo boost adjustable from 10 to 15 psi, Baker's team could run up to about 250 hp through the front wheels. Equipped with V-rated Eagle GT tires and no fuel cutoff in the computer chip, this Riv's good for 144 mph with off-the-shelf Buick parts!

Here's how it did on the test track at various boost pressures:

BOOST	0-60 MPH	¼ MILE
10 psi	10.5 sec.	18.0 sec.
12 psi	8.1 sec.	16.5 sec.
15 psi	5.8 sec.	14.4 sec.

That's Ferrari/Porsche performance from a Riviera!

I've driven the car on the road course at Lime Rock, Connecticut. With all that power and flaccid Riv steering, it's a handful. But there's little torque steer, thanks to modifications in the drive-axle and front suspension geometry.

Because the car has no mufflers or catalysts, and a straight 2¾-in. exhaust pipe that looks like it was borrowed from a school bus, it isn't exactly street legal. But it's not objectionably noisy, either. The turbo takes a lot of the starch out of the exhaust below. If you hung on a catalytic converter, you might not even need a muffler.

Baker's crew is adding an experimental speed-sensitive variable-ratio power steering system to overcome its current lack of road feel. When that's in, the turbo Riv should go a long way toward convincing skeptics that you can too put more than 200 hp through the front wheels.

Peugeot Slighted

In our December '86 *Wonder Wagons* comparison test (page 58), we miscalculated the cargo volume of the Peugeot 505 Turbo wagon, listing it in third place behind the Audi 5000S and Chevy Celebrity Eurosport, and only marginally bigger than the Volvo 740 Turbo wagon.

A number of Peugeot fans called to say that couldn't possibly be right, and we vowed to remeasure the Peugeot.

This month the tape says 69.8 cu. ft. of cargo space, putting the huge Peugeot more than 9 cu. ft. ahead of its nearest competitor, and bringing it even closer to the first-

place Volvo in the overall Wonder Wagon ratings.

Dubious Premiere

Just as photos of the new AMC-Renault Premier crossed our desks, news came in of Chrysler's offer to buy out Renault's 46-percent share of debt-ridden American Motors. Chrysler then wants to buy up the rest of AMC. Where does that leave the Premier? Unchanged (for now) say PR people from all three firms. The plan is to build 90,000 of the 6-passenger Premiers per year in AMC's most modern automated plant in Bramalea, Ontario.

The proposed takeover deal contains a guarantee that Chrysler will buy 300,000 compact Renault Medallions from France over the next five years. There's also a clause about buying V6 engines and 4wd components for the Medallion, which should be some car! If Chrysler can't sell 300,000 Medallions, they have to pay a penalty of \$1300 a car. Having just driven a 2.2-liter 4-cylinder Medallion LX, I think Chrysler could learn a lot about making smooth, powerful Fours from Renault.

The fate of the oft-delayed Renault Alpine sports car is less clear. The Alpine is a high-priced 2-seater that will compete with the upcoming Chrysler-Maserati 2-seater.

What Chrysler really gets out of this deal is access to AMC's four under-utilized North American factories, plus the profitable Jeep Division as a bonus.

Renault, the government-owned French firm, has never had any long-lasting success in the U.S. AMC hasn't done well since they tried to move upmarket from the Rambler in 1962. Maybe Lee Iacocca can pull another one out of his magic hat. **FM**



GN turbo parts fit neatly onto Riv engine.



Upsize, upmarket AMC/Renault Premier will be built in Canada.

Tool Tests



Quick-Draw Drill

Black & Decker recently introduced a compact, cordless drill/screwdriver that's designed to handle light-duty jobs around the home and shop. The easy-to-use drill/driver (model No. 9021) has several unique features including a keyless chuck, holster with belt clip,

and an ON/OFF rocker switch that allows you to quickly change bit rotation from forward to reverse. Also, the tool's ratchet lock has two functions. First, it will open and close the 1/2-in. capacity chuck. Second, with the lock engaged, it can be used like a standard screwdriver on

Cordless drill/screwdriver has a compact, user-friendly design. It comes with five bits, clip-on holster and a plug-in charging stand.

stubborn screws. The tool operates at 300 rpm—a speed selected to handle both drilling and screwdriving. Don't exceed the drill's bit capacity of 1/4 in. I tried boring in wood with reduced-shank bits and found the task somewhat labored.

The drill/driver comes with

a wall-mountable charging stand, holster, a Phillips bit and a standard screwdriver bit, and three drill bits. Recharge time, from dead to full power, is 3 hours. It costs about \$55. Contact Black & Decker, 325 E. Oliver St., Baltimore, MD 21202.

—Rosario Capotosto



The easy-to-operate keyless chuck accepts bits up to 1/4 in. dia. Engage the ratchet lock to tighten or loosen the chuck.



Change bit rotation with rocker switch. Squeeze lower half of switch for forward rotation; press upper half for reverse.



Ratchet-lock settings: L to loosen chuck and stubborn screws; RUN to drill and drive screws; T to tighten chuck and screws.



Set the ratchet lock to the L position and use the tool like a standard screwdriver to loosen stubborn, rusted screws manually.

Portable Surface Planer

Most surface planers are too big and too expensive for a typical home workshop. The Ryobi 10-in. planer (model AP-10) is the exception.

The compact AP-10 weighs only 58 pounds and stores on a shelf or can be

placed under your workbench. The surface planer's suggested retail price is \$699, though it's often discounted at hardware stores and through mail-order tool companies for a price as low as \$400.

The planer will handle stock up to 5 in. thick x 10 in. wide. Maximum depth of cut per pass is 1/8 in. Chain-driven feed rollers maintain a rather quick planing rate of 26 ft. per minute.

I tested the planer on a variety of wood species from very soft to very hard. The planed

surfaces were as smooth as finish-sanded stock and there were no visible knife scallops—a problem common to many planers.

The AP-10 is powered by a 13-amp motor that develops 2 hp. A 2-blade, belt-driven cutterhead operates at 8000 rpm to produce 16,000 cuts

per minute.

It comes with two support rollers, wood-mounting blocks, blade-setting gauge and adjustment tools. For more information and retail sources, contact Ryobi America, 1158 Tower Lane, Bensenville, IL 60106.

—Rosario Capotosto



Compact planer handles stock up to 5 in. thick x 10 in. wide. The unit comes with two support rollers and wood-mounting blocks.



Maple was no challenge for 2-blade, 8000-rpm cutterhead powered by a 13-amp motor.



Portable planer weighs only 58 pounds. The infeed and outfeed rollers collapse for easy storage.

THE TASK MASTER.

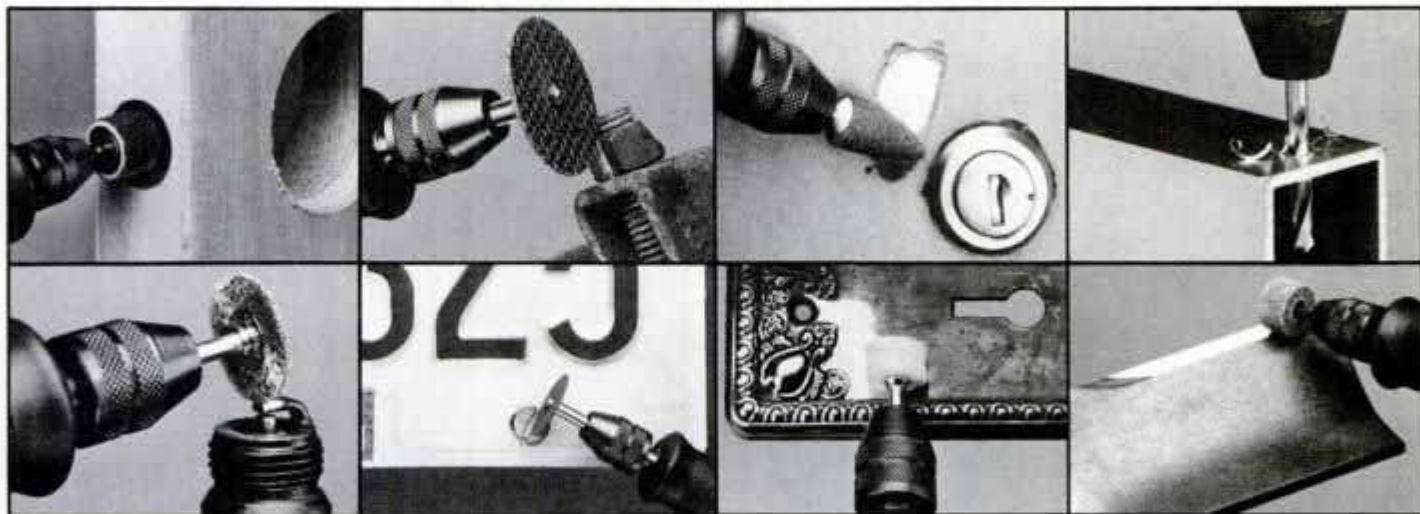

Better known as the Dremel Moto-Tool®. A tool that tackles dozens of different do-it-yourself projects quickly and easily.

The Moto-Tool is a compact, handful of power that accepts a wide variety of bits to perform a wide variety of tasks. From the front door to the back yard. And everywhere in between.

For starters, you can fit a lockset in no time flat with the sanding drum. The Moto-Tool makes sawdust fly in places where other tools barely have room to scratch the surface.

If the surface is metal, the Moto-Tool is perfect for the job. Like sharpening your lawn mower blades quickly and easily. Right in the back yard without having to remove any parts. Simply drop in the grinding stone and let the Moto-Tool's 30,000 RPM do all the work.

That's the kind of powerful speed you need in the garage to remove rusty screws from a license plate. And the kind of compactness it takes to do the job in a hard-to-reach place. Just slip in the cut-off wheel to reslot the screws. Or use the same bit to cut them off in seconds. The Moto-Tool does whatever it takes.

That goes for working under the hood, too. Use the wire brush to clean corroded spark plugs and dirty metal parts. The Moto-Tool turns this task into a quick clean-up.

It masters do-it-yourself projects all over the house with just the change of a bit. The same tool you used today to cut copper tubing, you can use tomorrow to safely polish antique brass. Now that's versatility.

The Dremel Moto-Tool. Put it to the task for all the tasks you want to put behind you.

THE DREMEL MOTO-TOOL®



DREMEL®
Gets the job done bit by bit.

Call 1-800-852-0852 for more information on Dremel products.

© 1987 Dremel



BY DENNIS ESKOW

Waking In A New Light



In the NASA wind tunnel, lasers give accurate readings on design.

As the Army moves closer to the development of a 21st century Light Helicopter (LHX), basic physics problems are emerging. The new choppers are expected to move at speeds rivaling fixed-wing aircraft, and they will make turns as sharply as those made by a fighter plane. The most interesting problems surround the combined motions of wind, air moving around the chopper in motion, and vortices created in the wash of the rotor. At NASA's Langley Research Center in Virginia, scientists have begun using lasers to measure air motion in a wind tunnel. Combining highly accurate laser light with high-speed photography allows the scientists to measure the effect of different moving masses of air in a much more accurate way than the traditional wind tunnel smoke test. In the traditional test, smoke is placed in the wind tunnel and the way it moves over the model under study provides data for aerodynamic design. The new method is expected to yield far more advanced results.

Shades Of Science

Sunglasses look cool, and they can protect the eyes from intense glare. But we often over-use sunglasses. California State researcher Bill Puett, who has been working with athletes in his Dominguez Hills lab, says too much use of sunglasses is a bad thing.

"What sunglasses will do with prolonged use is weaken

the retina or its ability to utilize light," he explains. "What happens then is that a person's contrast vision will be poorer." Contrast vision describes the biological equivalent of contrast on a TV screen.

Puett recommends using sunglasses only in prolonged high glare, such as cross-country skiing or walking along a beach. Even if your ophthal-

mologist gives you a prescription for sunglasses, Puett suggests using them conservatively.

As for weaning yourself from sunglasses, Puett suggests closing your eyes tightly and facing the sun for about 10 minutes. If you shed tears, put the glasses back on and try the weaning again periodically.

Chemotherapy At Home

We're learning more every day about dealing with cancer, and the latest news shows a new step forward. Lung cancer patients will soon be able to do chemotherapy on their own with a doctor's prescription. That's thanks to VePesid, an oral form of etoposide, a cancer-cell combating agent often prescribed for lung cancer patients. Recently approved by the Federal Food and Drug Administration, VePesid will be available later this year. Patients whose cancer is under control and who have been taking etoposide by injection will now be able to skip visits to the hospital and take it at home orally. It should help many with a shot at recovery to reach their goal faster.

Old Salt

I'm doing a slow burn about an Old Wive's Tale I recently and reluctantly relinquished. I had always thought that our ancestors pickled and spiced their food to keep it from going bad. But a series of papers published in the past five years torpedoed that story. The more recent theory is that pickling and spicing served merely to cover up the odor of biodegradable food that was in the midst of biodegrading.

The U.S. Department of Agriculture's Robert L. Buchanan jolted me a few days ago with a report that makes me have to reconsider pickling all over again. Just when I was beginning to lash out against the old-liners, Buchanan reported that salt in large quantities is toxic to bacteria. The bacteria don't get killed off by the salt, mind you. They merely get so tired from pumping salt out of their systems that they burn most of their energy and don't leave

much in the way of waste products. Bacterial waste products are what make meat go bad or milk go sour. Not only that, but the bacteria are reportedly so busy pumping out salt that they have no time to eat, which keeps the waste products even at a lower level and makes the bacteria even more tired.

Buchanan and his colleagues at USDA are evaluating the impact of lowering sodium content in food. The government aims to see less sodium in food as a means of preventing heart diseases. But Buchanan's research suggests we better not throw out the salt with the bath water.

Placing Betas

It's a solid. It's a liquid. It glows. It can sense changes in light and heat. It's called beta alumina, and researchers at the University of Pennsylvania believe it will revolutionize battery technology and may lead to the creation of tiny, but powerful, lasers.

Beta alumina is a solid electrolyte, meaning it is a nonmetallic electric conductor whose ions flow, creating current. Most solid electrolytes have to be cooled to be good conductors, but Ford Motor Co. researchers discovered in the 1960s that substances like it could conduct current at room temperature, which puts beta alumina in the liquid electrolyte category from a chemist's point of view.

The U. of Penn. researchers have been toying with beta alumina as the possible conducting medium for batteries.

If their theories hold up, the beta alumina may store hundreds of times more energy than lead-acid systems.

The implications are great for those who envision an all-electric car. And for those physicists who are searching for the perfect laser material, the beta alumina holds out promise of big breakthroughs in the next decade.

Highlands Stonehenge

Please don't write letters defending the Stonehenge monuments as an ancient astronom-

(Please turn to page 52)

16 mg. "tar", 1.0 mg. nicotine av. per cigarette by FTC method.

SURGEON GENERAL'S WARNING: Cigarette
Smoke Contains Carbon Monoxide.

CAMEL FILTERS

Share a new adventure.



FIX THAT SCRATCH



WITH AN EXACT MATCH



FROM DUPLI-COLOR®

All Dupli-Color® touch-up paints are computer-matched to the original factory finish! And a wide array of colors are available for both domestic and import vehicles.



SCRATCH-FIX®—For touching up nicks, dings, minor stone damage and scratches on late model vehicles. Easy-to-use brush-in-cap.



AUTO SPRAY®—As the scrapes and scratches get larger... Auto Spray® is the answer. Dries quickly to a durable, high-gloss finish.



TRUCK & VAN PAINT—Perfect for touching up large areas on pick-ups, vans and RVs. Also ideal for custom painting tool boxes and other accessories.

FREE! For a step-by-step "You Can Do It" guide to expert auto touch-up, send self-addressed stamped envelope (4" x 9½") to: Dupli-Color Products Company, Dept PM, 1601 Nicholas Blvd., Elk Grove Village, IL 60007.

THE DUPLI-COLOR DYNAMITE DUO REBATE/SWEEPSTAKES

Purchase any two cans of Dupli-Color® or Original® brand aerosol products and receive a \$1.00 rebate check.

PLUS Enter to win a matching pair of ATVs or one of hundreds of other prizes.

See your favorite Dupli-Color retailer for complete details. Rebate and sweepstakes offer valid through July 15, 1987.

DUPLI-COLOR®

SCIENCE

(Continued from page 50)

ical observatory. There isn't enough evidence to determine exactly what the Stonehenge stones were used for. But British archeo-astronomers Roger Martlew and Clive Ruggles are studying a similar set of stones on the Isle of Mull in Scotland. The Mull stones are arranged in a similar circular fashion. The two, working with Earthwatch, the volunteer research organization, are trying to determine whether the Mull stones could have been used to follow the movements of planets, the sun and moon. If they could have been used for that purpose, the Stonehenge theory will be strengthened.

Chunnel Update

The financial underpinnings for one of this century's most ambitious public works projects—the high-speed rail tunnel linking England and France—is taking shape, according to Frank P. Davidson, author of PM's recent "chunnel" feature (*England's French Connection*, page 67, Sept. '86).

Davidson reports that the Eurotunnel consortium has raised an initial 206 million pounds sterling of equity. While the English and French governments are not guaranteeing construction bonds, a bill to ratify the Channel Tunnel cooperation treaty has passed its second reading in the House of Commons and is now working its way through the House of Lords. The final reading of the bill is expected soon. Ratification of the treaty will trigger an equity offering on the world's stock exchanges totaling 750 million pounds. Once the equity issues have been sold, about 40 major banks worldwide are expected to provide the approximately 5 billion pounds sterling it will take to carry out the project.

Envisioned since the time of Napoleon, the tunnel complex will run approximately 100 meters below sea level at its deepest point, with rock thickness above it varying between 27 meters and 40 meters. Two rail lines—with interconnecting service tunnels—will transport people, autos and truck freight between London and Paris in 4½ hours.

The Fusion Quest

The global drive to produce a clean, inexhaustible source of fusion energy has achieved new impetus with recent strides in superconducting electromagnets, and with the inclusion of Princeton University's Compact Ignition Tokamak on President Reagan's 1988 budget submission to Congress.

At Oak Ridge National Laboratory, scientists passed a major milestone in fusion research recently when six 45-ton superconducting electromagnets were brought up to full current, creating

a magnetic field 160,000 times that of the Earth. Extremely strong magnetic fields will be needed to contain the super hot hydrogen gas, called plasma, used in the fusion reactors of tomorrow. Normal electromagnets require too much power to produce magnetic fields capable of plasma containment at temperatures approaching 200 million degrees C. Superconducting magnets, offering little electrical resistance at extremely low operating temperatures, use a tenth the power of conventional electromagnets in a similar application.

The six superconducting magnets were mounted together inside a 35-ft.-dia., 40-ft.-high vacuum tank. Air was evacuated for the full-current tests and the complete 460-ton superconducting magnet array was cooled to -450° F. The Oak Ridge magnets were designed and produced by an international consortium under a development program called the Large Coil Task.

Advancements in superconducting magnets may also have an impact on the Superconducting Super Collider, a \$4.4 billion particle accelerator recently approved by President Reagan. (Watch for PM's continuing update on the SSC site selection and design.) The SSC will allow physicists to peer ever closer into the heart of matter, proving the existence of such elusive particles as quarks, muons and bosons. Other types of superconducting materials are also being developed by scientists. Researchers at Argonne National Laboratory recently confirmed the discovery of a Bell Labs compound that achieves superconductivity at 39° Kelvin (or 359° below zero F). The compound, composed of lanthanum, copper, strontium and oxygen, becomes superconductive with closed-cycle refrigeration instead of with more complex cooling methods using liquid helium and liquid hydrogen. The compound could have an impact on the maglev transportation systems, medical diagnostics and fusion research.

Concurrently, Princeton University's proposed Compact Ignition Tokamak at the Princeton Plasma Physics Laboratory (PPPL) will demonstrate the ability of an "ignited plasma" to sustain adequate reactor temperatures without energy-sapping auxiliary heating.

Princeton's fusion research program started in 1951, and its 16-year-old Tokamak Fusion Test Reactor (TFTR) is an important component in American fusion power developments. Scientists in charge of Princeton's TFTR are trying to achieve a break-even point where the fusion power produced by the plasma equals the auxiliary heating power required to maintain the plasma at reactor temperatures. The objective of the Compact Ignition Tokamak will be to demonstrate that an ignited plasma can

(Please turn to page 56)

NEW

Only NRI gives you a 27" high-resolution stereo color TV you build to prepare you for today's video servicing careers.



You Build a 27" Stereo TV

During the assembly process of your state-of-the-art Heath/Zenith 27" TV, you learn to identify and work with components and circuits as they actually appear in commercial circuitry. Then through tests, adjustments, and experiments you quickly master professional troubleshooting and bench techniques.



Inside Your TV

The Heath/Zenith 27" TV has all the features that allow you to set up *today* your complete home video center of the future. Flat screen, square corners, and a black matrix to produce dark, rich colors . . . even a powerful remote control center that gives you total command of video and audio operating modes.

NRI has purposely designed your training around equipment that has the same high-tech circuitry you'll encounter in commercial equipment. That means your training is real-world training.

Become one of America's most sought-after technicians . . . put your talents and spare time to work for you in the "explosive-growth" world of home entertainment electronics.

Train in state-of-the-art video/audio servicing and become a fully qualified service professional the uniquely successful NRI way. It's hands-on training, at home . . . designed around the latest electronic equipment you build and keep as part of your training.

The High-Tech Revolution in the Home Is Just Starting

Sweeping changes are taking place in our homes, changes brought about by the phenomenal growth of home entertainment electronics. Already available are high resolution TV, TVs with stereo sound, simultaneous multi-channel viewing, projection TV, Camcorders, 8 mm video cassettes, and compact disc players.

And the revolution has spread to the business sector as tens of thousands of companies are purchasing expensive high-tech video equipment used for employee training, data storage, even video conferencing.

Join the Future or Be Left Behind

Today the consumer electronics industry represents a whopping \$26 billion opportunity for the new breed of consumer electronics technician.

Today's consumer electronics revolution is creating huge servicing and repair mar-

kets that are just starting to boom.

Here is your chance to become a fully qualified professional the way tens of thousands have trained with NRI.

Totally Integrated Hands-On Training

Since NRI training is built around "learn by doing," right from the start you conduct important experiments and tests with your professional digital multimeter. You assemble the remarkable NRI Discovery Lab and perform a complete range of demonstrations and experiments in the process.



NRI's commitment to you goes beyond providing you with equipment appropriate to the latest technology. Best of all, we ensure that in the learning process you acquire the very skills that will make you a professional service technician on the job.

SEND COUPON TODAY FOR FREE NRI CATALOG!

NRI SCHOOLS

McGraw-Hill Continuing Education Center
3939 Wisconsin Avenue, NW, Washington, DC 20016

We'll give you tomorrow.

CHECK ONE FREE CATALOG ONLY

- | | |
|--|---|
| <input type="checkbox"/> TV/Audio/Video Servicing | <input type="checkbox"/> Small Engine Repair |
| <input type="checkbox"/> Computer Electronics | <input type="checkbox"/> Air Conditioning, Heating, & Refrigeration |
| <input type="checkbox"/> Satellite Electronics | <input type="checkbox"/> Locksmithing & Electronic Security |
| <input type="checkbox"/> Robotics & Industrial Control | <input type="checkbox"/> Photography |
| <input type="checkbox"/> Industrial Electronics | <input type="checkbox"/> Bookkeeping & Accounting |
| <input type="checkbox"/> Telephone Servicing | |
| <input type="checkbox"/> Digital Electronics Servicing | |
| <input type="checkbox"/> Basic Electronics | |
| <input type="checkbox"/> Electricians | |

For Career courses approved under GI Bill
 check for details.

Name (Please print) _____

Age _____

Street _____

City/State/Zip _____

114-067

Accredited by the National Home Study Council

INTRODUCING THE LITTER CRITTER: IT'S A SWEEPING IMPROVEMENT.

Shop-Vac presents the revolution-ary new machine that's sweeping the country.

It's called the Litter Critter. A time-saving device that cleans up anywhere, indoors or out, in half the time of a push broom. Without creating dust or dust pan clean-up hassle. And without the use of batteries or electricity.

The Litter Critter gobbles up grass, leaves, dirt, paper litter, gravel, twigs and other debris. Thanks to a unique rotating brush which automatically sweeps litter into a built-in tray as you push it.

What's more, the Litter Critter cleans driveways, pavements, sidewalks, patios, or workshop and garage floors.

So for the perfect solution to home cleaning, pick up the lightweight Litter Critter. From then on, it'll pick up after you.



Litter Critter® is a registered trademark of Shop-Vac Corporation, Williamsport, PA.



OLD SOUTH COLUMNS IN EXTRUDED ALUMINUM CAN BE USED TO REPLACE ROTTING WOOD COLUMNS IN 8 EASY STEPS!

1. Call 1-800-841-8674 for literature and prices.
2. Study literature and price sheet to determine that aluminum columns are less expensive and easier to obtain than wood columns.
3. Sell spouse on all advantages of aluminum columns.
4. Call factory at same toll-free number and place order for columns to be shipped immediately from stock of 50,000. Use credit card or mail check.
5. Schedule Saturday morning do-it-yourself project.
6. Columns will arrive in approximately 10 days.
7. Arrange for moral support, 2 soft drinks, 1 can elbow grease, hammer, saw, level, and jack.
8. Follow directions and install columns on Saturday morning, eat lunch, then play golf with friends.

Moultric Manufacturing Co.

Box 1179, Dept.
Moultric, GA 31776-1179
Toll-Free 1-800-841-8674

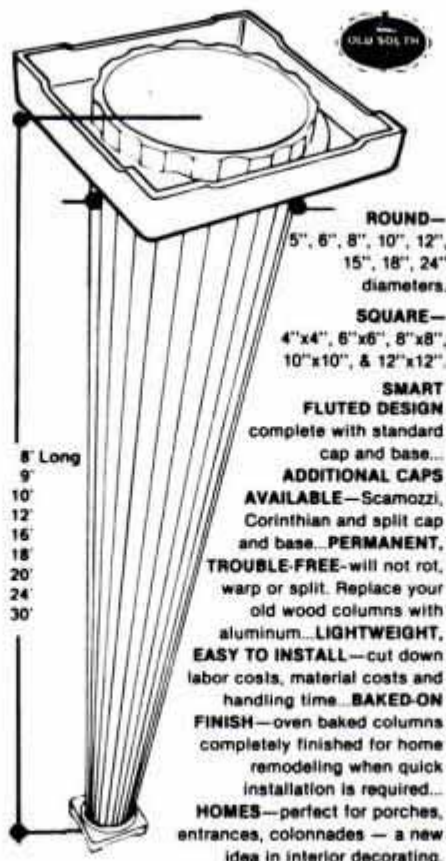

SCIENCE

(Continued from page 52)

maintain proper reactor temperatures during pulses lasting a few seconds without the need for auxiliary heating. CIT as designed is roughly one-half the size of TFTR, but is expected to generate 10 times the fusion power because of advances in plasma containment.

Scientific Assault On The Amazon

Brazil's Amazon Basin forms a significant portion of Planet Earth's total biomass, playing a key role in global air quality and climate. However, economic encroachment is beginning to affect the Amazon's ability to transport gases generated in swamps, rivers, forest soil and trees to the upper atmosphere.

Accordingly, scientists from the University of Virginia are traveling to the Amazon as part of NASA's Global Tropospheric Experiment to study the chemistry of the atmosphere over the world's most verdant rain forest. The primary objective will be to assess the role the Amazon plays in supplying trace gases and organic particles to the world's atmosphere.

There are two sides to the U.Va./NASA expedition, run in cooperation with the Brazilian Space Agency. Using a NASA research plane, 20 scientists will fly some 1500 miles out over the jungle, measuring the chemical makeup of the atmosphere over the Amazon at different altitudes. A ground-based group will use 140-ft.-tall towers, radar and balloons for similar measurements.

It's hoped that a better understanding of the atmosphere's chemical composition will provide a new way to gauge the interrelationship between Earth, the atmosphere and human activities, says U.Va. Professor Michael Garstang.

Pioneer 9 Declared Dead

After nearly two decades, 22 orbits around the sun, and 11 billion miles of faithful service, one of NASA's most productive Pioneer spacecraft has failed to respond to command signals from ground controllers at NASA's Ames Research Center, effectively ending a scientifically fruitful career. Pioneer 9 gave researchers new insight into the structure and flow of solar wind, the ionized gases that stream from the Sun, and helped predict the solar storms that can sometimes disrupt power distribution on Earth. In the late '60s and early '70s, Pioneer 9 gave hourly reports to Apollo Mission Control on potentially damaging showers of solar protons, and, in conjunction with Pioneer 10, successfully measured the speed, temperature and mass of one of the most intense solar storms ever recorded. **PM**

HINTS FROM READERS

Brake Drum Planter



My son, an industrial design student, spotted a rusted brake drum on the roadside and, with a burst of creativity, took it home and transformed it into an attractive planter. Actually, there wasn't much to transform.

All you need to do is just clean it off, but leave the rust, and cover the axle hole with a piece of plastic sheet or a cover from a food container.

Leave other holes exposed for drainage and fill it with soil appropriate for what you're planting. I liked the planter so much that I sent him out to pick up a few more. He returned from the local junkyards with four more, each different from the other, and costing 50 cents to \$2 each. Their rusty color complements nasturtiums and other yellow-orange annuals.

—Kay Haugaard

"The Dawn of a New Era in Transportation May Be Closer Than You Think!"

Michael W. Moshier

AURORA 400 VTOL AIRCRAFT



Take Off and Land Almost Anywhere. Cruise 225 MPH Above Daily Traffic.

Now in development, the first practical, vertical take-off and landing (VTOL) vehicle featuring the following design benefits for everyday personal and commercial use:

QUIET OPERATION—The Aurora aircraft's unique fluidic propulsion system, combined with state-of-the-art gas turbine technology, generates extremely low acoustical and IR signatures.

EFFICIENT—While having true vertical take-off and landing capability, the Aurora aircraft exhibits very favorable fuel economics of up to 30 PMPG (passenger miles per gallon).

MULTI-FUELED—Having no octane or cetane requirements, the Aurora aircraft's turbine engine can easily and efficiently use a variety of inexpensive and readily available fuels.

SAFE, EASY TO FLY—Automatic altitude stabilization and a redundant computerized control system make flying the Aurora aircraft very simple... even for the inexperienced pilot.

COMPACT—Only slightly larger than a full-sized automobile, the four passenger Aurora aircraft can take-off and land almost anywhere, making small, confined areas easily accessible.

MECHANICALLY SIMPLE—With the exception of its small, FAA certified turbopan engine, the Aurora aircraft has **no moving parts** in its propulsion system avoiding unreliable components such as propellers, clutches and gears.

MOSHIER TECHNOLOGIES CORPORATION's **VTOL Aircraft Development Report** is now available. The report is a comprehensive (47 pages, bound) presentation including a history of VTOL aircraft, the Aurora aircraft development evolution, specifications, product description, marketing considerations, and more. The report has been written in terms a non-engineer can easily understand, yet provides a thorough discussion of the aircraft's technology and operational characteristics.

If you are intrigued by the concept of a small VTOL aircraft, or have more than a passing interest in new and innovative aircraft design, we would like to hear from you. Learn more about this exciting new concept and participate in the Aurora aircraft marketing survey. To receive the comprehensive 47 page development report, color photograph and marketing questionnaire, please send \$37.00 check or money order in **U.S. funds only** (\$45.00 outside USA) to Director of Marketing, MOSHIER TECHNOLOGIES CORPORATION, 599-A Fairchild Drive, Dept. PM687, Mountain View, California 94043. All orders shipped first class mail.



"The development report is **must reading** for anyone wishing to keep abreast of the latest in VTOL technology."

Michael W. Moshier, CEO
Moshier Technologies Corporation

MOSHIER
Technologies Corporation

An Equal Opportunity Employer

©1987 Moshier Technologies Corporation

Машинерия, оборудование, авиационная техника

NEW/HOME

A Mow/Mulch Machine



Mower's cutting height adjusts from $\frac{3}{4}$ in. to $2\frac{3}{4}$ in. Easy-to-empty rear grass catcher accepts plastic trash bags (above).

If you're in the market for a new lawnmower, then check out the versatile Bolens Eliminator Plus. The mower shown (model No. 9062) is a 21-in., self-propelled, rear-bagging unit that converts easily to a mulching mower or, with an optional chute, a side-discharge mower. It's powered by a 4-hp, 4-cycle Briggs & Stratton en-

gine with solid-state ignition and recoil starter.

The 2-bushel capacity grass catcher accepts plastic trash bags to make it easy to dispose of clippings. It costs about \$485. Contact Bolens, 215 South Park St., Port Washington, WI 53074.

Wash And Go

New from Speed Queen is a space-saving washer and dryer designed for small homes and apartments. The Contempo Mate electric washer/dryer (\$700) measures 24 in. wide x 25 in. deep x $72\frac{3}{4}$ in. high and weighs 148 pounds. For optimum portability, Speed Queen offers a hose kit (\$16) and wheel kit (\$20). With these two accessories, the unit connects quickly to a sink faucet and, when not in use, it can be rolled into a closet or spare room. The washer has a durable polypropylene tub powered by a $\frac{1}{6}$ -hp motor. Features include a water-level selector, water-temperature control and multifabric wash-cycle timer. The 1520-watt dryer has a $\frac{1}{6}$ -hp motor. Its indoor-vent design requires no exhaust ducting. Speed Queen, Ripon, WI 54971.



Stackable washer/dryer hooks directly to sink faucet—no special plumbing. Wheel kit makes the 148-pound unit portable.

How To Be A Swinger

Create a backyard playground with a swing set kit from Swing Design, 33 Loring Dr., Framingham, MA 01701. The Adventurer swing kit (\$199) contains all the necessary hardware and components to erect the 3-position swing set shown. You provide the pressure-treated 2x4s: 14 that are 8 ft. long, and one that's 12 ft. long.

The kit also contains a climbing rope, two rubber belt swings, trapeze bar with rings, climbing cargo net, wooden ladder rungs and



Swing set kit has all necessary hardware and components—except the wood.

monkey bars. A complete kit is also available that contains all components, hardware and pre-cut and stained lumber for about \$325. The kits are sold at home centers and hardware stores.

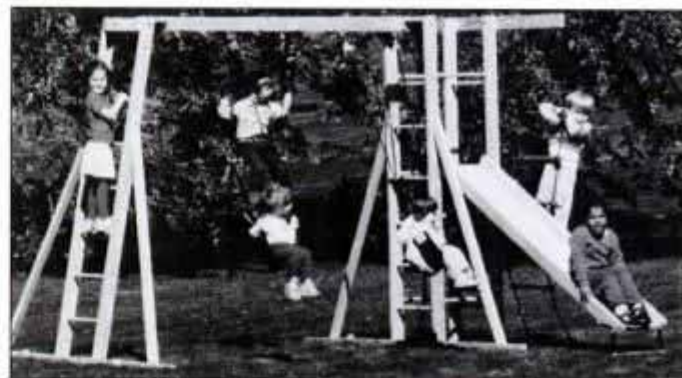

Completed swing set has two swings, a trapeze bar and cargo net.

Powerful Branch Biter

True Temper's new compound-action lopper (\$40) has two pivoting points instead of one. As a result, trimming branches requires only half as much pressure as conventional loppers, claims the manufacturer. The upper blade has a curved, serrated tip that prevents branches from escaping when cutting pressure is applied. True Temper, Box 3500, Shiresmantown, PA 17011.



Compound-action lopper has two pivoting points and a curved guide slot on upper blade.



Muscle-saving lopper has two ash handles. The tool's overall length is 29 in.

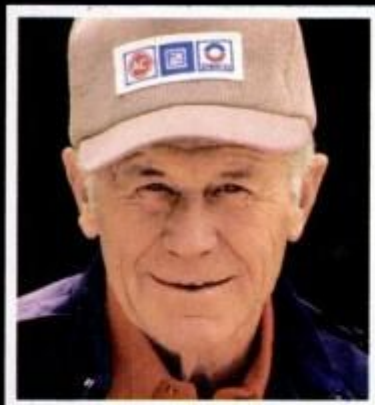

“WITH PARTS LIKE THESE, \$7 BACK IS ICING ON THE CAKE!”

— Test Pilot Chuck Yeager

These days, AC-Delco's sweetening the pot with more than top-notch parts. We're offering up to \$7 in rebates.

May 17, 1987, through July 18, 1987, get \$1.50 apiece back on AC air filters (limit 2). \$1.00 apiece back on AC oil filters (limit 2). And 25¢ apiece back on AC spark plugs (limit 8).

Your rebate requests must reach us by August 31, 1987. So see your AC-Delco retailer for coupons and details. To find your nearest retailer, call me toll-free at 1-800-AC-DELCO.

Keep in mind, a deal like this doesn't come around too often. So if you maintain your car yourself, I'd suggest you get over to your AC-Delco retailer today.

**Stay ahead of trouble
with AC-Delco.**



GENERAL MOTORS CORPORATION

Offer void where prohibited.





**SURGEON GENERAL'S WARNING: Quitting Smoking
Now Greatly Reduces Serious Risks to Your Health.**

Lights: 10 mg "tar," 0.7 mg nicotine—
Kings: 16 mg "tar," 1.0 mg nicotine
av. per cigarette, FTC Report Feb '85

5 more smokes for the long working day.



Marlboro 25's

NEW/AUTO

More Life From Old Wipers

Streaking windshield wiper blades can really make a rainy trip seem twice as long. Don't squint or use up gallons of washer fluid trying to make up for worn blades. When the edge of your wiper blade gets rounded from wear and oxidation, it won't squeegee the water away from the glass. As long as there is rubber left on the blade, don't throw them away—Nu blade is designed to put a new wiping surface on old blades. The compact, 3-in.-long tool stores easily in the glovebox, and puts a new edge on a blade in seconds, without removing the blade from the arm. Just wipe the \$3.95 Nu blade along the wiper to shave a small amount of rub-



Now you can save old wiper blades for another rainy day.

ber from the worn edge. This will restore the sharp edge of the rubber blade. Of course, if the rubber is in shreds, you are too late. Order direct from Holz Enterprises, 497 South 7th St., St. Helens, OR 97051. Or call 503-397-6236.

Optics To Bring Up the Rear

Backing out of a driveway full of kids, dogs and toys is guaranteed to give you a stiff neck and worry lines. Easipark makes it simpler. By looking over your shoulder, or even

in your inside rearview mirror, you can see entire objects on the rear or side as near as 3 ft. With a little practice, you can back up to within 6 in. of another car or the trash cans without turning around in the seat. Its safe, soft plastic lens sticks to your rear window off to one side, so it won't interfere with normal driving. The near-panoramic view covers a wide area, so it should be good for big and small cars, station wagons and vans alike. Just be sure you place it in between the wires for the rear-window heater. Order from the J. Goodman Co., Dept 14, Box 88 Livingston, NJ 07309. It's \$9.95 plus 50 cents postage.



Easipark's plastic lens for your car's rear window broadens the view.

Blow Your Garage Down

Convert your old VW Beetle or Bus engine into a high-capacity air compressor. Conversion kit replaces stock head with finned aluminum compressor cylinder heads for one or two cylinders. The other bank of two cylinders runs normally to provide power. A gallon of gas will provide ample compressed air for sandblasting or painting for an hour. Contact



Beetle motor can be converted to an air compressor.

Dunn-Rite Inc., Route 6, Box 184A, Anderson, SC 29624. A single cylinder kit costs \$279, a twin \$399.



Just brush this liquid tape on electrical connections.

Sticky Fingers

Electrical tape does a good job in the house, but on the car it leaves a lot to be desired. Moisture and dirt make the end of the tape flap in the breeze, and pretty soon the turn signals on the trailer are out again. Starbrite's Liquid Electrical Tape seals out moisture and corrosion permanently. The black liquid vinyl is applied with the built-in applicator brush and it dries in minutes. If you leave it on the dash of your car in the sun, it won't turn into a telescope from the heat. A 4-ounce can is \$4.95 from auto and marine stores, or call 1-800-327-8583 for information.

Lights Out?

Plews Broken Circuit Tester has a sharp little point in the end to pierce the insulation on the wires you're testing. If the 6- or 12-volt circuit is hot, the lamp in the handle will light up. Trigger action makes it easy to use in restricted areas with only one hand. Just grab the wire with the hook and squeeze. It costs \$13 and is available in auto parts stores. **PM**

It's not broken; it's for testing broken circuits.



Buckle up—Together we can save lives.

With a quality
record this
good...

1981.

Nationwide quality survey shows, Ford Motor Company is making the highest quality cars and trucks designed and built in North America.*

1982.

Ford does it again.

1983.

And again.

1984.

And again.

1985.

And again.

1986.

And again.

...we can offer
a warranty
this good:

6 0 0 0 0 0

Ford Motor Company's
new 6-year, 60,000
mile warranty.

With a quality record better than any other major American carmaker, we realized we could give you a better warranty than we ever had before.

A 6-year, 60,000 mile powertrain warranty on all our new Ford, Mercury, Lincoln and Merkur cars, our vans, and our light trucks.**

With a warranty like that, and a quality record like ours, there's really no reason to go with anyone else.

** Restrictions and deductible apply. Ask your dealer for a copy of this limited warranty.



Quality is Job 1.

Ford • Lincoln • Mercury • Merkur
Ford Trucks • Ford Tractors

*Based on an average of owner-reported problems in a series of surveys of '81-'86 models designed and built in North America.



TURN HOME REPAIR PROBLEMS INTO NO PROBLEMS.

WITH ELMER'S™—THE HOME SOLUTION™ PRODUCTS.

If you have a problem in your home that needs gluing, caulking, filling, glazing or spackling, Elmer's has the answer.

THE HOME SOLUTION™ line of products. Look for them at your favorite store.

© Borden Inc 1987



ELMER'S
THE HOME SOLUTION™



Problem: How to stop the draft from drafty windows.
THE HOME SOLUTION™: Elmer's Silicone Caulk. Gives you a long-lasting, flexible seal that insulates and waterproofs.



Problem: How to replace broken window glass.
THE HOME SOLUTION™: Elmer's Glaze-Tuff™ glazing compound. It's paintable in only 30 minutes.



Problem: How to reglue loose rubber on appliances.
THE HOME SOLUTION™: Elmer's Stix-All™ A strong, high-tech adhesive that bonds just about anything to anything else.



Problem: How to repair a crack in a wall.
THE HOME SOLUTION™: Elmer's Redi-Spax™ spackling compound. Fast-drying acrylic latex formula stays flexible but sands easily.



Problem: How to patch the deep gouge in the dining room table.
THE HOME SOLUTION™: Elmer's Carpenter's Wood Filler. Resists shrinking and accepts dark and light stain.



Problem: How to attach Formica® to a countertop.
THE HOME SOLUTION™: Elmer's Contact Cement. Forms a strong bond.



Problem: How to replace caulking around your tub and tile.
THE HOME SOLUTION™: Elmer's Tub Caulk. Provides a flexible seal that's water and mildew resistant.



Problem: How to protect your hands from paint, oil and grease.
THE HOME SOLUTION™: Elmer's Invisible Glove™ Protective Hand Cream. Just apply before any dirty job.

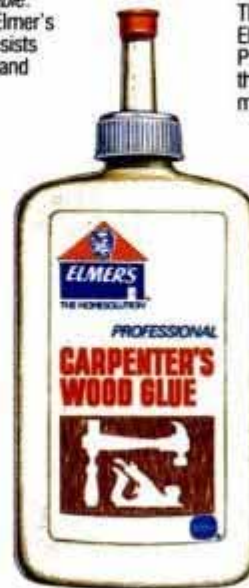

Problem: How to glue the arm back on the armchair.
THE HOME SOLUTION™: Elmer's Carpenter's Wood Glue. Penetrates wood deeply for a strong bond.



Problem: How to glue protective felt to the bottom of the statue.
THE HOME SOLUTION™: Elmer's Glue-All™. It's the ideal all-purpose household glue.

PM TECHNOLOGY UPDATE 6/87

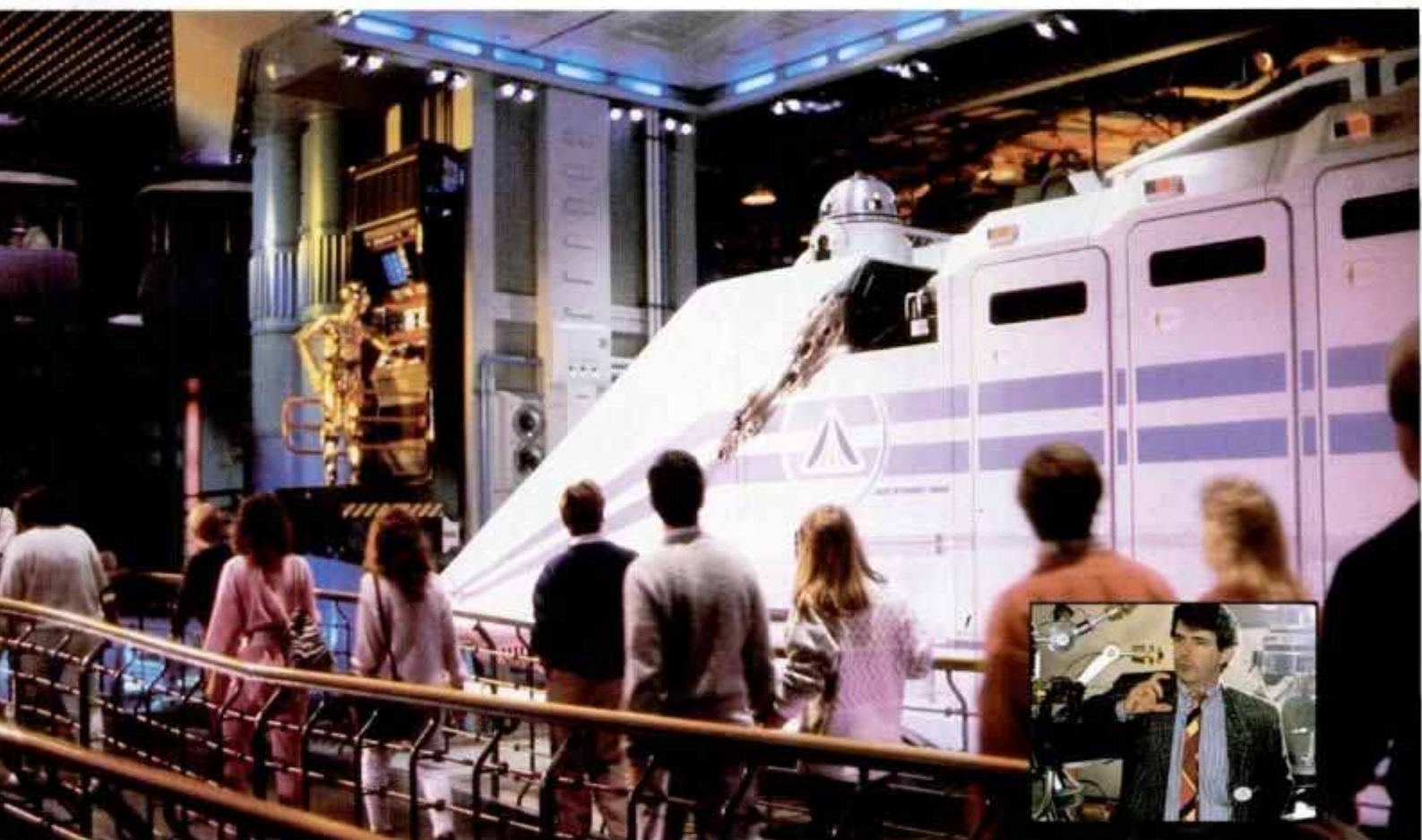

Technologies Merge In Fantasy Simulators

As you and 39 companions strap into your bucket seats, your pilot, Rex the robot, casually informs you that this is also *his* first flight aboard the Starspeeder 3000—which helps explain the ensuing 4½-minute misadventure. Rex takes a wrong turn and Darth Vader's Death Star looms on the horizon. What began as a vacation getaway to the Moon of Endor, winds up in a fight for survival. The Starspeeder climbs, banks, accelerates, even achieves mock light speed—all with white-

knuckle realism. It's part of Disneyland's latest triumph in "techno-fun" and a new trend in amusement park attractions. Disney engineers teamed with Star Wars producer George Lucas (inset)

to create Star Tours, which combines a hydraulically operated, flight simulator-based, 40-passenger capsule that is computer-synched to Star Wars wide-screen visuals.

Another flight simulator-based attraction has gone on line at Tour of the Universe in Toronto.

A Hermes space shuttle look-alike takes passengers on a flight to Jupiter. The flight simulator has 6° of motion, its 70mm film is increased to 60 frames a second for excitement and clarity and occupants are surrounded by quadrophonic digital sound. Beam us up!

George Lucas, inset above, teamed with Disney engineers to create the Starspeeder 3000 at Disneyland's new Star Tours attraction. The ride's flight simulator origins are clearly shown at Toronto's similar Tour of the Universe, left.



Editor: Tim Cole
Contributors: Wade Hoyt,
Ted Francis, Lisa Gosselin,
Jan Norbye, Nick Nichol

DISNEY PHOTOS, ABOVE;
TOUR OF THE UNIVERSE PHOTO, RIGHT

TECHNOLOGY UPDATE 6/87

SPACE

MCDONNELL DOUGLAS ILLUSTRATION



MLV Marks U.S. Space Comeback

The Air Force has awarded a \$316.5-million contract to McDonnell Douglas to produce the next generation expendable space launcher. The Medium Lift Vehicle is an updated version of the venerable Delta rocket, which has achieved a 97.7 percent success rate over the past 45 launches. The first seven MLVs will launch into space a series of Navstar Global Positioning System satellites, precision spaceborne navigation beacons for use by all branches of the U.S. military. McDonnell Douglas is also marketing the MLV to commercial space customers.



BOEING PHOTO

Space Station Housekeeper

The value of a single space station crewmember's time will be placed at \$20,000 an hour. So Boeing engineers are developing robotic systems that will perform mundane station-keeping chores. Currently in the works at Boeing's Huntsville, Alabama, facility is a lightweight dual-armed, aluminum-based robot (pictured)

that has articulating wrists, elbows and shoulders that can perform humanlike movements. While an early prototype is seen here manipulating stowage modules, one proposed offshoot will come complete with computer-aided vision and a transportation system to assist astronaut/engineers in finding tools or keeping inventory. Telerobotics and autonomous robotics are also under study for use in space.

AUTOMOTIVE

Pop-Up Spoiler Hits The Road

Moveable aerodynamic aids, long predicted in road-going cars, have finally hit the street on the Lancia Thema, a front-drive Italian sedan powered by a 3.2-liter, 215-hp, Ferrari V8 engine. (Lancia and Ferrari are both owned by Fiat, which makes such hot rodding possible in a production car.)

The aero aid is an electrically powered rear wing that flips up out of a cavity in the trunk lid at the touch of a



stalk-mounted switch near the steering wheel. At highway speeds, the spoiler cuts aerodynamic lift at the rear of the car in half. In fact, at 85 mph, the wing provides 26

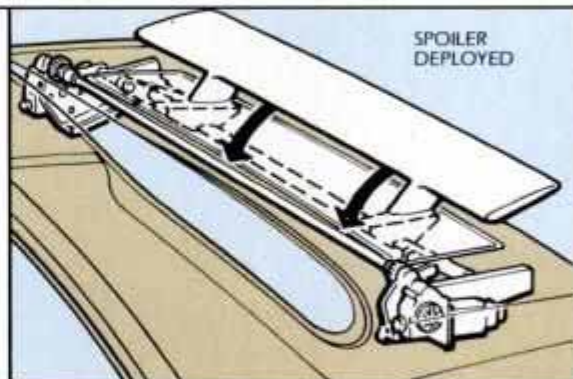

pounds of road-hugging downforce—67 pounds at 140 mph.

It also adds a last 1½ mph to the Thema's top speed of 145 mph, a speed that is not

uncommon on some European highways.

That's Corvette performance from a \$26,000 4-door sedan that may be sold in the U.S. by 1988.

PM ILLUSTRATION BY GEORGE RETSECK

AVIATION

PM ILLUSTRATION BY ED VAUGURSKY



New Chute System For F-111 Egress Pod

Developments in electronic warfare have added nearly 300 pounds to the Air Force's workhorse F-111, which means the plane's cockpit escape module (illustrated) must now descend by parachute at 35 ft. per second after an emergency punch out. The Air Force recently decided to reduce

the module's descent rate to a safer 25 ft. per second and asked Sandia National Laboratory to design a replacement for the F-111's single 70-ft. ringsail parachute. The result (pictured) is a cluster of three 52.5-ft.-dia. parachutes that rely on conventional ripstop Nylon and Kevlar in structural and sus-

pension lines. Each parachute weighs only 30 pounds and develops a drag force of 8000 pounds.

The new parachutes were recently attached to test vehicles (right) carrying on-board accelerometers, load-measuring instruments, cameras, cinetheodolites and tracking telescopes.



Light Weight, High Strength

The Pontiac Motorsports Division is testing a magnesium-based, inline, 4-cylinder engine block that is approximately 100 pounds lighter than its cast-iron equivalent. A typical "Magblock" is sand cast using ZE41 magnesium and weighs a scant 41.9 pounds. Compare that to the 116.7-pound weight of a conventional block of similar displacement. The engine was developed for off-road/motorsports applications.



MCDONNELL DOUGLAS PHOTO

F-15 Electronic Enhancements

The new and improved McDonnell Douglas F-15E will undertake deep interdiction fighter/bomber missions, relying on conformal fuel tanks for extra range and an updated electronics package. Items include the Hughes APG-70 radar, Martin-Marietta Low Altitude Navigation and Targeting Infrared

(LANTIRN) system and inertial navigation by Honeywell that incorporates the revolutionary laser ring gyro. The F-15E also has a second cockpit for a weapons system/countermeasures operator. The Air Force plans to add 392 F-15Es to the existing fleet of twin-engine supersonic F-15s.

TECHNOLOGY UPDATE 6/87

MARINE

FM PHOTO BY PETER ISLER

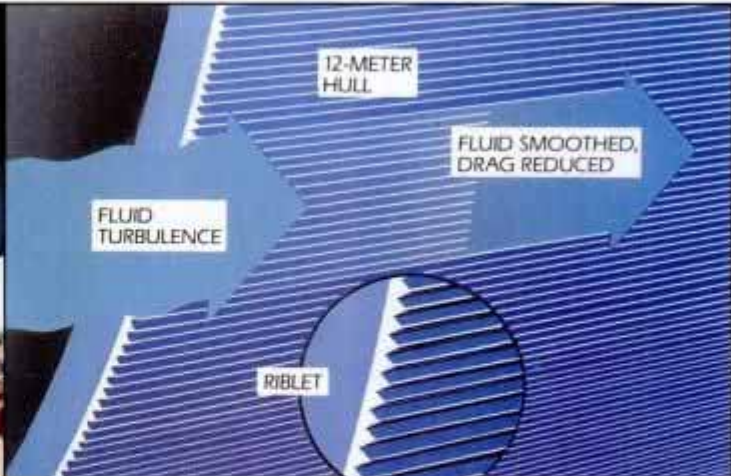

FM ILLUSTRATION BY GEORGE RETZACK

Cup Tech Continued

One of the more intriguing developments to emerge from Dennis Conner's resounding America's Cup victory last February concerns "riblets," another word for a new process from 3M Company called "microreplication." Three hundred panels of 3M's Scotcheal Drag Reduction Film, first developed by NASA's Langley Research Center, were applied to the 65-ft. hull of Conner's 12-Meter Stars & Stripes. Tiny V-shaped grooves (illustration inset) are etched into the film, giving it the tactile surface of a standard LP record. The application resulted in reduced water-flow turbulence because laminar fluid flow was allowed to continue farther back on the



FM PHOTO BY GUY QUINCY

hull before separation. In addition, the riblets guided the waterflow evenly, cutting down on cross-flow friction.

Other innovations in 12-Meter technology included the sail material used aboard French Kiss (pictured), an actual offshoot from a Franco-Soviet mission to the Planet Venus. The Centre National des Etudes Spa-



tiales (CNES) originally developed the material for a 30-ft. helium balloon that was to

be dropped into the Venusian atmosphere.

Mission requirements called for a tightly woven, acid-resistant cloth and the result is a composite of Kevlar fibers along with fluor and polyester films.

Another significant improvement in the America's Cup game involved new strides in spectating. CF Thomson, a French electronics company, developed an onboard mini-cam for ESPN that brought cockpit action into living rooms. Wrapped in plastic and bolted to the mast, it sent microwave signals to a helicopter overhead, which relayed the signals to a shoreside broadcasting station. The yacht cam aboard the Australian yacht Kookaburra III incorporated zoom, focus, pan—and windshield wipers.

MILITARY

Submachine Gun In A Box

Answering the call for concealable, high-volume firepower by security/counter-

terrorist agents at airports and embassies, ARES, Inc., of Port Clinton, Ohio, has unveiled a unique 9-mm Folding Machine Gun. The

weapon collapses into a compact rectangular box 10 x 3 x 1½ in. According to ARES, the FMG is intended to provide a quickly deployable firearm that could be carried without causing public alarm.

The FMG's magazine holds 32 rounds of ammunition and can fire selectively in semi-automatic or fully automatic mode. The nominal cycling rate is 650 rounds a minute. Fully loaded, it tips the scales at about 4 pounds—half the weight of the vaunted Israeli Uzi.

FM PHOTOS BY JACK HAMMOND



7,321 miles...



and still working.

Of course they are. They're Red Wings. And here's the proof that 20 mile-a-day comfort doesn't come with a limit. These Red Wings have actually walked over 7,000 measured miles.* They've been doing exactly what we made 'em for... working. Red Wings are America's finest shoes for work. When we promise quality, fit and comfort, you get our best.

For more information and your nearest dealer, call toll free 1-800-255-2550.

*Unsolicited testimonial from Bob Vande Weerd, Rock Valley, IA.



RED WING
SHOES®
MADE IN THE U.S.A.

20 MILE-A-DAY COMFORT

We confidently invite you to give your brand new Buick its 201st inspection.

The first 113 quality inspections happen while your Buick is being built. But that's just a good beginning. Once it reaches your dealer, 87 additional items must be checked before it can be subjected to the most important inspection of all: yours.

And that's just one of the important things we pay attention to. Things that make us a place where better really matters. For example...

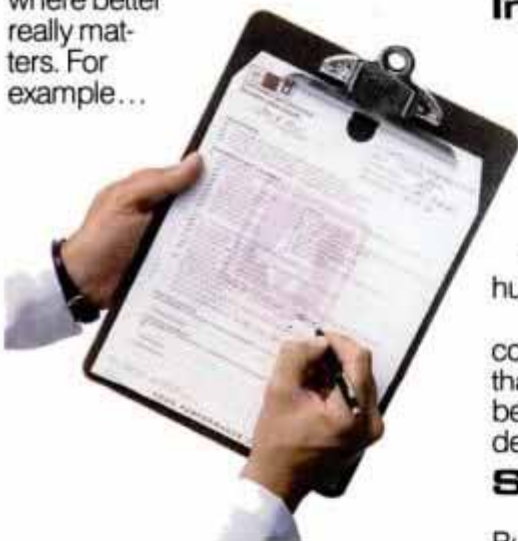

Underneath

The road of life has its share of potholes, washboards and bumps. Fortunately, it also has an occasional sweeping curve or twisting, tree-lined lane. Century is prepared to deal with it, either way.

Its independent front suspension, computer-selected springs and shock absorber valving deliver the kind of smooth, effortless ride for which Buick has long been



Buick Century

admired, while taking very good care of business when the going gets brisk and sporting.

Inside

When you sit behind the wheel of a Century, you find that the controls are where you want them for ease of operation. That's because of our dedication to ergonomics — the science of matching machine design to human design.

Other reasons for Century's comfort include things like seats that provide real support without being hard or harsh. Aerodynamic design to cut down on wind noise.

Satisfaction

Century is the best-selling Buick in history. The reasons are many. But one of them surely is the way this automobile manages to blend today's technology with traditional grace and comfort.

It is a front-wheel-drive car, with an engine controlled by microchips. It was designed with the aid of computers and wind tunnels for superb aerodynamics. It represents what can be done with the application of the latest technology.

But all this electronic wizardry is there to fulfill one simple, single function: to provide satisfaction. A car that starts when you want it to, has the kind of power you expect and provides quiet, solid comfort on the road.



If that sounds like the automobile you've been looking for, buckle up and see your Buick dealer.

For more information, a brochure or a test drive, call

1-800-87-BUICK
(1-800-872-8425).



See your dealer for the terms and conditions of this limited warranty.



Where better really matters.

B U I C K

RAGTOP FEVER

Popular
Mechanics
JUNE 1987

Born-again convertibles
bring back driving fun.

It was a tough job, but somebody had to spend a week proving that convertibles are fun. Blasting down a canyon road toward the ocean, hairpin after hairpin, top down, hair blown back, shades on. It doesn't get much better than this.

For a while, in the '70s, a lot of the fun went out of driving, and top-down models disappeared. Happy to report, you can't keep a good top up. The latest convertibles retain all the fun of open-air motoring, while

eliminating the chassis flex and leaky roofs that plagued early soft tops.

The eight cars we assembled in California are all the new factory convertibles on the U.S. market. We deliberately excluded 2-seater roadsters and aftermarket conversions. Also out are the VW Cabriolet which is not new, but based on a '70s Rabbit chassis; the BMW 325i which wasn't available here at the time of our test; and the absurdly expensive Rolls-Royce Corniche



CHEVROLET CAMARO IROC-Z

RAGTOP FEVER

and Aston-Martin Volante. Obviously, it's not fair to compare a \$15,000 Renault to a \$28,000 Saab, nor a 2-liter Sunbird to an IROC-Z. So this is not a comparative ranking of the new convertibles. It's our impressions after a week driving around California. Top down. Shades on.

Chevrolet Camaro IROC-Z

In Southern California, a Z-28 won't get you a second glance on the freeway, let alone a date for the prom. But an IROC-Z convertible—that's different. Our bright red Camaro, complete with Ferrari-like 5-spoke alloy wheels and



wide Eagle gatorbacks, was everybody's favorite, including Valley Girls and their moms.

Cutting the top off gives the Camaro a surprisingly different look—more rounded, more modern. Underneath the sheetmetal, it's still all Z-28, which is quite a compliment. The top is a stressed panel on unit-body cars, so maintaining structural integrity is tough. There's just a hint of cowl shake over bumps. Otherwise, this convertible feels as stiff as Camaro coupes we've tested.

It's also just as fast. Our test car was a tired-out prototype, yet it still managed .85 G on the skidpad, 60 mph through the slalom, and sub-15-sec. quarter-miles at L.A. County Raceway in Palmdale.

If this were our IROC-Z convertible, we'd replace the



uncomfortable front bucket seats with a pair of Recaros and recover the chintzy interior to match. The Camaro's striped cloth and plastic don't reflect its \$21,000 price tag. The IROC-Z works great at the track, but it's all over the place on a bumpy road. Put the top down and boot the gas a couple of times, though, and these niggling complaints disappear.

This Camaro is more comfortable than its sibling Corvette convertible, half the price and offers not only the same status points, but also the same high-strung feel of a thoroughbred waiting to be let loose.

Chevrolet Cavalier RS

Cutting the top off is the best thing GM has ever done for the J-car. Our metallic-gray convertible was tasteful and conservative in this group of bright red screamers, with only its pretty "snowflake" alloy wheels to add a little jazz. The matching gray cloth interior might have been cut by Halston—pretty and distinctive.

At \$17,000, it's not cheap. Even when fitted with a 2.8-liter V6, it's no ball of fire; the only slower convertibles are Pontiac's Sunbird and the Renault GTA—both have 2-liter engines. The Cavalier was last or near-last in all our track testing, in spite of being fitted with heavy-duty RS equipment. This is a *boulevardier*, not a racer.

And that's okay. The fact that the top goes down excuses a multitude of sins. As a convertible, the Cavalier works just fine. The power top is a model of easy operation, and the

Produced by PM Auto Dept.; Text by Rich Taylor, Photos by Rich Cox and David Bush



CHRYSLER LE BARON



RENAULT GTA

chassis is stiff enough to eliminate torsional twisting and cowl shake on everything but the worst roads.

The Cavalier—at least in convertible form—seems like a perfectly nice little car. It's something you could drive around without counting the days until the lease runs out.

Chrysler LeBaron

The new Chrysler-only convertible—the only convertible on the market engineered from the ground up and *not* built from a cut-down coupe—is an absolute knock-out. This is the best-looking Chrysler product in decades—smooth, contemporary and thoughtfully integrated from bow to stern.

Our test LeBaron was the full-tilt version, and still it costs only \$18,000 complete with turbocharger, electronic dashboard, leather interior and Eagle GTs.

Compared to the last Shelby Charger we tested—which has the same engine in a lighter Omni-derived chassis—the LeBaron is, as you'd expect, slightly slower and less agile in every test, but only slightly. It's one of the better performers in this group. And remarkably enough, that svelte derriere hides more trunk space than many family sedans.

The LeBaron's wonderful exterior styling isn't matched by the interior. The electronic instruments are hard to read. The bucket seats have poor support, the steering wheel is at an odd angle, and the combination of high window sills and low seats results in a claustrophobic feeling for driver and passengers alike, especially with the top up. The extra-long doors are heavy and hard for smaller people to close.

All in all, however, the LeBaron is terrific. It really does look and feel like a luxury car. Most passengers and passers-by overestimated the price tag by \$10,000. The LeBaron Coupe, at under \$12,000, is equally pretty and equally a bargain. Chrysler dealers probably won't be able to keep either version in stock.

Ford Mustang GT

Ford has really done a number on the Mustang GT for 1987—everything new. Whether or not it's better than before is another question. Some people thought the add-on plastic airdam and running boards were neat, others thought the look was horrible. The fake louvers over the taillights are especially controversial. Happily enough, you can still buy an unadorned Mustang convertible with all the GT underpinnings and 225-hp V8.

In any version, the Mustang V8 is the best bargain performer in America. It's directly comparable to archrival Chevrolet Camaro in every track test, but costs a whopping \$3000 to \$4000 less, model for model. It's also more fun to drive, in an athletic tail-out, sideways sort of way. It can be a handful at the limit—the Camaro is more stable and easier to drive fast—but at saner speeds, the Mustang GT is a *ball*.

The Mustang is the most popular convertible in the country, Suzuki and Jeep aside. Ford sells more than 20,000 a year. It's also been in production longer than any of its competitors, so most of the glitches have been worked out. There are things wrong—the seats are uncomfortable, the power steering too light, the convertible chassis not rigid

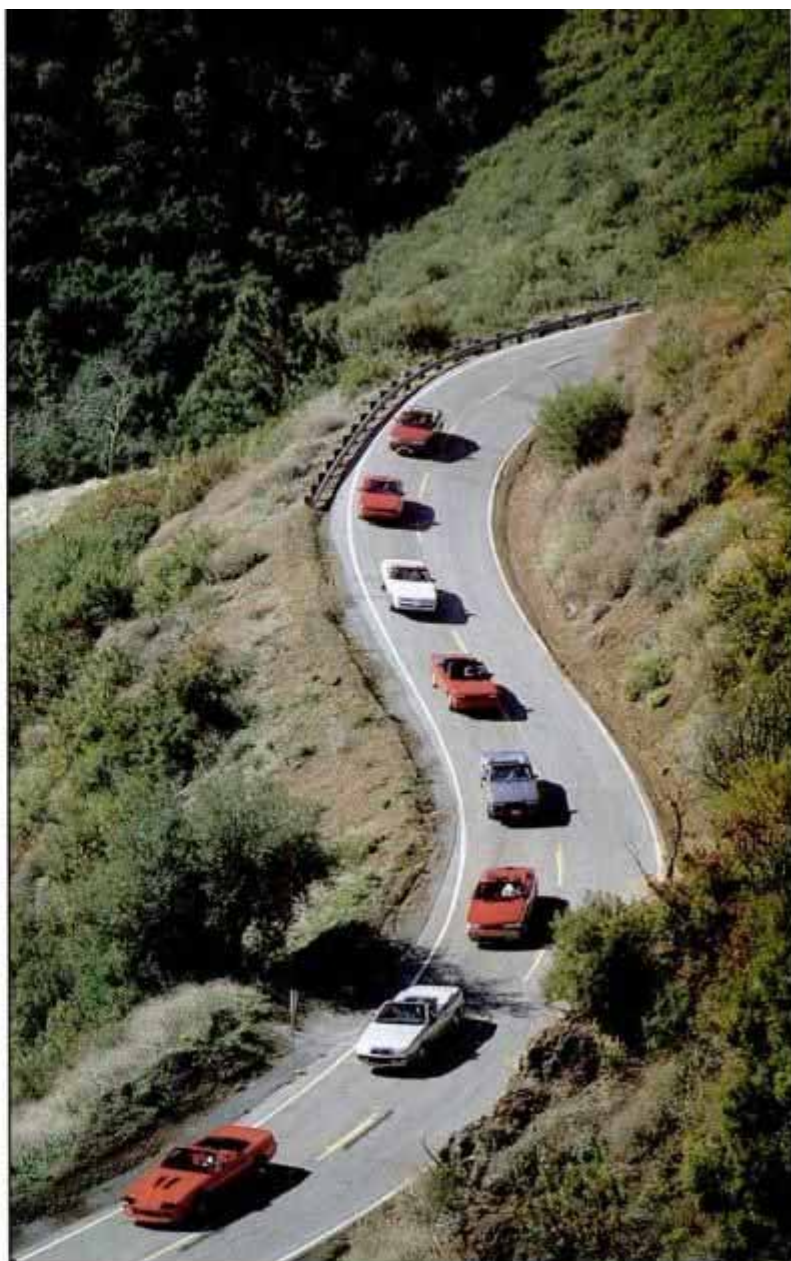

enough—but for the same price as a Cavalier or Celica, the Mustang GT offers the performance of a Porsche.

Pontiac Sunbird GE

The Sunbird is Pontiac's version of the J-car, basically identical to Chevy's Cavalier. The \$1400 difference between the two cars in our test essentially pays for a V6 and RS trim—and that accounts for the slightly faster acceleration of the Cavalier. Interestingly, the Sunbird was significantly better in our handling tests. Pontiac has obviously done a more thorough job of matching tires and suspensions.

Otherwise, there's little to choose between the two cars. The Chevy has a plainer grille and taillight treatment, while the interiors are essentially identical. The Sunbird is available with a turbocharged 2-liter rated at 165 hp—35 hp more than Chevy's V6—which would have made our test cars more equal in performance and price. In actual fact, the standard fuel-injected, 96-hp 2-liter is probably the smartest choice and more in keeping with the economy car nature of the Cavalier/Sunbird.

The convertible conversion adds \$3000 to \$4000 to the price of all these cars, compared to the equivalent coupe. Somehow, that price hike is more easily swallowed on a Camaro or Mustang than it is on a J-car. Like the convertible Cavalier, this is a pleasant little car, but there are a lot of much fancier cars you can buy for \$16,000, even if their tops don't retract. If you want an inexpensive convertible, dollar-for-dollar a Mustang or LeBaron is a much better buy.

RAGTOP FEVER

Renault Alliance GTA

Renault's GTA package is really excellent, transforming the bland Alliance econobox into a veritable Pocket Rocket. Low-profile Michelin tires and a stiffish suspension are responsible for the GTA's excellent slalom and skidpad figures. And while the 95-hp 2-liter was only an eyeblink faster than the last-place Sunbird in acceleration, the GTA feels much faster thanks to a raspy exhaust, easy-revving engine and torque-induced steering twitchiness—all adding up to a pleasing driver's car.

Cutting the top off emphasizes the brick-like silhouette,



SAAB 900
TURBO

which AMC stylists have successfully softened with add-on rocker moldings, airdam and spoiler. Nobody is going to mistake a GTA convertible for a racing car, but it's an attractive and sporty-looking package.

Renault's unrelenting Frenchness is evident in the interior's bizarre controls and ergonomics. The front bucket seats are quite comfortable, but the nearly horizontal steering wheel requires an upright driving position that grows tiresome after awhile. The electric window and mirror switches can't be found without the owner's manual, while the unmarked stalks flanking the steering wheel are impossible



TOYOTA
CELICA GT

to decipher. We like the GTA convertible. It's cute, fun and economical. At \$15,000, it's hardly a bargain. But the car itself has a winning personality, and certainly in Europe, Renault is a viable nameplate.

Saab 900 Turbo

It's interesting how cutting the top off dramatically improves so many cars. The Saab 900 Turbo is positively transformed by being carved into a convertible.

Compared to the 900 hatchback, the 900 convertible's long nose seems unobtrusive when balanced by a rear deck, and the topless body becomes beautifully long and elegant. Even the curious addition of a spoiler wrapping around the cockpit lip doesn't spoil the new look. Pump jockeys more attuned to a 396 Chevelle admired the Saab's fabulous paint job, flawless leather interior and hot turbocharged engine.

The Saab was third fastest in acceleration behind the two V8s, second in braking, third through the slalom, and only mediocre on the skidpad. That skidpad performance is typical of European cars, in our experience. Recent American cars can post .80-plus G cornering figures, using Eagle gatorbacks and a stiff suspension—a suspension that's often too stiff for everyday driving.

European performance cars, like the Saab, are comparatively mediocre at the track, but much more capable in the



CHEVROLET CAMARO IROC-Z	CHEVROLET CAVALIER RS	CHRYSLER LEBARON	FORD MUSTANG GT
Base price: \$17,632	Base price: \$13,816	Base price: \$14,000	Base price: \$16,226
Price as tested: \$21,017	Price as tested: \$17,208	Price as tested: \$18,000	Price as tested: \$17,673
Engine: 215-hp OHV 5.0-liter V8	Engine: 130-hp OHV 2.8-liter V6	Engine: 146-hp SOHC 2.2-liter Inline-4 Turbo	Engine: 225-hp OHV 5.0-liter V8
Transmission: 4-speed automatic	Transmission: 3-speed automatic	Transmission: 5-speed manual	Transmission: 5-speed manual
Wheelbase: 101.0	Wheelbase: 101.2	Wheelbase: 100.3	Wheelbase: 100.2
Length: 192.0	Length: 174.5	Length: 184.9	Length: 180.8
Weight: 3400	Weight: 2700	Weight: 2700	Weight: 3250
EPA city mpg: 16	EPA city mpg: 19	EPA city mpg: 22	EPA city mpg: 19
Quarter-mile: 14.813 @ 94.30	Quarter-mile: 17.007 @ 79.93	Quarter-mile: 16.705 @ 82.19	Quarter-mile: 15.000 @ 93.80
Braking: 131.6	Braking: 135.3	Braking: 137.6	Braking: 116.8
Slalom ¹ : 60.52/Skidpad ² : .85/.84	Slalom ¹ : 57.72/Skidpad ² : .73/.75	Slalom ¹ : 57.33/Skidpad ² : .76/.80	Slalom ¹ : 57.53/Skidpad ² : .78/.81
Trunk space ³ : 4	Trunk space ³ : 12	Trunk space ³ : 15	Trunk space ³ : 9
Interior space index ⁴ : 130.2	Interior space index ⁴ : 117.54	Interior space index ⁴ : 139.50	Interior space index ⁴ : 131.66

1. Best speed while weaving through seven cones placed 100 ft. apart; the higher the speed, the better the transient handling.
2. G-forces generated during steady-state cornering around a 200-ft.-dia. circle; cw=clockwise, ccw=counterclockwise.



FORD MUSTANG GT

real world of potholes and frost heaves. The Saab would never lower itself to be something so plebian as "fun to drive," but it's awesomely competent on a canyon road—not to mention a worn-out freeway sliced with rain grooves.

Nothing much has changed on the Saab interior for years. The ignition key is still in the console, the styling is still offbeat, but the ergonomics are excellent once you remember where everything is. The seating position is superb. Unlike the Camaro or Mustang, which are obviously aimed at drivers who never travel more than 45 minutes from home, the Saab's interior is comfortable for the long haul.

All of the convertibles we tried have some compromise in the way the top folds and stores. But only the Saab's is absurd. All the others have soft vinyl boots that snap on in various ways, with varying degrees of difficulty. The Saab, on the other hand, has a 3-piece rigid plastic boot. The center is held in place by straps inserted beneath the lip of the trunk lid; the side pieces must be perfectly aligned to snap into place, then they shift and blow off at the first corner anyway. When the top is up, you have to store this bulky gizmo in the trunk. All in all, it's an uncharacteristically poor design for a

(Please turn to page 123)



PONTIAC SUNBIRD SE	RENAULT ALLIANCE GTA	SAAB 900 TURBO	TOYOTA CELICA
Base price: \$14,169	Base price: \$12,899	Base price: \$27,115	Base price: \$16,798
Price as tested: \$15,830	Price as tested: \$15,284	Price as tested: \$27,582	Price as tested: \$19,183
Engine: 96-hp SOHC 2.0-liter In-line-4	Engine: 95-hp OHV 2.0-liter In-line-4	Engine: 160-hp DOHC 2.0-liter In-line-4 Turbo	Engine: 115-hp DOHC 2.0-liter In-line-4
Transmission: 3-speed automatic	Transmission: 5-speed manual	Transmission: 5-speed manual	Transmission: 5-speed manual
Wheelbase: 101.2	Wheelbase: 97.8	Wheelbase: 99.1	Wheelbase: 99.4
Length: 175.7	Length: 164.0	Length: 186.6	Length: 173.6
Weight: 2700	Weight: 2300	Weight: 2900	Weight: 2700
EPA city mpg: 21	EPA city mpg: 26	EPA city mpg: 21	EPA city mpg: 25
Quarter-mile: 17.964 @ 75.40	Quarter-mile: 17.842 @ 75.88	Quarter-mile: 16.023 @ 85.20	Quarter-mile: 16.822 @ 81.68
Braking: 120.4	Braking: 125.2	Braking: 117.0	Braking: 134.4
Slalom ³ : 58.30/Skidpad ² : .78/.81	Slalom ³ : 58.38/Skidpad ² : .82/.83	Slalom ³ : 58.67/Skidpad ² : .75/.79	Slalom ³ : 58.77/Skidpad ² : .76/.75
Trunk space ³ : 10	Trunk space ³ : 8	Trunk space ³ : 9	Trunk space ³ : 9
Interior space index ⁴ : 119.04	Interior space index ⁴ : 113.78	Interior space index ⁴ : 122.56	Interior space index ⁴ : 112.53

3. The number of standard-size grocery bags that will stand upright (1-in. crush space permitted) in trunk with rear seats up.

4. Front-seat width × headroom × legroom + rear-seat width × headroom × legroom + 1000.



DETROIT SNEAK PREVIEW

Detroit's automakers have a lot of offerings for the last two model years in the decade. Completely redesigned cars from General Motors, Ford and Chrysler will appear in the middle- and upper-price classes. American Motors will begin production of a flagship sedan to compete against near-luxury models from both domestic and import competitors.

Biggest changes will come from GM, where completely new mid-range cou-

Our intelligence agent in Motown spies the future.

BY JIM DUNNE
Detroit Editor

pes—Grand Prix, Cutlass Supreme and Regal—will replace the current 10-year-old designs and the twice-delayed Reatta sports coupe may finally get on the road. But GM competitors are pre-

paring all-new designs of their own. Ford will have its slick aero-shaped Lincoln Continental to lure well-heeled customers to its showrooms, while Chrysler will introduce a new line of luxury sedans to replace the Fifth Avenue, Gran Fury and Diplomat.

In addition to the compact Medallion imported from France, AMC will offer a Canadian-built Premier 4-door mid-size model to sell against Celebrity, Taurus and LeBaron.



Lincoln Continental

Ford will take its successful Taurus/Sable plan and extend it to the smaller luxury sedan in the Lincoln lineup. The Continental will truly be all new for 1988. Look for front-wheel drive, a V6 engine, independent rear suspension and an aerodynamic shape. The car will compete against Cadillac's Seville. Prices will be in the upper 20s if they don't breach the \$30,000 barrier.

Improvements for the buyer, aside

from more room inside, will be better traction from the front-drive, slightly better fuel economy from a 3.8-liter V6, and a luxury-car appearance that is almost as distinctive as Lincoln's Town Car. Wheelbase will be a hair longer at 109 in. Look for air springs to be carried over from today's Continental.

Buick Reatta

A first for Buick, this 2-seat luxury coupe will make its appearance in show-

rooms during the 1988 model year, probably next spring. Reports indicate that the price will be in the high \$20,000 range, which makes the Reatta a competitor with many of the more expensive sports cars. But look for luxury to take precedence over performance.

Chassis details include a 3.8-liter V6 engine driving through the front wheels, independent rear suspension, adjustable ride (firm or soft) and anti-

(Please turn to page 124)

BLAST FROM

START FINISH

We race Stirling Moss at 160 mph in 30-year-old race cars as vintage racing sweeps the nation.

BY RICH TAYLOR, Contributing Editor
Photo by Art Eastman

It's one lap from the end, and all I can do is watch as the small red car grows larger in my mirrors. In true Sebring fashion, my brakes have disappeared completely. I wrestle the big Kellison through Turn Three, brutally downshifting into Third, then Second, in order to get through the Esses on the ragged edge of control and good sense.

He catches me as we accelerate side by side under the Camel Bridge, passes on the outside and tucks in front as I shift into Fourth again. By the time I get back down to Second for the hairpin, still brakeless, Stirling Moss in the Birdcage Maserati has opened up a 100-yard gap. He's chasing Peter Sachs in a Ferrari Testa Rossa, but even he must know it's hopeless. As

for me, I'm perfectly content to finish third behind them, my first time at Sebring, in a brand-new car.

Wait a minute. Stirling Moss? Birdcage Maserati? Ferrari Testa Rossa? Sebring? Brand-new Kellison? What kind of race is this?

It's vintage road racing, about as neat a time warp as you're likely to find. All over the world, otherwise sane car enthusiasts are resurrecting old race cars—20, 30, 50 years old—and racing them, wheel-to-wheel, as fast as they will go which, in the case of something like a Maserati Tipo 60 or my

THE PAST



The author at speed
in his 1959 Kellison J-4R
at the Bahama Grand Prix.

Kellison J-4R, is
very fast indeed—on
the far side of 160 mph.

There are more than 60 major vintage events in America each year, in every part of the country. The most important take place at: Sebring, Florida, in March; Elkhart Lake, Wisconsin, in July; Laguna Seca, California, in August; Lime Rock, Connecticut, in September; Palm Springs, California, in November; and Freeport, the Bahamas, during the first week of December. You can expect to

see about 200 cars at each event, along with such famous drivers as Juan Manuel Fangio, Phil Hill, Carroll Shelby, Dan Gurney and Stirling Moss.

Each weekend, there usually will be eight to 12 classes, divided into specific areas such as "Sports/racers, 1955-1959" or "Production-based sports cars, 1955-1962." Before you rush out and restore just any old sports car, you'd better make sure you'll be allowed to race it with the vintage group in your part of the country (see *Where To Sign Up* on the following page).

The general rule is that your car must be restored as it was the year it was manufactured. Adding American Racing Torque Thrust D wheels to your '63 Corvette is okay; fitting them with low-profile racing slicks is not.



Chevy-powered '67 Cheetah coupe (left) speeds down Lime Rock straight. Stirling Moss drove a '57 Aston-Martin DBR2 in the Bahamas.

Most racing groups allow modern radial street tires, shaved for racing, as long as you use 70-series or above. The requirements for drivers are less strict than for "real" racing. Typically, you must attend an approved racing school like Bob Bondurant's or Skip Barber's. If you already have an SCCA or IMSA license, you're also in. Safety equipment follows SCCA specifications for the most part—a rollbar, fire extinguisher, electrical cut-off switch and fuel cell for the car; Nomex suit, gloves, socks and a Snell 1980-approved helmet for you.

By far, the least expensive way to go vintage racing is in the SVRA's Groups 1 or 3. Inexpensive choices in these classes include Mini Cooper fwd sedans, Austin-Healey Sprites, Triumph TR-3s, MGAs, Alfa Juniors, Fiat-Abarths and many other "beginner"

sports cars. You should be able to put any one of them on the track for well under \$10,000.

Like any other type of racing, the faster you want to go, the more you need to spend. Mercedes enthusiast Joel Finn is said to have more than a million dollars in his late-'30s factory Grand Prix racer, and it's not uncommon to see collector cars in the \$500,000 range out there at top speed. Can-Am, Formula One, and Trans-Am cars from the 1966-1972 era are just coming into popularity, and consequently getting very expensive.

I literally inherited the Kellison coupe from the late Don Rodimer, one of the founders of the Sports Car Club of America, through the good offices of our mutual friend Chuck Kirkbride. The Kellison was one of several old race cars Don had stashed in barns all over

New Jersey. According to advertisements in old car magazines, in 1959 Kellison Engineering & Mfg. Co. of Folsom, California, would sell you a "complete, ready-to-drive production sports car—light, strong, sleek and surpassing Europe's most distinguished designs." This hand-build delight cost \$6700 in Eisenhower dollars.

By comparison, a new Corvette was only \$3875 and you could buy a full-size Ford or Chevy for under \$2500. On the other hand, a Ferrari Testa Rossa or Maserati Tipo 60 with comparable performance was \$12,000 to \$15,000.

The Kellison is typical of "big bore" American V8 sports/racing cars of the late '50s. The most famous were Lance Reventlow's Chevy-powered Scarabs and Max Balchowsky's Buick-engined Old Yaller, but forgotten marques, like Bocar, Lister-Chevrolet, Devin SS, Kurtis and dozens of others, built cars to challenge the all-conquering Ferraris, Maseratis, Jaguars and Porsches. The Shelby Cobra and Bill Thomas's Cheetah were the last holdovers, in the mid '60s.

As you might expect from a car that sat untouched in a barn for 25 years, our Kellison J-4R was a mess.

I towed it directly to Heads-Up Performance in Edison, New Jersey, where Wayne Celco and Timothy Shepherd duplicated the rusted-out frame with all-new tubing and remounted the fiberglass body.

They also rebuilt the engine, transmission and suspension, using primarily Moroso parts. Koni supplied the shock absorbers, VDO the white-on-black gauges. The tires are 235/70VR-15 Goodyear Eagle GTs on stock 15 x 7-in. Chevrolet steel wheels. Wayne and Shep also added a rollcage, fuel cell and other modern safety equipment required by the sanctioning group.

Augie Pabst's old Chevy-Scarab restored with its original Team Meister Brau colors.





Over a million dollars' worth of nostalgia at speed: a '58 Ferrari 250 Testa Rossa leads a '55 D-Type Jaguar at Laguna Seca, California.

To preserve that old-time look, we fit Offenhauser cast aluminum valve covers and authentic '50s speed equipment throughout the engine compartment. About the only late-model part is a stock GM alternator. Even the fiberglass racing seat is a "new-old stock" (NOS) part we found in the attic at Heads-Up and reupholstered.

Joey Welfel of Bodies By Hollywood in Upper Nyack, New York, restored the body and interior, using an acrylic enamel with hardener for the Corvette Bright White paint. Finally, racing tuner Greg Colletti of Controlled Performance in Roselle, New Jersey, went through the entire car, detailing it into an authentic world-class sports/racing car, circa 1959. The total cost was just about \$20,000—dirt cheap for a car with this quality of construction and performance.

After the usual last-minute thrash, my wife Jean and I loaded the nearly finished Kellison onto a new 4-wheel trailer custom-built by D&D Trailers of Trenton, New Jersey, hooked it up to PM's long-term Mazda B2000 pickup, threw a few spares and tools in the back, and headed for Florida.

We had a ball. The primary vintage racing group on the East Coast is the Sportscar Vintage Racing Assn. (SVRA) run by a young car nut named Ford Heacock and his wife, Kate. They cleverly arranged an all-vintage weekend at Moroso Motorsports Park in West Palm Beach the week before Sebring, so we could all get our cars sorted out—at least a little.

Then it rained. And it rained. A Kellison J-4R has no side windows and no windshield wipers—the windshield is scratchable plexiglass pop-riveted in place—so I spent the entire weekend delicately trundling around, getting soaking wet, breaking in the engine, and generally learning just what a beast I'd inherited. I wasn't racing, I was touring around a race track in the rain in an old car—cold, wet and too scared to be miserable.

Sebring was very different. The vintage race is half-time entertainment for



Max Balchowsky's Buick-powered mongrel Old Yaller in better-than-new condition.

Where To Sign Up

The major vintage racing groups are SVRA, Box 2896, Lakeland, FL 33806 (813-686-3104); HMSA, Box 30628, Santa Barbara, CA 93105 (805-966-9151); Vintage Racing, Box 7000-728, Redondo Beach, CA 90277 (213) 540-4498; VSCCA, 116 Long Ridge Rd., Bedford, NY 10506 (914-234-6494); and Chicago Historic, 825 West Erie St., Chicago, IL 60622 (312-829-7066). SVRA also publishes a quarterly magazine called *Vintage Motorsport*, with schedules and race reports from every vintage racing group.—R.T.

IMSA's 12 Hours of Sebring. So, instead of separate races for each of SVRA's eight classes, the older cars

are all lumped together into one "vintage" group, while the newer cars are called "historic." This gives a starting grid of something like 80 cars.

Just like an old-time Sebring endurance race, there's a tremendous performance spread between the 3-minute, 9-second laps Stirling Moss and Peter Sachs are turning and the 4:40s of the tiny Sprites, Fiat-Abarths, Panhards and Alfas. Even in our short 5-lap race, the fast cars pass the back-markers twice. I spend all my time threading through traffic, watching out for slower cars in front, checking the mirrors for faster cars behind.

The amazing thing is how *real* it all is. The lightweight Lotus XIs and Porsche RSKs dart around me in the corners, then my big V8 blows by them on the straights. The international stars—Moss, Augie Pabst, Murray Kempton Smith—drift through the corners so smoothly it makes my heart ache. The once-a-year amateurs bobble on—and sometimes off—the track, just as they did in the old days.

I'm not pretending to be racing against Stirling Moss in a Tipo 60, I am racing Stirling Moss. I'm not reading about Sebring in 1959, I'm *living* the Golden Age of American racing. Vintage racing is as real as you can get and still be driving antique cars.

I mean, when was the last time Augie Pabst came over to compliment you on your car and bench race about Scarabs for a while?

FM



Austin-Healey Sprite makes an excellent entry-level vintage racer for \$3000-plus race prep.

PM COMPARISON TEST

STACKED

Performance and conviviality converge in a 5-way deck boat showdown.



BY FRANK SARGEANT; Photos by Skip Gandy

Want to haul a pair of slalom skiers? No sweat. Blast out to that tree-rimmed island for a picnic? Hold on tight. Ferry skads of second cousins to an overnight beachhead? The line forms here.

All you need to accomplish these diverse objectives is a modern deck boat, the performance party boat that's sweeping Midwestern lakes and rivers. They're actually derived from the more sedate pontoon boats that populate most inland waters—with a major twist.

They're designed with comfortable padded seating in an amidships cockpit and in a bowrider area forward, along with a plush sunpad that doubles as an engine hatch. They've got endless storage for such indispensables as skis and coolers. They come with pop-up dinner tables to make mealtime more civilized. Some even come with sophisticated stereo FM radio/tape deck combos.

All of them mix the good times with hard-charging performance—enhanced by modified cathedral hulls and power options up to the

DECKS



Pleasure platforms from Four Winns (left) and Harris (right) combine 260-hp get-up-and-go with comfortable seating for 12. Beamy cathedral hull is the secret.

rip-snortin' OMC Cobra 5 liter, the stern-drive we chose for a recent head-to-head comparison conducted at the Stuart Marine Center in Stuart, Florida. The 230-horse V8s rocketed our party-decks up to speeds approaching 50 mph, yet ran so quietly and smoothly that normal conversation was never a problem in the cockpit.

So who needs a boat that looks like a tram and runs like a Cigarette? Lots of people—the boats offer tremendous versatility, especially for the family man. There's enough accelera-

tion and speed for serious slalom skiing, adequate rough-water performance to take on both big lakes and coastal bays, plenty of space to wet a line if fishing is your thing, transom swim platforms to assist in taking a dip or scuba diving, and just acres of space to stretch out and soak up the sun.

The five test boats came from Harris/Kayot, Four Winns, Godfrey Marine, Murray Chris Craft and Sunchaser. There was a lot to like in every model, but after several days of tests, the PM team selected a winner based on

STACKED DECKS

obvious advantages in performance and comfort. Here are our results by the numbers:

Harris FloteDek 2000 LSI

With top scores in acceleration and efficiency at cruise, the Harris is an easy boat for the performance-minded skipper to like. Add the tremendous eye appeal of the beautifully finished interior upholstery, the high-tech look of the command post and the luxurious feel of the seats and sun pads, and it was hard not to make the FloteDek our top pick. The boat has full windshields on both consoles, which kept spray and wind off driver and copilot during rough, open water runs on the Indian River. The padded, sports car-style wheel is easy to grip even in locked-over high-speed turns, and the entire steering system feels exceptionally solid and smooth. The boat tracks well, and because of a significant freeboard, gave a more secure feeling than most of the competition during high-speed maneuvers through a series of 90° turns on the narrow St. Lucie River.

Well-positioned analog gauges are easy to read with both hands on the wheel, and the digital-look faces give the command post a high-tech appearance that's clean and striking. The tilting steering wheel allows adjustment for any size skipper, but interferes with the stereo controls in the full up position. All switches are on the dash, with fuses directly under them—a blessing for those who hate nose diving under the console when there's a short.

The sun pads fore and aft provide lots of lounging space, and the raised lip on the after side of the stern pad should offer security against rolling overboard by sleepy or juvenile loungers. The boat has an exceptionally large ski-tow eye,

mounted on a raised pedestal at the transom for easy access. The broad plastic rub rail is well located to prevent scratches on the gel coat. The only other functional problem experienced was in opening the teak cover over the ski-stowage area—wet, swollen wood made the fit so tight that considerable prying with appropriate tools and words were necessary to release it.

Four Winns 200 Candia

Because it was the deepest of the deckboats tested and had the cleanest hull form, the Four Winns was a natural favorite with the test crew. However, it finished last—not by much, but still last—in each of the performance categories. Despite top ranking in rough water ride, stowage space, seating space and lounging area, the boat had to be dropped to the No. 2 spot on weak performance.

But the boat has an exceptionally solid feel, thanks in part to the five 5-stringer system stiffening the hull, and to the extreme 19° deadrise, which also accounted for the easiest rough-water ride of any of the contenders.

The Candia has about the same LOA and beam as the Harris, yet has actual seating space for 15 and is rated for 13 adults. The Four Winns has considerably more deck space than the other boats tested, and makes a quantum leap when it comes to storage space—more underseat and underfloor storage than in any other model, plus two voluminous boxes on either side of the engine in areas that are totally filled by wiring and accessories in the other boats. The sun decks and swim platform were also the largest of any boat tested.

There is also an evident attention to design details that we particularly liked. The engine hatch, for example, has a positive lock in the center of the boat, easy to get to and smooth to open—something that could not be said of any

Test Parameters

Each deckboat was equipped with a 230-hp OMC Cobra V8 sterndrive turning a 14½ x 19 SST prop. Prop selection was performed by an OMC tech team in accordance with factory recommendations. Top-end and acceleration tests were performed with two adults aboard using a Decatur radar gun and Heuer digital stopwatch. Efficiency at cruise was established with four adults aboard using the radar gun and an OMC Quartach tachometer.

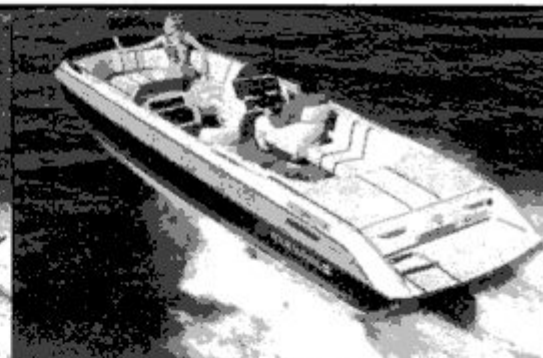

OVERALL RANKING/MAKE/MODEL	1. HARRIS FLOTEDEK 2000 LSI	2. FOUR WINNS 200 CANDIA
LOA/Beam/Weight/Fuel Capacity	20'6"/96"/2750 lbs./25 gal.	20'0"/96"/2716 lbs./27 gal.
Deck Area (sq. ft.)	30.14/Easy access to cockpit from dock welcomed	34.02/Easy passage fore and aft
Sun Pad: Forward-Aft (sq. ft.)	21.2-16.40/Room for two aft, but still crowded	25.7-16.71/Most spacious platforms offered
Stowage: Total under seat, gunwales (cu. ft.)	19.68/Adequate, but not a strong point	25.87/Clearly superior in this category
Stowage: Under cockpit sole (cu. ft.)	5.25/Built with skiers in mind	4.75/Acceptable, but could use more space here
Seating: Actual-rated	10-12/Extremely spacious despite rating question	15-13/Honest seating; great wrap-around bench aft
Hull Construction: (see key)	4 LY CR/2 LY WR/FG Wd SS/Inj. PU	3 LY CR/2 LY WR/FG Wd SS/Inj. PU
Top-end: Speed/Ranking	45.75/3 (tie)/Amenities cause slight speed loss.	45.50/5/Won't win any prizes
Acceleration 0-30: Time/Ranking	6.35/1/Winner by a whisker	7.59/5/Sufficient for partying, but skiing, too?
Efficiency: MPH at 3000 rpm/Ranking	32.5/1/Slightly faster with less effort	31.1/5/Obviously sluggish
Performance Course: Time/Ranking	1.06.67/4/Slow but comfortable handling	1.08.77/5/Extremely slow, but still solid
Fit-and-Finish: Ranking	1/Striking upholstery and glass work	2/Detailing excellent throughout
Price with OMC Cobra 230 test engine	\$22,388	\$19,400

Hull Construction Key: HLU=Hand Layout; LY=Layer; M=Mat; CR=Chopped Roving; WR=Woven Roving; FM=Fabmat, combination mat and roving; SS=Stringer system; Wd=Wood; FG=Fiberglass Reinforcement; Inj.=Injected; Spr.=Sprayed; PU=Polyurethane Foam Flotation



Superb cockpit configuration. Easy access to entertainment stack on left. Tilt-wheel greatly appreciated.



Analog gauges give digital impression. Trim gauge failure a disappointment. Comfortable throttle, switch access.

WHAT MAKES A DECK BOAT SPECIAL?



other boat in the test. The Bimini top fits neatly under the hatch, and even the support poles drop out of sight.

The high console windshields, super-deep freeboard and well-fitted bucket seats gave a feeling of security even at maximum speed through the performance course. Steering is very positive and smooth, and the padded sport wheel is easy to grip, even with wet hands. The dash has digital-look analog gauges, all easy to read from the driver's seat. The

seats are controlled with positive lock ratchet devices, much more dependable than the friction locks on some models.

Problems were minimal, and included a side bolster that interfered with throttle operation in reverse—easily cured by mounting the control on a shim—and the fact that four of the six drink holders aboard were mounted in side pockets where it was just about impossible to fit a 12-ounce can without spilling. *(Please turn to page 128)*



3. GODFREY HURRICANE 196	4. CHRIS CRAFT VIKING 190	5. SUNCHASER 1908 DC
18'10"/90.5"/2825 lbs./24 gal.	18'6"/92"/2519 lbs./21 gal.	18'6"/93"/2700 lbs./20 gal.
31.02/Passable, but cramped	30.57/No change from Hurricane	29.7/Meager, still permits easy passage fore, aft
21.0-18.86/Small, but comfortable for one	23.20-17.07/Up with the big boys in forward area	20.08-17.19/On the tight side
11.54/Suffers badly in the storage category	23.83/Surprisingly roomy given small overall size	19.72/Not bad; on a par with the Flotetek
4.62/Minimal, but still adequate	4.39/Suffers slightly here	0/Absence of ski stowage a clear drawback
12-12/An even dozen still gets a little crowded	10+-9/Honest capacity	10+-10/Still a little crowded
3 LY M/2 LY WR/FG Wd SS/Inj. PU	4 LY M/FG Wd SS/Inj. PU	2 LY WR/2 LY CR/FG Wd SS/Inj. PU
45.73/3 (tie)/Brisk performer, a standout	47.25/1/High speed an obvious function of all-up wt.	47.0/2/The boat's obvious strong suit
6.49/2/Superb for skiing and over long haul	6.60/3/Should have done a little better here	7.28/4/Hole shot suffers, however
32.3/3/Consistent with competition	32.45/2/Achieves speed, smooth running at cruise	31.4/4/Extremely sluggish
1.04.41/1/Magnificent; tight sportscar feel	1.04.85/2/Slightly off the pace but still solid	1.06.80/3/Steering loose; no confidence in turns
3/Nicely detailed; good glasswork	4/Cost cuts show in interior	5/Rough glass work and detailing
\$18,010	\$15,230	\$16,000



Only deckboat with tight, padded steering and high-performance "feel." Throttle, wheel, gauges in perfect balance.



Metallic wheel a definite drawback in wet, slippery conditions. Wheel also obscures gauges, blocks switch access.



We'd prefer to have mph and tach closer together to wring out last available rpm. Otherwise, well-balanced layout.

COVER STORY

NEW AGE RVs

Today's motorhomes shed the clunker image with computer-generated aerodynamic styling, molded construction and more efficient chassis design.

BY BOB LIVINGSTON



The engine grabs your attention: a turbo-charged BMW diesel rated at 115 horsepower, neatly tucked into the rear of the vehicle. A DeDion suspension and gas shocks control the rear wheels while the front suspension utilizes independent A-arms, also with gas shocks. The transaxle includes a 5-speed Renault transmission, which gives the vehicle good gear versatility. Drag coefficient is only 0.295, even though the vehicle has enough stand-up space for a shower.

A shower?

Indeed, we're talking about a motorhome—albeit a very different one. It's the Vixen, one of several new motorhomes that form the leading edge of technology in the recreational vehicle (RV) field. The Vixen is different in that its designers, former auto company engineers and

executives, are trying to entice the yuppie crowd into the home-on-wheels lifestyle.

Traditionally, motorhomes have never been fancied by car buffs who want real driving machines. Aluminum-clad boxes on wheels are still around for those who want them, but the industry now offers a wide variety of shapes, styles and accommodations. The more sophisticated of today's motorhomes feature aerodynamic styling, advanced suspensions, high-tech computer-controlled appliances and improved fuel economy.

Leading the way into future motorhome design and function are manufacturers who integrate science and technology into coaches already packed with amenities and luxury. While the trend seems to be shifting to



The Chevrolet Astro Van forms the aerodynamic nose and chassis system for Allegro's Class C motorhome, far left. Aboard Eldorado's new Starfire, center, Ford's new specially designed motorhome chassis permits spacious interior and radical exterior styling. Winnebago, right, bids adieu to traditional corrugated aluminum in the Itasca Windcruiser. Steel underbody and molded synthetic body panels highlight industry trends.

Class A coaches with wind-cheating aerodynamics and European-inspired interiors, it is actually going in two different directions.

Motorhomes with an automotive approach to styling and handling have always attracted a more spirited crowd. Other potential buyers, who gravitate to plush interiors with ample storage, appear to consider exterior styling secondary. Many RVers are certainly ready for sleek motorhomes with high-tech interiors and drivetrains, but at the same time, others find high-profile rigs featuring enormous storage capacity and maximum length genuinely appealing.

Vixen and Eldorado are the leaders in innovative, automotive-type motorcoaches. The RV giants—Fleetwood, Winnebago and Coachmen—have been more modest in their aerodynamic approaches, but are also building models with curved fronts and sidewalls—aesthetically good-looking RVs that handle well.

In the opposite direction, the raised floor, basement-type motorhomes, inspired by the Fleetwood Bounder, have taken the consumer by storm. Many buyers seem to be infatuated with conventionally styled motorhomes that offer huge storage capacity. These rigs are built reasonably well and are good values. The fact is, variety in the motorhome segment of the RV industry is excellent. Buyers can choose from relatively inexpensive, fully equipped coaches suitable for large families or opulent, 40-ft. rolling mansions. The young executive who wants something fun to drive that also provides overnight accom-

Airstream's Tag Axle

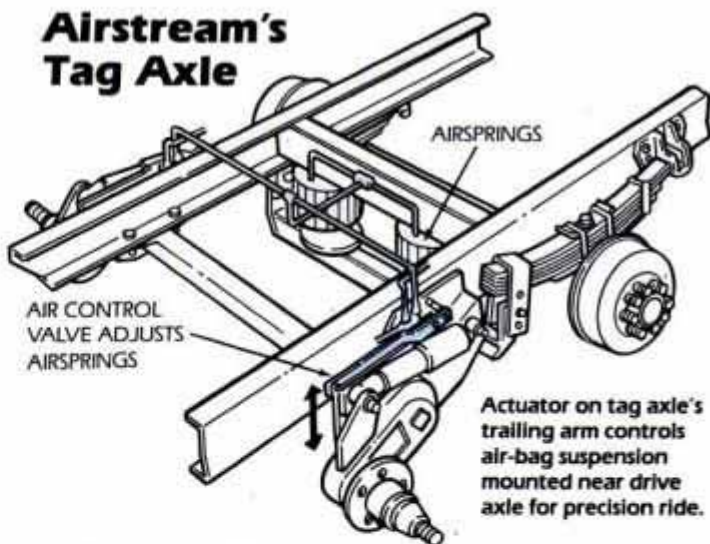

modations doesn't have to settle for the traditional motorhome, and the buyer who places storage and livability higher in priority than style will find plenty of choices.

For the independent thinker, the Vixen may be just the ticket. The brainchild of former GM executives William T. Collins and Robert M. Dewey, the Vixen is new from the ground up and is called a motorhome only for lack of a better term. It features components that are uncommon in most recreational vehicles and an appearance all its own. Fully loaded, the Vixen sells for \$41,000.

Inside, the Vixen takes the Mercedes approach—somewhat Spartan by American standards, but rugged and functional. The coach sleeps two adults on a permanent double bed in the rear and two people (if they're cozy) on the front convertible dinette. An automatic roof expands headroom to 6 ft., 6 in. Vixen's approach to interior amenities uses many ideas from the boating trades and from European RV manufacturers. Propane is missing, as is an AC generator. Power is supplied by a 12VDC-to-120VAC inverter and by outside hookups. The stove runs on alcohol; a diesel-fired furnace and heat exchangers provide hot water for showering, washing dishes and for comfort heating. Some of these items can be found in high-line Class A motorhomes, but for the most part, the majority of motorhomes produced in the U.S. continue to be equipped with the more conventional RV appliances.

Starfire's niche in the market is its innovative exterior treatment and Euro-style interiors. It was the first coach engineered exclusively for the new Ford Class A chassis. The Ford chassis is an effort to compete with Chevrolet in the RV market, which has long held dominance. Its steering wheel is positioned farther forward than Chevy's, which permits a smaller, more aerodynamic shape outside—and more volume inside. A smooth, 1-piece fiberglass exterior and ultralight honeycomb insulation are key weight-reduction factors built into the Starfire's construction. Performance is brisk; driver position and handling are good. The Starfire is available in 27- or 31-ft.

Tailgate-Party Van Of Tomorrow



Sculpted front end, contour seating and integrated roof storage characterize the Plymouth dream machine. Party module, top, inserts in tailgate.

Van conversions are an important element of the recreational vehicle industry, and Plymouth hopes to get a significant leg-up on the market in the future with lessons learned from its new Grand Voyager concept mini-van. From the ground up, the Grand Voyager sports individual high-tech automotive innovations that may become commonplace in the mid-1990s. Details include four, dual Goodyear tire assemblies that eliminate the need for a spare. Further, sculpted hood, headlight and grille packages blend with the bubble windshield and raised roof. A separate roof cavity incorporates an enclosed curbside tray that slides out for gear storage. The left-side commander's seat allows easy access to switches, gear selector, cruise control and the computerized navigation terminal. A centerline jump seat up front folds back to become a CRT monitor for TV viewing. Special tables fold down for the convenience of rear-seat passengers. At party time, a special modular tailgate section is inserted aft, which contains cargo shelves, flip-up grocery bag holders, a cooler and a tiny, self-contained manual-pump sink. Plymouth says its Grand Voyager concept van will probably never see a showroom floor, but we can expect various features—particularly the seats—to appear on the production line soon.—T.C.



Streamlined dash also includes onboard navigation terminal.



Rear passengers have access to CRT for TV viewing and games.

lengths; that includes an extended nose, capped by the look-alike grille from Ford's Continental Mark VII series automobile. Price is under \$70,000.

The Euro coach also appears in Champion's "poorman's bus-conversion," the Eurocoach, which has become an instant success. The name may imply that the coach has European origins, but in fact, it's all American. In developing this coach, the company mated a John Deere Class A chassis and a steel/fiberglass structure to create a coach that gives the impression of a converted bus.

The Eurocoach is 33 ft. long, which is somewhat shorter than a bus-conversion (most are 35 to 40 ft.), but many elements make it seem longer. Huge exterior storage compartments, similar to those in Greyhound buses, are built into the sides of the coach. The base price for Champion's bus-conversion mini-clone is \$52,000.

Although Class As have dominated the motorhome field for the past few years, the mini retains special appeal. Mini motorhomes (Class Cs), have not seen much design change in recent years except in units built on the new Chevrolet Astro and GMC Safari vans. In what could be a good balance between power, size and fuel economy, a few manufacturers have cut away the Astro or Safari bodies and installed conventional RV amenities.

Establishment's Aerolite and the Allegro (pictured) are prime examples. These coaches are a generous step up from a micro-mini (based on an imported truck chassis), are considerably smaller than traditional Class Cs, and are affordable. The Aerolite, for example, sells for \$27,500 with an average amount of optional equipment. The available interior space is limited, but well-thought-out floorplans and tasteful decor have made these rigs suitable for a couple or young family.

GM's 4.3-liter V6 does a remarkable job of powering 3 tons of coach—spunky performance for a rig that averages 17 mpg. These coaches are fun to drive, and people who are too intimidated to drive large vehicles will quickly feel right at home. The downside is the limited load capacity.

Class Cs have always appealed to families because they have good sleeping facilities and are less costly than Class As. But Fleetwood, the nation's largest builder of recreational vehicles, last year introduced the Bounder, a Class

Best-Selling Bounder

Raised floor permits flexible interior design and immense storage capacity.



A that can honestly compete with a high-priced Class C. The Bounder's claim to fame is the aforementioned raised floor positioned at the same level as the driver's compartment. This unique design allows for massive storage compartments in the space between the interior and exterior floors. The process didn't do much for aesthetics. Doubters agreed that it was a great family coach, but figured it would never sell because styling was a step backward for the RV industry. At best, the coach looked awkward and hard to handle. But it sold like it was the latest fad! And handling, surprisingly, is good.

Bounder's instant success convinced other manufacturers that the raised-floor concept is here to stay. A number of companies, including Komfort, Establishment, Allegro and Winnebago, are currently producing basement-equipped coaches. The benefits are obvious: maximum storage capacity, versatile floorplans suitable for large families, exceptional visibility for passengers while traveling, and, most of all, low price. It's not uncommon to find a fully equipped 34-ft. Bounder retailing in the \$40,000 range. Bounder-type coaches may lack futuristic style and glitz, but they qualify as affordable rigs, especially desirable for first-time buyers.

The age of computerization has helped many manufacturers, especially Winnebago. The pioneer motorhome builder created the Itasca Windcruiser and Elandan Class As with extensive use of computers. These coaches and similar models by other companies such as the Fleetwood Eleganza and Eagle, are very popular. They feature curved sidewalls and aerodynamic front caps with varying degrees of windshield slant.

Windcruiser and Elandan models are built in one of the most advanced assembly plants in the world. A Detroit-type assembly line is used to create an automobile-style cab structure for the Windcruiser and Elandan models. A few years ago, Winnebago applied special emphasis to the frame by building the first independent cab cage that's later added to the chassis. The concept provides a truck-type front end for the coach where the dash, windshield, driver and passenger doors, firewall and floor are supported by a steel structure. Prior to installation, the entire cab is electrodeposition painted, which provides state-of-the-art rust protection. Currently, Winnebago manufactures the majority of the parts necessary to

(Please turn to page 130)



For the performance-minded, the BMW-powered, pop-top Vixen combines excellent fuel economy and sporty road handling with basic accommodation. Price is \$41,000.

The Art Of Motorcycle Touring

Driving a motorcycle across the country or around the globe begins with the right equipment—and lots of friends.

BY MALCOLM FORBES

Having discovered the turn on of motorcycling at the age of 48—having had a deprived childhood in that regard!—I've been trying to catch up ever since. In purchases, I'm making up the lost ground quickly—there are 40 bikes in the garage at home now, two that stay on our boat, *The Highlander*, four or five in London, and four, I think, in Morocco. And two or three at our *Chateau de Balleroy* in Normandy.

Of course, there's also a number of dirt bikes and street bikes out at the ranch in Colorado, which we keep there for summer tours.

The variety of machinery at these locations runs the full gamut of motorcycling's many choices. We've got the fully loaded touring mounts—Honda's Gold Wing and Yamaha's Venture most notable among the long distance specialists—and a mouth-watering array of Harley Davidson's finest. There's the pure sport bikes such as the Italian-built Bimotas, sport tourers personified by BMW R and K-series cycles, and even outrageous hot rods like the Yamaha V-Max.

I've also acquired a number of very limited-production machines: a pair of Kawasaki-based Vetter Mystery Ships, an Amazonas from Brazil and a Munch from Germany. There's also a pair of British Heskeths and a sprinkling of old favorites such as the Soviet bike we picked up on our tour of Russia.

More than a simple matter of conspicuous purchasing, the widely spread motorcycle supply of the Forbes fleet is just a way of saying that I don't want to ever have to be without one to ride. Sometimes it's just for pleasure with friends; other times the tours are a recess from the

Malcolm Forbes will tour East Germany by motorcycle sometime this summer.

Brimming with bikes, Malcolm Forbes's garage reflects a most unusual passion for 2-wheeling.

PM PHOTO BY HUMPHREY SUTTON





international business concerns of Forbes Inc. And there's the well-publicized Goodwill Tours, which marry two of my deepest devotions—cycling and hot-air ballooning—in order to promote friendship and understanding between the U.S. and our global neighbors.

The experience accrued in planning these excursions has taught a lot of practical lessons and a number of philosophical ones as well. Touring by motorcycle is such a refreshingly different way to go. It allows sightseeing the way it can't be done in a car.

To reporters probing the sanity in my passion for motorcycling, I've patiently explained that on a motorcycle you don't just see the environment, you integrate with it. You feel the temperature change from mountain to valley. You smell the crops in the fields. You're alert to what's going on around you because motorcyclists who do not stay alert tend to have very short careers.

Personally, I find that anytime I'm in a car, I wish I were on a bike. Not wasting a good opportunity to enjoy the going. Even here in New York City, I use the two bikes I keep in the office garage very often.

Riding in the city traffic is great—in traffic you can get all the way to the head of the column waiting for a red light and away you go. It's been hard, but by now I've acclimated most of the doormen in places like the Waldorf Astoria and the Twenty One Club to the fact that a motorcycle has as much right to the curb as the limos do.

Whether it's a Sunday Poker Run or a 2-week trek through China, our tours always begin with the end—the destination—in mind. Generally, we sketch out a few possible routings, seeking out the widest variety of scenery and roads that are graced with both a multitude of curves and a dearth of traffic.

The tone of a tour is dictated by the number of riders and the locale in which we're traveling. The solo rider may well find a certain freedom in camping along the way, but 3½ years of it in the infantry during World War II, plus one more recent nighttime visit by bears, gave me my fill.

Personally, I think there's much to be said at the end of the day for a nice motel and a good restaurant, particularly if you're of a vintage age. That really makes the day's ride and lifts considerations about having to stop soon enough to pitch camp and cook a meal.

In summertime, you really can't ex-



Leader of the pack Malcolm Forbes, foreground above, departs for a Poker Run from Timberfield, his New Jersey estate. Bottom, Forbes and company blaze the Polish countryside enroute to the Soviet Union. Right, the first formal motorcycle tour of the U.S.S.R., including (from left) Bob Forbes, Malcolm Forbes and Moira Forbes.

pect to roll up at the end of a day to empty hotels with rooms available, so you have to figure it all out ahead of time and make reservations before leaving. In Europe, even with just one or two companions, I make reservations in my name at the best hotels so when we drive up on the motorcycles they can't very well cancel. But we've strewn consternation behind us when we've pulled up to the snobbiest 4-star hotels of Geneva or Rome. They're just not accustomed to having a leather-clad, helmeted crew in their lobby. You know, it not so much startles, but it bemuses, intrigues and occasionally

alarms the stuffed shirts and ample-bosomed dowagers, sitting in the lobby, looking for something to cluck over.

The friendship tours are even more structured, with every point of interest and overnight stop planned far in advance by the host government or a national agency of tourist affairs. What with receptions and dinners and meeting the mayors, governors and prime ministers, it all has to be very organized. On these trips, we essentially travel by cavalcade—eight bikes are air-freighted in, there are two or more news film crews, and our support truck for the hot-air balloon flights.

The process of obtaining permission and setting up an itinerary is rigorous work, but worth it because of the interesting destinations.

This summer's goodwill tour will be to Germany—East as well as West—if all goes as planned. We'll fly a balloon in the likeness of Beethoven to honor the 160th anniversary of his death. More than anything, it's connections to friends with inside connections that get our foot in normally closed doors.

The pace of our tours, and therefore the routes our ride can take, is a function of the miles between this morning's starting-out point and tonight's sleeping place. We usually plan not to go much more than 300 miles. Here in the U.S., we go 400 with no problem, but 450 is tops because we like to arrive at our overnight spot at 4 in the afternoon



The cross-channel hovercraft provides supplementary transport on one Forbes tour.

PHOTO BY BOB FORBES



LEFT AND INSET PHOTOS BY BOB FORBES, RIGHT PHOTO BY C.V. AUGUSTUS

for the chance to relax, swim, see what's to be seen, case the town.

Traveling on a motorcycle, there's so much fun in the moving that you hate to interrupt it until your bladder is full or your gas tank is empty. Even though the Forbes business concerns include a number of museums, I'm not really a heavy museum goer. It takes a conscious effort to stop where it says Historical Marker, but when I do gear up mentally to stop at the next one, it's a rewarding experience. The rare-enough chance to trade pinstripes for riding leathers tends to make me savor the going and pass on the sightseeing.

The early morning start, for me, is part and parcel of the experience to see the dawn and the beginning of the day—by 10 a.m. you've got a lot of mileage under your belt and that mileage is fresh, not gas-fumed or smogged yet. The countryside is always more exhilarating in the dewy morning.

Keeping a group of riders together on the road is no small trick. We've not found a satisfactory voice linkup yet, but we can make sure that everyone at least catches up by the end of the day. Every rider in the group gets a photocopy of the area map, with the roads highlighted in felt-tip pen. A route schedule, detailing each turn and change of course is taped to the gas tank of every bike on the ride. Lunch is generally marked down for somewhere near our day's halfway point, and two

fuel stops are planned. Everyone also gets a list with the location and phone number of each overnight stop, an emergency "base" phone, and the number of the mobile phone if we've packed it into one of the saddlebags. Experience has shown that this obsession for preparation is not wasted effort.

On the international trips, keeping the pack pointed all in the same direction is made simpler by the chase vehicles hauling luggage, spare parts and the balloon gear. We don't use that sort of backup in our stateside tours generally, but on last year's run to Maine with 20 or so people on our bikes we had

the Forbes helicopter tag along for support. As it happened, the riders at the front of the group were pulled over on the Interstate for a little discussion with the keepers of law and speed limits. The officer first took note as the rest of the group pulled alongside, but when the helicopter came to a hover overhead he was good-natured enough to return driver's licenses and wish us all a happy ride!

Beyond the choice of an appropriate motorcycle for the touring you prefer—a beast of burden for heavily packed 2-up duty, or an agile sport machine for solo jaunts—the equipment most important is proper protective gear. Leather happens to be the strongest material practical for motorcycle clothing—it's the only armor between you and ripped skin in case of a fall. In spite of their bad image, leathers indicate total good sense. If you see someone on a motorcycle in cutoffs, T-shirt and sneakers, then you can properly conclude not that they're crazy for riding a motorcycle, but that they're crazy for not respecting the motorcycle. To the rest of the world, you should be less suspect in leathers than if you were wearing cutoffs!

The superiority of leather may not hold forever. I have a set of Kevlar-lined denims, made by a company that tried to make a go of it in motorcycle clothing about 10 years ago. Kevlar, of course, is stronger than steel, but by



Father and son arrive alive near the top of the world after a stint through Scandinavia.

PHOTO BY DR. JAN ENGELIUS

the time you build it into a suitable lining, it's pretty bulky. I gave one of the jackets to President Reagan after the shooting incident, suggesting that he might make us all feel safer if he wore it for horseback riding and wood chopping. Anyway, if the problem of making it more supple can be solved, there's a future for this type of garment somewhere down the road.

Maybe riders should have the option of wearing helmets, but I think it's mighty foolish not to. Based on my experience, I would be dead now as a result of the accident I had in Montana's Glacier National Park had I not been wearing a helmet.

I recovered from the concussion, collapsed lung and three broken ribs quickly—in just 10 days I felt up to a balloon ride—but without the helmet, it might have been my last ride.

Not wearing a helmet is not a matter of freedom, it's a matter of losing your freedom, vegetating yourself.

Why put yourself up against such heavy odds?

Wearing a helmet that meets the specs is the first requisite. In New York City, I wear a half helmet, because total visibility is necessary in the dense traffic flow, and you're not apt to be going the speeds at which open-road accidents happen.

My mechanical knowledge ends after I turn the key on, so it's fortunate that we have a couple of cycle expert enthusiasts—Dave Stein and Jack Creelman as well as Errol Ryland out at our ranch—to look after the machinery. Judging by the lack of mechanical trouble experienced on the road, they are doing a first rate job.

What they tell me works best is a

strict, by-the-book maintenance program for all the regular, scheduled lubrication and tuneup work. Major repairs are handled by local dealerships, as it would take some kind of genius to work on all the different machines in our garage. On the road, every morning the fluid levels and tire pressures are checked. Drive chains are lubed and adjusted daily on those bikes that are so equipped. The majority of the Harley-Davidson line has now converted to belt-drive systems, and it seems maintenance free.

Preventing possible breakdowns is just as vital. Batteries are regularly removed for a specific gravity check and charged on the workbench. When reinstalled, the cable clamps get a touch of RTV sealant on the fasteners—that way, if something works loose, at least that part will be right there to bolt back on. Clutch and throttle cables are treated to a Teflon pressure-lubing. Before this riding season gets underway all of our maintenance, repairs and mileage will be tracked by an IBM computer setup dedicated solely to the motorcycle operations. Close to home, we fill gas tanks with our own 109-octane Cam 2 Gasoline to prevent detonation damage to the engines.

When we go on our tours, we take a full supply of tools for repair work and a selection of commonly needed spares such as sparkplugs, fuses and oil. Because our time is not unlimited, we prefer to keep going if at all possible, leaving a bike in need of repair for later pickup. Tires are changed at 4000- to 5000-mile intervals, and if we have a flat we can repair it most times with a standard tubeless tire plug gun and refill it using the on-board compressor of the Honda Gold Wing, for instance. Major rebuilds are a rare occurrence for most of our machines—they're traded or sold before they clock that many miles, and regular exercise seems to be as good for the motorcycles, mainstream or exotic, as it is for me.

Naturally, a proper touring bike must have the comforts that will let you enjoy the miles. A windshield, or fairing, is the bare minimum, and most fully equipped factory offerings come with them as standard equipment.

As the rider leading the pack, I find a radar detector to be a necessity, and I have them on most of my bikes. The Passport is great. It lights up, and buzzes very audibly. Other essentials: A VDO quartz clock is mounted on every bike, and a helmet lock added if the factory lock is insufficient. There's not a motorcycle made with a horn loud enough to satisfy any safety-minded cyclist, so we've done some development here. A second stock horn helps, a Fiamm electric horn is a little better

(Please turn to page 132)

What's Up With Malcolm Forbes

What can the man who has done almost everything look forward to for amusement? After amassing one of America's largest fortunes in the family publishing empire, collecting some of the world's most precious art treasures, founding a few museums and hobnobbing with the planet's power elite, most of the normally accessible forms of enjoyment would have to seem unbearably tame.

Don't take pity on Malcolm Forbes, though—he's found his own way through this quandary.

Thanks to his abundant supply of hot air (courtesy of the propane tanks, of course) and his considerable collection of motorcycles, he's able to set off on adventures that mere mortals can only dream of. Gathering up family, friends and press, Malcolm Forbes and his International Goodwill Motorcycle Gang finagle invitations to countries which normally ignore the requests of sightseeing throngs. The Forbes entourage brings some special attractions, though—the warmest wishes of the American people,

the delicately sowed message of capitalist advantages, and the inevitable hot-air balloons specially commissioned for each Goodwill Tour. In Egypt it was a Sphinx, in Thailand an elephant, in Pakistan a 240-ft.-tall replica of the Minar monument. The balloons, displayed in public spectacles of lighter-than-air flight, are an effective method of carrying the message of global amity, and making friends is high on Malcolm Forbes' list of things worth doing.

Forbes' addiction to the slow and nearly silent world of hot-air transportation was an interest that he pursued in his usual full-speed-ahead manner. Within a year and a half after his first early-morning balloon ride he completed a record-setting cross-country flight that ended with a nearly fatal dunking in Chesapeake Bay. Barely a year later, he set off to cross the Atlantic Ocean by gas balloon, that project canceled by a near tragedy on the launch attempt.

On his Friendship mission to China, where no Americans had toured since 1947, an unauthorized freeflight near the Great Wall was topped off with a landing on a Red Army base restricted zone and a tense detainment of several long hours.

Through it all, Malcolm Forbes insists that, like the entourage of Harley-Davidsons in a foreign land, the hot-air balloon works as a "barrier breaker, not just a bone breaker." His latest friend-maker is a 174-ft.-long replica of Harley's Heritage Softail model, and you can't help but agree that its chubby lines and lethargic

pace are friendly to a fault. So the collector, curator, publisher, capitalist—and nearly a state governor—now takes on the role of International Goodwill Ambassador at large, bringing an impression of Americans to the world that covert aid and secret arms shipments never could. With the added incentives of unexplored lands to ride through and glide over, that's about the most enjoyment a mission of humanity could ever be.

—Norman Meyersohn

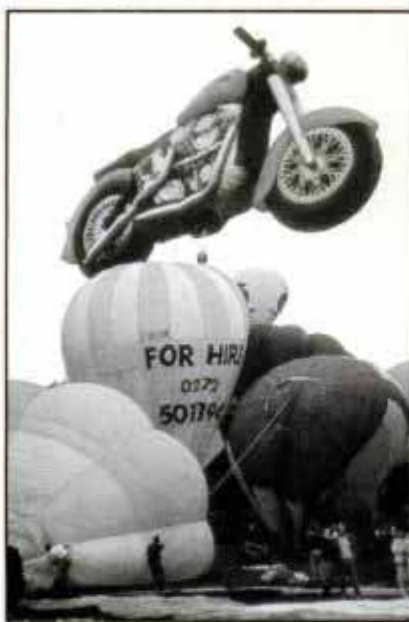



Passions merge: Forbes' latest hot-air balloon, shaped like a Harley-Davidson.

Levels

Simple hand tools that establish dead-on accuracy.

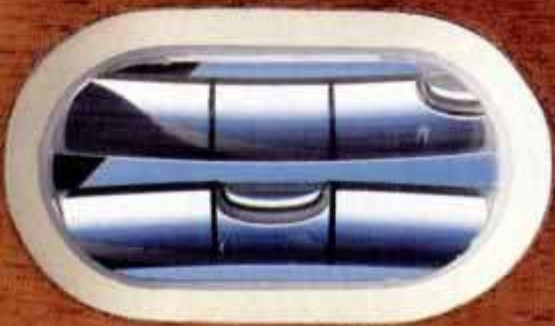
BY JOSEPH TRUINI, Shop And Tools Editor
Photos by Brian Kosoff



No homeowner's toolbox would be complete without at least one level. For do-it-yourself home improvement projects, a level is needed to determine level (horizontal) and plumb (vertical) alignment. The level, thought of first as a carpenter's tool, is also essential to masons, plumbers, electricians, engineers and millwrights.

One of the original levels, a wood A-frame with a weighted line hanging from its vertex, was used by ancient Egyptian pyramid builders. The spirit, or bubble, level was invented around 1660 and used on telescopes. However, it wasn't until the mid-19th century that the sealed glass tube containing alcohol and an air bubble was set in a wood or iron rail for use by craftsmen.

Today, there are many different types of levels available. Some are general-purpose levels while others are specially designed for a particular type of work. Levels are made of various materials including wood, aluminum, magnesium, cast iron and plastic. They range in size from about 2 in. to 10 ft. An active do-it-yourselfer should own at least four levels: a line level, a 9-in. torpedo level, and 2-

Levels

ft. and 4-ft. carpenter's levels. The vials are made of glass or plastic and are often protected behind a window. Most levels have vials that can be replaced if broken—a highly recommended feature. Note that some levels have two vials behind each window. This original design provides one vial per tool edge. A more recent design, uses a single vial per window. A single-vial level will work 360° on both edges or when laid flat. And, not all levels need liquid-filled vials. The battery-operated electronic level (No. 6 in the photo) offers the latest in level design and technology.

Before purchasing a level, always test it for accuracy. Place the level on a flat, even surface and note the position of the bubble. Then, reverse the tool end for end, keeping the same edge down. Now check the bubble's position a second time and compare it to the first reading. If the level is accurate, the bubble should come to rest in the same position for both readings. This is a good way to test old levels, too.

Remember that a level is a precision tool that you'll be relying on for accuracy. Try to reduce the inevitable banging about a tool suffers by never leaving the level where it may be knocked over, dropped, kicked or otherwise abused. Now let's take a look at the 17 levels shown here.

1. Magnetic bevel finder—Here's proof that good things come in small packages. This pocket-size tool is really four tools in one: a level, protractor, square and pitch gauge. A single vial is enclosed in a dial that can be adjusted 360°. To read level, set the dial to 0. To find plumb, turn the dial to 90°. It's excellent for measuring and transferring angles, too. The 2½-in.-dia. tool is made of high-impact plastic with a magnetic base. It costs \$11.05 postpaid from Garrett Wade, 161 Avenue of the Americas, New York, NY 10013.

2. Bench level—Designed primarily for machinists, use this highly accurate level for all types of precision work. The tool features ornate cast-iron construction with a black wrinkle finish. There are two plumb vials and one level vial on the 18-in. model shown (\$71). Top-reading feature permits viewing the level vial through the tool's edge. The opposite tool edge has a modified V-shaped groove, known as an involute groove, for use on round work. It's available in six sizes ranging from 4 in. to 24 in. long. Contact Starrett Tools, Athol, MA 01331.

3. Aluminum bench level—Die-cast aluminum I-beam construction makes this 24-in. mechanic's bench level extremely stable and lightweight. The tool has four durable Pyrex vials: two plumb, one top-reading level, and one 45°. Affixed to the level's edge is a dual-function steel rule that is marked with 1/16-in. graduations on one edge and a 1/8-in. centering rule on the other. It's available in 24-in. (\$45) and 18-in. (\$40) models. For details, contact Exact Level, 54 Eastford Rd., Southbridge, MA 01550.

4. Brass-bound mason's level—This handsome level, designed for use by masons, features a solid mahogany rail that is reinforced with wear-resistant brass edges and end caps. Take readings from the six clear-glass vials: two double plumb and one double level. It's available in a 2-ft. (\$35) and 4-ft. (\$45) model in hardware stores. Contact Stanley Tools, 600 Myrtle St., New Britain, CT 06050.

5. Engineer's and plumber's level—Here's a unique 3-function tool made specifically for engineers, plumbers and other mechanics. It features a fixed-level vial, a plumb vial and an adjustable-level vial that reads degree of incline. Incline is indicated by the pointer at the end of the adjustable tube and read off a steel plate that has 1/16-in.-per-ft.

Here's a sampling of the many types of levels available for do-it-yourselfers. Some are designed for specific jobs while others, like Nos. 8 and 9, are general-purpose levels. Most levels come in several different lengths. A 2-ft. and 4-ft. model will be sufficient for most home and shop projects. With a minimum of care, a quality level will last a lifetime.





1. Magnetic level finder; **2.** Cast-iron bench level; **3.** Aluminum bench level; **4.** Brass-bound mahogany mason's level; **5.** Engineer's and plumber's level; **6.** Electronic level; **7.** Torpedo level; **8.** Top-reading aluminum carpenter's level; **9.** Magnesium level; **10.** Aluminum I-beam mahogany level; **11.** Angle meter.

graduations. The level will read up to 2 in. per ft. of incline. An involute groove in one edge fits on round work. The level is made of high-grade cast iron. The 15-in. tool shown costs about \$93.50 at hardware stores. A 10-in. model (\$85.60) is also available. Contact Starrett Tools, Athol, MA 01331.

6. Electronic level—Levelite uses blinking lights and a beeping signal to indicate level, plumb, preselected angles and unknown angles. The electronic unit (\$50) operates on a 9-volt battery and clips into an aluminum rail. Levelite has an adjustable protractor dial, durable polycarbonate housing and it's effective in low-light situations. Rails come in 2-

(\$10), 3- (\$15), 4- (\$20) and 6-ft. (\$30) lengths. Contact Fourth Corner International, 1805-B West Bakerview Rd., Bellingham, WA 98226.

7. Torpedo level—Every toolbox needs a 9-in. torpedo level. Its back-pocket size makes it ideal for working in restricted areas. The Sears model shown has an aluminum I-beam rail with replaceable vials for reading level, plumb and 45°. One edge has a magnetic strip for no-hands use on metal workpieces and the other edge has a V-groove that fits on round stock. It's sold at larger Sears stores and through the

(Please turn to page 144)



Build our board-and-lattice
fence and fanciful moon
gate that's really
—surprise!—
three fences in one.

BY EUGENE AND
ELIZABETH THOMPSON

FIRST-CLASS FENCE



Take a stroll through most residential neighborhoods and you'll discover that fences are no longer being used strictly to separate one piece of property from another. Fences, depending on the design, provide varying degrees of privacy and protection. They help to control roaming children and pets and establish boundaries for gardens, pedestrian traffic and work and play areas. An attractive, well-designed fence will enhance the beauty and add to the value of your home. Conversely, an ill-considered fence, installed with no thought to its surroundings, will detract from your property.

After shopping around for a fence, we were disappointed in what was

Easy-to-build fence system comprises three styles of fences: 4-ft.-high lattice fence with moon gate; 6-ft. board-and-lattice fence; 6-ft. fence with 1x6 boards for maximum privacy.

Color photo: Peter Tenzer
Black-and-white photos and technical art: Eugene Thompson

available and decided to design and custom-build a fence to suit our specific needs. Our objective was to design a fence system that would provide varying degrees of privacy.

As a result, three types of fences were built. On the side of the house, dividing the front lawn from the backyard, we constructed a 4-ft.-high lattice fence that incorporates an attractive

round-top moon gate. Perpendicular to the lattice fence, separating our property from the neighbor's, is a 6-ft.-high fence constructed of vertical 1x6 boards topped with 2 ft. of lattice. This design offers slightly more privacy while maintaining an open, airy feeling. To provide maximum privacy for the backyard, we installed a 6-ft.-high fence of just vertical 1x6 boards.

Material selection

The fences shown are built of pressure-treated lumber. Redwood or cedar could also be used. The framework of the fences is constructed with common-size stock including 1x4, 2x2, 2x4 and 2x6. Use 4x4 stock for the posts.

The pressure-treated lattice comes in 4x8-ft. sheets for about \$20 per sheet. Each lattice strip measures 1/4 in. thick



1 Dig fence post holes to about 30 in. deep with a post-hole digger. The hand tool is available from most rental equipment dealers.



2 Support the post in the hole with two diagonal braces clamped to stakes driven in the ground. Use a level to plumb post.



3 Backfill around the post and tamp the soil with a spare 2x4 rail. Continue to add soil and tamp until it's level with the lawn.

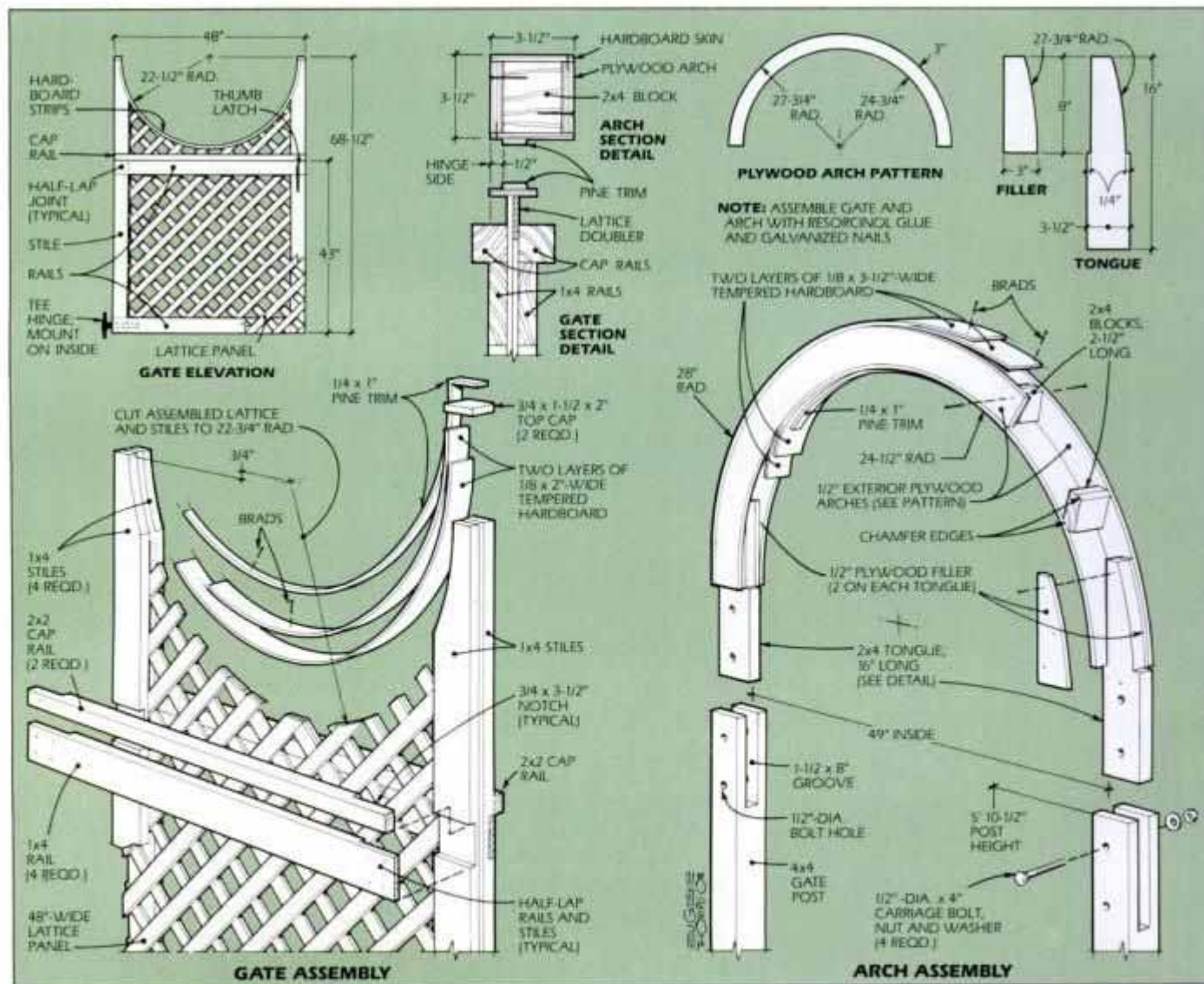

x 1½ in. wide. Make the curved arch above the moon gate out of ½-in. exterior-grade plywood and ⅛-in. tempered hardboard. To help resist corrosion, use hot-dipped galvanized nails and screws. Teco metal fence brackets (No. 2-4) are used to install the 2x4 rails to the fence posts; see photos 5 and 6.

Use 2-part waterproof resorcinol glue to laminate together the hard-

board strips that form the curved arch.

We decided not to finish the fence, but rather, allow it to weather naturally to a silvery gray. If you decide to apply paint or stain, you must wait three to six months for the pressure-treated wood to dry out. If the wood was wet during construction, you may need to wait up to one year; even longer in rainy regions.

Because of the various chemicals used in pressure-treated wood, there are certain health precautions that should be obeyed. Always wear a dust mask and goggles when sawing, boring and planing pressure-treated wood. Dispose short cutoffs and scrap; never burn pressure-treated wood.

After handling pressure-treated wood, be sure to wash your hands



4 Mark position of metal fence brackets on the 4x4 posts. The galvanized brackets are used to join the 2x4 rails to the posts.



5 Mount brackets to posts with ¼-in. galvanized screws. Electric screwgun provides no-sweat way to drive screws.



6 Place a 2x4 rail in the bracket and bore pilot holes to prevent splitting. Then, fasten the rail with ¼-in. galvanized screws.

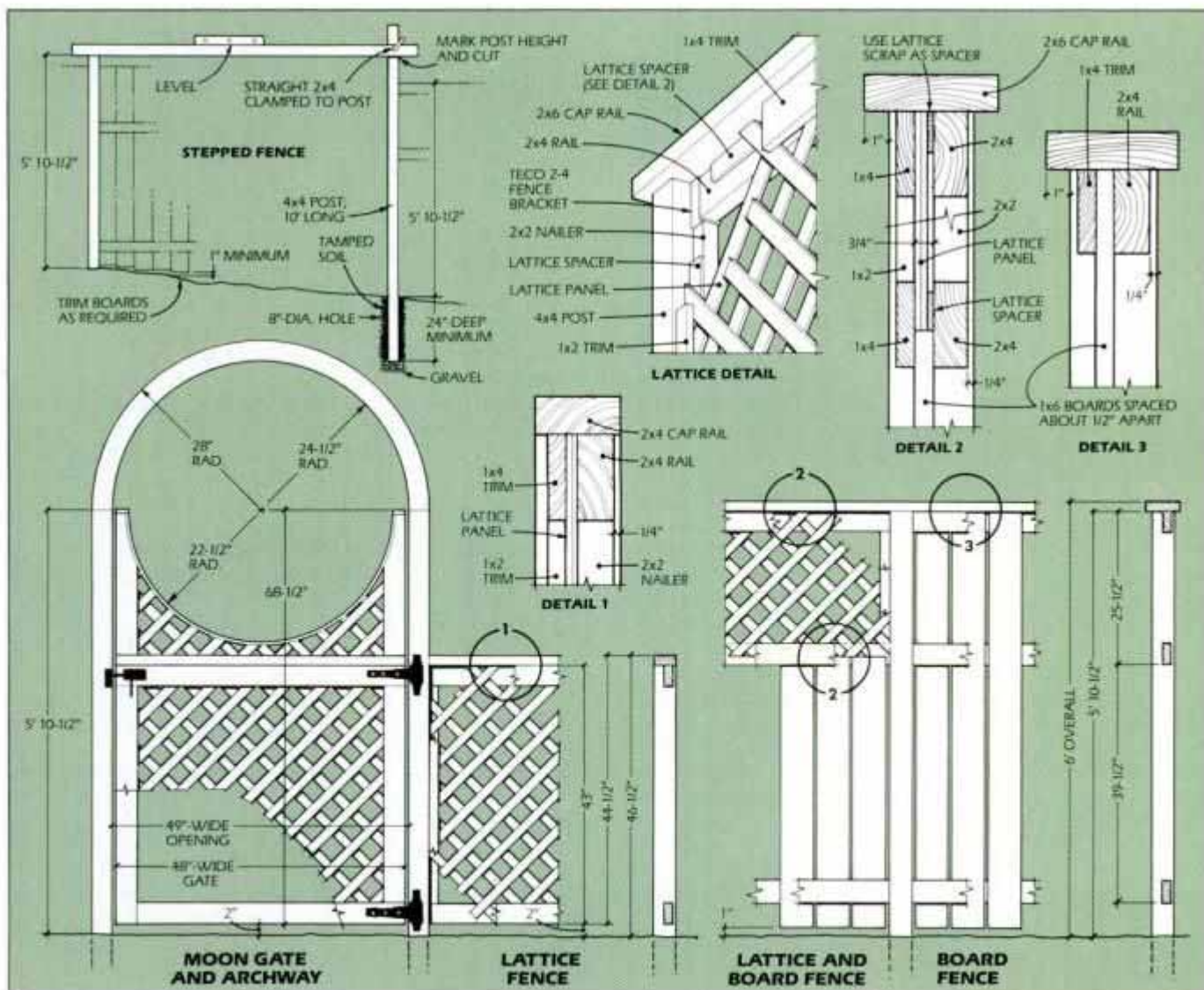



7 Fasten 1x6 fence boards to the 2x4 rails with 1½-in. screws. To keep boards even, butt them against cleat clamped in place.



8 Attach 2x2 nailer strips to the fence posts with 2½-in. screws. The strips provide a solid surface for fastening the lattice.



9 Bore pilot holes to prevent splitting the lattice. Then, attach it to the rails and 2x2 nailers with 4d galvanized finishing nails.



10 Use 1x4 trim to conceal the joint where lattice meets 1x6 boards. Fasten 1x4 trim with 2½-in. galvanized screws.



11 Attach vertical 1x2 trim at the ends of the lattice panels with 2-in. screws. Bore pilot holes first to avoid splitting the trim.



12 Top off the fence with a 2x6 cap rail. Fasten the rail with 20d (4-in.) galvanized nails. Space the nails about 24 in. apart.

thoroughly before eating or drinking.

The first step before starting construction is to find out *exactly* where your property line is. A copy of your house survey will help to determine this. Plan to erect the fence about 6 in. inside the property line, or according to your local building codes. Then, draw a rough sketch of the fence layout to help estimate materials and total cost.

Setting the posts

Begin by stretching a string between two stakes along the proposed fence run to determine the fence posts' locations. Use 6-ft.-long 4x4 posts for the 4-ft.-high lattice fence and 8-ft. posts for the 6-ft.-high fences.

Also, use two 8-ft. posts to support the arch. Each post hole must be about 30 in. deep. Add 6 in. of gravel to each hole to provide a solid foundation and adequate drainage.

Start by digging holes for the two gate posts. Be sure the *inside* dimension between the posts is 49 in. to provide clearance for the 48-in.-wide gate. Dig the holes about 8 in. square using a post-hole digger (available at rental equipment dealers) and a shovel. After adding gravel to each hole, be sure that the gate posts stand out of the ground 5 ft., 10½ in.

Next, cut a 1½-in.-wide x 8-in. groove in the top end of each gate post to accept the 2x4 tongues of the arch. To form the grooves, first bore a 1½-in.-dia. hole through each post to establish the bottom of the grooves. Then,

use a portable circular saw or handsaw to cut away the waste. Square-up each groove bottom with a chisel.

Place one of the posts in a hole and support it temporarily with two diagonal braces (photo 2). Check it for plumb with a level, and then backfill around the post with soil. Install the second gate post and support it with two 2x4 braces clamped to the first post. Plumb the second post and backfill around it. Now use a 2x4 to firmly tamp the soil around each post (photo 3). Add more soil as needed and compact it again. Leave the 2x4 braces clamped to the posts to maintain the 49-in. dimension until the arch is installed.

Next, starting from one of the gate posts, lay out and dig post holes for a run of lattice fence. Use 6-ft.-long posts spaced 96 in. apart (inside dimension) to accommodate an 8-ft. lattice sheet. Here's how to level the tops of the fence posts. Mark a line on the gate post 45 in. above the ground.

Then, using a line level, stretch a level string from this mark along the proposed fence run. Now install the posts at the same height as the line. If the property runs up or downhill severely, install a stepped fence, as shown in the drawing detail.

Construct the lattice fence using the drawing as a guide. Note that the lattice, ripped to 43 in. wide, is sandwiched between 2x4 rails and 1x4 trim (drawing detail 1). Join the rails to the posts with fence brackets (photo 6). Top off the fence with a 2x4 cap rail.

Arch and gate construction

Refer to the arch pattern drawing and cut two arches of ½-in. exterior-grade plywood. Next, from 2x4 stock, cut two 16-in.-long tongues that will fit in the grooves in the gate posts.

Also, cut four ½ x 3 x 8-in.-long plywood fillers, and five 2½-in.-long blocks from 2x4 stock. Glue and nail one filler to each side of both tongues. Then, glue and nail the tongues to one of the plywood arches.

Be sure the tongues are exactly parallel and 49 in. apart (inside dimension). Glue and nail the 2½-in.-long blocks to the arch at a slight angle so the corners of each block extend beyond the arch ¼ in. Now glue and nail the second arch to the assembly. Use a plane to chamfer the 2x4 block corners flush with the plywood arches. This creates solid nailing surfaces for attaching the hardboard skin.

Rip four 3½-in.-wide x 8-ft.-long strips of ¼-in. tempered hardboard. Glue and nail one strip to the top edge of the arch assembly using ¾-in. brads and resorcinol glue. Then, glue and nail a second strip over the first strip. Use a backsaw to trim the overhanging strips to length. Attach the two remaining hardboard strips to the inside curve of the arch using the procedure described above. Also, attach a ¼ x 1-in.-wide pine strip to the inside curve of the arch ½ in. from the edge (see arch section drawing detail). Now attach the assembled arch to the gate posts by inserting

(Please turn to page 134)

SPECIAL REPORT

AUTOSOUND



• **HIGHWAY HI-FI**
What's New In On-The-Go Gear

• **CHANGING GEAR**
Upgrading Your Present System

• **SOUND SOURCES**
Super Car Stereo Systems

• **ROCKIN' & ROLLIN'**
Installations For Vans And RVs

PHOTO BY BILL ASHE
AUTOSOUND SYSTEM BY TECHNICS

SPECIAL REPORT

HIGHWAY HI-FI

Today's car stereo rivals the sophistication of home hi-fi with a wide variety of gear.

BACKGROUND PHOTO BY CHARLES SCHRIDDLE
INSET PHOTOS BY ALLEN ZENREICH



Just 23 years ago this spring, Ford's first Mustang hit the streets at \$2368 and forever embellished the folklore of the road. You could get it with a monaural AM radio, but FM wasn't even an option—let alone stereo or tape.

Fact is, there wasn't much stereo broadcasting around back when the stars of TV's "Route 66" motored from adventure to adventure. The cassette and even the 8-track cartridge had yet to emerge from the twilight zone when "77 Sunset Strip" cruised the airwaves.

With only AM radio for fuel, the '64 Mustang didn't pack much more musical horsepower than the first radio-equipped cars of 1927. But highway hi-fi has come a long way since Babe Ruth's 60-home-run season, Lindbergh's transatlantic flight or, for that matter, the year when Lee

Iacocca and The Beatles began the stuff that creates popular legends.

Yesteryear's tube-based squawkboxes have evolved into dashboard systems that put digital electronics and fiber-optic transmission at the service of music. Supplementing original AM are stereo FM, magnetic tape, the optical-laser digital disc, and soon, digital audio cassettes.

These last-mentioned digital sources are propelling autosound along exciting new paths.

For too many years, autosound suffered technological neglect as the poor relative of home hi-fi. One automaker did build a record player into the dashboard, but it proved about as popular and workable as the double-nickel speed limit.

When the hi-fi boom of the late '60s created an awareness of just how good canned music could sound, a mobile generation of listeners began

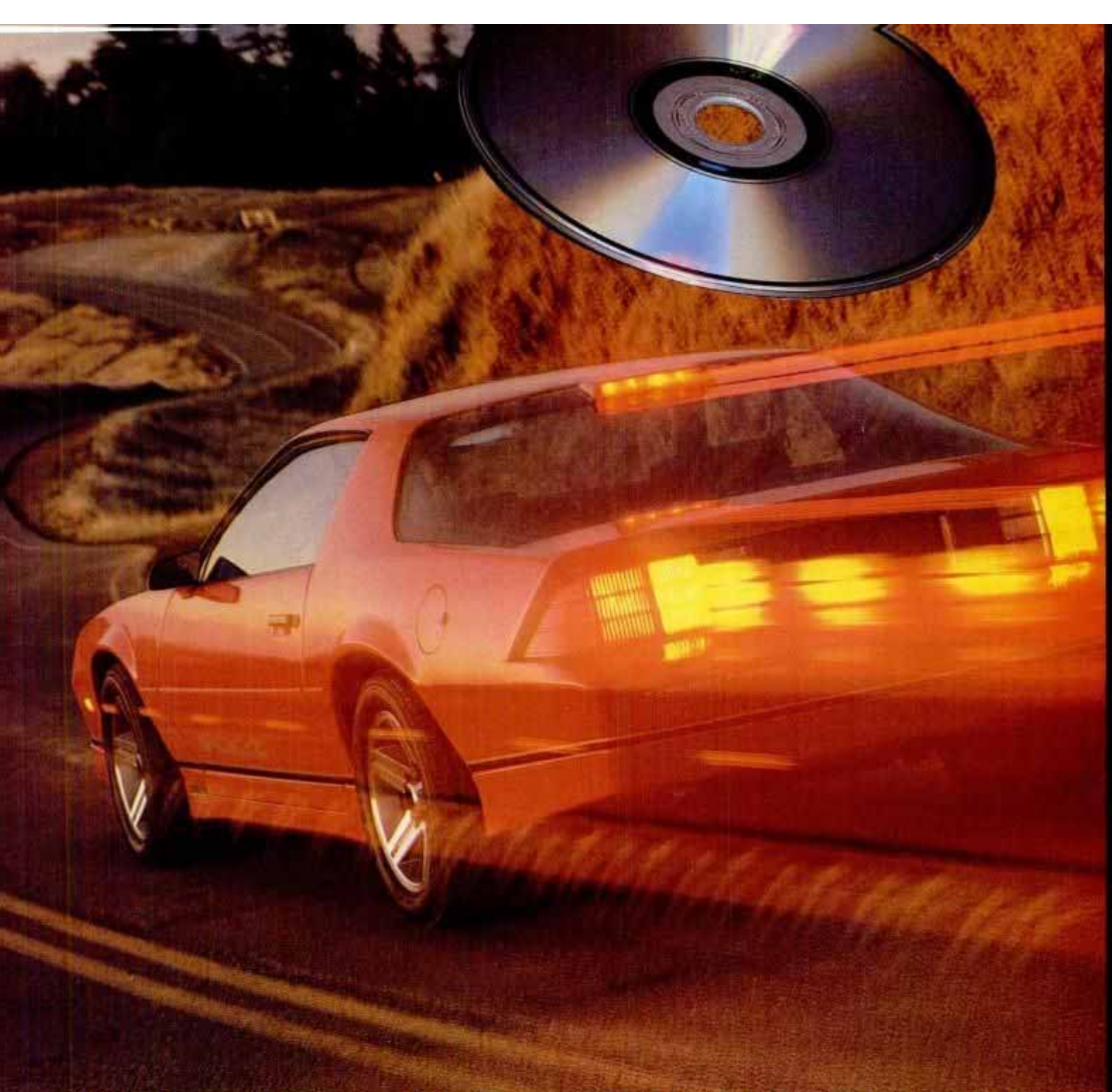

demanding comparable performance for its Bonnevilles and Bugs. Audio manufacturers rose to the task—and quite a task it was.

Because of the hostile environment and troublesome acoustics of the car, the routes to high fidelity must be more imaginative and technologically innovative than those required for living-room listening. The space available for electronics and loudspeakers in a car is relatively small. This has prompted a high degree of miniaturization in electronic circuits and components, to the extent that today's in-dash source units shoe-horn the controls and features of a home system into a package the size of a cigar box. Loudspeakers must derive their punch from the increasingly shallower doors and decks used for their enclosures. More compact but powerful amplifiers must drive those speakers above road and vehicle

noise, and sustain the music against sound-absorbing interior upholstery. Finally, to survive temperature extremes and physical vibration, autosound gear must be built tough.

Most of these goals and challenges have been met, but now the entry of digital sound has raised the ante once again. Digital sources will reveal any flaws in a sound system. Accordingly, today's gear is designed with digital in mind.

It's also designed to accommodate a wide range of musical tastes and purchasing budgets. With more than 100 brands competing in the marketplace, you're sure to find the combination of features and performance that suits your ears and your wallet. Moreover, this competition assures you continued innovation and improvement to match advances in recorded-music mediums.—S.A.B.

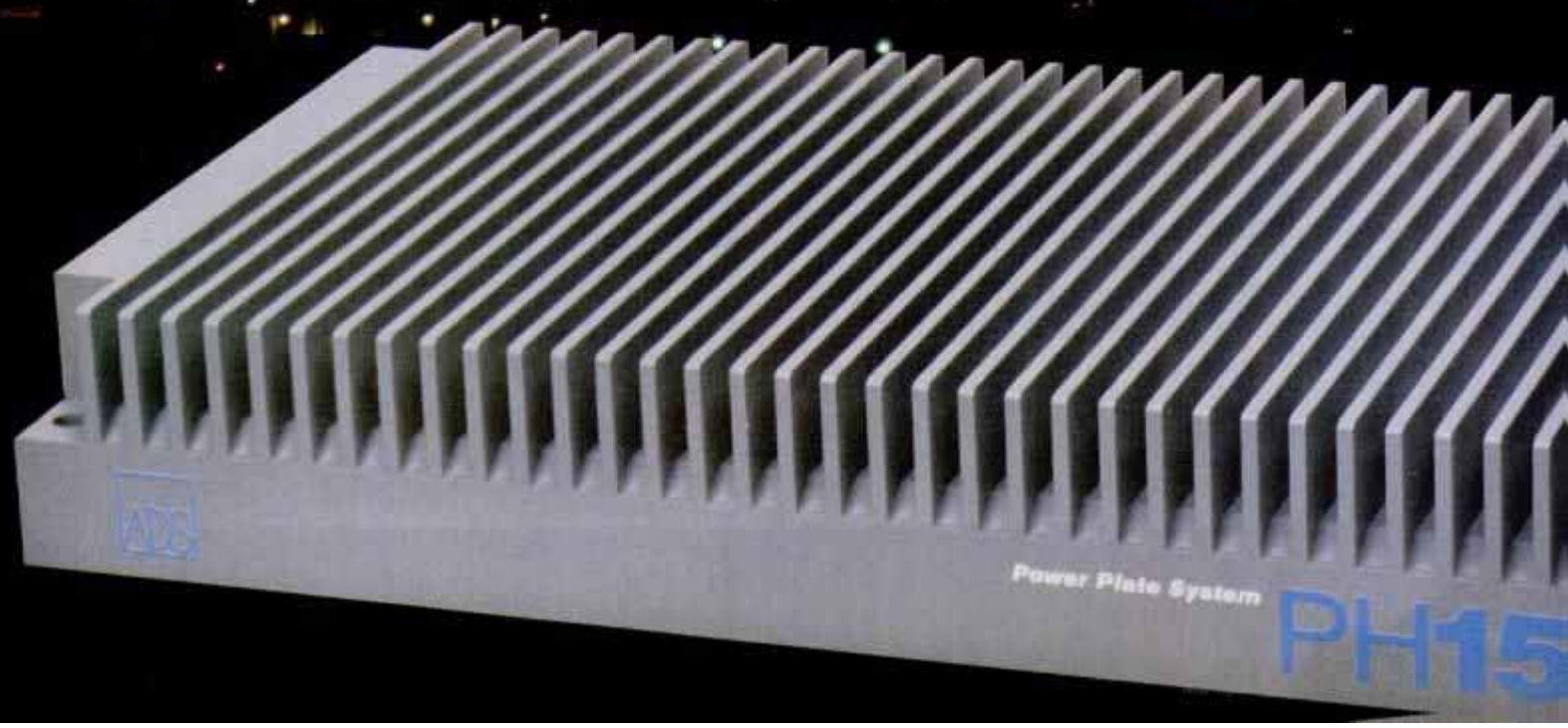

SOUND SOURCES

Digital stereo is mobile and accelerating. New electronics and speakers can match the pace.

If you imagine autosound to be a pair of back-shelf speakers connected to a dash-mounted radio/cassette unit, then wipe your memory banks clean. Picture, instead, loudspeakers mounted front and rear, acoustically supported by a subwoofer producing enough bass for a sonic body massage. One or more discreetly placed amplifiers drive the speakers with the power required by the digital compact disc player mounted in-dash.

Cassettes still abound for the car, but like an old Hollywood star, today's cassette/receivers have gotten a facelift.

The newest cassette/receivers sport flat-panel faceplates with pushbutton controls in place of yesterday's dials and knobs. Cassette/receivers offer better performance and features than ever before—and more change is on the horizon.

Digital audio tape (DAT) players for the car will be introduced over the next year or two.

DAT offers the same sound quality as compact disc but in a smaller configuration than today's analog cassette—an important consideration in today's shrinking automobile dashboards. In convenience features and operation, DAT players should be similar to existing cassette/receivers.

SOUND SOURCES

Though it will be some years before DAT becomes widely available, the compact disc is well on its way. CD already comes in multiple configurations for the car. CD player-only models have been on the market the longest. These units are designed to supplement existing cassette/receiver-based systems—an arrangement that allows you the option of listening to either radio, tape or CD.

Most people who have listened to CD seem to gravitate almost exclusively to the digital format, and abandon conventional cassettes. This has prompted manufacturers to introduce combination CD/radio tuners. Typical of this new breed of "head unit" is the model 7902 from Alpine.

AM/FM/CD

Miniaturization of the laser-transport and the laser itself has enabled Alpine to combine every component of the radio and CD player—including power supply—all in one chassis. An important feature of this engineering design is the use of extensive shielding and double voltage-regulators, to prevent internal motor noise and digital-switching impulses from becoming audible as low-level sound signals. This protection is what allows all the electronics to be enclosed in a single chassis for in-dash mounting.

The 7902 offers many of the impressive programming functions found in other CD/tuners. Up to 20 tracks or selections can be programmed in any desired sequence. A "disc scan" feature lets you sample the first 10 seconds of each programmed track while a "music sensor" function lets you skip tracks entirely as you scan. A pushbutton returns the scanner to the disc's beginning. Other manufacturers add a repeat button, which automatically replays the previous track or the entire disc.

Perhaps the most forward-thinking feature of the Alpine 7902 (\$850) is not readily apparent. It's an auxiliary input for either a conventional cassette player or a DAT player when the latter becomes available. Upgrading from the old cassette technology to DAT becomes as simple as switching from one player to another.

Existing analog cassettes also can be used with Sony's CDX-R88 CD/tuner (\$750). It's done with an optional cassette player, model XK-8 (\$270), which measures about half the height of the CDX-R88 and has a sliding drawer which accepts the cassette. The XK-8 has its own dedicated input jack on the CDX-R88, which is also noteworthy for its use of a separate subchassis to supply 50 watts of amplifier power to loudspeakers. Separate preamp out-



Pioneer's KEH-8282TR, especially suitable for utility rigs, boasts high-power multichannel amp, 9 dB of bass boost, preamp out, ambience circuit that expands soundstage.



Most recent car CD players now include an AM/FM tuner, thanks to miniaturized components and improved internal shielding. Alpine's 7902 adds a cassette input, too.

puts are provided for additional outboard power-amplifiers.

CD changers

Sony's CDX-R88 also has an auxiliary input jack which, theoretically, could be used for a DAT player. In the near term, however, CDX-R88's auxiliary jack will be the connection for a planned CD "changer." Two CD changers, one from Sony and the other from Alpine, are already on the market.

Both these models feature optional tuners so that they can be installed as complete sound systems. Alternately, each changer easily interfaces with any cassette/receiver that has an auxiliary input. Many new cassette/receivers are designed with CD in mind, often having a "CD" button on the faceplate to simplify switching.

CD changers can be mounted in the trunk (or wherever convenient), and are connected by cable to a control unit that remains in the passenger compartment. The controller can be dash-mounted or left loose, for easy use by back-seat maestros. Sony's DiscJockey (\$1000) can access a 10-disc magazine while Alpine's (\$1500) stocks 12 discs.

Radio and tape

Cassette/receivers may be products of a bearded technology, but the relatively high price of CD players guarantees the livelihood of conventional analog tape and decks for some time.

Today's cassette/receivers boast many new features that will carry over to tomorrow's digital tape products. For example, electronic tuning of AM and FM radio stations is now so commonplace that it's easy to forget that this superior tuning method was a high-priced feature just a few years ago.

Antitheft security codes, entered through the preset buttons of the tuner section, prevent anyone but you from using the stereo or starting your car. Another new antitheft option is the removable cassette/receiver—which slides into and out of a sleeve mounted in the dashboard. You can take it with you for safekeeping—or for use in another vehicle, even a boat.

Dolby B and C noise-reduction circuitry and sophisticated hiss-killers which quiet tape noise are common on many cassette/receivers. A few, such as Kenwood's KRC-939, offer dbx, an even more effective noise killer than Dolby. These noise-reduction systems can make cassette/receivers formidable signal sources—especially when playing tapes dubbed from CDs.

Computer control

Among the most sophisticated cassette/receivers on the market is Blaupunkt's TQR-07 Berlin (\$1500). The TQR-07 lacks dbx but includes Dolby B and C. Among its army of features are two tuners and antenna leads. This "diversity reception" system enables the Berlin's onboard computer to select the clearest radio signal—an important consideration since moving cars are subject to multipath distortion.

Controlling the TQR-07 is a 16-bit 32K microprocessor that utilizes a "data bus" for split-second relaying of information between a dashboard-mounted control unit and a separate subchassis that houses the tuners, volume and tone-control components. Data bus technology is likely to be applied elsewhere in car audio at considerably less cost in the future, largely because of its space-saving capability. Control units can be mounted in the

TOYOTA TRUCKS

THE #1 TRUCK FOR YOU

Get the sport truck with a 1640-lb. work-truck payload.* Big payloads have helped make Toyota #1 in compact truck sales** and #1 in truck satisfaction.†



XTRA ROOM

The SR5 Xtracab gives you plenty of in-cab cargo space behind the seats, plus real stretch-out room for driving and riding comfort.

**XTRA STYLE.
XTRA COMFORT.
XTRA POWER.
SR5 XTRACAB.**

Toyota's SR5 Xtracab Sport Truck puts xtra accent on sport. Xtra sport truck performance from a potent, responsive 116 hp electronically fuel-injected engine. Xtra sport truck good looks with custom-like touches. And the sportiest truck option of all: gas-turbo power available only from Toyota.

LOOKING OUT FOR YOU HAS MADE TOYOTA #1.



**WHO
COULD ASK TOYOTA
FOR ANYTHING
MORE!**

Get More From Life... Buckle Up!

*Including occupants, equipment and cargo.
**Ward's Automotive Reports, 1986 calendar year to date through June, combined compact pickups.
†J.D. Power & Associates 1986 CSI (for 1985 vehicles).
© 1986 Toyota Motor Sales, U.S.A., Inc.

SOUND SOURCES

dashboard while the bulkier playback systems, power supplies and other electronic circuitry can be installed out of sight in roomier locations.

Space-saving considerations also have prompted the introduction of cassette/receivers with built-in multichannel amplifiers. Models such as JVC's KS-RX515 (\$450) send 8 watts of power to each of four speakers, two in the front and two in the rear. Alternately, the KS-RX515 can offer 22 watts to a front pair of speakers, while a separate amplifier drives the rear speakers—an arrangement that results in a more powerful system overall. Either way, the cost and space consumed by extra amplifiers is avoided.

Versatile amps

Newly developed multichannel amplifiers act in a similar space-saving fashion, in that only a single powerplant is required to drive front and rear speakers without stalling or hesitating.

Kenwood's KAC-8070 (\$279) amplifier, for instance, delivers 20 watts to each front channel and 37 watts to each rear channel. This asymmetrical power configuration results in a primary stereo image emanating from high-power-handling rear speakers with the front speakers providing ambience. Generally speaking, front-door speakers can't handle high-power loads as well as rear-mounted drivers. But since ambient sound signals require little volume to be effective, Kenwood's 40 up-front watts more than do the trick.

You'll find additional versatility in multichannel amps such as the new ADS PH15 (\$560). In a 4-channel system, the PH15 delivers 80 watts into each of two channels and 40 watts each to an additional two channels—for a total of 240 big watts. The PH15 also can act in a 6-channel mode, delivering 40 watts to each channel. The fifth and sixth channels can be used to power one or two subwoofers that reproduce very low bass frequencies. And because a subwoofer can be configured as either a single, large woofer or a pair of smaller woofers, the PH15 will act in a 5-channel mode too—sending 80 watts to the single subwoofer and 40 watts each to the other four channels. Until recently, more than one amplifier would have been required to power a 5- or 6-channel system. The PH15 is also "bridgeable," which means it can be connected to other amplifiers to produce superpowered systems.

Loudspeakers

Aiding and abetting today's new crop of amplifiers are electronic crossovers that manage the complex task of routing audio signals to the appropriate



Car stereo—or computer? Blaupunkt's new TOR-07 Berlin head unit uses microprocessor and data bus to relay signals from dash-mount controller to hidden components.



Some equalizers are more equalizing than others. Ceres V parametric EQ by HiFonics gives pinpoint control.

tweeter, midrange or woofer speakers. These "drivers" might either stand alone as component speakers or be arranged together in different combinations or systems. "Coaxial" speakers—formed by mounting a tweeter and a woofer or midrange on the same axis—are quite commonplace in car audio. Three- and sometimes 4-way combinations also are available. Speaker makers often angle the tweeter in these combinations so it will "fire" treble sounds more directly at the listener.

Space-age materials

Paper cones are still the mainstay of autosound speakers, but many manufacturers now offer a variety of other cone materials designed to better withstand the rigors of the car environment, particularly heat and moisture. Materials such as woven carbon, graphite, polypropylene and other synthetic compounds are being used to create hi-fi speakers that can weather the elements and deliver top sound.

In addition to cone materials, high-energy magnets are finding a new application in loudspeakers. Bose Corp., for example, incorporates a new class of neodymium magnets in some recent General Motors cars equipped with its Delco/Bose car audio system. The high-energy content of neodymium means smaller magnets can be used, thereby significantly reducing the depth of the speaker. A shallower speaker will fit more easily into a greater number of cars—a lesson aftermarket manufacturers are also heeding.

Speakers range in size from 3/4-in. tweeters to 6x9-in. woofers and even larger subwoofers. From among this

large selection, you should be able to find speakers that fit not only your car but also your budget.

Equalizers

Whatever the number, size and shape of the speakers you choose, autosound systems sometimes benefit from the addition of a graphic equalizer. These units are, essentially, sophisticated tone controls which allow you to boost or cut specific frequencies at various points along the audio spectrum. This gives you greater flexibility than simpler bass/treble controls, which boost or cut all of the bass or treble sounds.

Graphic equalizers come as independent components for in-dash, under-dash, console or glove compartment installation. Sometimes, they incorporate an amplifier to boost system power. Many cassette/receivers also offer built-in "EQ"—but separate units provide greater control. Extremely sophisticated equalization is available with the HiFonics Ceres V parametric equalizer (\$400)—a unit which allows you to literally dial in troublesome frequencies for correction by adjusting three overlapping bandwidths over a range of several octaves.

Equalization, long used in recording studios, concert halls and even the home, probably faces its greatest challenge in the automotive environment. Autosound systems, and the methods used to install them, are the object of constant innovation and new technology developed to shoehorn good sound into a car—something to which vehicles everywhere seem opposed. But much as in the old days of bronco-busting, the car can be tamed.—F.V.

America's New Symbol Of Toughness.

One look at Cub Cadet and you'll discover, like millions of other homeowners, why a Cub Cadet lasts so long.

Cub Cadet's durability starts with a powerful direct drive transmission that's designed tough, like a farm tractor, to tackle the demands of plowing, tilling, mowing, snowthrowing and more.

There's also a cast-iron front axle that absorbs stress and strain, a twin channel steel frame for solid support, and your choice of single and twin cast-iron cylinder engines ranging from 12 to 20 horsepower.

Cub Cadet goes a long way on convenience, too.

Hydrostatic drive provides an infinite speed range without clutching. Hydraulic lift and electric PTO operate attachments effortlessly. And power steering makes maneuvering around trees and shrubs easier.

You'll also find a wide variety of optional attachments including smooth cutting 38", 44", 50" and 60" decks, grass baggers, snowthrowers, tillers and carts.

See for yourself what makes a Cub Cadet garden tractor America's new symbol of toughness. Take a test drive today. Simply check the Yellow Pages for the Cub Cadet dealer nearest you.



Cub Cadet

Power Equipment

One Tough Tractor

Cub Cadet Corporation, P.O. Box 36930, Cleveland, Ohio 44136

SPECIAL REPORT

CHANGING GEAR

Highway hi-fi comes plain or fancy. Here's how to upgrade to match your budget and aspirations.

So, where have you been listening to your music lately? Just think about it: TV, videotapes and even that new best-selling novel all compete for your free time. If you're like an increasing number of people, you're probably listening to your favorite tunes in your car as you commute to work or play.

If this is the case, it makes sense to upgrade your autosound equipment for maximum enjoyment. Upgrading your car stereo needn't be an expensive proposition. A few dollars well spent will increase your musical return many times.

Let's assume you now have a factory-installed radio/cassette player and two speakers. The least expensive upgrade simply involves replacing the speakers with better models.

Many of the finest home-speaker manufacturers, including Infinity, Acoustic Research, Boston Acoustics, Polk, Canton and JBL, have branched out into autosound and offer the same high-quality sound reproduction you'd expect at home.

If you "trade up" to a coaxial or a 3-way speaker,

BACKGROUND PHOTO BY AARON KILEY
INSET PHOTOS BY ALLEN ZENREICH





Upgrade gear, from top, includes ASK3010 and ASK 3000 amplified speakers by Sparkomatic; Panasonic's CY-SG60 equalizer/amplifier combo; Autotek's SR-500 electronically tuned autoreverse cassette/receiver with CD input, Dolby-C, 40 watts total power. Left: Jensen JS-6400 cassette/receiver with input and power plugs for portable CD player.

CHANGING GEAR

you'll get better sound in the same amount of space that your existing full-range speakers occupy. A coaxial speaker divides the work of a full-range speaker in two, employing a midrange/tweeter to reproduce the high (treble) notes and a woofer to reproduce the low (bass) ones. Similarly, a 3-way speaker splits the work among a woofer, tweeter and midrange driver. The idea is to specialize when possible.

Nearly every loudspeaker supplier has a wide selection of 2-way and 3-way models. Within that selection, there also is a wide variety of designs to choose from. Many of the newer coaxial and 3-way models, for instance, feature adjustable tweeters that can be aimed directly at the listener. This type of configuration improves sound dispersion throughout the car and enhances stereo imaging.

New construction techniques and materials also make upgrades in speaker size more feasible. For example, the standard 4-in. speakers found in the doors of many of today's downsized cars can be replaced with 6½-in. coaxials that have a shallower mounting depth than conventional 6½-inchers. Shallow-mount speakers are available from most manufacturers.

Power up!

If you install larger speakers, or, if you install an additional pair to complement the two already in place (whether in the front or rear), you might need more amplifier power to drive them. Most basic radio/cassette players, including factory head units, rarely offer more than 6 watts total.

You could upgrade your head unit. We'll have more to say on this later. An alternative approach is to install the recent breed of self-amplified speakers.

Several manufacturers now offer speakers with built-in amps, both in small and large configurations. For example, the amplified speakers in Sparomatic's ASK 3000 series come in door-mount and shelf-mount versions. These 2-way systems are actually bi-amplified: There's one amp for the tweeter and another for the woofer, for a total 50 watts of power in each enclosure. The company even offers a powered subwoofer with 50 watts. This is a sensible option, because the smaller speaker sizes mandated by today's smaller cars often means that not enough bass is generated. Subwoofers reproduce the lowest notes in the musical spectrum. Since bass notes are omnidirectional, only one speaker is necessary—and you have a great deal of flexibility in its placement.

Yet another economical way of add-

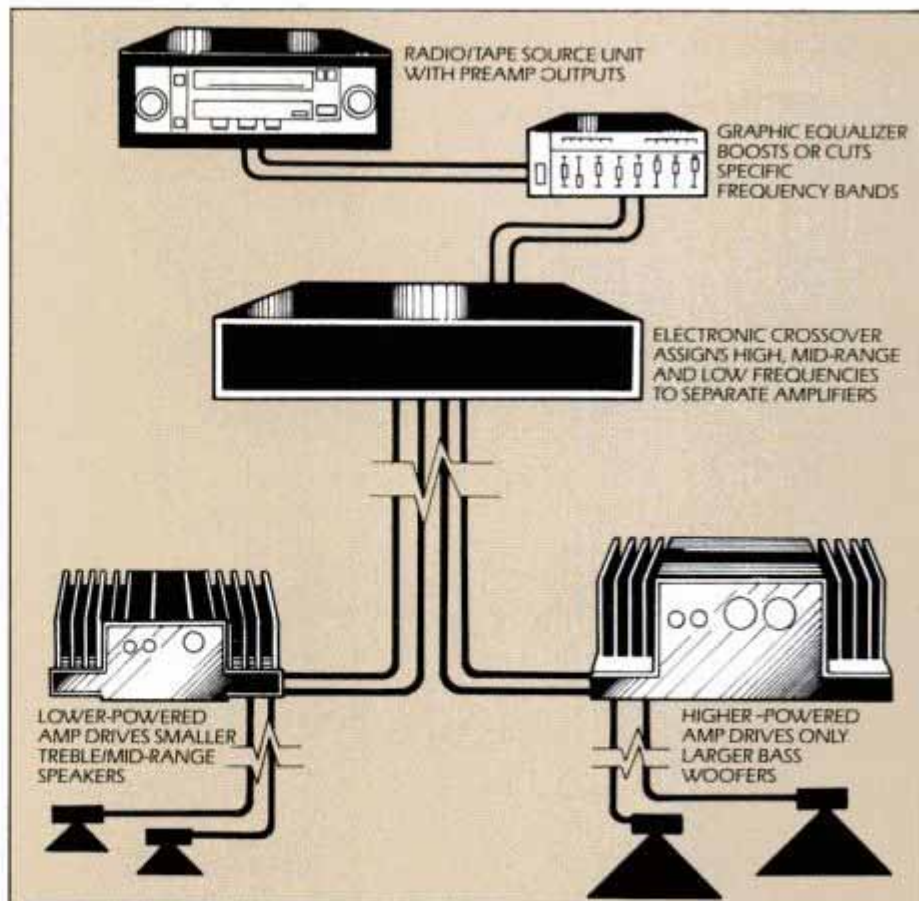

Sophisticated autosound installations use separate amps to power treble, midrange and bass speakers. Crossover assigns specific music frequencies to proper amp/speaker combo.

ing power without replacing your head unit is to add an equalizer/amplifier.

This combo unit wires in between the radio/cassette and your speakers, and can be installed in-dash, under-dash, in the glove compartment or wherever you have ready access to the equalizer controls. The EQ section enables you to cut or boost sound levels at five to nine points (depending on the model) along the audio spectrum, from bass to treble. The amp section adds from 25 to 50 watts to your system's power, depending on which model you install.

There are shortcomings to the EQ/amp, compared to separate equalizers and amplifiers. One is power: The mightiest combo units pack a maximum of 50 watts, whereas separate power amps run much higher. Another is size. Though a few slimline units exist, most combo units are as large as radio/cassette players. Separate (or passive, unamplified) EQs generally are small enough to fit anywhere, and stand-alone amps can be hidden out of sight beneath a seat, in the trunk or on the firewall. Finally, EQ/amps will pass along and amplify any distortion present in the amp section of your head unit. So might a separate EQ and power amp, but if you're thinking of installing these, it's really time to start rethinking the system as a whole—beginning with the head unit.

Better sources

The first level of electronic-upgrading involves replacing your existing radio/cassette player with one that has more power, better specifications, and some *sound-enhancing* features (compared to *operating-convenience* features such as tape autoreverse and radio presets). On the tape side, sound-improving features include noise reduction (either Dolby, dbx or DNR), and metal/chrome (70-EQ) tape-selection ability in addition to the standard normal (120-EQ) position. On the radio side, look for electronic quartz-synthesis tuning, multipath-rejection circuitry, and either DNR noise reduction, or automatic high-blend, or stereo/mono switching to maintain good sound when signal conditions deteriorate. AM stereo is another option, if your local stations broadcast it. General sound-enhancing features include a front/rear fader, left/right balance control and a built-in graphic equalizer (in place of conventional bass/treble controls).

If your ultimate goal is to own an autosound system that rivals the best home hi-fi—or even if you would like to reserve that option for the future, you'll be wise to purchase a cassette/receiver with "preamp-out" capability. The preamp out lets you bypass the cassette/receiver's built-in amp in favor of a direct connection to a better-perform-



Denon DCR-5320 cassette/receiver (top) retracts from dash; DCA-3500 amp has five channels, 240 watts.

CHANGING GEAR

ing (and more powerful) separate amplifier. The result is better sound.

The preamp-out feature makes a building-block approach to autosound much easier and, in the long run, less expensive. A cleaner signal is maintained through each successive stage—a particularly important attribute should you eventually install a digital audio tape or compact disc player.

How many amps?

The digital age is likely to prompt more multi-amplification—often called bi-amplification—in autosound. At this level of upgrading, car audio installations begin to assume the status of an art form. Bi-amplification involves the use of separate amplifiers to drive the woofers and the tweeter/midranges. Simply stated, the audio signal is passed through an electronic crossover which divides it in two: bass and treble. Each signal is then sent to a separate amplifier and set of speakers.

The advantage to bi-amplification is more sound with fewer watts. Two 15-watt amplifiers, for example, can play louder than a single 30-watt amplifier. And since each amp has only part of the music to reproduce, there is less distortion as well.

This approach can be expanded upon to include separate amplifiers for tweeters, midranges, woofers and sub-woofers. Many amplifiers have built-in crossover networks for this type of installation. In a new twist on this scheme, several manufacturers now offer multichannel (2/4/6) amps. This space-saving arrangement means a single power chassis can direct the appropriate frequencies to the appropriate speakers and drive them, instead of having separate power amps for tweeters, midranges and bass woofers.

In the esoteric world of car audio, it's not uncommon to see hookups involving 24 speakers with a complicated pattern of crossovers and amps. These systems sound wonderful. But you'll be surprised how the sonic improvement from every little upgrade adds to your listening pleasure.—F.V.

RISLONE

**TOTAL
ENGINE
PROTECTION**



IN THE CRANKCASE

Eliminates the varnish, gum and sludge which cause noisy valves, lost compression and power.



IN THE GAS TANK

Specifically formulated to remove carbon, varnish and harmful deposits from the upper cylinder area.

For free Lube Tips booklet send a stamped, self-addressed envelope.



THE SHALER COMPANY

DEPT. P67 • P.O. BOX 471 • WAUPUN, WI 53963

MOLDS



for making Ornamental Concrete Items

Book about Aluminum Molds including over 425 designs, prices and production trade secrets from world's largest mold manufacturer.

ONLY \$700

CONCRETE MACHINERY CO., INC.

P.O. Box A-99 Hickory, NC 28603

Make \$25 to \$100 per hour

with

Badge-A-Minit

Yes, it's really possible by making and selling bright, colorful Badge-A-Minit buttons. Buttons are proven money-makers at fairs, flea markets, conventions, or anywhere people congregate. They're fast and easy to make with Badge-A-Minit and inexpensive!

Send for a FREE full color catalog and idea book, or send for a Starter Kit, only \$26.95 plus \$1.75 shipping (IL residents add \$1.62 tax)



Badge-A-Minit, Dept. PM-667
348 North 30th St., Box 800, LaSalle, IL 61301. Phone (815) 224-2090

SPECIAL REPORT

ROCKIN' AND ROLLIN'

Wagons, hatchbacks and sport/utility rigs pose acoustical challenges. Here are solutions.

Pickup trucks, sport/utility vehicles, wagons and hatchbacks look different from the outside, but they share one characteristic that makes installing an autosound system a sonic challenge: None of these vehicles has a trunk.

No trunk means no bass. For most notchbacks, the trunk serves not only as a cargo hold but also as an enclosure for woofer speakers installed on the rear deck of the passenger compartment. For good bass response, the woofer must be enclosed.

A pickup truck, sport/utility vehicle and even a hatchback might haul bigger loads than a sedan's trunk can, but big sound is more easily achieved in the notchback. Factory cutouts in the doors and dashboard provide easy installation for tweeters and midranges that reproduce high and mid-level frequencies. More importantly, cut-outs

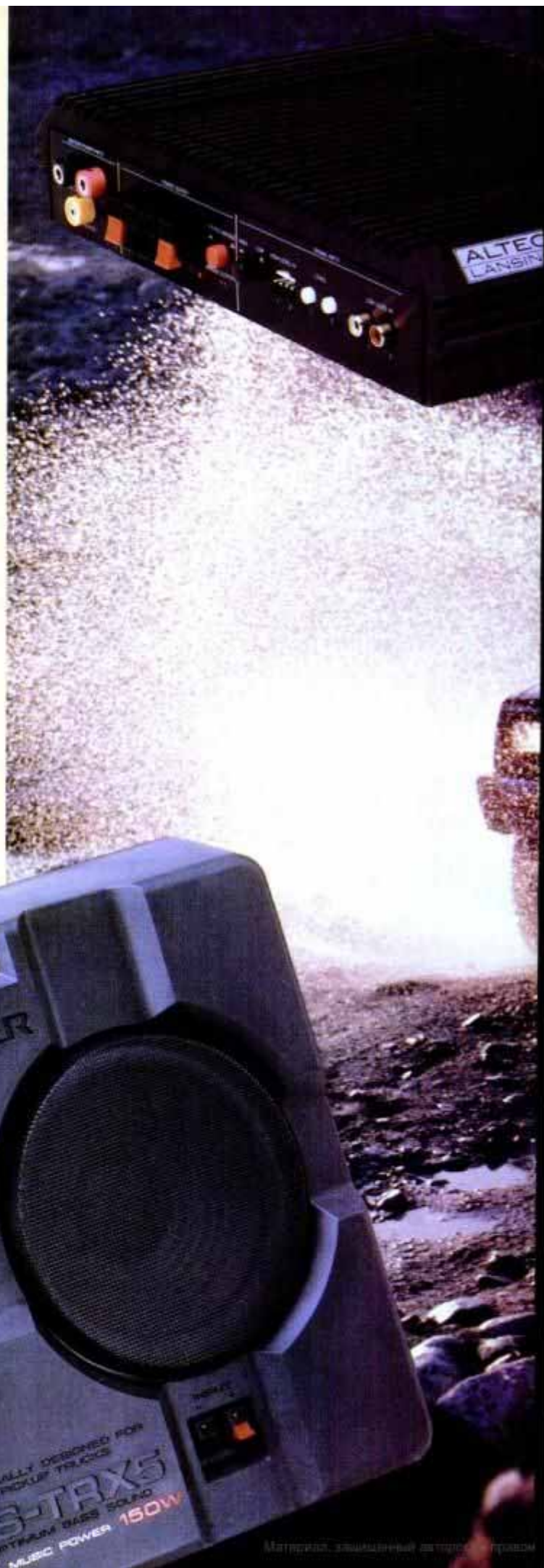



ALA270

JENSEN
A-1000-1000000

Keep on truckin' with rough-and-ready gear such as Altec-Lansing's compact, 140-watt ALA270 power amp; The Force, a 2-way speaker with prefabricated enclosure, by Jensen; Pioneer's DEX-77 combo CD player/tuner with remote control and TS-TRX5 self-enclosed speaker.

BACKGROUND PHOTO BY CHARLES SCHRIDDE
INSET PHOTOS BY ALLEN ZENREICH

TUNER CONTROL CD PLAYER DEX-77

CODE

FREQUENCY STATION

FM 106.1

MINUTE SEC TRACK

TREBLE + BSM/RPT

BASS + R SCAN

SCAN/MEMO

BAND/REL

1 2 3 4 5

LOC S

R.PLAY M.PLAY

VOL/BAL-L/H

VOL/BAL-R/M

EJECT/RELOAD

FU

FUNCTION

LD

LOUD

VOLUME

PIONEER



Increase Tire Shop Safety and We Will Give You This Solid Bronze Buckle.

Heavy truck wheel/rim servicing can be dangerous.

Motor Wheel Rim Safety Training kit has material and instructions to help you teach safe wheel/rim servicing and help avoid needless accidents.

Send for free kit.

Post the safety material. Present the program to your service people. Return validation certificate. And we'll send you a Motor Wheel Think Safety belt buckle.

Write: Dept. 91074,
Motor Wheel Corp.,
Lansing, MI 48910



MOTOR WHEEL

A Career Start in 21st Century Electronics



Since 1905, National Technical Schools has helped over 300,000 people just like you learn at their own pace and build successful careers. Enter the boom in electronics through home study courses in Microcomputer Technology & Servicing, TV & Radio Servicing, Video Technology, Industrial Controls (Microprocessing), Robotics or Basic Electronics. Call 1-800-B-BETTER or write us today for complete details: NTS, Dept. PM-409, 456 West M.L. King Jr. Blvd., Los Angeles CA 90037.

FREE NTS Catalog

Name _____

Address _____

City _____ State _____

Zip _____ Phone _____

Area of interest _____

Accredited by National Home Study Council

ROCKIN' AND ROLLIN'

in the rear deck generally allow large woofers to be simply installed.

Compared to notchbacks, the pickups, sport/utility vehicles, wagons and hatchbacks present many obstacles to optimal speaker installation. Your choice of electronic equipment might also be affected by the lack of space in vehicles such as pickups. A working knowledge of the autosound gear available—and a dash of creativity—can help you lick the sound problems posed by these vehicles.

Pickup Trucks

The flatbed of a pickup truck is a good place for loading 2x4s, but it's no place for speakers. And at first glance, it may seem there is no interior space for speakers, either. The exception is trucks with super-king-size cabs—these spacious interiors are as easy to work with as sedans.

A second look inside the pickup's cab will reveal a pair of cut-outs in the doors and perhaps another pair in the dash. But these holes will accept only relatively small and shallow speakers such as tweeters and midranges. The problem of bass response remains unsolved.

Like every other aspect of autosound, there are various schools of thought on providing proper bass response in pickup trucks. Many manufacturers now offer prefabricated enclosures that house variously sized woofers combined with top-firing tweeters. These wedge-shaped enclosures stow away behind the front seats. The woofers fire straight ahead while the tweeters fire straight up to reflect off the rear window and into the cab.

Prefab bass enclosures are priced according to their capabilities. Sparkomatic, for example, houses a 6½-in. woofer and a 2-in. tweeter in an enclosure dubbed the SK480 (\$60). It has a power-handling capability of 10 watts per channel with 20-watt peaks, making it suitable for use with either modestly-powered, low-power amplifiers or with high-power cassette/receivers.

An upgraded version of this type is offered by Jensen. The Force, as the company calls it, houses an 8-in. woofer and a 2½-in. top-firing tweeter. Bass response gets a boost by the addition of a vent cut into the bottom front of each enclosure (there are two). This vent allows bass frequencies to radiate forward under the front seat for better sound dispersion. Power-handling capability is 40 watts per channel with peaks of up to 75 watts per channel, making The Force (\$300/pair) more suitable for systems with separate high-power amplifiers. The Jensen unit is also a little larger than the Sparkomatic SK480: It measures about 13 x 18 x 6¾ in. versus 14 x 11 x 5 in.

While the Sparkomatic and Jensen models utilize a single woofer, Pioneer favors a dual-woofer design. The TS-TRX5 (\$270/pair) combines two 6½-in. woofers with a top-firing tweeter in a single enclosure while the TS-TRX3 (\$150/pair) utilizes two 5-in. woofers in a smaller version.

These truck speakers from Sparkomatic, Jensen, Pioneer and others might more aptly be termed "lifestyle" speakers. They are portable enough to become the sound system for a picnic or similar outdoor event—and even have carrying handles.

When the party's over, just put them back behind the seat.

Despite their versatility, these lifestyle speakers have critics who contend



Hatchbacks, such as this Corvette, lack shelf and trunk for good bass. The built-in platform here (housing subwoofer, CD changer) serves same purpose and supports cargo.

BEWARE THE BOTTOM.

PROTECT YOUR BOAT AND PASSENGERS WITH A LOWRANCE DIGITAL DEPTH SOUNDER.

When you're on the water, it's important to know where the bottom is.

Changing water levels and underwater obstacles can turn



Digital Depth Sounders: Available in bracket-mount or in-dash models.

a pleasure trip into a disaster. That's why the Lowrance engineers have developed two computerized Digital Depth Sounders, the 3200 bracket-mount and the in-dash model.

The Depth Sounder instantly displays the exact water depth – to the nearest one-tenth of a foot. In any water, day or night, even at high speeds. An audible alarm warns you of shallow water and can be set for any depth so you can slow down to avoid possible danger.

Computer-driven sonar

technology lets you "read" the bottom with pinpoint accuracy – whether you're running over rough water, navigating a narrow channel, or lying at anchor.

The Digital Depth Sounder from Lowrance: It's tops for finding the bottom. Ask for it at your favorite marine dealer.

I want to know more about the Lowrance Digitals.

NAME _____

ADDRESS _____

CITY _____

STATE _____

ZIP _____

Mail to: Lowrance Electronics, Inc.
12000 East Skelly Drive Tulsa, OK 74128
Dept. 0113/001-0587

LOWRANCE



Coy Lermon

Advertisement, unauthorized reproduction or distribution prohibited

ARROW®

Makers of the World Famous T-50 Staple Gun

**Now Brings You A Full Selection
Of Professional Quality Fastening Tools
For All Your Fix-It Fastening Needs!**



ARROW
ELECTRO-MATIC

Model **ETN-50**
Electro-Matic
Professional
Quality

**ELECTRIC
STAPLE
GUN**
FLUSH
FRONT
EXTENDED NOSE

Permits easy fastening in recessed areas, close corners, and other hard-to-get-at places with pin-point accuracy!



ARROW
XPANDO

Model **T-50XP**
XPANDO
FASTENING SYSTEM

Attachment & Fasteners
Instantly converts the Arrow
T-50, T-50M, or T-55 Staple Gun
into a multi-purpose
fastening tool!

Easily slips on front of Staple Gun!

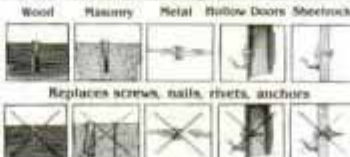

HOT MELT GLUE GUNS

Model **TR-550**
Professional
Automatic Lever Feed
HOT MELT GLUE GUNS

- Electronic Solid State
- Hi-Impact/Hi-Temp Housing
- 4 Types of Glue Stix available
- Uses 2" or 4" Glue Stix
- Cool contoured handle
- Interchangeable nozzle
- Re-usable storage box
- Light weight
- Uses 4 types of Glue Stix
- Built-in Drip Tray/Stand



Model TH-500 Thumb Feed

ARROW
EZ-Pull™
Rivet Tool

Model **RH-200**
Professional
E-Z Pull RIVET TOOLS

- Extended nose for hard-to-get-at places
- Uses 4 rivet sizes: 3/32", 1/8", 5/32", and 3/16"
- Spring-loaded handle for easy rivet loading and ejection
- All steel construction
- Comfortable vinyl grip
- 4 nose pieces with wrench
- Handle locks when not in use



Model RL-100 Light Duty

ARROW FASTENER COMPANY, INC.
271 Mayhill Street, Saddle Brook, NJ 07662

In Canada: Jardel Distributors, Inc., 6505 Metropolitan Blvd., East, Montreal H1P 1X9 Quebec
Available at all leading Hardware, Home Center, and Discount Department Stores everywhere.

ROCKIN' AND ROLLIN'

they provide nothing more than blasts of energy—"loud fi" rather than "hi fi." At fault is the upward-firing tweeter whose position on top of the enclosure contributes little to proper stereo imaging. Tweeters and midranges are more effective when they're located high and as far forward in the doors as possible (dashboard mounting for tweeters is also desirable).

Given such an arrangement, bass notes can then be generated by one or two subwoofers mounted in an enclosure behind the front seat. Companies such as ADS, Becker, Stillwater Designs and others specialize in making subwoofer enclosures for pickups. Many installers also make their own enclosures for more customized jobs. List price for a pair of ADS 7-in. dual subwoofers mounted in an enclosure is \$400. A version with dual 10-in. subwoofers lists for \$650.

Unfortunately, the cabs of some pickups are so small that the seat back butts directly against the rear wall. In these instances, an installer might construct door-mounted subwoofer enclosures with front-firing ports or slots. This "slot-loaded" construction allows the bass frequencies time to properly unfold before reaching your ears. Instead of feeling right on top of the speaker, your ears feel they are 8 to 10 ft. away, a better distance at which to enjoy music. In some instances, the rear window can be replaced with a speaker enclosure. A pair of large side-view mirrors is generally enough to pass inspection. (In a loaded pickup, the rear window is often useless anyway.)

Another alternative is offered by a company called Challenger Top Sound of West Palm Beach, Florida. The company's 1-piece enclosure spans the truck roof and houses a pair of 5-in. woofers and a pair of 2-in. tweeters. It's available in six colors and costs \$240. A tweeterless version sells for \$159.

If space permits, still another route to good truck-fi deploys an amplifier rack along the cab's rear wall with a subwoofer installed at the bottom. High-power is also available through the use of new, space-saving 4-channel and 6-channel amplifiers from companies such as Alpine, Kenwood, Altec-Lansing, Denon and ADS.

The growing popularity of utility vehicles has also prompted the development of cassette/receivers specifically designed for these applications. Pioneer is introducing its KEX-8282TR with 25 watts per channel, a "super bass" button to boost bass up to 9 dB, and a "stereo wide" switch that broadens the soundstage to make the cab interior seem bigger.

*****PRESENTING*****
CABLE TV EQUIPMENT
*****STARRING*****
JERROLD, HAMLIN, OAK
AND OTHER FAMOUS MANUFACTURERS

- FINEST WARRANTY PROGRAM AVAILABLE
- LOWEST RETAIL/WHOLESALE PRICES IN U.S.
- ORDERS SHIPPED FROM STOCK WITHIN 24 HOURS

FOR FREE CATALOG ONLY 1-800-345-8927
FOR ALL INFORMATION 1-818-716-5914

PACIFIC CABLE CO. INC.
7325 RESEDA BLVD., DEPT. 1707
RESEDA, CA 91335

MEN PAST 40 Troubled With Getting Up Nights
Pains In Back, Hips, Legs
Nervousness, Tiredness

If you are disturbed by these symptoms, your troubles may be caused by glandular inflammation of your prostate. Methods that merely give temporary relief for this condition cannot be expected to remove the cause of your trouble.

The Excelsior Institute Clinic, devoted to the **NON-SURGICAL** methods of treatment for diseases peculiar to older men, has a new **FREE BOOK** that tells how these troubles may be corrected. The **NON-SURGICAL** treatments described in this book require no surgery, hospitalization or long period of convalescence. Treatments take but a short time and the cost is reasonable.

Write today. This book may prove of utmost importance to you. No obligation.

Excelsior Institute Clinic, Dept. 1288
110 E. Broadway, Excelsior Springs, Mo. 64024

Uniden

The **PRO 520e**
When the End of the Road is just the Beginning.



High Performance Communications, The Pro Series by Uniden.

From the company that leads the world in radio communications technology comes the next logical step in the evolution of the CB radio, the Pro Series by Uniden.

The Uniden line of Citizens Band Radio Transceivers is the most extensive in the industry today. Melding today's lifestyle with the latest audio features, precise engineering and contemporary styling.

Styled to compliment other mobile audio equipment, the Pro series renders all other CB's obsolete. From the feature packed PRO 540e to the 310e handheld there is no better Citizens Band Radio on the market today.

Uniden Pro Series, a new generation of radio transceivers to ensure that when you're out, you're never out of touch.

For more information about Uniden CB Radios or any other Uniden product, fill out the coupon and mail it today.

Uniden Corp. of America
Consumer Products Division
6345 Castlesway Ct.
Indianapolis, IN 46250

Name _____
Address _____
City _____ State _____ Zip _____
 Scanners CB Radios
 Home Satellite Receivers Radar Detectors
 Telephones Marine Electronics

The Choice of Professional
Golfers Jack Nicklaus
Winner of 20 Major Championships
© 1987 Uniden Corporation of America



uniden[®]
A New Generation of Communications

Материал защищенный авторским правом

FACTORY DIRECT GRANDFATHER CLOCKS

Do-It-Yourself Clock Kits



Prices Starting
Under **\$300**

(including movement and dial)

OR
Completely Assembled
and Finished

- Solid 3/4" hardwoods: black walnut, cherry, oak
- Heirloom quality
- Solid brass West German chiming movements and dials
- Easy to assemble kits or completely assembled and finished
- Money back guarantee

SEND \$1 FOR
32-PAGE FULL
COLOR CATALOG



**EMPEROR
CLOCK COMPANY**

WORLD'S LARGEST MANUFACTURER
OF GRANDFATHER CLOCKS

Dept. 2316, Emperor Industrial Park,
Fairhope, Alabama 36532 • Phone 1-205-928-2316

I am interested in Do-It-Yourself Kits
 Finished Clocks

Name _____

Street _____

City _____

State _____ Zip _____

(please print)

BANKS TURBO POWER Flattens Out Those Hills

BANKS DIESEL TURBO SYSTEMS



FORD 6.9L TURBO
GM 6.2L TURBO ALSO AVAILABLE

- EMISSIONS LEGAL IN ALL 50 STATES
- UP TO 50% MORE HORSEPOWER
- EXCELLENT HIGH ALTITUDE POWER
- DEALERS NATIONWIDE
- YOUR POWER SOURCE "SINCE 1958"

banks™

Gale Banks Engineering
546 Duggan Avenue, Dept. 650
Azusa, Ca. 91702 (818) 969-9605
© 1987 GALE BANKS ENGINEERING

ROCKIN' AND ROLLIN'

Sport/Utility Vehicles

The Chevrolet Blazer, GM Jimmy and Isuzu Trooper look like they're made for work, but they're also meant for play. With 4-wheel drive, these vehicles can go just about anywhere. Your fun levels might go up with an off-road vehicle, but so does the noise level.

To keep the music playing at audible levels you'll need extra power. One solution is to purchase a cassette/receiver with built-in power amplifiers. All cassette/receivers come with at least 3 watts per channel but some models, such as Sharp's RG-F882 (\$500), offer 25 watts per channel. These high-power cassette/receivers can drive a complete system, or, their built-in amps can serve to power front-mounted tweeters and midranges while separate, outboard amps drive woofers or subwoofers. Keep in mind that compact disc-based systems automatically require separate outboard amplifiers since there are no CD/tuners offering built-in amplification in a single chassis.

Although sport/utility vehicles generally have large factory cutouts suitable for large speakers, the noisy environment of a 4-wheel drive often encourages music-lovers to add free-standing subwoofer enclosures similar to those used in pickup trucks. For a more customized high-powered sound system, installers often construct a foot-high platform with speakers con-



Better bass: Speaker in prefab enclosure, such as Jensen's Force, snuggles behind seat.

cealed underneath—and sometimes with amplifiers, too. Upon completion, a carpet matching the interior color is laid over the cargo platform.

Sound in sport/utility vehicles can also be improved by adding door speakers. Generally, the factory cutouts are located toward the bottom of the door, but your legs and other obstacles can block dispersion of higher frequencies. You'll enjoy better stereo imaging by mounting tweeters and midranges higher in the doors. Surface-mount models will do the trick when in-door speakers can't be used.

Wagons and Hatchbacks

A hatchback or station wagon is like every other car in that there are appropriate speaker locations in the front of the car. But the absence of a rear deck and trunk makes it difficult to achieve sufficient bass response. Though you'll sometimes find factory cutouts in the rear of hatchbacks, their size and location is often inadequate to the task of reproducing low bass notes.

Like pickup trucks and sport/utility vehicles, wagons and hatchbacks can have a subwoofer enclosure retrofitted. These enclosures sometimes house other equipment not easily installed otherwise. In one instance, a subwoofer enclosure built into the rear of a Corvette not only houses a pair of subwoofers, but also a Sony "DiscJockey" CD changer. A cable connecting the CD changer to a control unit gives the driver access to 10 compact discs.

Large subwoofer enclosures can be obtrusive in small hatchbacks so specialty companies such as Classic Research & Engineering of Tuscon, Arizona, have developed enclosures for specific cars including Chevy's Camaro and the Porsche 928. These enclosures are customized cosmetically to match the interior of the car.

Less tailored cosmetically but effective in delivering bass is Alpine's 6491 subwoofer. Though suitable for pickups and sport/utility vehicles, the Alpine 6491 (\$140) is particularly effective in hatchbacks because of its small size. Longer than it is tall, the 6491 mounts about 6 in. from the end of the car, with its slot opening aimed toward the rear. The corners of the car create a "folding horn" effect, which greatly enhances the bass produced by the woofer inside the box. Because the speaker is inside the box, it is protected from the elements and other potential hazards. Bass output, rated at 15 watts per channel, is not as great as that provided by larger enclosures but the 6491 is far more discreet. Its compact dimensions are 7⁵/₈ x 5⁵/₈ x 19¹/₈ in.

A more high-powered version of the same principle is offered by Southern Audio Services, Inc., of Baton Rouge, Louisiana. The company offers two cylindrical subwoofers that use a 6¹/₂-in. and 8-in. woofer, respectively. The T16 and T18 "Bazookas" measure 36 in. long x 10 in. in diameter. Power-handling capacity is 100 watts per channel for the smaller T16 and 150 watts for the T18 (\$279). Split versions measuring 17¹/₂ in. long are also available.

The hatchbacks and wagons offer you the luxury of additional cargo space. But, to get good sound into these vehicles, you'll have to reclaim some of that space. If you like hard-driving music to go with driving hard, you'll find the trade-off well worth it.—F.V.

RAGTOP FEVER

(Continued from page 75)

company that prides itself on engineering. At nearly \$30,000, the Saab convertible's only competition is going to come from BMW's new 325i. This Saab is satisfying to drive, beautifully trimmed out and loaded with options.

Toyota Celica

The only thing wrong with the Celica convertible is that it's not available as a 135-hp GT-S. Why? With the top cut off, the Celica chassis has only marginal torsional stiffness; there's cowl shake even on smooth roads and enough twisting in hard corners to create noticeable gaps around the side windows. Considering its \$19,000 price tag, the Celica needs to be better engineered.

It also needs to be quicker. We loved the GT-S coupe we tested last year. It was fast, good-handling and eager to rev. This car, by comparison, was faster than the two J-cars and the Renault, but slower than every other convertible. It also had mediocre brakes and poor skidpad performance, though it zipped through the slalom quicker than any competitor except the Camaro. Stiffening the chassis enough to fit Toyota's existing GT-S equipment would eliminate most complaints.

Typical of Toyota, the Celica convertible is immaculately finished. The bodywork is flawless, the interior beautifully trimmed. The rounded Celica body responds well to having the top cut off. It has some of the same sleek ambience that makes the Saab so distinctive. And the driving position is excellent thanks to an adjustable seat and steering wheel.

This is really a 2+2, however. The cramped back seat could hold another couple for a short distance, but that's about all. Not surprisingly, the Celica interior measured the smallest in this group. Because it's based on the standard Celica, the convertible has more of an "econobox" feeling than even the Alliance or Sunbird. In sum, the Celica desperately needs the GT-S package to bring it up to par with the competition—and its own inflated price tag.

Conclusion

The convertibles currently available on the U.S. market are all so different, they're impossible to compare. We do know, however, that if we were making the payments, we'd prefer the Camaro IROC-Z, Mustang GT and Chrysler LeBaron, in that order. These are all serious performance cars that would be fun to drive, easy to maintain and still rewarding to own after the new wears off. What's the use of a car like this if it doesn't make you feel special everytime you get into it? **PM**

Be Your Own Boss ...IN YOUR OWN BUSINESS!

Hundreds we've trained have succeeded in this fascinating and highly profitable profession ...
... YOU Can Do It, Too!



"No more hard, nasty work for me. Now I have my own business and with hardly any effort I average around \$50 a day. Thanks for my new start in life."
Sam Walker Prichard, Alabama



"I opened my own business, spare time, seven months after I enrolled and made a profit of \$329 for the first week."
B. A. Deberry Littleton, Colorado

"Before enrolling I checked other courses and also asked for advice from several of the professional locksmiths in my area. They all said Foley-Belsaw was top and has the most versatile Key Machine."
"I always wanted to have my own business and now I do, thanks to Foley-Belsaw."



David Fairbrother—Dave's Locksmith Service
Milwaukee, Wisconsin 53209

Work Part Time, Full Time — Right at Home.

Be a LOCKSMITH!

Get into this booming high-profit business that's
Easy to learn—Easy to do—Easy on You!

Never before have money-making opportunities been so great for qualified Locksmiths. Now lucrative regular lock and key business has multiplied a thousandfold as millions seek more protection against zooming crime. Yet there's only one Locksmith for every 17,000 people!

Make Up to \$26.00 an Hour — even while learning!

Train FAST at Home!

You're "in business" ready to earn \$10 to \$26.00 an hour a few days after you begin Foley-Belsaw's short-cut training. Take advantage of today's unprecedented opportunities in locksmithing for year-round EXTRA INCOME in spare time — or fulltime in a high-profit business of your own. Hundreds we've trained have done it. So can YOU! All tools plus professional Key Machine given you with course. These plus practice materials and equipment, plus simple, illustrated lessons, plus expert supervision, plus business-building guidance will enable you the KEEP THE MONEY COMING IN! Ideal for retirement — good jobs, too.

SEND FOR EXCITING FACTS—No Obligation

Discover what's in Locksmithing for you — how Foley-Belsaw's master-locksmith-approved training can give you the skill you can depend on to EARN MORE — ENJOY LIFE MORE.

PRO KEY
MACHINE
YOURS
TO
KEEP!



This Pro Key Machine can alone add up to \$200 a month to your income... and it won't cost you a penny extra with your training.

YOURS FREE

30-DAY
NO RISK
TRIAL!

SEND FOR
FACTS TODAY!

Find out all about it!

Just fill in and mail coupon below (or send postcard) to receive full information and details by return mail. **DO IT TODAY!**

RUSH
COUPON

No Extra Cost! Included With Your Locksmith Training



**BURGLAR
ALARM
and SECURITY
SYSTEMS**

training Covers all phases of Burglar, Hold-Up and Fire Alarm servicing and installation. This valuable and timely instruction includes all special tools and supplies. ONLY Foley-Belsaw offers such extensive training in this rapidly expanding field as a part of your Locksmith training.

ADVANCED Locksmithing!

How to change combinations, install and service Safe, Vault and Bank Safe-Deposit Box locks. You'll find it fascinating and highly profitable work.

ALL SPECIAL TOOLS AND
EQUIPMENT INCLUDED!



FOLEY-BELSAW INSTITUTE

6301 Equitable Rd., Dept. 11180
Kansas City, Mo. 64120

There is NO OBLIGATION and NO SALESMAN Will Call—ever!

RUSH COUPON TODAY
FOR THIS FACT-FILLED

FREE
BOOKLET!

Tells how you quickly train to be your own boss in a profitable Sparetime or Fulltime business of your own PLUS complete details on our 30-Day NO RISK Trial Offer!



Send for your
copy today!

FOLEY-BELSAW INSTITUTE
6301 EQUITABLE RD., DEPT. 11180
KANSAS CITY, MO. 64120



YES, please send me the FREE booklet that gives full details about starting my own business in Locksmithing. I understand there is no obligation and that no salesman will call.

Name _____

Address _____

City _____

State _____ Zip _____

From Europe . . . The Ultimate in

HISTORIC SHIP MODEL KITS.

Plank-on-frame Construction



World famous kits from Europe. Large, magnificent replicas (many over 4 feet long) with beautiful walnut and mahogany planking, fittings and details exquisitely cast in bronze, brass and rare hardwoods. Large scale plans, step-by-step instructions, all materials included. VHS Video tape cassette on how to build also available.

Send for 64-pg. full-color catalog only \$1.00

MAIL THIS COUPON TODAY!

MODEL EXPO, INC. Dept. PM-67S
23 Just Road, Fairfield, N.J. 07007

Please send me a full color ship model catalog. \$1.00 is enclosed.

Name _____
Address _____
City _____
State _____ Zip _____

Overstock Sale Famous South Bend Industrial Quality Metalturning Lathes



20% off list price!

10" SWING, BENCH OR CABINET MODELS

Turn precision parts for models, prototypes; cut up to 48 different thread pitches; make replacement parts for tools, equipment and much more. You'll get industrial precision and ruggedness with hardened and ground bedways and 12 easy-to-change speeds, now at a special one-time price! Includes motor, control, one-year warranty.

BENCH MODELS: 3 1/2" bed—was \$2744, NOW \$2195.

CABINET MODELS: 3 1/2" bed—was \$3271, NOW \$2617.

VISA VISA accepted.

IMMEDIATE DELIVERY

Phone collect to place order, 1-219-289-2253.

SBL South Bend Lathe

400 W. Sample Street, South Bend, IN 46625

DETROIT SNEAK PREVIEW

(Continued from page 77)

lock brakes. The body is made in the traditional way, with steel panels over a steel structure, but you will see lots of plastic panels on the extremities, front and rear. One body style will be produced in 1988—a 2-seat hardtop coupe—but insiders look for a T-top or perhaps a convertible version sometime in the future. Buick's goal is 20,000 sales in 1988, but with all the competition in the 2-seat market, 10,000 may be closer to reality.

Pontiac Grand Prix

A new, front-drive GM-10 (or W-body) car from GM will replace the old, rear-drive Pontiac Grand Prix, Olds Cutlass Supreme and Buick Regal, popular G-body designs that have been in production for 10 years with little change. Chevrolet's version of the G-body—the Monte Carlo—will stay in production during 1988, then go to the front-drive W platform in '89.

Smaller on the outside and lighter in weight, the '88 models will deliver 2 to 3 mpg better fuel economy when the biggest 3.8-liter V6 of the new car is compared to the 5-liter V8s of the '87s. The wheelbase of 107.9 in. will vary only fractionally from the old models.

Top engine on all three brands will be the 3.8 V6, with a 3-liter V6 as the intermediate choice and a 2.5-liter Four as the base powerplant. By mid-'88, Olds is expected to offer its 2.3-liter, double-overhead-cam, 16-valve Quad Four engine as the high-performance option on the Supreme.

In an attempt to get better brand recognition, none of the body panels on any of the three Division's cars are interchangeable. Some models will get vertical "beer-tap" door handles mounted on the B-pillar between the side windows, similar to the Chevy Beretta. Others will have traditional horizontal handles on the doors.

Each car line has its own distinctive front end, rear end and roofline. The Pontiac has a semifastback roof, the Buick a more upright "formal" roofline, and the Olds has window glass wrapped around the outside of the C-pillar for a flush look similar to the Mercury Sable. The Pontiac and Olds cars won't hit the showrooms until spring, but the Buick will have a few months head start.

Ford LTD Crown

Yes, the identity of this Olds look-alike has been confirmed as the big Ford for 1988. The line gets what is now called a "freshening" in the form of new grille, taillights, trunk and rear-fender extensions. In the old days, this passed for a "minor facelift."

Despite the lack of change in this

model during the past 10 years, sales are still strong. Buyers recognize the value of a full, 6-passenger car powered by a V8 engine and built on a separate frame. This is one of the last of America's do-everything, carry-anything cars, and its minor changes this year are not aimed at rejuvenating its popularity, but preserving it for another decade or longer.

Chrysler

The 1988 Chrysler New Yorker Brougham will be an all-new model with a new body and chassis. It will fit alongside the rear-drive Fifth Avenue in the Chrysler lineup. Major features for the New Yorker include a switch to front-drive, the use of V6 engines, and independent rear suspension.

Chrysler will use its top front-drive powertrain in these models. That means a new Mitsubishi 3-liter V6 will be standard on some models, with the Chrysler 2.5-liter Four as the base.

Later, possibly in 1989, a Dodge version called the Dynasty will be added to the line. Available engines then will include 3.3- and 3.8-liter V6s.

Styling is formal, highlighted by a nearly vertical backlite, large deck surface and a fairly level hoodline. This car is slated to sell against Ford's Crown Vic and GM's Bonneville.

Tempo

Get a close-up view of this Ford compact, and you see more than a few changes in body shape. Fenders bulge outward a couple of inches to give a huskier appearance. Bumpers are full wraparound type that stretch all the way back to the wheel openings. A small change in the roofline at the rear window imparts a more formal appearance and makes the trunk look bigger. The net effect is a bigger, more substantial appearance. Chassis and drivetrain, however, are essentially the same as the 1987 models.

Pontiac Sunbird

Pontiac, Buick, Olds and Chevy will smooth out the awkward body lines of their subcompacts by altering the beltline, roofs and grilles of the Sunbird, Skyhawk, Firenza and Cavalier. Changes seen on a Sunbird under test at GM's proving grounds in Milford are typical of what you'll see throughout the 1988 line. Note that the harsh, angular line of the '87 hardtop roof will be replaced with a softer, curved shape, while the beltline dips as it travels over the rear fender.

Plans are for Olds and Buick to offer only two body styles in this line for '88, while Pontiac and Chevy continue with the full line of coupe, hatchback, convertible and 4-door sedan models.

(Please turn to page 126)

Train at Home for One of These 38 Career Opportunities

SEND FOR FREE CAREER FACTS ABOUT DIPLOMAS OR DEGREES

If you want more money, more security and a better way of life, the decision to train for a better career could be the most important one you will ever make. And now you can train at home in your spare time for a diploma or even a degree to help you get a better job. This is the same kind of training program that has been used by nearly 2,000 American Corporations to train their employees... General Electric, Ford, DuPont and many others.

An Ideal Way to Learn

No need to change your daily routine or take time from your job or family. Learning is easy because everything is explained step by step with plenty of drawings, diagrams and photos. And like many colleges—all these courses use "open book" exams that let you refer to your texts and apply what you have learned. If you do have a question, your instructor is as close as your telephone. And all courses include necessary tools, instruments and materials...what ever you need for your training.



Could a Career Diploma or a Degree Be Worth Thousands of Dollars to You?

Compare your present salary with the amount of money you could be making in any of the careers shown to the right. Training in a trade or earning an Associate Degree in Specialized Business or in Specialized Technology could make a giant difference in your lifetime earnings. But it's not the money alone...think of the security, satisfaction and the fun of working in a job you like. Get more information at no cost! Check the career you're most interested in and mail the coupon today. There's no obligation and no salesman will visit you.



Or Get Your Degree... Without Attending College

Now without attending class, you can get your Associate in Specialized Business Degree in Accounting or Business Management—or choose an option in Marketing or Finance! Or get a Technical Degree in Civil, Mechanical or Electrical Engineering Technology or Electronics Technology. If you already have some college or if you have worked in the field, you may be entitled to advanced standing toward your degree.

5622

ICS International Correspondence Schools, Dept. PBS67

Scranton, Pennsylvania 18515
Please send me free facts, color brochure and full information on how I can train at home for the career I have chosen. I understand I am under no obligation and no salesman will visit me. **CHECK ONE BOX ONLY!**

ASSOCIATE DEGREE IN SPECIALIZED BUSINESS PROGRAMS

- Business Management
- Business Management with option in Marketing
- Business Management with option in Finance
- Accounting

ASSOCIATE DEGREE IN SPECIALIZED TECHNOLOGY PROGRAMS

- Civil Engineering Technology
- Mechanical Engineering Tech.
- Electrical Engineering Tech.
- Electronics Technology

CAREER DIPLOMA PROGRAMS

- High School
- Auto Mechanics
- Hotel/Restaurant Management
- Surveying & Mapping
- Drafting
- Air Conditioning & Refrigeration
- Travel Agent
- Wildlife Forestry Conservation
- Art
- Police Sciences
- Veterinary Assistant
- Diesel Mechanics
- Electrician
- Small Business Management
- Electronics
- Bookkeeping
- Computer Programming
- Microcomputer Repair
- Gun Repair
- Motorcycle Repair
- Catering/Gourmet Cooking
- Fitness & Nutrition
- TV/VCR Repair
- Medical/Dental Office Assistant
- Secretary
- Interior Decorating
- Child Day Care
- Legal Secretary
- Fashion Merchandising
- Legal Assistant

NAME _____ AGE _____
ADDRESS _____ APT. # _____
CITY/STATE/ZIP _____
PHONE () _____

A Subsidiary of National Education Corporation

Mail coupon today for free facts and color brochure.

16⁹⁵



Easy To Use! Place Image Underneath & Focus Projects 3-D Objects Too!

IDEAL FOR STUDENTS, TEACHERS, ARTISTS, WOODWORKERS, NEEDLEPOINTING, ARTS AND CRAFTS AND HOURS OF FAMILY FUN!

Craft Projector Enlarges

ANY PICTURE, PATTERN OR DRAWING EVEN 3-DIMENSIONAL OBJECTS UP TO 25 TIMES ORIGINAL SIZE!

Project: Prints, Plans, Photos, Stamps, Coins, & Gems In Natural Color — Onto Almost Any Surface: Wood, Wall, Screen, Paper, Fabric.

This BRAND-NEW EPISCOPE PROJECTOR projects directly from snapshots, books, even solid objects like coins, mineral specimens, etc. Fine reflector and mirror system, Hi-intensity projection lens that enlarges images up to 16 feet cooling vents and "on-off" switch.

No. 4500A—Episcopo Projector\$16.95
EXTRA BULBS FOR YOUR PROJECTOR ONLY \$2.00

True To Life Coloring - Fascinating Action MALLARD WEATHERVANE

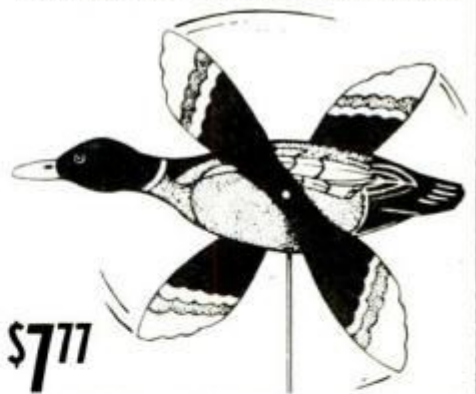

\$7.77

... His Wings Twirl With Every Breeze!

A splash of color... as wings twirl in realistic flying motion! The perfect landscape accent for your yard, lawn or garden... keeps pest away from vegetable patch and fruits too! Action duck measures about 18" long and is completely Weather Resistant. Comes complete with 18" high metal support rod. Full color. Specially priced!

No. 8136—Mallard \$7.77 - TWO \$12 - THREE \$17

ARMY



MARINE



NAVY

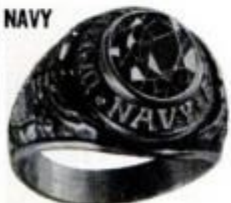

AIR FORCE



★★★★★ YOUR OWN ★★★★★

ARMED SERVICES RING

LAYERED IN RICH 18KT GOLD Set With a Ruby-Red, 3 Carat, Faceted Stone

IT'S OFFICIAL! Now, you can get an ARMY, NAVY, MARINE, AIR FORCE or COAST GUARD RING, no matter how long it has been since you served! Here's the ring you always wanted — so rugged... so manly and so finely detailed. Each one has deeply sculpted official insignia and symbols for that particular branch of service. Electroplated in GENUINE 18 KT GOLD... not ordinary plating but certified HEAVY GOLD Electroplate that will last and last! Big, 3 CARAT Multi-faceted, Ruby-Red Stone. It's the ring you can really wear with pride because you served your country well. Available in sizes 7-13.

WHEN ORDERING: SEND SIZE OR A SLIP OF PAPER CUT TO YOUR SIZE — SPECIFY ARMY, NAVY, MARINE, AIR FORCE OR COAST GUARD

No. 5623—Armed Services Ring\$12.95
Special: Two only \$22.95

NOW AVAILABLE! COAST GUARD RING

Send Order To: FOSTER-TRENT, INC., DEPT. 522-F
2345 BOSTON POST RD., LARCHMONT, N.Y. 10538
Include \$1.90 Postage & Handling.

QUAN.	SIZE	ITEM NO.	DESCRIPTION	PRICE
			SHIPPING & HANDLING	1 90
			N.Y. Residents Must Add Sales Tax	
			Total Enclosed	



DOW CORNING

Want to apply silicone sealant like a professional? Use a soapy old spoon!

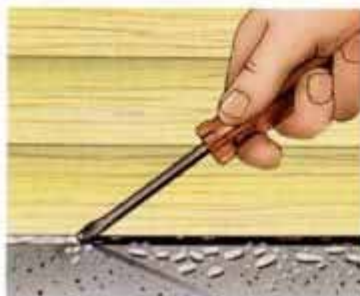

Over time, ordinary caulk cracks and falls apart. When that happens, it's time to remove the old caulk with a screw driver and replace it with a durable seal.



DAP® DOW CORNING® General Purpose Silicone Sealant is the perfect solution. It's so flexible, it adjusts to movement and weather changes. Just squeeze it into place.



The trick to getting a smooth bead is to tool over the fresh sealant with an old spoon dipped in a soap solution. You'll have a professional-looking long-lasting seal to protect your house!

Depend on DAP

Dow Corning Silicone Sealants were used on the Statue of Liberty in its recent centennial restoration.

*Dow Corning is a registered trademark of Dow Corning Corporation, USA



DETROIT SNEAK PREVIEW

(Continued from page 124)

AMC Premier

A late addition to the AMC 1988 line will be this 5-passenger, intermediate-size Premier, a European-designed sedan that will be built in North America. Premier is a takeoff of the Renault 25 and will probably match the French car closely, unless AMC's new majority stockholder, Chrysler, changes the AMC plan.

Subtle differences in the body of the Premier set it off from the styling of the 25. While the 25 is a hatchback, the Premier is a true 4-door sedan. Windshield wipers are hidden on the Premier, bumpers are more angular, and the hood does not wrap over the top of the fenders. V6 and 4-cylinder engines plus automatic and 5-speed manual transmissions will be supplied from Europe to the Ontario, Canada, plant.

'89 Ford Thunderbird

Ford will stick with rear drive for its Thunderbird and Cougar models through the mid-1990s, at least. But big changes are scheduled in the personal coupes a year from now. Wheelbase will be stretched from the current 104.2 in. to 109 in. The object: more room inside and a more stable ride.

Electronic advances available only on the Turbo Coupe today will include adjustable shock control and antilock brakes. Also possible are air springs and electric power steering. Definitely in the works for '89 are an independent rear suspension, along with a supercharger for the top performance model. The supercharger will go on top of a 3.8-liter V6 and replace the present turbocharged 2.3-liter Four.

'90 GM Minivan

Chevrolet and Pontiac will sell this small front-wheel-drive passenger van beginning in 1990. Designed to compete with the Chrysler minivan, the GM model takes van design further into the future. The body is plastic, overlaid on a steel frame. Drivetrain is a front-drive unit taken from the GM A-car lines—Celebrity and 6000. And sunshade glass is used in all windows.

Front-seat passengers enter through doors set behind the front wheels, which makes entrance/exit more convenient than when the wheels are located under the doors, as in some import models. A unique, single windshield wiper is planned, as seen on this prototype being tested at GM's Milford Proving Grounds. Most frequently reported powerplants are GM's 2.5-liter Four and 2.8- or 3.8-liter V6s. The taillights are mounted above the beltline, a position that allows a wider hatch so that bulkier cargo can be loaded. **PM**

**ALSO AVAILABLE IN
AN ELECTRIC MODEL**

The Biggest Name In Small Tillers. Mantis.

It's a fact. Our best-selling Mantis is preferred by more suburban gardeners than any other small tiller on earth. Why? Because it's the only tiller that's perfect for every size garden. It weighs just 20 pounds, handles like a dream, yet works like a dynamo. It churns tough soil to a fine, fluffy loam. And it speed-weeds a sensible 9" wide, so you can get between narrow rows and along fences. And remember: Mantis does more than just your gardening. With its affordable attachments, it also cuts crisp borders for your flower beds. Trims your hedges. Digs holes and furrows. Even aerates and de-thatches your lawn. Your entire property will shine! Mantis even comes with a 3-Week Risk-Free Home Trial. Plus the best guarantees in the business. So, don't let other tiller companies lead you down the garden path. There's only one Mantis. It's truly the only name in town.

We're changing the way Americans garden.

Mantis Manufacturing Co.
1458 County Line Rd., Dept. 22067
Huntingdon Valley, PA 19006
1 (800) 344-4030
(In PA, 1 (800) 342-0052)

Mantis

Yes, rush me full details on the amazing Mantis.

- Mantis Gas Model
 Mantis Electric Model

Name _____
Address _____
City _____
State _____ Zip _____

© 1987 MMC



OPPORTUNITY CALLING FROM NRI

Start your own telephone/ cellular radio service & repair business

New Bootstrap Industry Lets You Be Your Own Boss

Since the breakup of AT&T, things aren't the same in the telephone business. Now there's a perfect new business opportunity for thousands of independents who have been trained to service, install and repair old phones, plus all the new cordless and cellular mobile car phones, that are becoming more and more popular. NRI's training and start-up equipment offer you the option of starting your own bootstrap business or cashing in on the jobs being created by the new telephone technologies.

NRI shows you how you can make a good living in telephone servicing, with a practical combination of electronic fundamentals and hands-on experience with all types of phones in use today in homes and offices—cord, cordless and cellular.

Learn troubleshooting—with cordless and memory phones you keep!

The heart of NRI telephone training is eight Action Learning kits. You master the "reason why" theory, then you move immediately

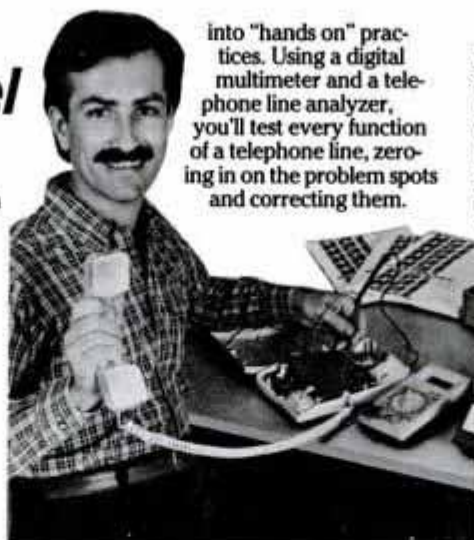

into "hands on" practices. Using a digital multimeter and a telephone line analyzer, you'll test every function of a telephone line, zeroing in on the problem spots and correcting them.

As an NRI student, you learn at home, at your convenience. Without rigid night-school schedules or classroom pressures. NRI's tested "bite-size" lessons lead you step-by-step toward your goal of independence as a telephone service expert.

Send coupon for FREE catalog

Find out for yourself exactly what this new NRI training can do for you.

NRI's free catalog gives you all the facts on training for Telephone Servicing & Repair or other technical fields such as Microcomputers, TV/Audio/Video System Servicing and Communications Electronics.

If coupon has been removed, write to NRI Schools, 3939 Wisconsin Ave., Washington, DC 20016.

NRI SCHOOLS

McGraw-Hill Continuing Education Center
3939 Wisconsin Avenue
Washington, D.C. 20016

WE'LL GIVE YOU TOMORROW.

Please rush me the one free catalog I have checked. I understand there is no obligation.

For Career courses approved under GI Bill
 check for details.

Name _____ (Please print) Age _____

Address _____

City/State/Zip _____

Accredited by the National Home Study Council.

- Telephone Servicing Course
- Air Conditioning, Refrigeration, Heating and Solar Technology Courses
- Small Engine Repair Course
- Appliance Servicing Course
- Locksmithing Course
- Automotive Mechanics Course
- Building Construction
- Industrial Electronics
- TV/Audio/Video Servicing, Communications, Electronics, Microcomputers, Electronic Design Technology, Electronics Courses

121-067

Overseas

TAX-FREE SALARIES

POSITIONS NOW AVAILABLE IN:

- ★ N. AFRICA ★
- ★ EUROPE ★ ASIA ★
- ★ MID-EAST ★
- ★ S. PACIFIC ★
- ★ W. GERMANY ★
- ★ S. AMERICA ★ UK ★
- ★ CARIBBEAN ★

FIRST \$70,000 EARNED IS TAX FREE

FREE TRAVEL • FREE FOOD
FREE HOUSING • FREE MEDICAL

World's Oldest and Largest
LICENSED AND BONDED
Overseas Employment Agency.

15,000+ OPENINGS
AVAILABLE IMMEDIATELY

GENERAL, PETRO CHEMICAL
ENGINEERS, ELECTRICAL
CONSTRUCTION, EX-MILITARY
ACCOUNTING, FINANCE
MD's, DDS, RN's, EDP
NEEDED URGENTLY

All Positions offer: 1-2 year contracts, free housing, free food, transportation, R & R, medical, dental, etc.

\$450 Advance Fee

100% REFUND IF YOU ARE NOT MATCHED
WITH AT LEAST 3 COMPANIES

Call NOW, or send resume to:



CALL NOW (213) 739-8080

3460 Wilshire Blvd., Suite 908SA, Los Angeles, CA 90010

OR CONTACT (208) 344-0442

290 Bobwhite Ct., Suite 240SA, Boise, ID 83706

For the following states only: Idaho, Michigan, Minnesota, Montana, N. Dakota, S. Dakota, Oregon, Washington, Wyoming, Canada.

OR CONTACT (813) 985-7300

7402 N. 56th St., Suite 800SA, Tampa, FL 33617

For the following states only: Alabama, Arkansas, Florida, Georgia, Kentucky, Louisiana, Maryland, Mississippi, N. Carolina, S. Carolina, Tennessee, Virginia, Washington D.C., W. Virginia.

OR CONTACT (201) 624-3700

Gateway One (at Penn Station), Suite 501SA
Newark, NJ 07102

For the following states only: Connecticut, Delaware, Maine, Massachusetts, New Hampshire, New Jersey, New York, Pennsylvania, Rhode Island, Vermont.

Employment Not Guaranteed

STACKED DECKS

(Continued from page 85)

Godfrey 196 Hurricane

The Hurricane was shorter and narrower than the top-ranked boats, and that decrease in size probably helped it to a No. 1 finish on the performance course. The boat feels rock-solid in extreme turns at speed, with no tendency to skid or trip. The padded sport wheel is just right for the fast maneuvers the boat invites. The wetted portion of the hull is a modified vee—sponsons forward don't touch the water at speed, but they do provide added flotation at rest.

Despite its somewhat smaller LOA and beam, the Hurricane stacked up well in deck space, ranking second only to the Four Winns in usable area. It fell down in storage, however, due to wasted space under the bow seats. In a boat that will comfortably seat 12, that added space for gear is needed. The analog gauges are easy to read from behind the wheel, and the fuses are all next to the switches that they monitor on the Hurricane's dash.

The engine hatch covers the folded top neatly, but we found the slide-bolt hatch locks difficult to see and operate. The gas fill on this boat is set at about 60° on the transom, not vertical like all the other deck boats tested, and this helped in avoiding fuel spills. The skiing tow eye is mounted low on the stern and is hard to get to without stepping out on the swim platform. Overall, this boat was judged well-finished and a good handler by the test crew, but couldn't quite match up to the Cadillac size and appointments of the Harris and the Four Winns.

Chris Craft Sportdeck 190

The Canadian-built 190 is a driver's boat; it finished first in top speed and a very close second on the performance course. However, small design flaws prompted a fourth-place rating—but considering the fact that both this boat and its near-cousin, the fifth-place Sunchaser, costs from \$3000 to \$7000 less than the top finishers, price will certainly be a consideration in any poten-

tial buyer's choice. Though the beam is only 84 in., the forward and aft sunpads offer better than 40 sq. ft. of room to stretch out. Storage space was also very good, with every nook and cranny utilized. The molded fiberglass table, fitted to floor grommets when in use, stows neatly out of sight.

The analog gauges are easy to read, though test drivers would have preferred having the tach and speedometer closer together to wring out the last mph. The stainless-steel wheel looks salty, but the cold steel was not as easy to handle as the comfortable padded wheels on other models.

The engine hatch is held down only by flexible plastic snaps, hard to find and easy to forget. If you do, the hatch flies up at speed with enough force to break the hinges. A visible, positive lock would make better sense. The ski hatch cover on this boat, like that on the Harris, was a pressure fit—makes you wonder if there is a sandpaper shortage at the factories.

Sunchaser 1908 DC

The Sunchaser has breakers on the dash switches, rather than fuses—a nice touch. The dash featured no-nonsense analog gauges, easy to read. The boat looked rather basic compared to some of the plusher models, but lists for thousands less.

Drivers and co-pilots of these boats wished all had console windshields to cut spray. More importantly, they wished for elimination of the small windshield at the bow—a piece of this unsupported plastic on the Sunchaser was knocked out by a wave during a speed run on open water, and barely missed the driver on its way out of the boat! There were other problems with the Sunchaser: Hard-to-find plastic tie-downs on the engine cover were overlooked, resulting in a hatch that broke its supports at 45 mph.

The boat had loose steering and was not as predictable in turns as others. There was no retainer on the gas fill cap, which makes it almost a sure thing that the cap will be lost overboard—it pops out of the vertical fill hole unpredictably when loosened to refuel.

It was a bit short on storage space, in part because no ski locker was built into the floor. A large box extending the width of the back seat will hold skis, however.

Though the Sunchaser had its problems, it too would make a useful boat for the large family looking for a versatile weekend rig that requires minimal care and a moderate investment.

In fact, the entire fleet had a lot to offer any prospective boatman in need of maximum space. And the performance is an unexpected plus. **PM**



Deck boat test power was supplied by OMC's Cobra 5-liter sterndrive, a rip-sportin' 230-horse V8.

Save Gas, Save Engine with "POLY"

The following introduces one of the most fully tested and proven gas saving, friction-reducing engine treatments ever to reach the market!

The Secret is "Poly"

"Poly" is short for polytetrafluoroethylene (TFE), the slipperiest substance known to man. (1981 Guinness Book of World Records). Petrolon Corporation, makers of Slick 50, invented a way to permanently bind this slippery chemical to your engine with one treatment. Just one quart of Slick 50 can reduce engine friction, increase gas mileage and horsepower and reduce engine operating temperature, causing your oil and engine to last longer. . . plus it reduces metal wear, defraying costly overhauls.

Years of Testing and Use Have Proved it True!

Slick 50 has been thoroughly tested in independent laboratories and out on the road:

The March/April 1982, p. 35 issue of "Consumer Digest" magazine stated, "Slick 50 does reduce engine heat and ordinary wear, and our informal tests indicate that it will improve gas mileage by about 2 or 3 miles per gallon."

One of the country's most respected research institutes reported applying a powerful ultrasonic cleaning process to a Slick 50 treated engine and were surprised at its permanence. "We actually expected the Petrolon Slick 50 TFE Resin coating to also be removed, but later found it was still there."

"Dune Buggies & Hot VWs" magazine April 1983 issue records the results of their one year testing of Slick 50. "We can indeed say scientifically that Slick 50 does work, and that it does reduce engine wear! . . . for the price of one treatment when compared to engine rebuild, we feel that you'd be money ahead using Slick 50."

The Federal Aviation Administration has fully accepted a similar product for aircraft—Slick 50 Aircraft Piston Engine Treatment (F.A.R. #33.49). This FAA endurance test simulated 1400 hours of engine use.

The power technology laboratory at a leading southwestern university stated, "Slick 50 does increase horsepower and decreases fuel consumption in tests done at the university."

The Space Shuttle Columbia uses the chemical "poly" in its gears and bearings because it is the only chemical lubricant which can withstand the heat and corrosive elements of space.

Perhaps most dramatic of all is a torture test overseen by the Automotive Services Council for Pennsylvania and shown on WTVE television. Three cars with 75,000 to 129,000 miles on them were treated with Slick 50. Six months later the oil was drained from each vehicle, and the cars driven without the oil plugs for about a half hour. The water temperature never rose and the engines sustained no apparent damage.

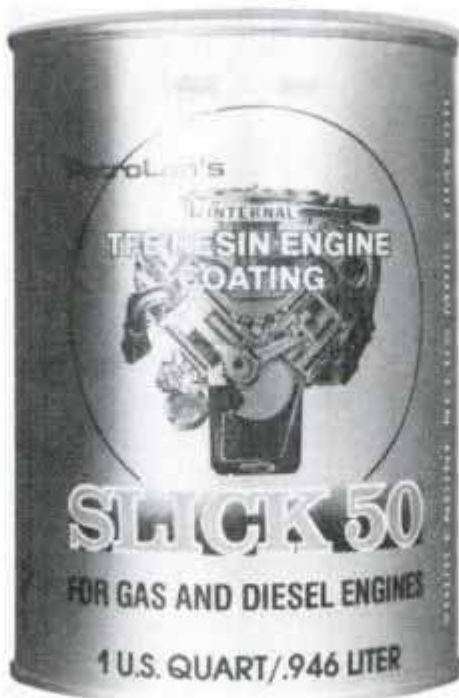

There isn't room here to tell you about the dozens of other tests proving that Slick 50 is everything we say. However, if you're still skeptical, send \$2.00 to cover printing and postage costs, and we'll send you detailed test results plus actual letters from users who report how Slick 50 saved their engines and saved them money!

It's Easy to Treat Your Engine

A few minutes before oil and filter change, add the engine flush you get free with each order to clean out the engine. Let the engine idle for 5 minutes. Then drain the oil, change the filter and add the proper amount of oil, less one quart. Add one quart of Slick 50, drive for 30 minutes, and leave it in the crankcase for at least 3,000 miles. As the engine operates, the oil carries the "poly" between the parts where it is burnished into the pores of the metal.

Only One Treatment Necessary

It's permanent, so you do it only once, not each time you change oil. One quart of Slick 50 will treat all standard 4, 6 and 8-cylinder gasoline and diesel engines.

Works with Most Oils

Slick 50 will work with all petroleum-based oils and all synthetics compatible with petroleum-based oils with the exception of graphite oils. However, once an engine is treated, you can go back to a graphite type if desired.

4 Ways Slick 50 Saves You Money

Your actual percentages may vary depending on your driving, vehicle condition, weather and geographic location, but no matter what your conditions, Slick 50 can:

1. Increase mileage
2. Increase horsepower (small economy cars and large RV's really need this)

3. Reduce operating temperatures, thus increasing the lubrication and life of the oil and engine
4. Minimize or eliminate costly overhauls by reducing engine wear

Up to 90% of the engine wear on a car can be caused by lubrication starvation cars experience when first started before the oil begins to circulate. Slick 50 can eliminate this problem for less than the cost of two tanks of gas.

Slick 50 Will Not Affect Your Warranty

Slick 50 is suspended in an excellent grade of petroleum oil which meets or exceeds every manufacturer's engine warranty requirements. In addition, this oil carries an American Petroleum Institute service classification SF-CC-CD.

There's No Risk with Our Money Back Guarantee

Use Slick 50 for 3000 miles. If you don't notice an improvement in engine performance, return your invoice with a short note telling why, for a prompt full refund — no questions asked.

Profit from Selling Slick 50 Yourself

Here's an opportunity to make handsome profits. Having such solid test results from major institutions make Slick 50 easier to sell than many other products. Free dealership information is sent upon request.

For purchase or further information call toll-free 1-800-525-8624, ext. 6 (in California 1-800-233-9559) or send to: Progressive Energy Corporation, 255 South Bent Avenue, #B-1, Dept. PM687, San Marcos, California 92069.

Yes, I want to improve my car's performance and save my engine — rush me risk free

One Slick 50 at \$39.95 + \$4.00 shipping and handling. Calif. Residents add 6% Sales Tax.

Give me free shipping and handling for my order of 2 or more at \$39.95 each.

Check C.O.D. Visa/MasterCard

Card # _____

Exp. Date _____

Name _____

Address _____
(Give street address if possible for UPS delivery)

City _____ State _____ Zip _____

PEC

Progressive Energy Corporation

255 South Bent Avenue, #B-1, Dept. PM687
San Marcos, California 92069
CALL NOW, TOLL FREE 1-800-525-8624.
IN CALIFORNIA, TOLL FREE 1-800-233-9559.
©1987 Progressive Energy Corp.

NEW AGE RVs

(Continued from page 89)

produce its top-of-the-line coaches.

Winnebago's aggressive modernization of its facilities is supported by a computerized design center and an electronic bridge used during the clay-modeling process. With this equipment, company engineers can use a probe on a clay model and enter dimensions into a computer that provides valuable input. Winnebago boasts that the auto companies do not have this equipment yet. Computer-aided design is expected to lead to further refinements in the full Winnebago line.

Foretravel, a long-time builder of luxury Class A coaches, last Spring introduced its first unibody motorhome. Again, computers played an important role in the design of a monocoque chassis. This type of construction eliminates a rail-type chassis structure and spreads the stress normally concentrated in the platform throughout a unitized superstructure. The benefits are improved road-worthiness and a smoother and quieter ride. The price for the new Foretravel Unihome is \$285,000.

The demand for good ride quality in luxury RVs has forced manufacturers to concentrate on improving suspensions. Airstream makes good driving machines of its aircraft-style coaches by reworking the Chevrolet P-30 chassis. Airstream developed the CMA Tag Axle to provide improved weight-hauling capacity for the heavier coaches along with a substantially better ride. To achieve this, a self-leveling air-bag system was incorporated with a rubber torsion axle and trailing-arm assembly that controls air-bag inflation levels. Tag-wheel movement automatically keeps the chassis level, even if the load is not evenly distributed. The result is a very stable, controlled ride, even while load capacity is increased.

Down the road, the direction of the automobile industry will have a direct bearing on the future of the motorhome. Consumers are becoming more performance oriented; as automobiles become more sophisticated, so will motorhomes. Aerodynamic styling, improved chassis design and aftermarket or OEM suspension retrofits are key elements in the industry's general design upgrade. As progress is made in microprocessor and electronic component development, today's luxury items such as microwave ovens, satellite dishes, stereo televisions, video cassette recorders and computer-controlled leveling systems will become commonplace.

And, of course, there is the shower—even in a vehicle that goes 28 miles on a gallon of fuel.

PM

THREE WIPING EDGES INSTEAD OF ONE!

TRIPLEDEGE
LIFETIME WIPER BLADE

GUARANTEED FOR THE LIFE OF YOUR CAR—OR YOUR MONEY BACK

- First edge removes water & snow
- Second edge removes bugs, road film, dirt.
- Third edge squeegees glass clean.

WORLD'S FIRST SYNTHETIC WIPER BLADE. Made from DuPont Nardel™ —the same material used in 50,000 mile radial tires. Will never tear, crack, split, rot, dry out or stick. Not affected by ice, snow, blizzing sun, smog or road chemicals.

EASY, DO-IT-YOURSELF INSTALLATION. Includes 2 complete units: High Quality Black Metal Superstructure complete with Tripledge Lifetime Wipers. They snap on in seconds. Custom fit virtually every U.S. and import car, van or truck

PRICE PER PAIR ONLY
\$12.95 Plus \$1.95 Shipping & Handling
Specify make, model, year of car.

CALL TOLL-FREE!
1-800-847-0653

PA residents call 1-215-638-8008 or send check, money-order or card number and expiration date of your Visa or MasterCard.

TRIPLEDEGE WIPER CORP.
Dept. PM-687, 3165 Tucker Road, Bensalem, PA 19020

YES! Send me _____ pair of Tripledge Lifetime Wipers—the only wiper **GUARANTEED** for the life of your car.

Name _____
Address _____
City _____ State _____ Zip _____

VISA/MC# _____ Exp. Date _____

Car #1: Year _____ Make _____ Model _____
Car #2: Year _____ Make _____ Model _____
Car #3: Year _____ Make _____ Model _____
Car #4: Year _____ Make _____ Model _____

1 pr. \$12.95
2 pr. \$23.90 Save \$2.00
3 pr. \$34.85 Save \$4.00
4 pr. \$45.80 Save \$6.00
(Single Blades \$6.50 ea.)
Shipping \$1.95 first pair (Shipping 2nd, 3rd, & 4th pair, only \$1.00 each)

PA Residents Add Sales Tax

Homeowners!

Rid Your Property of Unsightly Brush Piles!

Turn a mess like this...

...with the Amazing New **SUPER TOMAHAWK® Chipper/Shredder... exclusively from Garden Way!**

- It's a powerful Chipper... handles big branches up to 3" in diameter with ease!
- It's an efficient Shredder... turns almost any organic matter into perfect mulch and compost instantly!
- Revolutionary New Compact Design... 7 ways better than bulky "old-style" chipper/shredders!
- Professional Quality... designed, sized and priced for the homeowner!

into beautiful **FREE** mulch in less than one hour!

Send for **FREE** details today!

FROM THE MAKERS OF TROY-BILT Roto Tillers

Garden Way Mfg. Co., Dept. A583 3 13
102nd St. & 9th Ave., Troy, N.Y. 12180

YES! I want to know more about the amazing SUPER TOMAHAWK Chipper/Shredder! Please send me complete details including prices, models and SPECIAL SAVINGS OFFER right away!

Name _____
Address _____
City _____
State _____ Zip _____

© 1987 Garden Way Inc.

SAKRETE®

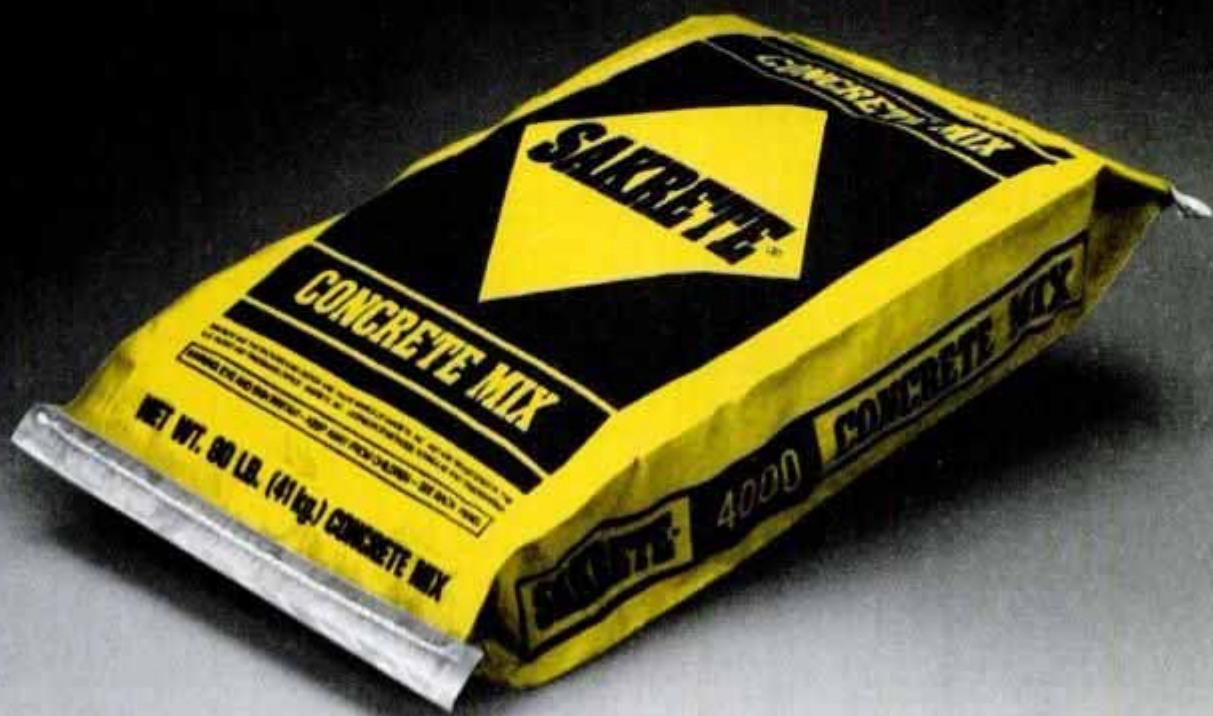

THE STANDARD OF THE PACKAGED CONCRETE INDUSTRY.

The ® after the brand name SAKRETE® indicates that SAKRETE® is a registered trademark and has been recognized throughout the world. More than one billion bags have been sold in fifty years.

It stands for high quality.

Professional builders and do-it-yourselfers follow a basic rule.

For over 50 years, they have asked for SAKRETE®, the standard of quality in mixtures of aggregate and cementing materials.

Don't forget to ask for your free project book when you buy SAKRETE®. Or, send 50¢ mailing and handling to SAKRETE®, Inc., P. O. Box 17087, Cincinnati, OH 45217.



SAKRETE®
Concrete and Mortar Mixes

©1987 SAKRETE, INC.

Материал защищен авторским правом

Start your own money making business!



Get in on the PROFITS in SMALL ENGINE service and repair



BEAT INFLATION! Work part time, full time right at home - we help you every step of the way.

In just a short time, you can be ready to join one of the fastest growing industries in America... an industry where qualified men are making from \$25.00 to \$30.00 per hour... and that's just for labor. Parts, engines and accessories add even more to the profits. Because the small engine industry has grown so quickly, an acute shortage of qualified Small Engine Professionals exists throughout the country. When you see how many small engines are in use today, it's easy to understand why qualified men command such high prices — as much as \$49.95 for a simple tune-up that takes less than an hour.

65-million small engines are in service today!

That's right — there are over sixty-five million 2-cycle and 4-cycle small engines in service across the U.S.A. That's the official count from the Engine Service Assn., and new engines are being built at a rate of one-million per month! With fully accredited and approved Foley-Belsaw training, you can soon have the skill and knowledge to make top money servicing these engines. Homeowners and businessmen will seek you out and pay you well to service and repair their lawnmowers, tillers, edgers, power rakes, garden tractors, chain saws, mini-bikes, go-carts, snowmobiles... the list is almost endless.

You get all this Professional equipment with your course, PLUS 4 H.P. Engine... ALL YOURS TO KEEP... All at NO EXTRA COST.



RUSH COUPON TODAY FOR THIS FACT-FILLED

FREE BOOKLET!

Tells how you quickly train to be your own boss in a profitable Sparetime or Fulltime business of your own PLUS complete details on our 30-Day NO RISK Trial Offer!



Send for your copy today! No obligation.

No experience necessary.

You don't need to be a 'born mechanic' or have prior experience. If you can read, you can master this profitable trade right at home, in your spare-time, without missing a single paycheck. Lessons are fully illustrated — so clear you can't go wrong.



Learn At Home In Your Spare Time.

We guide you every step of the way, including tested and proven instructions on how to get business, what to charge, how to get free advertising, where to get supplies wholesale... all the "tricks of the trade"... all the inside facts you need to assure success right from the start.

INCREASED INCOME

"I've had about 8 years experience repairing small engines... but repairs were only minor... until I started the Foley-Belsaw Course!"

Walter H. Strick
Campbell, California



With our famous 'learn-by-doing' training method, you get actual 'hands-on' experience with specialized tools and equipment you'll receive with your training, plus a brand-new 4HP engine — all yours to keep.

Send Today for FREE facts!

You risk nothing by accepting this offer to find out how Foley-Belsaw training can give you the skills you need to increase your income in a high-profit, recession-proof business of your own.

Just fill in and mail coupon below (or send postcard) to receive full information and details by return mail. **DO IT TODAY!**

FOLEY-BELSAW INSTITUTE

6301 Equitable Rd., Dept. 51187
Kansas City, Mo. 64120

No obligation... No salesman will call

FOLEY-BELSAW INSTITUTE
6301 Equitable Rd., Dept. 51187
Kansas City, Mo. 64120



YES, please send me the FREE booklet that gives full details about starting my own business in Small Engine Repair. I understand there is no obligation and that no salesman will call.

NAME _____

ADDRESS _____

CITY _____

STATE _____

ZIP _____

MOTORCYCLE TOURING

(Continued from page 94)

and a forced-air horn, with its own electric compressor, is better yet. GM's truck air horn, charged by a nitrogen tank in the saddle bag regulated to 100 psi, comes close to ideal, but the final answer is a Grover air horn, normally used on fire engines, installed with its own electric compressor kit. Now that sounds a warning when someone's about to cut across your bow!

When taking off on a ride with our group, each rider gets a red Capitalist Tool vest to wear for visibility's sake as well as identity. In the saddlebags we carry, as an everyday necessity, rain-suits. I haven't yet found one that's totally waterproof, and still the big decision is when to stop and put it on.

In any event, Totes overboots are a good bet to keep your feet dry, and Dry Rider mittens with a chamois to wipe the face shield work well. And if the rain suit has a clear pocket on the knee for a route map, so much the better.

As for cold weather gear, I've always thought that more layers of clothing are probably less bother than the wires of electrically heated vests and such.

Some device to hold the throttle in a constant position—I still find Harley's little screw unit as good as any—is a handy way to relax your right hand as the miles pass under you, but I have gotten hooked on Honda's new Aspen-cade cruise control, which lets you lock in on a speed, uphill or down.

When first starting out as a 2-wheeled tourer, I learned a bit of discipline about packing lightly, and no matter how spacious your motorcycle's carrying capacity there's always a need to conserve. The one item I won't compromise though, is a spare pair of eyeglasses. I once lost a pair while riding to Quebec. Without that spare, I'd have been in deep soup.

When all is said and done, the one touring necessity that would make me turn around and head back home if I left it behind would be money or plastic! That's very hard to travel without.

Whatever the motorcycle, whenever the time, the bottom line is that in motorcycle touring, getting there is half the fun. The best place to tour is anywhere you haven't been. In this country, you could leave Las Vegas, the artificial city personified, at 4 in the morning, hit the heat of Death Valley about noon, and end up in Yosemite throwing snowballs, all in a day's gamut. The old winding roads, now bypassed thanks to the Interstates, are full of their own vintages, and the broad expanse of the prairie states are stunning in themselves. On a motorcycle, anywhere you haven't been is a great place to go.

PM

**We not only give you the money for college.
We also give you the time.**

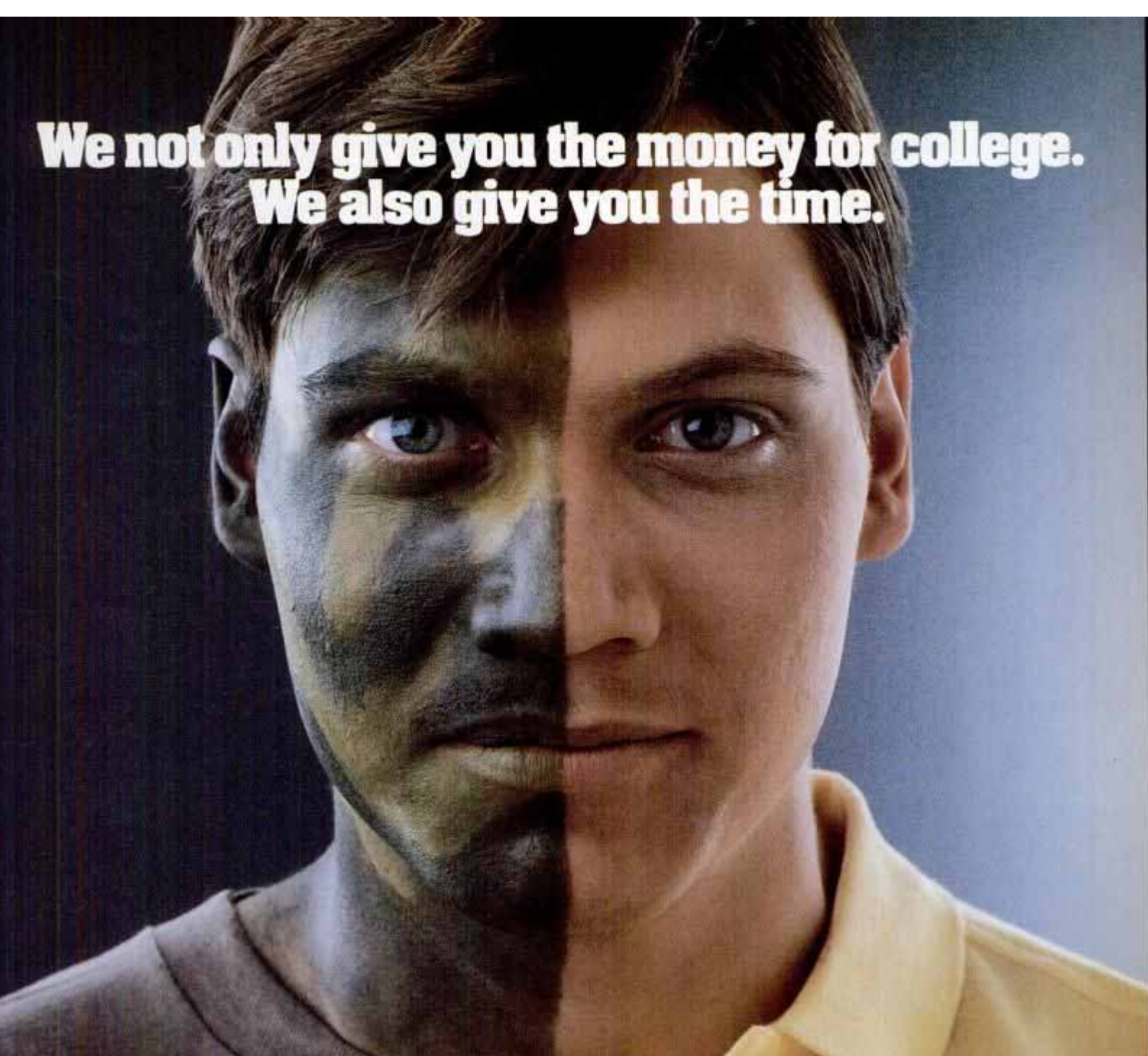

If you think the best way to pay for college is to put it off for a few years and join the military, you're half right.

Because with the New GI Bill, you can join the Army National Guard and get a guaranteed minimum of \$18,000 for college.

But best of all, you serve two days a month and two weeks a year. Which means you can go to school full-time. Right now. On us.

So the question you have to ask yourself is not, can you afford college.

The question is, can you afford to wait.

For more information about the Army Guard and the New GI Bill, fill out the attached coupon and mail it in. Or call **800-638-7600***

*In Hawaii: 737-5255; Puerto Rico: 721-4550; Guam: 477-9957; Virgin Islands (St. Croix): 773-6438; New Jersey: 800-452-5794. In Alaska consult your local phone directory.

MAIL TO: **Army National Guard**, P.O. Box 6000, Clifton, NJ 07015

NAME _____ M F

ADDRESS _____

CITY/STATE/ZIP _____

AREA CODE PHONE _____ US CITIZEN YES NO

SOCIAL SECURITY NUMBER _____ BIRTH DATE _____

OCCUPATION _____

STUDENT HIGH SCHOOL COLLEGE
PRIOR MILITARY SERVICE YES NO

BRANCH _____ RANK _____ AFM/MOS _____

THE INFORMATION YOU MUST PROVIDE, INCLUDING YOUR SOCIAL SECURITY NUMBER, WILL BE USED FOR RECORDING PURPOSES ONLY. YOUR SOCIAL SECURITY NUMBER WILL BE USED TO VERIFY YOUR RESPONSIBILITY TO THIS AD. AUTHORITY: 50 USC 5032.



National Guard
AIPMMC**06/PS

© 1998 UNITED STATES GOVERNMENT AS REPRESENTED BY THE SECRETARY OF DEFENSE. ALL RIGHTS RESERVED.

Army National Guard
Americans At Their Best.

1/2 Million Bics Sold Daily



Patent pending

Not affiliated with Bic Corp.

NEW! Bic Lighter Vending Machines!

Let America's 50,000,000 smokers line your pockets with money.

GROUND FLOOR OPPORTUNITY to be the first in your area to own and operate a vending route. Placed next to all cigarette machines.

PART OR FULL TIME

- ★ ALL CASH BUSINESS
- ★ NO SELLING
- ★ NO EXPERIENCE NECESSARY
- ★ INVESTMENT SECURED BY EQUIPMENT
- ★ NATIONAL ADVERTISING
- ★ FINANCING AVAILABLE O.A.C.

LIMITED WORLDWIDE DISTRIBUTORSHIPS

Call 24 hours for free brochure

1-800-722-4773

In California call (714) 894-1889

Vendgood Manufacturing Corp., Dept. PM6
5011 Argosy, #5 • Huntington Beach, CA 92649

FIRST-CLASS FENCE

(Continued from page 102)

the tongues into the grooves in the posts. Secure the arch with four carriage bolts, as shown.

Next, build the gate using the drawing as a guide. Cut four 1x4 stiles 67 $\frac{1}{4}$ in. long and four 1x4 rails 48 in. long. Also, cut two 2x2 rails 48 in. long. These members form the frame around a 48-in.-wide x 67 $\frac{1}{4}$ -in. lattice panel. Cut half-lap joints, as shown, and assemble the gate with glue and nails. Be sure the gate is square.

Then, use a string and pencil to mark a 22 $\frac{1}{4}$ -in. radius on the stiles and lattice. Cut the radius with a sabre saw. Glue small lattice strips to the lattice section above the 2x2 rails. This double-thick lattice provides a solid surface for attaching the hardboard skin. Glue and nail two layers of 2-in.-wide hardboard to the gate radius. Attach a $\frac{3}{4}$ x 1 $\frac{1}{2}$ x 2-in. top cap to each stile. Then, add $\frac{1}{4}$ x 1-in.-wide trim to the hardboard to align with the trim on the arch.

Hang the gate with a pair of Stanley tee-hinges (No. CD1291). Fasten the hinges to the gate with carriage bolts and to the post with screws. Install a thumb latch, or similar hardware, to hold the gate closed.

Six-foot fences

Construction of the two 6-ft.-high fences is virtually identical except that one is topped with 2 ft. of lattice. Set 8-ft.-long posts 8 ft. apart. Leave 5 ft., 10 $\frac{1}{2}$ in. of the first post out of the ground. Stretch a level string from the top of the first post and set the remaining posts to the line.

Next, attach metal fence brackets to the fence posts and install 8-ft.-long 2x4 rails (photos 5 and 6). Each 8-ft. fence section requires three 2x4 rails.

Then, attach 1x6 fence boards to the rails with 1 $\frac{1}{2}$ -in. galvanized screws (photo 7). Space the boards approximately $\frac{1}{2}$ in. apart.

Now screw 2x2 nailer strips between the upper and middle rails to support the half-sheet lattice panels (photo 8). Attach the lattice to the fence with 4d galvanized finishing nails (photo 9). The all-board fence doesn't require 2x2 nailers. Simply screw 5-ft., 9 $\frac{1}{2}$ -in.-long 1x6 boards to the 2x4 rails.

Next, attach three 1x4 rails to each 8-ft. fence section with 2 $\frac{1}{2}$ -in. galvanized screws (photo 10). Position the 1x4s opposite the 2x4 rails (see drawing details 2 and 3).

Finally, install a 2x6 cap rail to the top of the fence using 20d galvanized nails (photo 12). Bore pilot holes first and space the nails approximately 24 in. apart. Finally, prime and paint—or stain—the gate arch to match the rest of the fence.

PM

CALL 1-800 DECODER (332-6337)



CABLE TV DECODERS

ALL UNITS WARRANTED 1 YEAR
NEW Original Factory Equipment
by FAMOUS MAKERS

JERROLD, ZENITH, HAMLIN, OAK others

- 1 YEAR WARRANTY - longest in the business
- Quick & continuous service long after the sale
- Computer data base selects proper decoder for your system based on your location.
- Customer confidentiality

Send \$3. for extensive catalog, refundable w/order.

A.B. KAUFMANN ASSOCIATES since 1980
Route 527, Box 140 M, Livingston, NJ 07039

CALL 1-800 DECODER (332-6337)

FREE
40 page catalog

hobby tools

Small lathes to turn metal, wood or plastics. Milling machines, saws, hand tools, power woodworking tools, and more!

Call or write for FREE Catalog

hobby products co.

Dept. PM7 P.O. Box 218117
Columbus, OH 43221-8117
614/771-5996



Are You A Credit Card Reject?

Try one more time FREE for your VISA or MasterCard directly from our federally-insured bank. Enjoy \$500 to \$5,000 credit with a secured deposit account.

- No Annual Fees
- No Agent Fees
- No ANY Fees!

For your application call today

1-800-242-3600

or write now to
Key Federal Operations Center
Box 6056PM, Newark, DE 19714



CUT TALL WEEDS AND BRUSH IN IMPOSSIBLE PLACES



Handles grass, brush & saplings up to 1 $\frac{1}{2}$ ". Commercial quality self propelled sickle bar mower used for years by rental yards and highway departments. COSTS LESS than expensively advertised "homeowner" model. Compare before you buy.

Send Now for Free Literature and Factory Pricing Today

KINCO

WRITE OR CALL TODAY:
Dept. 5876, 170 N. Pascal,
St. Paul, MN 55104, (612) 644-4666



How To Repair A Patio SCREEN DOOR

Many homes feature sliding patio doors as an efficient and attractive way to connect indoor space with the backyard, deck or balcony. As with most parts of the home, these doors require periodic maintenance. And, like most maintenance, the hardest part is getting around to the job. Usually, the job involves repairing or replacing damaged screen and cleaning the rollers and tracks for smooth sliding.

Patio doors glide on hidden rollers which run on metal tracks. Bad sliding, however, is rarely due to damaged rollers. Instead, the problem is usually

BY ROSARIO CAPOTOSTO
Illustrations by George Retseck

caused by debris on the tracks or around the rollers. Therefore, your first job is to inspect the tracks and clean them if necessary. But, if rough sliding persists, you'll have to examine and clean the rollers.

Typical sliding screen doors have four spring-held adjustable rollers. Two on the top and two on the bottom. Each roller has an adjustment screw. To remove the door, first back off the adjustment screws. Then, slide a piece

of thin cardboard between each bottom roller and the track to lift the rollers off the track. Remove the door by pulling the bottom towards you.

The rollers in the screen door can be removed by prying them out with a screwdriver. Soak the rollers in mineral spirits and clean them with a brush. Then, wipe dry and lubricate with light oil. You can get replacements for damaged rollers at glazing shops, home centers or direct from the door manufacturer.

The rollers in the glass door should be checked also. Unlike the screen door, the sliding door has only two

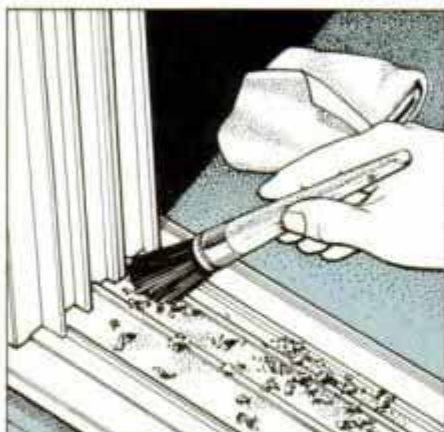

1 Most trouble starts with dirty tracks. The best way to maintain your sliding patio doors is periodic cleaning.

rollers, both at the bottom. To remove the sliding glass door, first remove the fixed door which is secured to the jamb with retaining brackets. Remove the brackets and slide the fixed door about halfway open. Then lift it into the top track and pull the bottom out. The sliding glass door can now be removed in the same way. Lift and then pull the bottom out toward you. The sliding glass door rollers are held in place with retaining screws. Remove these screws to free the rollers.

Inspect the screen for small punctures. Holes about $\frac{1}{4}$ in. dia. or less can be repaired by applying a dab of household cement or quick-setting epoxy as shown in drawing No. 8. Holes or tears up to about 1 in. can be repaired with screen patches available at hardware stores. These are small squares of screening that have hooked ends that lock into the screen when pressed against it.

For larger damage, you must replace the entire screen. You'll need an inexpensive screen installation tool which is available at hardware stores where screening and replacement spline is sold. It comes with two rollers; one with a convex-edge profile for pressing the screen into the groove of the door frame, and one with a concave profile for installing the retaining spline. This tool comes in various roller thicknesses, so make sure you get the one that corresponds to the groove size in your screen door.

Remove the screen by prying out the old retaining spline which is pressed in the frame groove. If the old spline is still flexible, you can reuse it. Otherwise, purchase new plastic spline of the same size. Lay the new screening over the frame and trim it about 2 in. longer and wider than its finished size. Then,



2 After cleaning, apply a light spray lubricant to discourage dirt buildup and help keep the rollers moving smoothly.

temporarily fasten the screen to the frame with masking tape at a few points along each edge to keep it from shifting. To avoid bunching up at the corners when forming the screen groove, make a diagonal cut across the corner of the

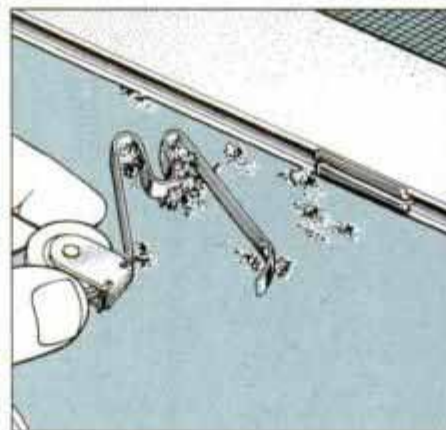

6 Dirt and debris on the tracks eventually collect in the rollers. This can cause rough operation or lock up the rollers.

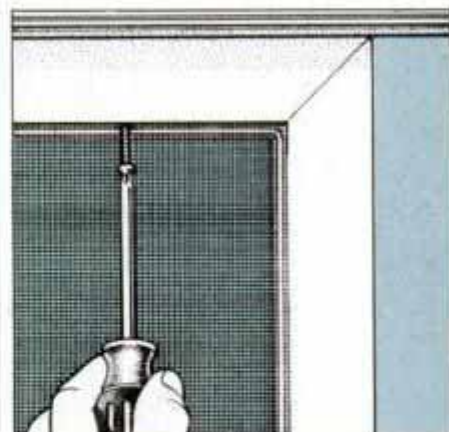

3 To remove the sliding screen door, first release the tension on the door rollers by retracting the adjusting screws.

screen up to the groove corner. Next, remove the tape along one long edge and use the convex roller on the screen tool to press the screening into the groove. Use moderate pressure and make several passes until reaching the



7 Thoroughly wash the rollers in mineral spirits. After wiping them dry, lubricate with a light oil for smooth running.

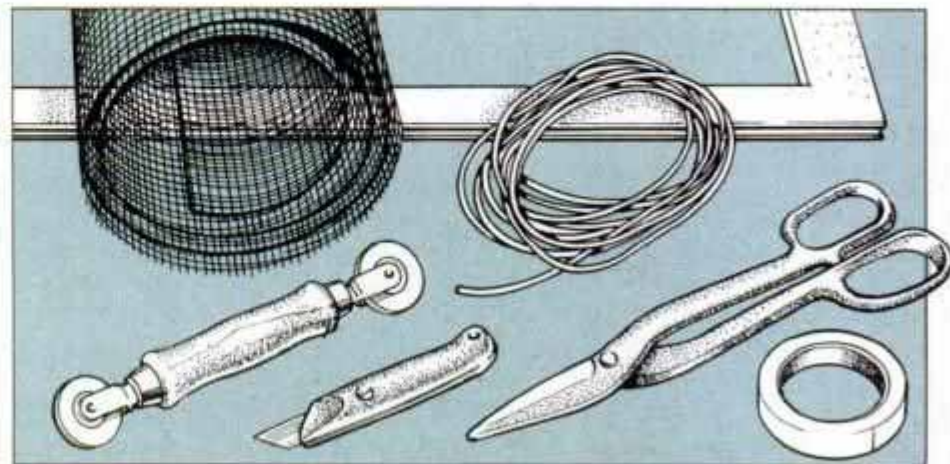

11 Screen-repair materials and equipment include replacement screen and spline, installation tool with concave and convex roller, utility knife, tin snips and tape.

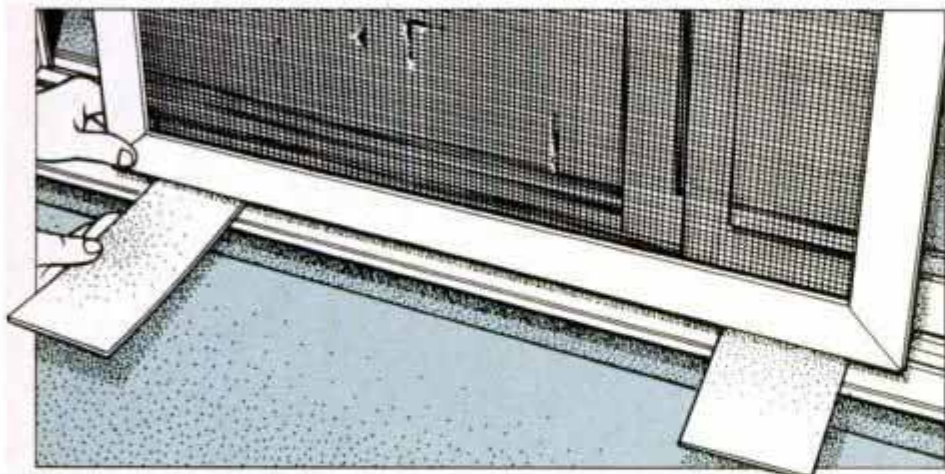

4 After loosening the roller adjustment screws, slip a piece of cardboard under each of the bottom rollers to clear them from the track. Then, pull the bottom out.

required depth. Remove the tape from the opposite side as you go to prevent overstretching the screen. Then, move to the other side, do the same thing, and finish up with the shorter ends.

After the screen is in place, install

the retaining spline. Using the concave roller, firmly press the spline over the screen and into the groove. Use a screwdriver to push the spline in at the corners. Complete the job by trimming the excess screen with a sharp utility

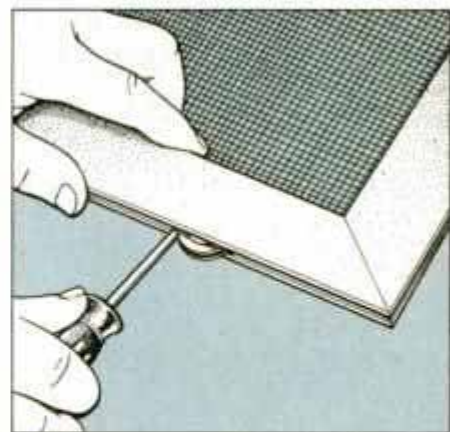

5 After the screen door has been removed the rollers can usually be extracted by prying them out with a screwdriver.

knife. Using moderate pressure, run the blade along the top of the spline so the screen is trimmed neatly to the groove edge. Then you can reinstall the doors by reversing the removal procedure. **PM**

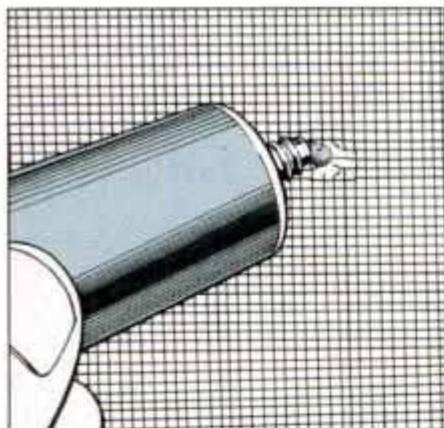

8 A dab of fast-drying cement or epoxy will plug a small hole in screening. For larger holes— $\frac{1}{4}$ to 1 in.—use a patch.

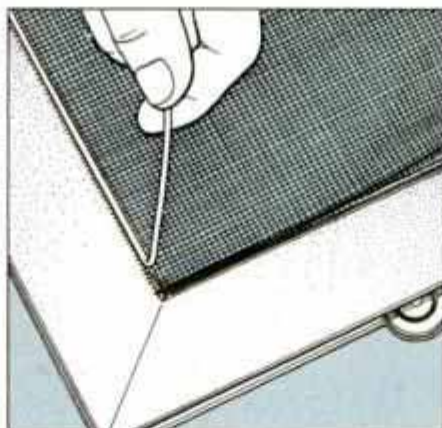

9 To remove the old screen, pry up an end of the spline and pull it out. If the spline's not old and brittle, you can reuse it.

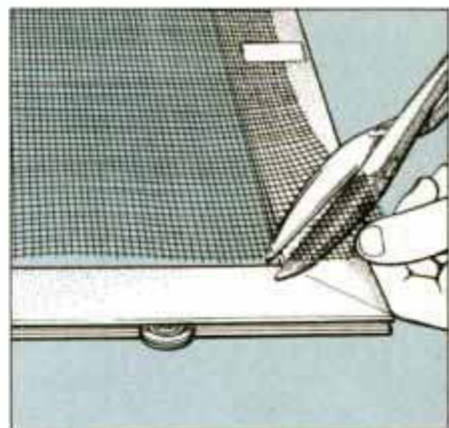

10 Cut the new screen so it extends about 1 in. beyond the frame groove on all sides. Trim the corners to avoid bunching.

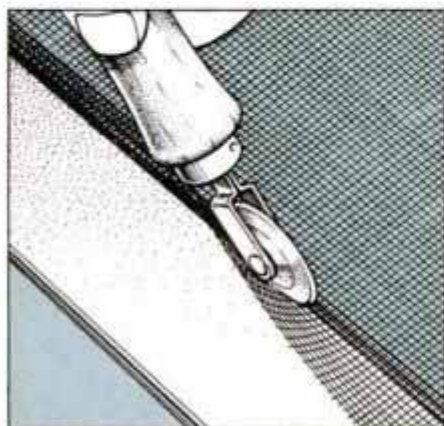

12 Use the convex roller to force the screen in the frame groove. Make several light passes rather than one heavy pass.

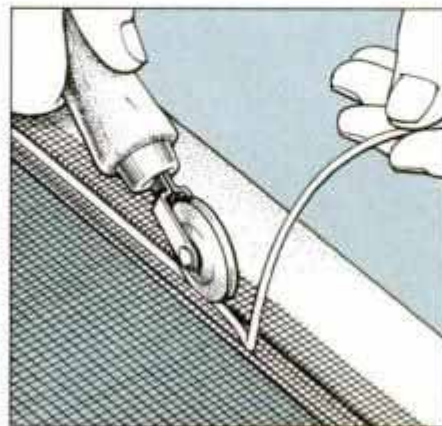

13 The retaining spline is pressed into the groove with the concave roller. Use a screwdriver to handle the corners.

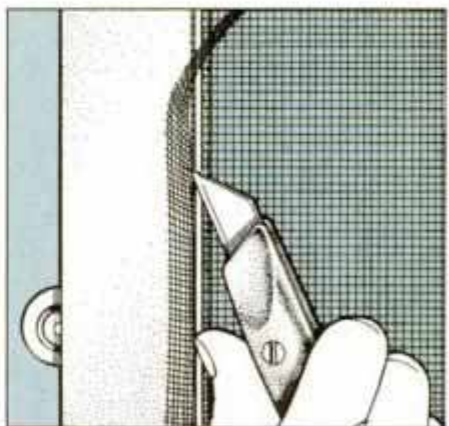

14 Remove screen excess with a utility knife. Using minimum pressure, cut along the groove slightly above the spline.

KEEPING COOL

Air conditioners:
How they work and
how to buy one.

BY LEE GREEN

Illustrations by George Retseck

Home air conditioning, over the relatively brief span of a Baby Boomer's lifetime, has erupted from an almost unheard-of luxury to a virtual necessity. In 1948, despite a multimillion-dollar promotional campaign, there was so little interest in home air conditioning that the Carrier Corp. was considering chucking the whole idea. By the mid-'80s, about 85 percent of the new homes built came with air conditioners. In many areas, air conditioning has become the largest single user of electric power. As a nation, we now spend about \$10 billion dollars a year—more than the entire gross national product of many Third World nations—to keep cool and dry.

Modern air conditioning really started about 1900, when Willis Carrier conducted his pioneering investigations into the relationships between air temperature and humidity that led to the world's first air conditioner installation. It took another quarter-century before air conditioning was used just to make people comfortable, and then it was still enough of a novelty to draw crowds at movie theaters—signs outside proudly proclaimed "20 degrees cooler inside!" But it wasn't until the early '50s that air conditioner sales took off. Since then, areas of the country that had been thought of as just too hot became prime real estate for sunbelt living.

What they do

An air conditioner does two different, though related, jobs: cooling indoor air and removing unwanted moisture from that air. Both tasks require taking energy from inside and dumping it outside. It's easy to see that if an air conditioner pulls energy (in the form of heat) out of the air, the air's temperature will drop. How it removes moisture is a little less obvious.

The basic point to keep in mind is that the warmer air gets, the more moisture it can hold. If air—at any tempera-

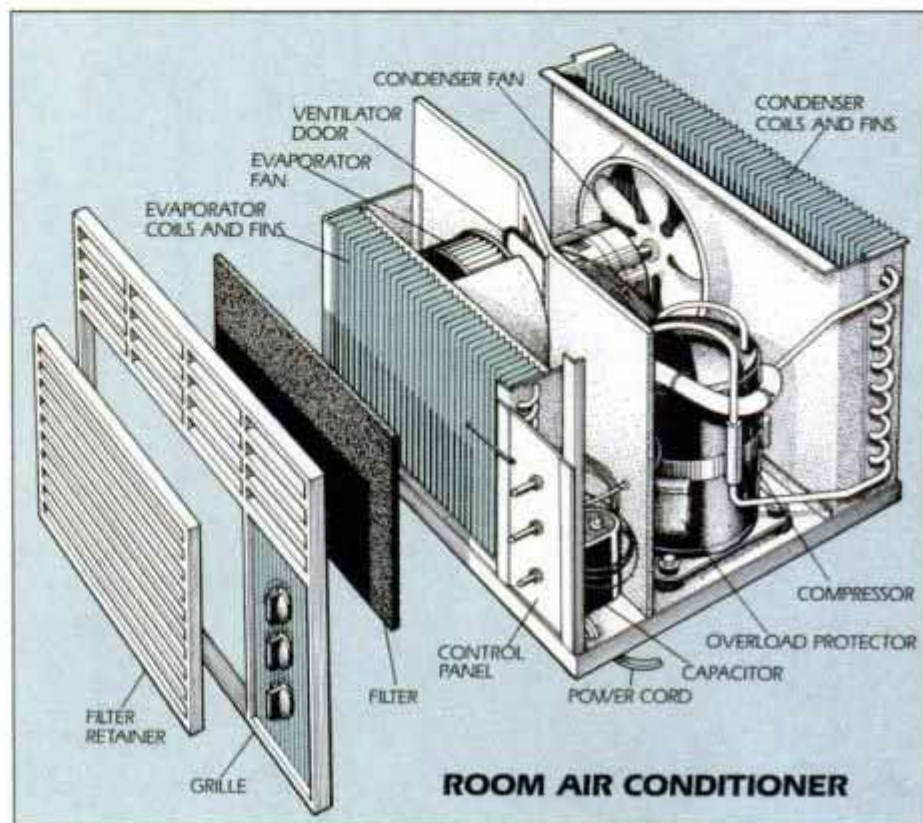

An air conditioner is a relatively simple appliance. It has four basic parts: an evaporator that absorbs heat from a room, a condenser that expels this heat outside, a working fluid that changes from gas to liquid as it circulates between the two coils, and a compressor.

ture—is holding all the water vapor it can, it's said to be saturated, or to have a relative humidity (RH) of 100 percent. If it contains, say, half that amount, its RH will be 50 percent. If you lower the temperature of the air without adding or removing any moisture, its capacity for holding water vapor would drop, and its RH would rise. Drop the temperature low enough, and the air can no longer hold all its moisture: that's why air conditioners sometimes drip water. If the cool air is reheated by mixing with the warmer air in the room, the air will have a lower RH due to the water removed when the air was cold.

How they work

Many people think air conditioners are mysterious gadgets. They're really not. Although they are more complicated than, say, electric fans or space heaters, they do their job by making use of only a couple of basic principles. First, when a gas is compressed, it gets hot—think of how a bicycle pump heats up

when you inflate a tire—and when a liquid evaporates, it gets cold—think of an alcohol rub-down. Secondly, a hot material gives off heat to its surroundings and a cold one absorbs heat.

The essential components of an air conditioner, or heat pump or refrigerator, for that matter, are a compressor, a condenser, an evaporator and a working fluid. The fluid liquifies when compressed and evaporates when the pressure is released. Nowadays this fluid is a fluorocarbon, such as DuPont's Freon compounds. In times past, sulphur dioxide and ammonia were widely used.

In an air conditioner, the evaporator is located indoors while the compressor and condenser are located outdoors, where the room's heat is to be dumped. The working fluid is cycled back and forth between them. Here's how the cycle works:

In the evaporator, liquid refrigerant is allowed to evaporate by releasing the pressure applied to it. Its temperature drops sharply, and the cold gas absorbs heat from the room, via the fins on the

evaporator's coils. The gas, somewhat warmed now, is then pumped to the compressor. There, the gas is compressed until it liquifies, becoming quite warm (about 200° F.) in the process. The hot liquid then goes to the compressor's condenser coils where it loses heat to the outside air. The cooled liquid is then pumped to the evaporator, where the entire cycle starts again. The net result? Heat from the indoors absorbed by the evaporator's coils is "dumped" outside the house.

Just about all air conditioners used in the home work this way, but there are some major variations in design. Probably the most popular kind of home air conditioner is the room, or unitary, type. Unitary models are so called because the entire assembly is built in a single unit, designed to be mounted in a window or through an exterior wall.

The next most popular type is the central air conditioner. This is a single unit that services a number of rooms, or a whole house. Typically, the evaporator is located in a furnace duct that supplies air to many rooms of a house. The condenser and compressor are separated from the evaporator, and are mounted outdoors. Insulated tubing connects them all.

The third, and newest, type of air conditioner is the so-called split model. Introduced a few years ago by the Japanese, split air conditioners use a single condenser and compressor, much like central units.

But, instead of using a single duct-mounted evaporator, the split models have multiple point-of-use evaporators—one for each room that requires cooling. Instead of circulating cooled air, like the central units, the split units circulate refrigerant to the various locations being cooled.

Each type has its advantages and disadvantages. Unitary air conditioners have the lowest installed cost—their packaged design makes for a "plug-in" installation. All that is needed is a wall or window that separates indoors from outdoors and an adequately sized electric line. Everything, compressor, condenser, evaporator, and air-circulation fan, is built into the package. Unitary air conditioners only cool the area in which they're installed. But if you want to cool several rooms, you're stuck with purchasing several units.

Also, because a unitary model has its condenser and evaporator located fairly close together, it's hard to avoid heat from the hot side leaking over to the

cool side, and lowering efficiency. The proximity of the compressor also makes for noisy operation.

Central air conditioners, on the other hand, are more demanding in terms of installation and, as a result, have higher installed costs. However, central models do tend to have higher efficiencies than unitary ones and can be designed to filter air better than the unitary type. The remote compressor also helps keep noise levels low.

The split types, as you might guess, are a sort of compromise between the other two. Installation problems are

takes a bit of calculation to see which air conditioner is best for you.

To begin with, you'll have to determine the cooling requirements of your home. If you are planning to purchase a central or split system, it's best to have a cooling contractor come to your house and do a cooling audit. He or she will measure the volume of air in each room, the number of windows, the area they occupy and their orientation toward north, south, east and west, the type and amount of insulation present in the walls and ceiling and many other subtleties of the estimating business.

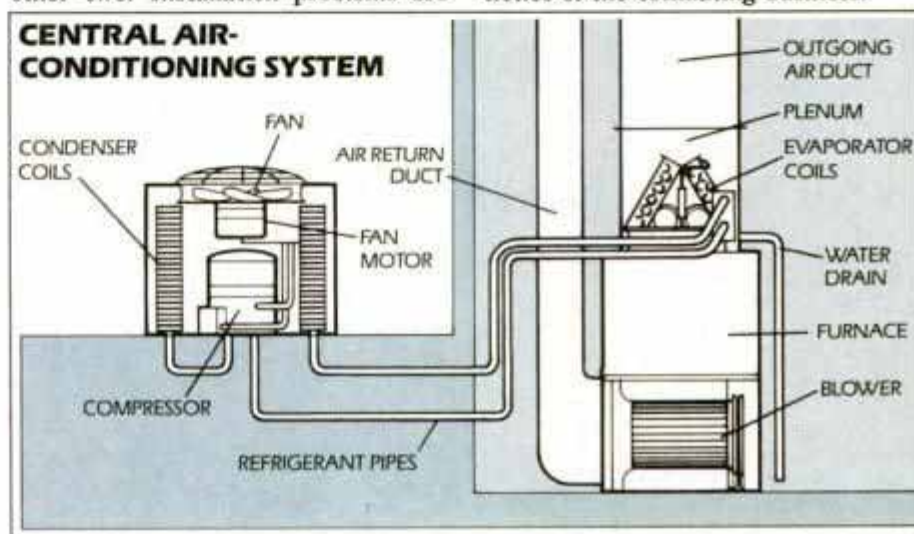

A central air-conditioning system has the same basic components as a room air conditioner but they are positioned differently. The central system has the compressor and condenser coils located outside the house, the evaporator coils are located inside your home's furnace, and the working fluid passes between the two locations in insulated pipes.

similar to those of central air conditioners. In homes without existing ductwork, the split models are considerably simpler to install than central units. But if the ductwork is in place, installation costs of split units are apt to be higher. Splits share the central models' quiet operation. They also offer the advantage of easy zoning, which central models lack. Efficiencies of split type air conditioners are typically quite high, in part because they tend to make the most of the latest technology. Since splits don't use a common air-circulating duct, they're not suited for whole-house filtered air supplies.

How to buy

Moving heat from one place to another isn't cheap. In fact, over the past 10 years or so, most of the research and development on air conditioners has focused on reducing the operation costs. While this effort has paid off in models with improved energy efficiencies, the units tend to cost more. It

It's important to realize that any air-conditioning system must be sized properly to the cooling load, otherwise the high efficiencies of the equipment will be lost. While it is possible to do this audit yourself, it's a better idea to have at least three different contractors do it for you. Get written estimates from each one and make sure the specifications are for the same equipment.

If, however, you are looking for a room air conditioner that you plan to install yourself, you'll have to do the audit. For a thorough job, the best source is a booklet called *The Consumer Selection Guide For Room Air Conditioners*, published by the Association of Home Appliance Manufacturers. It costs \$1 from AHAM, 20 North Wacker Dr., Chicago, IL 60606.

The result of this audit will be the required cooling load expressed in BTU/hr. This is how the units are sold. If you don't have time to do the full-scale audit, a ballpark figure can be determined by multiplying the square

footage in your room by 27 to get the estimated BTU/hr. But do keep in mind that this represents the roughest of estimates. The audit is by far the best way to go.

Energy Efficiency Rating

After you've determined the number of BTU/hr. you need, shop for the unit that meets your load requirements. The two key numbers are the purchase price and the Energy Efficiency Rating. The EER is simply a measure of how much electricity an air conditioner consumes per unit of heat removed from the room. It's expressed in BTUs per watt. The higher the EER, the more efficient the air conditioner.

The EER is like a car's EPA rating. It's a useful number for comparing air conditioners, but it's less useful for

estimating just what an air conditioner will cost over a cooling season's actual operation. That's because EERs are measured under a carefully controlled set of circumstances. They can't reflect the machine's performance under the different conditions.

The EER number appears on a bright yellow label, marked *Energy Guide*, that all air conditioners must carry. The label also carries the unit's BTU/hr. cooling load rating and shows where the particular unit falls in comparison to other models of the same capacity. The label also gives the estimated costs for running the unit for a year in the area of the country in which you live. (For more on estimating your yearly costs, see the box on this page.) Low efficiency models generally have EERs around 6. High efficiency units

sport EERs around 9. Keep in mind that split and central units have higher EERs than room models, often between 10 and 15.

Another number you may find listed on some air conditioner specifications is the dehumidification capacity, generally in terms of pints per hour.

Unfortunately, there is no generally accepted test procedure for this characteristic. Therefore, it's not clear what these numbers mean or how much to rely on them when comparing different units.

With all this information on hand, your choice should be based on a reasonable estimate of how much the unit will cost to operate for your cooling season. As mentioned before, the high efficiency models often have the higher price tags, but their increased efficiency can spell out lower operating costs that could pay for the higher price within a few years. This is why your home cooling audit and intelligent shopping with the Energy Guide label are so important.

Warranty and repair

Before you make your final decision, be sure to factor in the type of manufacturer warranty and whether the retailer has a service department with a good local reputation. Generally, room air conditioners perform remarkably well, but when they don't, you need a local repair facility.

Finally, how you run your air conditioner can make as much difference to your electric bill as which model you buy. First and foremost, don't run it unless you need it.

Once outdoor temperatures drop to about 80°F, you can often do just as well by opening a window. Also, try raising the temperature setting a little bit. It's hard to predict exactly what this will save in any particular situation, but some studies have shown that raising the setting 2° or 3° can provide between 10 and 25 percent savings in operating costs.

Also, keep windows closed during the day when you are not air-conditioning because most houses take a relatively long time to heat up if they are sealed. Keep shades or blinds closed, particularly on windows that face east and west because in the summer, heat gains from these two directions are greater than from windows that face south. Finally, keep the filter clean and whenever possible, run the unit in the recirculating mode, rather than its ventilating mode.

PH

What Are The Savings Of High Efficiency?

A high-efficiency air conditioner will definitely cost less to run than its lower-efficiency counterpart. It will also generally have a higher price tag. The chart and map below should help you decide which unit is the best buy.

To fill in the chart, you'll need to find out—or estimate—a few numbers. The first is the number of hours during the year that the unit will be operating. The map below shows the average number of hours for the various regions of the United States. This is a rough but serviceable number.

Next you need the BTU/hr. rating. This depends on the size and other characteristics of the room you want to cool. To

determine this, see the explanation on page 139. Then you need the EER rating for the unit you want to buy. This appears on the bright yellow Energy Guide label attached to every unit. The last piece of information you need is the rate you pay for electricity. You can obtain this either from an old electric bill or by calling your local utility. The .001 column is simply to convert your answer into dollars per year.

In the sample below, we are comparing the estimated yearly operating costs of a low-efficiency room air conditioner (EER 6) and one with a high rating (EER 9.5). As you can see, the higher EER unit would save more than \$26 a year in operating costs.

Hours of Operation (from map)	×	Air Conditioner Rating (BTU/hr.)	÷	EER (from label)	×	Electric Rate (\$/KWH)	×	Conversion Factor	=	Yearly Operating Cost
600	×	8000	÷	6	×	.09	×	.001	=	\$ 72.00
600	×	8000	÷	9.5	×	.09	×	.001	=	\$ 45.47

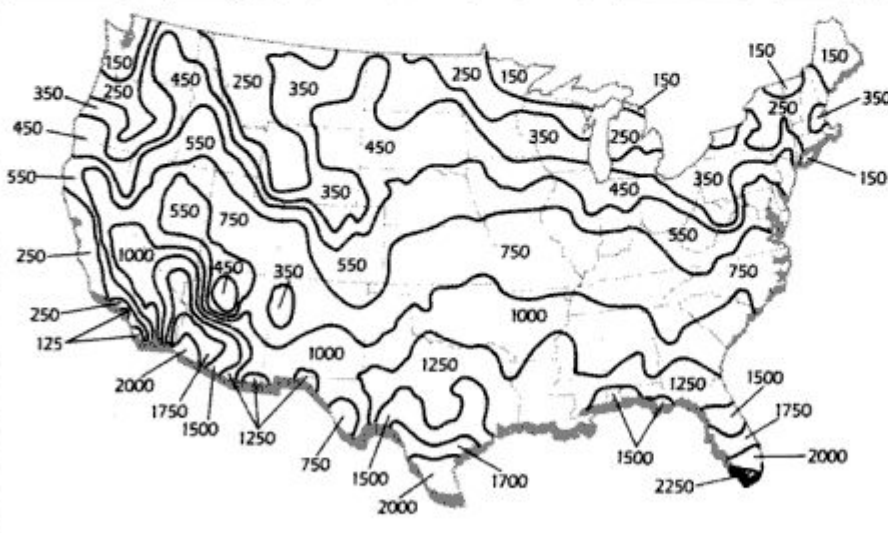

Map derived from Association of Home Appliance Manufacturers booklet *Consumer Selection Guide For Room Air Conditioners*.

Homeowners' Clinic

BY NORMAN BECKER, P.E.

Chimney Flashing

I have leaks on three sides of my chimney every time it rains. The roof was recently installed over a flat roof and is pitched at about 30°. Metal flashing was installed around the chimney. After applying roof tar, the problem disappeared at one lower corner.

I've seen an advertisement for an aerosol spray product claiming to act as a water repellent for roofs. Do you know where I could get such a product and will it be effective in my situation?

VINCENT DOYLE
N. MYRTLE BEACH, SC

I'm not familiar with the ad you refer to and I don't recommend using a water repellent spray to seal leaks around a chimney. Your leaks are probably due to problems with the flashing.

Proper chimney flashing is constructed to accommodate possible movement between the masonry and the roof. It's installed in two parts; base sections that are secured to the roof deck and extend up the side of the chimney, and cap sections which are secured to the chimney and overlap the base sections. If movement does occur, the cap sections slide over the base sections without affecting the water-shedding characteristics of the joint.

Check the flashing at the chimney joint for the source of the leak. The flashing may not be installed properly or only partially installed. I have seen a number of chimneys where the cap flashing was omitted entirely. Often, in this case, the base sections are sealed with asphalt cement in an attempt to make them watertight. This installation is "makeshift" and leakage readily occurs along the top edge where the flashing joins the mortar line.

If this is the case with your chimney, it can be corrected by setting metal cap flashing into the brickwork. Rake out a mortar joint to a depth of 1½ in., and insert the edge of the flashing in the cleared joint. Refill the joint with Portland cement mortar. When the mortar is dry, bend the flashing down to cover the

joint between the base flashing and the chimney to seal against water intrusion.

Going To Ground

I recently purchased a personal computer and need information on the proper way to protect my investment. I wish to use a surge protection device that requires a grounded three-prong receptacle. I presently live in an older building that doesn't have the grounded outlets. How can I safely connect my equipment? Because I will not be living

light if the box is grounded. If the first slot you try doesn't light the tester, try the other one. Only one slot is hot.

If your box is grounded, you can solve your problem with an adapter that converts a 2-slot outlet to three slots. It has a ground connector that must be fastened under the cover plate screw. If the outlet box is not grounded, you can still use the adapter. Fasten a wire to the ground connector on it and clamp the other end of the wire to the nearest water pipe.

Then, check the adapter (as described above) to make sure it's grounded. If it isn't, there's discontinuity in the water pipe ground. You'll have to locate this point and connect a jumper wire across it.

Torrential Vent

I built my own home two years ago and installed an exhaust fan in my bathroom. My problem occurs when warm moist air meets the cold dry air via the flexible duct. The water pours out of the fan duct which is vented in the ridge vent.

GARY BRENNAN
FARMINGTON, MI

As you know, moist air condenses when its temperature drops below the dew point.

Usually the exhaust fan can move the warm, moist air fast enough so that its temperature doesn't reach this point.

*In your case there is enough heat loss along the duct to cause the moist air to condense. Your problem can be solved by insulating the duct. This reduces the heat loss and keeps the temperature of the moist air above the dew point. If you can, try reducing the flexible duct length. This will result in a higher temperature of the discharging air which may be enough to eliminate the condensation. If not you'll have to insulate the duct. **FM***

Do you have a home-maintenance or repair problem? Send it to Homeowners' Clinic, Popular Mechanics, 224 West 57th St., New York, NY 10019. Letters cannot be answered individually, but problems of wide interest will be discussed in the column. For more home-repair and maintenance help, get PM's Home Care Guide, \$2.45 postpaid. Send your order(s) to Popular Mechanics, Box 1014, Radio City Station, New York, NY 10101.

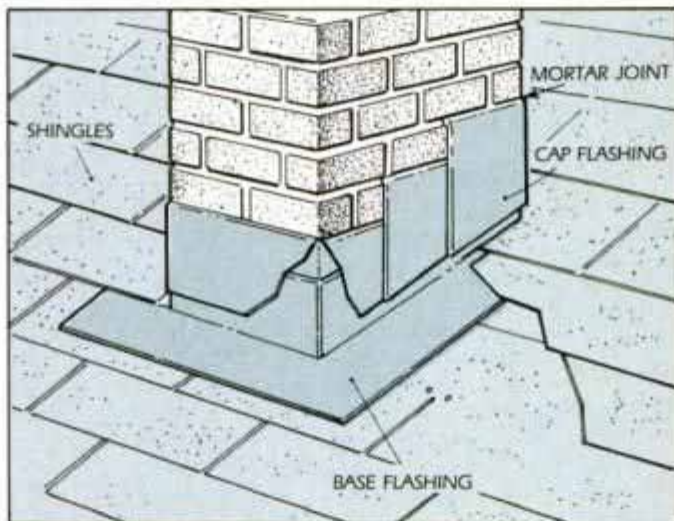

Proper chimney flashing is composed of base sections secured to the roof and cap sections set into the brickwork mortar lines.

at the above residence for long, I need a simple and inexpensive solution. So far, no electronics store has been able to solve my problem.

My only thought was to run a ground wire from the nearest cold water pipe to the outlet I intend to use.

LOREN D. COEN
HYATTSVILLE, MD

If BX cable was used in wiring your building, then the outlet boxes in which the receptacles are mounted are grounded and solving your problem is easy.

You can check to see if the box is grounded with a neon circuit tester available at electrical supply stores for about \$2. Stick one end of the tester in one of the slots of the receptacle and hold the other end on the cover plate screw. If the screw is painted over, scrape it clean for good contact. The neon tester will

Appliance Clinic

BY STEVE TOTH

Doesn't Drain

I have a Sears washer model No. 110.7204612W, serial No. C.2.2.32033 that doesn't drain completely at the end of the wash cycle. We've replaced the timer, checked for kinks or blockage in the drain hose, cleaned the water pump, tightened the belt, cleaned the manifold trap and the problem still exists. Can you help?

RAMAN PATEL
WEST CHESTER, PA

First try removing the manifold trap and check to see that the air bleed hole in the top is not clogged or restricted. If it is, this will create an air lock which will reduce the flow of water during the pump-out phase. Due to production changes, this hole has been enlarged over the years and is now $\frac{3}{16}$ in. dia. I suggest you drill out the present hole to this size. Be sure to remove any burrs from the hole edges. Alternatively, you can replace the manifold trap with Sears part No. 84091 which costs about \$6. Install the modified or new manifold trap and try a test run to see if the water empties.

If the problem persists, then try checking the self-cleaning filter for free flow. Remove all the water from the machine and take off the rear access panel. The filter is located on the lower right side. Then, remove the top and bottom hoses from the filter. Connect the hoses together with a hose connector, or $\frac{3}{4}$ -in. water pipe to bypass the filter. Turn the machine on and check it through each cycle. If all the water empties, replace the self-cleaning filter Sears No. 358790 (\$20).

If bypassing the filter doesn't help,

I'd suspect that the side check valve, mounted on the outside of the tub about 5 in. from the bottom, may be the problem. The flappers inside the valve may be broken, not seating properly or there may be something caught in the valve. To check this part, you'll have to remove the wash basket and physically inspect the valve. If it's bad, the replacement side check valve is Sears No. 350229 and costs about \$13. To remove the valve, first remove the hoses and then unscrew the spanner nut from the inside of the tub and pull out the valve. When you install the replacement, be sure that the rubber washer is on the outside of the tub and the fiber washer is on the inside before tightening.

Radiating Caution

I have a Sanyo microwave oven. Recently, it stopped before the timer was finished. I removed the back cover and found that a fuse had blown. I installed a new fuse, replaced the cover and now everything works fine.

The next day I was talking to a friend who said that anytime you remove the cover to make repairs you break a seal that protects against radiation leaks. When I removed the cover, I didn't notice any seal. Is there a seal that I've broken and am I risking a radiation leak?

ROGER CHOY
SAN FRANCISCO, CA

There is no seal, as such, on your microwave oven. However, when you do remove any cabinet parts to make repairs, you should always have the oven checked for radiation leaks. This should be done both for your safety as

well as peace of mind. Replacing the fuse may only be a temporary cure. Something caused the fuse to blow.

The best suggestion I can give you is to take your microwave to an authorized Sanyo service center and have a radiation leak test performed. There may be a charge for this. If you have trouble locating a service center, call Sanyo direct. In California the number is 213-608-7800. Outside California call 1-800-421-5029. Ask for customer service to get the name and address of the nearest service center.

Be aware that manufacturers sometimes void their warranties if they notice that the oven has been opened. There are strict safety standards on microwaves and owner service is strongly discouraged.

Hinging Issue

I have a Whirlpool refrigerator model No. EPT-14CWRU with a right-hand door. Due to the layout of my kitchen, I need a door that opens on the left side. Can you tell me if there is a kit available to convert my refrigerator to open on the opposite side.

JACK WALSH
ASHLEY, PA

Your 20-year-old refrigerator cabinet was originally designed to accept either a right- or left-hand door. That's why you see the extra holes with caps over them on the top of the cabinet. Unfortunately the doors on your refrigerator are not reversible. The only way to change the swing is to replace the outer door panels on both the refrigerator and freezer.

I checked with the manufacturer and discovered that, due to the age of your refrigerator, Whirlpool no longer offers a left-hand door for your model. Neither do they offer a kit to reverse the swing. It looks like you'll have to either make do with what you have or take this opportunity to check out the new energy-saving models with reversible doors to solve your problem. **PM**

If you have a problem with any appliance, send your question, along with the model and serial numbers, to Appliance Clinic, Popular Mechanics, 224 West 57th St., New York, NY 10019. Sorry, but letters cannot be answered individually. Problems of wide interest will be discussed in this column.

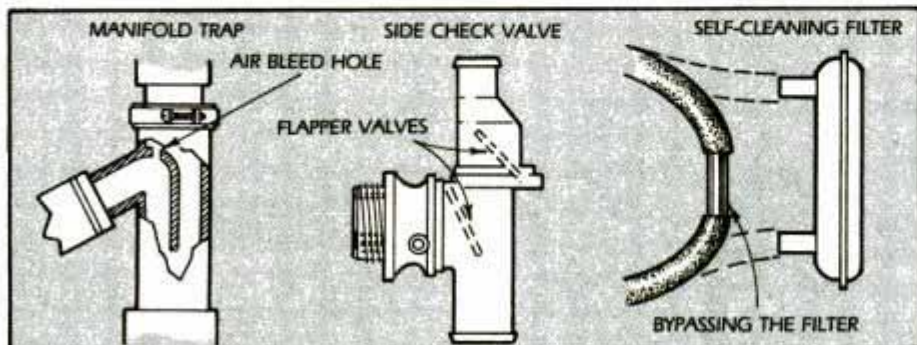

Inspect the manifold trap for a clogged air bleed hole and the check valve for stuck flappers. Disconnect and bypass the filter to check its condition.

8 oz. of TufOIL® in your motor oil, and these faces will never look the same.



1. Start your engine—quicker. TufOIL® helps your engine start much quicker, hot or cold, as shown by tests the Kapuscasing lab performed for the government of Canada (they know about starting under adverse conditions).



2. Add pep—even to old engines. U.S. National Bureau of Standards and tests all over the world prove TufOIL reduces friction better than any other lubricant. And a lot less friction means a lot more power (especially noticeable in older engines).



3. Save gas, too. After testing TufOIL, *Popular Mechanics* reports 10.3% gas savings. "Absolutely spectacular... does what it promises," says their report (also see *NASA TECH BRIEFS*, Nov.-Dec. 1986).



4. Your car mechanic won't get much business from you. Says *Home Mechanic* "Field tests and scientific evidence back TufOIL's claims for improved lubrication." And improved lubrication means better performance and longer engine life.

Tests all over the world prove TufOIL is the slipperiest known lubricant. TufOIL's patented formulation includes synthetic and mineral oils, friction modifiers, and PTFE, commonly known as Teflon or Fluon—the slipperiest substance ever. Or so it was thought.

Teflon's surface friction coefficient is .04. But the U.S. Bureau of Standards established that TufOIL's friction

coefficient is just .029—almost half as much!

No other PTFE lubricant even comes close. The reason is simple: Only our patented technology solves the problem of suspending the tiniest particles in the lubricant.

PTFE *suspended* in TufOIL easily passes through the oil filter and lubricates the engine—even after you shut down. So you don't tear up the motor,

starter, and battery by cold-starting. (Conventional oil takes a while after starting to lubricate the engine.)

This kind of lubrication means a lot of wonderful things for your engine (see items 1, 2, 3, 4, above).

If you expect something from your car, do something for it: send us the coupon below. Today. Or call us right away toll free: **1-800-922-0075** (in New Jersey, 201-825-8110).



With TufOIL, you get results. Or you get your money back.

Try an 8 oz. bottle of TufOIL for 30 days or 1,000 miles. If you don't see any improvement, send us proof of purchase and a brief note. We'll refund your money right away.

Special 3 for 2 offer.

Are you our customer already? Here's a great saving for you: Check this box, fill out an order for 2-8 oz. bottles, and we'll send you one—**free!**

YES! Rush my Tufoil order.

One 8 oz. bottle... treat one car for \$14.25 (plus \$3.50 shipping and handling). See money back guarantee.

Two 8 oz. bottles... treat two cars for \$25.00 (plus \$4.00 shipping and handling). **Save \$6.00.**

Special Offer

After you've tested TufOil, and like it, buy a gallon to share with your friends & **Save \$159*!!**

One gallon... treat 16 cars for \$125.00 (plus \$6.00 shipping and handling).

*over the single bottle price

Fluoramics Inc.

103 Pleasant Avenue
Upper Saddle River, NJ 07458

PM67

Check or money order for \$_____ is enclosed. Charge my Am. Express MasterCard Visa

Card No. _____

Exp. Date _____

Signature _____

Name _____

Address _____

City _____

State _____ Zip _____

NJ residents please add 6% sales tax. Orders to Canada: send check or money order in U.S. currency. Add \$4 extra shipping charges.

Additional levels, shown here, are for more specialized applications, but are indispensable when doing certain jobs. They include:

- 12. Strap-on level
- 13. Post level
- 14. Multifunctional level
- 15. Circular level
- 16. Line level
- 17. Mechanic's bench level

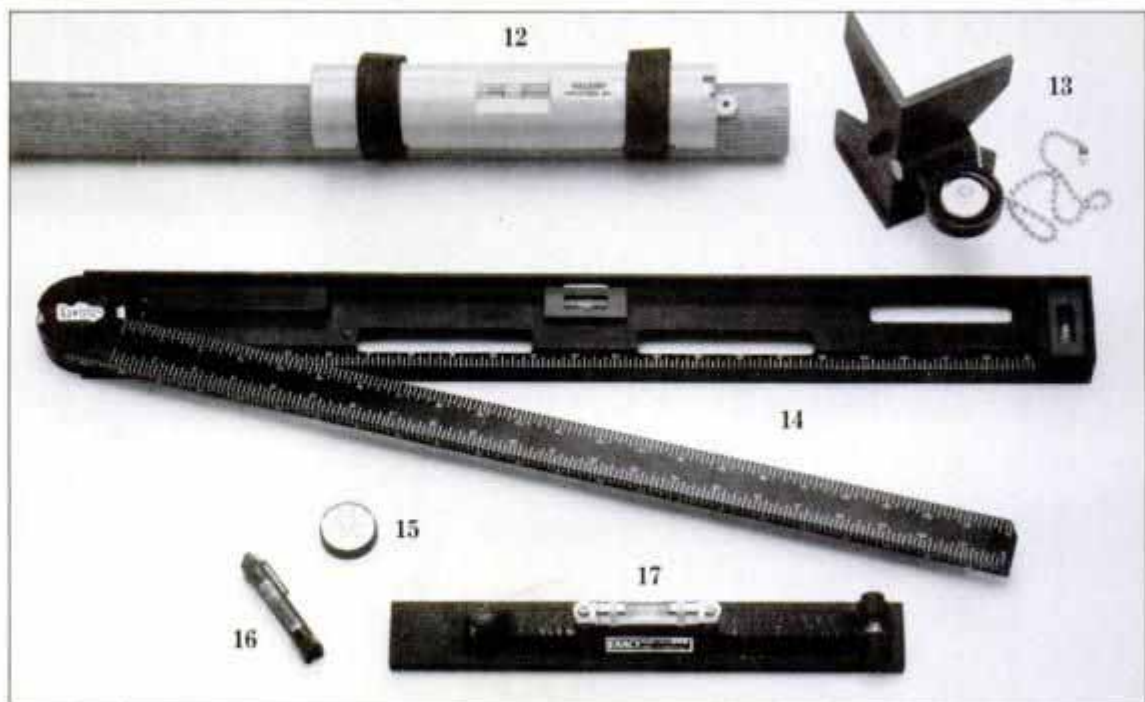

LEVELS (Continued from page 97)

Sears tool catalog for about \$11. Contact Sears, Sears Tower, Dept. 703-PM, Chicago, IL 60684.

8. Aluminum carpenter's level—Here's a good all-purpose level: a 24-in. aluminum level with three replaceable vials; two plumb, one top-reading level. The vials are tinted yellow for easy reading and the aluminum rail has a black enamel finish. In two sizes: 2 ft. (\$17) and 4 ft. (\$25). Contact Stanley Tools, 600 Myrtle St., New Britain, CT 06050.

9. Magnesium level—Lighter in weight and more durable than aluminum, magnesium levels are the choice of many professional carpenters. The Exact level shown has a heavy-duty extruded magnesium I-beam rail with three replaceable single vials for reading level and plumb. It's available in sizes ranging from 2 ft. to 10 ft. The 4-ft. model shown costs about \$53 at hardware stores. For details, contact Exact Level, 54 Eastford Rd., Southbridge, MA 01550.

10. Mahogany and aluminum level—The manufacturer claims that this tool can withstand more heat, cold, moisture and overall abuse than any conventional level. The reason is its unique construction: continuous aluminum I-beam reinforced with kiln-dried mahogany. Full-width aluminum edges and end caps protect against wear. The 4-ft. level shown (\$64) has six vials: four plumb, two level. Other models vary in length from 2 ft. to 6½ ft. Contact Exact Level, 54 Eastford Rd., Southbridge, MA 01550.

11. Angle meter—Measure any angle easily, including level (0) and plumb (90°), with this versatile angle meter. The easy-to-read ¾-in.-dia. plastic dial is marked 0 to 90° in each quadrant. Magnetic strips on the tool's base and back hold fast to metal work. Use the movable pointer to repeat and transfer angles. On the back of the meter is a calculator for finding rise, run, pitch angle and rafter-to-run ratio. It costs about \$17 at hardware stores. Contact Exact Level, 54 Eastford Rd., Southbridge, MA 01550.

12. Strap-on level—Keep both hands free with this clever strap-on level (\$10). Two Velcro straps hold the level securely to round, square and irregular-shape work. The 2 × 10-in. polystyrene tool has a ½-in.-dia. circular level for reading plumb and a level vial. Use it to plumb and level pipes, poles, fence rails and posts and deck supports. It will

wrap around posts up to 8 in. dia. Contact Halkist, 88 Market St., Poughkeepsie, NY 12601.

13. Post level—Here's another hands-free level, but this one is designed specifically for determining plumb. Made of high-impact plastic, the tool has an easy-to-read 1½-in.-dia. circular level and a length of bead chain that will accommodate work up to about 5½ in. dia. Additional chain can be added for use on virtually any size object. Use it to plumb posts for mailboxes, signs, fences, decks and antennas. Send \$7.95 to Plumb-Master, Eadens Enterprises, Box 313, Charlestown, IN 47111.

14. Multifunctional level—Read level and plumb with this versatile 24-in. level that unfolds to become a 48-in. level. It will also read and transfer angles up to 180°. A locking lever secures the tool at the desired angle. Made of tough ABS plastic, the level is marked with inch graduations along its edges. The 24-in. model shown costs about \$30; with magnetic edge: \$36. A 12-in. model (that opens to 24 in.) costs about \$23; with magnetic edge: \$27. Contact Rawlings Co., 13161 McGregor Blvd., Fort Myers, FL 33907.

15. Circular level—Also called a bullseye level, this simple tool reads level in all directions. It's indispensable for leveling machines, appliances, turntables and pool tables. The 1½-in.-dia. level is made of acrylic. It costs about \$2.80 at Sears stores and through Sears tool catalog. Contact Sears, Sears Tower, Dept. 703-PM, Chicago, IL 60684.

16. Line level—Level great distances across walls with this mini-level. Clip the level's two hooks onto a taut string. Adjust the string until the bubble reads level, then mark the wall. Use a line level to install chair-rail molding and suspended ceilings. The Sears model shown (\$2.29) can also be used on flat surfaces and the vial is graduated to read up to ½-in.-per-ft. pitch in ⅛-in. increments. Contact Sears, Sears Tower, Dept. 703-PM, Chicago, IL, 60684.

17. Mechanic's bench level—This type of bench level is used by machinists and millwrights to set up sophisticated machinery. Made of heavy-duty cast iron, this supersensitive 12-in. tool has three vials: level, plumb and cross-test that reads perpendicular to the level vial. The level vial is graduated to read .005-in.-per-ft. pitch and it's protected by a rotating metal tube. It costs about \$98. Contact Exact Level, 54 Eastford Rd., Southbridge, MA 01550. **PM**

"ADD EDELBROCK TO YOUR VEHICLE FOR THE BEST BOLT-ON PERFORMANCE YOU CAN GET."

That's what I tell customers who want more power, better performance and better mileage. I installed an Edelbrock Performer manifold on my own truck, and now I'm a believer.

Swapping a stock manifold for an Edelbrock manifold is a simple conversion. Performer manifolds are perfect for most kinds of daily driving, 4x4's and RV's because they're stock replacements that work in the street rpm range--off-idle to 5500 where your engine spends most of its life! My Edelbrock-equipped vehicle has power to spare, whether I'm towing a trailer full of dirt bikes or bumper-deep in mud.

What a difference! My mileage is better too. I added the matching Performer-Plus camshaft and Pro-Flo air cleaner too. More improvement again and great looks.

So if it's bolt-on performance you want, I'd suggest an Edelbrock intake manifold and matching cam. They're available for most domestic engines.



Edelbrock

Products shown are available by mail. Prices range from \$30.95 to \$185.95 plus tax, shipping & handling.

Send \$2 for your catalog and price list to: Edelbrock Corp., 411 Coral Circle, Dept. PM687, El Segundo, CA 90245.

Spring Savings!

Save Up To 15-50%

On Name Brand Products.



Look At The Gigantic Savings Below!

Deluxe Garden Cart



Hauls up to 300 lbs. 40"x25"x14" box carries big loads. Rugged 1/2" plywood, 1" galvanized steel edging. Includes FREE dumpster door. Big 20" wheels. Can ship UPS. 67 lbs.

Item #14521. **\$69.95**

Trailer Parts For Your Every Need

- 480 x 8 Tire & Wheel
- 4 & 5 Hole..... **\$19.95**
- 570 x 8 Tire & Wheel
- 4 & 5 Hole..... **\$32.95**
- 2000 lb Hub & Spindle Set
- A complete Set..... **\$38.45**
- Trailer Coupler 1 7/8"..... **\$6.45**
- 12 Ton Pintle Hook..... **\$34.95**
- Deluxe Lite Kit..... **\$18.95**

Shipping & Handling Not Included.

Gas Engines Always the Lowest Prices And the Largest Selection!

One Year Warranty!

Gas Engines Horizontal

- 5 HP..... **\$132.95**
- 6 HP..... **\$187.95**
- 10 HP..... **\$227.95**

Vertical Engines

- 3 1/2 HP..... **\$102.95**
- 5 HP..... **\$151.95**

We have a wide variety of horizontal and vertical gas engines available. From 3 to 23 HP in brand names like Tecumseh, Briggs, Honda, Wisconsin Robin, and Kohler. **SUPER LOW DISCOUNT PRICES!**



KARCHER® Pressure Washer

New, powerful, lightweight, 110v Pressure Washer delivers 870 PSI of water pressure. 1.8 HP electric motor delivers 2.2 gallons per minute. 33' of high-pressure hose.

Item # 157161 ...33 lbs. **\$314.95**

2"

3 HP 8,400 GPH



Chemical & abrasion resistant seals. Uses 2" suction. Pumps 8,400 GPH with 28 foot lift. 3 Hp. 4-cycle Briggs engine. Sh. wt. 37 Lbs. Lists for \$329.95! **\$175.95**

Item #10996



For your free catalog, send in the coupon below.



UPS 2 Boxes

Complete road ready kit. With Fenders 1,060 lb. capacity. 40"x48" bed size. Ship wt. 124 lbs. Lists for \$279.95.

Item # 12542 **\$139.95**

120/240 Duplex Receptacles

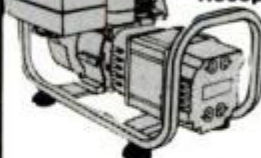

4000 WATT CONTINUOUS RATED GENERATOR

Ideal for homeowners, farmers, contractors and vacationers! Powered by an 8 Hp Tecumseh engine with cast iron sleeve for extra strength and durability.

Item #16425 108 lbs. **\$389.95**

4000 WATT Electric Start

Same specs as above but with electric start. Item #16426 113 lbs. **\$459.95**

NH Northern Hydraulics INC. Dept # 68019 Sale Expires June 30, 1987

Call Toll Free 1-800-533-5545 24 hours a day, 7 days a week!

Send for a FREE catalog Mail to NORTHERN HYDRAULICS, INC. Dept # 68019 P.O. Box 1499 Burnsville, MN 55337-0499

Name _____
Address _____
City _____
State _____ Zip _____



YUGO GV

America loves a bargain.

BY MICHAEL LAMM, Contributing Editor

At \$3990, the Yugo is the least expensive new car sold in the United States. But what sort of bargain do you drive home when you buy this Yugoslav version of the old Fiat 128?

"You have to keep the car in perspective," pointed out an Illinois electrician—one of the 1000 Yugo buyers we surveyed for this Owners Report. "I expected a basic \$3990 car when I bought the Yugo and wasn't looking for all the features I'd want in a more expensive automobile. If you keep that in mind, it's a nice little car; has everything I need to get me from A to B."

There's no question why people buy Yugos. "The price is right," beamed a Minnesota student, and many other owners echoed this South Carolina medical technologist's reasoning: "I wanted a *new* car, not a used one."

We specifically asked Yugo purchasers whether they'd opt for a new car again next time or choose a used one instead. Nearly 63 percent said "new," with a mere 3 percent willing to consider a used car. Here's the kicker, though: Only 42.4 percent thought they'd purchase a *Yugo* again. This represents one of the lowest repeat-buy figures we've ever recorded, but remember that many of our respondents

were young, first-time buyers who looked forward to upgrading their transportation next time around.



Spartan interior seems acceptable to survey owners, but only because they realize they're buying a bottom-line car.



Look like a Fiat 128 engine? Yugo is basically a recycled Fiat design. Full-size spare would just about fill up trunk.

In terms of quality and workmanship, just over half of our owners rated the Yugo's workmanship good, with another quarter giving it an unqualified excellent. That's not a great testimonial, but we've often surveyed more expensive cars that came off no better.

Yugo owners, though, reported a fair number of mechanical problems: 57.2 percent had taken their cars back for repairs. And not many said nice things about dealer service. "They treat you like garbage," growled a New York museum engineer, who wasn't at all alone in that opinion.

A Michigan letter carrier added, "It took my dealer three tries to fix a leaky fuel tank, and I'm still waiting for parts for the gas gauge." And a Massachusetts auto mechanic observed, "My car developed a defective head gasket between two cylinders."

In his repair, the dealer mistimed the engine; two exhaust-valve shims wore prematurely and the dealership didn't have new shims or the cam-cover gasket in stock.

"What they need are more knowledgeable mechanics and parts people." In all, 42.4 percent of our respondents rated dealer service as fair to poor—a much lower-than-normal proportion.

Owners also noted what they consid-

ered price gouging by dealers. "The Yugo dealer charges \$7.85 for an oil filter, but I can buy a Fiat filter, which is larger, for \$3.40 at any parts store," said a New Hampshire field engineer. A Michigan boiler operator remarked, "I'd like to purchase a service manual,

but the dealer wants \$75, which I think is too much." And a Massachusetts chauffeur felt that, "...\$400 for the AM/FM tape player is way too expensive!" (Yugo lists four optional sound systems, ranging in price from \$255 to \$435 plus dealer installation.)

Among minor but persistent annoyances, brake squeal headed the list. After that came surface rust, weak keys that bent or broke, wind noise and water leaks around the front vent windows, out-of-round tires, too-small fuel

(Please turn to page 148)

SUMMARY OF YUGO OWNERS REPORTS*

Total miles driven	1,008,092	Not enough power	6.8	No	21.6	Average	15.9
Average miles per gallon		What changes would you like?		Maybe	36.0	Poor	5.9
In town	27.7	No changes	12.2%	Would you buy another new car next time?		Excellent	23.4%
On the highway	32.7	Easier shifting	12.2	Yes	62.8%	Good	54.6
Series choices		Better transmission	10.9	No	8.8	Average	19.0
Yugo GV sedan (standard)	99.6%	Less brake squeal	8.6	Maybe	28.4	Poor	2.9
Yugo GVX Sport Sedan	.4	Better overall quality	6.3	Dealer service opinion:		Excellent	6.2%
Why did you choose the Yugo?		Excellent	19.6%	Good	38.0	Good	45.3
Price	88.2%	Average	20.8	Poor	21.6	Average	34.8
Economy of operation	24.4	Number of vehicles owned:		Would you buy a used car instead?		Poor	13.7
Styling	11.1	This one only	28.1%	Yes	3.2%	Had any mechanical trouble?	
Size	9.9	Two cars	39.6	No	72.3	Yes	57.2%
Specific likes:		Three cars	18.5	Maybe	24.5	No	42.8
Economy	51.8%	Four or more cars	13.6	Age distribution of owners:		What type of trouble?	
Price	48.6	Makes of other cars owned:		Under 29 years	38.2	Electrical	22.7%
Handling	32.7	Chevrolet	24.7%	30-49 years	44.9	Dragging or noisy brakes	11.7
Styling	21.4	Ford	22.2	50-plus	16.5	Transmission and shifter	9.7
Comfort	13.6	Pontiac	10.3	How much did you pay for your Yugo? ¹		Fuel gauge	9.1
Size	13.6	Toyota	10.3	Average	\$4345	Oil leaks	8.4
Special dislikes:		Volkswagen	10.3	Range	\$3795-\$6675	Dealer repairs satisfactory?	
Squealy, dragging brakes	20.8%	Would you buy a Yugo again?		Workmanship opinion:		Yes	51.4%
Hard to shift	12.2	Yes	42.4%	Excellent	22.5%	No	48.6
Poor dealer service	8.6			Good	55.7		
Noises and rattles	8.1						
Long waits for parts	7.2						

*Percentage might not equal 100% due to rounding or insufficient data.

¹The \$3990 figure represents the importer's suggested retail price. Actually, with transportation charges, emissions, dealer prep, and excluding tax and license, the Yugo's delivered price comes to about \$4500. After some dickering, however, several of our respondents reported paying as little as \$3795 for their cars, but a few also paid as much as \$6675.

If you like to build things, NRI can show you how to make money building homes.

Get in on the 1980's building boom. Learn to be a building contractor at home in your spare time with NRI's Building Construction Course.

Within the next ten years, this country will need 18 million new homes... and the contractors to build them. You can be a part of that building boom by preparing yourself to be a building contractor. No experience needed, we teach you everything you need to know, get you ready for management and supervisory jobs or even your own business.

Learn to Make and Read Plans, Estimate Costs

We start you right at the beginning, with key lessons on site selection and planning. Then, you learn to lay out a home, read blueprints, and estimate costs accurately. Working with a complete set of plans for an NRI energy-efficient home, you get experience in every stage of construction.

Learn How to Hire and Supervise Sub-Contractors

You're trained to work with all the trades. You learn the basics of carpentry, masonry work, electricity, plumbing and heating, and more. And because you know what it takes to do the job, you know what to look for when supervising and inspecting.

Hands-On Training Built Around Energy-Efficient Home

You learn better because NRI training is practical training. You get over 100 action projects from scale-model construction to building

actual framing sections. Lessons and projects are coordinated with a contemporary energy-efficient home designed especially for NRI. You keep these plans to build your own home or select from more than 50 low-cost optional plans. You even get samples of building materials and hardware so you know how to select and use them correctly.

Get all the facts on this big new career opportunity. Send the coupon for your free copy of NRI's Building Construction Catalog showing the growth and future of the building industry, all projects, and descriptions of all lessons.

If coupon has been removed, write to NRI Schools, 3939 Wisconsin Ave., Washington, DC 20016.



NRI SCHOOLS

McGraw-Hill Continuing Education Center
3939 Wisconsin Avenue
Washington, D.C. 20016

For Career courses approved under GI Bill
 check for details.

WE'LL GIVE YOU TOMORROW.

Please rush me the one free catalog I have checked. I understand there is no obligation.

Name (Please print) _____ Age _____

Address _____

City/State/Zip _____

Accredited by the National Home Study Council.

- | | |
|--|---|
| <input type="checkbox"/> Building Construction | <input type="checkbox"/> Telephone Servicing Course |
| <input type="checkbox"/> Air Conditioning, Refrigeration, Heating and Solar Technology Courses | <input type="checkbox"/> Industrial Electronics |
| <input type="checkbox"/> Small Engine Repair Course | <input type="checkbox"/> TV/Audio/Video Servicing, Communications, Electronics, Microcomputers, Electronic Design Technology, Electronics Courses |
| <input type="checkbox"/> Appliance Servicing Course | |
| <input type="checkbox"/> Locksmithing Course | |
| <input type="checkbox"/> Automotive Mechanics Course | |

1302-067

INTRODUCING

The 1987 **Rascal** 



Medicare
Approved

OUR HIGHEST QUALITY AFFORDABLE ELECTRIC 3-WHEELER

Take this compact, portable 3-wheeler anywhere. Easy One-Hand Operation. Built-In Battery Charger. Rear Suspension System. **MEDICARE** and private insurance reimbursable. 30 DAY FREE trial. Call or send coupon below for a FREE 20 page color catalog.

1-800-662-4548

Electric Mobility Corp., Dept. 1488
#1 Mobility Plaza, Sewell, NJ 08080

Name _____

Address _____

City _____ Zip _____

Phone () _____

THIS COULD BE YOUR LUCKY BREAK.



For a modest investment, you can be your own boss, get the training you need to be successful, and earn the money you've dreamed of.

Because Novus, the leader in stone-damaged and scratched windshield repair, has valuable franchises available in your area.

The Novus process is patented and is currently being used successfully and profitably by thousands of dealers in the U.S., Canada, and 20 countries abroad.

So get more information on the break that you've been looking for. Call 1-800-328-1117, or write: Novus, 10425 Hampshire S., Dept. PM-67, Mpls., MN 55438.

In Minnesota call (612) 944-8000.

NOVUS.

© 1986 NOVUS INC.

YUGO GV

(Continued from page 147)

tank (8.5 gallons), and a hard-to-remove locking gas cap. "I tried to order a nonlocking gas cap," complained a Massachusetts loan adjuster, "but there's no such animal."

Other owners, though, pointed out the Yugo's unexpected extras: "It comes with standard equipment most basic cars don't have, like the rear-window defroster, rear wiper, reclining front buckets, fold-down rear seats, temperature gauge, low-fuel warning light, and the full-sized spare tire."

As for the Yugo's performance and handling characteristics, a South Carolina builder observed, "Contrary to what I read about the Yugo, it has good pickup from a peppy engine." A Michigan music-store owner claims: "My Yugo runs like a scared deer; I call it my Balkan bullet!" A Minnesota press operator: "Quick, responsive handling thanks to rack-and-pinion steering, and good acceleration for a 1.1-liter car." A Massachusetts teacher testified, "It'll hold 65 mph all day long and is very nimble in traffic, due mostly to its small size." But a New York student countered, "The Yugo lacks power and is hard to shift."

In all, 12.2 percent of our respondents yearned for easier shifting. "Shift pattern is too small and vague," stated a Michigan jeweler, "making the gear slots difficult to distinguish. Reverse is really hard to find sometimes."

Comfort? The majority rated the Yugo's comfort good. "I'm 6-foot-4 and weigh more than 300 pounds," noted an Ohio forklift operator, "and am very comfortable. The car could use a little more headroom, though."

Our sampling reported averaging 27.7 mpg in town and 32.7 mph on the highway. A Michigan factory worker volunteered, "We drove our Yugo from Michigan to Florida and back pulling a tent camper. Our fuel bill for the entire trip was under \$90, and we experienced no trouble whatsoever."

One self-described "Yugonaut" from Michigan confessed that he'd owned three Fiats previously and enjoyed them all. "Purchasing the Yugo started out as a joke," he wrote. "I liked the idea of an affordable, free-market car and had no inclination to go back into debt for the next-cheapest car available, which at that time cost about \$6000." Summing up, a Maryland physician neatly captured the majority opinion. "I'm very satisfied with my Yugo," he wrote. "It's not for the car buff, but it provides what it advertises: simple, reliable transportation at an unbeatable price. It's the ideal automobile for a student or as a second family vehicle."

PM

POPULAR MECHANICS • JUNE 1987

Материал защищен авторскими правами



**Locked
for sure
because...
nobody
steals from
the
cobra**

Cobralinks loops around property for virtually unbreakable security. Just slide its case-hardened steel links through the solid hardened steel cobra head...depress the snap-action lock...and forget about theft. Choice of heavy- or lighter-duty models. Full-year guarantee.

For more information, call or write...



LOCKING SYSTEMS

J.J. Tourek Mfg. Co.
1800-18 Touhy Ave. □ Elk Grove, IL 60007
Outside Illinois 1-800-323-8172
In Illinois 1-800-942-0389

"Easy to Use!"

WATER WELLS FOR EVERYONE!

You can drill water wells for less than \$1 per foot with our easy-to-use drills.

5 low-price models for home, farm, and commercial use.

Check one or both boxes for information and mail today!

Homeowner Model Commercial Model

VIDEOTAPES AVAILABLE

Call or Write for FREE Brochures

DeepRock

5239 Anderson Road
Opelika, Alabama 36802

CALL TOLL FREE
1-800-633-8774
(Ask for Operator 5239)

Print Name _____
Address _____
City/State/Zip _____ Phone _____ 5239

The Intelligent Window tells all.

Here's why more and more people are choosing the comfort, beauty, energy savings and value of The Intelligent Window®—the one with *Sungate*® coated glass from PPG.



It's the exclusive *Sungate* coating: it lets in the sun's light and heat, but reflects the heat

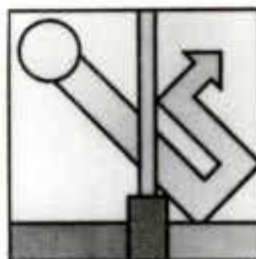

from your furnace, and the other radiant heat in your home, back into your rooms.

You can get the full story on how *Sungate* coated glass works by filling out and returning this coupon. Or, to find out who in your area sells windows and doors with *Sungate* coated glass, just call 1-800-2-GET-PPG.



Be Your Own Boss and Make

\$18.00
to
\$30.00
AN HOUR!



Your FREE Lifetime Security Fact Kit tells you how to make \$18.00 to \$30.00 an hour in your own Foley-Belsaw Full-Service Saw and Tool Sharpening Business. Your FREE Fact Kit explains how you can:

- be your own BOSS!
- work full time or part time, right at home.
- do work you enjoy and take pride in.
- operate a CASH business where 90¢ of every dollar you take in is clear CASH profit.

And it is so easy to learn. Foley-Belsaw gives you all the facts and instructions. No experience or special training is necessary. Foley-Belsaw tells you everything you need to know to be successful.

And there's plenty of business available in your area. You will be able to sharpen all types of saws, garden and shop tools for home, farm and industry.

You will be able to set your own hours and not have to worry about layoffs and strikes. And there are no franchise fees. Any age person can succeed.

But you've got to get the FACTS before you can get started. So write NOW for your FREE Lifetime Security Fact Kit. It's yours to keep with NO OBLIGATION.

... send NOW for your FREE Lifetime Security Fact Kit!

FOLEY BELSAW FREE LIFETIME SECURITY FACT KIT

Foley-Belsaw Co.
6301 Equitable Rd., Dept. 20480
Kansas City, Mo. 64120

YES, I want to know more!
Please rush my FREE Lifetime Security Fact Kit.

Name _____
Address _____
City _____ State _____ Zip _____
(Area Code) Phone _____

PPG INDUSTRIES, INC.
SUNGATE MARKETING GROUP SC-240
P.O. BOX 8727
HARRISBURG, PA 17105

Please send me more information on how windows with *Sungate* coated glass from PPG can add to the beauty, comfort and value of my home.

Name _____
Address _____
City _____
State _____ Zip _____



How do I learn more about what a quality hair replacement will do for me?

TaylorMade has the answer!

"It's so secure & undetectable I don't even know it's there!"



"Swim or water ski? You bet! I'm as physically active as I want to be!"



"Our social life is great since my husband called TaylorMade!"



For a FREE discount coupon and a listing of the distributors in your area, return coupon or call toll free:

Name _____
 Address _____
 City/State/Zip _____
 Telephone _____
 PM6

1-800-231-4984

In California call (415) 589-2686
 Or send coupon to: Taylor Topper
 1641 El Camino Real, Millbrae, CA 94030

CABLE T.V. CONVERTERS

WHY PAY A HIGH MONTHLY FEE? All Jerrold, Oak, Hamlin, Zenith, Scientific Atlanta, Magnavox and all specialized cable equipment available for shipment with 24 hours. For fast service MC/VISA or C.O.D. telephone orders accepted (312) 658-5320 60 Day Warranty (Quantity Discounts) 9 A.M. to 6 P.M. Monday through Friday Central Time. Stamp Envelope (60¢ postage) for FREE Catalog.

Midwest Electronics Inc.
 5143 W. Diversey • Chicago, IL 60639
 No Illinois Orders Accepted

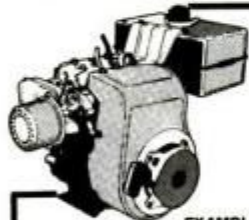

GASOLINE ENGINES

Generators, Troy-Built Tillers, and more

FREE CATALOG
 DISCOUNT PRICES

EXAMPLES

5HP Briggs Horizontal.....	\$143.95
8HP Tecumseh Horizontal.....	\$199.95
3 1/2HP Tecumseh Vertical.....	\$99.95
10HP Tecumseh Vertical Elect.....	\$239.95
500 Watt Toro Generator.....	\$239.95

2 to 18 HP Engines, 500 to 5000 watt Generators, all at Discount Prices
SMALL ENGINE CITY
 2612 Lyndale So. Dept. PM6
 Minneapolis, MN 55408, 612/872-4288
 1-800-645-4488

THERE IS MONEY TO BE MADE SELLING KNAPP SHOES



Start earning extra cash instantly... plus receive a 30% discount on a pair of cushion comfort Knapp shoes for yourself from the largest direct selling shoe company in the entire country. Over 20,000 sales people like yourself are making money every day selling from our full color catalog featuring over 250 attractive styles for men and women including dress, casual, work, safety, and outdoor styles. Knapp will send you a complete FREE SELLING KIT, including everything you need to get started earning extra money immediately. There is no risk when you sell Knapp shoes. We support our sales people with free training and back our shoes with an unconditional money back guarantee. No cost! No obligation! **Send coupon today!!**

Thomas McCallister, KNAPP SHOES, One Knapp Centre
 Dept. 5905 Brockton, MA 02401

Name: _____
 Address: _____
 City: _____ State: _____ Zip: _____
 Tel. No.: _____

KNAPP America works in Knapp shoes

TELEPHONE LISTENING DEVICE



Record telephone conversations in your office or home. Connects between any cassette or tape recorder and your telephone line. Starts automatically when phone is answered. Records both sides of conversation. Stops recorder when phone is hung up.

\$19.95 EACH Qty. Disc. Avail.



Super Powerful FM TRANSMITTER
 Many times more powerful than other transmitters. Transmits up to 1/4 mile to any FM radio. Easy to Assemble. Kit - up to 9V battery (not incl.)
 For catalog of Transmitters, Voice Scramblers and other specialty items, enclose \$2.00 to USI Corp.

Celebrate July 4th & All Events CARBIDE CANNON

BIG BOOM!



Mammoth 25-inch cannon shoots with terrific boom! Have bang-up time at special events. Uses powdered carbide as ammo. Hundreds of shots for few cents. All metal construction with large, rugged cast iron wheels. Machined brass mechanism for easy loading & firing. Made in USA to last a lifetime. Authentic design. Handsome decor when not in use. Send check, money order or phone your order. Visa, MasterCard, Amex accepted by mail or phone (813) 747-2356. Give card no. & expiration. Money back guarantee. 25-inch Cannon, \$59.95 postpaid. Carbide Ammo, about 200 shots, \$2.25; 3 packs for \$5.95. Johnson Smith Co., Dept. B104, 4614 19th St. Ct. E., Bradenton, FL 34203.

ALL NEW! The Homebuilt **JET HELICOPTER**
 LOW-COST DESIGN - SIMPLIFIED ASSEMBLY
 • Uses low-cost fuel • No license needed
 E-a-p-o-n-d-e-d CONSTRUCTION MANUAL Fully illustrated. Only \$13.95*
 BOTH BOOKS: Only \$19.95
 THE Helicopter Experimenters' HANDBOOK
 • photos • designs • data
 Only \$10.95*
 NEW: An exciting Kit Helicopter! Details sent with book orders.
 P.O. Box 50
 Riderwood, MD 21139
 24 hr. TOLL-FREE Quick Order Line 1-800-338-0337
 (Book Orders Only - by Credit Card) In Maryland: (301)583-4366

Wood-Mizer
 Portable Bandsaw Mills
 • One Man Operation • Safe - Precise
 • Capacities to 32" Dia. x 33' Long
 • More Lumber Per Log
 3 factory locations
 For catalogs on our complete product lines, send \$1.00 to:
 Wood-Mizer Products Dept. D30
 8180 W. 10th St.
 Indpls, IN 46214 (317) 271-1542

MUSCLES HOW TO BUILD A MORE POWERFUL BODY!
 FREE BOOKLET
 New Muscle Pumping Methods gives you wider shoulders • Trimmer waist • Powerful chest • Bigger arms • Gain weight and strength. Write today!
UNIVERSAL BODYBUILDING
 Dept. 04 • BOX 6084, DETROIT, MI 48240

CARBURETOR TOOL KIT
 Contains basic tools necessary to service GM Rochester Carburetors
BT-8627 Carburetor Kit \$151.00
 BORROUGHS TOOL & EQUIPMENT CORP.
 2429 N. BURDICK ST. • KALAMAZOO, MI 49007-1897
 Send for complete tool catalog!

GO KARTS, MINICARS MINIBIKES
 ENGINES-KITS-PARTS
 72 PAGE CATALOG
 \$3.00 REFUNDABLE
 Largest Selection.
 (216) 357-5569
KW KART WORLD Dept. M
 1488 Mentor Ave., Painesville, Ohio 44077
 DISCOUNT PRICES

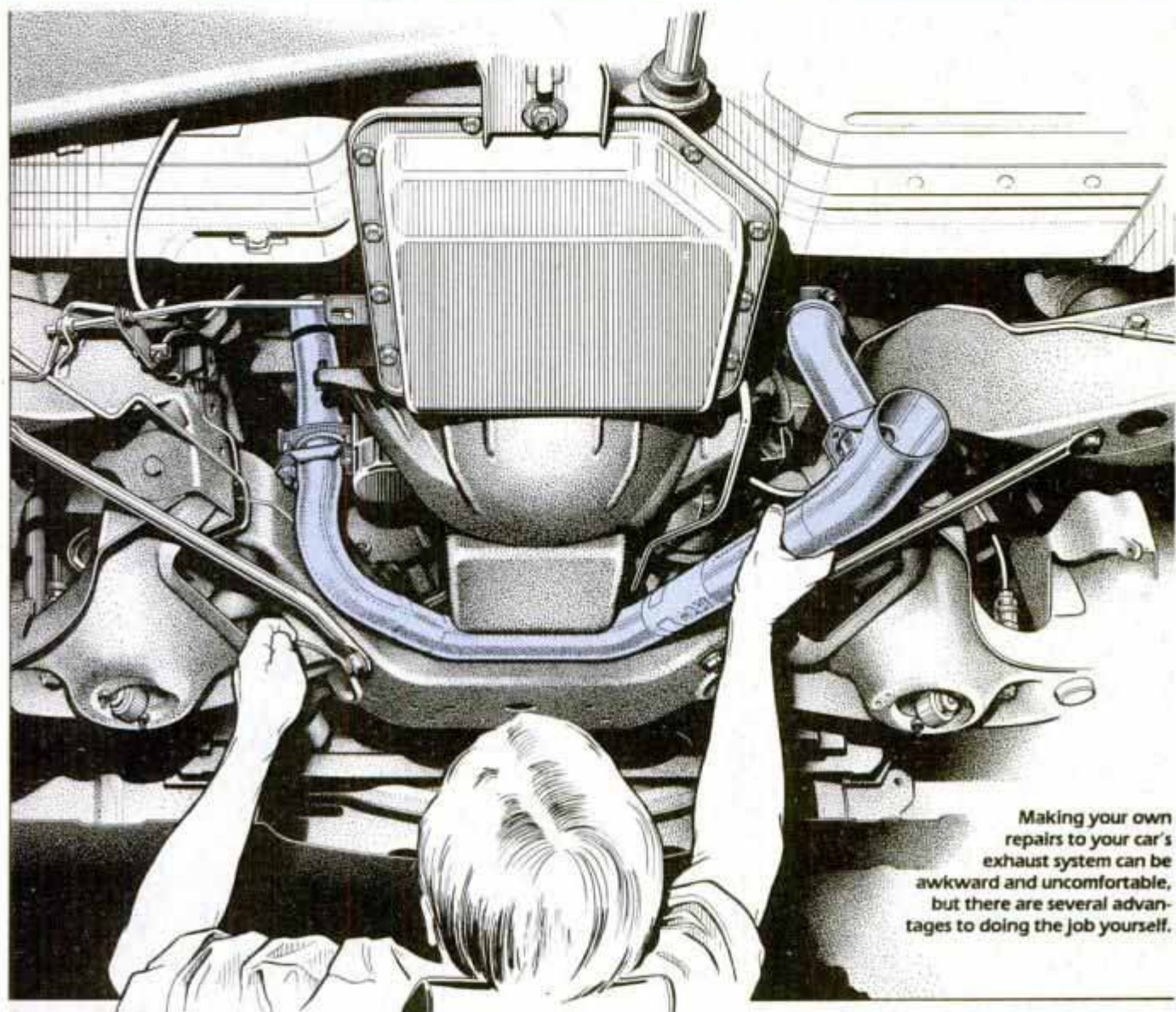

Making your own repairs to your car's exhaust system can be awkward and uncomfortable, but there are several advantages to doing the job yourself.

REPAIRING YOUR EXHAUST SYSTEM

It's a nice quiet Sunday morning and your boss has invited you to have brunch with him, his wife and several important guests. Just a few blocks from his house the front tube of your muffler, which has been corroding for the three or four years you've owned your car, breaks off completely. As you roar up to your employer's house with the muffler dragging on the pavement, all of the guests who've gathered on the patio

BY PAUL STENQUIST

turn to witness your arrival.

An embarrassingly noisy car isn't the only price you pay for exhaust system neglect, there's also the very serious problem of toxic gases leaking into the vehicle's interior. And then there's the danger to other motorists when exhaust parts drop onto the roadway.

Why do it yourself?

Exhaust repair is a tough, dirty job that can only be performed while lying under the greasy side of the car. But there are a couple of good reasons to do it yourself. First of all, discount muffler stores generally don't install original equipment spec parts. "Universal" mufflers and clamps are the standard in most of these establishments. That's why the exhaust systems of cars they service frequently

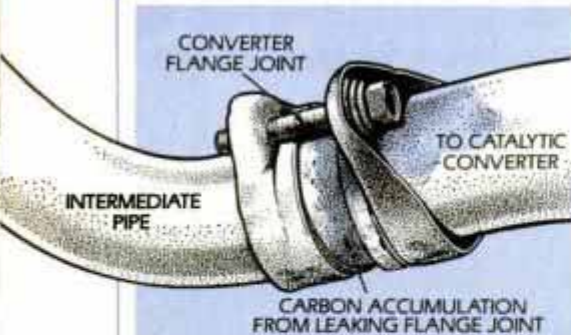

1 Carbon accumulation around converter flange is sure tipoff of leaking.

produce strange resonance and ringing noises. On the other hand, a really top-notch job, using only premium parts, can be quite expensive. If you service your own exhaust system, make sure only original equipment spec parts are used. Factory exhaust engineers go to great lengths—particularly with vibration-prone 4-cylinder engines—to make sure that the system doesn't transmit resonance vibration. An inferior part here or there can make a big difference.

Some tools you'll need

A few special tools are needed to efficiently swap exhaust system parts. First, you should have a pair of ramps on which the jacked-up rear wheels can rest. Jack stands alone won't suffice here because the car has to be resting on its suspension when you position the tail pipe over the axle. A bushing cutter, which is nothing more than a chisel with a concave, curving blade, is needed if you intend to replace a muffler while reusing the old tailpipe or intermediate pipe. A cone expander, which is used to straight-

en and slightly expand the opening of a female pipe joint, is necessary. Or, you can use any metal cone-shaped object that can be pounded into the tube.

If you're going to remove the exhaust pipe or Y-pipe (the forward pipe in the system), you'll probably also need a stud removal tool. Finally, never ever attempt any work under a car without safety glasses that offer full protection both in front of your eyes and to the sides. There's nothing more painful than a metallic flake of rust in your eye, and it's almost sure to happen if you attempt exhaust work without eye protection.

Inspecting the exhaust

Exhaust system repair begins with a careful inspection. As you inspect, make a list of all parts that will have to be purchased. Look for obvious holes, corrosion and restrictive dents. Pay particular attention to the flange right behind the catalytic converter. On most cars, this will be the first part to rust and it will begin leaking.

Look at every joint for signs of leakage, such as carbon accumulation (Fig. 1). On cars with aluminized pipe, check the weld seams for corrosion. Carefully examine all brackets and hangers. If any hangers appear to have been jury-rigged, replace them with original-equipment hardware. Count on replacing all clamps because the old ones will probably break when you loosen the nuts.

On all cars produced since 1975, the parts forward of the converter are stainless steel and should last at least 10 years, so you may not have to replace anything forward of the cat. Eventually, however, even these parts will deteriorate. The first thing to go may be the exhaust manifold-to-exhaust pipe gasket. Carbon around the joint is usually the first visible sign of leakage.

2 Front-drive cars have a flexible bushing to let the engine rock, something not seen on rear-drive cars. Spherical bushing can wear even if pipe is still okay.

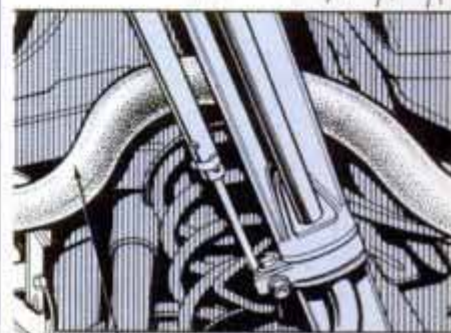
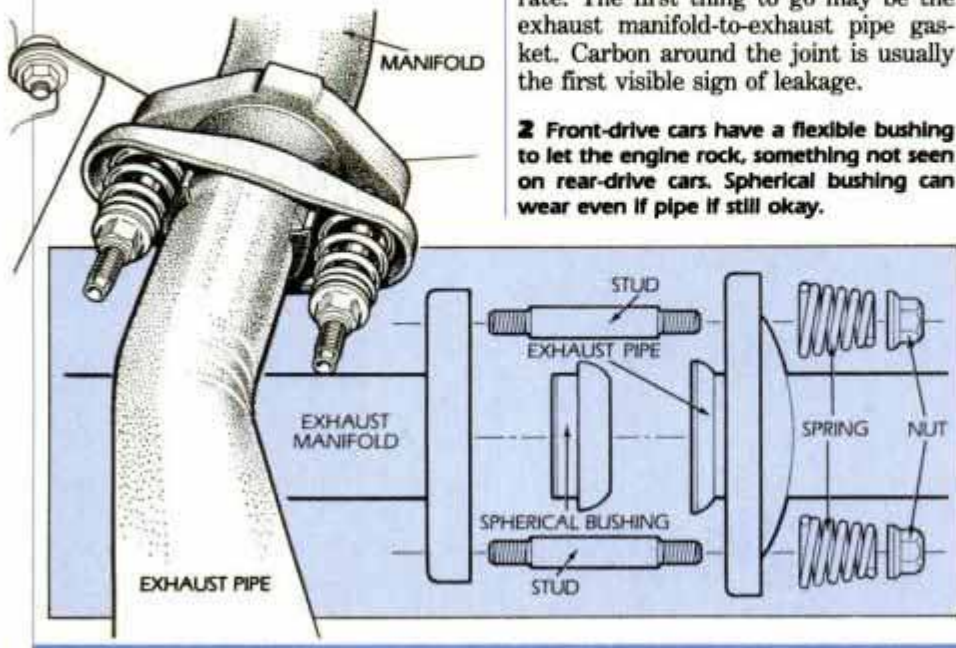

3 Check placement of old exhaust pipes before disassembly to avoid rattles later.

Even if your muffler appears to be almost new, pay special attention to small rust holes or spots that may be appearing on its surface. On many cars the muffler mounts at the rear of the system, runs very cool and rusts from the inside out. Close inspection may find a rotten muffler that appears to be good at first glance.

Some cars have a second muffler-like device, called a resonator, located between the tailpipe and an intermediate axle pipe. This component rarely gets warm enough to dry condensed water and, consequently, corrodes rapidly.

Rust, holes and noise aren't the only symptoms of exhaust system problems. There's also increased back pressure due to catalytic-converter clogging or collapsed pipes. And, because some new cars have double-wall pipes, physical inspection may not reveal a collapsed pipe. A clogged cat is impossible to detect through external inspection.

On front-wheel-drive cars you should carefully examine the bushing joint that connects the exhaust pipe to the exhaust manifold (Fig. 2). These joints don't seem particularly prone to leakage, but

they can wear out. If you've allowed the engine locating strut to deteriorate to the point where vibration and torque loading cause a lot of engine movement, this joint may be bad. As with a rear-drive exhaust manifold gasket, carbon around the joint is generally an indication of leakage. If the joint is bad, replace the spherical bushing and springs.

Purchasing new parts

Buying the exhaust parts you need may be the most important part of the repair job. Order heavy-duty clamps for all bushings in front of the muffler, even if the car was not originally fitted with these. Better parts stores will stock both heavy-duty and service-grade clamps.

If you have a good relationship with your parts store counterperson and you know you're getting OE spec parts, go ahead and purchase them through your parts store. You'll probably get a better price there than at a dealer. But remember to insist on all OE type parts—right down to the hangers. Don't accept universal hangers. This is especially important if your car has unusual hangers. If you have to, go to the dealer for these. And, if the parts store tries to sell you something off the shelf that isn't advertised as an original equipment equivalent,

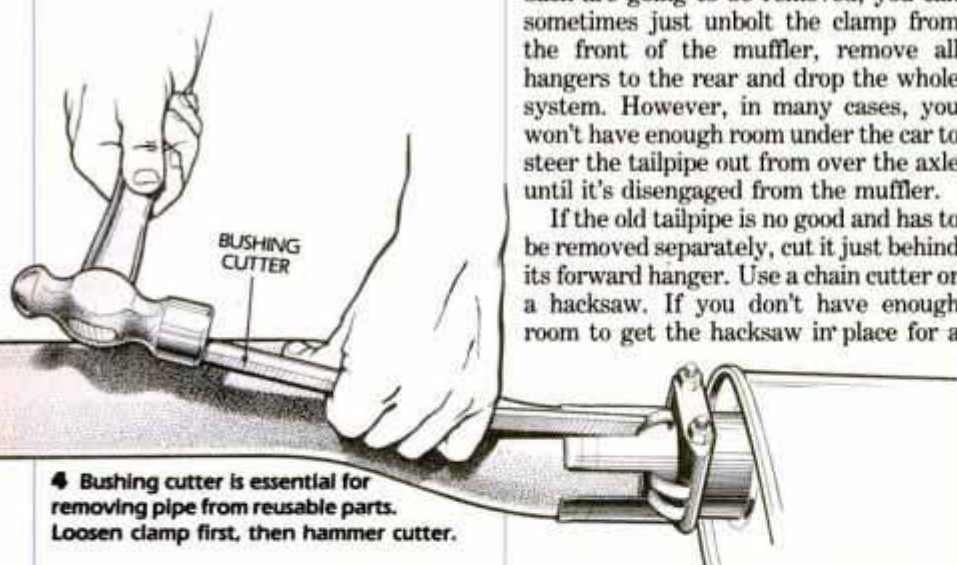

4 Bushing cutter is essential for removing pipe from reusable parts. Loosen clamp first, then hammer cutter.

lent, bid him adieu and head for your new-car dealer's parts counter.

Unfortunately, even some new-car dealers stock universal hangers in place of the right pieces. Some dealers may try to tell you the OE pieces aren't available. Don't believe them if your car is less than 10 years old or so. Ask them to try ordering the part.

If your catalytic converter has to be replaced, be prepared to hand over some big money. For example, on some dual-

exhaust V8s, a pair of new, original-equipment catalytic converters might cost you \$500 or more.

On cars that don't have back-pressure-controlled EGR valves, you might want to purchase one of the aftermarket universal cats in place of the OE item. Some of these units sell for less than \$100. Check your service manual to see if your car has a back-pressure-controlled EGR valve. If it does, the original-equipment catalytic converter is probably your smartest choice, because a change in exhaust back pressure can seriously affect engine operation.

In addition to the exhaust components, you'll also need some penetrating oil, some antiseize lubricant and a tube of exhaust sealing compound, all of which are available at most auto parts stores.

Off with rear pipes

Once you've purchased the new parts, carefully examine the existing layout for clearance and positioning. Take particular note of the way the tailpipe or axle pipe is positioned in respect to the fuel tank and rear axle (Fig. 3). Spray any nuts or bolts that will have to be loosened with penetrating oil.

Begin removing parts from the rear of the car. If all parts from the converter back are going to be removed, you can sometimes just unbolt the clamp from the front of the muffler, remove all hangers to the rear and drop the whole system. However, in many cases, you won't have enough room under the car to steer the tailpipe out from over the axle until it's disengaged from the muffler.

If the old tailpipe is no good and has to be removed separately, cut it just behind its forward hanger. Use a chain cutter or a hacksaw. If you don't have enough room to get the hacksaw in place for a

cut, you'll have to rent the chain cutter. Once the pipe is cut, remove its rear hanger and guide it out over the axle.

If you're saving the tailpipe or intermediate pipe, cut the muffler off of it using the bushing cutter. To do this, cut a slice out of the bushing joint so it will expand enough to free the pipe within. Start the tool at the edge of the joint, catching the blade just under the lip of the outer pipe. Allow the tool to work its way in as you hammer (Fig. 4). Don't



5 Stud removal tool and careful use of heat can save a corroded manifold.

push it down into the other pipe.

If the forward pipes don't have to be replaced, remove the muffler and intermediate pipe from the converter by unbolting them from the converter flange. If the bolts are rusted tight and you can't break them off with the wrench, you'll have to chisel them off.

Removing forward pipes

If you have to replace pipes forward of the cat, you can almost always remove the muffler, catalytic converter and Y-pipe or exhaust pipe as a unit. If the fasteners are severely corroded, you'll have a much better chance of getting them off if you pound on a socket that is slightly too small for the nut. A 13-mm socket, for example, can usually be driven onto a $\frac{9}{16}$ -in. nut. Heat applied to the socket and nut with a propane torch will help as well. Avoid heating the manifold at this point as the cast iron might crack. Be extremely careful to avoid any fuel lines or grease spills.

If you're trying to dislodge the nuts on studs that are more than 5 years old or so, the studs will inevitably break before

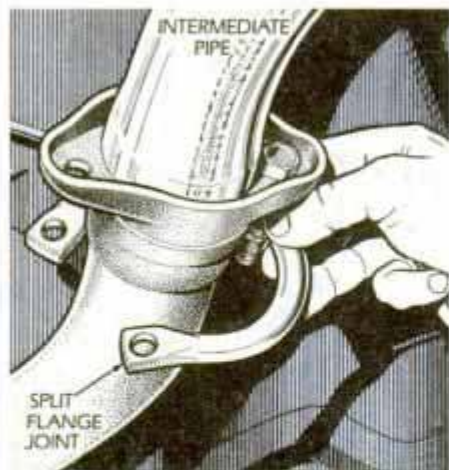

● Cut off the remains of the old converter flange, replace it with split flange.

the nut turns. Luckily, the studs erode the greatest amount in the middle and usually break off there. If you break off the first nut or two, chisel or torch the others off, so you'll have a full stud left to work with.

Once the Y-pipe or exhaust pipe has been dropped, you'll probably be able to get the studs out by heating the corners of the manifold flange while turning the studs with a stud puller (Fig. 5). As we mentioned earlier, applying heat to the manifold can crack it, but limited heating will usually not cause problems. The alternative is replacing the manifold.

Installing new parts

Obviously, you should begin the installation of new parts at the farthest forward point. If you're replacing the Y-pipe or exhaust pipe, use new doughnut gaskets, even if the car was equipped with sintered-iron gaskets that appear okay.

If you use the old ones, you'll probably end up with a leaky system, as these gaskets warp over time. Reuse the internal collar if the replacement exhaust or Y-pipe is not equipped with an integral collar. Use brass nuts and antiseize lubricant. Don't tighten the nuts fully until the converter is in position.

Secure the cat to its mounting bracket using new hardware where necessary. Make sure the cat does not contact any part of the vehicle, and that adequate clearance exists between it and all flammable materials and any brake or fuel lines. With it located properly, tighten the exhaust manifold connection nuts.

If the old converter is to be retained, make sure it is securely attached to its bracket and that it shows no signs of leakage. If the flange joint at the back of the converter is corroded, cut it off with a hacksaw or torch and replace it with one of the split flange joints that are available

from aftermarket sources (Fig. 6). Attach the intermediate pipe to the converter flange joint, but leave the bolts slightly loose.

Check the inlet and outlet tubes of the new muffler. If they're not round, straighten them by pounding the cone expander or a similar hunk of hardware into the tube. Don't overdo it, just drive the expander in to the point where it fully rounds the tube.

On male joints, use the inside of the cone to round and chamfer the end of the tube (Fig. 7). Before installing the new muffler, coat the inside of its female joint with an exhaust system adhesive. Use the adhesive on all joints from this point back, but don't use it on the converter or manifold joints.

Bolt the muffler and the muffler hanger in place, using the OE equivalent hardware. Hold the muffler in place with a jack stand or screw jack while you attach the hanger. Leave the hanger clamp slightly loose until the other pipes are in place. All clamps will be installed and fasteners tightened after the pipes are in place and correctly positioned.

To properly install the tailpipe or axle pipe, the car's rear wheels must be supported on ramps. If the wheels are allowed to hang free, it will be impossible to properly locate the pipe in respect to the rear axle. However, in some cases it may be necessary to raise the car on jack stands, located under the frame, when you first insert the pipe, as the ramps may not leave you with enough room to pass the pipe over the axle.

Carefully locate the tailpipe or axle

pipe above the axle in the same position as the old pipe. Attach it to the back of the muffler (or, where applicable, the second intermediate pipe). Use exhaust sealer on the joints and use the cone expander, if necessary. Bolt the rear pipe hanger in place, leaving the clamp slightly loose. Center the clamp on the bracket.

Clearance and alignment

Once all pipes are in place, examine the system for clearance and alignment. Pay particular attention to the tailpipe routing above the rear axle. If a pipe contacts the vehicle, exhaust resonance will be transmitted through the entire chassis. Make sure the muffler is flat and level.

Install the heavy-duty clamps from the muffler hanger forward. You can use standard clamps on the tailpipe. Install the clamps with the bolts pointing to the side, so they won't come into contact with roadway obstacles. Position the converter flange joint similarly.

When you're sure that alignment is correct and all clamps are properly positioned, make them as tight as possible. Then, rap the back of the clamp with a hammer to help it form a sealing ring in the pipe, and tighten it a little bit more. Check all fasteners to make sure they've been tightened. Finally, make a careful inspection of the entire system for clearance and alignment to make sure nothing shifted while you were tightening clamps and hangers.

FM

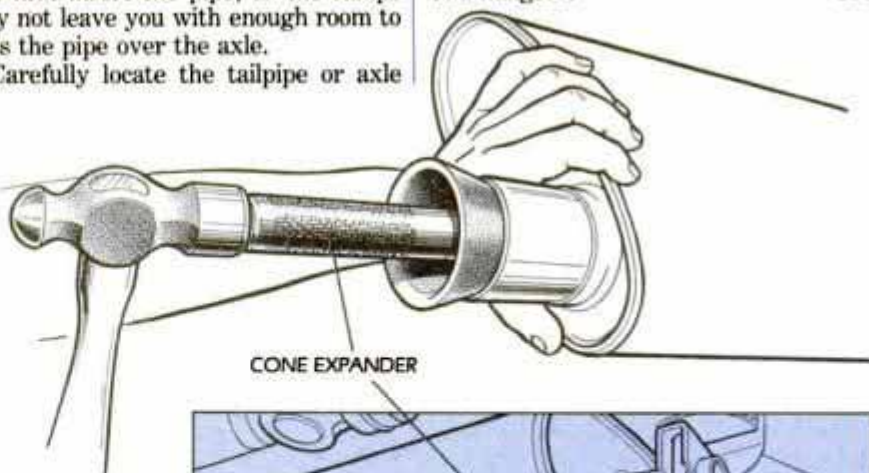

7 Cone expander, or a similar piece of metal, can be used to chamfer either end of the pipe for easier installation.

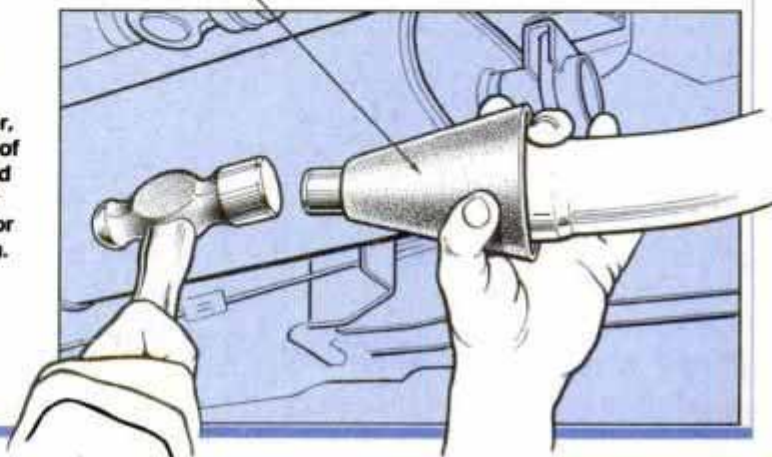

HINTS FROM READERS

Fan Shelf

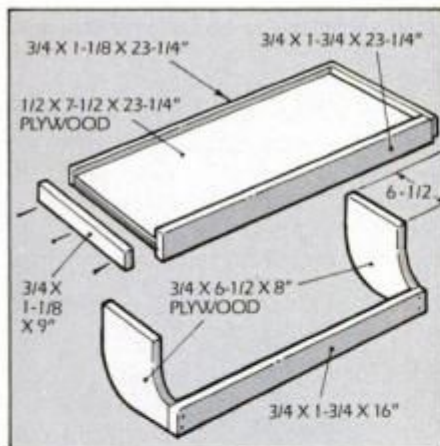
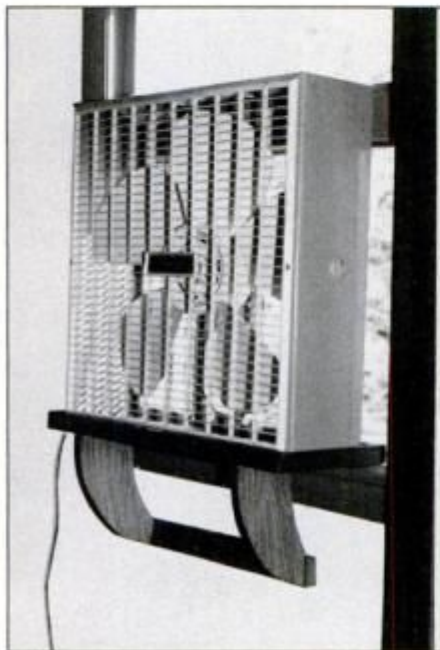

This shelf holds your fan where it can be most effective in improving ventilation. Its tray will accommodate most 20-in. fans and it can be built from scrap 1/2- and 3/4-in. plywood and 3/4-in. pine. Cut the pieces for the tray and the support to size and assemble each. Don't fasten the tray and support together yet. Because each window is different, your shelf may need some adjustment to hang correctly. Hold the tray on the sill so that it's level and place the support underneath it. With the support against the wall, mark its position on the underside of the tray. Then remove the tray and support and join them together permanently on the marks.

—J.G. Hick

\$28.00 Woodworker's Package For Only \$9.95!

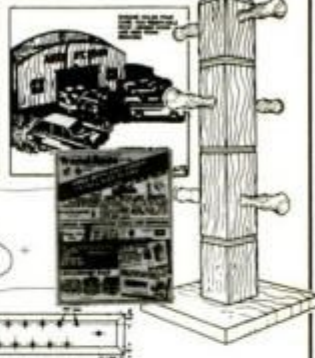
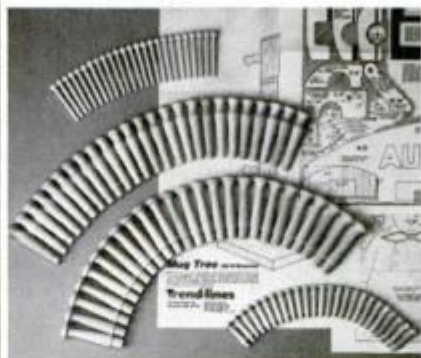

As an introductory promotion, a leading mail order company is offering \$28.00 of their most popular woodworking items at an amazing price of \$9.95. The complete package includes 25 full size shaker pegs, 25 mini-shaker pegs, 25 mug rack pegs, and 25 tie rack pegs—plus a detailed full size unique horse design shaker peg plan, a full size plan for a beautiful tie rack, and a full size plan for a useful mug rack.

This alone would be a tremendous value. But you'll also receive full size patterns for 10 great items—a hanger for pot holders, note pad holder, napkin holder, muffin server, doughnut holder, pretzel holder, cleanser holder, knife rack, towel bar, and spice shelf. Plus: full size plans for four nifty cars with their own garage. You'll also receive a woodworking catalog loaded with page after page of discount power tools, hand tools, wood parts, wood fasteners, sanding supplies, wood finishes and much, much more. You may order up to four of these \$28.00 woodworker's packages for \$9.95 each. Include only \$2.95 shipping and handling regardless of how many you order.

**\$28.00 worth of
woodworking items
for only \$9.95!**

Name

Address

City State Zip

Quantity Price Ea. TOTAL

TOTAL: Add \$2.95

Shipping/Handling

(MA residents add .50 each order

for sales tax)

DO NOT MAIL CASH. USE

CHECK OR MONEY ORDER

Mail to:
Trend-Lines, Inc.
375 Beacham St.,
Box 6447M
Chelsea, MA
02150

PM67

NEW

SOLOAIRIUM™

from Lord & Burnham
MORE PLEASURE NOW... MORE RESALE LATER
(FOR LESS THAN A CONVENTIONAL ROOM.)

SOL*AIR*IUM/VENT™
full-ridge ventilating sash

Low-E Glass

Lord & Burnham's new SOL*AIR*IUM gives you features you'll find in no other glass-enclosed sun room. First, SOL*AIR*IUM/VENT™ full-ridge ventilating sash reduces heat buildup in the summer. Opens automatically at the thermostat setting you choose, to let in fresh air. Low-E glass™ reduces heat buildup further in summer and keeps heat inside, in winter. SOL*AIR*IUM from Lord & Burnham gives you more comfort and more value added to your home! Write for Buyer's Guide. *Optional



MAIL TO:
Dept. 2060R

Lord & Burnham
Division
Burnham Corp.
CSB-3181
Melville, N.Y.
11747

SEND FOR YOUR 32-PAGE BUYER'S GUIDE

I enclose \$2.00 for Lord & Burnham's 32-page Buyer's Guide to greenhouses and SOL-AIR-IUM's™ with full-ridge ventilating sash.

NAME

ADDRESS

CITY STATE ZIP



LORD & BURNHAM Since 1856



NEW/WORKSHOP

Handful Of High Speed

For the hobbyist/craftsman who is looking for greater precision, speed and versatility in a power tool, Precision Turbine offers the model 450K compact, air-powered hand tool. It consists of a 1/3-hp, tankless air compressor, handpiece with coiled hose, and a foot-operated ON/OFF switch. The tool's high speed—it operates at an astonishing 450,000 rpm—allows you to perform the most intricate, delicate work. The handpiece accepts any of the hundreds of burs available. Choose from carbide, stone and diamond-grit burs to grind, carve, polish, engrave, mill, debur and etch a variety of materials including metal, wood, glass, gem stones,



Superhigh-speed handpiece has a 1/3-hp oilless diaphragm, tankless air compressor and a convenient foot-operated switch.

porcelain, plastic and enamel. The 450K costs \$365 post-paid from Precision Turbine, 58760 E. Highway 26, Sandy, OR 97055. Burs are available from Precision Turbine or dental equipment dealers.

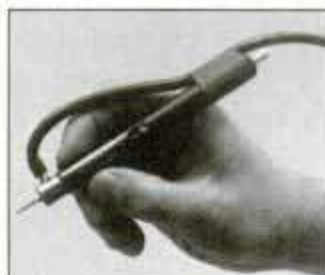

Held like a pencil, the handpiece connects to the compressor with a coiled rubber hose.



The handpiece and wrench are shown with just a few of the hundreds of burs available.

Perfect-Choice Stain Pads

Selecting stain for a woodworking project has always been a little tricky. The in-store color charts are helpful, but they're not usually representative of what a particular stain will look like on your project. To make stain selection easier, Benjamin Moore offers pre-test applicator pads. Each sealed foil packet contains a stain-soaked pad. Simply wipe the pad on an inconspicuous area of the project, or



Wipe-on test pads come in the 12 penetrating stains offered by Benjamin Moore.

on a piece of similar scrap wood, wait for the stain to dry and check the results. The pads are free at Benjamin Moore dealers.

Invisible-Nails Deck Fastener

These simple metal fasteners, called Dec-Klips, allow you to lay 2-in.-thick decking without face-nailing the boards. This creates a clean, attractive deck that's free of visible nailheads, rust stains and unsightly hammer marks. Dec-Klips are designed to be installed between deck boards at each joist. Fasten each Klip with two galvanized nails. First, use a 10d nail to toenail the board through the Klip and into the joist. Then, secure the Klip directly to the joist with an 8d nail. To install the next board, simply jam it into the Klips protruding spikes.

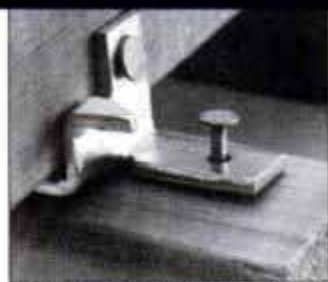

Heavy-gauge steel Klip is held with two galvanized nails. Klips' protruding spike holds the adjacent board securely.

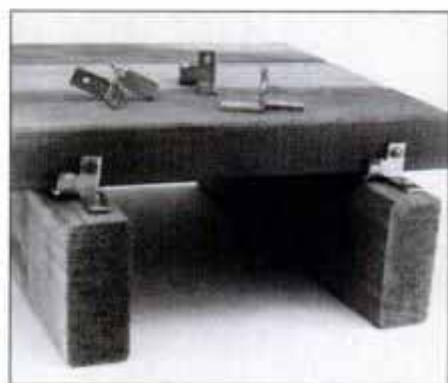

It may be necessary to use a pry bar or wood block and hammer to drive the board into the spikes. The 1/8-in.-thick, electroplated steel Klips hold the decking securely and automatically create spacers between the boards. Dec-Klips cost

Install Klips between boards and to the joists for a clean, low-maintenance deck with no visible nailheads or hammer marks.

about 25 cents apiece and can be found at, or ordered through, lumberyards. Contact G.L. Field, Inc., Box 51188, Wedgewood Station, Seattle, WA 98115.

Mighty Miter Saw

Skil, a long-time maker of fine circular saws, has just introduced a power miter saw. The versatile saw has a powerful 15-amp, 3-hp motor that operates at 5200 rpm. A 10-in.-dia. blade handles large work easily. Capacity at 90° is 3 1/2 x 4 1/2 in. At 45°, it's 3 1/2 x 3 1/2 in. This means that at 45° you can cut through a 2x4 on edge or a 4x4, in a *single* pass. Features include a dust bag, electric blade brake, safety lock-off switch, ball-bearing construction and a spindle lock for quick blade changes. The Skil power miter saw is available at hardware stores



Power miter saw has cast-iron base and 15-amp motor. Pivoting worktable has positive stops at 0, 15°, 22 1/2°, 45° and 90°.

and home centers for about \$245. Contact Skil, 4801 W. Peterson Ave., Chicago, IL 60646. **PM**

File Boxes and Indexes

No more missing magazines or messy shelves!

Keep your *Popular Mechanics*' magazines neatly sorted by year with these sturdy, attractive, red-lacquered file boxes. Each box stands alone and holds 12 issues. Line them up on your bookshelf and you've created a valuable reference library of *Popular Mechanics*' magazines. With each order, you also receive FREE self-adhesive decals for the years 1975 to 1990. Just peel and place the appropriate year on your file box.

- 1 file box: \$2.95
- 2 file boxes: \$2.75 each
- 3 or more boxes: \$2.50 each



Indexes from 1975 to 1986!

Searching for a particular *Popular Mechanics*' article? Let our yearly indexes make it easier to find. Every article published in the magazine is referenced here—automotive, home and shop, photography, outdoors, science, electronics, boating and more. Thousands of entries cross-referenced.

All years available from 1975 on, plus 1973. Price for each index is \$2.95. Order by year.



To order your file boxes and/or indexes, send a check or money order payable to *Popular Mechanics* and mail to: Popular Mechanics, Dept. M, Box 1014, Radio City Station, New York, N.Y. 10101.

Popular Mechanics is a publication of Hearst Magazines, a Division of The Hearst Corporation. ©1987 The Hearst Corporation. All rights reserved.

INTRODUCING THE MERLIN 200 AEROBOT™

SAFE AND EASY VTOL FLIGHT FROM ANY SITE



With 30 years experience Moller International is the recognized leader in ducted fan powered aircraft. Our advanced technology has created a family of computer controlled aircraft called **AEROBOTS™** that can take-off and land vertically. Currently under contract with the U.S. government to develop electric powered aerobots, Moller International is also teamed with Hughes Aircraft Company (the payload supplier) to provide rotary engine powered aerobots for various military applications. After demonstrating numerous manned and unmanned aerobots including the recent 200XR, Moller International is now accepting production position reservations for its latest two passenger aerobot called the **MERLIN 200**:

- Top speed 403 mph
- Range 1050 miles
- Automotive fuel
- 4900 fpm climb
- Quiet and safe
- Proven systems
- Multi rotary engines
- Computer stabilized
- Fits a one car garage

If you would like to reserve a delivery position for the MERLIN 200 aerobot or just want more information, please write or call Moller International. Introductory information is available for \$8.50. The complete information package including history, technical report, flight scenario, color print, production position order form, and newsletter updates is available for \$39.00.



200XR TEST FLIGHT



PHONE: 1-800/247-5462 To Place Orders or 916/753-2217 For Information
WRITE: MOLLER INTERNATIONAL • Dept. M • 1222 Research Pk Dr. • Davis, CA 95616



TRASH BAG SUPPORT

NEW! Holds Trash Bags Open. Portable! Stable! Easy-to-Use! FREE bag included! Not sold in stores. \$9.95 plus \$3.00 shipping & handling. Send check or money order to: Alexander Associates, 1499 W. Palmetto Park Road, Suite 111, Boca Raton, Florida 33432. Money back guarantee.



SUN-SHIELD-VISOR

Pliable, durable see-thru vinyl. Static-Cling holds to windshield in cars, trucks, RV's. Reduces glare for sensitive eyes.

- 4" x 54" - \$5.99 + \$1.50 ship
- 6" x 54" - \$8.99 + \$1.50 ship
- 12" x 54" - \$16.99 + \$1.50 ship
- WA State res. add .079 tax.



Dealers Inquire

TRAVEL 'n SHADE 4229 1st N.W., Dept. PM7/Seattle WA 98107

REPLICA MODELS

HISTORIC NON-FIRING MODEL GUNS...

Safe! Full size. Zinc alloy. Realistic. Over 30 parts. Cannot chamber or fire real ammo. Assembled. FREE Catalog. **COLLECTOR'S ARMOURY** Credit Card Orders. 800 Sitters Lane, Box 59, Dept. PM, Alexandria, VA 22313. (800) 608-2000. Toll Free 24 Hrs.



U.S. M1911 45 AUTO. \$79 PPG. Length: 8.5". Weight: 41 oz.

Pay For Your Hobby!

With White's NEW Series 3 Metal Detectors



Sensitive detectors locate the rare and valuable for fun and profit. \$99.95 & up!

Call Toll Free: 1-800-547-8911

WHITE'S ELECTRONICS Dept. PA-6 Sweet Home, OR 97386

Your home workshop can PAY-OFF

BIG...

Earn Extra Income
Right At Home.

START YOUR OWN MONEY MAKING BUSINESS!



SEND FOR FACTS TODAY!

3-IN-1 Power Feed Power Tool.

Planer Molder Saw

Three power tools in one — a real money-maker for you!

The Planer/Molder/Saw is a versatile piece of machinery. It turns out profitable precision molding, trim, flooring, furniture... in all popular patterns. Rips, planes, molds separately... or all at once. Used by individual home craftsmen, cabinet and picture framing shops, lumber yards, contractors and carpenters.

Never before has there been a three-way, heavy-duty woodworker that does so many jobs for so little cost. Saws to width, planes to desired thickness, and molds to any choice of patterns. Cuts any molding pattern you desire. Provides trouble-free performance. And is so simple to operate even beginners can use it!

30-Day **FREE Trial!** SEND FOR EXCITING FACTS
NO OBLIGATION—NO SALESMAN WILL CALL

RUSH COUPON TODAY!

Foley-Belsaw Co.
6301 Equitable Rd., Dept. 91096
Kansas City, Mo. 64120

FOLEY BELSAW

Foley-Belsaw Co.
6301 Equitable Rd.
Dept. 91096
Kansas City, Mo. 64120

FREE BOOK

YES, please send me the FREE Booklet that gives me complete facts about your Planer-Molder-Saw and full details on how I can qualify for a 30-Day Free Trial right in my own shop. I understand there is No Obligation and that No Salesman will call.

Name _____

Address _____

City _____

State _____ Zip _____

COMING

NEXT MONTH



Muscleboats launch out of the water with MerCruiser V8 power.

Muscleboat Test

5 of the sexiest boats afloat, powered by big V8 engines, go head-to-head at a sizzling 65 mph.

Shopwork Guide

3 projects you build:

- High-tech workbench
- Tool-fixture table
- Unique storage cabinet



Workbench is one of 3 shop projects.

Digital Audio Tape Recorders

PM exclusive! First hands-on report of this new audio revolution and how DAT compares to CDs.

Korean Import: Your Next Car?

We test 8 Korean and Asian imports with domestic nameplates.

The Hot Wheels Of Miami Vice

The inside story on why Miami Vice uses the cars they do and where they get them.



Miami Vice's Ferrari-like Daytona Spyder.

Popular Mechanics

PVC Furniture Plans



PVC Furniture Plans

\$1995 plus shipping

Eight great plans with complete instructions for one low price:

- patio table/chairs
- easy chair
- hammock
- sofa
- sling chair
- chaise lounge
- etagere
- patio glider

With lightweight, durable and easy-to-use PVC, your furniture will look as though a master craftsman created it.

To order, send \$21.45 (includes \$1.50 for shipping and handling) to: Popular Mechanics, Box 1014, Radio City Station, New York, NY 10101. Please allow 3-4 weeks for delivery.

Popular Mechanics is a publication of Hearst Magazines, a Division of The Hearst Corporation. © 1987 The Hearst Corporation. All rights reserved.

DOME HOME KITS

Spacious... Efficient... Affordable... Monterey Domes Homes are designed for a lifetime of savings.

Up to 50% more energy efficient than everyday homes. Patented building system comes pre-cut and color coded.



Send for 100 page color Catalog & Plans Book. \$7.00. Fully Guaranteed!

MONTEREY DOMES

Please rush my Monterey Domes Catalog & Plans Book. Enclosed is \$7.00.
 Also, send me the Basic Dome Assembly Manual for an additional \$3.00.

Name _____
Address _____
City/State/Zip _____

Send To: MONTEREY DOMES
1760 Chicago Ave. Dept. AQ-6
Riverside, Calif. 92517

Credit card orders call
800-634-2265
(In Calif. 909-847-6663)



BUILD YOUR OWN ROCKET MOTORS!

- 40 POUNDS THRUST!
- FIFTY CENTS EACH!
- BUILD A DOZEN IN AN EVENING!

Write for our catalog, and we'll send you a WORKING SAMPLE of an electric igniter that YOU CAN MAKE YOURSELF from materials you'll find around the house.

Send \$2.00 to:
THE TELEFLITE CORPORATION,
Dept. PM-6, 11620 Kitching St., Sunnymead, Calif. 92388

Escape ...

With Folbot

Catalog of Boats & Accessories

- Explore streams, rivers, lakes, and seacoasts.
- Lightweight, quiet, easy-to-paddle.
- Superior construction for years of rugged use.
- Much more stable than a canoe or kayak.
- Perfect for cruising, fishing, and family fun.

Folding, Rigid, and Kit Boats
Prices from \$395

Two new rotomolded polyethylene boats now available.



FACTORY DIRECT PRICES
SATISFACTION GUARANTEED

Send \$1.00 for color catalog.
(Mailed First Class)

Folbot, Inc.
P.O. Box 70877, Dept. PM687
Charleston, SC 29415-0877

Name _____
Address _____
City _____ State _____ Zip _____

CUSTOM VAN SEATING

BRAND NEW! FAMOUS MAKE!



NEW

Manufactured in the U.S.

By a Nationally known
Van Seat MFG. Co.

• SUPER strong MIG welded steel frames! Meets or exceeds all D.O.T. & Federal safety codes!

• FULL "FLEX" suspension & high density foam cushioned comfort!

• LUXURIOUS fabric selection in your choice of TEN COLORS! Camel, light camel, walnut, dark walnut, sky blue, navy blue, silver, charcoal, black, burgundy

• CAPTAIN'S chairs recline effortlessly with just a touch of a lever! Chairs also have optional map pockets & skirts included FREE at no extra cost!

• CAPTAIN'S chairs can be shipped by UPS!

• FREE seat tracks—a \$25 value with each captain's chair!

• ALL FABRIC matching SOFA BEDS offer you Functional Luxury with cushioned comfort while sitting or sleeping and ease of operation, all at the lowest retail price in the U.S.—only \$198!

• SOFA BEDS are 65" x 77" when folded out into bed position!

• CALL OR WRITE for free fabric samples & literature!

One Year Limited Factory Warranty!
FULLY GUARANTEED! Returnable unused within 30 days for full refund of purchase price except shipping & handling.

• QUALITY seat design materials and construction!

• SOFA BED comes complete with front & rear skirts and mounting clamps for easy installation.

• Spare Tire storage under Sofa Bed!

ALL FABRIC SOFA BEDS

Manufacturer's Suggested Retail

\$449.95

LIQUIDATION PRICE ONLY:

\$198

ALL FABRIC Reclining Captain's Chairs

Manufacturer's Suggested Retail

\$289.95

LIQUIDATION PRICE ONLY:

\$138

Price subject to change after 30 days. Worldwide shipping available.

BRADD & HALL ASSOCIATES Warehouse Liquidator Dept. PL
P.O. Box 10643 Arlington, VA 22210-1643

Send _____ Captain's Chairs at \$198 each and _____ Sofa Beds at \$198 each.
Color _____ Shipped freight collect. (Virginia residents add 4 1/2% sales tax. Allow 3-5 weeks for delivery. Sorry no COD orders.
My check or money order is enclosed.

PLEASE PRINT CLEARLY

Name _____

Address _____

City _____ State _____ Zip _____

Phone _____

Sign Here _____



CHOICE Credit card members can order by phone

703-892-0966

BRADD & HALL

PO BOX 10643
ARLINGTON, VA 22210-1643
Warehouse Liquidators

Portable Steam Cleaner

Steam in 60 seconds

CLEAN: Engines, Air Filters, Lawn Mowers. 3-yr. guarantee on fire box, coils. Uses liquid soap, propane fired. Wt. 120 lbs. Auxil. pump required on low water pressure.

WEDCO MFG. INC., Dept. M-18
P.O. Box D, 940 West Broadway,
Jackson, Wyoming 83001



Radio Shack Tandy

Our 10th year of DISCOUNTS
COMPUTERS & CELLULAR PHONES
Fgt. Prepaid. Save Tax—Toll Free 800-231-3680

MARYMAC INDUSTRIES INC.
22511 Katy Fwy., Katy (Houston) TX 77450
1-713-392-0747 Telex: 374133

BASEMENT TOILET

FLUSHES UP To Sewer or Sump Tank

No Digging Up Floors
Install It Yourself - Anywhere

Write McPherson, Inc., Dept. 16
Box 15133 Tampa, Florida 33684



CLASSIFIED ADVERTISEMENTS

Sophie Gronowicz, Classified Sales Manager Dorothy Nolan, Classified Service Manager
Rate: \$7.00 per word payable in advance each insertion. Minimum insertion ten words.

Bold face capitalized words—\$1.00 per word additional (First word set in Bold Face at no extra charge, Zip Code Free.) Centered Headlines in All Bold-Face Letters—\$45.00.

The next available issue to place an advertisement in America's No. 1 Classified Section is **AUGUST**. The closing is **JUNE 5th**. Send remittance payable and order to Popular Mechanics, Classified Department, 224 West 57th Street, New York, New York 10019.

Please indicate Heading under which ad is to appear. As a consumer service and in cooperation with our mail-order advertisers who use post office box addresses for their convenience in handling your order, Popular Mechanics maintains a register of such mail-order advertisers containing their complete names and street addresses.

Advertisers using P.O. Box number must furnish complete name and street address for our records.

To avoid delay in the publication of your ad, please send samples and descriptive materials with your request if your ad does not state clearly what is being offered.

**PLEASE NOTE: WE HAVE 142 CLASSIFICATIONS TO CHOOSE FROM.
FOR OUR LIST WRITE TO ADDRESS ABOVE AND REQUEST OUR ORDER FORM.**

PUBLISHER'S MART BOOKS & PUBLICATIONS

UFO COVERUP REVEALED in shocking Congressional testimony by courageous scientist. Free details and UFO photo. Jerome Eden, Box 399, Careywood, ID 83809.

PUBLISH Your Book! Join our successful authors. All subjects invited. Publicity, advertising, beautiful books. Send for fact-filled booklet and free manuscript report. Carlton Press, Dept. PM, 11 West 32 Street, New York 10001

CHANGE Bad Credit Into Good Credit rating almost overnight. Enjoy life again! Free Report. Caldwell, 216 Harmon Hl., Hopkins, S.C. 29061

LOTTERY PLAYERS!!! Everything you need to play your state lottery and **WIN!** How, where and what to play. Easy to learn systems. Tips to increase your winnings and much more! For "The State Lottery Players' Guide To Winning", send \$12 to: Winning Enterprises, Box 5623, Hopkins, Mn 55343.

LOTTERIES! Systems INCREASING LUCK Dramatically. \$10.95 Money Order. Heric Publications, Box 220, Dorion, Quebec J7V 7J5

BOOKS Hundreds of unique titles, 24 page catalogue only \$2.00. Gemstore, Box 399, Holland, N.Y. 14080

START YOUR own profitable business at home! Become financially secure, 252 pages tell you how! Free details. Turnbull Publishing, 3330 West 114 St. Suite 101B, Chicago, IL 60655

CHARISMA that special magic. New book release \$8.00. McNeil-Dube, POB 336, Manville, R.I. 02838

SLASH MORTGAGE PAYMENTS in half! Barlow, Box 697, Blairdsen, CA 96103

BUILD YOUR OWN BUSINESS Silk Screening Jackets, Hats, T-Shirt And More. Publication Includes Set Up, Listings For Suppliers Of Quality Equipment, Supplies And Raw Goods Also Techniques In Sales Marketing. Learn What Takes Years Of Experience, Start Your Successful Business Send \$10.00. H&H Screening, Dept. A, 60171 CR13, Elkhart, IN 46517.

HOME BUYING? REFINANCING? Avoid Pitfalls! Save \$10,000's Advantage Publications, 18861A Gregory, Huntington Beach, California 92646.

1987 INTERNSHIPS: 35,000 ON-THE-JOB TRAINING OPPORTUNITIES FOR ALL TYPES OF CAREERS. \$17.00, 400-book wholesale catalog, \$5.00. Rebate Marketing, POB 30302, Gahanna, Ohio 43230

OUT Of Print Books. Send Wants. 2035 PM Everding, Eureka, CA 95501

YOU Can Prepare For Coming WORLDWIDE CREDIT COLLAPSE! Free. Write: Genesis, P.O. Box 339X Kearneysville, West Virginia 25430

FLORIDA! Is it for you? How to earn very good living in Florida. Booklet gives tips on buying property. Plus fishing & hunting details. Guaranteed! Act now! Send \$3.00 to: KERK Publishers, Box 388 PM, Tremont, Ill. 61568

POPULAR MECHANICS "PLANS AND IDEAS" CATALOG #1700 — Hundreds of ideas on workshop projects, plans for shop tools, storage houses, boats, furniture, toys — just about everything! Send \$1.50 to: **POPULAR MECHANICS P.O. BOX 1014, RADIO CITY STA., NEW YORK, N.Y. 10101**

MAGAZINES

101 FUNNIEST New Jokes & Stories "Enter the Funhouse!" \$5.00 to: Funhouse, Box 284PM, Burke, VA 22015

CATALOGS

FLAGS! FLAGS! FLAGS! American, State, Religious, Foreign. Home and business **FLAGPOLES. FREE CATALOG!** Write: **LIBERTY FLAG, 424-PM East Main Street, Reedsburg, WI 53959** or **CALL 608-524-2834.**

HEATING, COOLING, EQUIPMENT. PARTS, CATALOG. All makes. \$3.50 Refundable. Plus thousands of items for industry, home. Source Distributors, P.O. Box 863, Arlington Heights, Ill. 60006

FREE literature personalized pin or adhesive name plates, any wording. Write: Dependable, 12 Kenilworth, Prospect Heights, Ill. 60070

BUY KNIVES, CUTLERY ITEMS at Wholesale. Save up to 60%. Huge Selection, Satisfaction Guaranteed, Fast Service. Send for **FREE Catalog.** Smoky Mountain Knife Works, Box 714PM, Sevierville, TN 37862.

LEATHERCRAFT Supplies, tools, kits. Catalog \$1.00 (Refundable.) Crafter, Tombean, TX 75489-0699.

ALARM Systems Home/Auto Easy to install save \$\$\$. Catalog \$1 (Refundable). MDS, Box 407, Norfolk, Ma. 02056

PORTER'S FREE PHOTO/VIDEO CATALOG BEST IN THE INDUSTRY

OVER 4,000 products - Brand names, many unique and unusual items, discount prices and Fast service. For your Free copy write: Porter's Camera Store, Inc., Box 628, Dept. PM, Cedar Falls, Iowa 50613 or phone: 1-800-553-2001.

WHOLESALE 62 Page Colorful Catalog \$2.00 Refundable. D&R Brothers, 523 South Castle Drive, Salem, IL. 62881

BUILD SMALL UNIQUE PROJECTS Small electromechanical parts. Send \$2 for new catalog and idea book. **FREE** product sample included. Investors Hardware, Box 8460, Anaheim, California 92802

FREE The San Francisco Man Catalogue. Evolution toiletries, Cologne, Aftershave, Glycerin Soaps, Extraordinary Men's items. Name, address for Complimentary Fragrance sample. International Marketing Division, 690 Market Street, 1500P, San Francisco, CA 94104

DISTINGUISHED GIFTS at reasonable prices. Quality guaranteed. Free catalog. Shamaron, Inc., Dept-PM1, 2271 Devon, Elk Grove Village, Il 60007.

AUTOMOBILES

IS IT True You Can Buy Jeeps for \$44 through the U.S. government? Get the facts today! Call 1-312-742-1142 Ext. 7133

SAVE TIRES; BRASS tire gauge-key chain. Measures to 50 pounds. Compact. **ENGRAVED.** \$6.95 plus \$2.00 shipping. Include initials. Variety House, Dept. PM1, Box 396, Milheim, Pa. 16854

FREE AUTOMOBILE SECURITY CATALOG: Largest selection available. Do-it-Yourself. Pagers, alarms, hood/locks, glass detectors. Allow 4 weeks. Immediate Delivery. Send \$1.00. Automotive Security Equipment, Dept. 2, P.O. Box 382, Plainview, New York 11803

VAPOR Carburetor Triples MPG. Free Information. H&A, R2 PV, Bowling Green, MO 63334

SUPER Mileage Carburetors! Do They Work? FREE DETAILS. TDC, Dept. 687A, 304 San Miguel, St. Charles, MO 63303

PICKUP TRUCK TAILGATE LOCKS. Protect your tailgate from theft, two stainless steel locks, with instructions. Send \$24.95. Tailgate Saver, 2310 Fernwood Ave., Dallas, Texas 75216

VIDEO: ENGINE REBUILDING Small block Chevrolet disassembly and complete rebuilding. View 103 minutes of step by step instructions and procedures. Call free 1-800-346-4336. \$39.00. Videosmith, Box 19156, Cheyenne, WY 82003

AUTO APPRAISALS. Current market evaluation. Include year, make, model, miles. \$9.95. Car Consultants, Box 8956, Fountain Valley, CA 92708.

FREE CAR REPAIRS POSSIBLE. SAVE MONEY Send \$1.95. Mike Hillard, G4296 W. Court, Flint, Michigan 48504

10,000 AUTO PARTS below wholesale, in stock for immediate shipment! **FREE** information. Consumer Discount, 10420 Lackland, St. Louis, Missouri 63114. 314-427-0890

HOW TO SAVE \$\$\$ buying new and used cars. Avoid overpricing - Discounts revealed - Buying Smart - easily applied - Rush \$3.00 for report to: C&C Dist, Inc., P-Box 24554, New Orleans, La. 70184-4554.

START Your Own Performance Van Custom Shop 100 pg. Book, \$14.95 Money Back Guaranteed. Performance Listing, Box 2708, Washington, DC 20013

HYDROGEN AUTO FUEL FROM WATER. Amazing Free Report. Merit, 2307 Tyler Lane, Louisville, KY 40205

USED CAR FINDING BUYING TECHNIQUES, Professionals, Beginners Earn, Save Thousands, \$4.95. Jontar, Box 421PM, East Meadow, NY 11554

RUST-CURE eliminates rust and protects against rusting. Liquid formula applies easily. Gives rusted objects years of additional life. \$6.95 + \$1.50 P&H. Coracle Products, Mail Order Dept., P.O. Box 29547, Cleveland, OH 44129

CAR SHOPPERS! Avoid Pitfalls. Save \$1,000+! Advantage Publications, 18861A Gregory, Huntington Beach, California 92646.

SAVE on your next **AUTO.** \$3.00 **FORMER SALESMAN. TIPS.** Suite 495, 1151 Aquidneck Avenue, Middletown, R.I. 02840

HOW TO MAKE YOUR CAR LAST LONGER, even 20 years. Six guaranteed solutions \$10.00. Arlie's Car Cling, Box 206, Blackfoot, ID 83221

AUTO REPAIRS, MAINTENANCE, GLOVEBOX RECORD BOOK \$3.00. G-A Enterprises, Box 596, Fort Hamilton Sta., Brooklyn 11209

(Continued on next page)

Материал, защищенный авторским правом

AUTOMOBILES

(Continued from preceding page)

DRIVE a 1987 Cadillac, Lincoln, or Mercedes for \$25.00 Monthly. No down payment, No credit check. Earn Hundreds to Thousands of dollars by participating in this car club. Details 25¢/SASE to: G&M, P.O. Box 335, Berwyn, IL 60402

SAVE Gas. Gain 5 to 8 MPG. Simple installation instructions. Satisfaction guaranteed. \$9.95 plus \$1.00 P&H. Fuel Innovations Unlimited, P.O. Box 222A, 862 Farmington Ave., Bristol, Conn. 06010

SLICK 50!!! \$5.00 OFF "BIG" ADVERTISEMENT PRICES: \$38.95 POSTPAID!!! Easily Handles 65+ MPH!!! **AUTO-CYCLE H.E.L.P.S.**, Box 517, Timnath, Colorado 80547

HOT SEATS, Locked Doors, Lost Keys ...? No more! Unique new driving accessory catalog. **FREE.** MCI, Box 4800-D, Sparks, NV 89432-4800

POPULAR MECHANICS September issue will feature **ANOTHER** of its famous editorial specials—**SPORT/UTILITY VEHICLES!** Take advantage of this opportunity to present your automotive products to 8,000,000 PM readers. Closing date for this issue is July 3rd.

AUTO SUPPLIES & EQUIPMENT

AUTO Book Center stocks 2000+ Repair, Owner's Manuals. All Makes 1920-86. Catalog \$1.00. ABC, 48PM Appleton, Auburn, MA 01501. Call 617-832-3081 for immediate service.

ALTERNATOR Generator Rebuilding Book. Price: Hedelund Engineering, Box 26024, Las Vegas, NV 89126.

PARTS: Army Jeep and truck parts. Spare Parts & Equipment Co., P.O. Box 751, Lexington, Kentucky 40587-0751

AUTOMOTIVE air conditioning parts discount prices: Catalog \$2.00. Auto Air Supply, 166 Placid Heights, Seguin, Texas 78155.

MOTALOY ring valve job while driving. Guaranteed. \$10.00, two \$18.00. Postpaid. Andris, Box 34081, San Francisco, CA 94134. Dept. A

ENGINE OVERHAUL KITS: WHOLESALE CATALOG \$2.00. ESG, Dept. PM, Box 13053, Lansing, MI 48901

PARTS: Jobbers, Engine Rebuilders, Automatic Transmission Shops. Buy Rebuilding Kits Below Wholesale. Foreign and Domestic. Catalogue \$3.00. Rebuilders Wholesale Warehouse, Box 125, Cliffside Park, N.J. 07010

ECONO Carbs Save Gas. Increase power \$1.00 for brochure information: Vacuum Carburetor, 575 Spencer Lane, San Antonio, Texas 78201

SAVE MEGABUCKS ON FUEL with Better Gas Mileage, improved Horse-Power, increased Compression, Longer Engine Life. **SATISFACTION GUARANTEED** For Brochure plus **DISCOUNT** Send \$1.00 to: J.C. Supply, Rt. 3, Box 748(A), LaCombe, LA 70445.

VERY Unique, 58-74 American Auto Repair Manual. Free Brochure. Chaparral Productions, 836C Hermosa, Chaparral, N.M. 88021

BUY DIRECT - Name brand **TOOLS** and **EQUIPMENT** below wholesale prices. Power tools, socket sets, tool boxes, hardware, spray guns, specialty tools and much more. Over 20,000 items. Send \$2.00 now for large catalog. DFS, Inc., P.O. Box 689, Marietta, GA 30061. **UNCONDITIONAL SATISFACTION GUARANTEED.**

MOTORCYCLES, MOTORSCOOTERS & SUPPLIES

MINI-BIKE Kit-\$49.00. Go-Karts, 2, 3 and 4-Wheel ATV's, Engines, Wheels, Tires, Clutches and Accessories. 1987 40 Page Wholesale Catalog-\$2.00. Go-Karts & Kits, P.O. Box 755, Closter, NJ 07624-0755.

GO-KARTS factory direct, from \$39.95 to \$239.95 complete catalog \$1.00. Schmieder, P.O. Box 142, Springtown, PA 18081

GO KARTS, Minibikes, Atv's, Kits, Parts, Engines. Lowest Prices. Largest Selection. 80 Page Catalog \$3.00. Refundable. Kart World, Dept. C., 1488 Mentor Ave., Painesville, Ohio 44077

AVIATION, HANG GLIDING

DESIGN-Build Airplanes, Hang Gliders. Simplified publications brochure 25¢. McCoy Aircraft, Suite 243, Box J, Manhattan Beach, CA 90266

"LESS EXPENSIVE FLYING FOR A RECREATIONAL PILOT" Send for information. FISHER AVIATION, Rt.3 Box 552, Marthasville, MO 63357.

747 PILOTS EYE VIEW VIDEO. Takeoffs, landings, from 747 cockpit. 20 minutes. Classic music. VHS/BETA. \$24.95 to: Havis Productions, 103-49 104 Street, Ozone Park, NY 11417

NEW WAY TO FLY

AMAZING 179lb flying machine **CLIMBS** to 10,000 Feet. **NO LICENSE** Required, **NO WINGS** or Helicopter Blades. **FOLDS** to Fit in Trunk of Car. **SAFEST, Easiest, Cheapest** Way to Fly. Buy One Be a Dealer (if open). For Complete information & **FREE** Demo flight send \$5.95 to: Freedom Flyers, P.O. Box 135M, West-Pittston, PA 18643.

AIRBOATS-Hovercraft. Plans, Kits, Engines, Airdrives, Propellers, Accessories. Catalog \$3.00. Sportsraft, Box PM, Meeker, OK 74855

"ALL ABOUT LEARNING TO FLY" Written by Certified Flight Instructor. Covers what it takes, Costs, Getting Started, and how to get your private Pilots License for a Lot Less Than You Think! Booklet \$3.00. Crockett Press, 2208 Altoona, Tallahassee, FL 32308

PROPELLERS

PROPELLERS - for Hovercraft, Ultralights, Homebuilts, Wind Generators. Information \$1.00. Aerotec, Rt. 1 Box 1025, Quinlan, TX 75474. 214-447-2010

SPACE & ASTRONAUTS

NASA emblems, toys, gifts, collectibles. Catalog \$1.25. Refundable. Collector Trends, Box 361, Dayton, Ohio 45409

BOOMERANGS ... HI-TECH RETURNS! Polycarbonate, Paxolin, Wood Constructed. World's Best! Collectible. 11th Annual Catalog. **FREE!** BoomerangMan, 1806-1 N. 3rd., Monroe, LA 71201-4222

HOVERCRAFT

HOVERCRAFT Plans All Sizes. Catalog \$1.00. Universal Hovercraft, Box 281, Cordova, Illinois 61242

AERO-CAR Amazing Hovercraft built easily with ordinary tools. Lawnmower engine power. Carries one man plus. Hovers, flies forward, backward. Sideways over land/snow/water. Complete construction plans and brochure. \$10.95. Aero-Projects, Box 5118PM, Clinton, New Jersey 08809.

HOVERCRAFT PLANS & PUBLICATIONS Catalog, \$1.00. Lansing Aero-Marine, P.O. Box 27855, Lansing, Michigan 48909

VW HOVERCRAFT Information \$10, Plans \$25. Neoteric, Box 2438, Melbourne, Australia, 3001

BARTLETT Flying Saucer Ultra-Light Hovercraft Featured in Documentary Film, "Force Beyond." Powered By Ordinary Lawn Mower Engine. Complete Plans \$10.00 Info-Pak \$1.00 Send To: Herb Bartlett, P.O. Box 156M, Silverdale, WA 98383

CB'S, RADIO & HAM EQUIPMENT

POLICE Scanners, Bearcat, Regency, HPR, Box 19224, Denver, CO 80219.

ELECTRONICS

MINIATURE Electronics like James Bond. Catalog \$2.00. F & P Enterprises, POB 51272, Palo Alto, Calif. 94303

EARN \$30-\$48 PER HOUR! **WITH** only a **BASIC** knowledge of electronics, **YOU** can start your own **PROFITABLE** full/part time **MOBILE TV REPAIR BUSINESS.** Write: Dowdell TV, P.O. Box 8057, Temple Hills, MD 20748

BUGGED? WIRETAPPED? Find out fast! Countermeasures equipment catalog \$1. Capri Electronics, Box 589P, Bayfield, CO 81122

ELECTRONIC PROJECTS, 30 Designs, Schematics. Fun! Profit? \$5.00 - P.O. Box 378, Bay Pines, FL 33504-0378

ELECTRONICS FOR SECURITY, COUNTERSURVEILLANCE AND PERSONAL PROTECTION CATALOG \$1. HUNTEREX, BOX 12922, WINSTON-SALEM, NC 27117

SURGE SUPPRESSOR 120V US Made Single Socket - \$7.00, Six Socket Unit - \$24.00. Elkay Unltd., Box 118, Chaffee, NY 14030

"BUGS" Miniature Transmitters, "James Bond" - type Spy Gadgets. Catalog \$2.00 (Refundable). CUDWELL, Salsiva, Kentucky 40372-0034

MINIATURE FM WIRELESS MICROPHONE. Powerful. Simple assembly. Plans \$3.00 Complete kit \$9.95. **RADIO,** Box 3543, Williamsport, PA 17701

LOW COST, FUN, EASY TO BUILD PLANS! Home Security System \$5.00. Auto Security System \$5.00. Metal Detector \$5.00. Bugging Equipment \$5.00. Parabolic Microphone \$5.00. All Five \$20.00. **HUGE CATALOG** of **PLANS, KITS, ROBOTICS, UNUSUAL ITEMS,** \$2.00. Design Craft, P.O. Box 146PM, Eden, NC 27288

COMPUTERS & SOFTWARE

TI-99/4A Software/Hardware bargains. Hard to find items. Huge selection. Fast Service. Free Catalog. Dynamic, Box 690, Hicksville, N.Y. 11801

XT/AT clone, system or kit, warranty, bargain. DAO MICRO, 1520 55th Street, Long Beach, CA 90805. 213-422-4444

FREE programs!! IBMpc's/Apples/Commodores/Adam/TRS80's/T199-4A. EZRAE2RA, Box 5222MJU, San Diego, 92105.

SOFTWARE. IBM, compatible, or Apple, less than \$4.00 disk, send stamp for catalog. PSCa, Box 1057 Capitola, CA 95010

COMPUTER FACT BOOK Learn about Computers the Easy Way, for **FREE** Information write: Computer & Arts, 5580 La Jolla Blvd., Suite 472-H, La Jolla, CA 92037

TV & VIDEO EQUIPMENT

NOTICE: USE OF CERTAIN ITEMS IN THIS CLASSIFICATION REQUIRES STATION AUTHORIZATION.

VIDEOS, Rent-by-mail. Boating, Travel, Crafts, How-to, Sports, Business, Star Trek, much more. Catalog \$2.00 refundable. Armchair Video, Box 16K1350, Miami, FL 33116

DON'T Get left behind in the Video craze. Technical information is available to help you better understand it. For listing send \$1.00 to: Ric's Photo, P.O. Box 4232, Visalia, CA 93278.

CABLE TV CONVERTERS. Scientific Atlanta, Jerrold, Oak, Zenith, Hamlin. Many others. "New" **VIDEO HOPPER** "The Copy Killer". Visa, M/C & Amex Accepted. Toll Free **1-800-826-7623.** B&B Inc., 10517 Upton Circle, Bloomington, Mn. 55431

RAILFANS! Railroad video rentals finally available. Practical, inexpensive plan! Write: Clear Signal Video, Box 418, Sharpsburg, MD 21782

CABLE-TV Converters. Microwave Antennas. Large Selection. Free Catalog, TCE, Box 343, Brooklyn, NY 11230

CAMPERS & TRAILERS—KITS, PLANS

BUILD YOUR OWN - Travel Trailer - Fifth Wheeler - Motorhome - Camper - Pickup Cover - Plans - Patterns - Kits - Catalog \$1 - Glen-L R-V's, 9152PM Rosecrans, Box 1804, Bellflower, CA 90706.

BOATS, OUTBOARDS, TRAILERS, & KITS

BOAT KITS - PLANS - PATTERNS - 250 Designs - 8'/70' - Plywood - Fiberglass - Steel - **POWERBOATS** - Cruisers - Houseboats - Hydroplanes - Runabouts - Duckboats - Canoes - Kayaks - Dories - Prams - Sailboats - Daysailers - Trailersailers - Multihulls - **SUPPLIES** - Epoxies - Polyesters - Cloth - Foam - **CATALOG** \$3.00 (Airmail \$5.00)-(Book Amateur Boatbuilding. \$6.00). **CLARKCRAFT,** 16-P Aqualane, Tonawanda, NY 14150

EVINRUDES - NEW 1985 BARGAINS - TOP BRANDS ... all sizes ... \$2.00 handling ... Scott McCulloch parts ... Electra Marine, 610 Merrick Road, Lynbrook, New York 11563

BOAT Plans - Patterns - Kits - Hundreds of designs - 7'/55' - Sailboats - Powerboats - Sportfishers - Houseboats - Rowboats - Duckboats - Bassboats - Canoes - Kayaks - Hydroplanes - Dories - Boattrailers - Simple construction - Proven instructions - Tremendous savings! Gigantic 160-page catalog \$3.00 (\$4.00 Airmail) - Includes Free "Boatbuilding Supplies" catalog - Fiberglass - Fastenings - Glues - Books. Revolutionary "Poxygrip/Poxyshield" manual \$2.00. Glen-L, 9152 Rosecrans, Box 1804MP, Bellflower, CA 90706

BOAT KITS - SAIL 16'-30' FIBERGLASS. Save half. Anyone can assemble. **FREE** 40 page catalog. **LUGER,** Dept. BC-67, P.O. Box 1398, St. Joseph, MO 64502. 1-800-BOAT KIT in MO: (816) 233-5116.

FIBERGLASS Boat Building Materials Call or Write for **FREE** Catalog 1-800-237-9511 or Fl. residents 1-800-282-9498. Suncoast Fiberglass, 2680 Palm Beach Blvd., Fort Myers, FL 33901

(Continued on next page)

BOATS, OUTBOARDS, TRAILERS, & KITS

(Continued from preceding page)

SEE BOATS YOU CAN BUILD FROM OVER 300 PROFESSIONAL DESIGNERS! In Boatbuilder's International Directory, the established completely independent guide for **PLANS, KITS, HULLS, MATERIALS, ENGINES, RIGGING, TOOLS, etc. DINGHYS TO YACHTS WORLDWIDE.** New 8th edition bigger & better than ever, only \$5.50 plus \$1.50 shipping. **BOATBUILDER'S DIRECTORY**, 1001 Bridgeway Dept. 621M, Sausalito, CA 94965.

LANDSAILER Plans. Class five, easy to build. \$20.00. Fast Five, P.O. Box 5072, Hilton Head, So. Carolina 29938.

USED Outboards. Know What You're Buying. Free Information. Edwards, P.O. Box 1124P6, York Harbor, ME 03911

ATHLETIC EQUIPMENT AND BODY BUILDING COURSES

BIGGER, More Powerful Muscles - faster! Free Booklet! Universal, Box 6694A, Detroit, Michigan 48240

KUNG-FU Free Lessons. Send \$1.00 for Postage. McLisa, Box 1755, Dept. PM87F, Honolulu, Hawaii 96806

FISHING, TACKLE, LURES

FREE Sinker Mold Catalog over 100 molds 25 shapes. Carmen's, Box 220PM, West Newton, PA 15089

BATTERY REBUILDING SCHOOL

TECHNICAL breakthrough in battery chargers-uses 1/2 the electricity compared to old type. Technical breakthrough in carbon pile testers-no burnout! Moore Tool & Cover Company, 10415 US 98, Sebring, FL 33870. 813-655-1616

ENGINES, MOTORS

SMALL ENGINES Galore! Free Discount Catalog. Engines, Box 166P, Ashland, MO 65010.

VIDEO Briggs & Stratton Engines Tuneup. 2 Hours 3-10 HP Recoil Starters, Ignition, and much more. VHS/BETA. Send \$39.95 Check or M.O. To: Portable Services, P.O. Box 1082, La Salle, IL 61301.

GENERATOR KIT 5 H.P.-2400 Watt, Assemble in minutes. Save hundreds. Send \$5.00 (refundable) to: Gen-Kit, PM8703, P.O. Box 160, Rockford, MN 55373

TOOLS FOR SALE

BOLTS, SCREWS, TOOLS, WHOLESALE, DIRECT. Guaranteed. Catalog \$1.00 (Refundable). Camelot, Dept. 44, Box 65, Bristol, Wisconsin 53104

REPLACEMENT HARDWOOD TOOL HANDLES High quality, low cost! Send \$2.00 (refundable) now: Ozark Handle Catalog, Box 390M, Eureka Springs, AR 72632

7 TOOLS IN ONE chromed steel hammer tool, may also be used as wrench, pliers, wire cutter, screwdriver, bottle opener, tack or nail remover. Handles vinyl wrapped, for insulated steady grip. Measures 8" overall. Unlimited uses for home, office, car, boat or camper. Only \$8.50 ppd. Francis George, 7101 Shore Road, Brooklyn, N.Y. 11209

INDESTRUCTIBLE Solid steel wire lifetime **TOOL HOLDER** for home-industry-sports. **Only \$4.95 + 1.95 P.H. FREE** details + 10% DISCOUNT coupon. Slinger Hardware Inc., Box 374, West Long Branch, N.J. 07764.

UPHOLSTERY SEWING MACHINES

UPHOLSTERY Sewing Machines with Walking Feet. Complete ready to use-only \$510.00. Thompson Model PW201-AVAILABLE FROM YOUR LOCAL DEALER, or order direct (Master Charge-Visa). Datho Mfg. Inc., P.O. Box 12110, Lubbock, Texas 79452-Phone: (805) 744-6774

MACHINERY, TOOLS & SUPPLIES

METALS, Plastics, Hardware, Tools ... Catalog \$2.00. MBM, 18170 Davidson, Brookfield, WI 53005.

4 METAL Cutting Lathe \$104.50. Taig, 15048 Proctor, Industry, CA 91746

BEST Prices. Woodworkers Machinery Catalog. Free. McKilligan, PMC87, Johnson City, N.Y. 13790

SMALL FOUNDRY Furnaces, Supplies. Free literature. Pyramid Products, 3736 South 7th Avenue, Phoenix, Arizona 85041

"SHARPENERS REPORT" Monthly Newsletter, Sharpening Guidebook, Angle Wall Chart. Free details. Skog Company, Dept. PM6, P.O. 22559, Minneapolis, MN 55422

BANDSAW BLADES, Any Size, Free literature. King Saw, 8541 Tidewater Drive, Norfolk, Virginia 23509

LATHES, Mills, Tools. New catalogs \$1.00. Blue Ridge, Box 536V, Hurricane, WV 25526. 304-562-3538.

LATHE OWNERS Low Cost Quick Change Tool Post. KRF, Box 783A, St. Joseph, MI 49085. 616-429-7050

STEEL, Aluminum, Brass-Sheet, Bar, Shop Supplies, Plans. Write: CEI, RR1, Box 163, Cameron, IL 61423.

LATHES - INDUSTRIAL/HOBBY FROM \$295.00, METALS, SUPPLIES. LARGE CATALOG \$2.00. CAMPBELL TOOLS 32nd YEAR. 2100-D SELMA RD., SPRINGFIELD, OHIO 45505. 1-513-322-8562.

FREE WOODWORKERS CATALOG: Waverly Woodworks, Dept. 42, Route 5 Box 1204, Forest, Virginia 24551. (804) 525-7247

POWER TOOL ELECTRONIC MOTOR SPEED CONTROLS; Many models, other control devices. \$15.95 up. Free information, Progressive Controls, Box 768B, Dearborn, Michigan 48127

WORK GLOVES, wholesale prices. Women's sizes, tool SASE: The Glove Box, P.O. Box 5, West Hartford, CT 06107

AIR BLOWERS, Below Wholesale, 76 CFM, 5 3/4 High, 3" Squirrel Cage. 2 1/8 x 2 21/32 Outlet, 4 Bolt Hole Flange. 2800 RPM 115 Volts 60/50 HZ Thermal Protected: \$19.00. Variable Speed Controls: \$5.50. 8' 3 Wire Cord, With In-Line Off/On Switch: \$4.50. All UL Listed. 50c Shipping. Ram's Air, Rt. 1 Box 163, Dufur, OR 97021

CHAINSAW CHAIN - Tungston Carbide coated. Rarely needs sharpening. Lasts 5 times longer. Free literature. Tungston Carbide Coatings, Dept. 302, 2115 W. 8th St., Erie, Pa. 16505

ENERGY SAVING

SAVE Money On Gas Bill. Install Gas Saver On Water Heater. Send \$1 For Brochure. Refundable. Walker, P.O. Box 12029, Omaha, Neb. 68112

SOLAR & ALTERNATE ENERGY

CATALOG-SOLAR, HYDRO-ELECTRIC, WIND POWER Equipment. Over 350 items. Send \$3.00 U.S. to: WESCO, Box 936, Redway, CA 95560

FREE! Solar Energy Products catalog. Gil Electronics, Box 1628-J, Soquel, CA 95073

SOLAR ELECTRICITY. Unbreakable, waterproof photo-voltaic panels. Operate radios, recharge batteries and other applications. 6, 9 and 12 volt adaptor. Send \$1 for complete catalog to: Avtec, P.O. Box 34382, Blaine, MN 55434

"SOLARMAT" collector panels for pools \$88. Send \$4 for literature and manual. Dealer inquiries welcome. Nutec, #11-15243-9 1st Ave. Surrey, B.C., Canada V3R 8P8

HOME CRAFTSMAN

STEAM ENGINE KITS Power models at savings to you! Send \$1.00 for literature. P.M. Research Inc., Dept 7 RD #2 Box 29, Wellsville, NY 14895

WOOD Craftsman. We Offer 6 Lightweight Rugged Aluminum Clamps 0-72" Opening. Colt Clamp Co., 33-C Swan St., Batavia, NY 14020. (716) 343-8622

WOODCRAFT PATTERNS, Windmills, Wishing Wells, Bird Houses, Feeders, Flying Duck, Pheasant, Outdoor Planters, Catalog \$1.00. Crafters, 11840 US. 27 North, DeWitt, Michigan 48820

FAVORITE WOOD TOYS, Patterns, Parts, Wheels, Catalog \$1.00. Toys and Joys, Box 628M, Lynden, Wash. 98264

CATALOG FULL-SIZE FURNITURE PLANS - \$2.00. Refunded with first order. Traditional, Early American, over 180! Furniture Designs, 1827 Elmdale, Dept. CP-87, Glenview, Illinois 60025.

PVC PIPE FURNITURE Plans, Kits And Supplies. Free Brochure. Casual, Box 206, Tewksbury, MA 01876

PROFITABLE WOODEN "COUNTRY CRAFTS". Made \$2,000 one weekend. 100 full size patterns and details only \$6.00. Hartville Woodcrafts-P67, 12355 Market, Hartville, OH 44632

PROFIT & FUN! Wood Birdhouses & Feeders - 5 plans - includes Free marketing tips .. \$7.95 - Alfred Otto Publishing Co., Box 690765G, Houston, TX 77269

STOP TOILET SWEAT (No Hot Water). Plans \$3.00. 340 Pine St., Centerville, MA 02632

REPAIR Silver, Pewter, Brass, More. Profitable Craft. Free information. SASE. Institute Of Metal Repair, 1558 So. Redwood, Escondido, CA 92025

OVER 125 FULL SIZE PATTERNS! Create profitable wooden gifts, toys, household accessories ... more! Patterns PLUS "Shop Secrets" and brochure. Only \$7.00. Accents (P-67), Box 7387, Gonic, NH 03867

TOYS Of Wood, Free Info. Tarjany Designs, Box 8846, Calabasas, CA 91364

BELIEVE \$5 FOR A COMFORTABLE BED? IT'S true. Your own WATERBED from easy plans & pictures. Free information: Waterbeds, Dept. P. Box 338, Granby, MA 01933.

BATTERY CLOCK MOVEMENTS. Below wholesale prices. Best Quality. Catalog \$1.00 (refundable). Yankee, Box 26, Thompson, Connecticut 06277

WOOD, WOODWORKING

UNIQUE WOODWORKING PLANS, 5 Projects, \$10.00. Ernie Ledbetter, P.O. Box 60417, Las Vegas, NV 89160

PLANS, BLUEPRINTS, PROJECTS

DEPRAVED Technologies, **SPACE** age gadgets. Catalog. \$1.00 refundable. Box 11487, Chattanooga, Tennessee 37401

PLANS. Mystifying Illusions, Exotic Electronic Gadgets. Catalog \$1.00. D. Taylor, P.O. Box 1612, Destin, FL 32541

PLANS FOR 200+ TOOLS, Catalog \$1.00 Refundable. Wood-Met, 3314 Schoff, Peoria, IL 61604

STORAGE Buildings, Playhouses. 16 **COMPLETE PLANS** for \$10.00. Easy instructions. Kempf, Box 88, Toutle, WA 98649-0088.

GIANT PATIO CHESS SET. 8 ft. Square Board, Pieces 18" to 29" Tall. Easy to Build. Complete Plans, Instructions. Full Size Templates. \$10.00. Blackett Designs, 663 East 2800 North, Ogden, Utah 84404

FULL SCALE Toy Model-T Wood Working Patterns For 3 Models. Send \$5.00 to: R-D Enterprises, P.O. Box 1933, Dept TPM2, Mount Vernon, WA 98273

TREADLE LATHE PLANS, Simple construction, Efficient. Send \$9.95 to: Treadle Design, 2775 44th St. S.W., Suite 160, Wyoming, MI 49509

PERMANENT FENCE POSTS for **WOODEN FENCES**, variable lengths. **IDEAL** for **LANDSCAPING, BORDERS**, etc. **LOW COST**, fast, easy construction. Plans \$5.00 - P. Moore, Box 580034, Orlando, FL 32858-0034

SINGLE SHEET Plywood. Desks, beds, tables, more, 10 plans, \$10.00. Specify PMSet. Quale, 3633 Pamplona, Hephzibah, GA 30815

"ROLLAWAY" VOLLEYBALL POLES-Easy To Build! Inexpensive Outdoor Fun! Details-Home Recreation, Box 370PM, Coloma, MI 49038

172 TRAILER PLANS Motorcycle, Utility, Car, Construction - Strong, Streamlined, good looking, easily built. Catalog \$4.00 (Refundable). Tag-Along, Box 15107, Salem, OR 97309

WATER BALLOON CATAPULT, Range over 200', kit \$15.00 plans \$5.00. Burns, P.O. Box 1654, Collegedale, TN 37315

MULTIPURPOSE UTILITY SHED: This 12 x 16 structure is ideal for storing all lawn and garden equipment, including a tractor and compact car. Special features include "a 7-ft-wide overhead garage door. "Fold-down stairway and exterior doors, for convenient access to the storage loft, both are extra wide for easy handling of building of materials. "Built in workbench with roll-out storage bins below and cabinets above provide plenty of work room. (PC-4-85-\$17.50) Write: Popular Mechanics, P.O. Box 1014, Radio City Station, New York, N.Y. 10101

FOR THE HOME

PROGRAMMABLE 7-DAY TIMER - Program on/off times your lights or appliances. Plug timer to outlet and plug lamp to timer. Snap program tabs forward at desired operating period. Has 12 settings per day - 84 for the week. \$24.95 plus \$4.20 shipping. Apex Enterprises, 6539 Chaucer Road, Hinsdale, IL 60521

NEW bathroom electric, outside exhaust system; fits on stool. Guaranteed No odors - \$89.00. Box 272, Amery, WI 54001. 715-268-8317

(Continued on next page)

Материал, защищенный авторским правом

FOR THE HOME

(Continued from preceding page)

HARD WATER, POOR FUEL ECONOMY? Write for **MAGNETIZER** Include This Ad For Information and Offering. Regular \$150.00 Offered At \$99.00. Fully Guaranteed. Van Dommelen Marketing, 254 Rt. 206, Sommerville, NJ 08876. 201-359-4554

HOME BUILDING & REMODELING

INCREASE THE VALUE OF YOUR TOWNHOUSE OR HOME with a well designed backyard. This 3 dimensional kit allows design flexibility and satisfaction before you landscape. Send \$25.00 to the Backyard Architect, 2585 Reagan Ave., Suite 201, Virginia Beach, VA 23454.

LOG AND NATURAL WOOD FRAME HOME OWNERS—ideal preservatives, caulks, sealants, more for your special home in our new, free catalog. Other products for your lifestyle, tool Woodland Home Products, Dept., P. 549 Southampton Rd., Westfield, MA 01085. 1-800-225-5669.

PLASTICS

CASTOLITE Liquid Resins and Molding Supplies to cast, embed, coat, fiberglass, repair and reproduce; in industry, laboratories, craft work. Catalog \$2.00. **CASTOLITE**, Dept. L87G/PM, Box 391, Woodstock, IL 60098.

PLASTICWORKING, Supplies, plans, manuals, videos. Free catalog. Bewley Associates, Box 7290, Moore, Oklahoma 73153

AIR CONDITIONING & HEATING

BUYER BEWARE Purchasing Residential Central A/C? **BE INFORMED**, Free Details. A/C Buyer's Guide, 13 Kings Rd., Chatham, New Jersey 07928

AIR CONDITIONING Components Explained **EASY TO READ** Guidebook. \$10.00 to: Thomas Publications, P.O. Box 1736, Merritt Island, FL 32952

DO IT YOURSELF

WIND CHIMES, CHURCH SOUNDING. Make your own for less than \$5.00. Plans \$5.00. **WIND CHIMES**, 3020 Bay Shore Drive, Tallahassee, Florida 32308

WATER PROOFING FORMULA For Decks, Siding, Fences, Etc. "SIMPLE" To Make With Readily Available Materials. "SAVE 50% AND MORE" Compared To Commercial Brands And Does The Same Job! \$9.95. **PRESERVE IT**, 9336 Waymond, Highland, Ind. 46322

BELT BUCKLES for coins or stones, specialty buckles, jewelry mountings, cut stones, clock works. Wholesale catalog 25¢. Eloxite Corp., 806 1/2 10th Street, Wheatland, Wyoming 82201

INSTALL YOUR OWN IN GROUND SWIMMING POOL for as low as \$1,695.00. Cheswick Pools, Rt. #28, Cheswick, PA 15024. 412-274-6400

ELECTROPLATING. Complete Textbook. Electroplate Metals/Nonmetals. \$11.95. Details Free. Tropix, Palm Bay, FL 32906-0095

BUY WHOLESALE! Parts for Lawn, Garden Equipment, Small Engines, Chainsaws, Minibikes, Karts, More. Includes repair manuals, specialty tools. Send \$4.00 for 184 page catalog. Sav-On-Parts, P.O. Box 45231, Dept. P., Somerville, MA 02145

COMPLETE In-ground swimming pool kits from \$1595.00. Free Brochure & Price Lists. Burnett, 341 Hilliard Road, North Little Rock, Arkansas 72118.

HOMEOWNERS, Check and service your own A/C and Heating system. Complete instructions and illustrations. Save on service calls. \$5.00. T's A/C and Heat, P.O. Box 3049, Spring, TX 77383.

KITCHEN REMODELING-EUROPEAN CABINETS Ready To Assemble/Install. **SAVES HUNDREDS.** Layout/Planning Kit \$5.00 (Refundable With Order). Construct-A-Kitchen, Dept. PM105, P.O. Box 640316, Miami, Florida 33164

PVC PIPE FURNITURE Plans, Kits, Material. Free details. Mountain Leisure, Rt. 1, Box 361A-PM, Sautee, GA 30571

4,321 Catalogs Listed. Sources for Anything! \$5.00. Directory, Box 92452N, Atlanta, Georgia 30314

VIDEO-Professional Haircutting Instruction \$16.95. Image Video, Box 157487, Irving, TX 75015

AIR condition, refrigeration, home automobile. Nuts, bolts, troubleshooting, and repair the easy black box method. \$14.95 guaranteed. E. Z. Way, 215 Postoffice, Suite 1205B, Galveston, TX 77550.

PIANO TUNING KITS, books and tools for piano repair. Send 50¢ for catalog to: CMS-Dept. P, Box 641, Wayne, NJ 07470-0641

"**SAVE HUNDREDS**" on Small Engine Service. Basic Upkeep and Principals \$2.50. Tom Cason, 8 "L" St., Lowell, Mass. 01850

ARROWHEAD MAKING!!! Inexpensive Fun Hobby. Free Information. Commons Crafts, P.O. Box 5012-M, Central Point, Oregon 97502

ELECTRIC Trolling Motor, Easy/Inexpensive to build. Unique Design. Plans \$4.00. AMAL, P.O. Box 1396, Clifton Park, NY 12065.

EASY... Weld, Braze, and Solder **ALUMINUM** to Stainless Steel, Brass, and Copper. Use only your acetylene torch or 110V A/C Arc-Welder... **YES...** Easy Instructions Mail SASE with \$5.00 to: E-MAC Enterprises, Route 2 Box 169W, Hastings, Nebraska 68901

STOP NEIGHBOR'S LOUD STEREO, FAST! Simple plans, instructions. Legal. \$7. **BAILEY'S**, 424M West Commonwealth, Fullerton, CA 92632

DUTCH TREAT Do-it-yourself plans and instructions for building your own Dutch Mini Barn. Attractive and practical. Offers large storage area — 10' x 13 1/2' with 8 feet of headroom. Detailed drawings and materials list. (BC-1279—\$5.95) Write: Popular Mechanics, P.O. Box 1014, Radio City Station, New York, NY 10101

ARTS, CRAFTS, SUPPLIES

STAINED GLASS WINDOWS. Make stained glass windows for fun and profit. Easy step-by-step instruction with "how-to" illustrations. \$4.95. Windows, 19515 F.M. 149, Box 183P, Houston, Texas 77070

CLOCK WORKS. Wood clock blanks, rockhound supplies, belt buckles, cut stones, etc. Wholesale catalog 25¢. Eloxite Corp., 806 1/2 10th Street, Wheatland, Wyoming 82201

STAINED GLASS SUPPLIES: EXCITING SUPER CATALOG-PM \$3.00. CORAN-SHOLES INDUSTRIES, 509 E. SECOND, BOSTON, MA 02127.

QUARTZ CLOCK MOVEMENTS—digitals \$1.50, epoxy resin \$16.00 gallon, foil prints 95¢, music movements \$1.40, complete clock kits \$6.50, components, plans—much more! 52pg. wholesale catalog \$3.00 (credited). Steebar, P.O. Box 463P, Andover, NJ 07821-0463.

ROLL YOUR OWN - 100% beeswax candles 31 colors. Knorr Candles, 14906 Via de la Valle, Del Mar, CA 92014

STAINED GLASS INLAYING: easy, no leading. Illustrated instructions \$5.00. M. Wood, 2470 Berryessa Rd., Suite HM319, San Jose, CA 95133

BUTTON/BADGE PARTS for less. Manufacturer information. \$1.00. Buttons, P.O. Box 858, Iowa City, IA 52244.

STAINED GLASS Supplies. Complete catalog \$2.00. Sunshine Glassworks, 3690 Harlem, Buffalo, NY 14215

CARTOONING, COMMERCIAL ARTS, SIGN PAINTING

CARTOON for Fun and Money!!! Free Booklet!!! Cartoons, Box 40614A, Detroit, Michigan 48240

LEARN Sign Painting, Pin Stripping. Free Catalog. Kaufmann Company, Centertown, Missouri 65023

MODELS, MODELS SUPPLIES

FIRING CANNON Model Plans **CATALOG \$2.00.** GREEN-PM67, Box 892, Shalimar, FL 32579-0892

RADIO CONTROL Airplanes, Boats, Helicopters, Supplies. Big Discount Catalog \$5.00 (Refundable). Modelers Supply, Box 310P, Eclectic, AL 36024

R/C CARS, BOATS. Latest **CATALOG**, \$1.00. P.O. Box 204, Queenstown, MD 21658

"**WORKING STEAM MODELS**"! **KITS or ASSEMBLED.** New! Fire Engine, Locomotives, Limousine, Roadster, Truck, Marine, Stationary Engines and Accessories. One of the largest stock in North America. Two Steam Books total 68 Color pages \$5.95 (refundable) Colored Circular \$1.00 **LARGE DISCOUNTS.** **DIAMOND ENTERPRISES**, Dept PM6, Box 537, Alexandria Bay, NY 13607. (613)-475-1771

MAGIC TRICKS, JOKES, VENTRILOQUISM

FREE! World's Leading Novelty Catalog. 1600 Jokes, Tricks, Science, Sports, Hobbies. Johnson-Smith, F-01, Bradenton, Fla. 34203-3796

LEARN VENTRILOQUISM! Guaranteed Instruction. Supplies. **DUMMIES.** Information Free! Maher, Box 420-PM, Littleton, Colorado 80160.

FREE! Insider Magic Report. **MAGICIANS INTELLIGENCE**, 3380 Sheridan, Amherst, NY 14226

FREE Magic Catalog. Enclose 50¢ Postage. Winkler's Warehouse Of Wonders, 24 P Doyle Road, Oakdale, CT 06370

HOBBIES & COLLECTIONS

EMBLEM. Space Shuttle 1986. Cloth, three inch. \$3.00. Emblem, Box 36651, Strongsville, OH 44136

NAZI & Historical Military Collectibles. **FREE** catalog. HMA, Box 1806PS, Lafayette, CA 94549.

MILITARY Medals Catalogue \$1.00. Subscription Yearly \$6.00. Vernon, Box 1387PM, N. Baldwin, NY 11510.

DECALS, EMBLEMS, PATCHES

CUSTOM EMBROIDERED EMBLEMS, PINS, DECALS. Free Catalog/Quotes. Rush Sketch. Stadri, 61P Jane, N.Y.C. 10014. (212) 929-2293

ANTIQUES, RELICS, INDIAN GOODS & CURIOS

FREE List to Serious Collectors. 30,000 Indian Artifacts. Pots, Spears, Axes, Slate, Beadwork. Caddo Trading, Box 669, Murfreesboro, AR 71958

INDIAN Relics List 50¢. Identification Guide Book \$11.44. Arrowhead Samples \$20.00. Secrist's, Deerfield, MO 64741

STAMP COLLECTING

50 YEARS Old fifteen different United States, over fifty years old-25¢ with approvals. Jaxon, Box C11-P, New Rochelle, New York 10804

FREE 25 World Wide Stamps Plus Free Catalogue With Over 2,000,000 Stamps. No Approvals. Jefferies, 3480 Middlebelt, West Bloomfield, MI 48033

FREE 10 triangle stamps! Approvals. Gordon Davison, 307M, Confoocook, N.H. 03229

50 DIFFERENT Old U.S. between 1861 and 1939 - \$1.00. Ed Roush, 423 Shepard, Mansfield, Ohio 44907.

FREE Gift With First Purchase. U.S. Approvals And Want List Service. 20¢ for Handling. The Stamp Boutique, P.O. Box 456, Madison, N.J. 07940

100 Different U.S. 25¢. Approvals. Bradley, Box 425P, Midlothian, VA 23113

FREE 50 Canadian stamps with approval request. Briner's, P.O. Box 5607, San Mateo, California 94402

OLD U.S. stamps on approval. Sherman, Box 15355E, Philadelphia, PA 19111

"**INVERTED ERROR**" + 100 Different United States, 50¢ with approvals. Luray, P.O. Box 7088, Silver Spring, MD 20907

UNITED Nations 3 Complete Mint Sets 25¢. Approvals. Cornetta, POB 1509-M, Lake Placid, Florida 33852

WORLD, 80 different, 20¢. Approvals. KSG, Box 651, Nelson, BC, Canada V1L 5R4

COLLECTIBLES, Bird, Duck & Wildlife Stamps & Prints. Free Catalog. Depot, Dept. PS, Sullivan, Ill 61951

200 DIFFERENT Canada \$1.00. Worldwide approvals. Quebephil, Box 68, St-Jerome, Canada J7Z 5T7.

CANADA. 100 different 25¢. Approvals. Oroszky, Box 1-C, Sarnia, Ontario, Canada N7T-7H8.

BARGAIN 100 World-wide Stamps 25¢. Quality Approvals. R. Parker, Box 143, West Brookfield, MA 01585

WORLD Wide Stamps mounted in books on approval 2¢ and up. **TRUST STAMP COMPANY**, P.O. Box 100-P, Jamaica, N.Y. 11435

FREE! Surprise Collection with approvals. Gould, Box 750128, Petaluma, CA 94975

ONE! Two! Three! Cent Stamp Approvals, Regardless Catalog. Kloster, 4164 52nd St., San Diego, CA 92105

AUSTRALIA 50 DIFFERENT BEAUTIFUL COMMEMORATIVES 10¢. Approvals. Pence, POB 3041, Winchester, Virginia 22601

300 WORLDWIDE 25¢: Approvals. J. Martin, Box 245, New York, NY 10023

40 EUROPE 25¢ Approvals. Birmell, 2304 Hancock #9E, Austin, Texas 78756

ICELAND collection. 20 different \$1.00. Sandell, Box 6666, St. Paul 55108

(Continued on next page)

STAMP COLLECTING

(Continued from preceding page)

SELECT foreign, \$2.00, earns free plate block. Redgrave, 2453 Keystone, Tarpon Springs, Florida 33589

FREE Big Bargain Catalog - New Edition listing thousands of bargains including U.S. & B.N.A. stamps, packets, albums, accessories and supplies. Also fine stamps from our approval service. Buy only what you like. Return balance promptly! Thank you. Jamestown Stamp Co., Dept. E67PM, Jamestown, NY 14701

FREE Worldwide Packet. Penny approvals. Froehlich, Box 177DA, Pine River, WI 54965

SAVE BIG. Our catalogue shows you how. No approvals. Stamps, Box 15258PC, Sarasota, Florida 34277-1258.

107 Different Triangles, Space, Animals, Etc. \$4.00 Value Only 10c. Approvals. Fayette Stamps, Dept. 418M, Fayetteville, NY 13066

101 worldwide stamps 25c. Approvals. White, Box 24166AE, Indianapolis, IN 46224

U.S. AIRMAILS, 45 Different used \$2.00, mint \$15.00. Eberling, Box 2216, Neptune City, NJ 07754

FREE, U.S. Mint pictorial set complete, Mint approvals included. Hildebrand, Box 4867, Santa Clara, California 95054

FREE! 125 Different Foreign, \$10.00 Catalog Value. Approvals. Rick's, 520 South 23rd, Herrin, IL 62948.

WALT Disney's Donald Duck Birthday Celebration - Free! "Approvals" plus 101 Bonus Sets. William Deems, 226H Race, Ravenswood, West Virginia 26164

COINS, TOKENS, CURRENCY

FREE foreign \$10 bill. Approvals. MJS, Box 1479, Moose Jaw, Canada S6H 7A8

CLAY POKER CHIPS, Casino quality, weigh 9 grams, all colors. Specify quantity and color(s). \$25.00 per 100. K & K Enterprises, Dept. A, P.O. Box 6336, Hemet, CA 92343

BINOCULARS, TELESCOPES, MICROSCOPES, MAGNIFIERS

DISCOUNT OPTICS. Buy at WHOLESALE prices. Complete line. 110% Guaranteed! FREE Catalogue. Optical Advantage, Box 32791PA, Pikesville, MD 21208. (301) 653-3306

PLAYS, SONGS, MANUSCRIPTS

POEMS, Songs Wanted. Free Recording/Publishing. Broadway Music Productions, Box 7438PM, Sarasota, FL 33578

MUSIC INSTRUCTIONS & INSTRUMENTS

ACCORDIONS, NEW, USED. Electric, electronic. Cordovox, concertinas. Button Boxes. Hohners We Buy. Sell. Trade. Exchange. Repair. Tune. 50 Years Experience If Dealers unavailable. Call or Write for Brochures. Mastercard And Visa Accepted. **CASTIGLIONE ACCORDION,** 12644 E 7 Mile, Detroit, MI 48205. 313-527-1595/1-800-325-1832.

PIANOS, PLAYERS, PUMP ORGANS. Rebuild and repair. Catalog of "How-To" books, \$2.00 (refundable). Vestal Press, Vestal 11, New York 13850.

VIOLIN, GUITAR, etc., making materials, accessories, books. Catalog, \$1.00. International Luthiers Supply, Box 580397, Tulsa, OK 74158

INTERNATIONAL VIOLIN COMPANY, Catalog for instrument makers, repairers. Imported tonewood, tools, varnishes, parts, accessories, strings, cases. European instruments, bows. Assemble yourself violin and guitar kits. Catalog \$1.00 includes 10% discount certificate. Dept. HS, 4026 W. Belvedere Ave., Baltimore, Md. 21215.

INSTRUMENT Kits! Build Appalachian and hammered dulcimers, banjos, mandolins; even harps, harpsichords. Free Catalog. PM Hughes, 4419 West Colfax, Denver, CO 80204

ACCORDION Top Brands, Cordovox, Buy Direct. Tremendous Discounts. Trades accepted. Free brochure. PM, Accordion-O-Rama, 16 West 19th Street, New York, NY 10011. Phone 212-675-9089.

PLAY guitar in 7 days. \$8.35. Charles Irving, 2650 East 29th, Kansas City, Missouri 64128

AT LAST ... Write your own HIT song. **FAMOUS** songwriter shares secrets. Rush \$8. **GARKE,** P.O. Box 126, Tempe, AZ 85281

GUITAR, BANJO, FIDDLE AND MANDOLIN STRINGS. Harmonicas, straps, tuners, and more. Catalog \$1.00. Orion Music, P.O. Box 10302, Kansas City, MO 64111

ELECTRIFY Player Pianos, Pump Organs Quickly. Inexpensively with Lee Silent Suction Units. Write: Lee Music, P.O. Box 308F, Culver, Oregon 97734

SELF IMPROVEMENT

STRESS CONTROL "Fast" "Easy" \$3.50. Research Unlimited, Box 4328PM, Evansville, Ind. 47711

RELAX the easy way. \$2.00. A. Ouimet, 10,455 Andre - Jobin 1A, Montreal, Quebec, Canada H2B 2V7

NEGOTIATE TO WIN! Learn How. Free Details Long SASE. G&S, Box 23332P, Tampa, FL 33623

NEW METHOD. How to Stop Smoking. Send \$3.00. Box 6048, Clinton, Iowa 52732

EDUCATION & INSTRUCTIONS

UNIVERSITY DEGREES! Economical home study for Bachelor's, Master's, Doctorate. Prestigious faculty counsels for independent study and life experience credits. (5600 Students, 600 Faculty). Free information - Richard Crews, M.D. (Harvard), President, Columbia Pacific University, 1415 Third St., Dept 2E86, San Rafael, CA 94901; Toll Free: 800/227-0119; California: 800/552-5522; or 415/459-1650

HANDLE YOUR OWN LEGAL AFFAIRS. Be a Paralegal Accredited Attorney Instruction. Home Study. **FREE CATALOG.** Southern Career Institute, Drawer 67PM-2158, Boca Raton, FL 33427. (305) 368-2522

OBEY Jesus. Include Acts 2:21-47. Tracts For Printing \$1.00. 1127 N.E. Fifth St., Ocala, Fla. 32670

EXTENSION And Post-Graduate Awards in Philosophy, Art, Science, Botanic, Medicine, Homeopathy, Radionics, and others. 30 subjects Curricular free (airmail \$1.00 refundable). Registrar, Sussex College of Technology, Highfield, Danehill, Sussex, England.

RADIESTHESIA, Radionics, Dowsing E.S.P. Courses and Equipment Illustrated Catalog \$1.00 (refundable) Established 27 years. Dept. PM/R, Bruce Copen, Highfield, Danehill, Sussex, England RH17 7EX.

HIGH SCHOOL DIPLOMA AT HOME. NO CLASSES. Low cost. Information Free. Call toll free 1-800-228-5600 or write: American School, Dept. #345, 850 E. 58th St., Chicago, IL 60637

PIANO TUNING PAYS - Piano tuning - Electronic organ servicing. Learned easily at home. Free booklet. Niles Bryant School, P.O. Box 20153, Sacramento, CA 95820

L-EARN Clock Repair. Enjoyable, lucrative. Free Details. School of Clock Repair, 6313 ComeAbout Way, Rm. M, Awendaw, SC 29429

BECOME an Electronic Or Video Technician in only 14 months. Financial Aid, Placement Assistance and an Associate's Degree. Call Now! (214) 263-2613 Dallas, (213) 595-1660 Long Beach, or (713) 956-0010 Houston, TX

AUTOSUGGESTION. Sleep-learning headquarters! Tapes, records, books. Gigantic catalog free. Research Association, Box 24PM, Olympia, Washington 98501.

UNIVERSITY DEGREES By Mail. Accredited Bachelors, Masters, PhD's. Free Facts Revealed. Careers-PM6, Box 470886, Tulsa, OK 74147

LOCKSMITHING, Universal School of Master, Correspondence and Shop Training. Box 214652PM, Sacramento, CA 95821

LEARN Auctioneering - Free Catalog. Nashville Auction School, Box 2026, D-4, Columbia, Tennessee 38402-2026

EARN MORE IN 90 DAYS. Free 1987 catalogue describes 200 success proven correspondence Diploma courses. Granton Institute, 263A Adelaide Street West, Toronto, Canada M5H 1Y3

DOCTORATES, MASTERS, BACHELORS ... Without Attending Classes. Convenient, Inexpensive, Fully Accredited. Write: **KENSAM,** Box 1383, Rockaway, NY 11691

DETECTIVE Profession. Easy Home Study. Free legal pin, certificate, future. Professional Investigator Training School, Dept. CP, P.O. Box 41256, Los Angeles, CA 90041

LEARN SIGN PAINTING. Earn good money. Be job ready in 15 months. Financial and Placement assistance. **ROCKY MOUNTAIN COLLEGE OF ART AND DESIGN,** 1441 Ogden St., Denver, Co. 80218. (303) 832-1557.

YOUR child can love learning! Details \$3. Ferris, Rt3 Box 657, Ogdensburg, NY 13669

PHOTOGRAPHY. Proven high-dollar money making plans. Spare-time or full-time possibilities. Details free. Triple-XXX, POB 226523, Dallas, TX 75222.

SUPER-INTELLIGENCE! Amazing results guaranteed! Info. **EDEMP,** Box 1462, Glendora, CA 91740

DETECTIVE training home-study program. Free information. Global, Box 191 PM, Hanover, Mass. 02339

PARALEGAL GRADED CURRICULUM. Approved in-depth training by correspondence. **BLACKSTONE SCHOOL OF LAW:** 100 years of legal training. Write for free catalog. P.O. Box 790906, Dept. PM, Dallas, Texas 75379

SCHOOLS

WORLD WIDE COLLEGE OF AUCTIONEERING, INC. Since 1933. Term Soon. Free Catalog. **COL. GORDON E. TAYLOR,** Box 949, Dept. 19, Mason City, IA 50401. 515/423-5242.

MERCHANT-Seaman School World Travel, Room Board Tuition Paid. Free Information. 116 14 St. #C, Manhattan Beach, CA 90266

EMPLOYMENT INFORMATION

\$3,555.00 Yearly. Skilled but Unemployed, Retired. Local, National, Overseas Work. Additional Information, SASE. Box 8696, Asheville, NC 28814

JOBS, CRUISESHIPS, TUGS, SHIPS, RIVERBOATS, OIL-RIGS: Women-Men. Work month-Home month. USA + Overseas. Information \$3.00. Marine Employment, Box 207, Central, IN 47110

OVERSEAS Jobs \$20,000 to \$60,000. Free information. Doycorp, Box 697SZ, Pocatello, ID 83201

PROFESSIONAL resumes. Prepare your own. Sample kit includes award-winning resume, dynamic cover letter, follow-up thank-you letter, helpful hints. SASE \$10.00 to: Box 2885, Tupelo, MS 38803.

GET A JOB YOU LIKE! Our self-test and informative handbook help you find work you enjoy. Send \$8.00 to: Career Choices, Dept. ME17, P.O. Box 26614, Rochester, NY 14626.

SOPHISTICATED EXECUTIVE SALES High Commission. Exclusive Territory Possible Call Now (800)426-7788 in NY (212)477-5110.

HELP WANTED

OVERSEAS ... \$25,000 - \$75,000+. Free Report! Employment, Box 19760-AS, Indianapolis, IN 46219.

AUSTRALIA WANTS YOU! Big Pay! Transportation! Newest Employment Handbook—\$2.00. International, Box 19107-AS, Washington, DC 20036.

GOVERNMENT JOBS \$16,040 - \$59,230/yr. Now Hiring. Call 805-687-6000 Ext. R-20024 for current federal list.

FOR INVENTORS

PATENT AND DEVELOP Your Invention. Registered Patent Agent and Licensed Professional Engineer. Send for **FREE PATENT INFORMATION** Every Invention Should Have, Richard L. Miller, 12 Parkside Drive, Suite M, Dix Hills, NY 11746 (516) 499-4343

NONPROFIT Foundation helping inventors over 11 years. Free recording forms. Free evaluation. Affiliated Inventors Foundation, 501-B Iowa, Colorado Springs, CO 80909, or call 1-800-525-5885.

INVENTORS! Can you patent and profit from your idea? Call or write for your free information package. Over a decade of service. **AMERICAN INVENTORS CORPORATION,** 82 Broad Street, Dept. PM, Westfield, Massachusetts 01086. 1-800-338-5556. In Massachusetts or Canada call (413) 568-3753.

PATENT IT ECONOMICALLY! Free Details. Licensed since 1958. N. Raner, 2008 Fondulac, Richmond, VA 23229

INVENTIONS Wanted! **PATENTVESTMENTS INTERNATIONAL,** 1050 Connecticut #300, Washington, DC 20036

REGISTERED PATENT ATTORNEY Reasonable rates. Edwin D. Schindler, 1523 East 4 Street, Brooklyn, NY 11230.

REGISTERED PATENT ATTORNEY Washington, D.C. Suburb. Donald A. Kettlestrings, 414 Hungerford Drive, Rockville, Maryland 20850

INVENTORS: Free information on offering your invention for sale. Kessler Sales Corporation, C-5-F1, Fremont, Ohio 43420

(Continued on next page)

FOR INVENTORS

(Continued from preceding page)

NATIONAL Marketing Institute For Inventors - Free Details. P.D. Distributors, Seneca, S.C. 29679-1465

INVENTORS: Learn how to submit your ideas to industry. Call free 1-800-528-6050. Canada, 1-800-528-6060. X831.

INVENTIONS WANTED

INVENTION MARKETING. FREE INFORMATION. REPRESENTING MANUFACTURERS. Patmart, 77 Fulton, 26D, Financial District, New York, NY 10038

INVENTORS! Have an idea? Don't know what to do? Call AIM for free information kit. Toll Free 1-800-225-5800

INVENTORS! If you have an invention for sale or license, write for free booklet explaining how we can help you. Kessler Sales Corp., C-5-1W, Fremont, Ohio 43420

REAL ESTATE & FARMS

MONTANA LAND 20 Acres (or more) starting at \$6950. with \$500. down, \$98.22/month. Near Beautiful Yellowstone Park and National Forests. In the heart of trophy elk, deer, moose, antelope and turkey hunting. Blue ribbon trout streams. Guaranteed Access. Insured Title And Warranty Deed. Your Inspection Welcomed. Free Color Brochure. **CALL TODAY TOLL FREE: 1-800-252-5263. YELLOWSTONE BASIN PROPERTIES,** 1119 N. 7th Ave., Dept. PM, P.O. Box 3027, Bozeman, MT 59772-3027. (406) 587-5469

UNITED NATIONAL REAL ESTATE . . . New FREE Catalog! Top real estate values coast to coast. Full Color Premier Properties section. **UNITED . . .** For every type of real estate! **UNITED NATIONAL REAL ESTATE,** 4700-PM Bellevue, Kansas City, MO 64112.

CALIFORNIA. Lots. Acreage. \$40 Down. \$40 Monthly. Box 35291, Los Angeles, 90035.

GOVERNMENT HOMES FROM \$1 (U REPAIR). DELINQUENT TAX PROPERTY. REPOSSESSIONS. CALL 805-687-6000 EXT. GH-20024 FOR CURRENT REPO LIST.

FREE CATALOGS - FLORIDA, GEORGIA. Homes, Land, Businesses. Please Specify State & Property Preferred. **COUNTRY NETWORK,** Box 368PM, Gainesville, MO 65655 (417) 679-4632

\$50,000.00 in 4 years! Be a Real Estate Investor. Buy a 2nd house with little cash & let inflation make you wealthy. Send \$1. for proof. Prosperity, Box 182K, Custer, Wa. 98240-0182

YOUR OWN FISH AND HUNT LAND LOW AS \$39/ACRE \$50 DOWN!

BEST areas for fish and game. Government report more fish and game per square mile. **TITLE GUARANTEE. BUY-BACK GUARANTEE.** Bought thru **ESTATE LIQUIDATIONS** across Canada. **EASY PAYMENTS.** Get your **FREE** catalog **NOW! CANADIAN ESTATE LAND,** Dept. PM6, 3089 Bathurst Street, Suite 303, Toronto, Ontario, M6A 2A4. Phone any time 1-416-488-0444.

STUDY AT HOME—REAL ESTATE—Secure Your Future in Brokerage or Investment. Professional Course. RGA Diploma. Full Details Write: R.G.A., Box 3132, Station B, Fredericton, N.B. E3A 5G9

AUSTRALIA (Sunny South) Land, Houses Etc. Current Catalogues Airmailed \$5.00. Western Press, Box 216, Henley Beach, Australia 5022

CANADIAN COUNTRY PROPERTIES. Acreages for recreation, development, farming, fishing, hunting, investment, minerals, etc. **OUR 72ND YEAR.** Terms available. Titles guaranteed. Catalog airmailed \$1.00. **DIGNAM CORPORATION,** Suite 496, 85 Bloor Street East, Toronto, Canada M4W 1B5

EXPORT-IMPORT

MAXON RADAR DETECTOR. Model RD-2. Latest in technology at an affordable price. Money back guarantee. Only \$69.95 plus \$2.00 shipping. The Chandler Company, 1135 Winnrose Street, Jackson, MS 39211.

IMPORT Hong Kong, Taiwan, Worldwide. Dirt Cheap. Free Details. Gary Enterprises. 88-1 PM6 Quigley Drive, Scottsville, N.Y. 14546

BUY IT WHOLESALE

FREE 16 page PRINTING PRICE LIST, 1 to 5 colors, sheets to catalogs. Copen Press, 100 (PM) Berriman St., Brooklyn, N.Y. 11208.

BELTS, Buckles, Key Tags, Hat Tacs, Jewelry, More. Complete line fast sellers. Big Profits. Complete dealer set up. Color catalog \$1.00 (refundable). Anchor, Box 3958-PMR, North Providence, RI 02911

CLOSEOUT Jewelry 55¢ dozen. (Catalog 25¢). Roussels, 107-1631 Dow, Arlington, MA 02174

WORLDWIDE BARGAINS . . . Imports - Dropship - Closeout - Surplus - Freebies - (Stamped Envelope). Marnees, Box 1717PM, Highland, Ind. 46322

EARN MONEY selling rings, jewelry, buckles, watches—buy direct. 130% below retail. Catalog \$1.00 (refundable). Anka-PM, 90 Greenwich Ave., Warwick, RI 02886

400,000 BARGAINS Below Wholesale: Many Free! Liquidations . . . Closeouts . . . Job Lots . . . Single Samples. Free Details. Bargainhunters Opportunities, Box 1409-A, Holland, Michigan 49422.

SINGAPORE, HONG KONG, TAIWAN DIRECTORIES. Listing 11,000 suppliers, 20,000 products. Buy direct. Information \$1.00. Merrick Distributing, Box 274M, Merrick, NY 11566

VACUUM CLEANERS "Discount Prices" New Rainbow \$499.95, Kirby, Filter Queen, Panasonic, Royal, Oreck. Details: ABC Vacuum Warehouse, 6720 Burnet-PM, Austin, TX 78757

CLOSEOUTS! Discounts! Below Wholesale! Freebies! Information/stamp: DDN, Box 20152K, Ferndale, Michigan 48220

REPLICA WATCHES!! Send \$1.00 for color brochure, prices. High Quality, Low prices! Dealers needed. JJ's, Box 73027, Houston, TX 77273

217 WHOLESALE JEWELRY SOURCES, Listed and described, order now, \$1.00. **SATISFACTION GUARANTEED.** Hilltop Publications, 310 Nocturne Court, Chula Vista, CA 92011-3633.

TELEPHONE systems & supplies— Wholesale! Price list \$2.00; installation manual \$10.00. Telephones To Go, Box 880694, San Diego, CA 92108

ADVERTISING AGENCIES, ADV. SER. MAILING LISTS

NEW NAMES MONTHLY! MIXED STATES AVAILABLE! IMMEDIATE SHIPMENT! Adhesive Labels; Computerized - Guaranteed Opportunity Seekers 200/\$15, 500/\$25; 1000/\$40. Others. **ADVON,** Drawer B2, Shelley, ID 83274. Visa/MC/AmEx 1-800-992-3866.

FREE Mailing List Consultation. Details. GOC-40P, Box 1107, Stuart, FL 33494. (305) 334-5205. 1-800-554-5478

OPPORTUNITY SEEKERS/MLM NAMES. FREE SAMPLE. Venture-LP, Box 336, Riviera, AZ 86442

HOT list - many categories. Credit card orders 1-800-843-0755/1-515-232-6789. List, Box 1033, Ames, IA 50010

NAMES! FRESH, HOTLINE, DELIVERABLE LABELS! GUARANTEED! QUALITY PRICES! 1-(800)-992-9405.

FRESH HOT NAMES!! OPPORTUNITY SEEKERS. Peel/ Stick Labels. Zip Coded. **GUARANTEED DELIVERABLE!** 500/\$20; 1000/\$35; 2000/\$60. JFR Enterprises, 809 Briarwood-PM6, Victoria, Texas 77904

FREE sample of mailing lists that get results! McCann, 32 Maine, Carteret, NJ 07008

COMPUTERIZED LISTS. BUYERS MANY CATEGORIES. Peel/Stick, Guaranteed Deliveries. Low Prices. 200,000 Names Monthly. Fast 1st Class Mail Return. Free Price And Ordering Brochure. Eva Lists, Dept. 203, Box 6061, Torrance, CA 90504

RESPONSIVE Opportunity Seekers Names! Free Sample! SASE: The Mail Lists Factory, Dept. O, 320 N. Plymouth Blvd., Los Angeles, CA 90004

HIGH QUALITY Mailing Lists, guaranteed deliverable, send for **FREE** details. Marshall Gilbert Co., P.O. Box 12925, Seattle, WA 98111

BUSINESS SERVICES

INCORPORATE without legal fees! Free booklet tells how, includes forms. Call Harvard Business Services, now 800-345-CORP.

PRINTING PRESSES, RUBBER STAMP OUTFITS

TYPE Fonts, Hand Printing Presses, Hot Stampers, Supplies. 120 Pages. \$2.00 Deductible first order. Acme Type, 1720 N. Marshfield, Chicago, 60622

MAKE rubber stamps—big profits. Complete supply and equipment catalog with instructions. \$1 deductible with order. Star Stamp Supply, 1720 N. Marshfield, Chicago 60622

TYPE for printing. Catalog \$1.00/deductible 1st order. Quaker City Type, R.D. 3, Box 134, Honeybrook, PA 19344

BIG Profits Making Rubber Stamps. \$1.00. Martin, 1432 Major, Jefferson City, MO 65101-3664.

PRINTING Presses, new and used supplies. List 50¢. Turnbaugh Printers Supply, Mechanicsburg, Penna. 17055

PRINTING SUPPLIES

QUICK Copy Printing. Low Prices. Write: Nationwide, 614 North Main, Bloomington, Illinois 61701

GIFT SHOPPING

AFRICAN WILDLIFE Color Posters, 13.5x15.5, Perfect Gift. Six Posters \$11.95. Deltatron, Box 72, Windsor, Vermont 05089

CLOCKS, WATCHES, OLD GOLD, JEWELRY

HIGHEST CASH for Gold, Jewelry, Gold Teeth, Rings, Diamonds, Watches, Silver, Platinum. Mail Articles Today. Free gift with information. Chicago Gold & Precious Metals, 10 South Wabash, Dept. 1058, Chicago, 60603

TAKE NO CHANCES. Deal with oldest, most reliable firm in old gold business. Established in 1934. We buy Gold, Silver, Platinum, Diamonds, Highest Cash. Free Information: Rose Industries, 29-A East Madison, Chicago 60602

CLOCKWORKS, wood clock blanks, rockhound supplies, belt buckles, cut stones, etc. Wholesale catalog 25¢. Eloxite Corp., 806 1/2 10th Street, Wheatland, Wyoming 82201

DUTCH CLOCK KITS. Build Your Own Zaanse Weight Driven Wall Clock or Mantle Clock With Beautiful Delft Blue Tiles. Van Dommelen Clocks, 254 Rt. 206, Summerville, NJ 08876. (201) 359-4554

CLOCKS, MOVEMENTS, ACCESSORIES (German). Free catalog. 1-800-556-2674. Instruments Services, Dept. PM, 433 So. Arch, Janesville, WI 53545.

SWISS WATCH REPLICA. 100% Details! Satisfaction! #1 Wholesaler! **ORDER.** 213-305-8949.

LOWEST PRICES paid by you for first quality diamond jewelry. Guaranteed. **FREE** color catalog. Diamond Limited, Box 66, Dept. 12, Granger, IN 46530. (219) 277-9938.

TREASURE FINDERS

TREASURE—Locate quarter mile away with ultra sensitive locator—brochure free. Research Products, Box 270270-AMC, Tampa, Florida 33688

SAVE up to 40% on metal detectors. All major brands including White's and Garrett. **FREE** discount catalog. Northwoods General Store, Dept. DPM6, 1325 Greenway Cross, Madison, WI 53713, (608) 274-4680.

PROFITABLE OCCUPATIONS

FREE Information Starter & Alternator Rebuilding. Box 422, Seymour, TN 37865

PLASTERCRAFT . . . Profitable Home Business 3000 Molds Available. Details. Lynnette, 6251C Mentpark, Mentor, Ohio 44060.

FREE Brochures. Repair air conditioning, Refrigeration. Tools, Supplies, full instructions. Doolco, Inc., 11252 Goodnight, Dallas, TX 75229.

REPAIR lawnmowers thousands of parts and tools wholesale list 50¢. Ellwanger's, PM, P.O. Box V, Port Jervis, NY 12771

MAKE \$1000 WEEKLY DETAILING AUTOMOBILES! Legitimate—satisfaction guaranteed. Info: Gnopubco, Box 61291, Oklahoma City, OK 73146

FT. SMITH Auction School, Ft. Smith, Ark. 72903. Resident & Home study. Veteran Approved.

REPAIR lawnmowers thousands of parts and tools wholesale list 50¢. Ellwanger's, PM, P.O. Box V, Port Jervis, NY 12771

SALESMEN-DIST.

DEALERSHIPS Sell safety, security, and other unique products. Send \$2.00 for information package. Valley Forge Sentry, Inc., Box 205, King of Prussia, Pa. 19406.

AGENTS WANTED

YOUR OWN OFFICE SUPPLY CATALOG Write: Bemis, Box 51586, Knoxville, TN 37950-1586

POPULAR MECHANICS • JUNE 1987 165

BUSINESS OPPORTUNITIES

IMPORT-Export opportunity, profitable world-wide, mail order business from home, without capital. We ship plan for no risk examination. Experience unnecessary. Free Report. Mellinger, Dept. A2706, Woodland Hills, California 91367

GUARANTEED! \$1.00 Pound from "Junked" tires! (Send Stamp). LeValleys, Fountain, FL 32438.

EARN Thousands! Home Mailing Program. Goodworld, Box 26233-R, Tamarac, FL 33320

ARAB BUSINESSMEN have money to buy & invest. Top finders fees paid. IMEA, 187PM6, Box 3574, Newport Beach, CA 92663.

\$40,000 ON 1/3 ACRE! New Hydroponics - inexpensive, pleasant, practical! Free information. Robin's, Box 1214, Franklin, TN 37065-1214

MONEY MAKERS. Goldmine of Home Businesses that Produce. Details: Clifford's, 130 E. Main, Suite 285C, Medford, OR 97501

START MONEYMAKING WOODCRAFT BUSINESS making "Easy - Quick" toys, gifts, novelties. Free details. **WILLIAMS**, 3600L San Sebastian, Tucson, AZ 85715

START AN EASY BUSINESS Large income possible Write for free info. Kurtz, P.O. Box 58, Dept. C, Fredericksburg, PA 17026

BECOME IMPORT AGENT, BUY AT 70% BELOW WHOLESALE. Start Your Own Business-Newsletter-Write: T.S.I., 350 Fifth Ave(P), Suite 3308, New York, N.Y. 10118

HEALTHY BUSINESS OPPORTUNITY, TERRIFIC MARKETING PLAN. Free Complete Information. HBK, Box 3478, Peabody, MA 01961

MAILORDER OPPORTUNITY: Start profitable home business without experience or capital. Write for free book, plus details. No obligation. Mail Order Associates, Inc., Dept 756, Montvale, NJ 07645.

DEALER WANTED! Custom Embroidered Emblems, Pins. Free Catalog. Quotes. Rush Sketch. P.O. Box 515, Taipei, Taiwan.

CONSTRUCTION - Every trade from laborer to electrician \$19.01 - \$29.85 per hour. There are thousands of positions that are required to pay these rates. We supply the information that most workman are not aware of to locate these projects. Send \$11.00 to: Carefree Enterprises, P.O. Box 490, Ft. Ord, Ca. 93941

\$200 from gallon of \$8 paint. Easy, overlooked moneymaker. Details free. Paintman, Box 226523, Dallas, TX 75222.

EASY BUSINESS! Earn \$1,000's Weekly. Free Details. Write or send stamped addressed envelope. Toddco, Dept. PM, 4219 West Olive Ave., Burbank, CA 91505.

GET RICH NOW! Quick! Easy! Foolproof! Free Details! Moneyplan, 6520 Selma, #32P67, Los Angeles, CA 90028.

CLIP newspaper items--\$2 - \$25 EACH!! FREE Report! Clippings/B, Box 6109, Pompano, FL 33063

GET RICH using OTHER PEOPLE'S MONEY!! Unique - amazing business!! Details FREE!! Finance/B, Box 4605, Margate, FL 33063

GET RICH!! Secret law smashes debts--brings Cash, Credit! FREE report!! WealthKit/B, Box 4036, Pompano, FL 33063

\$100,000 OPPORTUNITY That Most People Miss. Russell's, 308 McDonald, Baton Rouge, LA 70808.

\$25,000 LOANS INTEREST FREE!! Secret Federal law WIPES OUT DEBTS!! Details FREE!! Moneywise/B, Box 636679, Margate, FL 33063

VINYL'S Where the money is! Professionally repair, refinish, recolor furniture, car tops. Quick, easy. Two small \$20 jobs a day earn you \$1,000 a month. Homes, cars, offices, restaurants. unlimited customers. Start earning after a few days practice. Details free. VIP, 2007 Montrose, Chicago, 60618.

RECYCLE METALS. NO, NOT BEER CANS! Easy \$456 weekly! Free information. Recycler, Box 1214, Franklin, TN 37065-1214

TAKE Catalog Orders. We drop-ship 2955 best selling specialty products. Lowest below wholesale prices. Immediate delivery. Spectacular home business opportunity. Free Book. SMC, 9401 De Soto Avenue, Dept. 20-78, Chatsworth, CA 91311-4991.

MAILORDER Books, 1,000% Profit Report. Selective, Box 1140, Clearwater, FL 33517

MAKE BIG MONEY REPAIRING WINDSHIELDS & Plate Glass! Up to \$60,000 yearly! Call TOLL-FREE for Valuable FREE report. 1-800-321-2597. Glas-Weld Systems, Box 5755D6, Bend, OR 97708.

\$1,000 weekly mailorder. Immediate opportunity. No obligation. Enterprise, 210 Welch-PM, Ames, IA 50010

CONCRETE Block Machines: Catalog \$1.00. Route One, Box 3740, Rapid City, South Dakota 57702-3740

REPAIR HYDRAULIC JACKS--DETAILS FREE. WRITE: HYDRAULIC PARTS SUPPLY, BOX 4157, BROWNSVILLE, TEXAS 78520.

VENDING MACHINES. No selling. Routes earn amazing profits. "Big Catalogue FREE." Parkway Corporation, 1930 PMB Greenspring Drive, Timonium, Maryland 21093

LEARN Sewing Machine Repairing. Men, Women. Lucrative Profits. Gresslin Correspondence School, Box 5104, Spencer, Iowa 51301.

MAKE MILLIONS MANUFACTURING BATTERIES!! Supplies available. Everlast, Box 365, Bogota, NJ 07603

PREPARE Tax Returns. Earn high fees, dignified work. Train at home. Accredited Program. National Tax Training School, Monsey, 2FU, New York 10952.

EARNINGS unlimited! Mail our burglar alarm advertisements from home! RBM Merchandising, Box 59314, Chicago, IL 60659

\$1,000 Weekly. Home Business Directory. Box 2019-PM, New York, New York 10163.

\$192.00 From Square Foot Plywood. (Huge Demand) Revealing Proof 50¢. (Refundable). Woodwin, Bridgewater, Mass. 02324

MAKE HOMEMADE BOOKLETS. I've earned \$187,000 with mine. Free information. Falcon, P.O. Box 1039, Gallinburg, TN 37738

NEW discovery in battery reconditioning. Eighteen months guarantee means "Big Profits Fast"! Electone, 7415 Gable Dr., Little Rock, AR 72205

ASSEMBLE wooden novelties at home. We pay \$232.88 weekly. No experience. SASE. Walpine, Box 660M, Pinellas Park, FL 34290-0660

ALUMINUM SCRAP - Recycle Yourself - MAKE \$25.00/ POUND! Free Information: Industrial-PM76, Box 127, Alexandria Bay, New York 13607

EXTRA INCOME. Assemble products at home. No experience. Details. 1-813-545-8421. Ext. 698.

MULTI-Level Mailorder. Two Opportunities. O'Neil-M, 10 Oak Lane, Suisun, CA 94585

LEARN MIRROR RESILVERING free information. Silvercraft, Box 127, Lansdowne, PA 19050.

BATHTUB REGLAZING, product sales, service and training. Call Unique Coatings Corp. (313) 538-8600.

BUMPERSTICKER PRINTER. Cheap. Simple. Portable. Free Details. Bumper, POB 22791 (GC), Tampa, FL 33622

MAKE Rubber Stamps. Highly Profitable. Free Details. **STAMPER**, P.O. Box 22809 (GC), Tampa, FL 33622

SCREEN PRINT T-SHIRTS. Inexpensive kits. Free Details. T-Printer, P.O. Box 23991 (GC), Tampa, FL 33623

MAKE BALLOON ANIMALS. \$400 Weekends! FREE SAMPLES INSTRUCTIONS: Funnyman's - PM76, Box 250, Alexandria Bay, New York 13607

ASSEMBLE PRODUCTS AT HOME. Many opportunities paying High Weekly Profits presently available without investment. Write: Businesses, 92B Brighton 11th, Brooklyn, New York 11235

\$10,000 MONTHLY Taking Photographs at Home! Call recorded message: (303) 674-8155

ASSEMBLE Electronic parts. We supply components and instructions. No experience, no selling, guaranteed payment. Write: SouthTech Electronics, Box 28217P, Kenneth City, FL 33709

"MORTGAGE Brokerage." Lucrative! (Particulars \$2.00). Sources-P7, Box 291332, Davie, FL 33329

UNLIMITED INCOME GUARANTEED! Seven Most Profitable Home Businesses! Easy To Start, Low Investment! Free Information: Pollard Enterprises, 2581-PM3 Country Wood, Greenville, MS 38701.

NEW OPPORTUNITY! Learn Telephone Service And Repair At Home. AVERAGE \$35.00/HOUR. Free Brochure. Setcomm. 2186-J Collins Blvd., Gulfport, MS 39507

\$1000'S WEEKLY Mailing. Stamped Envelope: CENTER, Box 931747, Los Angeles, CA 90093

FREE!... TREASURE OF HOME BUSINESS OPPORTUNITIES ... MAILCO, BOX 34370, BARTLETT, TENNESSEE 38134-0370

MAKE PVC FURNITURE. Turn your spare hours into \$31,200 yearly! Easy home assembly business. Write: PVC, 771PM, Battle Ground, Washington 98604

MAKE YOUR DREAM COME TRUE. EARN \$60,000 YEARLY REPAIRING SMALL CRACKS IN WINDSHIELDS NOT REPLACING THEM. CALL TOLL FREE 1-800-626-8523 OR WRITE: THE GLASS MECHANIX INC., BOX 17693, PLANTATION, FLA 33318

HUGE PROFITS - Making Planters-Growing Herbs. Write: Planters, P.O. Box M421, Brush Prairie, WA 98606

FIRST USA OFFER. \$10 wood into \$480 quickly, easily. VERY LARGE MARKET - can be done IN THE HOME! Details \$3. A.G., Box 208, Belleville, Ontario, Canada, K8N-5A2.

SEIZED IN GOVERNMENT NARCOTICS RAID!! Automobiles ... Vans ... Boats ... Furniture ... Thousands other items. But Dirt Cheap--Resell for Big Profits! Free information: Marcel, Box 7557-M, Monroe, LA 71211

FABULOUS HOME BUSINESSES-Pick from several-Free bonuses, Free details- Wayne Publishing, Rt4 133 Fairway Rd., Morehead City, N.C. 28557

INDEPENDENCE! WEALTH! Proven Home Businesses, Free Details. MacKinnon Publishing, Dept. PM6, 219 N. Orange St., La Habra, CA 90631

RETIRE early--I did at 45. Learn safe, easy, profitable investment methods that work. \$4.00. Retire Early, Box 447, Cedar Knolls, NJ 07927

EXCITING New program. Work three years and retire. RWD, 7333 Grand, Indianapolis, IN 46250

INCREDIBLY EASY INCOME. Free information. Multi Services PM, 1731 Howe #236, Sacramento, CA 95825.

TIRED of Money-making Ideas That Don't Work? This One Does! Free Information Reveals All. Brant Consulting, Box 6027, Williamsport, PA 17701

OPPORTUNITY SEEKERS LIST \$1.00 ... List, 364 Indiana Street, Wabash, Indiana 46992

MAKE A FORTUNE in Your Driveway! NEW Released Manual!!! "Buy and Sell Used Cars For Profit and More." GOLD Mine Opportunity. EXCITING Details. Automoney, 1298 Somcenter, Cleveland, OH 44124.

FREE DEALERSHIP - SELL MAILING LISTS! Grab your share of the Big Profits in this Multi-Million dollar industry! Complete program free! PCW, Box 1302PM6, Valley Stream, NY 11582

MAKE \$1000 WEEKLY in mailorder. \$2 brings complete instructions. Horizons, Box 1043, Escanaba, MI 49829

MAKE \$50/HR assembling computer clones. Experience unnecessary. SASE: PCIFI, 14102 Woodlawn, Tustin, CA 92680.

NEW PRODUCTS-Dealerships-Franchises-Free Details-Davart, P.O. Box 103, Ashland, Ky, 41105

14,947 HONG KONG-TAIWAN Products Cheap. Small lots. Some samples free. Harbor, Box 1719PM6, Yuba City, CA 95992

MILLIONS Need Loans/Credit! Cash in with your own prestigious money consulting business. No educational requirements. Start part-time. 10-year old national firm provides training, support. Free valuable report. PFA, Box 697-PN, Dana Point, CA 92629. (714) 240-0405 X104-PN

\$15,000 MONTHLY Income! Easy Moneymaking Plan. No investment! McDowell #M-6, 3680 Wilshire, Los Angeles, CA 90010.

MAKE-SELL ACRYLIC KEYTAGS With Colorful Designs. Professional. Highly Profitable Business. Free Brochure. Peacock Designs®, Inc. (PM687), P.O. Box 597814, Chicago, IL 60659-7814

COLOMBIAN EMERALDS Unique Jewels, Marvelous Personalized Gift. Fabulous Investment. Free Information: GREENSTAR, A. A. 85394, Bogotá-Colombia.

SHORT CUT TO EASY STREET. Ideal home business. Free brochure. Dickinson-PM687, Box 37775, Milwaukee, WI 53237-0775

FREE Details For Ten Profitable Home Businesses. Results GUARANTEED! SASE. Motivations, RR, Arthur, IA 54313

HOW TO Start And Operate Your Own PROFITABLE Home Business. Free Information. Creative Concepts, JW1-1, 530 Stevens, Suite #4, Addison, IL 60101

(Continued on next page)

BUSINESS OPPORTUNITIES

(Continued from preceding page)

\$5000/Month-Free Information - No Obligation - Longs. Box 1465, Garden Grove, CA 92642 - 714/638-2167.

GET RICH! New Moneymaking Businesses. Free Report! G.J. Mailorder Co., Box 409232PM, Chicago, IL 60640

FREE LIST! U.S. And Foreign Suppliers. Belli, Box 1182, St. Albans, W.V. 25177

EXCEPTIONAL OPPORTUNITY. Serious. Independent, business oriented individualists only. Earn while learning. \$50-\$100,000 annually. American Fidelity, P.O. Box 9185, N. Charleston, SC 29418

FREE Details! How To Start Your Own Home Business! Home Businesses, 1484-P Iverson, Atlanta, GA 30307.

LOCATE HEIRS and make big money. Complete course: \$14.50 plus \$1.50 postage and handling: Haley, P.O. Box 1573, Gardnerville, Nevada 89410

SWIMMING POOL CONSTRUCTION Sell & Install Vinyl Liner In-Ground Pools Full Time Summer or Year Round 1-800-428-3254 For Free Information.

EARN \$75,000+ PER YEAR

REPAIRING damaged windshields, not replacing them! For **FREE** information package call **TOLL FREE 1-800-STAR5 44** or write: Orion, 3375 Park Avenue, 2000A, Wantagh, NY 11793.

SOFTWARE MARKETING. Distribute my financial software. Must have direct mail or marketing experience. Send for application. Advantage Software Inc., #43-A Salem Street, Woburn, Ma 01801.

HOW To Start And Operate Your Own Profitable Business. Rush Stamped Addressed Envelope For Your Free Details. Stela Publishing, P.O. Box 1592, El Cajon, CA 92022

CAMERA OWNERS! Earn Extra Money! Sarafian, Box 799K, Detroit, Michigan 48231.

410,000 Millionaires can't be wrong! Start your own business! Wealth Builder, Box 10286, Oakland, CA 94610

SHINGLE-GARD 'N' Cleaning 'R' US. Vehicle, Training, Advertising. Write: 658 Firestone St., Palm Bay, FL 32907

STARTING YOUR OWN BUSINESS. **FREE** Subscription to Opportunity Magazine tells how. Write Opportunity, Dept. J54, 6 N. Michigan Avenue, Chicago, IL 60602.

FREE REPORT. "The Easiest Most Profitable Mailorder Business of Them All." Write: Hilltop Publications, 310 Nocturne Court, Chula Vista, CA 92011-3633

FREE \$10.00 BOOK! "Make \$400 Daily Selling Books By Mail." Profit, 8361 Vickers, #304PM, San Diego, CA 92111

AUTO INTERIOR CUSTOMIZING AND UPHOLSTERY are today's high demand skills - yet easily learned at home! Fabulous profit potential. Send for **FREE** Opportunity Kit, details. Auto Upholstery Institute, 2118 S. Grand, Dept. SA722, Santa Ana, Ca. 92705.

HOW TO PUBLISH YOUR OWN NEWSLETTER. Booklet \$4.00. Larkin's Ltd., Dept. PM6, Foster Drive, RR3 Box 1782, Bennington, VT 05201

PIANO Tuning learned quickly at home. Free information. Empire School, Box 1014PM, Jupiter, FL 33468.

HIGH SCHOOL DIPLOMA AT HOME, NO CLASSES. Low cost. Information Free. Call toll free 1-800-228-5600 or write: American School, Dept. #345, 850 E. 58th St., Chicago, IL 60637

\$1,000 weekly. Repairing Air Tools. Instructions. Parts and Tools Wholesale. Free Details. Box 534, Wichita Falls, TX 76307.

FILL MAIL ORDERS AT HOME. Many High Earnings opportunities presently available. Begin immediately! Write: Communications, 996 (M6), New York, N.Y. 10268.

TURN YOUR HOBBY INTO YOUR FORTUNE. Free details. SNP, Suite 18-270F, 12416 North 26th Drive, Phoenix, Arizona 85029.

FLEA Market Profits, Free Report: O'Donnell's, 9PM Sewanois, Lincoln Park, New Jersey 07035

PROMOTE 500 everyday necessities. No overhead - selling optional. Established company. 2747 Del Medio, 209C, Mt. View, CA 94040.

EARNING MORE MONEY - Profitable home businesses and self-employment opportunities. Information free. Golden Publishers, Box 5629, Winston-Salem, N.C. 27113-5629

REFRIGERATION REPAIR, good earnings from your home, part or full time. Free brochure. CTS, P.O. Box 1729, Milwaukee, Wisconsin 53201.

\$200 Profit Daily With Your Own Professional Housecleaning Service. No investment. Details. Westfield, Box 83P, Middleton, Wisconsin 53562

\$1,000'S WEEKLY!! MAILING FROM HOME! Immediate opportunity! Century Publishing Company, Box 2659PM, Danbury, CT 06813

LOCKSMITHING. The perfect part-time or full-time money-maker. Quick, easy methods. Free information. Keyman, POB 226523, Dallas, TX 75222.

STAY HOME, MAKE MONEY. Hundreds of Plans. Free information. DPB Enterprises, Box 243PM, Station A, Mississauga, Ontario L5A 3A1

\$40 - \$108/HOUR. Amazing breakthrough process restores Burned/Cut/Damaged Countertops **WITHOUT REPLACEMENT.** 2 hours/day earn \$30,000/year. Millions of apartments, homes pay profits immediately! Free information. **RENEW,** Box 19636-PC, Portland, Oregon 97219.

RUB-R-SLATE, Hornite, Insulrock, Bestaco. Bays Laboratory, 2086-2075 Drive, Cedaredge, Colorado 81413-9628.

RECONDITION BATTERIES! Easily Earn Hundreds Weekly. Untold Secrets. Free Information. Battery Outlet, Box 3300M, Hickory, N.C. 28603.

EASIEST BUSINESS On Earth! Start Small - Expand Fast! Free Details. Amity Publications, 824 Oakdale, Anderson, IN 46011.

\$1,000 WEEKLY Possible Bronzing Baby Shoes **FREE BROCHURE SHOWS HOW.** NBPM, 398 Airport, Sebring, FL 33870

EARN \$400 TO \$1000 PER WEEK. INITIAL INVESTMENT \$100. YOU CAN LETTER TRUCKS & VANS WITH COMPUTERIZED CUSTOM VINYL LETTERS. SHIPPED TO YOU PRESPACED. EASILY APPLIED, PERMANENT, USED WORLDWIDE, BETTER THAN PAINT. MANY STYLES, MANY COLORS. OUR PROGRAM INSTRUCTS YOU COMPLETELY. 40 YEARS EXPERIENCE AIDS YOU WITH FLEETS, DEALERS, CORPS. & SMALL BUSINESS. INFO: \$5 TO: AMERICAN VINYL GRAPHICS, 703 JERICHO TPKE., ST. JAMES, NEW YORK 11780

VENDORS NEEDED! No experience or investment required. Begin immediately! Paid monthly. Write: Caligan, 3368 Governor, Suite F, San Diego, CA 92122

5,001 Moneymaking Opportunities! Free Catalog! Dynamics, Box 18039G, Stow, OH 44224.

MAILORDER! Smart opportunity for lucrative home business. No experience necessary, small investment. Free details: Sable Publishing, Box 15572, Denver, CO. 80215

PROFITABLE Home businesses. Choose from several. Free details. Positive Promotions, 244B Vaughn Rd., Canton, Ga. 30114

MANUFACTURE CYPRESS CLOCKS And Tables! Start your own business with 6 figure income potential for full or part time. We give manufacturing instructions, free advertising for mail orders, the opportunity of supplying sales crews, student employment. For color brochure write: I.C.M., Box 158, Intercession City, FL 33848.

WINDSHIELD REPAIR resin \$35 oz. U.V. cured. Finchers, 483 Timber Ridge Rd., K-ville, N.C. 27284

NEW PRODUCTS NEWSLETTER. Exclusive opportunities. Free information. International. Box 636PM, Newark, NJ 07101

FULL-Flash -Part-Time \$180 Per Roll Guaranteed Taking Photographs. Experience Unnecessary 35MM Camera and Film Supplied Free. 1-416-482-2100 X1907 Days/Evenings/Weekends.

BUILD And **SELL** Cedar Strip Canoes. Make \$900.00 Profit. Trent, 908 Niagara Falls Blvd., North Tonawanda, N.Y. 14120-2060

PERSONAL COMPUTER OWNERS CAN EARN \$1000 to \$5000 monthly selling simple services part time. Free list of 100 Services part time. Write: A.I.M.F.K., P.O. Box 60369, San Diego, CA 92106-8369

HOME IMPORT MAIL ORDER plus 6 other home businesses. Start any without capital. Free report. Globe, Dept. A017, Box 2512, Palm Coast, FL 32037

MONEYMAKING OPPORTUNITIES

PICK PROFITABLE HOME BUSINESS you prefer. Dozens described. Free report. Success-N, Box 622, Midway City, CA 92655.

FIND AND FIX OLD HOUSES. Excellent profits. Book gives details. Send \$7.95. Blair Resources, Box 418, Flourtown, PA 19031

NEED Money? Funds, Grants Available. Aid Society, 112 1/2 S. Brand-J, Glendale, CA 91204

GET RICH!! Zero Investment, No Borrowing. Free Details! Money, 6520 Selma, #32P67, Los Angeles, CA 90028.

AMAZING! MAKE \$1000.00 PROFIT SELL 70 MONEY MAKING REPORTS. FREE INFORMATION. BOX 1867, HIALEAH, FLA 33011

GET RICH!! Secret law smashes debts—brings Cash, Credit! **FREE** report!! WealthKitB, Box 4036, Pompano, FL 33063

FANTASTIC earnings mailing from home!! Offer: Rush Stamped Addressed Envelope. Imperial, P-8 X17410, Fort Lauderdale, FL 33318

MAKE Rubber Stamps. Highly Profitable. Free Details. **STAMPER,** P.O. Box 22809 (GG), Tampa, FL 33622

MONEY From discarded tires! Details. Brownie, Box 53, Fishers, Indiana 46038

HIGH Profits With Custom T-Shirts And Caps. Transfer machines, supplies. Press, P.O. Box 22809(GG), Tampa, FL 33623

FREE details-New wealth! Sweep Parking Lots: Scarbrough, 212 So. Chestnut, Copan, Okla. 74022

ADVERTISE Free in 507 Magazines. \$5.00. Directory, Box 11N, Atlanta, Georgia 30301

\$15,000 MONTHLY Income! Easy Moneymaking Plan. No Investment! McDowell #MQ-6, 3660 Wilshire, Los Angeles, CA 90010.

HIGHLY PROFITABLE Home-Based Business Requiring No Phone, Equipment, Experience, Inventory, or Major Investment. Full or Spare Time. Fun and Profitable. SASE to: J. Doussa, 1513 Fillmore Avenue, New Orleans, LA 70122

GET RICH AT HOME. Free Moneymaking Information. LTD's, Box 16437PM, Greensboro, N.C. 27416

HORSERACING FANS! WIN! WIN! WIN! Free How-to Catalogue. Jafco, Inc., 114-41 Queens Boulevard, Suite 198A, Forest Hills, New York 11375.

EARN 250,000 MLM, Four Reports \$6.00. J. Parrish, 214 Homewood Acres, Eastaboga, AL 36260

NEED EXTRA MONEY? 105 of the hottest moneymaking ideas around. \$2.00. Homemakers, 22 Glade, Jacksonville, AR 72076.

RELAXING \$20,000+ HOME DESK BUSINESS! APPROVED BY VISA, MASTERCARD, AMEX! Kit \$5.00. **GUARANTEED!** "Consumers", 5647 Yonge, #1209, Toronto Canada, M2M 4E9

NEW! 21 BUSINESSES. Start cheap, build fast, restore independence. Pierce, Box 1730A, Lewisville, TX 75067

INCREASE CD YIELDS 60%-100+%! Methodical system really works! Advantage Publications, 18861A Gregory, Huntington Beach, California 92646.

WANT TO GET RICH? Plan Revealed Secret Formula! Only \$5.00! (refundable) : Blessings J1, Box 580, Kissimmee, Florida 32741

\$100,000 part-time mailorder. Starter Packet \$1.00. SPM-6, Box 23134, Honolulu, HI 96822.

MAKING EXTRA MONEY MADE EASY. **FREE** Subscription to Opportunity Magazine offers hundreds of proven ways. Write: Opportunity, Dept. J59, 6 N. Michigan Avenue, Chicago, IL 60602.

PART Time, full time, your jewelry business with few dollars. Step by step plan. Send \$12.00. GT&E, Box 2923, Miami, FL 33116.

ATTENTION flea marketers -new paint and hardware sells instantly. Send \$2.50 for sample and information. Refundable. Halton's, Box 723, Osseo, MN 55369

99 MONEY Making Mail Order Ideas Very Profitable. Proven Methods! Detailed Manual. \$29.95 Postage Paid. Information Send SASE. Monex, Box 1507, Kearney, NE 68847

EVALUATE "Moneymaking" Opportunities! Avoid Scams, Ripoffs And Losers! Complete Report \$9.95! Details Free! SeaBert Associates, 1205-A Prospect Dr., Stratford, CT 06497

\$1000'S Mailing From Home! Sunshine, Box 8528-PM, Deerfield Beach, FL. 33441

FIX DIRTY HOUSES. Earn \$100,000 Annually. Be Your Own Boss. Illustrated Brochure Tells How You Can Start. Send \$2.00 Postage Handling To: Fixer Jay, Dept. 3039, Redding, CA 96049

(Continued on next page)

MONEYMAKING OPPORTUNITIES

(Continued from preceding page)

MAKE MONEY IN SPARE TIME. Earn generous commissions as a subscription representative for leading magazines. For free details, send this ad with your name and address to: **POPULAR MECHANICS**, Dept. AB-S, 250 W. 55th St., New York, NY 10019

MAILORDER OPPORTUNITIES

MILLIONAIRE Mailorder Expert Reveals Money-Making Secrets. Free, Exciting, Hour Cassette: Mel Powers, No. Hollywood, California 91609.

FREE Details How To Start And Operate Your Own Profitable Business At Home. ACT Marketing, 5915 Fairway Dr., Hope Mills, NC 28348

HAVE you a great idea, a fantastic plan or a very interesting project? Why not put them to work for you! Classified Advertising can be of tremendous value in promoting all these things and more. Learn **HOW TO MAKE MONEY THROUGH CLASSIFIED ADVERTISING** by sending away for **POPULAR MECHANICS PROFIT BOOK**. Price \$1.00. Send to: PM Classified, 224 W. 57th St., New York, NY 10019

RABBITS-CHINCILLAS-FUR BEARING ANIMALS

GUARANTEED INCOME. Raise Chinchillas. Send \$10.00 (refundable) to: Chinchillas, Dept. B, P.O. Box 7463, Mesa, Arizona 85206.

OF INTEREST TO ALL

DEAD OR ALIVE. God will save ALL! Free. Write: Box 18292, Fort Worth, TX 76118

FREE PRIVACY CATALOG. Cash income opportunities. Hiding assets. Secret loans. New identity. Eden, Box 8410-PC, Fountain Valley, CA 92728.

FREE Promotional Albums, Concert Tickets, Stereos, etc. Information: Barry Publications, 477 82nd Street, Brooklyn, NY 11209

HUMEROUS Collectibles, Laughs, Smiles Guaranteed. Xeroxed Office Cartoons You Wished You Had Kept. \$1.00 For Sample - \$3.25 For 25. Box 664, Chippewa Falls, WI 54729

YOU'LL BE READY! Easy-to-use First Aid charts, magnetized plastic pocket. Send \$10.00. **GUARANTEED.** D.Milan, 6499 NE 7th Ave. 5P12, Boca Raton, FL 33431

WIN AT BLACKJACK! Anyone can. **EXPERT STRATEGY CHART.** Send \$2. Suburban, 430 South 21st East, Duluth, MN 55812

TREASURE? Black and white photo of loved one fading away? Outstanding artists create superb living likeness, flesh colors. Details \$1.00. Meno Studio, 110 Rathburn, Islington, Ontario, M9A-1R7, Canada

CREDIT PROBLEMS? How to improve your credit rating legally, inexpensively! \$1.00. The Idea Company, Box 2978, Gallup, NM 87301

OVERCOME YOUR FEAR OF SNAKES - Enjoy the outdoors more! Florida expert's proven method. Send \$6.00 for 24 page booklet to: Mark Smith, Box 1424, Gainesville, FL 32602-1424

WOMEN'S INTERESTS

CANNING Lids - Save! (Flats) case \$32, half-case \$17; 60 dozen regular (#70) or 36 dozen widemouth (#86). Small lids (#63) 10 dozen, \$8. Ring sets (#63) two dozen, \$5.25. Satisfaction guaranteed. Gardener's Kitchen, Box 412PM, Farmington, CT 06034.

GOVERNMENT SURPLUS

NARCOTICS RAID SEIZURES... Autos... Vans... Boats... Airplanes... Millions Surplus Bargains... many 1% original cost! "Nationwide Sales Directory"—\$3.00. Disposal, Box 19107-AS, Washington, DC 20036.

How to buy: Govt. Surplus, bankruptcy property, property seized in illegal drug traffic in your state \$3.00 ea. report. \$2.00 each additional state. SKS, 760 Coleman #318, Mt. Pleasant, S.C. 29464

DISCOUNT Catalog - Viet-nam Boots, Canteens, camouflage Fatigues, Helmets, Field Jackets, Knives, Packs, Sleeping Bags, Tents, Etc. Send \$1.00 (Refundable With Order). Dixie Military Surplus, Box 4525PM, Fort Lauderdale, FL 33338

LOANS BY MAIL

LOANS by mail! Instant reply! Rush stamped addressed envelope: Marigold, Box 2030, Richardson, TX 75080.

VISA® Mastercard® Simple Effective Guaranteed Program. 1-800-626-8902 (California) 1-800-843-4046.

FREE MONEY! \$300,000,000 Giveaway. Grants. Never repay. Details \$1.00. Jakla, Box 3066-PM67, Seminole, FL 33542

BORROW \$40,000 "overnight." Any purpose. Keep indefinitely! Free Report! Success Research, Box 19739-AS, Indianapolis, IN 46219.

VISA/MASTERCARD! Quick Personal/Business Loans! Refused elsewhere? Write! National Finance, Box 35726FN, Richmond, VA 23235.

MONEY Problems? Free Book describes Loans, Cash, Government Grants, Other benefits, available to individuals. Write: Associates, Box 98-AX, Brooklyn, New York 11235

BORROW \$500 - \$40,000 on Signature! 97% Eligible! Any Purpose! Free Application: United, Box 3789M, Downey, CA 90242.

NEED MONEY? Cash, Loans, Government Grants, 99% eligible-no investigation. KPA, Box 400PNM, Jamesport, New York 11947

BORROW \$500-\$40,000! "Overnight" On signature. Keep indefinitely! Action #R-6, 3660 Wilshire, Los Angeles, CA 90010.

10.5% VISA/MASTERCARD... Major Banks list... Send \$9.96 to: Americard, Box 1858, San Pedro, CA 90731

NEED Money? When Banks Stop... We Start. No Collateral, Credit Check, Or Co-Signers. Free Details. J.C. Knott, 3323PM Knott Road, Owensboro, KY 42301

\$100,000 Line Credit Without Investigation! Private Swiss Bank Account! Other Financial Benefits! Free Valuable Report! NAAC-PM6, Box 5399, Torrance, CA 90503

LOAN Broker - Loans For Any Purpose. No Maximum (305) 735-5243.

INSTANT CREDIT! VCR's, TV's Etc. Stamp to: Sullen, Box 3058, Rochester, NY 14614

BORROW \$100,000, OVERNIGHT Action. Guaranteed. Rush SASE: Financing, Box 3923, Abilene, TX 79604-3923.

BORROW Cash Fast! 24-Hour Response! Write: NRCPA, Box 2440, Midland, MI 48641.

DIVORCE

WINNING Information \$2.00 **MEN'S RIGHTS ASSOCIATION**, 17854 (Lyons), Forest Lake, MN 55025

REMAILING SERVICE

TRUSTWORTHY forwarding. Stamped remails \$1.00. Diamond-H, Box 129A, Caddo, Texas 76029.

FREE Remailers List. Agents Needed. PS, Box 29656, San Antonio, Texas 78229

UNLISTED ADDRESS Discreet and confidential. Remail \$1.00 Single Mail Forwarding Service, 8050 S. Main, Houston, Texas 77025

CONFIDENTIAL Mail Receiving/Forwarding. Mail Drop, Box 608039PM, Orlando, FL 32860

CONFIDENTIAL, Unlisted Forwarding Address. Remails \$1.00. MS, Box 31511, Phoenix, AZ 85046

YOUR PERSONAL OVERSEAS ADDRESS, Manhattan, Suite 602, 36 Soi Langsuan, Bangkok 10500 Thailand

PROMPT Forwarding, Stamped Remails. \$1. Box 4055, Wilmington, Delaware 19807

FREE Information! Remailing/Forwarding-Mail Store, Box 2523, Santa Barbara, California 93120

SECURITY, Confidentially. Details: Consumer Warehouse, 6333 Pacific #508, Stockton, CA 95207

CONFIDENTIAL Receiving/Forwarding Sensitive Foreign Mail. Details \$2.00, International Marketing Services, Box 3553, Monrovia, Liberia, West Africa.

SECRET MAILBOX. Free details. Private Postman, Box 87210P, San Diego, CA 92138

REMAILS \$1.00 Monthly Service \$7.00. Frank, Box 45181, Little Rock, Ark. 72214

POSTAL AUCTIONS

POSTAL AUCTIONS are selling thousands of items of unclaimed merchandise from 39,270 post offices. Complete facts, information, tips, locations. \$15.00. Nationwide Research, P.O. Box 7307, Houston, TX 77248-7307. Allow 4-6 weeks for delivery.

MISCELLANEOUS

CASSETTE Holder, clips to car's visor. Holds four cassettes. \$3.00 postpaid. Ashley's, 319 Crestview, Parsons, Kansas 67357

HOW To Train Your Dog! Easy... Effective Method! Free Details! Graber Publications, P.O. Box 31068PM, Sarasota, FL 33582

"ATTENTION Poker Players" Newly developed Poker game with excitement and gambling fun. Get out of the "same old games rut". May become your favorite! For Copyrighted rules-instructions, Send \$1.00. LEA Creations, 513 Bernard St., Johnstown, PA 15904

WANTED MISCELLANEOUS

BUYING Tungsten Carbide, Tungsten, Molybdenum, Silver Solder, Silver Contacts, Gold, Platinum. 800-321-6914 Ohio 216-531-8333 collect.

GOLD, Silver, Platinum, Mercury, Tantalum. Samples Evaluated Free. Ore Assaying Service. Call Wholesale Terminal Toll Free: 1-800-932-1010.

SCRAP SILVER CONTACTS, FORKLIFT CONTACTS, Silver Solder, Sterling Gold Plated. Robert Leszczak, 652 Myrtle St., Elizabeth, NJ 07202

PERFECT KNOWLEDGE

SURVIVE under Universal Law into Millennium as Godated by **CREATOR'S** original **MEASURES**, embracing **TOTAL** knowledge for unlimited free **ENERGY**; monadic gravity, friction-free, work/Travel **VEHICULES**; instant **MANNA**. Do not write. Must prove yourself. **ATA** Base, 1500 North Texas, Weslaco, Texas 78596

HEARING AIDS

HUGE SAVINGS Eliminate Dealer Markups. Free Trial. Batteries Wholesale. Terms Arranged. Call Toll Free 1-800-323-1212. Or Write: Lloyds-PMC, Rockford, IL 61110

FREE HEARING AID CATALOG- Save 1/2 by mail! Write: "MoneySavers", 9530PM-6 Langdon, Sepulveda, California 91343.

SAVINGS On All Brands Of Hearing Aids. National Hearing Aid, POB 30, Brooklyn, NY 11236. 718-531-7585

TOBACCO

CIGARS BY MAIL — **SINCE 1934** Domestic and Imported. Free brochures. The House of Delmage, Inc., P.O. Box 22706, Tampa, FL 33622-2706

SCIENCE & CHEMISTRY

FREE, SCIENTIFIC CATALOG. RJM Laboratories Inc. Presents its Latest Catalog Containing Scientific Laboratory Equipment And Supplies. Including A Complete Line of Specialty Laboratory Glassware. Write Today For Your **FREE** Catalog. RJM Laboratories Inc., P.O. Box 899, Santee, CA 92071

ANATOMICAL CHARTS, MODELS, SKELETONS, \$1.00 Catalog. **CHARTS**, 7124 North Clark, Chicago, IL 60626

LABORATORY CHEMICALS, GLASSWARE - APPARATUS, Established 1953 - Catalog \$1.00. **HAGENOW LABORATORIES**, 1302 Washington, MAINTOWOC, WISCONSIN 54220

FORMULAS, PLANS, ETC.

MONEYMAKING CHEMICAL PRODUCT FORMULAS! **SOLD SEPARATELY - BUY ANY AMOUNT! CATALOG LISTING THOUSANDS ONLY \$5.00 (REFUNDABLE) GWA3**, Box 193, Brookfield, Wis., 53008-0193.

ENGINEERING Conversion Factors \$6.00. Rocky Harris, 315 Spring, Haysville, Kansas 67060

FREE Lists! Moneymaking Formulas. Research P6, Box 291332, Davie, FL 33324

ANY Formula \$10.00. Catalog \$3.00. J. Belfort, Box 568, Chicago, 60690

DEADLINE FOR ADS: Copy and Payment must be in by the 5th day of the 2nd preceding month for the issue in which the ad is to appear. See Head of Classified Section.

HOW TO COUNT WORDS: Name and address must be included in counting the number of Words in your ad. Each initial or number used counts as 1 word: J.J. Smith, 224 West 57th Street, New York, New York 10019: 9 WORDS. Zip codes are not counted. Phone #: 2 Words. Symbols used as keys are charged for. City or State count as 1 word each: New Brunswick, New Jersey: 2 words. Abbreviations such as C.O.D., F.O.B., R.P.M., U.S.A., P.O., 5x7, 16mm are counted as 1 word. (P.O. Box 392 counted as 3 words) Webster's International Unabridged Dictionary will be used as our authority for spelling, compound words, Hyphenations, abbreviations, etc. Please make checks payable to **POPULAR MECHANICS**.

Only \$70.00 for 10 word minimum

\$7.00 each additional word

BOLD FACE CAPS add \$1 per word

(First Word: No Charge For Bold Face)

Remittance of \$ _____ is enclosed to cover _____ insertion(s) in the _____ issue(s). _____ Classification

No Charge for CAPS	2	3	4	5	6	7
8	9	10-\$70.00	11-\$77.00	12-\$84.00	13-\$91.00	14-\$98.00
15-\$105.00	16-\$112.00	17-\$119.00	18-\$126.00	19-\$133.00	20-\$140.00	21-\$147.00
22-\$154.00	23-\$161.00	24-\$168.00	25-\$175.00	26-\$182.00	27-\$189.00	28-\$196.00
29-\$203.00	30-\$210.00	31-\$217.00	32-\$224.00	33-\$231.00	34-\$238.00	35-\$245.00
36-\$252.00	37-\$259.00	38-\$266.00	39-\$273.00	40-\$280.00	41-\$287.00	42-\$294.00
43-\$301.00	44-\$308.00	45-\$315.00	46-\$322.00	47-\$329.00	48-\$336.00	49-\$343.00
50-\$350.00	51-\$357.00	52-\$364.00	53-\$371.00	54-\$378.00	55-\$385.00	56-\$392.00

YOUR NAME _____ PHONE: _____

FIRM (NAME IN AD) _____ (PLEASE PRINT)

YOUR ADDRESS _____

CITY _____ STATE _____ ZIP _____

DATE: _____ YOUR SIGNATURE _____

(PLEASE PRINT OR TYPE COPY • FOR ADDITIONAL WORDS ATTACH SEPARATE SHEET)

SPECIAL SERVICES

INFORMATION On anything. Ferguson Research Specialists, 60-15 Woodside, Woodside, New York 11377.

PERSONALIZED name and address stencil. 1/2" lettering. Professional, reusable. **GUARANTEED.** \$3.00 ppd. Stencilcraft, Box 104, Morris, Ill. 60450

MICRODOT Identification custom made for you. Protect anything. Almost invisible. Write for info. I-Dot, Inc., P.O. Box 6738, Lake Charles, LA 70606

GRANTS AND LOANS from the Federal Government. Unmatchable complete directory of how and where to get them for arts, science, veterans, students, housing, small business. No better publication available. Don't miss out. Send \$12.00. New Publications, 3240 Martha Custis Dr., Box 16911, Alexandria, VA 22302

HERBS

HERBS - Yohimbine, Pau D' Arco, and Others. Catalog \$1.00 (refundable). Jude Herbs, Box 563PM, Huntington Station, New York 11746

HEALTH, VITAMINS

PSORIASIS Sufferers: Discouraged? Write for Free Important Information that is helping thousands. Pixacol, P.O. Box 28117PM, Dallas, TX 75228

PSORIASIS Story - Cause And Relief. Postal Order #A50 To: Gee, Box 11, Palmwoods 4555, Australia. Be Free.

WORK CLOTHING

OSK B'Gosh work clothes (Railroadiana) Free Catalog. Depot, Dept. PC, Sullivan, Illinois 61951

FLOWERS, PLANTS & NURSERY SUPPLIES

FRESH AND SILK FLOWER arranging made easy! Send \$3.50 plus \$1.00 handling to: Karen Ross, 110PM Lurene, Fremont, CA 94539. Calif. residence add 6.5% tax.

RECIPES, COOKING, ETC.

TRY SOMETHING DIFFERENT! ... 20 original Byelorussian recipes. They'll be your favorite. Order now!! \$5.00. Koscielniak, Box 50226, Raleigh, NC 27650

CAJUN Carl's Cookbook. Over 30 Fantastic Recipes. \$4. C. Naquin, 116 Edgewood, Carriere, MS 39426.

FLAMBE, FLAMED 10 Exotic Recipes. \$5.00. WisCo, P.O. Box 13264, Akron, Ohio 44313

TRADITIONAL Maine Lobster Clam Bake. Detailed Recipe. \$4.00. P.O. Box 1124P6, York Harbor, ME 03911

EASY Hor D'Oeuvres. \$4.95. Texas Party Fixins, P.O. Box 430327, Houston, TX 77243.

"BUBBLY" Brew Pink Champagne In 17 Days. Complete Recipe — \$3.00. T&SD, 6120 Wendy, Flint, MI 48506.

MAKE VENISON taste as good as BEEF. Recipes - \$3.00. Lintelwood Press, P.O. Box 2565, Springfield, Virginia 22152

GRANDPA'S TRAIL DRIVE BEEF JERKY. \$1.00 SASE. Jerky, Box 1402, Columbus, NE 68601

OUTSTANDING DESSERT RECIPES \$4.00. Barbara Martin, Box 486PM, Fallston, Maryland, 21047

WHAT'S FOR DINNER? BRAND NEW RECIPES AND MORE! \$4.50. Arleen, 1358 Cutforth Court, San Jose, CA 95132.

RANDALL'S GOOD TIME SUMMERTIME BURGERS \$1.00 NOW with SASE to: W342N6990 Circle, Oconomowoc, WI 53066, to enjoy at your Independence Day cookout.

MOUTHWATERING recipes! One Jerky, three marinades, one bonus. \$2.50. SASE. GVM Company, Box 109PM, Oregon, WI. 53575

FREE BARBECUE SAUCE RECIPE. Original Authentic Southern Recipe. Send \$2.00 Handling To: West, P.O. Box 20174, Englewood, CO 80156

CHEF Owen's Cook Book With Friends \$6.95. \$1.00 P&H. Lawler, 76 Wesley Ave., Atlantic Highlands, N.J. 07716

SINGAPORE LADY will share favorite authentic Oriental recipes. \$3.00. LSASE, P.O. Box 4892, Culver City 90231

MUFFIN MANIA Unique Recipes. Send \$3.00. Box 72, Stringtown, OK 74569.

BREAD BOOKLET 75 RECIPES Plus Sourdough Starter \$5.00 Plus 90c Postage and Handling To: Burns, 309 S.E. 3rd, Hoxie, AR 72433

7 DELICIOUS VEGETARIAN ENTRÉES. Send \$2.00 SASE. P.O. Box 3388, Reston, VA 22090

125 DELICIOUS CASSEROLE RECIPES \$2.50. PRESSLAFF, 7435 Blvd. East, North Bergen, N.J. 07047

JUST FOR TWO, 20 recipes created for one or two people. Send \$3.00 to: Michael Bush, 4790 Irvine Blvd. Suite 105-214, Irvine, Calif. 92714

OMA'S ORIGINAL GERMAN SPECIALTIES. 25 Recipes. Send \$3.95 to: Reschreiter, P.O. Box 2878, Sedona, AZ 86336.

TOMATO DUMPLINGS. \$2.00 SASE. JIMCO Associates, 160 E. Central, La Follette, Tenn. 37766

WINEMAKING, BEERMaking, ETC.

WINEMAKING—BEERMaking—GASOHOL. Free Supply Catalog. Yeast Equipment. Continental, Box 188PM, Casselberry, FL 32707

WINEMAKERS—BEERMakers: FREE ILLUSTRATED CATALOG OF SUPPLIES, SEMPLIX, BOX 11476R, MINNEAPOLIS, MINNESOTA 55411

WINEMAKERS—BEERMakers - Free Catalog - Fast Service - Large Selection: Kraus, Box 7850-L, Independence, Missouri 64053

BEERMakers ONLY! FREE Catalog/Newsletter. William's, Box 2195-M7, San Leandro, CA 94577

WINEMAKERS BEERMakers SODAMakers Free Catalog. Joe and Sons, P.O. Box 11278, Cincinnati, Ohio 45211

BEERMaking - WINEMaking Catalog. Lowest Prices. BEERGEAR, Box 25093N, Lansing, Michigan 48909.

WINE/BEER MAKING Catalog: B&J Enterprises, 1845 South 19th, Springfield, Illinois 62703

BURGLAR ALARMS & HOME PROTECTION

"COMPLETE GUIDE To Home & Auto Burglar Alarms" 192 pages, \$13.95 postpaid, Guaranteed. **FREE** Brochure - Baker Publishing, Box 8322-PM, Van Nuys, CA 91409.

DO-IT-YOURSELF Home Security Guide. Use what you already have to protect family and home. \$2.95. Security, Box 205, Macungie, PA 18062.

TIME MACHINE

75 YEARS AGO: June 1912



Learning about elephants.

Elephant Handling

The study of the behavior of elephants was beginning to yield new thoughts in several branches of science in 1912. In Ceylon, elephant handlers were observed training the huge beasts. It appeared that elephants were able to understand human speech and gestures on a far more sophisticated level than previously thought. The elephant was seen as a remarkably social animal. In one instance, an elephant had to have a tooth extracted. It took 15 men to do it, but the elephant cooperated.



Titanic Lessons From Shipwreck

Naval engineer D.W. Taylor wrote a reprise on the sinking of the Titanic. He doubted that the Captain of the ill-fated ship was negligent. Taylor said if the captain had anticipated danger he would have stayed on the bridge,

which he didn't do. Taylor wrote: "Picked captains of Atlantic liners cling to the bridge to the point of exhaustion whenever they consider the circumstances to involve the least danger to the ship."

50 YEARS AGO: June 1937



A plane-like speed boat.

Speed Boat

Low center of gravity, "liberal" beam and light construction were the hallmarks of America's latest speed boat. It looked a lot like an airplane, with its two wings and sleek body. The wings were actually planes to give the speeding vessel balance and maneuverability. Its motor was forward of the cockpit, with a shaft running at a downward angle to the rear propeller screw. The driver sat in a padded seat. The 18-ft. boat was framed in cedar and clad in plywood. Top speed was 75 mph.



America's Newest Sub

Her armaments were secret, but at the launching of the U.S. submarine *Pompano* in 1937, we reported that she carried the "latest" weapons. These included short-range torpedos, and a close-combat cannon that could be mounted at the conning tower for ship-to-shore battery at night. Crew size was classified too, but the subs of the day were carrying more than 40-man crews and using diesel power. They saw action when America entered WW II and were the major weapon at the start of combat.

Old Clue

A body found in waters off Goteborg, Sweden, was estimated to be 600 years old. But its clothing was preserved in salt water. A tear and puncture in the back of the woolen poncho indicated the person had been stabbed to death. Identity, of course, could not be made.

25 YEARS AGO: June 1962

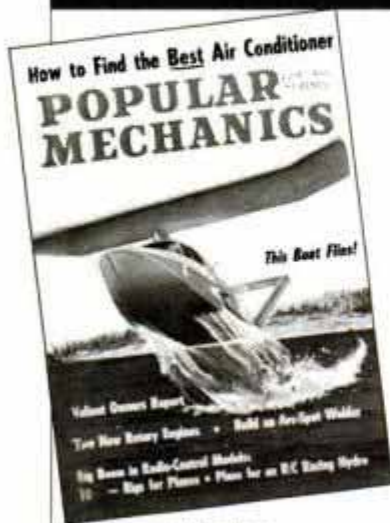

A dingy with wings.

Wing Dingy

The world's newest flying boat was a stepped-hull speedboat with wings. It had a water ski-like planing platform on either side. The 22-ft. wing was made of sturdy aluminum. The hull was steel framed and plywood clad. Gross weight was a little over 1200 pounds. A powerful little Continental engine took it to 129 mph at 15,000 ft. With a 25-gal. gas tank, it had a 400-mile range. The Wing Dingy, as its builders called it, used a pusher propeller, useful to sea planes and sport planes.

Seat Flying

Yes, the plane in the photo (right) is flying upside down. Yes, there is a man walking the wing. (Actually, his feet are strapped to the wing.) It's Duane Cole, one of the last great barnstormers. He and his family did aerobatic tricks in a Stearman biplane. At one air show, Duane climbed to altitude, switched off the engine, and went through some breathtaking aerobatics. Asked later why he did it with the engine off, he said, "I had a headache and couldn't stand the noise the damn thing made."

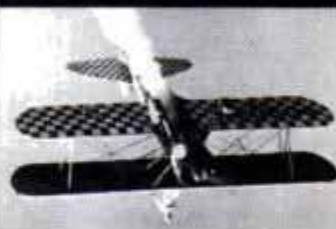

Radar Watch

We set up a series of tests in 1962 to find out how well highway radar worked. We concluded that it wasn't very accurate. The biggest problem was sorting out cars. The radar systems used by police could not accurately tell one from another. **PM**

POPULAR MECHANICS (ISSN 0032-4560) is published monthly by The Hearst Corporation, 224 West 57th Street, New York, NY 10019, U.S.A. Subscription prices: United States and possessions, \$13.97 for one year; \$25.97 for two years. Canada and all other countries, add \$16.00 for each year. Second-class postage paid at New York, NY, and additional mailing offices. Authorized second-class mailing-in-Canada privileges by Canada Post, Windsor, Ont. Registered as second-class matter at the Post Office at Mexico D.F., Mexico, June 29, 1960. © 1987 by The Hearst Corporation. All rights reserved. Printed in U.S.A. POSTMASTER: Please send address changes to Popular Mechanics, P.O. Box 10064, Des Moines, IA 50320.

If you're ever in this situation, remember...

It's your car. And it's your choice.

"Most people assume that GM cars automatically get fixed with genuine GM parts. Especially when it's a hood, fender, or door that needs replacing.

What they don't realize is that there are literally thousands of imitation GM parts out there. And some don't even come close to GM specifications. They don't have to meet rigid General Motors standards for fit, finish and corrosion protection the way genuine GM parts do.

How can you protect yourself against these imitations? Ask to see your repair order before the work begins. If it specifies non-genuine parts, call your insurance agent and insist on genuine GM parts.

You'll be happier with the results."

E. H. Marshall

Insist on genuine
General Motors Parts.





Real Partners

**Real people
want real taste.
Winston**

SURGEON GENERAL'S WARNING: Smoking By Pregnant Women May Result in Fetal Injury, Premature Birth, And Low Birth Weight.

