

AUGUST 1985 \$1.50

Popular Mechanics

EASY GLIDER
Make This
Summer Fun
Porch Swing



4-Wheel ATVs For Fun— And Work

**HEAD-TO-HEAD
TEST:** 6 Fastest Little
Cars You Can Buy

HOME VIDEO
New Camcorders
Go Underwater

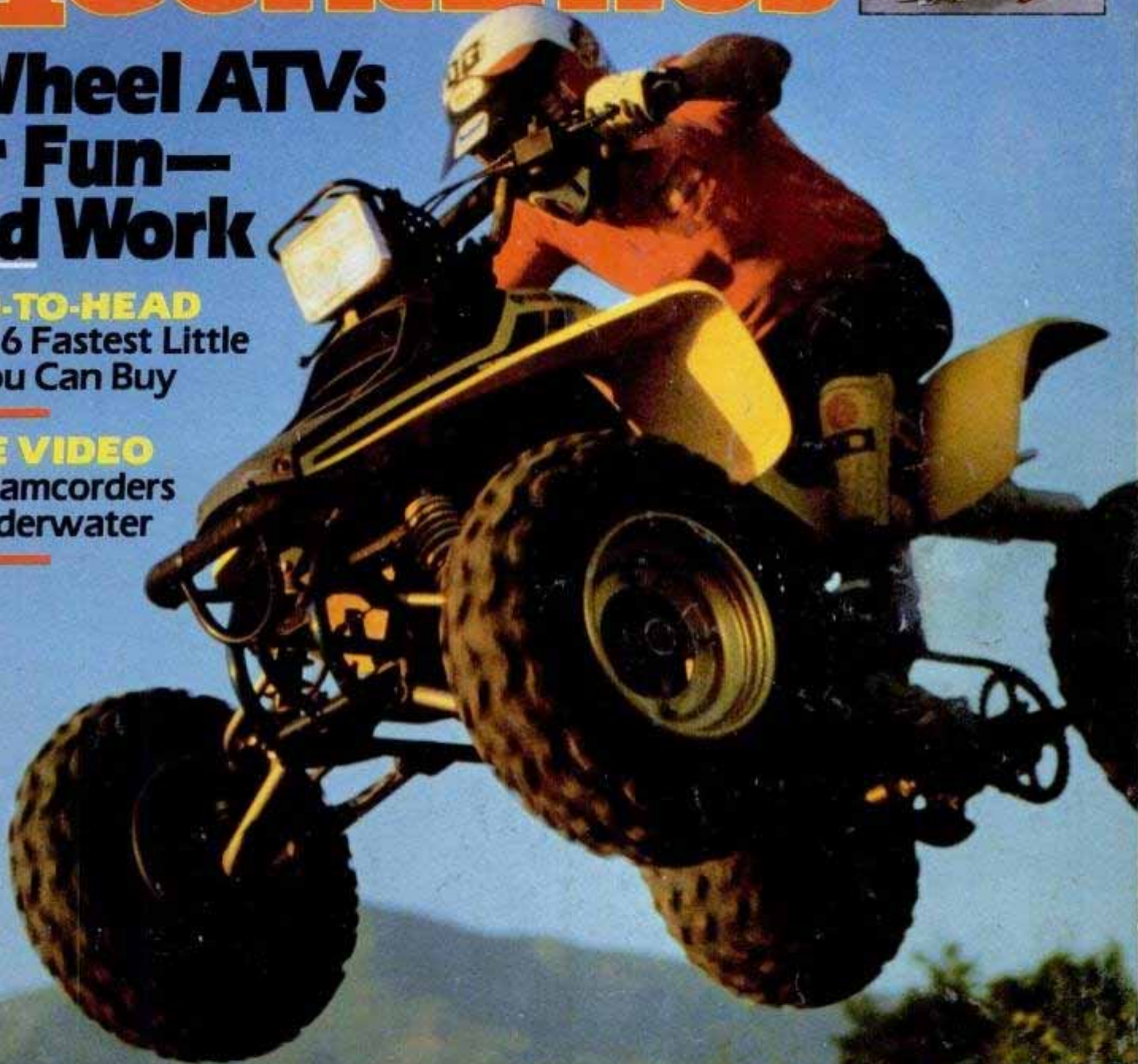

HOUSE BEAUTIFUL
5 All-American Fence
Designs You

A-BOMB SHOCKER!
Blowing The Lid Off
A 40-Year Coverup

SNEAK PREVIEW
Time Machine Movie Magic
From Steven Spielberg



9 mg. "tar", 0.7 mg. nicotine av. per cigarette, FTC Report FEB. '84.

Warning: The Surgeon General Has Determined That Cigarette Smoking Is Dangerous to Your Health.

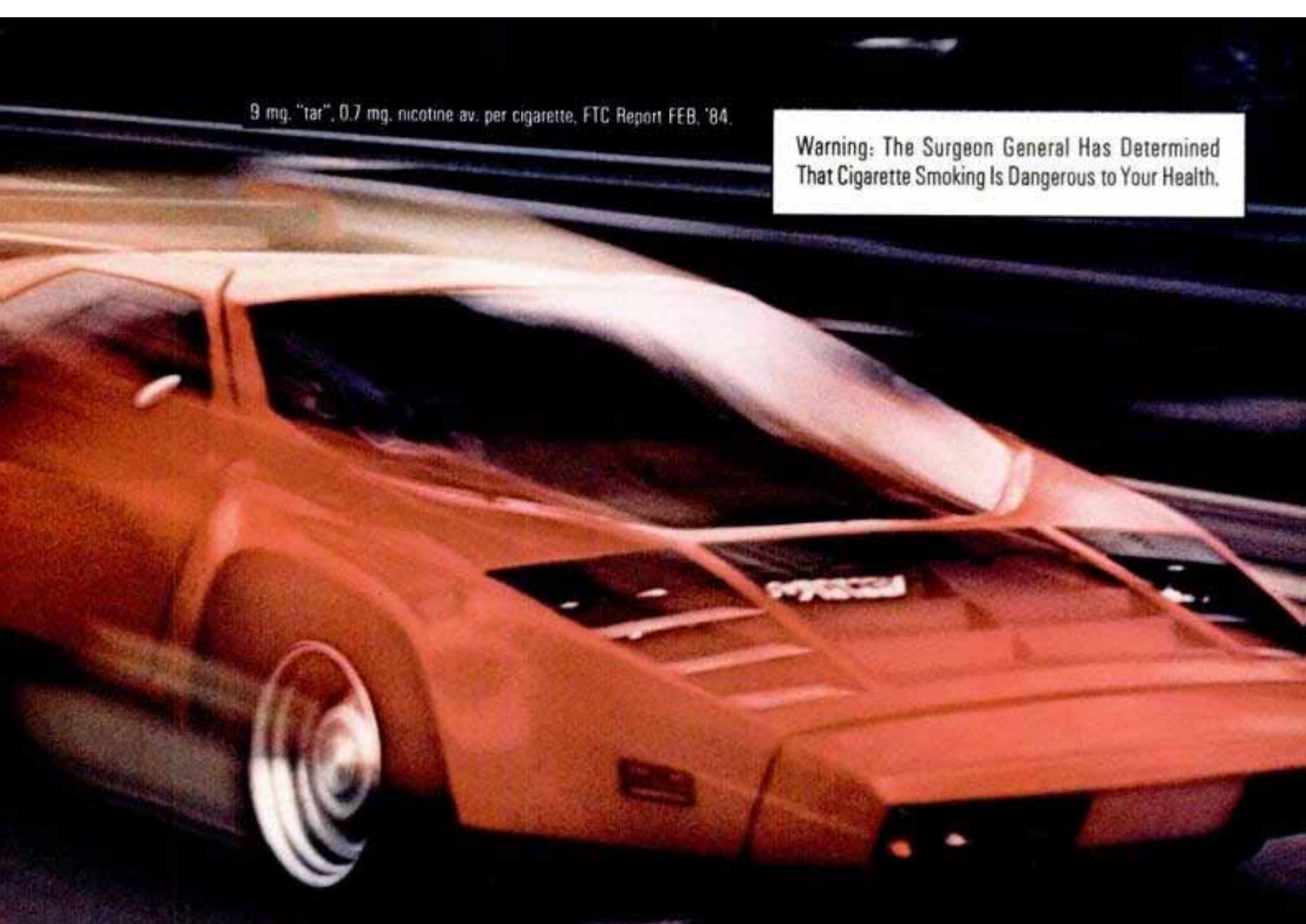

VANTAGE PERFORMANCE COUNTS.

*Performance so good
you can taste it in a low tar.*



© 1985 R. J. REYNOLDS TOBACCO CO.

DEAL DIRECT WITH WHOLESALE SATELLITE TV DISTRIBUTOR

INVENTORY STOCK REDUCTION

1/2 OFF

1/2
OFF

SALE

1/2
OFF

Wilson Wilson Wilson Wilson Wilson Wilson

by Richard Kruger

I just bought 10 truckloads of Wilson satellite tv systems at rock bottom prices, allowing me to pass on this savings to you.

THOUSANDS SOLD NATIONWIDE

Thousands of these Wilson systems have been sold nationwide at over \$2400 per system. Now because of my excellent buy you can have this same top quality system at only \$1199! That's exactly 1/2 off. At this price, stock will be depleted quickly, so order now.

\$1199

10' available for \$100 more

THAT'S 1/2 OFF

**SO HURRY
ORDER TODAY**

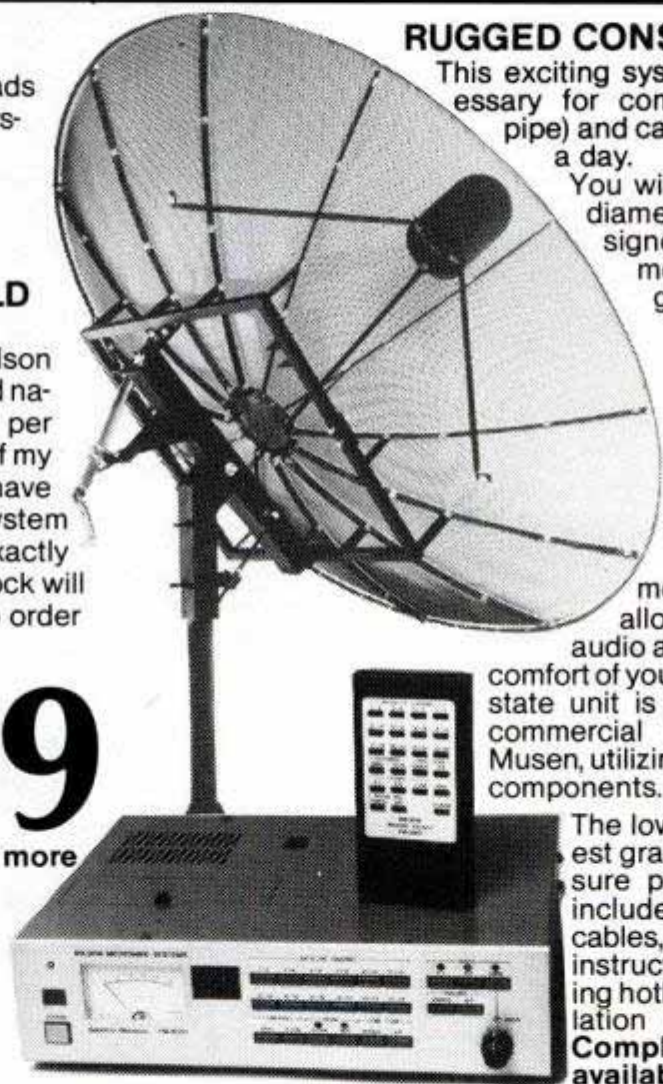

RUGGED CONSTRUCTION

This exciting system includes all parts necessary for completion (except mounting pipe) and can be assembled in less than a day.

You will receive a beautiful 9 foot diameter perforated antenna, designed to blend with any environment. This commercial grade, galvanized dish comes complete with a true polar mount for easy tracking of all 16 satellites.

REMOTE CONTROL CONVENIENCE

The Wilson YM 1000 satellite receiver is an infrared remote control unit designed to allow you access to all channels, audio and volume controls from the comfort of your easy chair. This totally solid state unit is manufactured in Japan by commercial radio manufacturer Yaesu Musen, utilizing only the finest in electronic components.

The low noise amplifier is the highest grade 85°K unit available to ensure premium quality video. Also included is 100 feet of matching cables, feed assembly and complete instructions. A toll free trouble shooting hotline is available for any installation questions you may have. Complete video installation tape available for Beta or VHS.

MONEY BACK GUARANTEE

If you are not 100% satisfied with your product, simply return the product in its original cartons within 30 days of purchase, for a courteous refund. Warranted by Wilson Microwave Systems, Inc.

TO ORDER CALL TOLL FREE

1-(800)-558-3474



By mail send to address below. Credit cards, money orders, bank check, certified wire transfers processed immediately. Personal or company checks require 18 days. All systems shipped by common carrier, COD freight.

R&K Distributors, 2200 Patrick Lane #27, Dept. 10, Las Vegas, NV 89015



“Work out.
Run.
Sweat.
Shower.
And Speed Stick® protection
to help keep me dry.

That's how I give
my career
an extra edge.”



**THE
WIDE
STICK™
GIVES
YOU THE
EDGE.
by MENNEN**



ON THE COVER

Taking to the air in a flying leap is just one of the many thrills you can expect from the tough new breed of four-wheeled ATVs. PM test-drives four of these go-anywhere, off-road machines in the exciting story starting on page 80.

—PM photo by Rich Cox



73 The Bomb



76 Testing pocket rockets



88 Underwater video



93 PM's porch glider



69 SST comeback

AUTOMOBILES AND BIKES

Imports And Motorsports	12
Detroit Listening Post	22
The PM Garage	30
Car Clinic	37
Saturday Mechanic	51
Solving five tough cooling system problems	
Suspension	58
A century of progress	
How To Install	
A Third Brake Light	61
'Commando' Fights Fires	66
Cooling Engine	
Combustion Chambers	68
Pocket Rockets	76
We test six pint-size cars with gallons of performance	
New Cycle, New Engine	90
The Gerace engine may be the next great breakthrough in piston engine technology	

SHOP AND CRAFTS

The PM Workbench	19
Workshop Minicourse	46
Joining edges without a jointer—part 2	
PM Looks At	
A Router Accessory	48
Hints	71, 144, 146
Build Our Porch Glider	93
PM's oak porch swing seats two comfortably and is built to stand up to the weather	
Using The Drill Press	100
Accurate hole boring is only one of its many functions	
Hot Seats	104
Each of our five oak and canvas folding chairs can be built in a weekend	

HOME AND YARD

New Now	
For Home And Shop	16
Homeowners' Clinic	28
Appliance Clinic	44
All-American Fences	96
Use our guide, with five attractive designs, to plan and install your fence	

BOATING AND OUTDOORS

All Outdoors	40
Four-Wheel ATVs	80
From super utility to race-ready, we write out these go-anywhere off-roaders in our tests	

SCIENCE AND ENGINEERING

Science Worldwide	20
New Hull Aids	
Gulf Exploration	65
Fish Farming For Profit	65
Halley's Comet Probe	
From Japan	66
Telescope Powerhouse	66
Durable Steel Alloy	66
Oil Rig Rescue	67
Mini Life Raft	67
New Era In	
Robotic Movement?	67
Tiny Tank	68
New Speedboat	
Takes On Smugglers	68
How They Hid The Bomb	73
The first atomic bomb exploded 40 years ago, but the story of how the bomb was hidden from the public is still unraveling	
Steven Spielberg Builds	
A Time Machine	84

In his latest hit, he transforms a De Lorean into a nuclear-powered time transporter

ELECTRONICS AND PHOTOGRAPHY

Photo Hints	27
PM Electronics Monitor	42
Cockpit Talks Back	67
Video Takes A Dive	88
Capture the undersea world with the new lightweight camcorders and watertight equipment	
Tune Up Your VCR	140

AVIATION

Runway Skid Tester	66
Crafty Combat Copter	68
SST Strikes Back	69

NASA is testing a supersonic transport that could lead the way to a 250-seat, Mach 2.7 jet

Hefty Lockheed C-5A	
Gets Heftier	69
Flying Sternwheeler	69

EVERY MONTH

Editor's Notes	5
Letters To The Editor	7
Technology Update	65
PM's Time Machine	160

WORTH WRITING FOR

Looking for more ideas?	145
--------------------------------	------------

INTERNATIONAL EDITIONS:
CARIBBEAN, MEXICO,
SOUTHERN HEMISPHERE

POPULAR MECHANICS (ISSN 0032-4558) is published monthly by The Hearst Corporation, 224 West 57th Street, New York, N.Y. 10019, U.S.A. Subscription prices: United States and possessions, \$11.97 for one year, \$21.97 for two years. Canada and all other countries, add \$16.00 for each year. Second-class postage paid at New York, N.Y., and additional mailing offices. Authorized second class mailing-in-Canada privileges by Canada Post, Windsor, Ont. Registered as second-class matter at the Post Office at Mexico D.F., Mexico, June 20, 1950. © 1985 by The Hearst Corporation. All rights reserved. Printed in U.S.A.

POSTMASTER: Please send address changes to Popular Mechanics, P.O. Box 10064, Des Moines, Iowa 50350.

SUBSCRIPTION SERVICE: Popular Mechanics Magazine will, upon receipt from its reader of a complete new or renewal subscription order, undertake fulfillment of that order so as to provide the first-copy delivery either to the Postal Service or alternate carriers within six to twelve weeks. If for some reason this cannot be done, you will be promptly notified of the issue date that will begin your subscription, with a request for any further instructions you may have concerning your order. Please address all such orders to us at Popular Mechanics, P.O. Box 10064, Des Moines, Iowa 50350. • Should you have any problem with your subscription, please write Joan Harn, Customer Service Department, Popular Mechanics, P.O. Box 10064, Des Moines, Iowa 50350 or call toll-free 1-800-247-5470; Iowa residents call 1-800-532-1272. Please enclose your mailing label when writing to us or renewing your subscription. • Renewal orders must be received at least eight weeks prior to expiration to assure continued service.

Use this address for subscription orders & inquiries: POPULAR MECHANICS, P.O. Box 10064, Des Moines, Iowa 50350. **POSTMASTER:** Please send address changes to this address.

IF YOU CAN DO THIS,



YOU CAN FIX A
ROUGH-
RUNNING ENGINE.

You don't have to be a do-it-yourselfer to take care of your engine with Gumout®.

It's easy. Just add Gumout to your gas tank, to clean away deposits that gum-up the fuel system. Gumout helps rough-running engines start easy, run smooth, even stop stalling.

With Gumout, you really can fix it yourself. And save money between tune-ups.



THE BETWEEN TUNE-UPS TUNE-UP.

A Quality Product of the Pennzoil Company.



Popular Mechanics

Editor-in-Chief: Joe Oldham
Managing Editor: Bill Hartford
Graphics Director: Bryan Canniff

Special Editorial Features: Sheldon M. Gallager, editor

Automotive: Wade A. Hoyt, SAE, editor; Norman S. Mayersohn, assistant; Michael Lamm (West Coast)

Home and Shop: Steven Willson, editor; Joseph Truini, Shop and Tools editor; Arthur Rooze, associate editor

Electronics: Stephen A. Booth, editor

Boating/Outdoors: Timothy H. Cole, editor

Science/Technology: Dennis Eskow, editor

Editorial Production: Peter Francesconi, chief; John Bostonian Jr., art; Rebecca Harth, David Meyer, assistants

Design Director: Ira Herrick

Art: John Johaneck, director; Alan Andresen, Ann Bennett, associate art directors

Editorial offices: 224 West 57th St., New York, N.Y. 10019. We cannot be responsible for loss of unsolicited queries, manuscripts, or photos. For return, they must be accompanied by adequate postage.

Reader Service Department: 224 West 57th St., New York, N.Y. 10019; (212) 262-4292

Advertising Director: Floyd Sembler

Advertising Offices:

New York: 224 West 57th St., New York, N.Y. 10019; (212) 262-8824

Chicago: 1 South Wacker Drive, Chicago, Ill. 60606; (312) 984-5190

Detroit: 377 Fisher Rd., Grosse Pointe, Mich. 48230; (313) 881-3520

Cleveland: PDC Building, 3659 Green Rd., Cleveland, Ohio 44122; (216) 292-7334

Los Angeles: 460 East Carson Plaza Dr., Carson, Calif. 90746; (213) 532-8101

Director of Marketing: Edward Vaquero

Production Manager: Lori Ellwood

Advertising Production: Patricia Woods; (212) 262-4800

Classified Sales Manager: Sophie Gronowicz; (212) 262-4825

Published by The Hearst Corporation

President: Frank A. Bennack Jr.

Chairman: Randolph A. Hearst

President, Magazines Division: Gilbert C. Maurer

Publisher, Popular Mechanics: Daniel J. Coleman

Publishing Consultant: Richard E. Deems

POPULAR MECHANICS IS PUBLISHED MONTHLY by the Hearst Corporation, 959 Eighth Avenue, New York, N.Y. 10019, U.S.A. Frank A. Bennack Jr., President; Randolph A. Hearst, Chairman; Harvey L. Lipton, Vice President and Secretary; Edwin A. Lewis, Vice President and Treasurer; Hearst Magazines Division: Gilbert C. Maurer, President; K. Robert Brink, Executive Vice President and General Manager; George J. Green, Executive Vice President; Raymond J. Petersen, Executive Vice President; Thomas J. Hughes, Vice President and Resident Controller; William S. Campbell, Vice President; Director of Circulation: Daniel J. Coleman, Vice President for Popular Mechanics.

AS A SERVICE TO READERS, Popular Mechanics publishes newsworthy products, techniques and scientific and technological developments. Due to possible variance in the quality and condition of materials and workmanship, Popular Mechanics cannot assume responsibility for proper application of techniques or proper and safe functioning of manufactured products or reader-built projects resulting from plans published in this magazine.

EDITOR'S NOTES

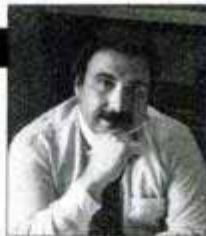

Science/Technology Editor Dennis Eskow was in the midst of researching security measures surrounding our first atomic bomb test when other business took him to Japan. While there, he decided to take the five-hour bullet train ride to Hiroshima. Eskow found Hiroshima to be a thriving city today, showing almost no evidence of the A-bomb blast that leveled the city and killed hundreds of thousands in August 1945. He had to travel across town to the city's Peace Memorial Park for the first glimpse of the bomb's destruction. There, monuments to the dead, a museum and a building that nearly vaporized at ground zero "flood the senses with commemoration of the bomb. It was all too much. Gloom overcame me," Eskow says. Once back in this country, Eskow visited White Sands, Alamogordo and other places that recall textbook accounts of how



Eskow at the Peace Park in Hiroshima.



Mayersohn, Sundahl, Nye talk ATVs.

more stable, and a lot more "automotive" in their handling and feel, the 4-wheelers are just the ticket for open-air, off-road fun. They've proven to be capable beasts of burden, too. As you can see from this month's cover, they also travel well through the air. Since no good pilot would leave the ground without proper instruction, Assistant Auto Editor Norman Mayersohn enlisted expert tutors Dean Sundahl, champion ATV racer, and dirt bike expert Derek Nye. In a couple of days of coaching, they had weaned Mayersohn into a semi-veteran. No small task. . . . **A new name** on the masthead: Timothy C. Cole joins our staff with this issue as Boating/Outdoors Editor. Cole spent six years at the helm on behalf of *Yachting* magazine and one year at the helm of an IBM personal computer in NBC's electronic publishing department. "Boats are better," Cole says. Welcome aboard, Tim.

The Bomb was developed. But he was after a different story—how the *secret* was kept. Eskow sorted through tons of documents obtained from Defense Department and other government agencies through the Freedom of Information Act. They contained much just-declassified information that led to several startling revelations (page 73). How we kept the bomb a secret, even from the residents who lived right next to the test site, is a chilling reminder that things aren't always what they seem. And that military secrets are unbelievably capable of being kept. . . . **With 3-wheel** all-terrain vehicles getting so much bad publicity due to their alleged unsafe operating record, it's no wonder the manufacturers—and we—have turned our attention to the newest of the breed: the 4-wheelers (page 80). Inherently



New staffer Cole at sea.



TOOL VALUE OF THE MONTH





3⁹⁹

FLANO[®] Tote-More

Rugged tote with 9-compartment drawer carries what you need for the job, whether you're in the garden or workshop! Offer good from July 10 only while supplies last, at participating True Value Hardware Stores. 311



HARDWARE VALUE OF THE MONTH

3⁹⁹

Woods Wire[®] Telephone Extension Cord Reel

Hi-impact case houses 50-ft. cord, 2 modular jacks. For indoor/outdoor use, pulse or tone systems. Rewinds easily! Offer good from July 20 only while supplies last, at participating True Value Hardware Stores. 955

CHARGE IT at participating True Value Hardware Stores. For store nearest you, see "Hardware" in the Yellow Pages.





**You may never need
an off-road tire
this good.
Unless you also drive
on the road.**

Uniroyal's Laredo S/R radial is one all-terrain tire that won't punish you on the toughest terrain of all: the street. It has been engineered for excellent all-weather traction and smooth, quiet operation both on and off the road.

Using advanced computer aided design systems, Uniroyal engineers achieved an optimum tread design. With the

computer they were able to project tread noise and traction capabilities before the

first test tires were even constructed. The result is a design that delivers low road noise and promotes long tread life.

Thanks to Uniroyal technology, Laredo S/R is much more than just another all-terrain light truck tire. In fact, most of the time you may never need a tire this good. The only problem is knowing when those times are.

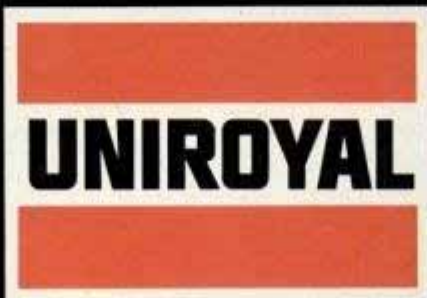

You may never need a tire this good. Laredo S/R.

LETTERS TO THE EDITOR



After 20 years, still full of fun

It certainly pays to save old issues of PM. Back in August '65 you had plans for building an outdoor railroad for youngsters (*Backyard & Birdbath R.R.*, page 118). I ran across the project recently and was so taken by its clever design that I decided to build it for our grandchildren.



It turned out beautifully, as you can see from the photo (below, left). I did make one change that might interest other readers. I substituted a 3-hp Briggs & Stratton lawnmower engine for the electric solenoid drive. This saves the time and work of building the drive and eliminates the need for a battery that would require frequent recharging.

RONALD ZIMMERLY
INDEPENDENCE, IOWA

You did a great job. Photocopies of the plans are available for \$6.50 from Popular Mechanics, Box 1014, Radio City Station, New York, N.Y. 10101.

PM's kid-size steam locomotive built by reader Zimmerly.

Fighter flak

Your article *I Flew The World's Hottest Fighter* (page 75, Apr. '85) was an insult to the intelligence of your readers. First, the X-29 is not a fighter, it is a research plane. Second, your statement that it is believed to be capable of flying faster than any other winged aircraft is ridiculous. Its top speed can't even begin to approach that of planes like the SR-71, X-15 or many current first-line fighters.

D.E. ROETMAN
BEAVERCREEK, OHIO

You're right that the X-29 is technically not a fighter, but it is a prototype for a future fighter—that's the whole purpose of its design. Actual top speeds are frequently many times greater than those made public. The X-15, for example, had a published top speed of Mach 2.1, but was later revealed to have reached Mach 6.5. No one is saying just how fast the X-29 is, but there's certainly good reason to believe that it may eventually outfly anything else currently in operation.

Monkey business

In your article *Hot New Gear For Firefighters* (page 87, Mar. '85), you

showed a tool described as a new Hurst Spreader. That's funny. We've been using a similar tool for many years—only we call it a monkey wrench.

LES SCHNARS
FALCONER, N.Y.

Yes, the tool that was shown was a wrench. The Hurst Spreader is primarily a tool that is used for prying open stuck doors.

Help save a ship

The only still-active World War II aircraft carrier, the U.S.S. *Lexington*, is in her 42nd year of service and her future is in doubt. We who served on her from Tarawa to Tokyo believe that, when retired, the "Blue Ghost" should be returned to Boston as a floating memorial and tourist attraction.

We are preparing a petition to this effect that will be presented to the U.S. Navy. If any of your readers are sympathetic to our cause, they can help. Just write "Save the Lex" on a postcard, include your name and address, and send it to me at the address below.

JOHN OPAROWSKI
2486 CORBIN AVE.
NEW BRITAIN, CONN. 06053

One-plane air raid

I was very interested in your report on Britain's plan to launch and retrieve Harrier fighter planes from submarines (*Technology Update*, page 68, Apr. '85). The article reminded me of a little-known incident that occurred during World War II.

The only time the U.S. mainland was bombed by an enemy aircraft was when a small, obsolete seaplane was launched by catapult from a Japanese submarine off the West Coast on Sept. 9, 1942. The plane managed to reach Cape Blanco, Ore., dropped its bombs in a forest, returned to the sub and was never seen again. The attack was said to have been made in retaliation for Doolittle's earlier raid on Tokyo.

JACK HAMMOND
SPICELAND, IND.

Insurance gap

In your article *Why PM Readers Need More Homeowners' Insurance* (page 125, Apr. '85), you suggested that people with basement workshops in flood-prone areas might want to invest in a federal flood insurance policy to cover the loss of shop equipment.

The federal flood insurance program has a couple of shortcomings your readers should be aware of. First, it carries a minimum deductible of \$500. Second, it covers only utilities like furnaces, food freezers, washers and dryers, not shop tools. Don't get me wrong. Flood insurance can be a good thing if you're susceptible to flood damage. I just wanted to point out what the program does and doesn't cover.

THOMAS O. BRADY
INDEPENDENT INSURANCE AGENT
CLARENCE CENTER, N.Y.

German, not Dutch

In your *Letters* column for March '85 (page 8), a reader argued that the Fokker Eindecker was not a German plane because it was "Dutch-built." This needs clarification. It's true that Tony Fokker was Dutch, but his aircraft factory was located in Johannesthal, Germany, during World War I.

All WWI Fokkers were made in Germany and nowhere else. It was only after Germany's defeat that Fokker returned to the Netherlands to found the aircraft company that still bears his name today.

PAUL WATSON
GALLATIN, MO.

Nobody 4x4's like Ford!

Tough Fords are America's best-selling 4x4's.* And for '85, high-output engines help make an even more powerful statement!

What makes Ford's best-selling 4x4's king of the off-road? Performance. Full-size or small-size, these tough 4-wheelers are built to handle rugged terrain... with power and toughness.

Power to spare.

Ford gives you the power to rule the off-road. With Ford's full-size F-Series pickup, the standard engine is a powerful 4.9L Six. Or you can

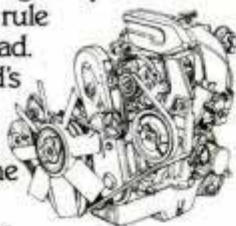

choose from several V-8's, each one the most powerful in its class.

Like the 5.8L V-8, a high output engine with 4-barrel carb.† And the small-size Ranger's husky 2.8L V-6 option has horsepower that no other small V-6 pickup beats!

But pure power is only part of the story. Ford puts technology on your side, too! Ford's big pickup gives you the option of 5.0L V-8 with new electronic fuel-injection. And Ranger comes with a 2.3L fuel-injected 4-cylinder engine,

plus 5-speed manual over-drive, standard!

Tough as they come.

Tough 4-wheeling calls for Ford's rugged Twin-Traction-Beam front suspension. The independent wheel action soaks up bumps and helps provide sure-footed traction. And now the Mono-Beam front suspension is available for those extra heavy duty jobs.

And no matter which tough Ford 4x4 you choose—the big F-Series or the small-size Ranger—you get Ford's proven 4-wheel drive system with manual or optional automatic lock-

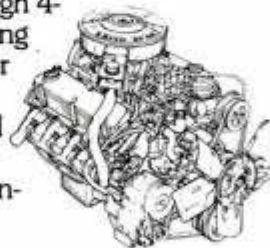

ing hubs. Add in big Ford payload capacity and the strength of double wall box construction and you'll know why nobody 4x4's like Ford!

Best-Built American Trucks.

At Ford, Quality is Job 1. A 1984 survey established that Ford makes the best-built American trucks. This is based on an average of problems reported by owners in the prior six months on 1981-1983 models designed and built in the U.S.

Lifetime Service Guarantee.

As part of Ford Motor Company's commitment to your total satisfaction, participating Ford Dealers stand behind their work, in writing, with a Lifetime Service Guarantee. No other car companies' dealers, foreign or domestic, offer this kind of security. Nobody. See your participating Ford Dealer for details.

Dealer-installed Ranger light bar not for occupant safety

* Based on new truck calendar year registrations thru October, 1984.

† Optional; not available in California or with manual transmission.



"My Ford Pickup & Me."

"My Ford Ranger & Me."

AMERICA'S
TRUCK **BUILT FORD TOUGH**



This One



EDXA-1ER-QZ3A

Get it together. Buckle up!

More Bauer to you!

Ford Bronco and Bronco II—not one but two tough 4-wheelers for '85—both with Eddie Bauer style. They're all dressed up with everywhere to go!

Now Ford offers you a choice of big Bronco (seats 5 or 6) or trim-size Bronco II (seats 4) in special Eddie Bauer editions. Both have a lot of good things in common—besides Ford toughness and Bauer class.

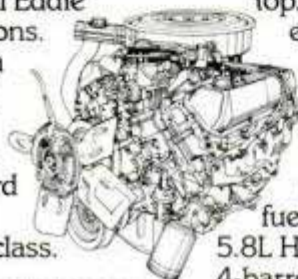

More power to you.

Both have plenty of power on tap. Power that eases you through hard off-road going and makes

all driving more fun.

Bronco II's 2.8L V-6 gives you power no other small V-6 4-wheeler can top. It's standard at no

extra cost. Bronco starts with a big high-torque 4.9L Six, standard. Adds a 5.0L V-8 with new electronic fuel injection. Plus a 5.8L High Output V-8 with 4-barrel carb—and 27% more horsepower than Blazer's biggest engine.*

Unique suspensions.

Both Broncos have

independent front suspension to absorb off-road jolts so you don't have to. And to help keep wheels glued to the ground for solid traction.

Both give you a proven 4-wheel-drive system with a choice of manual or optional automatic locking hubs.

And now both offer you the special looks and luxury of Eddie Bauer editions.

The Bauer Broncos.

These unique 4-wheelers have high-styled interior and exterior trim. They include dual Captain's Chairs, floor console and much more. Plus Eddie Bauer gear bag, travel blanket and visor organizer. And, to top it all, "Ford Care" extended maintenance

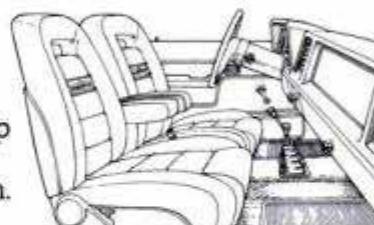

and limited warranty program. One beautiful package!

Best-Built American Trucks.

At Ford, Quality is Job 1. A 1984 survey established that Ford makes the best-built American trucks. This is based on an average of problems reported by owners in the prior six months on 1981-1983 models designed and built in the U.S.

Lifetime Service Guarantee.

As part of Ford Motor Company's commitment to your total satisfaction, participating Ford Dealers stand behind their work, in writing, with a Lifetime Service Guarantee. No other car companies' dealers, foreign or domestic, offer this kind of security. Nobody. See your participating Ford Dealer for details.

*Optional, not available in California or with manual transmission. Horsepower based on SAE Standard J1349.



"My Ford Bronco & Me."

"My Bronco II & Me."

AMERICA'S
TRUCK **BUILT FORD TOUGH**



Ford Bronco



Get it together—Buckle up!

Ford Bronco II

IMPORTS & MOTORSPORTS



New Renault Alpine



France's fiberglass sports car is coming here to compete with the likes of Corvette and Porsche 944.

It's one of the fastest—and friendliest—cars we've driven. A French supercar that civilized our high-speed *autoroute* cruising, and made even higher speed lapping at Le Mans easy. The Renault Alpine turned road and track into a blur during our streak from the Dieppe factory to Le Mans, and then as we

here. Well, it's not sold here yet, but it will be next year.

The fiberglass-bodied, 2+2 sport coupe is the latest Alpine in the series, replacing the A310 which has been France's Corvette since 1971. The new French 'Vette is already on sale there with either normally aspirated, 2.8-liter V6 or 2.5-liter turbo. We're slated to get the V6 Turbo model, which we drove in its U.S. prototype version.

With 40/60 front/rear weight ratio, the 150-mph Alpine is better balanced than the A310 (30/70) and is also better proportioned—though acceptance of its styling here will be an acquired taste. At the wheel, however, there's nothing quirky about the Alpine. Seats, instruments and controls are perfect and right where you want them. Jutting out from the center console is a short magic wand of a gear selector: The five-speed is smooth and quick—60 mph dials in just under 7 sec. Price is supposed to come in just under \$30,000, which, come to think of it, makes the Alpine much too fast for me.

1987 Chrysler-Maserati

Lee Iacocca, who, while at Ford in the '60s, sold Mustangs to the masses, has discovered where the action is. His "yupmarket" Maserati, a \$25,000 to \$30,000 sportster, will be introduced in the spring of 1987. Latest concept of the Q-Coupe, as it's called by insiders, shows it with top down. The fwd



C-M roadster will have a removable hardtop.

"Chrysler made by Maserati" will be assembled in the Milan, Italy, factory where Maserati Biturbos are built. Competition (other than Mercedes) will be from Cadillac's Pininfarina-styled Alante, also to be built in Italy.

Own your own GT40



Ford or Chevy V8 powers the GT40 replicar.

Those were heady days in '68 and '69 when Ford won Le Mans with its GT40 Mark 1. Now you can own one—not a \$200,000 original, but a knock-off from Era Replica Automobiles.

The \$18,500 GT40 joins the first replicar in Era's line—the Ford Cobra (see *Imports & Motorsports*, page 12, Jan. '81). All you have to do is provide a small-block V8 and about 100 hours of PM skill and you're on the road.



Rear-engine Alpine has its V6 longitudinally mounted under the hatch with enough room left for two small, rear bucket seats.

went round and round the Circuit Bugatti at the 24-hour course. But, you might not want to be teased about the rear-engine Alpine, figuring that it's just another exotic car that's not sold

Fast parts

In Japanese, *mugen* means "unlimited" and it's the name taken by the

company that specializes in competition parts. Mugen Co. Ltd. (pronounced Moo-gan) has prepared Formula 2 racing engines and motorcycles, and is Honda's choice to be its supplier of performance equipment. The factory-approved add-ons are at Honda dealers for the Civic CRX.

Fast tires are known by the letters they keep, with a V-
New Pirelli P700 ultra-low profile radial outperforms the P7 it replaces.



CRX performance parts range from valve and spring sets to wheels and body kits.



rating the tops and ULP the type. Ultra-low profile radial tires have become the standard for speed and Pirelli pioneered low-aspect-ratio designs with the P7 in '74 and the P6 in '77. Pirelli's second-generation ULPs are now hitting the road: The P700 is original equipment on Porsches starting this month and the P600 on Saab's 9000 Turbo. The new tires are available in 55, 50 and super-slim 45-percent aspect ratios. **PM**

Marlboro Country



Marlboro Red
or Longhorn 100's—
you get a lot to like.



© Philip Morris Inc. 1985

Warning: The Surgeon General Has Determined
That Cigarette Smoking Is Dangerous to Your Health.

16 mg "tar," 1.0 mg nicotine av. per cigarette, FTC Report Feb '85

© 1985 Philip Morris Inc. All rights reserved. Marlboro and Longhorn are registered trademarks of Philip Morris Inc.

ATX RADIAL

ATX



INTRODUCING THE FIRESTONE OUTDOORSMAN.

The ultimate outdoors machine rolls on
Firestone ATX 23[°]™ light truck radials.

Firestone has long had a reputation for tough, go-anywhere light truck tires. So we started with a set of our best, Firestone ATX Radial 23^o™ tires. Built for toughness with a strong steel belt and polyester cord body construction. Built for traction with a tread design based on the same one that's made Firestone farm tires traction leaders in the field.

Then we asked the experts to build a go-anywhere hunting, camping, and fishing truck just as special. And we asked the Hess & Eisenhardt Company, one of the world's most respected automotive coachbuilders, to help us put it all together.



Kelsey-Hayes cast aluminum Five Star E-T Mag wheels and Firestone ATX Radial 23^o tires provide an extra rugged wheel/tire combination.

The result, the Firestone Outdoorsman — as rugged, versatile, and affordable as the tires it rolls on.

It starts with a tough, go-anywhere Chevrolet S-10 4x4 Maxi-Cab with automatic transmission, a 2.8 liter V-6 engine, and shift-on-the-go two-wheel to four-wheel drive. A combination that's lean

on fuel, long on power, long on comfort, too.

Then we added everything else it takes to take to the great outdoors in style. From Kelsey-Hayes Five Star E-T Mag wheels specially designed for the S-10 to heavy duty Firestone shocks to a Warn winch, a Brahma Cab-Hi cap, Cibie and Marchal lights, Coleman camping gear, and more.

So if you're looking for a tough, go-anywhere light truck, write Firestone, P.O. Box 1474, Hudson, OH 44236 for more information. And if you're looking for tough, go-anywhere light truck tires, like our ATX Radial 23^o or our original Radial ATX,[®] just talk to your nearest Firestone retailer.



Two Firestone Supreme[®]HD batteries add extra power to handle the electrical load. Firestone Gas Charged PV4 Master[™] Shock Absorbers add superb ride and handling.

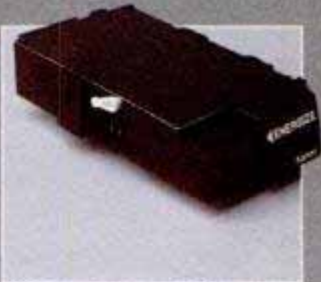

A Kelsey-Hayes 100% electronic brake controller #81741 offers state-of-the-art, maximum trailer braking reliability. A built-in load control lets you balance trailer brakes to the S-10 braking system for smooth stopping.

Firestone

LIGHT TRUCK TIRES

WE BUILD THEM TOUGH FOR YOU.

The Firestone Outdoorsman Supplier Roster

A&A Specialties ABS Sunvisor. **Bestop/Dualmatic** In-Bed Spare Tire Carrier. **Brahma[®] Inc.** Cab-Hi Bed Cap. **Chevrolet** S-10 Maxi-Cab Four Wheel Drive Pickup Truck. **Cibie** 275 Amber Foglights (2), 35 Clear Foglights (3), 190+ "Oscar" Driving Lights (2). **Coleman Company** Air Mattresses (2), Black Cat[™] Propane Catalytic Heater, Folding Camp Oven, Folding High Stands (2), Inflate-All 1^{1/2} 12-Volt Tire Pump, Poly-Lite[™] 48 Qt. Cooler, Propane Camp Lantern, Propane Camp Stove, Sleeping Bags (2) with Duffel Bags, Sundome V[™] 4-5 Person Dome Tent with Carrier. **Cotter & Company/True Value Hardware/Master Mechanic** Tools. **D.H. Buck Company** Urethane Fender Flares with Splash Guards. **Durakon[®] Industries** Duraliner[®] Bed Liner. **Firestone** ATX Radial 23^o™ Tires, PV4 Master[™] Shock Absorbers, Supreme[®] HD Batteries (2). **Gunslinger** Stowage Pocket. **Kelsey-Hayes** Electronic Trailer Brake Controller, Five-Star Cast Aluminum E-T Mag[™] Wheels. **Marchal** High Intensity Back-Up Light, High Intensity Tail Light, Quartz-Halogen Headlights. **Midland[®] International Corporation** Citizen Band Walkie-Talkies with Cases (2), Microphone Control C.B. Radio, Mirror Mount C.B. Antennas (2). **OSRAM Inc.** Copilot "L" Mounted Interior Light, Copilot "M" Plug-In Interior Light. **Reese Products** Frame Mount Trailer Hitch. **Reflexion Industries** Rear Step Bumper. **Warn Industries** Warn MX6085 Winch, Brush/Grille Guard and Accessories. **Walter Kilde Company** Fire Away 1A10BC[®] Dry Chemical Fire Extinguisher, Force 9[®] Halon Fire Extinguisher. **Whistler[®]/Controlonics Corporation** Spectrum[™] Super-heterodyne Radar Detector.



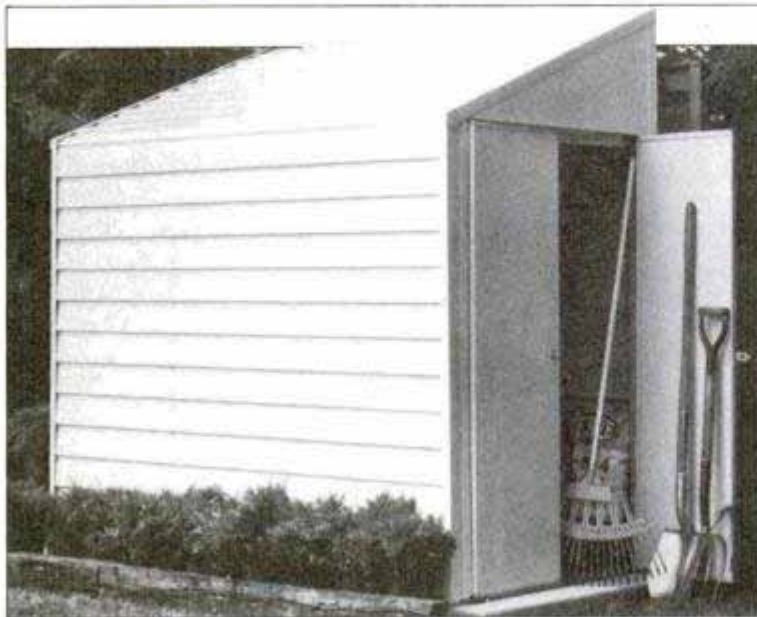

Space-saving shed

You can gain valuable storage space without sacrificing a large area of your lawn with the compact Yardsaver utility shed. The shed measures 4 ft. wide × 7 ft. long and comes in kit form for easy assembly. It measures 62½ in. high at the wall and 82½ in. at the peak. The angled roof prevents rain and snow accumulation.

The Yardsaver is designed to be installed against an existing structure such as a garage or house. It's made from 100-percent galvanized steel and features wood-grain embossed horizontal steel siding. The siding comes painted white, but can be painted to match your home. The shed's two doors can be mounted on either end of the unit. The Yardsaver (\$200) and the 7 × 7-ft. Yardsaver Plus (\$240) are available at home centers. For details, contact Arrow Industries, 100 Alexander Ave., Pompton Plains, N.J. 07444.

Kit-form yard shed is constructed of galvanized steel. All parts are precut, predrilled and numbered for easy assembly.

Tangled-cord tamer

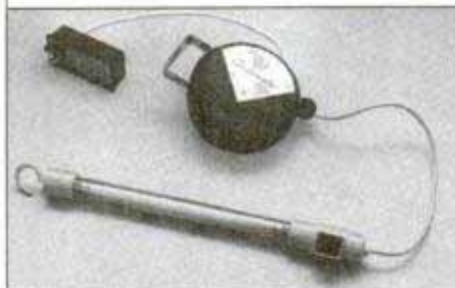

Bring sufficient light and electrical power right to the job with Cordomatic's fluorescent light reel (No. 600FL) and multiple-outlet cord reel (No. 500LA). Each unit features a spring-loaded reel that locks and retracts a 20-ft. cord automatically. Find the light reel (\$59.15) and cord reel (\$26.51) at hardware stores. Contact Cordomatic, 1510 Skokie Blvd., Northbrook, Ill. 60062.

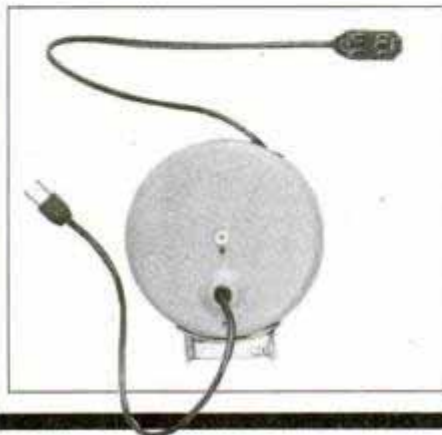

One-step wood finish

Polyshades from Minwax, 102 Chestnut Ridge Plaza, Montvale, N.J. 07645, combines stain and polyurethane varnish in one easy-to-use product. Polyshades can be applied to bare wood and to finished surfaces, usually without stripping the old finish, according to the maker. It comes in six shades at hardware stores in ½-pint (\$4.49), pint (\$5.79) and quart (\$9.99) cans.



Under-cabinet toaster

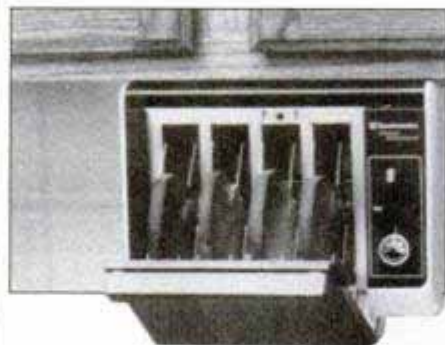

Toastmaster's Model 785 toaster mounts under the upper cabinets to free valuable counter space. The four-slice toaster has an adjustable mounting bracket to fit any cabinet. The dark brown/almond colored unit measures 7½ in. high × 8 in. deep × 10½ in. wide and costs about \$70. Contact Toastmaster, 1801 N. Stadium Blvd., Columbia, Mo. 65202.

Go-anywhere gas grill

New from Weber is a portable tabletop gas grill that's just the right size for balconies, picnics and tailgate parties. The porcelain-covered steel grill (No. 1530) uses disposable LP gas cylinders or can be adapted for use with refillable tanks. Its features include a pushbutton ignitor and 160 sq. in. of cooking surface. It's available at hardware stores for about \$40. For details, contact Weber-Stephen Co., 200 E. Daniels Rd., Palatine, Ill. 60067. **FM**

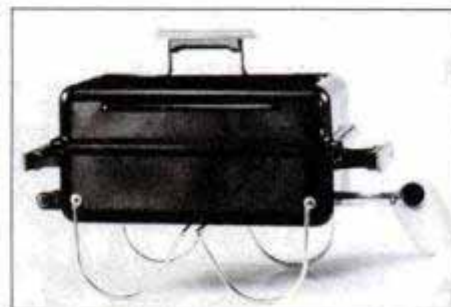

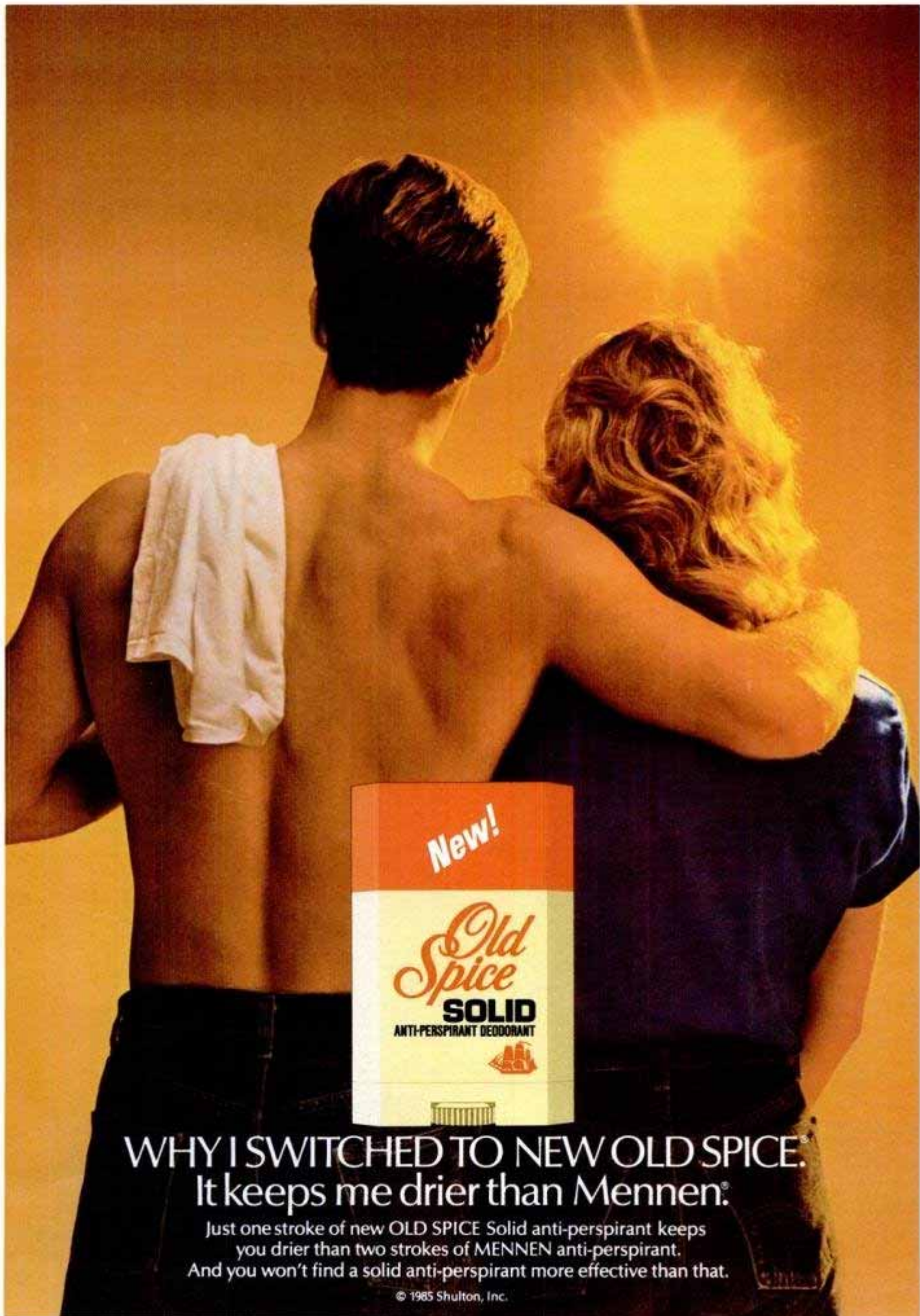

**WHY I SWITCHED TO NEW OLD SPICE.[®]
It keeps me drier than Mennen.[®]**

Just one stroke of new OLD SPICE Solid anti-perspirant keeps you drier than two strokes of MENNEN anti-perspirant. And you won't find a solid anti-perspirant more effective than that.

© 1985 Shulton, Inc.

"Vermont American power tool accessories make your power tools better tools."

Johnny Rutherford
Johnny Rutherford, 3-time Indy 500 winner and driver of the Vermont American Race Car.

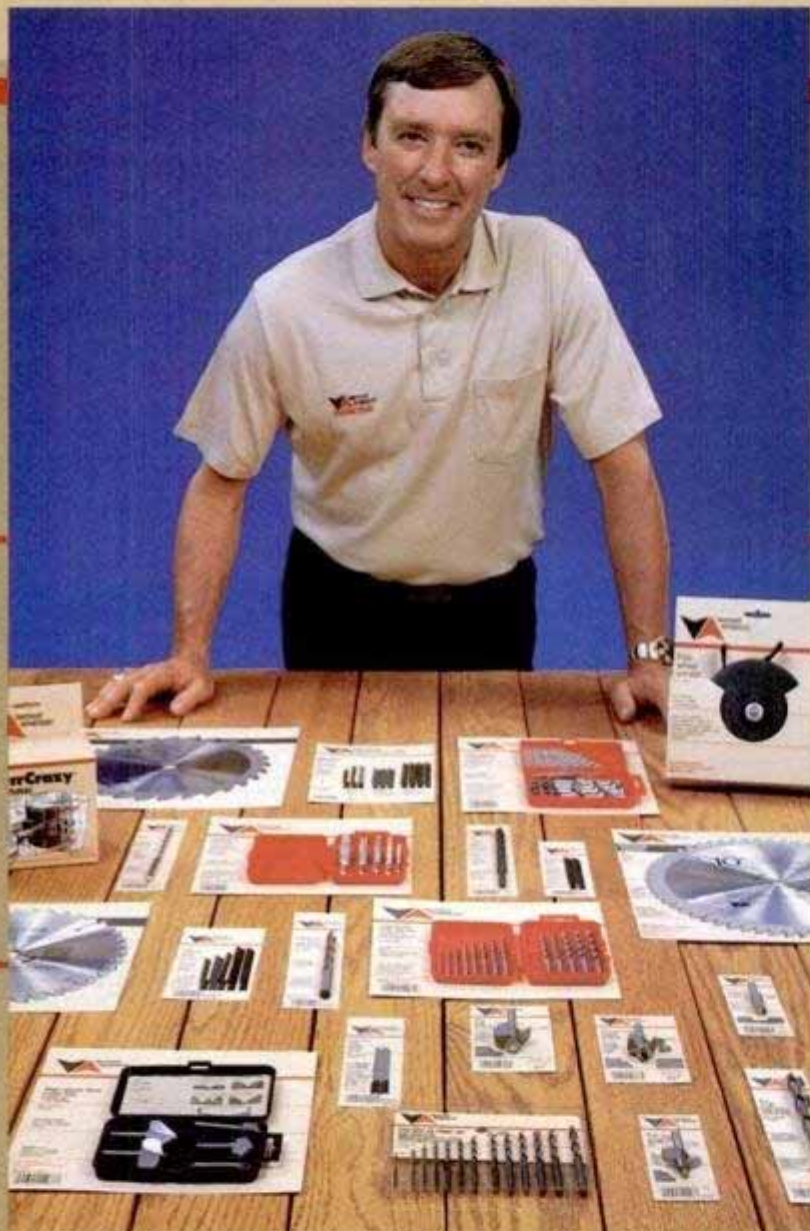

"The better the blade or the bit in your power tool, the better it performs. The smoother and faster it cuts. There's less strain on you and the tool. That's where Vermont American power tool accessories make the difference. Vermont American makes their saw blades, drill and router bits, and other accessories to the highest quality standards. In fact, Vermont American power tool accessories are the choice of professionals. That tells you how good they are.

"As someone who has worked with tools all my life, I appreciate Vermont American's professional quality... quality that's backed up with a free replacement policy. But, more important, that professional quality is available at a do-it-yourself price. In my opinion, that's a winning combination.

"So, no matter what brand of power tools you own, Vermont American will make them better."

For a free copy of the Vermont American tool guide and a list of the Vermont American dealers near you, call 800-554-6783. (North Carolina residents, call 800-334-0085) Or, write to: Vermont American, Department T, Lincolnton, North Carolina, 28093-0340.



When the job really counts

Before you use your power tools again, make sure you've got power tool accessories from Vermont American working for you. Ask for them by name wherever you buy tools.

THE PM WORKBENCH



Portable saw and router guide

Making precise cuts with a portable circular saw or router is easy with the saw and router guide (No. 26775) from Vermont American, Hardware Tool Division, Box 340-PM, Lincolnton, N.C. 28092.

Mount a portable circular saw to the guide's sliding base plate to make accurate crosscuts, right and left miters and compound miters up to 45°. Install a router to the base plate for routing decorative edges, grooves, rabbets and dadoes. The guide accepts workpieces up to 3 3/4 in. thick x 17 1/2 in. wide. It's available at hardware stores and home centers for about \$70.

—Rosario Capotosto



Adjustable guide allows you to cut accurate miters with circular saw. Track assembly swings to the left and right 45°.



The guide's sliding base plate also accepts a router. Adjust the track assembly to secure the router at the desired cutting height.

A nifty nibbler

This simple tool, called the Nibbler (\$12), enables you to make neat cuts in sheet metal, plastic and tubing without distorting the material's surface. Each squeeze of the handles causes a cutting edge to bite away a small chip. The Nibbler cuts steel up to 18 ga., copper, aluminum and plastic up to 1/16 in.



The tool's unique compound leverage cutting mechanism makes it easy to cut slots in steel tubing, sheet metals and plastics.



Use the Nibbler to make neat cutouts in plastic laminates. Bore a 1/16-in.-dia. hole in the waste area to start the cut.

thick and tubing with an inside diameter of 1 in. or greater. For details contact Vaco Products, 1510 Skokie Blvd., Northbrook, Ill. 60062.

—Rosario Capotosto

Timber bed lathe

Here's a unique woodturning lathe that mounts to a bed made of two 2x6s. This allows you to turn pieces of any length by using longer 2x6 boards. The 16-in. lathe (\$895), offered by Conover Woodcraft Specialties, 18125 Madison Rd., Parkman, Ohio 44080, comes with a cast-iron headstock and tailstock, 6-in. and 12-in. toolrests, spur and cup centers and knockout bar. Motor and 2x6 bed are not included, but are available from Conover Woodcraft Specialties. For details send \$1 to Conover for its catalog.—J.T.



Wood lathe features unlimited center-to-center capacity for turning extra-long pieces such as porch posts and columns. Custom-make the lathe bed from two 2x6s.

Dovetail gauge

When cutting dovetail joints by hand, marking the angles of the pins and tails accurately is essential to achieve tight fitting joints.

This simple, solid brass gauge provides two angles—one for hardwoods, one for softwoods. Position gauge on workpiece and scribe along template edges to mark the pin or tail. The double angled plate is pinned firmly to a 3/8 x 3/8 x 1 1/2-in. brass base to permit marking angles up to 1 in. long. It's \$14.95 postpaid from Woodcraft, 41 Atlantic Ave., Box 4000-PM, Woburn, Mass. 01888.—J.T.

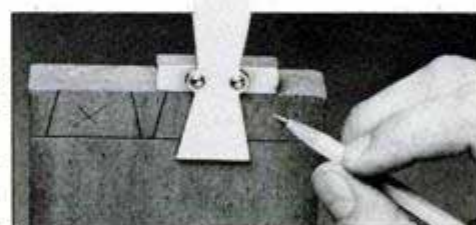

Lay out dovetail joints accurately with this solid brass marking gauge. Double angled plate offers two different dovetail angles.

If you've come across a new product with some special features, let us know about it. Write to PM Workbench, Popular Mechanics, 224 West 57th St., New York, N.Y. 10019.

SCIENCE WORLDWIDE



Ancient wings fly again

Stephen Winkworth displays his radio-controlled pterodactyl. It's being studied by anthropologists and aeronautical engineers.

The pterodactyl, a flying reptile, disappeared from the Earth more than 50 million years ago. But interest in the animal has flared anew in the past two years. Scientists are trying to figure out how the pterodactyl flew and whether its flight mechanics can be applied to airfoil design. The Smithsonian Institution, partly inspired by a scene from the 1983 movie *War Games*, currently is constructing a radio-controlled model pterodactyl. British inventor Stephen

Winkworth has the jump, however, with his 10-pound model. Its 8-ft. wingspan is flapped by balsa rib spars. Studies from earlier Winkworth prototypes have helped scientists rule out the legendary "backward flight" of pterodactyls.

Future research will help aeronautical engineers design a flying wing, an aircraft with super-fast takeoff and ultrahigh flight capabilities. Such a plane could be flying by 1995.

Comet Halley

My Commodore Sky Travel computer program indicates this is a good time for amateur astronomers with telescopes that have 8-inch or better apertures to start looking for Halley's Comet. It will be faintly visible in the late night sky with only the best equipment. Newcomers to astronomy and those who have equipment that isn't too powerful will have to wait until mid-winter for a look at the comet.

If you're expecting to see a fireball with a bright tail sweeping the night sky, you will be disappointed. An authority on the matter (we first reported the bad news in this column in June, page 36) says this may be the worst showing Halley has put on in more than 1,000 years.

But Terence Dickinson, writing in his new book *Halley's Comet: A Mysterious Visitor From Outer Space* (Edmund Scientific, \$12.95), says persistent searchers will find Halley.

Last days of condor?

Interior Department scientists are worried that the California condor is about to become extinct. The entire wild population of condors appears to be under 15. Researchers at the Condor Research Center in Ventura, Calif., last year spotted five breeding pairs nesting. All produced offspring, but their fate is not certain. Earlier this year, three single condors set down separately on territories taken last year by breeding pairs. Researchers are not sure whether the singles are from the original pair. Of nine condors outfitted with radio transmitters last year, one died from lead poisoning after taking a bullet fragment. Another is missing, leaving only seven still accounted for.

A remaining breeding pair has hatched a pair of eggs which were taken to San Diego Wild Animal Park for incubation. I'll have more to report on the incubating eggs next month. Stay tuned.

Dust in the wind

Although the Earth has been spinning for millions of years, we've only begun to get a handle on how winds have shifted over the past decade. Perhaps a complete history of Earth's wind movements would give scientists cycles on which to base predictions. David Rea and his associates at the University of Michigan are trying to map historic global wind shifts in a unique way.

Rea's team is extracting dust particles from deep sea sediment drill cores taken from the Northern Pacific. The sediments are treated with chemicals to separate dust particles from the sand. Rea counts, weighs and measures the particles. The amount of dust per given volume of sediment indicates the strength of winds in the area. And the mineral content gives clues to where on Earth the dust originated before being carried to sea. From this, Rea hopes to formulate a method to predict worldwide weather changes.

Light dimensions

Aircraft parts come in strange sizes and shapes, and accurate measurement is a tough assignment. But Northrop Corp. is using a new computer-controlled laser scanner to measure lengths and angles on aircraft parts to millionths of



A Northrop researcher follows 3-D laser light as it measures part of an aircraft.

an inch. The three-dimensional scanner reads both depth and contour as it moves across a part. It is expected to help speed up production with vastly increased accuracy. The light can be controlled by a robot. **FM**

OWN A MOVIE FOREVER FOR THE COST OF SEEING IT ONCE. JUST \$4.95.

WITH MEMBERSHIP



Now you can own any movie here for just \$4.95 with membership in the CBS Video Club! That's less than the price of a single movie ticket, less than the price of most rentals, and it's yours for keeps!

Choose from the best, too. *The Empire Strikes Back*, *Romancing the Stone*, *Splash* and more. There's no membership fee, and you don't have to buy a lot of movies.

Just two more within the next year. The movies you order will be mailed and billed at regular Club prices which currently range from \$39.95 to \$79.95 per cassette—plus shipping and handling. (Extra-long films and specials may cost a bit more.)

BONUS PLAN—SAVE 50%

After buying two movies at regular Club prices in the next year, you can cancel. Or stay with us and save even more under our Bonus Plan. With each movie you buy, the plan currently allows you to help yourself to another movie of equal value or less at 50% off. And, right now, save up to \$50 more—see the Advance Bonus box above.

About every four weeks (up to 13 times a year) we send you our CBS Video Club Program, reviewing our Director's Selection plus many alternate movies.

CHOOSE FROM HUNDREDS OF HIT MOVIES

If you want the Director's Selection, don't do a thing. It will arrive automatically. If you prefer an alternate title, or none at all, just return the card always provided by the date specified.

You'll always have two full weeks to decide. And a toll-free number to call if you have any questions or service requests. (If you ever receive a tape that you had less than two weeks to consider, send it back at our expense.)

Join today and we'll send your movie for just \$4.95, along with details of how the Club works. If you're not satisfied, return everything within 10 days for a full, prompt refund—no further obligation.

For faster service, use your credit card and our toll-free number to order. Just call 1-800-457-0866 (in Indiana 1-800-742-1200). Or mail coupon.

Advance Bonus:

SAVE UP TO \$50 MORE!

... by ordering a second movie right now. Any movie listed in this ad—yours for just \$29.95 on videocassette. See coupon below.

CBS VIDEO CLUB

1400 North Fruitridge Avenue, Terre Haute, IN 47811

CBS VIDEO CLUB

Dept. 60H, P.O. Box 1111, Terre Haute, IN 47811

Yes, please enroll me in the CBS Video Club under the terms outlined in this advertisement. As a member, I need buy just two more movies within the next year.

Check one: BETA
 VHS

Send me movie # _____ for \$4.95

Please check how paying:

My check is enclosed. Z54/Z56
 Charge my introductory movie(s) and future Club purchases to:
 MasterCard Diners Club
 American Express VISA

Account # _____

Expiration Date _____

Signature _____

Also send me as my Advance Bonus:

movie # _____ for \$29.95 on videocassette plus \$3.00 shipping and handling which I'm adding to my above payment.

Name _____

Address _____

City _____ State _____

Zip _____ Phone (____) _____

Note: CBS Video Club reserves the right to reject any application or cancel any membership. Offer limited to continental U.S. (excluding Alaska). Applicable sales tax added to all orders.

60 TOP HITS TO CHOOSE FROM

TITLE	SELECTION NUMBER	TITLE	SELECTION NUMBER	TITLE	SELECTION NUMBER
THE EMPIRE STRIKES BACK	0910092	JANE FONDA'S WORKOUT CHALLENGE	5260042	ROBIN HOOD (Walt Disney)	5298092
ROMANCING THE STONE	0894092	CASABLANCA	0907082	EXCALIBUR	6021022
SPLASH	5304022	TOOTSIE	1509042	TIGHTROPE	6051052
THE BIG CHILL	1527022	DUMBO	5251052	BACHELOR PARTY	0925012
WARGAMES	0829002	THE AFRICAN QUEEN	0511022	COUNTRY	5341072
RISKY BUSINESS	6033082	ON GOLDEN POND	0523082	BODY DOUBLE	1713062
THE NATURAL	1649052	THE LONGEST DAY	0577032	REVENGE OF THE NERDS	0925022
STAR WARS	0564162	DIRTY HARRY	6017082	GREYSTOKE—THE LEGEND OF TARZAN, LORD OF THE APES	6045042
YENTL	0895082	STRIPES	1513082	EDUCATING RITA	1593012
HIGH ROAD TO CHINA	6022012	FUNNY GIRL	1511002	THE ROAD WARRIOR	6028052
CADDYSHACK	6023022	CHRISTINE	1580062	SUPERMAN III	8040092
MAKING MICHAEL JACKSON'S THRILLER	7103012	OCTOPUSSY	0856052	TWILIGHT ZONE—The Movie	6034072
KING KONG (The Original)	5502022	PORKY'S	0775112	ANNIE	1516052
POLICE ACADEMY	6049002	CLOSE ENCOUNTERS OF THE THIRD KIND—Special Edition	1510012	THE MUPPETS TAKE MANHATTAN	0923042
ARSENIC & OLD LACE	0735102	THE RIGHT STUFF	6043062	ALIEN	0002322
THE COMANCHEROS	0782242	NATIONAL LAMPOON'S VACATION	6039022	THE MAGNIFICENT SEVEN	0534212
KARATE KID	1710092	TRON	5263012	THUNDERBALL	0709042
PRIVATE BENJAMIN	6018072	ARTHUR	6024092	BUTCH CASSIDY & THE SUNDANCE KID	0517302
SHE WORE A YELLOW RIBBON	5504002	ROOSTER COGBURN	1018082	PURPLE RAIN	6048012
RED RIVER	7507032	NEVER SAY NEVER AGAIN	6042072	THE MALTESE FALCON	0508072

DETROIT LISTENING POST

Twice-blown, 250-mph 'Bird

Let's just suppose you and your buddies enjoy an occasional run out to the mailbox on the edge of your property—about 15 miles from the house. Then one spoil-sport ups the ante with a \$175,000 Kremer-modified Porsche, a nifty little 180-mph runabout.

What's a competitive sort of guy to do? Ring up Gale Banks, of course, the southern California *turbomeister*. Banks recently delivered this innocuous looking '83 Firebird to such a European customer, who should now be the first to read the postcards from Aunt Effie. From the outside, you'd be hard pressed to detect the deviations from



Firebird looks stock, has 1,100-hp wallop!

factory spec—a 200-mph speedometer, a waste gate adjustment knob, some pyrometers on the dashboard.

But neatly tucked under the hood is 430 cubic inches of Chevrolet muscle, pressurized by twin intercooled turbos, linked to a Doug Nash five-speed transmission by a dual-disc clutch. The 850-cfm Holley carbs nestle way out in the corners of the engine bay on preheated iron manifolds, to ensure all-weather driveability. It totals up to 1,100 hp at 7,200 rpm on 20 psi of boost, and that's good for 250 mph according to GM's own wind tunnel figures. It also means that under boost the Cheviac can spin its rear tires at 150 mph!

Banks didn't forget handling either, adding a whale-tail spoiler and air dam for high-speed stability and a suspension good for .95 skid pad figures.

Banks' Azusa, Calif. emporium will whip you up a duplicate for \$70,000, including the original price of the car.



Twin Gale Banks turbos on big-block Chevy stuff engine bay.

Probing Ford's future

Another radical Ford aerodynamic study, this one named Probe V, will debut at the Tokyo auto show in November. Expect it to have an incredibly low Cd number—below the 0.15 of Probe IV, which was already roughly equivalent to the drag of a jet fighter. Stylistically, Probe IV was a bit of a mish-mash. Probe V will look smooth and sleek, somewhat like a flattened and elongated version of GM's Citation IV aerocar!

Buick showboat

Buick will unveil a wild new show car at the SEMA trade show in October. The swoopy mid-engined two-seater will feature the Division's new 24-valve V6 engine and four-wheel drive. Looking like a streetable version of a GTP racing

sports prototype, the Wildcat will showcase Buick's computer electronics and CRT technology. Although supposed to be hush-hush, engine photos leaked out to the press months ago.

Peppier Fours coming

Ford and Chrysler have bigger banging Fours coming along within the next several months. Both of these will be 2.5 liters. Ford is doing a 2.5 pull-off of its 2.3 liter and Chrysler has a 2.5 version of its 2.2. Chrysler is a few months ahead of Ford and will offer a 2.5 as an option on some '86 cars. Ford reveals it will have a 2.5 for its new intermediates, Taurus (Ford) and Sable (Mercury). Carroll Shelby has already designed a four-valve cylinder head for the Chrysler 2.5, and Yamaha is doing the same for Ford.

V6 Vette from Britain?

Mechanicals from Motown, body design from Britain? That's the plan for the new Corvette coming as an '87½ or '88 model. It will be a new car, not a warm-over, and mark the first time Chevy's gone outside the U.S. for a production body design. It will be a trimmer, lighter car than the present version—GM doesn't want the Vette tagged as a guzzler for failure to meet fuel economy regulations—and the V8 engine will give way to a V6. All of which could make the current car a collector's piece because it will have the shortest run of any Corvette. There's also talk about the possibility of going to a mid-ship engine, but don't bet on that just yet.

GM's hot V6

GM has a V6 coming in 1988 or '89 that could signal the end of the turbocharger as an option on GM cars. If not the end, at least a retrenchment of the turbo. The turbo isn't a favorite hangon in Detroit, even though all companies offer them. They're tricky, temperamental and you can get hit with a cruncher of a repair bill at about 50,000 miles. Detroit would like to ditch the device, except for special-purpose vehicles, but is reluctant to do so because there's a profitable margin for power options. If the V6 GM is tooling for is as hot as tipsters say it is, the turbo will do a fade-out on GM makes. First cars to get the super Six will likely be the Chevy Camaro and Pontiac Firebird.

Positive thinking

When the Thunderbird gets its complete reskin in 1989, Ford will also add the first positive-displacement supercharger to be used on a modern American car. Developed by Eaton Corp. for the 3.8-liter V6, this pressure booster will be a dry-flow design. Rather than routing fuel through the blower, the engine will use a port-injection setup. It'll also have an air-to-air intercooler.

This Roots-type supercharger dates back to an 1850's pump design, used to move air for metal forges after it failed as a water wheel in woolen mill applications. Drag racers have used them for years on the nitromethane-burning ground shakers, but those have always been GMC diesel 'chargers adapted to the job. Eaton's design improves on

(Please turn to page 26)

Sooner or later— it's Copenhagen.[®]

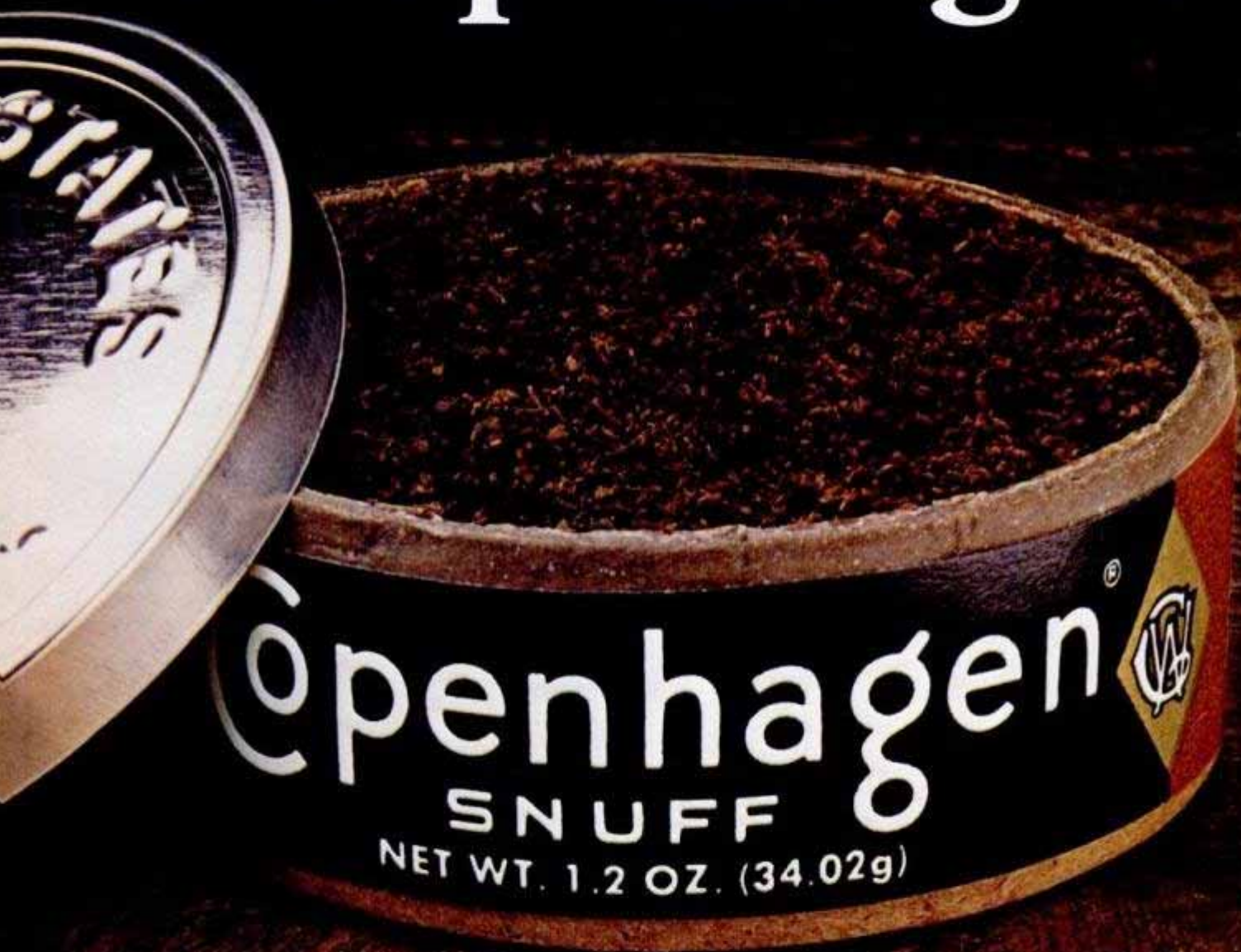

There are a lot of smokeless tobaccos out there, but for a lot of guys there's only one. Copenhagen. For one good reason.

It satisfies.[™]

Send for our color catalog packed with the newest caps, jackets, shirts and more. Send your name and address along with \$1.00 (which may be applied toward initial purchase) to: Copenhagen, Department 55-W330-1, P.O. Box 729, Sparta, NC 28675

© 1985 U.S. Tobacco Company

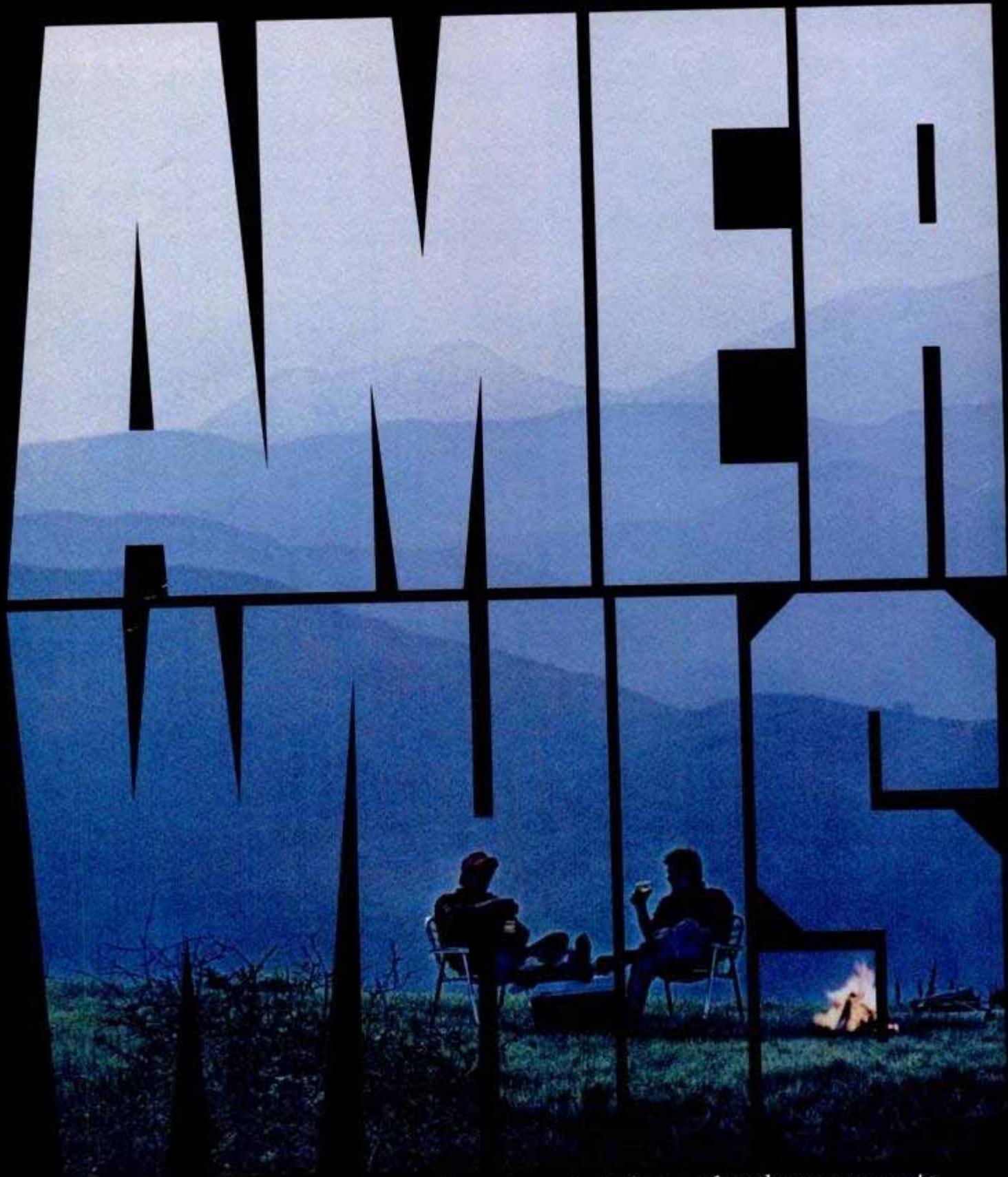

A chance to get away. Americans look forward to those moments. Moments to unwind. Moments to enjoy the things you appreciate in life.

NOBLES



And because Seagram's 7 has always been part of that enjoyment, you've made it America's most popular whiskey for nearly 40 years.

REMEMBER—ALL ARE EQUAL IN ALCOHOL CONTENT



DETROIT LISTENING POST

(Continued from page 22)

that technology, driving the blower at 2.4 times engine speed with a Poly-V belt to produce 10-psi boost at very low engine speeds. That's the big advantage—extra low-end power, as opposed to a turbocharger's top-end kick. Also, it's self-contained, so it won't affect service life of the engine oil.

Eaton is working with a number of domestic and European carmakers, so we might conceivably see the unit on the street in 1988 on another brand of car. Originally, it was planned to go on

the Mark VIII Lincoln (which will be built on the front-drive Taurus platform) but that project has been delayed. Ford is committed, however, to using the blower on future versions of the 3.0-liter Vulcan V6 developed for the Taurus/Sable.

L-car specs

We now have more details on the '87 Chevy Corsica and Baretta pictured in last month's *DLP* (page 32). Chevrolet will be given an exclusive—no sharing with other GM divisions on the new 103-in. wheelbase. Standard engine will be a 2-liter Four with electronic fuel

injection, paired with a four-speed manual shift. The optional engine will be a 2.8-liter V6. Optional transmissions will include two five-speeds and an automatic. The '87 four-door will have four windows on the sides. The six-window version seen in our spy pix won't be added until 1988.

GM will pit the Corsica against Nissan Stanza, Honda Accord, Isuzu Aska, Ford's Tempo/Topaz and Chrysler's Reliant/Aires. The Aska is a four-door not currently imported to the U.S., but since GM owns 34 percent of Isuzu, they are probably not guessing about the Aska's future.

The two-door Baretta will be slotted against four Ford products—Mustang/Capri, Thunderbird/Cougar—and four imports: Toyota Celica/Supra, Honda Prelude and Nissan 200SX. No details yet on prices, but they'll be priced above the present J-cars. Chevy will have the Ls exclusively, at least until the 1991 model year. Other divisions of GM could get spin-offs after '91.

Life-of-car muffler

Next year or the year after, you'll be able to buy a car with a muffler that will outlast the car. There are a couple of assumptions in that statement: 1. You don't hit something in the road that damages the muffler; 2. If you drive the car more than 100,000 miles you might have to replace the muffler. A 100,000-miler is already available as a replacement muffler. It's made by Walker Manufacturing, a supplier to both the car companies and aftermarket shops. The way it differs from a conventional muffler is that it contains a canister of a chemical—Walker calls it Absorbite—that soaks up moisture. The reason mufflers rust out from the inside is that water and acid vapor condense in the bottom of the muffler when you shut off the engine. With the Walker muffler, the Absorbite holds the moisture until you restart the car, then the exhaust gas drives the moisture out the tailpipe leaving no liquid inside. Walker has supplied samples of the design to all the car companies and it's only a matter of a year to 18 months before it shows up as original equipment.

D-i-y body panels

GM and Ford are looking at the idea of using do-it-yourself body panels for some future small cars. If a fender, grille or deck lid is damaged in an accident, the car owner could remove and replace the banged-up panel by undoing a few bolts with common hand tools. This is still a few years off, assuming it can be done, and you'd see it only on the lowest-priced cars. It's not really a new idea, Ford models A and T and the VW Bug had d-i-y sheet metal, and the Fiero boasts d-i-y plastic. **PM**

FOR YOU WHO WANT THE BEST.

Impeccable workmanship in every detail. Precision made parts. Hand honed, perfectly mated cutting edges. Fine polished finish. Blue plastic comfort grips. The best. At no premium in price. Tools by CHANNELLOCK. Send for your free catalog. Channellock, Inc. Meadville, Pennsylvania 16335

Tools by

CHAN NEL LOCK

For you who want the best.



Channellock Pliers Are American Made

PM PHOTO HINTS

Trash bag darkroom



Carry a large plastic trash bag in your camera bag. It can protect your gear if you encounter bad weather. In bright sunlight, use the bag as a portable darkroom to change your film.

—Bob "Greenie" Grewell

Makeup artist



Use a white tile for a palette when you're retouching dust spots on enlargements. The white tile palette's smooth surface is perfect for mixing up just the right shade of spotting color.

— Bob Berger

Instant mix

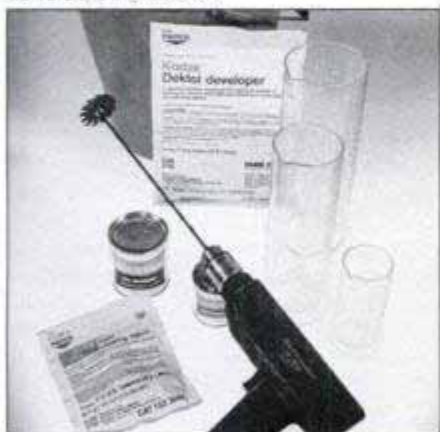

Mixing powdered photographic chemicals can be reduced to minutes by using a paint-mixing attachment on an electric drill.—Kenn Oberrecht

Just when you thought it was safe
to buy another wrench...

Great Neck

"One Touch" Wrench

Finally...one wrench to solve all your problems. Tighten and loosen nuts and bolts...even pipes.

Push the button to open the jaws of this drop forged and heat treated tightening and loosening machine with ratchet action and automatic adjustment. Choose the size you need—6", 8", or 10".

The Great Neck "One Touch" Wrench combines all the features of adjustable, multi, box, open end, and pipe wrenches to solve just about any problem.

Available now at a Great Neck hardware counter near you.

Great Neck

165 East Second Street
Mineola, NY 11501

Great Neck—The Best Value in Hand Tools for Over 60 Years.

Patent pending. Exclusive design developed and owned by Great Neck.

SAVE \$10.*

On Any Hitch

with this coupon



Get towing with the only hitch that's backed by an exclusive nationwide warranty honored at over 1,250 locations in the U.S. and Canada.

Have your hitch installed while-you-wait with fast and convenient service.

We're open 7 days a week. Find us under U-Haul in the white pages.

More for your money

at your **U-HAUL** Center

* Installed price. Cannot be combined with other U-Haul discounts or special offers.



EXPIRES 12/85 PMHW-4

HOMEOWNERS' CLINIC



Moist-curing concrete

Our article on patching spalled concrete in the February '85 *Homeowner's Clinic* (page 26) specified that the new concrete patch be kept damp for at least three days. Thomas Freeman of Chapel Hill, N.C., suggests I inform you that the longer the patch is kept moist, the greater its strength will be. This is a point worth passing along—not just for spalled surfaces needing a patch, but for any concrete work.

Keeping concrete moist helps in the curing process. Concrete hardens as a result of a chemical reaction, called hydration, between cement and water. The hardening, or curing, continues as long as moisture remains in the concrete. If too much water is lost from the concrete through evaporation, hydration—and the hardening process—slows down or ceases.

As the accompanying chart shows, the longer concrete is kept moist, the greater its strength. Although the greatest gain is in the first week or two after pouring, the curing process continues for several months.

Concrete that is not moist-cured at all dries too rapidly, and reaches less than half its potential design strength. It will

also have a greater number of shrinkage cracks.

The most frequent moist-curing method is to spread moisture-retaining fabric such as burlap over the concrete after it has hardened enough to prevent surface damage. The fabric should be kept thoroughly soaked with a garden hose so a film of water remains on the entire surface of the concrete throughout the curing period.

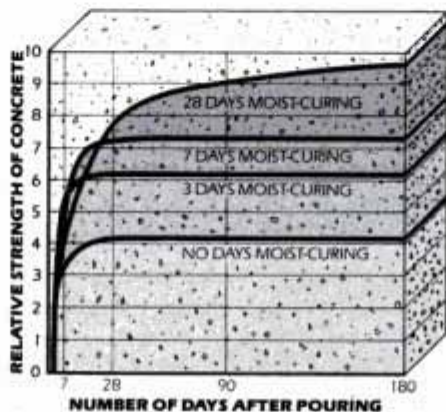

Concrete continues to gain strength after pouring for as long as it retains moisture. Moist-curing concrete can more than double its strength and reduce shrinkage cracks.

Faulty circuit breakers

Recently, an electrical wall outlet in our home shorted out and threw sparks around violently. To my amazement, the circuit breaker failed to trip. An electrician examined our service panel and told us it was made by the Federal Pacific Co., about 25 or 30 years ago. According to him, the split bus panel is illegal by today's standards and he recommends replacing the entire panel box with a new one that would cost between \$500 and \$600. Is there a better or more reasonable solution? We are concerned for our safety and are looking for help.—James Donze, Overland, Mo.

There may be a more reasonable solution than replacing the entire electrical panel box. Your split bus panel is not causing your circuit breaker problem even though it is not in compliance with the latest Electrical Code.

In 1981, the National Electrical Code was modified to disallow the future installation of a split bus in residential construction. Electrical Code modifica-

tions are not retroactive, and do not affect existing installations. The purpose of the code change was to ensure that the panel box electrical bus would have a master disconnect.

After 25 years, if a circuit breaker never tripped it is possible that corrosive deposits have formed around the tripping mechanism which would cause the breaker to malfunction. As a precautionary measure, a homeowner should—once a year—trip the breaker (move it to the off position) and reset it for each circuit including the master disconnect, if there is one.

Since one of your Federal Pacific breakers malfunctioned, it would be prudent to replace all the circuit breakers. This would be less costly than replacing the entire panel box. For your protection, the new circuit breakers should be approved by Underwriter's Laboratories (U.L. Listed) or other independent testing laboratory.

However, if present-day circuit breakers will not fit your panel box, you will have to replace the entire box.

Damp basement room

I am interested in making a below-grade finished basement into a comfortable office. There is no water seepage, but even so, the basement is cold and clammy in the winter and humid and musty in the summer. I'm using a dehumidifier and a portable heater but cannot overcome the discomfort. Any suggestions?—Raymond Christy, Mineola, N.Y.

You have the ingredients for making the finished basement into a comfortable office all year long—a dehumidifier for the summer and a space heater for the winter. However, either you need additional units or you are not using the units that you have for a sufficient time period.

If you have two or more rooms in your basement, a single dehumidifier in one room will not effectively reduce the humidity in the other room, especially if the door between the rooms is closed. If the door is open and you want to use a single unit you will need a fan to provide sufficient air circulation between the rooms.

Most humidifiers are equipped with an automatic control switch which will shut off the unit when a predetermined humidity setting is reached. In order for the humidifier to wring out a sufficient amount of moisture from the air to reach a comfortable level, you must let the unit operate until it shuts itself off. During hot, muggy summer days the dehumidifier may run almost continuously. If you allow the dehumidifier to run for only one or two hours a day, it will not reduce the relative humidity to the comfort level.

A space heater is effective in heating a single room. If you want to heat more than one room, you will need a fan to circulate the air between the rooms. Even in a single room, a fan will be helpful in achieving a uniform heat distribution. A thermostat that is mounted on a wall across from the heater, rather than on the heater itself, will also improve heat distribution within the room. **PM**

Do you have a home-maintenance or repair problem? Send it to Homeowners' Clinic, Popular Mechanics, 224 West 57th St., New York, N.Y. 10019. Letters cannot be answered individually, but problems of wide interest will be discussed in the column. For more home-repair and maintenance help, get PM's Home Care Guide, \$4.95 postpaid. Send your order(s) to Popular Mechanics, Box 1014, Radio City Station, New York, N.Y. 10101.

New Home Security Device Stops Burglars

The following introduces one of the best bargains in low cost home security ever to reach the market! Now you can protect your home and family for as little as \$19.95.

Imagine it's midnight. A burglar is watching your home. His mission — to rip you off! In the dark, he approaches your door. Suddenly, your yard is flooded with light. He wonders if you're armed and waiting. Shocked, the thief runs. Your home and family remain untouched. And you weren't even home.

The professional burglar was fooled by a new idea in home protection — the AudioLite. This ingenious security device reacted to the sound of a burglar and turned on lights, preventing an attempted break-in.

Safety and Convenience

Now, with the AudioLite as your "thief stopper," as you drive up, the sound of your car turns on the yard lights. Your footsteps turn on the porch light. Your key in the door turns on lights in the hallway. And, after you're safely inside, the AudioLite turns the lights off automatically.

Simple to Use

Never touch a light switch again with AudioLite. Your voice is the remote control for instant lighting. You set the exact amount of sound needed to activate the AudioLite. Anything from a whisper to a loud shout (what a lifesaver for senior citizens or the handicapped).

When you're away, inside lights will turn on at the sound of common house noises, such as the doorbell or telephone, making it appear that you're home.

Lights are timed to stay on up to two minutes. Each new sound triggers the internal timer, and it begins a new count-down, so lights stay on while you're in a room and go off automatically when you leave. However, for quiet activities, such as reading, the AudioLite has a manual on-off switch.

Combine 3 Models for Total Security

• **Wall-Plug Model** just plugs into any standard outlet. Plug a lamp into the AudioLite, it's that simple. Any room with a lamp can be sound activated. The plug is portable so you can use it anywhere.

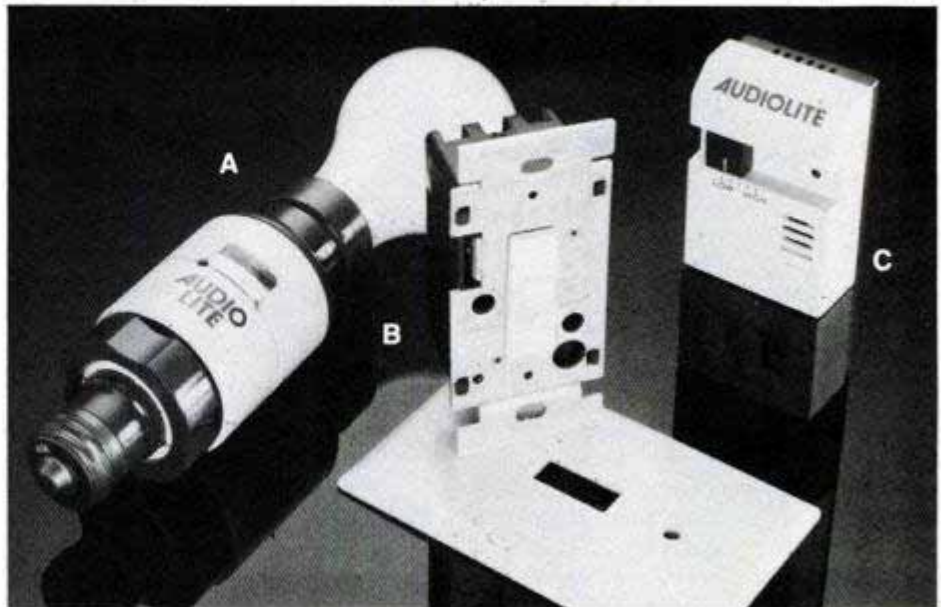

AudioLite stops burglars by turning on lights at the sound of an attempted break-in. Three models for your total security: (A) Screw-In, (B) Wall Switch and (C) Wall Plug.

• **Screw-In Model** For outdoor light sockets, it can stop a burglar in your yard, before he gets near your home. Frightening to burglars, but welcoming to friends. So easy to use, just screws into your outside light socket.

• **Wall Switch Model** turns on ceiling lights. It's terrific for dark stairways, hallways, entry ways, basements and garages. Installs quickly and easily in place of your present light switch. It takes only a few minutes, even for a novice.

Saves You Money

Since your lights automatically go on when you enter a room and go off when you leave, you don't pay for lights you're not using — slashing your electric bills. For additional savings, AudioLites can operate lights at reduced energy.

AudioLite's solid state construction will outlast conventional systems by years. The **Switch and Screw-In models** work with up to 150 watts, the **Plug** up to 300 watts. They are UL approved and have a one year replacement warranty.

Order Four — Save over \$20

Order one AudioLite for your home at the new low price of \$24.95 or for total home security, order a set of 4 for only \$79.80 (that's \$19.95 each — **SAVE \$20**) and get **FREE SHIPPING!** Try AudioLite for 30 days, risk free, you'll wonder how you ever lived without them. Discover the

security of a home that scares the daylight out of burglars.

Order Today — Free Gift

Eight **FREE** Burglar Alarm Warning Stickers (for windows and doors) with orders of 4 or more (\$3.95 value). Call **TOLL FREE 1-800-525-8624** (in Colorado 303-762-1385) or send to: Progressive Energy Corp., 3148 South York, Englewood, CO 80110.

Yes, I want the best bargain in home security. If in 30 days, I am not fully satisfied, I can return AudioLite for a prompt refund.

Please send me ___ AudioLite(s) at \$24.95 each and \$2.50 shipping and handling (shipping is \$3.50 for 2 or 3).

I want to save \$20 and have total security. Send me 4 AudioLites at \$19.95 each. That's \$79.80 total (shipping is FREE).

3 models (order any combination):

___ Plug(s) ___ Screw-In(s) ___ Switch(s)

Check MasterCard/VISA C.O.D.

Card # _____

Exp. Date _____

Name _____

Address _____

City _____ State _____ Zip _____

Send to: Progressive Energy Corp.
3148 South York, Englewood, CO 80110.
Toll Free 1-800-525-8624. In CO 303-762-1385
©1985 Progressive Energy Corp.

THE PM GARAGE



It's a coverup!

The high-tech looks are enough to sell me on this covering for fluid lines and wires, but there's more to the Spectre line of braided hose sheathing than meets the eye. The flexible material protects against cuts and chafing, and is unaffected by acids, solvents, gasoline, antifreeze and alcohol.

Three variations are available: Nylabraid, which comes in a selection of colors; Magnabraid, a stainless-steel hose covering; and Fyrebraid, the high-temperature sheathing. A Nylabraid universal engine kit includes five sizes of hose shield, a dozen chromed or anodized clamps and eight heat-shrink bands for \$69.95. Available at high-performance parts shops, the kits are by Spectre, 160 South Whishman Rd., Mountain View, Calif. 94041.—*W.H.*

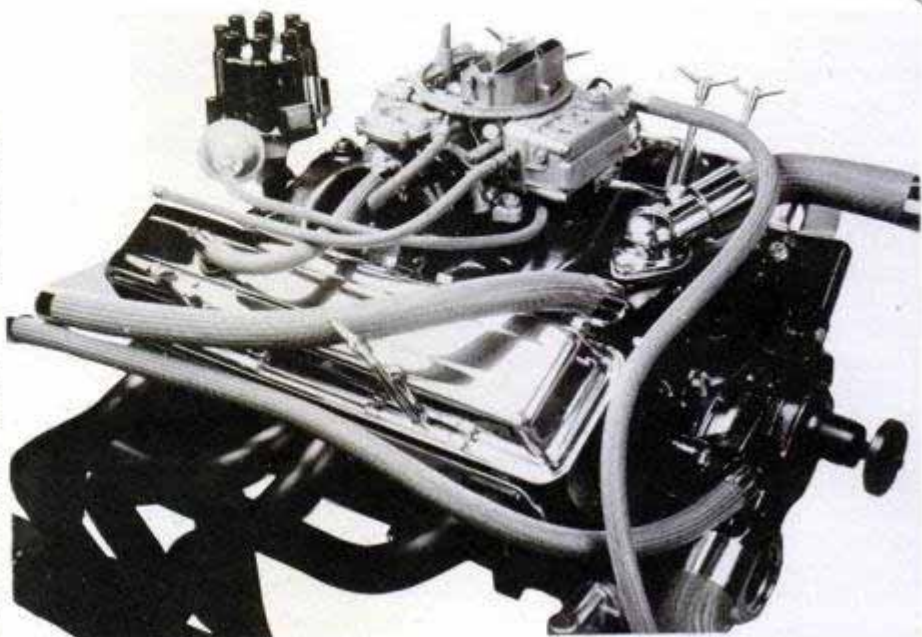

Braided hose cover kit adds underhood sparkle and protects against cuts and chafing.

Tape in a can

Taping up electrical connections works for a while, but after seasons of heat and cold, even the best tape becomes brittle and unsticky. It tends to unravel and then vibrates loose. That's what makes Liquid Lectric Tape so attractive. Even though the brush-on black vinyl takes five minutes to set, once it does it's there forever. Liquid Lectric Tape fuses with existing insulation and makes a form-fitting sheath around wire that keeps out moisture, grease, oil and even acid. The four-ounce can costs \$4.95 at most parts stores. It's distributed by Marine Development & Research Corp., 116 Church St., Freeport, N.Y. 11520.—*M.L.*



Liquid Lectric Tape is long-lasting insulation that suits all types of wiring connections.

Speedy setup



Co-Ax Indicator speeds setup of machining by simplifying the centering operation.

Machine work on car parts is only slightly less fussy than brain surgery. That's why I take time to center work accurately for drilling, milling or turning—but it takes very little time, thanks to the Co-Ax indicator. It looks a lot like a dial indicator, but can be used while the machine is running—up to 800 rpm. It has a shaft, and can be chucked just like a drill bit. To use the Co-Ax, you roughly center the work, then switch on the machine. With a milling

table or lathe, you then adjust the feed screws to position the work until the Co-Ax pointer steadies, indicating perfect centering. Price of the Co-Ax in hardwood case, with feelers for outside diameters, inside diameters and center-punch-work, is \$157.50 plus UPS charges from Blake Mfg., 15310 Proctor Ave., City of Industry, Calif. 91745.

—*Bob Berger*

Balancer act

When I see someone hammering a crankshaft harmonic balancer back into place, I wince. Potential damage to crankshaft, balancer and thrust bearings makes an installation tool a wise purchase. This one presses the balancer in place using the threaded portion of the crank snout for a mounting point. For Chevy V6, V8 and Ford V8 engines, the installer costs \$45.95 from B & B Performance Sales, 23190 Del Lago Drive, Laguna Hills, Calif. 92653.

—*N.S.M.*



No more hammers! Balancer tool installs on crankshaft snout, works in tight quarters.

IF YOU WANT TO IMPROVE
YOUR BIKE'S CHANCES OF WINNING THE BAJA 1000,
DON'T UNLOAD IT.

Well, up to you.



If you think of a pickup as just a way to lug your high performance machinery to and from the dirt, the Isuzu 4x4 is going to be something of a shock.

Because under its hood is the same incredibly potent 2.3-liter overhead cam engine design that powered Team Isuzu to a victory in the stock mini-pickup class of the grueling Baja 1000.

And it's surrounded by features that sound like they belong on some sophisticated off-road racer instead of one of the world's most

reasonably priced 4x4's. Including all-terrain tires. Stagger-mounted rear shocks. Front disc brakes. Triple skid plates. Variable rate power steering. An independent double-wishbone front suspension. And auto-locking hubs.

With all this going for it, you've probably decided that buying an Isuzu 4x4 to carry your bike would be a wise decision.

You've probably decided something else. Racing your bike against it might not be.



THE FIRST CAR BUILDERS OF JAPAN.

ISUZU

Cast-Iron Stoves Unequaled In Design.



Receive a Catalytic Combustor Free with each Stove now through November 26, 1985.

Chances are, if you are considering a stove, you are approaching its purchase in a serious manner. Gone are the days when all stoves were assumed to be equal. Educated consumers know they're not, and that differences from one brand to the next can be substantial. This is so because some wood stoves have been undergoing a quiet revolution in function, a revolution masked by the constant nature of the outer forms.

Extraordinary Features

No stoves more reflect this revolution than Consolidated Dutchwest's Federal Airtights. These stoves include a combination of features which just a decade ago would have been impossible to imagine. The best selling model of that time was the Franklin, an attractive stove with an operating efficiency of 10-15%. It burned only wood, required frequent loading, and was impossible to control. In its place today we offer 100% cast-iron Federal Airtight stoves and inserts which burn wood and coal and convert from one fuel to the other in a few moments. Depending on size, they hold wood fires from 6 to 14 hours while squeezing as much as three quarters of the potential heat from each log. They vent from the top and back and install freestanding, and in some cases, as fireplace inserts. Front and side door loading, convection systems, fans, ceramic windows, shaker grates, ashdrawers, and polished cooktops are standard features. As well, this past year we reengineered each stove and insert for catalytic operation. Why? Because with the inclusion of a catalytic combustor, airtight operating efficiency can approach 80% while reducing creosote build-up and smoke pollution up to 90%.



Conversion from wood to coal takes 30 seconds



Standard probe thermometer & polished cooktop.



Front & side doors provide for easy loading of wood.



Slide out ashbin makes emptying easy and clean.

Federal Period Styling

While concentrating on function, we haven't compromised on appearance. We've employed the simple clear lines of Federal period architecture (1810-1830), as elegant today as they were then, to create a unique and beautiful pattern of raised lines and arches. Our distinctive pebble finish and solid brass trim highlight the classic styling. We know our stoves will frequently be sited in living rooms and we've gone to great lengths to assure they belong there. Those of you who eventually own a Federal Airtight will find our trademark pebble finish is not only beautiful, but also increases our stoves' radiant surfaces by a third. Even while stressing appearance we never forget performance.

A Free Information Package

These days, understanding woodstoves well enough to select one with the most appropriate features for your situation is a demanding undertaking, made harder by the many conflicting manufacturer claims. We have tried to simplify the process by providing substantial background information to support an informed decision. We've gone a step further and kept selling prices to the minimum, so that the best stove and the best stove value can be the same. Delivered prices begin at \$379.95. We invite you to write for our free 76-page color catalogue, "Stovebuyer's Guide," and Installation Planner. We believe the more you know the better we'll look.



CALL OR WRITE FOR A FREE CATALOG

Toll-Free 1-800-225-8277

or 1-800-722-5556

(in Mass. 617-747-1963)

FREE CORNING CATALYTIC COMBUSTOR

This Fall Save \$80.00.

Since the emergence of the airtight stove as the woodstove industry's best product, there's been belated but growing awareness of the downside of airtight wood-burning—creosote buildup and pollution—problems caused by the lower firing temperatures of controlled combustion. Technology's answer is the inclusion of a catalytic combustor in each airtight stove. The 'combustor' reduces the temperature at which woodsmoke burns from 1,200 degrees F to under 500 degrees F. The result is an almost complete burn, a big boost in operating efficiency, and major reductions in creosote buildup and pollution. In short—a great idea that works. Each Federal Airtight is designed to accept a catalytic combustor in the secondary combustion chamber. This fall we'll pro-

vide a Corning Catalytic Combustor free with each stove and insert purchased. Offer expires November 26, 1985.

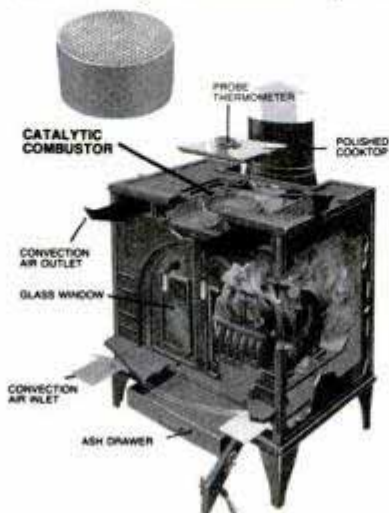

SEND ME YOUR FREE INFORMATION PACKAGE.

Please send me Free 4-part information package, including 76-page color catalogue, "Stovebuyer's Guide," pricing and details of your free Corning Catalytic Combustor offer.

I plan on purchasing a stove:

- within the next 60 days
- within the next 6 months
- within the next year
- in more than one year or uncertain

Name _____

Address _____

City/State _____ Zip _____



Box 1019, Dept. 5PMS, Plymouth, MA 02360



EARTH MOVER.

WRANGLER

ENGINEERED FOR SURVIVAL

Goodyear engineered the Wrangler All-Season Radial to take on virtually everything off-road driving could throw at it. Rugged inclines. Dried-up washes. And torn-up muddy trails. Wrangler Radials are designed with a unique, mud-biting block-tread. And strong sidewalls to help withstand the beating off-road driving inflicts. The all-season, all-terrain Wrangler. Because too often, survival off-road depends on the tires you drive on.

GOODYEAR



Fiero's cracked block problems

Are reports concerning a rash of cracked engine blocks with 1984 Pontiac Fieros true? If so, my Fiero may be affected. Coolant level keeps dropping and a yellow, pasty emulsion has built up on the inside of the oil cap. What's the story?—Harry Dapron, Fairview Heights, Ill.

The story is that many 1984 Fieros that were operated in cold weather have experienced cracked blocks at the engine parting line. The parting line is where the upper and lower parts of the block are cast together.

One theory has it that the reason for the separation lies with the distance between the engine, which is in the car's midsection, and the radiator, which is at the front of the vehicle. The long distance the coolant travels from radiator to engine causes it to cool down substantially in cold weather. As a result, cold fluid enters a hot engine. Whether or not the theory is true, the fact is that the parting line in early Fiero engines is not strong enough.

It certainly sounds as if your Fiero is suffering the consequences. The yellow, pasty emulsion indicates coolant is mixing with oil. You can check it out by warming up the engine, withdrawing the oil dipstick and letting some oil drop on the exhaust manifold. If the oil sizzles, there's coolant present, verifying that a cracked block exists.

When Pontiac recognized the problem, there was an immediate attempt to strengthen the parting line of engine blocks in production. As for an owner of an older Fiero with a cracked block, he's entitled to a new block, so return your car to the dealer.

Good in the clutch

I have a 1984 Ford F250 pickup truck that's equipped with the 6.9-liter diesel engine. The problem I'm having is a rattling, chattering clutch when the truck is stopped in traffic. The dealer says the noise is normal and the throwout bearing is not shot. Can I take his word for it?—Billy Collins, Delta Junction, Ark.

Tough question to answer because there are two ways of looking at this. If your diesel-equipped F250 is like most Ford diesel-equipped light trucks, it's common for the clutch to be noisy under the circumstances you describe. The condition even has a name—*neutral gear rollover*—and exists because of the strength needed by the clutch to withstand the high torque of the diesel. If the throwout bearing is not bad, you have nothing to fear. Noise doesn't mean the clutch and transmission are going to fall apart. This is one way for me to answer your question.

The other way lies with the fact that the clutch disc in a 1985 Ford diesel-equipped truck is different from the one in your 1984 and makes less noise. If the noise is annoying and you want to get rid of it, you can have this new disc (part No. E5TZ-7550-G) installed.

As long as I'm on the subject, rattling and chattering also affect 1984 and some 1985 F100 and F250 models with

4.9-liter gasoline engines. Again, the clutch isn't going to fall apart, but if the noise is bothersome have a dealer install a revised clutch disc (part No. E5TZ-7550-B).

PM CAR CARE



Save your new camshaft

Experienced home mechanics know you should run a newly rebuilt engine at about 2,000 rpm when you first start it up. Few know why, or why the new camshaft and valve lifters may fail in the first few thousand miles if they break in the engine at a gentle idle speed.

Lubrication is the key. Even if you carefully applied assembly lube to all parts when building up the engine, it may not protect heavily loaded steel-on-steel rubbing surfaces long enough for splash lubrication to get to them. Running the engine at 2,000 rpm, blipping the throttle to 2,500 rpm, for

Oil pain

The 301-cu.-in. V8 engine in our 1979 Buick LeSabre and the 350-cu.-in. V8 engine in our 1976 Buick Century have the same problem. Sufficient oil collects in air cleaner pans to completely saturate new filters after only 500 miles. Servicing the PCV systems hasn't helped. Is this a common condition with older GM V8 engines?—Edward Arakelian, Kokomo, Ind.

Generally, yes. Because of the closed crankcase ventilation system, any condition in the engine causing a pressure differential could force oil through the crankcase hose into the air cleaner. Something minor like a leak in a valve cover gasket could do it. So could something major like worn exhaust valve guides or piston rings, or a defective head gasket. Compression and vacuum tests will tell you if the rings or head gaskets leak. Partial disassembly is necessary to check the valve guides.

There's another situation that can cause oil to be drawn into the air cleaner. It relates to a topic I've discussed often in *Car Clinic*—not using SAE 10W-40 engine oil in a GM engine. It's GM's contention that the polymers

(Please turn to page 38)

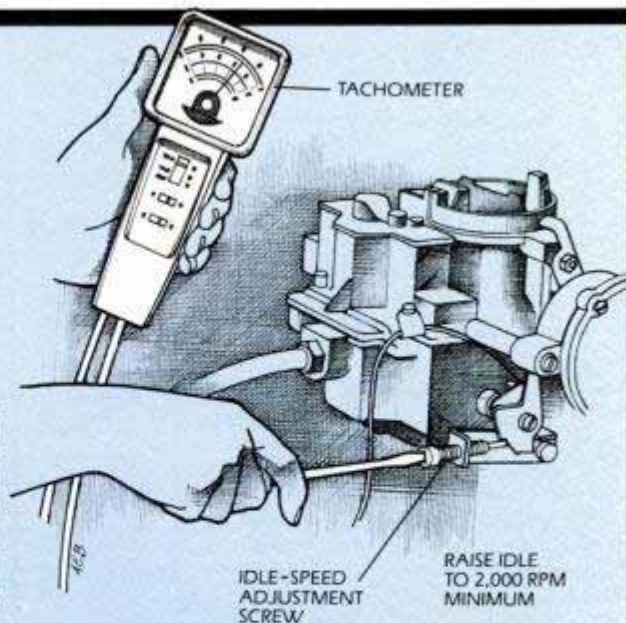

about 20 minutes greatly increases splash lube to the valve train on pushrod V6 and V8 engines.

Fast-idle startup also helps protect a car that's been in storage for weeks, for months or even for years for the same reason.

—Angus Laidlaw

CAR CLINIC

(Continued from page 37)

in SAE 10W-40 oil will cause piston ring sticking.

If the problems with your Buicks are being caused by sticking piston rings, you may be able to reverse the situation. Try a can or two of GM Top Engine Cleaner, which is available from a GM dealer, and use only SAE 5W-30 or SAE 10W-30 oil.

Hail—the gang's here

The question from R.W. Broadstone of Grand Island, Neb., in the April '85 *Car Clinic* (page 28) about using dry ice to get out hail-caused body dents brought two interesting, but divergent, comments. The first is from Auto Damage Appraisers Inc. of Wichita, Kan.:

"The dry ice idea has been proven to be ineffective except in cases of very small dents where the metal has not been stretched. The proper method of hail-dent removal is to heat the dent to dull red with a small torch and then quench the dent with a wet rag or sponge. The metal will shrink on the upper surface first, causing the dent to pop up. Then, a sharp body file is used to level the surface."

Paul C. Hauschildt of Cedar Rapids, Iowa, tells a different story. He says he repaired over \$600 in hail damage to

SERVICE TIPS

■ You may not have to put up with squealing brakes from your 1984-'85 GM car. Reclinch outboard shoes tightly to calipers. This should dampen pad vibration that causes squeal. Move the pad into the caliper with a screwdriver and have someone in the car apply the brake pedal firmly. This holds the pad in position. Now, knock the tab with a ball peen hammer to reclinch the shoe.

■ If your 1984 or '85 Honda Civic automatic transmission doesn't get you moving in "D" when the engine is cold, but it will move the car when in "R" or "2," the one-way clutch in the tranny may be bad. Parking gear and countershaft low gear may also be damaged. Have a dealer make repairs outlined in TSB 85-017.

■ Strange things are happening to some 1984-'85 Chrysler 2.2-liter turbo and EFI engines. With the gasoline level at 1/4 tank or less, the engine sags noticeably when the car's in a hard left turn. The reason is that the filter in the fuel tank is uncovered and exposed to air during the turn. If your car has this problem, ask your dealer to look at TSB 14-49-84.

■ Don't panic if the low oil level warning light comes on or flickers in your 1985 Ford-built car with a 3.8- or 5.0-liter engine. This is happening with engines that have ample oil, because the low oil level sensor doesn't have sufficient resistance. Ask your dealer to install a new sensor (part No. E4AZ-6C624-A) according to TSB 85-6-3.



Strap hanger

You're in for a surprise when you remove the thermostat from a 1982-'85 GM 2.5-liter or 1.8-liter engine. The part is unique in that it can be handled easily—and I mean handled in the true sense of the word.

The thermostat has a metal strap that makes it the easiest of any thermostat to remove and install. The part is in a housing at the end of the upper radiator hose. To remove it, make sure the engine is cold and turn the housing cap counterclockwise. You don't have to drain coolant as with other cooling systems.

Caution: If you get resistance as you turn

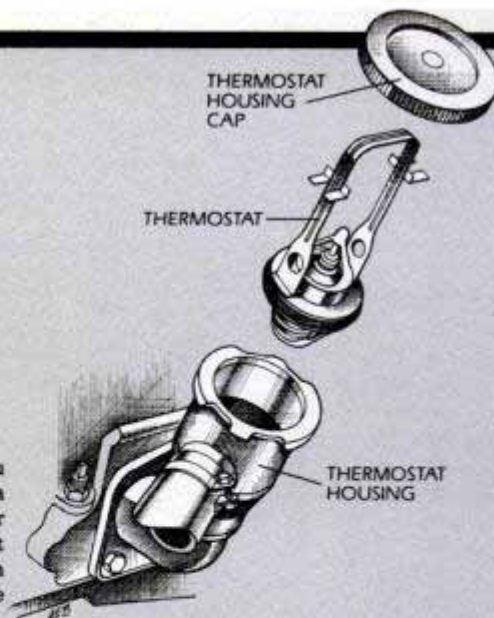

the cap, signifying pressure in the housing, stop turning to let pressure subside.

With the cap off, grab the strap and pull the thermostat out of the housing. Then, install the new thermostat by pushing it into the housing. It's as easy as that.

the hood, top and trunk of his car with pellets of dry ice.

"Wash and dry the surface, and place the car in the sun to get metal as hot as possible," he states. "Put on heavy gloves. Place the end (not the side) of a dry ice pellet on the outside of the dent. Using a circular motion, slowly work in toward the center. Keep the ice moving slowly. If the dent doesn't come out fully, let the metal get hot again and give it another treatment."

Paul cautions that you not begin the repair at the center of a dent. The metal will bulge. Start at the outside.

Thanks for your comments.

A little cry is good

I have trouble with oil leaking around the valve cover of a slant Six engine in a 1981 Dodge pickup. Service centers have used silicone and double thickness gaskets on the cover to try and stop the leak, but no luck. What now?—P. Buttle, Marshfield, Wis.

Someone probably aggravated what started as a normal condition. The fact is that a cover often doesn't make a perfect seal, and there's going to be some wetness around the flange. This is not leaking. It's weeping.

In an attempt to stop this normal condition, some mechanics remove the valve covers and coat them with RTV. During reinstallation, they overtighten the cover, which distorts the flange. Now they have a leak, and only straightening the flange or replacing the valve cover will stop it.

I'm guessing, of course, that this happened in your case. My advice is to check the cover to see if the flange is straight. Check bolt hole areas carefully. They should be flush with the rest of the flange. If they're not, you may be able to hammer them flat while supporting the other side of the flange with a piece of wood. If you can't straighten the flange, get a new valve cover. When you install the cover, use a rubber-impregnated cork gasket. Tighten nuts to 80 in.-lb. or finger-tight plus 1/4 turn. If leaking (not weeping!) persists, give nuts another 1/4 turn—no more. Expect some wetness and don't try to stop it.

Hoodwinked

My two Nissan Stanzas are giving me a big headache for the same reason. When the rear edge of the hood is raised, it hits the windshield wiper arms. I've tightened wiper arm nuts, but that doesn't seem to do a thing. Please help me solve this problem.—T. W. Wagner, Camarillo, Calif.

You should try tightening the nuts securely as you push down on the windshield wiper arm an inch or two above the arm's pivot point. Now see what happens. I'll bet this technique works for your two Nissans. **PM**

DO YOU HAVE A CAR PROBLEM?

Just ask Mort about it. Send your question to the *Car Clinic*, Popular Mechanics, 224 West 57th St., New York, N.Y. 10019. While letters cannot be answered individually, problems that are of general interest will be discussed in the column.

NEVER RENT AGAIN!

NEVER borrow a trailer again either.
NEVER even take up space storing one again!

Introducing the



Folding Utility Trailer The heavy-duty tilt-bed trailer that folds up and stores in 2 feet of space... folds out to a big 4'x8' half-ton trailer when you need it! Easily carries up to 1000 lbs! Folds to snuggle up against a garage wall and takes up just 2 ft. of space!

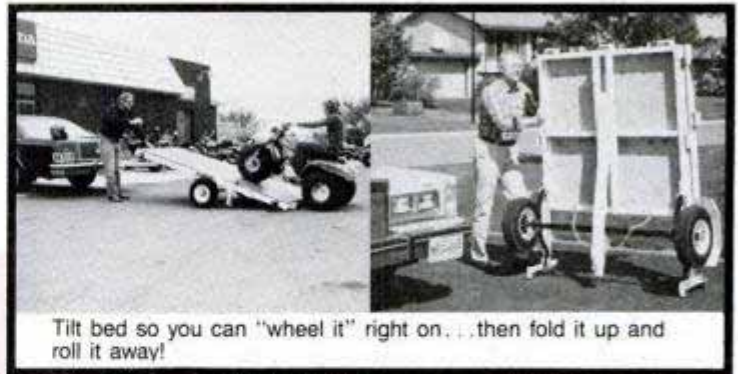

Tilt bed so you can "wheel it" right on... then fold it up and roll it away!

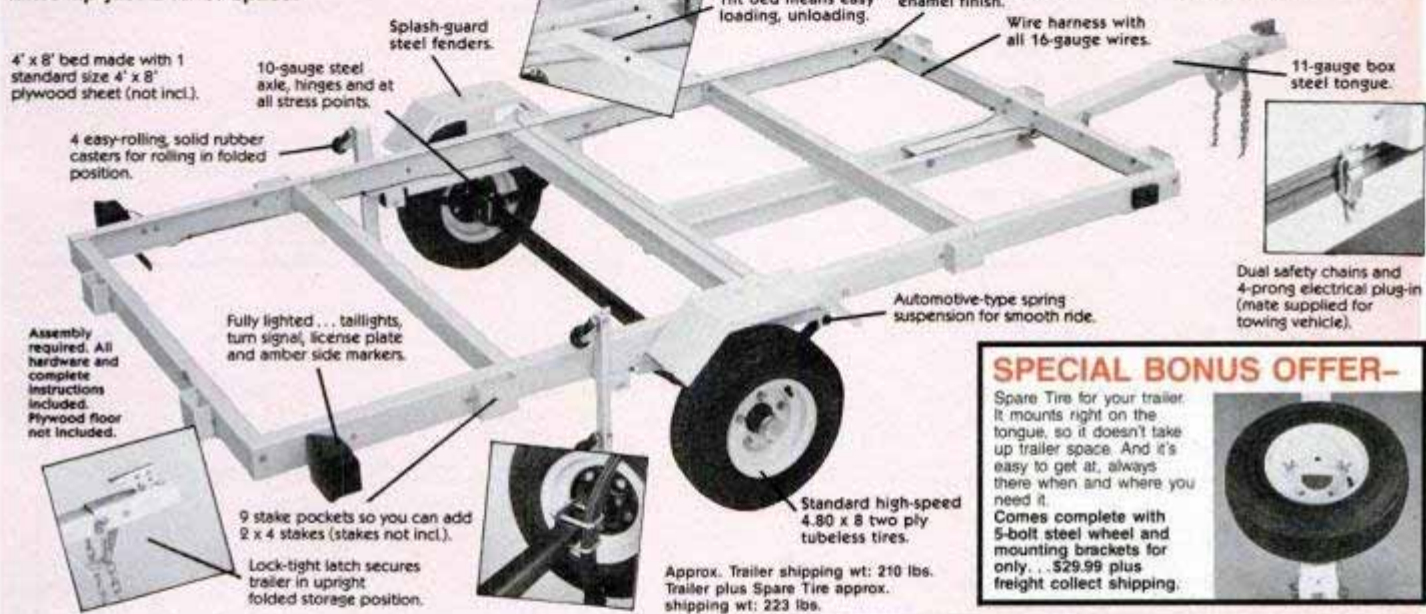

SPECIAL BONUS OFFER—

Spare Tire for your trailer. It mounts right on the tongue, so it doesn't take up trailer space. And it's easy to get at, always there when and where you need it. Comes complete with 5-bolt steel wheel and mounting brackets for only... \$29.99 plus freight collect shipping.

Saves time, space, money and work... it even saves wear & tear on your vehicle!

2-wheel travel convenience and 4-wheel foldability. That's the secret. Foldability. The average utility trailer may do the job of hauling... the problem is where to store it. The 6-Wheel Wonder eliminates storage problems. Instantly folds down for space-saving storage. A big roomy carry-all for hauling, a compact little roll-away for storing! And because the bed tilts, you cut down on back-straining lifting. Roll anything with wheels right onto the trailer... even your ATV.

Judge for yourself. Try the 6-Wheel Wonder FREE of obligation to keep it. Put it to work... load it up and try it out. Then see how quickly and compactly it stores. If you're not 100% satisfied with it, send it back for a full, complete refund... including freight charges.

Mail in your order today! Credit card buyers can also call Toll-Free, 24 hours-a-day, 7 days-a-week—800-228-5000. (In Nebraska — 800-642-8777.)

Save at least 55% over average retail prices for a comparable trailer.

JUST **\$199⁹⁹**

No trailers are shipped OUTSIDE the continental U.S.

Save up to 45% on freight

Because of a special arrangement made ONLY for D.R.I. customers... you pay just the actual freight costs less 20-45%! Freight costs vary depending on where you live. We ship your trailer motor freight collect.

2 YEAR LIMITED WARRANTY

Warranty statement included with product or you can write for free advance copy to: D.R.I. Industries, Inc., Dept. 88215, 11300 Hampshire Ave. S., Bloomington, MN 55438-2498

88215 **SPECIAL OFFER COUPON** MAG-147



Try it free of obligation to keep it!

If not totally satisfied, you can return your order for a complete refund, including freight.

SEND TO AND MAKE REMITTANCE PAYABLE TO:
D.R.I. INDUSTRIES, INC., Dept. 88215, 11300 Hampshire Ave. So.,
Bloomington, MN 55438-2498

INDICATE ORDER How Many? Utility Trailer(s) @ \$199.99 each. (00017702)
 How Many? Spare Tire and Mounting Bracket Set(s) @ \$29.99 each. (00017703)

CHECK METHOD OF PAYMENT I've enclosed my check or money order. (Minnesota residents add 6% sales tax.)
 I've enclosed my company purchase order. (This card MUST accompany ALL purchase orders.)
 Charge it to: VISA MasterCard American Express Diners Club Carte Blanche

Card No. _____ Exp Date _____

SIGNATURE _____ (Need sign only if charging)

Because of the size and weight of the Utility Trailer, it must be shipped by truck. To make delivery arrangements with the carrier, we need a phone number you can be reached at during the day, and if possible, supply street address for truck delivery (fill in below).

I will pay shipping charges to driver upon delivery.

PLEASE PRINT NAME Mr. _____
Mrs. _____
Ms. _____

AREA CODE (_____) NUMBER _____

ADDRESS _____ Street & No.

CITY _____ STATE _____ ZIP _____

PLUS FREE GIFTS!
Just for ordering the 6-Wheel Wonder... yours to keep, whether or not you decide to keep your order. They're simply our way of doing everything we can just to get you to try the 6-Wheel Wonder.
FREE... 2 Bungee Cords. One 24" and one 40".
FREE... Heavy-duty 6'x10' tarp, made of high density 10x10 weave polyethylene. Ideal for protecting your trailer against the elements.
FREE... Valuable Surprise Free Gift. From our huge inventory of unique products.



©Copyright 1984 D.R.I. Industries, Inc.
* 6-Wheel Wonder is a registered trademark of D.R.I. Industries, Inc.
Product of ROC Taiwan

ALL OUTDOORS



Entry-level powerboating

High expense has long barred the general public from participating in the sport of powerboat racing, and would-be Bob Magoons and Betty Cooks have had to find a release for their competitive urges in eight-foot plywood hydros. But now the American Powerboat Association, in cooperation with major outboard manufacturers and BAJA Boats of Bucyrus, Ohio, has unveiled "Mini Grand Prix" racing. The sport debuted at the OPC Marathon Nationals in May. The rule book for this new class places a 25-hp limit on engines and a 10-foot minimum on overall length, which is intended to spark innovations



The new Mini Grand Prix racing class packs a lot of excitement in an affordable package.

in design. While radical engine modifications are discouraged, cupping, shaving and repitching class legal props are allowed. The cost of this Lilliputian package? A digestible \$5,000. Compare that to Formula One Hydroplane

racing, where a single outboard powerplant can cost up to \$20,000 a copy. For more information, contact the American Powerboat Association, 17640 East Nine Mile Road, P.O. 377, East Detroit, Mich. 48021.

Camp pots

Talk about five-star hotel luxury and convenience at the campsite! How about having constant hot water at your campfire without covering the fire with your pot?

The Water-Heatr integrates a copper



Place the heating coils in your campfire. Coffee, soups, or stews stay hot all day.

coil with a lightweight aluminum pot. You simply fill the unit with water, place it next to the fire and it heats water to a boil. The heater comes in sizes as small as five cups and up to five gallons. You can special order a heavy-duty unit that will hold up to 20 gallons, too. The copper coil detaches and stores handily inside the pot when it is not in use.

The Water-Heatr camp pots range in price from \$39.95 to \$49.95 and they are available from Mi-Ken Co., 760 N. Bertelsen Rd., Eugene, Ore. 97402 (503) 689-5562.

Target analysis card

You're having trouble hitting the bullseye at your local handgun shooting range, but you're hardpressed to figure out why. With the Caswell Handgun Target Analysis Guide, you can quickly determine what you're doing wrong—and take corrective measures. If you are consistently firing above the bullseye when you shoot right-handed, for instance, you may be breaking your wrist up when you squeeze the trigger. If you shoot high and to the right, you may be reacting to recoil prematurely, and if you shoot low and to the right, you may be squeezing your whole hand as you squeeze the trigger. The target



The Caswell target analysis card helps spot shooting errors and suggests improvements.

analysis card (for both right-handed and left-handed shooters) quickly identifies problem rounds and suggests solutions. It's free from Caswell Equip-

ment Co., makers of shooting range equipment and accessories. Send a stamped, self-addressed envelope to Caswell, 1221 Marshall Street, Minneapolis, Minn. 55413.

Outboard steering

Now, any size outboard—from the smallest dinghy mover to the biggest V8—can be equipped with no-play hydraulic steering if it has a provision for through-the-tube steering. HyDrive's



HyDrive's steering unit fits most motors.

bull-horn steering cylinders come with mounting brackets that clamp onto the motor and hold the cylinder under the front of the outboard. The system will work on virtually any powerboat and will accommodate dual-engine setups. Designed for saltwater use, the system has no parts that jam under load or wear, and it won't seize up due to corrosion or long periods of disuse. It sells for \$475 from HyDrive America, 36-29 Vernon Blvd., Long Island City, N.Y. 11106 (718) 706-0080. **PM**

QUADRUPLE YOUR FUN.

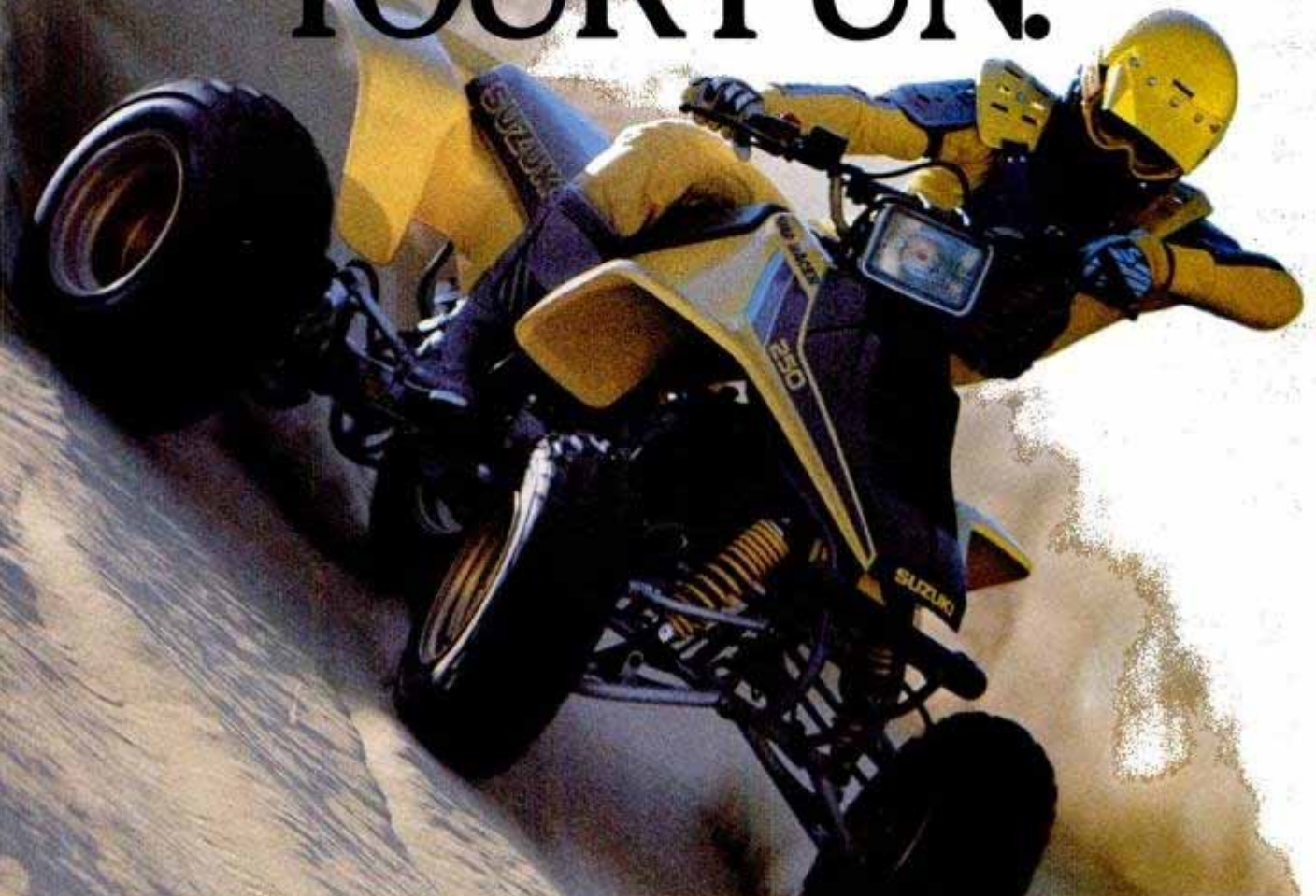

LT50

LT125

LT185

LT230GE

LT250E

LT250EF

LT230SF
QuadSport

LT250RF
QuadRacer

Nobody has more ways to have fun off-road than Suzuki. Because nobody has more four-wheelers. There are eight Suzuki Quadrunners in all: From the LT250R QuadRacer for everyone whose idea of a good time is recording a winning time, to the kid-size LT50 that's just right for first time riders. Quadrunners with reverse, utility racks, electric start, even one with shaft drive. All built with legendary Suzuki dependability

and attention to detail. Everyone who knows the fun begins where the road ends, can have more fun on a Suzuki Quadrunner.

So hop on a Quadrunner and head for the hills. Or the valleys. Or the desert. Or any of the places you've always wanted to go, but thought you never could, until Suzuki invented the fourth wheel.

Professional rider pictured above. Always wear protective helmet and riding gear. Never carry passengers. Read owner's manual.



QUADRUNNERS™
FOREMOST IN FOUR-WHEELING.

PM ELECTRONICS MONITOR



Digital race escalates



Sony's tiny CD player tops off the new CFD-5 boombox with AM/FM radio, cassette and detachable speakers.

Hi-fi's answer to the cruise missile is here. It had to happen sooner or later—the boom-box armed with a digital audio Compact Disc player.

Audio makers have been threatening such a product since 1983. Now, Sony's delivering on the dare. By the time you read this, the battery-powered CFD-5 literally will be on the streets. From what we heard around Tokyo this April, it's 17 pounds of pure hi-fi on a handle.

Sony has built its downsized D-5

Compact Disc player into a 22 by 8 by 8-inch bundle that includes an AM/FM tuner, five-band graphic equalizer and auto-reverse cassette deck. Thanks to the efficient speakers (which use flat diaphragms instead of cones) the CFD-5 generates convincing sound on only four watts per channel. At \$550, it's a good entry-level system—one that can join you on picnics or vacations. The CD player also connects directly to home hi-fi systems.

Add to your vocabulary

Smith-Corona has sent its typewriters to summer school—and it shows.

In May's *Electronics Monitor* (page 14) we described the company's Spell-Right feature, a 35,000-word electronic dictionary that beeps when the typist misspells a word. Now, just in time for the fall semester, Smith-Corona's top-of-the-line SD-300 has arrived. The \$499 typewriter can be fitted with the company's new 50,000-word vocabulary Spell-Right II module. This \$100 option also lets you program it to recognize 300 specialized words not already in the module.

The SD-300 also allows you to compose on a 16-character display before you print, lets you erase an entire word at the tap of a key and offers 3,000 characters (about 1½ pages) of memory. What's more, it doubles as a letter-quality computer printer.



Typewriter with college education: Smith-Corona's SD-300. Module's 50,000-plus word dictionary alerts typists to errors.

Mobile babysitter

A color monitor with four-way power supply means you can watch TV in your car, at the beach, the stadium or anywhere else you travel. Samsung's compact 5-in. portable (Model C5101M, \$300) fits the bill. We don't use the word monitor lightly: The unit's direct video and audio inputs and outputs let you view your videocamera movies on the go. You can even connect a portable VCR to watch movies—or use the monitor's VHF/UHF tuner to record programs on the VCR as you travel.



Inputs and outputs on side of Samsung's 5-in. monitor allow connection of VCR, camera.

Currents

■ You read it here first: The autosound systems in '86 cars from Chrysler and Ford might have fidelity on a par with sophisticated aftermarket systems—thanks to proposed joint ventures between the car companies and hi-fi speaker makers Infinity and JBL. Though the automakers remain mum, our sources say Ford will couple JBL speaker systems with its own high-tech electronics in some 10,000 Lincoln Continentals. Meanwhile, Chrysler's playing to the masses. Seven Iacocca-mobiles will boast amplified speaker modules from high-end hi-fi stalwart Infinity Systems. For the first time, Chrysler's radiocassette players will have Dolby noise reduction. And Ford is endorsing Loran-brand cassettes for its cars. These road-rated tapes have warp-proof shells.

■ General Electric has abandoned its Personal Radio Communication Service project. As detailed in last December's column (page 30), PRCS promised low-cost, limited range communication between motorists and their home phones. An uncertain regulatory climate and lower cellular phone prices were factors in the cancellation of the PRCS project. **PM**



Rickie Smith's Motorcraft Pro Stock Thunderbird



Willy T. Ribbs
Chris Kneifel
SCCA Trans-Am
Mercury Capri



Wally Dallenbach Jr.
John Jones
IMSA Mustang GT



Ricky Rudd's NASCAR
Motorcraft Thunderbird

All these winners go with winners: Motorcraft parts.

The Motorcraft Mustang didn't win by just a mile at the 1985 Daytona 24-Hour. It left competition 135 miles behind as Dallenbach, Jones and Bundy took the GTO class. The same car also finished miles ahead of competition in the 12 Hours of Sebring. Mercury Capris flying Motorcraft colors are out to capture the SCCA Trans-Am manufacturer's championship again this year. Motorcraft is on the 1985 NASCAR Winston Cup Circuit with Ricky Rudd in his Thunderbird. Bud Moore, one of the most promising newcomers, is teamed with veteran car builder driver to break the 180 mph and 8 second barriers—is driving his Pro Stock Motorcraft Thunderbird in '85 NHRA and IHRA events. All of these are proof positive of Motorcraft parts' exceptional performance under all types of rugged racing conditions. Get Motorcraft's out-to-win performance going for you out on the street. Motorcraft. Quality parts for all makes of cars and trucks.



Motorcraft

EXCEEDS THE NEED

APPLIANCE CLINIC



Multiproblem dishwasher

I waited too long to write for help, now I have three problems with my Kitchen Aid dishwasher, Model KDS-14, serial No. 802972. First, the lower front panel must be removed and the slide lever that turns the dial must be pushed by hand to start the machine.

Second, when water-spot remover is poured into the rinse dispenser, the solution runs out when I close the door, before the machine is started. The third problem happens while the machine is running. Water drips from the bottom of the heating element motor fan guard.

I know this is quite a request for information. I would appreciate any help you can give me. Can I purchase a book listing the parts, and instructions on repairing the machine?—John Szapian, East Greenwich, R.I.

To correct your first problem, disconnect the power to the dishwasher. Then, remove the outer door panel by

removing the four screws which hold it to the inner door panel. Once the panel is removed, you will see a thin stainless-steel rod that comes down from the latch mechanism in the top of the door. This rod unlocks the timer when the door handle is latched.

Follow the rod down to the bottom of the inner panel. It fits inside a small brass bushing just above the timer. Apparently, because of corrosion which has occurred over the years, the rod has become frozen inside the bushing. Apply penetrating oil in the bushing area. Work the rod up and down by hand until the latch operates freely.

Your second problem sounds like you may have to replace the entire rinse dispenser. Corrosion has probably built up inside the dispenser, making the lock and release valve inoperative. The replacement rinse dispenser comes as a kit costing about \$24 plus tax and

shipping. The part number is ML-17208. The kit can be ordered through Kitchen Aid or from your local appliance part distributor.

Your third problem is probably caused by water leaking between the vent cover (on the inside rear wall of the tank) and the cover gasket. Correct this problem with RTV silicone sealer (G.E.-102 RTV Silicone Rubber Adhesive and Sealant, G.E. part No. WX6X200, or the equivalent).

Put a bead of the sealant along the top of the cover and down the sides, then level it off with a wide screwdriver. This should take care of the leak.

As for a repair manual or parts list for your machine, write to Kitchen Aid Headquarters, Hobart Corp., Kitchen Aid National Service, Troy, Ohio 45374. Enclose a letter stating what literature you want and the model number of your dishwasher.

Cool oven

I have a Sears Kenmore Gas Range, model No. 103.7297442, serial No. 4J18414 that will not come up to medium or high temperature settings in the oven. Both the oven and broiler settings are controlled by the oven control and both light normally at a preselected temperature, but the oven will only come up to 200° to 225° and recycle at that level. The broiler will light (reluctantly) and heat to about 250° and then go out. Repeated relighting changes nothing. Help!—John E. Gerber, Wausatosa, Wis.

Your gas range has a selector switch mounted on the backguard control panel just below the clock assembly. The selector switch is marked "timed bake" (up position) and "bake" (down position). For normal baking operations without the use of the timer, make sure the switch on your range is in the "bake" position.

Your problem may be as simple as the selector switch being in the wrong position. If you have the selector switch in the right position and the oven still doesn't work properly, I would suspect the selector switch is faulty and should be replaced.

The range's selector switch is part No. 109705 and is available at any Sears parts center.

To replace the switch, first unplug the range and move it away from the wall. Next, remove the screws that hold the metal wirecover to the rear of the control panel and backguard supports.

Remove the cover. Hold the switch

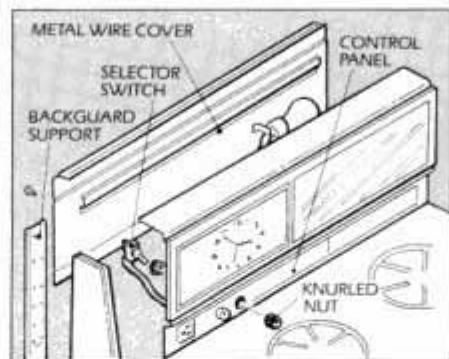

To replace the oven selector switch, remove wire-cover panel, then unscrew knurled nut.

with one hand while reaching over the control panel with the other hand to loosen the knurled nut that holds the switch to the panel.

Remove the defective switch. Remove the wires from the slip-on wire clips and put them on the new switch. Now, reinstall the assembly with the new switch. Put the rear panel back on, along with the supports. Plug in the range, and reset the clock.

Impulsive garage door

Occasionally, my automatic garage door (Montgomery Ward, model No. 34025) opens spontaneously. I don't know the source of the signal but I suspect planes from the local airport, or some other radio signal. Is there some way I can shield the antenna from extraneous signals and still use my remote transmitter?—Gardner G. Gremillion, Frederick, Md.

I checked with the manufacturer of your garage door opener. They don't think there is any way to shield your antenna from the phantom signal. Your opener is 12 to 15 years old. Back then, door openers were not as sophisticated, nor did they have the security of today's openers. Apparently a very powerful signal is reaching the circuitry in the opener, triggering the door.

Changing the frequency of your opener will not guarantee that this won't happen again. The only real cure for your problem is to invest in a new state-of-the-art door opener which is digitally encoded, and designed to prevent phantom operation. **FM**

If you have a problem with any appliance, send your question, along with the model and serial numbers, to Appliance Clinic, Popular Mechanics, 224 West 57th St., New York, N.Y. 10019. Sorry, but letters cannot be answered individually. Problems of wide interest will be discussed in this column.

Know your car inside and out.

Your car can run better, last longer and get better gas mileage.

Know how to fix it . . . to tune it . . . to keep it running right. The TOTAL SERVICE MANUAL for your car will show you how to do everything from a minor adjustment to a major repair.

factory workshop manuals. Each one is carefully rewritten for use by the do-it-yourself car owner. Clear and easy to follow, yet complete and detailed enough even for professional use. You get all the important information plus hundreds of the best pictures, diagrams, and specifications.



TOTAL SERVICE MANUALS are digests of official

CREDIT CARD ORDERS CALL 516 676-8043

TOTAL SERVICE MANUALS

- 1713 Alfa Romeo 62-78 Giulia, Spider, plus \$13.95
- 9641 Alfa Romeo 73-80 all GT, GTV & sedans \$13.95
- 0448 Alliance 83 all models plus Fuso \$12.95
- 1244 AMC 70-85 all Green/Spirit, Hornet/Concord \$13.95
- 8194 AMC 75-82 AMX, Eagle, Metador, Pacer, + \$12.95
- 0991 Arrow 76-80 covers all models \$13.95
- 8019 Aspen 76-80 for all 6 & V8 models \$12.95
- 7122 Audi 100 70-77 all models inc 100LS \$13.95
- 1229 Audi 4000 80-82 all sedan & coupe \$13.95
- 9699 Audi 5000 77-83 factory shop manual \$39.95
- 0726 Audi FF 73-79 covers all models \$13.95
- 0379 Barracuda 65-72 all 6 & V8 inc Cuda \$12.95
- 1042 BMW 2002 59-77 all inc 160i, no CS \$13.95
- 8813 BMW 320i 75-82 covers all models \$13.95
- 9199 BMW 528i, 530i 75-80 for all models \$13.95



- 9760 BMW 2500, 2800, 3.0 all models, no CS \$13.95
- 0504 Bronco 66-81 all 2 & 4 whl dr models \$12.95
- 9332 Bronco II 84 all 2 & 4 whl dr models \$13.95
- 6308 Buick 68-76 Electra, LeSabre, Wildcat \$14.95
- 8473 Buick 77-85 Electra, LeSabre, Wildcat \$13.95
- 8082 Buick 74-84 Century, Regal inc turbo \$13.95
- 9851 Buick 82-83 Skyhawk & Cal Cimarron \$13.95
- 0727 Cadillac 68-74 all except El Dorado \$14.95
- 6016 Cadillac 75-84 all full size models \$12.95
- 8678 Camaro 67-81 all 6 & V8 models \$13.95
- 2488 Camaro 82-84 covers all models \$13.95
- 9557 Camo 70-76 all 2000, 2600, 2800 models \$13.95
- 9386 Caori 79-83 all engines & models \$13.95
- 9851 Cavalier 82-83 all + Pontiac J-2000 \$13.95
- 8465 Celebrity 82-83 all + Ford Century \$13.95
- 0379 Challenger 70-72 all 6 & V8 models \$12.95
- 9462 Challenger 78-83 all inc Szeppon \$13.95
- 8331 Charger 67-70 for all inc 500 & R/T \$12.95
- 0383 Chevelle 64-69 for all inc Malibu \$12.95
- 8469 Chevelle 70-84 + Malibu, Monte Carlo \$13.95
- 0838 Chevelle 76-84 all mds + Pont 11000 \$13.95
- 1038 Chevrolet 49-54 all 6-cyl models \$22.95
- 0888 Chevrolet 59-64 repair factory manual \$22.95
- 0919 Chev 69-81 BelAir, Bison, Capric, Impala \$13.95
- 8187 Chev 82-88 all 4, 6 & V8 models \$12.95
- 0779 Chev LUW 72-82 all 2 & 4whl-drive \$13.95
- 2477 Chev 82-85 5-10 pick-up + GMC 5-15 \$13.95
- 8464 Chev 82-83 5-10 pick-up + GMC 5-15 \$13.95
- 8849 Chev 83 5-10, 5-15 Blazer + Jimmy \$12.95
- 8154 Chev 67-82 pick-up, subrn, Blazer, GMC \$13.95
- 1462 Chev 67-83 vans all models + GMC \$13.95
- 1257 Chrysler 72-84 tune all rear-whl dr mds \$11.95
- 9756 Chrysler Laser 84-85 all inc turbos \$12.95

- 0020 Chrysler 74-79 factory man. give year \$26.95
- 9148 Citation 80-85 all mds + Buick Skylark \$13.95
- 9588 Citroen id, DS 67-75 all DS19, 20, 21 \$13.95
- 8732 Colt & Champ 78-83 front whl drive \$13.95
- 8032 Corvair 60-69 all models inc turbo \$12.95
- 0478 Corvette 57-65 all 283 & 327 models \$13.95
- 9481 Corvette 66-82 all engines & models \$14.95
- 9585 Corvette 84 factory shop manual \$35.95
- 1242 Cougar 67-73 covers all 6 & V8 models \$12.95
- 1756 Cricket 70-73 all + Hillman Avenger \$13.95
- 8188 Dart & Demon 68-76 covers all models \$12.95
- 9592 Datsun 200SX 80-82 \$13.95
- 8065 Datsun 1200/8210 71-78 all models \$13.95
- 0783 Datsun 210 79-82 for all models \$13.95
- 8127 Datsun 240Z, 260Z, 280Z 70-78 all mds \$13.95
- 9152 Datsun 280ZX 79-82 all inc turbo \$13.95
- 3739 Datsun 310 78-82 covers all models \$13.95
- 9583 Datsun 510, 610, 710 68-77 all models \$13.95

- 8271 Datsun 810/Mazda 77-84 all gas eng mdl \$13.95
- 0542 Datsun/F 10 76-79 covers all models \$13.95
- 9398 Datsun/Nissan Sentra 82-83 all mds \$13.95
- 7138 Datsun/Nissan Stanza 82-83 all mds \$13.95
- 9297 Datsun 70-81 pick-up all 2-whl dr mds \$13.95
- 0925 Datsun 80-82 pick-up 720 2 & 4 whl dr \$13.95
- 0871 Dodge 68-77 all Monaco, Polara mds \$12.95
- 1257 Dodge 72-84 tune all rear-whl dr mds \$13.95
- 8066 Dodge Aries 81-83 for all models \$13.95
- 9756 Dodge Daytona 84-85 all inc turbo \$12.95
- 1259 Dodge Omni 78-84 all + 024, Chrg, Rmpg \$13.95
- 0953 Dodge 67-84 pick-up all 4-whl dr mdl \$12.95
- 1298 Dodge 71-84 pick-up all 2-whl dr mdl \$13.95
- 2497 Dodge 79-81 D-50 pick-up plus Arrow \$12.95
- 8203 Dodge 70-79 vans to 1 ton + Plymouth \$12.95
- 6070 Dodge 71-83 vans to 1 ton + Plymouth \$13.95
- 0861 Dodge Caravan 84-85 + Plymouth Voyager \$12.95
- 8192 Duster 70-76 all models inc Scamp \$12.95
- 9688 Escort 81-82 all mds inc EXP \$13.95
- 8189 Fairlane 62-70 for all models \$12.95
- 8366 Fairmont 78-83 for all models \$13.95

- 9776 Fiat 124 67-82 all, Spyder, 2000, turbo \$13.95
- 9640 Fiat 128 72-79 all mds + SL, Rally \$13.95
- 8106 Fiat 131 75-80 all 1.8 & 2.0 engs \$13.95
- 0399 Fiat X1/9 71-80 covers all models \$13.95
- 6222 Fiat Strada 79-80 all models \$13.95
- 1073 Fiesta 78-80 covers all models \$13.95
- 6309 Firebird 70-81 all V8 mds + TransAm \$13.95
- 1685 Firebird 82-84 covers all models \$13.95
- 9436 Ford Granada 75-82 covers all models \$12.95
- 9611 Ford 71-82 Elite, LTD II, Rchro, Ford \$12.95
- 0872 Ford 68-83 Custom, Galaxie, LTD, XL, + \$12.95
- 9736 Ford Tempo 84-85 covers all models \$13.95
- 9369 Ford Courier 72-82 covers all models \$13.95
- 8205 Ford 65-68 pick-up 2 & 4 whl to 1 ton \$12.95
- 0451 Ford 69-83 pick-up 2-whl F-mds + desks \$13.95
- 8458 Ford 73-79 pick-up 2 & 4 whl F-mds \$13.95
- 0403 Ford 80-83 pick-up 4-whl dr 4whl F-mds \$13.95

- 9322 Ford Ranger 83-84 all 2 & 4 whl dr mds \$13.95
- 8204 Ford 61-68 vans all to 1 ton \$12.95
- 0453 Ford 69-83 vans all 6 & 8 cyl mds \$13.95
- 8848 Honda Accord 76-82 covers all models \$13.95
- 9787 Honda Prelude 69-82 \$13.95
- 8694 Honda Civic 73-83 covers all models \$13.95
- 8565 Interim/FI 62-80 wagon, pick-up, Scout \$13.95
- 8206 Int'l Scout 67-73 A, B, H, 8000 mds \$12.95
- 1043 Jaguar E-type 61-72 all 6-cyl models \$13.95
- 9399 Jaguar XJ6 68-84 covers all models \$13.95
- 9617 Jaguar XJ12 72-80 all inc XJS \$13.95
- 9769 Jeep Willys 46-65 sta wagon + pick-up \$12.95
- 0481 Jeep 66-84 Cherokee, Wagoneer, Commodo \$12.95
- 9805 Jeep Wagoneer J-series w/230 chg eng \$21.95
- 8195 Jeep CJ 68-84 all CJ-5, -6, -7 models \$13.95
- 0596 Lancia Beta 76-80 sedan, coupe + HPE \$13.95
- 1254 Landrover 59-77 2, 2A, 3 mds + diesel \$13.95
- 0481 Lancia 69-71 all 6-cyl models \$12.95
- 8211 Lancia 72-77 all models + Comet \$12.95
- 1550 Mazda GLC 77-82 rear whl drive mds \$13.95
- 0812 Mazda GLC 81-84 front whl drive mds \$13.95
- 0444 Mazda 71-78 includes RX4 & Cosmo \$12.95
- 9941 Mazda RX7 79-83 covers all models \$13.95
- 8105 Mazda 626 79-81 covers all models \$13.95
- 0593 Mazda 808, 818 72-78 covers all mds \$13.95
- 9486 Mazda 72-82 pick-up B-1600, 1800, 2000 \$13.95
- 8197 Mercedes 59-70 all 190, 200, 220, 230 mds \$12.95
- 9485 Mercedes 250, 280 68-72 all 250 \$13.95

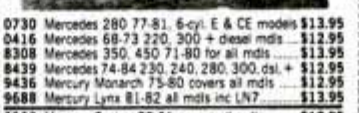

- 0730 Mercedes 280 77-81, 6-cyl, E & CE models \$13.95
- 0416 Mercedes 68-73 220, 300 + diesel mds \$12.95
- 8308 Mercedes 350, 450 71-80 for all mds \$13.95
- 8439 Mercedes 74-84 230, 240, 280, 300, ds1 + \$12.95
- 9436 Mercury Monarch 75-80 covers all mds \$12.95
- 9688 Mercury Lynx 81-82 all mds inc LN7 \$13.95
- 0922 Mercury Zephyr 78-81 covers all mds \$13.95
- 1098 MG Midget 68-80 all + Sprite 58-71 \$13.95
- 6038 MG MGA 56-62 covers all models \$13.95
- 1720 MG MGB, MGBGT 62-81 roadster, coupe mds \$13.95
- 0911 Mini 59-78 all mds inc Mini-Cooper \$13.95
- 0864 Monza, Chev 75-80 + Astre, Strir, Skyk \$12.95
- 0479 Mustang V6 65-73 covers all models \$13.95
- 8272 Mustang 74-78 all 4, V6 & V8 mds \$13.95
- 9386 Mustang 79-83 all engines & models \$13.95
- 0951 Nova 71-79 covers all models \$13.95
- 8206 Oldsmobile 69-76 all 88, 98 models \$14.95
- 8473 Oldsmobile 77-85 for all 88 & 98 mds \$12.95
- 7107 Olds Cutlass 70-84 rear whl dr mds \$13.95
- 8465 Olds Cutlass Sierra 82-83 + Pont 6000 \$12.95
- 9851 Olds Firenza 81 mds + Pont J2000 \$13.95
- 9148 Olds Omega 80-85 all + Pont J2000 \$13.95

CHASSIS & BODY REPAIR

- 1223 Brakes, Steering & Suspension 76-83 \$16.95
- 8478 Customizing Cars inside & out \$12.95
- 3720 Auto Body Repair, tech training man \$25.95
- 1659 Auto Body Repair, the fundamentals \$16.95
- 8712 Metal Fabricator's Handbook, custom \$12.95
- 5104 Auto Body Repairing & Repainting, best \$16.95
- 0745 Auto Collision Work, vocatn train manual \$19.95
- 0827 Automotive Refinishing, for the pro \$8.95
- 8470 Fiberglass Repair & Construction \$11.95
- 5106 Glass Fiber Auto Body Construction \$6.95
- 0906 Old Car Value Guide, 1900-69 all \$10.95
- 1000 Restoration of Antique & Classic Cars \$14.95
- 9780 Auto Restoration Guide, very complete \$17.95
- 0995 Car Interior Restoration, for any car \$7.95
- 8364 How to Restore Car Interiors \$14.95
- 8903 How to Restore Paintwork \$14.95
- 8912 How to Restore Fiberglass Bodywork \$14.95
- 0802 Essential Upholstery & Trim - classic cars \$15.00

BOATS & MOTORCYCLES

- 9560 Chrysler/Force D.B. 66-84, 3.5-140 hp \$22.95
- 9562 Evinrude/Johnson 73-84 all 2-40 hp \$22.95
- 9564 Evinrude/Johnson 73-84 all 50-235 hp \$22.95
- 9566 Mercury O/B 72-84 all 3.5-40 hp \$22.95
- 9569 Mercury O/B 72-84 all 50-225 hp \$22.95
- 1085 Mercruiser stern drives 64-83 for all \$22.95
- 3771 OMC stern drives 64-84 all eng & drvs \$22.95
- 0725 Volvo stern drives 68-84 all eng & drvs \$22.95
- 0929 Motorcycle Man 68-81 all Jpn & US \$24.95

- 8273 Opel 66-75 all GT, Kadett, Mantra, 1900 \$13.95
- 0107 Opel Inuzu 76-79 fact man. give year \$20.95
- 7124 Peugeot 504 68-79 all gas eng models \$13.95
- 0811 Peugeot 504 Diesel 74-80 all models \$13.95
- 0783 Pinto 70-80 all mds + Mercury Bobcat \$13.95
- 0874 Plymouth 68-76 Fury, VP, Gran, Suburban \$12.95
- 1259 Plym Horizon 78-84 inc TC3, Turismo, Scamp \$13.95
- 8066 Plymouth Reliant 81-83 all models \$13.95
- 8473 Pontiac 77-85 all full size \$12.95
- 9710 Pontiac 74-84 LaMts, GTO, GP, GrandAm, + \$12.95
- 8601 Pontiac Fiero 84-85 covers all models \$12.95
- 0489 Pontiac Tempest 68-73 + GTO, LaMans \$12.95
- 9535 Porsche 911 65-82 inc E, S, SC & T \$13.95
- 9634 Porsche 914/4 69-76 \$13.95
- 1635 Porsche 924 76-82 all mds inc turbo \$13.95
- 8708 Porsche 928 76-81 all models + 924 \$12.95
- 8058 Pontiac LeCar 75-83 covers all models \$13.95
- 8429 Renault 12 69-79 for all models \$13.95
- 0645 Renault 15, 17 73-79 all except T3 \$13.95
- 9804 Renault 18 78-81 all inc GTL, GTS, LS \$13.95
- 9552 Renault Fuego 82-84 covers all models \$13.95
- 0750 SAAB 99 65-79 covers all models \$13.95
- 9613 SAAB 900 76-83 all mds inc Turbo \$13.95
- 8058 Subaru 72-82 all 1300-1800, Brat, MPV \$13.95
- 8584 Subaru 80-83 all models, 2 & 4 whl dr \$13.95
- 8996 Sunbeam Alpina, 260 Tiger, Rapier mds \$10.95
- 8189 Torino 68-75 all inc Elite, Ranchero \$12.95
- 0829 Toyota Celica 71-81 all excpt Supra \$13.95
- 9002 Toyota Celica 82-83 all excpt Supra \$13.95
- 9812 Toyota Corolla 68-83 all models \$13.95
- 7132 Toyota Corolla 70-82 all 4-cyl models \$13.95
- 8198 Toyota Cressida 78-82 all models \$13.95
- 0923 Toyota Starlet 81-84 covers all models \$13.95
- 0576 Toyota Supra 79-81 covers all models \$13.95
- 8501 Toyota Tercel 80-82 for all models \$13.95
- 0904 Toyota Land Cruiser 68-82 all mds \$13.95
- 0647 Toyota 68-82 pick-up all 2-whl dr mds \$13.95
- 8124 Toyota pick-up 79-83, gas, 2 & 4 whl dr \$13.95
- 1200 Triumph Spitfire 62-81 all models \$13.95
- 1015 Triumph TR5, TR6 67-76 all inc TR250 \$13.95
- 8693 Triumph TR7 75-81 for all models \$13.95
- 8192 Valiant 68-76 all inc Scamp, Signette \$12.95
- 0513 Vega 70-77 all mds except Cosworth \$13.95
- 8019 Volvo 76-80 covers all models \$12.95
- 1227 VW Beetle 54-67 for all models \$13.95
- 0140 VW Beetle 68-77 for all models \$13.95
- 8300 VW Rabbit 75-83 gas & diesel mds \$13.95
- 8294 VW Scirocco 75-83 for all models \$13.95
- 8383 VW Jetta 80-81 gas engine models \$13.95
- 1125 VW Bus 61-79 all transporter mds \$13.95
- 9626 VW Vanagon 80-82 for all models \$13.95
- 9682 VW Type 3 62-73 squareback, fastback \$13.95
- 9778 VW 411, 412 68-74 covers all models \$13.95
- 8748 VW Dasher 74-79 covers all models \$13.95
- 1754 Volvo 142, 146, 145 66-74 all models \$13.95
- 9558 Volvo 164 68-75 for all models \$13.95
- 3729 Volvo 242, 244, 245 75-83 all models \$13.95
- 8311 Volvo 264, 265 75-80 for all models \$12.95

GENERAL REPAIR

- 0850 Chilton Auto Repair 78-85, all U.S. cars \$21.95
- 0932 Chilton Auto Repair 72-79, all U.S. cars \$24.95
- 7137 Chilton Auto Repair 64-71, all U.S. cars \$24.95
- 1763 Chilton Auto Repair 54-63, all U.S. cars \$24.95
- 8001 Chilton Import Car Repair 76-83 all makes \$24.95
- 1251 Chilton Truck Repair 77-84 all 2 1/2 ton \$24.95
- 8561 Chilton Truck Repair 61-71 all 1/2 & med \$24.95
- 2526 Engine Repair & Rebuilding, 300 pages \$16.95
- 9411 Engine Repair, heads & valves, best \$26.95
- 9128 Convert your Car, Van, Pickup to diesel \$8.25
- 1262 Diesel Repair Man all cars & trks \$19.95
- 0667 Diesel Fundamentals, Service, Repair \$19.95
- 9838 Diesel & high comp gas engs, vocat, textbook \$22.95
- 9320 Automatic Trans 67-79 adjust all U.S. \$16.95
- 1749 Automatic Trans 74-80 repair all U.S. \$16.95
- 0632 Auto Power Trans: rld man trans, drfrnt+ \$16.95
- 8174 Clutch & Flywheel Handbook, 184 pgs \$9.95
- 1557 Auto Mechanic's Fundamentals, textbook \$28.95
- 0968 Auto tune-up & troubleshooting \$10.95
- 1165 Diagnosis & Repair GM Cars 70-83 \$17.95
- 8857 Understand Auto Electronics: all systems \$6.95
- 0653 Automotive Oscilloscope, how to use \$12.95
- 0565 Auto Electrical Systems, 393 pages \$17.95
- 1740 Alternator service manual, all makes \$17.95
- 0625 Auto Air Conditioning, vtech textbook \$22.95
- 7154 Auto Air Conditioning handbook - basic \$10.95
- 1102 Auto Air Conditioning, professional rehd \$15.95
- 8231 Welding Guidelines, gas & electric \$9.95
- 8387 Welder's Bible elect, gas, braze, solder \$14.95

FUEL SYSTEMS

- 0706 Bypass Ford Emission Controls 73-77 \$15.95
- 8474 Bypass GM Emission Controls 71-77 \$14.95
- 9976 Carb Basics, Irishroot, rehd all U.S. \$8.95
- 0882 Carter Carburetors, all 4-bbl models \$10.95
- 8534 Holley Carburetors, all 4-bbl models \$10.95
- 9411 Holley Carburetors, all 2 & 4-bbls \$12.95
- 9652 Rochester Carbs, all 1, 2 & 4-bbls \$9.95
- 9423 Stromberg CD Carburetors, all trs 76 \$10.50
- 6354 SU Carburetors all models thru 76 \$10.50
- 1211 Weber Carburetors all models thru 79 \$10.50
- 9835 Fuel Injection & Carbs 77-85 \$16.95
- 3759 Bosch Electronic Fuel Inj thru 77 \$13.95
- 9773 Electronic Fuel Inj Man. all sys to 83 \$29.50
- 9410 Turbochargers, best on your engine \$9.95
- 0791 Fuels & Lubricants, gas, diesel & oils \$7.95
- 8872 Propane Conversion of Cars, Trucks, RVs \$9.95

LAWN MOWERS & TRACTORS

- 9651 Small Tractors 65-81, 8-30 hp, 960 pgs \$19.95
- 8301 Allis-Chalmers B, C, CA, G, RC, WC, WD, WF \$12.95
- 9822 Ford 2N, BN, BN \$12.95
- 8490 Ford 501, 600/1-900/1, 1801, 2000 \$12.95
- 1028 H A B, C, H, M, MT, A, 4, 6, W67A, 9 \$12.95
- 9620 H-I farm trctr for Cub mds, 1958 on \$12.95
- 8518 John Deere A, B, D, G, H, M, MT \$12.95
- 1020 Massey-Ferguson T20, T20T, T030 \$12.95
- 8756 Riding Lawnmower Serv. all pop makes \$10.95
- 9770 Lawnmowers, push-type, all 2 & 4 cyl eng \$10.95
- 9147 Excavator Operation, all earthmoving \$11.95
- 9686 Tractor-loader-backhoe - operate techniqs \$24.95
- 9807 Heavy Equip Repair, earthmoving \$21.95
- 8658 Large Air Cooled Eng, 15 cid & up \$11.95
- 9419 Small Engine Service man. under 15 cid \$12.95
- 0557 Chain Saw Service Manual, 24 top makes \$10.95

TV, HOME REPAIR, ETC

- 8024 All About Home Satellite TV \$13.50
- 9959 Beginner's Guide to TV Repair, 224 pgs \$9.95
- 0533 TV Field & Bench Service's Handbook \$9.95
- 0450 Television Electronics: theory & service \$37.95
- 0804 Television Repair, manual & electronic \$17.95
- 0396 Videocassette Recorders Handbook \$12.95
- 8023 Home Video Equipment, all sys & comprt \$9.95
- 3752 Master Handbook of Telephones \$12.50
- 7133 Repair Your Own 35mm Camera, all SLR \$10.25
- 1268 Sewing Machine Repair, 308 pages \$9.25
- 9804 Typewriter Repair, manual & electric \$12.50
- 8724 Locks & Locksmithing, 392 pages info \$16.95
- 9791 Oil Burners, instal, service, repair \$16.95
- 9426 Electrical Wiring house, barn, garage, + \$16.95
- 9447 Home Electricity from Wind, Water, Sun \$9.95
- 9525 Machining Fundamentals, 512 pages \$29.95
- 8357 Cast Small Metal & Rubber Parts \$8.95
- 1652 General Carpentry const wood houses \$30.95

BOOKS BY CAR MAKE

- 8094 Barracuda/Challenger: Source Book \$12.95
- 9534 Buick Power Manual, tuning the V6 \$9.95
- 0774 Buick Muscle Cars 65-70 road tests, more \$11.95
- 9409 Chev Small-Block, How to Hotrod \$9.95
- 8125 Chev Small-Block, How to rebuild \$9.95
- 8421 Chev Racing Engine, prep small block \$10.95
- 1243 Chev Small-Block, Racing the 152 p \$9.95
- 9795 Chev Performance, from small block \$10.95
- 1601 Chev Big-Block, How to Hotrod \$9.95
- 9938 Chev Big-Block, How to Rebuild \$9.95
- 8303 Chev Heavy Duty Parts Book \$5.00
- 0830 Chev Super Sports 61-76 info on all \$14.95
- 0487 Chevelle 55, A Source Book, factory info \$12.95
- 3725 Building the V6/V8, step-by-step \$7.95
- 8060 Corvette Repro/Mod Parts Book, 53-82 \$8.95
- 0929 Corvette Restorers Source Book \$3.67
- 8683 Datsun, How to Hotrod & Race 510/280Z \$17.95
- 0794 Firebird: Source Book, factory info \$12.95
- 1725 Firebird, TransAm High-Perf Hbook \$8.95
- 0940 Ford Small-Block, tuning & rebuilding \$9.95
- 0494 Ford Big-Block, How to Rebuild, 160 p \$9.95
- 9497 Ford V8: How to rebuild you \$9.95
- 8195 Ford Performance, from all V8 engines \$10.95
- 1076 Fearsome Fords 59-73 tech data, pics \$14.95
- 7115 How to keep your Honda alive, 73-82 \$10.00
- 0930 Mazda RX-7 road tests, tech data, plus \$8.95
- 8384 Mopar Small-Block, How to rebuild \$9.95
- 8736 Mopar Suspension Tuning \$10.95
- 8307 Mopar Performance, hi-perf eng bldg \$10.95
- 8532 Mopar Connection engine modifications \$15.00
- 0892 Mustang: How to restore, all 65-73 mds \$14.95
- 8095 Nova 35: A Source Book, factory info, pics \$12.95
- 8144 Olds 4-4-2: Source Book, factory info \$12.95
- 9963 Opel GT, road tests, tech data, plus \$11.95
- 0758 Muscle Pontacs, all hi-perf models 55-85 \$8.95
- 9965 Pontiac Racer/Hi-perf from 60s, 70s \$19.95
- 8054 Big "Little GTO" Book, 64-74 mds \$14.95
- 6351 Porsche Buyer's Guide, 210 illus \$13.95

WORKSHOP MINICOURSE



Jointing edges without a jointer: Part 2

As promised last month, in this *Mini-course* we're showing several ways to joint stock using a handheld portable router. With the proper techniques and high-quality cutters, this high-rpm tool can joint edges nearly as well as costly stationary jointers. And set up is not all that time consuming either.

The basic approach isn't much different than for the portable circular saw. The tool can cut single edges straight, as well as cutting mating edges simultaneously. However, the results will only be as good as the router bits you use. We recommend the more expensive carbide-tipped straight cutters because of their long wear and smooth cuts. And, be sure that the guide you use is absolutely straight and clamped securely in place when jointing single edges.—Rosario Capotosto



To joint single edge (above), elevate stock with scrap blocks, position straightedge guide, then clamp whole assembly to bench. Keep router base against guide while cutting. Rough and jointed edges (right) show smooth cut that's possible with carbide bit.

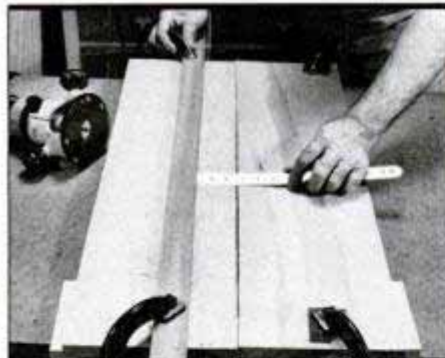
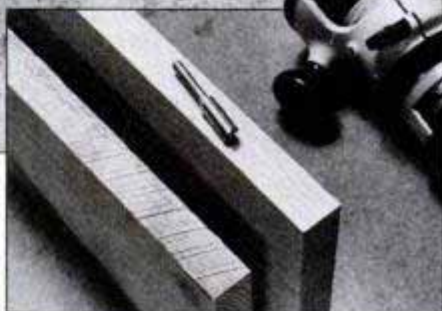

To joint mating edges, place stock on scrap blocks, then position and clamp straightedge so cutter is centered over joint line.

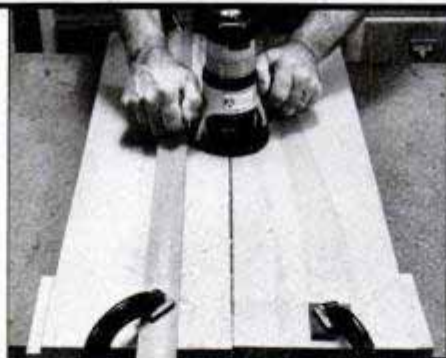

Choose cutter diameter that is slightly greater than widest gap between boards. Set depth for 1/8 in. and make first pass (above, left). Check that both edges have been cut, then increase cutter depth by 1/8 in. for each subsequent pass (above, right).

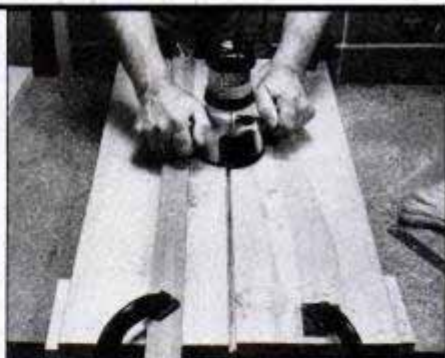

Because last jointing cut must go through stock—and into support blocks—use soft wood for blocks to prolong cutter life.

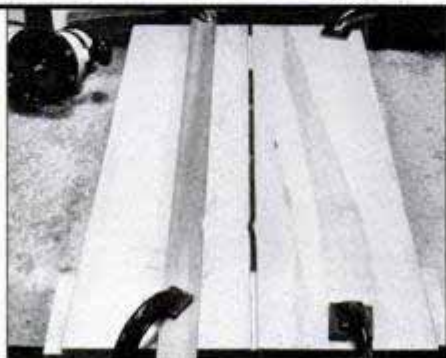

By routing both edges at once, any irregularity in guide (above, left) is transferred identically to both boards; edges will still mate (above, right). In fact, shallow dip is sometimes preferred because it keeps boards from sliding when glued and clamped.



Call 1-800-533-5545 today and ...

SAVE 20-50%

On These Brand Name Parts, Tools & Equipment!

HEAVY DUTY LOG SPLITTER SALE!

Excellent Buys on Heavy Duty Log Splitters!

- 8 Ton Electric, 110 volt, #1110.....\$459.00
 - 12 Ton Splitter, (Pictured), #1125.....\$689.00
 - NEW! 16 Ton Splitter, #1134.....\$789.00
 - 24 Ton (Low Profile), #1142.....\$1399.00
- (Some assembly required)



A
\$1200.00
VALUE!

Item #1125

SPLITS LOGS UP TO 25"
25,000 POUNDS OF
SPLITTING FORCE!

ONLY \$689.50



GAS ENGINES

(VERTICAL)

- 3 1/2 HP Tecumseh, 1/2" Shaft #7031.....\$98.95
- 3 1/2 HP Briggs, 1/2" Shaft #7030.....\$121.95
- 5 HP Briggs, 1/2" Shaft #7050.....\$165.95
- 8 HP Tecumseh, 1" Shaft #70R2.....\$198.95
- 8 HP Briggs, 1" Shaft #70R0.....\$217.95
- 10 HP Tecumseh, 1" Shaft #7010.....\$221.95
- 10 HP Tec. (Elec Start) 1" Shaft #70101.....\$272.95

(HORIZONTAL)

- 5 HP Tecumseh, 1/2" Shaft #6051.....\$139.95
- 5 HP Briggs, 1/2" Shaft #6052.....\$139.95
- 5 HP Briggs I/C, 1/2" Shaft #6054.....\$181.95
- 8 HP Briggs, 1" Shaft #6060.....\$215.95
- 10 HP Tecumseh, 1" Shaft #6010.....\$232.95
- 10 HP Tec. (Elec Start) 1" Shaft #60101.....\$278.95

3-20 HP Horizontal and Vertical engines available at SUPER LOW DISCOUNT PRICES!!



40"x48"
BED



UTILITY TRAILER KIT

1,060 POUND CAPACITY!

Complete road ready kit. Easy assembly w/basic tools. #12542
1 lists for \$279.00 ONLY.....

\$145.00

(Will ship 48 states \$30 Prepaid)

LOG SPLITTER PARTS



- 11 GPM 2 Stage Pump, #1012.....\$99.95
- 13 GPM 2 Stage Pump, #1013.....\$129.00
- 16 GPM 2 Stage Pump, #1015.....\$157.00

- Standard 4-Way Control Valve, #2010.....\$46.50
 - Auto-Detent Valve, #2020.....\$49.95
 - 4x24x2" Cylinder (Welded Type), Item #902424 (Can ship UPS).....ONLY.....\$119.95
 - 5x24x2" Cylinder (Tie Rod Type), Item #909524 ON SALE NOW.....\$222.00
- Many Other In Stock at Low Discount Prices!

5 HP 60 Gal. Air Compressors

Stationary Single Stage, 2 cyl. pressure gauge w/safety relief valve. 230 volt. 11.8 CFM @ 40 PSI, 9.4 CFM @ 90 PSI. 25" x 22" x 65" high. Sh.wt. 315 lbs. Item #15954, List \$1160.....\$498.00

5 HP, 2 Stage, 60 gallon tank, 230 volt. 17.26 CFM @ 100 PSI, 13.39 CFM @ 175 PSI. 12 CFM pressure gauge. Ship wt. 356 lbs. Lists for \$1202.00.....ONLY Item #15975.....\$964.00 (Shipped Truck Freight Collect)



GENERATORS

4000 Watt, 8 HP Briggs, 33 amps @ 120 volts, 16.6 amps @ 240 volts..... Item #16402 Lists \$1009.....SALE \$447.00 (With Elec Start).....\$559.95

5000 Watt, 11 HP Briggs, 42 amps @ 120 volts, 21 amps @ 240 volts..... Item #16404 Lists \$1174.....SALE \$689.00 (With Elec Start).....\$789.00 (Will Ship 48 states \$45)



TRAILER PARTS



High speed hub and spindle set, 2000 lb. capacity, 4" bolt circle, 4 hole, 2 hubs & 2 spindles, dust caps, tapered bearings, lug bolts & cotter pins...\$37.50/set

High speed trailer wheels & tires, fit all 4 hole boat and snowmobile trailers.

Item#	Size	Ply	Cap.	SALE	Tire Only
1211	480x8	4	590 lb.	\$23.95	\$15.95
1212	570x8	4	715 lb.	\$33.95	\$24.95
1216	480x12	4	780 lb.	\$39.95	\$24.95

Trailer Springs, 1 1/4" wide w/eye center of 25 1/2"

Item#	Capacity	Springs	Leafs	Sale
1250	1000 lb.	2	2	\$22.00/pr
1251	2000 lb.	2	3	\$24.00/pr
1252	3000 lb.	2	3	\$27.00/pr

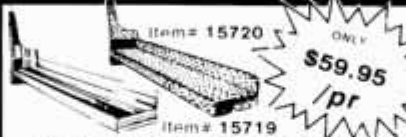

PICKUP RUNNING BOARDS

Universal - fits all full and mid-size standard cab pickups. Also adapts to 4x4's!

Other running boards available!

TARP SALE!

Ours are heavier 12 mil, not 6 or 8 like many others! Totally waterproof polyethylene w/grommets approximately every 3 feet.

Item #	Size	Ship wt.	SALE
1770	6' x 8'	3 lbs.	\$2.69
1772	10' x 12'	4 lbs.	\$5.95
1774	12' x 20'	11 lbs.	\$12.95
1776	20' x 30'	23 lbs.	\$39.95

(Many other sizes at comparable sale prices!)



NH Northern Hydraulics INC.

We Ship UPS, Bus or Truck

801 East Cliff Road, Box 1219, Burnsville, MN 55337
Call our order dept. at 1-800-533-5545
In MN 612-894-8310

SALE EXPIRES
AUGUST 31st
1985!

PHONE ORDERS:
Monday-Thursday: 8:00am-8:30pm
Fridays: 8:00am-6:00pm
Saturdays: 8:00am-5:00pm

ORDER TOLL FREE 1-800-533-5545

Send for free catalog or send \$6.00 and receive catalog and splitter design booklet.

Mail To: Northern Hydraulics
801 E. Cliff Rd.
Box 1219
Burnsville, MN 55337
Dept. #9085

Name _____
Address _____
City _____
State _____ Zip _____

Please rush me my FREE Discount Catalog!

Use your Mastercard or Visa



PM LOOKS AT...



A router accessory

Every now and then, I come across a tool that makes me wonder, "Why didn't someone think of this sooner?" The Sears Door and Panel Decorating Kit is just such a product. Controlled decorative cuts no longer require painstaking figuring and preparation, or jigs that become useless as soon as you use

them once. The kit is designed for making face cuts on cabinet doors and drawer fronts, but it can be used for decorating any square or rectangular panel up to 1 x 36 x 36 in.

Each kit includes four, 36-in.-long extruded, anodized aluminum guide rails. The rails are equipped with eight

special clamps for aligning and attaching to the workpiece. Once the rails are secure, any of seven sets of four templates are snapped into the corners formed by the rails. Also included is one set of blank templates that you can use to make your own pattern. A radius attachment will allow you to plow arcs with different radii from 5 in. to 17½-in.

Not included is a ⅝-in. guide bushing (part No. 9GT-25082) that rides along the rails and templates. It's \$7.49 from Sears. The bushing will fit any Sears router as well as some other router models.

To cut a pattern, clamp the work in the rails. If your workpiece is smaller than the rails in either dimension, the rails just extend beyond the abutting rail. This first step requires the workpiece to be upside down. Now flip the assembly over and snap in the set of templates for the design you want into the four corners.

Install the grooving bit in your router and set it to the desired depth. Practice with a test piece before making your first run on the workpiece. Then, simply run the router along the rails and the templates in the corners.

To use the radius attachment, you should clamp one of the rails to the workpiece. Then attach the arm-mount to the router base and fit the assembly into a pivot bracket that's mounted to the rail.

Priced at \$79.99, this router accessory is available at Sears stores or by mail through the Sears catalog. It's part No. 9GT 25472C.—Rosario Capotosto

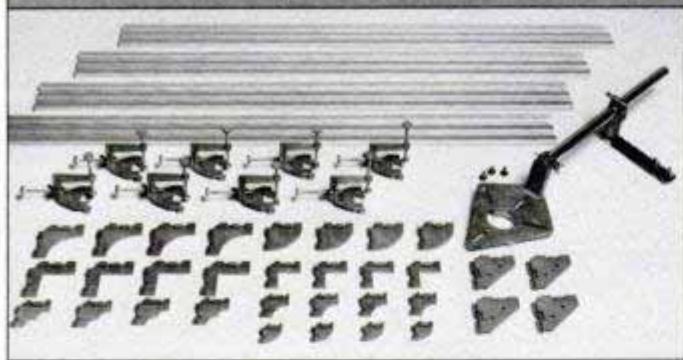
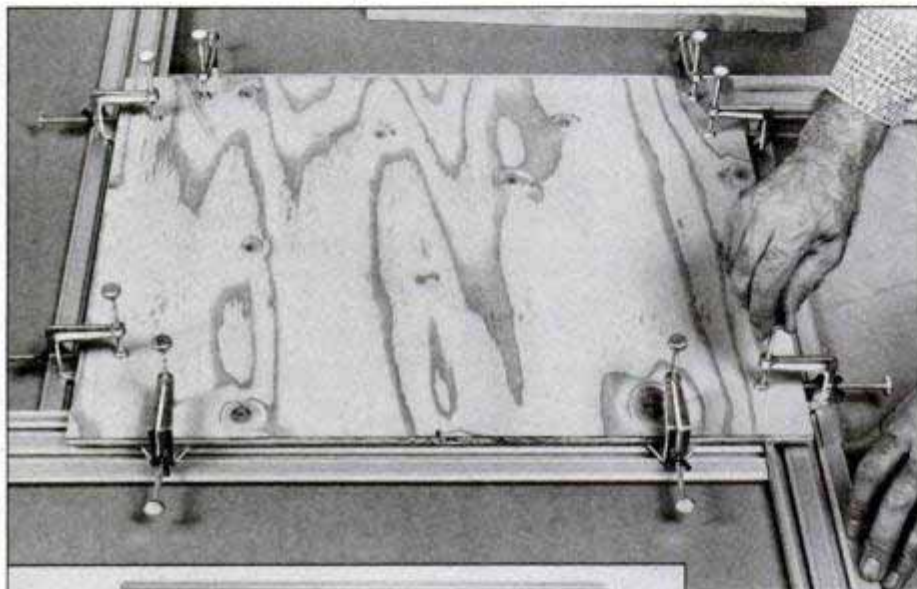

Clamp work within guide rails, back side up (top). Then flip assembly over and snap templates into the corners for the design you want. Kit has seven design sets (left).



Grip router with both hands, and set and lock depth adjustment. Then run the router around workpiece periphery with the bushing riding on rails and templates.

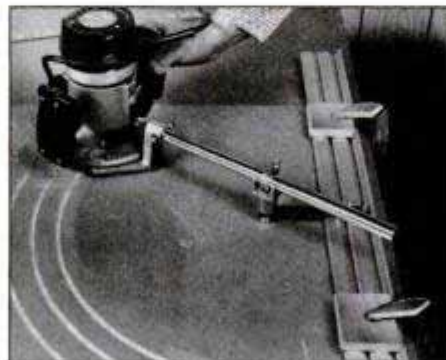

Only one rail is needed to work with the arc routing accessory. The radius is set by lengthening or shortening the arm's reach and securing the pivot point lock.

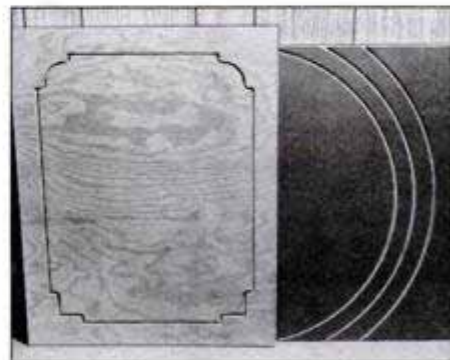

Centering designs on panels is no problem with this kit. Straight lines are true and the curves are smooth and graceful. Groove width and depth are always uniform.

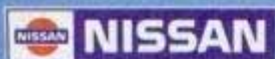

THE 'MORE' TRUCK: \$5999*

NISSAN REGULAR BED

Nissan's lowest-sticker-priced truck. Now re-engineered with advanced technology to give you more pickup, not more payout.

- **More power** than ever. Nobody tops Nissan for power in a leading standard compact truck. You've got the innovative Nissan twin-spark, crossflow, hemihead NAPS-Z engine pulling for you.
- **More payload** than Toyota, Chevy S-10 or Ford Ranger base models: 1,460 pounds—almost 3/4 ton—a truck payload!
- **More corrosion resistance** in the seamless, smooth-side strongbox. Welded double walls resist dents.
- **More value.** All standard: 5-speed transmission with overdrive; 3-across seating on a full

bench seat; steel-belted radials (full-size spare); black-out grille; front stabilizer bar; plus lots more standards, all quality-built to Nissan's standards.

No wonder more truckers have been driving more Nissan-built trucks for more years than any other compact.

The "More" Truck, at the same sticker as last year. No other truck works so hard for so little pay.

- **Best extended-service plan available:** up to 5 years/100,000 miles. Ask about Nissan's Security Plus at participating Nissan/Datsun dealers.

*Mfr.'s suggested retail price excluding title, tax, license and destination charge.



THE NAME IS NISSAN



It's Unanimous

(Even the competition says ESCORT's the one to beat)

It's easy to see who sets the pace in radar warning. Just read all the detector ads. Most of them claim to be as good as ESCORT. A few say they're better.

At least they agree on one thing. ESCORT is the one they have to measure up to.

A modern classic

ESCORT was a radical piece of electronic engineering in 1978 when it was introduced, the first practical use of superheterodyne technology to warn of police radar. *Car and Driver* magazine said, "...the radar detector concept has finally lived up to its promise."

Since then, our engineers have never stopped refining that technology. ESCORT may look the same on the outside, but it never stops getting better on the inside.

Standard of comparison

Now, when experts refer to the high-water mark in radar protection, they automatically turn to ESCORT. In March of this year, *Car and Driver* published its latest detector test, this one comparing remote-mounted models. ESCORT is designed for dashtop or visor mounting. But the magazine included ESCORT in the test anyway, as the reference against which the performance of the others would be measured. ESCORT scored 412 points in the final rating, compared to 274 for the highest-finishing remote. You might say the comparison showed that there is no comparison.

A gilt-edged reputation

Seven years is a long time in the radar warning business, but there is no shortcut to a good reputation. *Car and Driver* said, "The ESCORT radar detector is clearly the leader in the field in value, customer service, and performance..."



These excerpts were taken entirely from advertisements for other radar detectors.

So it's easy to understand why other detectors would try to stand in our limelight. ESCORT has seven years worth of credibility, the one quality that money can't buy in this business.

Check our references

Credibility doesn't come from extravagant claims. It comes from satisfying customers. You probably know someone who owns an ESCORT (nearly a million have been sold). So ask about us.

ESCORT pioneered superheterodyne receiving circuitry. Ask if our radar warnings always come in time.

ESCORT's reporting system combines an alert lamp, a variable-rate beeper that distinguishes between X and K band, and an analog meter, all to give an instant indication of radar strength. Ask if our warning takes the panic out of radar.

ESCORT is sold in one place only, the factory that makes it. This lets you deal directly with experts. Any of our staff of over 60 sales people will be glad to answer any questions you may have, about ESCORT or about radar in general.

We've been solving people's radar problems since 1978. How can we help you?

Try ESCORT at no risk

Take the first 30 days with ESCORT as a test. If you're not completely satisfied return it for a full refund. You can't lose.

ESCORT is also backed with a one year warranty on both parts and labor.

ESCORT \$245 (OH res. add \$13.48 tax)

TOLL FREE . . . 800-543-1608



By mail send to address below. Credit cards, money orders, bank checks, certified checks, wire transfers processed immediately. Personal or company checks require 18 days.

ESCORT

RADAR WARNING RECEIVER

Cincinnati Microwave
Department 100-068-A08
One Microwave Plaza
Cincinnati, Ohio 45296-0100

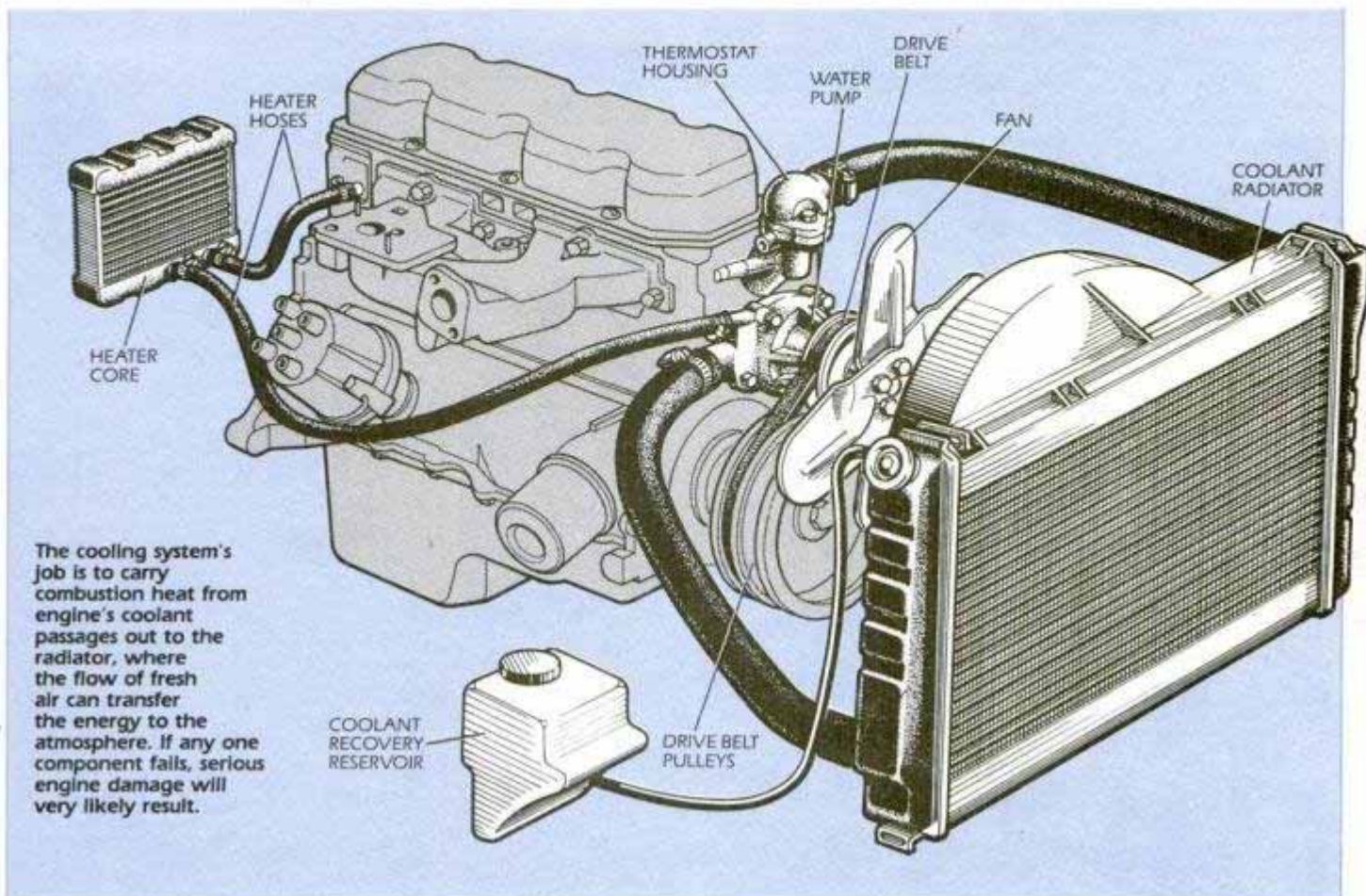

The cooling system's job is to carry combustion heat from engine's coolant passages out to the radiator, where the flow of fresh air can transfer the energy to the atmosphere. If any one component fails, serious engine damage will very likely result.

SOLVING FIVE TOUGH Cooling System Problems

BY PAUL STENQUIST

Every Saturday mechanic knows it's the heat of combustion that makes a car go. But did you know that your engine generates enough heat to warm a five-room house in the dead of winter?

Only one-third of that heat is converted to power. Another third is carried away with the exhaust gases. The remainder is absorbed by the pistons, cylinder walls, and other engine parts. It's up to the cooling system to control the temperature of these components (see lead illustration). If they run too cold, the engine won't operate efficiently, fuel will be wasted and power will be limited. If they run too hot, spark knock will occur and the engine will be severely damaged. If an engine operates

for more than a few minutes without coolant, the pistons can literally weld themselves to the cylinder walls. Cooling system problems require your immediate attention.

Fortunately, most cooling system headaches are easily cured by the experienced Saturday mechanic. In the sections that follow, we'll outline five cooling system problems and tell you how to solve them.

Excessive coolant overflow from reservoir

If coolant pours from the reservoir overflow line every time you shut off the engine, or even while the engine is running, something is forcing the coolant out of the system. Of course if the

problem happens once and doesn't repeat, it could just be a matter of the reservoir being overfilled. But if it happens repeatedly and you're sure you haven't overfilled each time, it may be due to combustion gases leaking into the engine coolant jackets or an air leak on the suction side of the water pump.

To determine if an air leak is the source of the problem, remove the lower radiator hose and inspect it for damage on both ends. If any part of the hose is suffering from deterioration or shows other signs of physical damage, replace it. If the lower or upper hose is more than three years old, replace it.

Before reinstalling the lower hose, clean both hose connection areas thoroughly and inspect for any damage that might allow air to be drawn into the cooling system.

If aeration is not the cause of the overflow condition, it could be due to a blown head gasket or cracked cylinder head, which allows combustion gases to enter the cooling system. The easiest way to detect such a leak is with an emissions analyzer (Fig. 1). Ask your mechanic to hold the probe of the analyzer over the filler neck area of the open radiator. The engine must be fully

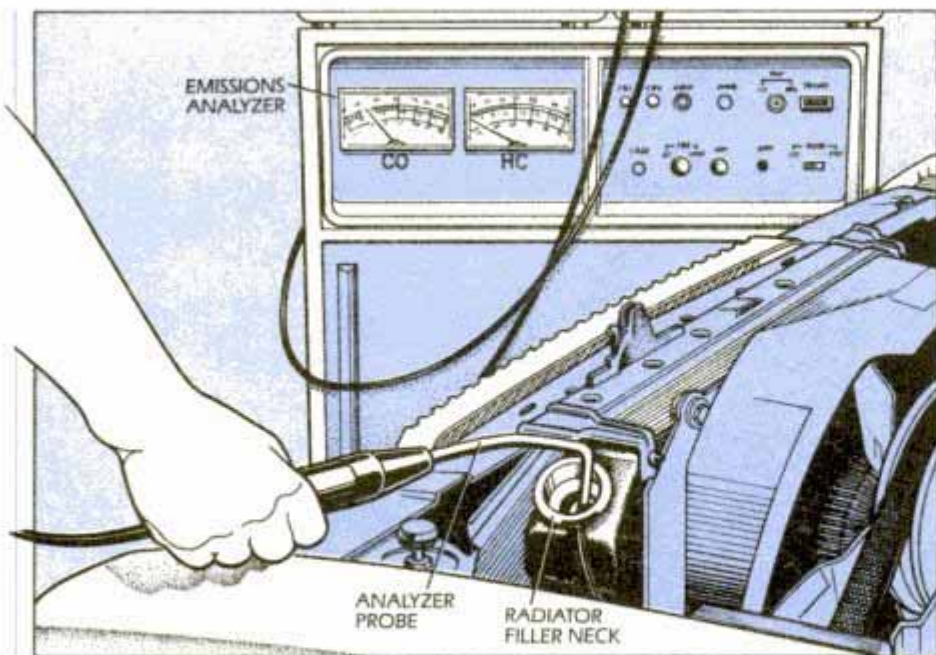

1 Combustion gases leaking into the cooling system, such as through a failed head gasket, can be detected with an emissions analyzer held at the radiator filler neck opening.

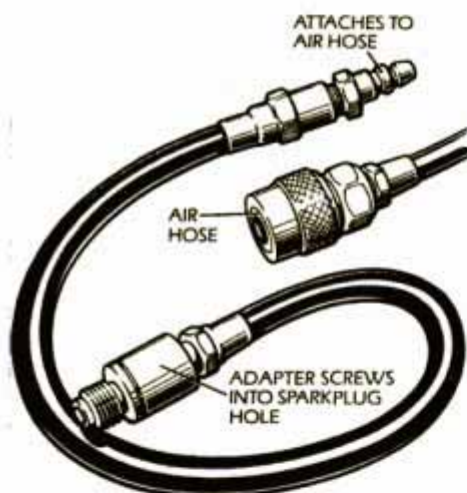

2 Use an air chuck/sparkplug hole adapter to pressurize individual cylinders.

warmed and running. If CO emissions are rising from the radiator, either a head gasket is blown or the block and/or cylinder head is cracked.

If you don't want to pay a mechanic to check for emissions, you can detect most combustion leaks using a cylinder leakage tester or cylinder pressurizing tool. The part of the tool that you need for this test is the air chuck/sparkplug hole adapter—nothing more than an air chuck that screws into your plug hole (Fig. 2). You can buy the air chuck connector from an auto parts store.

To test, remove the upper radiator hose, thermostat housing and thermostat. Reinstall the housing without the thermostat and fill the system with

coolant. Remove the plugs and install your air chuck/plug adapter into the No. 1 plug hole. If you have a simple child's whistle, attach it to the air chuck end of the adapter with a piece of hose (Fig. 3). Turn the engine to TDC compression stroke for the No. 1 cylinder. You can tell when it's on compression because air rushing from the plug hole will blow the whistle as the piston rises. Attach the air supply.

Watch for bubbles of air in the thermostat housing outlet neck (Fig. 4). A cylinder that produces bubbles has a leaking head gasket or cracked combustion chamber.

Premature V-belt failure

V-belts don't last forever. Three years is about the limit for some highly stressed belts, and replacement every three years makes a lot of sense. You should not, however, have to replace belts more frequently than every three years under normal conditions. If you're constantly changing a belt, try to determine why it fails prematurely.

The way the belt rides in its pulley grooves is one important factor. A conventional V-belt should ride flush with, or slightly below, the top of the pulley groove. If the belt rides too high, it will not fully grip the pulley and the edges of the pulley will wear into the belt sides. If it rides too low, it will bottom out in the pulley groove and slip. Slippage will destroy the belt and the pulley itself.

If the belt appears to ride correctly on

its pulleys but still wears out faster than normal, the failure may be caused by misalignment of the pulleys. If space permits, you can detect misalignment by holding a straightedge between the pulleys. Or you can watch the belt while it's running. If it has a noticeable kink or appears to twist as it rides in the pulley grooves, the pulleys are misaligned. To correct alignment, file the mounting areas of the brackets or shim them away from the engine.

Too much maintenance can also lead to belt failure. In most cases, the use of belt dressing should not be necessary and can sometimes weaken the rubber compounds that make up the belt.

Poor heater performance

Most car owners give little thought to their car's heater during the summer. Then, when the weather turns cold, they find out that it doesn't work. A quick check in the summer can pay big dividends.

When the heater is operating, hot coolant is delivered to a radiator-like heater core located behind the dashboard or in the firewall. Outside air or recirculated inside air is forced past the core by a blower fan. The amount of air passing through the core is determined by control doors. Some vehicles are also equipped with a heater control valve that limits the amount of coolant circulated through the core.

The air that blows from your heater outlets when the engine is fully warmed and the heater is set for high heat should be 60 to 70°F, above the ambient temperature. You can check the temperature of the heater's output by holding a thermometer directly in front of the heater outlet. If the temperature is not up to spec and the control doors seem to be functioning properly, either something is restricting the flow of coolant to the core or the engine temperature is too low.

Begin by checking the heater hoses for signs of physical damage. A hose

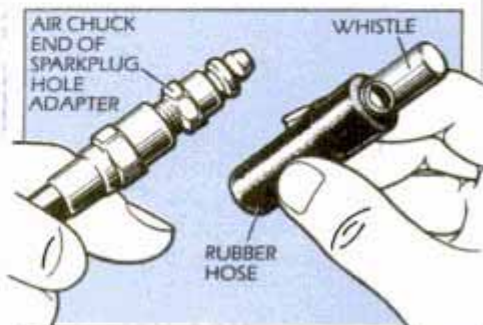

3 A whistle fitted to the air chuck will quickly indicate compression stroke TDC.

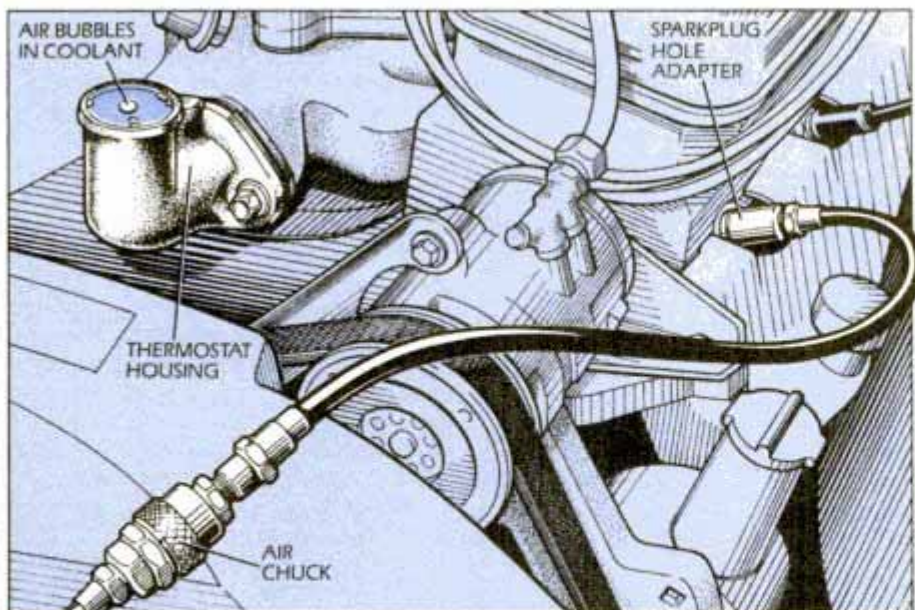

4 Internal leaks of combustion gas into the cooling system can be confirmed by the presence of bubbles in the thermostat housing after pressurizing a cylinder with air.

that looks okay on the outside could be restricted on the inside. If the hoses are three years old or older, replace them. If one of the hoses is fitted with a heater control valve, make sure the valve is opening when the temperature control is set to the full WARM position.

Under normal conditions your heater core shouldn't clog. But if you own an older car that has not had its cooling system backflushed on an annual basis or if you've been dumping can after can of cooling system sealant into your radiator, the core could be clogged. If you suspect that it is, disconnect the heater hoses from the engine. Turn all heater controls to the full WARM position. Then attach a garden hose to the heater inlet hose and see if water passes through the core and runs out of the other hose. If it doesn't, the core will probably have to be replaced.

If you find that coolant is reaching your heater core but output is still below spec, your engine is probably running too cool. In most cases, reduced engine temperature is the result of an incorrect or defective thermostat. In some cases, where the thermostat is stuck open or missing, heater temperature may eventually reach an appropriate level but it will take much longer than it should.

To check the thermostat, remove the thermostat housing after the engine has cooled completely. You should find the thermostat closed. If it's open, replace it with the recommended part. (Don't think you're doing your engine a favor by using a thermostat that causes it to run cooler. Reduced engine tem-

perature causes condensation, which leads to sludge formation.)

If you find that your thermostat is closed, remove it and look for a temperature indication stamped somewhere on the thermostat housing or mechanism. If the temperature indication is lower than that recommended by the vehicle manufacturer, replace the thermostat with the correct unit.

To test a thermostat, suspend it and a thermometer in a pan of water. Heat the water and note the temperature at which the thermostat opens. If it opens too soon, it could be the cause of reduced or delayed heater output.

When installing a new thermostat, follow instructions regarding which end of the unit goes toward the engine. After cleaning all old gasket material from the thermostat housing and water neck, the thermostat fits in the recess provided for it (Fig. 5). Use a new gasket and coat both sides with gasket compound or wheel-bearing grease. Reinstall the water neck and torque the bolts to the recommended figure, usually about 15 ft.-lb.

Engine runs hot

Most cases of overheating are due to obvious reasons: the loss of coolant through a large external leak or the loss of fan or water pump operation due to belt failure. But there are also times when an engine may overheat for no immediately apparent reason.

In order to prevent the boiling of coolant and subsequent overheating of the engine, your cooling system must

remain pressurized. Pressure raises the boiling point of the coolant. Even a pin-size hole in a core plug or a leaking radiator cap seal will quickly relieve pressure.

A cooling system pressure test can tell you if you've got a leaker on your hands. This tool is commonly available through auto parts stores. Begin the pressure test by checking the radiator cap, using the adapter that comes with the pressure tester (Fig. 6). The cap should hold an amount of pressure equal to the system pressure specified for your vehicle in your service manual. If it doesn't, it must be replaced.

Once you're sure the cap is okay, attach the tester to the radiator neck and pump the system up to the pressure rating of the cap. If pressure remains steady, the system is leak-free. If leakdown occurs, check all hoses, clamps and gasket joints. Inspect the radiator, heater core and water pump vent for any signs of escaping coolant (Fig. 7). Jack up the car, support it on stands and check the core plugs. A deposit of dried coolant could be a clue to a slow leak.

An incorrect water/antifreeze solution can also contribute to a boilover problem. If your coolant contains less than 50 percent antifreeze, you're not getting adequate boilover protection.

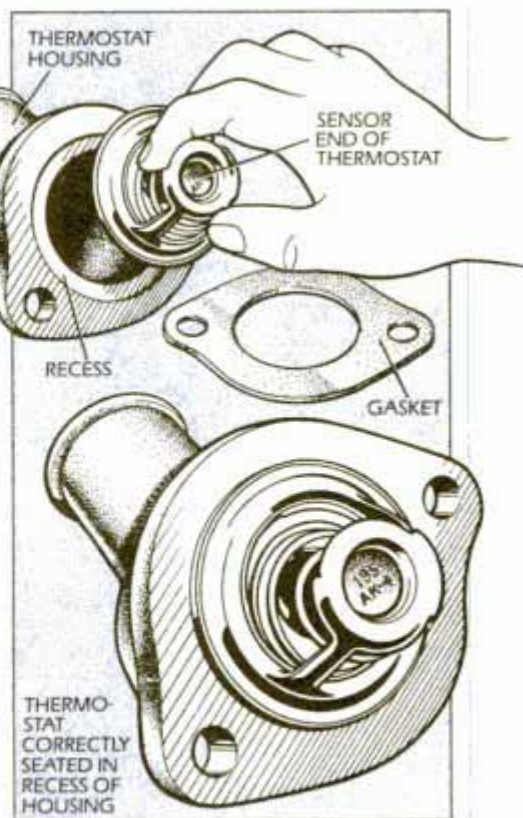

5 Thermostat must seat squarely in housing recess, sensor end facing engine.

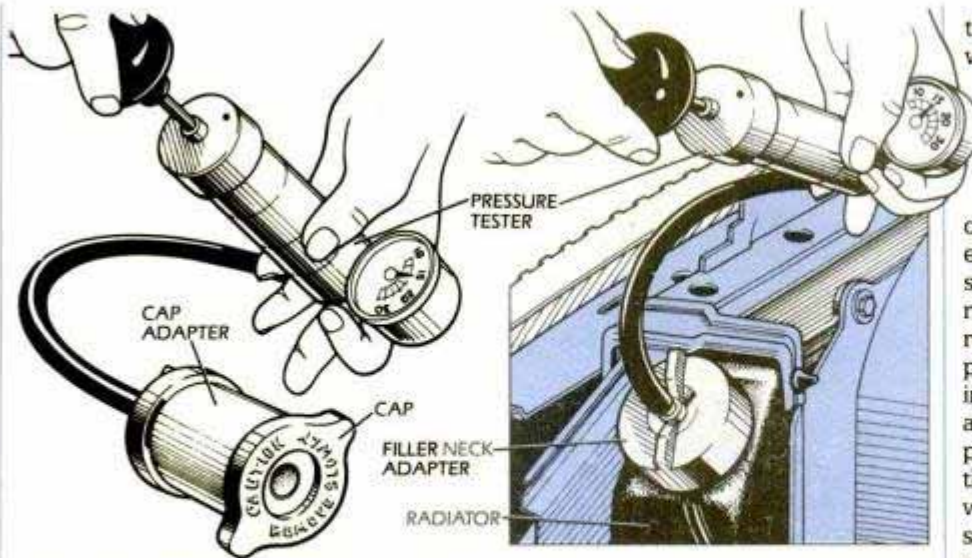

6 A full cooling system checkup must include a pressure test of both the radiator cap (left) and the coolant radiator, hoses and engine coolant passages (right).

As you increase the percentage of antifreeze, boiling point rises. However, as percentage rises above 68 percent, freeze protection is lost.

Radiator blockage is a principal cause of overheating problems that do not involve obvious equipment failures. One way to check for severe blockage is to remove the radiator cap (while the engine is cool), warm the engine fully and quickly open the throttle. If the radiator core is severely blocked, it won't be able to handle the increased flow that the water pump delivers when you rev the engine, and coolant will spurt from the filler neck. Be extra careful when performing this test. If you stare down into the radiator and crack the throttle, you could end up

with severe burns from the coolant.

If the radiator appears to be severely blocked, have your mechanic backflush the cooling system using a machine that can reverse the flow through the radiator. If this doesn't clear the blockage, the radiator will have to be removed for rodding or recoring.

If you've been following our Saturday mechanic maintenance schedule, you flush your cooling system and refill it every year. If this is the case, corrosion should not be a significant problem. If you've neglected your cooling system, some of the passages in your engine could be blocked by corrosion. A professional power backflush and chemical treatment might help. If not, teardown and parts replacement may be necessary.

If none of the above proves to be the cause of your problem, it could be the result of a slipping fan clutch. The fan clutch should permit the fan to free-wheel when the engine is cold but should engage as the engine warms. Start the engine cold and listen to the fan as the engine warms. When the clutch begins to engage, the sound of the engine should change noticeably. You can speed the warmup by restricting airflow around the radiator.

Another way to detect a slipping fan clutch is to have a helper shut off the warm engine while you watch the fan. The fan should stop spinning almost immediately. If not, the clutch is malfunctioning.

If you've made all the standard diagnostic checks and still can't find the cause of an overheating problem, you should check for a worn or slipping water pump impeller. You can some-

times get a clue to this problem by watching coolant flow in the top of the radiator with the engine warm. The only way to rule out water pump damage conclusively is to remove the pump and inspect it.

There are a few other unusual causes of overheating that you should consider. One is a restriction in the exhaust system, such as a jammed exhaust heat riser valve. In most cases, exhaust restriction will also cause performance problems, accompanied by a reduction in manifold vacuum. Overheating can also be caused by brake drag. Other potential causes include the same things that can cause spark knock: the wrong type of gasoline, EFE or hot-air system failure, EGR system failure, severe carbon buildup, incorrect ignition timing or the wrong sparkplugs. In most cases, these conditions will only cause mild overheating.

Unexplained loss of coolant

The coolant level in your reservoir will change somewhat as temperature and operating conditions vary, but it should stay within the recommended limits. If you find that the level drops continuously and there's no evidence of an external leak, the problem is probably due to an internal cooling system leak. Unfortunately, these leaks are hard to find and expensive to fix.

If you find that your oil level is constantly increasing while your coolant level is decreasing, you know where the coolant is going. A foam-like coating on the dipstick is another indication of internal leakage. In some cases, one of the heavy-duty block sealer compounds that you add to the coolant may seal it. Don't use more than recommended as it could clog your radiator and heater core.

If you're forced to disassemble the engine in your search for an internal leak, look for signs of a leaking gasket that could allow coolant to escape into the crankcase. On many engines, the timing cover gasket is a likely candidate. A leak on the periphery of a head gasket that doesn't involve the combustion seal might just dump coolant into the oil.

If you can't find a leaking gasket, the internal coolant leak is probably the result of a cracked cylinder head or engine block. An automotive machine shop can usually find the leak by pressure-testing the cylinder heads and the engine block. Once the leak is found, castings must either be replaced or welded by a shop experienced in cast-iron or cast-aluminum repairs. **PM**

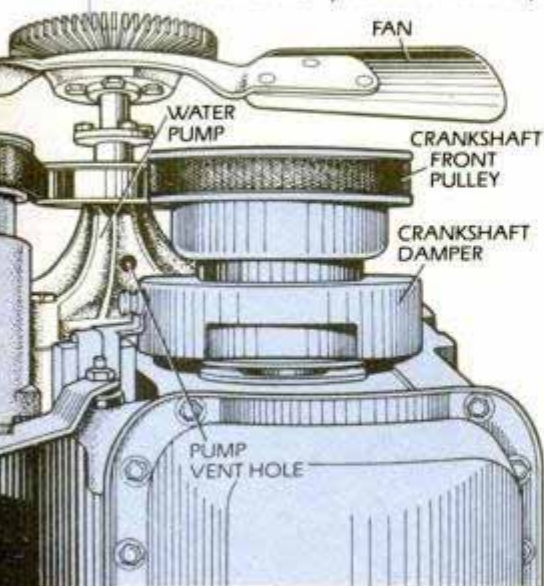

7 When coolant leaks from the pump vent hole (seen here from under the car) it indicates failure of the pump shaft seal.

Train for the Fastest Growing Job Skill in America

Only NRI teaches you to service and repair all computers as you build your own 16-bit IBM-compatible micro

As computers move into offices and homes by the millions, the demand for trained computer service technicians surges forward. The Department of Labor estimates that computer service jobs will actually *double* in the next ten years—a faster growth than any other occupation.

Total System Training

As an NRI student, you'll get total hands-on training as you actually build your own Sanyo MBC-550-2 computer from the keyboard up. Only a person who knows *all* the underlying fundamentals can cope with *all* the significant brands of computers. And as an NRI graduate, you'll possess the up-to-the-minute combination of theory and practical experience that will lead you to success on the job.

You learn at your own convenience, in your own home, at your own comfortable pace. Without classroom pressures, without rigid night-school schedules, without wasted time. Your own personal NRI instructor and NRI's complete technical staff will answer your questions, give you guidance and special help whenever you may need it.

The Exciting Sanyo MBC-550-2—Yours To Keep

Critics hail the new Sanyo as the "most intriguing" of all the IBM-PC compatible computers. It uses the same 8088 microprocessor as the IBM-PC and the MS/DOS operating system. So, you'll be able to choose thousands of off-the-shelf software programs to run on your completed Sanyo.

As you build the Sanyo from the keyboard up, you'll perform demonstrations and experiments that will give you a total mastery of computer operations and servicing techniques. You'll do programming in BASIC language. You'll prepare interfaces for peripherals such as printers and joysticks. Using utility programs, you'll check out 8088 functioning. NRI's easy step-by-step directions will guide you all the way right into one of today's fastest growing fields as a computer service technician. And the entire



NRI is the only home study school that trains you as you assemble a top-brand micro-computer. After building your own logic probe, you'll assemble the "intelligent" keyboard...

Your NRI Course Includes a Sanyo MBC-550-2 Computer with 128K RAM, Monitor, Disk Drive, and "Intelligent" Keyboard; The NRI Discovery Lab[®], Teaching Circuit Design and Operations; a Digital Multimeter; Bundled Spread Sheet and Word Processing Software Worth \$1500 at Retail—and More.

system, including all the bundled software and extensive data manuals, is yours to keep as part of your training.

100-Page Free Catalog Tells More

Send the postage-paid reply card today for NRI's big 100-page color catalog, which gives you all the facts about NRI training in Microcomputers, Robotics, Data Communications, TV/Video/Audio Servicing, and other growing high-tech career fields. If the card is missing write to NRI at the address below.

... then install the computer power supply, checking all the circuits and connections with NRI's Digital Multimeter. From there you'll move on to install the disk drive and monitor.



NRI SCHOOLS

McGraw-Hill Continuing Education Center

3939 Wisconsin Avenue, NW
Washington, DC 20016

We'll Give You Tomorrow.

IBM is a Registered Trademark of International Business Machine Corporation.

SUSPENSION

A CENTURY OF PROGRESS

100
YEARS

From cart springs to air bags, suspension design has smoothed the road of automotive progress.

BY MORT SCHULTZ

Illustrations by Pat Ruggero

On a summer day in 1904, a young man by the name of William Brush helped bring about the modern automobile suspension system. Driving his brother Alanson's Crestmobile, Brush was rolling along too fast for the unpaved roads of the day and went into a curve at 30 mph. The car's right front wheel skittered onto the dirt shoulder and whammed into a deep rut.

Almost at once, the steering wheel started to shimmy violently. The undulations of

the jarred right-front elliptic leaf spring had sent shock waves across the solid I-beam axle to the left side of the vehicle. This set the entire front of the car to vibrating furiously. Brush was caught unawares and lost control. The car crashed through a barbed-wire fence, hit a ditch and overturned in a cow pasture.

Several hours later young William 'fessed up to Alanson, whose demeanor switched from stern to thoughtful, since he was trying to design a better car. That car, dubbed the Brush Two-Seat Runabout, finally appeared in 1906. It featured a revolutionary suspension system that incorporated two innovations never before assembled together: front coil springs and devices at each wheel that dampened spring bounce—shock absorbers—mounted on a flexible hickory axle.

Some European car makers had tried coil springs, with Gottlieb Daimler in Germany being the leading exponent. However, most manufacturers stood fast with leaf



Early cars had simple multileaf springs bolted between the frame and a solid I-beam front axle. High speeds caused wheel shimmy. With the exception of shock absorbers, much the same setup is used on heavy trucks today.

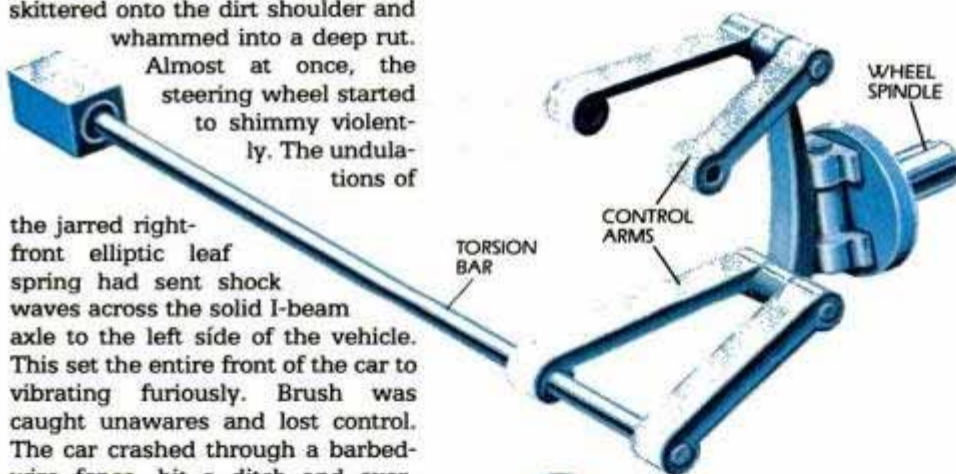

In a torsion bar suspension (left), a bar of resilient spring steel is twisted by the suspension arms. Popularized by Porsche and Chrysler, a torsion bar operates like a coil spring that's been straightened out.

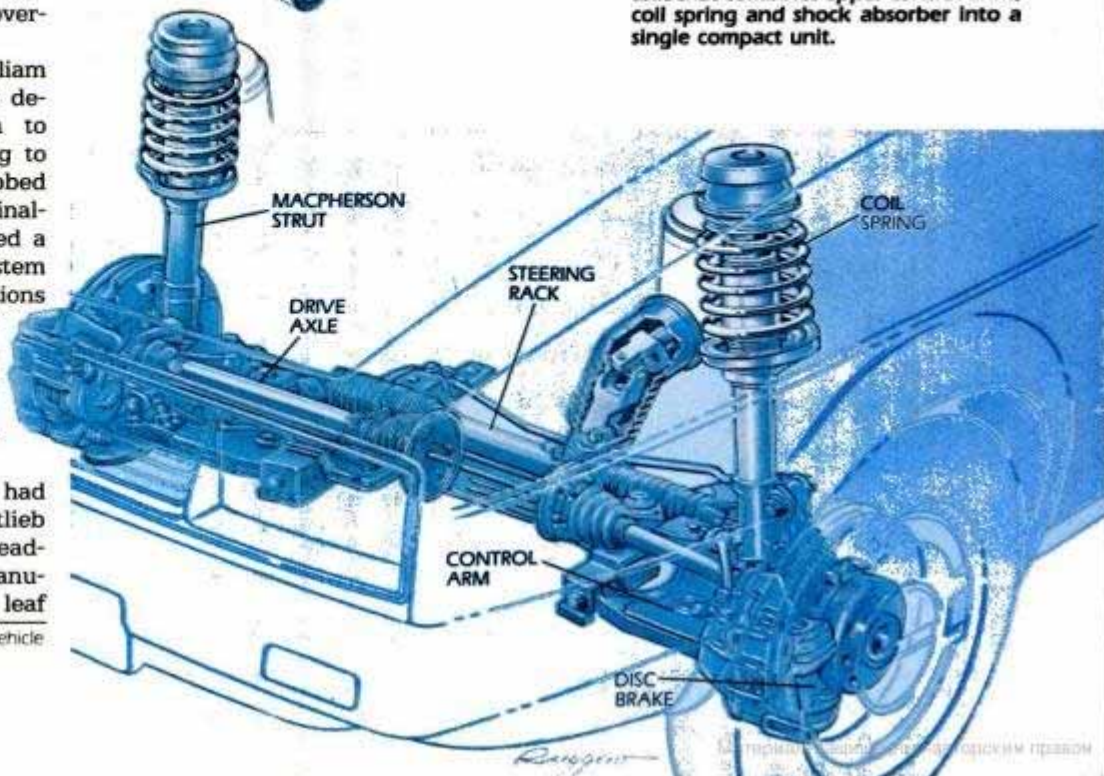

Coil springs (below) are used on most modern cars. On this front-drive VW, the spring is part of a MacPherson strut unit that combines upper control arms, coil spring and shock absorber into a single compact unit.

PM thanks the research library of the Motor Vehicle Manufacturers Assn. (MVMA) for its help in preparing this series of articles.

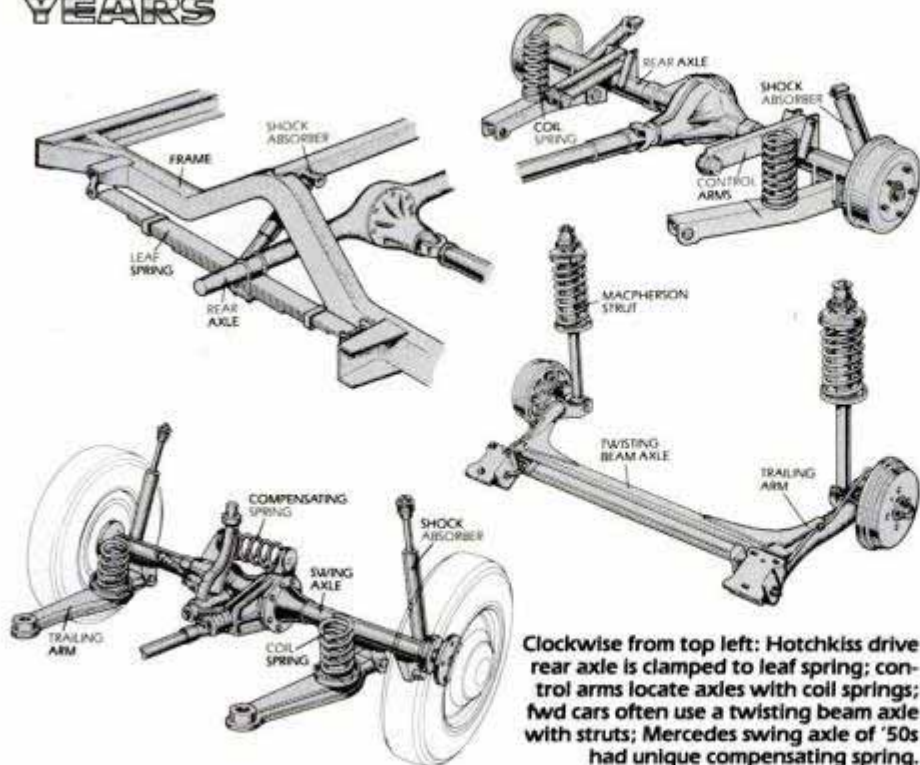

Clockwise from top left: Hotchkiss drive rear axle is clamped to leaf spring; control arms locate axles with coil springs; fwd cars often use a twisting beam axle with struts; Mercedes swing axle of '50s had unique compensating spring.

springs: They were less costly, and by simply adding leaves or changing the shape from full elliptic to three-quarter or half elliptic, the spring could be made to support varying weights.

Leaf springs in one form or another have been used since the Romans suspended a two-wheeled vehicle called a *Pilentum* on elastic wooden poles. The first steel spring put on a vehicle was a single flat plate installed on carriages by the French in the 18th century.

The venerable leaf spring, which some manufacturers still use in rear suspensions today, was invented by Obadiah Elliot of London in 1804. He simply piled one steel plate on top of another, pinned them together and shackled each end to a carriage.

The coil spring isn't a spring chicken, either. The first patent for such a spring (British patent No. 792) was issued to R. Tredwell in 1763. The main advantage of coil springs was that they didn't have to be spread apart and lubricated periodically to keep them from squeaking, as leaf springs did.

Henry Ford's 1908 Model T Ford featured old-fashioned leaf springs with a novel twist—he used only one spring at each axle, mounted transversely, instead of one at each wheel. Ford's adaptation of high-strength vanadium steel from a French racing car allowed him to save weight and cut costs in many areas of the Model T without compromising its durability.

With the exception of a car here and there, independent coil spring front suspension remained in limbo for 25

years after the introduction of the Brush Runabout. Then suddenly in 1934, General Motors, Chrysler, Hudson and others reintroduced coil spring front suspension, this time with each wheel sprung independently. In that year, most cars started using hydraulic shock absorbers and balloon (low-pressure) tires. Coupling a solid front axle with shock absorbers and these tires really aggravated front end shimmy. Suspending each wheel individually lessened the effects of spring bounce.

Not all cars used coil springs at first. Some had independently suspended leaf springs. But soon after World War II, all manufacturers switched to coil springs for the front wheels.

Buick became the first U.S. manufacturer to use back-end coil springs in 1938. Manufacturers have switched back and forth from model to model between leaf and coil springs since then. Generally, large, heavy cars are equipped with leaf springs, while small light cars have coil springs.

Independent rear suspension became popular on the rough, twisty roads of Europe because it can offer improved ride and handling. The cheapest method is the swing axle, for which early VWs were infamous. The differential is bolted to the frame, with constant-velocity joints on each side. However, as the wheels bounce over bumps, the tire camber and rear track change radically, causing some handling quirks. In extreme maneuvers, an outside wheel can actually tuck under

(Please turn to page 60)

Your Ultimate Weapon Against Athlete's Foot.

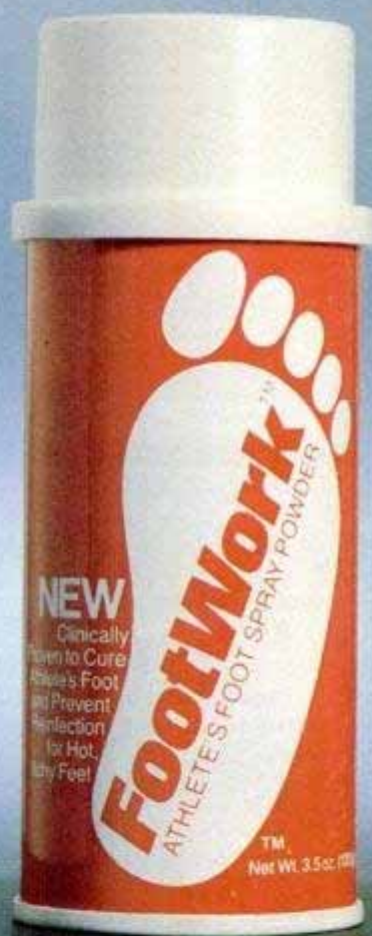

New
FootWork™
TOLNAFTATE 1% ATHLETE'S FOOT REMEDY

There's no stronger, more effective way to prevent and cure athlete's foot without a prescription.

Also available in cream, powder & solution.

Do-It-Yourself DOME HOMES

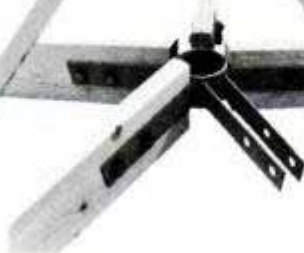

Whether you purchase our complete kit (ready-to-assemble with no special tools or skills needed) or just our plans and connectors, you'll find all our products to be stronger, better-engineered, and less expensive than others on the market.

- Our heavy-duty connector system is the strongest and most versatile available
- 2" x 6" construction throughout (at no extra cost)
- Or save \$1000's by purchasing our connector system and plans and cutting your own lumber
- Unique ledger hanger system for easy second-floor framing
- Larger-size Domes available for churches and industry

Our heavy-duty connector with 2" x 6" struts

Send \$6 (or charge to your MC or Visa) and you'll receive:

- Informative 28-page Dome Catalog
- Assembly Manual • Floor Plan Catalog
- Price List • And more!

Name _____
Street _____
City _____ State _____ Zip _____
Timberline Geodesics, Inc., (415) 849-4481
2015 Blake Street, Berkeley, CA 94704

PM-8

100 YEARS SUSPENSION

(Continued from page 59)

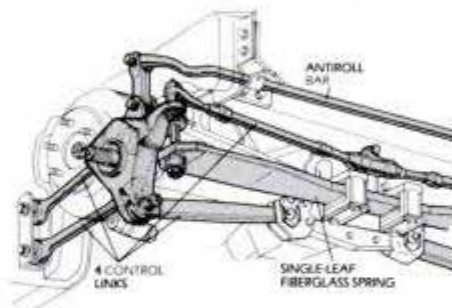

Transverse rear leaf springs: multileaf steel spring of Model T Ford (top); and single-leaf plastic spring from '85 Corvette.

the car, causing it to flip.

Axles with joints at both ends do a better job of keeping the wheels upright in a turn, and an amazing variety of control arms have been used to meet this end. Trailing arms, once popular, sometimes allow *trailing throttle oversteer*—lift your foot off the gas pedal in a turn and the rear wheels shift slightly, throwing the car into a skid. Modern designs use up to six control links at each wheel to prevent such erratic behavior as bump steer and trailing throttle oversteer.

Air suspension, which Lincoln ballyhooed for some models only last year, was introduced in 1909 by the Cowey Motor Works of Great Britain. It didn't work well because it leaked.

The first practical air suspension was developed by Firestone in 1933 for an experimental car called the Stout-Scarab. This was a rear-engined vehicle that used four rubberized bellows in place of conventional springs. Air was supplied by small compressors attached to each bellow. As you might imagine, the air bag suspension was an expensive setup—still is, in fact.

The first automobile to use torsion bar suspension was the 1921 Leyland. Most of the credit for the wide acceptance of torsion bars in Europe goes to Dr. Ferdinand Porsche who made it standard on most of his cars, beginning with the 1933 Volkswagen prototypes. By 1954, 21 makes of European cars were equipped with torsion bars.

By contrast, in America, only Chrysler went the torsion bar route on its large-sized cars. Despite its excellent ride qualities, high cost has limited its acceptance in this country.

The role of shock absorbers in suspension development will be reviewed next month.

PM

Our New Catalog At Our Old Price. Free.



Once again, the catalog filled with gifts that are free has a price tag to match.

Send us this ad, and we'll show you all the new and wonderful things you can get just by saving Raleigh or Belair coupons.

For your free copy, just send this ad to: Raleigh-Belair Catalog, P.O. Box 12, Louisville, KY 40201. Or call free from anywhere in the Continental U.S., 1-800-626-5510.

You must be 21 or older, allow 4 to 6 weeks for shipping.

Name _____ Address _____
City _____ State _____ Zip _____

Warning: The Surgeon General Has Determined That Cigarette Smoking Is Dangerous to Your Health.

RALEIGH Kings, 16 mg. "tar", 1.1 mg. nicotine av. per cigarette by FTC method.
BELAIR Kings, 10 mg. "tar", 0.7 mg. nicotine av. per cigarette, FTC Report Feb. '85. © 1985 B&W T Co.

001



HOW TO INSTALL

A THIRD BRAKE LIGHT

All the 1986 cars will have this new safety device.
Here's how to add one to your car.

BY FRANK COGGINS

Effective Sept. 1, 1985, under NHTSA mandate, all passenger vehicles must be built with a single, center, high-mounted stoplamp, in addition to the pair presently required. The Insurance Information Institute claims that such an installation can reduce your chances of being involved in a rear-end crash by 53 percent. General Motors jumped the gun by making the third brake light standard equipment on some of its '85 models and optional on others. Chevrolet offers the light in kit form (part No. 988607) for dealer installation. The kit costs \$38 with an added charge of \$30 for installation. A similar kit will be available from Buick, Oldsmobile and Pontiac. The aftermarket kit shown here costs \$19.95 plus tax.

Do-it-yourself installation of a "third eye" brake light, in conformance with NHTSA requirements, is fairly simple, depending upon where the unit is mounted. It can be installed within the vehicle, showing through the rear window, outside and below the rear window (but not more than six inches below on convertibles), or on the roof. We recommend the roof for hatchbacks and some station wagons. No special shape is specified, though the light must produce 25 candela of illumination and the minimum lens area should be no less than 4½ square inches. Lights mounted on the outside of a vehicle must meet certain dust,



"Third eye" is mounted on the deck lid of conventional sedans (top). On station wagons and hatchbacks, the most practical location is at the rear of the roof (above). Installation is relatively simple.

moisture and corrosion-resistance requirements, so any kit should be checked before purchase.

Installation can be done easily with hand tools, a good drill and a test light. Off-the-shelf kits have comprehensible instructions, which should be read through carefully before proceeding.

The lights we installed are sold under the brand-name "Hi-Lite," made by the Laser Corp., Santa Monica, Calif., and are said to be approved for use in all states. Everything required came with the kit with the exception of enough 16-gauge wire to ground the unit properly on the best exposed metal point in the trunk area. Additionally, the ground

wire can be fitted through the ¼-inch mounting hole with far less difficulty if the mounting lug is snipped off and the extra wire spliced on after the unit is mounted.

Mounting is simple on the exterior of sedans, especially on cars with a few inches of flat area between the back window and the trunk lid. Interior mounting poses a problem in that the package shelf between the back seat and the bottom of the rear window may be as much as three inches below the window, requiring a bracket to raise the lamp so that it can be seen.

Station wagons and hatchbacks have their own built-in problems: Mounting on a hatchback door requires snaking

(Please turn to page 70)

Pack it full. Fuller. Pile it high. Higher.

Whether it's a Cargo Van, a Standard Bed Truck, or a One-Ton Truck you need to get your work done best, chances are you'll find Toyota has the best selection for the job.

MORE CAPACITY. The 1985 Toyota Cargo Van gives you the most cargo capacity of any small van. No discussion.

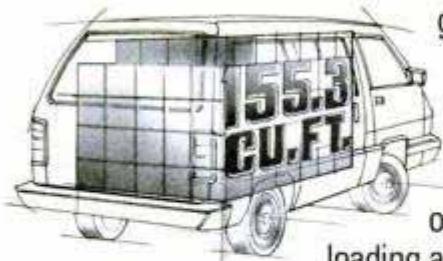

The doors open wide for easy loading and unloading of over 155 cubic feet. So you can carry more packages, pipes, plants or parts without going back to

the store for more.

With the highest miles per gallon, 25 Highway MPG, (23) City MPG,* and the best service interval of any van in its class, you get even more on-the-road, on-the-job time, too. When it comes to exclusive features, it never quits either.

Consider: This is also the only van with platinum-tipped spark plugs designed to go 60,000 stop & go, grueling miles—without changing. And its 2.0 liter engine with Electronic Fuel Injection, like every Toyota engine, is built with dedication to avoid repairs like the plague.

MORE VALUE. For the money, \$5,998,** Toyota's **\$5998.**** 1985 Standard Bed Truck

**THE MORE YOU GET INTO YOUR VAN OR TRUCK,
THE MORE YOU GET OUT OF IT.**

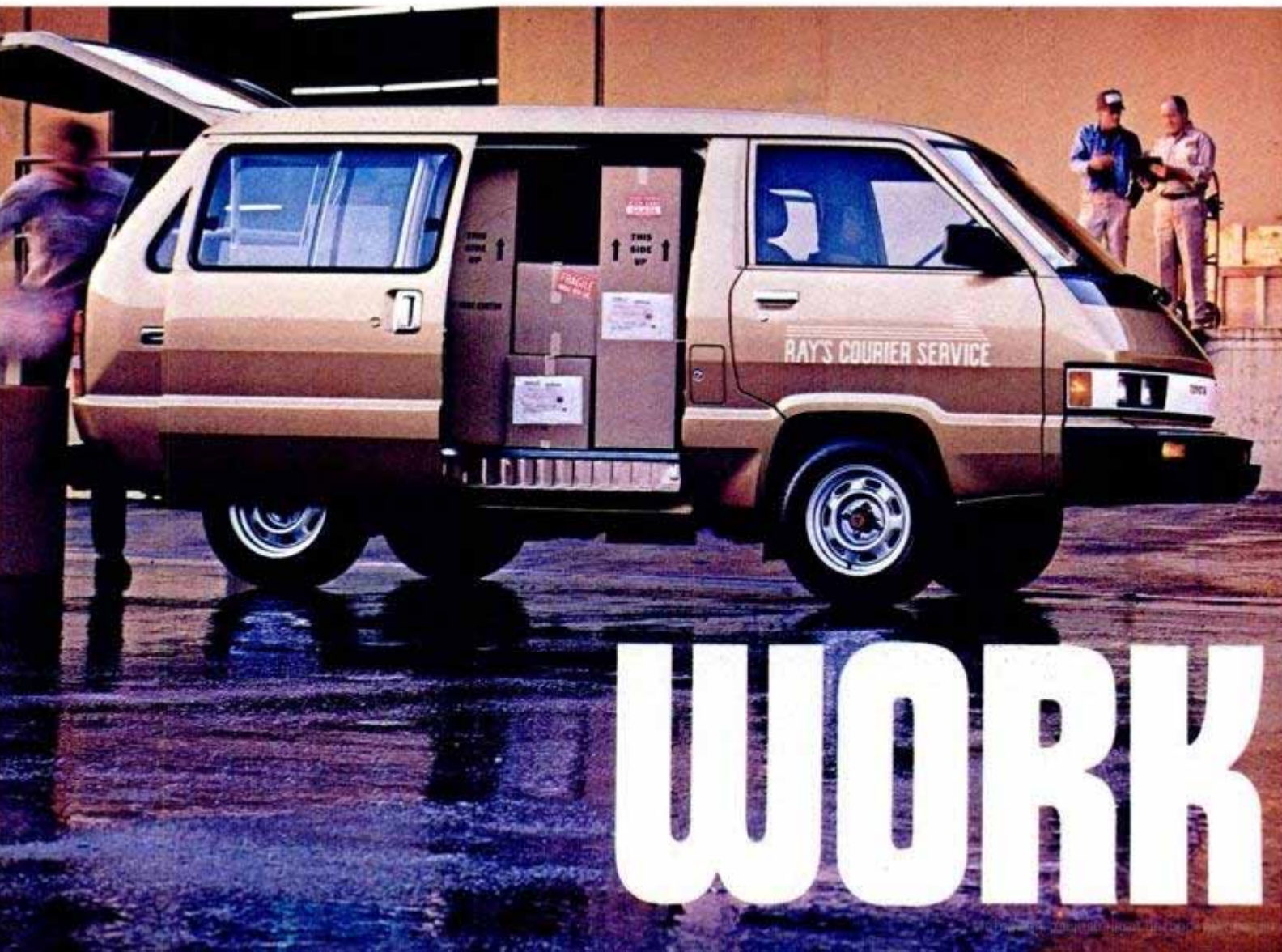

gives you more than just a 1,400 lb. payload,^{***} rugged full-box frame construction, space in the cab for three without skimping on head or leg room, 31 Highway MPG,⁽²⁷⁾ City MPG* and a powerful 24 liter engine that works overtime without complaints.

Like all Toyota Trucks, Toyota's Standard Bed also gives you more confidence. Ask around. Toyota owners reported the lowest incidence of repairs for any small truck—imported or domestic.^{****}

That's one big reason why more than 95% of all Toyota Trucks ever sold are still on the road,[†] still working and still carrying spectacular resale value.

Maybe that's why nobody sells more small trucks than Toyota. Nobody. **MORE PAYLOAD.** If you need the highest payload of any small truck, you need the 1985 Toyota One-Ton Truck.

2500 lbs.*
PAYLOAD**

This heavyweight has double-wall construction, heavy-duty rear suspension and 8-ply, steel-belted

OH WHAT A FEELING!

radial tires to keep doing business even when you're hauling 2,500 lbs.^{***}

Want more? Toyota's One-Ton can tow up to 5,000 lbs.^{***} with its optional towing package. **MORE INFORMATION.** Find out how the wide selection of Toyota Trucks and Vans can help you get more out of your work at your local Toyota Dealer. Take a Toyota out for a test drive today and learn firsthand.

* With Standard Transmission. Remember: Compare this estimate to the "EPA Estimated MPG" of other vans or trucks. You may get different mileage, depending on how fast you drive, weather conditions and trip length.
** Manufacturer's suggested retail price. Dealer's actual retail price may vary. Price does not include tax, license, transportation, optional or regionally required equipment.
*** Including occupants, equipment and cargo. On One-Ton, max. GVWR not to exceed 8,500 lbs. for vehicle and trailer combined.
**** 1984 J.D. Power Compact Pickup Truck Survey.
† R.L. Polk registrations.
†† Calendar year 1984, Ward's Automotive Reports.

#1 SELLING SMALL TRUCK IN AMERICA.††



FORCE!

To Celebrate Our 10 Millionth Sale!

45-PIECE TOOL KITS

ONLY \$5

WITH THIS AD

This is *NOT* a Misprint.

This special offer is being made to celebrate the 10 millionth sale of the famous New York importing firm of Abernathy & Closther and is open to every person who mails this original printed ad to the address below before Midnight, October 31, 1985.

***NOTE: This original printed ad must accompany your request. Copies or photostats are not acceptable.**

To celebrate its 10 millionth sale, the famous New York importing firm of Abernathy & Closther will distribute one million Universal Tool Kits for only \$5 apiece to the first one million people who write to the address below before Midnight, October 31, 1985.

These are the same nationally advertised Universal Tool Kits to be featured in leading media with 45 special tools designed to aid in virtually every kind of home, workshop or auto repair project.

Each Universal Tool Kit includes a hammer, 12-piece set of regular and Phillips screwdrivers, 9-piece set of hex wrenches plus driver, 7-piece set of offset and box wrenches, 5-piece set of Allen wrenches, plumber's thumb-knurl "monkey-wrench", pair of slip joint pliers, holemaker and screw starter, scratch awl, metal and wood punch, retractable metal tape measure, hack saw for cutting metal, electrical circuit tester, etc.

A mechanic's snap-lock folding case included free of charge (see photo). It keeps each tool neatly in place and actually *folds the entire set of all 45 tools into just one-inch of space*, for handy storage in kitchen drawer, car glove compartment, office shelf or home workshop.



This 45-Piece Universal Tool Kit will not be sold at this price by the company in any store. To obtain one at this price, apply in writing to the company address no later than Midnight, October 31, 1985.

Each tool kit carries a full one-year money-back guarantee, and will thus be replaced or refunded by the company, free of charge, if it fails to function. There is a limit of two (2) tool kits per address at this price, but requests which are mailed early enough (before Oct. 25) are permitted to order up to 5 kits.

To obtain a Universal Tool Kit, mail *this original printed ad* together with your name and address and \$5 for each kit. Add \$2.75 shipping and handling per kit. (New York residents add sales tax.) Allow up to 6 to 8 weeks for shipment. Mail to: **Abernathy & Closther, Tool Kit Offer, Dept. 114-101, Box 1600, Westbury, New York 11595.** (A22730)

© 1985 PDM, Inc.

PM TECHNOLOGY UPDATE 8/85

ENGINEERING

Hull aids Gulf exploration

The waters in the Gulf of Mexico are often rough and choppy. *Twin Drill*, a geotechnical survey, salvage and maintenance vessel, is especially suited for the Gulf's churning seas. Using SWATH (Small Waterplane Area Twin Hull), a catamaran-type hull design, *Twin Drill* rides steady in white-capped water. *Twin Drill's* unique configuration allows it to moor in water as deep as 600 feet. The ship is held at station either through a four-point, winch-driven mooring system or by manual T-stick control of thrusters. The ship's deck has a 23-foot, circular access port known as a moon-pool. Submersible vehicles can be recovered or delivered through the opening. *Twin Drill* is equipped with a full-scale laboratory for on-the-spot analysis of core samples and information on soil conditions. Although soil analysis and ocean-floor probes are the craft's main activities, its other functions are sub-sea work, diving, platform and cable maintenance, and inspection. *Twin Drill* this summer is conducting a search for new oil fields in the Gulf of Mexico.



Twin Drill's SWATH hull gets final touches in Rotterdam.

Fish farming for profit

Why is multimillionaire industrialist Robert Abplanalp raising tropical fish? Because there's money in it. Abplanalp recently opened the world's largest saltwater

Editor: Dennis Eskow
Assistant Editor: Ted Francis
Contributors: Sheldon M. Gallager,
Ken Sanders, Angus Laidlaw,
Chris L. Mitchell, Steve Eskow,
Dennis Mahanna, Wade Hoyt,
Peter Francesconi, Jack Hammond

fish hatchery, capable of producing 1.5 million fish a year. The 23,000-square-foot fish farm, located in the Bahamas, uses the latest mariculture technology to net an estimated \$2.5 million a year. Overhead tubes (top) supply clean sea water to 200 brood stock tanks. Fish mature in one of 250 growing tanks (bottom). This may improve reef ecology, since tropical fish traditionally are caught after being stunned by toxins or explosives.



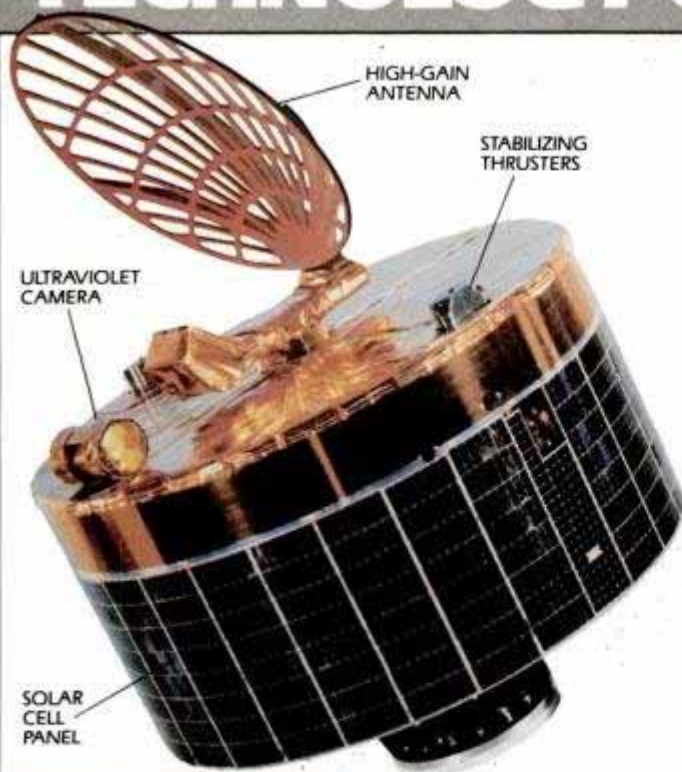

AEROSPACE

Comet probe from Japan

Japan's most advanced satellite launch vehicle, the M-3SII, will propel its research satellite Planet-A (above, left) into a heliocentric orbit this summer. Planet-A and its previously launched sister satellite, the MS-T5, will rendezvous with Halley's Comet in the winter of '86. Planet-A

will take ultraviolet images of hydrogen emissions in the comet's plasma tail. The M-3SII (above, right) is designed to inject scientific packages weighing about 1300 pounds into low-altitude orbit.

The solid-propellant, three-stage rocket is approximately 100 yards tall and weighs 61 tons. The launch of the M-3SII will make Japan a contender in satellite and launch-vehicle technology.

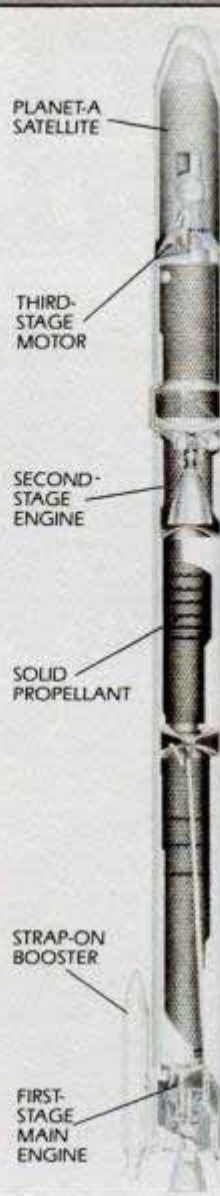

Telescope powerhouse

For years, Mount Palomar's 200-inch telescope reigned as the world's largest. The University of California, however, is now stepping forward with plans to build a 400-inch giant that will have at least four times Palomar's light gathering power. The telescope is scheduled for completion in 1990, and it will have a moving weight of 158 tons and a pointing accuracy of better than 1 arc second. UC's monster also will sport the latest in telescopic technology: segmented mirrors composed of 36 6-foot-wide hexagons that together form a paraboloid. Each of the elements will be controlled individually for greater accuracy.



AUTOMOTIVE

Skid tester

Pilots landing in rain, snow or icy conditions can find out just how slippery the runway is through warning alerts radioed from this Saab Friction Tester devised by Saab-Scania of Sweden. The Friction Tester measures runway friction from the amount of drag on a computer-controlled fifth wheel.



'Commando' fights fires

Since forest fires seldom occur near paved, even roads, rural-based fire fighting companies will find Ottawa-Brimont's four-wheel-drive, four-wheel-steering, center-pivoted Commando ideal for

negotiating rough terrain. The 27,500-pound, 117-in. fire truck is powered by a 171-hp Mack turbodiesel which can speed the truck to a fire scene at 56 mph. Independent asymmetrical (crab) steering enables the Commando to climb crests without toppling.

INVENTIONS

Durable alloy

A New Jersey engineering firm has developed a durable, low-cost steel alloy. Tests show the alloy will withstand twice the wear of stainless steel and five times as much as aluminum. It was tested, and is being marketed, for a propeller. It has a low incidence of failure and resists salt, pollution and galvanic corrosion.





RESCUE

Cable car evacuation

While fire or severe weather could prevent rescue of oil rig personnel by helicopter, a two-ton, 20-man capacity capsule under development by a British firm could evacuate 200 workers in 75 minutes: Personnel fire a light line to the rescue vessel by which load-bearing cables

are run. The connection takes about 10 minutes. Electrohydraulic winch drums aboard the vessel adjust to the ship's movement, maintaining the cable loop shape so the capsule doesn't dip into burning seas. The cable car is also a lifeboat and would float should it break free from the cables. Sea trials are under way. The system may be used for routine transfer of personnel when choppers are unavailable.

Mini life raft

Airmen forced to eject at sea stand a better chance of survival in this one-man shelter—the world's smallest fully enclosed life raft. Inflated

by CO₂ cartridges, it has a quilted canopy with a clear plastic faceplate that covers the occupant, providing insulation against the cold as well as keeping out water.

Water-filled chambers underneath serve as keel-like stabilizers to prevent the raft from capsizing in heavy seas. A fabric sea anchor also minimizes drift. Made by Beaufort Air-Sea Equipment Ltd., England, the raft fits into standard ejection-seat survival packs.

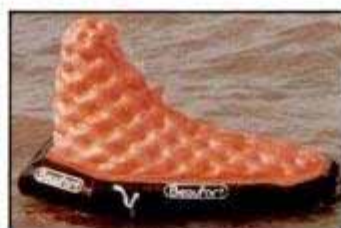

ELECTRONICS

Talking cockpit

Many pilots talk to their planes, but few expect them to answer back. Now there's one that does just that. In a new voice command system designed to simplify the flying of complex fighter jets, the pilot literally talks to his



instrument panel, requesting such information as air-speed, altitude, angle of attack, remaining fuel and distance to target.

A computerized voice-recognition processor in the panel compares the verbal sounds with a prerecorded vocabulary of spoken words. The processor selects the appropriate response, then answers the pilot in synthesized speech.

The system, developed by Crouzet of France, can also provide verbal warnings, such as for low fuel or an engine malfunction, and may eventually permit hands-off flying through voice-activated controls. Similar research programs are also being conducted by the U.S. Air Force.

The day of the android

The movements of robotic limbs often are stiff and halting. McAndroid the Android (right), a fusion of art and engineering, may herald a new era in robotic movement. "Mac" was developed as a sounding board for advanced manipulation technology. He is endowed with pneumatic valves which regulate the flow of air into rolling diaphragm "muscles" at each of Mac's joints. The valve is simple, yet gives sensitive control of the android's limbs. Limb motions are key to more sophisticated industrial and home-use robots.

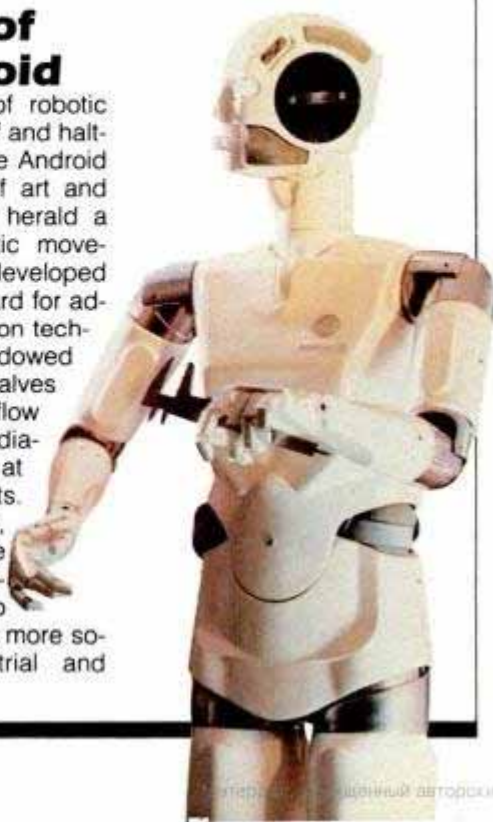

AUTO RACING

How a champ keeps cool

Cooling engine combustion chambers is a major problem in grand prix racing. Most of the cylinder head is occupied by four valves per cylinder, intake and exhaust passages and sparkplug ports, leaving little room for water passages. One method of dealing with the limited cooling area is to cool the bottoms of the pistons with a continuous spray of oil. Porsche has gone that extra step by adding a unique two-part piston to one of the most successful grand prix racing engines, the TAG Porsche 900-hp, 1.5-liter, twin-turbocharged V6. The new piston's skirt is separate from its crown—the two parts are locked together by the wrist pin. Cooling oil is pumped through the area between the two pieces whenever the piston is at bottom dead center (up to 200 times a second at 2,000 rpm). During the rest of the stroke, oil simply sprays out of its fitting



ton. The oil is then pumped out of the crankcase and through a radiator-like oil cooler. Results: more reliability, fuel economy and an opportunity to go that extra inch or two to the finish line without reaching the fuel limit. The TAG V6 engine won the 1984 grand prix World Championship. And this year, the Porsche champ stands a very good chance of taking the championship one more time.

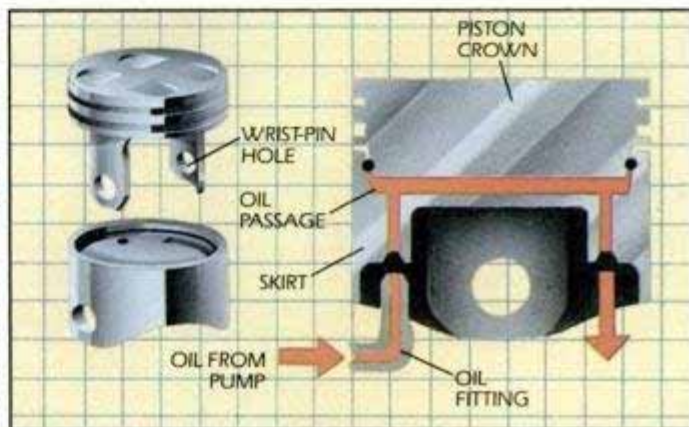

MILITARY

Crafty copter

In the heat of combat, helicopter pilots are often hard-pressed to perform the complicated maneuvers needed for a quick attack or evasive action. Now, in an experimental system developed jointly by Bell Helicopter and Honeywell, a pilot can exe-

ecute a variety of automated maneuvers merely by pressing a button.

In the "bob-up" (diagram below), the craft rises rapidly to a preselected altitude, makes a 90° turn in either direction, then drops back down—all without the pilot touching the controls. Another button puts the copter into a series of swings from side to side, known as jinking, to confuse the enemy and make it harder to hit.



Tiny tank

While most battle tanks tend to get bigger, at least one is going the other way. Barely 11 feet long, the Weasel weighs only 2.9 tons—20 times less than the huge 58-ton M-1 Abrams—making it the world's smallest tank.

Designed for rapid deployment, the Weasel is so light it can be flown into battle by helicopter or parachute-dropped from cargo planes. It can mount a 20-mm cannon or TOW antitank missile launcher and has a top speed of 53 mph. Developed by Porsche, it is under test by the U.S. Army.

MARINE

Smugglers in for 'thunder'

Blue Thunder, a Don Aronow-designed speedboat, is undergoing baptism as the U.S. Customs' newest weapon in its battle against smugglers in South Florida waters. *Thunder* cruises at better than 60 mph, turns on a dime and slices through rough water with her catamaran hull. The 39-foot, 900-hp, twin-gasoline-engine speedster weighs a hefty six tons. Dopers, beware!



AVIATION

The SST strikes back

America's quest for a supersonic transport (SST), killed by Congress in the early 70s, is making a comeback. Under test at NASA's Langley Research Center is a long, arrow-winged wind-tunnel model that could lead the way to a 250-seat, Mach 2.7 super jetliner capable of whisking you from Los Angeles to Tokyo in three hours.

According to NASA, lighter materials, fuel-efficient engines and a larger seating capacity would make the SST economically successful where the smaller, 140-seat Anglo-French Concorde has had economic problems.

Meanwhile, NASA's Ames Research Center is exploring an even more radical concept known as an oblique wing (lower right). The pivoted wing swings crosswise for low-speed landings and takeoffs, then is angled fore and aft for supersonic flight. This reduces drag and sonic boom because the wing spears the air like a sword, and doesn't hit it broadside.

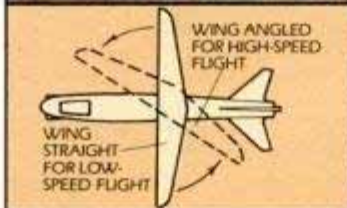
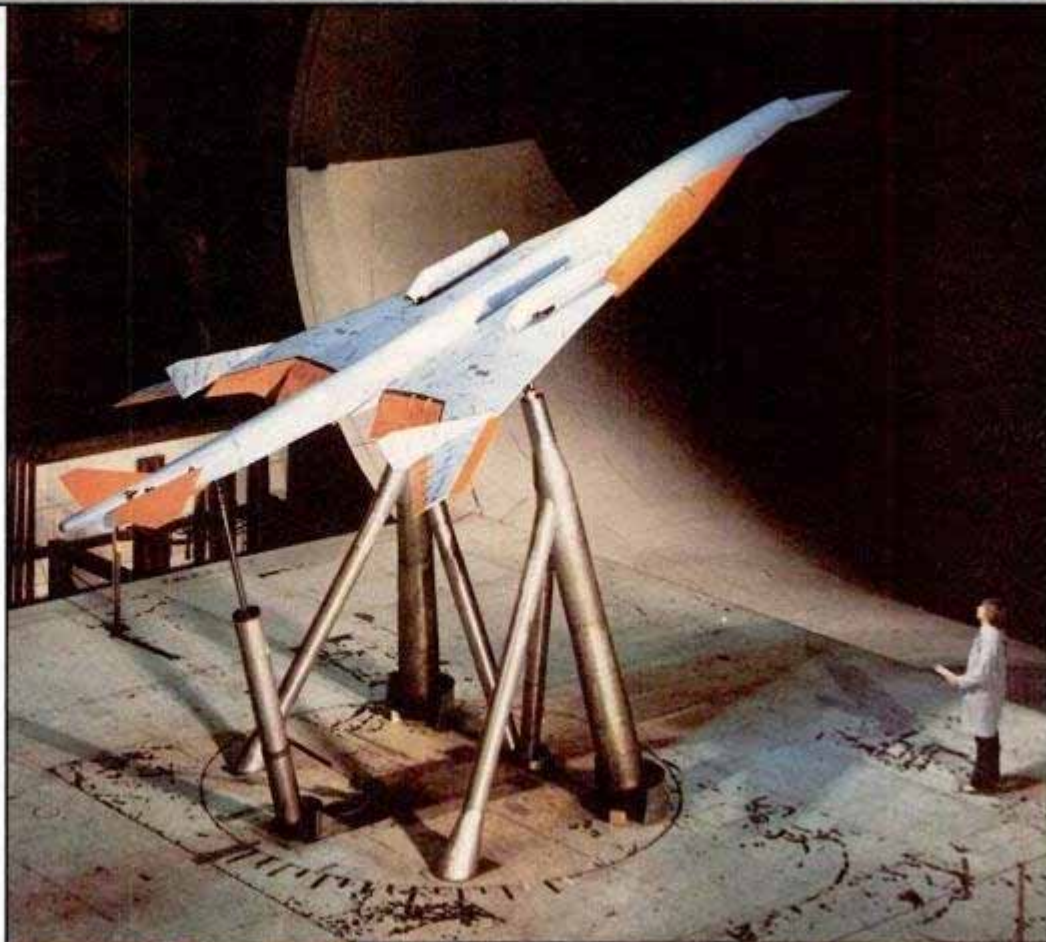

Hefty plane gets heftier

It's hard to imagine anything mightier than the mammoth Lockheed C-5A Galaxy, one of the world's largest military cargo transports. But now there's a new, more powerful version capable of even greater feats. The C-5B now under construction is the first of 50 updated C-5s that Lockheed-Georgia will build for the Air Force at a cost of about \$90 million per plane.

New high-lift wings, bigger engines and a beefed-up airframe will give the C-5B a payload capacity of 264,700



pounds, compared to 220,967 pounds for the C-5A—an increase of almost 22 tons. The 28-wheel, four-engine giant is 248 feet long, has a wingspan of 223 feet and 164,400 pounds of thrust. Just to put on her camouflage makeup takes nearly 200 gallons of paint.

Flying sternwheeler

Engineers at Lockheed-Georgia have a way of coming up with far-out ideas for futuristic airplanes. This unusual design for a next-century air freighter is no exception. It's powered by rotating fan blades that work much like the paddle wheel on a Mississippi riverboat. Driven by small turbines, the fans are mounted crosswise along the wing's trailing edge, expelling their exhaust through hinged flaps. Now comes the clever part: With the flaps lowered, the thrust



can be directed downward. According to Lockheed this downward thrust, along with added lift provided by canards on the nose, would greatly shorten landing and takeoff distances, enabling the huge freighter to operate from small airstrips less than 2,000 feet long.

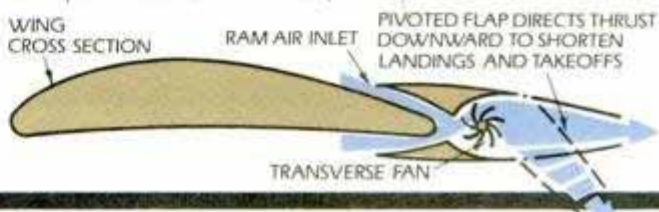

HINTS FROM READERS

Cord reel

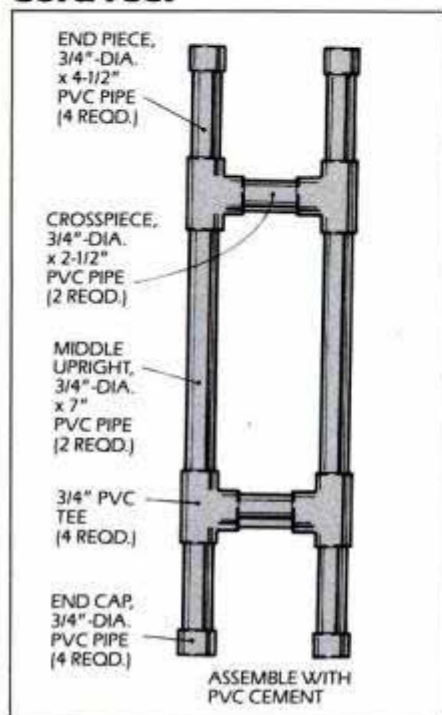

When my reel for electrical cords broke recently, I decided to make my own from scraps of $\frac{3}{4}$ -in. PVC pipe. From a 4-ft. section of pipe I cut four end pieces, two crosspieces and two middle uprights. I cemented the pipe with four PVC tees at the joints and capped the four ends. Total cost of the materials was about \$6. The reel is quite sturdy and capable of winding up to 150 ft. of 110-v. electric cord for neat storage.

—Rick Burr

Wax-dipped nails

To prevent bending nails when working on a hard piece of wood, try my solution: Bore a $\frac{3}{16}$ -in.-dia. \times $\frac{1}{2}$ -in. hole into the wooden hammer handle near its head. Melt some candle wax into the hole. Then when you work on a piece of hard wood, stick the point of the nail into the wax. The wax will act as a lubricant between the nail and the wood fibers.

Be careful not to get wax on the hammer head. Before the nailhead is flush with the wood, you should use a nailset to drive the nail flush or below the work surface. This eliminates any hammer marks on the work.

—Arthur M. Takamori

Overstock Sale

Famous South Bend Industrial Quality Metallurning Lathes



20%

off list price!

10" SWING, BENCH OR CABINET MODELS

Turn precision parts for models, prototypes; cut up to 48 different thread pitches; make replacement parts for tools, equipment and much more. You'll get industrial precision and ruggedness with hardened and ground bedways and 12 easy-to-change speeds, now at a special one-time price! Includes motor, control, one-year warranty.



BENCH MODELS: 3 $\frac{1}{2}$ ' bed—was \$2744, NOW \$2195.
CABINET MODELS: 3 $\frac{1}{2}$ ' bed—was \$3271, NOW \$2617

VISA accepted.

Call collect to order,
1-219-289-2253.
Ask for me, Ed LaVelle

IMMEDIATE DELIVERY

SBL South Bend Lathe

400 W. Sample Street, South Bend, IN 46625

SURE CURE!

LOOK FOR THE GUARANTEE ON THE BRIGHT BLUE K&W CAN.



SINCE 1933

BURDEN'S SURPLUS CENTER

2-HP Dual Shaft Motor
DOERR ELECTRIC

FREE CATALOG

BRAND NEW \$124.99

F.O.B. Lincoln, NE Shpg. 34 lbs.

• ITEM 10-1073 -- 2-HP, 3450-RPM, 115/230-VAC, 60-cycles, 1-phase, 24/12-amps. Cont. duty. Shafts: 1/2" diam. \times 1-1/2", 7/8" diam. \times 2". Size (excluding shaft) 11-1/2" \times 8-1/2" \times 8". Ball bearing. Reversible rotation.

BURDEN'S SURPLUS CENTER/ BOX 82209 - PM
Lincoln, NE 68501/Phone 800-228-3407

NordicTrack

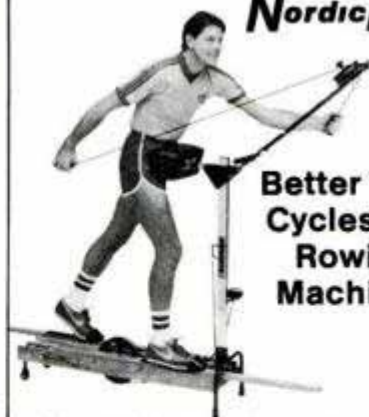

Better Than Cycles and Rowing Machines

Jarless total body cardiovascular exerciser duplicates the smooth rhythmic motion of X-C skiing for the best way to fitness. Arm and leg resistances adjust independently. Patented flywheel action for matched smoothness. Quiet. Life time quality. Folds for storage.

More Effective Than Exercise Bikes

NordicTrack adds important upper body exercise and provides more uniform leg muscle usage. Higher pulse rates, are easier to attain because more muscle mass is exercised.

Better Than Rowing Machines

All rowing machines have the same resistance for both arms and legs. Since your legs are 3 times as strong as your arms, your arms are over worked while your legs loaf. NordicTrack's arm and leg resistances are independent and are adjusted according to individual muscle strength. Safer too, no back strain involved.

Free Brochure

Toll Free 1-800-328-5888 MN 612-448-6987
PSI 141 PM Jonathan Blvd. N Chaska, MN 55318

ATTENTION CRAFTSMEN

we wrote the book



on how to build your own gun and SAVE \$\$\$

Make money in your spare time by building and repairing your friends' guns.

Over 300 gun kits and parts listed in our giant KIT GUN DIRECTORY.

176 pages of detailed construction articles, step by step instructions, and hundreds of detailed photos show you how to build your own working pistol, rifle or shotgun.

Build guns such as the British STEN, the XM-15 Shorty, the classic M1 and many many others.

Try KIT GUNS & HOBBY GUNSMITHING at our risk. Read KG&HG for 90 days. If you don't like it, we'll send your money back — right away — no questions asked.

Ordering Instructions: cash, check, MC or VISA accepted. Send \$9.97 plus \$2.00 shipping and handling (Ohio residents add \$.60 sales tax) to KG&HG, Box 2204, Dayton, Ohio 45429.

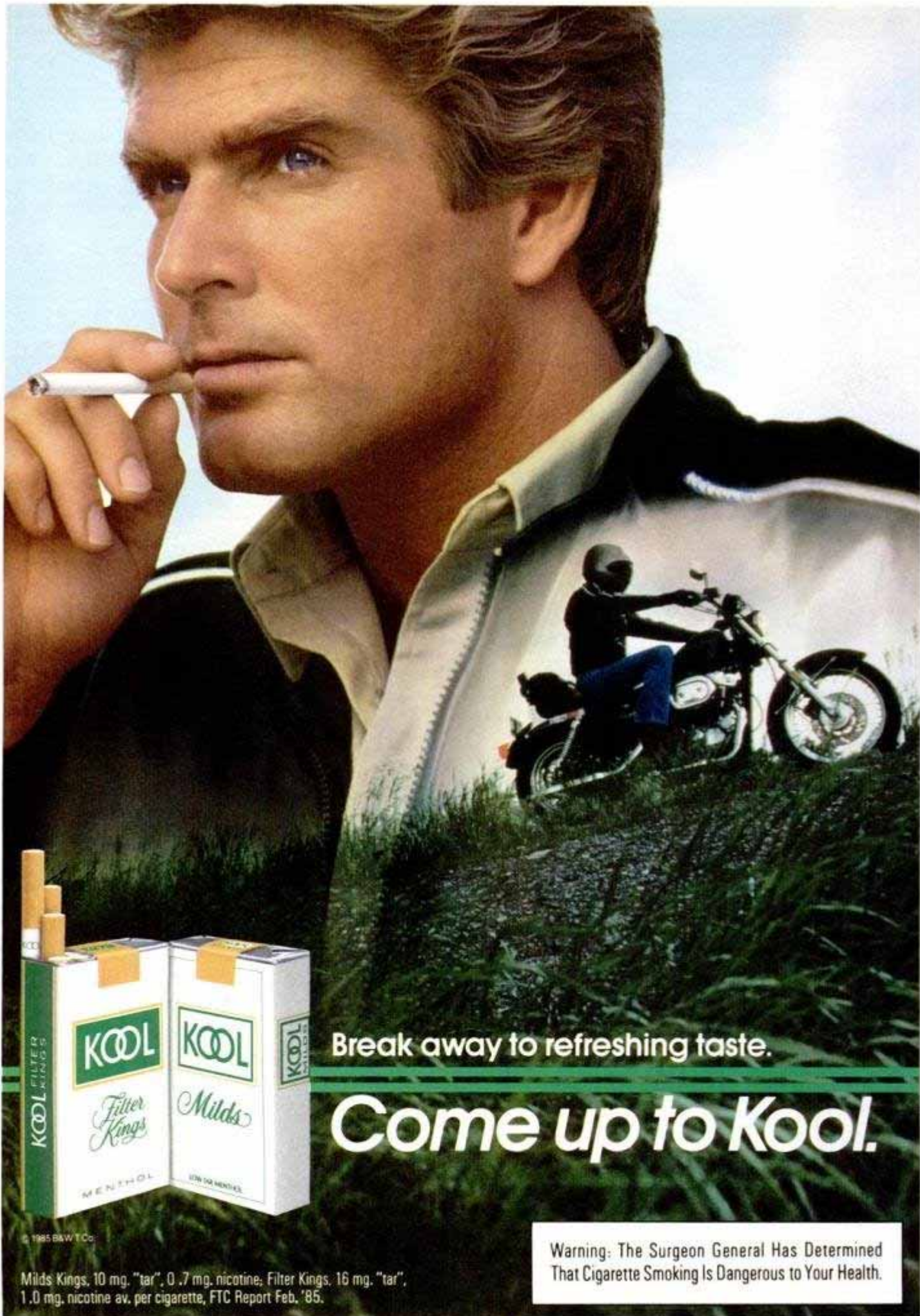

Break away to refreshing taste.

Come up to KOOL.

© 1995 B&W T Co.

Milds Kings, 10 mg. "tar", 0.7 mg. nicotine; Filter Kings, 16 mg. "tar", 1.0 mg. nicotine av. per cigarette, FTC Report Feb. '85.

Warning: The Surgeon General Has Determined That Cigarette Smoking Is Dangerous to Your Health.

HOW THEY HID THE BOMB

TOP SECRET

When the first A-bomb exploded 40 years ago, the world was shocked. So were the people who lived next door to where it was made.

BY DENNIS ESKOW
Science Editor

Fierce thunderstorms and unpredictable winds had kept Norbert Deare awake late into the sweltering summer night. He had helped batten down the filling station near Socorro, N.M., the night before, thinking there might even be an overnight flood. About 5:30 the next morning, Deare's worst fears seemed trivial as he was thrown out of bed by an apocalyptic explosion far more frightening than the worst thunder he'd ever heard.

"The state police said it was an accidental explosion at the Army camp," Deare told an interviewer in docu-

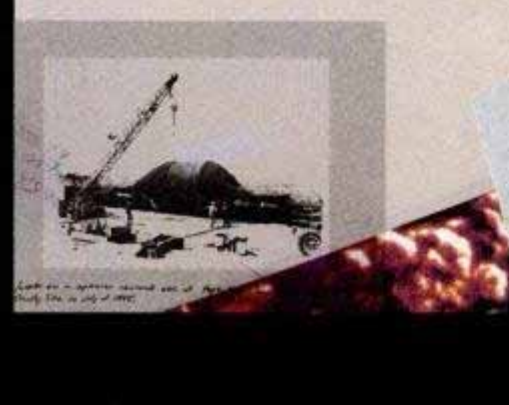
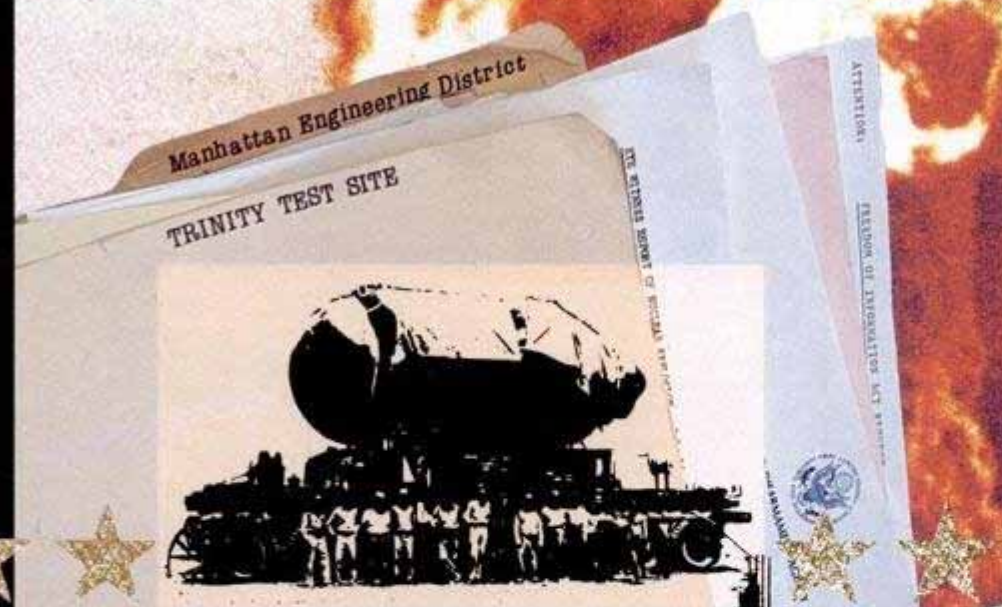



Buildings left by the Los Alamos Ranch School were taken over by the Manhattan Project. The area population grew from under 250 to over 7,000 in three years.

ments released to Popular Mechanics by the Defense Department under the Federal Freedom of Information Act. "But it seemed more like the end of the world."

That explosion, which took place seconds before 5:30 a.m. on July 16, 1945, was, perhaps, the most significant event of the 20th century.

Yet it was almost a month later before the people who witnessed it, and the rest of the world, learned of its true importance. They had witnessed the explosion of the first atomic bomb.

Despite the fact that hundreds of scientists and thousands of support personnel had moved practically overnight into a sparsely populated part of the country; despite the strict security surrounding an enormous canvas-colored device that moved for days along the New Mexico prairie on a train; and, though the first A-bomb blast shook buildings all the way to El Paso, Texas, the War Department managed to keep the bomb a secret.

How they built the bomb is a story that will be told over and over again during this, the 40th anniversary of the atomic era. But how they *hid* the bomb may be an even more spectacular tale.

Even today, hundreds of documents relating to the first A-bomb test remain locked away under secret classification. Still unavailable are several documents relating the results of radiation tests following the test blast at what is now

the White Sands Missile Range. Also still under wraps are correspondences that might shed light on how much information leaked during the weeks between the test and the dropping of the bomb on Hiroshima in August 1945.

Among the startling facts uncovered in our investigation:

- Dozens of documents that had been available to the public but were never used suddenly became classified sometime in the 1970s.
- The governor of New Mexico in 1945 was not informed of the nature of the test until after the bomb was dropped on Hiroshima the next month.
- FBI agents visited the publishers of several major newspapers the day after the test to quash potential stories that might raise questions about the test.
- Defense Department officials—who have acknowledged that three different stories were prepared to explain the test to the public—actually had prepared a half-dozen explanations. Among those not revealed until now was an explanation to cover civilian deaths in the Alamogordo, New Mexico, area. (In the end, the simplest explanation was released since no deaths were involved.)

The security set up around the A-bomb development and test had a very composed and easy appearance, from the front gate to the dozens of labs where the bomb was being built. Be-

The first A-bomb blast is shown in sequence (right, top to bottom) as seen from two miles away on July 16, 1945. The big blast was kept secret for weeks.

PHOTOS COURTESY OF LOS ALAMOS NATIONAL LABORATORY



neath the genteel surface, however, stood a hard-as-nails network to protect the secret. Dorothy McKibbin typifies this security network.

"When newcomers arrived, it was my job to make them feel comfortable, get them located and not answer any questions," Mrs. McKibbin told us in a brief interview. In the two years before the first A-bomb was exploded, she was the official greeter at Los Alamos, the northern New Mexico mountain town where the A-bomb was developed. Mrs. McKibbin's job was to greet personnel arriving at the research camp and direct them to their quarters. Anyone arriving without orders was to be directed away by Mrs. McKibbin, now in her eighties.

Keeping a secret

To get an idea of how hard it was to keep the secret, consider the speed at which the Los Alamos compound grew. When the Army took over the 54,000-acre site in 1942, the local population was under 250, including the faculty and students of the Los Alamos Ranch School. By the time the bomb was ready to be tested, the Los Alamos population hovered around 7,000. Directly or indirectly all worked for the Manhattan Engineering District, an Army unit whose name evolved into The Manhattan Project.

Besides Los Alamos, the district itself also included uranium-processing facilities in Tennessee and Washington state. The two areas combined had fewer than 30,000 residents before the Manhattan Project, but by August 1945, nearly 90,000 people lived and worked around the two facilities.

Under the direction of General Leslie Groves, who headed the Manhattan Project, security gradually came under the control of a special detachment headed by Major John Landsdale. The FBI, which had worked closely with the War Department's Counter Intelligence Corps in the first year of the project, began working directly with Landsdale in 1943, when security became his responsibility. The CIC had poor communications with the FBI, according to newspaper reports written over the past 20 years.

In addition to sheer numbers, Groves had to contend with scores of expatriate German scientists and with some American scientists who had shown sympathy to the Soviet Union.

Groves was under White House or-

ders to develop the bomb quickly. The Manhattan Project did, in fact, yield a nuclear explosion less than three years after it was organized. To work at such breakneck speed, normal security checks would not be possible. Not only that, but it was impossible to check deeply on scientists who had escaped Nazi Germany. Groves settled on the simplest solution to each security problem, reasoning correctly that the more elaborate the security, the more attention would be drawn to Manhattan Project activities.

Standard security forms were used on new personnel. These would reveal names of friends, associates and organizations to which the applicant belonged. The FBI provided the Manhattan Project security people with backgrounders on all incoming person-

(Please turn to page 132)

The first A-bomb used in combat was the *Little Boy* (right). Crater below was photographed 24 hours after the first A-bomb explosion at the Trinity Test Site.

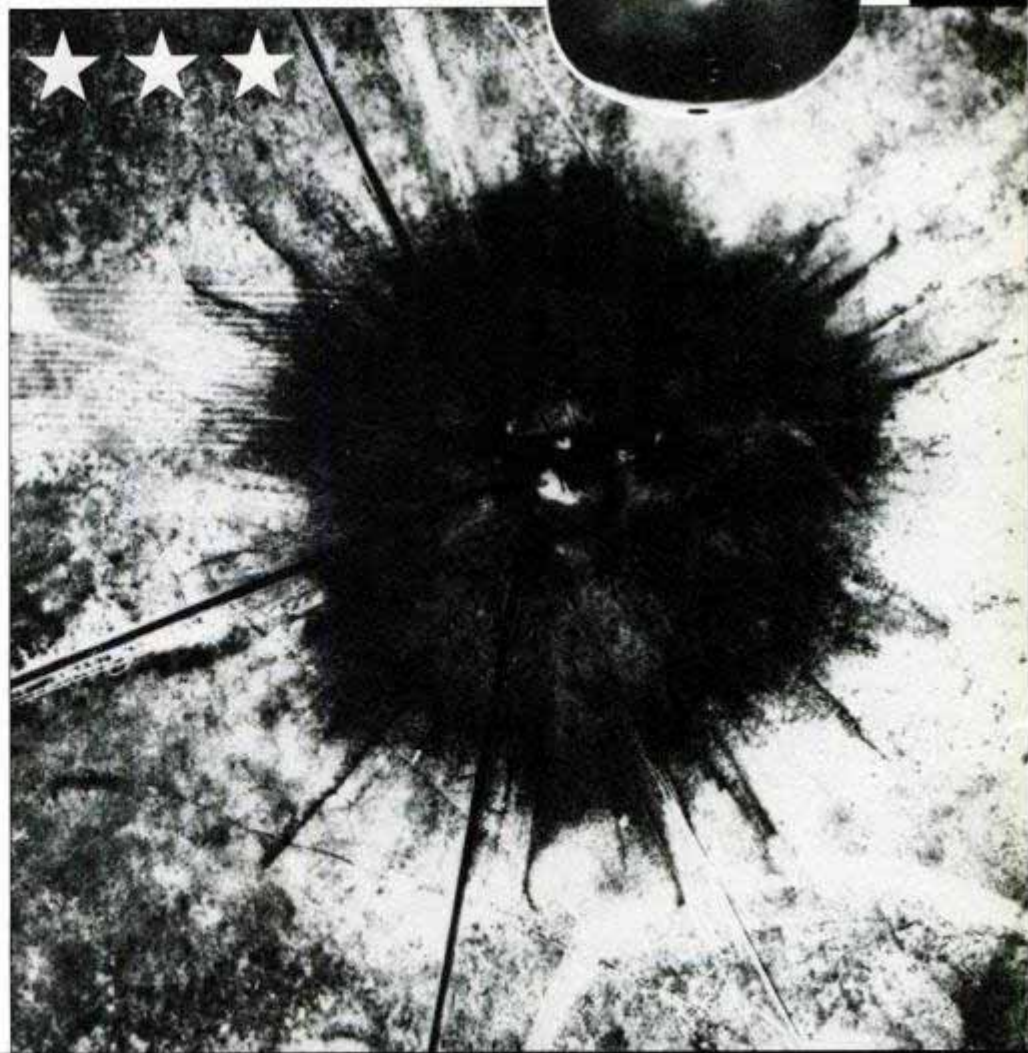



MITSUBISHI MIRAGE TURBO



DODGE OMNI GLH TURBO

A Pocket Rocket is the automotive equivalent of a punch in the mouth—direct and unequivocal, and tending to concentrate your attention wonderfully. It's also the best performance buy on the market, as well as the best all-around combination of fun, utility and price on four wheels. Where else can you spend \$9,000 and get a sedan that your family will think you bought for its fuel economy and five-passenger room, but can outrun a Porsche, out-corner a Corvette and let you pretend you're Mario Andretti every time you slide behind the wheel?

To create a Pocket Rocket, all a manufacturer has to do is take the cheapest, lightest economy sedan in his line and add 50 percent more horsepower. He can use a turbocharger, a larger engine, fuel-injection—or all of the above. To control this extra power, he adds a stiffer suspension, fat tires, bigger brakes and a five-speed gearbox.

For added appeal, he jazzes up the body with some

stripes and spoilers, the interior with bucket seats and a sporty steering wheel. The result is kind of like a miniature muscle car, not particularly sophisticated, but able to get the job done better than anything else near its price.

We identified eight Pocket Rockets for our test. Unfortunately, Chevrolet's Cavalier V6 Z-24 seems to have been postponed indefinitely, while Ford is not building the Escort GT Turbo it showed to the press last summer. So, we brought cars from six manufacturers to our test site at Raceway Park in Englishtown, N.J.

From Volkswagen we had a Golf GTI, lineal descendant of the famous Rabbit GTI. Toyota sent its rear-drive Corolla GTS, which uses the same dohc, 16-valve engine as the red-hot MR2 sports car. The all-new Mirage Turbo from Mitsubishi was as fully optioned as possible, while Honda's sleek Civic S was quietly understated in this company. We had two exuberant American hot rods: Pontiac's Sunbird Turbo



HONDA CIVIC S



TOYOTA COROLLA GTS

POCKET ROCKETS

and Dodge's Omni GLH Turbo. Each car was rated by seven different drivers, and ranked in order of preference. These rankings were then averaged with the rankings from our track testing to arrive at our overall test results.

Overall, this was the most enjoyable group of cars we've tested in years. Driving fast in a Corvette or Ferrari is somehow serious work, while booting around in a berserk econobox is playful fun. An expensive two-seater or sport sedan will earn you more status, but in the real world of policemen, insurance underwriters and harried service managers, you'll get more laughs-per-dollar in a Pocket Rocket.

Dodge Omni GLH Turbo

The new GLH Turbo is the perfect Pocket Rocket—cheap, useful and an absolute ball to drive. It's probably the best car Chrysler makes, head and shoulders above the LeBaron GTS or Daytona. It has more room, more style and more performance than Chryslers that cost twice as much. It's a great combination of boxy five-door styling and awesome power-to-weight ratio.

Every Chrysler performance car uses the same turbocharged, single-overhead-cam 2.2-liter Four, rated at 146 hp. But both the Lancer/GTS and Laser/Daytona weigh about 2,750 pounds. Even the Shelby Charger—which is built off the Omni chassis—weighs 2,550. The GLH is only 2,400 pounds.

Our GLH Turbo roared through the quarter-mile in under 16 seconds at nearly 90 mph. That's faster than any sports car you can buy for under \$20,000, and competitive with such



The Honda Civic S had one of the shortest stopping distances we've ever recorded from 60 mph—120 ft. The VW and Dodge were close behind it, both stopping in 124 ft.

red-hot V8s as the Camaro Z28 and Mustang GT. The GLH can smoke the tires on demand, but the turbo's power is smooth and not at all peaky. Slip it into FIFTH and you'll quietly cruise the highway at 25 miles per 1,000 rpm.

When the road turns twisty, the GLH looks even better. We rammed through the slalom at nearly 64 mph, 1.5 mph faster than any car we've ever tested. The GLH also posted a fantastic .87g on the skidpad—faster than the Corvette or Olds Ciera GT, our previous bench-

marks. It also stopped in just 124 ft. from 60 mph, shorter than many fancy performance cars.

Most of the credit has to go to the Goodyear Eagle GT 195/50HR15s, which Chrysler has squeezed under the flared Omni fenders. Their stiff-walled stickiness is just what the GLH needs. Mounted on Chrysler's "pizza" wheels, they also add to the Omni's mean look.

Its rough-and-tumble personality is just right for this kind of car, but we wouldn't be adverse to a few improvements that would make the GLH Turbo a lot more livable. For example, Chrysler has to do something about torque

Produced by the PM Auto Dept.
Text by Rich Taylor
Photos by Peter Terzer

TEST RESULTS

CAR	GAS MILEAGE (EPA city/ PM test)	¼-MILE (sec. @ mph)	SLALOM ¹ (mph)	SKIDPAD ² (cw/ccw)	BRAKING (ft.) (60-0 mph)	TRUNK ³ CAP. INDEX	INTERIOR ⁴ SPACE INDEX	TEST ⁵ TRACK RATING	ROAD ⁶ TEST RANKING	OVER ⁷ - ALL RATING
Dodge Omni GLH Turbo	19.0/20.7	15.91 @ 87.04	63.84	.82/.87	124	11	98.46	1	2	1
Honda Civic S	26.0/28.0	17.98 @ 74.38	58.23	.75/.82	120	9	104.20	4	4	5
Mitsubishi Mirage Turbo	24.0/19.1	16.55 @ 80.75	59.53	.79/.82	139	11	104.32	3	1	2
Pontiac Sunbird Turbo	21.0/17.8	16.47 @ 82.98	57.88	.80/.84	159	10	93.87	6	6	6
Toyota Corolla GT-S	26.0/22.3	16.78 @ 80.75	59.23	.81/.79	158	10	88.76	5	3	4
Volkswagen Golf GTI	23.0/24.4	16.82 @ 80.39	58.23	.80/.88	124	10	111.12	2	5	3

- Best speed achieved while weaving through seven cones placed 100 feet apart; the higher the speed, the better the transient handling.
 - G-forces generated during steady-state cornering around a 200-foot-diameter circle; cw = clockwise, ccw = counterclockwise.
 - The number of standard-size grocery bags that will stand upright (1-inch crush space permitted) in hatchback cargo area with folding rear seatbacks upright.
 - Front-seat width x headroom x legroom + rear-seat width x headroom x legroom ÷ 1,000.
 - Points are awarded from best (1) to worst (6) in each category. The car with the fewest total points ranks first, next lowest second, and so on.
 - Subjective ranking on the road by a team of testers; cars are graded by "feel," independent of test track results.
 - Average of Test Track and Road Test ratings. Ties are decided in favor of Road Test score.
- Bold numbers indicate best performance.

SPECIFICATIONS AND DIMENSIONS

CAR	VEHICLE* TYPE	BASE PRICE	PRICE AS TESTED	ENGINE	TRANS- MISSION	WHEEL- BASE (in.)	LENGTH (in.)	WEIGHT (lb.)
Dodge Omni GLH Turbo	5-passenger, 5-door	\$8,492	\$ 9,371	146-hp SOHC 2.2-liter inline-4 turbo	5-speed manual	99.1	162.1	2,400
Honda Civic S	4-passenger, 3-door	\$5,399	\$ 8,208	76-hp SOHC 1.5-liter inline-4	5-speed manual	93.7	150.0	1,800
Mitsubishi Mirage Turbo	4-passenger, 3-door	\$7,749	\$ 9,421	102-hp SOHC 1.6-liter inline-4 turbo	5-speed manual	93.7	157.3	1,900
Pontiac Sunbird Turbo	5-passenger, 3-door	\$9,765	\$12,464	150-hp SOHC 1.8-liter inline-4 turbo	4-speed manual	101.2	173.7	2,700
Toyota Corolla GT-S	4-passenger, 3-door	\$8,058	\$11,265	112-hp DOHC 1.6-liter inline-4	5-speed manual	94.5	168.7	2,300
Volkswagen Golf GTI	5-passenger, 3-door	\$8,990	\$10,320	100-hp SOHC 1.8-liter inline-4	5-speed manual	94.5	155.3	2,200

*All cars are front-engine, front-drive except the Toyota Corolla GT-S, which is front-engine, rear-drive. All are hatchbacks.

steer under acceleration. If you don't have the front wheels pointing straight ahead when you stomp the throttle in FIRST gear, you'll be dancing sideways into the next lane. You soon learn to drive around this quirk, but it can be alarming to the uninitiated.

We'd also like to see a more modern steering wheel, smoother shift linkage and higher grade interior trim and controls. We don't want to jeopardize that \$9,000 price tag, but a few creature comforts would go a long way.

Otherwise, stand back and let 'er rip. The "fierce, fun and friendly" Omni GLH Turbo is the best idea Carroll Shelby has had since the Cobra, and the neatest small sedan since the Mini Cooper. It's no secret that GLH stands for "Goes Like Hell." Never has a car been more honestly named.

Mitsubishi Mirage Turbo

Dodge dealers have a lock on the Pocket Rocket market. The Omni's only close competitor is the Mitsubishi Mirage Turbo, also sold by Plymouth and Dodge dealers as the Colt Turbo. Restyled last year, the Mirage is a sporty-looking three-door hatchback, dripping with Japanese-style features.

For \$9,400, our test car came with a moonroof, power accessories, infinitely adjustable Recaro-copy bucket seats, full instrumentation and a sleekly modern interior. It earned high marks from all our testers for its excellent ergonomics, terrific controls, comfort and style. The only things we could find to criticize were the "yucky" upholstery material and marginal headroom.

The Mirage *felt* quick and fast, but at the track it proved to be a middle-of-

the-pack performer in every category. We think the basic Colt chassis is rather overextended with 102 turbocharged horsepower, finding salvation in a set of Yokohama A-008 185/60R14 tires that are close to racing rubber.

Mitsubishi should firm up the compliant suspension and revamp the steering to provide more feel and less effort. The Mirage could also use better brakes. It stopped acceptably well when cold, but the brakes faded rapidly after a couple of firm stops.

Otherwise, our testers liked the Mirage. Indeed, they voted it first, ahead of the Omni, over the road. Only the GLH's fabulous track performance moved it into first overall. The heavily

optioned Mirage is probably better all-around transportation than the Omni—it's certainly more livable. But the whole point of a Pocket Rocket is performance, not docility.

Volkswagen Golf GTI

The Rabbit GTI was the first modern Pocket Rocket—a 90-hp engine in a lightweight three-door hatchback. The 100-hp Golf GTI is heavier, larger and not as pretty, but it's still a very nice little sedan. If the Omni is a miniature American muscle car and the Mirage a fine example of Japanese gadgetry, the Golf is traditionally Germanic in its smooth functionalism, never mind that

(Please turn to page 120)



Dodge Omni GLH Turbo (right) and VW set skidpad numbers that are right up there in sports-car country. Not bad for nine grand!

Wringing Out The New FOUR-FOOTED ATVs

These off-road blasters range from super utility to race-ready.

BY NORMAN MAYERSOHN, Assistant Auto Editor; Photos by Rich Cox

In the beginning, All-Terrain Vehicles were a three-wheeled species, designed to bust berms and dash over dunes with their fat, low-pressure tires. This season's brood moves out in a new direction—four-wheelers that improve stability and steering, with a giant step forward in off-road performance.

The tires remain the same, but take a look at the mechanical improvements: independent front suspensions; single-shock, rising-rate rear ends; shaft drive; and race-tuned, liquid-cooled, two-stroke engines. Go-fast modifications aren't the whole story, though. Features like a reverse gear, electric starter and hefty cargo racks make the ATV a valuable partner for hunters, farmers and outdoorsmen. It doesn't stop there—new kiddie-sized machines let the whole family join in the fun, and

Drifting in the dirt, flying over the moguls or fording streams, the four-footed ATVs open up new worlds in off-road recreation.



SUZUKI QUAD RACER 250



**HONDA
FOURTRAX 250**



YAMAHA MOTO-4 200



KAWASAKI BAYOU 185

FOUR-FOOTED ATVs

Yamaha even offers a fat-tire two-wheeler with the climbing capability of a mountain goat.

The four-wheelers arrive at a time when *three-wheeled* ATVs are getting a close look from the consumer products safety watchdogs in Washington. All of that furor has centered on the three-wheeled machines. But we've found from days of blasting up mountains, across streams and over dirt piles, that those with a pair of wheels at each end are an unflappable lot. They'll wheelie, power slide and fly over jumps, but our testers, ranging from first timer to pro racer never could get one to turn turtle.

The No. 1 rule of ATVs still holds true: Don't put your foot down in turns! Invariably, the rear tire will catch it, run it over and spit it out the back. Other than that quirk, the four-wheelers are just like dirt bikes, with familiar controls. Gear changing is accomplished with a flick of the left toe and brakes are actuated by handlebar-mounted levers. Most have centrifugal automatic clutches. In our group, only the Suzuki had a motorcycle-style hand clutch. For fast travel over rough terrain, the best plan is to stand up on the footpegs, knees bent and body loose to absorb the bumps, and gas it as hard as you dare. Throttle actuation is by a thumb lever rather than a motorcycle-type twist grip, but you can adapt to that easily.

When you do get the hang of it, there's a thrill to be found at every patch of loose ground you can find. Pick your way through a rocky streambed at a crawl or leap over the moguls, but make sure your trip ends you up in the deep sand. There you can hang out the tail end in a graceful, under-control slide and grin into your helmet. Get a little too cocky and they'll lift up the inside wheels a tad, delivering a clear message that it's time to back off a bit.

For PM's firsthand look at the four-footed, fat-tire breed, we rounded up a diverse cross section of machines, running the gamut from the race-ready Suzuki Quad Racer to the tractor-like Honda Fourtrax. The Yamaha Moto-4 and Kawasaki Bayou fall between those extremes as multipurpose sport and utility vehicles.

Suzuki Quad Racer 250

Suzuki is the original player in the four-wheeler game and its lead in development time shows most in the LT250RF Quad Racer. Not only is it the most serious in competition readiness, it bristles with the latest technology.

Starting with the ground level, we find a fully independent front suspension using tubular A-arms and load-adjustable coil spring/shock absorber



YAMAHA MOTO-4 200

LIST PRICE	\$1,899
ENGINE	196-cc, sohc, air-cooled, four-stroke, single-cylinder
TRANSMISSION	5-speed with reverse, shaft drive
SUSPENSION	F: rigid R: rigid
STARTER	electric and recoil
WEIGHT	331 lb.
GROUND CLEARANCE	4.7 in.



KAWASAKI BAYOU 185

LIST PRICE	\$1,749
ENGINE	182-cc, sohc, air-cooled, four-stroke, single-cylinder
TRANSMISSION	5-speed with reverse, shaft drive
SUSPENSION	F: swing axle R: rigid
STARTER	electric and recoil
WEIGHT	333 lb.
GROUND CLEARANCE	5.7 in.

units. Rear suspension is Suzuki's Full Floater design, borrowed from the motorcycle line. It has a single linkage-actuated shock absorber to control the box-section aluminum swingarm, and offers adjustments for load and rebound damping. Wheel travel is a generous 7.9 in. at each end, which allows the Quad Racer to pass over ruts and rocks without transmitting the shock back up to the rider.

The Quad Racer is the best stopper of the ATVs, too, by virtue of two hydraulic disc brakes up front and a single one in rear, on the drive axle. Its high performance spirit also dictates the use of a chain final drive system for easy gearing changes.

Owners will have to spend more time and bucks to keep the exposed chain in good shape than they would with a shaft-drive machine, but that simply comes with the territory.

The no-holds-barred attitude carries over to the engine as well. The 249-cc, liquid-cooled two-stroke is a distant cousin of the legendary RM-series motocross powerplants, using the Power Reed induction system and a 32-mm flat-slide Mikuni carb. There's no oil-injection setup, so you'll have to premix oil with the gas. One major concession to civilized operation is the gear-driven engine counterbalancer, which dampens vibration. Press us for niggling complaints and all we can really whine about is the primary kick start—the lever bottoms sharply at the end of its travel, making fire-up a bit of a wincer. With the hand-operated clutch and light flywheels, beginners tend to stall the Quad Racer easily, and though it re-

starts quickly, that kick lever is less user-friendly than it might be.

Kawasaki Bayou 185

Kawasaki's first entry into the four-wheeler fray is a sure sign of its commitment to this genre of machines. The 185 Bayou is a well-balanced, all-around ATV, neither the pure sports vehicle nor the agricultural workhorse.

Neatly styled and well-packaged from every angle, the KLF185 Bayou is a rugged piece, with a tubular-steel, double-cradle frame. Up front, an independent swing axle suspension with coil spring/shock absorber struts provide 4.9 in. of wheel travel. The rear end is rigid, a reliable design and not that detrimental to ride qualities, since the low-pressure balloon tires do a fair job of bump absorption. Steering response is sharp and precise, due partly to the car-type Ackerman system design. In turns, the front wheels have a built-in geometric correction to allow for the fact that each is traveling a different-sized circle.

Power comes from a 182-cc, air-cooled, sohc four-stroke engine, fitted with an automatic compression release system to ease starting. The five-speed gearbox has an easy-to-use REVERSE gear and extra-low FIRST. Shaft drive makes it a low-maintenance ATV.

The success of Kawasaki's ATV racers and the release of a new Bayou 300 indicate that Kawasaki will be more aggressive with future machines. The 300, not available in time for our evaluation, is a military-looking bruiser, replete with cargo racks and a trailer hitch. But we're looking for some trick-



SUZUKI QUAD RACER 250

LIST PRICE	\$2,299
ENGINE	249-cc with counter-balancer, liquid-cooled, two-stroke, reed valve, single-cylinder
TRANSMISSION	5-speed, chain drive
SUSPENSION	F: double A-arm R: shock/swingarm
STARTER	primary kick
WEIGHT	293 lb.
GROUND CLEARANCE	5.9 in.



HONDA FOURTRAX 250

LIST PRICE	\$2,198
ENGINE	246-cc, sohc, air-cooled, four-stroke, single-cylinder
TRANSMISSION	5-speed with reverse, shaft drive
SUSPENSION	F: trailing arms R: swingarm
STARTER	electric and kick
WEIGHT	467 lb.
GROUND CLEARANCE	6.3 in.

le-down of features to more sports-oriented machines, nifty tidbits like a dual-mode differential for one- and two-wheel drive, and a semi-independent (by virtue of rubber mounting) torque-tube rear suspension. It also has the more sophisticated wishbone front end with shocks that automatically compensate for speed and terrain.

Yamaha Moto-4 200

The widest range of four-wheelers comes from the Yamaha folks, in sizes from 60 to 225 cc. The YMF200 Moto-4 is a first-generation design, with rigid axle mounting at both ends, all suspension being provided by the cushy 3-psi balloon tires. Still, it's a super-tough hard runner, adaptable to both fire trail blasting and sober ranch chores.

Driving power is provided by a 196-cc, ohc, single-cylinder, air-cooled four stroke. The electric starter is backed up by a simple recoil rope mechanism. The five-speed transmission drives through an automatic centrifugal clutch, and a somewhat balky REVERSE gear is provided. Between the reach for the REVERSE lever and the tricky lockout system, we usually found a steep bank to drive up when we wanted to turn around, changing the direction of travel as the machine rolled back down the slope.

Yamaha hasn't forgotten about your young 'uns, either. For them, there's the 60-cc 4-Zinger. It's got a single-speed transmission and is loaded with safety devices like a tethered ON/OFF

switch for parental remote control, an exhaust system restrictor and an adjustable throttle stop. The last two items will let you increase the vehicle's speed potential as the child's skill increases.

Honda FourTrax 250

It may well be that Honda deserves credit for creating the first four-wheel ATV, the roll-cage equipped Odyssey. By a purist's definition, though, that's a buggy, with car-type seating, seat belts and even rear-view mirrors. What we

checked out was the leader of the working-class ATVs, the TRX250.

Here is your heavy-duty, no-nonsense workhorse. With a 467-pound heft and an 850-pound towing capacity, the FourTrax makes a logical replacement for a farmer's John Deere or a hunter's 4X4. It won't do every job that the tractor or pickup truck can, but it can haul worker and tools through uninviting terrain to get the job done. And it won't need to take the weekends off—strap on a tent and sleeping bag and head off to the wilderness.

The FourTrax uses a 246-cc ohc, air-cooled, four-stroke single designed specifically for ATV installations. It's a torquey powerplant, powerful and quiet, and smooth by virtue of a vibration-controlling counterbalancer system. The five-speed gearbox incorporates an extra-low FIRST cog and the easiest to engage REVERSE we saw. Shaft drive further ensures troublefree service.

Ride quality is a good compromise between comfort and load capacity. The front end uses independent, single trailing arms and hydraulic shock absorbers. The back end has a roller bearing-mounted swingarm with a single-shock arrangement. Instead of stacking up technological showpieces, Honda opted for practical features. The high-wattage headlight is removable to double as a worklight, and a parking brake is standard equipment. With the exception of the Suzuki, the Honda was the only other machine with front brakes.

(Please turn to page 131)



The heavyweight (467-pound!) utility task-master of the group is the Honda FourTrax, a gutsy workhorse machine.

STEVEN SPIELBERG BUILDS A TIME MACHINE

In the film wizard's latest hit, "Back to The Future," he transforms a De Lorean into a nuclear-powered time transporter.

By SOLANGE De SANTIS; Illustration By Jeff Mangiat

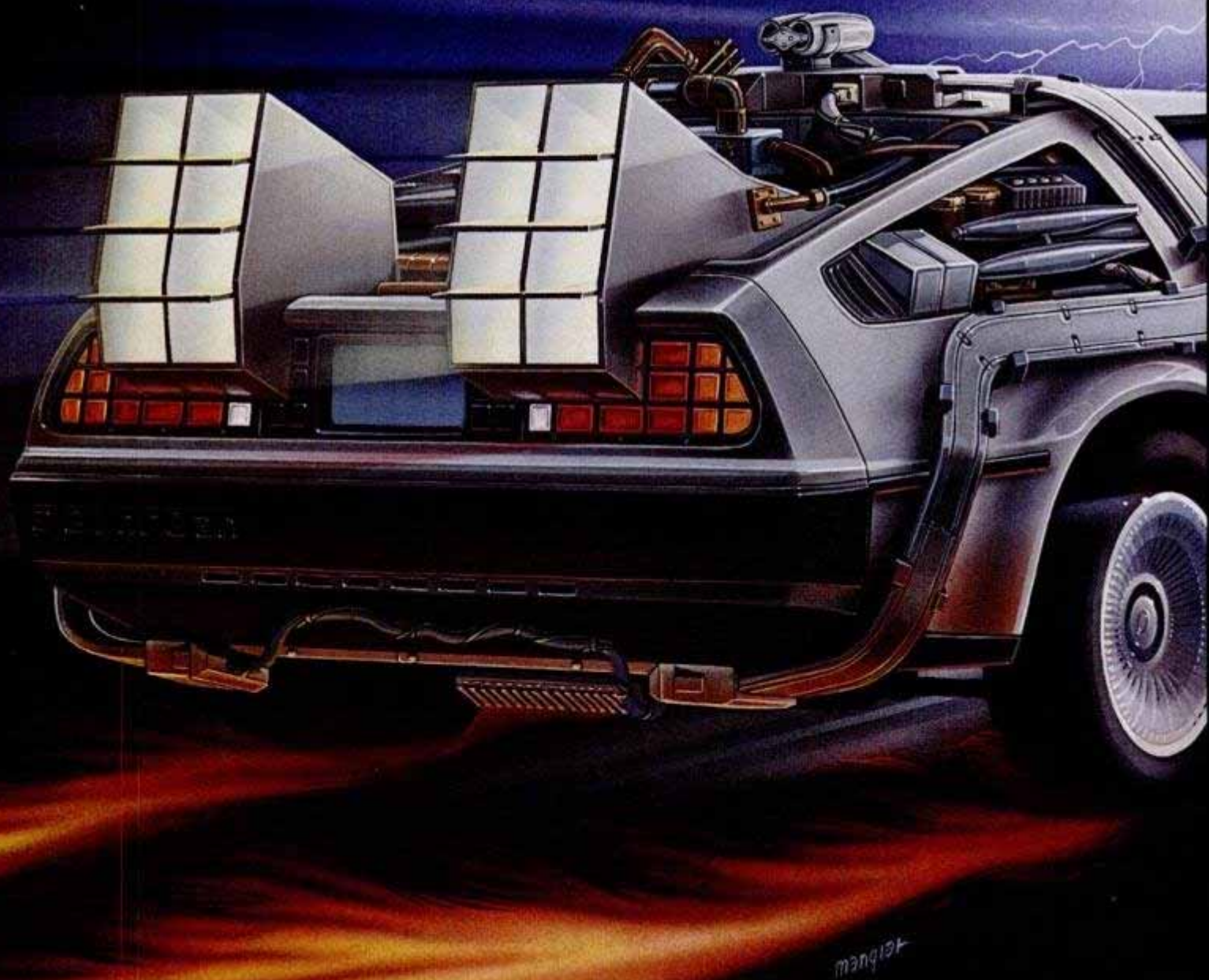

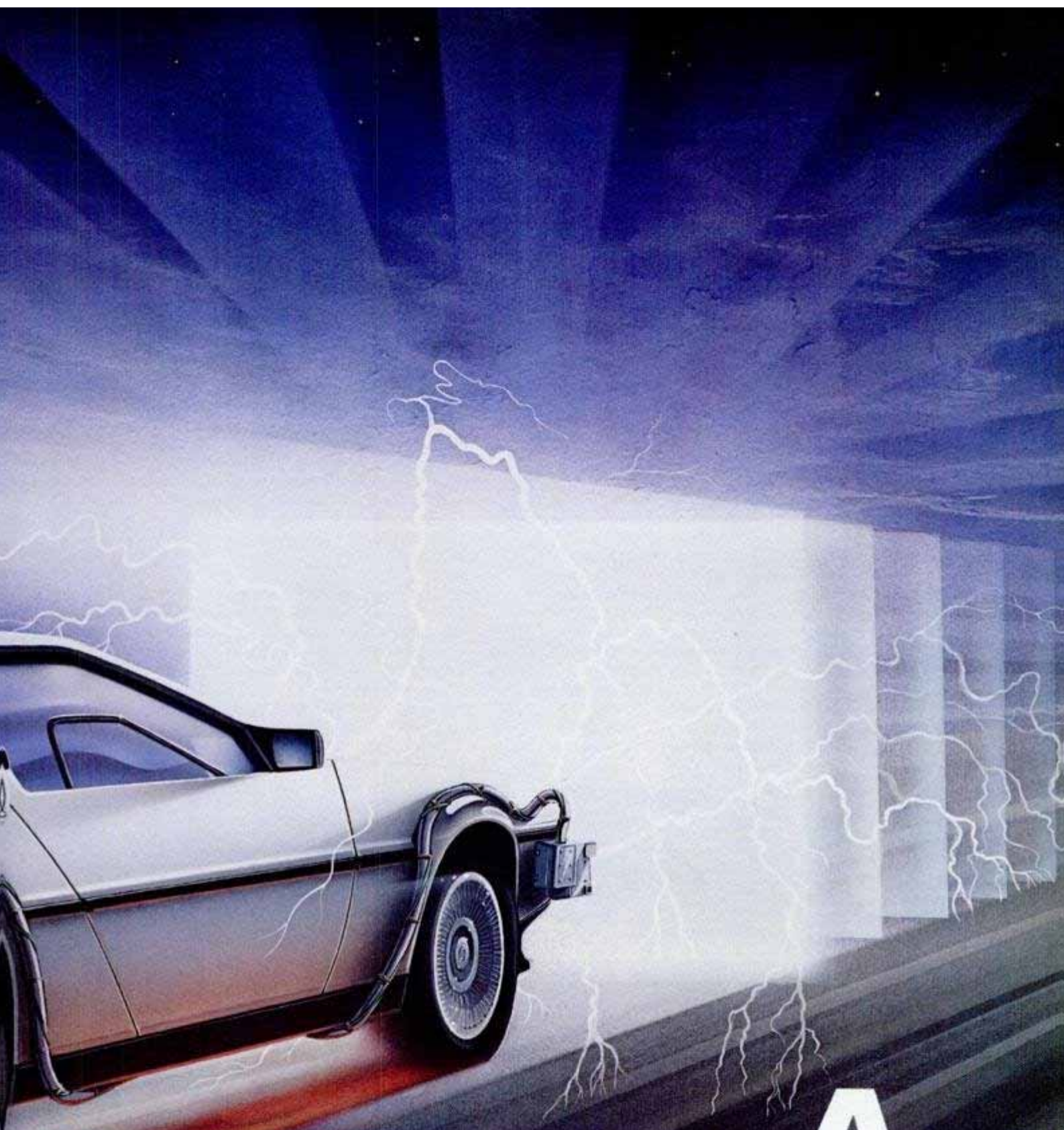

Automaker John DeLorean once had big dreams for his sleek silver cars. But even *he* never imagined they might travel through time. They can't, in real life. But in "Back To The Future," a new movie produced by Steven Spielberg's Amblin Entertainment and featuring special effects by George Lucas's Industrial Light and Magic company, a supercustomized DeLorean, aided by a portable street-legal nuclear reactor, bursts through the veil of time and helps teenager Marty McFly answer an eternal question: What were my parents like when they were my age? Modifying the three DeLoreans in the film took as much en-

TIME MACHINE



ergy and imagination as the fictional construction of the time machine by a certain Dr. Brown, an eccentric, white-haired inventor played by Christopher Lloyd, Reverend Jim from the television series "Taxi." In the film, the doctor has toyed with an invention that can read people's thoughts. But the time machine is his crowning achievement. McFly, played by Michael J. Fox, blasts the DeLorean back to 1955, where he meets his parents as teenagers, gets stuck in the past and must convince the then-young Dr. Brown to help him get "back to the future." Along the way, he invents rock 'n' roll, gives it to Chuck Berry and, naturally, engages in several other inventions.

Coproducer Bob Gale and director Robert Zemeckis, who filmed "Romancing The Stone" last year, kicked around various ideas for a time machine when the movie was in the script-writing stage. "In the earlier draft, we had a time machine that wasn't mobile, just a lot of stuff in the laboratory that took up a whole room," Gale said. They discarded methods of time travel, such as the atoms-reassembling special effect nearly patented by "Star Trek," and decided on a moving car as a more exciting, kinetic idea.

"The DeLorean's gull-wing doors were a real important idea. It looks like a spaceship. There's a scene where the car lands in a field and a farmer in the '50s thinks it's a flying saucer. The gull-wings are also our homage to 'The Day The Earth Stood Still,'" Gale said. In the film, the good doctor also explains that the car's stainless-steel body helps flux

dispersal, which is a necessary aid to time travel.

Reasoning that a garage inventor would have relatively limited technology at his disposal, the writers decided that the machine would be able to travel through time but not through space. So, when Marty drives through a shopping center mall and zooms back 30 years, he's in the same spot, then an open field.

Despite the automobile's futuristic look, Zemeckis and Gale were determined not to end up with a slick machine like television's "Knight Rider" car. "It was important to create the illusion that the car moved fast and was dangerous, but it had to have some eccentricity about it," Zemeckis said. They imagined the sort of homemade time machine Dr. Brown could pull together working in his shop, using, say, a milling machine, a band saw, a lathe, router, drill press and some welding equipment. He doesn't have a bending brake though, so the car sports some naked welding.

Artist Ron Cobb, whose credits include "Alien," drew the first set of blueprints for the time machine, incorporating a portable nuclear reactor at the rear. The machine, of course, needs a tremendous amount of power, digital readouts in the cockpit, a "temporal flux capacitor" to hold the reactor's energy and propel the car through the years, and coils, wires and tubes everywhere. Production illustrator Andy Probert, who designed the supersonic helicopter in "Airwolf," further refined the designs.

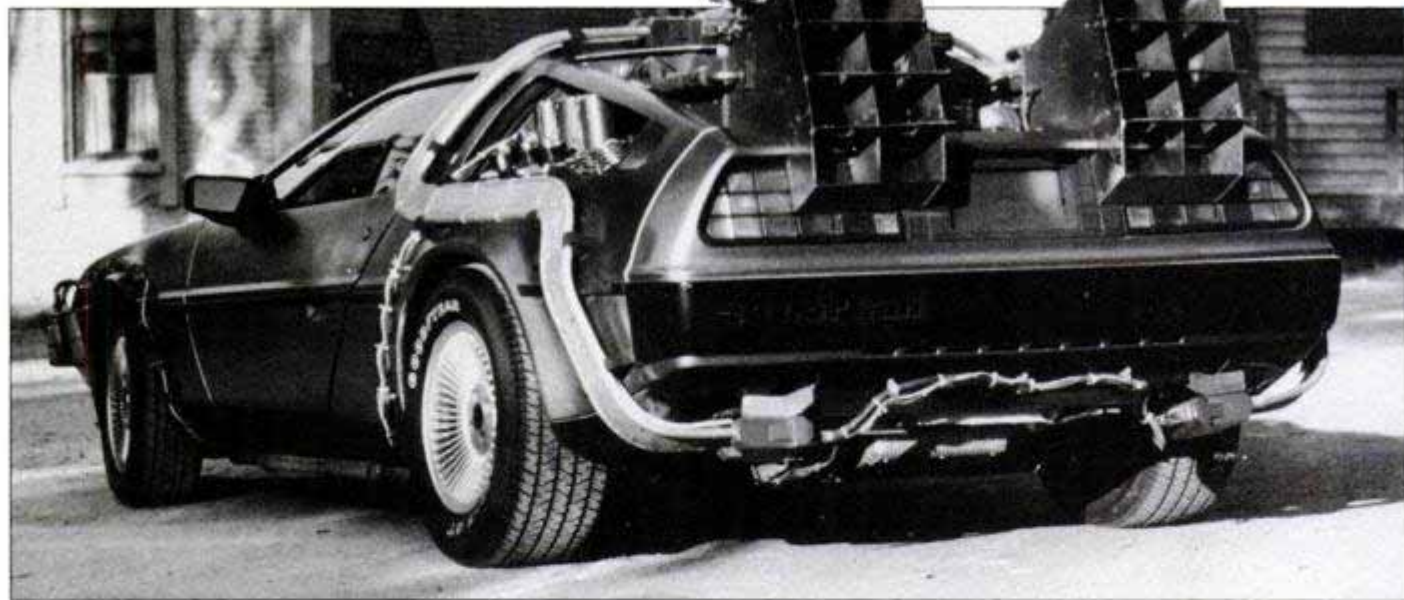

Spielberg's special effects team added military surplus parts to ordinary DeLorean to create the time machine (above). Banks of digital readouts transformed the car's interior (right) and a plastic scale model of a real nuclear engine was installed through the rear (far right), all for \$150,000, low-budget by most film industry standards.





Original story boards drawn for Spielberg (left to right) show car entering time warp, breaking through, disappearing and leaving a fiery trail behind it.

Probert rearranged some elements at the rear of the car, including the distinctive exhaust vents, which are meant to vent the nuclear reactor. Originally, there was one exhaust, but Zemeckis, Gale and the designer felt four exhausts gave a more dramatic look and made the reactor's power seem more impressive.

Gale and coproducer Neil Canton, who brought out "The Adventures Of Buckaroo Banzai" last year, sent their transportation crew to the classified ads to find three used De Loreans in fairly good condition. Purchased at a total cost of about \$50,000, the three cars were transformed at special effects expert Kevin Pike's Filmtrix Inc. shop in North Hollywood, which also had a hand in Spielberg movies, including the "Raiders" films.

At this point, the producers made an important decision. To keep costs down (the final cost of purchase and modification of all three cars was about \$150,000) and enhance the homemade look of the machine, almost no parts were machined from scratch. Production designer Larry Paull, whose previous credits include "Blade Runner," and vehicle construction coordinator Michael Scheffe scoured military and industrial surplus outlets around Southern California for hollow tubing, engine housings, coils, gauges, fittings—anything that would reflect the technical drawings.

Paull was also responsible for the mind-reading "brain wave analyzer," which looks like something Buckminster

Fuller, inventor of the geodesic dome, would have built if he had been a hat designer. Paull said he found the inspiration for this contraption in an issue of *Life* magazine dating from the mid-1950s. "We came across this incredible strange-looking machine that was some sort of machine that detects blood clots in the brain and was developed in the mid-'50s," Paull said. Scheffe had the headgear cut from aluminum stock, some twinkling lights added and the whole thing pop-riveted together.

Before arriving at Spielberg's comfortable environment, Scheffe learned his way around industrial surplus stores by shopping for "some low, low, low budget" science-fiction features. "I think a good deal of the surplus stores sales are to people making science-fiction movies, since the prices seem to have escalated in recent years. The customers are a mix of guys in business suits, Caltech physicists building little home projects, real crackpots and shoppers for the movies," Scheffe said.

Two cars retained their engines, the third remained stationary for inserts, or close-ups, and to provide cannibalized engine parts if the others broke down. The special effects crew's first step was to remove the rear window louvers in order to build the nuclear reactor on the heavy plastic engine shield over each car's engine.

Two systems had to be constructed—the imaginary time travel fuel and power systems and the real special effects

(Please turn to page 132)

THE SPIELBERG TIME MACHINE

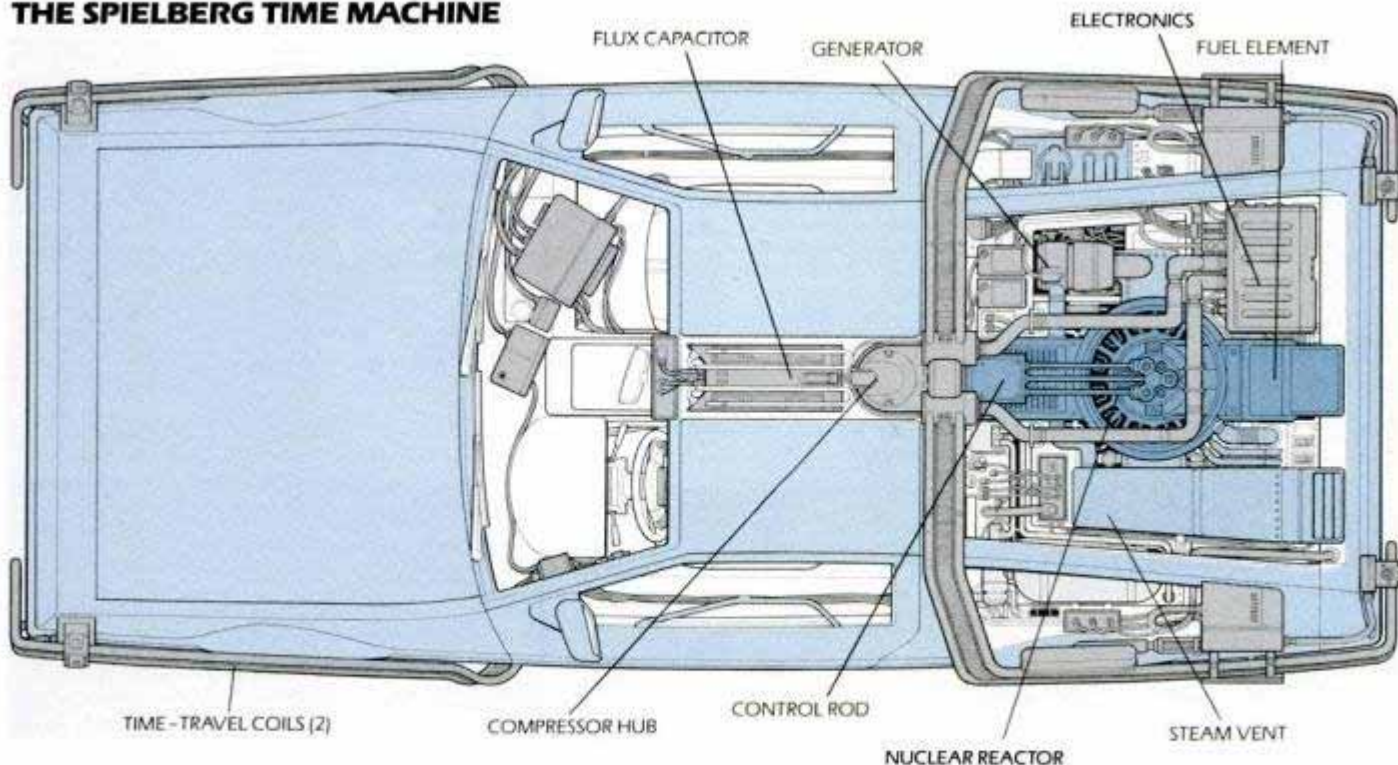

Ron Cobb's blueprints for the time machine, and the technical drawing he created (above) called for eccentricity and simplicity. The nuclear reactor was miniaturized, based on a real one.

The engine system was given a large steam-venting system, and small control rods for the reactor. A flux capacitor was added to provide fireworks for special time-travel effects.

VIDEO TAKES A DIVE

Watertight bags are available for Sony's Betamovie camcorder, which uses standard-size Beta tapes. Bags are coming for 8-mm and regular VHS units.

Lightweight camcorders and watertight gear let you capture Neptune's kingdom on tape.

BY JAMES B. MEIGS; Photos by Skip Gandy

Diving with expensive video gear used to be a plunge into lunacy, financial and otherwise. But the recent availability of compact camcorders—and watertight enclosures to keep them dry—means you can document all the beauty and wonder of your underwater vacation without the budget and staff of a Jacques Cousteau.

Video is well-suited to the demands of underwater moviemaking. It can record images in low light, producing sharp pictures in conditions where film might capture little more than murk. And though today's videotapes don't reproduce the very brightest colors as brilliantly as film can, the videocamera's circuitry compensates for this by balancing colors. This means your tape will show less of the dark, bottle-green cast often seen in underwater movies shot on film.

(Please turn to page 114)



See-worthy movies are in the bag with a camcorder in watertight housing from EWA. Seen here and below is JVC's VideoMovie, which uses 20-minute mini-VHS tape. Glove built into bag gives access to controls.



NEW CYCLE,

The gasoline and diesel engines were both patented next great breakthrough in

Simplest Gerace engine is an in-line Four in which alternating cylinders compress air only (as in a diesel engine) and an air-fuel mixture (as in a gasoline engine). When the highly compressed air becomes hot enough to ignite the fuel, transfer valves between adjoining cylinders open, allowing combustion to take place. The ignition-air piston leads the air-fuel piston by 40° of crankshaft rotation. Except for the transfer valves, all other engine hardware is conventional.

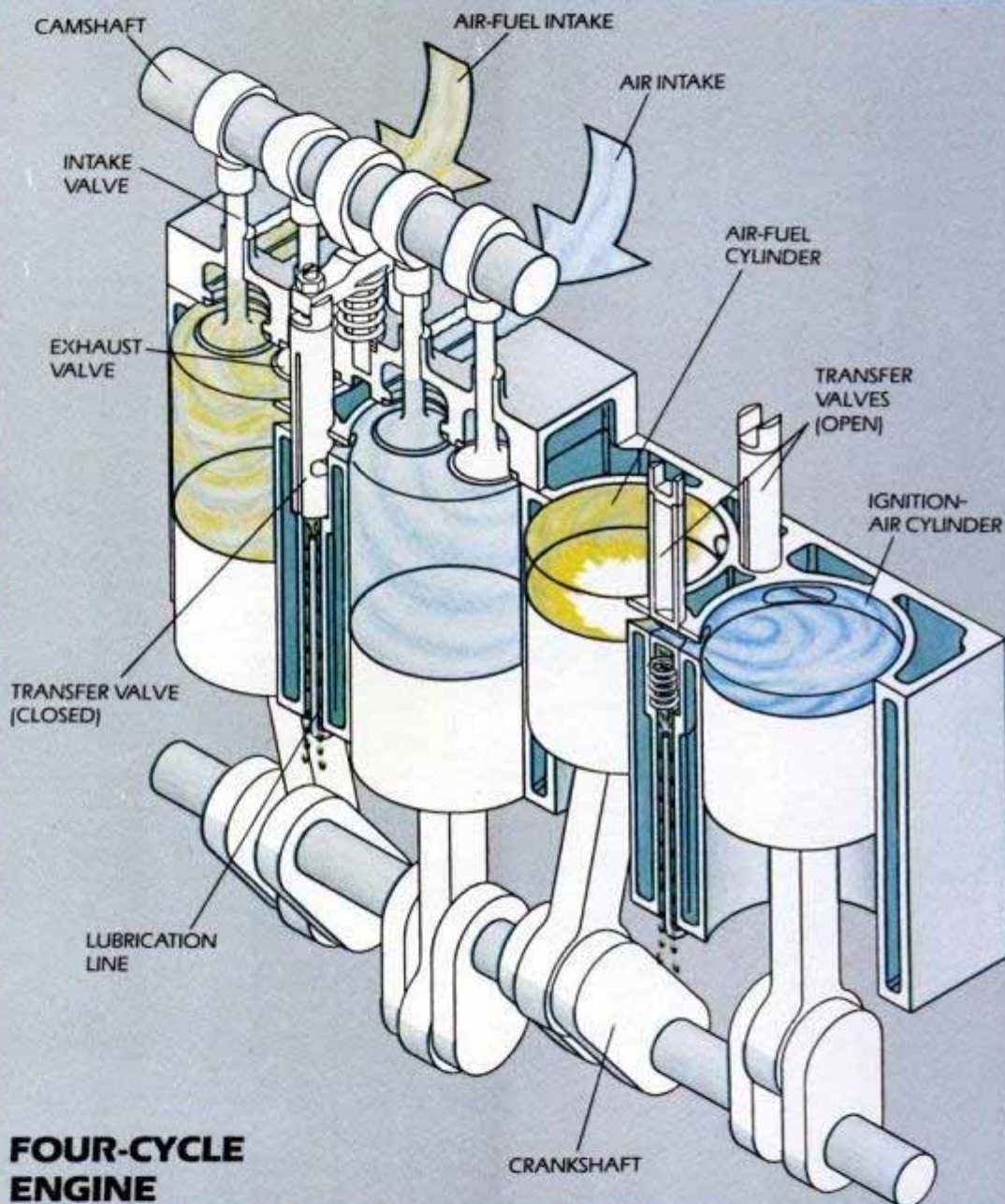

FOUR-CYCLE ENGINE

BY MARK WALLACH
Illustrations by Robert Rothe

The gasoline engine was patented in 1866, the diesel in 1892. PM has just had an exclusive preview of the Gerace engine, the first real breakthrough in internal combustion design in this century. The U.S. Patent Office has issued Anthony Gerace a process patent

not just for another mechanical variation on the gasoline or diesel themes, but on a whole new combustion cycle. To fully understand the Gerace cycle, a little history is in order:

In the beginning there was steam, and it was good. The external combustion engine was crude, but it did its job and pulled the 19th century into the industrial age. External combustion is almost a forgotten term now, but at one time that was the only engine available

NEW ENGINE

in the 19th century. The Gerace engine may be the piston engine technology.

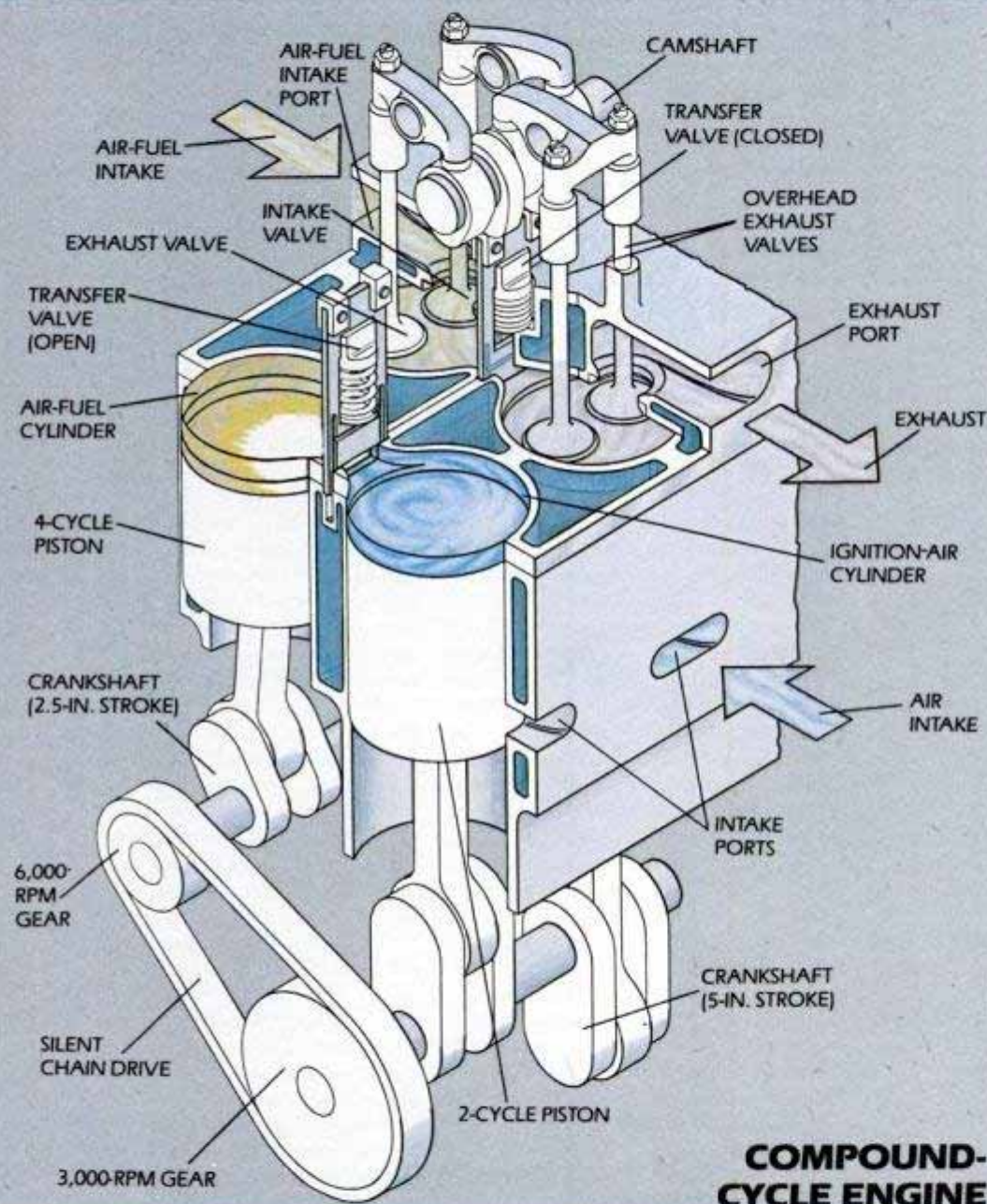

COMPOUND-CYCLE ENGINE

A more complex variation on the Gerace cycle is proposed in this Square-Four engine. Here, the air-only pistons operate on a two-stroke cycle at half the speed of the four-stroke air-fuel pistons. Side intake ports and overhead exhaust valves are adapted from a common industrial diesel design. The parallel crankshafts are linked by a "silent" chain drive similar to that used in some GM front-drive transaxles. The process patent covers any and all mechanical means of achieving the Gerace cycle.

after the water wheel. Water boilers heated by coal or wood developed steam that was piped to a cylinder and piston. The expanding steam drove the piston down and a connecting rod and crankshaft turned a flywheel. The steam was admitted to the cylinder by a sliding valve operated by a young boy pulling a rope back and forth.

One boy, being lazy, designed a mechanical linkage to do the job for him automatically. His

name was James Watt and his invention allowed the steam engine to operate at higher speeds and become the prime mover in the industrial revolution after 1840.

The burst of creative talent that followed the development of the steam engine ushered in a golden age of invention with countless tinkers burning the midnight oil inventing. That oil was kerosene and other high-end petroleum products from Pennsylvania wells, which were

The Gerace Cycle

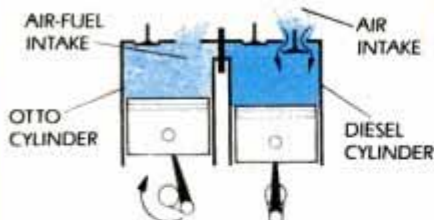

1 Otto cylinder draws in air-fuel mixture while diesel cylinder draws in air only.

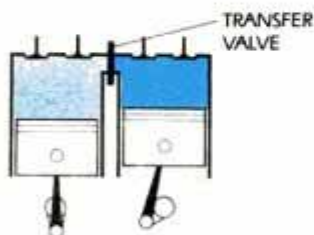

2 Both cylinders begin compression strokes while the transfer valve is closed.

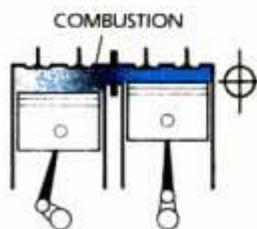

3 Combustion begins when transfer valve opens and hot air meets air-fuel mixture.

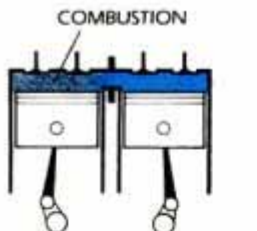

4 Combustion continues across Otto cylinder as diesel cylinder begins its descent.

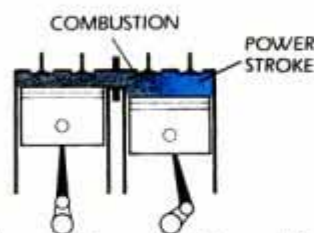

5 Expanding gases travel back through the transfer valve and into the diesel cylinder.

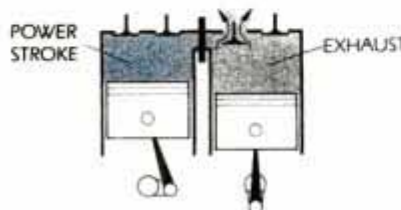

6 Transfer valve closes; exhaust stroke begins in diesel, followed by Otto cylinder.

originally drilled for water but accidentally hit sub-surface oil deposits. Some distillates were lightweight and very fluid. When put in a confined space, they could burn instantaneously and explosively.

Otto and diesel cycles

The process, when finally developed, was called "internal combustion." The words describe the process completely. The sliding steam valves were not compatible with the new combustible fluids, but all of the basic engine components were there: cylinder, piston, connecting rod, crankshaft and flywheel. An idea whose time had come was put together into a brilliant concept by Nikolaus August Otto in 1866. His concept, the "Otto cycle," had two valves in each cylinder and the familiar four-stroke cycle of intake, compression, power and exhaust.

If the fuel mixture burned in the Otto cycle produces more force than that needed to operate the valves, rotate the crankshaft and overcome the friction of the various moving parts, then the surplus force can be used to operate machines. The four-stroke Otto engine has dominated all other engine types because of its ability to be engineered to user requirements from power generators to racing cars.

When air is compressed it gets hot because the molecules rapidly collide in a confined space. Rudolf Diesel used this basic physics law to increase the compression ratio of an engine and compress only air with a piston. At maximum compression, fuel oil was injected into the combustion chamber and the heat of the air started burning the oil. The piston was pushed down by the expanding gases and power was applied to the crankshaft.

The high compression ratio and mechanical shock of the burning oil made the diesel engine slow-turning and very heavy, but using cheap oil that was a byproduct of gasoline refining made it perfect for ships, power stations, trucks and industrial applications. Diesel cars are popular in countries where gasoline is heavily taxed.

Over the years, many mechanical designs have been patented following the basic Otto and diesel principles, including two-stroke variations of both cycles, the Wankel engine, swash plate rotary engines, engines with two pistons in each cylinder, Chrysler's 30-cylinder tank engine, radial aircraft engines with 18 cylinders, and rotary aircraft engines that have the crankshaft bolted to the firewall and the cylinders rotating around it!

The Gerace engine is different from all the rest preceding it for over 100

years. Tony Gerace, a machine designer from Towson, Md., has looked at the Otto and diesel cycles from a new viewpoint and has been issued a process patent for the "Gerace cycle." The granting of a patent does not in itself guarantee success, only that the concept is new, unique and has not been done before. The elegance of the Gerace cycle combines design details of the past with the potential to be the engine of the 21st century in many shapes and configurations.

Hybrid cycle at work

In its simplest form, the cycle uses two cylinders side by side and a common crankshaft with traditional connecting rods, pistons and valves. One piston leads the other by 40° of crankshaft rotation. The lead piston is in a cylinder that compresses only air, like a diesel engine, and the trailing piston is in a cylinder that compresses fuel and air like an Otto engine. Between the two cylinder heads is a passage blocked by a slider valve, similar to those used in steam engines. Gerace calls it a transfer valve.

The compression ratio of the diesel cylinder is 20:1, the Otto cylinder, 8:1. The diesel piston reaches top dead center first, the air becomes very hot, the transfer valve opens and the high-pressure hot air flows through the connecting passage and into the Otto chamber. The hot air starts the mixture burning. The diesel piston begins its downward stroke while the rising Otto piston forces the expanding gases back through the transfer passage to mix with the remaining air in the diesel cylinder. This interaction of the pistons allows the mixture to burn in a chamber of constant volume, utilizing all the latent energy in the fuel.

After both pistons have begun their power strokes, the transfer valve closes. When the pistons reach the ends of their strokes, the exhaust valves in both cylinders open to expel the burned gases as both pistons begin to rise. When the pistons reach the top of their strokes, the exhaust valves close, the intakes open and the cycle starts again.

Why is this engine so interesting? It has solved several limiting design and thermodynamic problems that have perplexed engineers for years.

Normally, the fuel/air ratios that can be burned in an Otto cycle engine are quite narrow. If there's too much fuel, there's not enough air to support combustion. Too little fuel and the mixture will not burn. With the air/fuel mixture premixed in the Otto cylinder of the Gerace engine, almost any mixture ratio will burn due to the hot air igniter.

(Please turn to page 134)



Summer Swinging

Porch-sitting is a venerable American pastime that many still consider one of life's better enjoyments. Whether sitting on a cool night watching the sun set, or having a late breakfast on a weekend morning, the porch is the perfect place to relax and take stock of your affairs.

One refinement of this pleasure is sitting in a porch-swing glider like the classic we show here. Its gentle back-and-forth motion is not only an antidote to the pressures of modern living, it also keeps you moving even when the air

Enjoy summer's long days
and cool evenings
with PM's porch glider.

BY ROSARIO CAPOTOSTO

around you is not. It's made of solid red oak, seats two comfortably and is built to stand up to the weather.

Start by building the free-standing glider frame from which the seat hangs. First, cut the vertical and horizontal

frame members (parts G and K in the materials list) to size. Next, use a dado blade to cut end rabbets in each vertical member. Then, saw two notches in each horizontal frame member. Make the table saw jig shown on page 95 to accurately cut the tapered ends on each horizontal member.

Now dry-assemble the frame and

Black and white photos: Rosario Capotosto
Color photo: George Ancona
Styling: Gabe Herck
Technical art: Don Mannes
Original glider design: Harold Jones

PORCH GLIDER

27" DEEP x 32-1/2" HIGH x 60-1/2"

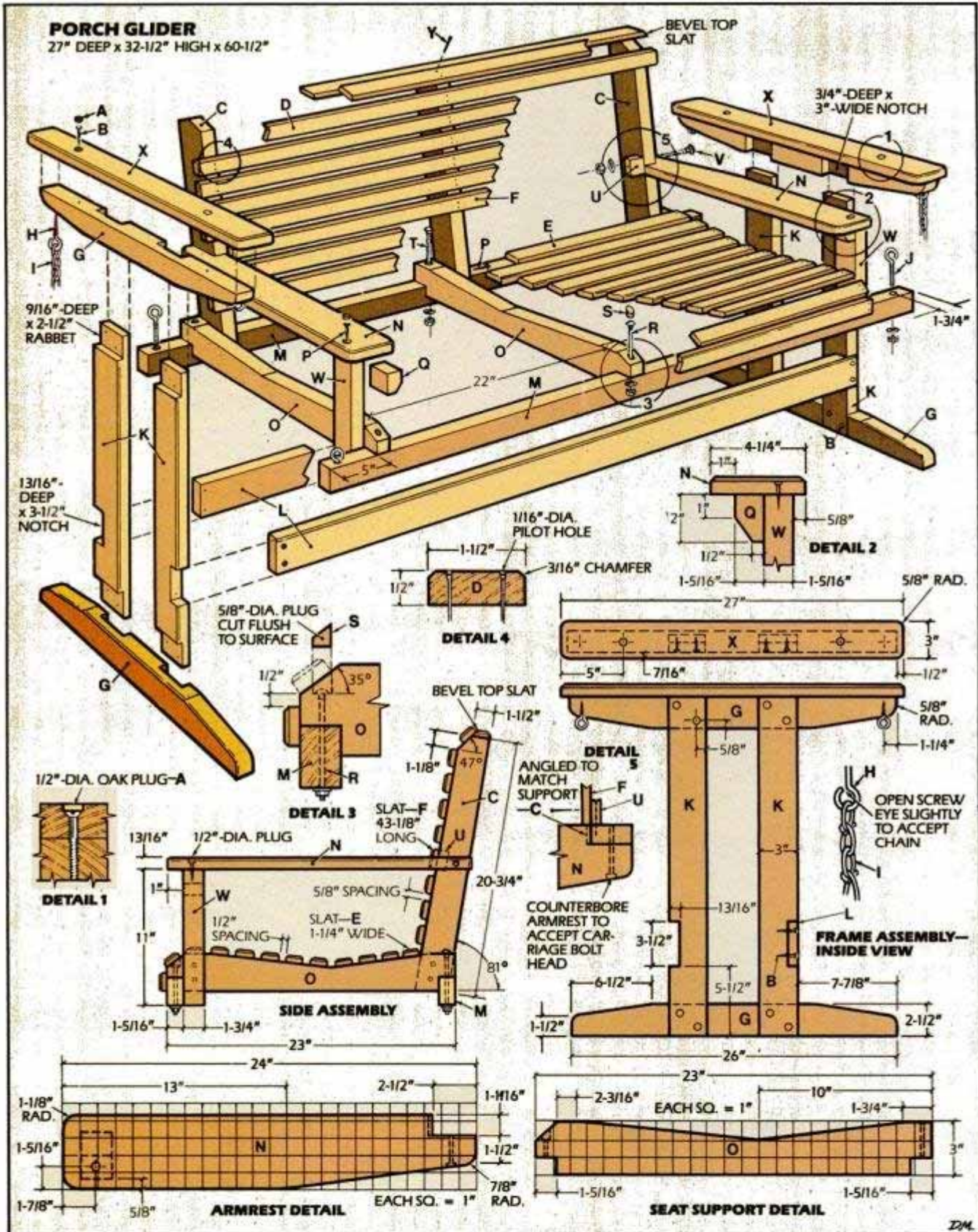

MATERIALS LIST—PORCH GLIDER		
Key	No.	Size and description (use)
A	1	1/2"-dia. oak plug
B	1	1 1/4" No. 12 fh screw
C	3	1 1/16" x 2 1/2" x 20 3/4" oak (seat-back support)
D	20	1/2" x 1 1/2" x 48" oak (seat slat)
E	1	1/2" x 1 1/4" x 48" oak (rear seat slat)
F	1	1/2" x 1 1/2" x 43 1/4" oak (short slat between armrests)
G	4	1 3/4" x 2 1/2" x 26" oak (horizontal glider frame member)
H	4	1/4"-dia. x 1 1/2" screw eye
I	4	11 1/4" of double-loop swing chain
J	4	1/4"-dia. x 2 1/2" eyebolt with washer and nut
K	4	1 3/16" x 3" x 27" oak (vertical glider frame member)
L	2	1 3/16" x 3 1/2" x 58" oak (stretcher)
M	2	1 3/16" x 2 1/8" x 58" oak (horizontal seat rail)
N	2	1 3/16" x 4 1/4" x 24" oak (armrest)
O	3	1 3/16" x 3" x 23" oak (seat support)
P	2	No. 12 fh screw
Q	2	1 3/16" x 1 3/4" x 2" oak (corner block for armrest)
R	3	1/4"-dia. x 3 1/2" carriage bolt with washer and nut
S	3	3/8"-dia. hardwood plug cut from dowel
T	3	1/4"-dia. x 4 1/2" carriage bolt with washer and nut
U	2	3/4" x 1 1/2" x 1 1/2" oak (nailing block for F)
V	2	1/4"-dia. x 3" carriage bolt with washer and nut
W	2	1 3/16" x 1 3/4" x 11" oak (vertical armrest post)
X	2	1 3/16" x 3" x 27" oak (frame cap)
Y	1	1/4" finishing nail

Misc.: Plastic resin glue, exterior polyurethane varnish. Chamfer edges using a router and 45° chamfering bit.

mark the notch locations for installing the stretchers (L) to the vertical members. Also, at each screw location, counterbore $\frac{1}{2}$ -in.-dia. plug holes and bore pilot holes for $1\frac{1}{4}$ -in. No. 12 flathead screws. Disassemble the frame and bore screw-shank clearance holes through the counterbored frame parts. Then, band-saw a $\frac{5}{8}$ -in. radius on the ends of each horizontal frame member.

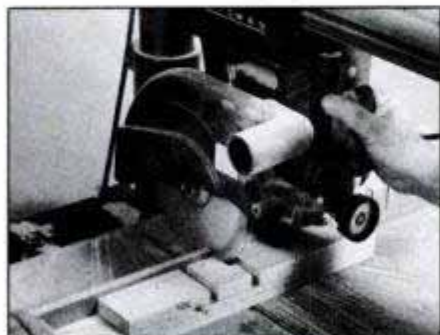

1 Notch horizontal frame members with a dado blade. Make two passes to establish the notch width, then clear out the waste.

Next, use a router fitted with 45° chamfering bit to chamfer edges of frame parts that won't be accessible after assembly. Assemble the frame using highly water-resistant plastic resin glue and $1\frac{1}{4}$ -in. No. 12 screws. Install the frame caps (X) to upper horizontal members. Glue $\frac{1}{2}$ -in.-dia. oak plugs into counterbored holes to conceal screwheads. Sand the plugs



2 Insert vertical frame part into horizontal member's notch. Then mark the vertical part to indicate the end rabbet length.

flush and finish chamfering the edges.

Begin seat assembly by cutting the three seat supports to size. Notch both ends of each support to receive the seat rails. Next, make the table saw jig shown below to cut the angular depression in the seat supports that form the contoured seat. Make the first cut in each seat support, stopping when the saw blade's undercut kerf reaches the



3 Assemble frame temporarily and position stretchers on vertical parts to permit marking the notch locations accurately.

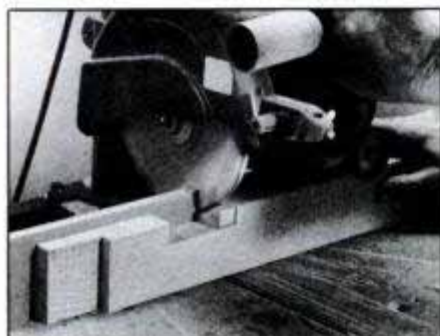

4 Using a dado blade, notch the vertical parts to accept the stretchers. Install a high saw fence to support the workpiece.

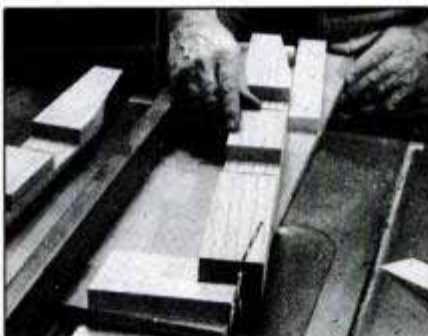

5 Construct this homemade table saw jig to cut tapered ends safely and accurately on horizontal glider frame members.

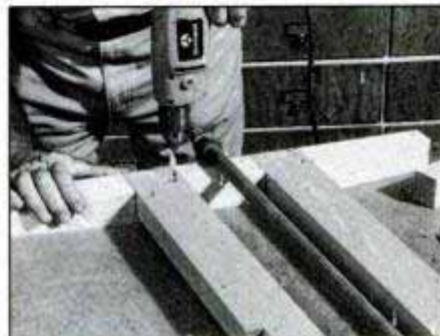

6 Clamp frame together and bore screw pilot holes. Code each part with a letter to avoid confusion when reassembling.

HORIZONTAL FRAME MEMBER CUTTING JIG

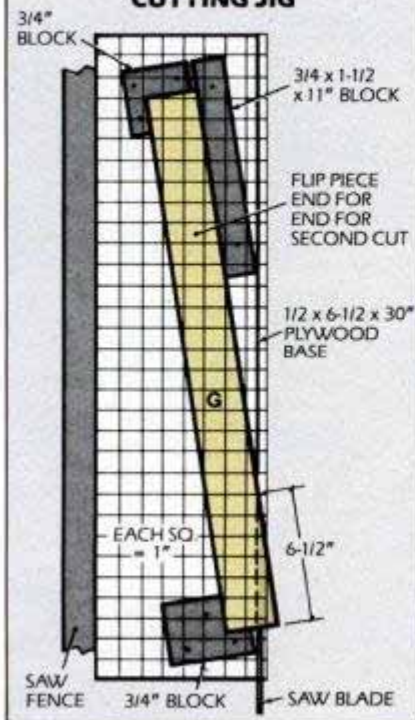

SEAT SUPPORT CUTTING JIG

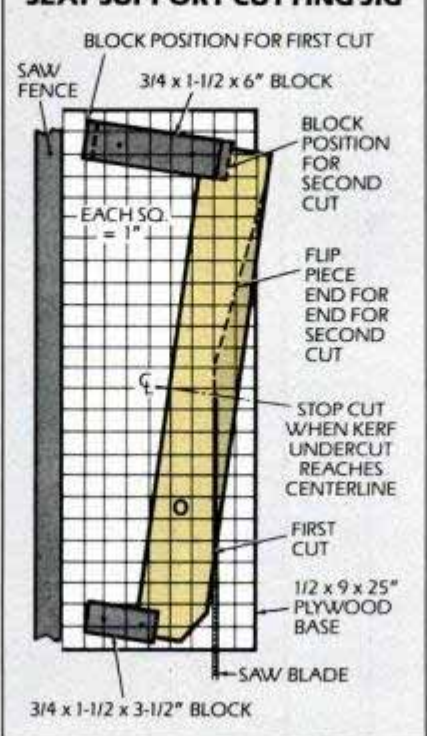

support's centerline. Apply masking tape to the plywood jig base and saw fence to indicate when to stop the cut. Then, reposition the jig's guide block, as shown, to make the second cut in each support. Use a hand saw to extend the two kerfs and free the waste.

Now bore a $\frac{5}{8}$ -in.-dia. hole in the top, front end of each seat support deep enough to accept the carriage bolt head (R) and the plug (S). Then, bore $\frac{5}{16}$ -in.-dia. bolt-clearance holes. Also, bore bolt-clearance holes through the rear end of each support. Finally, trim the front ends of the supports to a 35° angle (see Detail 3 on the drawing).

Cut the two seat rails to size. Position the seat supports on the rails and continue the $\frac{5}{16}$ -in.-dia. carriage bolt clearance holes through the rails. Bolt the supports to the rails temporarily. Cut the three seat-back supports to size, and notch the ends to accept the rear seat rail. Then, bore pilot holes through the lower end of the seat supports. Now clamp the back supports to the seat supports and continue the pilot holes

(Please turn to page 116)



ALL-AMERICAN FENCES

Here's our guide to planning and installing a fence, plus attractive fence designs.



RAIL FENCE AND GATE



LATTICE-TOP FENCE



BOARD AND BOARD FENCE



PICKET FENCE



From the first settlers who fenced in their livestock and fenced other animals out of their gardens and orchards, Americans have always been enthusiastic fence builders. Today we also use fences as decorative borders to frame the lawn and to define boundaries, to serve as wind breaks and as sun screens. And, as properties become smaller and houses are built closer together, fences are used as privacy walls between neighbors and to muffle the sound of traffic.

The four fences shown here fulfill a range of needs from purely decorative to highly functional. A fifth fence—a

saw-tooth picket fence on page 125—serves as a decorative security fence.

When you select a fence design, consider the purpose your fence will serve. Also consider the architecture of your house and the look of the land in your area. Select a fence that will be harmonious with its surroundings.

Before beginning work, call your local planning or zoning department to learn the current ordinances and regulations regarding fence building. Make certain you know your property lines. Plan the fence the distance required by zoning laws within these lines.

After selecting a fence design, care-

The lattice-top fence serves as a boundary marker and as a handsome backdrop for flowers. The crisp white of the rail fence and gate contrasts with the rich greenery in the setting. The gate is a passage through a hedge wall. The board and board fence can serve as a security fence and privacy wall with both sides presenting a finished appearance. The diminutive picket fence is a decorative border.

Lattice-top fence and picket fence photos: George Taloumis
 Rail fence and gate and closed picket fence (page 125) photos: Derek Fell
 Board and board fence photo: Josh Dayton

fully measure the proposed fence perimeter to see how many fence sections you'll need. Most fences are built in identical 6 or 8-ft. sections. Prepare a list of materials and amounts needed for one section and multiply this by the number of sections you need. Posts are commonly 4x4s, although 6x6s and 8x8s are used, especially at corners and as gate posts.

Rails commonly are 2x4s, and fence pickets or vertical boards often are 1x4s and 1x6s. To prevent rust, use aluminum or hot-dipped, galvanized nails and other hardware. Estimate the amount of gravel you'll need for drainage. If you set the posts in concrete below the frost line, figure that a 90-pound bag of premixed concrete occupies two-thirds of a cubic foot.

Selecting wood

Use wood that has been professionally pressure treated with a preservative to resist rot and insect infestation, or wood that's naturally decay resistant. Pressure-treated wood can last 30 years or more if it's treated properly.

One way of assuring proper pressure treatment is to purchase wood stamped by a regulatory agency such as The American Wood Preservers Bureau (AWPB). The AWPB gives a rating of LP-22 to posts treated for ground-contact use. Wood that can be used above ground for fencing is rated LP-2.

A number of native trees contain wood that is naturally decay resistant. Trees commonly used are cedar, redwood, cypress and locust. Heartwood—the dark-colored core of the tree—is recommended for posts, and for rails lower than 6 in. above ground. But decay-resistant trees grow in limited ranges and heartwood is expensive.

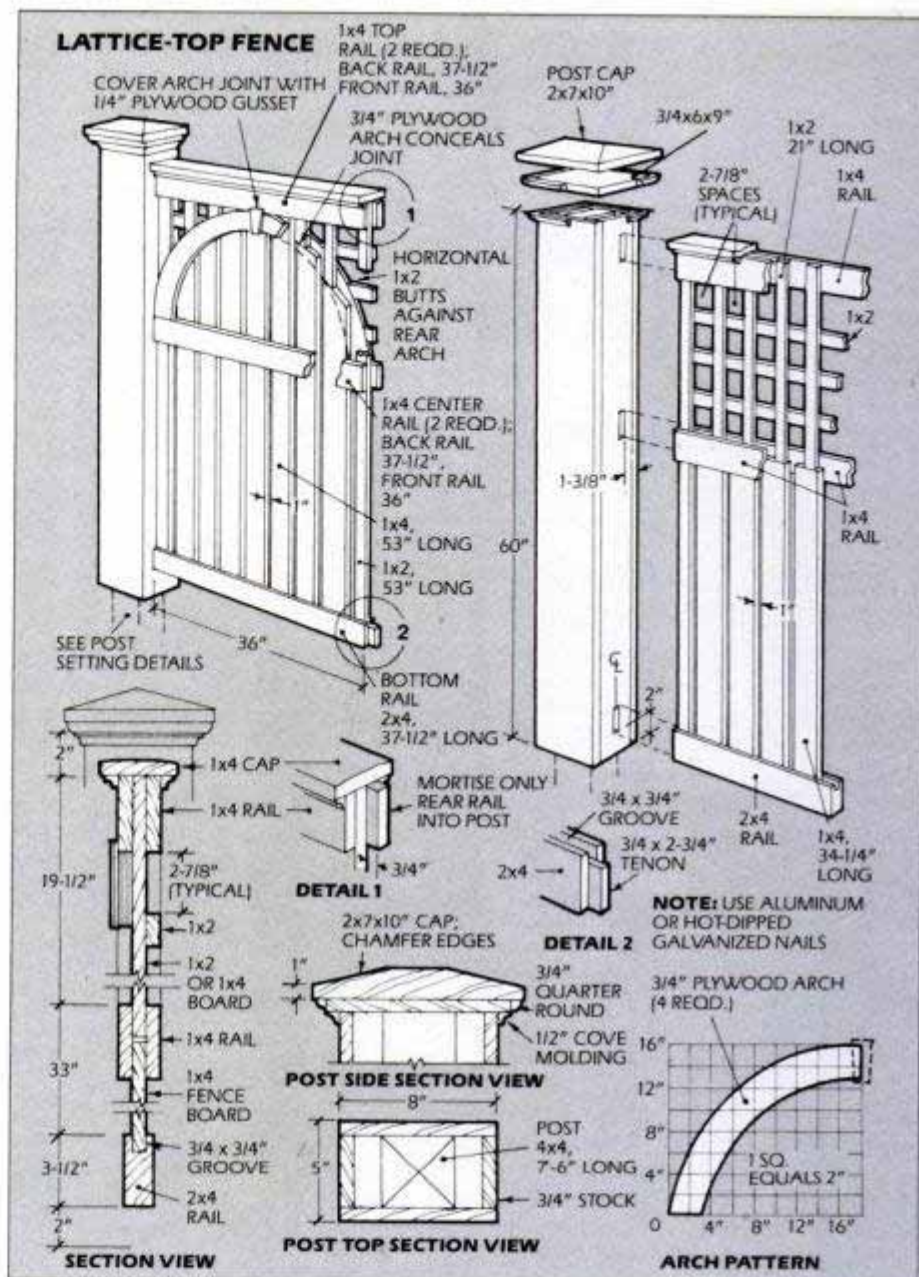

4 WAYS TO SET POSTS

POST HOLE DIAMETER 2 TO 3 TIMES POST WIDTH

SLOPE EARTH AWAY FROM POST FOR DRAINAGE

EARTH

ROCKS TO PREVENT MOVEMENT

EARTH

6" GRAVEL

FLARE HOLE FOR MORE SOLID BASE

1 POST SET IN GRAVEL AND EARTH

DEPTH 1/3 OF POST HEIGHT ABOVE GROUND PLUS 6"

CONCRETE

GRAVEL

LARGE, FLAT STONE

2 POST SET IN CONCRETE; DIG TO BELOW FROST LINE

NOTE: LET POST STAND FOR 2 DAYS BEFORE ATTACHING RAILS

SLOPE TOP

POST ANCHOR

CONCRETE

GRAVEL

2x4 CROSS CLEATS, 18" LONG

ADD EARTH

LARGE, FLAT STONE

4 GATE POST SET WITH CROSS CLEATS

3 POST ANCHOR SET IN CONCRETE; DIG TO BELOW FROST LINE

RAIL FENCE AND GATE

NOTES

1. USE ALUMINUM OR HOT-DIPPED GALVANIZED NAILS
2. ASSEMBLE GATE FRAME WITH RESORCINOL GLUE AND NAILS

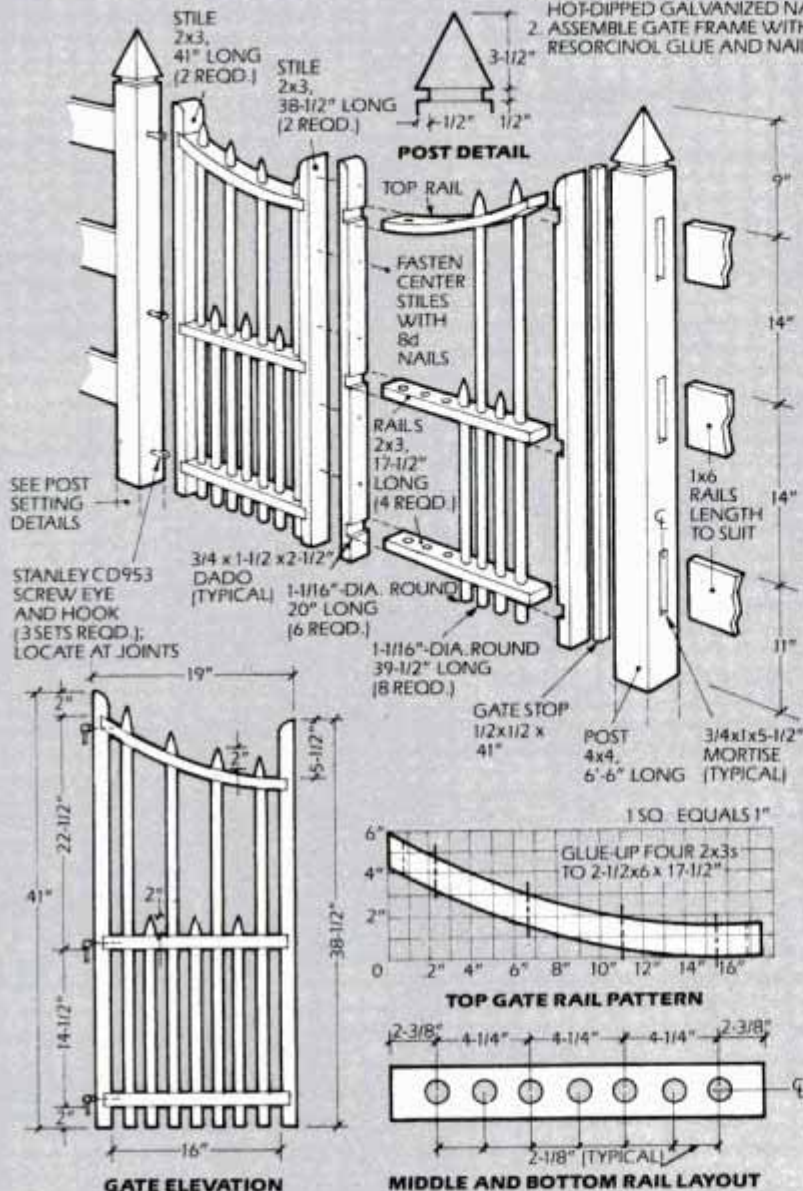

Tools you'll need to build and install a fence include a hammer, saw, 50-ft. tape measure, mason's twine, plumb line, clamshell post-hole digger (or hand or power auger), 2x4 soil tamper, spirit level and line level.

Laying out the fence

Begin laying out the fence by locating the corner posts and driving in stakes at these points. Then run mason's twine tautly between two corner posts. Mark on the twine with chalk the correct on-center position of each intermediate fence post.

You'll probably have to adjust the length of a fence section or two between posts. Hold the plumb line against the mark to transfer the exact center of the post to the ground. At this point, put in a stake.

If you have sloping land, there are two choices for installing the fence: run it parallel with the land or in stepped sections.

To determine the amount of drop for each stepped section, you must find the slope height. You can do this by setting stakes at the beginning and end of the slope. Then attach mason's twine at ground level of the uphill stake. Next tie the twine tautly to the downhill stake. Level the twine with a line level. Measure the distance between the line and the ground at the lower stake.

Finally, divide this distance by the number of fence sections to get the amount of drop for each section. The top edges of adjacent rails differ in height by this amount.

Setting posts

Setting and aligning posts are as important to producing a durable fence

(Please turn to page 124)

7 WAYS TO FASTEN RAILS TO POSTS

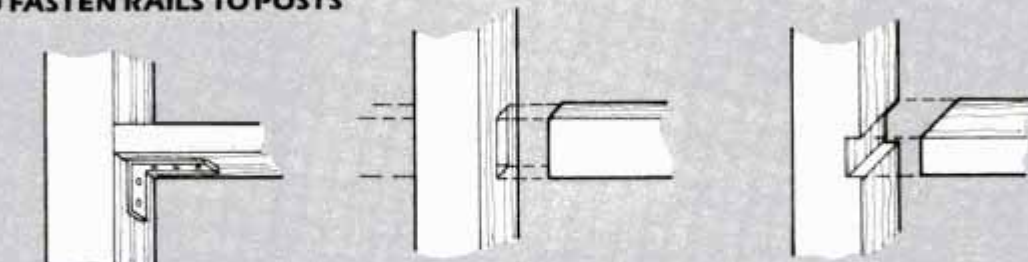

1. METAL FASTENER

2. THROUGH MORTISE

3. DADO-RAIL ON SIDE

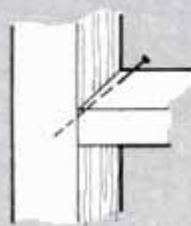

4. TOE-NAIL

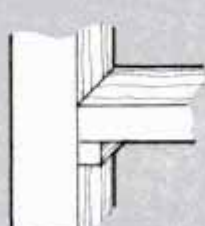

5. BLOCK

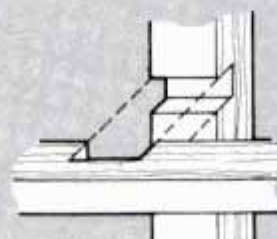

6. CROSS LAP

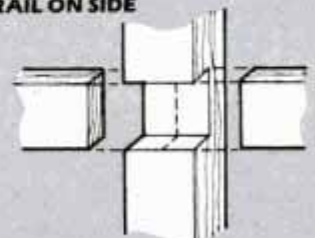

7. DADO-RAIL ON EDGE

PART ONE:

DRILL PRESS

NOT JUST ANOTHER BORING TOOL

Accurate hole boring is only one of the many functions offered by this versatile shop tool.

TEXT AND PHOTOS
BY ROSARIO CAPOTOSTO

Are you getting the most out of your drill press? You're not if the drill press is used for hole-boring operations only.

The drill press is an affordable, superversatile tool that is second only to the table saw and radial-arm saw in importance to a home workshop. Originally designed for metalworking, the drill press has become a valuable asset to all woodworkers regardless of their skill level. In addition to boring a variety of holes accurately and easily, the drill press can sand, rout, polish, saw, shape, grind, sharpen and mortise.

Discover here, and again in Part Two, in October, how the drill press can be a vital part of your metal and woodworking activities (see *Six Drill Press Accessories You Can Build*, page 115, Mar. '84, for more homemade drill press aids).

Meet the machine

Drill presses are available in

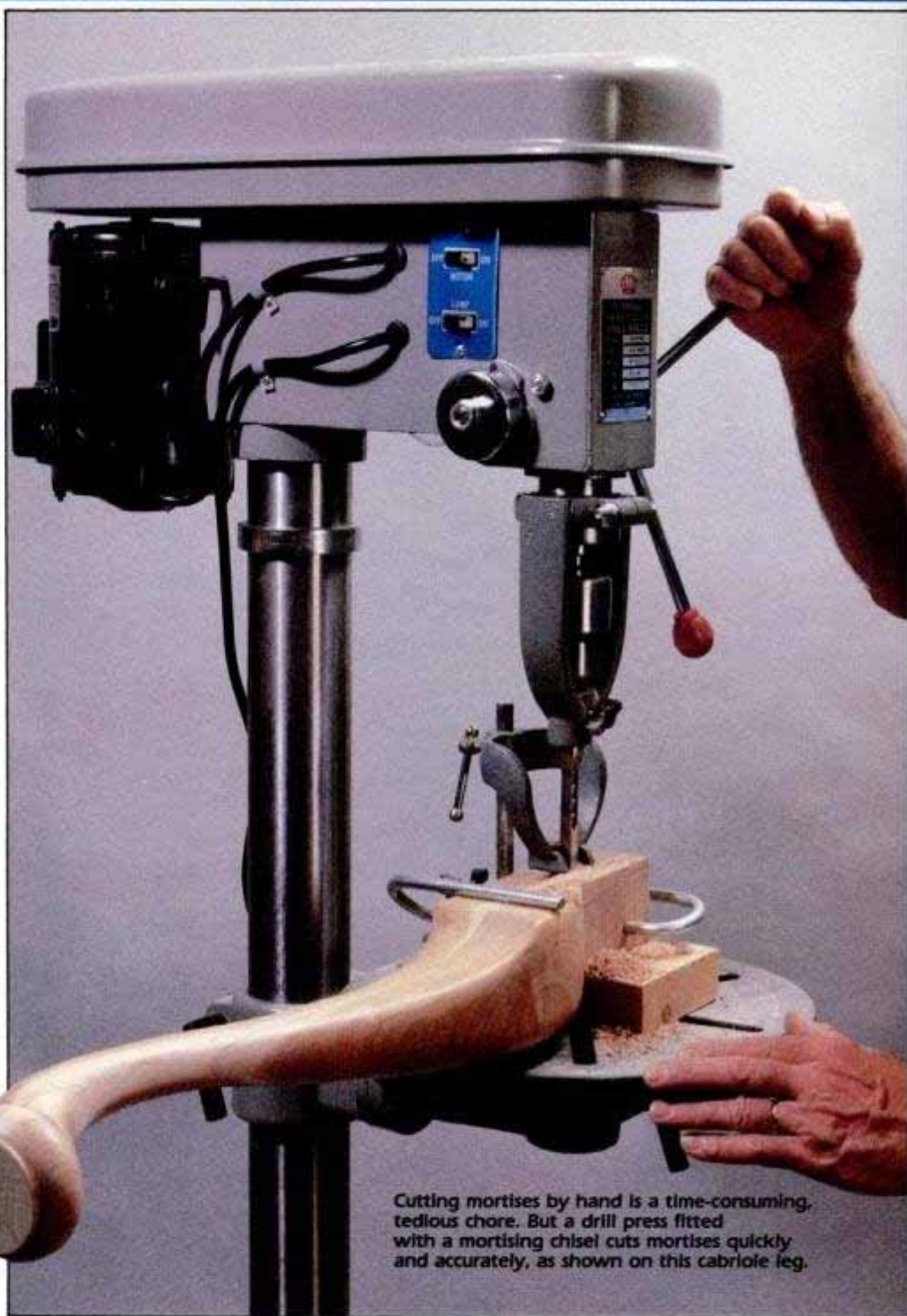

Cutting mortises by hand is a time-consuming, tedious chore. But a drill press fitted with a mortising chisel cuts mortises quickly and accurately, as shown on this cabriole leg.

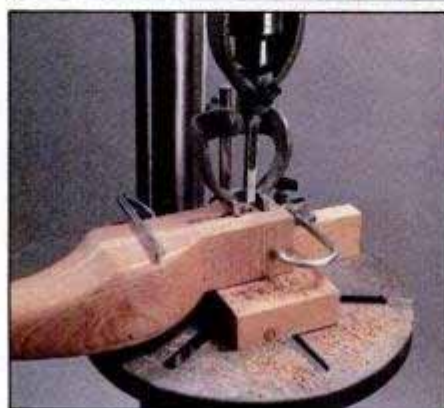

Form the mortise by boring a series of overlapping square holes. Be sure the work is clamped securely to the drill press table.



The mortised cabriole leg is shown with a five-piece mortising attachment. Note the drill bit and hollow chisel (front, left).

DRILL PRESS ADJUSTMENTS

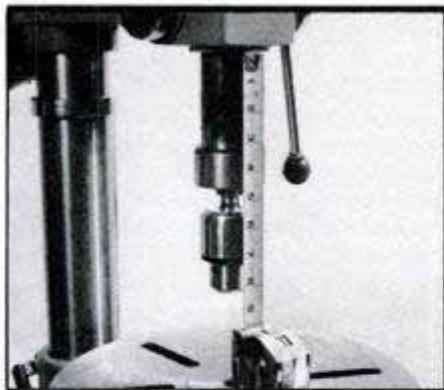

The stroke or travel length of the quill determines how deep the drill press can bore. This model has a 3/4-in. stroke.

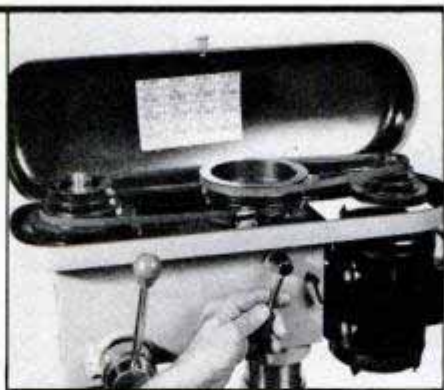

To change speeds, shift the tension lever to relieve belt pressure. Then, reposition the belts and move the lever back to tighten.

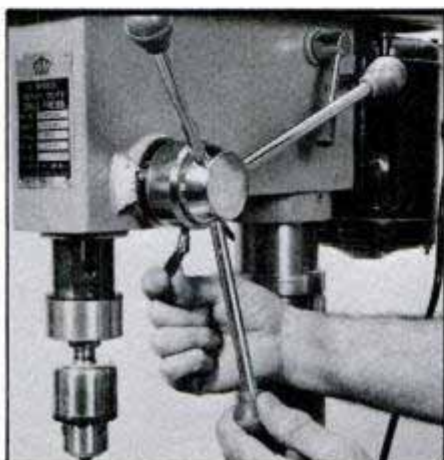

On this particular drill press model, lock the quill in place or limit its travel by adjusting and then locking a rotating sleeve.

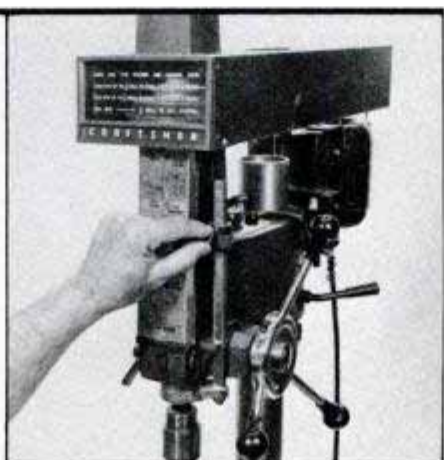

The depth stop on this drill press is controlled by adjusting a knurled collar up and down on a threaded, calibrated rod.



An adjustable, tilting worktable is an important drill press feature. This table tilts 45° and pivots 360° around the column.

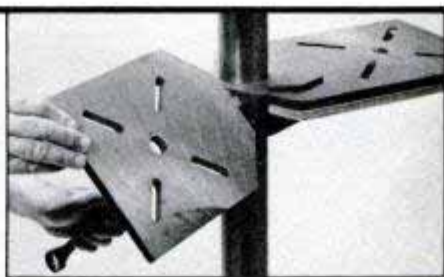

Accessory tilting tables are available for fixed-table drill presses. Pivot fixed table around back and attach tilting model.

benchtop and floor-standing units. The additional power and versatility of the floor models make them a better choice for nearly all workshops.

The drill press consists of four basic parts: the head, column, worktable and base. The head, located at the top of the column, contains the motor, a belt and step-pulley system, and a spindle which is housed in a movable sleeve or quill. The geared chuck is attached to the spindle end. The quill is moved up and down with the spring-loaded feed lever and the depth stop locks the quill in place or limits its travel. The stroke or travel length of the quill varies, but most home workshop drill press models

range between 3 to 6 in.

The spindle speed is adjusted by changing each V-belt's position on the pulleys. On a typical four-speed drill press, speeds range from about 600 to 5,000 rpm. Machines with 12 or 16 speeds range from about 240 to 4,800 rpm. Use low speeds for drilling in metal, moderate to high speeds for boring in wood, and very high speeds when using the machine for routing and shaping operations.

The worktable moves up and down on the column and pivots 360° around it. Many drill presses, including the one shown, feature tilting tables that are invaluable for boring angled holes. Ac-

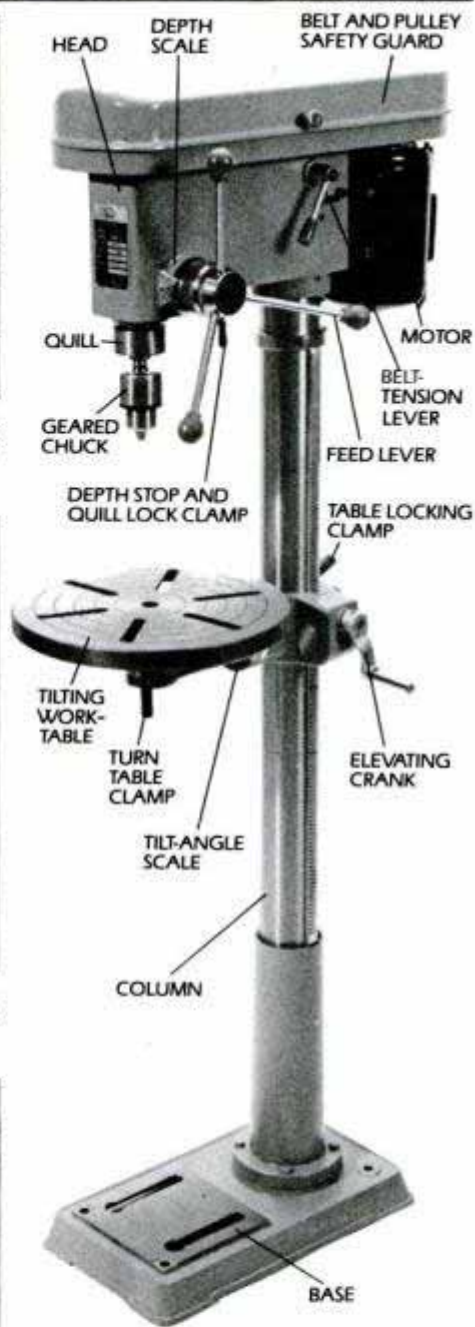

Here's a typical floor-standing 16-in. drill press with its major parts identified. This particular drill press model has 16 speeds.

cessory tilting tables are available for some drill press models, such as Sears and Delta, that have fixed tables, or you can build one yourself (see *Drill Press Angle Guide*, page 107, Nov. '83).

To determine the size of a drill press, double the distance from the column to the center of the chuck. For example, a 16-in. drill press measures 8 in. from the chuck to the column. This size machine permits boring to the center of a 16-in.-wide workpiece.

When shopping for a drill press, the features to look for include a 1/2-in. dia. or greater chuck capacity, a wide range of speeds, overall solid construction and a cast-iron, ribbed worktable and base.

Be certain that the tool manufacturer provides service and offers a full line of accessories and replacement parts. Also, lower the quill and check for any side to side movement. There should be no play evident.

Bits and drills

Nowadays, the words bit and drill are used interchangeably. But to be technically accurate, bits are used for boring in wood and drills are used to drill in metal. However, the common twist

drill, which is designed for metalworking, is used frequently for boring in wood. In fact, for boring holes less than 1/4-in. dia., there's no choice but to use twist drills.

For boring larger, flat-bottom holes up to about 2 1/8-in. dia., wood bits come in several styles, including spade, spur, brad point, multispur and Forstner. Special metric-sized, carbide-tipped hardware bits are available for installing European cabinet hinges.

Spade bits are the most popular because of their wide range of sizes and relative low cost. The main disadvantage of spade and spur bits is that maximum blind hole depth is limited because the bit's long point will penetrate through the workpiece. Brad point, multispur and Forstner bits have wide cutting rims that provide unparalleled control for boring angled holes and any portion of a hole in a board edge.

Before boring a hole, align the bit with the center hole in the worktable. Then, clamp a backup board to the table to prevent splintering the workpiece underside as the bit exits. To bore a blind hole, first mark the desired hole depth on the side of the workpiece. Then, lower the bit to the mark and adjust the quill depth stop to prevent the bit from cutting deeper than the desired depth.

MORTISING ATTACHMENT

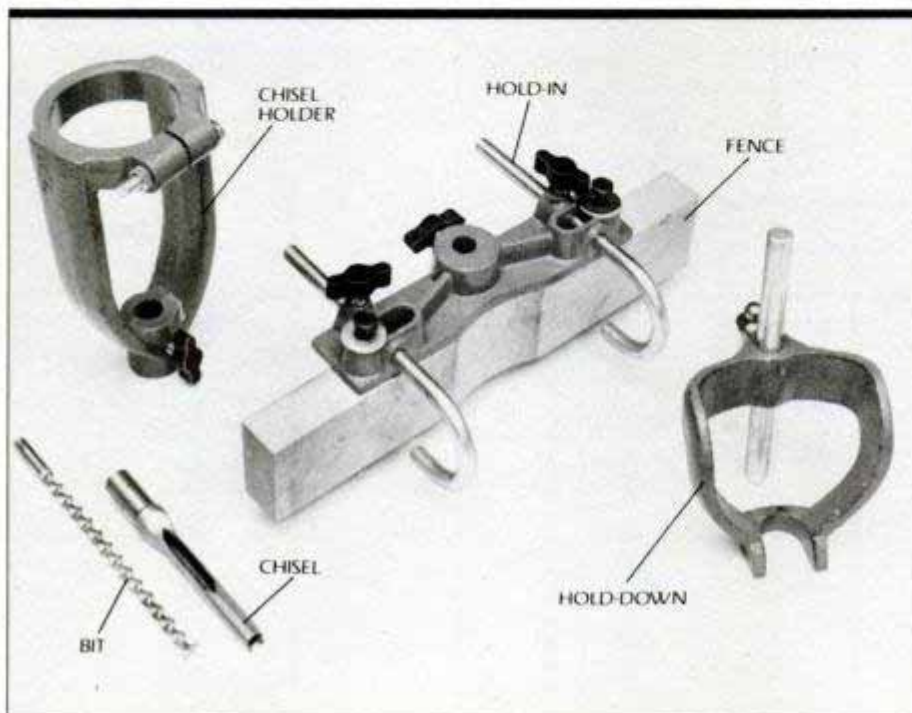

Here are the components of a typical drill press mortising attachment. Note the square, hollow chisel that houses the bit. The chisel holder or yoke attaches to the quill.



Slip the chisel holder over the chuck and onto the base of the quill. Then, tighten the locking bolt to hold it securely in place.

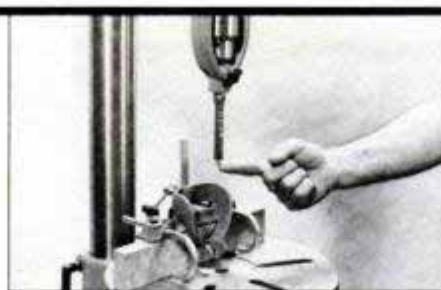

Secure the chisel in the holder and then tighten the bit in the chuck. Be sure the bit projects from the chisel about 1/16-in.

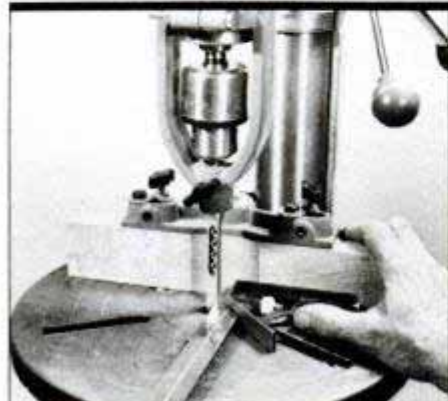

Check the chisel to make certain that it's perfectly square to the fence. Make any adjustments before cutting the mortise.

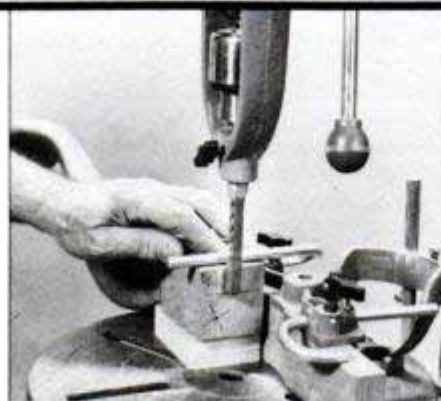

Mark the mortise depth on the end of workpiece. Lower the chisel to this mark and set the tool's depth-stop mechanism.

Holding devices

Nearly all drill press operations require a workpiece holding device to ensure safety and accuracy. Many of these devices are available as accessories from the tool manufacturer, but here are a few simple devices that you can make.

To bore holes accurately in round stock, make a V-block cradle. First, tilt the saw blade 45° and rip an 18-in.-long 2x4. Then, screw the 2x4 pieces to a plywood panel to form a V-shaped holder. Clamp the cradle to the worktable with the stock placed in the V-groove.

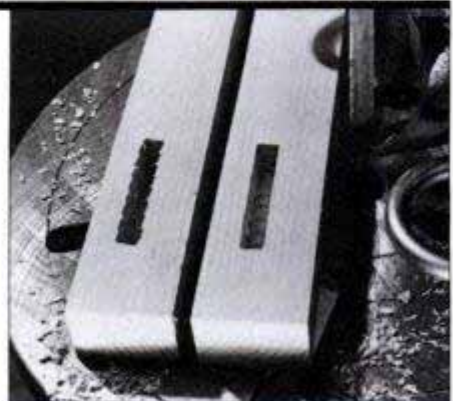

Rough-cut mortise (left) is the result of the chisel being out of square with the fence. Properly cut mortise is shown on the right.

Now, bore into the side of the stock. Reposition the worktable vertically for boring into the end of the stock.

Make a second device to hold circular disks. Join two 1×4s in an L-shape using dowel pins. Use the device in a horizontal position to bore holes in the face of the circular disk. Reposition the table vertically in order to bore holes in the disk edge.

Another useful device consists of two L-shaped blocks that make it easy to bore perfectly aligned dowel-pin holes in mitered pieces. First, set the worktable in a vertical position and clamp the block and the workpiece to the table. Be sure that the edge being bored is perpendicular to and centered under the drill bit.

Now bore one hole in each mitered end. Then, add the second block to the table to reposition the workpiece in preparation for boring the second set of dowel-pin holes.

There's also a way to bore a hole that's about twice as deep as the travel length of the quill. The trick is to bore in from both ends of the stock.

To insure that the holes bored from each end meet in perfect alignment, start by boring a hole in one end of the workpiece as deep as possible. Next, bore the same size diameter hole in a plywood panel. Then, install a straight steel rod in the chuck and clamp the panel in place so that the rod and hole are aligned perfectly.

Now insert a short dowel into the hole in the plywood panel. Place the workpiece over the dowel and bore the second hole. To bore extra deep holes, use a bit extension or an 18-in.-long electrician's bit.

Mortising

Cut square and rectangular mortises easily on a drill press using a mortising attachment. The attachment consists of a square, hollow chisel that houses a special bit, a chisel holder that clamps to the quill and a fence that guides the

work. A bracket on the fence supports an adjustable hold-down fixture and two hook-shaped hold-in rods. Mortising chisels with matching bits are available commonly in four sizes: 1/4-, 3/16-, 3/8- and 1/2-in. square.

There are two important adjustments that must be made before attempting to cut the mortise. First, adjust the bit so that its cutting spurs extend about 1/16 in. below the end of the chisel. This

(Please turn to page 112)

HOLE BORING TECHNIQUES

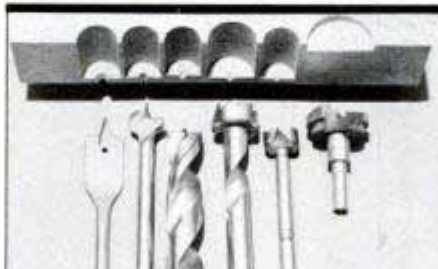

Wood-boring bits (left to right): spade, spur, brad-point, multispur, Forstner and European hinge bit. Cutaway sample shows through penetration by spade and spur bits.

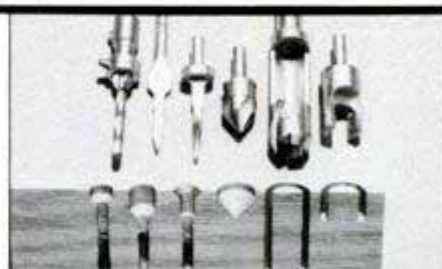

This cutaway sample shows (left to right) three different types of screwhole bits, countersink, 1/2-in.-dia. x 2-in. dowel and plug cutter, and a 1/2-in.-dia. plug cutter.

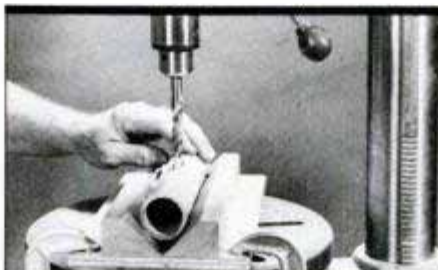

Build this automatic-centering V-block cradle holding device for boring round stock. Make the cradle from mitered 2×4 stock screwed to a 1/2-in. plywood panel.



To bore into the end of round stock, adjust the worktable into a vertical position with the V-block device clamped in place.

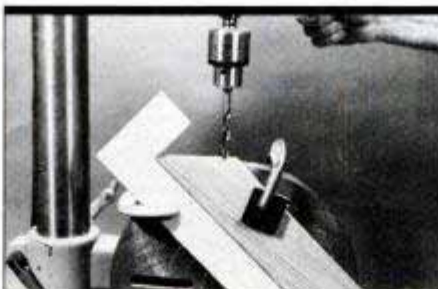

Bore dowel-pin holes in mitered work with the aid of L-shaped blocks. Clamp one block in place and bore the first set of holes.

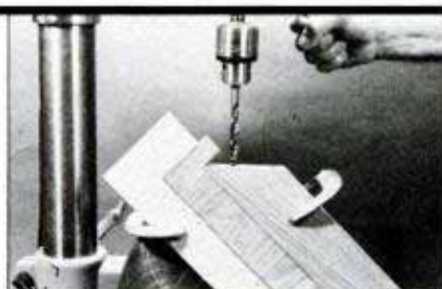

Then, add a second block to reposition the workpiece for boring the second set of holes. Be sure bit is centered on work.

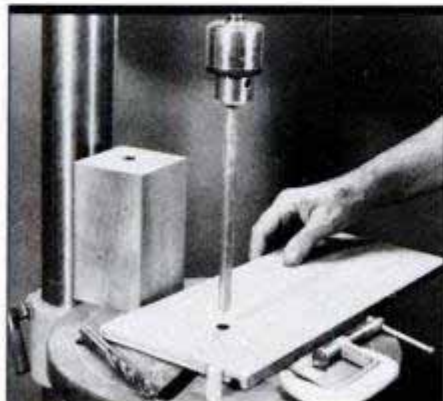

After boring into a plywood panel, use a straight rod to align the hole with the chuck center. Then, clamp panel to the table.

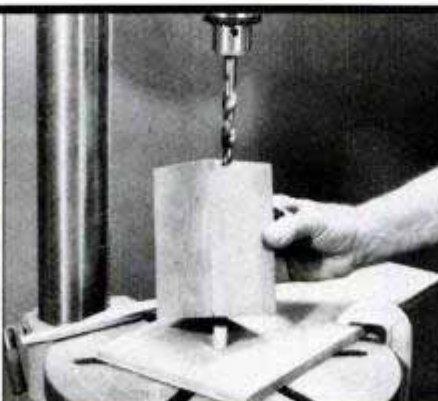

Insert a short dowel section into the plywood's hole. Then, place the previously bored hole in the workpiece over dowel.

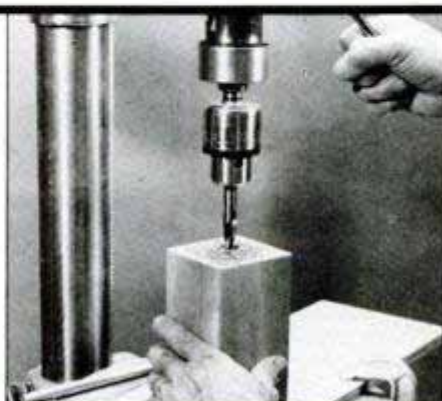

Now bore a second maximum depth hole to meet the first. This trick allows boring a hole twice as deep as the tool's capacity.

HOT SEATS

Build one of these oak and canvas folding chairs in a weekend, with time left over to test it in the sun.



Slide-together chair gives stretch-out comfort on the beach or deck. Seat and backrest sandwich together flat for easy carrying and storage. The canvas back, removable for washing, is held in place with wood dowels in grooves.

Super-lightweight camp chair, with oak frame and hardwood dowels, folds into a compact package you can take anywhere. Folded chair measures just 19 x 23 inches square.

Classic deck and beach lounge with candy-striped canvas offers four positions—from reclining to nearly upright. Chair is designed to give comfortable support to head, back and legs. It folds completely flat, measuring only 1½ in. thick.

Director's chair is equally at home around a picnic table or in your living room. Its deep seat and swiveling back support adjust comfortably to your size, weight and seating position.

Easy-to-tote beach chair provides a soft seat in the sand and a sturdy, adjustable backrest. Seat flap wraps around the folded-up chair and attaches with Velcro strips. Hardwood frame and dowels are cut and bored easily, then assembled with screws.

The five chairs in our hot-seat collection are built of $1\frac{3}{16}$ -in.-thick red oak joined with hardwood dowels and solid oak cross members. All of the wood pieces were finished with three coats of high-gloss exterior-grade polyurethane varnish before sliding the canvas in place.

BY ROSARIO CAPOTOSTO

The brightly colored canvas, available at most fabric stores, is detached easily for washing, either by sliding out a thin wood dowel, or removing a few of the drywall assembly screws. These screws have deep threads that drive in and out of the frames and dowels easily, and hold the pieces together firmly.



DECK CHAIR

Begin building the deck chair by cutting all the frame pieces to length and width. Then, mark the four leg and seat members for mortises. Use a spur bit (which cuts a flat-bottom hole)

in a drill press or portable drill guide to bore overlapping holes to form the mortises. Then, clear out the excess wood from the mortises with a sharp chisel.

Cut the crosspiece tenons on a table or radial-arm saw by making several passes on each frame piece face with a regular blade, or a single pass with a dado blade. Use a sharp knife and file to round the tenon corners to fit the mortises.

The locknuts for the pivoting joints are recessed into hex-shaped holes. Shape these holes by first boring a $\frac{7}{16}$ -in.-dia hole $\frac{5}{16}$ in. deep; then attach a regular, nonlocking hex-nut to the end of a screw. Drive the nut into the hole with a sharp hammer blow, then withdraw the nut. The locknut will fit the hole snugly and won't spin when the screw is turned into it.

Round the ends of the seat and backrest legs and the backrest support by making $\frac{3}{4}$ -in.-rad. cuts with a jigsaw or band saw. Also round the edges of all the parts with a $\frac{3}{16}$ -in. rounding-over router bit.

Cut a 32° bevel on the support crosspiece, and cut matching notches in the seat legs. Then, cut the canvas to size as shown in the drawing, hem it and slide it on the crosspieces. The mortise and tenon joints are glued on one side only to allow removal of the canvas for washing. Assemble the chair with drywall screws. Bore clearance holes and pilot holes, and counterbore for the screwheads.

Sand all parts smooth with 220-grit sandpaper and finish the chair with exterior polyurethane varnish.



Cut crosspiece tenons on a table or radial-arm saw. Then, trim tenon corners with a knife and file to match round ends of mortises.

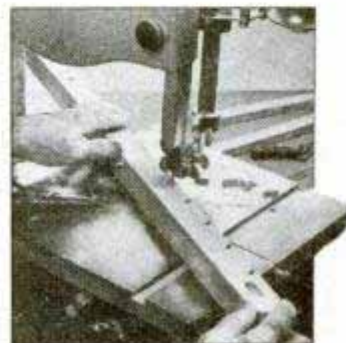

Cut notches in seat legs together so both match the 32° bevel of support crosspiece.

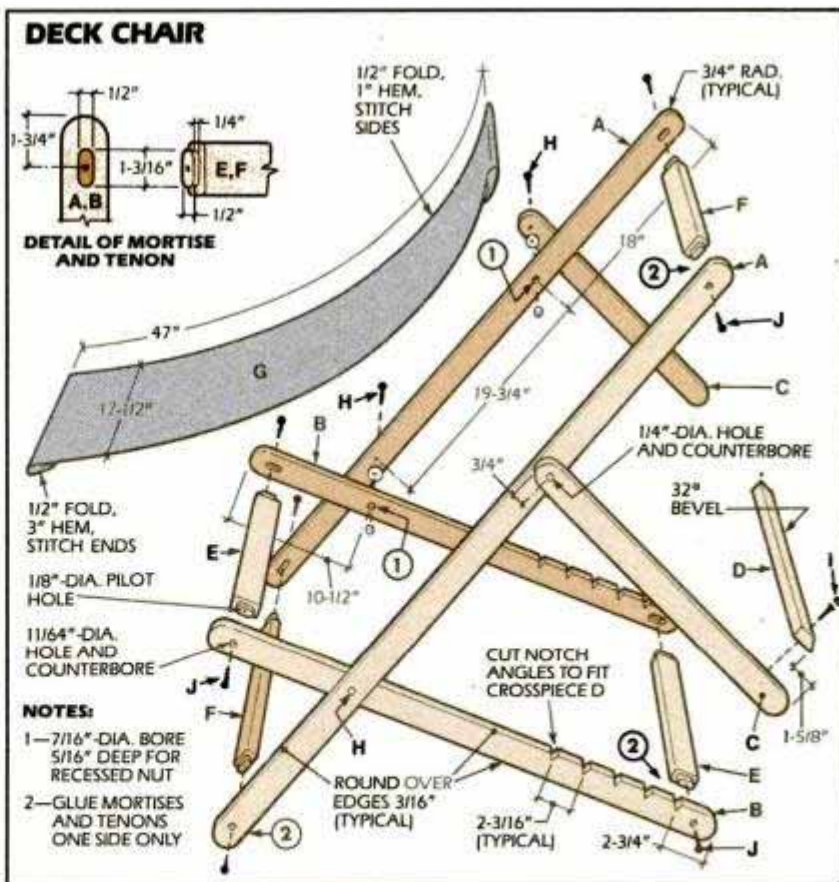

MATERIALS LIST—DECK CHAIR

Key	No.	Size and description (use)	F	2	$1\frac{3}{16} \times 1\frac{1}{2} \times 19\frac{3}{4}$ " oak (crosspiece)
A	2	$1\frac{3}{16} \times 1\frac{1}{2} \times 51$ " oak (backrest leg)	G	1	$20\frac{1}{2} \times 54$ " canvas
B	2	$1\frac{3}{16} \times 1\frac{1}{2} \times 36\frac{1}{2}$ " oak (seat leg)	H	4	$\frac{1}{4}$ -20 \times $1\frac{1}{4}$ " fh machine screw, $1\frac{1}{4}$ " fender washer and locknut
C	2	$1\frac{3}{16} \times 1\frac{1}{2} \times 23$ " oak (support)	I	2	$1\frac{1}{2}$ " No. 10 fh screw
D	1	$1\frac{3}{16} \times 1\frac{1}{2} \times 22\frac{3}{4}$ " oak (crosspiece)	J	8	$1\frac{1}{2}$ " No. 8 drywall screw
E	2	$1\frac{3}{16} \times 1\frac{1}{2} \times 18$ " oak (crosspiece)			

Color photo: Bill Ashe
Black and white photos: Rosario Capotosto
Technical art: Eugene Thompson



BEACH CHAIR

Our beach chair is made with $\frac{5}{8}$ -in.-dia. maple cross-dowels fitted into $\frac{1}{4}$ -in.-deep mortise holes in the side pieces. Cut all the stock to size, then bore the holes to receive the dowels.

Bore pilot holes for the drywall assembly screws and counterbore for the screwheads.

The half-holes in the base sides are made by clamping the two pieces together and boring through the joint line. The holes for recessing the locknuts are made in the same way as described for the deck chair. However, note that the dimensions differ: a $\frac{5}{16}$ -in.-dia. hole is bored $\frac{1}{4}$ -in. deep for the smaller locknut used here.

Cut and hem the canvas, and form the pocket for the end stiffener slat. Attach the four Velcro strips for the flap. Then assemble the chair, gluing one side only.

MATERIALS LIST—BEACH CHAIR

Key	No.	Size and description (use)
A	2	$\frac{13}{16} \times 1\frac{1}{2} \times 26"$ oak (backrest arm)
B	2	$\frac{13}{16} \times 1\frac{1}{2} \times 17"$ oak (base)
C	2	$\frac{13}{16} \times 1\frac{1}{2} \times 11\frac{1}{2}"$ oak (backrest support)
D	2	$\frac{5}{8}$ "-dia. \times $23\frac{1}{2}"$ hardwood dowel
E	1	$\frac{5}{8}$ "-dia. \times $21\frac{1}{2}"$ hardwood dowel
F	1	$\frac{5}{8}$ "-dia. \times $25\frac{1}{4}"$ hardwood dowel
G	1	$\frac{1}{4} \times \frac{13}{16} \times 20\frac{1}{2}"$ oak (stiffener slat)
H	1	$23\frac{3}{4} \times 45"$ canvas
I	4	$\frac{3}{4} \times 1\frac{1}{2}"$ Velcro
J	2	10-24 \times $1\frac{3}{4}"$ fh machine screw, 1" flat washer and locknut
K	4	$1\frac{1}{2}"$ No. 8 drywall screw



Clamp the base side pieces together and bore through the joint line to form the half-holes. Use a drill press or drill guide for accuracy.

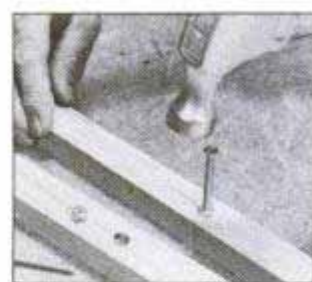

Form locknut recesses by pre-boring a $\frac{5}{16}$ -in.-dia. hole, then drive in hexnut.

BEACH CHAIR

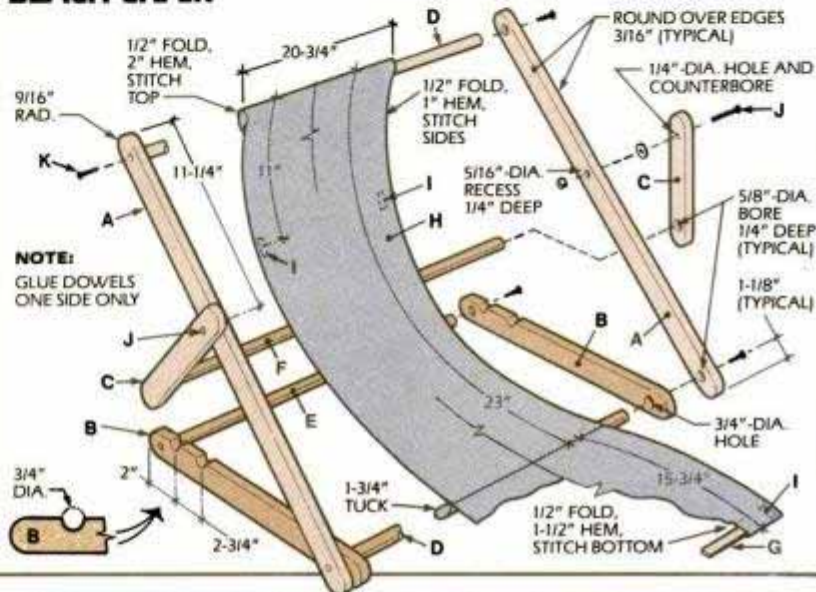

CAMP CHAIR

The construction procedures for the camp chair are similar to those for the beach chair, except that slightly heavier, $\frac{3}{4}$ -in.-dia. dowels are used.

As with both the deck chair and the beach chair, the crosspieces are glued in place on only one side to allow removal of the canvas for washing.

Cut all the pieces to size, then shape the curved backrest pieces using a band saw or



Bore $\frac{3}{4}$ -in.-dia. holes $\frac{1}{4}$ in. deep to receive the crosspiece dowels. Use drill press or drill guide to assure an exact right angle.

CAMP CHAIR

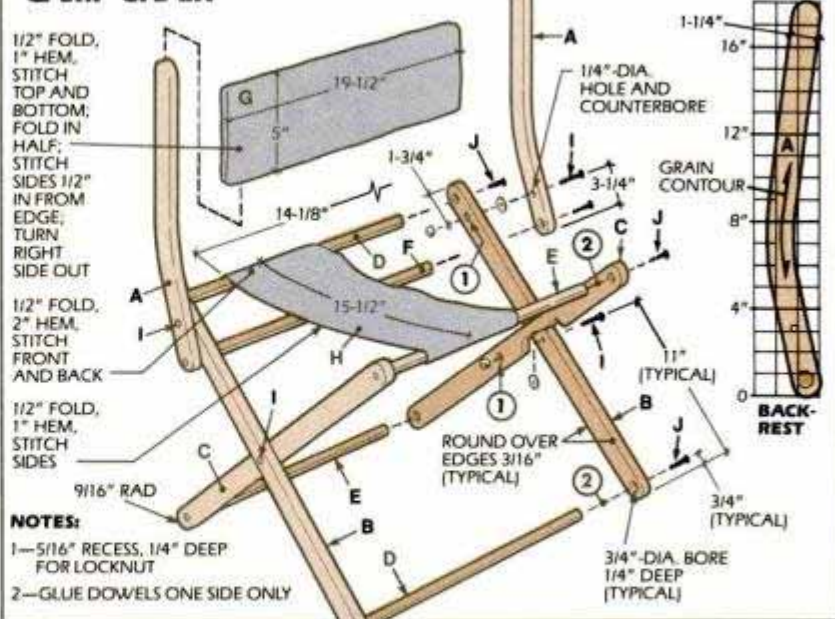

MATERIALS LIST—CAMP CHAIR

Key	No.	Size and description (use)	F	1	$\frac{3}{4}$ "-dia. \times $18\frac{1}{4}"$ hardwood dowel
A	2	$\frac{13}{16} \times 2\frac{1}{2} \times 18"$ oak (backrest)	G	1	$13\frac{1}{2} \times 21\frac{1}{2}"$ canvas (backrest)
B	2	$\frac{13}{16} \times 1\frac{1}{2} \times 22"$ oak (leg)	H	1	$17\frac{1}{2} \times 20\frac{1}{2}"$ canvas (seat)
C	2	$\frac{13}{16} \times 1\frac{1}{2} \times 23"$ oak (leg)	I	4	10-24 \times $1\frac{3}{4}"$ fh machine screw, 1" flat washer and locknut
D	2	$\frac{3}{4}$ "-dia. \times $16\frac{1}{2}"$ hardwood dowel	J	10	$1\frac{1}{2}"$ No. 8 drywall screw
E	2	$\frac{3}{4}$ "-dia. \times $14\frac{1}{8}"$ hardwood dowel			

jigsaw. When laying out the curved pieces, transfer the pattern onto the stock as shown in the drawing. This will align the wood grain across the curve, which is stronger than the grain running parallel to the straight section of the piece.

Bore 1/4-in.-deep mortise holes for the dowels, then round the ends of the legs and backrest. Clamp the frame pieces together and prebore pilot holes for the screws. Counterbore for the screwheads and for the lock-nuts that are located at the four pivot points. Then, cut and hem the canvas as shown in the drawing. Slide the seat canvas into place and assemble the frames with drywall screws. The backrest canvas forms a pocket that slides over the two backrest uprights.

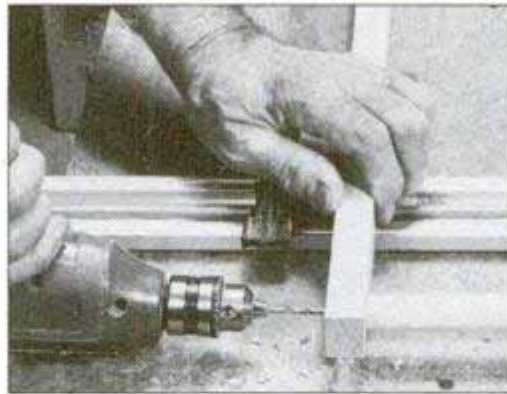

Clamp dowels in place while boring holes for the drywall assembly screws. Counterbore for screwheads to keep them flush with surface.

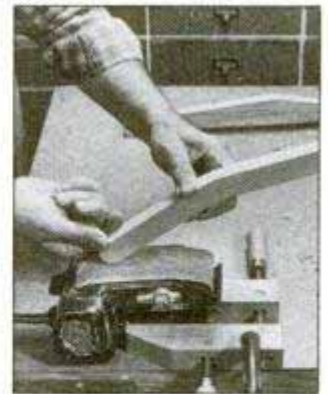

Round leg and backrest ends with a jigsaw, then sand smooth using a belt sander.



SLIDE-TOGETHER CHAIR

This chair is assembled with glue and screwed butt joints. The screwholes are counterbored and fitted with wood plugs, sanded flush.

After all the pieces have been cut to size, make the dovetail grooves in the backrest legs. These grooves secure the canvas and 3/16-in.-dia. dowels, which are slid in place from the top.

To make these grooves, tilt the blade of the table or radial-arm saw 20° and make a 3/8-in.-deep cut. Make an identical cut with the other side of the piece against the fence to form a V-shaped groove. Make a third cut with the blade set at 0° to clean the waste from the groove bottom.

The finished groove does not run the full length of the piece. So, after cutting, plug the lower portion of the groove with a filler strip as shown in the photo on the next page.

Bore 1 1/8-in.-dia. holes for the seat support dowel. Round the corners of the front seat slat and front ends of the seat legs, and bevel the leg bottoms.

Join the backrest sides with their cross members, and the seat sides with the seat slats. Let dry, sand and finish.

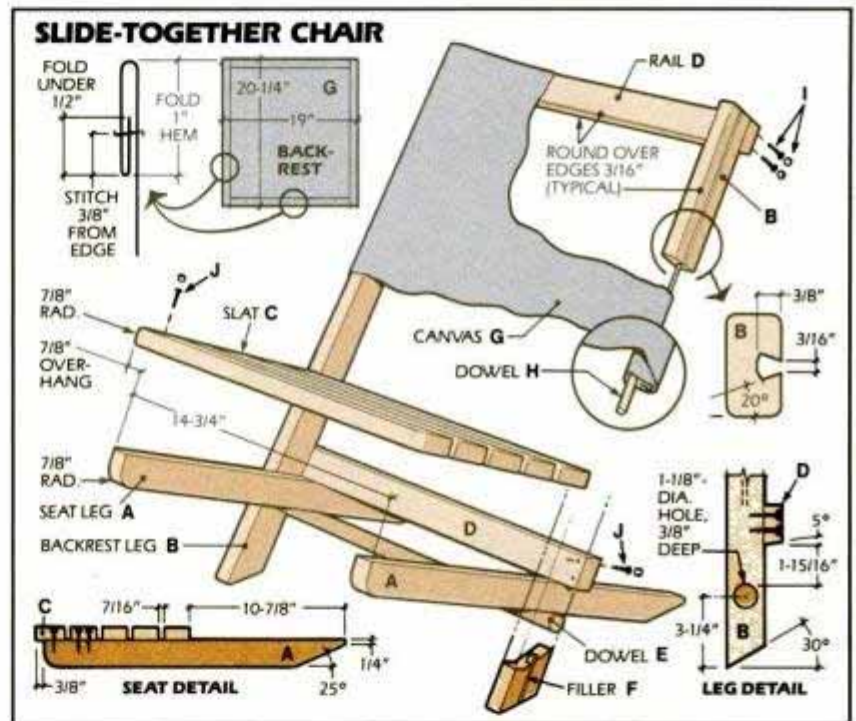

MATERIALS LIST—SLIDE-TOGETHER CHAIR

Key	No.	Size and description (use)		
A	2	1 3/16" x 1 3/4" x 21" oak (seat leg)	F	2
B	2	1 3/16" x 1 3/4" x 28 1/4" oak (backrest leg)	G	1
C	5	1 3/16" x 1 3/4" x 16 1/2" oak (slat)	H	2
D	2	1 3/16" x 1 3/4" x 16 1/2" oak (rail)	I	4
E	1	1 1/8"-dia. x 15 1/4" hardwood dowel	J	22
				(seat support)
				3/16" x 3/4" x 7 1/4" oak (filler)
				22 x 23 1/4" canvas
				3/16"-dia. x 20 1/4" hardwood dowel
				1 1/4" No. 8 fh screw, wood plug
				1 1/2" No. 8 fh screw, wood plug



Glue and tape filler strip into lower portion of the dovetail grooves to plug them. Then, after glue dries, plane strips flush to surface.

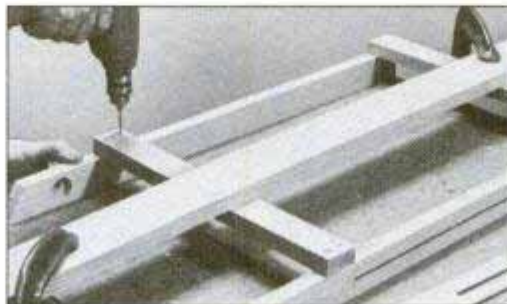

Clamp backrest legs and crosspieces together so they are square, then bore pilot holes for the screws and counterbore for wood plugs.

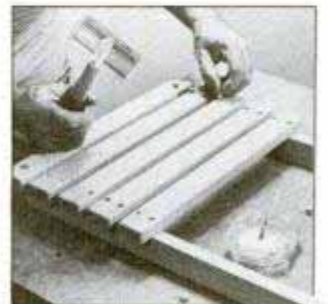

Cut radius on slat corners and sand before assembly. Sand plugs flush with belt sander.

DIRECTOR'S CHAIR

Begin building the director's chair by cutting all the parts to length and width. Then, mark the location for mortises, tenons, screw and dowel holes. The mortises in

the arms and legs are $\frac{3}{8}$ -in. wide and are made with a $\frac{3}{8}$ -in.-dia. spur bit, which makes a flat-bottom hole. Bore two separate holes for the smaller mortises and five overlapping holes for the larger one. Trim out the waste with a chisel.

Cut the tenons on a table or radial-arm saw. Parts that are similar can be taped together and the tenons gang-cut to save time.

Shape the back ends of the armrests and cut a $\frac{1}{4}$ -in. rad. on the front corners. Round the armrest and leg edges with a $\frac{1}{8}$ -in. rounding-over router bit.

Cut the dovetail grooves for attaching the canvas to the seat and back supports in the same way as described for the slide-together chair on the previous page.

Form the metal brackets from $\frac{1}{16} \times \frac{1}{2}$ -in., cold-rolled flat steel, which is available at most well-equipped hardware stores. Bend the strips to shape in a vise, using forming blocks and $\frac{3}{16}$ -in.-thick hardwood spacers as shown below. Then, drill the holes in the bracket ends.

Assemble each side section in the following order: dowels to rail, legs to rail, and armrest to dowel and leg tops. Test-fit the sections, then glue and clamp them together on a flat surface.

Glue and clamp the seat supports and cross legs together. Determine the location of all the flathead machine screws, and counterbore the screw holes. Then, assemble the four sections with the brackets, bolts and locknuts. Place washers between all moving wood parts, and dowel spacers between the two adjoining cross legs.

Fabricate the canvas seat and backrest, and after the polyurethane finish has dried, slide the canvas pieces into place on the $\frac{3}{16}$ -in.-dia. dowels. The backrest assembly is attached with wingnuts for easy removal. **PM**

DIRECTOR'S CHAIR

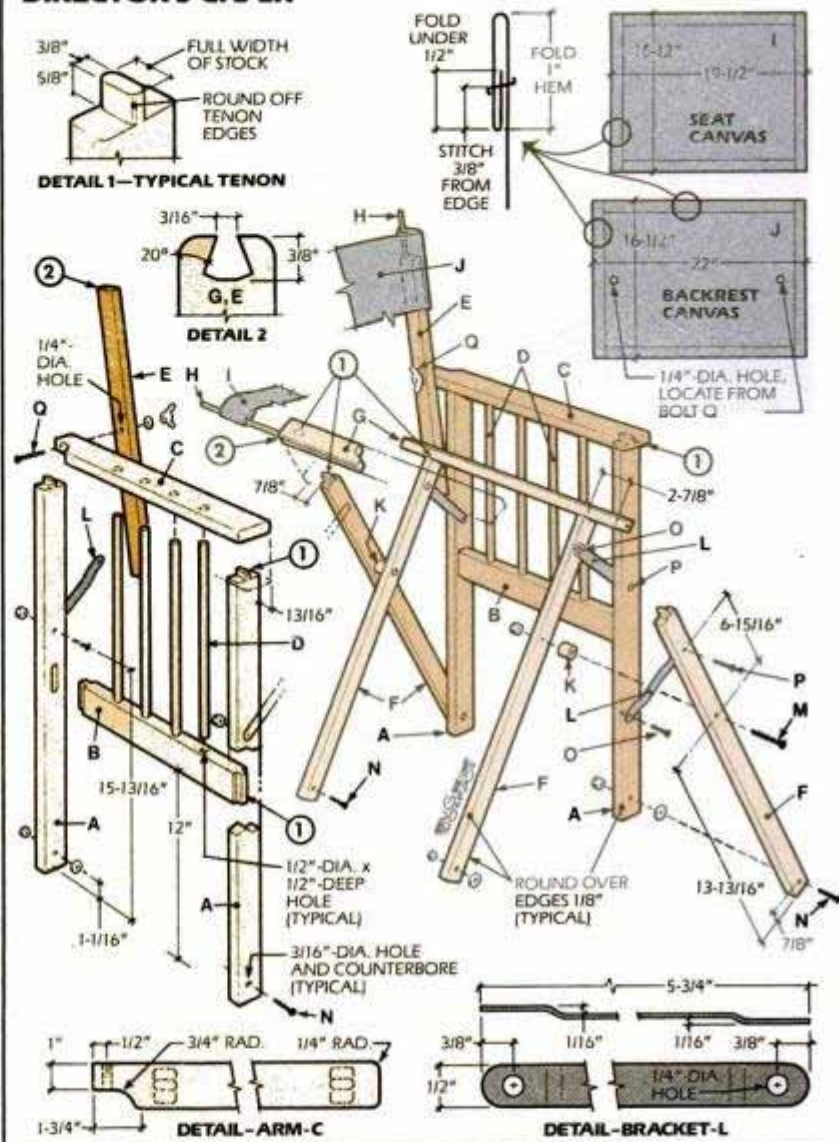

MATERIALS LIST—DIRECTOR'S CHAIR

Key No.	Size and description (use)	Qty	Description
I	19 1/2 x 22 1/2 canvas (seat)	1	
J	19 1/2 x 25 canvas (backrest)	1	
K	3/4-dia. x 1" hardwood dowel (spacer)	2	
L	1/16 x 1/2 x 5 1/4" rolled steel (bracket)	4	
M	10-24 x 3" fh mach. screw, locknut	2	
N	10-24 x 2" fh mach. screw, 1" flat washer, locknut	4	
O	10-24 x 1 1/4" rh mach. screw, locknut	4	
P	10-24 x 1 1/4" fh machine screw, locknut	4	
Q	1/4-20 x 2 1/2" carriage bolt, washer and wingnut	2	
A	4	1 3/16 x 1 1/4 x 26 3/4" oak (leg)	
B	2	1 3/16 x 1 3/4 x 14 1/2" oak (rail)	
C	2	1 3/16 x 1 3/4 x 18 1/2" oak (armrest)	
D	8	1/2-dia. x 13" hardwood dowel	
E	2	1 3/16 x 1 1/4 x 16 3/4" oak (backrest support)	
F	4	1 3/16 x 1 x 25 1/2" oak (crossleg)	
G	2	1 3/16 x 1 1/4 x 18 1/2" oak (seat support)	
H	4	3/16-dia. x 16 1/2" hardwood dowel	

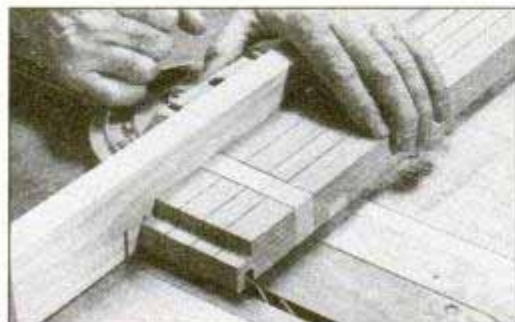

Tape all four legs together and gang-cut to form tenons. Repeated passes over a standard blade will work, or use a dado head.

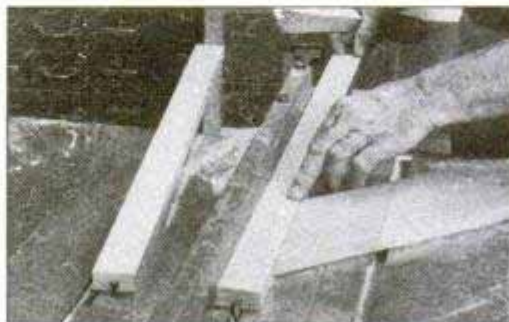

Make two cuts with a 20-degree tilted blade, set 1/2 in. deep, to produce the dovetail groove. A third pass with blade straight completes the cut.

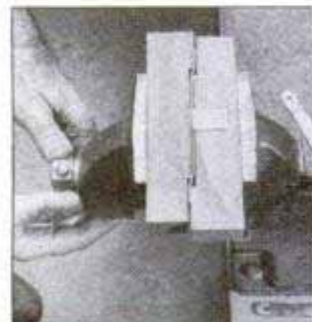

Bend metal brackets to shape with forming blocks and 3/16-in.-thick stepped spacers.

The IBM-compatible NTS/Heath HS-151 PC is included in three training programs.

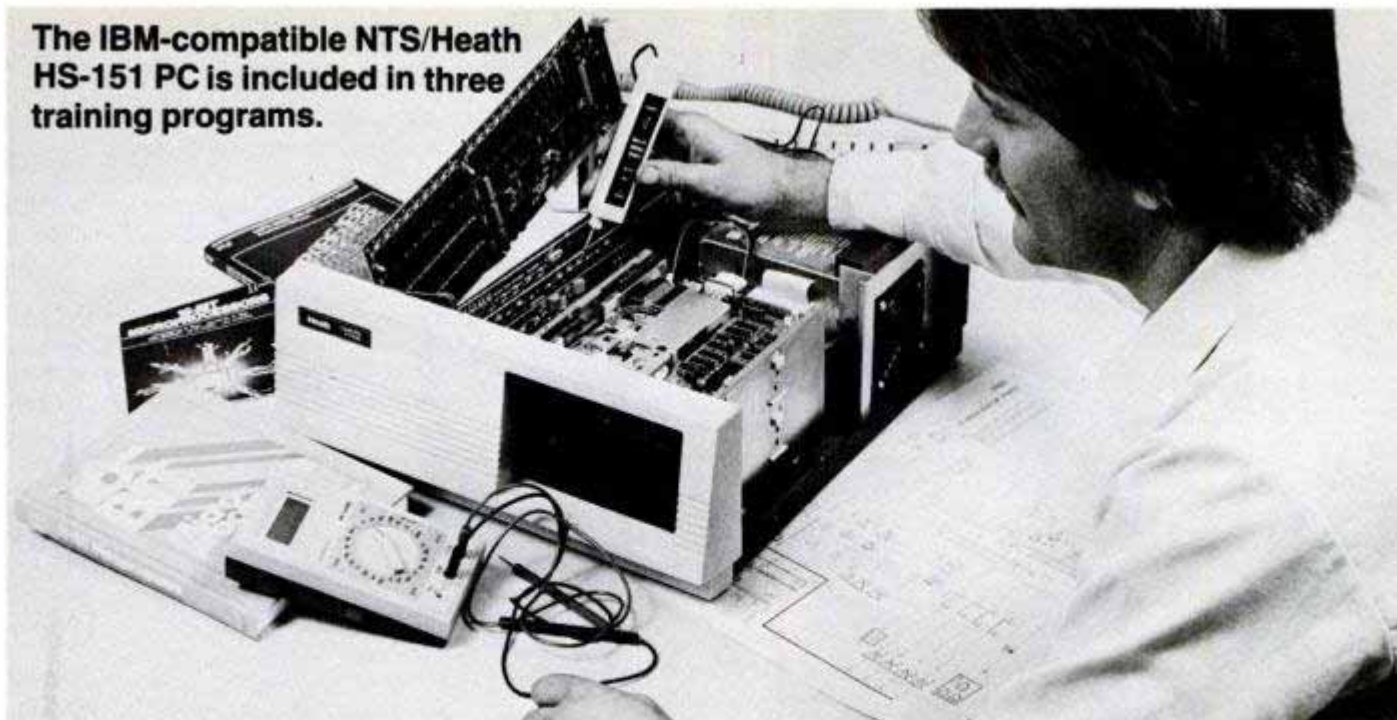

IF YOU WANT TO GET INTO PC SERVICING YOU HAVE TO GET INTO A MICROCOMPUTER

Learn PC Servicing By Building Your Own NTS/HEATH HS-151 Desk-Top Computer

NTS Intronic home training gets you right down into the heart of computer circuitry. Learn how microprocessors function, how they operate and are used to solve problems. Your program includes a wide variety of tests and projects you perform as you build your own PC, circuit board by circuit board unit by unit.

The NTS/HEATH 16-Bit HS-151

This remarkable desk-top PC is the most powerful and versatile ever offered in any home study course. Advanced features include:

- 128 KB RAM user memory, expandable to 640 KB. This power translates into high speed operation,

IBM is a Registered Trademark of International Business Machines Corp. MS is a Registered trademark of Microsoft Corp.

- Two video outputs provide connections for either a color or monochrome video display monitor.
- 16-Bit 8088 microprocessor runs most IBM and MS-DOS software.
- 4 open slots provide for expansion, will accept most peripheral boards designed for IBM PC.

Your NTS training course will teach you how to program on this powerful PC using lessons, texts and diagrams showing you how to make full use of its remarkable capabilities.



NTS Offers Many Additional Courses in Electronics, and other fields:

Robotics: Build the NTS/Heath Hero 1 Robot as you learn robotic programming.

Video Technology: Build the NTS/Heath System 3 advanced Color TV as you learn circuit diagnostics.

TV and Radio Servicing: A specialized course featuring training in both analog and digital test equipment. Learn servicing of monochrome and color TV receivers.

NTS also offers courses in Auto Mechanics, Air Conditioning/Solar Heating, Home Appliances.

If card is missing, write direct to the address below and specify the course in which you are interested. A FREE color catalog will be sent to you by return mail.

NTS NATIONAL TECHNICAL SCHOOLS

TECHNICAL TRADE TRAINING SINCE 1905
Resident and Home-Study Schools

4000 So. Figueroa St., Los Angeles, CA 90037

STUCK?

**STP
UNSTICKS
YOU
FOR LESS
THAN
WD-40***

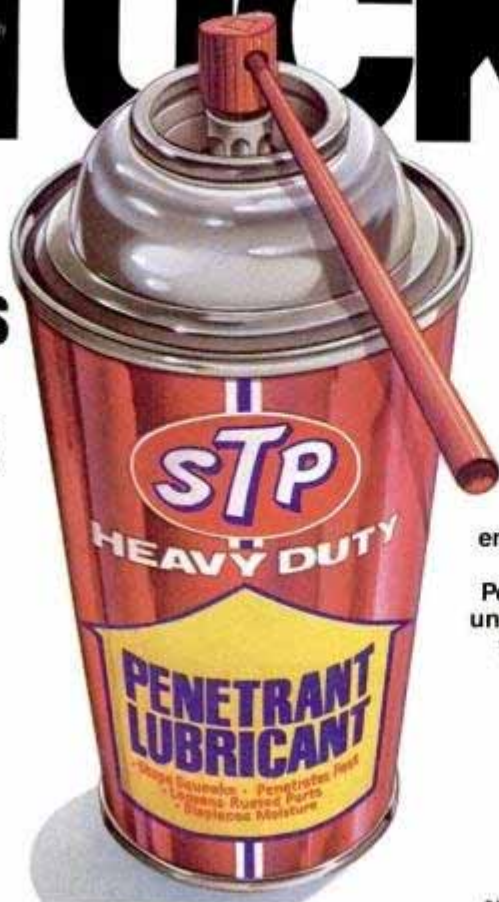

STP® Penetrant Lubricant does everything WD-40 does, but costs less. Use STP on locks, doors, windows, bicycles, fishing reels, and firearms. It even helps wet engines start. When you see that STP Penetrant Lubricant unsticks you for less than WD-40, you'll stick to it.

*WD-40 is a trademark of the WD-40 Co.



© 1985 STP Corporation, Boca Raton, Florida 33431

DRILL PRESS: PART ONE

(Continued from page 103)

slight projection prevents the bit from striking the chisel. Second, be sure that the chisel is square to the fence to avoid an uneven, rough-cut mortise.

Next, outline the mortise on the workpiece. Set the spindle speed to about 1,000 rpm for hardwoods and 2,000 rpm for softwoods. Then, adjust the depth stop and position the fence to accommodate the workpiece. Adjust the hold-down fixture and hold-in rods to secure the work firmly against the table and fence.

Now bore a hole at each end of the outline to establish the mortise length. Apply steady, even pressure with the feed lever. Then, move the workpiece about three-quarters of the chisel width and bore an overlapping hole. Repeat this procedure until all the waste is removed.

Accurate hole boring is only one of the many functions possible with the drill press. In PM's October issue, we'll have more drill press techniques. **PM**



Make this 90° holding device for boring circumference of disks. Position the worktable vertically and bore into the disk edge.



Reposition the worktable horizontally for boring into the face of the disk. Draw centerlines to help bore evenly spaced holes.



Drill through glass using a special spear-point carbide bit. Make a caulking dam to hold a puddle of turpentine lubricant.

Dupli-Color turned Bea into an auto touch-up expert



You can do an expert touch-up job, too. It's easy with Dupli-Color's exact original color match and easy, step-by-step instructions.

Scratch-Fix®—For late model vehicles. Comes with handy Brush-In-Cap applicator.

Auto Spray® Touch-Up—Convenient 5 oz. aerosol can for larger touch-up areas.

Truck & Van Paint—For pickups, vans and RVs. Great for accessories, too.



**FREE
AUTO
TOUCH-UP
GUIDE**

Write: Dupli-Color Products, Box 11,
1601 Nicholas Blvd., Elk Grove Village, IL 60007

DUPLI-COLOR®
AUTO TOUCH-UP PAINT

Spectrum by Whistler. It's the *smartest* radar detector made — anywhere. And we'd like you to test drive one yourself! For a full 30 days! At our risk!



Spectrum. It's a highly sophisticated, uncannily alert and accurate radar detector. It's a *triple conversion, superheterodyne* unit that can spot police radar signals miles away. It can single out a radar gun around curves, beyond hills, from far to the rear. It *alerts* you to trouble, *sniffs out* radar traps, *reminds* you to check your speed — and, ultimately, it could save you from many a speeding ticket (some 8,000,000 citations are handed out yearly on the interstates alone — and they can be pretty expensive "awards").

But a radar detector is no mere electronic toy. It's a valued car accessory for people who have to log a *lot* of mileage on business and to whom posted speed limits — whether 55, 40 or 35 mph — aren't easy to maintain when the car's new, time's tight, and the road is clear. Further, more and more detectors are being bought by, or for, women — whether as commuters themselves or as family chauffeurs.

What Goes Into A Good Radar Detector?

Well, you don't buy one just for styling, color, or even size. What you want is a unit compact enough to clip to a visor or perch on the dash — and fit in a tote bag, a briefcase, or the glove compartment. You want one that's easy to "understand" — that is, you can "get the message" without having to peer at sweep dials or moving bars of light. Spectrum's design/function theory is simple: *you do the driving . . . we'll do the watching.*

Consequently, Spectrum is simplicity itself to use. You have just 2 small light bars — *amber* (caution!) and *red* (warning!). Ditto for the sound. When trouble is far enough off to give

you plenty of time to slow down, you hear some soft low "beeps." But when you're *too close for comfort*, the crescendo of "beeps" let you know it! *For real!*

It's What's Deep Inside That Counts

But all the easy-to-catch signals wouldn't help if your radar detector didn't have both *range* and *reliability*. In engineering parlance, that's called "Sensitivity" and "Selectivity" — *how far* ahead a detector can pick up police band (K and X) signals and *how successfully* it can screen out any and all other microwave signals that create distracting false alarms. Really, it is as simple as that: get the *police signals at the earliest*, get rid of the non-police signals *before* they cry wolf.

Spectrum is a wizard at doing both! **Road & Track** magazine (in its April '85 issue) rates Spectrum #1 and #2 in *K-Band* and *X-Band Sensitivity*, and #1 in that other vital measure of Sensitivity, *Around a Corner*. As a matter of fact, **Road & Track** writes about Spectrum: "Judging by our first few runs, this thing must have an antenna 10 miles wide; it picks up virtually everywhere!"

And Spectrum also has two unique engineering features — *Filter Mode* and *Signal*

Screen — that ensure that non-police signals are ignored yet when you get an *urgent warning*, it's the *real thing!*

Send Today For Spectrum's FREE Test-Drive Information Kit

If you've never owned a radar detector, here's the chance to *test* one without obligation. Take us up on this Special Offer — a 30-day *risk-free trial* of one of the world's best made, best known radar detecting units. *Try it, test it, use it* night and day, rain or shine. If then, after 30 days, you decide you don't *need a detector* or *want Spectrum*, we'll *refund your payment in full!*

Send for our Test-Drive Information Kit today. *No commitment, no obligation!* It covers the way both police radar and radar detectors work...*how* Spectrum is engineered...*why* Spectrum's signals are made so "easy to read."

You'll find out about the *two* models Spectrum offers you: the small, portable 15 ounce Dash/Visor unit or the permanently mounted, and hidden,

"Under-the-Hood" Remote with its miniature console. You'll also learn about the Black & Decker Floodlight/Spotlight (a \$20 retail value) you'll receive as a gift just for agreeing to try Spectrum.

Rush us this coupon. You can't lose — for if you decide to order Spectrum you know it comes with a *100% money-back Guarantee*. Could anything be fairer than that?



Dash Mount or Visor Clip
Plugs into lighter. Instantly removable for storage in glove compartment.



"Under-the-Hood" Remote
Detector hides behind car grille. Tiny signal box fits under dash.

SPECTRUM WHISTLER Radar Detector

472 Amherst Street, Dept. 31A85
Nashua, N.H. 03063
(603) 886-1310

Please RUSH my free Test-Drive Information Kit (including details of Spectrum's Special Offer and Bonus Gift).

Name _____
Address _____
City _____
State _____ Zip _____

MIGHTY LIFT!™

Gas Filled Lift Supports

\$2.00 Rebate Offer

Mighty Lift! is your money saving solution to the problem of sagging and weak trunk, hatch, and hood lift supports. Gas filled lift supports are available for almost any domestic or imported car. They are economically priced, easy to install with our step-by-step instructions, and covered by the only "Lifetime Warranty" available. **Mighty Lift!** gas filled lift supports are American made to exacting standards — even better than the original — to insure strength, quality, and dependability.

For your \$2.00 rebate, clip this ad and send it to: Motor-mite Mfg. Div. R&B Inc., Dept. MLR 2695 Philmont Ave., Huntingdon Valley, PA 19006. Be sure to enclose with this ad a stamped self addressed, envelope along with date and place of purchase and appropriate proof-of-purchase (proof-of-purchase = sales slip & part number from top of Mighty Lift! card). Offer expires Nov. 30, 1985.

Save Money and lift your spirits while we lift your hatchback, hood, trunk, and camper cap.



*Limited Lifetime Warranty - consult product package for full details.

©R&B Inc. 1985 2PM

UNDERWATER VIDEO

(Continued from page 88)

Besides these performance advantages, videotape is economical and practical. A single tape can record many times longer than the three minutes possible on a roll of Super 8 movie film—and there's no development costs. You can review what you've recorded—on location—and erase and reshoot if need be.

Owners of Videomovie and Betamovie camcorders (one-piece combination videocamera/recorders) who enjoy snorkeling or shallow-water scuba can take the simple approach. Watertight

black and white viewfinders on video-cameras give you no indication of color quality. Moreover, they're tough to eyeball through a diving mask, regardless of whether you're using a solid or soft enclosure.

Setting focus

Fortunately, it's possible to shoot acceptable underwater movies without using the camera's or camcorder's viewfinder. Set the lens at its maximum wide-angle setting, focus at infinity and simply aim the camera at the desired subject (with the EWA bags, sight along the sealing rail on top). It only takes a little practice to figure out how much of

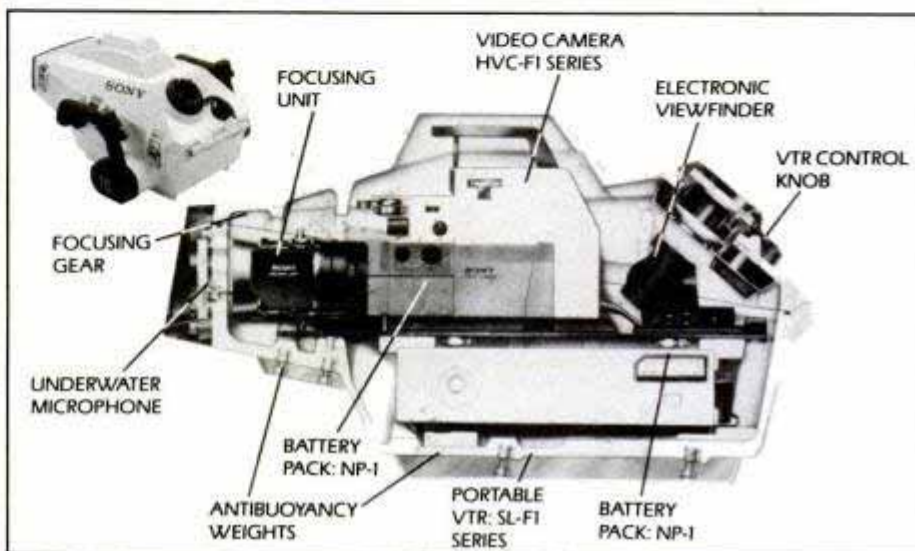

Sony's deep-diving MPK-60 houses a color monitor, separate camera and video recorder.

plastic bags, such as the ones from EWA-Marine used for this article, will keep the camcorder safe and dry while allowing access to the most used controls. These bags, available from Pioneer & Co., Westmont, N.J., cost less than \$200—little compared to the \$1,500 or so you've invested in a camcorder. They're designed to remain watertight down to 100 feet, but divers should limit their use to 25 feet or less. This is because the soft bag can't protect the camcorder from the crushing pressure of greater depths.

For deeper waters

Those who want to venture deeper should look into the variety of solid plexiglass and fiberglass housings offered by companies including Ikelite, Jay-Mar, Nekton and Sony. These are made from fiberglass or plexiglass and range in price from several hundred dollars to \$3,000 for Sony's MPK-60. Housings come in a variety of configurations. Some handle camcorders, others are designed to contain a separate videocamera and portable VCR. More elaborate rigs, like the Sony, even accommodate a small color TV monitor that shows you what the camera is picking up. Why a TV? Because the tiny,

the underwater scene will wind up on the videotape.

Water magnifies objects by about a third, so even with the lens set on infinity, everything beyond just a few feet from the lens will be in sharp focus. By the way, autofocus camera systems are impractical underwater—and can't be used at all with the bag-type enclosures. So, if you have an autofocus camera, be sure to set the focus switch to manual.

Color balancing

Part of the challenge of underwater videography is catching the remarkable colors of sea creatures. Unfortunately, water itself selectively filters the color out of sunlight. Yellows and reds disappear first, starting to weaken at around 20 feet, while greens and blues linger on to much greater depths. This is why so many underwater movies have a blue-green cast.

This "blue movie" effect isn't a problem for snorkelers, because video-cameras compensate electronically for the composition of light. Scuba divers plumbing deeper waters might want to use with lense filters or artificial lights.

Even on dry land, videocameras usually have to be "white balanced" by

aiming briefly at a white object before shooting.

For underwater shoots, it's easiest to white balance the camera while standing in shallow water. Hold the enclosed camera underwater, aim it at a patch of white sand or other white object and press the white balance button for a few seconds (a viewfinder indication will confirm that it is set).

In clear water on a sunny day, a color-balanced camera should have no trouble making bright pictures down to about 30 feet. Below this depth, the addition of red filters (available at photo stores) might help counteract the preponderance of blues and greens—though no filter can restore light wavelengths that already have been removed by the water.

Deep-water videographers sometimes use artificial lights to bring out color at greater depths. The EWA-Marine bags don't have an attachment for lights, but most solid housings do.

Plan your dive

The chances of emerging from the drink with a splendid tape are improved if you get used to your gear beforehand. With solid housings, practice manipulating the external controls for camera and recorder. In the case of waterproof bags, adjust for buoyancy.

During our shoot in Florida's Homosassa Springs, we learned that it's necessary to add weights to the EWA-Marine bag. The weights compensate for trapped air that makes the camera difficult to hold steady.

As for the quality of your video production, Ikelite video expert David Combs says "Plan your dive and dive your plan"—a diver's maxim that applies equally well to moviemaking.

"Don't just shoot everything that moves," advises Combs. Though it's easy, back at home, to transfer the best scenes from the camcorder to a tape in another VCR, Combs notes that with a little planning you can shoot a tape that won't need editing.

Leisurely movements

For the sake of your viewers, keep all camera movements as leisurely as possible, and make each shot last long enough for the viewers to become oriented to the scene. The actions and reactions of people underwater are among the more interesting aspects of an underwater video. Just make sure your subjects face the camera: Shots of flippers have limited appeal.

This means you'll have to plan some scenes ahead of time and coach the actors on what they should do. Let the aquatic creatures supply the spontaneity: They don't take well to coaching anyway, but make up for it by adding fascination to your movie. **PM**

For BETTER ENGINE PROTECTION and IMPROVED PERFORMANCE

RISLONE and RISLONE CONCENTRATE keep internal engine parts clean and free of the power-robbing deposits of varnish, gum and sludge.

ADD ANYTIME...15 oz. Rislone Concentrate is especially designed for adding between oil changes.

At OIL CHANGE TIME...or when you're down a quart use Rislone in the big quart can.

Send a stamped, self-addressed envelope for your free Lube Tips booklet



THE SHALER COMPANY • BOX 471
WAUPUN, WI 53963

\$12 AN HOUR
YOU CAN EARN UP TO THAT AMOUNT

Start Your Own Business!
Earn Extra Income Right At Home.



Sharpen Saws...
... ALL Garden and shop tools for home and industry

Get In On The Profits!

Yes there's plenty of business waiting for the man who can professionally sharpen saws and all types of edge-cutting tools. SHARP-All does them all, and at big profit for you. No inventory is involved... no selling. You earn a year-round Cash income and make 90% profit out of every dollar you take in. Work sparetime hours or fulltime right at home, and no experience is needed.

Send TODAY for details of our 30-Day FREE Trial Offer!



With SHARP-ALL It's Easy To Get Started!

You don't need to invest thousands of dollars to get started in business for yourself. Low cost Sharp-All and our 50 years of experience in helping sincere men to earn extra income, plus the desire to get ahead is all you need. Complete Operators Manual gives clear, step-by-step instructions, shows exactly how to sharpen each tool, where to get the "tricks of the trade". And Sharp-All does the kind of precision job that brings customers back time after time.

There are NO franchise fees of any kind. With Sharp-All YOU are the boss... YOU set the hours you want to work... you put the profits in YOUR pocket.

FREE BOOKLET!
Send for your copy today. No obligation.

LIFETIME SECURITY
with YOUR OWN BUSINESS

If coupon has been removed, just send us a postcard with your name and address to—



FOLEY-BELSAW CO.
60494 FIELD BLDG.
KANSAS CITY, MO. 64111

There is NO OBLIGATION and NO SALESMAN Will Call!



FOLEY-BELSAW CO.
60494 FIELD BLDG.
KANSAS CITY, MO. 64111

RUSH COUPON TODAY!

YES, please send me the FREE booklet "Lifetime Security" and full details on your 30-Day Free Trial Offer. I understand there is No Obligation and that No Salesman will call on me.

FREE BOOK

NAME _____

ADDRESS _____

CITY/STATE _____

ZIP _____

SUMMER SWINGING

(Continued from page 95)

into the seat supports. Unclamp the back supports and countersink and bore clearance holes for 2-in. No. 12 screws.

Cut the armrests and armrest posts

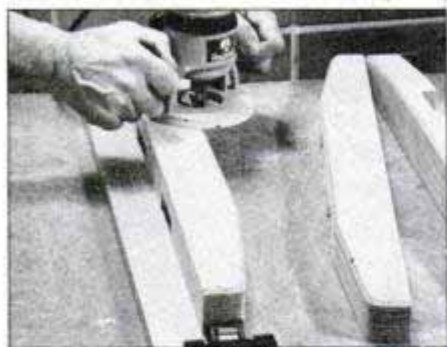

7 Chamfer the edges of the glider frame parts prior to final assembly using a router fitted with a 45° chamfering bit.



8 Assemble the glider frame with plastic resin glue and screws. Be sure to prebore screw pilot and 1/2-in.-dia. plug holes.



11 Before making second cut, reposition rear guide block. Tape markers on fence and jig base indicate when to stop cutting.

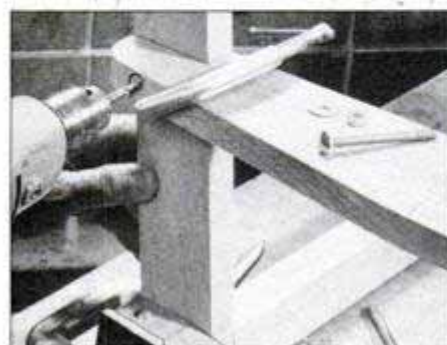

14 After counterboring the bolt location on the armrest, clamp armrest to seat-back support and bore a bolt-clearance hole.

to size. Counterbore the rear end of the armrests and then bore 5/16-in.-dia. carriage bolt clearance holes. Clamp the armrests and posts to the seat frame and continue the bolt-clearance holes through the seat-back supports. Bore screw pilot holes through each armrest and into the posts. Now disassemble the parts and chamfer the lower edge of the front seat rail, armrest posts and top edges of the armrests. Sand all parts with 120-grit abrasive paper.

Next, glue and bolt the seat frame together. Then, glue and screw the seat-back supports and armrest posts to the seat supports. Attach a small oak block (U) to the inside surface of the left and right seat-back supports to provide a nailing surface for the short seat slat located between the armrests. Don't install the armrests until all the seat slats have been nailed in place.

Now cut 5/8-in.-dia. plugs from a

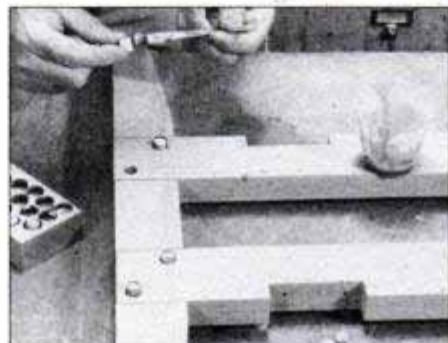

9 Glue oak plugs into counterbored screw locations to conceal the screwheads. Sand the plugs flush after the glue dries.

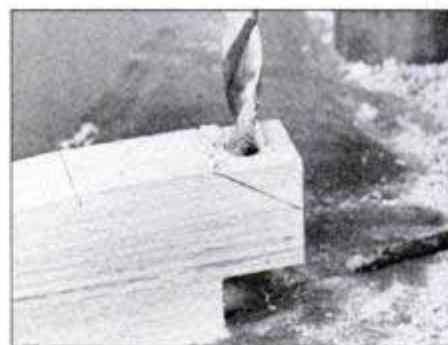

12 Counterbore carriage bolt location in the front end of seat supports before cutting the angle. Then, bore bolt-clearance holes.



15 Cut an angled plug to conceal the bolt at seat supports' front end and to provide a solid nailing surface for the seat slat.

hardwood dowel to conceal the carriage-bolt heads at the seat-support/front-seat rail connection. Before gluing the plugs in place, cut them to a 35° angle to match the seat-support profile. Next, rip the seat slats from 1/2-in.-thick stock. Chamfer the top edges of each slat and sand them thoroughly to prevent splintering. Note that the uppermost seat slat located on top of the back supports is beveled along the front edge to fit tightly against the next slat. Fasten the slats to the seat frame with glue and 3d finishing nails. Be sure to bore pilot holes to prevent splitting.

Set the nails and fill the holes with wood putty. Finish-sand the seat and glider frame before applying an exterior stain or varnish. Finally, when the finish has dried thoroughly, install the screw eyes and eyebolts and hang the seat from four lengths of double-loop swing chain. **PM**

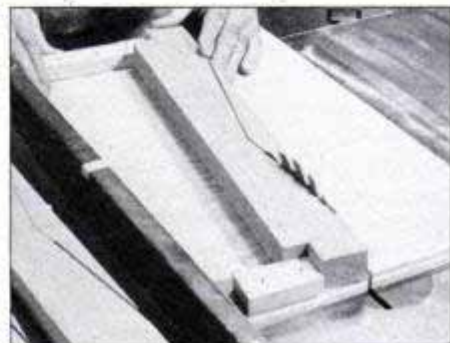

10 Use this simple jig to cut the depression in the seat supports. Maximum blade elevation reduces the undercut kerf length.

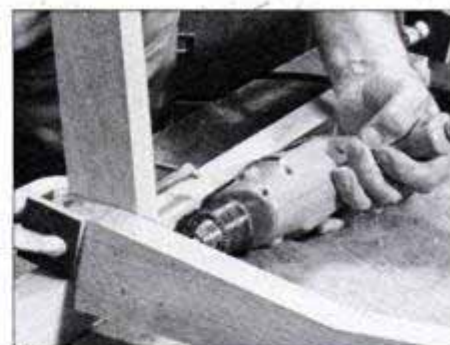

13 Clamp vertical seat-back members to the seat supports to permit boring pilot holes for 2-in. No. 12 flathead screws.



16 Insert 1/2-in.-thick spacer blocks between the seat slats to ensure even spacing. Set nails and fill the holes with putty.



**GET THE BEST
OF BAD WEATHER.
FIGHT BACK.
MAKE IT EAGLE.**

A dark sky and threatening forecast is enough to humble the greatest drivers among us. At times like these you need an automobile like Eagle.

With the simple flick of a switch, Eagle gives you the confidence and security of 4-wheel drive. You can even "shift-on-the-fly," which is a luxury you shouldn't be without

when faced with a sudden shower, blizzard or stretch of bad road.

Of course, security isn't the only luxury you'll enjoy in an Eagle, with features available like power windows and door locks, cruise control, 6-way power seats and plush carpeting.

The American Eagle. It's the best thing going for you when you're going in bad weather.



EAGLE  **THE 2-WHEEL /4-WHEEL DRIVE SECURITY SYSTEM**

AVAILABLE FOR PURCHASE OR LEASE AT PARTICIPATING AMC DEALERS

Матеріал SAFETY BELTS SAVE LIVES  AMC

INTRO THE NEW G THE ARMY COL AN INVITATION TO AND CAPTURE UP TO



Starting July 1st, the Army has two new educational programs that could enrich your finances as well as your mind.

If you have plans for college, these programs can change the way you plan to pay; and if you hadn't planned on going, they could change your plans completely.

They're called the New GI Bill Plus the New Army College Fund. And if you think the titles are big, wait'll you see the benefits.

MONEY FOR COLLEGE

With the New GI Bill Plus the New Army College Fund, you can earn up to \$25,200 while you serve. Here's how:

First, you contribute to your education—



\$100 per month for the first twelve months of your enlistment.

Then the government contributes—up to \$9,600. That's what the New GI Bill's really all about.

Then the Army contributes up to \$14,400—courtesy of the New Army College Fund.

Of course, how much you save depends on how long you serve and the specialty you qualify for; right now, there are over 80 specialties that entitle you to benefit from both programs. For maximum returns, see the chart.

YEARS	NEW GI BILL	THE NEW GI BILL PLUS THE NEW ACF
2	\$9,000	\$17,000
3	\$10,800	\$22,800
4	\$10,800	\$25,200

GET AN EDUCATION BEFORE YOU GET TO COLLEGE
It's called the Army experience. And with

REDUCING THE GI BILL PLUS THE NEW ARMY COLLEGE FUND. SERVE YOUR COUNTRY \$25,200 FOR COLLEGE.



every sunrise run and field exercise, night patrol and pat on the back, you'll learn about the kinds of things no one can put a price on: self-reliance and discipline. Team-

work and pride.

THE REWARDS OF BEING A SOLDIER

They go far beyond the chance to earn money for college. And include the opportunity to serve your country.

As well as the opportunity to see it—and perhaps other countries, too. For as a soldier, you'll have the chance to travel; to meet people, make new friends and visit places you may never have thought you'd see.

You'll also have the opportunity to grow before you attend college. So that you can get the most out of it when you decide to go.

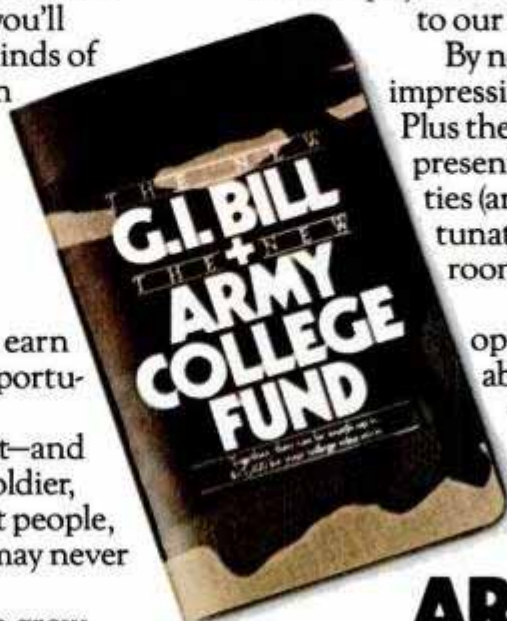

Plus, there's the opportunity to get into the best physical shape of your life—thanks to our Physical Training program.

By now you may be getting the impression that the New GI Bill Plus the New Army College Fund present all kinds of opportunities (and you're right); unfortunately, there isn't all kinds of room left to describe them.

So if you'd like the opportunity to learn more about our opportunities, visit your local Army Recruiter. Or call, toll free, 1-800-USA-ARMY.

ARMY. BE ALL YOU CAN BE.

POCKET ROCKETS

(Continued from page 79)

it's actually built in Pennsylvania.

At the track, the Golf was next to last in acceleration, and middle-of-the-pack everywhere but on the skidpad. There, it managed to understeer its way to a remarkable .88g, the fastest skidpad run we've ever seen in our years of road testing. All credit to Volkswagen's engineers and Goodyear's 185/60HR14 Eagle GT tires.

Our testers were not so impressed with VW's stylists. The brand-new exterior styling was castigated as

"straight from the '70s—terribly dated" and "homely and ungainly." The best we can say about this model is that, unlike some more trendy cars, the Golf won't quickly go out of style. It's already old-fashioned!

Our group also complained about the interior styling, particularly a row of fake switches on the dash and the unskilled use of plastic. The seats were applauded as "firm, supportive and attractive," while everybody liked the Scirocco steering wheel.

Overall, the GTI struck us as a mildly overpriced economy car with above-average performance. Engine mainte-

nance is the simplest in this group—there are no complicated electronics or turbocharger to go wrong—the car is comfortable and quiet.

Toyota Corolla GT-S

This car uses the same 112-hp, fuel-injected, double-overhead cam, 16-valve engine we loved in the MR2 two-seater tested last month, and weighs 50 pounds less. But it was .7 second and 4 mph slower at the dragstrip, and returned 2 mpg less, though the EPA figure is identical. We'd have to conclude that our particular Corolla was feeling a little ill, though it sure acted perky enough.

To achieve this perkiness, the GT-S works its little engine unmercifully. The tachometer registered 4,000 to 4,500 rpm at highway speeds, and the engine was always howling. You have to keep the revs up to achieve reasonable performance, which means the Toyota Corolla's engine, gearbox and differential were all at full cry. There was also a lot of wind noise.

At the track, the GT-S was neither fast nor slow. Its neutrally balanced front-engine/rear-drive chassis did not handle as well as the front-wheel-drive cars. Some of the blame can be laid to the Dunlop SP Sports D87J 185/60R14 tires, which generated much higher slip angles than the Eagle GTs and quickly lost all grip when hot. Surprisingly for the only car in the group with four-wheel disc brakes, the braking distances were very long.

At \$11,200, the Corolla was the second most expensive Pocket Rocket, but it didn't feel it. As one tester summed up: "The GT-S is sporty and has civilized road manners. It's lots of fun to fling around. But it's too noisy and uncomfortable. I'll bet if you owned it, you'd get tired of it real fast."

Honda Civic S

"A very nice car, but doesn't belong in this test." Right. What the 76-hp Civic S needs is the 91-hp fuel-injected engine from the CRX Si, which would subtract about 1.5 seconds from the quarter-mile times and add 10 mph. That would be a Pocket Rocket.

The fuel-injected Civic S is sold in Europe right now, and in Japan you can get a rip-snortin' 135-hp twin-cam 16-valve engine in both the Civic and CRX. We can only hope that Honda will be smart enough to bring one of these engines to the States. At the same time, they should fit something sportier than 175/70R13 Michelin MXL tires.

Otherwise, the Civic S is already a front-runner. The exterior styling is superb, even prettier than the CRX. It's modern, efficient and without flaw. As our resident artist said, "This is a great design. Honda could use it for many

What cleans a dirty carburetor instantly? You just put your finger on it.

Gumout® Jet Spray is America's best-selling carb cleaner, number one with do-it-yourselfers and professionals alike. Cleans instantly, on contact—carburetor throats, barrels, ports, jets, linkages and more.

Nothing cleans faster, better or more professionally than Gumout Jet Spray. Available in 5 oz., 13 oz., and new 19 oz. sizes.

GET YOUR HANDS ON SOME.

A Quality Product of the Penzoil Company

years without change. There's nothing that could be improved."

Our testers were just as enthusiastic about the interior. Fit and finish is fantastic, and the ergonomics are unsurpassed: Huge gauges, wonderful controls and lots of room make this a great driver's environment. The seats need more lumbar support, but that's our only complaint.

We had nothing but praise for the user-friendly steering, brakes, shifter and handling. The Civic is fun to drive hard, and totally without vice. This car is just terrific in every way, and it costs \$1,000 to \$4,000 less than the other cars in the group. Give it more engine and high-performance tires and there'd be no four-seater to touch it for less than \$15,000.

Pontiac Sunbird Turbo

We had high hopes for the ultimate J-car, but we were disappointed. At \$12,400, the Sunbird Turbo is substantially more expensive than the cars that beat it, not to mention more powerful, larger and heavier all-around. Yet the Sunbird interior was the most cramped, except for the tiny Corolla, and the car was mediocre at the track.

Despite excellent 205/60R14 Eagle GT tires, the Sunbird was last in transient handling through the slalom, last in braking and middle-of-the-pack at everything else. The car has terminal understeer, and plows like a John Deere.

Everything about the Sunbird is user unfriendly. The cable-operated shifter is stiff and uncooperative, the engine is balky, the steering is slow and numb and the brakes are soft. Severe torque steer under acceleration wants to wrest the wheel from your hands, and the handling is twitchy. Even the seats are uncomfortable, and there's not enough headroom.

We liked the engine's straight-line performance, we thought the fit and finish was much better than GM's previous level and we found the interior commendably quiet. But the J-car needs a complete redesign. Summed up one unhappy tester: "This car is no fun at all to drive, and that means it's no Pocket Rocket."

Conclusion

On the road, it's a tossup between the ultramodern Mitsubishi and the old-fashioned but fun Dodge. Factor in its blistering track performance and the Omni GLH Turbo pulls ahead. The Honda and VW are both outstanding small family cars that are fun to drive—they just don't have enough *oomph* to make it in the Pocket Rocket category. The Toyota Corolla and Pontiac Sunbird struck us as flashy kid stuff—all noise and no substance. **PM**

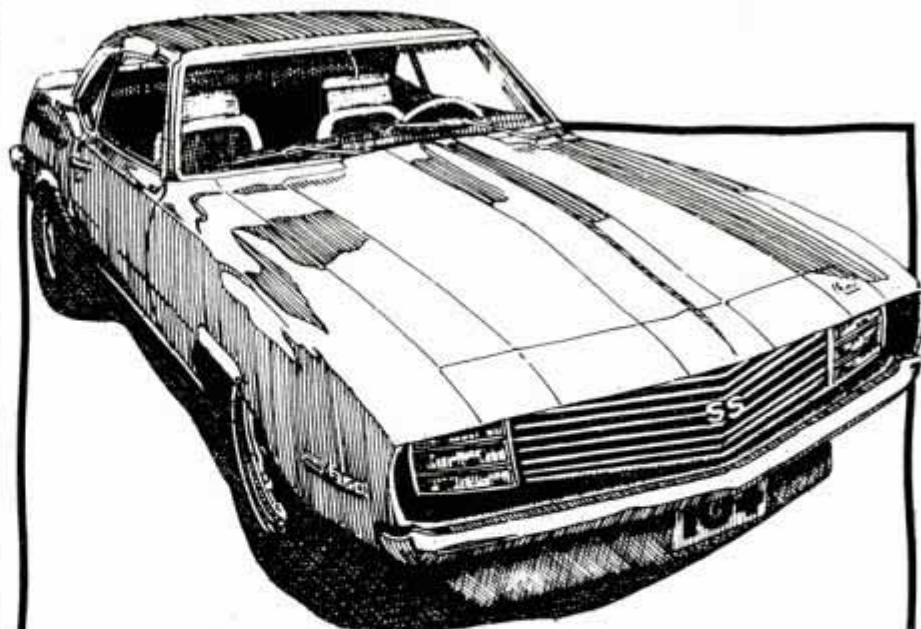

+16.1% HORSEPOWER!

That's what this '69 Camaro got from 104+ Octane Boost. Chassis dynamometer tests showed just one 12-ounce can of 104+ charged up its SS 350 engine by a cool 16.1%!

But 104+ does more than increase HP. It also cleans fuel lines, carburetors, and injection systems. Eliminates harmful knocks and pings. And provides cleaner, cooler, smoother performance.

Plus, 104+ contains no lead, no alcohol, and no dangerous chemicals like xylene, MTBE, aniline or toluene.

104+ for street machines. Super 104+ for extra high compression racing engines.

Powerful solutions!



Order Direct:

"KICKGAS" T-shirt
104+ logo on bright yellow
50/50 polyester/cotton
Sizes S, M, L, XL—\$6.



Powerful Solutions.

OCTANE BOOST CORPORATION
Box 271148
Dallas, Texas 75227





88K *Lowest Price In The USA!* 152K

Computer System Sale

• Students • Word Processing • Home • Business

88K System \$449
152K System \$499*



EDUCATE WITH ATARI



¹ **Rated "Best Buy" by Consumers Digest Buyers Guide, January 1985**

LOOK AT ALL YOU GET FOR ONLY

\$449
SYSTEM PRICE

- Atari 800XL 88K Computer
- Atari 1050 127K Disk Drive
- Atari 1027 Letter Quality 20 CPS Printer
- Atari Writer Word Processor
- Atari BASIC Tutorial Manual

All connecting cables & T.V. interface included.
Monitors sold separately.

LIST PRICE

INDIVIDUAL
SALE PRICE

\$179.00

\$109⁰⁰

299.00

199⁰⁰

299.00

199⁰⁰

59.95

39⁹⁵

16.95

12⁹⁵

TOTALS

\$852.90

\$559.90

SAVE \$100
All 5 ONLY

\$449⁰⁰

SYSTEM
SALE PRICE

152K SYSTEM
\$499⁰⁰

Other Accessories

- 12" Hi Resolution Green or Amber Screen Monitor
- 13" Hi Resolution Color Monitor
- * ATARI 130XE 152K Computer

List

Sale

Add \$9.95 for
Connection Cables
(Monitors Only)
(Ltd. Qty)

\$199.00

69.95

Add \$10 for UPS

\$399.00

169.95

\$249.00

159.00

15 DAY FREE TRIAL. We give you 15 days to try out this ATARI COMPUTER SYSTEM!! If it doesn't meet your expectations, just send it back to us prepaid and we will refund your purchase price!! **90 DAY IMMEDIATE REPLACEMENT WARRANTY.** If any of the ATARI COMPUTER SYSTEM equipment or programs fail due to faulty workmanship or material within 90 days of purchase we will replace it IMMEDIATELY with no service charge!!

Best Prices • Over 1000 Programs and 500 Accessories Available • Best Service
• One Day Express Mail • Programming Knowledge • Technical Support

Add \$25.00 for shipping and handling!!

Enclose Cashiers Check, Money Order or Personal Check. Allow 14 days for delivery. 2 to 7 days for phone orders. 1 day express mail! We accept Visa and MasterCard. We ship C.O.D. to continental U.S. addresses only. Add \$10 more if C.O.D.

COMPUTER DIRECT

We Love Our Customers

22292 N. Pepper Rd., Barrington, Ill. 60010

312/382-5050 to order



Commodore 64 Accessories



SUPER



Summer Sizzler Sale

Sale Positively Ends 9-10-85

Prices will go back to regular sale prices

C128 Commodore Computer

Expandable to 512K, runs C-64, CPM, and 7.0 Programs.
(Add \$10 Shipping)

List \$349⁰⁰

Reg. Sale Price \$299⁰⁰

Summer Sizzler Sale

\$289⁹⁵*

15 1/2" Commodore 150-170 CPS Printer

Near Letter Quality, Multiple Pin Tractor / Friction Feed.
Best Printer Value in U.S.A. (Add \$17.50 Shipping)

List \$895⁰⁰

Reg. Sale Price \$299⁰⁰

\$249⁹⁵*

Commodore-64 IEEE Interface

Allows you to run Pet Peripherals on the C-64, including the
One Megabyte Disk Drive and 15 1/2" Printer

List \$109⁹⁵

Reg. Sale Price \$69⁰⁰

\$65⁹⁵

Juki Printer/Typewriter

Letter Quality, daisy wheel, use as typewriter and/or printer
(auto correction) (Add \$10 Shipping)

List \$349⁰⁰

Reg. Sale Price \$249⁰⁰

\$229⁹⁵*

SCM 80 CPS Printer

Tractor / Friction 10" Famous Name Printer does Graphics
w/Interface. (Add \$10 Shipping)

List \$299⁰⁰

Reg. Sale Price \$159⁰⁰

\$149⁹⁵*

Cardco G Plus Interface

Converts Commodore to centronics for use with most printers, plus
does Commodore graphics on graphic printers

List \$109⁰⁰

Reg. Sale Price \$59⁰⁰

\$49⁹⁵

Alphacom 40 Column Printer

Thermal technology - does graphics. (Add \$10 Shipping)
Alphacom C-64 or Atari Interface \$8.95.

List \$99⁰⁰

Reg. Sale Price \$24⁹⁵

\$22⁹⁵

190K Slim-Line Disk Drive

Cooler, 20% faster, quieter than 1541 drive (Add \$10 Shipping)

List \$249⁰⁰

Reg. Sale Price \$169⁰⁰

\$139⁹⁵*

One Megabyte Disk Drive (1000K)

Double sided drive hooks up to C-64 with IEEE interface, perfect as a
second drive. (Add \$10 Shipping)

List \$889⁰⁰

Reg. Sale Price \$199⁰⁰

\$179⁹⁵*

13" Premium Quality Color Monitor

Better than 1702, with separated video inputs. (Add \$14.50 Shipping)

List \$399⁰⁰

Reg. Sale Price \$199⁰⁰

\$169⁹⁵*

Voice Synthesizer

Allows you to talk through your computer. Optional software lets
you play talking adventure games (Zork, etc.)

List \$89⁰⁰

Reg. Sale Price \$49⁰⁰

\$39⁹⁵

80 Column Board - 4 Slot Expander

Allows you to program in 80 columns, plus gives you a 4 slot switch
selectable expander

List \$149⁰⁰

Reg. Sale Price \$79⁰⁰

\$59⁹⁵

Auto Dial Modem with Super Smart Software

Upload, Download, Print, Catalog, This Package has it all!!!
Best Modem Value in the U.S.A.!!

List \$129⁹⁵

Reg. Sale Price \$59⁰⁰

\$39⁹⁵

Musicalc I Software

The Best Musical Software for the C-64, allows you to change all
parameters.

List \$59⁹⁵

Reg. Sale Price \$29⁹⁵

\$14⁹⁵

Oil Barrons Software

Better than Monopoly, comes with game board, disks and
instruction manual, Strike Oil or Live in the Poor Farm

List \$49⁹⁵

Reg. Sale Price \$19⁹⁵

\$9⁹⁵

* plus Software Coupon Discounts

Add \$3.00 for shipping, handling and insurance. Illinois residents
please add 6% tax. Add \$6.00 for CANADA, PUERTO RICO, HAWAII,
ALASKA, APO-FPO orders. Canadian orders must be in U.S. dollars.
WE DO NOT EXPORT TO OTHER COUNTRIES, EXCEPT CANADA.

Enclose Cashiers Check, Money Order or Personal Check. Allow 14
days for delivery, 2 to 7 days for phone orders, 1 day express mail!

VISA — MASTER CARD — C.O.D.

No C.O.D. to Canada, APO-FPO

PROTECTO

We Love Our Customers

22292 N. Pepper Rd., Barrington, Illinois 60010

312/382-5244 to order

DO-IT-YOURSELF KITS

BUILD YOUR OWN GRANDFATHER CLOCK



Prices Starting **\$280**
Under (including movement and dial)

- Do-it-yourself case kit, parts pre-cut
- Finished clocks
- Solid 3/4" hardwoods: black walnut, cherry, oak
- Heirloom quality
- Factory direct prices
- Solid brass West German chiming movements
- Money back guarantee
- Prompt shipment
- No woodworking experience necessary

WRITE FOR FREE COLOR CATALOG



EMPEROR CLOCK COMPANY

WORLD'S LARGEST MANUFACTURER OF GRANDFATHER CLOCKS

Dept. 1611, Emperor Industrial Park
Fairhope, Alabama 36532 • Phone 1-205-928-2316

I am interested in Do-It-Yourself Kits Finished Clocks

Name _____

Street _____

City _____

State _____ Zip _____

(please print)

ALL-AMERICAN FENCES

(Continued from page 99)

as choosing decay-resistant wood. If your posts have dadoed or mortised joints cut before installation, leveling posts so that joints line up as discussed below is also important. If posts and rails have mortise and tenons or other interlocking joints, the parts must be joined before the posts are set. Otherwise, posts are normally set first and rails are installed later.

Posts can be set in earth or in concrete. Where the soil is loose and sandy, it is best to use concrete. However, use concrete only in frost-free areas or in situations where the post will be set below the frost line. Generally, set one-third of the post height in the ground.

First, set the corner posts. Whether

you set a post in gravel or in concrete, dig the post hole 4 to 6 in. deeper than the post will be set to allow for drainage material—a large, flat stone or gravel. Flare the hole at the bottom for good support. Pour the drainage material into the hole. Then stand the post in place.

If you plan to set the post in earth, fill in with 6 in. of gravel and carefully tamp down the material. Then fill in the hole with excavated soil several inches at a time and tamp each layer. Use a spirit level positioned vertically on two adjacent sides of the post to make certain the post is plumb in both dimensions. As you approach ground level, add a layer of rocks to increase stability. Build a tamped earth slope up above ground level so that rain will run away from the post.

If you set the post in concrete, first

Planer Molder Saw

3 Power TOOLS in 1



Now you can use this ONE power-feed shop to turn rough lumber into moldings, trim, flooring, furniture—ALL popular patterns. RIP-PLANE-MOLD . . . separately or all at once with a single motor. Low Cost . . . You can own this power tool for only \$50 down.

30-Day FREE Trial! SEND FOR NO OBLIGATION—NO SALESMAN WILL CALL

RUSH COUPON TODAY!

FOLEY-BELSAW CO.
90689 FIELD BLDG.
KANSAS CITY, MO. 64111



Foley-Belsaw Co.
90689 Field Bldg.
Kansas City, Mo. 64111

YES Please send me complete facts about PLANER—MOLDER—SAW and details about 30-day trial offer.

Name _____

Address _____

City _____

State _____ Zip _____

BOARD AND BOARD FENCE

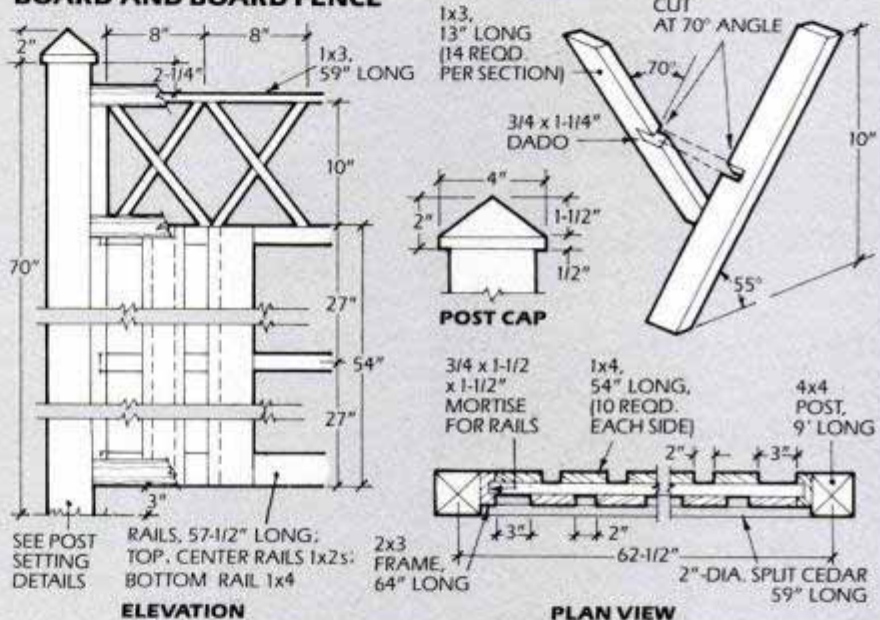

PICKET FENCE

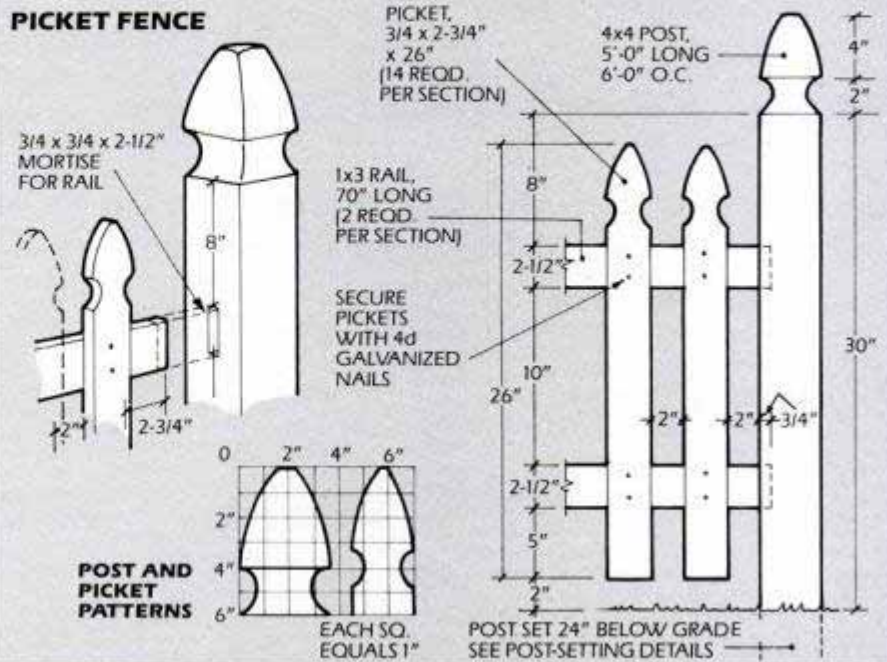

add the drainage material, then install the post. Add 6 in. more of gravel, then fill the hole with concrete. Slope the top surface away from the post for moisture runoff. Check that the post is plumb in both dimensions. Brace it until the concrete cures.

Leveling the posts

If the rails of your fence will be simply butted and nailed to the posts, you can cut the posts to height after they are installed. However, if joints must be cut in the posts to receive the rails, you must cut the post to height and cut joints the same distance from the top of each post. Then level the installed posts so the joint cuts align. A line level is an indispensable tool for this job.

After you set the first corner post at the correct height, tack a nail into the center top and tie enough mason's twine onto it to reach an adjacent corner post. Set the other corner post in place and tack a nail partway in its center top to hold the twine. Draw the twine taut between the two corner posts.

Hang the line level on the twine to determine when the second corner post is level. Shift the second corner post until it is at the proper height and fill in the hole, checking that the post is plumb.

Use the same leveling and aligning procedure for installing the intermediate posts.

Aligning intermediate posts

After the corner posts are installed, you must set, level and align the intermediate posts. Three 1×2×2-in. spacing blocks and mason's twine help in alignment. Tack one block on the outside surface of each corner post at the same height—about 1 ft. above ground level. Stretch mason's twine taut between the nails that hold the blocks. Set an intermediate post along the line holding the third spacing block between the post and twine to achieve perfect alignment. Plumb the post with the spirit level.

If the posts are set in concrete, let them stand for several days before continuing work. If they are set in earth, begin adding the rails.

Attaching rails and fence boards

Rails made of 2×4 stock usually are sturdy enough to hold the vertical fence boards. Thinner stock may bend under the weight.

Rails can be attached to posts in several ways. Their ends can be toe-nailed to the posts or rails can be nailed to cleats mounted on posts. Other fastening methods include letting rails into dados or mortises cut into posts.

Fence boards are generally of 1-in. stock 3 in. or more wide.

They most often are face-nailed to the rails. To assure even spacing, rip a

(Please turn to page 126)

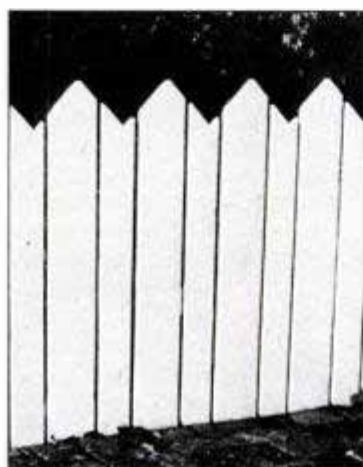

This fence is built of alternating 1×4 and 1×6 pickets. The top is cut in an offset saw-tooth pattern.

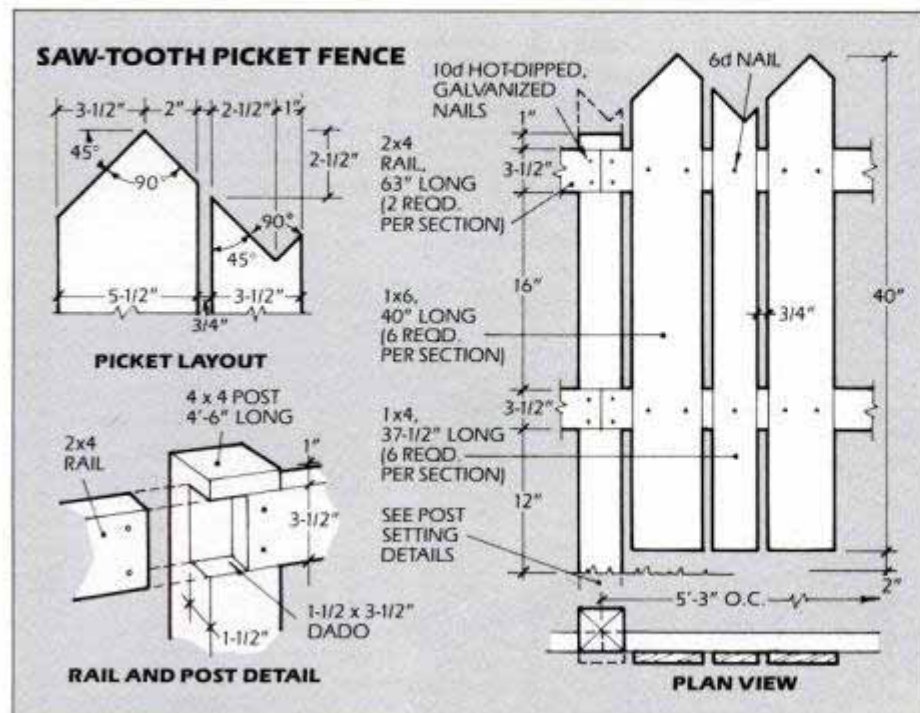

NOW GETTING RID OF RUST IS NO SWEAT.



Eliminate rust without sanding or priming. Just apply Rust Reformer™ to rusty surfaces and it will chemically convert rust to a protective coating.

RUST-OLEUM.
Nobody fights rust like Rust-Oleum.

©1985 Rust-Oleum Corporation

NOW! Get in on the PROFITS in

SMALL ENGINE REPAIR!



Work part time, full time — right at home — we help you every step of the way.

No doubt about it... as a small engine pro, you can cash in on the huge demand for qualified men in one of America's fastest growing industries. You'll be able to command top hourly rates of from \$25.00 to \$30.00 per hour — and that's just for labor. A simple tune-up earns as much as \$49.95 for less than an hour's work, and parts, engines and accessories will add even more to the profits.

Plenty of business waiting for qualified men.

65,000,000 Small Engines Are In Use Today!

That's the official count from the Engine Service Assn., and one-million new engines are being built each month. With fully accredited Foley-Belsaw training, you can soon have the skills and knowledge to make top money servicing these engines. People will seek you out and pay you well to service their lawnmowers, tillers, edgers, power rakes, garden tractors, chain saws, minibikes, snowmobiles, generators, go-carts, paint sprayers, snowblowers... the list is almost endless.



Professional Tools and Equipment, PLUS 4 H.P. Engine ALL YOURS TO KEEP... All at No Extra Cost. NO EXPERIENCE NECESSARY!

You don't need to be a 'born mechanic' or have any prior experience. You can master this profitable trade right at home in your sparetime. Lessons are fully illustrated...so clear you can't go wrong, and with our famous 'learn-by-doing' method you get practical 'hands-on' experience. We also show you how to get business, what to charge, where to get supplies wholesale...all the inside tricks of the trade you need to assure success right from the start.

Send for FREE Facts — Do It TODAY!

NO Obligation — NO Salesman Calls!

You risk nothing by accepting this offer to see how easily you can learn the skills you need to increase your income in a high-profit business of your own. Just fill in and mail coupon below (or send postcard with name and address) to receive full information by return mail.

RUSH COUPON TODAY
Foley-Belsaw Institute
50712 Field Building
Kansas City, Mo. 64111



FREE BOOKLET!
Send for your copy today!

FOLEY-BELSAW INSTITUTE
50712 FIELD BUILDING
KANSAS CITY, MO 64111



YES, please send me the FREE booklet that gives full details about starting my own business in Small Engine Repair. I understand there is No Obligation and that No Salesman will call on me.

NAME _____

ADDRESS _____

CITY _____

STATE _____

ZIP _____

ALL-AMERICAN FENCES

(Continued from page 125)

board to the width of the spaces you want on the fence. Butt the spacing board against the last fence board and position the next board against the spacing board.

Gates

The gate posts are often larger (for example, 6×6s) and set more deeply than the rest of the fence posts to withstand the additional stress that they receive. It is crucial that gate posts be installed perfectly plumb. When measuring the space for the gate between the posts, allow for hinge and latch clearance.

When making the gate frame, check with a carpenter's square to make sure the frame is perfectly square. Often, gates have an additional diagonal brace stretching from the hinge side of the lower rail up under the latch side of the top rail. The brace should fit tightly between rails. When the gate boards are in place and you are ready to hang the assembly, attach the hinges to the gate first.

Repairing posts

You can repair a fence post that has rotted underground by adding a new post support to it. Dig a post hole right next to the old post and set in a 5-ft. post brace so that 2½ ft. are above ground. Then, bolt the brace to the old post with two ½-in.-dia. carriage bolts, nuts and washers.

Another way of handling a rotted fence post is to install an entirely new post a foot or so along the fence away from the rotted post.

Giving wood a rustic look

You can give a rough-hewn, natural look to dressed lumber by using a hatchet to round off the corners. Then, chamfer the edges with a spokeshave to produce an irregular edge.

Roughen and distress the board surfaces with a wirebrush wheel in a drill, or, if you have a large band saw, run the board through perpendicular to the blade so it rakes the board. **Caution:** Wear safety glasses.

In two years or more, pressure treated wood will weather to a driftwood gray. However, you can apply semi-transparent stain immediately for a weathered look.

PM's fence projects

Following are tips for constructing the fences shown in this article:

Lattice-top fence: The posts of the lattice-top fence are actually 4×4s. They are encased above ground in ¾-in. stock. Mortises in the posts hold the bottom 2×4 rail. The rail is grooved to

receive the vertical 1×4 fence boards. The center and top rails are pairs of 1×4s. The back rail of each pair fits into a mortise on the post.

Be sure that you cut the mortises off-center, 1½ in. from the back surface of the post. Slide the back and bottom rails into the posts, then stand up the whole assembly at one time. Slip the vertical 1×2 edging and vertical 1×4 fence boards in the bottom rail and nail them to the center back rail with 4d nails. Nail the vertical 1×2s that make up the lattice to the center and top back rails with 4d nails. Nail the horizontal 1×2s to the vertical members. Install trim and caps.

Rail fence and gate: This simple rail fence is made of 4×4 posts and three 1×6 rails that fit into mortises before the posts are set. The gate has the look of two smaller gates. However, these two panels are fastened together with 8d nails.

The gate frame is 2×3s. The stiles are dadoed to receive the rails. The top gate rail is glued-up then cut to shape on a band saw or with a sabre saw. Bore holes for the 1½-in.-dia. round stock before shaping the rail.

Board and board fence: A board and board fence offers privacy and presents a pleasant appearance on both its sides. Mortise the 2×3 frame to hold the 2×2 rails. Then, nail evenly spaced 1×4 fence boards on both sides of the rails. The decorative crosspieces on the upper part are 1×3s with cross-lap joints at their center points. Lengths of split cedar, available at fencing suppliers and home centers, conceal joints in three places.

Picket fences: There are several special considerations in building a picket fence—whether it's a small-scale picket fence with traditional, arrowhead-shaped pickets, or a closed picket fence with an offset saw-tooth design as shown on page 125.

Use a framing square to make sure that rails are at right angles to the posts and that posts are plumb and level. Any discrepancy is readily seen after the pickets have been installed. Check with a plumb line or spirit level to make certain that the first picket is plumb. If you use a spacing block to position pickets, make sure it is straight and has consistent width. **PM**

ADDITIONAL INFORMATION

How To Build A Fence, 20-page brochure; send \$1 to Koppers Company Inc., 1900 Koppers Building, Pittsburgh, Pa. 15219

Redwood Fences, 8-page brochure; send 50 cents to California Redwood Assn., Dept. PM, 591 Redwood Highway, Suite 3100, Mill Valley, Calif. 94941

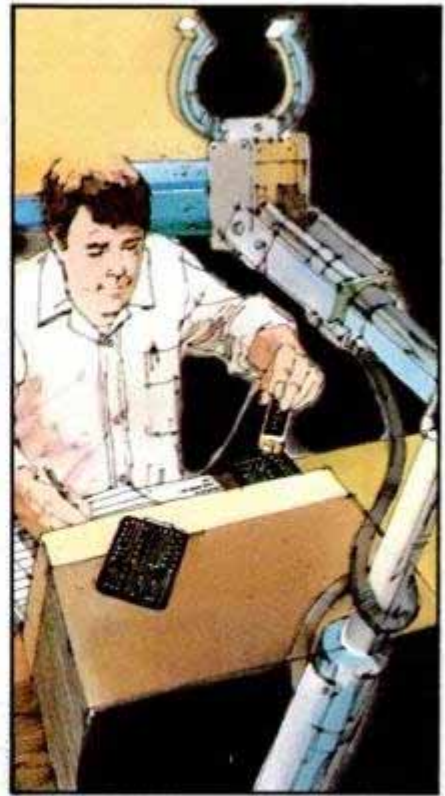
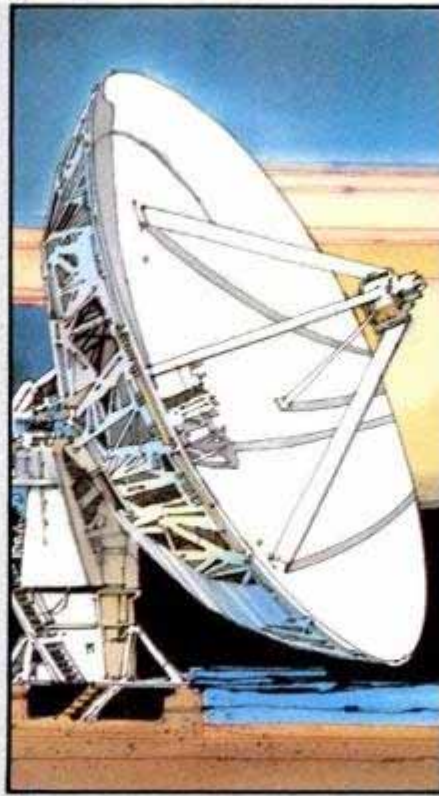
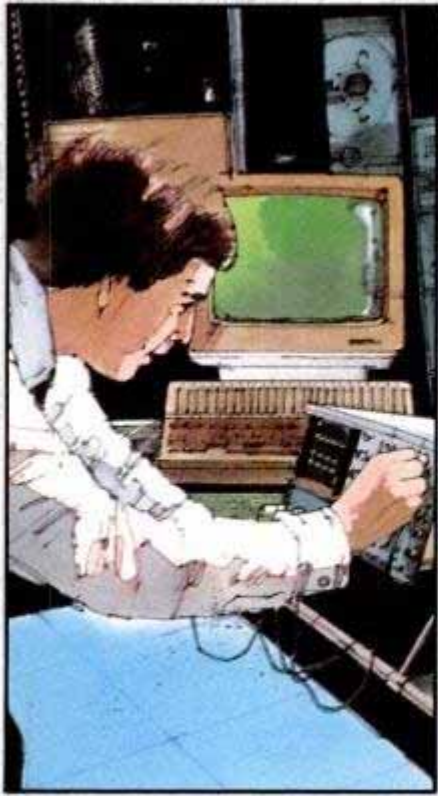

What can you do with electronics? Ask CIE.

Computer technology. Satellite communications. Cable television. Cellular radio. Digital electronics. Robotics. The hottest careers in electronics. And CIE can get you started. By teaching you the basic theory and principles of how they work.

Why CIE? Because we're the leader in specialized electronics education with over 25,000 students. With over 50 years of proven experience teaching electronics **without** classroom sessions. And with plenty of hands on, practical experience using our specialized training laboratories.

Whether it's learning new skills or upgrading old ones, CIE can start you where you want, take you as far as you want. From the basics to CIE's Associate in Applied Science Degree in Electronics. We've done it for thousands of students. We can do it for you.

Let us get you started today. Just call toll-free **1-800-362-2155** (in Ohio, 1-800-362-2105) or mail in the handy reply coupon below or card to Cleveland Institute of Electronics, 1776 East 17th Street, Cleveland, Ohio 44114.

CIE World Headquarters

Cleveland Institute of Electronics, Inc.
1776 East 17th Street • Cleveland, Ohio 44114

- Please send me your CIE Off-Campus Studies Catalog, including details about the Associate Degree program. I understand there is no cost for the catalog and a CIE representative may call, but there is no obligation.

Print Name _____

Address _____ Apt. No. _____

City _____ State _____ Zip _____

Age _____ Area Code/Phone No. _____ / _____

Check box for G.I. Bill bulletin on Educational Benefits

Veteran Active Duty

MAIL TODAY!

PM-13

Why Are We Giving Away Diamond-Inlaid Wristwatches for only \$3?

Hard to believe, but true.

As part of a nationwide publicity campaign, a famous New York jewelry firm will give away one million (1,000,000) of its most expensive diamond-inlaid wristwatches for the astonishing price of only \$3 each to the first one million persons who return this publicity ad to the company before midnight, October 31, 1985.

This *original* publicity ad must accompany your request. Copies or photostats are *not* acceptable.

These are the same diamond-inlaid designer wristwatches being nationally advertised throughout America by this leading New York jewelry house. The face of each watch is distinctively set and inlaid with a genuine 17-facet .25 pt solitaire diamond of the same size and value as is regularly sold by this famous multi-million dollar firm to its most fashionable New York clientele; and it will be accompanied by a Certificate of Authenticity to that effect issued by GCI, Ltd., of New York.

Not some "pretty" piece of jewelry created to adorn the wrists of the idle rich, each watch is a precision timepiece with a genuine quartz movement that is so powerful it never needs winding and is accurate to within seconds per month. The most expensive diamond-inlaid

designer wristwatch of its kind ever sold by this large New York jewelry firm, it is astonishingly lightweight, elegantly slim in profile, and available in both men's and ladies' models.

These diamond-inlaid designer wristwatches will not be sold at this price by the company in any store. To obtain one at this special publicity price, mail this *original* printed ad to the company before midnight, October 31, 1985.

Each watch is covered by a full one-year money-back guarantee and will thus be replaced or refunded by the company, free of charge, should it fail to function. There is a limit of two (2) watches per address at this price, but orders mailed early enough (before Oct. 25) may request up to five.

To obtain your diamond-inlaid designer wristwatch, mail this *original* publicity ad (no copies or photostats) together with your name and address and \$3 for each watch. Add only \$2 shipping and handling no matter how many watches you are requesting. Specify Men's (Item #V27901) or Ladies' (Item #V27902). (New York residents add sales tax.) Allow up to 6-8 weeks for shipment. Mail to: **Carter & Van Peel, Diamond Watch Offer, Dept. 114-102, Box 1225, Westbury, New York 11595.**

FOUR-FOOTED ATVs

(Continued from page 83)

There's also an oil temperature warning light and a gas gauge.

When the dirt settles . . .

Take them to the mountains, flog them as hard as you know how and what do you learn about four-wheel ATVs? For one thing, there are as many designs and types as there are needs to be filled. Secondly, any one of the machines is as much fun as the law seems to permit these days. For the competition-minded as well as the frustrated Baja 1000 hero, the Suzuki Quad Racer provides as many thrills as money can buy. Honda's FourTrax is the king of the utility vehicles, and would prove nearly indestructible in recreational use. Kawasaki's Bayou would be the choice as an introductory machine, being both rugged and forgiving. Yamaha's Moto-4 can handle both the work and play roles admirably, making a better hot-dogger than the more practical machines and a superior workmate to the pure sports vehicles. Any way you go, you can't lose. **PM**



Two wheels, too!

Can't decide which of the four-wheel ATV is right for you? Looking for something a little more traditional? Try on the Yamaha BW200 for size. Sure, it's only got two wheels, but they're each easily as wide as any two enduro bike tires.

Brought along on our photo session primarily to carry a photographer and his gear, the BW, a.k.a. Big Wheel, quickly became a hit. One tester, after conquering the slippery rocks of a swift-running stream, commented, "This thing's got four-wheel drive!" Well, it does plonk along happily at a crawl, lifting the front end easily to clear obstacles. The wide tires take it across sand and muck that would bog down a motocrosser. Narrower than the four-wheelers and with the balance of a trials bike, the BW200 fills an absolutely uncontested market niche—a mountain goat that won't eat your straw hat.—*N.M.*



P R E S E N T S

**DIRECT MAIL
CALL DIRECT
1-800-247-4528**

OR SEND THE
HANDY ORDER
FORM TO:

Auto Frog, Inc.
P.O. Box 3925 Dept. PM
Urbandale, IA 50322



Deflecta-Shield®

Auto Frog has the famous Deflecta-Shield® available in Clear, Red, Amber, Solar Grey, Blue, Smoke, Green and Light Blue.

They fit most vehicles back to 1958 and they come with the necessary mounting hardware. The Deflecta-Shield® is instrumental in deflecting bugs, snow, gravel and other road particulates from your vehicle year 'round.

Just tell Auto Frog the make, model and year of your vehicle, and we'll send you your own shield in the color of your choice for only.

\$29⁹⁵ Clear
Add \$4.00
for color.



"SATISFACTION GUARANTEED —
MOST MODELS AVAILABLE FOR IMMEDIATE SHIPMENT"

Call Auto Frog today!



USE THIS FORM WHEN ORDERING BY PHONE TO MAKE
PROCESSING YOUR ORDER AS ACCURATE
AS POSSIBLE

QTY.	ITEM AND COLOR	PRICE

Add \$5.00 shipping (Iowa incl. 4% sales tax) →

Make check payable to AUTO FROGG.

My vehicle is a

make _____ model _____ yr. _____

Name _____ PLEASE PRINT

Address _____

City _____ State _____

Phone _____ Zip _____

CARD EXP. DATE _____

TOTAL



SPIELBERG'S TIME MACHINE

(Continued from page 87)

systems. Three banks of real digital readouts were constructed in a cockpit jammed with gauges, knobs and handles, including a main power switch located on the right side of the driver's seat that's really a car battery cleaner. One readout sets current time, one sets destination time and one is time of last place departed, according to Dr. Brown. Although the original speedometer was retained, a digital one was added to emphasize an important story point—logically enough, the car must move to travel through time and when it hits 88 mph, Dr. Brown's "flux capacitor" kicks in and it's off to the world of bobby socks and felt skirts.

Since the car now sported a bank of flared exhaust vents behind the nuclear reactor (which has a Dodge Polaris hubcap for a base), Pike's staff rerouted the vehicle's original exhaust system to vent in front of the rear wheels. Two CO₂ extinguishers were installed in the passenger compartment and the gas was piped to the exhaust bank, where a trumpet with a special built-in baffle expelled the gas, simulating a nuclear reactor's exhaust. (For PM's look at the original De Lorean, see *Stirling Moss Road Tests The De Lorean Sports Car*,

page 65, June '81.) Pike's special effects crew also connected three 100-amp auto batteries, set parallel to boost the amperages, to two inverters which converted d.c. current to a.c. and to a transformer which boosted the system's output to 25,000 volts to light the neon tubing.

One of the most spectacular special effects takes place as the car zooms toward the point of disappearance at the instant of time travel. Dr. Brown first shows Marty his invention late one night in a deserted shopping mall parking lot. He powers the car by a remote control unit and as it speeds toward the two, fire shoots from beneath the wheels and a path of flame blazes toward the astonished pair.

Fire jets were attached beside each wheel, triggered by a high-voltage igniter and controlled by a special effects crew member scrunched down in the passenger seat of the car. "The system uses one tank each of compressed air, propane and acetylene under pressure, regulated and metered and released by solenoids at the end of the lines so there's no backfire," according to Kevin Pike. However, the car had to be traveling at 40 mph or faster before the jets ignited, or the danger of fire engulfing the car would have been too great.

The path of flame was achieved by

laying down fire lines of quick-burning, smokeless pyro fluid, ignited by squibs and torches. Lloyd and Fox were doubled by stuntmen wearing fireproof suits beneath their costumes. Another awesome display of pyrotechnics occurs late in the film, when a lightning bolt hits a clock tower in Marty's town. Devices called lycopodium machines were set up—hoppers 14 feet tall full of aluminum dust.

"The dust is drafted up to the top by compressed air and ignited by an acetylene pilot and it burns brilliantly," Pike explained.

After all the "time machine" components were piled on and in the cars, the film-makers discovered that the De Lorean's original systems occasionally failed to stand up under the rigors of moviemaking. The pneumatically assisted gull-wing doors tended to droop down if left open for any length of time in chilly weather, so Pike's crew had to warm the pneumatic cylinders near the hinges with portable hair dryers during several long, cold nights.

The auto's engine, which is entirely capable of moving the machine at 88 mph, was left untouched. "You could drive this to the 7-Eleven if you wanted to," said Pike. Or to the local malt shop for a 10-cent Coke with the doo-wop crowd. **PM**

HIDING THE BOMB

(Continued from page 75)

nel. Jobs were separated as much as possible so that no one person working on the project would know what another person was doing. For the most part, there were no security breakdowns. But the one that got away was explosive.

German-born and English-educated physicist Carl Fuchs was arrested, after the bomb was developed, for passing secrets to the Russians. Neither court records nor documents obtained through the Freedom of Information Act shed light on what Fuchs told the Russians, and he never publicly revealed his activities.

Keeping the press out of the picture was a major headache. Probably because there was a war on, the press was more cooperative than might be expected. Words like "atomic energy" were banned successfully from news stories. If a local Texas newspaper picked up a story that might reveal something about the A-bomb project, it stopped there. A Chicago newspaper, for example, would be barred from reporting the news to its readers.

On the day of the blast at Trinity Test Site in New Mexico, a Chicago resident was traveling through New Mexico by train. He felt the blast and saw the sky

light up. At the next stop, according to one published account, he raced to a telephone and called a Chicago newspaper. The traveler thought he had witnessed the fall of a giant meteor. The reporter wrote a brief article and filed it with the city editor.

The next day, when she returned to work, FBI agents were waiting for her in the publisher's office. They explained to her that she should forget the story, and it never appeared.

Explaining the blast

Any accounts of the blast on July 16 were based on the terse news release finally issued by Los Alamos. It read:

"Several inquiries have been received concerning a heavy explosion which occurred on the Alamogordo Air Base reservation this morning.

"A remotely located ammunition magazine containing a considerable amount of high explosives and pyrotechnics exploded.

"There was no loss of life or injury to anyone. . ."

The true story would eventually be told, but only after the bomb was dropped on Hiroshima. To help provide the public with a credible account, the Manhattan Project allowed *New York Times* reporter William Laurence to live on the Los Alamos compound in the

months leading to the blast. He kept the secret and wrote a celebrated series in the *Times* after Hiroshima.

In the days before the blast, Jumbo—a 180-ton steel container for testing the A-bomb—had to be moved under canvas wraps across the New Mexico desert to the Trinity Test Site. It rode on a specially designed, 200-ton freight car. Even the military policemen riding with the train knew nothing of its contents. They were told that it would be used to store high explosives.

However, the container's unmistakable ballistic shape showed through the canvas, and many legends emerged. The most preposterous had it that the Army was working on a secret submarine in the desert.

How the government hid the A-bomb in New Mexico from even those who lived next door already is an intriguing story. When the remaining documents are released, it may prove even more exciting. **PM**

For more background on the development of the atomic bomb, read *The Day The Sun Rose Twice* by Ferenc Morton Szasz (University of New Mexico Press, \$14.95); *Now It Can Be Told* by General Leslie M. Groves (Da Capo Press, \$9.95), and *The German Atomic Bomb* by David Irving (Da Capo Press, \$9.95).

BACKYARD GARDENERS

Don't Buy A BIG TILLER

For a small job.

Buy a Mantis



Tines so strong they're guaranteed for life.

If your garden is an acre or less, hire somebody to plow it once a year... and buy a Mantis-20 for yourself. Mantis tills and weeds a practical 6" to 9" wide, turns on a

dime and weighs only 20 pounds! Simply turning a 300-pound tiller in a backyard garden is a challenge.

Most big tillers were designed to just till (but many now offer clumsy "add-on" attachments as an attempt to justify their high cost). The Mantis was designed from the beginning to precisely match a small, powerful engine to a variety of useful attachments for your yard and garden.

Most big tillers cost an arm and a leg. The

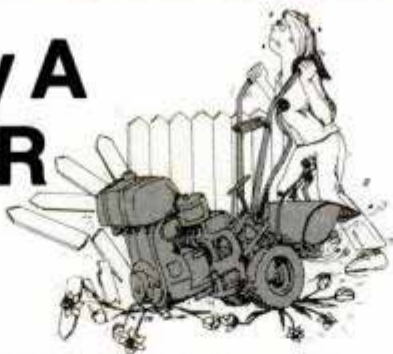

Mantis-20 is a tough, durable, precision instrument... yet it costs a fraction of what you'd pay for a big tiller.

3-WEEK TRIAL

Most machines are partially covered for 90 days to a year. Mantis has a Lifetime Warranty on the tines, a Lifetime Replacement agreement on the engine. Best of all, you get a 3-Week In-Your-Garden Trial (if you don't like it we'll buy it back for every penny you paid!).

**LIMITED TIME BONUS
FREE \$41.00 Border/Edger!**

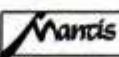

Mantis Manufacturing Co.
1458 County Line Rd., Dept. 735
Huntingdon Valley, PA 19006

Please RUSH details on the Mantis Tiller/Cultivator and FREE 3-Week In-The-Garden Trial.

Name _____
Address _____
City _____
State _____ Zip _____

WOODWORKING MACHINES 5 in 1 Combination

WITH ELECTRIC MOTOR WHICH DEVELOPS 3 HP.

- 34" LATHE
- 10" TABLE SAW
- 11 1/2" DISC SANDER
- 16 1/2" VERTICAL DRILL PRESS
- HORIZONTAL DRILL PRESS

NEW MODEL
CENTURY XXI



VERY IMPORTANT

The only machine built with:
A. ALL CAST IRON TABLES
B. HEAVY DUTY DESIGN
C. DEVELOPS 3 HP MOTOR
D. BUILT AS AN INDUSTRIAL MACHINE

ONE PLACE FOR ALL YOUR NEEDS...

CALL NOW!!! FOR FREE GIFT
Toll Free (1-800) 421-2467

IN CALIFORNIA CALL COLLECT (213) 549-0761

VISA MASTERCARD MONEY ORDER

PLANT:

MASTER WOODCRAFT CO.
800 SPRUCE LAKE DRIVE • P.O. BOX 669
HARBOR CITY, CA 90710
(A Republic-Lagun Group)

Dealership Available

PHONE LISTENING DEVICE

Record telephone conversations in your office or home. Connects between any cassette or tape recorder and your telephone line. Starts automatically when phone is answered. Records both sides of conversation. Stops recorder when phone is hung up.

19⁹⁵ ea. Qty discounts available

WIRELESS MIC (super powerful)

10 times more powerful than other mics. Transmits up to 1/2 mile to any FM radio. Easy to assemble kit. 15V battery (not incl.) Call (305) 725-1000 or send \$19.95 + \$1 shipping per item to USI Corp., P.O. Box #M-2052, Melbourne, FL 32901. COD's accepted. For catalog of transmitters, voice scramblers and other specialty items, enclose \$2 to USI.

Bolt-on A Breakthrough!

Build Your Own
Vapor-Power
"SUPER CARB"

Road Testers Report:

"Gas Mileage
Doubled
and Tripled!"

NEW Design!

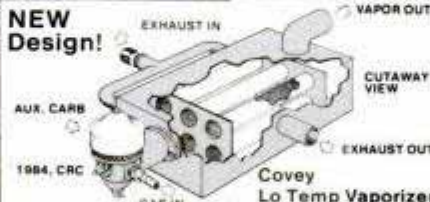

Now - actual Road Tests reveal high as 400% MPG increase! C. Ashton reports 35 mpg, big 461 V6 Motor Lodge; W. Shelton claims 51 mpg, 350 V8 Chevy; startling gains, other vehicles! You may do as well or better. We Guarantee: YOU MUST AT LEAST DOUBLE MILEAGE, or we'll refund price of "How To" Manual! New, simplified Covey design is low cost, easy to build. Most components stock. Only 10" to 12" long, 5" wide, 3" high. Fits under hood. Small B & S type auxiliary carb sprays air/fuel mix into exhaust-heated tubes; it's instantly vaporized, sucked into modified air cleaner/present carb. Dual system, fast change-over. Dash-mounted controls divert fuel and air from regular carb to vaporizer, and vice-versa. System has optional automatic controls, MPG Computer, vapor line heater for winter.

Join our Road Test Team. Build your own vapor carb or have it built, at local metal shop. Provide data requested and big Manual costs you nothing! Learn how you may vastly increase MPG of your car, truck, or RV. Free Hi-Mileage Report, Road Test Application, full details. Write!

**CPC Carb Research Center, Dept. PM-8
Box 1 Foyil, OK 74031**

NEW CYCLE, NEW ENGINE

(Continued from page 92)

The ability to increase the thermodynamics efficiency by consuming all of the fuel gives a higher output with little or no pollution. Cheaper grades of fuel can be made to burn, down to powdered coal. As envisioned, the engine does not use diesel-type, high-pressure fuel injection, electrical spark ignition, high-octane fuel or lead additives.

Realizing the concept

The current status of the project is beyond theory. That was proven by computer analysis to be valid, and reviews by engineering teams confirm its advantages. A test engine is being built from standard industrial diesel components. There is no interest in going public with stock offerings or quick-buck "investment" schemes. For the 17-year life of its process patent, the Gerace Cycle Group will have a lock on any mechanical means used to achieve the Gerace cycle, and the blue-sky engineering types are taking it to the limit, first spinning out variations of common in-line designs employing familiar gasoline engine hardware. In wilder permutations, one cylinder of each pair operates in two-cycle mode while the other turns at half speed through four cycles (see illustration on page 90). The design was then extended into opposed-piston units in which the piston crowns become the combustion chambers. The ultimate design has its cylinders arranged in a circle. The connecting rods push against a rotating disc with a wavy cam contour. This package is likely to have aircraft applications.

The Gerace cycle needs much development work to operate as envisioned. One of the major questions is the design of the transfer valve. It has to sit in an almost leak proof chamber, open quickly to allow the very hot air into the Otto cylinder, take extremes of temperature and resist wear. Water and oil cooling should keep temperatures below those of today's exhaust valves. With all of the aerospace materials and wear-resistant coatings now available, the problem can be resolved.

The Patent Office is filled with designs that could not be made to work because the necessary materials were not available. The Gerace engine has luckily emerged at a time when all of the help and material is available thanks to a research program being developed with the aid of Johns Hopkins University in Maryland.

The development of a prototype is a slow step-by-step program. Since the work has no precedent, it's a change-one-thing-at-a-time job. This takes time and money, and again the Gerace cycle

(Please turn to page 139)

MUST LIQUIDATE NOW AT BELOW DEALER COST!

PUBLIC NOTICE!

We are authorized liquidators of consumer products that must be quickly sold by manufacturers at drastic price reductions for many reasons, such as:

Discontinued lines. Last year's models. Distributor surplus. Cancelled orders. Bankruptcy. Factory overproduction. Out-of-season products. Tail-ends of inventories.

Whatever the reason for the liquidation you are assured of fine quality at money-saving low prices! Supplies are limited. Order now!

ANOVA Automatic Control Center

Automatic control of up to 16 lights or appliances in your home or office . . . even when you're on vacation!

Anova was a prominent innovator in modular electronic communications. But Anova's parent company decided to close that division and liquidate remaining warehouse inventory. Now YOU can get a great buy on a push-button, automatic Control Center at FAR BELOW dealer cost!

All you need for this computerized, "intelligent" Control Center is 8" x 6 1/2" of desk space! Then, program different times and days of the week for electrical items to go on/off. For security, have a radio, lights or TV operate while you're away. Or, for convenience, set Anova to have your coffeemaker come on before you wake up!

Easy to install! Modules plug into standard household outlets and receive signals from Control Center over existing AC house wiring.

Security! Turn lights, radio, TV, etc. on/off in RANDOM pattern, when you're away from home!

Auto Prompt! Questions appear on the display to assist you, step-by-step in programming Control Center.

Program Review! Lets you check Anova's memory bank for correct operation.

Battery Backup! Keeps memory going in case of temporary power failure.

LED Calendar Clock! Displays day-of-week, am/pm.

Lamp Failure Detection! If a light fails, Anova will alert you!

Program Override! You can instantly control lights/appliances without waiting for pre-set times. Just push a button!

Three Modules Included: You get two lamp, one appliance module. Each lamp module accepts TWO items (incandescent bulbs only; max. 300 watts combined). Appliance module accepts ONE item (max. 500 watts or 1/3-hp.). Modules plug into 115V AC outlet. To control more items, order kit at right.

30-Day Limited Factory Warranty from date of purchase.
(Warranty expires December 31, 1985)

With
Built-in
LED
CLOCK!



FCC
Certified

Manufacturer's
Suggested Retail
\$199.95

OUT THEY GO AT ONLY:

\$48

Item X-234-63469-00
Shipping, handling: \$5.00

Add EXTRA
Anova plug-in
modules in
SETS of THREE

Each kit contains
2 lamp modules; 1
appliance module.

Reg. \$89.95

Price
Now **\$28**

Item X-234-63645-11
Ship, hand.: \$4.00

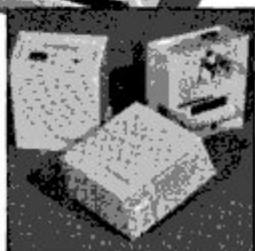

29-piece HIGH-SPEED DRILL BIT SET

Excellent
Quality!
Industrial
Grade!
Factory New!
First Quality!

An importer's overstock allows us to offer these fine drill bits at FAR BELOW dealer cost! They're rugged, industrial grade high speed steel. Sizes 1/16" through 1/2". Hardened at high temperatures for superior strength and dependable cutting power. Full jobber length. Straight shank, black oxide finish. Bits come individually housed in all-metal case that's 8 1/4" x 4 1/4" x 2".

Mfr. List: \$69.95
Liquidation
Price Now Only

\$19

Item X-234-63421-00 Ship, handling: \$4.25



C.O.M.B. 90-Day
Limited Warranty!

Two bits,
pilot drill,
incl.

Cordless Electric SCREWDRIVER

In the process of tearing down a warehouse, the vendor found these units behind a wall. Now we are able to liquidate this "misplaced find" at BELOW dealer cost!

Take this Cordless Screwdriver with you ANYWHERE! Use it indoors or outdoors. Has 50:1 gear reduction for professional power. Spring detent collet holds any standard 1/4" hex-shank bit. Driver recharges to full power overnight with AC plug-in adapter included. Approx. 1 1/4 lbs.

Mfr. List: \$91.95
Liquidation
Price Now Only

\$39

Item X-234-64104-00 Ship, handling: \$5.50

GRACO Airless Paint- master Painter

- Works with both Latex and Oil based paints!
- No nozzle to clog!
- Plugs into 115V outlet!
- Factory new! First quality!



1-Year
Limited
Factory
Warranty!

Manufacturer's overstock! Now paint like a pro with Paintmaster at a liquidation price BELOW dealer cost! NO thinning required! Control valve adjusts for thin to thick paint. Paints swath from 1/2" to 18" wide. Snap on 1-qt. container. Trigger-controlled. Comfort handle.

Mfr. List: \$119.95
Liquidation
Price Now Only

\$58

Item X-234-64125-00 Ship, handling: \$4.50



Credit card members can order by phone,
24 hours a day, 7 days a week.

Toll-Free: 1-800-328-0609



Your check is welcome!
No delays when you pay by check!

C.O.M.B. CO.

Authorized Liquidator

14615 28TH AVENUE NORTH
MINNEAPOLIS, MINNESOTA 55441 3357

SEND ME THE ITEMS I HAVE LISTED BELOW

Price subject to change after 60 days. Sales outside continental U.S. are subject to special conditions. Please call or write to inquire.

Item No.	How Many	Item	Ship/Handl.	Price

C.O.M.B. CO.®

Item X-234

14615 28th Ave. N./Minneapolis, MN 55441-3357

Send the items indicated at left. (Minnesota residents add 6% sales tax. Please allow 3-4 weeks delivery. Sorry, no C.O.D.)
 My check or money order is enclosed. (No delays in processing orders paid by check, thanks to TeleCheck.)

Charge: MasterCard® VISA Am. Ex. Diners Club

Acct. No. _____ Exp. _____

PLEASE PRINT CLEARLY

Name _____

Address _____

City _____

State _____ ZIP _____

Phone _____

Sign here _____



PERFORMANCE AUTOMOTIVE WHOLESALE, INC.
21122 Lassen Street, Chatsworth, CA 91311
818-998-6000

HOME REBUILDER SPECIALS

TOP NAME BRANDS AT WHOLESALE PRICES

WHY ARE P.A.W. PRICES LOWER?
WE BUY DIRECT, WE SELL DIRECT & THAT SAVES YOU MONEY.

STOCK & HIGH PERFORMANCE PARTS FOR THE SHOP & HOME REBUILDER

NEW HIGH QUALITY CHROME ACCESSORIES



VALVE COVERS
AMC 200-401 V8 19549 \$28.95 PR
Buick 231 V6 19448 \$24.95 PR
Chevy V6 19201 \$24.95 PR
Chevy S8 Short 19196 \$18.95 PR
Chevy S 8 Tall 19195 \$18.95 PR
Chevy B 8 Short 19333 \$28.95 PR
Chevy B 8 Tall 19338 \$28.95 PR
Mopar S 8 19330 \$24.95 PR
Mopar S 8 19547 \$28.95 PR
Ford S 8 19331 \$24.95 PR
Ford 351C-351M 400 19332 \$26.95 PR
Ford 300-300-426 19543 \$26.95 PR
Ford 429-400 19542 \$29.95 PR
Oldsmobile V8 19544 \$28.95 PR
Pontiac V6 19525 \$26.95 PR



WATER NECKS
Chevy Angled 19298 \$5.00
Chevy Straight 19297 \$5.00
Mopar (60 Val) 19296 \$5.95
Ford S 8 19295 \$5.95



CHROME DIFFERENTIAL COVERS
Chevy 12 Bolt 19125 \$9.95
Chevy 10 Bolt 19129 \$9.95
Chevy 510/Camaro 80 up 19122 \$9.95
GM Truck 14 Bolt 7381 19123 \$9.95
Dana 44 19124 \$9.95



TIMING CHAIN COVERS
S.B. Chevy 19122 \$3.95
S.B. Chevy 19221 \$2.95
S.B. Timing Tab 19197 \$1.50
S.B. Timing Tab 19265 \$1.50



AIR CLEANERS
14" Low Profile 19112 \$16.95
10" Low Profile 19375 \$10.50
6" 4 Barrel 19612 \$7.95
6" 2 Barrel 19613 \$7.95

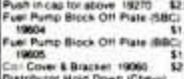

VALVE COVER ACCESSORIES
Breather & Grommet Price For Each 19198 \$3.50
V.C.T. Bolts Long 19281 \$1.75
V.C.T. Bolts Short 19282 \$1.65
Head Down Taps Long 19409 \$1.30
Head Down Taps Mini 19293 \$1.60



WATER PUMPS
310130 S.B. Chevy (short) 54.95
310184 S.B. Chevy (tall) 54.95
310145 S.B. Chevy (tall) 59.95
Rot Sets 1.95

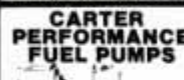

MISC.
S.B. Chevy Dipstick 19177 \$3.95
S.B. Chevy Dipstick 19170 \$4.99
S.B. Chevy Early Breather Tube 19294 \$2.99
Push in Cap for above 19270 \$2.99
Fuel Pump Block Off Plate (SBC) 19604 \$1.50
Fuel Pump Block Off Plate (BBC) 19605 \$1.95
Cot. Cover & Bracket 19060 \$1.60
Distributor Hold Down (Chevy) 19066 \$2.50
Distributor Hold Down (S.B. Ford) 19069 \$2.50
Fuel Line (3310-2 Holley) 19519 \$8.50
Fuel Line (Double Pumpers) 19520 \$8.50

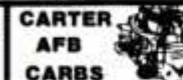

ALTERNATORS
300654 Chevy 91 Amp 94.95
300676 Chevy 95 Amp 93.95



STARTERS
286521 S.B. Chevy (H-torque) 96.95
294484 Suggested 96.95



OIL FILTERS
Available Most V8 Engines 5.95

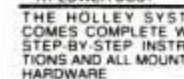

CHROME RADIATOR SUPPORT
4442 70-81 Camaro/Firebird Stock Rad \$14.95
4443 70-81 Camaro/Firebird H.D. Rad \$14.95
4445 66-77 Chevrolet N.A. \$14.95



CHROME COIL & BRACKET
19442 Early S.B. 55-78 \$34.95
19443 Late S.B. 79-84 \$34.95

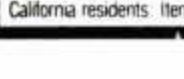

HOLLEY PERFORMANCE CARBURETORS
Brand New No Seconds. No Rebuilds.

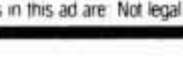

4 BARREL UNIVERSAL VACUUM SECONDARY
Manual Choke
600 CFM 1950 \$96.95
750 CFM 32150 \$107.95



4 BARREL UNIVERSAL VACUUM SECONDARY
Manual Choke
600 CFM 1950 \$96.95
750 CFM 32150 \$107.95

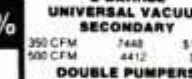

2 BARREL UNIVERSAL VACUUM SECONDARY
350 CFM 7448 \$109.95
500 CFM 4412 \$96.95



DOUBLE PUMPERS
600 CFM 4776 \$157.95
600 CFM 4777 \$159.95
700 CFM 4778 \$169.95
750 CFM 4779 \$169.95
800 CFM 4780 \$219.95
800 CFM 4781 \$219.95

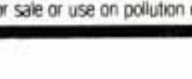

CHEVY STRAIGHT BORE QUADRAJET REPLACEMENTS
850 CFM 8210 Mec. Sec. \$163.95
850 CFM 8679 Val. Sec. \$162.95



HURST SHIFTERS



AUTOMATIC
Indy Matic \$39.95
Dual Gate 2 \$129.95
Auto Stick 3 \$109.95
AutoStick Van \$89.95
AutoStick Pick up \$89.95
Lightning Rods \$154.95
Quartershock \$129.95



MANUAL
Super Shifter (4 Spd.) \$129.95
Indy 3 Spd. \$42.95
Indy Pick up (4 Spd.) \$42.95
Indy (4 Spd.) Performance \$79.95
Super III (4 Spd.) \$129.95
with reverse gate lever \$129.95
Competition Plus (4 Spd.) \$139.95



ACCEL BREAKERLESS ELECTRONIC IGNITION DISTRIBUTORS
Mechanical Advance
Chevy V8 48.95
Ford 289-302 54.95
Ford 351C-400 54.95
Ford 429-460 54.95
Mopar 318-340-360 54.95
Mopar 383-440 54.95



UNILITE
Mechanical Advance
Chevy V8 89.95
Ford 289-302 99.95
Ford 351C-400 99.95
Ford 429-460 99.95
Mopar 318-340-360 99.95
Mopar 383-440 99.95



ACCEL DUAL POINT DISTRIBUTORS
Mechanical Advance
Chevy V8 48.95
Ford 289-302 54.95
Ford 351C-400 54.95
Ford 429-460 54.95
Mopar 318-360-360 54.95



ACCEL DUAL POINT DISTRIBUTORS
Mechanical Advance
Chevy V8 69.95
Ford 289-302 79.95
Ford 351C-400 79.95
Ford 429-460 79.95

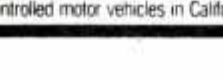

ACCEL SUPER COILS
Your Low Price
Accel Supercoil HEI \$26.95
Accel Supercoil HEI \$26.95
Accel Yellow Superstock \$14.95
Mallory Voltmaster \$29.95
Chrome Coil & Bracket \$14.95
Mallory Pro-Master 36.95
O.E.M. Universal Replacement 12V \$ 6.95



GENUINE HAYDEN RAPID COOL ELECTRIC FANS
WITHOUT THERMOSTAT
10 #2630 \$49.95
12 #3645 \$49.95
14 #3655 \$49.95

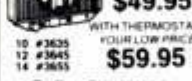

S.B. CHEVY WEIAND MANIFOLD SPECIAL
OPEN PLENUM RPM RANGE 2000 - 6000
Your Low Price
7546 S.B. Chevy \$69.95



STAINLESS STEEL FLEX-A-LITE FANS
UNIVERSAL FIT
8000 RPM RATING
#1070 17" DIAMETER
#1080 18" DIAMETER
YOUR LOW PRICE \$10.95

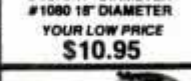

WIRES
7mm Yellow Silicone 8.95
8mm Yellow Silicone 15.95
Straight or angle boots, copper or suppressed wire
MALLORY PRO WIRE
The Wire the Pro's Use
V8 Set \$24.95
Straight or Angle Boots
Cover of Suppressed Wire



AUTOMETER AUTOGAGE PERFORMANCE STREET TACH'S
Your Low Price
#2300 Setin Black \$27.95
#2301 Chrome \$29.95
Full 3/4" Diameter, 0-6,000 RPM
Red Line Pointer
Universal Mounting
AUTO-GAGE'S
Oil Pressure #2321 \$11.95
Water Temp #2331 \$14.95
Vacuum #2371 \$11.95
Amps #2386 \$8.95



ACCEL DUAL POINT DISTRIBUTORS
Mechanical Advance
Chevy V8 48.95
Ford 289-302 54.95
Ford 351C-400 54.95
Ford 429-460 54.95
Mopar 318-360-360 54.95

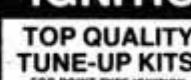

ACCEL DUAL POINT DISTRIBUTORS
Mechanical Advance
Chevy V8 48.95
Ford 289-302 54.95
Ford 351C-400 54.95
Ford 429-460 54.95
Mopar 318-360-360 54.95

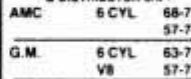

ACCEL SUPER COILS
Your Low Price
Accel Supercoil HEI \$26.95
Accel Supercoil HEI \$26.95
Accel Yellow Superstock \$14.95
Mallory Voltmaster \$29.95
Chrome Coil & Bracket \$14.95
Mallory Pro-Master 36.95
O.E.M. Universal Replacement 12V \$ 6.95

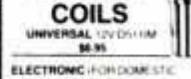

ACCEL SUPER COILS
Your Low Price
Accel Supercoil HEI \$26.95
Accel Supercoil HEI \$26.95
Accel Yellow Superstock \$14.95
Mallory Voltmaster \$29.95
Chrome Coil & Bracket \$14.95
Mallory Pro-Master 36.95
O.E.M. Universal Replacement 12V \$ 6.95

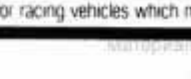

ACCEL SUPER COILS
Your Low Price
Accel Supercoil HEI \$26.95
Accel Supercoil HEI \$26.95
Accel Yellow Superstock \$14.95
Mallory Voltmaster \$29.95
Chrome Coil & Bracket \$14.95
Mallory Pro-Master 36.95
O.E.M. Universal Replacement 12V \$ 6.95



GENUINE HAYDEN RAPID COOL TRANSMISSION OIL COOLERS



1518 CARS (MEDIUM DUTY) YOUR LOW PRICE \$19.95
1522 CARS, TRUCKS & TOWING (MEDIUM DUTY) YOUR LOW PRICE \$29.95
1526 MOTORHOMES, TRUCKS & ALL HEAVY TOWING YOUR LOW PRICE \$34.95



RAPID COOL FAN CLUTCHES
BY HAYDEN
NON THERMAL (CARS)
THERMAL (CARS)
HEAVY DUTY TRUCK
FORD-GM
\$22.00
\$32.00
\$59.95



RAPID COOL ENGINE OIL COOLERS
BY HAYDEN
8000 FORD-MOPAR
9001 A.M.C.-GM
YOUR LOW PRICE \$39.95



O.E.M. REPLACEMENT IGNITION PARTS



TOP QUALITY TUNE-UP KITS
FOR POINT TYPE IGNITION
Available For Most Domestic 6 CYL & V8 Engines.
KIT INCLUDES ROTOR & CAP.
G.M. ONLY \$ 8.95
MOPAR 6 CYL 78-83 FORD V8 75-84 MOPAR FORD V8 80-84 FORD V8 78-84 \$ 3.95



ELECTRONIC IGNITION KITS
Available For Most Domestic 6 CYL & V8 Engines.
KIT INCLUDES POINTS-ROTOR-CONDENSER & DISTRIBUTOR CAP.
AMC 6 CYL 68-74 57-74
G.M. 6 CYL 63-73 V8 57-74
MOPAR 6 CYL 62-72 V8 66-72
FORD 6 CYL 56-65 V8 60-73
YOUR LOW PRICE \$5.95

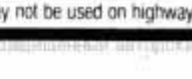

STARTER SOLENOIDS
FOR DOMESTIC 6 CYL AND V8 ENGINES
YOUR LOW PRICE
AMC 47-72 4883 \$4.95
FORD 56-84 4933 \$4.95
GM 57-84 3261 \$3.95

VOLTAGE REGULATORS
AMC 63-64 0635 \$7.95
"5.8" 0669 \$5.95
GM 63-78 0439 \$7.95
63-78 0439 \$7.95
63-78 0439 \$7.95
FORD 61-78 0408 \$5.95
MOPAR 61-69 0428 \$5.95
LOW INTERNAL REGULATOR

ON SALE SAVE OVER 50%



HOLLEY WATER INJECTION KITS
• SUPPRESSES DAMAGING ENGINE KNOCK
• OPERATES ONLY WHEN ENGINE IS WARMED UP
• USES WATER ONLY AS NEEDED
• MAXIMUM RELIABILITY AT LOWER COST
THE HOLLEY SYSTEM COMES COMPLETE WITH STEP-BY-STEP INSTRUCTIONS AND ALL MOUNTING HARDWARE
LOW COMPRESSION # 19-1 REGULAR PRICE \$58.95
HIGH COMPRESSION # 19-2 SAVE OVER 50%
RV'S/MOTORHOMES # 19-3 YOUR SPECIAL LOW PRICE \$19.95

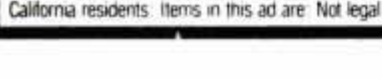

HOLLEY WATER INJECTION KITS
• SUPPRESSES DAMAGING ENGINE KNOCK
• OPERATES ONLY WHEN ENGINE IS WARMED UP
• USES WATER ONLY AS NEEDED
• MAXIMUM RELIABILITY AT LOWER COST
THE HOLLEY SYSTEM COMES COMPLETE WITH STEP-BY-STEP INSTRUCTIONS AND ALL MOUNTING HARDWARE
LOW COMPRESSION # 19-1 REGULAR PRICE \$58.95
HIGH COMPRESSION # 19-2 SAVE OVER 50%
RV'S/MOTORHOMES # 19-3 YOUR SPECIAL LOW PRICE \$19.95

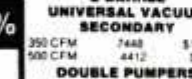

NEW TRW FUEL PUMPS
Your Low Price From
\$12.95
S.B. CHEVY
Available for all Makes & Models
Phone for Your Low Price



NEW TRW FUEL PUMPS
Your Low Price From
\$12.95
S.B. CHEVY
Available for all Makes & Models
Phone for Your Low Price

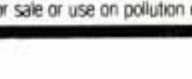

NEW TRW FUEL PUMPS
Your Low Price From
\$12.95
S.B. CHEVY
Available for all Makes & Models
Phone for Your Low Price

ON SALE ON SALE

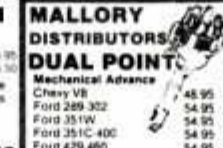

MALLORY DISTRIBUTORS DUAL POINT
Mechanical Advance
Chevy V8 48.95
Ford 289-302 54.95
Ford 351C-400 54.95
Ford 429-460 54.95
Mopar 318-340-360 54.95
Mopar 383-440 54.95



UNILITE
Mechanical Advance
Chevy V8 89.95
Ford 289-302 99.95
Ford 351C-400 99.95
Ford 429-460 99.95
Mopar 318-340-360 99.95
Mopar 383-440 99.95



ACCEL DUAL POINT DISTRIBUTORS
Mechanical Advance
Chevy V8 48.95
Ford 289-302 54.95
Ford 351C-400 54.95
Ford 429-460 54.95
Mopar 318-360-360 54.95



ACCEL DUAL POINT DISTRIBUTORS
Mechanical Advance
Chevy V8 48.95
Ford 289-302 54.95
Ford 351C-400 54.95
Ford 429-460 54.95
Mopar 318-360-360 54.95

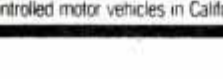

ACCEL SUPER COILS
Your Low Price
Accel Supercoil HEI \$26.95
Accel Supercoil HEI \$26.95
Accel Yellow Superstock \$14.95
Mallory Voltmaster \$29.95
Chrome Coil & Bracket \$14.95
Mallory Pro-Master 36.95
O.E.M. Universal Replacement 12V \$ 6.95

ON SALE ON SALE



MALLORY DISTRIBUTORS DUAL POINT
Mechanical Advance
Chevy V8 48.95
Ford 289-302 54.95
Ford 351C-400 54.95
Ford 429-460 54.95
Mopar 318-340-360 54.95
Mopar 383-440 54.95

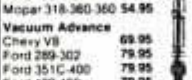

UNILITE
Mechanical Advance
Chevy V8 89.95
Ford 289-302 99.95
Ford 351C-400 99.95
Ford 429-460 99.95
Mopar 318-340-360 99.95
Mopar 383-440 99.95



ACCEL DUAL POINT DISTRIBUTORS
Mechanical Advance
Chevy V8 48.95
Ford 289-302 54.95
Ford 351C-400 54.95
Ford 429-460 54.95
Mopar 318-360-360 54.95



ACCEL DUAL POINT DISTRIBUTORS
Mechanical Advance
Chevy V8 48.95
Ford 289-302 54.95
Ford 351C-400 54.95
Ford 429-460 54.95
Mopar 318-360-360 54.95

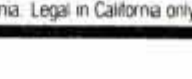

ACCEL SUPER COILS
Your Low Price
Accel Supercoil HEI \$26.95
Accel Supercoil HEI \$26.95
Accel Yellow Superstock \$14.95
Mallory Voltmaster \$29.95
Chrome Coil & Bracket \$14.95
Mallory Pro-Master 36.95
O.E.M. Universal Replacement 12V \$ 6.95

ON SALE ON SALE



MALLORY DISTRIBUTORS DUAL POINT
Mechanical Advance
Chevy V8 48.95
Ford 289-302 54.95
Ford 351C-400 54.95
Ford 429-460 54.95
Mopar 318-340-360 54.95
Mopar 383-440 54.95

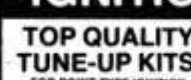

UNILITE
Mechanical Advance
Chevy V8 89.95
Ford 289-302 99.95
Ford 351C-400 99.95
Ford 429-460 99.95
Mopar 318-340-360 99.95
Mopar 383-440 99.95

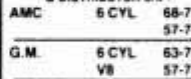

ACCEL DUAL POINT DISTRIBUTORS
Mechanical Advance
Chevy V8 48.95
Ford 289-302 54.95
Ford 351C-400 54.95
Ford 429-460 54.95
Mopar 318-360-360 54.95

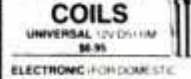

ACCEL DUAL POINT DISTRIBUTORS
Mechanical Advance
Chevy V8 48.95
Ford 289-302 54.95
Ford 351C-400 54.95
Ford 429-460 54.95
Mopar 318-360-360 54.95

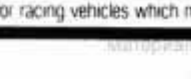

ACCEL SUPER COILS
Your Low Price
Accel Supercoil HEI \$26.95
Accel Supercoil HEI \$26.95
Accel Yellow Superstock \$14.95
Mallory Voltmaster \$29.95
Chrome Coil & Bracket \$14.95
Mallory Pro-Master 36.95
O.E.M. Universal Replacement 12V \$ 6.95

ON SALE ON SALE

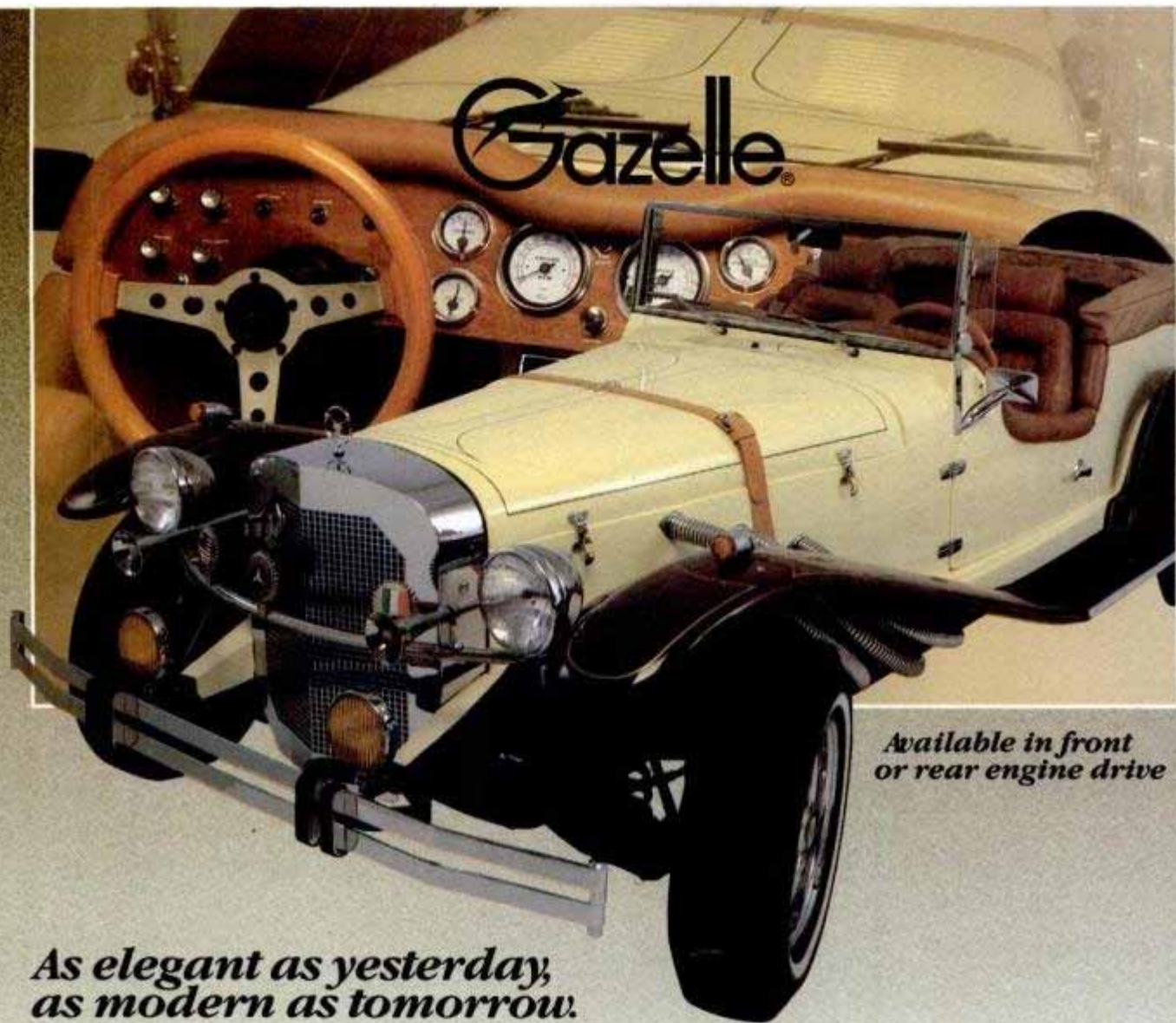

Available in front
or rear engine drive

**As elegant as yesterday,
as modern as tomorrow.**

Classic Motor Carriages, the world's largest replicar assembly manufacturer, presents its classic line for the 80's. Millions of dollars have been spent in engineering research to enable Classic Motor Carriages to produce the finest replicar assemblies available. Gelcoat finish... no rusting ever! All replicar assemblies are fully warranted by a company that cares.

Classic owners report gas mileage of 30-34 MPG. Our replicar assemblies are designed for the person of average mechanical skills using ordinary tools.



Classic TD



Speedster

Fill out the coupon below and begin the most rewarding experience of your life.

CLASSIC MOTOR CARRIAGES

16650 N.W. 27th Ave., P.O. Box 10
Miami, Florida 33054. (305) 625-9700
Mon.-Fri. 9AM-9PM Sat. 9AM-5PM Sun. 11AM-4PM

Enclosed is \$1 ea. for a full color brochure and consumer buying guide for Replicar Assembly: Gazelle _____ Classic Speedster _____ Classic TD _____ Classic Speedster C _____

Enclosed is \$5 ea. for a full color brochure on the handcrafted, factory-finished:
Gazelle _____

Name _____
Address _____
City _____ State _____ Zip _____
Phone Home (Area Code) _____
Bus. (Area Code) _____
Please charge on my: MasterCard _____
VISA _____ Am. Express _____
Acct. No. _____ Exp. Date _____
Signature _____

15-H-5

Look for our displays at airports in Amarillo, Baltimore/Washington International, Boston, Chicago, Cincinnati, Cleveland, Dallas/Love, Detroit, Grand Rapids, Gulf Port/Biloxi, Jacksonville, Kennedy, LaGuardia, Memphis, Miami, Minneapolis/St. Paul, Monterey, New Orleans, Palm Springs, Phoenix, Portland, Reno, San Jose, St. Louis, Tulsa.

© 1984 Classic Motor Carriages, Inc. Some equipment depicted is optional.

NEW CYCLE, NEW ENGINE

(Continued from page 134)

is lucky to be developed by a technical group and not a commercial company pressed for quick results.

The two-cylinder test engine now under construction uses major components from a large two-stroke diesel engine with overhead exhaust valves. Since the parts are stressed for diesel loads, the Otto cycle cylinders will be able to operate without undue stress. The cylinder head is being modified to connect the two combustion chambers with a transfer valve, whose timing can be varied for further experimentation. Testing should start this fall and PM will be there to cover it.

Application possibilities

The aircraft use of the Gerace engine has interesting possibilities for a piston engine with no ignition system that could run on jet-type fuel. It would give higher performance and run quieter than conventional engines. A muffled version holds the hope of silent operation for military use, in police helicopters or in commercial flights over populated areas. Business aircraft with quiet props and engines may be possible using lower-cost fuels.

Operating costs of stationary engines running 24 hours a day year after year become very important. Saving even pennies per hour can make a new engine attractive. Gerace believes that a clean coal-burning engine would be an ideal alternative for nuclear power plants. He is presently working on an engine for locomotives, ships and stationary power plants that could burn dry powdered coal.

The conversion of fuel into energy is presently restricted to narrow bands of fuels that will burn in conventional engines. Any liquid fuel, and even powdered fuels such as coal or wood dust, can be made to rapidly burn in the Gerace cycle. If the fuel has a high ignition level, then the compression of the diesel cylinder is raised to get the charge burning. Detroit engineers who've seen Gerace's patent note that the added manufacturing cost of the transfer valves will be offset by the lack of an ignition system. The use of lubricating fuels could also extend engine life and reduce maintenance.

The engine's final destiny may have little to do with its design, only economics and the availability of fuel in the 21st century. It took decades for the Otto and diesel engines to be developed into useful machines, and they are still being perfected today. If the Gerace cycle proves more powerful, cheaper to operate and has the running life of today's four-cycle engines, then it will be the prime mover of the 21st century. **PM**

ENDLESS HOT WATER!



Woman Takes 18-Hour Steaming Hot Shower!

A world record? We don't know. We did it to prove how you can get endless hot water

with an AquaStar Tankless Water Heater . . . and cut your water bill in half too!

AquaStar heats your water only as you use it, as long as you use it. Enjoy instant, endless hot water at the exact temperature you want it. No bulky tank. No running out of hot water. No more wasting energy. Millions of AquaStar tankless water heaters are in use today!

AquaStar is the ideal replacement for the tank. Designed to last a lifetime so AquaStar may be the last water heater you ever buy! Read what Popular Science, New Shelter, Mechanix Illustrated and others say about these amazing, economical tankless heaters.

Send coupon today for free information!

AquaStar Controlled Energy Corp.
Fiddler's Green Dept. 15085
Waitsfield, VT 05673

Yes! Please send more information right away!

Name _____
Address _____
City _____
State _____ Zip _____

FREE 7 CIGAR SAMPLER KIT

The World's Most Expensive Cigar Tobaccos



We searched the imported tobacco markets to find the World's most expensive cigar tobaccos and paid top dollar for the finest.

Rare, Imported Havana from the vintage crop of 1959, beautiful mild Cameroon, light silky Honduras, rich Mata Fina from Brazil, plus Dominican Cubanitos grown from smuggled Cuban seed. All blended by expatriate Cuban cigar makers into luxury cigars selling for up to \$1 apiece.

To make new friends, I'll send you a FREE Sampler Kit of 7 different cigars to TEST SMOKE at my risk. Send me nothing for the cigars, I've written them off... please just send \$1 to help defray postage and handling.

If not delighted, return the empty box and I'll refund your \$1. You can't lose, the risk is mine, U.S.A. only and 1 to a customer.

WALLY FRANK Ltd. Dept. LL 140
58 State Street
Westbury, N.Y. 11590
Send \$1., Print Name, Address & Zip

TOOL DISPOSAL



BIG TOP



TARPAULINS

- Brass Plated Grommets Spaced Every 3 Feet

- Mildew Proof, Safety Brite Color



- Meets All OSHA Requirements

INDUSTRIAL GRADE

POLYETHYLENE NYLON REINFORCED

- Designed for Maximum Strength and Durability: Giant Sizes, Weather And Water Resistant
- Ideal Cover For Farm Equipment, Machinery, Sports Equipment, Grain, Hay, Contracting Equipment, Tools, Or Any Material Kept Out Of Doors
- Used By Painters, Masonry Companies, And Many Schools

CONDITION: BRAND NEW UNOPENED CASES

Send me

Qty.	Size	Lot No.	Price Each
	6' x 8'	953-555	\$2.75
	8' x 10'	877-555	\$5.00
	10' x 12'	878-555	\$6.75
	12' x 16'	926-555	\$10.50
	16' x 20'	879-555	\$17.50
	18' x 24'	880-555	\$23.50
	26' x 40'	882-755	\$39.50
	26' x 55'	954-555	\$74.50
	30' x 60'	955-555	\$89.00

Minimum order is \$25.00. KY & CA residents add sales tax. **FREE DELIVERY**

Total amount of order \$ _____

Check or money order enclosed

Charge M/C Visa Exp. Date _____

Acct. No. _____

Name _____

Address _____

City _____

State _____ Zip _____

Phone () _____

Sign Here _____

HARBOR FREIGHT SALVAGE CO.

3491 Mission Oaks Blvd., P.O. Box 6015
Camarillo, CA 93011-6015

TOLL FREE 800-423-2567 T555

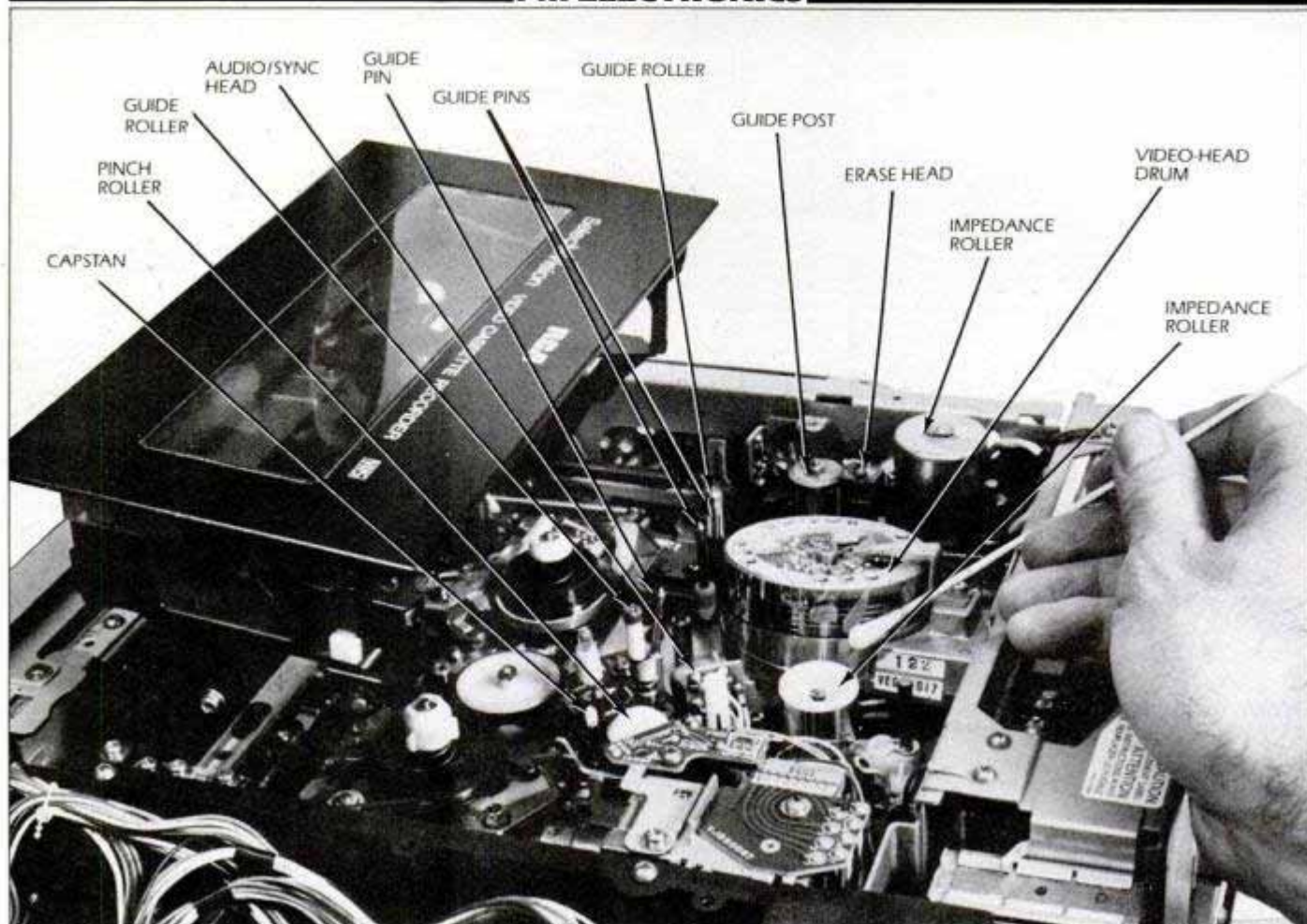

VCR Tuneup

Careful maintenance and cleaning keeps videocassette recorders in tiptop shape.

BY WALTER SALM

Cleaning your videocassette recorder (VCR) entails more than wiping off the top with a dustcloth. To maintain sharp pictures and crisp sound, you sometimes have to get inside and clean the tape mechanism.

What makes a VCR dirty? The principal culprits are the oxide particles that shed from your videotapes and attach themselves to components of the tape transport mechanism. Other factors are airborne dust and household fumes.

Fortunately, videocassettes today don't shed as much as they used to, so cleanups will be few and far between. When should you head for the cleaning tools? When you notice persistently noisy pictures or muffled sound.

Commercially available cleaning cartridges—the kind you use just the way you play a videocassette—do a reasonably good job of removing oxide depos-

its from the VCR's tape path. In fact, they're all you need if your VCR is the front-loading type.

The construction of front-loaders pretty much seals them off from dust and fumes. Older top-loading VCRs are more vulnerable to airborne contaminants because of their comparatively open design. So, you have to get under the hood occasionally to give your top-loader a good, thorough cleaning.

VCR manufacturers discourage do-it-yourselfers from poking around inside the machine. They feel it's too easy to damage or misalign the delicate video heads—and they're right. If you're careless, you might need a trained repairman to undo your damage.

Because the manufacturers don't want you puttering around in their VCRs, they do not make any technical or servicing information available to the

consumer. But if you're a reasonably careful worker, you can perform the simple maintenance chores outlined here. If you're really serious, you can perform more complex repairs. One publisher offers service manuals for most VCRs. They're available for \$8 from Howard W. Sams, 4300 West 62 St., Indianapolis, Ind. 46268. Request the *Photofact* for your particular brand and model of VCR.

You'll find that it's pretty easy to get the cover off the VCR. Typically, there are two or three Phillips-head screws toward the rear of the top and one or two in the back. The case cover should lift off in one piece.

At first glance, the innards of a VCR will baffle you. Whether your VCR is Beta or VHS, you'll find the video head assembly mounted on a large, rotating

(Please turn to page 142)

An Absolutely Amazing Offer!!!
You've seen them advertised for over \$200!!!

115-PIECE DRILL BIT SET

The most complete set of trade-shop quality High Speed Steel (HSS) drill bits on the market... now at an unheard-of low price!



Each TRADEMASTER set comes with a factory assigned Serial Number... and a full 5-Year Warranty Certificate to record it.

3 sets in one... all organized and labeled in a sturdy steel case... and all yours for one unbelievable low price!

60-Piece Set of Wire Gauge Size Bits from number 60 (.040) to number 1 (.228)



26-Piece Set of Letter Size Drill Bits from A (.234) to Z (.413)



29-Piece Set of Fractional Size Bits from 1/16" (.062) to 1/2" (.500) in 1/64" increments



- Made of M-2 roll-forged steel hardened to Rockwell C66-64 on the tips
- Coated with black oxide so bit runs cooler, lasts longer
- Meets or exceeds industry Standards ISO, DIN
- Steel case has fold-out trays with labeled index

Whether you're a home-handyman or professional, you can drill the exact bore sizes to meet Federal Specifications, the Unified Form Thread Standards — any technical instructions calling for a specific bore size. This set is that complete. Has every bit for every bore size to tap threads up to 1/2". The exact bits to install blind rivets, solid rivets, grommets, sheet metal screws, threaded inserts and rivets — hundreds of fasteners.

What's more, these are among the finest HSS bits made. Rugged, dependable even under severe trade-shop use. That's why we warrant each set for a full 5 years.

Then why the low price for such high quality? Volume buying and direct shipment cut our costs a lot. But the main reason for the low price is, quite frankly, to entice you to just try us with an order. Because we've found — if someone will just place a single order with us — odds are good that they'll "get hooked" on our uniquely good prices and expansive tool line. And we'll have them for a customer for years to come. That's why we include our big new catalog in each shipment.

JUST **79⁹⁹** plus shipping and handling

Average retail price is over \$200!!!

ALL ARE FULL JOBBER LENGTH AND FIT 3/8" DRILLS

Order now — you must be 100% satisfied or your money back.

Fill in the order form and mail with your check, money order, company purchase order or credit card information.

For faster service, credit card customers can call Toll Free 24 hours a day, seven days a week. **800-228-5000** (in Nebraska, 800-642-8777)

© Copyright 1985 D.R.I. Industries, Inc.
Made in China
TRADEMASTER is a trademark of D.R.I. Industries, Inc.

3 FREE GIFTS just for ordering!

We'll do just about anything to get you to try a set. Order now and we'll sweeten the deal with these gifts: a handy Drill Bit Gauge plus a Key Hole Saw plus a Surprise Free Gift! All 3 are yours absolutely FREE TO KEEP, even if you return your order!

FULL 5-YEAR WARRANTY

For an advance copy, write 115-Piece Drill Bit Set, D.R.I. Industries, Inc., Dept. 79353, 11300 Hampshire Ave. S., Bloomington, MN 55438-2498.

79353

DR I INDUSTRIES

SPECIAL OFFER COUPON

MAG-138

Try it free of obligation to keep it! If not totally satisfied, you can return your order for a complete refund, including shipping and handling.

Send and make remittance payable to:

D.R.I. INDUSTRIES, INC., Dept. 79353, 11300 Hampshire Ave. So., Bloomington, MN 55438-2498

Check method of payment (00028501) Ship me _____ How Many? 115-Piece Drill Bit Set(s) @ \$79.99 each = \$ _____

I have enclosed my check or money order for the full amount. (Minnesota residents add 6% sales tax.) Please add \$4.99 Shipping and handling on first set, = \$ _____

I have enclosed my company purchase order (this card MUST accompany ALL purchase orders). \$1.50 S & H on additional sets

Charge it to: VISA MasterCard American Express Diners Club Carte Blanche

PAY THIS AMOUNT—TOTAL = \$ _____ (MN residents add 6% sales tax)

Card Number _____ Exp. Date _____

Signature _____ (Need sign only if charging order)

Name _____

Address _____ (Street and Number)

City _____ State _____ Zip _____

I don't wish to order now. But please send me your catalog. I've enclosed \$1 (refundable with first order). (00005828)

MAKE UP TO \$26⁰⁰ an HOUR

BE YOUR OWN BOSS

START YOUR OWN MONEY MAKING BUSINESS

Hundreds of FOLEY-BELSAW trained men have succeeded in this fascinating and highly profitable field...

You Can Do It Too! ... BE A

LOCKSMITH

Never before have money-making opportunities been so great for qualified Locksmiths. Now lucrative regular lock and key business has multiplied a thousandfold as millions seek more protection against zooming crime. Yet there's only one Locksmith for every 17,000 people! Train FAST at Home — Collect CASH PROFITS Right Away. You're in business ready to earn up to \$26.00 an hour a few days after you begin Foley-Belsaw's shortcut training. Take advantage of today's unprecedented opportunities in Locksmithing for year-round EXTRA INCOME in spare time — or full time in a high-profit business of your own. Hundreds we've trained have done it. So can YOU! All tools plus professional Key Machine given you with course. These plus practice materials and equipment, plus simple, illustrated lessons, plus expert supervision, plus business-building guidance will enable you to KEEP THE MONEY COMING IN! Ideal for retirement — good jobs, too.

SEND FOR EXCITING FACTS — NO OBLIGATION! PRO KEY MACHINE YOURS TO KEEP FREE

This machine can add up to \$200 a month to your income... it won't cost you a penny extra with your training.

FOLEY-BELSAW INSTITUTE
10717 FIELD BLDG.
KANSAS CITY, MO. 64111

There is NO OBLIGATION • NO SALESMAN Will Call - ever!

FREE FOLEY-BELSAW INSTITUTE
10717 FIELD BLDG., KANSAS CITY, MO. 64111
PLEASE RUSH FREE BOOK "Keys To Your Future"

NAME _____
ADDRESS _____
CITY-STATE-ZIP _____

STEEL RUST REPAIR PARTS

Restore your Chevy or Ford truck to showroom condition with American-made TABCO steel rust repair parts. Also available for most Japanese, European and British cars.

Send \$3.00 for illustrated catalog. Mailed 1st class (refundable). Dealer inquiries invited.

TABCO 30500 Solon Industrial Parkway
Dept. PM, Cleveland, Ohio 44139
(216) 248-5151

MOLDS

for making Ornamental Concrete Items...

Book about Aluminum Molds with prices and production trade secrets direct from world's largest mold manufacturer.

SEND \$5.00

CONCRETE MACHINERY COMPANY, INC.

P. O. BOX A99 - HICKORY, N. C. 23601

GEMINI
THE AUTONOMOUS ROBOT

IS NOW PRICED FOR EVERYONE!



Buy each subassembly as a kit or factory assembled and create your own GEMINI Robot.

Or, for convenience, start with GEMINEX, our starter kit, and expand to GEMINI later with upgrade kits.



Either way, Buy a piece of tomorrow TODAY!

CALL or WRITE For Our FREE Brochure.

arctec systems
9104 Red Branch Road
Columbia, Maryland 21045
(301)730-1237
Telex 87-781

VCR TUNEUP

(Continued from page 140)

stainless-steel drum that sits at a crazy angle. There are numerous guide posts—also at odd-looking angles—several guide rollers, roller pins, a capstan which squeezes the tape against a pinch or pressure roller, and two stacks of stationary heads. One contains the erase heads. The other houses the audio and sync-control heads.

All of these components need to be cleaned. We've identified them in the photograph of a typical VHS model. Beta VCRs have the same parts, but their layout is different. Beta or VHS, you should familiarize yourself with the tape travel path by playing a cassette with the VCR's cover off (this is possible on most toploaders). Note the components the tape contacts. These are what you clean—after you've ejected the cassette and unplugged the VCR.

Hard-to-reach dust

Before you clean the tape mechanism, look for accumulated dust in hard-to-reach places. If you've got a mini-vacuum with a small, flexible pick-up hose, use it. Otherwise, commercially available canisters of compressed air (used for cleaning cameras) will do.

For actually cleaning your VCR's heads and tape-transport components, get long-stemmed cotton swabs and a bottle of head-cleaner solvent from an electronics store such as Radio Shack.

These cost about \$3. Bathroom swabs will not reach where you want them to, and will leave globs of cotton on the parts. Also, household rubbing alcohols contain impurities that might cause damage. Don't let the clerk force a demagnetizer on you. Contrary to myth, VCR makers insist demagnetizing is unnecessary with today's video and audio decks. Ditto for lubrication.

Once you've cleared out the loose dust, start swabbing—very carefully. The swab should be damp, not sopping wet. If you saturate the swab, flick off the excess alcohol. Clean the minuscule video heads on the drum with a horizontal motion—not up-and-down.

Rub gently. These heads are delicate, and should never be touched with objects that could scratch them. Similarly, never foul them with a fingerprint. Rotate the cylinder to move the other heads into reachable position by touching the top only. Your VCR might have just two heads on the cylinder or as many as five. Clean them all.

After you've swabbed the video heads, go on to clean the other parts. The order in which you clean doesn't matter, but following the tape path is a good idea. Just be sure to start a fresh swab as soon as you see dirt on the one you're using.

FM

Texas Lady Makes \$9,000 In First Four Months! Georgia Man Starts Broke And Builds \$150,000 A Year Business From Scratch!

YES! PEOPLE WHO NEED MONEY ARE MAKING THOUSANDS AND THOUSANDS OF DOLLARS! AND IT WON'T COST YOU A CENT TO FIND OUT HOW YOU CAN ENJOY THE SAME OPPORTUNITY!

People all over America are joining a unique money-making organization. And the results they're achieving are fantastic! Evelyn Rosales of Texas made \$9,000 in just four months. Danny King of Georgia started broke—and had a \$150,000 year! John P. Mendez of California has taken in as much as \$20,000 in a single month!

And Richard Spier received \$1,000 in the mail in a single day!

What is this money-making organization—how does it work? and how can you join?

Well, pay close attention, because that's the subject of this article.

The organization's name is Specialty Merchandise Corporation. And, while SMC has been helping people make money for over 25 years, you may never have heard of it because its many benefits are available only to members.

A Unique Concept That Lets You Make Money Right From The Start!

Specialty Merchandise Corporation makes its products available only to its members. A few such products are pictured on this page: Popular top-quality credit-card size calculators for only \$3 each; a genuine, beautifully-styled diamond ring for only \$4.95; super accurate mens' and ladies' fashion-designer quartz watches for only \$2 each! In all, over 2500 quality items that only SMC members have the right to distribute. With cash profits as high as three, four, even five times your low cost!

No Personal Selling Required!

Our products are priced far below wholesale—and the quality and variety is so outstanding—that no real "salesmanship" is required. Many members write to tell us that our products actually sell themselves, especially when they follow the detailed, step-by-step instructions we provide in over 20 proven programs. And some of these programs, like our Mail Order and Catalog Sales plans allow you to make money working entirely from your home, without any personal selling at all.

Are You Interested In Making Money Fast?

—if so, you'll want to mail in the coupon on this page. As soon as we receive it, we'll rush you our comprehensive money-making report, along with a special invitation that will allow you to join SMC without a single cent of

risk on your part.

This report is yours absolutely free. There is no cost or obligation. And no salesman will ever call and bother you.

The report you get free will be the very same detailed money-making report that has started other SMC members on the road to financial security.

CHOOSE FROM OVER 2500 FAST-SELLING ITEMS IN STOCK!

 Credit Card Size CALCULATOR Your Cost Only \$3.00	 Indoor/Outdoor THERMOMETER Your Cost Only 65¢
 Deluxe Chain BURGLAR ALARM Your Cost Only \$1.40	 Halogen Auto SPOTLIGHT (Plugs into Cigarette Lighter) 50,000 Your Cost Only \$4.60
 Genuine PORCELAIN CLOWN Your Cost Only \$2.65	 Candle Power Your Cost Only \$5.95
 Battery-Operated DELUXE PENCIL SHARPENER Your Cost Only \$1.65	 JUMPER CABLES Jump-Start Your Car Thru The Cigarette Lighter Your Cost Only \$4.60
 8-Pack 60-Minute CASSETTE TAPES WITH CASE Your Cost Only \$1.65	 UL Approved AIRLESS PAINT SPRAYER Your Cost Only \$11.80
 Genuine DIAMOND RING Your Cost Only \$4.95	 100-BELL WINDCHIMES Your Cost Only \$1.30

COMPREHENSIVE REPORT YOURS ABSOLUTELY FREE!

Get your copy of our famous report that's started others on their Road to a Fortune!!



HERE'S PROOF! THESE PEOPLE HAVE SOLVED THEIR MONEY PROBLEMS AS OWNERS OF THEIR OWN SMC WHOLESALING BUSINESSES

If you want to make money, SMC will show you how. We provide you with everything. Merchandise. And detailed step-by-step instructions. You don't need special experience or education. And you can get started without a cent of financial risk.

Evelyn Rosales of Texas made \$9,000 in her first four months. She says, "I only wish I had discovered SMC long ago."

Danny T. Harris was broke when he started out with SMC. He used our proven money-making plans that let him generate a quick cash income without investing a cent in inventory. And he had a \$150,000 year.

John P. Mendez used SMC's exclusive wholesaling plans to take in as much as \$20,000 in a single month. He says, "I can't imagine anyone becoming an SMC wholesaler and not making money."

The very same free report that helped Mary Ellen Rendon of Colorado to earn three to five times her salary as a teacher. The free report that allowed Gloria D'Abian of Hawaii to make over \$500 in a single day. The very same free report that enabled a college student, Fred Parker of Ohio, to amaze his business professors by bringing in as much as \$7,000 in a single month!

Your Free Report Will Tell You Everything You Need To Know To Get Started!

You'll learn how to start your own mail order business that you can operate right from your own kitchen table—sorting out thousands of dollars in checks that people send you in the mail.

You'll learn how you can make hundreds of dollars in a single evening in your own home just by following our detailed, step-by-step instructions.

You'll learn about our exclusive merchandise racks that earn money for you automatically—day in and day out. How

to make hundreds of dollars every weekend at local flea markets and swap meets. How to set up your own SMC Catalog program that will let you make money without investing a cent in merchandise.

You'll learn all this, and much, much more. Too much, in fact, to even begin to tell you about in this short article.

So send for your free report now. And maybe we'll soon be telling others about your success. Just as we're telling you about Bobby W. Ford of Tennessee who made \$703.80 in a single hour. Bernardine W. Wilson of Arizona who made \$2500 in a single week. Angel Santos Jr. of California who gave up his restaurant business because he expects to clear \$40,000 this year through his SMC membership. And Cordelia Osui, a California housewife, made \$1200 on a single sale.

The list of people who have made money through their SMC membership goes on and on. But, before you can make money as an SMC member, you have to do one simple thing—mail in the coupon on this page and get your free report!

SMC SPECIALTY MERCHANDISE CORP.
9401 De Soto Ave., Dept. 401-56
Chatsworth, CA 91311

You bet I'm interested in making money fast! I want to see how others got started on the road to a fortune. Rush me my FREE comprehensive report on how I can start my own wholesaling business. I understand there's no obligation, and no salesman will call.

NAME _____
ADDRESS _____
CITY _____ STATE _____ ZIP _____



BUILD YOUR OWN ROCKET MOTORS!

- * 40 POUNDS THRUST!
- * FIFTY CENTS EACH!
- * BUILD A DOZEN IN AN EVENING!

Write for our catalog and we'll send you a WORKING SAMPLE of an electric igniter that YOU CAN MAKE YOURSELF from materials you'll find around the house.

Send \$2.00 to
Dept. PM-8 THE TELEFLITE CORPORATION,
11620 Kitching St., Sunnyvale, Calif. 92386

Wood-Mizer® Bandsaw Mill

Turn Logs Into Lumber — And Cash
Portable • Precise

Accurately cuts a log
30" dia. X 16' long

"We manufacture quality sawmills so you can cut quality lumber. That's why we sell more portable bandsaw mills than anyone else in the world."

For more information send \$1.00 to:
WOOD-MIZER, Dept. D17
8180 W. 10th Street
Indianapolis, IN 46224
Or Call (317) 271-9642

AT LAST!

Electronic water leak sensors engineered for all cars, vans, trucks. Buzzes when coolant runs low or leaks. Anyone can install. We are the original manufacturer. One year warranty. Fast delivery, free shipping. Send \$14.50 to:

CARE-A-VAN Co.
2151 Tomlinson Avenue, Bronx, N.Y. 10461
Phone (212) 931-8970

Portable Steam Cleaner

Steam in 60 seconds

CLEAN: Engines, Air Filters, Lawn Mowers. 3-yr. guarantee on fire box, coils. Uses liquid soap, propane fired. Wt. 120 lbs. Auxil. pump required on low water pressure.

WEDCO MFG. INC., Dept. M-16
P.O. Box D, 940 West Broadway,
Jackson, Wyoming 83001

New from Burro! 17 ft. fiberglass travel trailer and original 13 ft. model. Assembled or kit. 750-1500 lbs. Ready to tow. Sleeps 4. Color Catalog. Send \$3 to Burro, 12775 Co. Rd. 43, Chaska, MN 55318 PM885

SMALL ENGINES

GENERATORS, TROY-BELT TILLERS, LAWNMOWER PARTS, MUCH MORE

FREE CATALOG DISCOUNT PRICES

SMALL ENGINE CITY
2612 Lyndale So., Dept. PM-2
Minneapolis, MN 55408
612-872-4288

INSTALL YOUR OWN SATELLITE SYSTEM

WITH OUR EASY TO UNDERSTAND BOOK YOU CAN!
SO DO-IT-YOURSELF AND SAVE
KNOW WHAT WORKS BEST BEFORE YOU BUY
WHERE NAME BRANDS DO COST LESS!

DOWNLINK Home available

FOR YOUR BOOK SYSTEMS CATALOGUE AND PRICING PLEASE SEND CHECK OR MONEY ORDER FOR \$12.95 TO:
P.O. BOX 519 • GLENDALE, OREGON 97443

\$1,000'S WEEKLY

Home Business Directory
Exciting Free Details. Write:
Box 2019-PM
New York, NY 10163

MUST LIQUIDATE AT FAR BELOW DEALER COST! FAMILY PAGER Communication System



Up to 1/2 mile range or more!

Factory new! First quality!

High Technology paging systems have long been available to doctors and executives at an expensive price. Now you can bring that same technology into your home at a very small fraction of the cost! Due to a bankruptcy, we are now authorized to liquidate this family communication system at FAR BELOW dealer cost!

At Home:
Call children home from the neighborhood playground with the push of a button! Signal your child to merely "phone home" from the neighbor's house for a message! Stay in touch with family members at home while you are out in the yard! Bring your "family" mechanic in from the garage for important phone calls!

On the Farm:
Call farm hands in from the barn, instantly!

- **Home-Based Transmitter!** Plugs into standard household outlet.
- **Two Portable Receivers!** Durable vinyl covering and belt clips. 12-hour rechargeable batteries and charger are included.
- **Personalized Coding!** Prevents interference with similar paging systems in neighborhood.
- **Electronic "Beeps"!** You can send TWO different signals: for "come home" or "phone home."
- **1/2 Mile Range or More!** Depending on local geographic conditions.
- **Warning "beep"!** Lets receiver/wearer know when he/she has wandered out of range!

Mfr. List \$80.00

Liquidation Price ... \$18

Item H-596-63124-02
Price subject to change after 60 days. Offer void outside original 48 states.

Credit card customers can order by phone, 24 hours a day, 7 days a week

Toll-Free: 1-800-328-0609

Your check is welcome!
No delays in orders paid by check.

C.O.M.B. CO.® Item H-596-63124-02
14615 28th Ave. N. / Minneapolis, MN 55441-3357

Send _____ Family Pager(s) at \$18 each plus \$4 each for shipping and handling. (Minnesota residents add 6% sales tax. Allow 3-4 weeks for delivery. Sorry, no C.O.D. orders.)

My check or money order is enclosed. (No delays in processing orders paid by check, thanks to TeleCheck.)

Charge: MasterCard VISA Am. Ex. Diners Club

Acct. No. _____ Exp. _____

PLEASE PRINT CLEARLY

Name _____
Address _____
City _____
State _____ ZIP _____
Phone _____

Sign here _____

C.O.M.B. CO.®
Authorized Liquidator
14615 28TH AVENUE NORTH
MINNEAPOLIS, MINNESOTA 55441-3357

HINTS FROM READERS

No-spill funnel



Make a funnel of a soap bottle to pour oil into a truck engine. Cut a side out of the lower half of the bottle. Place neck in the oil filler pipe and pour oil through cutout.

—Alice and Robert Tupper

Prolonging fences

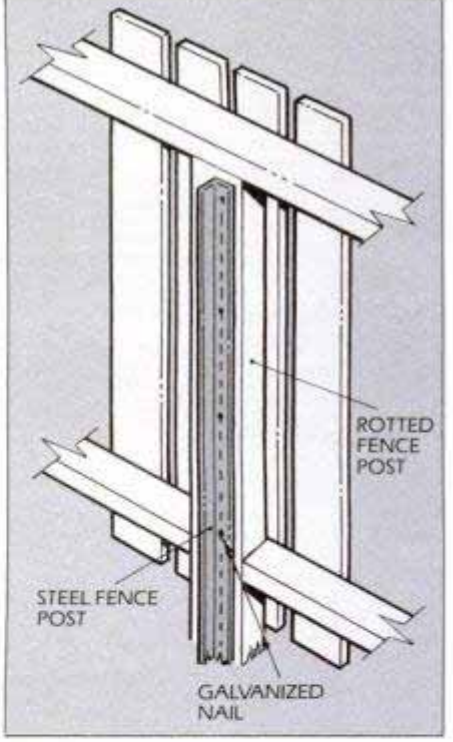

Even though the supporting posts have rotted, you can add years to the life of wooden fences otherwise in good condition. Drive a steel fence post normally used for barbed-wire enclosures into the ground beside the rotted post. Drive galvanized nails through slots in the steel post to secure it to the wood post. For more stability, install a second steel post on the other side of the wood post.

—C.M. Luchessa

WORTH WRITING FOR LOOKING FOR IDEAS ON TOOLS, HOME IMPROVEMENTS, HOBBIES & MORE? CHECK THESE LISTINGS, THEN USE THE COUPON BELOW.

100 TOOLING AROUND

Ralmike's 304-page catalog details over 940 "off the shelf" short run tooling specialties. Includes cut-off sawing, E.D.M. drilling/tapping, boring/milling, turning/grinding and more. Complete specifications and prices. \$5.00 (Refundable on first order.)

101 A REAL PICK-UP

The go-anywhere, do-everything Ford F-Series and Ranger pickup trucks are described in two full-color catalogs. Illustrations and photos bring to life the trucks that are built Ford Tough. Free

102 CAR RESTORER'S BIBLE

The Eastwood Company's 70-page Spring 1985 catalog contains everything for antique and specialty car restoration. Also includes new tech article on pinstriping techniques. Free

103 ENLARGE YOUR VISION

Relieve eye stress when you do detail and precision work with Precision Optical's magnifiers. 32-page catalog includes over 16 magnifiers for reading, sewing, crafts . . . helpful to jewelers, craftsmen, homeowners, do-it-yourselfers. Free

104 THERAPEUTIC LUXURY

Watkins Manufacturing wants you to know about the therapeutic luxury of the Hot Spring Spa® featuring the exclusive Moto-Massage™ Jet. Complete catalog lists product features, specifications, models and operating costs. Free

105 HOUSEHOLD INVENTORY RECORD

Handy folder from Allstate Insurance provides a room-by-room inventory record for your personal property. Includes tips on identifying lost or stolen property and a place to record where important papers are kept. Free

106 TOOLS OF THE TRADE

Illustrated 16-page tool catalog from Alway Tools contains an extensive listing of saw blades and saws, woodscrapers, knives and blades, putty knives, painting scrapers, accessories and sanders. Free

107 CORROSION CONTROL

Neutra Rust, a non-toxic, organic liquid-compound, is the do-it-yourselfer's defense weapon against rust. Three-page flyer gives product information and explains theory and process. Free

108 THINGS ARE HEATING UP

An alternative heating method offered by HAUSA - Heating and Heat Storage Apparatus - is described in an illustrated four-page brochure. Both a furnace and a heat storage system, it can be built to complement the design of your home. Free

109 GRAND ILLUSION

24-page brochure demonstrates how small rooms can be made to appear larger with the exclusive use of mouldings. See the results in detailed before and after shots. Includes do's and don'ts. \$1.50

110 GO BRONCO!

Meet the exciting Bronco and Bronco II in these two full-color catalogs from Ford. Ford workmanship, handling, specifications and safety features are discussed. Free

111 A LESSON IN FAN CLUTCHES

Imperial's 6-page pamphlet is an informative discussion on how the fan clutch operates. Explains the function of the fan clutch and how to tell when it should be replaced. Free

112 ENCYCLOPEDIA OF HAND TOOLS

The complete selection of over 2,200 Great Neck hand tools, illustrated and described in this 144-page catalog. Screwdrivers, woodworking, finishing tools, measuring tools, craft, automotive tools and more. \$2.00

113 THE CUTTING EDGE

Olson Saw's new brochure provides safety tips and general how-to's such as choosing the correct tooth style and set, proper blade length and speed for cutting wood or other materials, plus basic troubleshooting. Includes listing of Olson saws and blades. Free

114 HANDY HOME/WORK PRODUCTS

Disstim offers brochures about three products designed to make your work projects easier: the "Stepmate" folding, aluminum all-purpose stepladder; "Hook 'n Hand" storage system featuring snap lock hooks; "Scru-Drill" adjustable wood screw drill and countersink. Free

115 PERFORMANCE PARTS

Brand new 80-page catalog available from GM Parts. Featuring "performance parts," part numbers which are available through GM dealers. Separate sections on Chevrolet, Buick, Pontiac and Oldsmobile. \$4.50

116 WOODWORKING STOP N' SHOP

This catalog from 173-year old Albert Constantine & Son contains 3,000 items for woodworking and hobby work. Fine woods, tools, finishings, unusual hardware and crafts are offered in this fully-illustrated 116-page reference guide. \$1.00

117 DUAL-TOOL SOCKET SYSTEM

Each Test Rite Metrinch® socket fits both inch and the equivalent metric size. 4-page brochure illustrates and describes how Metrinch® can help save you money and space. Free

118 THE ABC'S OF CEDAR SIDEWALLS

20-page step-by-step illustrated Wallbanger Pocket Guide from Red Cedar Shingle and Handsplit Shake Bureau describes sidewall application of cedar shakes or shingles. Tools and equipment, rewalling and overwalling, single-coursing and double-coursing are discussed. 50c

119 A CATALOG OF SERVICE

Comprehensive 16-page catalog lists nearly 200 popular service manuals offering repair information for almost any type equipment. From snowmobiles to chainsaws . . . outboard motors to tractors and more. From Technical Publications. \$1.00 (Credited towards your first order.)

120 POWER TOOL SOURCE

84-page illustrated catalog from Porter Cable displays full line of portable electric tools: saws, sanders, polishers, paint removers, screw drivers, drills and more. Complete and detailed specifications. Free

121 THE DEVIL CAN HELP YOU DO IT

This 10-page folder from Red Devil takes you through the proper procedures for installing or repairing drywall. Covers planning, preparation, tools and finishing touches. Free

122 READY FOR TAKE OFF

You're up and away with AViation Publishers' brochure on building your own plane from a kit. Select from no license ultralights to racers, aerobats and fighter replicas. Brochure includes 200 makes and models. \$1.00

123 POWER TOOL GUIDE

This 266-page book from Dremel contains hundreds of photos and charts showing how to get the most from Moto-tools, Dremel power tools, attachments and accessories. Contains quick-fix ideas and project plans. \$7.95

124 THAT IMPORTANT OUNCE OF PREVENTION

Chemical Specialties Manufacturers Association believes preventive car maintenance is cheaper and more effective than later corrective action. Fact sheet includes how to maintain and restore paint, glass, vinyl, rubber, chrome. Free

Popular Mechanics 8/85
Box 1718, Sandusky, Ohio 44870

This Coupon Expires October 31, 1985

Please see that I receive the items checked below

<input type="checkbox"/> 100 \$5.00	<input type="checkbox"/> 105	<input type="checkbox"/> 109 \$1.50	<input type="checkbox"/> 113	<input type="checkbox"/> 117	<input type="checkbox"/> 121	Total money for priced items \$ _____
<input type="checkbox"/> 101	<input type="checkbox"/> 106	<input type="checkbox"/> 110	<input type="checkbox"/> 114	<input type="checkbox"/> 118 50c	<input type="checkbox"/> 122 \$1.00	Service Charge \$ _____ .50
<input type="checkbox"/> 102	<input type="checkbox"/> 107	<input type="checkbox"/> 111	<input type="checkbox"/> 115 \$4.50	<input type="checkbox"/> 119 \$1.00	<input type="checkbox"/> 123 \$7.95	Total money enclosed \$ _____
<input type="checkbox"/> 103	<input type="checkbox"/> 108	<input type="checkbox"/> 112 \$2.00	<input type="checkbox"/> 116 \$1.00	<input type="checkbox"/> 120	<input type="checkbox"/> 124	Total items requested \$ _____
<input type="checkbox"/> 104						

Name (Please Print) _____

Address _____

Town _____ State _____ Zip Code _____

(Please send cash, check or money order made out to POPULAR MECHANICS. NO stamps, please)

Note: Popular Mechanics processes your requests for the above information and forwards these inquiries to the organization making the offer. Each company mails the material directly. Your order will be on its way to you within 90 days.

AMAZING SCIENTIFIC AND ELECTRONIC DEVICES

LASERS, PHASERS for shock wave, weapons, burning, cutting, holography, cloud writing and visible light beam application. PLASMA TORNADO, FORCE FIELD, ION WIND, ION MOTORS, LIGHTNING GENERATION, TELSIA COILS, ANTI-GRAVITY, MAGNETIC IMPULSE GUNS, INFRASONICS and ULTRASONIC DEVICES. SHOCK and STUN GUN PROJECTORS for personal protection. SEE IN TOTAL DARKNESS, LONG RANGE VOICE TRANSMITTERS, DIRECTIONAL MICROPHONES, INTRUSION DETECTORS for security, SATELLITE TV, ENERGY and INSECT/RODENT KILLERS, REPELLERS for the home. SEND \$1.00 FOR CATALOG OF PLANS, KITS AND COMPLETED ITEMS TO

INFORMATION UNLIMITED
BOX 716, DEPT M8
AMHERST, NH 03031

GUARANTEED 10 YEARS!

The knife for hunting, fishing and all around use. Mirror polished sharp stainless steel blade. Rugged.



\$1.96
SIZE CLOSED
3"-\$1.96
4"-\$2.96
5"-\$3.96

Goens with a flick of finger and automatically locks into position. Press button in handle to close. Safety finger guard. Sure-grip black handle. **IF BROKEN WITHIN 10 YEARS WE WILL REPLACE AT NO CHARGE!** Use 30 days, money back if not pleased. Add 99c postage & handling but **ORDER ANY 3 KNIVES & WE SHIP FREE.** ORDER TODAY. Midwest Knife Co., Dept. C-4308 9043 S. Western Ave., Chicago, IL 60620. Mail orders only. **DUR 49th YEAR.**

30 DAY MONEY BACK OFFER

Dupli-Carver

Affordable Precision Wood Carving Machines

Duplicate virtually ANYTHING

- Gunstocks
- Signs & Plaques
- Figures & Statues
- Furniture Restoration
- Create carved mouldings

3 MODELS AVAILABLE

For More Information Send \$1.00 to:
Dupli-Carver Dept. TD-SC
8380 W. 10th St.
Indianapolis, IN 46224
(317) 271-1542

Chimney Caps 25 yr. Guarantee 100% Stainless Steel No Maintenance

- Helps Prevent Fire • No Corrosion • No Rust
 - Keeps Animals Out • Easy Installation
- | | | |
|---|-----------------|---------|
| S | 8 1/2" x 8 1/2" | \$39.95 |
| S | 8 1/2" x 12" | \$44.95 |
| L | 13" x 17" | \$49.95 |
| Z | 8 1/2" x 17" | \$54.95 |
| E | 13 1/2" x 17" | \$61.95 |
| S | 17" x 17" | \$74.95 |
- Send: Money order or check. Allow 3 to 5 weeks Del.

Crown Chimney Caps

P.O. Box 474 Greek Kills, Staten Island, N.Y. 10308
Add \$3.50 shipping N.Y.C. add 8 1/2% sales tax. For more information and sizes send \$2.00 for brochure.

Pay For Your Hobby!

With White's NEW Series 3 Metal Detectors



Sensitive detectors locate the rare and valuable for fun and profit. \$99.95 & up!

Call Toll Free: 1-800-547-6911

WHITE'S ELECTRONICS
Dept. PA-6 Sweet Home, OR 97386

The Homebuilt

JET HELICOPTER MANUAL

LOW-COST DESIGNS / ASSEMBLY METHODS

- Carries one person-plus • Vertical take-off & landing
- Hand-tool construction • Can be flown without a license • Uses low-cost fuel



the Helicopter Experimenters' HANDBOOK
Filled with designs, data, methods and suppliers for the rotary-wing hobbyist (illus.). Only \$9.00*

*BOTH ABOVE BOOKS: ONLY \$17.00
POSTAGE and 5% sales postage. 2000 U.S. Funds only.

Kit a plans into \$2 or FREE with \$17 order!



P.O. Box 16488
Baltimore, MD 21217

NEW BOOK OF WOOD/COULD II



featuring 23 REDWOOD PROJECTS

...created by professionals in fine woodworking. Complete plans, working with wood tips, plus the fascinating story of redwood. \$3.95

Enclosed is \$3.95.
Please send me a copy of the Redwood Book of Wood/Could II. (CA residents add 6% tax)

Name _____
Address _____
City _____
State _____ Zip _____

Simpson

Simpson Timber Company, California Operations
P.O. Drawer V, Arcata, CA 95521 Dept PM-41

Dome Home Kits



Affordable. Ready to Assemble.

A Monterey Dome is the home for all seasons. Engineered in kit form for the novice builder. All parts are pre-cut and color coded. Prices start at \$3995.

Send now for Monterey Domes 100 page color Catalog & Plans Book. \$6.00.

- Please send my 100 page copy of Monterey Domes Catalog & Plans Book. Enclosed is \$6.00.
- Also please send me the Monterey Domes Basic Home Assembly Manual for an additional \$5.00. Thank You.

Name _____
Address _____
City/State/Zip _____

Send To MONTEREY DOMES
1760 Chicago Ave., Dept. AQ-8
Riverside, Calif. 92517

HYDRAULIC JACK REPAIRS



A Business of your own.

Earn while you learn at home. Millions of jacks in gas stations, trucking firms, etc. need servicing. We show you HOW. Start spare time in your basement or garage. Big opportunity for mechanics.

Write for folder No. PM8 and free bonus offer.

HYDRAULIC JACK INC.
P.O. BOX 18, ACCORD, NY 12404



New from Burro. A full line of lightweight fiberglass folding tent trailer kits. Color catalog send \$3.00 to Burro 12775 County Road 43 Chaska, Minn. 55318 Dept. PM85 F.D.P.M. 57

BUILD BIZARRE BIKES

Build your own super bikes and trikes. Aluminum frames. No welding. Easy to build. \$1.00 for brochure and list of plans.



E.T. Cycle
539 - 17 Avenue S.W.
Calgary, Alberta, Canada
T2S 0A9

FREE CATALOG!

Outstanding How-To, Electronics, Computer, Aviation, and Automotive books! Over 700 titles.

TAB BOOKS Inc. DEPT. PMX-85
P.O. Box 40, Blue Ridge Summit, PA 17214

HINTS FROM READERS

Window mirror

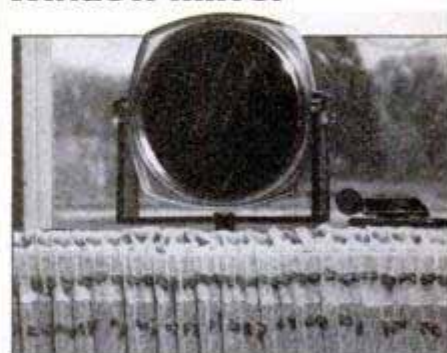

A mirror mounted near the center of a window so that natural light can illuminate the user's face is a useful and inexpensive bathroom accessory. The mirror shown is fastened to the lower sash of a standard double-hung window with a 1/4-in.-dia. bolt. The bolt slides through a hole in the mirror bracket and into a hole bored in the sash. You can pivot the mirror laterally, or flip it to the magnifying side when desired.—Walter E. Burton

V-block guide

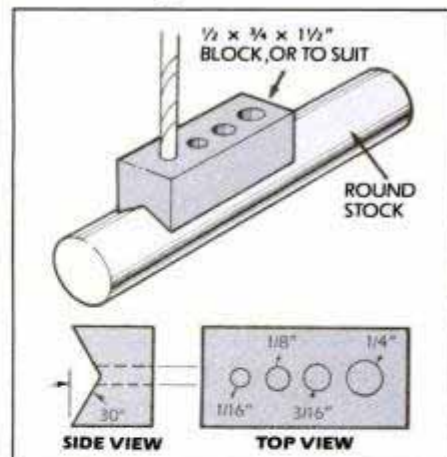

I made a guide for drilling in round wood or metal stock by cutting a V shape in the bottom of a rectangular block. The V was angled at 30° from both sides of the block. You can rip the V on a table saw or use a V-groove chamfering bit in a router. Then, bore the desired holes through the flat surface of the block so they fall in the middle of the V. To use the guide, hold the round stock and block together, then simply select the proper hole.

—Ronald Schilling

QUIT YOUR JOB or START PART-TIME. Chimney Sweeps Are Urgently Needed Now!

My name is Tom Risch. I'm going to show you how to make \$200.00 a day saving people from dangerous chimney fires.

This is serious business. People are paying \$45.00 to have their chimneys cleaned, and the average sweep completes the job in less than an hour. You can make \$200 a day part-time—\$1,000 or more a week full-time. Now before you turn the page, let me explain.

Tens of millions of people are burning wood to supplement the high cost of oil, gas, and electric heat. There are now over 50 million woodburning chimneys in the U.S.—an increase of 10 million in only one year.

As a result, an estimated 44,000 chimney fires killed almost 1,000 people last year and destroyed over 180 million dollars in property.

Thousands of chimney sweeps are needed now.

Time Bomb In Your Chimney

A dirty chimney with about a quarter inch of soot contains a highly flammable substance called Creosote. If a spark from your fireplace or woodstove ignites the creosote in your chimney—watch out! The draft gets stronger and stronger, and before you know it, the entire inside of the chimney catches on fire.

As the fire grows in your chimney, the draft also increases to a tremendous velocity. The heat, generated from the draft and the burning creosote reaches a temperature of up to 3,000° F which is hot enough to melt the mortar holding the bricks together. Secondly, small flaming balls of creosote loosen from the side of the chimney and are projected out of the top with the force of a jet engine.

Like a roman candle, these flaming creosote balls shower the area. Some land on your roof, on your lawn and on your neighbor's home. The excessive heat of the chimney can catch the wood framing of your house on fire.

The only way to avoid a disaster like this is to clean the chimney before it catches fire. This is where you come in.

Chimney Sweeping

Here's a new business where you can earn more in one hour than most jobs pay for a whole day. More in one week than a lot of people make in an entire month. You're the boss. You set the hours and best of all, it's fun. You'll work your tail off, but the business will be your baby. I've had people tell me that the August West Chimney Cleaning System literally changed their lives. Not just because of the money they are making or the fact that they use more Ivory soap, but mainly because they are motivated. They're doing their own thing and loving it.

How Much Money?

Recently I telephoned some of the people we helped get started in the chimney cleaning business. I wanted to find out—first hand—just how well they were doing. Here's what a couple of them said....

Dave Richison, Ohio

"The 3rd quarter of this year I did \$23,000. The 4th quarter I did \$24,000. We should hit between 55 and 60 thousand this year."



"Home heating is now the number one cause of residential fires. Eighty-six percent of wood heat related fires originate in the chimney. The demand for qualified chimney sweeps is skyrocketing and now is the time to get started," says Tom Risch, Founder and President of August West Systems, Inc.

Chris Nestor, Massachusetts

"My first day on the job, I cleaned seven fireplaces. Now, after sweeping over 8,000 flues, I still look forward to going to 'work' every morning—six days a week, all year round."

John Moszulski, Canada

"Last month I worked 18 days, and I made 2,600 bucks!"

Ed & Mo Simonson, Texas

"We're very pleased with it. We're making a dream come true. We've always wanted some land, and thanks to chimney sweeping we now own 30 acres."

Just what do these people do to earn that kind of money? Sweep chimneys. Six to eight a day if they're full-time. Two to three an evening, plus ten or so on the weekends for those part-timers who keep their present jobs. Since the average charge is \$45 for the first and \$35 for each additional in the same house, it's easy to see how John Moszulski made \$2,600.00 in 18 days!

The Height of Technology

How do you clean a chimney? You do it as quickly and efficiently as possible. The more chimneys you can clean in a day the more lives and loss of property you'll save. And how do you do a good job in record time? You use the most advanced system available—The August West System.

One of the key elements in the August West System is the SootSweeper. This machine is a high-powered, high-volume dust collection unit that was designed specifically for cleaning chimneys. New filter technology is the key to its efficiency and dependability.

Other key elements of our system are an assortment of high carbon steel brushes, spe-

cially designed fiberglass cleaning rods (that let you do most jobs from below), an easy-to-follow handbook with everything from advertising to chimney design, a bi-monthly newsletter, telephone consultation and much, much more. I don't have room to go into all the details right now. Our information kit will explain everything to you.

10 Years of Dependable Service

I'd just like to say that many years and a tremendous amount of devotion have gone into the development of the August West System. We are a strong, national company with thousands of dedicated sweeps in our network! You can join us and count on us to help you build a business you can be proud of. We take pride in the quality of our equipment and service to you.

Sweep John Moszulski says, "Not only do I think your System is fantastic, but I am also totally impressed by the way you treat people who have bought your System. I have just finished my third \$1000 week—on a part-time basis."

To Sum Up, Then...

Sweeping chimneys may not exactly be a "Lazy man's way to riches"... you'll work hard—but the pay is exceptional, the demand is steadily growing, and new equipment and methods make the job far easier, faster and safer than ever before. Perhaps best of all, this is one of those "dream" businesses that so many of us are always looking for: a cash business with flexible hours, low overhead and a reasonable start up cost—figure about \$1800 to get started.

And don't forget, when you run a small business out of your home, you can take tax deductions for that portion of your home you use for your office and work area, as well as car payments, phone bills, utilities and anything else you use in business.

As a matter of fact a lot of sweeps pay for their system in tax savings alone.

FREE Information Kit

Find out more about what it's like to be a chimney sweep cleaning 25 chimneys or more a week. Just call TOLL-FREE 800-225-4016 and ask for extension 217. I'll rush you a detailed information kit with the complete August West Story and your 33 1/3 RPM record entitled, "Now Hear It From The Sweeps." We urge you to call us at no obligation, TODAY.

Call TOLL-FREE 800-225-4016

Ask for extension 217
or write: Tom Risch
August West Systems
38 Austin Street
Box 658, Dept. 2177
Worcester, MA 01601



Yes, please rush me your FREE information kit.

Name

Address

City

State Zip

Phone

Copyright © 1985 August West Systems, Inc.

28 Ways to Help You Qualify for the Job You Want

Free Facts about Diplomas and 2-Year Degrees

Now at home in your spare time, without any previous experience, you can train for a money-making career...even get a Two-Year Degree. Send for free career facts about the exciting career program that interests you most. You will receive color brochure and information on employment opportunities in the field you choose. Mail coupon today and see how easy it is to train at home for a great new career or advancement on your present job.



SEND FOR FREE FACTS! 16028

ICS International Correspondence Schools SINCE 1891 Dept. PBS75, Scranton, PA 18515

Send free facts and color brochure how I can study at home for the career I have chosen. No obligation, no salesman will visit you. CHECK ONE BOX ONLY!

- | | |
|--|---|
| BUSINESS TWO-YEAR DEGREE PROGRAMS | CAREER DIPLOMA PROGRAMS |
| <input type="checkbox"/> Business Management | <input type="checkbox"/> Bookkeeping |
| <input type="checkbox"/> Accounting | <input type="checkbox"/> Drafting |
| <input type="checkbox"/> Marketing—Sales & Advertising | <input type="checkbox"/> Air Conditioning & Refrigeration |
| <input type="checkbox"/> Finance | <input type="checkbox"/> Electronics |
| TECHNICAL TWO-YEAR DEGREE PROGRAMS | <input type="checkbox"/> Electrician |
| <input type="checkbox"/> Mechanical Engineering | <input type="checkbox"/> General Law Enforcement |
| <input type="checkbox"/> Technology | <input type="checkbox"/> Art |
| <input type="checkbox"/> Civil Engineering Technology | <input type="checkbox"/> Small Business Management |
| <input type="checkbox"/> Electrical Engineering Technology | <input type="checkbox"/> Wildlife Forestry |
| <input type="checkbox"/> Electronics Technology | <input type="checkbox"/> Conservation |
| CAREER DIPLOMA PROGRAMS | <input type="checkbox"/> Diesel Mechanics |
| <input type="checkbox"/> Computer Programming | <input type="checkbox"/> Gun Repair |
| <input type="checkbox"/> High School | <input type="checkbox"/> Motorcycle Repair |
| <input type="checkbox"/> Catering Gourmet Cooking | <input type="checkbox"/> Surveying & Mapping |
| <input type="checkbox"/> Microcomputer Repair | <input type="checkbox"/> TV VCR Repair |
| <input type="checkbox"/> Auto Mechanics | <input type="checkbox"/> Fitness & Nutrition |

NAME _____ AGE _____
 ADDRESS _____
 CITY-STATE-ZIP _____
 PHONE () _____

GARDENERS...

"Easy to Operate!"



Drill a water well or a free-flowing spring in your backyard. Have all the pure fresh water you want...FREE!

Over 99,000 home water wells drilled this easy, low-cost way since 1962!

FREE Color Brochure

CALL TOLL-FREE
1-800-821-7700

(Ask for Operator 5832)

Or clip coupon and mail TODAY!

DeepRock 5832 Anderson Road
 Opelika, Alabama 36802
 Please mail your FREE Brochure.

Print Name _____
 Address _____
 City-State-Zip _____
 Phone _____ © 1985 DeepRock

Free Fund Raising Ideas Catalog

Each year, Revere Company helps thousands of school, church, civic and social groups (just like yours) earn the money they need. Our colorful catalog contains all of the latest, most lucrative products and programs available to fund raisers. You can have a free copy sent directly to you simply by calling toll-free or mailing this coupon. Order now!

1-800-528-6050 Ext. 147
 In Ariz. 1-800/352-0458 Ext. 147

To: Revere Company
 Department Q90
 Scranton, PA 18504-0119

Please send me Revere's latest "Catalog of Fund-Raising Ideas."

Name _____
 Group _____
 Address _____
 City _____
 State/Zip _____

Revere

AMERICA'S FOREMOST FUND RAISING CONSULTANT

BAND SAW BLADES

DESIGNED SPECIFICALLY FOR
 Portable Band Saw Lumbermills
BLADE 1 1/4" wide x .035" thick with 0.8" tooth spacing.

PRICE is \$.10 per inch of band length plus \$1.85 weld charge per blade.

COMPLETE BAND SAW BLADE LINE
 MINIMUM ORDER \$10.00. Add \$2.50 per order for packing and shipping. MasterCard and VISA accepted.

TO ORDER Phone or write to:

BUCKEYE SAW COMPANY
 P.O. Box 14794, Cinti., OH 45214
1-800-543-8664 (Except Ohio)
1-513-621-2159 (In Ohio)

ELECTRIC AUXILIARY Lawn Mower Starter



Installs on 1 1/2 to 5 hp Briggs-Stratton WITH UP-PULL START ONLY. (For side-pull, Sears, Tecumseh, Ward, Toro etc. send for Brochure) Installs in minutes with few simple tools. Use any 2.5 amp drill with 3/8" chuck. Money back guarantee. \$14.95 plus \$2.00 postage. Check or money order to...

JOSUCO

402 E. MARY ST. VALDOSTA, GA 31601

FREE GARDEN EQUIPMENT

Free your garden equipment of toxic, corrosion-causing spray lubricants with Freeway. Save yourself money and extra work!

- Special non-toxic formula.
- Will not corrode aluminum or any non-ferrous metals.
- Safe for use around gardens and pet areas.
- Odorless, clear and will not stain clothing or other fabrics.
- All-aluminum can won't rust.

To order, send \$4.75, plus \$1.00 postage & handling (NC residents include 4 1/2% sales tax) for each 6 1/2 oz. can, to: Hyltec, Dept. 157, P.O. Box 880, Washington, NC 27889. Card holders call TOLL-FREE 1-800-422-5639 and ask for Ext. 157. In NC 1-800-682-8520. If not completely satisfied, return unused portion within 30 days for a complete refund.



DEALER INQUIRIES INVITED.

© 1985 Hyltec A Division of Hackney Industries, Inc.



Compact 5-5 x 14 cc shown w accessories

Milling machines, Accessories
 Precision tools, Metal,
 and Cutting Tools
 108 Page Catalog-\$2.00
 Refundable

We accept Mastercard & Visa

CAMPBELL TOOLS CO.
 2100-D Selma Rd
 Springfield, Oh 45505 513/322-8662

OptiVISOR PRECISION INSTRUMENT

Optical Glass Binocular Magnifier
 Improve Vision & Efficiency
\$23.95
 LENS Working Indicate Lens No.
 # POWER Distance *Add \$1.00
 #2 1 1/2 x 20" For #10 Lens
 #3 1 1/2 x 14" Add \$4.75 For
 #4 2 x 10" 2 1/2" Power Opticase
 #5 2 1/2 x 8" Check or M.O. Only
 #7 2 1/2 x 6" Md. Residents Add
 #10 3 1/2 x 4" 5 1/2" Sales Tax

+1.50 Ship. & Handling
 PLUS FREE 250 Page TOOL AND SUPPLY CATALOG

CHARLES NUSIMOV & SONS, Dept. K, 6635 Belair Rd. Balt., Md. 21206

SUPER CARBURETOR

BIG V8 GETS 72 MPG



Computer Verified; Learn How To Build Your Own High Mileage Carburetor, Too. Send 22¢ Stamp For Free Brochure!

H & A INDUSTRIES - DEPT PM
 #2 BOX 35E
 BOWLING GREEN, MO 63334

ELIMINATE THE "DO IT YOURSELF'S CURSE" WITH CARRY-LONG™



Reg. \$24.95
 Factory Direct Price
\$14.95
 Limited time offer
 EXPIRES SEPT. 30

Enables you to carry long items (2 x 4's, PVC pipe, guttering, extension ladders, etc.) safely and easily. Set of two cushioned steel brackets fits on almost any vehicle. Complete! ORDER FROM:

THD COMPANY
 P.O. BOX 855221
 RICHARDSON, TX 75085-5221
 Money back guarantee
 Plus \$1.75 postage and handling
 Texas residents add 6% sales tax

GOVERNMENT SEIZED PROPERTY
LITTLE-KNOWN SECRET REVEALED!
 Buy Dirt Cheap - Automobiles, Trucks, Vans, Boats, Furniture, Stereo, Appliances & TVs - thousands of other items seized in narcotics raids - Resell at Big Profits!

Write Today! Free Information!
MARCEL Dept. MB
 Box 7557, Monroe, LA 71211

Could Make You RICH!



BUILD A BIKECAR
 The Amazing Mini Car Built with Bicycle Parts! Electric-Pedal Powered! Fun to Drive! Easy to Build!

PLANS \$7.95
 Postpaid and Mailed First Class

Send To: **SPORTRAN CO.**
 P.O. Box 7077-R, Endicott, NY 13760

Plans include Optional Body Design!



BASEMENT TOILET
 FLUSHES UP To Sewer or Septic Tank
 No Digging Up Floors—Installs Easy, Anywhere!

Write McPherson, Inc., Dept. 16
 Box 15133 Tampa, Florida 33684



STAGE PROP GUNS
 OUR 17th V.I.

NON-FIRING REPLICAS MODELS OF HISTORIC FIREARMS COMPLETELY SAFE!
 OVER 100 TYPES
 ONLY \$34 PER GUN

MODEL SHOWN: 18TH CENTURY BLUNDERBUSS

FREE FULL-COLOR CATALOG

Collector's Armory, Inc.
 800 SLATERS LANE, BOX 1081, DEPT. PM 1480
 AUBURNDALE, VA 22114 800 536 3005



Sell Mason Sport & Work Boots

and earn instant commission

BE A MASON DEALER and sell our rugged, quality-made sport and work boots to your friends and neighbors. Earn instant cash commissions from \$10.00 to \$20.00 per hour. Absolutely no investment required. All you do is show the full-color Mason catalog to your customers. Let them select from over 400 styles of footwear for men and women. Write for details.

Send for FREE Sales Kit. Mason Shoe Mfg. Co.
 Chippewa Falls, WI 54774



MASON SHOE MFG. CO., Dept. F-680
 Chippewa Falls, WI 54774

Please rush giant FREE catalog & dealer starter kit to:

NAME _____
 ADDRESS _____
 CITY _____
 STATE _____ ZIP _____

IF YOU LOVE TO COOK OUTDOORS

IT'S A GRILL! IT'S A BARBECUE! IT'S A SMOKER!

A 55-GALLON DRUM/
 COOKER-SMOKER
 IN KIT FORM
\$59.95
 STANDARD KIT



FIRST TIME EVER IN KIT FORM!

PROFESSIONALLY DESIGNED, EASY-TO-ASSEMBLE. YOU SUPPLY THE DRUM AND SIMPLE TOOLS. WE SHOW YOU HOW. COMPLETE ILLUSTRATED INSTRUCTIONS. KIT CONTAINS 50 LBS. OF PRE-CUT, DRILLED AND FORMED STEEL PARTS THAT BOLT TOGETHER.

FOR DETAILS SEND FOR INFORMATION KIT.

andyman PRODUCTS P.O. BOX 79086 H CLEVELAND, OH 44107



BURG-ALERT

IS HERE!!

ELECTRONIC THEFT DETERRENT

Looks like an expensive alarm system, but only you know its secret. Simple to install, easy to use.

Blinking red LED indicates the device is activated. It's enough to make any thief think twice before entering YOUR car, van, truck, boat or house. Send a check or money order for \$11.95 plus \$1.50 shipping & handling to:

MARSHALL-EASTMAN ASSOC., LTD.
 2554 LINCOLN BLVD., SUITE 1038-PM
 MARINA DEL REY, CA 90291

California residents add 6 1/2 % sales tax. Please allow 3-4 weeks for delivery. Money back guarantee if not satisfied. BATTERIES ARE INCLUDED.

Get these professional advantages at no extra cost when you take Locksmithing Institute training.

BE A LOCKSMITH!

Learn the money-making art of Locksmithing! Home study with the famous Locksmithing Institute is like an actual apprenticeship...in your OWN well-equipped lock shop. You work under a Master Locksmith instructor, receive your own electric

key machine, locks, keys, parts, picks—all at a price many graduates say would be fair for just the instruction!

START NOW!

In mere weeks you can be ready to make money copying keys or installing locks. Later, you can get into even more profitable areas of locksmithing. Our course also includes a special unit on Fire and Burglar Alarm Systems—another field with new earning potential

due to rising crime. The Institute, of course, can't guarantee you a job or income, but we have successfully trained thousands of men and women with basic mechanical aptitude in this most essential profession. If you can study at least 1 hour a week, we can do the same for you. Write us. It could be the key to a new future!



Approved by N.J. Commissioner of Education. State Approved Diploma.

LOCKSMITHING INSTITUTE

Established 1948 • Division of Commercial Technical Institute
 Little Falls, New Jersey 07424

SEND TODAY FOR FREE BOOKLET

TO: Locksmithing Institute, Dept. 110-085 Little Falls, New Jersey 07424

Please send FREE Opportunity Booklet and sample lesson materials. No obligation. No salesman will call.

NAME _____
 ADDRESS _____
 CITY _____
 STATE _____ ZIP _____

Check here if Veteran



"I have already master keyed my Elks Lodge and 38 apartments...so you see my locksmith course is practically paid for! I was never so enthused with lessons in my entire life!"
 Adelindo Orsi, Jr.,
 Azusa, Calif.



"The lessons, materials and instructors were EXCELLENT... I really enjoyed the Locksmithing course. Am telling my friends about the course, as it is well worth the tuition."
 Frank R. Bishop,
 Holt, Mich.

CLASSIFIED ADVERTISEMENTS

Sophie Gronowicz, Classified Sales Manager Dorothy Nolan, Classified Service Manager

Rate: \$6.25 per word payable in advance each insertion. Minimum insertion ten words.

Bold face capitalized words—\$1.00 per word additional (First word set in Bold Face at no extra charge. Zip Code Free.)

The next available issue to place an advertisement in America's No. 1 Classified Section is **OCTOBER**. The closing is **AUGUST 5th**. Send remittance payable and order to Popular Mechanics, Classified Department, 224 West 57th Street, New York, New York 10019.

Please indicate Heading under which ad is to appear. As a consumer service and in cooperation with our mail-order advertisers who use post office box addresses for their convenience in handling your order, Popular Mechanics maintains a register of such mail-order advertisers containing their complete names and street addresses.

Advertisers using P.O. Box number must furnish complete name and street address for our records.

To avoid delay in the publication of your ad, please send samples and descriptive materials with your request.

PUBLISHER'S MART BOOKS & PUBLICATIONS

SINGLES CLUB Organizing Guide. Information. THS-C. Box 3752. Reston, VA 22090

SAVE on parts for Lawnmowers, Minibikes, Karts, Chainsaws, Small Engines. **THOUSANDS OF PARTS**. Send \$3.00 For Catalog. Sav-On Parts, P.O. Box 231, Somerville, Mass. 02145

PUBLISHERS' OVERSTOCKS, BARGAIN BOOKS 2,000 titles, all subjects! Free catalog: Hamilton, Box 15-A, Falls Village, CT 06031

PUBLISH Your Book! Join our successful authors. All subjects invited. Publicity, advertising, beautiful books. Send for fact-filled booklet and free manuscript report. Carlton Press, Dept. PMT, 11 West 32 Street, New York 10001

MEDICAL INSURANCE PROBLEMS? Send For **HOW TO COLLECT ON YOUR MEDICAL INSURANCE**. Medicare, Group, Personal. Send \$9.95 M.O. Or Check To: Insurance Help, P.O. Box 186A, Provo, Utah 84602 please print.

SAN DIEGO! Jobs, Housing, More! \$10.00. RGA, 405 W. Washington #50-B, San Diego, CA 92103

MAKE \$50,000 a year rebuilding discarded washers and dryers. Start in your own backyard. Complete details \$12.95. Mike Moore, 12 Scott Lane, Rockledge, FL 32955.

CHILDREN'S BOOKS: First quality, hardcover books, discounted and shipped postpaid. Enjoyable children's books from our family to yours. Free catalog. Children's Collection PM, 1980 County Road 150, Elizabeth, Colorado 80107

CATALOGS

SMOKEY MOUNTAIN KNIFE WORKS has over one million knives and cutlery items at wholesale prices. \$2.00 gets you our giant catalog by first class mail. The Knife Catalog, P.O. Box 714PM, Sevierville, TN 37862.

MOWER Deck, Trimmer and Tiller Kits. Use Your Old Engine! Great Savings! Catalog \$2.00 - Refundable. Blacklick Service, Box 5, Blacklick, Ohio 43004

WOODEN playground sets. Catalog of plans available, \$2.00 handling. (Allow six weeks). Seems Like Old Times, Inc., P.O. Box 2225, Woodbridge, VA 22193

50% DISCOUNT on fashion jewelry. Free catalog. Eva's, Dept PM, 1685 Sperry's Forge, Westlake, OH. 44145

FREE Gadget, gift catalog. Berkeley House, 817 New York, Martinsburg, WV 25401

FREE CATALOG - BEST IN THE INDUSTRY
A COMPLETE CAMERA STORE IN A CATALOG
ONE of the World's Great Catalogs, and it is photographic. Send to Porter's Camera Store, Inc., Box 628, Dept. PM, Cedar Falls, Iowa 50613 for your Free Copy (U.S. Only). 112 tabloid size pages filled with 4,000 items many of them exclusive and very unusual. Plus popular brand cameras, lenses, flash, etc., at discount prices. Huge inventory, fast service, great packaging. You must see it to believe it. Order your Free copy today.

DISTINCTIVE Gifts. Catalog \$1.00 Refundable First Order. Zeld's Gifts, Box 65294, Washington, D.C. 20035

AUTOMOBILES

BUYING a new car? Be prepared with invoice price information. Send \$10.00 and make/model to: Prices, P.O. Box 667, Wiggins, MS 39577

METZ LUGGAGE MOUNTS. Install on Roof or Trunk Lid. Stainless and aluminum with lock. \$79.95 Send self addressed stamped envelope for pictures. Box 27234, Indianapolis, Indiana 46227

TWO BLADE WINDSHIELD WIPER. Positive **BLADE** tilting for reliable squeegee wiping. Eliminate that hazardous blind driving interval on rainy days, traveling Interstate Highway speeds and hit by thrown water and road dirt when passing or being passed by cars or trucks. SASE for circular. Peter Speth, 239-25 88th Ave., Bellerose, New York, 11426

200 MPG Carburetors: FACT or FRAUD? A Special Report. Now only \$6.00. Special Report, 304 San Miguel, St. Charles, MO. 63303. Moneyback guarantee.

NEW CAR BUYERS: YOUR CAR MIGHT BE A LEMON. Under the laws of most states, you can get your money back if you have proper records. For information and valuable forms prepared by attorneys, send \$5.00 to: Consumer Forms & Information Services, Inc., P.O. Box 11737, Milwaukee, WI 53211

EMERGENCY FAN BELT KIT. Replace a missing belt in minutes without tools. Avoid costly road service or towing. **ONLY \$6.95** postpaid. Pumps Plus, Inc., Box 252A, Bloomingdale, N.J. 07403

COMPREHENSIVE USED CAR BUYERS/SELLERS Guide. Valuable facts about buying or selling a used car. Save make hundreds. \$3.95. C.G. Services, POB 235, Bergersville, IN 46106

FREE AUTOMOTIVE SECURITY CATALOG: Largest selection available. Do-It-Yourself. Pagers, alarms, hood/locks, glass detectors. Allow 4 weeks. Immediate Delivery. Send \$1.00. Automotive Security Equipment, Dept. 2, P.O. Box 382, Plainview, New York 11803

LIKE working on your vehicle with **CHRYSLER 2.2L ENGINE?** Then you'll love the **TRANS FOUR OWNERS GROUP!** For information, send a business sized SASE to: T4OG, Box 208, Raleigh, NC 27602

INGENIOUS METHOD, CARRY LOADS ON CAR TOP, 4x8 SURFACE, FOR INFORMATION PICTURE, CARTOP, BOX 52-2276M, MIAMI, FLORIDA 33152

INCREASE mileage 50% on your diesel. Information \$1.50. Hahn, 315 Northeast 16, Owatonna, Mn. 55060

HOW TO QUALIFY FOR FREE AUTO REPAIRS - Detailed book only \$6.00. Thacker, Box 832613A, Richardson, Texas, 75083-2613

SPECIAL REPORT, Preventive Auto Maintenance on American Cars. Send \$2.00 to: RWM, P.O. Box 53, Lancaster, Ohio 43130.

HOW to find an honest car repair shop in your area. Cut bills by 40%. Free news. Auto Owners Co., Box 9771M, Savannah, Georgia 31412

TURBO Mini vacuum. Plugs right into your cigarette lighter. Lightweight but powerful. Ideal for cars, boats and campers. **SATISFACTION GUARANTEED!** Send \$14.95 to: Dave Merritt, 4427 Stockholm, Cincinnati, Ohio 45244

PTFE TREATMENT Coats Engine With World's Slipperiest Substance! Improves Performance! \$10.45. Teknol Corporation, Box 22961, Denver, Colorado 80222

AUTO SUPPLIES & EQUIPMENT

IGNITION PERFORMANCE MONITORS. Free Details! "Lightnin' Bug," Box 996-8PM, Conifer, Colorado 80433

ALTERNATOR Generator Rebuilding Book. Price: Hedelund Engineering, Box 26024, Las Vegas, NV 89126.

PARTS: Army Jeep and truck parts. Spare Parts & Equipment Co., P.O. Box 751, Lexington, Kentucky 40587-0751

CARPETS, top, shocks, suspension parts for all cars 1935-1980. Free catalogue. Karier Auto Products, 76P Monroe, Boonton, NJ 07005. 800-526-1096.

IMPORT AUTO PARTS - New and Remanufactured at Bargain Prices. Send \$2.00 for catalog. State Year, Make & Model of Car. Same day service. Sech-A-Deal Box 23621, Rochester, N.Y. 14623

ASTROSHIELD POLISH: Shines, Protects, Restores Color. Three Year Money Back Guarantee! Only \$11.95/Quart. Box 76, Valhalla, N.Y. 10595

SWITCH HITCH. Pull trailer with Lunette Eye behind vehicle with Ball Hitch. Adapts 1 7/8" or 2" **BALL TO 3" ID EYE**, \$45.00. LWS, Route 6, Box 108, Lake Wylie, SC 29710

MOTALOY Ring Valve Job While Driving Guaranteed. \$9.99, two \$17.50 postpaid. Andris, Box 34061, San Francisco, CA 94134.

EMERGENCY TOW ROPE 3/4" x 17 Ft. with **STEEL HOOKS** and durable bag for trunk storage. **\$9.95/EA. DELIVERED.** N.C. Twine, P.O. Box 1647, Mount Airy, N.C. 27030

SAVE GAS! TIRES! MONEY New Device monitors Tire Pressure - Free Automotive Report - Eurowood D208, Box 297, Cleveland, NC 27013

AUTO Parts Wholesale For Details Send Large SASE To: Frank Shockley Ent., P.O. Box 80, Pennsauken, N.J. 08110

HYDRAULIC JACK Repair Manuals and Kits. Catalog \$2.00. Hydraulic Jack, Inc., P.O. Box 18, Accord, NY 12404.

MOTORCYCLES, MOTORSCOOTERS & SUPPLIES

GO Karts, Minibikes, Atvs, Kits, Parts, Engines. Lowest Prices. Largest Selection. 72 Page Catalog \$3.00. Refundable. Kart World, Dept. C., 1488 Mentor Ave., Painesville, Ohio 44077

\$49-Mini-Bike Kit, Go-Karts, Frames, Engines, Wheels, Clutches, Tires. Including Moped Parts and Accessories. More Parts-Lower Prices. 1985 Wholesale Catalog-\$2.00. Karts & Kits, P.O. Box 1028, Maywood, NJ 07607

BUILD Electronic Cycle Alarm for \$15.00. Plans - \$2.00 SASE. P.O. Box 452, New Berlin, WI 53151

MOPED parts and accessories - send \$1.00; Mayfield Mopeds, 5651 Mayfield Road, Lyndhurst, Ohio 44124.

AVIATION, HANG GLIDING

AVIATION VIDEO WWII Through Vietnam, Catalog \$2.00. C.A.V., P.O. Box 47, Burlingame, California 94010

DESIGN Build Airplanes, Hang Gliders, Simplified Publications. Brochure 20c. McCoy Aircraft, 12820 S. Figueroa, Los Angeles, CA 90061.

(Continued on next page)

Материал защищен авторским правом

AVIATION, HANG GLIDING

(Continued from preceding page)

HOBBY HELICOPTER. "Choppy" Ultralight Single-Seat Helicopter. Simplified Construction—Motorcycle Engine. Brochure \$3.00. Polynova, Box 670M, St. Remi, Quebec, Canada JOL 2L0

BOOMERANGS—INCREDIBLE RETURNS! You can do it. Exciting! Order your **FREE** Catalog Now! BoomerangMan, 1806-1 N. 3rd., Monroe, LA 71201

MASTER Guide To Small Homebuilt Helicopters \$6.95 H-C Guide Publishing, Box 50485, Midwest City, OK 73140

SPACE & ASTRONAUTS

GRAVITY FIELD GENERATOR, gravitational polarity, UFO operation, designs. \$7.77. Box 77M, Skamokawa, WA 98647

SPACE VIDEOS / LASERPRINTS / WALL MURALS Catalog \$1.00 includes discount offer. MMI Corporation-PM, Box 19907, Baltimore, MD 21211

SPACE TRANSPORTATION SYSTEMS REFERENCE Explains All Shuttle Systems. 280 Pages, 100's Photos. Hard-bound. Embossed Cover. \$24.95 ppd. Card Orders Call Now 1-800-268-6364. Apogee Books, 26 Leamill Road, NDC-M, Toronto, Ont. M3B 2T8

HOVERCRAFT

HOVERCRAFT Plans All Sizes. Catalog \$1.00. Universal Hovercraft, Box 281, Cordova, Illinois 61242

AERO-CAR Amazing Hovercraft built easily with ordinary tools. Lawnmower engine power. Carries one man plus. Hovers, flies forward, backward. Sideways over land/snow/water. Complete construction plans and brochure. \$9.95. Aero-Projects, Box 5118PM, Clinton, New Jersey 08809.

PEGASUS: Hover over fields, parking lots or any surface that's flat and hard in this floating machine. Build it yourself for about \$150 worth of plywood and paint and an old lawnmower engine. The Pegasus has a 7-Ft. Dia. and hovers 10' above the ground. A gallon of regular gas provides 3 hours of flying time. PL-1800 - \$9.95; Send Order To: Popular Mechanics, P.O. Box 1014, Radio City Station, New York, NY 10101

CB'S, RADIO & HAM EQUIPMENT

POLICE Scanners, Bearcat. Regency. HPR, Box 19224, Denver, CO. 80219.

CB MODIFICATIONS, Conversions, Books, Plans, Kits. Catalog \$2. CBCI, Box 31500M, Phoenix, AZ 85046

CB MODIFICATIONS, Linear Planbook, Kits \$1.00 refundable. APS, POB 263, Newport, RI 02840. 401-846-5627

ELECTRONICS

ELECTRONIC EAVESDROPPING DEVICES. SURVEILLANCE AND COUNTERSURVEILLANCE. GIANT CATALOG \$1.00. HUNTEREX, Box 12922, WINSTON-SALEM, NC 27117-2922.

GOVERNMENT Surplus receivers, transmitters, snooper-scopors, parts. Catalog 25c. Meshna, Nahant, Mass. 01908.

LASER and **NIGHTVISION** surplus. Free Catalog. Meredith Instruments, 6517 Westeva, Glendale, AZ 85302

COMPUTERS & SOFTWARE

FREE Programs! Commodore/Timesex/T199-4A/TRS-80's. EZRAEZRA, Box 5222MAU, San Diego, 92105.

FREE Software Catalog: IBM, CP/M, Apple, Commodore. Dynacomp, Box 18129, Rochester, N.Y. 14618.

BEGINNERS GUIDE TO PERSONAL COMPUTERS illustrated booklet \$6.00. Personal Computer Workshops, Inc., 1025 W. Arrow Highway, Suite 210, Dept-PM85, Glendora, CA 91740

PERSONALIZED DUSTCOVERS with Monogram, Free Catalog. AC Marketing, Box 2338, La Puente, CA 91746

STEREO, CASSETTE TAPES, ETC.

THOUSANDS OF OLDIES! Hard-to-find 45rpm hit records from the last 40 years including pop, country, rock, and soul. Send \$2.00 for catalog to: American Pie, P.O. Box 66455, Dept. PM, Los Angeles, CA. 90066

TV & VIDEO EQUIPMENT

NOTICE: USE OF CERTAIN ITEMS IN THIS CLASSIFICATION REQUIRES STATION AUTHORIZATION.

SATELLITE TELEVISION ANTENNAS complete detailed plans for home construction by anyone. \$5.00. Jansen Electronics, P.O. Box 168-M, Dundee, OR 97115

ENJOY SATELLITE TELEVISION. Save money with easy guaranteed, do-it-yourself antenna plans/kits. Electronic knowledge not necessary. Send \$1.00 for catalog or \$8.95 for "Consumer Guide to Satellite Television." GFI-36, Box 9108, Missoula, MT 59807.

SATELLITE TELEVISION SYSTEMS, Wholesale price catalog. Send stamped envelope. Satellite Warehouse, R.D. 4, Box 273, Clarks Summit, Pa. 18411.

CABLE TV EQUIPMENT, Jerrold, Hamlin, Zenith—many others. Factory Units/Lowest Dealer Prices. Complete illustrated catalog, \$2.00. Pacific Cable Co., Inc., 7325 1/2 Reseda Blvd., Dept. 103, Reseda, CA 91335. 818 716-5914

SATELLITE TV SYSTEM. Buy direct and install yourself and Save. Prices start at \$595.00 Call or write today for our Free booklet and prices. Video Choices, 1155 Zion Rd., Bellefonte, PA 16823. (814) 355-7539

BUILD Your Own Satellite TV Receiving System and Save! Instruction manuals, circuit boards, kits! Send stamped envelope for information: XANDI, Box 25647, Dept. 28J, Tempe, AZ 85282.

SATELLITE System \$595. Information \$1.00. Starlink, 2603-16 Arlie, Huntsville, AL 35805

SATELLITE TV Name Brands - Low Cost Catalog \$2. Anderson Satellite TV, 1091 Woodlake, Lawrenceburg, Ky 40342

SATELLITE TV—Get the facts! Install yourself! **FREE** information. M&EW-PM3, POB 18315, Austin, TX 78760.

SATELLITE DISH INSTALLATION AND ALIGNMENT GUIDE. \$2.00. Boyd, Box 1463D, Oakdale, CA 95361

VIDEOS all types \$2.00 brings list. Aaron's Video, 929 South High Street, West Chester, PA 19382

CABLE and Satellite Equipment. Wholesale Prices. HMR Sales, 221 East Camelback #1, Phoenix, AZ 85012 602-993-0398.

HOME SATELLITE TELEVISION Wholesale to the public. Send \$5.00 for catalog. Dealers Wanted. Wholesale Satellite Supply, Box 1044M, Lake Oswego, OR 97034. 503-246-8335.

CAMPERS & TRAILERS —KITS, PLANS

BUILD YOUR OWN - Travel Trailer - Fifth Wheeler - Motor-home - Camper - Pickup Cover - Plans - Patterns - Kits - Catalog \$1 - Glen-L R-V's, 9152PM Rosecrans, Box 756, Bellflower, CA 90706.

BOATS, OUTBOARDS, TRAILERS, & KITS

BOAT KITS-PLANS-PATTERNS-FRAME KITS - 200 Designs - 40th year - 8'80" - Plywood - Fiberglass - Steel - **POWERBOATS** - Cruisers - Sportfishers - Houseboats - Hydroplanes - Runabouts (Canoes Kayaks) - **SAILBOATS** - Daysailers - Trailersailers - Multihulls - **SUPPLIES** - Epoxies - Polyesters - Cloth - Foam - **CATALOGUE** \$3.00 (Airmail \$4.00) (Book Amateur Boatbuilding \$6.00) **CLARKCRAFT**, 16-P Aqualane, Tonawanda, NY 14150

BOAT PLANS - PATTERNS - KITS - Hundreds of designs - Wood - Fiberglass - Steel - Sailboats - Powerboats - Canoes - Kayaks - Rowboats - Duckboats - Dories - Houseboats. Simple, amateur-proven methods. Instructions assure professional results! Huge 152-page catalog \$3.00 (\$4.00 Airmail). Includes Free "Boatbuilding Supplies" Catalog - Discount Prices! - Fastenings - Fiberglass - Resins - Glues - Books. Investigate "Poxyshield"/"Poxygrip" wood-epoxy system - Manual = \$2.00. **GLEN-L** Marine, 9152 Rosecrans, Box 756MP, Bellflower, CA 90706.

EVINRUDE - 1984 Bargains . . . all sizes . . . \$2.00 handling . . . Scott McCulloch parts . . . Electra Marine, 610 Merrick Road, Lynbrook, New York 11563

CAMPING EQUIPMENT & TENTS

FREE Price List. Quality Camping, Backpacking Accessories. **TEMPLE MOUNTAIN SPORTS**, RD 2, Box 245, Central Square, NY 13036

OUTDOOR EQUIPMENT

BARBECUE: Rotating; Heavy duty; Gearmotor driven; Stainless Steel. Send \$6.00 for photos, instructions; build or buy. RBBQ, POB 279, Milford, NJ 08848

ATHLETIC EQUIPMENT AND BODY BUILDING COURSES

NEW Discovery Builds Muscles Fast Without Weights!! Write: VRT, Box 93026P, Milwaukee, WI 53202

KUNG-FU Free Lessons. Send \$1.00 for Postage. McLisa, Box 1755, Dept. PM85H, Honolulu, Hawaii 96806

BIGGER, More Powerful Muscles - faster!! Free Booklet! Universal, Box 6694A, Detroit, Michigan 48240

SPORTING GOODS AND EQUIPMENT

AVOID TROUBLE traveling or backpacking. Eliminate Hazardous Bacterial Drink **PURE WATER** worldwide with 5 drops **NON-TOXIC** Molecular Liquid Oxygen. New **TRAVEL RESCUE KIT**. Small—Invaluable—Guaranteed. Complete information **FREE**. Life Quality Products, 6333 Pacific #501D-8, Stockton, California 95207

SOCCER BALLS WHOLESALE write: Dee Enterprises, Department 8, 19 Kathy Drive, Haverhill, MA 01830

FISHING, TACKLE, LURES

FREE Sinker Mold Catalog over 100 molds 25 shapes. Carmen's, Box 220PM, West Newton, PA 15089

GUNS, DECOYS, HUNTING

RWS PRECISION AIRGUN PRODUCTS - Air Rifles, Air Pistols for Adults, made in Germany, with Lifetime Warranty. High Quality - Meisterkugelein Match, Superpoint, Hollowpoint, Hobby and Standard Pellets. Plus Targets, Traps, Scopes and Accessories. For New 1985 Precision Products Catalog send \$2.00 for 1st class, \$1.00 for 3rd class delivery to: Dynamit Nobel of America, Dept. PM, 105 Stonehurst Court, Northvale, NJ 07647

BATTERY REBUILDING SCHOOL

BATTERY Rebuilding And Reconditioning. Information Free. Sun Battery, 10415 98, Sebring, Florida 33870

ENGINES, MOTORS

ENGINES For Mowers, Tillers, Etc. Free Discount Catalog. Engines, 166PM, Ashland, MO 65010.

SKID-Loader Replacement engines and parts. Save. (612) 338-5404

TOOLS FOR SALE

MAKITA ELECTRIC TOOLS Save 20%-40% Send \$3.00 Catalog, Handling (Refundable) Direct Tool Sales, P.O. Box A, Allen, Kentucky 41601

TIRE repair tools, supplies. **FREE** catalog. Gemplers, Box 617P, Stoughton, WI 53589

UPHOLSTERY SEWING MACHINES

UPHOLSTERY Sewing Machines with Walking Feet, complete ready to use—only \$498.00. Thompson Model PW200-AVAILABLE FROM YOUR LOCAL DEALER, or order direct. (Master Charge-Visa). Datho Mfg., Inc., P.O. Box 12110, Lubbock, Texas 79452—Phone: (806) 744-6774

(Continued on next page)

MACHINERY, TOOLS & SUPPLIES

4" METAL Cutting Lathe \$104.50. Taig, 15048 Proctor, Industry, CA 91746

SMALL FOUNDRY Furnaces, Supplies. Free literature. Pyramid Products, 3736 South 7th Avenue, Phoenix, Arizona 85041

STEEL, Aluminum, Brass—Sheet, Bar, Shop Supplies. Plans. Write: CEI, RR1, Box 163, Cameron, IL 61423.

BEST Prices, Woodworkers Machinery Catalog. Free. McKilligan, PMC85, Johnson City, N.Y. 13790

"SHARPENERS REPORT" Monthly Newsletter, Sharpening Guidebook, Angle Wall Chart, Free details. Skog Company, Dept. PM8, P.O. 22559, Minneapolis, MN 55422

SILVO Hardware, 188-page Hand & Power Tool Catalog \$1. PM-5-8, 5301 Tacony St., Philadelphia, PA 19137-2399

QUALITY welds anywhere. 250 AMP battery powered arc welder. 115VAC chargers. Easy plans \$9.95. Details and weld sample \$2.00. Advance, 3232 Shawnee, Fort Worth, Texas 76135.

BANDSAW BLADES, Any Size, Free literature. King Saw, 6541 Tidewater Drive, Norfolk, Virginia 23509

ENERGY SAVING

BULBS LAST 8 YEARS with **THE CUP**. UL approved. Used in leading hotels, resorts, restaurants. \$22.00 dozen. Details: Edwards Associates, PO Box 57121M, Philadelphia, PA 19111

ENGINE DRIVEN ELECTRIC GENERATOR HEATS WATER. The Medlin Corporation, 6413 Edgemoor, Houston, Texas 77074

CONVERT Your Furnace To Hi-Energy; Results \$1.00; With Plans \$8.00; SASE. Telle, POB 308, Rolla, MO 65401

SAVE to 70%. Cooling Bills. Plans, kit, \$11.98. C&E Systems, Box 10356, Scottsdale, Az, 85271.

SOLAR, GREENHOUSE, AND ENERGY SAVING PRODUCTS CATALOG!

COMPLETE systems, components. Features famous Sun-Lite® products. 84 pages. Order from one expert source. America's largest energy saving mail order house! \$1.00 ppd. Solar Components Corporation, Dept. M, P.O. Box 237, Manchester, NH 03105.

SOLAR & ALTERNATE ENERGY

FREE HYDROGEN FUEL and Oxygen Generator uses Water and Solar Cells. Plans and Kit \$12.00. Prairie Power, Box 8291, Edmonton, Alberta, T6H 0L0, Canada

PLANS: To convert low value energy to useable energy. Patented idea can supplement your energy needs. Send \$9.50 to: "Plans", P.O. Box 30,200, Suite 150, Reno, NV 89520-0200.

HOME CRAFTSMAN

WOODEN Toy Parts and Patterns, Fun With Wood Catalog \$1.00. Howard Co., Dept. PM, Box 442, New Albany, IN 47150

CATALOG FULL-SIZE FURNITURE PLANS - \$2.00. Refunded with first order. Traditional, Early American, over 180! Furniture Designs, 1425 Sherman, Dept. CP-85, Evanston, IL 60201.

FAVORITE WOOD TOYS, Patterns, Parts, Wheels, Catalog \$1. Toys And Joys, Box 628M, Lynden, Wash. 98264

UNFINISHED picture frame moulding. Factory closeout. 50% discount. 200 styles. Write: Japs, 126-PF Seventh North, Hopkins, MN 55343

WORLD'S LARGEST CATALOG? Three pounds 704 pages. Every Tool, Supply, Machine Imaginable \$5.00. Refundable. McKilligan, PM-8-85, Johnson City, New York 13790

BEST Country Furniture Plans. Catalog \$1.00 (refundable). Hammermark Associates, Box 201PM8, Floral Park, New York 11002.

CEILING FAN WOBBLING? Maintenance, operation and balancing guide by ceiling fan professionals. \$5.00. Satisfaction guaranteed. Otho Steele, 5623 Goodwin, Dallas, Texas 75206

BATTERY CLOCK MOVEMENTS. Below wholesale prices. Best Quality Catalog \$1.00 (refundable). Yankee, Box 26, Thompson, Connecticut 06277

HARDWARE CATALOG \$1.00 Refundable with first order. The Bever's, P.O. Box 12, Wills Point, Texas 75169

WOODCRAFT PATTERNS, Windmills, Wishing Wells, Bird Houses, Feeders, Flying Duck, Pheasant, Outdoor Planters, Catalog \$1.00. Crafters, 11840 US. 27 North, DeWitt, Michigan 48820.

PVC PIPE FURNITURE PLANS and supplies. Stamp brings **FREE** catalog. J&L Casual Furniture, Box 208, Tewksbury, MA 01876

MONEYMAKING WOODCRAFT PLANS, KITS. Unusual "Easy-Make" toys, gifts, accessories. Free Brochure. Williams, 32L Titus, Glen Cove, NY 11542.

WATERBEDS and bedroom furniture catalog of plans, \$2.75. Over 50 beautiful selections! Kraemer Furniture Designs, P.O. Box 33, 1350 Main St., Plain, WI. 53577

LATHE Miniature wine goblets, From Exotic Wood-For Pictorial Instructions. Send \$5.00 To: Woodtalk, Box 7116, Renton, Wash. 98057

STAINLESS Steel And Brass, Screws And Bolts. Small Quantities, Free Catalog. Elwick, Dept. 555, 230 Woods Lane, Somerdale, N.J. 08083

KNOCK HOCKEY GAME Fun for all ages, Easy to build, Plans \$3.00. Davey's Wooden Toys, P.O. Box 161, New Kingstown, PA 17072

ORIGINAL WOODEN TOY PLANS. . . . Catalog \$1.00. . . . Refundable. Phillips, Box 518, Mount Pleasant, NC 28124

UNIQUE BIRD FEEDER, Highly visible reservoir. Attracts all birds. Constant pleasure! Simple household items. Plans \$3.00. JCB, Box 5182, Athens, GA 30604

OVER 50 "FOLK ART" PATTERNS! Create profitable "Country Cut" woodworking designs. Hundreds of unique projects! Only \$6.00. Accents (CP-85), Box 282, Danvers, MA 01923

RARE Northwestern Red CEDAR BURL CLOCK KITS Send SASE to: HUB Enterprises, P.O. Box 1866, Dept. M, Aberdeen, WA 98520-0308

OVER 400 WOODWORKING DESIGNS! Shop-Tested Plans/Full Size Patterns. Create Profitable Toys, Gifts, Household Accessories. BROCHURE PLUS SAMPLE PATTERN \$2.00. Accents, (BP-85), Box 262, Danvers, Ma 01923

CRAFTSMAN WORK CENTER: Build the **MASTER CRAFTSMAN WORK CENTER**. A portable tool center, two cabinets and deluxe assembly bench allow you to keep all your tools close at hand. A grid top makes clamping easier; covers with a sheet of plywood for other tasks. Swivel casters with brakes; drawers that open on either side and your choice of finish gives you a personalized work center. Plans and materials list. (PL-1760 \$5.95). Write: Popular Mechanics, P.O. Box 1014, Radio City Station, New York, NY

WOOD, WOODWORKING

PEG-1000 WHOLESALE -10 pounds Polyethylene Glycol green wood stabilizer \$17.00 plus \$2.90 shipping. **FREE** wood finishing guide and products catalog from: General Finishes, Box 14363, West Allis, WI 53214. Phone (414) 774-1050.

WOODWORKER'S supplies catalog! . . . Hundreds veneers, toymaking, turning squares, carving blocks, hardwoods, patterns, books, cane, dowels, pegs, spindles, more! Bargain offers included. Send \$1.00. Morgan, P01M24-D, 1123 Bardstown, Louisville, Kentucky 40204.

TOY biplane plans. 15 variations \$6.00. Warner Aeroworks, Box 13576, Fort Carson, Colorado 80913.

FREE CATALOG, Woodworking Supplies. Odd Ball Supply, Box 133, North Attleboro, MA. 02761

CRAFTSMEN We supported ourselves two years doing craft shows. Full size plans and instructions 8 best selling wood items. \$5.00: Woodworking, P.O. Box 488, Kingsbury, TX 78638

CARBIDE TIPPED CUTTING TOOLS, POWERED HAND-TOOLS, Freud, Bosch, Amana, Hitachi Plus Many Other Lines. 30-50% Savings. Call For Prices 1-800-641-3322 Ext. 2.

7 CARBIDE TIPPED ROUTER BIT SET; 1/2" Cove, Round-over, Dovetail, Straight; 3/32" Roman Ogee; 3/8" Rabbet; 1/4" Straight. 1/4" Shank \$64.95 pp, 1/2" Shank \$69.95 pp, Satisfaction Guaranteed. Cascade Precision Tool Co., Box 848, Mercer Island, WA 98040. Catalog \$1.00

WOODEN Toy Plans, Catalog \$1.00, Free Plan With First Order. Toyrcraft, 601-PM8 East Main, Waynesboro, PA 17268

WOODWORKERS Complete 64-page Catalogue of Fine Tools & Hardware. Send \$3.00 to: M.F.S. Tools, Box 67, Port Huron, MI 48061-0067

BUILD A WOOD LATHE turn 6 x 6 wood on very solid lathe, \$9.95. Plans, 2545 Cityview, Eugene, Oregon 97405

PLANS, BLUEPRINTS, PROJECTS

CUSTOM PLANS, easy to follow, Queen size canopy bed, Dollcase, Plate display racks, China cupboard, Swiss Chalet doll house, \$4.00 each. Custom Made, P.O. Box 1175, Johnstown, Pa. 15907.

WOOD DECK DESIGN PACKAGE Instructions, Material Lists, 66 Plans. Send \$4.00. Deck Designs, Box 111, Oxford, MI 48051

SPOTWELDER-VAPOR DEGREASER - 400,000 B.T.U. TORCH + more build yourself. Free plans catalog. M&N Publishing, 7766G Salida, Mentor-on-the-Lake, Ohio 44060

POPULAR MECHANICS TOOL CHEST. Compact, made from cherry wood. For handling ease, it's actually two boxes. Organized compartments for easy access. Expert construction protects tools from rust. Includes plan for dolly. Send for Plan PL-1745 + \$4.75 to: Popular Mechanics, Box 1014, Radio City Sta., New York, NY 10101

LOG CABINS & "A" FRAMES

RECONDITIONED Cabin Building Tools! Catalog \$2.00 (refundable). **TIMELESS TOOLS**, Deerton, MI 49822

FOR THE HOME

ATTENTION HOME BUYERS! Easy to use House Inspection Checklist developed by architect/house inspector. Save money! Detect hidden costs before you buy. \$4.95. Housechecker, 1907 Mapleleaf Ct., Lake Oswego, Ore. 97034

70 HOUSEHOLD Tips. Do It Like The Professionals! Send \$3.50 To: Tips, P.O. Box #7013, Dearborn, MI 48121.

FREE VALUABLE REPORT, "Home Burglar Protection". WSI Systems, Box 32393, Charlotte, N. C. 32393

AUTOMATIC NIGHTLIGHT. An attractive on-and-off night-light. High quality. Send \$4.95 to: P.O. Box 2166, Hawthorne, CA 90251. No C.O.D.'s. Delivery: 4 to 8 weeks.

HOME BUILDING & REMODELING

SAVE THOUSANDS building your **DREAM HOME**. Learn from others mistakes. Guide book includes financing to landscaping. \$8.95 money back guarantee: K.V. Publishing, 3116 E. Shea #236, Phoenix, AZ 85028

DO-IT-YOURSELF HANDBOOK OF MATERIALS. 350 page guide to what's available and best in materials for the home builder or remodeler. Includes 250 specialized manufacturers and suppliers list, complete with addresses. \$9.98. Books Unlimited, 4975 Highland Rd., Pontiac, MI 48054. Money-Back-Guarantee

(Continued on next page)

PLASTICS

CASTOLITE Liquid Plastics. Crystal clear, colors. For casting, embedding, coating, fiberglassing; in industry, laboratories, craft work. Reproduce your designs with our mold materials. Catalog \$2.00. **CASTOLITE**, Dept. 85K/PM, Box 391, Woodstock, IL 60098.

DO IT YOURSELF

1400 Catalogs listed and Described. Sources for Everything Imaginable \$4.00. Masterlog, Box 879-F, Fairfax, CA 94930.

PROTECT VALUABLES! Engraving tool for home or shop. Writes on glass, wood, metal. \$3.95. Satisfaction Guaranteed! The Brook House, One Brook Road, Box 996, Honesdale, PA 18431

1600 VALUABLE CATALOGS! Every Subject Imaginable! Directory \$4.00. Catalogs Galore, 7914-M8 Springfield Village, Springfield, VA 22152.

COMPLETE In-Ground Swimming Pool Kits from \$1595.00. Free Brochure and Price Lists. Burnett, 4601 Bunkerhill, North Little Rock, Arkansas 72116. 1-800-251-4663 Ext. D10.

BELT BUCKLES for coins or stones, specialty buckles, jewelry mountings, cut stones, clock works. Wholesale catalog 25¢. Eloxite Corp., 806 1/2 10th Street, Wheatland, Wyoming 82201

ELECTROPLATING. Complete amateur's textbook. All metals Electroplate metallic/nonmetallic items \$11.95. Details free. Tropic, Box 95-P3, Palm Bay, Florida 32905.

INSTANT SIDEWALK - \$15 buys 15' - 18' round or square Poly Steppingstones, (also 12" sizes). Dealers wanted. Free sample. PATRICO, Drawer 2PM, Francis, OK 74844.

2003 Catalogs listed. Sources for Anything! \$4.95. Directory, Box 92452N, Atlanta, Georgia 30314

VIDEO cassettes for the novice or experienced handyman. Step by step narrated instructions. Send \$2.00 (refundable) for information. Video Crafts, P.O. Box 687, W. Jordan, Utah 84084.

BUILD AIR COMPRESSOR using discarded appliance, plumbing parts. Easy! Inexpensive! Complete instructions, illustration, \$1.00 (U.S.). Expansions, P.O. Box 683, Lenoir, N.C. 28645

SAVE Dollars on rescreening. Complete instructions \$6.95. Griffin Screening, Rt. 40, Box 6, Ft. Myers, Fla 33903

SAVE THOUSANDS - HOME ADDITIONS GUIDE \$5.95, **HOME REPAIRS** \$4.95, **EASY PLUMBING** \$4.95, **APPLIANCE REPAIR** \$4.95. K.W. McCaw, Dept 18, 1991 Bahia Way, La Jolla, CA 92037

IN-GROUND POOLS. Build your own and save thousands. Detailed plans. \$4.00. Percifield, R.R.1, Versailles, Ind. 47042

WATER HEATERS - Gas - Electric - Plumbing, Wiring, Repairs. Booklet \$4.00 - Hubbard Publications, Box 6553, Phoenix, Az. 85005.

SOLAR SPACE PANEL - SAVE UP TO \$4,000.00! Easy and complete directions with diagrams for building and installing your own Solar Panel. \$11.95 Postage Paid. Kenric Co., P.O. Box 6236, Boise, Idaho 83703

FINALLY; EASIER MOWING! New design adaptable to all push mowers. Details \$3.00. EZMOW, Box 2923, Springfield, Illinois, 62703

DUTCH TREAT Do-it-yourself plans and instructions for building your own Dutch Mini Barn. Attractive and practical. Offers large storage area—10' X 13 1/2' with 8 feet of headroom. Detailed drawings and materials list. (B-1279—\$3.95.) Write: Popular Mechanics, P.O. Box 1014, Radio City Station, New York, NY 10101

ARTS, CRAFTS, SUPPLIES

"GETTING Started in Stained Glass" \$1.00. Whittemore, Box 2065T, Hanover, Mass. 02339.

CLOCK WORKS. Wood clock blanks, rockhound supplies, belt buckles, cut stones, etc. Wholesale catalog 25¢. Eloxite Corp., 806 1/2 10th Street, Wheatland, Wyoming 82201

STAINED GLASS SUPPLIES Complete Catalog \$2.00 (refundable). Sunshine Glassworks, 3690 Harlem, Dept CT, Buffalo, NY 14215

STAINED GLASS SUPPLIES: EXCITING SUPER CATALOG-PM \$3.00. CORAN-SHOES INDUSTRIES, 509 E. SECOND, BOSTON, MA 02127.

PICTURE FRAMES METAL AND WOOD BUY DIRECT FREE CATALOG: AMERICAN FRAME, 1340 TOMAHAWK, MAUMEE, OHIO 43537

ILLUSTRATED Craft Booklet, \$2.00. Bobby, P.O. Box 45251, Boise, ID 83711-5251.

CARTOONING, COMMERCIAL ARTS, SIGN PAINTING

CARTOON for Fun and Money!!! Free booklet!!! Cartoons, Box 40614A, Detroit, Michigan 48240

MODERN Cartooning taught by mail. Write for free brochure. Cartoonorama, Box 263-82, Branford, Conn. 06405

35 LESSON cartooning course. Cartoonist's Magazine, both \$5.00, Hartman, Box 30367, Lincoln, Nebraska 68503-0367

CARTOONING-Assignments Criticized, Lesson, \$1.00. Graphics, 106 Wampum, Lake Kiowa, Texas 76240

SIGN PAINTING—Easy method. Free catalogue. Kaufmann Company, Centertown, Missouri 65023

MODELS, MODELS SUPPLIES

FIRING CIVIL WAR 2" - NAPOLEAN Model CANNON PLANS, \$8.00: CATALOG \$1.00. Green-PM85, Box 892, Shakmar, FL 32579-0892

RADIO CONTROL - Airplanes, Boats, Helicopters, Supplies. Big Discount Catalog \$5.00 (Refundable). Modelers Supply, Box 7185, Montgomery, AL 36107

"WORKING STEAM MODELS" Kit, ready to run. Tractors, Locomotives, Limousine, Roadster, Truck, Engine. Steam Book \$4.95 Colored Circular, Prices \$1.00 refundable order. Large discounts. Diamond Enterprises, Dept PMA, Box 537, Alexandria Bay, NY 13607. Phone: 613-475-1771.

TOYS, GAMES, KITES, PUZZLES, NOVELTIES

CHILD-POWERED DIGGER: Here's an ideal project for the craftsman who wants to build an exceptional toy for his youngster. The digger works beautifully and provides hours of fun and exercise for its proud young owner. Plans and material list. PL-1822-\$4.95. Send order to: Popular Mechanics, P.O. Box 1014, Radio City Station, New York, NY 10101

MAGIC TRICKS, JOKES, VENTRILOQUISM

LEARN VENTRILOQUISM! Guaranteed Instruction, Supplies, **DUMMIES.** Information Free! Maher, Box 420-PM, Littleton, Colorado 80160.

FREE! World's Leading Novelty Catalog. 1600 Jokes, Tricks, Science, Sports, Hobbies. Johnson-Smith, C-6013, Mt. Clemens, MI 48043

HOBBIES & COLLECTIONS

NAZI & Historical Military Collectibles. **FREE** catalog. HMA, Box 1806PS, Lafayette, CA 94549.

NAZI war souvenirs. **FREE** illustrated catalog. Delta, Box 31224PS, Honolulu, Hawaii 96820

TOY SOLDIER MOLDS plus Chess, Medieval, Fantasy 25 MM. For hobbyists, collectors. Fun and profit! Rush \$1.00 (refundable). Castings, P.O. Box 3482-PM, Longwood, FL 32779.

MILITARY Medals Catalogue 50¢. Yearly Subscription \$4.50. Vernon, Box 1387PM, Baldwin, NY 11510

HISTORICAL NEWSPAPERS, 1600s-1945. Catalog \$1. **ALSO BUY!** Lyons, Box 608PM, Mountainview, CA 94042.

DECALS, EMBLEMS, PATCHES

EMBLEMS, Embroidered-Your Design. Low Minimum. Free Catalog with Prices. Southern Emblem, Box 8P, Toast, NC 27049

CUSTOM EMBROIDERED EMBLEMS, PINS, DECALS. Free Catalog/Quotes. Rush Sketch. Stadl, 61P Jane, N.Y.C. 10014 (212) 929-2293.

ANTIQUES, RELICS, INDIAN GOODS & CURIOS

FREE List to Serious Collectors. 30,000 Indian Artifacts. Pots, Spears, Axes, Slate, Beadwork. Caddo Trading, Box 669, Murfreesboro, AR 71958

INDIAN Artifacts list 50¢. Arrowheads \$20.00 Dozen. Identification Guide \$8.94 pp. Secrist's, Deerfield, Mo. 64741

PRIMITIVE ARTS & CRAFTS Amazon Indian Blowguns, etc. Also a Variety of Nature & Wildlife Books. Free Catalog - **FREE GIFT** w/first order. Sun City Specialties, P.O. Box 5085, Sun City Center, Fla. 33571

ANTIQU TOOL PRICES. New Book. 5,000 old woodworking tools priced and illustrated. **STANLEY, KEENKUTTER, WINCHESTER, SARGENT,** etc. 9 x 12, 230 pages. Rush \$12.95 plus \$1.05 postage. Satisfaction Guaranteed. Windmill Publishing Co., 2147 Windmill View Rd., Dept. PM, El Cajon, CA 92020

STAMP COLLECTING

50 YEARS Old fifteen different United States, over fifty years old—25¢ with approvals. Jaxon, Box C11-P, New Rochelle, New York 10804

FREE! Big Bargain Catalog - New Edition listing thousands of bargains including U.S. & B.N.A. stamps, packets, albums, accessories and supplies. Also fine stamps from our approval service. Buy only what you like. Return balance promptly! Thank you. Jamestown Stamp Co., Dept E85PM, Jamestown, NY 14701

101 Large Pictorials 50¢ when requesting worldwide approvals. Benat, P.O. Box 210244, Dallas, TX 75211.

500 different World + 100 different Mongolian beauties \$2.00. Approvals. **ADULTS ONLY.** Gouge, Box 1320-MC, Elizabethton, Tennessee 37644.

U.S. six commemorative plate blocks or 30 mint commemoratives \$1.00! Approvals. Gordon Davison, Contoocook, NH 03229

UNITED Nations 3 Complete Mint Sets 25¢, Approvals, Cornetta, POB 1509-M, Lake Placid, Florida 33852

BREATHTAKING Beautiful. 50 Different mint Monaco pictorials commemoratives only \$1.50 with mint complete set approvals. Pagoda, Box 132P, Sidney, Ohio 45365.

FREE - U.S. Discount Catalogue. Shelton, Box 547B, North Miami, Fla. 33161.

WORLD Wide Stamps mounted in books on approval 2¢ and up. **TRUST STAMP COMPANY,** P.O. Box 100-P, Jamaica, N.Y. 11435

50 DIFFERENT Old U.S. between 1861 and 1939 - \$1.00. Ed Roush, 423 Shepard, Mansfield, Ohio 44907.

BARGAIN 100 World-wide Stamps 25¢. Quality Approvals. R. Parker, Box 143, West Brookfield, MA 01585

FREE Surprise Collection with approvals. Gould, Box 2130, Petaluma, CA 94953

100 Different U.S. 25¢. Approvals. Bradley, Box 425P, Midlothian, VA 23113

ONE! Two! Three! Cent Stamp Approvals! Regardless Catalog. Kloster, 4164 52nd, San Diego, CA 92105

FREE Gift With First Purchase. U.S. Approvals And Want List Service. 20¢ for Handling. The Stamp Boutique, P.O. Box 456, Madison, N.J. 07940

50 RUSSIA 25¢ Worldwide Approvals. Birrell, 2304 Hancock #9P, Austin, Texas 78756

FREE SUBSCRIPTION— Rare Stamp News. JKI, Box 775PM, Orient, N.Y. 11957

FREE 100 different, plus approvals. Stamps, Box 422P, Sneedville, TN 37869

FREE 50 U.S. Approvals: Cartwright, Box 108-PM, Hopkinsville, KY 42240

(Continued on next page)

STAMP COLLECTING

(Continued from preceding page)

"INVERTED ERROR" + 100 Different United States, 50c with approvals. Luray, P.O. Box 7088, Silver Spring, MD 20907

FREE US Mint Coil Pair With Approvals. Carlson, RT 2, Box 112M, Annandale, MN 55302

"WHOLESALE" U.S.—Foreign Pricelist and catalog Free! Everything Guaranteed. No Approvals. Schneider, Box 1240, Grand Rapids, Michigan 49501

35 DIFFERENT Old U.S. Revenue Stamps \$1.00. Winchester Stamps, Box 3592, Mansfield, Ohio 44907

4 FOREIGN SETS only 10c. Approvals. R.G. Sales, Box 1065-M, Jamaica, N.Y. 11431

FREE 50 Different Worldwide Stamps when Requesting Approvals. Lewington, Box 6149, San Mateo, CA 94403

125 DIFFERENT. Pictorials, definitives, airmails, etc. \$5.00. Low-priced approvals. Loveland Stamp, Box 8224, Loveland, Colorado 80537

150 Different Beautiful Worldwide Stamps for 25c. For requesting Approvals. Pinevalley, 64 Abitibi Ave., Dept. MP8, Willowdale, Ontario M2M 2V4, Canada.

U.S. AIRMAILS, 45 DIFFERENT \$2.00. Mint \$15.00. EBERLING, Box 2216, Neptune City, N.J. 07753

LIQUIDATING Tremendous Stamp Accumulation. Bargain Lists Free. Alatalo, Maynard, MA 01754

101 worldwide stamps 25c. Approvals. White, Box 24166AE, Indianapolis, IN 46224

FREE 100 Canada with request of World Wide approvals. Briner's, P.O. Box 5607, San Mateo, Calif. 94402

PHOTOS & PHOTO SUPPLIES

PHOTOGRAPHY'S Finest Products At Nationally known low prices from a small town dealer you can trust. Free Catalog. Norman's, 3602 South Westnedge, Kalamazoo, Michigan 49008. Since 1957.

KODAK COLOR FILM, 100 ROLLS, \$9.95. Free Enlargements, Coupons, **GUARANTEED.** Compu-tec Marketing, 1200 Patton Avenue, Lith, Illinois 60102.

CAR CLUBS

TOYOTA CELICA SUPRA CLUB. Quarterly publication loaded with how to's maintenance and technical information for supras and celicas. Discounts \$20 year or \$4 for sample. 904 Silver Spur, Suite 182P, Rolling Hills Estates, CA 90274

PLAYS, SONGS, MANUSCRIPTS

POEMS, Songs Wanted. Free Recording/Publishing. Broadway Music Productions, Box 7438PM, Sarasota, FL 33578

FREE SONGWRITING SUCCESS BOOK! Top Records, Box 23505PM, Nashville, TN 37202

MUSIC INSTRUCTIONS & INSTRUMENTS

ACCORDIONS, NEW, USED. Electric, electronic, Cordovox, concertinas, Button Boxes, Hohners We Buy, Sell, Trade, Exchange, Repair, Tune, 50 Years Experience. If Dealers unavailable, Call or Write for Brochures, Mastercard And Visa Accepted. **CASTIGLIONE ACCORDIAN,** 12644 E. 7 Mile, Detroit, MI 48205. 313-527-1595

VIOLIN, GUITAR, etc., making materials, accessories, books. Catalog, \$1.00. International Luthiers Supply, Box 580397, Tulsa, OK 74158

INTERNATIONAL VIOLIN COMPANY, Catalog for instrument makers, repairers. Imported tonewood, tools, varnishes, parts, accessories, strings, cases. European instruments, bows. Assemble yourself violin and guitar kits. Catalog \$1.00 includes 10% discount certificate. Dept. GT, 4026 W. Belvedere Ave., Baltimore, Md. 21215.

ACCORDION Top Brands, cordovox, Buy Direct. Tremendous Discounts. Trades accepted. Free brochure. PM, Accordion-O-Rama, 16 West 19th Street, New York, NY 10011

VIDEO PIANO INSTRUCTION. VHS, Beta. Brochure \$3.00 (refundable). GME-PM, Box 7562, Long Beach, CA 90807.

INSTRUMENT Kits! Build Appalachian and hammered dulcimers, banjos, mandolins; even harps, harpsichords. Free Catalog. PM Hughes, 4419 West Colfax, Denver, CO 80204

SELF IMPROVEMENT

THINK Your Way To Success. Excellent Book. Discounted \$5.00 PPD. Order Now! **FREE** listing Self-Help Books. D&P Product Selections, 150.700 Lambert Road, Glen Ellyn, IL 60137

HOW-TO BOOKS On Personal, Financial Success. Free Brochure. Dysucon, Box 18471, Oklahoma City, OK 73154.

EDUCATION & INSTRUCTIONS

WELDING TRAINING. Skills taught using all major arc welding processes on plate and pipe. Majority of time spent in supervised welding practice. Non-profit school. Approved for eligible veterans. Accredited member NATTS. Write for school bulletin, course schedule. **HOBART SCHOOL OF WELDING TECHNOLOGY,** Box M-85, Troy, OH 45373

LEARN Sewing Machine repairing. A profitable Trade. Easy to learn. Free details. Sewing Center, 187 FR, Rochelle, GA 31079.

ACTS 2:1-47 Enter 1 Cor.1:2 Church. 1127 NE Fifth St., Ocala, FL 32670

BE A PARALEGAL—Handle your own legal affairs. Accredited Attorney Instruction. Home Study. **FREE CATALOG.** Southern Career Institute, Drawer 85PM-2158, Boca Raton, FL 33427. (305) 368-2522

"JET/GAS TURBINE CAREERS!" Homestudy courses — theory, maintenance, overhaul — Established 1957. **AMERICAN JET SCHOOL,** Department PM-3, Darby, Montana 59829. (406) 349-2100

AUTOSUGGESTION. Sleep-learning headquarters! Tapes, records, books, Gigantic catalog free. Research Association, Box 24PM, Olympia, Washington 98501.

HIGH SCHOOL DIPLOMA AT HOME. NO CLASSES. Low cost. Information FREE. Call toll free 1-800-228-5600 or write: American School, Dept. #30845, 850 E. 58th St., Chicago, IL 60637

UNIVERSITY DEGREES BY MAIL! Accredited Bachelors, Masters, Ph.D.s... Free revealing details. Counseling, Box 317-PM8, Tustin, California 92680.

EXTENSION And Post-Graduate Awards in Philosophy, Art, Science, Botanic, Medicine, Homeopathy, Radionics, and others. 30 subjects Curricular free (airmail \$1.00 refundable). Registrar, Sussex College of Technology, Highfield, Daneshill, Sussex, England.

RADIESTHESIA, Radionics, Dowsing E.S.P. Courses and Equipment Illustrated Catalog \$1.00 (refundable) Established 27 years. Dept. PM/R, Bruce Copen, Highfield, Daneshill, Sussex, England RH17 7EX.

LEARN Asleep or awake. Records, tapes, equipment! Free catalog! Drawer PM-400, Ruidoso, New Mexico 88345

FREE Catalog. Learn Auctioneering. Nashville Auction School, Box 190, Lawrenceburg, Tennessee 38464

UNIVERSITY DEGREES By Mail. Accredited Bachelors, Masters, PhD's. Free Facts Revealed. Careers-PM8, Box 470886, Tulsa, OK 74147.

BUILD Your Own Sewing Machine. Kits And Instructions Available. Info \$2.00 (Refundable). CVS, Box 12552, El Cajon, CA. 92022

DEGREE Studies Off Campus Law school. Qualify for CA Bar. Bachelor's, master's, doctorate in business, engineering, health service management and public administration. Prepare for CPA, CMA, CFA and CIA exams. In engineering, E.I.T. and P.E. exams. Credit for work experience. Southland University, 35 No. Craig Ave., Dept. M8H, Pasadena, CA 91107. National Information Line 818-795-5558.

DESIGN STRESS CALCULATIONS MADE EASY "Your stepping stone to excellence". Box 1073E, Scottsdale, AZ 85252

PIANO TUNING PAYS - Piano tuning - Electronic organ servicing. Learned easily at home. Free booklet. Niles Bryant School, P.O. Box 20153, Sacramento, CA 95820

LOCKSMITHING, Universal School of Master., Correspondence and Shop Training. Box 214652PM, Sacramento, CA 95821

SUPER-INTELLIGENCE Amazing method sent Free! **EDEMP,** Box 1462, Glendora, CA 91740

BECOME a specialist technician. **FREE** catalogue describes 200 different correspondence courses. Granton Institute, 263A Adelaide Street West, Toronto, Canada. 1-800-268-1121.

WELDING technology by independent study. Arc, Mig, Tig, Flux cored, Welding Metallurgy, Blueprint Reading, Welding Symbols. Write for free details. For complete details on "How to Become a Certified Welder" send \$6.00 to: Huenel Enterprises, P.O. Box 11496, Indianapolis, IN. 46201

LOCKSMITHING. Free book. Locksmithing Institute, Dept. 310-085, Little Falls, NJ 07424

DETECTIVE training home-study program. Free information. Global, Box 191 PM, Hanover, Mass 02339

SCHOOLS

WHY NOT INVESTIGATE COMMERCIAL DEEP SEA DIVING AS YOUR CAREER? Our Graduates are working worldwide making excellent money. Send \$5.00 (fully refundable upon enrollment) for catalog containing disclosures, credentials, course outline, employment statistics, instructor qualifications, progress standards, financial assistance to: Divers Institute of Technology, Inc., P.O. Box 70312, Dept. PM, Seattle, WA 98107

WORLD WIDE COLLEGE of Auctioneering, Inc. The original—50-yrs.—World's largest! Term soon. Approved for V.A. Free catalog. **COL. GORDON E. TAYLOR,** Box 949, Dept. 19, Mason City, IA 50401. 515/423-5242.

EMPLOYMENT INFORMATION

BECOME A LAS VEGAS DEALER! Exciting career! Complete report. \$10.00 ppd. TJM Enterprises, 3661 Maryland Pkwy., #3-192 Dept. P55, Las Vegas, NV 89109

SHIPS, Tugs, Cruiseships, Riverboats. Women, Men. \$15,000-\$60,000 Work month, Home month. Experience unnecessary. U.S. 112 Countries. Free report. **SASE Marine Employment,** Box 207, Central, IN. 47110

SHIP OUT-GO TO SEA! ADVENTURE TRAVEL, MALE FEMALE. Passenger, Freighters, Tankers, deep sea lakes rivers. I'll tell you all you need to know. Send \$5.00 to: Seaman, Box 670807, Dallas, TX. 75367-0807

AIR TRAFFIC CONTROL How to apply and what to expect in this challenging career. Free Details. Cathcart Company, P.O. Box 941, Paw Creek, N.C. 28130

ROCKY MOUNTAIN EMPLOYMENT NEWSLETTER!! Colorado, Idaho, Montana, Wyoming! Current openings - All occupations! **FREE INFORMATION!!** Intermountain-L, 3115 N. Hancock, Colorado Springs, Colorado 80907. 1-303-630-7478 X112.

HOW To Get An Overseas Job, Detailed Report \$5.95. Schneider, 11933 Magnolia, N. Hollywood, California 91607

ALASKA Jobs Weekly Newsletter, Homesteading, Cost Of Living, Business Opportunities—Alaska Jobs-M, H.C. Box 217B, Bemidji, MN 56601

HELP WANTED

OVERSEAS Employment ... \$20,000-\$60,000+. Free Report! Employment, Box 19760-AH, Indianapolis, Indiana 46219.

AUSTRALIA — Openings Now! Top pay! Transportation. Plus Worldwide listings: \$2.00. Jobworld, Box 681E, Cypress, CA 90630.

AUSTRALIA WANTS YOU! Jobs! Big Pay! Transportation! Newest Handbook — \$2.00. **AUSTRALIAN INTERNATIONAL,** Box 19107-AH, WASHINGTON, DC 20036.

OVERSEAS U.S. Jobs Available. Unlimited opportunities. Write for application. Employers, Box 3239-G, Gulf Shores, AL. 36542 or call 205-966-2500.

(Continued on next page)

Материал, защищенный авторским правом

FOR INVENTORS

PATENT AND DEVELOP Your Invention. Registered Patent Agent and Licensed Professional Engineer. Send for **FREE PATENT INFORMATION** Every Inventor Should Have. Richard L. Miller, Woolworth Building, 233 Broadway, Suite 3612-M, New York, NY 10007. (212) 267-5252.

NONPROFIT Foundation helps inventors. Free recording forms. Free evaluation. Affiliated Inventors Foundation, 501-B Iowa, Colorado Springs, CO 80909. Or Call 1-800-525-5885.

PATENT IT ECONOMICALLY! Free Details. N. Raner, 2008 Fondulac, Richmond, VA 23229

PROTECT Your Invention. Registered Patent Attorney. Many Years Experience, all Fields. Individual Inventor's Problems Given Special Consideration. Very Reasonable Charges. Write for Free information. Paul H. Gallagher, 2530 Crawford Ave., Evanston, Illinois 60201

INVENTORS! Can you profit from your idea? Call us today regarding the marketing of your invention, or write for your free information package. Over a decade of service. **AMERICAN INVENTORS CORPORATION**, 82 Broad Street, Dept. PM, Westfield, Massachusetts, 01086. (413) 568-3753. (not an answering service) Offices nationwide.

WE'RE searching for energy-related inventions. Win the Boston Edison Centennial competition and we'll provide assistance to you in introducing and promoting your invention. Deadline is October 31, 1985. There are no entry fees and submittal forms are available from: The Office of the President, Centennial Invention, Boston Edison Company, 800 Boylston Street, Boston, MA 02199. For information call (617) 424-2447.

REGISTERED PATENT ATTORNEY Washington D.C. Suburb. Donald A. Kattiestrings, 414 Hungerford Drive, Rockville, Maryland 20850

INVENTORS: If you have an invention for sale or license, write for free booklet explaining how we can help you. Kessler Sales Corp., C-5-FI, Fremont, Ohio 43420

200 Exotic Energy Inventions. Rare Technical Data. Amazing Catalog. \$1.00. Rexfax, P.O. Box 1258, Berkeley, CA 94704

ORIGINAL, expired U.S. patents in manufacturing, electronics, agriculture, solar, etc. are now available to collectors, inventors, teachers. Send \$5 to: The Public Domain, P.O. Box 123, Inverness, CA 94937.

INVENTORS RESOURCE. A complete reference guide to over 50 LEGITIMATE PRODUCT DEVELOPMENT COMPANIES. Information on venture capital, university programs, marketing and more. \$13.95: KC Associates, 8718 Roaring Point, Houston, Texas 77088. M.C. Visa

PATENT ATTORNEY: Fast, responsive service. Free information. Keefe & Associates, P.C., 17925 Martin, Roseville, MI 48066.

PATENT IT YOURSELF - Complete instruction manual \$28.00. Box 5192, Arlington, VA 22205

INVENTIONS WANTED

EARN ROYALTIES. NUPRODUX INTERNATIONAL, 1377 K STREET, #203, WASHINGTON, DC 20005

INVENTORS! Have an idea? Don't know what to do? Call AIM for free information kit. Toll Free 1-800-225-5800

NEW idea? American Patent in Washington, D.C. Gets Results! Best References - Free Kit - 1-800-257-7880.

LEARN how to offer your invention for sale or license. Free booklet outlines procedures, royalty rates, requirements. Kessler Sales Corporation, C-5-IW, Fremont, Ohio 43420

INVENTION MARKETING. FREE INFORMATION. REPRESENTING MANUFACTURERS. Patmart, 77 Fulton, 26D, Financial District, New York, NY 10038

REAL ESTATE & FARMS

YOUR OWN FISH AND HUNT LAND LOW AS \$29.00 ACRE—\$50.00 DOWN!

BEST areas for fish and game. Government report more fish and game per square mile. **TITLE GUARANTEE. BUY BACK GUARANTEE.** Bought thru **ESTATE LIQUIDATIONS** across Canada. **EASY PAYMENTS.** Get your Free Catalog **NOW!!** **CANADIAN ESTATE LAND**, Dept. PMC, 2411 Yonge Street, Suite 303, Toronto, Ontario M4P 2Z1. Phone any time: 1-416-488-0444.

CANADIAN Country Properties. Our 70th year. Terms available. Catalogue airmailed \$1.00. Dignam Corporation, Suite 496, 85 Bloor East, Toronto, Ontario M4W 1B5.

CALIFORNIA. Lots. Acreage. \$40 Down. \$40 Monthly. Box 35291, Los Angeles, 90035.

REAL ESTATE FOR SALE New Spring-Summer Catalog, thousands of properties & pictures! Send \$2 for postage & handling. Free at any local United office. **UNITED FARM AGENCY**, 612-PM West 47th, Kansas City, MO. 64112

WESTERN NORTH CAROLINA Mountain Acreage, Farms, Cabins, Homes, Waterfront Property. **FREE** Brochures. Call Toll-Free: 1-800-438-8159. Raper Realty Inc., P.O. Box 619, Murphy N.C. 28906

FREE REAL ESTATE CATALOGS. Midwest and Southeast Sun Belt States. Specify Property and Area Desired. Call or Write: **COUNTRY NETWORK**, Box 368PM, Gainesville, MO 65655. 417-679-4632.

MONTANA LAND 20 Acres (or more) starting at \$12,500. with \$175. down, \$175.05/mo. Near Beautiful Yellowstone Park and National Forests. In the heart of trophy elk, deer, moose, antelope and turkey hunting. Blue ribbon trout streams. Guaranteed Access. Insured Title And Warranty Deed. Your Inspection Welcomed. Free Brochure, Maps, Color Photos. **CALL TODAY TOLL FREE: 1-800-252-5263.** **YELLOWSTONE BASIN PROPERTIES**, 1119 N. 7th Ave., Dept. PM, P.O. Box 3027, Bozeman, MT 59772-3027. (406) 587-5469

RETIRES: Happiness, Security, Contentment-Beautiful Southern Ohio. Near Major Cities-Independent Living-Individual Homes Starting At \$19,000.00-Life Lease Or Rental-Modest Monthly Fees - Bristol Village, Waverly, Ohio 45690

CENTRAL MAINE'S most complete selection of Rural Properties. Free brochure: Maine Land Realty, Pittsfield, Maine 04967. 207-487-3263

PLASTIC BAGS

HUNDREDS of Sizes, Plain and Ziplock. Lowest prices! Immediate delivery! Free Catalog. Action Plastic Sales, 1690D 94th Lane NE, Minneapolis, Minn. 55434. Tollfree: 1-800-328-8484.

BUY IT WHOLESALE

400,000 BARGAINS Below Wholesale: Many Free! Liquidations . . . Closeouts . . . Job Lots . . . Single Samples. Free Details. Bargainhunters Opportunities, Box 730-A, Holland, Michigan 49423.

BELTS and Buckles. Complete line fast sellers, including truckers, motorcycles, wildlife, westerns etc. Big Profits. Complete dealer set up. Catalog \$1.00. Anchor Specialties, Box 3958-BPM, North Providence, RI 02911

CLOSEOUT Jewelry 55¢ dozen. (Catalog 25¢), Rousseis, 107-1631 Dow, Arlington, MA 02174

WORLDWIDE BARGAINS . . . Imports — Dropship — Closeout — Surplus — Freebies — (Stamped Envelope). Marnees, Box 1717PM, Highland, Ind. 46322

EARN MONEY selling rings, jewelry, buckles, watches—buy direct. 130% below retail. Catalog \$1.00 (refundable). Anka-PM, 90 Greenwich Ave., Warwick, RI 02886

BIG PROFITS! Drapes, Priscillas, Country Ruffles, Bedspreads—Low Price—Outlet Sales! Details \$1.00: Alford's, Box 339P4, Middlesex, N.C. 27557

CLOSEOUTS! Discounts! Below Wholesale! Freebies! Information/stamp: DDN, Box 20152K, Ferndale, Michigan 48220.

600,000 Bargains! Below wholesale, closeouts - 1000 free samples! Everything-\$2.00. Hurlocker, Rt. 5, Charlotte, NC 28208-20

BUY DIRECT FROM OVERSEAS SUPPLIERS. Revealing report contains World Traders' Digest, Directory of Foreign Suppliers, and more! Satisfaction Guaranteed. \$3.00. C & S Marketing, 594 E. Jefferson, Reedley, CA 93654

ADVERTISING AGENCIES, ADV. SER. MAILING LISTS

OPPORTUNITY SEEKERS/MLM NAMES. FREE SAMPLE. Venture-PM, Box 336, Riviera, AZ 86442

FREE Mailing List Consultation. Details. GOC-18P, Box 1107, Stuart, FL 33494. (305) 334-5205. 1-800-554-5478

MAILING lists information free details. D&B Sales, 271 North Pearl Street, Galesburg, ILL. 61401

ELITE LIST, repeat buyers only, updated and screened by computer. Box 428, Syracuse, NY 13214

GROW—Succeed With The Best Mailing Lists Available. Brochure: Galley Bros., 3541 Park Blvd. #205, San Diego, CA 92103

MAILORDER NAMES THAT REALLY PULL!!! Peel and stick labels. **ZIP CODE ORDER. GUARANTEED DELIVERABLE!!** For details **RUSH SASE** to: **RAINBOW ENTERPRISES**, 11087 Sue Ave., Lynwood, Calif. 90262

MAILING LISTS THAT PRODUCE! Actual Buyers. **GUARANTEED** Deliverable! Rush SASE. Glenview, Rd 2, Box 267c, Lebanon, New Jersey 08833

BUSINESS SERVICES

INCORPORATE without legal fees! Free booklet tells how, includes forms. Call now 800-345-CORP.

PRINTING PRESSES, RUBBER STAMP OUTFITS

PRINT FOR PROFIT - Earn extra money; printing press, type supplies, direct from factory. Famous since 1872. Send \$1.00 for catalog and samples to: Kelsey Company, DM, Meriden, CT 06450

PRINTING Presses, new and used supplies. List 50¢: Turnbaugh Printers Supply, Mechanicsburg, Penna. 17055

BARCO Type Founders. Type and Rubber Stamps catalogue. Mail \$2.00 refundable on first order. 237 S. Evergreen, Bensenville, 60106

TYPE for printing. Catalog \$1.00/deductible 1st order. Quaker City Type, R.D. 3, Box 134, Honeybrook, PA 19344

TYPE Fonts. Hard Printing Presses, Hot Stampers, Supplies. 120 Pages. \$2.00 Deductible first order. Acme Type, 1720 N. Marshfield, Chicago, 60622

COMPLETE Rubber Stamp Outfits, Supplies. Same day shipment. Sign Engraving Machines, Wholesale Catalog \$1.00 Deductible. Star Stamp, 1720 N. Marshfield, Chicago, 60622

PRINTING SUPPLIES

24HOUR PRINTING . Low prices. Write: Printing, 10660 Plano Road, Dallas, Tx, 75238

QUICK Copy Printing. Low Prices. Write: Nationwide, 614 North Main, Bloomington, Illinois 61701

BUSINESS CARDS (Thermographed) Free Samples. BG, 808 Taylor, Pittsburgh, PA 15202

GIFT SHOPPING

GOLD Electroplated gifts. Free literature. **WRIGHT**, 3115 Gus Thomasson-885, Dallas, Texas 75228.

(Continued on next page)

CLOCKS, WATCHES, OLD GOLD, JEWELRY

HIGHEST CASH for Gold, Jewelry, Gold Teeth, Rings, Diamonds, Watches, Silver, Platinum, Mail Artifacts Today. Free gift with information. Chicago Gold & Precious Metals, 10 South Wabash, Dept. 1258, Chicago, 60603.

CLOCK WORKS, wood clock blanks, rockhound supplies, belt buckles, cut stones, etc. Wholesale catalog 25¢. Eloxite Corp., 806 1/2 10th Street, Wheatland, Wyoming 82201

CLOCK MOVEMENTS, Dials, Gifts, Free Color Catalog. Low Prices. Newport, 2313 Burbank Blvd., Dept. PM, Burbank, CA 91506.

CYPRESS CLOCKS Do It Yourself Catalog And Instructions. Free; Quartz Movements, Cypress Slabs, Resin! Cypress Corner, 6104 South Trail, Sarasota, FL 33581

TAKE NO CHANCES. Deal with oldest, most reliable firm in old gold business. Established in 1934. We buy Gold, Silver, Platinum, Diamonds. Highest Cash. Free Information: Rose Industries, 29-A East Madison, Chicago, 60602

TREASURE FINDERS

FIND coins, jewelry, nuggets, treasure. New revolutionary patented detector. Astounding range. Unaffected by black sand, mineralized ground. Rejects metallic trash. Free Catalog. Gardiner, 4729M N. 7th Avenue, Phoenix, AZ. 85013

TREASURE- Locate quarter mile away with ultra sensitive locator - brochure free. Research Products, Box 270270 - AMC, Tampa, Florida 33688

SAVE up to 40% on metal detectors. All major brands including White's and Garrett. **FREE** discount catalog. Northwoods General Store, Dept. DPM-8, 1325 Greenway Cross, Madison, WI 53713. (608) 274-4680.

PROFITABLE OCCUPATIONS

FT. SMITH Auction School, Ft. Smith, Ark. 72903. Resident & Home study. Veteran Approved.

REPAIR lawnmowers thousands of parts and tools wholesale list 40¢. Ellwanger's, PM, P.O. Box V, Port Jervis, NY 12771

PLASTERCRAFT . . . Profitable Home Business 3000 Molds Available. Details. Lynette, 6251C Mentpark, Mentor, Ohio 44060.

FREE Brochures. Repair air conditioning, Refrigeration. Tools, supplies, full instructions. Doolco, Inc., 11252 Goodnight, Suite 600, Dallas, TX 75229

MAKE MONEY IN SPARE TIME. Earn Generous commissions as a subscription sales representative for leading magazines. For full details and instructions, send this ad with your name and address to: **POPULAR MECHANICS**, Dept. AB-M, 250 W. 55th St., New York, NY 10019

SALESMEN-DIST.

MOBILEHOME OWNERS BECOME DISTRIBUTOR for new mobilehome accessory everyone needs. Griffway, 3326 Hutton, Harrison, MI. 48825

MAKE EXTRA MONEY DURING YOUR SPARE TIME! Earn weekly commissions showing our exciting line of Calendars, pens and other popular Advertising Gifts. Prompt, personal service from AAA-1 firm. Our 76th year. No experience necessary. No investment or collections. Set your own hours. Full Time potential! Write to Kevin Peska, **NEWTON MANUFACTURING COMPANY**, Dept. CPM8, Newton, Iowa 50208

AGENTS WANTED

WITH Mason Shoes, pay day is when you want it! Take orders from friends and neighbors. Watch your business build, without risk or investment. Write: Mason Shoes, K-920, Chippewa Falls, WI 54774.

BUSINESS OPPORTUNITIES

IMPORT - Export opportunity, profitable world-wide, mail order business from home, without capital. We ship plan for no risk examination. Experience unnecessary. Free Report. Mellinger, Dept. R2709, Woodland Hills, California 91367

MAKE \$15.00 Hourly building custom luggage/cases at home. Huge nationwide demand. Fill mail orders. We supply materials, instructions, everything! Free details. Custom Case, 9329 De Soto Ave., Dept. C20-56, Chatsworth, CA 91311-4991.

MAKE Money At Home! Valuable Report! Immediate Openings! All Ages! S., 2311 4th Street, Peru, Ill 61354

COMPLETE Line of High Quality Low-Priced Cutting Tools, Holding Fixtures, Precision Instruments, Tool Steel, Electric Power Tools, Hand Tools, Metal Machinery and much more. Most Items Delivered Free. Send \$4.00 for 324 Page 1985 Catalog. Refundable with First Order. To: KBC Tools, 6300 18 Mile Rd., Sterling Heights, Mich. 48078

MAILORDER Opportunity: Start profitable home business without experience or capital. Write for free book, plus details. No obligation. Mail Order Associates, Inc., Dept. 686, Montvale, NJ 07645.

BE YOUR own boss! 1001 fast, easy ways to make money! Free! Rush name, address. Money Making, Dept. 158, Box Z, Studio City, CA 91604

TAKE Catalog Orders. We drop-ship 2500 best-selling specialty products. Lowest below wholesale prices. Immediate delivery. Spectacular home business opportunity. Free Book. SMC, 9401 De Soto Ave., Dept. 20-56, Chatsworth, CA 91311-4991.

MAKING EXTRA MONEY MADE EASY. FREE Subscription to Opportunity Magazine offers hundreds of proven ways. Write: Opportunity, Dept. F11, 6 N. Michigan, Chicago, IL 60602.

ARAB BUSINESSMEN Have Money to Buy & Invest. Top Finders Fees paid, International Middle East Association, 885PM1, 8291 Flaxman, Huntington Beach, CA 92646. (714) 964-1006.

ALUMINUM SCRAP - Recycle Yourself - **MAKE \$25.00/ POUND!** Free Information: Industrial-PM58, Box 127, Alexandria Bay, New York 13607

HOW TO MAKE MONEY IN SATELLITE TV. Where To Find The Best Deals. \$25.00 Year. Satellite TV Opportunities Magazine, 305PM Jackson, Oxford, MS. 38655

CASH Loans-\$500-\$25,000! All Eligible! Any Purpose! American, Box C-16, Lynbrook, New York 11563

\$700 Per month earnings possible preparing income tax returns at home or tax office. We show you how. Quickly learned. Details free. No salesmen. Federated Tax, 2065 Montrose, Chicago, 60618.

HIGH PROFITS WITH CUSTOM T-SHIRTS AND CAPS. Inexpensive, professional heat transfer machines. All supplies. **PRESS MAGIC**, P. O. Box 22809 (GC), Tampa, FL 33623

MAKE Rubber Stamps. Highly Profitable Business. Free Details. Stamper, POB 22809 (GC), Tampa, FL 33622.

BUMPER STICKER PRINTING DEVICE. Cheap, Simple, Portable. Free details. Bumper, POB 22791 (GC), Tampa, FL 33622.

SCREEN PRINT T-SHIRTS. Inexpensive kits. Free Details. "T-Printer," POB 23991 (GC), Tampa, FL 33623.

PROFITABLE GOLD FOIL PRINTER. Personalize business cards, pencils, matches. Free Details. Gold, POB 24986 (GC), Tampa, FL 33623.

VINYL'S Where the money is! Professionally repair, refinish, recolor furniture, luggage, car tops. Quick, easy. Two small \$20 jobs a day earn you \$1,000 a month. Homes, cars, offices, restaurants, unlimited customers. Start earning after a few days practice. Sensational details free. VIP, 2007 Montrose, Chicago, 60618

ASSEMBLE PRODUCTS AT HOME. Many opportunities paying High Weekly Profits presently available without investment. Write: Businesses, 92B Brighton 11th, Brooklyn, New York 11235.

PIANO Tuning quickly learned with home study courses. Diploma granted. American Tuning School, 17050 Teller Drive, Morgan Hill, Calif. 95037.

PICTURE Framing—Profitable full or spare-time business. Easy to learn with handbook-course "Guide To Picture Framing Profits." \$3.00 Guaranteed. Free framing-supplies catalog included. Japs, 128-PM Seventh North, Hopkins, Minnesota 55343.

CONCRETE Block Machines: Catalog \$1.00. Route One, Box 3740, Rapid City, South Dakota 57702-3740

REPAIR HYDRAULIC JACKS — DETAILS FREE. WRITE: HYDRAULIC PARTS SUPPLY, BOX 4157, BROWNSVILLE, TEXAS 78520.

VENDING MACHINES. No selling. Routes earn amazing profits. "Big Catalogue FREE." Parkway Corporation, 1930 PMB Greenspring Drive, Timonium, Maryland 21093

\$1,000.00 WEEKLY Possible Bronzing Baby Shoes **FREE BROCHURE SHOWS** How. NBPM, 396 Airport, Sebring, FL 33870

LEARN Sewing Machine Repairing. Men. Women. Lucrative Profits. Gresslin Correspondence School, Box 5104, Spencer, Iowa 51301.

MAKE MILLIONS MANUFACTURING BATTERIES!! Supplies available. Everlast, Box 365, Bogota, NJ 07603.

\$25,000 LOANS INTEREST FREE!! Secret Federal law WIPES OUT DEBTS!! Details FREE!! Moneywise/B, LaGrange, NY 12540

GET RICH using OTHER PEOPLE'S MONEY!! Unique—amazing business!! Details FREE!! Finance Consultants/B, Billings, NY 12510

CLIP newspaper items—\$2 - \$25 EACH!! FREE Report! Clippings/B, Billings, NY 12510

GET RICH!! Secret law smashes debts—brings Cash, Credit! FREE report!! WealthKit/B, Billings, NY 12510

NEW discovery in battery reconditioning. Eighteen months guarantee means "Big Profits Fast"! Electone, 7415 Gable Dr., Little Rock, AR 72205

MAKE BIG MONEY REPAIRING WINDSHIELDS & Plate Glass! Up to \$60,000 yearly! Call TOLL-FREE for Valuable FREE report. 1-800-321-2597. Glas-Weld Systems, Box 5755D, Bend, OR 97708.

HUGE profits! Reconditioning used car batteries. Secrets others don't tell. Stamp please. Battery Outlet, Box 3300, Hickory, N.C. 28603.

RECONDITION JUNK BATTERIES. Easy moneymaker! Write: Owen, 771PM, Battle Ground, Washington 98604

MULTILEVEL MAILORDER CAN MAKE YOU RICH! Ground floor opportunity. FREE cassette reveals how! WMC-1, 7249 Amhurst Way, Clearwater, FL 33546

I MADE \$40,000 Year by Mailorder! Helped others make money! Details 25¢. Torrey, Box 318YY, Ypsilanti, Michigan 48197.

SELL Books by Mail. Dealership-25¢. Midwest, Box 44R2-PM, Shawano, Wis. 54166

CONFISCATED Ex-Drug Vessels, Aircraft, Vehicles Auctioned By State, Local Agencies, Customs, Etc. Twice Monthly National Auction Bulletin \$35/yr. \$20 Six Month. 3600+ Items Reported 1984 1-(800) 327-2049, Fla. 1-(800) 223-3291

CLIP newspaper articles - \$25.00 EACH! FREE details! National, Box 85518, Los Angeles, CA 90072.

FREE! . . . "TREASURY OF HOME BUSINESS OPPORTUNITIES" . . . MAILCO, BOX 34370, BARTLETT, TENNESSEE 38134-0370

LIFETIME Security. Multi-Level Mailorder Two Opportunities. Oneil-M, 10 Oak Lane, Suisun, CA 94585

LEARN Gold, Silver Scrap Recycling Business. Free information: Recycling, Box 11216P, Reno, NV. 89510

\$1000 Weekly, Mailorder. Free Details: Northwind, Box 11368, Houston, Texas 77293

IMMEDIATE IMPORT BUSINESS! European And Far East Companies Looking For Importers, Agents/Representatives. Our **TELEX SERVICE** Starts You At Once. 1,000's Of Products and Lines. Write: Artek-D, 127 East 59th Street, New York, NY 10022.

MAKE PVC PIPE FURNITURE. Easy profits! Write: Owen, 771PF, Battle Ground, Washington 98604

(Continued on next page)

BUSINESS OPPORTUNITIES

(Continued from preceding page)

PAYTELEPHONES Untouched Market, Easy Money. Continental Communications, P.O. Box 177, Iron Mountain, Michigan 49801. (906) 774-4847 MI.

SAVE! Two stamps sends your name to Thousands of Opportunity Advertisers. B/Assoc.; Box 4222, Rockford, Illinois 61110.

RECEIVE complete training servicing Fire Extinguishers and Systems. NorthernTier, 865 Kienas Road, Kalispell, Montana 59901.

EASY, Own your own Business Earn big bucks fast. Write: Best Systems, Inc. Vinyl Repair, 13459 Kit - 136, Dallas, TX. 75240

TOLL FREE. Exceptional Opportunity. Profitable business. 800-824-7888 operator 1779. Minimum investment \$620.25.

"WATKINS" QUALITY PRODUCTS! Spices, Flavorings, Medicines-Profits to 61%-Multi Level-Dealers & Distributorships available-Details \$1.00. Allford's, Box 399PW4, Middlesex, N.C. 27557

\$500.00! Weekly Possible Mailing Our Burglar Alarm Advertisements! RBM Merchandising, Box 59314, Chicago, Ill. 60659.

PRODUCE BEAUTIFUL COPPER OR BRASS SIGNS. Fast, Inexpensive, Profitable. Details. Signet, 50 High, Suite LL 7-C, Buffalo, N.Y. 14023

\$192.00 From Square Foot Plywood. (Huge Demand) Revealing Profit 25¢. (Refundable). Woodwin, Bridgewater, Mass. 02324

\$25.00/hour from home. Men, women, all ages. Immediate opportunity. Rahmani, 210 Welch-PM, Ames, IA 50010

CHEMICAL, Science Supply Business, starting inventory. Box 161A, Brighton, Mass. 02135

"OPERATE exciting **PROFITABLE** businesses at home." Details ... **FREE** ... CIB, Box 1356-PM7, STAMFORD, CT 06904.

MAKE money at home! Hundreds of profitable plans. Free information. GAC, Box 124PM, Middletown, CT 06457

\$480 Weekly. Home mailing program. Goodworld, Box 26233-R, Tamarac, Florida 33320

LEARN MIRROR RESILVERING free information. Silvercraft, Box 127, Lansdowne, PA 19050.

\$1,000 Weekly Home Business Directory. Box 2019-PM, New York, New York 10163.

\$40,000 ON 1/3 ACRE! New Hydroponics - inexpensive, pleasant, practical! Free information. Robin's, Box 1214, Franklin, TN 37065-1214

RECYCLE METALS, NO, NOT BEER CANS! Easy \$458 weekly! Free Information. Recycler, Box 1214, Franklin, TN 37065-1214

BOSS yourself wholesale 2500 items **BIG** catalog \$3.50 refundable: Richerson, 5858 Southurst, Houston, TX 77033

BIG Profits In Mailorder! Details Free! Frontier, Box 43475, Tucson, AZ 85733-3475.

MAKE BALLOON ANIMALS. Weekends \$37,500 Yearly! Free Sample / Details! Write: Funnyman's - PM58, Box 250, Alexandria Bay, New York 13607

DISTRIBUTORS Wanted. Sell Hottest Item in 50 Years - Pay Telephones. WTS Communications, 14 Sunnyside Drive, Herminie, PA 15637

CONCRETE brick block machines. ABDM Roxboro Ltd., 19FG Centre Commercial, Roxboro, Quebec H8Y 2N9

UNIQUE, valid, unlimited financial opportunity. Our volume is doubling this year, and we need dealers. Write: R&L Log Buildings, Inc., P.O. Box 237PM, Mt. Upton, New York 13809.

MAILORDER FORTUNES. Wholesale Books, 100% Profit. Selective, Box 1140, Clearwater, FL. 33517

MAKE THOUSANDS with your own Auto Detailing Business. \$10.00 (Refundable) for complete details. AD Enterprises, P.O. Box 1262, Clearwater, Fla. 33517.

PREPARE Tax Returns. Earn high fees, dignified work. Train at home. Accredited Program. National Tax Training School, Monsey, ZHS, New York, 10952.

GET Rich Servicing VCRs!! Free Report Reveals Exciting Details of Revolutionary New Business Plan. Video/Medic, 1400 Seneca #302, Broadview Heights, Ohio 44147.

PIANO Tuning Business. Low investment, quick profit! Free information. Careers, Box 383PM, Urbana, IL 61801

TURN \$4 into \$39.95 (Woodworking) - Pine Shop, 2 Morrill, Hooksett, NH 03106

DISTRIBUTORS Wanted. Full Merchandise Line. No Inventory! Unlimited, Box 71382, Los Angeles, CA 90071-0382

MAKE \$1000 monthly with classified ads. \$11.95. Complete catalog of How-to books. \$1.50. Hanson Enterprises, RR1, Box 46, Turtle Lake, N.D. 58575

HUGE Profits! Sell Cars Instructions-\$18.00. Mr. Ledbetter, P.O. Box 5097, Hialeah, Florida 33014

"SELL MONEY!" Become a Loan Broker! Free details. Financial Planning, Dept. PM-209, 210 5th Avenue, New York, 10010, (718) 768-6803 Ext. 200

BIG profits from your home. Free details. Dave Smith, Box 6501(A), Ocala, FL 32678

SOURCE BOOK, money making reports, how to books, motivational tapes. \$1.00. M & M Specialties, Box 1896, Farmington, N.M. 87499

NEW Luxury Car Without Cost! Write: AMCO 9, 1601 E. Main, Plainfield, IN 46168

HOW TO START AND OPERATE YOUR OWN PROFITABLE BUSINESS AT HOME. This new and extraordinary book reveals seven of the most profitable home based businesses! Legal, Inexpensive, Guaranteed to be of practical value or money back! For details: send stamped, addressed #10 envelope to: G&W Advertising Co., 2717 Peck, Box 4352F, Muskegon Hts., MI 49444.

HOW to start and operate several profitable businesses. **START** small or big at home or office. **FREE DETAILS.** Sunbird General Corporation, Dept. M-8, 5630 Phillips Highway, Suite 103, Jacksonville, Florida 32207.

NAME YOUR INCOME! Homework. Millionaires' **PROVEN** method. No selling. No inventory. Daily profits. **GUARANTEED!** Send 22¢ postage for Free information Today! Canpro-8, Box 1013, La Mesa, CA 92041

BORROW By Mail \$500-\$25,000 Fast! Easy! Confidential! For Info Application Write: Accurate, 2120 Crestmoor, Nashville, TN 37215

CONCEPT SEVENTY 7 REWARDING NEW BUSINESS - FREE Cassette. P.O. Box 2458, Pinellas Park, FL 33565

GUARANTEED Lifetime Income. **NO INVESTMENT** Required! Easy, Proven! Free details. Lifeplan-1, 320 Alder, Everett, Wa. 98203

FREE information. Hundreds of Products. Buy Wholesale. Make Huge Profits. Shelton, Box 9016PM, Newark, N.J. 07104

STAGGERING Profits in Sparetime **HOME PRINTING.** Easy. Free Information. Printing, Box 25297, Colorado Springs, CO 80936

FREE Catalog. Home Business Opportunities. Books, Reports. Youngers, Princeton, Iowa 52768

HEALTH FOOD Distributors Needed: Tremendous Income Potential. Free Details. Wade-P, 4509 Beckford, Greensboro, NC 27407.

SELL books by mail. 400-900% profit. Free sales kit. Speedbooks, 23860-8J Miles, Cleveland, Ohio 44128

PRINTING BUSINESS on a shoestring, information: Greenlee, Box 3382, Whittier, CA 90605

\$875 WEEKLY with this One-Man Business. Today, Box 19636, Portland, OR. 97219

THIS IS A CENTERED LINE AD NOTICE how it stands out against the other ads. If you like it, ask for it. The charge for this line is only \$40.00. The remainder of your ad stays the same at \$6.25 a word. Send your request to: PM Classified, 224 W. 57th St., New York, NY 10019.

CARPETLAYERS Earn to \$4000. Monthly. Easy Home Training. Big Demand. Free Catalog. Carpet Crafts, 1115J Ave. Acaso, Camarillo, California 93010

BATHTUB reglazing product sales, service, and training. Call Unique Coatings Corp. (313) 538-8600

BUY GOLD AT \$30 AN OUNCE! Pawnbrokers do every day. Just published. "Open and Operate Your Own Pawnshop." \$9.95. Star North Publications, Box 63, Duluth, MN 55802.

WORLDS Bargains: Below Wholesale. Closeouts. 35 Countries Free Catalogs - Samples. Free Information. World, P.O. Box 1269 T2, Freedom, CA 95019-1269

\$30-\$50/HOUR. Amazing Restoration Process **REPAIRS** Burned and Damaged Countertops **WITHOUT REPLACEMENT.** Renew, Box 19730PH, Portland, OR 97219

IMPORT European Automobiles. Strong dollar means strong profits. Boas, 664 N. Michigan Ave., Chicago, IL 60611

MULTI-LEVEL ENTHUSIASTS: Committed Downline Sponsoring is now operational. Send SASE to: Bedford, Box 15354, Houston, TX 77020

FINANCIAL success from NetWorld Distributorships. Write: Hicks Co., 60 Butternut, Greenwich, Conn. 06830

SEIZED IN GOVERNMENT NARCOTICS RAID! Automobiles . . . Vans . . . Boats . . . Furniture . . . Thousands other items. Buy Dirt Cheap - Resell for Big Profits! Free Information: Marcel, Box 7557-M, Monroe, LA 71211

MAKE HOMEMADE BOOKLETS. I've earned \$187,000 with mine. Free information: Falcon, Box 37169, Ft. Worth, TX 76117

BIG MONEY! 70 Money Making Opportunities Details: Rush \$1; SASE; Dept. G1, Box 4458, 1430 Concordia, St. Paul, Mn 55104.

BUSINESS STARTER KIT Turns Opportunity into Cash! Explosive Potential! Write: Direction, POB 380 (AH), Marysville, WA 98270

OUT OF WORK? NEED MONEY? \$1.00 booklet shows you how to start your own business through classified advertising. Popular Mechanics, Dept. KC, 224 W. 57th St., New York, NY 10019.

MONEYMAKING OPPORTUNITIES

GET MAILORDER CHECKS DAILY! Details - "Money", 58M Madsen, Beaconsfield, Quebec, H9W 4T7.

START A SUPER PROFITABLE BUSINESS from scratch. Free Subscription to Opportunity Magazine tells how. Write: Opportunity, Dept. F17, 6 N. Michigan, Chicago, IL. 60602.

BUY Cheap Direct . . . Hong Kong And Taiwan. Trade Suppliers. All Types Products Wholesale. Small Lots. Rocchio Enterprises, Box 19396PM, Minneapolis, MN 55419

ALUMINUM SCRAP - Recycle yourself - **MAKE \$25.00/ POUND!** Free Information: Industrial - PM58M, Box 127, Alexandria Bay, New York 13607

MAKE Rubber Stamps. Highly Profitable Business. Free Details. Stamper, POB 22809 (GG), Tampa, FL 33622.

FANTASTIC earnings mailing from home! Offer: Rush Stamped Addressed Envelope. Imperial, P-8 X17410, Fort Lauderdale, FL 33318

GET RICH!! Secret law smashes debts—brings Cash, Credit! **FREE** report!! WealthKit/B, Billings, NY 12510

BUMPER STICKER PRINTING DEVICE. Cheap, Simple, Portable. Free details. Bumper, POB 22791 (GG), Tampa, FL 33622.

\$1,000 Weekly Possible! 2500 Legitimate Home Income Opportunities! Free Report! Quality, Box 587CRT, Floral Park, New York 11002

GROW RICH! Secret Federal Program Uncovered! Free Details. Classic, Box 15564PM, Honolulu, 96815

MAKE MONEY collecting stamps \$3.00. KariesKent, 40 W. Main St., Malone, NY 12953

EARN up to \$2,000 every week for life. Work at home. Write: URBooks, 27833-A Camp Plenty Rd., Canyon Country, CA 91351

EARN MONEY AT HOME! **FREE DETAILS!** Book explains different methods. Tim Gorman, P.O. Box 26903, Tempe, AZ 85282

BUY WHOLESALE/Sell Retail. 2,500 Items. Catalog \$5.00 (Refundable). The Source, Box 311PM, Jackson, MI 49204.

(Continued on next page)

MONEYMAKING OPPORTUNITIES

(Continued from preceding page)

TURN YOUR TRAVEL PICTURES into Cash. Possible \$25 to \$200 for one photo. Informative report \$3.00: AJD Enterprises, 521 Transit Ave., Highgrove, Ca. 92507

GOVERNMENT GIVEAWAYS, Get Your Share. Write: GRS (N196), Box 506, Livingston, NJ 07039

LET ME SHOW YOU how to earn \$\$\$\$ at home the easy way! Write: Money, P.O. Box 29087, Charlotte, NC 28229.

600,000 bargains! Below wholesale, 1000 free samples, closeouts! Everything-\$2.00. Hurlocker, Rt. 5, Charlotte, NC 28208-21

BORROW By Mail! \$500-\$25,000 Fast! Easy! Confidential! For Info Application Write: Accurate, 2120 Crestmoor, Nashville, TN 37215

CAREER OPPORTUNITY - HOMEWORKER'S PROGRAM. For Application write: Penningway, Box 4268, Reading, PA 19606.

NEW Luxury Car Without Cost! Write: AMCO 9E, 1601 E. Main, Plainfield, IN 46168

SENSATIONAL money maker! Sell the new "35 Mail Order Ideas" and earn \$9.50 on every \$10.00 sale! Free details! Rush SASE: Lamax Publishing Company, Dept. 1A, 331 Crystal Hills Blvd., Manitou Springs, CO 80829.

DISTRIBUTORS Wanted. "Fun" Tastic big Money-Making item in Great Demand. Send For Free Information. **UNIQUE**, P.O. Box 370807, El Paso, Texas 79937

FREE Details. Financial Freedom Report. C. Banks, Box 287, Chicago, IL 60606-7093

EARN EXTRA INCOME. Balance your food budget, a tasty Opportunity, free details. **SUNSHINE HILL**, P.O. Box 77, Afton, New York 13730

NEW Offer, How to Invest Under \$10.00 for Your Own Window Tinting Business. \$5.00: Fineline Productions, 1858 St. Louis Drive, Honolulu, Hawaii 96816.

\$300.00 A DAY PROFIT

RESTORE used wet cell batteries to new life. Enclose \$5.70 check or money order for details how we do this for a cost less than \$3.00 each. Dar-Ray Battery, P.O. Box 396, Darlington, Indiana 47940

ADVERTISE Free in 507 Magazines. \$5.00. Directory, Box 11N, Atlanta, Georgia 30301

RABBITS-CHINCHILLAS-FUR BEARING ANIMALS

\$500-\$1000 Month Plan raising rabbits for us. Free details. White's Rabbitry, Box 49PM, Clarence Center, NY 14032-0049

RAISE RABBITS SUCCESSFULLY 68 Page Booklet Tells How. \$1.00. American Rabbit Assn., H1, P.O. Box 426, Bloomington, Illinois 61701

EARTHWORMS, LIVE BAIT

FREE Literature. Raise Fishworms, Crickets, Redworms—1000-\$8.95, 5000-\$42.50. Book on How and Where to Sell with Order. Carter Fishworms, Plains, GA. 31780.

OF INTEREST TO ALL

VACUUM Cleaners "Discount Prices" "New" Rainbow \$399.95, Kirby, Filter Queen, Compact, Details: ABC Vacuum Warehouse, 6720 Burnet-PM, Austin, Texas 78757.

FREE Promotional Albums, Concert Tickets, Stereos, etc. Information: Barry Publications, 477 82nd Street, Brooklyn, NY 11209

STOP BURGLARS! Amazing "Security Pen" identifies stereo, TVs, cameras, etc. with invisible ink (glows under Police "black light"). Kit includes 3 window warning decals. Limited supply, moneyback guarantee. Rush \$3.95 to: Signature Products, Dept. 1PM885, 521 S. Andrews Ave., Suite 11, Ft. Lauderdale, FL 33301

QUIZLETTER. Solve it! Win \$100.00. Copy \$2.00. Quiz Publications, Box 10745, Cleveland, Ohio 44110

VISA CARD! No Credit Check. Send SASE To: Credit Consultants, 6421 Siegal - Suite 6A, Commerce City, CO 80022.

ATTENTION! Now, with little as \$100, start investing like millionaires do! Hedge inflation. Make money on money! Become financially independent. Complete how-to instructions, \$6.95. Slosberg's, Box 370577, Miami, 33137.

FEEL SAFE AND SECURE! SOS Key Chain Alarms, small and easy to carry. \$15.50. Executive Style, 5699 Kanan, Box 133P8, Agoura, CA 91301

SAVE. No need to buy expensive machine to add and subtract feet, inches, and sixteenths. Use your inexpensive electronic calculator. No conversion to decimals. Direct entry. Instructions \$5.00 and self addressed stamped envelope. Adder, Box 632, Taylors, S.C. 29687

SAVE Up To 84% On Books. Write Today For Catalog. Earmonite, Box 1649, Bridgeview, IL 60455.

PERSONALIZED tee shirts. Free information. Conerll Enterprises, P.O. Box 2136, West Helena, Arkansas 72390.

PRIVACY CATALOG. Cash income opportunities. Secret loans. Underground businesses. New identity. \$1.00. Eden, Box 8410-PC, Fountain Valley, CA 92728.

OF INTEREST TO MEN

AFRICA CALLS volunteer for 3 years single Catholic men professionally qualified. Missionaries of Africa, 2020 West Morse Ave., Chicago IL 60645 312 274-4292

GOVERNMENT SURPLUS

IS IT true you can buy jeeps for \$44 through the U.S. Government? Get the facts today! Call 1-312-742-1142 Ext. 7133.

G.I. SURPLUS, Hunting and Camping Equipment, 56 Page Catalog \$2.00. Red Bank Army Navy, 12-M Monmouth Street, Red Bank, NJ 07701

"GOVERNMENT SURPLUS" JEEPS \$30.00! 5,000,000 Items! Complete Information Your Area. **1985 OFFICIAL DIRECTORY.** \$2.00 (Guaranteed). Surplus, (A828), 4620 Wisconsin Northwest, WASHINGTON, D.C. 20016

LOANS BY MAIL

BORROW \$25,000 "overnight." Any Purpose. Keep Indefinitely! Free Report! Success Research, Box 19739-AV, Indianapolis, Indiana 46218.

CASH Loans-\$500-\$25,000! All Eligible! Any Purpose! American, Box C-15, Lynbrook, New York 11563

LOANS By Mail Guaranteed! Borrow Any Amount! Free Details, Applications Rushed! Creditmasters, Box 507-PP, Floral Park, New York 11002

BORROW \$400 - \$40,000 overnight on your signature! Everyone eligible. Repay anytime. Free details! Infohouse-PM, 808 Post, San Francisco, CA 94109.

QUICK Cash **LOANS!** Write: FICPA, P.O. Box 748, Pinconning, MI 48850.

ESTABLISH CREDIT Get Credit Cards, Low Interest Loans, Details. Blöse, Box 1626, Fort Lee, NJ 07024

BORROW \$100 - \$30,000 - No Cosigners - Convenient - Confidential - Free Details - Marco, Box 814584M, Dallas, TX 75381-4584.

VISA-Mastercard Guaranteed! Without Credit-Check! Instant Reply! TLV, Box C-40, Lynbrook, New York 11563

MONEY Problems? Free Book describes Loans, Cash, Government Grants, Other benefits, available to individuals. Write: Associates, Box 98-A4, Brooklyn, New York 11235

BORROW \$100-\$100,000! Instant Reply! No Co-signers! Rush Stamped Envelope! Financial, Box 548(P), Richardson, TX 75080

GRANTS, Low-Cost Loans, \$10,000 To \$1,000,000. Free Report. Famerco, Box 18471, Oklahoma City, OK 73154.

\$20,000 Free! Never Repay! Anyone Eligible! AID, 112 1/2 S. Brand-J, Glendale, CA 91204.

PERSONAL

BIBLE Questions answered. Stamped envelope. Bylon, K7167 Bentler, Detroit, Michigan 48219

DON'T DIE WITHOUT A WILL! Complete Instructions & Legal Forms. **RUSH** \$12.95. K.W. McCaw (Dept 18), 1991 Bahia Way, La Jolla, CA 92037

VIETNAM-VETS! join **THE WHEELBARROW CLUB!** Write: P.O. Box 95009-0372, Campbell, CA

COMPLETE Will Kit \$3.95, Booklet, Instructions, Forms. Satisfaction Guaranteed. Lunsfords, 1000 Mountain Oaks Dr., Birmingham, AL 35226

I.Q. QUESTIONS GUARANTEED TO RAISE YOUR SCORES ON THOSE IMPORTANT CORPORATE OR MILITARY TESTS. Rush \$12.95. K.W. McCaw (Dept 18), 1991 Bahia Way, La Jolla, CA 92037

REMAILING SERVICE

CONFIDENTIAL Receiving/Forwarding/Remailing. Stolz, 5001 Iowa Avenue, Las Vegas, Nevada 89107

FREE Details! Postal Shoppe, 396 East 900 South, Salt Lake City, UT 84111

FREE Remailers List. Agents Needed. PS, Box 29656, San Antonio, Texas 78229

TRUSTWORTHY forwarding. Stamped remails \$1.00. Diamond-H, Box 129A, Caddo, Texas 76029

UNLISTED ADDRESS Discreet and confidential. Remail \$1.00 Single. Mail Forwarding Service, 8050 S. Main, Houston, Texas 77025

VIRGINIA Full Service. Confidential, Dependable. Mailon, Box 22PM, Dilwyn, VA. 23936

CONFIDENTIAL FORWARDING / Remailing. PRIVATE-MAIL. Box 544. **STONE MOUNTAIN, GEORGIA** 30086-0544

DISCREET Receiving/Forwarding, Remailing. Vaughn, Box 3191, Culvercity, California 90231

MAIL Forwarding and Message Service World Wide. Established 1970. Member Chamber of Commerce. MCCA, Inc., P.O. Box 2870, Estes Park, Co 80517. (800) 525-5304

WANTED MISCELLANEOUS

BUYING Tungsten Carbide, Tungsten, Molybdenum, Silver Solder, Silver Contacts, Gold, Platinum. 800-321-8914 Ohio 216-531-8333 collect.

SCRAP SILVER CONTACTS, FORKLIFT CONTACTS, Silver Solder, Sterling, Gold Plated. Robert Leszczak, 652 Myrtle St., Elizabeth, NJ 07202

GOLD, Silver, Platinum, Mercury, Tantalum. Samples Evaluated Free. Ore Assaying Service. Call Wholesale Terminal Toll Free: 1-800-932-1010.

FOR SALE MISCELLANEOUS

RELAXATION Brazilian Way **HAMMOCKS** Handwoven Cotton Hardwearing Exotic Beauty **FREE CATALOGUE.** Rolene, Dept. PM7, 216 White Horse, Collingswood, NJ 08107

FLASHING ARROW SIGNS at bargain rates. Details: Carolina Sign Co., 310 S. Oak St., Pageland, S.C. 29728. 803-672-7384

HEARING AIDS

HUGE SAVINGS Eliminate Dealer Markups. Free Trial. Batteries Wholesale. Terms Arranged. Call Toll Free 1-800-323-1212. Or Write: Lloyds-PMC, Rockford, IL 61110

FREE HEARING AID CATALOG - Save 1/2 by mail! Write: "MoneySavers", 9530PM-8 Langdon, Sepulveda, California 91343.

SAVE Half Buying Aids by Mail. All Major Brands Available. REA Company, Box 364, Bridgeport, Ohio 43912

NAME Brands For Less. Batteries. Accessories. Guaranteed Repairs. Hearing Aids, Box 23071, Richfield, MN 55423

SAVE \$200+. Modern name-brand aids improve understanding. No Salesmen. Free Trial. Free Catalog. J&M, Dept. 132-F, 329 Third, DeKalb, IL 60115.

FREE batteries for your hearing aids. Sigmotek, 327 Clarkin Ct., Walnut Creek, CA 94596

SAVE Half, Free Details: EarChek-PM, Box 28763, San Diego, California 92128. Phone (619) 480-6530

SMOKER'S SUPPLIES

CIGARETTE COUPONS Save on favorite brands at local stores. Free details. Send stamped self-addressed envelope. Smokers Coupon Club, 1417 Wauwatosa Avenue, Wauwatosa, Wisconsin 53213

(Continued on next page)

Материал, защищенный авторским правом

DEADLINE FOR ADS: Copy and Payment must be in by the 5th day of the 2nd preceding month for the issue in which the ad is to appear. See Head of Classified Section.

HOW TO COUNT WORDS: Name and address must be included in counting the number of Words in your ad. Each initial or number used counts as 1 word: J.J. Smith, 224 West 57th Street, New York, New York 10019: 9 WORDS. Zip codes are not counted. Phone #: 2 Words. Symbols used as keys are charged for. City or State count as 1 word each: New Brunswick, New Jersey: 2 words. Abbreviations such as C.O.D., F.O.B., R.P.M., U.S.A., P.O., 5x7, 16mm are counted as 1 word. (P.O.Box 392 counted as 3 words) Webster's International Unabridged Dictionary will be used as our authority for spelling, compound words, Hyphenations, abbreviations, etc. Please make checks payable to **POPULAR MECHANICS**.

Only \$62.50 for 10 word minimum

\$6.25 each additional word

**BOLD FACE CAPS add
\$1 per word**

(First Word: No Charge For Bold Face)

Remittance of \$_____ is enclosed to cover _____ insertion(s) in the _____ issue(s) _____ Classification

No Charge for CAPS	2	3	4	5	6	7
8	9	10-\$62.50	11-\$68.75	12-\$75.00	13-\$81.25	14-\$87.50
15-\$93.75	16-\$100.00	17-\$106.25	18-\$112.50	19-\$118.75	20-\$125.00	21-\$131.25
22-\$137.50	23-\$143.75	24-\$150.00	25-\$156.25	26-\$162.50	27-\$168.75	28-\$175.00
29-\$181.25	30-\$187.50	31-\$193.75	32-\$200.00	33-\$206.25	34-\$212.50	35-\$218.75
36-\$225.00	37-\$231.25	38-\$237.50	39-\$243.75	40-\$250.00	41-\$256.25	42-\$262.50
43-\$268.75	44-\$275.00	45-\$281.25	46-\$287.50	47-\$293.75	48-\$300.00	49-\$306.25
50-\$312.50	51-\$318.75	52-\$325.00	53-\$331.25	54-\$337.50	55-\$343.75	56-\$350.00

YOUR NAME _____ PHONE: _____

FIRM (NAME IN AD) _____ (PLEASE PRINT)

YOUR ADDRESS _____

CITY _____ STATE _____ ZIP _____

DATE: _____ YOUR SIGNATURE _____

(PLEASE PRINT OR TYPE COPY • FOR ADDITIONAL WORDS ATTACH SEPARATE SHEET)

TOBACCO

CIGARETTES - Roll Your Own Custom Tobaccos, Papers, Filters, Rolling Machines, Accessories. Free Catalog and Sample. Green River Tobacco, P.M., Box 1313, Owensboro, Kentucky 42302

SCIENCE & CHEMISTRY

1985 CHEMICAL CATALOG Lab Equipment-Glassware \$3.00 Refundable. Scientific Supply, P.O. Box 490, Ranger, Texas 76470

LABORATORY Chemicals, Glassware—Apparatus, Catalogue \$1.00. Deluxe Scientific, 934 S. 13 Street, Manitowoc, Wisconsin 54220

FORMULAS, PLANS, ETC.

MONEYMAKING CHEMICAL FORMULAS - THOUSANDS! CATALOG \$5.00 (REFUNDABLE): GWA3, Box 193, Brookfield, Wisconsin 53005-0193

ANY Formula \$10.00. Catalog \$2.00. J. Bellfort, Box 568, Chicago, 60690

SPECIAL SERVICES

INFORMATION On anything. Ferguson Research Specialists, 60-15 Woodside, Woodside, New York 11377.

HEALTH, VITAMINS

"WONDER FROM DOWN UNDER!" Unique Australian oil is very useful treating and soothing acne, burns, athlete's foot, cuts, cold sores, cancer sores, chicken pox, boils, and other skin irritations, infections, including vaginal and fungi. Details \$1.00. IMS, 350 Ward Avenue 106A, Honolulu, Hawaii 96814.

KICK SMOKING. Booklet shows way. \$3.00. Normandy Press, 1892 Lighthouse St., Englewood, FL 33533

QUIT SMOKING NOW! We'll share our proven method. It Works! Send \$3.00 to: Daybreak, P.O. Box 232PM, Two Harbors, MN 55616

GUARANTEED WEIGHT LOSS! Most efficient and reliable method. Send \$7.00. "The Real Me", 2627 Fairfield Ave., Shreveport, LA 71104

GARDENING & LAWN CARE

HYDROPONICS Grow Vegetables, Herbs, Plants Year Round Indoors. Plans, information \$10.00. Hydroponics, P.O. Box 1600, St. Marys, Ontario, NOM-2V0

BUILD A WINDOW GREENHOUSE - Converting a window in your home to a mini-greenhouse amounts to little more than attaching a box-like plexiglass enclosure to the outside. The beauty is that you don't do a thing to the window other than add screweyes to the frame—the window stays intact. No drafts in winter, no need for caulking. Send for Plan PL-1719 + \$2.95 to: Popular Mechanics, Box 1014, Radio City Sta., New York, N.Y. 10101

RECIPES, COOKING, ETC.

COOKING with booze 102 recipes - Anisette to Zinfandel. \$3.98 To: Paul, P.O. Box 2831, Winston-Salem, N.C. 27102

SECRET Egg Roll Manual 15 Specialties made easily-inexpensively. \$3.00: Darryl's, 18 Hamilton Ave., Groton, CT 06340

ONLY \$2.00 for 25 Gourmet Chinese Creations anybody can prepare easily. Recipes, PO Box 843, Branford, CT 06405

JERKEY ... Nine Great Recipes!!! Send \$1.00. SASE. Jacat Enterprises, Box 37727, Honolulu, HI 96837

NEW England's Finest Clam Chowder (also red). \$2.50 for both recipes. David's, Box 2418, Woonsocket, RI 02895

BEVERLY Hills, dinners lower calorie, delicious, gourmet, economical. 7 interchangeable recipes, \$5.00. TCT, Box 6187, Beverly Hills, CA 90212

BREAD Recipes \$3.98. CDF Systems, Box 827, Cucamonga, Calif. 91730

THREE Authentic Old Fashioned Mexican Recipes \$3.00. Mary's, P.O. Box 1896, Farmington, New Mexico 87499

LOSE WEIGHT, TRIM WAISTLINE, delicious meals including desserts, Low Calorie Cookbook, over 250 recipes. \$4.95 plus \$1.00 postage and handling. Decker's Inc., 1633 Lake Drive, Suite 57, Haslett, Michigan 48840

REAL Men DO Eat Quiche! Delicious Quiche Lorraine - Perfect Crust Recipe \$2.00. Postage Paid. Kenic Co., P.O. Box 6236, Boise, Idaho 83707

HOME CANNING MADE EASY Methods Terminology Time Tables \$4.75 C/MO. Strawberry Enterprises, P.O. Box 9726, New Iberia, Louisiana 70560

POLISH COOKBOOK - Delicious favorites, Soups, entrees, desserts. \$7.00. Box 452, Stratford, Ct. 06497

WINEMAKING, BEERMaking, ETC.

WINEMAKING-BEERMaking-GASOHOL. Free Supply Catalog. Yeast Equipment. Continental, Box 188PM, Casselberry, FL 32707

FREE BEERMaking CATALOG. —Best Value. Selection. 24-hr. Service. **HOMEBREW**, Box 158M, Haslett, Michigan 48840.

WINEMAKERS-BEERMakers— Free Catalog—Fast Service—Large Selection: Kraus, Box 7850-L, Independence, Missouri 64053.

WINEMAKERS-BeerMakers: Free illustrated catalog of supplies. Semplex, Box 12278R, Minneapolis, Minnesota 55412-0276

WINEMAKERS — BeerMakers Free Catalog. Low Prices, Free Recipes. Cellar-M, Box 33525, Seattle, Wa. 98133

WINEMAKERS-BEERMakers Fresh Stocks, Fast Service, Free Catalog. O'Briens, Box 284D, Wayne, IL 60184

BEERMakers ONLY! Free Catalog/Newsletter. Williams', Box 461MV, Oakland, California 94064

WINEMAKING HOMEBREWING HERBS SPICES FREE catalogue. 1535 Windsor Street, Cornwall, Ontario K6H 3N6

WINE/BEER MAKING Catalog: B&J Enterprises, 1845 South 19th, Springfield, Illinois 62703

SIMPLE SPACEAGE WINEMAKING—apparatus unnecessary, dandelion, chokecherry, beet—others. \$2.00. Box 16, Phillips, Wisconsin 54555

FREE - Beer-making instructions. Newman's Homebrewings, R.D. 1, Box 3PM, Port Matilda, Pa. 16870.

BEER LOVERS— Brew your own. Delicious! Inexpensive! Free Catalog. Beer Gear, Box 25093M, Lansing, Michigan 48909

FREE BEERMaking BOOK Plus Catalog. Finest Equipment, Ingredients. Fully Guaranteed. SP1, Box 784-M, Chapel Hill, NC 27514

BURGLAR ALARMS & HOME PROTECTION

PROTECT YOUR LOVED ONES! Easy to install, professional alarm equipment. **PEACE OF MIND** starts with our **NEW** catalog. Designed for you, the do-it-yourselfer. Send \$2.00 for catalog and **FREE** decals. Money refunded with first order over \$25.00. Alarm Component Sales, 544 Boston Post Road, Milford, CT 06460

PM'S TIME MACHINE

75 YEARS AGO: August 1910



Modern ways in the kitchen.

Cooking with science

Food experts at the Department of Agriculture recommended using a microscope as a necessary kitchen utensil in large establishments for the detection of "adulteration in various common foods." The article gave potential microscope users a course in identification of various foodstuffs: "But under the microscope, grains and granules are seen which vary more or less in the shape, size, rings, etc." Food service workers today rely on three senses—sight, taste and smell—to determine edibility of prepared food.

Sub tragedy

The French submersible *Pluviose* was struck by the steamer *Pas de Calais* in the English channel. The ship's officers thought they had struck a log until the *Pluviose's* bow emerged from the water. A boat was lowered, but repeated tapping on the sub's metal bow brought no response from the 26 men trapped within. Within 15 minutes, the sub disappeared from view. Divers found it in 72 feet of water. Finally, heavy chains were bound around the wreck, attached to large barges and the vessel towed.



Cross-Section of Latest League Baseball

Latest baseball

Cowhide replaced horsehide in 1974. Also, an extra layer of rubber was added and the color of yarn changed to blue-gray. Despite the alterations, the old bean ball is the same. Batter up!

50 YEARS AGO: August 1935

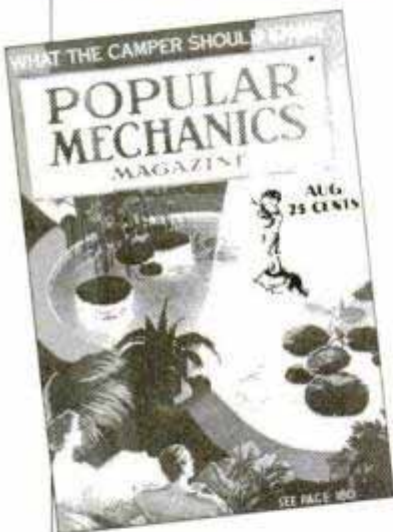

Paint your garden with light.

Garden decorations

Painting Your Garden With Light advised readers that there could be no more "pleasing transformation than that which the garden owner can produce with a few electric lamps, some wire and inexpensive accessories." The article showed how to wire and string lights safely through water and over and under obstructions. Today's garden lighting, while decorative, tends to be energy-conservative and security-conscious as well as technologically upbeat, such as solar-powered lighting arrangements.

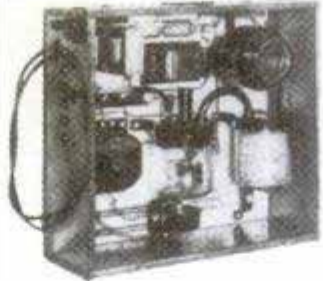
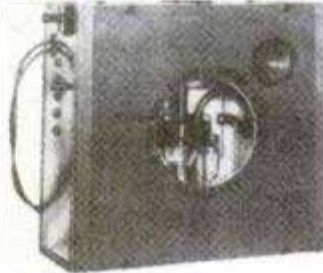

An alarming idea

Two Massachusetts inventors devised a gas and smoke detector. When a ray of light focused on a photovoltaic cell was disturbed by airborne gas or smoke, the detector sounded. Smoke detector makers still use it.

Auto turn signal

With the touch of a switch a driver could signal right or left turn. The switch activated a 50-blink-per-minute arrow. The system hasn't changed. The only innovation is the sequential flasher, which gives signals a stroboscopic effect.

25 YEARS AGO: August 1960



An all-season hobby craft.

Ski or swim

Skimak was a prototype of what was expected to be the new family hobby vehicle. Skimak was an air-screw driven, high-performance craft that could reach 100 mph on snow. Its selling point was its all-season versatility. With a marine conversion kit, Skimak could ski over water and snow. Once Skimak was mounted with pontoons it became Snowmak, and it maneuvered over nonmountainous, snow-covered terrain. The skimo-bile, developed in 1958, and later the motorized ski, proved more popular.

A contender

Flying Caduceus (below) was Dr. Nathan Ostich's challenge to John Cobb's 394.2 mph land speed record. Ostich's GE turbojet-driven beast was one of the first high-speed cars that required a parachute to stop it. The engine was expected to push Caduceus to nearly 500 mph.

Homemade sub

Two amateur drivers successfully launched a homemade submarine built from surplus aircraft parts. The sub's body and buoyancy tanks were constructed from aircraft wing tanks while surplus oxygen bottles supplied air. The improvised submarine was powered by a battery-driven motor. **PM**

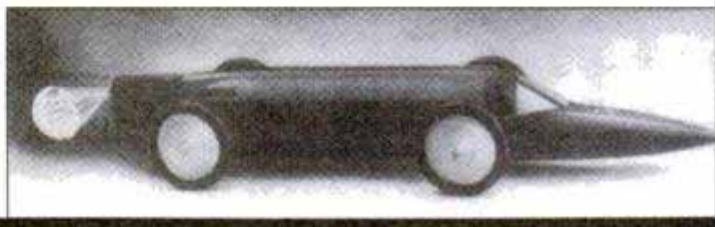



The Gunnell/Flanders Copper Plus-sparked Camaro Z-28 captures Sebring crown.

Copper Plus fires Z-28 to victory in Firestone Firehawk opener.

The inaugural race in the IMSA Firestone Firehawk Endurance Championship was staged at Sebring International Raceway.

And after six hours—and over 510 grueling miles—the Camaro Z-28 of Skip Gunnell and Scott Flanders shot to victory in the Sports Class.

To help ensure their triumph in Firestone's prestigious race, Skip and Scott replaced the

factory-installed spark plugs in their Z-28 with Champion Copper Plus.[®]

These are the spark plugs uniquely designed to deliver superior fouling protection.

For fast, sure starts. Quick acceleration. And maximum overall performance.

Performance so positive we back it with an exclusive 60-day, money-back Performance Guarantee.*

Copper Plus. It can fire up *your* car's performance, too. Positively guaranteed.

*Offer expires December 31, 1985. Aviation and industrial plugs excepted.



NOTHING SPARKS LIKE A CHAMPION

©1985 Champion Spark Plug Company
Toledo, OH 43661-0001

COPPER PLUS THE PLUS IS PREMIUM PERFORMANCE.

If you smoke *please try Carlton*

Warning: The Surgeon General Has Determined
That Cigarette Smoking Is Dangerous to Your Health.

Box: Less than 0.5 mg. "tar", 0.05 mg. nicotine; Soft Pack, Menthol and 100's Box: 1 mg. "tar", 0.1 mg. nicotine;
100's Soft Pack and 100's Menthol: 5 mg. "tar", 0.4 mg. nicotine; 120's: 7 mg. "tar", 0.6 mg. nicotine
av. per cigarette; FTC Report Jan. '85. Slims: 6 mg. "tar", 0.6 mg. nicotine
av. per cigarette by FTC method.