

APRIL 1983 \$1.50

48-PAGE SPECIAL:  
HOME IMPROVEMENT

# Popular Mechanics

## ARMY'S NEW A TOUGH TANK-BU

APRIL 1983  
FILE COPY  
DO NOT REMOVE FROM THIS OFFICE

1,317,000-MILE REPORT

### Chevy Camaro Owners Bought For Styling, Praise Handling, Too

### PLANS: Build PM's Compact In-A-Wall Workshop

### 22 Window Treatments That Save Energy

### How To Fix Leaks In Any Home Faucet

### Giant Luxury Dirigibles Fly Again

### Step-By-Step: The Fastest Way To Paint Your House—Brush Or Spray

### PM Drives Ford's New Turbo T-Bird

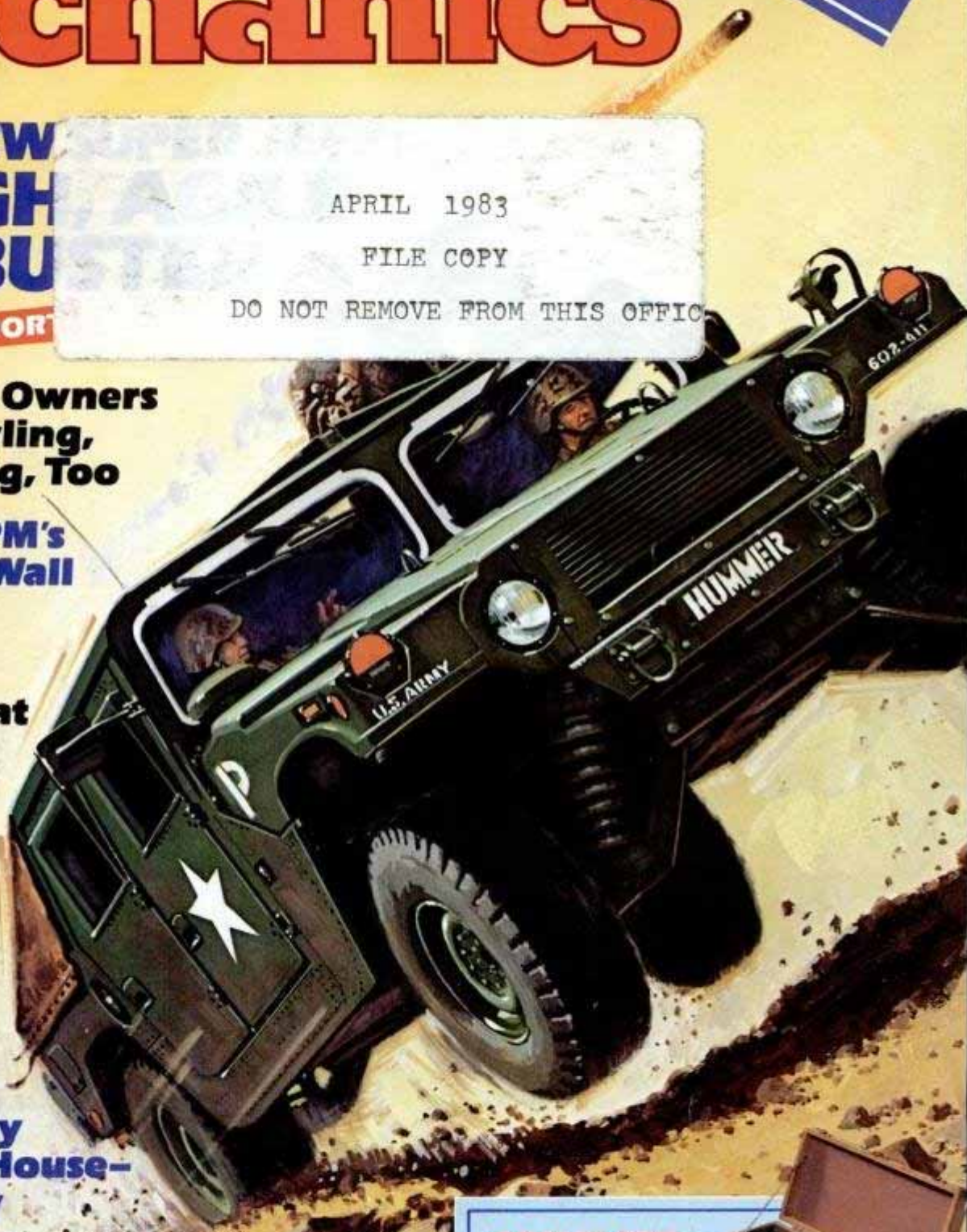

**COMPLETE PLANS INSIDE:**  
Build Our Classic Craftsman's Toolbox



A photograph of several horses in a stable. In the foreground, a dark brown horse with a white blaze on its face is looking towards the camera. Behind it, other horses of various colors (brown, white, and black) are visible. In the background, a person wearing a white cowboy hat is partially visible, looking towards the horses. The stable has wooden walls and a metal railing.

# Come to Marlboro

© Philip Morris Inc. 1983

Warning: The Surgeon General Has Determined  
That Cigarette Smoking Is Dangerous to Your Health.

Kings: 16 mg "tar," 1.0 mg nicotine—100's: 16 mg "tar,"  
1.1 mg nicotine av. per cigarette, FTC Report Dec '81

Marlboro and Marlboro are registered trademarks of Philip Morris Inc.

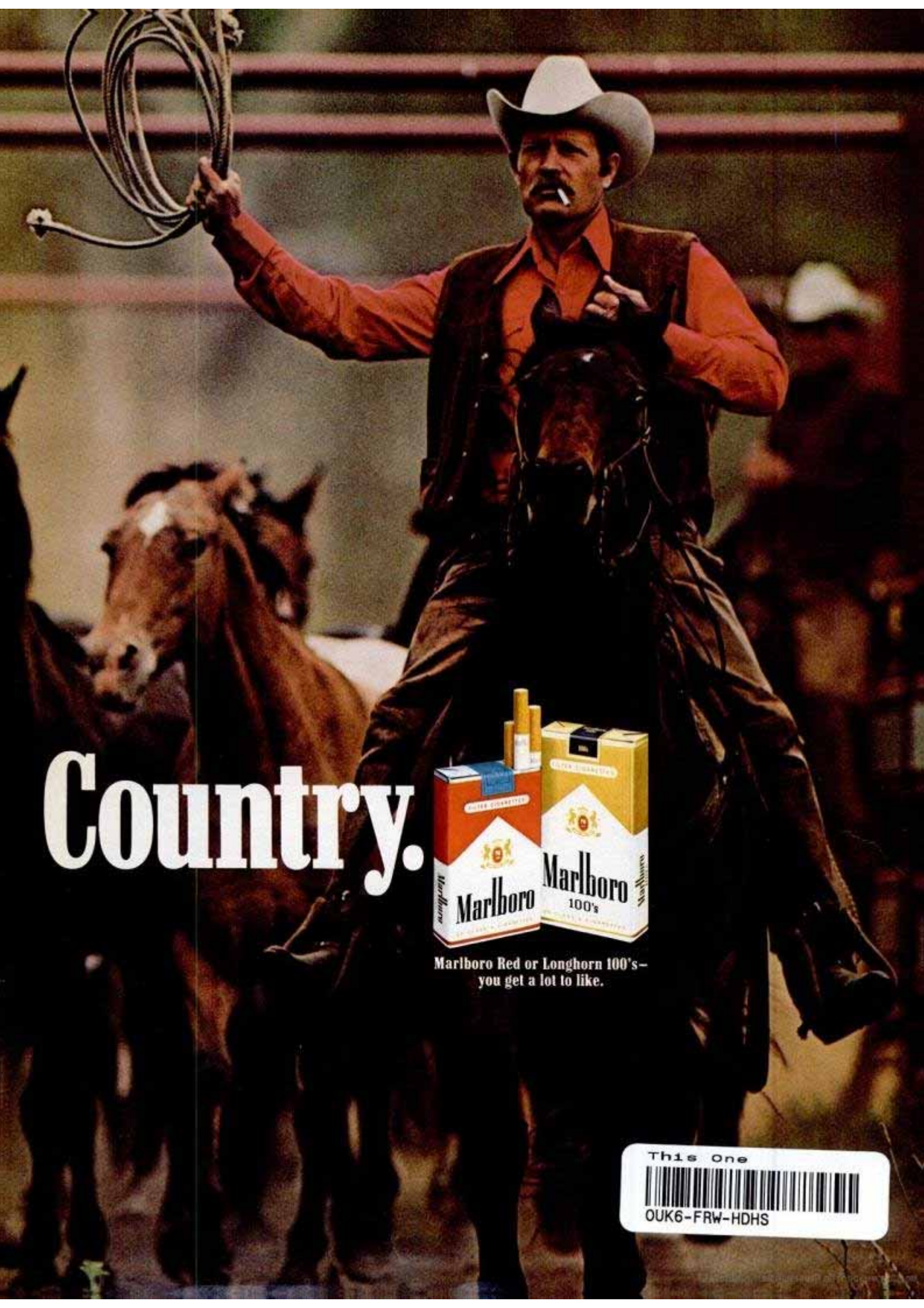

Country.



Marlboro Red or Longhorn 100's—  
you get a lot to like.

This One



OUK6-FRW-HDHS

# ITS ENGINEERING SO CLOSELY RESEMBLES A FINE WATCH, YOU'D EXPECT IT TO TICK.

Like a fine watch, a Mariner Outboard demonstrates an ingenious use of space. Every part that's not absolutely essential has been eliminated. This not only makes the motors more compact and exceptionally lightweight for the horsepower they deliver, but it also helps reduce maintenance.

And, if you could look inside each one, you'd see an attention to detail seldom found in an object too large to strap to your wrist. For example, CD ignition eliminates the

need for troublesome breaker points. Most models feature thru-prop exhaust for more speed and more efficiency. They're quieter, too.

All driveshafts, shiftshafts and propshafts are made of stainless steel to protect against saltwater corrosion and give you years of dependable, trouble-free performance.

In short, Mariner makes the most refined outboard motors in the world.

Yet, in our engineers' vocabulary, refined certainly does not mean docile. Open the throttle and you'll experience acceleration that's surprising

if not downright exhilarating.

In that respect, our motors are more like sports cars than watches. Efficient, yet exciting.

For a free catalog of Mariner Outboards from 2 to 200 horsepower, write Mariner, Dept. 83, 1939 Pioneer Road, Fond du Lac, WI 54935. In Canada, write Mariner, 1156 Dundas Highway East, Mississauga, Ontario, L4Y 2C2.

**MARINER.  
BETTER IN THE  
LONG RUN.**

 **MARINER<sup>®</sup>  
OUTBOARDS**





### On the cover

After more than 40 years, the historic Army jeep is being replaced—but may not be mourned for long. Its successor, a tough new breed of missile-toting tank-buster, promises to be even more awesome. Read how the Army is choosing the new super jeep from three competing designs. Story begins on page 89.

—PM painting by Ed Valigursky

# Popular<sup>®</sup> Mechanics

APRIL 1983

CONTENTS

VOLUME 159 NUMBER 4

INTERNATIONAL EDITIONS: CARIBBEAN, MEXICO, SOUTHERN HEMISPHERE

## Special features:

### PM Owners Report: Chevrolet Camaro

Great looks and handling outweigh minor complaints.

**106**

### Workshop in a wall

Build our clever, space-saving work center that can be either recessed or free-standing.

**126**

### How your windows can save you money

New energy-efficient shades and shutters help keep heat in during winter, out in summer.

**132**

### Stop faucet leaks in any fixture

A complete guide to quick and easy faucet repairs, including all the new washerless designs.

**149**

### Dirigibles fly again

After a troubled past, giant airships now offer new vistas in cargo hauling and luxury travel.

**92**

### Two fast, sure ways to paint your house

Whether you brush or spray, here's how to get top-quality results with either method.

**115**

### Make your own master craftsman's toolbox

Complete plans for a classic wooden chest in the grand style for fine tools or keepsakes.

**108**

### Automobiles and bikes

- [10 Imports and Motorsports](#)
- [22 Car Clinic](#)
- [28 Detroit Listening Post](#)
- [39 Saturday Mechanic:](#)  
Troubleshooting your cooling system—Part 1
- [49 The PM Garage](#)
- [81 Firsthand Report: Driving the European Ford Sierra](#)
- [96 Firsthand Report:](#)  
Driving the Ford Tempo, Topaz and all-new Thunderbird
- [100 PM Owners Report:](#)  
Dodge Charger
- [105 Firsthand Report: Driving the Mercedes 190 and BMW 318i](#)
- [106 PM Owners Report:](#)  
Chevrolet Camaro
- [168 How to build an engine hoist](#)

### Science and engineering

- [52 Science Worldwide](#)
- [89 The Jeep is dead, long live the HMMWV!](#)
- [102 Put your own project on the Space Shuttle](#)
- [195 Not all of space is empty](#)
- [195 Go soak a bridge](#)
- [195 No more bum steers](#)
- [196 Split-second bomb snuffer](#)
- [197 Foam sweet home is completed](#)
- [198 The drill you steer](#)
- [198 Cleaning blood for transplants](#)
- [198 Breast cancer war](#)

### Electronics, radio and TV

- [16 PM Electronics Monitor](#)
- [84 PM Video Monitor](#)
- [98 New video games put you in the action](#)
- [196 Electronics gone "in-seine"](#)
- [196 Testing, by Jove](#)

### Aviation

- [92 Airships rise again](#)
- [197 Economy-class fighter](#)

### PM'S 1983 HOME IDEAS GUIDE

- [113 Cover](#)
- [115 The right way to paint a house](#)
- [121 A pro's secrets for spray painting a house](#)
- [126 Build PM's in-the-wall workshop](#)
- [132 Energy-saving with windows](#)
- [145 Build a pantry on wheels](#)
- [149 How to stop a leaking faucet](#)
- [156 New for home improvement](#)
- [160 Energy-savers for your home](#)
- [164 Terms builders use](#)
- [166 PM looks at window security](#)

### SPECIAL CAMPING SECTION

- [55 Cover](#)
- [57 10 family camping adventures](#)
- [62 New tents for better shelters](#)
- [71 Where to go—what to take](#)
- [76 New for family camping](#)

### Shop and crafts

- [20, 21, 185 Hints from readers](#)
- [44 The PM Workbench](#)
- [86 PM looks at Skil's 551 Trim Saw](#)
- [108 Build our craftsman's toolbox](#)
- [112 Workshop Minicourse:](#)  
Joining with dowels

### Home and yard

- [26 Appliance Clinic](#)
- [37 New Now for home and shop](#)
- [50 Homeowners' Clinic](#)

### Boating and outdoors

- [14 All Outdoors](#)

### Photography

- [32 PM photo hints](#)

### Every month

- [5 Editor's Notes](#)
- [6 Letters to the Editor](#)
- [195 Technology Update](#)

### Worth writing for

Looking for more ideas and information? See page 167.

**AS A SERVICE TO READERS.** Popular Mechanics publishes newsworthy products, techniques and scientific and technological developments. Due to possible variance in the quality and condition of materials and workmanship, Popular Mechanics cannot assume responsibility for proper application of techniques or proper and safe functioning of manufactured products or reader-built projects resulting from plans published in this magazine.

**POPULAR MECHANICS** (ISSN 0032-4558) is published monthly by The Hearst Corporation, 224 West 57th Street, New York, N.Y. 10019, U.S.A. Subscription prices: United States and possessions, \$11.97 for one year; \$21.97 for two years. Canada and all other countries, add \$16.00 for each year. Second-class postage paid at New York, N.Y., and additional mailing offices. Authorized as second-class mail by the Post Office Department, Ottawa, and for payment of postage in cash. Registered as second-class matter at the Post Office at Mexico D.F., Mexico, June 20, 1950, © 1983 by The Hearst Corporation. All rights reserved. Printed in U.S.A.

**POSTMASTER:** Please send address changes to Popular Mechanics, P.O. Box 10064, Des Moines, Iowa 50350.

**SUBSCRIPTION SERVICE:** Popular Mechanics Magazine will, upon receipt from its reader of a complete new or renewal subscription order, undertake fulfillment of that order so as to

provide the first-copy delivery either to the Postal Service or alternate carriers within six to twelve weeks. If for some reason this cannot be done, you will be promptly notified of the issue date that will begin your subscription, with a request for any further instructions you may have concerning your order. Please address all such orders to us at Popular Mechanics, P.O. Box 10064, Des Moines, Iowa 50350. • Should you have any problem with your subscription, please write Joan Harris, Customer Service Department, Popular Mechanics, P.O. Box 10064, Des Moines, Iowa 50350. To assure quickest service, please enclose your mailing label when writing to us or renewing your subscription. • Renewal orders must be received at least eight weeks prior to expiration to assure continued service.

Use this address for subscription orders & inquiries

POPULAR MECHANICS  
P.O. Box 10064  
Des Moines, Iowa 50350

POSTMASTER, Please send address changes to this address

# THE FRAM EXTRA LIFE AIR FILTER 50% EXTRA LIFE. 0% EXTRA MONEY.



It seems like everything costs more these days. Especially anything to do with cars. So you'll be glad to learn that Fram has something that, comparatively speaking, actually costs less.

Our Extra Life air filter.

It lasts longer because it's made with two different layers of filtering material, instead of the usual one. The outer layer traps small particles of dirt, while the inner layer removes the larger particles.

Together, they do a terrific job of teamwork.

So much so that the Fram Extra Life lasts 50% longer than our single-stage filter.\*

And best of all, it doesn't cost a cent more.

So put a little extra life in your car with the Fram Extra Life.

And put a little extra money in your pocket.

Result may vary according to car condition, filter change interval and where and how you drive.



Fram and Autolite are Bendix Companies  
Fram Corporation, Providence, Rhode Island 02916

## Popular Mechanics

**Editor-in-Chief:** John A. Linkletter  
**Executive Editor:** Joe Oldham  
**Managing Editor:** Bill Hartford  
**Design Director:** Ira Herrick  
**Design Consultant:** Eberhard Lütke

**Special Editorial Features:** Sheldon M. Gallager, editor  
**Automotive:** Tony Assenza, editor; Michael Lamm (West Coast); Gary Witzenburg (Detroit)  
**Home and Shop:** Harry Wicks, editor; Penelope Spangler, Michael Chotiner, Joseph Truini, assistants  
**Boating, Outdoors and Travel:** Wm. T. McKeown, editor  
**Electronics:** Neil L. Shapiro, editor  
**Science:** Dennis Eskow, editor  
**Technology:** Robin C. Nelson, editor  
**Editorial Production:** Peter Easton, chief; John Bostonian Jr., art; Shannon K. Kelley, Peter Francesconi, assistants  
**Art:** Don Mannes, technical art director; Douglas Quinn, Alan Andresen, assistants

**Special Publications:** Clifford B. Hicks

**Editorial offices:** 224 West 57th St., New York, N.Y. 10019. We cannot be responsible for loss of unsolicited queries, manuscripts, or photos. For return, they must be accompanied by adequate postage.

**Reader Service Department:** Hilde vonThorax, director; 224 West 57th St., New York, N.Y. 10019. (212) 262-4292

**Advertising Manager**  
Frank P. Camastro

**Advertising Offices:**  
**New York:** 224 West 57th St., New York, N.Y. 10019; (212) 262-8824  
**Chicago:** 520 North Michigan Ave., Chicago, Ill. 60611; (312) 527-2400  
**Detroit:** 377 Fisher Rd., Grosse Pointe, Mich. 48230; (313) 881-3520  
**Cleveland:** PDC Building, 3659 Green Rd., Cleveland, Ohio 44122; (216) 292-7334  
**Los Angeles:** 460 East Carson Plaza Dr., Carson, Calif. 90746; (213) 532-8101

**Production Manager:** Ronald Tuosto  
**Advertising Production:** Patricia Woods (212) 262-4800  
**Classified Sales Manager:** Sophie Gronowicz (212) 262-4825

Published by The Hearst Corporation  
**President**  
Frank A. Bennack Jr.  
**Chairman**  
Randolph A. Hearst  
**President, Magazines Division**  
Gilbert C. Maurer  
**Publisher, Popular Mechanics**  
Daniel J. Coleman  
**Publishing Consultant**  
Richard E. Deems

**POPULAR MECHANICS IS PUBLISHED MONTHLY** by the Hearst Corporation, 959 Eighth Avenue, New York, N.Y. 10019, U.S.A. Frank A. Bennack Jr., President; Randolph A. Hearst, Chairman; Harrison A. Mitnick, Vice President and Treasurer; Harvey L. Lipton, Vice President and Secretary. Hearst Magazines Division: Gilbert C. Maurer, President; K. Robert Brink, Executive Vice President and General Manager; Raymond J. Petersen, Executive Vice President; Thomas J. Hughes, Vice President and Resident Controller; William S. Campbell, Vice President, Director of Circulation; Daniel J. Coleman, Vice President for Popular Mechanics.



# EDITOR'S NOTES

*John A. Spletter*

**This is our kind of guy.** A young acquaintance, recently married in Des Moines, was feted at a surprise shower. The table centerpiece for the occasion was a toolbox filled with flowers. Most unusual, though, was the fact that his name had been registered at a hardware store—just as a bride's name is listed at a department store—for wedding gifts. The groom's gifts were hammers, saws, drills and such to set up a shop in his first new home. And he carried all his new tools home in the centerpiece. We haven't heard yet how the local society columns reported it.

**Should you paint right over your windows when you paint your house?** We wouldn't have, at least until we learned from a 40-year veteran that it's really quicker to spray paint and scrape than it is to mask all the windows. Complete instructions for painting your home—by spray gun or by brush—are just one part of our idea-packed *Home Ideas Guide* (page 113).

The writer of the spray painting article, staff member Michael Chotiner, appears on this page for the first time since he joined us last July. After graduating from Rutgers University with a degree in comparative literature, he started working for a home-improvement contractor, he says, to support his habit of writing poems. "I found myself in a trade that captured my imagination," he adds.

From home remodeling to making elegant built-in furniture for Fifth Avenue apartments, he went on to run a cabinet shop and then into his own contracting business. Michael has also written a vocational training course, as well as three books on building crafts.

Another byline in the *Home Ideas Guide* is that of Rosario Capotosto. He's far from being a first-timer in PM's pages, as regular readers know.

Rosario built and photographed the In-A-Wall Workshop (page 126) in the craftsmanlike way that he's done dozens of similar projects for us in the past 10 years. With 30 years of preparing how-to articles and books plus 29 years of teaching commercial photography in New York schools, Rosario has an unbeatable wealth of skills.

But he doesn't let his expertise blind him to one PM basic: "My first consideration always," he says, "is to devise construction methods for the guy who has only a limited supply of tools and experience."

PM



Chotiner sprays windows and all, while Capotosto builds a shop in a wall.

## DIRECT FROM U.S. OPTICS™ QUALITY SUNGLASSES AT FACTORY PRICES

Each pair features: Impact resistant lenses • Handcrafted • Polished glass lenses • Hardened metal frames • No non-sense guarantee. FREE—limited time only—deluxe velour lined case with each pair of glasses ordered (a \$3.00 value). Credit cards accepted. Dealer inquiries invited.

**NOTICE: Don't be fooled by cheap imitations. These glasses are made exclusively for U.S. Optics™. To make sure you get the best, order now and if not completely satisfied return for refund within 30 days.** ©Copyright 1982 U.S. Optics™



Only \$7.95

### World Famous Pilot's Glasses

These precision flight glasses are now available to the public for only \$7.95. If you could buy them elsewhere, they'd probably cost you over \$20.00. #20P available in gold or silver frame. A \$20.00 value only \$7.95. Two pairs for \$14.00.



Only \$9.95

### Aviator Teardrop Flight Glasses

Flexible cable temples. #30A gold frame only. A \$30.00 value only \$9.95. 2 pairs for \$18.00.

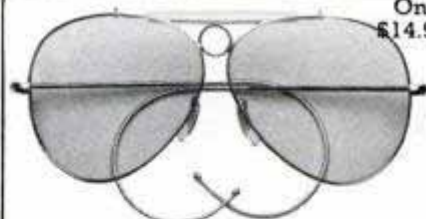

Only \$14.95

### Professional Driving & Shooting Glasses

Wide angle amber lens brightens visibility. #30D gold frame only. A \$30.00 value only \$14.95. 2 pairs for \$28.00.

To order your U.S. Optics™ sunglasses, send check or money order to U.S. Optics,™ Dept. 510, P.O. Box 14206, Atlanta, Georgia 30324. Credit card customers please fill in card # and Exp. date.

| QUANTITY | MODEL # | GOLD | SILVER | PRICE |
|----------|---------|------|--------|-------|
|          | 20P     |      |        |       |
|          | 30A     | X    |        |       |
|          | 30D     | X    |        |       |

Add Postage, Handling, and Insurance \$1.00 per pair

Total

Credit card orders may call 1-404-252-0703.

Visa or Master Charge # Exp. Date

Name

Address

City

State

Zip

**FREE case with each pair.**

# LETTERS TO THE EDITOR



## A spectacular rescue nevertheless

Helicopter pilot Don Usher certainly did a superb job of flying, as you reported in your story on last year's tragic air crash in Washington, D.C. (*The Most Amazing Rescue Of '82*, page 80, Jan. '83). Unfortunately, however, he shouldn't have had to be there at all. In fact, the powerful downwash from his rotor blades may have made it doubly difficult for the weakened survivors to hang onto whatever bits of floating wreckage there were.

It seems like a crude rescue effort. Where were the professional rescue units? Did someone order them to stay clear? I have a feeling that something

about the story hasn't been fully told.

R.S. LONG  
FALLS CHURCH, VA.

Many emergency units were called to the scene, as our story explained, but rescue boats were hampered by heavy ice in the river, and firemen on shore were unable to heave lines far enough out into the water to reach the victims. Under the circumstances, it is truly remarkable that the U.S. Park Police helicopter team, though admittedly not equipped to handle such an emergency, was able to save all but one of those in the water.

## Headlight hassle

In your article *Tomorrow's Car: PM Drove It* (page 77, Jan. '83), you called attention to the government's confusing and conflicting pronouncements on headlight covers. The situation is ridiculous, indeed, with one branch of DOT saying they're desirable and another saying they're illegal.

President Reagan once promised to get the government off our backs. Maybe he can get the stupid regulation banning the covers abolished if enough of us ask for it.

ROBERT D. SMITH  
SWISHER, IOWA

## Friendly computer advice

Your excellent article on computers (*The Five Friendliest Computers*, page 94, Feb. '83) was a big help. I had bought the VIC-20, but was unhappy with the instruction manual that came with it. I then purchased the two books you recommended, *Introduction to Computing . . . On the VIC* and *Introduction to Basic Programming*. Now I am very well satisfied.

WALTER HASS  
TAMPA, FLA.

A great article—the type of responsible journalism that keeps me a faithful PM subscriber.

RONALD L. KING  
HOUSTON, TEX.

## Compressor update

Here's a photo (below) of the PM air compressor I recently built from your plans (*Build Your Own Air Compressor From PM's Plans*, page 36, April '78). The plans were excellent and the compressor works very well.

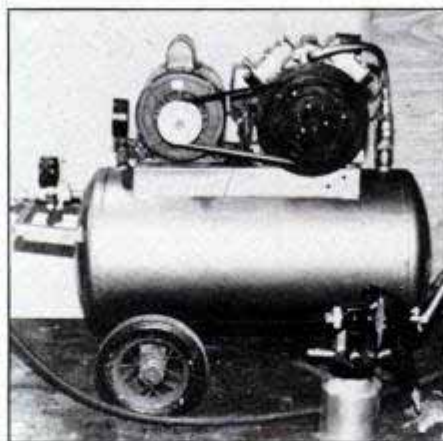

PM's air compressor made by reader Coleman. The substitute works fine.

Incidentally, I had some difficulty locating the York compressor you specified, but a knowledgeable junk-yard operator understood what I needed and told me a Chrysler AirTemp compressor used in cars would work just as well. It does. Your readers may find this information useful.

HOWARD COLEMAN  
INKSTER, MICH.

Thanks for the helpful tip. In using the Chrysler or any other make of compressor as a substitute for the York, one specification is important: It should have a displacement of at least 10.3 cubic inches to function properly in the PM design. Some automotive compressors may have less.

For others who may be interested, plans for building the PM air compressor are \$6.70 postpaid from Popular Mechanics, Box 1014, Radio City Station, New York, N.Y. 10101.

## A scroll saw in every shop?

I'd like to compliment you on your fine article *Use Your Scroll Saw Like A Craftsman* (page 96, Jan. '83). I learned cutting tricks I never knew.

JAMES LEWIS  
WEST SOUTHPORT, ME.

It was a great article; it made me want a scroll saw. But I have a question: Is a \$1,200 tool really for the average home workshop?

J. R. MULVANEY  
ST. PAUL, MINN.

Scroll saw prices vary widely depending on capacity and convenience features. That \$1,200 is for a top-of-the-line model. Both Sears and Dremel sell smaller models for under \$100.

## Not playing square

Thank you for the handsome stained-glass apple pattern (*Make This Classic Stained-Glass Light Box*, page 54, Aug. '82). The results were well worth the effort, but I think there was an error in your plans. If the top and bottom pieces are both 9½ inches long, the light box won't come out square because of differences in the rabbet depths. Right?

JIM McGRATH  
WILMINGTON, ILL.

Our apologies to all who encountered this problem. The top was correctly indicated as 9½ inches long, but the bottom should have been shown a ½ inch shorter. Fortunately, no wood is wasted. Merely lop ½ inch off one end, recut the rabbet and the piece will fit properly.

PM





## 80 years went into this Century. 1983 Buick Century.

That's how long Buick has been carrying on a love affair with the automobile. A devotion to bringing you comfortable, prestigious, quality cars. And that, of course, is exactly what Buicks have been down through the years.

Right down to today's state-of-the-art Buick Century. With its pleasing and efficient form. And its eminently luxurious passenger environment.

Among Century's impressive engineering credentials: front-wheel drive and a highly efficient 2.5 liter four-cylinder powerplant (see EPA mileage estimates below). Also available are V-6 gasoline and V-6 diesel engines.

|                 |                    |
|-----------------|--------------------|
| EST. HWY.<br>39 | EPA EST. MPG<br>24 |
|-----------------|--------------------|

The fact that 80 years went into this Century is surely reason enough to put yourself into one. You can do that at

your Buick dealer's today. Oh, and before you turn the key, buckle up.

Use estimated MPG for comparison. Your mileage may differ depending on speed, distance, weather. Actual highway mileage lower. Some Buicks are equipped with engines produced by other GM divisions, subsidiaries, or affiliated companies worldwide. See your Buick dealer for details.

*Official Car of the XXIIIrd Olympiad  
Los Angeles 1984*



**BUICK**  
Wouldn't you really rather have a Buick?

# T/A<sup>®</sup> HIGH TECH<sup>®</sup> RADIALS



**Objective:** Build a remarkably tough radial with a rugged appearance that's aggressive enough to meet the challenge of any terrain.

**Solution:** The Radial Mud-Terrain T/A<sup>®</sup>



The Radial Mud-Terrain T/A<sup>®</sup> tire's aggressive, nondirectional tread design offers excellent traction in deep mud or snow. Scalloped/offset shoulder lugs give maximum bite. And low rubber-to-void ratio in tread area provides excellent self-cleaning action.

The Radial Mud-Terrain T/A—the first and only race-proven radial mud tire—is available in standard sizes to fit most original equipment wheels. And every Radial Mud-Terrain T/A is as aggressive as it looks, with bold raised white letters and a large rugged tread pattern.



# BFGoodrich

*BFGoodrich makes a complete line of advanced T/A® High Tech® Radials, including the Radial Mud-Terrain T/A and Radial All-Terrain T/A.™ These radials are respected worldwide for their impressive racing record and outstanding road performance. If you're looking for a rugged radial with performance you can depend on, there's a T/A High Tech Radial designed for you.*

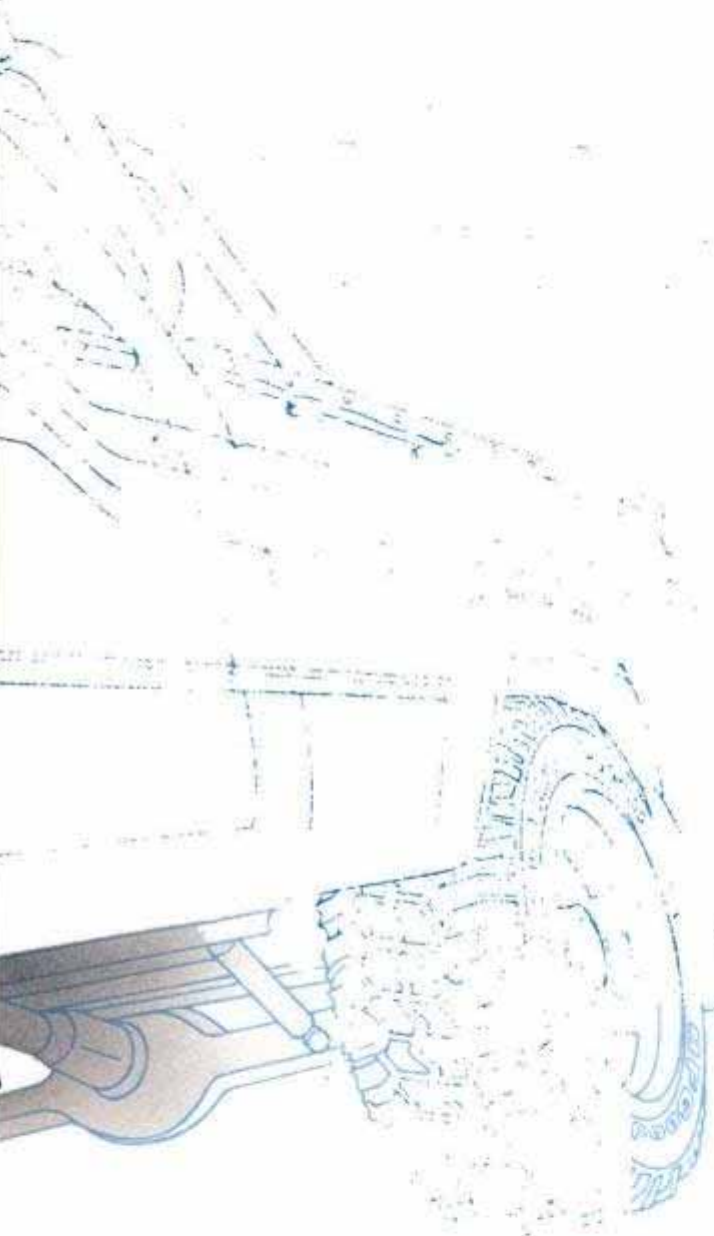

- The design of the Radial Mud-Terrain T/A includes this unique combination of advanced materials and technology:*
- A. Tread pitch sequencing for a quiet ride.*
  - B. Large center grooves to help reduce hydroplaning.*
  - C. Three-ply radial construction helps reduce sidewall bruising.*
  - D. Four-ply DuroGard® folded belt system for durability in the critical stress areas.*

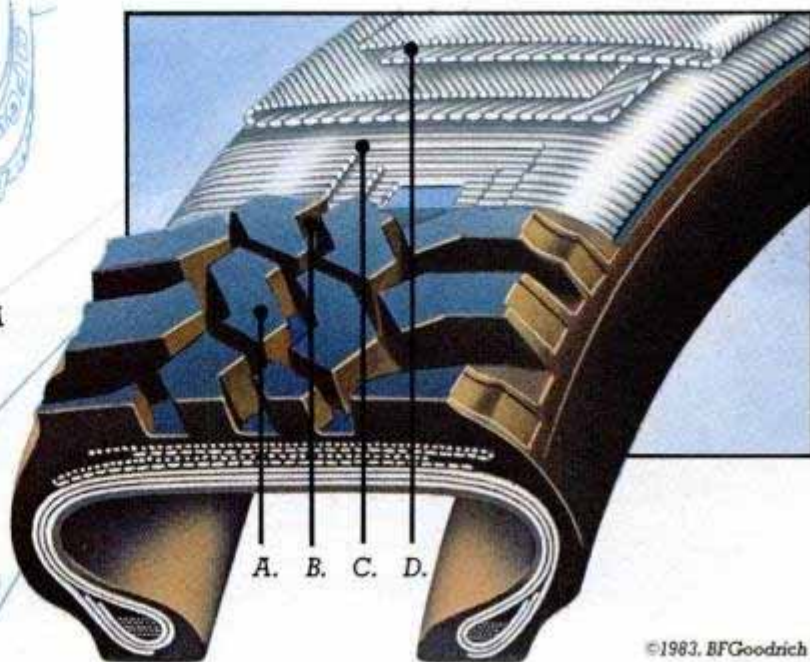

©1983, BFGoodrich Co.

# IMPORTS & MOTORSPORTS



## Opel Corsa

We all know the five General Motors divisions: Chevrolet, Pontiac, Buick, Oldsmobile and Cadillac. But GM has what I call a secret division. It makes cars in Europe and is known as Adam Opel AG. Rüsselsheim, Germany, is headquarters, but this GM-owned automaker produces parts and assembles cars all over Europe.



*Newest Opel is the Corsa, available as sedan (here) and hatchback.*



*Corsa grille sports simple Opel emblem.*

We used to get German Opels here, but they're no longer imported for Buick dealers' showrooms.

That is why we will never see the latest Opel, the Corsa. It's the new baby of the Opel range which includes the Kadett, Ascona, Manta, Rekord,

Commodore, Senator and Monza.

It was apparent that the Corsa has a certain magic from the stir at the Paris Auto Show last fall when the car was first seen.

Of the two body styles that are available, notchback and hatch, my choice is the hatch with its subtle, Quattro-like fender flares. Engine choices are 1.0, 1.2 and 1.3 liters. There are four equipment levels so you can set up a very plain or sporty little machine.

On the practical side, it has excellent interior room for a car its size (192.6 in. overall), low Cd and good fuel economy.

However, best of all is that dream-car quality we don't get enough of. I think of the Corsa every time I see a Chevy Chevette go by.



*Corsa hatchback has subtle fender flares.*

version is that it gets a new pair of bucket seats for better support. And, if you don't think driving this little screamer will provide enough of a thrill, you can order the seats equipped with Body-Sonic, a sound system that includes transducers hidden in the seats to transmit sound directly to your body.

Hey, is this a bumpy road, or is the music too loud?

## Short March

Competing with Honda's City, the popular Japanese micromini, won't be easy.

However, Nissan will be trying with the introduction of its new, 143-in.-



*Nissan March is new micromini in Japan.*

long, one-liter, front-wheel driver called the March.

The 1,400-pound March is conventional in its appearance: It doesn't imitate the very upright stance of the City, but does resemble a scaled-down Mazda GLC. Like the City, it's not scheduled for export to the United States at this time.

## Slicker City



*A Honda City Turbo has a hood bulge.*

If the seat mounts can take the forces, Honda's got another winner. The automaker has added a turbo to the 1.2-liter Four in its City model and boosted hp 50 percent to a fierce 100.

The City Turbo, recognized by its hood bulge, is the world's first mass-produced turbocharged car of such small displacement. Honda's small-engine turbo experience, you'll recall, started with motorcycles (see *Small-Bore, Blown And Beautiful: Riding Honda's CX500 Turbo*, page 90, Nov. '81).

Among the ways the City Turbo is different from the normally aspirated

## U.S. GP × 4

This year there will be no less than four Grand Prix races for Formula One cars in the United States. That's because the GP is coming to New York City.

The Big Apple race is scheduled for Sept. 25 on a circuit to be laid out around the lake at the old World's Fair grounds at Flushing Meadow.

As usual, the Las Vegas event will end the season—on Oct. 9. The Detroit GP is on the calendar for June 5, and, if you're reading this issue of PM early enough, you still have time to make plans for the first U.S. GP of the year, which is at Long Beach, Calif., on the 27th of March.

**PM**

# America's Best.

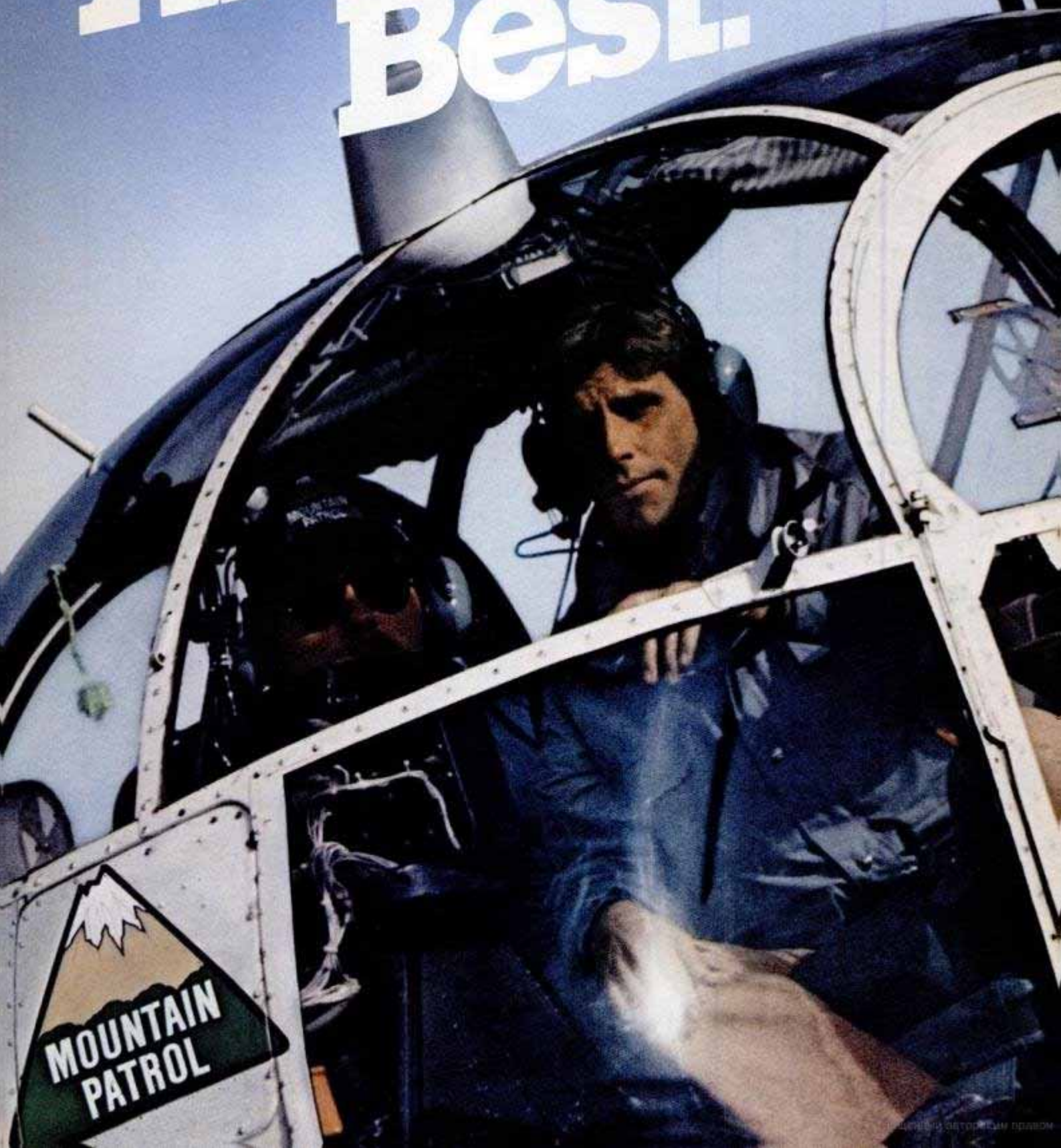

# Winston. America's



MOUNTAIN  
PATROL

Warning: The Surgeon General Has Determined  
That Cigarette Smoking Is Dangerous to Your Health.

# s Best.



Join the first team.  
Reach for Winston.

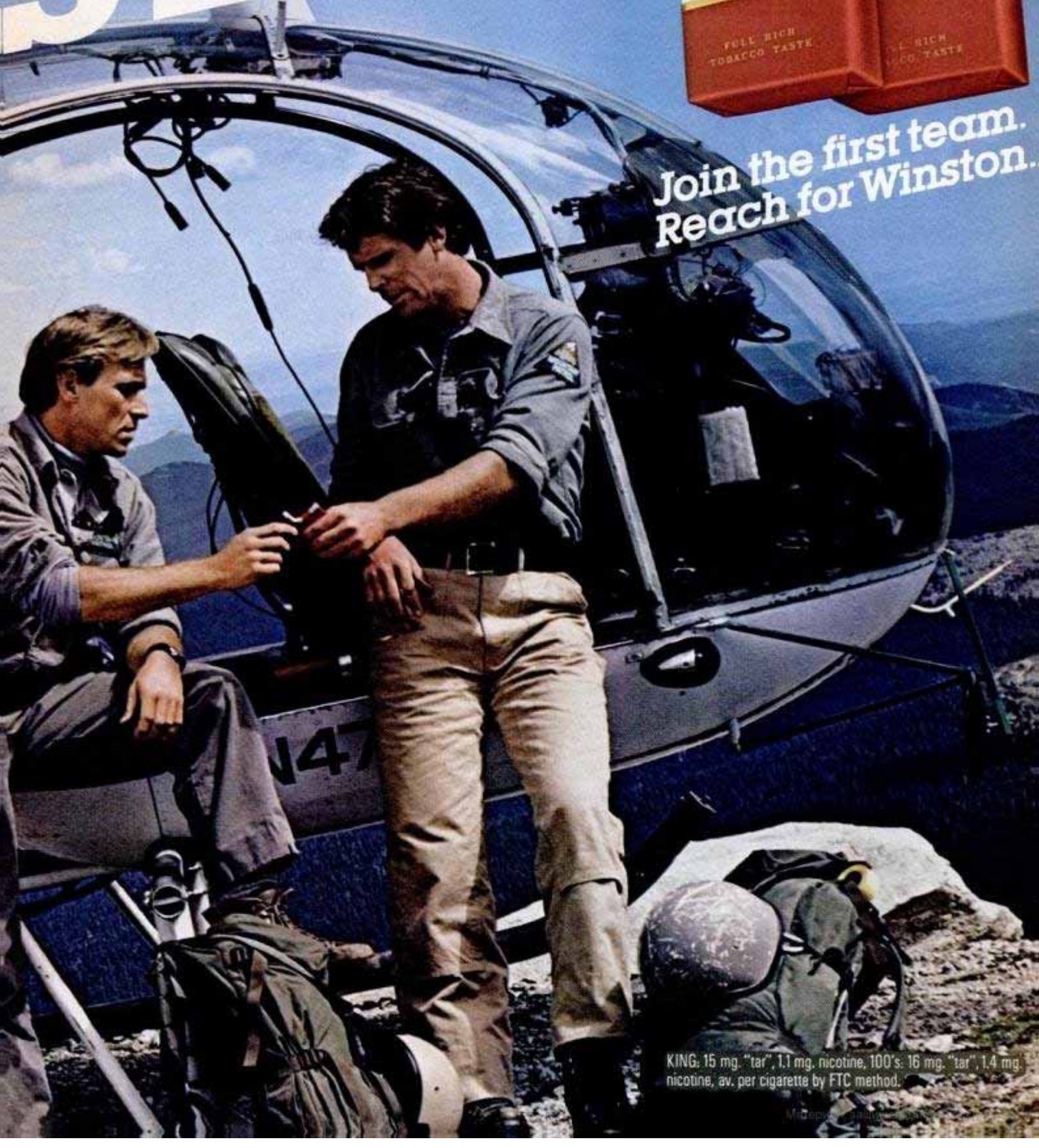

KING: 15 mg. "tar", 1.1 mg. nicotine, 100's: 16 mg. "tar", 1.4 mg. nicotine, av. per cigarette by FTC method.

© 1988 Winston

# ALL OUTDOORS



## Sailboard sculling

Rowing is returning as a popular exercise sport, and a clever device to combine the activity afloat and ashore comes from Martin Marine, Goodwin Rd., Kittery Point, Me. 03905. Naval architect Arthur Martin calls it the Oarmaster, and with it almost any small craft using oars can be adapted for that most advanced of sculling pleasures, sliding-seat rowing.



*Any sailboard is turned into a rowing shell by adding a sliding-seat Oarmaster, a rig from Martin Marine.*

The \$305 Oarmaster can be quickly mounted in a skiff, kayak or canoe, and the latest adapter kits allow it to be fitted on a sailboard for an additional \$30. One wingnut secures it. In the works is an attachment that can convert the Oarmaster into an indoor exercise rowing machine, as well. A Mini-Oarmaster has a fixed seat. Martin also supplies the Kittery Rowing Skiff (a \$285 kit for home building). Alden single and double rowing skiffs in fiberglass and Appledore Pod sailing skiff.



*The Oarmaster can also be mounted in a Kittery Skiff. This Martin Marine kit boat has curved ends for a smooth ride.*

## Sew-it-yourself boating

Here's an unconventional way of getting out on the water. Noted yachtsman Phil Reavis of Cherbourg, France, reports that local boatbuilders of Pondicherry, India, south of Madras on the Bay of Bengal, are still stitching up wooden craft, just as they always have. Planks are shaped with a keen eye to fit hull ribs. They are clamped and tourni-

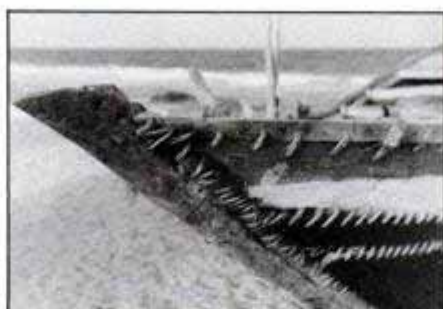

*Planks are stitched together to simplify hull assembly, with edge holes drilled to take laces that lash boat together.*



*Fishing craft in India's Bay of Bengal show construction shortcuts that modern do-it-yourselfers could use, as well.*

queted into place with rope, and a series of holes are drilled along each edge. Hemp cord dipped in tar is used to lace the planks and lash them to the ribs and thwarts. Seams are caulked with pitch and hemp, fed in from the outside so that water pressure helps seal the joints. With modern synthetic cord for the lacing, plus epoxy and silicone for the seams, you could launch similar little dory-shaped boats. Don't forget your personal flotation devices.

## More kick for kickers

Just announced for spring are new outboards from Evinrude and Johnson that are the most powerful production engines they've ever built. They're the Evinrude 2.6 Litre XP and the Johnson 2.6 Litre GT. Even though both new engines have the same displacement as the current top-of-the-line 235-hp. V6 motors, powerhead redesign with enlarged and reshaped ports, lighter reeds and relieved exhaust are report-

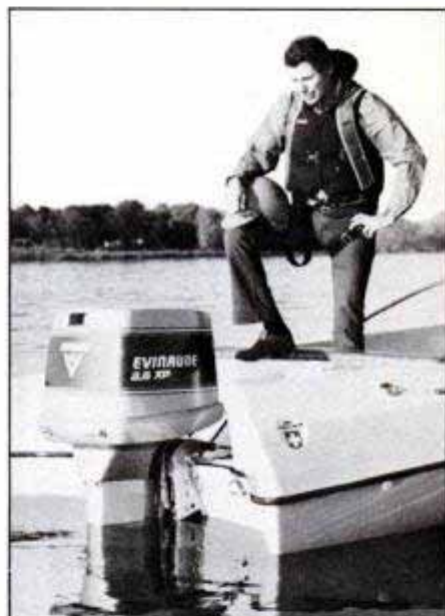

*Evinrude's newest and fastest production outboard, the 2.6 Litre XP, is checked by racing ace Jimbo McConnell.*

ed to increase power substantially. How much more horsepower, they're not saying. Largest production motor is probably still the special-order Mercury 300; and the fastest, the 3.5 Litre Johnson and Evinrude V8s. GT and XP motors of 150 hp will also be available.

## Where to find out

Two of the best fishing books are a pair just published. *The Fishermen's Sourcebook*, by Bill Wisner, \$25, from Macmillan, is a treasury of salt and fresh water fish and fishing, tackle and lore. And for the most challenging of salt water sports, Mark Sosin and Lefty Kreh have recorded the special techniques in *Fishing The Flats*, \$14.95, from Winchester Press. **PM**



**EVINRUDE**  **FIRST IN OUTBOARDS**

**TEAM EVINRUDE**

## **GO FOR THE BEST**

New 2.6 XP. The biggest, hottest V-6 ever from the raceworks at Evinrude.  
New high-performance heads. Enlarged intakes and exhaust.  
Tuned carbs. Tuned exhaust.

High-speed lower unit. And that's just the beginning.  
Nobody else gives you this much excitement from 2.6 liters.  
Only at your Evinrude dealer.

A PRODUCT GROUP OF **OMC** OUTBOARD MARINE CORPORATION

Outboard Marine Corporation 1983. All rights reserved.

# PM ELECTRONICS MONITOR



## Can CED meet the laser challenge?

Readers of this column are aware of the ongoing battle for standardization in the videodisc field between CED (capacitance-effect disc) and laser systems. A movie to one is an unreadable disc to the other.

One of the main advantages of the more costly laser system over the CED has been that laser-style discs could be interactive. Now, RCA has announced that it will soon offer an advanced CED player with the same capability.

Interaction is a result of the ability to go from one frame of a videodisc to another, without touching on the scenes in between. While this does

allow the viewer to skip back and forth to favorite parts of a classic film, this so-called *random access capability* has a far greater benefit. The random access allows for the design of discs that let the viewer become a real participant in an educational, or just plain fun, experience.

Interactive discs, so far available only on the laser machines, have run the gamut from teaching children numbers and magic tricks to demystifying complex gridiron plays for the video-equipped football widow. With an interactive disc, you can slow down the action, jump to a sequence further on

or perhaps go back and review a scene.

It is this interaction which has made the field of videodisc technology so wildly exciting and far more than just another way to watch a movie. And, in the past, it has been the main reason that the real excitement has centered in the laser camp.

The new, advanced CED players should be available "late in the second half of 1983." Until now, while the videodisc field has been far from moribund, it has not taken off the way some industry forecasters thought it might.

Now, with the advent of more inexpensive and interactive videodiscs, 1983 may indeed mark the true beginning of a new video age.

## Tip-top Talaria

While there are many big-screen TVs on the market that deliver quality video at screen sizes of up to 10 feet, the real, wall-size television is not yet here. When you go from the big-screens to the great-big-screens (of 10 to 25 feet or more, measured diagonally), you begin to lose image quality, and brightness levels fall below even movie standards.

GE recently demonstrated its Talaria system, which is a method of projecting good-looking video on a 25-foot screen. But don't get your heart set on buying one unless you're far richer than most videophiles.

The cost is about 75 grand (yes, \$75,000) a unit. Now, when you throw in the cost of a popcorn popper, that's talking big bucks.

The system, which uses an oil film and one electron gun instead of three conventional cathode-ray tubes, is not yet near the retail stage. But GE says not to write off Talaria as a corporate plaything. It may be seen in some living rooms within the next five years, when they hope to have costs down.

## Better sounding Beta

You don't often hear a video company going on about the audio part of its system, but then you don't often hear audio like Beta Hi-Fi. Sony's new system (to be licensed to other manufacturers) produces not only the usual

high-quality video, but audio that is just about the level of perfection achieved on digital sound systems. It's a breakthrough in both concept and technological implementation—and it should also prove one of the hottest new items in consumer electronics.

Old Beta-format videotapes will play on the new decks, but the thrill comes when you play back the new Beta Hi-Fi tapes. The sound track is recorded by the quickly rotating video heads instead of the usual stay-on-the-track

audio head. This results in the equivalent of a very, very fast tape speed. (Video quality remains the same.)

How good is good? The best home system of turntable, amp and speakers can deliver a dynamic range of slightly more than 60 dB (dynamic range being the difference between the loudest and softest notes). Beta Hi-Fi delivers 80 dB. Other specs are as impressive.

The new Beta Hi-Fi decks will hook to your stereo set or to stereo-capable TVs.

PM

### As the ray is bent . . .

Sony's new Watchman TV set, which is about the size of a transistor radio, features a new-technology, flat-screen TV tube. The electron gun sends out a stream of electrons that is swept back and forth by deflection plates. But then, a reflex plate bends the electron ray upward to the screen above. This side-firing gun makes the flat screen possible. The picture's black and white, but color may be in the future.

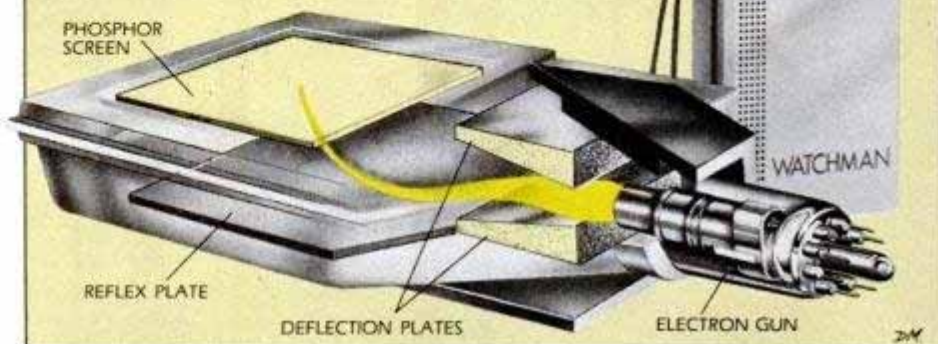

# Now NRI takes you inside the TRS-80 Model III microcomputer with disk drive to train you at home as the new breed of computer specialist!

NRI teams up with Radio Shack advanced technology to teach you how to use, program and service state-of-the-art microcomputers...

It's no longer enough to be just a programmer or a technician. With microcomputers moving into the fabric of our lives (over 250,000 of the TRS-80™ alone have been sold), interdisciplinary skills are demanded. And NRI can prepare you with the first course of its kind, covering the complete world of the microcomputer.



## Learn At Home In Your Spare Time

With NRI training, the programmer gains practical knowledge of hardware, enabling him to design simpler, more effective programs. And, with advanced programming skills, the technician can test and debug systems quickly and easily.



Now training includes either the TRS-80 Model III Microcomputer with Disk Drive or TRS-80 Color Computer with Computer Access Card; professional LCD multimeter; the NRI Discovery Lab; and hundreds of demonstrations and experiments.

(TRS-80 is a trademark of the Radio Shack division of Tandy Corp.)

Only NRI gives you both kinds of training with the convenience of learning at home. No classroom pressures, no night school, no gasoline wasted. You learn at your convenience, at your own pace. Yet you're always backed by the NRI staff and your instructor, answering questions and giving you guidance.

## TRS-80 Model III Plus Disk Drive to Learn On and Keep

NRI training is hands-on training with practical experiments and demonstrations. You not only learn to program your computer, you learn all about it... how circuits interact... interface with other systems... gain a real insight into its nature. Under NRI's carefully planned training, you even install a disk drive, verifying at each step its operation.

You also work with a professional 4-function, 3½ digit digital multimeter and the NRI Discovery Lab®, performing over 60 separate experiments. Both microcomputer and equipment come as part of your training for you to use and keep.

## Same Training Available With Color Computer

NRI offers you the opportunity to train with the TRS-80 Color Computer as an alternative to the Model III. The same technique for getting inside is enhanced by using the new NRI-developed Computer Access Card. Only NRI offers you a choice to fit your specific training needs.

## Send for Free Catalog

Get all the details on this exciting course in NRI's free, 104 page catalog. It shows all equipment, lesson outlines, and facts on other electronics courses such as Electronic Design, Industrial Electronics, Video/Audio Servicing... 12 different career opportunities in all. Keep up with the latest technology as you learn on the latest model of the world's most popular computer. If card has been used, write to:



**NRI Schools**  
McGraw-Hill Continuing  
Education Center  
3939 Wisconsin Avenue  
Washington, D.C. 20016

**We'll give you tomorrow.**

# When there's no room for an ordinary tool.

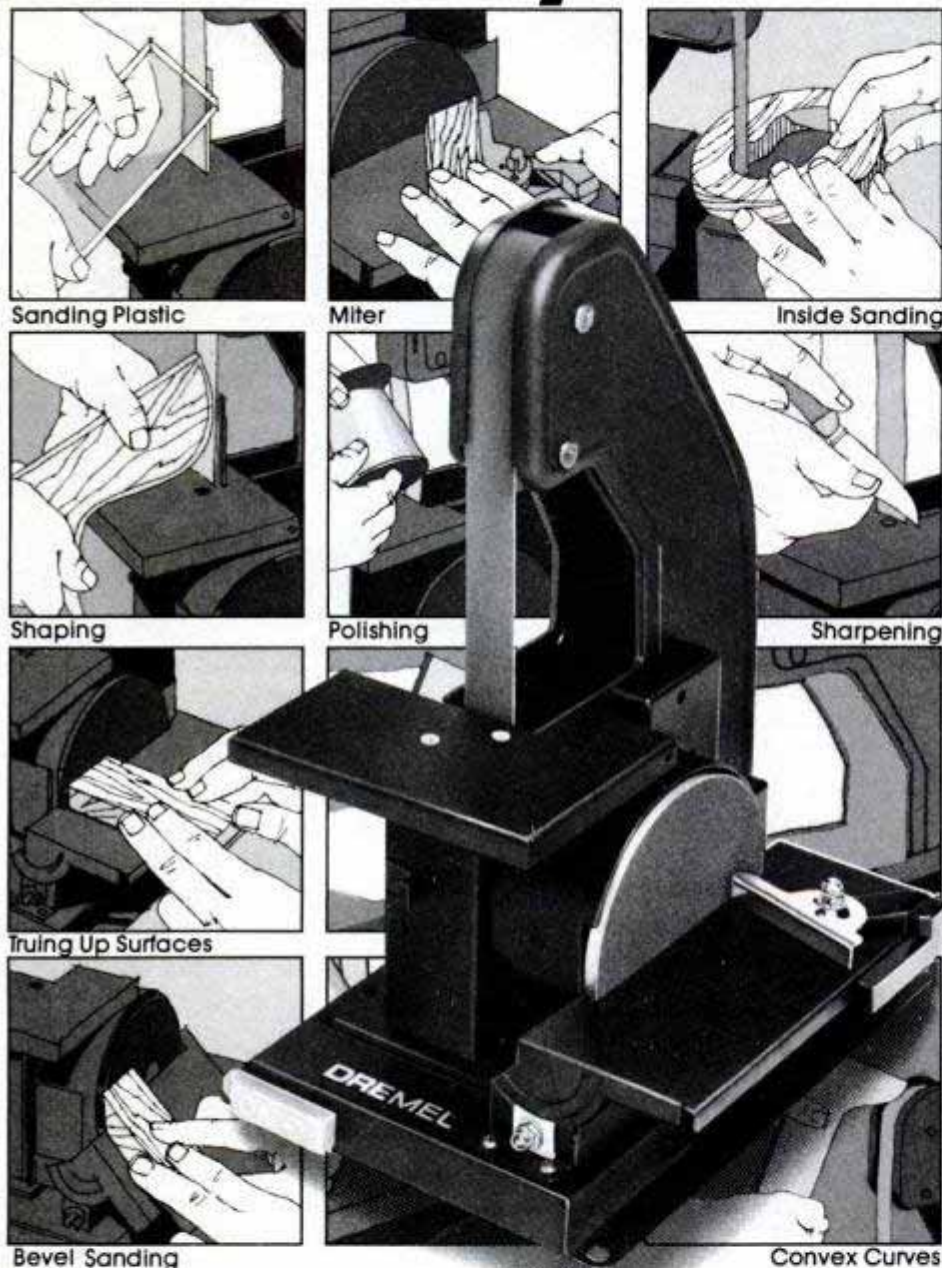

The combination of a quiet-running, 5" disc sander and 1" wide x 30" long sanding belt makes this the most useful single power tool you'll ever own.

The disc handles rough sanding and shaping. The belt sander takes care of finishing, sharpening and polishing.

3" throat depth, easy belt adjustment makes inside sanding simple. Has a platen that provides a rigid sanding surface if you need it but removes for flexible belt sanding.

Great tool if you don't have a workshop. Great tool if you do. Available wherever fine power tools are sold.

Dremel, Division of Emerson Electric Co., Racine, WI 53406.

## THE DREMEL® DISC-BELT SANDER

## HINTS FROM READERS

### Hanger doubles as compass

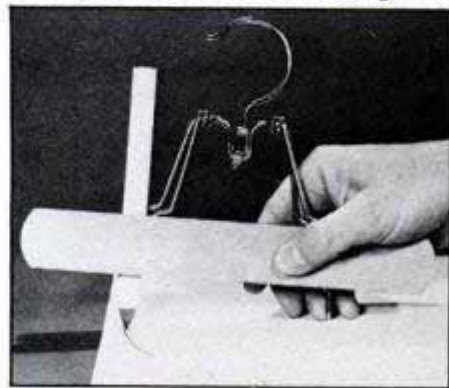

To make a wood and wire locking trouser hanger into a large compass, clamp a sharp nail into one end of the hanger and a flat carpenter's pencil into the other. Space them so that they equal the radius of the desired circle.

—Ken Patterson

### Cut plywood on sawhorses

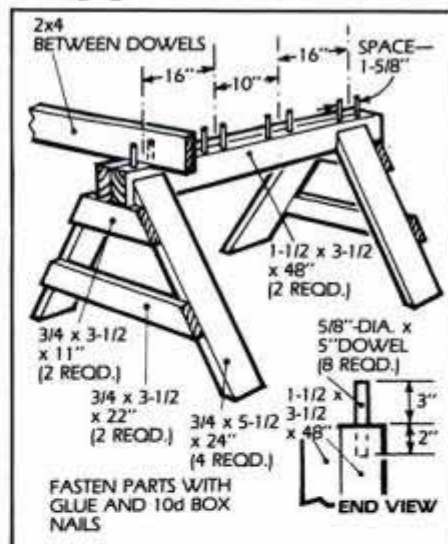

A pair of sawhorses like the one shown lets you cut large sheets of plywood without a helper. With the support the sawhorses provide, you won't have to worry about plywood pinching the saw blade, resulting in possible kickback. Plus, the cut pieces remain aboard the 2x4s. Four 2x4s, each held by dowel pins spaced to permit the cutting of various width rip cuts, straddle the two sawhorses. Bore the eight dowel holes with an 1/16-in. drill bit. Fasten the legs and the four cross braces with glue and 10d box nails.—Bert H. Griesbach

# HINTS FROM READERS

## Detect loose nuts

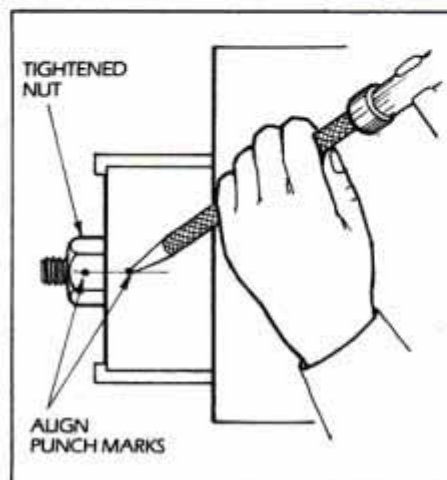

Here's a quick way to visually determine if a nut has loosened due to vibration or use. Strike a punch mark on the tightened nut and on a nearby surface. A loosened nut is quickly detected when the marks are misaligned. If you prefer, use dabs of paint for the alignment marks.—*Albert Rafanan*

## Veneering tip

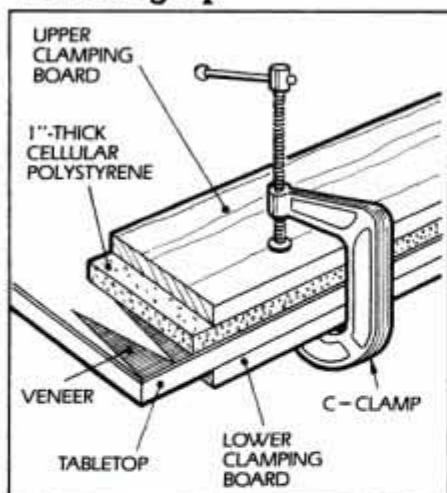

I use this improved clamping technique when simultaneously veneering small pieces of wood. First, cover the veneer with 1-in.-thick cellular polystyrene. Then place one rigid clamping board over the styrene and one under the tabletop. Position and tighten all C-clamps. The polystyrene conforms to any surface irregularities and allows clamping with sufficient pressure.

—*Hugh O. Sprague*

**NEW**

## Gas Rider Shock Absorbers... smooth riding comfort you can feel at a price you won't.

You'll be amazed by the satin-smooth ride Gas Rider delivers in big cars, small cars and in-between cars.

Gas Rider harnesses the buffering action of gas and all-weather fluid with a unique, patented check valve and other special valving. The result is the

durable, consistent performance of gas with the pillowy, soft riding comfort you've wanted.

Gas Rider is economical, too... priced right down with conventional shocks.

So float over the rough spots. Feel the difference in your ride; not the price.

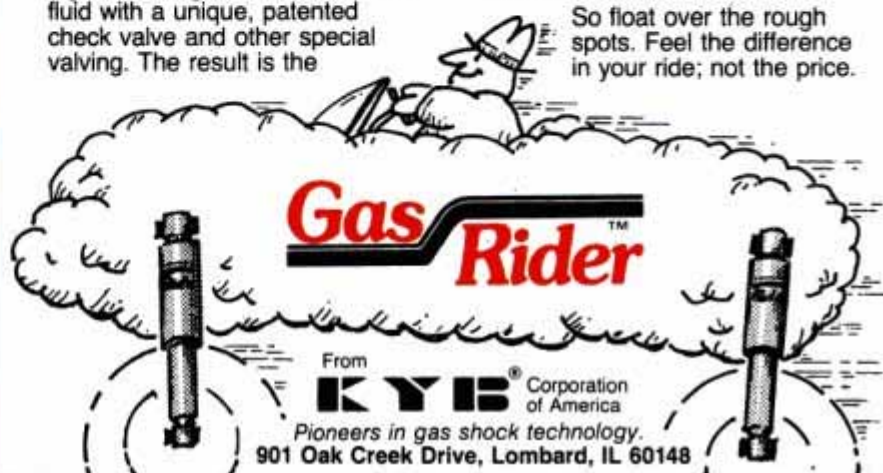

DRIVE IN COOL COMFORT ON HOTTEST, MUGGIEST SUMMER DAYS!

## 12 VOLT AUTO-FAN HAS INCREDIBLE COOLING POWER



ONLY \$9.98

- Saves money... Lets you drive without using energy-wasting air conditioner
- Plugs into any 12V cigarette lighter
- No batteries to burn out... Ever
- Made of unbreakable plastic
- Installs anywhere in car with powerful 2" suction cup
- Ball swivel adjusts to any position
- Has safety guard and off-on switch
- Perfect for cars, trucks, boats and campers

30 day MONEY BACK GUARANTEE.

**American Automotive Technologies AFA-69**  
365 N. Rt. 9W, Congers, New York 10920

Please send me \_\_\_\_\_ 12 volt AUTO-FAN(s) @ \$9.98 plus \$1.35 postage and handling. I must be completely satisfied or I may return them within 30 days for a full refund (except postage and handling).

**SPECIAL SAVINGS:** Order 2 for \$18.98 plus \$2.25 pstg. & hdg. (save \$1.43)

**EXTRA SAVINGS:** Order 4 for \$34.98 plus \$3.50 pstg. & hdg. (save \$6.84)

Enclosed is my  check or  money order for \$ \_\_\_\_\_ (Sorry, no C.O.D.'s.) New York residents please add appropriate sales tax.

CHARGE-IT  VISA  MASTERCARD EXP. DATE \_\_\_\_\_  
CARD # \_\_\_\_\_  
NAME \_\_\_\_\_  
ADDRESS \_\_\_\_\_  
CITY \_\_\_\_\_  
STATE \_\_\_\_\_ ZIP \_\_\_\_\_

Why suffer in your car or truck through another hot summer? Just plug our 5" mini-fan into your cigarette lighter and you'll be comfort-cooled even in the worst summer traffic jams. Attractively styled, unbreakable unit really moves the air around... so much so that you can actually measure the drop in temperature.

# CAR CLINIC



## Eager Beavers

*A few days after I bought a new 1982 Pontiac 6000LE, it developed an excessive engine vibration when wheels were turned to the right or left and when backing up, but also sometimes when driving forward. The dealer, in addition to other things, has installed vibration damper assemblies (part No. 14011736), but the trouble continues. Can you help me?—Lawrence M. Beavers, Tacoma, Wash.*

Maybe—if your 6000 is equipped with a standard 2.5-liter electronic fuel-injected engine and an automatic trans-axle. Then, a different computer PROM (Programmable Read Only Memory),

which tailors Computer Command Control system performance to your car design, may be of help.

The new PROM, which has revised spark timing and slightly increased low-engine-speed calibrations, was issued three months after you bought your car. The increased engine speed helps reduce vibration, while the different timing prevents spark knock while you're accelerating at 40 to 55 mph.

The part number for the new PROM is 1226169. Ask your dealer to install it according to service bulletin 82-I-195. If your 6000 doesn't have the 2.5-liter EFI engine, this won't work.

## Hope beats eternal

*I own a 1975 Ford Granada with front disc and rear drum brakes. Since the car's early days, it's given me chatter and vibration in the front suspension when brakes are applied and this has become worse with age. Wheels have been balanced, aligned, rotated and replaced several times. Brakes have been overhauled and wheel bearings, shocks and tires changed. In other words, the suspension system and brakes have virtually been rebuilt. Nothing's helped. You're my last hope.—E.J. Corner, Kaplan, La.*

Sounds like this could be a case of excessive rotor thickness variation (parallelism), which your brake overhauling hasn't resolved. A rotor turning machine that's been properly maintained and calibrated, used by a specialist, may bring rotors back to where they belong.

Other than this, there is a repair that could help. Although at first glance it may seem farfetched, my engineering friends at Ford agree it's worth a shot.

Some Granadas and Monarchs manufactured in the mid-1970s have a tendency to drift to the left. If repairs are not made to correct this, and the condition is allowed to progress, it could lead to "chatter and vibration."

The repair is to install a strut bushing kit (part No. D3DZ-3A187-B) to bolster the front end. Also, have steering-gear preload tested. Then, adjust camber to

$\frac{1}{4}^{\circ}$ , caster to  $\frac{1}{4}^{\circ}$  and toe-in to  $\frac{1}{8}$  inch.

I'll keep my fingers crossed. Good luck.

## Teaching a Lerner

*Maybe you can tell me why my 1976 Toyota Celica runs roughly when the engine is cold, but runs like a charm once it's warmed up. When I bought the car used last year, I had it gone over from stem to stern, but the short-*

*ing and bucking continue. Any ideas?—Bill Lerner, Columbus, Ohio*

One good one. Toyotas built in 1975 and 1976 have a tendency to develop a leak in the auxiliary accelerator pump (AAP) diaphragm. When coupled with an open thermostatic vacuum switching valve (the valve is open only as the engine warms up), a leaking AAP can cause fuel leanness, which would make a cold engine run roughly.

To determine if this is so, start a cold engine and check inside the hose connected to the AAP, on the carburetor. If the hose is wet with fuel, the AAP diaphragm is leaking.

To install a new diaphragm, which you can get from a Toyota dealer, remove the three cover screws (four if the car is a Mark II) and pull off the cover. Place the textured side of the new diaphragm away from the carburetor. The tab with the squared-off end must be aligned with the bolt hole on top of the carburetor (with a four-screw type, it doesn't matter).

Install the spring in its seat in the center of the diaphragm. Then, replace the cover and tighten screws to between 0.9 and 1.5 ft.-lb. Overtightening could distort the cover and create another leak.

*(Please turn to page 24)*

## Gas-saving guide

Here's a tip for those drivers in need of a quick guide to help them solve an excessive fuel-consumption problem. There are many causes.

At the head of the list is the way people drive. Then there is always the possibility of a fuel leak. But after these have been investigated, it's time to turn your attention to mechanical conditions.

Use this diagram as a guide. It shows primary causes of abnormal fuel consumption.

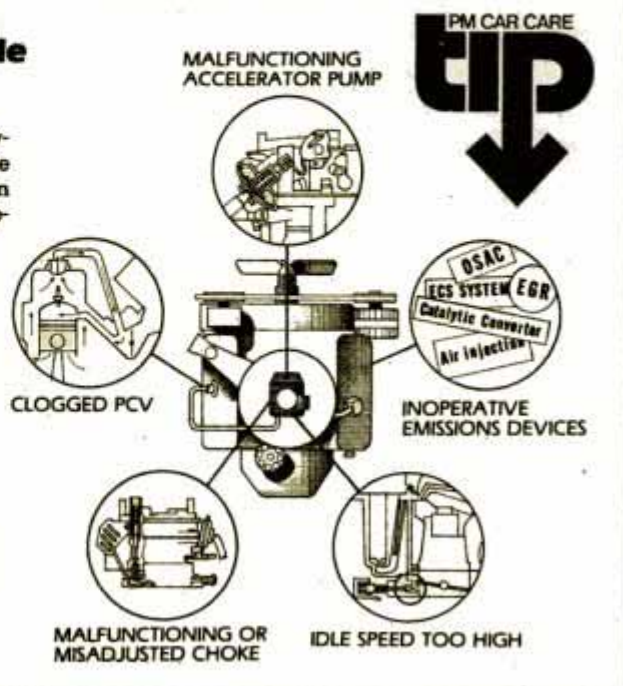

1983 FORD ESCORT



# THE CAR NINE OUT OF TEN WOULD BUY AGAIN.



## But we didn't leave well enough alone.

Nine out of ten Escort owners were so satisfied they'd buy Escort again. That's what an independent survey for the '82 model-year said. But rather than leave well enough alone, we've added over 90 new improvements, ranging from sound insulation to a new fuel-conscious shift indicator light.

## It's America's favorite car for lots of reasons.

Ford Escort outsold every foreign and domestic car in America last year to become America's favorite car.\* And Escort's front-wheel drive, four-wheel independent suspension, and no-cost

optional FS engine with improved mileage ratings will help keep it out in front of the pack.

**47** EST  
HWY

**33** EPA  
EST  
MPG

For comparison. Applicable only to sedans without power steering or A/C. Requires FS engine. Your mileage may vary depending on speed, distance and weather. Actual highway mileage lower. Not available in California.

Whether you buy or lease, see '83 Escort at your Ford Dealer. And remember, get it together—buckle up.

\*Based on manufacturers' reported retail deliveries. Model-year 1982.

HAVE YOU DRIVEN A FORD...LATELY?



FORD DIVISION

## CAR CLINIC

(Continued from page 22)

### Red-flagging transmission

I want to warn owners of Plymouth Reliants and Dodge Aries about the chance of damaging a manual transmission if they continue driving their cars after the transmission has jumped out of gear. After my 1981 Reliant rolled up 18,000 miles, it started jumping out of third gear during deceleration, especially when descending hills. Sometimes, it would also jump out of second and fourth.

A dealer told me if I had continued driving the car, I could have ripped apart the whole transmission. The problem lies with a gear shift detent lever spring that breaks, I believe, because of a design flaw. The detent spring is riveted to a bracket and breaks off at the rivet hole because of insufficient edge distance on both sides of the hole.

Anyway the dealer pulled the broken spring and roller from the transmission where it could have caused damage far in excess of the \$108 it cost me. K-Car owners should be warned. Will you do it?—Albert F. Weiland, West Bend, Wis.

I've done it, thanks to you. But I want to add a few facts. The condition you

describe applies only to a limited number of 1981 Aries, Reliants, Horizons and Omnis equipped with the A-460 manual transaxle. The problem was recognized early in the production run, and design changes were made.

Jumping out of gear is one indication that trouble is brewing. Another is difficult shifting into third or fourth gear. If the problem hits an A-460 transaxle, the owner should go to a dealer as soon as possible for the repair outlined in technical service bulletin (TSB) 21-02-

81. Instructions tell the dealer to install a new selector shaft housing assembly (part No. 4030874)—the part that Weiland says is flawed.

### Knocking around

Since my 1981 Chevrolet Chevette turned 5,000 miles (it now has 10,000), there's been a severe and frequent spark knock. Upping fuel to a 91 octane level from the 87 recommended hasn't lessened the knock. The dealer says his

### Don't get shafted

A worn carburetor throttle shaft is one reason why an engine may run roughly. However, you don't want to rip apart and overhaul or replace a carburetor unless you're certain it's causing the trouble. The fact that the shaft seems loose in the throttle body is not proof enough that damage exists.

To make sure you're not going to spend time and money, try this:

1. Connect tachometer.
2. Warm up the engine and let it run at idle.
3. Wiggle the throttle shaft and try sliding it sideways. If idle speed changes by more than 50 rpm, you have proof that the throttle shaft is too loose. If it doesn't change, look elsewhere for the cause of rough idle.

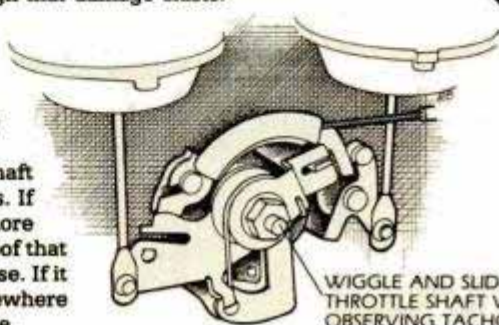

PM CAR CARE  
**TIP**

## GET YOUR CAR READY FOR SPRING AND SUMMER MOTORING!

GET THE JOB DONE RIGHT THE FIRST TIME! WITH SOLDER SEAL/GUNK PRODUCTS!



**GUNK**

RADIATOR SPECIALTY CO. CHARLOTTE, N.C. 28234

LOOK FOR THESE MONEY SAVING OFFERS AT \*PARTICIPATING STORES WHERE AUTOMOTIVE SUPPLIES ARE SOLD!

1. Buy any 2 different products . . . Get one of them **FREE!**
2. **50% FACTORY REBATE!**
3. Buy 1—**Get a \$.75 REBATE!**  
Buy any 2 different products—**Get a \$1.25 REBATE!**  
Buy any 3 different products—**Get a \$2.00 REBATE!**

\*PRODUCT SELECTION MAY VARY AT PARTICIPATING STORES.





**"Well, that was easy."**

### Quick 'N Easy™ Applicators for quick and easy repairs.

Just squeeze the applicator and apply the right amount of Duro adhesive to the right spot. No miss. No mess. There are nine Quick 'N Easy Applicators for all kinds of repairs. From Loctite Corporation, makers of Loctite®, Duro® and Permatex® fix-it products.



**DURO**

All the experience you need.™

©1983 Loctite Corporation

test equipment shows all systems are adjusted to specification. What now?—*J.W. Fugate, Warner Robins, Ga.*

**1. Pour in a can or two of GM Top Engine Cleaner** and give it a week or two to work. This will get rid of carbon that may have accumulated and is causing premature ignition when it gets hot—a problem with engines used mostly for short trips. I would classify your Chevette, averaging 5,000 miles a year, as a short-range car.

**2. Move ignition timing** to 18° BTDC.

**3. Pull the sparkplugs.** Clean or replace them if tips are coated with carbon. Check that gap is 0.35 inch.

**4. Check that exhaust gas recirculation (EGR) valve and thermostatically controlled air cleaner** work properly.

### Joint disease

*My 1979 Honda Prelude has racked up close to 70,000 carefree miles, which speaks for its engineering and my fastidiousness about maintenance. It gets serviced by the book—many times, more often than the book recommends. That's why I'm concerned about a vibration on acceleration which has suddenly developed. Service departments of two Honda dealerships checked the car and found nothing. I'm enclosing a list of items inspected. Can*

*you find something that was missed? —Les Greenberg, Hollywood, Fla.*

If the vibration shows up as a rotational oscillation in the steering wheel, the tires may be the cause. If it's more an instrument panel shudder, then the front-wheel drive (FWD) constant velocity (CV) joints may be damaged. Perhaps your mechanics didn't suspect them, because your CV joint boots are in good shape, but joint wear can take place anyway.

A common reason for joint failure is foreign material attacking joints through damaged boots. Watch for:

1. Slight humming. Joints may be starting to wear. Clean and lubricate them and install new boots to try and forestall failure.

2. Clicking on turns. Outboard CV joints may be worn or damaged.

3. Clunking on acceleration. An inboard CV joint may be worn.

4. Vibrating on acceleration.

Once the condition gets to points 2, 3 and 4, there's no way to save the joint. Replace it and the boot. **PM**

### DO YOU HAVE A CAR PROBLEM?

*Just ask Mort about it. Send your question to the Car Clinic, Popular Mechanics, 224 West 57th St., New York, N.Y. 10019. While letters cannot be answered individually, problems that are of general interest will be discussed in the column.*

### SERVICE TIPS

■ Chrysler says that tough N-1, 1-2 and 2-1 shifts in 1982 Ramcharger and B150 and B250 vans and wagons with overdrive four-speed transmissions may be caused by interference between the 1-2 synchronizer hub and sleeve. TSB 21-24-82 says to replace the 1-2 synchronizer assembly (part No. 4295288).

■ If there's a rattle from the parking brake handle of your 1982 Oldsmobile Firenza, the release rod and pawl could be loose. Cut a 1-inch thick by 1-inch in diameter piece of polyurethane foam. With brake handle engaged, push the foam in the open slot on underside of the handle, wedging it against the pawl. Make sure the parking brake releases.

■ If a dealer installed air conditioning in your 1982 Ford car or pickup truck, and you're experiencing evaporator freeze-up, the company says to have the dealer install a new electronic evaporator thermostat (part No. E2FZ-14A606-B). Article 82-22-1 of TSB 82-22 shows how.

■ In 1979, Toyota began coating the contact tips of distributor rotors with a substance that prevents ignition noise in car radios. Many good rotors have been replaced or filed off because the coating looks like corrosion. Leave it alone. If you have to replace the rotor because it's cracked, get a replacement from a Toyota dealer. It will be coated.

# APPLIANCE CLINIC



## Thermostat problems

*I replaced the defective thermostat on my Frigidaire, model FD-14B-64, serial No. 56342, with a Gemline GC-400 universal therm. When set to the warmest position, the center of the box is about 40° F. and the bottom of the box and under the crisper drawers freeze. The circulation fan operates properly and the door gaskets are tight. What did I do wrong?—Arthur Leslie, Natick, Mass.*

It sounds as if the insulation between the refrigerator and the freezer compartments may be wet. This could be caused by a crack in the refrigerator

liner or possibly a leaking drain tube. When this happens, the cold air in the freezer compartment freezes the water-soaked insulation. The cold temperatures permeate the bottom of the food compartment, causing food to freeze in the crisper drawers.

You might try defrosting the refrigerator completely by leaving it unplugged for three or four days. By defrosting the refrigerator for this length of time, it may help to dry the insulation. If this doesn't work, you will have to call a service technician in to replace the insulation.

## Fixing a hair dryer

*I have a Norelco "Gotcha Gun" 1200 hair dryer, model HB1777. My problem is how to open it for repairs. The air screens are partially plugged with fuzz and lint. Removing the end screws which hold the screen doesn't seem to help dislodge the screen. How can I remove them?—Marcel Edward, El Centro, Calif.*

To clean the screens, you could use a brush or a can of compressed air. If you want to take the hair dryer apart, you will have to remove the screws which hold the unit together.

Your hair dryer housing consists of a two-part handle and a two-part, upper and lower housing. Remove the two screws in the front (inlet) screen; then remove the two screws in the back (outlet) screen. In the right handle section there are two small plastic plugs. Use an awl to remove them.

Under each plug is a Phillips screw. Remove both plugs and take out both screws. The handle will now come apart. Simply pry the two pieces apart with a small screwdriver.

Next, locate the final plastic plug and screw in the lower housing that must

be removed before both halves of the housing can be pried apart. When taking apart the handle and housing, be careful not to break the plastic clips which hold the halves together.

Note: Opening the housing of some appliances voids the warranty. Check the warranty of your hair dryer before you begin work.

## Loaded with lint

*I have a General Electric electric dryer model No. DDC0580NLLWH, serial No. DA233774G. It doesn't exude any vapor or steam and there seems to be a lot of lint in the basket after each load. We've removed the pipe from the dryer to the outside two times and vacuumed it, but the problem remains. Hope you can help.—Mrs. E. Hooley, Riverside, Ill.*

Sounds as if your problem is in the area of the blower wheel. Lint may have accumulated on it, or possibly a sock or washcloth may have fallen down into the blower wheel through the lint trap restricting airflow.

To check the blower wheel, remove the front of the dryer. However, first disconnect the power to the dryer. Now stand in front of the dryer and open the front door. Look up under the upper lip. Remove the four Phillips-head screws. When these screws are removed, the dryer top can be raised.

Next, while still in front of the dryer, reach down to the bottom left and right front of the dryer. Loosen the two 5/16-in. screws on the toeboard. Then remove the two screws at top left and right corners on the inside of the dryer. These screws hold the front to the cabinet. Close the door and lift the front up and off and set it to the side.

Now the blower wheel is exposed on the lower left-hand corner. Remove any lint or blockage. Use a vacuum to clean out the wheel and duct work inside the cabinet front which goes from the lint filter to the blower inlet. Reassemble the dryer. **FM**

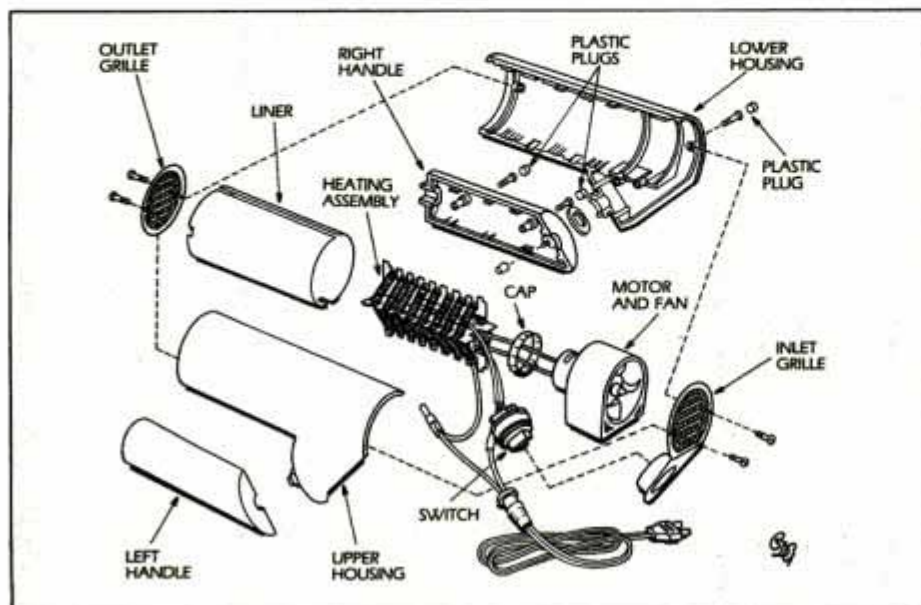

To disassemble the Gotcha Gun housing, remove three plastic plugs and screws.

*If you have a problem with any appliance, send your question, along with the model and serial numbers, to Appliance Clinic, Popular Mechanics, 224 West 57th St., New York, N.Y. 10019. Sorry, but letters cannot be answered individually. Problems of wide interest will be discussed in this column.*

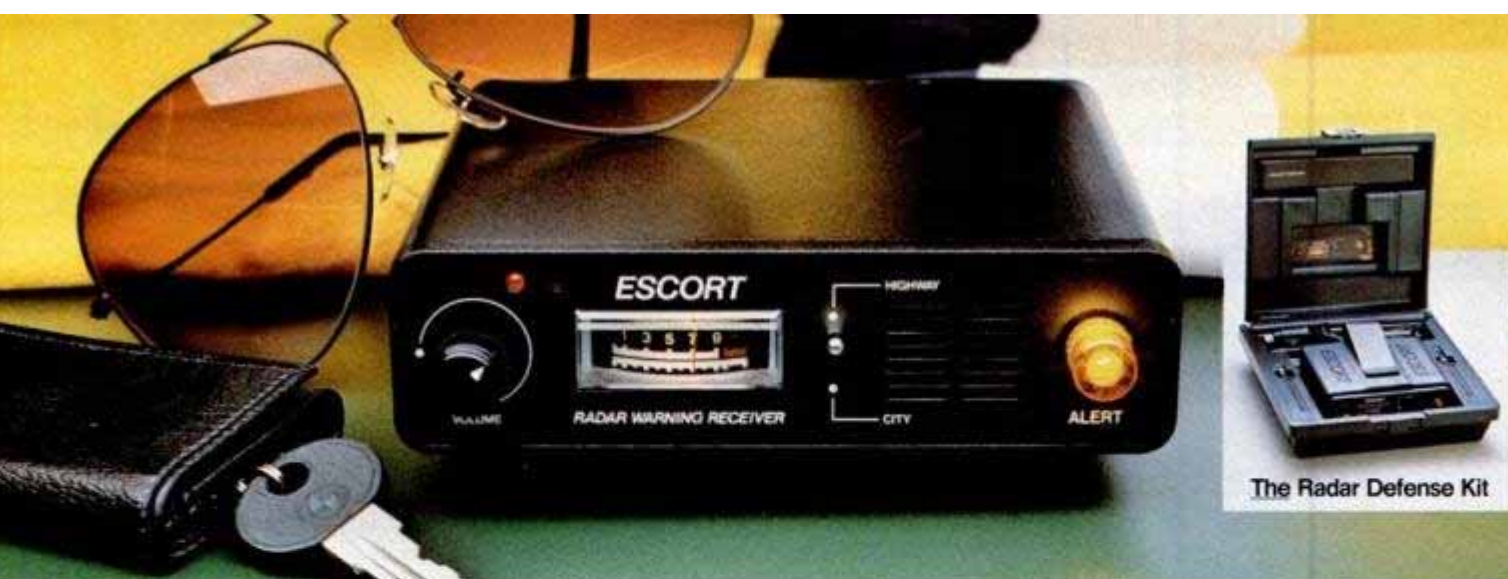

# Radar warning. Hear the difference.

## What Could Be Better Than Unbelievable Range?

By now, you've probably heard some tall sounding stories about how far away the ESCORT® radar warning receiver picks up radar traps. You know, the ones where they talk in miles instead of car lengths. The stories go on to say that ESCORT's superheterodyne receiving circuits provide as much X and K-band warning as you can possibly use, and then some. If you've never used an ESCORT, they may seem pretty far fetched, but most of them are true. Over hills, around corners, and from behind.

## Car 54 Where Are You?

Maximum detection range is wonderful, but it's far from the whole story. In some ways, radar detectors are like smoke alarms; you want to make sure that you don't miss anything, but you don't want a lot of false alarms. ESCORT won't disappoint you. Beyond that, when a smoke alarm sounds off, the most pressing thing on your mind is: Where is the fire? Is it ahead of you, behind you, above you, or below you? In the same room, or at the other end of the house? Your senses can help you find fire, but, on the highway, you can't feel or smell radar. ESCORT is your sixth sense.

## Hearing Is Believing

ESCORT reports its findings straight to your ears in a way no other detector can match. Its vocabulary includes a Geiger-counter-like pulsating rhythm that relates radar intensity in a smooth, natural, and intuitive manner, making it easy to sense the distance to radar. It can tell you if radar is ahead of you, behind you, or even traveling along with you in traffic. ESCORT also speaks different languages for each radar band. Since the two bands behave differently, the distinctive tonal differences eliminate surprises. You'll even be able to tell "beam interrupter," "trigger," or "instant-on" type radars from other signals just by the sounds they make. Ditto for radar burglar alarms and door openers. ESCORT has a lot to say, and we've developed a new way for you to get acquainted quickly.

## Play It, Sam

ESCORT's instruction book contains a wealth of information. Actually, it's the ESCORT user's Bible. But, the quickest way to become fluent in ESCORT's language is to play the Radar Disc on your stereo turntable. You'll hear firsthand how to interpret what ESCORT tells you in a number of situations. We now include this special Disc with every ESCORT so you can take a test drive as soon as you open the box.

## No Stone Unturned

The ESCORT Radar Disc is the latest addition to a long list of standard features. We don't scrimp on anything. Here they are: ■ Patented Digital Signal Processor ■ Different Audio Alerts for X or K Band Radar ■ Varactor-Tuned Gunn Oscillator tunes out false alarms ■ Alert Lamp dims photoelectrically after dark ■ 1/64 Second Response Time covers all radar ■ City/Highway Switch filters out distractions ■ Audio Pulse Rate accurately relates radar intensity ■ Fully Adjustable Audio Volume ■ Softly Illuminated Signal Strength Meter ■ L.E.D. Power-On Indicator ■ Sturdy Extruded Aluminum Housing ■ Inconspicuous size (1.5H x 5.25W x .5D) ■ Power Cord Quick-Disconnect from back of unit ■ Convenient Visor Clip or Hook and Loop Mounting ■ Protective Molded Carrying Case ■ Spare Fuse and Alert Lamp Bulb.

## Your stereo will demonstrate ESCORT's unusual abilities.



New!  
33 1/3 RPM Radar Disc

## What The Critics Say

*Car and Driver:* . . . "The ESCORT, a perennial favorite of these black-box comparisons, is still the best radar detector money can buy . . . All things considered, the ESCORT is the best piece of electronic protection on the market."

*BMWCCA Roundel:* . . . "The ESCORT is a highly sophisticated and sensitive detector that has been steadily improved over the years without changing those features that made it a success in the first place . . . In terms of what all it does, nothing else comes close."

*Playboy:* . . . "ESCORT radar detectors . . . (are) generally acknowledged to be the finest, most sensitive, most uncompromising effort at high technology in the field."

*Autoweek:* . . . "For the third straight year, no manufacturer has bettered the ESCORT's sensitivity . . . the consistent quality is remarkable."

## Made In Cincinnati

If you want the best, there's only one way to get an ESCORT. Factory direct. Knowledgeable support and professional service are only a phone call or parcel delivery away. We mean business. In fact, after you open the box, play the Radar Disc, and install your ESCORT, we'll give you 30 days to test it yourself at no risk. If you're not absolutely satisfied, we'll refund your purchase as well as pay for your postage costs to return it. We also back ESCORT with a full one year limited warranty on both parts and labor. So let ESCORT change radar for you forever. Order today.

## Do It Today

Just send the following to the address below:

- Your name and complete street address.
- How many ESCORTs you want.
- Any special shipping instructions.
- Your daytime telephone number.
- A check or money order.



Credit card buyers may substitute their card number and expiration date for the check. Or call us toll free and save the trip to the mail box.

**CALL TOLL FREE . . . 800-543-1608**  
**IN OHIO CALL . . . . . 800-582-2696**

**ESCORT (Includes Everything) . . . \$245.00**  
Ohio residents add \$13.48 sales tax.

## Extra Speedy Delivery

If you order with a bank check, money order, credit card, or wire transfer, your order is processed for shipping immediately. Personal or company checks require an additional 18 days.

# ESCORT®

**RADAR WARNING RECEIVER**

- Cincinnati Microwave  
Department 468  
One Microwave Plaza  
Cincinnati, Ohio 45242

DETROIT  
LISTENING POST

## Cadillac and Olds

By now, the fantastic '83 Corvette should be on view in your local Chevy showroom. And soon the '84 Pontiac Fiero, another car that we have previewed in these pages, will be in production.

Now, it's time for an early look at the '84 C-cars (Cadillac deVille, Buick Electra, Olds 98) and an even sneakier preview of the '85 N-cars, designed to replace the current rear-drive Buick Regal, Olds Cutlass and Pontiac Grand Prix.

The deVille prototype pictured here is a fairly accurate representation of the Cadillac's front-wheel-drive luxury sedan scheduled for public introduction this fall (though insiders tell us it's better looking in person). There's a family resemblance to the smaller fwd A-cars that debuted a bit over a year ago, but the C's are not stretched A's. They're all-new bodies on a new 108-in.-wheelbase platform. Suspension is fully independent, with MacPherson struts and disc brakes at all four corners, and rear-seat room is said to be substantial.

The Cadillac versions will offer that division's lightweight aluminum 4.1-liter V8, but the Buick and Olds will be powered by a standard Buick-built, 3.0-liter, port-fuel-injected V6. The Olds-built 4.3-liter diesel V6 will be optional. All engines, of course, will be transversely mounted to save space and weight, and all will be coupled to four-

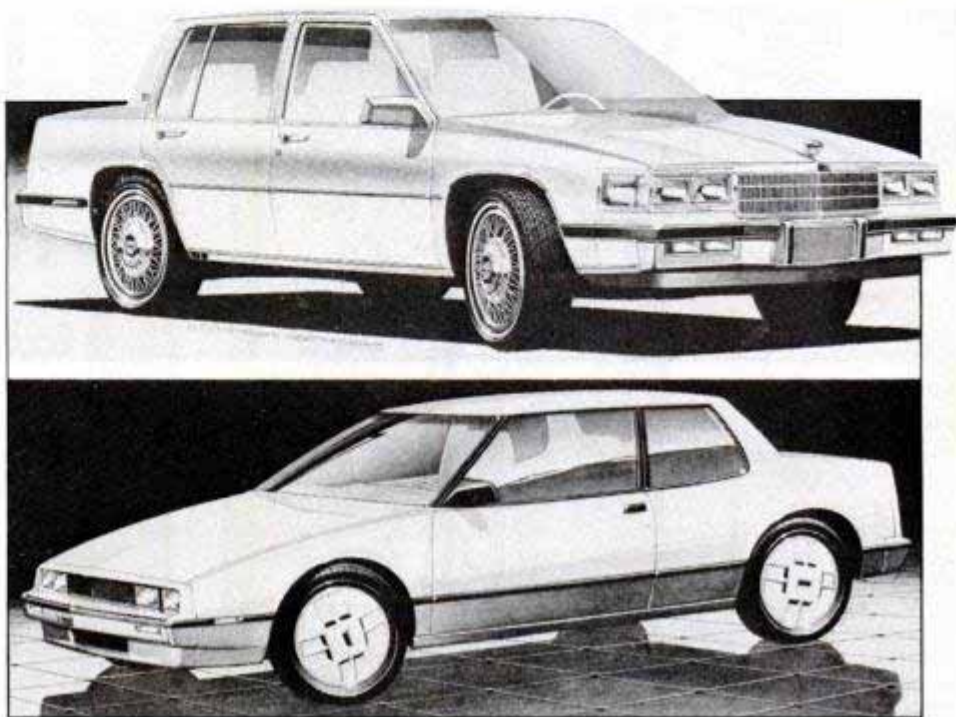

The '84 Cadillac deVille (top) will have front-wheel drive and will be powered by a 4.1-liter V8 engine. The '85 N-bodies (Cutlass, Regal and the Grand Prix shown above) will be based on the current J-cars (Cimarron, Cavalier, 2000 and Skyhawk).

speed overdrive automatic transaxles. With base weights around 3,200 pounds, both performance and fuel economy should be more than respectable.

The N-bodies will be coupes at first (probably followed by four-door versions a year later), and they will be derived from the current J-car—just as the excellent mid-size A-cars are built

on stretched and much improved compact X-car platforms. Interestingly, it seems there will not be a version for Chevrolet Div., which will stick with its rear-drive Monte Carlo until an A-based replacement (or some other alternative) can be developed. This will allow N-car production to be handled by a single factory, at least until GM sees how well first-year sales go.

## '83 or '84 Corvette?

Last month we called the new Corvette an '83 model in our driving report and on our cover. Well, it has turned out to be an '84 and there will be no 1983 model of the Vette. The 1982 models will be available right up until the time you can buy an '84.

Prior to the car's introduction, virtually all the descriptive information coming out of Chevrolet pegged the car as an '83. It was also listed as an '83 in the Motor Vehicle Manufacturers' Assn. (MVMA) specifications issued to us at the press preview. It was *after* we went to press that the model year became officially 1984.

So, just to set the matter straight, the



Here's the '84 Corvette coming at you in '83. Remember, it's an '84, okay? Okay.

new Vette's an '84; all the Vehicle Identification Numbers (VIN) will call it an '84; dealers will be selling it as an

'84 and Chevrolet wants you to know that it is an '84. Whatever year you call it, the new Corvette is still the best car that ever came out of Detroit.

## GM racing revival

General Motors has long been criticized for dragging its heavy corporate feet on performance and motorsports while its competition (primarily Ford and the better imports) have stolen away much of the excitement-starved American "youth" market. Now, finally, it's starting to do something.

First, the corporation has lifted its 25-year ban on racing—to a point.

(Please turn to page 30)

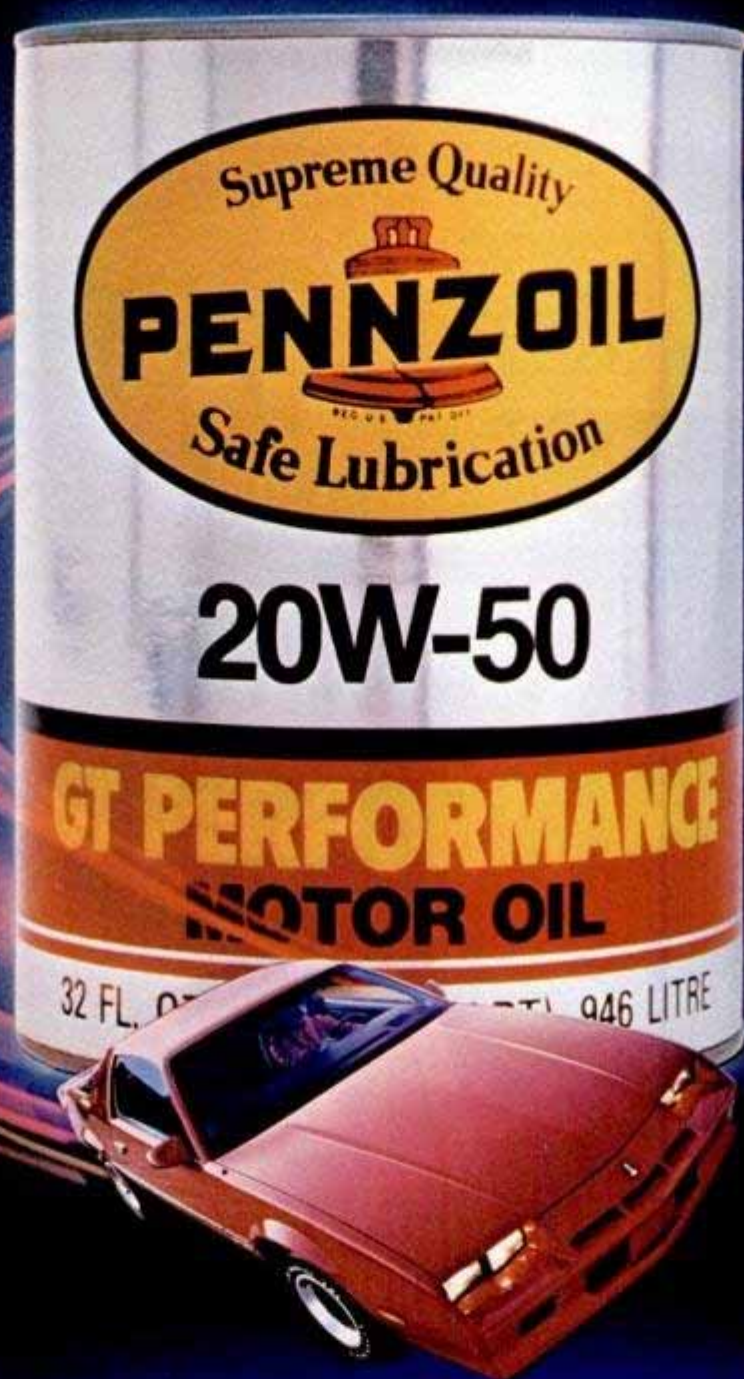

## It's worth its weight in tough protection.

If you're driving one of today's precision-engineered, high performance cars, you need tough engine protection. That's why Pennzoil GT Performance is specially formulated in an SAE 20W-50 weight to stand the strain high RPM's put on motor oil. GT Performance is also available in an SAE 20W-40 weight.

This extra weight oil has the

staying power to keep giving your engine the protection it needs—even under intense pressure. And GT Performance has built-in friction reducers to help high revving engines run easier, increasing their efficiency.

Pennzoil GT Performance

provides tough protection, too, for hard-working, load-carrying pick-ups, vans and RV's.

A top quality product of Pennzoil's long on-track experience...this is the oil with the extra weight to give tough engine protection for your high revving, high performance car.

**Pennzoil GT Performance Motor Oil**

Extra Weight for Tough Protection

## DETROIT LISTENING POST

(Continued from page 28)

Only four divisions are allowed to participate officially: Chevrolet, Pontiac, GMC (Truck) and AC Spark Plug. And only with certain products: Corvette, Camaro and light trucks for Chevy; Firebird and Fiero for Pontiac; light trucks for GMC.

This specifically excludes the other three car divisions, even (unbelievably) Buick, which has invested much sweat, time and money in development of high performance components for its V6 engines. It also leaves out GM's cur-

rent rear-drive G-car intermediate coupes (Regal, Cutlass, Grand Prix and Monte Carlo), which have dominated the NASCAR Grand National stock car circuit for years.

Will the GM divisions have to abandon all involvement in NASCAR, handing the series on a plate to the sleek, new, factory-backed Ford Thunderbirds? Or will they carry on business as usual out their back doors? Will Buick continue V6 competition engine development? What about the Turbo V6

Indy-car engine programs at both Buick and Chevrolet? Sounds like a bad soap opera, you say? Stay tuned.

Meanwhile, on the street performance front, all sorts of exciting things are going on deep in the bowels of all five car divisions:

Chevrolet promises a much-needed power transfusion soon for its Camaro Z-28: perhaps the 200-hp, 5.7-liter Corvette engine, but more likely an HO version of the current carbureted 5.0 V8. Corvette-type independent rear suspension is also a possibility. Several other performance projects, including a supercharged, 2.0-liter, J-car engine, are keeping Chevy's development engineers busy.

Pontiac recently unveiled its 10,000th experimental engine, which just happened to be a turbocharged, fuel-injected 1.8-liter ohc Four like the one being prepared for a killer STE version of its '84 2000 (J-car). Also under development is an aluminum-block, 2.9-liter Turbo V6 for the future Firebird Trans Am.

Both Buick and Cadillac will market versions of the former's much-discussed luxury sports car, possibly by the '86 model year. Some say these will be mid-engine convertibles; I'll buy the ragtop part, but not the mid-engine—too impractical. At any rate, they'll be spinoffs of the '86 downsized front-wheel-drive E/K-car (Eldorado, Riviera, Toronado, Seville) with injected V6 power and \$30,000-plus stickers. Also—get this—Cadillac's been testing a Cimarron (J-car) powered by a V6 derived from its 4.1-liter aluminum V8.

### Hotrod Lincolns, Escorts

Not that Ford is standing still, you understand. Inside word from Dearborn is that both the Lincoln Continental and the coming '84 Mark VII coupe will get optional performance packages.

These will include super suspensions, wheels, tires, brakes and—are you ready?—the 177-hp, HO, 5.0-liter V8 straight from the company's ultra-hot Mustang GT and Capri RS. Look out Mercedes, BMW and Jaguar!

The new Mark VII, considerably smaller and prettier than the brick-shaped Mark VI it will replace, seems cut from the same aerodynamic cloth as the '83 Thunderbird. It's very similar in appearance to last year's striking Continental Concept 90 show car.

At the other end of its size and price scale, Ford plans to one-up VW's delightfully quick Rabbit GTI next year with turbocharged Escort GTs, EXPs and LN-7s.

FM

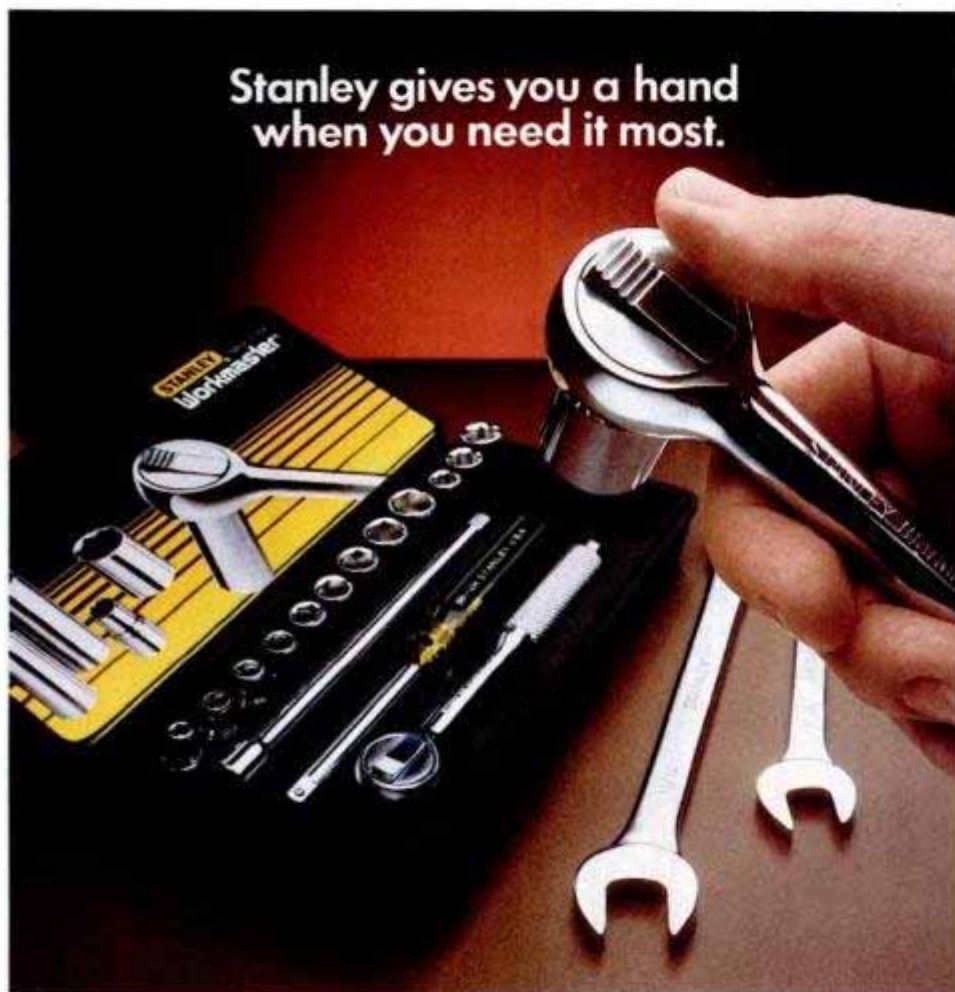

### Stanley's new "Flip Drive"™ Ratchet lets you change ratcheting directions with one hand.

Around your home, workshop or garage, Stanley's unique Flip Drive ratchet does with one hand what used to take two. Its patented "Flip Drive" feature lets you change ratcheting directions easily, with one quick flip of a

finger. There's no other drive tool like it. And it's part of Stanley's new line of Workmaster™ Sockets and Wrenches.

The Workmaster line delivers the selection you'd expect. All the most needed drive tools, sockets, wrenches and accessories. And a complete line of sets for a wide variety of jobs. All in reusable packages for

convenient home storage. All featuring Stanley quality for years of performance.

Simplifying do-it-yourself projects and repairs is what Stanley does best. The new Flip Drive ratchet and Workmaster line of sockets and wrenches prove it.

**STANLEY**  
helps you do things right.

# YOU DON'T RUN MILLION-DOLLAR EXPERIMENTS WITH A CHEAPLY MADE OIL FILTER.



## Motorcraft

**EXCEEDS THE NEED**

What existing oil filter could be selected for automobiles of such valuable technological stature?

Incredibly, many million-dollar experiments are guarded by a Motorcraft FL-1A filter — right off the shelf. Engineered to outperform all leading filters, the FL-1A's unique six-slot base accommodates oil flow rushes to nine gallons per minute. And an exclusive filter design incorporating a pleated filter element is blended with tough



man-made fiber. A superior material not found in cheaply made oil filters. The result? Motorcraft FL-1A lasts longer and traps more abrasives than any other leading filter. So which would appear the better choice to protect your car? The Motorcraft filter proven in million-dollar experiments? Or one proven to trap less dirt for a shorter period of time? Motorcraft. Quality parts for all makes of cars. Get it together — buckle up.



# Start your own money making business!



## Get in on the PROFITS in SMALL ENGINE service and repair



**BEAT INFLATION!** Work part time, full time right at home - we help you every step of the way.

In just a short time, you can be ready to join one of the fastest growing industries in America... an industry where qualified men are making from \$10.00 to \$15.00 per hour... and that's just for labor. Parts, engines and accessories add even more to the profits. Because the small engine

industry has grown so quickly, an acute shortage of qualified Small Engine Professionals exists throughout the country. When you see how many small engines are in use today, it's easy to understand why qualified men command such high prices—as much as \$17.50 for a simple tune-up that takes less than an hour.

### 65-million small engines are in service today!

That's right — there are over sixty-five million 2-cycle and 4-cycle small engines in service across the U.S.A. That's the official count from the Engine Service Assn., and new engines are being built at a rate of one-million per month! With fully accredited and approved Foley-Belsaw training, you can soon have the skill and knowledge to make top money servicing these engines. Homeowners and businessmen will seek you out and pay you well to service and repair their lawnmowers, tillers, edgers, power rakes, garden tractors, chain saws, mini-bikes, go-carts, snowmobiles... the list is almost endless.

You get all this Professional equipment with your course, PLUS 4 H.P. Engine... ALL YOURS TO KEEP... ALL at NO EXTRA COST.



**RUSH COUPON TODAY FOR THIS FACT-FILLED**

**FREE BOOKLET!**

Tells how you quickly train to be your own boss in a profitable Sparetime or Fulltime business of your own PLUS complete details on our 10-Day NO RISK Trial Offer!



Send for your copy today! No obligation

### No experience necessary.

You don't need to be a 'born mechanic' or have prior experience. If you can read, you can master this profitable trade right at home, in your spare-time, without missing a single paycheck. Lessons are fully illustrated — so clear you can't go wrong.

We guide you every step of the way, including tested and proven instructions on how to get business, what to charge, how to get free advertising, where to get supplies wholesale... all the "tricks of the trade"... all the inside facts you need to assure success right from the start.



Learn At Home In Your Spare Time.

### INCREASED INCOME

"I've had about 8 years experience repairing small engines... but repairs were only minor... until I started the Foley-Belsaw Course."

Walter H. Strick  
Campbell, California



With our famous 'learn-by-doing' training method, you get actual 'hands-on' experience with specialized tools and equipment you'll receive with your training, plus a brand-new 4HP engine — all yours to keep.

### Send Today for FREE facts!

You risk nothing by accepting this offer to find out how Foley-Belsaw training can give you the skills you need to increase your income in a high-profit, recession-proof business of your own.

Just fill in and mail coupon below (or send post-card) to receive full information and details by return mail. **DO IT TODAY!**



**FOLEY-BELSAW INSTITUTE of SMALL ENGINE REPAIR**  
50191 Field Bldg., Kansas City, MO. 64111

No obligation... No salesman will call

Foley-Belsaw Institute

50191 Field Bldg. • Kansas City, Mo. 64111



YES, please send me the FREE booklet that gives full details about starting my own business in Small Engine Repair. I understand there is no obligation and that no salesman will call.

NAME \_\_\_\_\_

ADDRESS \_\_\_\_\_

CITY \_\_\_\_\_

STATE \_\_\_\_\_

ZIP \_\_\_\_\_

# PM PHOTO HINTS

Behind the letters

**ISO 125/22°**

**ASA 125/22 DIN**

Many people are curious as to what film-speed abbreviations stand for. The letters ISO are the International Organization of Standardization; ASA is for American Standards Assn. and DIN stands for Germany Industry Standard. You won't take better shots, but you'll be informed.—Robert Hertzberg

## A safer safe



The hinged lid of a paper safe will close more firmly if you weight the front edge with strips of iron or brass, taped down. For additional convenience, you can cement or screw an old radio knob behind the strips to act as a pull.

—Robert Hertzberg

## Positive grip

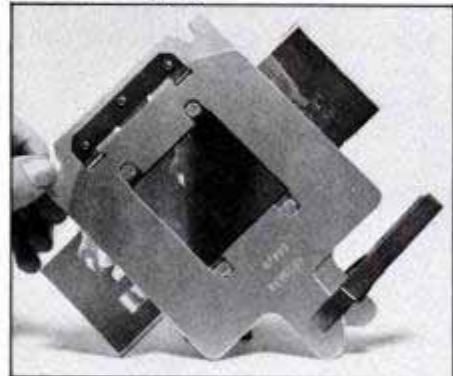

If you've ever wanted a third hand to put a film strip in a negative holder and place the holder in an enlarger's jaws, here's a way. A spring-type clothes pin helps to keep the negative holder closed.—Robert Hertzberg



# NEW FLAIR NEW FIRE NEW PHOENIX



## 1983 PHOENIX LJ

The instant you take your place in the new standard notchback seat with center armrest you'll know you're not here just to relax.

So get it in gear. And gage the excitement of our Phoenix LJ with a gaze or two at the sporty, black-accented instrument panel.

Up front lies the heart of the matter. It's a

responsive 2.5 liter 4-cylinder engine with electronic fuel injection that's ready to take you and our front-wheel-drive Phoenix LJ down a new road to excitement.

Some Pontiacs are equipped with engines produced by other GM divisions, subsidiaries, or affiliated companies worldwide. See your Pontiac dealer for details.



**PONTIAC**  **WE BUILD EXCITEMENT**

# Mail Postage-Paid Card for Free Facts Choose From 35 Career Opportunities

Get an Associate Degree or Career Diploma  
at Home in Spare Time



Send for free facts and color brochure to find out what career training in the field of your choice may do for you—there's no obligation to buy anything now or ever. Now at home in spare time, you can earn an Associate Degree or learn new job skills that could be your ticket to a better paying career. Just check the one program that interests you most. Eight of the programs listed let you actually earn a FULLY-ACCREDITED DEGREE without attending college classes! The other 27 are designed primarily to help you in your career...to learn new skills or improve the ones you have. With these programs, you are awarded a Career Diploma. Use the card to find out everything you need to know about one of these 35 programs. We'll send you free facts—with no obligation to buy anything now or ever—and no salesman will call. Mail the card today and see how easy it is to train at home for an Associate Degree, a great new career or advancement on your present job.

## School was never like this!

Home study is a great way to learn because it's so convenient! We send lessons and training materials directly to your home. You learn the material, then take an "Open-Book" exam using your lessons for easy reference. Simply fill out an answer sheet and mail it to the school. An analysis of your graded exams will be returned to you with comments as needed to tell you how you did and how you might improve. And this method really works!

Reports from our graduates indicate they really like home study because it's so flexible! You choose your own study hours and learn in the privacy of your own home. There's no time wasted traveling to and from class...no worry about parking. There's no need to wait for the next semester, you can enroll right now. You set your own pace...as fast or slow as you like. And all the time you're getting your Associate Degree or training for your new career, you can continue with your present job, so you never have to miss a paycheck!



ICS Central Headquarters

## Skilled Instructors as close as your phone

Your materials are especially written for home study and are easy to understand. But should you have a question, just pick up the phone and talk directly with an instructor. Or if you prefer, write to us at the address shown below. We'll get back to you with help and suggestions as quickly as possible.

## Same training system used by major corporations

You can be sure you're getting great career training because this is the same high-quality training that ICS has been known for since 1891. In fact, it's the same training system that's offered by many well-known companies to their own employees.

## You Can Get a Career Diploma That Could Change Your Life

Statistics show that specialized career training has helped thousands of men and women make more money, get better jobs, even start whole new careers. Compare your present salary with the money you could be making in any one of the careers listed on the card. And it's not the money alone that's important! Being around people you like, doing something you really enjoy, feeling successful in your career...all these can make a big difference in your future and in your entire outlook on life!

Accredited Members National Home Study Council • No Obligation • No Salesman will call

## Or Get Your Associate Degree Without Attending College

Now a two-year Associate Degree can be yours...and you never have to set foot on a college campus. You study the same subjects taught at major universities, yet never have to wait in lines or worry that a class is full. And if you have already completed college classes, seminars, military training, we may be able to grant you advanced standing. The degree is fully accredited.

International Correspondence Schools  
American Correspondence Schools  
Offer You a Wider Choice Of Courses  
Established in 1891, International Correspondence Schools is the oldest and largest home school in the U.S. North American Correspondence Schools, founded in 1900, is the originator of quick-learn instruction. Both these schools have joined together to offer you the 35 outstanding career opportunities listed on the attached card.

35 CAREERS  
YOU CAN  
LEARN AT  
HOME IN  
SPARE TIME

MAIL  
POSTAGE-  
PAID REPLY  
CARD FOR  
FREE FACTS

International and North American  
Correspondence Schools, Department PSS33  
Scranton, PA 18515



Front-mount mower  
for mini-dozer

Struck-Kit now offers a front-mount, heavy-duty mower for their Mini-Dozer Crawler tractor. The all-gear-driven mower features a new safe start and quick-braking system. The safe start will not allow the tractor to be started unless the mower is in neutral. Struck-Kit claims that the quick-braking system will bring the mower to a stop within three seconds of being shut off.

The front-mounted, free-floating design permits mowing under bushes and low

tree branches. The free-floating design also allows the mower to follow uneven terrain smoothly without scalping the high spots or flying over low areas.

The Mini-Dozer tractor (models from \$1,000 to \$2,400) and its front-mount mower (\$500) are available through the manufacturer. For more information, contact Struck-Kit, Struck Lane, Cedarburg, Wis. 53012.



## New tool for quick repairs

Skil Corp. has introduced a rechargeable, cordless, reversible screwdriver said to possess the power of larger heavy-duty models. The Model 2000 (\$39.99) weighs only 1½ lbs., yet Skil claims a three-hour charge of the nickel cadmium batteries provides enough power to drive 200 ½-in. No. 5 wood screws into pine. Its triple reduction gearing is capable of driving up to No. 12 wood screws. The Model 2000 comes with one slotted and one Phillips screw bit, but will accept any ¼-in. hex bit. For details, contact Skil Corp., 4801 West Peterson Ave., Chicago, Ill. 60646.

## Cutters for smaller shapers



Rockwell International has added more than 30 new profiles to its existing line of tungsten, carbide-tipped shaper cutters.

The cutters will fit ½- and ¾-in.-dia. spindles (four exceptions fit 1- and

1¼-in.-dia. spindles) found on smaller, more affordable shapers. The cutters include straight, bead, ogee, sash and various door lip and panel-raising profiles, plus three cabinet molding sets.

Prices for individual cutters range from \$57 to \$140; cabinet molding sets (each with six cutters) are \$295.

For more information, contact Mat Patulski, Rockwell International, Power Tool Div., 400 North Lexington Ave., Pittsburgh, Pa. 15208.

## Quiet plastic pipe holders

A plastic device for installing water or drain pipes has been developed by J-Hook Inc. It's made of ABS plastic. The maker claims that J-Hook's tight grip can prevent the noisy banging

of loose pipes and will not distort even at 250° F.

J-Hooks are available in ½-, ¾-, 1-, 1½-, 2-, 3- and 4-in. dia. Single-hook models range from 40 to 70 cents each; double-hook

models from 60 to 90 cents each.

Available at hardware stores and plumbing supply houses, they're made by J-Hook Industries Inc., 4425 44th St. S.E., Box 8637, Grand Rapids, Mich. 49508. **PM**

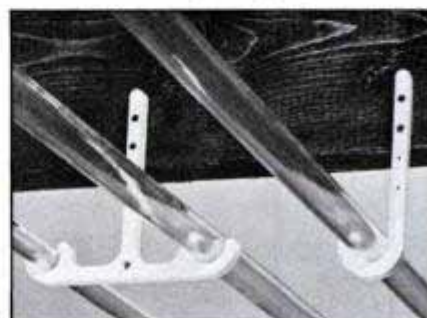

# New UDS Computer Telephones To Be Sold For Only \$10 Apiece In Mammoth Publicity Drive

*All who wish to apply for a new Computer Telephone  
should write to the company address below  
before Midnight, June 30, 1983*

NEW YORK—One million new UDS Computer Telephones with electronic memory and pushbutton dialing will be sold as part of a publicity campaign for only \$10 apiece to the first one million persons who write to the company address before Midnight, June 30, 1983.

These are the same famous UDS Computer Telephones to be nationally publicized in *The New York Times*, *TV Guide* and other leading magazines, with *electronic re-dial* (which automatically keeps re-dialing busy or unanswered numbers till they answer) and *electronic "mute"* (which lets you talk "confidentially" without putting your hand over the mouthpiece.)

Only half the size (and half the weight) of standard phones, they also have adjustable electronic ringers, which means you can turn them "off"—for complete silence—whenever you don't want to be disturbed. And when you finish your call, you don't have to bother hanging up—simply put the unit down (anywhere you please) and it will hang *itself* up, automatically.

These new UDS Computer Telephones are FCC-approved and require no installation. Simply plug them into the same modular outlets as your present



rotary dial or pushbutton phones. *You can then legally return your present phones to the phone company, saving yourself up to \$8 a month (or over \$90 a year) for each phone you return.*

These new UDS Computer Telephones will not be sold at this price by the company in any store. To obtain one at this price, apply in writing to

the company address no later than Midnight, June 30, 1983.

Each phone carries a full one-year money-back guarantee, and the company will replace it, free of charge, if it ever fails to function. There is a limit of two (2) phones per address at this price, but requests which are mailed early enough (before June 22) are permitted to order up to 5 phones.

To apply for a new UDS Computer Telephone, mail *this original printed notice* together with your name and address and \$10 for each phone desired. Add \$2 shipping and handling for each phone you are requesting. Mail to: **Carter & Van Peel, UDS Computer Telephone Offer, Dept. 114-6, Box 1220, Westbury, New York 11595.**

**(V21410)**

# Troubleshooting Your Cooling System

BY MORT SCHULTZ

## PART 1

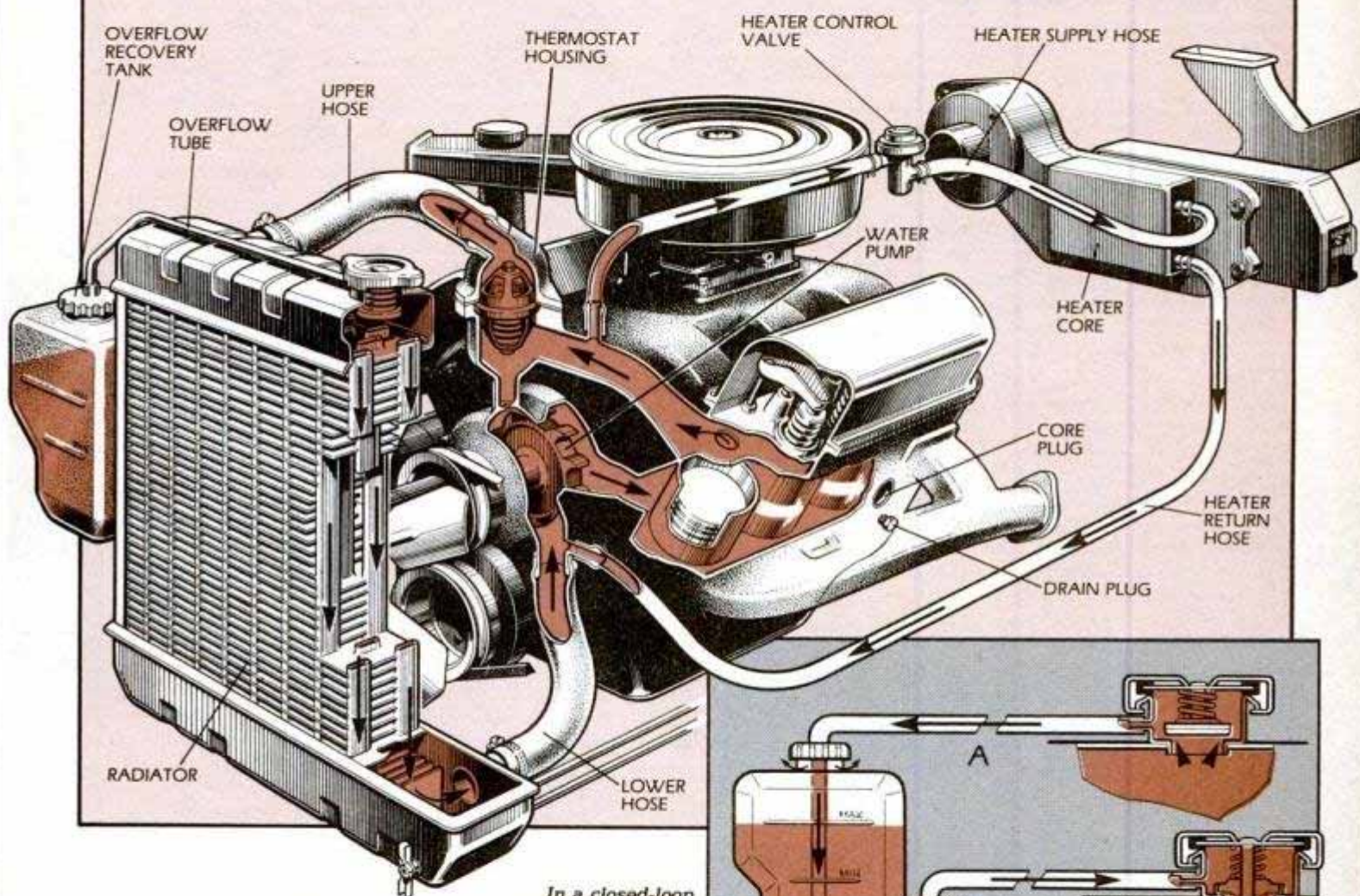

**W**e estimate that 3 million motorists are marooned each year by disabled cooling systems. You don't have to be among them.

Cleaning and refilling cooling systems is important, of course, but it's no guarantee that cooling-system parts won't fail. So, if you don't want to wind up waiting for a tow truck, make sure you include the inspection of parts in your regular maintenance schedule.

Those parts you can get at easily, should be checked frequently. The others you can test less often.

However, every cooling-system part should be examined at least once a year. This means hoses, radiator pressure caps, thermostat, fan and drive

*In a closed-loop overflow system, excess pressure is blown off into the reservoir bottle (A). Vacuum created when engine cools draws the fluid back into the radiator (B).*

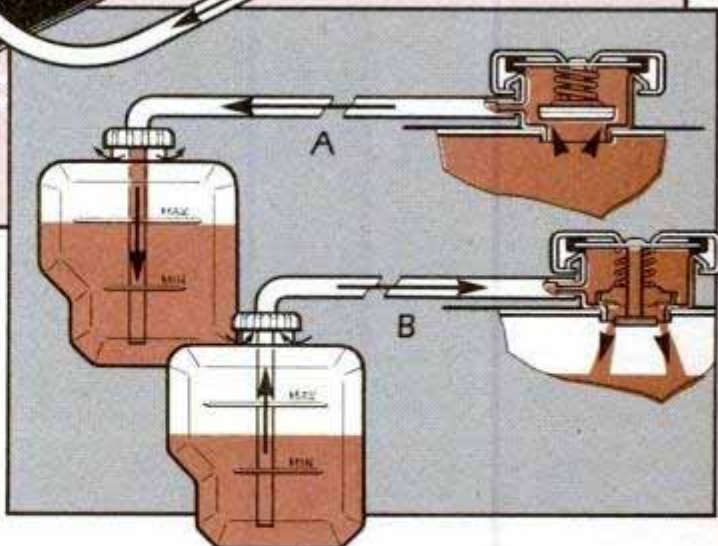

belts, radiator, water pump and engine drain plugs.

### Start with hoses

Hoses will fail faster than any other cooling-system component. Fortunately, they are visually in full view and easy to inspect.

Although hose life expectancy is approximately 25,000 miles, don't take

chances. Inspect your hoses every couple of months.

Just squeeze 'em, but do so with the engine turned off and cold. If a hose isn't firm and doesn't regain its shape as soon as you release pressure, replace it. Scrap a hard or mushy hose, one that shows cracks under pressure or one that's swollen.

Don't forget to include inlet and out-



To remove a stubborn hose, slit it with a blade. Take care not to gouge connector.

let heater hoses in your inspection. They're as much a part of the cooling system as the upper and lower radiator hoses. Some cooling systems also have a thermostat bypass hose jutting off the water pump. Check this, too. Remember—if any hose suddenly splits, the cooling system will lose most or all of its coolant and shut the vehicle down.

### Tips to ease replacing hoses

Replacing a bad hose requires that you drain the radiator below hose level, loosen clamps and twist the hose off its connectors (radiator necks). You may encounter resistance, but don't use excessive force or a prying tool. You might damage a connector, and that could result in a major repair.

So, slit the hose lengthwise at three or four points. Use a sharp knife, such as a drywall knife. Be careful not to slice into the connector. Then, peel the hose off.

As for old clamps, throw them away. New clamps are inexpensive.

Worm-drive clamps are easiest to work with, but they do have a tendency to vibrate loose; so be sure to tighten the clamp screws every so often.

Replacement radiator hoses are molded or flexible (accordion-type). Although they're a bit more difficult to install, use molded hoses; we think they hold up better.

Generally, replacement hoses come in one size—long. You usually have to cut them to fit between connectors. If the hose is too long, it will peak and may restrict the flow of coolant.

To cut a new hose, measure the old hose before you throw it away. Mark off the length on the new hose and use a sharp knife to make the cut.

This isn't as simple as it sounds, because you want a square end. If the cut end is slanted, the hose may not fit securely on the connector.

To get a square cut, slide the clamp on the new hose. Place it so that one side is on the measurement mark. Tighten the clamp. Now, use the side of

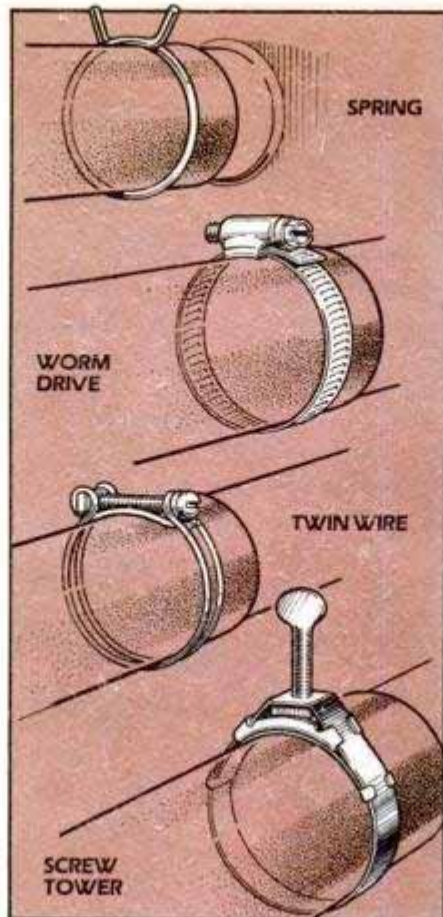

Of the various types of hose clamps, the easiest one to use is the worm-gear type.

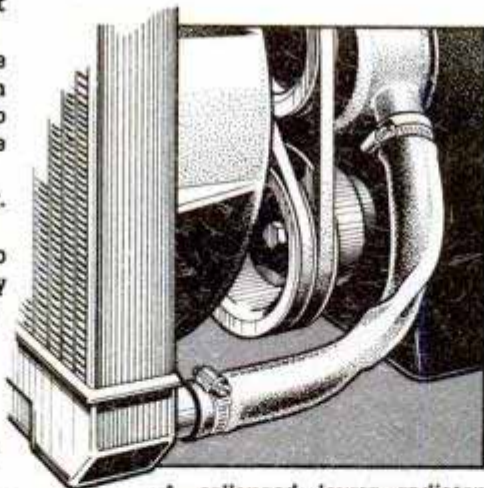

A collapsed lower radiator hose is the result of a failed stiffening spring. When you replace this hose, make sure that the spring is of the right type and length for the application.

the clamp for a guide as you cut the hose.

There is a way to make the installation of a molded hose less of a battle. First, use a wire brush to clean off the connectors. Then, coat the connectors with a water-proof sealer. Do not put any sealer inside the hose. It may flake and fall into the radiator.

Now, slip the clamps onto the hose and dip the ends of the hose in coolant

(ethylene glycol). The coolant acts as a lubricant and makes it easier for you to push the hose fully onto the connectors.

Finally, slide the clamps into place. Generally, inlet and outlet connectors of the radiator have a round protuberance. Make sure that the clamp is behind this bead. In any case, place the clamps about 1/4 inch from the ends of the hose.

Tighten the clamps snugly, but don't use excessive force. If you do, you could deform the connector. Refill the radiator, start the engine and make sure that no coolant is leaking from around the ends of the new hose.

### That lowdown lower hose

That lower radiator hose is a sneaky devil. It has a coil spring inside that can lose tension. This causes the hose to collapse at higher engine speeds, cutting off the flow of coolant. The result is overheating on the highway.

To make sure this won't happen, have someone start and accelerate the engine as you watch the hose. (Keep away from the fan, belts and pulley.) The hose should stay in shape. If it flattens, replace it.

The lower radiator hose can cause another problem if you have to replace it. Make sure the one you get has a coil spring in it. Lower radiator hoses are entering the market without springs. This isn't a problem if you're replacing the old hose, because it's cracked or leaking. Just transfer the spring from the old one to the new hose.

However, you can't do this if you're replacing the hose because of a weak spring, so keep looking until you find a new hose with a spring. If you can't find one, go to an auto salvage yard and get one off a junker. Just make sure it's the correct length.

### Keeping the pressure on

The radiator pressure cap is reliable, but it doesn't last forever. It has two important jobs. If it fails to do them, the cooling system will overheat.

One job is to seal the cooling system. The cap gasket pushes against the radiator filler neck to do this. Sealed, the cooling system builds up pressure that raises the boiling point of coolant. For example, the boiling point of a 44 to 56 coolant-water mixture is raised approximately 50° at sea level, and a higher engine operating temperature is more efficient.

The second job the radiator cap has is to release pressure when it reaches a critical level. Depending on the cap design, a pressure vent, cap gasket or a

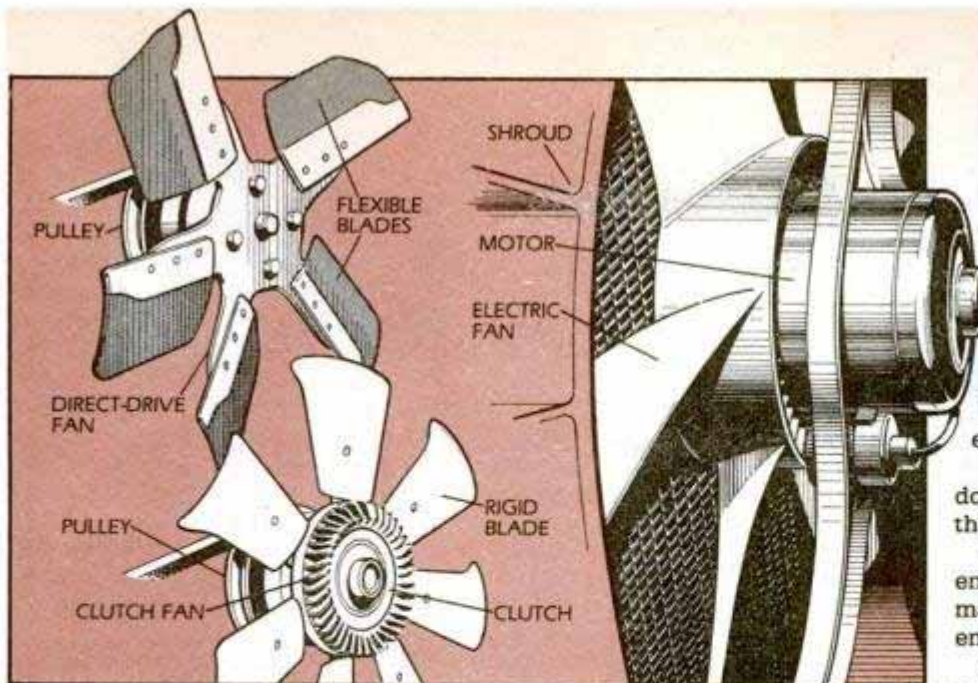

The three types of cooling fans are direct-belt-driven, clutch-belt-driven and electric-motor-driven. All three can be tested, using different procedures for each one.

rubber washer around the rim of the cap will move when the pressure gets too high, and pressure is released.

In older cars, this pressure is released through an overflow hose that extends down the side of the radiator. As it's released, some coolant flows from the radiator through the overflow hose and is lost.

Newer cars are equipped with sealed overflow systems. As the pressure is released, the coolant flows from the radiator through the overflow hose into a plastic tank. When the engine cools, vacuum created in the radiator draws the coolant back into the radiator.

### Capping it off

Here's what you should know about servicing pressure caps:

- Never remove one from a hot radiator. As careful as you are, there's always a chance that hot coolant will gush and scald you. Burns are the main injury suffered by those who work on cars.

- Wash the cap in water and examine the gasket or gaskets. Whenever a crack is found, replace the cap.

- If the cap has locking tabs, be positive that neither one is bent. If a tab is bent, replace the cap.

- Press down on the spring. It should offer strong resistance. If there is but slight resistance, replace the cap.

- Attach the cap to a cooling-system analyzer and pump up the pressure so that the dial records the pressure stamped on the cap body. If the pressure falls off rapidly, the cap is not functioning properly. Replace it.

Analyzers (pressure testers) are sensitive to small air leaks which can cause the pressure to drop off slowly. Don't be fooled and replace a good cap. If

you're not losing coolant, keep the cap in service.

- If a replacement is called for, buy a new cap that's designed for your cooling system. Doing otherwise will result in a loss of coolant and overheating. Furthermore, aluminum radiators require the use of aluminum radiator caps to prevent galvanic action that results in corrosion.

- Inspect the radiator filler neck to check for bent tabs and rim. Also, make sure that the neck is firmly soldered to the radiator tank. A damaged filler neck will have to be replaced.

- Replace the overflow tube and/or plastic tank if either one is not in good shape.

- Finally, in many cars with plastic coolant recovery tanks, radiator caps have to be secured so that an arrow or mark on the cap will line up with the overflow tube. This is your assurance that the valves are in place to permit the release of pressure and syphoning.

### Pressure-testing the system

With the engine cold and turned off, remove the radiator pressure cap. Make sure the radiator is filled; then wipe the filler neck clean.

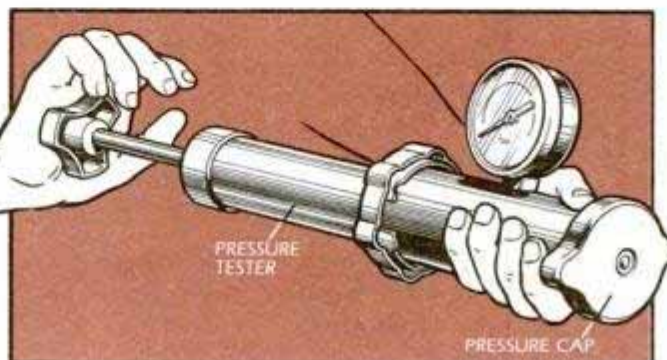

Cooling-system pressure analyzer is a must for checking the integrity of the system and radiator cap. To test the cap, attach tester and pump the handle until pressure on the gauge matches that stamped on cap.

Attach the tester securely to the filler neck and pump up pressure until the tester gauge reads the level at which the cooling system is rated. This rating is stamped into the top of the radiator cap.

Watch the gauge needle. If it falls, keep the system under pressure and examine for coolant leaks.

Suppose the needle drops, but you don't find a leak. What do you do then?

Loosen the tester and start the engine. Let it run until it reaches normal operating temperature. Now, tighten the tester.

**Caution:** Be careful when doing this test. With the cooling system tester connected and the engine running, pressure builds up quickly. Don't let pressure exceed 20 p.s.i. When it starts coming close, loosen the tester carefully. Hot coolant may spew out, so be ready to jump back.

If the needle fluctuates, there's probably a combustion leak because of a bad head gasket.

If the needle doesn't fluctuate, race the engine and watch the tailpipe. If a heavy amount of white smoke (steam) is expelled, it may indicate an internal coolant leak because of a cracked engine block or a cracked cylinder head.

One way of verifying an internal leak is to examine the oil dipstick. If water globules are mixed in with the oil, there's an internal leak.

### Tips on thermostats

Most thermostats contain a wax pellet that expands when heated and contracts when cooled. The pellet is connected to a piston that operates a valve.

When the pellet heats and expands, it forces the valve open. As the pellet cools down and contracts, pressure is released, and a spring allows the valve to close. In other words, with a cold engine the thermostat valve remains closed. This keeps coolant out of the radiator and forces it to circulate

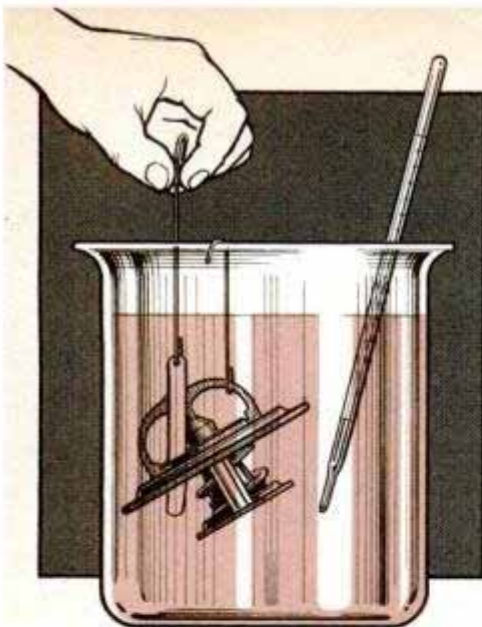

To test a thermostat, place it and a thermometer in water under heat. Check temperature when thermostat opens.

through the engine, so that it warms up quickly.

As the engine gets hot, the pellet expands, the thermostat valve opens and coolant is allowed to flow into the radiator, so cooling can take place before coolant starts to boil.

There are, therefore, two ways of recognizing that a thermostat has become defective:

1. The engine overheats. The thermostat valve may become stuck in the closed position, thus preventing the coolant from working its way into the radiator.

2. The engine warms up slowly, with the result that little or no heat comes from the heater. The thermostat valve is stuck in the open position.

### Gauges better than lights

Owners of cars equipped with temperature gauges can determine if one of these problems is developing much better than car owners having only temperature warning lights. With a gauge, you can see if temperature is staying below normal. Not so with a light, which will turn off the instant when you start the engine and goes on again only if the engine overheats—if it's working as it should.

Furthermore, a thermostat that's causing overheating often begins to stick gradually; that is, over a period of time. As the situation gets worse, the engine will run hotter and hotter. This you can readily determine with a temperature gauge, but a warning light goes on only when the problem reaches a critical point—too late to be of help.

### Replacing a thermostat

Admittedly, removing the thermostat every year for testing is a real pain. You have to drain the coolant; then unbolt and remove the thermostat housing—

which will destroy the gasket—in order to get at the thermostat.

You have to hang the thermostat on a pan filled with water, so that it's fully immersed; then heat the water as you keep one eye on the thermostat valve and the other eye on a thermometer. When the thermometer records the temperature stamped on the thermostat body, the valve should be wide open. If not, you have to replace the part.

Then, to reinstall the old thermostat or install a new one (make sure it's rated at the temperature specified by the car manufacturer), you have to clean the housing surfaces and install a new gasket.

### An easier test

Here's an easier way to test the thermostat. General Motors advocates the use of temperature sticks. These are pencil-like devices which contain wax materials that will melt at specific temperatures. The temperature rating is specified on each stick.

You'll need two temperature sticks, or crayons, to test the thermostat—one that's rated at approximately 25° below

*Crayons sensitive to temperature can check a thermostat without the need to remove it from the engine. Such crayons can be had from many laboratory supply houses. See text for instruction in how to use them.*

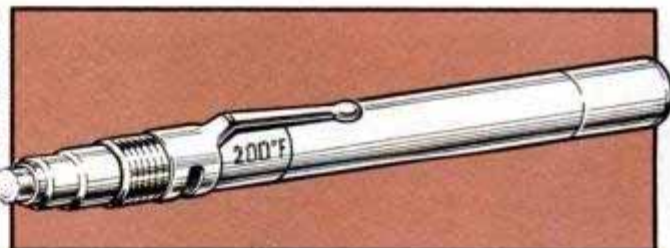

the rating of the thermostat in your car and the other rated at about 10° above your thermostat.

If the thermostat in your car is rated at 195° F., you should use crayons rated at 169° F. and 206° F. These crayons are available from Omega Engineering, 1 Omega Drive, Stamford, Conn. 06907. They cost \$5 each.

When the engine is cold, remove the radiator-pressure cap. Clean the thermostat housing and rub wax from each stick onto the housing.

Start the engine and run it at a fast idle. As the "low-temperature" mark (169° F., for example) starts melting, look in the radiator (not the overflow tank). You should *not* see coolant moving (flowing). If coolant is flowing, it's a sign that the thermostat valve is probably stuck open.

Now, before the "high-temperature" mark (206° F.) starts melting, you should see coolant flowing. If you don't, the thermostat valve is probably stuck closed.

### Fanfare

Your car has either a direct-drive, clutch-type or electric fan. Direct-drive and clutch-type fans are driven by belts, and bad belts are the most common cause of fans not working. If the fan isn't working, air can't circulate through the radiator to carry heat away, and overheating results.

So, to avert trouble because of a direct-drive or clutch-type fan that suddenly poops out because of a bad belt, inspect the belt for cracks, grease, frayed edges, or any other damage. Also, make certain that the belt is tight.

With the engine off and cold, look for bent and cracked fan blades. Replace the fan if blades are damaged.

If you have a clutch-type fan, turn the fan.

It should rotate freely, but you should feel slight resistance. Also, check the area for a fluid (silicone) leak from the clutch. If the fan is hard to turn or there is a leak, replace the fan.

As for an electric fan, there is no test to determine if the switch and motor are about to fail. However, it is possible to test the heat-sensitive actuating

switch which turns the fan motor on and off. These thermostatic switches are usually bolted into the engine block or cylinder head and their sensing ends are in direct contact with coolant. When the engine coolant reaches a specified temperature, the switch opens or closes a circuit and switches on the fan. A workshop manual will tell you at what temperature this should happen.

You test this switch in the same way you would check a conventional wax-pellet thermostat, but you must also make a circuit using a 12-volt power source and a test light in addition to a thermometer.

Immerse the sensor and the attached wires into a pan of heating water and keep an eye on the thermometer and test light. When the switch reaches its design temperature, the light should go on.

We'll have more tips on the all-important cooling system in Part 2 in our June issue. **PM**



# FRESH AIR BREAKTHROUGH!

AMERICA'S NEWEST AND MOST POWERFUL BIPOLAR IONIZING-PRECIPITATOR CLEANS YOUR AIR OF HARMFUL, IRRITATING POLLUTANTS BETTER THAN ANY OTHER ROOM IONIZER.



**IF YOU WANT CLEAN FRESH AIR OR YOU'VE UNPLUGGED YOUR POPULAR FILTER-FAN UNIT BECAUSE IT DOESN'T WORK THEN READ THIS...**

Is your indoor air fresh, clean and alive? Indoor air pollution is becoming a national health hazard. Energy efficient airtight buildings are stifled with stale polluted air which contains tobacco smoke, smoke and soot from fireplaces, heating systems and cooking appliances, as well as dust, pollen, viruses, and bacteria. Most of these pollutants are so small (under 5 microns) that they are not effectively removed by common small filter-fan units. Scientific tests show that these noisy toy-like devices which emit chemical "citrus" odors are no match for high-powered ionizers in thoroughly cleaning indoor air.

#### ANOTHER IMPORTANT DIFFERENCE

You know how fresh and vibrant the air feels right after a rainstorm, in the mountains, or near a waterfall. That clean, alive fresh air is rich in something important that is greatly depleted in our urban and indoor air. That missing element is negative ions, nature's own air cleaners. Many users experience great benefit from these amazing active ions, including feelings of aliveness, alertness and vitality similar to that experienced in the fresh mountain air. In addition, even hospitals use ionizers in some units.

Filter fan units do not emit negative ions. The COLLECTOR, by Zestron, creates trillions of these beneficial ions every second, while giving you the best performance, value and technology in air cleaning.

#### THE ZESTRON BREAKTHROUGH!

Most ionizers clean your air but leave an untidy deposit of pollutants on room and furniture surfaces near the ionizer. The COLLECTOR by Zestron takes ion technology a giant step forward by giving you super-powered ion output while depositing pollutants from your air on the collector panel. This easy to clean panel features a scientifically formulated surface that electrostatically attracts the vast majority of airborne pollutants to it rather than to the floor or walls near the ionizer. Other bipolar ionizers with porous collecting surfaces that absorb odors and unsightly grime are almost impossible to clean.

#### AMAZING DEMONSTRATION!

Unplug your COLLECTOR, place the ionizer unit and an ash tray on top of the panel. Place a lit cigarette in the ash tray and watch the smoke rise into the air. Now plug it in, and amaze yourself and friends as the smoke barely rises above the ash tray and then nose-dives onto the collector panel before it can enter the room air. This is accomplished entirely electronically with no moving parts! The COLLECTOR by Zestron is the only ionizer on the market that cleans the air powerfully enough to accomplish this test.

#### ADJUSTABLE OUTPUT

Some people prefer fewer ions at night. The COLLECTOR is the only adjustable bipolar ionizer that allows you to set the ion level to your personal preference.

#### THOUSANDS OF SATISFIED USERS

Don't you, your family and friends deserve the healthy clean fresh air that Zestron ionizers have brought to thousands of satisfied users? Users write: "I simply can not believe how much better I feel!" Dr. E.K., DDS—MA; "I smoke heavily and it has cleared the air as advertised" G.P.—WA; "I haven't taken the top off my nasal decongestant spray since using your product. I was previously a chronic user." G.S.—SD.

When you use your COLLECTOR, you'll quickly feel the difference it makes and smell the freshness in your air. You'll actually see the elimination of smoke and dust in your air!

#### SILICON VALLEY TECHNOLOGY

The COLLECTOR, incorporating years of high reliability design experience, is built with quality parts in the heart of Silicon Valley, USA, to give you years of trouble free service.

The COLLECTOR operates anywhere in your home or office for pennies a month and has nothing to wear-out or replace.

#### SUPERPOWER OUTPUT

The COLLECTOR by Zestron is the only bipolar collecting ionizer with superpower output. The thoroughness and speed of air cleaning increases with more ion output, and Zestron ionizers give you the highest output (without detectable ozone). Check the comparison chart below. Note that many of the other ionizers on the market do not come equipped with a COLLECTOR or do not state ion output as measured in the industry standard of ions/cc/sec. at one meter.

| IONIZER                  | ADVERTISED OUTPUT (1 m.) ions/cc/sec. | COLLECTOR |
|--------------------------|---------------------------------------|-----------|
| The COLLECTOR by Zestron | 1,200,000                             | YES       |
| JSA Bubble               | not stated                            | YES       |
| Orbit                    | not stated                            | YES       |
| AirCarell                | 236,000                               | YES       |
| Ion Fountain             | 540,000                               | NO        |
| Ion Cloud                | 350,000                               | NO        |
| Ionosphere               | 350,000                               | NO        |
| Modulian                 | 75,000                                | NO        |
| Ion Breeze               | not stated                            | NO        |

#### FREE ION DETECTOR

A FREE remote ion detector comes with each ZESTRON to verify and compare output. When you place the detector next to a ZESTRON and a competitive unit, you will see greatly reduced or no output from the competitive unit!

#### SATISFACTION GUARANTEED

Order a COLLECTOR now and try it in your home or office risk free for 30 days. If for any reason you are not satisfied, return the unit for a full refund including return postage. The COLLECTOR has a full one year warranty on both parts and labor excluding abuse.

#### ADDITIONAL DEALERSHIPS AVAILABLE

Reorders are pouring in, customers write: "We are enjoying the results of the first one and are ordering two more" Dr. J.B., M.C.—CA; "I'm a distributor for three other ion companies, and have to say I am extremely, extremely impressed." T.N.—CA.

ZESTRON, the leader in ion technology, has created a unique DEALERSHIP PROGRAM. Call or write for details on this RISK FREE OPPORTUNITY.

#### TO ORDER—FREE SHIPPING

Send your check or money order for \$119.95 for one or \$104.95 each for 2 or more (Calif. res. add 6.5% tax) or credit card users may call:

TOLL FREE: (800) 372-1200  
In Calif.: (800) 392-1200  
or (408) 371-1200

ZESTRON, INC. Dept. M4  
667 McGilncey Lane  
Campbell, CA 95008

# THE PM WORKBENCH



## Coal miner's offspring?

When I spotted this little light at the National Hardware Show last year, my first reaction was that it was a gimmick. The maker challenged me to try one and I did. I have since (gratefully) used it on my head when working in a dark cellar to cut holes through flooring and sill for a plumbing installation, when working on a ladder and for other tasks for which a good light that didn't have to be held was welcome. Now my son has glommed it for exploring caves on his backpacking trips to the mountains.

The little Handi-Brite is a dandy light. It sells for \$10.95 postpaid, and you can wear it on your head or simply hold it. The light panel tilts, which is great when you wear it coal-miner style. If you do your own home carpentry, you should add this light to your toolbox. To order, write: Handi-Brite Inc., Box 1735, Haines City, Fla. 33844.—H.W.



Headband that comes with Handi-Brite is removable when you want to store it.



Light panel tilts up or down for job at hand. Housed in plastic, lamp is powered by two standard-size C batteries.

## How to sand a crevice

A line of round abrasive cords and flat tapes sold by E.C. Mitchell Co. Inc., Box 607, Middleton, Mass. 01949, will let you sand smooth otherwise inaccessible spots. The cords come in diameters from .150 to .012 in., tapes in widths



Round abrasive cords quickly smooth areas like the fine grooves in spindles.



Author found flat tape indispensable on tight deburring jobs and when stripping old finishes from furniture.



Tapes and cords are available in a number of different sizes. Free sample cards are available from the manufacturer.

## Eliminate tangled cords

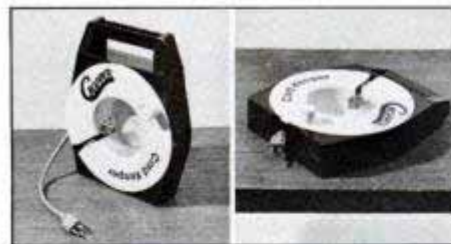

Cord Keeper stores 100 ft. of electric cord, which can be wound in or out with relative ease—an asset in the shop.

Chopper Industries, Box 87, Easton, Pa. 18042—the folks who gave us the Chopper 1 log-splitting ax—have unveiled another good one. It's the Chopper Cord Keeper which can be used to store electrical extension cord, rope, flat hose, chain or anything else that you can logically think of winding into the unit. I now have one in my shop—filled with electrical extension line—and it works like a charm. It is well-constructed and I simply hang it on a dowel when not needed. It's available in many home centers or by mail from the manufacturer for \$12.95 postpaid.—H.W.

## Power to the workshop

Most multioutlet strips require you to clear valuable tool storage space on shop walls for installation. For that reason, I decided to give Snapit's multioutlet power center (Cat. No. 48725-6) a try. I can connect a half-dozen portable power tools to it without worrying about an overload. The unit has a 15-amp. reset breaker built right into the box. About \$24 at home centers, it's from Cable Electric Products, Box 6767, Providence, R.I. 02940.—H.W.



Multioutlet extension cord has 6 ft. of 14/3 wire (grounded), reset breaker (A) and switch (B) that glows if power is on.

from 1/16 to 1/4 in. Cords and tapes are available in aluminum oxide, crocus and silicon carbide. Oil cords are also a stock item. A 75-ft. spool is about \$5. Write the maker for more information and a free sample card.—H.W.

If you've come across a new product with some special features, let us know about it. Write to PM Workbench, Popular Mechanics, 224 West 57th St., New York, N.Y. 10019.

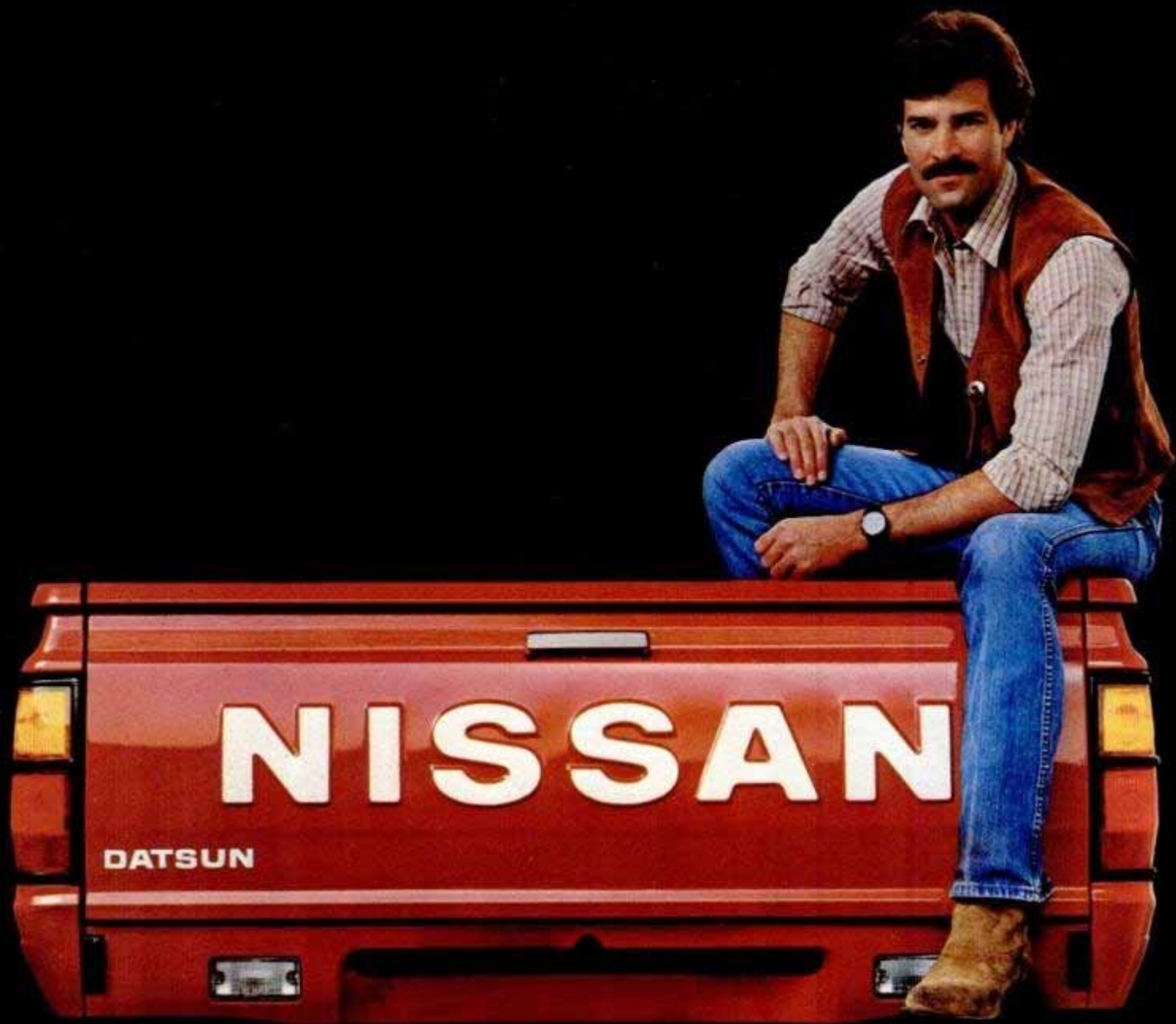

**ONE  
HECK-OF-A-HUNK-  
OF-A TRUCK!**  
NOW AT YOUR DATSUN DEALER.

# NEW NISSAN TRUCKS.

Here they come. A whole new line of trucks wearing a whole new name: Nissan. Check 'em out. You'll find the most powerful standard engine in its class. You'll find new roominess to seat two, three or four.

You'll find double-wall bed construction and brawny 5-speed overdrives. You'll find why more truckers drive Nissan-built compact pickups than any other.

And you'll agree: the newest Nissan is one heck-of-a-hunk-of-a truck.

## ONE HUNK-OF-AN ENGINE.

The most power of any standard engine in its class.



More than Toyota, Chevy S-10, Ford Ranger and everyone else.

- Most horsepower: 103 hp @ 4800 RPM.
- Most torque: 133 ft.-lbs. @ 2800 RPM.
- Exclusive NAPS-Z overhead-cam

engine is so revolutionary, it's protected by more than 250 patents.

- Two sparkplugs per cylinder, crossflow hemihead and unique "fast-burn" design give maximum operating efficiency, minimum pollution.
- Electric fuel pump for reliable operation in extreme heat.

### The most power of any standard 4-cylinder diesel!

Nobody else has a 2.5-liter diesel this brawny.

- Most horsepower: 70 hp @ 4000 RPM.
- Most torque: 114 ft.-lbs. @ 2000 RPM.
- All-new technology for rugged durability and superior performance, built on Nissan's almost two decades of diesel experience gained powering big trucks all over the world.
- Filter removes water from diesel fuel; electronic sensor tells you when to drain.

\*Normally aspirated. Available soon.



(Clockwise from upper right):  
Nissan Long Bed, Nissan Standard, Nissan King Cab 4 X 4, Nissan King Cab 2WD.

Nissan ST Sport Truck



## ONE HUNK-OF-A BODY.

### Double-wall construction

- Double steel walls (except in MPG standard) prevent damage to cargo box's exterior sheet metal from shifting cargo. Not in Toyota.
- Heavy-Duty Long Bed hauls a remarkable 1,990-lb. payload of cargo and passengers. Not Toyota, Chevy S-10, Ford Ranger.
- Bigger payload than many full-size pickups.
- Bigger beds: longer King Cab bed than Chevy S-10; longer and wider Long Bed than Ford Ranger.
- Bigger King Cab payload than Chevy S-10 4 X 4.
- Welded steel ladder-lattice chassis—like the big rigs.
- Tailgate lowers 90°; 180° or removes entirely to carry your load.
- Double rear-wheel Cab & Chassis model: the only compact pickup with factory-installed duals for better stability and handling under load.

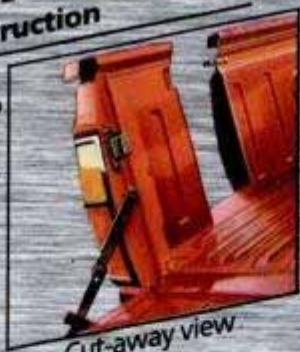

Cut-away view

## ONE HECK-OF-A CAB.

### Seat 3 in a conventional cab, 4 in the King Cab.®

- New cab seats 3 abreast (except 4 X 4 conventional cab and ST) in new comfort.
- More hiproom than Chevy S-10 or Toyota.
- More legroom than Ford Ranger, Chevy S-10 or Toyota.
- More headroom, legroom, seatback rake adjustment than in any Nissan-built standard compact ever.
- The original King Cab: up to nine cubic feet of extra inner space for safe storage and jump seats.
- Flip-out side windows standard in King Cab. Not in Chevy S-10.
- Sliding rear window available. (Standard on Sport and XE models.)



### The Sport Truck that lives up to its name.

- Unique grille and bumper designs for contemporary styling: sleek in 2WD, rugged-looking in 4WD.
- Bucket seats designed like a sports car's with lateral support for extra comfort, control.
- Cloth upholstery on seats and doors; special trim on dash.
- Full instrumentation, laid out for maximum visibility.
- AM/FM multiplex stereo...standard.
- Day/night antiglare mirror on all Deluxe and XE models... and more.



# ONE HECK-OF-A-HUNK-OF-A 4x4.

On-demand 4-wheel drive.

- Shift from 2WD to 4WD High at the flick of a stick—without stopping to lock front hubs. Not in Toyota.
- Highest minimum ground clearance of any compact. Higher than Toyota, Chevy S-10, Ford Ranger.
- New wide-clearance torsion-bar independent front suspension for a smooth, level ride. Unlike any other compact truck before.
- Tightest turning circle for maneuvering in tight spots. Runs rings inside Chevy S-10, Ford Ranger, Toyota.
- Front stabilizer bar; wide rear track for a solid stance.
- Wide radial tires standard: P215/75R X 15.



**Everything you could want in a compact truck.**

- Automatic transmission with lock-up torque converter for extra efficiency.
- Power steering with tilt column for extra thigh room.
- Sun roof standard on ST and optional on XE.
- Step bumper. And lots more available options.

| SPECIFICATIONS-4 WD King Cab |       | EQUIPMENT        |                                       |
|------------------------------|-------|------------------|---------------------------------------|
| Wheelbase (in.)              | 110.8 | Brakes           | power-assist front disc/rear drum     |
| Length (in.)                 | 187.0 | Wheels & tires   | 5. SK 15, GR7B 15                     |
| Width (in.)                  | 66.3  | Front suspension | steel-belted RWL radial independent   |
| Height (in.)                 | 67.1  | Rear suspension  | adjustable torsion bars self-leveling |
| Min. ground clearance (in.)  | 8.7   | Radio            | leaf springs                          |
| Max. GVWR                    | 4550  | Selected options | 2-speaker stereo                      |
| Payload (lbs.)               | 1400  |                  | air conditioning                      |
| Fuel capacity (gal.)         | 15.9  |                  | light bar, winch, grille guard        |
| Bed length (in.)             | 73.4  |                  |                                       |
| Bed width (in.)              | 56.9  |                  |                                       |
| Bed depth (in.)              | 15.6  |                  |                                       |

\*Mfr's. sug. retail price excluding title, tax license and destination charges.  
 \*\*Not avail. in Calif. and high-altitude areas.

Nissan 4WD King Cab



# ONE HECK-OF-A SAVER.

Only \$5,995<sup>†</sup> for the Nissan MPG Standard.<sup>†</sup>  
 Big value, little money.

Economy is a tradition at Nissan, and has been for 50 years. That heritage continues this year with quality, advanced technology and standard equipment like radial tires (most models) for reduced rolling friction.

- Every Nissan truck gives you solid value for your money, with extra features at no extra cost. Prices start at just \$5,995<sup>†</sup>. That's less than Toyota, Ford or Chevy, but look what you get:
- 5-speed overdrive transmission.
  - Power front ventilated-disc brakes.
  - Transistorized ignition for strong starts, low maintenance.
  - Maintenance-free battery.
  - Brake load-sensing valve.
  - Flow-thru ventilation with side-window defoggers; bi-level heater.
- Nissan is one heck-of-a-hunk-of-a truck, now at your Datsun Dealer.

**NISSAN**  
**WE ARE DRIVEN**  
**DATSUN**



# THE PM GARAGE



## Superfast fire extinguisher

Halon gas fire extinguishers work so fast you'll hardly believe your eyes. When two Halon gas compounds act together inside the unit, one reacts as the propellant and one as the extinguisher. The extinguishing agent leaves no residue, so there's no cleanup after use. Because it works so fast, much less extinguishing agent is necessary to put out a given fire. The units are perpetually charged until completely exhausted of Halon gases. The Model 2500 has 15 seconds discharge capacity, but most fires are extinguished in fractions of a second with this unit. ASP makes four models. The 1000 is a tiny car unit. Model 2500 contains 1.2 pounds of Halon. The larger 3000 (2.2 pounds) and 4000 (3 pounds) models are for home use. When you figure the amount of use of a given unit compared



*Halon-filled fire extinguishers don't need to be recharged after each use; they're disposable.*

to a conventional extinguisher (which must be recharged after each use) the ASP units are competitively priced.

Available postpaid from ASP Northeast, RR4, Box 61, South Salem, N.Y. 10590. Prices are \$29.95 (for the 1000), \$49.95 (2500), \$69.96 (3000) or \$89.95 (4000).—J.O.

## Hand cleaner



*Hand cleaner has no ammonia or petroleum distillates and is biodegradable.*

Tarkhelp, a new hand soap, does its job without leaving any smelly residue. The product is a mixture of wood flour and smooth round pumice suspended in a soap base. Tarkhelp also contains pine tar, kelp and lanolin to help condition your hands, and doesn't contain petroleum distillates or ammonia that can give your hands a bad smell. A 6-pound container costs about \$8.50 and the small size is under a buck. Tarkhelp Mfg. Corp. is at Box 605, Kirkland, Wash. 98033.—Joel Breault

## Mower injection

Pull-starting a small four-stroke can leave you panting, but this fuel-injection system fires up first shot. You replace the gas cap with a plunger to which a fuel line is attached. The line connects to a fuel injector you install on the intake manifold. You have to drill a hole and tap it for the nozzle. The tap comes with the kit. When you're ready to start, give the plunger a squirt and pull the cord. It worked great on our portable generator.

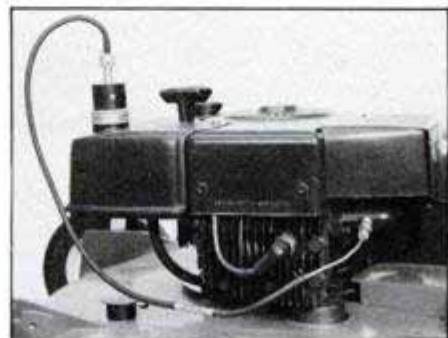

*Fuel-injection system for small four-stroke motors fires them up first try.*

The price is \$19.95 plus \$1.50 for shipping from JLM Products & Design, 6805 Boysenberry Way, Colorado Springs, Colo. 90818—T.A.

## Stick-on antenna

Using a new type of foam tape adhesive, the base of this CB antenna may be mounted directly to the vehicle's rear glass or windshield and it needs no wire hookup. There are no holes to drill or special tools needed. The antenna signal is picked up through the glass by a sensor.

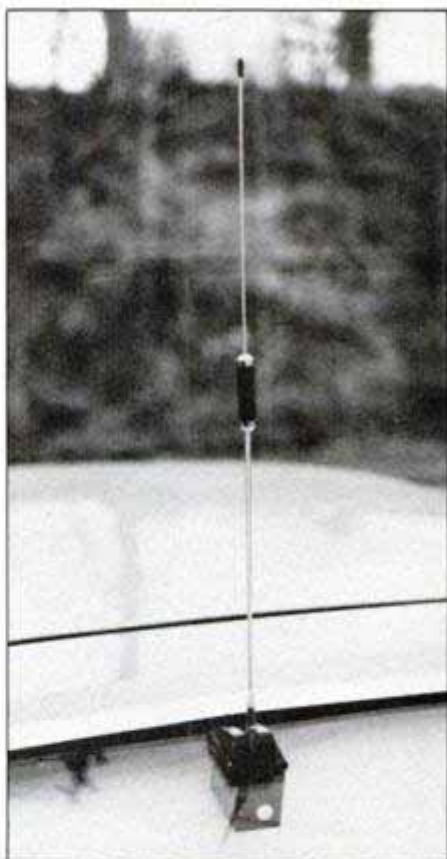

*Adhesive-backed antenna sticks on outside of glass; pickup mounts inside.*

The Avanti may be mounted to any nonconductive surface less than 3/4-inch thick so it can be used on cars, boats or motorhomes.

It's approximately \$40 at CB/Stereo outlets, or, write directly to the Antenna Specialists at 12435 Euclid Ave., Cleveland, Ohio 44106.

—Joel Breault

# HOMEOWNERS' CLINIC



## Antifreeze in hot-water system

*I have a 20-year-old, cast-iron boiler hot-water heating system with copper tubing. Could I use an antifreeze solution when we're away in the winter to prevent the system from freezing?—Name Withheld, New Hartford, N.Y.*

You can add antifreeze (glycol) to the closed hot-water system. However, this is one job that is best left to professionals for the following reasons:

1. The hot-water system must be drained.
2. About 50 percent of the system should be filled with antifreeze.
3. It's difficult to determine the necessary amount of antifreeze to add to the system.

You can purchase glycol at plumbing supply houses. However, you will still have to deal with the domestic water.

If your steeple is metal and you can't sandblast, the old paint must be removed mechanically, prior to applying a good grade of primer. Leonard cautions, "Don't stint on the primer and paint." If your painting contractor isn't certain what precautions to take, consult the manufacturer.

## Mildew and more mildew

*My 6-year-old house with textured siding was painted with Glidden latex stain. It has good drainage and gets very little shade. However, within a very short time mildew started to appear under the eaves and gradually covered the trim and siding. Two years ago we washed the mildew off with a brush and solution of bleach, tri-sodium phosphate and water. Then we rinsed well and sprayed on full-strength bleach. After the bleach dried, we sprayed the house with two coats of Glidden oil-base stain. Within six months the mildew reappeared. It's worse than ever. What do you suggest?—Stephen Ensminger, Auburn, Ala.*

Sure Cote, by Jomaps Inc., Box 88583, Atlanta, Ga. 30356-8583, is a liquid that is applied to any surface to resist mildew for a long period of time. Following the manufacturer's directions, you may even use it on book covers, wallpaper, drapes and ceramic tile. It's used for both interior and exterior applications.

My front door had recurring mildew, just as you've had with your house. After I removed the mildew the second time I used Sure Cote. The door hasn't had mildew since.

Available in pint and gallon sizes, the manufacturer's suggested price is \$12.50 per gallon. Coverage is about 400-450 sq. ft. per gallon depending on the surface. It can be sprayed, brushed or rolled on. The company recommends a reapplication of the clear acrylic coating every year to keep a mildew-free surface. **PM**

## Foam insulation

*My insulation installer recommended urethane foam in my attic. He claims that 1 in. of urethane will equate to an R-30 value. I have heard that plastic foams should be avoided. Also, how can 1 in. of urethane equal an R-30 value, when 6 in. of fiberglass can't get anywhere near that?—Fred Weitzel, Pine Apple, Ala.*

Foam in your attic? Never. Foam was developed for use in walls, or on flat roofs (mainly commercial ones). Seriously consider changing installers, as a check with the Insulation Contractors Assn. of America, Washington, D.C., revealed the following R-values for 1 in. of various foam-type insulations: (Although they are usually sold as a board product, they are sometimes sprayed or poured in place.)

Polystyrene R-5

Polyurethane R-6.2

Polyisocyanurate R-7.2

The above R-values are for average density material.

Do not confuse all "foam" insulations with urea-formaldehyde, which the Consumer Product Safety Commission has deemed harmful to your health. As most foams are flammable, certain precautions should be taken. (See "I Stand Corrected," *Homeowners' Clinic*, page 59, Sept. '82.)

## Peeling paint on church

*The paint on the tower of my church is peeling. Any advice before we start repainting?—Monsignor Brennan, St. Peter's Church, Kingston, N.Y.*

I observed beautiful St. Michael's church and steeple in Charleston, S.C., being repainted. This harbor city is

subject to both heat and high humidity, conditions that are tough on paint jobs. Paint contractor Leonard Fulghum of Ferguson Fulghum Inc. brought out some interesting points:

Ventilation is important for any painted surface, as moisture behind the paint will peel the paint off as the moisture tries to escape (see "Mildew and Peeling Paint," *Homeowners' Clinic*, page 52, Oct. '80; also see our paint story in the Home Ideas Guide, page 115). This will be the case even more so in a steeple, which is exposed to the elements at all times. Tell your contractor to check for adequate ventilation prior to starting the painting.

Leonard prefers an oil-base paint, as its glossy surface helps repel mildew. (X-14 or M-1 paint additives can also help fight mildew.)

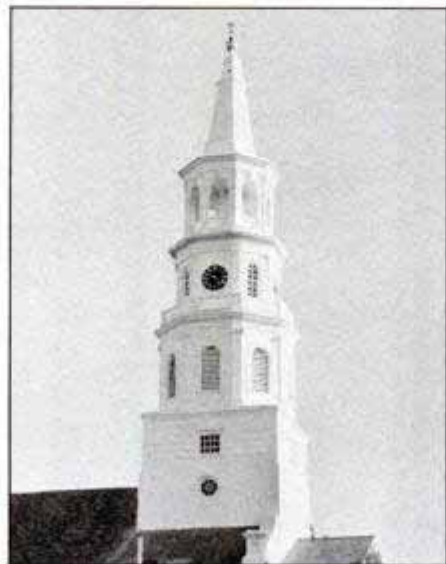

**Adequate ventilation helps the paint on St. Michael's steeple endure the weather.**

*Do you have a home-maintenance or repair problem? Send it to Homeowners' Clinic, Popular Mechanics, 224 West 57th St., New York, N.Y. 10019. Letters cannot be answered individually, but problems of wide interest will be discussed in the column. For more home-repair and maintenance help, get PM's Home Care Guide, \$4.95 postpaid. Send your order(s) to Popular Mechanics, Box 1014, Radio City Station, New York, N.Y. 10101.*



# WIN A POTHOLE FULL OF DOUGH FROM MONROE.

## The Bump Stops Here Sweepstakes.

Whoever thought those annoying, troublesome potholes could bring you \$10,000 in cash?

Well, they can during "The Bump Stops Here" Sweepstakes from Monroe.

It's easy to enter. And easy to win. Just stop at any participating Monroe retailer, fill out the entry form and mail it in.\* That's it. There's no obligation . . . nothing to buy.

You could then win the Grand Prize of \$10,000. Or one of the three second prizes of \$1,000.

And while you're at your Monroe retailer, ask him about his colorful Bump Stops Here T-shirts. They're a fun way to tell the world you've had it with America's roads. And don't forget to

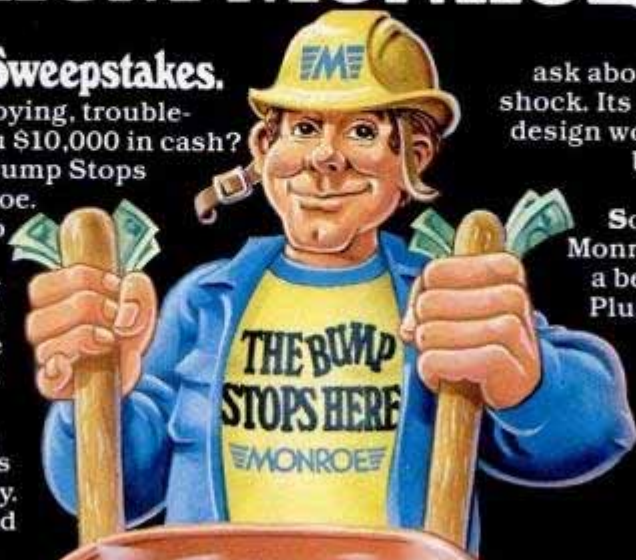

ask about the Monroe Gas-Matic™ shock. Its low-pressure gas charging design works like a cushion against bumps, tarstrips and other small car road hazards.

So stop at your participating Monroe retailer today. You'll get a better ride in your small car. Plus, a chance to win \$10,000.



*Small Car America Rides Monroe.*

\*Or, print your name and address on a plain piece of 3x5 paper. No mechanically reproduced entries accepted. Enter as often as you wish. Each entry must be mailed separately. Mail it to: Monroe "The Bump Stops Here" Sweepstakes, P.O. Box 7, NY, NY 10046. Entries must be postmarked by midnight, 7/31/83, and received by 8/12/83. You must be 16 years or older to enter.

## THE BUMP STOPS HERE.

# MONROE

Monroe Auto Equipment   
Division of Tenneco Automotive

# SCIENCE WORLDWIDE



## Testing parts for breeders

America's slow and deliberate breeder-reactor program enters a major development stage this month with the start of a year-long experiment at Richland, Wash. That's where Westinghouse-Hanford operates the Fast Flux Test Reactor, a standard, fission-type atomic reactor outfitted for experiments leading to the breeder's devel-

lower a 40-foot-long tube into the depths of the cavernous Hanford reactor building with a four-story-high pulley, part of the handling machine. Inside the tube are hundreds of samples of alloys—all candidates for making parts to be used inside the Clinch River, Tenn., breeder-reactor now under construction. The alloys will be

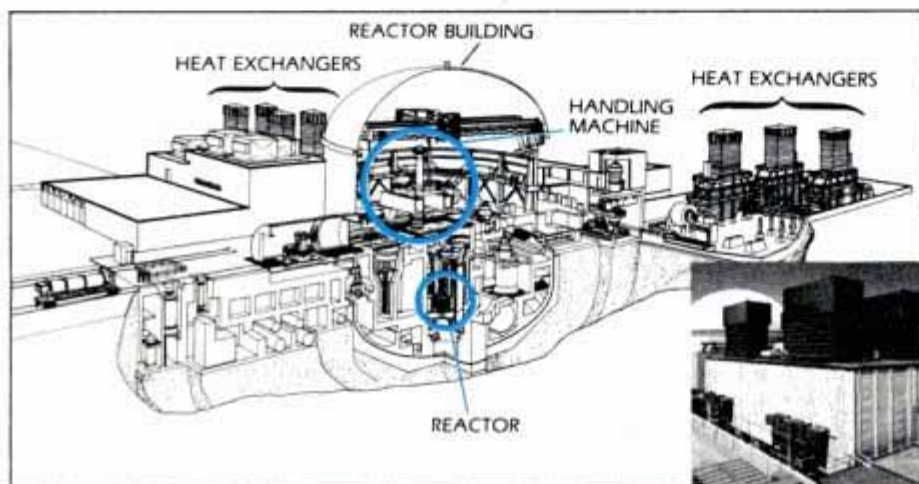

Tests at Hanford will use a huge handling machine to lower potential parts for breeder-reactor construction into the heat and radiation of the facility's reactor.

opment. (A breeder uses radioactive material to produce energy plus additional radioactive material. Thus it produces more fuel than it consumes.)

The tests will begin when engineers

subjected to the reactor's 1,000°F. plus temperatures for weeks on end to see how they take the heat. Seven three-story heat exchangers will maintain livable temperatures in the building.

## Let the chips fall

Microchips have revolutionized the computer industry, turning tiny bits of silicon into memories that drive an amazing array of electronics devices. But is there something better than silicon? Would you believe biochips?

Theoretically, a biochip would use chemicals found in the human body to form a computer chip as complex as a human brain cell. *Physics News*, while noting such chips are only on the drawing boards today, still says a major step was taken by British researchers last year that could lead to biochips. The researchers found that a molecule called Hemiquinone—found in human blood—can oscillate two atoms of hydrogen back and forth between two

segments of the molecule. That action creates binary off-on circuits. The next problem to solve: how to hook thousands of such molecules together to form an intelligent chip.

## Follow that meteor!

Some reported sightings of meteorites have contained gross exaggerations, according to Florida meteor watcher Stephen L. Morgan. He says many such reports note the duration of the fireball in a casual manner. Some, he writes in *Meteor News*, are exaggerated by a factor of two or three. Morgan advises observers to be extremely conservative in estimating meteor duration, which is usually less than 3 seconds.

## Fighting decadent art

Some of Europe's greatest historical and artistic treasures are falling apart with age. But a team of Austrian scientists reports a new technique that may save hundreds of such objects. Treating several ancient maps, manuscripts and paintings with a magnesium-carbonate compound, the scientists say they were able to arrest the decay of paper and cloth containing copper-base pigments. The Austrians say the compound forms a tight chemical bond between the pigments and the surfaces to which they were applied. Two years have gone by, but it will take more time to prove that the effect is lasting.

## Rain, by thunder!

Thunder always comes in rainy weather, but the relationship between rain and thunder may be deeper than we've imagined. Rutgers University Aerospace Dept. head Samuel Temkin believes that thunder claps often cause rain. His research with large amplitude sound waves has included setting up a simulated thunder clap in a lab near tiny droplets of water. For one thing, he says, the sound wave from a thunder clap moves water droplets close together, making rainfall more likely. Temkin also notes that post-lightning shock waves tend to break up water droplets, sending them flying until they collide. The heavier droplets, he says, are what we call rain. Temkin cautions that his theories are based on laboratory work and field experiments will have to be conducted to prove them.

## Send no flowers

Bees that eat something other than pollen have been discovered by a Smithsonian Tropical Research Institute team in eastern Panama. The bees, named *Trigona hypogea* by David W. Roubik and his fellow researchers, eat carrion—the decaying flesh of dead animals.

Meat-eating bees may strike a chilling note for most of us, but Roubik reports the *T. hypogea* has no stinger and searches for dead flesh only. The bees partially digest the meat, then take it back to the hive, regurgitating it to other bees. **PM**

**More horsepower and torque than Chevy S-10!**

Ford's Ranger is already the best-selling 4-cylinder pickup built in America. Now it offers V-6 power and performance, too! Ranger's new 2.8L V-6 is available in 4x2 and 4x4 models.

**More payload than Chevy S-10.** Ranger's 1755-lb. payload option is the largest of any American-built small pickup.

R. L. Polk & Co. CYTD registrations for 4x2 models through October, 1982.

Ford's new Electronic Engine Control, EEC-IV, constantly monitors the Ranger V-6 for most effective performance. It can process a million commands a second!



**Widest choice of engines.** Only Ranger 4x2 offers two 4-cylinder gas engines and a V-6, plus a new diesel that the Chevy S-10 can't match.

**FORD**

FORD DIVISION



# FORD **V-6** RANGER.

## THE MOST POWERFUL V-6 IN ANY SMALL PICKUP!



Get it together—Buckle up.

# AMERICA'S TRUCK

**TOUGH  
FORD  
RANGER**

© 1982 B&W T Co.

Warning: The Surgeon General Has Determined  
That Cigarette Smoking Is Dangerous to Your Health.

Kings, 9 mg. "tar", 0.8 mg. nicotine, 100's, 10 mg. "tar",  
0.9 mg. nicotine av. per cigarette by FTC method.

# KOOL LIGHTS

**There's only one  
way to play it.**

There's only one  
sensation this refreshing.  
Low 'tar' Kool Lights.  
The taste doesn't  
miss a beat.

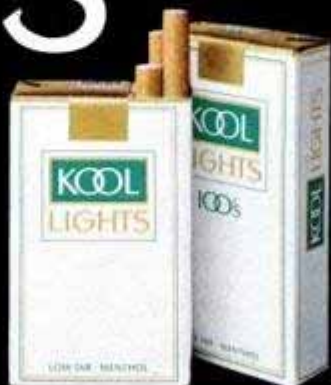

# CAMPING '83

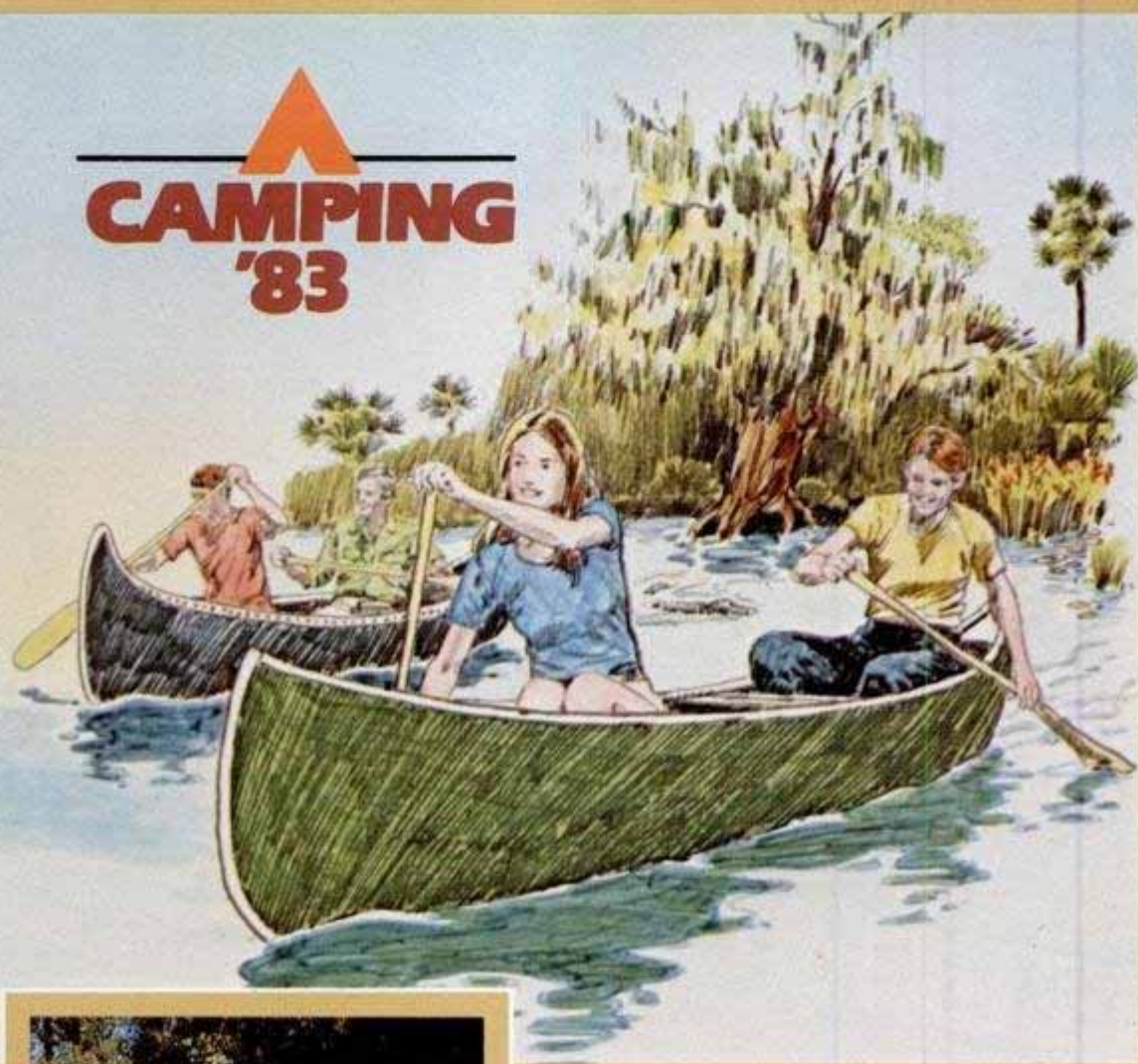

*Pick cruising canoes for day travel and a family-sized tent, like White Stag/Henderson's new Gold Miner, for budget roughing-it.*

**T**oday, the outdoors is still the best of bargains for family vacations. A campground is a great base of action for sightseeing and biking, backpacking and boating, climbing, spelunking, water sports, photography, bird-and-wildlife watching, hunting, fishing, rock-hounding—choose one or all.

Here are new places to go, new tents to pitch when you get there and new gear and supplies to take along—plus where to write for more information on campgrounds and gear.

# WHITE HEAT



**2.6 GT**  
**OUR BOLD, NEW**  
**OUTBOARD**  
**POWER LEADER**

Introducing the world's hottest new production outboard: the 2.6 GT from Johnson. Designed for the bold breed of boating enthusiast who demands uncompromising performance, the 2.6 GT delivers more power than any production model we've ever offered. The awesome performance of this 2.6 litre outboard is the result of advanced technology, tested and refined in the heat of boat racing competition throughout the world.

There's a bit of race driver in all of us. If you're bold enough, the Johnson® 2.6 GT is hot enough.

**Another reason  
Johnson leads the world.**



 **Johnson**

A Product Group of **OMC** Outboard Marine Corporation  
100 Sea-Horse Drive, Waukegan, IL 60085 © Outboard Marine Corporation 1983. All rights reserved.

Моторы Johnson продаются во всех магазинах.

# Family Camping Adventures

# 10

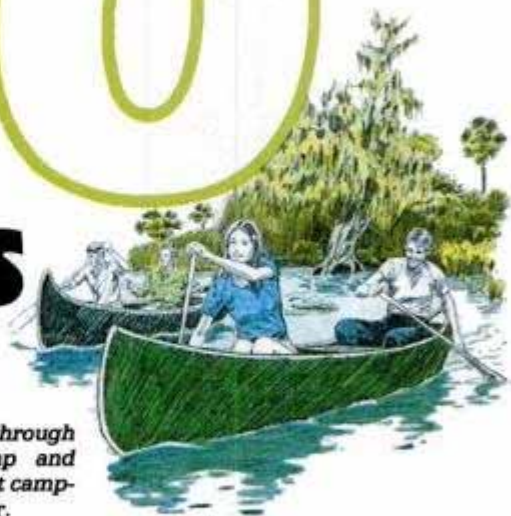

**Canoeing:** Paddling trails through Georgia's Okefenokee Swamp and down many waterways connect camping sites to the Suwanee River.

Only in the great outdoors are there so many sights and activities for a 1983 vacation you won't forget.

BY RICHARD DUNLOP

**T**his year, why not pitch your tent close to where the Vikings erected their long houses at L'Anse-aux-Meadows in Newfoundland? Or set up at Carlsbad Caverns National Park, New Mexico, and hike through the wild New Cave? You can camp and look for diamonds in Crater of Diamonds State Park, Arkansas, or go boat camping in Alaska's Glacier Bay National Park.

Camping combines with all sorts of family vacation possibilities. Go cycling, riding, hiking, backpacking, canoeing and sightseeing on your vacations and still spend your nights in your tent or RV. Here are 10 family camping suggestions.

## North to the Viking past

You can wade into a stream that flows into the sea at L'Anse-aux-Meadows on the far northern tip of Newfoundland, and catch salmon with your bare hands. The Vikings did it there over 900 years ago, as archaeologists learned from the Norse sagas. When archaeologists dug into the mounds of what nearby fishermen had always thought were the remains of an Indian camp, they found the foundations of Viking long houses. Today, L'Anse-aux-

Meadows can be the goal for family camping adventure.

Drive through the Canadian Maritimes to North Sydney on Nova Scotia's Cape Breton Island, from where a sea-going ferry takes motorists across Cabot Strait to Port-aux-Basques in Newfoundland. From there it is only a short drive along Route 1, the TransCanada Highway, to the J.T. Cheesman Provincial Park where a family can set up its tent by the sea. The surf surges ashore, and the wind sighs through the pines.

The road to the Viking past allows campers to stop at such outstanding salmon streams as Flat Bay Brook, and camp at Barachois Pond. Rangers lead youngsters on nature hikes during the summer. Another night's camp might be made at Blue Ponds, where swimmers splash in fresh-water ponds fed by limestone-based springs.

It is at Deer Lake, a logging town that's surrounded by thick

forests, that Highway 430, the Viking Trail, leaves Highway 1 and strikes northwest into Gros Morne National Park. Dramatic fjords off Bonne Bay cut deep into massive mountains, and there are many campgrounds. The Viking Trail leads north along the west coast past striking dolomite arches set in the sea to Port au Choix. At this park, prehistoric Indian burial grounds were excavated in 1968. Dorset Eskimo sites are nearby. Northward along the coast, scores of fishing villages such as Deadman's Cove, St. Barbe and Blue Cove rival one another in beauty and friendliness. Then at the northern tip of Newfoundland there is L'Anse-aux-Meadows where the Norse settled 500 years before Columbus's voyage. Camp at nearby Pistolet Bay, where archaeologists first looked unsuccessfully for the lost Viking settlement, and



**Exploring historic sights:** About 500 years before Columbus, Viking sailors built a camp near the modern campsites now at the northern tip of Newfoundland.

**CAMPING  
'83**

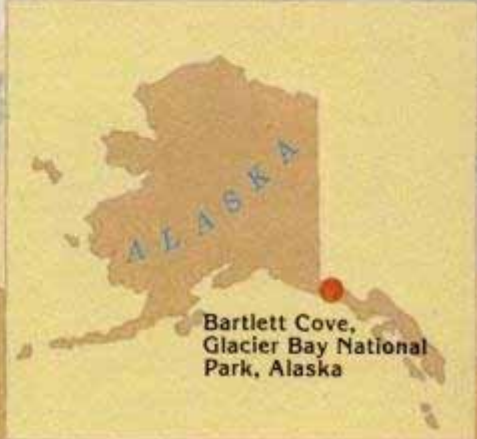
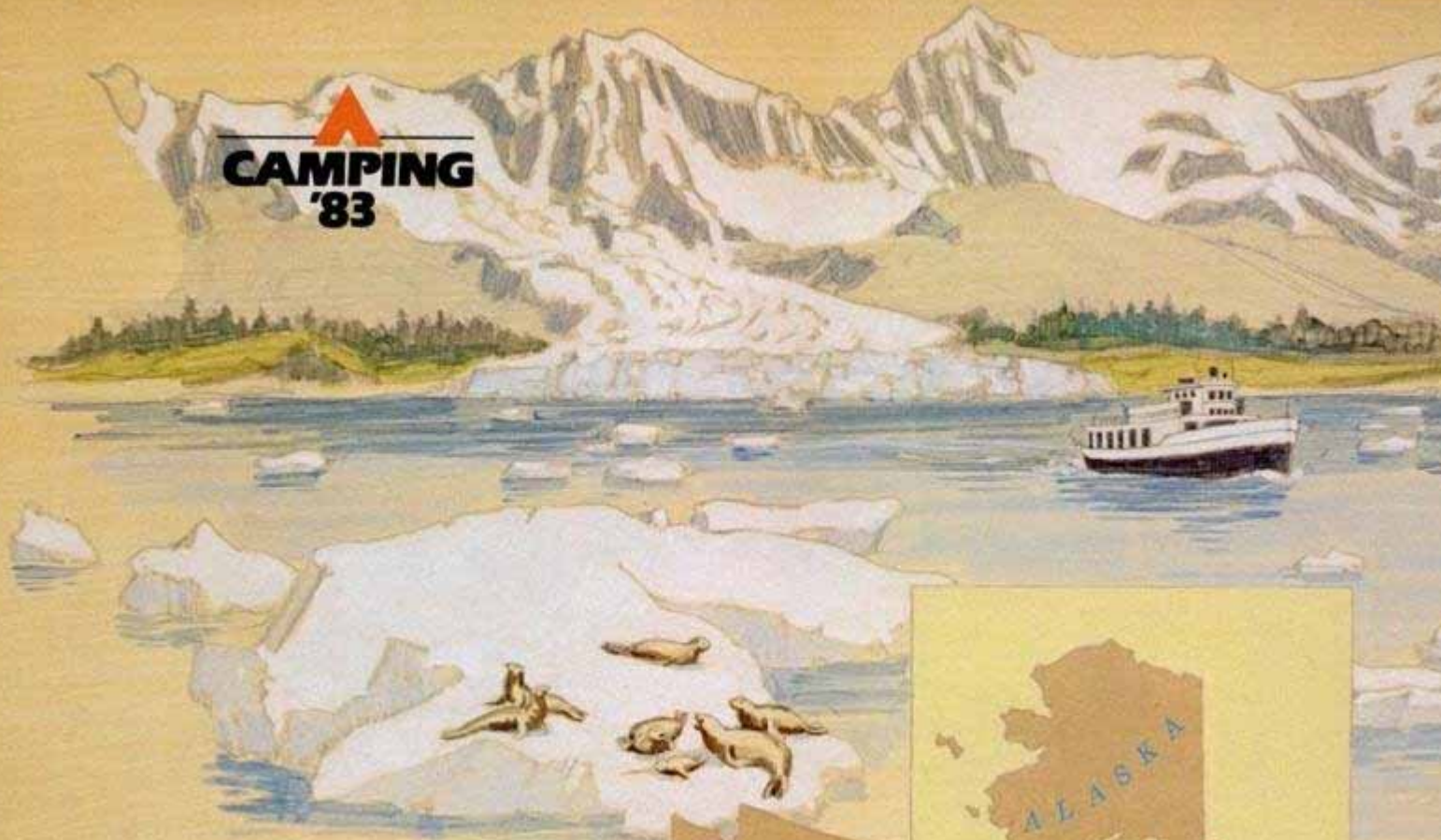

Bartlett Cove,  
Glacier Bay National  
Park, Alaska



**Spelunking:** For under-this-world adventure, try exploring caves like Carlsbad. Many caves and grottos are found near campgrounds across the country.

drive over the dirt roads to L'Anse. Canada has erected replicas of Viking structures close to the original sites; for a family gazing out to sea from a Norse dwelling it almost seems as if the long boats of the Northmen might again be seen.

**Spelunking at Carlsbad**

Rangers at Carlsbad Caverns National Park in New Mexico are tricky.

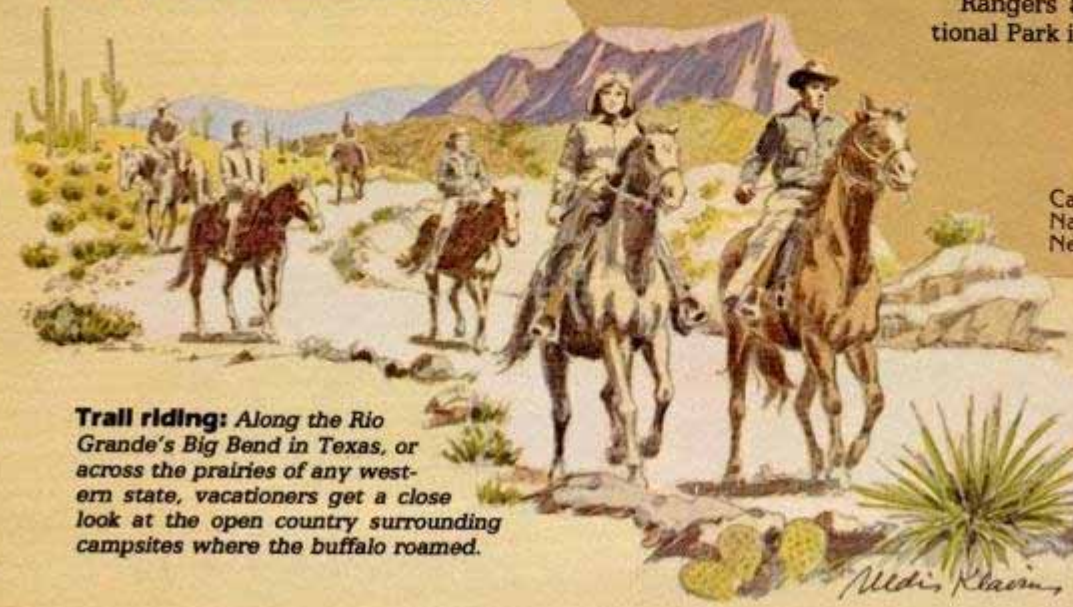

**Trail riding:** Along the Rio Grande's Big Bend in Texas, or across the prairies of any western state, vacationers get a close look at the open country surrounding campsites where the buffalo roamed.

Carlsbad Caverns  
National Park,  
New Mexico

Big Bend National  
Park, Texas



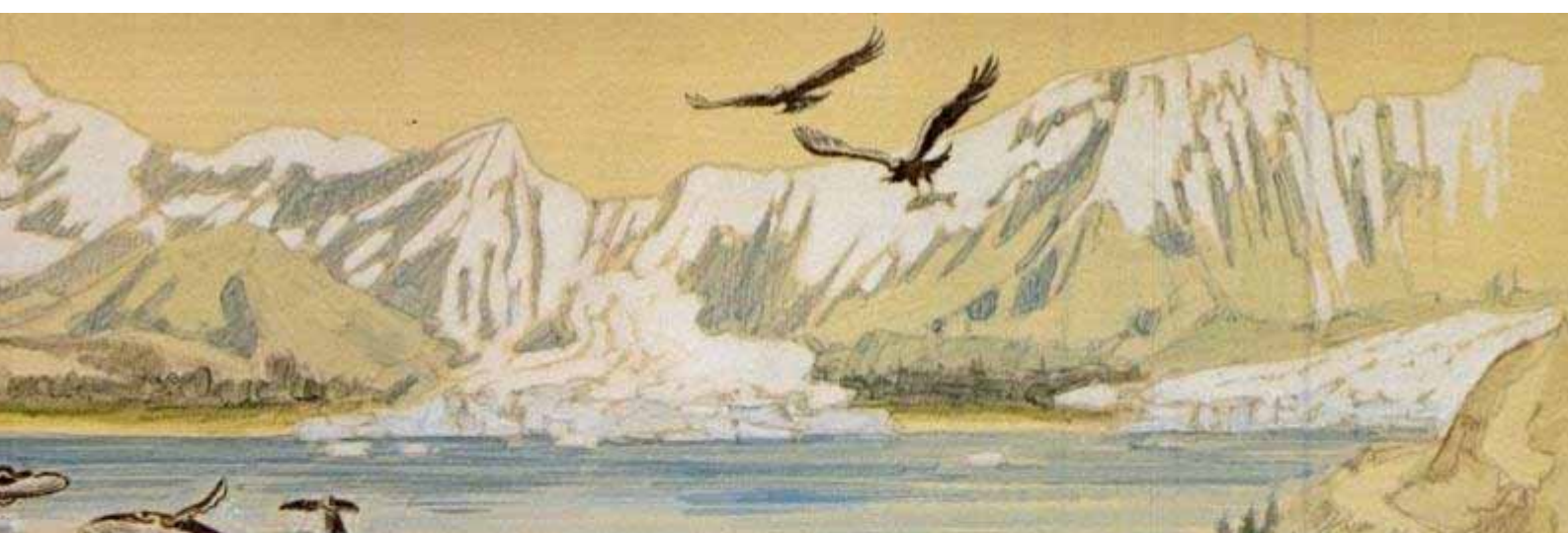

**Nature cruises:** At Bartlett Cove, far-north vacationers can glide through ice floes to see wildlife that seems to be almost untouched by time and encroaching civilization.

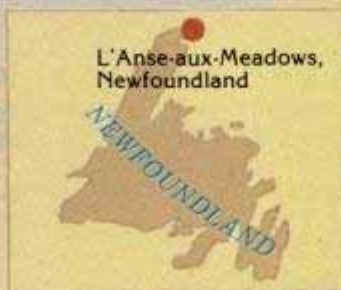

L'Anse-aux-Meadows,  
Newfoundland

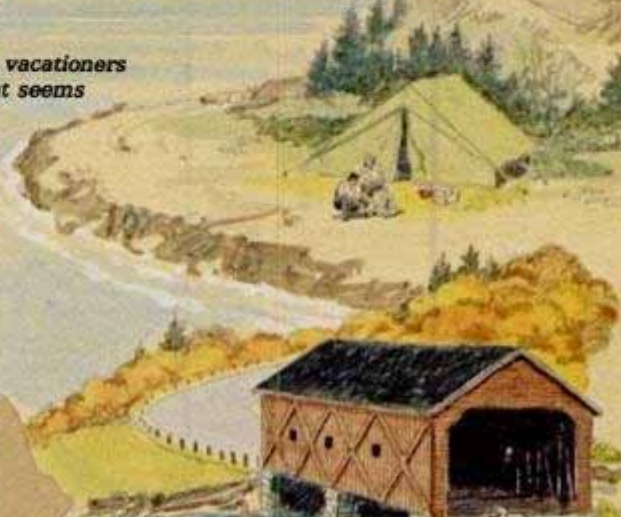

Porcupine Mountains  
State Wilderness  
Park, Michigan

They tell spelunkers who want to explore the wild New Cave to meet them at the cave entrance. This means that family hikers must first climb for a mile up a steep trail that switchbacks up Slaughter Canyon.

"We know if a hiker can get up to the entrance of the cave, he can make it through the cave itself," says Ranger John McLaughlin.

Hikers zigzag down a slippery



**By bike:** Take back roads from Guilford, Vt., and wind through New England's aging reminders of early colonial architecture.

Guilford,  
Vermont

Assateague  
National Seashore,  
Maryland



**Shoreline sights:** Wild ponies of the Eastern Shore descended from survivors of shipwrecks.

Crater of  
Diamonds  
State Park,  
Arkansas

New Iberia  
Louisiana

Okefenokee  
Swamp, Georgia



**Gem collecting:** Jewels reward amateur prospectors at Crater of Diamonds and other back-country campsites.

**Old-home tours:** Plantations survive in Louisiana bayou country.



slope at the entrance to the cave. They pass a pool that looks 3 feet deep in a flashlight's gleam but actually is over 30 feet deep. They slide down slopes of guano using a technique that would do credit to a crosscountry skier. They penetrate the domain of cave crickets and the spiders that dine on them. Narrow passages emerge into gigantic rooms. Reed torches on the floor were thrown down by cave-exploring Indians generations ago. As a climax, the rangers leave the hikers alone in the gloom to know what it really is like to be in the dark. After the spelunking, a family can camp in Carlsbad National Park.

### Crater of Diamonds

Diamonds are a rockhound's best friend, as any camper in Crater of Diamonds State Park, Arkansas, will say. A Dallas woman scrounged about in the clay until she found what turned out to be a diamond worth \$75,000. The largest stone yet discovered in the 78-acre diamond-bearing volcanic pipe is the Uncle Sam, which weighed 40.23 carats. Kids usually find more diamonds than grown-ups. An electrician from Pine Bluff, Ark., and his family had no luck until his toddler daughter popped a stone in her mouth. Afraid that she might choke, he pried it out of her jaws. It turned out to be a diamond worth \$5,000. Sites with modern facilities are on the campground loop.

### Boat camping in Glacier Bay

Sail from Bartlett Cove in Glacier Bay National Park, Alaska, aboard the *Glacier Bay Explorer*. The captain will put a camping family ashore with its gear at one of several wilderness areas and pick them up when desired. Other campers kayak to their sites. Every year 3,500 back-country campers try out the shores of the bay where killer whales sport and blow, and harbor seals rest on icebergs.

**Backpacking:** Through the Porcupine Mountains in Michigan and hundreds of other areas, family packers can get almost uncomfortably close to nature.



### Backpacking in the Porkies

The Porcupine Mountains State Wilderness Park in Michigan's Upper Peninsula gives family backpackers a challenging escarpment to mount, also as streams and limpid lakes on whose shores tents can be set up. The fishing is excellent, and rock formations intriguing to study. Backpackers must take precautions against bears. At night it is necessary to hang provisions from tree branches.

### Wild ponies of Assateague

No one—young or old—who visits the Assateague National Seashore in Maryland will ever forget his first sight of the wild ponies, their shaggy manes flying as they run free beside the sea. It is said their ancestors swam ashore from a foundering Spanish galleon. Campers on Maryland's Eastern Shore also visit such spots as Winter Place Farm near Salisbury, where thoroughbred jumpers and hunters are trained for the Olympics, and the Blackwater National Wildlife Refuge, the most important resting and feeding area for migrant and wintering waterfowl on the Atlantic Flyway.

### Cajun lagniappe

Family campers in the Cajun country of Louisiana find the Creole word "lagniappe" applies. It means a little bit extra thrown in for good measure, and could apply to such fascinating places as Lauren Valley Plantation on Bayou Lafourche near Thibodaux, the largest collection of old outbuildings in the state. The weatherbeaten houses gather around the ruins of a sugar mill where their inhabitants worked until a hurricane blasted it in 1965. Lagniappe also includes Avery Island and its gardens, and St. Martinville, site of the oak where Evangeline, Longfellow's Acadian heroine, stepped ashore. Best is Shadows on the Teche, one of the

South's most beautiful mansions, at New Iberia. Private campgrounds are at Lafayette and New Iberia.

### Okefenokee canoe trails

Paddlers enter Georgia's Okefenokee Swamp from the Folkston side, either at Kingfisher Landing, Duck Island or the Suwanee Canal. As one outfitter says, "There is no fast water and very little dry land. Your paddle will be used every inch of the way." This doesn't keep family canoe campers from threading this mysterious swamp to see alligators and other wildlife. At night they pitch tents on platforms over the wet ground. Some even obtain guides, cross to the far Florida side, and descend the Suwanee River.

### Biking in Vermont

Close by the Massachusetts line, the Vermont Hostel Tour begins at Guilford, and winds its way over rugged hills and dales for 200 miles to Richford near the Canadian border. Bike campers stay in hostels or campgrounds. Details about the route may be obtained from the American Youth Hostels.

### Trail riding the Big Bend

Western historian Walter Prescott Webb said "Big Bend fever is being homesick for a place you can never call home." Big Bend National Park, Texas, is much too rugged to make a home for most families, but is a spectacular place for riding and camping. Of a dozen trails, the one to Window is most popular. It winds down into a canyon between high cliffs where often a red hawk wheels overhead. A waterfall dashes out of a cleft in the mountain and tumbles hundreds of feet to the valley floor. Sitting around a campfire in the Chisos Mountains is camping at its best. **FM**



## In a tough town like El Paso, we beat the big gun.

It was a classic duel out of the Old West. Except the gun-fighters were out of the Far East. There was Toyota. The big company with the big name. And there was Isuzu. The young company with the unusual name.

The setting, El Paso, Texas. A town with temperatures that would make a sun dial ask for salt tablets.

A town of over 500,000 people—and not one of them afraid to get dirt under their fingernails. In short, a town that doesn't cotton to city slickers.

It's not surprising then, to learn that in a town that still retains so much of the frontier spirit, a tough truck like Isuzu has managed to outsell Toyota\*\* in only a very short period of time.

And the reasons are simple. The Isuzu long-bed's diesel's range of 840 miles\* is the greatest

range of any truck in its category. And when you're riding the range of El Paso, this becomes very important.

What's more, Isuzu delivers the greatest mileage of any imported pick up in America—with an incredible 49 MPG highway—and an estimated [38] MPG in the city. And that's better than Toyota or Datsun.

Of course, while all of this should make you think the Isuzu is one tough truck, you should also know Isuzus do have a soft spot. The inside. Once you step inside the cab, you'll have more leg and head room than a mini-pick up is supposed to have. With a choice of three across seating or bucket seats.

What it all comes down to, is after 67 years of proving how tough we are all over the world, Isuzu has just added a new chapter of how the West was won.



Tougher than the world's toughest roads.  
Isuzu. Driving into your future.

\*ISUZU DIESEL 4-SPEED TRUCK. 38-EST. MPG, 49-EST. MPG HIGHWAY. USE ESTIMATED MPG FIGURES FOR COMPARISON. ACTUAL HIGHWAY MPG MAY BE LESS THAN ESTIMATED. YOUR OWN MILEAGE MAY VARY DUE TO SPEED, WEATHER, TRIP LENGTH AND ROAD CONDITIONS. CALIFORNIA DIESEL MPG WILL BE LESS.  
\*\*SALES FIGURES BASED ON R.L. POLK NEW VEHICLE REGISTRATIONS FOR THE PERIOD JANUARY 1982 THROUGH AUGUST 1982.

**CAMPING**  
**'83**

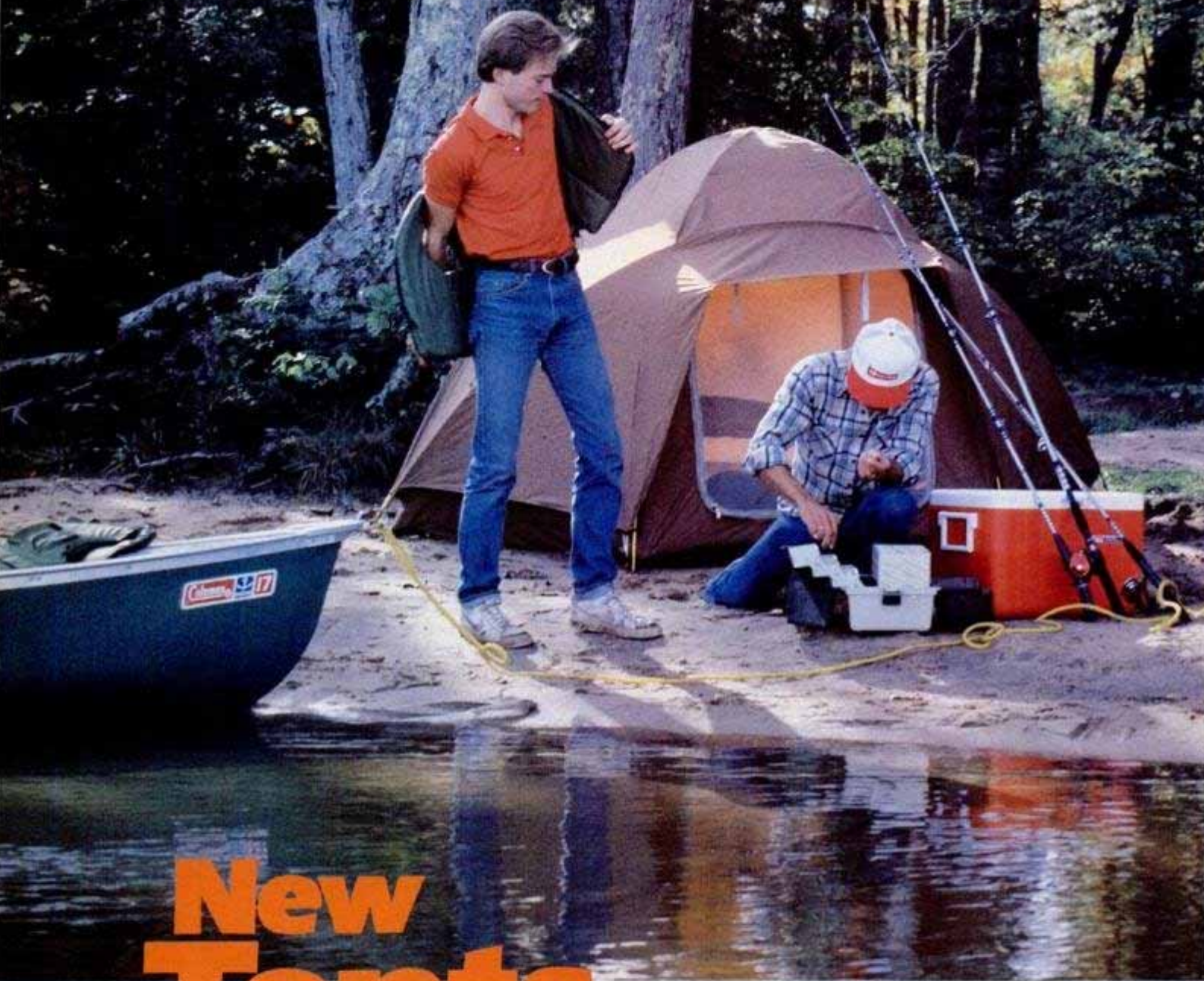

# New Tents For Better Shelters

They're lighter, stronger, easier to pitch,  
and some are engineered to stand on their own.

*Peak 1 A-Line, with wet-weather fly,  
uses shock cord to make framing easy.*



Coleman's new Peak 1-Omega (left) is two tents in one. With outer shell (fly) installed, as shown here, tent is warm and rainproof. With fly removed, breezes can blow through porous inner tent for summer cooling. Wenzel's Sunsetter screen house (below) is suitable for back-yard or back-country family activities.



The simple A-frame is still popular this spring, but many new tents look as if they were designed by a spider or intended as the dwelling of a caterpillar or a chambered nautilus.

"I'm always finding designs in nature which I have used in my tents," observes Charles William Moss, who has become the most important guru of tentmakers since Omar fashioned fabled fabric shelters in ancient Baghdad.

In 1955, Moss created the first umbrella tent, which soon replaced the pup tent. Its metal framework outside the fabric led to the current crop of membrane tents in which aluminum rods are inserted in the material. Moss, who was trained as an artist at the University of Michigan, designs tents with a painter's eye for form, but when his tents were subjected to computer analysis at the Massachusetts Institute of Technology, they were proven to be as aerodynamic as those created by engineers. His tents are also tough. In 1978 Moss set up an entire tent city in the deserts of Saudi Arabia to test his designs, and they were all blown away by the angry winds. This sent him back to the drawing board to create a group of tents that will stand up to Arabian winds and the frigid blasts outside his headquarters in Camden, Me., as well.

Moss's Optimum 200 and other big tents are constructed of cotton duck, but his backpacking tents employ nylon taffeta uppers and nylon Ripstop floors. They are supported by ribs of aircraft alloy aluminum tubing connected to the fabric by elastic cords. These tents are organic shaped, which is to say they are hyperbolic paraboloids, and the wind has a difficult time getting a firm hold on them.

The new tents manufacturers are showing this spring are as rugged as they are lightweight. They are easy to set up and take down, and they are well

PM photo: Ben Magro

ventilated. They favor the geodesic dome because it provides the most volume with the least surface area, and its supple framework bends with the wind. Campers who prefer the A-frame will still find it available among new tents, for few can deny it sheds the rain best even if it takes a buffeting by the wind. Tunnel-shaped tents, in reality a variant of the A-frame, are competing successfully with the geodesic models.

Among top tent manufacturers to offer an A-frame this spring is Johnson Camping. Speaking about the Eureka line, Johnson's Linda Snupik says, "The Alpine Meadows was developed as an extension of our classic A-frame design. While the front and rear maintain the A-shape, we add-



The Flagship (above) from Moss Tent Works in Camden, Me., is free-standing, roomy, sleeps four. Curvilinear cabin tent by Wenzel (left) has a 6-foot, 4-inch headroom and can sleep up to five campers.



ed a center hoop which has increased shoulder and headroom and provides greater stability."

The importance of effective tent poles has never been more fully appreciated. James Thomsen, president of Wilderness Experience, one of the most highly regarded West Coast tentmakers, confesses that his company has found it necessary to strengthen the poles of its Sanctuary Tent, even at the cost of adding weight.

"Testing told us to be leery of fiberglass poles, so we switched to heavier yet stronger solid poles," he says. "When we made the ferrules sturdier, the total weight gained." On the other hand, Sierra West's Roger McDevitt says this spring's poles in all six of their tents will be of extruded aluminum or fiberglass, both being very light.

Fabric is the other major topic for



Small tent with big headroom, the Moss Landmark can add waterproof-fly cover.



A geodesic dome that is free-standing with a fiberglass frame, the White Stag Star Dome from Henderson weighs nine pounds.



The Stargazer can sleep two and withstand strong winds. This new White Stag model is for mountains.

**CAMPING**  
**'83**

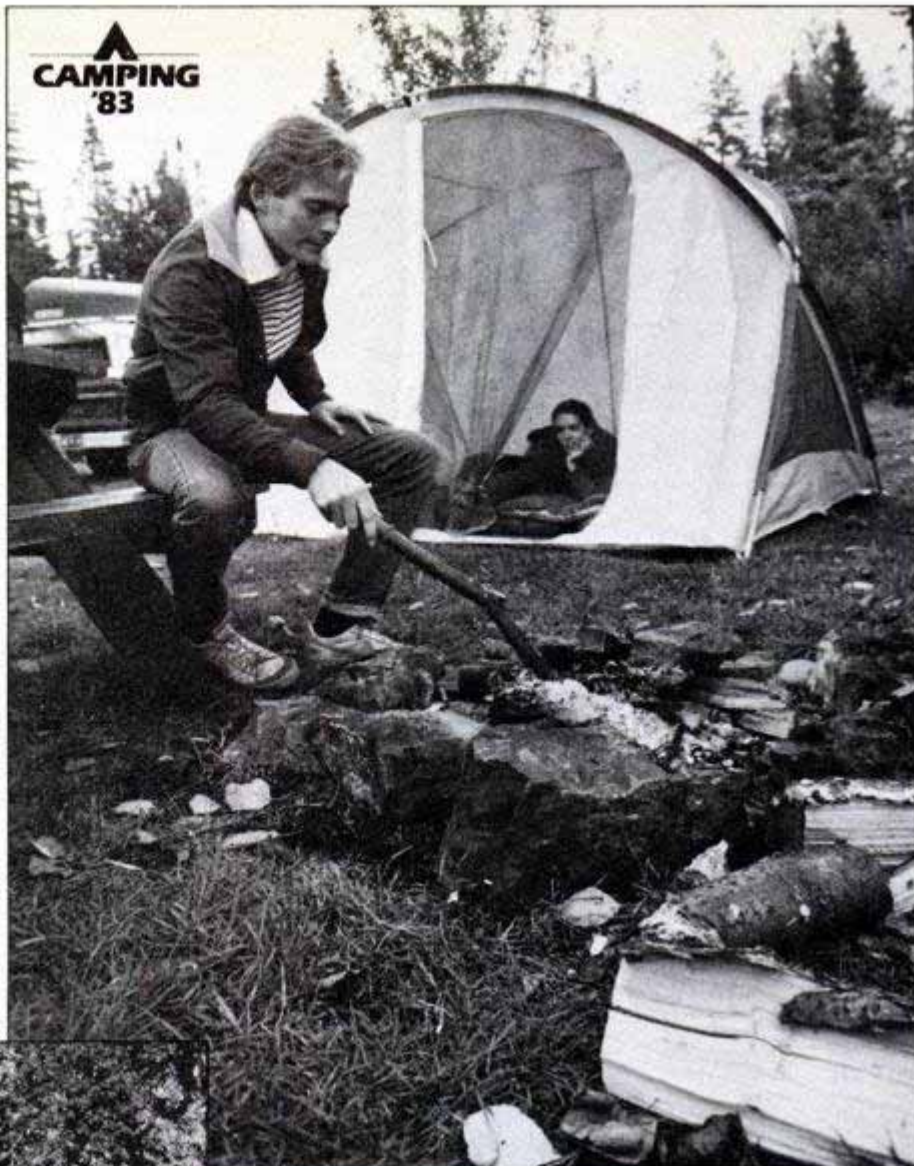

Made of Kimberly-Clark's Evolution 3 material, the new 8 x 10 Odyssey from Coleman has two triangular side windows, a D-style door, is free-standing using shockcorded aluminum poles.



Moss's Starlet at only 4½ pounds is free-standing two-sleeper compact with open net top for easy breezes.

tenters to think about this year. Developed at Kimberly-Clark's Neenah, Wis., research facilities as long ago as 1976, Evolution fabric was first introduced in 1981. Jim Mechlin of Kimberly-Clark's Research and Development Center, now at Rosewell, Ga., says, "In 1981, four manufacturers offered eight styles of tents. In 1983, six manufacturers offer 14 styles." Mechlin points out that the body respire eight pints of water in a day. "Five to six people in a tent give off a lot of moisture," he says. "Evolution fabric's high vapor-transmission rate keeps the interior fresher."

Evolution 3, a three-layer laminate of  
*(Please turn to page 68)*

Warning: The Surgeon General Has Determined That Cigarette Smoking Is Dangerous to Your Health.

SOFT PACK 100's FILTER, MENTHOL: 2 mg. "tar", 0.2 mg. nicotine av. per cigarette by FTC method.

© 1983 R.J. REYNOLDS TOBACCO CO.

Competitive tar levels reflect either the Dec. '81 FTC Report or current advertising. NOW. THE LOWEST OF ALL BRANDS.

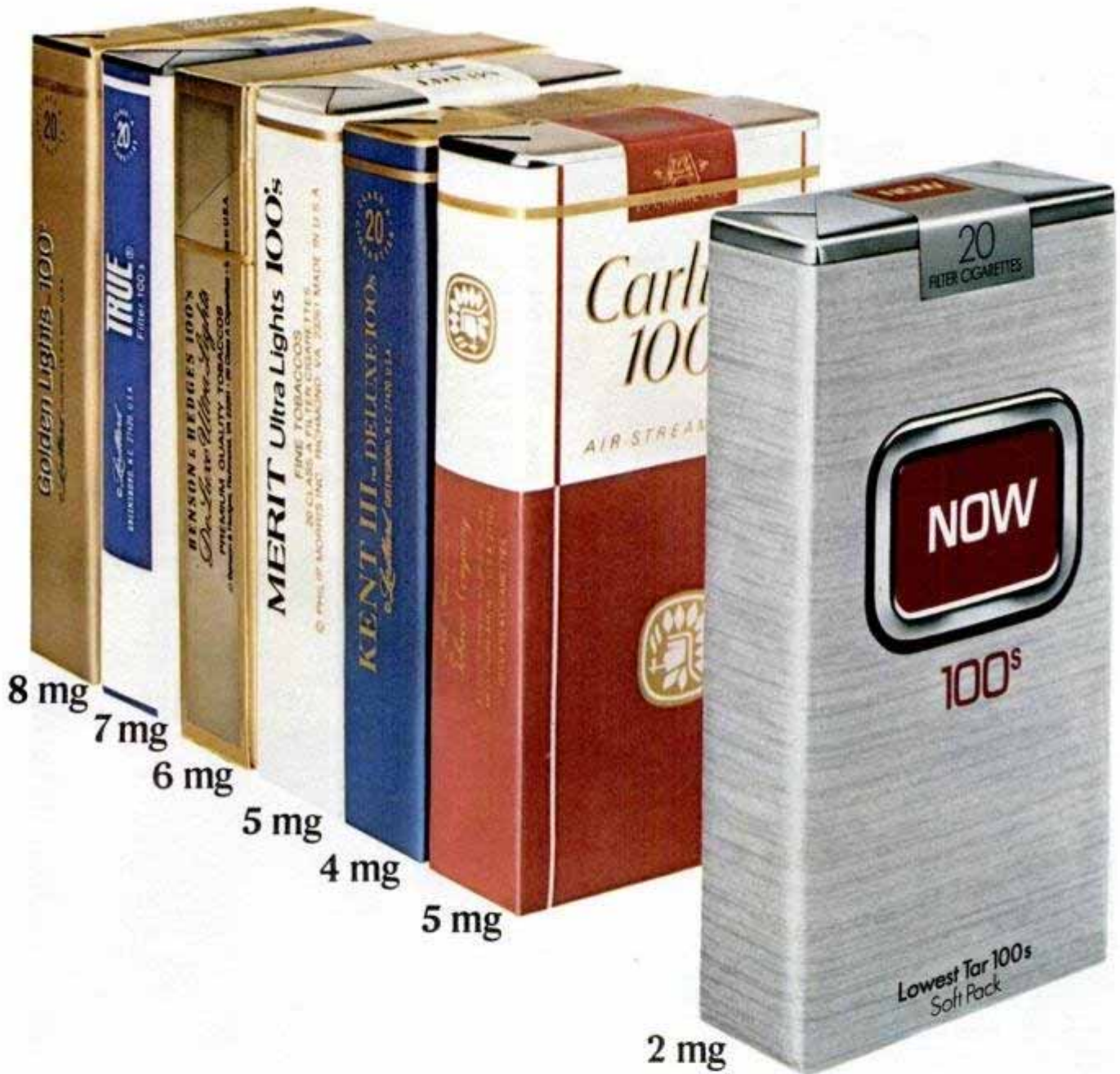

**We promise you less.**

**NOW**

**THE LOWEST**

CONFIRMED BY THE LATEST U.S. GOV'T. REPORT ON TAR

# This summer is by Coleman.

You remember Coleman: the name that meant camping to you as a kid. Now meet *today's* Coleman, with outdoor equipment varied enough to stock the summer for your entire family.



Camp close to the fun with tents like this freestanding Coleman® Odyssey™. It's made of Evolution 3®, a light-weight fabric that "breathes" for comfort and resists rot and mildew.

6' high

10' wide

8' deep



You'll rest easy when your sleeping bags are from Coleman.

We make more than 20 styles to choose from, each 100% machine washable, colorfast and pre-shrunk.



Here's an old reliable. The Coleman® Stove, liquid-fueled or propane, adjusts from simmer to sizzle in seconds. Or for variety try a Coleman® Smoker-Grill (right), available in gas or charcoal.



For a big, bright, full circle of light, you can't do better than the legendary Coleman® Lanterns, liquid-fueled and propane.



Announcing another way to enjoy the water, Coleman style: SunCutter™ water skis. They're

loaded with features to make learning quick for beginners, but measure up for experienced skiers, too.



# brought to you

Power-stroking "T" paddles

Wide, flat hull for stability

Comfortable contoured seats

Buoyant foam-filled bow and stern



Take a run at a river or lake in a Coleman® Canoe, the world's most popular. It's versatile enough for fishing, floating or white water. And get into the new Coleman® Life Jackets,

designed for confidence and comfort, plus the right touch of style.



Use a Coleman® Smoker-Grill to moist-smoke, dry-smoke, steam, roast, bake or grill.

Every family needs a couple of Coleman® coolers, so a good place to start is with the chest-type Poly-Lite® coolers (all plastic) and Snow-Lite® coolers (steel-belted). You'll also like the personal-sized Oscar® family, with big, wide handles and lids that double as food and drink trays.



Take your own air anywhere with a Coleman® Inflate-All®. It plugs into your car lighter to let you pump up tires, air mattresses, balls, toys – just about anything that takes air.



If you lean more to power than paddling, get your family into a Coleman® Scanoë®. It carries three adults, or two adults and two children. And its broad, square stern handles up to a 5 hp motor.



**We outfit your outdoors.**

© 1983 The Coleman Company, Inc.



Look for rebate offers on many fine Coleman products. Details and coupons available at participating dealers. Offer good Feb. 15 through July 5, 1983.



**You can lose your wallet,  
But you can't lose your  
Uncle Henry.**

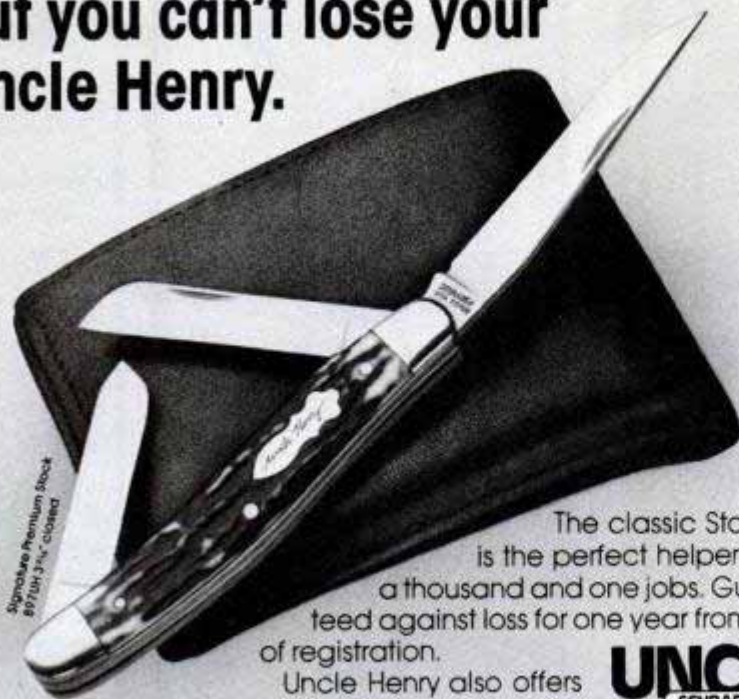

The classic Stockman is the perfect helper for a thousand and one jobs. Guaranteed against loss for one year from date of registration.

Uncle Henry also offers a selection of pocket knives with one and two blades.

**UNCLE  
SCHRADE  
HENRY**

Write for your free Schrade Almanac to Schrade Cutlery Corp., Ellenville, N.Y. 12428-0590.

**CAMPING  
'83**

spin-bonded polypropylene, provides superior dimensional stability, thus enabling tentmakers to have greater design freedom. It is highly water repellent, mildew- and rot-proof, acid and stain resistant, and has no odor. The Coleman Co., which in 1981 pioneered the use of Evolution 3 in its Genesis tent, will use it in three family tents.

Other tent innovations include Eureka's roof of no-see-um fabric for its Wisp I and II tents. They also have breathable panels of uncoated Ripstop between floor and roof. Window and door hoods in front and rear allow these air passages to remain partially open in a rainstorm. Black Ice's Meridian tents also provide for air circulation in a rain. Two tunnel vents



New from Eureka Tents, Wisp II is a 4½-pound lightweight Ripstop sleeping two.

## Free Deluxe Canopy with a new Coleman® Camping Trailer



A retail value of up to \$129.95, this free, self-storing vinyl canopy makes your new Coleman® trailer an even greater value.

- Sets up quickly and easily.
- Adds up to 70 sq. ft. of living area.
- Protects you from the sun and rain.
- Provides a fully protected living area when combined with Coleman's screened-room option.

See this attractive, matching canopy along with all the new '83 Camping Trailers at your local Coleman Dealer today. (He's in the yellow pages.)

Offer starts April 1, 1983; only at participating dealers while promotional supplies last. Applies to all new Coleman models except Jamestown™, Jamestown™ Ltd. and Columbia™.



**A BRIGHT REPUTATION FOR QUALITY  
FOR OVER 82 YEARS.**



Send for your  
**free 1983 Coleman  
Camping Trailer Brochure today.**

Mail to Dept. PM, The Coleman  
Company, Inc., Camping Trailer  
Division, Somerset, PA 15501

Name \_\_\_\_\_  
Address \_\_\_\_\_  
City \_\_\_\_\_ State \_\_\_\_\_ Zip \_\_\_\_\_  
Phone \_\_\_\_\_

©Copyright 1983 The Coleman Company, Inc.



The Olympic, another of the distinctive Moss designs, has handy front vestibule.

are built into the upper canopy, and there is a snow tunnel in the rear. Diamond Brand's Super Spirit 3, a free-standing A-frame, also has a large front door and a standard-size back door which, because of its double vestibule, provides excellent ventilation.

Other new features to look for are lap-folded seams, well-finished fabric edges, and threaded stitch lines for extra strength. Guy lines with automatic tension adjusters provide extra security in a windstorm. There are also inside storage pockets for small objects and laundry-drying loops.

All told, the tents being offered this spring are more versatile, lightweight, easy to erect and better ventilated than ever before. Thanks to designers like Bill Moss, they are also more pleasing to the eye.

**PM**

## GOES WHERE A THREE-WHEELER CAN'T!

Models Base Kit  
Priced from

**\$629<sup>95</sup>**



American Made  
by YOU!

There's places those fat, foreign ATV's don't dare go. Places you want to reach. Like along loose-gravel mountain paths. Across sand dunes and streams. Between, not around trees. Or up sharp gullies. And sharp turns in rocky country are near impossible with three wheels. That's when you need a two-wheeler, the Super Bronc from Carl Heald.

Super Bronc II features a gutsy American made 318 cc or more powerful 357 cc 4-cycle cast iron sleeve Tecumseh engine Heavy-duty torque converter drive, front and rear shocks, low-pressure wide tires and no-fade disc brakes are standard. Many options and accessories available.

You save hundreds of dollars on Super Bronc's kit price, too, because you build it. Semi-kit bolts together in 8-10 hours with common tools. No mechanic's know-how needed. Complete instructions. Get details in our full color catalog.

Call TOLL FREE 1-800-253-1030  
(except Michigan 1-616-849-3400), or write:

**Carl Heald, Inc., Dept. NIM, P.O.**  
Box 1148, Benton Harbor, MI 49022-1148

Send for FREE color brochure.



- Our Sea Eagle 9
- 11' x 4' 8" inflated
- holds 5 adults
- weighs 43 lbs.
- 6 hp capacity

## Quality Inflatable Boats from \$110 to \$560!

Fishing platform, motor runabout, river raft, camp boat, yacht tender and now a true sailboat.

Sea Eagles last for years, go almost anywhere and cost \$110 to \$560.

Lakes, rivers, ponds, bays and oceans — Sea Eagles give you real value for your money.

Write for FREE color brochure or send \$1 for 24-page color catalog showing the full range of Sea Eagle boats and products.

- Sea Eagle, Dept. PM34B,  
St. James, NY 11780
- Or telephone: 516-724-8900

**SEA EAGLE**

# Marine Surplus Sale! NOTICE!!!

(all in original casings)

## MARINE HEAVY-DUTY TRUCK, BOAT & AIRCRAFT TARPAULINS

### to be offered to the public Starting Midnight Tonight!

Starting midnight tonight—Marine Surplus will accept orders from readers of this publication for Marine Heavy-Duty Tarpaulins. Each of these 'Lifetime Tarps,' (all still in original casings), are constructed of high-density 1000D polyethylene weave 25 per sq. in., waterproof, mildewproof, rotproof fabric—the same thick, 'strong as steel' specifications required to withstand heavy-duty action in ocean storms, jungle downpours, blazing tropic heat or even 100-below zero cold of high-altitude flights. Each is designed to withstand water pressure of over 1000 lbs. per sq. in.—and raging tornado-force winds of

250 m.p.h. (a force greater than any maritime vessel is ever exposed to). Each of these marine life-time tarps also features double stitched hems, reinforced triangular corners, rust-proof grommets every 3 ft., nylon naval rope; and are so watertight they are hurricane-proof!

Recommended for all sorts of heavy-duty civilian uses: for yachts and sail boats, for cars and trucks, for farm equipment or outdoor furniture, pools, plus all bulk stored materials exposed to the elements. GUARANTEED FOR LIFE or free replacement at any time. ORDER TODAY!

#### ★★★★ SIZES AVAILABLE FOR THIS RELEASE ★★★★★

|   |  |
|---|--|
| ★ <input type="checkbox"/> 12 x 16.....\$22 | ★ <input type="checkbox"/> 20 x 40.....\$61  |
| ★ <input type="checkbox"/> 12 x 25.....\$29 | ★ <input type="checkbox"/> 25 x 45.....\$84  |
| ★ <input type="checkbox"/> 20 x 20.....\$34 | ★ <input type="checkbox"/> 30 x 60.....\$135 |
| ★ <input type="checkbox"/> 20 x 30.....\$47 |  |

IMPORTANT: INDICATE QUANTITY OF EACH SIZE TARP DESIRED AND ENCLOSE THIS NOTICE WITH YOUR REMITTANCE.

(PLUS the following freight and casing charges: \$5 for each 12 x 16, 12 x 25, or 20 x 20 tarp; \$6 for each 20 x 30 tarp; \$7.50 for each 20 x 40, or 25 x 45 tarp; \$15 for each 30 x 60 tarp). Purchase price refunded in full if not completely satisfied upon receipt of your Ma-

rine Lifetime Tarps. LIMIT: 10 (ten) tarps per address, no exceptions. Send appropriate sum together with name and address or should you wish to charge your order on VISA or MASTERCARD, give credit card name, number and expiration date. To avoid disappointment or future regret, you must place your order immediately. Enclose this original notice with quantities indicated above. ACT NOW!

**MARINE SURPLUS DEPOT** LTNH-132  
Box 9800, Port Washington, NY 11050

# GMC SUPER SELLIN' DAYS '83



**GM** GMC  
Truck & Coach  
General Motors  
Corporation

## GOOD DEALS COME IN GMC PACKAGES.

Right now, during Super Sellin' Days, your GMC truck dealer has great package deals on '83 models. They're the GMC Red Tag Special options packages. And they're great ways to get some of the options you want on a new GMC truck for less. Because if you buy a new GMC S-15 regular cab or Club Coupe 2- or 4-wheel-drive pickup equipped with one of our Red Tag options packages, you can get things like a V-6 engine, tilt wheel or halogen headlamps at

no extra charge. But that's just to name a few.

There are other no-extra-charge options, too, depending on which package you choose. Or, buy a Red Tag Special group of options on a new GMC Wide-side full-size pickup, Rally or Vandura. And depending on the group you buy get air conditioning or an automatic transmission at no extra charge.

No matter what you choose, you end up with a hard-working GMC truck that's just the way

you want it. For Red Tag savings, select from dealer stock while supplies last. So stop in at your GMC Truck dealer during Super Sellin' Days.

Some GMC trucks are equipped with engines produced by other GM divisions, subsidiaries, or affiliated companies worldwide. See your GMC truck dealer for details today.

**GMC**  
TRUCKS ARE WHAT WE'RE ALL ABOUT.

# New For Family Camping

**CAMPING**  
**'83**



Now you can take perishables anywhere you go in your car or boat. Ice chests like Model 660 from Norcold, Sidney, Ohio, store frozen food or hold kitchen refrigerator temperatures. Powered by a 12-v.d.c. battery (or 115-v.a.c. household current), Norcold's Refrigerator/Freezer has an automatic temperature control that can be turned down to 0°F. The 660 portable lets you take up to 100 pounds of foodstuffs with you.



Day sacks can carry assorted supplies and rain gear for a hike from camp. The Cordura Model 725 from Coleman's Peak 1 Div. is light, has a waist belt, haul strap, padded shoulder straps, top pocket.



Latest in outdoor clothing is durable, washable, styled for warmth without bulk. Vest with zip-on sleeves by Powderhorn Mountaineering, New York, has Eastman Kodolite polyester fiberfill insulation.



Multipurpose gear saves pack-space and weight. This five-blade knife, the Swedish Kombi Survival Set from Precision Sports, Ithaca, N.Y., can switch blades for sawing, skinning and filleting game.



Solar heating can be easy at a campsite with Solar Spray by Reliance Products, Winnipeg, Man. A five-gallon polyethylene container unfolds to hold shower water that warms up quickly in the sun.



Safari Pack from Rod Hall Racing, Reno, Nev., is a handy car-trunk stow kit for off-road and on. Bungee straps, duct tape, first-aid kit, flares, flashlight, tire gauge and tow strap are included.



Somehow, when you're camping you always need to hold a light when your hands are already full. Berkley, of Spirit Lake, Iowa, now has a new Outdoorsman Lite with stainless steel clip that fits on a cap, clips on a pocket or belt or stands on its own.

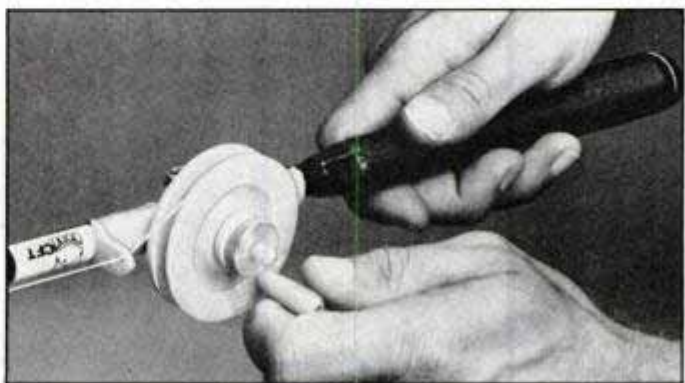

Keeping fishing simple was the goal of Mississippi angling champ Eddie Slater, of Indianola, when he designed a lightweight reel of Du Pont Zytel for taping onto any pole. It has adjustable drag, takes lines down to two pounds.

(Please turn to page 72)

**Revolutionary <sup>NEW</sup>**  
**Concept in Outboard Motor Design!**  
**The ELLIOTT POWER PADDLE**  
**The Innovative Outboard**

- Flexible Shaft Drive - No Inefficient Gear Boxes or Maintenance
- Light Weight - Under 10 lbs.
- Single Control Operation



- 4 Position Transom Bracket (Shown in Auto-Reverse Lockdown Position)
- Unlimited Height Adjustment - Fits Any Water Craft
- Efficient Small Propeller - Great For Weed Beds and Fishing
- High Quality Engine - Forged Crankshaft - Needle Bearings Throughout
- Centrifugal Clutch
- Electronic Ignition
- Spark Arresting Muffler

**SPECIAL INTRODUCTORY PRICE**  
**\$199.00 plus \$7.00 shipping**

(NYS residents add applicable sales tax)

**BONUS!** Order Today And Receive A Beautiful Nylon Pack Cloth Carrying Case - Worth \$26.00 - **FREE!** Send In Coupon Or Call 607-772-0404 Today. We Gladly Accept Master Card & Visa

Name \_\_\_\_\_  
 Address \_\_\_\_\_  
 City \_\_\_\_\_ State \_\_\_\_\_ Zip \_\_\_\_\_  
 ELLIOTT MFG. CO. Dept. PM  
 P.O. Box 773 - Binghamton, NY 13902

**SEE 145 BOATS...<sup>NEW!</sup>**  
**you can build from KITS**



Save 50% on your next boat!

**GIANT BUYERS GUIDE**  
**POWER & SAIL • 8 - 70FT**  
**WOOD • STEEL • FIBERGLASS**

From dinghies, daysailors, and runabouts, to ocean cruising sailboats, sportfishermen, and trawlers: **THE COMPLETE GUIDE TO BOAT KITS, BARE HULLS & CUSTOM BUILDERS** uncovers them all...dozens you've never seen before...all sell for a fraction of the factory-built cost!

THE GUIDE features over 300 photos; complete specs and prices; colorful, illustrated, in-depth articles; kit financing information; money-making and money-saving info; construction techniques and product reviews.

Save Even More! **BOATBUILDER** magazine keeps you abreast of the latest developments in design and construction, new kits, new plans, new products and techniques, tips, trials, and owner/builder interviews. Six BIG issues each year!

**BONUS FREE!**

**The Complete BOAT PLAN Directory**  
 Yours Free when you order THE GUIDE or BOATBUILDER magazine. **Order both!**  
 Your satisfaction is guaranteed.

**<30 Day Money-Back Guarantee>**  
 OCEAN LOGIC, INC.  
 PO Box 1109  
 Department G3  
 W Palm Beach, FL 33402

Mail **BOAT KIT Guide** and **BOAT PLAN Directory**  
 \$10 (3rd Class - US Only)  
 \$12 (RUSH DELIVERY)  
 \$15 (Foreign - US Funds)  
 Boatbuilder magazine \$15/yr

NAME \_\_\_\_\_  
 ADDRESS \_\_\_\_\_  
 CITY/STATE/ZIP \_\_\_\_\_

CARD# \_\_\_\_\_  
 EXP DATE \_\_\_\_\_  MasterCard  VISA



Order **TOLL-FREE** Day or Night  
 MasterCard or VISA **REQUIRED**  
 CALL 1-800-327-8456 ext 236  
 (in Fla.) 1-800-432-2382 ext 236  
 Operator CANNOT answer questions - no CDS



**NEW FOR FAMILY CAMPING**

(Continued from page 71)



Designed for firm footing while fishing streams with slippery rocks, Red Ball Master wading shoes have felt soles, nylon uppers, sponge collars to keep out sand, space for Bama Socklets, waders.



For cross-country hiking or orientation sports, Normark, in Minneapolis, has two new compasses with luminous arrows, adjustable grids. Advanced model (right) has conversions for chart, map scales.



New tent bags from Coleman, Wichita, Kan., come in sizes for medium and large Coleman family tents. Duffel bags, tent canopies, van conversion kits and seam sealer are also new to the canvas line.

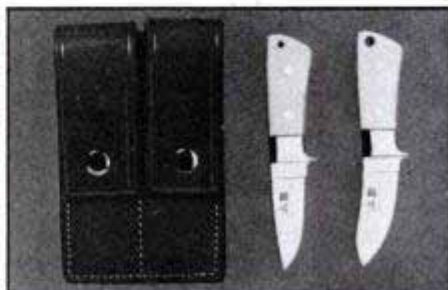

Campers and outdoorsmen are collecting and wearing custom-type knives, and Al Mar Knives, Wilsonville, Ore., offers a pair, Pack Rat I and II, you can wear on a belt in a combination scabbard.



For plinking and target practice, Beeman Precision Airguns, in San Rafael, Calif., is producing a short, light, carbine-sized air rifle, the CI, with magnum power of 830 feet per second and a rifled barrel for .177 and .22-cal. pellets.



Small enough to tow behind mini compact cars with little trunk space or motorcycles with none, the Time Out Cargo Trailer from T.O. Corp., Elkhart, Ind., has a fiberglass compartment of 20 cu. ft. and optional electrical brakes. (Please turn to page 74)



## GET YOUR KNIFE READY FOR FISHING SEASON

**Smith's**

**CERAMIC  
SHARPENING  
STICKS**

**SHARPENS  
KNIVES  
QUICKLY**

**Smith's** THE SYMBOL OF SHARPENING

**"AVAILABLE ANYWHERE KNIVES ARE SOLD"**  
Smith's Whetstone Inc. — Hot Springs, Arkansas 71901

## Giant Heavy Duty Inflatable Boats

**2 MAN  
\$38**

**3 MAN  
\$50**

**4 MAN  
\$65**

Before Midnight May 1

Viking Ind. will send any of the above size boats to any reader of this publication who reads and responds to this program before midnight, May 1. Each boat is constructed of tough, high density fabric (resistant to abrasion, sunlight, salt & oil), electronically welded embossed seams, nylon safety line grommeted all around, heavy duty oar locks, three separate air chambers for extra safety, self locking safety valves, bow lifting and towing handle, and are recommended for marine, ocean, and fresh water recreation, camping, fishing, or a family fun boat, and will be accompanied with a LIFETIME guarantee that it must perform 100% or it will be replaced free. Add \$7 handling and crating for

each boat requested, Viking Ind. pays all shipping. If your order is received within the next ten days you will receive FREE a high volume combined hand/foot inflator/deflator bellows style pump for each boat requested. Should you wish to return your boats you may do so for a full refund. Any letter postmarked later than May 1 will be returned. LIMIT: Three (3) boats per address, no exceptions. Send appropriate sum together with your name and address to: Boat Dept. #117CR, Viking Ind., 6314 Santa Monica Blvd., Los Angeles, CA 90038, or for fastest service from any part of the country call collect before midnight 7 days a week.

**CALL COLLECT (213) 462-1914**  
(Ask exchange operator for)  
**BOAT DEPT. #117CR**  
Before midnight, 7 days a week  
Have credit card ready

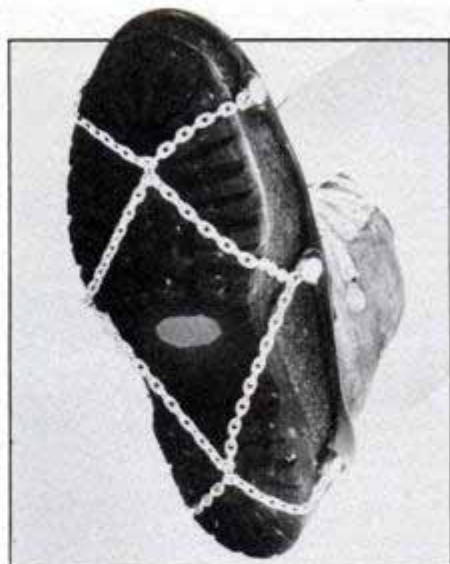

Walking over slick ground, ice or underwater mossy rocks when fishing is easier with accessory traction chains from Saf-T Shoe Chains, Mount Prospect, Ill. Shoe Chains fasten easily to any shoes or boots with rubber loops, and are available in both standard and heavy-duty models.



New Sporting Glasses from Hoppe's, the maker of No. 9 Solvent for gun cleaning, now come with clear, yellow and smoke-gray lenses and side shields. The glasses provide eye protection for home hobbyists, shooters, industrial workers, and come with a protective belt case.



Double-sized for double-up sleeping in the back of a station wagon, camper or travel trailer, the White Stag Wagon model sleeping bag from Henderson Camp Products, Chicago, has 4 pounds of Dacron Hollofil 808 insulation: 1½ pounds on top, 2½ pounds below. **FM**



**For 1983, Chrysler increases its warranty protection to two years.**

Only one major outboard manufacturer has enough confidence in its product quality and reliability to offer a limited warranty for not one, but two years. That's Chrysler Marine.

For 1983, all domestic outboards, purchased from authorized U.S. Chrysler Marine dealers, will carry a 2-year limited warranty against defects in materials and workmanship on the entire product. Both parts and labor.\*

**America's longest warranty. America's lowest dealer prices.** It's not surprising that

Chrysler Marine leads the industry in warranty protection. Chrysler is a leader in bringing design simplicity/easy maintenance to outboard engines. And model for model, Chrysler offers its dealers the lowest wholesale prices of any major manufacturer. So, our dealers can pass along important outboard savings to you.

**Exciting new graphics . . . new models highlight Chrysler's '83 lineup.** Chrysler Marine outboards feature attractive new graphics, designed to complement any craft. Choose from a complete lineup of 1983 performers from the 3.5 to the 140 HP, including three of the highest-thrust sailor engines designed for displacement hulls.

And introducing the Charger 90. A real high-torque powerhouse with stainless steel prop, standard.

Our 1983 outboard lineup is the product of over 50 years of engineering innovation, testing and in-use proving.

Compare. Nobody pulls it all together like Chrysler Marine to give you price, warranty, quality and serviceability.

See your Chrysler Marine dealer now.

\*Excludes normal maintenance service and parts, and outboards that are part of boat builder packages. \$25 deductible required in second year. See dealer for details.

**NOW FROM CHRYSLER MARINE: THE INDUSTRY'S LONGEST OUTBOARD WARRANTY.**



**CHRYSLER MARINE**

# Where To Go- What To Take

**CAMPING**  
**'83**

**F**or the family heading out with no idea where they'll camp for the night, the trip can be a pleasant adventure—or the source of a lot of worry. Planning ahead is important. Contact the tourist departments at state capitals for descriptions of campsites and points of interest. Consult the guides listed here and write or phone ahead for reservations.

But sometimes plans change. Fishing may be good at the lake and you want to stay several extra days. Rain may be making the children restless and you want to move on to a campground that has indoor

playground activities. One or more of the directories below should go along in your car or RV as part of your traveling equipment.

The camping gear you choose will also make the difference between a delightful time and a disaster. Tents that leak or blow down, sleeping bags that are cold and get wet, boots that create blisters can often be avoided if you stick with quality. Yet the best equipment items are as near as your mailbox after you study the mail-order catalogs described below. Use this directory of directories as insurance.

## Camping

**Rand McNally Campground & Trailer Park Guide For The United States, Canada and Mexico;** \$10.95.

**Rand McNally Campground & Trailer Park Guide, Eastern Edition;** \$6.95.

**Rand McNally Campground & Trail-**



**er Park Guide, Western Edition;** \$6.95.

**Trailer Life Campground and Service Directory;** \$11.95.

**Woodall's Campground Directory,** covering the United States, Canada and Mexico; \$10.95.

**Woodall's Campground Directory,** Eastern Edition; \$8.95.

**Woodall's Campground Directory,** Western Edition; \$8.95.

**National Park Guide,** by Michael Frome; Rand McNally; \$8.95.

**Rand McNally Backpacking & Outdoor Guide,** Richard Dunlop; \$6.95.

**K O A Campground Directory;** \$1 at K O A Campgrounds or from Box 30162, Billings, Mont. 59107.

## 10 Destinations

**North to the Viking Past:** Superintendent, Gros Morne National Park, Box 130, Rocky Harbor, Newfoundland AOK 4N0.

**Spelunking in Carlsbad's Wild New Cave:** Superintendent, Carlsbad National Park, 3225 National Parks Highway, Carlsbad, N.M. 88220.

**Crater of Diamonds:** Superintendent, Crater of Diamonds State Park, Route 1, Box 324, Murfreesboro, Ark. 71958.

**Boat Camping in Glacier Bay National Park:** For reservations on *Glacier Bay Explorer*, write Exploration Holidays and Cruises, 1500 Metropolitan Park Bldg., Olive Way at Boren Ave., Seattle, Wash. 98101.

**Backpacking in the Porkies:** Porcupine Mountains State Wilderness Park, Rte. 2, M107, Ontonogan, Mich. 49953.



**Wild Ponies of Assateague:** Assateague Island National Seashore, Rte. 2, Box 294, Berlin, Md. 21811.

**Cajun Lagniappe:** Chamber of Com-

merce, City Hall, Civic Center, Box 27, New Iberia, La. 70560.

**Okefenokee Canoeing Trails:** Stephen Foster State Park, Fargo, Ga. 31631.



**Biking in Vermont:** American Youth Hostels, 1332 I St. N.W., Washington, D.C. 60005.

**Trail Riding in the Big Bend:** Big Bend National Park, Tex. 79834.

## Equipment sources

**Eddie Bauer:** Box 3700, Seattle, Wash. 98130; quality cold-weather clothing, sleeping bags, accessories.

**L.L. Bean:** Freeport, Me. 04033; famous for rubber-bottomed Maine hunting shoe and wide assortment of camping and outdoor gear by mail and from retail store that never closes.

**Cabella's:** 812 13th Ave., Sidney, Neb. 69162; hunting, fishing, camping gear.

**Campmor:** Box 999N, Paramus, N.J. 07652; wide choice at bargain prices.

**Dunn's:** Box 449, Grand Junction, (Please turn to page 79)

# "4X4 OF THE YEAR"

## NEW-SIZE CHEVY S-10 BLAZER

This never-before sport utility vehicle has been named "4X4 of the Year" by *4-Wheel & Off-Road* magazine, plus "Four Wheeler of the Year" by *Four Wheeler* magazine. And now Chevy S-10 Blazer is taking on Ford's brand-new Bronco II—with some decided advantages.

**4-cyl. or optional V6 power.** A standard 4-cyl. engine or available V6. Ford Bronco II offers only a V6.

**Insta-Trac 4X4—or 2WD.** Every S-10 Blazer 4X4 has the revolutionary Insta-Trac 4X4 system. For the first time ever, you can shift from freewheeling, fuel-efficient 2-wheel drive to 4-wheel-drive High—and back—at any speed. Ford Bronco II offers nothing like it. A 2-wheel-drive S-10 Blazer is also available.

**Highest towing capacity in its class: 5000 lbs.**

Including trailer and cargo. That's 950 lbs. more than a Ford Bronco II with a V6. Optional V6 and heavy-duty trailering package are required.

**More options Bronco II doesn't offer.** They include big, fat P235/75R-15 on/off-road tires, power windows, power door locks, and much more.

**More payload capacity and cargo room than Bronco II.** With the available rear seat folded down, you get long cargo length (68.6 inches) and big cargo space (67.2 cubic feet). Plus a 1000-lb. payload capacity. Payload includes people and cargo.

The Chevy S-10 Blazer 4X4 with optional V6 and 4-speed manual transmission has some impressive mileage figures, too. **31 Est. Hwy., [21] EPA Est. MPG.\*** Chevy S-10 Blazer—the "4X4 of the Year"! See it soon at your local Chevy dealer's.

\*Use estimated MPG for comparisons. Your mileage may differ depending on speed, distance, weather. Actual highway mileage lower. Estimates lower in California. Some Chevrolet trucks are equipped with engines produced by other GM divisions, subsidiaries, or affiliated companies worldwide. See your dealer for details.

Let's get it together... buckle up.

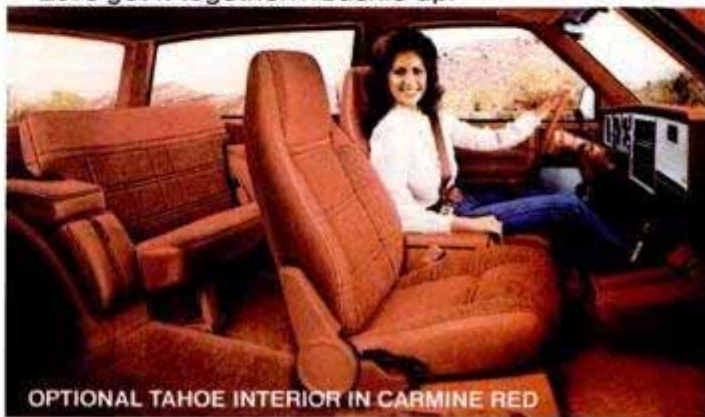

OPTIONAL TAHOE INTERIOR IN CARMINE RED



CHEVY S-10 BLAZER 4X4

## TOUGH CHEVY TRUCKS ARE TAKING CHARGE



## OUR OUTDOOR LINE COMES IN SMALL, MEDIUM AND LARGE.

Honda can give you all the power you need for good times in the great outdoors. With a complete line of lightweight, portable generators from 500 to 800 watts. Each is really easy to operate. Just turn it on, pull the cord and you're off and running.

Honda generators are ideal

for lighting up a campsite, charging the boat battery, powering small appliances, or providing standby power.

Each one features a quiet, reliable Honda four-stroke engine. An advanced Oil Alert™ system that warns when the oil level gets too low.\* An Automatic Decompression system

and CD Ignition for quick, easy starts. And a USDA approved spark arrestor muffler so it can even be used in National Parks.

So if you're looking for the best generator to fit your outdoor power needs, size up a Honda.

Check your Yellow Pages for the Honda Generator dealer nearest you today.

\*Except on EM500

©1983 American Honda Motor Co., Inc. For optimum safety and performance, we recommend that you read the owner's manual before operating your Honda Power Product.

# IT'S A HONDA

Материал, защищенный авторским правом

## WHERE TO GO

(Continued from page 76)

Tenn. 38039; hunting clothing and equipment, plus accessories for dogs.

**Early Winters:** 110 Prefontaine Place S., Seattle, Wash. 98104; extensive selection of clothing, gear, gadgets.

**Eastern Mountain Sports (EMS):** Vose Farm Rd., Box 811, Peterborough, N.H. 03458; cold-weather clothing and gear from store chain and by mail.

**Frostline Kits:** Frostline Circle, Denver, Colo. 80241; sew-it-yourself items, many of them down-filled.



**Indiana Camp Supply:** Box 344, Pittsboro, Ind. 46167; camping accessories and books, plus extensive wilderness medicine kits.

**Lands' End:** Lands' End Lane, Dodgeville, Wis. 53533; outdoor and boating clothing, bags.

**P & S Sales:** Box 45095, Tulsa, Okla. 74145; outdoor clothing, equipment and supplies, plus some bargain surplus items.

**Patagonia Software:** Box 150, Ventura, Calif. 93002; the clothing division of the Great Pacific Iron Works, makers of Chouinard technical-climbing gear.

**Recreational Equipment (REI):** Box 88125, Seattle, Wash. 98188; a cooperative with extensive outdoor and mountaineering equipment that pays divi-



dends to members purchasing gear.

**Stow-A-Way:** 166 Cushing Hwy., Cohasset, Mass. 02025; source for a broad selection of dried foods for camping, survival and expeditions.

**The Yak Works:** 2030 Westlake Ave., Seattle, Wash 98121; items of clothing, gear and outdoor gadgets. **PM**

# HOMEOWNERS INSURANCE.

If you're looking for a dependable power source, it's a good policy to keep Honda's EX5500 heavy duty generator around the house.

With 5500 watts, it's ideal for main or auxiliary power. Thanks to a specially designed OHC liquid-cooled engine, it runs so much more quietly than air-cooled generators with similar output, you'll have to hear it to believe it. And it consumes up to 30% less fuel and oil.

The EX5500 also gives you the most advanced features

found on a generator today. Including an Oil/Temperature Alert system that helps prevent damage. An Automatic Idle Control for increased economy. An Automatic Voltage Regulator for steady output. And a CD Ignition for quick, reliable starts.

So whether your home is miles away from power, or you just need a strong back-up, check into the Honda EX5500. Look for your nearest Honda Generator dealer in the Yellow Pages.

**IT'S A HONDA**

For optimum performance and safety we recommend that you read the owner's manual before operating your Honda Power Product.  
©1983 American Honda Motor Co., Inc.

# Pall Mall A Step Ahead

Step up in taste,  
step down in tar



9 mg. tar  
0.8 mg. nic.

Warning: The Surgeon General Has Determined  
That Cigarette Smoking Is Dangerous to Your Health.

9 mg. "tar", 0.8 mg. nicotine av. per cigarette, FTC Report Dec. '81.

## FIRSTHAND REPORT

*Slick, aerodynamic styling, light weight and first-rate engineering have made Sierra the terror of the Autobahns. It will arrive here in 1985.*



# Driving The European Ford Sierra

Going one-on-one with Mercedes and BMW—and winning convincingly!

BY RICH TAYLOR

PM photos by the author

The heart of the worldwide automobile market is what Germans call the "1,000-kilogram class," four-door sedans that weigh between 2,000 and 2,500 pounds, carry four passengers, are driven by roughly two-liter engines and cost \$8,000 to \$12,000. Because this niche is so big and important, it's terrifically competitive. If your entry has been on the market more than a year or two, it's already outdated.

The upscale end of the 1,000-kilogram class is dom-

inated by the Germans—the revamped BMW 3-series, the all-new Mercedes-Benz 190/190E (see *Firsthand Report*, page 105) and most important of all, the knockout Ford Sierra. If you think a BMW can cut around a corner, try a Sierra. If you think a Mercedes is quiet and smooth, try a Sierra. If you think a Mazda 626 is filled with electronic wonderment and inexpensive for what

you get, try a Sierra. Not to put too fine a point on it, Ford's Sierra is not only the best car in the 1,000-kilogram class, it's one of the best sedans in the world.

Now you have to understand about the German market. In Germany, the 3-series BMWs which Americans think of as expensive sports sedans cost about \$9,000 to \$12,000. The new Mercedes, which will cost \$24,000 in the United States, starts at \$11,500 in Germany. Ford's Sierra is priced from \$6,000 for a real stripper to slightly under \$12,000 if you order the full-tilt version. In other words, it's directly competitive with BMW and Mercedes.

It's pretty hard to ignore the Sierra's aerodynamic body. Where BMW is ultra-conservative and Mercedes-

*(Please turn to page 82)*



*XR-4 has biplane rear spoiler, which lowers Cd from .34 to .32.*

## DRIVING FORD SIERRA

(Continued from page 81)

Benz is, well, Mercedes-Benz, Ford has gone out on a limb to build the most futuristic-looking sedan in production. What other manufacturers are showing as their styling studies for the Year 2000, Ford of Europe is building now. This must have taken some pounding to get through the product planning meetings, and the Fordvolk must be biting their nails to see if the car is going to be a success.

Well, if it's any consolation, I drove all over Germany for 10 days in the

Sierra, and everywhere I went, the car was a sensation.

### Fighting off buyers

People literally can't keep their hands off it. I finally gave up trying to photograph the Sierra in a Cologne park on Sunday morning—every passerby felt compelled to caress the car, despite my protestations. If that's any indication, Ford dealers are going to be fighting buyers off with a stick.

The slick body not only looks terrific,

it works superbly. Aerodynamic drag coefficient is .34, which is as clean as any production sedan in the world, and by adding a pair of rear spoilers, which Ford mounts on its XR-4 high-performance version, it can reach .32 Cd. But unlike some cars with ultra-aero bodies, the Sierra is not disturbed by side winds or high speeds. I saw a genuine 193 km/hr (120 mph) on the rain-swept

### A trigger-squeeze breeze in the hands of the handy homemaker!

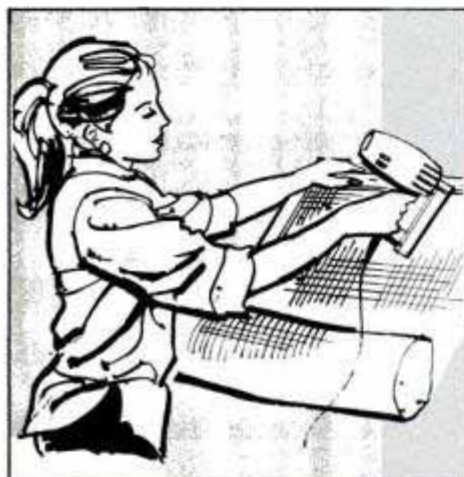

### A powerful, useful tool in the hands of the home handyman!



**ARROW**  
ELECTRO-MATIC

## Model ET-50 ELECTRIC STAPLE GUN

It's TRIGGER-FAST!  
Just plug in... and SHOOT!

Just plug it into standard house current... and you're ready to fire staples as fast as you can squeeze its feathertouch trigger!

With her lightweight, trigger-fast Arrow ET-50 Electro-Matic, the handy homemaker will breeze effortlessly through scores of light decorating and repair chores... trimming a kitchen shelf, lining a closet, mending a torn screen or covering a headboard

And, the Arrow ET-50 Electro-Matic is a fastening tool with the heavy duty staple-driving power the home handyman needs for putting up ceiling tile, installing insulation, applying weatherstripping, etc.

Uses Arrow No. T-50 staples exclusively, in 6 sizes: 1/4", 5/16", 3/8", 1/2", 9/16" and Ceiltile.

Available at all leading Hardware,  
Home Center & Discount  
Department Stores everywhere.

**ARROW FASTENER COMPANY, INC.**

271 Mayhill Street, Saddle Brook, N. J. 07662

Operates  
on any  
110 Volt  
AC-60 Cycle  
Outlet.



Cockpit is loaded with instrumentation and there's ample room for four adults.

Autobahn to Frankfurt, and the Sierra felt as stable as a Pinto sitting in your driveway.

I interviewed Ford chief engineer Hans-Georg Gaffke, who was in charge of the Sierra program. Says Gaffke, "The devil sits in the details." Look closely at the Sierra, and you can see what he's talking about: the flush fitting windows, door handles and trim, the "moon disc" wheelcovers, even the way most wind-catching body seams have been eliminated through new assembly and stamping techniques.

### A people-mover

Even more remarkable, the Sierra's high-aero body works as a people-mover. I fitted three American businessmen inside, and everyone commented on the generous head, shoulder and leg-room—including a 6-foot-6 publisher wearing cowboy boots. He said, "This is the only car I've ever been in where I feel truly comfortable."

Fortunately, Ford's interior designers have met the challenge of the body with an equally futuristic interior. The nubby cloth bucket seats are as comfortable as Recaros—the accepted standard of excellence in automotive seating—and infinitely adjustable. The rear quasi-buckets have a 60/40 split, which fold down to give the high-tailed fast-back the effective carrying capacity of a station wagon.

The dash layout and controls are near perfect, from the fat-rimmed steering wheel to the nicely located shifter. There's a full set of instruments in front of the driver, plus an onboard computer with digital readout for fuel economy, trip mileage and service intervals. There are power windows,



power door locks, electric mirrors and every other gadget that the Japanese have led us to expect on a 1,000-kilogram car, including a terrific digital radio.

Chief engineer Gaffke tried both front-wheel drive and rear-wheel drive chassis before deciding to go with a conventional layout. As he points out, BMW and Mercedes both went through a similar test program before also deciding on rear-wheel drive. His arguments are persuasive: better weight distribution, elimination of front torque steer, straightforward maintenance and the ease in which different power trains can be plugged in.

### Many engines offered

The Sierra is offered with an incredibly wide range of engines: 1.3, 1.6 and 2.0-liter Fours; 2.0, 2.3 and 2.8-liter V6s and a 2.3-liter diesel—all with four-speed, five-speed or automatic gearboxes. The top option is a fuel-injected, 150-hp version of the 2.8-liter V6 which Ford of North America used to offer in the Capri, and which is now to be available in Ranger trucks.

The Sierra's suspension is remarkably straightforward, with MacPherson struts at the front and independent swing axles on semitrailing arms at the rear. It all works superbly, however, because of some clever engineering with rising-rate polyurethane bump stops and basic suspension geometries. The Sierra feels safe as a house at 120



Base Sierra comes with a 1.3-liter Four and a starting price of \$6,000 in Europe.

mph, and has a marvelously compliant ride over Belgian block and inner city potholes.

### A U.S. version

As Gaffke says, "When we brought the Sierra to Arizona for testing, American people said to us 'Holy Smoke, why can't we have these cars?'" Well, in a manner of speaking, we can. Lincoln-Mercury is going to bring some version of the Sierra into the country starting in 1985. According to Gaffke, there will be only 20,000 to 50,000 units. And according to rumors from Detroit, these will all be dressed-up XR-4 versions, with a Brazilian-made, turbocharged 2.3-liter Four and a Mercedes-like price tag of \$24,000.

That's a damn shame. The nicest Sierra is the five-door hatchback, with the 2.8-liter V6, an engine which Ford has already certified for the United States. Thousands of these V6s are already driving around U.S. highways, and Ford mechanics and parts people are already familiar with them. If Ford people wanted to do themselves a favor—and us, at the same time—they'd import the Sierra V6 by the hundreds of thousands, and sell it for \$12,000.

Even better, they'd build them over here. Know why that will never happen? Because while chief engineer Hans-George Gaffke was developing the best sedan in the 1,000-kilogram class, Ford engineers in Detroit were creating the Tempo/Topaz, a car that is not nearly as capable as the European Ford Sierra. The Tempo/Topaz isn't quite in the same ballpark when it comes to quality, sophistication, performance or handling. But it, too, weighs 1,000 kilograms. **PM**

## MUST LIQUIDATE AT BELOW DEALER COST! Gas Operated, Emergency Power Generator

FACTORY NEW! FACTORY PERFECT!

**DON'T let a storm rob YOUR home of vital electric power! With this 4000 watt generator, you ALWAYS have a reliable standby source of 120V and 240V plug-in power!**

- 8 hp. Briggs & Stratton 4-cycle gasoline engine!
- U.S. made, U.S. quality!
- Mfgs. 1 year warranty!

Four outlets, 16.5 amps on each, 120V & 240V service.

A storm could knock out electrical power for hours, or for days! Food could spoil in your refrigerator. A motor in your furnace could stop running in winter and leave your family shivering in the cold. A well could stop pumping water needed for cooking or bathroom facilities. The losses could cost you up to hundreds of dollars or more!

But . . . you never have to worry when you have this excellent quality portable generator. It's U.S. made! It provides you with 4 convenient plug-in outlets for 120V and 240V service . . . 16.5 amps at each outlet. You can run your electric lights, power tools, a sump pump or well pump, etc. Plug in small kitchen appliances, a refrigerator, a freezer. No, you can't run everything at one time. But you can run enough items to keep vital functions operating as needed.

- 4-cycle, single cylinder, Briggs & Stratton engine.
- Produces 8 hp. at 3600 rpm.
- Recoil start. Manual choke.
- 4-quart capacity gasoline tank.
- Chrome plated piston and aluminum alloy cylinder help dissipate heat for cooler running.
- Sturdy, durable construction.
- Size: 17½" W x 28" L x 17" H.
- Ship weight, approx. 150 lbs.

To determine max. "load" you can put on generator, use this formula: Volts x Amps = Watts. (Do not exceed 4000 watts.)



FOR HOME! Keep sump pump, well pump, appliances operating in case of any power outage.



IN THE FIELD! A reliable source of portable power anytime, anywhere.



FOR CABIN or CAMP! In the wilderness, you can enjoy comforts of electricity with this generator.



FOR WINTER STORMS! No freezes or burst water pipes when you have this generator on hand.

### PUBLIC NOTICE!

Bankruptcy and Financially Distressed Merchandise!

We are authorized liquidators of inventories that must be quickly sold at sacrifice prices due to a variety of reasons, such as:

Overproduction . . . last year's models . . . order cancellations . . . bankruptcy . . . out of season . . . plant closings . . . excessive competition . . . financial problems, etc.

If you know of any company with surplus inventories that must be liquidated for immediate cash, call us Toll-Free: 1-800-328-0609. Only products in perfect operating condition will be considered.



**4000 watts of emergency power quickly available when you need it!**

Compare at over **\$1,000.00**

OUT THEY GO AT ONLY:

**\$488**

Price subject to change after 60 days. Offer void outside original 48 states.

Now available at a huge savings



Credit card members can order by phone, 24 hours a day, 7 days a week.

**Toll-Free: 1-800-328-0609**

If busy signal, or if no answer, call:

**Toll-Free: 1-800-328-5727**

In Minnesota, call: **1-800-742-5685**

**C.O.M.B. Co.**

ONE OF THE NATION'S LARGEST AUTHORIZED MAIL ORDER LIQUIDATORS OF CONSUMER PRODUCTS  
6850 WAYZATA BLVD. / MINNEAPOLIS, MN 55426

C.O.M.B. Co / Liquidators Dept. B-942-1180  
6850 Wayzata Boulevard, Minneapolis, Minn. 55426

Send \_\_\_\_\_ 4000 watt Generator(s) at \$488.00 each. I will pay shipping charge to driver upon delivery. (Allow 4-5 weeks for delivery. Add 2-3 weeks more if paid by check. Sorry, no C.O.D. orders.)

My check or money order enclosed. (Minn residents add 6% sales tax.)

Charge my:  MasterCard  VISA  Am. Express  Diners Club

Acct. No. \_\_\_\_\_ Expires \_\_\_\_\_

PLEASE PRINT CLEARLY:

Name \_\_\_\_\_

Address \_\_\_\_\_

City \_\_\_\_\_

State \_\_\_\_\_ ZIP \_\_\_\_\_

Phone \_\_\_\_\_

Rural Route Customer: If truck carriers do not normally deliver to your home, include a note with this order stating town address of nearest store, friend, truck terminal where we can ship.

# PM VIDEO MONITOR



## Atari 5200—first impressions

Atari's new 5200 is a bright explosion of sound and color, fast moving graphics and stunning capabilities. From the design of the slick, Lucite case to the electronic maze of a full, 64K memory inside, this 5200 is one mean, powerful gaming machine.

Many fine details all add up to a worthwhile new addition to the gamer's choice of possibilities. The joystick, for example, features new engineering techniques that make it easy to control on-screen movement. The stick itself moves in a smooth, noncentering manner that becomes second nature after a few minutes. Atop the stick on the hand controller are three buttons—START, PAUSE and RESET. The PAUSE button is great when the phone rings, just when you're about to reach that all-time high score. The keypad below the stick features real keys and the whole unit fits the hand like an electronic glove.

Cartridges include such coin-op arcade favorites as *Galaxian* (shown) and *Star Raiders*. That's right, a full version of *Star Raiders* on a gaming system!

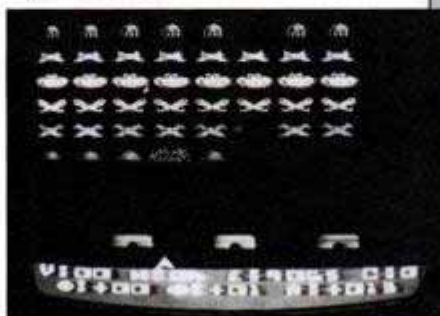

Swarms of aliens swoop by in *Galaxian* (above) running on new Atari 5200 machine (right). Hand controllers feature a smooth joystick, as well as a full keypad of switches—even START, PAUSE and RESET buttons (inset) so you can stop the action when you want.



One of the most complex, challenging and visually exciting of all video games, *Star Raiders* was responsible for selling a lot of Atari 400 and 800 computers. Now, we predict, it'll sell even more 5200s.

While there aren't yet as many cartridges as one might hope, there's no doubt that Atari and other manufacturers will rush to support the 5200. As always, Atari is a video force to reckon with.—N.S.

## Coleco's expansion modules

Colecovision has made a point of featuring games that look as close to their arcade counterparts as possible. For the most part, the company has succeeded admirably. *Zaxxon*, *Mouse Trap*, *Venture* and others feature the

same scintillating graphics and addictive play value as the arcade versions.

Now, Coleco has taken its game machine two steps further with its first two expansion modules.

Expansion Module Two features a small-size but maneuverable steering wheel and a real gas pedal. Plant the plastic pedal deep into your shag rug's pile, grip that tiny wheel and drive into the screeching world of *Turbo*. Like the coin-op game,



Coleco's Expansion Module Two adds a steering wheel and a plastic gas pedal (not shown) to Colecovision game. With these options, the fast-paced *Turbo* game (right) puts you in the driver's seat.

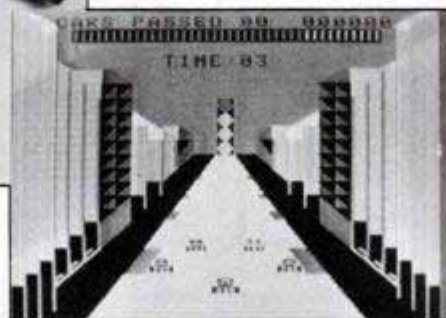

*Turbo* is as close to driving a souped-up race car hell-bent through city streets and around treacherous curves as most of us will ever want to come. It seems almost impossible that the three-dimensional graphics can move so fast and so convincingly on the home TV set. If you've ever doubted that any home video game could duplicate the thrill and wet-palm feeling of arcade play, try Colecovision's *Turbo*.

Right now, *Turbo* is the only cartridge available for use with the steering-wheel module. But more driving games loom just around the bend.

And let's not forget Expansion Module One, which lets you use all the Atari 2600 cartridges. We've tried it out and have yet to find a cartridge it wouldn't accept. So, while Atari is less than thrilled with Coleco for doing this (it is, in fact, suing Coleco), there's no doubt of the module's consumer value. If you have a library of Atari 2600 games, Coleco wants you to use them—on Colecovision.—N.S.

# Get Ram Tough values during DODGE PROSPECTOR DAYS!

The range of savings is dramatic... up to \$1000 on a wide selection of Prospector option packages specially created for these and many other '83 Ram Tough trucks. And they are options most truck owners prefer. For example:

**RAM PICKUPS. SAVE \$1000.†** Select light package—bright rear bumper, wheel covers and low-mount mirrors—30-gallon fuel tank—oil and temperature gauges with trip odometer—tinted glass—intermittent wipers—Ram hood ornament—AM radio—Royal SE decor—air conditioning. With special Dark Brown metallic two-tone paint.

**RAMCHARGER. SAVE \$1000.†** Start with convenience package—digital clock—oil and temperature gauges—trip odometer—sunscreen glass—bright grille and hood ornament—bright low-mount mirrors and wheel covers. Add Royal SE decor—front bumper guards—AM/FM stereo w/electronic tuning—special Dark Brown metallic two-tone paint—air conditioning—power door locks and windows—speed control.

**RAM WAGONS. SAVE \$1000.†** Choose the convenience package—bright front and rear bumpers—digital electronic clock—36-gallon fuel tank—oil gauge and odometer—bright grille and quad headlamps with

halogen high beams—bright wheel covers and low-mount mirrors—bumper guards and nerf strips—Royal SE decor—AM/FM stereo radio (manual)—air conditioning. With special Dark Brown metallic two-tone paint.

**RAM VANS. SAVE \$575.†** Choose hi-back bucket seats—tinted glass—convenience package—36-gallon fuel tank—full gauges—bright low-mount mirrors, wheel covers, front and rear bumpers—intermittent wipers—exterior appearance package—AM radio. With special Dark Brown metallic two-tone paint.

**RAMPAGE. SAVE \$200.†... ON ONLY TRUCK IN AMERICA WITH 5-YEAR/50,000-MILE PROTECTION PLAN.†** Get white side wall tires—light package—dual remote mirrors—power steering—AM radio—cargo box side rails.

**RAM 50. SAVE \$125.† ON AMERICA'S LOWEST-PRICED PICKUP.** Choose two-tone tape—bright step bumper—low-mount mirrors—box top molding—sliding window—clock—wheel trim rings.



RAM 50



**RAM  
TOUGH**

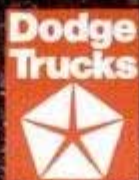

\*Limited warranty covers engine and powertrain components plus outer body rust through for 5 years or 50,000 miles, whichever comes first. A deductible may be required.

†Savings based on manufacturers' suggested retail price of options listed if purchased separately.

Keep your car  
on the road...



all the way  
to HAWAII!

## Enter Marvel Oil's 1983 Sweepstakes

You can win any one of 1001 prizes including a trip for two to Hawaii, Nikon cameras, nylon racing jackets and Marvel tote bags. Details and entry blanks at your automotive supplies dealer. Enter early and often. No purchase necessary.

After you've sent in your entry, stock up on —

### MARVEL MYSTERY OIL

When added to the crankcase, Marvel gives your car impressive efficiency and performance. Cuts maintenance costs. Cleans as it lubricates. Keeps internal parts covered with a tough protective film that protects against excessive wear. Marvel puts real snap into throttle response, and even starts at cold temperatures.



### MARVEL GAS TREATMENT

Companion to Mystery Oil, Marvel's Gas Treatment provides better fuel combustion which means less power robbing ash and residue in the combustion chamber. Reduces engine maintenance. Minimizes engine feedback (dieseling). Prevents spark plug fouling and misfiring. Prevents carburetor clogging.



Make your car an economical Powerhouse of Performance.

Use Marvel Products. Available at all auto supplies dealers coast-to-coast... and Hawaii.



Marvel Oil Company, Inc.

331 N. Main Street  
Port Chester, NY 10573

# PM LOOKS AT...

## Skil's 551 Trim Saw

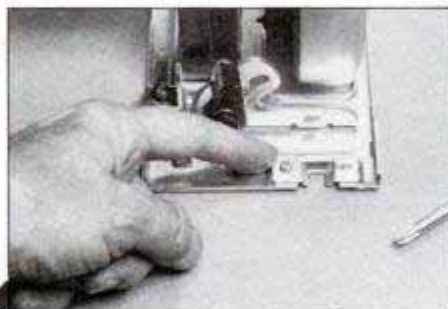
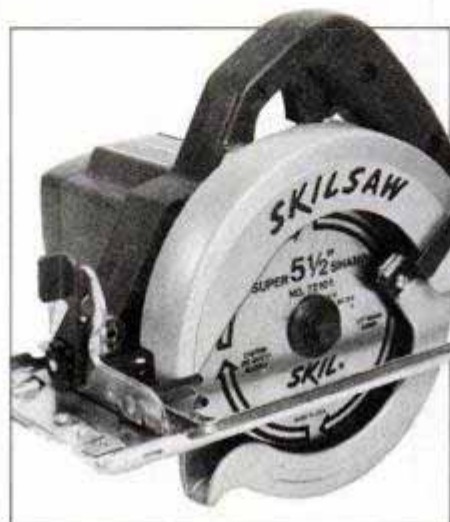

All it takes is a quick twist of the screwdriver and the line-of-cut can be suited to the blade.

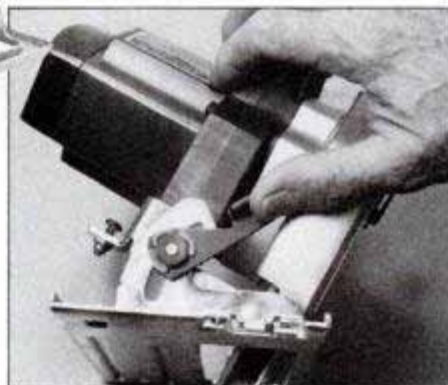

Bevel-locking lever does job quickly and easily without causing sore fingertips.

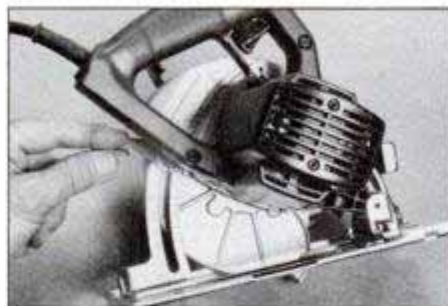

Same is true for depth-of-cut adjustment.



Although it's mainly a trim saw designed for relatively light precision work, the gutsy little saw zips through heavy stock. Rip guide is accessory you should buy.

The latest Skilsaw is a heavy-duty, quality product which reflects careful and good design. Weighing just 6½ pounds and measuring 12 in. long, it is an easy saw to handle. It performs with precision cutting accuracy for tight-tolerance trim work, yet it is the only Trim Saw we know of that can rip 2-by stock effortlessly.

Some features you will appreciate include an adjustable line-of-cut gauge which can be aligned for the blade in use regardless of kerf width, and sensible, heavy-duty, lock-lever depth and bevel adjustments which are easy to set, with clearly visible calibrations in ¼-in. increments.

The heavy-gauge steel wraparound foot is quite rigid and it doesn't flex under heavy hand pressure. The high-torque, 6.5-amp. motor is burnout protected and is mounted to the right with the blade on the left for good visibility of the cutting line (for the majority of right-handers). The 5½-in.-dia. blade gives a maximum depth of cut at 90° of 1-23/32 in. and 1-5/16 in. at 45°.

We were impressed with this saw and think you will be, too. Skil's 551 Trim Saw is priced at \$89.95, but you may find it for a few dollars less in some areas.

It is made by Skil Corp., 4801 West Patterson Ave., Chicago, Ill. 60646.  
—Rosario Capotosto and Harry Wicks

A young man with short blonde hair, wearing a military camouflage uniform, is smiling while working on a helicopter engine. He is holding a wrench and is surrounded by various mechanical parts and tools. The background is dark and industrial, suggesting a hangar or workshop.

# 67 VICTOR

**HELICOPTER REPAIR**

Learn the mechanics of flying. "67 Victor" is Army shorthand for an Army-trained helicopter mechanic. In today's Army, you can choose from over 300 career training areas, including over two dozen in aviation alone. Qualify, and we'll guarantee your choice of training. Which means you can serve your country in the way that best suits your talents.

So if it's not 67 Victor, it might be 68 Foxtrot.\*

**ARMY.  
BE ALL YOU CAN BE.**

\*Aircraft Electrician

For more information, call toll free, 800-421-4422. In California, 800-252-0011. Alaska & Hawaii, 800-423-2244.

Material, защищенный авторским правом

Lights Kings, 8 mg. "tar", 0.7 mg. nicotine;  
Lights 100's, 9 mg. "tar", 0.8 mg. nicotine  
av. per cigarette, FTC Report Dec. '81.

© 1983 B&W T Co.

Warning: The Surgeon General Has Determined  
That Cigarette Smoking Is Dangerous to Your Health.

**Take the road  
to flavor in a  
low tar cigarette.**



*Genuine tobacco flavor  
in Kings and 100's.*

# RALEIGH LIGHTS

# THE JEEP IS DEAD, LONG LIVE THE HMMWV!

It stands for High-Mobility, Multipurpose, Wheeled Vehicle—so devastating a 4×4 it could very well make the Army forget that there ever was a jeep.

BY MURRAY RUBENSTEIN

**A**fter more than 40 years of faithful service, the historic Army jeep is being retired, put out to pasture. How do you say goodbye to the end of an era, to the last days of an old friend? Since 1940, the jeep has stood as a symbol of Yankee guts and ingenuity—a runty little battlefield workhorse that was tough, dependable, easy to maintain, seemingly immune to the indignities of war, and ultimately beloved by all it touched, from foot-weary GIs to four-star generals.

Throughout World War II, the vehicle known officially as the M151 ¼-ton truck served with distinction on every front, in every branch of the armed services, and with every one of our Allies, including the Russians (who loved it, but

couldn't quite accept the fact that it was not made in the U.S.S.R.). Later, it soldiered on in Korea, Vietnam, Africa, the Middle East and many other remote and inhospitable outposts far from home. Along the way, it spawned a new breed of rugged, sporty, off-road civilian vehicles—the ubiquitous 4×4s that are popular today the world over.

Now the military jeep is being replaced. But why? If it's been so good for so many years, why get rid of it? The answer lies in the changing needs of war. For its day and purpose, the jeep was unsurpassed. But modern weapons systems have become bigger, heavier and more sophisticated, requiring larger crews to

*Jeep successor: New HMMWV mounts 40-mm grenade launcher, can also fire antitank missiles. Shown is AM General's entry, one of three in stiff Army competition.*



Wide variety of HMMWV configurations can be seen here and on facing page—all interchangeable on same chassis using add-on kits. At right are General Dynamics' mobile command post, fitted with sophisticated communications and detection gear, and its Hellfire missile carrier. Photo at far right shows GD's air-cooled diesel and swing-up hood that fully exposes engine and running gear for easy field servicing. Below are two ambulance modes—Teledyne's four-litter "mini" rig (top) and AM General's eight-litter "maxi" rig (bottom). Teledyne version has telescoping body that, when lowered, permits transport by helicopter.



man them and more auxiliary equipment to support them. Handling the TOW missile launcher, for instance, now requires two jeeps and a support trailer. The TOW (for Tube-launched, Optically tracked, Wire-guided missile) is the most powerful antitank weapon used by the infantry, and a single carrier for it is vitally needed. Other modern-day gear is also straining the little 4x4 beyond its practical limits.

While the jeep has a rated payload capacity of 1,200 pounds, it can actually carry only about 800 pounds when operating cross-country, and then not at top speed. In addition, the current jeep population is getting old. Of the 58,152 now in the Army's inventory, more than 20,000 are over 12 years old, their normal life expectancy. By 1985, more than 40,000—almost all of the present supply—will be nearing the end of their usefulness.

In 1980, faced with these grim prospects, the Army conducted a study of

Key survival features are shown below. Deep-water breather system (left) has extended intake and exhaust stacks that permit HMMWV to ford streams up to 5 feet deep. Run-flat tire (center) has rigid internal vane that continues to support vehicle if casing is ruptured. All three HMMWV contenders offer these two features. At right is AM General's rim-drive wheel, a clever innovation that raises axle to achieve high ground clearance with low overall silhouette.

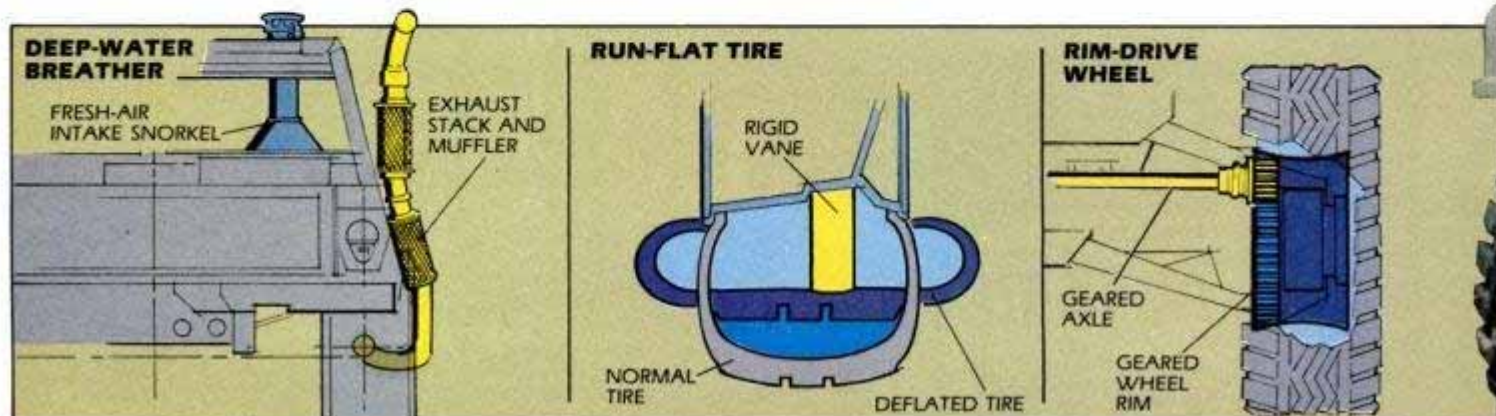





**HELLFIRE MISSILE LAUNCHER**



**AIR-COOLED DIESEL**

tactical vehicle requirements and concluded that, instead of replenishing its aging jeep fleet with more of the same design, what was really needed was a completely new vehicle. It would be larger, faster and more powerful than the jeep, with a considerably greater payload, more multi-role versatility, increased battlefield mobility and improved combat survivability. Instead of the jeep's relatively light ¼-ton rating, it would have a hefty 1¼-ton capacity (sometimes referred to as a ¾-ton rating).

The Army's designation for this ambitious new

concept is HMMWV (for High-Mobility, Multipurpose, Wheeled Vehicle). The closest you can come to pronouncing this mouthful of consonants is "Hum-vee," a name not likely to stick once imaginative and irreverent GIs get their hands on the vehicle.

But by whatever name the Humvee will come to be known, its advance notices are impressive. Like the jeep, it will have four-wheel drive, but the sim-

ilarity stops there. It will be longer than a jeep (195 inches compared to the jeep's 133), yet it will be several inches lower, making it less vulnerable to enemy ground fire. The Humvee will carry a 2,500-pound payload under combat conditions—three times the jeep's capacity. Designed to satisfy a wide range of battlefield requirements, it will also be a multiservice vehicle, serving the requirements of not only the Army, but the Marines and the Air Force, as well.

Using interchangeable body kits,

*(Please turn to page 174)*

*Pop-up gun turret can be raised and ready to fire in only seconds. It swivels 360°, takes TOW missile (shown here on AM General's Hummer), as well as other armament. Retracted (far right), turret is hidden.*

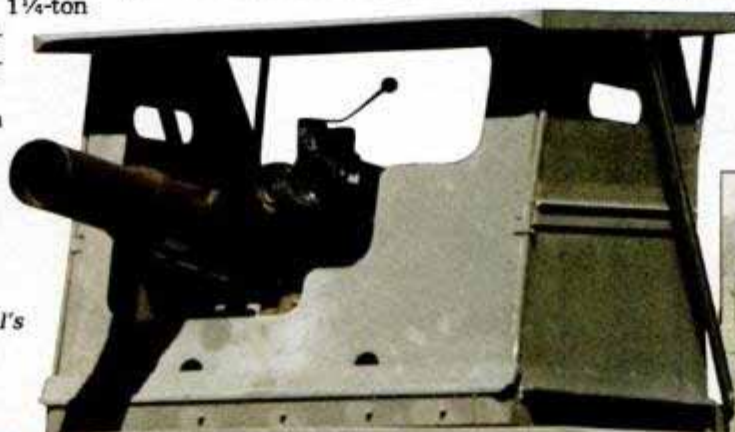

**TOW MISSILE LAUNCHER**



For spy missions, radar boom inside Skyship's envelope (below) can perform surveillance.



The support rigging (above) for Skyship's gondola is of Kevlar cable attached to load curtains.

# Airships Rise Again!

They float along ponderously, seeming relics of the past. But airships are making a comeback!

BY MIKE STOWERS

## Flying Golfball: The Airship Inspired By PM

It's often described as a flying manta ray carrying a basketball on its back. But maybe giant golfball would be a better word for the experimental heavy-lifter LTA 20-1. One of its designers, Frederick D. Ferguson, says the 20-foot-high airship was inspired in part by a PM article on the aerodynamics of a golfball (see *Golf's Secret Weapons*, page 78, Dec. '78). The craft's balloon, currently being scaled up to a diameter of 160 feet by Van Dusen Commercial Development of Canada, gets lift in three ways: from helium, from rotating fan engines and from the Magnus effect. To take advantage of the Magnus effect, the LTA 20-1 rotates on pins that connect the balloon to the tips of the manta ray's wings. A boundary layer of air forms around the smooth balloon, giving the whole craft enormous lift.—D.E.





*Skyship 500, now in service over London, flies at 10,000 feet with a 12-man crew and two-ton load.*

**O**n a chilly day last fall, a British Royal Air Force squadron went into alert status to investigate a flying object visible for miles with the naked eye, but which made only a very faint blip on radar screens. The massive object chugged along beneath the cloud cover, gliding right into the approach pattern generally used by the Royal family returning to London from trips to Balmoral Castle in Scotland. To the surprise—and relief—of just about everyone, the UFO turned out to be a friendly dirigible—an Airship 500 making a test run for Airship Industries.

"There's no metal in the structure," explains Reg Hillsdon, Airship's North American representative. "It's all plastics and composites. They stay well-hidden from radar."

Silent running is just one major feature bringing airships back on the scene. Various design configurations make helium-filled vessels front-runners for some futuristic assignments. Hauling lumber or other heavy loads, even taking the place of military spy satellites at less than one-hundredth the cost are among the possibilities. In the very near future, airships are expected to carry passengers around the 2,000 islands off Greece. There are airports on only a few of the islands so airships, which can land on very small and rough fields, will be competitive with airplanes. Airship Industries has sold three vessels to an Aegean touring company.

Airships have been out of the luxury passenger business for the most part since the German rigid vessel *Hindenburg* crashed in flames in Lakehurst, N.J., 46 years ago next month, killing 21 people. That tragedy and several military accidents helped end the much-heralded flying machines' popularity.

But the ships plying the skies today are far safer than even the safest airships of the past. (Incidentally, air-



*Goodyear, whose famous blimps are the only airships that are currently operating in the United States, has prepared this concept for a heavy-lifter.*

# Airships Rise Again!

ships had almost three accident-free decades at the turn of the century, but this fact is overshadowed by a few spectacular accidents.)

The new vehicles are filled with non-combustible helium instead of volatile hydrogen. And latest-generation plastics give the new airships the structural toughness of old-time rigid ships with the lightness of nonrigid vessels. The Skyship 500 in the middle of last fall's royal scramble carried two tons of load and a crew of 12 in its gondola. It moved around almost noiselessly, powered by two 200-hp Porsche engines at speeds up to 60 knots, and soared above 10,000 feet with a full load.

In a Toronto hangar, an Airship team is in the midst of assembling a Skyship 500 for testing later this year by the U.S. Navy. The dirigible will take about one week to meander along the Atlantic coast to Weeksville, N.C., where Navy pilots will be trained to fly it. Then the Navy plans to test the vessel as a radar platform, a sonobuoy-dragger for submarine hunting and a fleet escort vessel.

Even while the Navy puts the skyship through its paces, the Forest Service

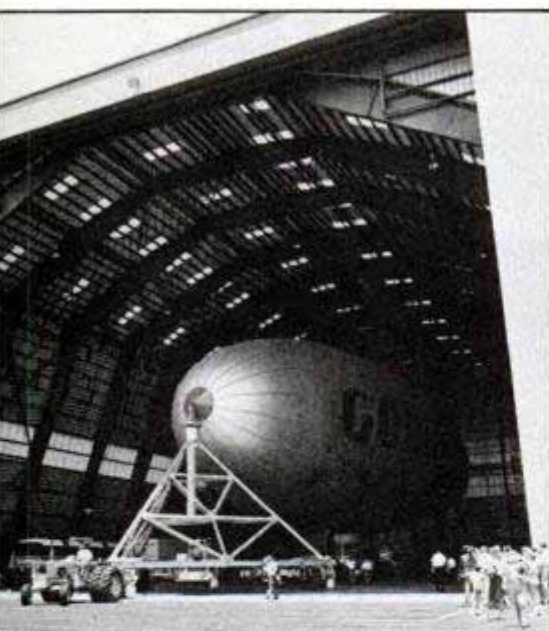

The large hangar space required by airships, such as those built for the Goodyear blimps (above) have discouraged potential airship users. Still, the airships are excellent candidates for flying radar platforms. Goodyear has added experimental radar to the *Enterprise* (right).



PM photo: Hal Denison

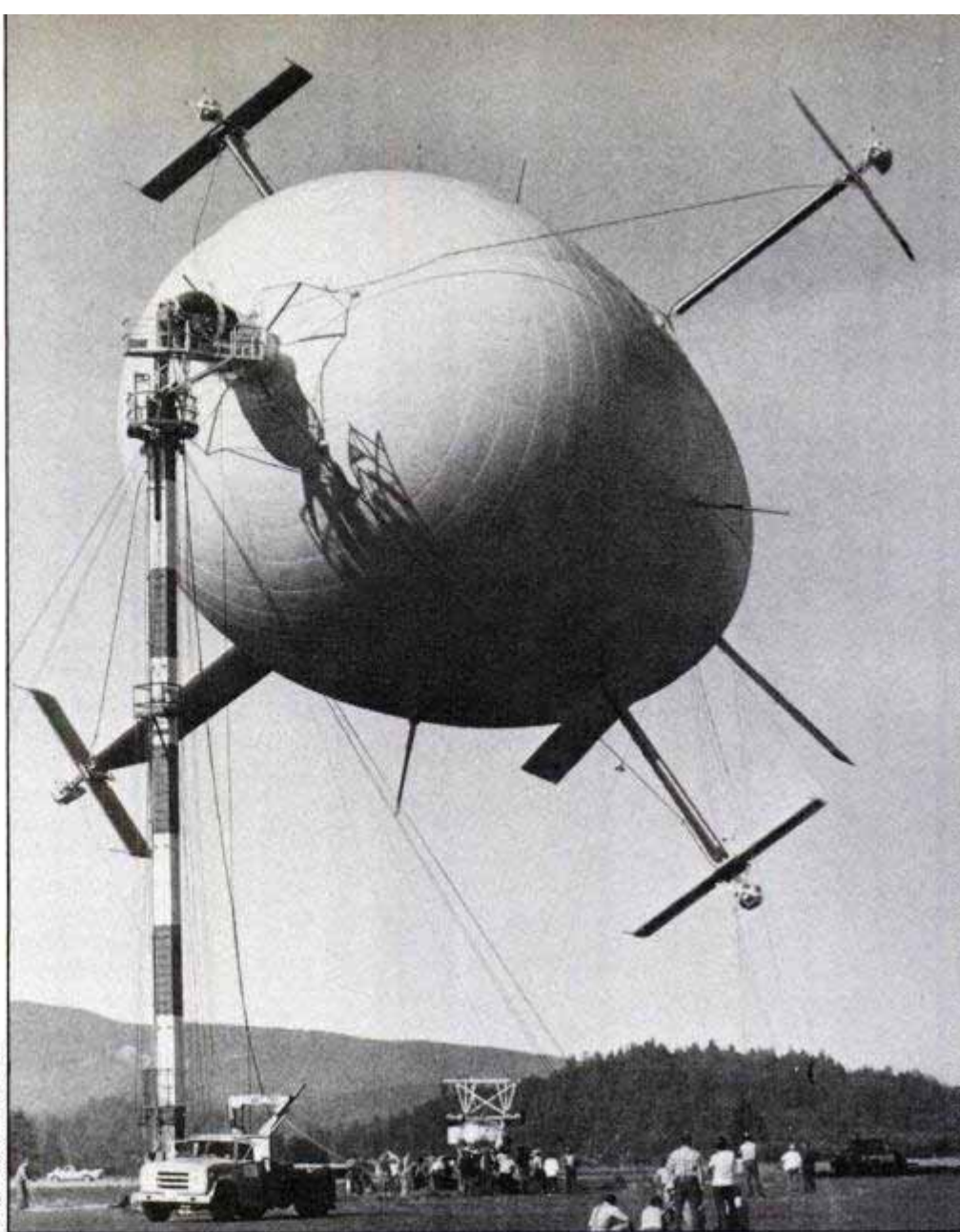

The Cyclo-Crane (above), its helicopter engines operating, and its nose cockpit instrumented, was flight-ready shortly before a storm dashed it against its moorings.

will be testing engines for a heavy-lifter called the Heli-Stat (photos on facing page) being developed by Piasecki Aircraft Corp. at Lakehurst. The lifter, still under construction at press time, is similar to one that crashed in a freak accident two days before its first scheduled test flight in Oregon last year. It also resembles a lifter still on the drawing boards at Goodyear Aerospace.

All of the lifters place helicopters or helicopter-like rotors at four corners of

a light frame that hangs under the airship. The propellers give the airship extra lift and greater ground speed as they haul tons of lumber or other heavy cargo. Goodyear's concept would use a 2.5-million-cu.-ft. nonrigid airship as its basic lifter. The Piasecki craft under construction uses 1.1 million cu. ft. of helium to lift a maximum 37 tons.

## Lifter destroyed

So far, the only heavy lifter ever completed was destroyed in a storm at its moorings in Tillamook, Ore. "The crew went home for the night and a storm blew up," says Hal Denison, who has photographed the Aero Lift Co.'s vehicle extensively. "When they arrived at the mooring site in the morning, the Cyclo-Crane was dashing itself against its own moorings. Apparently, it was pulled loose from a tether in a high gust."

Aero Lift, working with an \$850,000 U.S. Forest Service contract, is rebuilding the heavy lifter and will start tests

later this year. The lifter has a cockpit in its nose and can carry a gondola beneath the airship for more instrumentation or additional crew.

Other airship experiments in the works center on the vessel's potential as a radar platform. Goodyear has mounted a radar system on the airship *Enterprise*, demonstrating to the Coast Guard its maritime control capabilities in flights over the South Florida coast. The Navy, which last year commissioned Lockheed to develop a concept for an airship that can hover at 70,000 feet to perform the same tasks as a spy satellite, has also asked airship developers to come up with radar concepts.

On several certification flights, the Skyship 500 has been equipped with a radar boom mounted inside the main airbag which tested out successfully.

The Skyship envelope is laminated polyester sandwiched between layers of polyurethane and gas-retention film. The envelope fabric was designed for Airship by a French chemical company. Inside the envelope are two large bags that can be filled with air scooped in through lightweight pipes running to the outside of the skyship. These air bags—called ballonets—are made of Polyamide 66 woven fabric and coated with polyurethane spray. In flight, the ballonets have a maximum air capacity

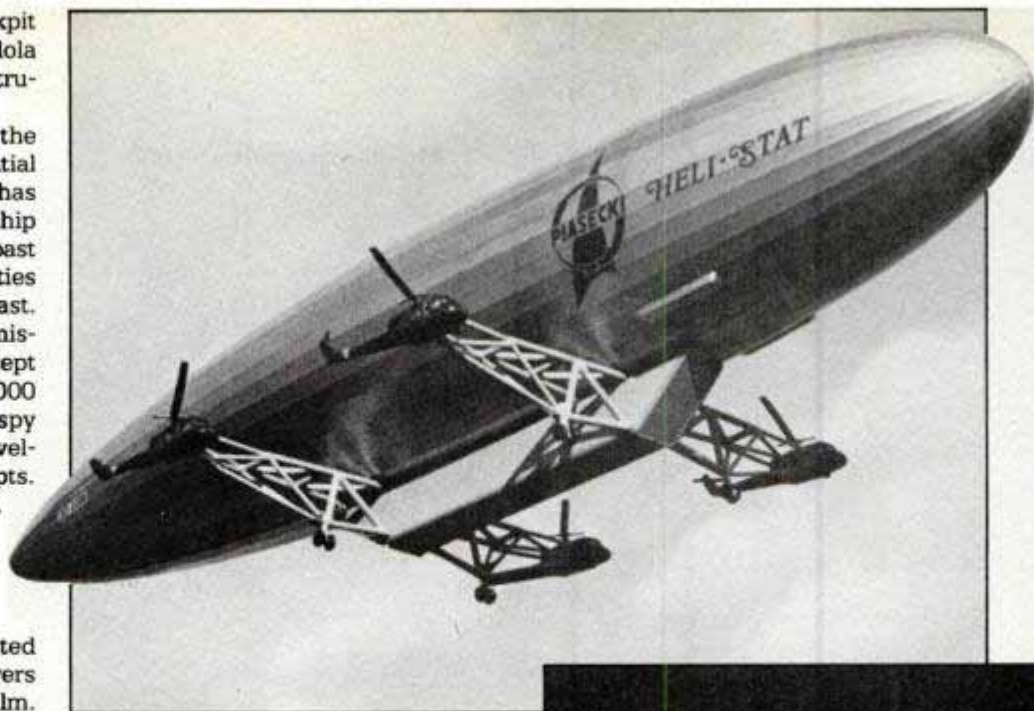

A model of Piasecki's heavy lifter (above) shows the four helicopters adding to the airship's lift and speed. The airship undercarriage (right) has been completed and the first chopper (below right) was mounted late last year.

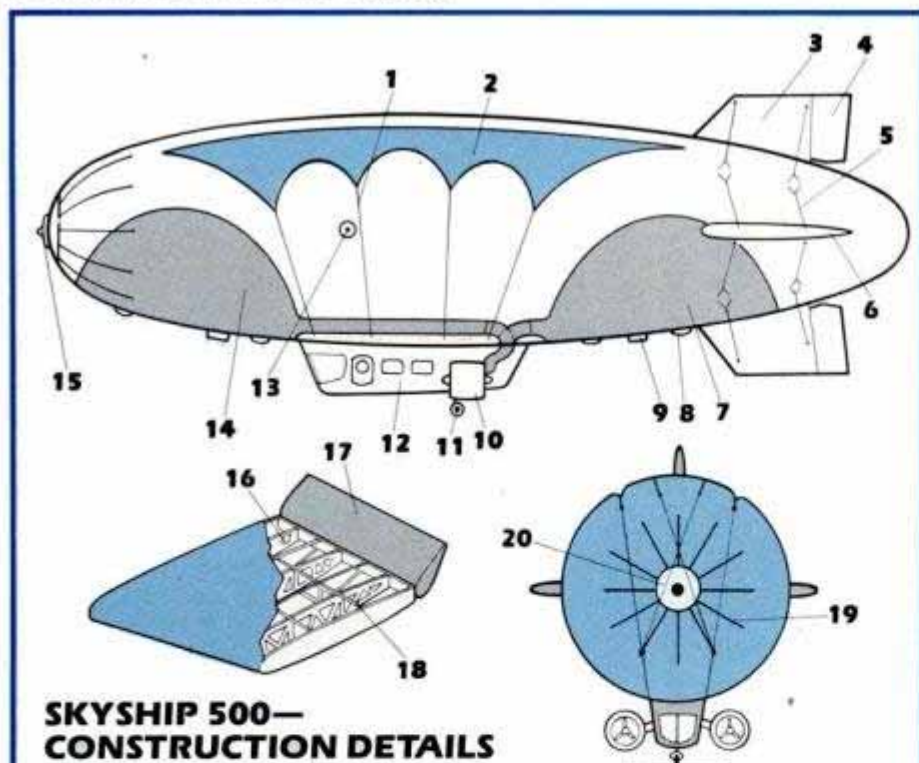
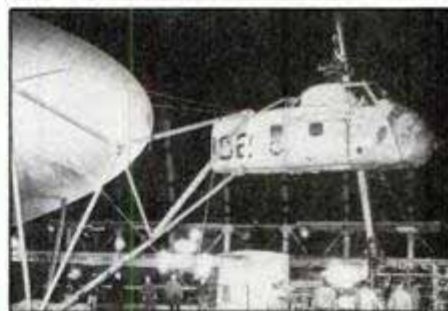

### SKYSHIP 500— CONSTRUCTION DETAILS

- |                              |                         |                                     |
|------------------------------|-------------------------|-------------------------------------|
| 1. Kevlar gondola cables (8) | 8. Ballonet air valve   | 15. Nose probe for tether           |
| 2. Gondola support curtain   | 9. Air blower           | 16. Nomex ribs                      |
| 3. Tail fins (4)             | 10. Engines (2)         | 17. Nomex rudder                    |
| 4. Plastic rudders (2)       | 11. Landing gear        | 18. Nomex spar                      |
| 5. Wire bracing for tail fin | 12. Kevlar gondola      | 19. Nose battens (externally laced) |
| 6. Plastic elevators (2)     | 13. Emergency air valve | 20. Molded nose cone                |
| 7. Aft ballonet              | 14. Forward ballonet    |                                     |

of about 40,000 cu. ft. each. They must be kept in balance—there's a ballonet fore and aft of the ship's gondola—to minimize surge, the sudden turning of the ship's nose sharply up or down. Also helping to keep the ship's flight stable are six 20-inch valves, two in each ballonet and two in the midst of the envelope.

### Ride like a submarine

Flying an airship has often been compared to running a submarine. The ship has to be kept as close to perfectly stable as possible or it will go into a killing dive. Of course, pilots who have flown the Skyship 500 think of it in gentler, more romantic terms.

"Flying a nonrigid is similar to operating a light aircraft," says Nick Bennett, chief test pilot for Airship. "You just need to know Boyle's law (stating that gases expand with heat and

*(Please turn to page 190)*

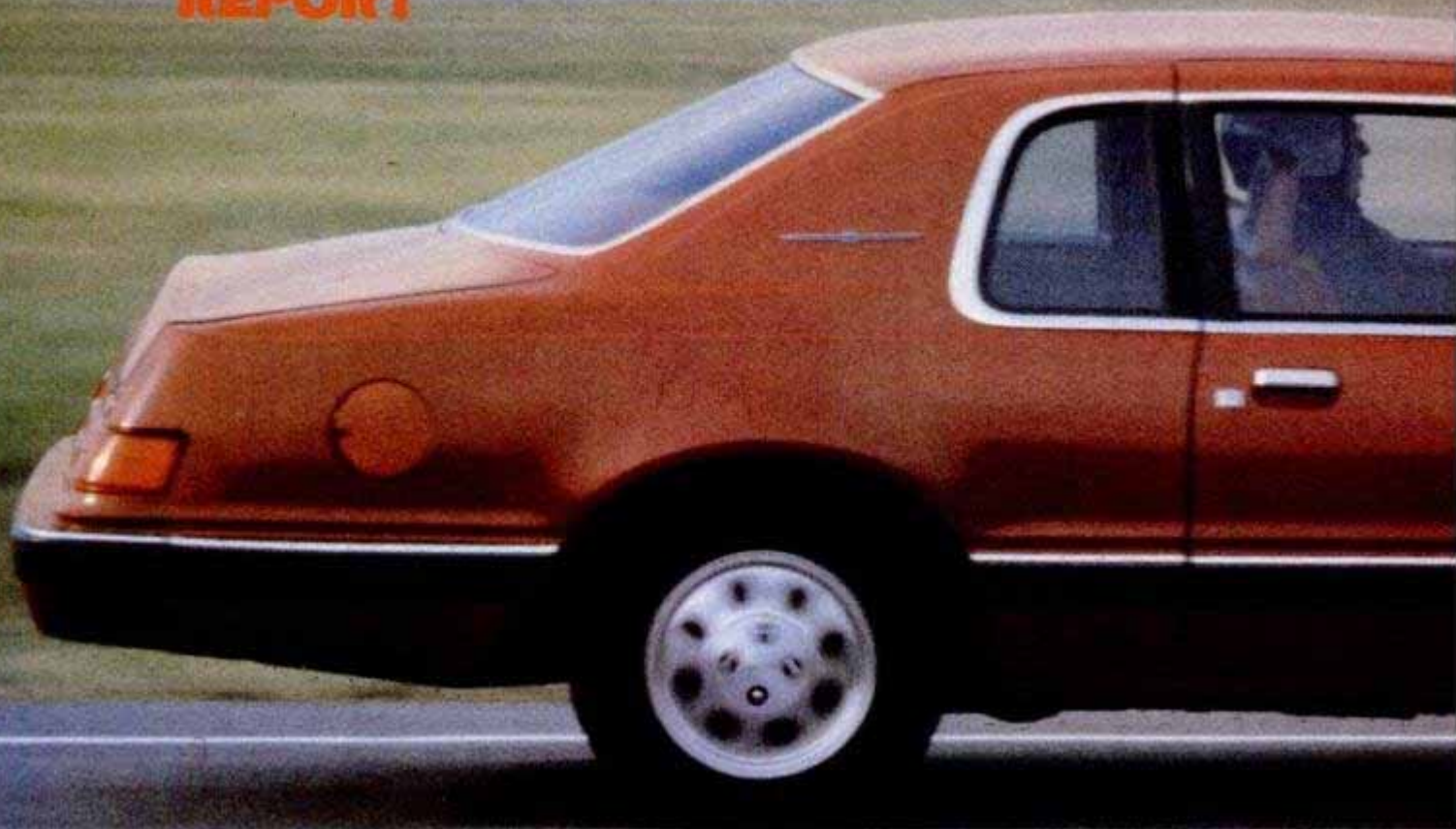

# Driving The Ford Tempo, Topaz And All-New Thunderbird

These '83s are more of  
the right stuff from Ford.

BY GARY WITZENBURG  
DETROIT EDITOR

**A** few months ago Ford introduced its stunning new Thunderbird and Cougar, downsized STD and Marquis family cars, and vastly improved Escorts and Lynxes. Now, it's time for the all-new, front-wheel-drive Tempo and Topaz compacts, a very impressive Turbo Coupe T-Bird and the Ranger-based Bronco II.

This is the second wave of exciting new '83 vehicles designed, engineered and developed under the "new" Ford regime of Board chairman Philip Caldwell and president Donald Petersen. There's not a turkey in the bunch.



*Tempo has all-independent suspension and transverse-mounted, 2.3-liter Four. EEC IV computer controls engine.*

The first thing you'll notice about the 99.9-in.-wheelbase Tempo and Topaz is their exceptionally clean, uncluttered, aerodynamic styling. These cars spent more than 450 hours getting their corners smoothed in wind tunnels, and they show it.

Doors are "aircraft-style," wrapping up into the roof (over concealed water drain troughs), and both windshield and rear window are sloped at a slip-

pery 60° from the vertical. With drag coefficients of .36 for the two-door and .37 for the four-door, they're slicker than GM's competitive J-car sedans and make the GM Xs and Chrysler Ks look like shoeboxes by comparison.

Ford Div.'s Tempo sedan is distinguished by its three-window profile, while Mercury's Topaz sports a Mercedes-like two-window design. These



Powered by a turbocharged, fuel-injected, 145-hp Four, T-bird is unlike its predecessors. Five-speed manual and 205 Goodyear Eagles make it more of a Euro-sedan than a traditional cruiser.

will compete with Toyota's Corona, Nissan's Stanza, Honda's Accord and Mazda's new 626 as well as the domestics noted above. The fairly rakish coupes, looking much like baby T-Birds, are intended to take on the likes of Toyota's Celica, Nissan's Datsun 200-SX, Honda's Prelude and GM's J-car hatchbacks, among others. Divisional identity is provided by different bum-

per, parking lamp and grille designs (the Tempo has body-color horizontal bars) in front and specific rear panel and taillamp themes in back.

The Tempo/Topaz interiors are nearly as tasteful and restrained as the bodies are smooth. The instrument panels are not quite European in character (stick-on wood grain still prevails in upmarket models) but a long way from

"Yankee flash" gaudy. An optional gauge package provides fuel and temperature dials between the large, circular speedometer and a matching tachometer, but the oil-pressure gauge and ammeter are console-mounted below the radio. Base cars have handy door bins and a small storage box above the radio, while higher-series models

*(Please turn to page 176)*



Part of Tempo's uncluttered, aerodynamic styling includes doors which wrap up into the roof. Tempo's Cd is a low .37.

# New Video Games

Now these video adventures offer three-dimensional, animated scenes of challenge and excitement.

BY NEIL SHAPIRO ELECTRONICS EDITOR



PM photos by the author

Views from bridge of your starship in Sublogic's game *Space Vikings* show animation that's so great you feel you've been transported to other worlds. Readouts below screen give overview of ship's condition. Once past planetary defenses, the pilot flies ship above a landscape grid watching for targets. Other screens (not shown) detail everything from ship status to galactic map.



# Put You In The Action

New games that flash their excitement through scene after shifting scene are cropping up everywhere that there's a video screen to view them on.

A typical video game used to feature a static scene in the background; only the "players" would move. Aliens would shift back and forth above your missile-firing gun—but the animation was confined to gun and targets. Now, things have changed into a complete orchestration of animation with set-

with a real feeling of "being there."

The next stage of simulating reality comes with the *Turbo* game (also arcade and Colecovision). In this one, you're seeing a completely 3-D view of the scenery rushing at you, much as you might see from the windshield of a real, speeding racer.

Already, games such as these are a far cry from static backgrounds and repetitive play. But the next stage of video play is now showing up in home computers and will probably be finding

ples of this new philosophy of total gaming involvement in as complete an environment as possible. They foreshadow what we think will be the next big wave in video gaming.

In *Space Vikings* the player is in complete control of a starship. The displays that he sees on screen seem to us very similar to the displays that a real starship commander might be watching. The animation is superb as you pilot your starship closer to the enemy planet. Meanwhile, you keep track of every-

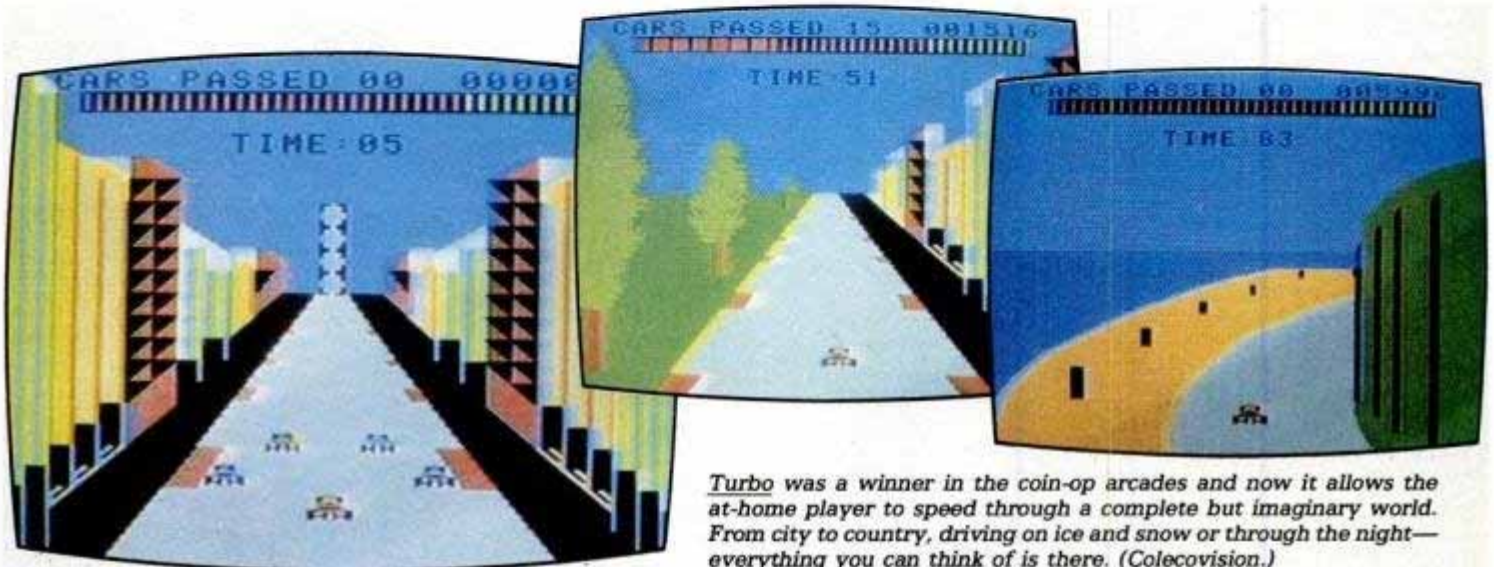

*Turbo* was a winner in the coin-op arcades and now it allows the at-home player to speed through a complete but imaginary world. From city to country, driving on ice and snow or through the night—everything you can think of is there. (Colecovision.)



*Ultima II* from Sierra Online is incredibly detailed. Movement on the main map of the world (left) can take you into castles (center), dungeons (right) and literally hundreds of other places on a quest through both Time and Space. (Apple II.)

ting—the latest games resemble stage plays with complete scenery changes.

In some, such as *Zaxxon* (available both in the coin-op arcades as well as a home version for the Colecovision game) the scenery scrolls by "below" you as you fly three-dimensionally above the video landscape. These scrolling-landscape games provide you

its way into the video game cartridges soon. These new games are so complex, so detailed and so incredibly real that they boggle the imagination.

## Detail upon detail

*Space Vikings* from Sublogic and *Ultima II* from Sierra OnLine (both for the Apple II computer) are prime exam-

thing ranging from damage control to your crew's morale via many different auxiliary screens of computer readout. The bottom line is that the game features just about as much real-life feedback as you could get without feeling the actual vibrations of the engines.

Other games, such as *Ultima II*, do [\(Please turn to page 186\)](#)

# DODGE CHARGER

*"Eliminate the back seat. It's useless!"*

MINNESOTA MANAGER

*"A whole lot of fun to drive under any conditions."*

MAINE GROCERY DISTRIBUTOR

*"Sharp-looking, very fast for a Four, good gas mileage."*

MICHIGAN REPAIRMAN

**"SOMETIMES HAVE TO FORCE TRANSMISSION INTO FIRST OR REVERSE."**

MAINE TELEPHONE OPERATOR



It's fast, fun and economical, and owners love their nickel rocket.

**"A** good-looking, have-your-cake-and-eat-it sporty car," exclaimed a young Michigan design engineer, "with very impressive acceleration and equally impressive fuel mileage. Where else can you find a front-wheel-drive car that's made in America, is cheaper than the competition, and has a five-year, 50,000-mile warranty?"

That paragraph pretty much sums up what most owners like about the 1982/



*The cockpit, with its dished four-spoke wheel, matches the car's sporty looks.*

83 Dodge Charger. Not only were about 72 percent of the buyers we surveyed attracted by the car's looks, but

53 percent praised its economy, and 24.2 percent commented very favorably on the Charger's strong acceleration. That's an unusual combination—sporty looks plus mpg plus performance. It's not often that all three come together in the same automobile.

Basically, the Charger coupe uses the mechanicals and body platform of Chrysler's Omni and Horizon sedans. For 1982, Dodge offered a base model, called the 024 Miser. Above that came the Custom 024. Both used the Volkswagen-built 1.7-liter overhead-cam Four.

Last year's Charger 2.2 marked the hot ponycar of the line and carried Chrysler's own 2.2-liter ohc engine. It's

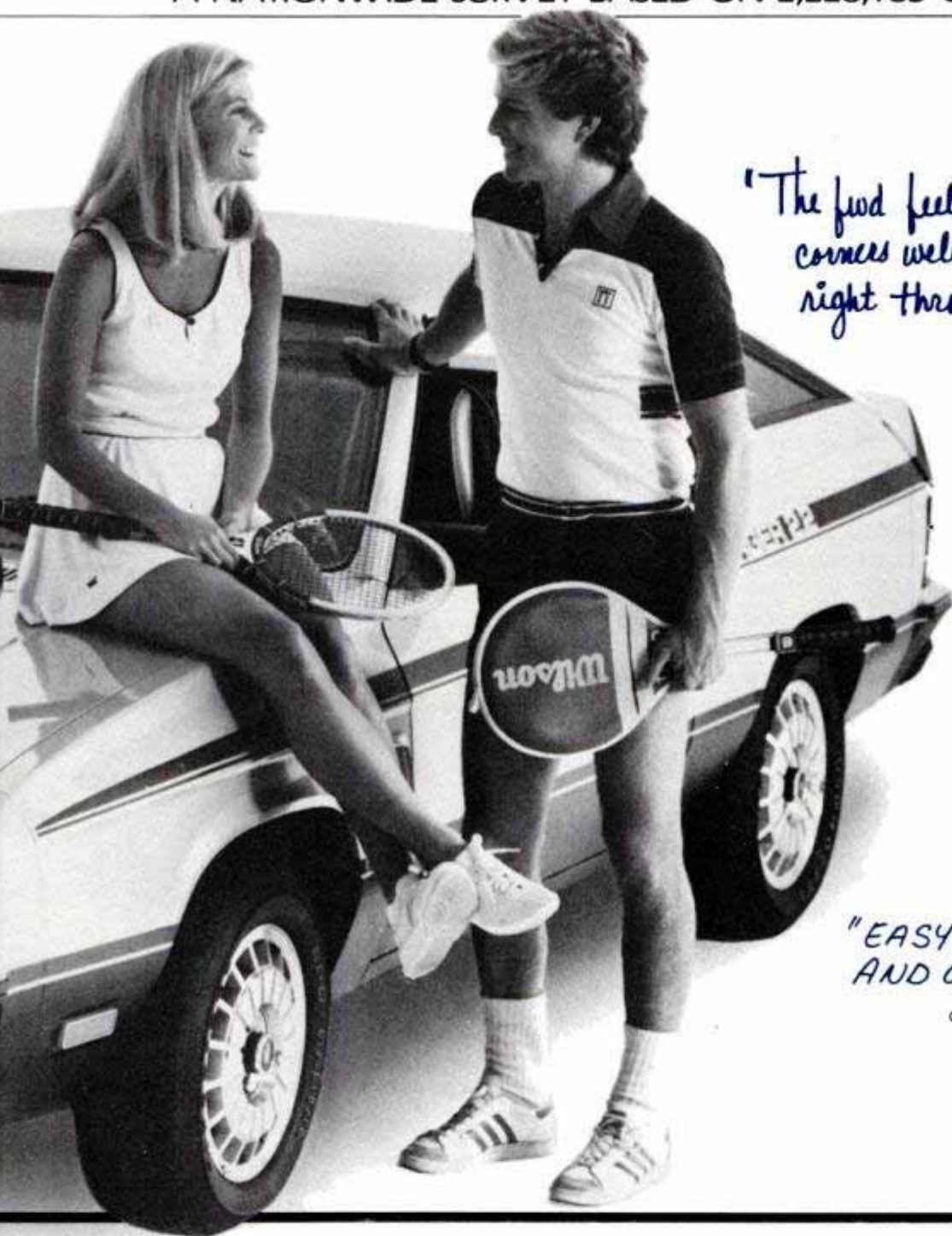

*"The fwd feels stable on the road,  
corners well, plows  
right through the snow."*

MONTANA DAIRYMAN

*"EASY ACCESS TO PLUGS  
AND OIL FILTER."*

OHIO INSURANCE SALESMAN

PM photos: Bill Ashe

this powerplant that gives Chargers their snap. This year, the 024 name has been dropped and all versions are called Charger.

There's the base 1983 Charger, with a Peugeot-built 1.6 engine, plus the Charger 2.2 and the Shelby Charger. Chrysler now offers a five-speed transaxle and has upped the 2.2's horsepower from 84 to 94, with 107 in the Shelby.

A West Virginia salesperson: "It's a very peppy car, and I love the way it handles. It's comfortable and easy to drive, with a good factory stereo system and a convenient hatchback."

Throughout their comments, many owners emphasized basic, simple val-

ue. No one accused the Charger of being the world's greatest car, but purchasers continually compared this cou-

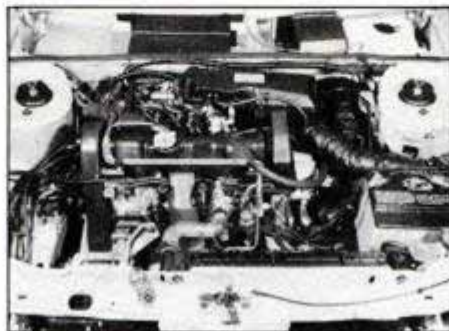

Owners love the Chrysler-built 2.2-liter Four, which combines power, economy,

pe with its competition, and the Charger mostly won.

For example, a Colorado engineer added, "I carefully weighed performance, style and economy against price. When analyzed in a studied way, no other car comes close to the Charger 2.2 in terms of value, including the VW Scirocco, Honda Prelude, Ford EXP, Mercury LN7, Toyota Celica and Renault Fuego."

A Tennessee book layout apprentice echoed, "I tested a number of cars before selecting the Charger. First, I took out a new Camaro Z-28, which listed for \$12,530. Next, I drove a new Capri RS with the 302 V8. That one had

*(Please turn to page 192)*

# PUT YOUR OWN PROJECT ON THE

**If PM picks your experiment to go on the Space Shuttle, you'll fly to Florida free to see it launched!**

BY DENNIS ESKOW SCIENCE EDITOR

If there's any pioneering spirit in you, hang onto your seat—you're about to get invited aboard the Space Shuttle. Think of it as "T-minus three months and counting." PM has purchased space in the cargo bay of the Shuttle, and we're inviting you to think up an experiment to send into orbit. The winner of this competition and a friend or relative will be flown free to Florida to watch the launching, then on to Houston to join ground control in monitoring the Shuttle mission, and finally to California or Florida to watch the Shuttle touch down.

We're the first magazine in our field to join NASA's Getaway Special (GAS) program, but we probably won't be the last. At this writing, more than 400 universities, corporations, private individuals and one Japanese newspaper have purchased the right to fly an experiment. We have ticket No. 68, which means your experiment could be launched within a year after we start putting it together.

Your travels to the launch, mission control and landing will be sponsored by the Bushnell Div. of Bausch & Lomb. The winner also will receive Bushnell's Criterion 4000 telescope, an outstanding reflector scope. The runner-up will win a Celestron C-90 spotter scope, a compact telescope well suited for plane-



## COMPETITION RULES

### Phase 1

**1. Entries should be typewritten or block-printed on a single sheet of white paper.** Your name and full address should be centered at the top of the page.

**2. Experiments should fit inside a 2.5-cu.-ft. canister and weigh less than 60 pounds.**

**3. Any experiment involving plant or animal life should explain how life would be sustained,** since we're traveling in the airless cargo bay.

**4. No project involving lithium batteries will be accepted.** NASA won't allow them on the shuttle. Small, commercial-quality NiCd packs and off-the-shelf batteries for microprocessor systems are the best.

**5. Materials should be able to withstand temperatures up to 200° F. and gravitational forces of 4 g—**four times the gravity of earth. They also should be able to handle noise levels of 145 decibels. Vertical acceleration of

4 g, forward acceleration of 1.8 g and lateral acceleration of 1.2 g may occur at the same time with some Space Shuttle maneuvers.

**6. Some structural plastics and composites may outgas and deteriorate in a vacuum.** The idea you submit should take this into account.

**7. On touchdown, cargo bay temperatures could rise to 180° F.** Forced air circulated around the bay at about room temperature should keep it cool, but some provision should be made for sudden temperature variations.

**8. Your experiment will be kept in storage a maximum three months before and a minimum three weeks after launch** at room temperature and prevailing moisture conditions.

**9. Experiments involving possible dangerous substances—such as explosives, or possibly dangerous configurations, such as gas containers—should pro-**



### VALUABLE PRIZES

Win PM's Space Shuttle competition and you'll get an expense-paid trip for two to Cape Canaveral for the launch. Then you'll fly to Mission Control in Houston and, finally, go on to either Florida or California for the landing. You'll also win a Bushnell Criterion 4000 telescope (far left). It's a twin to the Dynamax, which we praised last year (see *Back-Yard Voyage To The Stars*, page 86, June '82). Runner-up wins a Celestron C-90, also highly rated last June.

# SPACE SHUTTLE!

Winner's experimental apparatus will be sent into orbit in this 2.5-cu.-ft. canister.

3-D CAMERA

SOLAR BALLOON

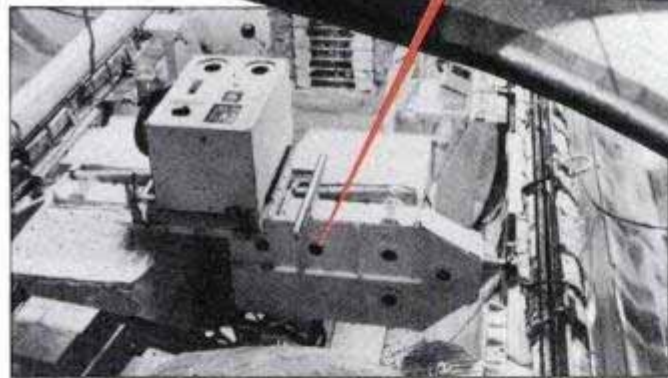

PM's canister will be loaded on a cargo bay pallet (left). Possible experiments could use solar balloon, 3-D camera.

**vide for safety to the vessel and bay area.** Most shuttle systems require a safety factor greater than one, meaning you must provide for basic safety with backups to reduce the chances for failure.

**10. All proposals for multiple experiments should include proposals for monitoring the experiments.** Telemetry, or any equipment that beams a radio signal to earth, is generally not permitted in the cargo bay area. Multiple experiments may be turned on and off by conditions in the bay area, such as sudden gravitational shifts or sudden changes in temperature.

Regardless of the number of experiments we carry, the astronauts will be permitted to throw our command switch only twice. That is why all experiments have to feed off the common switches.

**11. All entries become the property of Popular Mechanics,** which reserves the right to print all or part of the entry and the author's name. Devices designed for this mission may be patented by PM or one of the participating institutions with PM's permission.

**12. All entries must be postmarked by midnight, July 30, 1983.** Only winners will be notified. No entries will be returned. Sorry, but the volume of mail may prohibit us from answering inquiries.

## Phase 2

The top 25 entries from Phase 1 will be entered into the second phase of the contest automatically. Finalists will be notified in late August and receive more detailed information on the experimental conditions. Each finalist must then write an expanded version of his proposal—to a maximum of 10 pages, including illustrations. The final proposals must be submitted to PM postmarked no later than midnight, Dec. 1, 1983.

If there's room in our canister, PM may send the second-prize entry aloft with the winner. In addition, the experimental apparatus may differ from the submitted proposal. PM reserves the right to construct the final version under its direct supervision.

tary or lunar observations. More prizes will be announced in coming months.

Thinking up experiments to put on the Space Shuttle is exciting and mind-expanding. We've already toyed with a few concepts to help you organize your own thoughts. *Shuttle Program Debut Was A Real 'GAS'* (see story below) describes one project

launched in a container similar to ours last year.

The story's author, Herbert Fox, is vice president for engineering and research at New York Institute of Technology, which will build PM's experimental apparatus as suggested by the winning reader. Other institutions will be working with us on specific areas of design of the final experiment.

We'll be reporting on their work in future issues.

Whatever the experiment, it must fit inside a 2.5-cu.-ft. canister, and must weigh 60 pounds or less. Our rules (see page 102) spell out the major constraints and possibilities, but consider some of the proposals we've already dreamed up to help you visu-

*(Please turn to page 191)*

## SHUTTLE PROJECT

### Shuttle Program Debut Was A Real 'GAS'

**H**ard work and perseverance by a team of Utah State University students helped send the first Getaway Special (GAS) project into orbit aboard the Space Shuttle last June. The 5-cu.-ft. canister—19.75 inches in diameter and 28.25 inches high—was donated to the Utah students by Gilbert Moore, an executive of Thiokol Corp., which makes the solid-fuel boosters that carry the Shuttle into orbit. The canister carried a total of 200 pounds. (PM has purchased a smaller canister space of 2.5 cu. ft. and 60 pounds.)

The students rigged up the canister to carry nine experiments, including one on the effects of low gravity on soldered joints, which I investigated at length. Other experiments included development of test hardware for conducting automatic analysis of green algae growth in orbit, the calculation of heat-conducting abilities of an oil-water mixture, and the study of the effects of low gravity on metal alloys.

The Utah Payload Actuation and Control System (PACS) monitored and controlled the multiple experiments with a 2 million-bit, low-power (100-megawatt) digital recorder.

The microgravity soldering experiment used PACS to control four separate heating and temperature-monitoring systems, with each melting 24 solder samples. The systems worked off a common (battery) power supply.

#### How it works

When the astronauts flipped the bipolar switch in the flight deck, it activated the heaters, which melted the solder samples on a copper foil. Whenever a temperature above 525° F. (oven temperature) was sensed by a device inside

the canister, the heater turned off instantly. If no oven temperature was sensed, the heat shut off 15 seconds after it started.

The heaters were mounted on printed circuit board material. Each was composed of a Kapton-insulated heating foil bonded between a layer of copper foil and a fiberglass insulating layer. The bonding agent employed was a silicon adhesive manufactured by General Electric.

The payload is currently being analyzed for trapped pockets of flux, and the solder points are being compared to those similarly created on earth. The experiment may prove useful in any future GAS projects which call for soldering as an incidental, but important, part of the mission. —Herbert Fox

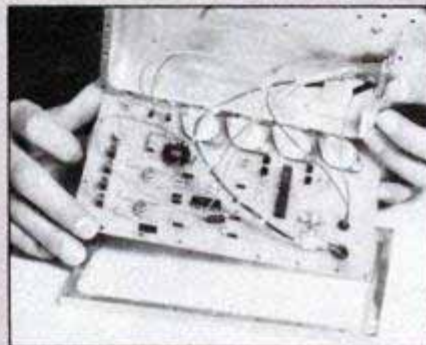
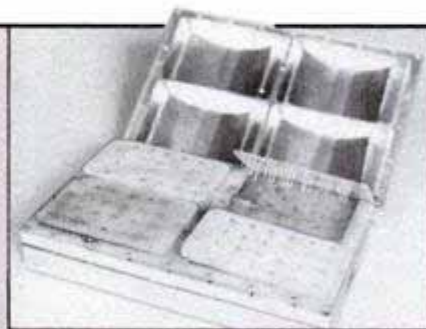

*The Utah State experiments featured low-gravity soldering kit (above top), which was capable of soldering 24 points at one time. The control circuitry (bottom) could stop the soldering process in seconds.*



PM photos: James K. Huffaker

*A Utah State team member works on the circuits which operate the payload control system. The testing equipment placed on top of the 5-cu.-ft. canister helped team in preflight trouble-shooting.*

# FIRSTHAND REPORT

*Mercedes-Benz 190, the European-market model which we drove in Spain, will arrive here in the fall with a different engine, designated as the 1984 220E.*



## Driving The Mercedes 190 And BMW 318i

When you're talking *blitzwagens*, smaller never means cheaper.

**Y**ou know you're in a Mercedes. It feels like every other Mercedes-Benz automobile you've ever driven. The engineers have seen to that. Same solid, weighty feel. Same road-flattening, press-on-regardless stability that you've experienced in a dozen other Mercedes models. Even the same steering wheel and general interior layout.

But this one's different. Very different.

First of all, it's quick. In fact, it's one of the quickest you've driven in a long time. On a deserted road out here in the hinterlands of Spain, where you've come to be part of the worldwide press introduction of this car, you've racked up several 0-to-60-mph times of just over 10 seconds. One run seemed like a 10 flat. Yes, other Mercedes-Benz cars are great, once you're on a roll. But off the line, they are quite lethargic. This one's different. Rev it up, dump the clutch and you're gone. You can get rubber going into second, too, if you shift quickly enough and declutch at precisely the right instant.

*Declutch? A clutch? In a Mercedes?*

Yes. Remember, this one's different. Up to now, the only Mercedes you've ever seen with a clutch was a lowly 240D with its tractor-like performance. And you've done your darndest to stay away from them. But now, here's a Mercedes-Benz with a clutch and a stick shift, a five-speed if you like, and all the performance of, well, yes, let's say it, a sports sedan from BMW.

Say that around a Mercedes-Benz public relations man and he'll tell you that his company has no intention of competing with BMW, in car concept or in price. In price, he's right. By the time this new, small Mercedes-Benz 190 (it'll be called the 220E in the United States) hits American shores, the price will be a staggering \$24,000.

In concept, though, the comparisons will be inevitable. This new Mercedes-Benz is sized right near a BMW 318i, and the 318i and its predecessor, the 320i, has long been a benchmark of performance for small, two-liter, sporty sedans in this country.

The engineers have told you that the 1,997-

cc, overhead-cam, four-cylinder engine you've experienced in both carbureted and fuel-injected versions here will not be available in the U.S. model. Instead, we'll be getting a fuel-injected version of the 2.3-liter Four formerly used in the old Mercedes 230 models. Later, a diesel engine option will join the lineup. The larger 2.3-liter engine will be used to compensate for the addition of power-robbing emission controls to be installed on the U.S. engine.

If it performs like the European 1.9-liter version, American buyers should be well satisfied with the performance

*(Please turn to page 178)*



*Although it's all new, the 318i looks a lot like the 320.*

## PM OWNERS REPORT:

BY MICHAEL LAMM WEST COAST EDITOR

# CHEVROLET CAMARO

*"The styling of a sports car,  
good passing performance,  
excellent stereo."*

ALABAMA SECRETARY

*"Exhaust system hits body,  
creates banging noises."*

OHIO ENGINEER

*"Dealers need to be educated  
on the importance  
of decent service."*

MASSACHUSETTS PROGRAMMER

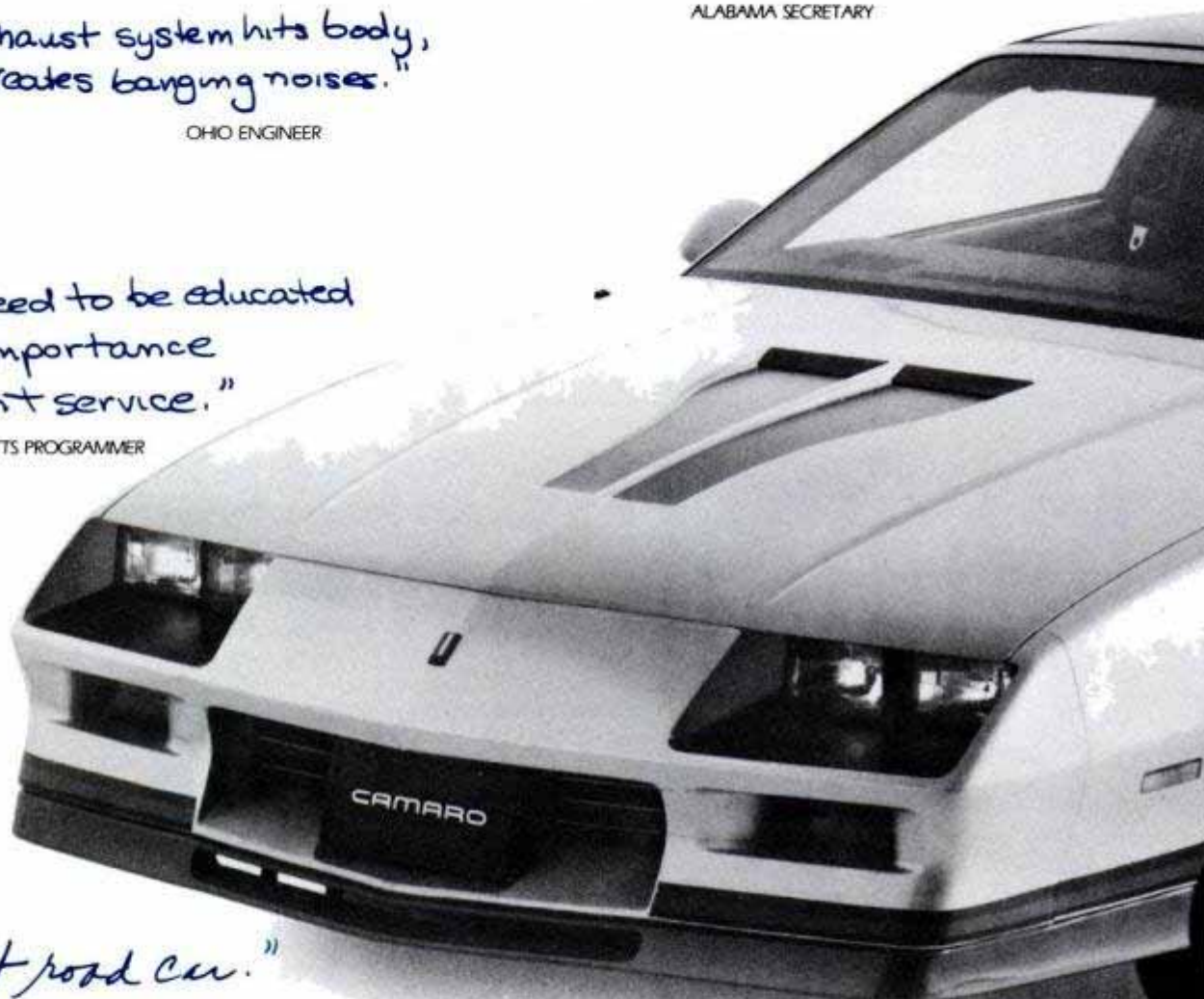

*"An excellent road car."*

CALIFORNIA ANALYST

Looks seduced buyers,  
but it's the great handling  
that keeps them satisfied.

**Y**ou don't have to look far to know why people buy new Camaros. Styling tells the story. Chevrolet's Camaro and its cousin, the Pontiac Firebird, have both been bright spots in a lackluster automotive sales year, and there's basically one reason: People like the way GM's ponycars look.

Nearly 90 percent of the 1982-83 Camaro owners we surveyed listed "styling" as their No. 1 reason for purchase. That unsurprising figure is very



*Front-seat room and comfort got good grades. Rear seats didn't do so well.*

close to the 82.7 percent logged by the new Firebird (see *PM Owners Report: Pontiac Trans Am*, page 150, Jan. '83). To give you some idea of the enthusias-

tic response to the new Camaro's design, here's a sampling of love letters.

A New Hampshire industrial safety instructor observed, "I like the stares I get from passers-by. My Z-28 serves me as a businessman's sports car."

A North Carolina truck driver: "Best-looking and best-handling car on the road today!"

A Texas lab assistant: "It's a very sharp-looking car. I fell in love with this white-and-gold Z-28 at first sight. Besides, it handles just beautifully!"

Handling ranked right behind styling in our "Specific likes" category, and a Massachusetts U.S. Navy aviator confided, "The Z-28's handling beats the



A NATIONWIDE SURVEY BASED ON 1,317,594 OWNER-DRIVEN MILES

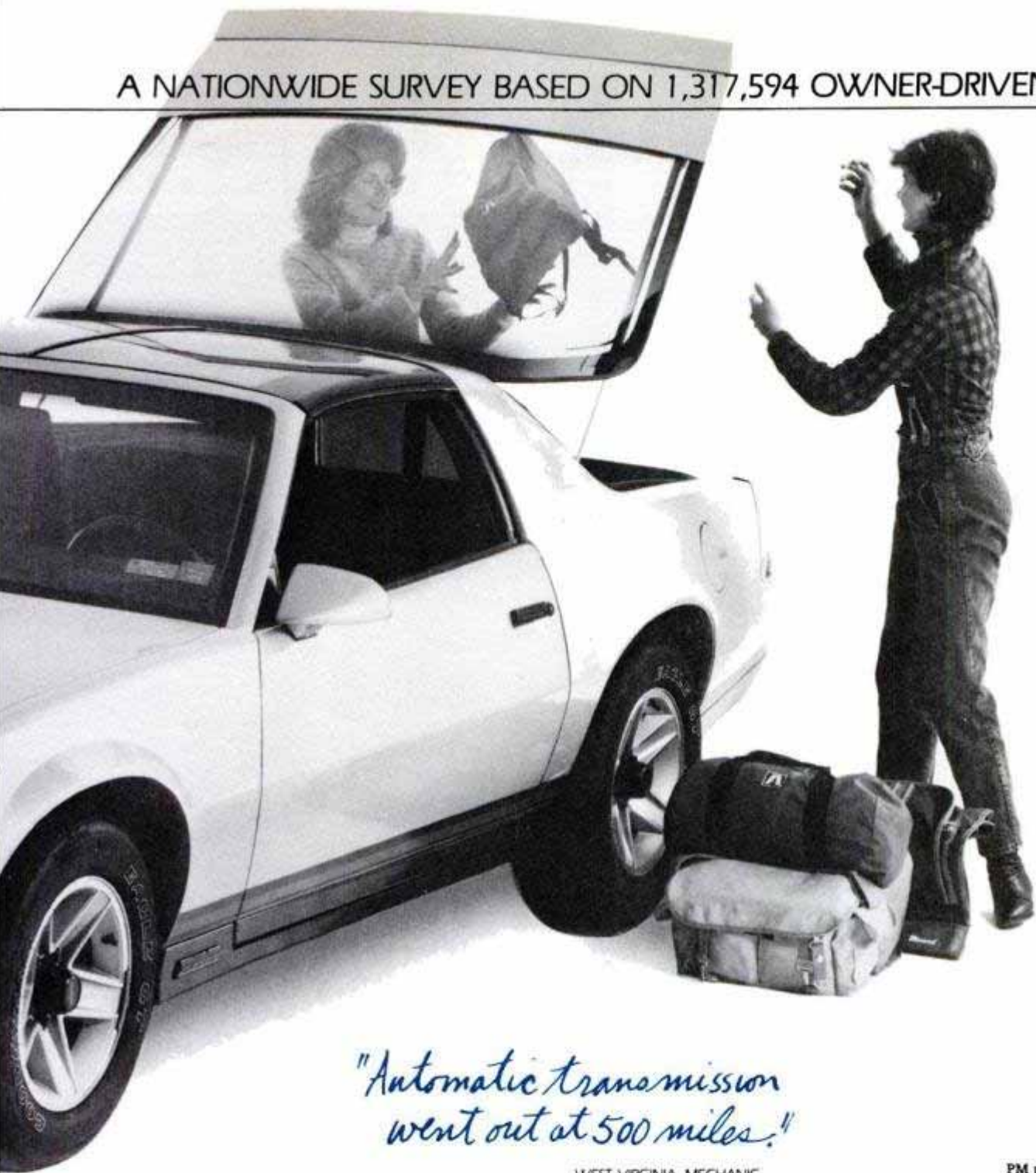

*"Automatic transmission  
went out at 500 miles!"*

WEST VIRGINIA MECHANIC

PM photos: Bill Ashe

imports, yet the car costs \$1,000-\$6,000 less. I shopped for over a year, comparing the Z-28 to the Boss Mustang, Mazda RX-7, Celica Supra and Datsun 280-ZX. The Mustang was faster off the line, but not by much. It cost \$2,000 more and didn't touch the Z for handling. And the others were just too expensive. For my money, the Z-28 is the best car on the road."

A Michigan hospital orderly said, "I'm just delighted to own the '82 Camaro Z-28. It handles like my brother's Corvette, but without the harsh ride, and I think it looks better. Construction is very good. Everything fits and looks nice, inside and out. Good attention to detail. After all the talk

about American cars being thrown together, the Camaro is a nice surprise."

In all, 74 percent of our respondents rated workmanship good to excellent.



*Most thought V8 provided "decent" power, but some felt it wasn't enough.*

That's not a remarkably high figure, but it is four points above the Trans Am and about average for Detroit-built cars.

However, 61.4 percent reported mechanical troubles—mostly of a minor nature. But a 61.4-percent repair rate is considerably higher than most of the cars we report on. The greatest problem area seemed to be the transmission.

"A nut on the shift lever fell off, causing the gears to lock," complained a Maine accountant. Nor was a Massachusetts water worker alone when he pointed out, "The transmission gasket didn't seal due to a burr on the mating

*(Please turn to page 181)*



# Build Our Master Craftsman's Toolbox

This beauty was built by a craftsman to hold his prized tools.  
Using PM's exclusive plans, you can build your own.

BY WALTER E. BURTON



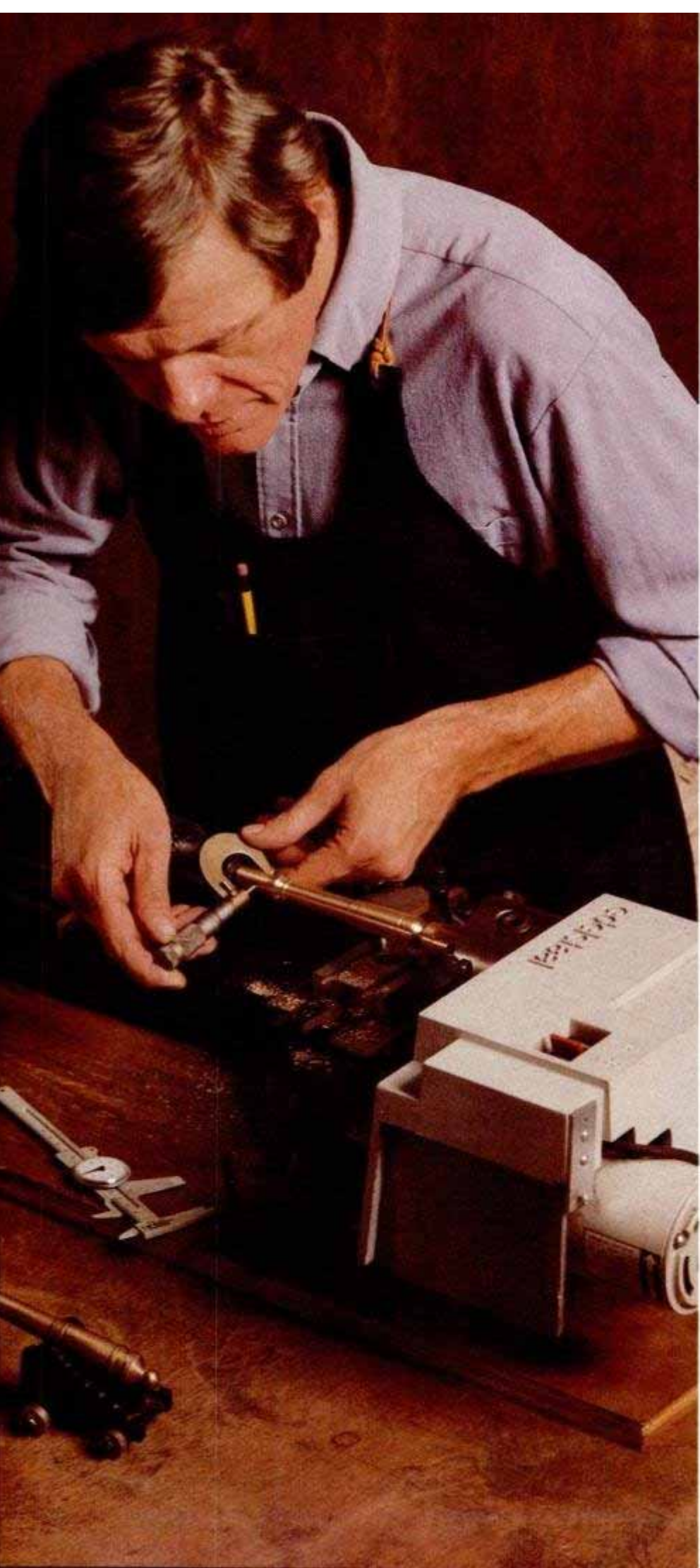

*Our solid cherry toolbox with brass hardware is handsome enough to grace any living room or den. It's equally at home in the shop for storing fine tools.*

**O**ld wood toolboxes originally designed to hold micrometers, gauges and other machinist tools have become valuable items at antique shows. Although similar toolboxes are still manufactured, the design and quality of the old boxes have made them more popular than ever. Nowadays, old machinist toolboxes are used for such purposes as storing camera equipment, hobby collections and jewelry, as well as tools. It's not easy finding an old toolbox in good condition, so build a replica, using our plans.

Many of the antique boxes were made of walnut, oak or other hardwood. We used 1/2-in.-thick cherry from The Woodworkers' Store (see materials list at end of story). The toolbox is finished with a cherry stain and satin varnish. The hardware can be either brass or brass-plated.

To obtain the full-width panels for the toolbox top, bottom, sides and back, it's necessary to edge-join two 5-in.-wide cherry boards. The edge-joints are cut on a table saw with a molding cutter head fitted with glue-joint cutters. This shape requires just one pass per board to produce mating edges. After shaping all the edges, apply glue to the joints and clamp each panel. After the glue has dried, finish-sand all pieces and cut them to size.

Box joints are used at the lid corners and to join the bottom to the sides. The box joints are cut on a table saw with a 1/4-in.-wide dado head.

Notice that the back panel receives a 1/8-in.-deep  $\times$  1/2-in. wide blind dado (a dado contained within the piece, not plowed to an outside edge). The side pieces receive stopped dados (dados plowed into one edge, but not through to the other). Cut the dados with a router and a 1/2-in. mortising bit. When the box is assembled these dados will hold the top compartment's plywood bottom. Install the partition centered on the underside of the compartment bottom by screwing down into the partition.

Dry-assemble the main box, checking that all joints fit properly. To temporarily hold the box together, screw the upper compartment in place with 1 1/4-in. No. 6 fh screws. Be sure to position the screws so that the brass corner

PM photos: Color, George Ratkai; black and white by the author  
Construction: Walter E. Burton  
Consultant: Peter Johnke  
Tools: Garrett Wade, 161 Avenue of the Americas, New York, N.Y. 10013

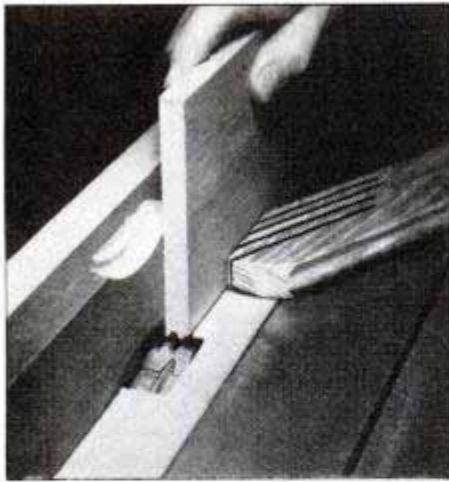

Cut edge glue-joints with a molding cutter head to form full-width boards.

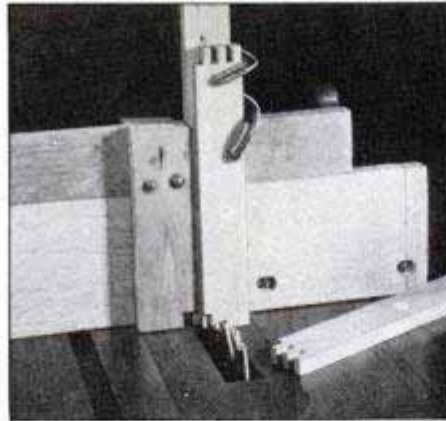

Homemade jig bolts to saw miter gauge for cutting box joints. The vertical upright properly aligns the workpiece with the 1/4-in.-wide dado head.

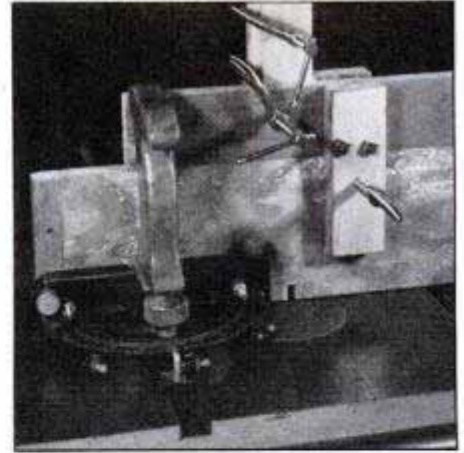

Box-joint cutting jig (rear view) has thumbscrew to adjust the vertical fence for each pass over the blade.

angles will cover up the screw heads. With the box temporarily assembled, you can now build the drawers with any necessary adjustments to the box made easily.

The drawer joints are cut on a table saw, but a router with the correct bits could be used, as well. The decorative bead along the top edge of each drawer front is made by routing a shallow V-groove 1/8 in. from the top edge. Hand-sand the rounded bead with 80-grit abrasive paper. The drawer fronts are made of cherry, while the sides and back are pine. Drawer bottoms can be

of sheet aluminum (aluminum siding scraps work fine) or 1/8-in.-thick tempered hardboard. Be sure to plow the necessary dados and rabbets in all the pieces before assembling the drawers.

Next, cut the drawer slides from hardwood maple. Temporarily fasten the drawer slides to the box with brads. Install each drawer, making drawer-slide adjustments where necessary. Drawers should have 1/16-in. clearance on both sides. Bore pilot holes and countersink the slides for 1/2-in. No. 2 flathead mounting screws.

Dismantle the box and stain all wood

surfaces that will be visible in the finished toolbox. We used Zar cherry stain-sealer No. 116.

Slow-setting hide glue, which allows time for adjustments, is used in the final assembly. Spread the glue between box-joint pins (fingers) with a small brush. Reassemble the box and clamp square until the glue dries. With the box completed, lid assembly and installation are next.

Dry-assemble the lid to ensure that it matches the box dimensions before gluing and final assembly. Install the lid hardware with the lid clamped to

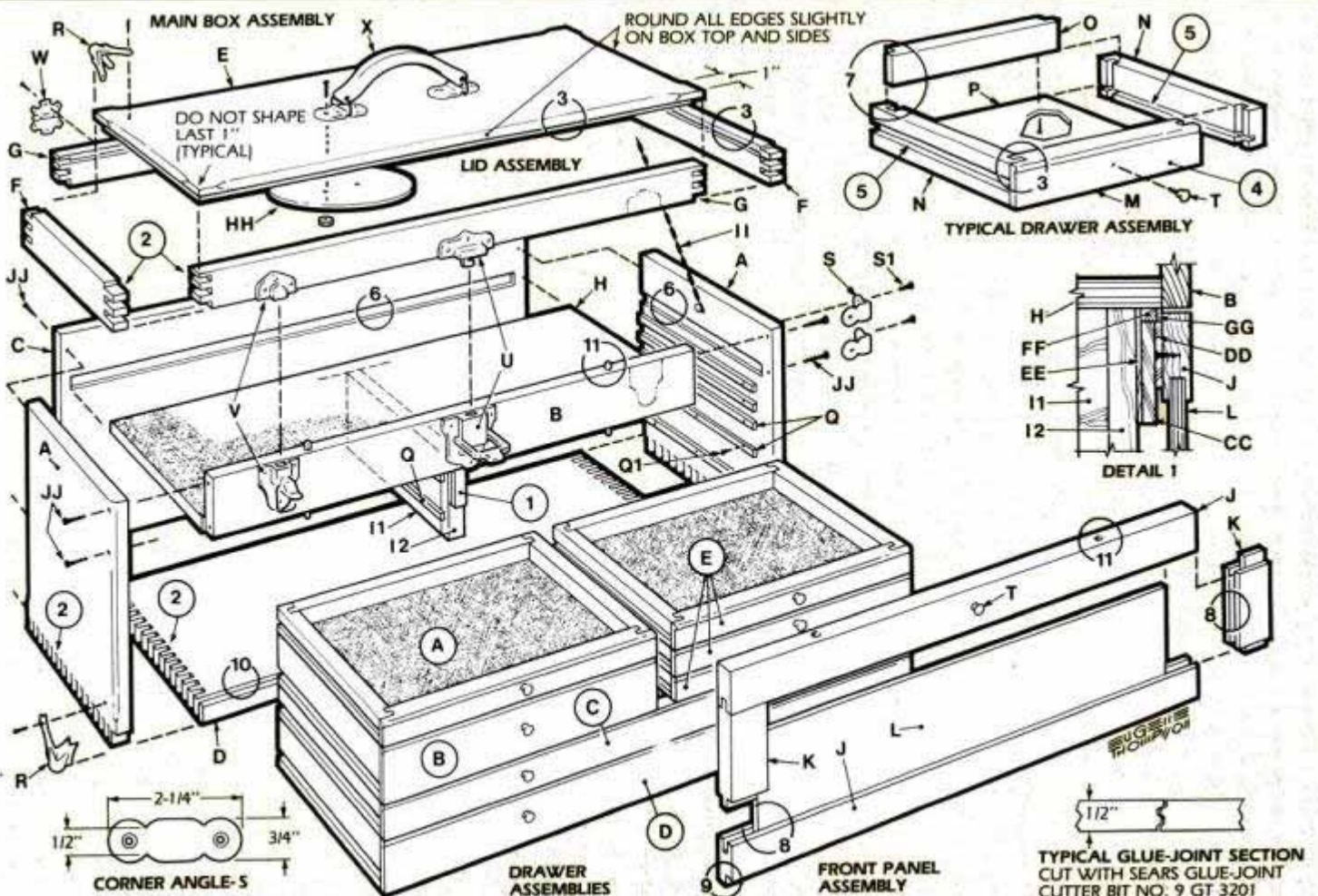

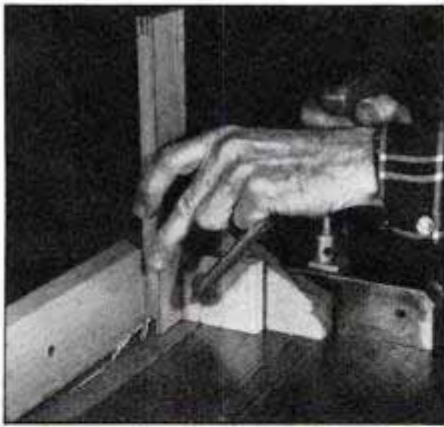

Cutting drawer fronts for rabbet-in-dado joint. Extra block on miter gauge holds the workpiece against the fence and prevents dangerous kickback.

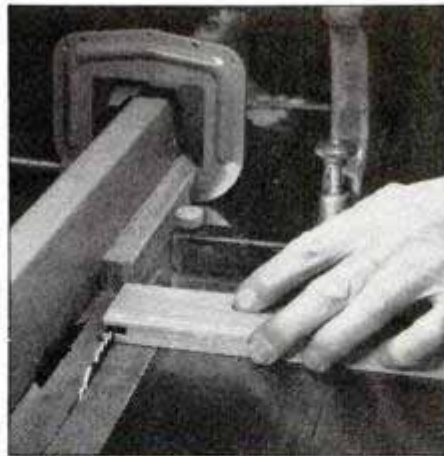

With the drawer front face up, the final cut produces the rabbet which then fits into the drawer side dado.

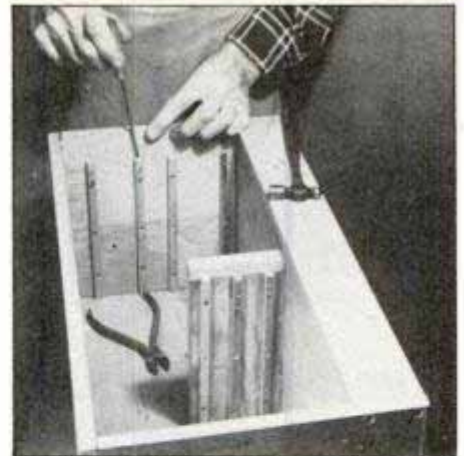

Tack-nail the drawer slides and test-fit all drawers. Make any necessary adjustments before screwing in slides.

the box for proper hinge and latch alignment.

### Toolbox locking pins

When the toolbox lid closes, two spring-loaded pins are pushed down into the front panel's top edge to prevent the panel from being opened. There are two ways to fabricate the pins. One is to machine the pins on a lathe from  $\frac{1}{4}$ -in.-dia. steel or brass rod. The second way is to bore a  $\frac{1}{8}$ -in.-dia. hole into the end of a  $\frac{1}{4}$ -in.-dia. rod, and then drive in a section of  $\frac{1}{8}$ -in.-dia. steel rod. Bore a No. 51 (.067-in.-dia.)

hole in the top of each pin, then tap both holes with 2-56 threads. On the off-chance that a pin should become jammed, insert a 2-56 bolt to pull the pin free.

To install the pins, first find the pin locations on the box front and bore  $\frac{1}{4}$ -in.-dia.  $\times$   $1\frac{3}{4}$ -in.-deep holes. Then continue boring  $\frac{1}{8}$ -in.-dia. through holes. Make springs by winding No. 22 music wire around the  $\frac{1}{8}$ -in.-dia. section of the pin. Drop the pins and springs into the box front holes. Cut the springs down to adjust the tension until  $\frac{1}{4}$  in. of the pin sits above the box edge. Once

the spring and pin have been properly adjusted, trim the pin's  $\frac{1}{8}$ -in. section flush with the box front's bottom edge. Bore  $\frac{1}{4}$ -in.-dia.  $\times$   $\frac{1}{2}$ -in.-deep holes in the front panel to accept the pins when they're pushed down. Then insert  $\frac{1}{4}$ -in.-outside diameter  $\times$   $\frac{1}{2}$ -in. copper tubing sleeves to form wear-resistant liners. Directly over each pin, mortise the lid's front edge  $\frac{1}{8}$  in. deep for a flush-mounted strike plate.

Next, round the edges of the toolbox with a router and a  $\frac{3}{8}$ -in. rounding bit. Pass the router to within 1 in. of the

(Please turn to page 183)

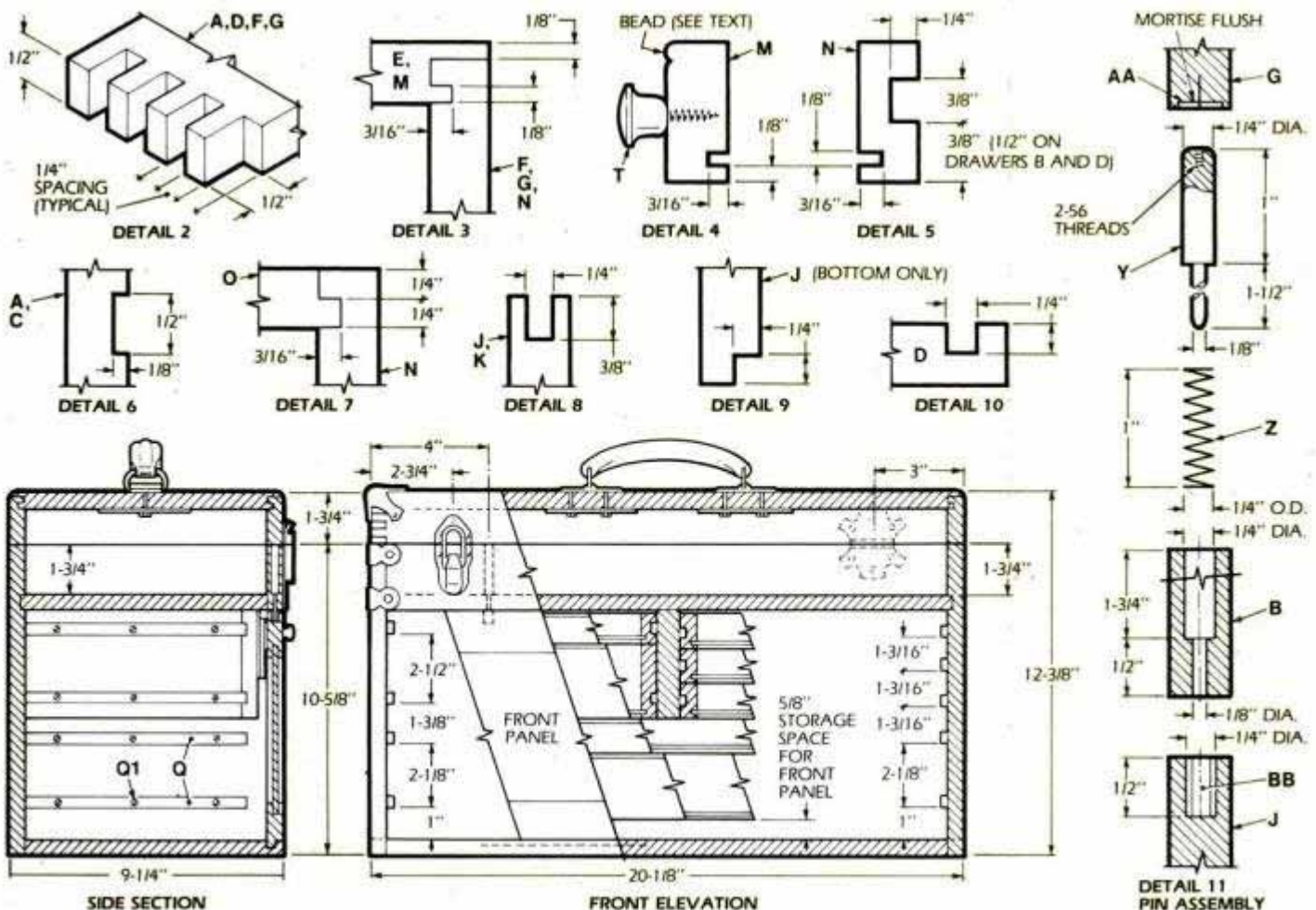

# WORKSHOP MINICOURSE



## Joining with dowels

When I conceived the Minicourse column about six years ago, the idea was based upon what I had learned as an adult education woodworking teacher. The plain truth is that just about every student who enrolled did so to learn the basics. Thus, zeroing in on the basics has been our aim in this space. Judging by reader response, the column has been right on target.

One reader, Bob Parker of Oklahoma City, wrote: "You might consider some articles on joining with dowels. I am strictly a novice and I would appreciate some pointers."

Bob goes on to emphasize that it is the basics that he is interested in—choosing dowels, dowel length and so on. In short, he said that he hasn't been able to find the basic information that he wants.

As simple as the dowel appears, there is much to be learned about using this effective joining tool.

### Selecting dowels

Except for very rare instances, you should always work with hardwood dowels.

The cheapest way to buy them is in 3-ft. lengths at a hardware store or lumberyard. You will find hardwood dowels available in a variety of diameters. I keep a supply of 1/4-, 3/8-, 1/2- and 3/4-in. dowels on hand in wall-hung canisters. This inventory services about 90 percent of my dowel needs.

### Points to remember

There are three very important points to keep in mind when using dowels to join boards:

1. The dowel holes must be bored deep enough to provide a slight "well" at both ends of the dowel (see photo at bottom right).

2. The dowel must be scored with glue-escape grooves so that glue can be squeezed one way or the other. Failure to provide such relief can result in pressure that can split the boards.

3. For a craftsmanlike dowel joint—which means a glue line that's just about invisible—you must make sure to use clamps.

More about dowels, and the right way to use them, next month. **FM**

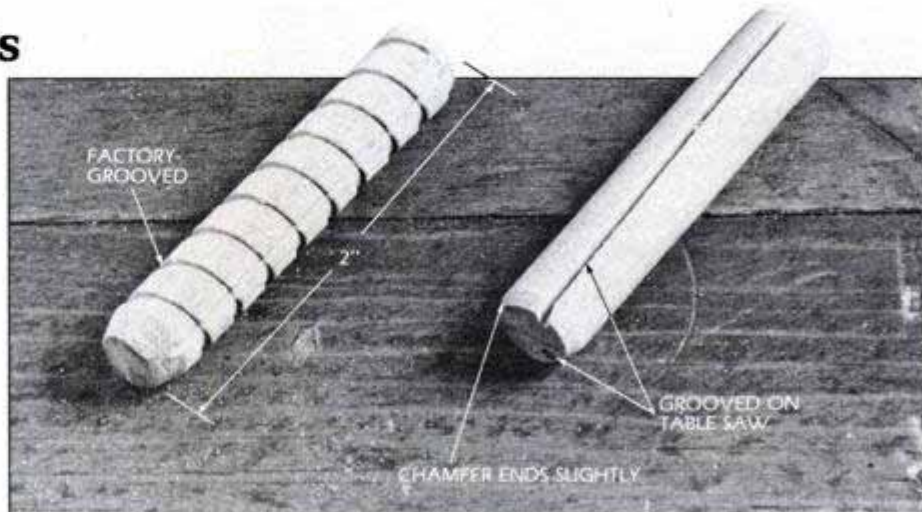

**1** To be used effectively, dowels must have a glue-escape groove. If you do a lot of dowering, it pays to buy the commercially available ringed type (shown at left). For the occasional dowel job, and where special lengths are required, buy a 3-ft. length of dowel, cut escape grooves on table saw, then cut dowel to length.

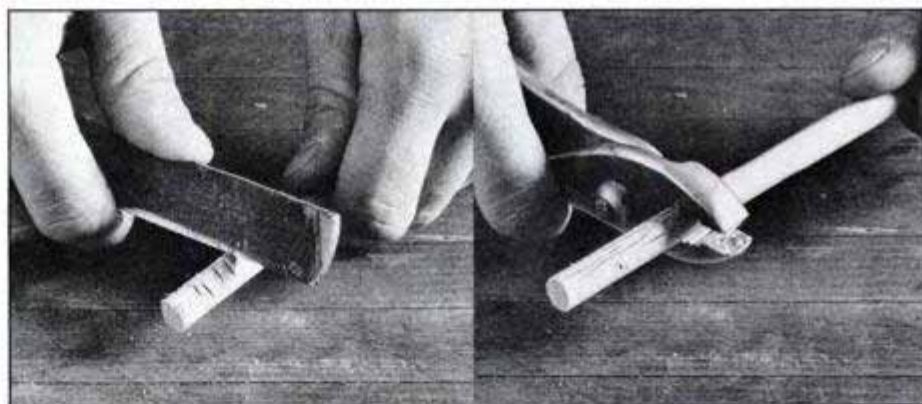

**2** Two other techniques for roughening a dowel surface before inserting it into hole: Left, use a smooth file corner to cut nicks around dowel perimeter. Right, grip a length of dowel with pliers, drag it to end to create grooves and texture.

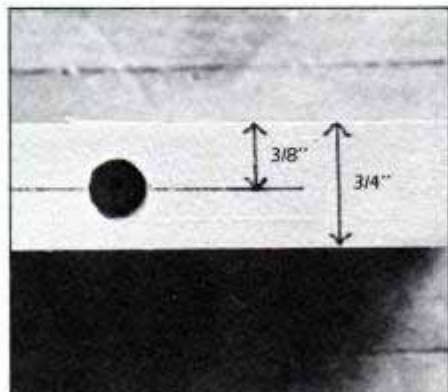

**3** Except for special assemblies, a dowel should always be located at exact center of workpiece edge, as here.

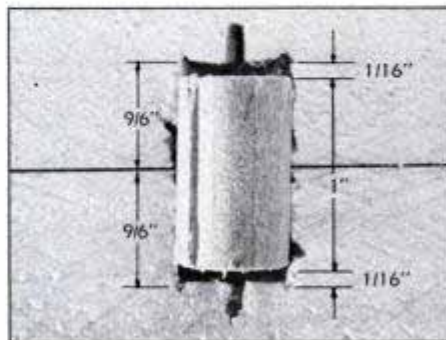

**4** Holes for the dowel should be bored to a depth that leaves space at both ends for glue to escape to. Here, holes in both boards were bored to a 9/16-in. depth to receive the 1-in. dowel.

# '83 HOME IDEAS GUIDE

Now is the time to get your house into tip-top shape. Here are the how-to tips that'll make your repairs easier, and ideas to make your improvements the best-looking ones on the block.



Window treatments that save energy

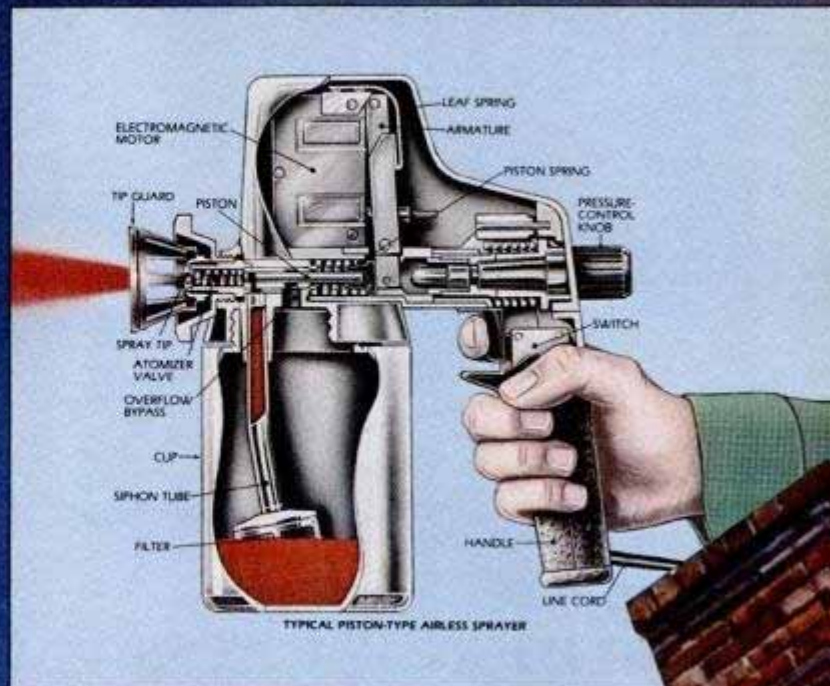

How a pro paints a house with a spray gun

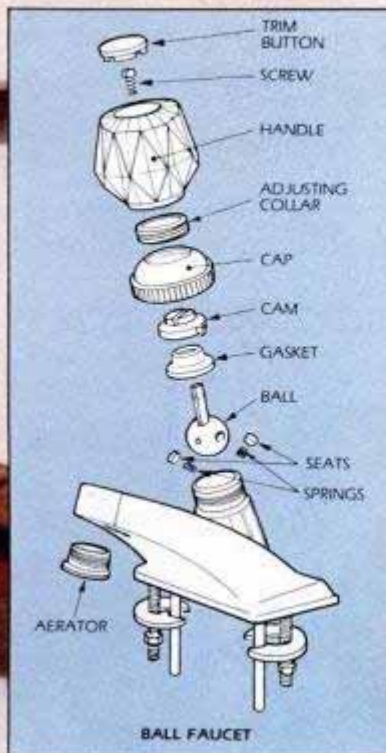

All about faucet repair

Secrets for getting a great paint job



## Even more impressive than what they can do is how many years they can do it.

What you can put on a John Deere 650 or 750 Compact Utility Tractor goes on and on; there's a list of more than 20 power-matched implements, including mid- and rear-mounted grooming mowers, a rotary cutter, box scrapers, front and rear blades, rotary tillers, a front loader, a log splitter, a posthole digger and a post driver, to list a few.

But it's what goes into every John Deere 650 and 750 that makes them go on and on. Both are designed around rugged, fuel-stingy, water-cooled diesel engines: a 2-cylinder, 17-hp unit (14.5 at PTO) in the 650; a 3-cylinder 20-hp unit (18 at PTO) in the 750.

And both come equipped with big-tractor standard features: a sliding-gear transmission with 8 forward and 2 reverse speeds; differential lock; Category 1 3-point hitch; 540-rpm rear PTO; hand and foot throttles; and adjustable rear wheel tread. All that, plus a reputation for reliability that's second to none. And a dealer organization to match.

The John Deere 650 and 750. You'd have to look a long, long time to find compact utility tractors built to last longer.

For the name of the nearest dealer, or a free folder on John Deere compact utility diesel tractors, call 800-447-9126 toll free (800-322-6796 in Illinois) or write John Deere, Dept. 67, Moline, Illinois 61265.

Nothing Runs Like a Deere®





# The Right Way To Paint Your House

Here's a complete guide for getting a high-quality exterior paint job.

BY CLIFF GROMER  
PM photos by the author



*Bare areas on shingles were spot-primed; painter now applies a primer—tinted with finish color—to those spots. Finally, the finish coat goes on, starting at the top.*

**W**hen you decide to paint your house, you want the best job possible without expending more money and effort than necessary. And you want the assurance that you won't have to repaint again sooner than you should have to.

Start by getting organized. Check the exterior of your house and jot down notes about areas that require special attention. After sizing up the job, gather all the equipment and materials you'll need so that work can progress without interruption. Repair any dam-

aged trim and siding. Replace defective gutters and leaders (but keep in mind that painting may be easier and more thorough if done with old gutters and leaders off and before new ones are installed). Cut or tie back shrubbery that brushes against siding or interferes with work, so that you'll be able to go nonstop.

## Analyzing symptoms

Different types of paint failure are symptoms of conditions that should be corrected if you want your paint job to last. Moisture problems are the primary cause of paint failure.

Condensation that works its way from inside the house through the siding lifts paint as it evaporates. In areas where there is excessive blistering and peeling, place a vapor barrier between

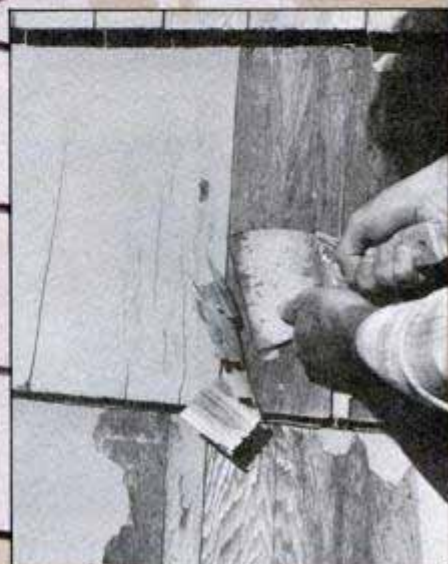

*Remove all of the blistered and peeling paint, using wide putty knife or scraper.*

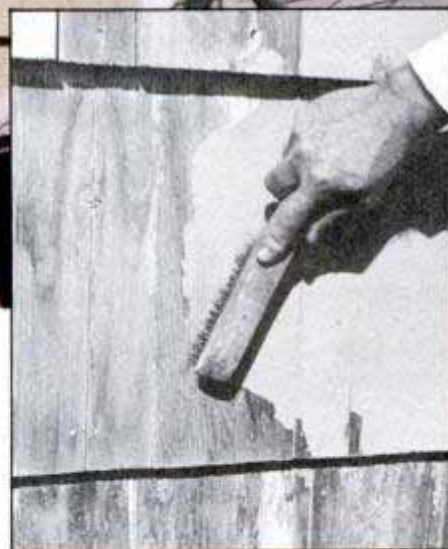

*Use wire brush to remove loose paint and dirt on wood, metal, masonry surfaces.*

the interior wall and the siding, on the room side of the insulation. Another cure is to install small screened vents in the siding through which moisture can escape.

Peeling can also result from a surface that is too hard, smooth, glossy or dirty. Whereas peeling due to moisture tends to expose the bare siding, peeling caused by a bad surface flakes down

Latex paint and primer, ladders:  
Sears, Roebuck and Co.  
Caulking material: UGL  
Brushes, scrubbers, pad applicators:  
Kiefer Brush Co.  
Paint contractor/consultant:  
Russell Winters, Old Bridge, N.J.



A special scrubber tool is useful for cleaning and smoothing rough surfaces.



For a smooth finish use 100-grit sandpaper to feather all sound paint edges.



Remove mildew and chalking stains by washing with a solution of trisodium phosphate, detergent, bleach and water.

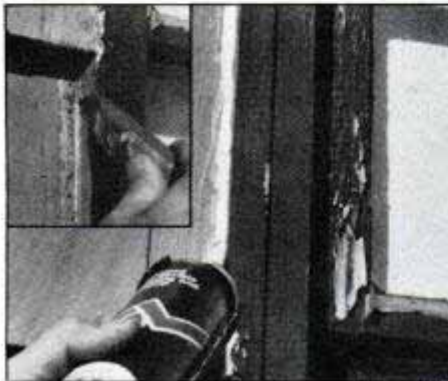

Remove dried caulking from the joints between siding and window frames. After priming, lay a fresh bead of caulking to seal all joints around the frames.

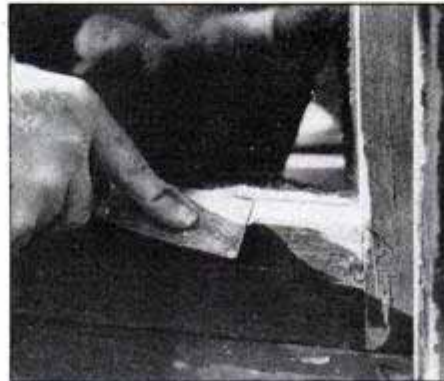

Press glazing compound around window panes with fingers. Smooth this with a corner of a putty knife pressed against glass. Excess peels off neatly.



Secure loose siding by face-nailing it with galvanized nails. Replace siding that's rotten or damaged beyond repair.

only to the offending layer. Sand the poor surface with 100-grit sandpaper to clean and roughen it for improved paint adhesion.

Alligatoring is usually caused by the build-up of too many layers of paint. The remedy for this paint problem is to strip off all the old paint layers by disc or belt sanding or by applying chemical stripper.

All unsound paint must be removed; there are several options for removal: In most cases, a putty knife or a hooked scraper will do. To remove large amounts of paint or to get down to bare wood, use a disc sanding accessory with a portable drill. Sand first with medium paper, then with fine. Sand out swirl marks by hand.

### Bleeding and stains

Sometimes it is difficult to differentiate between dirt and mildew on siding. Both appear as dark stains on the surface and both prevent paint from bonding. Dirt will usually wash away with soap and water, but mildew is more stubborn. The best way to remove mildew is with bleach. The appearance of mildew is also a clue that a fungicide should be mixed into the paint.

Where rusty nails cause staining, set the nailheads slightly below the surface

and fill the holes with an exterior wood filler. Prime the filler with corrosion-resistant primer.

Resin from knots often bleeds through paint and appears in the shape of the knot. To prevent a recurrence, use a turpentine-soaked rag to remove

as much resin as possible from the knot. Then coat it with a special knot-sealer available at paint stores.

Pink or brown stains can result from the water in latex paints dissolving some of the tannin in wood. This is a common problem when cedar and red-

## PRIMER/SURFACE COMPATIBILITY

These charts show primers and top coats right for exterior surfaces. Find primer or choice of primers for the surface, then top coat; or work backward from desired top coat to find primer. Make sure coatings are right for the surface.

| PRIMER TYPE                             | SURFACE TYPE       |                   |                     |         |           |                        |                            |                |                  |          |  |  |
|---|--------------------|-------------------|---------------------|---------|-----------|------------------------|----------------------------|----------------|------------------|----------|--|--|
|   | Smooth wood siding | Rough sawn siding | Shingles and shakes | Plywood | Wood trim | Concrete block, stucco | Brick, stone, cinder block | Iron and steel | Galvanized steel | Aluminum |  |  |
| 1. Oil Primer                           | ●                  | ●                 | ●                   |         |           |                        |                            |                |                  |          |  |  |
| 2. Alkyd Primer                         |                    |                   |                     | ●       |           |                        |                            |                |                  |          |  |  |
| 3. Latex Primer                         | ●                  | ●                 | ●                   | ●       |           |                        |                            |                |                  |          |  |  |
| 4. Stain-Blocking Primer                | ●                  | ●                 | ●                   | ●       | ●         |                        |                            |                |                  |          |  |  |
| 5. Alkyd-Base Metal Primer              |                    |                   |                     |         |           |                        |                            | ●              | ●                | ●        |  |  |
| 6. Oil-Base Metal Primer                |                    |                   |                     |         |           |                        |                            | ●              | ●                | ●        |  |  |
| 7. Latex Metal Primer                   |                    |                   |                     |         |           |                        |                            | ●              | ●                | ●        |  |  |
| 8. Portland Cement Paint (for metal)    |                    |                   |                     |         |           |                        |                            | ●              | ●                |          |  |  |
| 9. Masonry Surface Conditioner          |                    |                   |                     |         |           |                        |                            | ●              | ●                |          |  |  |
| 10. Portland Cement Paint (for masonry) |                    |                   |                     |         |           |                        |                            | ●              | ●                |          |  |  |
| 11. Top Coat Material Used for Primer   |                    |                   |                     |         |           |                        |                            | ●              | ●                |          |  |  |



Quality brushes have a strip in the heel and split bristle-ends called "flags."



"Boxing" paint—mixing contents between cans—will ensure uniform color.

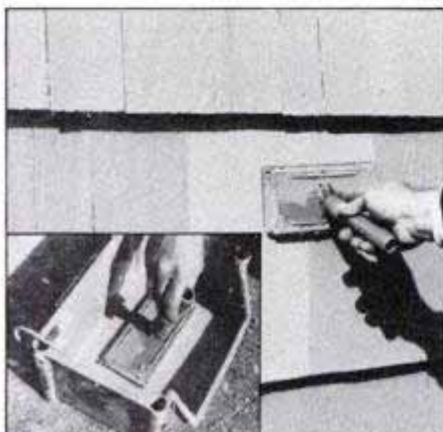

Working with a pad applicator or roller tray can save you time on large areas.



When painting windows, you get more control using an angle-cut sash brush.

wood are painted. Use a stain-blocking oil-base primer to prevent it.

It's a good idea to wash down your entire house before painting, particularly if you find chalking of existing paint. The best all-purpose mixture for washing surfaces is made from  $\frac{2}{3}$  cup

of trisodium phosphate,  $\frac{1}{2}$  cup of detergent (without ammonia), 1 quart bleach and 3 quarts water.

### Caulking, glazing, priming

The joints where siding meets door and window casings must be sealed.

Examine the old caulking and remove all cracked and failing beads. For the best seal, use silicone caulking on a primed surface.

On older houses and where glass has been replaced, joints around window panes can be sealed with glazing compound. Remove dried putty and replace it with fresh glazing compound as shown in the photo on page 116.

All bare wood, new caulking and new glazing compound should be primed before the finish coat is applied. Priming seals porous surfaces and provides a good bonding texture for the topcoat. Be sure to select a primer that's compatible both with the surface being painted and the topcoat material. Use charts below as a guide.

### Exterior paints

Exterior paints fall into two major classifications: oil-base and latex (alkyd paints are oil-base but have acids mixed into their formula). Both are suitable for exterior painting, but each has different workability and wear characteristics.

The linseed oil and solvents in oil paints penetrate wood for superior adhesion. Alkyd paints dry a little faster and smoother than simple oil-base paints. Working with oil paints is slow. Each brushful needs to be worked to form an even coat. Drying time of about 24 hours is required between coats. Clean-up requires turpentine or mineral spirits. Both are flammable and caustic.

Latex paints use acrylic polymers as a binder and water as the solvent. They form a flexible, breathing layer on the surface. Latex paint is best applied in heavy coats, not brushed out.

Oil-base paints can yield a higher luster and stand up somewhat better than latex in high-traffic areas. But latex colors are more resistant to fading. Cleaning up after a job with latex paint is simpler, requiring only soap and water.

With either type of paint, color can significantly affect durability. Bright yellows and reds are most likely to fade because of the effect of the sun's ultraviolet rays on their organic pigments.

### Estimating paint quantity

For most house paints, manufacturers estimate that a gallon will cover approximately 450 sq. ft. To determine how many gallons to buy, measure the perimeter of your house, multiply it by the average height, subtract the area of doors and windows, then divide by 450 to get the number of gallons needed per coat.

For rough or porous surfaces, add 20 percent to the estimate. Add 10 percent for siding applied 6 in. or less to the weather (6 in. wide or less; extra paint

## PRIMER/TOP COAT COMPATIBILITY

| TOP-COAT TYPE                       | PRIMER TYPE |   |   |   |   |   |   |   |   |    |    |
|-------------------------------------|-------------|---|---|---|---|---|---|---|---|----|----|
|                                     | 1           | 2 | 3 | 4 | 5 | 6 | 7 | 8 | 9 | 10 | 11 |
| Oil-Base Gloss House Paint          | •           |   |   | • |   | • |   |   |   | •  |    |
| Oil-Base Flat House Paint           | •           |   |   | • |   | • |   |   |   | •  |    |
| Alkyd-Base House Paint              |             | • |   | • |   | • |   |   |   | •  |    |
| Alkyd-Base Enamel                   |             | • |   | • | • |   |   |   |   | •  |    |
| Latex Flat House Paint              |             |   | • | • |   |   | • |   |   | •  |    |
| Latex Trim Enamel                   |             |   | • | • |   |   | • |   |   | •  |    |
| Alkyd-Base Masonry Paint            |             |   |   |   |   |   |   |   |   |    |    |
| Latex Masonry Paint                 |             |   |   |   |   |   |   |   |   | •  | •  |
| Alkali-Resistant Coatings           |             |   |   |   |   |   |   |   |   | •  |    |
| Portland-Cement Paint (for masonry) |             |   |   |   |   |   |   |   |   | •  | •  |
| Oil-Base Exterior Metal Paint       |             |   |   |   |   |   | • |   |   |    |    |
| Alkyd-Base Exterior Metal Enamel    |             |   |   |   |   | • |   |   |   |    |    |
| Aluminum Paint                      |             |   |   |   |   | • |   |   |   |    |    |
| Portland Cement Paint (for metal)   |             |   |   |   |   |   |   |   |   | •  |    |

Regular, 1 mg. "tar", 0.2 mg. nicotine  
av. per cigarette, FTC Report Dec. '81.

© 1982 B & W T Co.

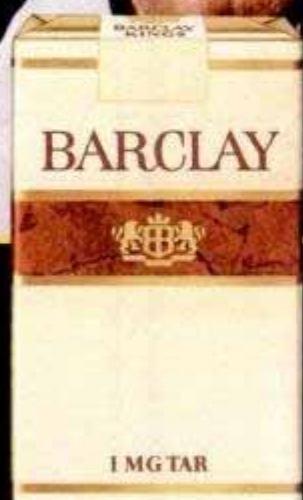

*99% tar free.*<sup>TM</sup>

*The pleasure is back.*  
**BARCLAY**

Warning: The Surgeon General Has Determined  
That Cigarette Smoking Is Dangerous to Your Health.

## USING LADDERS SAFELY

Ladders are rated by category according to their load capacity and durability. The rating appears on a sticker found on one of the ladder rails. Ladders marked as Type I are rated for loads up to 250 lbs. Those marked as Type II carry a 225-lb. rating. Type III ladders are not advisable for exterior work.

The length of a ladder is another critical safety factor. Check the size chart below to select a safe length for the particular job you have to do. Never store a wooden ladder outside exposed to the weather. And be aware of overhead wires, especially with an aluminum ladder, because of the shock hazard.

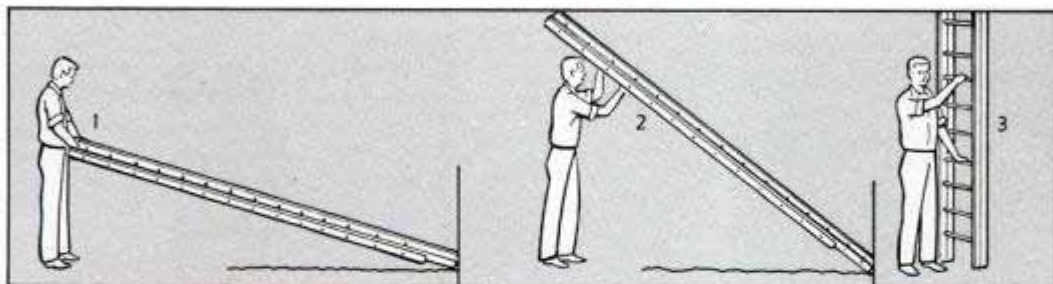

To raise a tall ladder when you're working alone: 1. Lift the top end with the feet resting against a wall; 2. "Walk" the ladder up with your hands, rung by rung; 3. Achieve a vertical balance.

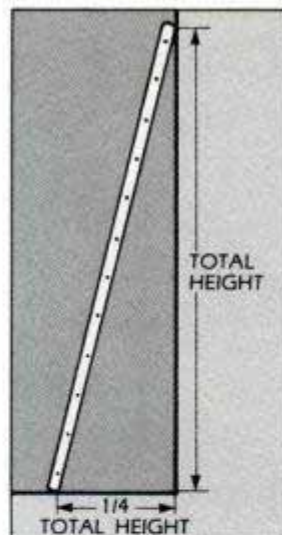

Relation between ladder height and feet position.

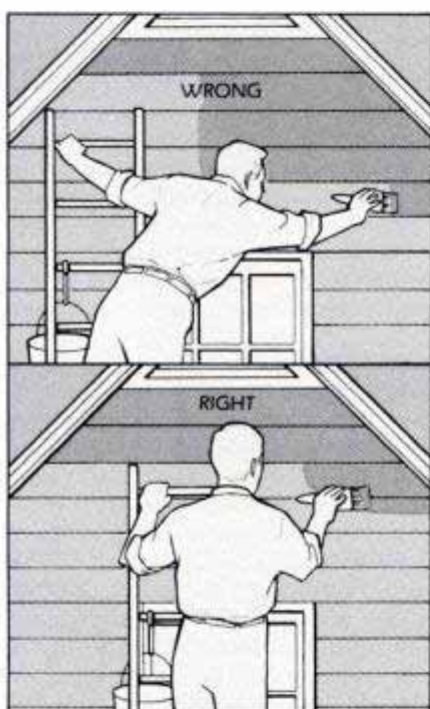

Never over-reach when you're standing on any ladder. If it slides along the house wall, you may lose your balance and fall. The center of gravity must remain between the ladder feet.

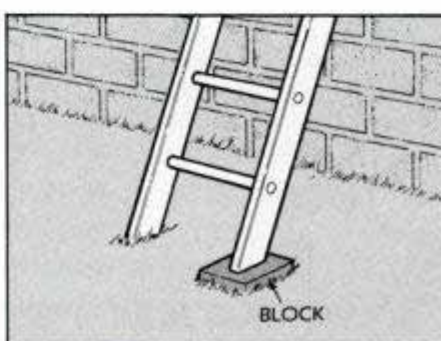
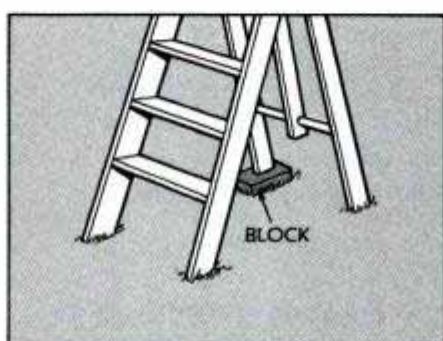

The feet of a ladder must always be level to assure stability and prevent slipping. Use blocks to shim them level or to keep them from sinking into soggy ground.

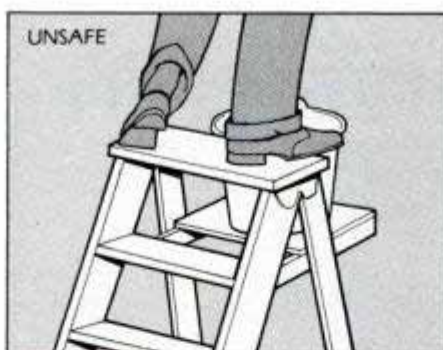

Never stand on stepladder's top shelf. One step down gives you better position to maintain your balance; two steps down means less bending down to load your brush.

is needed to cover more butt edges). Add 33 percent for corrugated metal and 100 percent for the first coat on concrete or cinder block.

To estimate the amount of paint needed for trim, figure that one gallon will cover eight doors or windows, or 200 linear feet of gutter and fascia.

### Paint applicators

For primers and first coats, good quality brushes offer you the most flexibility. Use a 4- to 6-in. brush for siding and a 2- to 3-in. brush for windows and other narrow trim. Nylon brushes

*(Please turn to page 120)*

## HOW TO SELECT THE RIGHT SIZE EXTENSION LADDER

| When working on a roof with a height of* | or, when the top support point against a vertical wall will be | select a ladder with a manufacturer's designated size of | Maximum Extension (open) | Minimum Extension (closed) |
|--|--|--|--------------------------|----------------------------|
| 5 to 11½                                 | 7¼ to 12½  | 16   | 13                       | 8                          |
| 6¾ to 15½                                | 9½ to 16½  | 20   | 17                       | 10                         |
| 8¾ to 19¼                                | 11½ to 20  | 24   | 21                       | 12                         |
| 10½ to 23¼                               | 13½ to 24  | 28   | 25                       | 14                         |
| 12½ to 27                                | 15½ to 28  | 32   | 29                       | 16                         |
| 14½ to 31                                | 17½ to 32  | 36   | 33                       | 18                         |
| 16½ to 33 (wood)                         | 19 to 34 (wood)  | 40   | 35 (wood)                | 20                         |
| 34 (metal)                               | 35 (metal)   |  | 36 (metal)               |                            |

\*Selection of a proper ladder for use when you're climbing onto and off a roof must allow for an extension of 1 to 3 feet above the roof eave.

All dimensions above are given in feet.

## The Original Ventarama presents a New Look..



Original DOME



NEW "LO-DOME"



## the "LO-DOME"™ ventilating skylight

The VENTARAMA SKYLIGHT with its 33 years of consistent quality introduces a sophisticated new look, the "LO-DOME". Lowering the profile of our original dome has created a "flat look" unit with the advantages of an acrylic double-dome.

Our easy to use screen/storm panel system, our silent-motorization and our pole or hand crank operator are all guaranteed to give years of easy carefree service.

**VENTARAMA: Our quality and experience keeps us on top.**



Write or call today for information about sizes and easy one-day installation to:

**VENTARAMA® SKYLIGHT CORP.**

140 Cantiague Rock Road, Hicksville, N.Y. 11801 (516) 931-0202

## Curtis Puts the Own Back Into Homeownership



### You Can Beat High Housing Costs and Build NOW!

Save \$1000's by Completing it Yourself.

- We do the difficult framing on your lot and foundation.
- You do all or part of the finishing with Curtis-supplied materials and instructions.

Affordable Financing Makes it Possible.

- No down payment or deposit.
- Low monthly payments while building.
- Your land may not have to be fully paid for.

There's a Representative Near You!  
CALL TOLL FREE 1-800-228-6505  
IN NEBRASKA CALL: 1-800-642-9606  
OR CALL (612) 542-4300  
Complete It Yourself

**Curtis Homes** 

If you have desire... We have the trust!



Send coupon today for full details.

Send me your FREE Homes Catalog,  
CURTIS HOMES, DEPT. PM-1  
2201 Florida Ave. So., Minneapolis, MN 55426  
(Please Print)

Name \_\_\_\_\_

Address \_\_\_\_\_

City \_\_\_\_\_ State \_\_\_\_\_ Zip \_\_\_\_\_

Phone ( ) \_\_\_\_\_

We own land.  
 Enclosed is \$1.00 for priority handling.

Continued from page 119

should be used for latex. Use natural bristles for oil paints.

Rollers and pads speed up second coats as long as they're used in conjunction with brushes that allow you to reach siding butt edges, and behind shingle butts. Thick-nap rollers are especially good for painting rough or porous surfaces like cinder block, and certain textured sidings.

Most applicators other than brushes can be fitted with extension poles. This can save some climbing and reaching and also increase the length of your strokes.

### The right conditions

Temperature and humidity at the time of paint application can affect the quality of the job. It's safest not to paint if the temperature is above 90° F. or below 50° F., since extremes can and will cause paint to cure improperly.

It's safe to paint with latex if the surface is damp, but it must not be wet. When painting with oil-base, wait at least a day after rain before painting. Rain on oil or latex surfaces that aren't dry may cause spotting in the finish.

It's best to paint with an oil-base paint in early spring or fall—times when insect populations are low. Resins in the paint tend to attract bugs.

### Applying paint

Many pros recommend painting the trim before siding. By doing this, you can avoid placing ladders against freshly painted surfaces. Work from the top of the house down to avoid dripping paint on previously painted surfaces.

Fill a working pail about half-full. Dip your brush only about one-third the length of the bristles and tap it gently against the side of the can to remove the excess paint. Don't drag it across the rim. Apply a healthy dab of paint to the surface and work it into an even coat using the tip of the brush. Apply paint to siding butt edges first, then to the weatherface.

With latex paint, work from the dry area into the wet to avoid lap marks. If you must stop before a side is finished, pick a spot where some architectural feature breaks up the surface (for example, the bottom of a shingle course or a corner) to avoid creating lap marks when you resume.

Don't try to extend paint beyond the manufacturer's recommendations for coverage. If you do, it will not perform up to specifications. If you're trying to get by with a one-coat color change, but finding the new paint doesn't hide the old, try adding a little burnt umber. If you're satisfied with the coverage after testing, mix as much paint as you'll need using the boxing method to ensure uniform color. **PM**

# A Pro's Secrets For Spray Painting A House



Kurt Laemmerhirt (right) shows the author one of the time-saving tricks of the trade: Instead of masking, he sprays windows, then scrapes glass.

Airless sprayers do the job right—and in a lot less time.

BY MICHAEL CHOTINER ASSISTANT HOME AND SHOP EDITOR

It's no secret that spray painting is much faster than painting with a brush—yet relatively few do-it-yourselfers consider spray painting at house-painting time.

A great variety of airless spray equipment is available to homeowners. While high-performance commercial equipment is relatively expensive (\$300-\$3,000), it can be rented for about \$75 a day. Airless units designed for do-it-yourself house-painters cost \$100 to \$200—not much when you consider that spraying is at least twice as fast as brushing and that it drastically reduces fatigue.

Reliable equipment is only part of the story—know-how is just as important. We asked Kurt Laemmerhirt of Toms River, N.J.—a professional with nearly 40 years' experience—to help us spray paint a house. His expertise not only helped us to do the job fast, but also the right way.

## Why 'airless' spraying?

Conventional sprayers use air to atomize paint to a fine mist. For this you need a compressor, and that means a significant investment. It also means that paint follows the airstream out of the tip in a sort of cloud, causing a high percentage of the paint to trail away from the surface being painted. The trail is called *overspray*.

There are two basic designs for airless sprayers. In piston-type systems, paint is forced through an atomizing valve at high pressure. Diaphragm pump systems atomize paint by means of a mechanical screw and deliver it to a gate valve at relatively low pressure. In

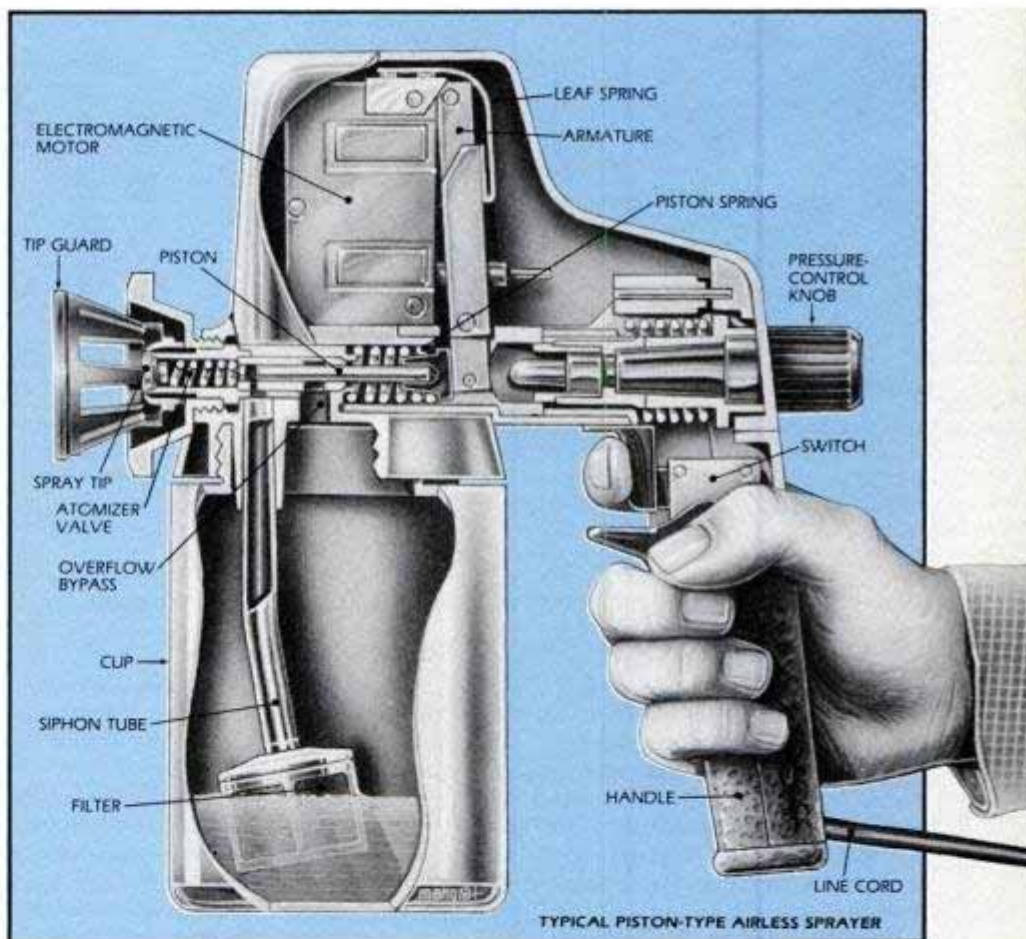

Paint is drawn into siphon tube and pumped at high pressure through atomizer valve.

both cases, the result is a cleaner, faster spraying system.

Most sprayers designed for do-it-yourselfers have the pump built into a handheld unit. Since piston-type airless units deliver paint at pressure high enough to break skin at close range, you must keep your fingers away from the tip to avoid getting an injection of paint or solvent. Most sprayers for do-

it-yourselfers cannot operate without pressure-diffusing tip guards and are safe. All commercial airless sprayers are labeled with warnings against directing the spray tip at any part of the human body.

## Preparation

Prepare surfaces for spray painting as you would for brushwork. Trim and

PM photos: Peter Tenzer  
Equipment: Wagner Spray Tech Corp.  
Latex paint: PPG Industries



Mask fixtures, doorknobs and latches with paper or plastic. Tape lamp base carefully for even contrast line.



Before spraying, remove all nameplates, screens, storm sash and other fixtures that are difficult to mask.



Cover plants near the house with dropcloths. Cut or tie back all foliage that brushes against the siding.



Strips of hardboard or scrap come in handy for holding down dropcloth edges. Space them 1/2 in. from foundation.



Shutters were laid flat to reduce the chance of paint sag and drips. We numbered the backs of the shutters to keep track of where they came from and replaced them using the same nail holes.



An extension tube allows you to work directly from the can. Clip the can to your belt so you can keep a hand free.

siding must be clean and free of unsound paint; all bare spots should be primed.

Mask lamps and other fixtures. If you remove doorknobs and latches, stuff the holes with paper to keep out the spray. Close all windows tight.

Remove screens and storm windows. Aluminum storm doors and windows can be removed, but consider that factory-finished metal surfaces make an excellent base for spraying latex when they are clean.

Windows may be masked, but Kurt feels that's time-consuming. Scraping paint from glass panes goes quickly. The 8-over-12 windows on the house we painted took about 10 minutes each to clean.

Airless units can be used to spray latex, oil and alkyd-base paints, also for stains and varnishes. All paints are somewhat abrasive and latex paints will cause more wear to equipment than other types. When spraying acrylic latex, resins tend to build up on pistons and may cause them to seize. To pre-

vent piston seizure, mix Floetrol—a lubricating additive—with paint.

### Spraying techniques

Prime the pump by first spraying onto paper or other uncritical surface. If the pump won't prime, the paint probably needs to be thinned.

Start the sprayer with the nozzle pointing away from (off) the work surface, then move it into position about 12 in. away. Work with rhythmic strokes, keeping the sprayer upright and parallel to the plane of the wall. Don't go over previously painted areas until they are dry. Work from the top down, spraying a thin, even coat. If drips, runs or sags occur, remove excess paint with a brush. Remember that several thin coats of paint produce a better finish than one thick one.

Remove all masks when the paint is dry to the touch. Inspect the job; areas where masking blocked paint and edges of double-hung windows will need to be finished with a brush.

If trim will be a different color from

### ATOMIZATION PATTERNS

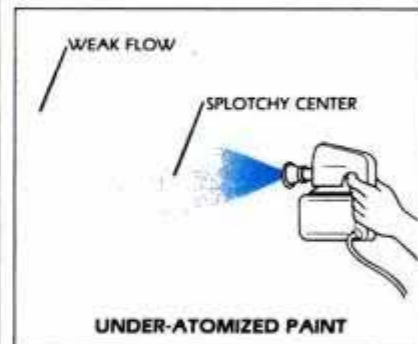
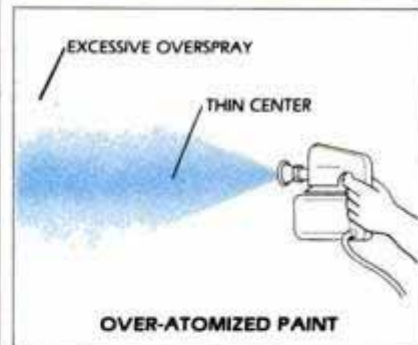
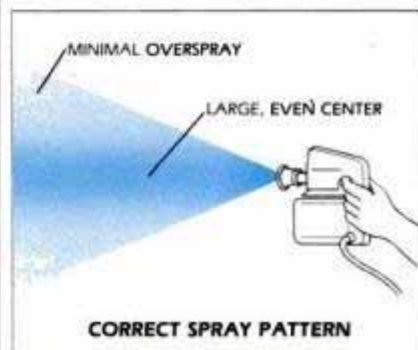

Overatomization is caused by using too large a tip, too much pressure or paint that's too thin. Underatomization results from using too small a tip, too little pressure or paint that's too thick. Most of the spray units come equipped with a pressure control knob and a choice of spray tips that have different aperture sizes.



# CRAFTSMAN LAWNMOWERS AMERICA'S #1 CHOICE.\*



## NOW THIS "EAGER 1" #92133 IS THE CRAFTSMAN BRAND CHOICE FOR APRIL.

When it comes to lawnmowers, Sears outsells the two leading competitors combined. When it comes to reasons, one just might be innovation.

Solid state ignition got things off to a good start. Craftsman was the first to have it. It was designed to give you dependable starts, while it cut the cost of expensive tune-ups down to the simple replacement of a spark plug.

ON SALE APRIL 3-16

NOW \$189<sup>99</sup> **SAVE \$30<sup>00</sup>**

Minimum savings nationally.

Prices and dates apply only to the Continental United States except Alaska. Available at Sears Retail Stores.

Sears, however, was not content to leave well enough alone. So in 1971, Craftsman lawnmowers had the first no-maintenance, replaceable air filter. A big improvement over the sponge filter, which requires frequent cleaning and soaking with oil.

But Sears wanted to make life even easier yet. So a little device called a mechanical compression release was introduced. The result? It made the starting cord easy to pull and the mower easy to start.

What more could you ask for? How about a maintenance-free mechanical governor that helps prevent stalling in tall grass. Or a pressurized lubrication system that continually bathes engine parts in oil. A no-adjust carburetor. And the list goes on.

Of course, you won't find all these innovations on every Craftsman lawnmower, but there's one thing you will find. We'll never stop perfecting the lawnmowers that carry the name Craftsman.

And now's a perfect time to make a Craftsman Eager-1, 20-inch lawnmower, with 3.5 reserve power engine, your choice. Because from April 3-16 it's the Craftsman Choice for just \$189.99... a \$30 savings. And that's an "innovation" that's pretty hard to improve on.

\*Based on independent survey data July 1981-June 1982

**Sears**

© Sears, Roebuck and Co., 1983



Use hardboard or cardboard strip for a handheld shield to protect adjacent surfaces, such as roof shingles, from overspray.



Use shield to mask trim from the siding color. Here, casing face is left partly exposed for thorough coverage at siding-casing angle.

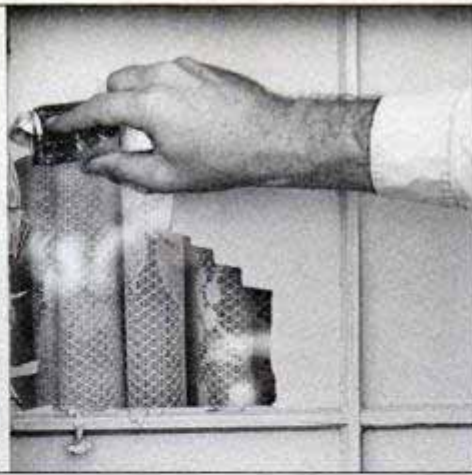

Latex paint scrapes from the window panes easily after about two hours. Oil-base paint would need to dry somewhat longer. If paint is allowed to cure, however, it becomes very difficult to remove.



Touch up the oversprayed areas on the window casings and other trim with a brush when paint is dry to the touch.



When the job is finished or when you set the sprayer aside for a while, flush it out with the appropriate solvent.

siding, paint the trim first. Use a handheld shield to mask trim from siding.

### Equipment maintenance

The single most important maintenance practice for airless sprayers is to keep them clean. If you work directly from the paint container with a long siphon tube, tape the tube to the container rim to keep it off the ground. Flush the tube thoroughly with solvent if it should contact a foreign substance.

When you're finished for the day, spray solvent through the gun for several minutes. Then, disassemble the unit and soak the nonelectrical parts in solvent. Wipe all built-up paint from both cup and cap. Reassemble the unit and put a drop of light oil in the suction hole. Switch the unit on for a few seconds to circulate the oil.

Several parts on some airless spray equipment are particularly prone to

wear. After spraying 10 to 15 gallons of latex, many models designed for homeowner use will require replacement of the spray tip and atomizer valve. Pistons should be checked and replaced if scored. Piston springs are subject to wear and breakage. Replacement of key parts should be under \$20. **PM**

### MANUFACTURERS LIST

- For consumer information about airless spray painting equipment contact:
- Acme Burgess, Rte. 83, Grayslake, Ill. 60630.
  - American Products, 5550 Elston Ave., Chicago, Ill. 60630.
  - Binks Manufacturing Co., 9201 West Belmont Ave., Franklin Park, Ill. 60131.
  - Campbell-Hausfeld, Div. of Scott & Fetzer Co., 800-T Production Drive, Harrison, Ohio 45030.
  - DeVilbiss Co., Box 913-T, Toledo, Ohio 43692.
  - EZ Painter, 4051 South Iowa Ave., Milwaukee, Wis. 53207.
  - Graco, Drawer 1441, Minneapolis, Minn. 55440.
  - Sears, Roebuck and Co., Sears Tower, Chicago, Ill. 60684.
  - Speeflo Manufacturing Corp., 4631 Winfield Rd., Houston, Tex. 77039.
  - Wagner Spray Tech Corp., 1770 Fernbrook Ia., Minneapolis, Minn. 55441.

### SPRAYING TECHNIQUE

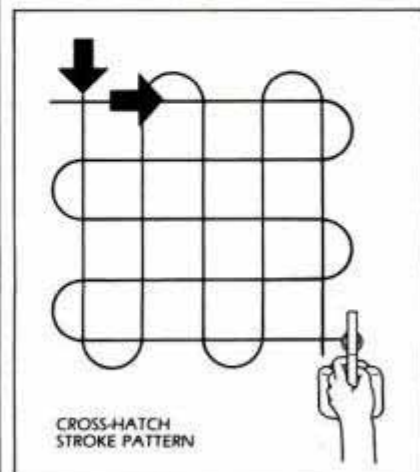
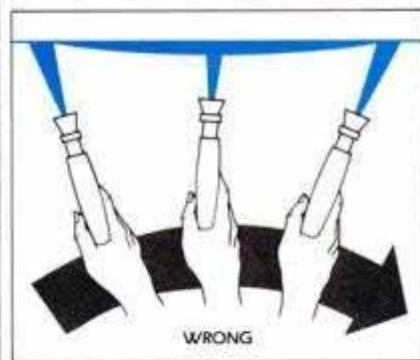
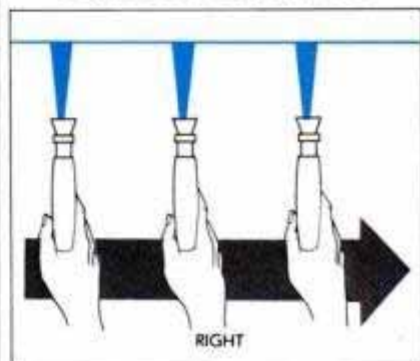

Keep the spray tip at an even distance from the surface and use cross-hatch strokes to spray an even coat.

# CAMEL

Where a man belongs.



Experience the Camel taste in Lights and Filters.

LIGHTS: 8 mg. "tar", 0.7 mg. nicotine av. per cigarette, FTC Report DEC. '81.  
FILTERS: 15 mg. "tar", 1.1 mg. nicotine av. per cigarette by FTC method.

Warning: The Surgeon General Has Determined That Cigarette Smoking Is Dangerous to Your Health.

# Build PM's In-The-Wall Workshop

Created out of redwood, this cabinet will look good in any family room. Opened, it's an instant workshop for both hobbyist and craftsman.

**T**his handsome redwood workshop is a fully equipped, organized work center designed for either in-the-wall installation or as a surface unit fastened to the wall.

Recessing the workshop between wall studs results in a built-in that reduces the unit's projection into the room by 4 in. If the wall is a load-bearing one, reinforce the existing studs as shown in the drawing and install a header to the wall opening as illustrated. If you decide to make your workshop a free-standing unit, the electrical outlet box should not be side-mounted. Instead, mount the outlet on the cabinet back. If installed as a recessed unit, secure the cabinet to the studs with 2-in. No. 14 screws driven through the cabinet sides. If the unit is free-standing, secure it by screwing through the cabinet back into the wall studs.

The workshop is the result of a joint effort by the California Redwood Assn. and Popular Mechanics. It is made entirely of clear, all-heart KD redwood. If you wish to economize on the cost of clear redwood, you can use a clear sapwood grade.

The cabinet parts are cut from one-by (nominal 1-in. stock) boards in 4-, 6-, 10- and 12-in. widths. Notice that 1-in.-nominal redwood is actually dressed to  $1\frac{1}{16}$  in. thick. Since redwood is soft, the fold-down tabletop is made of  $\frac{1}{4}$ -in. hardwood veneer plywood laminated to both sides of  $\frac{3}{4}$ -in. fir plywood. We used  $\frac{1}{4}$ -in. oak veneer plywood, but birch, maple or ash can also be used.

The workshop is built as two individual units which are glued together side by side after they're assembled. Construction starts with the door fronts and back panels which are made by edge gluing three redwood boards with plywood

*This space-saving workshop provides an organized work center for creating home projects. Open (below), it displays ample shelving for tool storage and a fold-down workbench. Closed (below, right), the redwood doors conceal the work center and the room is returned to everyday use.*

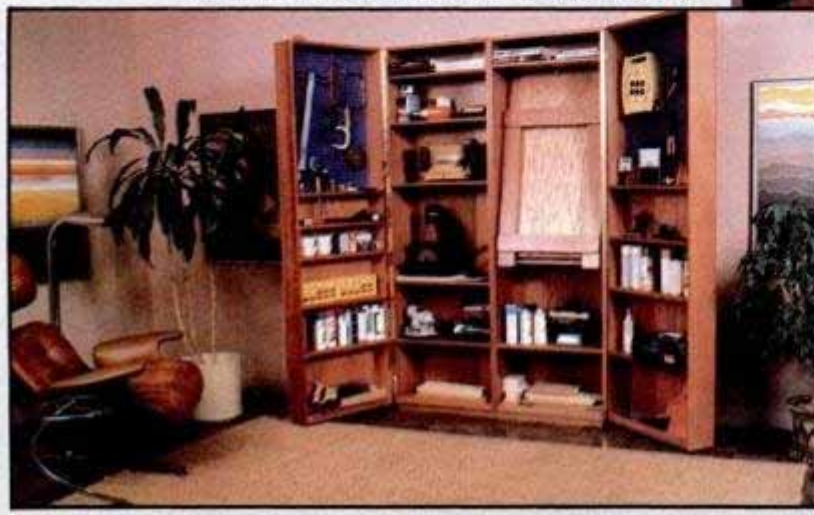



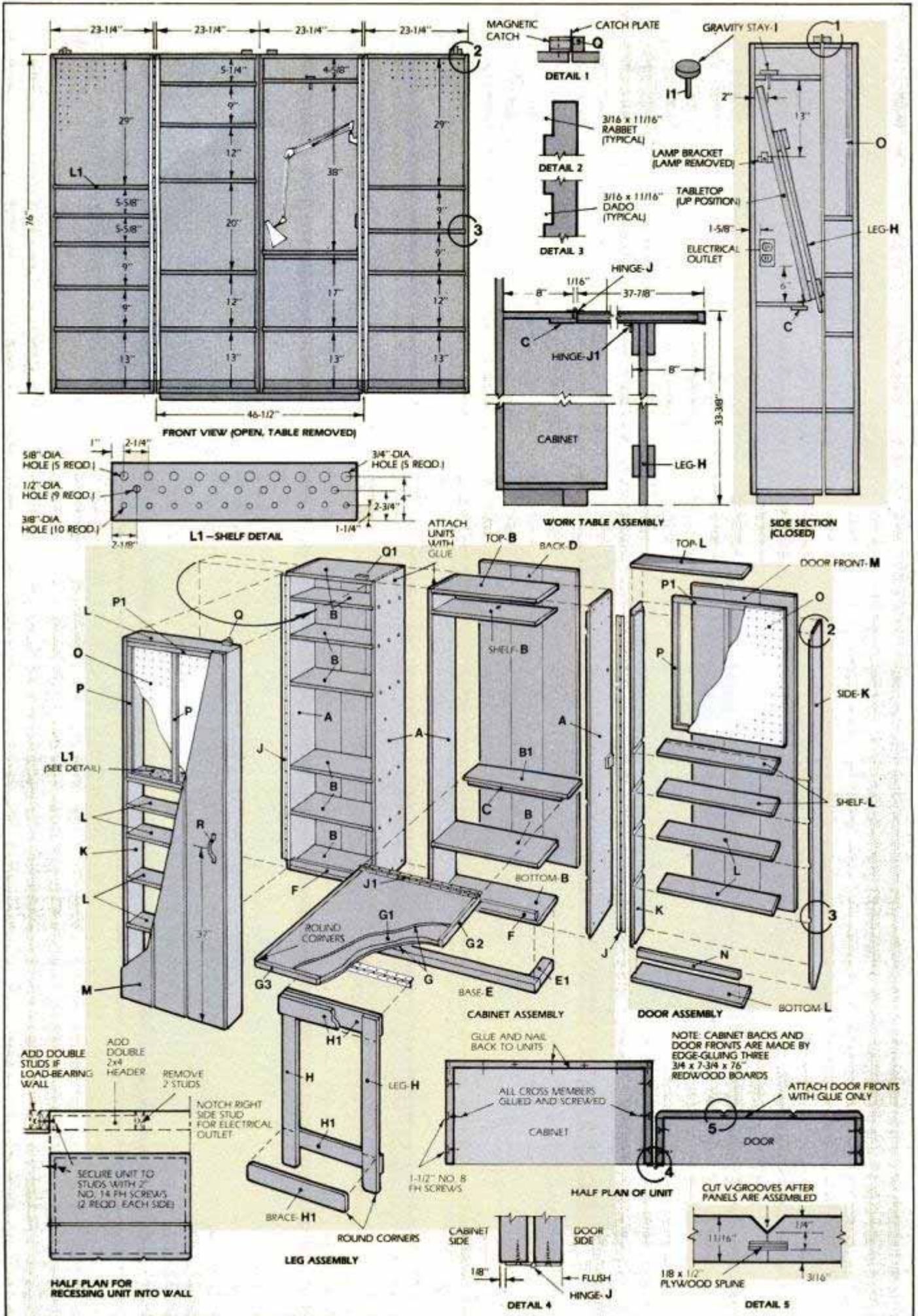

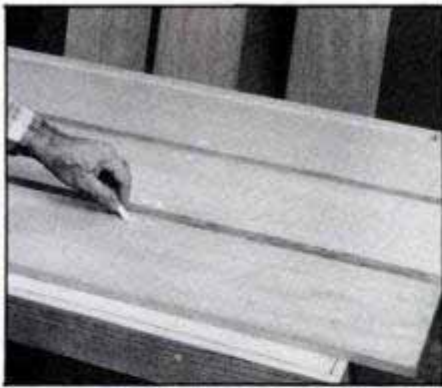

Lay out boards for edge-joining to get a pleasing grain pattern. Use chalk to key sequence with letters and numbers.

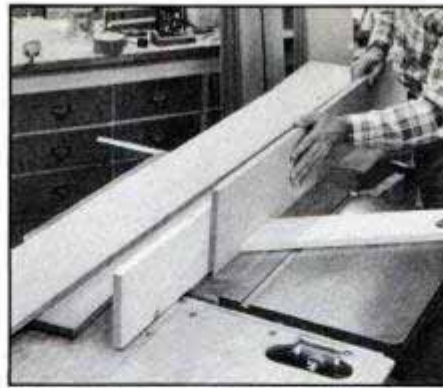

To aid in cutting spline grooves, add a wood auxiliary fence to the rip fence and clamp a featherboard to the saw table.



Light pressure on C-clamps holds the boards flat. Tighten up on the bar clamps to draw the edge-joints closed.

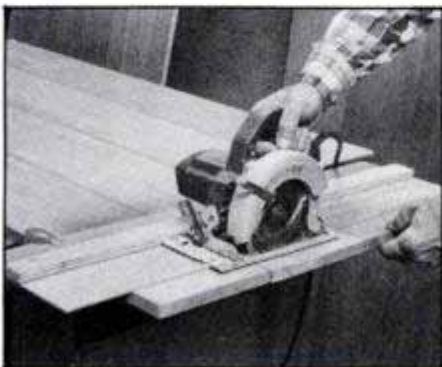

The wide end cutoffs of edge-joined panels are best handled with a portable circular saw and a clamp-on guide.

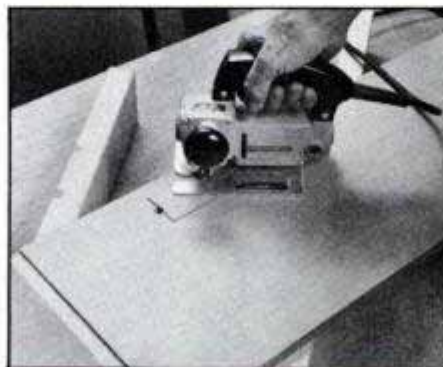

Before assembling the units, determine the electrical outlet location and use a sabre saw to make the cutout.



The pilot holes are bored into the shelf ends after the plug and pilot holes have been bored in the side pieces.

splines. The splines reinforce the joints and ensure flush surface alignment.

Successful edge gluing requires absolutely straight mating edges. Check the edges of the boards and eliminate any unevenness; to cut perfectly true edges, tack-nail a straightedge guide to the board with a slight overhang. The straightedge then rides against the table saw rip fence. Many craftsmen find a length of Reynolds H-section aluminum extrusion works well for this purpose.

Lay out the boards for the most desir-

able grain pattern and key them with numbers and letters using chalk to avoid marring the surface. Select a saw blade with a 1/8-in.-wide kerf for edge-cutting the spline groove. For accurate grooving, attach a 3/4 x 6 x 48-in. board to the rip fence by screwing through the back of the fence and into the board. Clamp a featherboard—a board "feathered" with kerfs positioned against the workpiece to ensure straight cutting—so it abuts the work directly opposite the blade. Note that when a featherboard is used for ripping

it must be placed *before* the saw blade; the exception shown is made only for grooving. When cutting the grooves, keep the same surface of each board against the rip fence; use the chalk marks to assist you.

To glue the boards together without buckling them when applying clamp pressure, sandwich them between three pairs of 2x4 cross supports. Apply glue to the board edges, grooves and splines before joining the boards. Lightly clamp the 2x4 supports to hold the boards flat, then tighten the bar clamps to draw the edge joints closed. After the glue has dried, use a portable saw to make the wide end cutoffs. Finish-sand the inside of all pieces before the next operation.

Dadoes and end rabbets are plowed into the cabinet side pieces to receive the tops, bottoms and shelves. Use a radial-arm saw with a dado head or a router with a mortising bit to make these cuts. Notice that a stopped dado is required at the tabletop shelf location. The dado stops short of the cabinet's front edge. Before assembling the

#### MATERIALS LIST—IN-THE-WALL-WORKSHOP

| Key                | No. | Size and description (use)                            |                  | No. | Size and description (use)                            |
|--------------------|-----|---|------------------|-----|---|
| <b>CABINETS(2)</b> |     |   |                  |     |   |
| A                  | 4   | 3/4 x 11 1/8 x 76" redwood (cabinet side)             | K                | 4   | 3/4 x 5 1/8 x 76" redwood (door side)                 |
| B                  | 11  | 3/4 x 11 1/8 x 22 1/4" redwood (top, bottom, shelves) | L                | 13  | 3/4 x 5 1/8 x 22 1/4" redwood (top, bottom, shelves)  |
| B1                 | 1   | 3/4 x 8 x 22 1/4" redwood (hinge shelf)               | M                | 2   | 3/4 x 23 1/4 x 76" redwood, edge-joined (door front)  |
| C                  | 1   | 1/2 x 3 x 21 1/8" hardwood (hinge cleat)              | N                | 2   | 3/4 x 1 1/4 x 21 1/8" redwood (rail)                  |
| D                  | 2   | 3/4 x 23 1/4 x 76" redwood, edge-joined (back panel)  | O                | 2   | 1/8 x 21 1/8 x 28 7/8" Peg-Board                      |
| E                  | 1   | 1 1/2 x 3 x 45" redwood (base front)                  | P                | 6   | 3/8 x 1 1/8 x 27 5/8" furring strip (Peg-Board frame) |
| E1                 | 2   | 1 1/2 x 3 x 8" redwood (base sides)                   | P1               | 4   | 3/8 x 1 1/8 x 21 1/8" furring strip (Peg-Board frame) |
| F                  | 2   | 3/4 x 1 1/4 x 21 1/8" redwood (rail)                  | Q                | 2   | 3/4 x 1 x 2 1/2" redwood (catch plate block)          |
| G                  | 2   | 1/4 x 20 x 37" oak plywood (tabletop veneer)          | Q1               | 2   | Heavy-duty magnetic catches                           |
| G1                 | 1   | 3/4 x 20 x 37" fir plywood (tabletop core)            | R                | 2   | Brass door handles, Amerock No. BP 302BB              |
| G2                 | 2   | 1 1/8 x 1 1/4 x 37 1/8" redwood (edging)              | <b>DOORS (2)</b> |     |   |
| G3                 | 1   | 1 1/8 x 1 1/4 x 20" redwood (edging)                  |                  |     |   |
| H                  | 2   | 3/4 x 3 1/2 x 32 1/8" redwood (legs)                  |                  |     |   |
| H1                 | 4   | 3/4 x 3 1/2 x 21" redwood (braces)                    |                  |     |   |
| I                  | 1   | 3/4 x 3"-dia. redwood (gravity stay top)              |                  |     |   |
| I1                 | 1   | 3/8"-dia. x 3" hardwood dowel (gravity stay pin)      |                  |     |   |
| J                  | 2   | 1 1/2 (open) x 72 3/4" continuous hinge (for doors)   |                  |     |   |
| J1                 | 1   | 1 1/2 (open) x 21" continuous hinge (for tabletop)    |                  |     |   |

Misc.: Carpenter's glue, 8d common nails (to attach cabinet backs), 1 1/2" No. 8 fh screws (to attach shelves), 1" No. 6 fh brass screws (to attach table hinge to shelf B1), 2" No. 14 fh screws (4, to secure unit), 1/8 x 1/2"-dia. wood plugs, 1/8 x 1/2 x 76" plywood splines, 1 standard electrical outlet box, 1/4 x 3 1/4" capscrew with washer and nut (for installing lamp bracket).

Note: Use nominal 3/4" clear all-heart KD redwood (actual dimension: 1 1/8"). Other lumber as noted.

PM photos: Color, Harry Hartman; black and white, Rosario Capotosto  
Room styling: Gabe Herrick  
Workshop concept: Marshall Roath  
Design and construction: Rosario Capotosto  
Tools: Black and Decker Service Center, 50 West 23rd St., New York, N.Y. 10010  
Electronic equipment: Radio Shack, 250 West 57th St., New York, N.Y. 10019  
Lamp: Sears, Chicago, Ill. 60684

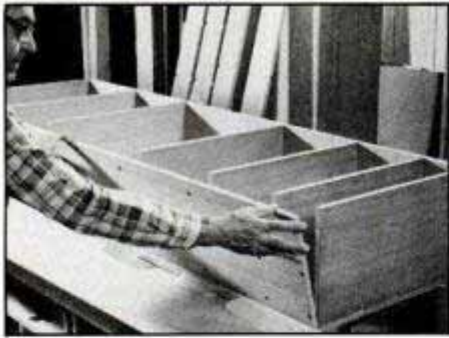

End grains receive bead of glue spread evenly with a brush. A second bead of glue is applied at the last moment. Wax paper prevents glue squeeze-out from getting on the back panel.

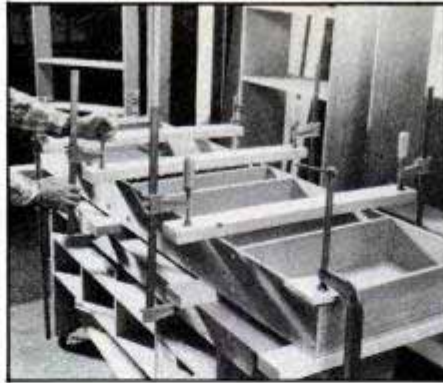

After glue has dried on the assembled door frames, glue on the front of the doors using the same procedure.

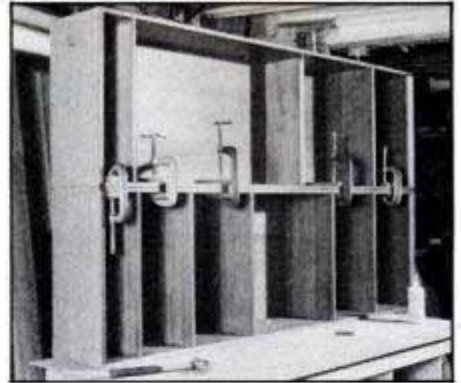

The two assembled cabinets are glued and clamped. Prior to applying clamp pressure, tack in two alignment nails.

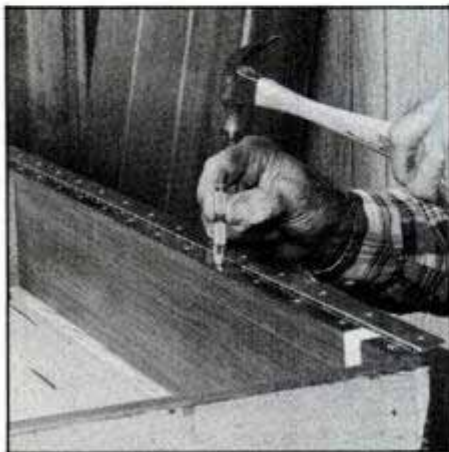

Tape door hinge in place, then secure it with three screws. Using a self-centering punch (shown) or an awl, mark remaining screw centers. Be sure the screwheads are even with the hinge surface.



Use a jack to support the tabletop while you're screwing the hinge to the shelf.

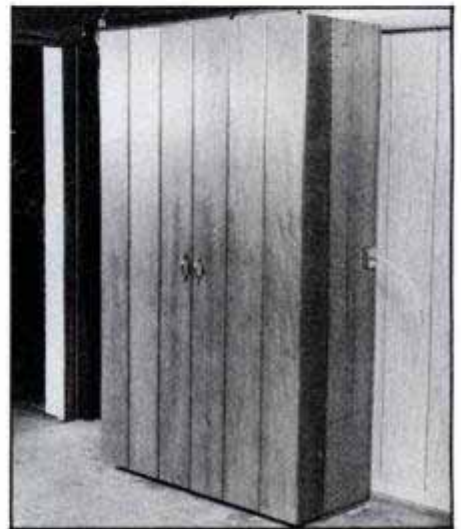

The completed workshop is now ready for installation into its wall opening.

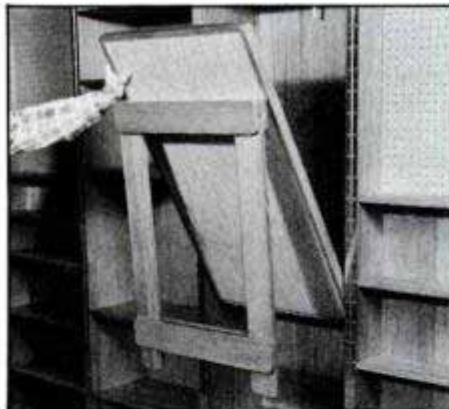

Release the gravity stay to lower the tabletop. Hinged log remains vertical.

units, make the cutout for the electrical outlet and bore the holes in the left door's upper shelf.

Follow this procedure for boring screw holes: Bore  $\frac{1}{2}$ -in.-dia.  $\times$   $\frac{1}{8}$ -in.-deep holes for the plugs. Next, bore  $\frac{1}{8}$ -in.-dia. through holes, dry-assemble the parts and bore pilot holes into the cross-member edges. Glue and screw the sides to the cross members and clamp them to their door fronts or back panels, respectively, until the glue sets.

Glued and nailed butt joints attach

the back panels to the cabinets. The door fronts are attached to the door frames with glue only. Tack-nail the door fronts to the door frames and clamp as shown in the photo.

The decorative V grooves in the door panels are cut after the doors are completed. Use a router with a  $\frac{1}{4}$ -in. V cutter guided by a straightedge. Facing the guide, pass the router left to right, bearing down firmly to avoid off-course drift.

Glue and tack-nail the two assembled cabinets together. Use C-clamps in front, bar clamps across the back.

Install the continuous door hinge  $\frac{1}{8}$  in. from the inside edge of the cabinet. This results in the desired gap between the doors when they're closed. Tape the hinge in place and secure with three screws, one at each end and one in the middle. The second leaf of the hinge is positioned flush to the door frame edge for the necessary offset. A note of caution about hinges: Stanley hinges are recommended simply because they are well made. Many commonly available imports have edge bow which makes them difficult to install properly.

The Peg-Board is glued on the inside of the doors to a  $\frac{3}{8}$ -in.-thick furring

strip frame. Cut the Peg-Board with about  $\frac{1}{8}$ -in. clearance on all sides. Paint and install the tool boards.

Construct the tabletop by laminating  $\frac{1}{4}$ -in.-thick hardwood-veneer plywood to both sides of the  $\frac{3}{4}$ -in.-thick fir plywood core. Cover both sides of the core to prevent warping. The tabletop mounts on a backup shelf reinforced on the underside with a hardwood strip. Use 1-in. screws on the hinge's back leaf to penetrate the hardwood.

The worklamp shown (from Sears, No.9 GT 2484, worklight) provides a mounting bracket that screws to a flat surface. For a solid installation, use a  $\frac{1}{4}$   $\times$   $3\frac{1}{4}$ -in. cap screw (not supplied) to mount the bracket. The lamp will clear the retracted tabletop provided you position the bracket precisely as indicated in the drawing.

While the weight and angle of the tabletop allows it to rest safely in the up position, install the simple gravity stay to prevent children from pulling the table down.

For a satin finish that enhances the redwood, apply two coats of Deft semi-gloss clear finish. We used Krylon No. 1910 blue spray paint on the perforated hardboard.

FM





# HOW-TO BOOK CLUB

*YOU CAN* do-it-yourself,  
*you can* do it right, and  
*you can* save money too!

18 years experience

Select 5 exceptional books  
for only \$2.95 (values to \$101.75)

|  |  |   |   |  |  |  |  |
|--|--|---|---|--|--|--|--|
| <br>2103<br>List \$14.95   | <br>1172<br>List \$8.95 (paper) | <br>1320<br>List \$21.95   | <br>1314<br>List \$19.95   | <br>1275<br>List \$14.95          | <br>1486<br>List \$17.95   | <br>1415<br>List \$19.95          | <br>1336<br>List \$17.95  |
| <br>1460<br>List \$18.95  | <br>1361<br>List \$18.95       | <br>1160<br>List \$13.95  | <br>1384<br>List \$16.95  | <br>1375<br>List \$15.95         | <br>1403<br>List \$13.95  | <br>1424<br>List \$19.95         | <br>1281<br>List \$12.95 |
| <br>1440<br>List \$15.95 | <br>1412<br>List \$13.95      | <br>1287<br>List \$18.95 | <br>1298<br>List \$18.95 | <br>1122<br>List \$9.95 (paper) | <br>1433<br>List \$18.95 | <br>1204<br>List \$8.95 (paper) | <br>335<br>List \$14.95 |

|  |   |   |
|--|---|---|
| <br>1279<br>List \$16.95  | <br>2094<br>List \$15.95  | <br>1312<br>List \$16.95          |
| <br>1321<br>List \$11.95 | <br>1046<br>List \$12.95 | <br>1292<br>List \$12.95 (paper) |

## 7 very good reasons to try How-To Book Club Blue Ridge Summit, PA 17214

- **Reduced Member Prices.** Save 20% to 75% on books sure to increase your know-how
- **Satisfaction Guaranteed.** All books returnable within 10 days without obligation
- **Club News Bulletins.** All about current selections—mains, alternates, extras—plus bonus offers. Comes 13 times a year with dozens of up-to-the-minute titles you can pick from
- **"Automatic Order."** Do nothing, and the Main selection will be shipped automatically! But... if you want an Alternate selection—or no books at all—we'll follow the instructions you give on the reply form provided with every News Bulletin
- **Continuing Benefits.** Get a Dividend Certificate with every book purchased after fulfilling membership obligation, and qualify for discounts on many other volumes
- **Bonus Specials.** Take advantage of sales, events, and added-value promotions
- **Exceptional Quality.** All books are first-rate publisher's editions, filled with useful, up-to-the-minute information

## HOW-TO BOOK CLUB Blue Ridge Summit, PA 17214

Please accept my membership in How-To Book Club and send the 5 volumes circled below, billing me at \$2.95 plus shipping and handling charges. If not satisfied, I may return the books within ten days without obligation and have my membership cancelled. I agree to purchase 4 or more books at reduced Club prices (plus shipping/handling) during the next 12 months, and may resign any time thereafter.

335 1046 1122 1160 1172 1204 1275 1279  
1281 1287 1292 1298 1312 1314 1320  
1321 1336 1361 1375 1384 1403 1412 1415  
1424 1433 1440 1460 1486 2094 2103

Name \_\_\_\_\_ Phone \_\_\_\_\_

Address \_\_\_\_\_

City \_\_\_\_\_

State \_\_\_\_\_ Zip \_\_\_\_\_

(Valid for new members only. Foreign and Canada add 20%. Orders outside U.S. or Canada must be prepaid with international money orders in U.S. dollars).  
This order subject to acceptance by How-To Book Club. PM-483

# Energy-Saving Ways With Windows

20th-century materials, old-fashioned ingenuity help produce these new window treatments.

BY JOHN H. INGERSOLL

**O**ur ancestors knew it. Working window shutters were as common as fireplaces in the 17th, 18th and 19th centuries. It's true that one of the reasons for shutters was security. But another was clearly protection from the winter cold.

Here we are in energy-expensive 1983, and window shutters are being rediscovered—though they're not the wooden wind-bangers our forefathers built: We're discovering that window treatments can keep our homes cooler in summer and reduce the need for air conditioning. When high-tech materials are used, shutters, shades, blinds and screens can be lighter, better engineered and far more effective than their predecessors at blocking heat loss and heat gain.

You know from experience that single glazing is a poor insulator. It has a meager R-value (measure of a material's resistance to heat loss by conduction) of 0.9. Double glazing raises the window insulating value to R-1.84, which is far below the R-19 minimum that's expected in present-day wall construction.

Although single-glazed windows in a Michigan home without storms could account for more than 50 percent of the house heat loss in winter, that same building, when fitted with insulating shutters properly installed and used could build up protection against heat loss at windows to around R-10. This would reduce fuel consumption for the house by as much as 25 percent.

## Shopping for window treatments

Window-insulating products, often called movable insulation, are for the most part less than a decade old. But now a host of companies are selling materials, kits and finished insulators. Before you buy any of them, however, weigh the answers to these four questions:

**1. How much energy do they save?** Window insulation ranges in



*Solar screen, such as Phifer's Sunscreen (above), blocks out 60 to 70 percent of the sun's heat, thus cutting demand on the air conditioner. To replace conventional*

*screening you'll need a screen roller (inset). Screening is about \$1 per square foot; new screen plus frame and labor costs about \$2.50 per square foot.*

value from less than R-2 to a figure that's very close to R-10. These values represent the rating for the insulation only. When they are combined with existing double- or triple-glazed windows, plus dead-air space between the glazing and insulation, these values in many cases jump above R-12.

## 2. Are you content with the

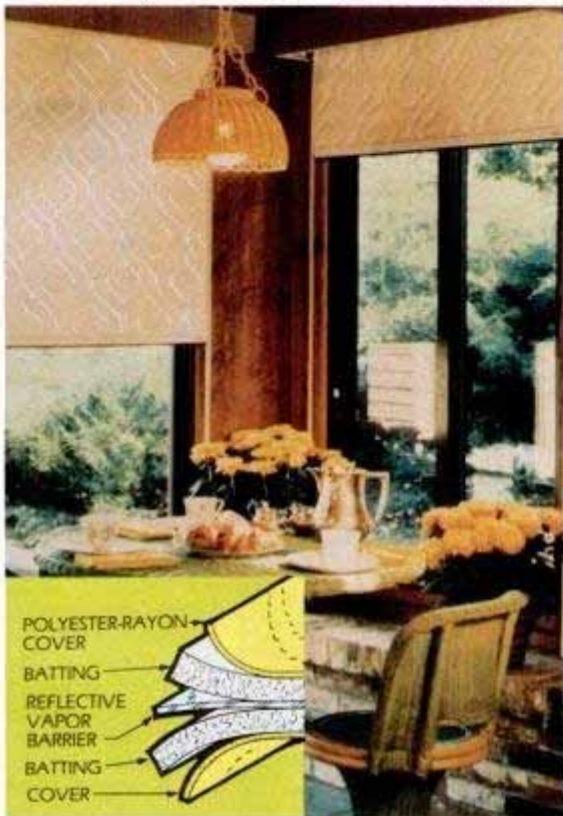

*Window Quilt is a custom-made shade of five layers of fabric with an R-value of 3.4. The shades are available in 48 colors, seven with a white dot pattern. They range from 22 to 99 in. wide and are up to 158 in. long. The cost is about \$5.50 per square foot. Window Quilts come with concise installation directions and a list of parts shipped.*



*On a southern exposure, canvas awnings can block from 55 to 65 percent of the heat gain through a window. On a western exposure, blockage can be from 72 to 77 percent, according to the American Society of Heating and Air Conditioning Engineers. Scientists have also found that white or light-colored awnings are best for reducing indoor temperature.*

**appearance?** How will the window or glass door look with insulation? Some of the first-off-the-production-line units lean heavily to the practical. Some more recent models of shutters and shades feature color, pattern or molding on the inside face. Others suggest that you attach the fabric of your choice to the panels or shades.

**3. How easy are they to install and operate?** Insulating shades operate in practically the same way as ordinary window shades. They are wrapped on spring-loaded rollers. The differences: They are heavier than paper shades, and many slide in tracks rather than swing free. Some of these

*(Please turn to page 134)*

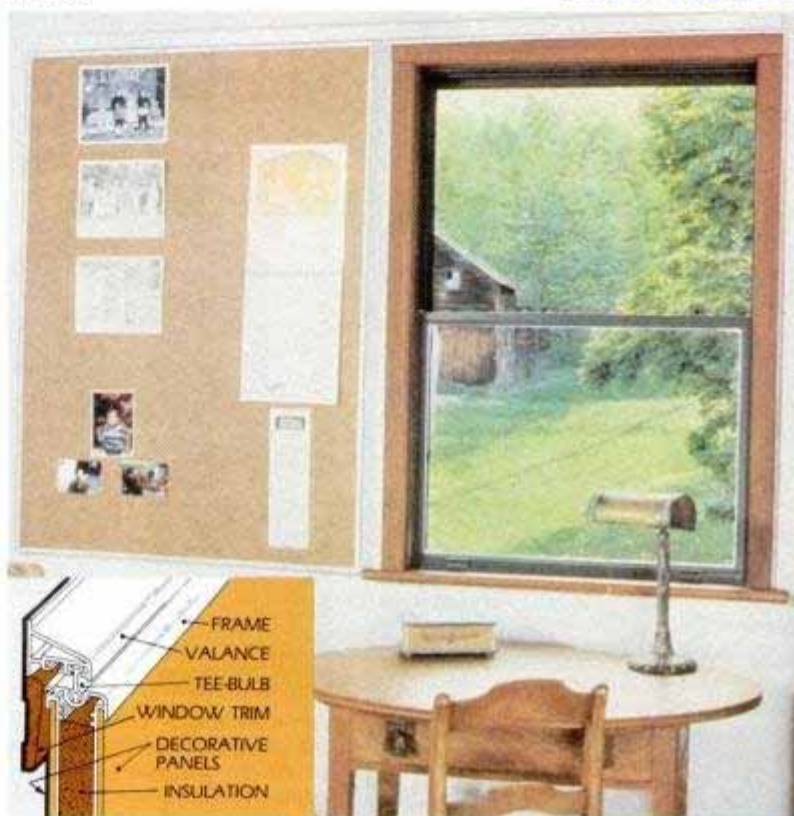

*The bulletin board is an insulated sliding shutter enclosed in Thermal Wall's vinyl framing system. Parts needed to cover a 30x60-in. window cost about \$58 and include vinyl valance, vinyl frame, weatherstripping, corner reinforcements and hardware. You supply board insulation and decorative panel and assemble the parts. A swinging shutter system is also sold. The maker claims that a 1-in.-thick urethane foamboard backed with aluminum foil and topped inside with fabric racks up an R-12 rating.*



*The Insulating Curtain Wall, operated electrically, has an R-9 to R-12 insulating value. An outside temperature sensor signals the automatic shades to open or close. Thermal Technology, the maker, provides six finishes for the interior surface; or you can attach your own fabric following directions provided. The surface facing outdoors is a reflective metallic. Price for a 4x4-ft. covering (smallest size) is \$780. The company also makes a manually operated version called SuperShade which has an R-value of 4.*

(Continued from page 133)

shades can be electrically operated. For the most part, the new insulating shutters are positioned inside the house. They lie back against the wall and swing forward or slide over the window. For an exception, one type (Thermax) is a panel that must be inserted and removed manually when not in use. Shutters are available as sin-

gle or double-fold panels. The installation of insulating shades and shutters is a task that's no more difficult than the putting up of a Roman shade or louvered, interior shutters. Insulation fixed within windows—some blinds, for example—comes built into the window and calls for window replacement. Insulating draperies require only a couple more steps beyond the installation of standard draperies.

## WINDOW-BLIND NEWS

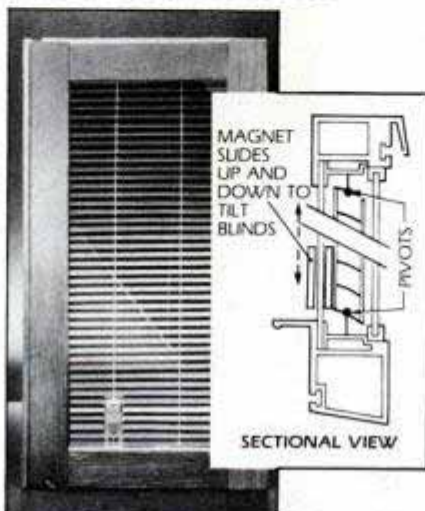

A magnetically controlled blind in a double-glazed window has been developed by Hunter Douglas, and is available as a complete window unit. Since no outside mechanical connection is needed to operate the blind, there are no holes in the glass. You can get the blinds in both horizontal and vertical styles.

**4. Finally, what is the cost?** At present, the costs for several of the more innovative treatments are somewhat erratic. The producers of these products presently have limited production-line capabilities. Some units are practically handmade. As production output increases, the prices should stabilize. Approximate prices for the treatments shown are revealed in the captions appearing below them. You can write to the manufacturers listed at



*Slimshade, a narrow-slat blind in Pella's double-glass insulated windows, is controlled by a dial in a corner of the window. The exterior pane is fixed; interior one removes for cleaning. A 2½ × 5-ft. window with Slimshade sells for about \$250. Solar-heat gain in summer is cut by 82 percent, the maker claims.*

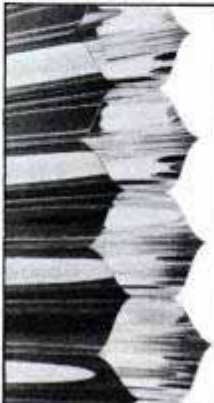

*Thermocell insulating window blind, with flexible honey-comblike structure (see detail), opens and closes like an accordion. Dead air spaces in cells give R-values of about 2.5 for the transparent finish, 4.5 for the white and 6 for the chrome finish shown, reports the manufacturer, Thermal Technology. Retracted, each foot of blind compresses into a ½-in. space. Blinds will sell this spring for about \$4 per sq. ft.*



*The Ready Made blind by Levolor in alabaster or white costs one-third less than the maker's custom blinds. A 30-in.-wide blind sells for \$25 to \$36 depending on the retailer. The blinds come 23 to 72½ in. wide and 64 in. long. You adjust the length by removing the slats. A patio door double blind is also available.*

**HASTINGS MANUFACTURING CO.**  
Hastings, Michigan 49058  
FILTERS • PISTON RINGS • CASITE PRODUCTS • TOOLS

## WATER WELL DRILL KIT



Drill a water well or a free-flowing spring in your backyard. Have all the pure, fresh water you want FREE! Easy to operate as your power lawn mower.

30,000 SOLD!

FOR FREE BROCHURE  
**CALL TOLL-FREE**  
**1-800-821-7700**

(Ask for Extension 770)

Call anytime including Sundays

OR WRITE TODAY!

**DeepRock**

770 Anderson Road  
Opelika, Alabama 36802

©1983 DeepRock Mfg.



the end of this story for further information and specific pricing.

### Federal tax credit not given

As this is written, insulating shades and shutters, and other movable window insulation do not qualify for a federal tax credit, as do certain other energy-saving products such as insulation, storm windows and solar collectors. According to the Internal Revenue Service, government specifications require that an energy-saver be installed permanently.

However, the encouraging news is that the IRS is taking a hard look at its rules and, may make an adjustment in the next 12 months. Meanwhile, in a number of states (California, for example) state tax credits are offered for movable insulation. Call your state energy office for more information.

### Cost-effective placement

If you live in a house with single-glazed windows and where no window or door is protected by storm sash, insulation over every opening would slash fuel bills. But even in this extreme example, a combination of glazing replacement/addition and adding less expensive window treatments to strategic windows not only would prove much less costly than adding storms to all of your windows but would also significantly reduce your fuel bills.

Architect William K. Langdon, author of *Movable Insulation* (Rodale Press), emphasizes that to save money you can be selective in treating windows. To save money, limit window insulating materials to the north openings, and possibly to the west openings, or on the side prevailing winds blow in winter.

Limiting the use of movable insulation makes good sense especially when your home is already tightly sealed and protected at windows and glass doors with at least double glazing, or possibly triple glazing. Then heat loss through windows (minus normal heat gain on sunny winter days) accounts for less than 20 percent of the total loss.

Another saving is made by *mixing* the various types of movable insulation. Save the more expensive, high R-value treatments for the coldest sides of your house. On the less vulnerable sides, lined draperies pulled over the windows at night could do the trick.

In those states subjected to more summer than winter, an exterior treatment such as shutters, awnings or screens can be more effective than movable insulation indoors. To save money along the southern belt or in other areas having hot summers, consider installing insulation on south and west windows.

The other side of cost effectiveness, [\(Please turn to page 136\)](#)

# POP<sup>®</sup> RIVETOOL. Whenever nuts and bolts aren't holding their own.

- Easy to use—POP<sup>®</sup> brand Rivets fasten two surfaces from one side in seconds, permanently.
- POP brand Rivets won't strip, can't shake loose like screws, nuts and bolts.

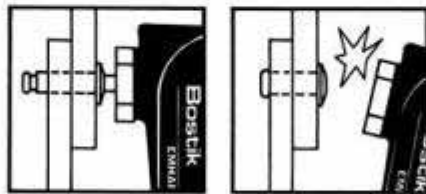

Rivets insert easily, even when working from one side. When end is fully expanded, rivet stem pops and rivet locks in place permanently.

- Hundreds of uses inside and outside. Lets you: assemble gutters; install downspouts; make auto repairs, customize cars and vans; fix lawn furniture; repair storm doors, leather goods and much more.
- Fastens metal, wood, cloth, plastic, leather, etc.
- Ideal for year-round gift giving.
- Available wherever hardware is sold.

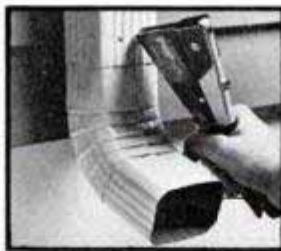

**Bostik**

CONSUMER DIVISION

Reading, PA 19605 **EMHART**

(Continued from page 134)

however, is creature comfort. On a cold winter evening, sitting alongside a window protected with a high-R shutter is downright comfortable. When that's vital to you and your family, budget worries evaporate.

When you begin shopping for these items, you'll discover that 1. distribution is spotty and 2. some makers will claim their product not only blocks heat loss or gain through windows, but seals up losses by infiltration through cracks around the window. Architect Lang-

don, with no profit ax to grind, believes that infiltration ought to be plugged normally with such items as caulk, weatherstripping, foam and fiberglass insulation. "Movable insulation should protect the glazing, period," he emphasizes.

No one has to tell you energy conservation is a serious matter. Your utility and/or fuel bill makes you aware of this every month. However, movable window insulation is one more effective plug in the energy wall. **PM**

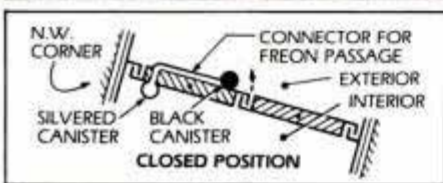

The Skylid by Zomeworks lets sun in skylight during the day, seals it against heat loss at night automatically. Panels open and close by the weight of Freon shifting between two canisters (there's only enough Freon to fill one), one on the room side and the other facing the skylight. Freon always moves to the cooler container. The system has a manual override. Panels have an R-value of 3 to 5. A unit for a 48 x 54-in. opening weighs 70 pounds and costs \$550.

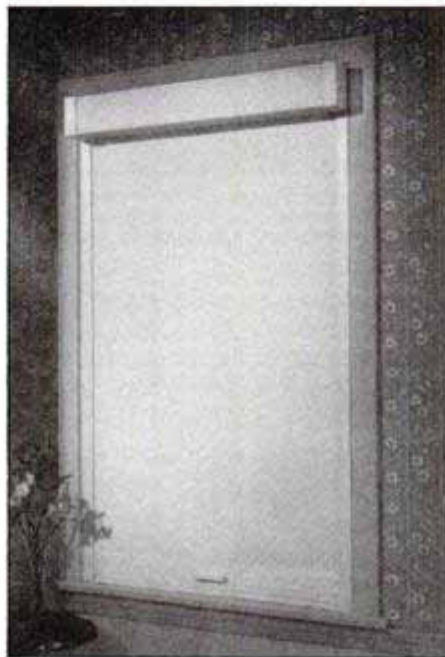

The Window Seal System by Graber is a shade made with five layers of fabric that produce an R-value of 3. White acrylic on the outside reflects the sun. Quilted polyester in brown or oatmeal faces the room. Shades come with vinyl side tracks, cornice and installation instructions. A 3x5-ft. shade is approximately \$98.

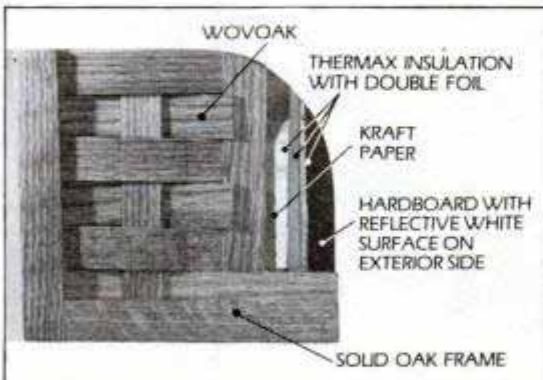

Interior shutters of FTR's Wovook for windows and patio doors provide an R-8 insulation value when Thermax insulation is used, and an R-4.8 value when fiberglass is substituted. Single panels and bifolds are available. The price of a typical 3x5-ft. window is about \$286 for a single bifold with a Thermax core. The shutters are shipped fully assembled. You simply install them.



Plastic film sheeting held by transparent tape to the window casing cuts air infiltration up to 97 percent, says 3M, its maker. A hair dryer eliminates wrinkles. One Window Insulator kit (\$4.50) has tape and plastic to cover a 3x5-ft. window.

## Window Treatment Makers

Following is a partial list of movable insulation manufacturers. Several are small and their lines of distribution are not firmly established. Thus, you may find only a few of the products mentioned in your local home center. However, except for products sold as part of a completed window, most firms listed will ship f.o.b. from the factory. Write for information.

### Blinds, exterior

Nichols-Homeshield Inc., 1000 North Harvester Rd., West Chicago, Ill. 60185

### Blinds, interior

Levolor Lorentzen Inc., 1280 Wall St. West, Lyndhurst, N.J. 07071

Thermal Technology Corp. of Aspen Inc., 600 Alter St., Atlas Industrial Park, Broomfield Colo. 80020 (Thermocell insulating miniblinds)

### Plastic insulating film

3M Household and Hardware Products Div., Bldg. 223-4S, 3M Center, St. Paul, Minn. 55144 (3M Window Insulation Kit)

Stanley Hardware, Div. Stanley Works, 195 Lake St., New Britain, Conn. 06050 (interior and exterior applications)

### Shades

Appropriate Technology Corp., Old Ferry Rd., Brattleboro, Vt. 05301 (Window Quilt)

Graber, Graber Plaza, Middletown, Wis. 53562

Jaksha Solar Systems, 5900 Deerhaven Rd., Lincoln, Neb. 68516 (Insulider)

Thermal Technology Corp. of Aspen Inc., 600 Alter St., Atlas Industrial Park, Broomfield, Colo. 80020 (Insulating Curtain Wall, electrically operated; Super Shade, manually operated)

Warm Window, 3288 Lake City Way N.E., Seattle, Wash. 98115

### Shutters

Columbia Moulding Extrusion Div., Jim Walter Plastics, 4747 Hollins Ferry Rd., Baltimore, Md. 21227 (Thermax)

FTR-Wovook, 5725 Arapahoe, Boulder, Colo. 80303

Homesworth Corp., 18 Main St., Yarmouth, Me. 04096 (Sunsaver)

Shutters Inc., 110 East Fifth St., Hastings, Minn. 55033 (Thermafold)

Thermal Wall Insulating Shutters Inc., R.D. 1, Box 462-A, Voorheesville, N.Y. 12186

Zomeworks Corp., 1221 Edith Blvd. N.E., Albuquerque, N.M. 87125 (Skylid for skylights)

### Solar screens

Phifer Wire Products, Box 1700, Tuscaloosa, Ala. 35403

J.P. Stevens & Co Inc., 1185 Avenue of the Americas, New York, N.Y. 10036

### Complete windows

Rolscreen Co., Pella, Iowa 50219 (Pella Slimshade)

### Window Makers using magnetic blind:

(Magnetically-controlled between-glass blind made by Hunter Douglas Inc., 87 Route 17, Maywood, N.J. 07607)

Efco, 200 West Dairy St., Monett, Mo. 65708

Envirolite Enterprises, 6 Carol Ave., West Haverstraw, N.Y. 10993

Sun Windows Inc., 1515 East 18th St., Owensboro, Ky. 42301

**Note:** Many shades and shutters in a slider design will adapt to skylights.

# SPRING FLX UP VALUES



Pat Summerall

"The folks at True Value can help you save money as you spruce up for Spring. They offer expert advice, finest brand-name products and low prices ...to make every do-it-yourself project a complete success!"

## True Value

HARDWARE STORES & HOME CENTERS

**MASTER PLUMBER™ Kitchen Faucet** with aerator installs easily on sink deck. Solid cast brass with bright chrome plating. 0-1 1/4" adjustment. 261-20MP



15<sup>95</sup>

**TRUE VALUE® Garbage Disposer.**



Chews up wastes, even bones, fast. Sound insulated, resists jamming and corrosion. Is easy to install with rugged 1/2 hp motor. TV103

49<sup>99</sup>

**TRU-TEST® Select Redwood Stain** colors, seals and protects with 1 coat. Dries fast, cleans up easily. Ideal for fences, siding, shingles and shakes. Gal.



3<sup>98</sup>

**MASTER ELECTRICIAN™ Interrupter/15** protects against ground faults in electrical appliances. Halts current to prevent serious shock. Easy to install. 1591F1



16<sup>66</sup>

**MASTER MECHANIC® Professional Hammer** has polished octagon head forged of fine-grained US-made steel. Contour crown resists chipping, sets nails flush without marring surfaces. Beveled claw grips nails. Shock-absorbing hickory handle is triple-wedged and epoxy-sealed to the head. F16MM/RMM

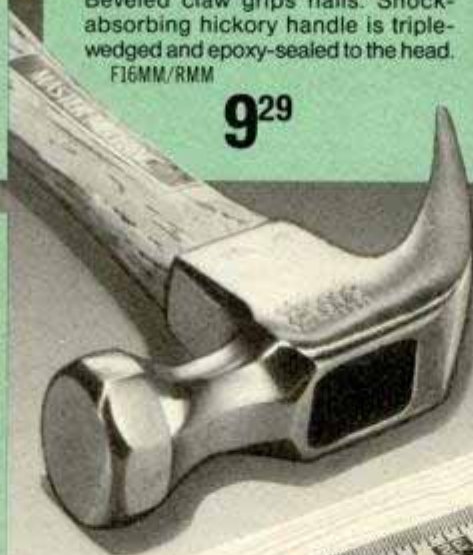

9<sup>29</sup>

**TRU-TEST® X-O Rust®** stops old rust on the spot, seals out air and moisture to prevent new rust. Wide choice of colors to restore anything metal. Quart 4.98



3<sup>98</sup> PL

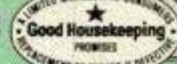

**MASTER MECHANIC® 25' Power Tape** in high-impact Cyclocac® case with positive toggle lock, smooth power return. Self-adjusting end hook allows easy single-handed measuring of inside and outside dimensions. 1" yellow blade has easy-to-read markings, 16" centers. Removable belt clip. MM425

6<sup>99</sup>





**2 for the price of 1**

With this coupon get 2 keys duplicated for the price of one!

Single-bitted only. Limit one pair per customer. Offer expires April 30, 1983 at participating



Tear out and save this 8-page section.

**MASTER MECHANIC®** portable workbench has movable vise, tilt adjustment, tool holder. Holds materials to 27" wide. MM1000

**49<sup>99</sup>**



**MASTER MECHANIC®** Oxy-Propane Torch has 2 fuels, dual controls to 5,000°. Cut, weld, braze, solder, etc. Complete, portable and versatile. MMW5000

**32<sup>99</sup>**



**MASTER MECHANIC®** 40 pc. Tap and Die Set with tempered steel edges cuts NC, NF, NPT threads. Tap and t-handle wrenches, thread gauge, etc. 442657

**44<sup>99</sup>**



**Tool up while**  
Big values on all your workshop needs. Just say



**MASTER MECHANIC®** Tool Chests feature solid steel "strongbox" construction throughout, enamel finish, smooth compound drawer glides. **A** 6-drawer chest has 3 large and 3 smaller drawers, plus 4-section lift out parts tray. 15x26x13½". MM1806

**94<sup>50</sup>**

**B** 3-drawer roller cabinet has large lower storage area, brakes on 2 of 4 casters. 33½ x 26½ x 18". MM1903

**121<sup>50</sup>**

**C** **MASTER MECHANIC®** Reinforced Tool Box. 19" strongbox with nickel plated hardware has divided tote tray, protected hinge, padlock eye. MM429

**9<sup>99</sup>**



**D** **MASTER MECHANIC®** 35-pc. Socket Set has ¼" and ⅜" drive sockets, 12 SAE and 16 metric, plus extension, ratchet, adapter, spinner and more. MM735

**21<sup>49</sup>**

**E** **MASTER MECHANIC®** 8-pc. Screwdriver Set handles all jobs with 5 slotted and 3 Phillips tips. Precision ground blades, high-impact handles. TT8

**7<sup>49</sup>**

**F** **MASTER MECHANIC®** 7" Diagonal Pliers forged from tough alloy tool steel. Cutter is electronically hardened. Forged rivet keeps its precise fit. MM40-7C

**6<sup>99</sup>**

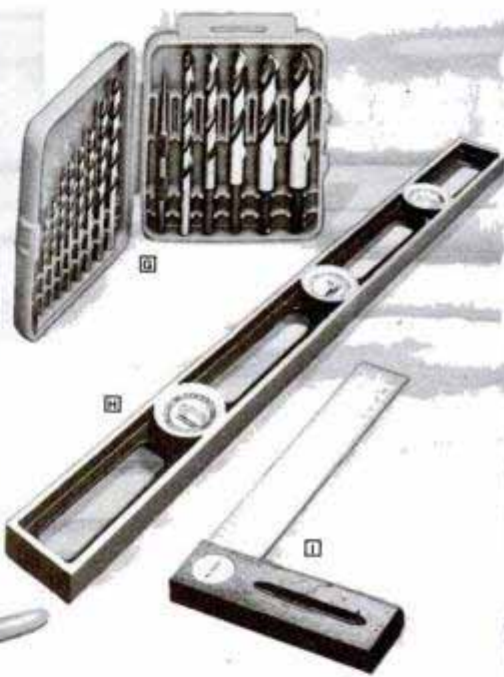

**G** **MASTER MECHANIC®** Drill Set has 15 high-speed bits sized in 32nds, ⅛-½". Heat hardened power points bite deep. ¼" shanks on all, fitted case. M15

**18<sup>89</sup>**

**H** **MASTER MECHANIC®** 28" Level has six unbreakable vials, 4 plumb and 2 level, sealed against moisture and dirt in rugged cast aluminum frame. 10122

**16<sup>99</sup>**

**I** **MASTER MECHANIC®** 8" Try Miter Square has rust-resistant copper-clad blade, top edge reads inches, lower in metric. 6" mahogany handle. 10191

**5<sup>99</sup>**



**REMINGTON®** 12" Electric Powercutter with 12" hard nose bar cuts trees 24" thick. Caged 1¼ hp motor, safety trigger lock, hand guards. 76728E

**44<sup>95</sup>**



**HOMELITE®** Super 2 Chain Saw has 1.9 cu. in. gas-powered engine with 16" Power Tip guide bar and chain. With twin trigger control. Case. Super 2CC

**194<sup>50</sup>**



**DREMEL®** Chain Saw Sharpener easily attaches to the Chainsaver tool and quickly restores dull saw teeth to a fine cutting edge. 1246

**29<sup>99</sup>**





**WISE GRIP® Set** includes new 9" long nose pliers with wire cutter and 10" straight jaw pliers. Both have famous locking grip for maximum versatility. 219A **11<sup>99</sup>**



**CRESCENT® 10" Adjustable Wrench** is drop forged alloy steel, heat treated for toughness and durability. Chromium plated to resist corrosion. AC110V **7<sup>99</sup>**

**MASTER MECHANIC® Power Vac** picks up everything! High performance wet/dry cleaning. 1.25 peak hp, advanced features, with tool set. 10-gal. capacity. MMP800-10 **62<sup>99</sup>**



# prices are down

"charge it" at participating True Value Hardware Stores and Home Centers.

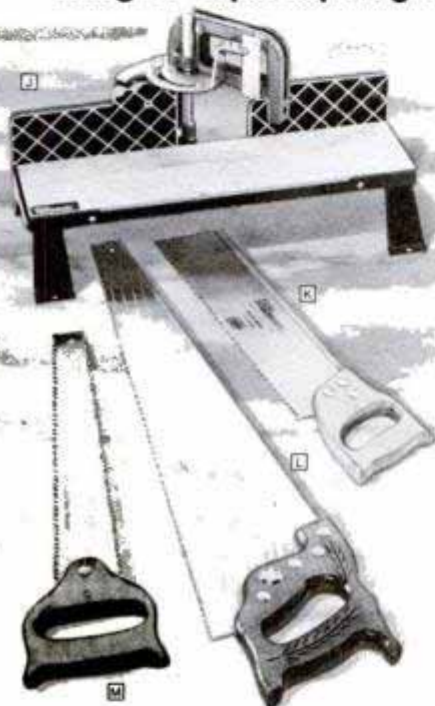

**MASTER MECHANIC® Metal Miter Box** has floating saw guide for accurate cuts up to 45° right or left. MM3622 **29<sup>99</sup>**

**MASTER MECHANIC® 14" Backsaw** for use with miter box. Precision ground heavy steel blade, wood handle. MM11014 **5<sup>99</sup>**

**MASTER MECHANIC® 26" Handsaw**, 8 pt. coarse crosscut, taper ground steel blade, wood handle. MM10080 **12<sup>49</sup>**

**MASTER MECHANIC® Pruner** has both coarse and fine-cutting edges on steel blade, wood handle. MMP14018 **7<sup>79</sup>**



**NATIONAL® ¼" Socket Set** for work on appliances, motors, cars. 17-pc. set has 11 sockets, ratchet, spinner, speeder disc, t-bar, 6" extension. C17-4 **5<sup>95</sup>**

**GEDORE® 6-pc. Combination Wrench Set** in chrome vanadium steel with open and box end sizes ⅜" to ¾". Highly polished chrome finish. 171/66A **5<sup>79</sup>**

**SCREWBALL® Power Grip Screwdriver**. 3 tips store in handle. Rib grip boosts turning power. Your choice of Phillips or regular tips. SB901/11. Each set, **6<sup>49</sup>**

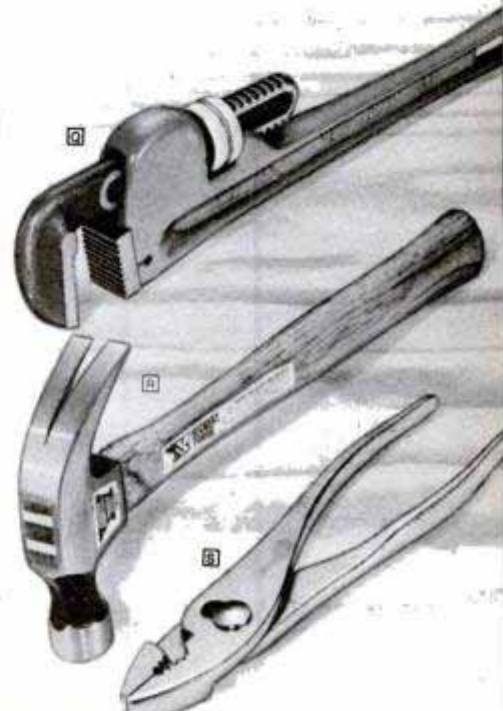

**SERVESS® 14" Pipe Wrench** has powerful drop-forged jaws with induction hardened teeth. Full floating hook jaw for instant grip, quick release. 514S **6<sup>99</sup>**

**SERVESS® 16-oz. Nail Hammer** has highly polished, heat-treated steel head. Flame hardened, shock absorbing U.S. hickory handle. 3-16HFN **4<sup>49</sup>**

**SERVESS® Slip Joint Pliers** with smooth jaw action. Drop-forged steel, nickel plated against rust. Pick up a spare at big savings. 2475 Now only, **1<sup>19</sup>**



**DREMEL® Moto-Tool Kit** with 30,000 rpm motor drives over 34 accessories to sand, drill, carve, polish. Lifetime bearings, storage case and accessories. 2501 **37<sup>98</sup>**



**GREAT NECK® 7-in-1 Hole Saw** fits any electric drill, lathe, drill press. Furnace steel blades cut 1-2½" holes through ¾" thick wood or plastic. HC7C **3<sup>99</sup>**



**GREAT NECK® 10" Spiral Screwdriver** with 6 different bits. 1 is attached, with 3 drill points and 2 screwdriver bits stored in the handle. 97AC **5<sup>59</sup>**

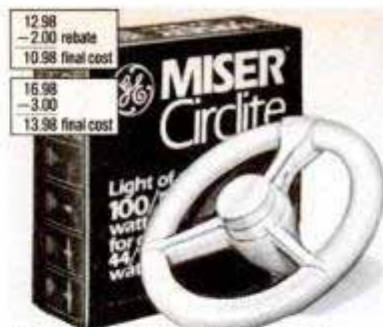
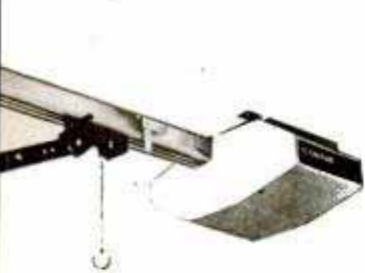

**GENIE® Garage Door Opener.** Deluxe screw drive, automatic light, Cryptar® II control. Rails snap together, it's easy to install. GS850 **179<sup>99</sup>**

**ITT® Bright Beam Security Light** for tennis court, driveway, patio. 300W quartz lamp sheds more light than 2 incandescent. R300Q2 **28<sup>99</sup>**

**SNAP-IT® 6-Outlet Power Surge Controller™** with RFI suppressor protects solid-state electronics from line disturbance. 48733 **39<sup>99</sup>**

**G.E.® Circlites** give twice the watts they use. 100W, FCA44SW, **12.98** less \$2 factory rebate. 50/100W, FCA44SW-2 **16.98** less \$3. 22W Cool White, FC8T9/CW . . . **3.49**

# Money saving work

Make your headquarters for home care one of more than 6,000 True Value Hardware Stores



**MASTER ELECTRICIAN™ Power Extension Cords.** 3-wire grounded for heavy-duty tools or major appliances indoors or out. 30-ft. 239558 . . . . . **3.99**  
60-ft. 239335 . . . **6.99** 100-ft. 240705 . . . **9.99**

**MASTER ELECTRICIAN™ Vinyl Tape** splices and insulates for easy wiring repairs. Resists weather, flame and acid. 3/4"x20' 468249 . . . . . **49¢**  
3/4"x66' with dispenser. 468264 . . . **1.19**



**MASTER ELECTRICIAN™ Weatherproof lamp holder.** 369785 . . . . . **1.99**  
Round 3-outlet cover. 370536 . . . . . **1.69**  
Rect. 3-outlet box. 243998 . . . . . **2.39**  
Duplex snap cover. 247114 . . . . . **1.69**

**ELECTRIPAK® Power Center** has six 15-amp grounded receptacles. Shuts off automatically if overloaded. 6 foot, 3-wire cord. Heavy-gauge steel. MOC6C **12<sup>99</sup>**



**SKIL® Sandcat™** has ease of control of orbital, plus fast removal and low vibration of belt sander. Locking lever, with 5 belts. 593 **47<sup>99</sup>**

**SKIL® 6½" Circular Saw** has 1½-hp motor and Vari-Torque clutch for burnout protection. Cuts 2¾" at 90°, 1¾" at 45°. Sawdust ejection. 534 **38<sup>99</sup>**

**SKIL® Cordless Screwdriver** recharges in 3 hrs., powerdrives and removes up to #5x½" wood screws. With tips and charger. 2000 **29<sup>99</sup>**



**SNAP-IT® Stor-A-Cord.™** 25' heavy-duty extension cord plus 3 grounded outlets in handy reel-in case, power-on indicator light. 48770 **11<sup>88</sup>**



**DIABLO® Security Switch** programs 8 on/off light settings daily. Dim control saves energy. Choose single or 3-way switch. SSW1/3 **17<sup>88</sup>**



**WOODS WIRE® Retractable Reel Light** has 20' SVT cord, grounded guard, outlet. 212. **14.88**  
**Power Block 25' 3-wire extension, 3 grounded outlets.** 825. **9.99**

**DUR-O-PEG® TV antenna.** 19-element VHF/UHF/FM for sharp B/W or color. 8072 . . . . . **19.99**  
Plus full line of cables, splitters, and adapters for easy hook-up.



**GERBER® Hardwood Legs**, ready to paint, stain, or antique. Choose tapered or Early American. Four 6" legs with mounting hardware. WDV6/EAV6 **4.19**



**KIDDE® Home™ Fire Extinguisher** fights all common home fires. UL rated 1A:10BC. With vehicle bracket. H110 . . . . . **13.44**  
10BC Fire-Away™. FA10 . . . . . **10.99**



**TRUE VALUE® Royal Roll® Casters** in handy 2 pack, ball bearing swivel for easy movement at any angle. 2" dia., plate or stem fastener. 884849R/94 Pair **7.88**



**TRI-FLOW® Lubricant** with Teflon® penetrates to free frozen mechanisms, reduce friction and wear, shields against rust. 3-oz. spray. 13000 **2.00**

# savers from True Value HARDWARE STORES®

and Home Centers. Look under "Hardware" in the Yellow Pages.

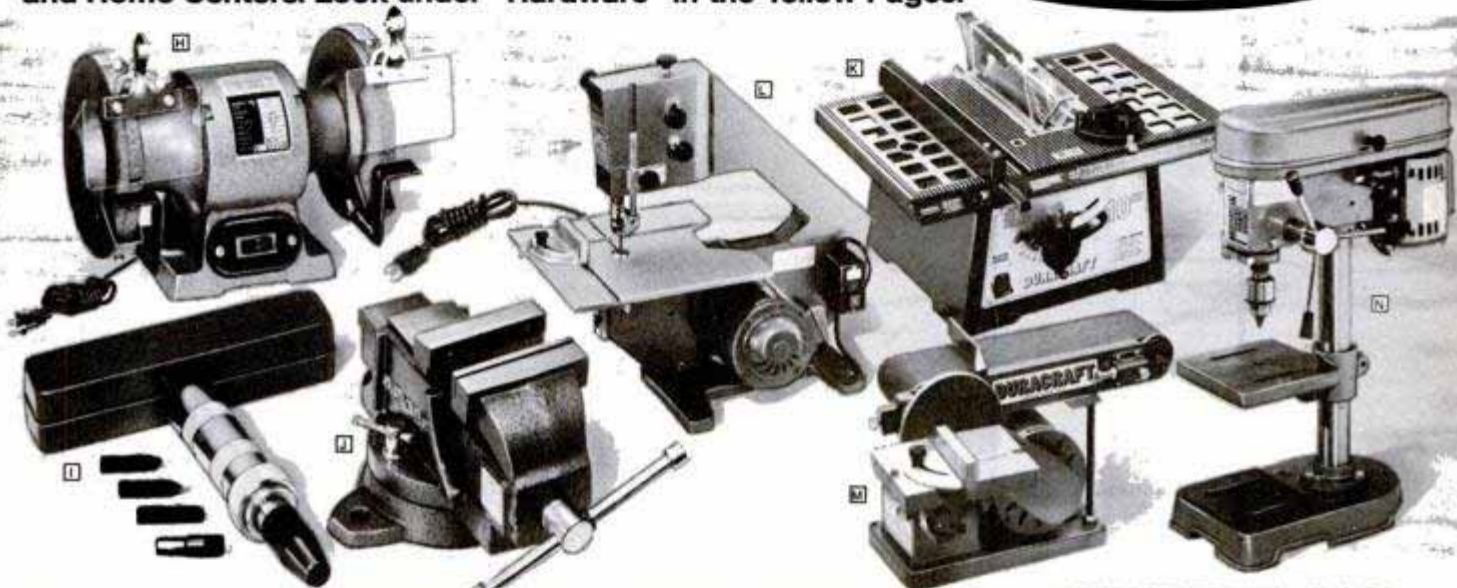

**DURACRAFT® Bench Grinder** has 5" wheels, direct-drive ½-hp motor, permanently lubricated bearings, safety features. 33-5 **27.50**

**DURACRAFT® Impact Driver** easily loosens tough screws. ⅜" drive with 2 slotted, 2 Phillips bits and adapter in handy steel box. 2500 **4.29**

**DURACRAFT® Mechanic's Vise** has locking swivel base, smooth action steel screw, 5¼" jaw with replaceable faces. Cast iron body. HDV5 **31.95**

**DURACRAFT® 10" Table Saw** rips and crosscuts to 3⅝" deep, miters ± 60°, bevels to 45°. Hi-torque motor, precise controls, power-lock key. Portable. BTS-10 **119.99**

**DURACRAFT® 12" Bandsaw**, 11¼x13½" aluminum table, ½-hp motor, 350/1300 fpm. Cuts 3⅝"x12" stock, bevels 45°. Locking miter gauge, depth guide. VS312 **119.99**

**DURACRAFT® ½-hp Belt-Disc Sander** with 6" disc and 4x36" belt. Table tilts 45°, belt sands any angle. With backstop, tension, track adjustment. BDS636 **119.99**

**DURACRAFT® Drill Press** drills hard and soft woods, metals, plastics at 700, 1560 & 3270 rpm. 4" depth, ½" capacity. ¼-hp motor. SP30 **89.95**

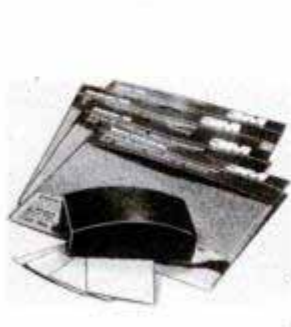

**3M® Sanding Block Kit** with adhesive-backed papers. 9248. **2.22**  
9"x11" Sandpapers: 5-pack fine, 5-pack med., 3-pack coarse, 3-pack ex. coarse. 9001/2/3/4 Each pack. **99¢**

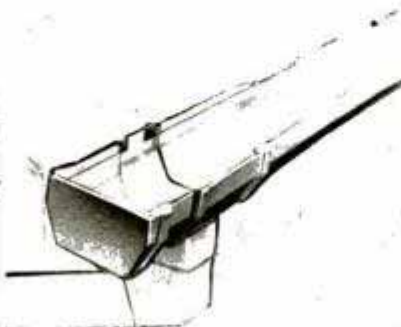

**GENOVA® Raingo™ Gutter System**. Solid white PVC vinyl snaps together. Gutter. RW100 Per ft. **45¢**  
PVC Downspout. RW200 Per ft. **66¢**  
Downspout Converter. RW204. **1.29**



**TOTEM® Plastic Gas Can** is ideal for water or volatile liquids. Spout inverts, screws down tight to travel. UL listed. 2½-gal. cap. 604T . . . . . **5.99** 5-gal. 606T . . . . . **8.99**



**DURACRAFT® Stowaway Stool** folds 1" flat, stores anywhere. All-steel construction, non-slip step and non-skid feet. Lightweight, 18" high. SS2 **8.99**



**WAGNER® Heavy-duty Power Painter™** airless electric sprayer does big jobs fast. Paints, stains, varnishes. No fog or overspray. 3058/200 **99<sup>99</sup>**



**CAMPBELL HAUSEFELD® Power Pal™**. Professional help to do-it-yourself. To paint, caulk, staple, inflate. MT-4100 . . . . **119.99**  
Accessory Kit. MA1000 . . . . **22.99**

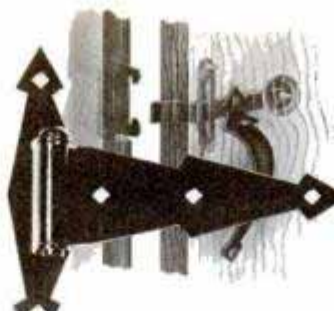

**NATIONAL® Ornamental "T" Hinge** with decorative lag screws for gate and door. V849 Pair . . **7.88**  
Latch for outswinging gate. Can be padlocked. V29A . . . . . **7.44**



**CONTICO® Curbside Mailbox**. Charm of the farm in an actual model of a weathered barn, ready to receive mail in suburb or countryside. Brown. MB101 **19<sup>88</sup>**

# Check these savings

Get the newest fix-up products and "charge it," at participating True Value

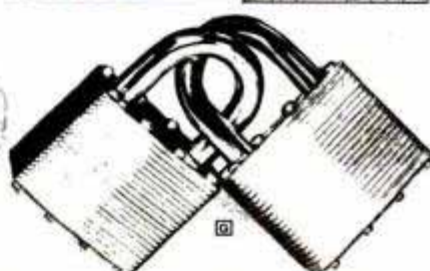

**A TRU-TEST® Woodsman® Polyurethane Varnish** seals wood against moisture and stain. Resists chipping and peeling. Gloss, satin, or flat. Qt. **4<sup>98</sup>**

**B TRU-TEST® Latex Gloss Enamel** beautifies wood or metal indoors or out. Mar-resistant, quick drying, easy soap 'n water cleanup. Qt. **5<sup>98</sup>**

**C TRU-TEST® Orel® Brushes**. DuPont® polyester filament outwears hog bristles 3 times, works in all paints. Not affected by heat or solvents. See our low prices.

**D FORMBY'S Furniture Refinisher** renews varnish or lacquer finishes without stripping. Qt. 0013 . . . . . **6.68**  
Aerosol Paint Remover works easily on hard-to-reach areas. 15-oz. 0041 . **3.44**

**E TUCK® Masking Tape**. Now's the time to stock up on masking tape for dozens of home, hobby uses. 60-yd. rolls.  
¾" 1221 . . . . . **49¢** 1" 1222 . . . . . **66¢**  
1½" 1223 . . . . . **99¢** 2" 1224 . . . . . **1.33**

**F STERLING® Burglar Bars** guard against break-in. Four-bar for double-hung windows. Mount vertically or horizontally inside or out. 1134 . . . **14.99**  
For basement windows. 3 bars. 1133 **9.88**

**G TRU-GUARD™ Padlock Pair**. High-security 1¾" laminated locks have solid brass cylinders, 5-pin tumblers and chrome-plated hardened steel shackle. Keyed alike. 344-22-51-KA2 **6<sup>99</sup>**



**SUNNYSIDE® Wood Saver**. Penta Water Repellent protects outdoor wood from moisture and insect damage. Can also be used as a primer. Gal. **6<sup>99</sup>**



**EZ PAINTR® 7-Pc. Set**. 9" tray, frame and cover, edger, extension, brush, holder. 908-FPO-09 . . . . **6.99**  
Roll 'n trim set; two 9" covers, 1½" sash brush. BRH-FPO-09 . . . . **3.99**



**THOMPSON® Water Seal**. Waterproof wood, masonry, fabric, anything porous. Lets surface breathe yet bars moisture. 12-oz. spray. 101-0A. **2.99** Gal. 101-01. **8.99**



**G.E.® Silicone Seals** are durable caulk for fixtures, tile and more. White, clear, black, metallic. 2.8-oz. tube. 372/61/43/29 . . . . . **1.99**  
10.3-oz. 2567-7/0/3/5/112 . . . . **3.99**

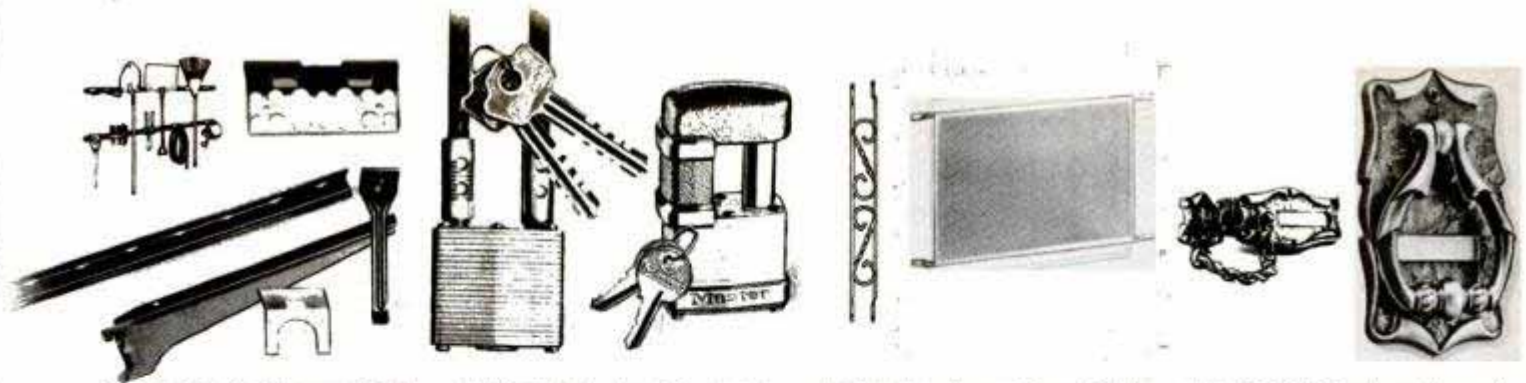

**STEEL CITY® Storage Tools.**  
 4' Channel. C4-10 . . . . . **2.44**  
 6" Tool Caddy. TCR24 . . . . . **77¢**  
 6" Utility Hanger. UHR-24 . . . . . **67¢**  
 Tool Holder. T60 . . . . . **47¢**

**MASTER® Locks.** 36" steel aircraft cable permanently attached to laminated padlock. 119 . . . . . **3.77**  
 4-pin tumbler Armorlock, case-hardened steel shackle. 37D . . . . . **5.89**

**M-D® Aluminum Door Grille** protects screen or glass in wood or aluminum doors. 19-36 . . . . . **11.88**  
 Decorative Push Grille. 34" Satin, anodized Albright. 4-36 . . . . . **8.88**

**AMEROCK® Carriage House™** Hardware in antique English finish adds finishing touch to your door. Door Knocker. C9061-AE . . . . . **8.88**  
 Security Chain. C9065-AE . . . . . **6.88**

# inside out

Hardware Stores and Home Centers.

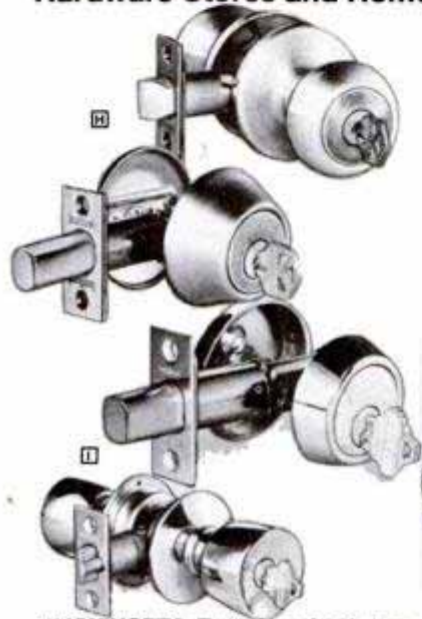

**KWIKSET® Entry Lockset** has deadlatch. Keyed outside, turnbutton inside. Antique brass. 400C-CP-5KA2 . . . . . **16.99**  
 Single cylinder 1" deadlock for use where extra security is needed. 660CP-5-KA2 **14.99**

**SCHLAGE® Locks**, brass finished. Single-cylinder deadbolt, 1" throw, hardened steel roller. 8160 PV605 . . . . . **14.99**  
 Entry lockset has deadlatch, prevents credit card entry. F51PDV BEL 605 . . . . . **15.99**



**MAYFAIR® Dial-On™ Soft Seat** adds soft, foam-cushioned beauty to bath. Installs without tools. Position and turn dial to fasten. Color choice. 13D . . . . . **9.95**



**ALSON'S® Personal Shower** replaces regular showerhead with new push-button convenience. 59" hose, wall mount, swivel connector. Hang or hold. 410PB-PK . . . . . **18.95**



**INTERMATIC® Timer** controls electric water heater's operation to save energy. WH40 . . . . . **29.98**  
 Super Cop™ cordless, variable timer. D711 . . . . . **8.99**



**MASTER PLUMBER™ Energy-saving Water Heaters.** Extra insulation helps trim fuel costs. Gas unit has low-consumption pilot light. Electric heater is protected from overheating. Both give fast heat transfer, high heat retention, low operating cost. Your choice of 40-gal. natural gas or 50-gal. electric. Each, **159.95**  
 NOTE: LP and NOx water heaters are available at extra cost.



**MASTER PLUMBER™ Tub & Shower Caulk.** Acrylic latex adheres to tile, aluminum, resists mildew, stays flexible and watertight. 8-oz. tube. 032080 . . . . . **1.39**



**MASTER PLUMBER™ Toilet Tank Kit** has replacement ball cock, all parts and instructions for easy do-it-yourself repair. 4082C . . . . . **6.99**



**FLOTEC® Drill-Powered Pump** attaches to electric drill to remove water, drain oil, etc. Port couplings for easy hose connection. DMP21SA . . . . . **2.99**



**TRUE VALUE® Sump Pumps.** Cast iron. 1/3-hp. TVSPV500 . . . . . **84.95**  
 1/2-hp upright. TVSPV800 . . . . . **84.95**  
 1/3-hp submersible. TVCDU790 . . . . . **72.95**  
 1/2-hp submersible. TVCDU800 . . . . . **89.95**



**EMERSON® Designer™ Ceiling Fan** stirs a breeze to cut heating, cooling costs. Quiet 3-speed motor, 36" blades. Simple to install. White. CF2036W **79<sup>99</sup>**

**EMERSON® Whole-House Attic Fan** has 3-speed direct drive motor, sturdy shutter construction for max. airflow. WH20WS **149<sup>95</sup>**

**HUNTER® Ceiling Fan** supplements heat/air conditioning. Quiet, rugged motor with 52" wooden reverse-air blades. 22272/580 **149<sup>99</sup>**

**NAUTILUS® Attic Ventilator** expells heat to cut cooling costs, or add comfort to non-air conditioned homes. Roof-mount. N340D **44<sup>99</sup>**



# Spring Fix-up Values

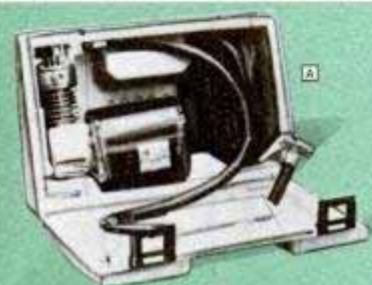

**COLEMAN® Inflate-All® Air Compressor** pumps up tires, toys, balls and more in minutes! Plugs into car's cigarette lighter. 2239D641 **34<sup>95</sup>**

**CASE® Sportsmen's Sets:** 3½" Mini-Trapper Knife with clip and pen blades, Crook Stick® honer. 269 **22.88**  
8¼" double-plated utility shear, serrated blade. 367 **19.99**

**RAY O VAC® Fluorescent Lantern** casts light 360°, resists moisture and impact. Battery not incl. 360B **24.99**  
Value Lite Lantern, battery not included. LM1B . . . . **1.49**

**MR. MEAT® Super Smoker** cooks meat, fish or fowl 6 different ways without tending, turning or basting. Steel charcoal and water pans, porcelain finish. 271-1 **49<sup>99</sup>**

**CHARMGLOW® Bantam Portable Gas Grill** is ideal for picnics or camping. Travels light, no charcoal mess. Uses disposable or refillable LP tanks not incl. 6110 **69<sup>99</sup>**

**FIRST ALERT® Smoke Alarm** helps protect lives and property. Sounds 85-decibel alarm at first sign of smoke, lights the way to safety. SA120 **27<sup>99</sup>**

**FIRST ALERT® Ready Lite™** recharges in wall bracket for 2½ hours of continuous use. Beam width, angle and intensity adjust. RL100 **24<sup>99</sup>**



**ALADDIN® Stanley® thermos** is all steel, inside and out, virtually indestructible. To keep beverages hot or cold all day. Quart size. A944C

**20<sup>99</sup>**



**G.E.® Home Sentry® Smoke Alarm** uses 9V battery, blasts 85-decibel horn as smoke rises. Has low battery alert and tester. 4½ x 5½". 8201-401 **17<sup>99</sup>**



**EVEREADY® Batteries** are built to last, stock up now at special money-saving prices. General purpose 4-pack "C" or "D." 935-4/950-4 **79<sup>99</sup>**



**DURACELL® Alkaline 9V**, pair "C" or "D." MN1604B/1400/1300B2 Ea. **1.99**  
6V Spring Top Battery. MN908 **5.49**  
2-pack "AAA." MN2400B2 . . . . **1.59**  
4-pack "AA." MN1500B4 . . . . **2.79**

There are more than 6,000 True Value Hardware Stores and Home Centers in 50 states. Look under "Hardware" in the Yellow Pages.

COTTER & COMPANY, General Office, Chicago, IL 60614. 100% member-owned warehouse distributor serving over 6,000 True Value Hardware Members who own their own stores, set their own prices and reserve the right to limit quantities. Because participating True Value Hardware Stores and Home Centers vary in size and merchandising policies, some may not stock all items shown. Prices may vary and are subject to change without notice. Prices expire April 30, 1983.

8-page tear-out section.

# Build Your Own Pantry On Wheels

BY WALTER ALAN KERR

**A**fter repeatedly digging into our deep, dark pantry to retrieve a bottle of soy sauce or a can of tomato paste, I designed these roll-out racks of shelves. The racks stand side by side and are mounted on rollers. When one of the racks is pulled out, all items on its shelves are visible and accessible.

The racks are easy-to-build, 3/4-in.-plywood frames, assembled using butt joints. Cleats at the joints serve as

strengtheners. The 1/2-in.-plywood shelves provide further rigidity.

The racks move on appliance rollers. These multiwheeled plastic or aluminum supports are used for moving refrigerators and stoves. You can purchase them at hardware and discount stores or by mail from Sears. You'll need one set for each rack.

I built some of my prototype racks less than 8 in. wide. These narrower

racks require retainers (lips) on both sides of the shelves. I used venetian blind slats as retainers.

You can roll out the racks easily with a brass pull, positioned slightly above waist height on the side of the rack facing out.

To assemble and finish the racks, you'll need a hammer, drill, screwdriver, nailset, paintbrush and some 80- and 120-grit sandpaper. A corner clamp is also handy. Use the clamp at each shelf corner to hold the parts in place while you attach them with nails or screws.

To determine the number and size of racks your pantry can accommodate, measure the depth of the pantry or closet and the height and width of the opening. Allow 1/2 to 1 in. clearance at the sides and between racks. Racks at *(Please turn to page 146)*

*Nearly every size package is visible and readily accessible in this pantry on wheels (left). Labeling each rack with its contents makes locating items even easier. On racks 8 in. or wider (rack, far left), appliance roller mates can be extended the same length and fastened to a rack. On narrower racks, stagger rollers.*



*Before building the pantry on wheels, the 30-in.-deep pantry (above) was too cavernous to display its contents. You had to take everything off the front of a shelf to locate items pushed to the back.*

# REMODELING?



# FREE!

Andersen Concept IV™ shows how to add big beautiful glass areas to your remodeling without significantly adding to heating costs. How this bright idea was applied to the 12 major U.S. climates is explained in this colorful 12 page folder. You'll also learn some of Concept IV's findings... discoveries that can put your remodeling solar years ahead.

For free copy of the 12-page Concept IV folder mail to Andersen Corp., Box 12, Bayport, MN 55003. 026-0483

Name \_\_\_\_\_  
 Address \_\_\_\_\_  
 City \_\_\_\_\_ State \_\_\_\_\_  
 Zip \_\_\_\_\_ Phone (\_\_\_\_) \_\_\_\_\_  
 Area Code

Come home to quality. Come home to Andersen.™

**Andersen Windowalls**

©1983 Copyright © 1983 Andersen Corp., Bayport, MN

## PANTRY ON WHEELS

(Continued from page 145)

least 8 in. wide accept the rollers best, since both mates of a set can be extended the same length. Subtract the height of the appliance rollers from the height of the opening to get the maximum height of the rack sides.

Next, decide upon the number of shelves you would like per rack. Either draw a rough sketch to scale for each rack, including the shelves, or use the dimensions on the drawing below, if your pantry can hold this size rack. From the drawing, make a materials list you'll need when purchasing lumber and hardware.

### Assembly and painting

Cut the parts to size, then sand them smooth, dusting with a clean brush between steps.

Lay out the rack sides. Prebore the cleats and, using a corner clamp, fasten them to the sides with glue and screws. Fasten the top and bottom pieces to the cleats with glue and nails. Then hammer finishing nails through the rack sides into the ends of the top and bot-

tom. Set nails and fill holes with wood putty.

Prime and paint the shelves with a semigloss plastic or acrylic latex paint before installing. You can hang each shelf to dry by a string fastened to a small nail driven partway into one end. Then prime and paint the rack.

After the paint is dry, lay the rack on its front edge and measure and mark shelf placement. Then, stand each shelf on edge within the rack, secure it with the corner clamp and drive nails to fasten it in place. Set the nails and fill the holes.

Make retainers of venetian blind slats nailed to rack sides and shelf bottoms. Or use 1/4-in.-thick lattice.

If possible, snap out the rollers and shafts from their housings. Position the housing on the bottom of the racks so they're within 1/4 in. of the edge. Bore a small hole in each end and secure with screws. Snap the rollers and shafts back in and stand the rack upright.

Touch up nail holes with paint and attach the brass pulls. If there is a saddle on the floor below the closet door, remove it, so it won't interfere with the rack's mobility. **PM**

*Each unit is a 1/4-in. plywood frame with butt joints. Shelves are 1/2-in. plywood. Appliance rollers allow unit to move easily and the retainers keep items from falling off pantry shelf. A brass pull lets you pull the unit out of the pantry and return it when you are finished.*

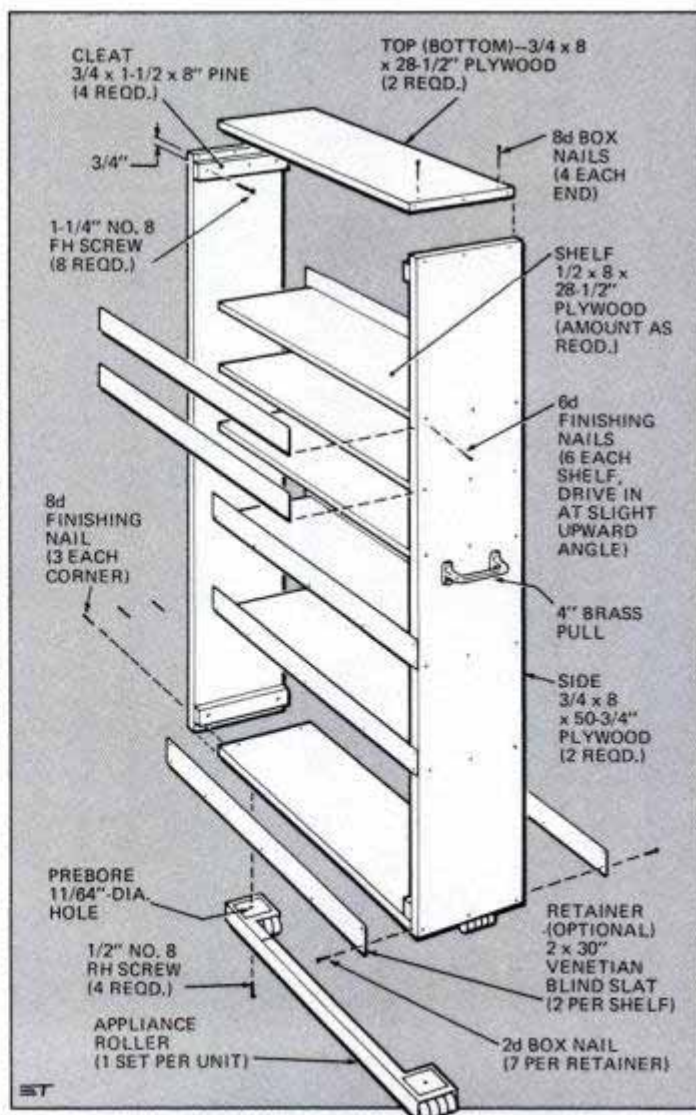



# Seed.



A good home garden is like a good homemade soup. If you use the right ingredients, there's nothing more satisfying.

At Burpee® we supply the right ingredients—Burpee Seeds and Burpee Grow Fertilizers. Let's start

with the seed. Burpee Seeds have always been bred with the home gardener in mind. You can choose seeds bred for a big yield in a smaller space, disease and heat tolerance, a shorter growing season, a sweeter taste, bigger

flowers, even smaller flowers. The fact is we make sure all our seeds live up to the Burpee tradition of quality... because what you seed is what you get.

Now, seedlings need food to grow on. Good food. That's where Burpee can also help—with Burpee Grow Fertilizers. Just sprinkle some on and you can rest assured your plants will get

the right nutrients at the right time.

# Feed



The result? Greater yields. So if you want more flowers, more vegetables and fuller shrubs (and who doesn't), make sure your garden's eating right with Burpee Grow Fertilizers.

# Succeed.

There's more good news. For the first time ever, both

Burpee Seed and Burpee Grow are available in your town. So get your good home garden going. Simply visit your local store and bring home some Burpee seed and feed. Just add water, pull up the weeds, and watch your Burpee Garden grow.

And grow. And grow. We've been guaranteeing it for 100 years.

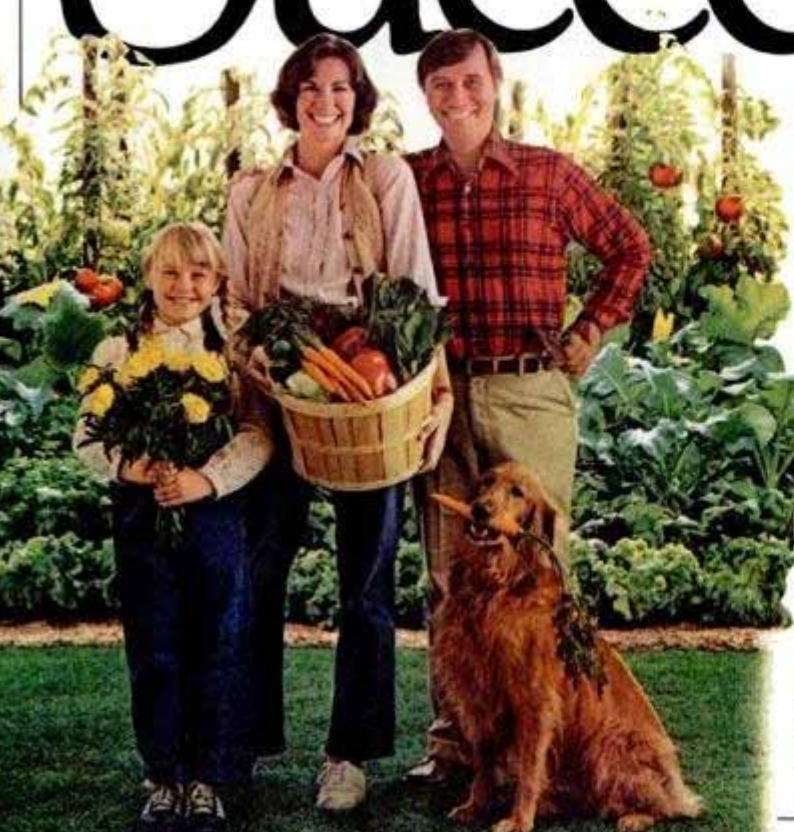

# Burpee

GARDENS | GROW™

**SOMETHING  
NEW**

# Popular Mechanics FILE BOXES & SEPARATE INDEXES

**No more untidy shelves or magazines stacked on top of each other.**

POPULAR MECHANICS FILE BOXES will help you keep your magazines and bookshelves trim and orderly. PM is now offering a sturdy glossy lacquered File Box to keep a year's supply of PM issues neatly together. The FILE BOX stands alone with all twelve issues intact! Line them up by year on your bookshelf and always have a wealth of do-it-yourself information at your fingertips.

With every order you will receive FREE self-adhesive labels covering the years 1975 through 1984. Peel off the year required and place on appropriate PM File Box. Turn the File Box any way you choose. Place the year on the side that's convenient for you. Expose all the magazines on the shelf, or keep the solid side in view. It's your choice! Either way you'll have a valuable, convenient and very attractive reference library.

Price for 1 File Box,  
\$2.95

Price for 2 File Boxes,  
\$2.75 each

Price for 3 or more  
File Boxes, \$2.50 each

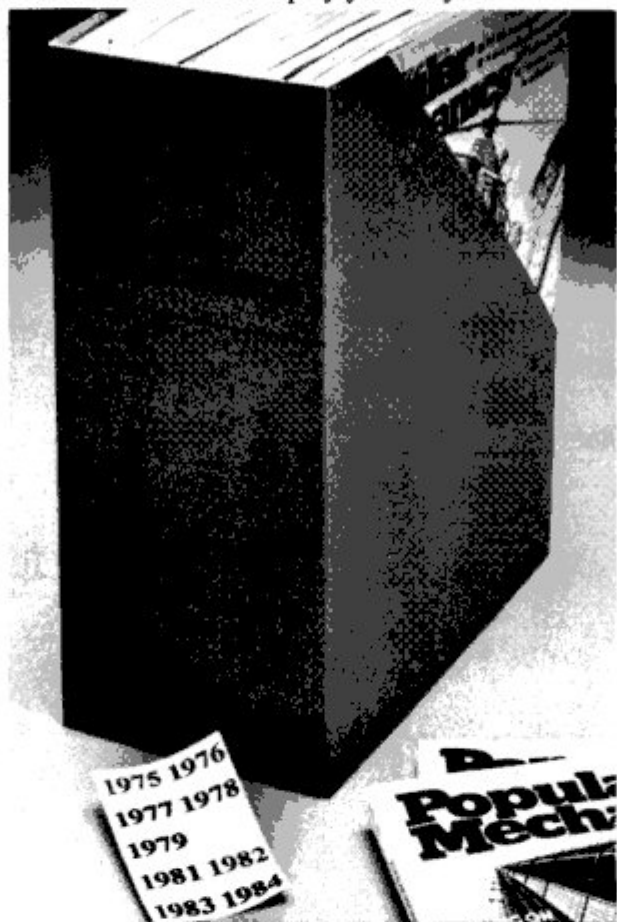

**PM Indexes  
for the years  
1975-1982  
are here!**

Find the answers to your shop, home and car problems faster than ever. Thousands of entries cross-reference the articles that have appeared in PM over these years.

Broad category listings help you locate articles on home remodeling, boats, car maintenance, shop projects and many other subjects.

**ORDER BY YEAR! PRICE  
for each index is \$2.25.**



## **SEND YOUR ORDER TODAY!**

**Make Check or Money Order Payable to Popular Mechanics**

Please allow three to four weeks for delivery

**POPULAR MECHANICS**

**Box 1014, Radio City Station, New York, NY 10101**

## How To Stop Any Faucet From Leaking

Step by step, here are the repairs for each of the common types of faucets.

BY RICHARD DAY

Photos by the author

**T**he toughest part of fixing a leaking faucet is getting to the job. But you shouldn't put it off. Only one drop a second will waste a shameful amount of water—2,300 gallons a year. And the repairs after a year of dripping will be no easier than they were when you first noticed the leak.

Tools needed for faucet work are a large adjustable wrench, flat-blade screwdriver, Phillips screwdriver and pliers. You may need some special tools for seat work on compression faucets.

Actual steps vary with the type of



*If a swing-spout-type kitchen faucet leaks at the spout joint, it probably needs a new O-ring. Remove the spout and retaining parts and take the old O-rings to your plumbing supplier so that they can be matched with a new set.*

faucet. Basically, there are two faucet types: compression (washer-type) and noncompression (washerless).

The first step in making repairs on any faucet is to turn off the water supply. If you're fixing just one side—hot or cold—of a dual-handle faucet and

the fixture has handy shutoff valves beneath it, you need turn off only the side to be worked on. Lacking under-fixture shutoffs, you'll have to turn off either the branch water supplies or the house main water shutoff.

To repair any but a tipping-type faucet, discussed later, you remove the handle and take out the faucet's innards. Compression valves on tub/shower controls that leak are fixed similarly to compression faucets.

### REPAIRING COMPRESSION FAUCETS



**1** To repair a leaky washer-type (compression) faucet, such as this U.S. Brass Ventura, first remove handle and unscrew packing nut with an adjustable wrench. Wrap nut with plastic tape to protect it. Turn nut counterclockwise.



**2** With the packing nut off, unscrew the stem by turning it in its "on" direction. You can probably do this by hand, but if the stem should prove to be very difficult to turn, temporarily reinstall the handle to get extra leverage to turn it.



**3** A single screw holds the old seat washer to the stem. Remove screw and washer. This assembly uses a Phillips screw. However, most assemblies use a standard slotted brass screw.



**4** Lift out the old seat washer and fit a new one the same size into the recess. A worn or grooved washer could have caused the leaks. If the screw is corroded, replace it with a new brass one.

### Repairing washer-type faucets

Compression faucets (see drawing, page 150) are inexpensive and common. They also cost little to repair. They leak either at the spout or past the stem. Leakage past the stem can be cured by tightening the packing nut or replacing the stem's rubber O-ring if there is one. Sometimes the faucet's stem packing, if used, must be replaced.

To remove a faucet handle, loosen the Phillips-head screw that holds it to the stem. Sometimes this is located beneath a decorative trim cap in the center of the handle. The cap either unscrews or can be snapped off by prying with a chisel or putty knife.

Handles lift or are pried off of the upper end of the stem. If your old faucets are badly corroded, you may want to replace rather than repair them. Any decorative parts should be padded with cloth or tape before unscrewing them with pliers.

Beneath the removed handle is the packing nut. Unscrew it from the top of the faucet body (see photo 1) to expose the stem. Be especially careful with the plastic parts used on many of today's

*(Please turn to page 150)*

faucets. Then, by rotating in the "on" direction, you can unthread the stem from the faucet.

If the old faucet stem is badly corroded or worn, you'll want to replace it with a new one. If your dealer does not have a match for your old one, ask him to order one. If the stem is dirty, clean it with fine steel wool. Discard the old, hardened packing if there is packing on the stem.

At the lower end of the stem, you'll see the seat washer. If it is squeezed flat or has a groove from being closed tightly against the faucet seat, it likely is the cause of the drip. It should be replaced. So should one that looks ragged or is hard with age. If the old seat washer screw is damaged, replace it with a new brass one.

You can often make a temporary seat washer repair by turning the old washer over and using its backside as the working surface. However, follow this with a more permanent repair as soon as possible.

It's not easy to tell much about a faucet seat by looking at it. For best results, replace or reface the seat as shown on this page. In any case, a compression faucet that requires frequent washer replacements is a candidate for seat rejuvenation.

More than likely a new seat washer is what's needed. Be sure to get one of the same size and shape—flat or beveled—as the old washer. Faucet seat washers come in sizes from 1/2 in. to more than 1 in. (rare). They're given nominal designations. However, the best way to get the size you need is to match the old washer with a new one.

Long-lasting swivel-head seat washers do away with the friction between washer and seat upon closing. The washer meets the seat in a straight-down action rather than with a twist. To install, you drill out the threads of the old stem washer screw and push the swivel-washer into the hole. The washer screw isn't used. If the new swivel-washer is too large to fit into the recess for it, file off the edges of the recess, leaving the stem flat. In any case, follow directions with the swivel-washer you use.

Some compression faucets made by American-Standard and Kohler (Valvet) use a combination replaceable washer-seat faucet unit. With unit replacement, all wearing parts are renewed: stem, washer, seat and housing. Naturally, the cost is more than for just a seat washer or seat. But the job's easy.

A faucet that chatters when opened  
(Please turn to page 152)

## COMPRESSION FAUCET MAINTENANCE



To install a long-lasting swivel-seat washer, file the stem edges if needed, drill out the screw threads and insert the swivel-washer prongs into the stem opening. Swivel washers do not grind closed on seats; thus wear is reduced.



Most faucets have replaceable seats. A seat with a square or hex opening is replaceable using a faucet-seat tool. This one has various square and hex heads.



Before you reassemble the faucet, install new packing on stem (if it is used). With flexible packing, install three turns; with stiff packing, a single turn will do it.



Modern washer-type faucets use O-rings rather than packing to eliminate stem leaks. If there is an O-ring (arrow) on the lower end of the stem, the faucet does not require any packing. See below.



If the faucet leaks water beneath the handle it's another sign the O-ring should be replaced. In making the replacement, carefully roll on the new O-ring to keep it from stretching out of shape.

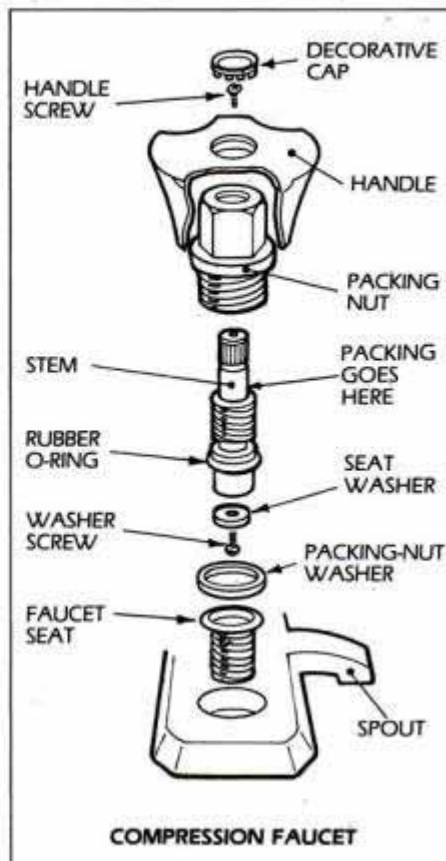

If the washer requires frequent seat washer replacements, the seat is probably damaged. You can correct this by dressing the seat with a seat-refacing tool. This one by Push-Tite mounts in a hand drill. Follow directions furnished.



To work on compression tub/shower faucets, you may need a set of special socket wrenches (about \$10). These reach behind the wall to remove the packing nuts so you can remove the long stems. With the stem out, tub/shower washer service proceeds as with smaller faucets.

# S A L E

## MOW IT. TRIM IT. DIG IT. PRUNE IT. AND RAKE IN SOME SAVINGS, TOO.

Take another look at your Sears Lawn and Garden Catalog. It's brand-new, and it's crammed with more lawn and garden supplies than we've ever put on sale before. You'll find fencing, lawnmowers, tractors, garden tools and hundreds more items, all with the quality and value you expect from Sears.

You can get many of these tools only if you shop this Catalog. What could be more convenient...or

easier on your pocket? But hurry! Act now to take advantage of these prices.

If you don't already have your Sears Lawn and Garden Catalog, pick one up at any Sears Catalog Department. Then call Sears

### TAKE ANOTHER LOOK.

**sears  
LAWN AND GARDEN  
CATALOG**



only \$29<sup>99</sup>\*

Craftsman®  
"Bushwacker"®  
18 in. Hedge  
Trimmer.

and order today. Use your Sears Credit Card, and ask about home delivery. There are great bargains just waiting to fill up your tool shed.



only \$179<sup>99</sup>\*

Craftsman® Eager I  
20 in. cutting width. **Save \$40.**

\*plus shipping and handling,  
and state and local taxes.

Sale prices for a limited  
time only. Check your  
Lawn and Garden Catalog  
cover for dates.

**Sears**  
CATALOG

© Sears, Roebuck and Co., 1983

# S A L E

# FREE COLOR CATALOG

## Build Your Own Grandfather Clock



Prices Starting Under

# \$255

(including movement and dial)

- Do-it-yourself case kits, parts pre-cut
- Finished clocks
- Solid 3/4" hardwoods: black walnut, cherry, oak
- Heirloom quality
- Factory direct prices
- Solid brass West German chiming movements
- Money back guarantee
- Prompt shipment

MASTERCARD and VISA ACCEPTED



**EMPEROR  
CLOCK COMPANY**  
WORLD'S LARGEST MANUFACTURER  
OF GRANDFATHER CLOCKS  
Dept. 705 Emperor Industrial Park  
Fairhope, Alabama 36532

IN CANADA: Emperor Clock Company, Inc., Dept. 705  
506 Newbold Street, London, Ontario N6E 1K6

Mill Supply Sells Over  
1,000 Different Die-Formed

## STEEL REPLACEMENT PANELS

To Repair Rust or Collision Damage  
on Many American Cars, Pick-up  
Trucks and Vans - and Most Imports

These 1982 Prices in Effect  
Through March 31, 1983

Most orders shipped  
within one working  
day of receipt



Specify left  
or right

### PICK-UP FENDER REPAIR PANELS

Part #FRP-80 **29.95** Fits '73-'79 Ford Pick-up  
Tax 1.78

Part #RCC-15 **32.50** Fits '73-'79 Ford Pick-up  
and '78-'79 Bronco (not  
Supercab)  
Tax 1.80

Freight Prepaid Ohio Residents add Tax  
Our catalog of panels for U. S. Vehicles sent free  
to you with any order

OUR 80-PAGE CATALOG 20-PAGE TARGO CATALOG of Foreign Car  
(without order) \$3.99 (sheet metal (with or without order) \$2.99)

HOW TO ORDER: Order parts by check, money order,  
credit card. If credit card, include kind of card (Visa or  
MasterCard), card number, and expiration date. Be  
sure to indicate the quantity of merchandise you want,  
left or right panel. Include your name, address and zip  
code, and phone number with area code.  
Sorry, no C.O.D.'s.

Send self-addressed, stamped long envelope for FREE  
information on any ONE car or truck.  
Allow three weeks for delivery of catalog. In Canada  
add \$1 postage.

Dept. PM-304 **Mill Supply**  
3241 Superior Ave. • Cleveland, OH 44114  
Phone (216) 241-5072

## '83 HOME IDEAS GUIDE

(Continued from page 150)

part way is telling you that it has a loose  
seat washer or seat.

### Seat service

Faucet seat-dressing is done with a  
low-cost tool. You can get one where  
plumbing supplies are sold. The Push-  
Tite (Push-Tite Mfg. Co., 215 South  
Highway No. 7, Olathe, Kan. 66061)  
uses a grinding stone rather than a se-  
rated cutting wheel. It does a smoother  
job of seat-dressing. Follow the manu-  
facturer's directions for whatever tool  
you use. Be sure to blow out the chips  
after you finish; wear eye protection  
when you do.

It may be just as easy to replace a  
faucet seat as to dress it, provided it's  
the replaceable screw-in type of seat. If  
it has a square or hexagonal hole in the  
center, it's replaceable. You'll need a  
valve-seat removal tool with square and  
hex ends. The seats thread out by turn-  
ing counterclockwise. Show the old seat  
to your plumbing supplier and ask for a  
new one just like it. It helps to know the  
make of faucet. Put a little silicone rub-  
ber sealant such as bathtub caulk or  
pipe joint compound on the threads of  
the new seat before threading it in.

Before reinstalling the stem it's a  
good idea to put some petroleum jelly

### REPLACING A DIAPHRAGM



A faucet with a diaphragm can last for  
years without leaking. But if yours leaks  
around the stem, you must replace the  
diaphragm. To get at it you must first  
remove the faucet stem.

or silicone grease on the threads to  
smooth faucet action. Use of nylon-cov-  
ered or graphite-impregnated packing  
helps, too. Avoid the temptation to use  
ordinary string for packing. It won't  
last. Give the packing nut half a turn  
past hand-tight.

### Repairing washerless faucets

Leaks in washerless faucets are not  
common. When repairing one, it helps  
to have the manufacturer's instruction  
sheet. You can probably get one by  
sending a faucet description to the  
maker.

### REPAIRING A DISC FAUCET



American Standard's Aquarian single-  
handle disc faucet has a replaceable disc  
unit that changes all moving parts. To  
change discs, remove the handle and two  
screws. Then lift off the old disc (left).

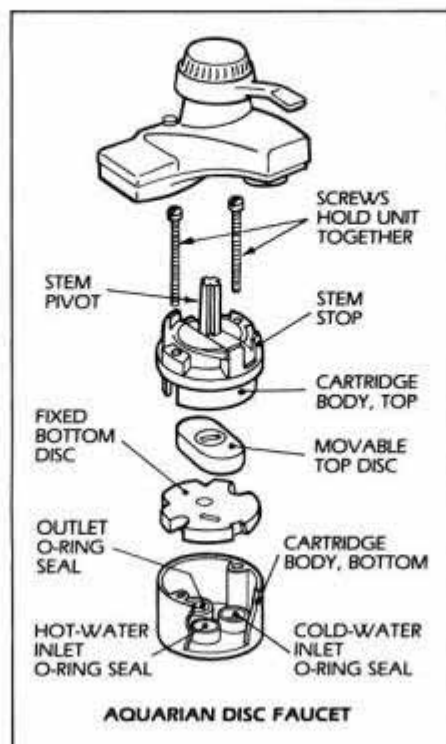

To repair common two-handle disc fau-  
cets, as this Delta Delex, remove handle  
and lift disc assembly up and out, pulling  
it with pliers. Adding a new assembly  
replaces moving parts of the faucet.



At bottom of the Delex disc cavity is a  
tiny rubber seat on a spring. If changing  
discs doesn't stop a leak, pick out the disc  
and replace the seat and spring.

The diaphragm-type faucet is most like a compression faucet. It puts a rubber diaphragm between the swiveling spindle and a fixed seat, making a straight-down closing action. American Standard's Aqua-Seal faucet works like this (see top photo, page 152).

Disc-type faucets (see drawing and photos, page 152) are available in both single- and dual-handle. Discs with holes or slots are rotated, one on the other, so that the openings line up (water flows) or misalign (water is off). O-rings may be used to prevent interdisc leaks. While there is some friction between the discs as they move, they are made of hardened material to take it without wearing much. Delta's Delex, U.S. Brass's Aqua-Line series, American Standard's Aquarian, most newer models of Universal-Rundle/Sears, and many other faucets use discs. Disc faucets are fixed simply by replacing the seats (if the unit has them) or else by replacing the entire disc assembly. On the American Standard Aquarian with ceramic discs, look for dirt between the discs or worn rubber O-ring disc assembly seals.

**Repairing ball-type faucets**

The single-lever ball-type faucet such as those made by Delta and Peer-

less (see drawing and photos below) routes the water through holes in a brass or plastic ball worked by a single handle. Spring-loaded soft rubber seats on the hot and cold sides contact the ball. These let water through only when they're aligned with a hole in the ball. A rubber gasket with cam and adjustable tension ring seals the ball from leaking to the outside at the handle.

Ball-type faucet repair kits come several ways: seats and springs only; cam, seats and other parts; and all parts including the ball. The major ones contain a faucet tool; the spanner wrench on one end turns the adjusting ring, and the hex wrench on the other end tightens the setscrew on the faucet handle. If one of these faucets leaks just beneath the handle, often removing it and slightly tightening the adjusting ring will cure this.

If the faucet leaks at the spout, it needs new rubber seats and springs. Unscrew and remove the cap assembly. Pull the ball stem up to lift out the ball and cam. Then take the rubber seats and springs out of the faucet body. Install new springs and put the new rubber seats down over their tops. Reassemble the ball and cam, making sure the slot in the side of the ball and

*(Please turn to page 154)*

**REPAIRING A BALL-TYPE FAUCET**

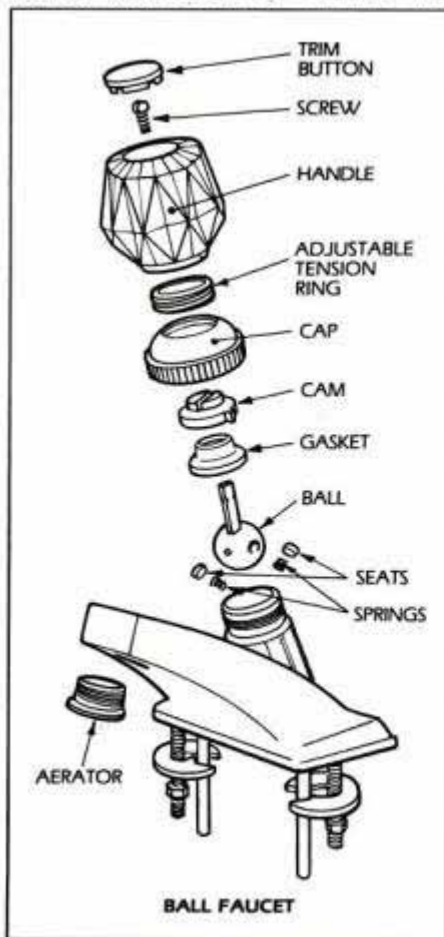

**1** Whether used for tub/shower, sink or lavatory, ball-type faucets are serviced alike. First, remove the bonnet (cap) assembly with water-pump pliers, protecting chrome with tape.



**2** Pull out ball, bringing the cam with it. If ball appears worn or corroded, buy a replacement.

**3** A ball faucet that leaks at the spout needs new seats and springs. Pick out the old ones with long-nose pliers. Replace with new ones from a kit.



**DO YOU HAVE WHAT IT TAKES TO START AT \$22,500<sup>00</sup>**

**WITHOUT A COLLEGE DEGREE?**

**Most Tulsa Welding School Grads Do!**

In fact, the first paychecks for students who graduated in the first four months of 1981 and went to work welding... ranged from a low of \$793 to a high of \$6,846. This is a yearly salary range from \$9,516 to \$82,152. Worldwide construction and pipeline firms compete for our graduates. Full course is only 16 weeks (others as little as 10 weeks). There are more jobs open throughout the U.S. — and the world — than there are qualified welders.

Tulsa Welding School, established for over 30 years, is recognized for the quality of its graduates throughout the world. Do well at T.W.S. — work hard — and your income as a welder can be higher than many college graduates.

**TO TAKE COMMAND OF YOUR FUTURE . . .**  
 Call Toll Free 1-800-331-2934  
 In Oklahoma, call (918) 587-6789  
 . . . OR FILL IN AND MAIL TODAY!

Admissions Director  
 Tulsa Welding School PM4/83  
 P. O. Box 9829  
 Tulsa, OK 74157

We'll send you a complete course catalog plus job list and pay at which recent grads have gone to work.

NAME \_\_\_\_\_  
 ADDRESS \_\_\_\_\_  
 CITY \_\_\_\_\_ STATE \_\_\_\_\_  
 ZIP \_\_\_\_\_ PHONE (\_\_\_\_\_) \_\_\_\_\_  
 Area Code

Accredited Member of Nat'l Assoc. of Trade and Technical Schools. Approved for Veteran Training.

## REPLACING A FAUCET CARTRIDGE

The moving parts of some cartridge faucets like this Moen single-handle are in one long and slim replaceable cylindrical case. To remove this cartridge pry out a retainer clip hidden under or behind the handle with a small screwdriver (near right). If a unit leaks, it's best to replace the cartridge. Use the handle to remove and replace cartridges on two-handle faucets (far right). The quarter (foreground) is a handy tool for turning the slotted cartridge retainer.



## Made to be walked on!

Cabot's Decking Stains, especially formulated for decking, fencing, and furniture, preserve the wood, are water-repellent and mildew-resistant. Decorative and durable; will not rub off or track off. Choice of 8 colors.

For color card & information, write:

**Samuel Cabot Inc.**

One Union St., Dept. 450, Boston, MA 02108  
Send 35¢ for Cabot's handbook on wood stains

## 2nd MOST IMPORTANT TOOL FOR EVERY WOODWORKING SHOP

VERSATILE  
**W&H**  
MOLDER-  
PLANER

Almost as basic as your saw... molds, planes, rabbets.

From \$430

- Master Charge
- VISA



FREE BROCHURE

**WILLIAMS & HUSSEY MACHINE CO.**  
Dept. 17, Milford, N. H. 03055  
Toll-free 1-800-258-1380

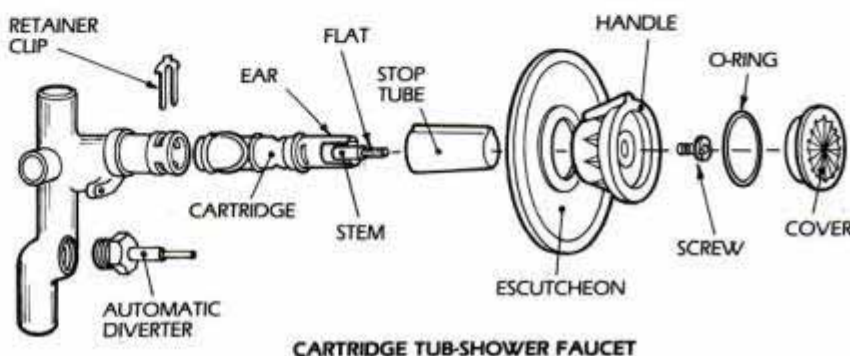

the pin in the faucet body engage. The cam also must fit into a notch in the body. Install the cap and adjust the ring. If you have trouble stopping leaks around the ring, then the cam with gasket should be renewed as well.

### Repairing a cartridge faucet

Cartridge faucets (see drawing and photos above), such as those made by Moen and Kohler, have a single moving part: the stem. It selects the water temperature as well as controls volume. All wear occurs inside the cartridge. If this type of faucet ever leaks, the cartridge can be replaced. Pliers may be needed to lift the Moen cartridge from the faucet against O-ring tension. The Kohler Centura system uses a three-part cartridge consisting of valve sleeve, body and noncorrosive cam. The cartridge lifts out once the single-handle faucet is taken apart.

In the Moen system two identical cartridges—one brass, one plastic—fit all single-handle faucets and valves made after 1959. The plastic ones are best for hard-water use as they don't tend to collect scale. A third Moen cartridge fits only its two-handle lavatory faucets.

Moen and a few other faucets use retainer clips to hold the cartridge. On some faucets the clip may be seen at the rear of the faucet just beneath the handle. On others the handle has to be

removed first. A tube beneath the handle may hide the retainer clip, so simply lift that off. A few makes have two retainer clips, the second by the handle. Pry the retainer clip out with a small screwdriver or long-nose pliers; then pull out the cartridge with pliers.

Install a new cartridge with arrow, spot or other mark aimed up. Then re-install the retainer clip, ring and handle.

The tipping-valve faucet used in some older models of Universal-Rundle/Sears uses a single handle with cam at the rear of the unit to push hot and cold water tipping valves off-center to control water. The parts are accessible through plugged openings on each side of the body.

The wearing parts are fully replaceable. They come in a kit from Sears with a complete set of parts for each side of the valve. To get the old ones out, remove the spout-retaining nut and lift off the spout and escutcheon to expose the faucet body. Remove brass plugs on both sides of the body and take out strainer, spring and tip-valve stem. Unscrew the valve seat and replace parts with new ones from the kit. **FM**

### FAUCET REPAIR INFORMATION

Gerber Plumbing Fixtures Corp., 4656 West Touhy Ave., Chicago, Ill. 60646. Brochure: "Tip From Your Plumber," 25 cents.  
U.S. Brass, 901 10th St., Plano, Tex. 75074, attention: Advertising Manager. Free brochure: "Faucet Replacement Guide."



Get 'em clean with





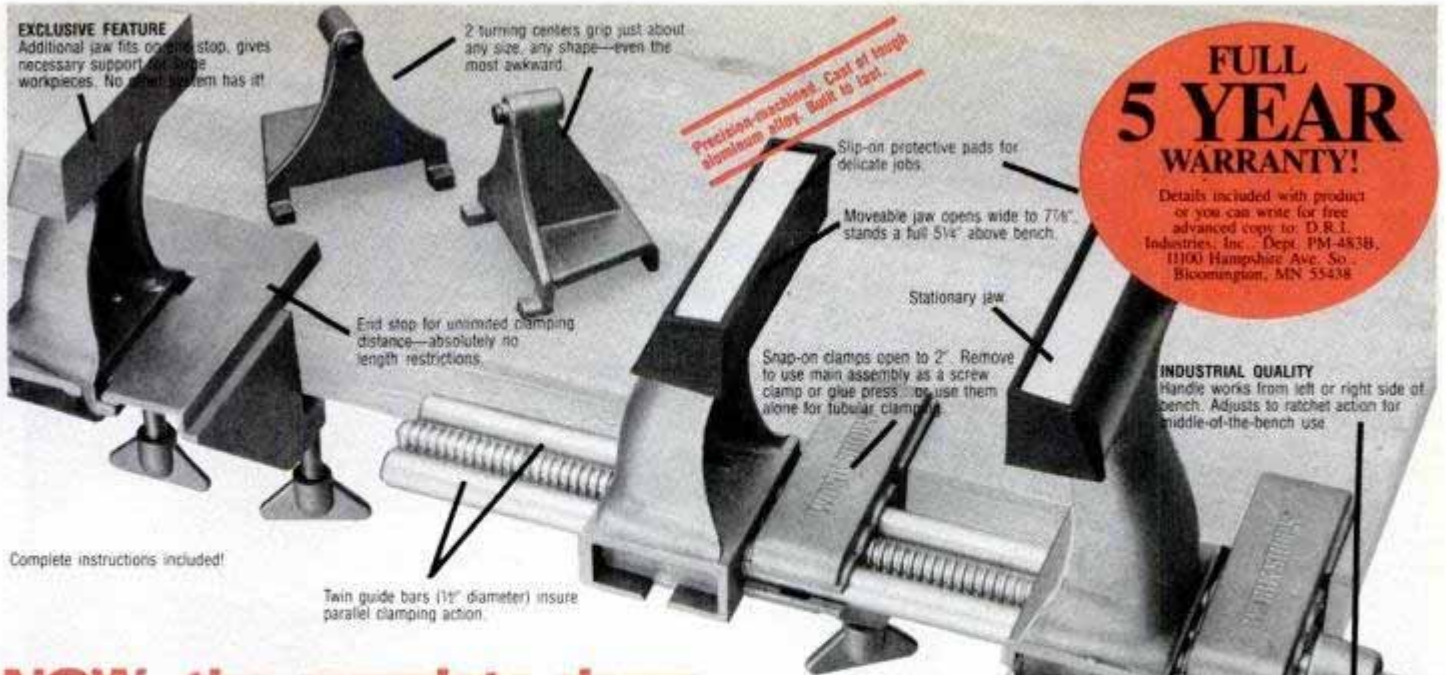

**FULL 5 YEAR WARRANTY!**  
 Details included with product or you can write for free advanced copy to: D.R.I. Industries, Inc. Dept. PM-483B, 11100 Hampshire Ave. So., Bloomington, MN 55438

**INDUSTRIAL QUALITY**  
 Handle works from left or right side of bench. Adjusts to ratchet action for middle-of-the-bench use

Complete instructions included!

Twin guide bars (1/2" diameter) insure parallel clamping action

**NOW...the complete clamp-and-vise system, at an unheard of price!**

# Vunder Vise™

the most versatile clamp and vise system there is...and total, rugged quality...and construction!

With our exclusive "third jaw"—no other system has it—gives you unlimited size range to handle the biggest jobs!!

D.R.I. Industries! We've introduced the NUT & BOLT SHOP® the 4 Wheel Wonder® and dozens of other high-quality, unique handyman products. OVER 2 MILLION SATISFIED CUSTOMERS

- Like a whole workshop full of clamps and vises—all in one compact system!
- Clamps any material—wood, metal, plastic, fiberglass
  - Takes on any size from minute watches to full size doors and even bigger...and everything in between
  - Works in any position. Above the bench and below the bench, on the left or right side, even in the middle
  - Puts a super hold on any shape—whether flat, round, jointed, bulky or awkward

A fraction of what you'd pay for all the tools it replaces ... a fraction of what you'd pay for any other similar system! **just \$49.99** plus \$4.90 shipping and handling.

Try the Vunder Vise FREE of risk ... FREE of obligation to keep it!

To order, just fill in the attached order form and send it with your check, money order, company purchase order or credit card information.

**In a hurry?** Credit card customers can call our 24-hour Toll-Free number:

**800-228-5000**  
 (in Nebraska, 800-642-8777).



**Order Yours Now!**

**Money-Back Guarantee of Satisfaction!**  
 Test Vunder Vise FREE of obligation to keep it. If you don't agree it's the ideal system, send it back for a complete refund, including shipping and handling charges.

Shop and compare. Anything comparable costs about twice as much. But you get the same high quality plus the extra jaw!

**Order now and get 2 FREE GIFTS!**  
 Free Shop Apron valued at \$4.99 plus a Surprise Free Gift ... BOTH yours to keep, even if you return your Vise!

Just a flip of the jaws or a switch of the parts and you have a whole new clamping tool!

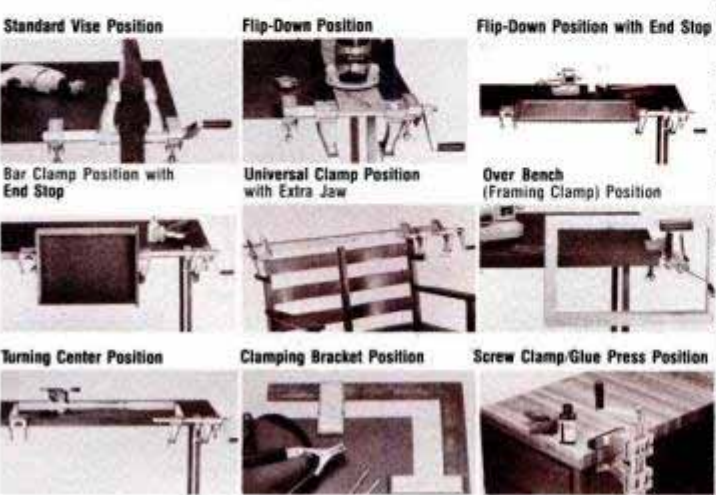

Vunder Vise is a trademark of D.R.I. Industries, Inc. © Copyright 1982 D.R.I. Industries, Inc.

## SPECIAL OFFER COUPON

11600 Try it FREE of obligation to keep it! If not totally satisfied, you can return your order for a complete refund, including shipping and handling. Make remittance payable to and send to: D.R.I. Industries, Inc., Dept. PM-483B, 11100 Hampshire Ave. S., Bloomington, MN 55438

INDICATE ORDER Vunder Vise(s) @ \$49.99 plus \$4.90 shipping and handling each. (00007201)

CHECK METHOD OF PAYMENT  
 I have enclosed my check or money order for the full amount. (MN residents add 6% sales tax).  
 I have enclosed my company purchase order (this card MUST accompany ALL purchase orders).  
 Charge it to:  VISA  MasterCard  American Express  Diners Club  Carte Blanche

Card No. \_\_\_\_\_ Exp. Date \_\_\_\_\_

SIGNATURE \_\_\_\_\_ (Need sign only if charging)  
 Mr. \_\_\_\_\_  
 Mrs. \_\_\_\_\_  
 Miss \_\_\_\_\_

PLEASE PRINT NAME \_\_\_\_\_  
 ADDRESS \_\_\_\_\_  
 CITY \_\_\_\_\_ STATE \_\_\_\_\_ Street & No \_\_\_\_\_ ZIP \_\_\_\_\_

# New For Home Improvement

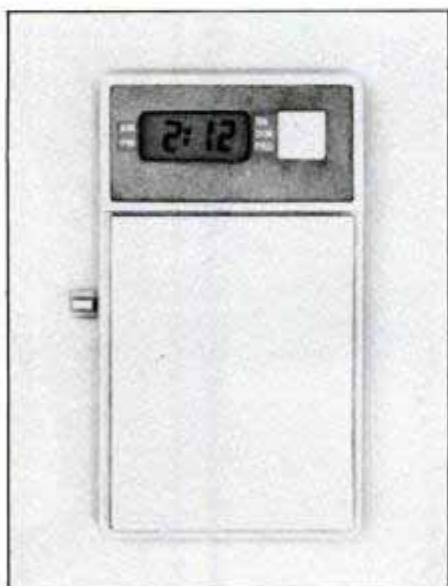

Tork's energy-saving time switch turns lights on and off and burns them at full brilliance or dim. It replaces any conventional wall switch. It's about \$30 from Tork, Electronic Systems Div., 1 Grove St., Mount Vernon, N.Y. 10550.

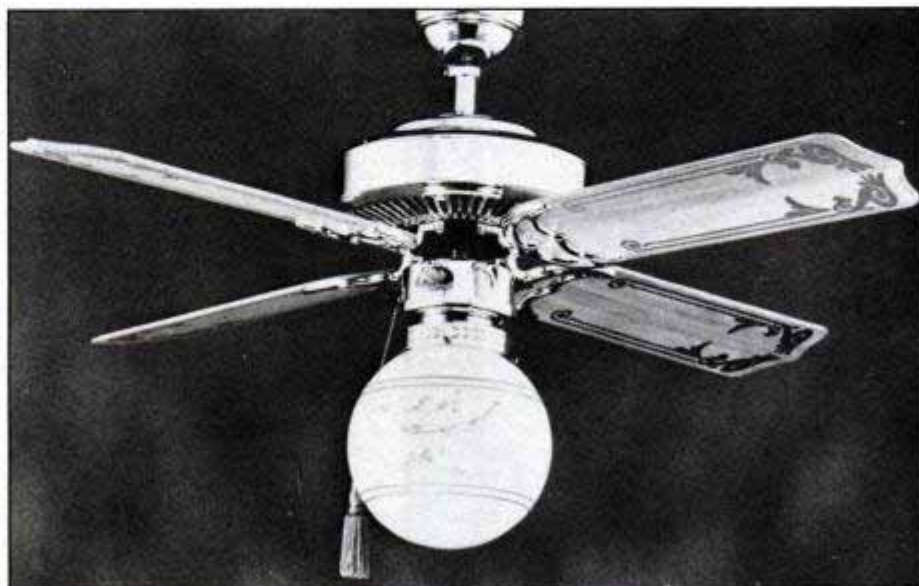

Smaller proportions make the Custom Trim-Line ceiling fan suitable for rooms unable to house standard fans. Its 10-in. housing features a three-speed, 1-amp. motor. The fan is available with 38- or 42-in.-long blades. Models range from

\$200 to \$450 and are sold by Old Jacksonville Ceiling Fan, Nichols-Kusan Inc., Box 1191, Jacksonville, Tex. 75766. For the location of the dealer nearest to you, call 1-800-527-8419; Texas residents should call 1-800-442-8955.



Armstrong captures the natural look of rush-fiber matting in its new Sundial Solarian line of vinyl flooring. The realistic rustic weave pattern is achieved by a process that combines photography and printing. A no-wax finish is used to help protect the pattern and make the flooring easy to keep clean. The vinyl flooring is available in 6- and 12-ft. widths and costs approximately \$11.50 per sq. yd. This price does not include installation. It is manufactured by Armstrong Inc., Box 3001, Lancaster, Pa. 17604.



Protect home valuables by installing Benchmark's Safe-T-Closet steel door and frame to an existing closet opening. Safe-T-Closet's preassembled units are designed for do-it-yourself installations and come in 24- (\$300), 28- (\$315) and 30-in. (\$330) widths to fit most closet openings. The steel units are available through building supply dealers. Prices will vary with dealers. For additional information about Saf-T-Closet units, contact General Products Co. Inc., Box 7387, Fredericksburg, Va. 22404.



KitchenAid's model KCS-200 (\$529) trash compactor features two front panels with the flip side of each a different color: almond/white or wheat/black. Each panel can be easily reversed or interchanged with the other. Additional features include: loading small items through the litter bin door while the unit is operating, a 1.7-cu.-ft. trash drawer and a 1/2-hp motor which is claimed to exert 3,000 lbs. of force. For details, write Customer Relations, KitchenAid Div., Hobart Corp., Troy, Ohio 45374.

# SMART IDEAS

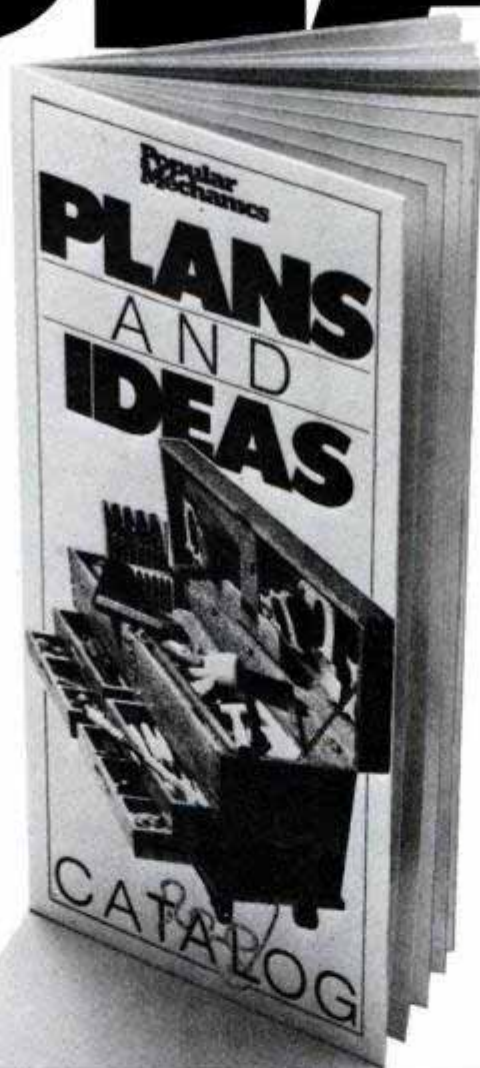

If you're looking for ideas to save time and money — while enjoying what you're doing — send away for PM's catalog immediately.

We have plans for shop tools, boats, storage houses, campers. Scuba tow, ACV, log splitter, air compressor. Smart ideas in furniture! Also dollhouses! Projects the whole family can enjoy.

And best of all — we offer a special and unique service — photocopies of past PM articles.

What's more, we tell you the year the projects were published. It may be as early as a 1902 glider to a most recent 1981 solar garden shed. You'll have fun just browsing through the approximately 900 different plans and projects. You'll find our GREAT WORKSHOP series listed. Also our SHOP MINI-COURSES. Timely energy-saving ideas! You'll see it all in our new POPULAR MECHANICS PLANS AND IDEAS CATALOG.

**Price \$1.00**

---

## SEND FOR YOUR CATALOG TODAY!

Send Your Name and Address with Check or Money Order to  
Popular Mechanics, Box 1014, Radio City Station, New York, N.Y. 10101

# THINGS TO DO: PLACE TO GO:

*Because everything on this*

Save 33% on  
**FORMBY'S  
FURNITURE REFINISHER**  
(0013) Refinishes varnished,  
lacquered or shellacked furniture  
without stripping. Saves work.  
**\$7.93**  
Reg. \$11.99



Save 33% on  
**WHEDON DELUXE  
SHOWER SAVER (SSC2)**  
With throttle valve. Reduces  
water flow without sacrificing  
comfort. Chrome-plated solid brass.  
**\$7.94**  
Reg. \$11.95

Save 38% on  
**WARPS GARDEN MULCH (NH350)**  
3' x 50' 1.5 mil black plastic mulch.  
Controls weeds, maintains constant ground  
temperature and conserves moisture  
in soil.  
**\$1.66** Reg. \$2.69  
(NH18) 1.5' x 100' \$1.66 Reg. \$2.69  
(NH3100) 3' x 100' \$2.96 Reg. \$4.79  
(NH625) 6' x 25' \$1.66 Reg. \$2.69



Save 50% on  
**DAP WHITE ACRYLIC  
LATEX CAULK (11465)**  
Terrific for sealing,  
waterproofing,  
and weatherproofing.  
**\$1.49** (10.3 oz.)  
Reg. \$2.99

Save 35% on  
**THOMPSON'S  
WATER SEAL (100A)**  
An excellent clear  
waterproofing sealer  
for wood, concrete,  
brick, natural fabrics  
and leather.  
**\$10.97** Gal.  
Reg. \$16.99

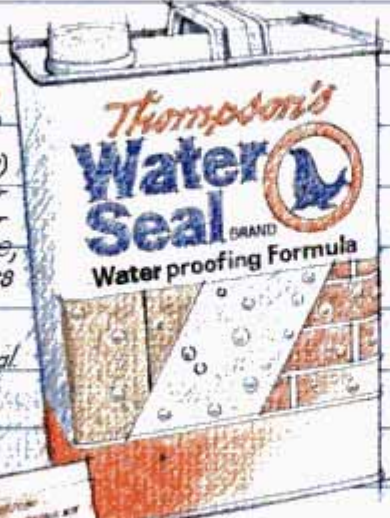

Save 32% on  
**SERVISTAR  
OXYGEN/PROPANE  
TORCH KIT (SSR8-5000)**  
Operates like a professional  
welding torch up to  
5,000°. Ideal for brazing,  
welding, cutting,  
and soldering.  
**\$32.88**  
Reg. \$48.95



**SPECIAL OFFER  
SAVE 50%  
SERVISTAR  
WIRING KIT**  
(604652) **\$9.47** Reg. \$18.95

All-purpose wiring kit. Cuts and  
strips wires easily. Makes  
connections safer, longer-lasting  
and more affordable with  
a savings of over \$9.00.

# SPRING PROJECTS!

# SERVITAR®

*page is now 20 to 50% off!*

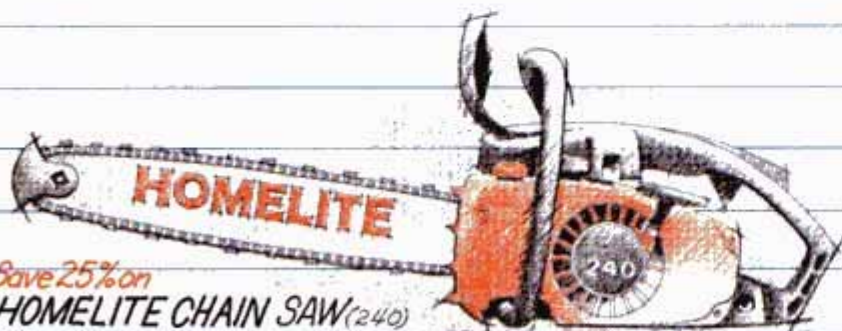

**Save 25% on  
HOMELITE CHAIN SAW (240)**

16" medium duty chain saw. Light enough for pruning, yet tough enough for the bigger jobs. Safe-T-Tip anti-kickback device offers greater protection. Cuts its price nearly \$70.00.

**\$199.99**  
Reg. \$269.95



**Save 20% on  
WERNER (386-6)  
5-WAY COMBO LADDER**

Converts to step-ladder, stairway ladder, extension ladder, 2 man ladder or 2 single ladders. U.L. approved.

Save nearly \$20.00.  
**\$78.97**  
Reg. \$98.95

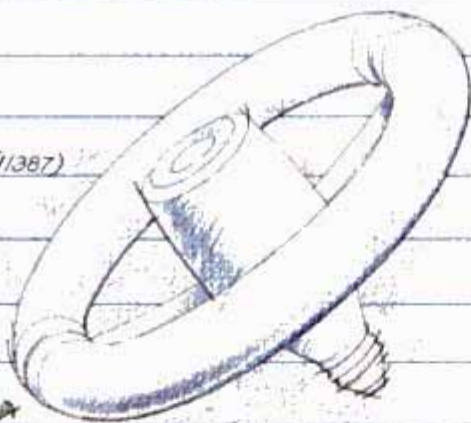

**Save 25% on  
G.E. MISER CIRCLITE (11387)**

22 watt fluorescent light. Saves energy, lasts 11 times longer than equivalent 60 watt bulb.

**\$8.97**  
Reg. \$11.95



**Save 42% on  
SAVOGRAN  
STRYPEEZE**

(11oz.) Semi-paste clings to rounded and vertical surfaces. Cuts deeper through many layers of paint.

**\$2.96 qt**  
Reg. \$5.15



**Save 26% with rebate on  
SCOTT'S DROP SPREADER**

(7146) PF-1 21" spreader. Precision flow control assures even spreading. Easy to recalibrate for accuracy.

**\$39.97**  
Less \$7.00 mail-in-rebate.  
Reg. \$44.95



**Save 27% on  
HUDSON POLY SPRAYER (61183)**

Hudson's finest. Perfection 3 gallon heavy duty sprayer with corrosion resistant polyethylene tank. Light, easy to carry.

**\$29.83**  
Reg. \$40.99

# SERVITAR®

**NEXT TO THE MAN WHO OWNS THE STORE,  
IT'S THE GREATEST NAME IN HARDWARE.**



**SEE YOUR YELLOW PAGES FOR THE DEALER NEAREST YOU** SALE ENDS APRIL 30, 1983  
AT PARTICIPATING DEALERS.

## GARDENERS:

### Do You Really Need A BIG Expensive Tiller?

A good, big tiller is a great machine to own... if you have a huge garden.

But what about furrowing, planting and weeding? (That's 90% of what's left once the ground is ready.) Why arm-wrestle a 200-300 pound monster all summer?

Rent a big tiller once a year (or hire the job out). Then use the Mantis-20 the rest of the season. It will do every job...quickly, precisely, economically. Mantis is so easy to use. Try it yourself with our **3-Week In-The-Garden Trial!**

Send for details today!



c. MMC 1983

For more information write  
**Mantis Manufacturing Co.**  
2651 Huntingdon Pike DEPT. 151  
Huntingdon Valley, PA 19006

Name \_\_\_\_\_

Address \_\_\_\_\_

City \_\_\_\_\_

State \_\_\_\_\_ Zip \_\_\_\_\_

## SAVE BIG!



All-Gear  
**MAGNATRAC**  
Crawler  
Tractor  
KIT!



All New  
**YARD TRUCK**  
KIT!  
1/3 Ton  
Capacity

Bolt together a **STRUCK-KIT** Tractor in a weekend and pocket Big Savings. Choose our famous **MAGNATRAC** Crawler or our newest 16HP **YARD TRUCK** Kit. Use for odd jobs to earn extra cash. Thousands of **STRUCK-KIT** Tractors in use. 30 Attachments - loader, backhoe, mower, plow, etc. Buy factory direct for greatest savings. Send **NOW** for:

- **CATALOG** of KIT construction and uses — \$1.00 (specify Magnatrak or Yard Truck)
- **ASSEMBLY MANUAL** for KIT — \$7.00 (specify Magnatrak or Yard Truck) Money refundable on any purchase.

**STRUCK-KIT** Dept. PM43 Cedarburg, WI 53012

## '83 HOME IDEAS GUIDE

# Energy-Savers For Your Home



General Electric's silicone masonry seal repairs cracks in exterior and interior masonry surfaces, such as foundations and fireplaces. It can prevent cold air from escaping during the summer and keep warm air in during the winter. Each 8½-oz. cartridge is about \$5. For more information write to General Electric Co., Silicone Products Div., Waterford, N.Y. 12188.



Conserve energy and water by replacing your existing shower head with the Ultra-Sperse 310 hand-held shower by Minnco. The maker claims a 10-minute Ultra-Sperse shower uses about 4 gal. of water as compared to 30 gal. used by a conventional shower head. The Ultra-Sperse 310 can also be made to work with an existing shower or attached to a tub faucet, with accessory parts available from Minnco. It's \$49.95 plus \$2.50 for postage and handling. Write to Minnco, Box 310, Arnold, Md. 21012.



You can detect tiny, fuel-wasting air drafts around doors, windows, vents and other spots with a Heat Sleuth-100 energy audit tool. Heat Sleuth's temperature sensitivity of 1/25 of a degree can show where to insulate to prevent heat loss. The hand-held unit is powered by a 9-volt battery (included) and operates from 35° to 95°F. Mail \$49.95 to Enertron Corp., 241 Crescent St., Waltham, Mass. 02154.

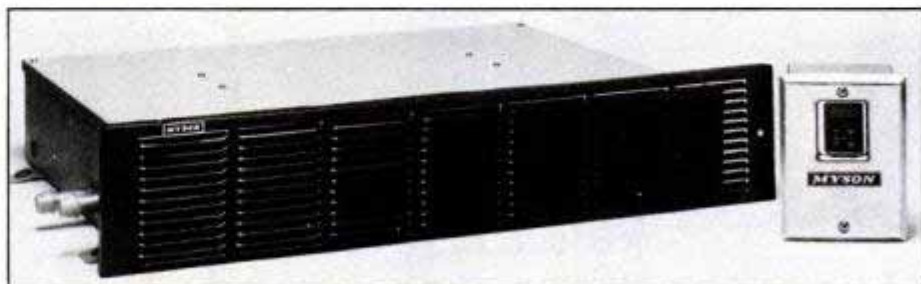

Myson's Kick-Space fan convector heater is designed for installation in the kick-board space below kitchen cabinets and bathroom vanities. Its space-saving size—3¾ in. high x 16¾ in. deep x 20 in. wide—contains just .076 gal. of water for

quick and efficient heating. The unit comes with a two-speed, remote-control box for approximately \$270. To obtain more information, contact Myson Inc., Box 5025, Falmouth, Va. 22403.

(Please turn to page 162)

**NEW!  
IT'S FILTERED!**

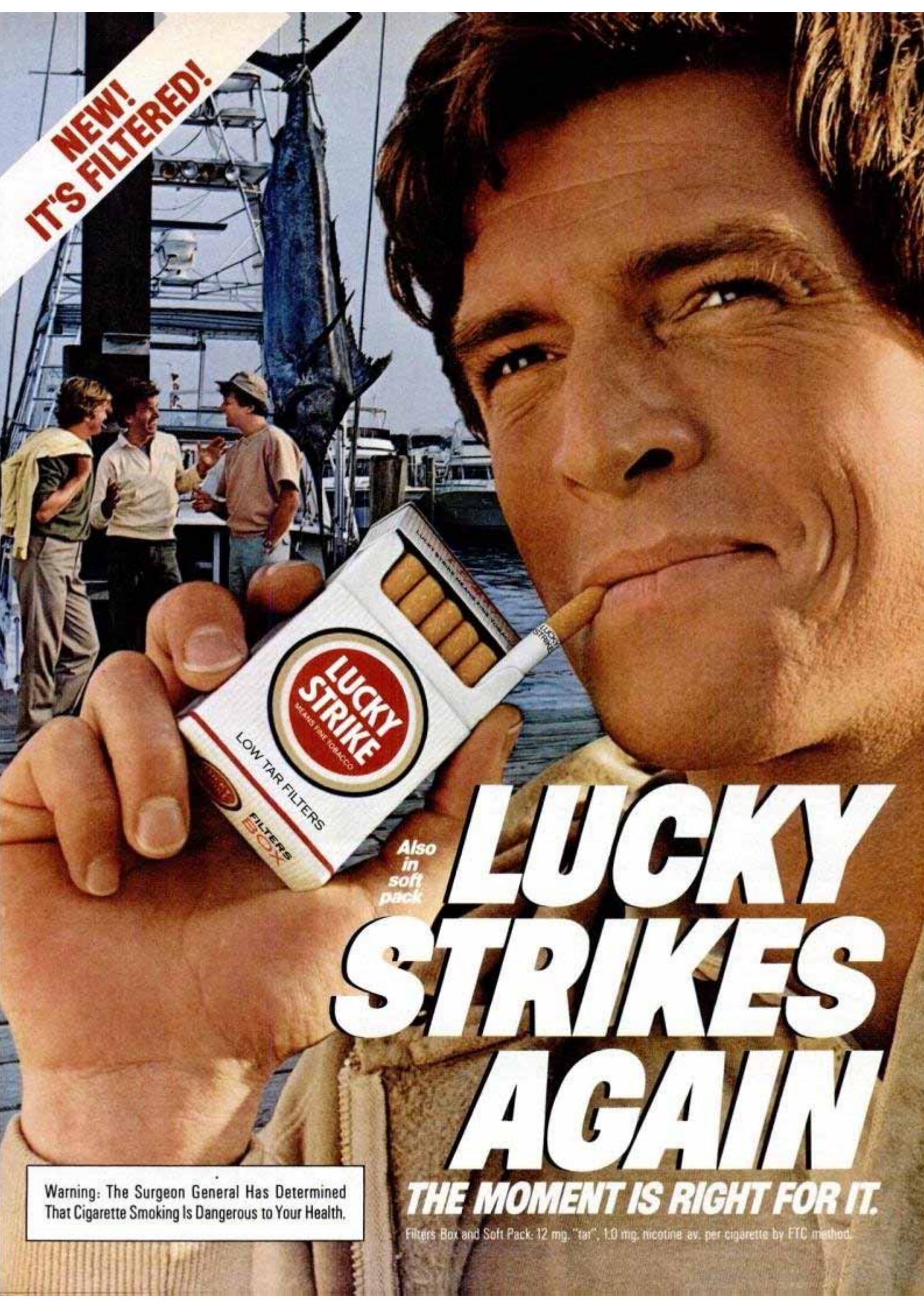

Also  
in  
soft  
pack

# **LUCKY STRIKES AGAIN**

**THE MOMENT IS RIGHT FOR IT.**

Filters Box and Soft Pack: 12 mg. "tar", 1.0 mg. nicotine av. per cigarette by FTC method.

Warning: The Surgeon General Has Determined  
That Cigarette Smoking Is Dangerous to Your Health.

**CRANK UP SOME EASY, ECONOMICAL LIVING IN THE GREAT OUTDOORS.**



A Jayco fold-down camping trailer makes it possible.

On the road, a Jayco fold-down keeps a low profile. The result: less wind drag, less fuel consumption — greater savings.

At the campsite, Jayco's easy-to-operate patented crank lift system helps you set up your fold-down in minutes. Inside, you'll find plenty of comfort and convenience.

Beat the cost of motels, avoid the discomforts of a tent, and get closer to nature. With a Jayco fold-down. For a free brochure, write Jayco, Inc., Dept. PM0483 P. O. Box 460, Middlebury, IN 46540



## '83 HOME IDEAS GUIDE

### ENERGY-SAVERS

(Continued from page 160)

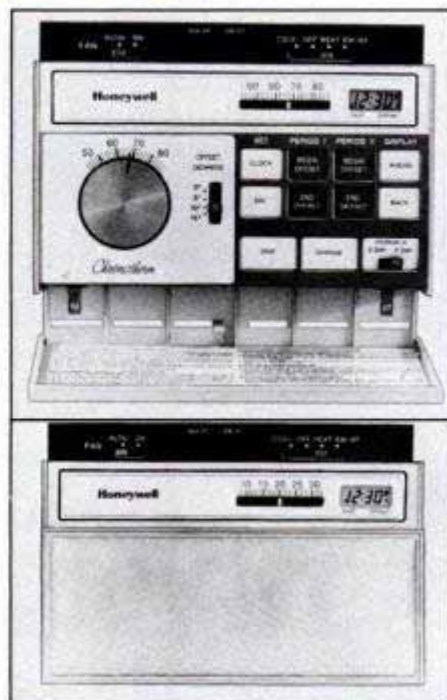

Honeywell Inc. introduces the T8300 Intelligent Recovery offset thermostat, which is designed to be used with heat pumps. A microcomputer allows programming of night setback (which automatically lowers the temperature) during the heating season and day setup (which automatically raises the temperature) during the cooling season to save on both heating and cooling costs. The thermostat costs about \$225. For details, contact Honeywell Inc., 10400 Yellow Circle Dr., Minnetonka, Minn. 55343.

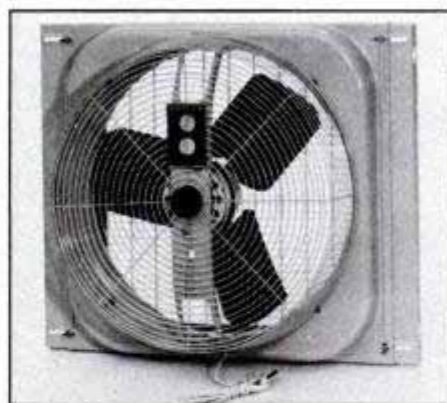

Patton Electric offers a thermostat-controlled window fan for home cooling. The Whole House 20-in. window fan's automatic temperature control shuts down the fan when the house temperature drops to the desired level. The unit is powered by a 1/6-hp motor with three reversible speeds. Its side panels adjust to fit any 27- to 35-in.-wide window opening. The fan is available at hardware stores and home centers for about \$115. It is made by Patton Electric Co. Inc., Box 128, New Haven, Ind. 46774. **PM**

# Free.

**Up to \$120 worth of free merchandise with every new 8" or 6"/7" Black & Decker Professional Bench Grinder you buy.**

Get the new Professional B&D 8" or 6"/7" Bench Grinder with the industry's highest HP, and get a bonus. Up to \$120 worth of accessories of your choice. Free. Including goose neck lamps, wire-wheel brushes, powerful Spotlifter™ lights, even a heavy-duty bench grinder pedestal.

Both new bench grinders have the wide wheel clearance for easier grinding, and wide wheel guards for wide wire-wheel brushes. And both have integral exhaust chutes, 3-way tool rests, sealed motors, and  $\frac{1}{2}$  approval.

Your nearest participating Black & Decker Distributor or Dealer has all the details. See him before this offer ends.



**B-D Black & Decker**

Industrial/Construction Division, Hampstead, MD 21074



# SEE THE OLD WORLD WITHOUT LEAVING THE NEW.

This summer, visit your fun-loving, friendly neighbours next door – and discover a land where the rich traditions of a glorious past are blended with the fabulous delights of a modern culture.

We're eager to treat you to an exciting array of travel experiences, interesting folklore, five-star cuisine and a spirit of hospitality you will find only in Canada.

Come brew a bit of magic. Slip back in time. Ride a calèche down cobble-stone streets...enjoy spectacular landscapes... take grand tours of magnificent cathedrals, towering fortresses, national historical parks, or...discover a castle.

Explore our clean, vibrant, cosmopolitan cities by day and by night...add a dash of history to the luxuries of the new. For a week-end or a vacation, there is so much to see, so much to do and so many new friends waiting to meet you... in CANADA.

So come up soon, for the best of the Old World *and* the New!

Send today for your FREE "Travel Inspiration Kit" and start planning right away! If coupon is missing, call 1-800-842-9000 and ask for Canada.

YES!  Send me my FREE "Travel Inspiration Kit", which includes information on how to get a souvenir of my Canadian vacation FREE!

Mr.  Mrs.  Miss  Ms.

\_\_\_\_\_  
First Name (PLEASE PRINT) Last Name

\_\_\_\_\_  
Address

\_\_\_\_\_  
Apt. R.R. # P.O. Box

\_\_\_\_\_  
City State

\_\_\_\_\_  
Zip Code Area Code Telephone Number

Fill in this coupon and mail today to:  
CANADIAN GOVERNMENT OFFICE OF TOURISM  
P.O. BOX 1122, GLENVIEW, IL. 60025 OR  
CALL 1-800-842-9000 AND ASK FOR CANADA.

0096

Canada 

## A space age polish that removes and prevents pitting!



### MONEY BACK GUARANTEE!

**MET-ALL** aluminum polish. Cleans, polishes, waxes and protects in one application. Safe, fast, easy to use.

**MET-ALL** shines aluminum and all other metals to a mirror-like finish. Great for home, auto, marine and aviation use. Tested and approved by the three largest producers of aluminum.

**MET-ALL**. Removes the dullness, not the metal.

Ask your retailer or write to:  
**DARS MET-ALL INDUSTRIES, INC.**  
29-00 Review Ave., Long Island City,  
NY 11101 (212) 937-3535

## MOLDS

for making  
Ornamental Concrete  
Items...

Book about Aluminum  
Molds with prices and  
production trade secrets  
direct from world's largest  
mold manufacturer.



SEND  
\$5.00

CONCRETE MACHINERY COMPANY, INC.

P. O. BOX A99 - HICKORY, N. C. 28601

## NEW! 24½ IN. 3-SPEED BAND SAW 30-DAY FREE TRIAL!



Now, a pro-size, band saw priced for the home shop! Big 24½-in. throat easily handles large scrollwork, complex curves, 4 x 8 sheets. 9-in. vertical cut makes it easy to resaw valuable hardwoods. Ball bearing construction. All-steel welded frame eliminates deflection. Includes motor, stand, rip fence, scroll table, full instructions. Send for complete facts today! Easy Terms!

Call Toll-Free 1(800) 824-7888 Oper. 642  
In California Call 1(800) 852-7777 Oper. 642.

**WOODMASTER TOOLS DEPT. SP8,**  
2849 TERRACE, KANSAS CITY, MO 64108

## TERMS BUILDERS USE

**W**hether you are a once-in-awhile do-it-yourselfer, or an active homeowner who does anything and everything in the area of home improvement, it will pay you to have at least a basic understanding of words and terms that various professionals use. From time to time, *Popular Mechanics* will run a column which zeroes in on those words which are used frequently in its pages. This month's words are those that builders and carpenters use. —John Gaynor

### Frost line

This is the depth of frost penetration in the soil. The frost line can and does vary from one geographic area to the next. Check with your local building department to learn the depth for your area. The bottom of the footing *must* be at this depth.

### Footing

This is the masonry base poured on undisturbed soil, in a rectangular form. Located under the foundation wall, a footing's size is based upon the total load (size and dimensions) of the foundation wall and upon the type of soil that will support it.

### Foundation

This is either a concrete block or poured concrete wall that is the supporting portion below the first floor of a structure. When a pro speaks of a foundation, he is including that portion below the wall, the footings.

### Sill plate

This is the lowest frame member in a structure. The sill rests on and is fastened to the foundation with anchor bolts. The floor joists, in turn, are toenailed to the sill.

### Bridging

These are usually small metal or wood members inserted in a diagonal attitude between floor joists at mid-span (and no farther apart than 10 ft.), to prevent joists from twisting and tipping over. Solid bridging—pieces cut from the same stock as the joists—can also be used.

### Bearing wall

A bearing wall is one that supports any vertical load in addition to its own weight. In standard frame construction, a bearing wall is generally constructed of 2x4s spaced 16 in. on center, with a doubled-up 2x4 top plate and a single 2x4 sole plate. A bearing wall should *never* be cut into or removed without first supporting the load above it with the correct new construction. If in doubt, consult a licensed architect or engineer.

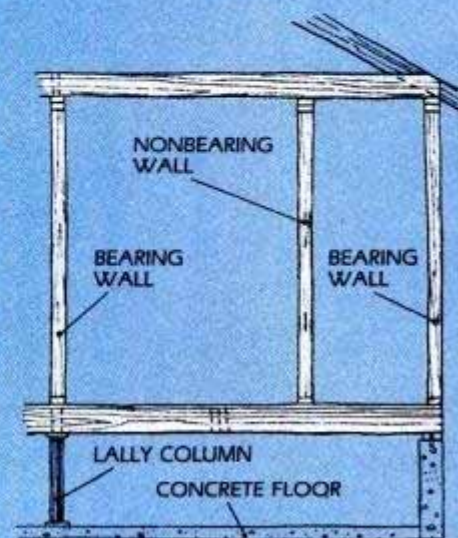
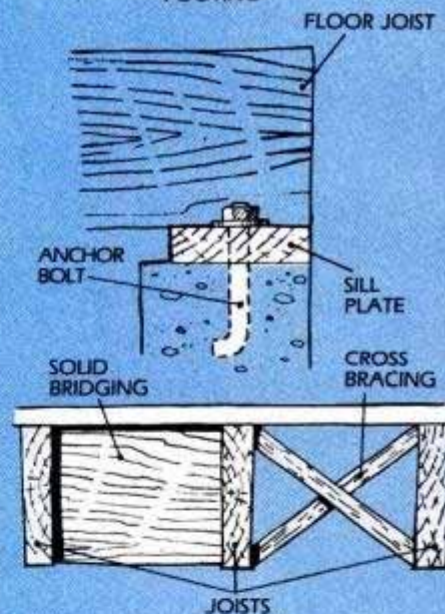
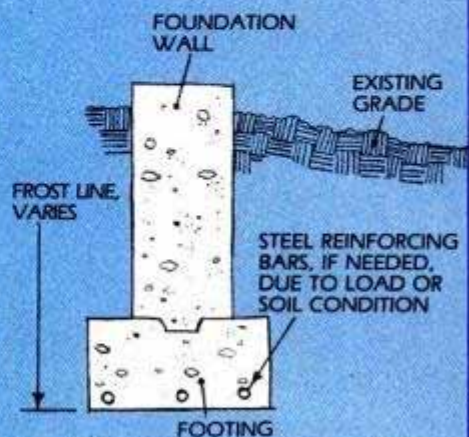

A COMPLETE SET OF ORANGE

# SHOP TOWELS



**NOW AVAILABLE... BRAND NEW 100% COTTON, LARGE ORANGE SHOP TOWELS!**

(approximately 16" x 16" when washed)

ONE-HALF GROSS... 72 TOWELS!  
SPECIAL OFFER... **ONLY**

# \$19.99

Plus \$3.90 shipping and handling

Send Your Order Today!

Re-order information shipped with each order!

The same high-quality commercial-grade shop towels used by service stations, garages, printing plants, repair shops, maintenance services and thousands of other businesses throughout the country... **NOW offered FOR SALE at an almost unbelievable low, low price!**

- Now... all the clean shop towels you need... right at your fingertips!
- No more searching for clean rags!
- No more "making do" with non-absorbent, lint-filled, odd-sized rags!
- No more flimsy, fall-apart paper towels!
- No more waiting for laundry services!
- **NO MORE HIGH PRICES!** (Buying our Towels costs a fraction of renting!) office, shop, garage or plant... washing windows, dusting, cleaning anything!
- These are **not** "cheap" towels... **not** used towels... **not** "seconds"...
- **not** anything but brand new, quality commercial-grade towels.
- If not completely satisfied, return them for a full and immediate refund.

### PLUS FREE GIFTS!

Just for ordering we'll send you Two Free Cans of go-go® Hand Cleaner. Plus, a Valuable Surprise Free Gift. Both yours to keep - whether or not you keep your order.

MAG-68

11516

### SPECIAL OFFER COUPON

Try them **FREE** of obligation to keep them! If not totally satisfied, you can return your order for a complete refund, including shipping and handling.

Send to and make remittance payable to:  
**D.R.I. Industries, Inc. Dept. PM-483A**  
11100 Hampshire Ave. So., Bloomington, MN 55438

sets (72 Towels per set) @ \$19.99 plus \$3.90 shipping & handling for each set = \$ (00003905) & handling for each set = \$ (MN residents add 6% sales tax)

How Many?

CHECK METHOD OF PAYMENT

- I've enclosed my check or money order.
- I've enclosed my company purchase order (this coupon **MUST** accompany ALL purchase orders).
- I wish to charge it to  VISA  MasterCard  American Express  Diners Club  Carte Blanche

Card No. \_\_\_\_\_ Exp. Date \_\_\_\_/\_\_\_\_/\_\_\_\_

Signature **X** \_\_\_\_\_ (Need to sign only if charging order.)

MR. \_\_\_\_\_  
MRS. \_\_\_\_\_  
MISS \_\_\_\_\_

PLEASE PRINT

ADDRESS \_\_\_\_\_  
CITY \_\_\_\_\_ STATE \_\_\_\_\_ ZIP \_\_\_\_\_

© Copyright 1981 D.R.I. Industries, Inc.

D.R.I. Industries, Inc.  
Dept. PM-483A  
11100 Hampshire Ave. So. Bloomington, MN 55438  
Made in China

### ORDER TODAY ... IT'S EASY!

Fill in order form and send with check, money order, company purchase order or credit card information.

Credit card buyers can also call our 24-Hour Toll-Free Order Number: 800-228-5000 (In Nebraska 800-642-8777)





## The Husqvarna 50 Rancher cuts weekends down to size.

No matter how often a saw is used, it should have the same high standards of quality and performance that professionals demand. That's why the Husqvarna 50 Rancher is built to the same professional standards of all our chain saws.

Besides its easy-to-handle design and excellent power-to-weight ratio, the Husqvarna 50 Rancher features electronic ignition. An automatic oiler. An anti-vibration system. Plus a totally automatic, permanently adjusted inertia chain brake. Also, it's easy to start, and restart.

The Husqvarna 50 Rancher. Designed to make the non-professional work like a pro.

**New Price Roll-Back.** People have always been glad to pay for the high quality of a Husqvarna. But now, the prices have been rolled back, lower than they've been in years. So if you've ever considered owning a Husqvarna, now is the time to get one.

For the dealer nearest you, write Husqvarna, 224 Thorndale Avenue, Bensenville, Illinois 60106, or consult your Yellow Pages.

**Free Offer**

Get our unique safety helmet when you buy any new Husqvarna.

- Flexible flip-up visor.
- Special hearing protectors.
- A \$27.95 retail value.

Offer good thru May 31st from participating dealers.



**Husqvarna**  
SWEDEN  
The Chain Saw Professionals.

## PM LOOKS AT...

### Security for your windows

If you have an area that is filled with valuable equipment (such as a workshop), you might want to install the Vigilante window system. The Burglar Bars shown are available in three adjustable sizes to fit any window from 19 to 76 in. wide. The vertical members are  $\frac{3}{16} \times 1$ -in. steel flat bar; the horizontal members are  $\frac{1}{2} \times \frac{1}{2}$ -in., 16-gauge structural steel tubing. If the window must be used as an emergency



After boring pilot holes, install Burglar Bars with one-way screws (top). Unit prevents entry without making a racket.

exit, you can order a Window Gate Kit which converts the unit in minutes. To install the Burglar Bars, hold the unit in position and mark locations for the tamperproof (one-way) mounting screws. Remove the unit, bore the lead holes and complete the installation in minutes. For information, write Vigilante Security Products, Box 37394, Houston, Tex. 77036.—H.W.

# WORTH WRITING FOR

LOOKING FOR IDEAS ON HOME IMPROVEMENT, TOOLS, COMPUTERS, CAMPING, OUTDOOR SPORTS AND MORE? CHECK THESE LISTINGS. THEN USE THE COUPON BELOW.

## 655 Fascinating Fastening Tool

Brochure from Arrow Fastener describes and illustrates the many time-saving, do-it-yourself applications for the Arrow staple gun. Includes helpful how-to home hints. 40¢

## 656 Home Computers

Full-color pamphlets describe the ATARI Home Computers and how they make learning about computers fun for people of all ages. Free

## 657 Quick And Easy House Painting

An informative new brochure from Wagner identifies common painting problems and the correct solutions. Topics discussed in the 16-page, illustrated brochure include surface preparation techniques, safety tips, paint selection advice and other hints. Free

## 658 How To Play The Angles

Super Square can be the good news carpenters have been waiting for. This all-in-one-tool helps find angles for roof framing, stairs and other complicated cuts. Illustrated brochure from Orem Research. Free

## 659 Get Off Your Hands And Knees

Compact 68-pound tiller does your toughest weeding and cultivating. Ideal for small and medium gardens. Information kit from Masport America. \$1.00

## 660 For The Woodworker

An information kit from Total Shop highlights the versatility of this compact 5-in-1 home power tool. Also includes certificate for \$300 off purchase price. Free

## 661 Sawing Safely

A full-color, 16-page guide to safe and efficient chain saw use. Also includes maintenance tips. From Husqvarna. 25¢

## 662 Classic Old South Beauties

Replace your old wood columns with strong, extruded aluminum columns. Moultrie Manufacturing shows you how to add beauty and durability to your home. Seven simple installation steps are outlined in their information kit. Free

## 663 Move Yourself

Moving yourself can be easy, as well as economical. Jartran shows you how with this Mover's Guide. Includes professional packing tips, how to figure the rental size needed, and sometimes forgotten details like utilities and mail. Free

## 664 A Warehouse Full Of Tools

The Tool Warehouse catalog is chock full of name brand tools at discount prices. All the tools you need for home maintenance tasks. \$1.00

## 665 Beautiful Wood Finishes

12-page, four-color booklet from Watco-Dennis shows how to create professional finishes the first time with all types of wood. Watco Danish Oil seals, primes, finishes, hardens, protects, beautifies and penetrates . . . in one application. Free

## 666 A Real Computer For The Price Of A Toy

Four-color brochure from Commodore Business Machines features the VIC 20 home computer. Includes descriptions of the low cost, fully expandable VIC 20 and its complete line of software. Free

## 667 Unique Four-In-One Tool

Combitalool is a versatile 4-in-1 tool for the workshop, kitchen, tool kit or tackle box. This handy tool combines pliers, screwdriver, wrench, and wire cutters in one. Free brochure.

## 668 For The Discriminating Dog

Brochure from Canine Clubhouse of Beverly Hills describes build-it-yourself doghouses in five designs. Plans available for Western Saloon, Country Barn, Spanish Hacienda, Swiss Chalet, or English Tudor. Free

## 669 The Cutting Edge Of Woodworking

Beautiful 96-page, full-color catalog features Carbide-Tipped Saw Blades, Dado Heads, Planer and Jointer Knives, Cutter Sets, Bits and other precision tools. From Freud U.S.A. \$5.00 refundable with proof of purchase.

## 670 Outboard Heritage

Evinrude has been making outboard motors since 1909. Colorfully illustrated, 32-page catalog details innovations over the years and highlights their full range of outboards for virtually all your boating requirements. Free

## 671 Camping Trailers

Full-color 12-page Folding Camping Trailer brochure from Coleman. Describes features, floor plans, accessories, and specifications for all 10 new models for 1983. Free

## 672 Photo Fantasies

Turn ordinary snapshots into creative photographs with Cokin filters and any 35 mm SLR camera. Brochure from Cokin includes hundreds of photos and examples. \$1.00

## 673 Water Power

Johnson Outboards features their 1983 line of outboard motors in an eye-catching 32-page, color catalog. Includes descriptions of 55 models, from powerful workhorses to compacts and portables, specifications and a 1983 Buyer's Guide. Free

## 674 Outdoor Outfits For All Seasons

Cabela's presents thousands of quality items for fishing, hunting and outdoor recreation in seasonal catalogs. Five catalogs per year. Free

## 675 All Hands On Deck

A colorful 18-page catalog by Smoker-Craft displays their full line of boats. Includes aluminum sport boats, fishing boats, pontoons and canoes. Free

## 676 Home On Wheels

The people at RVC want you to know that home comfort and driving ease can be yours in the timeless luxury of a Legend Motor Home. Illustrated brochure includes standard features and options. Free

## 677 Knife Know-How

16-page, informative booklet from Buck Knives shows how to sharpen a knife, field-dress a deer, skin and fillet fish. Also includes safety techniques and much more. Free

## 678 Outboard Adventure

Mercury Marine offers to share the possible dream and help you discover boating. Its annual-edition, four-color catalog includes a full line of outboard motors for all your boating needs. Plus accessories and specifications. Free

## 679 Discover Camping Fun

Tents for every camping need in the four-color brochures from Eureka! Tent describe a complete line of tents for both the individual and the whole family. Includes pictures, diagrams and specifications. 50¢

## 680 Treasure Hunters . . . Dig This

How to find gold nuggets, old coins, jewelry, and other buried treasures. Gardiner Electronics shows you how in this free 48-page catalog.

## 681 Sight In Your Future

Leupold would like you to know that computer programmed optical design makes their 1983 gun scopes the finest ever. Scopes for both rifles and pistols are highlighted in a 16-page, four-color catalog. Free

POPULAR MECHANICS 4/83  
Box 1718, Sandusky, Ohio 44870

Please see that I receive the items checked below

- |                                     |                                     |                                     |                              |
|-------------------------------------|-------------------------------------|-------------------------------------|------------------------------|
| <input type="checkbox"/> 655 40¢    | <input type="checkbox"/> 661 25¢    | <input type="checkbox"/> 667        | <input type="checkbox"/> 673 |
| <input type="checkbox"/> 656        | <input type="checkbox"/> 662        | <input type="checkbox"/> 668        | <input type="checkbox"/> 674 |
| <input type="checkbox"/> 637        | <input type="checkbox"/> 663        | <input type="checkbox"/> 669 \$5.00 | <input type="checkbox"/> 675 |
| <input type="checkbox"/> 658        | <input type="checkbox"/> 664 \$1.00 | <input type="checkbox"/> 670        | <input type="checkbox"/> 676 |
| <input type="checkbox"/> 659 \$1.00 | <input type="checkbox"/> 665        | <input type="checkbox"/> 671        | <input type="checkbox"/> 677 |
| <input type="checkbox"/> 660        | <input type="checkbox"/> 666        | <input type="checkbox"/> 672 \$1.00 | <input type="checkbox"/> 678 |

Name (Please Print) \_\_\_\_\_

Address \_\_\_\_\_

Town \_\_\_\_\_

State \_\_\_\_\_

Zip Code \_\_\_\_\_

(Please send cash, check or money order made out to POPULAR MECHANICS. No stamps, please.)

Note: Popular Mechanics processes your requests for the above information and forwards these inquiries to the organization making the offer. Each company mails the material directly. Your order will be on its way to you within 90 days.

This Coupon Expires June 30, 1983

679 50¢      Total money for priced items \$ \_\_\_\_\_  
 680      Service Charge \$ \_\_\_\_\_50  
 681      Total money enclosed \$ \_\_\_\_\_  
 Total items requested \_\_\_\_\_



*With its hefty 3-ton load-rated hydraulic jack, PM's engine hoist can handle just about any engine—car or truck. Its rugged construction details and heavy-gauge steel will ensure a lifetime of service. It also disassembles quickly for handy storage.*

# HOW TO BUILD AN ENGINE HOIST

If major engine work is your thing, give yourself a big lift with PM's ultrastrong hoist.

BY RALPH deMASI

**W**hen we began laying out the design for this engine hoist, we had three goals. First, the hoist had to be big enough to handle an average car engine as well as a pickup truck's engine. Second, it had to be strong enough so it wouldn't bend or fatigue

with repeated use. Third, we wanted the hoist to be portable.

This hoist is as big as we wanted, and so strong that it will probably last a lifetime. The gauge of the steel is thicker than virtually any commercially made units, with the exception of the "monster" cranes used for commercial truck engines. This might be a little overkill for the home mechanic but you can take a certain amount of pride in the fact that this hoist will still be work-

ing long after Brooke Shields is collecting Social Security.

We made it easy to disassemble for storage or transportation by allowing the legs and the mast to slide out of their supports, and by using dowels with cotter pins as the pivot points for the boom and the hydraulic jack. The whole assembly can be taken down in two minutes and laid flat in the back of a pickup for carrying to a work site.

The most critical aspect of this project is the welding. If the welds aren't done properly your hoist will be weak, which could be dangerous. If

*(Please turn to page 170)*

PM photos: Peter Tenzer  
Design and construction:  
Ralph deMasi, Tony Assenza

# For ZX81 or TS1000 software savings, rip off this ad.

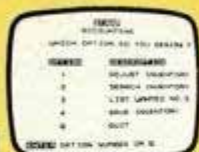

**THE STAMP COLLECTOR (#31)** Inventory and store up to 600 SCOTT numbers in a single session showing quantity on hand, by major classification, and provide full want list support.



**STATES AND CAPITOLS (#32)** Test yourself on the fifty states and their capitals. Three options of review are available. (1) States, you provide capitals. (2) Capitals, provide states. (3) A mix of states and capitals.

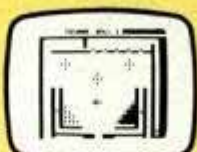

**PINBALL (#35)** Plays like real pinball complete with flippers, bumpers, "nudge," bonus points and more. Uses fast, efficient machine code to choose its moves.



**VU-CALC (#11)** This program constructs, generates, and calculates large tables for financial analysis, budget sheets, and projections. An immensely powerful analysis chart.



**THE FLIGHT SIMULATOR (#6)** Take control of highly maneuverable light aircraft. With full controls, instrumentation and navigational aids to avoid hazards in landing.



**STOCK MARKET GAME (#27)** Bull or bear? This realistic simulation lets you analyze information, buy and sell stocks, take out and pay off loans... and win, if you can accumulate \$50,000 in "The Market."



**SUPERMAZE (#34)** Navigate your way through a three-dimensional maze, with trapsdoors, gold bars, marker stones, and compass. Ten separate mazes. Three-dimensional graphics.

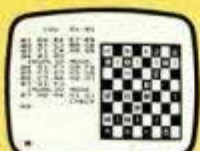

**CHESS AND CHESS CLOCK (#7)** Six levels. All the legal moves including castling and enpassant. Keeps a separate record of plays made for easy reference. Play another opponent or match wits with the computer.



**FORTRESS OF ZORLAC (#36)** A super fast game in which you are the commander of a fleet of spaceships. Your mission is to rid the galaxy of the dreaded alien, ZORLAC.



**PERSONAL FINANCE PLANNER (#28)** Perform calculations, finance a house, a car, keep savings accounts, repay loans and calculate an amortization schedule which can be generated for any of the financial programs.

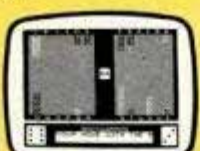

**BACKGAMMON AND DICE (#8)** A perfect blend of chance and skill. Uses machine code to choose its moves. Full game including graphics board, rolling dice, and double cube. Play the computer or another opponent.

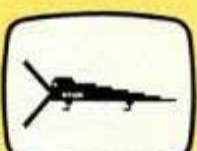

**ATOR THE ABC GATOR (#33)** Designed to teach recognition and sequence of the alphabet. Combines computer instruction, music and video games.



**SUPER MATH (#14)** Drill yourself on addition, subtraction, multiplication, and division with five levels of difficulty. Each problem graphically depicted.



**THE CUBE GAME (#9)** The cube can be displayed in three views: (1) Solid; (2) Two-Dimensional (unfolded), and (3) See-thru cube (3-D). You start with the cube solved, set it up any way you like, or pick up from a previous session.

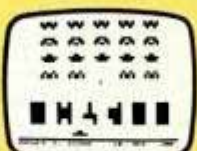

**SPACE RAIDERS, BOMBER (#5)** Timex/Sinclair version of the popular arcade games full of bombs and rockets and collisions with skyscrapers.



**THE HOME IMPROVEMENT PLANNER (#29)** Store up to 20 room measurements (length, width, height), compute total area in each (wall, floor), estimate costs of painting, wall papering and carpets and draw house blueprints.



**REAL ESTATE INVESTMENT ANALYSIS (#30)** Two different investment strategies. The first selection allows the user to choose between renting or buying. The second selection consists of a detailed analysis of the rental investment property.



**FROGGER (#37)** Plays like the arcade game. Hop the frog over traffic, snakes, crocodiles, and treacherous diving turtles before time runs out.

Sinclair\*, the company that invented the world's most affordable computer, has invented a way for you to order the most affordable software—right from your home!

You've never had this wide a selection before. You can play games that challenge you, instead of bore you. You can learn new household applications and business programs that reduce work dramatically.

Only Sinclair offers this special software savings. Only ZX81 or Timex TS1000 owners are eligible.

**The more you buy, the more you save. A serious Sinclair software offer.**

The first cassette you buy, you buy at normal cost: \$15.00. But every cassette thereafter, you get at a savings.

The list below explains how much you save, based on how much you buy. It couldn't be easier.

You were smart to buy the ZX81 or the TS1000. You'll be even smarter to take us up on this software offer. All cassettes listed at left work on both the ZX81 and the TS1000. All cassettes are 16K, which means you need the 16K Memory Module. (If you want more information on this component, please write Sinclair at the address listed below.)

But don't delay. This is a limited time software offer while supplies last.

**How to order today!**

Just call our toll-free number and use your MasterCard or VISA. Or send this ad with a check or money order. It's as easy as that.

Call toll-free: 800-543-3000. Ask for operator 509. In Canada call 513-729-4300, operator 509. Have your MasterCard or VISA ready when calling. Phones open 24 hours a day, 7 days a week. These numbers are for orders only.

If you simply want information, please don't call, write Sinclair Research, Ltd., 2 Sinclair Plaza, Nashua, NH 03061.

(Sorry, no refunds on software. Defective cassettes will be replaced.)

**Call toll free**

**800-543-3000**

(operator 509)

Ad. code: Mail to: Sinclair Research, Ltd.  
B4PM One Sinclair Plaza, Nashua, NH 03061

Check the boxes of all cassettes you want at left.  Check or money order enclosed.

Fill in the space beside total for your total payment  
Plus Shipping/Handling \$5.00

1 cassette: \$15.00  
 2 cassettes: \$25.00 (save \$5.00)  
 3 cassettes: \$35.00 (save \$10.00)  
 4 cassettes: \$45.00 (save \$15.00)  
 5 cassettes: \$50.00 (save \$25.00)  
 6 cassettes or more: \$10.00 each \$

Total:

U.S. Dollars

Name

Street

City

State  Zip

**sinclair**

\*Sinclair technology is the heart of both the ZX81 and the Timex/Sinclair 1000.

## Spring Savings On Log Splitter Parts

Sale Ends 6/20/83

### 2-Stage Cast Iron Gear Pumps

II GPM @ 650 PSI until more pressure is needed. Kicks down to low GPM & up to 2500 PSI. Right hand rotation, can direct couple to 5HP+. 3600 RPM max.  
 #1011 ..... \$98  
 13.6 GPM @ 650 PSI, use 5 HP+.  
 Item #1013 ..... \$135  
 16 GPM, use with 8 HP+. Item #1015 ..... \$156  
 22 GPM, use with 10 HP+. Item #1017 ..... \$245



### 4-Way Control Valve

Built-in relief valve, 1/4" in-out ports, 1/2" cylinder ports. Item #2010 ..... \$42  
 Has pressure sensitive detent, hands free on return stroke up to 3000 PSI. Top quality. Item #2020 ..... \$56



### Special Cylinder Valves

Tie rod cylinders, with one year warranty  
 4x24, 1 1/2" shaft, 68 Lbs. #906024 ..... \$116  
 4x24, 1 3/4" shaft, 71 Lbs. #906224 ..... 130  
 4x24, 2" shaft, 75 Lbs. #906124 ..... 137  
 5x24, 2" shaft, 100 Lbs. #909524 ..... 204  
 Welded Tee, can go UPS  
 4x24, 1 1/4" shaft, 49 Lbs. #90424 ..... \$132



### Quality Gas Engines

Horizontal  
 5 HP Tecumseh, recoil, 1/2" shaft, #6051 .. \$132  
 5 HP Briggs recoil, 1/2" shaft, #6052 ..... 132  
 8 HP Briggs recoil, 1" shaft, #6080 ..... 198  
 Vertical  
 5 HP Briggs recoil, HD fly-wheel, 1/2" shaft #7050 ..... \$145  
 8 HP Briggs recoil, 1" shaft, #7080 ..... 205  
**Save \$50 on Heavy Duty Log Splitters**  
 Sale good until 6/20/83



12 Ton Splitter ..... \$749  
 15 1/2 Ton Splitter ..... Reg \$855 **NOW \$805**  
 24 1/2 Ton Splitter ..... Reg \$1385 **NOW \$1335**

### Engine/Pump Combinations

—Includes engine, direct couple bracket, flex coupling, 2-stage pump.  
 5 HP Tecumseh & II GPM pump #8050 ..... \$265  
 5 HP Briggs & 13 GPM pump #8053 ..... 293  
 8 HP Briggs & 15 GPM pump #8030 ..... 375

### Trailer Parts

480x8 4-hole wheel & tire ..... \$24  
 570x8 wheel & tire ..... 33  
 16.5x6 5x8 wheel & tire ..... 32  
 480x12 wheel & tire ..... 36  
 530x12 wheel & tire ..... 37  
 Trailer Light Kit ..... 16  
 2000 Lb capacity sprint set ..... 24  
 High speed 4-hole hubs & spindles set is 2000 Lb capacity ..... \$37.50



## "We ship UPS, Truck & Bus" DISCOUNT CATALOG

Send \$1 for catalog filled with savings on industrial, agricultural, and energy saving supplies. Or \$6 for "Splitter Design Booklet" and catalog.

### Northern Hydraulics

Dept. 1N43 P.O. Box 1219  
 Burnsville, Minnesota 55337

Order directly from this ad!

612-894-8310



## ENGINE HOIST

(Continued from page 168)

you've never done any welding, we'd recommend you practice with scrap pieces of metal first. Most arc-welding kits come with instructions which will give you the basics. If you don't feel comfortable with this information in the booklets, look for professional advice.

When you're welding, always wear a full welder's mask, leather gloves, leather apron and long-sleeve shirt.

### Stock steel shapes used

Construction is simplified by use of steel shapes normally in stock at local steel distributors. In our case all tubing

was available at a steel tubing dealer while the plate and angle iron were purchased at an iron works outlet.

We cut pieces to size using an abrasive-wheeled cut-off saw. If you don't have access to one, have all pieces cut to size by the distributor; he'll charge you about \$1 or so per cut.

The rectangular hole in the upper base plate can either be torched out or cut by drilling 3/8-in. holes around the perimeter, then connected by sawing through with a jig saw. Final shaping can be accomplished with a file. The hole should be centered 16 1/4 in. from either end of the upper plate. Once the proper fit of the mast support in its hole

(Please turn to page 172)

## ENGINE HOIST

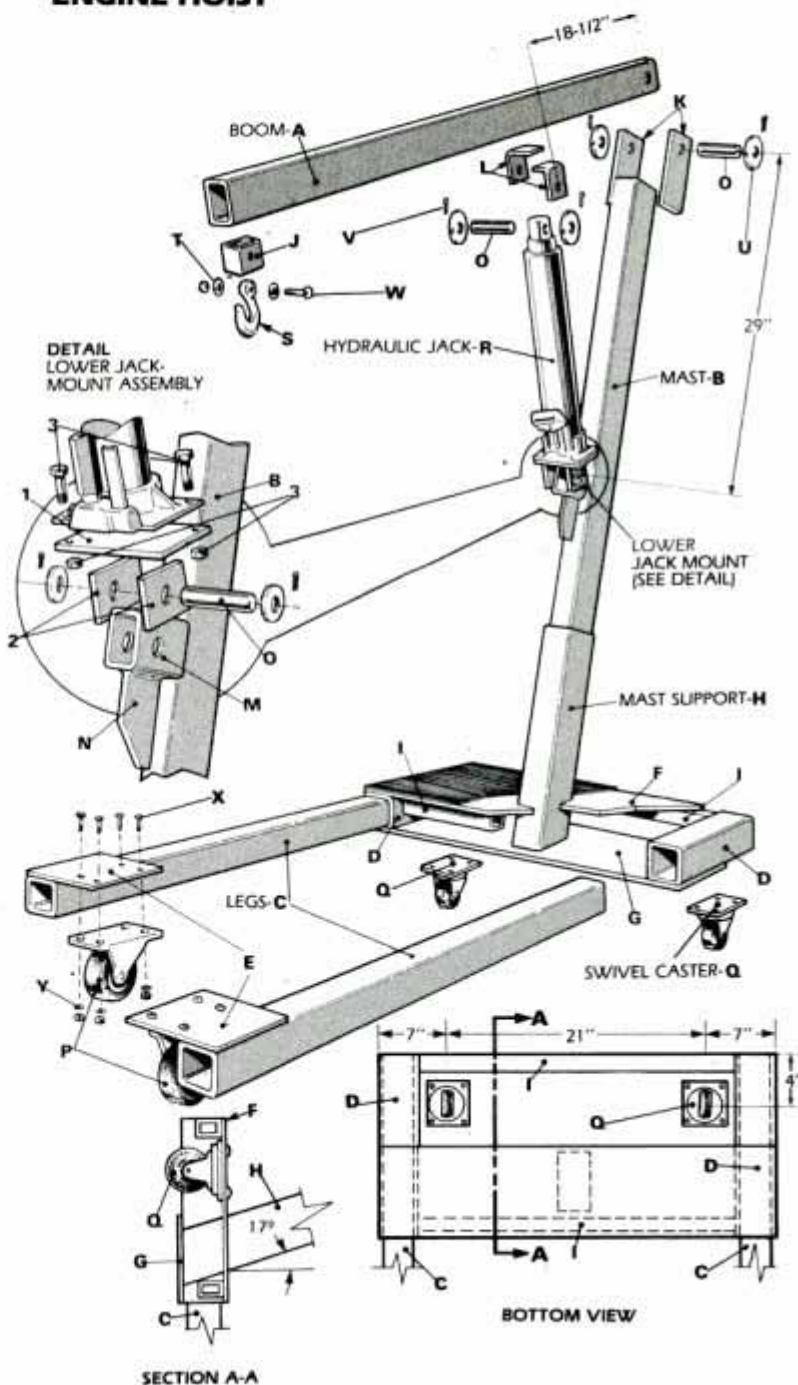



# Move over, Science-fiction writers. We're selling your secrets.

From Anywhere in the World, Listen to What's Going On  
In Your Home or Office (Without Anyone Knowing It).  
Or – Listen Right Through a Brick Wall As Though It Weren't There.  
Or – Change Your Telephone Voice So Your Own Mother  
Wouldn't Know Who's Calling.

## The "Listener"

The LISTENER is small, unobtrusive, not the kind of thing anyone would look at twice.

But plug it into any modular phone outlet and it gives you an open ear into what's going on, from any phone in the world.

Visualize this:  
You're a few blocks away and want to know if the baby is awake. Dial your number. The phone won't ring, so no sound will disturb the baby's sleep. But your "beeper" puts a signal into the line, turning on the LISTENER.



What a powerful listening device it is! The LISTENER will pick up not only a baby's whimper but water running in the tub 80 feet away.

Suppose you suspect that because you're out of town your employees are playing poker in the office at night. Call from any phone. The LISTENER will tell you. It also will tell you if a piece of equipment is operating.

If you're not invited to a meeting in your conference room, go anyway; the LISTENER will send you every word, wherever you are.

The LISTENER can save your property — and even your life. Suppose you're coming home late at night and think you see a shadow inside your home. Go to any phone and call. If there's a sound, you'll hear it. The LISTENER is your silent, hidden watchman!

Private detectives have dreamed of such an electronic eavesdropper. They want it for more exotic uses than you do, but the LISTENER will give you peace of mind you never had before. The kids said that while you're on vacation, they'll be in bed by eleven. Are they? One quick call will tell you.

### Call From Anywhere in the World

Plug the LISTENER into any modular phone plug, out of sight, and forget it until you want to use it. Carry the beeper with you. What security you'll feel, knowing you can "tune in" to your home or office whenever you like.

The complete LISTENER, including beeper, is **\$199.95**, plus \$2.50 shipping. Peace of mind is worth ten times that, don't you agree?

## The Telephone Voice Changer

It's right out of James Bond! Push a button and the VOICE CHANGER gives your voice completely different characteristics. The person on the other end of the phone won't know it's you.



The VOICE CHANGER is more than an "electronic handkerchief" — it doesn't cause your voice to sound filtered, it literally changes tone and timber.

Choose from two separate, distinct Change Channels. If you're alone in a business office, it'll sound like an employee answering. If you live alone, you can get rid of pesky calls by pushing Channel 1 or Channel 2 and saying, "Sorry, that person isn't in."

### How It Works

The VOICE CHANGER is powered by two ordinary penlight batteries. One set of lead-in wires connects to your telephone base; the other clips to the wires leading to the handset.

Pushing the button labeled "Ordinary" puts your normal voice through the line. Pushing "Channel 1" changes timber and texture. Pushing "Channel 2" creates different characteristics from Channel 1. Thus you have three voice options — your own, plus two changed voices.

MAKE NO MISTAKE! THE VOICE CHANGER DOESN'T MUFFLE YOUR VOICE OR MAKE IT UNINTELLIGIBLE. It literally changes the quality of sound — space-age electronics at work.

Use the VOICE CHANGER to reach that doctor, lawyer, or business executive whose secretary knows your voice and who always is "out" when you call. Use it to screen your own incoming calls. Use it for just plain fun. Any time you like, during a conversation, push the "Ordinary" button and your regular voice returns to the wire.

The VOICE CHANGER is yours for **\$99.95** — two for **\$89.95** each (Plus \$2.50 shipping per total order). When you consider the many uses of this brilliant electronic instrument, it's a real bargain. Of course it has the standard New Horizons guarantee.

## The Super Ear

You'll hear it all. Effortlessly, you can hear not just a baby's cries, but quiet breathing — through a concrete wall a foot thick. Put the earphone in your ear and place the SUPER-EAR on the wall. That's all there is to it.

SUPER-EAR hears everything — and, even more astounding, hears it clearly. It's as though the wall weren't there. If you're coming home late at night and think intruders are in your residence, let SUPER-EAR find out for you. Want to know if the meeting is over in the room with the closed door? SUPER-EAR will tell you in a second.



SUPER-EAR is undetectable from the other side of the wall. The quality of sound has amazing fidelity — good enough to record, and SUPER-EAR has its own built-in recorder jack.

Because SUPER-EAR is the ultimate listening device, you can use it to pinpoint hidden squeaks in your car or the source of mysterious engine noises. Construction experts use it to check for flaws or cracks in buildings.

### It Works Anywhere!

Ever put your ear to a railroad track to try to hear the train? Try it with SUPER-EAR. You'll hear that train many miles away. Use it as a powerful stethoscope on yourself, a friend, or a pet. You can even hear a bird's breathing.

The only source for SUPER-EAR is New Horizons. Choose from two models — Model SB-5, with ultrasensitive microphone, **\$139.95** (two for only **\$129.95** each); or Model SB-1, with suction-type microphone **\$99.95** (two for only **\$89.95** each).

### We Absolutely Guarantee!

Use any electronic instrument acquired from us for up to 30 days. If you decide for any reason you don't want to keep it, return it for a 100% refund.

### ORDER TOLL-FREE

For fast delivery on credit card orders, call toll-free 24 hours a day, seven days a week:

**1-800-824-7888**

Ask for Operator No. 551  
(in California, call 1-800-852-7777)

Or send check or money order.  
Please add \$2.50 per total order for shipping.

## NEW HORIZONS

1 Penn Plaza, Suite 100  
New York, NY 10119  
For information, call 201-370-8029

### \*THE LISTENER

- Electronic Security Monitor **\$199.95**  
 (two for only **\$189.95** each)

### \*THE VOICE CHANGER

- Voice "Timber" Changer **\$99.95**  
 (two for only **\$89.95** each.)

### \*THE SUPER EAR

- Through-the-Wall Microphone  
 Model SB-5 **\$139.95**  
 (two for only **\$129.95** each.)  
 Model SB-1 **\$99.95**  
 (two for only **\$89.95** each.)

### NEW HORIZONS DEPT PM41 Penn Plaza, Suite 100 • New York, NY 10119

Please add \$2.50 per total order for shipping.

I enclose:  Check  Money order

Charge my:  Visa  MasterCard

Card No. \_\_\_\_\_ Expiration date \_\_\_\_\_

Signature \_\_\_\_\_

Name \_\_\_\_\_

Address \_\_\_\_\_

City \_\_\_\_\_ State \_\_\_\_\_ Zip \_\_\_\_\_

Cut Out This Whole Ad And Mail It In!

## ✓ WHICH OF THESE WAYS TO MAKE BIG MONEY DO YOU WANT TO TRY?

(Check as Many as You Wish)

- RACK MERCHANDISING
- SWAP MEETS  FUND RAISING
- PARTY PLANS  WAGON JOBBING
- SUB-WHOLESALE
- MAIL ORDER  CATALOG SALES
- BUSINESS GIFTS  PREMIUMS

Plus 12 more exciting ways to go into BUSINESS FOR YOURSELF!

We provide complete step-by-step marketing plans for all 23 business programs. We provide more than 2,500 items of heavy-demand merchandise at below-wholesale prices for immediate delivery in all quantities

(even drop ship). We provide all the promotional material you need, including 3 different catalogs, letters, ads, business kits, etc. Everything you need to start you in business and keep you going!

**YOU DON'T RISK A PENNY!** We assure your satisfaction and business success with the strongest DOUBLE guarantee ever!

**SEND FOR FREE INFORMATION!** Discover how you can get started in a profitable new full-time business or rewarding part-time career.

**SPECIALTY MERCHANDISE CORP.**  
6061 De Soto Ave., Dept. 308-28  
Woodland Hills, CA 91365

I'd like to know more about your no-risk, low cost, guaranteed business plan.

Name \_\_\_\_\_

Address \_\_\_\_\_

City \_\_\_\_\_

State \_\_\_\_\_

Zip \_\_\_\_\_

## NEW! 3 IN 1 POWER-FEED PLANER/MOLDER JOINTER

The first affordable shop of its kind!

Now turn low cost rough lumber into valuable finished stock for grandfather clocks, furniture, house-trim, picture frames... sell to others. Molds all popular patterns & custom designs. Planes and joints without change-over. Comes complete ready to use.

30-DAY FREE TRIAL! EASY TERMS.

**PLANER FACTS & PROFITS**

**FREE INFORMATION KIT**

CALL TOLL-FREE 1(800)824-7888, Oper. 642

In Calif. 1-800-852-7777, Oper. 642

OR WRITE TO:

**WOODMASTER TOOLS, INC.**

2849 Terrace, Dept. PP21, Kansas City, MO 64108

## The "Gelding" Lock Blade

5" Length Overall - 3" Closed

- Hand-made features
- Surgical Steel Blade
- Brass Lined
- Brass Bolsters



**\$250 EA.**

Model K-24  
Add 50¢ Post. & Handl.  
Black Belt Case Available \$1.00 ea.

Just The Right Size For Cutting Or Dressing and Small Game.

Money Back Guaranteed If Not Fully Satisfied!

**WESTBURY SALES CO. DEPT. G-4PM**  
373 Maple Avenue, Westbury, New York 11590

## ENGINE HOIST

(Continued from page 170)

is determined, the upper plate can be turned over and marked for the mounting of the casters.

Our casters were placed with their centers 7 in. from the outside of the plate and 4 in. in from the rear. Since they are the ones which will steer the unit and need to turn, place them so they will not bind against the lateral or leg support. There must be a minimum

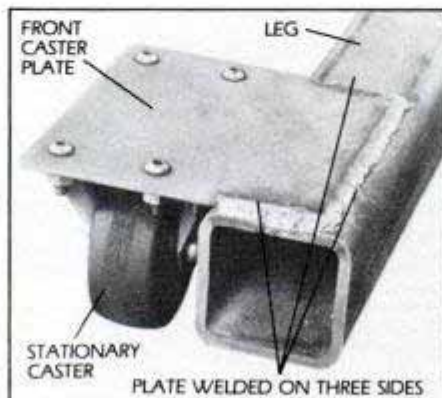

Front casters are stationary and bolted to the plate. The latter is welded to the top of the leg on all three sides.

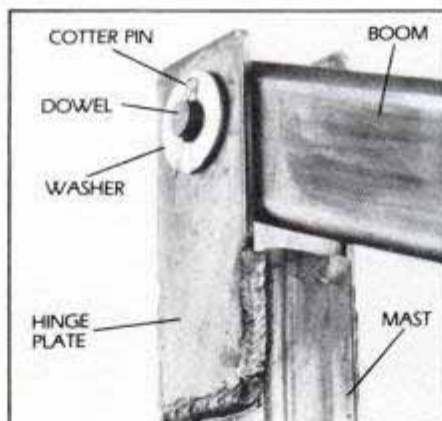

A 1/8-in. hole is drilled 1 in. from the top of each hinge plate. Hinge plates must extend at least 4 in. from top of mast.

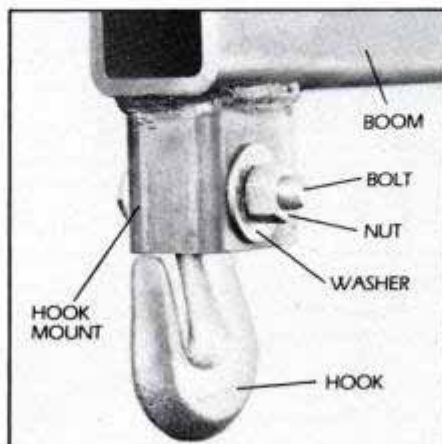

Drill a 1/8-in. hole into the hook mount and hold the hook with a 1/2-13 bolt. When fastening nut, use locking compound on nut.

caster height of 6 in.; otherwise the hoist will bottom when negotiating garage or driveway bumps.

Next, using a square, attach the lateral leg supports to the overturned upper plate with clamps and spot-weld them. Stop occasionally to check for squareness. Take into account any cutting errors.

Once the base has been spot-welded together (with the exception of the lower plate), finish the welds by extending them 2 1/2 to 3 in. long. The lower base

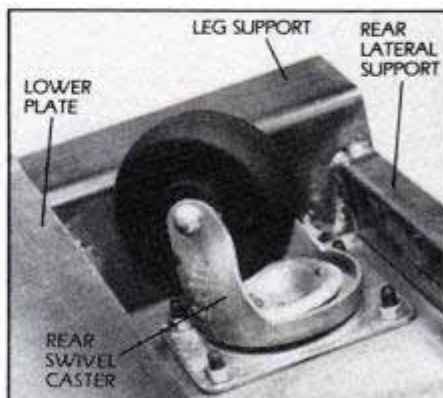

Fix the rear casters with their centers 7 in. from the outside of the plate and 4 in. from the rear. Check for binding.

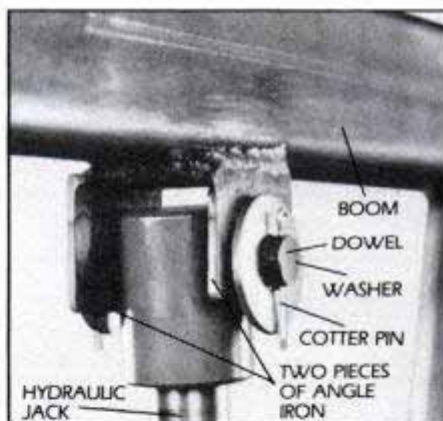

Upper jack support consists of two pieces of angle iron. After welding them, drill 1/8-in. hole and weld assembly to boom.

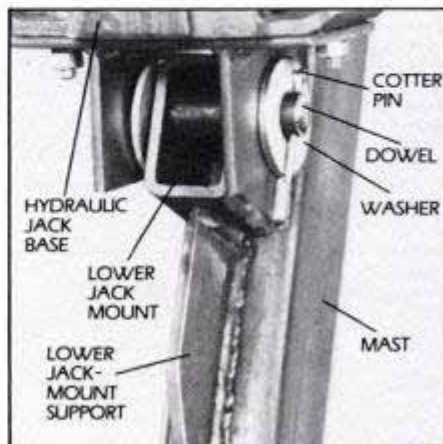

Lower jack mount is fixed 29 in. from the top of the mast. The mount support can be any piece of scrap steel plate.

plate should now be welded into place.

The mast support is placed inside its hole and slanted back for a rearward measured angle of 73° from the horizontal plane or 17° from the vertical. Make sure the support is bottomed on to the lower plate and weld the mast support's leading edge to the lower plate. Then, from the top, weld its entire perimeter to the upper plate.

Next, mark the front caster plates to be drilled for the casters. Using the caster as the template, position it as far outside as possible since the caster will be sharing the plate with the hoist leg. Then weld the caster plates on three sides to the top of the leg, and install the casters using 5/16-18 nuts and bolts.

Now move along to the boom hinge plates, lower jack-mounting bracket and upper jack-mounting point. Using a 7/8-in. hole saw, drill a hole 1 in. from the end of the lower mounting bracket through both walls (see jack detail). The boom hinge plates receive a hole 1 3/8 in. from the top and the upper jack-mounting bracket's holes are centered on the bracket. The lower jack bracket is welded 29 in. from the top. The support bracket is welded directly below it. The boom hinge plates are placed on either side, extending 4 in. beyond the top and welded on three sides.

The upper jack-mounting bracket is made up of two angle-iron plates welded together to make a U-bracket. Since this causes one side to be 1/8 in. higher, take it into consideration when drilling 7/8-in. dowel holes. The bracket is first welded together, then welded on to the boom. Its center is 18 1/2 in. from the rear of the boom. The boom receives two more modifications: First, drill a centered 7/8-in. hole 1 1/2 in. from the rear of the boom. Second, prepare the hook mount. It's drilled with a 5/8-in. drill bit through both walls. Then weld it to the end of the boom with a 1/2-13 bolt and nut to hold a hook with an eyelet in place.

After the dowels are drilled 3/32 in. from each end to accept the cotter pins, the mast can be installed into the mast support. The boom is installed into the hinge on the mast and fixed with the dowel flanked by a washer on each side locked in with the cotter pins. Install the jack using the two remaining dowels, again placing a washer and a cotter pin on each end.

Degrease the completed hoist, apply a base coat of Plasti-Kote primer and then add two coats of Plasti-Kote top coat. If you are unable to find Plasti-Kote at a local dealer, contact the firm directly at 1000 Lake Road, Medina, Ohio 44258. **FM**

#### MATERIALS LIST—ENGINE HOIST

| Key | No. | Size and description (use)                                   |
|-----|-----|--|
| A   | 1   | 2 x 3 x 60" steel tubing (boom)*                             |
| B   | 1   | 2 x 4 x 64" steel tubing (mast)*                             |
| C   | 2   | 3 x 3 x 60" steel tubing (legs)*                             |
| D   | 2   | 3 1/2 x 3 1/2 x 16" steel tubing (leg supports)**            |
| E   | 2   | 6 1/2 x 6 1/2" steel plate (front caster plates)**           |
| F   | 1   | 16 x 35" steel plate (upper plate)**                         |
| G   | 1   | 8 x 35" steel plate (lower plate)**                          |
| H   | 1   | 2 1/2 x 4 1/2 x 21" steel tubing (mast support)**            |
| I   | 2   | 1 x 2 x 29" steel tubing (front and rear lateral supports)** |
| J   | 1   | 1 1/2 x 2 x 2 1/2" steel tubing (hook mount)*                |
| K   | 2   | 3 x 7" steel plate (boom hinge plates)*                      |
| L   | 2   | 2 x 2 x 2 3/4" angle iron (upper jack-mounting point)        |
| M   | 1   | 1 1/2 x 2 1/2" steel tubing (lower jack-mounting point)*     |
| N   | 1   | 2 x 4" steel plate (lower jack-mounting point support)*      |
| O   | 3   | 3/4"-dia. x 3 1/4" round steel rod pivot                     |
| P   | 2   | 6" high stationary casters                                   |
| Q   | 2   | 6" high swivel casters                                       |
| R   | 1   | 24" Blackhawk hydraulic jack                                 |
| S   | 1   | 4 1/2" x 2 1/2" x 3/4", 1/2"-hole-size hook                  |
| T   | 2   | 1/2" washers   |
| U   | 6   | 3/4" washers   |
| V   | 6   | 2" cotter pins   |
| W   | 1   | 1/2"-13 bolt 2 1/2" long, and nut                            |
| X   | 16  | 5/16 x 3/4 x 18 button Allen-head screws and nuts            |
| Y   | 16  | 5/16" lock washers   |

\*1/4" wall thickness      \*\*3/16" wall thickness

Parts 1, 2 and 3 come preassembled with the Blackhawk hydraulic jack unit; thus, they're not listed in our materials list and no assembly instructions are given. The jack is available from Metro Hydraulic Jack Co. of N.J., 52 Elm St., Newark, N.J. 07105—telephone (201) 589-4663. When ordering, use part No. 960-00003-109. It's \$158.50.

**MAKE EXTRA \$\$\$ EVERY DAY!**  
Get into the big, year-round  
**EXTRA MONEY BUSINESS**  
that's EASY to learn—EASY to do—  
and EASY ON YOU!

**Be a LOCKSMITH!**

You Can Make Up to \$12.50 an Hour  
—even while learning! Train FAST at Home!

Never before have money-making opportunities been so great for qualified Locksmiths. Now lucrative regular lock and key business has multiplied a thousandfold as millions seek more protection against zooming crime. Yet there's only one Locksmith for every 17,000 people!

Start Collecting CASH PROFITS Right Away

You're "in business" ready to earn \$5 to \$12.50 an hour a few days after you begin Foley-Belsaw's shortcut training. Take advantage of today's unprecedented opportunities in locksmithing for year-round EXTRA INCOME in spare time — or fulltime in a high-profit business of your own. Hundreds we've trained have done

**THIS PRO  
KEY MACHINE  
YOURS TO KEEP**

can add \$25 to \$40 a week to your income... and it won't cost you a cent with your training!

**ALL TOOLS, MATERIALS AND PRACTICE  
EQUIPMENT COME TO YOU WITH YOUR COURSE.**

POPULAR MECHANICS • APRIL 1983



**FREE**  
KEYS TO YOUR FUTURE  
Tells how to make money in Locksmithing almost from the start!

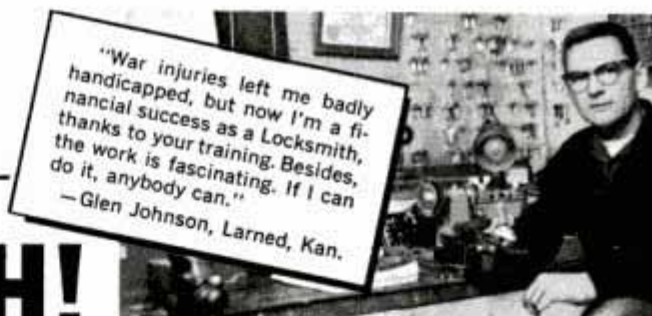

it. So can YOU! All tools plus professional Key Machine given you with course. These plus practice materials and equipment, plus simple, illustrated lessons, plus expert supervision, plus business-building guidance will enable you to KEEP THE MONEY COMING IN! Ideal for retirement — good jobs, too.

**SEND FOR EXCITING FACTS—No Obligation**

Discover what's in Locksmithing for you — how Foley-Belsaw's master-locksmith-approved training can give you the skill you can depend on to EARN MORE — ENJOY LIFE MORE. Just fill in and mail the coupon below to receive full information by return mail. Do it TODAY!

FOLEY-BELSAW INSTITUTE, 10189 Field Bldg., Kansas City, Mo. 64111

**MAIL THIS COUPON—NO SALESMAN WILL CALL**

FOLEY-BELSAW INSTITUTE, 10189 Field Bldg.  
Kansas City, Missouri 64111



Please send me free of cost or obligation your publication "Keys to Your Future" on how Foley-Belsaw can quickly train me to make money in Locksmithing and how all tools and Key Machine are given me to keep.

Name \_\_\_\_\_

Address \_\_\_\_\_

City \_\_\_\_\_ State \_\_\_\_\_ Zip \_\_\_\_\_

## LONG LIVE THE HMMWV

(Continued from page 91)

will be quickly convertible to three different configurations—weapons carrier, utility vehicle and field ambulance. Within these categories, still more variations are possible. Three ambulance versions will carry from four to eight litter patients and in their smaller modes will be readily transportable by helicopter (as will most of the combat-support configurations).

In its utility role, the Humvee will haul troops, cargo and communications gear, carry out front-line reconnaissance patrols, function as a mobile command post and—like its predecessor—may occasionally serve as a refuge for certain extracurricular GI activities involving the opposite sex.

### Deadly firepower

As an attack vehicle, the Humvee will carry a potent mix of weapons ranging from machine guns and grenade launchers to the deadly TOW anti-tank missile. A clever pop-up gun turret and ballistic-resistant armored shell provide crew protection in combat, allowing it to pursue an enemy far more aggressively than the exposed, open-top jeep ever could. It can even mount the Hellfire missile, an advanced, laser-guided antitank weapon, normally air-launched from helicopter gunships, that actually has more range and striking power than the TOW missile system.

The Humvee is so versatile, in fact, that it will eventually replace not only the jeep, but also the ½-ton M274 Mule and the big six-wheel-drive, 1¼-ton M561 Gama Goat, both, like the jeep, well past their prime. The Humvee will thus take over the roles of three tactical vehicles ranging in capacity all the way from ¼ to 1¼ tons. The result will be standardization of parts, reduced maintenance costs, easier battlefield service, and greater operational availability.

### Three-way competition

To obtain competitive bids for the Humvee, the Army's Tank-Automotive Command (TACOM) selected three prominent manufacturers of military equipment—AMC's AM General Div., maker of both Army jeeps and American Motors' commercial Jeep; Teledyne Continental Motors; and General Dynamics, which recently acquired Chrysler Corp.'s prestigious Chrysler Defense Div. Each of the three came up with its own version of the Humvee and submitted 11 prototypes to TACOM for testing and evaluation early last year.

To the victor will go a lucrative contract for the production of as many as 50,000 Humvees over the next five years, with a potential of many thou-

sands more well into the next decade. By the time you read this, the winner should be known, or soon will be. AM General, incidentally, has already coined a name for its entry—it's the Hummer, an eminently more appealing moniker than either Humvee or the unpronounceable HMMWV.

### Stiff Army requirements

Whichever is chosen, all three entries will be basically similar in many respects in order to meet stiff requirements established by the Army. In addition to the capabilities already noted, the new jeep of the future must accelerate from zero to 30 mph in 6 to 8 seconds, maintain a top speed of 60 mph on the highway and 40 mph off-road, climb a 60-percent (54°) grade, operate on a 40-percent side slope without slipping or tipping, and have a cruising range of 300 miles. It must be

able to climb over obstacles 18 to 22 inches high and ford streams up to 30 inches deep (60 inches deep with an added engine-breather kit).

### Automatic transmission

Unlike the jeep, its successor will have a diesel engine and—of all things—an automatic transmission. The latter is not for luxury. The Army's reasoning: Most of today's teen-agers have learned to drive in cars with automatic transmissions. An automatic-shift Humvee will thus be more familiar and easier to handle, while also saving expensive repairs on certain-to-be-abused manual gearshifts and clutches.

While the jeep depended solely on its agility for survival, the Humvee specs call for ballistic protection from 16-grain fragments traveling at 1,400 ft./sec.—enough to stop some small arms

## The Legendary Jeep: A Hard Act To Follow

The jeep came into being in 1940, born of a need for a new breed of mechanized packhorse that could carry men and messages to the front lines with speed and agility and not necessarily with the benefit of roads. The motorcycles of WWI, with their quaint little sidecars, had proven woefully inadequate in the mud, sand, snow and shell holes that wars are inevitably fought in. It was time for something better.

As in the current competition for the new Humvee, there were three contenders for the jeep title—Ford, American Bantam and Willys-Overland. The Ford and Bantam entries were judged underpowered and Willys emerged the victor (though Ford was given a contract to share the production and some Bantam vehicles were also used).

Officially, the jeep was a command/reconnaissance car, but in practice it became whatever an enterprising dog-face could make it. It mounted machine guns, chased tanks with bazookas, ferried troops into battle and the wounded back out, and was occasionally pressed into service to forage for beer and friendly *Frauleins*.

Although primitive, even by the standards of its own day, it had a 60-hp, four-cylinder engine, four-wheel drive with synchromesh transmission, high ground clearance and a bone-jarring but virtually unbreakable suspension—a combination that managed to get it most of the places it had to go.

An incredible number of the scrappy little 4×4s—more than 600,000—were produced during World War II. They saw



A jeep under fire in North Africa early in WWII.

action in every theater, from the desert sands of North Africa and the quagmires of Europe to the frozen wastes of Russia and the steamy jungles of Pacific atolls, ultimately jerking and jouncing their way into the hearts of GIs throughout the world.

The origin of the jeep name is still disputed. Some say it came from a comic strip character called Eugene the Jeep, a creature endowed with extraordinary powers. Both Willys and Bantam insisted they coined it, and Willys later commandeered it as a proprietary trade name, spelling it with a capital J. The Army, however, not one to be caught in the crossfire of public controversy, has diplomatically maintained that "jeep" is merely the natural spoken sound for the acronym GP, standing for general-purpose vehicle.

However it got its name, the immortal jeep has been a cherished American legend for more than 40 years. For the fledgling Humvee, it will be a hard act to follow.—S.G.

fire and shrapnel. The Humvee will also have an explosion-proof fuel tank and so-called "run-flat" tires designed to provide emergency support even when ruptured.

Despite their enforced similarity, the competing Humvees do differ in some significant and surprising ways. General Dynamics, for instance, is pinning its hopes on an air-cooled diesel, while the other two use liquid cooling. GD's argument: 30 to 40 percent of all engine-related breakdowns in combat are caused by failures in the complex plumbing of a liquid-cooling system. An air-cooled engine, GD claims, would be free of such problems and would operate in temperature extremes from desert heat to arctic cold without supplementary equipment.

### The powerplants

The General Dynamics diesel is a 160-hp, 400-cu.-in. Deutz V8, a German design made in Canada. AM General's Hummer uses a 130-hp, 378-cu.-in. V8 diesel from Chevrolet, while Teledyne has adopted International Harvester's 170-hp, 420-cu.-in. V8 diesel.

All three transmissions are stock three-speed automatics with dual-range transfer cases, with one notable difference: Both AM General and Gen-

eral Dynamics have full-time four-wheel drive, while Teledyne's is selective. The two-wheel-drive option, claims Teledyne, improves gas mileage and reduces drive-train wear on good road surfaces where 4wd is not needed. All three manufacturers offer power steering and braking.

### The high/low problem

While high ground clearance and a low silhouette are both major needs in an off-road combat vehicle, the two obviously work against each other: How do you design a vehicle that's both high and low at the same time? AM General attacks the problem in a novel way. The wheels on its Hummer are driven at the rim rather than the hub. A ring gear around the rim engages a pinion gear on the axle at the top of the wheel. This means that the axle is 4 inches above the wheel hub, which provides both high ground clearance—a full 16 inches—and low overall height. The Hummer also has independent coil-spring suspension all around.

Both General Dynamics and Teledyne favor a more conventional layout, contending that the reliability of a proven drive arrangement outweighs the advantages gained through the use of an unorthodox approach. General Dynamics has independent coil-spring

suspension in front, but a solid rear axle, maintaining that high ground clearance between axles is more important than clearance between opposing wheels.

Teledyne has independent suspension on all four wheels, controlled by a unique variable-rate torsion-bar system that's designed to provide a soft ride under light loads and a stiffer, more stable ride under heavy loads. Although the manufacturers arrive at it in different ways, all three contenders meet the Army's maximum height allowance of 69 inches, which is 2 inches less than the classic jeep's profile.

### More for the money

Whoever builds it, the new Humvee will cost an estimated \$27,000 per copy—not an exorbitant price when you consider all the things it can do compared to its far more primitive predecessor. (Just to replicate the current jeep as it stands would cost a hefty \$15,000 per copy.)

While the Humvee may never have an opportunity to match the fame and glory of the immortal World War II jeep, if the vehicle is half as durable and half as well-loved, it could turn out to be a bargain at almost any price. **PM**

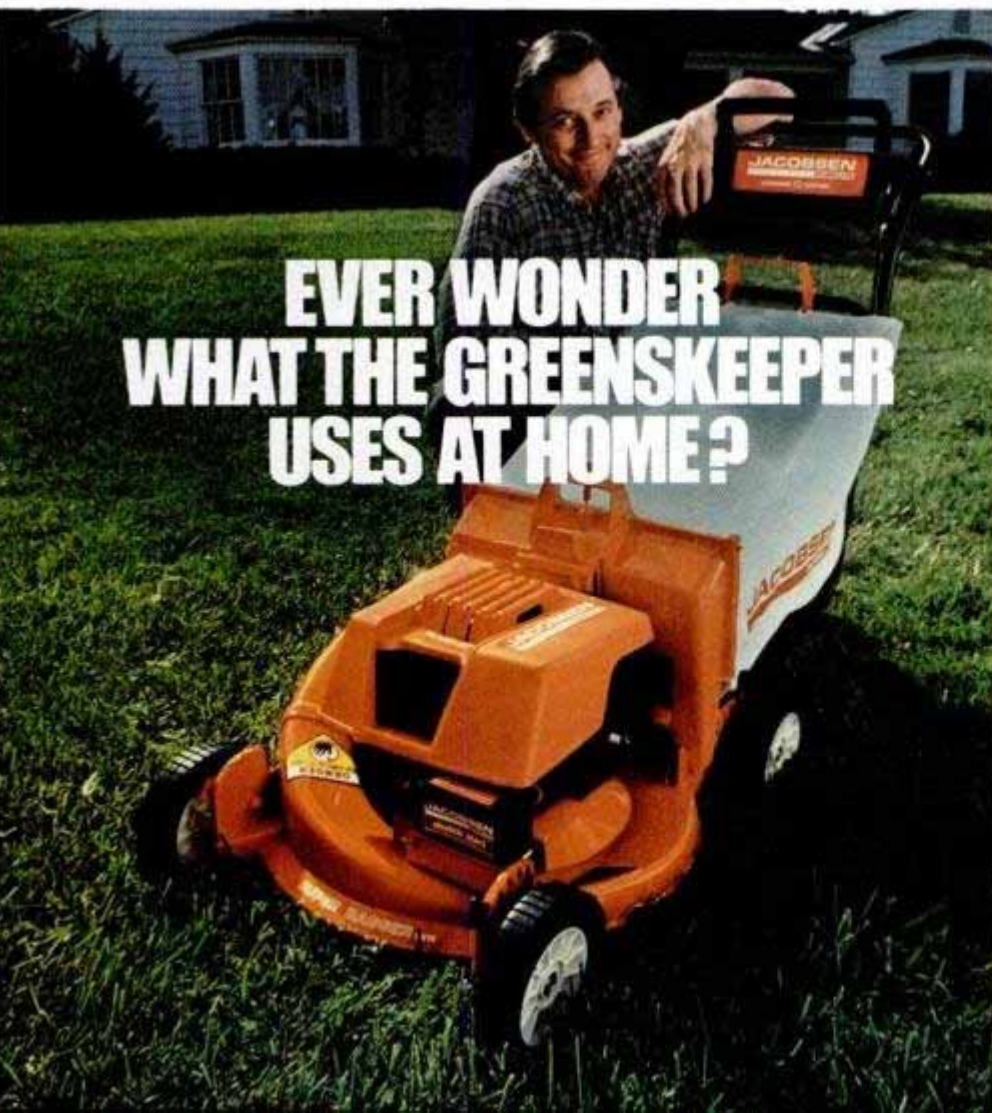

If he wants to give his lawn the same professional touch he gives his golf course, he probably uses a Jacobsen® Super Bagger™ power mower.

The Super Bagger's high-vacuum action stands up uncut grass for a close, even cut that's adjustable to within fractions of an inch. The new professional-style Command Control™ System puts all the operating controls on the handle for convenient fingertip access. The super-large 3-bushel rear catcher is zipperless for quick, easy emptying. And, like all Jacobsen walk-behind mowers, it complies with latest CPSC safety standards.

The Jacobsen Super Bagger. The power mower for perfectionists who want to mow like a pro.

**NOBODY DOES THE JOB  
AROUND THE HOME OR FARM LIKE  
HOMELITE/JACOBSEN.**



**HOMELITE/TEXTRON**

Homelite Division of Textron Inc.

Материал, защищенный авторским правом

## DRIVING FORDS

(Continued from page 97)

add a central console with additional storage. A larger optional console adds a covered bin and a graphic warning module—or the gauges (unfortunately, you can't have both).

The base bucket seats, which are otherwise fairly nice in both shape and appearance, don't recline; the optional highline seats are excellent, and they do.

Exclusive to the Tempo/Topaz is a new 2.3-liter, pushrod, four-cylinder engine—a distant relative of Ford's 3.3-liter Six (same bore centers), but no relation to the overhead-cam 2.3 that's been around for years. It's short and compact for transverse mounting and about as conventional as a carpenter's claw hammer below the head gasket. The block and head are iron, but the intake manifold, water pump and front



Ford's Bronco II will go against Chevy's mini-Blazer. It'll be available in 4x4.

cover are aluminum. The most innovative uses of lightweight material, however, are a die-cast aluminum oilpan and an aluminum radiator with plastic end caps.

What engine trickery exists is primarily in cylinder-head and combustion-chamber design, plus state-of-the-art electronic control. Using techniques adapted from their PROCOC (Programmed Combustion) research work of a few years back, Ford's engine engineers have come up with special intake valve shrouds to impart swirl to the fuel/air charge as it enters the chamber. This swirling motion (around a centrally located sparkplug) continues through the compression and ignition stages, creating a highly efficient fast-burn condition without detonation at the relatively high compression ratio of 9.0 to 1. The bottom line is impressive economy with respectable performance, the latter coming more from a hefty 125 ft.-lb. of torque at 2,700 rpm than from the engine's mediocre 90 hp at 4,700.

With their standard four-speed manual "FS" (Fuel Saver) transaxle, the Tempo and Topaz are EPA rated at an estimated 28 mpg city and 43 highway. The optional close-ratio five-speed delivers 26/41 mpg EPA economy, and the available three-speed automatic gives 25/35 (preliminary estimates). The five-speed, incidentally—built by

Toyo Kogyo of Japan to a Ford design—has excellent shift feel and quality. It does need a stronger detent or a lift ring to avoid your getting into the reverse slot by mistake when looking for first or downshifting to second in a hurry.

Control of the engine, sensing of its operating parameters and built-in service diagnostics are all handled by Ford's most powerful car computer yet, EEC IV. This fourth-generation electronic engine control does everything from sniff oxygen content in the exhaust (to maintain the proper fuel-air mixture at the electronically controlled two-barrel carburetor) to adjust idle speed according to accessory load and compensate for friction changes and wear as the engine ages. It also stores any malfunction in the memory for later diagnosis by a technician.

Front suspension is a fairly standard MacPherson strut arrangement with the spring axis offset from the strut shocks for reduced friction. A stabilizer bar is standard; the "scrub" radius is negative for braking and steering stability on uneven-traction surfaces, and a combination of unequal-length steering arms, increased left-wheel camber and a special torque tube in the right-side driveshaft eliminates most of the usual fwd torque steer.

Rear suspension is fully independent, also with MacPherson struts, with each strut located by two parallel transverse arms and a fore-aft tie rod. This system is new for Ford in this country, and it works exceedingly well, minimizing geometry changes for excellent handling while sponging up road shocks and bumps through specially designed bushings.

The dual-circuit brake system is split diagonally—one (low-drag) front disc and the opposite rear drum will operate

if one circuit fails—and the quick-fill master cylinder gives fast response. Steering is rack-and-pinion, with optional power assist. The parking brake lever is tunnel-mounted and uses a low-friction, self-cleaning cable. Tires are all-season, low-rolling-resistance, steel-belted radials individually indexed to their wheels for optimum balance.

The unitized body is rust-protected, and even the car's door hinges and weather stripping are specially designed for a "luxury-car quality door-closing sound." Among the more interesting options are an antitheft alarm system, remote-control rear quarter windows, power-adjusted outside mirrors, a Class I (light-duty) towing package and a "TR" handling package with Michelin TRX tires on cast-aluminum wheels.

In other words, Ford's Tempo/Topaz designers, engineers and planners have done their homework well. Unlike the smaller Escort/Lynx series, which have matured and improved tremendously since their somewhat disappointing '81 introduction (and with which they share only a few components and some interior sheet metal), the Tempo and Topaz seem correct and complete right out of the box.

While the Tempo/Topaz twins aren't as technically sophisticated as their distant relative, the Sierra (see *Firsthand Report: Driving The European Ford Sierra*, page 81), they're more than competent enough to deal with the American market competition. They deliver respectable performance with excellent economy, room and comfort for their size. With all that, plus handsome looks and prices expected to start well below \$7,000, they can't lose.

### T-Bird Turbo Coupe

While the '84 Tempo and Topaz are handsome but practical, Ford's new

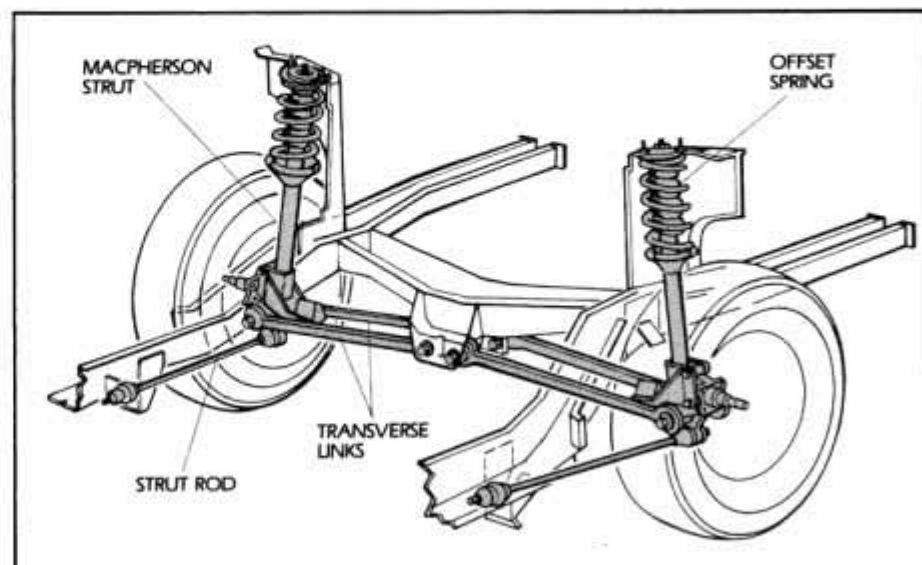

The rear suspension for the Tempo/Topaz is located laterally by parallel transverse links and longitudinally by strut rods. This kind of a setup is called Quadralink.

Thunderbird Turbo Coupe is pure driving excitement.

First, the Turbo Coupe is motivated very smartly (about nine seconds 0-60) by a 145-hp, turbocharged, fuel-injected, 2.3-liter Four bolted to the same close-ratio Borg Warner five-speed that sits behind the Mustang/Capri 5.0-liter HO V8.

Second, the car is supported by a specially tuned performance version of the T-Bird/Cougar gas-shock suspension, complete with a 15 to 1 fast-ratio power steering gear, standard rear sway bar, Traction-Lok differential and twin horizontal dampers to control rear axle movement during acceleration, braking, cornering and transitional maneuvers.

On the outside, it's identified by blacked-out headlamp bezels, twin recessed fog lamps, P205/70HR14 Good-year Eagle blackwall tires on special "Swiss cheese" aluminum wheels and wide, black side moldings that mate with matching bumper rub strips to completely encircle the body. Inside are contoured, articulated bucket seats with five different manual adjustments including a Toyota-like inflatable lumbar support. Dual electric remote-control mirrors, a leather-wrapped sport steering wheel and a digital electronic clock are standard.

Only the Thunderbird's pedestrian instrument panel will disappoint the serious driver at which this automobile is aimed: it's brush-finished black (not wood grain, thankfully) in the Turbo Coupe but has no provision for gauges.

There is a tachometer, but everything else a driver would like to know about the sophisticated engine's sta-



*The top-of-the-line XLS Bronco II comes with huge tires and some flashy visuals.*

tus—including turbo boost—is handled by idiot lights.

That one complaint aside, driving the Turbo Coupe is a revelation. Forget everything you ever heard about the noisy, shaky, limp-wristed Turbo 2.3 that found its way into a handful of Mustangs and Capris a few years ago. This one uses the same basic overhead-cam Four as a starting point, but the similarity ends there. It's a blow-

through system, boosted before the throttle to minimize lag, with multiport injection and EEC IV sensing and control, and it flat flies!

Because it's considerably lighter than a V8, the turbo engine puts less weight on the front wheels, reducing understeer and making the Turbo Coupe the best-handling Ford product we've driven in many, many years. For those who care, the Turbo Coupe is EPA rated at an estimated 21 mpg city, 33 highway and the car seems a performance bargain at \$11,790. And the Turbo Coupe's very impressive high-tech engine will also be available in Turbo Mustangs and Capris.

## Bronco II

Equally impressive in its own way is the new Ranger-based Bronco II, which features optional automatic-locking 4wd hubs, standard V6 power (with EEC IV) and a choice of five-speed manual or three-speed automatic transmission.

The Bronco II is broad-shouldered, hairy-chested handsome, rides and handles surprisingly well and slogs through mud and snow like a pro. In other words, it's fully competitive with Chevy's S-10 Blazer and GMC's S-15 Jimmy—as the compact truck wars get hotter still.

PM

**THANKS TO HOMELITE/JACOBSEN ENGINEERING, THE RMX™ RIDER WON'T TAKE YOU FOR ONE.**

Responsive rack and pinion steering.

Quick, effortless fingertip deck height adjustment.

Optional rear catcher—supports standard trash can.

High vacuum through-the-deck discharge system.

PACE COMMAND drive control—for simple "no hands" shifting.

It's amazing how many riding mowers are little more than lawn mowers with seats.

The Jacobsen® RMX™ Riding Mower, on the other hand, is a heavy-duty mowing machine, engineered for years and years of trouble-free service. With advanced design features that are inexcusably absent on other riders—easy-to-use features that help you get the big jobs done in a hurry, and in comfort.

Like the unique optional rear catcher that supports any standard round trash can, so clippings can be conveniently discharged directly into your trash can liner. And the innovative through-the-deck discharge system that even picks up pine needles and leaves.

Compare the RMX with other riding mowers on the market. In fact, test drive it! You'll see why it's earned its reputation as the most machine for the money.

**NOBODY DOES THE JOB AROUND THE HOME OR FARM LIKE HOMELITE/JACOBSEN.**

**HOMELITE  
JACOBSEN**

**HOMELITE/TEXTRON**  
Homelite Division of Textron Inc.

Материал, защищенный авторскими правами

## DRIVING MERCEDES, BMW

(Continued from page 105)

of this car. The European engine has been very responsive to the throttle in all your tests, revving smoothly to the redline and feeling like it's producing more than its 90 rated hp in fuel-injected trim. Even the carbureted version has performed well. You've already pushed a 190E to a top speed of 200 km/h (124 mph) on a closed-off stretch of test road and the engine felt ready to do it again and again. It was



Interior of 190 is characteristically M-B and is roomy despite interior downsizing.

just as at home cruising at 55 mph.

There's no question that buyers will like the handling and road feel. Daimler-Benz engineers examined 70 different rear-suspension systems before they decided to design their own. This new system gives the 190 ride and handling as good as or better than any other Mercedes. And that's saying something. The suspension has five links to control wheel movement, along with coil springs, gas-pressurized tubular shock absorbers and an antiroll stabilizer bar. Unlike other independent rear suspensions, this five-link setup will not toe in or out when loadings change abruptly, which is what causes the phenomenon known as trailing-throttle oversteer. In layman's terms, it means the rear spins around on you if you suddenly lift off the gas in a turn.

### Safe and unflappable

You've already tried to flap the 190 on all kinds of country roads—flat, bumpy, turns with bumps, hills, potholed and chucked dirt paths. It has remained unflappable. In fact, because of its inherent stability, this could be one of the safest cars ever built. You can do really stupid things in this car and not hurt yourself. The car's handling is so good that you don't have to be a good driver to look like one. Of course, if you are a good driver, you can use this car to its limits—and yours—

and really have a good time. In the event that you go too far and exceed the car's—or your—limits, it's nice to know that the 190 is one of the most crashworthy cars ever built. The structure of the car is designed from the ground up to deform in a controlled way, thereby managing the kinetic energy of a crash in a manner least harmful to passengers.

In addition to the handling capability built into the suspension, Daimler-Benz engineers also dialed in antidive and antisquat geometry. Combined with a fairly conventional modified MacPherson strut front suspension (with the spring mounted on the control arm), the 190 gives its passengers an incredibly smooth, big-Mercedes ride.

Backing up the engine is a plethora of transmission selections—a four-speed stick, five-speed stick and a really trick two-mode, four-speed automatic. In the S-mode, the transmission allows you to make full use of power reserves and shifts through all four gears in a conventional manner. In the E-mode, the transmission starts in second rather than first on rollaway, and the upshifts are made at lower speeds. This gives more economical operation and is really handy on slippery roads. Out of character, though, is the fact that of the four stick shift cars you've driven, all four have had loose, sloppy shift linkages.

Steering is conventional Mercedes-Benz, meaning manual recirculating ball with power assist optional. It's curious that a leading-edge technology company like Daimler-Benz should still use a steering system considered archaic in many circles. Yet, their engineers claim it's simply better than a rack-and-pinion system.



New suspension design has cured BMW of most of its trailing-throttle oversteer. Spoiler is only on European models.

Standard tire is a 175/70R14 on a 5x14 wheel. Brakes are power-assisted discs at all four corners. In Europe, the excellent antiskid ABS brake system is optional. Too bad they don't offer it on U.S. versions. Still, the standard four-wheel disc system is as good as you'll find.

You wonder why Daimler-Benz engineers didn't go to front-wheel drive on their small sedan. The engineers have told you the previous evening that there were several reasons. When the steer-

ing and driving wheels are separate, it's easier to tune suspension components. And ride and handling were among the prime considerations in the development of this car. It's also easier to fit different engines into a rear-wheel-drive package, and this car will be fitted with several different engines in different parts of the world. Additionally, they've told you, simply put, that in this size and weight of car, rear drive is superior. And who will argue with a Daimler-Benz engineer?

### Significant differences

Yes, this new Mercedes-Benz is different. And the biggest difference of all is that it's small. Not cheap. Just small. The executives you've met with here in Spain have made it very clear that they had no intention of building a cheap Mercedes, just a smaller one. So forget all the rumors about a \$10,000 Mercedes. It just ain't gonna happen.

What has happened is that the engineers at Daimler-Benz recognized that the forces of conservatism had to affect even the mighty three-pointed star and its customers. And so they took their customary seven years and developed a fine, small automobile. At a price.

Externally, the car bears a strong resemblance to the newer S-class Mercedes sedans. The same attention to aerodynamic detail is evident wherever you look, from the laid-back windshield to the partial bellypans covering the underside of the chassis, to the clipped-in rear end. In fact, the 190 sports one of the lowest coefficients of drag ever recorded for a production sedan—0.33. Clean aerodynamics helps fuel economy which, naturally, was a consideration in building this car.

Dimensionally, the W201 (its engineering designation) sits on a 105-in. wheelbase and is just over 174-in. long. Curb weight is 2,375 pounds. That's 12 in. shorter and about 600 pounds lighter than the 300D and 22.6 in. shorter and a whopping 1,000 pounds lighter than the large S-class sedans. Yet, the car is a full four-door model (only) and the front seats are virtually the same size as those on larger Mercedes-Benz models. Interior seating comfort is excellent for four, tight in the back for five.

### Fuel mileage

But you don't buy a car like this for hauling passengers and freight, so you don't expect room for eight. What you do expect is high fuel mileage. The engineers have told you that, in tests, the European version of the car has scored between 24 and 27 mpg on the highway. On the European urban mpg cycle, the 190 racked up 22.8 mpg.

Like other Mercedes-Benz models, the company expects to sell all the 190s



(220s) they export to the United States. And like other Mercedes-Benz models, most of these outrageously priced \$24,000 compacts will be sold to people who don't know a thing about the car's engineering, about its handling, its stability, its acceleration, or its braking prowess. And they couldn't care less. All they know is that they're driving a Mercedes that costs \$24,000.

And right now, you don't care either. You've got a 100-mile drive ahead of you from Cadiz on the coast up to Jerez. The road is flat and smooth and traffic-free. You'll be there in an hour.

Wonder what the poor people are doing today?—Joe Oldham

## BMW 318i

Success is tough to handle. Take BMW, for example. Sixteen years ago, they invented the sports sedan—a boxy, inexpensive two-door that could handily outperform any small sports car, but carry four passengers and their luggage all the while. This 2002 established a whole new market segment, of which BMW was the acknowledged standard of excellence.

The 2002 was followed in turn by the 320i, which was more of the same in a rounder, softer package. The 320i nev-

er became a cult car like the 2002, but it did capture an even larger market share among the upwardly mobile doctor/lawyer/accountant types who had outgrown their Cutlass Supremes, but weren't quite ready for a Mercedes. BMW sales soared even as other car companies headed for bankruptcy.

This wonderful success is now BMW's biggest liability. To be blunt, the company is scared to tamper with the formula which has been so good to them for so long. Which brings us to the third generation of BMW's small sports sedan, the 1983 318i. Unless you're a BMW zealot with foam-flecked lips, you'll scarcely be able to tell the new car and the old one apart.

Which, of course, is deliberate on the part of BMW director Dr. Ing. Rademacher. In his view, BMW is much better off to keep building conservative, rear-wheel-drive sedans, rather than break new ground with a sleekly aerodynamic body, advanced front-wheel drive or state-of-the-art electronics. There are no fads at BMW.

## No alienation

That isn't to say there aren't improvements. There are no carryover parts on the new 318i except the basic engine/transmission. Even though the body looks nearly identical to the old

320i, every panel is new. Slightly more rounded contours have reduced aerodynamic drag to 0.38 Cd, which is not particularly low for an all-new sedan, circa 1983. Still, the new body easily accomplishes what must have been Dr. Rademacher's main purpose—not to alienate the traditional BMW buyer.

Hidden under this blunt box are new front and rear suspensions. The front MacPherson struts look pretty conventional, but they're designed to induce a slight amount of understeer in hard cornering. This allows an independent rear suspension with considerably less camber change than the old one. And that means, for the first time ever, the little BMW doesn't try to lift the inside rear wheel in the midst of a corner. Hallelujah!

## Hidden differences

Even a loyal BMW enthusiast will have a hard time spotting the interior differences on the new car. There are nearly 2 inches more rear legroom, a little more headroom and elbowroom, but rear passenger space is still limited. The front passengers, however, will be a happy pair. The all-new dash looks just like the old one, which is to say there aren't as many gauges as an enthusiast might desire. But otherwise,

*(Please turn to page 180)*

**THE BLOWER ATTACHMENT  
WE GIVE YOU FREE,  
OTHER STRING TRIMMERS  
DON'T OFFER AT ANY PRICE.**

With its free blower attachment, the Homelite® ST-120 string trimmer can be quickly converted into a powerful clean-up tool that blows away grass clippings and leaves with a big 100-mph wind velocity. Take the blower attachment off, and the ST-120 converts back into a rugged string trimmer featuring automatic string advance, a wide 20-inch cutting swath, and built-in



vibration isolation to reduce fatigue. What's more, all Homelite gasoline-powered string trimmers now come with the only 2-year warranty in the industry.

**NOBODY DOES THE JOB  
AROUND THE  
HOME OR FARM LIKE  
HOMELITE/JACOBSEN.**

**HOMELITE  
JACOBSEN**

The free blower attachment comes packaged with the ST-120, and is available for models ST-100 and ST-200 with this coupon.

**HOMELITE TEXTRON**  
Homelite Division of Textron Inc.

**FREE! HOMELITE® Power Blower Attachment**  
**\$21.95 VALUE** with proof of purchase and \$2 to cover postage & handling.

To receive your FREE Power Blower Attachment, fill in your name, address and the serial number of your new ST-100 or ST-200 string trimmer on this coupon, and send it together with proof of purchase (sales receipt or register tape) and \$2.00 (check or money order only) to cover cost of postage & handling, to: The Homelite Power Blower Offer, P.O. Box 631, Newell, NC 28126.

Name \_\_\_\_\_

Address \_\_\_\_\_ Apt \_\_\_\_\_

City \_\_\_\_\_ State ZIP \_\_\_\_\_

String Trimmer Serial Number \_\_\_\_\_

Limit 1 free blower attachment per address. Void where prohibited, licensed, restricted, or taxed. Employees of Homelite, Coresco, licensed retailers and distributors are not eligible. Please allow 4-6 weeks for delivery. Coupons reproduced by mechanical means are not acceptable. Free blower attachment requests must be postmarked no later than expiration date, June 30, 1993.

## MARINE SURPLUS SALE

# NOTICE!!!

## SEA & FIELD BINOCULARS

— (all in original cases) —  
**50 MILE RANGE—  
Only \$9 a pair**

will be offered to the public  
starting midnight tonight!

**FEATURE SUPER 7 × 50 LENSES—IDEAL FOR NIGHT  
VIEWING SO POWERFUL YOU CAN ACTUALLY TELL  
TIME ON A CLOCK A FULL MILE AWAY!**

**S**tarting midnight tonight, Marine Surplus Depot will accept orders directly from the public for 50-MILE-RANGE SEA & FIELD BINOCULARS! Each of these precision-ground non-prismatic LONG-RANGE BINOCULARS are so powerful you can actually sit in the grandstands and 'lip-read' a quarterback calling signals a whole football field away! Precision-engineered with haze-resistant lenses, these rugged, light-weight Sea & Field

Binoculars withstand rough conditions—all sorts of weather. Giant 7 × 50 lenses capture and magnify so much light—great for nighttime viewing. Each super power binoculars features 7 × 50 high-impact shatterproof lenses . . . instant center focusing . . . custom eye-width adjustment . . . wide-angle field of vision. Perfect for sport fans, nature lovers, theatre goers, boat owners, airplane pilots, hunters, travellers, etc.

### TECHNICAL SPECIFICATIONS:

✓DEPTH OF FIELD: 5.0 feet to 50 nautical miles  
✓LENSES: Non-prismatic, full 7 × 50, shatterproof  
✓RANGE SPECTRUM: 7 × 50 wide angle  
✓LENS COVERS: Both water-resistant and dust-proof protective covers for ocular viewer and tele-power lenses

✓FOCUS: Fast center rotary  
✓CLARITY: Total spectrum intensity—no distortion  
✓HOUSING: Rust-proof and Water-resistant  
✓OPTIC SYSTEM: Refractory based  
✓COLOR: True color value over entire spectrum; filtration loss approx. 0.0

To avoid disappointment or future regret you must place your order immediately. Should you wish to charge your order on VISA or MASTERCARD, give credit card name, number and expiration date. Enclose this original

notice and indicate quantities desired. LIMIT: NO MORE THAN 5 PER ORDER, no exceptions. Send \$9 plus \$2 shipping and handling for each pack of SEA & FIELD BINOCULARS.

**MARINE SURPLUS DEPOT BCRB—8**  
OPTICS DIVISION  
Box 9300, Fort Washington, NY 11050

## DRIVING MERCEDES, BMW

(Continued from page 179)

the front seat of a BMW 318i is a surprisingly comfortable place to be.

About this "318i" business. In Germany, BMW sells the 3-series with a wide choice of engines, from a 1.6-liter Four to a 2.3-liter Six, and the model name reflects the displacement—316, 318, 320, 323. Americans have always received the 1.8-liter Four, even though the car was called 320.

All this is about to change. This year, we'll get the same fuel-injected, 1.8-liter Four we've always had, now properly called the 318i. But next year, Americans will be the beneficiaries of a new 2.6-liter Six, which will add about 30 hp and bags of torque to the 2,400-pound BMW.

### Worth the wait

Is the Six worth waiting for? Well, it cuts 0-to-60 times from 12 seconds to 10.5, increases top speed from 99 mph to 120, preserves the 28-mpg EPA rating and makes the car a lot more pleasant to drive. The Six is uncannily smooth, like all BMW Sixes. The Four is buzzy and busy, like most under-two-liter Fours. Yes, you might say the Six is worth waiting for.

You might also want to wait for the four-door. Indeed. After 16 years of clambering over the front seats, BMW-kinder will have their own set of doors starting in 1984. The four-door is literally built from the two-door pan, so there's no increase in legroom, but there is a giant step forward in convenience. Dr. Rademacher expects the new four-door to capture between 60 and 80 percent of all 3-series sales, worldwide.

Of course, the Six and the four-door will cost more. In fact, the 318i will cost more than the 320i it replaces. Base price on the four-cylinder, two-door in the United States will be around \$14,000. Add the normal BMW options, and you'll be hard-pressed to buy a 318i for less than \$17,000. Add in another hefty premium for two more cylinders and two more doors, and you'll surely be ogling the first \$20,000 BMW 3-series.

The bottom line is that the little BMW sports sedan has finally grown up, gone all smooth and refined and expensive on us. And BMW, for all its conservative my-goodness-don't-change-anything approach to styling and engineering, has lost sight of just what it was that made the 2002 such a success—an affordable price tag, the aesthetics of a brick and astounding performance. Luckily, you can still buy a modern-day BMW 2002. It's called a Volkswagen GTI, and it costs just \$7,995.—Rich Taylor

## OWNERS REPORT: CAMARO

(Continued from page 107)

surface, so it leaked when I got the car."

An Alabama poultry raiser fumed, "I've already had three automatic transmissions installed, replaced the starter once, the T-top leaks, and the throttle-body injectors still need to be

adjusted. I've met other owners who've had similar problems or worse. Two have traded off their cars. Chevrolet did their homework on styling and handling, but I fear they've ignored some other important areas."

In the odd-but-true category, one owner mentioned that rain water, leaking into the induction system through the cold-air hood scoops, ended up

causing a connecting rod to break when he tried to start his car. His engine was exchanged under warranty.

Nearly half of all the Camaro buyers we queried had chosen the 305-cu.-in. V8—the same engine that Chevrolet supplies for the Trans Am. And as in our Trans Am Owners Report, a nagging complaint from Camaro owners

(Please turn to page 182)

### SUMMARY OF 1982-83 CHEVROLET CAMARO OWNERS REPORTS\*

|                                     |           |                                     |                |                                       |       |   |       |
|-------------------------------------|-----------|-------------------------------------|----------------|---------------------------------------|-------|---|-------|
| <b>Total miles driven</b>           | 1,317,594 | <b>Specific likes:</b>              |                | <b>Workmanship opinion:</b>           |       | <b>Dealer service opinion:</b>                  |       |
| <b>Average miles per gallon:</b>    |           | Styling                             | 78.8%          | Excellent                             | 26.4% | Excellent                                       | 18.0% |
| Ohv 2.5-liter Four                  |           | Handling                            | 56.8           | Good                                  | 47.6  | Good  | 36.5  |
| In town                             | 23.5      | Comfort                             | 23.4           | Average                               | 16.9  | Average   | 25.6  |
| On the highway                      | 28.5      | Performance                         | 22.1           | Poor                                  | 9.1   | Poor  | 19.9  |
| Ohv 3.8-liter V6                    |           | Economy                             | 15.8           | <b>Comfort opinion (front seats):</b> |       | <b>Number of vehicles owned:</b>                |       |
| In town                             | 19.6      | <b>Specific dislikes:</b>           |                | Excellent                             | 59.7% | This car only                                   | 39.2% |
| On the highway                      | 24.9      | No complaints                       | 18.4%          | Good                                  | 30.3  | Two cars  | 41.9  |
| Ohv 5-liter V8                      |           | Disappointing fuel                  |                | Average                               | 8.2   | Three cars                                      | 13.7  |
| In town                             | 14.8      | mileage                             | 12.4           | Poor                                  | 1.7   | Four or more cars                               | 5.3   |
| On the highway                      | 18.8      | Quality of materials                | 10.6           | <b>Comfort opinion (rear seats):</b>  |       | <b>Makes of other cars owned:</b>               |       |
| <b>Engine choices:</b>              |           | Workmanship                         | 7.8            | Excellent                             | 7.3%  | Chevrolet                                       | 34.8% |
| Ohv 2.5-liter Four                  | 11.5%     | Rattles and noises                  | 6.5            | Good                                  | 33.9  | Ford  | 15.2  |
| Ohv 3.8-liter V6                    | 38.8      | <b>What changes would you like?</b> |                | Average                               | 33.0  | Oldsmobile                                      | 12.3  |
| Ohv 5-liter V8                      | 49.8      | Five-speed transmission             | 13.2%          | Poor                                  | 25.7  | Cadillac  | 8.0   |
| <b>Transmission choices:</b>        |           | Better materials                    | 11.8           | <b>Had any mechanical trouble?</b>    |       | Datsun  | 7.2   |
| Automatic three-speed               | 75.1%     | No changes                          | 11.3           | Yes                                   | 61.4% | Pontiac   | 7.2   |
| Manual four-speed                   | 24.9      | Better fuel mileage                 | 6.6            | No                                    | 38.6  | <b>Age distribution of owners:</b>              |       |
| <b>Why did you choose this car?</b> |           | Seat shape/style                    | 5.7            | <b>What type of trouble?</b>          |       | 15-29 years                                     | 55.1% |
| Styling                             | 88.0%     | <b>How much did you pay?</b>        |                | Transmission                          | 25.7% | 30-49 years                                     | 35.9  |
| Handling                            | 16.9      | Average                             | \$11,383       | Electrical                            | 8.6   | 50-plus   | 8.0   |
| Performance                         | 11.6      | Range                               | \$7,000-16,000 | Oil leaks                             | 7.1   | <b>Would you buy another Chevrolet product?</b> |       |
| Past experience                     | 9.3       |                                     |                | Clutch                                | 7.1   | Yes   | 84.0% |
| Economy                             | 7.1       |                                     |                | Air conditioner                       | 5.7   | No  | 16.0  |
|                                     |           |                                     |                | Shifter                               | 5.7   | <b>Would you buy another Camaro?</b>            |       |
|                                     |           |                                     |                | <b>Dealer repairs satisfactory?</b>   |       | Yes   | 75.0% |
|                                     |           |                                     |                | Yes                                   | 57.1% | No  | 25.0  |
|                                     |           |                                     |                | No                                    | 42.9  |   |       |

\*Percentages might not equal 100% due to rounding or insufficient data.

## Your home workshop

### 3-in-1 Power Tool!

This one power-fed tool—  
**SAWS** to desired Width...  
**PLANES** to desired Thickness...  
**MOLDS** all popular Patterns...  
 —all in one fast operation!

Only Complete Workshop Tool Of Its Kind In The World!

From the day it arrives the Planer/Molder/Saw will make and save you money. With shortages and inflation driving lumber prices skyhigh, this versatile power tool quickly pays for itself by easily converting low cost rough lumber into high value finished stock. Make your own quarter-round, base mold, door and window stop, casing, tongue-and-groove... all popular patterns. Other operators turn out picture frames, fencing, clock cases, furniture, bee hives, bed slats, surveyor's stakes... all kinds of millwork. Handles tough oak and walnut as easily as pine using only one small motor, and so simple to operate even beginners can use it.

Men and women everywhere are using this one low-cost power-feed machine to start and build their own new businesses... and YOU can do the same. Supply lumberyards, carpenters and contractors in your area with door and window trim... base shoe... bed mold... cove and quarter round... ALL of their trim. You can sell picture frame to custom framing shops, paint stores, department stores and direct to users. All patterns available or design your own. **Get FREE Booklet with facts and full details... RUSH COUPON TODAY!**

POPULAR MECHANICS • APRIL 1983



## can PAY-OFF... ...BIG!

Try The  
 Foley-Belsaw In Your  
 Own Shop On Our  
**30-DAY FREE  
 TRIAL OFFER**  
 Mail Coupon Below  
 For Complete  
 Details!

Send TODAY  
 for this  
 fact-filled  
**FREE  
 BOOKLET!**



### Does The Foley-Belsaw Pay? YOU BET!

#### READ WHAT OWNERS SAY:

"I bought a batch of walnut in the rough, and after planing it on the Foley-Belsaw I figured I saved enough money to pay for two-thirds the cost of the Planer. It really does a good job."  
**R.S. Clark — Springfield, Ohio**

"This machine pays for itself making money out of scrap boards. It is a very well built machine and I confess it is more than I really expected for the price. It does everything you say it will."  
**Stephen Schultz — Orangeville, Penns.**

"I've been a planer man for years and am now retired. The Foley-Belsaw has earned me \$80,000 in eleven years... it's the best investment I ever made."  
**Robert Sawyer — Roseburg, Oregon**

"I recommend the Foley-Belsaw as the most useful shop tool any craftsman could own. We use one every day in the Workbench model shop... couldn't get along without it."  
**Jay Hedden, Editor  
 Workbench Magazine**

There is **NO OBLIGATION** and  
**NO SALESMAN WILL Call—ever!**

If coupon has been removed, just send postcard with name and address to:

FOLEY-BELSAW CO.  
 90217 FIELD BLDG.  
 KANSAS CITY, MO. 64111

**FOLEY BELSAW** Foley-Belsaw Co.  
 90217 Field Bldg.  
 Kansas City, Mo. 64111 **FREE BOOK**

**YES** please send me the **FREE Booklet** that gives me complete facts about your Planer-Molder-Saw and full details on how I can qualify for a 30-Day Free Trial right in my own shop. I understand there is No Obligation and that No Salesman will call.

Name \_\_\_\_\_  
 Address \_\_\_\_\_  
 City \_\_\_\_\_  
 State \_\_\_\_\_

# \$19,500



The Trenton

## NO DOWN PAYMENT BELOW-MARKET FINANCING

SEND TODAY FOR  
MORE DETAILS

If you thought you couldn't afford a home of your own, think again. You still can! Over 20,000 families just like you have built Miles Homes using our step-by-step instructions. Over 50 exciting do-it-yourself models plus a full selection of optional materials - like heating, plumbing and electrical packages - are available to give you the home you want at a price you can afford.



No money down, below-market financing, low monthly payments. It's not too good to be true, just too good to be passed up.

Please send me (check one):

- Free color brochure
- 80 page, full color catalog. (Please enclose \$3 check or money order.)

Mail to: Miles Homes™  
4700 Nathan Lane, P.O. Box 9495  
Mpls., MN 55440

PHONE NUMBER ( )

NAME

ADDRESS

CITY STATE

ZIP MPM3-0483

### OWNERS REPORT: CAMARO

(Continued from page 181)

was lower-than-expected fuel mileage. According to our survey, this five-liter V8 delivers 14.8 mpg in town and 18.8 on the highway. Compare that with the EPA's 17/23 mpg city/highway and you'll understand the disappointment.

There was a little disappointment, too, with the V8's performance. This was by no means universal, because plenty of people praised this engine's peppiness. But a few—as always—want more power. However, it's important to balance out the never-ending lament for lost horses with a growing satisfaction. This satisfaction was expressed by a Texas architect:

"As a general statement, the Z-28 is a good step toward cars of the future. I sincerely hope Chevrolet doesn't go backward into a larger-displacement engine to get more performance at the cost of fuel economy. Instead of the 350 V8 they've been talking about, I'd like to see them offer a high-output V6, perhaps with a turbocharger. High performance requires efficiency, and efficiency delivers more mpg."

Only 25 percent of our respondents had opted for the manual four-speed gearbox, and an amazing 13.2 percent told us they would like—and presumably would have bought—a five-speed if it had been available. Unfortunately, at the time we conducted our survey, the 1983 Camaros had just come out. The 1983 models offer five-speeds (the Warner T-5) with all three engines.

Front-seat comfort came in for rave reviews, with no less than 90 percent rating that area good to excellent; quite a high score. An unemployed Tennessean said, "Comfort in the Z-28's Contour seats is great, and the Extended Range stereo is even greater. Everyone compliments the stereo system."

However, the rear seat received considerably less praise, especially from a California dispatcher who has an amusing way of referring to children: "The rear seats are for rug rats only."

On the whole, praises outweighed complaints by a wide margin. These comments pretty well sum up what Camaro owners think of their cars:

"The 1982 Camaros are the sharpest Chevrolet has offered. I'm proud to own one."—New York student.

"It's a great head-turning looker, with fantastic handling and good inside comfort. Also, it's fun to drive."—Kentucky store clerk.

And finally, from a California manager, "Show me another \$12,500 car that'll pull .836g on the skidpad, that looks this good, with clean, smooth styling, fast-enough performance, great ergonomics, and a good stereo. I think I got a deal!"

FM

If you appreciate quality,  
we'll get along just fine..

Total Shop™

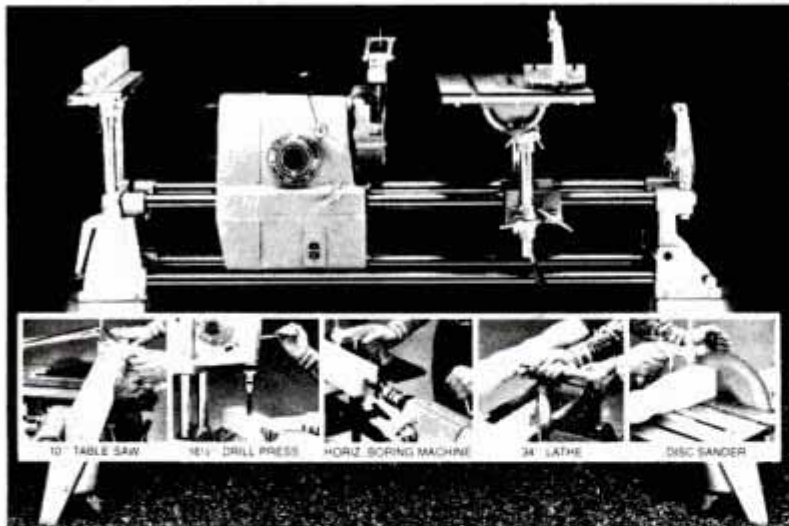

Total Shop is the ultimate home power tool. In fact, it's five of the most important power tools in one compact package.

It's got everything. A 10" Table Saw, 16 1/2" Drill Press, Horizontal Boring Machine, 34" Lathe, and Disc Sander.



CALL TODAY  
toll free  
1-800-845-9356  
In SC call 288-4174

clip and mail coupon for: Free Informational Kit

Total Shop™

Dept. I  
P.O. Box 16297  
Greenville, SC 29606

Your Name \_\_\_\_\_

Address \_\_\_\_\_

City \_\_\_\_\_ State \_\_\_\_\_ Zip \_\_\_\_\_

Phone \_\_\_\_\_

Charge to my  Visa  Master Charge

my check or money order is enclosed

Account No. \_\_\_\_\_ Exp. Date \_\_\_\_\_

Pop. Mech. United Metal Services, Inc.

## BUILD OUR TOOLBOX

(Continued from page 111)

corners, then restrain where necessary. After rounding all the edges, install the eight brass corner caps.

The eight right-angle corner braces are made from 18-gauge (.040-in. thick) sheet brass. Cut out the rough shape of the corner angles with metal shears or a sabre saw with a metal cutting blade. Then finish-shape each piece on a grinder or a rotary file mounted in a drill press. Wear safety glasses throughout this procedure.



Install hinges with the lid clamped in position. Pipe clamps with wood blocks ensure proper alignment.



Corners conceal the screws which are used to hold the top compartment together.

Next, bend each corner angle around a 3/8-in.-dia. rod to conform to the rounded box edges. Bore two 1/8-in.-dia. mounting holes in each piece and countersink for 3/8-in. No. 5 fh screws.

To help strengthen the luggage-style carrying handle, steel reinforcement plates are mounted inside the lid.

A felt liner is glued to the toolbox interior for both appearance and tool protection. Use wood glue or contact cement on hardboard or wood surfaces. Adhere the felt to metal surfaces with an appropriate glue, such as Goodyear Pliobond cement.

A magnetic catch prevents the front panel from falling open whenever the lid is raised. Make the catch by gluing a 2-in. length of flexible magnetic strip to the partition end. Mount a steel strike plate (an electrical outlet box knock-out disc) to the front panel directly op-

(Please turn to page 184)



## The Lincoln AC/DC- Professional results at a do-it-yourself price.

Big brother to the AC-225-S. Easy to use. Easy to afford. The ideal welding tool for fabricating, maintenance, farm repair and construction, piping and hardsurfacing.

Gives you the choice of DC or AC and runs on single phase 230 volt power. Great for code quality welding with Fleetweld® 5P. Easier welding in all positions. Low range stability for thin metal where a smooth arc is essential. Ideal for Stainweld®, low hydrogen,

non-ferrous and many other electrodes.

Standard features include input plug and receptacle, electrode holder, work clamp and cable. Plus a free "Welder's Guide" with illustrated instructions and tips to better welding.

Look for your Lincoln Distributor in the Yellow Pages under Welding Equipment. Or write: The Lincoln Electric Company, Cleveland, Ohio 44117, Canada, France and Australia.



**LINCOLN**  
ELECTRIC

## Convert Your Drill Press Into a Milling/Drilling Machine

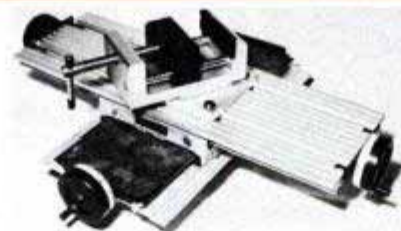

By attaching our Mill Table to your drill press you can perform facing, slotting, milling and drilling operations on almost any machinable material. The Mill Table allows precise positive movement of any workpiece in two directions relative to the drill press spindle, just like a full size milling machine. Adding our Swivel Vise - as shown above - lets you hold small or round parts and adds angle machining to the operations you can perform.

**MILL TABLE** - 17" x 5.5" work surface, aluminum construction, satin anodized finish, 11" long, travel, 7" cross travel wt. 10#, \$69.95 + 4.00 S&H

**SWIVEL VISE** - 3" wide jaws, aluminum construction, satin anodized finish, wt. 7#, \$39.95 + 2.50 S&H

**END MILLS** - Four flute, HS steel, 1/8, 3/16 & 1/4" dia. available, any 3 for \$13.95 PPD.

Satisfaction 100% guaranteed. (Send for new larger 1983 catalog.)

Michigan residents please add 4% sales tax.

**M.J. LAWRENCE, INC.** Dept. 204  
P.O. Box 1841, Warren, Michigan 48090  
313-798-3598 VISA & MASTERCARD ACCEPTED

## NEW! GOLDEN OPPORTUNITY PERFECT MITER



IDEAL GIFT  
FOR FATHER

Incredible Tool  
For This Generation.

\$1725

LIMITED  
QUANTITY OFFERED

U. S. \$  
POSTAGE PAID

Selling out Canadian inventory... preparing to move to U.S.A.

SATISFACTION  
GUARANTEED

A must for your table saw. Guaranteed perfect mitering & perfect 90° cutting in seconds, every time.

## 100% Satisfaction By Users

You owe it to yourself to try it. Amateurs get instant perfection. You will be encouraged to do all your own carpentering and save \$\$\$! The PERFECT MITER does it all for you! Incredible, but true! Avoid the expensive tradesmen. With the PERFECT MITER you now get perfect workmanship and your money goes three times as far. Free brochure available.

### BAR SIZES:

- 1/2" x 1/2" (Most ROCKWELL Saws)
- 1/2" x 7/32" (Most CRAFTSMAN Saws)
- 5/16" x 7/20" (Most SHOPSMITH Saws)
- 1/2" x 1/2" - 1/2" x 3/4"
- 5/16" x 1/2" - 1/2" x 3/4"
- 3/16" x 1/2" - 1/2" x 15"
- 3/16" x 1/2" NOTE: All Steel Bars - 18" Long

Due to the many odd sizes made, the PERFECT MITER will be sold by mail order. Offer Expires September 30, 1983.

**NATIONWIDE MANUFACTURING CO., LTD.**  
P. O. Box 457 • Edmonton, Alberta, Canada T5J 2K1

Please send \_\_\_\_\_ PERFECT MITERS — \$17.25 each.

Enclosed is my cheque, money order or charge to my:

Card No:  Visa  MasterCard Expires: \_\_\_\_\_

Name: \_\_\_\_\_

Address: \_\_\_\_\_

City/State/Zip: \_\_\_\_\_

Size of bar requested \_\_\_\_\_ x \_\_\_\_\_ x \_\_\_\_\_

## BUILD OUR TOOLBOX

(Continued from page 183)

posite the magnet. Attach a small felt-covered wood block to the partition above the magnet. This will serve to act as a stop against which the panel can close.

### Finishing the toolbox

Complete the toolbox with a coat of Pratt and Lambert satin varnish (No. R-11) thinned 50 percent with turpentine. Let it dry overnight, then sand

lightly with 220-grit abrasive paper. Remove the sanding dust with a brush, then wipe with a tack cloth. Finally, brush on a second coat of *unthinned* varnish for the final coat. **FM**

### MATERIALS LIST—MASTER CRAFTSMAN'S TOOLBOX

| Key | No. | Size and description (use)                                | P  | 1  | 1/2 x 7 1/2 x 8 1/2" hardboard (bottom)          | X      | 1  | 5" luggage-type handle   |
|-----|-----|---|----|----|--|--------|----|--|
| A   | 2   | 1/2 x 8 3/4 x 10 5/8" cherry (box end)                    |    |    | <b>DRAWER C (1 Req'd.)</b>                       | Y      | 2  | 1/4"-dia. x 2 1/2" rod, brass or steel (pin)   |
| B   | 1   | 1/2 x 2 1/4 x 19 1/8" cherry (box front)                  | M  | 1  | 1/2 x 1 1/4 x 19 1/8" cherry (front)             |        |    |  |
| C   | 1   | 1/2 x 10 5/8 x 20 1/8" cherry (box back)                  | N  | 2  | 1/2 x 1 1/4 x 7 5/8" pine (side)                 | Z      | 2  | 1/4"-o.d. x 1" spring  |
| D   | 1   | 1/2 x 8 3/4 x 20 1/8" cherry (box bottom)                 | O  | 1  | 1/2 x 1 x 18 1/2" pine (back)                    | AA     | 2  | 1/8 x 3/8 x 1/2" brass (strike plate)  |
| E   | 1   | 1/2 x 9 1/4 x 20 1/8" cherry (lid top)                    | P  | 1  | 1/8 x 7 1/2 x 18 1/2" hardboard (bottom)         | BB     | 2  | 1/4"-o.d. x 1/2" copper (liner)  |
| F   | 2   | 1/2 x 1 3/8 x 9 1/4" cherry (lid end)                     |    |    | <b>DRAWER D (1 Req'd.)</b>                       | CC     | 1  | 1/2 x 2" flexible magnetic strip   |
| G   | 2   | 1/2 x 1 3/8 x 20 1/8" cherry (lid front/back)             | M  | 1  | 1/2 x 2 1/4 x 19 1/8" cherry (front)             | DD     | 1  | 1/8 x 3/8"-dia. steel (strike plate)   |
| H   | 1   | 1/2 x 8 3/4 x 19 3/8" A/C plywood (compartment bottom)    | N  | 2  | 1/2 x 2 1/4 x 7 5/8" pine (side)                 | EE     | 1  | Spacer, size as needed   |
| I1  | 1   | 3/4 x 3 3/4 x 7 3/8" pine (partition)                     | O  | 1  | 1/2 x 2 x 18 1/2" pine (back)                    | FF     | 1  | 3/8 x 3/4" x depth to suit, pine (stop)  |
| I2  | 1   | 1/2 x 3/4 x 3 3/4" cherry (edging)                        | P  | 1  | 1/8 x 7 1/2 x 18 1/2" hardboard (bottom)         | GG     | 1  | 3/8 x 3/4" felt (pad)  |
| J   | 2   | 1/2 x 1 1/2 x 19 1/8" cherry (front panel rails)          |    |    | <b>DRAWER E (3 Req'd.)</b>                       | HH     | 2  | 1/8 x 3 1/2"-dia. steel (reinforcing plates)   |
| K   | 2   | 1/2 x 1 1/2 x 6 3/4" cherry (front panel stiles)          | M  | 3  | 1/2 x 1 3/8 x 9 1/8" cherry (front)              | I1     | 1  | 7" chain   |
| L   | 1   | 1/4 x 5 1/4 x 16 1/8" cherry plywood (front panel insert) | N  | 6  | 1/2 x 1 3/8 x 7 5/8" pine (side)                 | I2     | 11 | 1 1/2" No. 6 fh screws   |
|     |     | <b>DRAWER A (1 Req'd.)</b>                                | O  | 3  | 1/2 x 1 3/8 x 8 1/2" pine (back)                 | Misc.: |    | Hide glue, felt, 3/4" brads, 80- and 220-grit sandpaper.   |
| M   | 1   | 1/2 x 1 1/8 x 9 1/8" cherry (front)                       | P  | 3  | 1/8 x 7 1/2 x 8 1/8" hardboard (bottom)          | Note:  |    | The Woodworkers' Store, 21801 Industrial Blvd., Rogers, Minn. 55376, offers a materials package containing all the cherry hardwood and major brass hardware items needed to build the toolbox as shown. Here's what each package includes: |
| N   | 2   | 1/2 x 1 1/8 x 7 5/8" pine (side)                          | Q1 | 42 | 1/2" No. 2 fh screws                             |        |    | Lumber: All the cherry hardwood (surfaced three sides) required to build one toolbox, 1/4-in.-thick cherry plywood (for front panel), 1/8-in.-thick cherry plywood (for drawer bottoms), pine edging (for partition edge).                 |
| O   | 1   | 1/2 x 7/8 x 8 1/8" pine (back)                            | R  | 8  | Brass corner caps                                |        |    | Hardware: One locking chest latch, two chest latches, eight corner caps, ten 1/2-in.-dia. brass knobs and one pair of butterfly hinges. Total cost: \$65.  |
| P   | 1   | 1/8 x 7 1/2 x 8 5/8" hardboard (bottom)                   | S  | 8  | 3/4 x 2 1/2" 18-gauge sheet brass (corner angle) |        |    |  |
|     |     | <b>DRAWER B (1 Req'd.)</b>                                | S1 | 16 | 3/8" No. 5 fh screws                             |        |    |  |
| M   | 1   | 1/2 x 2 1/2 x 9 1/8" cherry (front)                       | T  | 10 | 1/2"-dia. brass knobs                            |        |    |  |
| N   | 2   | 1/2 x 2 1/2 x 7 5/8" pine (side)                          | U  | 1  | Brass locking catch                              |        |    |  |
| O   | 1   | 1/2 x 2 1/4 x 8 1/8" pine (back)                          | V  | 2  | Brass catch                                      |        |    |  |
|     |     |   | W  | 2  | Butterfly hinge                                  |        |    |  |



**Does The Sharp-All Pay YOU BET**

**\$100.00 a day**

"Recently I had three days in a row here I made over \$100.00 a day."

William J. Mitchell, Tempe, Arizona

**Can't beat it**

"I have had excellent results with the Sharp-All . . . you just can't beat it . . . it is easy to set-up, doesn't take long to change stones . . . all in all, it is no trouble to work with."

LaVern Heim, Canton, Kansas

**\$32 in 2 hours**

"There's always work in a sharpening business of your own if you want it . . . Yesterday, I made \$32.00 in two hours."

Dave R. Lewis, Hoquiam, Washington

**Wanted to Retire**

"I had dreamed of retiring for years, but was afraid to quit my salaried job. I had never used this type of equipment, but the Sharp-All was real easy to learn. I sharpened 30 blades my first week — without advertising at all. Now, for the first time in my life, I can say that I am content."

Farris Cornelius • Wellington, Texas 79095

**Makes Over \$60.00 EXTRA a Week In His spare Time Sharpening Shop!**

"My Sharp-All made me an extra \$3,500 last year. Now I am going full time. It's great to be your own boss."

DAVID SWANSON — Utica, Michigan

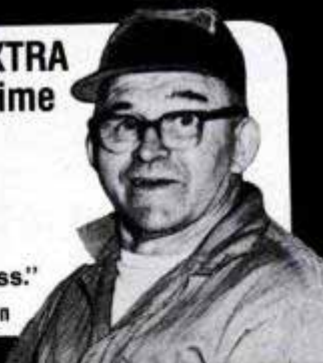

**Let FOLEY BELSAW PROVE**

**You can do it too! On our**

**30-DAY FREE TRIAL OFFER**

**SEND FOR FREE FACTS!**

You risk nothing by accepting this offer to see how easily you can turn your spare time into big Cash Profits with your own Complete Sharpening Shop. No selling . . . no previous experience needed. Our famous Sharp-All and show-how instructions set you up to make \$200, \$500, \$700 a month CASH sharpening Saws, Knives, Scissors, Lawnmowers, Shop and Garden Tools . . . all cutting edges.

Our Free Book tells how to start a profitable, lifetime home sharpening business, how we help you grow, how we'll finance you.

**FIND OUT ALL ABOUT IT No Obligation — No Salesman will Call**



**FOLEY-BELSAW CO.**  
60172 FIELD BLDG.  
KANSAS CITY, MO. 64111

**No Obligation . . . No Salesman Will Call**

FOLEY BELSAW CO. 60172 FIELD BUILDING, KANSAS CITY, MO. 64111  
Send details of FREE TRIAL OFFER and Free Book "Lifetime Security"

NAME \_\_\_\_\_  
Address \_\_\_\_\_  
City \_\_\_\_\_ State \_\_\_\_\_ Zip \_\_\_\_\_



**FREE BOOK**

**RUSH COUPON TODAY!**

**No Selling, No Inventory . . . Year Round Cash Profits and YOU Set The Hours!**

# HINTS FROM READERS

## Vacuum nozzle adapter

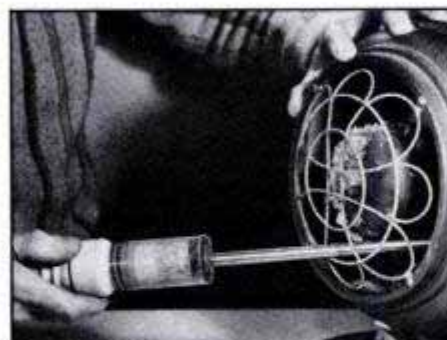
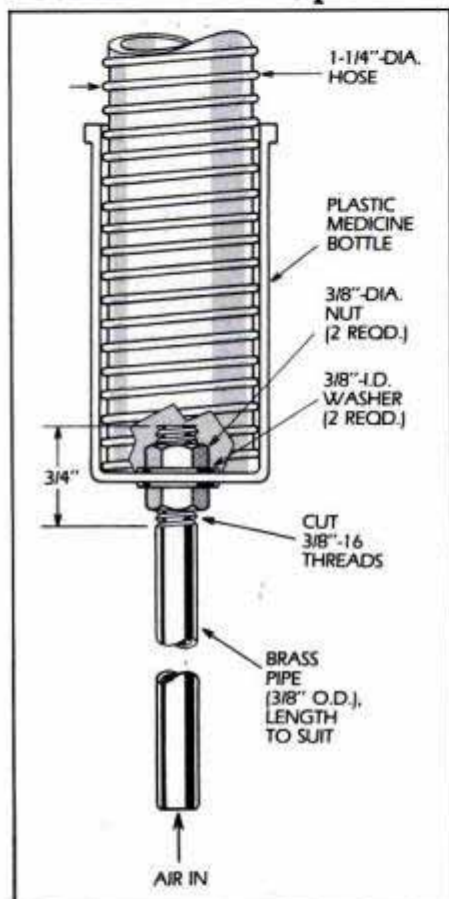

Standard home and shop vacuum cleaner nozzles are too large to reach dust and dirt in narrow crevices. But the simple adapter shown overcomes the problem. Install a length of  $\frac{3}{8}$ -in.-o.d. brass fixture pipe through the bottom of a plastic pill bottle into which the vacuum hose fits snugly. If the plastic bottle is too large for the vacuum hose, wrap masking tape around the inside to make up the difference.

—Walter E. Burton

# MasterShop...

## cast iron tables make the difference!

MasterShop measures up to the toughest woodworking project with the accuracy of cast iron tables, like those used in industry—to give you results you can be proud of every time!

A complete home workshop in one easy to handle unit equips you to tackle almost any job. Converts in seconds to a powerful 10" table saw, 12" disc sander, 16½" drill press, 34" lathe and horizontal drilling machine—powered by a heavy duty 18 amp ball bearing motor. A variable speed range from 900 to 5400 RPM's allows the precise speed selection necessary for any operation.

Make your own furniture, remodel a room—build any project large or small. You can do it easily and professionally and save money too! Even beginners find themselves quickly achieving beautiful results on every project.

MasterShop is affordable—More value, quality and accuracy for substantially less money than other home workshop systems.

Send for free information or call today and learn why more and more people are turning to MasterShop to satisfy their home workshop needs.



**MasterShop**  
MULTI-TOOL

FOR INFORMATION  
CALL TOLL FREE  
**1-800-543-5620**  
In Ohio Call (513) 866-5300

For Free Information Package Mail to:

MasterShop Multi-Tool Division · ABCA, Inc. Dept. B304  
3728 Benner Rd., Miamisburg, Ohio 45342

NAME \_\_\_\_\_

ADDRESS \_\_\_\_\_

CITY \_\_\_\_\_

STATE \_\_\_\_\_ ZIP \_\_\_\_\_



# "STEAM"

YOUR WAY TO SUCCESS  
\$150 TO \$400 PER DAY  
STEAM CLEANING CARPETS & UPHOLSTERY  
UNIQUE SYSTEM, NO EQUIPMENT TO BUY — EVER!

\$150 TO \$400 PER DAY? YES, OUR TRAINEES ARE DOING IT RIGHT NOW, WITH THE FAMOUS ROGERSEN SYSTEM. SO CAN YOU. GOOD TIMES OR BAD. FULL OR PART-TIME. ANYTIME, ANYWHERE.

NO EQUIPMENT TO BUY. NO NEED TO SPEND THOUSANDS ON EQUIPMENT OR FRANCHISE FEES. NO NEED TO GO IN DEBT. AFTER TAKING OUR COURSE START MAKING BIG MONEY WITH LESS THAN \$50.00. WE WILL SHOW YOU THE SECRET.

ARE YOU STEAMED ABOUT TODAY'S ECONOMY, LAY-OFFS, INSECURITY? THE NEED TO SPEND THOUSANDS TO SET UP A BUSINESS. NOT WITH THE ROGERSEN SYSTEM. WE WILL SHOW YOU HOW TO START AND SUCCEED IN THIS FANTASTIC HIGH PROFIT BUSINESS. WE DON'T SELL EQUIPMENT. JUST SUCCESS.

FANTASTIC BREAKTHROUGH. PROVEN ON OVER 20,000 JOBS. NO SYSTEM LIKE IT ANYWHERE. WE WILL SHOW YOU HOW EASILY, STEP BY STEP. ALL OUR SECRETS ON EARNING \$40 TO \$50 THOUSAND A YEAR.

NO SPECIAL VAN OR TRUCK TO BUY. ANY CAR WILL DO. NO NEED FOR A SHOP, GARAGE OR STORE. WORK RIGHT OUT OF YOUR HOME. LOW OVERHEAD, HIGH PROFIT. CASH BUSINESS.

EASY TO LEARN. FULLY ILLUSTRATED COURSE TEACHES YOU AT HOME IN 2 WEEKS OR IN 3 DAYS AT OUR FIELD SCHOOL. NO EXPERIENCE OR TECHNICAL ABILITY NEEDED. ANYONE CAN LEARN THE ROGERSEN STEAM SYSTEM.

EASY WORK WITH THE ROGERSEN STEAM SYSTEM. AS EASY AS VACUUMING. MEN, WOMEN, HIGH SCHOOL, COLLEGE STUDENTS, RETIRED. YOU SET YOUR SCHEDULE. WORK THE HOURS YOU WANT. YOU'RE IN CONTROL, YOU'RE THE BOSS. YOU KEEP THE CASH. ALL OF IT.

## SEND FOR FREE BOOK

STEAM  
YOUR  
WAY TO  
SUCCESS

FILL OUT  
COUPON AND  
SEND TODAY

OR CALL TOLL FREE  
1-800-243-2697 — CONN. 779-0579

PLEASE RUSH ME FREE DETAILS ON THIS FANTASTIC NEW SYSTEM. NO OBLIGATION, NO SALESMEN WILL CALL.

NAME \_\_\_\_\_ AGE \_\_\_\_\_

ADDRESS \_\_\_\_\_

CITY \_\_\_\_\_ STATE \_\_\_\_\_ ZIP \_\_\_\_\_

ROGERSEN STEAM SYSTEMS INSTITUTE  
676 SQUAW ROCK ROAD, DANIELSON, CT 06239

## NEW VIDEO GAMES

(Continued from page 99)

not capture the mind's eye with animation. Rather, they weave around the player a razzle-dazzle feeling of incredible detail.

The game begins as you move your tiny character on a colorful map of the world. You visit towns and villages, and as you enter them the world map is replaced by detailed maps of these

areas. Then you go through "time doors" which take you to yet other world maps in various areas of time—all while searching out an evil enchantress. Finally, you can get yourself a spaceship and take off to completely new worlds.

Meanwhile, you can chart your course on a real cloth tapestry of the Universe's time doors that's included with the game.

All of these games use new and rev-

olutionary techniques in video entertainment—and they are all more believable than their early counterparts. Playing them is less like playing a game on your monitor or TV set than it is experiencing a whole new world.

### You're in the picture

Another new style of gaming features open-ended animation where the player becomes the star of the show

(Please turn to page 188)

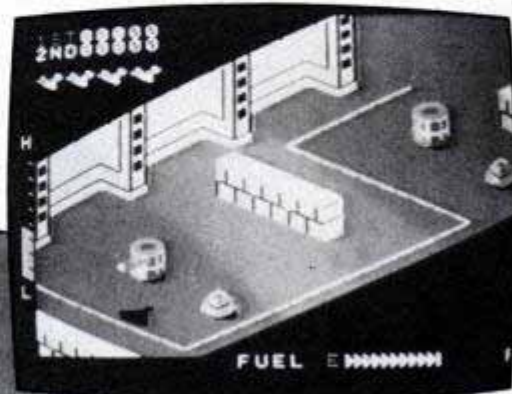
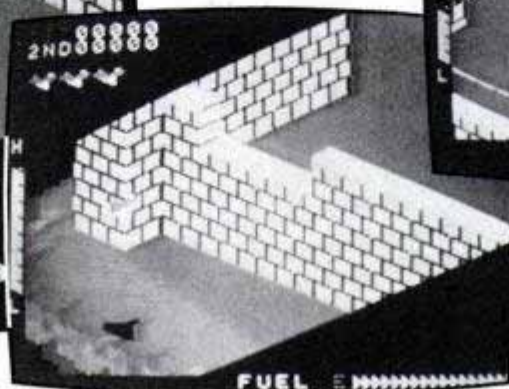
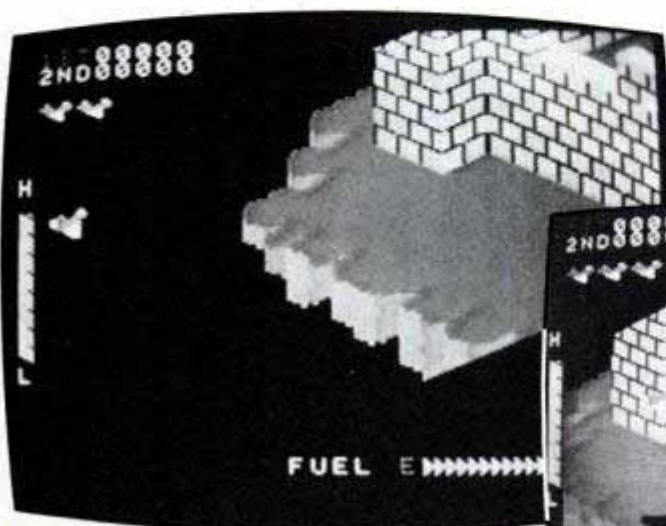

*Xaxxon features a detailed, scrolling landscape of an incredibly hostile asteroid base somewhere in outer space. You must fly three-dimensionally above walls and weave about obstacles while constantly firing. A hit in the arcades, it's now a hot living-room sensation. (Colecovision.)*

*Aztec from Datamost is almost as much fun to watch as it is to play. You control the walking, climbing, ducking, fighting, altogether charming little man's movements as he searches room after room in an underground maze for a golden statue. From level to level he fights dangers in complete, convincing animation. A tour-de-force for the Apple II.*

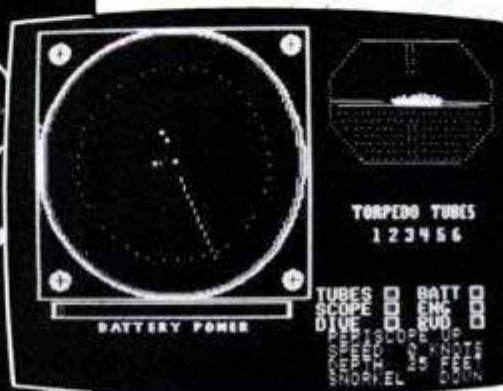
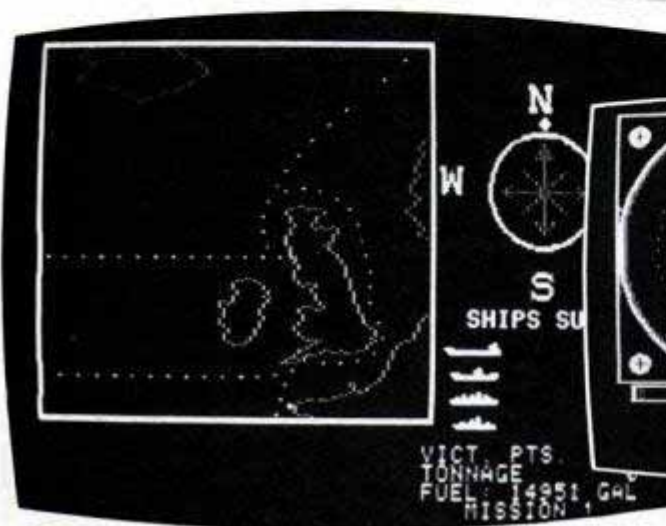
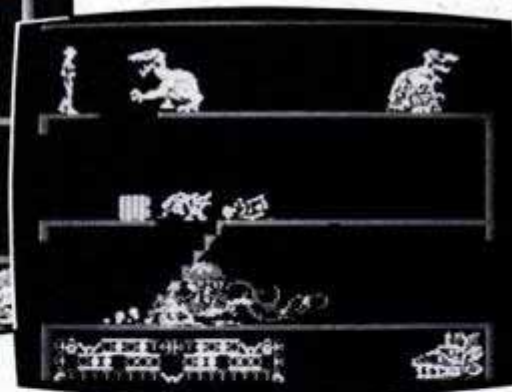
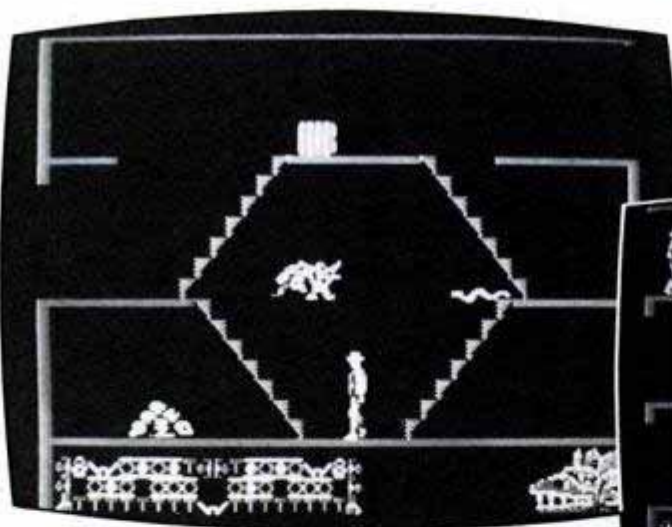

*Fathoms 40 from Datasoft puts you in the position of shanghaied captain pressed into U-boat service. You plan your strategy on one screen (far left); then on tactical display (left) you aim your torpedoes, keeping in mind every variable of submarine warfare from battery level to snorkel depth as well as using your sonar. (Apple II, Atari 800.)*



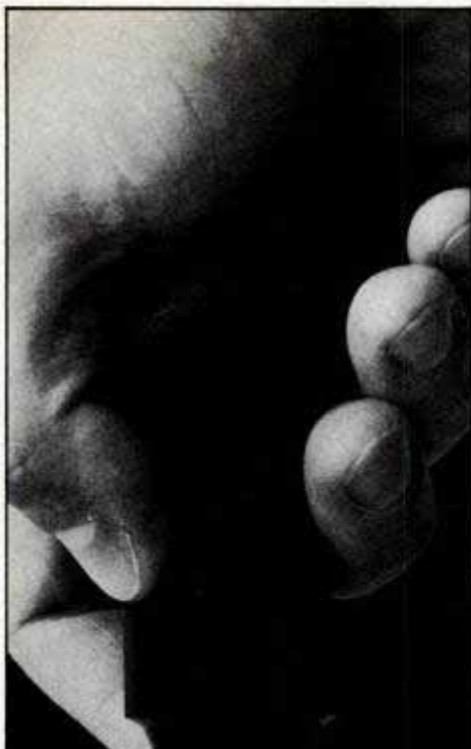

CLICK-CLICK

Fingertip "speeder"

All-metal ratcheting mechanism

High torque handle design

Convenient thumb switch

Adjustable adapter for bits, sockets



**Wrist Ratchet**

## EASCO CLICKS WITH A NEW, BETTER RATCHET TOOL.

Unique features like adjustable adapter for quicker change of bits and sockets, strong all-metal ratchet mechanism, new handle design for greater driving power, all make Easco's Wrist Ratchet superior. Now at your Easco dealer.

**Easco**<sup>®</sup>

© 1983 Easco Hand Tools, Inc.



# Cord Keeper<sup>™</sup>



## Eliminates Tangled Cords!

Now there's an easy solution to your cord storage problems—the new Cord Keeper<sup>™</sup> from Chopper:

- Winds and stores 100' of 16-2 electrical cord or rope.
- Unbreakable, weather resistant, heavy-duty construction.
- Perfect for home, workshop, outdoor work area or campsite.

Store more cord in less space with Cord Keeper—from the makers of the world-famous Chopper 1<sup>™</sup>!

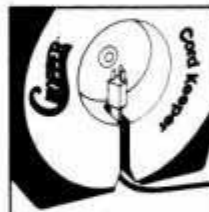

**CHOPPER**<sup>™</sup>

Chopper Industries • P.O. Box 649  
Phillipsburg, NJ 08865 • (201) 454-8666

## affordable housing... the Cathedralite geodesic way...

- |  |  |
|--|--|
| <input type="checkbox"/> Substantial savings for the owner-builder | <input type="checkbox"/> Complies with uniform building code               |
| <input type="checkbox"/> 30% to 50% energy savings                 | <input type="checkbox"/> Unmatched quality, strength and design simplicity |
| <input type="checkbox"/> One-day assembly of structure             | <input type="checkbox"/> Free one-day building seminars                    |



For more information:  
Send \$6.00 for 40-page brochure and/or \$7.95 for geodesic plan book to: Cathedralite Domes, Inc.  
P.O. Box 2490, White City, OR 97503  
Telephone (800) 538-0782 • in Oregon (503) 826-7200  
TELEX: 176070 CATHDOMES

**CATHEDRALITE**

ME3

## THE 5 MOST IMPORTANT WOODWORKING OPERATIONS . . . IN ONE COMPACT MACHINE

**BONUS:** Act now and receive also free tooling package.

- 34" LATHE
- 10" TABLE SAW
- 11 1/2" DISC SANDER
- 16 1/2" VERTICAL DRILL PRESS
- HORIZONTAL DRILL PRESS

REGULAR PRICE \$1,240  
SAVE \$ 251 Today  
**\$ 999.**

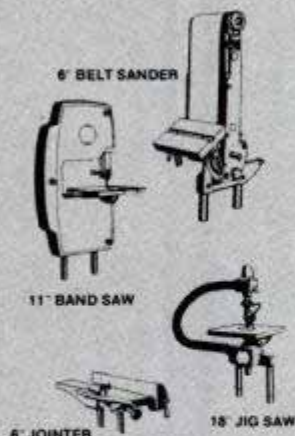

These special accessories also fit similar machines



### VERY IMPORTANT

The only machine built with  
A. ALL CAST IRON TABLES  
B. HEAVY DUTY DESIGN  
C. DEVELOPS 3 HP.  
D. BUILT AS AN INDUSTRIAL MACHINE

ONE PLACE FOR ALL YOUR NEEDS

CALL NOW!! FOR FREE GIFT

Toll Free (1-800) 421-2467  
In California (213) 549-0761

**MAIL NOW!!!**

VISA    MASTERCARD    MONEY ORDER

PRINT

YOUR NAME \_\_\_\_\_

ADDRESS \_\_\_\_\_

CITY \_\_\_\_\_ STATE \_\_\_\_\_ ZIP \_\_\_\_\_

PHONE ( \_\_\_\_\_ ) \_\_\_\_\_ BEST TIME TO CALL \_\_\_\_\_

PLANT

**MASTER WOODCRAFT CO.**

(A Republic-Lagun Group)  
800 SPRUCE LAKE DRIVE • P.O. BOX 669  
HARBOR CITY (Los Angeles), CA 90710



Dealership Available

## A GOOD WARRANTY IS A JOY FOREVER.

Until you have to use it.

A good warranty is the mark of a superior manufacturer, or the last refuge of a scoundrel. When somebody sells warranty instead of product, he knows something you *don't*.

Less than one-half of one-percent of AquaBug's income is spent on warranty; which says more about our quality than it does about our warranty. The manufacturer who gives a warranty and spends a lot of money *performing* that warranty is an honest man...and a lousy manufacturer. The best warranty in the world is no damn good if you have to use it all the time.

*The foregoing is excerpted from "The Book of Bugs", AquaBug's intimidating and somewhat hostile new catalog, which is free for the asking. Send for it NOW, before the lawsuits start.*

### AQUABUG INTERNATIONAL, INC.

100 Merrick Rd., Rockville Centre, NY 11570, (516) 536-8217

Name \_\_\_\_\_

Address \_\_\_\_\_

City \_\_\_\_\_ State \_\_\_\_\_ Zip \_\_\_\_\_

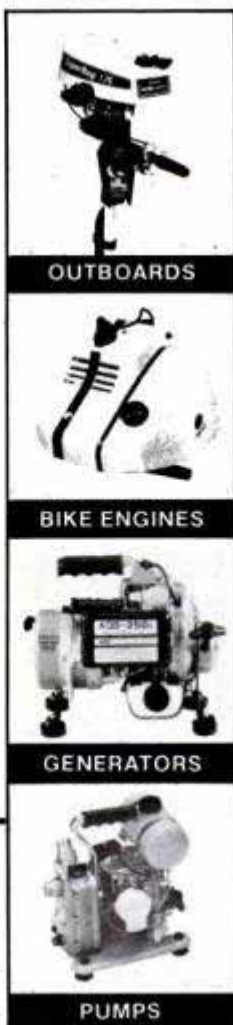

OUTBOARDS

BIKE ENGINES

GENERATORS

PUMPS

## NEW VIDEO GAMES

(Continued from page 186)

and controls the antics of a cartoon hero.

The game *Aztec* uses the theme of the intrepid explorer venturing into dank and frightening caverns seeking a golden statue.

### Duck, fight and fire

During your trek through this multi-leveled maze of rooms, stairways and surprising traps the keyboard is used to control and guide the figure which quickly becomes your own alter-ego.

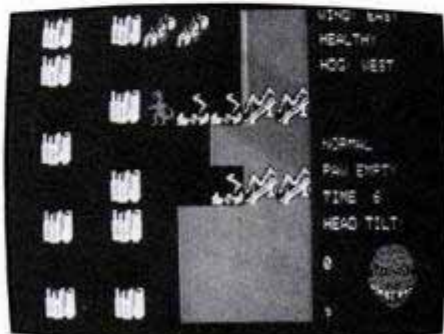

*Crush, Crumble and Chomp* through cities as monster of your choice. From Epyx for Apple II, Atari 800, IBM PC.

You can make the character duck, leap over fissures, fight with a machete, fire a pistol and generally try to avoid or do away with everything ranging from the creepiest and toothiest tyrannosaurs you've ever seen outside a Fifties horror film to pan-eared demons with sharp spears.

This type of game pictorially ensnares you into identifying with your on-screen representation. Once you get past learning to hit "J" for jump—and having to think about it first—you find that your reflexes and thought-processes easily transfer to the screen.

### Choose your fantasy

The home video game has become, for many people, a way to enter an alternate and complete world of fantasy and challenge. While some would call this mere escapism, the popularity of such video travels cannot be denied. And, on closer examination, this popularity is hardly surprising.

In the dim past, a warrior could settle by the fireside and listen as the tribal bard spun alliterative chants of legendary deeds while the night beyond the fire made it all seem real.

### Video fireside

Today's high-tech warriors, faces lighted by the flickering video fire, have their eyes fixed on their own legends—and for just a few moments can believe in worlds where anything may come true.

FM

# GETS RID OF ROACHES—MICE— FLEAS—& OTHER ANNOYING PESTS!

*IT REALLY WORKS! Effective against:*

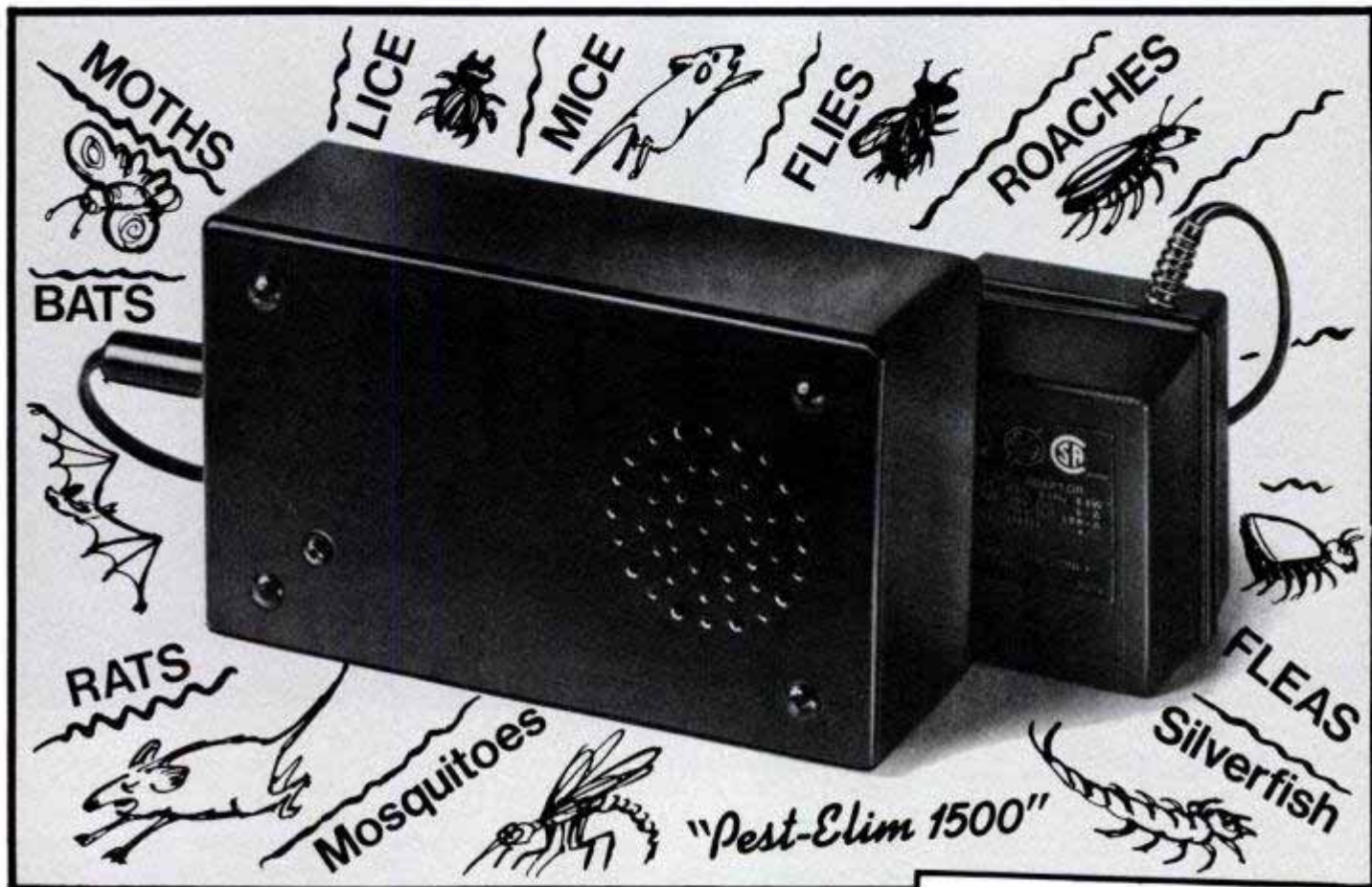

**Revolutionary new pest eliminator  
uses ultrasonic sound waves... No  
chemicals... No mess... Harmless  
to people and pets!**

**IDEAL PROTECTION FOR:**

- Home • Apartment
- Restaurant • Warehouse
- Farm buildings

**INCREDIBLE ELECTRONIC UNIT USES  
ULTRASONIC WAVES . . . Drives Away  
Flying and Crawling Pests, Yet Com-  
pletely Safe for Humans, Pets, Farm  
Animals, Plants.**

*Pest-Elim 1500* bombards your home with "silent sound" . . . high frequency sound waves that won't bother you but wreak havoc with roaches, mice, and other disgusting "visitors". The sonic waves affect their nervous systems, turning them into nervous wrecks—and they gladly vacate your premises. Safer than using poisonous chemicals—and more economical in the long run. Tested and proven effective against flying and crawling pests of every description . . . It will even keep your dog free of fleas!

**GETS RID OF PESTS IN 2 TO 6 WEEKS  
—PROTECTS 1500 SQ. FT., YET USES  
ONLY 4 WATTS OF ELECTRICITY!**

Easy to use, just plug in anywhere. Solid-state "black box" blends with your decor, takes up less space than a paper-back book. Uses a mere 4 watts of power; covers a huge 1500 sq. ft. area. Great for home use—and for boat, camper, restaurants, grain storage bins, dairy barns, and more. Cabinet design and size may vary slightly. No mess, no danger, no poisons; Includes instructions, manufacturer's 1-yr. warranty.

**FULLY GUARANTEED—TEST IT FOR 30 DAYS!**

If not delighted, return to us for full refund (except ship. & handl.). Why live with filthy, disgusting pests . . . Order your *Pest-Elim 1500* today!



**New Hampton General Store, Hanover, PA 17331**  
Serving Satisfied Customers Since 1934

**Great Buy! \$38.88**  
NOW ONLY  
Compare elsewhere  
at \$70.00—and more!

—SATISFACTION GUARANTEED—MAIL TODAY!—

**New Hampton General Store, Dept. BZ-8197  
340 Poplar St., Hanover, PA 17331**

Yes! Please rush me the *Pest-Elim 1500* ultrasonic pest eliminator(s) (Z547398) as indicated below, on full money back guarantee.

- One *Pest-Elim 1500* for only \$38.88 plus \$3.50 shipping & handling.
- SAVE!** Two for just \$70.00 plus \$6.00 shipping & handling.

Enclosed is \$\_\_\_\_\_ (PA res. add sales tax)  
**CHARGE IT:**  American Express  
 Diners Club  MasterCard  VISA

Acct. No. \_\_\_\_\_

Exp. Date \_\_\_\_\_ (please print)

NAME \_\_\_\_\_

ADDRESS \_\_\_\_\_

CITY \_\_\_\_\_

STATE \_\_\_\_\_ ZIP \_\_\_\_\_

© H.H.I., Inc., 1983

# The 1983 Plymouth Reliant K Backed for 5 years, 50,000 miles.



41 est. hwy. 29 EPA est. MPG\*

## AIRSHIPS RISE AGAIN

*(Continued from page 95)*

always fill a volume) and a bit about 'super heat.' " With the latter phenomenon, gases can expand so much that the action of the ship's rotating props and its airplane-like elevators may not assure a landing. "It can happen that as you are coming in for a landing, you suddenly 'bounce off' just as the crew attempts to take hold of the tethers," Bennett adds.

### 1,000 pounds of water

After a preflight check, the Skyship is "weighed off," a procedure to make sure the vessel has about 1,000 pounds of ballast in the form of water. With ballast on, the engines are started from Skyship's own batteries. They push the airship back away from its portable docking mast.

Trimmed to level with ballonet adjustments, the airship's tether lines are loosed by its ground crew. It usually takes off at a 45° vector, but can rise vertically when necessary in close quarters.

Prior to landing, trim is checked again. Cruising speed may be maintained while the ballonets' air is adjusted until the ship flies level with its elevators in mid-position. Then a normal

aircraft descent can be made, using vectored thrust from the engines. As a ship comes to a stop, ropes are dropped and a ground crew can pull it to a permanent or portable mooring. Water ballast may be added by the crew to ground the vehicle.

Airships have many advantages over airplanes and land vehicles. Fuel efficiency is a big advantage: According to Goodyear, any of its four blimps can operate eight hours a day for nearly a week on the amount of fuel it takes a passenger jet to taxi from the ramp to the runway for takeoff. The airships also have tremendous lifting capacity and can land or take off on any space big enough to hold them—they don't need a smooth runway.

### Some wrinkles remain

Still, there are some wrinkles. There are good reasons why Goodyear hasn't jumped onto the renewed airship bandwagon.

Mooring requirements make airships difficult to park for the long term. Vast hangars are necessary to keep an airship inside during rough weather. (At Goodyear's Akron facility, the hangar is so big that it has its own weather system; clouds sometimes form near the ceiling.)

A lack of free-spending airship cus-

tomers has also kept Goodyear conservative. Without a buyer, Goodyear isn't ready to build the heavy-lifter and several other experimental airships that are on its Aerospace company's drawing boards. In the words of Goodyear Aerospace spokesman Paul A. Turk:

"Except for continuing work (on Goodyear's airship fleet), we aren't engaged in airship production or research for any other customer at this time. We stand ready, of course, to build airships for qualified customers."

### Getting off the ground

Airship Industries' U.S. Navy demonstration flights this year will be financed mostly by the airship company; the Navy is just providing crews for training and docking space. Still, it was the Navy that ordered the Lockheed Hi-Spot flying spyship concept. And the Navy has permitted the Forest Service to use its Lakehurst facilities for development of the big-lifter. Maybe the Navy will be the one big paying customer that the airship business needs to get it off the ground. And maybe the Greek tourist trade will lure others into using the ships for passenger service. That seems to be the kind of speculation that has kept several airship entrepreneurs floating high this year. **PM**



## Plymouth is making Made in America stand for quality, durability and value.

America's lowest price 6-passenger front-wheel drive car: \$6,718\*\*

The Plymouth Reliant K success story continues into 1983. It's solidly based on computer-designing, testing and assembly. Robot-welding means uniform long-lasting bodies. Front-wheel drive gives you and your family secure, safe, consistent going through snow and over wet spots.

Plymouth has added still more value to Reliant K: power brakes, halo-

gen headlamps and maintenance free battery. Standard. Ten horsepower has been added to a 2.2 litre engine.

**5 years or 50,000 miles protection and 11.9% financing available**

Every Reliant K is backed with 5 years or 50,000 miles\* protection on engine, powertrain and transmission and against outer body rust-through.

Chrysler gives 11.9% annual percentage rate financing\*\* on all new '82 and '83 cars. Your dealer has details.

Hundreds of thousands of Plymouth Reliant K owners know: This is the American way to get your money's worth.

Buy or lease from your Chrysler-Plymouth dealer.

Buckle up for safety.



**The American way to get your money's worth**

THE NEW CHRYSLER CORPORATION  
Quality engineered to be the best.

\*Use EPA est. MPG for comparison. Your mileage may vary depending on speed, trip length and weather. HWY & CA. mileage lower. \*\*Base sticker price excludes title, taxes and destination charges. †Whichever comes first. Limited warranties. Deductible may be required. ††Through participating lenders & dealers for qualified buyers taking delivery by March 31. SEE DEALER FOR DETAILS. HIS CONTRIBUTION MAY AFFECT YOUR PRICE.

## SPACE SHUTTLE

(Continued from page 104)

alize the mission. In one project, we split the canister in half, with the experiments stacked on top of each other. The upper-half experiment includes a flexible air canister with tubes running to a Mylar balloon that inflates to a maximum 2 cu. ft. On a signal from the flight deck inside the ship, a solenoid switch opens the air canister's main valve and the Mylar balloon begins to inflate. A light metallic chute directs the balloon outside the canister. When it inflates, the balloon should float freely from the canister, held by thin wires and cables. Motorized pulleys and a bleeder-valve system would pull it back in.

The balloon is lined with composite solar panels which power one of three sets of batteries tucked in the very bottom of the canister. It also carries heat and light sensors connected to micro-processor recorders that are also stored in the upper chamber. The main mission is to test the effects of open space on the inflated balloon. Here, PM might give NASA a hand, since the space agency is testing balloon configurations for an unmanned probe of Jupiter.

On the second deck of the canister, we'd mount a stereo camera to take

photos of the earth from the cargo bay. Special portholes would be cut all around the canister, allowing the camera to rotate and shoot three-dimensional pictures. In addition to the solar batteries, we'd also have off-the-shelf camera and calculator batteries running our electronics.

The GAS program lets us use the astronauts twice during a three-to-seven-day mission. Two bipolar switches are connected by wire from the cargo bay to the flight deck and at two prearranged times the astronauts can flip the switches. With such a limit on the number of commands that can be given in flight, any experiment should have automatic switching wherever possible, and every switch should have at least one twin.

Other experiments suggested by PM staffers and several space experts include putting bits of plastic together with various glues in orbit. This would help determine which adhesives work best in weightless and near-vacuum conditions, an important point for space do-it-yourselfers of the future.

Astrophotographer Robert Little, a consultant to Bushnell, has suggested we fill our canister with an infrared camera. It would make an infrared map of the United States. Meanwhile, on Earth, PM would send up one or two

aircraft to take infrared photos from beneath the cloud deck. When the experiment returns, we'd run a computer analysis of the difference in heat thrown off by the Earth above and below the cloud deck. The differences would help us create a new insulation index, like an R-rating, for clouds.

NASA officials have told us that the experiment doesn't have to be absolutely original. After all, man hasn't been in space long enough to have repeated many experiments. Thus your proposal could well be a repeat of a previous gem. Most public libraries carry NASA publications on previous space experiments and on plans for future experiments. Also, check your regional office of the U.S. Government Printing Office for books on NASA programs. Two outstanding volumes are *Photography Equipment and Techniques: A Survey of NASA Developments* (GPO stock No. 330-000-453-2, \$2.60), and *The Space Shuttle* (GPO stock No. 033-000-00672-1, \$2.50). Both can be ordered from Superintendent of Documents, U.S. Government Printing Office, Washington, D.C. 20402.

Our competition is in two phases. Phase 1 doesn't require a lot of detailed information, and you may not need too many references to get into it. Remember, the countdown has begun. **PM**

## OWNERS REPORT: CHARGER

(Continued from page 101)

a sticker price of \$10,320. Finally, I tested the new Charger 2.2 and was so impressed by how it handled, its sporty looks, and its power that I ordered one. I paid \$9,325, including tax and license, but the price made no difference. I could've afforded any of them. I just liked the Charger better."

An Illinois production manager commented, "I appreciate what Chrysler Corp. is trying to do for the American auto industry. For the most part, workmanship seems very good. The only exception is the flat-black paint atop the rear bumper. But I'm 6-4 and find the front very roomy and comfortable. The rear seat could use more legroom, and the front seats should fold flat so people can sleep inside the car."

On the topic of comfort, a Massachusetts plant employee wasn't by himself in observing. "The rear seat is a joke. I'm 5-10 and can't even sit back there without bending my head forward. Might as well call this a two-passenger car and make the hatch floor deeper and larger."

An arsenal worker from Alabama volunteered, "I like the way the Charger rides, and it really handles well in

## SUMMARY OF 1982-83 DODGE CHARGER OWNERS REPORTS\*

|                                     |           |                                       |                |                                      |       |  |       |
|-------------------------------------|-----------|---------------------------------------|----------------|--------------------------------------|-------|--|-------|
| <b>Total miles driven</b> .....     | 2,228,983 | <b>Finish, peeling decals</b> .....   | 8.3            | <b>Poor</b> .....                    | 0.7   | <b>Number of vehicles owned:</b>       |       |
| <b>Average miles per gallon:</b>    |           | <b>Gearshift mechanism</b> .....      | 7.3            | <b>Comfort opinion (rear seats):</b> |       | <b>This car only</b> .....             | 39.9% |
| In town .....                       | 25.2      | <b>Transmission (general)</b> .....   | 6.9            | Excellent .....                      | 5.3%  | <b>Two cars</b> .....                  | 39.5  |
| On the highway .....                | 32.5      | <b>No rear legroom</b> .....          | 6.9            | Good .....                           | 17.3  | <b>Three cars</b> .....                | 11.3  |
| <b>Transmission choices:</b>        |           | <b>What changes would you like?</b>   |                | Average .....                        | 35.9  | <b>Four or more cars</b> .....         | 9.3   |
| Automatic three-speed .....         | 21.8%     | Five-speed transmission .....         | 10.6%          | Poor .....                           | 41.5  | <b>Makes of other cars owned:</b>      |       |
| Manual four-speed .....             | 76.5      | No changes .....                      | 10.2           | <b>Had any mechanical trouble?</b>   |       | Dodge .....                            | 24.9% |
| <b>Why did you choose this car?</b> |           | More rear headroom .....              | 10.2           | No .....                             | 52.9% | Chevrolet .....                        | 21.0  |
| Styling .....                       | 71.7%     | More rear legroom .....               | 8.2            | Yes .....                            | 47.1  | Plymouth .....                         | 18.8  |
| Economy .....                       | 43.0      | Move heater/vent control .....        | 7.2            | <b>What type of trouble?</b>         |       | Ford .....                             | 17.1  |
| Performance .....                   | 21.5      | <b>How much did you pay?</b>          |                | Transmission .....                   | 21.0% | Pontiac .....                          | 13.8  |
| Price .....                         | 19.2      | Average .....                         | \$8,264        | Electrical .....                     | 16.8  | <b>Age distribution of owners:</b>     |       |
| Handling .....                      | 11.6      | Range .....                           | \$6,500-11,150 | Fuel induction .....                 | 11.2  | 15-29 years .....                      | 60.0% |
| <b>Specific likes:</b>              |           | <b>Workmanship opinion:</b>           |                | Oil leaks .....                      | 9.1   | 30-49 years .....                      | 33.0  |
| Styling .....                       | 59.1%     | Excellent .....                       | 29.5%          | <b>Dealer repairs satisfactory?</b>  |       | 50-plus .....                          | 7.0   |
| Economy .....                       | 53.0      | Good .....                            | 52.3           | Yes .....                            | 57.7% | <b>Would you buy another Chrysler?</b> |       |
| Handling .....                      | 50.7      | Average .....                         | 14.3           | No .....                             | 42.3  | Yes .....                              | 85.4% |
| Performance .....                   | 24.2      | Poor .....                            | 3.9            | <b>Dealer service opinion:</b>       |       | No .....                               | 14.6  |
| Comfort .....                       | 22.8      | <b>Comfort opinion (front seats):</b> |                | Excellent .....                      | 20.5% | <b>Would you buy another Charger?</b>  |       |
| <b>Specific dislikes:</b>           |           | Excellent .....                       | 56.4%          | Good .....                           | 45.6  | Yes .....                              | 78.6% |
| Rattles and noises .....            | 12.8%     | Good .....                            | 39.1           | Average .....                        | 22.3  | No .....                               | 21.4  |
| No complaints .....                 | 12.5      | Average .....                         | 3.9            | Poor .....                           | 11.7  |  |       |

\*Percentage might not equal 100% due to rounding or insufficient data.

# Gazelle



*As Elegant As Yesterday, As Modern As Tomorrow*

*It's Classic Motor Carriages recreation of the Famous 1929 Mercedes Benz SSK. Average mechanical skills combined with our assemblies will provide you with the car you've always wanted. Your exotic will use modern components, offer excellent mileage and won't rust. Available in front or rear engine drive.*

**CLASSIC MOTOR CARRIAGES**

16650 N.W. 27th Ave., P.O. Box 10  
Miami, Florida 33054 (305) 625-9700

©1982 Classic Motor Carriages, Inc. Some Equipment depicted is optional

Enclosed is \$2.00 for full Color brochure and buying guide on all Classic Replicar Assemblies including the Gazelle

Enclosed is \$5.00 for full Color brochure on Classic handcrafted, factory finished exotics including the Gazelle

Name \_\_\_\_\_  
Address \_\_\_\_\_  
City \_\_\_\_\_ State \_\_\_\_\_ Zip \_\_\_\_\_  
Phone: Home ( ) \_\_\_\_\_  
Business ( ) \_\_\_\_\_  
Please charge on my:  
MasterCard \_\_\_\_\_  
VISA \_\_\_\_\_ Am. Express \_\_\_\_\_  
Diners Club \_\_\_\_\_  
Acct. NO. \_\_\_\_\_  
Exp. Date \_\_\_\_\_  
Signature \_\_\_\_\_

15-D-3

turns and sharp corners. Has great pickup out of the hole. I feel safe pulling out into traffic. It's also a popular car with the ladies."

The biggest single complaint from Charger drivers centered on rattles and general noisiness. Said a Rhode Island grocer, "Too much engine vibration and buzziness. The car needs more sound insulation." And an Alabama farmer: "Seems like you hear an awful lot of road noise inside the car. The engine backfires, too."

Nearly 53 percent of our respondents reported no mechanical difficulties. That's strictly an average score, though, and the satisfaction rate with dealer service also ranked just average.

Most Charger owners felt pleased with Chrysler's 5/50 warranty, and it definitely influenced a number of buying decisions. But a minority expressed something of a backlash.

To illustrate, a Maryland veterinarian complained, "I always feel I'm getting the bum's rush through the service department, because they know they'll have to honor my warranty a long time. I believe they don't want me to get too comfortable with it. Frankly, I don't know whether the warranty is worth all the resentment and hassle."

Not surprisingly, the Charger remains a young person's car. Sixty percent of those who answered our questionnaire were under the age of 29. Nearly 80 percent told us they'd buy another Charger next time, but several mentioned that they expected to have larger families by trading time and thus would want a bigger automobile. "Growing family requires a larger car," stated a Wisconsin accountant, who added that he would purchase another Dodge product because, "... Chrysler Corp.'s overall quality and engineering are excellent."

Most owners felt about their cars the way a South Carolina phone serviceman did when he wrote, "Workmanship and value are the best in many, many years. Charger has come alive again!"

And, finally, a highway patrolman who asked us not to mention his state, looked at his Charger in more philosophic terms: "Five or six years ago, I was convinced that Chrysler *should* be allowed to fail. That was because they were building such lousy cars at the time.

"However, I'm really impressed with the high quality of my new Charger, and I'm told that the same assembly standards also apply to other Chrysler products. I hope the trend continues, because my little Charger makes driving fun again. It brings back memories of the '60s and the great cars we used to enjoy back then." **FM**

# Top Quality 8" Hardwood Hand-Screw Clamps only \$14.00 each *2 for \$14.00 - limited time only*

**W**hether you need to clamp wood, plastic or any other material, these 8" hardwood Hand-Screw Clamps are your best choice. Not only do they provide superb clamping flexibility by allowing quick adjustment to regular or irregular shapes, but they'll give firm pressure without marring the workpiece surface.

By turning just a single screw, the jaws will close at an angle. This way you can concentrate the pressure in a small area.

However, by turning both screws for parallel closing, pressure is spread out over a large area, providing an evenly distributed grasp for a superior glue bond.

You can count on these clamps for years of dependable use thanks to their oiled, hard maple wood and cold drawn steel spindle construction.

Best of all, these rugged 8" Hand-Screw Clamps are yours at two for only \$14.00! Half our regular price! It's our way of welcoming you to the wonderful world of woodworking... the Shopsmith Way! Be sure to place your order today.

Limit 2 clamps per customer.

These top-quality clamps have been sold nationally at \$14.00 each.



\*Shopsmith, Inc., 1983

**Credit card customers call FREE 1-800-543-7586; In Ohio call 1-800-762-7555**

**Send me two 8" Hardwood Hand-Screw Clamps (CA-2054) at .....\$14.00**

Add local sales tax \_\_\_\_\_ % .....

Shipping & handling ..... \$3.40

Grand total ..... \$ .....

I currently own a Shopsmith power woodworking tool

**Shopsmith Inc.**  
The Home Workshop Company  
750 Center Drive  
Vandalia, Ohio 45377

**Payment:**

Check enclosed (Make checks payable to Shopsmith, Inc.)

MasterCard     Visa

Card No. \_\_\_\_\_

Interbank No. \_\_\_\_\_ Expires \_\_\_\_\_

(MasterCard only)    Month    Year

**Send To:**

Name \_\_\_\_\_

Address \_\_\_\_\_

City \_\_\_\_\_

State \_\_\_\_\_ Zip \_\_\_\_\_

**Dept. AXDZ**

Featured in  
this Month's  
Popular Mechanics!

Limited Offer - Save Up to 33%!

## With the New BULB SAVER, You Can Multiply the Life of Your Light Bulbs Up to FIVE Times!

The new Piezo Electric Products' BULB SAVER extends the life of any light bulb up to FIVE times... spotlight, tracklight, or household bulb, up to 150 watts (except three-way bulbs)... indoors or out! And there's NO perceptible brightness loss!

Completely safe and easy to install, BULB SAVER comes with a money-back guarantee. Call toll-free today... BULB SAVER pays for itself many times over!

Call TOLL-FREE or mail NO-RISK coupon today!

**800-328-5727 ext. 87 CALL TODAY!**



Piezo Electric Products, Inc.  
212 Durham Avenue  
Metuchen, NJ 08840

Please RUSH me the number of BULB SAVERS checked below. If I am not completely satisfied, I may return them for a complete refund.

- 12 BULB SAVERS, Only \$13.99.  
 Buy 18 and SAVE 19%. 18 BULB SAVERS, Only \$16.99!  
 SUPER SAVER! Buy 36 BULB SAVERS and Save 33%. Only \$27.99!

Add \$1.00 postage and handling to all orders. No CODs. Call 800-327-5727 ext. 87 or use VISA or MASTERCARD. NJ residents please add sales tax.

Amt. enclosed \$ \_\_\_\_\_

- Check  
 VISA   
 MASTERCARD

Card No. \_\_\_\_\_

Expiration date \_\_\_\_\_

Name \_\_\_\_\_

Address \_\_\_\_\_

City \_\_\_\_\_

State \_\_\_\_\_ ZIP \_\_\_\_\_

PM483

## MESSY SHELVES?

Magazines all over the place! What you need are Popular Mechanics FILE BOXES to help you keep those bookshelves neat and orderly. Each box stands alone with all twelve issues intact. With every order you receive FREE self-adhesive labels covering the years 1975 through 1984. Peel off the year required and place on appropriate box.



- 1 File Box, \$2.95**  
**2 File Boxes, \$2.75 ea.**  
**3 File Boxes or more, \$2.50 ea.**

Send order to Popular Mechanics, Dept. FL, Box 1014  
Radio City Station, New York, NY 10101.

For more on interesting projects send for PM's  
Plans and Ideas catalog. \$1.00

## LIVE STEAM

A Fascinating  
MAGAZINE...

A Fascinating  
HOBBY!

Come join a worldwide brotherhood of enthusiasts who have discovered model and full-scale Live Steam.

Live Steam Magazine is your key to information about locomotives, marine, stationary, traction and automotive engines, as well as machine shop techniques and how-to-build projects. It will keep you up to date on Live Steam news and activities everywhere.

You may be reviving an old interest or taking up an exciting new hobby - whichever it is, Live Steam Magazine will be a primary resource.

\$24.00 per year (12 issues), \$27.00 Canada and other countries (US Funds). "Fire up" today, call operator 35 Toll Free 800/824-7888. In California call 800/852-7777. Visa and MasterCard accepted. Or write:

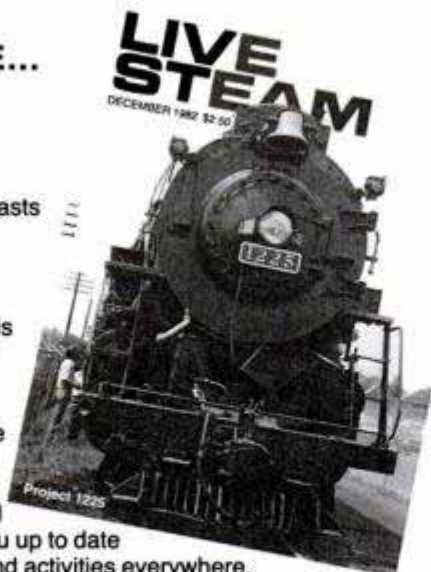

**LIVE STEAM**

P.O. Box 629-PM, Traverse City, Michigan 49685

## THE HOME SHOP Machinist

Whether you're in machining as a hobby or a business, you'll find this bimonthly magazine to be one of the most valuable resources in your shop.

- Hobby projects to build
- Money-saving tools & attachments to build
- New developments, approaches & products
- A forum for sharing your ideas.

Dedicated to precision metalworking! A great new shop partner! As useful as any other tool in your shop!

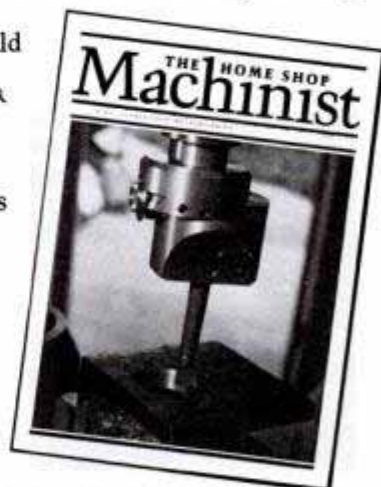

\$17.50 per year (6 issues) in USA, \$20.00 Canada and other countries (US Dollars). VISA or MasterCard orders: phone operator 660 Toll Free 800-824-7888 except California. In California 800-852-7777. Or write:

**The Home Shop Machinist**  
P.O. Box 1810-PM • Traverse City, Michigan 49685



# TECHNOLOGY UPDATE

## SPACE

### Not all of space is empty

The recent trouble with an out-of-control Soviet nuclear-powered satellite has dramatized the point that we need a way to retrieve space junk. In addition to any danger a falling space satellite or lab might pose for earthlings, the man-made debris that orbits earth presents a serious danger to the Space Shuttle or any manned craft. Some dead satellites are moving at speeds near 20,000 miles per hour, making them as dangerous as guided missiles for anything that crosses their paths.

The North American Aerospace Defense Command currently knows the whereabouts of 5,000 pieces, each a yard in diameter or larger. By the year 2000, NASA researchers say, the odds of a collision between a piece of debris and a spacecraft will be one in 200.

One solution currently under study by NASA is a "subsattellite" with its own propulsion system.

The subsattellite would be carried into orbit by the Space Shuttle. Then the vehicle would rocket to a set point, follow a piece of space debris a few minutes, then seize it with a robot arm. After

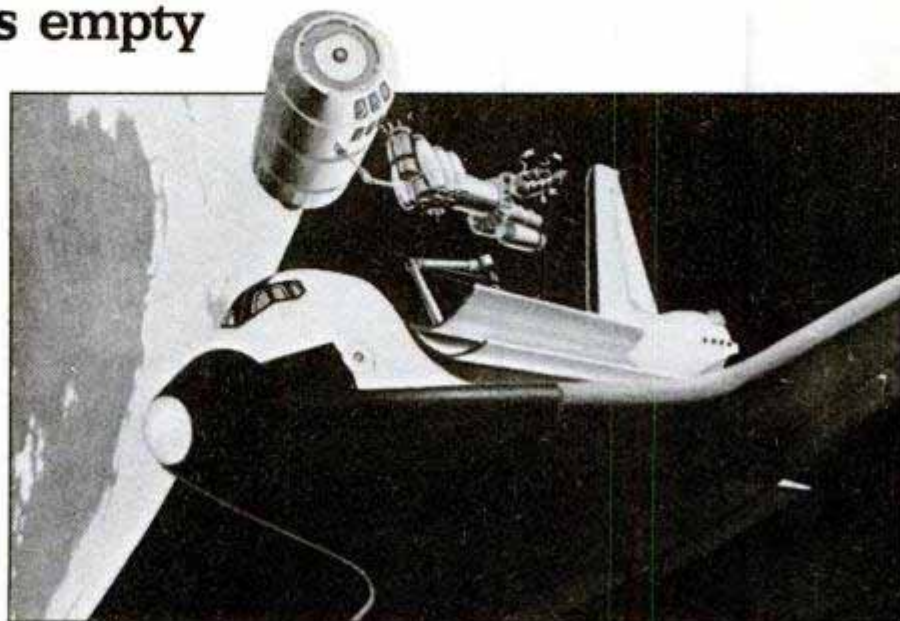

A "subsattellite" would grab space debris with its robot arm, then hand it to Shuttle.

retrieving the space junk, the vehicle would return to the Shuttle, which would pull the junk inside with its own robot arm. The retrieving vehicle would then be pulled inside, or sent on another mission to collect more space garbage.

## INVENTIONS

### Go soak a bridge

The air over most rivers is salty, and the salt soaks into the traffic decks of bridges causing severe damage—potholes. But Penn State researchers Philip Cady and Richard Weyers may have found a solution. They cut grooves into existing concrete decks and then fill them with liquid plastic. Then an infrared heater is run over the deck to superharden the plastic.

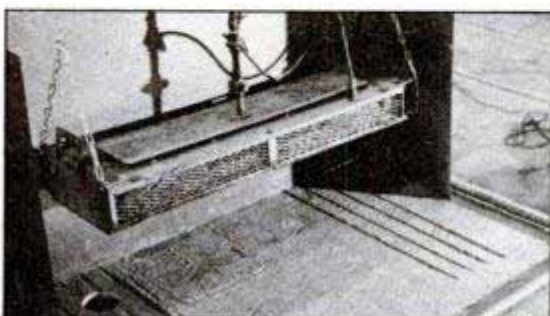

Infrared heater runs over bridge deck and superhardens a protective plastic in grooves cut into concrete.

The researchers say that no new salt can get in, and salt already inside the concrete is held in place. The method may extend by decades the life of a bridge deck.

### No more bum steers

Take a tough cut of meat from the scrawniest steer, place it inside a new machine in Oregon State University's Meat Science Laboratory, and out comes a mess of succulent sirloins.

The device, a cylindrical steel canister filled with warm water to maintain the meat's muscular structure, applies 15,000 pounds of pressure per square inch of meat. As a hydraulic cylinder squeezes the meat to about half its carcass length, the beef grows noticeably denser and thicker.

OSU nutritionists say the meat is just as flavorful as good cuts of beef, and perhaps easier



Inside the warm, water-filled tenderizer, meat is subjected to very high pressure.

to digest than meat that has not been pressurized.

Prof. Walt Kennick developed the concept after reading about pressure-tenderizing theories in an Australian journal. He and his colleagues are still working on an explanation of why the pressurizing works.

But they're so sure it does work that they've begun building a model for commercial use.

## MILITARY

### Split-second bomb snuffer

**A** gasoline bomb tossed into an enclosed space can kill or seriously burn people. But a Hughes Aircraft subsidiary has come up with a computerized fire-suppression system that can sense and snuff out an explosion within one-tenth of a second after it starts. Santa Barbara Research Center designed its Dual-Spectrum system to meet military specifications. But New York City already has shown an interest in placing them inside the tightly closed booths from which clerks deal out subway tokens. Two booths were firebombed in the past five years.

In order to start the superfast system, two of its four infrared sensors have to register heat that comes from an exploding bomb. Two milliseconds after registering the heat, the sensors notify a computerized control box. (A millisecond is one-thousandth of a second.) Within four additional milliseconds, the computer sends a signal to the valves in two 5-pound (1.44-cu.-in.) cylinders filled with a

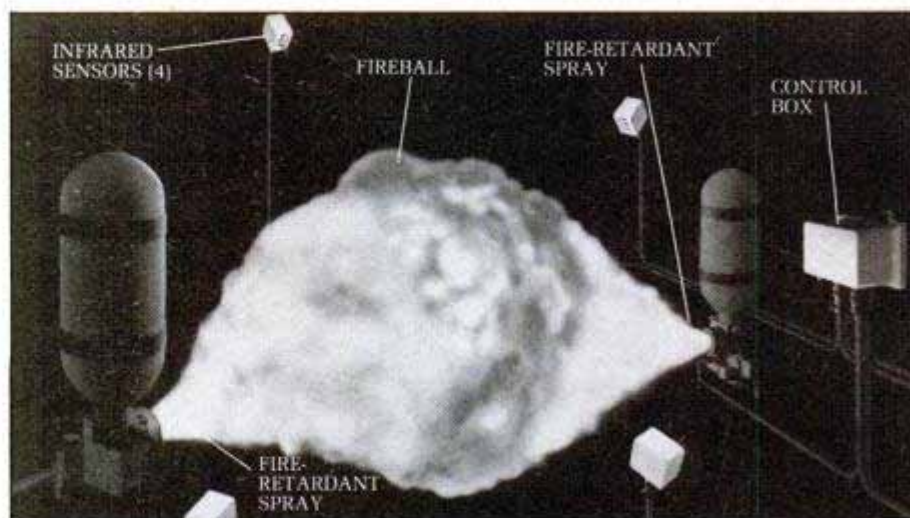

The Dual-Spectrum device smothers a firebomb in one-tenth of a second. Sensors send a signal to the control box that a fireball is emerging and it turns on retardant spray.

fire suppressor such as Halon. After about five more milliseconds the Halon is shooting at high pressure at the fire. It discharges all the fire suppressor within 50 milliseconds.

Total sensing and response time, lab officials say, is just under 100 milliseconds.

That, they say, is fast enough to prevent a token booth clerk or anyone standing near an explosion from getting seriously burned.

Similar systems already have been installed in M-1 tanks and other armored vehicles.

## MARINE

### Electronics gone 'in-seine'

**T**o seine for fish you drop a large, weighted net into the ocean, marking off its boundaries with floats that bob to the surface. Spot a school of fish in the center of the net, and you quickly pull in the net—and a large catch. Such fishing has been made easier recently with the introduction of micro-chip-based systems that pinpoint a school of fish with far greater accuracy than mere sonar or human vision.

Wesmar Marine's system, shown below, lowers a sonar device from a box carried under the ship at centerline. The school shows up on a screen, and the picture is vivid and dramatic even in black and white.

The Wesmar system pinpoints the location of a school of fish and gives you its distance from the ship. The system, which was introduced early this year, is expected to be used mostly for tuna and herring fishing.

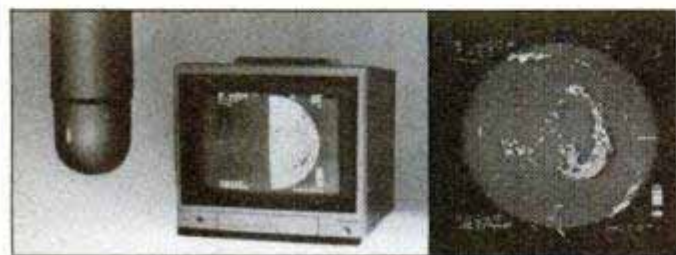

Sonar map (right) produced by Wesmar's boom (left) shows a sickle-shaped school of herring gathering near nets under a seiner.

## ELECTRONICS

### Testing, by Jove

**W**hen America's Galileo mission is launched later this decade, it likely will carry a soil analyzer designed for a now-scrubbed hard landing on Mars. Designed by Duwayne Anderson—dean of natural sciences at New York's State University at Buffalo—the analyzer is composed of simple "off-the-shelf" parts to keep its price down. Rows of temperature and moisture sensors would be able to evaluate surrounding terrain so accurately that the analyzer should be able to tell the difference between mere rocks and ice or snow. If Galileo is launched as planned in 1986, it would land on one of Jupiter's moons within two years. The landing would be "hard," with the capsule carrying the analyzer expected to penetrate slightly the icy ground of a moon. By digging into the surface of a Jovian moon, scientists hope to settle the question of whether any of them possibly contain life-supporting water. The Anderson analyzer would be connected to a telemetric system that broadcasts soil-water test results back at regular intervals for months at a time. Anderson is working with Bell Aerospace researchers on adding some circuitry to the analyzer to perform additional tests.



Duwayne Anderson holds analyzer going to Jupiter's moons.

## AVIATION

### Economy-class fighter

**R**arely do defense contractors spend their own money developing weapons. But Northrop's F-20 Tigershark jet fighter has flown its 100th test mission without a single order from the defense department.

The F-20 was developed in response to a defense department call for a tactical air defense fighter good enough to sell to friendly nations around the world. No sales were promised, but Northrop has begun demonstration flights for the Jordanian and Egyptian air forces. The Mach 2-class fighter is billed as perfect for the needs of most friendly nations for the next 20 years. It has a scramble time of three minutes, meaning that within three minutes after being strapped into his seat, the pilot has his craft 17,000 feet up, 10 miles from home base with all systems combat-ready. In addition to advanced radar and communications devices, the F-20 carries heat-seeking AIM-9 missiles. The \$9



Northrop's \$9 million F-20 Tigershark has a scramble time of three minutes.

million craft—a bargain by international military standards—has flown missions at Mach 1.9 at 50,000 feet using internal fuel only in a 2-hour, 12-minute flight. Northrop bills the F-20 as an all-weather flier. Although the published figures on the Tigershark are somewhat more modest than those of the latest MiGs, the scramble time is expected to be a decisive factor in selling the jets to Middle Eastern and Asian nations. The current craft is designed as a one-seater, but plans are afoot to build a two-seater. With today's advanced avionics and electronics, jet fighter pilots stay very busy during a mission, and a second seat makes it possible to carry a gunnery officer to operate radar and missile systems in close combat.

## ALTERNATIVES

### Foam sweet home is completed

**I**t doesn't sound like the best possible building material for Wisconsin's icy winters, but polystyrene foam is the stuff of which Steve and Mary Nelson's home is made. And, as if to draw a line under the word icy, the Nelsons moved into the three-bedroom ranch in McFarland on Dec. 10. Electric baseboard heating is keeping the home quite comfortable, Steve says. And Mary adds that she can look out her window at a crowded ice-skating rink across the street, but she never hears traffic through the foam walls.

The house, the first of four being built this year by Cubic Structures Inc., is made of 4x8-foot blocks of 12-inch-thick foam anchored to a foundation by reinforced steel bars. The blocks are coated on the

outside with Insul/Crete, a polymer modified Portland cement that can produce either a textured stucco or stone finish when sprayed on. The walls have an insulation rating of R-46, slightly snuggier than required by local building codes.

Foam house designer Don Peterson says the homes are selling for \$68,000 to \$80,000, which he calls competitive with traditional homes. Peterson has gone to great lengths to show how tough an insulating foam can be. He drove a 7¼-ton truck onto the Nelson's foam roof before it was installed to show that the blocks can take tremendous amounts of weight.

Although the first heating bill hadn't arrived by press time, the Nelsons told us they expect to spend much less on heat this season than they did last year.

Steve was surprised at the speed with which the foam walls went up. "They actually put the outside walls up in a single day," he notes.

Some small-scale foam houses have been built at Department of Energy research centers around the nation. But no one



The walls are 12-in.-thick foam blocks coated on the outside with Insul/Crete.



The polystyrene roof was tested with a load of 7 tons before it was installed.



The Nelsons pose outside their home of polystyrene foam.

lives in any of those structures. The DOE foam buildings were outfitted with sensors and are still undergoing evaluations for insulating and other properties. Meanwhile, Cubic Structures is building two more foam houses in Minnesota and another model in Houston. They will go up for sale later this year.

Editor: Dennis Eskow  
Contributors: Mort Schultz, Yvonne Michie Horn

## ENGINEERING

### The drill you steer

**T**here's got to be something better than brute force," says Harold Nissley, chairman of California's Advanced Drilling Co. Nissley's company will find out this summer whether there is something better when it comes to drilling for oil. They'll be using the firm's new steerable drill that, instead of pounding through layers of rock, can be steered from ground-level to avoid hard pockets of rock as it seeks out oil or water deposits. Called the Robot Drill, the system uses a hydraulic inflatable cuff to angle off as it digs into the earth.

Invented by two Stanford University researchers—Robert Horstmeyer and Larry Weick—the drill's cuff, located behind the drill head, can be inflated to grip the sides of the drill hole. The cuff's four compartments can be inflated separately, pushing against just one side of the drill hole and steering the drill head. Nissley says a more advanced model of the Robot Drill will have, in addition to the cuff, a set of hydraulic jacks radiating out from the area just above the cuff. The jacks will provide extra accuracy in steering the snake-like drill.

Horstmeyer conceived the drill while at

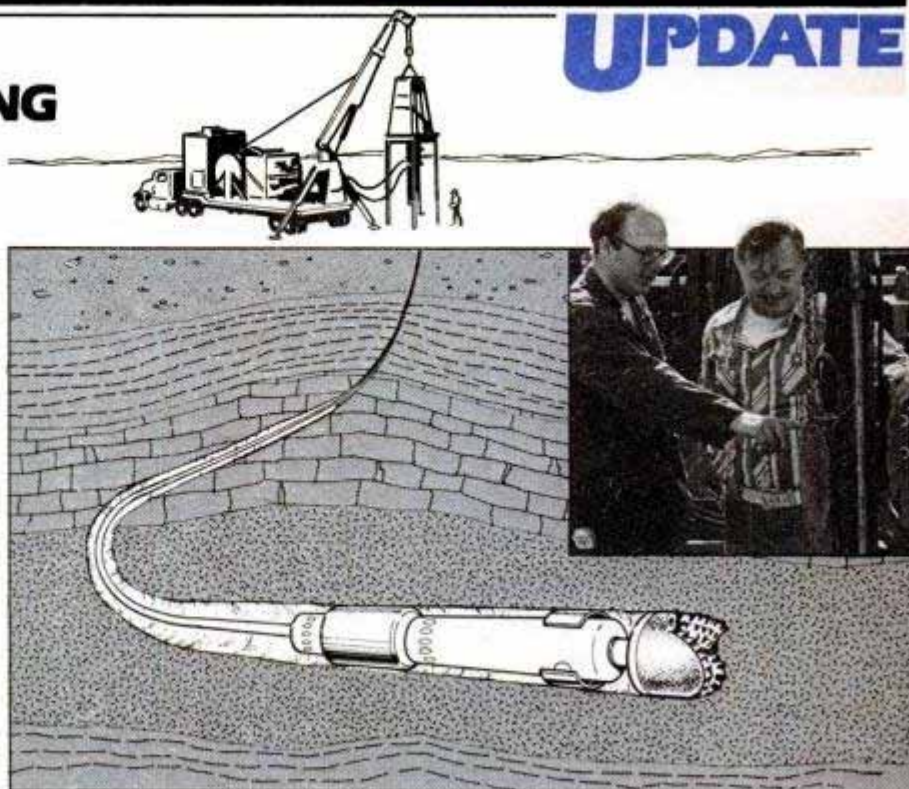

Harold Nissley (inset, left) examines the Robot Drill's steering shaft with Robert Horstmeyer. The drawing shows the shaft snaking under a layer of thick rock.

the U.S. Naval Academy. He says he was impressed by the ways the Navy uses hydraulics in nuclear submarines.

In a standard drill rig, a drill head is stuck at the end of a 93-foot-long pipe. Weight is added to the pipe to force it down. By holding onto the side of the drill

hole, the Robot Drill can offset the torsional and forward thrust of the head.

The drill stem is 10 to 20 feet long. With the steerable drill, Nissley says, the drill head can be pulled out of the ground about 10 times faster than with standard systems, making replacement cheaper.

## MEDICAL

### Cleaning blood for transplants

**O**rgan transplant patients are in greatest danger just after surgery. That's when their blood contains high levels of white blood cells which can trigger organ rejection. But Battelle Memorial Institute researchers have developed a portable blood irradiator that can kill off enough white blood cells to prevent organ rejection without seriously damaging other body cells. The device, so far tested only in animals, fits in the palm of your hand and can be hooked up to blood vessels at any part of the body. One end of the tubular structure is attached to an artery, which pumps blood into the irradiator and out the other end into a vein. Inside the irradiator, a small amount of thulium 170 puts out 2,000 to 5,000 rads per day of radiation. That's a very small

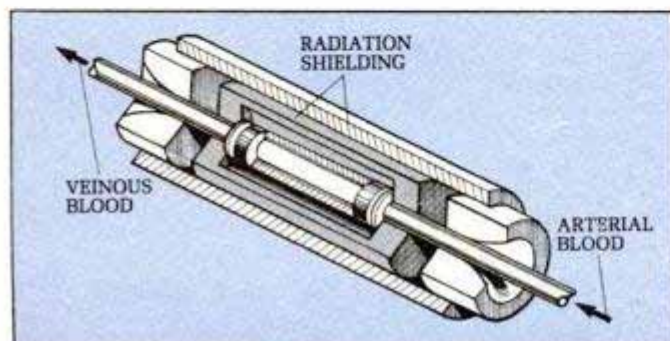

dosage. But researchers at the institute say the level lowered the white cell count in experimental animals by up to 25 percent within five days.

### Breast cancer war

**M**edicine needs every weapon it can get in the war against breast cancer. And now a new breast cancer detection system that uses no X-rays has been introduced into the arsenal. It is not meant to take the place of mammography, the low-dose X-ray system that detects breast cancer early. But the new system lets doctors examine a patient's breasts more frequently than before without subjecting her to increased dosages of X-rays. The new device, Thermascan, is a wrap-around Mylar belt containing encapsulated liquid crystals whose colors change when exposed to heat. By taking several readings over an extended period, the doctor can see changes in the breast's temperature profile, indicating very early growth of a tumor. The Thermascan company says the product will soon be available by prescription for women to use at home.



Thermascan senses breast heat to find tumor growth.

This talking phone TELLS you in clear English what numbers you're dialing.

# We'll Try to Describe Everything This Space-Age Phone Does In One Page of Small Type. It Won't Be Easy.



The Everything Phone is a handsome, contemporary ivory phone with a standard modular plug, ready to go.

It's as though someone said—  
"Let's think of *everything* any telephone can do, and combine them into one fantastic instrument."

Someone did say that. This is it. We call it THE EVERYTHING PHONE because it does everything. It advances the science of phone communications by ten years, even in this age of wild changes and improvements.

For example—  
**This Phone Actually TALKS To You**  
The Everything Phone speaks to you in a warm, gentle voice. It never tells you wrong. Touch the "Voice" switch and when you push a button, the phone tells you the number you've pushed. If you're working in dim light, you won't dial a wrong number, because your friendly phone voice repeats each digit immediately, as you dial it.

**A Complete Phone Answering System**  
If you press the "Prefix" key, the "Clear" key, the Direct Memory Keys, or any of the other special function keys (more about these later), your Phone Voice tells you what you've pushed. If you get tired of company, you can shut off the voice; but it's like having a friend right inside your phone.

This feature takes some explaining. In the bank of keys to the right of the dial pad are three marked M1, M2, and M3. M1 and M2 will tell a caller, when you're out, either when to call back or another number where you can be reached.

What about M3?  
M3 makes any cassette recorder an answering device. Using the connector (supplied), your recorder can take messages up to the total length of any tape cassette. The Everything Phone turns the recorder on and off automatically when a call comes in.

So—you have your voice of 1) a message, in the phone's own voice, to call back at whatever hour you designate; 2) a message that you're out and can be reached at whatever number you designate; 3) an invitation to leave a message after the tone, with a capacity as long as the cassette—an hour or more.

## Memory Keys Galore for Automatic Dialing

At the left of the numeric keypad are ten Direct Memory Keys. The key at the upper left is for MCI, Sprint, or other computer-code dialings. It holds the access number and your personal code number.

The other nine let you dial stored numbers, including long distance numbers, by pressing one key. You can inset a tab showing whose number is stored.

But you ain't see nothin' yet!  
You actually can store up to 50 numbers of 20 digits each, using a two-number code. Example: if you already have 30 numbers in memory and you want to store 1-305-473-2044, punch in that number, use the "Store" key and "31", and you'll be able to dial that number in the future just by pressing "31".

## Quality Speaker-Phone

Of Course The Everything Phone has one-way speaker-phone capability. Of course it's high quality sound.

Just press the "Speaker" button and you have a hands-free phone. A volume control gives you just the right amount of amplification.

## Music on Hold: "Mute" Switch

You can put a caller on hold just by pressing the "Hold" key. What a pleasant surprise! Instead of dead sound, the person on hold hears a pleasant melody. (You'll hear it too, so you won't forget he's on hold.)

You have a "Mute" privacy button, and it couldn't be more convenient—it's right in the center of the modern hand-phone. Press that button, and although the other party won't be able to hear you, you'll still be able to hear him or her. Release the button and communications are normal again. (No tell-tale "click" when you press the Mute button.)

**Here's a List of Other Built-in Benefits**  
Your Everything Phone is an electronic butler. It has—

— Automatic redial. Press this key and your phone will redial the last number you called either once (if the phone is off the cradle) or four times (if the phone is in the cradle).

Each key has a separate function. Each one talks to you, if you want it to. What a conversation piece The Everything Phone is!

- Pulse/Tone selector switch. In areas with rotary dialing only, slide the switch to "P". In areas with touch-tone, slide it to "T".
- Ringer off switch. You can turn off the pleasant "chirper" (it isn't a bell) when you don't want to be disturbed. A separate ringer l.e.d. light will alert you, if you're interested.
- Access pause key. For Sprint, MCI, and other code numbers, the Pause button gives you the proper gap between the original dialing and the time the system takes to answer with a tone. The Pause has other uses, too, but we just can't list all of them here.
- Secretarial aids. Open a little door and you have a memo pad to jot notes. For the numbers stored in automatic dialing memory, slide out the Directory Card, concealed under the phone unit.
- Battery backup. Two tiny, easily replaceable batteries keep your memory intact. A power failure, even one that lasts for months, won't wipe out what's stored in the memory.

## Anything Else?

Probably. We ourselves haven't figured out all the phone assistance The Everything Phone can give you. But we do know this:  
*No other phone ever made has all the benefits and comforts this one has for you.*

**CAN YOU BELIEVE IT?  
THE EVERYTHING PHONE  
IS YOURS FOR JUST**

**\$199.95**  
two for only **\$189.95**  
(+ \$4.50 shipping each)

Order your EVERYTHING PHONE  
by lifting your old-fashioned phone  
and calling toll-free:

**1-800-824-7888**

Ask for Operator 551.  
(In California: 1-800-852-7777)

Have your VISA or MasterCard handy.  
Phones are manned seven days a week,  
24 hours a day.

## We Absolutely Guarantee!

The Everything Phone is a lot of fun, and it's the darnedest electronic instrument you ever owned. But if at any time during the first full month you own it you decide not to keep it, send it back and we'll refund every cent you paid.

Send check or money order, or charge card information (**\$199.95 + \$4.50 shipping— Total, \$204.45**) to New Horizons, or call the toll-free number above.

The Everything Phone  
is another electronic marvel from  
**NEW HORIZONS**  
Dept. PM4, 1 Penn Plaza, Suite 100  
New York, N.Y. 10119

# EAGLE BELT BUCKLE



*The American Eagle*  
*Symbol of Strength, Liberty, Power, and Pride.*

## INDIVIDUALLY NUMBERED AND ELECTROPLATED IN GENUINE 24-K GOLD

Our master craftsmen and artists have created an Eagle Belt Buckle which will be individually numbered, and electroplated with genuine 24-Karat Gold.

### Permanent Registry

Each original owner will be permanently registered in our official archives, and a certificate of authenticity attesting to the Buckle's gold content will accompany each order. And, to further protect the integrity of this edition, the dies for this buckle will be destroyed at the end of the year, December 31, 1983.

Wear this authentic collector's buckle as a striking fashion accessory and unmistakable symbol of your love for your country. Then, hand it on to become a treasured heirloom as well. Your buckle will be sent to you in a specially designed presentation case and your satisfaction is assured by our unlimited money back guarantee.

### Order Early For Lower Serial Numbers

Since registry numbers are assigned to each order as it is received, we strongly urge that you order promptly to receive the coveted lower numbers that are still available. **LIMIT: FIVE (5).**

International Mail Marketing, Dept. BZF-23  
 390 Pike Road, Huntingdon Valley, PA 19006

Please send me American Eagle Belt Buckle(s) electroplated in genuine 24-karat Gold as indicated below:

- One Eagle Buckle only \$7.99 plus \$1.75 p&h.
- SAVE \$2!** Two Buckles only \$14.99 plus \$2.25 p&h.
- SAVE \$6.70!** Three Buckles only \$19.99 plus \$2.50 p&h.
- SAVE \$18!** Limit of Five Buckles Just \$30 postpaid.

Enclosed is \$\_\_\_\_\_ (Pa. residents please add 6% sales tax)

**CHARGE IT!**  Visa  American Express  
 Diner's Club  MasterCard Exp. \_\_\_\_\_

Card No. \_\_\_\_\_

Signature \_\_\_\_\_

Name \_\_\_\_\_

Address \_\_\_\_\_

City \_\_\_\_\_

State \_\_\_\_\_ Zip \_\_\_\_\_

© 1983 International Mail Marketing

## NEXT MONTH IN PM

- **Indy 500 preview—plus PM drives the red-hot pace car!**
- **Brooklyn Bridge 100th birthday: Tribute to a great artistic and engineering feat.**
- **Guide to video cameras.**
- **Victorian sideboard—a beauty to build for your dining room.**
- **Special Car Care Guide: How to make your car last forever.**

**SUBSCRIPTION SERVICE:** Popular Mechanics Magazine will, upon receipt from its reader of a complete new or renewal subscription order, undertake fulfillment of that order so as to provide the first-copy delivery to the Postal Service within six to twelve weeks. If for some reason this cannot be done, you will be promptly notified of the issue date that will begin your subscription, with a request for any further instructions you may have concerning your order. Please address all such orders to us at Popular Mechanics, P.O. Box 10064, Des Moines, Iowa 50350. Should you have any problem with your subscription, please write Joan Harris, Customer Service Department, Popular Mechanics, P.O. Box 10064, Des Moines, Iowa 50350. To assure quickest service, please enclose your mailing label when writing to us or when renewing your subscription.

Renewal orders must be received at least eight weeks prior to expiration to assure continued service.

## Popular Mechanics

P.O. Box 10060, Des Moines, Iowa 50350

**YES!** Please enter my subscription to POPULAR MECHANICS for: **WMPM**

- 1 year \$11.97
- 2 years \$21.97

Payment of \$\_\_\_\_\_ is enclosed.

Bill Me \_\_\_\_\_  
 Initial here

Name \_\_\_\_\_ (please print)

Address \_\_\_\_\_

City \_\_\_\_\_ State \_\_\_\_\_ Zip \_\_\_\_\_

Your first copy will be on its way to you in six to twelve weeks. Watch for it!

A publication of the Hearst Corporation.

Charge orders subject to publisher's acceptance. (Above prices apply in U.S. & Possessions only. Canadian and foreign prices upon request.)

## CHANGING ADDRESS?

If you're planning to move, please let us know at least eight weeks before changing your address. Attach current address label and fill in your name and your new address. This will serve to insure prompt service on your subscription.

Send old label with your name and new address to:

**POPULAR MECHANICS**  
 P.O. Box 10064, Des Moines, Iowa 50350  
 or call toll-free: 800-247-5470  
 State of Iowa residents call: 800-532-1272

NAME \_\_\_\_\_ (Please print)

NEW ADDRESS \_\_\_\_\_

CITY \_\_\_\_\_ STATE \_\_\_\_\_ ZIP CODE \_\_\_\_\_

# MAKE CLOCKS

WITH BATTERY QUARTZ MOVEMENTS  
**EARN EXTRA INCOME!**  
KLOCKIT OFFERS WHOLESALE  
PRICES FOR MOVEMENTS, DIALS  
AND ACCESSORIES.



**CALL TODAY!**  
(414) 248-1150

NEW CLOCK PLANS

**KLOCKIT** DEPT. PM43  
P.O. BOX 629  
LAKE GENEVA, WI 53147

# FREE CATALOG

## HYDRAULIC JACK REPAIRS



A Business of your own.

Earn while you learn at home. Millions of jacks in gas stations, trucking firms, etc. need servicing. We show you HOW. Start spare time in your basement or garage. Big opportunity for mechanics.

Write for folder No. PM4 and free bonus offer.

**HYDRAULIC JACK INC.**  
P.O. BOX 18, ACCORD, NY 12404



FOR COMPLETE INFO  
ON OUR AIRCRAFT  
SEND \$5 TO:

**PTERODACTYL LTD.**  
P.O. BOX 191-PM  
WATSONVILLE, CA  
95076

## LEARN MEAT CUTTING



Train quickly in 8 short weeks at Toledo for a bright future with security in the vital meat business. Big pay, full-time jobs—**HAVE A PROFITABLE MARKET OF YOUR OWN!** Time payment plan available. Diploma given. Job help. Thousands of successful graduates. **OUR 60th YEAR!** Send NOW for a big new illustrated FREE catalog. No obligation. G.I. approved. **NATIONAL SCHOOL OF MEAT CUTTING**, No. 71-02-0197T, Dept. 50-N, 33 N. Superior, Toledo, Ohio 43604.

## GARAGE DOOR OPENERS



• Radio  
Controlled

- Buy Factory Direct and Save
- Thousands In Use • Free Brochure
- Easy Homeowner Installation
- Immediate Shipment by UPS or PP

HELPMATE Equipment Co. Dept. PM-483 Baroda, MI 49107

**HOW TO BUILD A MORE POWERFUL BODY!!**  
Fantastic muscle pumping methods!

**FREE BOOKLET!**  
HOW YOU CAN HAVE

- Wider Shoulders
- Trimmer Waist
- Powerful Chest
- Bigger Arms

**YOU CAN:**

- Gain Strength
- Lose Fat

Universal  
Box 6694, Dept. 1  
Detroit, Michigan 48240

## GAS GRILL REPLACEMENT PARTS SPRING SPECIAL MOST MAJOR BRANDS

|                    |         |                           |          |
|--------------------|---------|---------------------------|----------|
| S.S. Single Burner | \$29.95 | Briquette Rack            | -\$11.95 |
| S.S. Double Burner | \$35.45 | Roper Model No. 1106-1108 | \$19.95  |
| Warming Rack       | \$ 5.95 | 80 pc Briquettes          | -\$11.95 |
| Cooking Grid       | \$14.95 | Roper 20 pc               | \$10.25  |
| If 2 Needed        | \$29.90 | 36 pc                     | \$30.20  |
|                    |         | 66 pc                     | \$31.95  |

Send check or money order plus \$3.50 P&H to:

**R&R PARTS**  
609 Hertel Ave., Dept. 32, Buffalo, N.Y. 14207

Special on orders over \$50  
P&H FREE plus FREE Grill Scrub

When ordering specify make, model # & rack sizes  
N.Y.S. residents add 7% sales tax  
Complete brochure available — Free

Train at home for an exciting



career as an  
**ELECTRICIAN**

- MAINTENANCE
- CONTRACTOR
- CONSTRUCTION

Check electrician's wages against the money you are now making! Make extra money in spare time while you train for a full-time job. Do odd jobs for friends and neighbors. Save money doing your own electrical work. Learn everything from repairs and maintenance to complete electrical installations. No previous experience needed. Everything explained in easy-to-understand language with plenty of drawings, diagrams and photos. Tools, materials, test equipment included with course. Approved for Veterans and G.I.'s. Be ready to take almost any electrician licensing examination offered by state, city or county. **No cost, no obligation, no salesman will call.**



MAIL COUPON TODAY!

Electrician School, Dept. PB033  
ICS Center, Scranton, PA 18515

Rush free facts that tell how I can train at home in spare time to be an electrician.

NAME \_\_\_\_\_ AGE \_\_\_\_\_  
ADDRESS \_\_\_\_\_  
CITY/STATE/ZIP \_\_\_\_\_

## INVENTORS

Problems with developing marketing and mfg your product? We offer complete service domestic and international. Free consultation. Patented products preferred.

**KORUNA CORP.**  
212 5TH AVE.  
NEW YORK, NY 10010  
EST. 1955  
TEL: (212) 679-9730

## LEARN CLOCK REPAIR

EARN BIG MONEY!  
WORK AT HOME • BE YOUR OWN BOSS  
FOR DETAILS SEND \$1.00 TO



P.O. BOX 448, LEWISTOWN, PA, 17044

Now! Make up to  
**\$12.00**  
PER HOUR

In Your  
Own Spare  
or Fulltime



## SHARPENING BUSINESS!

Now you can quickly turn spare time into handsome CASH profits! No selling or previous experience required. With this Complete Sharpening Shop, you can be your own boss, set your own hours! Customers come to you and pay you cash to sharpen saws, knives, chisels, scissors, garden tools ... all cutting edges.

**45-DAY FREE TRIAL!**

Send today for free facts on our 45-Day Free Trial! See how our clear, illustrated instructions and proven design make it easy to start earning extra income right away! **Easy Terms!**

MAIL COUPON TODAY or:  
Call Toll-Free 1 (800) 824-7888 Oper. 642  
In California Call 1 (800) 852-7777  
Oper. 642

**FREE INFORMATION KIT**

Woodmaster Tools, Dept. 45D, 2849 Terrace  
Kansas City, Missouri 64108

Yes, please rush me free and without obligation your complete information KIT and details on your 45-Day Free Trial Offer.

Name \_\_\_\_\_  
Address \_\_\_\_\_  
City \_\_\_\_\_  
State \_\_\_\_\_ Zip \_\_\_\_\_

## One Man Portable Sawmill



Cuts 30% more lumber from up to 30" Dia. x 16 1/2' logs. Safe bandsaw carriage for smoother more accurate lumber. Ready to operate.

## Wood Carving Duplicator

Accurate, simple,  
1 to 1 wood duplicator  
3 models available,  
easy to operate.



## Bandsaw

Large 24.5" throat, 9" vertical cut tilt table, wood and metal cutting, rugged construction, affordable.

Save — Buy Direct

**Dupli-Carver** (317) 243-7565

4004 West 10th St. Dept. 2003  
Indianapolis, IN 46222

Enclosed is \$1.00 for 32 page catalog and information on 30-Day Free Trial

Name \_\_\_\_\_  
Address \_\_\_\_\_  
City \_\_\_\_\_ State \_\_\_\_\_ Zip \_\_\_\_\_

## Fabulous Folboting NOW

Avoid the risks and discomfort of floppy canoes, skimpy kayaks, wobbly inflatable rafts! NOW, you GLIDE securely in perfected Folbot, completely relaxed in EXCLUSIVE swivelback COMFORT. America's foremost small craft in various styles and colors from 1 to 4 seaters. GLIDE smoother, faster with EASIER lightweight double blades, efficient yacht smart sails, small motors. Perfect for nature study, scouting, float cruising, supreme in White Water, Surf, Waves and sea. Most INEXPENSIVE in EASY PREFAB KITS or ready FACTORY BUILT, also travel-smart FOLDING types to fit inside trunk or aircraft!

## FOLBOT

Super Craft at  
**BIG SAVINGS**

Easy PREFAB  
Kits from \$182  
or cartop  
**FACTORY  
BUILT**  
from \$348  
FOLDING  
from \$612  
ideal  
Sail Rig  
\$279

Smart  
Economic  
BASIC Kits  
12 foot  
Single \$40  
16 foot  
Double \$52  
Big Sailer  
16 foot \$61

## FREE

Action Color Catalog  
With Facts & Figures  
For rush inc. \$1  
First Class Postage

Mail coupon or address

to: **FOLBOT CORP. PM483**  
Charleston, S. C. 29405

Print  
Name \_\_\_\_\_  
Address \_\_\_\_\_  
City \_\_\_\_\_ State \_\_\_\_\_  
Zip Code \_\_\_\_\_

# Master Keys to Car Care



through the repair and maintenance procedures.

This handy packet can be kept very conveniently in your car. Referred to at a moment's notice! If your battery and cable need checking you pull out folder number 11 and find the answer. To repair a car dent, folder number 1 will show you how. Why isn't the air conditioner keeping your car cool? Number 12 has the answer. IT'S THAT SIMPLE!

This information packet will help keep your car in top running order and will show you how to repair your car if something does go wrong, especially on an isolated road or highway. Just think how convenient it will be and the money you can save.

**PM's Master Keys to Car Care \$4.95 is available for**

Send check or money order to: Popular Mechanics, Box 1014, Radio City Station, New York, NY 10101. For faster mail service add an extra \$1.00

Popular Mechanics is a Publication of Hearst Magazines, a Division of The Hearst Corporation.

## If you drive a car, you need these Master Keys!

POPULAR MECHANICS MASTER KEYS TO CAR CARE packet can help you out! In this handy packet you can find your basic car repair needs in step-by-step instructions, all shown on numbered sheets, supplemented by photos and diagrams that show what you'll see under the hood of your car as you go



## SUPER BARGAIN SPECIALS!

### Powerful Permanent Magnet Motor/Generator



ITEM 10-1023 \$14.95

Prepaid In Continental U.S.A.

With Bridge Rectifier \$16.50

\* ITEM 10-1023 - - Runs on 12 to 120-v. AC or DC. (Rectifier req. for AC). Very powerful for its size. Torque 50 in./oz. at 6500-RPM. 5.5-amps. No load speed, as motor, 1,000 to 10,000-RPM. Reversible rotation. As generator, use wind, pedal, water power to produce 12-volts at 950-RPM, 24-volts at 2000-RPM. Ball bearing equipped. Shaft 15/32" diam., 2-3/4" long, threaded end. O'ring size 3" diam. x 7-1/4" including shaft. (3-1/2 lbs.) **Brand New**

### Waterproof All-Steel .50 Cal. Ammo Boxes

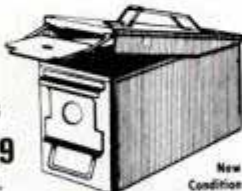

ITEM 1-1038 \$8.49

Prepaid In Cont. U.S.A.

New Condition

\* ITEM 1-1038 - - Genuine U.S. Gov't. issue, heavy gauge steel ammo boxes. Not imported, lightweight copies. Tight sealing lid with rubber gasket. Waterproof protection for tools, camera gear, fishing tackle, valuables, ammo, important papers, etc. Carry handle folds flush. 11-3/4" x 7-1/4" x 6-1/8". (6 lbs.)

Send \$1.00 For 100 Page Equipment Catalog



( Your Can Order Direct From This Ad )

OUR TELEPHONE: ( 402 ) 474-4366



**SURPLUS CENTER**

Dept. PM-043 Lincoln, NE 68501

## WORLD'S FINEST FLASHLIGHT

**NEWMAN** \$29.95  
(Lifetime Guarantee) ANY SIZE PPD



This could be the last FLASHLIGHT you'll ever buy! Money-Back Guarantee

- From spotlight to floodlight with just a twist of the wrist
- D-ringed throughout for maximum water resistance
  - Waterproof lens and reflector
  - Totally sealed, self-cleaning push button switch
  - Blue anodized, indestructible anodized aluminum
  - Small numbered for positive identification
  - Spare bulb in the handle of every 2-cell flashlight
  - Available in 2 cell thru 6 cell (C or D)

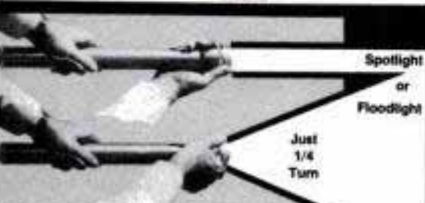

Spotlight or Floodlight

Just 1/4 Turn

Color Brochure \$1.00 Flashlight \$2.00 any size plus Money Orders Only (A/R orders shipped within 24 hours) Sold by NATIONAL FLASHLIGHT P.O. Box 721318 - D Houston, TX 77272

# Rare TECHNICAL BOOKS!

## Incredible "how to" books!

Discover hundreds of manuals, industrial handbooks, paperbacks, reprints, and privately published papers on unusual technical subjects ranging from melting metal to building windmills, and from tanning hides to flying the space shuttle!

You'll see instantly why this is the most remarkable mailorder bookstore ever! You don't know what you've been missing! We probably have just the information you've been searching for for years!



## Wide Variety!

Discover books on motor rewinding, hydraulics, hydroponics, wind and water power, converting autos to LP gas and other fuels. Tan a hide! Make soap! Books on magnets, Stirling engines, batteries, inverters, alternators, sundials, mushrooms, papermaking, dynamo design, steam power, more! Set up a chem lab! ...a plating shop! ...a mailorder business! Learn calculus! Plastics technology! Transistor electronics! Build radios! More!

## Highest quality!

Every book is guaranteed to be high quality. This is NOT a book club. You're free to buy what you want when you want. No obligation. We are free to pick and choose only the very best books from the best publishers. Since we cannot possibly offer every book published, we guarantee that only the best books are listed in our catalog.



## Build a lathe!



Build a precision lathe for less than \$50 without power tools or precision instruments! It's true! Build a shaper, milling machine, drill press, rotary table and indexing head, a sheet metal brake! Learn how to make a surface plate and rebuild machine tools! Build a small engine without castings! Collect and restore old steam engines! Build a welder! Make your own drill bits, taps, dies, reamers, end mills, and much more! Discover an incredible 2000 page mechanical engineer's handbook! ...a huge machinist's handbook! See books on machine design, strength of materials, optimization, more! Learn about plastics, carbon-graphite composites, injection molding and much, much more!

Learn how you can turn an old pail and a blower into a powerful furnace that can melt aluminum cans and scrap, pot metal and brass. We built one for about \$10! Uses grocery store charcoal! Pour custom castings! See books on sand casting, lost wax casting, casting small metal and rubber parts, patternmaking, cupola secrets (for melting cast iron), foundry materials, and more! Discover how to make and melt glass, build dynamos, batteries, dividing machines, magnets! Discover the secrets of Whitworth's 1853 micrometer that could measure to a millionth of an inch! Discover books on electric furnaces, making charcoal and coke, boilers, and much more!

## Melt Metal!



## Much more!

See technical school textbooks on industrial drafting, diesel repair, and refrigeration. Learn how the ancients refined all types of metal from iron to gold! Get thousands of watts from a common auto alternator! Run three phase motors on single phase! Learn the secrets of lead-acid batteries and inverters! See the original Stanley Steamer patents! Repair small gas engines! Learn locksmithing! Be a small time operator! More!

## Write for a catalog!

Write for your own copy of the latest jam-packed edition of Lindsay's Technical Books catalog. Send \$1.00 US & CAN (\$3.00 airmail foreign) to cover first class postage and handling. You'll see in a minute why everyone is talking about this incredible mailorder bookstore! Many of these special interest books suddenly go out of print! You've already missed out on some incredible books! Write for a catalog and order the books you need while they're still available. Write for a catalog TODAY!



**Lindsay Publications Box 12-JX BRADLEY IL 60915-0012**

Send a catalog! I've enclosed \$1.00 US & CAN (\$3.00 foreign airmail)

Name \_\_\_\_\_  
Street \_\_\_\_\_  
City \_\_\_\_\_  
State \_\_\_\_\_ Zip \_\_\_\_\_

## BUILD YOUR OWN BOAT

Join the thousands who build each year AND SAVE \$\$\$! GLEN-L's proven methods are especially intended for amateurs. Step-by-step pictorial and written instructions with material listings assure **PROFESSIONAL RESULTS!** HUGE 144-page catalog describes over 200 designs, 8' to 55'. Sail & power boats, boat trailers, boating books, AND MORE! Order catalog now and also receive FREE "BOATBUILDING SUPPLIES" brochure.



## KITS · PLANS · PATTERNS

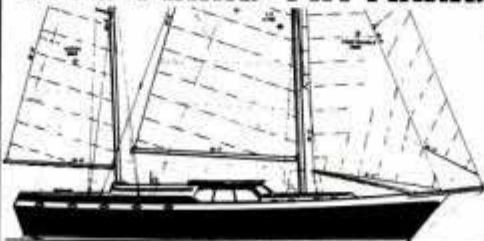

### GLEN-L MARINE DESIGNS

9152 Rosecrans, Box 7567, Bellflower, CA 90706

- GLEN-L catalog @ \$2.00 (sent 4th Class) OR
- GLEN-L catalog @ \$4.00 (sent AIR MAIL)
- "FIBERGLASS BOATBUILDING-AMATEURS" @ \$19.95 ppd.
- "BOATBUILDING WITH PLYWOOD" @ \$15.95 ppd.
- "INBOARD MOTOR INSTALLATIONS" @ \$14.95 ppd.
- "HOW TO FIBERGLASS BOATS" @ \$ 8.50 ppd.
- "RIGGING SMALL SAILBOATS" @ \$ 6.50 ppd.
- "HOW TO BUILD BOAT TRAILERS" @ \$ 6.50 ppd.

NAME \_\_\_\_\_  
STREET \_\_\_\_\_  
CITY \_\_\_\_\_  
STATE \_\_\_\_\_ ZIP \_\_\_\_\_

**GLEN-L** GLEN-L MARINE DESIGNS  
9152 Rosecrans, Box 7567, Bellflower, CA 90706

## Build this beautiful Dome Home by yourself!

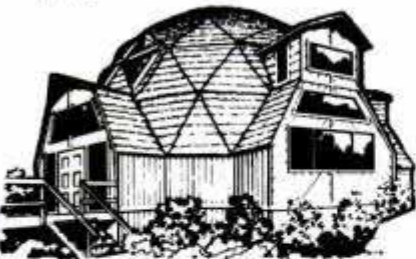

### Enjoy super affordable payments and low energy bills

Save up to 60% on building costs and up to 50% on utilities. Beautiful Monterey Domes geodesic home kits are extremely energy-efficient, unbelievably strong, earthquake resistant, and easy to assemble. No special tools or skills necessary. Our unique, patented building system makes home construction a reality for the novice.

Monterey Domes pre-cut, color-coded shell packages start at \$3995. Models up to 3,500 sq. ft. Send for our exciting color Catalog & Plans Book — over 90 fact-filled pages of beautiful affordable homes.

Write today! **Monterey Domes, Inc., 1760 Chicago Dept. AQ-4, Riverside, Calif. 92517**

Rush me your 90 page CATALOG & PLANS BOOK. Enclosed is \$6.00, postage included.

Also send your ASSEMBLY MANUAL for an additional \$5.00.

NAME \_\_\_\_\_

ADDRESS \_\_\_\_\_

CITY, STATE, ZIP \_\_\_\_\_

Mail To: **MONTEREY DOMES, INC.**  
1760 Chicago, Dept. AQ-4  
Riverside, Calif. 92517



## WANTED NOW! SALES AGENTS MEN, WOMEN

Your chance to make some real serious money fast!

All experts agree that **absolutely nothing** sells better and faster by mail than information. Sell **how to make money books, manuals, and special report** by mail. Start now part time or full time. As your **Key Source**—I'll supply you with everything you need to operate your own home business. The market is extremely huge millions of potential buyers. There is no place like home to start a new business of your own. For full details send \$2.00 (Refundable) to—

**NEW YORK  
SUCCESS EXCHANGE®**  
POST OFFICE BOX 1242 DEPT. P483  
GRAND CENTRAL STATION  
NEW YORK, N.Y. 10163



# Li'l PUP

by *Shoreline*



FORGET THE REST  
PULL THE BEST

TOURING  
CAMPING or  
CARGO

Highest quality  
gel-coated fiberglass

ORDER BY MAIL  
AND SAVE 20-30%

- LIGHT WEIGHT • SAFETY ENGINEERED
- AERODYNAMIC STYLING
- 27.5 CUBIC FOOT CAPACITY
- HIGH SPEED WHEEL BEARINGS
- LOCKABLE SPRING LOADED LATCHES
- 1000 POUND CAPACITY

WRITE TODAY FOR FREE BROCHURE AND PRICES

**T-G Trailer Sales**

PM483

1115 W. Mayfield Road, Arlington, Texas 76015 (817) 487-4166

## RANGER BUSH HAT



\$11.95 ppd

The Ranger Bush Hat in popular woodland camouflage pattern is an excellent hat for hunters, campers or hikers. 50% nylon/50% cotton, four wire mesh ventilators in the crown, plus a 3/4" wide nylon webbed band with loops for adding natural camouflage. Floppy brim, 3" wide. Adjustable nylon chin strap. Hand washable. Available in sizes Small (7), Medium (7 1/4), and X-Large (7 3/4). We honor VISA and MasterCard. Moneyback Guarantee

**P&S Sales Dept. PM-43**  
P.O. Box 1500, Chapel Hill, NC 27514

## NON-GUNS!



That's right, these precision-built replicas of famous firearms CANNOT CHAMBER OR FIRE REAL AMMUNITION! Made of machined metal, they look, feel and weigh same as the originals. CAN BE DISASSEMBLED. Over 30 Guns, hand-labeled parts. Comes fully assembled. Safe and perfect for display. MONEY BACK GUARANTEE. Send for FREE CATALOG of over 90 different models. Model shown: U.S. SOFT 45 AUTOMATIC. COST: \$50 (U.S. ONLY). THE COLLECTOR'S ARMOURY, Inc., Dept. PM 800 SLATERS LANE, ALEXANDRIA, VIRGINIA 22313

## FREE SOLAR HEATING

Do-it-yourself 4' x 8' solar panel easily assembled with common hand tools. All aluminum — ONLY \$269.95!! Send \$4.00 for brochure and fully illustrated instructions to:

**Associated Energy Specialists**  
Box 534 Newton, Iowa 50208

## Be an ELECTRONICS SPECIALIST

No previous experience needed. LEARN AT HOME IN SPARE TIME

Now the same home-study training used by some of the country's biggest corporations for their own employees is available to you. Everything explained in easy-to-understand lessons with plenty of pictures and drawings. Get free facts about basic electronics programs that can lead to an exciting career in communications, TV and radio, manufacturing, computer industry and more. No obligation. No salesman will call. State age. Write: 401

ICS Electronics School, Dept. PB033, Scranton, PA 18515

## A SINGER'S DREAM!

**REMOVES VOCAL FROM MOST STEREO DISCS**

The Thompson Vocal Eliminator can actually remove most or virtually all of a solo vocalist from a standard stereo record and yet leave most of the background music untouched! Not an equalizer! We can prove it works over the phone. Write or call for a 24 page brochure and demo record.

Write to: **LT Sound, Dept. PM, P.O. Box 338, Stone Mountain, GA 30086** Phone (404) 493-1258 COST: \$349.00

## PUMPS

BUY DIRECT AND SAVE  
Drain • Irrigate • Circulate • Spray

Heavy duty ball bearing pump. All metal, rust-proof Type XB. Stainless shaft. Use 1/4 HP or larger. 1 HP 1,200 GPH 60" high or 3,000 GPH 25" well. 5,200 GPH max. 1 1/4" in. 1" out. Belt or direct drive. \$21.95 Type P won't rust or clog. Bronze bearing. To 2,400 GPH. 1" in. 3/4" out. \$15.95 ADD \$2 p/b & h/dng. Money back Guarantee. **LABAWCO, 80 Hwy 206, Belle Mead, N.J. 08502**

## Affordable Contemporary Homes

### The WeatherBloc™ System.

Enter the affordable world of The WeatherBloc System. The construction system that takes the 6 tedious steps necessary to build conventional housing and reduces them into one easy procedure. Saving you time. And money.

WeatherBloc has been designed for structural integrity and energy efficiency.

Each design in The WeatherBloc System is customized. And our design service is free.

You can even build one yourself.

So, no matter if you're dreaming of a teal blue two bedroom contemporary in the suburbs. Or a cozy mountain chalet for your weekends. Your dream can become reality.

Write for free information. Send your name, address and telephone number to the address below. Or call 800-833-2461 (in New York State call 518-494-2426).

Exclusive Dealership Territories Available



**THE  
WEATHERBLOC  
SYSTEM**

A Division of Lincoln Logs Ltd.  
63043 Riverside Drive  
Chestertown, NY 12817

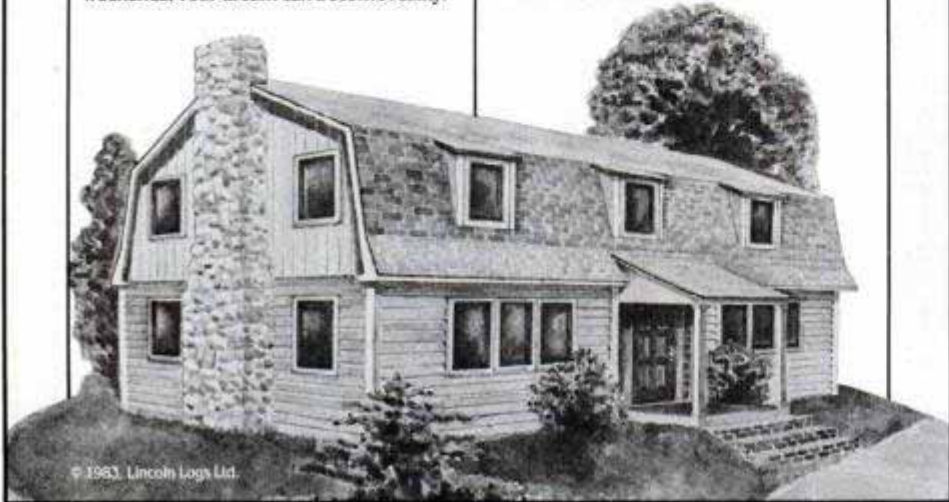

© 1993, Lincoln Logs Ltd.



**STANDARD GARAGE**

Easy to build with our plans and complete materials list specify size:

- 12' x 20'
- 14' x 20'
- 16' x 20'
- 18' x 20'
- 20' x 20'
- 22' x 22'
- 24' x 24'
- 26' x 30'
- 28' x 30'
- 30' x 30'

Larger size on request. Plans and material list \$6.00. We also have plans for large variety of other buildings from dog houses to large pole buildings. Send \$8c for brochure on other projects to build.

**Crown Building Products,**

Dept. C-483 P.O. Box 34542 Omaha, NE. 68134

**HUMUNGUS! THAT'S WHAT THEY'LL SAY WHEN YOU GROW TOMATOES THE SIZE OF GRAPEFRUIT.**

ATCO'S REVOLUTIONARY NEW SYSTEM OF TILLAGE GIVES YOU GIANT PEPPERS, ONIONS, POTATOES AND CARROTS (ENDORSED BY DEPT. OF AGRICULTURE) 30 DAY FREE TRIAL PERIOD. SEND FOR LITERATURE NOW... YOU MIGHT WIN A FREE TILLER!

Want a better garden? Try a better tiller... new ATCO Tiger Tiller with Vari-Atak Tines, so gentle it tills single handed... gives you more power per pound of machine than any other tiller... Built for commercial use with 16 adjustments for operator comfort and better tillage... Does the work of a rear ender but costs 65% less... Send for literature now...



Weights 22 lbs. runs 8 hrs. on 1 gal. of fuel. Tills deep from 18 to 12 inches wide. Weeds fast from 12 to 2 inches wide.

Not sold in stores-free gardening guide

Write: Allentown Tiller Co. c/o Allentown Feed Co., Main Street Allentown, New Jersey 08501...Dept. P



Tills in rough stuff. Good sod buster. Won't bounce

Name \_\_\_\_\_  
Street \_\_\_\_\_  
City \_\_\_\_\_  
State \_\_\_\_\_ Zip \_\_\_\_\_

For rush delivery of literature call 201-530-9380 24 hrs. a day

**THE BOSS LOG SPLITTER!**  
Splits EASIER & FASTER!  
Only \$49.95 plus \$8 p. & h. for adaptable cone. or \$99.95 plus \$10 ready-to-attach to hub of car or light truck (specify vehicle). Pa. — send 6% sales tax. Free info—send stamped self addressed envelope. Good Products, Route 3 Box 88-A PM, Kutztown, Pa. 19530

**NOW BRASS BAR RAILS For Your Home**  
and other solid brass bar accessories  
Now you can have solid brass bar rails, standoffs, end caps, flanges, etc. for your home bar. The same quality as you see in the finest restaurants and pubs.  
For Catalog send \$1.00 to: MIDWEST CUSTOM BRASS, 208 E. Main Street, Dept. PM43 Round Lake Park, IL 60073

**Telephone Listening Device**  
Record telephone conversations in your office or home. Connects between any cassette or tape recorder and your telephone or telephone LINE. Starts automatically when phone is answered. Records both sides of phone conversation. Stops recorder when phone is hung up. This device is not an answering service.  
Each \$19.95 (by disc Avail.)  
**Super Powerful Wireless Mic**  
10 times more powerful than other mics. Transmits up to 1/4 mile to any FM radio. Easy to assemble kit. 15V battery (not incl.)  
Call (305) 725-1000 or send \$19.95 + \$1.00 shipping per item to USI Corp., P.O. Box PM-2062, Melbourne, FL 32901. COD's accept. For catalog of transmitters, voice scramblers and other specialty items, enclose \$2.00 to USI Corp.

**START WITH 24,221 PRODUCTS!**  
Many you can buy one at a time or order in quantity. Example, one LCD Watch \$4.99 odd, or 10 for \$3.95 odd. Price drops to only \$1.95 job in larger orders. New government ruling makes thousands of imports free of any duty whatsoever. You deal direct my International Traders way. Cut out greedy U.S. specialty merchandise middlemen. Really deal direct.  
Moped \$220  
Tiger Eye Ring \$3.75  
COMPUPHONE Auto dials 10 numbers. Built in computer. \$17.  
South American Orion Poncho \$6.38  
Diamonds & Sapphire Low, low prices from Bangkok  
Lock Blade Knife \$1.34

**SAMPLE IMPORT FREE!**  
...and I'll tell you exactly how to turn it into big money!

MAIL FREE SAMPLE CERTIFICATE — Get Full Facts How to start your own big profit

**HOME IMPORT BUSINESS**

MY PLAN STARTS YOU FAST... Shows you how to Buy Below Wholesale

MEN—WOMEN... Turn Spare Hours or Full Time into INCOME!

**DISCOVER PROFITS OF IMPORT!** My Home Mail Order Import Business Plan guides your every step... it is based totally on my personal success. Shows how to deal direct and cut out costly middlemen... so you keep all the profits! I do the "hard work" for you... by traveling the world to find dazzling "first time offered" new imports. The actual sample I will send you Free is typical of my import discoveries. You can pick and choose from more than 24,000 products. Deal in one product or 1000's. Buy below wholesale.

**YOU CAN START IMMEDIATELY.** I arrange free membership in exclusive International Traders organization... instantly puts you in direct contact with suppliers abroad. I show how to operate anywhere. Age no barrier. Ideal for spare time husband/wife or retirement business. My report, "How to Import and Export" tells how to do it. No obligation. No salesman will call. Certificate brings your free gift sample import and everything else.

**FREE CATALOG!**  
Now! Quick Double Profits As a Member of International Traders you also get free catalogs of specialty merchandise to order at rock-bottom prices from big U.S. warehouse. Products subject availability, price fluctuation.

**B.L. Mellinger, Famous World Trader, Internationally-known Mail Order Expert; President, Mellinger Co.** "I started only a few years ago, part time, in my garage with less than \$100. Today my business empire spans the globe. I will help you succeed using my personal experience. Mail coupon for FREE REPORT."

- LCD Watch \$1.95
- Video Game Cartridges Below Wholesale
- Metal Detector \$9.25
- Field Glasses \$3.55
- Jade Ring \$1.28
- Spinning Reel \$1.30
- STEREO CASSETTE RECORDER PLAYERS AM/FM \$27.
- Swiss Electric Razor \$3.70
- Mink Coat \$299.
- Cassette Recorder \$11.45
- TV Many Models Below Wholesale
- Radio Watch Jugglers delight \$7.80

*This Certificate Good for*  
**ONE SAMPLE IMPORT - FREE**

B. L. Mellinger/The Mellinger Co. 6100 Variel Ave., Dept. E2254 Woodland Hills, CA 91367

Send FREE REPORT, "How to Import and Export"... also actual Free sample import. Everything you send me is mine to keep without obligation. Show me how I can start a profitable home business of my own.

**IMPORTANT**  
Your initials must appear below to qualify for Free sample import. Because of high cost and limited supply, I hereby agree to limit my request to one, and one ONLY, Free sample import. I have not previously requested this Free sample. I am over 18 years of age.  
Initial here \_\_\_\_\_

Name \_\_\_\_\_ Age \_\_\_\_\_  
Address \_\_\_\_\_  
City \_\_\_\_\_  
State \_\_\_\_\_ Zip \_\_\_\_\_

**PERSONAL GUIDANCE!**  
I believe in giving you my personal help! Regularly I meet 1-1. Members at regional closed door Seminars across the country. You will be invited to these meetings.

1000's more dazzling products you can buy DIRECT!

- Walkie Talkie
- Golf Balls
- Baseball Glove
- Telescope
- Electric Calculator
- Sapphire Ring
- Spinning Reel
- Radio
- Cigarette Lighter
- Beer Steins
- Rifle Scope
- Phone Amplifier
- Movie Camera
- Fishing Rod
- Swords
- Black Forest Clock

**Learn how to MAKE MONEY in DRAFTING**  
Train at home in spare time. No previous experience needed. Tools and materials included with course. No special talent required. We show you what to do, how to do it. **LEARN DRAFTING AT HOME!**  
FREE! "CAREER KIT"  
NAME \_\_\_\_\_ AGE \_\_\_\_\_  
ADDRESS \_\_\_\_\_  
CITY \_\_\_\_\_ STATE \_\_\_\_\_ ZIP \_\_\_\_\_  
NORTH AMERICAN SCHOOL OF DRAFTING, 4408 Campus Dr., Dept. PB033, Newport Beach, CA 92660

**Get into COMPUTER REPAIR**  
Train at home in spare time. No previous experience needed. Home-study course includes tools and materials, shows you how to start. Send for free facts. No obligation. No salesman will call.  
Name \_\_\_\_\_ Age \_\_\_\_\_  
Address \_\_\_\_\_  
City/State/Zip \_\_\_\_\_  
Computer Repair, Dept. PB033, Scranton, PA 18515

**WOODWORKERS!**  
A magazine for both novice and veteran bringing you over 75 project plans per year...for building the best of Early American, Shaker, English, Contemporary furniture, clocks, toys, lamps, gifts and much more...  
**ALL FOR LESS THAN 20¢ PER PLAN**  
PLUS Regular articles on shop tips, jig-building, finishing techniques and money-making ideas.  
1 YEAR (6 bimonthly issues)—only \$12.00  
2 YEARS (12 bimonthly issues)—only \$22.00  
Foreign Rates: 1 year—\$14.00, 2 years—\$26.00 (Please make payment in U.S. Funds)  
**The Woodworker's Journal**  
P.O. BOX 1629-314 NEW MILFORD, CT 06776  
NAME \_\_\_\_\_  
ADDRESS \_\_\_\_\_  
CITY \_\_\_\_\_ STATE \_\_\_\_\_ ZIP \_\_\_\_\_  
money back if you're not satisfied

## TILLER USERS...

Can your machine do all of this?

- ★ Handle with just ONE HAND.
- ★ EVENLY break, turn & till soil.
- ★ Shred vegetation without tangling.
- ★ Leave NO WHEELMARKS or FOOTPRINTS.

The TROY-BILT® ROTO TILLER-POWER COMPOSTER can do all this and more! That's why serious gardeners consider it the finest tiller available. See for yourself! For complete details, "OFF-SEASON" SAVINGS, and FREE 26 page booklet clip this and mail today to:



### TROY-BILT® Tillers

102nd St. & Ninth Ave.,  
Troy, N.Y. 12180

TROY-BILT® Roto Tiller-Power Composters  
Dept. A1716  
102nd St. & 9th Ave., Troy, N.Y. 12180

Please send the whole wonderful story of TROY-BILT® Roto Tillers including prices and "OFF-SEASON" SAVINGS now in effect for a limited time.

(Please Print Clearly)

Name \_\_\_\_\_  
Address \_\_\_\_\_  
City \_\_\_\_\_  
State \_\_\_\_\_ Zip \_\_\_\_\_

© 1982 Garden Way

**BEAT the HIGH COST of LIVING!**

**HERE IS A BEAUTIFUL WAY TO MAKE MONEY!**

**UPHOLSTERY BOOKLET MAILED FREE!**

**LEARN UPHOLSTERY AT HOME...** restore old chairs, sofas to like-new condition! A clean, enjoyable way to put spare hours to profitable use. Old cast-offs picked up for dollars, worth hundreds when reupholstered. Fascinating home study course includes tools, kits, supplies. Earn as you learn — start your own business!

**SEND FOR OUR FREE BOOK TODAY! YOU'LL GET A BIG ILLUSTRATED 24 PAGE BOOK ON UPHOLSTERY** and the upholstery business and a sample lesson showing how the fabulously successful MUI system is taught. It costs you nothing to get the information and there's no obligation. No salesman will call.

Modern Upholstery Institute,  
80132 Field Bldg., Kansas City, Mo. 64111

**GET STARTED NOW • MAIL THIS COUPON TODAY**

Modern Upholstery Institute,  
80132 Field Bldg., Kansas City, Mo. 64111

Please mail me a copy of your book, "PROFESSIONAL UPHOLSTERY for Fun and Profit." I understand no one will call and there is no obligation.

Name \_\_\_\_\_ Age \_\_\_\_\_  
Address \_\_\_\_\_  
City \_\_\_\_\_ State \_\_\_\_\_ Zip \_\_\_\_\_

## PRINT YOUR OWN

Print cards, stationery, envelopes; advertising, labels, tickets; holiday, sympathy, birthday, QSL cards. Satisfying pastime/money-maker. Work with your hands, use your imagination, see results.

**Own a Printing Business.**

Send \$1 for Kelsey Catalog

Have your own shop. Add to income. We supply instructions, hand presses and all supplies direct from factory. Famous since 1872. Send \$1.00 for a catalog. **Kelsey Presses, 83BD, Meriden, CT 06450**



## BURRO Fiberglass Travel Trailer Kit

Build Yourself! Save Gas



**TRAILER FOR THE '80's**—Burro Travel Trailer kit sleeps four. Under 1,000 lbs. Fiberglass. Ready to tow. Finish interior only. Write Burro PM4 14143, 21st Avenue North, Plymouth, MN 55441. For full color catalog send \$3.00 to cover handling. Rental Opportunities.

## HANDGUNS

AT LAST! Latest info on prices, models, sources, combat shooting, special ammo. Loaded with color. America's only exclusive **AMERICAN HANDGUNNER** magazine. \$1.00 for 80 pg sample - one year subscription at less-than-half news stand price, only \$5.95. Send check, money order or credit card info to **AMERICAN HANDGUNNER** Dept PM BOX 16439, SAN DIEGO, CA 92116



## LEARN HOW TO HANG DOORS

**EARN \$30pr hr \$100-\$200 PER DAY REPLACING DOORS** Part time, Full time or Save \$3 doing your own Step by step instructions by a professional with 2,500 doors hung. I know your problems.



ORDER YOUR MANUAL TODAY ONLY \$6.00

**GARRETT DOOR & LOCK CO**  
1853 Denison, Pomona CA 91766



## Find twice the treasure...

with a WHITE'S ELECTRONIC MINERAL/METAL DETECTOR

White's instruments detect rings, jewelry, coins, plus other valuables and it's profitable! Metal detecting is a hobby for the whole family to enjoy. Models from \$79.95. Covered by U.S. Patents.

WHITE'S ELECTRONICS, INC. 1011 Pleasant Valley Rd., Sweet Home, OR 97386



In half the time

FOR THE NEAREST WHITE'S DEALER AND A FREE CATALOG CALL TOLL FREE

1-800/547-6911

PA-3

• DISH ANTENNA'S  
• PREAMPLIFIER  
• RECEIVER

**397**  
TOTAL PKG.

### Satellite TV, Inc.

P.O. Box 3108, DEPT. M-4 Lantana FL 33462  
Send your REFERENCE BOOK for \$11.95 plus \$2.95 shipping & insurance (U.S. funds) or call our 24-hour C.D.D. Order Line (305) 276-2941.  
Name \_\_\_\_\_ Info for authorized TV programming  
Address \_\_\_\_\_



## Satellite TV STOP LOOKING!!!

**NEW! SUPER LOW PRICED COMPLETE SYSTEMS WITH 8", 11" etc. DISHES.**

"WE HAVE IT ALL" 100+ Channels • LNA's • Antennas • Receivers • Sources • Photos

Our book is not OVERLY TECHNICAL MUMBO JUMBO but takes the mystery out of the sophisticated technology of satellite reception. The prestigious Mass. Inst. of Tech. U.S. Army, libraries worldwide have bought this book.

**FREE**

## THE GREAT ELECTRONIC THINGS & IDEAS BOOK!

HUNDREDS OF UNUSUAL PARTS, GADGETS & IDEA ITEMS, UNAVAILABLE IN STORES OR CATALOGS ANYWHERE! Bargain prices on everything! New items in every issue! Rush postcard for your copy!

**ETCO** ELECTRONICS  
Dept. 323  
Plattsburgh, N.Y. 12901



## SCAMP TRAVEL TRAILER ALL FIBERGLASS - LIGHTWEIGHT SCAMP 13 & 16 & 19: 5TH WHEEL

Tol FREE 1-800-346-4962 • or  
Write for free color brochure.

-Box 2-Backus, MN

56435

**Scamp**

**CUSTOM BUY A WHOLESALE INCLUDES STORAGE BAG**  
**III CAR COVER \$29.00**



FITS ALL SIZE CARS FROM AUSTIN HEALEY SPRITE TO CADILLAC. ANY CAR FROM 1900 TO DATE.

|                           |                            |                           |
|---------------------------|----------------------------|---------------------------|
| SMALL<br>LENGTH-150"-170" | MEDIUM<br>LENGTH-170"-190" | LARGE<br>LENGTH-191"-225" |
| 29.00                     | 35.00                      | 39.00                     |

**WATER RESISTANT AND REPELLENT**

- MIRACLE NYLON TAFFETA CLOTH FABRIC
- QUALITY CONSTRUCTION
- DOUBLE SEWING
- ELASTIC SEWING FRONT & REAR
- DURABLE, LIGHT WEIGHT
- MACHINE WASHABLE
- AVAILABLE FOR PICK UP TRUCK

- PROTECT YOUR CAR'S PAINT & WAX TOP
- WEATHER PROOF
- RUBBER INTERIOR
- PROTECT YOUR CAR FROM
- INDUSTRIAL POLLUTANTS
- RAIN • SNOW • SLEET
- ICE • DUST • SAND

**TOLL FREE**  
 NATIONWIDE  
 800-421-5734  
 CALIFORNIA  
 800-252-2295

american wholesale arpaufin&over inc.  
 319 W. 17TH ST., LOS ANGELES, CA 90015

**TUNE YOUR GUITAR IN ONE MINUTE**



Six precision-tuned reeds make exact tuning a snap. Slip the "VIEW-PITCH" guitar tuner on your guitar and adjust the strings. When the proper pitch is reached, the corresponding reed vibrates. As easy as that! This fantastic invention, ideal for all guitars, has been praised by over 200,000 beginner and professional users.

Gift Boxed.  
 Only \$12.95 Postpaid Money Back Guarantee  
 ED SALE GUITAR CO.  
 64 E Main St., Grand Island Fla. 32735

"ARC WELDED PROJECTS"—VOL. II  
 Instructions, and drawings, for making 140 useful projects. 272 pages — \$5.00

"NEW LESSONS IN ARC WELDING"—2ND ED.  
 100 lessons: materials, exercises, questions and answers for manual welding. 320 pages — \$4.50

Check and clip ad, mail with check or money order to publisher: Lincoln Arc Welding Foundation, Cleveland, Ohio 44117

**NEW SHIPMENT JUST ARRIVED**

Hardened Steel. For filing, drilling, milling, carving, routing any metal or wood. Cutting edges from 1/4" to 1", all shanks 1/2". Brand new in air-tight G.I. packs.

- 32-Tool Set, G.I. cost \$295<sup>00</sup> now \$129<sup>00</sup>
  - 14-Tool Set, G.I. cost \$126<sup>00</sup> now \$119<sup>00</sup>
  - Save Even More, Both Sets now \$138<sup>00</sup>
  - Two 138 Sets (limited time) \$258<sup>00</sup>
- Money Back Guarantee. Add 13<sup>00</sup> for shipping. Texas orders add 5% tax. Export orders add 14. U.S. SURPLUS CENTER, Dept. 503, 715 Camden, San Antonio, Texas 78215



**CALL TOLL FREE NOW!**

**AMAZING VINYL REPAIR — \$10 to \$20 in an hour!**

Big earnings, repeat business. Car shops, homes, motels, restaurants, bars, etc. FREE FACTS BY MAIL.

Call toll free 1-800-621-6633 (Ill. 1-800-572-0444) or write VIP, 2021 Montrose, Dept. 182, Chicago, IL 60618

**INSTALLERS NEEDED**

Earn electricians wages installing safe, energy saving-Low Voltage, gas light conversion kits. 12 million nation-wide to Convert

Convert-A-Lamp, Inc.  
 7818 Trentway,  
 Houston, Tx 77040  
 713-462-6508



**SAVE as much as 80% with AMT Quality Power Tools**

American Machine & Tool Co., Dept. PM43, 4th Ave. & Spring St., Royersford, PA 19468

- Please send me the units checked.
- Payment in full enclosed \$\_\_\_\_\_ or \$5.00 deposit each item enclosed, balance C.O.D. or charge my  MasterCard  VISA
  - 8" Tilt Arbor Saw \$52.50
  - Standard rip fence \$6.50
  - Long Cabinet Rip Fence \$7.50
  - Ball-bearing Spindle \$12.50
  - 12" Swing, 4 Ft. Lathe \$67.75
  - Ball-bearing Model \$79.50
  - Face Plate \$4.50
  - Set of 3 Chisels \$11.00
  - Set of 8 Turning Chisels \$29.00
  - Belt Sander \$52.00
  - Disc Sander Attachment \$17.00
  - Mitre Gauge for Sander \$3.50
  - Jointer-Planer \$63.30
  - Ball-bearing Spindle \$15.70
  - Spindle Shaper Kit \$44.40
  - Drill Press \$89.90
  - General Electric Motor \$49.50 (with other item)
  - \$54.55 (Purchased Separately)
- Card No. \_\_\_\_\_  
 Expiration Date \_\_\_\_\_  
 Signature \_\_\_\_\_ Name \_\_\_\_\_  
 Address \_\_\_\_\_ City \_\_\_\_\_ State \_\_\_\_\_ Zip \_\_\_\_\_

**FANTASTIC VALUES WITH THIS COUPON!**

**DIRECT FACTORY OFFER AND REVOLUTIONARY PATENTS** decrease costs, increase efficiency. Full scale power tools of heavy duty 100% cast iron and steel. Streamlined design reduces weight, cuts material and production costs. Special patents provide added efficiency, accuracy, savings. Parts made, assembled, tested, packed in our own factories, shipped direct. **ENDORSED BY AMERICA'S TOP MAGAZINES . . . OVER 2 MILLION USERS** confirm their precision, versatility and rugged performance.

**\*10-YEAR LIMITED WARRANTY.** Any part or parts of any AMT power tool which become inoperative for any reason within 10 years of the purchase date will be repaired or replaced by the factory. Your only cost: for return postage.

\*\*Except motors to which the same terms for one year warranty will apply.

**10-DAY MONEY BACK GUARANTEE**  
 Try any AMT power tool for 10 days. If not fully satisfied, return for full refund of purchase price. We will pay return freight.



**8" TILT ARBOR POWER SAW**

**DOES WORK OF \$150.00 BENCH SAW as is.** Converts easily to equal any \$300.00 floor model cabinet units! Crosscuts, rips, mitres, cuts compound angles, dados, makes coves and moldings.

**\$52.50** f.o.b. factory. Wt. 22 lbs. Including completely assembled cast iron and steel 8" saw with ground cast iron table, blade guard, mitre gauge. Less blade. **RIIP FENCE**, if desired, for easier work alignment, \$6.50 add'l.

**PRECISION BALL BEARING SPINDLE** for commercial service, \$12.50 add'l.

**SAW BLADE TILTS . . . TABLE STAYS LEVEL.** Lock securely at any angle up to 50°. Raises, lowers, 0° to 2-1/4". Takes standard blade, saw insert removes to take dado heads, if desired for easier work alignment. Takes 1-3 HP motor or larger (not included). **RIIP FENCE**, for cabinet base (as shown). Standard size (for bench saw) \$6.50; long rip cutters, etc. (not included). Takes 1-3 HP motor or larger (not included). **RIIP FENCE**, for cabinet base (as shown). Standard size (for bench saw) \$6.50; long rip cutters, etc. (not included). Takes 1-3 HP motor or larger (not included). **FREE CABINET BASE PLANS** Use bench saw as received (inset photo) . . . or transform easily and inexpensively into floor model (as shown) guaranteed to do work of floor models costing \$300. **FREE plans** . . . all you need are a sheet of 3/4" plywood and 3-4 hours. Use your AMT saw for cutting. Plans provide 27" x 24" work surface, 33" height.

**10-YEAR LIMITED WARRANTY\***

**INDUSTRIAL SIZE 12" SWING 4 FT. WOOD LATHE**



DOES WORK OF \$200 UNITS.

**\$67.75** Complete as shown.

**10-YEAR LIMITED WARRANTY\***

Comparable in speed, precision and durability to units selling for \$200 and more. 36" between centers. For wood and plastics. Tubular steel bed rails with dual point suspension increase accuracy, ease of operation. Precision ball thrust cup center, heavy spur center, graduated T-rest, 3-Speed pulley for different work diameters. Heavy-duty ball-bearing model \$79.50.

f.o.b. factory. Shipping Wt. 30 lbs. Faceplate (optional) for turning bowls, lamp bases, etc. \$4.50. Set of 3 high speed turning chisels, \$11.00 add'l; Set of 8, \$29.00.

**PRECISION 4" x 36" BELT SANDER**

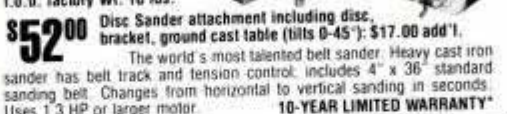

f.o.b. factory Wt. 18 lbs.  
**\$52.00** Disc Sander attachment including disc, bracket, ground cast table (tilts 0-45°); \$17.00 add'l.  
 The world's most talented belt sander. Heavy cast iron sander has belt track and tension control. Includes 4" x 36" standard sanding belt. Changes from horizontal to vertical sanding in seconds. Uses 1-3 HP or larger motor. **10-YEAR LIMITED WARRANTY\***

**32" RADIAL DRILL PRESS**

**\$89.90** All cast iron and steel. f.o.b. factory. Wt. 30 lbs. 1/2" capacity Jacob's chuck included.  
 Industrial quality precision unit with all standard features, many extras. Head raises, lowers. Depth of throat up to 16". Preset to any angle for on or off table drilling, even horizontal drilling. Complete as shown less motor, belt and motor pulley.

**10-YEAR LIMITED WARRANTY\***

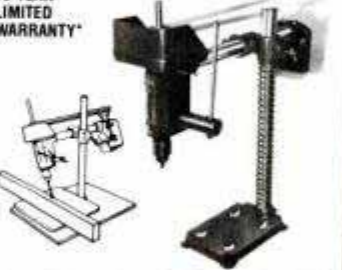

**22" LONG, 4-1/8" JOINTER-PLANER**

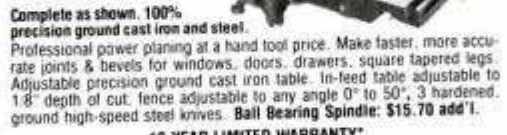

**\$63.30** f.o.b. factory. Wt. 19 lbs.  
 Complete as shown. 100% precision ground cast iron and steel. Professional power planing at a hand tool price. Make faster, more accurate joints & bevels for windows, doors, drawers, square tapered legs. Adjustable precision ground cast iron table. In-feed table adjustable to 18" depth of cut; fence adjustable to any angle 0° to 50°, 3 hardened, ground high-speed steel knives. **Ball Bearing Spindle: \$15.70 add'l.** **10-YEAR LIMITED WARRANTY\***

**SPINDLE SHAPER KIT with holddown**



**\$44.40** f.o.b. factory. Shipping Wt. 6 lbs. Complete less wood parts, motor.  
 Makes beads, coves, moldings, tongue-and-groove joints, etc. Easy assembly plans. Has sealed greased-for-life ball bearings, adjustable height control, fence assembly. Takes 1-4 HP or larger motor. Standard 1 1/2" bore cutters available. **10-YEAR LIMITED WARRANTY\***

**BRAND NEW MOTOR**



Develops a full 1 HP. New General Electric Motor for use with any power tool in this ad. Features 1 1/2" shaft, 1725 RPM \$49.50 if purchased with any AMT tool (\$54.55 if purchased separately). Covered by a one year limited warranty, 17 lbs. f.o.b. factory.

**AMERICAN MACHINE & TOOL CO., INC., 4th Ave. & Spring St., Royersford, PA 19468**

Visit our Royersford FACTORY SHOWROOM for these same low prices. 4th and Spring Sts. From 9 to 4:30 on weekdays and 9 to 12 on Sat.

# Pumping is Pumping, Right?



Automotive



Marine



Industrial



Recreational

**WRONG!** Pumping with anything short of a Milburn Stirling PalmPump can be a real nightmare. PalmPump is the only hand-powered pump that offers up to 2.5 gallons per minute capacity for under \$30. But with features like self-priming and reverse pumping, PalmPump can outperform any pump in its class.

The ideal tool for transferring fuel, pumping oils, bailing small boats and providing a ready supply of potable water for R.V.'s, PalmPump is also compact and rugged, weighing less than 28 ounces.

Order now, and discover the difference PalmPump can make in your fluid handling problems. After all, doing things right is just a matter of using the right tools.

Send \$29.95 in check or money order, plus \$2.00 postage and handling to:

**Milburn Stirling Corporation**  
1840 Commerce, C-North  
Boulder, Colorado 80301

If not completely satisfied, return PalmPump within 30 days for a full refund. Please allow 6-8 weeks delivery.



**Turning into a better craftsman can be as simple as turning the pages of our new catalog.**

Our new 244 page catalog is filled not just with pictures of great hand and power tools, but carefully written specs, detailed illustrations and recommendations from craftsmen who've spent much of their lives making, using and testing tools.

You'll know what they look and feel like, and you'll know how they fit your needs.

We believe you're not the average craftsman. So why should we give you an average catalog?



Garrett Wade Co., Dept. 148  
161 Ave. of Americas, N.Y., N.Y. 10013

Please send me your 244 page catalog of wood working tools, machinery and accessories. Enclosed \$3.00.

Name \_\_\_\_\_  
Address \_\_\_\_\_  
City \_\_\_\_\_  
State \_\_\_\_\_ Zip \_\_\_\_\_



**Preserve the legendary beauty of America's most famous motor car in your home!**

Recapture the frenzied age of art deco, "bathub gin" and breadlines when you own your own authentic hand cast metal replica 1930 Duesenberg. It's the ultimate collectible commemorating the ultimate dream machine that everyone wants. Be assured of the loving, painstaking care that went into the creation of this fine 6 1/2" brass tone finish reproduction. We know you'll treasure this collector's item and display it proudly in your home or office.

You don't have to be a millionaire to own a Duesenberg! **regularly \$14.95 NOW \$9.95** only postage paid Illinois Residents Please Add 6% Tax.

Indicate method of payment below.  
 Check or Money Order  VISA  MasterCard  
totaling \$9.95  
Account Number \_\_\_\_\_ Date \_\_\_\_\_ mo. yr. \_\_\_\_\_  
**Peter Thomas Sales Co.**  
P.O. Box 717, Highland Park, IL 60035  
Name \_\_\_\_\_  
Address \_\_\_\_\_  
City \_\_\_\_\_  
State \_\_\_\_\_ Zip \_\_\_\_\_  
Phone ( ) \_\_\_\_\_

**NEW VIC-20**  
**VOICE SYNTHESIZER**  
**\$79<sup>00</sup> sale price**

Limited Quantities  
VOTRAX based  
Unlimited words  
Adjustable volume and pitch

**PROTECTO ENTERPRIZES**  
Box 550 • Barrington, IL 60010  
Phone Orders: (312) 382-5244

## Solve your Hauling Problems

950 lb. Capacity

**The Stowaway Folding Trailer**

**Hayes Garden Carts**

2 Sizes Available

**Standard Dump Front**

Call Toll Free **1-800-243-8550**  
For Free Color Brochures

**Hayes** **Hayes Equipment Corporation**  
P.O. Box 526 PM  
Unionville, CT 06085

ESTABLISHED 1945 © 1982 HAYES

**BUILD YOUR OWN JET HELICOPTER**  
EASY TO FLY—INEXPENSIVE TO BUILD!

- Carries one person-plus
- Simple hand-tool assembly
- Uses low-cost fuel

Plans—completely illustrated: \$9.00

**The HELICOPTER HOBBYBOOK**  
Includes Plans for building a piston-engine-powered Helicopter (illus.): \$8.00

**BOTH ABOVE BOOKS: only \$14.00**

**HELICRAFT, Inc.**  
P.O. Box 16468 Baltimore, MD 21217



### The Mean Little Kit

This 24-piece kit of computer/electronic tools includes 7 screwdriver sizes, adjustable wrench, 2 pair pliers, wire stripper, knife, alignment tool, stainless rule, hex key set, scissors, 2 flexible files, burnisher, soldering iron, solder aid, coil of solder, and desoldering braid. Highest quality padded zipper case measures approximately 6 x 9 x 1-3/4" inside. Send check or money order, or charge VISA or MASTERCARD. We pay the shipping charges. Guaranteed satisfaction. Free tool catalog on request.

Order PM-6 \$95.00.

**Jensen Tools Inc.**  
Dept. PM 7815 S. 46th St.  
Phoenix, AZ 85040 (602) 968-6231

### DUNE-BUG

Complete plans & specs on how to build or buy - disc, prices on parts, kits, engines, & raw material.



Send \$3 for DUNE-BUG pkg to:  
K & P Mfg.  
Box 987 M4  
Azusa, CA. 91702 Dealer Inquiries Invited

### GREAT SAUSAGE RECIPES

227 page illustrated book explains sausage making plus home curing and smoking of meat, fowl and fish. Over 100 recipes. Free equipment and supply catalog has more information.

For yours, send to:  
**The SAUSAGEMAKER**  
177-6 Military Road Buffalo, N.Y. 14207

### Build this Bar

Elegant Bars, Back Bars, and Conopia Bars. Available nowhere else. Easily built from simplified plans using proven methods. Plans adjust to fit anywhere, using standard lumber & moldings. Plus other woodworking plans, Brass Rails and Wood Carvings.

**NEW '83 Brochure - \$3.00**  
(Free with Purchase of Plans)  
**CUSTOM BAR DESIGNER**  
Dept. PM-1 7504 Seward Ave., St. Louis, Mo. 63118

### STOP HUNTING for SMALL mechanical parts!

Giant new 768 page SDP Catalog for 1982 features over 24,000 inch and metric off-the-shelf parts. Timing belts, pulleys, chain drives, gears, motors, speed reducers, couplings, shafts, bearings, fasteners etc. for building, repairing, inventing any small machine, engine, model. Low prices. CATALOG 75¢ to just \$5.95 POSTPAID.

**STOCK DRIVE PRODUCTS, DEPT. A**  
55 SOUTH DENTON AVE., NEW HYDE PARK, N.Y. 11040  
**FREE METRIC/INCH CONVERSION SLIDE RULE INCLUDED!**

### Portable Steam Cleaner

Steam in 60 seconds

**CLEAN:**  
Engines, Air Filters, Lawn Mowers. 3 year guarantee on fire box, coils. Uses liquid soap, propane fired. Weight 120 lbs. Auxiliary pump required on low water pressure.

**WEDCO MFG. INC., Dept. M-13**  
940 West Broadway, Jackson, WY. 83001

### ADD TO YOUR INCOME

Earn a second income through Popular Mechanics Classified. \$1.00 booklet shows you how to start your own business with Classified advertising. (\$2.00 rebate with first order). **Popular Mechanics**, Dept. DN, 224 W. 57th St., New York, NY 10019.

ONCE IN A LIFETIME...

### PTC MACHINIST SAVER



Look at these standard PTC measuring instruments furnished in a kit in a fitted case.

**\$59<sup>95</sup>**

PTC MACHINIST KIT with Standard "PRECISE" Measuring Instruments  
ORDER NO. PTC-904



Available Only As A COMPLETE KIT No. PTC-904 PRICE \$199.00

|   |  |   |
|---|--|---|
| <b>MICROMETER</b><br>No. 100<br>• 0-1" Range<br>• 0.001" Graduation<br>• Carbide Tip<br>• Locking Clamp<br>• Fraction Thimble | <b>DIAL CALIPER</b><br>No. DC-A<br>• 0-6" O.D. and Depth Measurements<br>• 1/16" Range<br>• 0.01" Graduation<br>• 1 1/2" Jaw | <b>RULE</b><br>No. 202<br>• 18 Inch Size<br>• Fully Flexible<br>• Stainless Steel<br>• 1/32" Graduation |
|---|--|---|

**LOWEST PRICES - HIGHEST QUALITY**

### PTC PRECISION TOOLS & MACHINERY SPECIALISTS!

SEND FOR FREE CATALOG



Phone Toll Free  
800-526-4956  
(in N.J. (201)761-4343)

Name \_\_\_\_\_  
Address \_\_\_\_\_  
City \_\_\_\_\_ State \_\_\_\_\_ Zip \_\_\_\_\_

SHIPPING CHARGES: \$3.00

CHECK MONEY ORDER/VISA  
MASTERCARD/AMEX ALL ACCEPTED

NY RESIDENTS PLEASE ADD 4% SALES TAX

Enter your name and address in \_\_\_\_\_  
Exp. Date \_\_\_\_\_

**PENN TOOL CO.** 1776 Springfield Avenue  
Maplewood, N.J. 07040

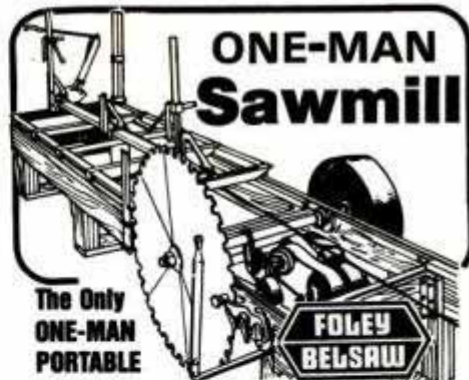

### ONE-MAN Sawmill

The Only  
**ONE-MAN PORTABLE**

**SAWMILL** Of Its Kind In The World!

**FOLEY BELSAW**

If you need good, high-quality lumber, don't let inflated lumber prices stop your important building projects. The Foley-Belsaw goes right to the trees and turns out smooth, true-cut lumber... even beginners get excellent results. Just one man (no crew needed) can easily cut enough on weekends to save hundreds of dollars over high lumberyard prices. For power use tractor PTO or other low HP diesel or electric unit. Factory-direct selling keeps price low, and convenient time payments may be arranged.

Send for **FREE BOOK!** Just mail coupon below for "How To Saw Lumber" booklet and complete facts on the One-Man Sawmill. There is **NO Obligation** and **NO Salesman Will Call on you. Do It TODAY!**

**FREE BOOK**

**Foley-Belsaw Co.**  
30158 Field Building  
Kansas City, Mo. 64111

Please send all facts and details in your **FREE BOOK** "How To Saw Lumber". I understand there is **No Obligation** and that **No Salesman** will call on me.

Name \_\_\_\_\_  
Address \_\_\_\_\_  
City-State \_\_\_\_\_ Zip \_\_\_\_\_

### Never change a light bulb again!

You may never change a light bulb again! Just think, no need to buy bulbs, or climb on wobbly chairs or ladders. Now, a new scientific development extends bulb life and saves electricity, too. It's called **The Button**.

**The Button** is a solid-state micro chip diode. It converts AC current to DC current and extends the life of a bulb filament up to 100 times!

For example, a regular bulb rated for 750 hours would last for about 32 days if burned continuously. But, with **The Button**, that same bulb's life would be extended to 75,000 hours or 8 years. Less often used bulbs could last a lifetime!

This amazing development works with any regular incandescent light bulb (not 3-way type). There is even a model for candelabra size bulbs. Just stick a Button to the bottom of a bulb and screw into socket.

The results are amazing. Bulbs burn cooler, and give a softer less glaring light. You save up to 30% on electricity and just think of the money saved on light bulbs!

**The Button** is absolutely ideal for lights that run 24 hours a day like exit signs and security lights. (Don't replace them until 1991!) Major hotels, restaurants and corporations are already using **The Button** and saving considerably on maintenance costs.



**The Button** has no moving parts so there is nothing to wear out. All materials meet or exceed U.L. standards and each Button carries a 10-year warranty.

If you're sold on the idea of saving money, **The Button** comes in packages of 12 for \$29.95 (plus \$2.45 shipping and handling). If you're still a bit of a skeptic (or don't have 12 bulbs), order a package of six for only \$15.95 (plus \$1.50 shipping and handling). Either way, you're covered by Baystar's guarantee of satisfaction or your money back in 30 days. Be sure to specify candelabra or regular size.

To order: send your check or money order to Baystar. Credit card holders can use our toll free number.

Save bulbs, electricity and labor. Order **The Button** today!

**CALL TOLL FREE**  
Mon-Fri 9 a.m. to 5 p.m. Eastern Time

**(800) 638-6170**

All other times call

**(800) 257-7850**

**Baystar** Dept. 84C  
110 Painters Mill Road  
Owings Mills, MD 21117  
(301) 363-4304

© The Baystar Company 1983

Материал, защищенный авторским правом

# FAMILY OF SEVEN CUTS HOT WATER BILLS IN HALF!\*

Tankless Heater Provides Endless Hot Water



The Hughson family of Pennsylvania

The Hughson family just took 7 showers in a row — the 7th was as hot as the first — and they're saving hundreds on their hot water bills too.

## Sound, Simple, Money-Saving Idea

Did you know that much of the energy used to heat your basement tank of water is dissipated right through the walls of the tank itself and into your storage or crawl space area?

### The Perfect Answer—New Thermar™ Tankless Instant Hot Water Heaters

If heat losses are created by the need to keep large volumes of water standing in a tank, why not eliminate the tank? And, that's just what Thermar™ has done. In its place we have developed a tiny, super powerful instantaneous heating unit which ACTUALLY CREATES HOT WATER AS YOU USE IT. A microswitch on the unit automatically turns on the moment hot water is needed. Then a continuous stream of delightful, sparkling hot water flows from the tap for shower or wash basin. IMAGINE — as much hot water as you want — produced in a never-ending stream as long as you need it.

The ordinary Tank-Type Hot Water Heater is the most "Energy Costly" appliance in your home. In this day of rising

costs and energy consciousness, a new THERMAR™ TANKLESS INSTANT HEATER should be considered by everyone interested in saving money and saving energy.

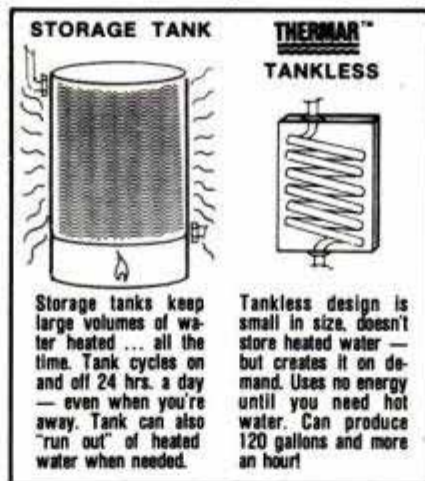

Storage tanks keep large volumes of water heated... all the time. Tank cycles on and off 24 hrs. a day — even when you're away. Tank can also "run out" of heated water when needed.

Tankless design is small in size, doesn't store heated water — but creates it on demand. Uses no energy until you need hot water. Can produce 120 gallons and more an hour!

U.L. Listed Electric and AGA Certified Gas Models  
Thousands in Use Around the World

You'll recover the initial costs many times over in fuel savings as the years pass. And, you'll enjoy a lifetime of hot water — shower after shower after shower!

\* Savings will depend upon local cost of fuel, type of fuel used, condition, age and type of present heater equipment.

- Selected For Energy House 1982 World's Fair
- Featured in *Popular Science Magazine*
- Seen on TV!
- Member — Gas Appliance Manufacturer's Assoc. Inc.

FOR RUSH DELIVERY OF FREE ENERGY CATALOG  
AND FULL DETAILS USE COUPON BELOW

RUSH!

**THERMAR™**

Johnson Power Tech  
Melrose Square  
Greenwich, CT 06830

FREE!

I would like to cut my hot water heating bills in half! Please RUSH your FREE catalog of THERMAR™ INSTANT, TANKLESS HEATERS. Include details of the absolutely unique 10 year guarantee and replacement plan. I understand that I am under no obligation to buy anything and no salesman will contact me.

Name \_\_\_\_\_

Address \_\_\_\_\_

City \_\_\_\_\_ State \_\_\_\_\_ Zip \_\_\_\_\_

Canadian Residents send to: 56 Bramstele Rd., Suite 8, Brampton, Ontario L6W3N4

PM0483

## Build This Popular Mechanics Air Compressor.

It adds a new dimension to your home workshop.

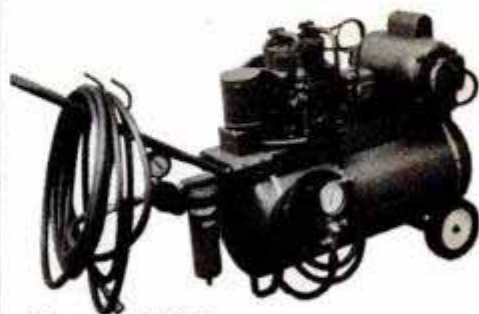

When you build the rugged Popular Mechanics air compressor, you'll get one of the most versatile shop tools around. It's a tough workhorse that can tackle jobs you never dreamed of doing before — riveting,



sand-blasting, spray painting, inflating and countless other projects. And, unlike ordinary compressors, the PM air compressor can evacuate your car's air conditioning system. But best of all, it's affordable. With plans from the Popular Mechanics Plans Library, you can build the PM air compressor yourself and save up to \$200.



Send today for your Popular Mechanics Air Compressor plans, and add a new dimension to your workshop. Only \$5.95 (add 75¢ for first-class mailing).



Send check or money order to: 483  
Air Compressor, Popular Mechanics Plans Library,  
Box 1014, Radio City Station, New York, NY 10101.  
(Make checks payable to Popular Mechanics.)  
Please send me \_\_\_\_\_ sets of Popular Mechanics air  
compressor plans at \$5.95 each (add 75¢ each for first-  
class mailing). I enclose my check or money order  
for \_\_\_\_\_

Name \_\_\_\_\_

Address \_\_\_\_\_

City \_\_\_\_\_ State \_\_\_\_\_ Zip \_\_\_\_\_

Please allow four to six weeks for delivery.  
Popular Mechanics is a publication of Hearst Magazines, a Division of THE HEARST CORPORATION



## AMAZING SCIENTIFIC and ELECTRONIC DEVICES

PHASER shockwave and invisible FORCE FIELD generators. LASERS for weapons, cutting, burning, cloud writing, holography and special effects. NUCLEAR particle accelerators and detectors. PLASMA, ION, HIGH VOLTAGE, HIGH FREQUENCY TESLA COILS and LIGHTNING generators. TRANSMITTERS and CONTROL devices for security, telephones, intrusion detection, nature listening. PLUS PLUS INFRASONICS, ULTRASONICS, ENERGY, CHEMICAL and PERSONAL PROTECTION and SAFETY DEVICES. SEND \$1 for catalog of plans, kits and completed items to:

**INFORMATION UNLIMITED, INC.**  
P.O. Box 716, Dept. M8  
Amherst, N. H. 03031

## HOW TO FIND GOLD NUGGETS ELECTRONICALLY



Finding gold nuggets or coins is now made easy with a new patented gold finding detector. Before with other detectors it was virtually impossible because of interference from black sand. This new detector is unaffected by black sand and can detect pinhead size gold nuggets at great range. Its maximum range is 17 feet. It is very lightweight and has perfect balance. One of our customers who had tried five other makes and couldn't find a single nugget now reports finding up to six nuggets in one hour with his Gardiner detector. Recently a 400 ounce gold nugget was found with a detector. Free catalog.

**GARDINER ELECTRONICS**  
Dept 31 • 4729 N. 7th Ave. • Phoenix, AZ 85013

## GET \$300.00 FREE Professional Software

**when you buy a  
Commodore-64**

**PROTECTO ENTERPRISES**  
Box 550 • Barrington, IL 60010  
Phone Orders: (312) 382-5244

## BUMPER STICKER PRINTING DEVICE

FUN, INEXPENSIVE, PORTABLE  
EASY - NO TRAINING NEEDED  
ANY MESSAGE IN MINUTES

Get FREE DETAILS  
P.O. BOX 22791 (G)  
TAMPA, FLA. 33622

## Movies, Sports, Shows - 24 Hours a Day !

Imagine . . . the highest quality, most popular selling, micro-wave receiver system in the country . All for only \$165.00.

Receive 24 hour a day movies, specials, sporting events, and more, all on your present television set. Install this high-powered parabolic dish system in just minutes, then sit back, relax and enjoy great 24 hour, commercial-free programming. The HMR-20C microwave receiver



### SPECIFICATIONS

HMR-20C

**GAIN-** 45db

**FREQUENCY-**  
2.1 - 2.6GHz

**DISH SIZE-**  
20" full  
parabolic

**TUNING-**  
55 thru 75 Mhz

**REGULAR  
SUGGESTED**

**RETAIL - \$ 325**

FOR AUTHORIZED TV RECEPTION ONLY.

system is designed to be installed within sixty miles of the microwave transmission station in your area (unobstructed line-of-sight), and comes complete with all hardware: 60 feet of coaxial cable, cable adapters, power supply tuner, and installation instructions . . . All for only \$165.00, including shipping and handling. We also offer our newest and most powerful antenna, the HMR-28C . . . with 40% more power for the sharpest picture possible and the longest signal distance . . . only \$220.00 including shipping and handling. Both of these great antennas are tuneable through 44 frequencies, providing you the greatest selection of programming. Both units carry a 6-month limited warranty on defects in material or workmanship\*. So don't wait another minute, call us right now, our lines are open 24 hours, our operators are ready to take your order.

*TOLL FREE FOR ORDERS ONLY.*

1-800-854-0561 Ext. 806

in California, Alaska, Hawaii

1-714-953-8168

*For Information: (213) 956-5508*

*Sorry, no collect calls*

We gladly accept VISA or Mastercard or money order (allow 2 wks). If you prefer, your personal check (allow 4 to 6 wks).

\*All units returned for refund that are not defective are subject to a 15% restocking charge.

## SELECT MARKETING INC.

COMPLETE AND MAIL - SELECT MARKETING, P.O. BOX 833, CORONA, CA. 91720

|                        |  |  |  |  |   |  |
|------------------------|--|--|--|--|---|--|
| NAME _____             |  |  |  |  | ADDRESS _____   |  |
| CITY, STATE, ZIP _____ |  |  |  |  | CITY, STATE, ZIP _____  |  |
| PHONE _____            |  |  |  |  | PHONE _____ <input type="checkbox"/> VISA <input type="checkbox"/> MASTERCARD |  |
| ACCT. NO. _____        |  |  |  |  | EXP. DATE _____   |  |
| SIGNATURE _____        |  |  |  |  | SIGNATURE _____   |  |



## EEM. A MUST FOR EVERY ELECTRONICS LIBRARY.

The 1982-83 EEM/Electronic Engineers Master is the world's largest electronics catalog. Over 4,500 pages. Two giant volumes filled with detailed technical data and specifications on products from almost 1000 manufacturers. Components. Connectors. Capacitors. Power Supplies. Whatever you need you'll find in EEM. A complete sales directory and handy selection guide make ordering products fast and easy. Over 100,000 copies of EEM are distributed worldwide. To get yours, fill out the order form below. And, for a limited time, save over 50% off the regular price.

**If you're not totally satisfied, return EEM within 30 days for a full refund.**

Yes! I want the 1982-83 EEM at over 50% off the regular price.

A check/money order for \$29.95 is enclosed. EEM will pay all sales tax and shipping charges (U.S. only).

Charge \$29.95 to my:  MasterCard  Visa

Name \_\_\_\_\_

Address \_\_\_\_\_

City \_\_\_\_\_ State \_\_\_\_\_ Zip \_\_\_\_\_

Credit Card No. \_\_\_\_\_ Exp. Date \_\_\_\_\_

Signature \_\_\_\_\_

Mail to: EEM (Hearst/UTP), 645 Stewart Avenue, Garden City, NY 11530

Please allow 30 days for delivery.

PM43

# Build your own library with Popular Mechanics Books

**PRACTICAL TIPS AND INSTRUCTION  
FROM THE EDITORS OF POPULAR MECHANICS**

Step-by-step, fully-illustrated POPULAR MECHANICS' BOOKS are complete manuals of information and practical advice.

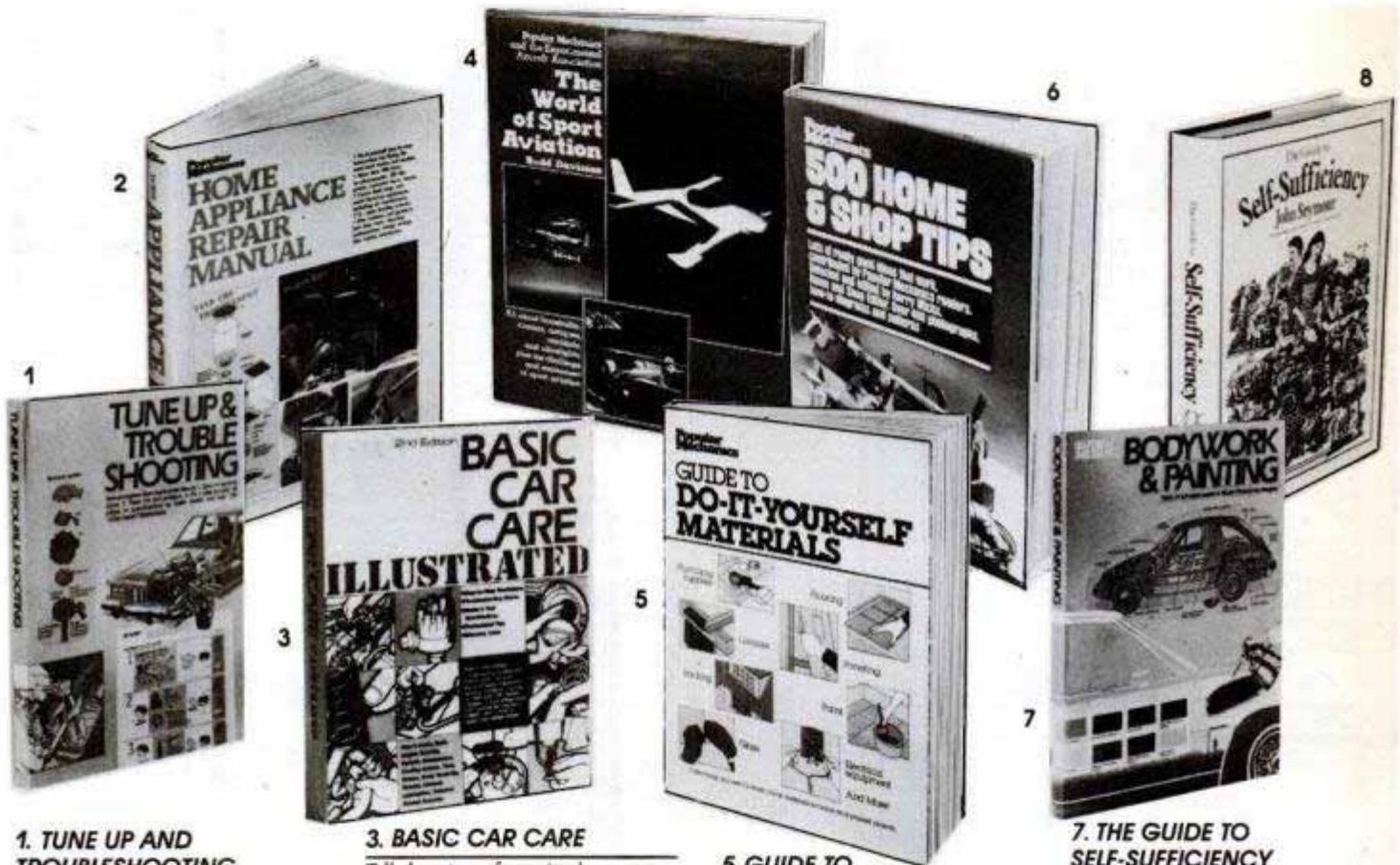

## 1. TUNE UP AND TROUBLESHOOTING

Over 50 pages of charts, showing how to trace and solve most common problems. Covers all modern U.S. cars and four most popular imports including pickups, vans, four-wheelers, and diesels. Over 90 pages of tune-up specifications for U.S. models from 1974-1979 plus Datsun, Toyota, Rabbit and Beetle. (B-1757, \$19.95 - B-1757A, paper \$11.50)

## 2. HOME APPLIANCE REPAIR MANUAL

Provides step-by-step repairs for more than 50 different kinds of appliances. More than 800 photographs, 200 diagrams and charts. Lists appliance part suppliers. Gives a basic introduction to electricity and instructions for operating electrical testing equipment. Illus. (B-1752, \$23.50)

## 3. BASIC CAR CARE

Tells how to perform simple maintenance checks, prevent or delay breakdowns, do tune-ups, handle basic repair jobs. Highly illustrated with clear-as-crystal photos, diagrams, and drawings. Covers electronic ignition, diesels and front-wheel drives. (B-1756, \$19.95 - B-1756A, paper \$13.00)

## 4. THE WORLD OF SPORT AVIATION

The focus is on four basic types of sport aircraft - homebuilts, antiques and classics, warbirds, and ultra-lights - explaining the state of the art in each category. Discusses the types of materials used, space requirements, engines, certification and safety. Lists various organizations one can join. This book brings to life the thrilling world of sport aviation. 32 pages of color illustrations. (B-1755, \$24.00)

## 5. GUIDE TO DO-IT-YOURSELF MATERIALS

Provides answers to every do-it-yourselfer's questions about materials and supplies used for home improvement projects. Discusses lumber, millwork, plywood, hardboard, siding, plumbing, and electrical supplies. The only up-to-date reference work that furnishes complete information on the thousands of standard building products available today. (B-1759, \$8.95)

## 6. 500 HOME AND SHOP TIPS

Here's a ready reference for solving all home, shop and craftsman problems. Eight chapters cover areas where most of us need help: improving workshop techniques, painting, yard care, metalwork, home emergency plumbing and electrical problems. (B-1754, paper \$12.95)

## 7. THE GUIDE TO SELF-SUFFICIENCY

Practical advice on being totally or partially self-sufficient in every way. Over 600 2-color illustrations show step-by-step how to do it. Learn to brew beer, bake bread, pickle onions, design a diary, convert to solar energy, build a slaughterhouse or spin yarn. (B-1753, \$18.95 - B-1753A, paper \$10.00)

## 8. BODYWORK AND PAINTING

This is the first book whose table of contents was designed to match the needs of rapidly growing do-it-yourself market. It shows how to save time and money by doing your own work. Step-by-step illustrations, 16 pages of photographs, including color matching, pinstripping techniques and custom designs. (B-1758, \$19.95 - B-1758A, paper \$12.95)

**TO ORDER**, use the "B" numbers and send check or money order to  
POPULAR MECHANICS, Box 1014 Radio City Station, New York, NY 10101.

Popular Mechanics is a publication  
of Hearst Magazines,  
a division of THE HEARST CORPORATION.

# CLASSIFIED ADVERTISEMENTS

Sophie Gronowicz, Classified Sales Manager

Rate: \$5.70 per word payable in advance each insertion. Minimum insertion ten words. Bold face capitalized words—\$1.00 per word additional (First word set in Bold Face at no extra charge, Zip Code Free.) The next available issue to place an advertisement in America's No. 1 Classified Section is JUNE. The closing is APRIL 4th.

Send remittance payable and order to Popular Mechanics, Classified Department, 224 West 57th Street, New York, New York 10019. Please indicate Heading under which ad is to appear. As a consumer service and in cooperation with our mail-order advertisers who use post office box addresses for their convenience in handling your order, Popular Mechanics maintains a register of such mail-order advertisers containing their complete names and street addresses.

Advertisers using P.O. Box number must furnish complete name and street address for our records. To avoid delay in the publication of your ad, please send descriptive materials with your request.

## AUTOMOBILES

**SAVE GASOLINE!** Bypass pollution devices - - easily, reversibly! Posco (GB-4), LaGrangeville, NY 12540

**HIGH Mileage Carburetors**, Free Details, Box 89, Draper, Utah 84020-0589.

**OLD CAR FANS:** subscribe to **HEMMINGS MOTOR NEWS**, world's largest old car marketplace since 1954. Over 450 pages of ads each month, crammed with thousands of old cars for sale—plus parts, literature, restoration shops and more. Only \$15.50 for 12 giant issues. Subscribe to the 'bible' of old car nuts today. Write to: Hemmings Motor News, Dept. 14C, Box 100, Bennington, Vermont 05201

**PROPANE/GASOLINE DUAL-FUELED AUTOMOBILE!** Complete Plans, Instructions and Parts Sources for converting your car. \$10.00. RDA, Box 873, Concord, NC 28025

**SAVE YOUR ENGINE, STOP ENGINE KNOCKING AND PING** with the amazing Carter Engine Knock Eliminator. Works automatically, easy to install, complete easy instructions. Works on U.S. and import cars, trucks, 4x4's, RV's \$79.95 plus \$6.00 tax and shipping. Guaranteed! Sorry no diesels, rotary, odd-fire V6's or positive ground vehicles. AMMEC, P.O. Box 15178, St. Louis, MO. 63110

**SELLING YOUR CAR:** Make Hundreds Of Dollars More, Reconditioning And Sales Hints From 20 Year Professional. Send \$2.00. Don, P.O. Box 324, Lincoln Park, N.J. 07035

**SUPERCARBI Fact/ Fiction?** Free Details! MPG-PM383, Box 2133, Sandusky, OH. 44870-7133.

**MOTOR LIFE INCREASED 100%**—Economy 30%—BPI Inc., Dept. PM1, One Colonial Way, Weston, MA 02193.

**INCREASE MPG - Reduce CFM** Through Present Engine. Very Simple Device Drawings, Charts, Test Information \$3.50. Extender, 512 Royal Dr., Jackson, Mich. 49201

**TREMENDOUS Savings** On All Auto Parts! Proven step by step method. Wholesale buyer reveals confidential industry secrets that anyone can apply. Complete eye-opening package only \$4.00. Start Saving Today! Trade Secrets, Box 64130PM, Tacoma, WA 98464.

**SECRETS REVEALED**, Save Thousands Of Dollars On Next Car. Pro-Print, Box 2689PM4, Merced, CA 95344

**SCOUT II AND TRAVELER STOP RUST** To Rear Quarters And Wheel Wells. Easy Installation Of Unseen Gravel Shields Close The Door On Cause. \$20.00 Includes Booklet of Tips. K And J Products, Box 359, Baldwin, New York 11510

**CHILTON** Domestic, and Import Repair, and tune-up guides. \$8.95 each. State car make, model, year. Include \$2.00 P. & H. Auto Manuals Co., 955 Greenacres Dr., Sheboygan Falls, WI 53085

**FRICTION STOPPING new POWERUP** saves money, triples engine life, thousand uses: automotive, home, marine, industrial. Miracle lubricant, penetrant, anti-acid, concentrated, guaranteed. Sample and details \$8.00. POWERUP, Box 874, Provo, Utah 84601

**CLYMAR** Import car repair, and tune-up manuals. \$10.95 each. State car make, model, year. Include \$2.00 P. & H. Auto Manuals Co., 955 Greenacres Dr., Sheboygan Falls, WI 53085

**SECRETS OF FANTASTIC GAS MILEAGE!** - Details FREE! - DynaTek B4, 720 Jordan, Rockford, Illinois, 61108

**GASOLINE 85¢ a gallon!** INCREASED mileage 30%-50%! Booklet \$3.00 (refundable) tells how. Reid Enterprises, Box 103, St. George, Utah 84770.

**67 MPG in CHRYSLER 400 CID HIGH MILEAGE CARBURATOR.** Complete Working Plans. KNISS, R2PM, Bowling Green, Missouri 63334

**DETAIL** Cars Professionally. Used Car Reconditioning Made Easy. Booklet \$5.00. KAR Distributing, 312C Downer Road, Williamstown, NJ 08094

**NEVER** Again Locked Out Of Car! Installation in Minutes! \$5.00. Strong Publications, Dept. PM, P.O. Box 64012, Lubbock, Texas 79464

**SAVE GAS! WATER INJECTOR**, complete plans: \$3.95 - **GUARANTEED!** Brammis, 1607 Tannehill, Houston, Texas 77008

**200,000 Miles** from your Car! Revealing Report FREE! CarSavers, 53 Vineyard Avenue, Highland, New York 12528

**FREE OIL** for your car - Report \$3.00. Starbright, Box 411, Jericho, N.Y. 11753

**TRIKESTER—THREE** Wheeled Two Place Side By Side, V-W Powered, 50 MPG. Semi-Enclosed Body. Simple Const. Information Pack, \$2.00, Plans \$25.00. P.O. Box 1942, Bonita Springs, Fla. 33923

## MIDGET CARS

**SOAP-BOX DERBY RACER** Plan. Photocopy of articles as they appeared in Popular Mechanics 1936 issues, available for \$4.00. Send Check to: Popular Mechanics, Dept. PMC4, Box 1014, Radio City Station, New York, NY 10101

## AUTO SUPPLIES & EQUIPMENT

**HYDRAULIC JACK** Repair Manuals and Kits. Catalog \$2.00. Hydraulic Jack Inc., P.O. Box 18, Accord, NY 12404

**BOOST, RECHARGE** Batteries Safely. Plans \$10.00. Pow-Boost, P.O. Box 364, Staten Island, NY 10302

**ALTERNATOR** Generator Rebuilding Book. Price: Hedelund Engineering, Box 26024, Las Vegas, NV. 89126.

**PARTS:** Army Jeep and truck parts. Spare Parts & Equipment Co., P.O. Box 751, Lexington, Kentucky 40501-0751

**ALTERNATOR/Starter** rebuilding made easy. Start without Capital. Details. Box 33, Buffalo, N.Y. 14207

**ALARM, BACK-UP.** Intermittent Beep-Beep. Installs 15 minutes to back-up light or switch. OSHA O.K.. Forklifts, trucks, R.V.'s. \$9.83 to: Acorn Products, Dept. PM-1, Box 21485, Casa Cornero Station, Concord, CA 94521.

**STARTERS-ALTERNATORS** Most Japanese Auto \$34.99. T&J Enterprises, 3555A Haddonfield Road, Pennsauken, New Jersey 08110. 609-662-1754

## MOBILE HOMES

"**SKIRTING INSTALLED EASY** with Skirting-Mates®." Free Brochure. Glacier, Box 8367, St. Paul, Minn. 55113

## MOTORCYCLES, BICYCLES, MOTORSCOOTERS & SUPPLIES

**ENGINES.** Industrial Wheels. Wholesale Catalogs \$3.00. Lorenzo-AZUSA, Danville, Ill. 61832

**GO KART, MINI-BIKE, MOTORBIKE PARTS.** Tires, Clutches, Motors and Complete Carts and Mini-Bikes at Discount Prices. 3 1/2 Hp, motors \$106, 5 Hp. \$123. Send \$1.00 for Booklet. Northern Hydraulics, P.O. Box 1261, Dept. PM-MB, Burnsville, MN 55337

**GO KARTS,** Minibikes, ATV's. Kits, Parts, Lowest Prices. Catalog \$2.00 Refundable. Kart World, Dept. C, 1488 Mentor Ave., Painesville, Ohio 44077

**NEW!** . . . Buying a **USED MOTORCYCLE?** Learn how to check it out, before you buy. It's easy. Send \$2.95. Talon Enterprises, P.O. Box 317, Dept. 1B, Startup, WA 98293

**BICYCLE SUPPLIES.** Free Bargain Catalog. BIKERY, 1800 Beryl Lane, Newport Beach, CA 92660

## HANG GLIDING-AVIATION

**CHOPPY** ultralight single seat helicopter. Simplified construction motorcycle engine. Informations \$3.00. Polynova, Box 670 "M", St. Remi, Quebec, Canada J0L 2L0

**DESIGN** Build Airplanes, Hang Gliders, Simplified Publications. Brochure 20¢. McCoy Aircraft, 12820 S. Figueroa, Los Angeles, CA 90061.

Kathy Cusumano, Classified Service Manager

"**ON FINAL**" 5th dimensional aviation art by Jim Dungey a stunning perspective from the left seat in beautiful color, the buffs delight!! 22x37 poster \$3.50 plus \$1.50 p/h. Check or Money Orders to: 5D Art, Box 474, Mt. Vernon, N.Y. 10550

**60 ULTRALIGHT AIRCRAFT PLANS!** Illustrated Catalog \$5.00. Aerofun-M, Salda, CA 95368

## SPACE & ASTRONAUTS

**ANTI GRAVITY** Propulsion Device. Free Brochure! RDA, Box 873N, Concord, NC 28025

**SPACE SHUTTLE** Three Framable Color Prints - Two Dollars. Box 1239, Cocoa, FL 32922

## HOVERCRAFT

**AERO-CAR** Amazing Hovercraft built easily with ordinary tools. Lawnmower engine power. Carries one man plus. Hovers, flies forward, backward. Sideways over land/snow/water. Complete construction plans and brochure. \$9.95. Aero-Projects, Box 5118PM, Clinton, New Jersey 08809.

**HOVERCRAFT** Plan All Sizes. Catalog \$1.00. Universal Hovercraft, Box 281, Cordova, Illinois 61242

**BOOMERANGS—INCREDIBLE RETURNS!** You can do it. Exciting sport! Order **FREE CATALOG** today. BoomerangMan, 306 Park, Monroe, LA 71201

**HOVERCRAFTS,** \$5.00 Cash Moneyorder. Leonard Whatley, Dept. 2, Rt. 2, Box 118, Canton, Texas 75103

## CB-RADIO & HAM EQUIPMENT

**POLICE** Scanners, Bearcat, Regency, HPR, Box 18224, Denver, CO. 80219.

**LINEARS -** Send Stamp for Details - MATCO Electronics, Box 316C, Cadillac, MI 49601

**IMPROVE CB PERFORMANCE!** Modification hardware, books, plans. Catalog \$2.00. CBC International, Box 31500M, Phoenix, AZ 85046

**BEARCAT** Scanners. Discounted. **CRYSTALS** \$2.75. **RADIO SALES**, 3462 Oakland, Oshkosh, Wis. 54901

## ELECTRONICS

**SPEAKER REPAIR - RECONING** Guaranteed.....Stereo.....Pro-systems EV.....JBL Warranty Center, Send Post Paid To: TRS Music, 8400 Secor Rd., Lambertville, Michigan 48144

**CRYSTAL,** Tube Experimenter's Supply Catalog \$1.00. Laboratories, 1477C, Garden Grove, Calif. 92642

**GOVERNMENT** Surplus receivers, transmitters, snoooper-scopes, parts. Catalog 25¢. Meshna, Nahant, Mass. 01908.

## COMPUTERS

**TIMEX/Sinclair** Owners. Get your **FREE** Program. Super Library, Box 4035, Winter Park, FL 32793

**FREE** Timex 1000 program! SASE brings catalog! Dealers Welcome. EZRAEZRA, Box 5222M, San Diego, California 92105.

**Ti-99/4A** Computer Discounts! Also Home Business. Experience Unnecessary. Details \$2.00. Computers, P.O. 27116, Cincinnati, Ohio 45227

**HAVE** your computer pay its own way. Sample newsletter \$1. Compu-Profit, Dept. PM3, Fairfax Station, VA 22039-0332.

**TRS-80 COMPUTER DISCOUNTS.** Lowest prices anywhere. Free price list. Radio Shack, 175B N. Delsea Dr., Vineland, NJ 08360. 800-257-0426.

**INTRODUCE** Yourself to Microcomputers with the **POWER-SHARING** Videotapes. Five Day Rentals from \$35. Martha Stuart Communications, Inc., Post Office Box 246M, Hillsdale, N.Y. 12529

(Continued on next page)

## COMPUTERS

(Continued from preceding page)

**EXCHANGE** your TI-99/4A cassette programs with others. Write, Exchange, PM1, P.O. Box 48, Sterling, Virginia 22170

**COMMODORE VIC20 OWNERS!** Send \$3.00 for Cassette with Five New Games: D. Radke, Box 25938, Chicago, IL 60625

**TRS-80\* GAMES** diskette for Model III. Chinese Solitaire, Boxes, Four in a Row. \$19.95. Martian Software, Box 936, Pinellas Park, FL 33565. (\*TRS-80 is TM of Tandy Corporation).

## TV-VIDEO EQUIPMENT

**VIDEO MOVIES.** Sold. Exchanged. Big catalogs—mail \$5.00. Tower, Dunkirk, MD 20754-0213

**7" TV PROJECTOR KIT** Wallsize Image! Gives 3-D illusion!! **FREE DETAILS.** BigTime TV, Box 1609-P1, San Anselmo, CA. 94960

**VIDEO SURVEILLANCE - CCTV** Equipment, Catalog \$3.00 (Refundable). RMA, P.O. Box 74, Mira Loma, CA 91752-0074

## STEREO, CASSETTE TAPES, ETC.

**RECORD-TAPES!** Discounts to 73%; all labels; no purchase obligations; newsletters; discount dividend certificates; 100% guarantees. Free details. Discout Music Club, 650 Main St., P.O. Box 2000, Dept. 1-0483, New Rochelle, New York 10801.

## CAMPING EQUIPMENT AND TENTS

**BUILD A STOWAWAY PICNIC TABLE**—Here's a unique design you can fold into an incredible small space of 2x5 ft. Park it in your garage or basement with room to spare. All the members are of stock lumberyard width which you just cut to length required. Easy to follow directions! For plans send \$3.95 to: Popular Mechanics, Dept. PMC4, Box 1014, Radio City, NY 10101

## BOATS, OUTBOARDS, TRAILERS & KITS

**BOATKITS - PLANS - PATTERNS - FRAMEPACKS - LARGEST CATALOG - 300 Designs 8'/80" - Plywood - Fiberglass - Steel - Strip Planking - POWERBOATS - Inboards - Outboards - Cruisers - Sportfishers - Hydroplanes - Runabouts (KAYAKS CANOES - Large Selection - Plywood - Fiberglass) - SAILBOATS - Daysailers - Trailersailers - Multihulls - FIBERGLASS MATERIALS - Cloth - Resins - Foam - CATALOG \$2.00 - Includes FREE Materials Brochure - Equipment - Rigging - Book "AMATEUR BOATBUILDING" - Fiberglass - Plywood - Wood/Epoxy - \$6.00. CLARKCRAFT, 16P Aquilane, Tonawanda, NY 14150**

**AIRBOATS - 5hp** Airdrive for small boats. \$450.00 Complete. Information \$1.00. Propeller Engineering, Inc., Box 513, Morgan, Utah 84050

**EVINRUDE** 1982 Bargains... all sizes... Scott McCulloch parts... \$1. handling... Electra Marine, 610 Merrick Road, Lynbrook, New York 11563

**BOAT PLANS - Frame Kits - Patterns - Hundreds of designs - Wood - Fiberglass - Steel - Powerboats - Sailboats - Outboards - Canoes - Kayaks - Rowboats - Houseboats - Duckboats - Sportfishers.** Easy, proven methods include instructions especially for amateurs to assure professional results. No Lofting! "Supplies" - Fasteners - Fiberglass - Resins - Glues - Spars - Books. Send \$2.00 for Huge 144-page catalog or \$4.00 Airmail. Includes Free "Boatbuilding Supplies" brochure. **GLEN-L** Marine, 9152 Rosecrans, Box 756MP, Bellflower, CA 90706.

**FIBERGLASS - RESINS - Foams - cloth - epoxies - mat - etc.** Factory prices - **CATALOGUE \$1.00** - (Book "COMPLETE FIBERGLASSING" \$6.00) - Clarkcraft, 16-P Aquilane, Tonawanda, NY 14150

**BOAT KITS - 27** trailerable models - **POWER** and **SAIL - 8'-30'**. Molded fiberglass hulls and decks come factory assembled - you install factory supplied interior. Save half factory-built cost. No experience required. 48-page catalog - \$1.00. Luger, Dept. BC-83, 3800 West Highway 13, Burnsville, Minnesota 55337. 612-890-3000

**BOATBUILDER'S PLANS, Patterns - Kayaks, Canoes, Sailboats, Pirogues, Fishing Boats, Duckboats, 40** models. Catalog 25¢. Outdoor Sports, Box 871C, Brentwood, TN 37027

**FREE BOOK OF BOAT PLANS.** Build Your Own In Steel, Glass, West. All Full Size Patterns And Large Scale Plans. Book Sent 4th Class or Enclose \$2.00 For Airmail. Bruce Roberts, 35PM Bellevue Dr., Severna Park, MD 21146

**BOATS** you can build in a weekend. Plans in every issue. \$12 yearly subscription. BoatSmith, P.O. Box 06476, Fort Myers, Florida 33906.

## CAMPING EQUIPMENT AND TENTS

**SURVIVAL, MILITARY, POLICE, HUNTING, CAMPING, BACKPACKING** equipment, **CAMOUFLAGE** clothing. Get your **FREE** catalogue. **BRIGADE QUARTERMASERS**, 266-P2 Roswell Street., Marietta, GA 30060

## ATHLETIC & BODY BUILDING COURSES

**BIGGER,** More Powerful Muscles - faster! Free Booklet! Universal, Box 6694A, Detroit, Michigan 48240

**KUNG-FU** Free Lessons. Send \$1.00 for Postage. McLisa, Box 1755, Dept. PM83D, Honolulu, Hawaii 96806

**LIFESAVER!** Beginning Joggers Handbook; Free Details. Sunflower Press, Box 2686, Kansas City, Kansas 66110

## AIRGUNS

**BEEMAN** high power adult airguns. European precision. Velocity, accuracy, durability, quietness — all greater than domestics. No pumping, CO<sub>2</sub> or valves. 100 models: \$50-\$800. The finest in the best value. \$1 Lifetime Repair Policy. Mention code PC for **FREE** catalog/guide. Beeman, 47PC Paul Drive, San Rafael, Calif. 94903. Phone (415) 472-7121 - 24 hours, 7 days.

## DOGS AND KENNELS

**SOOTHING** Lotion Heals Most Skin Problems Naturally. Concentrate (Makes Four Gallons) \$3.00. H. Leon Enterprises, Atlanta, Georgia 30357-77343.

## BATTERIES, GENERATORS

**SENTRY** Generators With/Without engine. Big discount. JJ Enterprises, Box 693, Oshkosh, WI 54902

## BATTERY REBUILDING SCHOOL

**TOOLS** And Instructions \$326.00. Training available. Tested and proven method. Instructor has 32 years experience. Sun Battery Inc., 10415 U.S. 98, Sebring, FL 33870. (813-655-1314).

## ENGINES, MOTORS, MAGNETS

**REPAIR ELECTRIC MOTORS!** ILLUSTRATED INSTRUCTIONS! Modequip, Box 7266, Kansas City, Missouri 64113

**SMALL ENGINES** Large Discounts. Send Stamped Business Envelope To: Engines, Box 166-PM, Ashland, MO. 65010

## TOOLS FOR SALE

**DISCOUNT TOOL** Catalogue - \$1.00. Hoosier Distributing, 3009 Sample, South Bend, Indiana 46619

**COMPLETE LINE** of high quality, low-priced **CUTTING TOOLS, HOLDING FIXTURES, PRECISION INSTRUMENTS AND TOOLS, TOOL STEEL, PORTABLE ELECTRIC AND AIR-TOOLS, HAND TOOLS AND MUCH MORE.** Most items delivered free. Send \$4.00 for 368 page 1983 catalog, refundable with first order. **KBC TOOLS**, P.O. Box 343, Sterling Heights, Michigan 48078

**AUTOMOTIVE** Specialty Tools. Top Quality. Catalogue \$2.00. EHT, P.O. Box 7254, Orlando, FLA 32854

## UPHOLSTERY SEWING MACHINES

**UPHOLSTERY** Sewing Machines with Walking Feet, complete ready to use—only \$459.00. Thompson Model PW103-AGBP AVAILABLE FROM YOUR LOCAL DEALER, or order direct. (Master Charge-Visa). Detho Mfg., Inc., P.O. Box 12110, Lubbock, Texas 79452—Phone: (806) 744-6774

## MACHINERY, TOOLS & SUPPLIES

**SHOPMATE, POWERHOUSE, MCGRAW EDISON, MANNING BOWMAN, VILLAGE BLACKSMITH** electric tool repair parts. Deco Parts Service, Dept. P, 8122 Gravois St., St. Louis, MO. 63123 (314)353-4900.

**4" METAL** Cutting Lathe \$83.50. Taig, 15048 Proctor, Industry, CA 91746

**SILVO** Hardware, 188 page Hand & Power Tool Catalog \$1.00. Dept. PM3-4, 2205 Richmond St., Philadelphia, PA 19125

**FREE** Industrial Buyers catalog for home craftsmen. Buy equipment at same **LOW** prices as large industrial plants. Turnkey, 36PO, Letchworth St, Buffalo, NY 14213

**BANDSAW BLADES,** Carbide Tipped Saws, Any Size, Free literature. King Saw, 6541 Tidewater Drive, Norfolk, Virginia 23509

1400 Catalogs Listed and Described. Sources for Everything Imaginable. \$4.00. Masterlog, Box 879-B, Fairfax, CA 94930.

**SMALL FOUNDRY** Furnaces, Supplies. Free literature. Pyramid Products, 3736 South 7th Avenue, Phoenix, Arizona 85041

**LATHES**—Unimat—Maximat—Sherline Enco. Catalog \$1.00. Shop Supplies \$1.00. Campbell, 21000 Selma Road, Springfield, OH 45505. (513) 322-8562.

**STEEL,** Aluminum, Brass—Sheet, Bar, Shop Supplies, Plans. Write: CEI, R.R.1, Box 163, Cameron, IL 61423.

**MACHINISTS'** aids, ideas, plans. \$5.00 for set. Innoventions II, 3725 Anueha St., Honolulu, Hawaii 96818.

**SOLVENT PARTS WASHER.** Professional Style. Supplies. Kits. Free Literature. Diesel Systems, Box 1273, Arvada, Colo. 80001

**NEW AUTOMATIC WRENCH!** SAVE— Does the job of several wrenches. Sold only by mail. Money back guarantee. \$21.00 Postpaid. The Halbo Company, P.O. Box 3348, Portland, Oregon. 97206

**SAWMILLS!** Inexpensive kits, plans. Free details. Sawmill, 35045K Ede, Lebanon, Oregon 97355

**BRASS,** Steel, Aluminum, Stainless, Acrylic, Nylon, Teflon. No minimum. Catalog \$1.00 (Refundable). **METALS,** Box 11204, Clayton, MO 63105

**BELSAW SHARP-ALL OWNERS.** Save Over 30% on Name Brand Wheels, Files, Belts & Parts! **IMMEDIATE SHIPMENT!** Free Catalog. Woodmaster, Dept. H2G, 2849 Terrace, Kansas City, MO. 64108. 800-821-8651.

**WOOD LATHE - 5"** Innovative D-I-Y Kit. Easy Assembly \$29.95 + \$3.50 Shipping. Toolmaker Lathe, 68 Eagle Lane, Hauppauge, NY 11788.

**TILLERS & ENGINES** Buy tillers and engines wholesale prices. Catalog \$1.00. Dearing Sales, P.O. Box 813, Mission, KS. 66201

## BLACKSMITH SUPPLIES

**FORGES:** gas, coal — hammers — tongs — anvils — anvil benches—all blacksmith supplies. Catalog \$2.00 (refunded first order) Mankal Blacksmith Shop, 7836 Cannonsburg, Cannonsburg, MI 49317.

## ENERGY SAVING

**SAVE MONEY,** Wholesale Energy Products, \$1.00 For Literature and Prices (Refundable). Energy, P.O. 923, Niles, Mich. 49120

**PROVEN JAPANESE ENERGY SAVING APPROACHES CAN SAVE 50+% !!** Send \$6.95 for New 1983 Report/Guide to: **JAPAN RESEARCH,** Box 42361-PM, Cincinnati, Ohio 45242

**CUT HEATING COSTS DRastically!** Build Attractive FIREPLACE INSERT That Efficiently Heats Entire Home. Stove Burns Surprisingly Small Amount Of Wood! For Information About Detailed Plans, Send Self-Addressed Stamped Envelope and \$2.00 For Handling To: The Energy Saver, P.O. Box 934, Canyon, Texas 79015.

**CHANGE** your metal lamp into **TOUCH LAMP!** Your Touch is the Switch! \$24.95 Each Adapter. Free Information. Heirloom, 1634 St. Michael's, Santa Fe, NM 87501

**YOUR** Attic can provide Cool in Summer, Warmth in Winter, No operating expense. \$10.00. Dept. PM 1117, McLindon, P.O. Box 207, Arlington, VA 22210

**GENERATE** ELECTRICITY With Unmodified Induction (Washer Type) Motor. Legally Reverses Electric Meter. Simple Instructions \$3.88. EPS, Box 3572, Shawnee Mission, KS 66203

## SOLAR & ALTERNATE ENERGY

**SOLAR ENERGY.** Beginner's experimental kit and 32 page handbook. \$11.95 ppd. Solarcrafts, P.O. Box 2557, Laurel, MD 20708.

**BEER** cans will Heat your Home. Do-It-Yourself Photo Booklet \$6.00. Solar Canned Heat, R.R. 2, Jesup, Iowa 50648

**SOLAR AND ENERGY SAVING PRODUCTS CATALOG!** MATERIALS; Components; Complete System. 80 Pages, 18 Sections. Our 10th year! Order from one expert source—the country's largest energy saving mail order house! Call us at 603-668-8186 or send \$1.00 ppd. **SOLAR COMPONENTS CORPORATION,** Dept. M, P.O. Box 237, Manchester, NH 03105

**HYDROGEN - ACETYLENE!** Super fuels Complete directions, home manufacture. No special equipment needed. Hydrogen - \$3.00. Acetylene - \$3.00. Horizon Enterprises, Box 3334M, Enfield, Connecticut 06082.

**HYDROGEN FUEL!** Complete Electrolyzer and Auto Conversion Plans. Plus information on Safe Storage and Generating Hydrogen Free. Complete Package: \$10.00. RDA, Box 873, Concord, NC 28025

**SOLAR** Kits, Windmill, Oil Pumper, Train, Helicopter, Bi-Plans. All Materials Needed Are Included Only \$24.95 ppd. or Write for Further Information. M and W Sales, P.O. Box 3-597, Dept. PM, Anchorage, Alaska 99501

**WIND** Generator, build your own for about \$300. Free information. Send 25¢ to cover postage: Wind Energy, PM, P.O. Box 841, Paradise, CA 95969

## HOME HEATING, FUEL SAVERS

**FIREWOOD LOGS** from SAWDUST Easy to make simple instructions. \$10.00. Today's Ideas, Box 22304C, San Francisco, CA. 94122

### "LOG SPLITTER PLANS"

**15 TON** Push, 2 Speed Hydraulic, High Speed Running Gear, Professional Quality, \$10.00. Tangent Designs, Box 572, Pottstown, PA. 19464.

**GAS WATER HEATING** - Save up to 40% and More!! New Timer. Excellent! Free Details: Perry Marketing, Box 303-PM4, New York, N.Y. 10021

**GAS** burner for starting fires in Fireplaces, or any wood heater. Easy to install and operate, Starts fires in seconds, inexpensive. Specify whether Natural or Lp. Send \$15.00 Check or Money Order to: Ashley Burners, Route One, Box 115, Crawford, Georgia 30630.

**FABULOUS FUEL** savings. 24 hour programmable heat monitor. Build yourself, about \$20 Instructions \$2.50. B-Frank, Box 1702, Jackson, Michigan 49204.

**FURNACE SPRAY** Humidifier, Complete Plans, \$5. JC Enterprises, 2824 SW Miller, Des Moines, Iowa 50315

## HOME CRAFTSMAN

**AMERICAN FOLK ART PLANS, CATALOG** \$1.00. P.O. Box 29351, Dallas, TX 75229

**OVER 75 PATTERNS!** Enjoy making profitable wooden gifts, toys, household accessories. PLUS "Shop Secrets". Only \$5.00. Accounts (P-43), Box 262, Danvers, MA 01923

**UNFINISHED** picture frame moulding. Factory closeout. 50% discount. 200 styles. Write: Japs, 126-PF Seventh North, Hopkins, MN 55343

**MAKE TOYS** - Plans, Kits - Hardwood Wheels, Parts, Dowels - Catalog \$1.00 - Cherry Tree Toys, Belmont, Ohio 43718.

**CATALOG FULL-SIZE FURNITURE PLANS** — \$2.00. Refunded with first order. Traditional, Early American, over 170! Furniture Designs, 1425 Sherman, Dept. CP-83, Evanston, Illinois 60201.

**PLANS & Supplies** for toys, clocks, furniture and accessories. Catalog \$1.00. Armor Products, Box 290, Dept. CT., Deer Park, NY 11729

**WOODEN** Toys Are Better. List Of Plans \$1.00 U.S. Currency Only. Woodbutchers Toys, Box 514, Leslie, Mich. 49251

**CHANGE** Color Of Vinyl Or Leather Upholstery. Easy, inexpensive. For information SASE TO: Clausen, P.O. Drawer 140-N, Fords, NJ 08863.

**WORLD'S LARGEST CATALOG?** Three pounds 704 pages. Every Tool, Supply, Machine Imaginable \$5.00. Refundable. McKiligan, PM-463, Johnson City, New York 13790

**BATTERY CLOCK MOVEMENTS.** Hands, Hardware, Finest Quality, Discount Prices. Catalog \$1.00. Refundable, Yankee, Box 26, Thompson, Connecticut 06277

**WALNUT** Lumber cabinet grade. Squares, Gunstock blanks, Veneer. Iowa-Missouri Walnut Co., Dept. M, Station A, Box 66, St. Joseph, MO 64503

**"WOODWORKERS" BUILD THIS "ELECTRONIC INSECT KILLER".** Easy, Inexpensive To Build. Full Size Patterns, Photo Section. Free Details. Britton, 15635 Brookhurst, 46M, Westminster, California. 92683.

**KIENZLE** Quartz Clock Movements. (Battery operated). From \$4.80. Also accessories. Free price list. North American, Box 77-ADK, Fox River Grove, Illinois 60021.

**NEW!** \$500.00 From one sheet of Plywood. Guaranteed. Oakstump Woodcraft, 3630-PM4 Pacific Way, Longview, Wash. 98632

**YOU CAN BUILD** Furniture, Toys, Accessories and Shop Equipment. Five Free Plans with Illustrated Catalog 700 items. Send \$1.00 for Details. Mayco Sales, Box 2931PM, Mesa, Arizona 85204

**FAVORITE WOOD TOYS,** Patterns, Parts, Wheels, Catalog \$1. Toys And Joys, Box 628M, Lynden, Wash. 98264

**PLANS** and instructions for concrete flower pots, for patio, porch, and gravestones. \$2.00. Stapley Masonry, P. O. Box 364, Findlay, OH 45840

**OUTDOOR** Fitness Center Including Treehouse. Complete Plans. Send \$4.95. Miller Designs, Valley St., Cassville, MO. 65825.

**WOODWORKERS:** Make \$100.00 this Saturday with your shop scraps! Complete instructions \$3.00. Woodscenes, P.O. Box 744, Oregon City, Oregon 97045

**WOODWORKERS**— 10 Quick And Easy Spare Time Projects, Useful Items. All 10 Plans - \$5.95. Denny's Woodshop, 304 Brian, Mount Horeb, WI 53572.

**35 WOODEN TOY PATTERNS**— Easy, Profitable— Cars, Trucks, Train, Airplanes, Earthmovers—\$5.00—FRANKS, 1202P6 Second, Booneville, MS 38829

**BIRDHOUSE** Kits, Precut. \$3.98 Each. Crafter, 1909 75N, Sherman, TX. 75090

**FREE FULL-SIZE BOOKSHELF PATTERN** when you send \$1.00 for Gifts/Accessories Pattern list. Wood World, Box 2833, Lake City, FL 32056.

**YOU Can EARN \$15,000.00 PART-TIME.** Send Today. **FREE** Details. Begin IMMEDIATELY! Craftsman, PM 43, 306 W. 15th Street, Suite 101, Panama City, FL 32401

**MAKE** Wooden Cradles. Wheelbarrows. Birdfeeders. Racecars. Easy-Profitable. List Of Plans—\$1.00. (Refundable). Keepsakes, Box 18733, Shreveport, LA 71138

**PLANS:** Multi-size furniture; Details: 25c. Flexiplan-GG, 48 Lowell, Westwood, NJ 07675.

**STAINLESS** Steel And Brass, Screws And Bolts. Small Quantities, Free Catalog. Elwick, Dept. 479, 230 Woods Lane, Somerdale, N.J. 08063

**NEW SUPER YARD WAGON,** Air-Tired Beauty. Practical, Sturdy, Useful. Use As Work Wagon, or as coaster Wagon, Or Trailer. Kids Love It. Easy To Follow Plans, Materials List, And Sources For Materials—\$4.00 PPD. Designs By Dane, 33 Lorna Drive, Little Rock, AR 72205.

**\$100.00 FROM ONE SQUARE FOOT OF WALNUT LUMBER!** Easily Made - High Demand Item. Complete Details - Only \$3.50. Keepsakes, Box 18733, Shreveport, LA 71138

**PLANS** For Unusual Animated Wooden Toys. Send SASE For Free Catalog. **TOYS,** 5606 Graves Ave., Encino, CA 91316

**SWING-SET GYM-SET** Combination Outdoor Wood, Inexpensive, Plans, Material List \$2.98. Practical Plans, 4524 Conlieth, St. Louis, MO 63129

**FOLD UP DRAFTING TABLE** under \$30.00. Storage Space under 36x24 drawing board top. Folded 36x36x36. Plans \$5.00. Bowen Designs, 614 Warnke Rd., Michigan City, IN 46360

**CATALOG FURNITURE PLANS,** plus sample plans \$1.00 (refundable). Country, Contemporary. Sunnywood, Box 82, Norwood, PA 19074

**SHAPER CUTTERS** direct from manufacturer. Send for Free cutter offer. Corob, 53 Westwood, Shrewsbury, MA 01545

**WOOD WHEELS, SHAKER PEGS - WHOLESALE** Free Catalogue. Bogert & Hopper, Inc., 175P West Carver St., Huntington, NY 11743

**TOOL CABINET** - Wooden Roll-around - 31x26x19 - 3-Drawer - 2-Door - Complete Illustrated Plans. \$3.50. - B & B Wood Projects, Box 95, Hartford, Ohio 44424.

**WOODWORKERS,** unique **RINGMASTER** creates hollow cylindrical projects (lamps, bowls, etc.) easily, repeatedly, PROFITABLY. Dealerships also available. Brochure \$1.00. Ringmaster, Box 8527A, Orlando, FL. 32856.

**WIND CHIMES. FUN. PROFIT. GIFTS.** 3 Plans \$5.00. Ben Corbin, 237 Bailey, Harahan, LA. 70123

**UNBELIEVABLE** linking wires. **SEEMS IMPOSSIBLE.** Easily constructed. Plans \$2.00. Tippet, Dept. 469, 104 N. Lake St., Joseph, Ore. 97846

**WOODCRAFTERS** Instructions And Diagrams For 7 Original Projects, Beginners or Advanced, Gifts or Profit, \$2.00. WR, Box 28, Hatboro, PA. 19040

**KIDS LOVE IT:** Simple Plans, Build Home Video Game Center. Under \$20. Holds Atari, Intellivision plus TV. \$6.95. OWOD Designs, Box 2366, Topeka, Kansas 66601

## CONSTRUCTION PLANS, BLUEPRINTS

**BUILD** Pole Buildings, Techniques, Details, Material Lists, Typical Plans, \$25.00. Planex, Box 70081, St. Paul, Minnesota 55107

**PASSIVE** Solar Home Building Blueprints 1 set-\$15.00, 3-\$40.00, 5-\$65.00. Solco, P.O. Box 37376, Omaha, NE. 68137

## HOME BUILDING & REMODELING

**750** Home Plans, Solar, Underground, Envelope and More! Blueprints available. Free Information or \$19.50 for the 10 Volume Collection. Garlinghouse, P.O. Box 299, Dept. 30018, Topeka, KS 66601

**\$50. OCTAGONAL WINDOW** save \$200. USA orders welcome. Instructions drawings \$4.50. B. M. R., Box 929 Ridgeway, Ontario, Canada LOS 1N0

**YOU DESERVE** a Lovely Home. All can AFFORD Plans and Prints. \$2.95. Home's Inc., Box 10651, Fort Wayne, Ind. 46853

**SURVIVALIST** Homes multi/single unit self-contained housing above or below ground on private lots in Maine Write: Country Builders, RFD#3, Belfast, Maine 04915.

**SAVE 50% BUILDING** Remodeling Free Information. Consumeraction, 13257-BL, Pittsburgh, 15243

**SAVE 50%+** "Unitruss" shell home, build yourself! Entirely trussed, superinsulated, unique. Complete "how-to" build trusses, shell manual, ... wood foundation, ... superinsulated home designs. ... \$5.00 each, ppd. Unitruss, Box 13, Plover, Wis. 54467

## PLASTICS

**CASTOLITE** Liquid Plastics. Crystal clear, colors. For casting, embedding, coating, fiberglassing; in industry, laboratories, craft work. Reproduce your designs with our mold materials. Profitable. Illustrated Catalog \$1.00. **CASTOLITE,** Dept. 83D/PM, Box 391, Woodstock, IL 60098.

## AIR CONDITIONING

**BEST AIR CONDITIONING AND HEATING** Text and Reference Book Available, Twenty-Four Chapters, Over 1000 Pages of Valuable Information. Many Illustrations. \$32.50. Shanco Supply Co., Box 590212, Houston, Texas 77259-0212

**HEAT PUMPS, CONDENSERS, EVAPORATORS, FURNACES, ETC.** at Huge Discounts. Do It Yourself and Save Hundreds or Even Thousands of Dollars. Major Brands. Latest High Efficiency Equipment. Catalogue \$3.50. Shanco Supply Co., Box 590212, Houston, Texas 77259-0212

## DO-IT-YOURSELF

**YOU** can spend 100's of dollars having your furniture refinished or \$3.00 for easy directions on how to do it professionally yourself. P. O. Box 9082, Dept. FM, Newark, DE 19714-9082

**ADULT** Wood Work Bench With L-Shape Top, Plus Circular Saw Cutting Guides. Plans - \$1.00. Deneco, Box H, Summit-Argo, IL 60501

**REPAIR DAMAGED CONCRETE FLOORS, SIDEWALKS, DRIVEWAYS.** Inexpensive ordinary materials available local suppliers. Booklet describing procedures \$4.00. **INFOSERV,** 11058 Westridge Rd., Elyria, OH. 44035

**PROJECTION TV** ... Convert your TV to project 7 Foot picture ... Results Comparable to \$2,500 projector ... Total cost less than \$20.00 ... **PLANS & LENS** \$17.50 ... Illustrated Information FREE ... Macrocobmh, Washington Crossing, Pennsylvania 18977, Creditcard Orders 24Hrs. 1-215-736-3979.

**\$3.95** Buys Successful Bread-Making Instructions, Eliminating Failures. The "SMELL'S" Worth \$3.95. K. Morris, 318 North, Spencerville, OH 45887

**CHAIR CANING SUPPLIES**—Cane Webbing, Rush, Splint, Rawhide, Cord, Embossed Seats. Free Catalog. The Canning Shop, 926 Gilman (PM), Beckeley, CA 94710.

**BELTSANDER-SAVE**— Make your own. Write for details. Kathon Inc., 4801 Hunter Trail, Chattanooga, Tennessee 37415.

**SHRIMPING** Manual Tells How To Catch Your Own. Save Money. Includes Baiting. Illustrated. \$5.00 To: Waterway, Box 5058, Jacksonville, Florida 32247

**COMPLETE** In-Ground Swimming Pool Kits From \$1595.00. Complete Acrylic Spas From \$1995.00. Free Brochure And Price Lists. Burnett, 4601 Bunkerhill, North Little Rock, Arkansas 72118

**SURVIVE!!** — Three Dozen Controversial Survival Publications — Energy, Banking, Firearms, Medical. "AUTOMATIC TELLER MACHINES" (\$20.00), "GAS FO' ALL!!" (\$16.00), "SURVIVAL GUNS & AMMO!" (\$16.00), ... Super-Survival Brochure (\$1.00). INTERVIEWED BY CBS "60 MINUTES". WILLIAMS, MSEE, P.O. Drawer 537M, Alamogordo, NM 88310

**PLANTER** Boxes, 10 Plans \$5.00. Ashmore, Box 771, Grass Valley, CA 95945

**NEW! ... REPAIR ANY TV ... EASY.** Write: Research, Box 517X, Brea, CA 92621

**ELECTROPLATING.** Complete amateur's textbook. All metals Electroplate metallic/nonmetallic items \$11.95. Details free. Tropic, Box 95-P4, Palm Bay, Florida 32905.

**1400** Catalogs Listed and Described. Sources for Everything Imaginable \$4.00. Masterlog, Box 679-F, Fairfax, CA 94930.

**SAVE** on parts for Lawnmowers, Minibikes, Karts, Chainsaws, Small Engines. **THOUSANDS OF PARTS.** Send \$3.00 For Catalog. Sav-On-Parts, P.O. Box 231, Somerville, Mass. 02143

**WATERBEDS!** Plan And Accessory Catalogue \$1.00. Waterbeds, 1210A "Z" Street, Vancouver, Washington 98661

**SURVEILLANCE ELECTRONICS.** Build your own. Details Free. Lextek Laboratories, Box 8485B, Silver Spring, MD 20907

**SILVER,** Dead Batteries Contain It: You Can Reclaim It. \$5.00. Goldbond Ltd., Box 10669, Pittsburgh, PA. 15235

**REPAIR,** Air Conditioning - Refrigerators - Illustrated - Manual \$10.00. Doves Inc., Box 771B, Hammond, Louisiana 70404

(Continued on next page)

## DO-IT-YOURSELF

(Continued from preceding page)

**LEARN GLASS ETCHING** Complete starter kit \$4.95 ppd. Guaranteed! Eastern Art Glass, Greenwood Ave., Box 341, Wyckoff, NJ 07481

**HOW TO GO INTO BUSINESS AND SUCCEED.** Free Literature, Write: PIRA, Box 3145, Laval, MD 21502

**CARPENTERS!** Flush nailing tool eliminates hammer tracks on finish work. Fits all finish nails. Send \$3 to: Blue Chip Enterprises, P.O. Box 699, Cannon Beach, Or. 97110

**POTTERY KILNS,** inexpensive, propane, plans \$5.00. Box 7497, Winter Haven, Florida 33883

**BODYBUILDERS,** build a cable Lat Machine. Features removable seat, overhead pulley, floor pulley, uses standard barbells weights. Easy to build from 2x4's plywood, and steel. Minimum welding. Very detailed plans and instructions \$6.50. Jacobson, 2098-44 Grip Rd., Sedro Woolley, WA. 98284

**TELEPHONE OWNERS MANUAL-** Deregulation, Trouble Identification, Testing, Repair. \$4.00 PPD. Hess, 1020A E. Los Altos, Fresno, CA 93710

**LEARN ARC WELDING AT HOME - Easy - Inexpensive - Instruction manual \$3.95, details free. Moneyback Guarantee.** Box 2067M2, Cridersville, OH 45806

**RESILVER MIRRORS** Easy Step By Step Instructions Send \$2.00. P.O. Box 2791, Olympia, Washington 98507

**CUT/STYLE Hair EASILY! ONLY \$5.50!** Danny Morrison, Rt. 7 Box 1680, Lufkin, Texas 75901

**PORTABLE HOIST** for Pick-up, Build mostly from scrap parts Plans - \$3.50. Hoist, Box 104, San Angelo, TX 76902

**LIGHTNING ARRESTOR KITS.** Kit Includes Parts, 75' Cable And Instructions. Send \$70.00 To: Mercury Electrical Co., P.O. Box 10374, Jefferson, LA. 70121

**TIRE Changer—**Plans \$8.00. Parts, Complete Units Available. M-K-2, 2520 Tryon Road, Ashtabula, Ohio 44004

**HOME OWNER'S GUIDE TO PLUMBING** Complete Step by Step Instructions to Solve your Plumbing Problems \$5.95. JRP Enterprises, 5201 Clarendon Rd., Rm 3A, Brooklyn, N.Y. 11203

**EASILY APPLIED LIFETIME LIQUID ROOFING. MECCO,** 1664 Tchoupioulas, New Orleans, 70130

**PVC TYPE FURNITURE.** The Money-making Opportunity For Prints And Prices. Send \$3.00 To: Easy Living Furniture, Box 238, Thornwood, NY 10594

**SAVE Money - Install Your Own Ceiling Fan.** Simple Directions. Send \$5.00 To: Fans, P.O. Box 12880, Fort Worth, TX 76121

**BUILD YOUR OWN PVC** pipe furniture, chair, chaise, end table, plans \$4.00. Creative Sales, Box 247M, South Milwaukee, WI. 53172

**GIANT Screen TV Projector Plans.** Easy construction. \$3 To: Mountain Sun, Box 251, Hayden, Idaho 83835.

**PAY TV / AMATEUR TV RECEIVERS** Watch 24Hrs Movies, Specials, Sports, Etc., GUARANTEED Finest Models anywhere. FREE BROCHURE, Jarik, 632 W. Doran - Suite A, Glendale, CA 91203. 213-856-5839. Infor. for Authorized TV Programming.

**1600 CATALOGS** on every subject imaginable!!! Directory \$4.00. Catalogs Galore, 7914-E Springfield Village, Springfield, VA 22152.

**SHARPEN** Philips or Norelco Electric Shaving Blades at Home in Seconds. Send \$2.00 for instructions. Box 2865, Sarnia, Ontario, Canada N7T 7W1

**PLANS** build your own bee hive \$5.00; GM Company, PM4, 3901 Merrywood Lane, Chattanooga, TN. 37416

**LADDER HELPER** Rungs Hurt Your Feet - No More. Moveable Rung Extension Moves to Desired Rung without leaving Ladder. Plans \$3.00. Orsino, P.O. Box 71, DPT4MP, Dresher, PA 19025

**LOCKSMITHING** tools, books, training. Introductory booklet, catalog. \$1. RALCO, Box 16434M4, Memphis, TN 38116

**2"x4" FURNITURE. PRACTICAL, PROFITABLE AND FUN.** Six Projects. 41 Page Manual. Photos And Instructions \$9.50, Illinois Residents \$9.98. A. B. L. Distributors, P.M., P.O. Box 1152, Jacksonville, Ill. 62651

## ARTS & CRAFTS

**"GETTING Started in Stained Glass" \$1.00.** Whittemore, Box 2065T, Hanover, Mass. 02339.

**CRAFT Jewelry Supplies.** (Wholesale Catalog .25c). Rousseis, 107-1630 Dow, Arlington, MA 02174

**STAINED GLASS SUPPLIES** Complete Catalog \$1.50 (refundable). Sunshine Glassworks, 785 Millersport, Dept. CT, Amherst, NY 14226

**STAINED GLASS** Catalogue-P. \$1.00. Supplies, Kits, Books, Tools, Glass. Staylescrafts, 171 Main, Nyack, N.Y. 10960

**WOODWORKERS: PEGMAN IS HERE!** Instructions, patterns, solutions for seven beautiful combination pegboard puzzle-games. Only basic tools required. Ideal for family fun, gifts. \$5.00. Ellis Enterprises, 31 Hummel Rd., P.O. Box 934, New Paltz, N.Y. 12561.

**LEATHERCRAFT** supplies. Catalog \$1.00 (refundable). Craftet, 1909 75N, Sherman, TX 75090.

**101 HELPFUL HINTS ON MACRAMÉ** Send \$3.00 to: Helpful Hints, Box 41216A, Atlanta, GA 30331

**COMPLETE** instructions for 10 art projects. \$2.50. Handbooks, P.O. Box 101, Holly, MI 48442.

## CARTOONING, COMMERCIAL ARTS & SIGN PAINTING

**MODERN** Cartooning taught by mail. Write for free brochure. Cartoonorama—Box 263-3P, Branford, Conn. 06405.

**SIGN** Painting -- Easy method. Free catalogue. Kaufmann Company, Centertown, Missouri 65023

**CARTOON** for Fun and Money!!! Free booklet!!! Cartoons, Box 40614A, Detroit, Michigan 48240

**35 LESSON** cartooning course. Cartoonist's Magazine, both \$4.00. Hartman, Box 30367, Lincoln, Nebraska 68503-0367

**LEARN** Sign Painting! Highly Profitable! One-Stroke Technique! Write: Eureka Press, Box 931, Fitzgerald, GA 31750.

## MODELS, CARS, SHIPS, TRAINS, PLANES, ETC...

**SCALE SHIP MODELS.** Since 1905 our Model Ship Kits and Fittings have been the Favorites of Discriminating Modelers. Send \$2.00 for Big Catalog. BLUEJACKET SHIPCRAFTERS, Box 533P, Shelton, CT 06484

**FIRING CIVIL WAR Model CANNON** Plans: Catalog free. Green—PM-43, Box 892, Shalimar, Fla. 32579

**BLIMPS** 11 foot radio-controlled kits. Catalog \$1.00. Peck-Polymers, Box 2498-P. La Mesa, California 92041

**RADIO CONTROL-** Airplanes, Boats, Helicopters, Supplies. Big Discount Catalog \$5.00 (Refundable). Modelers Supply, Box 7185, Montgomery, AL 36107.

## KITES, GAMES, PUZZLES NOVELTIES

**YOU CAN MAKE 3-D DRAWINGS.** Instructions, Glasses and Pens included. Free Details. Box 757D, Cache, OK 73527

**PITFALL!** Treasure map, 255 scenes, \$2.00. P. Tuchscherer, Box 735, Sisters, Oregon, 97759.

## MAGIC TRICKS, JOKES, VENTRILOQUISM

**PROFESSIONAL Magic!** Huge catalog, over 1,000 tricks and books. \$2.50. Hank Lee's Magic Factory, Dept. PM4, 24 Lincoln Street, Boston, Massachusetts 02111

**FREE!** World's Leading Novelty Catalog. 1600 Jokes, Tricks, Science, Sports, Hobbies. Johnson-Smith, C-6013, Mt. Clemens, MI 48043

**FREE!** Illustrated Ventriloquism/Puppetry Catalog. Maher, Box 420PM, Littleton, Colorado 80160

**LEARN MAGIC.** \$2.00 for Catalog. Same Day Service. 1512 Fremont, Las Vegas, Nevada 89101

**Joke TELLERS HANDBOOK.** 1999 Jokes. \$5.00. Theodore Enterprises, 3382 Par Dr., La Mesa, CA 92041

## HOBBIES AND COLLECTIONS

**MILITARY** Medals Catalogue 50¢. Yearly Subscription \$4.50. Vernon, Box 387PM, Baldwin, NY 11510.

**NAZI** war souvenirs. FREE illustrated catalog. Delta, Box 31224PS, Honolulu, Hawaii 96820

**TOY SOLDIER, CHESS FIGURE MOLDS** -- Free Information -- Special Offering. Castings - PM, P.O. Box 3482, Longwood, FL 32750

## DECALS, EMBLEMS, PATCHES

**PATCHES,** Decals, Custom Made. Free Catalog - Emblems, Box 35, Tappan, New York 10983

**SAVE** Big. Buy Patches, Decals, Pins & Caps Factory Direct. Free Catalog. Free Pricing. Eastern Emblem Co., Box 828-PM, Union City, N.J. 07087

## ANTIQUES, RELICS, INDIAN GOODS AND CURIOS

**FREE** List to Serious Collectors. 30,000 Indian Artifacts, Pots, Spears, Axes, Slate, Beadwork. Caddo Trading, Box 669, Murfreesboro, AR 71958

## STAMPS FOR SALE

**WORLDWIDE** Approvals. Superb Personal Service. Fine, 40 Browning, Toronto, Canada M4K 1V7

## STAMP COLLECTING

**U.S. 25 Different mint including Souvenir Sheet \$1.00.** Free list. Brooks, Box 62, Brooklyn, NY 11229

**50 YEARS** Old fifteen different United States, over fifty years old—25¢ with approvals. Jaxon, Box C11-P, New Rochelle, New York 10804

**1,000 DIFFERENT WORLD + 100 DIFFERENT MONGOLIAN BEAUTIES \$2.95.** Attractive approvals (pictorials). Cancel Service Anytime. **ADULTS ONLY.** Gouge, Box 1320ML, Elizabethton, Tennessee 37643.

**FREE!** Big Bargain Catalog - New Edition listing thousands of bargains including U.S. & B.N.A. stamps, packets, albums, accessories and supplies. Also fine stamps from our approval service. Buy only what you like. Return balance promptly. Thank you. Jamestown Stamp Co., Dept. E43PM, Jamestown, NY 14701

**50 TOPICALS 25¢** when requesting approvals. Comservco, P.O. Box 2715, Station "F", Scarborough, Ontario, Canada M1W 3P3.

**FREE** Gift To Introduce Unusual Service For Early U.S. Stamps. Garrett, Box 06625, Fort Myers, Florida 33906

**TOPS!** 100 Popular Poland Stamps (all different) only 25¢. Mystic, Dept. PS1, Camden, New York 13316.

**U.S. MINT** Plate Blocks, \$1.00. Approvals. Mark Carpenter, Box 11012, Cleveland, Ohio 44111

**WOW!** 50 All Different Germany-10¢! Super collection of genuine German Commemoratives, Definitives, Airmails, High Values. Free Big Catalog. Also fine stamps from our approval service. Buy what you like. Return balance promptly. Send 10¢ today! Thank you. Jamestown Stamp Co., Dept. A43PM, Jamestown, NY 14701

**50 MINT** or 200 used all different US \$1.00 approvals. Stamps, Box 1427PM, Bellflower, CA 90706

**U.S. 6 Commemorative Plate Blocks \$1.00!** Approvals. Gordon Davison, 58C, Nokomis, FL 33555

**"WHOLESALE"** U.S. - Foreign Pricelist and catalog Free! Everything Guaranteed. Schneider, Box 1240, Grand Rapids, Michigan 49501

**1,000 U.S.A. Mixture \$2.95.** St. Johns Stamps, Box 248P, Milford, CT. 06460

**FREE** Gift With Quality Approvals. Chapmans, Box 487-G, Galesburg, Michigan 49053

**GREAT** Gift free with 1st purchase—fine United States approvals and want list service. Send .15¢ for handling. The Stamp Boutique, P.O. Box 456, Madison, NJ 07940

**BREATHTAKING** Beautiful. 50 Different mint Monaco pictorials commemoratives only \$1.50 with mint complete set approvals. Pagoda, Box 132P, Sidney, Ohio 45365.

**PENNY!** Approvals! Regardless catalogue! Kloster, 4164 52nd St., San Diego, Calif. 92105.

**UNITED NATIONS** 3 Complete Mint Sets 25¢. Approvals. Cornetta, POB 1509-M, Lake Placid, Florida, 33852

**50 DIFFERENT** Old U.S. between 1861 and 1939 - \$1.00. Ed Roush, 423 Shepard, Mansfield, Ohio 44807.

**OLD U.S. Stamps** on Approval. Chester, Box 15355G, Philadelphia, PA 19111.

**WORLD** Wide Stamps mounted in books on approval 2¢ and up. **TRUST STAMP COMPANY,** P.O. Box 100-P, Jamaica, N.Y. 11435

**FREE** Surprise collection sent with approvals. Gould, 1784 Union, San Francisco, 94123.

**100** Different U.S. 25¢, Approvals. Bradley, Box 425P, Midlothian, VA 23113

**BARGAIN** 100 World-wide Stamps 25¢. Quality Approvals. R. Parker, Box 143, West Brookfield, MA 01585

**2,000,000** Stamps—150 Countries—2¢ Each. Beiden, Box 4149, Dearborn, 48126

**STUNNING!** 100 BEAUTIFUL MINT PICTORIALS. All Different Only 25 Cents with Attractive Worldwide Approvals. VANSTAM, Dept. PM-483, P.O. Box 11272, Chicago, Illinois 60611

**"INVERTED ERROR"** + 100 Different United States, 50¢ with approvals. Luray, P.O. Box 7088, Silver Spring, MD 20907

**50 TOPICALS 25¢** when requesting low priced approvals. Stewart Kent, Box 2398-G, Bellingham, WA 98227

**PENNY** Approvals. 1 - 2 - 3¢. CK Stamps, 17902 Marklee Drive, Jamul, CA 92035

**FREE** 100 Canada with request of World Wide Approvals. Briner's, P.O. Box 5607, San Mateo, Calif. 94402

**300 DIFFERENT WORLD WIDE \$1.00** when requesting approvals. Rail 'n Mail Stamp Mart, Box 325M, Okemos, MI 48864

**FREE - U. S. Discount Catalogue.** Shelton, Box 547B, North Miami, Fla. 33161.

**ABSOLUTELY FREE-** 50 different British Colonies COMMEMORATIVES. Approvals. Gobestamps, Box 660, Saco, ME 04072

(Continued on next page)

## STAMP COLLECTING

(Continued from preceding page)

**COMPLETE set FREE** when requesting worldwide approvals. Benat, P.O. Box 210244, Dallas, Texas, 75211

**CANADA.** 50 different 25c Approvals. Oroszky, Box 1-C, Samia, Ontario, Canada N7T 7R8

**100 Turkey 50c.** No Approvals. Gibson, Box T, Williamstown, N.J. 08094

**ISRAEL** 15 Different 10c Approvals. Sam Chazen, Box 666, Delray Beach, Florida 33444

**100 different, Foreign British Colonies 10c Plus Bargain Approvals.** City Stamp Co., Box 216, Station "W", Toronto, Canada M6M 4Z2

**FREE U.S. Mint Set.** Approvals. Hildebrand, Box 4867, Santa Clara, California 95054

**CANADA** Ten Late Commemoratives 10c Canadian Approvals. Harley Boardman, Little Valley, New York 14755

**107 Different Triangles, Space, Animals, Etc.** \$4.00 Value. Only 10c Approvals. Fayette Stamps, Dept. 418M, Fayetteville, NY 13066

**300 Different Worldwide Stamps 30c With Approvals.** R.G. Sales, Box 1065, Jamaica, N.Y. 11431

**75 WORLD WIDE STAMPS 50c Approvals.** EMERSON ENTERPRISES, P.O. Box 937, New Britain, CT. 06050

**HURRY!** 300 Different U.S.: \$1.00—500 Foreign: \$1.00. Hamm, 2221 N. Terrace, Milwaukee, WI 53211

**FREE 50 Different Canada.** Approvals. Myers, 633 West Michigan, Marshall, Michigan 49068.

**100 India 25c.** approvals. Capitol Stamps, 1232 Mel, Lansing, MI 48910

**BRITISH EMPIRE** 104 Different Includes Mint Pictorial Colonies 10c with Approvals. Kamco, Box 338M, Flushing, N.Y. 11367

**FREE Worldwide stamp mixture.** Approvals. White, Box 24166-A, Indianapolis, Indiana 46224

**GEORGE Washington Anniversary Collection - Nicaragua.** Bicolored - Free! Approvals. William Deems, Ravenswood, W. Va. 26164

**FREE 1962 Disney Issue.** Request Approvals. Alpaugh, Box 225, Highbridge, NJ 08829

**THE World's Cheapest Stamp Assortment, Just One-Penny With Approvals.** Tarheel Philatelics, Siler City, North Carolina 27344

**NEW ZEALAND** 120 Different \$5.00, Australia 120, \$5.00, Pacific Islands 50, \$5.00, Enquiries Welcome. CARRAD'S, Box 5210, Auckland, N.Z.

## COINS, TOKENS, CURRENCY

**COINS - U.S. & world list \$1.00 Refundable.** Westerly Enterprises, 28 Canal, Westerly, R.I. 02891

**10 DIFFERENT Foreign coins \$3.00.** Guaranteed. Preferred Coins, Box 8465, Cleveland, OH 44134

## PHOTOS & PHOTO SUPPLIES

**GET THE MOST FROM YOUR CAMERA** "20 Hints For Better Pictures" Send \$1.00 To: Johnson's Photo Co., P.O. Box 402, Davison, Michigan 48423

## BOOKS & PUBLICATIONS

**BOOKS:** Military Subjects, Free Catalog. MCN, Box 7582PM, Tulsa, Okla. 74105

**SURVIVING Nuclear Warfare - Practical Guide to PROTECTING FAMILY, WEALTH.** Moneyback Guarantee. \$8.75. Glenna, Box 1075, Aiea, Hawaii 96701

**"HOW to Save on Postage Stamps."** Free Details. Encoi, 5201/2d So. Berendo, Los Angeles, CA 90020

**FREE Book.** Prophet Elijah Coming Before Christ. Megiddo Mission, Dept. 63, 481 Thurston Road, Rochester, N.Y. 14619.

**PUBLISHERS' OVERSTOCKS, BARGAIN BOOKS.** 2,000 Titles, all Subjects! Free Catalog: Hamilton's, 98-51 Clapboard, Danbury, CT 06810

**OUT-Of-Print Books Found.** Send Wants. Booklook, 51 Maple Ave., Warwick, N.Y. 10990

**OUT Of Print Books.** Send Wants. Box 86PM, Cutten, CA. 95534

**EASY SAILING.** Beginner's Illustrated Guide. \$2.25. Pektas, Box 3233, Pittsburgh, PA 15230

**MANS' BEST FRIEND... CATS!** Poems/Drawings - \$2.00. Angelis, Box 189, East Islip, New York 11730

**COMPLETE Listing of Repair Books—Write Today—**Broadway Technical Book Co., 1186 Broadway, New York, NY 10001

**FREE Price and Title List on 400 Self Help & How To Books.** Write: Jimmy Enterkin, 3581 Strickland St., Lithia Springs, GA 30057

**HOW TO GET RICH IN MAILORDER.** Free Details. MPC Enterprises, Box 126, Pedricktown, NJ. 08067

## PLAYS, SONGS, MANUSCRIPTS

**POEMS,** Songs Wanted. Free Recording/Publishing. Broadway Music Productions, Box 7438PM, Sarasota, FL 33578

## MUSIC INSTRUCTIONS & INSTRUMENTS

**FREE Catalog!** Kits and Completed. Harpsichords, Hammered and Appalachian dulcimers, guitars, banjos, mandolins. Hughes Dulcimers, 4419 West Colfax, PM, Denver, Colo. 80204.

**POEMS Set To Music.** Nashville Music Productions, Box 40001-PM, Nashville, Tennessee 37204.

**PIANOS, PLAYERS, PUMP ORGANS.** Rebuild and repair. Catalog of "How-To" books, \$2.00 (refundable). Vestal Press, Vestal 11, New York 13850.

**SUPER-SAVINGS** Guitar Strings, Accessories, Effects Pedals, Microphones, etc. Free Catalog. Super-Save Music, Box 944, Morgantown, N.C. 28655

**ACCORDION Top Brands,** Cordovox, Buy Direct. Tremendous Discounts. Trades accepted. Free brochure. PM, Accordion-O-Rama, 16 West 19th Street, New York, NY 10011

**CATALOG** for makers, repairers of stringed instruments. Imported tonewood, tools, parts, accessories, strings, cases. Fine European instruments and bows. Catalog 50c, includes 10% discount certificate. International Violin Company, Ltd., Dept. FP, 4026 W. Belvedere Ave., Baltimore, Md. 21215.

**ORIGINAL CRIPPLE CREEK DULCIMERS.** Kits And Completed Instruments. Send For Free Brochure. Cripple Creek Dry Goods, Box 22, Cripple Creek, Colo. 80813

**PIANISTS!** Free three month subscription! **KEYBOARD STYLING NEWSLETTER,** Box 700-M, Medford, Oregon 97501.

## SELF-IMPROVEMENT

**SUCCESS - financial, personal.** Free, illustrated, self-improvement book catalog. JML Books, S99W20367C Parker, Muskego, WI 53150

**LOVELY? BORED? POOR?** — Never again. Free details on how to make a comeback. Edlin Associates, Dept. PM4, 15 Wooster Street, Seymour, CT 06483.

## EDUCATION & INSTRUCTIONS

**36 MONEY-MAKING Careers!** Train at home in spare time through independent study. Business. Technical. Fashion. Secretarial. Mechanics. Computers. Even degree courses without attending college. Get free facts. No salesman will call. Write: ICS Careers, Dept. PBF23, Scranton, Pennsylvania 18515.

**INVESTIGATION Career Start Working While Training.** Details. Shaw Investigation, Box 716M, Provo, Utah 84603

**BE AN Electrician.** Learn at Home in Spare Time. Get Free Facts. ICS Electrician School, Dept. PBC33, Scranton, Pennsylvania 18515.

**OCEANOGRAPHY - New Manual Gives Steps Now Required to Enter Oceanography.** Written by Marine Biologist! \$3.00. Seamouse, Box 279, Dept. PM24, Mays Landing, N.J. 08330.

**MOTORCYCLE Mechanic.** Train at home spare time. Motorcycle tools, test instruments included. GI/VA Approval. Write for facts: Motorcycle Repair School, Dept. PBCC2, Newport Beach, CA 92660.

**HELPED:** Jer. 31:33; Acts 8:17; Gal. 5:22. 1127 NE Fifth St., Ocala, FL 32670

**DRAFTING** is a great career! Men, women. No previous experience or special talent needed. We train you at home in spare time. Get free facts. Write: North American School of Drafting, Dept. PBCC2, 4500 Campus, Newport Beach, CA 92660

**PIANO TUNING PAYS -** Piano tuning - Electronic organ servicing. Learned easily at home. Free booklet. Niles Bryant School, P.O. Box 20153, Sacramento, CA 95820

**BOOKKEEPING Or Accounting!** Easy home-study plan prepares you quickly to do your own books . . . or others. Approved for Veterans. Free "Accounting Career Kit." Write: Accounting School, Dept. PBCC2, Newport Beach, CA 92660

**"JET/GAS TURBINE CAREERS!"** Homestudy courses — theory, maintenance, overhaul — Established 1957. **AMERICAN JET SCHOOL,** Department PM-3, Darby, Montana 59829. (406) 349-2100

**REISCH WORLD WIDE COLLEGE OF AUCTIONEERING, INC.** World's Largest-48 Years. Term soon, Free Catalog. Approved for VA. Modern Auction Library "FREE" with enrollment. 515-423-5242 - Col. Gordon E. Taylor, P O Box 949, Dept. 19, Mason City, IA 50401

**UNIVERSITY DEGREES BY MAIL** Programs! Bachelors, Masters, Ph.D.'s . . . Free revealing details. Counseling, Box 317-PM4, Tustin, California 92680.

**EXTENSION** And Post-Graduate Awards in Philosophy, Art, Science, Botanic, Medicine, Homeopathy, Radionics, and others. 30 subjects Curricular free (airmail \$1.00 refundable). Registrar, Sussex College of Technology, Highfield, Danehill, Sussex, England.

**RADIESTHESIA,** Radionics, Dowsing E.S.P. Courses and Equipment Illustrated Catalog \$1.00 (refundable) Established 27 years. Dept. PM/R, Bruce Copen, Highfield, Danehill, Sussex, England RH17 7EX.

**LEARN** Asleep or awake. Records, tapes, equipment! Free catalog! Drawer PM-400, Ruidoso, New Mexico 88345

**AUTOSUGGESTION.** Sleep-learning headquarters! Tapes, records, books, Gigantic catalog free. Research Association, Box 24PM, Olympia, Washington 98501.

**DETECTIVE Profession,** Easy home study; free tie-tack or lapel pin, certificate, future. Professional Investigators Training School, Dept. CP, P.O. Box 41256, Los Angeles, CA 90041

**INSTANT MEMORY . . . NEW WAY TO REMEMBER.** No memorization. Release "photographic" memory. Forget nothing! Liberates extraordinary knowledge, talents, ESP. Immediate results! Free information. Institute of Advanced Thinking, 845PM ViaLapaz, Pacific Palisades, California 90272.

**LEARN** Sewing Machine repairing. A profitable Trade. Easy to learn. Free details. Sewing Center, 187 FR, Rochelle, GA 31079.

**USED Courses! Books! Lists 25c.** Smith's, 124 Marlborough, Salem, Massachusetts 01970

**UNIVERSITY DEGREES BY SPECIAL EVALUATION** OF EXISTING Job Experience, Education, Achievement. Fast, Inexpensive. Call (614-863-1791). Or Write: Box 13151-T4, Columbus, OH 43213

**HIGH School** at home, no classes. Diploma awarded Information Free, Phone Free Anytime 1-800-228-5600, or write: American School, Dept 30445, 850 E. 58th St., Chicago, IL 60637.

**HANDLE YOUR OWN LEGAL AFFAIRS.** Be a Paralegal. Accredited Attorney Instruction. Home Study. Free Catalog. Southern Career Institute, Drawer 43B-2158, Boca Raton, Florida 33427. (305) 368-2522.

**COLLEGE DEGREES** By Mail. Accredited Bachelors, Masters, Ph.D.'s. Free Facts Revealed. Careers-PM4, Box 45886, Tulsa, OK 74145.

**FREE CATALOG—LEARN AUCTIONEERING!** Full and partial scholarships available. Nashville Auction School, 233 E. Gaines St., Box 190, Department 2, Lawrenceburg, TN 38464

**FREE 120 page Career Opportunities Guide -** shows how to train at home for top paying jobs. Granton Institute, 263A Adelaide Street West, Toronto, Canada M5H 1Y3.

**EARN** While You LEARN. Business of Your Choice Quickly Learned With Home Study Course. Unique Plan. Balong Teaching Systems, 1013 Springmill Road, P.O. Box 250-MP1, Ontario, Ohio 44862

**ACCREDITED College Degrees** By Mail. Details. **GRADUATE REFERRAL SERVICE,** 3010 Santa Monica Blvd., Suite 173-PM, Santa Monica, CA 90404

**LEARN to Draw!** For Profit! Huge Demand - Free Facts. Proart, Box 186PM, Brush Prairie, WA 98606

**PREPARE** to better handle your business, political and social opportunities. The Blackstone School of Law has met the law training demand for almost a century. Information: 307 No. Michigan Ave., Chicago, IL 60601

**HOW-TO STOP SMOKING** in 90 days. Free details. Apple Country Publications, Box 397PM, Cornelia, GA 30531

**NEED MONEY FOR SCHOOL?** \$15 billion available! Free information, send S.A.S.E., Acorn Press, Box 3894-PM, Oak Park, IL 60303

**MANAGEMENT AND LEADERSHIP** Self-Study Programs. Results GUARANTEED. Details Free. The Bridgewater Institute, Box 5075P, Eugene, Oregon, 97405.

**FREE Information about INDIANA UNIVERSITY'S** Indiana Degree and Correspondence Programs. Write: Indiana University, Owen Hall, Bloomington, IN 47405. Attn: Jean Coppage.

**EARN TREMENDOUS PROFITS!** Design, install and repair PROFESSIONAL BURGLAR/FIRE ALARMS. Career information \$3.00 postage. East Coast Security Systems, P.O. Box 1108, Melville, New York 11747

(Continued on next page)

**EDUCATION & INSTRUCTIONS**  
(Continued from preceding page)

**SCORE** high on qualifying examinations. Win scholarships, paid industrial schooling, military academy admissions, government jobs. Cramwell, Box 217, Norwell, Mass. 02061.

**PRIVATE DETECTIVE or FINGERPRINT TECHNICIAN** training. Learn at home quickly and easily. Audio/visual aids, detective kits, badge, Diploma. Free information. **GLOBAL SECURITY**, Box 191PM, Hanover, Mass 02339

**EMPLOYMENT INFORMATION**

**AUSTRALIA**—Discover the Secrets — Where the Money's at. Full Details. \$6.95. Bayland, Rt. 3, Box 339P4, Appleton, WI 54915

**JOBS OVERSEAS**... (Including Alaska). Free Details. Global Employment, Box 81933PM, San Diego, California 92136

**AUSTRALIA** - The World! 50,000 Jobs! Top pay. Transportation. Computerized reports \$2.00. Jobworld, Box 681E, Cypress, CA 90630.

**JOBS: COLORADO, WYOMING, UTAH, IDAHO, MONTANA!** Computerized newsletter with 200+ new jobs each week. Free details. **MOUNTAINWEST**, 925-PM Canyon, Logan, UT 84321.

**FLORIDA EMPLOYMENT NEWSLETTER**. Complete Sunshine State Coverage Weekly. Free Details. FEN, Box 845PM, Jupiter, Florida 33458

**JOBS Overseas** - Big money fast. \$20,000 to \$50,000 plus per year. Call 1-216-494-2900. Ext. 4560.

**OVERSEAS JOBS** \$20,000 to \$60,000 plus bonus. Doycorp, Personnel, Box 697-SZ, Pocatello, ID 83201

**CALIFORNIA** jobs! Entire state, hundreds of openings, updated weekly. \$3.00. Lotax, 2310 Airport Blvd. "C", Santa Rosa, 95401.

**ROCKY MOUNTAIN EMPLOYMENT NEWSLETTER!** Colorado, Idaho, Montana, Wyoming! Current openings - All occupations - greatest weekly selection! Free details: Intermountain-L, P.O. Drawer 809, Grand Lake, Colorado 80447-0809.

**CALIFORNIA JOBS!** Weekly Digest Covers San Francisco, Sacramento, Los Angeles, San Diego. \$5.00. Westwork, 6509 Seville, Coleta, California 93117

**RIVERBOATS** - Tugs \$15,000-\$60,000. Expenses paid. Work month. Home month. Experience unnecessary. All waterways including Alaska, Hawaii. Free report. Send stamp envelope. Marine Employment, Box 207, Central, Indiana 47110

**WINNING WITH WORDS** Secrets of the Job Interview. Free Details. 2211 Elliott Drive, Tallahassee, FL 32312

**INCOME**. Get the job you want. Free details. Jay, 2265 Westwood Blvd., Suite 590, Los Angeles, CA 90064

**RECESSION PROOF-THOUSANDS OF JOBS IN BUILDING MAINTENANCE**. Full-part time. Facts-list US employers \$4.00. YMO, 800 4th St SW #501N, Washington, DC 20024

**SAUDI ARABIA WANTS YOU!** Excellent pay. Free transportation. Newest guide \$2.00. ARAMACO, Box 820AD, Port Alice, B.C., Canada V0N 2N0

**GOVERNMENT JOBS** - Thousands of vacancies must be filled immediately. \$17,634.00 to \$50,112.00. Call: 716-842-6000. Ext. 3940.

**OVERSEAS** Jobs! \$20,000-\$80,000 and up! Call Now! (317)-839-1712. Ext. 24.

**ALASKA** - \$55,000.00 per year - men - women - room board paid. Mechanics, equipment operators, cooks, steam and power generation operators, radar techs, crypto techs, others. \$10.00. Nancy, P.O. Box 413, Ashland, Wis. 54806

**AUSTRALIA Needs You**... Jobs. Free Transportation. Complete details guaranteed. \$3.00. Beard, 4906M, Lambeth, San Antonio, TX 78226

**HELP WANTED**

**AUSTRALIA WANTS YOU!** Jobs! Big Pay! Transportation! Newest Handbook — \$2.00. **AUSTRALIAN INTERNATIONAL**, Box 19107-AD, WASHINGTON, DC 20036.

**OVERSEAS** Employment... \$20,000 - \$60,000+. Free Report! Employment, Box 19760-AD, Indianapolis, Indiana 46219.

**ELECTRONIC** Firm is Looking for Assemblers Interested in Working at Home. Send \$3.00 Application Fee: IRDC, (I), Joppa Hill Rd., Manchester, N.H. 03102

**FOR INVENTORS**

**PATENT AND DEVELOP** Your invention. Registered Patent Agent and Licensed Professional Engineer. Send for **FREE PATENT INFORMATION** Every Inventor Should Have. Richard L. Miller, Woolworth Building, 233 Broadway, Suite 3612-M, New York, N.Y. 10007. (212) 267-5252.

**NONPROFIT** Foundation helps inventors. Widest range of services. Free recording forms. Free evaluation. Affiliated Inventors Foundation, 501-B, Iowa, Colorado Springs, CO 80909

**PROTECT** Your Invention. Registered Patent Attorney. Many Years Experience, all Fields. Individual Inventor's Problems Given Special Consideration. Very Reasonable Charges. Write for Free Information. Paul H. Gallagher, 2530 Crawford Ave., Evanston, Illinois 60201

**REGISTERED PATENT ATTORNEY** Washington D.C. Suburb. Donald A. Kettelstrings, 414 Hungerford Drive, Rockville, Maryland 20850

**PATENT IT ECONOMICALLY!** Free Details. N. Raner, 2008 Fondulac, Richmond, VA 23229

**PROTECT YOUR INVENTION.** Registered Patent Attorney. **FREE** Preliminary Review Of Your Description. Box 392PM, Millwood, NY 10546

**LEARN** how to offer your invention for sale or license. Free Booklet outlines procedures, royalty rates, requirements. Kessler Sales Corporation, C-5-FI, Fremont, Ohio 43420.

**MONEY TO FINANCE INVENTIONS AND IDEAS!** Book lists 250 investment companies that lend starting capital to \$2,000,000. Tells how to get money. Send \$5.00. **MBENT**, 439 Cliff, Aptos, CA 95003.

**INVENTORS** Patent Your Invention. Free Initial Consultation. We are Registered by the U.S. Government. Victor J. Evans & Co., 4637 Eastern Ave. N.E., Washington, DC 20712. Since 1898.

**PATENT** Your Invention Yourself! Instructions/Forms! \$9.98. Retired Examiner, 7400, Washington, D.C. 20044

**INVENTIONS WANTED**

**EARN ROYALTIES.** NUPRODUC INTERNATIONAL, 1377 K. NW 141, WASHINGTON, DC 20005

**INVENTORS** Free Information How To Sell - F-M Service, 7345 Harlem, Niles, Ill. 60648

**INVENTIONS WANTED. FREE CONSULTATION NO IDEA TOO SMALL.** Disclosure registration. Potential cash or royalties from manufacturers seeking new ideas. For free information on how to register your idea, call or write: **AMERICAN INVENTORS CORPORATION**, 82 Broad Street, Dept. PM, Westfield, MA 01086, (413) 737-5376. A Fee Based Marketing Company. Offices Coast to Coast.

**INVENTIONS, ideas, new products** wanted for presentation to industry and exhibition at national technology exposition. Call 1-800-528-6050. Arizona, 1-800-352-0458. Ext. 831. Or write: IMI-PM, 701 Smithfield, Pittsburgh, PA 15222.

**INVENTORS:** Free Information on offering your invention for sale. Kessler Sales Corporation, C-5-IW, Fremont, Ohio 43420

**YOUR PRODUCTS/IDEAS IN EUROPE?** Unique opportunity for your products/ideas on the European market! Write: **PROMOVENTION**, P.O. Box 68, Vleuten, Holland.

**REAL ESTATE & FARMS**

**FREE!** Big Spring Catalog! Over 5000 best farms, homes, businesses, recreation, retirement values All Across America! **STROUT REALTY**, Plaza Towers, Dept. 5800, Springfield, MO 65804. Toll free: 1-800-641-4266. In Missouri call collect: (417)862-4402.

**NEW... FREE CATALOG!** Top real estate values coast to coast! Please specify type property and location desired. **UNITED FARM AGENCY**, 612-PM West 47th, Kansas City, MO. 64112.

**CANADIAN** Country Properties. Our 67th Year. Terms available. Moneyback guarantee. Catalog airmailed \$1.00. Dignam Corp., Ltd. Suite 496, 85 Bloor Street East, Toronto, Ontario, Canada M4W 1B5

**PROPERTY** And Lake Frontage from \$47 per acre. Investment Potential. Exchange Privilege. Free Catalog. Canadian Estate Land, Dept. 23C, 2411 Yonge St. #303, Toronto, Canada, M4P-2Z1. (416) 488-0444

**SAVE MONEY**, time, headaches. Learn what to ask and why. Country Property Guide. \$5.95 to: P. & J. Publishing, Box 7557, Bend, Oregon, 97708

**EXPORT-IMPORT**

+2500 "Fast-Sellers." Free brochures! Allrightpro, Box 91309-B4, Cleveland, Ohio 44101

**PLASTIC BAGS**

**ALL** Sizes. Buy Small Quantities. Free Catalog. SAKet, 6151-C Colibath, Van Nuys, Calif. 91401

**BUY IT WHOLESALE**

**WORLDWIDE BARGAINS:** Imports... Dropship... Closeouts... Surplus... Freebies... 25¢/Stamp... Marneqs, Box 1717PM, Highland, Indiana 46322

**BELOW Wholesale:** Clothing, Jewelry, Closeouts, Catalog \$1.00. Torrow Mac, P.O. Box 3333PM, Anderson, S.C. 29621

**BELTS** and Buckles. Complete line fast sellers, including truckers, motorcycles, wildlife, westerns etc. Big Profits. Complete dealer set up. Catalog \$1.00. Anchor Specialties, Box 3958-BPM, North Providence, RI 02911

**400,000 BARGAINS** Below Wholesale: Many Free! Liquidations... Closeouts... Job Lots... Single Samples. Free Details. Bargainhunters Opportunities, Box 730-A, Holland, Michigan 49423.

**CLOSEOUT** Jewelry 55¢ dozen. (Catalog 25¢), Roussels, 107-1631 Dow, Arlington, MA 02174

**CLOSEOUTS!** Discounts! Below wholesale! Freebies! Samples! DDN, Box 20152-PM, Ferndale, Michigan 48220.

**EARN** Money selling rings, jewelry, buckles, watches—Buy direct. 130¢ below retail. Catalog \$1.00 (refundable). Anka-PM, Box 89, West Warwick, RI 02883.

**FREE CATALOG!** Chainsaw, Motorcycle, ATC, Snowmobile, Small Engine, Parts. Woodstoves, Splitters, Energy Items. Manufacturer's Supply, Box 157-PM4, Dorchester, WI 54425.

**500,000 ITEMS** below wholesale—everything imaginable! 66 different catalogs! Send \$3.00 cash or stamps. Guaranteed! Bargains, Box 931PM, Cullman, AL 35055

**SATIN BASEBALL JACKETS... T-SHIRTS** Printing Available!! Info \$1.00: **BARKER JACKET** - PMB, 1000 Washington, St. Louis, MO. 63101. (314) 231-3339.

**BUY DIRECT!** 500,000 Bargains Below Wholesale. Gigantic Buyers Guide. Valuable details Free. Act now. Prairie Distributors, Route 2, Box 485A-1, Palmyra, WI 53156.

**STARTERS-ALTERNATORS** Most Japanese Auto \$34.99. T&J Enterprises, 3555A Haddonfield Road, Pennsauken, New Jersey 08110. 609-662-1754

**ADVERTISING AGENCIES, ADV. SERVICES MAILING LISTS**

**PROMOTIONAL BUTTONS**—Free sample with brochure. 62 Oak, Lake Forest, Illinois 60045

**MAIL ORDER ADVERTISERS!** Classified Advertising can be most Profitable and Rewarding. Problem is to Know What To Do. What Not To Do. Columbia can help you with your Mailorder Program. Over 25 years Classified Advertising Experience. Knowledge of Best Pulling Publications. Expert copy service is all yours at no increase over Publisher's Standard Rates. Chances are you will **SAVE MONEY**. Write today for free details plus your free copy of **"MAIL ORDER ADVERTISERS RATE GUIDE"**. **COLUMBIA ADVERTISING AGENCY, BOX 1255-PM-4, RICHMOND, IN 47374**

**BUSINESS SERVICES**

**SMALL** Businesses: New advertising concept will generate business for you! Send \$1.00 and your business card for sample and details: Mini-Billboard, 381 Durham Road, Newtown, PA 18940

**RUBBER STAMPS**

**BARCO** Type Founders. Type and Rubber Stamps catalogue. Mail \$1.00 refundable on first order. 237 S. Evergreen, Bensenville, 60106.

**PRINTING PRESSES — RUBBER STAMP OUTFITS**

**PRINT FOR PROFIT**-Earn Extra Money-Printing Presses, Type, Supplies, Direct from Factory. Send \$1.00 for Catalog and Samples to: Keisley Company, B4, Meriden, CT 06450.

**TYPE** Fonts. Hand Printing Presses, Supplies. 120 Pages. \$1.00 Deductible first order. Acme Type, 1720 N. Marshfield, Chicago, 60622

**TYPE** for printing. Catalog \$1.00/deductible 1st order. Quaker City Type, R.D. 3, Box 134, Honeybrook, PA 19344

**MANUFACTURE** Rubber Stamps. Regular and Pre-inked. Catalog 1-800-851-4945. Jackson, Brownsville Rd., S110, Mt. Vernon, IL 62864.

**COMPLETE** Rubber Stamp Outfits, Supplies. Same day shipment. Sign Engraving Machines, Wholesale Catalog \$1.00 Deductible. Star Stamp, 1720 N. Marshfield, Chicago, 60622

**PRINTING AND SUPPLIES**

**PRINTED** Duplicate Billheads—Small Lots, Samples—Statementprint, 1747 Selby, Saint Paul, Minnesota 55104

**THERMOGRAPHED** Business Cards, Free Samples. BG, 2501 Sapling, Glenshaw, PA 15116

**QUICK** Copy Printing. Low Prices. Write: Nationwide, 614 North Main, Bloomington, Illinois 61701

**QUALITY** Printing Letterpress and offset Low, Low Prices. Free Catalog. Dunn's Distributor's, Box 21083, Lansing, MI. 48909

(Continued on next page)

Материал, защищенный авторским правом



## PRINTING AND SUPPLIES

(Continued from preceding page)

1,000 Thermograph Business Cards. \$9.00. Catalog \$1.00. Printer, Box 61, Miami, Florida 33138.

LETTERHEADS, 2 Colors, w/env. \$17.50 Low, 24 Post, Newfoundland, NJ 07435

LOW COST PRINTING 1,000 Copies To 8 1/2" x 11" \$29.00 P.P.D. Typesetting \$15.00 Extra Price List \$1.00 Refundable W/Order. A-1 Printers, 3720 Sleepy Hollow, Brunswick, OH 44212. (216)225-8353

THERMOGRAPHED Business cards, free samples. P.J.W. Box 134, Barberton, Ohio 44203.

BOOKLETS, Catalogs, Manuals, 8-160pgs. Save! Ceejay, Box 1494, Boulder, CO 80306

## GIFT SHOPPING

FREE CATALOG of Distinctive Gifts from LURAN HOUSE. Bonus Gift! Personalized Gifts! Gifts of all Kinds! Write To: LURAN HOUSE, Dept. B, 15 Whipponwill Rd., P.O. Box 2262, Glens Falls, NY 12801

## CLOCKS, WATCHES, OLD GOLD, JEWELRY

HIGHEST CASH for Gold, Jewelry, Gold Teeth, Rings, Diamonds, Watches, Silver, Platinum. Mail Articles Today. Free gift with information. Chicago Gold & Precious Metals, 6 E. Monroe, Dept. 858, Chicago, 60603.

TAKE NO CHANCES. Deal with oldest, most reliable firm in old gold business. Established 1934. We buy Gold, Silver, Platinum, Diamonds. Highest Cash. Free Information. Rose Industries, 29-A East Madison, Chicago 60602

WATCH And Clock repairing books, tools, materials. Free Catalogs. North American, Box 77-AD, Fox River Grove, Illinois 60021

ANTIQUA POCKET WATCH REPAIR & RESTORATION. Quality work, reasonable prices. JOHNSON WATCH REPAIR (NAWCC, AWT), Box 121D, Keenesburg, CO 80643. Ph. (303) 536-8235.

## SILVER

SILVER! GOLD! RECOVER FROM JUNK LEAD! COMPLETE DETAILED INSTRUCTIONS. \$9.95. Free information. McKinney, 739 Quimby, Bend, Oregon 97701

## GOLD

ELECTROPLATING With gold and silver! Easy to follow instructions! Photocopy of article as it appeared in a past issue of Popular Mechanics available for \$2.00. Send order to: PM, Dept. PMC4, Box 1014, Radio City Sta., New York, N.Y. 10101

## PRECIOUS STONES & MINERALS

GET Free catalog no serious rockhound, gem cutter, jewelry maker, hobbyist or craftsman can be without. Full of bargains, exclusive items, low prices from largest suppliers and authorities in the field. Free new catalog just off the press, yours for the asking. Write: Grieger's, Dept. 1, 900 South Arroyo Pkwy., Pasadena, California 91109

## TREASURE FINDERS

TREASURE Hunters. Complete line. Electronic Detectors. Pendulums. Books. Hobby or profit. Free catalogue. Detectores, Apartado 7-905, 06700 Mexico.

FIND Lost coins, jewelry, buried treasure, gold nuggets, relics. New revolutionary patented detector analyzes objects, tremendous range, no ground pickup. Free catalog. Gardiner, 4729M N. 7th Ave., Phoenix, Arizona 85013

TREASURE- Locate quarter mile away with ultra sensitive locator - brochure free. Research Products, Box 270270 - AMC, Tampa, Florida 33688

SAVE up to 40% on new metal detectors. All major brands including White's and Garrett. FREE discount price list. Northwoods General Store, P.O. Box 9874PM4, Madison, WI 53715. (608) 274-4680.

## PROFITABLE OCCUPATIONS

REPAIR Lawnmowers, thousands of parts and tools. Wholesale list 35¢. Ellwanger's, PO Box V, Port Jarvis, NY 12771

PLASTERCRAFT . . . Profitable Home Business 3000 Molds Available. Details. Lynnette, 6251C Mentpark, Mentor, Ohio 44060.

MECHANICALLY INCLINED? ASSEMBLED ELECTRONIC DEVICES, YOUR HOME. KNOWLEDGE, EXPERIENCE NOT NECESSARY. SPARE/FULL TIME. NO INVESTMENT. FREE DETAILS WRITE: ELECTRONIC DEVELOPMENT LAB, BOX 1560PM, PINELLAS PARK, FL. 33565.

FREE Catalogs. Repair air conditioning Refrigeration. Tools, supplies, full instructions. Doolin, 2016 Canton, Dallas, Texas 75201.

FT. SMITH Auction School, Ft. Smith, Ark. 72903. Resident & Home study. Veteran Approved.

TECHNICAL WRITERS make big money! Free details. TekPubs, Box 2458-P, Oroville, CA 95965

## SALESMEN-DISTRIBUTORS

MAKE EXTRA MONEY DURING YOUR SPARE TIME! Show our New Line of Calendars, Pens and Popular Advertising Gifts to local firms. Prompt, friendly service from small town AAA-1 Company in our 74th year. No investment or collections. Weekly commissions. Be your own boss. Full time potential. No experience necessary. Write to: Frank Buckley, NEWTON MFG. CO., Dept. APM4, Newton, Iowa 50208

SELL SENSATIONAL LOW-COST BURGLAR ALARM. Lightning seller. Exceptional margin. Samples for trial. Northwest Electric-PM-4, Box 1046, Mitchell, SD 57301.

AGENTS Needed Immediately Your Own Business, sell books by Mail, \$2.00 for info: Quinley's Distribution, 3110 Parker, Irving, TX 75062

## AGENTS WANTED

WITH Mason Shoes, pay day is when you want it! Take orders from friends and neighbors. Watch your business build, without risk or investment. Call Toll Free 1-800-826-7030, Ext. 66; in WI 1-800-472-7003, Ext. 66, or write: Mason Shoes, K-700, Chippewa Falls, WI 54774.

UNLIMITED Potential. Work At Home. Send SASE For information. Baldwin, 10149 Hammerly #62P, Houston, Texas 77080

HELP Needed Selling How-To Books, Profitable. SASE. E & B Enterprises, Box 311PM4, Silverdale, Washington 98383

SELL FINANCIAL OPPORTUNITY BOOKS BY MAIL. Fantastic part or full time home business. No experience needed. Details \$1.00 ACT NOW! MSE, Dept. PMC04, 325 Westgate Drive, West Columbia, S.C. 29169

AGENTS Wanted, Sell How To Make Money Books, Details \$1.00. R. Ridley Associates, 19 Mass Ave., Box 424, Boston, MA 02215

MAKE MONEY IN SPARE TIME. As a subscription sales representative for leading national magazines, you can earn generous commissions while learning the art of selling. Instructions and supplies will be sent to you free. Send this ad with your name and address to: POPULAR MECHANICS, Dept. AB-L, 250 W. 55th St., New York, NY 10019

## BUSINESS OPPORTUNITIES

IMPORT-Export opportunity, profitable world-wide, mail order business from home, without capital. We ship plan for no risk examination. Experience unnecessary. Free Report. Mellinger, Dept. H2706, Woodland Hills, California 91367

MAILORDER!! Money Making Home Business Opportunity. Start Immediately. Free Details. Write: Products, 109 Canyon Ct., Lenoir, N.C. 28645

HUNDREDS Weekly With Homemade Rings. Details - \$1.00. Denbow, Box 571AD, North Highlands, California 95660.

START Small - \$100.00 Makes \$1,000. Big Profits, Catalog \$1.00 Refundable. Raf's Quality, 29 Elmridge Rd., Pawcatuck, CT. 06379

MAKE Durable Building Plastic Easily. Waterproof, Fireproof, Economical. Bays Laboratory, 2086-2075 Drive, Cedaredge, CO 81413.

SELL Mail Order Books. Low investment. Free Package. REYNOLDS, Box 740034, Houston, TX. 77274.

BECOME Tax Consultant. Our students earn \$1,000-\$3,000 every tax season preparing returns evenings. State approved. National Tax School, Monsey, 2DO, New York 10952.

PROJECTION TV . . . Make \$\$\$'s assembling Projectors . . . Easy . . . Results comparable to \$2,500 Projectors . . . Your total cost less than \$17.00 . . . PLANS, LENS & Dealer information \$15.50. Illustrated information FREE . . . Macrocombx, Washington Crossing, Pennsylvania 18977. Creditcard Orders. 24Hrs. 215-736-2880

PICKUP Truck owners. Make \$500.00 weekly. Kett, 2713 Walnut, Columbus, Georgia 31904

\$700 Per month earnings possible filling out income tax forms at home or tax office during tax season. We show you how. Simple, quickly learned. Details mailed free. No salesmen. Hurry. Big Demand. Federated Tax, 2065 Montrose, Chicago, 60618.

UNEMPLOYED? We need Agents, Details \$1.00. Hunts Enterprises, Rt. 1, Box 162, Greenwood, LA 71033

EARN Thousands!!! In the Exciting Home Income Program . . . Act Now! Write: KHE, 9236 Rosecliff, Dallas, Texas 75217

EARN \$\$\$ for your church, social group . . . or yourself. We will send you \$1.00 to \$2.00 for each subscription that you or your group sells to The Family Food Garden Magazine. Write for details and subscription sales instructions. The Family Food Garden, Dept. PM, 464 Commonwealth Avenue, Boston, MA 02215.

OPEN AND CLOSED ALUMINUM SIGNS. Sample \$6.00, information Free. Adams Sign Co., 2700 Montclair, Columbus, Ohio 43221

GUARANTEED - EXCELLENT - Income - Start - Immediately - At - Your - Home - Free Details - Write - Center, Box 66265B, Los Angeles, CA. 90066.

BELOW wholesale catalog. 1900 Money-makers. FREE \$5.00 certificate. Wilco Distribution, Box 411-B, Tinley Park, IL 60477

\$50,000 POSSIBLE!! FREELANCING Bathtub and Sink Refinishing FREE DETAILS!! Shepard, 4418 West 30th St., Los Angeles, CA. 90016

EXTRAORDINARY I Easy Start Home Businesses, Plus Fortune Building Information. Free Details. JSJ Enterprises, 212 Thistle Lane, Southington, CT. 06489

MAILORDER Opportunity! Start profitable home business without experience or capital. Write for free book, plus details. No obligation. Mail Order Associates, Dept. 663, Montvale, NJ 07645.

MAKE MONEY WOODWORKING - Easy profits making unusual gifts, toys, novelties. Free details. Williams, 32K Titus, Gian Cove, NY 11542

LEARN the Secrets of Profitable Mailorder Business. Details free! ASMDOB, Box 6707, Torrance, CA 90504

PIANO Tuning learned quickly at home! Free information. Empire School, Box 1014, Jupiter, Florida 33456

MAKE HOMEMADE BOOKLETS. I've earned \$187,000 with mine. Free information: Falcon, Box 548, Woodville, Texas 75979

SOLAR Heating learned quickly at home! Free information. Empire School, Box 193, Rockville, IN 47872

WANT Money? Try Selling Our Books. Free information. Poindexterco, 1011 Trevor, Detroit, Michigan 48207

MAKE MILLIONS MANUFACTURING Batteries. Supplies Available. Everlast, Box 365, Bogota, NJ 07603.

ASSEMBLE PRODUCTS AT HOME. Many opportunities paying High Weekly Profits presently available without investment. Write: Businesses, 92B Brighton 11th, Brooklyn, New York 11235.

VINYL'S Where the money is! Professionally repair, re-finish, recolor furniture, luggage, car tops. Quick, easy. Two small \$20 jobs a day earn you \$1,000 a month. Homes, cars, offices, restaurants, unlimited customers. Start earning after a few days practice. Sensational details free. VIP, 2007 Montrose, Chicago, 60618

MAKE WOOD TOYS FOR PROFIT. Toy parts, patterns wholesale. Lovebuilt Toys, PM-4, Tahoe City, CA 95730-5459

PIANO Tuning quickly learned with home study courses. Diploma granted. American Tuning School, 17050 Teller Drive, Morgan Hill, Calif. 95037.

PICTURE Framing—Profitable full or spare-time business. Easy to learn with handbook-course "Guide To Picture Framing Profits." \$3.00 Guaranteed. Free framing-supplies catalog included. Japs, 126-PM Seventh North, Hopkins, Minnesota 55343.

REPAIR HYDRAULIC JACKS — DETAILS FREE. WRITE: HYDRAULIC PARTS SUPPLY, BOX 4157, BROWNSVILLE, TEXAS 78520.

FREE BOOK 2042 Unique Proven Enterprises. Fabulous "unknowns," Second Inflation income. HAYLINGS, Carlsbad, CA 92008

LEARN Sewing Machine Repairing. Men. Women. Lucrative Profits. Gresslin Correspondence School, Box 5104, Spencer, Iowa 51301.

\$480 Weekly. Home mailing program. Goodworld, Box 26233-R, Tamarac, Florida 33320

\$92.00 From Square Foot Plywood. (Huge Demand). Revealing Proof 25¢. (Refundable). Woodwin, Bridgewater, Mass. 02324

CONCRETE Block Machines: Catalog \$1.00. Route One, Box 95, Rapid City, South Dakota 57701

SELL Books By Mail. Free Dealership. Midwest, Box 44R2-PM, Shawano, Wis. 54166

GET RICH using OTHER PEOPLE'S MONEY!! Unique — amazing business!! Details FREE!! Finance Consultants, 5B-4, Billings, NY 12510

NEW Discovery in Battery Reconditioning . . . Eighteen Months Guarantee Means "Big Profits Fast." Electone, 7415 Gable Drive, Little Rock, AR 72205

(Continued on next page)

## BUSINESS OPPORTUNITIES

(Continued from preceding page)

I MADE \$40,000 Year by Mailorder! Helped others make money! Details 25c. Torrey, Box 318YY, Ypsilanti, Michigan 48197.

CLIP newspaper items — \$2 - \$25 EACH!! FREE Report! Clippings-KB-4, Billings, NY 12510

LEARN The secrets of repairing junk batteries "Fabulous Profits." FIRST ESTABLISHED COURSE. Apex Engineering, 5454 Bolso, Atascadero, Calif. 93422

MONEY SECRETS! Help People and businesses get money. Easy home business. Fantastic Profits. No Experience—Own Hours. Continuous Assistance. Free Details: DFC, Dept. 10-G-4, 1145 Reservoir Avenue, Cranston, Rhode Island, 02920

VENDING MACHINES. No selling. Routes earn amazing profits. "Big Catalogue FREE." Parkway Corporation, 1930 PMB Greenspring Drive, Timonium, Maryland 21093

ARAB BUSINESSMEN Have Money to Buy & Invest. Top Finders Fees Paid. Int. MiddleEast Assoc., 483PM1, 8291 Flaxman, Huntington Beach, CA 92646

GET RICH!! Secret Law smashes debts—brings cash and credit!! Details FREE! WealthKit-WB-4, Billings, NY 12510

RECONDITION JUNK AUTOMOTIVE BATTERIES. Huge demand creates profitable home business! Free report. J&M, 771PM, Battle Ground, Washington 98604

MAKE \$15.00 Hourly building custom luggage/cases at home. Huge nationwide demand. Fill mail orders. We supply materials, instructions, everything! Free details. Custom Case, 6067 De Soto Ave., Dept. C20-28, Woodland Hills, CA 91365.

\$1,000 Weekly Home Business Directory, Box 2019-PM, New York, New York 10163.

HUNDREDS Weekly Possible For Ten Hour Work Week!! Guaranteed Home Business... Start Immediately!! Free Information - AHV, Box 102B-A4, Kalaheo, Hawaii 96741

14K Gold, Sterling Silver Jewelry. Make 300% Profit. Catalog \$1.00 (Refundable). Courticoo, 1634 Bogart, Bronx, NY 10462

HANDYMAN'S DREAM! DIE-MAKING SIMPLIFIED! New manual explains easiest methods. You can quickly master this extremely profitable profession. Postcard brings information. Director, Trimex Building, Moores, N.Y. 12958

\$50 to \$200 Daily. Easy for anyone. Send \$12 TO: V. Water, Suite 101, 2116 Greenbriar City Dr., Houston, TX 77032

TAKE Catalog Orders. We drop-ship 2500 best-selling specialty products. Lowest below wholesale prices. Immediate delivery. Spectacular home business opportunity. Free Book. SMC, 6061 De Soto Ave., Dept. 20-28, Woodland Hills, CA 91365.

WOODWORKERS - IDEAL HOME BUSINESS. Free brochure! Pine Shop, West Peterboro, NH 03468

HONG KONG, Taiwan, Buy Direct, Information. Long Sess. Birch, P.O. Box 142, Willow Springs, Ill 60480

HOW to Start and Operate your own Profitable Business at Home. Free Details. Rainbow Assoc., West 2203 Mission, Spokane, Wash. 99201

\$2,000.00 every week possible!!! Build and sell "PROFESSIONAL" QUIV SCREEN PROJECTION TVs... "Don't be fooled with cheap imitations!"... "Use EXACT SAME TYPE LENSES and SCREENS utilized by Sony, Zenith, Pioneer, and Magnavox!"... Simple construction!... Illustrated dealers information and complete parts catalog \$2.00... Money Back Guarantee!... POLI-VISION, 168-B Dunmore St., Troop, Pa. 18512

EASIEST business on earth. Make us prove it. Free details. Wealth Secrets, Box 15137M, Pinellas Park, FL 33565

REPAIR BOOKS & BIBLES. I earn \$26,000 yearly. Free information: Peeler, Box 632-PM, Bonham, Texas 75418

MAILORDER Success Means Big Profits!! Learn The Secrets; Join The Pros. Write: Jean, Box 5DN, Union, MO 63084.

101 BUSINESSES YOU CAN START & RUN WITH LESS THAN \$1000. 240 page guideline, only \$3.95. Modac, Box 26D, Seabrook, Maryland 20706

TAKE PICTURES for profit. Photomoney, 14589K West 32nd, Golden, CO 80401.

YOU Can Make Money Wholesaling. Free Details. Brokerage, 109D Circle, Burns, Tenn. 37029

MAKE MONEY- 2 to 3 Times Your Cost On Gifts, Novelties, Toys, Thousands of Products. Big Catalog \$2.00 Refundable. Amett Enterprises, Dept. PM4, 12383 10th St., Yucaipa, CA 92399.

SELL Books By Mail. 400% profit. Literature Free. Paragon, 344PM, Cass Lake, Minnesota 56633

SECRETS behind successful products and ideas reveal how to find your fortune! Free information — Fortune Maker, 425PM2, Clayton, Denver, Colorado 80206

AERIAL PHOTOGRAPHY Business, Pilot, Non-Pilot. Profitable, Non-Competitive. Eastern Aerial, Box 9587J, Baltimore, MD. 21237

YOU Too, can make it rich in the 1980's. Free details. KEMCO, P.O. Box 1364B, Kokomo, Indiana 46901

HOME BUSINESS OPPORTUNITIES! UNUSUAL! FREE BOOKLET. Vaughn, Rt. 2, Box 457, Haines City, FL 33844

MAKE Big Money Repairing Windshields And Plate Glass! Earn up to \$50,000 yearly. Send for Valuable Free Report. Glas-Weld Systems, Box 87D, Hillsboro, OR 97123. 503-640-2278

EARN \$30,000.00 WITH A LAWNMOWER. Start A Gardening Business. Makes Money For Me. Free Information. M. Rols, Box 231, Reseda, CA 91335

ALUMINUM SCRAP - Recycle yourself - SELL FOR \$25.00 / POUND! Free Information: Industrial Scrap Yard, PM4, Box 127, Alexandria Bay, New York 13607

HOMEWORKERS Wanted! Receive 35c each name & address you send us. Details Free. Quality, Box 431 - PH, Lynbrook, New York 11563.

SELL BOOKS BY MAIL, HIGH PROFITS. Free Information. Dodge Publishing, Box 06164P, Ft. Myers, Fla. 33906

FANTASTIC BUSINESS OPPORTUNITIES. Quick Start Up. Low Investment. Many Under \$50.00. FREE DETAILS. B&G Enterprises, Dept. PM-4, 859 Meadowridge Drive, Cincinnati, Ohio 45245

THOUSANDS HAVE AN IDEA BUT NEVER DEVELOP IT! Sell yours through mailorder. New book tells how. \$4.00. Satisfaction Guaranteed. XANDI, Dept. 101, Box 25647, Tempe, AZ 85282.

START your own Housekeeping business. Simple to start and a necessary Service in any community. Full detailed package \$25.00. SRC Services, P.O. Box 388, Flouctown, PA. 19031.

START Profitable Business's at Home. Free Information. D. J. P., Rt. 1. Box 108A, Bruno, NE 68014

GOLD! SILVER! FOR THE ASKING! \$25,000—\$50,000. Copper—\$100/day. Shoestring expenses. Free information. Recycler, Box 1657, Brenham, TX 77833

3,816 Money-making Opportunities! Free information! Dynamic, Box 1306G, Stow, OH 44224

UNIQUE MULTI-LEVEL MAIL ORDER OPPORTUNITY. 8000 Became Members in Recent Months. Inventory And Bookkeeping Handled By Parent Company. Free Details. John Kulesa, 13035 Brady Rd., Chesaning, Mich. 48616

BIG MONEY INCOME. Take catalog orders, over 2500 best selling specialty products, below wholesale prices. Ultimate home business. Send \$2.00 for giant catalog refundable on first order. Jo-Allen, Dept. PM4, 6233 Arabela St., Lakewood, CA 90713

HOW TO PROFIT FROM COMING high technology super-boom. Free Details. Dept 832801, 21st Century Research, 8200 Blvd. East, North Bergen, N.J. 07047

GUARANTEED Money Making Plan! Work at home. FREE INFORMATION! EM-JAY Publications, Box 8007, Maitland, FL 32751

\$500.00 WEEKLY Recycling Discarded Tires. Free Information. LeValleys, Fountain, FL 32438

FREE! PROOF "How I Made \$265,000.00" with small classified Ads. Southlander-PM4, Box 7437R1, Sarasota, FL 33583.

MOSQUITO HOUSES Hot Sellers, Craft Shows, Flower Shops, Bazaars. Step By Step Instructions \$3.50. The Woodpecker, Box 1580-PM, Collegedale, Tenn. 37315

MAKE MONEY RECONDITIONING-JUNK BATTERIES High Profits, Full/Part Time. FREE Report. Apollo, 1AD, Orluste, OK 73560

MANUFACTURE at Home! Huge Profits! Polishes... Cleaners... Disinfectants... Cosmetics. Professional Formulas. Free Details! Frontier, Box 44179, Tucson, Arizona 85733.

\$40,000 ON 1/3 ACRE! New Hydroponics inexpensive to start, maintain. Clean, pleasant, no manual labor. Free information. Robin's, Box 1657, Brenham, TX. 77833

WANTED: ... Profitable Home Business Opportunities. Send offers ... Home-workers, 7250A Berea, Winston, Georgia 30187

MAKE MONEY GROWING PLANTS INDOORS — easy! Complete instructions, sales plan. Free literature. Growers Associated, Box 585PM, Calistoga, CA 94515

\$20.00 per hour possible preparing tax returns. Our experience will benefit you. Part/fulltime. Instructions made simple. Free information. Nationwide Tax School, 14507 Warren, Dearborn A206, MI 48126.

SPECTACULAR Home Business Opportunity. Market Hundreds Of Best Selling Specialty Products. Below Wholesale Prices. Details Free. Journey Sales, Dept. PM104, 1505 Penny, Bakersfield, California 93306.

BECOME Real Estate Inspector - Large Income Potential. Be Boss. Home Operation Minimizes Investment. Simplified Instructions, Assistance. Free Information. Box 400 PM, Arnold, MO 63010.

DETAILED REPORT! Shows You How To Make Big Money in Lawn Care! \$3.00. Crosswinds, Box 97, Nixa, MO. 65714.

1000 UNIQUE HOME BASED BUSINESS OPPORTUNITIES LISTED IN BOOKLET. LOW OR NO INVESTMENT. SEND \$2.75 TO: MIDTOWN, 1242 UNIVERSITY DR., ATLANTA, GA. 30306.

THOUSANDS possible monthly! FREE INFORMATION shows how. Write: Farrell, Box 409, Occoquan, VA 22125-0409

101 Easy Businesses You Can Start Now. Free Details. Silvis, 1372 High St., Bradford, PA. 16701

EASIEST BUSINESS ON EARTH! Home operated. Huge profits. Insider reveals secrets. FREE DETAILS! Beebe, Box 2005, A-483, Syracuse, New York 13220

EARN \$20-\$30 AN HOUR. Unique New Process Repairs Burned And Damaged Countertops. Free Information. Countertop Repair Service of Austin, 12722 Burson Drive, Manchaca, TX 78652

OVER 100% PROFIT on sale of hundreds of quality gifts. Jewelry, stuffed animals, housewares, many others. \$2.00 brings color catalog, full details, refundable first order. Stag business with single item! Quality House, 2343 Price Way, San Jose, CA 95124

FANTASTIC PROFITS!!! Wholesaling At Home!!! 2500 Fast-Selling Gift Items! Below-Wholesale Prices! Free Details: J.R. Wholesalers, Box 27172(PMI), Milwaukee, WI 53233

WANTED to buy for wholesale books copyrights dealerships of proven moneymaking literature. Northern-Wholesale, Box 688, Sechart, BC, VON 3A0 Canada

NEW LUXURY CAR without cost! Write: AMCO 9, 1601 Main, Plainfield, IN 46168

HOLLOW Grind Scissors, Knives the Factory Way; Money-maker. Plans, Instructions \$10.00. Hanson, Box 1728, Payson, Arizona 85541

500% PROFITS assembling, packaging automotive and mail order specialties! Almquist Manufacturing, GT4G, Millford, PA 18337.

FANTASTIC PROFITS!! - It's Easy! - Details FREE - DynaTek A4, 720 Jordan, Rockford, Illinois 61108

GUARANTEED Home Business!! Earn Extra Income... Start Immediately. FREE Information: Berthume Publications, Box 611, Owosso, MI 48867

MAKE MONEY REPAIRING HYDRAULIC EQUIPMENT — JACK INCLUDED — Free Details... Hydraulic Training Institute, 2840 Greeley, PM4, Erie, PA. 16506

HOW TO GET RICH IN MAIL ORDER No Experience Or Capital Needed. Details Free, Case Histories Included. T.A. Nielsen, 16400 Ledgemont #A220, Dallas, TX 75248

CARPETLAYERS Earn To \$3000. Monthly. Easy Home Training. Big Demand. Free Catalog. Carpet Crafts, 390 Dawson Drive, Camarillo, California 93010

NEW! Free! Easiest Money Maker in Years. Leisure Company, Box 27724, Tucson, Arizona, 85726

\$87,000 by mail you would THINK is unheard of! I once did. Details: INITIATIVE, P.O. Box 10179, Alexandria, Virginia 22310

FREE!!! "Treasury Moneymaking — Homework — Mail-order Publications!" Lockbox, 3638A, Midland, Texas 79702-3638

OPERATE Your Own Lucrative Mailorder Business. Handle the 6 Best-Selling Products that'll gross you Thousands Monthly! We guide you. Investment less than pair of shoes. Success Guaranteed. Write: Budget-Ad, Box 189PMB, Buena Vista, GA 31803

MAILORDER opportunities directories. Dealers wanted. Make 2000% profit. \$4.00 refundable. Newlife, Box 85041/D, Los Angeles, CA. 90072.

BUMPER STICKER PRINTING DEVICE. Cheap. Simple. Portable. Free Details. Bumper, POB 22791 (GE), Tampa, FL 33622

FANTASTIC PROFITS ARE YOURS! Write: Frank Britton, PM4, 9103 Dentana Court, Richmond, VA. 23228

MAKE Rubber Stamps. Highly Profitable Business. Free Details. Stamper, POB 22809 (GE), Tampa, FL 33622.

PROFITABLE GOLD FOIL PRINTER. Personalize business cards, pencils, matches. Free Details. Gold, POB 24986 (GE), Tampa, FL 33623.

LEARN Major Home APPLIANCE REPAIR Business. Informative Book \$19.95 ppd. J&R Developers, Box 1372A, Salina, Kansas 67401

REAL-ESTATE FORECLOSURES: REPRESENTATIVES NEEDED For This Profitable Business. No Cash Required. Free Information. Horizon Financial Corp., Dept. P., 2474 N. Federal Hwy., Pompano Beach, FL. 33064

(Continued on next page)

## BUSINESS OPPORTUNITIES

(Continued from preceding page)

**CASH FOR TRASH** - Recycling Brings High Profits. Experts Tell You How, Where And What Goods To Recycle. No Non-sense Offer. Satisfaction Guaranteed. For Detailed Booklet Send \$3.00 & SASE To: Box 1254, Rilton, NY 12471

**ASSORTED PRODUCTS** - Wholesale - No Investment. Sheffields, 166 Tanforen, Placentia, CA 92670.

**FREE** a best seller, Think and Grow Rich with order of "How to Get Rich in Mailorder." 336 Pages - 200 Illustrations. \$12.00 Postpaid. United Realm Associated, P.O.B. 582, Jackson Heights, New York 11372

**LET Me Help You Make Nice, Monthly, Mail Order Income** - Just As I Do! Details \$1.00. Timberhill, Box 51, East Aurora, NY 14052

**OUT OF WORK? NEED MONEY?** \$1.00 booklet shows you how to start your own business through classified advertising. Popular Mechanics, Dept. KC, 224 W. 57th St., New York, NY 10019.

## MONEYMAKING OPPORTUNITIES

**MONEY** In Mailorder. Work With Us. Reach Satisfactory Income. Go On Your Own. Landrum Enterprises, 5928 South, Lakewood, CA. 90713

**BIG Money Selling Information Sample \$2.00.** Vernon Distributing, Box 903, Lemon Grove, CA 92045

**MYSTERY** of the Orient. How to make Money with Japan. Full Details-\$6.95. Bayland, Rt. 3, Box 339P4, Appleton, WI 54915

**STAGGERING** multi-level potential! Products used daily, every household! Norseman Products, Dept. T, P.O. Box 645, Chico, CA 95927

**LEARN** Small Business—Make \$75,000 Plus a Year. Guaranteed — \$75.00 an Hour. Send \$5.50 for Brochure To: Mark Morgan, 2120 Hassell Rd., Suite 203, Hoffman Estates, Ill. 60195

**MOST PROFITABLE** home based businesses in America today. Step by step instructions. Free details. ALMC Books, Dept 41, Box 1718, Montclair, N.J. 07042

**SALARIES** may be hazardous to your wealth! Send for easy low-cost plan for financial freedom — Waterworth Publications, 1820 Park Newport Drive, Suite 414-043, Newport Beach, California 92660

**EXTRA CASH** — You can earn it! Your FREE subscription to Opportunity Magazine shows you how with success stories of today's entrepreneurs. Write: Opportunity, Dept. 896, 6 N. Michigan, Chicago, 60602.

**SPARE** time fortune in Vinyl Repair. Huge demand creates exceptional profits. We supply everything. Details free. VIP, 2062 Montrose, Chicago, 60618

**GET RICH!!** Secret law smashes debts — brings Cash, Credit FREEreport!! WealthKit-WBM-4, Billings, NY 12510

**FANTASTIC** earnings mailing from home!! Offer: Rush Stamped Addressed Envelope. Imperial, P-8 X17410, Fort Lauderdale, FL 33318

**MAKE PVC PIPE FURNITURE.** Begin profitable home business without experience! Free report. J&M, 771PF, Battle Ground, Washington 98604

**EXCITING 10- \$25 HOURLY** income. Unusual opportunity making, assembling products at home. Merritt, Drawer 428P, Richardson, TX 75080

**FREE** details on business opportunities and wealth-producing secrets — Woodbine Distributors, Five Larkspur Way, #3PM3, Natick, Massachusetts 01760

**EARN \$2,000/month** offering loans, starting part time. Prestigious opportunity. PFA, Box 84068P, Los Angeles, CA 90073

**51 MOST POWERFUL MONEY MAKING TOOLS AVAILABLE** SEND \$6.95 FOR COMPLETE PACKAGE. WRA, DEPT. PM4, P.O. BOX 1090, WESTMONT, IL. 60559

**MONEYMAKING OPPORTUNITY** Start and Operate Profitable Business at Home. Free Details. Cook's Publications, 3PS1, 18314 School, Lansing, IL 60438

**PROFITABLE VACATION** Send \$10 SASE To: Profitable Vacation, Box 244, Boody, IL 62514

**\$300 Weekly Sparetime.** Mailing Salesletters. Mailworld, Box 805M, Pineville, NC 28134

**WORK HOME**-101 easy, proven ways to self-employment. Free details. DAVISCO, P.O. Box 925, Fairfield, CA. 94533

**CANADIAN** Million\$ in mail. Instant money information. Write: Million\$, Dept. PM, Box 1038, Station Q, Toronto, Canada M4T 2P2

**MAKE \$22.50 hourly.** Produce rubber stamps. Equipment, know-how furnished. Free particulars. Write: Roberts, Room RC-2-MD, 1512 Jarvis, Chicago, IL 60626

**MILLIONAIRE TELLS** How You Can Accumulate Wealth, Too? Free Details: Success World, Dept. PM4, P.O. Box 431, College Park, MD. 20740

**EARN EXTRA CASH ON POPULAR, FAST SELLING MILITARY SURPLUS . . . CAMPING SUPPLIES!!!** How to Kit includes easy instructions and \$4.00 COUPON Refundable with First Order. Money-Back Guarantee. **START TODAY, SEND \$2.00 TO: HILLS GENERAL STORE, 12841 HAWTHORNE, SUITE 527C, HAWTHORNE, CALIFORNIA 90250**

**OWN A Pick Up?** Report Reveals Simple, Easy Way To Unlimited Money And Independence!! \$4.95 for "Picking Up Cash With Your Pick Up". UFT, Box 772PM, Clearwater, Florida 34291-0772.

**700,000 BARGAINS.** Mail Order, Home Businesses, Imports, Free Details: American Money-makers, Box 8356PM, Tampa, FL 33674

**AMAZING** new multilevel company! Earn thousands of dollars monthly with zero investment thru Adventures in Health. Free details. Mata, Box 710-M, Artesia, CA 90701

**YOUR** ideas can make big money! Expert reveals his easy, success secrets. Results guaranteed. \$3.00 postpaid: Abdallah Enterprises, 1026 Ridgemont, Staunton, VA 24401.

**FREE** Information, Relax and get Rich! Select Enterprises, 14 Holly Court, Savoy, Illinois 61874

**MAKE MAIL ORDER FORTUNE.** Free Information. Childress, Route #1, Springville, TN 38256

**MONEY!!!** Free Info. KD&V, Box 430434, Houston, Texas 77243

**GREAT** Money-makers Concise Reports. Silver Recovery \$5.00, Gold Panning \$4.00, Franchises \$4.95, Cottage Industries \$4.95, Mail Order References \$5.00. Rolian Distributors, 6511-124 Street, Edmonton, Alberta, Canada T6H 3V4

**MAKE** Profitable Items. List 25c. Homecraft, 2350 W47P, Denver, CO 80211

**LISTEN** your way to \$\$\$! New Cassette reveals quick, easy, highly profitable, at home businesses, How to get started, Information by writing: Henry Farr, Applehurst, Box 212, Stockton Springs, Maine 04981

**FREE** Booklet: How To Turn Any Hobby Into Cash! Embee, Pinegrove, Kingston, NY 12401

**STRIKE IT RICH** at home with our Powerful Money-Making Plan. End Financial Worries! Free Details! JC Marketing, Box 198PM, New York, New York 10023

**MAKE** Big Money At Home. Learn The Secret. Free Proof. Beacon House, 3336 Cowley Way, Suite 4, San Diego, CA 92117

**PATENTED MACHINE PART-FULL TIME INCOME** Make money operating and or selling this exclusive machine in a market that is virtually without competition. Huge profits possible. For details send \$1.00 for postage and handling to: DWI, Suite 608, 40-19 164 St., Flushing, N.Y. 11358

**MONEY** Fun - Send \$4.00 For Booklet: "How I Turn Junk Into Fun And Profit." JR Milam, 513 Highland Ave., Mullens, W.Va. 25882

**HOW** to make money in your spare time. Complete details, only \$2.50. Satisfaction guaranteed. Davis, 7805-N Lookingglass, Roseburg, OR 97470.

**FORGET RECESSION** Millionaire's success secrets reveal method of attaining wealth you deserve. Free details. TMS, 349 N. Hwy. 101, Solana Beach, CA 92075

**101 EASY LUCRATIVE BUSINESSES.** Start on Shoe-string. Free Details. Paul Hoak, Box 1281, Montpelier, VT 05602

**UNEMPLOYED,** start your own business, selling fast moving products. Catalog and information on 50% discount-\$5.50. D&C Wholesaler, P.O. Box 386, Flourtown, Penna. 19031

**NEW MONEY MAKING INFO. NOW AVAILABLE. SIMPLE, STEP BY STEP INSTRUCTIONS DESIGNED TO EARN YOU EXTRA INCOME. FREE DETAILS.** Write: HOWARD PUBLISHING CO., P.O. Box 4000-38A, New Orleans, LA. 70119

**RELAX** And Get Rich! Your Pathway to Wealth. Free Details. Mark, Box 6A, Fremont, IN 46737

**PROVEN** Wealth Producer—Distribute Information By Mail—"Free Details!" Marketex, PM4, 5924 Catalina, Fairway, Kansas 66205

**MAKE** Up To \$750.00 Next Weekend. This Is The Best Guide To Quick Cash. This Amazing Book Gives You The Facts. Guaranteed. Your Money Is Refundable. Send Just \$6.00, Cheque or Money Order, To: Stanton Publishing, Box 6, Port Stanton, Ont., Can., POE 1L0.

**FREE INFORMATION, HOW-TO** start home business breeding birds. Profit & Financial Security. No Experience. Marsh Farms, P.O. Box 7JK, Garden Grove, CA 92642.

**TODAYS INVESTOR BULLETIN** For the **SERIOUS WEALTH BUILDER** Details. 3154 S. Cherry Cir., Dept. PM, Mesa, AZ 85202

**BUMPER STICKER PRINTING DEVICE.** Cheap, Simple, Portable. Free details. Bumper, POB 22791 (GH), Tampa, FL 33622.

**STOP** wasting time and money answering worthless ads. Now one source which examines over 1200 opportunities. Free details! Edlin Associates, Dept. PM4, 15 Wooster Street, Seymour, CT 06483

**HOW TO MAKE MONEY THROUGH CLASSIFIED ADVERTISING.** Booklet shows you how to start your own business with Classified Advertising. **ONLY \$1.00 FOR BOOKLET** — (\$2.00 coupon refundable with first order). **H.E. KAPPEL, POPULAR MECHANICS, DEPT. PMC4, 224 WEST 57TH ST., NEW YORK, NY 10019**

**\$800** Weekends: Your riding mower, My unique lawn areator. Free details. Areator, Box 925, Longview, TX. 75606

## RABBITS—CHINCHILLAS—FUR BEARING ANIMALS

**RAISE FUR BEARING ANIMALS** Fox, Raccoon, Cougar Others. \$1.00 Color Photos Information. Hidden Valley Fur Farms, RR 1, Guttenberg, Iowa 52052. 319-252-1637

**AMAZING** Profits! \$10,000 Yearly Raising Rabbits for Wool and Breeding. Details—\$2.00. American Angora, Malta 12, Montana 59538.

**RAISE RABBITS SUCCESSFULLY** 68 Page Booklet Tells How. \$1.00. American Rabbit Assn., H1, P.O. Box 426, Bloomington, Illinois 61701

**\$500-\$1000** Month Plan raising rabbits for us. Free details. White's Rabbitry, Box 1388PM, Hudson, Ohio 44236

**GUARANTEED** Income. \$10.00 (refundable) for literature. Chinchillas, Box 8294, Mesa, Arizona 85204.

## EARTHWORMS, LIVE BAIT

**FREE** Literature. Raise Fishworms, Crickets, Redworms—1000-\$8.95, 5000-\$42.50. Book on How and Where to Sell with Order. Carter Fishworms, Plains, GA. 31780.

## OF INTEREST TO ALL

**REGISTER YOUR KEYS.** Send S.A.S.E TO: Registry, 10149 Hammerly, #62, Houston, TX 77080

**SURVIVE NUCLEAR ATTACK!** Send Stamp. RADSADS, P.O. Box 40-A, Castor, LA. 71016

**LIGHT** -Boat, Shop, Sue's Gifts, 5103A NW Karen Blvd., Kansas City, MO 64151

**FREE** Information! Get Rich in Mail Order. Lee, 215 Pasadena Plaza, Suite 170PM, Pasadena, Texas 77504

**FREE** Promotional Albums, Concert Tickets, Stereos, etc. Information: Barry Publications, 477 82nd Street, Brooklyn, NY 11209

**VACUUM** Cleaners "Discount Prices" "New" Rainbow \$349.95, Kirby, Filter Queen, Compact, Details: ABC Vacuum Warehouse, 7021 Burnet - PM, Austin, Texas 78757

**FREE CATALOG!** Privacy, Credit, Divorce, Employment, Tax Problems? Our books have the solutions. Write to: Eden Press, 11623 Slater, Box 8410-PG, Fountain Valley, CA 92708.

**NOW,** You can draw. **FREE** - Complete details plus first easy lesson from Disney artist. Bruce McIntyre - PM-13, 3471 Crownsworth, Corona, CA 91720. (714) 953-7452

**SAVE THOUSANDS ON HOME MORTGAGES!** Homeowner? About to buy? Exciting Plan guaranteed to save you thousands! \$3. Opportunity, 10411 Floral, Adelphi, Maryland, 20783

**FREE** Information on how to Solve Weak Radio Reception. Send **SASE** to: Veegee Varieties, Box 1203, Santa Maria, California 93458

**"EXCITING" 1001 THINGS FREE** 64Pgs. Details. Box 86007PM, San Diego, CA 92138-6007

**STRUGGLING? FINANCIAL PLANNING KIT:** Materials, Simple Instructions, MBA Consultant Value. Send \$10.00 To: BR Enterprises, Dept. PMF31, Box 23831, Rochester, NY 14692

**THE BEGINNER'S GUIDE TO BUYING GOLD AND SILVER.** Send \$5.95. UseCar@Too, Box 881, Beatrice, NE 68310

**SAVE** money! Save Property! Save Lives! . . . Accident Preventive Device . . . Easy to install . . . Free Details . . . Write: M. J. Richard Co., Dept. PM1, Box 4862, Salinas, Calif. 93912

**ROGER ANDREWS** Obtained a \$225,000.00 Castle On An Average Income. \$10.00 Buys His Book, **"HOW TO SURPASS THE AMERICAN DREAM."** Andrews Enterprises, Box 2020 P.M., Sandusky, Ohio 44870

**CHECK BOOK BALANCING** made **EASY** for **INDIVIDUALS** and **SMALL BUSINESSSES.** Totally accurate system. Money back guarantee. Send \$3.00 to: Bank Bal Systems, Box 53377, Atlanta, GA 30305.

## OF INTEREST TO WOMEN

**SINGLES CALLING CARD!** Wallet Size. Name, Address, Phone Blanks. REVERSE Side - Compatibility Data Checklist. 40 Cards - \$3.00. Marigold Supply, Box 3098A, Warren, Ohio 44485

## GOVERNMENT SURPLUS

**1983 Surplus Army, Navy** store 64 pages illustrated catalog. Send \$2.00. Ruvel, 3037 N. Clark, Dept. J-4, Chicago, IL 60657.

**J-E-E-P-S, T-R-U-C-K-S** from \$30.00. Millions of items in Government Surplus; Typewriters, Boats, Clothing. Complete Directory On How And Where To Buy In Your Area - \$2.00. Surplus Bargains, Box 913-A, Holland, Michigan 49423.

**GOVERNMENT SURPLUS** . . . Millions of items (including Jeeps) . . . low as 1¢ on dollar! Most complete Directory available — \$2.00 (guaranteed). **DISPOSAL**, Box 19107-AD, WASHINGTON, DC 20036.

**GOVERNMENT LANDS FROM \$7.50 ACRE!** Homesites, farming, vacationing, investment! "Land Buyer's Guide" plus nationwide listings - \$2.00. Lands, Box 19107-AD, Washington, DC 20036

**IS IT True** you can buy jeeps for \$44 through the U.S. Government? Get the facts today! Call 312-742-1143. Ext. 7133.

**HOW To Make Money On Government Surplus.** Tells How And Where To Buy For Your Own Use Or For Resale. Send \$2.00 To: Oak Tree Sales, 111 South Michigan, Gaylord, Michigan 49735

**GOVERNMENT SURPLUS "No Fooling Around"**. Guaranteed Complete and Direct Connections. \$5.00. Hub City Wholesale Surplus, Box 2253, Hattiesburgh, MS 39401

**JEEPS - MOTORCYCLES - AIRCRAFT - AUTOMOBILES** . . . Government Surplus Directory - Moneyback Guarantee - How, Where - \$2.00. GS Information, Department 14, Box 3913, Springfield, Massachusetts 01101

"**GOVERNMENT SURPLUS**" **JEEPS \$30.00!** 800,000 items! Complete Information Your Area. **LARGEST OFFICIAL DIRECTORY.** \$2.00 (Guaranteed). **SURPLUS (A395)**, 4620 Wisconsin Northwest, WASHINGTON, D.C. 20016

**JEEPS . . . AUTOMOBILES . . . \$30.00!** 900,000 bargains! Complete Government Information—Your Area. **GUARANTEED DIRECTORY—\$2.00.** **SURPLUS**, Box 392MD, VALLEY FORGE, PENNSYLVANIA 19481

## LOANS BY MAIL

**\$1,000—\$5,000 Interest Free!** Send \$2.00 and SASE To: Diane, Box 7858, (POPM-4-83), Fresno, CA 93747

**BORROW \$30,000** without interest! All eligible. Repay anytime. Free details! Infohouse-508PM, 533 Sutter, San Francisco, CA 94102.

**BORROW \$25,000 "overnight."** Any Purpose. Keep indefinitely! Free Report! Success Research, Box 19739-AP, Indianapolis, Indiana 46219.

**MONEY Problems?** Free Book describes Loans, Cash, Government Grants, Other benefits, available to individuals. Write: Associates, Box 98-A4, Brooklyn, New York 11235

**BORROW FROM HOME!** Any amount, any worthwhile purpose, within 30 days. Competitive Rates. Also, you can earn substantial income as a Money Agent. No Experience—Own Hours. National Company to assist every way possible. No Gimmicks! Free Details: DFC, Dept. 10-C-4, 1145 Reservoir Avenue, Cranston, Rhode Island 02920

**CASH Loans—Borrow by Mail \$500.00 to \$25,000!** Free details, Application! LTD-PM, Box 937, Ft. Lauderdale, FL 33302

**GET cash grants—from Government.** (Never repay.) Also, loans. All ages eligible. Information, \$2.00 (refundable). Surplus Funds-PM, 1629 K. St., Washington, D.C. 20006

**BORROW \$100-\$100,000!** Instant Reply! No Co-signers! Rush Stamped Envelope! Financial, Box 5487(P), Richardson, TX 75080

**BORROW \$300 - \$30,000** Quickly! All qualified. Repay anytime. Details Free! FSC, Box 1432 - MD, Upland, CA 91786.

## DIVORCE

**WINNING** Information, \$1.00. **MEN'S RIGHTS ASSOCIATION**, 189B, Forest Lake, MN 55025-0189

## PERSONAL

**PENFRIENDS - England - USA** Make Lasting Friendships Through Correspondence. Send Age, Interests, Free Reply. Harmony, Box 89PM, Brooklyn, N.Y. 11235

**BIBLE** Questions answered. Stamped envelope. Bylon, 17167 Bertier, Detroit, Michigan 48219

**COLLEGE DEGREES BY MAIL.** Renowned Universities offer fully-accredited Bachelors, Masters, PH.D's . . . Free revealing details. Counseling, Box 317-MP-4, Tustin, California 92680.

**UNIVERSITY DEGREES BY SPECIAL EVALUATION OF EXISTING** Job Experience, Education, Achievement. Fast, Inexpensive. Call (614-863-1791). Or Write: Box 13151-T4, Columbus, OH 43213

"**HOW to Meet People Through the Personals Column**" guidebook, \$4.00. Cheera, Box 772, Victoria, Canada, V8W 2P9

## REMAILING SERVICE

**CALIFORNIA CONFIDENTIAL** from \$1.00. OMS, 4216 Bouquet Way, Sacramento, CA 95834

**REMAILING \$1.00 each.** "Confidential Mailer", P.O.Box 6161, South Bend, Indiana 46660.

**COLORADO** Remails; \$1.00 Each. Box 21575, Denver, Colorado 80221

**CONFIDENTIAL** Mail Receiving/Forwarding. Mail Drop, Box 18039PM, Orlando, FL 32860

**SASKATCHEWAN** Remailing. Central, Box 101, Foam Lake, Saskatchewan, Canada S0A 1A0

**UNLISTED ADDRESS.** Discreet and confidential. Remail \$1.00 Single. Mail Forwarding Service, 8060 S. Main, Houston, Texas 77025

**REMAILING 20¢.** Forwarding \$18.00 yearly. "Economail", Box 541, Ephrata, Washington 98823

**DEPENDABLE** Remail, Messages Daily, Central, 430 Lakeside, North East, MD 21901

**CHICAGO** Address? Call 800-621-7461 for information packet.

**NEW ZEALAND** Confidential Remails. 1/3 Ounce Maximum. \$2.00 includes New Zealand Airmail Postage. Erich, 4 Calvert Road, Flat 1, New Plymouth, New Zealand.

**NEVADA** Remails \$1.00. Confidential, complete service. Box 70747, Las Vegas, NV 89170

**PRIVATE ADDRESS.** Dependable and EXPERIENCED. Professional Mail Forwarding, Box 561A, Milton, Mass. 02186

**DEPENDABLE** Confidential Remailing. Washington, D.C. Suburb. HowTo, 2620 Kirklyn, Falls Church, VA 22043

## MISCELLANEOUS

**FLOATING ROCKS** Actually Float in Water. 1-2" Diameter \$5.00, 2-4" \$8.00, 4-8" \$12.00. FOB Lomen, P.O. Box 656, Toledo, WA 98591

**PHOTO ID.** Sealed in plastic. All states, provinces. 24-hours. **GUARANTEED.** Send \$6.00 (2/\$10.00), photo, name, address, height, weight, hair, eyes, birthdate. **CARDINAL**, 2071-46 Emerson, Jacksonville, Florida 32207.

**PHOTO IDENTIFICATION CARDS . . . Certificates . . . GUARANTEED!** Samples 25¢ . . . Bascoo, Box 3481-PM-83, Providence, R.I. 02909.

**ORNAMENTAL** Iron Designs. Book of 1600 beautiful practical designs for railings, columns, etc. Free Literature. Cunningham, Box 20005, Salt Lake City, Utah 84120-0005 — (3881 South 3200 West)

**COLLEGE STUDENTS!**—Improve your grades! — Research catalog—306 pages—10,278 topics—Rush \$1.00—Research, Box 25918K, Los Angeles, 90025. (213) 477-8226.

**STOP!** For Overworked Hair. It's a Shampoo & Conditioner & Rinse. 4oz. — \$7.00, 8oz. — \$10.00, \$2.00 Handling. H. Caldwell Associates, P.O. Box 34516, San Francisco, CA 94134

## WANTED MISCELLANEOUS

**MECHANICAL** Genius Wanted By Gallagher. Write: P.O. Box 657, North Hollywood, CA 91603

**GOLD,** Silver, Platinum, Mercury, Tantalum wanted. Ores assayed. Free circular. Wholesale Terminal, P.O. Box 191, Norwood, MA 02062.

**SCRAP SILVER CONTACTS, FORKLIIFT CONTACTS,** Silver Solder, Sterling, Gold Plated. Robert Leszczak, 652 Myrtle St., Elizabeth, NJ 07202

## FOR SALE-MISCELLANEOUS

**SILVER FORK-TRUCK CONTACTS AND SILVER SOLDER** CHEAP. Robert Leszczak, 652 Myrtle St., Elizabeth, NJ 07202

**PROTECT HANDS:** quality, disposable, often reusable touch sensitive gloves. **APPLICATIONS:** engine repair, cement work, painting, gardening, grubby jobs. 50 gloves \$7.25 postpaid. Marklive, Box 30, Contoocook, NH 03229

## HEARING AIDS

**HUGE SAVINGS** Eliminate Dealer Markups. Free Trial. Batteries Wholesale. Terms Arranged. Call Toll Free 1-800-323-1212. Or Write: Lloyds-PMC, Rockford, IL 61110

**HEAR** But Don't Understand? Modern Name-brand aids improve understanding. Save \$200+. No Salesmen. Free Trial. Free Catalog. Dept. 132A, J&M, 329 N. 3rd, DeKalb, IL 60115.

**HEARING AIDS** — From \$89.50 — 30 Day Trial. Gigantic Savings on Batteries. Write for Free Gift Offer and Brochure Today. Electronic Products, Box 2005-PM, Pinellas Park, Florida 33565

**MAIL ORDER** buying saves half on hearing aids. Month's trial. Rea Company Inc., Box 364, Bridgeport, OH 43912

**FREE HEARING AID CATALOG** - Save 1/2 by mail! Write: "MoneySavers", 9530-PM-4, Langdon, Sepulveda, California 91343. NOT sold in California.

**NEW All-in-the-ear** Hearing Aids. Huge Savings. Batteries - other aids. Free catalog. No salesman. Rhodes, Dept. 132K, Brookport, Illinois 62910

## TOBACCO

**MAKE** Pipes, Information: Pimo, Inc., P43, Box 59211, Chicago, Illinois 60659

## SCIENCE & CHEMISTRY

**LABORATORY** Chemicals, Glassware—Apparatus, Catalogue \$1.00. Deluxe Scientific, 934 S. 13 Street, Manitowoc, Wisconsin 54220

## FORMULAS, PLANS, ETC.

**ANY FORMULA** \$10.00. Catalog \$1.00. J. Belfort, Box 568, Chicago, 60690

**MONEYMAKING CHEMICAL FORMULAS** — THOUSANDS! **CATALOG \$3.00 (REFUNDABLE):** GWA3, Box 193, Brookfield, Wisconsin 53005-0193

## TRAVEL AND RESORTS

**ROAM** the World by Freighters. Deluxe - Exotic - Inexpensive. TravTlps Association, Box 189N8, Flushing, NY 11358.

## SPECIAL SERVICES

**INFORMATION** On anything. Ferguson Research Specialists, 60-15 Woodside, Woodside, New York 11377.

## BETTER HEALTH

**100% Natural Food Supplements** And Personal Care Products. Send \$1.00 For Catalog: Better Living, P.O. Box 736, Ignacio, Colo. 81137

**LOSE** Weight, Better Health, Worlds Simplest Exerciser. Illustrated Manual. \$6.00. Gene McLeod, Box 27A, Dixie, GA. 31629

**PROSTATITIS** (An infection of the prostate gland), the scourge of the over-40 adult male, signals pain, discomfort, worry and misery. Send for free valuable information describing this prostate problem and a nutritional approach for relief. Don't hesitate-do it now. Send to: Bio-Vim, Inc., Dept. PM, P.O. Box 7369, Naples, FL 33941.

**ASTHMA** sufferers—learn about your disease, information to live better \$9.90. Box 30339, Tucson, Arizona 85751

**MIRACLE** Oil. Any Pain, Guaranteed Relief!! Box A3420, Chicago, Ill. 60690

## FOR THE HOME

**EVICT INSECTS, RODENTS** Electronically, Economically, Permanently without Poisons, Traps, Sprays. Moneyback Guarantee. Free Information: Hamlin Products, P.O. Box 9325, Dept. PM43, Downers Grove, Ill. 60515

**WATER SAVER** Simple Device that Reduces Water Usage in Showers. \$2.25. Saver, P.O. Box 26021, Birmingham, Ala. 35226

**BUTCHER BLOCK KITCHEN TABLE.** Build this old-time chopping block for your home. Photocopy of plans available for \$1.25. Send order to: **POPULAR MECHANICS**, Dept. PMC4, Box 1014, Radio City Station, New York, NY 10101

## WORK CLOTHING

**WORK** Clothes - Save 80% Shirt, Pants, Coveralls. Free folder, write: Galco, 4004 East 71st Street, Dept. P-4, Cleveland, Ohio 44105

## WEARING APPAREL

**SATIN** BASEBALL JACKETS!!! T-Shirts . . . See "Buy It Wholesale" . . . "Barker Jacket."

**DEADLINE FOR ADS:** Copy and Payment must be in by the 5th day of the 2nd preceding month for the issue in which the ad is to appear. See Head of Classified Section.

**HOW TO COUNT WORDS:** Name and address must be included in counting the number of Words in your ad. Each initial or number used counts as 1 word: H.E.Kappel, 224 West 57th Street, New York, New York 10019: 9 WORDS. Zip codes are not counted. Phone #: 2 Words. Symbols used as keys are charged for. City or State count as 1 word each: New Brunswick, New Jersey: 2 words. Abbreviations such as C.O.D., F.O.B., R.P.M., U.S.A., P.O., 5x7, 16mm are counted as 1 word. (P.O.Box 392 counted as 3 words) Webster's International Unabridged Dictionary will be used as our authority for spelling, compound words, Hyphenations, abbreviations, etc. Please make checks payable to **POPULAR MECHANICS**.

Only \$57.00 for 10 word minimum

\$5.70 each additional word

**BOLD FACE CAPS add  
\$1 per word**

(First Word: No Charge For Bold Face)

Remittance of \$ \_\_\_\_\_ is enclosed to cover \_\_\_\_\_ insertions(s) in the \_\_\_\_\_ issue(s). \_\_\_\_\_ Classification

|    |    |    |    |
|----|----|----|----|
| 1  | 2  | 3  | 4  |
| 5  | 6  | 7  | 8  |
| 9  | 10 | 11 | 12 |
| 13 | 14 | 15 | 16 |
| 17 | 18 | 19 | 20 |
| 21 | 22 | 23 | 24 |
| 25 | 26 | 27 | 28 |
| 29 | 30 | 31 | 32 |

YOUR NAME \_\_\_\_\_ (PLEASE PRINT) PHONE: \_\_\_\_\_

FIRM (NAME IN AD) \_\_\_\_\_

YOUR ADDRESS \_\_\_\_\_

CITY \_\_\_\_\_ STATE \_\_\_\_\_ ZIP \_\_\_\_\_

DATE: \_\_\_\_\_ YOUR SIGNATURE \_\_\_\_\_

(PLEASE PRINT OR TYPE COPY • FOR ADDITIONAL WORDS ATTACH SEPARATE SHEET)

## REPAIRS & SERVICING

**REPAIR** Your Telephone. \$4.00. Zapco, P.O. Box 793, Metairie, LA. 70004

## GARDENING & LAWN CARE

**"URN STAND"** for Cemetery - Yard, Maintenance Free. Brochure. Glacier, Box 8367, St. Paul, Minn 55113

## FLOWERS, PLANTS & NURSERY SUPPLIES

**GROW GINSENG**, Very Profitable. Have seeds, roots. Goldenseal. Complete information. K. Collins, Viola, Iowa 52350

**TRIPLE HANGING PLANTER** made from coconut shells, rattan and fine sea shells. Only \$15.95. Kyle Everson, 795 Church SE, Salem, OR 97301

## HYDROPONICS

**NEW Hydroponic Home Planter**. Send \$1.00 for Report. Richard L. Zygmunt Specialty, 400-J Davisville Rd., Willow Grove, PA 19090

## RECIPES, COOKING, ETC.

**CHOCOLATE Zucchini**—the most delicious cake you'll ever eat. Send \$1.50 to: Bayland, Rt. 3, Box 339P4, Appleton, WI 54915

**SPANISH DELIGHTS**. 12 authentic appetizer recipes. \$3.00. Rodosa, Box 9128, Paramus, NJ 07652

**HAWAIIAN** Imu Cooking-Info. \$2.00 & SASE. Kanaka Keola, 127 Hookea Drive, Kailua, Hawaii 96734

**MEXICAN FOOD RECIPES**. Enjoy The Finest. \$3.00 booklet. Continental Graphics, 700 Gentleman-120, San Antonio, Texas 78201

**UNI-Q QUICHE RECIPES**. \$1 plus SASE. PCS, Box 15, Laguna Beach, CA 92652

**GRANDMAS RECEPTION RECIPES** 10 Budget Stretching Home Style Meals \$3.00. Beau's, PM4, Box 42, Oak Creek, WI 53154

**LEARN BAKER SECRET** Bake Professionally. Bakery Recipes Included. \$4.00. P.O. Box 98, Richmond, KY 40475

**CHILI** made the way you like it: "The Adjustable Recipe" \$2.00. SASE. J.R., 9224 SW 110 Terrace, Gainesville, Fla. 32608.

**WINE AND CHEESE BOOK** You too can be an Authority. Send \$4.98 today. JRP Enterprises, 5201 Clarendon Rd., RM 3A, Brooklyn, NY 11203

**EASY NO-BAKE COOKIES RECIPES** Send \$2.50 to: Helpful Hints, Box 41216B, Atlanta, GA. 30331

**TRADITIONAL ASIAN RECIPES** Send \$4.95. Arrasi, Box 15101, Salt Lake City, UT 84115

**50 PARTY PUNCH RECIPES** Send \$3.95 to: Helpful Hints, Box 41216C, Atlanta, GA 30331

**POTATO CHIPS**. Delicious Chips in Minutes. \$3.00 SASE. Chips, Box 43, Massillon, Ohio 44648. Free Dip Recipe

**WINE JELLY** Use Your Favorite Wine \$2.00. DJ Sales, Box 61168, Columbia, S.C. 29260

**ITALIAN Sausage Recipe/Press Plans**. \$4.95. Box 387, Green Valley, AZ. 85614

**CATALOG** with complete line of delicious, easy-to-prepare, lightweight, freeze-dry, recreational foods. For product/price list, send 25¢ to: Mountain House, P.O. Box 1066, Albany, OR 97321.

**HOMESTYLE** cooking. Send \$5.98. Bolter, Box 396, Station D, Toronto, Canada M6P 3J9

**DELICIOUS BEER CHEESE SOUP** \$2.00. Jeanette, Box 64, Bullhead City, AZ. 86430

**TV DINNERS** are great! Inexpensive, easy instructions, 20 low-cal recipes. \$3.50. Patty's Kitchen, 3857 Birch St., Suite 134-PA, Newport Beach, CA 92660.

**GOURMET BEAN RECIPES**, ten real pleasers. \$2.00 SASE. AJ, Box 520282, Salt Lake City, UT 84152

**HOW to Fix Sea Food** 110 ways. Send Only \$3.98. Winfield, 1940 McClelland Street #3, Salt Lake City, Utah 84105

**POLISH KIELBASA**. Make Your Own. Easy, Delicious. Send \$3.00 To: Energep, P.O. Box 1053, Southampton, PA. 18966

## WINEMAKING, BEERMAKING, ETC.

**WINEMAKING-BEERMAKING-GASOHOL**. Free Supply Catalog. Yeast Equipment. Continental, Box 188PM, Casselberry, FL 32707

**MAKE QUALITY BEER**. Wine. Free catalog. Village Store, Box C-51PM, Westport, MA 02790

**WINEMAKERS-BEERMAKERS**— Free Catalog—Fast Service—Large Selection: Kraus, Box 7850-L, Independence, Missouri 64053.

**BEERLOVERS!** Brew American and European beer. Complete kits, Equipment, Supplies. FREE details. Duane Imports Inc., Department PM, P.O. Box 433, Hershey, PA. 17033

**BEER LOVERS**— Brew your own. Delicious! Inexpensive! Free Catalog. Beer Gear, Box 25093M, Lansing, Michigan 48909

**FREE BEERMAKING BOOK** Plus Catalog. Finest Equipment, Ingredients. Fully Guaranteed. SPI, Box 784-M, Chapel Hill, NC 27514

**FREE ENCYCLOPEDIA** Winemaking, Beermaking, Supplies, Equipment Ingredients. Vyniox, P.O. Box PM7498, Rochester, NY 14615

**WINEMAKERS-BEERMAKERS** Fresh Stocks, Fast Service. Free Catalog. O'Brien's, Box 284D, Wayne, IL 60184

**WINEMAKERS-Beermakers**: Free illustrated catalog of supplies. Semplex, Box 12276R, Minneapolis, Minnesota 55412-0276

**BEERMAKERS ONLY!** Free Catalog/Newsletter. William's, Box 461M, Oakland, California 94604.

**MOONSHINE MAKING**. Whiskey! Gin! Vodka! . . . PLUS Automobile Alcohol! Homebrewing Manual, \$2.00 (refundable): Brewmaster, 723 Disaton, Philadelphia, 19111.

**"HOW To Make Moonshine"** 45 pages available \$2.30. B&J Enterprises, 1845 S. 19th, Springfield, Ill 62703

**FREE BEERMAKING CATALOG**. Lowest prices. Home Brew, Inc., Box 158, Haslett, Michigan 48840.

**BEERLOVERS** Brew Delicious, Inexpensive Beer. Complete Kits And Supplies. Free Catalog. American Homebrewers Supply, Box 85P4, Spring Grove, PA. 17362

## BURGLAR ALARMS & HOME PROTECTION

**SUPERIOR SYSTEMS!** Catalog 50¢ (Refundable). AAS, 414B Lorna Square, Birmingham, AL 35216

**BURGLAR ALARMS**, Free Catalog. Write: Security Services, 1881 N.E. 26th Street, Suite 204, Ft. Lauderdale, Florida 33305

**BUILD Your Own Safe**. Performance Security, P.O. Box 273, Lakewood, CA. 90714-0273.

# Answering Machine Price Breakthrough!

# THE "EVERYTHING MACHINE"

# FROM COBRA—NOW AT AN

# INCREDIBLE LOW PRICE

# PLUS A FREE

# PUSH-BUTTON TELEPHONE

**Full One-Year Warranty and Ten-Day Trial Period on this Exclusive Offer**



If you're like most busy people and haven't gotten around to picking up a telephone answering machine or if you're waiting for prices to come down, we think we can make it easy for you to decide. The Cobra Remote probably has every feature you could ever use. And you won't have to spend \$250 or \$300 to get those features. Plus, as a completely free bonus, you get a Cobra push-button telephone. Total price: \$149.95.

## LOOK AT ALL YOU GET:

### FULL REMOTE OPERATION SO YOU CAN CALL IN FOR YOUR MESSAGES ANYTIME FROM ANYWHERE.

Simply call your own phone number from any telephone in the world, "beep" your pocket-size remote device into the mouthpiece, and hear your messages played back to you.

**"VOX" VOICE ACTUATION CIRCUIT TAKES ANY LENGTH MESSAGE.** Your Cobra Remote begins recording an incoming message when it "hears" the caller's voice. It continues to record for as long as the caller talks or until he or she hangs up. And Cobra will take an unlimited number of messages.

**TWO CASSETTES FOR CONVENIENCE AND EASE IN CHANGING YOUR MESSAGE.** Your "hello" message is recorded on one cassette (just by pushing a button and speaking into the built-in microphone). Incoming messages from callers are taken on a second cassette. This gives you three advantages: 1. You need to record your announcement only once, not thirty

times as with some machines. 2. You can change your message at will—push a button and speak. 3. You can erase the messages you've already heard and re-use the cassette, or you can file cassettes away to keep a permanent record of your messages.

**EXCLUSIVE 'DISCONNECT DIRECTOR' MEANS NO ANNOYING DIAL TONES TO LISTEN TO.** If a caller hangs up without leaving a message, and a dial tone comes on, your Cobra will know the difference between a dial tone and a voice, and immediately stop recording.

**ADJUSTABLE NUMBER OF RINGS.** You can set the Cobra to answer your phone after four rings or two rings to give you the chance to answer the phone before the machine does.

**FREEDOM-OF-CHOICE CALL MONITORING.** If you're busy or not in the mood to talk, let Cobra answer the phone for you while you listen to the caller over the built-in loudspeaker. Then if you do decide to talk, simply pick up the phone yourself.

**RED L.E.D. LIGHT FOR CALLS RECEIVED.** Light will flash if messages have come in while you were away.

**FULL-FEATURED KEYBOARD** Simple and convenient, the Cobra Remote is the only all-push-button machine with all the luxury features including fast forward, fast rewind, and remote rewind.

**FAMOUS COBRA QUALITY AND FULL-YEAR WARRANTY.** We guarantee both the Cobra Remote and telephone for a full year because it is highly unlikely that anything will go wrong. Cobra manufactures these units with the same precision that goes into their famous CBs and cordless phones.

**ABOUT YOUR FREE COBRA PHONE.** You get easy push-button dialing whether you now have Touch-Tone or rotary phones...Automatically re-dials number if busy...Has built-in "HOLD" button...On/off switch for ringer. No wiring needed—just plug in...Save the Telephone Company rental charge—own your phone FREE!

**P. S.** If you think you've found a better value than this, let us know and we'll beat it. We love the Cobra for quality and price, but also carry every brand of phone equipment. Call or write us with your best price.

# THE RIGHT ANSWER

111 Third Avenue  
New York, NY 10003

### SAME-DAY SHIPPING

...if you pay by money order, certified check, or credit card. Outside USA, add First Class postage for 7 pounds, plus insurance.



**ORDER BY PHONE**  
Call 24 hours a day

Call collect for "Order Dept." **212/734-4455**

**TO: THE RIGHT ANSWER, 111 Third Avenue, New York, NY 10003**

Enclosed is \$ \_\_\_\_\_ for  COBRA REMOTES WITH PHONES

@ \$149.95 including FREE phone (Additional phones \$29.95 each.)  
(Additional remote beepers only \$19.95 each.)

UL2

Shipping & insurance \$2.95 per order. N.Y. residents add tax.

Charge my:  VISA  MC  DC  AM EX  Phone # \_\_\_\_\_

Card# \_\_\_\_\_ Exp Date \_\_\_\_\_

Name \_\_\_\_\_ Signature \_\_\_\_\_

Address (Not P.O. Box) \_\_\_\_\_

City \_\_\_\_\_ State \_\_\_\_\_ Zip \_\_\_\_\_



**FASTER THAN A FLUSHED QUAIL.  
MORE POWERFUL THAN A GIANT MUSKIE.  
ABLE TO LEAP RUSHING STREAMS IN A SINGLE BOUND.  
TOO BAD IT WON'T START.**

Why put featherweight parts in a heavy-weight machine? This fishing season look for this sign at participating stations, garages and NAPA stores. And keep your beast of a machine running super strong with tough NAPA parts. Or your fishing trip could come to a standstill.



Check Your Yellow Pages

If you expect a truck to quickly pay for itself in work done and fuel saved, you've come to the place where somebody did it right.

For a great price: \$5998,\* the new 1983 Toyota Standard Bed Truck delivers the goods. In the bed. Under the hood. And in driving comfort, too.

Out back it handles 1400 pounds of goods.\*\* With ease.

In performance, you get a dependable 24 liter SOHC engine — the largest engine in its class. With a hefty 100\*\*\* horsepower rating and fuel efficiency that's even more impressive: 32

Estimated Highway MPG. (26) EPA Estimated MPG.\*\*\*\* Add that to the electronic ignition system, 4-speed synchromesh transmission and power-assisted brakes, and you've got the goods to make the delivery easy. Normal maintenance an infrequent and simple affair. And durability something you can bank on.

The good news in driving comfort is a full bench seat with room for three. Steering-column mounted controls are also designed for easy operation.

The new 1983 Toyota Standard Bed Truck. Once you

OH WHAT A FEELING!  
**TOYOTA**

check it out, its price will convince you to drive it out.

\* Manufacturer's suggested retail price. Dealer's actual retail price may vary. Price does not include tax, license, transportation, optional or regionally required equipment.

\*\* Including occupants, equipment and cargo.

\*\*\* 96 HP in the State of California.

\*\*\*\* Remember. Compare this estimate to the EPA "Estimated MPG" of other gasoline-powered trucks with manual transmission. You may get different mileage depending on how fast you drive, weather conditions and trip length. Actual highway mileage will probably be less than the "Highway Estimate".

BUCKLE UP—IT'S A GOOD FEELING!

**THE LOW-PRICED TRUCK  
THAT MEETS HIGH EXPECTATIONS.**



**\$5998!**