



## "AND OH YES, I'LL TAKE ONE LIFE INSURANCE PLAN TO GO."

### Who has a quicker or easier way to buy life insurance than Allstate?

At Allstate, we've made buying life insurance as easy as shopping at Sears. Stop by, see an agent, answer just a few simple questions to qualify, and you can take home \$10,000 worth of life protection instantly.

And a new, unique feature automatically included is that if you lose your job after you've had your plan for six months, and receive four consecutive weeks of unemployment compensation, Allstate will pay

your premiums for the next half year.

Next time you're in Sears, ask about our Instant Life insurance policy. Or check it out at any Allstate office.

Right now, we're offering a lot of life insurance at our lowest prices ever. So, now's the time to get the protection you need.

Stop by today and pick up a life, home or auto plan—to go.

**Allstate**  
You're in good hands

Allstate Life Insurance Company  
Allstate Insurance Company  
Northbrook, Illinois

This one



NUJE-BUC-DPSU

Instant Life is our Whole Life with Non-level Premiums policy. Products available in most states.



**WHEN IT COMES TO VALUE,  
SOME GUYS ARE IN  
BETTER SHAPE THAN OTHERS.**



You'd use up two 3 oz. cans of the leading spray, start a third, before you'd use up one 2½ oz. Speed Stick Deodorant.

**THE WIDE STICK™**  
**FOR EFFECTIVE**  
**DEODORANT PROTECTION**



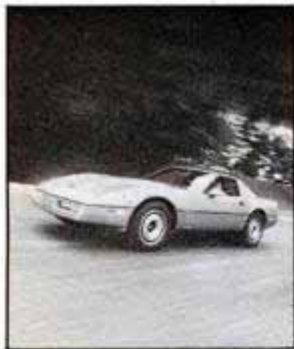

### On the cover

For three decades, the fabled Chevy Corvette has been America's one and only true sports car, inspiring a cult of admirers whose loyalty borders on fanaticism. PM recalls the great vintage Vettes and drives the sleek, new '83 model—clearly the best one yet—in the story that begins on page 84.

—PM photo by Peter Tenzer

# Popular Mechanics

MARCH 1983

CONTENTS

VOLUME 159 NUMBER 3

INTERNATIONAL EDITIONS: CARIBBEAN, MEXICO, SOUTHERN HEMISPHERE

## Special features:

### Dream cars that became nightmares

De Lorean wasn't the first to go bust. Read this fascinating tale of famous auto failures.

79

### Will it rain?

Set up a home weather station, or use our handy chart to tell you when to take your umbrella.

96

Plus: 4 old-time country weather vanes you can make.

98

### How to make your speakers speak again

When expensive stereo speakers blow, don't discard them. Here are simple repairs anyone can make.

170

### A master craftsman shares his secrets

From clamping tricks to finding centers, here are 10 great tips for faster, easier shop work.

106

### Build the PM back-yard barn

See our exciting plans offer for a handsome little storage barn with a loft and gardening center.

102

### RVs roar back: 24 slick new models

Now fuel-saving motorhomes and campers are out to beat the recession and high gas prices.

112

### Automobiles and bikes

- 10 Imports and Motorsports
- 14 Detroit Listening Post
- 20 Car Clinic
- 37 Saturday Mechanic: Troubleshooting your brake system
- 48 The PM Garage
- 72 PM Owners Report: Buick Skyhawk
- 79 Automakers who dared—and lost
- 84 Corvette: PM drives the '83 and remembers the vintage Vettes
- 154 Firsthand Report: Driving the Nissan Pulsar
- 160 Firsthand Report: Driving the Porsche Cabriolet
- 166 The bike that ate up New York City
- 176 PM's long-term car tests: Buick LeSabre, AMC/Renault Alliance, Pontiac 6000LE

### Science and engineering

- 30 Science Worldwide
- 82 High tech for Robin Hood
- 88 Strange bedfellows on the high seas
- 92 Here come the assembly-line genes
- 96 Make your own weather forecasts
- 130 Pier into the future
- 130 Here come the new flying fish

### Aviation

- 132 Rocket bailout

### Shop and crafts

- 26, 27 Hints from readers
- 55 The PM Workbench
- 65 2 plywood-cutting jigs you can make
- 98 Country weather vanes you can make in your shop
- 105 3 gardening aids you can build
- 106 10 secrets from a master woodcrafter
- 109 Make this squirrel-proof bird feeder
- 110 Workshop Minicourse: About driving nails

### Home and yard

- 24 Appliance Clinic
- 28 New Now for home and shop
- 32 Homeowners' Clinic
- 102 A barn for your back yard

### Boating and outdoors

- 35 All Outdoors
- 112 More-miles-per-gallon RVs
- 118 Tiny trailers for economy towing
- 120 New for spring fitting out

### Electronics, radio and TV

- 46 PM Electronics Monitor
- 129 3-D TV is here
- 170 Quick guide to speaker repair

### Every month

- 5 Editor's Notes
- 6 Letters to the Editor
- 129 Technology Update

**AS A SERVICE TO READERS.** Popular Mechanics publishes newsworthy products, techniques and scientific and technological developments. Due to possible variance in the quality and condition of materials and workmanship, Popular Mechanics cannot assume responsibility for proper application of techniques or proper and safe functioning of manufactured products or reader-built projects resulting from plans published in this magazine.

**POPULAR MECHANICS** (ISSN 0032-4568) is published monthly by The Hearst Corporation, 224 West 57th Street, New York, N.Y. 10019, U.S.A. Subscription prices: United States and possessions, \$11.97 for one year; \$21.97 for two years. Canada and all other countries, add \$16.00 for each year. Second-class postage paid at New York, N.Y., and additional mailing offices. Authorized as second-class mail by the Post Office Department, Ottawa, and for payment of postage in cash. Registered as second-class matter at the Post Office at Mexico D.F., Mexico, June 20, 1950, © 1983 by The Hearst Corporation. All rights reserved. Printed in U.S.A.

**POSTMASTER:** Please send address changes to Popular Mechanics, P.O. Box 10064, Des Moines, Iowa 50350.

**SUBSCRIPTION SERVICE:** Popular Mechanics Magazine will, upon receipt from its reader of a complete new or renewal subscription order, undertake fulfillment of that order as to

provide the first-copy delivery either to the Postal Service or alternate carriers within six to twelve weeks. If for some reason this cannot be done, you will be promptly notified of the issue date that will begin your subscription, with a request for any further instructions you may have concerning your order. Please address all such orders to us at Popular Mechanics, P.O. Box 10064, Des Moines, Iowa 50350. • Should you have any problem with your subscription, please write Joan Harris, Customer Service Department, Popular Mechanics, P.O. Box 10064, Des Moines, Iowa 50350. To assure quickest service, please enclose your mailing label when writing to us or renewing your subscription. • Renewal orders must be received at least eight weeks prior to expiration to assure continued service.

Use this address for subscription orders & inquiries

POPULAR MECHANICS  
P.O. Box 10064  
Des Moines, Iowa 50350

POSTMASTER, Please send address changes to this address



# WHAT DO YOU SCORE ON THIS WOODWORKER'S TEST?

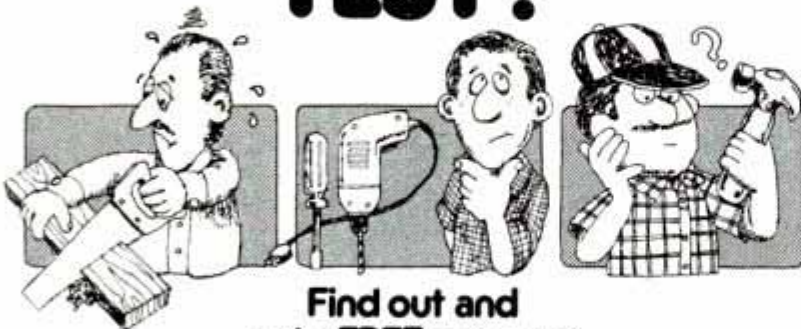

Find out and get a **FREE** one-year woodworking magazine subscription!

The test takes only a minute!

Just answer each question, total your score, then fill out the coupon and send it to Shopsmith.

We'll send you a **FREE** year's subscription (\$6.00 value) to **HANDS ON!**, the Home Workshop magazine!

So grab a pen or pencil and get started!

## Circle A, B or C for each question:

**1** How much experience have you had in woodworking, home repair and maintenance?

- (A) Little or no experience
- (B) Some experience
- (C) Quite a bit of experience

**2** Which phrase best describes your workshop?

- (A) A selection of hand and portable power tools
- (B) A table or radial arm saw, hand and portable power tools
- (C) A good selection of stationary and portable power tools

**3** How involved do you want to become with woodworking, home repair and maintenance?

- (A) Not very involved
- (B) Moderately involved
- (C) Heavily involved

**4** What's the likelihood that you'll buy a woodworking tool within the next year?

- (A) Not likely
- (B) Somewhat likely
- (C) Highly likely

**5** Which best describes you?

- (A) I do some home repairs and maintenance
- (B) I do some woodworking and a variety of home repairs
- (C) I'm primarily interested in fine craftsmanship woodworking

## How to find your score:

Simple! Count nine points for each (A), six for each (B), three for each (C). Then enter your total on the coupon, fill in your answer for Question #5, include your name and address and mail to Shopsmith!

Your first issue of **HANDS ON!** will arrive soon! We'll also send a **FREE** Information Kit on the Shopsmith MARK V, the complete home workshop that combines the five power tools needed most in one economical unit! *It's the tool to start with... the system you grow with!*

Mail the coupon today!

Quality Woodworking Tools Made in U.S.A.



**Shopsmith Inc.**

The Home Workshop Company  
750 Center Drive  
Vandalia, Ohio 45377

\*Shopsmith, Inc. 1982

### My Test Score is \_\_\_\_\_

On Question #5, I answered \_\_\_\_\_. Please start my **FREE** year's subscription (\$6.00 value) to **HANDS ON!**, the woodworking magazine, right away! And send a **FREE** Shopsmith MARK V Information Kit with the booklet "How to Determine Your Best Power Tool Buy." I understand I am under no obligation.

Name \_\_\_\_\_

Address \_\_\_\_\_

City \_\_\_\_\_

State \_\_\_\_\_

Zip \_\_\_\_\_

Send to:



**Shopsmith Inc.**

The Home Workshop Company  
750 Center Drive  
Vandalia, Ohio 45377

Dept. 360Z

## Popular Mechanics

Editor-in-Chief: John A. Linkletter  
Executive Editor: Joe Oldham  
Managing Editor: Bill Hartford  
Design Director: Ira Herrick  
Design Consultant: Eberhard Lütke

Special Editorial Features: Sheldon M. Gallager, editor

Automotive: Tony Assenza, editor; Michael Lamm (West Coast); Gary Witzenburg (Detroit)

Home and Shop: Harry Wicks, editor; Penelope Spangler, Michael Chotiner, Joseph Truini, assistants

Boating, Outdoors and Travel: Wm. T. McKeown, editor

Electronics: Neil L. Shapiro, editor

Science: Dennis Eskow, editor

Technology: Robin C. Nelson, editor

Editorial Production: Peter Easton, chief; John Bostonian Jr., art; Shannon K. Kelley, Steven C. Fox, assistants

Art: Don Mannes, technical art director; Douglas Quinn, Alan Andresen, assistants

Special Publications: Clifford B. Hicks

Editorial offices: 224 West 57th St., New York, N.Y. 10019. We cannot be responsible for loss of unsorted queries, manuscripts, or photos. For return, they must be accompanied by adequate postage.

Reader Service Department: Hilde vonThorak, director; 224 West 57th St., New York, N.Y. 10019. (212) 262-4292

### Advertising Manager

Frank P. Camastro

### Advertising Offices:

New York: 224 West 57th St., New York, N.Y. 10019; (212) 262-8824

Chicago: 520 North Michigan Ave., Chicago, Ill. 60611; (312) 527-2400

Detroit: 377 Fisher Rd., Grosse Pointe, Mich. 48230; (313) 881-3520

Cleveland: PDC Building, 3659 Green Rd., Cleveland, Ohio 44122; (216) 292-7334

Los Angeles: 460 East Carson Plaza Dr., Carson, Calif. 90746; (213) 532-8101

Production Manager: Ronald Tuosto

Advertising Production: Patricia Woods  
(212) 262-4800

Classified Sales Manager: Sophie Gronowicz  
(212) 262-4825

Published by The Hearst Corporation

### President

Frank A. Bennack Jr.

### Chairman

Randolph A. Hearst

### President, Magazines Division

Gilbert C. Maurer

### Publisher, Popular Mechanics

Daniel J. Coleman

### Publishing Consultant

Richard E. Deems

**POPULAR MECHANICS IS PUBLISHED MONTHLY** by the Hearst Corporation, 959 Eighth Avenue, New York, N.Y. 10019, U.S.A. Frank A. Bennack Jr., President; Randolph A. Hearst, Chairman; Harrison A. Mitnick, Vice President and Treasurer; Harvey L. Upton, Vice President and Secretary, Hearst Magazines Division; Gilbert C. Maurer, President; K. Robert Brink, Executive Vice President and General Manager; Raymond J. Petersen, Executive Vice President; Thomas J. Hughes, Vice President and Resident Controller; William S. Campbell, Vice President, Director of Circulation; Daniel J. Coleman, Vice President for Popular Mechanics.





# EDITOR'S NOTES

*John A. Spletter*

**"Striking . . . sleek . . . comfortable . . . handles nicely . . . but the performance doesn't match its pedigree."** That, in a cover line, was Stirling Moss's assessment of the new De Lorean Sports Car back in June



1981 when we ran it on our cover. Then in May 1982, we printed a PM Owners Report on the car. Most owners had purchased the stainless-steel auto on the basis of styling. But nearly 18 percent also felt it was a good investment. So far, it appears that the investment-minded will wind up disappointed. The De Lorean has joined other legendary grand failures of the auto world. Mike Lamm tells about them—some will surprise you!—in a story that begins on page 79.

June '81: De Lorean and Stirling.

**The United States is not enthusiastic** about cooperating with the Soviets when it comes to things like pipelines. But Americans and Russians are working together in a venture that produces the fish sticks you have in your freezer. Word of the joint fishing venture came as a surprise to us. If you're surprised, too, you can read more about it in John Burnett's article on page 88.

**The weather in southern California is always great.** Right? That's what the Chevrolet public relations people figured when they scheduled the press preview of the new Corvette last year in early December. But this time they figured wrong. The heaviest storm in 20 years hit Riverside International Raceway the night before the debut. It blew down a giant tent, destroyed dozens of displays—and left a coat of mud on several areas of the track. The introduction and driving went on as scheduled. But the event took on the look of a car washer's convention as drivers and camera teams shined up Corvettes between runs. We got pictures of the new Vettes, clean and shiny, courtesy of our car washing and driving experts Tony Assenza and Joel Breault. **PM**

*The storm is over, but the mud remains. Here, Joel Breault and Auto Editor Tony Assenza use window cleaner to put a shine back on their '83 Corvette.*



# MAKES THINGS WORK BETTER!

## BELT-EASE® BELT DRESSING

Long lasting, crystal clear, clean belt dressing gives extra traction and life to automotive V-belts and all drive belts on appliances, blowers, snowmobiles, and power equipment. 5.5-oz. aerosol.

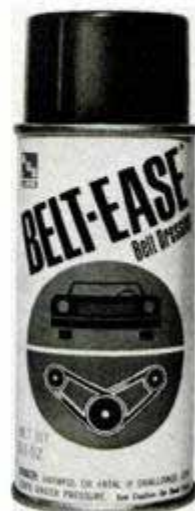

## LOCK-EASE® GRAPHITED LOCK FLUID

Keeps all locks working smoothly year 'round. Seals out moisture, protects against freezing and rust. Frees frozen and stuck locks. 3.5-oz. aerosol with snorkel; 3.4 oz. can.

## LITH-EASE® WHITE LITHIUM GREASE

An all weather grease for auto, farm, marine and shop use. Preferred because of its superior film strength plus water and heat resistance. LITH-EASE provides excellent lubrication and rust protection. 16-oz. aerosol; 1-lb. tub; 1¼-oz. tube.

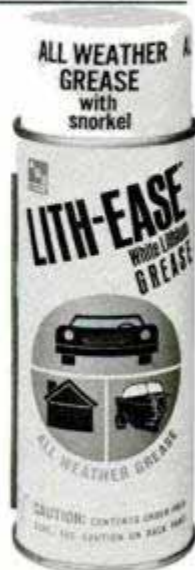

Available wherever fine automotive and hardware products are sold.



American Grease Stick Co. Muskegon, Michigan 49443



# LETTERS TO THE EDITOR



## Old warbirds live on—but not many

I read with great interest Budd Davison's article on restoring old World War II warplanes (*New Wings For Old Warbirds*, page 80, Dec. '82). He mentioned the P-47 Thunderbolt and how so few of them are still flying today. I was stationed at Drew Field, Fla., for four years during WWII and talked to many pilots returning from combat overseas. They had nothing but praise for the rugged P-47.

There would undoubtedly be even fewer still around today if it were not for their remarkable ability to return home even when riddled with bullets and flak. The P-47 was a truly awesome fighting machine.

GARDNER F. SMITH  
DANVERS, MASS.

Talk about the terribly wasteful destruction of WWII aircraft! The RAF used rows of Spitfires as strafing targets in the 1950s, and I've bombed Messerschmitt 109s that were used for target practice in Germany.

The P-51 Mustang was a fine fighter, as you say, but I'm pretty sure they all had Packard engines, not the Rolls-

Royce Merlin that you mentioned in your article.

W. J. McWILLIAMS, MAJOR, USAF  
MOOSE JAW, SASK.

It was a great story, but your listing of famous air museums left out the fine one we have here in Tucson. It has many historic fighters and bombers of WWII. The area was a major flight training center during the war, and many abandoned airfields can be found, along with old wrecks.

CHARLES G. GRIFFITH  
TUCSON, ARIZ.

*Our listing of air museums was intended primarily to cover those noted for having WWII aircraft in flying condition, where you can actually see them performing in the air. There are many fine museums offering static displays that we were unable to mention because of limited space.*

*Regarding the P-51 Mustang, several types of engines—Allisons, Packards and Rolls-Royce Merlins—were used in different models. The P-51 our author flew had the Rolls-Royce Merlin.*

## Yes, we have 'em

*For years I've been searching for plans on making wooden clockworks. I've seen kits, but they wouldn't be as much fun as constructing a works from scratch. Can you help me?*

WALLACE W. NELSON  
GRAND FORKS, N.D.

*You came to the right place. We ran two articles on making wooden clockworks, one early American and one Swiss. Photocopies are available from Popular Mechanics, Box 1014, Radio City Station, New York, N.Y. 10101. Ask for No. X178 (early American, \$6.50) or No. X179 (Swiss, \$2.50).*

## PM's 3-in-1 pedal car

Here is a picture (right) of the PM pedal car that appeared in your August '82 issue (*Build PM's Delivery Wagon*, page 62). We built the dump truck version. The plans were excellent, and the

car is a solid design that should last for many years.

PHILLIP D. MATHER  
NILES, MICH.

*Thanks for the great photo. For others who may be interested, plans for the car—a roadster, dump truck or delivery van—are \$9.95 postpaid from Stevenson Projects, Box 584, Del Mar, Calif. 92014.*



**Happy youngsters enjoy PM's convertible pedal car, built by reader Mather.**

## In defense of defense

In your December '82 *Letters* column (page 6), one of your readers criticized you for your coverage of military equipment. He said he wants to see only "peaceful things" in PM.

I'm glad we have battleships, bombers, tanks and, yes, even nuclear weapons. We need a strong defense to prevent war, so we can have "peaceful things." Keep up the good work.

J. E. GUY, M.D.  
FORT LAUDERDALE, FLA.

Doesn't he realize that he is free to voice his opinions in public only because America has a strong military to protect his rights? Let him go live somewhere else and see how much freedom he has then!

RUSSELL W. HOLDER, M.SGT., USAF (RET.)  
CARROLLTON, TEX.

## Turbocharging update

I must compliment you on Don Fuller's article on turbocharging (*Turbocharging: This Time It's Here To Stay!*, page 71, Dec. '82). It was a very complete and enlightening report on a system that we at Saab are happy to have helped launch.

I should, however, point out a few errors in statements regarding Saab. The boost pressure for the Saab Turbo was reported as 8.7 p.s.i. For the 1983 Saab Turbo, this figure is 9.5 p.s.i. Also, the EPA mileage (city) is 21, not 20 as reported.

Your price comparison was based on 1982 prices and was somewhat misleading since the Turbo price includes a very expensive sound system and electric side mirrors, items not included in the normally aspirated Saab 900S. The actual prices for 1983-model Saabs are \$13,550 for the 900S and \$16,510 for the Saab Turbo.

LENNART LONNEGREN  
SAAB-SCANIA OF AMERICA INC.  
ORANGE, CONN.

*Author Don Fuller replies: We regret that some of the differences between the 1982 and 1983 Saab models were not noted in our article because it was necessary to go to press before the latter figures could be confirmed. Thanks for the update.*

PM



# SO CLOSELY RESEMBLES A FINE WATCH, YOU'D EXPECT IT TO TICK.

Like a fine watch, a Mariner Outboard demonstrates an ingenious use of space. Every part that's not absolutely essential has been eliminated. This not only makes the motors more compact and exceptionally lightweight for the horsepower they deliver, but it also helps reduce maintenance.

And, if you could look inside each one, you'd see an attention to detail seldom found in an object too large to strap to your wrist. For example, CD ignition eliminates the

need for troublesome breaker points. Most models feature thru-prop exhaust for more speed and more efficiency. They're quieter, too.

All driveshafts, shiftshafts and propshafts are made of stainless steel to protect against saltwater corrosion and give you years of dependable, trouble-free performance.

In short, Mariner makes the most refined outboard motors in the world.

Yet, in our engineers' vocabulary, refined certainly does not mean docile. Open the throttle and you'll experience acceleration that's surprising

if not downright exhilarating.

In that respect, our motors are more like sports cars than watches. Efficient, yet exciting.

For a free catalog of Mariner Outboards from 2 to 200 horsepower, write Mariner, Dept. 83, 1939 Pioneer Road, Fond du Lac, WI 54935. In Canada, write Mariner, 1156 Dundas Highway East, Mississauga, Ontario, L4Y 2C2.

**MARINER.  
BETTER IN THE  
LONG RUN.**

 **MARINER<sup>®</sup>  
OUTBOARDS**





# Winston. America's

Warning: The Surgeon General Has Determined  
That Cigarette Smoking Is Dangerous to Your Health.

MOUNTAIN  
PATROL



# s Best.



Join the first team.  
Reach for Winston.



LIGHTS: 9 mg. "tar", 0.7 mg. nicotine,  
LIGHTS 100's: 12 mg. "tar", 0.9 mg. nicotine,  
av. per cigarette by FTC method.

Материал защищен авторским правом



# IMPORTS & MOTORSPORTS



## Measuring a Mercedes

Some old, simple formulas have long been dead: like cars costing a dollar a pound. Others—like buying the biggest and heaviest car for your money to

be assured of getting a car with great ride and feel—die a little harder.

The way a car feels no longer has anything to do with dimensions and weight (as any Renault Le Car driver will be glad to demonstrate by barreling over a railroad crossing).



*Smallest Mercedes-Benz will go on sale in fall as '84 model.*

looking little car that's already available in Europe, wearing a 190 or 190E badge (two-liter, gasoline Four, carbureted or fuel-injected).

When the car joins the line here in the fall, though, it will be a 220E and be powered by the Mercedes 2.3-liter, fuel-injected gas Four. A 220D with diesel power will follow.

The 220E/220D could knock the 240D out of the lineup if buyers flock to the new car, which will fall right into the 240D price niche: \$24,000.

The 220E/220D is built on a 105-in. wheelbase, is 174 in. overall and weighs plus or minus 2,400 pounds depending on engine, transmission and options. Unlike the larger M-B models (except the 240D), the new car will offer four- and five-speed manuals in addition to an automatic transmission. (The automatic has an economy mode which sets the transmission to start from a stop in second gear and make upshifts at lower speeds.)

For now that's the dimensions and weight story, but next month we'll describe that Mercedes feel which we experienced driving the 190/190E in Europe.



*Trunk volume of compact Mercedes benefits from aerodynamic wedge shape.*

That's why a luxury carmaker like Mercedes-Benz can field a compact car that still feels like a Mercedes. That feel may be too taut for Lincoln Continental owners, but it won't disappoint anyone who has enjoyed driving the larger M-B models.

The smallest Mercedes is a stunning-



*Instruments and controls are perfectly placed, right down to the glovebox latch, which is asymmetrically located in order to be as close as possible to the driver.*

## Four-door Ferrari

The most exciting and fastest Ferraris have no doors: They're the bright red Formula One racers, of course. Enzo Ferrari's street cars, also pretty quick, have all been equipped, up until now, with two doors. The first four-door, or *quattroporte*, Ferrari, which will debut



*Ferrari sedan, a Pininfarina design, is the first four-door from the automaker.*

this year, is expected to be the fastest four-door production sedan: 160 mph. The 5.0-liter, flat Twelve "Boxer" engine, the same as used in the BB 512i, will be the powerplant and the transmission will be automatic. It'll be a limited-production sedan, naturally, with only one copy coming out of Ferrari's shop door in Italy each working day.

## Audi station wagon

While we wait for spring and Audi's replacement for the 5000, already being sold in Europe as the Audi 100, the German car company is considering producing a station wagon model to



*Audi Avant is wagon version of the 100.*

join its very aerodynamic four-door sedan.

The Avant, as the wagon design is being called, has a swoopy new tail end to squeeze in a small, forward-facing jump seat behind the conventional rear bench.

**FM**



# "Today, you need an oil this good."

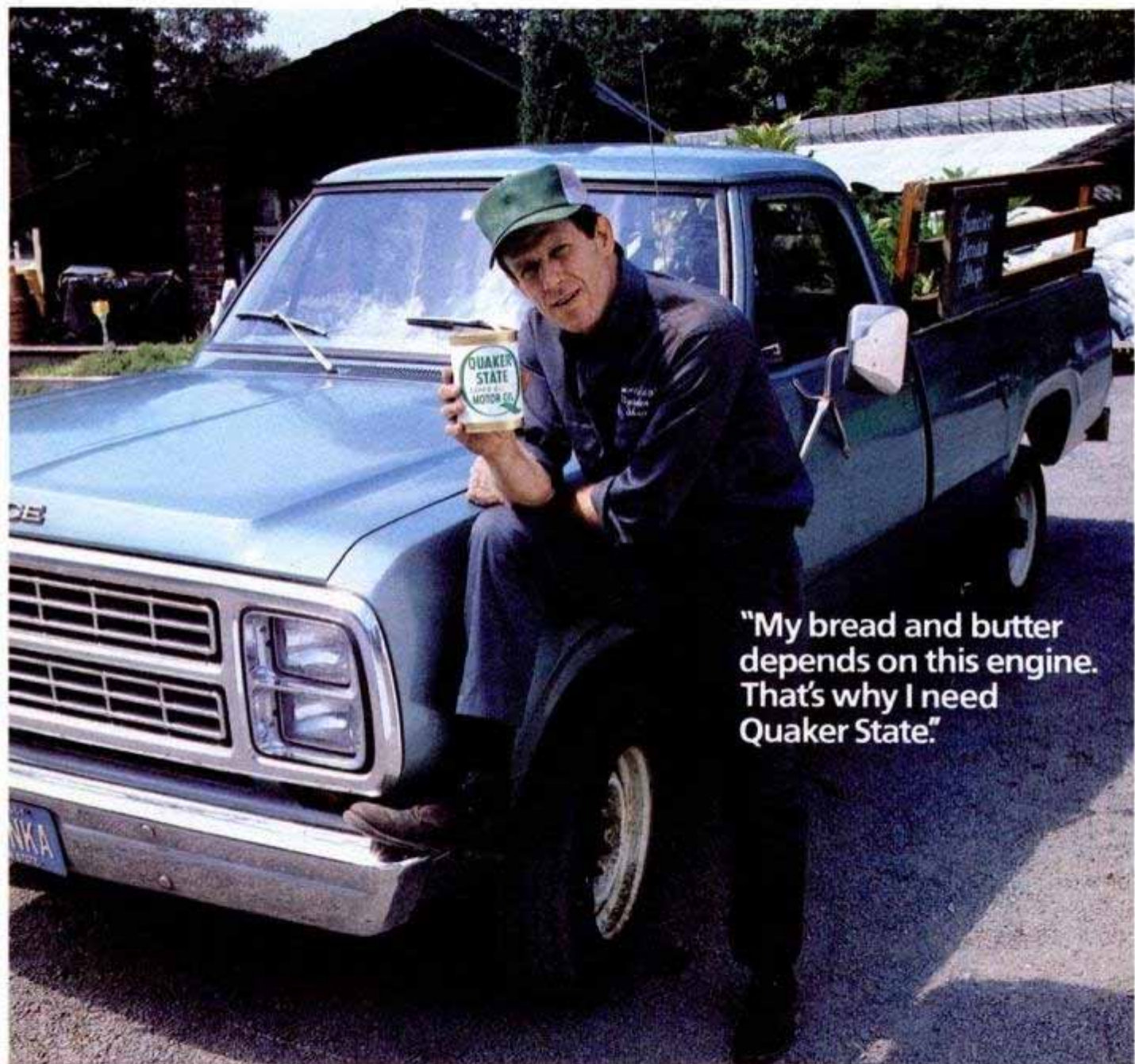

"My bread and butter depends on this engine. That's why I need Quaker State."

When you make a living with your vehicle, a costly breakdown can put you out of business. To keep your engine and business running smoothly, you need Quaker State quality. These Quaker State motor oils are made exclusively from Pennsylvania Grade Crude Oil. They offer quality protection for your vehicle. Quaker State: so good, it's America's best selling motor oil.

## Quaker State





**Professional service  
means a lot to me.**

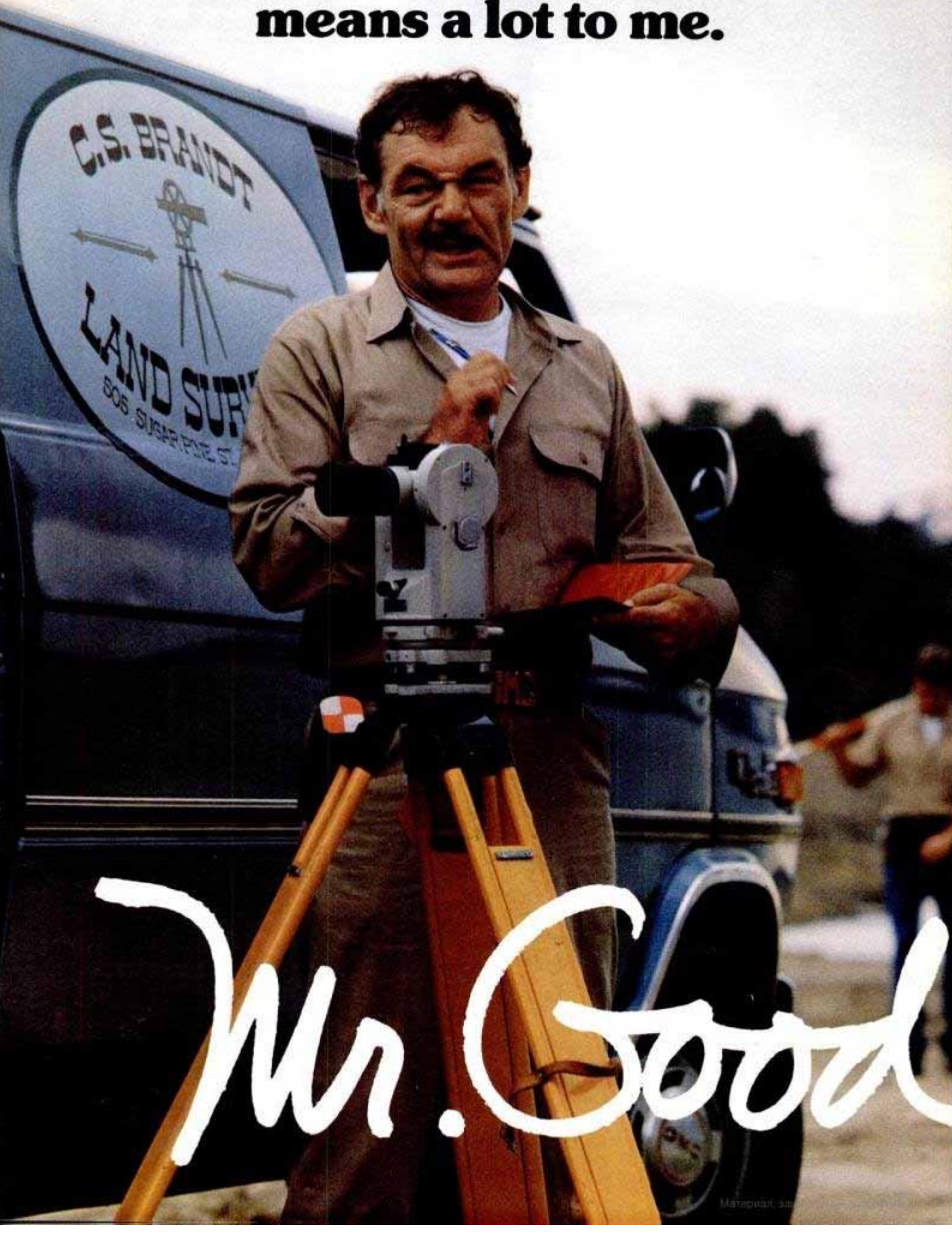

*Mr. Good*



# That's why I see Mr. Goodwrench even for simple jobs like brakes—or shocks.



**A professional technician** is committed to doing his work right. He doesn't just slap-dash a job together, sometimes he spots other problems that are about to happen. That kind of careful workmanship could save you money—keep a little problem from getting big. And costly. That's why I take my van to Mr. Goodwrench. He's a pro.

**Mr. Goodwrench has GM training** available to him, plus he has the right tools and he can get genuine GM parts. And even though I feel like he's worth more to me, he's committed to charging reasonable prices—he has pledged to be competitive with other places I can go around here for service.

**So keep that great GM feeling** with genuine GM parts at participating independent Mr. Goodwrench dealers selling Chevrolets, Pontiacs, Oldsmobiles, Buicks, Cadillacs, GMC and Chevy Trucks.

LET'S GET IT TOGETHER...BUCKLE UP

# Mr. Goodwrench



GENERAL MOTORS CORPORATION



# DETROIT LISTENING POST



## GM minicars

Apparently to demonstrate that it hasn't abandoned the bottom end of the U.S. market in its future planning, General Motors has been showing a tiny, two-passenger commuter (TPC) idea car at recent shareholder meetings. GM says there are no plans to build this car as such, but that certain of its features probably will turn up in future production vehicles.

The experimental fwd TPC is 33 inches shorter, 5 inches narrower and 6.6 inches lower than the current Chevette, yet has more usable space inside for its two passengers. It weighs only 1,040 pounds and uses flush, sliding window glass, plastic suspension springs and many other superlight-weight engineering and aerodynamic innovations.

With a 0.8-liter, port-fuel-injected, aluminum three-cylinder engine, five-speed manual transaxle and a drag coefficient of 0.31—but without any weight-adding emissions or safety equipment—it delivers an astounding 67.5 mpg in city driving and 95 mpg highway.



*This tiny vehicle is a serious study of the possible transportation modules of the future. Lightweight materials and small motor will yield near-100-mpg efficiency.*

Meanwhile, GM chairman Roger Smith acknowledges that his company plans to import 200,000 to 300,000 fwd subcompact "R-cars" from Japanese partner Isuzu, plus 100,000 or so even smaller cars from Suzuki, both beginning in mid-'85. Rumors indicate that another 300,000 of the Isuzu cars may be GM-built in the United States.

These will be about 156 inches long (9 inches shorter than Chevette) on a 94.5-inch wheelbase. They'll be powered by a 1.3-liter Four, with a 1.5-liter diesel optional, and should get 40-50 real-world miles per gallon. The small-

er Suzuki minis will do even better with their 1.0-liter gas engines.

I don't know yet how these plans will affect the pending deal that would have GM assembling 200,000 fwd Toyota Corollas (to share with Toyota) in a U.S. plant at about the same time; but I do know that none of these cars is intended to completely replace the current rear-drive Chevette.

Why? Because it's the cheapest and simplest volume car built in America, and Chevrolet general manager Bob Stempel believes there's a market for that for some time to come.

## Buick's potent six-packs

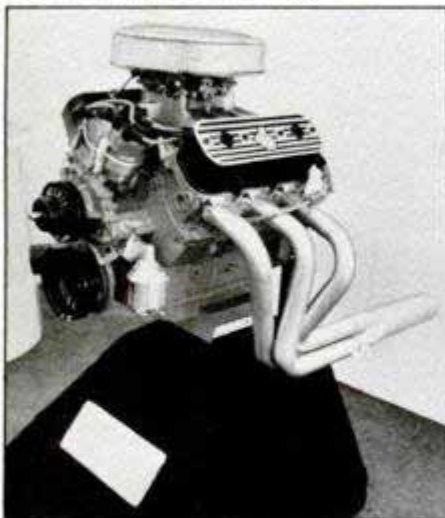

*Buick's 3.8-liter V6 in road race trim.*

For decades, the Chevrolet small-block V8 motor has been the engine of choice for hot-rodders, racers and high-performance street applications. The reason

was simple. The engine was, and is, virtually indestructible and the high-performance parts necessary to make it go fast were, and are, all available right from Chevrolet.

With a copy of the Chevy Power book, a large wallet and a cooperative

dealer, you can build as awesome a motor as you want without ever going to the aftermarket.

Buick would now like to be in the same market, but they would like to do it with their 3.8- and 4.1-liter

*(Please turn to page 16)*

## PM wins again

Remember our victory in the Quaker State Longest Day of Nelson Ledges (*Only The Strong Survive*, page 92, Nov. '82)? Well, PM chalked up another victory when Detroit Editor Gary Witzenburg won the coveted Jim Russell/British School of Motor Racing Media Challenge crown for '82. Behind the wheel of the single-seater Formula Fords were representatives of *Sports Illustrated*, *Autoweek*, *Motor Trend*, *Road & Track* and *On Track*. After two days of qualifying and heat races, Witzenburg came in first, with *Motor Trend* editor Tony Swan second and *Sports Illustrated's* Sam Moses third. On victory stand (left to right) are Linda Vaughn, Gary and Swan.

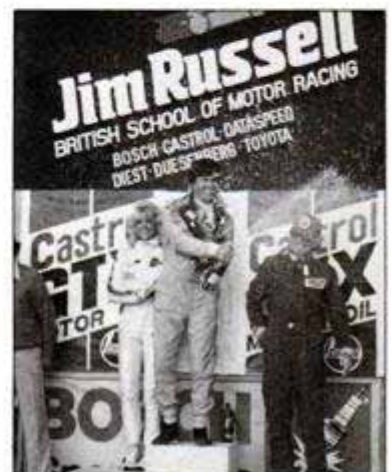



# Save now at Sears on the Tractor and Tiller the leading competitor can't touch.



**The tractor with 10% more horsepower at the drawbar.**

Delivers an average of 10% more horsepower at the drawbar than the leading competitor does. Loaded with features that include hydrostatic transmission for no-shifting ease. The optional front and rear P.T.O. (Power Take Off) lets you use the tractor's power to operate attachments. A lot of performance at a great price.

**Craftsman 20-HP Full Feature Garden Tractor**  
 NOW  
**\$2999<sup>99</sup>**



**The tiller that works in one pass.**

In tests, one pass of our C.R.T. Tiller dug a fine, 4-inch seed bed in sod-covered Texas soil. The leading competitor took six passes. The breakthrough design of our Counter Rotating Tines is the reason for this tiller's power. And chain drive transmission delivers plenty of muscle to the tines from the powerful 6-HP engine.

**Craftsman 6-HP Task Handler C.R.T. Tiller**  
 NOW  
**\$999<sup>99</sup>**

©Sears, Roebuck and Co. 1983

**SALE ENDS March 31, 1983**

Minimum savings nationally. Prices and dates apply only to the continental United States except Alaska. Available at most Sears retail stores.

**sears**

**SAVE 15%**  
**When you buy Sears Tractor or Tiller Attachments**

15% off regular price of any Sears Tractor or Tiller Attachment when you bring this coupon to a Sears retail store. Hurry! Offer ends March 31, 1983. Only one coupon valid per purchase. Cash value 1/20¢.

PM-M



## DETROIT LISTENING POST

(Continued from page 14)

V6 motors. Buick has drawn on the collective experience of engine builders like Jim Ruggles, Jim McFarland (of Edelbrock frame) and Smokey Yunick and published the Buick V6 Performance Guide.

Like the Chevy Power book, it tells you in exacting detail, everything you need to know to massage a V6 into high-performance trim. The book and parts are as close as your Buick dealer.

Buick is campaigning hard to shed its image as a maker of stodgy family cars

and wants to associate its name with exciting performance. With its emphasis on the inherently more fuel efficient V6, rather than an 8, it seems to be right on target for the '80s.

### Is faster safer?

An interesting bit of contradiction was recently issued by the Highway Users Federation. In August 1982 the group issued an alarm that traffic deaths would increase for the year because, according to its surveys, 7 out of 10 drivers exceed the national 55-mph speed limit. Woodrow Rankin, a direc-

tor of HUF, said, "We're seeing a return to slightly faster traffic on roads that were designed for 60 mph."

In a state-by-state breakdown, it was found the Western states were the biggest offenders, with North Dakota topping the list at an average 57.8 mph. On the whole, we are a nation of scoff-laws on the interstates.

Those sobering predictions didn't come true, however, because in November that same group issued statistics stating that traffic deaths would set a record low in 1982. For the first six months of '82, 3,000 fewer people lost their lives than in '81. That's a 13 percent reduction in fatalities.

The numbers aren't all in yet, so no conclusion can be accurately drawn, but it appears that while more of us are driving faster, fewer of us are involved in fatal crashes.

### Fwd Mustang/Capri

Ford is working on the next-generation Mustang/Capri for mid-'85 introduction, and both are said to be lighter, shorter and very different in styling, compared to the current models. Also—surprise—front-wheel drive.

They'll use transverse power trains from the coming Tempo/Topaz compacts, including an optional turbomotor, plus further developments of the Escort/Lynx front suspension and the more sophisticated Tempo/Topaz rear suspension.

That will leave the new T-Bird and Cougar as Ford's only rear-drive sporty cars—until they, too, go fwd for '87.

### Mirada/Cordoba/Imperial

Chrysler's three remaining rear-drive luxury coupes, Chrysler Imperial and Cordoba and Dodge Mirada, are also likely candidates for a downsize and fwd conversion in 1985. Like everything else in Chrysler's stable larger than the Omnirizon's twins, these will be built on the company's versatile K-car platform—but with their own unique sheet metal and "formal" look.

### More factory racing?

According to the latest J.D. Power *Automotive Consumer Profile*, the time couldn't be much riper for U.S. automakers to increase their motorsports activities. More than 25 million American drivers are interested in auto racing, and 24 to 36 percent of the people surveyed (depending on geographic area) said they favored more active participation by automakers. As expected, the majority of those showing a strong interest were young males—but a surprising 10 percent were women.

PM

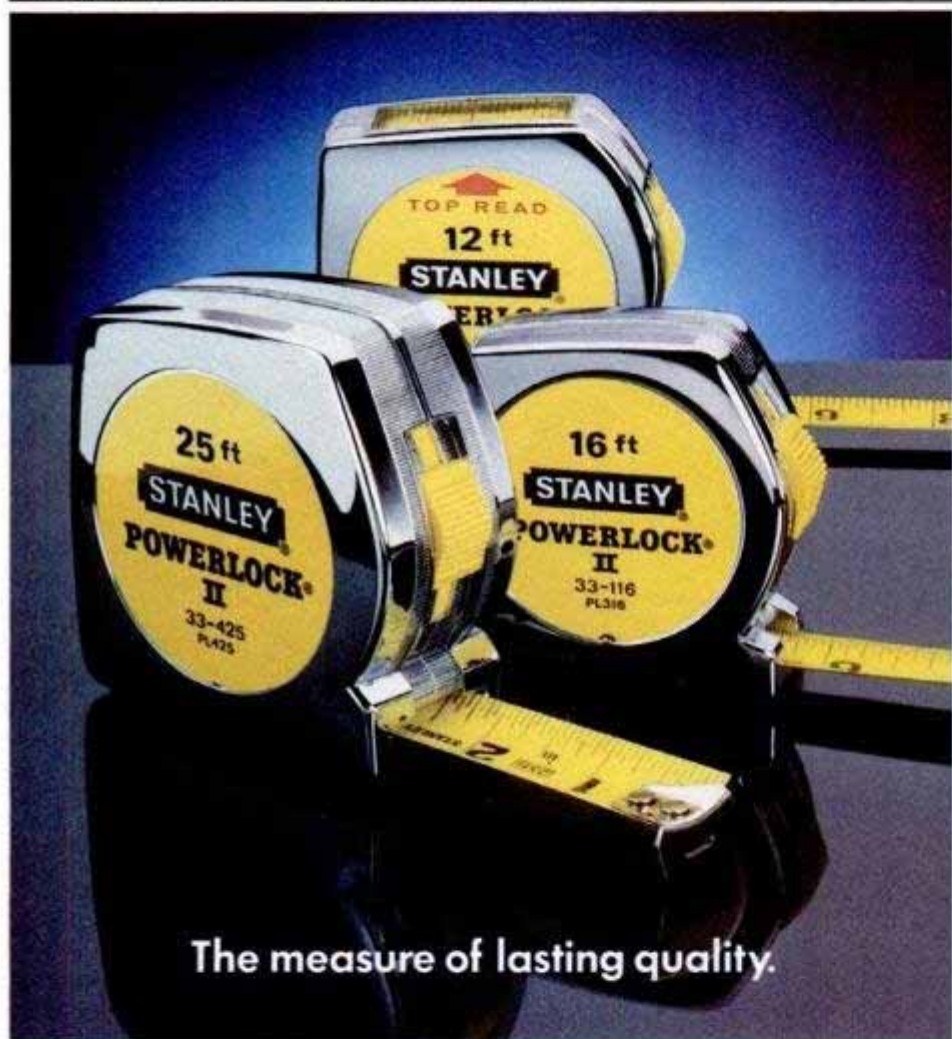

The measure of lasting quality.

When you buy a tape rule, you can be sure it will read inches and feet. But in many cases, that's all you can be sure of. Unless it's a Stanley Powerlock® Tape Rule.

Powerlock Tapes are built with quality that lasts. They offer you features you can't find in ordinary locking tapes. A DuPont Mylar® coated blade,

for durability. A Tru-zero hook, for precision measuring. Easy-to-read blade graphics. And patented speed control brake cams, for decreased whiplash and longer tape life.

Stanley Powerlock Tape Rules are available in a wide range of lengths and tape widths. For inside measurements,

there's even a top-reading Powerlock—the only tape rule of its kind.

For twenty years, Powerlock Tapes have been the "Badge of the Professional," and with good reason. They don't just measure. They measure up.

**STANLEY**  
helps you do things right.



# New from NRI... Industrial Electronics with color computer.

Get a head start in the emerging technologies with practical training in control systems, instrumentation, robotics, optoelectronics, and lasers. Exclusive computer-aided instruction!

Here's the training that gets you into the heart of American industry's rebirth. Over \$5 billion a year will be spent in automation alone...\$2.3 billion in computerized control systems...\$600 million in industrial robots and robotics is only just getting underway! To help meet the soaring demand for people to operate, maintain, repair, and design these control systems, NRI has created the only complete training in Industrial Electronics for Instrumentation and Control Technicians.



## Learn on Your Own Computer

NRI training is more than lessons... it's experiences. You learn by doing, using the TRS-80™ color computer to learn about control systems, programming, and troubleshooting. It comes with special computer-aided instruction programs to speed learning, is expandable for business and personal computing, and is yours to keep. And that's just the beginning.

NRI's exclusive Discovery Lab® is designed to interface with your computer and special breadboarding card so you build demonstration circuitry, "see" inside your computer, and follow its operation. You also get professional quality instruments, including your own digital multimeter and CMOS frequency counter. You'll use them during your hands-on training, keep them to use in your work.

## No Experience Needed

Your NRI training is thorough and complete. Starts you with the fundamentals, builds step-by-step up to the most advanced concepts. You learn about automatic control and feedback systems, control motors,

numerical control systems, lasers and optoelectronics, robotics, microprocessors, instrumentation, computer peripherals, and much more. NRI keeps you up with technology to make the most of the big demand for control and instrumentation technicians.

## Send for Free Catalog

Send the postage-paid card for NRI's big electronic careers catalog. There's no cost or obligation, and no salesman will call. In it, you'll find complete lesson plans, equipment descriptions, and career opportunities in this exciting field. You'll also get information on almost a dozen other electronic courses including Microcomputers, Electronic Design, TV/Audio/Video Servicing, Digital Electronics, and more. Act today and get on with your future. If card has been used, write to us.



Your training includes the TRS-80 color computer, the NRI Discovery Lab, interfacing breadboard, digital multimeter, frequency counter, computer-assisted training programs, audio instruction tape, and 46 profusely illustrated lessons.

(TRS-80 is a trademark of the Radio Shack division of Tandy Corp.)



**NRI Schools**  
McGraw-Hill Continuing  
Education Center  
3939 Wisconsin Ave.  
Washington, D.C. 20016

**We'll give you tomorrow.**



# CAR CLINIC



## Family feud

*Since the day I drove my 1981 Pontiac Trans Am out of the showroom, the 4.9-liter engine has had a rough idle and has hesitated on acceleration. I brought the car back to the dealer several times and was told that everything is adjusted to specification.*

*Then, one day I took the car to a Buick dealer. He checked it out and told me that one of the two ports in the four-barrel carburetor throttle pump chamber had not been drilled. He did the job, and the car has been running fine ever since.*

*I sent a letter to the Pontiac regional office in Cleveland to get them to pay for the job—after all, the problem had*

*started while the car was under warranty. The regional office told me that the port was not drilled because of emissions standards, and that Pontiac wouldn't pay for the job, because it violated emissions laws.*

*Back to the Buick dealer I went, and was told that Buick uses the same engine and carburetor, and that both ports are supposed to be open. Who's right—Pontiac or Buick?—Jim Phillips, Maple Heights, Ohio*

**Buick!** Pontiac should pay for the job. Call the Cleveland office again and speak to Ed Balas. Ask him to call Jim Colyer of Pontiac service in Pontiac, Mich. Jim knows all about this.

problem. That's why vehicles driven only around town should be taken on the open road at least once a week and driven for a minimum of 15 minutes at highway speed. This gets the engine hot enough to purge carbon from the cylinders. It also allows the O<sub>2</sub> sensor to reach a temperature which burns away carbon that's accumulated in it.

## Hotfoot

*My 1980 Datsun 310 starts and runs fine. The trouble happens when I turn the engine off and restart it. Then it runs lousy—bucking and surging—until I lean into the accelerator pedal. This seems to clear up the problem. Can you tell me the cause?—John Stillman, Waltham, Mass.*

The A-series engine in your car may be subjected to conditions that are causing fuel to percolate when you shut off the engine. Percolating fuel escapes from the fuel bowl and floods the cylinders. Then, the engine runs badly until you accelerate rapidly, which clears the overflow.

If this, indeed, is what's happening, there are two ways of solving the problem. First, check the carburetor fan, which is mounted on the right strut tower facing the rear of the carburetor. The carburetor sits right above the exhaust manifold and, therefore, is

*(Please turn to page 22)*

## Solution without a reason

*A few months ago, I purchased a 1982 Plymouth Horizon TC3 hatchback. The hydraulic valve lifters have been rattling from day one. I've taken the car back to the dealer who claims that nothing can be done about it. I would appreciate your help.—Bill Newcome, Brookville, Pa.*

Although you don't say so, I'm assuming the car has a 2.2-liter engine rather than the 1.7-liter. Why? First, because the 1.7-liter engine has mechanical valve lifters which, if adjusted properly, will not make noise. Second, because there have been reports of some 2.2-liter engines making noise.

Chrysler admits that it's happening, and that the noise is confined to the valve lifters. However, the cause has escaped detection.

According to Chrysler, treatment with engine oil supplement (Chrysler part No. 3419130) will get rid of the noise, but I still wouldn't let the condition slide by. Instead, get this problem on record and keep notes of what was done to try and correct the situation. Then, if it works into a serious condition later on, you'll have ample ammunition for a claim.

## Dry Martini

*I heard that additives such as Heet and Dry Gas that get rid of moisture in gas tanks and lines will damage the oxygen*

*sensor. Can you confirm or deny this? I own a 1981 Buick Skylark.—John Helm, Quincy, Ill.*

You heard wrong. A fuel-line additive having an alcohol base to dry moisture won't have any adverse effect on an O<sub>2</sub> sensor. However, let me tell you what will.

If you make repairs that require new gaskets, and you use an excessive amount of RTV or anaerobic sealer, and some of it flakes off into the engine and burns, fumes can contaminate the sensor. Furthermore, carbon can be a real

## Tire law lowdown

Under a new federal law, independent tire dealers are no longer required to register tires for you. They're only required to give you a registration form containing the tire identification number. It's your responsibility to complete the form with your name and address and then mail it back directly to the tire manufacturer.

The Tire Industry Safety Council suggests that you do this in case the manufacturer has to notify you about a recall. (Tire outlets owned by tire manufacturers and/or bearing the name of the manufacturer are still responsible for registering customer tires.)

Incidentally, if a dealer fails to give you a form, make sure that you get one and fill it out yourself.

You will find the tire registration number right on the tire. It's preceded by the letters DOT.

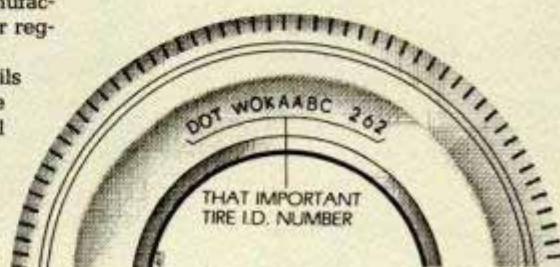





# AIM HIGH

## The potential is boundless.

Potential. In many people it goes unrecognized, undeveloped and unused. That's tragic. Because when a person's potential is never developed a terrible thing happens: nothing.

In the Air Force, we look for potential. And we challenge our people to explore and discover that potential for themselves. First with skill training, then with valuable experience.

We're happy to say it works. For them. For us. And for our country. Because as our people grow, we grow.

Developing potential is part of what aiming high is all about. If we all live up to our potential as individuals, there will be no limits to the potential of our nation.

The Air Force encourages young people to continue their education. Then, with diploma or degree, to accept the challenges of modern technology. For information about these challenges in the Air Force, call 1-800-423-USAF (in California 1-800-232-USAF) or contact a local Air Force recruiter.

**AIR FORCE**  
A great way of life.

1A947



## CAR CLINIC

(Continued from page 20)

subjected to a heavy concentration of heat. The fan, which is supposed to turn on when coolant reaches approximately 162° F., blows excessive heat away from the carburetor. Make sure this fan is working. If it isn't, the carburetor is having the hots and causing fuel to percolate.

The second thing to look at is a service bulletin that calls for the installation of a different needle and seat. These new parts supposedly prevent percolating fuel from leaking out of the fuel bowl into the cylinders. The part number for this new needle and seat is 16101H9060. Refer your dealer to technical service bulletin 82-0-84 in the engine fuels section.

### Peanut brittle

At 18,000 miles, I had to have the muffler and tailpipe of my 1978 Chevrolet Malibu replaced. They had been leaking rusty water for a while before the tailpipe broke off.

After having these new parts installed, I was called out of town for several weeks. When I came back and started the engine, chips of rust flew out of the tailpipe. I now have 19,000

miles on the vehicle. Do I have another exhaust system replacement to look forward to?—Anthony Militello, Toms River, N.J.

Probably. You drove 18,000 miles in four years. That's an average of 4,500 miles a year or 12 miles a day, which is peanuts.

At these short distances, the engine never gets hot enough to burn off water, which is a byproduct of combustion. This water is collecting in the exhaust system and rusting parts—a

common complaint among short-distance drivers.

All in all, when you consider time, and not mileage, a new exhaust system every four years isn't really such a bad record.

### From the King of Montebello

My 1981 Honda Accord has a hard-starting problem only when the engine is hot. Dealers have adjusted the carburetor, replaced the fuel filter, replaced



PM CAR CARE

### Don't KO your computer

If you need to have welding done on your car and it's equipped with a computer, be careful. Remember: Welding can damage that \$300 black box. In order to guard against this, disconnect and remove the computer from the car before welding.

REMOVE BEFORE WELDING

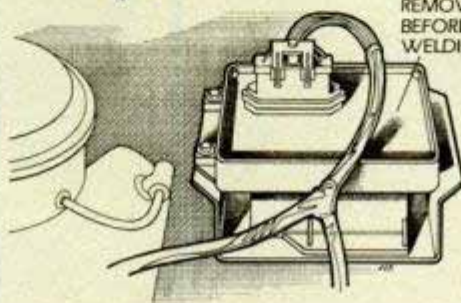

You also run the risk of damaging the computer when you jump-start a car. You can avoid this by turning off the ignition in both cars before you connect the jumper cables. Then restart the car with the good battery and turn the ignition key of the other car. After the engine of the weak-battery car starts, let both cars run a few minutes to charge the weak battery. Then, shut off both engines before you disconnect the jumper cables.

# Handcrafted Excitement

Style and engineering join together to create the best, most authentic component car money can buy. Complete, affordable, and easy to build, the 1937 Jaguar<sup>®</sup> SS 100 reproduction by Antique & Classic Automotive, Inc.



For the full story write or call TOLL FREE 800-245-1310. PA residents call (412) 898-3551.



ANTIQUE & CLASSIC AUTOMOTIVE, INC.

100 SONWIL DR., DEPT. PM-363  
BUFFALO, NY 14225

- \$3.00 enclosed for complete full-color brochure  
 \$20.00 enclosed for assembly manual (VW version)  
 \$20.00 enclosed for assembly manual (front engine version)  
 I am interested in a fully assembled model

CHARGE MY  MASTER CHARGE  VISA  DINERS CLUB  AMERICAN EXPRESS  Discover

NAME \_\_\_\_\_  
ADDRESS \_\_\_\_\_  
CITY \_\_\_\_\_  
HOME PHONE (\_\_\_\_) \_\_\_\_\_

STATE \_\_\_\_\_ ZIP \_\_\_\_\_  
BUSINESS PHONE (\_\_\_\_) \_\_\_\_\_

Expiration Date \_\_\_\_\_



# \$1000 A Month With Just A Hack Saw!

by Philip E. Brancato Sr.

Yes, you can make \$1000 a month and more with just a hack saw in your spare time.

## Will I Get Rich?

No, you will not get rich, but you can make over \$1000 a month in your spare time and have a ball doing it.

I tried all those "Get Rich" gimmicks that are advertised, that never tell you anything until you've sent them your \$25, and then you find out their gimmicks were not for you. Well, I've tried them all and I'm still not rich.

All I ever wanted was something I could do in my spare time with my hands, make a little money and enjoy myself and not have to buy \$3000 worth of tools or merchandise to do it.

## Believe It Or Not

I found the most enjoyable and profitable business working with my hands and the only tools I use are a hack saw and measuring tape. The really nice thing about it is any man, woman or ten-year-old can do it.

## What Do I Do?

I make beautiful indoor/outdoor P.V.C. pipe furniture. Such as chairs, lounges, tables, swings, and all kinds of baby furniture out of P.V.C. pipe; even birdhouses and feeders. P.V.C. pipe furniture is the hottest selling furniture on the market today, because it is unique and beautiful and will not rot or rust and it will virtually last a life time.

## Profit Unbelievable!

The fantastic part of this business is the profit.



Just go look at some of this furniture in the stores and see some of the unbelievable prices it is selling for.

A chaise lounge that costs \$42.25 in material and three

hours of work is selling for over \$228 in the stores. I can sell my chaise lounge for anything I think my labor is worth. For once, the big manufacturing companies cannot compete with me or you on prices. You will find you will have more orders than you want!

## Where can you buy the P.V.C. Pipe?

You can buy the P.V.C. pipe from any local hardware store to start. Plus I will supply you with the names and addresses of cushions and pipe manufacturers who will sell to you wholesale, plus I will supply you with my shop manual and six detailed shop drawings with pictures and measurements of six different designs.

## Do you need my shop drawings

No, you don't need my shop drawings unless you want to save hundreds of hours of trial and error work and thousands of dollars that I had to spend before I finally

found the right design and measurements and tricks to the manufacturing of P.V.C. pipe furniture. I only wish that when I started, I could have bought these shop drawings and I would have gladly paid \$100 for just one of them.

## I will pay you!

Yes, I will pay you \$25 for any unique design shop drawing that I can use in my collection and workshop manual.

## How do you start?

1) Decide if you like to work with your hands to create things and want to make money.

2) Can you afford \$12.00 for my shop manual and six drawings.

3) Send me your name and address along with your check for \$12.00 to:

Philip E. Brancato Sr.

P.O. Box 237 • P3

Riverview, Florida 33569

(813) 677-6948

Please allow about two weeks for delivery.

sparkplugs and replaced the carburetor float. The problem remains. What can I do about it?—Edward King, Montebello, Calif.

Have a cooling fan kit installed. It'll get rid of heat that's causing fuel percolation after the engine is shut off. The kit, which consists of an air temperature sensor and timer, automatically turns on the cooling system fan when the engine is off if under-hood temperature is too high. This gets rid of heat.

Percolation can affect not only a 1981 Accord, but also 1980 and 1982 Accords, 1980-82 Preludes and 1982 Civics. Fan kits for the various models differ, so make sure you get the correct one. Here's a list of models and Honda control numbers for the kits they need:

- 1980-81 Accord, 127615.
- 1982 Accord, 126459.
- 1980-81 Prelude, 126462.
- 1982 Prelude, 126461.
- 1982 Civic, 126458.

If you have a 1980 Accord or Prelude you should also be aware that a restriction in the original fuel evaporation canister can cause a flooded carburetor; this prevents engine restarting when the engine is warm. The original canister was replaced with a new one that's identifiable by two white paint

dots on its top. If you still have the old canister, you should have the new one installed. It carries Honda control No. 099795.

## Time warp

In your article on SE and SF engine oils (Car Clinic, page 44, Aug. '82) you said, "If I owned a 1980 GM model and were using SE oil, I would switch to SF."

Since the recommended oil change for my 1980 GM diesel is 3,000 miles, and it's 5,000 miles for 1981 models that use SF oil, would you say I could also change oil at 5,000 miles if I switch to SF?—John E. Mysza, Atlanta

I should say not. Even if you switch to SF oil, maintain the 3,000-mile oil interval. The reason is that your car has a standard cam-and-follower valve train. The valve train in 1981 and newer diesels have a roller-cam arrangement that operates with less friction. If you extend the servicing interval in your 1980 GM diesel, you'll subject the valve train to excessive stress. **PM**

## DO YOU HAVE A CAR PROBLEM?

Just ask Mort about it. Send your question to the Car Clinic, Popular Mechanics, 224 West 57th St., New York, N.Y. 10019. While letters cannot be answered individually, problems that are of general interest will be discussed in the column.

## SERVICE TIPS

■ General Motors has extended the warranty coverage on front-axle seals and shifter forks of 1980 X-body cars built through December 1980 to five years or 50,000 miles, whichever comes first. Transmission fluid leaks and defective shifter forks have been a problem. It's not a recall, so you won't get a notice. If you have trouble, return the car to a dealer who will inspect it and replace the seals and shifter fork, if necessary. If you've already paid for repairs you can get reimbursed by GM upon presentation of pertinent records.

■ If the 3.8-liter engine in your 1982 Ford or Mercury uses too much gas, have the dealer check article No. 82-20-9 of technical service bulletin 82-20. Then get a new fuel-enrichment valve installed. If your car is a T-Bird, Granada, XR-7 or Cougar, the part is either No. D5DZ-98565-A or D5AZ-98565-A.

■ If the 1.7- or 2.2-liter engine in your 1978-82 Chrysler car has a Holley carburetor 5220 or 6520, you could have a strange condition. The car may operate fine, but suddenly develop a poor idle because of a plugged idle circuit. You may need to replace the carburetor air horn or have the carburetor torn down and cleaned. TSB 14-32-82 explains this.



# APPLIANCE CLINIC



## Burning issue

I own a Montgomery Ward Signature electric range, model No. 4366, serial No. 88120772. When the oven is set for 325° or 350° F., the temperature in the oven goes to nearly 500° F. The thermostat has been replaced four times. After each installation, the serviceman checks the operation and it works fine, but the problem returns at a later date. What, besides a faulty thermostat, could be causing this problem?

—George W. Scott, Merrimac, Mass.

Perhaps the wrong replacement thermostat was installed. I contacted Montgomery Ward and they suggested that you write to Frank Cauweld, Montgomery Ward Plaza, Customer Service, Div. 4N, Chicago, Ill. 60671. Send him the name and address of the appliance service company that installed the replacement thermostats, and the part numbers of those replacements if you can. He'll handle your problem from there.

*Note:* Some models have a grommet on the end of the drain tube. Remove, rinse and reinstall this grommet. If the grommet is badly deteriorated, replacement part No. 849307 is available at a Whirlpool parts outlet.

## An agitated owner

We have a Maytag washer model No. A106, serial No. 014710AE. Occasionally a large item, like a towel or bath mat, comes out of the washer torn or with a hole in it. I can't find any sharp projections in the tub. Can you help?

—Sam Kamilos, Carmichael, Calif.

The Maytag agitator design has been around for many years. It's designed to push the water through the clothes, rather than drag the clothes through the water. The clothes tumble from the top of the machine to the bottom, away from the agitator. The only time something can get caught under the agitator is when the washer is overloaded and there's too little water in the tub.

I suspect that you're not using enough water for the amount of clothes in the tub. Another possibility is that the clothes have been weakened by chemical damage due to improper bleach usage.

## Faulty freezer

Help! I have a problem with my Sears refrigerator, model T-14-G-1, serial No. 26113374. The refrigerator itself keeps cool enough, but the freezer won't freeze. The cold control is on high and the manually operated defrost cycling clock works fine. Any suggestions?

—Eloi A. Laliberte, Lewiston, Me.

Sounds like your problem is the restriction of airflow between the refrigerator and the freezer section, caused by ice buildup on the evaporator. This could be caused by a defective defrost bimetal or defrost heater, or possibly by a defrost timer not functioning properly. I suggest you have a service technician inspect the unit and determine which part(s) you need. **PM**

## Glue for popcorn popper

Last year we purchased a West Bend Stir Crazy popcorn popper, model No. 15346. The popper works fine, but apparently we have butter fingers. We broke one of the handles off the base by knocking the popper off the counter. I tried to affix it with epoxy, but the first time it heated up the epoxy turned to goo and released. Is there any glue on the market that will stand up to the heat?—Roger McKee, Davenport, Ill.

I contacted West Bend with your problem. They don't know of any over-the-counter product that will withstand the 375° F. plus temperatures to which the base is exposed. They suggest you contact a West Bend appliance repair center and have the base replaced.

## Water accumulation

Our Whirlpool refrigerator, Model EAT19PTWRS, serial No. S43940098 has water accumulating in the bottom. We keep a bath towel lying in the bottom and every few days, it becomes soaked with water. What could be causing this?

—R. H. Lundstrom, Northridge, Calif.

Sounds as if the drain cup located behind the back wall control panel has become clogged. To correct this, first unplug the refrigerator. Get at the drain cup by removing the two light covers on the back control panel, then remove the temperature- and air-control knobs. Remove the two hex-head screws under the console and lift out the console carefully. You will see the drain cup approximately in the center of the panel; pull the cup forward and

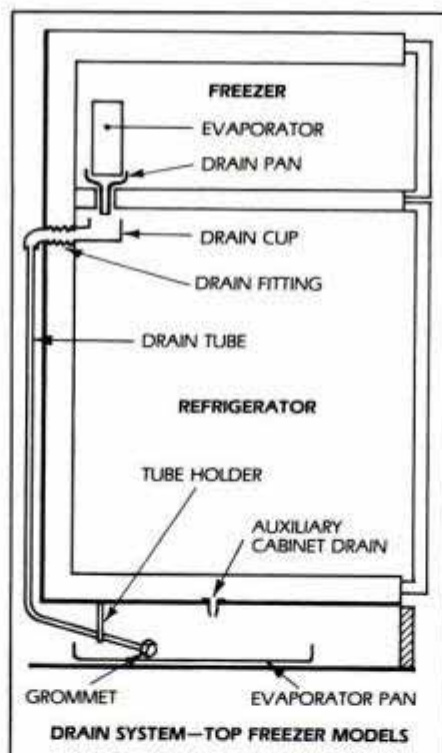

**Cross section showing the drain cup and drain tube: Be sure the evaporator pan is in place before cleaning out tube.**

out. Clean the cup with hot tap water.

Mix a cleaning solution of one tablespoon of baking soda to one cup of hot tap water. Fill a meat basting syringe with the solution and squirt it down the drain tube. Repeat this procedure several times to make sure the tube is thoroughly cleaned. Reinstall the clean drain cup, put the refrigerator back together and plug the unit back in. This should correct your problem.

*If you have a problem with any appliance, send your question, along with the model and serial numbers, to Appliance Clinic, Popular Mechanics, 224 West 57th St., New York, N.Y. 10019. Sorry, but letters cannot be answered individually. Problems of wide interest will be discussed in this column.*



**Start your own money making business!**

**Make up to \$12<sup>50</sup> an hour—  
even while learning!**

*Train FAST  
at home!*

*Get into this booming high-profit business that's  
Easy to learn—Easy to do—Easy on You!*

**Be  
Your  
Own  
Boss!**

Never before have money-making opportunities been so great for qualified Locksmiths. Now lucrative regular lock and key business has multiplied a thousandfold as millions seek more protection against zooming crime. Yet there's only one Locksmith for every 17,000 people!

**Start Collecting CASH PROFITS Right Away**

You're "in business" ready to earn \$5 to \$12.50 an hour a few days after you begin Foley-Belsaw's shortcut training. Take advantage of today's unprecedented opportunities in locksmithing for year-round EXTRA INCOME in spare time — or fulltime in a high-profit business of your own. Hundreds we've trained have done it. So can YOU! All tools plus professional Key Machine given you with course. These plus practice materials and equipment, plus simple, illustrated lessons, plus expert supervision, plus business-building guidance will enable you to KEEP THE MONEY COMING IN! Ideal for retirement — good jobs, too.

**SEND FOR EXCITING FACTS—No Obligation**

Discover what's in Locksmithing for you — how Foley-Belsaw's Master Locksmith-approved training can give you the skill you can depend on to EARN MORE — ENJOY LIFE MORE.

**No Extra Cost!** Included With Your Locksmith Training



**BURGLAR ALARM AND SECURITY SYSTEMS**

training. Covers all phases of Burglar, Hold-Up and Fire Alarm servicing and installation. This valuable and timely instruction includes all special tools and supplies. ONLY Foley-Belsaw offers such extensive training in this rapidly expanding field as a part of your Locksmith training.

**ADVANCED Locksmithing!** How to change combinations, install and service Safe, Vault and Bank Safe-Deposit Box locks. You learn-by-doing on the locks that we supply. You'll find it fascinating and highly profitable work.

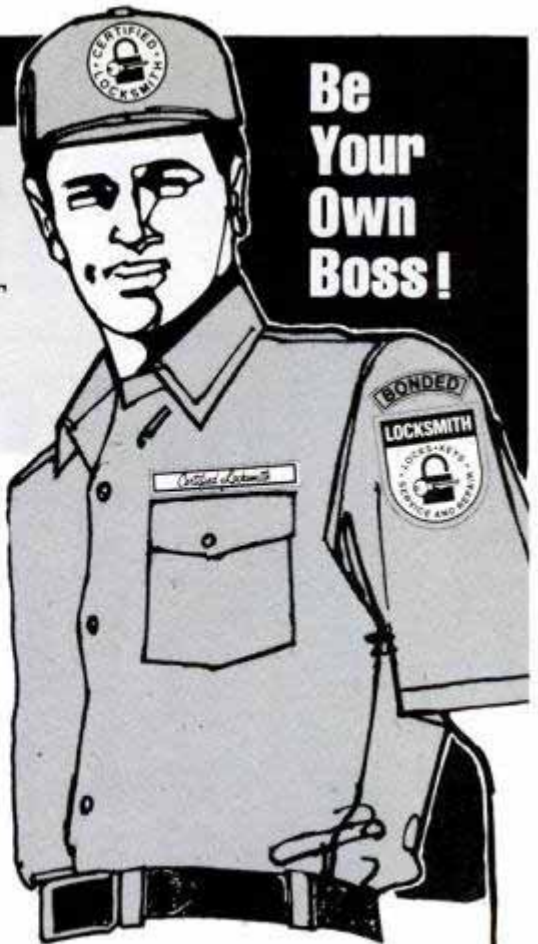

# BE A LOCKSMITH!

**Hundreds of Foley-Belsaw trained men have succeeded in this fascinating and highly profitable field . . .**

*"Before enrolling I checked other courses and also asked for advice from several locksmiths in my area. They all said yours was tops and has the most versatile Key Machine.*

*"I always wanted to be in business for myself and now I am . . . thanks to Foley-Belsaw Institute.*



**David Fairbrother—Dave's Locksmith Service**  
Milwaukee, Wisconsin 53209



*"I opened my own business, spare time, seven months after I enrolled and made a profit of \$329 for the first week."*  
**B. A. Deberry Littleton, Colorado**

*"No more hard, nasty work for me. Now I have my own business and with hardly any effort I average around \$50 a day. Thanks for my new start in life."*  
**Sam Walker Prichard, Alabama**



**10-DAY NO RISK TRIAL!**  
Send for details!

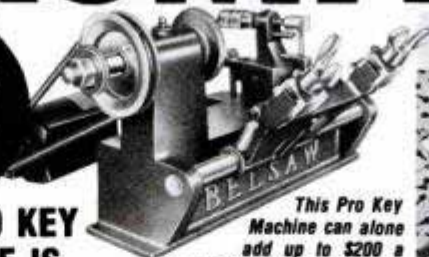

**THIS PRO KEY MACHINE IS YOURS TO KEEP!**

**FREE** This Pro Key Machine can alone add up to \$200 a month to your income . . . and it won't cost you a penny extra with your training.

**Find out all about it! Send for FREE Facts TODAY!**

Just fill in and mail coupon below (or send postcard) to receive full information and details by return mail. **DO IT TODAY!**

**RUSH COUPON!**

**ALL SPECIAL TOOLS AND EQUIPMENT INCLUDED!**



**FOLEY-BELSAW INSTITUTE**  
10171 Field Bldg., Kansas City, Mo. 64111

**There is NO OBLIGATION and NO SALESMAN Will Call—ever!**

**RUSH COUPON TODAY FOR THIS FACT-FILLED**

**FREE BOOKLET!**

Tells how you quickly train to be your own boss in a profitable Sparetime or Fulltime business of your own PLUS complete details on our **10-Day NO RISK Trial Offer!**



Send for your copy today!

**FOLEY-BELSAW INSTITUTE**  
10171 FIELD BUILDING  
KANSAS CITY, MISSOURI 64111



**YES**, please send me the FREE booklet that gives full details about starting my own business in Locksmithing. I understand there is no obligation and that no salesman will call.

Name \_\_\_\_\_  
Address \_\_\_\_\_  
City \_\_\_\_\_  
State \_\_\_\_\_ Zip \_\_\_\_\_

**... YOU Can Do It Too!**



MARINE SURPLUS DEPOT SALE!

# NOTICE!

—(all in original leather cases)—

## DIGITAL WATCHES WITH BUILT-IN QUARTZ- COMPUTERS

*to be offered to  
the public starting  
midnight tonight!*

**\$7**  
ONLY EACH

Starting midnight tonight—Marine Surplus Depot will accept orders directly from the public for automatic, digital quartz-computer watches—accurate even under the most rugged conditions—to military-precision of within one second per month! Each of these digital quartz-computer watches features a digital display panel that tells at the push of a button: exact hour—minute—second—day—date. Even has built-in illumination-switch for nighttime viewing, even under total blackout conditions. Engineered with most advanced electronic-circuitry . . . this precision chronograph even contains a built-in computer, so never needs winding. More than just a simple wrist-watch, you'll use it to calculate with 100 percent accuracy all sorts of vital information you need ON COMMAND at the flick of a switch! Recommended for wide variety of uses . . . and under all sorts of conditions. Includes brushed-stainless expansion band; **GUARANTEED FOR LIFE** or free replacement at any time. A wonderful opportunity to buy now while available, for future gift giving. **LIMIT: NO MORE THAN 5 PER ORDER**, no exceptions. To avoid disappointment or future regret you must place your order immediately. Send \$7 plus \$2 handling, shipping and insurance for each digital quartz-computer watch, to:

**MARINE SURPLUS DEPOT UWSA—44**

BOX 9306, PORT WASHINGTON, NY 11050

## HINTS FROM READERS

### Cement mixer



A five-gallon plastic bucket makes an excellent no-mess mixer for small amounts of concrete, plaster or similar material. Screw or bolt two wooden or angle-iron mixing paddles on opposite sides of the inside of the bucket. Fill the bucket to approximately two-thirds capacity and snap the lid on securely. Now roll the mixer back and forth on its side until the contents have been mixed thoroughly.—*Wayne Fugate*

### End clogged downspouts



My gutter downspout openings were shielded by low-profile, perforated metal screens (see top of photo). Leaves and seed pods collected over these screens, causing the gutters to overflow during heavy rains. To eliminate the frequent cleaning, I replaced the commercial screens with home-made models.

Each nonclogging screen is made from a 6 × 9-in. piece of ¼-in. mesh hardware cloth (available at hardware stores and home centers). Roll each piece of cloth into a 6-in.-high tube to fit tightly in the downspout opening, as shown.—*Wilson G. Walters*



# HINTS FROM READERS

## Driving concrete nails

Here's a sure-fire way to drive nails into concrete. Bore a  $\frac{3}{16}$ -in.-dia. hole with a carbide-tipped bit. Whittle a sliver of wood to fit loosely in the hole, but flush with the surface. Now drive a hardened concrete nail. This method is equally effective in poured concrete, block and precast concrete, and it even works with ordinary nails.

—Philip L. Monner

## Grip for pants hangers

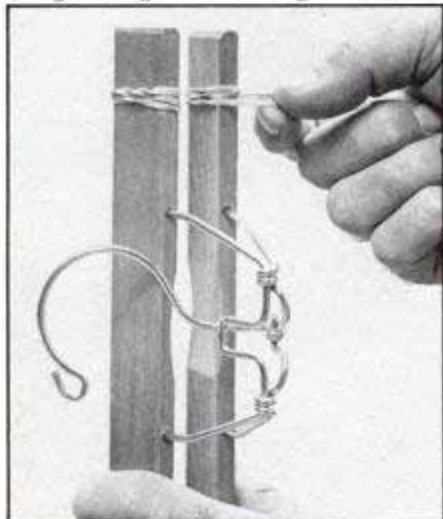

My clamp-on pant hangers had lost their gripping power, allowing the pants to fall to the floor. I solved this problem by winding rubber bands around the ends of the hanger. When the hanger's clamped, the rubber bands grip the pants, preventing them from falling. Adhesive-backed foam insulation also works.—Henry Fregly

# Start your own money making business!



## Get in on the PROFITS in SMALL ENGINE service and repair

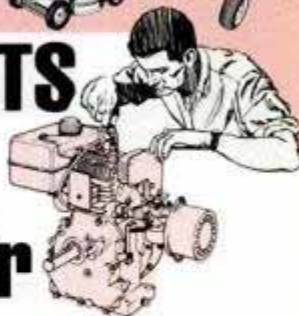

**BEAT INFLATION!** Work part time, full time right at home - we help you every step of the way.

In just a short time, you can be ready to join one of the fastest growing industries in America... an industry where qualified men are making from \$10.00 to \$15.00 per hour... and that's just for labor. Parts, engines and accessories add even more to the profits. Because the small engine

industry has grown so quickly, an acute shortage of qualified Small Engine Professionals exists throughout the country. When you see how many small engines are in use today, it's easy to understand why qualified men command such high prices—as much as \$17.50 for a simple tune-up that takes less than an hour.

### 65-million small engines are in service today!

That's right — there are over sixty-five million 2-cycle and 4-cycle small engines in service across the U.S.A. That's the official count from the Engine Service Assn., and new engines are being built at a rate of one-million per month! With fully accredited and approved Foley-Belsaw training, you can soon have the skill and knowledge to make top money servicing these engines. Homeowners and businessmen will seek you out and pay you well to service and repair their lawnmowers, tillers, edgers, power rakes, garden tractors, chain saws, mini-bikes, go-carts, snowmobiles... the list is almost endless.

You get all this Professional equipment with your course, PLUS 4 H.P. Engine... ALL YOURS TO KEEP... All at NO EXTRA COST.



**RUSH COUPON TODAY FOR THIS FACT-FILLED**

**FREE BOOKLET!**

Tells how you quickly train to be your own boss in a profitable Sparetime or Fulltime business of your own PLUS complete details on our 10-Day NO RISK Trial Offer!



Send for your copy today! No obligation

**No experience necessary.** You don't need to be a 'born mechanic' or have prior experience. If you can read, you can master this profitable trade right at home, in your spare-time, without missing a single paycheck. Lessons are fully illustrated—so clear you can't go wrong.

We guide you every step of the way, including tested and proven instructions on how to get business, what to charge, how to get free advertising, where to get supplies wholesale... all the "tricks of the trade"... all the inside facts you need to assure success right from the start.



Learn At Home In Your Spare Time.

### INCREASED INCOME

"I've had about 8 years experience repairing small engines... but repairs were only minor... until I started the Foley-Belsaw Course."

Walter H. Strick  
Campbell, California



With our famous 'learn-by-doing' training method, you get actual 'hands-on' experience with specialized tools and equipment you'll receive with your training, plus a brand-new 4HP engine—all yours to keep.

### Send Today for FREE facts!

You risk nothing by accepting this offer to find out how Foley-Belsaw training can give you the skills you need to increase your income in a high-profit, recession-proof business of your own.

Just fill in and mail coupon below (or send postcard) to receive full information and details by return mail. **DO IT TODAY!**



**FOLEY-BELSAW INSTITUTE OF SMALL ENGINE REPAIR**

50172 Field Bldg., Kansas City, MO. 64111

**No obligation... No salesman will call**

Foley-Belsaw Institute

50172 Field Bldg. • Kansas City, Mo. 64111



YES, please send me the FREE booklet that gives full details about starting my own business in Small Engine Repair. I understand there is no obligation and that no salesman will call.

NAME \_\_\_\_\_

ADDRESS \_\_\_\_\_

CITY \_\_\_\_\_

STATE \_\_\_\_\_ ZIP \_\_\_\_\_



## Pac-Man paper

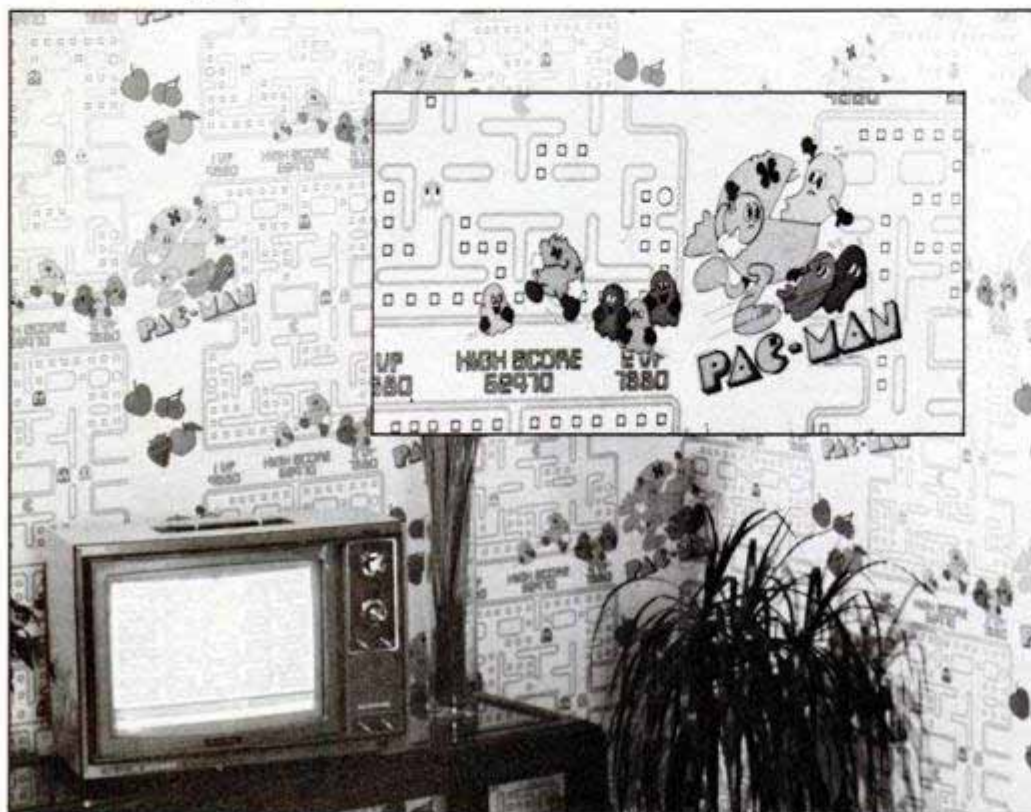

Pac-Man, the popular video game character, is re-introduced on a new colorful wall covering from Color Tile Supermarts Inc., Box 749, Dept. RL, Fort Worth, Tex. 76101. The easy-to-clean vinyl wall covering comes prepested for quick do-it-yourself installation. The video game's grid pat-

tern is reproduced in medium blue on white; Pac-Man is bright yellow and the ghosts are pink, red, blue and orange. Each 20½-in.-wide roll, containing 70 sq. ft., sells for about \$20. It's at home improvement/decorating centers, and at all Color Tile Supermart retail outlets.

## Ratchets with unique control

Stanley Tools has introduced a new line of ratchet wrenches featuring Flip-Drive control which enables you to change ratchet direction single-handedly. To do it, you simply press the Flip-Drive mechanism located on the ratchet head. Flip-Drive ratchets are sold separately in ¼-(\$10.65), ⅜-(\$13.49) and ½-(\$17.39) drive sizes. They also come in standard or metric socket sets. For a free brochure, contact Stanley Tools, Dept. PID-PM, Box 1800, New Britain, Conn. 06050.



## Superior spray lubricant

ExSIL spray and lube by General Electric is a new, silicone-based, lubricant/penetrant that is claimed to prevent corrosion when ap-

plied to almost any metal surface. The multipurpose spray is recommended for use on tools, sporting equipment and firearms. A quick spray application will keep doors and windows operating smoothly. The lubricant's silicone base is formulated with an anti-wear additive to extend its staying power. ExSIL comes in 2-oz. (\$1.50) and 9-oz. (\$2) spray cans—prices vary with dealer locale.

For more information contact General Electric Co., Silicone Products Div., Dept. PM, Consumer Products Operation, Waterford, N.Y. 12188.



## Small tiller has big features

Troy-Bilt Junior, a compact, rear-tine tiller designed for cultivating smaller gardens (up to 1,500 sq. ft.), is claimed to have many of the features found in larger machines. A 3½-hp, aluminum-block engine drives the tiller with two forward speeds and one reverse. The maker says Junior's 125 pounds are balanced well enough to permit single-hand operation. Maximum tilling depth is 6 to 8 in.; top width is 14 in. It's \$669 from Troy-Bilt, Dept. A1470-PM, 102nd St. and 9th Ave., Troy, N.Y. 12180. **PM**





# Wealthy Man Wants to Give You His Wealth Secret Before It's Too Late!

Dear Friend,

My name is John Wright. Not too long ago I was flat broke. I was \$30,000 in debt. The bank repossessed my car because I couldn't keep up with the payments. And one day the landlord gave me an eviction notice because I hadn't paid the rent for three months. So we had to move out. My family and I stayed at my cousin's place for the rest of that month before I could manage to get another apartment. That was very embarrassing.

Things have changed now. I own four homes in southern California. The one I'm living in now is worth more than half a million dollars. I own several cars, among them a brand new Mercedes and a brand new Cadillac. And as of now, I have \$178,000 cash in certificate of deposits in just one of my bank accounts in Beverly Hills.

I'm not really trying to impress you with my wealth. All I'm trying to do here is to prove to you that if it wasn't because of that money secret I was lucky enough to find that day, I still would have been poor or may be even bankrupt. It was only through this amazing money secret that I could pull myself out of debt and become wealthy. Who knows what would have happened to my family and me.

Knowing about this secret changed my life completely. It brought me wealth, happiness, and most important of all peace of mind. This secret will change your life, too! It will give you everything you need and will solve all your money problems. Of course you don't have to take my word for it. You can try it for yourself. To see that you try this secret, I'm willing to give you \$20.00 in cash. (I'm giving my address at the bottom of this page.) I figure, if I spend \$20.00, I get your attention. And you will prove it to yourself that this amazing money secret will work for you, too!

You probably are asking yourself, why is he sharing his secret with me? My response is, "why not". First, I've already made enough money to retire for the rest of my life. Second, my secret is so unique that we won't be competing with each other. Third, nothing is more satisfying to me than sharing my secret only with those who realize a golden opportunity and get on it quickly.

This secret is incredibly simple. Anyone can use it. You can get started with practically no money at all and the risk is almost zero. You don't need special training or even a high school education. It doesn't matter how young or old you are and it will work for you at home or even while you are on vacation.

Let me tell you more about this fascinating money making secret:

## FAST MONEY

With this secret the money can roll in fast. In some cases you may be able to cash in literally overnight. If you can follow simple instructions you can get started in a single afternoon and it is possible to have spendable money in your hands the very next morning. In fact, this just might be the fastest *legal* way to make money that has ever been invented!

## ALMOST NO-RISK

This is a very safe way to get extra cash. It is practically risk free. It is not a dangerous gamble. Everything you do has already been tested and you can get started for less money than most people spend for a night on the town.

## "WORK" AT HOME

One of the nicest things about this whole idea is that you can do it at home in your spare time. You don't need equipment or an office. It doesn't matter where you live either. You can use this secret to make money if you live in a big city or on a farm or anywhere in between. A husband and wife team from New York used my secret, worked at home in their spare time, and made \$45,000 in one year.

## SIMPLE

This secret is simple. It would be hard to make a

mistake if you tried. You don't need a college degree or even a high school education. All you need is a little common sense and the ability to follow simple, easy, step-by-step instructions. I personally know a man from New England who used this secret and made \$2 million in just 3 years.

## AGE DOESN'T MATTER

You can use this secret to make money no matter how old or how young you may be. There is no physical labor involved and everything is so easy it can be done whether you're a teenager or 90 years old. I know one woman who is over 65 and is making all the money she needs with this secret.

## NO PERSONAL SELLING

When you use this secret to make money you never have to try to convince anybody of anything. This has nothing to do with door-to-door selling, telephone solicitation, real estate or anything else that involves personal contact.

## LEGAL AND HONEST

Everything about this idea is perfectly legal and honest. You will be proud of what you are doing and you will be providing a very valuable service.

## NO LONG HOURS

It will only take you two hours to learn how to use this secret. After that everything is almost automatic. After you get started you can probably do everything that is necessary in three hours per week.

I know you are skeptical. That simply shows your good business sense. Well, here is proof from people who have put this amazing secret into use and have gotten all the money they ever desired. Their names are not mentioned here in order to protect their privacy but I have full information and the actual proof of their success in my office.

## PROOF

- A woman from Oregon started out by using my secret method in its simplest form. She later reported that it had brought her \$14,000 in cash.
- A man from Rhode Island applied my secret and with the help of his family, made over \$40,000 in a year in his spare time.
- A man from California, who was broke at the time, tried my secret and made \$147,000.
- On the basis of my secret, a husband and wife team from Virginia grossed over \$100,000 cash in eleven months.
- A man from California made over \$265,000 in one year, with this incredible secret.
- I talked to a man from Ohio, who now lives in Santa Monica, CA. He said: "Thank you for sharing your secret... with this amazing, yet simple secret, I received \$220,000 in just two months."

As you can tell by now I have come across something pretty good. I believe I have discovered the sweetest little money-making secret you could ever imagine. Remember — I guarantee it.

Most of the time, it takes big money to make money. This is an exception. With this secret you can start in your spare time with almost nothing. But of course, you don't have to start small or stay small. You can go as fast and as far as you wish. The size of your profits is totally up to you. I can't guarantee how much you will make with this secret but I can tell you this — so far this amazing money producing secret makes the profits from most other ideas look like peanuts!

Now at last, I've completely explained this remarkable secret in a special money making plan. I call it "The Royal Road to Riches". Some call it a miracle. You'll probably call it "The Secret of Riches". You will learn everything you need to know step-by-step. So you too can put this amazing money

making secret to work for you and make all the money you need.

To prove that this secret will solve all your money problems, I'm not even asking you to send me money. Instead, postdate your check for a month and half from today. Obviously it is not actually money because it is not negotiable for 45 days. You can easily stop payment on it any time you want. I can't cash your check for 45 days before I know for sure that you are completely satisfied with my material.

## IMAGINE HOW YOUR WHOLE LIFE WILL CHANGE IF YOU USE THIS SECRET TO GET ALL THE MONEY YOU NEED!

- You won't have to worry about bills.
- You will be master of your own time and fate and nobody can boss you around.
- You will have more time to spend with your loved ones and you will be able to take care of them in emergencies.
- You can have the house you want, the car you want, the vacations you want.
- And most of all, you will finally have PEACE OF MIND!

If you need (or just want) more money, there are a lot of reasons why you should take advantage of this amazing secret. (And I can't think of a single reason why you shouldn't). It will probably solve all your money problems forever. In fact, I am so completely convinced that my powerful secret works money miracles, that I'm willing to give you the most unusual *guarantee* ever offered. That is, if it doesn't solve all your money problems, I'll return your original uncashed check, plus an *extra twenty dollar cash bonus* just for doing me (and yourself) the favor of giving the secret an honest try according to my simple instructions.

## \$20.00 FREE!

There is no way you can lose. You either solve all your money problems with this secret (in just 30 days) or you get your money back *plus \$20.00 in cash FREE!*

Do you realize what this means? You can put my simple secret into use. Be able to solve all your money problems. And if for any reason whatsoever you are not 100% satisfied after using the secret for 30 days, you may return my material. And then I will not only return your original UNCASHED CHECK, but I will also send you an *extra \$20.00 cashiers check* just for giving the secret an honest try according to the simple instructions.

**I GUARANTEE IT! I have given references, therefore, there is absolutely NO RISK ON YOUR PART.**

To order, simply write your name and address on a piece of paper. Enclose your postdated check or money order for \$12.95 and send it to:

**WRIGHT PUBLISHING COMPANY**  
2385 Roscomare Road, Dept. D-11/111  
P.O. Box 24126  
Los Angeles, CA 90024

But the supply of my material is limited. So send in your order now while the supply lasts.

If you wish to charge it to your Visa or MasterCard — be sure to include your account number and expiration date. That's all there is to it. I'll send you my material right away by return mail, along with our unconditional guarantee.

## REFERENCES:

We belong to Los Angeles Chamber of Commerce, located at 404 South Bixel Street, Los Angeles, California 90017.

Our bank reference is: First Los Angeles Bank, Los Angeles, California 90067.

© 1981 Wright Publishing Company



# SCIENCE WORLDWIDE



## Speeding toward a fusion conclusion

We reported last September that America was on the threshold of making the first fusion-generated electricity (*Fusion—We're Harnessing The Power Of The H-Bomb*, page 86). But we were surprised to learn the project is moving much faster than planned.

Grumman engineers put in the last protective panels covering Princeton's doughnut-shaped Tokamak reactor last November, a month ahead of schedule.

Now comes a period of shakedown runs, scheduled to culminate in 1986 with  $Q=1$ , the state in which the fusion reaction produces more energy than is needed to start the reaction in the first place. Officials of Ebasco Services, which manages the reactor, tell me even  $Q=1$  may come six months ahead of schedule, largely because of rapid improvements in computer, construction and other technologies.

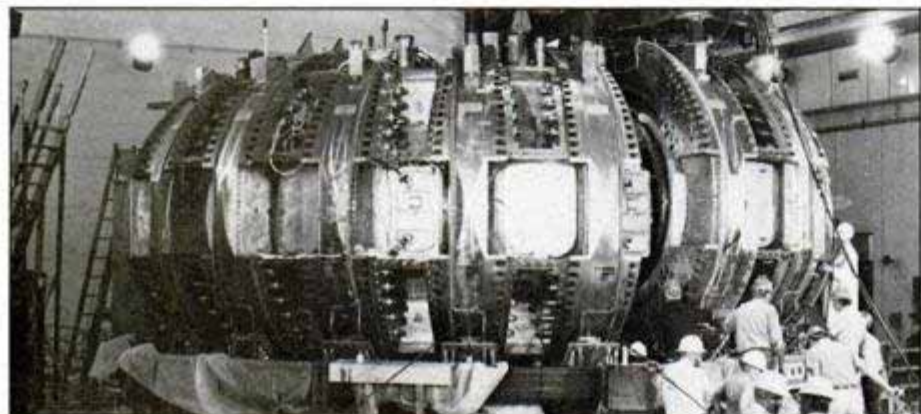

Engineers put in the final protective panel at Princeton's Tokamak fusion reactor.

## Baying at the cargo bay

Anyone with a couple of thousand dollars can purchase a little space in the Space Shuttle's cargo bay. And some of the more than 400 students, businesses and private individuals who have purchased shuttle space already are planning to photograph Earth from inside the bay area, using automatic cameras.

Unfortunately, NASA has a big problem with the cargo bay's environment.

Using an Apple II computer, I recently spent some days communicating with Space Shuttle users who are concerned about the ship's directional thrusters.

The rockets, they say, scatter atoms across the open bay. These, in turn, scatter light, making photography difficult. NASA says it's working on various ideas for equipping the cameras with filters. But there's nothing that can be done about the directional.

## Eely warning system

Swedish lake eels aren't electric, but they apparently use electricity to avoid being caught in fishing nets. A study of eels in central Sweden's Lake Hjälmaren indicated that the slight electric current generated by the Earth itself is "read" by a sonar-like mechanism in the eel's head.

Eels approaching fishing nets from a few yards away changed course quickly, apparently because the nets disturbed the surrounding geoelectric field. The eels were tagged with tiny transmitters and followed by radio signal as they migrated.

## Truck stop

Skid marks often help police estimate the speed of a car involved in an accident. But truck skid marks can be misleading, according to Pennsylvania State University engineer Gordon Hayhoe. "It seems truck tires have roughly a 10 to 15 percent reduction in the

coefficient of friction," he says. Thus, skid mark for skid mark, the trucks' are longer.

Hayhoe says much of the extra skid may be caused by the very hard compounding of rubber in truck tires.

## Fast alcohol, tight yeast

If manufacturers could turn sugar into alcohol quickly, America would have a very cheap fuel. And it just might, if Purdue researcher George Tsao's small-scale experiments work on a large scale.

Tsao has produced 100 grams (1/4 ounce) of alcohol per liter (slightly over a quart) of liquid sugar per hour by tightly packing the yeast cells that turn sugar into alcohol. Free-floating yeast cells, he says, produce about two grams of alcohol per hour from the same amount of sugar.

## In another vein . . .

The University of Utah, which brought us the first artificial heart implant, will soon be providing artificial blood vessels to people with vascular diseases. Utah researchers Donald J. Lyman and Dr. Dominic Albo head a team that has transplanted drinking-straw-sized plastic tubes into dogs, and the animals survived more than two years after implant surgery.

The blood vessel material is so flexible that it beats and throbs to the rhythm of the human vascular system. Human implants are scheduled to be done this year. **PM**

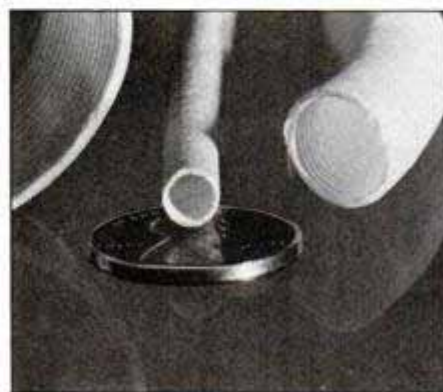

Humans will receive plastic blood vessel implants like these sometime this year.



LIGHTS: 8 mg. "tar", 0.7 mg. nicotine av. per cigarette, FTC Report DEC. '81; FILTERS: 15 mg. "tar", 1.1 mg. nicotine av. per cigarette by FTC method.

© 1982 R.J. REYNOLDS TOBACCO COMPANY

# CAMEL

Where a man belongs.



Experience the  
Camel taste in Lights and Filters.

Warning: The Surgeon General Has Determined  
That Cigarette Smoking Is Dangerous to Your Health.



# HOMEOWNERS' CLINIC



## Bleeding redwood

*We installed redwood siding on the outside of our house 26 years ago, and painted it with the best exterior oil paint. Every spring since, the paint blisters and red stains appear. We've sanded the siding and applied latex paint over the best undercoat available. Still, every spring the paint peels and the red stains return. Any ideas?*

—Amy Alexander, Vienna, W. Va.

I believe interior room moisture (vapor) is passing through your walls and popping the paint. You need to treat the interior walls so warm, moist air won't pass through to the outside.

You can apply an interior paint designed to minimize the flow of moisture (such as Glidden's Insul-Aid), or place a polyethylene vapor barrier between the studs and the dry wall. (See "Mildew And Paint Peeling," *Homeowners' Clinic*, page 52, Oct. '80. For a copy of this article, send 50 cents

to Popular Mechanics, Box 1014, Radio City Station, New York, N.Y. 10101.)

Once you've corrected the moisture problem, scrape off the blistered paint and sand the wood bare. Prime the blistered area with an oil-base primer, then repaint the entire area. Note: Primers containing zinc are sensitive to water and should not be used on redwood.

Latex or other water-base primers should not be used on woods containing water-soluble extractives (natural moisture which can be drawn out), such as redwood or cedar. The water in the primer base will cause bleeding stains. Latex top coats may be applied over an oil primer.

For an excellent booklet regarding your problem, send 25 cents to the California Redwood Assn., 1 Lombard St., San Francisco, Calif. 94111. Ask for data sheet 4B1-3, *Painting Exterior Redwood*.

When the grains cover only 50 to 70 percent of the backing, the abrasive is an open-coat sandpaper. These don't cut as fast, but they don't clog easily.

## Sweating toilet tank

*All summer long our toilet tank sweats and drips water, especially when it's humid. We've tried several products, but they only work for short periods. One plumber suggested we hook up the tank to the hot-water line, but others had never heard of this. Who's right?—Morton Bender, Brooklyn, N.Y.*

Mort, the first plumber knows his business. When warm, moist room air hits your water-cooled tank and bowl, condensation forms. Tell your plumber to install a mixing valve that will flush your toilet with room-temperature water (not straight hot water). The valve can be adjusted to maintain the correct water temperature without wasting hot water.

## Spalled walls

*The concrete walls of our old home were originally poured in small batches. Now the walls are spalling (chipping and breaking up) at these joints, and a white, powdery substance forms during the decomposition process. A previous owner mortared over these areas, but that's flaking off, too. I'd like to chip out the bad spots, remortar and apply a sealer. Should I seal or remortar first, and what kind of sealer is best?—Dan Avery, Baker, Ore.*

Your condition is a moisture problem occurring at the nonbonded joints (cold joints) between the pours. Moisture has let water-soluble salts, a concrete chemical reaction byproduct, leach out. This is known as efflorescence.

Using a bricklayer's hammer and a cold chisel, chip the spalled joints clean and chisel the edges in a dovetail shape (undercut on the inside) at least 3/4 in. wide x 3/4 in. deep. Patch the joint with a compound such as Waterplug, then apply two coats of Thoro-seal waterproof coating to prevent any further moisture problems. Both Thoro-seal and Waterplug are made by Thoro Systems Products, 7800 Northwest 38th St., Miami, Fla. For the nearest dealer

call 1-800-327-1570. Florida residents call 305-592-2081.

## Open or closed abrasive?

*I'm 70 years old and have been using sanding belts since they first came out. However, I still don't know the difference between open and closed coats.*

—Austin Simmons, Lexington, Ky.

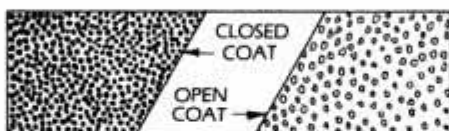

**Use closed-coat papers on surfaces that won't clog the abrasive (some metals, hardwoods). Open-coat papers don't cut as fast, but they're less likely to clog.**

Open- and closed-coat designations refer to the density of the abrasive grains (how close together they are) on the backing paper or belt.

Closed coat means that the abrasive grains cover the entire backing paper. Closed-coat papers cut much faster than open-coat grains, but they also clog more quickly. Use these on surfaces that won't clog papers quickly, like hardwoods and certain metals.

## Relinquishing support

*A support column in my basement is right in the way of my new pool table. Is there any way to remove that column without causing a sag in the floor above?—J.E. Miscoe, Pittsburgh*

As your drawing shows a girder joint over the column in question, I believe that removing the column would cause total collapse. Your problem can be corrected, but you should employ the services of a professional engineer.

Your structure will have to be temporarily supported to remove the existing column and girder. The new girder would span from the outside wall to the next column.

Sometimes fitch plates (steel plates bolted across girder joints for reinforcement) can be fastened on both sides of a wood girder to increase its span and to allow for the removal of a support column. Only an on-the-job structural engineer can tell you for sure. **PM**

*Do you have a home-maintenance or repair problem? Send it to Homeowners' Clinic, Popular Mechanics, 224 West 57th St., New York, N.Y. 10019. Letters cannot be answered individually, but problems of wide interest will be discussed in the column. For more home-repair and maintenance help, get PM's Home Care Guide, \$4.95 postpaid. Send your order(s) to Popular Mechanics, Box 1014, Radio City Station, New York, N.Y. 10101.*



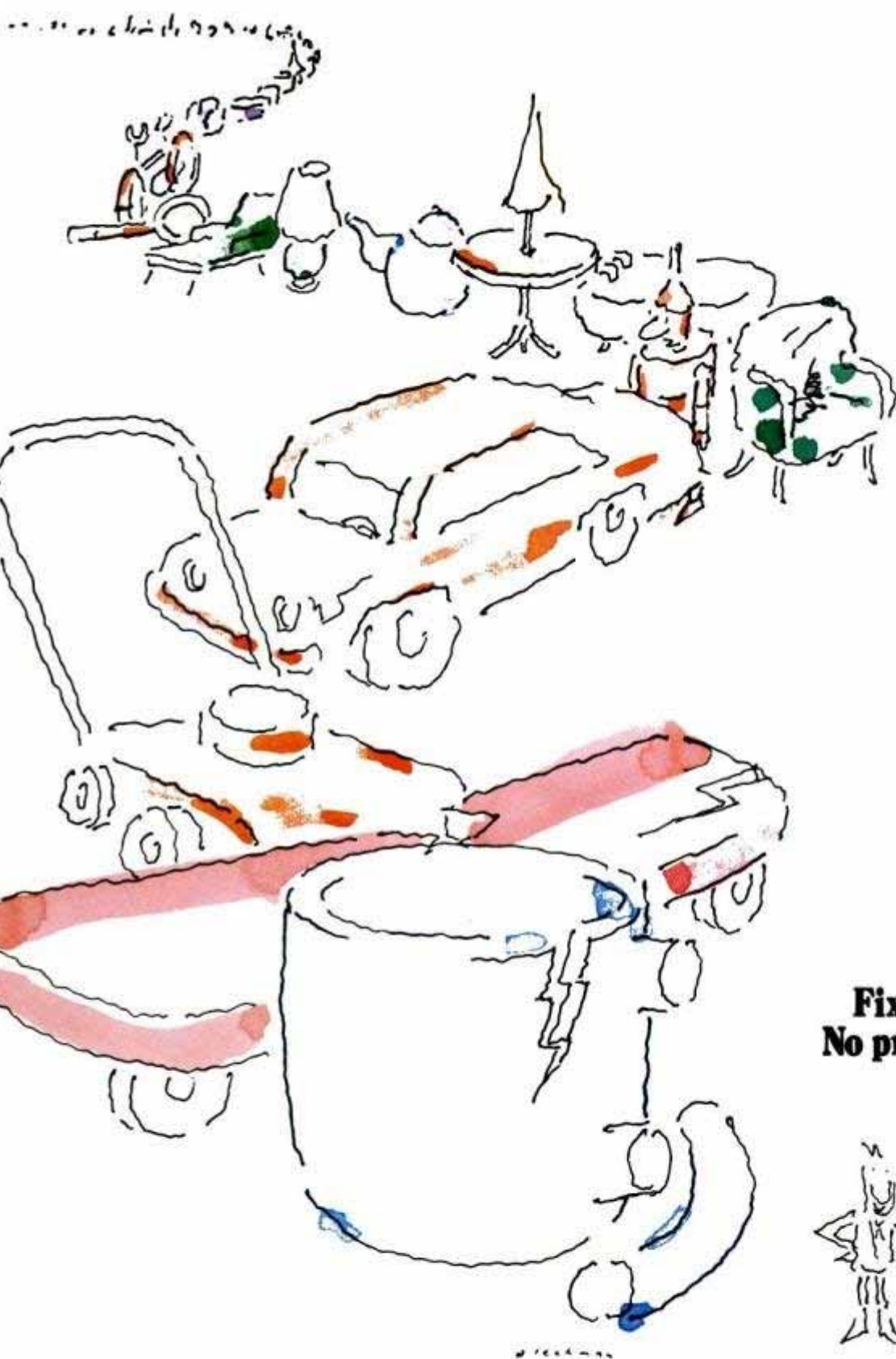

**Fix 'em?  
No problem!**



**Bring us your broken, busted, cracked and rusted.**  
 Leaky faucets and leaky gaskets, broken china and broken toys. Bent fenders.  
 Rusted lawnmowers. And much more. Just fix-'em-yourself with our complete line  
 of household and automotive products. From Loctite Corporation, makers of Loctite,<sup>®</sup>  
 Duro<sup>™</sup> and Permatex<sup>®</sup> fix-it products. **All the experience you need.™**

**LOCTITE**  
**DURO**  
**Permatex**  
 ©1983 Loctite Corporation



# The possible dream.

A world you had almost forgotten. And one your children will always remember.  
A Mercury® outboard can take you away to places like this. To worlds that are yours alone. To quiet shores where you and your family can be together...to talk...and to listen.

And it all begins at your Mercury dealer.

Today's Mercs are the best ever. Built to run economically. Run quietly. And run. And run. And run.

Every Merc is tested and re-tested. And every Merc is backed by a year-long limited parts and labor warranty honored by over 6,000 dealers worldwide.

Is discovering new worlds a dream of yours? See your Mercury dealer. He can show you just how possible it is. And how affordable.

Mercury Marine  
Fond du Lac, Wisconsin,  
Canada, Australia, Belgium,  
Mexico

**MERCURY**  
**OUTBOARDS**

© BRITNICK COMPANY





# ALL OUTDOORS



## Learning fishing luck

The art of angling is becoming a successful science as well with the help of Indiana State University. It has recruited a faculty of top fishermen as instructors at Bass Fishing Institutes that are being scheduled at colleges around the country.

Classes that include demonstrations,

instruction and practice will run for two days, and youngsters under 16 can enroll with their parents at no extra charge.

To obtain registration details, contact the Bass Fishing Institutes, Indiana State University, Terre Haute, Ind. 47809.

## Pistols with more punch

For handgun shooters with a need for super power, Remington Arms is introducing a new high-performance sporting cartridge this spring, and Sturm, Ruger is producing a new revolver to handle it.

The cartridge will be called the .357 Remington Maximum. With a case 1.605 inches long, it is nearly one-third of an inch longer than the .357 Magnum. Loaded with a 158-grain, semijacketed, hollow-point bullet, the Maximum is reported to test out with a muzzle velocity of 1,825 feet per second (f.p.s.) from a 10½-inch vented barrel. Downrange, its velocity at 50 yards is 1,588 f.p.s. At 100 yards, the bullet travels at 1,381 f.p.s. and still has 669 ft.-lb. of energy with a drop of only 1.7 inches. That is a much flatter trajectory curve than the .357 Magnum and an even greater improvement over the .44 Magnum.

Metallic silhouette competitors and handgun hunters will find that smaller sighting adjustments are necessary for targets located at varying distances.

To take advantage of this extra pow-

er, Ruger has announced a new .357 Maximum Blackhawk revolver. Models with 7½-inch and 10½-inch bull barrels chamber the new potent cartridge.

Careful comparison with the Super Blackhawk .357 Magnum and .44 Magnum will show that both the cylinder and the ejector rod and housing are longer.

Both barrel lengths of the Maximum will have rear sights that are adjustable for windage and elevation. Frames will be blued steel, while the grips are square-back Dagoon style. Both will use the wide-spur hammer and wide, serrated trigger of the Super Blackhawk.

The energy generated by the Remington Maximum puts it in a class with the .44 Magnum. Yet initial tests indicate that, fired in the new Ruger .357 Maximum Blackhawk, the cartridge delivers considerably less recoil than experienced with the .44.

With 7½- or 10½-inch barrel, this model is hardly a concealed weapon. But with the longer sight picture of the large barrel and added impact, it should become a favorite for metallic silhouette contests.

## Rigid inflatable

It's a deep-V fiberglass hull with an inflatable collar, or a rubber blow-up boat with a plastic bottom—take your pick. Avon Inflatables builds the 24-footer in Wales and calls it the Searider 7.4. The U.S. Navy is giving it sea trials and refers to it as an RIB (for rigid inflatable boat).

For rescue work, fishery patrols and Coast Guard service it seems to be a happy compromise, since it has the high buoyancy of an inflatable, and sea-keeping qualities of a hard deep-V keel. It is rated to carry 18 men, mounts a 60-gal. fuel tank for its diesel sterndrive engine, and has a range of



Avon's new Searider 7.4 is a combination hard-soft hull with advantages of both.

300 miles with minimum crew or 200 fully loaded.

The blown-up sponsons, each with seven separate air chambers, are permanently bonded to each side of the hull and are of rubber-impregnated nylon that are claimed to have great wear resistance. As a dinghy, tender or club launch that has to bump up alongside various boats and docks, the craft could become a chubby-looking but useful pleasure boat, as well.

## What if?

Fortunately, chances seem to go down every year that we'll be lost in a wilderness or shipwrecked on a desert island, but what to do in an emergency is always interesting. Courses with Outward Bound and the National Outdoor Leadership School are one way to learn, and a good recent addition to the publications in this field is the *Wilderness Survival Handbook* by Alan Fry (St. Martin's Press). Fry gives a concise, all-seasons summary of what you need to know before you get in trouble. **PM**



Ruger's Blackhawk .44 (top) has shorter cylinder than .357 Maximum (bottom).



# WINDSOR'S TASTE BEATS V.O.!

## Nationwide tests prove it.

Over 10,000 drinkers across the country have compared the taste of Imported Windsor Canadian to the taste of Seagram's V.O.

And they chose the mild, smooth taste of Windsor over V.O.—57% to 43%.

If you're a Windsor drinker, that will come as no surprise. But if you're not, try the taste of Windsor and find out for yourself why it's the Canadian that stands alone.

You can't beat the taste of Windsor. And you certainly can't beat the price.

**WINDSOR**   
ONE CANADIAN STANDS ALONE





# Troubleshooting Your Brake System

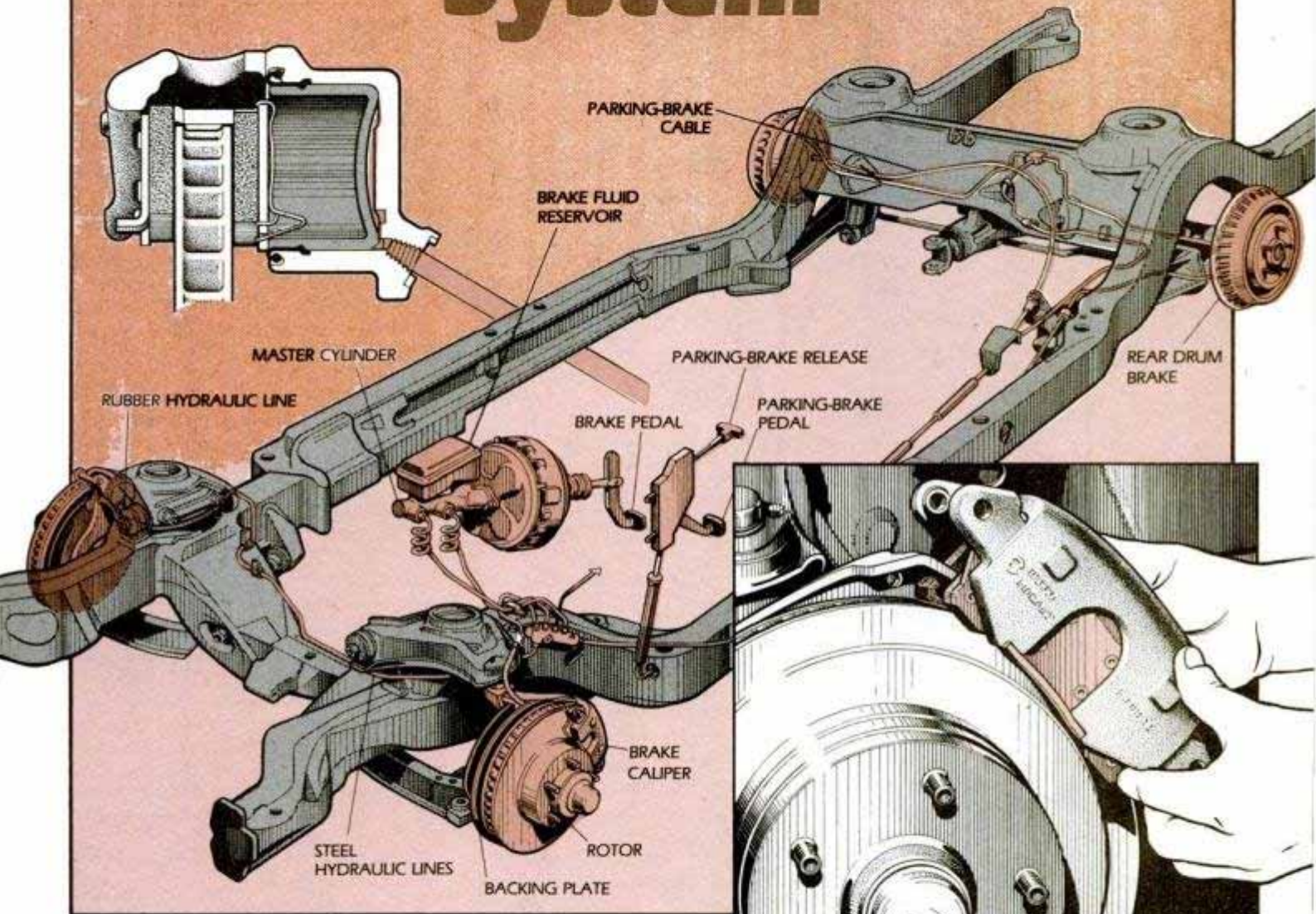

Today's typical braking system uses a two-stage master cylinder which operates disc brakes on the front wheels and drum brakes on the rear.

**B**rake-system maintenance is probably the most critical part of vehicle care. While the car that won't go may frustrate you, the car that won't stop can kill you. To avoid the complications that can occur when pads or shoes wear beyond limits, check brake condition at regular intervals.

Of course, brakes should always be inspected when their application results in noise or when the vehicle pulls to one side during braking. Some late-model GM and Ford products have brake-wear warning devices. But in

most cases, the only way to determine pad or shoe condition is to remove the disc caliper or the drum and inspect the friction material.

If the brake pedal pulsates when stopping, a rotor or drum is probably bent. If brakes don't perform as well as they should, if the pedal sinks or if the master cylinder loses fluid, the hydraulic system is probably at fault.

Before removing anything, inspect the entire brake system, including master cylinder, lines, valves, hoses and brake assemblies, for leaking

hydraulic fluid. If you find leaks, go to a professional.

### Caliper removal

To remove the pin-slider-type disc brake calipers found on most GM cars you'll need a 7-inch or larger C-clamp and a 3/8-inch hex key wrench. After lifting and securing the vehicle, remove the front wheels. Siphon two-thirds of the fluid from the master cylinder. Then place the C-clamp over the disc brake caliper so that the pad on the top of the clamp rests against the back of



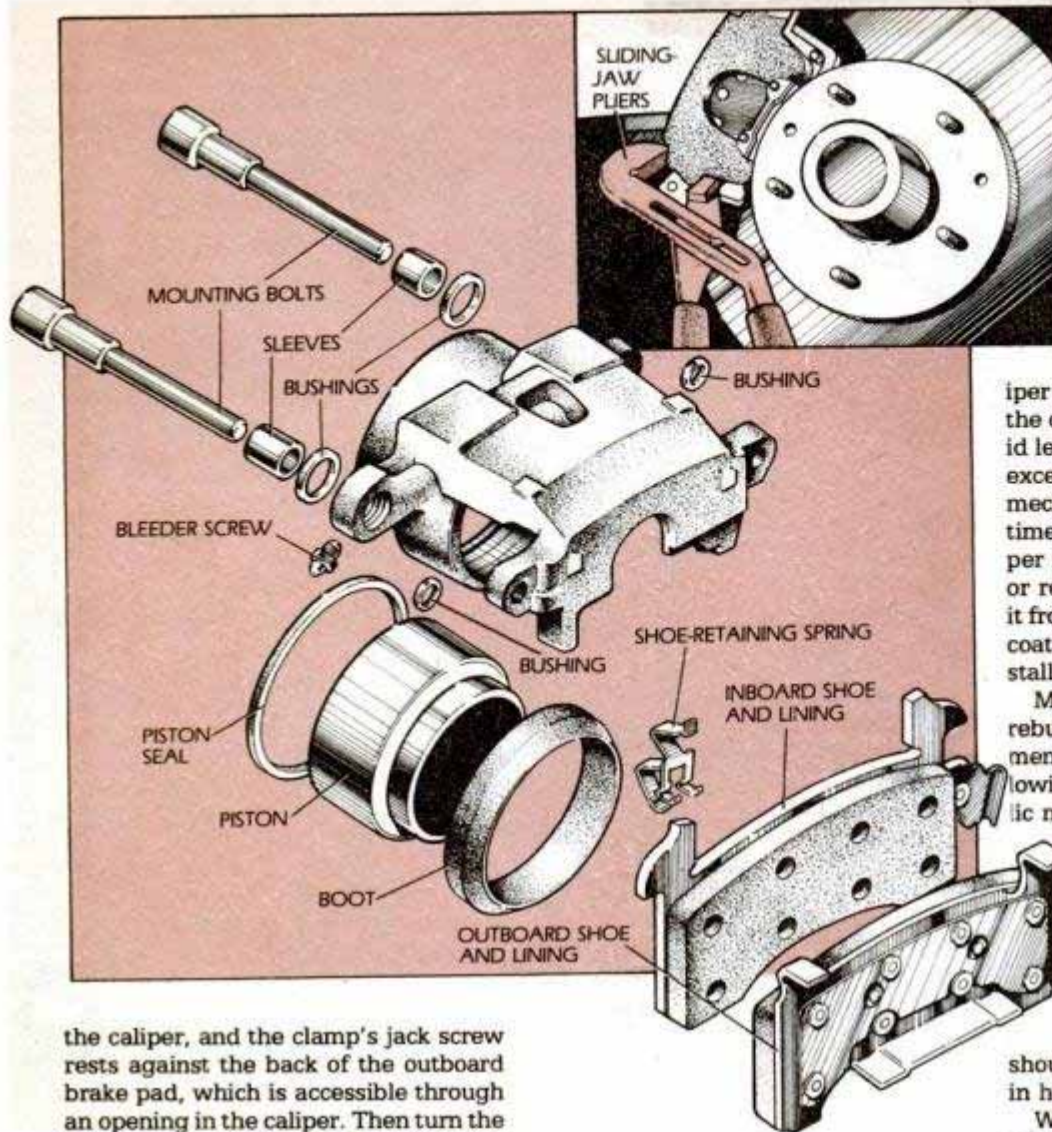

Most GM vehicles employ a floating-caliper disc brake at the front wheels. Piston and seals aren't removed from the caliper unless it must be rebuilt. Upon reassembly, clinch outboard pad ears over the caliper with sliding-jaw pliers as shown (inset).

iper surfaces clean and check around the dust boot and bleeder screw for fluid leakage. Inspect caliper bushings for excessive wear or deterioration. Some mechanics renew the bushings every time they remove a caliper. If the caliper is leaking it will have to be rebuilt or replaced. If the caliper's okay, hang it from a suspension arm with a piece of coat hanger until you're ready to reinstall it.

Most professional mechanics don't rebuild the caliper at every pad replacement. They contend that a road test following reassembly reveals any hydraulic malfunctions.

### Reassembly

When buying new pads, get the right type of friction material. Although inexpensive organic pads are available for some vehicles originally equipped with semimetallic pads, they shouldn't be used. Brake life may be cut in half.

While you're at the parts store, pick up a tube of brake silencing paste. Before installing the pads in the calipers, coat the back of the outboard pad with the paste and apply a strip of it to the back of the inboard pad. If there was an antirattle spring on the back of the old inboard pad, install it on the new pad. You can buy new antirattle springs if the old ones have been eaten up by corrosion.

Make sure the pads are retained in the caliper in the same manner as the old ones. On GM cars, you have to clinch the ears on the pad so that they fit tightly over the caliper. Squeeze them around the caliper with 12-inch sliding-jaw (slip-joint) pliers. Other pads may have pins in the back that fit into recesses in the caliper, or antirattle clips that hook into the caliper. The pads may differ from one side of the vehicle to the other. Check for left- or right-side designation.

When you reinstall the caliper, you may have to tap it into place on its mount, but don't use excessive force. If it won't go, the piston may not be retracted.

With pin-slider-type calipers, lubricate the pins before installing them, if the calipers have steel bushings. If they

the caliper, and the clamp's jack screw rests against the back of the outboard brake pad, which is accessible through an opening in the caliper. Then turn the jack screw, tightening it against the brake pad. As you tighten, the caliper should move away from the pad. This indicates that the caliper piston is being pushed back into its bore. If the piston won't retract, it may be frozen: See a mechanic.

Once the piston has been bottomed gently, the caliper guide bolts can be removed with the  $\frac{3}{8}$ -inch hex key wrench or an open-end wrench. Don't let the caliper hang from the rubber brake hose.

The procedure for removing non-GM calipers varies somewhat. In general, you should remove one caliper at a time, leaving the other side as a reference.

Most late-model Ford calipers are mounted similar to GM's. While the C-clamp is not necessary for caliper removal, you'll need a 4-inch clamp and a  $2\frac{3}{4} \times 1 \times \frac{3}{4}$ -inch block of wood to retract the piston once the caliper is off. Many Ford calipers slide on a machined surface and are held in place by a key. A locking screw holds the key in place. Late Chryslers use a caliper that slides on machined guides. These can be removed by disengaging the retaining clips that hold it in place. Other Chry-

slers use a pin-slider caliper that retains the pins with clips.

### Inspection and diagnosis

Once the caliper has been disengaged from its anchor and lifted off the rotor, inspect the friction material. Nonmetallic pads should have more than  $\frac{1}{16}$  inch of material above the rivets. Semimetallic friction material should be at least  $\frac{1}{32}$  inch above the rivets. If the friction material is bonded to the pad without rivets, the thinnest section of material should be at least as thick as the backing plate to which it is bonded. If you still have a lot of friction material on the pads, bolt everything back together. If the rotors are discolored or heat-cracked, replace them. If you encountered the previously mentioned pulsating pedal, send the rotors to a machine-shop-equipped auto-parts store for resurfacing. Rotors should likewise be resurfaced if they're scored more than a slight amount. If your rotors are too thin or warped for remachining, the machinist will tell you that they must be replaced.

Once the disc pads have been removed from the calipers, wipe all cal-



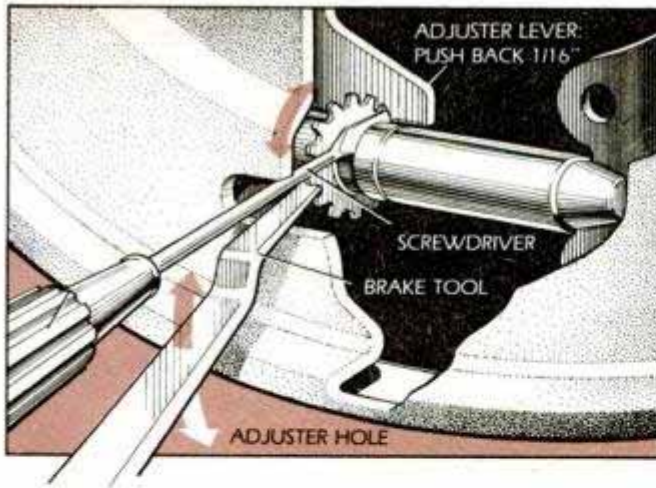

To remove the rear brake drums on most cars, shoes must be retracted. To do this, locate the adjusting slot, reach in with a screwdriver and push the self-adjusting lever away from the star wheel. Insert adjusting tool and back off adjustment.

have plastic bushings, install the pins dry, but make sure they're clean. If they're slightly corroded, you can polish them with No. 400 emery paper. Some mechanics lubricate all pins, but other experts contend that this can cause excessive dirt accumulation. If the pins look bad, replace them.

Hold the caliper and pads in place while you install the pins. Tighten bolt-style pins to the recommended figure with a torque wrench.

After you've renewed or inspected all disc brakes, refill the master cylinder with DOT 3 brake fluid.

### Drum-brake basics

Drum-brake service is more time consuming than disc service. Again, it is extremely important that you disassemble the brake mechanisms one at a time, so that you have the other side for reference.

Before the front drums of rear-drive cars or the rear drums of front-drive cars can be pulled, you'll have to remove the wheel bearings. These must be cleaned, inspected and re-packed with grease before reassembly.

The drums usually can't be removed until the brake shoes have been retracted. To retract the shoes on most vehicles with self-adjusting brakes, locate the adjusting slots, which are probably plugged with rubber inserts. Some adjusting slots may be blocked with metal slugs. In that case, knock out the slug with a hammer and chisel. Remove the insert, reach in with a very small screwdriver and push the self-adjusting lever away from the star wheel.

Hold the lever away from the wheel and insert a brake adjusting tool into the slot. Engage the end of the tool in the star wheel and turn the star wheel to back off the brake adjustment, using the edge of the slot as a fulcrum.

On most cars, the brake-tool handle should be moved upward to retract the brake shoes. Some Chryslers have a self-adjuster lever mounted behind the star wheel. For these cars you'll have to bend an old screwdriver or a piece of metal in order to reach the adjuster lever.

Before pulling the drums off the brake shoes, cover your mouth and nose with a breather mask, available where automotive paint is sold. This will prevent you from inhaling asbestos fibers.

Inspect the friction surface for scoring or other damage. If the drums are discolored or heat-cracked, replace them. If they are scored, take them to your parts store/machine shop for machining. Inspect the lining for wear. Bonded linings without rivets should be replaced when they wear down to  $\frac{1}{16}$ -inch thickness. Replace riveted linings when they wear to within  $\frac{1}{32}$  inch of the rivets. If the shoes are worn unevenly from side to side, have a machine shop check the drums.

### Disassembly

At the top of each shoe you'll probably find a return spring that secures it to an anchor above the wheel cylinder. This is best removed by inserting a brake tool between the spring and anchor. Turning the tool lifts the spring off the anchor. Some mechanics remove these springs by gripping them with a side-cutter and stretching them over the anchor. This is okay if the springs are going to be replaced, but not if the springs will be reused. Note the color and location of all springs, so they can be reinstalled correctly. You might want to color-code the old brake shoes with little dabs of paint to help in reassembly. Any springs that have been subjected to unusually high temperature or that have obviously stretched should be replaced. Some manufacturers recommend you replace the springs whenever the brakes are serviced. Once the springs have been disengaged, remove the shoe guide plate from the anchor pin.

Most drum brakes are equipped with a self-adjusting mechanism that turns the star wheel when lining wear creates excessive clearance. Some of these mechanisms consist of a cable, a cable guide, a lever and a spring. Others use a heavy-gauge wire link, a pawl, a pawl return spring, a lever and an adjuster spring. To disassemble the cable type, the cable is detached from the lever once the spring has been stretched

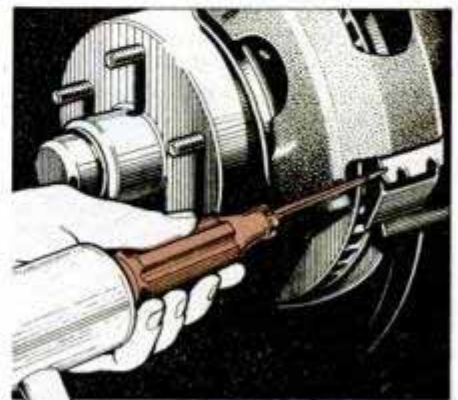
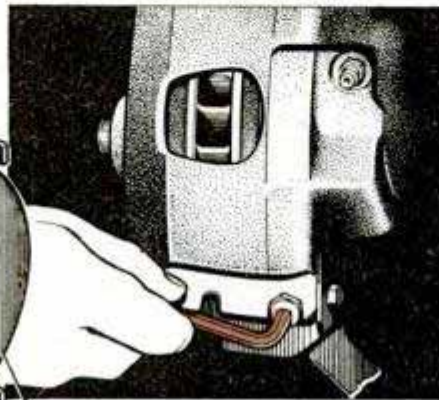
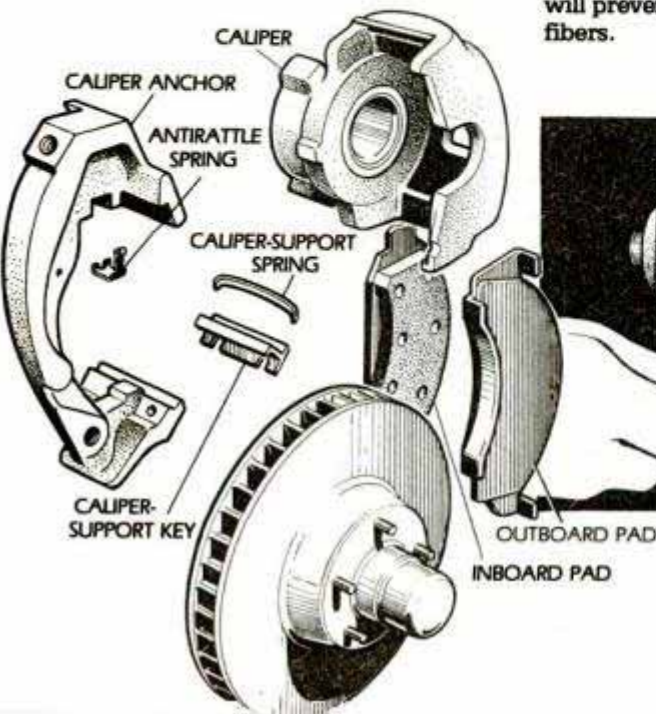

The Ford-AMC machined guide caliper is retained by a support key and screw. To disengage the caliper, remove the retaining screw and use a hammer and drift to drive the retaining key out of the anchor.



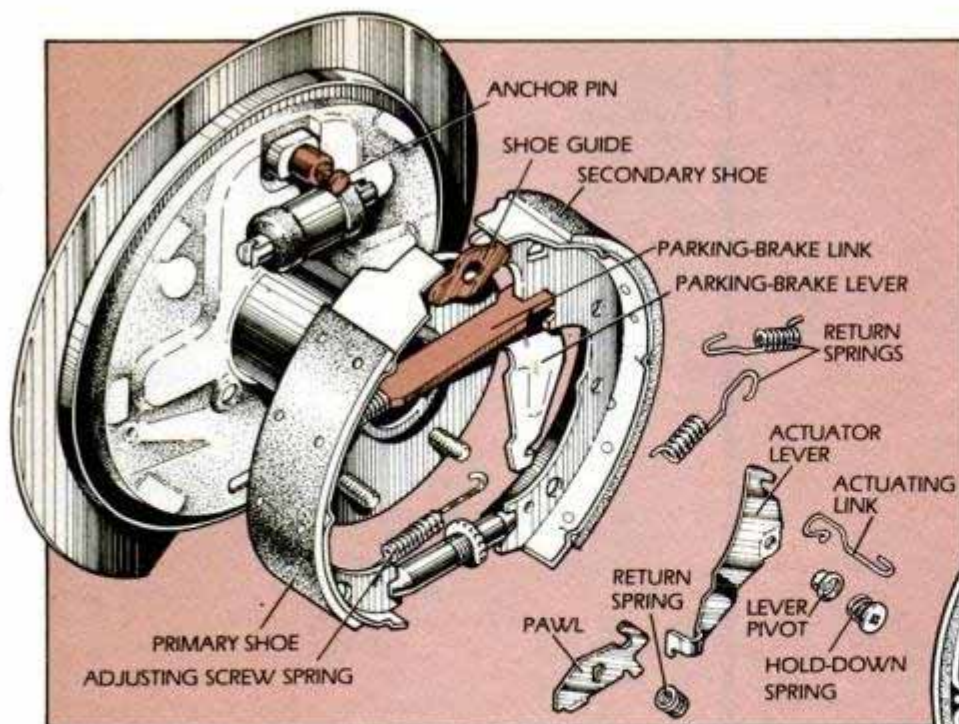

The self-adjusting mechanism at left is typical of GM cars. The actuating link joins the actuator lever to anchor pin.

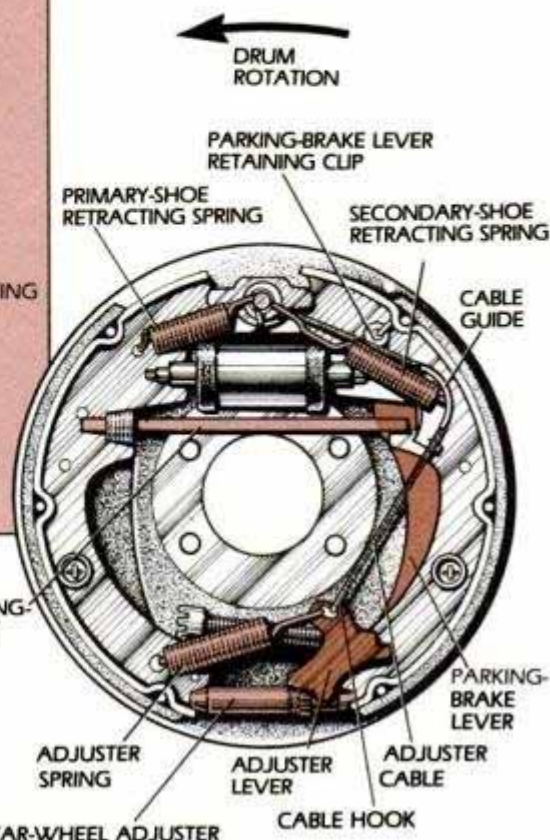

Cable-type self adjuster on the right is typical of Ford, Chrysler and AMC vehicles. Cable is hooked over the anchor pin at top and connected to the lever at the bottom. The adjuster is actuated when brakes are applied while the vehicle is backing up.

slightly by moving the lever away from the star wheel. Make a note of the hole in which the cable guide is inserted before removing the adjuster assembly.

Most brake shoes are attached to the backing plate by means of springs and retainers that lock on anchor pins. To remove, grasp the retainer between the jaws of a pliers, push down, and turn it until the slot in the retainer aligns with the locking tabs on the end of the anchor pin.

On many vehicles, you can remove the shoes with the lower adjuster connecting spring and star wheel adjuster in place. Most rear brake mechanisms have a parking brake lever attached to a shoe that must be removed.

Before installing the new shoes, inspect the wheel cylinders by lifting the rubber dust shields on each end of the cylinder and looking for signs of brake fluid that may have leaked past the pistons and seals. If you find fluid, the cylinders should be rebuilt or replaced.

Once the cylinders have been replaced and the brakes have been reassembled, the system will have to be bled. Make sure no one depresses the brake pedal while the drums are off the car or the pistons will pop out of the wheel cylinders.

Clean the brake backing plate using brake-cleaning fluid and a rag. Be sure to use a protective face mask and don't blow brake dust off with compressed air.

Then compare your new brake shoes to the old ones to make sure they're the same. Look for shiny spots on the backing plate where the shoes make contact and lubricate these with a small amount of white lithium grease. If the

shoes have ridges worn into the contact pads, file them smooth before lubricating. Lubricate the star wheel adjuster with the same grease.

### Reassembly

Reassembly varies with different brake configurations. If you've left the other side intact for reference, you'll be able to determine the order of component installation.

To reassemble the common GM self-adjusting brakes install the adjuster connecting spring on the primary and secondary shoes along with the star adjuster. The wheel should be on the side with the secondary shoe. The secondary shoe is the one with more lining than the primary, and is installed toward the rear of the vehicle. The primary shoe, the one with less lining material, is installed toward the front of the vehicle.

Position the shoes on the backing plate, making sure the shoes engage the wheel cylinder push rods and that the parking brake lever, on rear-wheel applications, engages the secondary shoe.

Position the adjuster lever and its spring on the secondary shoe, and install the shoe hold-down springs and retainers. On rear-wheel applications, position the parking brake link and its

antirattle spring between the primary shoe and the parking brake lever. Place the shoe-guide plate in position over the anchor pin. Install the self-adjuster pawl and actuating link. Next, insert the hooked ends of the brake return springs into their respective holes in the shoes.

Then, using a large Phillips screwdriver or a brake tool, stretch the springs until they slip over the anchor pin. Install the adjuster lever return spring on the adjuster and stretch it until you're able to hook it to the adjuster pawl.

Once you've reinstalled the brake drum and wheel, use a brake adjusting tool to expand the lining against the drum.

Hold the self-adjuster lever away from the star wheel, as you did before. Turn the adjuster until you feel a heavy drag while turning the wheel. Then turn the adjuster 16 clicks in the opposite direction.

Road test the car. If the pedal pumps up, air has entered the system and you'll have to bleed it out. Make a number of stops in reverse to equalize adjustment on self-adjusting brakes. If the car doesn't brake satisfactorily after you've made 20 or 30 stops to seat the lining material, go to a professional for assistance.

PM



**Answering Machine Price Breakthrough!**  
**THE "EVERYTHING MACHINE"**  
**FROM COBRA—NOW AT AN**  
**INCREDIBLE LOW PRICE**  
**PLUS A FREE**

**PUSH-BUTTON TELEPHONE**

**Full One-Year Warranty and Ten-Day Trial Period on this Exclusive Offer**



If you're like most busy people and haven't gotten around to picking up a telephone answering machine or if you're waiting for prices to come down, we think we can make it easy for you to decide. The Cobra Remote probably has every feature you could ever use. And you won't have to spend \$250 or \$300 to get those features. Plus, as a completely free bonus, you get a Cobra push-button telephone. Total price: \$149.95.

**LOOK AT ALL YOU GET:**

**FULL REMOTE OPERATION SO YOU CAN CALL IN FOR YOUR MESSAGES ANYTIME FROM ANYWHERE.** Simply call your own phone number from any telephone in the world, "beep" your pocket-size remote device into the mouthpiece, and hear your messages played back to you.

**"VOX" VOICE ACTUATION CIRCUIT TAKES ANY LENGTH MESSAGE.** Your Cobra Remote begins recording an incoming message when it "hears" the caller's voice. It continues to record for as long as the caller talks or until he or she hangs up. And Cobra will take an unlimited number of messages.

**TWO CASSETTES FOR CONVENIENCE AND EASE IN CHANGING YOUR MESSAGE.** Your "hello" message is recorded on one cassette (just by pushing a button and speaking into the built-in microphone). Incoming messages from callers are taken on a second cassette. This gives you three advantages: 1. You need to record your announcement only once, not thirty

times as with some machines. 2. You can change your message at will—push a button and speak. 3. You can erase the messages you've already heard and re-use the cassette, or you can file cassettes away to keep a permanent record of your messages.

**EXCLUSIVE 'DISCONNECT DIRECTOR' MEANS NO ANNOYING DIAL TONES TO LISTEN TO.** If a caller hangs up without leaving a message, and a dial tone comes on, your Cobra will know the difference between a dial tone and a voice, and immediately stop recording.

**ADJUSTABLE NUMBER OF RINGS.** You can set the Cobra to answer your phone after four rings or two rings to give you the chance to answer the phone before the machine does.

**FREEDOM-OF-CHOICE CALL MONITORING.** If you're busy or not in the mood to talk, let Cobra answer the phone for you while you listen to the caller over the built-in loudspeaker. Then if you do decide to talk, simply pick up the phone yourself.

**RED L.E.D. LIGHT FOR CALLS RECEIVED.** Light will flash if messages have come in while you were away.

**FULL-FEATURED KEYBOARD** Simple and convenient, the Cobra Remote is the only all-push-button machine with all the luxury features including fast forward, fast rewind, and remote rewind.

**FAMOUS COBRA QUALITY AND FULL-YEAR WARRANTY.** We guarantee both the Cobra Remote and telephone for a full year because it is highly unlikely that anything will go wrong. Cobra manufactures these units with the same precision that goes into their famous CBs and cordless phones.

**ABOUT YOUR FREE COBRA PHONE.** You get easy push-button dialing whether you now have Touch-Tone or rotary phones...Automatically re-dials number if busy...Has built-in "HOLD" button...On/off switch for ringer. No wiring needed—just plug in...Save the Telephone Company rental charge—own your phone FREE!

**P. S.** If you think you've found a better value than this, let us know and we'll beat it. We love the Cobra for quality and price, but also carry every brand of phone equipment. Call or write us with your best price.

**THE RIGHT ANSWER**

111 Third Avenue  
New York, NY 10003

**SAME-DAY SHIPPING**  
...If you pay by money order, certified check, or credit card. Outside USA, add First Class postage for 7 pounds, plus insurance.



**ORDER BY PHONE**  
Call 24 hours a day  
**212/734-4455**

**TO: THE RIGHT ANSWER, 111 Third Avenue, New York, NY 10003**

Enclosed is \$ \_\_\_\_\_ for \_\_\_\_\_ COBRA REMOTES WITH PHONES

(@ \$149.95 including FREE phone (Additional phones \$29.95 each.)  
(Additional remote beepers only \$19.95 each.)

Shipping & insurance \$2.95 per order. N.Y. residents add tax.

Charge my: VISA  MC  DC  AM EX  Phone # \_\_\_\_\_

Card# \_\_\_\_\_ Exp Date \_\_\_\_\_

Name \_\_\_\_\_ Signature \_\_\_\_\_

Address (Not P.O. Box) \_\_\_\_\_

City \_\_\_\_\_ State \_\_\_\_\_ Zip \_\_\_\_\_



# EQUIPMENT AND TRAINING NO OTHER SCHOOL CAN MATCH!

**NTS HOME TRAINING INVITES YOU TO EXPLORE MICROCOMPUTERS, DIGITAL SYSTEMS AND MORE WITH STATE-OF-THE-ART EQUIPMENT YOU ASSEMBLE AND KEEP!**

When it comes to electronics home study, no school matches the training you get from NTS.

For example, three microcomputer/microprocessor courses are available to the Electronics Beginner—Tech Writer—Analog Technician & Engineer. For your "hands-on" training, each course includes its associated microcomputer for you to assemble and keep. You will not only become acquainted with the fundamentals of troubleshooting, but also learn to communicate with a computer using



high-level BASIC programming language and Disc Operating Systems (DOS) software.

It's also important to note that our microcomputers are not home-made training devices. They are production model micro-systems, identical to many you'll encounter in the field. We believe this makes your training a lot more exciting and relevant.

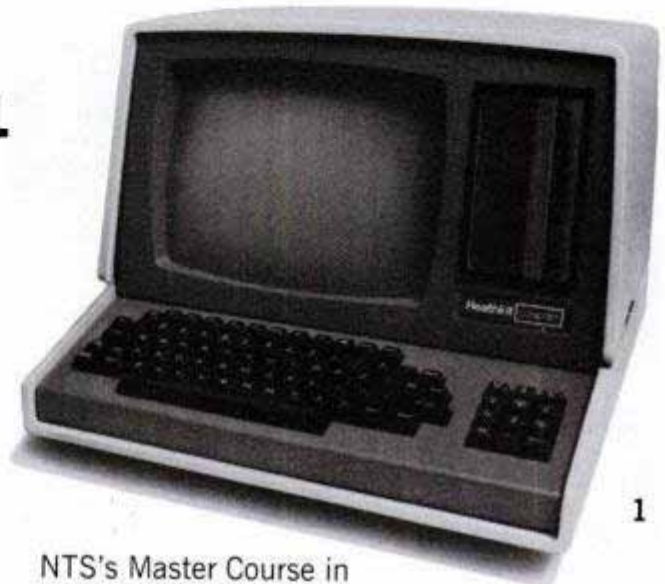

NTS's Master Course in Microcomputers includes the **NTS/HEATH HN89A Microcomputer (#1 above)**. It features floppy disc storage, "smart" video terminal, two Z80 microprocessors, 32K RAM memory expandable to 64K.

The **NTS/Rockwell AIM 65 Dedicated Microcomputer (#2)** is included in our Microcomputer Technology Course. It is a single board unit featuring an on-board 20 column alphanumeric printer with 20-character display. This 6502-based unit also has 4K RAM memory, (expandable,) 8K monitor ROM and 8K advanced BASIC interpreter on ROM. Application Functions: Central Processor—Controller/Monitor—Development System.

The **NTS/SYM-1 Microcomputer (#3)** is a 6502-based CPU-4K bytes ROM (expandable)—1K RAM (expandable) 51 active I/O lines for versatile interfacing disk drives, ASC II keyboards, cassette tape, etc. It is featured in the Master Course in Electronics and Industrial Technology.



## CONSUMER ELECTRONICS—VIDEO SYSTEMS

From the latest state-of-the-art Video Systems Technology, NTS offers its popular Color TV Servicing program. You build and keep the NTS/HEATH 25-inch (diagonal) Digital Color TV receiver as part of your "hands-on" training. Choose Communications and you'll train on an NTS/HEATH 2-meter FM Transceiver which you also build and keep. Most programs also include state-of-the-art test equipment as well as a digital multimeter.



Simulated TV Reception



**AUTO MECHANICS** Few technical fields offer the challenges and opportunities to equal that of the auto industry. To train for it with NTS you'll utilize "shop tested" instruction plus an impressive array of professional equipment, including a solid-state automotive oscilloscope. You'll learn engine diagnosis, motor overhaul, transmissions, and much, much more.



**AIR CONDITIONING/HEATING.** Equip yourself for opportunities in one of the most essential industries in the world. Learn servicing of commercial, industrial, and residential heating and cooling equipment. Your course includes such equipment as a hermetic unit analyzer, leak detector, and charging-testing-purging manifold set.



**HOME APPLIANCES** Here's an excellent full, or part-time opportunity with real potential. Saves you money on your own repairs, too! Course covers repair and servicing of washers, dryers, ranges and small appliances. Your equipment includes NTS's amazing circuit trainer, plus a multimeter for testing purposes.

For 77 years NTS has provided quality home training for thousands of students around the world. We look forward to helping you develop important new skills the proven NTS way. Take advantage of this opportunity now. Send the card or coupon today for a free color catalog in the field of your choice. We'll send complete details by return mail.

NO OBLIGATION. NO SALESMAN WILL CALL



TECHNICAL TRADE TRAINING SINCE 1905  
Resident and Home Study Schools  
4000 SO. FIGUEROA ST., LOS ANGELES, CA. 90037

**NATIONAL TECHNICAL SCHOOLS** Dept. 201-033

4000 South Figueroa Street, Los Angeles, CA 90037

Please send FREE color catalog on course checked below

- |   |   |
|---|---|
| <input type="checkbox"/> MicroComputers/MicroProcessors | <input type="checkbox"/> Color TV Servicing |
| <input type="checkbox"/> Communications Electronics     | <input type="checkbox"/> Auto Mechanics     |
| <input type="checkbox"/> Digital Electronics            | <input type="checkbox"/> Air Conditioning   |
| <input type="checkbox"/> Industrial Technology          | <input type="checkbox"/> Home Appliances    |

Name \_\_\_\_\_ Age \_\_\_\_\_

Address \_\_\_\_\_

Apt. \_\_\_\_\_ City \_\_\_\_\_

State \_\_\_\_\_ Zip \_\_\_\_\_

- Check if interested in G.I. information.  
 Check if interested ONLY in classroom training in Los Angeles.



# PM ELECTRONICS MONITOR



## Ham band expansion—when?

"A treaty has no meaning at all," a calm voice explained to us over the telephone, "until it has been ratified." We were speaking to James McKinney who is the Federal Communication Commission's Chief of the Private Radio Bureau. We were discussing WARC-79 (the World Amateur Radio Conference which was held in 1979) and what results it has had to date.

WARC-79 allocated three new, worldwide amateur radio bands (sets of frequencies). Many radio amateurs (or hams) expected that it wouldn't be long before they could fire up and begin using these new frequencies. Instead, they've waited three years already and only one of the new bands has been authorized.

Meanwhile, many thousands of amateurs have purchased equipment capable of operating on the new frequencies. The manufacturers, it seems, are much more efficient than the legislators.

What's interesting is to see just how slowly the government moves (some would say, *must* move) in a case such as this.

First, WARC-79 itself presented a pretty "iffy" situation. Many amateurs expected they would lose frequencies, rather than gain them. But when the dust settled, the 10-, 18- and 24-MHz ham bands looked to be a near-reality.

The first "expected" delay came when the WARC nations took half a year to write up their full treaty. The FCC received the treaty in the fall of 1981 and presented it to Congress. The same Congress that quickly passed a multimillion-dollar appropriation to study the issue of the snail darter fish has already waited a year and a half to act on ratifying the WARC treaty.

"I do expect that Congress will act early in the next session," McKinney told us. They were almost ready to discuss it, he said, when they broke the last session.

The American Radio Relay League (ARRL), which claims to represent the United States' amateur population, successfully lobbied the FCC to assign at least the 10-MHz frequencies on a temporary basis. The FCC felt that, in this

instance, it could grant the privileges since the frequencies were slated to be shared—and as 45 other countries had *already* given those frequencies to their ham populations. But the other two bands of frequencies will remain unutilized until the Senate gets its act together.

The ARRL, which is to be commended for getting what it did, puts a brave face on it. "We're happy with progress so far," ARRL's Hal Steinman told us, "but would have liked to have seen it sooner."

In the past, radio amateurs, through their unstinting and unpaid efforts, have been responsible for many worldwide disaster communications—more times than a complete magazine could detail.

And technologically, hams have made contributions to every facet of the radio and TV art. Suffice it to say that we all owe these electronic innovators a large debt.

But what of tomorrow's radio and TV pioneers? It seems appropriate for the United States Senate to act in a much speedier manner than it has demonstrated so far.



**HERO-1**, or *Heath Educational Robot One*, is a futuristic house pet. Building him is a complete course in robotics.

## Here comes HERO-1

Heath has announced a new kit—an electronic robot. HERO 1 (Heath Educational Robot One) incorporates many of the systems found in industry, but you can take HERO home. The 20-inch-tall robot has a computer and sensors to detect light, sound, motion and obstructions. We're building one now; look for his report card soon. **PM**



### The lights—fantastic!

*Lighting a video set is crucial. The set light, above the subject, helps to light up surroundings. The backlights separate subject from background. The*

*key light gives the main "direction" of light—shadow detail. The fill light ensures accurate highlights. Perfect lighting means perfect videotapes.*



Ultra Kings, 2 mg. "tar", 0.3 mg. nicotine; Lights Kings, 9 mg. "tar", 0.8 mg. nicotine av. per cigarette by FTC method; Filter Kings, 16 mg. "tar", 1.1 mg. nicotine av. per cigarette, FTC Report Dec. '81.

Warning: The Surgeon General Has Determined That Cigarette Smoking Is Dangerous to Your Health.



## There's only one way to play it...

Wherever the music is hot,  
the taste is Kool. At any 'tar' level, there's  
only one sensation this refreshing.



Original

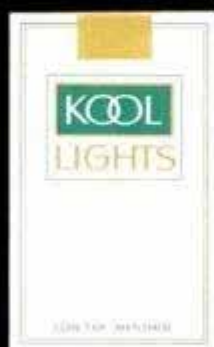

Low 'tar'



2 mg.



# THE PM GARAGE



## Good for openers

You can't appreciate an electric garage door opener until you have one. Now I don't have to get out of the car to go through the hassle of opening the door every time I use my car. This new model from Alliance Manufacturing, makers of the Genie automatic door openers for close to 30 years, is dubbed the Trac-Drive GS 840. It features a unique, nylon tape-drive system instead of the usual chain or worm-gear drive method. The new material allows for quieter operation, less maintenance (the nylon is permanently lubricated), and smoother operation since there is no chain slack and the nylon remains flexible in cold and freezing weather.

Other convenience features are in-house pushbutton operation, an outside radio control actuator, built-in safety reverse, a quick-release tether to disengage the drive in an emergency and four

lights that stay on for two minutes, 16 seconds after the door is activated.

It took only two hours to install, even though I had to fabricate my own hangers from angle iron and strap. Genie has a toll-free line for installation problems or questions (800-321-0885).

The new GS 840 that we tested retails for \$229 with one radio control. Write to Alliance Manufacturing Co., Alliance, Ohio 44601.—*Joel Breault*

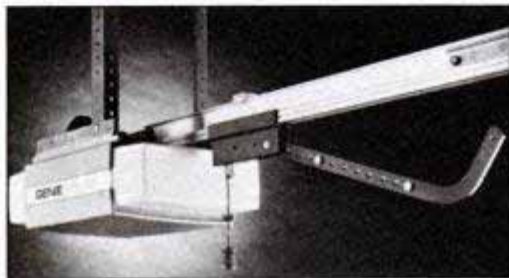

*Trac-Drive garage door opener has a nylon tape drive system rather than chain or worm-gear.*

## Quick circuitry

If you've ever stuck yourself while using the ice pick-style circuit tester, there's a good chance you'll appreciate Schu-Kay's Quickee Circuit Tester. This tool eliminates the possibility of sticking yourself, puncturing upholstery or snagging the dash as you check for current in such wires as power windows, stereo hot leads, trailer wire harnesses and so on.

The fluorescent yellow tool is easy to use. The tip has a hook designed to reach enclosed places or under the dash to grasp wires. A sharp steel rod is enclosed within the tool's housing and is trigger-activated at the handle. A



*Hook at end of new tester makes it easy to grab wires when testing for continuity.*

5-foot ground wire with 3/4-in. clamp provides room to find a suitable ground.

After grounding, all you do is hook the test wire, pull the trigger to push the steel rod into the wire and the light in the handle will glow if the lead is hot.

The retail price is \$12.50 including shipping. Contact Schu-Kay Inc., Box 19343, Cincinnati, Ohio 45219.—*Joel Breault*

## Mirrorized goggles

If you're tired of the usual goggle lenses, look at these new mirrorized eye protectors from MXL Products.

The goggle housings are available in red, blue, yellow or black. Lens choices are clear, smoke, amber and the new mirrorized model. The lenses are treated to be fog-free on the inside and scratch-resistant. The goggle housing has built-in vents and are large enough to fit over most eyeglasses.

MXL Products are at motorcycle dealerships or ski shops. The price is \$21 for the complete goggles. Replacement lenses cost \$7 for the mirrored jobbers and \$5 for the others.

To obtain an MXL Products catalog of



*Goggles from MXL are scratch-resistant.*

riding gloves, goggles and the like, send \$2 to National Hydron Inc., 1764 Rohrerstown Rd., Lancaster, Pa. 17601.—*Joel Breault*

## Big foot

If you own a motorcycle, you're probably familiar with that sinking feeling that comes from watching your bike fall over after you park it on hot tarmac or too-soft sand. You can reduce the chances of your bike's toppling over by increasing the surface area of the kickstand. The All-Safe Boot does just that.



*Plastic boot increases contact patch of a kickstand to keep bike from tipping.*

The flexible rubber cover merely slips onto your kickstand to increase the size of its footprint. Although the product wouldn't fit onto the kickstand of my Yamaha Vision, it did work well on one of my dirt bikes. It will also work on bicycle kickstands.

The boot costs \$4 from Clyde T. Johnson Assoc., Drawer 100, Escanabe, Mich. 49829.—*Joel Breault*



# DODGE RAM MISER



**AT \$5989\* IT'S A LOT MORE TRUCK FOR A LOT LESS MONEY THAN FORD RANGER OR CHEVY S-10.**

**More power, bigger payload, greater range and better equipped for hundreds less than Ford Ranger or Chevy S-10.**

## DARE TO COMPARE RAM MISER VS. THE COMPETITION

	Dodge Ram Miser	Ford Ranger	Chevy S-10
<b>Price</b>	<b>\$5989*</b>	<b>\$6321*</b>	<b>\$6343*</b>
GVW rating (lbs.)	4800	3740	3443
Payload (lbs.)	1465	1210	1000
Galvanized steel	310 sq. ft.	50 sq. ft.	265 sq. ft.
Std. Engine (liters)/Cylinder	3.7L/6	2.0L/4	1.9L/4
Fuel tank (gal.)	20	15.2	13.2
Est. hwy./EPA est. mpg	30 [21]**	36 [26]**	39 [27]**
Range†	600 [320]**	547 [412]**	515 [370]**
Box—Inside length	76.9"	72.2"	73.1"
Inside width	70.0"	54.3"	59.1"
Width between wheelhouse	51.0"	40.4"	39.9"
Cubic capacity	61 cu. ft.	37 cu. ft.	35 cu. ft.
4-speed manual overdrive transmission	Standard	Not available	Not available

## Compare Miser's Std. Engine To Ford's And Chevy's Largest Engines

	Dodge Ram Miser	Ford Ranger	Chevy S-10
Engine (liters)/Cylinder	3.7L/6	2.3L/4	2.8L/6
Additional Cost**	No Charge	\$112	\$490
Max. torque (lbs. ft.)	175	124	145
Est. hwy./EPA est. mpg	30 [21]**	33 [25]**	34 [23]**

\*Base sticker price. Title, taxes, dest. charges extra. Comparisons apply to Ford Ranger, not Ford Ranger S.  
 \*\*Use EPA est. mpg number for comparison. Your mileage range may vary depending on speed, distance and weather. Actual hwy. mileage and range probably less. CA est. lower. Range = EPA est. x tank cap.  
 †Greater range is based solely on fuel tank capacity. \*\*Based on comparison of manufacturer's suggested retail prices. Chevy S-10 includes required power steering.

Why spend your hard-earned dollars on a compact pickup when you can get America's best equipped, highest gasoline mileage, standard full-size pickup for less money?

Dodge Ram Miser gives you man-sized cab comfort for three adults, handsome trim detailing and big-job hauling capacity. The competition just doesn't measure up. Look at the chart (at lower left) and compare Ram Miser's standard 6-cyl. engine to Ford Ranger's and Chevy S-10's maximum engines.

Best of all, Ram Miser's a Ram Tough Dodge, built to last with the most rust-fighting galvanized steel in critical areas. There may never be a better time

than now to buy or lease a new Ram pickup at your Dodge dealer: we're building our trucks like we never did before.

Walt Garrison, Pro football and rodeo star, Dodge truck owner.



**"When you've got a load to haul, you need a truck, not a toy. Get a Dodge and put your money where the muscle is."**



**RAM TOUGH**



THE NEW CHRYSLER CORPORATION  
 QUALITY ENGINEERED TO BE THE BEST



# STEAM ENGINES

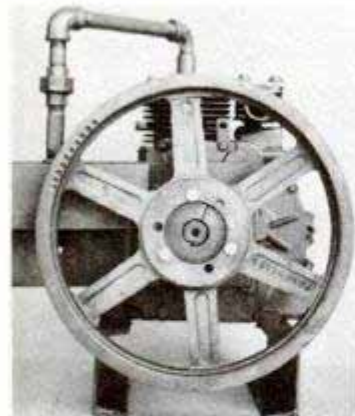

## Woodfired Boilers

### STEAM POWER FOR:

- ELECTRIC GENERATION
- WATER PUMPING
- WASHING MACHINES
- GRAIN GRINDING

- Plans for homebuilders, including converting gasoline engines to steam!
- Simple electrical generators that run off your woodstove!

Complete Catalog \$5.00 U.S. To:

## STEAM POWER PRODUCTS

P.O. BOX 5982, TALLAHASSEE, FL 32301

## TILLER USERS...

Can your machine do all of this?

- ★ Handle with just ONE HAND.
- ★ EVENLY break, turn & till soil.
- ★ Shred vegetation without tangling.
- ★ Leave NO WHEELMARKS or FOOTPRINTS.

The TROY-BILT® ROTO TILLER-POWER COM-POSTER can do all this and more! That's why serious gardeners consider it the finest tiller available. See for yourself! For complete details, "OFF-SEASON" SAVINGS, and FREE 26-page booklet clip this and mail today to:

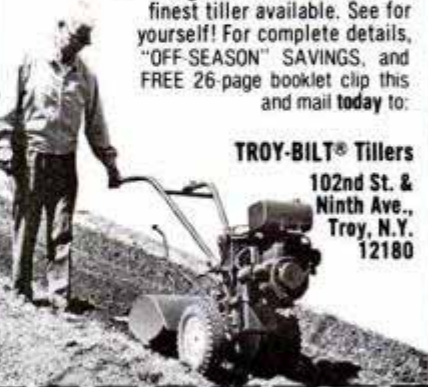

**TROY-BILT® Tillers**  
102nd St. &  
Ninth Ave.,  
Troy, N.Y.  
12180

TROY-BILT® Roto Tiller-Power Composters  
Dept. A1686  
102nd St. & 9th Ave., Troy, N.Y. 12180

Please send the whole wonderful story of TROY-BILT® Roto Tillers including prices and "OFF-SEASON" SAVINGS now in effect for a limited time.

(Please Print Clearly)

Name \_\_\_\_\_  
Address \_\_\_\_\_  
City \_\_\_\_\_  
State \_\_\_\_\_ Zip \_\_\_\_\_

© 1983 Garden Way



The press gave it a shot.

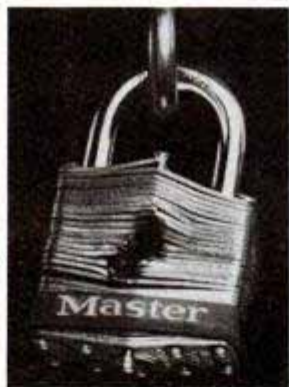

The police made us a target.

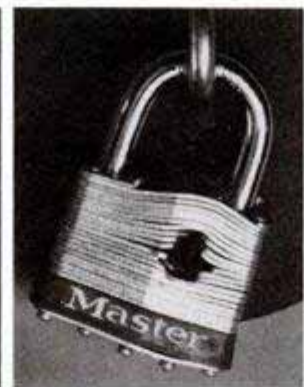

A consumer advocate fired away.

## MASTER TAKES SNIPERS' BEST SHOTS.

Newspapers, magazines, police departments, even a famous consumer advocate all thought it looked too good to be true. So they duplicated our amazing TV demonstration. They gave it their best shot, blasting Master padlocks with high-powered rifles. And in dozens of documented cases, the locks held tight — even after sustaining considerable damage. Bullet proof . . . that Master locks really are tough under fire!

 **Master Lock**  
Tough under fire.

**BEAT the HIGH COST of LIVING!**

**HERE IS A BEAUTIFUL WAY TO MAKE MONEY!**

**UPHOLSTERY BOOKLET MAILED FREE!**

**LEARN UPHOLSTERY AT HOME** . . . restore old chairs, sofas to like-new condition! A clean, enjoyable way to put spare hours to profitable use. Old cast-offs picked up for dollars, worth hundreds when reupholstered. Fascinating home study course includes tools, kits, supplies. Earn as you learn — start your own business!

**SEND FOR OUR FREE BOOK TODAY! YOU'LL GET A BIG ILLUSTRATED 24 PAGE BOOK ON UPHOLSTERY** and the upholstery business and a sample lesson showing how the fabulously successful MUI system is taught. It costs you nothing to get the information and there's no obligation. No salesman will call.

Modern Upholstery Institute,  
80120 Field Bldg., Kansas City, Mo. 64111

**GET STARTED NOW • MAIL THIS COUPON TODAY**

Modern Upholstery Institute,  
80120 Field Bldg., Kansas City, Mo. 64111

Please mail me a copy of your book, "PROFESSIONAL UPHOLSTERY for Fun and Profit." I understand no one will call and there is no obligation.

Name \_\_\_\_\_ Age \_\_\_\_\_  
Address \_\_\_\_\_  
City \_\_\_\_\_ State \_\_\_\_\_ Zip \_\_\_\_\_





**Spiral Stairs.**  
Before you invest  
hundreds of dollars  
send for our Handbook.

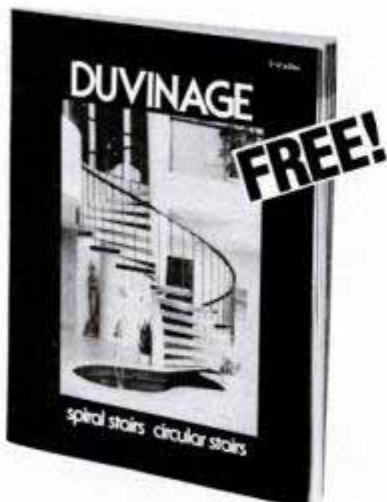

Learn everything you need to know about  
the finest spiral and circular stairs (shown in  
beautiful room settings). Mail coupon today  
for our free, full-color catalog.

Duvinage Corp. Box 828, Hagerstown, MD 21740

Name \_\_\_\_\_  
Address \_\_\_\_\_  
City \_\_\_\_\_ State \_\_\_\_\_  
Zip \_\_\_\_\_ Phone (\_\_\_\_) \_\_\_\_\_  
Area Code **PM-3-83**

# WE'LL PAY YOU \$1.00 TO STOP LEAKING ON YOUR GARAGE FLOOR.



America, you're leaking.  
In your garage, on your  
driveways and all over  
the road.

Now through June 30, 1983,  
we'll pay you \$1.00 to buy  
Wynn's® Engine  
Stop-Leak and  
Wynn's Transmis-  
sion Treatment.



They'll help rejuvenate  
seals and o-rings, help quiet  
your engine down, get you  
running smoother. And help  
stop the leaks.

Get all the details at par-  
ticipating stores.  
Then clean  
up those embar-  
rassing puddles.

WYNN'S FRICTION PROOFING SUPPLY, INC.  
2600 E. Nutwood Avenue Fullerton, Ca. 92631



© WYNN'S FRICTION PROOFING SUPPLY, INC. 1983

Now! Make up to  
**\$12.00**  
PER  
HOUR

In Your  
Own Spare  
or Fulltime



## SHARPENING BUSINESS!

Now you can quickly turn spare time into hand-  
some CASH profits! No selling or previous experi-  
ence required. With this Complete Sharpening  
Shop, you can be your own boss, set your own  
hours! Customers come to you and pay you cash  
to sharpen saws, knives, chisels, scissors, garden  
tools ... all cutting edges.

### 30-DAY FREE TRIAL!

Send today for free facts on our 30-Day Free Trial!  
See how our clear, illustrated instructions and  
proven design make it easy to start earning extra  
income right away! Find out how we finance you  
... help you grow! MAIL COUPON TODAY or  
Call Toll-Free 1 (800) 824-7888 Oper. 642  
In California Call 1 (800) 852-7777 Oper. 642

FREE INFORMATION KIT

FREE  
FACTS

Woodmaster Tools, Dept. 45C, 2849 Terrace  
Kansas City, Missouri 64108

Profits in  
Sharpening

Yes, please rush me free and without obligation your complete  
information KIT and details on your 30-Day Free Trial Offer.

Name \_\_\_\_\_  
Address \_\_\_\_\_  
City \_\_\_\_\_  
State \_\_\_\_\_ Zip \_\_\_\_\_

#1  
**Gas-a-just**<sup>®</sup>  
from  
**KYB**<sup>®</sup>



Bobby Unser, 3-time Indy 500  
winner, says: "Gas-a-just has  
built-in features that make the  
difference in *eliminating* per-  
formance fade and giving you  
'first mile' road control for the  
length of your ride."

- in gas shock sales
- in shock absorber performance

*Performance fade is built out...  
road control is built-in.*

Gas-a-just's one-tube design seals in high pressure gas  
and fluid, but separates them with a patented divider  
piston so they cannot mix. And Gas-a-just contains  
absolutely no air. Performance-reducing aeration is  
*completely eliminated*. You stay glued to the road.

In other kinds of shocks with their two-tube design, air  
or gas can mix with fluid. Performance can fade.

No wonder more motorists have replaced worn shocks  
with Gas-a-just than any other gas shock absorbers.

**Gas-a-just**<sup>®</sup>

Pioneers in gas shock technology  
**KYB Corporation of America**  
901 Oak Creek Drive, Lombard, IL 60148





**WRANGLER RULES THE ROAD.**



# WRANGLER RADIALS. ALL-SEASON. ALL-TERRAIN. ALL-POSITION.

Some light truck tires only do one thing well. If they're good off-road, they squirm on the highway. Or maybe they're good in clear weather, but in rain or snow they're completely out of their element. The solution? All-season, All-terrain, All-position Wrangler Radials. From Goodyear, #1 in radials.

Wranglers are tough year-round. Tough on all kinds of terrain. With longer tread life and greater strength than our bias-ply tires. And because Wranglers are all-position, there are no changeover problems.

Wranglers have won big at off-road races from the Baja to Riverside. On everything from mini-pickups to half-ton haulers. On the tires you buy. That's proven ruggedness.

So why choose between highway performance and off-road grit?  
Just choose Wrangler. You'll get it all.



**GOODYEAR**  
Quality and Innovation



# “Here’s how to save hundreds of dollars on new furniture. Don’t buy any.”

—Homer Formby  
3rd generation restorer & finisher

MARCH IS NATIONAL  
FURNITURE REFINISHING MONTH

**New Chest**  
Cost \$400

**Refinished Old Chest**  
Cost \$85  
Furniture Refinisher \$20  
**Total Cost \$105**

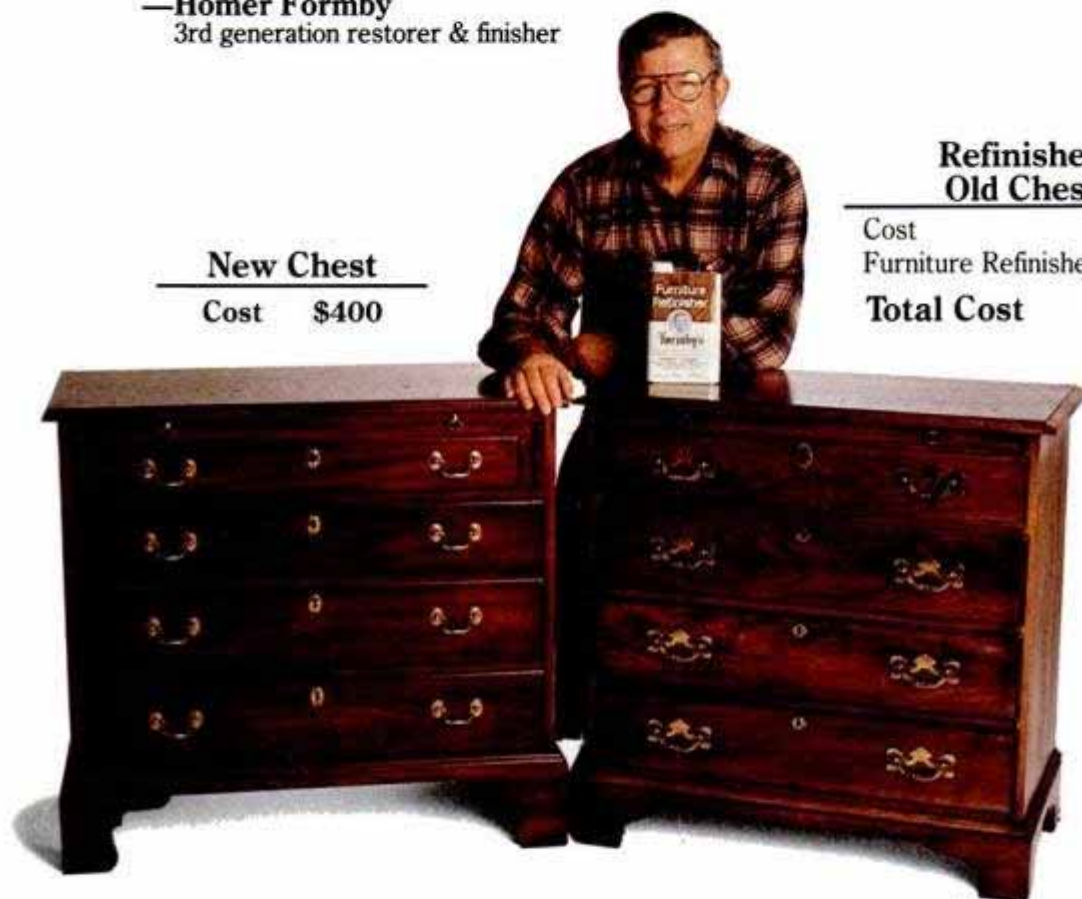

Have you priced furniture lately? Whew! It's not sticker shock—it's sofa shock! Even worse, it's almost impossible to find real quality and craftsmanship at *any* price. That's why so many people are looking for fine old furniture, and then refinishing with Formby's® Furniture Refinisher.

### My Refinisher to the rescue.

Formby's Furniture Refinisher rescues the beauty in fine old furniture. Beauty that's buried under layers of discolored varnish, lacquer and shellac. The darkened old finish actually dissolves before your eyes, as you watch the marvelous original color and grain reappear.

*Now don't use a paint stripper on varnish, lacquer, or shellac.* You'll remove everything, even the color from wood. Formby's Furniture Refinisher *restores*—it even recaptures the patina, the warm glow that only time creates. With no sanding or scraping whatsoever.

After you refinish, protect your investment with Formby's Tung Oil Finish. You can easily hand-rub a fine finish that both protects and enhances the grain.

### Two kinds of rewards.

How gratifying to bring back the original glory of a neglected old chair, desk or chest! And how satisfying to

recognize this triumph is also a smart financial move. You've created something that will only go up in value.

### Right under your nose.

Your attic or basement probably has furniture that's ready for the miracle of refinishing the Formby way. Flea markets, garage sales and antique shops are overflowing with candidates. Take advantage of these bargains.

After all, the smartest way to redecorate is to refinish.

For a copy of Homer Formby's Furniture Fact Book, write to:  
Formby's,  
P.O. Box 667, Olive Branch,  
Mississippi 38654.

## Formby's

No one knows wood as good.™

Formby's is a registered trademark of Formby's Inc. © 1983 Formby's Inc.



Formby's products are available at better paint, hardware, home centers and department stores.



# THE PM WORKBENCH



## Well-organized fastener storage

The new fastener storage cabinets from Reid Tool Supply Co. have many features that do-it-yourselfers and pros will appreciate. Made from cold-rolled steel and finished with acid-resistant enamel, this system has removable drawers with latching lids and handles.

Divider trays for separating items come with 24, 16 and 12 compartments. Without trays, the  $2 \times 9\frac{1}{4} \times 13\frac{1}{8}$ -in. drawers are large enough for storing hand tools. Cabinets and drawers are sold separately—the two-drawer cabinet for \$25.95, the four-drawer model for \$34.95 and the six-drawer model for \$46.95. Add \$8.95 for each drawer. From Reid Tool Supply Co., 2265 Black Creek Rd., Muskegon, Mich. 49444.—H.W.

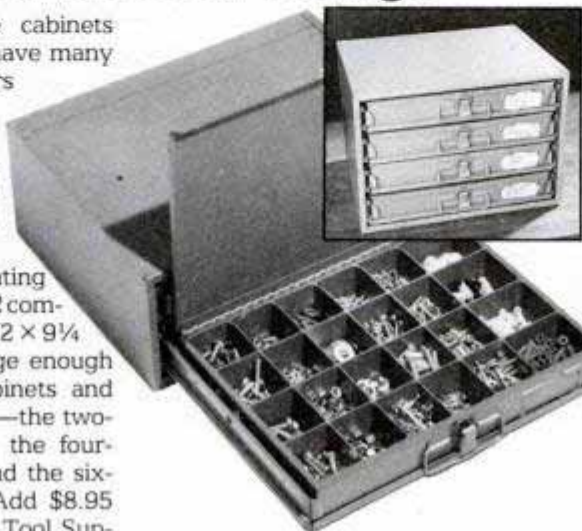

Heavy-duty lids and latches on drawers make the box ideal for on-the-job use.

## Two worthwhile booklets

A couple of good and useful little books recently crossed my desk and I believe PM's active readers will be interested in both. Each contains excellent information written in clear, concise form, and the price is right—one costs just 50 cents and the other is free.

*The Wallbanger Pocket Guide* is a 20-page, step-by-step illustrated booklet covering sidewall application of cedar shakes and shingles. The book gives information about the various shakes and shingles available, tools required for application, advice on handy shortcuts and straightforward how-to that makes the task a relatively easy one. A good value for 50 cents from the Red Cedar Shingle & Hand-split Shake Bureau, Suite 275-PM, 515 116th Ave. N.E., Bellevue, Wash. 98004, this guide shows a do-it-yourselfer how to save 60 percent of normal costs for shake and shingle siding.

*Operator's Safety Manual* is free from the chain-saw manufacturer Husqvarna, 224 Thorndale Ave., PM-383, Bensenville, Ill. 60106. The booklet covers basic chain-saw safety tips and specifics for various work techniques. Topics include a safety checklist, personal safety equipment, a chart showing saw parts, and tips on start-

ing, maintenance, felling, limbing and bucking. If your local Husqvarna dealer doesn't have any booklets in stock, write to the manufacturer.—H.W.

## Three-in-one scissors

Don't let the word "scissors" fool you—the tool shown here can actually cut a quarter in two. Although they look like an ordinary pair of scissors, Omni scissors can be used to cut tin, heavy plastics, nylon and leather. The scissors have a breakaway feature that adds to their versatility. Separated from its mate, one blade serves as an all-purpose utility knife, while the oth-



With breakaway feature built in, Omni scissors serve as three tools in one.

er, serrated blade can be used as a mini-saw.

Priced at \$31.90 postpaid, the scissors come with a one-year limited warranty. Write Omni Scissors, Box 2176-PM, Orange, Calif. 92669.—H.W.

## Palm-size electrical testers

Two hand-size voltage and continuity testers introduced by Triplett Corp., Bluffton, Ohio 45817, feature an internal sensor that protects them against burnout and overload. This new design eliminates the conventional fuse, thus avoiding annoying fuse blowouts.

Model 202 is a good choice for do-it-yourselfers. It has an a.c. voltage range



Snap-in probe and 3-ft. probe lead are convenient for various electrical tests.

of 12, 24, 120 and 240 and a d.c. range of 1.5, 6, 9, 12 and 22.5. The continuity range is 0 to 150,000 ohms (approximately 10,000 ohms at half-scale).

Model 203, for electricians and maintenance pros, has a voltage range of 1.5 to 480 v.a.c. or v.d.c. and a continuity range of 0 to 100,000 ohms (about 7,000 ohms at half-scale).

Model 202 is \$19.50; Model 203, \$24.50, batteries and instructions included. The testers are at home centers and electrical supply houses.—H.W.

If you've come across a new product with some special features, let us know about it. Write to PM Workbench, Popular Mechanics, 224 West 57th St., New York, N.Y. 10019.



INTRODUCING THE TRIM-SIZE

# ALL NEW FORD



Trim new Ford 4-wheeler seats four in comfort. Split fold-down rear seats add extra versatility, plus up to 64 cu. ft.\* of cargo space.

\*Based on SAE specifications.



V-6 engine standard, a V-6 with power the S-10 Blazer can't match. Extra pull for mud and snow. Big 23-gal. fuel tank.



Flip to 4-wheel drive from the driver's seat with auto-lock hub option. In snow or bad weather, shift to 4WD traction and relax.



Материал, защищенный авторским правом.



# BRONCO II



IT'S A BRAND NEW KICK!!



FORD

FORD DIVISION



Built Ford tough, with husky frame and chassis, tested Twin-Traction Beam front suspension. Proven manual or optional auto-lock hubs.



New sporty trim size makes driving and parking easy. Roomy, comfortable interior. Plus independent front suspension for controlled ride.



Perfect size for 4-wheeling—maneuverable Bronco II turns in less space than the S-10 Blazer or Jeep CJ's. Try it... for a brand-new kick!



Get it together—Buckle up



# SATURN V

STATE-OF-THE-ART

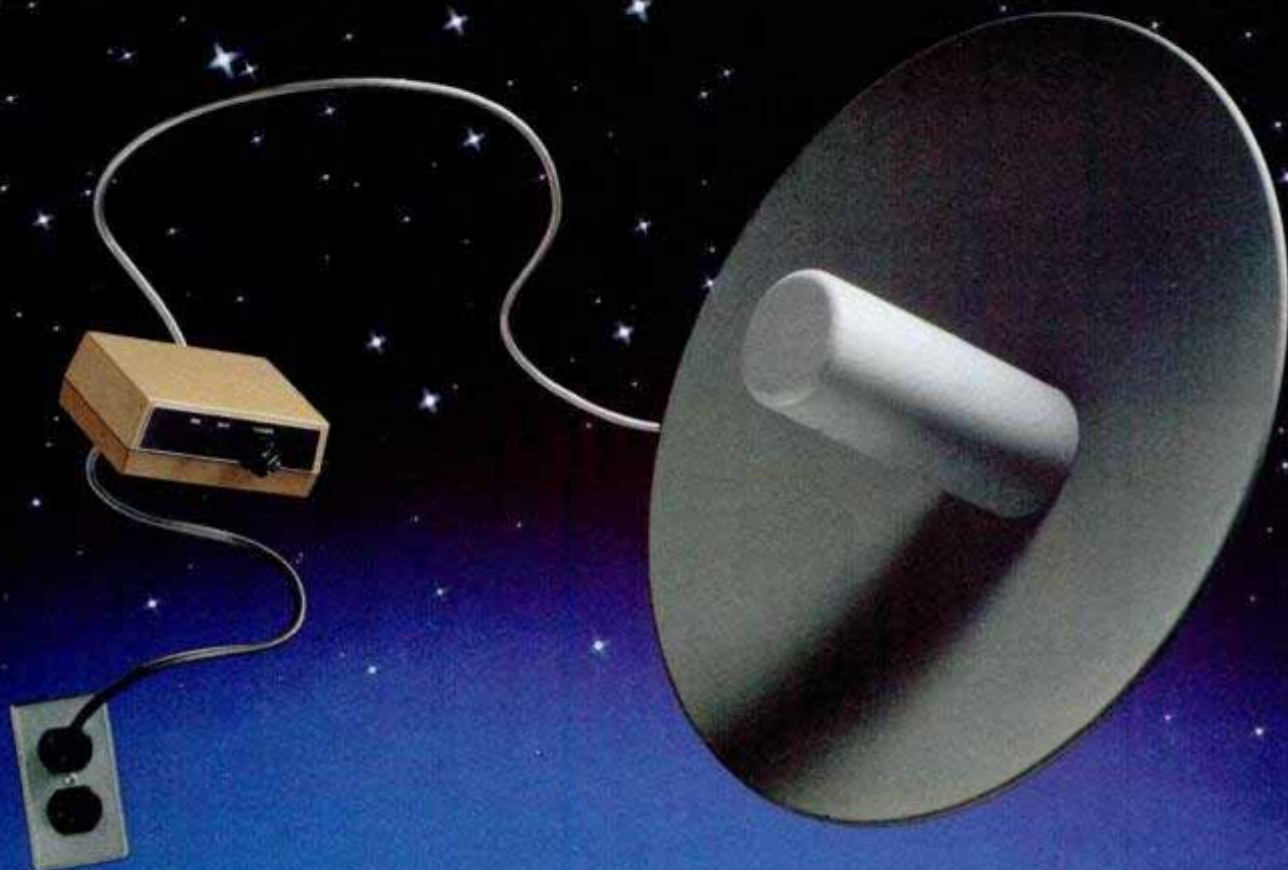

**Free** movies, sports and special events with the Saturn-V deep fringe microwave receiver for homeowners outside the service area of local over-the-air pay TV stations (i.e. HBO, Showtime). The Saturn-V is a high technology microwave downconverter featuring State-of-the-Art electronics for general microwave usage. Receiving range is 65 miles line-of-sight of a local transmitting tower.

PAY TV is distributed in two ways:

1. CABLE SYSTEM to each home. Saturn V **will not** work with this system.
2. PAY TV COMPANIES have a transmitter located on a tall building or tower and broadcasts an over-the-air signal to that entire area. A microwave receiver is mounted on the homeowners TV mast to receive the picture. **Only** with this system **will** the Saturn V work.

**Design/Performance features:**

- Gain 40 db • Frequency 2-2.5 Ghz • Tuning-Channels 2-6 • 20 inch Parabolic antenna • Power supply • 60 ft. cable, cable adapters, brackets and hardware included • Illustrated instructions • full 6 month warranty

For authorized reception of satellite video programming.

Suggested Retail ..... \$245.00  
Spring Special..... \$169.99

Order by UPS-COD save additional \$10.00. Pay only \$159.00. Offer does not apply to Visa or Mastercharge orders.

**ORDERS ONLY:** (no information this number)  
Call Toll Free: 1-800-824-7927.

For information for use of the Saturn-V in your area,  
Call: 1-916-454-2190.

We accept Mastercard and Visa. When ordering by mail, money-orders and cashiers checks only (sorry, no personal checks). Volume prices on request.

*Note: Saturn V will not receive any signal sent from microwave link towers to cable companies. This signal is a higher frequency. Saturn V will not decode or unscramble.*

Microwave and Satellite Systems

**JDL**  
Industries



4558 Auburn Blvd., Suite 208  
Sacramento, California 95841

Serving you today and tomorrow





# FRESH AIR BREAKTHROUGH!

AMERICA'S NEWEST AND MOST POWERFUL BIPOLAR IONIZING-PRECIPITATOR CLEANS YOUR AIR OF HARMFUL, IRRITATING POLLUTANTS BETTER THAN ANY OTHER ROOM IONIZER.

**IF YOU WANT CLEAN FRESH AIR OR YOU'VE UNPLUGGED YOUR POPULAR FILTER-FAN UNIT BECAUSE IT DOESN'T WORK THEN READ THIS...**

Is your indoor air fresh, clean and alive? Indoor air pollution is becoming a national health hazard. Energy efficient airtight buildings are stifled with stale polluted air which includes smoke, dust, pollen, viruses, and bacteria. Most of these pollutants are so small (under 5 microns) that they are not effectively removed by common small filter-fan units. Scientific tests show that these noisy toy-like devices which emit chemical "citrus" odors are no match for high-powered ionizers in thoroughly cleaning indoor air.

## ANOTHER IMPORTANT DIFFERENCE

You know how fresh and vibrant the air feels right after a rain storm, in the mountains, or near a waterfall. That clean, alive fresh air is rich in something important that is greatly depleted in our urban and indoor air. That missing element is negative ions, nature's own air cleaners. *Scientists claim that these amazing active ions are of great benefit to you and can actually make you feel alive, revitalized and alert while often relieving depression, headaches and allergies and even make plants grow better. In addition, hospitals use ionizers in burn units to destroy bacteria and reduce pain.*

Filter fan units do not emit negative ions. The COLLECTOR, by Zestron, creates trillions of these beneficial ions every second, while giving you the best performance, value and technology in air cleaning.

## THE ZESTRON BREAKTHROUGH!

Most ionizers clean your air but leave an untidy deposit of pollutants on room and furniture surfaces near the ionizer. The COLLECTOR by Zestron takes ion technology a giant step forward by giving you superpowered ion output while depositing pollutants from your air on the collector panel. This easy to clean panel features a scientifically formulated surface that electrostatically attracts the vast majority of air-born pollutants to it rather than to the floor or walls near the ionizer. Other bipolar ionizers with porous collecting surfaces that absorb odors and unsightly grime are almost impossible to clean.

## AMAZING DEMONSTRATION!

Unplug your COLLECTOR, place the ionizer unit and an ash tray on top of the panel. Place a lit cigarette in the ash tray and watch the smoke rise into the air. Now plug it in, and amaze yourself and friends as the smoke barely rises above the ash tray and then nose-dives onto the collector panel before it can enter the room air. This is accomplished entirely electronically with no moving parts! The COLLECTOR by Zestron is the only ionizer on the market that cleans the air powerfully enough to accomplish this test.

## ADJUSTABLE OUTPUT

Some people prefer fewer ions at night. The COLLECTOR is the only adjustable bipolar ionizer that allows you to set the ion level to your personal preference.

## THOUSANDS OF SATISFIED USERS

Don't you, your family and friends deserve the healthy clean fresh air that Zestron ionizers have brought to thousands of satisfied users? Users write: "I simply can not believe how much better I feel physically" Dr. E.K., DDS—MA; "I smoke heavily and it has cleared the air as advertised" G.P.—WA; "I haven't taken the top off my nasal decongestant spray since using your product. I was previously a chronic user." G.S.—SD.

When you use your COLLECTOR, you'll quickly feel the difference it makes and smell the freshness in your air. You'll actually see the elimination of smoke and dust in your air!

## SILICON VALLEY TECHNOLOGY

The COLLECTOR, incorporating years of high reliability design experience, is built with quality parts in the heart of Silicon Valley, USA, to give you years of trouble free service. The COLLECTOR operates anywhere in your home or office for pennies a month and has nothing to wear-out or replace.

## SUPERPOWER OUTPUT

The COLLECTOR by Zestron is the only bipolar collecting ionizer with superpower output. The thoroughness and speed of air cleaning increases with more ion output, and Zestron ionizers give you the highest output (without detectable ozone). Check the comparison chart below. Don't buy any ionizer not stating output using the industry standard of ions/cc/sec. at one meter.

IONIZER	ADVERTISED OUTPUT (1 m.) ions/cc/sec.	COLLECTOR
The COLLECTOR by Zestron	1,200,000	YES
JSA Bubble	???	YES
Aspen	???	YES
Orbit	???	YES
AirCarell	236,000	YES
Ion Fountain	540,000	NO
Ion Cloud	350,000	NO
Ionosphere	350,000	NO
Modulian	75,000	NO
Ion Breeze	???	NO

## FREE ION DETECTOR

A FREE remote ion detector comes with each ZESTRON to verify and compare output. When you place the detector next to a ZESTRON and a competitive unit, you will see greatly reduced or no output from the competitive unit!

## SATISFACTION GUARANTEED

Order a COLLECTOR now and try it in your home or office risk free for 30 days. If for any reason you are not satisfied, return the unit for a full refund including return postage. The COLLECTOR has a full one year warranty on both parts and labor excluding abuse.

## ADDITIONAL DEALERSHIPS AVAILABLE

Reorders are pouring in, customers write: "We are enjoying the results of the first one and are ordering two more" Dr. J.B., M.C.—CA; "I'm a distributor for three other ion companies, and have to say I am extremely, extremely impressed!" T.N.—CA.

ZESTRON, the leader in ion technology, has created a unique DEALERSHIP PROGRAM. Call or write for details on this RISK FREE OPPORTUNITY.

## TO ORDER—FREE SHIPPING

Send your check or money order for \$119.95 for one or \$104.95 each for 2 or more (Calif. res. add 6.5% tax) or credit card users may call:

**TOLL FREE: (800) 372-1200** ZESTRON, INC. Dept. M3  
**In Calif.: (800) 392-1200** 667 McGlincey Lane  
**or (408) 371-1200** Campbell, CA 95008



Popular Science Book Club gives you the hands-on how-to you need

*Do it yourself..*

**Take any**

with NO-RISK Trial Membership  
in Popular Science Book Club

**Choose from this giant list of  
best-selling handyman books!**

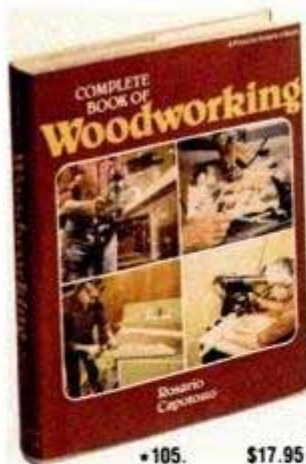

•105. \$17.95



•101. \$12.95

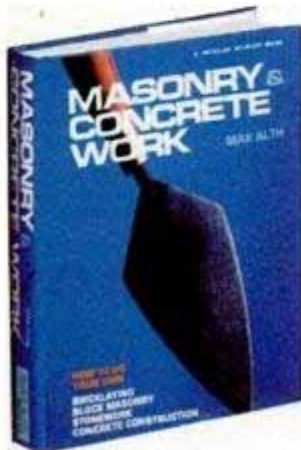

•089. \$14.95

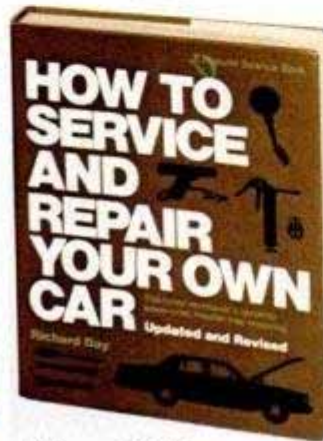

•056. \$14.95

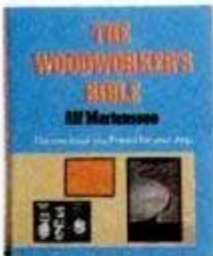

5508. \$17.95



1212. \$27.90  
(counts as 1)



•097. \$13.95

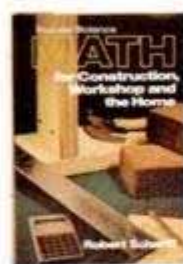

•160. \$22.50  
(counts as 2)



246. \$14.95

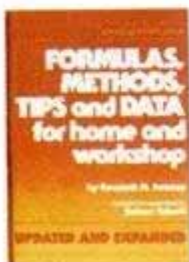

•042. \$17.95

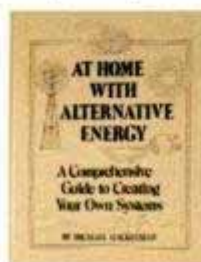

5731. \$12.95

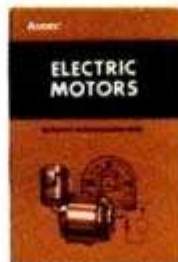

5547. \$8.95

**Enjoy Big Club savings on the  
how-to books you can really use!**

Join Popular Science Book Club and get first choice of the best new handyman books on home repair and improvement, remodeling, wiring, woodworking, furniture building, car and appliance repair, alternate energy, much more. Each is written by a do-it-yourself pro. Each is loaded with illustrated step-by-step instruction you can really use now! Whether you're a beginner or seasoned do-it-yourselfer, these books help save time, effort, dollars every time you use them. As a Club member, you can save up to 50% and more on many special book bargains offered yearly, including original custom-written "Popular Science Books" (see titles with asterisk \*), published specifically for Club members and offered nowhere else at Club discount. To protect your biggest investment—YOUR HOME—these timely books are a must. Choose your three selections and mail the card today!

*Mail attached card today!*



to save plenty on every home repair and improvement job you'll ever do!

and do it right!

3 for just \$3.95

You simply agree to buy just two more regular selections or alternates at regular club prices within a year—from the hundreds of brand new handyman books offered to you each year.

Values up to \$65.80!

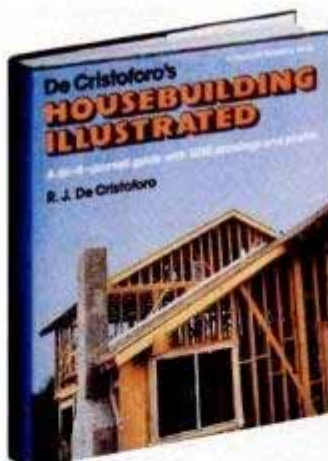

•116. \$19.95

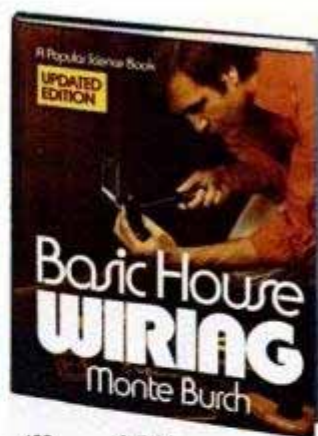

•109. \$15.00

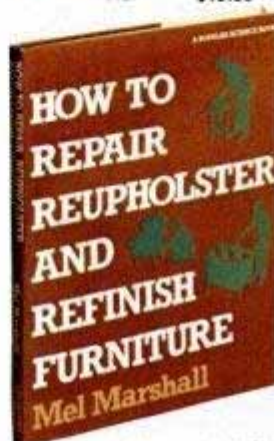

•150. \$13.95

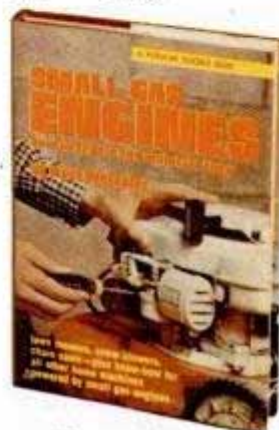

•113. \$12.95

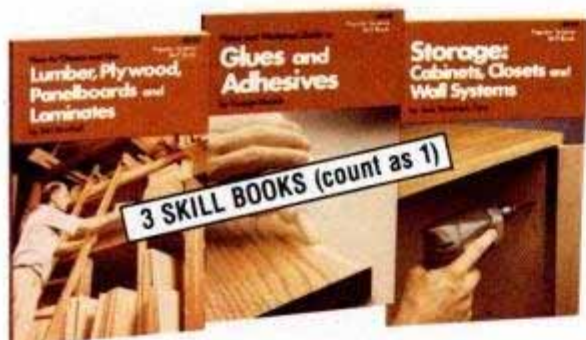

•1208. \$14.85 paperbound



•058. \$12.50

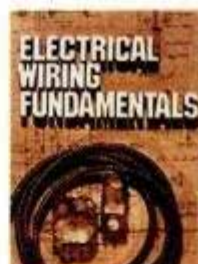

5727. \$10.96

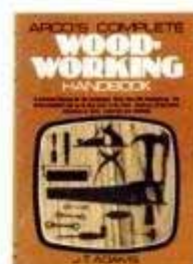

5621. \$19.95

Here's How Your Club Works

First, you get your choice of any three do-it-yourself books shown here for just \$3.95 plus delivery and handling. Simply mail the attached card. Your books will be sent right away along with your FREE 20-IN-ONE SHOP GUIDE.

Then, about every four weeks (15 times a year), you'll receive a Club bulletin describing the coming main selection and alternate books also available. (In addition, up to 4 times a year, you may receive selected mailings on seasonal and annual products of special interest to the membership—many at giant bargains!) If you want the main selection only, do nothing. It will be sent to you automatically. If you don't want the main selection, or want alternate books, or no books, simply indicate your wishes on the handy form that comes with the bulletin and return it by date shown. You will always have at least 10 days in which to do this. But in the unlikely event that you don't have 10 days, and you receive an unwanted selection, you may return it at our expense. Your only obligation is to buy just two more selections or alternates at regular Club prices within a year. After that, your membership may be cancelled by either you or the Club.

**DISCOUNTS:** Club books are comparable in every way to the original publishers' editions, yet you may save up to 50% and sometimes more on many special bargains offered each year in the Club. To become eligible for these bargains, mail the card today!

**NO RISK GUARANTEE:** If not completely satisfied with your three joining selections, after ten days' FREE TRIAL EXAMINATION at home, simply return the books at our expense and your membership will be cancelled. Whatever you decide, the Shop Guide is yours to keep FREE!

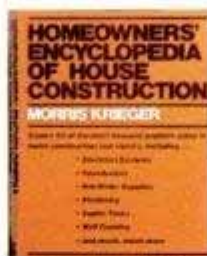

280. (counts as 2) \$19.95

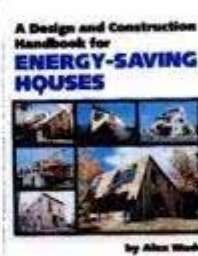

317. (counts as 2) \$19.95

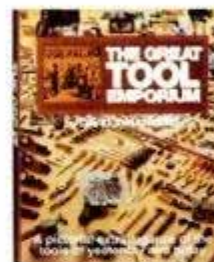

•128. (counts as 2) \$16.95

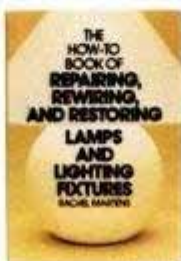

5528. \$13.95



•161. (counts as 2) \$18.95



5548. \$17.95

If card is missing, write to:  
**POPULAR SCIENCE BOOK CLUB**  
P.O. Box 2006, Latham, N.Y. 12111





## Introducing a lawn and garden tractor for the man who doesn't have everything.

This year, John Deere offers a lawn and garden tractor that leaves nothing to be desired. Introducing the John Deere 318, one of the most versatile, well-built machines in its class.

The powerful 318 features hydrostatic drive, improved brakes and axles, and a new twin-cylinder 18-hp engine that combines the cooling ability of a cast-aluminum block with the durability of cast-iron cylinder liners. It has power steering and a tight 26-inch turning radius for greater maneuverability. It also has two hydraulic functions for greater convenience. And a full-pressure oil system for longer engine life.

Options include a 2,000 rpm rear PTO and a Category "0" 3-point hitch, as well as nearly 50 power-matched attachments, including tillers, snow throwers, center- and rear-mounted mowers and just about anything else you'd need, from front blade to backhoe.

Now if all this isn't enough, consider the John Deere 420. With a full 20 hp and a bit more versatility, the new 420 is even better suited to handle the demands of tough grounds maintenance jobs.

With either the 318 or 420, you're getting a tractor that's hardworking, durable and well worth the investment. And if that isn't everything, what is?

For more information, or the name of your nearest dealer, call 800-447-9126 toll free (800-322-6796 in Illinois) or write John Deere, Dept. 50, Moline, Illinois 61265.



Nothing Runs Like a Deere®



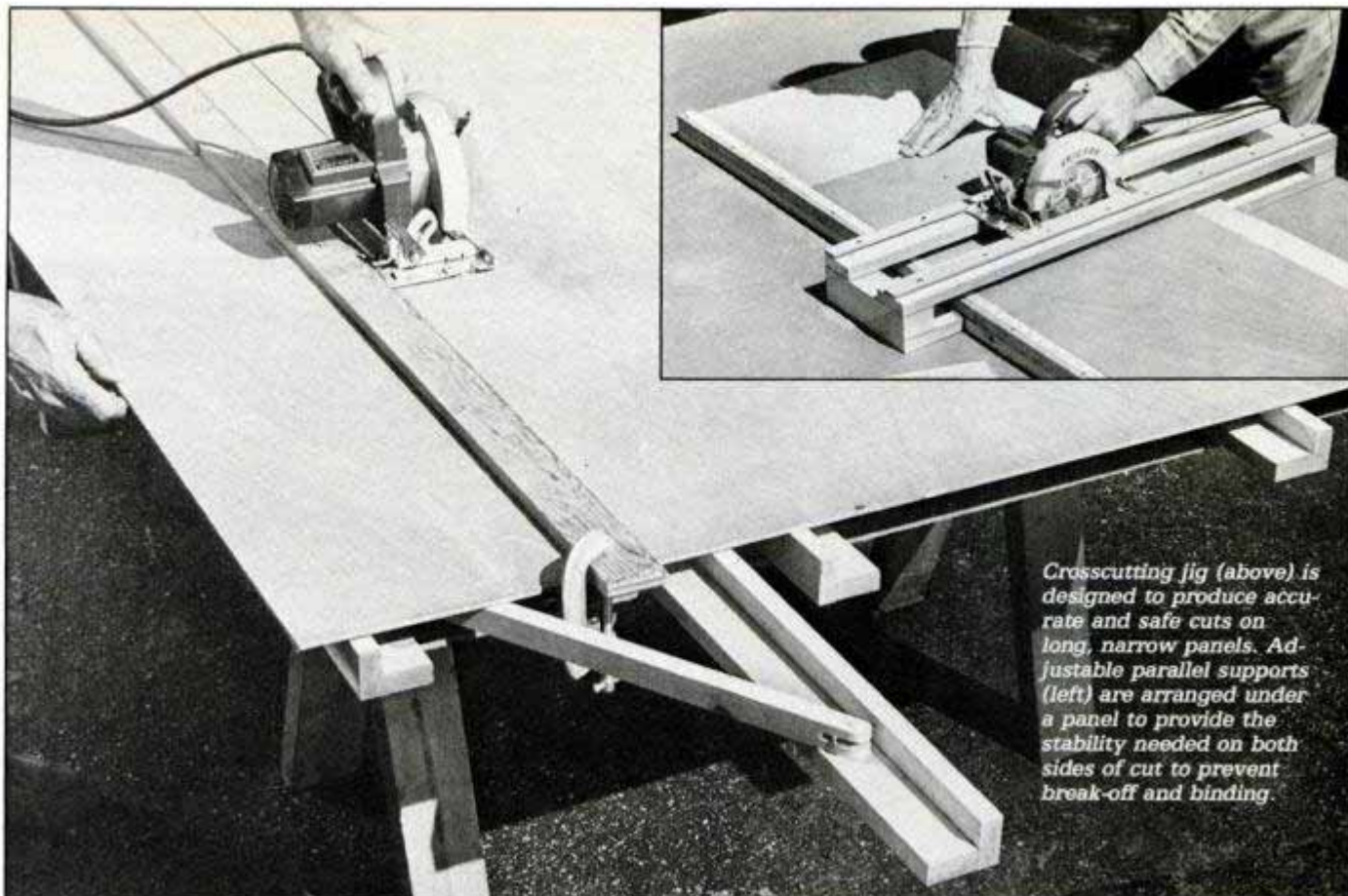

*Crosscutting jig (above) is designed to produce accurate and safe cuts on long, narrow panels. Adjustable parallel supports (left) are arranged under a panel to provide the stability needed on both sides of cut to prevent break-off and binding.*

PM photos: Rosario Capotosto

## 2 Plywood-Cutting Jigs You Can Make

BY GEORGE OBRADOVICH

**M**aking the initial rip in a 4×8 plywood sheet is tricky business for many home woodworkers, even those with table or radial-arm saws—especially when shop space is limited. The size and weight of large sheets often make control clumsy. Crosscutting long, narrow panels can be a scary proposition because most bench saws aren't large enough to support work well and the danger of kickback is high. Here are two jigs designed for coping with the problems of cutting large panels by using a portable circular saw:

### Crosscutting jig

This jig was built for working with panels of any length up to ¾ in. thick and up to 26 in. wide. By altering the width of the base and the length of the saw-guide assembly, you can build the jig to handle wider panels.

Start by cutting the base from a full sheet of particleboard. Attach the pine lattice fence to the mill edge so it is perpendicular. [\(Please turn to page 66\)](#)

### CROSSCUTTING JIG

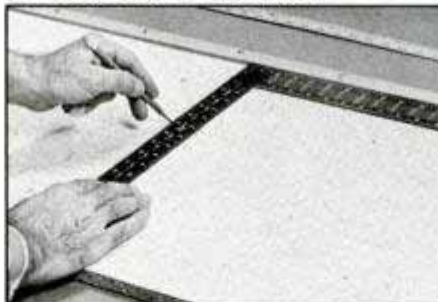

*Mark line-of-cut 30 in. from the right end of the base, using a carpenter's square.*

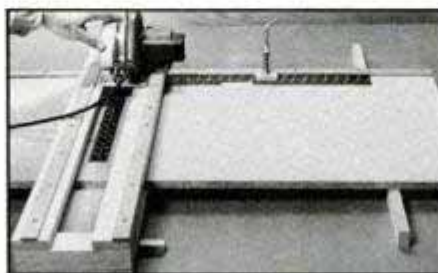

*Lay your square on the cutting mark and pass saw along the guide, adjusting guide position until blade touches square for its length. Then, fasten guide to base.*

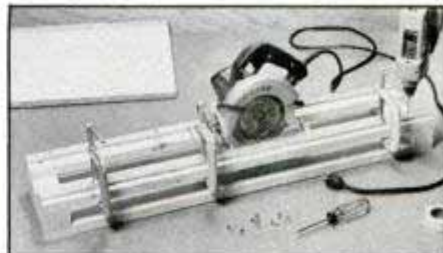

*Use the saw's shoe width to set space between shoe guides. Pass saw between the guides and eliminate any binding or play before fastening the guide strips.*

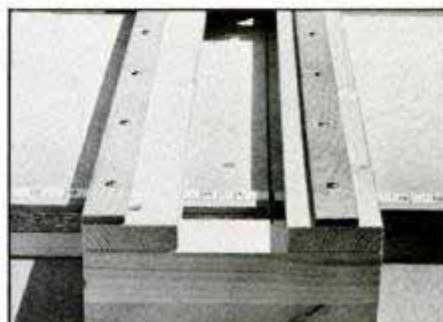

*Tape measures on fence save you the trouble of making layout marks on work.*



## PLYWOOD-CUTTING JIGS

(Continued from page 65)

fectly straight. Don't glue the fence in place; you may wish to replace it as the jig wears. Mark the base with a pencil line to lay out the line-of-cut.

Construct the saw-guide assembly next. Attach spacer blocks at either end of the saw-guide base to create a 1½-in. clearance between the top of the saw-guide assembly base and the bottom of the shoe base supports. Use your saw's base as a spacer for the shoe guides.

Slip the main base into the saw guide assembly and line up the parts to approximate their final positions. Follow the dimensions in the drawing labeled *bottom detail*. Square up the saw-guide assembly with your saw in place, making adjustments until the saw blade follows the line-of-cut already laid out on the base. Then, clamp the main base and the saw-guide assembly base together, flip the jig over and fasten the two components with screws through the bottom of the saw-guide assembly.

Finally, trim two cloth tape measures for mounting on the fence. Cut one to 30 in. and glue it to the right of the cutting mark. Trim the second tape to 42 in. and mount it upside down running to the left of the cutting mark.

### Adjustable parallel supports

The pivoting connectors on this jig allow you to adjust the distance

between the sides to support any size cutoffs and also permit the units to be folded up for storage. Four units like the one shown in the drawing will make it easier for you to cut 4×8 panels.

Cut the pieces for plates, uprights and connectors from defect-free stock.

Lay out centers for the ⅜-in. holes on the plates and connectors and then clamp the connectors in place on the plates, lining up the hole centers. Bore through the connectors and plates at the same time. Number or otherwise code the holes so you can match them

(Please turn to page 69)

## ADJUSTABLE PARALLEL SUPPORTS

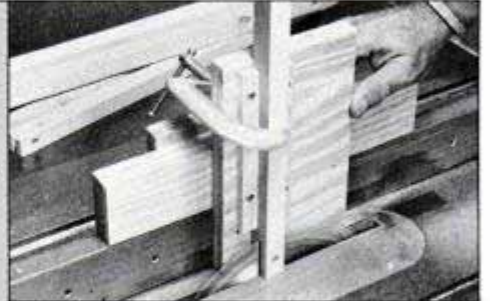
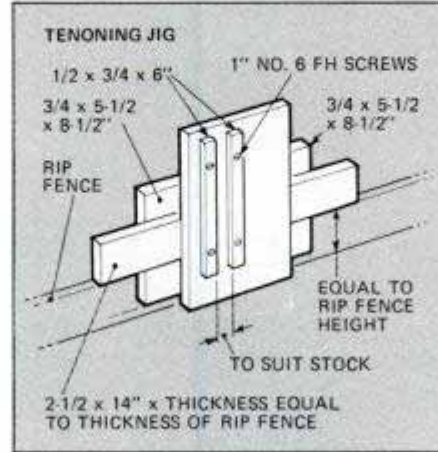

This tenoning jig, built from scrap, rides on the table saw's rip fence and holds the workpiece in a vertical position specifically for cutting a slot in the end.



Crimp one end of dowel pivot pins with pliers and glue them in holes in plates.



Fit end of connector over the pivot while slipping a washer into place in the slot.

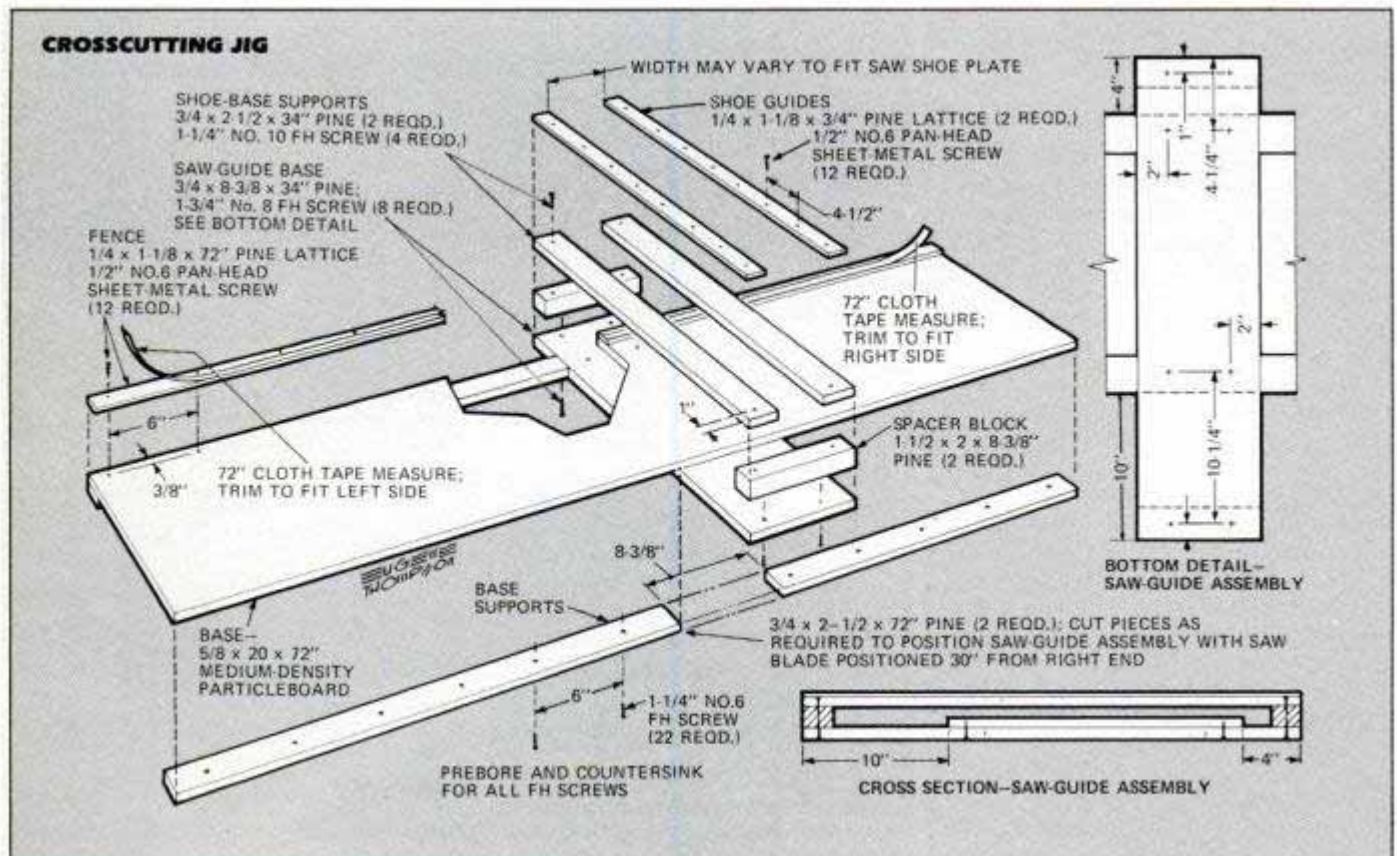



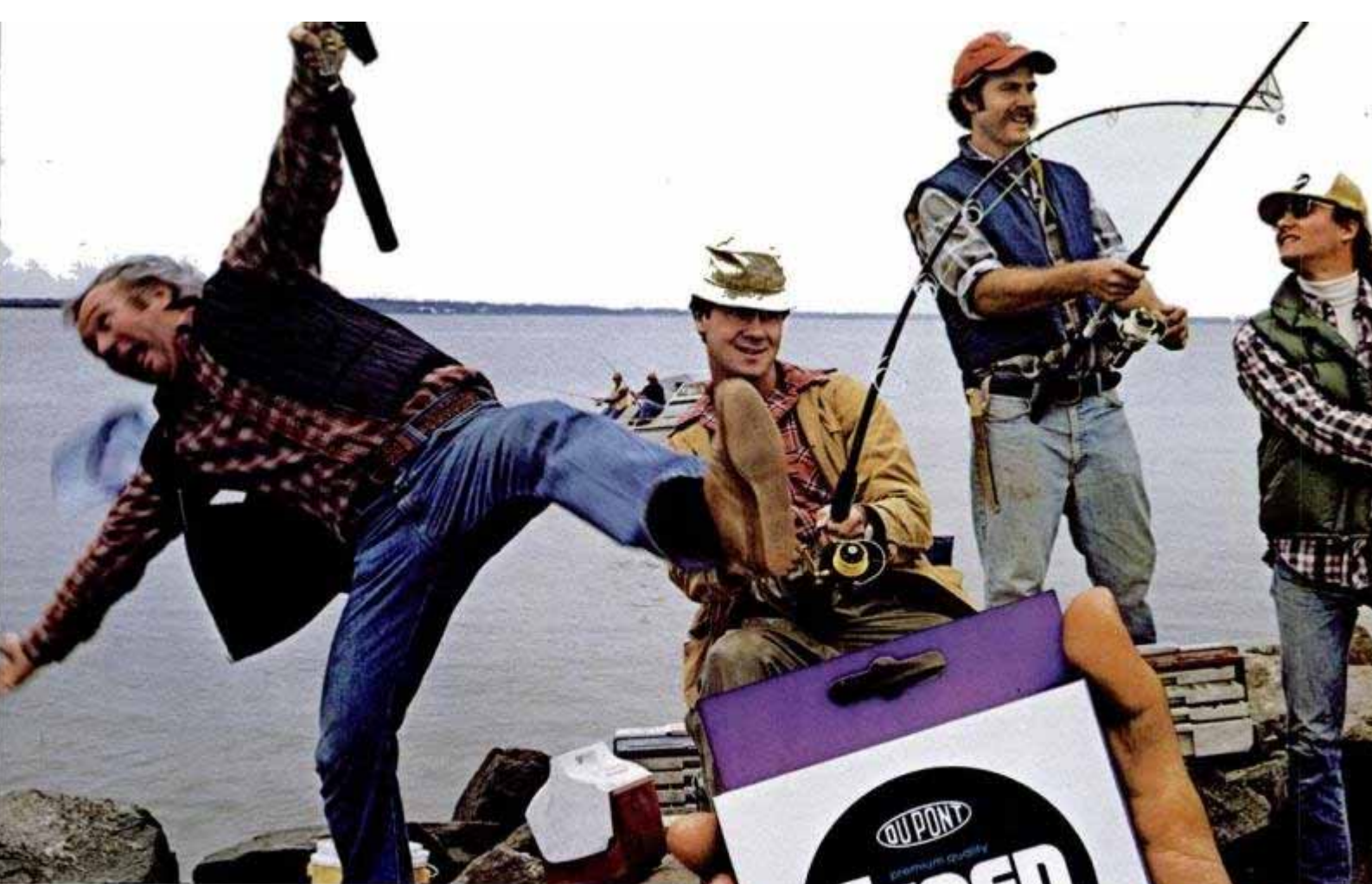

# When a big one's on the line, better fish Stren.<sup>®</sup>

You had him. But your line couldn't hold him. And you lost your balance as well as your fish. Head for the tackle shop and pick up some Stren, the all-purpose line from DuPont.

Because Stren has the unique balance of properties you need for victory at sea. Stiffness to set the hook. Stretch to absorb the strike. And toughness to beat the fish at his own game, cast after easy cast. So go after him again with Stren, the professional's choice. Available in clear/blue, golden, and new clear.

**Great fishing starts with Stren.**





# 23 FOR '83! FORD HITS NEW MPG PICKUP HIGH.



Ford does it again! Sets a new EPA gas mileage rating record for full-size six-cylinder pickups — 23 MPG.



The truck is Ford's fuel-saving F5 model — a big, tough pickup with full comfort for three. The engine, Ford's 300 Six. This husky 4.9L powerplant is more than fuel efficient. It's the biggest — and best-selling — Six in any pickup.\*

**MORE '83 NEWS.** New 6.9L pickup diesel, the most powerful diesel ever in heavy-duty F-250/350 pickups and 4x4's. Plus the 7.5L gas engine in pickups over 8,500 lbs. GVWR. See what's new in pickups — at your Ford Dealer!

\*Based on R.L. Polk & Co. registrations, May 1982.

**33** EST  
HWY

**23** EPA  
EST  
MPG

F5 model with  
4-speed over-  
drive. Use for

comparison. Your mileage may differ depending on speed, distance and weather. Actual highway mileage lower. FS not available in California.

Get it together — Buckle up.

FORD

FORD DIVISION



# AMERICA'S TRUCK

**BUILT  
FORD  
TOUGH**



## PLYWOOD-CUTTING JIGS

(Continued from page 66)

up in the final assembly. After the holes have been bored, ream the holes in the connectors so they'll pivot freely on the dowel pins.

Any of several methods can be used for cutting slots in the ends of the connectors, but if you plan to use a table saw, you should build a tenoning jig like the one shown on page 72. After slots are cut, round the ends of the connectors.

Fasten the uprights to the plates with screws and wood glue. Cut dowel pins, crimp the ends and glue the pins into the plates. Slip the connectors with washers inserted in the end slots over

the pivot pins and check that they pivot freely.

To complete the job, bore pilot holes in the dowel sides and insert nails to serve as retainer pins. **PM**



*Bore a 3/8-in. hole through the pivot and into side of upright. Insert a 2-in. finish nail to serve as a retainer pin.*



*Setup for ripping a 1/2-width from full panel; note clearance left for saw blade.*



*A setup such as that shown here is used to facilitate the making of narrow cutoffs.*



*Four units are arranged like this to make two cuts meeting in an inside corner.*



*Leave space between units along line-of-cut to provide clearance for saw blade.*

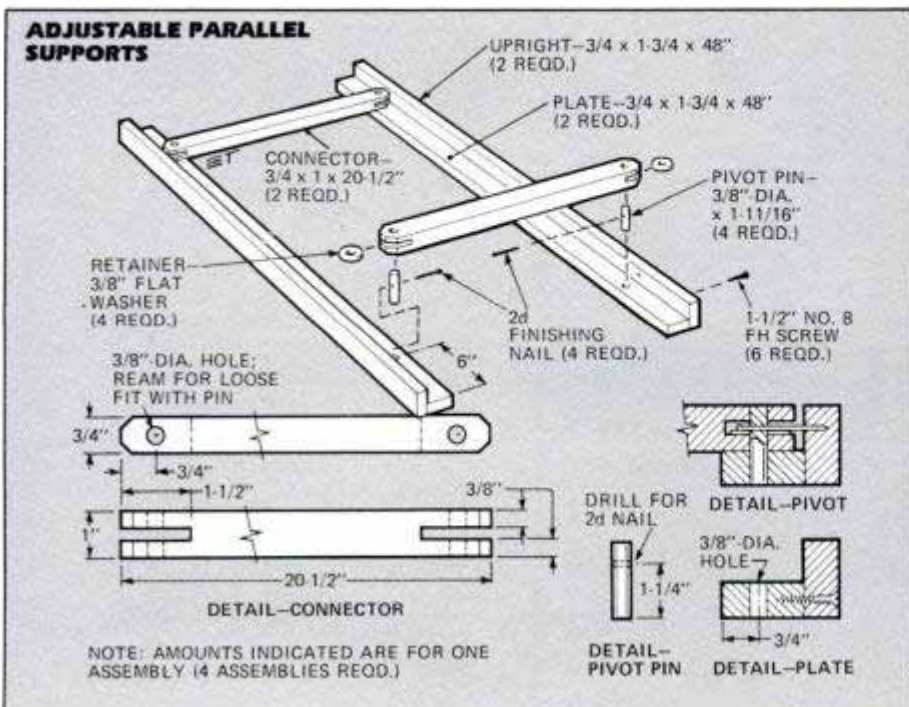

## BUILD YOUR OWN PONTON BOAT...



**AND SAVE \$1000 OR MORE WITH EASY TO ASSEMBLE KITS.**

- Economical, safe and practically indestructible. Ideal for family parties, fishing or swimming.
- 4 models to choose from, 17', 20', 21' and 24' lengths.
- Polyethylene pontoon sections are urethane foam filled. Retains buoyancy even if punctured. Highly resistant to abrasion and impact.
- Pontoons are maintenance free, colorfast—never needs painting.
- Assembly requires no special tools or equipment. Takes only 12 to 16 hours to complete.
- All kit components are of galvanized steel or marine grade aluminum.
- Kit contains pontoons, frame, motor mount, helm station, steering, railing and hardware.
- Send \$2.00 for complete information.

**CALL TOLL FREE**  
1-800-351-1363

In Texas call: 915-643-2517

**ROTOCAST FLOTATION PRODUCTS**  
P.O. BOX 1059, DEPT. PM  
BROWNWOOD, TEXAS 76801

## WORLD'S FINEST FLASHLIGHT

**WETHEAM**

**\$29.95**  
ANY SIZE  
P.P.O.

(Lifetime Guarantee)

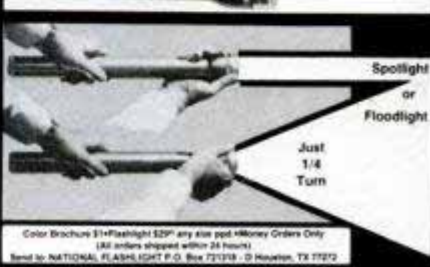
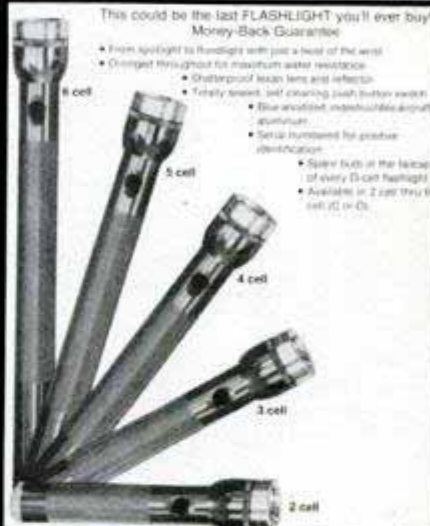

Color Brochure \$1+Flashlight \$29.95 any size plus Money Order Only  
(All orders shipped within 24 hours.)  
Send to: NATIONAL FLASHLIGHT P.O. Box 721319 - D Houston, TX 77272



# GO TO WORK O

## SEARS NATIONAL WORK C



### SAVE \$15

Save \$15 on our new *Fieldmaster*™ work shoes and boots. Great value. Great features. Genuine oil treated leather uppers in light brown. Padded collars and heel-to-toe cushion insole for all day comfort. Oil resistant soles and heels. Goodyear welt construction for added durability.

	Regular	Sale
Oxford	\$44.99	\$29.99
6" shoe	\$49.99	\$34.99
8" boot	\$54.99	\$39.99

(Safety toe shoes available at similar savings)

Available in most larger Sears retail stores. Prices and dates apply only to the Continental United States, except Alaska. © Sears Roebuck and Co., 1983



# ON BIG SAVINGS.

WORK CLOTHES SALE - MARCH 2-12



**SAVE \$2-\$4**

Save big on Perma-Prest® polyester and cotton blend work clothes.

Chambray shirt

Long sleeve reg. \$ 8.99 now \$ 6.99

Short sleeve reg. \$ 7.99 now \$ 5.99

Denim work jeans reg. \$14.99 now \$11.99

Denim bib overalls reg. \$19.99 now \$15.99

100% cotton white

painter jeans reg. \$12.99 now \$ 9.99

**SAVE 30%**

Sears Best Perma-Prest® polyester and cotton twill work clothes with soil-release finish.

Long sleeve shirt reg. \$12.99 now \$ 8.99

Coordinating pants in regular and full fit reg. \$14.99 now \$10.49

**Sears**



\$969.00 incl. B/W RO Pg.75  
Does not incl. chart

## PM OWNERS REPORT.

BY MICHAEL LAMM WEST COAST EDITOR

# BUICK SKYHAWK

"Needs a lot of highway to pass other cars at speed."  
—IOWA AUDITOR

"Turns on a dime and takes about \$6 to fill it up."  
—TEXAS RANCHER

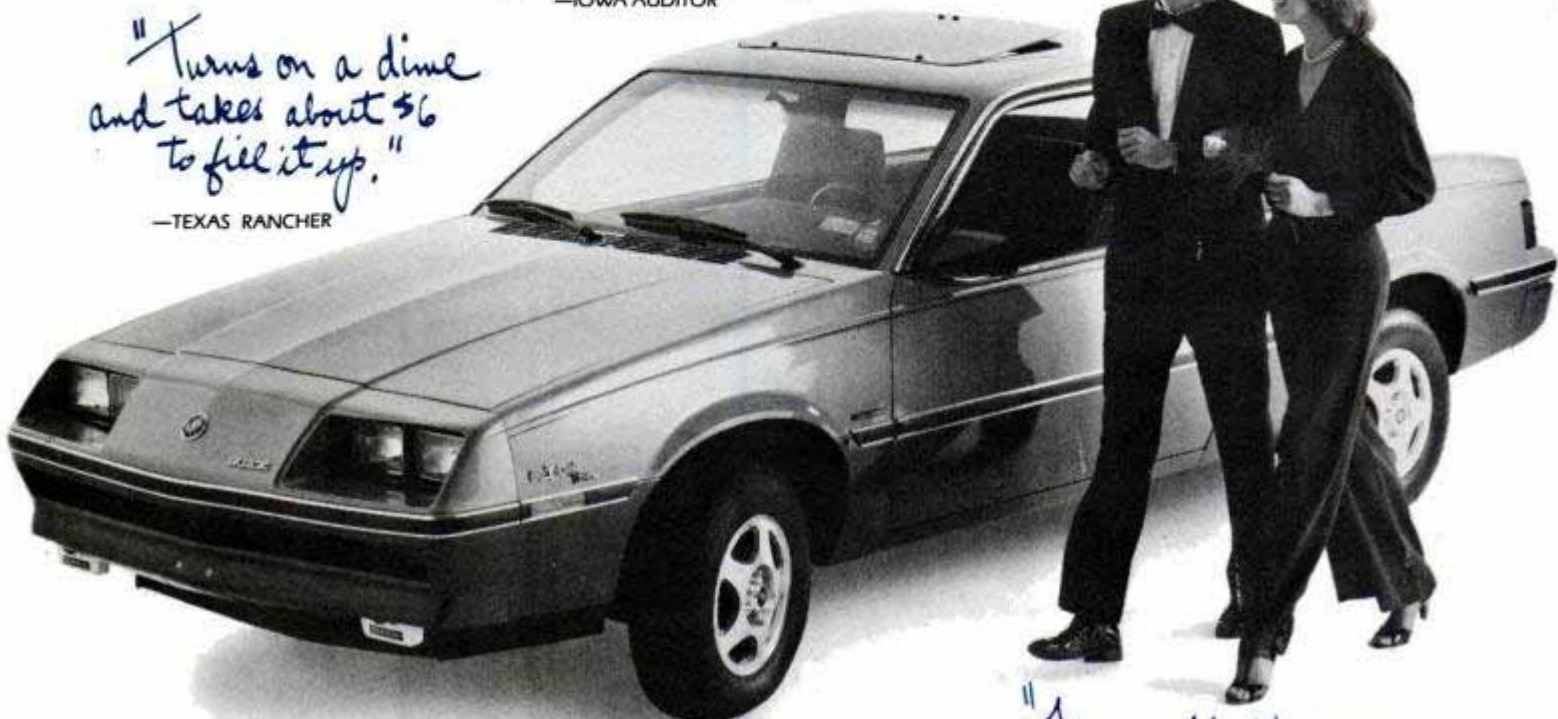

"THE PUSHROD 1.8 IS A WEAK ENGINE, AND THE AUTOMATIC SHIFTER IS VERY STIFF."  
—COLORADO ELECTRONICS TECHNICIAN

"Very sporty. I enjoy driving a car with this good quality inside and out."  
—MICHIGAN MACHINIST

"The seatbelts are extremely uncomfortable on the neck and shoulders."  
—COLORADO CPA

PM photos: Bill Ashe

Owners love the handling and fuel consumption, but they demand more power.

**B**uick got its J-car a little late, but the division's been making up for lost time with improvements and features.

Buick began marketing the Skyhawk last March. This is basically the same GM front-wheel-drive J-car that Chevrolet, Pontiac and Cadillac have been offering since May 1981 as the Cavalier, J2000 and Cimarron, respectively. Oldsmobile announced its version, the Firenza, concurrently with Buick.

Over the past year, Buick has added the Skyhawk T-type plus a new wagon body style and a five-speed manual transaxle. The original 1.8-liter pushrod Four has been dropped in favor of the Opel-designed, Brazilian-built overhead-cam engine, also displacing 1.8



Buick did a good job on the interior. Most found it comfortable and well laid out.

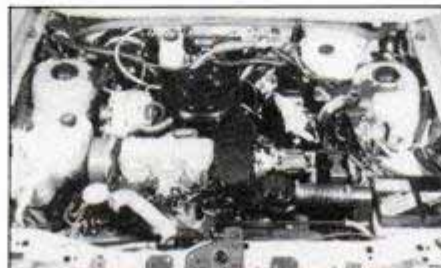

No. 1 complaint was lack of power. The most requested change? A better motor.

liters. This newer unit is more powerful and fuel-efficient than its predecessor. It uses an aluminum head and throttle-body fuel injection.

The Chevrolet-built, 2.0-liter pushrod engine, also with TBI, is now standard in all Custom (base) and Limited Skyhawks. The heavier 2.0 rates two more horses than the ohc 1.8 (86 versus 84 hp), but gives up a couple of foot-pounds of torque (100 at 3,700 com-

## A NATIONWIDE SURVEY BASED ON 1,130,449 OWNER-DRIVEN MILES

pared with 102 at 2,800 rpm).

At the time of our survey, the wagon and five-speed transaxle weren't yet offered, and the ohc 1.8 remained an option. Today, the ohc 1.8 and five-speed are standard in the T-type and

[\(Please turn to page 75\)](#)



# How Havoline Supreme can help you get the most out of your car.



**Proven protection up front.**



**Backed by improved mileage.**

Whether you change your own oil or someone else does, there are some important things you should know about Havoline Supreme.

First of all, Havoline Supreme has a Texaco-developed, balanced additive system with a built-in, special friction fighter.

And its multigrade rating offers the convenience of all-year-round, wide-temperature range protection.

## **Havoline gives you proven protection.**

The final test of a motor oil comes under actual driving conditions. Havoline Supreme has proven it delivers the kind of protection needed in



tough, high-speed state trooper cars and severe stop-and-go driving in New York City taxis.



## **Havoline helps save gasoline.**

Fuel economy tests proved it. Compared to a conventional motor oil, Havoline

**3 9 8 2 4 2**

Supreme, with its special friction-fighting additive, helps save gasoline.

## **Havoline is diesel tested.**

If you own a diesel, we have good news. Havoline 10W-30 has the API-SF/CC rating required by most engines like yours. And it's been proven in punishing diesel-powered taxis.



## **Listen to an expert.**

Top Indy 500 driver Tom Sneva calls

Havoline Supreme a "very sophisticated oil...one that a prudent car owner should use on a regular schedule." Shouldn't you?



You can trust your car to the products with the Star.



Some people get  
all the breaks.

*See you on  
the slopes  
next year!*



IMPORTED



Canadian Club

Blended Canadian Whisky

Distilled and Bottled under

Canadian Government Supervision by

Hiram Walker & Sons

Walkerville, Ontario, Canada

IMPORTED IN BOTTLE BY HIRAM WALKER IMPORTERS INC., DETROIT, MICH.

THIS WHISKY IS 6 YEARS OLD

86.8 U.S. PROOF

*Be lucky -  
it could have been  
you!*

THERE GOES  
THE GOLD!  
JOHN

Can I  
borrow your  
skis?  
BILL

LET WELL!  
DEB  
TOUGH  
BREAK!  
CHAMP!  
TOM

What a great  
setting -  
the snow, the  
mountains and  
your leg!  
DOC

Canadian Club  
"The Best In The House"



## OWNERS REPORT: SKYHAWK

(Continued from page 72)

optional in other series. Buyers seem to value the Brazilian engine's virtues, though, because 57 percent of the owners in our sampling had ordered it as an option.

For this Owners Report we'd like to break with tradition and change our established format slightly. Instead of categorizing comments, we let 11 representative Skyhawk owners present their opinions with minimal editorial comment from us.

The first remarks come from a 25-year-old account executive at a Minnesota radio station. "I'd owned imports in the past, but one of the main things that motivated me to buy this Skyhawk is that it's built in America. In addition, I was attracted by the car's styling, and when I drove it, it seemed sturdy and well built. I think the 1.8 ohc engine is



Convenience items such as this coin box abound on upscale Skyhawks, T-types.

great. Quality and workmanship are excellent—everything fits, no squeaks so far. Comfort, too, rates excellent up front and fair in the rear seat.

"I've had no mechanical problems,"

he continues, "although the AM/FM radio went out and had to be replaced. They replaced it while I waited. The dealership is superb, with a clean and efficient service department. The salesman made it very easy for me to buy this car. The sticker said \$9,900, but I ended up paying \$8,500."

A Massachusetts metalworker, age 48: "The oil filter is hard to get at, and the rear defroster isn't hot enough. But I've had no mechanical problems, and workmanship is excellent. It took about 5,000 miles to get the engine to peak performance. I'm now getting 25/35 mpg city/highway with the 1.8 ohc and automatic. I'm very happy with my Skyhawk."

A Texas salesman, age 59: "No road noise, and that's unusual for a small car. Price turned out to be good, especially since the dealer gave me a \$400 rebate. I've owned several Buicks, and I like the Skyhawk's size and comfort, although rear passengers say it's a little cramped."

An Alabama refrigeration servicer, age 25: "Poor quality control. Buick is supposed to be an upmarket GM car, but my Skyhawk came with a windshield leak, malfunctioning speedometer, sticking fuel gauge and squeaky brakes."

Now a Florida realtor, age 63: "We've had Buicks in the family for 55 years, and this is the best one I've owned over a 36-year period. It hasn't given me a moment's trouble. The dealer's excellent, quality is likewise, and the only thing I can find wrong is that the automatic shift lever is too stiff. I'm told this is caused by the linkage to the steering lock mechanism, but so far no one's been able to improve it." [In all, 7.6 percent of our respondents men-

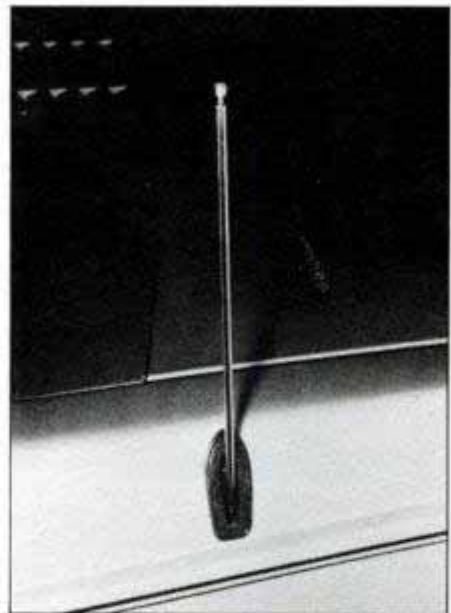

Frenched-in antenna base is an example of the attention to detail in the T-types.

tioned the balky automatic shift lever.]

An employment specialist from Idaho, age 45: "I wanted to get back into an American-made car and liked the looks of the Skyhawk. The dynamics, precision and updated technology impressed me. I found a hungry salesman who really went to a lot of effort to offer me a good deal. I hear GM's J-cars aren't selling too well, and I suppose this had something to do with it.

"I find quality good, but not fantastic. The back seat is great for children or legless adults, but front-seat comfort is very good. I particularly like the styling, tight construction, maneuverability and handling and well-grouped instrument cluster. I don't like the ashtray location;

(Please turn to page 76)

## SUMMARY OF 1982-83 BUICK SKYHAWK OWNERS REPORTS\*

<b>Total miles driven</b> 1,130,449	<b>Specific likes:</b>	<b>Workmanship opinion:</b>	<b>Dealer service opinion:</b>
<b>Average miles per gallon:</b>	Styling ..... 61.3%	Excellent ..... 37.0%	Excellent ..... 34.4%
Manual four-speed	Economy ..... 41.2	Good ..... 46.3	Good ..... 40.0
In town ..... 25.7	Handling ..... 40.7	Average ..... 11.6	Average ..... 12.4
On the highway ..... 33.0	Comfort ..... 32.8	Poor ..... 5.1	Poor ..... 12.9
Automatic three-speed	Ride ..... 26.0	<b>Comfort opinion (front seats):</b>	<b>Number of vehicles owned:</b>
In town ..... 24.9	<b>Specific dislikes:</b>	Excellent ..... 63.9%	This car only ..... 44.0%
On the highway ..... 31.3	No complaints ..... 26.3%	Good ..... 31.5	Two cars ..... 40.7
<b>Transmission choices:</b>	Not enough horsepower ..... 12.6	Average ..... 3.2	Three cars ..... 10.2
Automatic three-speed ..... 80.1%	Quality of materials ..... 9.6	Poor ..... 1.4	Four or more cars ..... 5.1
Manual four-speed ..... 19.9	Automatic transmission	<b>Comfort opinion (rear seats):</b>	<b>Makes of other cars owned:</b>
<b>Engine choices:</b>	shifter ..... 7.6	Excellent ..... 30.0%	Buick ..... 26.7%
1.8-liter overhead-cam	Rattles and noises ..... 6.6	Good ..... 47.8	Chevrolet ..... 17.5
Four ..... 57.8%	Mpg lower than	Average ..... 18.7	Ford ..... 16.7
1.8-liter pushrod Four ..... 35.4	expected ..... 6.6	Poor ..... 3.4	Oldsmobile ..... 12.5
2.0-liter pushrod Four ..... 6.8	<b>What changes would you like?</b>	<b>Had any mechanical trouble?</b>	Pontiac ..... 10.0
<b>Body style:</b>	More powerful engine ..... 18.4%	No ..... 58.1%	Dodge ..... 10.0
Two-door sedan ..... 57.5%	No changes ..... 17.8	Yes ..... 41.9	<b>Age distribution of owners:</b>
Four-door sedan ..... 42.5	Better materials ..... 10.3	<b>What type of trouble?</b>	15-29 years ..... 31.9%
<b>Why did you choose this car?</b>	Different seat shape ..... 6.9	Electrical ..... 15.1%	30-49 years ..... 35.3
Styling ..... 61.1%	Improved automatic	Oil leaks ..... 12.8	50-plus ..... 32.8
Economy ..... 37.9	transmission ..... 6.6	Air conditioner ..... 11.6	<b>Would you buy another Buick?</b>
Size ..... 24.1	<b>How much did you pay?</b>	Induction system ..... 10.5	Yes ..... 91.8%
Made in America ..... 12.8	Average ..... \$9,233	Transmission ..... 9.3	No ..... 8.2
Front-wheel drive ..... 12.8	Range ..... \$7,200	<b>Dealer repairs satisfactory?</b>	<b>Would you buy another Skyhawk?</b>
	to	Yes ..... 64.3%	Yes ..... 81.9%
	13,000	No ..... 35.7	No ..... 18.1

\*Percentages might not equal 100% due to rounding or insufficient data.



# New Parts For old favorites

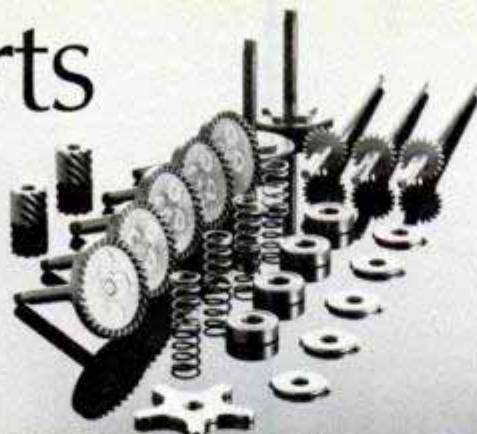

Now you can order parts direct from the factory for any Zebco reel that's less than 5 years old. It's your opportunity to turn your old reliable Zebco reel into a new one. Simply mail this coupon for a "Zebco Spare Parts Booklet." And here's the best part: It's Free!

Reel Type/Model No. \_\_\_\_\_  
 Name \_\_\_\_\_  
 Address \_\_\_\_\_  
 City \_\_\_\_\_ State \_\_\_\_\_ Zip \_\_\_\_\_

Zebco Division Brunswick Corporation  
 Box 270, Tulsa, Oklahoma 74101  
 ©1983 Brunswick Corporation, Zebco Division



From the folks you fish with



## OWNERS REPORT: SKYHAWK

(Continued from page 75)

it's inconvenient. And the 1.8 ohc engine clatters on cold mornings. The mechanic says there's nothing Buick can do about it. The noise does go away once the engine warms up."

From a California engineer, age 55: "The sport suspension option on my four-door sedan makes handling in mountain driving and on the open highway very good. Steering is so light that power seems a waste. Front and rear head- and legroom are better than in most full-sized cars of five years ago.

"I've gotten to know my dealer quite well," continues this engineer, "because second and high gears in the four-speed transmission had to be changed on my first service checkup. There was also a problem with engine idle and fuel consumption. The computer was fine, but they found a vacuum leak. I'm now averaging 22 mph in town and 32 on the road. I still feel I'm getting equal or better value than most imports in the same class. I paid \$8,000 and would definitely buy another Skyhawk."

A Colorado speech pathologist and university teacher, age 35: "The salesman promised me a full tank of gas when I bought the car, but it never materialized. The automatic transmission leaked when I got the car, and the gasket had to be replaced. Engine seems peppy, and I like the fuel economy. The armrests could be higher, and the transmission shifts back and forth at certain speeds for no apparent reason. I also wish the transmission would stay in passing gear to a higher speed."

A Texas clerk, age 66: "It's a very easy car to handle; like having my own 'body wheels.' The one thing I don't like about it is that the seats block my view diagonally out the back. I can't see behind me except with the rear-view mirror."

A Tennessee sale engineer, age 39: "Handles almost as well as my Corvette. It also gets good mileage and is dependable. I can't think of anything I'd change except perhaps to move the dimmer switch back on the floor. In my opinion, Buick builds one of the most trouble-free cars anywhere. I know this one will deliver 100,000 miles of service without a major repair, and its resale value will remain high."

And finally, from a New York letter carrier, aged 39: "I loved the styling of the Skyhawk. I had a Century before; best car I'd ever owned. I'm 6-1, with long legs, and there's plenty of room for me. When a person buys a new automobile and has no problems, no repairs, no complaints, and it turns out to be a very nice car, what more can he ask?" **PM**

# 2 EPOXIES THAT WORK

...IN 4-MINUTES!

## 4-MINUTE EPOXY REPAIR

Now! The only super-strong epoxy that dries in 4 minutes, with no sag, no drip, color coded, easy to mix, sand and paint, immediately.

**REPAIRS** woods, plastics and metals permanently. Guaranteed or your money back.



## 4-MINUTE EPOXY CONCRETE REPAIR

It works! Interiors or exteriors dry in 4 minutes and will never crack or fall out. Waterproofs, repairs, bonds and seals all masonry, (brick, cinder block, pools, basements and driveways) permanently. **FREE** carbide tool (router) included.



Mail check or money order today!  
 United Resin Corp. Dept. PM-3  
 14570 Barber, Warren, MI 48093

- 4-MINUTE EPOXY REPAIR** ..... 3.95
- Shipping & handling ..... 1.25
- Total ..... 5.20
- (Canadian orders: \$6.50)
- 4-MINUTE CONCRETE REPAIR** ..... 7.95
- Shipping & handling ..... 1.25
- Total ..... 9.20
- (Canadian orders: \$11.50)

Michigan residents: add 4% sales tax.



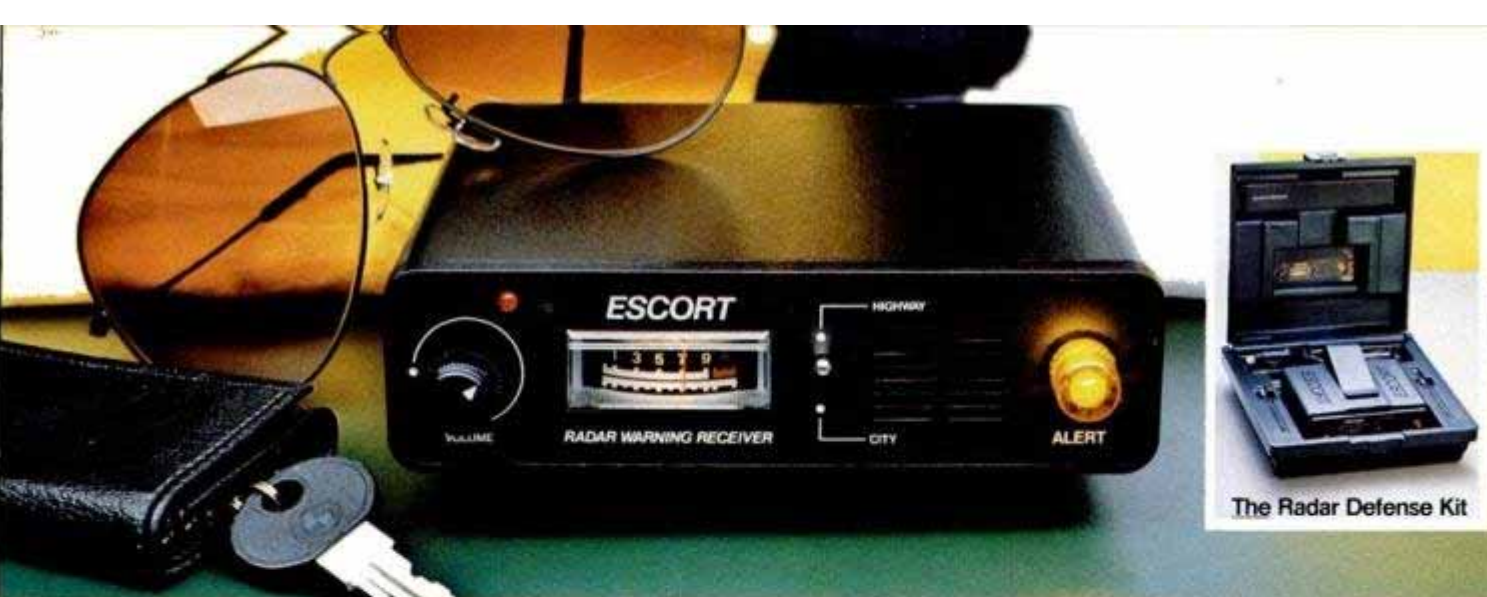

# Radar warning. Hear the difference.

## What Could Be Better Than Unbelievable Range?

By now, you've probably heard some tall sounding stories about how far away the ESCORT® radar warning receiver picks up radar traps. You know, the ones where they talk in miles instead of car lengths. The stories go on to say that ESCORT's superheterodyne receiving circuits provide as much X and K-band warning as you can possibly use, and then some. If you've never used an ESCORT, they may seem pretty far fetched, but most of them are true. Over hills, around corners, and from behind.

## Car 54 Where Are You?

Maximum detection range is wonderful, but it's far from the whole story. In some ways, radar detectors are like smoke alarms; you want to make sure that you don't miss anything, but you don't want a lot of false alarms. ESCORT won't disappoint you. Beyond that, when a smoke alarm sounds off, the most pressing thing on your mind is: Where is the fire? Is it ahead of you, behind you, above you, or below you? In the same room, or at the other end of the house? Your senses can help you find fire, but, on the highway, you can't feel or smell radar. ESCORT is your sixth sense.

## Hearing Is Believing

ESCORT reports its findings straight to your ears in a way no other detector can match. Its vocabulary includes a Geiger-counter-like pulsating rhythm that relates radar intensity in a smooth, natural, and intuitive manner, making it easy to sense the distance to radar. It can tell you if radar is ahead of you, behind you, or even traveling along with you in traffic. ESCORT also speaks different languages for each radar band. Since the two bands behave differently, the distinctive tonal differences eliminate surprises. You'll even be able to tell "beam interrupter," "trigger," or "instant-on" type radars from other signals just by the sounds they make. Ditto for radar burglar alarms and door openers. ESCORT has a lot to say, and we've developed a new way for you to get acquainted quickly.

## Play It, Sam

ESCORT's instruction book contains a wealth of information. Actually, it's the ESCORT user's Bible. But, the quickest way to become fluent in ESCORT's language is to play the Radar Disc on your stereo turntable. You'll hear firsthand how to interpret what ESCORT tells you in a number of situations. We now include this special Disc with every ESCORT so you can take a test drive as soon as you open the box.

## No Stone Unturned

The ESCORT Radar Disc is the latest addition to a long list of standard features. We don't scrimp on anything. Here they are: ■ Patented Digital Signal Processor ■ Different Audio Alerts for X or K Band Radar ■ Varactor-Tuned Gunn Oscillator tunes out false alarms ■ Alert Lamp dims photoelectrically after dark ■ 1/64 Second Response Time covers all radar ■ City/Highway Switch filters out distractions ■ Audio Pulse Rate accurately relates radar intensity ■ Fully Adjustable Audio Volume ■ Softly Illuminated Signal Strength Meter ■ L.E.D. Power-On Indicator ■ Sturdy Extruded Aluminum Housing ■ Inconspicuous size (1.5H x 5.25W x 5D) ■ Power Cord Quick-Disconnect from back of unit ■ Convenient Visor Clip or Hook and Loop Mounting ■ Protective Molded Carrying Case ■ Spare Fuse and Alert Lamp Bulb.

## Your stereo will demonstrate ESCORT's unusual abilities.



New!  
33 1/3 RPM Radar Disc

## What The Critics Say

*Car and Driver:* . . . "The ESCORT, a perennial favorite of these black-box comparisons, is still the best radar detector money can buy . . . All things considered, the ESCORT is the best piece of electronic protection on the market."

*BMWCCA Roundel:* . . . "The ESCORT is a highly sophisticated and sensitive detector that has been steadily improved over the years without changing those features that made it a success in the first place . . . In terms of what all it does, nothing else comes close."

*Playboy:* . . . "ESCORT radar detectors . . . (are) generally acknowledged to be the finest, most sensitive, most uncompromising effort at high technology in the field."

*Autoweek:* . . . "For the third straight year, no manufacturer has bettered the ESCORT's sensitivity . . . the consistent quality is remarkable."

## Made In Cincinnati

If you want the best, there's only one way to get an ESCORT. Factory direct. Knowledgeable support and professional service are only a phone call or parcel delivery away. We mean business. In fact, after you open the box, play the Radar Disc, and install your ESCORT, we'll give you 30 days to test it yourself at no risk. If you're not absolutely satisfied, we'll refund your purchase as well as pay for your postage costs to return it. We also back ESCORT with a full one year limited warranty on both parts and labor. So let ESCORT change radar for you forever. Order today.

## Do It Today

Just send the following to the address below:

- Your name and complete street address.
- How many ESCORTs you want.
- Any special shipping instructions.
- Your daytime telephone number.
- A check or money order.



Credit card buyers may substitute their card number and expiration date for the check. Or call us toll free and save the trip to the mall box.

**CALL TOLL FREE . . . 800-543-1608**  
**IN OHIO CALL . . . . . 800-582-2696**

**ESCORT (Includes Everything) . . . \$245.00**  
Ohio residents add \$13.48 sales tax.

## Extra Speedy Delivery

If you order with a bank check, money order, credit card, or wire transfer, your order is processed for shipping immediately. Personal or company checks require an additional 18 days.

# ESCORT®

**RADAR WARNING RECEIVER**

- Cincinnati Microwave Department 368  
One Microwave Plaza  
Cincinnati, Ohio 45242





# Marlboro

© Philip Morris Inc., 1983

Warning: The Surgeon General Has Determined  
That Cigarette Smoking Is Dangerous to Your Health.

16 mg "tar," 1.0 mg nicotine av. per cigarette. FTC Report Dec '81





DE LOREAN  
1981-'82

# AUTOMAKERS WHO DARED— AND LOST

Before De Lorean  
there were many others who went bust.

BY MICHAEL LAMM WEST COAST EDITOR

**T**he latest *successful* American mass producer of automobiles was Walter P. Chrysler who, in 1924, daringly launched the car that still bears his name. Did Chrysler realize he'd be the last entrepreneur to succeed? Could he know that, in the intervening 59 years, hundreds of equally daring men would try to create cars of their own and fail?

Some, like John De Lorean, Malcolm Bricklin, Henry J. Kaiser and Preston Tucker, had every bit as much vision and courage as Walter Chrysler. Each dreamed his own dream and went wrong in his own way. It's hard to find parallels.

In some cases, the men's personalities doomed these ventures either from the start or at the bitter end. John De Lorean's flawed ambition makes the

BRICKLIN  
1974-'75







## 1930 CADILLAC V16

Photo credits: Bricklin, Cadillac, Tucker: Henry Austin Clark, Jr.; Auburn, Cord, Duesenberg: A-C-D Museum; Lincoln, Edsel: Ford Motor Co.

most dramatic example. But Bricklin, Tucker, and even millionaire Kaiser simply didn't have the financial resources.

In other cases, the cars didn't live up to expectations. Or the cars turned out to be wrong for the times.

The De Lorean narcotics trial has gotten so much publicity recently that the car seems almost secondary. But the question remains: What would have happened to this automobile in a stronger economy? Would John De Lorean still be in business today?

In my opinion, he would. It's true that the car never fully lived up to all expectations (see *Stirling Moss Road Tests The De Lorean Sports Car*, page 65, June '81). But even so, it had some good points, and I don't believe the ho-hum han-

dling and acceleration, the hard-to-repair, hard-to-clean body, the awkward gullwing doors, or the relatively poor rear visibility necessarily doomed this coupe (see *PM Owners Report: De Lorean*, page 100, May '82).

If annual production could have come closer to the 40,000 cars that John Z. envisioned, he might

have held the price nearer his original \$10,500 than the \$25,000 it became. Through September 1982, only 5,474 De Loreans were sold in this country and that, basically, became the main reason for the car's demise. As so many people have already said, it was simply the wrong car at the wrong time.



1948 TUCKER





Some automakers who are solvent today lost a bundle on cars they once manufactured. Cadillac

V16s and V12s cost millions to put into production and General Motors once considered axing the Division. Ford

Motor Co.'s Lincoln Continental Mark II was another financial bomb,

even though the car itself was a wonder of the automotive world in 1956. And Ford's

1958-1960 experience with the Edsel translates into a loss—in 1983

dollars—of almost one billion dollars. Preston Tucker's Torpedo

sedan was an eye-catcher in 1948, but only about 50 were made

before he went bust. The Auburn-Cord-Duesenberg empire,

which was dead by 1938, was built up from three separate auto makers by Erret Lobban

Cord. The distinctive, "coffin-nosed" front-wheel-drive cars that bore his name are

classics today. The Cord 812 Supercharged Cabriolet is seen at

right. The '35 Auburn boat-tailed speedster was a supercharged

model with over 100-mph top speed. Fred Duesenberg's cars

—the SJ roadster is seen below—were luxury transportation for movie

stars, and Indy winners in '24, '25 and '27.

If it's any consolation to De Lorean, though, he's in very good company as a maker of doomed automobiles. Lots and lots of cars have come along at precisely the wrong moment—good and bad ones alike. And they all cost their makers dearly. While De Lorean managed to lose an estimated \$196.7 million through his daring and misguided judgment, that is by no means a record. Even many successful automakers have lost considerably more than that on nameplates and models that died in the marketplace. Some of these cars killed their

*(Please turn to page 150)*



1935 AUBURN



1956 MARK II



1937 CORD



1958 EDESEL



1933 DUESENBERG



#2,430.00—Spread

# High Tech For Robin Hood

Archers are stringing up new ways to speed arrows to the bull's-eye.

BY CHUCK ADAMS

Martin Overdraw



## PSE Crossfire

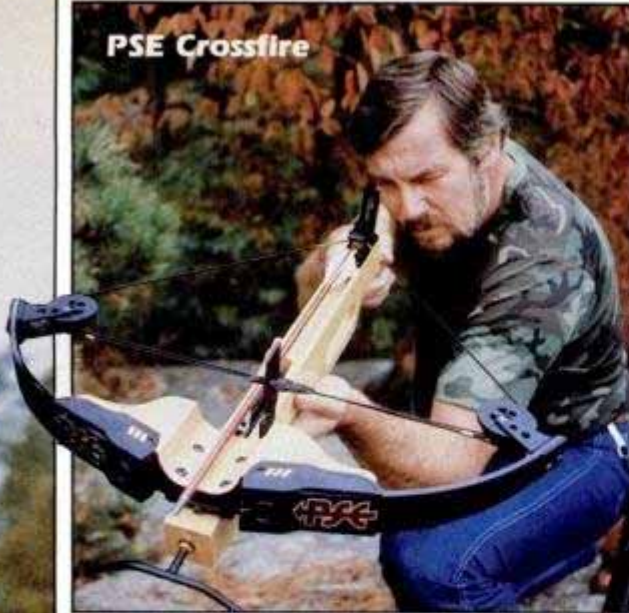

*Crossfire uses the compound principle in a crossbow with added power. Limbs are of Magnaglass and graphite. Front sight pins (above) adjust for windage, elevation. Bow is from Precision Shooting Equipment in Tucson, Ariz.*

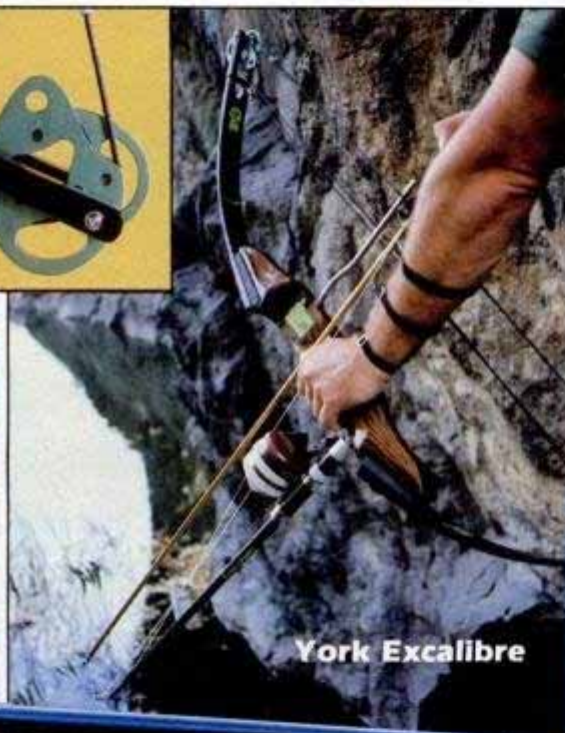
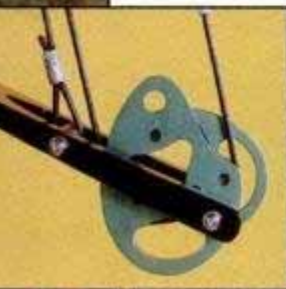

## York Excalibre

*Martin forward-handle overdraw bow with an Easton stabilizer (on facing page) is a type favored for high-velocity and distance shooting. Compound two-wheeler shown is made by Martin Archery, Walla Walla, Wash.*

*York Excalibre compound has interchangeable teardrop-shaped cams (detail inset), is shown mounting Jim*



## Graphite Vector



*Dougherty Fishgetter bow rod, arrow, Zebco 808 reel (above). Bow is from York Archery Div., Woodcraft Equipment, Independence, Mo. Dougherty is in Tulsa, Okla.*

*New PSE Power Cam Graphite Vector I compound bow, by Precision Shooting Equipment, has die-cast magnesium handle, adjustable alloy cams, 50 to 70 pounds peak draw weight. Easton Aluminum, Van Nuys, Calif., combines metal and graphite in the arrow.*

**G**iant improvements have been made in archery equipment during the last 20 years. The hand/eye coordination, precise shooting techniques and intense mental concentration necessary for placing an arrow directly on target haven't changed one whit over the centuries. But modern materials, technology and renewed interest in high-performance bows, arrows and shooting accessories have raised the sport to new levels of precision.

The most significant innovations were the creation and perfection of the compound bow, the introduction of rigidly uniform and accurate high-strength aluminum arrows, and the design of dependable archery range-finders. Today, manufacturers are perfecting their developments to produce maximum shooting enjoyment.

### Bows

The mechanical compound bow has been supplanting recurve bows, longbows and similar one-piece designs since its commercial introduction in 1968. The compound has passed through many stages of improvement during the past 15 years.

The most popular hunting and target bows today are the "two-wheel" compounds with sleek aluminum or magnesium handle risers and stubby, maple-and-fiberglass laminated limbs.

Such bows are quieter, faster and more dependable than the heavier, bulkier four-wheel and six-wheel compounds which were popular a few years back, and tend to produce better accuracy for both the expert and the beginning archer.

The best two-wheel compounds characteristically have handle risers with interchangeable grip shapes to fit just about every hand and shoot-  
*(Please turn to page 139)*



*Ranging Measuring System's Bowhunting LR-80 and Eagle Eye 50 aid accuracy.*



\$2,791.00—Spread



# Corvette

PM DRIVES THE '83 AND REMEMBERS THE VINTAGE VETTES.

BY TONY ASSENZA AUTO EDITOR

**C**orvette. Since 1953 it has been America's one and only true sports car. For all its faults, and through its many iterations of body styles and engine displacements, it has been the central love object of a hard-core group of Corvette fanatics. Real fanatics. The kind who can tell you, from memory, every change made since '53, who can tell you the part numbers of a revised shift linkage bracket or a through-bolt or the name of the guy running the paint booth the day the car first came off the line. Serious fanatics. They are a brotherhood unto themselves who for three decades have resisted the temptations of RX-7s, Z-cars and the swarms of British and German sports cars and have remained faithful to the one true and pure American sports car.

An indication of this addiction is the fact that

Corvette registrations exceed the total number of Corvettes ever produced. They're so desirable that they're stolen, chopped up, sold in pieces by thieves, rebuilt by the faithful and sold again. They multiply, sort of an automotive mitosis.

From the Vette junkies' point of view, it is clear that Chevrolet doesn't even own the car. Chevrolet Motor Div. is simply the design and manufacturing arm of this fiberglass-crazed group of Corvette berserkos. They own the car, which makes it really tough when you're in charge of redesigning it. I mean, it goes way beyond a design and engineering job, doesn't it? You have to live up to a legend. Do you mess with it a lot and maybe lose the identity altogether? It's tough enough to design any car without the added burden of having to meet al-



## 1973-82

*Emissions and fuel economy killed horsepower and the Vette became a boulevard cruiser for upwardly mobile secretaries. Only collector's item is '78 fastback, especially the Indy Pace Car replica with the 225-hp, L-82 small-block.*

## 1983

*All-new coupe is smaller, lighter, faster, smoother . . . and handles like an IMSA racer. With a fuel-injected 350 V8, its performance approaches Corvettes of the '60s, but is much more refined. It's the best Vette yet.*

PM art: Jeff Mangiat





### 1953-55

Early Vettes are more "personal car" than "sports car." Only 4,640 were sold in three years, most sporting Chevy's lackluster Blue Flame Six and the Powerglide automatic.

### 1956-62

Classic Corvettes: The ultimate collector's model is a fuel-injected, 283-hp '57 model. It's sleek, speedy and terrific. The later cars are even faster—up to 360 hp from the famous 327 V8—but not as classically pretty.



### 1963-67

Sting Ray, probably the '60's best street GT, has striking styling, all independent suspension, four-wheel disc brakes (after '65), does 150 mph from 435 hp, 427 cu. in. by '67.

### 1968-72

Longer, lower, heavier: Mako shark-inspired Vette could be ordered with 365 hp from a 454 big-block or 330 hp from a 350 LT-1 small-block up to '72 . . . the last American muscle car.





most unreal  
have your n-  
you mess it

3917.00---Spread

they turn away in groves, has what happened to Porsche with the 924, but they're liable to come to your house and break up your lawn furniture. Serious fanatics.

### Keepers of the flame

The two men whose lawn furniture was at stake here are Jerry Palmer, chief stylist at Chevy's Studio Three, and Dave McLellan, chief engineer. They were responsible for looking at the blank sheet of paper in 1978 and redoing the car from scratch. They are the keepers of the flame and the ones most likely to get burned by it if the car didn't quite meet those expectations.

They started out with H-points. That's engineer talk for hip points on an imaginary man-in-space. They knew the H-point for the old Vette and didn't like it. They moved it back about 3 inches and slightly down. This gave the man-in-space more head- and legroom. From that, they were able to figure out things like line-of-sight, hood and fender height, interior dimensions and a host of other numbers.

What they ended up with was a lower profile and cleaner line. Gone is the feeling of the old Corvette where you were way down there someplace, craning your neck to peer out between huge, hulking fenders and needing to sit up to find the nose lost some-

the horizon. In almost every interior dimension the new car is larger than the old one.

The exterior is smaller. The car lost 1.8 inches from its wheelbase, 8.8 inches in length and 1.4 inches in height. The only exterior dimension which increased was the width. It went up two inches, from 69 inches to 71 inches, and that translates directly into more shoulder and hip room.

Some other dimensions are pretty startling and demonstrate how different the new car is from the old. Windshield slope angle went from 57.0° to a very fast 64.7°, a figure which Chevy claims is the fastest of any windshield around. Another interesting statistic for you trivia fans is the total windshield glass area. This was bumped from 793.5 sq. in. to a massive 1,350.4 sq. in.. Welcome to the wide open spaces.

The Vette's newly minted lines are as clean as the numbers are revealing. From certain angles it will remind you of an RX-7, or a Porsche 944 or even a Ferrari 308. But it is unmistakably Corvette. The hard core will not be disappointed. The car is, design-wise, all-of-a-piece and it's as organically true to itself, and to its predecessors, as the part number memorizers could want. The lawn furniture is secure.

### Alcoa couldn't wait

From the beginning, the Vette had to be a driver's car, above all. That meant estab-

## THE BEST VETTE EVER

*Corvette's tilt-up nose makes engine access a cinch. The valve covers and air cleaner box are magnesium and coated with a crackle-finish epoxy.*

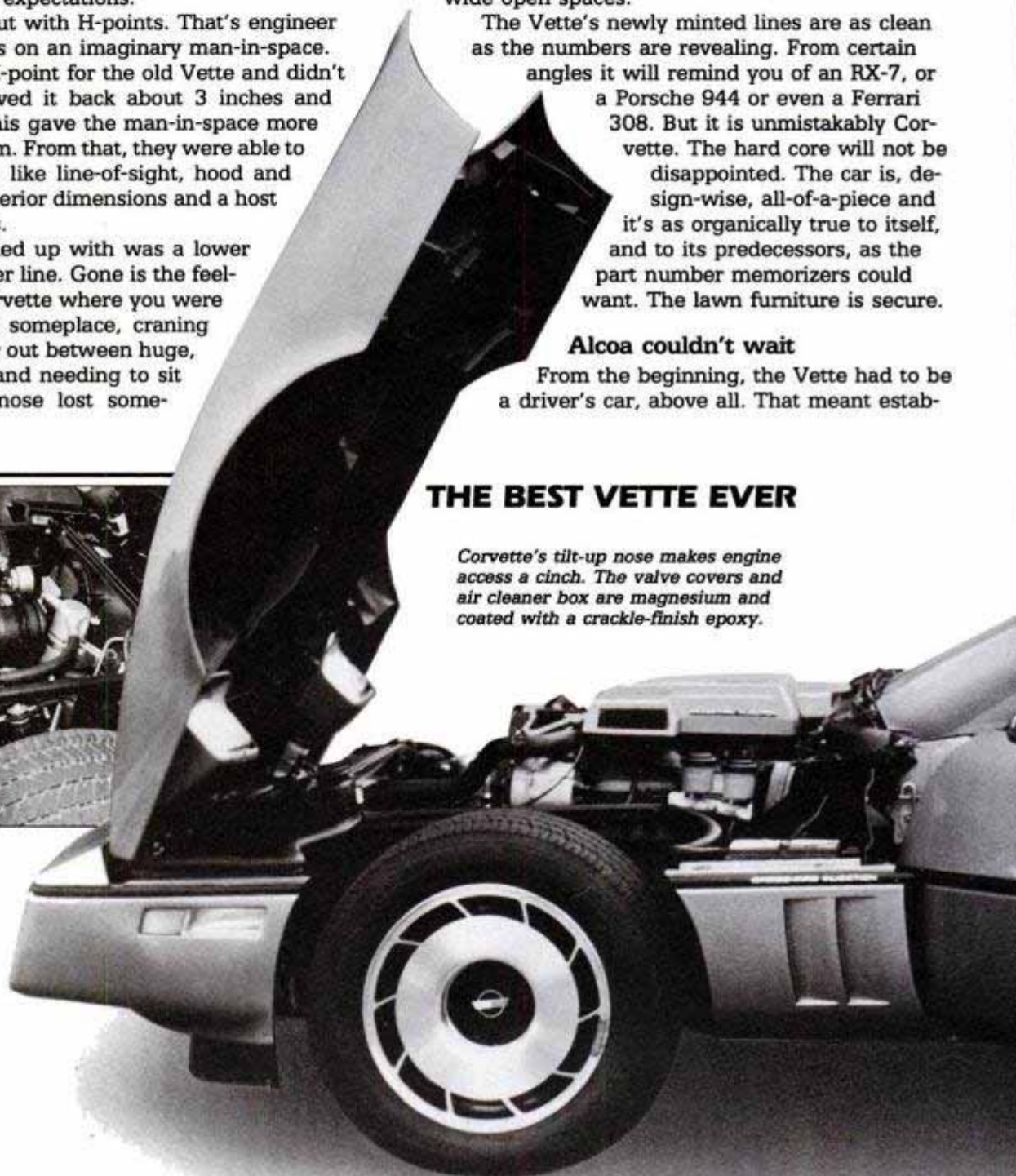



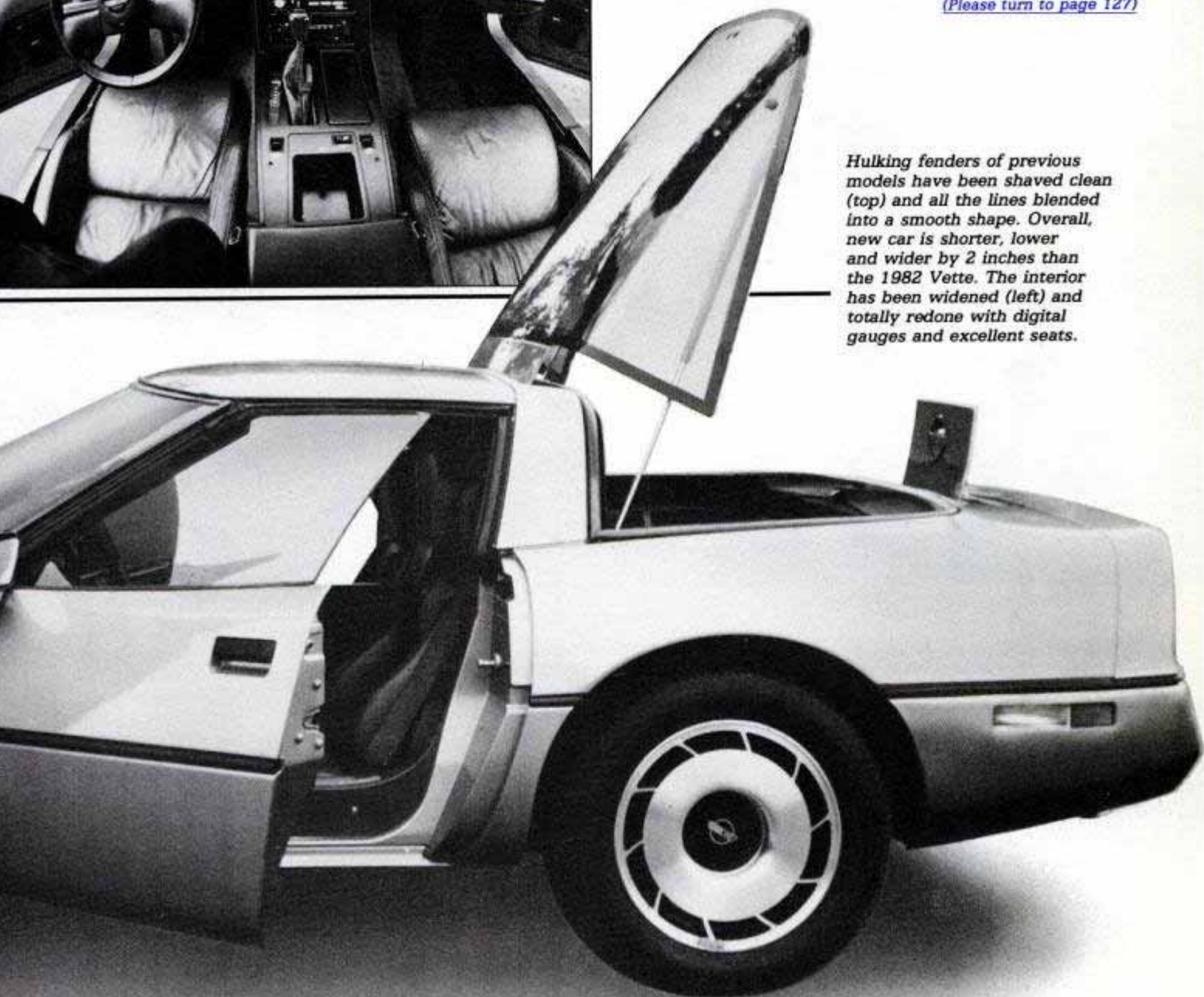
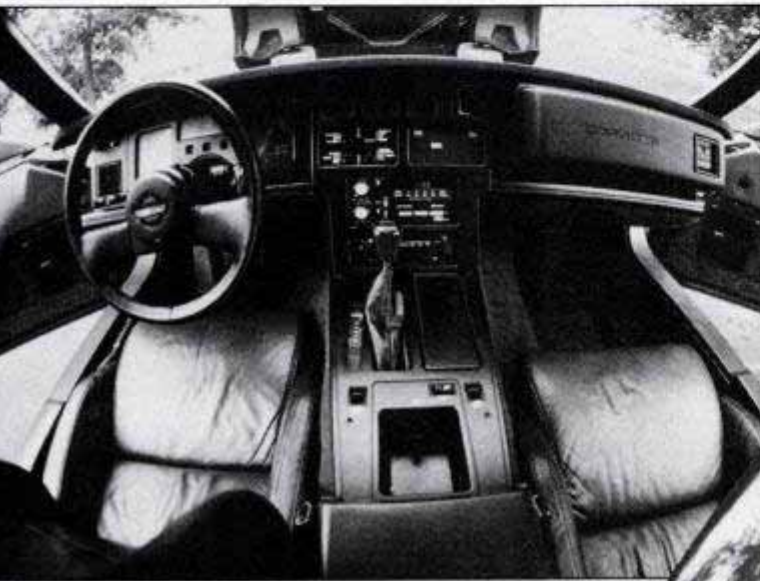
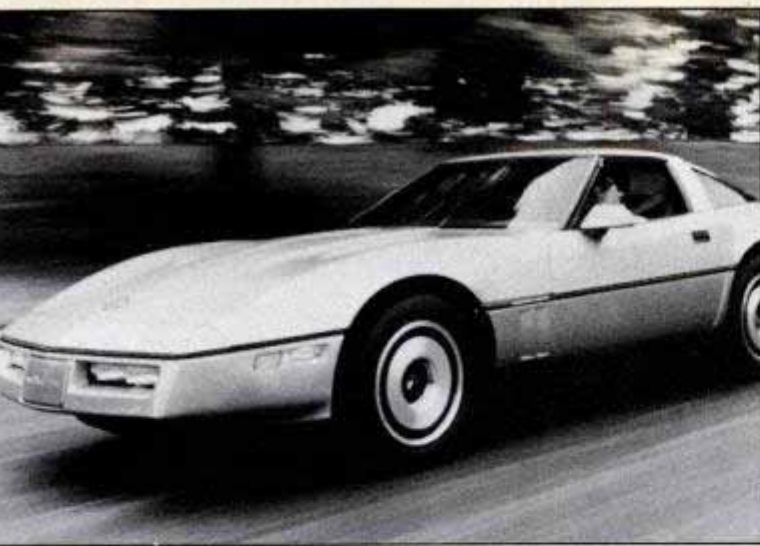

lishing some pretty ambitious design goals and accepting no compromises until those goals were met or exceeded. Just for the record, the Vette can generate .95 g lateral acceleration. That's right up there in ear-bleeding territory. For comparison, middle-of-the-pack, production-based road race cars on slicks with full tilt, no-compliance suspensions will generate maybe 1.2. The factors contributing to the Vette's high lateral acceleration number are a combination of tires, unsprung weight, suspension design and a 50/50 weight distribution.

Starting from the ground up, the top-of-the-line tire option is a Goodyear 255/50VR16 blackwall Eagle GT, mounted on 16-inch wheels, 8.5 inches wide in front and 9.5 inches wide in back. The tread design is derived from Goodyear's Formula 1 rain tire and it is oriented. That means it's meant to spin in one direction only. Yet, even if the local garage installs it backward, it will still outcorner just about anything else on the street,

*(Please turn to page 127)*

*Hulking fenders of previous models have been shaved clean (top) and all the lines blended into a smooth shape. Overall, new car is shorter, lower and wider by 2 inches than the 1982 Vette. The interior has been widened (left) and totally redone with digital gauges and excellent seats.*





\$1,522.00 Spread

# Strange Bedfellows ON THE High Seas

**T**he *18 Svezd Vlksm* (*18th Congress*), a large gray ship, its superstructure teared with streaks of rust, wallows gently in the swells among smaller fishing boats. She is not a handsome ship, nor has she the grace of line of the newer stern trawlers. Her only color is the yellow Soviet emblem of hammer and sickle on her stack and a tattered red flag that snaps crisply in the Arctic wind.

A hundred yards astern, bobbing with considerably less grace, is the *Great Pacific*, a small, blue-hulled American fishing boat. The seas, of little concern to the Soviet ship, toss the little American vessel from port to

starboard like a discarded bottle.

The Soviet ship hoists the *Great Pacific's* net, bulging with thousands of pounds of bottom fish, slowly up its stern ramp. Across the water the young crew of the *Great Pacific* lines the gunwales, watching its net disappear slowly up the Soviet vessel's gaping ramp.

"I hope they don't blow it," one of the Americans mutters as the huge bag of fish is lifted above the Soviet ship's wood trawl deck, casting a long shadow over the seas.

If there is tension between these two superpowers, it is difficult to discern. Their thoughts seem concentrat-

ed only on the difficult transfer operation and the success of their catch, part of a long, hard day's work.

Aboard the *18 Svezd Vlksm*, a Russian seaman pulls one net line and then another and tons of small olive pollock and larger whiskered cod spill out, rising thigh-high among the crew.

The *Great Pacific* and the *18 Svezd Vlksm* are fishing side by side here in the Bering Sea off the Alaska coast under the approbative umbrella of the Fisheries Conservation and Management Act of 1976. This so-called 200-mile-limit law was written by the U.S. Congress to encourage the develop-





are immediately being  
 American catch as well  
 American fishermen  
 can fishermen claim that for-  
 a leading American fishing  
 ry passage was granted when  
 can fishermen claim that for-

Soviet technology and American sweat make for a little-known joint venture in offshore fishing.

BY JOHN BURNETT

American fisherman bobs in his much smaller trawling vessel as he waves a greeting to large Soviet factory ship, *18th Congress*, working U.S. territorial waters off Alaska under a strict quota system supervised by the Coast Guard. Americans and Russians are cooperating to exploit bottom fish.



Below the decks of the Soviet factory ship *18th Congress*, trained crewmen, dressed in surgical garb, examine the fish to remove harmful parasites from them.



Russian crew (left) works on newly delivered catch. After deheading and filleting, the fish will be flash-frozen into blocks (above), then labeled appropriately.



ment  
indust  
Ameri  
eign f.

\$637.00-----Spread

the fish the  
as teach the  
to go after

subsidized by their governments, methodically swept the ocean bed clean of many species of fish before moving on to other seas. These "vacuum sweeps," as the fishermen call them, forced the law to tightly restrict the activities of these foreign vessels by placing quotas fixed by permit on each nation's fleet fishing within 200 miles of the U.S. coast.

The *18 Svezd Vlksm* and the *Great Pacific* are part of a unique Soviet-American arrangement in which development of the American fishing industry transcends the saber rattling of international tensions. Here, the Sovi-

the oft-neglected bottom fish off Alaska.

The sea-based Soviet processing includes deheading, filleting and flash-freezing the fish into frozen blocks which are then sold on the world market in boxes labeled: PRODUCT OF USSR-USA.

The Soviet-American joint venture is a step toward what the 200-mile law sought to promote. The purpose of the law, as it is written, is "to encourage development by the United States fishing industry of fisheries which are currently underutilized or not utilized by U.S. fishermen, including bottom fish off Alaska."



Crewmen aboard *18th Congress* (above) admire 20 to 30 tons of cod, a prized catch which fetches 9 cents per pound on the market.

At left, the Russian stern trawler *Alaska* pulls 16 tons of American-caught bottom fish up its stern ramp and into ship for processing.

Below, Russian-speaking American Beth Dunning, an observer aboard the *18th Congress*, takes a short breather from her duties. Under contract to the U.S. National Marine Fisheries Service, she and others collect statistical data of each catch's average species, weight, length and sex makeup.





In addition to processing the catch, the Soviets are teaching Americans how to trawl—sweep the bottom with nets—on a grand scale for “underutilized” bottom dwellers such as Pacific cod and walleyed pollock. The Soviets, better equipped and with many more years’ experience, have traditionally sought these bottom fish while the Americans have ignored the species, considering them “trash.”

However, the price per pound has now become attractive to the Americans because of the Soviets’ sea-based processing capability. Americans have never had these capabilities on the fishing grounds and immediate processing is mandatory because hormonal changes and parasites turn pollock to mush only hours after they are scooped off the bottom.

For the Soviets, the financial benefit of this arrangement is just as important; they get a good price for the processed product when they sell it on the world market. (The American fishermen are paid a fixed fee per ton for their catch.) However, the reason the Soviets are only processing and not fishing here is considerably more complicated.

Three years ago, President Carter ordered the hundred or so Soviet fishing boats from the rich Bering Sea in retaliation for the Soviet invasion of Afghanistan. But this joint venture between the Soviet processing vessels and the American fishing boats was protected by the 200-mile law because of its developmental assistance to the American fishing industry.

To the Soviets, this processing venture also provides them an opportunity to show that, despite Western reac-

tion to their military activities in southwest Asia, they are still willing to help the Americans develop their industry. In addition, they also hope that when new permits to fish these abundant grounds are issued, the U.S. will reflect favorably upon their help in developing the underutilized fishery.

The *Great Pacific's* net, containing thousands of pounds of bottom fish, is being transferred to the Soviet vessel. The American crew, lining the gunwales, watch their harvest intently as

foreign and American fishermen may harvest.

“There, that bunch is ready,” she mutters wearily, struggling to move the heavy baskets off to the side away from the work area.

“Ready to what?”

“Ready to sex,” she laughs. “I estimate the composition of species per catch—get weight and length of each fish, then get their sex.”

“Sex?”

“Yes,” she says. “My office requires that I figure the average num-

## ‘There’s as much luck involved here as in sitting in a bass boat with a bamboo pole in a down-home fishing hole.’

ber of each sex per catch.”

it is hoisted up the Soviet ship’s gaping stern ramp. To these young Americans, their net represents part of a long day’s work.

Aboard the *18 Svezd Vlksm*, a young American woman with wisps of auburn hair falling out from under her hard hat, stands in the middle of the pile of squirming fish and tosses a few into a plastic laundry basket. Beth Dunning, a Russian-speaking fish biologist under contract to the U.S. National Marine Fisheries Service, is taking statistical data on the catch. She is one of the many young people assigned to foreign vessels fishing within the 200-mile Fisheries Conservation Zone.

The information gleaned through Beth’s research is one of the tools the Government uses to determine the health of the fisheries resources and the subsequent quantity of fish for-

ber of each sex per catch.”

She places a small halibut along a plastic measuring chart laid out on the deck. Halibut, crab and salmon, universally prized species on any table, are fish prohibited to all foreign ships under the 200-mile law. Possession by foreign ships has resulted in seizure of the vessel.

An older crewman with some apparent authority and sporting a row of solid-gold front teeth approaches from behind and unexpectedly picks up Beth’s halibut.

“*Nyet, nyet!*” she says, quickly jumping to her feet and grabbing the man’s arm.

He rebukes her sharply in Russian, jerking his head toward the open sea. Defiantly, he walks to the edge and throws the halibut over the side. He turns to her, plants his fists into his

*(Please turn to page 134)*

Beneath the decks of the Soviet factory ship (below left), two busy assembly-line workers inspect and pack the fish into pans to be flash-frozen into blocks. Below right, the American catcher boat *Ocean Harvester* cuts the whitecaps of the Bering Sea.





\$4,458.75----Spread

# HERE COME THE ASSEMBLY-LINE GENES

To create life's most important proteins, we're building living cells with unprecedented speed.

BY DENNIS ESKOW SCIENCE EDITOR

PROTEIN CHAIN

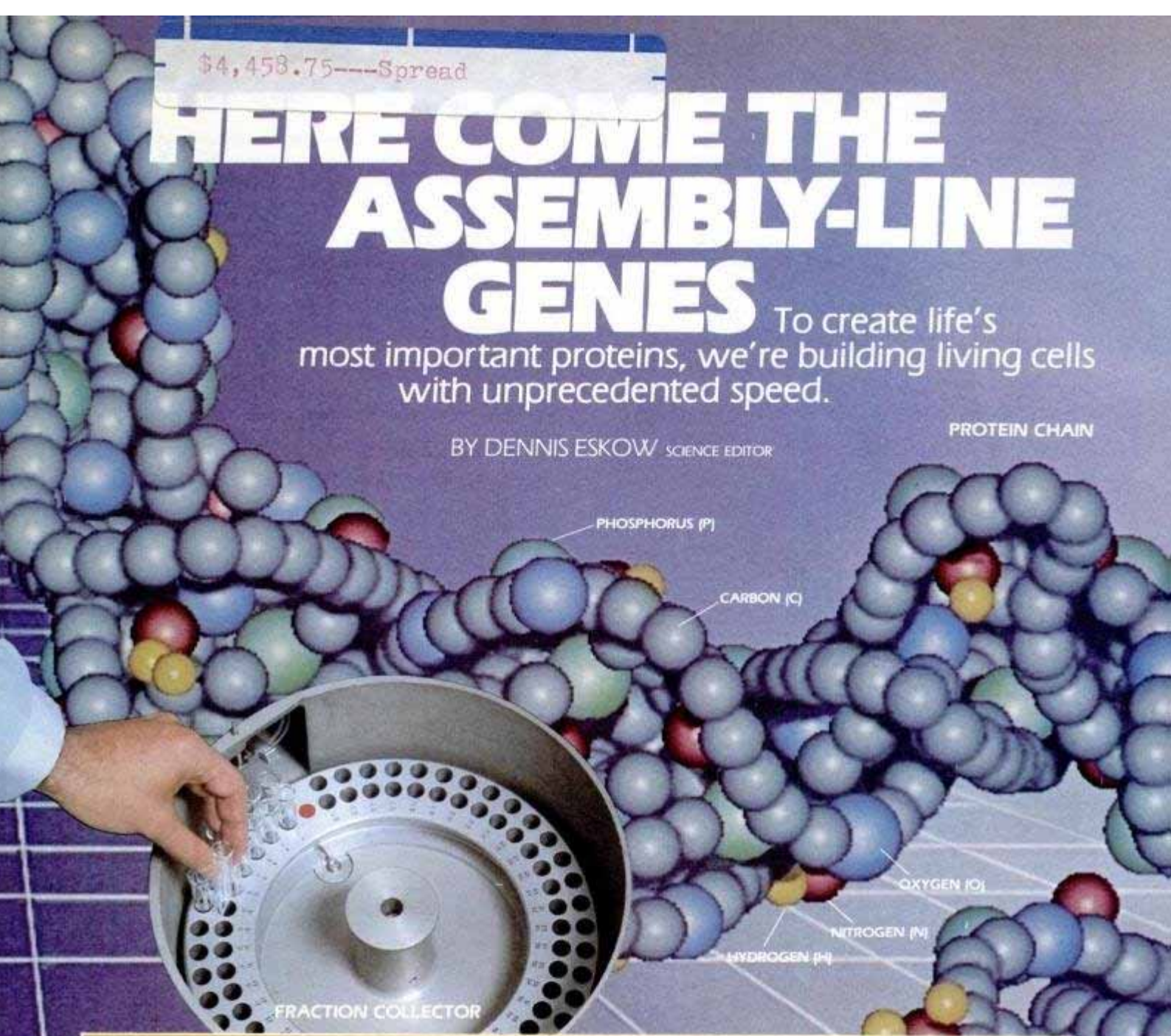

PHOSPHORUS (P)

CARBON (C)

OXYGEN (O)

NITROGEN (N)

HYDROGEN (H)

FRACTION COLLECTOR

## FREING AN AMINO ACID LINK FROM THE PROTEIN CHAIN

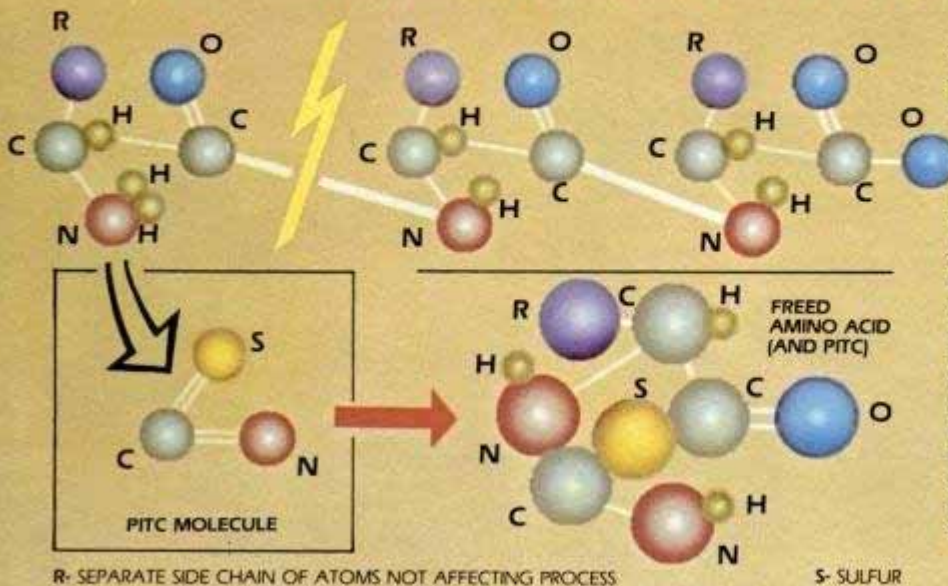

To mass-produce genetically engineered products like artificial insulin, scientists first have to figure out number, order of amino acid links that make up product's protein chain (long spiraling molecule in computer graphics above). One by one, individual amino acid links are pulled away from the protein chain in the reaction chamber of a protein/peptide sequencer (facing page). A link is freed (left) when a chemical called PITC acts on it. This is done until all amino acid links are separated, counted and tagged in the machine's fraction collector (photograph above).





In half the time it takes you to blink your eyes, nature links together thousands of chemical groups to form the tiny molecules that determine your size, shape, hair color, blood type—all the parts and specifications of a human being. And, while man isn't nearly as fast as nature, a revolution in genetic engineering machines is giving her a run for her money.

Already we're cloning human insulin; hormones to make cows double their milk production, and interferon—a protein that may become the most powerful weapon in the war against cancer. Using high-speed, computerized machines, scientists who are part biologist and part engineer have begun mass-producing bacteria that eat raw sewage and lick up oil spills.

"Before automation, one step could take one week; now it can be done in an hour," says Mehmet Pamukcu, a product manager for Beckman, the giant of the gene machine industry. "You can actually map out an entire protein in a week."

Insulin is a protein. So is interferon. In fact, the science now known as genetic engineering was originally a branch of biochemistry called

At left, a drop of protein is squirted into cup in sequencer's reaction chamber (seen below). There, the protein chain, depicted at left by computer graphics, is treated to obtain individual amino acids.

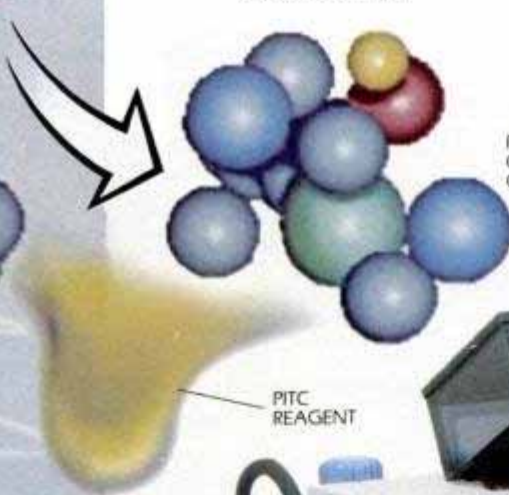
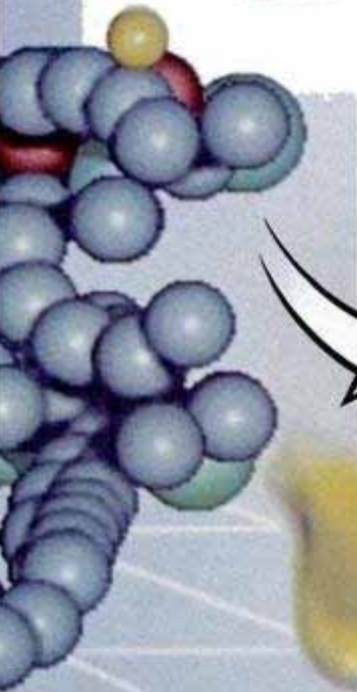

AMINO ACID

PROTEIN/PEPTIDE SEQUENCER

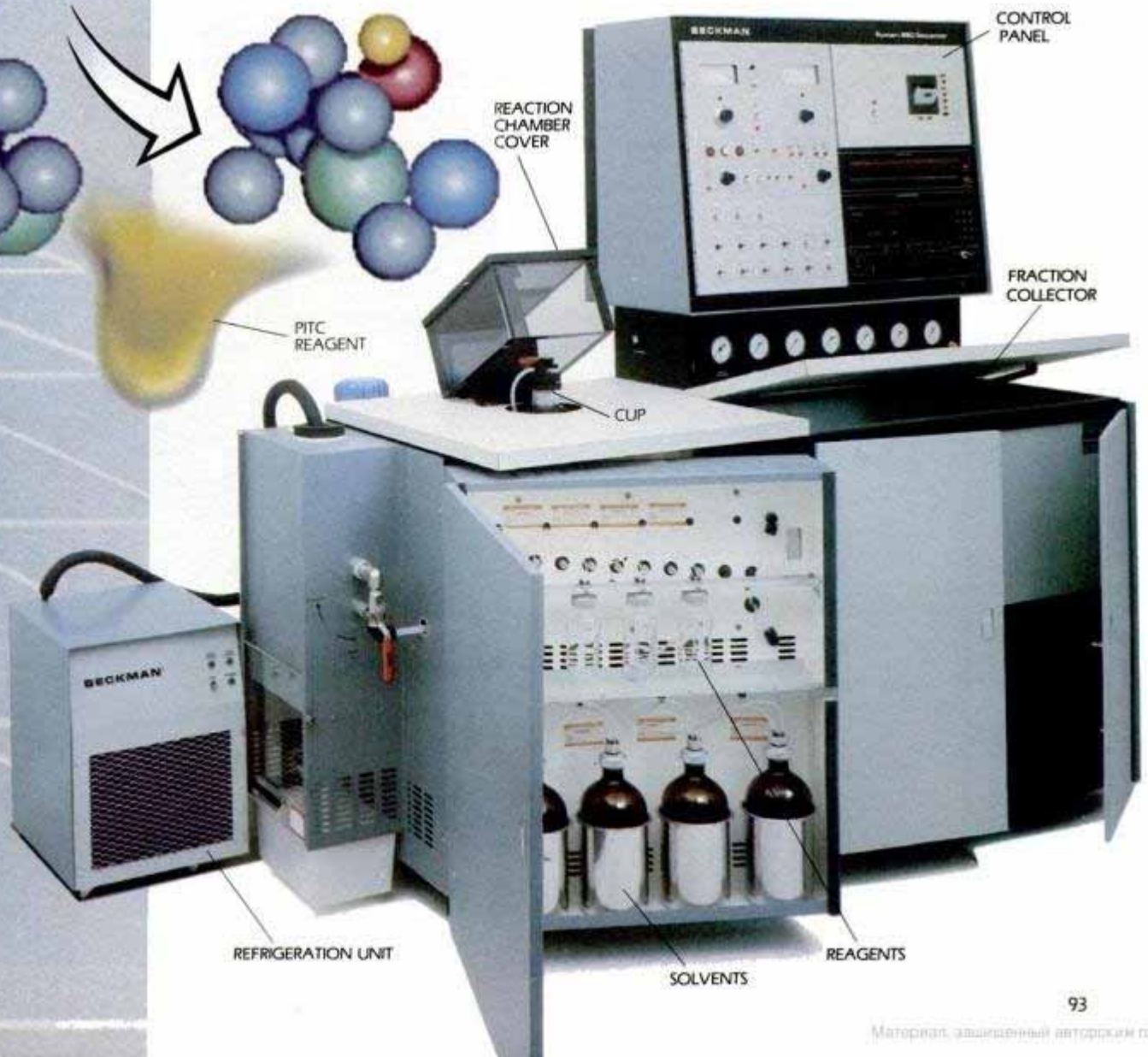

CONTROL PANEL

REACTION CHAMBER COVER

FRACTION COLLECTOR

PITC REAGENT

CUP

BECKMAN

REFRIGERATION UNIT

SOLVENTS

REAGENTS



protein synthesis. To create a protein, the body hooks together just 20 amino acids in hundreds, even thousands, of varying orders. A single protein molecule might be made up of thousands of amino acids. But it's not enough to know which acids make up the protein or how much of each acid is inside. Two different proteins can contain the same amount of the same acids and be as different as night and day. To know exactly what makes up a protein—which is necessary to clone it—you have to know the exact order in which the acid links made up the protein chain.

Enter machines like the Beckman 890D Protein/Peptide Sequencer. At first glance, it looks like a Xerox copier, but it helps scientists copy much more than office memos.

In the reaction chamber, a drop of protein in a shot-glass cup is spun gently. This keeps the protein from denaturing—undergoing an irreversible change in its chemical makeup. This begins a process that will break the chain into tens of thousands of amino acid links in exactly the order in which they are strung together.

On the first cycle of operation, the

## If you could unwind just a single DNA spiral—one molecule—it would stretch out for three feet.

Beckman machine automatically sprays a special chemical reagent into the cup. The most commonly used reagent is called PITC. It pulls on one end of the first amino acid molecule, while pushing the other end away with forces similar to magnetism.

In the next step, the machine adds buffer, washing away any excess PITC in the cup. Too much PITC would destroy the protein chain. (Of course, if too little were added, the amino acid would be left dangling from the end of the chain. It would be snipped, however, on a second or third pass.)

The PITC leaves the shot glass through a gravity tube. But the amino acid, after it has been cleaved, gets sucked into a vacuum tube and shunted to a revolving tray called the fraction collector, a Lazy Susan with circular rows of test tubes. When the first acid lands inside the first tube, the tray

rotates. The process continues until all the acids are counted out, one by one. Of course, no tray would be large enough to sequence all the acids of a typical protein, so the system has to be serviced by human hands every few hours.

Just as the proteins are chains of amino acids, the most basic molecules of life—the genes—are part of a long-chained molecule known as *deoxyribonucleic acid*, or DNA. A DNA molecule is shaped like a spiral staircase made of long strands of protein. The chemicals that link the sections of a DNA molecule are called nucleotides. And, in nature, these are split apart in a process similar to that used in the protein sequencer. The DNA molecule is among the largest in biology. If you could unwind a single DNA spiral, an American Chemical Society paper says, it would stretch out for three feet.

*Main culture unit at New Brunswick Scientific holds bacteria in a 125-gallon vessel filled with chemicals that keep desirable cells alive. These cells produce interferon and other chemicals. Cells are transferred in 50-gallon increments to suspension vessel, where bacteria are separated from nutritive chemicals. Small tanks maintain chemical environment for specific bacteria to reproduce.*

SUSPENSION  
VESSEL

BACTERIA  
VESSEL

CHEMICAL  
TANKS

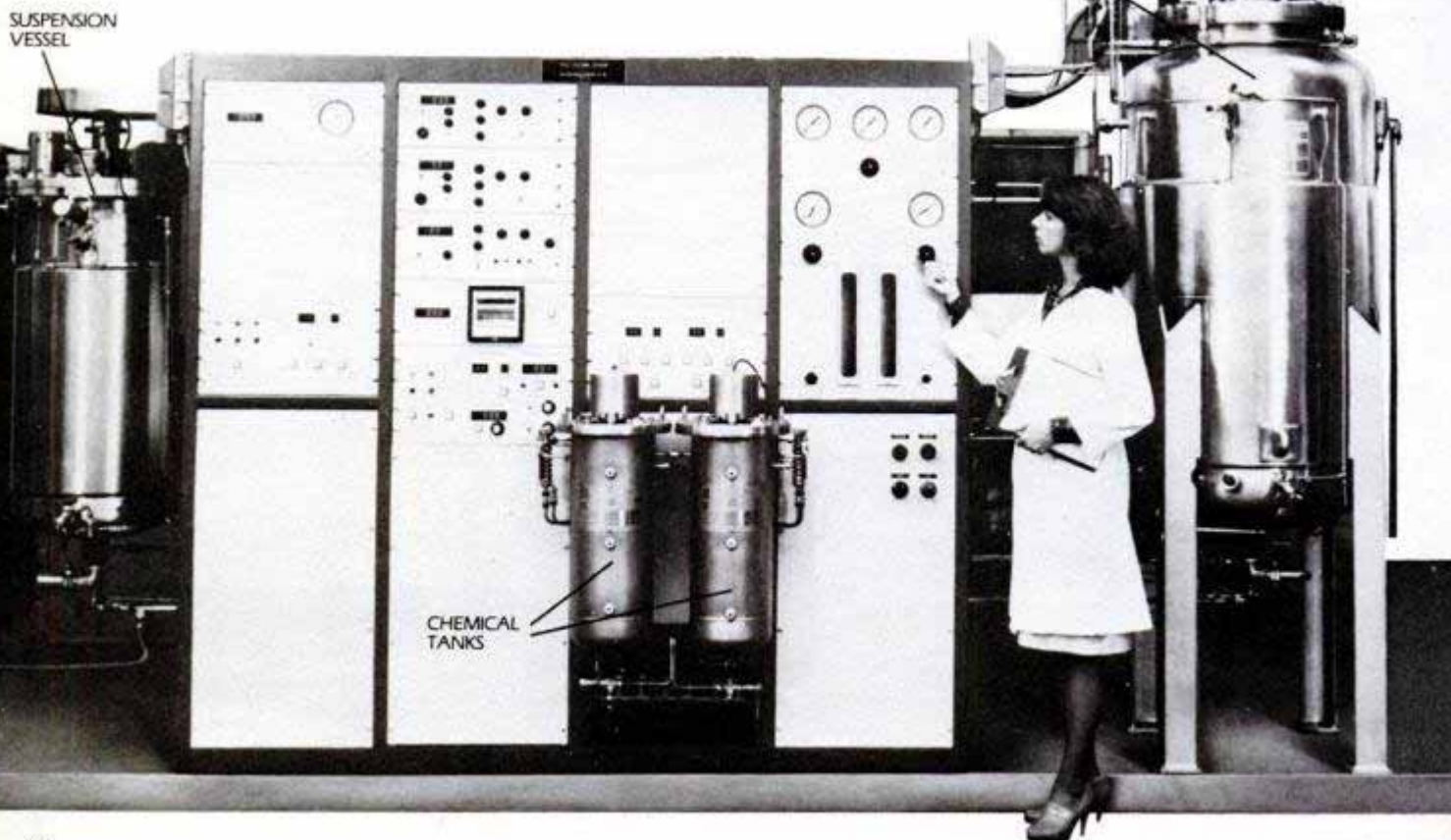



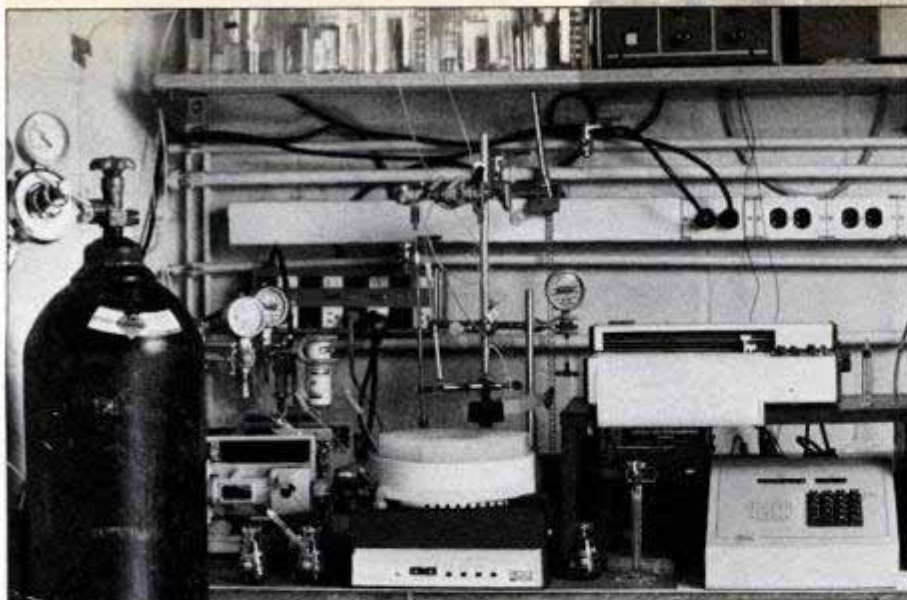

*Genetic engineering has a do-it-yourself side; High Performance Liquid Chromatography system (above) is put together from components. The HPLC separates amino acids for analysis. Cal Tech's sequencer (left) will be out this year.*

Until recently, the only way to analyze DNA molecules was to break them down into their protein parts. But even that hurdle has been overcome with the advent of high-speed "nucleotide sequencers" that can analyze DNA as fast as the Beckman machine maps out a protein.

On the market already are nucleotide sequencers made by Vega, whose equipment is instrumental in mass-producing cloned insulin. And California Institute of Technology researcher Leroy Hood is expected to introduce in the next year a new DNA sequencer that, working with other equipment, will be hundreds of times more sensitive than anything on the market.

Once scientists have the blueprint for a protein or DNA chain, they can copy it easily. With machines that reverse the sequencing process, they can mix the oxygen, carbon, nitrogen, phosphorous and hydrogen that comprise a protein chain. But most genetic engineers prefer to build a protein-sequencing system into living bacteria.

"Bacteria work faster, and perhaps more accurately, than any machine man can build," says MIT's Philip Sharp.

Creating a bacterial factory starts with knowing the protein sequence. Then, you have to find a bacterium—a one-celled microscopic creature—that will reproduce your chemical exactly. By getting one sequence wrong, a

researcher could turn a medicine into a poison. To get to the correct bacterium for reproducing your protein, you have to raise millions of bacteria in an incubation system. In a chemical broth, a group of bacteria—most often *E. coli* from the human intestines—is permitted to grow wildly. The researcher wants only one kind of *E. coli* bacterium, but he has to grow millions to raise one with the specific traits he needs.

During the weeks and months spent

searching for a prospective one-celled bacterium, the scientist notes conditions under which that particular specimen will survive—high temperature, the absence of a specific chemical or other factors. When the desired bacterium is born, conditions are changed in the incubator that allow only that type to survive. The undesirable creatures are then killed off.

With this technique, genetic engineers need only maintain tight controls on the vats that contain the bacteria and they can have a continuous supply of a protein, interferon, for example. The bacteria, as small as they are, only produce tiny amounts of interferon each, so quite a large batch—hundreds of gallons—must be raised to get a useful supply.

Once the bacteria are reproducing and making interferon, processors can separate the drug from the cell with chemical treatments. While the first ounce of cloned interferon reportedly cost tens of thousands of dollars, subsequent ounces have been far less expensive, permitting researchers in the United States and Europe to try it out on cancer patients. In a small number of tests here, it has shown an ability to slow the growth of tumors. But some French patients died earlier than expected under the treatment.

Genetic engineering has given rise to a whole new do-it-yourself market, especially among the 150 or so labs devoted strictly to protein chemistry.

"This is a young industry, and many of the smaller labs are trying out different equipment configurations for their

*(Please turn to page 124)*

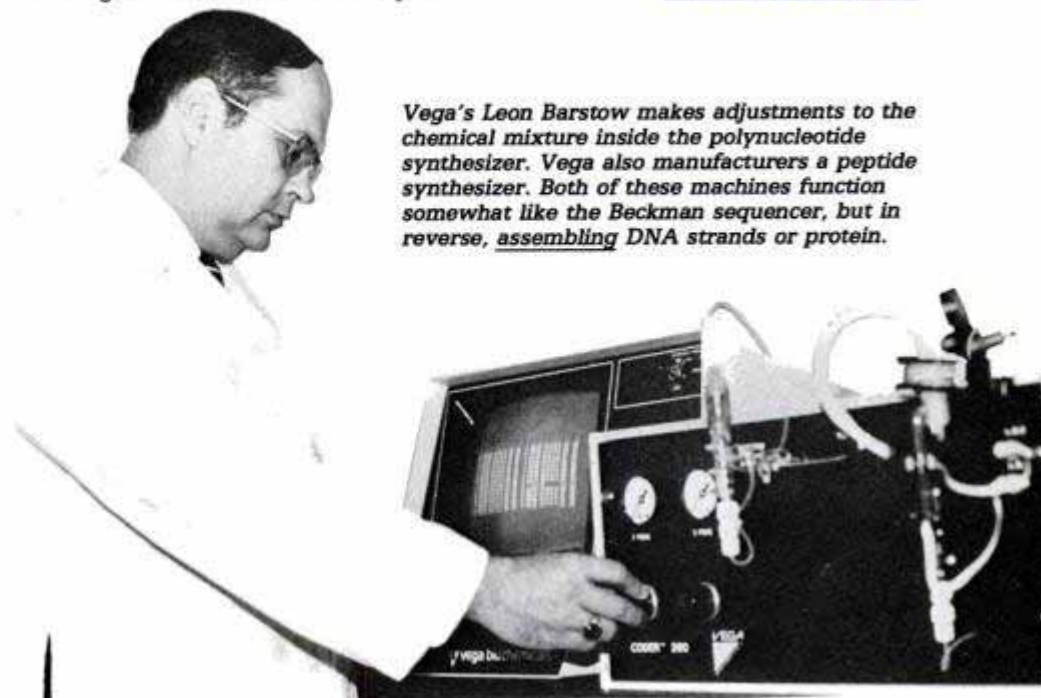

*Vega's Leon Barstow makes adjustments to the chemical mixture inside the polynucleotide synthesizer. Vega also manufactures a peptide synthesizer. Both of these machines function somewhat like the Beckman sequencer, but in reverse, assembling DNA strands or protein.*



\$2,918.00 — Spread

**MAKE YOUR OWN**

# Weather Forecasts

Use PM's chart to predict tomorrow's weather, or create a home weather station that's the rival of professional forecasting setups!

BY DENNIS ESKOW SCIENCE EDITOR

If you get all your weather forecasts from a radio or TV meteorologist, your life is about to undergo a radical change. By the time you finish reading this article, you'll be able to predict tomorrow's weather, and perhaps the next day's, with better accuracy than the eternally smiling TV weatherman. And, of course, you'll be more accurate than those ancient magicians who forecast the next day's weather by the number of halos around the moon. (Halo watching is often effective. It's explained later.)

Man has been forecasting weather since before the invention of the wheel. And with the advent of computers, satellite photos and advanced mathematics, we've gotten even better at looking ahead. But you can still improve on the predictions of the professional meteorologist. By combining his barometric reading with the local wind conditions in your area, you can use PM's weather chart to get a more accurate forecast of the weather in your own neighborhood for 24 hours. Add a \$10 analog forecaster and you can extend your prediction up to 36 hours or



**Capricorn II Digital Weather Console**



more. With PM's chart and a \$50 barometer, you can predict tomorrow's weather with uncanny accuracy, certainly better than the forecast your weatherman prepares from a distance away. Finally, by adding the information-storing and precision-sensing capabilities of a computerized weather station (\$399 to \$990), you'll be able to make three-day forecasts that are as good as, or better than, the weatherman's.

It isn't that television forecasters are brainless. Professional meteorologists generally are trained in the sciences and have at least a nodding acquaintance with the computer technologies on which they depend. Their problem is one of scope: They must forecast weather for an area roughly 50 to 80 miles in diameter, or thousands of square miles. Some of the territory is at high elevation, some is near water and some is surrounded by forests and hills. No one can make a 100-percent-accurate forecast under those circumstances.

But, armed with a \$795 Capricorn II Weather Station (from Edmund Sci-

*(Please turn to page 148)*

*With PM's weather chart (right) you can predict the next day's weather. Practice using it with barometric-pressure and wind-direction readings you hear over the radio.*

*In order to become a do-it-yourself weatherman, you'll need instruments and aids, some of which are shown below: Sager guide tells you how to read other indicators, like clouds. Mechanical instruments in the Downeaster station can be purchased separately. Rainwise unit provides digital readings. Add a rain gauge, a wind-chill meter and a tide clock and you have everything that a professional has, except a satellite- or computer-generated map.*

## HERE'S HOW TO FORECAST TOMORROW'S WEATHER

IF WIND SHIFTS...	AND BAROMETER READS...	THE WEATHER WILL BE...
SW to NW	30.1-30.2 Steady	Fair
SW to NW	30.1-30.2 RR	Fair; rain in 2 days
SW to NW	30.2 + Steady	Continued fair
Westward	29.8 - RR	Clearing, colder
S to SW	30.00 - RS	Clearing today
S to SE	30.1-30.2 FS	Rain
S to SE	30.2 FR	Increasing wind; rain tomorrow
SE to NE	30.2 FS	Rain in 12 hours
SE to NE	30.2 FR	Increasing wind; rain tomorrow
E to NE	30.1 + FS	Rain in 24 hours in winter; if wind's light, no rain in summer
SE to NE	30.00 - FS	Rain continues
SE to NE	30.00 - FR	Severe storm
E to NE	29.8 - FR	Heavy snow in winter; severe northeast gale in summer

RR: Rising rapidly    RS: Rising slowly    +: And higher  
FR: Falling rapidly    FS: Falling slowly    -: And lower

PM photos: Peter Tenzer

*Capricorn II weather station (left), placed indoors, connects to outdoor sensors, like the anemometer shown. Digital readouts give temperature, barometric pressure, wind speed and direction; features like alarm and memory alert you to sudden changes in weather.*





# Country Weather Vanes You Can Make In Your Shop

A premier designer of country-style furniture creates four weather vane replicas that you can build for display.

Designer: Adam Peck,  
American Design Inc.  
PM photos: Harry Hartman

\$2,041 — Spread

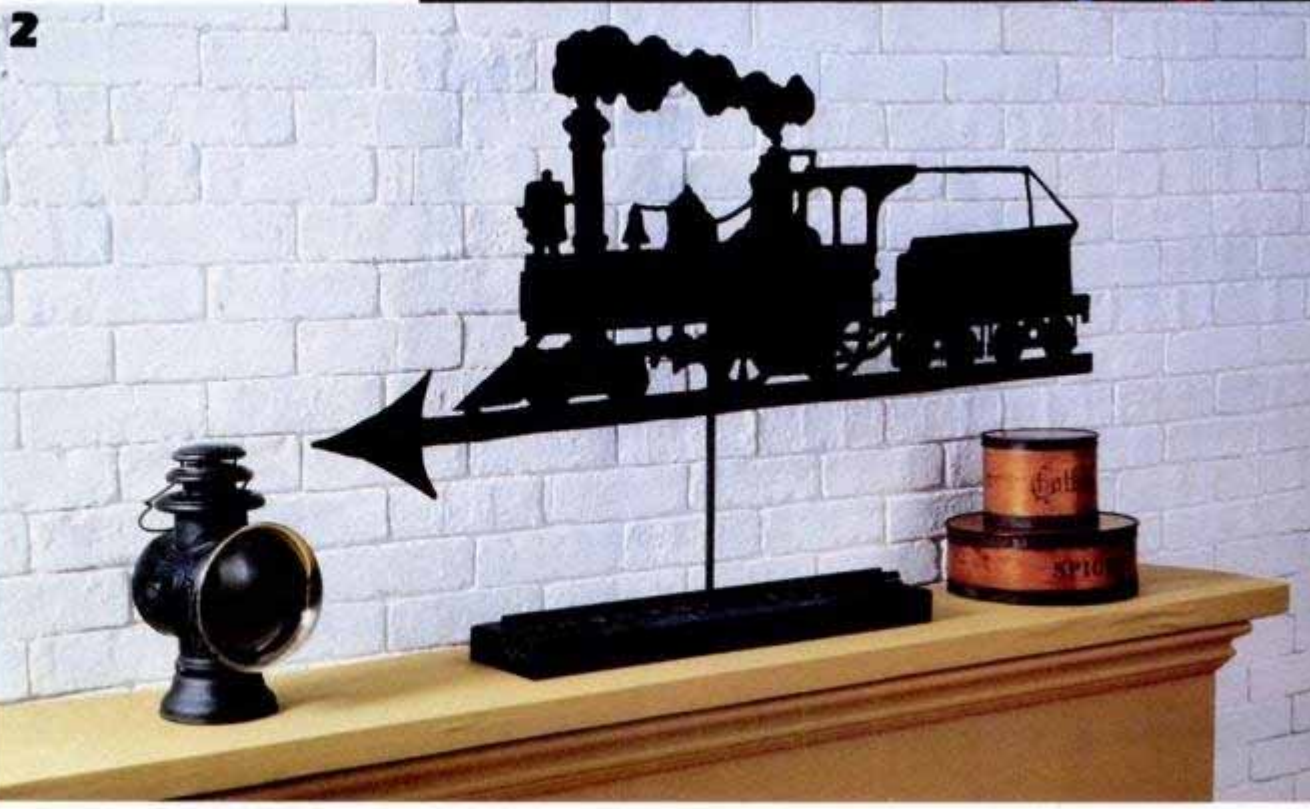
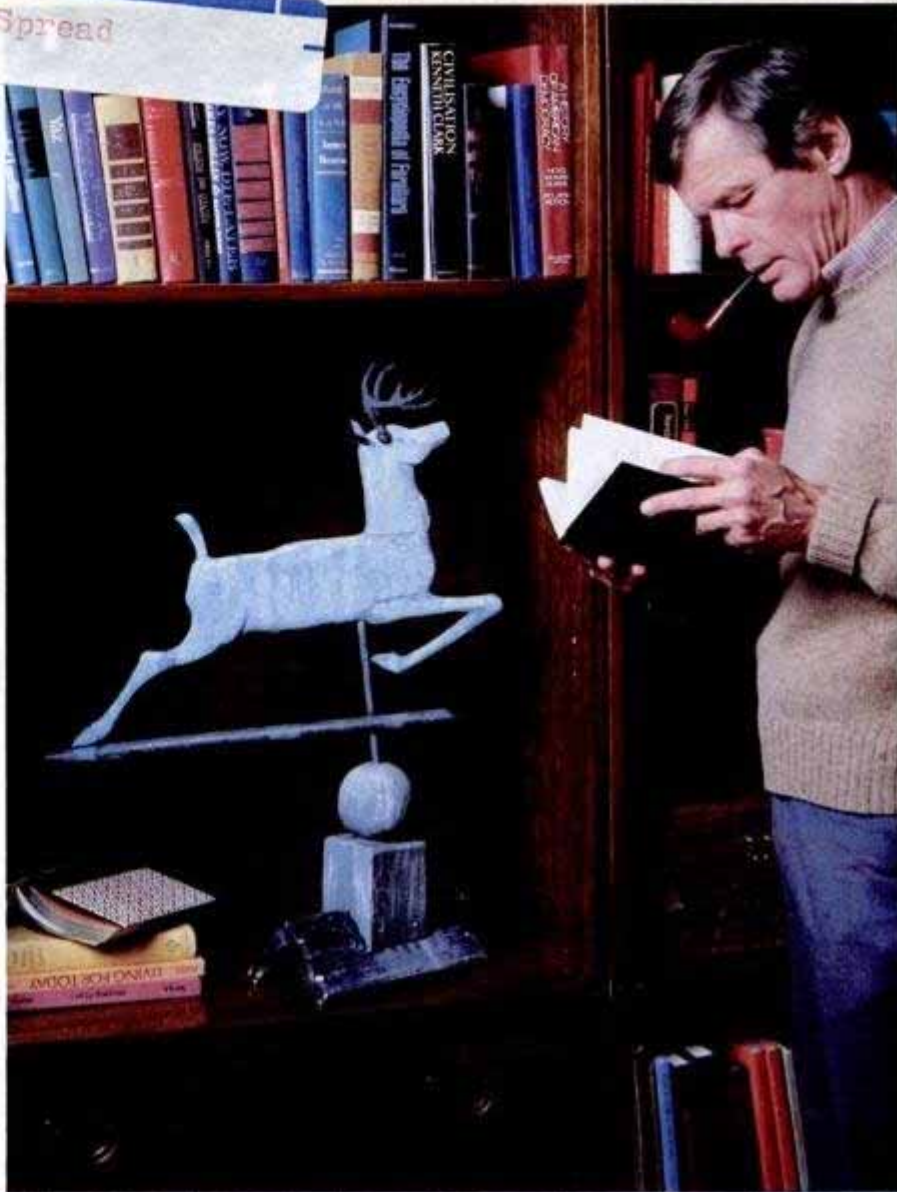



**W**eather vanes were a common sight on the landscape of early America. Not only did they prepare our agrarian ancestors for changes in atmospheric conditions, but weather vane construction served as a creative occupation during long winter evenings.

PM asked designer Adam Peck to create several display replicas. All vanes shown are created of either wood, metal or both. The authentic-looking finishes are achieved using Rust-Oleum paints. Complete instructions for building and painting follow.

## 1 Running stag

Although the running stag is made of wood, it is skillfully painted to look as if it's covered with verdigris, the greenish-blue substance that forms on copper, brass and bronze. Since all authen-

3



4



**1** Leaping stag is typical of country weather vanes fashioned by early craftsmen. Adam Peck created this one in wood and applied a finish to simulate look of old copper.

**2** Puffing steam locomotive recalls an earlier era. Constructed of sheet metal painted black, it is mounted on a hardwood base shaped like railroad tracks.

**3** Modeled after a gaff-rigged colonial sloop, PM's America is of wood with metal sails. The original boats of this type were used for pilot and fishing boats.

**4** The Indian stalking a bear can be hung on the wall. The figures are of wood inserted into a metal U-channel and underscored by an arrow carved of wood.



tic weat digris, creating the greenish cast on the running stag assures its authentic appearance.

Before you begin work, read the instructions through and round up all

need. Use To draw the stag, lay out a full-size grid on 3/4-in. clear pine; draw each square 2x2 in. Sketch in the stag pattern, following the drawing directly

below. Draw a grid and transfer the antler pattern onto 1/4-in. stock.

Carefully cut out the stag body with a scroll or band saw. Or rough-cut it with a sabre saw and finish-shape with a

(Please turn to page 143)

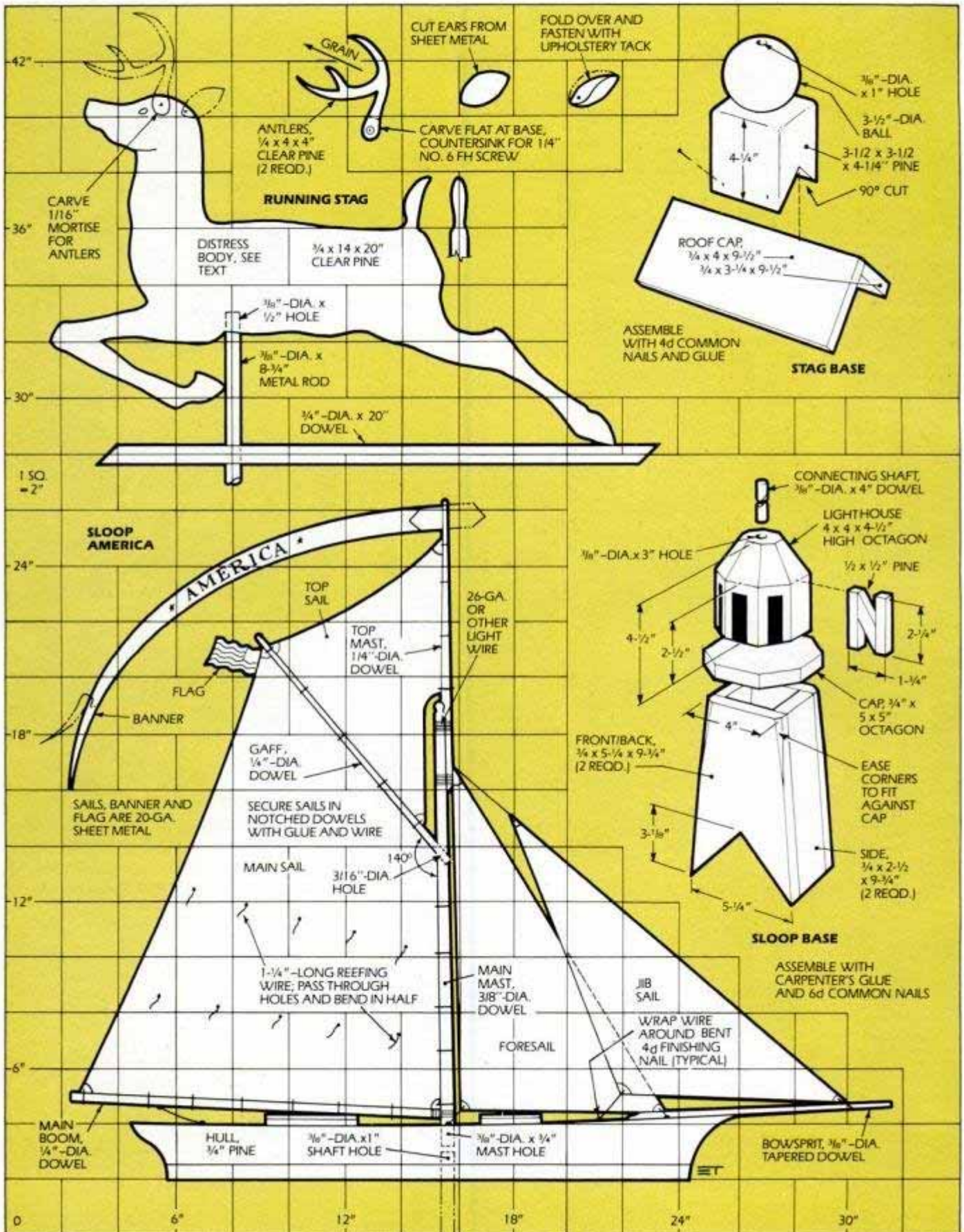



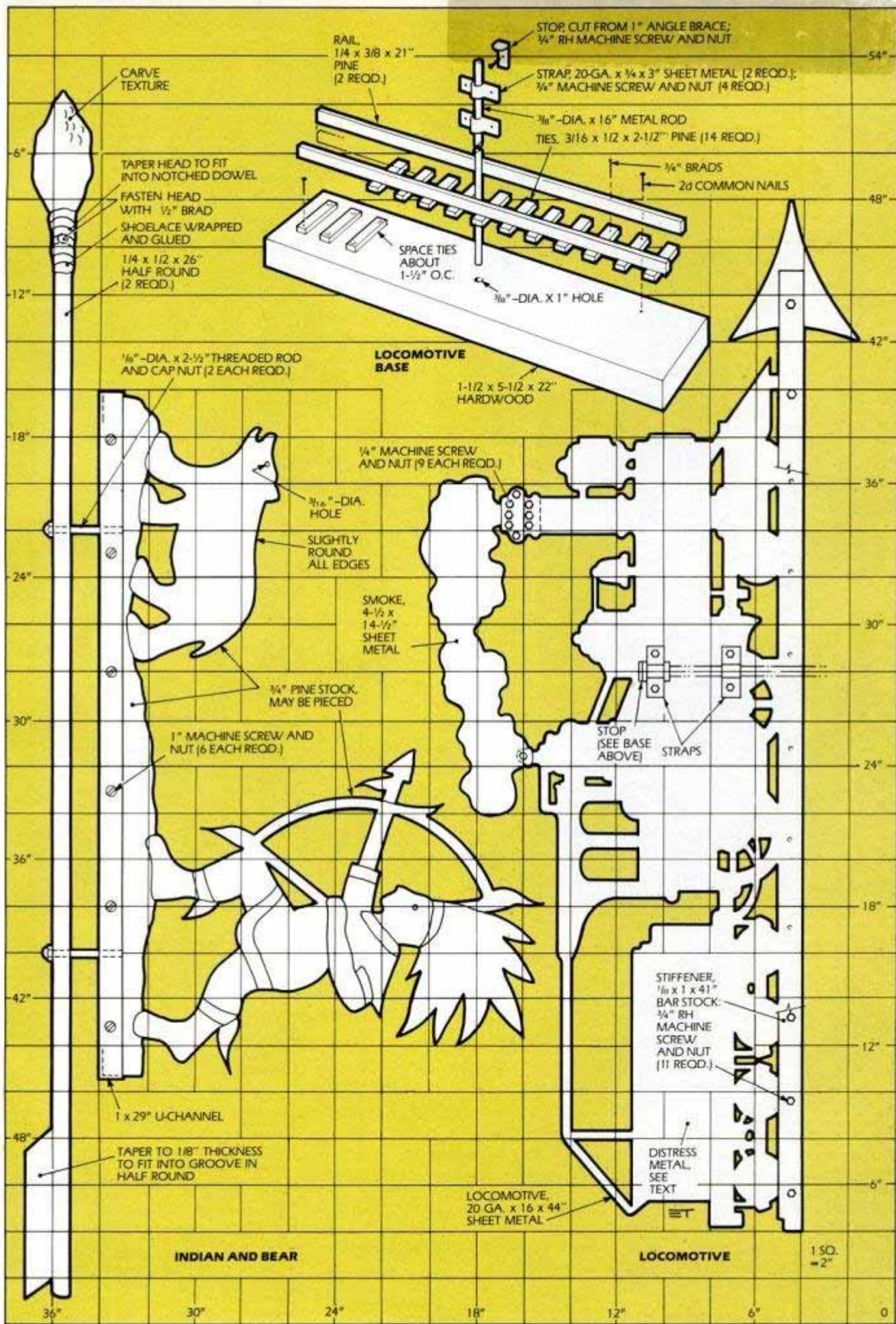





## A Barn For Your Back Yard

Our well-designed yard building provides handsome storage for yard tools, power equipment and gardening supplies. Build it from plans that you buy.

If you visit your local lumber yard or home center you're certain to find several factory-made back-yard buildings on display. Some of them will be relatively low in cost, while others will be more expensive. Many versions will fulfill the storage needs you have—but none will match the "down-home" good looks of the PM building.

Our build-it-yourself beauty was de-

signed and built by William I. Winans.

It provides such sorely needed amenities as storage space for large yard equipment and hand tools, and a gardener's center for the family "green thumb"—with attention to design de-

PM photos: Bill Barker  
John Deere garden tractor courtesy Falls Mower & Garden Center, Chagrin Falls, Ohio

### HOW TO ORDER PLANS

The plans for the PM Back-Yard Barn consist of four 17 × 22-inch drawing sheets, a detailed instruction manual and a materials list. A single set of plans is \$10.50. If you need a second set to file for a building permit, two sets can be obtained for \$17.50. Send check or money order to Storage Barn, Popular Mechanics, Box 1014, Radio City Station, New York, N.Y. 10101. Please allow four weeks for delivery.



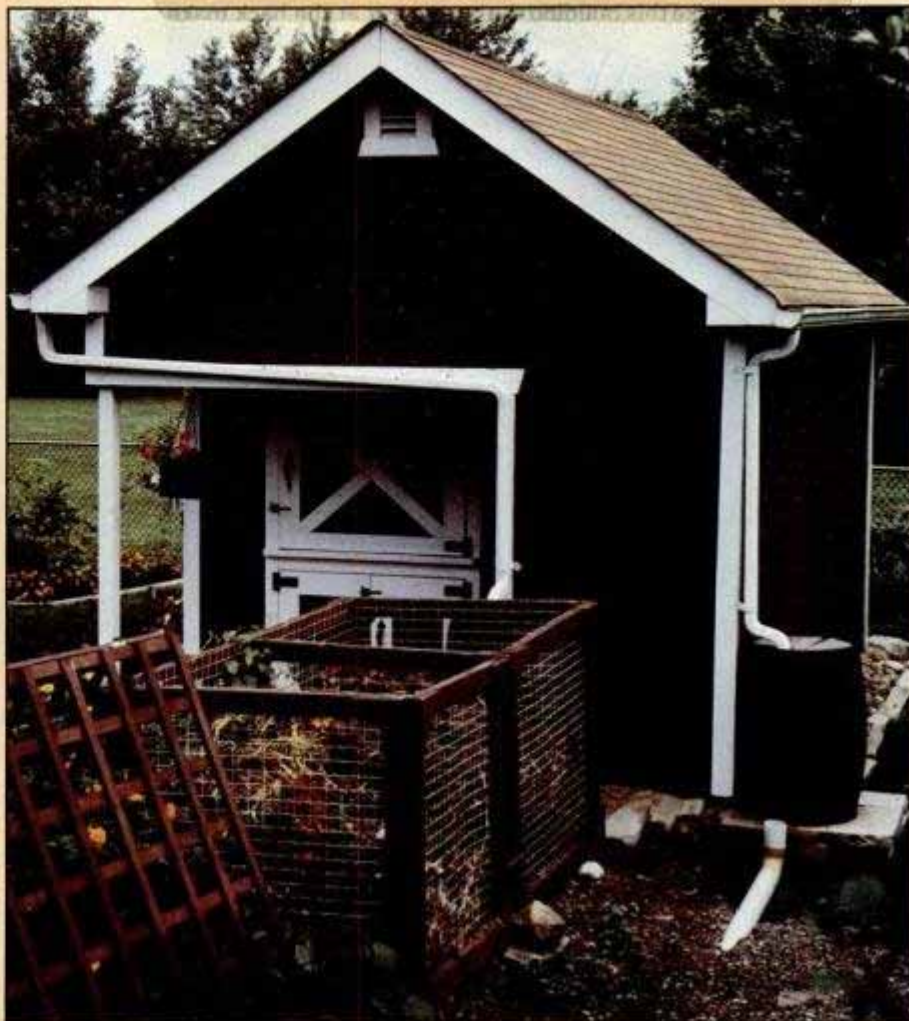

Overall view (facing page) shows wide barn doors at left end and porch with potting bench at right end. Loft can be reached from outside through overhead doors (center) or from inside by ladder (above). Potting bench (far left) has door with shelves on inside that put gardening supplies at your fingertips when opened. Access doors below bench (near left) let you reach additional supplies from outside barn.



\$3,016.50

tail that hit of your neighborhood. There's a bonus, too: Ours has an upstairs loft for additional storage (perfect for storing project lumber).

The carpentry details are easy to understand; designer Winans came up with construction methods that can be tackled by the average do-it-yourselfer, as you can see in the drawing below.

The building's basic dimensions are 12 x 16 ft. This permits economical use of building materials. The unusual upper-level kneewall in front and a joist

design.

To provide extra headroom in the loft—without using additional lumber—designer Winans "dropped" the loft floor, suspending it from joist hangers at the front and resting it on a ledger strip at the rear.

### A useful old trick

Here, an old carpenter's stunt makes it easy to align the hangers with the studs in the rear wall. Hold a straight-edge—a spare 2x4—along the back

wall and mark the stud locations on it. You can then transfer these marks to the front wall to establish the hanger locations.

Your community may or may not require you to have a building permit. To be safe, check with your building department before beginning construction. If a permit is required, you will need an extra set of plans for the building department.

The shed shown is built on a concrete slab which was poured over a well-compacted subgrade. **PM**

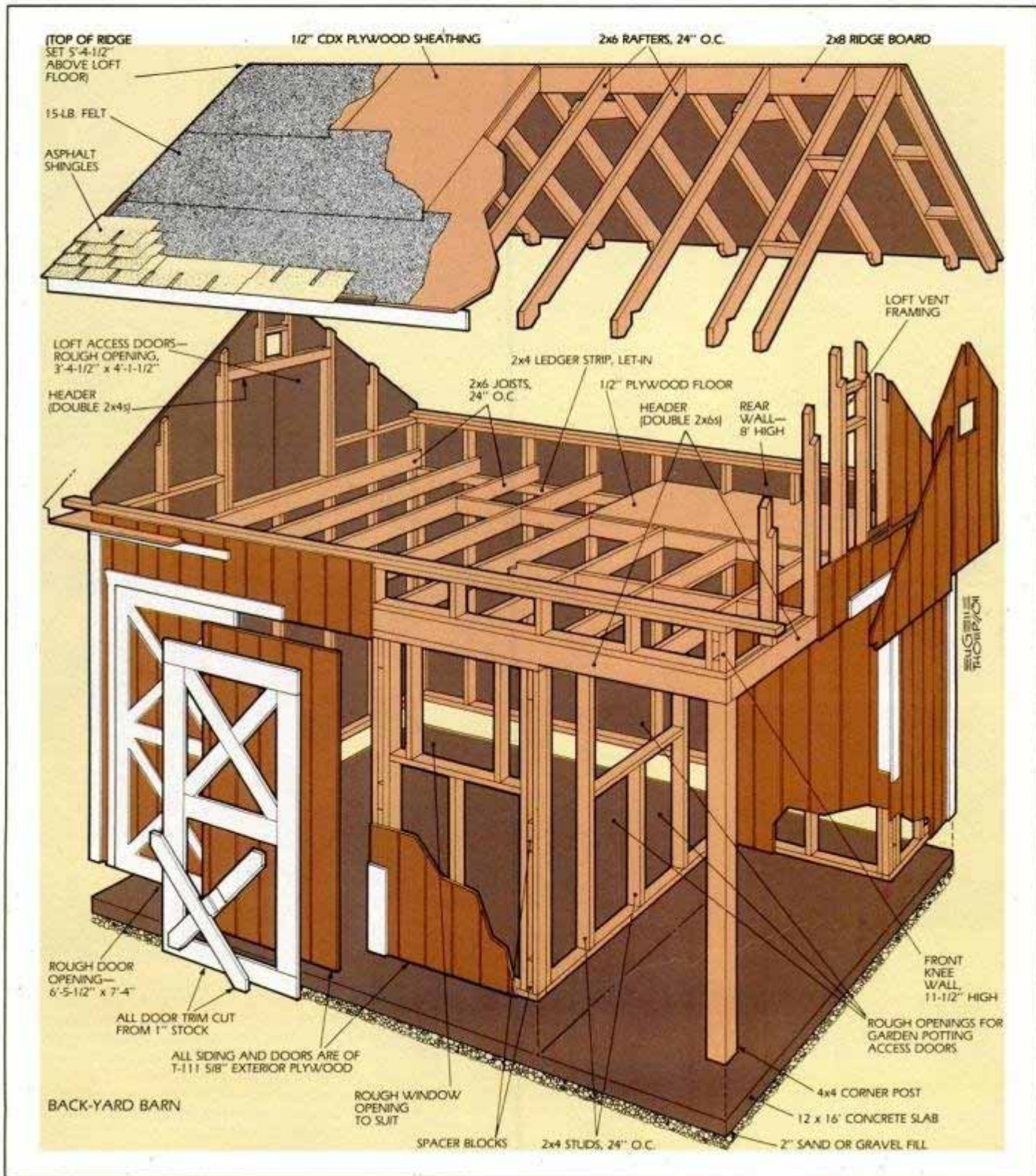



# 3 Gardening Aids You Can Build

The potting bench, lettuce shader and caterpillar cloche can turn an "all-thumbs" gardener into a green thumb.

- 1** The potting bench is a scaled-down version of one used in the professional nursery and garden center of Bob Thomson, host of the Victory Garden television program. All details that you need to duplicate it are shown.
- 2** Use a lettuce shader to protect loose leaf, bibb and other lettuce from the sun on sweltering summer days. You can plant a crop in early spring and use the shader to continue growing lettuce through the autumn months.
- 3** An easy-to-construct caterpillar cloche lets you plant outdoor crops earlier and harvest later in cold weather. Gardens For All showed us its cloche, which is based on plans from the National Center for Appropriate Technology.



Thomson in Victory Garden greenhouse.

(For building instructions, please turn to page 125)

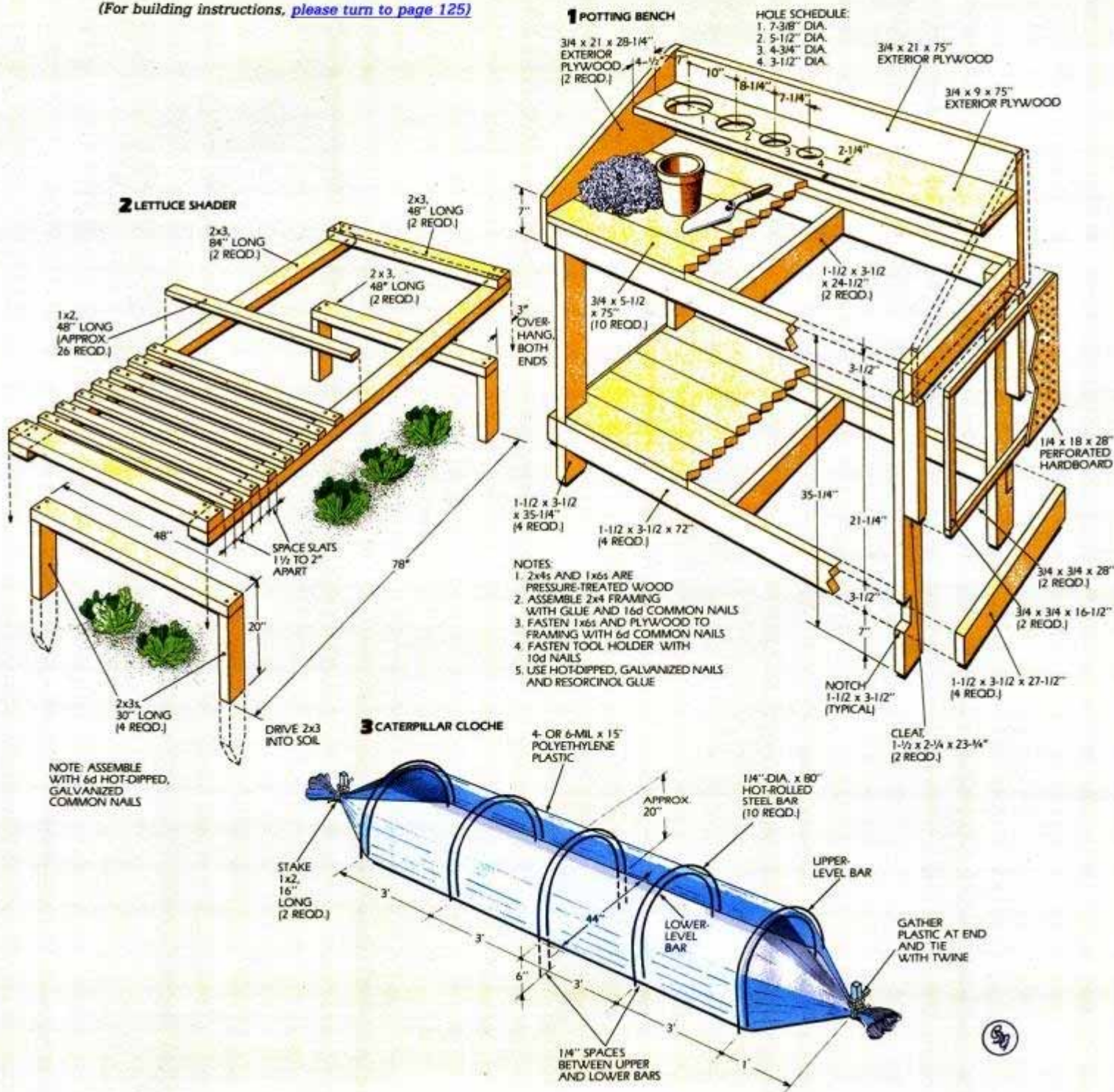



# 10

\$1,911.00 Processed as B/W plus  
pgs. 107, 103. Revised as 2/c by J.C.

## Secrets From A Master Woodcrafter

### 1 CLAMP STUNT

If the swivel pads on your C-clamps become loose and fall off, try this method for replacing them.

First, open the clamp wide and place it in a vise, as shown. Now, strike the end of the screw shaft with a ball-peen hammer to peen the shaft over. Be sure to strike the shaft accurately, for an errant blow could fracture the casting of the clamp.

Once the screw shaft is sufficiently peened, remove the clamp from the vise and position it on a hard surface. Hold the swivel pad in place and tighten the clamp by driving the peened shaft into the swivel pad collar.



Strike the screw shaft to peen the end over (left). Hold the swivel pad in place and tighten the clamp to drive the peened shaft into the collar of the pad (right).

### 2 EXTENDED PIPE CLAMPS



When you find that your pipe clamps are too short for use on a particular project, don't invest in an additional set of longer clamps. Simply extend your existing clamps with lengths of black pipe.

Keep your workshop well supplied with various pipe lengths—threaded on both ends—plus several standard pipe couplings, and you'll be able to clamp almost any project. You're limited only by the length of pipe you have on hand; this procedure works with

either 1/2- or 3/4-in.-dia. pipe clamps. Moreover, you'll obtain more professional results by creating the correct clamp for each job.

To lengthen a clamp, disengage the clamp's tail-stop assembly and slide it off the pipe. Choose the desired length of extension pipe and join it to the "short" clamp with a coupling. Do not use a wrench when adding an extension to a clamp. Hand-tightening is sufficient. Replace the tail-stop assembly and you've got a "new" clamp.

Lengthen your pipe clamps to suit any job. Add the desired length extension to clamp with a standard pipe coupling.

### 3 SCREW-EYE DRIVER

These homemade tools are great for driving screw eyes and hooks of all sizes. Each driver is a 4 1/4-in.-long hardwood birch dowel, and I recommend making four different-size drivers; 3/8-, 1/2-, 5/8- and 3/4-in. dia.

Start by cutting a 1/2-in.-deep saw kerf centered in one end of each driver. Cut the kerf narrow enough to provide a snug fit around the screw eye. Now, measure 1 1/2-in. down from the other end of each driver and center-bore a 1/4-in.-dia. hole to accept a 1/4-in.-dia. x 2 1/2-in.-long dowel handle. The handle adds leverage when you turn in a screw eye or hook. When driving a screw eye

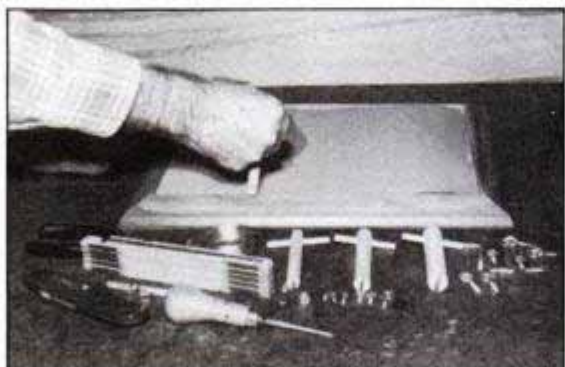

To drive screw eyes, cup hooks and screw hooks of all sizes, use these hardwood birch dowel drivers.

into very hard material, you may need to establish a starting point with an awl, or by first boring a pilot hole with a drill.

#### About the author

This is the seventh in a series of articles by master woodcrafters who have devoted many hours toward perfecting their craft.

This installment's craftsman is C. E. "Doc" Banister, who has shared his expertise with PM readers many times in the past. Doc has tested new equipment and reported the results for PM. He has also written many articles revealing shop secrets for obtaining professional woodworking results.

A resident of Oroville, Calif., Doc designs and builds custom furniture of all types, including wall units and music centers. Doc is also a master of special lathe-turning techniques and of designing workshop accessories.





## 4 WOODEN CLAMPS

No home workshop should be without a set of these hardwood oak clamps. Construction consists of a pair of wooden jaws joined by  $\frac{1}{8}$ -in.-dia. threaded rods. Draw the jaws together by tightening nuts placed on the rods.

I made two sizes of wooden clamps to satisfy most of my shop needs. In the larger pair each jaw measures  $1\frac{1}{2} \times 2 \times 22$ -in.; jaws in the smaller pair measure  $1 \times 2\frac{3}{4} \times 10\frac{1}{2}$ -in. The threaded rods pass through  $\frac{3}{4}$ -in.-dia. holes center-

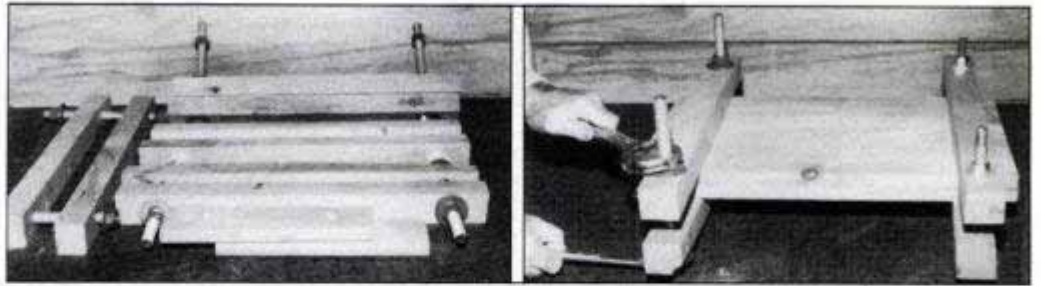

Wooden clamps (left) are limited by jaw length. Tighten nuts to add clamping pressure (right).

bored 2 in. in from each end of the jaw. The upper jaw of each clamp tapers  $\frac{1}{16}$  in. from the center out to each end. This

applies clamping pressure equally to center of the workpiece. Bottom jaws remain flat to keep workpiece true.

## 5 GLUE BRUSH STUNT



Make glue spreaders from nylon brushes (left). Cut bristles down to 1 in. long (right).



I have found an easy and effective way to apply glue to woodworking projects. Take several inexpensive nylon paintbrushes—from  $\frac{1}{2}$  to  $2\frac{1}{2}$  in. wide—and cut the bristles down to 1 in. long. The shorter, more rigid bristles spread glue evenly and quickly. The different-width brushes let you pick the best brush for each job. When you use water-soluble glues, store brushes in a jar of water to keep them pliable. But, first apply a coat of rust-resistant paint to the metal ferrules to prevent rust from contaminating the glue.

## 6 SANDBAGGED

Sandbags are a great help when you glue large or uneven projects. They're flexible enough to weigh down irregular shapes that are otherwise impossible to clamp. When gluing large areas of plywood or veneers, pile sandbags in the center to ensure total contact between surfaces until the glue dries.

Fold a  $10 \times 24$ -in. piece of lightweight canvas in half to form a  $10 \times 12$ -in. bag. Sew sides closed and turn the bag inside out. Add sand until it's three-quarters full, fold the top edges in  $\frac{1}{2}$  in. and sew the bag closed.



Gluing uneven projects, such as this tambour door, is easy with several sandbags.

## 7 MASKING-TAPE STOP

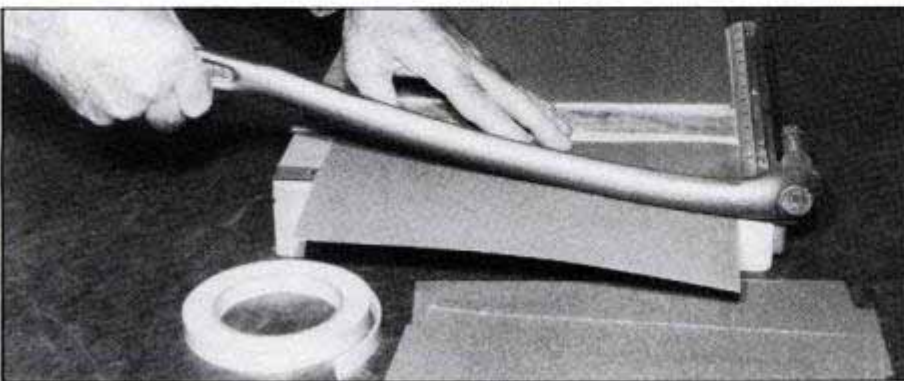

Try this masking tape stop on a paper trimmer when you cut sheets of sandpaper.

This simple idea provides a temporary stop for a radial-arm or table saw.

Make a  $\frac{1}{4}$ -in.-deep cut into a roll of masking tape ( $\frac{1}{2}$  or  $\frac{3}{4}$  in. wide) with a razor knife. Position a piece of the  $\frac{1}{4}$ -in.-thick tape on the fence or table at the desired distance from the blade. Abut the wood to the stop on each cut to produce identical-length pieces without measuring each one. You'll find many shop uses for this stop, such as cutting sandpaper on a paper trimmer. To reuse the stop, peel off the bottom layer of tape to reveal a clean adhesive surface.



## 8 IDENTIFYING DOWEL JOINTS

Correctly identifying and aligning dowel joints can be pretty tricky. Try this method to avoid misaligned joints when you build a frame.

After you cut the frame's stiles and rails, lay them out on a workbench and clamp the frame square. Draw a pencil line across each joint using a try square to indicate the dowel locations. These marks will be used to align the doweling jig when boring the dowel holes. Identify each mating piece with a letter to help you match the joints correctly during final assembly.

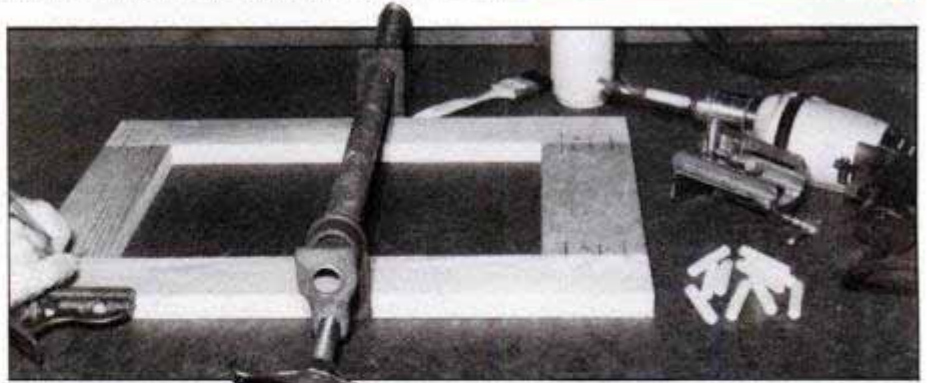

Mark for dowels with a try square. Initial each mating piece with a letter.

## 9 DRAWER KNOB AND PULL JIG

This homemade jig provides a quick, accurate way to mark knob or pull locations on cabinet drawers and doors.

To install drawer hardware, first mark a centerline lengthwise on the drawer face. Hold the jig with the stop bar against the edge of the drawer face, and align the centerline through the template holes. The  $\frac{3}{16}$ -in.-dia. hole is

for laying out knobs. The two  $\frac{1}{8}$ -in.-dia. holes are for laying out pulls. Note that the two pull template holes are 3 in. on center to accommodate standard hardware. You can easily alter the template to lay out hardware of all sizes.

To install hardware on cabinet doors, hold the stop bar on the top of the door, and keep the template edge flush with

the door edge. Mark and bore the mounting holes.

To assemble the jig, pass the template through the stop bar's saw kerf, and tighten the wingnut. The distance from the template holes to the stop bar should equal the distance from the desired mounting hole to the top of the door, or to edge of the drawer face.

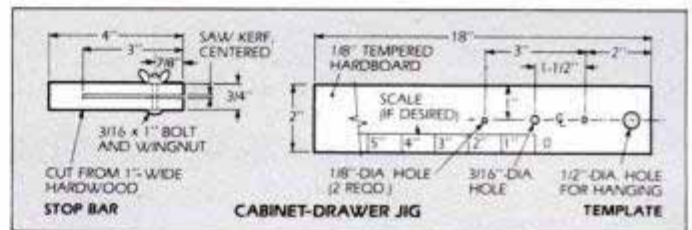

This jig is used to install knobs or pulls on doors and drawers.

## 10 CENTER FINDER

Use this homemade jig on your table saw to locate the centers of wood stock for lathe turnings. The jig's hardwood miter guide rides in miter grooves machined in the saw table top. Hold the lathe turning stock firmly on end in the  $45^\circ$  channel of the vertical member; pass the jig over the blade scoring the stock end. Rotate the stock  $90^\circ$  and

score the end again. Intersection of the two saw kerfs is exact center. Repeat on the other end. At exact center points the lathe's headstock and tailstock centers hold the wood for turning.

When finding the center of hardwoods for lathe turning, kerf the headstock end of the wood  $\frac{1}{8}$  in. deep; the tailstock end  $\frac{1}{16}$  in. deep. For soft-

woods, kerf the headstock end  $\frac{3}{16}$  in. deep; tailstock end  $\frac{1}{8}$  in. deep.

Construct the jig with the dado and the vertical member parallel to the saw blade. Glue the hardwood miter guide into the dado. Countersink vertical member mounting screws so they will clear the saw table. Apply three coats of polyurethane varnish. **FM**

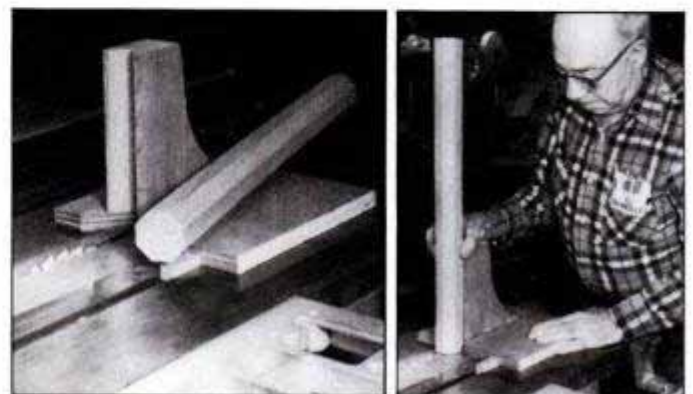
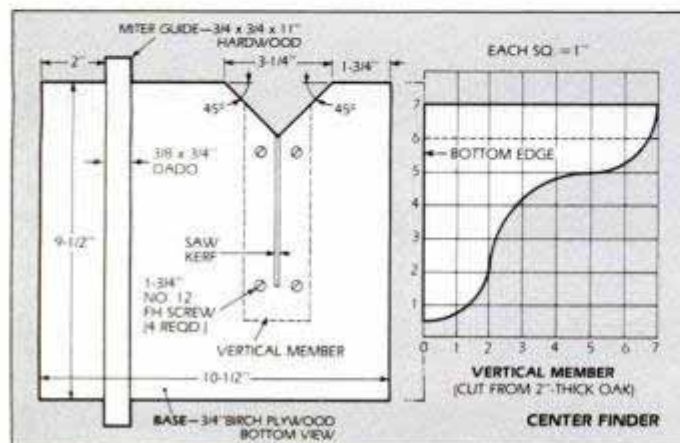

Find the center of any shaped stock. Blade height is exaggerated for clarity. Hardwood miter guide rides in saw table grooves.



# Make This Squirrel-Proof Bird Feeder

Here's a bird feeder that solves two common problems: It drains off rainwater, and it keeps squirrels from stealing the feed.

Basically, the feeder is a frame with wire screen stapled to the bottom to hold the seed. This permits rain to drain right through and lets the seed dry out quickly when warmed by the sun.

Half-inch hardware cloth, stapled across two sections of the top, effectively frustrates the squirrels. Birds can poke their beaks through the wire mesh to get at the feed, but the squirrels' paws are too big to gain easy entrance. There's a lot of entertainment in watching the antics of a squirrel as he tries to maneuver seed up through the mesh

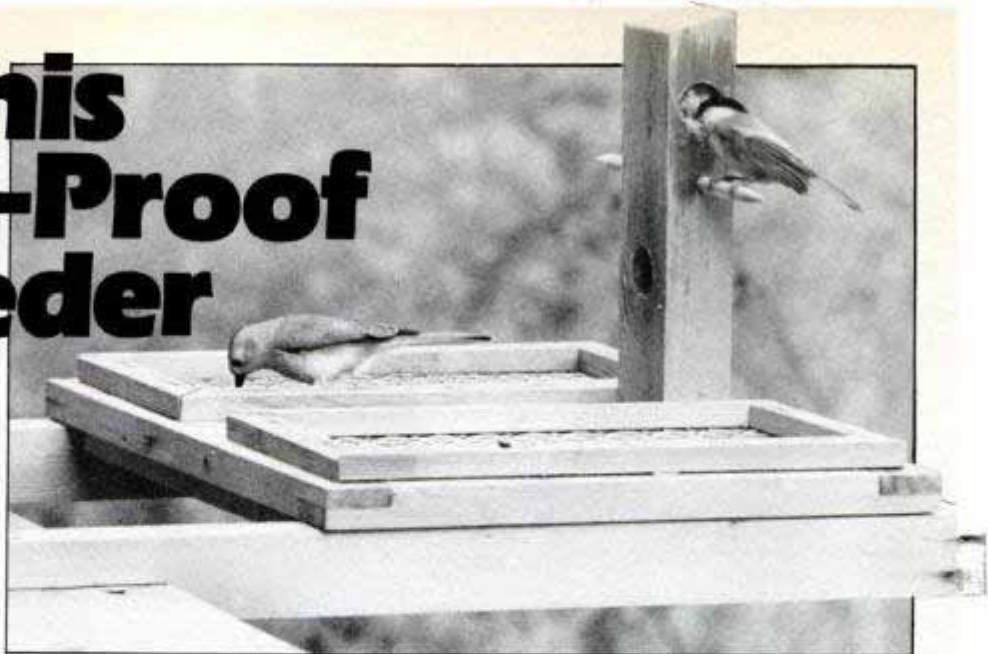

Birds of all kinds flock to feeder. Here, warbler enjoys a dinner that squirrels are unable to steal, while a chickadee on a suet spike savors peanut-butter mix.

with his paws, nose and tongue. Since even these squirrel thieves deserve some consideration, we left one section of the feeder open at the top just to feed them.

The feeding post has a dowel with

two sharpened ends through it. The sharp points make it easy to hang suet, a favorite food of most birds. The two 1-in.-dia. holes drilled through the post are for a peanut-butter mix that's an avian gourmet's delight. Here's a well-proven recipe for the mix:

Melt 2 cups of lard in a saucepan. Pour into a 3- or 4-qt. mixing bowl. Stir in 1 cup peanut butter and blend evenly. Stir in 2 cups corn meal, 2 cups flour and 2 cups mixed birdseed. Let mixture cool. Pack the mixture daily into holes in the feeding post. Store the mix covered, but don't refrigerate.

The dimensions and design of the feeder are not critical, except that the feed-holding sections should be  $\frac{3}{4}$  in. deep and should be covered with  $\frac{1}{2}$ -in. hardware cloth. The 2x3 mounting frame can be made almost any length, but it may require some bracing (not shown) for additional stability.

—Cliff Hicks

Feeder and mounting frame were made from one 8-ft. 1x4 and one 8-ft. 2x3. We used redwood, but pressure-treated lumber will do, too. Use waterproof glue in joints.

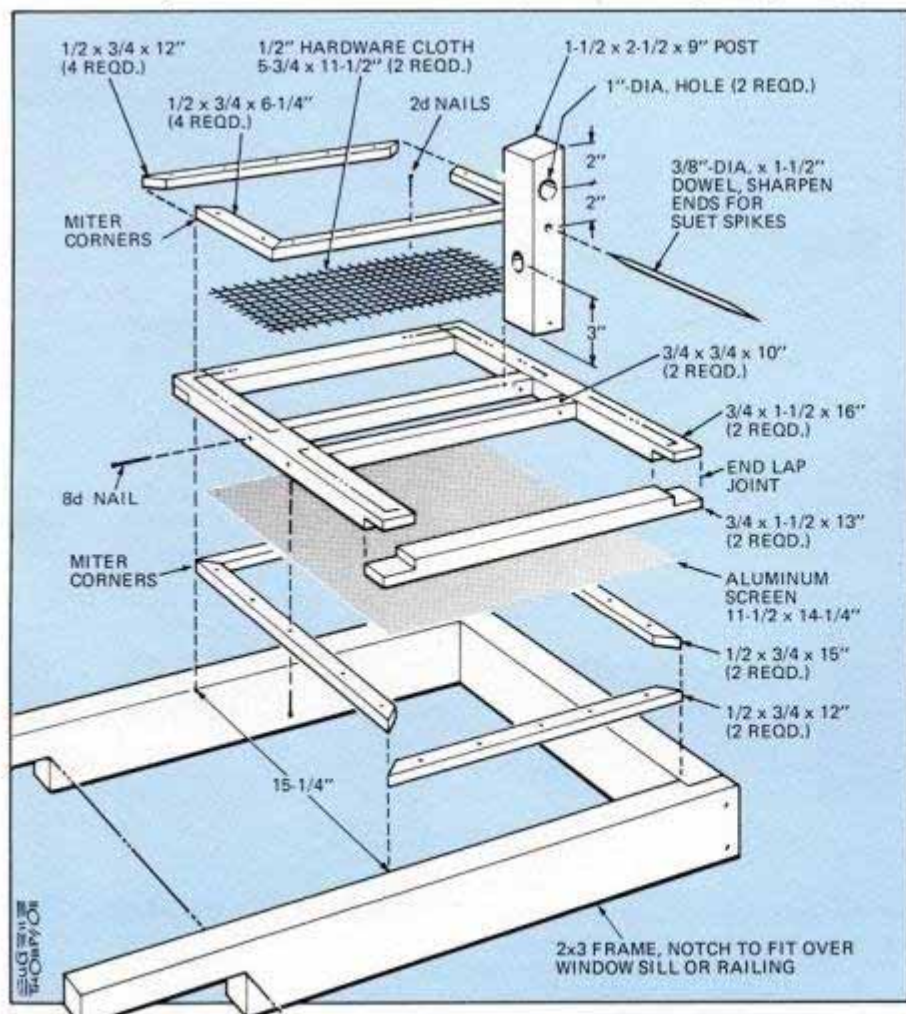

Easy removal means easy cleaning; simply turn it over to shake out old feed. For a more thorough wash, hose out screen from underside. Mitered screen retainers position feeder in mounting frame.



# WORKSHOP MINICOURSE

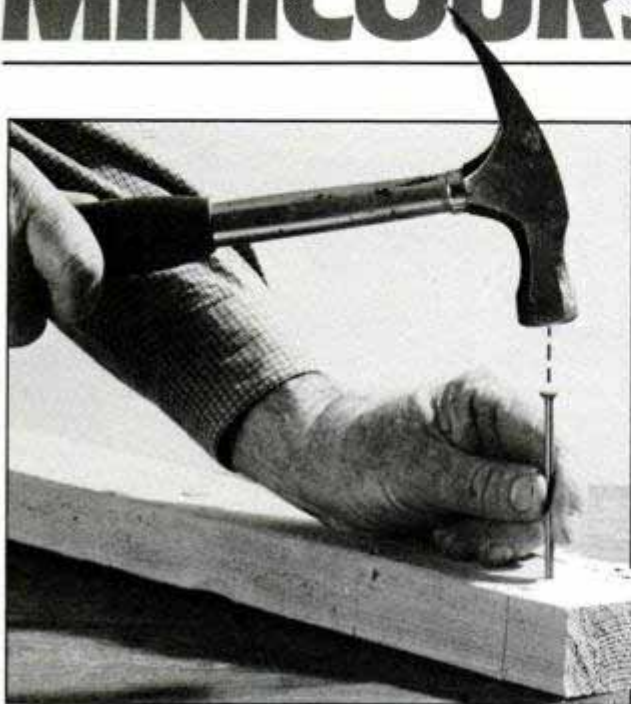

## About driving nails

**1** The usual method for starting a nail is to grasp it between your thumb and index finger and to tap the head lightly once or twice. Once the nail is seated in wood, the holding hand can be removed. The nailhead should be struck squarely by center of hammer's face (dotted line).

Driving a nail seems to be a natural act for human beings to perform. To help develop motor skills, one of the first toys many of us give our children is a mallet, various-shaped pegs and a board with holes to match. Yet, there are techniques to be learned to use a hammer correctly and safely.

For conventional nailing there is relatively little to master: **1.** You start a nail with several light taps, then, **2.** you remove the nail-holding hand and drive home the nail by hitting its head squarely with the center of the hammer's face.

Carpenters know that since the wrist is the pivot point for the hammer swing (arc), it must be adjusted downward continually as the nail is being driven home. Failure to do so will result in glancing blows to the nailhead.

But what about more complex nailing tasks? For example, when framing a wall from a ladder you must often reach out with your hammer hand to drive a nail while you hold onto the ladder with your other hand. Here, you can use either of the stunts shown in the last two photos. Do-it-yourself writers generally suggest the hold-the-nail-in-the-claws technique, then erroneously show it being done with the hammer hand on the handle. Don't believe it. There is no way that a nail—simply forced between hammer claws—will stay put. If you do try this method, grip hammer and nail as shown here.

However, most carpenters (myself included) prefer to use the nail-against-the-cheek method pictured in the fifth photo. Here you simply place nailhead against hammer cheek, flank it with fingers grasping the hammer as shown, and "punch" the nail point at the spot you want to drive it. Done correctly, one punch will seat the nail in the wood.

One final word about nails, and driving them. Many home carpenters hold nails in their mouths, because it expedites the task on a multinail job. Don't start this habit if you're a beginner, and try to break it if you already do it. Today, many nails are coated, and the galvanizing, resin or other coatings can cause a toxic reaction. **PM**



**2** One way of starting a small nail or brad is to grip it palm side up, as here. This way, hefty knuckles are out of way and you have a clear shot at brad.

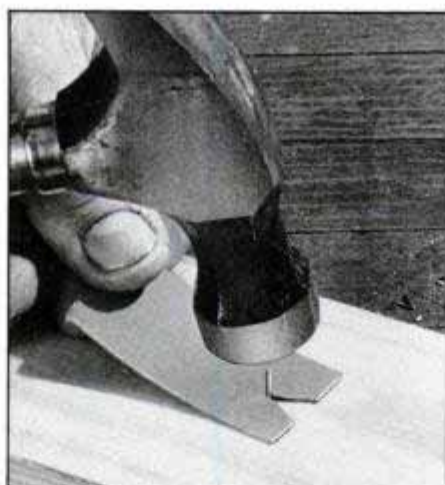

**3** Another way to hold a small brad is with a V-cut in a cardboard scrap. Method works for several brads, then V-notch becomes too big to hold nail up.



**4** With nail between claws, hold the nail with hand as shown. Some books show a no-hands start for this technique. That's nonsense—you must hold it.



**5** To start a nail in hard-to-reach spot using one hand, author prefers nailhead against hammer cheek, and grip shown. Nail is then "punched" to start it.



Warning: The Surgeon General Has Determined That Cigarette Smoking Is Dangerous to Your Health.

SOFT PACK 100's FILTER, MENTHOL: 2 mg. "tar", 0.2 mg. nicotine av. per cigarette by FTC method.

Competitive tar levels reflect either the Dec '81 FTC Report or current advertising NOW. THE LOWEST OF ALL BRANDS.

© 1984 R. J. REYNOLDS TOBACCO CO.



**Nobody does it lower.**

**NOW**

**THE LOWEST**

CONFIRMED BY THE LATEST U.S. GOV'T. REPORT ON TAR



\$2,487.75-----Spread



**1**  
Winnebago Warrior,  
Itasca Phasar.



**2** Itasca Phasar



**3** Sportscoach



**4** Sportscoach interior



**5** Champion  
Titan



**6** Fan Coach 32



# MORE-MILES-PER-GALLON

# RVs

Camping vehicles are making a comeback, with new looks and fuel economy two big reasons.

BY BILL McKEOWN RV EDITOR

**T**here have been a lot of turns and rough spots in the roads to recreation recently, and the manufacturers of family fun vehicles have had to change routes. Some makes pulled over into the slow lane or off the road for good. Others have been forced to do a U-turn in design and construction. But now a few brands are getting back up to speed and are rolling along again.

When low miles per gallon of fuel, high prices and interest rates, and the recession economy downshifted RVs into low-gear sales, the industry had to take a hard look at its vehicles. And they've come up with some interesting methods to improve performance without running up costs.

Winnebago's answer is to go lower and sleeker. One way to cut down the wind resistance that burns up fuel is to make a smaller, more streamlined vehicle. But that can result in a low-ceiling rig that makes it necessary to get dressed lying down and to move about inside in a crouch—rough during a rainy day at a campground, when you can't go outside to stretch. The solution, Winnebago engineers at Forest City, Iowa, found, was to go to front-wheel drive and lower the floors of their new Le Sharo motorhome, Centauri van and Itasca Phasar. That way, there is still 6 feet of standing headroom and a step up of only 10 inches from the ground.

Power comes from a Renault two-liter diesel that has proved successful in Europe. A special unitized body chassis assembled by Winnebago, called H-body, employs a drive train and some sheet-metal parts used overseas by Renault in its Traffic van. Ron Haugen, president of Winnebago, told us that eventually refinements such as turbocharging, automatic transmissions and the option of gasoline or diesel engines may be offered. But the 22 to 24-plus mpg fuel economy of the Centauri van and Le Sharo and Phasar motorhomes already seems to give Winnebago a head start in the economy performance sweepstakes.

Additional big names in this year's RV lineup include Coachmen, Fleetwood, Holiday Rambler, Jayco, Starcraft and Yellowstone,

## 8 Holiday Rambler Ambassador 33



7 Ambassador interior

*Smaller than Warrior and with 24-mpg diesel efficiency, Phasar (1 and 2), like Winnebago Le Sharo and Centauri, tops line. New Sportscoach (3 and 4), from Coachmen, offers luxury accessories. Champion Titan (5), TranStar and Champion motorhomes have been redesigned. Fan Coach travel trailers come in six lengths from 23 feet to Fan 32 (6). Ambassador motorhomes (7 and 8) come in seven models from Holiday Rambler.*



\$1,254.00 incl. page 116



Sunline Solaris

Up to 20 miles per gallon is claimed for Sunline Solaris with Toyota chassis from Sunline Coach, Denver, Pa. The lightweight, 17-foot, micro-mini motorhome can sleep four: two in a convertible dinette installed front or rear, plus a cab-over double.

among others. Several of these have become parent corporations for familiar names like Shasta, Fan, Sportscoach, Viking and Midas in the Coachmen camp; and Prowler, Wilderness, Cimarron, Terry, Taurus, Pace Arrow, Southwind, Tioga, Jamboree and Resort among the Fleetwood brands.

Larger companies in the field have learned the importance of after-sale service for their products, and owners have discovered that the big established builders that have weathered recent recessions are likely to be around when spare parts inevitably become necessary.

Latest recreational rigs are more rugged, with steel and aluminum frames taking the place of wood in many models. All manufacturers are looking at new ways to cut windage and weight. The heavy shoebox-shaped RVs of the past are out. They waste too much gas, look unattractive and won't sell.

Vans, slide-in campers and travel trailers with pop-up tops that raise for headroom at the campsite and lower for towing or rolling down the road, are still popular. Refinements like bathtubs

*(Please turn to page 116)*

Rated one of roomiest of compacts, 22-foot Falcon 220, from International Vehicles, Bristol, Ind., will sleep six in three double beds, and boasts luxury of a bathtub with shower, plus standing headroom throughout the van.



InterVec Falcon

Cruise Master

Excalibur

Cruise Air

Swinger



Improved aerodynamics are reported to increase fuel efficiency of latest motorhomes from Georgie Boy, Edwardsburg, Mich.

Chevrolet 6.2-liter diesel engines are available for four models shown. All feature light and streamlined bodies.



NEW WONDER-FORMULA—HAILED ON NETWORK TV!

# PEELS OFF PAINT JUST LIKE PAPER!

## LIFTS • PEELS • STRIPS AWAY UP TO 18 COATS OF PAINT WITH ONE SINGLE 60-SECOND APPLICATION!

- Simply apply—let dry—peel away paint like paper in one single action
- Ends sanding—scraping—spraying—chipping—steel-wool FOREVER!
- Amazing European discovery turns layers of paint to a single sheet of 'paper' so it peels away just like you'd lift and turn the pages of a book!

## WORKS ON ANY SURFACE . . . WOOD, BRICK, METAL, PLASTER, GLASS, STONE, ANTIQUES!

Amazing new formula actually penetrates old paint (varnish and lacquer, too), in minutes. Transforms it into a soft, plastic-like film. Then simply let set . . . lift, roll, strip up to 18 coats of paint away in a single peel-away action! Yes, years of built-up paint peel away as quick and easy as you'd turn this very page! Ends sanding, scraping, chipping and foul-smelling chemicals ONCE AND FOR ALL!

There's no dust up. No clean up. Just a single peel-away action restores the bare, original finish . . . good as new in a flash!

### SO EASY EVEN A CHILD CAN DO IT!

Called 'Peel-Away', this new wonder-formula has been officially registered with Gov't. patent offices throughout the World. It is completely odorless—completely safe! Reacts only with paint, varnish, lacquer or shellac . . . nothing else! So you can use it on even finest furniture, precious art frames, why even delicate wicker or valuable painted-over marble. In fact, it is so safe, so gentle, it is used by London's British Museum and world-famous art galleries to strip old art frames and century-old paneling. Even used by antique dealers to strip down priceless furniture treasures for restoration. Yes, 'PEEL-AWAY' literally lifts away every last layer of old paint even from hard-to-get-at places such as impossible-to-reach windowpane corners . . . grooved molding . . . finely tooled woodwork, etc., etc.

**SIMPLY COAT IT ON—SEE IT TURN PAINT TO "PAPER" IN JUST MINUTES . . . AND PEEL IT AWAY IN A SINGLE LIFT-OFF-ACTION!**

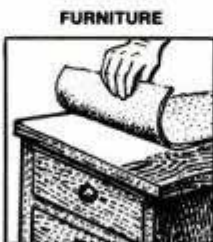
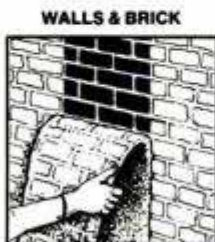

**ENDS: • sanding • scraping • spraying • chipping • steel wool • toxic chemicals FOREVER!**

**Removes years of built-up paint . . . WITH JUST A FEW MINUTES WORK!**

AGENTS, REPS, BULK USERS, NOTE: Case lot orders are now available. Write on your letterhead to our industrial division for wholesale prices.

**PEEL AWAY™ UP TO 18 COATS OF PAINT AT A TIME!**



Best of all this new wonder-formula is so easy to use. Simply mix with water and coat onto any painted surface. Then press down special 'Peel-Away' magic-fibre Lift-tex strip-away cloth, (included free) . . . let dry and adhere to surface . . . and without even dirtying your hands, lift away old paint, just like you'd peel a banana. It is as simple and easy as that. No mess. No fuss. No odor. Old paint lifts away like a single sheet of paper. Original bare-wood finish comes through like new again.

### SO ECONOMICAL TOO! MERE PENNIES PER JOB! AND THE PEEL-AWAY MAGIC-FIBRE CLOTH IS COMPLETELY RE-USABLE, GOOD FOR YEARS TO COME!

Peel-Away is every home-owners dream come true. Ideal for indoors on walls, windows, furniture, etc.—plus 101 outdoor uses too. And it costs only a little more than a penny per foot coverage. Homeowner's size alone gives enough coverage to strip away as much as 500 to 750 feet of wall and door trim, window frames, furniture molding, stair railing, patio furniture, roof-gutters . . . its uses are almost endless.

### SAVES WORK, SAVES TIME, SAVES MONEY . . . MAKES TAKING OFF PAINT EVEN EASIER THAN PUTTING IT ON!

So for the new low-cost, super-fast way to peel away old paint . . . lift away old lacquer, varnish and shellac . . . order PEEL-AWAY today on full money-back guarantee. REMEMBER: You must be able to simply coat . . . peel . . . lift and strip away up to 18 layers of old paint in a single peel-away action . . . without sanding, scraping, chipping or steel wool . . . or purchase price refunded in full. Order today.

### CLEAR & FREE 1-2-3!

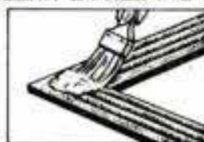

**STEP 1:** Simply coat 'Peel-Away' wonder-formula over old, encrusted paint; (up to 18 layers thick)—



**STEP 2:** Cover treated area with magic-fibre 'Lift-tex' stripper-cloth, (included FREE). Let set and adhere to coated surface.



**STEP 3:** Right before your eyes paint turns to "paper" . . . lifts, peels, strips away IN A FLASH!

© 1982, Brand Name Testing, Inc.

### MAIL NO-RISK COUPON TODAY

Dumond Chemicals, Dept. PWWB-274, Dumond Place, Glen Head, New York 11545

Please RUSH me the quantity of the "PEEL AWAY" New Wonder Formula checked below. If I am not completely satisfied with the way it "peels away" up to 18 coats of paint with just one single application, I may return for a full refund (less postage and handling, of course.)

#### CHECK OFFER DESIRED

- Small Size (enough for up to 3-room apartment) only \$9.95 plus \$2 postage & handling.
- Homeowner Size (enough for regular size homes) only \$16.90 plus \$3 postage & handling. **YOU SAVE \$4.00!**
- Handyman's Super-Size (enough for use in homes with extensive outside trim) only \$31.95 plus \$4 postage & handling. **YOU SAVE \$11.85!**

Amount enclosed \$ \_\_\_\_\_ (NY residents please add sales tax) No C.O.D.'s please.

**CHARGE IT!** (\$15 minimum charge)  VISA  MasterCard

Credit Card # \_\_\_\_\_ Exp. Date \_\_\_\_\_

Name \_\_\_\_\_

Address \_\_\_\_\_

City \_\_\_\_\_ State \_\_\_\_\_ Zip \_\_\_\_\_

Div. Brand Name Testing, Inc.





Oyster Tent



For penthouse tenting with standard or compact car, van with roof rack or pickup with cargo bars, Oyster from the Oyster Tent Co., Ann Arbor, Mich., rides with minimum windage folded, opens into large double-bed tent that cartops or can be set up on ground.



Sunrader FG-210

Even a small Toyota chassis can carry a micro motorhome, and Sunrader FG-210 from Gardener-Pacific, Vallejo, Calif., offers fuel-efficient recreation; four floor plans are available. The Trans-Awn 2000 side awning is an optional accessory.

are now appearing in RVs as small as International Vehicle's 16-foot, compact four-sleeper motorhome Horizon van and its Falcon 22-foot stretched van, which sleeps six. Rigs this size can combine the maneuverability and convenience of a station wagon or van, plus the full headroom and sleeping accommodations of a motorhome. And optional in Shastas is a Lift-A-Way installation that acts as an elevator for any family member who needs to board the motorhome in a wheelchair.

Among the big rigs—the fifth-wheel and park-model travel trailers that take up residence for months at a time in a resort area—there are innovations to stretch the walls.

Slide-out sections that can almost double the size of a living room or bedroom are options for some of the largest models. A few are designed so that once a trailer park is picked for the season, the complete back wall can be extended.

Latest models have more than the comforts of home. **PM**



# HOW TO DRILL A BACKYARD WATER WELL

BILL HARRINGTON

I've been drilling water wells in Oklahoma for about 15 years.

When I first saw the ad that claims a man can drill his own water well with a Hydra-Drill, I was extremely skeptical. I thought to myself — how can that be? That's impossible. It takes a big engine, it takes a big rig to drill a water well. But my curiosity kept nagging me, so I sent off for the information.

My daughter's boyfriend is a well driller over in Arizona. I showed him the Hydra-Drill literature. His first reaction was "I don't believe it. I don't believe a 3 hp. drill can do the same thing my 100 hp. drill does." But the more I studied it, the more it sounded like a good idea.

## A WATER SHORTAGE

Another thing on my mind was the drought. We're having the worst drought here since the dustbowl days back in the '30s. A lot of towns around here all the way over to Tulsa are running short of water, and some of them have started water rationing. It's very hard on a lot of people, but business is good for well drillers. I'd been thinking about buying another drill and putting my son Robert in business. He's 18 years old, and he'd never worked on a drill before. I decided he could learn with a Hydra-Drill.

## EASY SET UP

Now when I started out in the drilling business 15 years ago, I had a big drill that just about worked me to death. Later, I got a rotary drill. It was easier to operate, but it took a day and a half to set up and drill a well in this area. You can't imagine how I felt when they delivered our Hydra-Drill. It was so compact, very simple. Robert and a young friend of his took it out and set it up in just a few minutes.

## OUR FIRST HYDRA-DRILL WELL

The day we went out to drill our first well with the Hydra-Drill, I was all fixed to work with the boys and give them plenty of advice. However, it was a very hot day — about 100 degrees — and once they got started drilling I could see they didn't need me standing right there, so I went over and sat down in the shade of a tree. In about an hour, they came over and I asked them if they were taking a break, and they said no, they had just finished drilling the well.

It was amazing. They had drilled down forty-seven and a half feet and hit a layer of beautiful, coarse sand — the kind that produces good water and a lot of it. They had drilled that well in less time than it takes me just to set up my big drill.



PHOTO BY TONY JACOBY

Later, I figured they had drilled that well with less than one gallon of gas. My big drill would burn up at least fifteen gallons of gas for that job!

## MAKES MONEY

The next day we drilled a well 115 feet deep through rock, and it went fast too. The Hydra-Drill really takes the hard work out of it. It's fast and economical, and that's what it takes to make money drilling wells.

Also the Hydra-Drill is so portable we can set up and drill anywhere. In the past, I've lost out on some jobs because people were afraid my big drill would tear up their yard. With the Hydra-Drill, we can drill without tearing up anything or making a mess. This is a big selling point to my customers.

I'm just grateful to have this Hydra-Drill. I've got my son started in a good business he can make some money with. If I had bought another big drill, it would cost thousands of dollars, and that is just ridiculous because the Hydra-Drill does the job just as good. In fact, I figure we earned enough to pay for the Hydra-Drill the first week. From here on, we're in the blue chips.

## GOOD, PURE WATER

I believe anyone can drill a well with a Hydra-Drill. Even if they just wanted to drill their own well, they'd save money. It's simple and it's easy if they just read the instructions. And the best part about it is that you get good, pure water without all those chemicals in it, and the water costs you, say 5 cents for a thousand gallons. You certainly can't buy city water for that. And it's a great feeling to have all the water you want even when

the city is rationing water to everyone else.

The man who invented the Hydra-Drill really knew what he was doing. Modern technology is a wonderful thing, isn't it?

*NOTE: Readers can get a big, fully illustrated information kit on the HYDRA-DRILL including a booklet, "How to Drill Your Own Water Well." The information kit is available free, without obligation. Requests should be addressed DeepRock Mfg. Co., 777 Anderson Rd., Opelika, Alabama 36802.*

## WATER WELL DRILL KIT

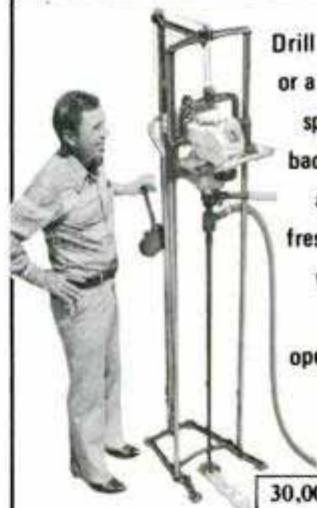

Drill a water well or a free-flowing spring in your backyard. Have all the pure, fresh water you want FREE! Easy to operate as your power lawn mower.

30,000 SOLD!

FOR FREE BROCHURE  
CALL TOLL-FREE  
**1-800-821-7700**

(Ask for Extension 777)

Visitors Welcome!

\*Call anytime including Sundays  
OR CLIP COUPON AND MAIL TODAY!

**DeepRock**

777 Anderson Road  
Opelika, Alabama 36802

SINCE  
1962

Please send me the big information package absolutely free!

Print Name \_\_\_\_\_

Address \_\_\_\_\_

City \_\_\_\_\_ State \_\_\_\_\_ Zip \_\_\_\_\_

I'm in a hurry. I have enclosed \$1. Rush the FREE information package by FIRST CLASS MAIL.

©1983 DeepRock Mfg. Co.



# TINY TRAILERS FOR

Rolling along behind the compacts are new little rigs with extra cargo and camping features.



A 17° slant on the front of Fleetwood's popular 19-foot Prowler lowers wind drag for small-car towing. The 14 tubular-steel-chassis models are 19 to 35 feet long.



Camping trailers still offer convertible convenience. Jayco, in Middlebury, Ind., provides seven floor plans in open lengths from 17 to 24 feet, plus six new J-series economy models, 11 to 15 feet long for towing, that can sleep up to eight.



Coleman's compact utility trailer, named the Caboose, can stow on end in little space. Other mini-models include PackHorse II and multipurpose VersaTrailer.



Happy Trails is a one-wheel cargo carrier from North Star Products, Hardwood, Mich. It's reported easy to back and garage while attached to compact car.

**S**mall rigs let you bring more comforts of home along to bargain campsites. Some new trailers have been designed for quick-change work or play assignments, as well. Camping trailers (tent trailers) are more versatile than ever, and new, tag-along luggage trailers now let you pack all the gear normally stowed in the trunk of a standard-size sedan.

Examples of the growth in small trailers are the new rigs from Coleman Camping Trailers in Somerset, Pa. This division of the Coleman Co. has six deluxe and three economy tent trailer camping models, plus four more mini-trailers for cargo, camping gear and even camping out. That quartet consists of the VersaTrailer, Coleman Caboose, one-wheel PackHorse and PackHorse II.

Many other builders have joined the minitrailer market. Models like Shoreline Trailers' Li'l Pup, single and two-wheel Car-Go units from Agri-Fab, Holsclaw's Compact, Bock Products' bolt-together kit BT Drag Star, the Trunk Trailer from Allied Aluminum and the Time Out tent camper from T.O. Corp. are among them. Some, like the Time Out and Shoreline Cargo, are light enough to trail behind all but the smallest motorcycles.

Pop-up tops with tent-type sidewalls are another way to get headroom, yet shrink wind resistance on the road. The Valor fifth wheel, a 21-footer from New Paris Enterprises, raises the roof for two extra feet. Bonanza Traveler's Bandit and Sun-Lite slide-in pickup camper do the same. Larger Hi-Lo travel trailers telescope up and down.

Aluminum and lighter plastic are being used in rigs of all sizes. Each weight and windage savings cuts gas costs, as well. **PM**



# ECONOMY TOWING



With a hitch weight of only 84 pounds and axle weight of 812, Starcraft's new AeroStar 17 can sleep five and is 16½ feet long when opened, but closes down to 12½-foot length and 45-inch height when ready for towing.



Especially designed for towing three-wheel and all-terrain cycles, Tuff 'N Lite trailer is from Unique Function Products, San Marcos, Calif.



With 50 percent of new cars being made with front-wheel drive, U-Haul dealers are providing a rental tow-dolly for trailing a car behind your truck or motorhome. The dolly acts as a substitute front axle.



For camping without pitching a tent, Jayco's European-style Jaytiki unfolds down and back in 20 seconds from trailer to four-sleeper.



Even a motorcycle couple can tow a two-bunk trailer (left) from Continental Industries, Davison, Mich. The larger Travelite model (right) sleeps four and can be towed by compact cars. Both open for 6½-foot headroom.



Coleman's One-Wheel PackHorse is 137 pounds, but can carry 400. Add-on stand and swivel-wheel lock converts it for back-yard use.



Hardwall Nordic camping trailer, new from Viking RV division of Coachmen, can sleep up to eight and opens from a 16½-foot road trailer to a 20-foot camper with a pushbutton electric lift system for quick setup.



\$1,042.00 incl. page 122

# New For Spring Fitting Out



**F**or boat owners getting ready to launch their rigs in the North, or haul out for refurbishing in the South, the latest hardware and accessories come in more durable metals and plastics for longer life with less maintenance.

## Aluminum hulls resist corrosion

Light enough to be towed easily with a mini-pickup, Starcraft's 15½-foot Bass 150 has a one-piece hull bot-

tom made of 5052 marine aluminum alloy that can resist the attacks of salt water and electrolysis. Long-wearing, marine-grade hardware and grass carpeting for the casting platforms should limit maintenance.



## Add-on stabilizer

To take the tipping out of canoeing, plans for a clamp-on Steady Fin are \$3 from Seamaster Boats, Drawer T, Duxbury, Mass. 02332.



## Self-tailer, self-cleater

A grooved rubber flange that fits on most winches, the Wincher is a self-tailing, cleating device from Watski, Box W, Charlestown, N.H.



## Keel-hauler cleaner

A bottom-scrubber for boats, the Hullmate requires no haul-out. With a clean hull, you'll cut drag. The synthetic scrub pad is \$30. It's available from LaMar Design, 3407 Harmony, Troy, Mich.

## Uncluttered lighting

For fishing boats whose decks must be unobstructed, new Perko 1612 combination side light can be removed and socket sealed with a waterproof cap. USCG approved, it's \$18.50 at Perko dealers.

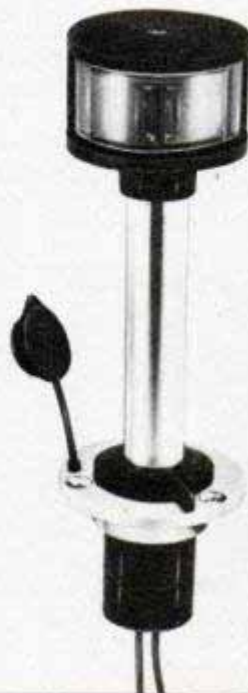

(Please turn to page 122)



# EARN UP TO \$12 AN HOUR

## TURN EXTRA TIME INTO EXTRA INCOME!



# BE YOUR OWN BOSS IN A MONEY-MAKING BUSINESS OF YOUR OWN!

No  
Experience  
Needed

# SHARP ALL

## lets you Sharpen Saws ...

### Shop and Garden Tools for Home and Industry

**NOW!** Use your SPARETIME to BEAT inflation and the high cost of living!

With Sharp-All it's easy to start your own business. No selling is involved, no inventory. People bring in their work... you take in year round CASH Profits and keep 90¢ out of every dollar you earn. Work sparetime or fulltime right at home in your garage, basement or tool shed. Work the hours you want — FREE Book tells how to start your own business even while working at your regular job.

**Big PROFITS — Plenty of business waiting for qualified men.** Every home and business has saws and tools that need periodic sharpening. There's plenty of business waiting for the man who can sharpen saws, planer knives, jointer blades, wood chisels, scissors, pinking shears, snips, lawnmowers, axes and other garden, shop and home tools. Sharp-All does ALL these jobs and more... quickly, and at a big profit. You will be sharpening headquarters for carpenters, builders, lumberyards, factories, home workshops and hobbyists... hundreds of jobs right in your own neighborhood.

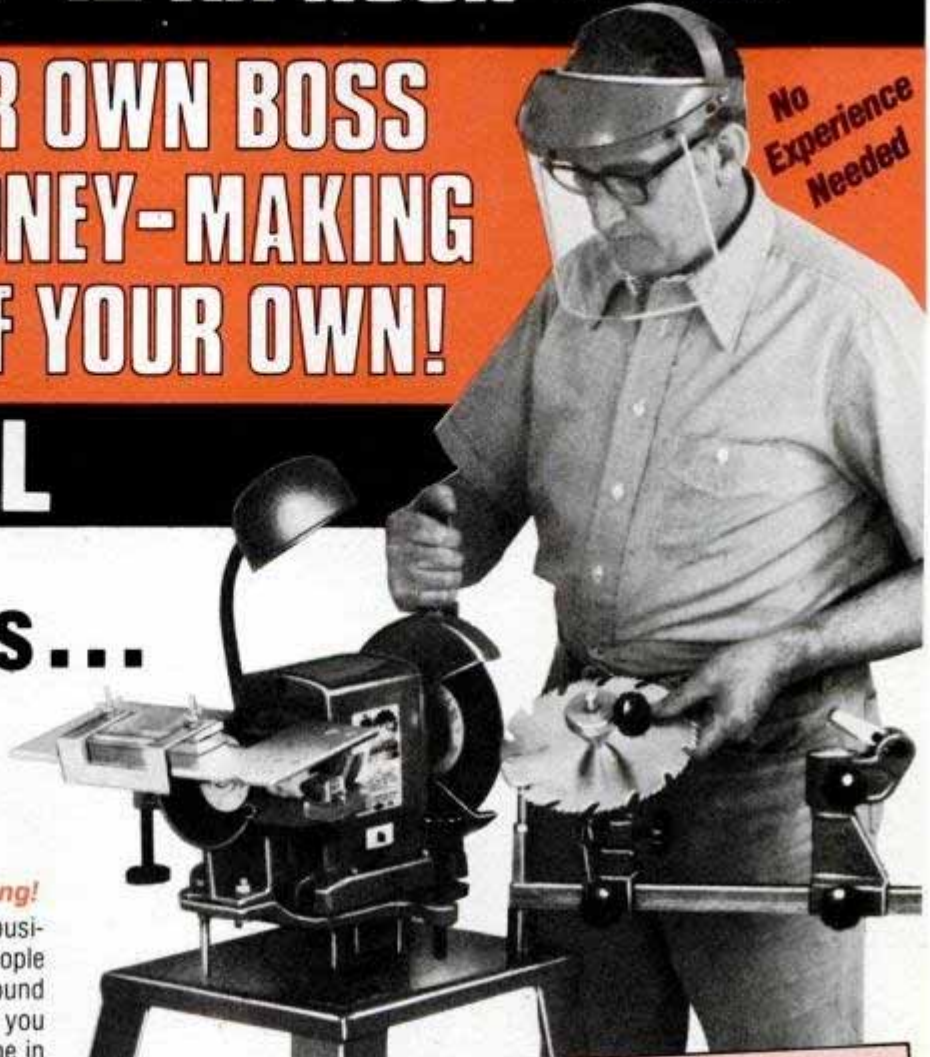

### It's EASY To Get Started — No Franchise Fees!

You don't have to invest thousands of dollars to get started in business for yourself. Low Cost SHARP-ALL and our 45 years of experience in helping sincere men earn extra income, plus the desire to get ahead is all you need. Fully illustrated Operators Manual gives clear, step-by-step instructions, shows exactly how to sharpen each tool, where to get business, what to charge, how to get free advertising... all the "tricks of the trade". And, SHARP-ALL does the kind of precision job that brings customers back time after time.

Send for FREE Book "Lifetime Security." Do It Today!

**ACT NOW!**  
Coupon  
Brings  
Full Details!

### There is NO OBLIGATION and NO SALESMAN Will Call!

### SEND FOR FREE FACTS TODAY!

You risk nothing by accepting this offer to see how easily you can turn your spare time into Big CASH Profits with your own Complete Sharpening Shop. Send coupon or mail postcard for full details on our exclusive

### 30-Day FREE Trial Offer!

FREE Booklet gives full details —

Our Free Book tells how to start a profitable, lifetime home sharpening business, how we help you grow, how we'll finance you.

Send for your copy today. No obligation.

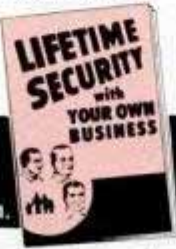

### No Obligation... No Salesman

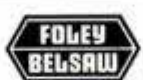

**FOLEY-BELSAW CO.**  
60159 FIELD BLDG.  
KANSAS CITY, MO. 64111

**FREE BOOK**

**RUSH COUPON TODAY!**

Please send my FREE copy of your book "Lifetime Security" and full details on your 30-Day Free Trial Offer!



Name \_\_\_\_\_  
Address \_\_\_\_\_  
City \_\_\_\_\_ State \_\_\_\_\_ Zip \_\_\_\_\_

FOLEY BELSAW CO.

60159 FIELD BUILDING, KANSAS CITY, MO. 64111



### Shock-absorber harness

The Ocean Sailing Flotation Harness from Stan Louden Products, Toronto, Ont., combines life-preserver flotation of foam with shock-absorbing safety harness; it's \$170.

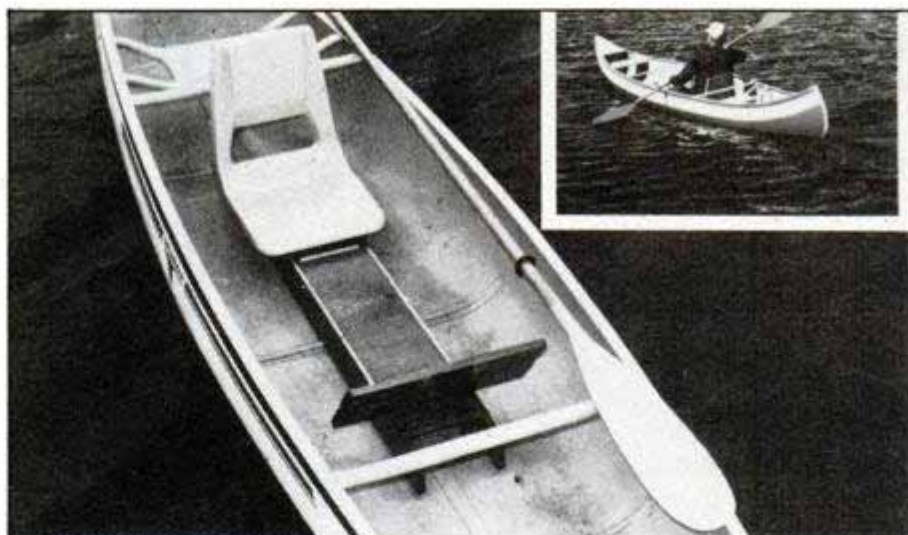

### Center seat for solo canoeing

Instead of sitting alone in the stern while the wind swings the bow around, or kneeling amidships, a paddler can build an inexpensive

drop-in seat with adjustable footrest from designer Bob Whittier's plans. They're \$3 postpaid from Seamaster Boats, Duxbury, Mass.

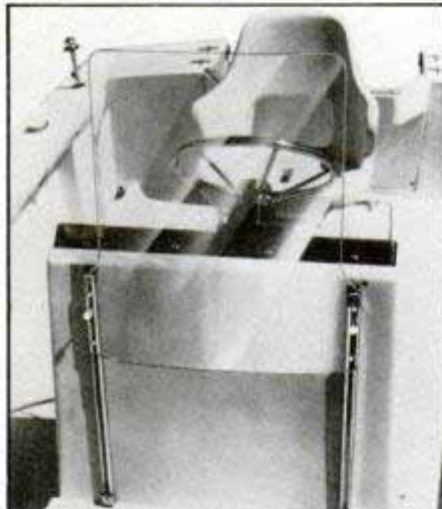

### Adjustable windscreen

New from N.A. Taylor, Gloversville, N.Y., is curved windshield for fishing boats that can move 23 inches up or down.



### Battery monitor

Electrical Systems Monitor gives battery condition with lights and buzzer. It's \$30 from Attwood/ESM, Box A, Lowell, Mich. 49331.



### Handheld signal

Red meteor distress launcher fires two simultaneous signals that are visible 30 miles at night. The Twin-Star, from Kilgore, Toone, Tenn., is U.S. Coast Guard approved.



### Sounding off afloat

Loud enough to signal at 125 decibels, the handheld Sea Guard has replaceable canisters. It's \$14 from Attwood hardware dealers.



### Disappearing cleats

Gunwale-mounted cleats and chocks, \$30 from Meachem Marketing, Sarasota, Fla., can drop out of sight so lines won't snag.



### Handheld compass

Rubber-collared and worn on a lanyard, the Mariner's Compass, \$85 from E & B Marine Supply, Box 747, Edison, N.J. 08818, is used by America's Cup yachts. **PM**





# IT DOESN'T TEAR UP THE NATION. IT TEARS UP A STATE.

## AND WHO'S THERE TO HELP PUT IT ALL TOGETHER?



The Army National Guard of Kansas. Or Mississippi. Or wherever that emergency may be.

You see, the Guard is the military branch that's first to come to a state's rescue.

The Army Guard is trained as a partner of the Army in case of national defense. Then it puts that training to work to protect your state and community.

Won't you join us? Two days a month and two weeks annual training (after your initial training) lets you earn extra income and learn new skills while you protect everything that's close to you.

For more information, call your local Army Guard recruiter or call toll-free 800-638-7600.\* And see if we can put it all together for you.

\*In Hawaii: 737-5255; Puerto Rico: 723-4550; Guam: 477-9957; Virgin Islands (St. Croix): 773-6438; New Jersey: 800-452-5794. In Alaska consult your local phone directory.

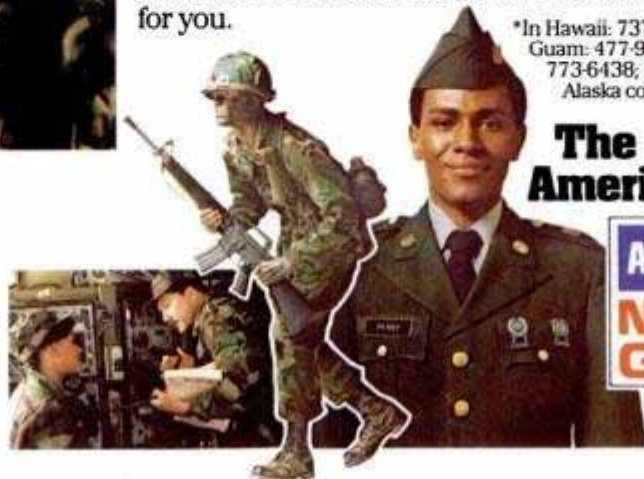

### The Guard is America at its best.



AIPMTU\*033NP



## The full size solid oak workbench. \$97.

Our workbench is crafted from 100% solid Appalachian oak. It is modeled after the finest European benches (costing over \$500), and is equipped with tool rack, oak mallet, vice mounting assembly and tool trough.

It is every inch a tough professional. Dimensions: 30"x50"x33"H. Legs - 2 1/2" square. Top - 1 3/8" with 2 1/2" aprons. Heavy. Unshakable. Immovable.

Our workbench costs only \$97, and is shipped direct from our Tennessee mill. For pure value, it totally outworks everyone else's workbench.

And it proves that quality can be honest. Not expensive.

Order today. Send \$1 for our workbench options list - drawers, sectioned bins, vice, etc. and for a catalogue of our complete line of fine solid hardwood furniture, furniture kits and workbenches. Your satisfaction is always guaranteed. (Sanding/assembly required.)



Available also in Pro Model size: 30" x 70" for \$122.

## The Tennessee Hardwood Company

Makers of fine oak furniture  
800 Main Street  
Woodbury,  
Tennessee 37190  
To order, please write us. Shipped freight collect.

## ASSEMBLY-LINE GENES

(Continued from page 95)

own needs," explains Beckman's Pamukcu. Many laboratories, he notes, build their High Performance Liquid Chromatography (HPLC) sets out of components.

All HPLC systems do one basic thing: they use a column of absorbent fluid to separate the molecules of a protein by weight, electrical charge or other specific property. Not only does this help sequence a protein, but it also allows investigators to identify even slight variations between two proteins.

The genetic engineering business has truly come of age. In addition to all the high-speed components, the industry has entire factories dedicated to the production of a specific protein. New Brunswick Scientific, for example, makes a cell-culture system for the production of interferon.

More than 100 gallons of cells can be produced in a single, computerized system. Speed of production depends on several factors, including the amount of interferon coming from each cell. The chemical broth is mixed and filtered in 250-gallon (1,000-liter) tanks before moving on to tanks filled with bacteria. After the desired number are grown, the broth is piped to suspension tanks to let the dead cells separate from the chemicals, which are then poured off. Finally, the cells are put in a centrifuge to spin out the interferon.

### Slave race

Is the new genetics just too good to be true? A presidential commission late last year announced its findings: that the day is far off when mad scientists will be able to clone a slave race out of "engineered" apes whose genes are rearranged to let them perform menial tasks. Still, the report cautioned, the genetic engineering revolution is here to stay, and some mechanism should be set up to watch it.

Weeks after the report was released, scientists at the Carnegie Institute of Washington announced they had bred red-eyed fruit flies from brown-eyed parents through genetic manipulation. They used pieces of DNA to carry the proteins for red-eye color into fertilized brown-eyed fly embryos. That's a mission unanticipated in the presidential report.

Just to be on the safe side, Rep. Albert Gore (D.-Tenn.) has ordered hearings on the genetic industry for the current session of Congress. Gore has expressed concern about the rapid advancement of genetic engineering without appropriate monitoring. Thus, we can expect to hear a lot this year over an issue that has kindled our best hopes—and worst fears.

FM

## SPLIT/SECOND USE! AUTOMATICALLY AT TOUCH OF A BUTTON!

THE IMPORTED  
"ELECTROMATIC"  
4-FUNCTION  
HAND TOOL LETS  
YOU:

**SLICE A CABLE  
SKIN A WIRE  
TEST A CIRCUIT  
DRIVE SCREWS**

Black, leather-like 4" Handle  
Opens to 7";  
Insulated &  
Takes 110-250  
Volts; Light Shows  
Live Circuit.

**\$12.95** each  
Plus \$1.50 S&H.

2 for **\$25.00!** Plus \$2.00 S&H.  
**MONEY BACK GUARANTEE!**

**BIG THREE PROMOTIONS, INC.**  
DEPT. PM3  
242 W. 26th St., N.Y., N.Y. 10001

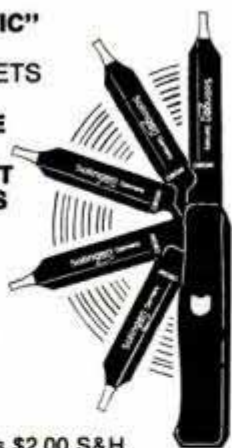

## WHEN YOU BUY A SCRAPER, GET A SAFE ONE! WARNER SAFETY SCRAPER



**SAFER!**  
FIRMLY MOUNTED  
BLADE RETRACTS  
INTO HANDLE.

**TOUGH STEEL,  
NO PLASTIC!**  
YOU'LL WORK  
SAFER WITH A  
WARNER.

**STANDARD  
SINGLE  
EDGE  
BLADES!**  
BUY  
REPLACEMENTS  
ANYWHERE.

THE NAME 'WARNER' ON  
A PAINTING OR DECORATING  
TOOL ASSURES  
A SUPERIOR PRODUCT — A WORKING TOOL  
NOT A GADGET.

Buy Warner Safety Scrapers at hardware, decorating, home centers everywhere.

**WARNER**

WARNER MANUFACTURING CO., 13435 INDUSTRIAL PARK BLVD.  
MINNEAPOLIS, MN 55441 • PHONE 612/559-4740

(Signature) \_\_\_\_\_  
(Name—Print) \_\_\_\_\_  
Address \_\_\_\_\_  
City \_\_\_\_\_ State \_\_\_\_\_ Zip \_\_\_\_\_  
METHOD OF PAYMENT  
 Check Enclosed  MC  Visa  
Account No. \_\_\_\_\_ Exp. Date \_\_\_\_\_



### 3 GARDENING AIDS

(Continued from page 105)

## 1 Potting bench

The potting bench is adapted from one used by Bob Thomson, host of the *Victory Garden* TV program, aired nationally on PBS. The simple but sturdy bench is built to withstand strenuous daily use. We show plans for a smaller version to suit a home gardener's needs and space limitations. We also added a top shelf for parking flowerpots during work sessions and a garden-tool board.

The bench is framed with pressure-treated 2x4s; work and storage surfaces are 1x6s. Or you can use common pine for the frame and work surfaces. If you opt for the latter, coat all surfaces of these members with a wood preservative, such as Woodlife, several hours before you assemble the parts. Give the bench a second coat.

We used exterior plywood for bench shelf, sides and back. The board to hold tools is perforated hardboard fitted with tool-holding hardware.

Cut frame members for the deck. Hold parts together temporarily with bar clamps. Check corners with a large square; adjust if needed. Then bore pilot holes for nails to prevent the wood from splitting. Use resorcinol glue and nails to assemble parts.

Cut the 1x6s for the work surface and the lower storage shelf to length. Cut the notches for the legs in two shelf members. Bore pilot holes and nail the work top in place.

Cut the plywood sides and back. Notice that the sides taper in height from 21 in. in back to 7 in. in front. Glue and nail the back and sides to the bench top and to each other.

Cut the upper shelf to size and bore the optional flowerpot holes. You can make these using a fly cutter in the drill press, but clamp the shelf firmly to the press table on both sides of the cutter. Or you can make the circular cuts with a sabre saw.

The bench legs are cut to length and the notches are cut. You can make the internal notches with a sabre saw and chisel. Or use a radial-arm saw in this manner: Mark for notch width and depth on the face of the leg and align the notch (waste) area with the saw blade. Adjust the blade to notch depth. Make successive overlapping passes with the blade. Clean using a chisel.

Rest the bench top bottom side up. Position the back legs; bore pilot holes and glue and nail the legs in place.

Rotate the bench onto its front assembly and install the front legs in the same manner. Let the glue dry for 24 hours. Next, cut the lower frame members to length. Test-assemble using clamps and bore pilot holes after checking that the frame is square. Then

secure the parts with glue and nails.

Finally, cut out parts for the tool board. Glue and nail the frame together with 4d nails and set it aside. Bore lead holes and fasten the cleats to the legs with 10d nails. Bore lead holes and fasten the perforated hardboard to the bench with 6d common nails. Apply veneer edge tape to exposed edges, if desired, using contact cement.

## 2 Lettuce shader

Our lettuce shader does a perfect job of partially shading lettuce from the sun. This minimizes leaf burn, and produces

a more bountiful crop. If you build it of No. 2 common pine and treat it with wood preservative, it will last for years.

Since the slat assembly is not attached to the legs, you can store it nearly flat against a wall.

The shader on page 105 has 1x2 slats spaced 1½ to 2 in. apart. These are secured by 6d hot-dipped galvanized nails to a base of 2x3 rails and end pieces. Or you can use 2x4s.

Cut stake points on the legs as shown. Secure the legs to their cross members. Apply a wood preservative.

Note: A pair of shading units can

(Please turn to page 126)



## Secrets of a fine wood finish

**Preparation.** Start with smooth, bare wood.

**Penetration.** In one easy step, stain and seal with Wood Finish by Minwax. It penetrates deep into fibers to become an integral, breathing part of the wood, not just a surface film.

**Protection.** Where extra durability is desired, as on table tops, choose from Polyurethanes and other protective finishes by Minwax.



Free 22-page Booklet. Send for it now and see how easy it is.

The difference shows with Wood Finishing Products by Minwax.

And that's no secret.



Minwax Company, Inc. Dept. PM33  
Box 995, Clifton, NJ 07014

Name \_\_\_\_\_

Address \_\_\_\_\_

City \_\_\_\_\_

State \_\_\_\_\_

Zip \_\_\_\_\_

**MINWAX**

© Minwax is a registered trademark.

Материал защищен авторским правом.



## THE 5 MOST IMPORTANT WOODWORKING OPERATIONS . . . IN ONE COMPACT MACHINE

BONUS: Act now and receive also free tooling package.

- 34" LATHE
- 10" TABLE SAW
- 11 1/2" DISC SANDER
- 16 1/2" VERTICAL DRILL PRESS
- HORIZONTAL DRILL PRESS

REGULAR PRICE \$1,210  
SAVE \$ 251 Today  
**\$ 999.**

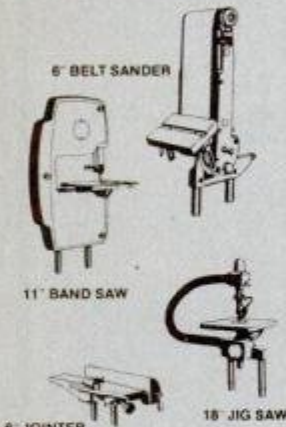

These special accessories also fit similar machines



### VERY IMPORTANT

The only machine built with:

- A. ALL CAST IRON TABLES
- B. HEAVY DUTY DESIGN
- C. DEVELOPS 3 HP.
- D. BUILT AS AN INDUSTRIAL MACHINE

ONE PLACE FOR ALL YOUR NEEDS . . .

**CALL NOW!! FOR FREE GIFT**

Toll Free (1-800) 421-2467  
in California (213) 549-0761

**MAIL NOW!!!**

- VISA    MASTERCARD    MONEY ORDER

YOUR NAME \_\_\_\_\_ PRINT

ADDRESS \_\_\_\_\_

CITY \_\_\_\_\_ STATE \_\_\_\_\_ ZIP \_\_\_\_\_

PHONE ( ) \_\_\_\_\_ BEST TIME TO CALL \_\_\_\_\_



**MASTER WOODCRAFT CO.**  
(A Republic-Lagun Group)  
800 SPRUCE LAKE DRIVE • P.O. BOX 669  
HARBOR CITY (Los Angeles), CA 90710  
Dealership Available

## 3 GARDENING AIDS

(Continued from page 125)

share a common (center) leg unit if each shaver is set to occupy just half the crosspiece width. This leaves a lip upon which the next shaver can rest.

## 3 Caterpillar cloche

The caterpillar cloche adds a season extender to your garden—and it costs less than \$25 to build. You can assemble it in several hours with tape measure, hacksaw, paintbrush, scissors or knife, and hammer.

Materials you'll need include: 1/4-in.-dia., hot-rolled steel bar; 4- or 6-mil polyethylene plastic; rustproof paint; two 16-in. wood stakes; and twine. Steel bar is sold in 20-ft. lengths (check the classified directory under "Steel distributors and warehouses"). The cloche shown covers a 40-in. wide × 12-ft. planting bed. You'll need four bars to cut ten 80-in. lengths. For beds of other dimensions, allow two arched bars for every 3 ft. of garden bed.

The cloche shown requires a 4 × 15-ft. piece of plastic. For other sizes, figure the amount of plastic by adding 3 ft. to the length of the growing bed. If your bed is wider than 4 ft., place two caterpillars side by side.

Use a hacksaw to cut the bars to 80-in. lengths. Clamp the bar stock in a vise to cut it. Apply two coats of rustproof paint to the bars using a paintbrush or old rag. Set aside to dry.

Starting at one end of the bed, mark the ground at 3-ft. intervals; you'll insert the steel bars at these points. Mark along one side of the bed, then along the other.

Push a steel bar for the lower level of bars about 6 in. into the ground. If it doesn't stand by itself, push it deeper. Straddling the bed, grip the top of the bar and slowly bend it toward the marked spot on the opposite side of the bed. Then push the end 6 in. into the soil. Repeat on the lower level bars.

Unroll and spread out the polyethylene plastic and cut it to size. Lay the plastic over the support bars. Gather the last 18 in. of plastic at one end and tie it with twine; repeat at other end.

Cut the wood stakes to 16-in. lengths. Tie one end of the plastic around a stake and hammer the stake in place. Then tie the plastic to the other stake and pull the plastic tight before hammering the stake.

Insert the upper level of steel bars directly over the lower ones, leaving 1/4 in. between them so the plastic slides freely for covering or uncovering.

The plastic skin should open roll-top-desk fashion. Pull the plastic up about 2 ft. at each support; then continue to pull it to reveal the entire bed.

PM

# Curtis Homes Assistance Money Plan

PUT THE CHAMP™ TO WORK FOR YOU!

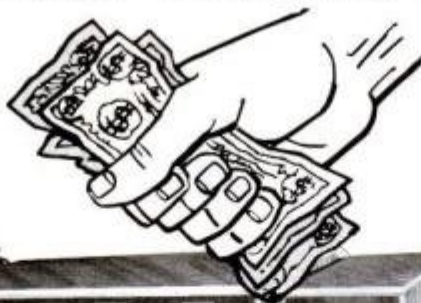

Handy, ambitious people don't have to wait to afford a home. Curtis has the "CHAMP" credit plan to put homeownership within your reach NOW! Curtis provides the easy credit during construction. We do the heavy, difficult framing on your lot and foundation. You complete it with Curtis quality materials and simple step-by-step instructions.

### THE "CHAMP" WORKS EIGHT WAYS FOR YOU!

- No down payment, no deposit.
- No bank qualifications at the start.
- Low monthly payments while building.
- Below market interest rates.
- Land may not have to be fully paid for.
- 6 month price guarantee.
- Build in city or country.
- Complete-it-yourself and save.

You, too, can join the Curtis family of new homeowners. For full details send coupon or call today.

There's a representative near you!  
Call Toll Free: 1-800-228-6505  
In Nebraska call: 1-800-642-9606 or  
(612) 542-4300

Complete It Yourself

**Curtis Homes**

If you have desire... We have the trust!

Send me your FREE Homes Catalog.  
CURTIS HOMES, DEPT. PM-1  
2201 Florida Ave. So., Minneapolis, MN 55426  
(Please Print)

Name \_\_\_\_\_

Address \_\_\_\_\_

City \_\_\_\_\_ State \_\_\_\_\_ Zip \_\_\_\_\_

- Phone( ) \_\_\_\_\_
- We own land.
- Enclosed is \$1.00 for priority handling.



rain or shine. Or so the car's designers tell us.

The V rating tells you that the tire is designed for sustained cruising at 130+ mph. The car, in fact, will easily do 140 mph.

Low unsprung weight was achieved by using some pretty radical (for a

street car) materials and applications. The most striking example is the extensive use of Alcoa forged aluminum. Pop the clam-shell, tilt-up hood and the first thing you'll notice is one of the most beautiful-looking aluminum suspension arms this side of a Formula Atlantic car.

(Please turn to page 128)

## THE VINTAGE VETTES

**A**nalyzing the Corvette is like trying to come to grips with John Wayne, Harley-Davidson or Coca-Cola. It's not a matter of right or wrong, better or worse. What we're talking about here is a symbol, an American institution, part of a shared national heritage, as immune to criticism as Motherhood and Old Glory. The Corvette simply is.

This automotive icon first came to us 30 years ago—in January 1953 at the Grand Ballroom of the Waldorf-Astoria, to be precise. The first prototype was the star of General Motors' annual Motordama auto show, and Dinah Shore posed for photos with George Montgomery, who proclaimed it snazzier than a Muntz Jet.

But, honestly, the 1953 Corvette wasn't much of a car. It had a Bel Air chassis shortened 13 inches through the middle, a hot-rodded Blue Flame Six of 150 reputed horsepower, a two-speed Powerglide automatic and a hand-glued, fiberglass, two-seater body. On the other hand, it was startlingly sleek for that time, and small—at least by American standards.

Only one thing kept this lackluster first-generation Corvette from also being the last. In 1955, Ford brought out the Thunderbird, which virtually guaranteed that arch-rival Chevrolet would field a competitor. Even though they sold fewer than 5,000 Corvettes from 1953 through 1955, Chevrolet simply had to keep plugging away.

Happily, Chevrolet was on a roll in the mid-'50s—the '55 through '57 Chevs are still cult cars among enthusiasts and collectors. Ed Cole was in charge of the division. Harry Barr and John Dolza were doing engines, Maurice Olley was doing chassis and Bill Mitchell was about to take over styling from Harley Earl. And, of course, Zora Arkus-Duntov, the father of the Corvette, was already blocking out his high-performance fiefdom.

In one of the great turnarounds of all time, this team transformed the hapless first-generation Corvette into the post-war American classic. For 1956, the car had a whole new body, with simple, timeless styling, a revamped chassis and, most important of all, well over 200 hp from the high-revving small-block V8. It

was a *tour de force* for everyone concerned.

The ultimate Corvette from a collector's point of view is a 1957—fuel-injected, 283-hp, 283-cu.-in. V8, four-speed, positraction, RPO 684 handling package, optional hardtop and Onyx Black paint with red/beige interior. Today, a collector can wisely spend \$25,000 for such a car and know he's got a bargain.

The 1957 Corvette was just about perfect, so, wouldn't you know it, it got a major redo for 1958 that made it heavier and uglier, without a compensating increase in quality or performance. The '59 and '60 were more of the same. The '61 and '62 were partially restyled by Bill Mitchell and got the rear end styling of one of the Corvette show cars of the era. The '62 was the first to get the 327 engine.

If there's a lost generation of Corvettes, it's these '58 through '62s. They're still comparatively inexpensive, but that's a direct reflection of supply and demand. Paradoxically, not only are the cars not as well liked by collectors, there are more of them not to like. Less than 10,000 Corvettes were sold in 1956 and '57 combined, while sales averaged over 10,000 annually the next five years.

The dividing line between classic and new-era Corvettes is 1963. Amazing as it may seem, there have only been two basic chassis in 30 years—the modified '53 Bel Air and the all-independent Sting Ray that's still in production. And discounting the Blue Flame Six of the first two years, just two engines—the small-block and big-block Chevrolet V-8s in various states of tune and displacement.

The '63 split window Sting Ray was perfectly timed. It was introduced just about concurrently with Jaguar's XKE and Shelby's Cobra, all three in the \$5,000, 150-mph, A-Production class. Corvette sales nearly doubled with the Sting Ray, and if there had been any justice in the world, they would have doubled again. The Sting Ray was that good.

The original Sting Ray was a styling exercise by Larry Shinoda which Bill

(Please turn to page 128)

## Log Splitter Parts



### 2-Stage Cast Iron Gear Pumps

11 GPM @ 650 PSI until more pressure is needed. Kicks down to low GPM & up to 2500 PSI. Right hand rotation, can direct couple to 5 HP or larger engines. 3600 max RPM. 12 LBS.

Item # 1011 ..... \$118  
13.6 GPM @ 650 PSI/3600 RPM max. Item # 1013 ..... \$135  
16 GPM, use with 8 HP + Item # 1015 ..... \$156  
22 GPM, use with 10 HP + Item # 1017 ..... \$245

### 4-Way Control Valves



Built-in relief valve, 3/4" in-out ports, 1/2" cylinder ports. Item # 2010 ..... \$42

Has pressure sensitive detent, hands free on return stroke. Item # 2020 ..... \$58

### Double-Acting Cylinders



TYPE	STROKE	ROD	WT	ITEM#	PRICE
Tie Rod*	3 1/2x24	1 3/8	50	909324	\$115
Tie Rod	4x24	1 3/4	74	909424	148
HD Tie Rod	4x24	2	78	909724HD	150
Tie Rod	5x24	2	100	909530	204
Welded Tee*	4x24	1 3/4	49	90424	132

\*These can be shipped U.P.S.

### Quality Gas Engines



HORIZ	HP	SHAFT SPECS	ITEM#	WT	PRICE
Tecumseh	5	3/4" Recoil	6051	40	\$130
Briggs	5	3/4" Recoil	6052	40	130
Briggs	8	1" Recoil, model 190432	6080	50	198
Tecumseh	8	1" Recoil, cst iron siv	6081	50	182
Tecumseh	10	1" Recoil, cst iron siv	6010	50	220
VERTICAL					
Briggs	5	7/8" Recoil, HD fly-wheel	7050	45	\$145
Tecumseh	5	7/8" Recoil, model	7051	30	125
Briggs	8	1" Recoil	7080	49	205
Tecumseh	8	1" Recoil, model VM80	7082	50	195
Tecumseh	8	1" Elec/Recoil, 12 volt	7083	55	239

3 1/2-18 HP available in horizontal & vertical  
Heavy Duty Splitters  
12 Ton Splitter, with 24,000 LBS of force - \$749  
15 1/2 Ton Splitter, with 31,000 LBS of force - \$855  
24 Ton Splitter, with 49,000 LBS of force - \$1385

### Engine/Pump Combinations

—Includes engine, direct couple bracket, flex coupling, 2-stage pump.  
5 HP Tecumseh & 11 GPM pump, #8050 ..... \$265  
5 HP Briggs & 13 GPM pump, #8053 ..... \$290  
8 HP Briggs & 15 GPM pump, #8030 ..... \$370

## IT'S A HONDA Honda EM-500 Generator



Quiet, reliable. Four stroke no fuel mixing. Spark arrester, oil alert system. USDA approved. 500 watts, portable 44 pounds. Item # 1660.

**\$297**

**Honda EM-600**  
Gives you 600 watts of power. # 1662. **\$327**

We will ship a generator anywhere in the 48 states for \$12.00.

Send \$1 for 72 page DISCOUNT CATALOG filled with savings on industrial, agricultural, and energy saving supplies. Or \$6 for "Splitter Design-Fact Booklet" and catalog.

**Northern Hydraulics**  
Dept. PM 3-22 PO Box 1261  
Burnsville, Minnesota 55337

**612-894-8310**



# FREE WATER and plenty of it!

TAP THE LIFETIME SUPPLY  
OF FREE WATER IN YOUR  
OWN BACK YARD

Drill your  
own well  
and save  
hundreds  
of \$\$\$.



## THIS MAN IS DRILLING A WELL

in his own backyard for less than 1/3 the cost of hiring a commercial well driller.

Thousands of home owners are now drilling their own wells from 50 to 200 feet deep! YOU can join them in saying good-bye forever to expensive, chemical-tasting city water! Forget about droughts! Ignore summertime water shortages!

Write or call today for our FREE information package including the booklet "HOW TO DRILL YOUR OWN WELL". There's no obligation—ACT NOW!

DEEPROCK MANUFACTURING CO.  
Opelika, Alabama 36802

CALL TOLL-FREE  
**1-800-821-7700**

(Ask for Extension 738)

Call anytime including Sundays  
or clip coupon and mail TODAY!

 **DeepRock**

738 Anderson Road  
Opelika, Alabama 36802

Please mail your free information kit.

Print Name \_\_\_\_\_

Address \_\_\_\_\_

City \_\_\_\_\_ State \_\_\_\_\_ Zip \_\_\_\_\_

I'm in a hurry! I have enclosed \$1.00. Rush the  
FREE information package by FIRST CLASS  
MAIL.

©1983 DeepRock Mfg. Co.

## CORVETTE (Continued from page 127)

Never have recycled beer cans been sacrificed for a better purpose. Upper and lower control arms, upper control arm shaft, steering knuckle, shock bracket, brake caliper, splash shields, retainers, the lot of it—all aluminum, forged or stamped. And if you look close-

er, you'll note the lack of a coil spring. The same filament-wound fiberglass rear spring, introduced in last year's car, has now also found a home at the front end. It's mounted transversely and bolted up in the center of the front

(Please turn to page 133)

## THE VINTAGE VETTES (Continued from page 127)

Mitchell fitted to one of Zora Duntov's Corvette Sebring SS chassis. Compared to other cars of the era, the Sting Ray looked like something from *Star Wars*.

It still does. Today, in 1983, Chevrolet could introduce the Sting Ray as a new car and set the world on its ear. The best of the production cars is probably the 1965. This was the first year for four-wheel disc brakes and the last year for the fuel-injected 327, rated at a conservative 375 hp. The styling was more refined than on the bulge-hooded, sweeping fendered cars that would come later. Yet you could still order knock-off alloy wheels.

The later Sting Rays were just about the ultimate in muscle cars. The 427-cu.-in. big block was nominally rated at 435 hp, but Chevy tuners reported seeing 560-600 hp on the dyno from stock V8s. In a 3,200-pound car, this gave a better power-to-weight ratio than anything except the 427 Cobra. The difference was that while Cobras were sold by the hundreds, Corvettes were sold by the tens of thousands. The Sting Ray was a world-class car. It was smaller, lighter, faster, quicker, smoother, quieter and not likely to leave you waiting for parts.

Today, the most desirable Sting Rays are either the very first split window 1963 coupes or the later 427s with horsepower that doesn't exist anymore. The ultimate would have to be the full-race L-88 427, with off-road side exhaust system, stuffed into a 1967 roadster.

Ironically, the '67 Sting Ray was never meant to be. The restyled car that debuted the following year was originally intended for 1967. This new body was derived from a GM show car called the Mako Shark. Like the Sting Ray, it was designed by Larry Shinoda. Unfortunately, the Mako Shark-derived car was heavier, bigger, softer and more expensive than the Sting Ray it replaced. At the time, Corvette enthusiasts considered the '68 Sting Ray a giant step backward.

Little did they know. There was still the racing L-88 engine and an aluminum block version called the ZL-1. The street 427 grew up to a 454, and the LT-1 350-cu.-in. small block, with mechanical lifters, was rated at 370 hp in 1970.

Then the emissions and safety regulations came into effect. Between 1970

and 1971, compression ratios dropped from 11:1 to 9:1 on the small blocks, and 12.5:1 to 9:1 on the big blocks. And the horsepower just galloped away.

Still, the Corvette kept selling as well as ever. It's just that the people who bought them changed dramatically. Up through 1967, the Corvette was bought by sports car enthusiasts. In any given year, 9 out of 10 buyers specified a four-speed manual transmission and manual steering.

In 1968, however, nearly 20 percent of all Corvettes were ordered with automatic transmissions, and by 1973, 60 percent were automatics. By 1978, only five percent were *not* automatics. By then, virtually all Sting Rays came with air conditioning, power steering, power windows and all the other accoutrements of personal/luxury cars.

Then there's the 1978 Indy Pace Car. This was the first Corvette in years to make it onto page one of the *Wall Street Journal*. The Pace Cars were the only modern Corvettes to be coveted by collectors, but for the wrong reasons.

Essentially a decal/paint treatment, the limited-edition Pace Cars became a phenomenon when investors started bidding the prices up over \$30,000 in the middle of 1978. Just as quickly, prices fell to under \$18,000, where they've stayed ever since. Realistically, Indy Pace Car prices will go up or down just as quickly as 1978 Corvette prices in general, but they'll stay about \$3,000 higher.

Which brings us to the first new Corvette in 15 years. The 1983 Corvette will be an instant collector's car. Not only is it strikingly pretty, but it's the first Corvette in over a decade with real performance. Besides, Corvette collectors always seem to attach special significance to the beginning of a new series. The '53, the '63, the '68, and now the '83, will always be worth a little more.

You can't judge a Corvette by normal automotive standards. It has survived a decade of emissions and safety emasculation with its performance image intact. And now that performance is back in style, Corvettes of all ages ought to be more popular than ever. Remember, this is an institution we're talking about here—America's Only Sports Car.

—Rich Taylor



## ELECTRONICS

### 3-D TV is here

Scientists generally believe that our ability to perceive depth is the result of our binocular vision. Now, challenging this concept, three University of Southern Carolina scientists have developed a technique that makes 3-D television, movies and slides a reality for everyone—even those with poor vision or vision in only one eye.

No special glasses, cameras, projectors or television sets are needed. And unlike traditional 3-D, the Visual Image Depth Enhancement Process (VISIDEP) produces images which have realistic depth and fullness, rather than exaggerated images which seem to leap outward.

Drs. Edwin Jones, LeConte Cathey and Porter McLaurin, experts in optics, electronics and media production, respectively, developed their novel approach by observing how a visually impaired person discerns depth. "We discovered that a one-eyed person perceives depth by moving his head and comparing a sequence of visual 'frames' from different angles," Dr. Cathey told PM. This concept was once considered impossible by physiologists.

VISIDEP simulates the optics of a one-eyed person by using conventional video equipment, plus a special encoding device which produces a time-sequence display of images captured from two different points of view on a single channel. Variations of the technique allow the South Carolina team to create 3-D images from slides, motion pictures and computers.



In recording, twin-screen monitor (right) shows two images before encoding. Combined, they appear as one on single monitor (rear).

To produce the 3-D effect on a movie screen, early filmmakers shot each scene simultaneously with two cameras. Each camera was positioned to duplicate the angle at which the viewers' eyes would see the scenes. Next, the two films were tinted, one red and the other



Seeing single from double: You can simulate new 3-D effect by holding a small piece of cardboard (3x5 file card) on edge between these two slightly different images. Start with your nose touching the edge of the card and look at the photos. As you move the page slowly away from your eyes, the two images will merge, giving an illusion of depth.

blue-green, then projected onto a single screen by two projectors. Viewers wore special glasses with one lens tinted red and one blue-green to match the film's tint. This forced each eye to view a slightly different image. The resulting jumping-out effect, limited to the screen's center, could be seen only by a stationary audience.

VISIDEP has none of these restrictions. Once encoded, the image may be reproduced by any single conventional video camera, movie or slide projector. The depth moves into the screen rather than out toward the audience, making the image more lifelike.

Since VISIDEP can be applied to images generated by virtually any means—including X-rays, sonar, infrared or visible light, as well as from fiber optics—potential applications range from undersea and satellite transmissions to medical and computer sciences.

One particularly exciting application involves VISIDEP's ability to produce three-dimensional computer-aided design and manufacturing. With VISIDEP it's possible to display these images in three dimensions.

For nontechnical applications, the most immediate use of VISIDEP probably will be for televising commercials and sports events.

VISIDEP also may have an effect on some long-standing theories of perception. As Jones stresses, "Our development will force people to take another look at standard theories of how people perceive depth and, thus, how all of us learn."



## Pier into the future

**T**he average active U.S. Navy ship is 15 years old. The average Navy port facility is 35. With the needs for continuous, extensive maintenance on sophisticated shipborne equipment—electronics systems, for instance—the Navy has been looking for something new in shoreside facilities. And the new technology would have to be modifiable itself.

One answer that recently surfaced at the Naval Civil Engineering Laboratory in Port Hueneme, Calif., calls for a floating pier. You may already have seen floating slips at small-boat basins, but the double-deck concept being developed by the Navy is on a vastly grander scale. The two-deck unit is built by hooking together a pair of steel-and-concrete modules each 600 ft. long by 75 ft. wide. The main, upper deck would stand 20 ft. above the waterline, allowing access for the key maintenance functions. Stairwells would lead to a lower deck with holding tanks, electrical substations and vehicle traffic lanes. The structure would ride up and down with the tides, eliminating the time-consuming chore of line-tending.

Replacing a fixed pier of similar size, the Navy estimates, currently takes about 18 months, but the floating pier could be assembled and tethered to its 58 pilings in as little as six months.

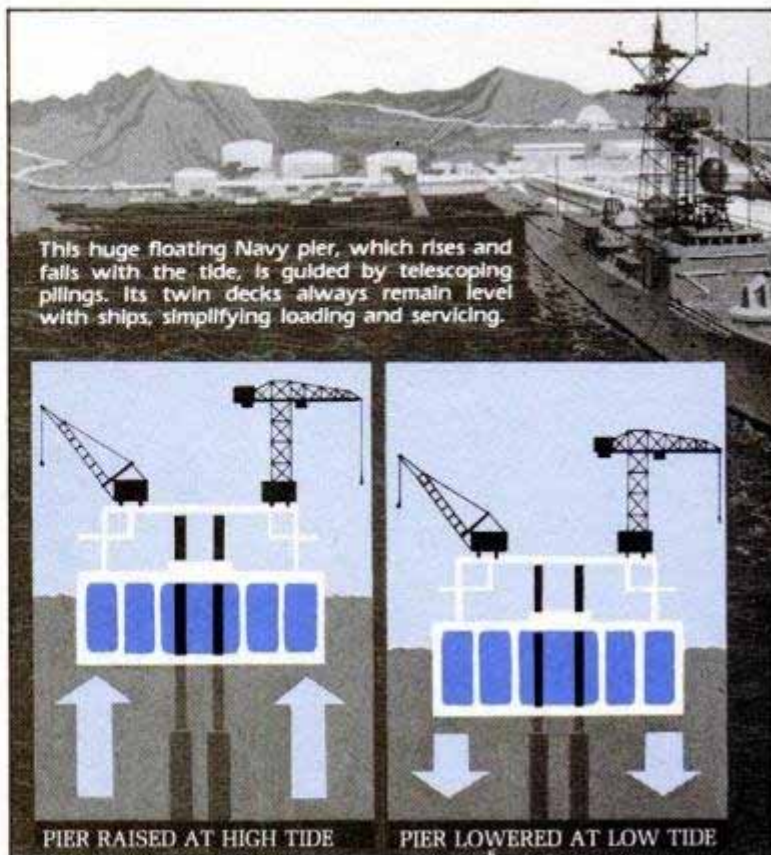

This huge floating Navy pier, which rises and falls with the tide, is guided by telescoping pilings. Its twin decks always remain level with ships, simplifying loading and servicing.

PIER RAISED AT HIGH TIDE

PIER LOWERED AT LOW TIDE

## Here come the new flying fish

**I**f you're enjoying the seas around Key West, Fla., and spot a couple of fast moving boats that don't seem to be touching the water, don't worry. It's not a mirage. You're looking at the Navy's new six-vessel Patrol Hydrofoil Missile ship (PHM) fleet. The pioneering squadron that operates out of Key West is made up of Jetfoils built by Boeing Marine Systems. The military vessels are similar to those already marketed to civilians by Boeing. But these flying fish have a few substantial differences: Each carries eight harpoon missiles and a 76-mm. rapid-fire cannon.

The PHMs resemble their civilian cousins in using Boeing's unique, fully submerged foils. These differ from traditional foils because the Boeing models are totally submerged, giving the vessel a smooth ride even in rough seas. Hydrofoils that just pierce the water rise and dip with the waves and often bounce passengers around the vessel.

The first Boeing Jetfoil "flew" in July 1974, and the first commercial operations began in Hong Kong the following year. Indonesia is already operating one of the military models off its coast.

Before delivery to the Navy, each of the Jetfoils undergoes tests conducted by the Navy Board of Inspection and Survey. In the tests performed at Boeing's Puget Sound facilities, the PHMs provided a smooth-operating platform at average speeds of 40 to 50 knots.

Vice Admiral John D. Johnson Jr., Commander of the U.S. Atlantic Fleet's Naval Surface Force, says that the PHMs may take part in Mediterranean exercises this year.

"The advantages of a PHM are that it has a terrific



Hydrofoils for peace or war: Boeing's passenger-carrying civilian ferry (right) teams up with Navy's new missile-firing PHM version (left), both high-speed, foil-borne vessels.



# TECHNOLOGY UPDATE

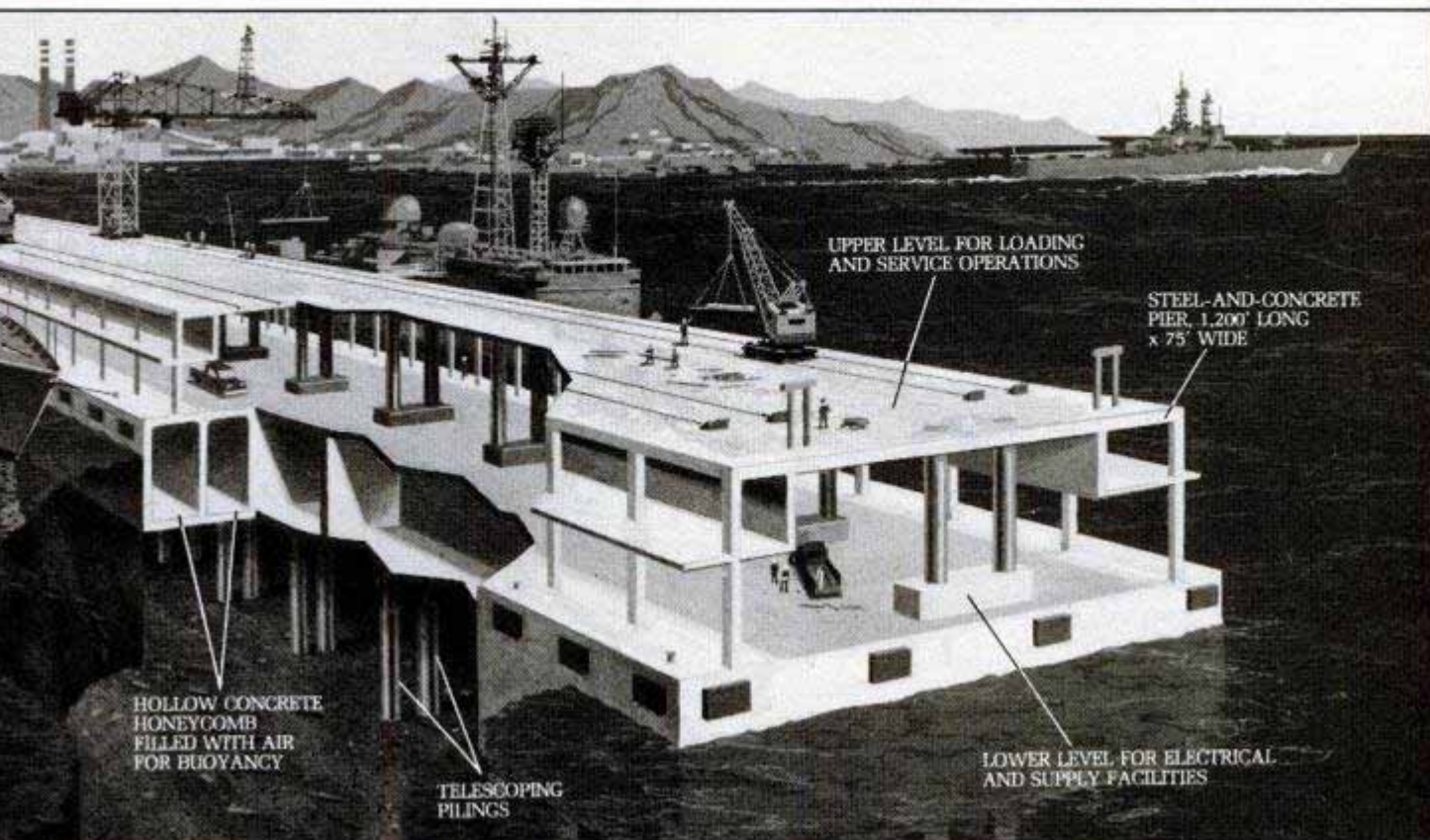

punch for a very small ship and it's a difficult ship to kill; it's a high-speed ship that can be deployed and repositioned very quickly," Johnson says.

Last year, Boeing gave a dramatic four-week demonstration of the Jetfoil in southeastern Alaska's Inside Passage, in the Juneau area.



Large winglike bow foil, retracted above, swings up on pivoted strut for low-speed maneuvering, docking.

The Jetfoils emerged with flying colors: They cut the time required by conventional ferries for a trip in half.

In the demonstrations, the Jetfoil *Aries* carried a total of 15,367 passengers

on 97 trips without a single breakdown.

The *Aries* even won a special commendation for her captain, Bruce Bryant, and crew. The Coast Guard presented the award because the *Aries* came to the rescue of a ferry, the *Majestic Alaskan Explorer*, that had run aground with 77 passengers aboard. Dozens of passengers were carried safely back to shore by the *Aries*.

The PHMs themselves have also established some preservice records. The *Pegasus*, commissioned in 1977 as a test vessel, has already logged more than 100,000

nautical miles, a record for Jetfoils, during more than 5,000 hours underway. It also recorded the fastest transit ever of the Panama Canal: two hours, 41 minutes in June 1979.

## Ship above water

The foils of the new craft are attached to the hull by a system of struts that lift the ship several feet above

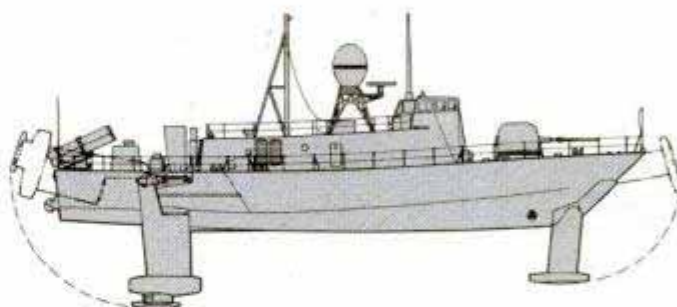

Drawing shows bow and stern foils both raised and lowered. the surface. The welded aluminum hull is not affected by water-resistance friction. It takes a crew of 21 men to keep a PHM on its military mission.

The five new hydrofoils that complete the current fleet were built for \$272 million. They're commissioned: *Taurus*, *Aquila*, *Aries*, *Gemini* and *Hercules*—all names of mythological gods and stellar constellations.

Editor: Dennis Eskow  
Contributors: Robin Nelson, Sheldon M. Gallagher, Larry Wood, Rae Ludwig



## AVIATION

### Rocket bailout

**P**ilots flight-testing new, high-speed airliners have a problem. If something goes wrong, they have no safe way of bailing out. Fighter-type ejection seats are impractical in big, enclosed-cabin aircraft, and anyone attempting to open a door and jump would almost certainly be dashed back against a wing, engine or tail surface.

Faced with this challenge, a team of high-tech escape artists came up with a scheme that's daringly ingenious, if slightly bizarre. At the first sign of trouble, a pilot moves to the nearest exit door and hooks a lanyard to a ring in the top of his helmet. He then crouches down and pulls a handle.

What happens next may come as a shock, but could save his life. When the handle is pulled, the cabin door is blown off by explosive charges and a rocket, trailing the lanyard, is fired from a launcher tube inside the doorway. The rocket literally yanks the pilot out by his head, hurling him safely clear of the doomed aircraft. In less than five seconds, the lanyard automatically disconnects and the pilot's parachute opens. (At high altitudes, chute deployment is delayed until the crewman reaches a safe, preset pressure altitude.)

The novel ballistic escape system, dubbed AWAY (for Aircrew Walk-Around Yankee), was originally devised for emergency use on test prototypes of the A300 Airbus. More recently, it has been installed on the new Lear Fan, a sleek, turboprop corporate transport designed to provide near-jet speeds at half the cost of using jet fuel (see *Lear's Light Pusher*, page 101, June '81). The Lear Fan's unusual configuration (photo be-



Pilot of disabled airliner crouches in doorway just before pulling emergency ejection handle. Sequence at left shows how rocket plucks him safely clear of craft so chute won't foul.

low), with its huge Y-shaped tail assembly and rear-mounted pusher prop, poses special bailout hazards, making it an ideal candidate for the AWAY concept.

While the system has not yet had to be used under emergency conditions, it has been successfully tested on the ground with dummies ejected from a 300-mph, jet-propelled sled. Although the initial rocket pull is on the pilot's helmet, the actual force of the blast is transmitted by cables to his chute harness, so there's no strain on his head or neck. (The helmet anchor point was chosen as the least likely to permit accidental fouling of the lanyard during ejection.)

A typical AWAY installation consists of three rocket launchers in an upward-angled stack, each with its own coiled lanyard and firing handle. Thus, up to three crewmen can eject from a disabled craft in rapid succession. Developed by Stanley Aviation (now Stencel Aero Engineering Corp.), the system is simple, compact, easily installed and reasonably inexpensive.

But sorry, folks, it's only for test pilots. We ordinary passengers will just have to take our chances.



New high-speed, turboprop Lear Fan has unusual Y-tail, is undergoing flight tests.



## CORVETTE

(Continued from page 128)

subframe and at the lower control arms on each side. And the closer you look, the more there is to see. There's the aluminum propshaft, aluminum C-section channel which ties the tranny and rear differential, aluminum differential, integral differential cover and transverse beam, driveshafts, hub carrier, trailing links and lower tie rods. Low unsprung weight? No problem.

The rear suspension has been redesigned to incorporate four trailing links. The rear axle is located laterally by the integral differential cover and transverse beam. The beam is bolted to the body on either side of the car at the side rails. Bolted to this assembly are four more transverse links: two control toe-in and two control camber. Longitudinally, four forged-aluminum trailing arms locate the rear axle. The fiberglass rear spring hangs off the end of the tranny cover/beam and is located at the top of the hub carrier. To that is added a stabilizer bar.

The front suspension is fairly straightforward, except for the extensive use of aluminum and the fiberglass spring. It uses unequal-length upper and lower control arms, with the shock absorber mounted on the lower arm and located on top to a perch bolted to the subframe. The steering rack has a very fast 13 to 1 ratio. Yet, even with all this wizardry, and given the vehicle's high-speed capability, there's very little on-center feel at the steering wheel. At elevated speeds we found the car needs constant correction to keep it going in a straight line.

### The cockpit

The Corvette interior is as done up as you could want. The seats are terrific. They're well-bolstered, with adjustments for fore and aft and rake, naturally, plus air-bladder adjustment and side-bolster adjustment. It's all power assisted. There's a tiny air pump buried in the seat that will inflate three pockets in the lumbar support. Each pocket can be deflated individually to suit you.

The dash sports a really spacey digital gauge package in the best multihued video games tradition. The speedo and tach displays are right where you want them, while oil temp, pressure, engine temp and voltmeter are off to the right.

At Riverside Raceway, the Vette seems to live up to the advertised .95 g cornering ability and the neutral handling characteristics expected from its ideal 50/50 weight distribution. The car just flat sticks. It will inspire you to attempt driving feats beyond the limits of mortal man. But it does have limits.

You can induce trailing throttle oversteer, which, depending on how

you look at it, is good or bad. Leg it into a corner a little too hot, and decide that maybe you don't have the courage or the room to see it through, lift off the throttle and the sudden unloading of the rear will get you sideways. That's not necessarily bad, of course. You do want to be able to steer with the rear wheels on occasion. But it might be a big surprise to someone who might not like to steer with them. On a racetrack in a rear-drive, understeering car, modulating the throttle to get the nose pointed where you want to go is often the only way around. But the Corvette is so

neutral that at the point where past experience tells you a 3,000-pound car *should* be understeering, you've actually got a lot more to go. Since its limits are a lot higher than most drivers would be willing to experience, it will mean a re-education process.

The brotherhood of America's only true and pure production sports car can stop fretting. Palmer, McLellan and Chevy have produced a suitable pad from which to launch another decade of legends. And with Chevy's renewed, albeit closet-bound interest in racing, it should be an interesting decade. **PM**

## Build your own air compressor from PM's plans



Once you have an air compressor in your home shop, you'll wonder how you ever got along without it. You can spray paint with it. You can inflate swimming gear, toys, auto and garden tractor tires. More important, you can sandblast parts and rivets in metal seams. You can blow-clean fine mechanisms and, with PM's unit, you can vacuum pump your car's airconditioning system prior to adding Freon—something you can't do with most ordinary air compressors. Finally, this unit features a filter/water trap—which is an optional extra on most commercial air compressors.

### PM AIR COMPRESSOR

You can do all these things with this versatile 1-hp compressor and, happily, you can build it for less than \$200. **PM**

Compressor evacuates car's airconditioning system prior to adding new refrigerant (far left). At left, routine inflation of tires saves trip to gas station.

#### HOW TO ORDER PLANS

Send check or money order for \$5.95 to Air Compressor, Popular Mechanics Plans Library, Box 1014, Radio City Station, New York, N.Y. 10101. Allow two to three weeks delivery; for first-class mail send 75 cents extra.

Popular Mechanics is a publication of Hearst Magazines, a division of the Hearst Corporation.



hips and shouts, "I want them thrown back now!"

"But I still have to measure them and . . ."

"Well," he interrupts, jabbing a finger at the halibut on the deck, "then get to work!"

Beth returns to the pile at her knees, unshaken.

"That was the fish manager. I go through this all the time. The crew is understandably paranoid—they know the Coast Guard is just looking for a 'bust' for possession of illegal species."

Beth has been aboard the *18 Svezd Vksm* for nearly three months, working amid tons of dead or dying fish in conditions that range from today's spring-like state to hurricane-force winds, towering seas and temperatures well below zero. She extended her original tour "because I love it," she says. Still, she admits, "It's grunt work."

**Factory at sea**

Below decks, it's a different world, hardly suggestive of the bowels of a ship. The busy processing plant is a space-efficient factory of conveyor belts speeding American-caught cod and pollock to deheaders, fillet machines and flash-freezers.

In the center of the processing area is an even stranger sight; standing over a 10-foot table, dressed in white cotton smocks, white caps, white gloves and masks are a line of men surgically removing harmful parasites from the flesh of the fish.

At the end of the factory line, carried aft by conveyor belts, are the boxes of 18.5-pound bricks of frozen pollock fillets which will end up in the world's supermarkets or in fast-food chains as fish sticks.

Later that evening, the Soviet captain, Nikolai Ivanovich Trushin, invites the skippers of the American catcher boats—the *Great Pacific*, *Ocean Harvester* and *Royal Atlantic*—to his ship for dinner. It is the first time any of these Americans has been aboard the vessel that has been processing their hauls.

The weather has rapidly deteriorated and a solid wet snow flies across the *18 Svezd Vksm* in horizontal sheets as the Russian lifeboat brings the men aboard. Nikolai, his black hair matted with ice, greets his guests a little shyly in Russian and leads them to his stateroom.

Nikolai presents a resplendent feast—borscht, lamb meatballs called pilmeni, Bulgarian white wine and naturally, vodka—for his American counterparts, Jonas, John and Olaf. These men, originally from the Norwegian island of Karmoy in the North Sea and

now living in Seattle, came to the United States because of the opportunities in commercial fishing.

Eventually the conversation, conducted by an English-Russian interpreter, gets down to what they each know best. The fishing has not been profitable, mostly undersized pollock that will fetch only a penny and a half a pound and good only as fishmeal. One of the Americans suggests that the fleet join the *Viking* and *American No. 1*, American trawlers which are currently combing the sea bed south of the Aleutians Chain several hundred miles away for cod. The three American captains discuss their proposal in an odd mixture of Norwegian and English.

It is agreed; the Americans want to head south. The request is translated to Nikolai and a cloud passes over his boyish face.

Nikolai proposes a toast. "Here's to friendship among fishermen of all nations and a hope that there are no misunderstandings among men of the sea."

The next day, the wind backs from out of the south, a sign that a storm system is moving up the Chain into the Bering. But despite the light snow and the short steep chop, the fishing has improved and the crews are jubilant.

Aboard the *18 Svezd Vksm*, we overhear another Soviet processing vessel radio Jonas: "The captain sends his compliments on that haul. Pour yourself a toast . . ."

"No, no. I had my toast last night. It must have brought us luck."

Nikolai, standing near the radio, smiles privately to himself.

**Bad-luck Viking**

A few days later I am on the *Viking*, the American trawler which has just returned empty-handed from the grounds south of the Chain. Spurred by reports that the other American boats may have hit the motherlode of spawning cod up here in the Bering, they have come to try their luck.

The *Viking* is a modern steel vessel equipped with tens of thousands of dollars worth of the latest and most sophisticated fish-locating equipment. Yet despite the gear, there is as much luck involved here as there is in sitting in a bass boat with a bamboo pole in a down-home fishing hole.

The *Viking's* skipper is Gary Bryant, a thoughtful, well-spoken man with a salty black beard and a quick smile. As part owner and captain of the 120-foot boat, Gary has pinned high hopes on the joint venture with the Soviets. And the *Viking* needs a few good hauls; its luck has been marginal at best with only a few productive days.

"The way I see it, this joint venture is a golden opportunity. The Soviets are providing us with a tool to explore our own fisheries. I'd like to see more Soviets and also Norwegians and the Danes up here helping us process our catches instead of giving all this fish away to the Japanese." He is referring to the heavy concentration of Japanese vessels with permits to fish for the "under-utilized" bottom fish found within the 200-mile limit.

After a 2½-hour drag across the bottom, picking up whatever is in the way of the giant-mouthed net, Gary signals the crew to retrieve the haul.

"Doesn't look too bad," Gary says with forced indifference as the "bag" pops to the surface. It is apparent by the dark cloud of sea birds hovering over the net that it is a respectable catch. Old-timers in the business say you can tell the size of the catch by the number of birds over the bag.

After the transfer to the Soviet ship, we watch the hoisted bag spill its contents onto the deck. The processing ship has taken a distinct list on the side where most of the *Viking's* catch has been dumped.

"All right, eh? All right!" Gary blurts, handing me the binoculars.

His crew on the deck below are hooting and hollering. Gary blows the ship's whistle, a salute to his crew and to himself. The processing ship radios later that the haul was mostly pollock.

"Yeah, I see," Gary radios back. His disappointment that it was not more of the higher priced cod is evident, for cod fetches nine cents a pound. Pollock is worth only a cent and a half.

**Sabotaged by cod pots**

Yet this haul was not as disappointing as one a few days earlier. Pulling in the net is always exciting business, a time when hope runs high. But there is hardly anything more frustrating than finding a yellow polypropylene rope wrapped around the warps—the hauling cables—before the net pops to the surface. It can mean only one thing. We had scooped off the sea bed two large wire mesh baskets—cod pots set by some fixed-gear fisherman. There had been no markers to indicate that anyone had set his gear in the area.

Ryk, one of the young crewmen aboard the *Viking*, angrily slashed the cod pots free with a razor-sharp fillet knife; most of the day's fishing would be forfeited while he and the others restrung the net.

Incidents of gear conflict between trawlers which drag the bottom and fixed-gear fishermen (crabbers, cod pot fishermen, lobstermen) have always

*(Please turn to page 138)*



# Energy crunch creates new jobs for trained technicians.

## Learn at Home in Your Spare Time as NRI Trains You for Heating, Air Conditioning, Refrigeration, and Solar Technology

As energy requirements increase and supplies tighten, as demands on established technologies increase and new ones are developed, the need for skilled technicians will continue to grow. And you can get a head start in this booming career field with NRI home training. You learn in your spare time, develop the professional know-how and skills that help you move ahead.

### Practical Training Includes Professional Vacuum Pump

Along with the basic theory you need, you get the practical servicing tips and actual "hands-on" experience with NRI demonstration kits. You get necessary working tools like a system analyzer, leak detector, tubing and joint tools, and more. You even get a top quality



vacuum pump, a professional "must" for evacuating and recharging refrigeration systems properly.

### Includes Optional Postgraduate Training at York Institute

Graduates of NRI's Master Course are eligible for a week of resident training at the world-famous York Institute. You'll get concentrated training on advanced industrial equipment under the guidance of expert instructors. There's no extra charge for tuition or training materials...an opportunity only offered by NRI.

### Send for Free Catalog...No Salesman Will Call

Get all the details in NRI's free catalog. It shows lessons, equipment, and more about this exciting, big field. NRI home training works, as over a million students can tell you. Mail the postage-paid

card today and take advantage of your opportunities. If card has been removed, write to the address below.

## Or check out these other growing fields

### Small Engine Repair

There's plenty of opportunity for the man who can service power mowers, garden tractors, chain saws, outboards, mopeds and other small engines. Training includes professional tools and an actual 5 HP engine you keep, plus optional residence training at the Tecumseh Factory Service School at no extra charge.

### Electrical Appliance Servicing

Good appliance people are hard to find. NRI trains you for your own full- or part-time business fixing everything from refrigerators to toasters. Includes professional tools and instruments.

### Auto Repair and Servicing

A good mechanic can work just about anywhere he wants. NRI trains you at home from headlight to taillight with pro tools

included. Approved by Richard Petty, NRI automotive consultant.

### Building Construction

Save up to 50% building your own home, get a better job, or even start your own contracting business. Covers everything from foundations to rafters with practical projects emphasizing energy-efficient construction.



**NRI Schools**  
McGraw-Hill Continuing  
Education Center  
3939 Wisconsin Avenue  
Washington, D.C. 20016

**We'll give you tomorrow.**





# Add bolts and love and what do you get?

**SUPER BRONC**



**A quality machine that YOU built!**

7 Tryke Models, and 6 Bike Models. Many accessories, including bench seat

**SUPER TRYKE**



For exploring, hunting, fishing, and occasionally even for work, these machines bring a lot of pleasure. If backwoods riding is your kind of fun, write today for a FREE color brochure, to:



**SUPER TRYKE**

Easy-to-build semi-kit saves you money. Engine is completely assembled, frame is welded and painted. With common tools and our 22" x 34", fully illustrated instruction sheet, you just bolt everything together and start riding!

- Rugged vehicles powered by 5 hp to 16 hp American-made engines.
- All have torque converters (no shifting), four-shock suspension and tough, tubular steel frames.
- Can be licensed for street riding in many states.
- Kit priced from \$479.95 to \$1279.95, less accessories.
- Can be registered as farm machinery.

**Carl Heald, Inc.**

Call TOLL FREE 1-800-253-1030; in Michigan call 616/849-3400. Dept. NCL, P.O. Box 1148, Benton Harbor, MI 49022

From the Largest Maker of Bike and Tryke Kits in the World — Carl Heald

**FREE COLOR CATALOG WITH VIKING'S SPECIAL FACTORY DIRECT PRICES**

Quality solid wood grandfather clocks, mantel clocks, wall clocks, movements, accessories, furniture and others including ¼" solid oak schoolhouse clock. Viking clocks are crafted of the finest solid oak, walnut or cherry with solid brass West German movements in pre-cut kits, assembled/unfinished or completely factory built and finished. Prompt delivery and moneyback guarantee. Call or write for our **FREE** color catalog.



Major Credit Cards Accepted

Create a family heirloom

**VIKING CLOCK COMPANY**

Phone 205/943-5081, Box 490, Dept. PM033, Foley, Alabama 36536

*Buy the Best...for Less*

**GO KARTS**  
3 to 8 H.P.



- **MINI BIKES** •
- Rough terrain models and the largest selection (with the lowest prices) of parts for complete assembly—engines, wheels, accessories. Send for complete Go Kart catalog—\$2.00 or call:

**NORTHERN HYDRAULICS**  
P.O. Box 1261, Dept. PM3-17  
Burnsville, MN 55337 612-894-8310

## BEAUTIFUL WOOD FINISHES

Watco Danish Oils provide an elegant, extremely durable penetrating finish IN the wood, not ON it! Primes, seals, hardens, protects and beautifies in one fast, easy application.



Natural and Medium, Dark and Black Walnut colors for all woods. Write Watco-Dennis Corp., 1756-22nd St., Santa Monica, Calif. 90404, Dept. PM-33

## STRANGE BEDFELLOWS

(Continued from page 134)

existed in fishing grounds all over the world. But because of the increasing number of American boats as a result of the 200-mile law, the gear conflicts involving foreign ships off the U.S. coasts have increased markedly.

In the Soviet port of Nakhodka, a fishing town far from the border of China and North Korea, Soviet captains blamed the Americans.

"The Americans are mostly at fault because they don't always mark their pots," says Ivan Petrovich Samsonov, who commanded a Russian fleet off the Oregon coast in 1979.

"The Coast Guard tells us it is very difficult to demand these fishermen tell where their gear is because there is no law that says they must."

### New role for the Coast Guard

Enforcement of the 200-mile limit law was mandated to the Coast Guard. The service, traditionally known for its heroic search and rescue missions in waters that extend far beyond the 200-mile limit, was also directed by the Congress to enforce tight fishing quotas now imposed on foreign fleets.

According to Coast Guard officials, the most extensive enforcement of the law is along the Alaska coastline, a coast longer than the U.S. Atlantic, Pacific and Gulf coasts combined.

I spent nearly a month during the most brutal part of the Arctic winter on the Bering Sea and the Gulf of Alaska aboard the Coast Guard cutter *Rush*, a sleek white-hulled ship armed with torpedoes and secret antisubmarine warfare equipment. She had been hurriedly dispatched from her home port of Alameda, Calif., to enforce President Carter's expulsion of the Soviet fleet from the Bering during the Afghan crisis. The fleet subsequently left without contest and has not returned.

On board the *Rush*, sipping a carefully measured ration of cheap brandy, I reflect that in this generation without heroes, these men, most of whom are still in their teens, risk their lives in a mission of routine danger in the world's wildest seas—far beyond the knowledge of anyone back home. And all to enforce the FCMA.

At one of the finer seafood restaurants in the old whaling port of Mystic, Conn., tilefish, a flaky white bottom fish, is priced at \$12 a serving. The portion on my plate is only one of several that will be served from the same fish. The fisherman probably was paid somewhere in the neighborhood of 30 cents for the whole fish. But then again, that's 30 cents more than the fisherman ever realized before from the depths of the ocean.

PM



ing style. They offer factory-tapped holes to accept stabilizers, bowsights, bow quivers and adjustable arrow rests. Lightweight, skeletonized metal or hard-plastic eccentric wheels produce the most efficient energy release during a shot.

Fortunately, such two-wheel compound bows are less expensive than most four-wheel and six-wheel bows—primarily because they have fewer parts and require less manufacturing and assembly cost. Almost all of this country's top tournament archers currently use two-wheel compound bows by various domestic manufacturers. The majority of hunting archers have followed suit with similar bows, appropriately camouflaged at the factory or at home. In addition, several large archery companies like Jennings, in Valencia, Calif., now offer two-wheel compound assembly kits with do-it-yourselfers in mind.

Primary goal of most modern bow manufacturers is producing ever higher arrow velocities. Serious target archers demand top arrow speed to minimize wind drift and maximize flat trajectory, and most modern bowhunters prefer flat-flying arrows, as well, to allow solid hits at unknown ranges.

A compound bow can be made faster

in two basic ways. First, limb and/or wheel design can be refined to store more energy and minimize energy loss during a shot. Second, arrow weight can be reduced to step up projectile velocity. Bow manufacturers have been experimenting with lighter, snappier limbs made with graphite and maple laminations, but many of these have proven far too fragile and expensive for practical use. And at this time, conventional round, compound wheels with needle bearings or solid bearings of turcite, brass, or similar low-friction material may be as fast as they are likely to get. As a result, compound manufacturers have recently turned to new eccentric-wheel shapes and so-called "overdraw" handle designs to increase arrow velocity markedly.

The average two-wheel compound bow, matched with an appropriate aluminum arrow, shoots that arrow about 200 feet per second (f.p.s.). By contrast, an average modern recurve bow of comparable draw weight shoots the same arrow at about 180 f.p.s. and a laminated-limb longbow shoots the same arrow at about 160 f.p.s.

Bow manufacturers have successfully increased average arrow speeds during the last two years by replacing con-

(Please turn to page 140)

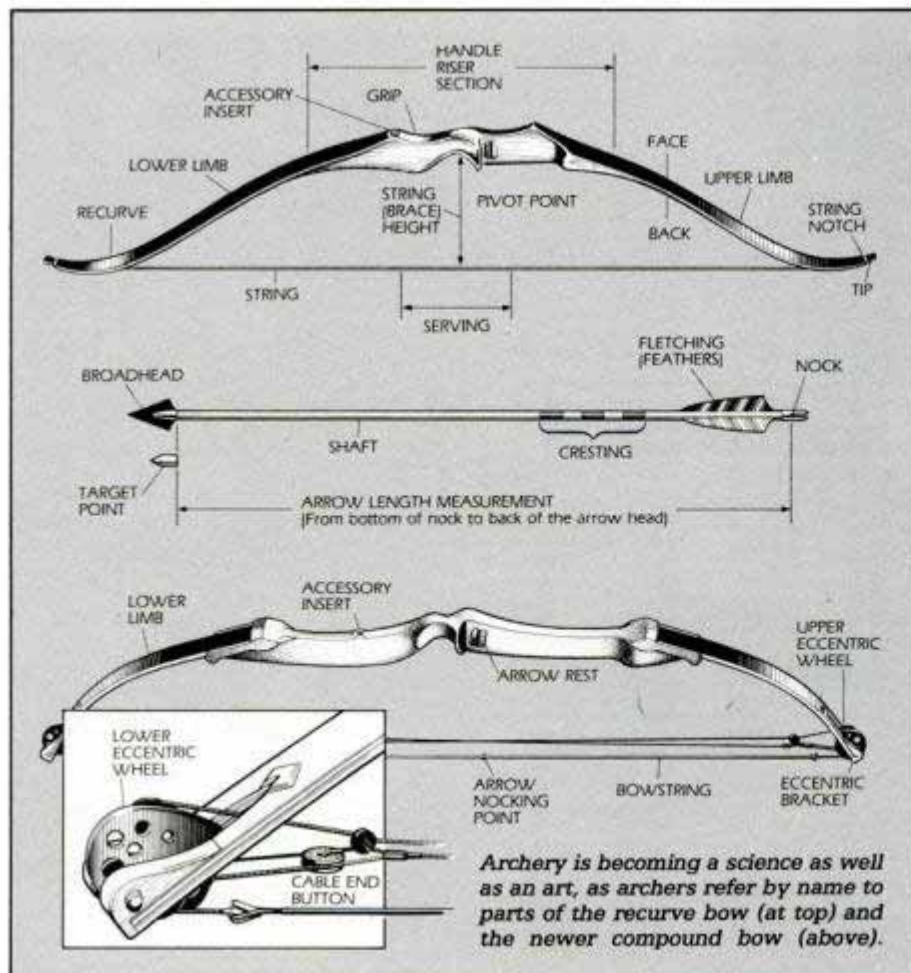

## Think of the MONEY YOU CAN MAKE...

**When You Buy Merchandise Like This At Prices Like These!**

<p><b>LCN Sports Watch</b> Sells For: \$9.95 Your Cost: \$3.95 Your PROFIT: \$6.00</p> <p><b>Deluxe Chain Burglar Alarm</b> Sells For: \$3.95 Your Cost: \$1.30 Your PROFIT: \$2.65</p>	<p><b>Solid Brass Musical Unicorn</b> Sells For: \$21.95 Your Cost: \$6.90 Your PROFIT: \$15.05</p>	<p><b>Genuine Diamond Ring</b> Sells For: \$19.95 Your Cost: \$4.95 Your PROFIT: \$15.00</p> <p><b>Lock-Blade Knife</b> Sells For: \$3.95 Your Cost: \$1.30 Your PROFIT: \$2.65</p>
---	---	---

**PLUS!** 2,496 more fast-selling big-profit items shown in our exciting 100-page full-color catalog.

**PLUS!** Detailed step-by-step plans that show you exactly how to sell our merchandise 21 different ways... from Mail Order to Swap Meets, Fund Raising to Party Plans. Part time or full time from your home.

**PLUS!** Every printed promotional piece and selling aid you need to make any plan work to perfection.

**PLUS!** Complete directions explaining how to set up and run a business—covering everything you need to know to make instant profits.

**PLUS!** Always-available business counsel, new selling ideas, additional merchandise and special extra-discount bonuses.

**Take the 1st Step Toward A Business of Your Own... MAIL THIS COUPON!**

**S.M.C. Specialty Merchandise Corp. Dept. 308-27**  
8061 De Soto Ave., Woodland Hills, CA 91365

**FREE!** Tell me about your 2,500 items which I can purchase at your amazingly low prices. Also send me information on your 21 home business plans. No cost or obligation, of course.

Name: \_\_\_\_\_  
Address: \_\_\_\_\_  
City: \_\_\_\_\_ State: \_\_\_\_\_ Zip: \_\_\_\_\_

## WOODWORKERS Do-it-Yourself CATALOG

**with 20 WOOD SAMPLES**

**104 giant pages**  
—14 kinds cabinet and furniture woods,  
79 veneers in 3-ft. lengths,  
19 flexible veneers to 36" wide x 8 ft., 11 fancy burl & crotch, 54 sizes, kinds carving blocks, 76 assembled inlays, 72 lamp parts, 39 clamps, 118 carving tools & chisels, 73 wood picture kits, 500 plans, 96 how-to books. Pic. framing, carved molding, period hardware, sliding, revolving hdwe. Cane, reed, wood finishes, coffee mill kit, clock parts, etc. Over 2,000 hard-to-find products in new Woodworker Catalog!

**TEAR OUT AD. MAIL TODAY.**

**CONSTANTINE Est. 1812**  
2051 Eastchester Road, Bronx N.Y. 10461

Enclosed \$1 for Catalog without samples.

I prefer Catalog with 20 Wood Samples. \$2 enclosed. Send 20 wood veneers from around the world. Identified. Useful when matching, naming & ordering fine woods. Educational. \$1.50 refunded on first catalog order.

Name: \_\_\_\_\_  
Address: \_\_\_\_\_  
Zip: \_\_\_\_\_



# NOTICE

## ★ TO HONORABLY DISCHARGED UNITED STATES VETERANS BORN BETWEEN 1908 & 1938. ★

If you did not take advantage of low-cost GI Insurance while on active duty, a National Toll-Free Hotline has been set up to administer **Guaranteed Life Insurance Benefits** to honorably discharged Veterans between the ages of 45 and 75.

Call now for the  
**FREE INFORMATION** you've earned!  
**1-800-345-8500**

Or Write:

DEPT. 50  
VETERANS GROUP BENEFITS  
ADMINISTRATIVE HEADQUARTERS  
P.O. BOX 8949  
WILMINGTON, DELAWARE 19899

VETERANS INSURANCE TRUST OF AMERICA  
Underwritten by  
CONTINENTAL AMERICAN LIFE INSURANCE COMPANY  
Wilmington, Delaware 19899 - Established 1907  
Not Affiliated with the V.A. or any Government Agency



THIS PLAN IS AVAILABLE IN MOST STATES  
NOT AVAILABLE IN NC OR KS

### HIGH TECH FOR ROBIN HOOD (Continued from page 139)

ventional round wheels with egg-shaped cams that drop off in draw weight more abruptly near full draw and, therefore, store more bow-limb energy. The new generation of cam-bows, which include Bear's Delta-V and several models by York and Precision Shooting Equipment, cast arrows an average of 10 to 15 percent faster than comparable round-wheel compound bows, using the same handle risers and limbs. Cam-bows tend to be noisier to shoot than round-wheel bows, and at this point seem less accurate. However, they currently produce the ultimate in snappy shooting performance.

Another bow modification which promises to be popular with hunters is the overdraw bow, which features a grip well forward of the arrow rest. Martin Archery has been a pioneer in this particular design endeavor.

An overdraw bow allows the archer to shoot a shortened arrow which, in turn, produces superior arrow velocity. Not only is a truncated arrow much lighter in weight than a full-length arrow, it is also much stiffer. This lets an archer use a smaller, thinner-wall, overdraw arrow than normally recommended for his draw weight on conventional shaft-selection charts. The shorter, lighter weight arrows shot from an overdraw bow produce an ultraflat tra-

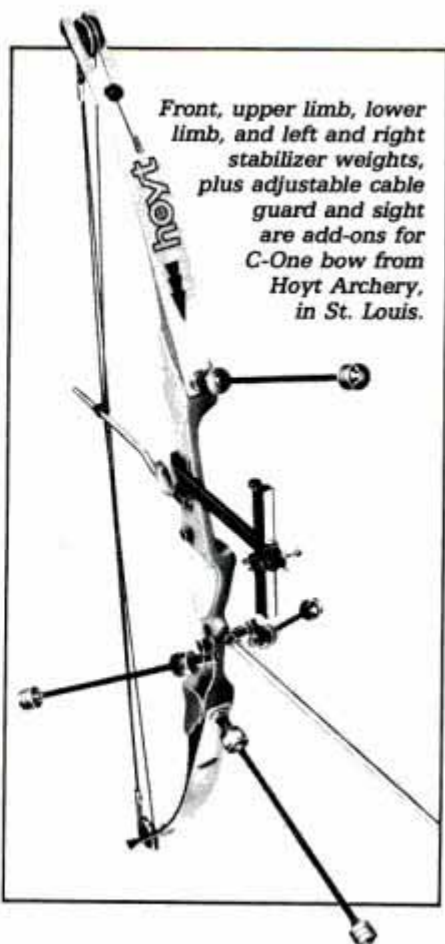

Front, upper limb, lower limb, and left and right stabilizer weights, plus adjustable cable guard and sight are add-ons for C-One bow from Hoyt Archery, in St. Louis.

**2nd MOST IMPORTANT TOOL FOR EVERY WOODWORKING SHOP**

VERSATILE  
**W&H**  
MOLDER-PLANER

Almost as basic as your saw... molds, planes, rabbets.

From \$430

- Master Charge
- VISA

FREE BROCHURE

**WILLIAMS & HUSSEY MACHINE CO.**  
Dept. 17, Millford, N. H. 03055  
Toll-free 1-800-258-1380

Looks like a screwdriver — Works like a wrench

### SCREWRENCH™

Handles the toughest screw with ease.

Made in the USA to meet rigid specifications, SCREWRENCH™ gives 50 lbs. of torque. Just use the swing-out lever. When done, flip up the swing-out. A magnet holds the lever firmly against the handle. • Shank does not touch the lever pin • ABS plastic handle • Chrome vanadium steel shank • No sharp edges

- Money-back guarantee
- 3 sizes
- Great gift for men or women!

SEND ME: \_\_\_\_\_ ROA1, large (14") SCREWRENCH™ @ \$5.95 ea.; \_\_\_\_\_ ROB1, medium (11") SCREWRENCH™ @ \$5.50 ea.; \_\_\_\_\_ ROP2, Phillips No. 2 (9") SCREWRENCH™ @ \$5.50 ea.

Shipping, add \$1.25 for each item ordered.

Name \_\_\_\_\_  
Street \_\_\_\_\_  
City \_\_\_\_\_ State \_\_\_\_\_ Zip \_\_\_\_\_

Send this form, along with your check or money order to: SCREWRENCH™, 210-A North 4th, P.O. Box 2070, Pasco, WA 99302 (Washington residents add 6.3% sales tax) Patent No. 3,963,693



jectory. Overdraw bows tend to be less accurate than bows with conventional handle risers because arrow-rest torque during a shot is accentuated by the frontal orientation of the grip. For this reason, the overdraw isn't popular with serious target archers.

Recurve bows and longbows, with modern fiberglass-and-wood laminated limbs, are faster and smoother to shoot than anything made before 1960, yet such bows are enjoying only limited popularity. Today, the compound bow is clearly the odds-on favorite.

One product of interest to archers is the compound crossbow, recently designed by Precision Shooting Equipment of Tucson, Ariz. This adaptation of the conventional crossbow shoots bolts with sizzling speed, an advantage for the hunter. Crossbow hunting has recently become legal in several states.

### Arrows

As with bows, advances in modern arrow design have been made with speed and trajectory in mind.

The XX75 and X7 aluminum-alloy arrow shafts introduced some 20 years ago have almost completely supplanted older style cedar and fiberglass shafts, primarily because aluminum can be drawn in tubular form, tempered and straightened with a rigid uniformity

unheard of in other less consistent shaft materials. Tubular aluminum arrow shafts also tend to recover more quickly when they leave a bow, bending slightly from side to side after the initial thrust of the bowstring, but not with the prolonged, exaggerated sluggishness of a heavier, whippier shaft of wood or fiberglass. The quick-recovery characteristic of aluminum arrows has proven especially desirable with compound bows, which tend to slam an arrow harder in the back end and thus increase initial arrow flexing. Over 30 sizes of aluminum arrow shafts are available to hunters and target buffs.

Additional major improvements made in recent years include durable, waterproof plastic fletching; nocks which snap to the bowstring for convenience and safety; threaded female arrowhead adapters in the ends of arrows instead of the older style, glue-on arrowhead tapers; plus durable, oxidation-free, hard-anodize finishes on all aluminum shafts.

But shaft manufacturers are constantly working toward improvements. At present, the most promising and innovative shaft experiment is the aluminum/graphite combination. This design is currently being tested by Easton Aluminum of Van Nuys, Calif., the world's largest arrow-shaft maker.

The aluminum/graphite shaft consists of a thin tube of high-tensile aluminum alloy coated with lightweight carbon graphite. Such a shaft has the stiffness required for accuracy, while weighing less than a conventional aluminum shaft of the same rigidity. The result is flatter arrow trajectory coupled with quicker bend-recovery—both of which give better target scores for discriminating archers. Because aluminum/graphite arrow shafts are relatively fragile and costlier than the best aluminum target shafts, they are likely to remain a low-production, special-order luxury of tournament competitors.

### Shooting accessories

The wide variety of extras available at archery stores supposedly enhance hunting and target accuracy. Some work as advertised, and some don't.

Bowsights have been around for many years, but modern sights are better than ever. The best hunting models are solid, all-metal designs with four or five sight pins to be set for various shooting distances. Compact electronic sight pins that allow pinpoint aiming in low-light conditions are popular. Target-shooting sights generally mount well out in front of a bow's handle riser to ensure sight definition, and usually

*(Please turn to page 142)*

## MOST STORE CLERKS CAN'T TELL IF YOU NEED A NEW WASHER, OR A NEW WASHER.

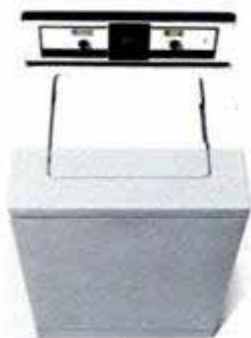

Sentry Hardware clerks can, though.

You see, Sentry clerks know hardware better than almost anyone.

Not only can they direct you to the right tools and supplies, they can give you the helpful advice you need.

And do-it-yourselfers know how important that can be.

Right now Sentry has bargains in almost every department. Check out the products below.

If you have any questions, you'll know who to ask.



Where hardware isn't a sideline.

Check the Yellow Pages under Hardware for the Sentry store nearest you. Sentry Hardware Corporation, Cleveland, Ohio 44113. Merchandise shown in this advertisement is available from participating dealers only. Offer expires March 31, 1983. All Sentry dealers own their own stores. They select their merchandise and set their own prices. There may be variations in products, available quantities and prices in individual stores.

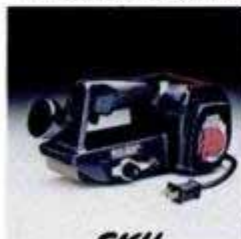

**SKIL**  
Sandcat™  
Belt Sander  
(593) \$44.88



**Black & Decker**  
Electric Hedge  
Trimmer, \$10.00  
rebate (Feb. 1—Apr. 30)  
(8124) \$35.88



**Arrow**  
Heavy Duty  
Staple Gun  
(T-50) \$12.99



**STANLEY**  
Powerlock®  
12' x 1/2"  
(33-212 RM) \$3.99



**EVEREADY**  
4-Pack "C" or "D"  
Batteries.  
Your choice.  
(950-4) (955-4) 96¢



**Bostik**  
"Pop"  
Rivetool  
(K-110) \$7.77



## HIGH TECH FOR ROBIN HOOD

(Continued from page 141)

feature micrometer-click adjustments for windage plus instant vertical adjustment to match any range. A majority of serious tournament shooters use 2-power or 3-power scopes on their sight bars instead of conventional sight pins—a practice which ensures exact aiming at distant bull's-eyes.

Bow stabilizers, spring-loaded arrow rests, bowstring peeps and similar gadgets are proven bow-shooting aids. The mechanical bowstring release is relatively new, and improves shooting accuracy dramatically. Favorite designs today are smooth and dependable. A bowstring release grips the string just below the arrow nock and allows the archer to shoot by pulling a trigger or pressing a button. Free-style archers find this gives shooting consistency that's impossible to get with conventional, three-finger release. The most common, the so-called "rope release," holds the bowstring with a torque-free loop of nylon cord and lets go with little or no noise. A mechanical release is slow to use, but many bowhunters are using various models for long-distance shooting.

The optical rangefinder is perhaps the most important aid to appear dur-

ing the last 10 years. A primary bugaboo has always been the arrow's dramatically arching trajectory which requires shooters to know range within a yard or two. Today, the worry of shooting at unmarked distances is largely past. Ultra-accurate, triangulation-type archery rangefinders are available at reasonable cost. The Model LR-80 from Ranging Inc., East Rochester, N.Y., is a typically good design, allowing an archer to estimate distance within half a yard at 80 yards.

### Bowfishing equipment

A dramatic recent change has also been the improvement in modern bowfishing equipment, due in part to the popularity of tournaments similar to bass fishing contests. Bowfishermen vying for prizes have scrapped old-style, drum-type bow reels, sluggish nylon line, inconsistent solid-fiberglass fish arrows and crude, one-piece fish points with heavy-wire barbs.

The serious tournament archer bent on taking record numbers of carp, gar, or similar rough fish generally uses a two-wheel compound bow, and a large-capacity, pushbutton bowfishing reel mounted on the front of the bow, holding small-diameter, perfectly round Dacron cod-fishing line in the 70-pound range. This attaches to an ultra-accu-

rate, heavy-wall XX75 aluminum bowfishing arrow with a special screw-in nock which holds the line, and a sharp, streamlined fish point with spring-loaded barbs that retract for instant release of a fish once it's been landed. Such a setup is accurate to 20 yards.

### Miscellaneous gear

Just about every phase of hunting and target archery has improved during the early 1980s. Camouflaged, dull-anodized finishes are available on aluminum items like tree stands and hunting arrows. Quiet, durable wool clothes in camouflage patterns can be treated with a great variety of odor-masking scents like acorn, skunk, apple, sweet corn, doe-in-heat, earth, pine and others. For target shooting, portable target butts are made of lightweight materials like self-healing ethafoam.

As archery becomes increasingly popular and equipment continues to improve, some revolutionary new bow design could change the complexion of the sport. But now, manufacturers continue to perfect the excellent compounds with faster limbs, more efficient cams, overdraw handle risers and the like. Coupled with these are the lighter, faster arrows and improved bow-shooting aids. Archers never had it so good. **FM**

## The Dry Look holds today's look all day.



Available in pump or aerosol.

Today's hair styles are neater, shorter and more natural. That's THE DRY LOOK® look. And THE DRY LOOK has a special 12-hour holding formula so you can keep that well-groomed look all day—even if you have fine or thinning hair. THE DRY LOOK hair spray. It keeps today's look looking good all day.

**The Dry Look.**  
12-hour holding power.

© The Gillette Co. 1983



## COUNTRY WEATHER VANES

(Continued from page 100)

Surform tool. Following the drawing and the color photo, use rasps and a whittling knife to shape the stag body (edges) realistically. A handheld grinder such as a Dremel or Foredom tool is very helpful. Sand the work smooth with medium-grit (80) sandpaper; however, don't sand away the detail.

Distress the stag in the following way to ensure an antique appearance. Tap at random with the ball end of a ball-peen hammer. Test on scrap wood to determine the amount of force required to make a smooth dent. The marks should be distinct. Use care on the tail and legs to avoid breaking them. Use an icepick or awl to add some "bullet holes" like those found on many antique vanes.

### Shaping the antlers

It's easiest to shape the antlers with a hand grinder, but you can use a whittling knife if you prefer. Alternate the direction of the antler tips to achieve a three-dimensional effect (when viewed from the front). Shape the bottom of the antlers into a flat, angled pad. Counter-bore for a No. 6 flathead screw. Cut a 1/16-in. mortise into the head at the antlers' attachment point.

Bore pilot holes in the head for the attachment screws. Set the antlers aside.

### Cutting the base

To make the base, first cut the two wood pieces that form the roof. Nail them together with 4d common nails. The ball resting atop a rectangular base is carved from a single piece of 4x4. You can substitute a ready-made gate post finial, if preferred.

Before you shape the ball, bore the hole for the metal rod that holds the stag. Then mark off the ball area. You may want to round off the edges and corners with a sabre saw before shaping the ball with a whittling knife or carving tools. Or, you can turn the ball and rectangle from a single block of 4x4 stock. Shape the ball on the lathe, remove stock from lathe and shape the rectangular base, using saw and hand tools. Then cut a 90° V-shape into the bottom of the rectangle to fit it over the roof.

Cut a 3/8-in.-dia. x 8 3/4-in. metal rod. Position the rod vertically under the stag so it touches the stag's front hoof. Bore a hole for the rod in the stag.

Cut a 3/4-in.-dia. x 20-in. dowel with tapered ends according to the drawing. Bore a 3/8-in.-dia. hole in the dowel for the metal rod. Install the dowel on the rod. Secure the dowel to the metal rod with epoxy adhesive; secure the dowel

(Please turn to page 144)

# Your home workshop can PAY OFF BIG!



This One Low-Cost Power Tool—

**SAWS** to desired Width...  
**PLANES** to desired Thickness...  
**MOLDS** all popular Patterns...

All at once or separately... All By Power Feed!

Only 3-in-1-Workshop Tool Of Its Kind!

From the Day It Arrives... Your Planer will make and save you money. With shortages and inflation driving lumber prices sky-high, this versatile power tool easily pays for itself by quickly converting low-cost rough lumber into high value finished stock. In just one pass turn out your own quarter-round, door and window stop, casing, tongue-and-groove... all popular patterns. Other Foley-Belsaw operators are making cases for grandfather clocks, furniture, picture frames, fencing, bee hives, bed slats, surveying stakes... all kinds of millwork.

Built For Pros... Priced For  
the Home Craftsmen

... it is engineered and built to industrial standards, but factory-direct selling keeps the price low. Handles tough oak and walnut as easily as pine, and so simple to operate even beginners with no experience can use it.

## Start Your Own Business Earn Extra Income Right at Home

With just this one low cost power-feed machine in a corner of your garage or basement, you can set up a profitable business by supplying lumberyards, cabinetmakers, carpenters, remodelers, contractors and hobbyists in your area with custom-planed lumber, trim, molding... ALL of their millwork requirements. Supply picture molding to art shops, hardware and department stores, or sell direct to framing shops. All standard patterns in stock... custom knives ground to your design or sample.



If coupon has been removed, just send postcard with name and address to

**FREE BOOKLET!**  
Get FREE Book with facts and full details... RUSH COUPON TODAY!

FOLEY-BELSAW CO.  
90204 FIELD BLDG.  
KANSAS CITY, MO. 64111

TRY THE FOLEY-BELSAW  
IN YOUR OWN SHOP  
**30 DAY FREE TRIAL OFFER**

**NO RISK 100%**

*Guarantee of Satisfaction*

"Try the Foley-Belsaw in your own shop for a full 30-Days and put it to work for you. Give it a thorough test and make it prove that it can do everything we say it will... use it as much as you want. Then if you are not completely satisfied, just send it back and we'll return every penny sent with your order. And YOU are the sole judge. There are no questions asked... there are no fine print "use" charges. Our flat guarantee is that YOU must be 100% satisfied or you get your money back."

### Does The Foley-Belsaw Pay? YOU BET!

#### READ WHAT OTHER FOLEY-BELSAW OWNERS SAY:

**A Good Investment:** "I believe that the Planer is the best investment I ever made. I've been a planer man for years and am now retired. The Foley-Belsaw has earned me over \$60,000 extra income in the past eleven years."

Robert Sawyer, Roseburg, Oregon

**Pays For Itself:** "I bought a batch of walnut in the rough, and after planing it on the Foley-Belsaw I figured up the money I had saved. It was enough to pay for two-thirds the cost of the Planer. It really does a good job."

R.S. Clark, Springfield, Ohio

**More Than Expected:** "This machine pays for itself by making money out of scrap boards. It is a very well built machine and I confess it is more than I expected for the price. It does everything you say it will."

Stephen Schultz, Orangeville, Penna.

... And Foley-Belsaw is The Choice Of Professionals: "I recommend Foley-Belsaw's Planer-Molder-Saw as the most useful shop tool that any craftsman could own. We use ours every day in the WORKBENCH model shop, and couldn't get along without it."

JAY HEDDEN — Editor of WORKBENCH Magazine

**NO OBLIGATION and  
NO SALESMAN Calls!**

SEND FOR  
**FREE BOOKLET**



Foley-Belsaw Co.  
90204 Field Bldg.  
Kansas City, Mo. 64111

YES, please send me the FREE Booklet that gives me complete facts about your Planer-Molder-Saw and full details on how I can qualify for a 30-Day Free Trial right in my own shop. I understand there is No Obligation and that No Salesman will call.

NAME \_\_\_\_\_  
ADDRESS \_\_\_\_\_  
CITY \_\_\_\_\_  
STATE \_\_\_\_\_

ZIP \_\_\_\_\_



## Convert Your Drill Press Into a Milling/Drilling Machine

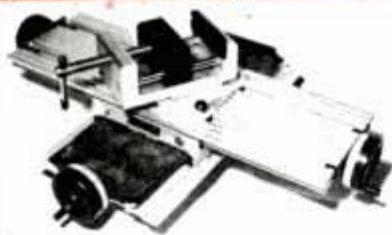

By attaching our Mill Table to your drill press you can perform facing, slotting, milling and drilling operations on almost any machinable material. The Mill Table allows precise positive movement of any workpiece in two directions relative to the drill press spindle, just like a full size milling machine. Adding our Swivel Vise - as shown above - lets you hold small or round parts and adds angle machining to the operations you can perform.

**MILL TABLE** - 17" x 5.5" work surface, aluminum construction, satin anodized finish, 11" long travel, 7" cross travel wt. 10#, \$69.95 + 4.00 S&H

**SWIVEL VISE** - 3" wide jaws, aluminum construction, satin anodized finish, wt. 7#, \$39.95 + 2.50 S&H

**END MILLS** - Four flute, HS steel, 1/8, 3/16 & 1/4" dia. available, any 3 for \$13.95 PPD.

Satisfaction 100% guaranteed. (Send for new larger 1983 catalog.)

Michigan residents please add 4% sales tax.

**M.J. LAWRENCE, INC.** Dept. 203

P.O. Box 1841, Warren, Michigan

313-798-3598 VISA & MASTERCARD ACCEPTED



## Train at Home for EXCITING OUTDOOR CAREER

### ... Learn Surveying!

Join the team of rugged individuals who help plan highways, cities, construction sites and land projects. Experts show you what to do, how to do it. No previous experience necessary. Learn at home...the hours most convenient for you. Everything explained in simple language...with plenty of photos, diagrams and drawings. Special supplies and instruments included. MAIL COUPON FOR FREE FACTS!

**ICS**  
SINCE 1891

**SCHOOL OF SURVEYING AND MAPPING**  
Dept. PB023, Scranton, PA 18515

Flush free facts on training at home for careers in Surveying and Mapping. No obligation. No salesman will call.

Name \_\_\_\_\_ Age \_\_\_\_\_  
Address \_\_\_\_\_  
City/State/Zip \_\_\_\_\_

## MAKE CLOCKS

WITH BATTERY QUARTZ MOVEMENTS  
**EARN EXTRA INCOME!**  
KLOCKIT OFFERS WHOLESALE  
PRICES FOR MOVEMENTS, DIALS  
AND ACCESSORIES.



**CALL TODAY!**  
(414) 248-1150

**KLOCKIT** P.O. BOX 629  
DEPT. PM33  
LAKE GENEVA, WI 53147

## FREE CATALOG

## COUNTRY WEATHER VANES

(Continued from page 143)

to the stag's hind hoof with white glue.

### Painting the stag

The weather vane was finished using Rust-Oleum paints; the catalog numbers for the paints that Adam used are in parentheses next to the colors. Apply the paint with a brush except as noted. First, paint only the roof with flat black paint (No. 7776). Apply two coats of paint.

The metal rod, wood dowel, ears and antlers are painted with the same color mixture: a black-green-bronze mix of flat black, sunset yellow (No. 7745) and hunter green (No. 7738). Daub the paint over the entire surface with a "sponge" of Turkish towel wadded into a ball.

Immediately after you apply the paint, add a little more yellow and green to lighten the mix. Blend this lighter color on about 80 percent of the antlers, dowel and rod for variation. The tips should be lighter than the rest of the antler. When they are partially dry, rub with steel wool through the paint on the ridges and tips back to the wood to create a bone effect.

To finish the stag and the ball, spray three coats of copper metallic paint (No. 7714), or enough to make a shiny surface. Let the paint dry thoroughly after the third coat.

Apply artificial beads of "solder" at the neck, tail base and points where the legs join the body, using a tube of plastic aluminum repair material such as Devcon AL-40. This gives the appearance of metal seams. Let this dry for approximately 10 minutes.

Mix some water putty (such as Durham's) to a thick consistency. Apply it to the stag and ball, completely covering the metallic color, but not filling in the details. Set the pieces aside for several hours until thoroughly dry.

Attach the ball to the roof and install the stag on the finial.

Mix a flat, dull yellow-green mixture using a flat white (No. 7790) as the base with smaller amounts of hunter green, sunset yellow, and touches of black and royal blue (No. 7727). Look at the color photo of the stag and a piece of weathered copper if available to get an idea of the shade. Brush the greenish mixture over the stag and the finial.

While the paint is still wet, dip the same brush or rag into a bit of flat black paint and lightly into a thinner such as turpentine. Touch the stag along the top edge across the body, tail, top edge of the legs and head, allowing the thinned paint mix to run down through the wet green mixture. Don't try to

touch up the runs. If too much black appears for your taste, quickly apply a little clear thinner at the top edge.

The dull black discoloration often appears on the under edges, under the jaw line, crotch, knee bend and at the lower edges of the solder seams. The results should leave some of the green mixture with light black "rain" marks and some whitish water putty showing through. The thinner should drip down on the roof, as well.

Let the stag dry for several minutes. Then hold a toothbrush dipped in black at a 60° angle to the stag, push the bristles back with your finger and let them spatter the stag. Do this only once on each side. Let the paint dry thoroughly.

Finally, if desired, use triple-O steel wool to reveal tiny amounts of copper on the hoof edges, tail tip and ridge of the nose. Also use steel wool to reveal the solder seams.

Secure the antlers with screws. Then fold the metal ears and attach them with an upholstery tack.

## 2 Locomotive

You can make the locomotive of metal roof flashing. It's commonly available at lumberyards and home centers.

Draw a grid of 2-in. squares on paper. Following the pattern on page 101, pencil in the locomotive outline. When you are satisfied, cut out the pattern. Tape it on the flashing and scribe around it with a nail. Note that the smoke is a separate piece of metal attached by machine screws.

Cut out the metal. First, clear metal away from the corners and other tight places with a drill. Then use a sharpened steel chisel, a scroll saw or a jeweler's saw to cut the lines.

File away the burrs, leaving some of the roughness for a hand-crafted appearance. Flatten the metal by laying it on a concrete surface and pounding the edges with a mallet or hammer. Go over the surface lightly, tapping to create slight dents to further the antique appearance.

Cut the bar stock to length and position it on the lower edge of the locomotive. Mark and drill through both pieces of metal for the machine screws. Installing one machine screw before making the remaining holes will avoid offset holes.

Make the stop for the vertical rod from a 11-in. angle brace. Cut off 1/2 in. from one side. This should remove any holes on that side. Use a file to round off the corners. Drill and attach the angle brace.

Cut two sheet-metal straps to hold



the rod in place. Rest the rod on the work surface and shape the straps over the rod with a hammer or mallet. Use a chisel to form a clean angle at the point where the strap meets the locomotive surface.

Position the rod against the angle brace. Use a square along the edge of the bar stock to make sure that the rod is perpendicular. Position the straps and bore or punch holes with a nail for the machine screws. Drill holes and secure the smoke in place with machine screws.

### Constructing the base

To give weight to the base, Adam Peck made it of a scrap piece of butcher block. But any piece of dense hardwood will do the job. If you use lighter pine, enlarge the base to support the vane.

Cut the base to size and round all edges lightly with a rasp. You can distress the base by striking the visible sides flat against a rough concrete surface.

Use a drill press or drill guide with your portable drill to bore a plumb hole centered on the block for the rod. Test-position the vane and rod to assure stability before proceeding.

Cut enough railroad ties to cover the length of the base. Place them 1½ in. on center. Cut rails and round their top edges with sandpaper. Lay the rails inside the nailheads on the ties.

### Finishing the locomotive

Brush two complete coats of metal primer (Rust-Oleum's No. 769 or other) over the train, rod and base. Apply the second coat as soon as the first is set enough not to lift. Lightly brush away runs or drips on the surface. Leave drips and beads of paint along the edges. Leave any puddles on to alligator. However, do not leave runs on the surface.

When the primer is set enough so it won't lift (about one hour), apply two heavy coats of flat black paint (No. 7776) in the same way you applied the primer. Let the paint dry thoroughly—about 48 hours.

To achieve a weathered look, apply the following techniques sparingly:

■ Use a wooden spoon or wooden stick to knock off beads of paint. Strike the edges and machine screws to reveal some prime coat.

■ When dry, wash the piece with detergent. Test a spot using a strong cleaner and a scrub brush.

■ Dust wood ashes on and wipe them off to achieve a "patina."

■ Bend the points of the arrowhead and straighten them so a crease is visible.

## 3 Sloop America

The sloop *America* is composed of a ¾-in.-pine hull, dowel masts and booms, and sails made of roof flashing or other sheet metal.

Begin work by drawing a grid of 2-in. squares directly onto the pine stock and sketching in the hull (see drawing, page 100). Cut out the hull and the two cabins. Then carve the bow and stern shapes with a hand grinder or a whittling knife. Sand the parts smooth with 80-grit abrasive.

Use a drill press to bore the mast and shaft holes according to the drawing.

Note that the holes line up. However, do not bore through the wood; make separate holes.

Drive 4d finishing nails into the hull as shown in the drawing. Bend the nails over so you can attach sail wires to them later.

### Making the masts

Cut the main mast dowel. Shape the ball on top. The gaff fits into an angled hole in the main mast. To bore the hole, insert the dowel in a V-block holder made of scrap wood. Bore the hole on a drill press. Glue the mast in place with white glue.

Cut the top mast. Taper it to shape at the top and cut away the surface next to the main mast for a flush fit. Carefully cut a ¼-in. notch in the top mast to fit the topsail.

Glue the top mast in place. Wrap the masts together with 26-ga. or other light wire and tuck in the loose ends neatly. Embed the end of the wire in glue; wipe off excess glue.

Cut the main boom. Attach it to the main mast with wire as shown in the drawing.

Cut the gaff and taper the free end. Reduce to ¼-in. dia. the end that is inserted into the main mast.

Cut the bowsprit, taper its free end and shape the other end according to the drawing. Bore a ¼-in.-dia. pilot hole, then glue and nail the bowsprit in place with a 4d finishing nail.

### Shaping the sails

On paper, carefully draw a grid of 2-in. squares to use in enlarging the four sails and the *America* banner patterns. Sketch in the sails and banner, then cut out the patterns. The flag and mainsail are one piece.

Tape the patterns to sheet metal, scribe around them with a sharp nail and cut out the sails and the banner. Use a sharpened steel chisel, a scroll saw or a jeweler's saw.

File away the burrs. Flatten the metal

(Please turn to page 146)

# FREE

The newest in home computers, fine stereo components, color TV, HAM radio, precision test equipment, innovative electronics for the home—all in easy-to-build, money-saving kits.

Send today for your

## FREE Heathkit® Catalog



If coupon is missing, write Heath Co., Dept. 017-992 Benton Harbor, MI 49022

Send to: Heath Co., Dept. 017-992 Benton Harbor, MI 49022

Send my free Heathkit Catalog now. I am not currently receiving your catalog.

Name \_\_\_\_\_

Address \_\_\_\_\_

City \_\_\_\_\_ State \_\_\_\_\_

CL-724A Zip \_\_\_\_\_



# FREE COLOR CATALOG

## Build Your Own Grandfather Clock



Prices Starting Under

# \$255

(including movement and dial)

- Do-it-yourself case kits, parts pre-cut
- Finished clocks
- Solid 3/4" hardwoods: black walnut, cherry, oak
- Hierloom quality
- Factory direct prices
- Solid brass West German chiming movements
- Money back guarantee
- Prompt shipment

MASTERCARD and VISA ACCEPTED



### EMPEROR CLOCK COMPANY

WORLD'S LARGEST MANUFACTURER  
OF GRANDFATHER CLOCKS  
Dept. 634, Emperor Industrial Park  
Fairhope, Alabama 36532

IN CANADA: Emperor Clock Company, Inc., Dept. 636  
506 Newbold Street, London, Ontario N6E 1K6

## Telephone Listening Device

Record telephone conversations in your office or home. Connects between any cassette or tape recorder and your telephone or telephone LINE. Starts automatically when phone is answered. Records both sides of phone conversation. Stops recorder when phone is hung up. This device is not an answering service.



Each  
**\$19.95**  
Qty. Disc. Avail.



## Super Powerful Wireless Mic

10 times more powerful than other mics. Transmits up to 1/2 mile to any FM radio. Easy to assemble kit. 15V battery (not incl.)  
Call (305) 725-1000 or send \$19.95 + \$1.00 shipping per item to USI Corp., P.O. Box PM-2052, Melbourne, FL 32901. COD's accept. For catalog of transmitters, voice scramblers and other specialty items, enclose \$2.00 to USI Corp.

## WHAT'S HE DOING!

Making a Concrete Flower Pot! ... and SO CAN YOU!

Make and sell your own Ornamental Concrete items. Rush \$5.00 for Book about Aluminum Molds with prices and production trade secrets direct from world's largest mold manufacturer. Over 350 designs to select from.



Send \$5.00 CONCRETE MACHINERY COMPANY  
Today To → P. O. BOX A99 - HICKORY, N. C. 28601

**HOW TO BUILD A MORE POWERFUL BODY!!**

**FANTASTIC muscle pumping methods!**

**Universal**  
Box 9694, Dept. 1  
Detroit, Michigan 48240

**MUSCLES**

**FREE BOOKLET!**

HOW YOU CAN HAVE

- Wider Shoulders
- Trimmer Waist
- Powerful Chest
- Bigger Arms

**YOU CAN:**

- Gain Strength
- Lose Fat

## WEATHER VANES YOU CAN MAKE (Continued from page 145)

if needed by laying it on a concrete surface and pounding the edges with a mallet or hammer.

Create ripples in the flag by tapping with a mallet or hammer over a 6d finishing nail. You might try this on scrap metal first to get the feel and master the technique. Shape the furl in the banner by bending the metal with needle-nose pliers.

### Fastening the sails

Begin securing the sails to the masts and booms. First bore holes in the mainsail for the reefing wire and wire to attach the sail to the gaff, main boom and main mast. Use a sharp nail to make the holes.

Attach the mainsail to the main mast with wire loops. Cut oversize wire lengths, feed them through the sail, twist them snugly to the mast to secure the sail, then cut the wire close to the loop. Attach the mainsail to the main boom in the same manner. Leave it free of the gaff.

Bore attachment holes in the topsail. For the moment, attach the topsail to the top mast with a single loop of wire at the top. Attach the gaff to the top and main sails with one wire running through both sails and around the gaff. Attach the remaining wires to the top mast.

Attach the mainsail wire from the main boom to a 4d finishing nail bent over behind the aft cabin.

Bore attachment holes in the jib. Using the jib to locate the spot, bore a hole through the top mast for a wire to secure the jib. Fit the wire through the top of the jib and secure it temporarily with a small twist.

Thread the loose end through the mast and leave it unsecured for now. Wire the lower rear foot of the jib to a bent 4d finishing nail at the bottom of the mast. Bore under the bowsprit to attach wire to the forward foot of the jib. Secure the wire. Bore three attachment holes in the foresail and secure it in place with wires.

Attach the banner by wrapping it around the top mast and tapping it with a mallet to form a collar. Wrap the banner so the tabs fold across the back side.

The banner should swing freely on the mast; it is removed for painting. Feed reefing wires through the mainsail and flatten them against the sail.

### Constructing the base

The sloop base is a lighthouse which rests on a stand with an octagonal cap. Lay out and cut the front and back of the stand, make the V-grooves and ease the top corners. Cut the stand sides. Glue and nail parts together with 4d

common nails. Lay out and cut the lighthouse from a 4x4. Use a drill press to bore a 3/8-in.-dia. hole for the shaft.

Nail the cap to the bottom of the lighthouse. Place this assembly on the stand and nail through the cap.

Cut the pieces for the "N," which designates North. Glue the parts together. After the glue has set, glue the N to the lighthouse and temporarily tape it in place. Cut the connecting dowel.

### Finishing the sloop

Apply the following Rust-Oleum paints (catalog numbers in parentheses) or oil-base paints with a brush. First, brush two coats of flat white (No. 7790) over the entire weather vane, including the base. The paint should fill the space around the wires and nails; however, don't let it run. Let the paint dry overnight.

Next, remove the banner and paint it. Paint the ground first and let it dry. The ground is regal red (No. 7765), the lettering and stars are sunset yellow (No. 7745) and there are touches of black (No. 7779).

Begin from the top and paint the sloop: First paint the flag with regal red and royal blue (No. 7727). Then paint the sails a sand color (No. 7771). The hull is gloss black, the cabin sides are hunter green (No. 7738) and the cabin tops are gloss black. Let the hull dry before painting the waterline regal red. Add other touches of color, following the color photo.

## 4 Indian and bear

The Indian and bear weather vane is made of 3/4-in. pine stock. Its features are carved in low relief.

Begin work by drawing a full-size grid of 2-in. squares on cardboard. Draw in the Indian and bear with the ground underneath them, the arrowhead and the feather (see plan, page 101). Cut out the patterns and trace them onto wood.

Cut out the designs with a scroll or band saw. Or rough-cut the figures with a sabre saw and finish with a coping saw.

Use a whittling knife, carving tools or a hand grinder to shape the headdress and to cut low reliefs into the surface to outline the details. It is easier to handle the pieces if you separate the bear and the Indian.

In shaping the headdress, start with the front feather, after the plume at the top of the bow. Round it off in an arc to the right. Then carve out a slight concave shape to create the appearance of the feather bending. Carve as much or as little as suits you. Repeat down the



headdress, shaping the tips in alternating directions.

The rest of the carving on the piece is low relief. For example, the headband rests over both the headdress feathers and the head. Therefore, carve the feathers and the head slightly down to meet the headband; shear-cut the headband to meet the feathers and the head. The same applies to the neck band, arm and leg.

Carve the plumes at the legs and on the bow to a point. Cut in at the base to form the plume shape.

Carve the arrowhead to a point. Round and smooth with 80-grit abrasive all of the uncarved outer edges on the piece. Simply round and smooth the bear.

Mark and bore holes for the eyes of both the bear and the Indian. Mount the two in U-channel stock. Drill and set machine screws. Installing one machine screw before proceeding will avoid offset holes.

#### Carving the arrow

Carve the large arrowhead to a sharp edge all around. Cut concave shapes into the surface. The "cutting" edge of the arrowhead should follow the midline of the material.

Whittle the tail of the arrowhead down to 1/8-in. width to fit between two pieces of half-round molding that form the arrow shaft. Whittle a fin along the top edge of the tail feather to 1/4 x 1/2 in. deep. It will fit between the two pieces of half-round. Then cut the molding to size.

Shape the lower part of the tail feather to a thin edge. Glue the flat surfaces of the half-rounds with white glue; clamp together lightly in the center. Quickly slip the arrowhead and tail feather in place. If necessary, carefully tack-nail the parts.

Coat a shoelace with glue and wrap it tightly around the shaft at the base of the arrowhead. Wrapping should be slightly irregular. The last wrapping should crisscross on one side. Use a pocket knife or other tool to slip the loose end of the lace under one of the wrappings. Wipe off any excess glue. An additional clamp behind the shoelace may be required to close the shaft. Set the arrow aside to dry.

Bore two holes through the channel into wood for 1/8-in.-dia. threaded rods which attach the arrow. Lay the arrow in place next to the channel and mark for the two 1/8-in.-dia. rod holes. Drilling will be through the glue joint, so be sure the glue is dry and the arrow is stable.

Thread the 1/8-in. rods up through the arrow shaft into the base of the vane. Fit plain or capnuts on the rod ends.

Once they're in place, lightly file the threads smooth.

#### Finishing the piece

Use three colors of Rust-Oleum or oil paints on the weather vane: flat black (No. 7776), flat white (7790) and terra cotta (7759). Numbers are Rust-Oleum catalog numbers.

Brush terra cotta onto the face, arms and upper legs of the Indian and on the ground and arrow shaft. Apply white to the headdress feather, tunic body, leggings, plumes and arrowhead wrap-

pings. Tips of the headdress feathers, headband, tunic trim, bow, bowstring, legging trim, arrowhead and bear base are black. Follow the photo to paint other details.

The paint should fully cover the area you are working on so that no wood grain or knots show. Apply several coats of each paint. Wait an hour between each coat until the paint sets. Let the entire piece dry for 48 hours after the last coat is applied. Carefully tone down the white if desired by wiping with fireplace ashes. **PM**

# THE ORIGINAL. COPIED BUT UNMATCHED.

We invented this style of plier. Improved it with patented can't-slip adjustment. Improved it again with our patented stress resisting flange. And still again with our new PERMALOCK fastener. All of which is why tongue and groove pliers by any other name can't match CHANNELLOCK. Be sure that name is on the pliers you buy. Send for free catalog. Channellock, Inc., Meadville, Pa. 16335

Tools by

**CHAN NEL LOCK**

For you who want the best.





**CASITE**  
**SPRAY-LUBE**  
ALL PURPOSE  
CLEANER • LUBRICANT

YOUR QUICK SOLUTION  
IF IT STICKS, SQUEAKS OR  
HAS A MOISTURE PROBLEM

Home, auto, farm, fleet, shop and  
recreational equipment maintenance

NET WT

**"YOU CAN'T  
BUY A BETTER  
PROBLEM  
SOLVER!"**

as seen on  
CBS-TV Morning News

**HASTINGS MANUFACTURING CO.**  
Hastings, Michigan 49058  
FILTERS • PISTON RINGS • CASITE PRODUCTS • TOOLS

**SAVE BIG!**

All-Gear  
**MAGNATRAC**  
Crawler  
Tractor  
KIT!

All New  
**YARD  
TRUCK  
KIT!**  
1/3 Ton  
Capacity

Bolt together a **STRUCK-KIT** Tractor in a weekend and pocket Big Savings. Choose our famous **MAGNATRAC** Crawler or our newest 16HP **YARD TRUCK** Kit. Use for odd jobs to earn extra cash. Thousands of **STRUCK-KIT** Tractors in use. 30 Attachments - loader, backhoe, mower, plow, etc. Buy factory direct for greatest savings. Send **NOW** for:

- **CATALOG** of KIT construction and uses — \$1.00 (specify Magnatrac of Yard Truck)
- **ASSEMBLY MANUAL** for KIT — \$7.00 (specify Magnatrac or Yard Truck) Money refundable on any purchase.

**STRUCK-KIT** Dept. PM33 Cedarburg, WI 53012

## MAKE YOUR OWN WEATHER FORECASTS *(Continued from page 97)*

entific, Barrington, N.J. 08007), I beat three local forecasters with next-day predictions in my neighborhood four times over a three-week period. (The pros differed in their forecasts only once, a strong indication that their approach is scientific.)

Of course, I couldn't predict the weather for midtown Manhattan, the forecasters' home base, which is 15 miles away. But the professionals could. And they were accurate to within 5° F. on 20 out of 21 days—far better than my record for my local weather.

Try forecasting the weather using the most basic equipment or PM's chart on page 97 and you'll soon learn the pleasures of being right, while developing a profound respect for the beleaguered TV forecaster.

Just by using your senses, you can

make surprisingly accurate predictions. At the next full moon, you may be able to impress your friends by calling the next day's weather based on the presence or lack of one or more halos. No halo and clear skies probably foretell a clear day ahead. A large halo in clear skies indicates a warm front is moving in and rain is on the way. The halo is formed by cirrus clouds, those high webby visages that ride the top of a warm front. In warm weather, a double halo, or two decks of clouds, indicates that a long-lasting rain is due. The double halo is a bit less accurate sign in cold weather. (You can spot halos on half-moons and even quarter-moons after you get some experience.)

While halo-watching is useful, there are more sophisticated ways to use the clouds as indicators. By knowing the

## Building Heathkit's Digital Weather Computer

To build Heathkit's ID-4001 Digital Weather Computer (\$399.95) you won't need much knowledge of electronics or meteorology, though the kit makes it easy to learn a little about each. When you uncrate the parts, you'll find everything laid out in good order, beginning with a very clear, easy-to-check parts inventory. The manual even opens

vides readings for barometric pressure, wind speed and direction, indoor and outdoor temperature, time and date. All read-outs—which appear on an attractive and fun-to-use board—are digital, using light-emitting diodes (LEDs). The unit operates on household current (110 or 220 v.a.c.), but can also run on battery power in a blackout

*Microprocessor-based sensors in foreground record the temperature and barometric readings in Heathkit weather station. Behind the sensors are the LED board, with the displays, the CPU board with the station's memory, and control panel board. Power supply board is not shown.*

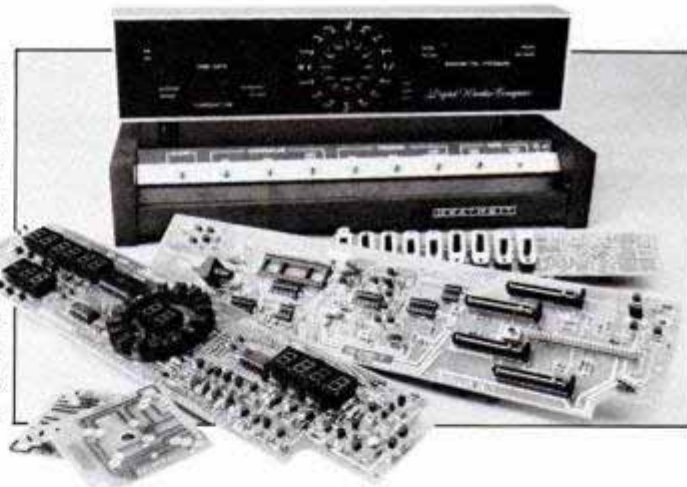

with a course on how to use solder, which may come in handy.

In the 28 hours or so it took me to inventory the parts and assemble and calibrate the set, I found only one flaw. In the assembly instructions for the central processing unit (CPU) board—the computer's memory—there's a diode called for in the middle of the board. But, on that same spot on the board itself, I found stamped information calling for a capacitor. Double-checking the schematic, I found it was, in fact, a capacitor and not a diode that was required. (Don't let words like capacitor and diode throw you; the plans have pictures and step-by-step instructions.) PM's Heathkit was an early set. Current models have an updated set of instructions that have cleared up the confusion.

The rest was smooth sailing. The set pro-

or on a boat. The electronics are laid out on four boards: LED; CPU, including the microprocessor chip; power supply; and control panel.

All components are spaced wide enough apart to prevent short circuits from accidental solder connections.

The Heathkit is designed to interface with any general-purpose computer, allowing you to chart long-range patterns and set up experiments. The weather sensors came online almost immediately after startup, and gave faithful readings.

To build the weather station, you'll need a 25 to 40 w. soldering iron, wire strippers, pliers, long-nosed pliers, diagonal cutters, 1/8" and 1/4" screwdrivers and a Phillips head screwdriver. The kit also suggests you have a desoldering bulb handy, but if you're careful, you won't need one.—*Angel Vargas*



relative altitude of clouds and the changes in wind direction, you can predict the weather as far as two days ahead. In fact, one of the most popular amateur tools, Pocket Weather Trends' Pocket Weather Forecaster, bases its very reliable forecasts on cloud and wind-change data.

The \$3 rectangular cardboard computer, available in many book stores, lists six different types of clouds by height and thickness. In a slot that accommodates wind data for five regions of the nation, you insert one of five cards appropriate for your area. If you live in the Northeast, for instance, and you have scattered, puffy vertical clouds overhead, you match those data to the wind direction. If the wind is blowing from the east, the card says to expect showers within 36 hours from May through October, or increasing cloudiness the rest of the year.

Another outstanding and simple weather calculator is the \$9.95 Sager Weathercaster. Another Edmund offering, it has a chart with a circular slide-rule-type dial. Match up current wind, barometer and sky conditions, and the Weathercaster will give you tomorrow's weather with almost 100-percent accuracy. I used it along with my Capricorn, which has a built-in barometer, indoor and outdoor temperature sensors, wind speed and direction meters and a wind-chill meter. The Capricorn gave me the barometric and wind-direction data I needed to compute on the Sager dial.

### Creating a weather station

Beyond the naked eye and analog calculator systems are the complete weather stations. You can build a microprocessor-based Heathkit system for \$399.95 (see page 148); buy a computerized weather station of professional quality for about \$1,500; or build an excellent system out of mechanical and electronic components for from \$50 to \$500.

"My brother-in-law built me a Heathkit and I use it at home all the time, but the Rainwise system is coming into the studio," says Carey Kinsey, meteorologist for WBLZ-TV in Bangor, Me. "It has more weather variables than any of the other systems."

The \$990 Rainwise system (from Rainwise, Bar Harbor, Me. 04609) uses a slender board to flash output from sensors that give the most important weather data, as well as degree days—the measure of how often and for how long your oil burner had to click on during the winter. The Rainwise barometer is guaranteed to be more accurate than an aircraft altimeter, which uses barometric pressure to detect altitude.

How accurate? A barometer at sea level—or an altimeter set at zero—

should read 29.92 inches of mercury. At 50 feet, it should read 29.89. At 50 feet below sea level, the barometer should read 29.96 inches of mercury. That's accuracy!

As you go higher in altitude, the atmosphere gets thinner and the air gets lighter. The higher you go, the less the pressure of the air and the lower the reading.

If, after studying and using PM's weather chart, you decide you want more accuracy or longer range to your forecasts, you can make out very well with either of the analog calculators, a weather vane and a barometer.

Outstanding mechanical barometers are available for under \$100 from Downeaster Manufacturing in Dennis, Mass. 02638 and from Maximum Inc. of Natick, Mass. 01760. These are highly accurate, although not as accurate as an altimeter. Knowing the barometric reading makes it possible to predict the overall pressure system. A "high" brings clear or clearing weather, while a "low" brings clouds and rain.

### One step at a time

One advantage to the mechanical and electrical components of Downeaster and Maximum is they let you build a weather station slowly and inexpensively. After you've purchased your barometer, you can add a wind-speed and direction meter, which is more exact than the dead-reckoning you use with a weather vane, and temperature gauges that are far more accurate than any household thermometer. You also might want to add a tide clock to tell you when it's high or low tide, and a wind-chill meter to help you decide how much of your body to protect when you go hiking or fishing. Your PM chart, however, will work well with or without these devices. Developed with help from National Weather Service forecasters, the chart relies on shifting systems to foretell the weather. When the wind has been coming from the southeast, but is now shifting and coming from the northwest, it probably means a low-pressure system is moving in. That will bring rain, and possibly windy weather.

The chart has a few limitations. Most notably, barometric readings will change slightly with altitude. These are sea-level readings. If you're 1,000 feet above sea level, normal readings will be somewhat lower. Also note that extreme conditions, such as those sometimes found in mid-winter or mid-summer, are not accounted for by the chart.

Still, for most areas during most of the year, you'll find our chart useful. And it won't be long before you think of your television weatherman as a colleague.

## QUICK START

250  
AMPS  
12 VDC

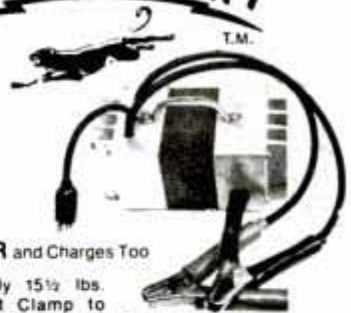

100%  
STARTER and Charges Too

Weights only 15½ lbs.  
Easy! Just Clamp to  
Battery and Plug into 120 V Outlet. Pat.

Quick Start Will Start your Engine in Seconds.

Only \$99.50 and we pay the freight.

**GREAT PLAINS PRODUCTS**

P.O. BOX 62632 Oklahoma City, OK 73148

## SANDING BELTS

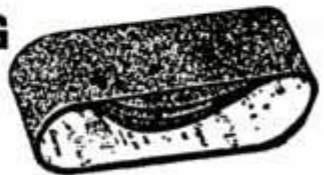

	Per Doz.		Per Doz.
1x42 Mead, etc. . . .	\$ 7.50	4x21¾ Skill . . . . .	\$13.90
2x21 Porter Cable . .	7.70	4x24 Misc . . . . .	14.25
2x21 Porter Cable . .	7.80	4x27 Porter Cable . .	14.50
2½x21½ Skill . . . . .	8.95	4½x26 Skill . . . . .	15.50
3x18 Wen, etc. . . . .	9.50	4x36 Hammond . . . .	17.50
3x21 Porter Cable . .	10.50	4x37½ Atlas . . . . .	17.75
3x23¼ Skill, Thor. . . .	10.85	4x52½ Walker . . . .	20.95
3x24 Porter Cable . .	10.90	4x54 Porter Cable . .	21.25
3x27 Porter Cable . . .	11.00	6x48 Delta-Sears . . .	39.95

1 All belts cloth backed. 2 Specify for wood or metal.  
3 Will Ship Assorted — Or Specify Grit.  
4—MONEY BACK GUARANTEE  
5—Other sizes available at lowest prices—Please Inquire.

Include \$2.00 for postage and handling. Send check or money order. NYS Res. Add Tax.  
**JACKSON TOOL CORP., DEPT. AMKG**  
27-55 Jackson Ave., Long Island City, N.Y. 11101

## Start A Sparetime Business for your Family with Mini Donuts

A money-making week-end business for use at county fairs, sports events, flea markets . . . wherever crowds gather. Anyone can operate. Completely automatic. The action of the machine and the aroma do all the selling.



"We earned \$350 for 3½ hours our first booking."

say A. & J. Wade of Texas.

For FREE Booklet Call (612) 545-1984 or write

Financing Available



**The DONUT MAN**

A Quantum Group Company  
9851 - 13th Ave. No., Dept. 672  
Minneapolis, Minnesota 55441

## HYDRAULIC JACK REPAIRS



A Business of your own.

Earn while you learn at home. Millions of jacks in gas stations, trucking firms, etc. need servicing. We show you HOW! Start spare time in your basement or garage. Big opportunity for mechanics.

Write for folder No. PM3 and free bonus offer.

**HYDRAULIC JACK INC.**

P.O. BOX 18, ACCORD, NY 12404



MAKE THIS SHADE FOR LESS THAN \$75.00

Send \$1.00 for our big catalog of stained glass supplies.

**WHITEMORE,**  
Box 2065EM, HANOVER, MASS. 02339



## SUPER BARGAIN SPECIALS!

### Powerful Permanent Magnet Motor/Generator



ITEM 10-1023  
**\$14.95**  
Prepaid in  
Continental U.S.A.

• **ITEM 10-1023** - - Runs on 12 to 120-v. AC or DC. (Rectifier req. for AC). Very powerful for its size. Torque 50 in./oz. at 6500-RPM. 5.5-amps. No load speed, as motor, 1,000 to 10,000-RPM. Reversible rotation. As generator, use wind, pedal, water power to produce 12-volts at 950-RPM. 24-volts at 2000-RPM. Ball bearing equipped. Shaft 15/32" diam., 2-3/4" long, threaded end. O' all size 3" diam. x 7-1/4" including shaft. ( 3-1/2 lbs. ) **Brand New**

### Waterproof All-Steel .50 Cal. Ammo Boxes



ITEM 1-1038 **\$8.49**  
Prepaid in Cont. U.S.A.

• **ITEM 1-1038** - - Genuine U.S. Gov't. issue, heavy gauge steel ammo boxes. Not imported, lightweight copies. Tight sealing lid with rubber gasket. Waterproof protection for tools, camera gear, fishing tackle, valuables, ammo, important papers, etc. Carry handle folds flush. 11-3/4" x 7-1/4" x 6-1/8". ( 6 lbs. ) **New Condition**



Send \$1.00 For 100 Page  
Equipment Catalog

( Your Car Order Direct From This Ad )  
OUR TELEPHONE: ( 402 ) 474-4366



**SURPLUS CENTER**

Dept. PM-033 Lincoln, NE 68501

## MEN'S WIDE SHOES

EE-EEEEEE, SIZES 5-13

Extra width for men who need it, in excellent variety, styling and quality. Available only through our FREE CATALOG. Send for it!



**HITCHCOCK SHOES, INC.**  
Dept. 28B, Hingham, MA 02043

### GARAGE DOOR OPENERS



• Radio  
Controlled



- Buy Factory Direct and Save
- Thousands In Use • Free Brochure
- Easy Homeowner Installation
- Immediate Shipment by UPS or PP

HELPMATE Equipment Co. Dept. PM-383 Baroda, MI 49101

### CLOCK COMPONENTS



Battery, Pendulum, China Quartz, Urgon, Hermic, Grandmother, Grandfather, Westminster, Triple Chime, Key Winder, Bell Chimes, Ban-Ban, 400 Day Weather Instruments, Music Box Movements, Clock Kits, Metal, Bezel, Paper Dial, Case Hardware, Brass & Plastic Numbers & Markers. Hundreds of Items. Quantities Prices. Send \$2.00 for 75 Page Catalog. Refunded on \$20.00 Order.

**NEWPORT ENTERPRISES INC. Dept. P.S.**  
2313 W. Burbank Blvd., Burbank, Calif. 91506

## LEARN MEAT CUTTING



Train quickly in 8 short weeks at Toledo for a bright future with security in the vital meat business. Big pay, full-time job—**HAVE A PROFITABLE MARKET OF YOUR OWN!** Time payment plan available. Discharge given. Job help. Thousands of successful graduates. **OUR OWN YEAR!** Send NOW for a big new illustrated FREE catalog. No obligation. C.I. approved. **NATIONAL SCHOOL OF MEAT CUTTING, No. 71-02-0197T, Dept. 50-M, 33 N. Superior, Toledo, Ohio 43604.**

## AUTOMAKERS WHO DARED

(Continued from page 81)

parent companies, but others didn't. Let's take a look at a few of the more noteworthy.

Ford Motor Co. lost an estimated \$250 million on the ill-fated Edsel. And that was in 1958-60 dollars. In today's money, the Edsel would translate into a bust of almost \$1 billion!

Yet the Edsel wasn't a bad car, really—just poorly timed and, with its horse-collar grille, an easy butt for TV gag writers. But if you look around the auto industry's voluminous attic, you'll find a lot more "Edsels" that weren't nearly so well publicized, but that lost money on every bit as grand a scale.

For example, right around the time of the Edsel, Ford launched another, more illustrious automobile, the 1956-57 Lincoln Continental Mark II. No one thinks of the Mark II as an "Edsel" or a money loser, and Ford released no profit-and-loss figures on it. Yet if you think about the car and its production totals, you have to conclude that the Mark II, car for car, had to be an even greater drain on Ford than the Edsel. Of the 3,012 Mark IIs built in their 22 months of production, each one amounted to \$1,000 down the drain.

### Mark II was special

To give it its due, though, the Continental Mark II was a cleanly styled, innovative, luxurious car that shared only its engine and running gear with the mass-market Lincoln. Its sheet metal, square-tube frame, suspension, interior and many accessories were unique. These vehicles were meticulously assembled, each bolt torqued by human muscle, not by machine; each car painted with four coats of hand-rubbed lacquer; each interior upholstered in matched hides; all plating exceeding industry standards by a factor of three; each engine and transmission individually bench tested, then road tested, then disassembled, inspected, reassembled and road tested again.

Fully equipped—with air conditioning being about the only extra-cost accessory available—the Mark II sold in 1956 for \$9,517. Air cost \$720 additional. William Jeanes, writing in *Car & Driver*, said that, "... to show a profit, the material and manufacturing that went into the Mark II would have required a price nearer to \$100,000 than \$10,000."

Not that Ford suffered money losers alone in that era. Cadillac had a lulu, too, and again it's a car we never think of in Edselian or De Lorean terms. The automobile I have in mind is the 1957-58 Eldorado Brougham, a model best remembered for its stainless-steel roof. It also happens to be the vehicle that

introduced quad headlights to U.S. production cars.

### Brougham answer to Mark II

The Cadillac Eldorado Brougham came in answer to Lincoln's Mark II Continental. It carried a price tag of \$13,074 and, in all, only 704 1957-58 Broughams saw the light of day (another 200 of a totally different body style were crafted in Italy for 1959-60 seasons). By conservative estimates, Cadillac lost \$10,000 on every Brougham it sold during 1957-58.

Again, I'm not deprecating the quality of the car itself. It was magnificent by any yardstick—luxurious to the point of excess in an era of unparalleled automotive excesses.

I couldn't begin to enumerate all the Eldo's factory equipment, but to give you just a sampling: automatic temperature control with air conditioning and individual dual underseat front and rear heaters; a matched set of six little magnetized silver tumblers; hollow rear armrests containing Arpège perfume and a custom atomizer, note pad, silver pencil and mirror; pillarless, four-door hardtop construction; air suspension (one of the car's weaker points); six-way memory seat; power everything else including ventipanes and door locks; electric decklid raiser and lowerer; automatic engine restarting; twin four-barrel or triple two-barrel carburetion; forged, vaned, aluminum-hub wheels; polarized sun visors that darkened when tilted; grey-smoked tinted glass; and an awful lot more.

Of course GM and Ford lost money on these two modern classics, but the cars weren't really intended to make great gobs—just break even if they could. I don't believe the manufacturers expected to lose quite so much as they did, but the Mark II and the Brougham were principals in a game of prestige-car one-upmanship—a battle for America's gold standard among luxury motorcars. Cadillac was trying to outdo Lincoln, and it succeeded in every way, including losing money.

Nor was this particular Cadillac the first to do so. General Motors' luxury division managed to lose plenty during the Great Depression, and at one time GM executives briefly considered dropping Cadillac Div. altogether. Part of the reason was the drain placed on Cadillac by the marvelous but very expensive 16-cylinder engines introduced in January 1930.

The first-series V16—and the V12 adapted from it in September 1930 by lopping off four cylinders—cost the company an estimated \$6 million to tool plus several million more to put into production. The engine necessitated a lengthened and deepened frame, longer hoods and fenders and different



springs. So again, while there's no accessible record telling how much the V16/V12 program cost Cadillac in all, you can bet it was plenty.

Cadillac's president, Lawrence P. Fisher, planned to use the V16 as ammunition against Packard. Throughout the late 1920s, Packard reigned as the absolute monarch of elegant American motorcars. Duesenberg launched the huge and powerful Model J in December 1929; Marmon had an aluminum V16 up its sleeve for 1931; and Fisher knew that if Cadillac didn't want to stay a bridesmaid all its life (throughout the '20s, Cadillac ranked fifth among prestige cars, well behind Packard), it had better come up with something spectacular. Which it did, in the form of the narrow-vee 1930 V16.

That first Cadillac overhead-valve engine had an aluminum block, cast aluminum pan and rocker covers, and the first hydraulic valve lifters in U.S. production history. It amounted to two Straight Eights on a common crankshaft. Each bank had its own intake and exhaust system, complete with separate updraft carburetors. The coffee-can-sized distributor used twin coils embedded in the radiator header tank. The engine itself was a work of art, beautifully detailed in polished aluminum and black, uncluttered by loose wires or unsightly plumbing.

### Too late to pull back

This engine—and the mostly Fleetwood-bodied cars it powered—had been planned several years before the stock-market crash. By the time Black Tuesday rolled around, it was too late to suspend production. The V16, though, and its spinoff V12, nearly bankrupted Cadillac, and it was only the solvency of other GM car divisions that saved the marque.

The senior Packards (V12s and Super Eights) didn't have any such corporate health plan, nor did Pierce, Duesenberg, Marmon and some of the other luxury cars that burst into the '30s and then promptly self-destructed. These great cars were "Edsels," too, in their own quiet ways.

Well, Cadillac didn't stop with the first-series V16s. After managing to sell only 3,878 of these fantastic cars in eight Depression years, but determined to get to the top of the luxury ladder, with Packard still twitching, Cadillac discontinued the magnificent first-series V16 at the end of 1937 and introduced yet another V16 for 1938.

This newer engine shared absolutely nothing with the first one. It was a flat-head design, all iron but 250 pounds lighter, with a 135° vee angle instead of the 1930-37 model's 45° vee. It mounted two downdraft carbs up top, had twin distributors, and delivered no

more horsepower (185 at 3,600 rpm) than the engine it replaced. It was, though, less expensive to produce, and yet, since Cadillac discontinued the series after 1940 and 508 cars built, GM lost a bundle on that V16, too.

As an aside, Cadillac hoped the 1938 V16 might eventually power PT boats. If it had, the division might have showed a profit on this engine.

### More bombers than boomers

By now you might suspect that the auto industry spawned "Edsels" galore during its long and diverse history, and you're absolutely right. Statistically there have been far more bombers than boomers, and that's why, of the 5,000+ American makes introduced over the years, only a handful from four major manufacturers survive.

Taking a further look at some of the majors, consider first the company that at one time produced the king, queen and prince of American classics: the Auburn-Cord-Duesenberg triumvirate of Indianapolis and Auburn, Ind. All three automobiles have been or are being reproduced as replicars today, which tells you something about the transient nature of success. But the darling E.L. Cord, who brought these marques to their highest flowering, had a trio of financial flops on his hands.

Great as his cars were, the public either couldn't afford them or didn't want them, even though the Auburn ranked among the genuine bargains of its later years. You could buy an Auburn V12 in 1932 for \$1,595 or a supercharged Auburn speedster in 1935 for \$2,245. Try that today!

Again, there's no way to tell exactly how much money A-C-D lost during the '30s, but it had to run to eight figures at a time when eight figures could buy entire nations. Remember that in 1933, a Ford V8 sedan cost \$560. By way of contrast, a 1933 Duesenberg J chassis went out the door for \$9,500, with a custom body costing at least that much again. No wonder Cord sold only 475 Duesies between the Model J's intro in 1929 and its last gasp in 1937. And on a car that hyper, you've got a lot to lose.

The J and SJ (S for supercharged) Duesenberg had no equal anywhere in the world. It out-rolled Royce and outran absolutely everything, easily beating the contemporary supercharged Mercedes. Its Straight Eight engine used twin overhead cams, four valves per cylinder, with a displacement of 420 cu. in. A Roots-type supercharger was added in May 1932, boosting power from 265 to a published 320 hp at 4,750 rpm (this horsepower figure is oft disputed; some claim it's high, some low, and factory-modified models are

*(Please turn to page 152)*



**THE LESS YOU USE  
YOUR CAR . . . . .  
THE MORE YOUR  
ENGINE NEEDS RISLONE!**

Engines used for stop and go trips, or run for less than half an hour at a time, form crankcase sludge! Sludge plugs oil filters and oil passages. It can block the oil pump screen so that working parts may starve for oil!

RISLONE cleans up on sludge. Dissolves it. Keeps it from fouling up your engine's lubrication system. And that's good. A clean engine starts easier, runs better, lasts longer and gives you more gasoline mileage.

So, if you run your car less today, take better care of it with RISLONE. RISLONE has been used for over 50 years by millions of motorists in big cars, small cars, foreign cars, trucks, boats and diesels too. Use it with every oil change.

Get RISLONE at your local auto merchandise store. It comes in a big quart yellow, red and black can . . . enough product to keep your engine clean and efficient.



**FREE:** 32 page LUBE TIPS Booklet. Information, ideas and discussion about lubrication, problems and performance. Send self-addressed stamped envelope 4 1/2 x 6 1/2 or larger.

**THE SHALER CO.**

Waupun, Wisconsin 53963  
In Canada: Warren Packaging Co. Ltd.  
Scarborough, Ontario



## AUTOMAKERS WHO DARED

(Continued from page 151)

said to have produced up to 400 hp).

At any rate, Ab Jenkins took a stock-engined but special-bodied Duesenberg roadster to Bonneville in 1935. There he posted 152.15 mph for one hour and averaged 135.47 mph for 24 hours—in a 142.5-inch-wheelbase car weighing nearly 6,000 pounds!

Of the approximately 475 Duesenbergs built by the factory, each one became a loss leader of monumental proportions. Yet each brings between \$100,000 to \$500,000 today from col-

lectors. Too bad Cord couldn't have simply warehoused his run of Duesies for half a century!

His front-drive Cord automobile turned out to be another magnificent money loser. As with Duesenberg and Auburn, Lycoming produced the Cord's engine, in Cord's first generation as an L-head Straight Eight (1929-32) and later an L-head V-8 (1936-37).

Here, again, was a car completely new from the ground up, sharing nothing with any other make. Cord tooling costs remain undocumented but must have been in the millions. Sales remained desperately low: 4,430 Cord

L-29s sold in 1929-32 and 2,320 Models 810 and 812 for 1936-37.

Auburn did a little better, but not enough. Ironically, that division's best year was 1931, with nearly 30,000 sales. Between 1929 and the end of 1937, in fact, Auburn managed to sell a grand total of just over 88,000 cars—almost enough to keep the company afloat through the Depression. But those sales tailed off toward the end, and cash flow must have been pulled down tremendously by the foundering Duesenberg and Cord. A-C-D expired peacefully in 1937.

Another daring and costly experiment that failed was Chrysler's beautifully ugly Airflow of 1934-37. The Airflow became another wrong-time launch, but its failure had as much to do with its looks as its timing. A very rational and well-thought-out design, it was among the first of U.S. cars to place the engine *over* the front axle and thus the rear passengers *ahead* of the rear axle. It also used a unitized, all-steel body and first introduced Warner Gear's transmission-mounted overdrive. The Chrysler and DeSoto Airflows were highly influential cars from an engineering standpoint, and they perhaps even influenced international styling to some extent, but the public couldn't abide them. Airflows were made on a variety of wheelbases, from DeSoto coupes to Imperial limousines, so they weren't inexpensive to tool and build.

### Different problems

Preston Tucker tried to bring another revolutionary car to market but ran into problems of a different sort. Unlike the Airflow, public enthusiasm for Tucker's 1948 Torpedo sedan ran high. The car had greatly advanced styling, with a "cyclops" central headlight that turned with the front wheels. It used an aluminum, opposed, six-cylinder, 334-cu.-in., 166-hp engine built by Franklin for Bell helicopters. The engine was converted to liquid cooling and lay lengthwise at the rear of the car, mated to a remanufactured version of the old Cord pre-selector transaxle. Tucker got most of these transaxles from wrecking yards.

The Tucker car stood very low for its day, and it had some other revolutionary eye-catchers, among them a "basement" or crash compartment that the front-seat passenger could throw himself into just before a crash. Doors lapped up into the roof for greater head clearance. And the trunk, of course, was under the hood.

Preston Tucker built some 50 cars before the U.S. Securities and Exchange Commission closed him down on purported stock-fraud charges. Meanwhile, his auto venture had put Preston Tucker some \$28 million in debt. He died in South America in 1956



## Kamei Spoilers Conquer The Wind

Performance in the eighties means handling and fuel economy. Kamei has used this definition for over 30 years in the development of wind tunnel designed and tested aerodynamic products.

Kamei's exclusive wind tunnel testing assures that every front and rear spoiler will reduce aerodynamic drag to deliver improved handling and

increased gas mileage.

Every Kamei impact-resistant ABS front spoiler also provides reduced body lift and controls crosswind buffet to improve stability. Complete instructions and hardware are included for easy do-it-yourself installation. Kamei front and rear spoilers can also be painted.

Now you can conquer the wind with Kamei aerodynamic spoilers.

**KAMEI**  
autoextras

300 Montowese Ave.  
North Haven, CT 06473

ACT NOW...Send \$2.00 for colorful 1983 catalog. Send \$3.00 for catalog, jacket emblem and decals to KAMEI, INC., Auto Extras, P.O. Box 426, North Haven, CT 06473.

NAME \_\_\_\_\_

STREET \_\_\_\_\_

CITY \_\_\_\_\_

STATE \_\_\_\_\_ ZIP \_\_\_\_\_ Dept. PM3



while trying to start up an auto-making company. It's generally agreed that he probably would have even if he'd absorbed even the Edsel and concrete lion up front, but the lack of money was a case of unavailability in credit.

Rumvile in credit man Joseph W. front-wheel-drive suspension. Prototype at configuration, settled on conventional using a Continental engine. The first-generation cars and Frazers of 1946-50 contemporary, but uninspired in design and engineering. The 1951-55 second generation looked a lot better, but kept the same basic engineering (with a centrifugal supercharger added for 1954), and the company stopped production in this country the next year.

Joe Frazer had been in the auto business most of his life, and if anyone knew how to make a car succeed, it was

he. Malcolm Bricklin, on the other hand, freely admitted he didn't know what he was doing when he decided to raise money to build a gullwing sports car bearing his name.

The Bricklin was a fairly modest bust by modern standards—only about \$26 million in the hole. Malcolm Bricklin might have been on his way to profitability given a little more time, but the New Brunswick government and U.S. banks turned off the spigot before anyone got a chance to find out.

The Bricklin SV-1 used a hefty perimeter frame with integral rollcage, fiberglass body and front-mounted AMC or Ford V8s. Cars were announced in 1975 at \$9,980, but each one cost the company up to \$16,000 to build. In all, Bricklin produced about 2,800 cars.

Perhaps you can't even call the Bricklin and De Lorean American cars, since both were produced outside our national borders. But the men who founded these companies were archetypal American entrepreneurs who operated in what's come to be described as a typically American way of launching a new car. Unfortunately, as each entrepreneur fails, he makes it that much harder for anyone else to follow.

Contrast all these expensive ironies with one of the great recent success

stories of international carmaking, namely Honda. Whether Honda had Japanese government backing for its car venture I don't know, but the company went into the auto business in a very un-American way, with very little hoopla, no grandstanding and virtually no announcement of plans. Honda just started building cars.

In this country, Honda's first two models turned out to be about as successful as the De Lorean and the Edsel—the tiny S.600 roadster of 1962 and the N.360 of 1968. But unlike De Lorean, Honda had the money and thus the time to keep going, and you can see what that led to: Honda now builds cars in America. It is a strange business, even for established auto manufacturers—and certainly no place for the novice or faint-hearted. **FM**

### Credit Where It's Due

I'm fully aware that my article ignores successful specialty car builders like the SS Corp. of Milwaukee, which manufactures the Excalibur, and the Elite Heritage Motorcar Corp., makers of the Duesenberg II. With due respect, my article concentrates on companies that at least tried to enter the world of mass production and marketing, and I've intentionally sidestepped the successful but mostly handcrafted marques from the smaller specialty car producers.—M.L.

## 31 Ways to Help You Qualify for the Job You Want

### FREE CAREER FACTS ABOUT DIPLOMAS AND ASSOCIATE DEGREES

If you want more money, more security and a better way of life, the decision to train for a better career could be the most important one you will ever make. And now you can train at home in your spare time for a diploma or even a degree to help you get a better job. This is the same kind of training program that has been used by nearly 2,000 American Corporations to train their employees... Union Carbide, Ford, DuPont and many others.

#### An Ideal Way to Learn

No need to change your daily routine or take time from your job or family. Learning is easy because everything is explained step by step with plenty of drawings, diagrams and photos. And like many colleges—all these courses use "open book" exams that let you refer to your texts and apply what you have learned. If you do have a question, your instructor is as close as your telephone. And all courses include necessary tools, instruments and materials... whatever you need for your training.



#### Could a Career Diploma or a Degree Be Worth Thousands of Dollars to You?

Compare your present salary with the amount of money you could be making in any of the careers shown below. Training in a trade or earning an Associate Degree in Specialized Business or in Specialized Technology could make a giant difference in your lifetime earnings. But it's not the money alone... think of the security, satisfaction and the fun of working in a job you like. Get more information at no cost! Check the career you're most interested in and mail the coupon today. There's no obligation and no salesman will call.

#### Or... Get Your Degree Without Attending College

Now without attending class, you can get your degree in business with a major in Marketing, Business Management, Accounting and Finance. Or get a technical degree in Civil, Mechanical or Electrical Engineering Technology or Electronics Technology. If you already have some college or if you have worked in the field, you may be entitled to advanced standing toward your degree.

1212



International Correspondence Schools, Dept. PBS23  
ICS CENTER, Scranton, Pennsylvania 18515

Please send me free facts, color brochure and full information on how I can study at home for the career I have chosen. I understand I am under no obligation and no salesman will call. **CHECK ONE BOX ONLY!**

#### BUSINESS ASSOCIATE DEGREE PROGRAMS

- Business Management
- Marketing
- Finance
- Accounting

#### TECHNICAL ASSOCIATE DEGREE PROGRAMS

- Civil Engineering Technology
- Mechanical Engineering Technology
- Electrical Engineering Technology
- Electronics Technology

#### CAREER DIPLOMA PROGRAMS

- High School
- Auto Mechanics
- Hotel/Restaurant Mgmt.
- Surveying & Mapping
- Drafting
- Air Conditioning & Refrigeration
- Travel Agent
- Wildlife/Forestry Conservation
- Art
- Police Sciences\*
- Veterinary Assistant\*
- Diesel Mechanics
- Electrician
- Small Business Mgmt.
- Electronics
- Computer Programming
- Appliance Servicing
- Income Tax Preparation\*
- Van/Car and Truck Customizing\*
- Gun Repair\*
- Motorcycle Repair\*
- Industrial Management
- Machine Shop

NAME \_\_\_\_\_ AGE \_\_\_\_\_  
ADDRESS \_\_\_\_\_  
CITY/STATE/ZIP \_\_\_\_\_

Mail coupon today for free facts and color brochure.



## FIRSTHAND REPORT

\$433.00 INCL P. 152

*Aimed at Econosport market, Pulsar features pop-up headlights and no grille. Just five slots provide fresh-air intake.*



# Driving The Nissan Pulsar

Nissan has another flavor in its jellybean jar.

BY DON FULLER

**N**issan wants to be your car company. When you walk into the dealer's showroom, Nissan wants there to be such a terrific selection that you won't be able to resist.

Did you ever walk into a Baskin-Robbins and *not* have at least *one* of those 31 flavors? That's Nissan's approach—lots of automotive flavors.

With the bread-and-butter Stanza and econoleader Sentra, Nissan has embarked, within the last year, on the path to front-wheel drive. In the sporty mid-size coupe market, the veteran 200-SX, with or without turbocharger and for two or four people, fills the sports car slot. But Nissan felt there was a gap between the Sentra and Stanza, now plugged by the newest front-driver, the Pulsar.

This new model is notched somewhere between the Sentra and Stanza in price. It's closer to the Sentra in size and skewed more toward the sporting side of the scale. Thus, Nissan offers sedans from bottom to top and sporty cars from low through middle to high.

The Pulsar will be available in three body styles. Introduced last November

as a 1983 model, the NX coupe is the sport version. Due for introduction in a month or so are three- and five-door hatchbacks. They're on the conventional side, but should be perceived as sportier and more desirable than the Sentra. The NX is slated to make up about 60 percent of total Pulsar production.

In Nissan's line, the Pulsar replaces the 310, a design in the tradition of the, uh, *unusual* styling of such memorable Datsun efforts as the F-10, original 200-SX and B-210. The NX coupe seems to have followed that unortho-

dox tradition. Styling is entirely a matter of taste, but I think the NX looks like one of those homebuilt balsawood model cars I made as a kid—after I sawed it out, but before I sanded it off.

Mechanically, the Pulsar holds more promise. The engine is Nissan's E-series, a four-cylinder design shared with the Sentra. An already undersquare engine reflecting Nissan's emphasis on compactness, low-end power, emission control and high mileage at the expense of performance and smoothness, it's been stroked even

*(Please turn to page 156)*



*The Pulsar coupe will soon be joined by new three-door and five-door hatchbacks.*



# AMAZING HARD-TO-FIND SCIENCE BUYS NOW ON SALE!

Bargains in Alternate Energy — Health — Weather  
Hobbies — Magnifiers — Magnets — Telescopes — More

**RADIOMETER LETS YOU SEE THE SUN WORK.** The silvered finish gives you a hemispherical mirror. At a glance, you see everything going on around you. Operates on invisible infrared radiation. 5" high, 3" in diameter. **660,529** Reg. \$7.50 **NOW \$6.75**



**OUR MOST POPULAR MAGNIFIER.** Provides 10 power magnification. Sturdily mounted in plastic with a swingout lens system so you can carry in your pocket or attach to key chain. 3" x 1 1/4" closed. **630,344** Reg. \$21.95 **NOW \$19.75**



**MINIATURE BATTERY POWERED PUMP.** Pumps 1 pt. per minute through 4" tube (included). Lifts liquid 24 inches. Self priming. Operates on 2 flashlight batteries (not included). **650,345** Reg. \$5.49 **NOW \$4.95**



**THIS FLASHLIGHT NEVER NEEDS BATTERIES!** Electricity is generated when you squeeze the fly-wheel—no recharging! Uses 2.2 V flashlight bulbs. It's compact, take it anywhere and never be stuck for a light! 5 1/2" x 2". **661,086** Reg. \$25.95 **NOW \$16.95**



**RECORD HIGH AND LOW TEMPERATURE EACH DAY.** Jumbo size steel and aluminum instrument with 12" diam. Blue and pink indicators are carried to the lowest and highest points of day and left to be read before resetting. **672,467** Reg. \$18.95 **NOW \$17.05**



**HYDROPONIC GREENHOUSE: GROW PLANTS INDOORS ALL YEAR!** Feeds plants a perfect mixture of water, nutrients and light using no soil at all! Get up to 10 times the yield of conventional soil. Contains nutrient mix and transport system. **631,129** Reg. \$42.95 **NOW \$34.95**



**SAVE WATER WITH SHOWERSAVER.** Cut hot water bill without giving up a stimulating hot shower. A perfect mixture of air and water provides increased velocity at 75% less volume. Easy to install. Chrome plated brass. **631,102** Reg. \$12.50 **NOW \$11.25**



**SUPERPHONE WITH MEMORY AND SILENCER.** Automatically repeats your last call at the push of a button. Silences the ring with an on-off switch. The cord is 8' fits into any modular phone jack. Have a phone with super powers...and stop paying phone rental. **633,026** Reg. \$29.95 **NOW \$21.95**



**GO FISHING WITH THIS MIGHTY MAGNET.** Lifts up to 150 pounds. Discover underwater treasures; locate items lost in water. Aluminum frame, bar-handle. Light enough for any fishing reel. Resists corrosion. Wt. 2 lbs. **671,135** Reg. \$26.95 **NOW \$19.95**



**KEEP A CLOSE WATCH ON YOUR BLOOD PRESSURE.** With this dependable, easy-to-use, and accurate Blood Pressure Gauge you monitor your heart with ease. The gauge is easy to read...and the Stethoscope is built into the cuff, with Case and instr **671,874** Reg. \$34.59 **NOW \$29.95**



**JOURNEY TO THE CRATERS OF THE MOON WITH THE EDMUND 76MM TELESCOPE.** Save \$20 and own a superb telescope with metal mount. This precision telescope is ready to use the minute you receive it. The 24mm eyepiece delivers 17X magnification, perfect for all-around viewing. Weighs a mere 5 lbs. so you can easily carry it with you. 13 1/2" x 17 1/2" x 11". **631,677** Reg. \$109.95 **NOW \$89.95**



**BUILD YOUR OWN WEATHER STATION.** Accurately forecast and check your predictions against the media. Kit includes anemometer, windvane, indoor indicator board, barometer, sling psychrometer, rain gauge to measure as little as 1/100 inch, 100 ft. lead in wire, color cloud ID chart, forecasting manual. Powered by 115VAC house current with safety cord. **671,022** Reg. \$29.95 **NOW \$26.95**



**SAVE \$9.00 ON THIS 30X MICROSCOPE WITH BUILT IN LIGHT.** Here is a pocket magnifier microscope that is ideal for detailed examinations of plants, gems, stamps, photos etc. Features a center focus wheel for precise one-hand operation. Retractable condenser lens pinpoints light so you zero in on your subject. Batteries not included. **631,291** Reg. \$18.95 **NOW \$9.95**



**LIGHT BULBS CAN NOW BURN 87,600 HOURS.** The secret is a small solid-state micro-chip that converts AC current to DC. The result is a cooler burning light bulb that generates light up to 100 times longer. The light is softer, too but still adequate. Saves about 30% of your energy cost. Lamp Lite Extenders simply screw onto end of the bulb. Pkg. of 8. **631,890** Reg. \$24.95 **NOW \$19.95**



**MAKE YOUR OWN 9 FT. OR 12 FT. HOT AIR BALLOON.** When fully inflated, these colorful paper balloons rise 200 feet on just hot air! Will lift anything up to a 1/2 lb. Kit comes with 10 pre-cut gores, 6 ft. of 14 gauge wire for ring and core. Easy to follow instructions included. Choose the size you want. **660,691 ( 9 Ft.)** Reg. \$6.95 **NOW \$5.95**  
**631,333 (12 Ft.)** Reg. \$9.95 **NOW \$7.95**



**POCKET-SIZE POWER WITH THIS 8 X 20 SPY SCOPE.** Small, it fits into the palm of your hand. A fine quality viewing instrument, perfect for nature studies, birdwatching or the races. Fully coated optics with accessible fingertip focusing. Stores easily in your pocket or glove compartment. Neck strap and leatherette case included. 3 1/2" x 2" x 1 1/2". **61568** Reg. \$29.95 **NOW \$22.45**

**FREE**

**GIANT SIZE CATALOG**

4,000 Unusual Bargains in Hard-to-Find Science Buys for Hobbyists, Schools & Industry

**COMPLETE AND MAIL TODAY**

To: Edmund Scientific Co. 7303 2103 Edscorp Building  
Barrington, New Jersey 08007

Stock No.	Qty.	Price
Total Price		
N.J. Add 5% Sales Tax		
Total Enclosed		

Send Free Giant Size Catalog

Signature \_\_\_\_\_

Name (print) \_\_\_\_\_

Address \_\_\_\_\_

City \_\_\_\_\_ State \_\_\_\_\_ Zip \_\_\_\_\_

CREDIT CARD  
HOLDERS  
ORDER TOLL FREE  
**800-257-6173**  
In New Jersey  
**800-232-6677**

Method of Payment:  Check encl.  
 MC  VISA  Am. Express  
 Diners Expires \_\_\_\_\_  
Card No. \_\_\_\_\_

**Edmund Scientific**  
7303 2103 Edscorp Bldg., Barrington, N.J. 08007



Men-Women! Make Money In Your Own Home Business!

# "I STARTED WITH \$100 AND MADE MILLIONS IN MAIL ORDER"

You can make a Mail Order Fortune much easier today. I want to help you but: If you are looking for a get-rich-quick-scheme... please turn the page. I did not get rich overnight. But I can tell you that within a short time in mail order I was making more money than any of my friends. The millions came later... and I owe every penny of it to mail order! If you are ambitious and willing to follow directions... I will help you get started on your way to mail order success!

## YOUR HOME MAIL ORDER BUSINESS

Just a few hours a week part time at the start! Then branch out into full time! Keep present income while adding welcome "second income." Use Mail Order profits for travel, savings, education, retirement. It's up to you.

I learned long ago the success secret in Mail Order is picking the right product. I reveal in my Free Course 3 tests your product must pass to be a Mail Order winner! I'll show how to make up simple little ads that bring in orders and cash. Everything I tell you is based on my own success. I know it works.

## BUY BELOW WHOLESALE FOR BIGGEST PROFITS

Imports are great for Mail Order. I travel the world searching out new imports you can turn into quick profits. Start with 24,221 best selling imports. Deal in one or many. Buy Below Wholesale direct from overseas supplier. You keep all the profit. I will also

**ACTUAL REPORTS OF MONEY MAKING!!** CUTS OUT GREEDY MIDDLEMEN. "Can make 80% more profit importing merchandise. The Mellinger Plan gave me new home, new car, own store." Bill Thieszen, Canada

**I.T. MEMBER STRIKES IT RICH.** "Followed your advice and got a free ad. 4,000 mail orders came in. I made \$12,000 this first try, without investment in stock." L.M., Pennsylvania

## INTERNATIONAL TRADERS

reveal my Drop Ship Plan that starts you with little or no product investment. Buy one at a time or in quantity.

## 1000's NEW PRODUCTS EVERY YEAR

With my Plan you get free Membership in International Traders. Vast world wide organization keeps you supplied with new products every month to sell by mail or other ways. Members also attend my personal seminars held in cities near you. Mail coupon for Course and home business report. No charge or obligation. No salesman will call! Find out what Mail Order holds for you!

**FREE MAIL ORDER COURSE**



R. L. MELLINGER, Famous World Trader, Internationally known Mail Order Expert.

I started in Mail Order a few years ago, part time in my garage. I had less than \$100. I discovered how to make Mail Order pay big. Today my business empire spans the globe... 1,253 acres of land, office buildings, warehouses. My Plan lets you use my experience to make a fast start in your own big profit home business.

## FREE MAIL ORDER COURSE COUPON

The MELLINGER Co., Dept. H2253  
6100 Variel Avenue, Woodland Hills, CA 91367

Send Free Mail Order Course... Show me how I can start a Mail Order/World Trade Business of my own. There is no obligation; no salesman will call.

Name \_\_\_\_\_  
Address \_\_\_\_\_  
City \_\_\_\_\_ State \_\_\_\_\_ Zip \_\_\_\_\_

\*Save 3 days, give ZIP for fast reply\*

## Giant Heavy Duty All Purpose Tarpaulins

12 x 16 .....	\$23	26 x 40 .....	\$89
16 x 20 .....	\$32	26 x 55 .....	\$115
20 x 20 .....	\$36	30 x 60 .....	\$145
18 x 24 .....	\$38	50 x 100 .....	\$390
18 x 32 .....	\$50	60 x 120 .....	\$547
20 x 30 .....	\$50	50 x 150 .....	\$562

Before Midnight April 3

Viking Ind. will send any of the above size tarpaulins to any reader of this publication who reads and responds to this program before midnight, April 3. Recommended for all heavy duty use, and all bulk or pallet riding material, and all yachts and sailboats. Also for awnings, camping equipment and tent floors, garden equipment, windbreak, wood, hay, canopy, outdoor storage, machinery and construction. Also many other commercial and private uses. Each tarpaulin is constructed of high density fabric (with virgin grade ingredients, supplied by Gulf Oil Co., Dow Chemical Co., and Union Oil Co.) with nylon reinforced rope hems, double lock stitched hems, electronically welded seams, 100% water proof, #4 (1/2"

dia.) metal grommets set on 3 ft. centers with reinforced triangular corner patches and will be accompanied with a LIFETIME guarantee that it must perform 100% or it will be replaced free. Add \$7 handling & crating for each tarp ordered, Viking Ind. pays all shipping. Should you wish to return your tarpaulins you may do so for a full refund. Any letter postmarked later than April 3 will be returned. LIMIT: Fifty (50) tarps per address, no exceptions. Send appropriate sum together with your name and address to: Tarp Dept. #143C, Viking Ind., 6314 Santa Monica Blvd., Los Angeles, CA 90038, or for fastest service from any part of the country call collect, before midnight 7 days a week.

**CALL COLLECT (213) 462-1914**

(Ask exchange operator for)

TARP DEPT. #143CJ

Before midnight, 7 days a week

Have credit card ready

## DRIVING THE NISSAN PULSAR

(Continued from page 154)

more to make 1.6 liters. It has a two-barrel carburetor, belt-driven overhead camshaft, and churns out 69 hp at 5,200 rpm with 92 ft.-lb. torque at 3,200. The engine is redlined at 6,000 rpm, but pulls comfortably only to about 5,000. The last 1,000 is noticeably buzzy, but few Pulsar owners will ever see their cars' tach needles in that part of the dial. Due to refinements, it's more responsive and predictable than in the earlier Sentras and it goes about its chores willingly.

Nissan should be given good marks



The car's interior is comfortable and well assembled. There's plenty of headroom, front and rear, due to high roofline.

for the transmission, a five-speed with a single-rail-type shifter. Gear selection is smooth and precise and two springs, a soft one on the first/second side and stiffer one on the fifth/reverse side, keep the lever properly centered in the third/fourth slot.

The chassis is essentially a refined version of the 310, with struts in front and trailing arms in the rear. There are coil springs all around, tubular shocks, a front antiroll bar, front disc brakes with drums in the rear and rack-and-pinion steering—all pretty standard fare.

The NX's behavior is also predictable. In the interests of maximum fuel economy the gearbox ratios are wide, with both fourth and fifth overdrive. Fifth is for freeways only, and third is the choice for around town and passing. The ride motion on asphalt is decent enough, but on concrete freeways, it's less pleasant. The car has trouble with expansion joints and lane divider dots, and so a trip down the interstate is a jiggly one. The NC also doesn't do very well on railroad track crossings. Although the hatchbacks may be slightly better, it seems Nissan engineers could stand a trip back to the computers to improve spring rates and shock absorber valving.

Handling is a different story. The Pulsar's steering is direct, if devoid of good feel, and the overall cornering

(Please turn to page 158)



# when I planned to retire before fifty

this is the business that made it possible

a true story by John B. Haikey

Starting with borrowed money Duraclean gave me the opportunity for financial security...  
In eight years I sold out at a profit and retired.

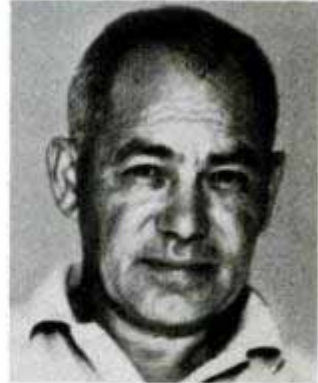

"Not until I was forty did I make up my mind that I was going to retire before ten years had passed. I knew I couldn't do it on a salary, no matter how good. I knew I couldn't do it working for others. It was perfectly obvious to me that I had to start a business of my own. But that posed a problem. What kind of business? Most of my money was tied up. Temporarily I was broke. But, when I found the business I wanted I was able to start it for a small amount of borrowed money.

"To pyramid this investment into retirement in less than ten years seems like magic, but in my opinion any man in good health who has the same ambition and drive that motivated me, could achieve such a goal. Let me give you a little history.

"I finished high school at the age of 18 and got a job as a shipping clerk. My next job was butchering at a plant that processed boneless beef. Couldn't see much future there. Next, I got a job as a Greyhound Bus Driver. The money was good. The work was pleasant, but I couldn't see it as leading to retirement. Finally I took the plunge and went into business for myself.

"I managed to raise enough money with my savings to invest in a combination motel, restaurant, grocery, and service station. It didn't take long to get my eyes opened. In order to keep that business going my wife and I worked from dawn to dusk, 20 hours a day, seven days a week. Putting in all those hours didn't match my idea of independence and it gave me no time for my favorite sport—golf! Finally we both agreed that I should look for something else.

"I found it. Not right away. I investigated a lot of businesses offered as franchises. I felt that I wanted the guidance of an experienced company—wanted to have the benefit of the plans that had brought success to others, plus the benefit of running my own business under an established name that had national recognition.

"Most of the franchises offered were too costly for me. Temporarily all my capital was frozen in the motel. But I found that the Duraclean franchise offered what I had been looking for.

"I could start for a small amount. You can start a dealership for as little as \$3,488. Another option is a \$11,588 full cash investment, and if you qualify, Duraclean can work out financing for half this amount. I could work it as a one-man business to start, and operate from my home. No office or shop or other overhead, no salaries to pay. Equipment would fit in my car trunk. (I bought the truck later, out of profits.) Best of all, there was no ceiling on my earnings. I could build a business as big as my ambition and energy dictated. I could put on as many men as I needed to cover my volume. And I could build little by little, or as fast as I wished.

"So, I started. I took the wonderful training furnished by the company. When I was ready I followed the simple plan outlined in the training. During the first period I did all the service work myself. By doing it myself, I could make much more per hour than I had ever made on a salary. Later, I would hire men, train them, pay them well, and still make an hourly profit on their time that made my idea of retirement possible—I had joined the country club and now I could play golf whenever I wished.

"What is this wonderful business? It's Duraclean. And, what is Duraclean? It's an improved, space-age process for cleaning upholstered furniture, rugs and tacked down carpets. It not only cleans but enlivens and sparkles up the colors. It does not wear down the fiber or drive part of the dirt into the base of the rug as machine scrubbing does. Instead it *lifts* out the dirt by means of an absorbent dry foam.

"Furniture dealers and department stores refer their customers to the Duraclean Specialist. Insurance men say Duraclean can save them money on fire claims. Hotels, motels, specialty shops and big stores make annual contracts for keeping their carpets and furniture fresh and clean.

"Well, that's the business I was able to start with such a small investment. That's the business I built up over a period of eight years. And, that's the business I sold out at

a substantial profit before I was fifty."

Would you like to have the freedom and independence enjoyed by Mr. Haikey? You can. Let us send you the facts. Mail the coupon, and you'll receive all the details, absolutely without obligation. No salesman will ever call on you. When you receive our illustrated booklet, you'll learn how we show you STEP BY STEP how to get customers; and how to have your customers get you more customers from their recommendations.

This is an opportunity for a career you will enjoy far more than a routine job. You make many friends who appreciate your quality services.

With no obligation, we'll mail you a 32-page booklet explaining the business. Then you, and you alone, in the privacy of your home, can decide. Don't delay. Get the facts before your location is taken by someone else. Mail the coupon, now.



**Duraclean  
International**



**The first step—send for  
FREE Booklet today!**

Duraclean International  
3-173 Duraclean Bldg., Deerfield, IL 60015  
WITHOUT OBLIGATION send free booklet that tells  
how I can have a Duraclean business. No salesman  
will call.

PLEASE PRINT

Name \_\_\_\_\_  
Address \_\_\_\_\_  
City \_\_\_\_\_  
State \_\_\_\_\_ Zip \_\_\_\_\_



**OLD SOUTH COLUMNS IN EXTRUDED ALUMINUM CAN BE USED TO REPLACE ROTTING WOOD COLUMNS IN 8 EASY STEPS!**

1. Call 1-800-841-8674 for literature and prices.
2. Study literature and price sheet to determine that aluminum columns are less expensive and easier to obtain than wood columns.
3. Sell spouse on all advantages of aluminum columns.
4. Call factory at same toll-free number and place order for columns to be shipped immediately from stock of 50,000. Use credit card or mail check.
5. Schedule Saturday morning do-it-yourself project.
6. Columns will arrive in approximately 10 days.
7. Arrange for moral support, 2 soft drinks, 1 can elbow grease, hammer, saw, level, and jack.
8. Follow directions and install columns on Saturday morning, eat lunch, then play golf with friends.

*Moultrie Manufacturing Company*  
 Phone 800/841-8674 toll-free  
 Moultrie, GA 31768

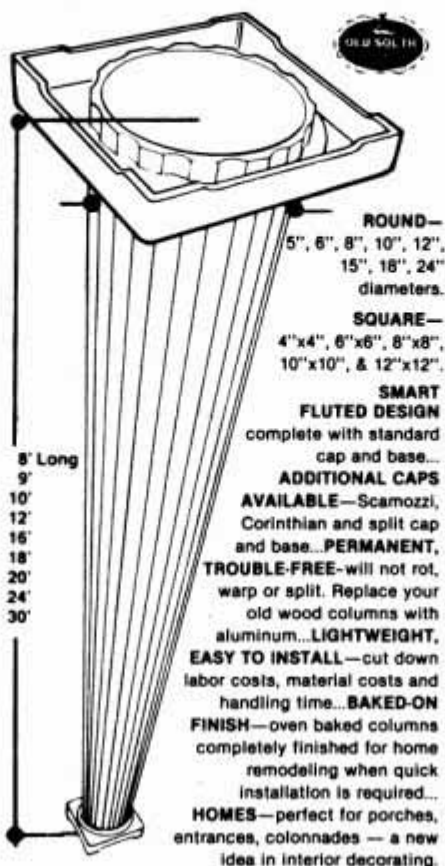

**DRIVING THE NISSAN PULSAR**

*(Continued from page 156)*

behavior is quite close to neutral for a front-wheel-drive car. Since there is no rear antiroll bar, this handling attitude may be due to stiffer rear springs and other tuning measures which could explain the less charming aspects of the freeway ride.

Still, what matters most are the mileage numbers the EPA allows a company to advertise. Nissan told its advertising agency to print up some nice, big ones for the Pulsar. The three-speed automatic will register 31 mpg in city, 39 on the highway. The five-speed offers 35 in the city and 50 on those jiggly highways.

For a high-mileage car, the NX carries a pizzazz interior. It's color coordinated and everything fits. There's a tachometer, detachable sunroof, 175/70 white-letter radial tires, full wheel covers, AM/FM stereo, halogen headlights, quartz clock, remote trunk and gas-cap door openers and rear-window defogger, among other features. The only options are automatic transmission and air conditioning.

The seats recline in small increments and the steering column is adjustable for height. Vision is good out the front, to the sides and directly to the rear through the large, rectangular back window, but not so wonderful to the rear three-quarter. The large rear pillar obscures a good portion of the scenery when you glance over your shoulder to change lanes. The remote adjustable mirrors move backwards—move the handle in to move the mirror out—and on the cars I drove, it couldn't be adjusted upwards enough to see much more than pavement. The high rear roofline offers adequate headroom for most people and overall quality appeared to be first rate.

**Mixed reactions**

The bizarre NX styling provokes mixed reactions. The people I talked to whose business involves knowing about cars thought it was pretty awful. But those not in the automotive field tended to like it.

Essentially, the Pulsar, is a Sentra that's a little bit shorter and a little bit heavier. It delivers the same EPA fuel economy from the same powertrain, should have identical performance, carries a sportier image with more features and "product content," and costs more money. Retail of the NX is \$7,399, and when the hatchbacks appear, they'll probably be in the region of \$6,500 to \$7,000. The Sentra is priced from \$4,949 to \$6,599.

In a way, it's a low-buck Honda Prelude—just one more of Nissan's 31 flavors in the car store. **FM**

**THE ONLY SLIPPAGE WITH THIS SCREW**



**IS IN OUR PRICE 25% OFF**

The square recessed head makes these screws virtually strip proof. Special D6520 offer includes: 9 packs (20 screws per pack) sizes 3/8" to 1 1/2" plus one square head driver. Regularly \$10.65 sale price \$8.40 (includes shipping) (Minnesota resident add 5%)

FREE CATALOG WITH PURCHASE (OR SEND \$1.00 FOR FULL COLOR 112 PAGE CATALOG)



Dept. E 703, 21801 Industrial Blvd., Rogers, MN 55374

**SEE 145 BOATS... NEW!**  
 you can build from KITS



Save 50% on your next boat!  
**GIANT BUYERS GUIDE**  
**POWER & SAIL • 8 - 70FT WOOD • STEEL • FIBERGLASS**

From dinghies, daysailors, and runabouts, to ocean cruising sailboats, sportfishermen, and trawlers: **THE COMPLETE GUIDE TO BOAT KITS, BARE HULLS & CUSTOM BUILDERS** uncovers them all...dozens you've never seen before...all sell for a fraction of the factory-built cost!

THE GUIDE features over 300 photos; complete specs and prices; colorful, illustrated, in-depth articles; kit financing information; money-making and money-saving info; construction techniques and product reviews.

Save Even More! **BOATBUILDER** magazine keeps you abreast of the latest developments in design and construction, new kits, new plans, new products and techniques, tips, trials, and owner/builder interviews. Six BIG issues each year!

**BONUS FREE!** **The Complete BOAT PLAN Directory** Yours Free when you order THE GUIDE or BOATBUILDER magazine. **Order both!** Your satisfaction is guaranteed.

**\*30 Day Money-Back Guarantee\***  
 OCEAN LOGIC, INC.  
 PO Box 1109  
 Department G2  
 W Palm Beach, FL 33402

**Mail BOAT KIT Guide and BOAT PLAN Directory**  
 \$10 (3rd Class - US Only)  
 \$12 (RUSH DELIVERY)  
 \$15 (Foreign - US Funds)  
 Boatbuilder magazine \$15/yr

NAME \_\_\_\_\_  
 ADDRESS \_\_\_\_\_  
 CITY/STATE/ZIP \_\_\_\_\_  
 CARD# \_\_\_\_\_  
 EXP DATE \_\_\_\_\_  MasterCard  VISA

Order **TOLL-FREE** Day or Night  
 MasterCard or VISA **REQUIRED**  
 CALL 1-800-327-8456 ext 236  
 (in Fla.) 1-800-432-2382 ext 236  
 Operator CANNOT answer questions -no CDOs





# PASSPORT TO FREEDOM!

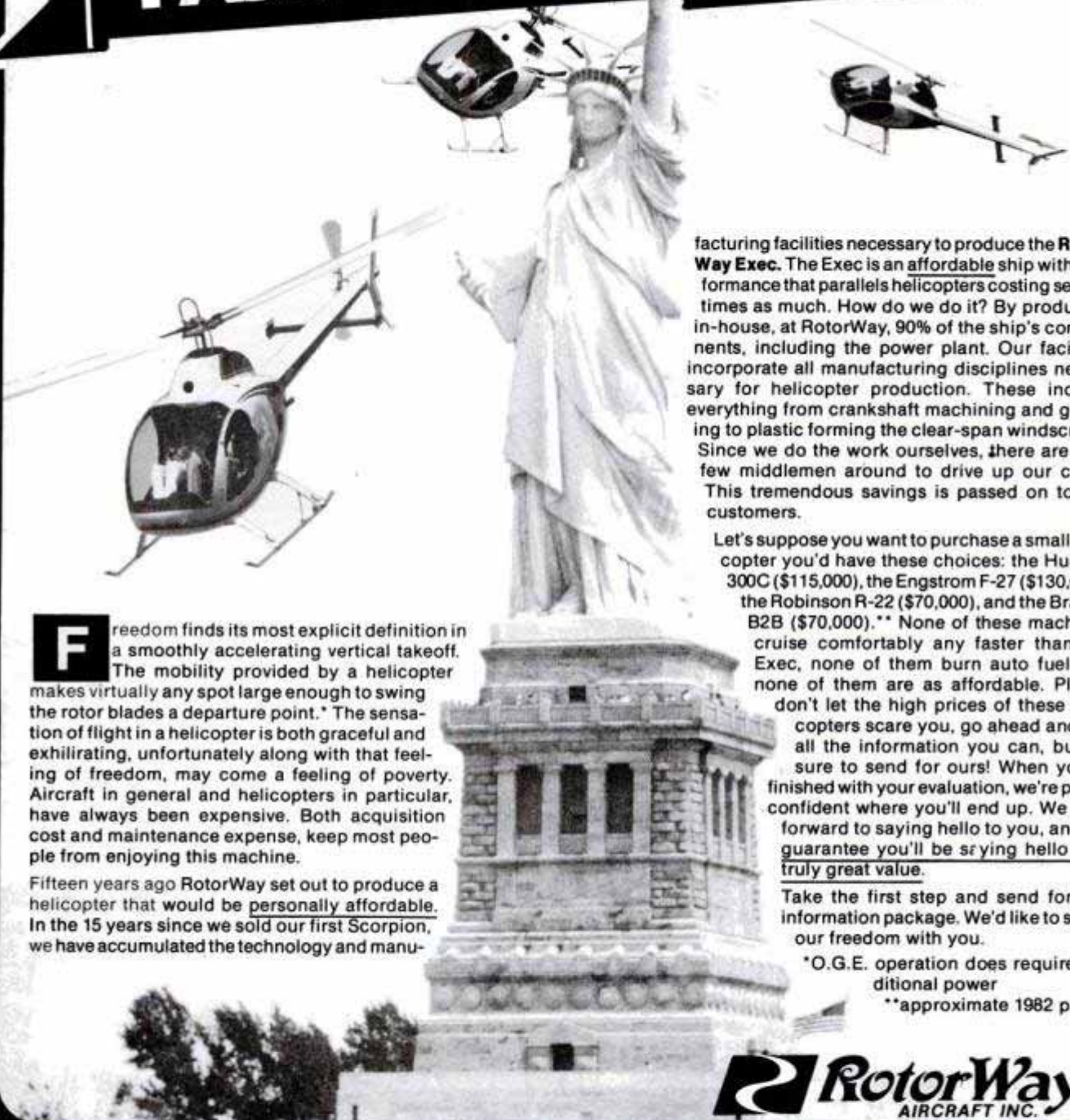

**F**reedom finds its most explicit definition in a smoothly accelerating vertical takeoff. The mobility provided by a helicopter makes virtually any spot large enough to swing the rotor blades a departure point.\* The sensation of flight in a helicopter is both graceful and exhilarating, unfortunately along with that feeling of freedom, may come a feeling of poverty. Aircraft in general and helicopters in particular, have always been expensive. Both acquisition cost and maintenance expense, keep most people from enjoying this machine.

Fifteen years ago RotorWay set out to produce a helicopter that would be personally affordable. In the 15 years since we sold our first Scorpion, we have accumulated the technology and manu-

facturing facilities necessary to produce the **RotorWay Exec**. The Exec is an affordable ship with performance that parallels helicopters costing several times as much. How do we do it? By producing in-house, at RotorWay, 90% of the ship's components, including the power plant. Our facilities incorporate all manufacturing disciplines necessary for helicopter production. These include everything from crankshaft machining and grinding to plastic forming the clear-span windscreen. Since we do the work ourselves, there are very few middlemen around to drive up our costs. This tremendous savings is passed on to our customers.

Let's suppose you want to purchase a small helicopter you'd have these choices: the Hughes 300C (\$115,000), the Engstrom F-27 (\$130,000), the Robinson R-22 (\$70,000), and the Brantly B2B (\$70,000).\*\* None of these machines cruise comfortably any faster than the Exec, none of them burn auto fuel and none of them are as affordable. Please don't let the high prices of these helicopters scare you, go ahead and get all the information you can, but be sure to send for ours! When you're finished with your evaluation, we're pretty confident where you'll end up. We look forward to saying hello to you, and we guarantee you'll be saying hello to a truly great value.

Take the first step and send for our information package. We'd like to share our freedom with you.

\*O.G.E. operation does require additional power

\*\*approximate 1982 prices

**RotorWay**  
AIRCRAFT INC.

## Helicopter Tidbits

### Why a Two Bladed Rotor?

1. The inherent simplicity in a two-bladed teetering rotor makes for a less costly system and the novice pilot now doesn't have to worry about things like lead/lag dampeners, which can cause trouble.
2. This type of rotor is difficult if not impossible to excite in ground resonance. Ground resonance is a condition which can occur in a multi-bladed rotor, while the helicopter is setting very light on its skids, just before lift off. If it starts to occur and the pilot isn't quick to respond, the helicopter may destroy itself right on the spot.
3. You can park a two-bladed helicopter in your garage or in a very narrow space.



Order our beautifully illustrated information package. We know that most pleasure flying has become just too expensive, until now!

That's exactly why we designed our helicopters to be affordable. Send for our exciting full color brochure to evaluate either the Scorpion or Exec. A step-by-step description of the RotorWay program and how you can be a part of this exciting evolution. Includes a 24" x 36" poster size view of all major components, 3 view drawing, autorotational information, pricing details and a special offer.

**ORDER YOUR PACKAGE TODAY!**

Credit card customers, to order package. **Call Toll Free Now.**

U.S. 800-824-7888  
California 800-852-7777 Alaska and Hawaii 800-824-7919, operator 169

Charge to Mastercard, Visa, Am. Ex. No. \_\_\_\_\_ Exp. date \_\_\_\_\_  
Signature \_\_\_\_\_

Send me all the information on how I can afford my own RotorWay helicopter.

- EXEC and SCORPION information \$15.00 (\$35.00 foreign)  
 EXEC only \$12.00 (\$25.00 foreign)  
 SCORPION only \$12.00 (\$25.00 foreign)

NAME \_\_\_\_\_

ADDRESS \_\_\_\_\_

CITY \_\_\_\_\_ STATE \_\_\_\_\_ ZIP \_\_\_\_\_

**RotorWay** 7411 W. GALVESTON  
AIRCRAFT INC. CHANDLER, AZ. 85224; PHONE 602-961-1001 3PM3



Fast, agile and now with a ragtop, the 911SC stands as the last of Porsche's rear-engined cars.

## Driving The Porsche Cabriolet

For the first time in 18 years, there's a Porsche with a ragtop.

BY CLIFF GROMER

**A** Porsche snapping through the tight turns in the mountains of Southern California is a common sight. The one I was driving, however, was no "ordinary" coupe or Targa. It was a new convertible (Porsche calls it a cabriolet)—the first drop top from Porsche in 18 years.

Why a convertible, er, cabriolet? Well, there's something special about true open-air driving in a thoroughbred sports machine. As a matter of fact, some Porsche Targa owners have shoveled piles of money over to shops that specialize in sawing off the Targa top and installing a folding soft top.

The Porsche factory also uses the basic Targa chassis for its soft-top derivative. Basic structural differences between the two models are minor. The motor support area is beefed up slightly

for added rigidity, and there's a new routing of the fuel line.

The folding top, weighing some 30 pounds less than the Targa system, is manually operated. Porsche promises that an automatic version is on the way. Two removable handles plug into sockets to unlock and lock the top in position. Large recessed handholds help you grip the top for easy raising and lowering. The rear window is zippered so it will lay flat when you're stowing the top, or for added ventilation when driving with the top up.

The top is supported by a three-bow frame and uses spring-loaded tension cables for a snug fit. Unlike its lesser cousin, the VW Rabbit convertible, whose top in the down position resembles the Great Wall of China, the Porsche top tucks neatly out of the way. You get a boot that fits over the folded top for that final tidy touch. A tonneau cover costs extra.



With top up, the lines conform to that of the hardtop.

The rear seats (a generous term at best) have release buttons so the backs can fold down when raising or lowering the top. The seat backs are angled forward more sharply in the Cabriolet than in the other 911s, making them even more uncomfortable than usual. The rear seats may be perfectly okay for small kids who don't know any better, but they're definitely off-limits to adults.

Working the top is hassle-free. It's a one-man, five-minute deal. When locked in place, you can forget about annoyances like the top flapping, wind

*(Please turn to page 162)*



# Powerful Portable Workshop In A Suitcase

Take it anywhere you drive,  
fly or sail - stows easily

Now even when you are out in the desert, up in the mountains, down on the farm, or out to sea, jobs normally difficult away from household power become easy! POWER MAX has developed a 12 volt set of the five most used power tools, and placed them, along with accessories, into a durable case. Each tool fits into its own pre-formed, recessed compartment, which holds them securely in place even if the case is turned upside down



or knocked around from rough handling in the back of a pick-up. Tools operate off of 12 VDC current from your car, truck, RV or boat. Wherever you are, you'll be able to drill, sand or polish with these compact, lightweight, versatile, yet powerful, portable hand tools. As vital to the prudent sailor, explorer or weekend adventurer as a first aid kit.

## Built tough to handle heavy duty jobs

The instant you attach the tool battery clip to your battery and squeeze the trigger, you'll know that you are holding one 12 volt tool that is really engineered to perform! The POWER MAX comes to life with a big, extremely high torque, 3/8 horsepower motor turning an exciting 2,350 RPM (no load). This Drill/PowerHead is the heart of the system.

The gear case is a heavy duty industrial aluminum casting, which is precision machined for a front ball bearing race and front accessory adaptor. The steel motor housing encases powerful, pre-oriented barium-ferrite magnets to yield ultimate power; a long life industrial switch and trigger lock; three (3) sets of ball bearings, with the motor output shaft supported with double ball bearings; linear motion carbon brushes for extended life; and a unique built-in noise suppression feature, just for starters!

The motor is hermetically sealed, making the PowerHead virtually rust proof and dust proof, adding tremendously to the tool's life. Plus, a 12-pole motor for really smooth running and a high efficiency, low loss magnetic-iron armature, are features that turn energy into torque and horsepower, instead of heat, again making the unit more efficient. Permanently lubricated helical gears make the unit almost indestructible and enhance the



### CARRYING CASE

Handsome, double wall molded, durable with recessed tool compartment. Heavy duty, rust proof with latches and integral handle. Resists oil, acids and alkali. Won't crack in extreme temperatures.

### 3/8 HORSEPOWER DRILL/POWERHEAD

Heart of the set develops 3/8 HP and 2,350 RPM (no load speed). Permanently lubricated helical gears. 3 sets of ball bearings, designed for maximum power with minimum current drain. Powerful, high torque portability.

### ORBITAL SANDER

Easy to use, beefy design uses ball bearings with a big spring clamp for quick changing of sandpaper grits. 20 assorted sheets included.

### DISK SANDER POLISHER

Five inch diameter flexible disk, complete with buffer pads and 10 assorted sandpaper disk grits

### CIRCULAR SAW

Cuts thru boards to 1 1/2" at 90°, adjustable depth and tilt. With blade guard, parallel cutting guide and two blades (28 tooth combination and 80 tooth finishing)

### SABER SAW

Steel base tilts 45° right or left for bevel cuts. Includes three blades. Full half inch stroke.

power to drive the Quick-Attach, add on accessories.

The PowerHead is designed to deliver the maximum power with the minimum power drain. Even after many hours of working with the tools, you will have more than ample starting power left in your battery!

Consider the convenience, versatility and reliability due to excellence in design and material quality. Once you've used POWER MAX tools, you will agree that this set is the most important, speciality portable power tools you'll ever own!

## The only outdoor enthusiast's total power tool set

Drill effortlessly thru wood, power your way thru Masonite or even steel. Remove the 3/8" German made chuck, screw on an adapter-nut, and you've got the PowerHead for driving the other tools. Quickly attach the circular saw and you've got the power to zip thru 2x4s. The saber saw can be attached upside down to any work table top (special clamp included), converting it to a jig saw, thus allowing both hands to be free to saw.

Also included in the set are a 1 - 2 1/2 inch hole saw; a five inch disc sander/polisher; a pack of 10 sanding disks; special 16 1/2 foot extension cord; a depth guide for the drill; a pack of three (3) saber saw blades; two (2) circular blades (28 and 80 tooth); three hex keys; 1 drill chuck wrench; adapter nut and a chuck key.

The set is perfect for the handyman, repairman or anyone needing quality power tools away from 110 VAC outlets!

## Our no risk trial means you must be delighted

Order your Workshop In A Suitcase today! Find out for yourself that POWER MAX tools are the ultimate high performance portables. Easily the best built, most powerful, and unquestionably most versatile power tools available! You be the judge - if you are not delighted with the quality and impressed with the power, send the set back to us within 30 days for a full refund. One year warranty. The cost of the set is surprisingly low, considering the all around quality and excellent design concept.

### ORDER TOLL FREE

Order NO. 860106. Visa or Mastercard holders call TOLL FREE, or send check or money order for \$299 plus \$9.50 delivery. California residents add 6% sales tax.

**800 854-8471**  
In Calif. 800 472-8456

**I. D. RATHERBY**  
18480 Bandilier Circle, Dept. SB  
Fountain Valley, CA 92708

Send for our free brochures of other products



## Fabulous Folbotting NOW

Avoid the risks and discomfort of flippy canoes, skimpy kayaks, wobbly inflatable rafts! NOW, you GLIDE securely in perfected Folbot, completely relaxed in EXCLUSIVE swivelback COMFORT. America's foremost small craft in various styles and colors, from 1 to 4 seaters, GLIDE smoother, faster with EASIER lightweight double blades, efficient yacht-smart sails, small motors. Perfect for nature study, scouting, float cruising, supreme in White Water, Surf, Marsh and Sea. Most INEXPENSIVE in EASY PREFAB Kits or ready FACTORY BUILT, also travel-smart FOLDING tubes to fit inside trunk of aircraft.

### FOLBOT

Super Craft at BIG SAVINGS

Easy PREFAB Kits from \$182 or cartop FACTORY BUILT from \$348

FOLDING from \$612 ideal Sail Rig \$279

Smart Economic BASIC Kits  
12 foot Single \$40  
16 foot Double \$52  
Big Sailer 16 foot \$61

## FREE

Action Color Catalog With Facts & Figures For rush inc. \$1 First Class Postage

Mail coupon or address

to: FOLBOT CORP. PM383 Charleston, S. C. 29405

Print Name \_\_\_\_\_

Address \_\_\_\_\_

City \_\_\_\_\_ State \_\_\_\_\_

Zip Code \_\_\_\_\_



## ONE-MAN Sawmill

The Only ONE-MAN PORTABLE

SAWMILL of Its Kind in The World!

If you need good, high-quality lumber, don't let inflated lumber prices stop your important building projects. The Foley-Belsaw goes right to the trees and turns out smooth, true-cut lumber... even beginners get excellent results. Just one man (no crew needed) can easily cut enough on weekends to save hundreds of dollars over high lumberyard prices. For power use tractor PTO or other low HP diesel or electric unit. Factory-direct selling keeps price low, and convenient time payments may be arranged.

Send for FREE BOOK! Just mail coupon below for "How To Saw Lumber" booklet and complete facts on the One-Man Sawmill. There is NO Obligation and NO Salesman Will Call on you. Do It TODAY!

**FREE BOOK** 

Foley-Belsaw Co.  
30142 Field Building  
Kansas City, Mo. 64111

Please send all facts and details in your FREE BOOK "How To Saw Lumber". I understand there is No Obligation and that No Salesman will call on me.

Name \_\_\_\_\_  
Address \_\_\_\_\_  
City-State \_\_\_\_\_ Zip \_\_\_\_\_

## PORSCHE CABRIOLET

(Continued from page 160)

whistles or water leaks. Credit for the top's excellent stability at any speed and its safe-like sealing security goes to a steel plate installed beneath the front section of the cloth top. And the top is so designed that its shape conforms to the 911's swoopy, sexy lines.

Underneath the soft top is pure 911SC. Unlike the more civilized, but very roadworthy 944 and the luxury starship 928, the 911 is the only Porsche for the hard-core enthusiast of the marque. A direct bloodline descendant of the classic 356 model, the 911SC embodies all that the good Dr. Ferdinand intended the car to be—and then some. The 911 may be more challenging to drive compared to the other models but, according to the purists, oh so much more satisfying.

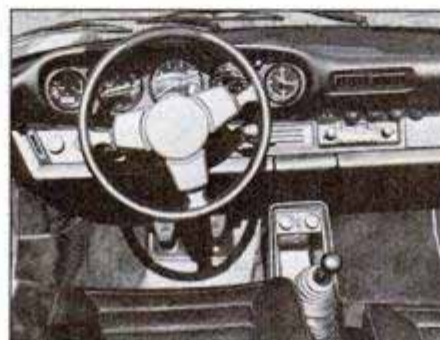

The interior of the Cabriolet is typically German: taut, crisp and well engineered.

The business end of the 911SC is the rear, where, according to tradition, you'll find the engine and transaxle. This makes for a rear-favored weight bias which can cause the car to be unforgiving at times. You'd be surprised at how white your knuckles can get when the back end unexpectedly decides to come around in a sudden blitz of oversteer.

The rear location of the transaxle also results in a long gearshift linkage which can make for vague gear engagement. At times, you feel like you're probing with the stick to see what gear you'll finally spear.

A drawback of design? Perhaps, but the traditionalists would have it no other way. They say that once you get used to the quirks of gear changing, it spoils you for anything else. Unfortunately, Porsche wouldn't let us keep the car long enough for us to be spoiled for anything else.

The concept of the 911SC is a serious sports machine that has high regard for comfort and even luxury, as well as performance. Few compromises have been made that would dull the razor reflexes of the machine.

The cockpit, cobbled in black leather, is all very businesslike—no frills or

doodads, just plain, readable, aircraft-style instruments, white numerals on black faces. The 911 resists the current trend of some carmakers to see who can come up with the trickiest digital readout or the most spectacular display of aurora borealis dancing lights for the dash. An exciting instrument panel is a poor excuse for a boring driving machine.

The front bucket seats are firm and comfortable, and give excellent support, especially in the lower back area. Lateral support is very good without using those cumbersome side wings that want to come around and digest you like a Venus' flytrap.

The footwells are small. You have to hunt for room to park your left foot. The bulge in the left side of the footwell doesn't help matters either, and it displaces the clutch and brake pedals slightly to the right of where you'd expect them to be. Something else to get used to.

Inserting the rather long ignition key into the lock is like stabbing the dash with a short bayonet. A quick twist to the right, and the flat Six responds with an enthusiastic exhaust. The clutch is another no-compromise item. It's either in or out. There's no soft, gradual range of engagement. Let up on the pedal and the engine hooks up *right now!*

And there's certainly nothing soft or gradual about the 911's power curve. Come off the line hard, and the 911 punches you back into the seat. First gear response, with its stiff 3.18 to 1 gearing, has all the alacrity of a whip crack. The brutality slackens some as you power through the milder-ratioed upper gears, but it always remains spirited.

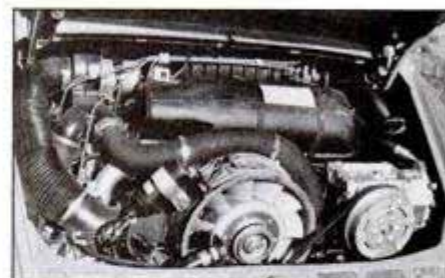

The very willing six-cylinder boxer motor is good for an observed 120-mph top end.

Acceleration is brisk up to an indicated 100 mph and then falls off before topping out at 120 mph. This is some 20 mph below the car's advertised top speed, and we don't know if Porsche lovers quibble about this sort of thing or not. It's certainly good enough for us in this day of the 55-mph limit.

Steering response, handling and braking action are what total performance is all about. It's what the 911SC was made for. All the controls are very

(Please turn to page 164)



# SENSATIONAL, ALL-NEW NONPRISMATIC 50 MILE BINOCULARS

IT'S A WONDERFUL,  
EXCITING GIFT!



GIANT 60MM  
OBJECTIVE  
LENSES!

NOW  
ONLY  
**7.98**  
WHILE  
THEY LAST!

**FREE!**

LENS COVERS AND SHOULDER  
STRAPS WITH EACH PAIR

- CHECK LIST OF  
QUALITY FEATURES
- Giant 60MM Lenses
  - Custom Eye Width Control
  - Free Carry Straps
  - Heavy Duty Body
  - Unbreakable Lenses
  - Variable Center Focusing
  - Revolutionary New Design
  - No Glare Black Body
  - Protective Lens Cap

FOSTER-TRENT proudly presents the Jubilee Model of the famous POWERHOUSE BINOCULARS. This Gigantic "SUPER 60" was created in Europe after years of extensive research. It's chock full of revolutionary new design ideas, such as Fluted Barrels for extra strength . . . Variable Focusing for smoother, pull-in power — from 50 Yards or 50 Miles away! Best of all, GIANT 60MM Objective Lenses for massive light gathering power. You'll get terrific views. Now, any reader of this publication can own these superb binoculars at rock-bottom cost.

Perfect For Sport Fans, Nature Lovers!  
Great For Secret Surveillance!

The Giant 60MM Lenses pull in the thrilling action . . . even from the bleachers. Study wild animals without disturbing them. Enjoy thrilling vistas from 50 MILES AWAY. See without being seen . . . it's fun to be your own detective. Study suspicious strangers from the privacy of your own home.

Try Them On 30 Day Free Home Trial!

No Risk . . . No Obligation. Enjoy them for 1 full month before deciding. If you're not 100% satisfied return them for a full, immediate refund except postage & handling. All orders received will be shipped on a first come, first served basis. Please act promptly for fast shipment.

\*\*\*\*\*  
**SPECIAL PURCHASE ON:  
SUPER DELUXE MODEL!**

A limited quantity of our NEW DELUXE MODEL (not illustrated) is now available. It has all of the great features of the model described in this ad PLUS Tinted Lenses and a New Body Design. Only \$2 more. It is our Model No. 195 — Only \$9.98 Each!

**10 YEAR CONDITIONAL GUARANTEE**

These Binoculars are fully warranted against Manufacturers defects for 10 YEARS. If they do not operate properly anytime in 10 years, return with \$2 to cover handling costs and they will be repaired or replaced free. Guarantee ends Dec. 31, 1993.

INDICATE QUANTITY WANTED BELOW

- ONE BINOCULAR — \$7.98
- TWO BINOCULARS — \$14.00
- THREE BINOCULARS — \$19
- SPECIAL BINOCULAR CASE ONLY \$2.00 EACH
- DELUXE MODEL—No. 195 — \$9.98

## Famous EPISCOPE HOME THEATRE

PROJECTS PHOTOS, PRINTS, STAMPS,  
SMALL INSECTS, SKETCHES, COINS,  
GEMS IN NATURAL COLOR AND  
TRUE TO LIFE ACTION!!!

only...  
**\$15.95**

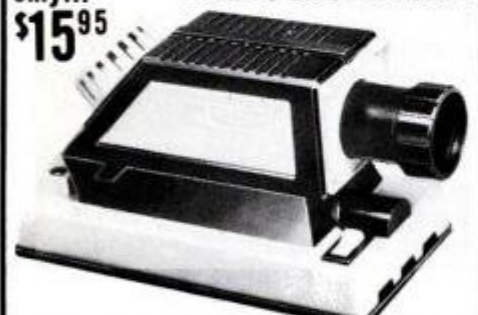

IDEAL FOR STUDENTS, TEACHERS,  
ARTISTS AND HOURS OF FAMILY FUN!

This BRAND-NEW EPISCOPE PROJECTOR projects directly from snapshots, books, even solid objects like coins, mineral specimens, etc. Fine reflector and mirror system, Hi-intensity projection lens that enlarges images up to 16 feet square! Rugged two-tone body and base with cooling vents and "on-off" switch.

No. 4500A — Episcopes Projector .....\$15.95

## A POWERFUL CO<sub>2</sub> PISTOL



FIRES 100  
SHOTS WITHOUT  
RELOADING!

- Precision Made
- Quality Materials
- Checkered Target Grips
- Adjustable Rear Sight
- Positive Safety Catch
- Velocity Regulator

A powerful new CO<sub>2</sub> semi-automatic BB Pistol that has the look, feel and balance of a regular automatic at a price that lets you enjoy real low cost target shooting at home! The ROGER is carefully engineered and precision machined of the finest alloys and materials with many features usually found only in handguns costing much more: 6" barrel, 10½" long overall, checkered thumb rest type target grips, rear sight adjustable for windage and elevation, positive safety catch, velocity adjustment and a handsome midnight black finish. This is the answer to target shooting without the cost of expensive fixed ammunition. The ROGER uses regular BBs obtainable anywhere and will fire 100 shots without reloading. The pistol comes attractively boxed, complete with CO<sub>2</sub> cartridge and a tube of BBs.

No. 2077—ROGER CO<sub>2</sub> BB Pistol Outfit ...32.95  
No. 2077A—Custom Holster .....4.95

## SUPER AWL WORKS LIKE A MACHINE... SEWS LEATHER, RUBBER, CANVAS, PLASTIC, UPHOLSTERY, NAUGAHYDE & ALL TOUGH MATERIALS!



**FREE**  
Accessory Kit

ONLY  
**\$4.98**

Made in USA

Repairs Luggage,  
Upholstery, Boots, Rugs,  
Convertible Tops, Tents,  
Auto Seat Covers, Awnings.

Super Awl works just like a machine. Sews and repairs tough naugahyde, upholstery, leather, canvas, etc. Makes permanent repairs to luggage, convertible tops, furniture. Used by saddle & harness makers for many years to make tough, durable lock stitch — automatically! Hardwood handle holds extra needles, wrench. Comes with 30 ft. spool of tough, waxed thread.

No. 5029—Super Awl .....\$4.98  
No. 5030—Extra 25 yd. Skein of Thread.\$1.59

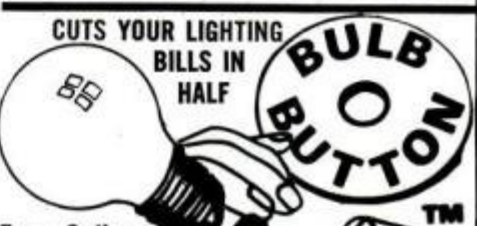

CUTS YOUR LIGHTING  
BILLS IN  
HALF

**BULB  
BUTTON**  
TM

Turns Ordinary  
Bulbs To  
Lifetime Bulbs!

Yes you can cut your lighting bill in half . . . and your ordinary bulbs become lifetime bulbs as a bonus!!! Just press a bulb button in place, at the base of your bulbs and it reduces the voltage used by 50% . . . instantly. Extra "soft start" feature eliminates bulb burnout problems. Fits all standard socket bulbs from 7½ to 350 Watts.

No. 1081—Bulb Button .....\$2.97

Special: 3 for 7.88

**Foster-Trent** INC  
2345 Post Road, Dept. 522-C, Larchmont, N.Y. 10538

RUSH the items ordered below on 30 DAY TRIAL — complete satisfaction GUARANTEED or my money back promptly (except postage & handling). My payment is enclosed including 1.45 for postage & handling. (Sorry! No C.O.D.)

QUAN.	SIZE	ITEM NO.	DESCRIPTION	PRICE
			Shipping & Handling	1 4 5
			N.Y. State customers please add sales tax	
			Total Enclosed	

Please use Street Address and Apt. No. for FASTER U.P.S. Delivery!  
Print Name \_\_\_\_\_  
Address \_\_\_\_\_ Apt. No. \_\_\_\_\_  
City \_\_\_\_\_  
State \_\_\_\_\_ Zip Code \_\_\_\_\_

NOTICE: Visa and Master Charge card holders may call in their order from 9 AM to 5 PM Eastern Standard Time. Call: 914-834-7370. Sorry, we cannot accept Collect Calls.

VISA No. \_\_\_\_\_  
 MASTER CHARGE No. \_\_\_\_\_  
Expiration Date \_\_\_\_\_ Interbank No. \_\_\_\_\_



# \$19,500



The Trenton

## NO DOWN PAYMENT BELOW-MARKET FINANCING

SEND TODAY FOR  
MORE DETAILS

If you thought you couldn't afford a home of your own, think again. You still can! Over 20,000 families just like you have built Miles Homes using our step-by-step instructions. Over 50 exciting do-it-yourself models plus a full selection of optional materials - like heating, plumbing and electrical packages - are available to give you the home you want at a price you can afford.

No money down, below-market financing, low monthly payments. It's not too good to be true, just too good to be passed up.

Please send me (check one):

- Free color brochure
- 80 page, full color catalog. (Please enclose \$3 check or money order.)

Mail to: Miles Homes™  
4700 Nathan Lane, P.O. Box 9495  
Mpls., MN 55440

PHONE NUMBER ( \_\_\_\_\_ ) \_\_\_\_\_

NAME \_\_\_\_\_

ADDRESS \_\_\_\_\_

CITY \_\_\_\_\_ STATE \_\_\_\_\_

ZIP \_\_\_\_\_

MPM3-0283



### PORSCHE CABRIOLET

(Continued from page 162)

direct and quick-acting. The four-wheel ventilated disc brakes could lock the wheels at any speed in straight-line stop. A series of panic bounces on the brake pedal at 70 mph was simply shrugged off by the car.

The suspension system is well sorted out, as indeed it should be. After all, Porsche has been playing around with this car's basic design since 1948, with the first of the 911 series going on sale in this country in '64. The current arrangement uses MacPherson struts (sans springs) combined with adjustable torsion bars on the lower control arms in the front, and semitrailing arms with torsion bars at the rear.

Making the most of the suspension technology is a wide footprint of Pirelli P7 rubber. The low-profile 55-series skins in front, and 50-series on the rear, all mounted on 16-inch wheels, do their part for maximum handling and steering response. The narrow sidewall flexes less and so gives more direct input to the wheel. An excellent tire overall, the P7s tended to "nibble" or pull at the wheel slightly. The steering wheel also picks up road vibration and kicks back on rough roads.

When you get tired of playing road racer, just plot the gear lever into FIFTH and sit back for low rev, quick highway cruising and 25-mpg economy. Even though the 911 is set up with a bias toward the sporting, overall ride quality keeps fatigue at bay.

#### Nothing hangs loose

Fit and finish are buzzwords that have been beaten to death in recent times. American consumers have developed tendonitis by pointing their fingers at Japanese products while shaking their fists at Detroit. Well, the Germans were experts at the game long before the Japanese came out on the field. And there's been no slacking off at Porsche. You just don't find rough edges, missing fasteners, or things hanging loose. Paintwork is show quality. Indications are that the 911SC Cabriolet will price in at about \$36,000.

What does Porsche plan as an encore for its venerable 911 series after its Cabriolet act? The factory currently is working on redoing the Turbo model, but there are no plans to drop the boosted engine into the Targa or Cabriolet. These bodies are not rigid enough to handle the extra power. So for the time being, at least, 911SC fans will have to make the most of the present mill which makes a healthy 172 hp at 5,500 rpm and 189 ft.-lb. of torque at 4,200 rpm from a 2.9-liter (183-cu.-in.) engine.

PM

## The No-Leak Log Home. For Less.



If you're about to purchase a log home, take a look at the construction technique you're going to live with. All log homes experience some checking, seam shrinkage or warping. But thanks to Lincoln Logs' Stack'n Build construction technique, your walls will remain sealed even if your logs shrink. And because of our exacting tolerances, walls always fit snugly together and are not as subject to joint and seam imperfections that cause other log homes to leak air at the joints.

All for a lower total erected cost than any other major log home manufacturer.

Write for your Lincoln Logs plans kit. Send your name, address and telephone number, with

check or money order for \$6.00, to the address below. Or call 800-833-2461 (in New York State call 518-494-2426). MasterCard and Visa accepted.

Exclusive Dealership Territories Available

Simple Log Home Living.  
For Less.



The Original  
Lincoln Logs Ltd.

16033 Riverside Drive  
Chestertown, NY 12817

© 1982, Lincoln Logs Ltd.



After 46-Yrs.-U.S. Gov't. Scientists did it!

# Scientists Create Super-Thriving Shade Tree That Equals an 18-Yr. old Oak for Size And Beauty-in 3 Summers!



## Hailed from Coast-to-Coast as virtually the *Fastest Growing Shade Tree Known to Man!*

Now there's a shade tree that practically grows right before your eyes, into a towering pillar of beauty. Yes, not only does it grow at an incredibly fast rate, but as you can see from the picture, it's exceptionally beautiful too!

### MEASURE UP TO A FULL FOOT OF NEW GROWTH PER MONTH IN ITS SUPER-SOARING GROWING SEASON!!

You've never seen anything like it. Homeowners from coast to coast report astonishing growth rates you can actually measure as the days go by! Order now, and your trees can enjoy the full growing season that Mother Nature intended. They can quickly grow up to eight feet the very first year! That's half the size of a mature Dogwood! And, that's just the start. It can hurtle up to 14 feet the second year. In no time at all, your tree can mature to heights of over 60 feet tall, with its dense, leafy branches spanning up to 35 feet wide! Few other shade trees can match this phenomenal growth speed. And best of all, no special attention is needed to achieve this fast skyrocketing growth and magnificent beauty.

### DEVELOPED BY SCIENTISTS FOR FAST, SURE GROWTH IN VIRTUALLY ANY SOIL, EVERYWHERE IN AMERICA - WITH NO SPECIAL CARE!

As a result of over forty-six years of U.S.D.A. Forestry department of testing research, you can rest assured that this tree will grow fast and well for you. Unlike fussy fruit and nut trees, which require spraying and pampering, this super-growing hybrid is NATURALLY RESISTANT TO MANY DISEASES, PESTS OR INSECTS.

Now stripped of their official Government test number N.E. 41, in favor of the designation - PRESTO POPULUS GIGANTEUS (*Androsroggin Cultivar*). These wonder trees

### "...Six Times the Growth Yield of Other Trees..."

-Ontario Ministry of Natural Resources-

are so easy to plant that even a child can do it!

These trees have proven themselves from rocky, acidic coal-mine slopes to the hot, humid tropics of the Gulf of Mexico, to the bitter, ice-blasted prairies of Canada. These trees...

- Require no special attention aside from regular garden care!
- Thrive in such hostile areas as mine-spoils and reclaimed sanitary landfills!
- Shrug off the effects of frigid winters!
- Need no special pruning or spraying!

Remember, results will vary with each locality. Trees take just moments to plant, and will reward you with years of quick growth and beauty...starting this very season.

### SURGES INTO A BEAUTIFUL SHADE TREE IN A MATTER OF MONTHS

Picture your family sipping ice-cold lemonade on the hottest day of summer... cool and relaxed beneath the spreading limbs

of one of the greatest scientific advancements in the world of trees. With so many fantastic attributes, it may be the finest shade tree ever! Now, picture your patio or lawn becoming the neighborhood show-place. This ornamental beauty stands straight and tall spreading the skies with Olympian vigor! You lay stretched out on your hammock beneath branches and boughs heavy with gorgeous green foliage that throws a massive "Beach Umbrella" over you. Recline in comfort with your favorite magazine... and beat the heat!

Best of all, is knowing that generations of your family will enjoy these strong, spreading, friendly branches that youngsters love to climb on. And generations of loved ones will be good-naturedly boasting to their neighbors and friends about how quickly this super-growing hybrid grew. And, how long this astonishing tree has been "like a member of the family."

### YES, THIS TREE CAN EVEN SAVE YOU DOLLARS AND MAKE YOU MONEY!

Nothing else you can plant can guarantee you practically immediate relief from your fuel bills!

- They'll block the blistering summer sun-Average 10° cooler on hot, sunny days!
- National Realtors estimate average \$2,000.00 additional value to your home when landscaped!
- When the leaves drop in the fall, the sun can easily penetrate and help in heating your home!
- Leaves make excellent garden compost!
- This same Wonder-Hybrid is nationally recognized as a superb source of firewood-energy!

In fact, the very same tree that we now offer you for planting in your yard is being planted by the thousands of acres for firewood purposes! The reason? An estimated 59.8 Million BTU's of energy per acre. More heat than OAK, MAPLE OR HICKORY!

### HOW TO GET YOUR TREES - FOR LESS THAN A CAN OF COFFEE!

That's right! Though you may think, and rightfully so, that a tree with this kind of pedigree, that grows this beautiful, this fast... just has to be expensive. Normally, you'd be right. But, we have a source close to the U.S. Gov't. hybrid program. And, if you order now, through this publication, you can completely forget about astronomical prices. THE TOTALLY UNSURPASSED OFFER: You may purchase two of these certified hybrid trees for just \$5.95. Less than a 3-lb. can of coffee! Elsewhere, quality shade trees cost you many times more, but only through this ad, your price is just \$5.95 for two trees.



THIS TREE IS THREE YEARS OLD! When this little girl was born three years ago, this Hybrid Populus tree had just been planted. Now, as they're both celebrating their 3rd birthday, the tree stands a stately 20-foot tall. This graceful Super-Thriving tree will give you virtually instant shade, and can add value to your home. Read this article on its Amazing Development, now presented for the FIRST TIME.

### WE GUARANTEE YOUR SATISFACTION TWO WAYS

If you feel that this gorgeous growing marvel just isn't for you... if you're not satisfied in every way with these quick growing shade trees, simply return them to us within a full three months of shipment for a full refund of the purchase price... ANYTIME WITHIN THE NEXT YEAR FOR FREE REPLACEMENT! What could be fairer?

### ORDER NOW - RISK FREE OUR SUPPLIES ARE LIMITED THE DEMAND IS GREAT

Because this wonder hybrid is so new, we're naturally limited on the number we can sell this year. So order now, and start enjoying what's virtually the fastest growing shade tree known to man... this very same summer! (Not available in Canada) ©1982

**SUPER SHADE TREE**  
Nursery Division, Dept. G-509  
710 Norwood Lane  
Canton, Ohio 44750

YES, please send me this extraordinary, beautiful, FAST-GROWING shade tree: the PRESTO POPULUS GIGANTEUS. I understand that if I'm not fully delighted, I may return the trees within 90 days for refund of my purchase price (less postage and handling), or free replacement. (Limit 50 trees per family.)

- 2 Trees for only \$ 5.95 plus \$1.20 postage & handling
- 5 Trees for only \$ 7.80 plus \$1.65 postage & handling
- 10 Trees for only \$12.50 plus \$2.00 postage & handling
- 25 Trees for only \$21.85 plus \$3.10 postage & handling
- 50 Trees for only \$39.95 plus \$5.00 postage & handling

CHECK ONE  Cash, check or money order (Make checks payable to Super Shade Tree)  MasterCard  VISA  Charge my

Acct. No. \_\_\_\_\_ Exp. Date \_\_\_\_\_

Total amount enclosed \$ \_\_\_\_\_  
Ohio residents add 5% sales tax. Sorry, no C.O.D. orders accepted (please print)

Name \_\_\_\_\_

Address \_\_\_\_\_

City \_\_\_\_\_ State \_\_\_\_\_ Zip \_\_\_\_\_

Order your Trees now. They'll be shipped at the U.S.D.A. recommended planting time for your neighborhood. And, you'll receive a free growing guide!



By the first year - already a man-high source of beauty and amazement to all who witness the amazing growth speed! Up to a FULL FOOT PER MONTH!



The third year brings cooling shade to comfort the entire family - even on the HOTTEST DAY OF THE YEAR! The beauty and astounding speed of growth really have the neighbors talking!



In its fifth year, your tree's densely foliaged limbs span up to 35 feet wide! And not only gives the whole family shade and enjoyment, but is also the most beautiful shade tree on the block.



\$443.00

# The Bike That Ate Up New York City

Conceived as a 'mountain bike,' the fat-tire flyer is the ideal commuter conveyance in a city where most of the streets are definitely off-road.

BY ROBIN NELSON

**T**he man was in a hurry. He'd already paid the cabdriver, so when the yellow monster cut me off as it pulled in toward the curb on New York City's busy Central Park West, I had nowhere to pass but on the right —braking just wouldn't do the trick. As he flung it open, the cab door caught the Stumpjumper's left handlebar (fortunately, inboard of my hand) as I roared by. I did a passable one-and-a-half in the pike position, with a glide ratio of about four to one, and hit the asphalt on two points—helmet and right shoulder. This, for the uninitiated, is bicycle commuting in New York City.

After I had gotten clear as to time of day, my name and other vitals, and vainly pursued my assailant into the lobby of a doorman-guarded apartment building, I started looking for something in which to put pieces of bicycle. But once again, I had underestimated the Stumpjumper. The handlebars were slightly cocked. I straightened them by hand, got on and rode off (a trifle shakily) on the same sure-footed, fat tires with the same quiet, smooth, 15-speed drive train. Some things still manage to work in this world, and this so-called "mountain bike," a durable machine that a har-

*(Please turn to page 180)*

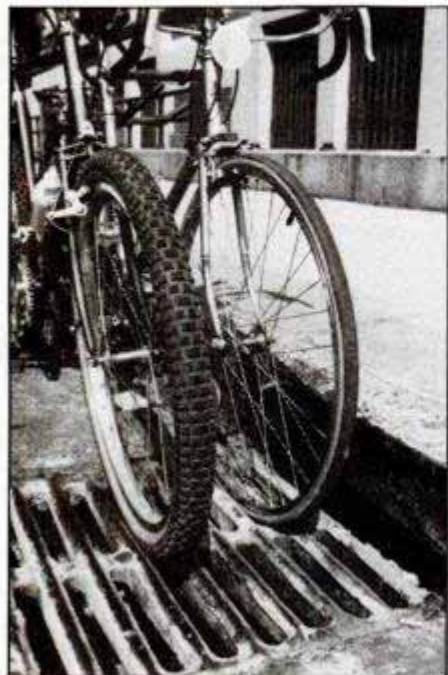

*Riding against traffic (above) is not our normal mode; here a quick fat-tire flyer U-turn helped get us out of a real New York traffic jam (and let our photographer get exactly the shot that he wanted).*

*Sewer grates (far left) are death to the normal 10-speed, thin-tire format, seen next to our off-road fat tires which really pull through.*

*Stumpjumper also conquered the tough crags of Central Park (left); after all —it's a "mountain bike."*





# Bionic "Ears"

Tiny, powerful electronic sensors give you superhearing — through walls, up to 1/2 mile away.

## The Dyna-Mike Transmitter

It's smaller than a quarter. But DYNA-MIKE will transmit every sound in the room to an FM radio tuned to the proper unused frequency, up to half a mile away.

If you're at a neighbor's home a block from your own, you can hear your baby's cry, or you can tell the instant your spouse comes home. If two of you are driving tandem in two cars, one or both of you can communicate with the other even if other cars drive between you.



DYNA-MIKE has as many uses as your imagination can think of. For a business conference, let the tiny microphone sit unobtrusively on the table or concealed on a shelf, and you'll be able to record every word. For businesses, put an FM receiver in a warehouse or remote office and "broadcast" instructions or orders to be filled.

Public speakers never had a better friend than the DYNA-MIKE. No wires or setup — just turn on one or more radios and your speech will come through with perfect fidelity. Put one on the front porch. If you hear a suspicious sound, turn on the radio and you'll hear the doorbell or even a muttered conversation.

### Choose Your Model

New Horizons is introducing three models of the DYNA-MIKE supersensitive broadcast microphone. Model AR-7 is the world's smallest microphone, it's a miracle of electronic miniature power, with a range of 750 feet and a battery life of 90 hours. Introductory price is \$129.95 (two for \$119.95 each).

Model 9-DX is a long-range microphone, broadcasting an unbelievable half-mile distance. This miniaturized wonder is \$149.95 (two for only \$139.95 each). Normal battery life is 25 hours, or you can have the special Power-Pak, which operates 200 hours, for \$19.95.

The AR-7 and 9-DX are sensitive. They'll pick up sounds from 40 feet away. But for super-sensitivity, nothing beats the A-5.

The A-5 will pick up a whisper from more than 60 feet away and broadcast it to a receiver 750 feet distant. The A-5 comes with a special 200-hour long-life battery and is introductory-priced at \$99.95 (two for only \$89.95 each).

## The Telephone Voice Changer

It's right out of James Bond! Push a button and the VOICE CHANGER gives your voice completely different characteristics. The person on the other end of the phone won't know it's you.

The VOICE CHANGER is more than an "electronic handkerchief" — it doesn't cause your voice to sound filtered, it literally changes tone and timber.

Choose from two separate, distinct Changer Channels. If you're alone in a business office, it'll sound like an employee answering. If you live alone, you can get rid of pesky calls by pushing Channel 1 or Channel 2 and saying, "Sorry, that person isn't in."

### How It Works

The VOICE CHANGER is powered by two ordinary penlight batteries. One set of lead-in wires connects to your telephone base; the other clips to the wires leading to the handset.

Pushing the button labeled "Ordinary" puts your normal voice through the line. Pushing "Channel 1" changes timber and texture. Pushing "Channel 2" creates different characteristics from Channel 1. Thus you have three voice options — your own, plus two changed voices.

**MAKE NO MISTAKE! THE VOICE CHANGER DOESN'T MUFFLE YOUR VOICE OR MAKE IT UNINTELLIGIBLE.** It literally changes the quality of sound — space-age electronics at work.

Use the VOICE CHANGER to reach that doctor, lawyer, or business executive whose secretary knows your voice and who always is "out" when you call. Use it to screen your own incoming calls. Use it for just plain fun. Any time you like, during a conversation, push the "Ordinary" button and your regular voice returns to the wire.

The VOICE CHANGER is yours for \$99.95 — two for \$89.95 each (plus \$2.50 shipping per total order). When you consider the many uses of this brilliant electronic instrument, it's a real bargain. Of course it has the standard New Horizons guarantee.

## The Super Ear

You'll hear it all. Effortlessly, you can hear not just a baby's cries, but quiet breathing — through a concrete wall a foot thick. Put the earphone in your ear and place the SUPER-EAR on the wall. That's all there is to it.

SUPER-EAR hears everything — and, even more astounding, hears it clearly. It's as though the wall weren't there. If you're coming home late at night and think intruders are in your residence, let SUPER-EAR find out for you. Want to know if the meeting is over in the room with the closed door? SUPER-EAR will tell you in a second.

SUPER-EAR is undetectable from the other side of the wall. The quality of sound has amazing fidelity — good enough to record, and SUPER-EAR has its own built-in recorder jack.

Because SUPER-EAR is the ultimate listening device, you can use it to pinpoint hidden squeaks in your car or the source of mysterious engine noises. Construction experts use it to check for flaws or cracks in buildings.

### It Works Anywhere!

Ever put your ear to a railroad track to try to hear the train? Try it with SUPER-EAR. You'll hear that train many miles away. Use it as a powerful stethoscope on yourself, a friend, or a pet. You can even hear a bird's breathing.

The only source for SUPER-EAR is New Horizons. Choose from two models — Model SB-5, with ultrasensitive microphone, \$139.95 (two for only \$129.95 each); or Model SB-1, with suction-type microphone, \$99.95 (two for only \$89.95 each).



## The Private Transmitter/Receiver

The NCZ-10 broadcasts on a special radio band. No one without equipment can hear your transmitted messages.

The reception is unbelievably clear and bright — commercial broadcast quality.

Your receiver clicks into any of three separate channels. In the suburbs the range is up to 2000 feet, and in the city 850 feet.



With your special receiver is an inconspicuous high fidelity earphone. You can put three transmitters in three locations and then switch back and forth, monitoring all three. Someone with an FM or police band receiver can tune his dial all day, but he won't pick up these signals.

With two receivers, you can have a complete two-way system without the inconvenience and annoyance of the semi-public CB channels. The NCZ-10 channels are private.

This professional-quality electronic miracle is easy to use and completely dependable. Monitor your baby's room. Leave a transmitter in an inconspicuous place in your office or your home, and you'll hear anything going on in that room.

One NCZ-10 receiver with one transmitter is \$279.95; with two transmitters (two separate bands), it's \$379.95; with three transmitters (three separate bands), it's \$479.95.

For a complete private communications system, order two receivers, each with a transmitter (we'll send them with different bands). Special high-performance batteries enable you to operate the receiver for 40 hours continuously, the transmitter for 35 hours.

### We Absolutely Guarantee!

Use any electronic instrument acquired from us for up to 30 days. If you decide for any reason you don't want to keep it, return it for a 100% refund.

ORDER TOLL-FREE  
For fast delivery on credit card orders, call toll-free 24 hours a day, seven days a week:

**800-824-7888**

Ask for Operator no. 551  
(in California, call 800-852-7777)

Or send check or money order. Please add \$2.50 per total order for shipping. Order any or all these state-of-the-art electronic instruments:

- \* Dyna-Mike AR-7, \$129.95 (two for \$119.95 each)
- \* Dyna-Mike 9-DX, \$149.95 (two for \$139.95 each)
- \* 9-DX rechargeable power-pak, \$19.95
- \* Dyna-Mike A-5, \$99.95 (two for \$89.95 each)
- \* Super-Ear Model SB-5 microphone, \$139.95 (two for \$129.95 each)
- \* Super-Ear Model SB-1 microphone, \$99.95 (two for \$89.95 each)
- \* Voice Changer, \$99.95 (two for \$89.95 each)
- \* NCZ-10 transmitter and receiver, \$279.95 (two transmitters, one receiver, \$379.95) (three transmitters, one receiver \$479.95)

**NEW HORIZONS**

DEPT. PM3 1 Penn Plaza, Suite 100 • New York, NY 10119  
For information, call 201-370-8029



# S-10 CONQU

**THE STOCK TRUCK WITH GUTS ENOUGH TO FINISH THE IS AVAILABLE THROUGH YOUR CHEVY DEALER NOW.**

On November 3, 1982, a Chevy S-10 Pickup—right off the assembly line—challenged the famous Baja 1000. It's the longest off-road event on the continent, running the length of the Mexican Baja peninsula. Over 985 miles of rocks, sand, dust and heat. A course so tough that even many specially equipped trucks did not finish.

But the new-size S-10 4X4, with optional V6 engine, the revolutionary new Insta-Trac 4-wheel drive, and optional Off-Road Chassis Package, entered with no special equipment except for safety items required by the sponsor. In fact, it was the *only* totally stock truck to enter. And for 37 hours, the S-10 took everything the



**TOUGH CHEVY TRUCKS**



# ERS BAJA.

## BAJA 1000

Baja could dish out.

Like all entries, the S-10 took its share of punishment. But at Baja, to finish is to win. Because in a field of 135 entrants, 70 could not even complete the course.

We think conquering the Baja says a lot about the way Chevy S-10s are built because

you can buy a pickup just like it—the one that conquered Baja—at your Chevy dealer's now.

Some Chevrolet trucks are equipped with engines produced by other GM divisions, subsidiaries, or affiliated companies worldwide. Ask your dealer for details.

Let's get it together... buckle up.

**CHEVY S-10** ★

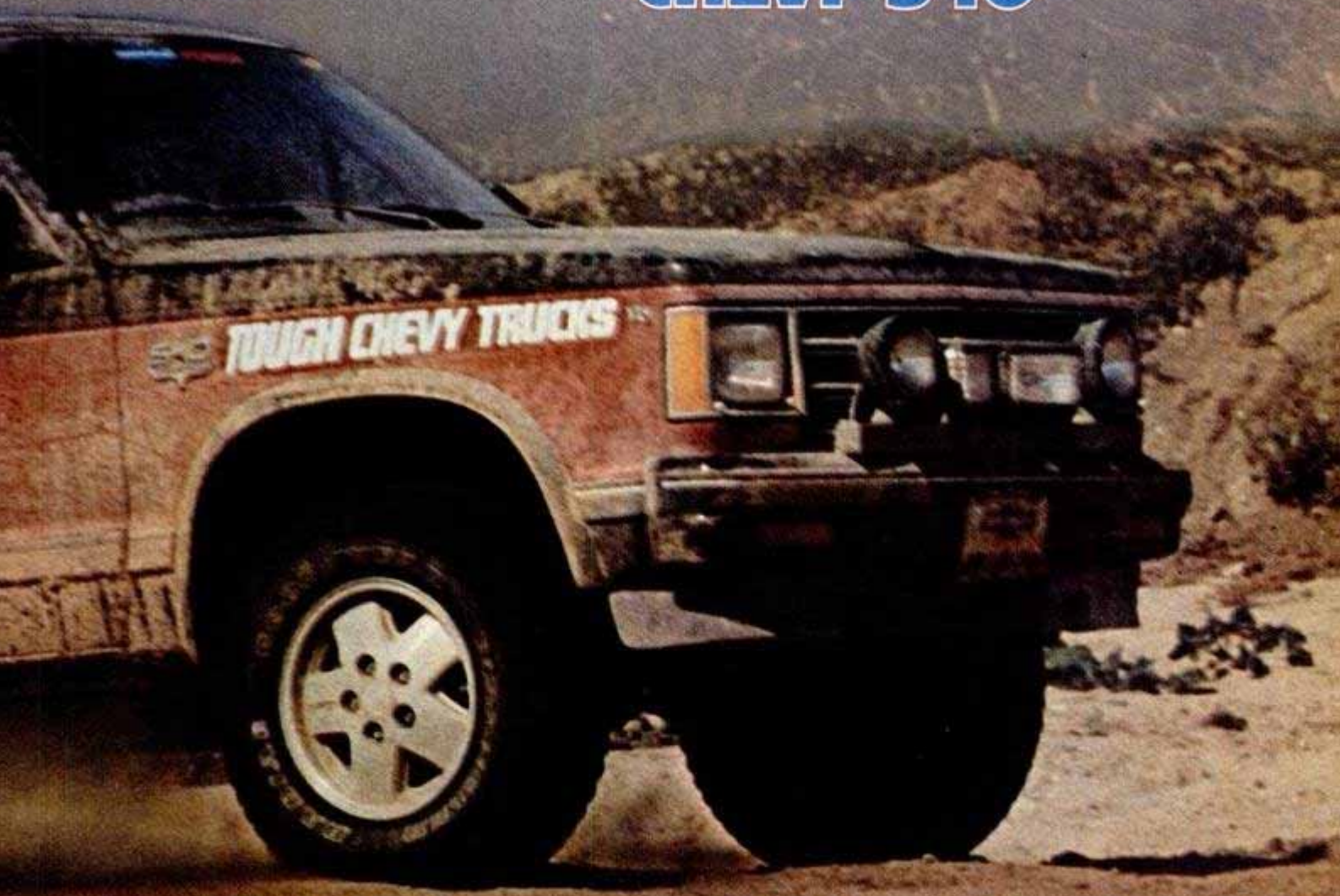

**ARE TAKING CHARGE**





# Quick Guide To Speaker Repair

Here's what you'll need to know to be a Saturday mechanic for your speakers.

BY MARC STERN



Tape Liquid, bonding glue, rubber cement and miscellaneous items like coffee filters, tweezers and scissors are all you need to make the repairs we detail.

There's probably nothing more frustrating to a music lover than turning on the stereo and hearing nothing but shrieks, howls, distortion or, worse, nothing at all. Looking everything over, the system seems okay. But check the speakers; that may be where the fault lies.

Speakers are perhaps thought about less than any other component in the audio picture. You may have the most expensive quad-radial (four-speaker) Super MegaBlast 1000s, but they have to be properly used and cared for. Speakers are really little more than fabric, magnets, wire and a metal frame, despite high-tech sounding names or specifications. Basic speaker construction is one of the few areas of audio which hasn't changed for many years.

Granted, speaker manufacturers are using some new materials and computer-assisted design, but in its basic configuration, the speaker is nothing more than a vibrating cone of material which reproduces sound.

## The inner story

In general, a speaker consists of a metal framework from which the cone is hung. At the center of the cone is a button-shaped item, which is the top of the voice coil. The voice coil is just a powerful magnet surrounded by paper and then covered with a fine coil of wire. This wire is cemented into place with varnish or lacquer. It is the interaction of the coil and magnet which starts the paper cone vibrating.

Of course, new speaker designs usually include three or four speakers in various ranges—the traditional low-range woofer, the high-range tweeter and either one or two mid- or super-range speakers. However, all of these different-range speakers adhere to the same rules.

Quite typically, a set of speakers will have a power-handling rating such as

*(Please turn to page 172)*

## REPAIRING A RIPPED CONE



**1** First cut a patch to cover the rip. Cut from a material like chiffon or a coffee or vacuum-cleaner filter.



**2** Contour the patch to speaker's shape and saturate the material with rubber cement. Use a cotton applicator.

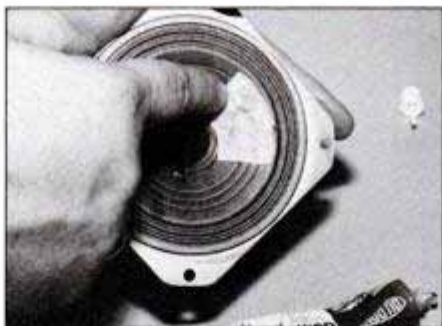

**3** Hold the rear side of the cone and apply the patch very gently. Rub smooth with even and gentle pressure.

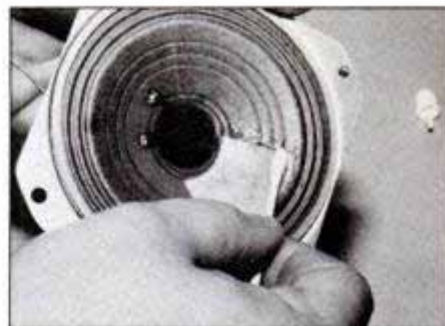

**4** Once glue sets, the speaker should sound about as good as new. Visible patch will be hidden by grille cloth.

## FIXING A SPLIT SEAM



**1** This cone is ripped along the upper seam where it joins the frame. This type of damage may be hard to spot.



**2** A paper clip makes an excellent hook-shaped tool to pull torn edges of the seam flush with the rest of the cone.



# VIC20™ PERSONAL COMPUTER

(List Price \$299)

## SALE!

# \$139<sup>00</sup>

(when you buy 6 tape programs at sale prices)

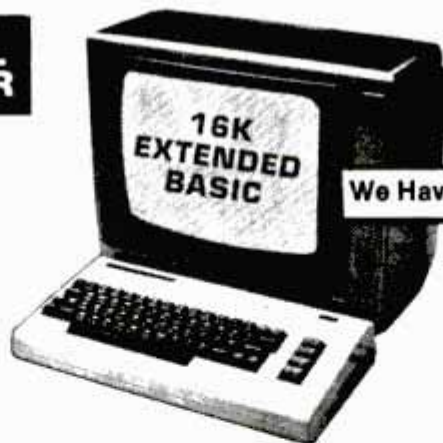

- We Love Our Customers Our Prices and Service Prove It!
- One Day Delivery Express Mail

**We Have Commodore 64 Computers In Stock**

- Commodore 64 Programmers Reference Guides Free With Purchase
- Over 500 Programs To Choose From
- Free Catalogs

You get the COMMODORE VIC-20 Computer for only \$139.00 when you buy 6 tape programs on sale for only \$59.00. These 6 tape programs list for \$96.00 to \$132.00! You can choose one of these three tape program packs: 6 GAME program pack \$59.00 (Alien Invasion, Target Command, Artillery, Chase, Snake Out, Cattle Round Up). 6 HOME FINANCE program pack \$59.00 (Check Book, Calculator, The Budgeter, Home Inventory, Income Tax, Utility Bill Saver). 6 SMALL BUSINESS program pack \$59.00 (Accountant, Accounts Receivable and Payable, Inventory, Order Tracker, Estimating and Bidding, Appointments).

### 33K COMMODORE VIC \$199 WITH 2½ TIMES MORE POWER

For only \$199.00 you get the COMMODORE VIC-20 Computer plus WE ADD 8,000 BYTES OF USER MEMORY to give you 2½ TIMES MORE PROGRAMMING POWER! This powerful full-sized extra featured computer includes the 6502 microprocessor (LIKE APPLE) 20,000 bytes ROM with a 16K extended LEVEL II Microsoft BASIC, 13,000 bytes RAM, a total of 33,000 bytes memory, plug in expandable to 60,000 bytes, 66 key typewriter professional expanded keyboard with graphic symbols on keys, color command keys, high resolution graphics, 512 displayable characters, text display is 22 lines 23 characters, sound and music, real time, upper lower case, full screen editing cursor, floating point decimal and trig functions, string arrays, scrolling, multi statement lines, file management, PEEK AND POKE. Assembly machine language is available. We have easy to use self teaching books and programs. Accepts TAPE-DISK AND PLUG IN CARTRIDGES, connects to any TV, includes AD adaptor, R.F. modulator, switch box, self teaching instruction book, comes in a beautiful console case.

### 41K COMMODORE VIC \$249 WITH FOUR TIMES MORE POWER

For only \$249.00 you get the 41K COMMODORE VIC with 400% MORE PROGRAMMING POWER THAN VIC-20! We add 16,000 bytes user memory to the VIC-20. You get a total of 41,000 bytes memory (20,000 bytes ROM, 21,000 bytes RAM and extended LEVEL II BASIC) plus all the extra features listed!

### 49K COMMODORE VIC \$299 WITH SIX TIMES MORE POWER

For only \$299.00 you get the SUPER POWERED 49K COMMODORE VIC with 600% MORE PROGRAMMING POWER than VIC-20! We add 24,000 bytes user memory to the VIC-20. You get a total of 49,000 bytes memory (20,000 bytes ROM, 29,000 bytes RAM and extended LEVEL II BASIC) plus all the extra features listed!

### TRACTOR-FRICTION PRINTER \$399

This all new COM-STAR deluxe line printer, prints 8½" x 11" letter quality full size, single sheet, roll or fan fold computer paper, labels, etc. 40, 66, 80, 132 columns. Impact dot matrix, bi-directional, 80 CPS. Includes special cable that plugs direct into the VIC-20 printer port — no other costly interface is needed! List \$599.00 Sale \$399.00.

### SUPER 10" COM-STAR PRINTER \$499

Has all the features of the COM-STAR printer shown above, PLUS! 10" carriage 100 CPS, Dot addressable bit image graphics, 2.3 buffer, 18 character sets, 40, 48, 66, 80, 96, 132 columns, prints true descender, super and subscript, underlining. Includes special cable to plug in to the VIC-20 printer port. List \$699. Sale \$499.

### 60K MEMORY EXPANDER \$79

Allows memory expansion to 60K total (20K ROM and 40K RAM). Has six slots to add six cartridges — you can switch select any combination of memory or programs. Stop and start any program with reset button, you don't have to remove cartridges or turn off computer. This expander is a must to get the most out of your VIC-20 Computer!

### PLAY ATARI GAMES ON VIC-20 \$79

WOW!! Plug in our new "GAME LOADER" and you can play all ATARI video game cartridges, Activision, Imagic M-Network on your VIC-20 computer. List \$99. Sale \$79.

### LOW COST PLUG IN EXPANSION

Accessories plug in direct to this computer, extra RAM memory, data cassette, telephone modem \$99.00, deluxe 80 column printer \$399.00, 170K disk drive \$349.00 all plug in direct! You do not have to buy an expensive expansion interface!!

### WE HAVE THE LOWEST PRICES

We sell direct to customers and you save the profit margin normally made by computer stores, department stores and distributors, we are willing to take a smaller margin to develop volume. WE LOVE OUR CUSTOMERS — OUR PRICES PROVE IT!

### IMMEDIATE REPLACEMENT WARRANTY

If your computer fails because of warranty defect within 90 days from date of purchase, you simply send your computer to us via United Parcel Service prepaid. We will "immediately" send you a replacement computer at no charge via United Parcel Service prepaid. This warranty applies to all products we sell because WE LOVE OUR CUSTOMERS!!

### 15 DAY FREE TRIAL

#### DON'T MISS THIS SALE-ORDER NOW

- VIC-20 for only \$139. plus \$59. for 6 pack of programs Specify pack wanted \_\_\_\_\_
- 33K-VIC for only \$199.
- 41K-VIC for only \$249.
- 49K-VIC for only \$299.
- Tractor Friction Printer \$399.
- Super 10" Printer \$499.
- 60K Memory Expander \$79.
- Game Loader—Atari \$79.

We ship C.O.D. and honor Visa and Master Card.

Name \_\_\_\_\_

Address \_\_\_\_\_

City \_\_\_\_\_

State \_\_\_\_\_ Zip Code \_\_\_\_\_

VISA  MASTER CARD  C.O.D.

Credit Card No. \_\_\_\_\_

Expiration Date \_\_\_\_\_

Add \$10.00 for shipping, handling and insurance. Illinois residents please add 6% tax. Add \$20.00 for CANADA, PUERTO RICO, HAWAII orders. WE DO NOT EXPORT TO OTHER COUNTRIES.

Enclose Cashiers Check, Money Order or Personal Check. Allow 14 days for delivery, 2 to 7 days for phone orders, 1 day express mail!

Canada orders must be in U.S. dollars.

**GET \$150 FREE SOFTWARE WHEN YOU BUY A COMMODORE 64 COMPUTER!!**

# PROTECTO ENTERPRISES (FACTORY-DIRECT)

BOX 550, BARRINGTON, ILLINOIS 60010  
Phone 312/382-5244 to order



## GUIDE TO SPEAKER REPAIR

(Continued from page 170)

20 w. RMS or 30 w. RMS listed on it. Essentially, this figure stands for a speaker's average power-handling capability. You can run speakers at or below this figure all day long and not worry about damaging them. Most sound systems are rated for their maximum RMS power output. So if your system puts out 30 w. RMS and your speakers are rated 30 w. RMS, you're in good shape.

Sometimes, though, speakers are rated for their maximum peak power, or the amount of output they can handle for a short time. This figure is about 1.5 times the value of the RMS or safe value. If you run your speakers at this level very long, you'll ruin them.

Therefore, if your speakers are only rated for their maximum peak power-

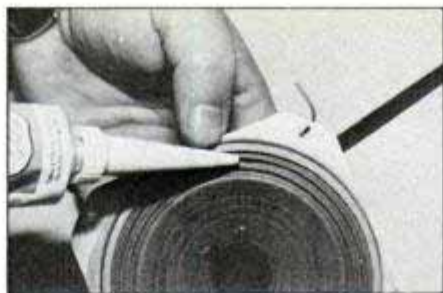

**3** Apply rubber sealant in a bead to front surface of cone, covering the now-flush edges of the ripped seam.



**4** While applying, and until sealant begins to set, apply slight pressure from back to keep seam edges in line.

handling capability, you'd be well advised to keep the power down.

### 'Cold' cones

According to Tom Grosvenor, owner of Colonial Audio in Wakefield, Mass., one of the East's leading Marantz repair centers, the two key elements in

speaker abuse are overdrive and distortion. Both cause the same type of failure—"frozen" speaker cones.

What happens is this: The speaker is driven to the point where its cone refuses to vibrate any further. At this point, excess heat is generated and

(Please turn to page 174)

## PLUGGING PINHOLES

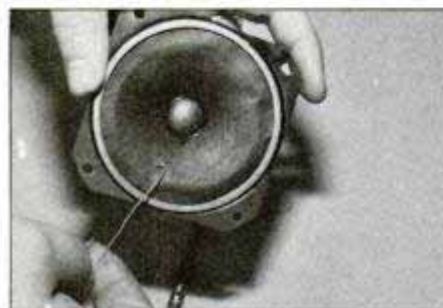

**1** Damaged material should be brought flush with the cone. Use a paper clip.



**2** Tape Liquid is popular for repair; you could also use a rubberized glue.



**3** Fill in pinhole while applying even, gentle pressure from behind speaker.

## WHEN ALL ELSE FAILS: REPLACEMENT SPEAKERS



**1** Removing speakers from most cabinets is simple: In this cabinet, each speaker was held by a few screws.

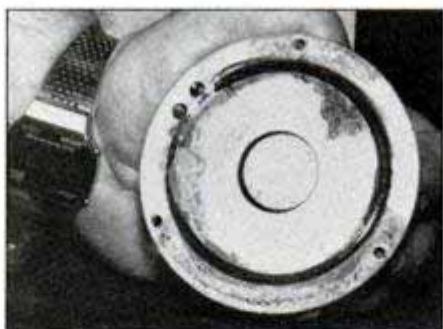

**2** Examine the tweeter: This cone was frozen as varnish oozed from voice coil when the tweeter was overdriven.



**3** Back of same tweeter shows overdriven voice coil. Tweeter must be discarded and a replacement bought.



**4** A new, "raw" speaker was used to replace woofers which were victims of overdriving resulting in frozen cones.



**5** When replacing a speaker, look for a mark (usually a red dot) that helps you attach speakers with same polarity.



# Games that challenge you at a price that won't.

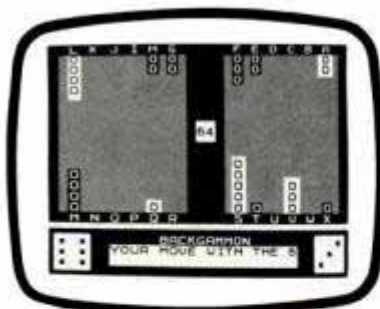

BACKGAMMON

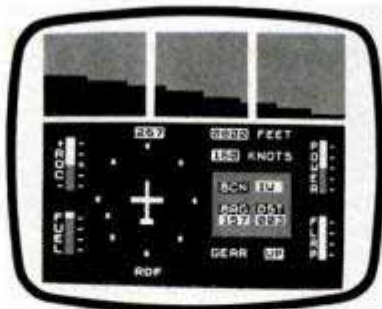

FLIGHT SIMULATOR



CHESS

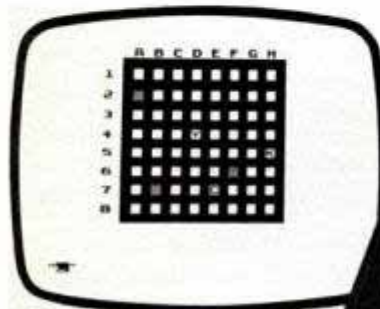

MIXED GAME BAG

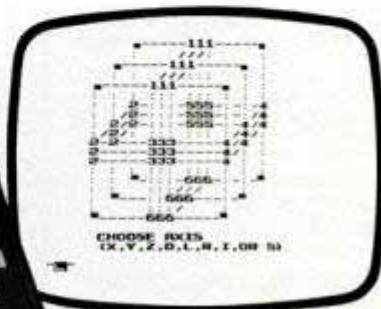

CUBE GAME

Look to Sinclair for the only \$99.95 computer and the first Serious Games Package. A special limited time offer. Call toll free today.

What could be more challenging than creating your own games on a personal computer? Or being intellectually challenged by serious games where you match wits with a computer or another opponent in a fierce trial of skills?

The Timex/Sinclair 1000\* is a fully programmable computer with a powerful BASIC language and complete instruction manual, all for only \$99.95. The moment you sit down with the TS1000 you can learn how to program your own games. Maybe you want to create a stock market game, a word game, a mathematical game. The challenges are endless.

For this one low price, the TS1000 comes with everything you need for connecting the computer to your color or black-and-white TV.

Of course, you might also want pre-programmed software cassettes for your \$99.95 computer. You'll have a wide choice with our free software catalog which comes with the TS1000. And the software cassettes play in any cassette recorder.

### The 16K Memory Module. More power to you.

Let's say you want to go one step further. The 16K Memory Module allows you and your family to be challenged by even more sophisticated games. Not mindless arcade games, but serious, intellectually stimulating games which are both fun and educational.

The Memory Module costs only \$49.95 and plugs onto the back of the TS1000 for 8 times more memory capacity. A whole new world of software is available to those with the 16K Memory Module.

### The Serious Games Package. A \$75 value for only \$50.

For those who want a lot of serious 16K games, Sinclair announces a special software offering with a \$25 savings! Now, for the first time, you can receive all five games shown above at the reduced price of only \$50.

Chess: You can play with another opponent or you can match wits with the computer.

Flight Simulator: Maneuver and land a light aircraft with full cockpit controls, instrumentation and navigational aids. You have to allow for wind velocity and direction, rate of descent and mountainous terrain.

Cube Game: Every bit as mind-baffling as Rubik's Cube.

Backgammon: Everyone's favorite. Again, you can play against another opponent or against the computer. Complete with a doubling cube.

Mixed Game Bag: A series of memory and concentration tests including Memory Magic where you have to repeat sequences on the screen.

There's never been a better value on a serious games package. And to think it all starts on a \$99.95 computer!

### Why order today?

In addition to saving \$25 on software, there are other reasons to buy your TS1000 today. Computers costing hundreds and even thousands of dollars rarely offer you games this serious or challenging.

Another reason to order today is convenience, by toll-free phone. No crowds, no waiting lines, no parking worries. It's never been easier to get started in the world of computers. Or more worthwhile.

### How to order today!

Just call our toll-free number and use your MasterCard or VISA. Or send the coupon with a check or money order. Then try out the Timex/Sinclair 1000 for 10 days at no risk. If you're not entirely satisfied, we will refund your money. It's as easy as that. (Sorry, no refunds on software.)

Call toll-free: 800-543-3000. Ask for operator 509. In Ohio call: 800-582-1364. Ask for operator 509. In Canada call 513-729-4300, operator 509. Have your MasterCard or VISA ready when calling. Phones open 24 hours a day, 7 days a week. These numbers are for orders only.

If you simply want information, please don't call, write Sinclair Research, Ltd., 2 Sinclair Plaza, Nashua, NH 03061.

**Call toll free 800-543-3000**

(operator 509)

Ad code: BGPM	Mail to: Sinclair Research, Ltd. One Sinclair Plaza, Nashua, NH 03061		
<input type="checkbox"/> Check or Money Order enclosed			
	Price	Qty.	Amount*
TS1000	\$99.95		
16K Memory Module	\$49.95		
16K Cassettes	\$15.00 each		
Special Serious Games Package (5 games valued at \$75.00)	\$50.00		
Shipping/Handling	\$ 4.95		\$ 4.95
*U.S. Dollars		Total:	
Cassettes for 16K Memory Module: \$15.00 each. Check the boxes of all the cassettes you want.			
<input type="checkbox"/> Flight Simulator #6		<input type="checkbox"/> Mixed Game Bag #26	
<input type="checkbox"/> Chess #7		<input type="checkbox"/> I'll take all 5 cassettes included in Sinclair's Special Serious Games Package.	
<input type="checkbox"/> Backgammon #8			
<input type="checkbox"/> Cube Game #9			
Name _____			
Street _____			
City _____			
State _____		Zip _____	
*Sinclair technology is the heart of both the ZX81 and the Timex/Sinclair 1000 computer.			

**sinclair**



## ORIGINAL OLD-TIME FARM AND CHURCH BELL



Alabama Foundry Has Reproduced This 18-Inch Bell By The Original Methods Used Over 100 Years Ago. Some Even Have Sand-Cure Marks On The Rim Just Like 100 Years Old Bells Do. Cast-Iron Construction. Large Size Weighs Over 40 Pounds And Comes Complete With Yoke And Clapper, Ready To Mount!

SHIPPED **\$49.50** ANY  
FREIGHT WHERE IN  
PAID CONT. U.S.

Master Card & Visa Call Toll Free  
1-800-633-3272 For Same Day Ship-  
ment Or Send Check Or Money  
Order To:

**Bowden Wholesale Co.**  
111 First Street N.E.  
Cullman, AL 35055

NAME \_\_\_\_\_  
STREET \_\_\_\_\_  
CITY \_\_\_\_\_ STATE \_\_\_\_\_ ZIP \_\_\_\_\_  
VISA or MASTERCARD Number \_\_\_\_\_  
EXP. DATE \_\_\_\_\_

## GUIDE TO SPEAKER REPAIR

(Continued from page 172)

begins to be dissipated. Since this heat is looking for a good conductor, it heats up the metal frame of the speaker.

This excess heat begins to work on the varnish or lacquer covering the voice coil, which begins to liquefy. About the only place this now-liquid substance can go is to the speaker cones.

Then, when you turn off the stereo and the speakers begin to cool, this varnish begins to harden. If this is repeated often enough, the cones can freeze stiff, resulting either in total distortion or no output at all.

This is what happened to a pair of speakers used in this story. When they were opened for repairs, we discovered that the cones of the woofers and tweeters were frozen. We had to replace both elements, as well as repair the crossover network. (The crossover network carries the right sound to the proper speaker and ensures it is phased correctly.) The excessive heat had destroyed a capacitor.

There are a few ways to prevent this occurrence. The best is never to overdrive the speakers. *If the only indication of their power-handling capability is the maximum peak power they can handle, multiply that figure by .7 and you will have their actual capability.*

Distortion-caused problems occur when worn stereo stylus cartridges cause strange audio frequencies to be generated. These are usually too high for you to hear, but the system hears them, the speakers heat up and the scenario repeats itself.

To prevent this, make sure the cartridge is in good shape and the tone arm isn't causing too much drag.

What happens if the speaker freezes? The only cure for this is replacement. You can buy replacement speakers from the speaker manufacturer. If not, many electronics stores sell "raw" speakers and they'll help you pick a suitable replacement.

### Repair rips

With the trend today toward removing speaker grille cloths for appearance, there are many opportunities for getting tears, rips or holes in your speaker cones. Speakers are fragile and can't take much abuse. But when small accidents occur, they usually can be repaired.

For instance, what happens if one of your speakers develops a rather large rip? The repair for this is easy.

First, remove the speaker carefully from its cabinet. Take a piece of light material, such as a discarded piece of chiffon or a coffee or vacuum-cleaner filter and contour it to the speaker's

shape, making sure it's large enough to cover the rip. When this is done, saturate the piece of shaped material with rubber cement. Then, holding the rear side of the cone gently, apply the patch and smooth it in place. Allow the glue to set and replace the speaker. It should be as good as new. (If the patch isn't the exact color of the speaker itself, you can re-cover the cabinet with grille foam. It is available at audio shops or from stores such as Radio Shack.)

### Pesky pinholes

If you find a pinhole in your speaker cone, place your hand on the rear of the cone and gently push the pinhole outward. This should cause it to fill in. Then, with a liquid vinyl repair chemical, such as Tape Liquid or rubberized glue, cover the pinhole gently. Resmooth the repaired spot from the rear and allow it to set. This should make your speaker as good as new.

### Severed seams

One of the trickiest types of repair involves fixing a rip along the upper seam of the cone where it joins the frame. For this repair, take a small stiff piece of wire, such as a paper clip, and bend an end into a small hook. Use this small tool to fish around gently and pull any part of the tear flush with the rim of the cone. (This method also works with other types of rips.)

Then, take some rubber sealant—available at Radio Shack or your local hardware store—and lay down a bead of it. Keep your finger on the rear of the speaker to assure a proper bond. This should repair the rip. Allow the sealant to set and put the speaker back into its cabinet.

### Split wire ends

Another problem from which a speaker can suffer is a broken or disconnected wire. This repair, too, is easy, but you'll need a soldering iron. Use only rosin-core solder, *never* acid-core.

After soldering, wrap the repaired area with vinyl tape so that it's insulated. You can also use heat-shrink tubing.

If the speaker wire is disconnected from the terminal, merely heat the terminal, causing the old solder on it to flow. Then hold the wire to the terminal until the solder cools and sets.

Be sure that the speaker wire colors match or you run the risk of cross-polarizing the speakers and affecting the sound output. And always be sure the impedances of your system are matched. This means your stereo output should match the figures on the speaker. If a speaker is rated from 4 to 16 ohms and you place a different load on it, all you'll hear is distortion. **PM**

## WATER WATER



Drill your own water well - 250 ft. in depth. Introducing the new larger, heavy duty, portable drilling rig.

Before you buy theirs, call us (You won't believe the difference!)

CALL TOLL FREE  
1-800-372-9317  
TEXAS RESIDENTS  
CALL:  
915-751-6458



P.C. Int. Marketing Inc.  
P.O. Box 24209  
El Paso, Texas 79914





# Now You CAN Afford One!

**FULL  
5 YEAR  
WARRANTY**

Complete statement included with product. If you call us for advance FREE info to

D. R. I. Industries, Inc.  
Dept. PM-383B  
11100 Hampshire Avenue South  
Bloomington, MN 55438

Plus, order now and get

**3 Free Gifts**  
just for ordering.

\*A \$4.99-value heavy-canvas Shop Apron \*2 solid-brass body padlocks \*A special Surprise Free Gift

All 3—yours to keep, whether or not you keep your Tool-Locker.

## The Tool-Locker™

**Tool Organizing System**

A heavy-duty portable tool chest plus roll-about cabinet—both for a price you'd expect to pay for one piece alone!

**FANTASTIC!! BOTH PIECES JUST**

**\$59.99**

plus \$9.90 shipping and handling

**Similar units sell for well over \$100!!**

**How do we do it?** Volume Purchasing...plus direct shipping. Both add up to big, never-before-heard-of savings!

You don't have to be a professional to know how important it is to keep your tools clean, safe and dry...to have them organized, right with you.

Now you don't have to make a big investment to enjoy that efficiency, to have a truly quality, heavy-duty all-steel organizer!

Over 4 cubic feet of storage capacity...plus special features you'd normally find only on the most expensive systems. **This is not a cheaply-made unit! It's quality through-out!**

**Try the Tool-Locker™ FREE of risk, FREE of obligation to keep it!**

Then you'll know why this Tool-Locker comes complete with a **FULL 5-YEAR WARRANTY**. Why D.R.I. backs it even further with a **100% Guarantee of Satisfaction**. If you're anything less than 100% satisfied, just send your Tool-Locker back for a full refund, including shipping and handling charges.

**ORDER TODAY...IT'S EASY!**

Fill in order form & send with check, money order, company purchase order or credit card information.

**Credit card customers can also call our 24-Hour Toll-Free Order Number:**

**800-228-5000** (In Nebraska 800-642-8777).

D. R. I. Industries! We've introduced the Nut & Bolt Shop®, the 4-Wheel Wonder® and dozens of other high-quality, unique handyman products. Over 2 million satisfied customers.

**\*Double-slide Safety Drawers.**  
Support more weight and prevent spills. Drawers lock automatically when cover is closed.

**\*Bolt latches and center padlock hasp on chest.**  
Padlock hasp on cabinet door.  
Total security and safety.

**\*3 large capacity drawers**  
(Inside dimensions: 16 1/4" W. x 21 1/4" H. x 8 3/4" D.) and **a big top storage tray** (Inside dimensions: 18 3/4" W. x 24" H. x 9 1/4" D.).

**\*Soft-foam Drawer Liners.**  
Protects tools and tool chest.

**\*Cabinet top has 1/4" lip on sides and back.** Keeps tool box in its place.

**\*Side-handle cord holder...** for neat storage of electrical cords.



**\*Adjustable, sturdy shelf in cabinet.** Handy hanger holes and hooks on inside of door.

**\*Large Capacity.**  
Tool Chest: 19" W. x 12 1/2" H. x 9 1/2" D. (Over 1.3 cubic feet of storage space.) Cabinet: 18 3/4" W. x 24 1/2" H. x 11" D. (Over 3 cubic feet of storage space.)

\*Height of combined units over 3 feet: 37 1/2 inches.

**\*Four steel ball bearing swivel casters...** smooth-rolling, solid rubber wheels.

Tools and supplies not included.  
Imported from Taiwan and Korea

© Copyright 1983 D. R. I. Industries, Inc.

\*\*Tool-Locker is a trademark of D. R. I. Industries, Inc.

11579

### SPECIAL OFFER COUPON

MAG 64

Try it FREE of obligation to keep it!

If not totally satisfied, you can return your order for a complete refund, including shipping and handling.

Make remittance payable to and send to:  
D. R. I. Industries, Inc., Dept. PM-383B 11100 Hampshire Ave. So., Bloomington, MN 55438

INDICATE

ORDER

CHECK (✓)

METHOD

OF

PAYMENT

How many? \_\_\_\_\_ Tool-Locker(s) @ \$59.99 plus \$9.90 shipping and handling for each. (00008000)

I have enclosed my check or money order for the full amount. (MN residents add 6% sales tax).

I have enclosed my company purchase order (this card MUST accompany ALL purchase orders).

Charge it to:  VISA  MasterCard  American Express  Diners Club  Carte Blanche

Card No. \_\_\_\_\_ Exp. Date \_\_\_\_/\_\_\_\_/\_\_\_\_

PLEASE

PRINT

NAME

Signature \_\_\_\_\_ (Need to sign only if charging order)

Mr. \_\_\_\_\_

Mrs. \_\_\_\_\_

Miss \_\_\_\_\_

ADDRESS \_\_\_\_\_ Street & Number

CITY \_\_\_\_\_ STATE \_\_\_\_\_ ZIP \_\_\_\_\_



\$605.00—Originally processed  
for 2/c. Had to run as B/W +P.173

# **BUICK LeSABRE**

**Traditional Luxury By The Acre**

## **AMC/RENAULT ALLIANCE**

**Blowing Away The Competition**

# **PONTIAC 6000LE**

**Capable, But Needs The V6**



*Our test Buick LeSabre has already proved itself as a people hauler. We'll let you know how it hauls itself in our next report.*

**S**ince our last update (*PM Long-Term Car Tests*, page 60, Jan. '83), we turned in a Pontiac, picked up a Buick and completed our testing of an AMC/Renault Alliance. Here's what's been happening.

### **Pontiac 6000LE**

When we turned in the car, it had 7,348 miles on the clock, 5,002 of which were accumulated by our staff. Our last impression of the car closely followed our first impression: "Gee, this is a really nice car with excellent handling. Wish it had more power."

Overall, our test car averaged 19.2 mpg over the 5,002 miles—not so great for a four-cylinder automobile. We expected more, since we ordered the four-cylinder engine thinking we'd get better mileage and knowing we'd be sacrificing performance.

Our recommendation is still to order

the V6 engine if you're considering a Pontiac 6000LE. We reported last time that our V6-powered Pontiac 6000 averaged 20.7 mpg over 1,700 miles. That was despite the larger engine, simply because we didn't have to drive the V6 as hard to make it move.

The only glitch that developed with this car since our last report was in the power window system, which conked out twice in the last 1,500 miles. In both instances, the windows were fixed free under warranty at a dealer.—*Joe Oldham*

### **Buick LeSabre**

In case you haven't noticed, not only have gas prices stabilized recently, but they're actually going down in some areas of the country. Whether this situation is permanent or long term, no one knows. However, the American car-buying public has reacted predictably.

We're buying big cars once again.

Let's face it. Americans love a big, roomy car. There's no substitute for cubic feet of interior room. So, despite all the doomsday predictions about how the world will end—or at least run dry of oil—we're buying big cars.

The result is that Cadillac has had to put on an additional shift at the home plant which makes the DeVille series; Buick's LeSabre and Electra sales are up about 10.9 percent; Chevrolet is selling more Impalas and Caprices than some of their smaller cars; and Chrysler can't make enough New Yorkers to fill the demand.

What's going on here? Lee Iacocca is going crazy because Chrysler has just spent billions outfitting production plants to make small cars, and big car sales take off again. What's going on is that the American predilection for large

*(Please turn to page 178)*



# DIRECT FROM U.S. OPTICS™

## QUALITY SUNGLASSES AT FACTORY PRICES

Metal Frame Sunglasses Feature • Impact resistant lenses • Handcrafted • Polished glass lenses • Hardened metal frames •

<p><b>A</b> <span style="float: right;">Only \$14.95</span></p>  <p><b>The Classic</b> Black metal frames, gray lenses. A \$30.00 value only \$14.95. 2 pairs for \$28.00.</p>	<p><b>E</b> <span style="float: right;">Only \$14.95</span></p>  <p><b>Black Metal Frames</b> Thin and durable black metal frames. Aviator teardrop style lenses. A \$25.00 value only \$14.95. 2 pairs for \$28.00.</p>	<p><b>I</b> <span style="float: right;">Only \$7.95</span></p>  <p><b>World Famous Pilot's Glasses</b> These precision flight glasses are now available to the public for only \$7.95. If you could buy them elsewhere, they'd probably cost you over \$20.00. Specify gold or silver frames. A \$20.00 value only \$7.95. 2 pairs for \$14.00.</p>
<p><b>B</b> <span style="float: right;">Only \$9.95</span></p>  <p><b>Rich Tortoise Shell Style</b> Classic style, large gradient lenses. A \$20.00 value only \$9.95. 2 pairs for \$18.00.</p>	<p><b>F</b> <span style="float: right;">Only \$14.95</span></p>  <p><b>Change-A-Matic Flight Glasses</b> Features lenses that darken outdoors and change back to lighter tints indoors. Specify gold or silver frames. A \$30.00 value only \$14.95. 2 pairs for \$28.00.</p>	<p><b>J</b> <span style="float: right;">Only \$9.95</span></p>  <p><b>Aviator Teardrop Flight Glasses</b> Flexible cable temples, gold frames. A \$20.00 value only \$9.95. 2 pairs for \$18.00.</p>
<p><b>C</b> <span style="float: right;">Only \$10.95</span></p>  <p><b>Mirrored Lens Flight Glasses</b> Unexcelled glare protection, gold or silver frames. A \$25.00 value only \$10.95. 2 pairs for \$20.00.</p>	<p><b>G</b> <span style="float: right;">Only \$14.95</span></p>  <p><b>Change-A-Matic Aviator Glasses</b> Gold frame, flexible cable temples. Lenses darken outdoors, change back to lighter tints indoors. A \$30.00 value, only \$14.95. 2 pairs for \$28.00.</p>	<p><b>K</b> <span style="float: right;">Only \$9.95</span></p>  <p><b>Standard Aviator Glasses</b> Traditional stems, gold frames. A \$20.00 value only \$9.95. 2 pairs for \$18.00.</p>
<p><b>D</b> <span style="float: right;">Only \$9.95</span></p>  <p><b>Girl Watcher</b> Gray mirrored lenses, black frames. A \$20.00 value only \$9.95. 2 pairs for \$18.00.</p>	<p><b>H</b> <span style="float: right;">Only \$14.95</span></p>  <p><b>The Sportsman</b> Sports-graphic on black metal frame. A \$25.00 value only \$14.95. 2 pairs for \$28.00.</p>	<p><b>L</b> <span style="float: right;">Only \$14.95</span></p>  <p><b>Professional Driving &amp; Shooting Glasses</b> Wide angle amber lenses brighten visibility. Gold frames. A \$30.00 value only \$14.95. 2 pairs for \$28.00.</p>

Style #	Quantity	Frame Color	Price
A		Black	
B		Brown	
C			
D		Black	
E		Black	
F			
G		Gold	
H		Black	
I			
J		Gold	
K		Gold	
L		Gold	

To order your U.S. Optics™ sunglasses, send check or money order to U.S. Optics,™ Dept. 849, P.O. Box 14206, Atlanta, Georgia 30324. Credit card customers please fill in Card # and Exp. Date. **FREE** — limited time only — deluxe velour-lined case with each pair of glasses ordered (a \$3.00 value). Dealer inquiries invited. **Credit card orders may call 1-404-252-0703.**

Visa or Master Charge # \_\_\_\_\_ Exp. Date \_\_\_\_\_  
 Name \_\_\_\_\_  
 Address \_\_\_\_\_  
 City \_\_\_\_\_ State \_\_\_\_\_ Zip \_\_\_\_\_

Add Postage, Handling and Insurance \$1.00 per pair \$ \_\_\_\_\_  
 Total \$ \_\_\_\_\_

**Free case with each pair.**

**NOTICE: Don't be fooled by cheap imitations. These glasses are made exclusively for U.S. Optics.™ To make sure you get the best, order now and if not completely satisfied return for refund within 30 days. No Non-sense 30 day guarantee.**

© Copyright 1982 U.S. Optics™



## LONG-TERM CAR TESTS

(Continued from page 176)

cars has not diminished, all the Arab sheiks notwithstanding. So big-car sales are up. Everything else is down.

We thought it would be a good idea to examine a traditional all-American sedan—a big one—to see if it still has the appeal of the old days for us, as it seems to have for many of today's car buyers. Your letters, too, indicated that you wanted us to write more about larger American cars.

So we asked Buick to loan us a LeSabre four-door sedan. The LeSabre is part of General Motors' B-body fami-



Room, room and more room: That's the big appeal of the traditional full-size car.

ly of cars. Other members include the Chevrolet Impala/Caprice and the Oldsmobile 88 (and used to include the Pontiac Catalina/Bonneville when they still made them).

A few years ago, the LeSabre would have been considered a large car, but not the largest. After all, Buick makes an Electra that is even larger. Today, despite the larger cars like the Electra, Olds 98 and Cadillac deVilles, the LeSabre looks enormous. Our perspective has changed because there are so many small cars on the road these days.

Compared to just about anything, the LeSabre is enormous. Its wheelbase is 115.9 inches, and the car measures 218.4 inches overall with a curb weight of 3,700 pounds. And remember, these cars were *downsized* in 1977.

All this size translates into interior room and lots of it. The huge front seat offers passengers 42.2 inches of legroom. Rear-seat passengers can stretch out in 38.9 inches of legroom. And headroom is a spacious 39.5 inches.

All this translates into enough space to carry six passengers, *real* passen-

gers, not kids, in comfort. Climbing into the interior of this car brings back memories of the good old days when a car was wide enough to carry six people without the middle guys feeling like they were in a sausage maker. And rear-seat passengers have enough legroom to sit like ladies and gentlemen. This is in contrast to what usually passes today for rear-seat legroom. In some cars we've tested recently, only a package of groceries could feel comfortable in the back seat.

The interior in our test car was even more luxurious than we wanted it to be. We ordered the car with the standard LeSabre vinyl interior with a notchback seat. What we got was a LeSabre Custom with the optional velour 45/55 seating and power assist. (We accepted the car, but we're going to find out why it wasn't delivered as we wished.) We like the 45/55 seating a lot. It allows you to get comfortable behind the wheel without disturbing your passengers. The electrically adjustable seat option and tilt wheel help here, too. However, we're not big fans of velour upholstery. It attracts every piece of lint in the universe and is so sticky you can't slide into a comfortable position on it. We'll see how it cleans up when the kids—or we—spill something on it.

The drive train on our test car is the most powerful Buick offers these days in this series. The 307-cu.-in. four-barrel V8 under the hood is rated 140 hp at 3,600 rpm. The car's 3,700 pounds is quite a bit of bulk to be moved around by 140 horses. But the 307 acquits itself nicely. It doesn't feel sluggish, although it turns out to be pretty slow when clocked. We've managed 0-to-60 times of 14.3 seconds, but the engine isn't broken in yet, so we expect this to improve.

We had ordered a 3.23 final drive ratio to make the car quicker, but the car came through with the standard 2.73 ratio instead. Similarly, we ordered the low-profile P225/70R15 tires available for LeSabres to maximize the car's handling. Instead, we received skinnier P215/75R15 radials. These taller tires produce better mpg numbers, albeit at a sacrifice in handling.

One thing we did order and get is the Gran Touring suspension option. This is a \$49 item that we wouldn't be without. The ride is still soft and cushioned, but there's a measure of control there that's missing on larger cars with standard suspensions. The option consists of higher rate springs, shocks and stabilizer bars and the addition of a rear stabilizer bar plus power steering.

In our next report, we'll have a complete rundown on the performance, handling and fuel mileage of this new addition to our test fleet. Meanwhile, we'll enjoy the room.—*Joe Oldham*

## AMC/Renault Alliance

After 4,000 miles and a zillion thumps on the treacherous West Side Highway, our long-term Alliance DL is ready to go back to its owners in Kenosha, Wis. AMC/Renault will get back its car still ticking with the precision of an atomic clock. A car in its first year of production, no matter what part of the world it's built in, usually needs another year of development before all the bugs are worked out. The Alliance seems to be one of those cars that has come complete and ready to go, right out of the box. Nothing seems to have been overlooked, either in the design stage, tooling or assembly. Everything just flat works.

We're not given to unqualified praise around these parts, usually because there's a lot to be critical about. But even the most demanding driver would have a hard time finding anything bad to say about the Alliance.

On the highway, at slightly higher than legal speed limits, the Alliance burns fuel at the rate of 32 mpg. In the city that number only goes down to 25 mpg, which is remarkable. On the coldest of mornings with a wind chill hovering around 0° F., the engine fires up first shot, thanks to the throttle body fuel-injection system. Cold drive-off is excellent, with no stuttering, lurching or stalling. California drivers will have even less trouble because they get multipoint port injection on their cars.

## Clever oil gauge

One feature that's particularly clever and appreciated is the oil-level indicator gauge. It only activates when you start the car. During the start cycle, a needle swings across a horizontal gauge to tell you how much oil is in the pan. After the engine fires, the needle disappears.

The System Sentry and Infrared Entry options weren't available when we took delivery of the car, but lucky prospective owners can now order them. After seeing those options work on other Alliances, I'd recommend them enthusiastically. For more details of those options, see *Saturday Mechanic Looks At The '83 AMC Cars*, (page 170, Oct. '82).

The only mechanical problem of any sort on our test car was a sticky left rear door lock. A 15-minute visit to the local dealer got it fixed under warranty and we haven't needed to visit him again.

If we were the kind of magazine that handed out Best Car of the Year awards, the Alliance would be it. In the highly competitive market segment which had been dominated by Japanese economy cars, the Alliance has risen to the top and simply blown the competition away.—*Tony Assenza*



# LOOK AT ALL YOU GET!

2,101 nuts, bolts, screws, washers and cotter pins. Heavy-duty, polystyrene cabinet, 12" W x 5 1/2" D x 9" H. \*25 preprinted labels \*55 individual compartments \*25 high-impact bins, 2" W x 5 1/2" D x 1 1/2" H.

### SHEET METAL SCREWS 6 Sizes (Panhead)



### WOOD SCREWS 6 Sizes (Flathead)



### MACHINE BOLTS 2 Diameters, 3 Lengths of Each Diameter (Hex Head)



### MACHINE SCREWS



### HEX NUTS 5 Sizes



### 1/8 x 3/4

### COTTER PINS 4 Sizes

### 1/8 x 1

### 1/8 x 1 1/2

### 1/8 x 2

### WASHERS 3 Styles, 4 Sizes of Each Style



# The Original NUT & BOLT SHOP® ...

Just About Every Nut, Bolt, Screw, Washer And Cotter Pin You'll Ever Need—Over 2,100 Pieces—All Organized & Labeled In A Multi-Bin Cabinet!

Just **\$19.99**

plus \$3.90 shipping and handling LESS THAN 1/2 OF WHAT YOU'D PAY AT RETAIL HARDWARE STORE PRICES!!!

**PLUS THREE FREE GIFTS... YOURS TO KEEP JUST FOR ORDERING!**

### SPECIAL BONUS OFFER! 105-PIECE WALL ANCHOR SET

Complete set includes a total of 105 plastic, conical wall anchors. There are 3 different color coded sizes: you get 35 for 4-6-8 size self-tapping screws; 35 for 6-8-10 size self-tapping screws; 35 for 10-12 size self-tapping screws. All organized in a handy plastic case.



The complete 105-piece set only **\$1.99** plus \$ .50 shipping and handling.

They'll work great for anchoring in wood, shear rock, dry wall, and for light duty anchoring in concrete, brick, stone and tile. Limit One Set with each Nut & Bolt Shop purchased. Wall Anchor Sets cannot be purchased separately.

## WORK SHOPS®

Now you can have just the right nut, bolt, screw, washer, or cotter pin at your fingertips... whatever the job! And for an almost unbelievable low price! With the NUT & BOLT SHOP—a complete size range of just about every kind of hardware you'll ever need. All organized in one 25-tray, 55-bin cabinet. Perfect for auto repair, home projects and hobbies. Office maintenance. And industrial shop use. Great as a gift, too!

No more time-consuming trips to the hardware store. No more coffee cans of odds and ends. No more searching through old less-than-professional looking repair jobs.

### OUR CUSTOMERS ARE AMAZED AT THE VALUE!

"I don't see how you make a profit at such a low cost! I found it much more than I expected!"  
**M. D. Dorsette, Rockville, Maryland**

"Quality is excellent. Great for do-it-yourselfers... and convenient!"  
**G. R. Daimage, Sunnyvale, California**

"I've priced these items separately—it would have cost far more for them (at a hardware store)."  
**J. D. Russell, Cicero, Illinois**

- \*Now... your own hardware store for home, shop, or office!
- \*2,101 fasteners total—all high-quality, zinc-plated (rust-resistant) steel.
- \*No more piece-at-a-time trips to the hardware store.
- \*Heavy-duty, polystyrene cabinet, high-impact plastic bins and bin dividers, printed I.D. labels.
- \*Truly a \$75-plus value!
- \*The most important "tool" in your workshop.

As featured by the editors of MECHANIX ILLUSTRATED, POPULAR SCIENCE, WORKBENCH, FAMILY HANDYMAN, HOT ROD, MOTHER EARTH NEWS, AND OTHERS.

OVER 2 MILLION COMPLETE SHOPS SOLD

**Order today, it's easy!** Just complete and send the Order Form to D. R. I. Industries, Inc., 11100 Hampshire Avenue South, Bloomington, MN 55438, along with your check, money order or company purchase order. Or you can charge it to any one of 5 major credit cards: VISA, MasterCard, American Express, Drivers Club, or Carte Blanche. (Credit card buyers can also call our 24-Hour Toll Free Number: 800-228-6000. Credit card buyers can also call our Express. Drivers Club, or Carte Blanche. (Credit card buyers can also call our 24-Hour Toll Free Number: 800-228-6000. Credit card buyers can also call our If you're not completely satisfied—if you're not truly amazed at all you get—just return it for a prompt, full refund, including shipping and handling charges. No questions asked! And you keep the FREE GIFTS for your trouble!

**CREDIT CARD BUYERS—JUST SAY CHARGE IT!**

© Copyright 1978 D. R. I. Industries, Inc.

### VALUABLE FREE GIFTS!

Yours to keep, just for ordering!

**FREE \$2.50 value 17 1/2" x 24" Specifications Chart**... tells you everything you need to know about nuts, bolts, screws and other fasteners for a quick, professional job—everytime!

**FREE \$2.50 value Nut & Bolt Gauge**... you can figure out nut, bolt, screw and washer sizes, right on the spot, in standard inch and metric.

**FREE Surprise Gift**... just for ordering promptly. It's sure to be something you can use.

All the Free Gifts are yours to keep, whether or not you keep your order!!



11551 **SPECIAL OFFER COUPON** MAG-66

SEND TO AND MAKE REMITTANCE PAYABLE TO:  
D. R. I. Industries, Inc., Dept. PM-383A, 11100 Hampshire Ave. So., Bloomington, MN 55438

How Many? **Nut & Bolt Shop(s)** @ \$19.99 plus \$3.90 shipping and handling each. (00000110)

How Many? **Wall Anchor Set(s)** @ \$1.99 plus \$ .50 shipping and handling each. (00000130)

(Limit: One Set per Shop ordered. Wall Anchor Sets cannot be purchased separately.)

I have enclosed my check or money order for the full amount. (MN residents add 6% sales tax.)

I have enclosed my company purchase order (this card MUST accompany ALL purchase orders).

Charge it to:  VISA  MasterCard  American Express

Drivers Club  Carte Blanche

Card No. \_\_\_\_\_ Exp. Date \_\_\_\_\_

Signature \_\_\_\_\_ (Need sign only if charging)

PLEASE PRINT NAME \_\_\_\_\_

ADDRESS \_\_\_\_\_

CITY \_\_\_\_\_ STATE \_\_\_\_\_ ZIP \_\_\_\_\_



# FAMILY OF SEVEN CUTS HOT WATER BILLS IN HALF!\*

Tankless Heater Provides Endless Hot Water



The Hughson family of Pennsylvania

The Hughson family just took 7 showers in a row — the 7th was as hot as the first — and they're saving hundreds on their hot water bills too.

## Sound, Simple, Money-Saving Idea

Did you know that much of the energy used to heat your basement tank of water is dissipated right through the walls of the tank itself and into your storage or crawl space area?

### The Perfect Answer—New Thermar™ Tankless Instant Hot Water Heaters

If heat losses are created by the need to keep large volumes of water standing in a tank, why not eliminate the tank? And, that's just what Thermar™ has done. In its place we have developed a tiny, super powerful instantaneous heating unit which ACTUALLY CREATES HOT WATER AS YOU USE IT. A microswitch on the unit automatically turns on the moment hot water is needed. Then a continuous stream of delightful, sparkling hot water flows from the tap for shower or wash basin. IMAGINE — as much hot water as you want — produced in a never-ending stream as long as you need it.

The ordinary Tank-Type Hot Water Heater is the most "Energy Costly" appliance in your home. In this day of rising

costs and energy consciousness, a new THERMAR™ TANKLESS INSTANT HEATER should be considered by everyone interested in saving money and saving energy.



Storage tanks keep large volumes of water heated ... all the time. Tank cycles on and off 24 hrs. a day — even when you're away. Tank can also "run out" of heated water when needed.

Tankless design is small in size, doesn't store heated water — but creates it on demand. Uses no energy until you need hot water. Can produce 120 gallons and more an hour!

U.L. Listed Electric and AGA Certified Gas Models Thousands in Use Around the World

You'll recover the initial costs many times over in fuel savings as the years pass. And, you'll enjoy a lifetime of hot water — shower after shower after shower!

\* Savings will depend upon local cost of fuel, type of fuel used, condition, age and type of present heater equipment.

- Selected For Energy House 1982 World's Fair
- Featured in *Popular Science* Magazine
- Seen on TV!
- Member — Gas Appliance Manufacturer's Assoc. Inc.

FOR RUSH DELIVERY OF FREE ENERGY CATALOG AND FULL DETAILS USE COUPON BELOW

RUSH!

**THERMAR™**

Johnson Power Tech  
Melrose Square  
Greenwich, CT 06830

FREE!

I would like to cut my hot water heating bills in half! Please RUSH your FREE catalog of THERMAR™ INSTANT, TANKLESS HEATERS. Include details of the absolutely unique 10 year guarantee and replacement plan. I understand that I am under no obligation to buy anything and no salesman will contact me.

Name \_\_\_\_\_

Address \_\_\_\_\_

City \_\_\_\_\_ State \_\_\_\_\_ Zip \_\_\_\_\_

Canadian Residents send to: 56 Bramsteele Rd., Suite 8, Brampton, Ontario L6W3N4

PM0383

## BIKE THAT ATE NEW YORK

(Continued from page 166)

ried commuter can learn to love, is one of them.

The mountain bike, like so much of our well-intentioned high-tech inventory, came out of California. One critic has called it the perfect blend of European precision, lightweight bicycle and American newsboy's old reliable. I can't argue with that. I have not ridden a wide variety of off-road bikes (as was the original premise for the format), but the Stumpjumper, which is assembled by Specialized Bicycle Components (844 Jury Ct., San Jose, Calif. 95112), appears to be the class of the breed.

Mind you, the company has no qualms about pricing this bicycle at over \$800 (although a \$500 version with economy components is now available). One of the reasons for the high price tag is its light weight. Even with the 26-inch balloon tires and "bomb-proof" custom wheels, plus motorcycle-type brake (Tomaselli levers), the Stumpjumper is less than 30 pounds.

### Commuter's nightmare

Urban commuting is a special challenge for a biker. When you're being chased over sewer grates, in and out of potholes and up and over curbs by the mechanized rodeo we call rush hour, you need a light armored vehicle. Yet the main reason you're riding a bike in the first place is to beat the system—high mass-transit fares, crowds, delays, inconvenience—and that calls for a fair turn of speed.

Recently, I rode a borrowed Motobecane ProLight bicycle (a European road-racing format) from my home in New Jersey to mid-Manhattan. The 16-mile trek took about an hour and 10 minutes, which is not bad when circuitous routing, unforeseen obstacles and inevitable traffic jams are factored in. On the Stumpjumper, I cut 15 minutes off that.

The point is that, while my personal format (at more than 225 pounds) is not that of a *Giro d'Italia* champion, the "fat-tire flyer" was a much better match for the urban/suburban route's terrain than any superlight, skinny-tired speed machine could be.

There are both street-version and off-road tires available. I used only the off-road type shown in the PM photos. They tend to "sing" as you get up to smooth pavement speeds, which indicates they're holding you back. Besides the tires, the raked fork's geometry is what makes the bike resilient enough to take on the worst surprises a metropolitan streetscape—the Big Apple leads the world in this event—can spring on you. And in lowest gear on your 15-speed, triple-crankset transmission, you can almost climb buildings. **PM**





# Know your car inside and out.

Know how to fix it... to tune it... to service it... to keep it running right, the TOTAL SERVICE MANUAL for your car will show you how to do everything from a minor adjustment to a major repair.

factory workshop manuals. Each one is carefully rewritten for use by the do-it-yourself car owner. Clear and easy to follow, yet complete and detailed enough even for professional use. You get all the important information plus hundreds of the best pictures, diagrams, and specifications.

TOTAL SERVICE MANUALS are digests of official

## TOTAL SERVICE MANUALS

## SATISFACTION GUARANTEED OR YOUR MONEY BACK

1713	ALFA ROMEO 62-78 for all Gnuks, GT & Spider models	\$12.95
9641	ALFA ROMEO ALETTA 73-79 covers all models	\$12.95
8677	AMC GREMLIN, HORNET, PACER 71-80 for all models	\$12.95
8194	AMC 75-82 covers AMC, Concord, Eagle, Maraca, Sport, plus	\$12.95
0991	ARROW, PLYMOUTH 76-80 covers all models	\$12.95
2437	ARROW PICK-UP for all models inc D-50	\$10.95
9404	ASPEK, DODGE 76-79 covers all models	\$12.95
7127	AUDI 100 70-77 for all models inc 100L	\$12.95
9596	AUDI 2000 79-81 covers all models	\$10.95
0664	AUDI 5000 77-79	\$12.95
0726	AUDI FOX 73-79 covers all models	\$12.95
0916	AUSTIN AMERICA 68-74 covers all models inc 1100, 1300	\$12.95
1203	AUSTIN HEALEY 100/6, 3000 56-68 for all models	\$12.95
0379	BARRACUDA & CUDA 65-72 all 5 & 6 V8 models	\$10.95
1042	BMW 2002 55-77 inc 1500, 1600, 1602, 2000 except CS	\$12.95
9813	BMW 320i 77-81 covers all models	\$12.95
9836	BMW 518i 79 inc 528, 530i, 630i, 633CS, 733i models	\$12.95
9760	BMW 520i, 2800, 3.0 all mtds inc Bavaria & CS	\$12.95
0504	BRONCO, FORD 66-81 for all 2 & 4 whl drive models	\$10.95
6308	BUNCK 68 76 inc Electra, Le Sabre, Savers, Wildcat	\$12.95
8002	BUXAL REGAL & CENTURY 74-80 for all mtds inc turbo	\$12.95
0727	CAJILLAC 68-74 all models except El Dorado	\$12.95
8678	CAMARD 67-81 covers all 6 & 8 cylinder models	\$12.95
9557	CAPRI 70-76 for all 2000, 2600, 2800 mtds	\$12.95
6021	CAPRI 79-82 covers all models and engines	\$12.95
0739	CHALLENGER 70-72 covers all 6 and V8 mtds	\$10.95
8446	CHAMP & SAPPORO 77-81 covers all engines & models	\$10.95
8331	CHARGER 67-70 for all models inc 500 & R/T	\$10.95
8212	CHARGER 71-75 covers all models	\$10.95
9851	CHEVROLET CAVALIER 82 all mtds + Camaron & J2000	\$12.95
0383	CHEVRELLE 64-69 covers all Malibu models	\$10.95
8469	CHEVRELLE 70-81 covers Malibu, Monte Carlo, El Camino	\$12.95
0838	CHEVRELLE 76-81 covers all models	\$12.95
1038	CHEVROLET 29-40 covers all 6-cyl models	\$18.00
0888	CHEVROLET 45-54 reprint of factory shop manual	\$20.00
1001	CHEVROLET 55-65 for all Bel Air, Biscayne, Impala mtds	\$12.95
0919	CHEVROLET 69-81 for Bel Air, Biscayne, Caprice	\$12.95
9148	CHEVROLET CITATION 80-81 also mtds plus Buick Skylark	\$10.95
0884	CHEVROLET MONZA 75-80 all mtds plus Buick Skylark	\$10.95
8177	CHEVY H1 62-68 covers all 4, 6 & V8 models	\$10.95
0729	CHEVY LUV 72-81 covers all models	\$12.95
8154	CHEVY PICK-UP 67-82 all inc Blazer, GMC plus Suburban	\$12.95
1662	CHEVY VANS 67-81 covers all models plus GMC	\$12.95
0020	CHRYSLER 72-79 factory manual, must give year	\$23.95
9588	CITROEN ID, DS 67-75 covers all DS15, 20, 21 mtds	\$12.95
8264	COLT & CHALLENGER 71-81 covers all models	\$12.95
8211	COMET 71-79 covers all models	\$10.95
8212	CORDETT, DODGE 71-75 covers all models	\$10.95
8032	CORVAIR 60-69 covers all models inc turbocharged	\$10.95
0478	CORVETTE 57-65 covers all 283 & 327 models	\$12.95
9481	CORVETTE 66-82 covers all models & engines	\$12.95
1756	CRICKET, PLYMOUTH 70-73 also covers Hillman Avenger	\$12.95
8188	DART & DEMON 68-76 covers all models	\$10.95
9592	DATSUN 200X 80-81	\$12.95
8065	DATSUN 1200 & 8210 71-78 covers all models	\$12.95
0783	DATSUN 2100 79-82 covers all models imported	\$12.95
8127	DATSUN 240Z, 260Z, 280Z 70-78 covers all models	\$12.95
0706	BYPASS EMISSION CONTROLS 73-77 all Ford-built cars	\$15.95
8474	BYPASS EMISSION CONTROLS 71-77 GM cars	\$14.95
0813	V-6 PERFORMANCE from Buick, Ford & Chevy V-6 engines	\$10.95
9534	BUICK POWER MANUAL, performance tuning V-6 models	\$8.95
0830	CHEVY SUPER SPORT 61-76 everything about every model	\$14.95
9795	CHEVY PERFORMANCE getting the most from small blocks	\$10.95
8125	CHEVY SMALL BLOCK, how to rebuild	\$7.95
9409	CHEVY SMALL BLOCK, how to hotrod	\$7.95
0949	CORVETTE RESTORATION SOURCE BOOK 53-67, the 'baw'	\$21.95
0946	FORD SMALL BLOCK, how to rebuild	\$7.95
9497	FORD V-8, how to rebuild 351C, 351M, 400, 429, 460 engines	\$9.95
9498	PINTO, how to rebuild the 4-cyl	\$9.95
8195	FORD PERFORMANCE how to get it for street or track	\$10.95
0892	MUSTANG, HOW TO RESTORE YOUR complete how to manual	\$14.95
0818	PAINT YOUR MUSTANG basic bookwork to finishing coats	\$7.95
8152	BOLT-ON PERFORMANCE what to buy & what it will do	\$10.95
0735	SUPERPOWER turbo & supercharging, fuel injn	\$10.95
1766	ENGINE POWER basics of high performance engine building	\$8.95
5117	DESIGN & TUNING COMPETITION ENGINES	\$14.95
8441	HOW TO MAKE YOUR CAR HANDLE street/track	\$9.95
8658	AIRCooled ENGINES manual for 1, 2 & 4-cyl over 15 cid	\$9.95
9419	SMALL ENGINE SERVICE MANUAL all 1-cyl under 15 cid	\$9.95
9770	LAWN MOWER fix all gas powered walking, push type	\$8.95
8755	RIDING LAWMOWER manual for all major makes and models	\$8.95
9651	SMALL TRACTOR manual 65-81 all makes/models 8-30 hp	\$19.95
9822	FORD FARM TRACTOR manual covers all series 2N, 8N & 9N	\$9.95
8490	FORD TRACTORS mtds 501,600,1,700,1,800,1,900,1,1801,2000	\$9.95
1028	IF FARM TRACTORS for A,B,C,H,M,MTA,4,6,WETA,9 models	\$9.95
8518	JOHN DEERE FARM TRACTOR manual for mtds A,B,D,G,H,M,T	\$9.95
8183	ALL ABOUT WELDING good intro to gas & electric welding	\$9.95
8180	SOLDERING the only book on the subject, very complete	\$5.95
9525	MACHINING FUNDAMENTALS to use all machine shop equip	\$24.95
9147	EXCAVATOR OPERATION dozers, backhoes, loaders, cranes	\$9.95
0592	FORK LIFT TRUCKS service, overhaul all gas, prop, elec	\$19.95
9807	HEAVY EQUIP REPAIR dozers, backhoes, cranes, plus	\$19.95
0929	MOTORCYCLE MANUAL 68-81 all Japanese makes + H-D	\$24.95
8126	MOTORCYCLE troubleshooting guide all 2 & 4-cyl models	\$9.95
0957	CHAIN SAW SERVICE MANUAL for top 3A makes	\$9.95
0555	SNOWMOBILE manual covers 300+ makes & models 65-78	\$9.95
8002	OH BURNERS How to install and service	\$9.95
8017	HOME PLUMBING & HEATING 672 pages cover every detail	\$8.95
7109	CLOTHES DRYERS fix all makes and models	\$5.95
1268	SEWING MACHINE REPAIR service, adjust, repair all makes	\$8.95
0530	HOME APPLIANCE REPAIR major wash mtn, refr, dshhwasher	\$6.95
0809	HOME VIDEO RECORDER service all cassette makes, models	\$12.95
7133	35mm CAMERA REPAIR all SLR makes and models	\$10.95
8458	How-to-PHOTOGRAPH SPORTS & ACTION races, games as a pro	\$9.95
8674	How-to-PHOTOGRAPH WOMEN posing, working with models, more	\$9.95
0798	TROUBLESHOOT COLOR TV RECEIVERS for all makes	\$11.95
9595	TV REPAIR Beginners guide for any color, B/W problem	\$6.95
8181	HI-FI & STEREO how-to for home, cars, boats & trailers	\$6.95
9447	ELECTRICITY FROM WIND, WATER & SUN how to get it	\$6.95
8724	LOCKS & LOCKSMITHING complete, step-by-step course	\$9.95
3752	TELEPHONES, Master Handbook every type & installation	\$11.95
8185	ALL ABOUT MICROCOMPUTERS clear, dr. tv-to-understand instru	\$6.95

## GENERAL REPAIR MANUALS — TUNING GUIDES — HOME REPAIR — TECHNICAL BOOKS

0575	CHILTON AUTO REPAIR 76-83 for all American cars	\$18.95
0532	CHILTON AUTO REPAIR 72-79 for all American cars	\$19.95
7137	CHILTON AUTO REPAIR 64-71 for all American cars	\$19.95
1763	CHILTON AUTO REPAIR 54-63 for all American cars	\$19.95
7111	CHILTON TRUCK REPAIR 75-82 American & import makes	\$19.95
8318	CHILTON TRUCK REPAIR 71-78 American gas & diesel mtds	\$19.95
8561	CHILTON TRUCK REPAIR MAN 61-71 for all 1/2 to 1 1/2 ton mtds	\$19.95
8091	CHILTON IMPORT CAR MANUAL 76-83 for all 4 major makes	\$19.95
0492	AUTO REPAIRS & PRICES list rate times 74-79 U.S. cars	\$7.95
1165	GM CARS Diagnosis & Repair 70-83 plus light trucks	\$14.95
1146	PERFORMANCE WITH ECONOMY power from tuning & building	\$10.95
7125	AUTO AIR CONDITIONING... service & repair all	\$7.95
8726	TRANSISTOR IGNITION SYSTEMS covers them all	\$8.95
1067	MORE MILES PER GALLON GUIDE How to do it good & cheap	\$7.95
8107	ALCOHOL DISTILLERS MANUAL for gasoline & spirits	\$12.95
7110	WEEKEND MECHANIC'S HANDBOOK, ideal manual for beginner	\$11.95
9622	HOW TO TUNE YOUR CAR good for all cars	\$5.95
9671	BASIC MAINTENANCE & REPAIR keep your car running right	\$4.95
1712	BASIC AUTO REPAIR MANUAL a must for any car	\$5.95
1749	BASIC BODYWORK & PAINTING	\$6.95
1711	BASIC CARBURETORS & FUEL SYSTEMS for all U.S. makes	\$6.95
1706	BASIC CHASSIS, SUSPENSION, BRAKES... tune & service	\$6.95
1708	BASIC IGNITION & ELECTRICAL SYSTEMS	\$6.95
0680	BASIC AUTO TROUBLESHOOTING for all cars	\$6.95
9410	TURBOCHARGERS most complete book on the subject	\$9.95
1658	EMISSION DIAGNOSIS & TUNE UP 75-79 all U.S. & imports	\$14.95
3759	ELECTRONIC FUEL INJ MAN 70-77 for all imported cars	\$9.95
9976	CARBURETOR BASICS troubleshooting/repair all U.S. makes	\$8.95
9411	HOLLEY carbs, all 2 & 4 bbl., tune & rebuild	\$7.95
9552	ROCHESTER CARBURETORS for all 1, 2 & 4 barrel models	\$9.95
9656	SOLEX CARBURETORS all 1 & 2 barrel down draft models	\$4.95
6354	SU CARBURETORS tune & rebuild all to 1976	\$9.50
9423	STROMBERG CD CARBS tune/repair/all to 1976	\$9.50
1511	WEBER CARBURETORS tune & rebuild all models to 1979	\$8.50
0827	AUTOMOTIVE REFINISHING best, professional paint book	\$8.95
8425	MINOR AUTO BODY REPAIR step by step how to	\$7.95
5104	AUTOBODY REPAIRING & REPAINTING... the best	\$14.95
1659	AUTO BODY SHEET METAL REPAIR for professionals	\$14.95
1016	GLASS FIBER AUTO BODY construction & repair	\$6.00
1071	CREATIVE CUSTOMIZING how to do it like a pro	\$6.95
9901	CUSTOM PAINTING practical tips for professional results	\$10.95
3726	ENGINE SWAPPING latest techniques with actual swaps	\$8.95
8491	PRACTICAL ENGINE SWAPPING how to do it right	\$7.95
6029	DIESEL GUIDE covers everything owner/buyer should know	\$8.95
0541	MODERN DIESEL CARS describes all models now sold	\$7.95
7128	DIESEL, HOW TO convert your car, vahn, pickup to	\$7.95
8432	DIESEL ENGINES, HOW TO REPAIR... complete training course	\$12.95
0647	DIESEL Fundamentals, Service, Repair covers all aspects	\$19.95
2526	ENGINE REBUILDING all U.S. & imports, gas & diesel	\$14.95
1017	AUTOMOBILE ENGINE REBUILDING	\$13.75
9320	AUTOMATIC TRANS SERVICE 68-79 all Ford & GM models	\$14.95
1749	AUTOMATIC TRANS REPAIR 74-80 AMC, Chrysler, Ford & GM	\$14.95
1223	BRAKES, STEERING SUSPENSION service all 76-83 cars	\$14.95
9780	AUTO RESTORATION GUIDE... best ever published... 291 pgs	\$15.95
0995	CAR INTERIOR RESTORATION useful for all cars	\$6.95
0906	OLD CAR VALUE GUIDE latest edition	\$9.95

## CARBOOK

181 Glen Avenue MP  
Sea Cliff, NY 11579

Name \_\_\_\_\_  
 Address \_\_\_\_\_  
 City \_\_\_\_\_  
 State \_\_\_\_\_ Zip \_\_\_\_\_  
 Prints shipped to all parts USA/Canada (US Dollars)  
 I enclose full payment phone orders (516) 676-8043  
 Charge  American Express  Visa  Mastercard  
 Acct. No. \_\_\_\_\_ Exp. Date \_\_\_\_\_  

ITEM NO.	QTY.	PRICE EACH	TOTAL
		\$	\$
		\$	\$
		\$	\$
PLEASE PRINT NAME & ADDRESS			postage/handling \$ 3.00
			TOTAL \$ _____

-NO COD-



# Melt Metal!

## Pour your own castings!

### Amazing Technical Books...

Discover the most remarkable mailorder bookstore ever! You'll find hundreds of manuals, industrial handbooks, paperbacks, reprints, and privately published papers on windmills, methane, lathes, milling machines, electric motor rewinding, industrial and mobile hydraulics, foundry books of all types, alcohol fuels, satellite tv, electric autos, hydroponic gardening, and much, much more!

This is NOT a book club — just the very best books from the best publishers. Buy only what you want, when you want. Each publication is guaranteed!

### Build a lathe! a windmill!

Build a precision lathe without power tools for about \$50. It's true! See how one man built a powerful Savonius windmill! Discover the original Stanley Steamer patents! Grow vegetables in chemicals in the dead of winter! Build radios that work for free! Make soap! Tan hides! Smoke meat! Start a mailorder business!

Build a professional quality sheet metal brake! Build jigs and fixtures! Design and build a powerful arc welder! Learn how to run three phase motors on single phase! Learn about alternator secrets! Discover a remarkable 2000 page mechanical engineer's handbook! Repair diesel engines! Learn electroplating! Run your car on wood! Make your own soda pop! Make and recycle tools! Be a blacksmith! And on, and on, and on...

Write for your copy of the latest jam-packed edition of Lindsay's Technical Books catalog. Send \$1.00 US & CAN (\$3.00 foreign airmail) to cover first class postage and handling.

We offer quality and only quality. When you order, you know you'll be getting the best books available. Discover for yourself what you've been missing. Write for a catalog today!



Learn how you can turn an old pail and a blower into a powerful furnace that can melt aluminum cans and scrap, pot metal, and brass. We built one for about \$10! Uses grocery store charcoal fuel. Pour custom castings! It's easy and relatively safe. Cast works of art, machine parts, or items for sale! Write today for a catalog!

## BURRO Fiberglass Travel Trailer Kit

### Build Yourself! Save Gas



TRAILER FOR THE '80's—Burro Travel Trailer kit sleeps four. Under 1,000 lbs. Fiberglass. Ready to tow. Finish interior only. Write Burro PM3 14143, 21st Avenue North, Plymouth, MN 55441. For full color catalog send \$3.00 to cover handling. Rental Opportunities.

### NO INVESTMENT! INSTANT INCOME!

Run your own profitable "shoe store" business from home in spare or full time. We give you—FREE—complete Starting Kit that makes you \$217.00 EXTRA each month for just 2 easy orders a day. You feature 350 fast-selling dress, sport, work shoe styles for men and women. Air-cushioned insoles, and over 75 years of shoe-making craftsmanship! Sizes 4-16—widths AA-EEEE. Draw on 500,000 pair stock. Earn prizes, bonuses, shoes for yourself. Rush postcard for your FREE Starting Kit today... Now!



MASON SHOE MFG. CO., Dept. F-202 Chippewa Falls, WI 54774

## Lindsay Publications Box 12-JU Bradley IL 60915-0012

Send a catalog! I've enclosed \$1.00 (\$3.00 foreign airmail)

Name \_\_\_\_\_

Street \_\_\_\_\_

City \_\_\_\_\_

State \_\_\_\_\_

Zip \_\_\_\_\_

## Guest Bed On A Shelf!



The Air Bed offers a revolutionary sleeping experience. Gently, but firmly supports you with 100% air. Features air coil construction with multiple controlled air chambers that hold your body evenly and independently.

Turns any room into a guest room. The ideal portable bed for holiday and vacation visitors...and it stores easily. Take the lightweight Air Bed camping, in your van, on your boat, in your summer home; sunbathe and float on it!

Available in twin, double, queen and king sizes. Inflates in minutes with most air pumps or canister vacuum. (High-power air pump available—optional.) Made of sturdy 20 gauge poly vinyl, cleans with soap and water. Repair kit and pump adapter included.

Don't be misled by imitations. Insist on the original red velveteen The Air Bed. 10-day Free Trial. If not satisfied, return it within 10 days for refund. Order now!

CREDIT CARD ORDERS CALL TOLL FREE

800-648-5600 Nevada Residents Call 800-992-5710

Offer void outside Continental U.S. Allow 4-6 weeks for delivery

Contemporary Marketing, Inc. 790 Maple Lane, Bensenville, IL 60106

The Original Velveteen from \$49<sup>95</sup>



Stores Easily on Shelf



Air Coil Construction

Please send me the following AIR BED SIZES:  
Twin #2339 \$49.95 plus \$6.95 shipping & ins.  
Double #2354 \$69.95 plus \$6.95 shipping & ins.  
Queen #2360 \$79.95 plus \$6.95 shipping & ins.  
King #2374 \$99.95 plus \$6.95 shipping & ins.  
AC Pump #0004 \$29.95 plus \$2.95 shipping & ins.  
DC Pump #0005 \$29.95 plus \$2.95 shipping & ins.  
Illinois Residents include 5 1/4% sales tax.  
Check/M.O. Enclosed Charge My Credit Card:  
MasterCard American Express Carte  
Visa Diners Club Blanche

Card No. \_\_\_\_\_ Exp. Date \_\_\_\_\_

Name \_\_\_\_\_

Address \_\_\_\_\_

City \_\_\_\_\_

State \_\_\_\_\_ Zip \_\_\_\_\_

Signature \_\_\_\_\_

MAIL TO: Contemporary Marketing, Inc. 790 Maple Lane, Bensenville, IL 60106 Dept. 242-095-06

### BUILD YOUR OWN JET HELICOPTER

#### EASY TO FLY—INEXPENSIVE TO BUILD!



- Carries one person-plus
- Simple hand-tool assembly
- Uses low-cost fuel

Plans—completely illustrated: \$9.00



The HELICOPTER HOBBYBOOK includes Plans for building a piston-engine-powered Helicopter (illus.): \$8.00.

BOTH ABOVE BOOKS: only \$14.00

HELICRAFT, Inc.

P.O. Box 16488

Baltimore, MD 21217

## MADE SIMPLE MATH Self Teacher

New Short Cut Math Skills in Only Weeks —10 minutes a day...for Higher Pay Jobs.

### BONUS! Pocket Math-Wizard!

with Math book "Math-Wizard" Get the Right Answers in a Flash Without Paper or Pencil! Instant answers convert fractions into decimals, percentages and reverse. Plus other tough math problems solved in a jiffy!



and illustrated. Learn theory and practice from "scratch", "brush-up", or reference. Summary makes review easy. Track your progress. Catch errors instantly. Pass civil service and job tests. A must for all office, sales, industrial jobs, home finances. Send \$9.95 plus 95¢ for shipping. 30 day Money Back Guarantee.

VALCO-Dept. 897 Box 2012, New Rochelle, N.Y. 10802

Splits EASIER & FASTER! **THE BOSS LOG SPLITTER!** Only \$49.95 plus \$8 p. & h. for adaptable cone, or \$99.95 plus \$10 ready-to-attach to hub of car or light truck (specify vehicle). Pa.—send 6% sales tax. Free info—send stamped self addressed envelope. Good Products, Route 3 Box 88-A PM, Kutztown, Pa. 19530



# The Freud Catalog... A must for every woodworker!



## CARBIDE TIPPED DADO HEADS

Freud can cut it...

Freud Carbide Tipped Dado Heads are guaranteed to produce a smooth and accurate groove either with or without glue. You will obtain excellent results when grooving in soft wood, hard wood, or plywood. As for durability, Freud Carbide Tipped Dado Heads will outlast all types of steel heads and give you better results than competitors. The outside cutter saws have a 500° pattern consisting of five cutting teeth beveled one way and one square taper tooth. Please... mount our dado with the high points of the beveled teeth to the outside.

## CARBIDE TIPPED DADO HEADS

SET NO.	MAXIMUM WIDTH OF GROOVE	NUMBER OF OUTSIDE SAWS	NUMBER OF INSIDE CUTTERS		
			1/8"	1/4"	1/2"
1	7/16"	2	1	1	—
2	1 1/16"	2	1	1	1
3	1 1/8"	2	1	2	1
4	1 1/4"	2	1	2	2
5	1 3/8"	2	1	2	4
6	1 7/8"	2	1	2	8
7	2 1/8"	2	1	2	15
8	2 1/2"	2	1	2	15

is word or two about quality

Freud Carbide Tipped Dado sets include all the features that make them available and the highest standards of workmanship. The outside blades are properly hardened and treated and the inside cutting pair designed with innovations that will produce the accurate results you can always expect from Freud.



**freud**

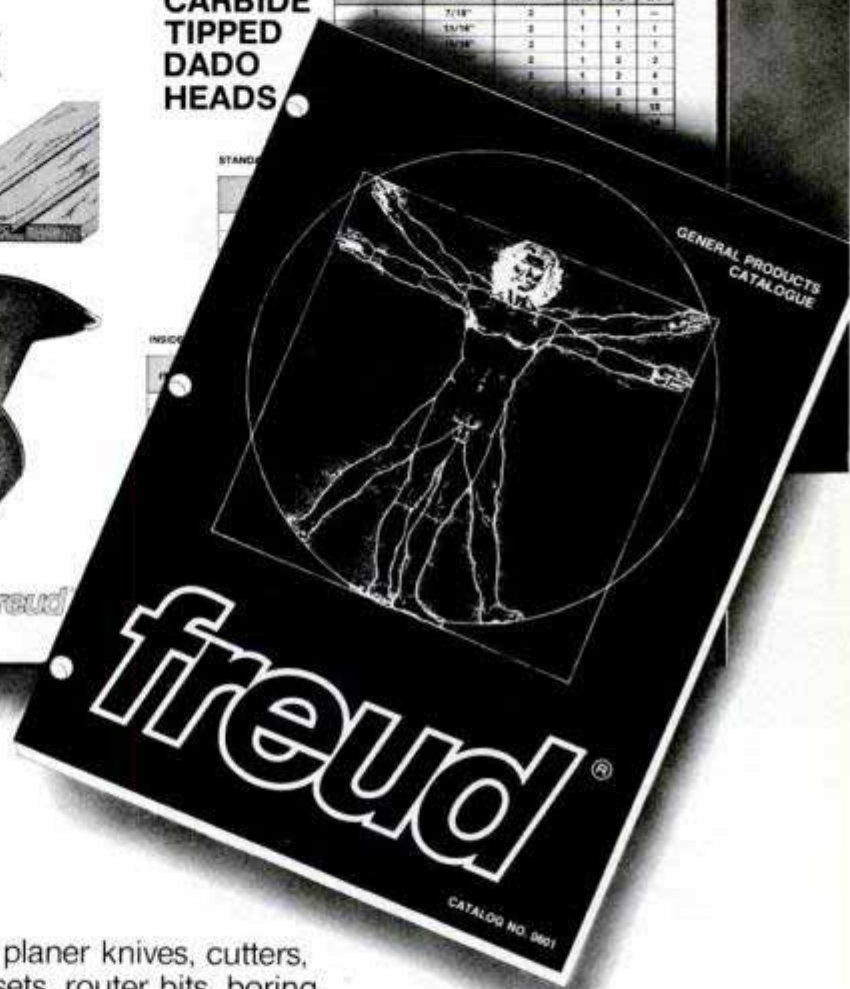

Used worldwide by customers and competitors alike as a guide for quality tools.

At Freud, we realize the woodworker's need to have a handy reference guide where most questions concerning tools, their applications, and availability can be answered.

Featured in the Freud catalog are thousands of precision tools including: carbide-tipped saw blades, dado

heads, planer knives, cutters, cutter sets, router bits, boring bits, and accessories.

Selecting the right tool for the job is made simple by the exacting descriptions and full-color illustrations in this beautiful 96-page catalog.

To get your Freud catalog, simply fill out the coupon

below. Send with proof of any Freud purchase and receive the catalog free, or send \$5.00 which will be refunded at the time of your next Freud purchase from any stocking distributor.

Catalog Coupon

Enclosed is my \$5.00. Please send me Freud Woodworker catalog. I understand I will receive a \$5.00 rebate on my next Freud purchase at any Freud stocking distributor.

Enclosed is my receipt of Freud purchase. Please send your catalog free.

Fill out coupon and mail to:

# freud®

P.O. Box 7187, 218 Feld Ave.  
High Point, N.C. 27264  
(919)434-3171 — Telex 578438

Your Name \_\_\_\_\_  
 Company Name \_\_\_\_\_  
 Street Address \_\_\_\_\_  
 City \_\_\_\_\_ State \_\_\_\_\_ Zip \_\_\_\_\_ Telephone \_\_\_\_\_



# Introducing PalmPump—The Solid Solution To Fluid Handling Problems

Transferring fuel to the family car, draining a clogged sink, or bailing a small boat, the new PalmPump can do it five times faster than old fashioned, hand-powered pumps -- and the price won't pump your wallet dry!

The PalmPump puts lightweight, high-volume pumping capability at your fingertips, thanks to its unique system of inter-running pistons. Weighing less than 28 ounces and delivering 2.5 gallons per minute at normal cranking speeds, a PalmPump is the logical choice for all marine, industrial and general utility applications where quick, dependable pumping is required.

Constructed of solvent-resistant

Delrin plastic, the patented PalmPump employs four piston, positive displacement action and can reverse pumping direction by changing cranking rotation. The PalmPump is also self-priming, able to draw liquid from six feet below pump level and deliver it to a height of 60 feet.

Order your PalmPump today! Come to grips with all of your fluid handling problems at home or work! If not completely satisfied, return it within 30 days for a full refund. Please allow six to eight weeks for delivery.

**Milburn Stirling**

Send \$29.95 in check or money order (Shipping included) to:  
**Milburn Stirling Corporation, Inc.**  
 1840 Commerce, C-North  
 Boulder, Colorado 80301

Please send my PalmPump to:

Name \_\_\_\_\_  
 Address \_\_\_\_\_  
 City \_\_\_\_\_ State \_\_\_\_\_ Zip \_\_\_\_\_



**STANDARD GARAGE**  
 Easy to build with our plans and complete materials list specify size:  
 12' x 20' 20' x 20' 18' x 22' 14' x 24' 22' x 24' 24' x 30'  
 14' x 20' 12' x 22' 20' x 22' 16' x 24' 24' x 24' 26' x 30'  
 18' x 20' 14' x 22' 22' x 22' 18' x 24' 24' x 26' 28' x 30'  
 18' x 20' 16' x 22' 12' x 24' 20' x 24' 24' x 28' 30' x 30'  
 Larger size on request: Plans and material list \$6.00. We also have plans for large variety of other buildings from dog houses to large pole buildings. Send \$0c for brochure on other projects to build  
**Crown Building Products,**  
 Dept. C-383 P.O. Box 34542 Omaha, NE. 68134

## FOLDING-PORTA-BOTES

Fold to 4' Flat. Sizes: 8', 10', & 12' Lengths  
  
 By: Porta-Bote International, PO Box 2287, Dept. PM Menlo Park, CA 94025. Call (415)961-5334

## At Last a New Amazingly Simple GAS TURBINE JET ENGINE

Build from easy to follow plans. Length 15", Dia. 8 1/2", Wt. 15 lbs. Fuel: Gasoline or Kero.  
 "Screaming Demon" develops 20 H.P. Ideal project for serious-minded hobbyists, students, scientific and industrial art classes. Made on 9" metal cutting lathe with milling attachment. For use on small racing boats, midget cars, etc. Full size assembly drawings with critical dimensions, bill of materials and photos. Price: \$8.00 No. C.O.D. 1910 200 \$1. P.O. Box 1358  
**SAVOY SCIENTIFIC SANTA MONICA, CALIF. 90408**

## CALL TOLL FREE NOW!

**AMAZING VINYL REPAIR**  
 —\$10 to \$20 in an hour!  
 Big earnings, repeat business. Car shops, homes, motels, restaurants, bars, etc. FREE FACTS BY MAIL.

Call toll free 1-800-621-6633 (Ill. 1-800-572-0444) or write VIP, 2021 Montrose, Dept. 182, Chicago, IL 60618

**DISH ANTENNA! PREAMPLIFIER RECEIVER**  
 MDS complete receiving system ready for TV hook up. All TV Cables included.  
**397 TOTAL PKG**  
**Satellite TV, Inc.**  
 P.O. Box 3108, DEPT. M-3 Lantana, FL 33462  
 Send your REFERENCE BOOK for \$11.95 plus \$2.95 shipping & insurance (U.S. funds) or call our 24-hour C.O.D. Order Line (305) 276-2941.  
 Name \_\_\_\_\_ info. for authorized TV programming  
 Address \_\_\_\_\_

**Satellite TV STOP LOOKING!!!**  
 "WE HAVE IT ALL" 100+ Channels • LNA's • Antennas • Receivers • Sources • Photos  
 Our BOOK is not OVERLY TECHNICAL NUMB JUMBO but takes the mystery out of the sophisticated technology of satellite reception. The prestigious Mass. Inst. of Technology, U.S. Army, and libraries worldwide have purchased this book. Now enjoy movies, Las Vegas shows, sports, news.

# BUILD YOUR OWN BOAT

Join the thousands who build each year AND SAVE \$\$\$! GLEN-L's proven methods are especially intended for amateurs. Step-by-step pictorial and written instructions with material listings assure PROFESSIONAL RESULTS! HUGE 144-page catalog describes over 200 designs, 8' to 55'. Sail & power boats, boat trailers, boating books, AND MORE! Order catalog now and also receive FREE "BOATBUILDING SUPPLIES" brochure.



**KITS • PLANS • PATTERNS**  
  
**GLEN-L GLEN-L MARINE DESIGNS**  
 9152 Rosecrans, Box 756T, Bellflower, CA 90706

- GLEN-L MARINE DESIGNS
  - 9152 Rosecrans, Box 756T, Bellflower, CA 90706
  - GLEN-L catalog @ \$2.00 (sent 4th Class) OR
  - GLEN-L catalog @ \$4.00 (sent AIR MAIL)
  - "FIBERGLASS BOATBUILDING-AMATEURS" ..... @ \$19.95 ppd.
  - "BOATBUILDING WITH PLYWOOD" ..... @ \$15.95 ppd.
  - "INBOARD MOTOR INSTALLATIONS" ..... @ \$14.95 ppd.
  - "HOW TO FIBERGLASS BOATS" ..... @ \$ 6.50 ppd.
  - "RIGGING SMALL SAILBOATS" ..... @ \$ 6.50 ppd.
  - "HOW TO BUILD BOAT TRAILERS" ..... @ \$ 6.50 ppd.
- NAME \_\_\_\_\_  
 STREET \_\_\_\_\_  
 CITY \_\_\_\_\_  
 STATE \_\_\_\_\_ ZIP \_\_\_\_\_

**PLANS AND INSTRUCTIONS FOR**

Go Kart	..... \$2.50
Mini Bike	..... \$2.00
Mini car	..... \$3.00
1/2 Sail Boat	..... \$4.00
Front Traction Go-Kart with Gearless Differential	..... \$10.00
Mini Jeep	..... \$3.00
Pedal Boat	..... \$4.00
8 H.P. Tractor	..... \$10.00
Soap Box	..... \$3.00

Mini Vehicles Plan Dept. C Chazy, N.Y. 12921

**DUNE-BUG**  
 Complete plans & specs on how to build or buy - disc, prices on parts, kits, engines, & raw material.  
  
 Send \$3 for DUNE-BUG pkg to: K & P Mfg. Box 987 M3 Azusa, CA. 91702 Dealer Inquiries Invited

Get Your 2-Year Degree At Home **Be a MECHANICAL ENGINEERING TECHNICIAN**  
 Learn at home in spare time. No previous experience needed—just a high school diploma. Associate degree awarded with major in Mechanical Engineering Technology. Graduate in as little as two years. No need to quit your job or school. Approved for G.I.'s and Veterans. Write for free facts. No obligation. No salesman will call.  
**ICS CENTER FOR DEGREE STUDIES**  
 Mech. Eng. Tech. Dept. PB023 Scranton, Pa 18515

**Portable Steam Cleaner**  
 Steam in 60 seconds  
**CLEAN:** Engines, Air Filters, Lawn Mowers. 3 year guarantee on fire box, coils. Uses liquid soap, propane fired. Weight 120 lbs. Auxiliary pump required on low water pressure.  
**WEDCO MFG. INC., Dept. M-13**  
 940 West Broadway, Jackson, WY. 83001

**BASEMENT TOILET**  
 FLUSHES UP To Sewer or Septic Tank  
 No Digging Up Floors—Installs Easy, Anywhere!  
 Write McPherson, Inc., Dept. 16  
 Box 15133 Tampa, Florida 33684

**FREE THE GREAT ELECTRONIC THINGS & IDEAS BOOK!**  
 HUNDREDS OF UNUSUAL PARTS, GADGETS & IDEA ITEMS UNAVAILABLE IN STORES OR CATALOGS ANYWHERE! Bargain prices on everything! New items in every issue! Rush postcard for your copy!  
**ETCO ELECTRONICS**  
 Dept. 323 Pittsburgh, N.Y. 12901



# Why Are These Makita Tools SO GOOD? POWER!

## You Can Put Your Whole Weight On This Sander... It Barely Slows Down!

The ideal power sander should be as much like a block sander as possible. It should have a heavy felt base, and use exactly one-quarter of a 9x11" sheet of sandpaper that's easily but firmly attached to the pad. It must be very powerful and be able to run for hours without even getting warm.

We just described the Makita, orbital-action, finishing sander! A great 180W motor produces 12,000 orbits/minute.

And you can sand into corners with ease because there's no handle overhang.

UL listed, double insulated. 8' cord. Ball-bearing construction. Only 2.4 lbs.

And look at the price!

90-day, money-back guarantee, if you're not tickled pink.

**Makita Sander** ..... \$49



Quarter  
Any Standard  
Sandpaper Sheet



Two Spring  
Clamps Secure  
Sandpaper

## More Power Than You'll Ever Need!



## The Makita 3/8" Drill- Engineered For Years Of Double-Shift Industrial Use!

What'll you have to do on your next project — push a 2" hole-saw through oak? Put a 1/2" blind hole into steel plate ... drill a 1/16" hole in plastic? Or will you be cutting a dovetail? Roar through or finesse any job with this variable speed, reversible 3/8" Makita drill.

The power is transmitted through precision-made gears, machined in sets to match perfectly. Add 4 multi-ball, sealed stationary bearings and torque loss is minimal. That's why you'll get full power at all speeds, up to 1800 rpm.

Double insulated, UL listed, 2.7A, 305W, continuous rating. 8' cord. Non-slip grip, handy belt clip. A comfortable 3 lbs.

Use the coupon at right. 90-day, money-back guarantee, if you're not completely happy.

**3/8" Makita Drill** ..... \$49



You Can Order Tools By Phone:

**CALL TOLL FREE**

**800-321-6840**

Ohio Residents Call: (216) 831-6191

Yes, Ric Leichtung, please send me:

Makita Palm Grip Sander @ \$49 .....

Makita 3/8" Drill @ \$49 .....

Shipping, Handling, Insurance .... **\$3.00**  
Ohio Residents Add 6 1/2% Sales Tax.....

**TOTAL** .....

**METHOD OF PAYMENT:**

Check Enclosed  VISA  MasterCard

Card # .....

Good Thru .....



Enclosed is \$1.00. Please send me your full-color Catalog of Fine Tools plus all catalogs and new tool bulletins FOR THE NEXT TWO YEARS.

Free with Sander and/or Drill Purchase

Name .....

Address .....

City .....

State ..... Zip .....

**LEICHTUNG**   
"THE Workbench People" Dept. 383 PM  
4944 Commerce Pkwy. Cleveland, Ohio 44128

**LEICHTUNG**  Dept. 383 PM  
"THE Workbench People" 4944 Commerce Pkwy.  
Cleveland, Ohio 44128



# THE TGS 172 SUPER SAW

The Perfect Workshop Companion!  
SPECIAL MAIL ORDER SALE

- Miters a 2x4, chops up to 2x8 & cuts large panels
- Portable: 77 lbs. fits in car trunk
- Free standing or bench top operation
- Positive locks: accurate 90° & 45° cuts

- Comes complete with: legs, saw blade, rip fence & miter gauge
- Changes from table to miter operation in seconds

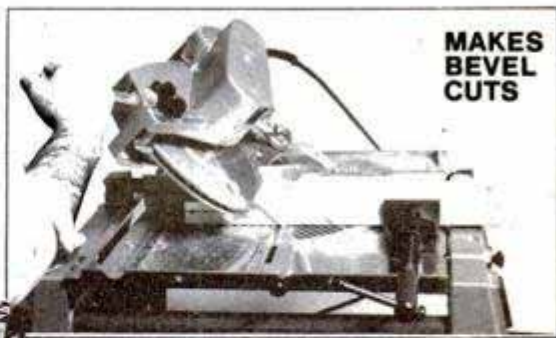
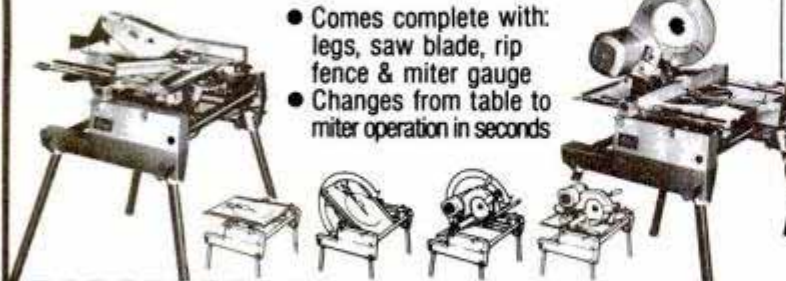

MAKES  
BEVEL  
CUTS

ORDER DIRECT FROM  
FACTORY AND SAVE!

ONLY \$495 COMPLETE

Credit card customers can order by phone:  
TOLL FREE 1-800-321-8379  
In Ohio call collect 216-425-3135  
or mail in coupon



## ELU CORP.

9040 Dutton Drive, Twinsburg, Ohio 44087

Send \_\_\_\_\_ Supersaws at \$495. each  
Mail coupon to: Elu Machinery Company, 9040 Dutton Dr., Twinsburg, OH 44087  
\_\_\_\_\_ Check enclosed \_\_\_\_\_ Moneyorder \_\_\_\_\_ Visa \_\_\_\_\_ Mastercard  
Account No. \_\_\_\_\_ Exp. Date \_\_\_\_\_  
Name \_\_\_\_\_  
Address \_\_\_\_\_  
City \_\_\_\_\_  
State \_\_\_\_\_ Zip \_\_\_\_\_ Phone \_\_\_\_\_  
Sign here \_\_\_\_\_  
30 day money-back guarantee FOB Twinsburg, Ohio



Sample Copy

## YOUR CHOICE... FREE



40 PIECE  
Standard  
& Metric

AUTO LOGIC PUBL., INC.  
P.O. Box 9187, Dept. PM33  
San Jose, CA 95157

Send No Money. Check Your Preference Below.

- YES! I know a good deal when I see it. Send me the free 40 piece, rugged-duty standard and metric socket set and begin my subscription at once. *Bill me.*
- YES! Send me the free sample copy. If I like it, I'll subscribe and you can bill me later.

\_\_\_\_\_  
To be eligible, you must print your  
Mastercard or Visa Number above. Expires

name (print) \_\_\_\_\_ age \_\_\_\_\_  
street (no p.o. boxes) \_\_\_\_\_ apt. \_\_\_\_\_  
city/state \_\_\_\_\_ zip \_\_\_\_\_  
 I hate to use credit cards. Here's my \$24 for 24 issues,  
plus the free socket set.

We're so excited about the new Kit Car Monthly that we'll send you a sample copy ... absolutely free! You can even have this 40-piece metric and standard socket set if you subscribe today.

Discover the thrilling, but unknown world of kit cars in America's only monthly kit car magazine. You won't find it on the news stands though, it's only sold by mail.

Imagine ... you can own and drive an authentically detailed classic like this Cobra replica or hundreds of others, many for less than the price of a Pinto. Learn how you can replace the body of your old clunker with a shiny new replica. See them all. Cobra to Pantera, Porsche, Mercedes and more.

To get your free sample copy, just fill out the coupon. (If you like it, we'll automatically enter your subscription for twenty-four issues at a buck each and bill your credit card direct.) There is no risk. If your sample copy isn't everything you want, just return the cover with your mailing label (within thirty days). Of course we'll stop your subscription before it begins and naturally there won't be any charge.



Easy to build!  
No welding!  
Holds 3/4 ton!

WHY BUY A PICKUP?  
SAVE \$\$\$ & ENERGY  
WITH A  
UTILITY  
TRAILER

- The original Odds Trailer System - a proven design since 1962.
  - Ideal for hauling firewood, moving, building, hunting, fishing, farm use, etc. - or start your own sales and rental business.
  - 48 1/4" wide inside, 6' long - front & back panels slide out for carrying 4' x 8' plywood sheets or other long objects.
  - Tough - not a toy - uses strong 14" American car wheels and springs.
  - Easily built for about \$135 with ordinary hand and power tools.
- PLANS - STEP-BY-STEP INSTRUCTIONS - PICTURES - MATERIALS LIST - USEFUL TRAILER HINTS ... ONLY \$8 PPD  
A QUALITY PRODUCT AT AN HONEST PRICE  
JAYBARK R & D CORP., BOX 109, DEPT. B,  
CHATEAUGAY NY 12920 SATISFACTION OR MONEY REFUNDED

Inventor Patents  
NEW Pogue-Type  
High MPG Carb!

CUTAWAY VIEW



Reports 67 MPG highway, 400 cid '75 Chrysler, much higher mileage, some tests ... and with other vehicles!

Is it here, a modern working version of the legendary Pogue high-mileage carb? Inventor Ray Covey says YES, reveals secret! Sealed cannister above is heated by hot coolant in coil manifold gases in base. Fuel, sprayed-in, is vaporized, drawn into existing carb by engine vacuum, on demand System is NOT pressurized.

Covey's Vaporizer runs on "regular," high as 100 to 1 air/fuel ratio. Dual system, instant change-over. Compact (about 8" high) under-hood device is reportedly safe, easy to build. Cost? Low as \$75 with stock/used parts. Many units in use, but Covey seeks more performance data, many vehicles, before manufacturing Parts Kit.

Join our Road Test Team! Build a vaporizer for your car/truck. We'll send complete working plans, specs, instructions and parts list, that can cost you NOTHING!

BUILD YOUR OWN AT LOW COST! Write for FREE report, performance verification, Road Test Application  
CARB RESEARCH CENTER  
Box 21, Dept PM-3  
Chalco, OK 74016 © 1982



## Find twice the treasure...

with a WHITE'S ELECTRONIC  
MINERAL/METAL DETECTOR

White's instruments detect rings, jewelry, coins, plus other valuables and it's profitable! Metal detecting is a hobby for the whole family to enjoy. Models from \$79.95. Covered by U.S. Patents.



In half the time



FOR THE NEAREST WHITE'S DEALER  
AND A FREE CATALOG CALL TOLL FREE

1-800/547-8911

PA-3

WHITE'S ELECTRONICS, INC. 1011 Pleasant Valley Rd., Sweet Home, OR 97386



# HOW TO FIND GOLD NUGGETS ELECTRONICALLY



Finding gold nuggets or coins is now made easy with a new patented gold finding detector. Before with other detectors it was virtually impossible because of interference from black sand. This new detector is unaffected by black sand and can detect pinhead size gold nuggets at great range. Its maximum range is 17 feet. It is very lightweight and has perfect balance. One of our customers who had tried five other makes and couldn't find a single nugget now reports finding up to six nuggets in one hour with his Gardiner detector. Recently a 400 ounce gold nugget was found with a detector. Free catalog.

## GARDINER ELECTRONICS

Dept 31 • 4729 N. 7th Ave. • Phoenix, AZ 85013

## PRINT FOR PROFIT

Print cards, stationery, envelopes; advertising, labels, tickets; holiday, sympathy, birthday, QSL cards. Satisfying pastime/money-maker. Work with your hands, use your imagination, see results.

Own a Printing Business.

Send \$1 for Kelsey Catalog. Have your own shop. Add to income. We supply instructions, hand presses and all supplies direct from factory. Famous since 1872. Send \$1.00 for a catalog. **Kelsey Presses, 83-BC Meriden, CT 06450**



## AMAZING

### SCIENTIFIC and ELECTRONIC DEVICES

PHASER shockwave and invisible FORCE FIELD generators. LASERS for weapons, cutting, burning, cloud writing, holography and special effects. NUCLEAR particle accelerators and detectors. PLASMA, ION, HIGH VOLTAGE, HIGH FREQUENCY TESLA COILS and LIGHTNING generators. TRANSMITTERS and CONTROL devices for security, telephones, intrusion detection, nature listening. PLUS PLUS INFRASOUND, ULTRASOUND, ENERGY, CHEMICAL and PERSONAL PROTECTION and SAFETY DEVICES. SEND \$1 for catalog of plans, kits and completed items to:

**INFORMATION UNLIMITED, INC.**  
P.O. Box 716, Dept. M8  
Amherst, N. H. 03031

## SAVE up to 90% GOVT. SURPLUS

AIRBORNE SALES 1983 SURPLUS CATALOG

Surplus and other bargains galore! Industrial, mfg., marine, aircraft, auto, hardware. A must for hobbyist, mechanic, handyman, outdoorsman. Our 38th Annual Catalog. Send \$1 today (deductible from first order of \$10 or more).

**AIRBORNE SALES CO.**  
8501 Steiler Dr., Dept. PM83  
P.O. Box 2727, Culver City, CA 90230

Name \_\_\_\_\_  
Address \_\_\_\_\_  
City \_\_\_\_\_  
State \_\_\_\_\_ Zip \_\_\_\_\_

## SAVE as much as 80% with **AMT** Quality Power Tools

American Machine & Tool Co., Dept. PM33, 4th Ave. & Spring St., Royersford, PA 19468

Please send me the units checked.

Payment in full enclosed \$ \_\_\_\_\_; or  
 \$5.00 deposit each item enclosed, balance C.O.D.; or charge my  MasterCard  VISA

Card No. \_\_\_\_\_

Expiration Date \_\_\_\_\_

Signature \_\_\_\_\_ Name \_\_\_\_\_

Address \_\_\_\_\_ City \_\_\_\_\_ State \_\_\_\_\_ Zip \_\_\_\_\_

- 8" Tilt Arbor Saw \$52.50
- Standard rip fence \$6.50
- Long Cabinet Rip Fence \$7.50
- Ball-bearing Spindle \$12.50
- 12" Swing, 4 Ft. Lathe \$67.75
- Ball-bearing Model \$79.50
- Face Plate \$4.50
- Set of 3 Chisels \$11.00
- Set of 8 Turning Chisels \$29.00

- Belt Sander \$52.00
- Disc Sander Attachment \$17.00
- Mitre Gauge for Sander \$3.50
- Jointer-Planer \$63.30
- Ball-bearing Spindle \$15.70
- Spindle Shaper Kit \$44.40
- Drill Press \$89.90
- General Electric Motor \$49.50 (with other item)
- \$54.55 (Purchased Separately)

## FANTASTIC VALUES WITH THIS COUPON!

**DIRECT FACTORY OFFER AND REVOLUTIONARY PATENTS** decrease costs, increase efficiency. Full scale power tools of heavy duty 100% cast iron and steel. Streamlined design reduces weight, cuts material and production costs. Special patents provide added efficiency, accuracy, savings. Parts made, assembled, tested, packed in our own factories, shipped direct.

**ENDORSED BY AMERICA'S TOP MAGAZINES...** OVER 2 MILLION USERS confirm their precision, versatility and rugged performance.

**\*10-YEAR LIMITED WARRANTY.** Any part or parts of any AMT power tool which become inoperative for any reason within 10 years of the purchase date will be repaired or replaced by the factory. Your only cost: for return postage.

\*\* Except motors to which the same terms for one year warranty will apply



**8" TILT ARBOR POWER SAW DOES WORK OF \$150.00 BENCH SAW as is.** Converts easily to equal any \$300.00 floor model cabinet units! Crosscuts, rips, mitres, cuts compound angles, dados, makes coves and moldings.

**\$52.50** f.o.b. factory. Wt. 22 lbs. including completely assembled cast iron and steel 8" saw with ground cast iron table, blade guard, mitre gauge. Less blade. RIP FENCE, if desired, for easier work alignment, \$6.50 add'l.

**PRECISION BALL BEARING SPINDLE** for commercial service, \$12.50 add'l.

**SAW BLADE TILTS... TABLE STAYS LEVEL.** Lock securely at any angle up to 50°. Raises, lowers, 0° to 2-1/4". Takes standard blade, saw insert removes to take dado heads.

cutters, etc. (not included). Takes 1-3 HP motor or larger (not included). RIP FENCE, if desired for easier work alignment. Standard size (for bench saw) \$6.50; long rip fence for cabinet base (as shown), \$7.50.

**FREE CABINET BASE PLANS** Use bench saw as received (inset photo) ... or transform easily and inexpensively into floor model (as shown) guaranteed to do work of floor models costing \$300. FREE plans ... all you'll need are a sheet of 3/4" plywood and 3-4 hours. Use your AMT saw for cutting. Plans provide 27" x 24" work surface, 33" height.

**10-YEAR LIMITED WARRANTY\***

**10-DAY MONEY BACK GUARANTEE**  
Try any AMT power tool for 10 days. If not fully satisfied, return for full refund of purchase price. We will pay return freight.

## INDUSTRIAL SIZE 12" SWING 4 FT. WOOD LATHE



DOES WORK OF \$200 UNITS.

**\$67.75** Complete as shown.

**10-YEAR LIMITED WARRANTY\***

Comparable in speed, precision and durability to units selling for \$200 and more. 36" between centers. For wood and plastics. Tubular steel bed rails with dual point suspension increase accuracy, ease of operation. Precision ball thrust cup center, heavy spur center, graduated T-rest, 3-Speed pulley for different work diameters. Heavy-duty ball-bearing model \$79.50.

f.o.b. factory. Shipping Wt. 30 lbs. Faceplate (optional) for turning bowls, lamp bases, etc. \$4.50. Set of 3 high speed turning chisels, \$11.00 add'l. Set of 8, \$29.00.

PRECISION 4" x 36"

## BELT SANDER

f.o.b. factory Wt. 18 lbs.

**\$52.00** Disc Sander attachment including disc, bracket, ground cast table (tilts 0-45°); \$17.00 add'l.

The world's most talented belt sander. Heavy cast iron sander has belt track and tension control. Includes 4" x 36" standard sanding belt. Changes from horizontal to vertical sanding in seconds. Uses 1-3 HP or larger motor.

**10-YEAR LIMITED WARRANTY\***

Mitre gauge: \$3.50 add'l.

22" LONG, 4-1/8"

## JOINTER-PLANER

Complete as shown. 100% precision ground cast iron and steel.

Professional power planing at a hand tool price. Make faster, more accurate joints & bevels for windows, doors, drawers, square tapered legs. Adjustable precision ground cast iron table. In-feed table adjustable to 1-8" depth of cut; fence adjustable to any angle 0° to 50°. 3 hardened, ground high-speed steel knives. **Ball Bearing Spindle: \$15.70 add'l.**

**10-YEAR LIMITED WARRANTY\***

**\$63.30** f.o.b. fact. Wt. 19 lbs.



## SPINDLE SHAPER KIT with holddown

**\$44.40** f.o.b. factory. Shipping Wt. 6 lbs. Complete less wood parts, motor.

Makes beads, coves, moldings, tongue-and-groove joints, etc. Easy assembly plans. Has sealed greased-for-life ball bearings, adjustable height control, fence assembly. Takes 1-4 HP or larger motor. Standard 1-2" bore cutters available.

**10-YEAR LIMITED WARRANTY\***

## 32" RADIAL DRILL PRESS

**\$89.90** All cast iron and steel. f.o.b. factory. Wt. 30 lbs. 1/2" capacity Jacob's chuck included.

Industrial quality precision unit with all standard features, many extras. Head raises, lowers. Depth of throat up to 16". Preset to any angle for on or off table drilling, even horizontal drilling. Complete as shown less motor, belt and motor pulley.

**10-YEAR LIMITED WARRANTY\***

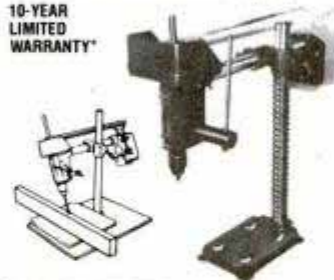

## BRAND NEW MOTOR

Develops a full 1 HP. New General Electric Motor for use with any power tool in this ad. Features 1-2" shaft, 1725 RPM \$49.50 if purchased with any AMT tool (\$54.55 if purchased separately). Covered by a one year limited warranty, 17 lbs. f.o.b. factory.

**AMERICAN MACHINE & TOOL CO., INC., 4th Ave. & Spring St., Royersford, PA 19468**

Visit our Royersford FACTORY SHOWROOM for these same low prices. 4th and Spring Sts. From 9 to 4:30 on weekdays and 9 to 12 on Sat.



# LOOK

## what you can do with Badge-A-Minit

You can increase your income in a hurry with Badge-A-Minit. Make good money supplying professional-looking badges to identify, instruct, amuse, inform. Contact local organizations who need badges for community events and projects, schools that want badges for the team, the band, choir or school play, or for fund raising. Buttons are ideal rewards for leadership and achievement.

It's fast, simple and economical with the Badge-A-Minit starter kit. Just \$24.95 gets you started with everything you need to make buttons fast.

FREE—colorful 64 page catalog and idea book that makes Badge-Making fun and profitable.



BADGE-A-MINIT, Ltd., DEPT. PM383  
Box 618, Civic Industrial Park, LaSalle, IL 61301

- SEND ME FREE, the all color Badge-A-Minit catalog.
- YES, SEND ME the Badge-A-Minit starter kit for only \$24.95 plus \$1.75 shipping (Ill. res add \$1.25 tax)
- Personal check or money order enclosed.
- Use charge card below.
- VISA  Mastercard  Am. Express  Diners Club Credit Card No. \_\_\_\_\_

Exp. date \_\_\_\_\_ Signature \_\_\_\_\_  
Name \_\_\_\_\_  
Address \_\_\_\_\_  
City \_\_\_\_\_  
State \_\_\_\_\_ Zip \_\_\_\_\_

Your purchase is always covered by our unconditional money-back guarantee.

## Super-Shears



CUTS THROUGH...  
STEEL WIRE  
SHEET METAL  
HARDBOARD  
STRAPPING  
PLASTIC  
LEATHER

**SUPER SHEARS.** NEW shears will cut just about anything... steel wire, sheet metal, leather - you name it. Wide gauge stainless steel. Comes with leather sheath & cord.  
**MONEY BACK GUARANTEE.**

**ORDER NOW!** \$12.95 postpaid NY residents add 8 1/4% tax.

**SENECA HOUSE,** Dept. 3 PM, 67-15G 190th Lane, Fresh Meadows, NY 11365

## GARDENING? AMAZING TILLER

SO GENTLE RUNS SINGLE HANDED WON'T BOUNCE OR JUMP

TEST THIS TILLER ON YOUR LAND FOR 30 DAYS SEND FOR LITERATURE YOU MIGHT WIN ONE FREE



Weights 22 Pounds Tills Deep from 18 to 12 in. wide Weeds fast from 6 to 2 in. wide

TILLS WIDE, WEEDS NARROW DOES THE WORK OF A REAR ENDER BUT COSTS 56 PERCENT LESS!

1. Built rugged for commercial use... 30 day money back trial period.
2. Adjustable from 18 to 2 inches wide hood tines and all.
3. Saves you time. Improves your soil and give you the best garden ever.

NOT SOLD IN STORES. FREE GARDENING GUIDE

Write To: Allentown Tiller Co., Dept. P  
c/o Allentown Feed Co., Main St., Allentown, N.J. 08501  
For Rush Delivery of Literature Call 201-530-9380

OWN TILLER TILLS DEEP WEEDS NARROW ALLENTOWN

## Build this beautiful Dome Home by yourself!



### Enjoy super affordable payments and low energy bills

Save up to 60% on building costs and up to 50% on utilities. Beautiful Monterey Domes geodesic home kits are extremely energy-efficient, unbelievably strong, earthquake resistant, and easy to assemble. No special tools or skills necessary. Our unique, patented building system makes home construction a reality for the novice.

Monterey Domes pre-cut, color-coded shell packages start at \$3995. Models up to 3,500 sq. ft. Send for our exciting color Catalog & Plans Book—over 90 fact-filled pages of beautiful affordable homes.

Write today! **Monterey Domes, Inc., 1760 Chicago Dept. AQ-3, Riverside, Calif. 92517**

- Rush me your 90 page CATALOG & PLANS BOOK. Enclosed is \$6.00, postage included.
- Also send your ASSEMBLY MANUAL for an additional \$5.00.

NAME \_\_\_\_\_  
ADDRESS \_\_\_\_\_  
CITY, STATE, ZIP \_\_\_\_\_

Mail To: **MONTEREY DOMES, INC.**  
1760 Chicago, Dept. AQ-3  
Riverside, Calif. 92517



## HEARING LOSS CAN BE HELPED!

Is "What?" your most commonly used word?

Does everyone seem to mumble?

Twenty-two million Americans have hearing impairments. The vast majority can be helped. If you suspect that you or someone you care about might have a hearing loss, send for our **FREE** pamphlet. Learn about the symptoms of hearing loss and how Bosch's New High-Technology Hearing Aids can help.

**BOSCH HEARING INSTRUMENTS**  
P.O. Box 278, St. James, New York 11780

Please send **FREE** pamphlet on hearing loss and Bosch's new high-technology hearing aids.

- I am presently using a hearing aid.

Name \_\_\_\_\_  
Address \_\_\_\_\_  
City \_\_\_\_\_ State \_\_\_\_\_ Zip \_\_\_\_\_

POPULAR MECHANICS • MARCH 1983

## WOODWORKERS!

A magazine for both novice and veteran bringing you over 75 project plans per year...for building the best of Early American, Shaker, English, Contemporary furniture, clocks, toys, lamps, gifts and much more...



ALL FOR LESS THAN 20¢ PER PLAN

PLUS Regular articles on shop tips, jig-building, finishing techniques and money-making ideas.

1 YEAR (6 bimonthly issues)—only \$12.00  
2 YEARS (12 bimonthly issues)—only \$22.00  
Foreign Rates 1 year—\$14.00, 2 years—\$26.00  
(Please make payment in U.S. Funds)

### The Woodworker's Journal

P.O. BOX 1629-313 NEW MILFORD, CT 06776

NAME \_\_\_\_\_  
ADDRESS \_\_\_\_\_  
CITY \_\_\_\_\_ STATE \_\_\_\_\_ ZIP \_\_\_\_\_

money back if you're not satisfied

## GREAT SAUSAGE RECIPES

227 page illustrated book explains sausage making plus home curing and smoking of meat, fowl and fish. Over 100 recipes. Free equipment and supply catalog has more information.

For yours, send to:  
**The SAUSAGEMAKER**  
177-6 Military Road Buffalo, N.Y. 14207

## NEW SHIPMENT JUST ARRIVED

Hardened Steel. For filing, drilling, milling, carving, routing any metal or wood. Cutting edges from 1/4" to 1", all shanks 1/4". Brand new in air-tight G.I. packs.

32-Tool Set, G.I. cost \$295 now... \$299  
14-Tool Set, G.I. cost \$126 now... \$128  
Save Even More. Both Sets now... \$389  
Two \$38 Sets (Limited Time)... \$589  
Money Back Guarantee. Add \$39 for shipping  
Texas orders add 5% tax. Export orders add 4%  
U.S. SURPLUS CENTER, Dept. 503  
715 Camden, San Antonio, Texas 78215

## PUMPS BUY DIRECT AND SAVE

Drain • Irrigate • Circulate • Spray

Heavy duty ball bearing pump. All metal, rust-proof Type XB. Stainless shaft. Use 1/4 HP or larger. 1 HP 1,200 GPH 60" high or 3,000 GPH 25" well. 5,200 GPH max. 1 1/4" in; 1" out. Belt or direct drive. \$21.95 Type P won't rust or clog. Bronze bearing. To 2,400 GPH. 1" in; 3/4" out. \$15.95  
ADD \$2 postage & handling. Money Back Guarantee.

LABAWCO, 80 Hwy 206, Belle Mead, N.J. 08502

## Be a LOCKSMITH!

EARN WHILE YOU LEARN  
Send for FREE BOOK

Locksmithing Institute, Dept. 110-033  
Div. Technical Home Study Schools, Little Falls, N.J. 07424

## NOW BRASS BAR RAILS

For Your Home

and other solid brass bar accessories  
Now you can have solid brass bar rails, standoffs, end caps, flanges, etc. for your home bar. The same quality as you see in the finest restaurants and pubs.  
For Catalog send \$1.00 to:  
MIDWEST CUSTOM BRASS  
208 E. Main Street, Dept. PM33 Round Lake Park, IL 60073

## 110 VOLT A.C. GENERATORS

Special price while they last. Up to 50% off. 60 cycles, 3000 watts, WL 27 pounds, 5" x 10", fanbelt driven from car or pickup. Operates T.V. all power tools. Over 18,000 in service. Guaranteed 6 months, \$199.00. Special Price Now \$99.00, add \$9.50 for postage and handling per unit. Send for our free catalog. This is our 33rd year.

VIRDEN PERMA-BILT COMPANY, P.O. BOX 7160PM  
2821 MAYS AVE., AMARILLO, TEXAS 79109  
PHONE 806-352-2761.

## Burglar-Fire Protection

Protect Your Life, Home, Business, Auto, etc.

Our catalog shows how. Install your own alarm systems and devices and save \$555. We offer FREE write-in engineering service.

FREE CATALOG Lowest Prices on Reliable, High-Quality Alarm Systems and Devices

Burdex Security Co. Box 82802-PM Lincoln, Ne. 68501



## FREE AIRCONDITIONING

Cool your home for free this summer. Professionally designed plans, specifications, and technical analysis to build a geothermal cooling system. Can be completely passive or connect it to your present air handling system. Perfect compliment to your solar home. Build it yourself for approximately \$1,200.00. Plans \$9.50 p.p.d. Send payment to:

**ENERGY SOLUTIONS**

Northgate Mall • Box 9207 • Cincinnati, OH 45247

## LEARN HOW TO HANG DOORS

EARN \$30pr hr \$100-\$200 PER DAY REPLACING DOORS Part time. Full time or Save \$5 doing your own Step by step instructions by a professional with 2,500 doors hung. I know your problems



ORDER YOUR MANUAL TODAY ONLY \$5.50

**GARRETT DOOR & LOCK CO**  
1853 Denison, Pomona CA 91766

info for authorized tv programming

## Satellite TV Price Breakthru!

Complete system, \$399. \$100 receiver. 10-ft. antenna, \$295. Latest 1983 info. Best Set TV consumer report/manual available. Top rated sources, lowest prices on equipment, kits, plans, portable systems. 8 1/2 x 11" illustrated, \$9.98 ea. + \$1.50 ship. Johnson Smith Co., Dept. 1003, Mt. Clemens, Mich. 48043



## Gas to Electric Conversion Kit

GAS LAMP BURNS \$72 TO \$120 OF GAS PER YEAR. OUR CONVERSION KIT OPERATES ON 1/2 THE COST OF GAS. Easy to install 2-bulb fixture duplicates the charm and increases the light output of any gas light. Includes automatic On-At-Dusk—Off-At-Dawn photo electric control. Available in 12 volt or 115 volt.

FOR MORE INFO WRITE:

**Gaslight Conversions, Inc.**

1039 CHARLES AVE. ST., PAUL, MN 55104



# DO YOU HAVE WHAT IT TAKES TO MAKE \$22,500 A YEAR WITHOUT A COLLEGE DEGREE?

## Most of Our Grads Do It!

In fact, the first paychecks for students who graduated in the first four months of 1981 and went to work welding... ranged from a low of \$793 to a high of \$6,846. This is a yearly salary range from \$9,516 to \$82,152. Worldwide construction and pipeline firms compete for our graduates. Full course is only 16 weeks (others as little as 10 weeks). There are more jobs open throughout the U.S. — and the world — than there are qualified welders.

Tulsa Welding School, established for over 30 years, is recognized for the quality of its graduates throughout the world. Do well at T.W.S. — work hard — and your income as a welder can be higher than many college graduates.

## READY TO TAKE COMMAND OF YOUR FUTURE?

Call Toll Free 1-800-331-2934  
In Oklahoma, call (918) 587-6789

Accredited Member of Nat'l Assoc. of Trade and Technical Schools. Approved for Veteran Training.

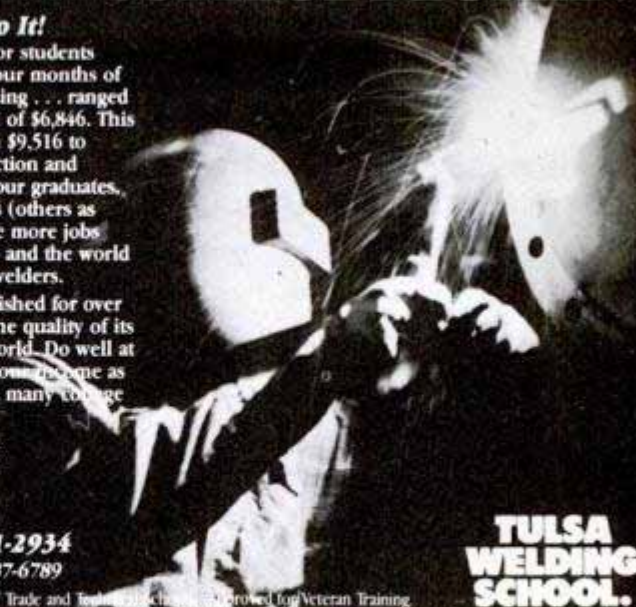

**TULSA WELDING SCHOOL.**

## Fill in and mail today!

PM-363

Admissions Director  
**Tulsa Welding School**  
3038 Southwest Blvd., P.O. Box 9829  
Tulsa, OK. 74107

We'll send you a complete course catalog plus job list and pay at which recent grads have gone to work.

NAME \_\_\_\_\_  
ADDRESS \_\_\_\_\_  
CITY \_\_\_\_\_ STATE \_\_\_\_\_  
ZIP \_\_\_\_\_ PHONE (\_\_\_\_) \_\_\_\_\_  
Area Code

## SEA EAGLE

### The Quality Alternative to High-Cost Inflatable Boats!



SEA EAGLE 8  
9'7" x 4'6" - 31 lbs.  
Holds 4 adults, 3 HP capacity  
Costs just \$220.

Why pay \$600, \$1000 or even more for an inflatable boat? Modern technology and new improved materials make possible inexpensive yet long-lasting Sea Eagle boats. Prices start at just \$110. Canoes, dinghies and motor-mount boats.

Write for our FREE brochure.

Sea Eagle, Dept. PM33B  
St. James, NY 11780  
Or phone 516-724-8900  
Monday - Friday  
8:30am to 4:30pm EST

## NEW! 3 IN 1 POWER-FEED PLANNER/MOLDER JOINTER



The first affordable shop of its kind!

Now turn low cost rough lumber into valuable finished stock for grandfather clocks, furniture, house-trim, picture frames... sell to others. Molds all popular patterns & custom designs. Planes and joints without change-over. Comes complete... ready to use.

30-DAY FREE TRIAL! Easy terms.



FREE INFORMATION KIT

CALL TOLL-FREE 1(800)824-7888, Oper. 642  
In Calif. 1-800-852-7777, Oper. 642

OR WRITE TO  
**WOODMASTER TOOLS, INC.**  
2849 Terrace, Dept. PP20, Kansas City, MO 64108

## GET INTO DRAFTING

Train at home in spare time. No previous experience needed. Tools and materials included with course. No special talent required. We show you what to do, how to do it. LEARN DRAFTING AT HOME!

APPROVED FOR VETERANS  
CAREERS IN DRAFTING  
FREE "CAREER KIT"  
NAME \_\_\_\_\_ AGE \_\_\_\_\_  
ADDRESS \_\_\_\_\_  
CITY \_\_\_\_\_ STATE \_\_\_\_\_ ZIP \_\_\_\_\_  
Accredited National Home Study Council  
NORTH AMERICAN SCHOOL OF DRAFTING,  
4480 Campus Dr., Dept. P8121, Newport Beach, CA 92660

## STOP HUNTING for SMALL mechanical parts!

GIANT new 788 page SDP Catalog for 1982 features over 24,000 inch and metric off-the-shelf parts: Timing belts, pulleys, chain drives, gears, motors, speed reducers, couplings, shafts, bearings, fasteners etc. for building, repairing, inventing any small machine, engine, model... Low prices. CATALOG 757 is just \$5.95 POSTPAID.

STOCK DRIVE PRODUCTS, DEPT. A  
55 SOUTH DENTON AVE., NEW HYDE PARK, N.Y. 11040  
FREE METRIC-INCH CONVERSION SLIDE RULE INCLUDED!

## Train at home in spare time Be an ELECTRONICS SPECIALIST

No previous experience needed. No need to quit job or school. Learn about electronic devices, test equipment, AM/FM receivers, TV, digital and computer circuitry, analog systems, servomechanisms... plus much more. Prepare for FCC License Exam. Course includes books, lessons, Volt-ohm meter, transistor experiments lab, electronics measurement lab. Approved for G.I.'s and Veterans. Get FREE FACTS. No obligation. No salesman will call. MAIL COUPON TODAY!

**ICS School of Electronics**  
Dept. P6023, Scranton, PA 18515  
Name \_\_\_\_\_ Age \_\_\_\_\_  
Address \_\_\_\_\_  
City/State/Zip \_\_\_\_\_

## REPAIR ATARI GAMES AT HOME

Complete repair course on 3 hour video tape (Beta or VHS) plus schematics and technical literature enables you to start earning money right away. All popular repair parts in stock for immediate shipment. \$1.00 for parts/price list and additional information refundable with order. Exclusive National Distributor.  
**ELECTRONICS WAREHOUSE CORP.**  
1910 Coney Island Avenue Dept. PM-3  
Brooklyn, N.Y. 11230 (212) 375-2700

## BASSET CIRCULAR SAW WRENCH

Patented  
change blades fast, safe, easy  
9.95 ea., 2 for 14.95 specify 1/2" - 9/16"  
1.75 postage, handling  
30 day money back guar.  
HSI INC., P.O. Box 22285  
Milwaukie, OR 97222



**NON-GUNS!**  
That's right, these precision-built replicas of famous firearms CANNOT CHAMBER OR FIRE REAL AMMUNITION! Made of machined metal, they look, feel and weigh same as the originals. CAN BE DISASSEMBLED. Over 30 sized, hand-finished parts. Comes fully assembled. Safe and perfect for display. MONEY BACK GUARANTEE. Send for FREE CATALOG of over 90 different models.  
Model shown: U.S. GUN\* 45 AUTOMATIC. COPY#45-300 \$50.00  
The COLLECTOR'S ARMOURY, Inc., Dept. PM  
800 SLATERS LANE, ALEXANDRIA, VIRGINIA 22313



## Canine Clubhouse of Beverly Hills™

9903 Santa Monica Blvd. #210  
Beverly Hills, Ca. 90212

Custom-designed quality homes for the discriminating dog! Choose from four fabulous designs and build it yourself! Plans include 8 x 10 photo, blueprint, instruction sheet, material list, and pattern. Each set of plans \$10.95 postpaid.

Name \_\_\_\_\_  
Address \_\_\_\_\_  
City \_\_\_\_\_ State \_\_\_\_\_ Zip \_\_\_\_\_



Check Style(s) desired:  
 English Tutor-Cape Cod duplex (shown)  
 Western Saloon with board-walk  
 Country barn with hayloft  
 Spanish Hacienda with bell-tower  
 FREE BROCHURE  
© Canine Clubhouse 1982



# "A GAS-SAVING DEVICE THAT REALLY WORKS!"

—CARGUIDE Magazine

## A TRUE FUEL SAVER THAT'S BEING USED BY CAR MANUFACTURERS

- Certified Auto Tests average 16.3% increase!
- Car magazine Tests average 10.7% increase!
- Newspaper Tests average 21.1% increase!
- Corporations average 18.2% increase!
- Individual results average from 10% to 30% increase!

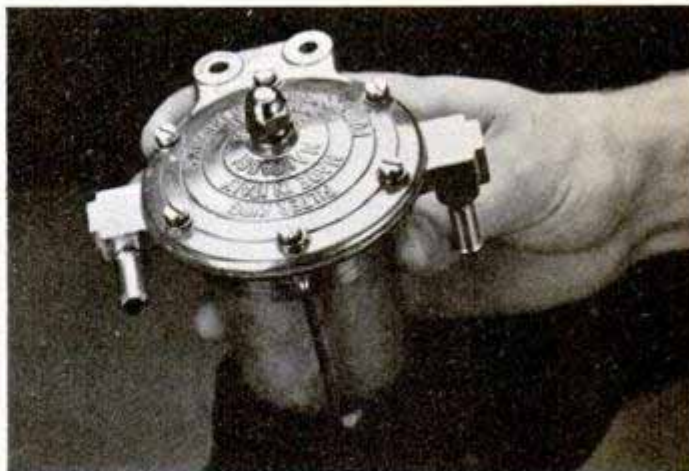

Standard factory equipment on Alfa Romeo, Lamborghini, Lancia, Maserati, and other quality cars.

## ONE MONTH OF FREE DRIVING

You may find it hard to believe, but there is an answer to the high price of gasoline. In Europe, where gasoline prices are much higher, we find the answer. It is a unique and outstanding product called Filter King 101.

Filter King 101 (F.K. 101) will give you at least one month of free driving per year. That is how much you can save on your yearly gasoline bills, enough to give you one free month. In fact, we will GUARANTEE at least 1.2 months of free driving per year. The amazing thing is, that actual experience indicates that you may get up to three months of free driving in just one year.

F.K. 101 can be simply installed in your car, in just a few minutes, by yourself or a mechanic. It will last for years and years to come and can be transferred to any car you may get in the future.

F.K. 101 is a true gas saver. It works on a unique principle of control, a patented method of metering the gasoline to the exact needs of your engine. It isn't just a short cut device that stops your air conditioner when your car is idling, in the hope of saving gas. It is in no way connected to your vehicle's electrical system. There is no adding of water or chemicals and no worry of burning your engine valves. F.K. 101 is a mechanical device that works in conjunction with the carburetor.

F.K. 101 was developed and is manufactured in Europe, where gasoline prices have always been higher than in North America. Naturally there, there seems to be a greater interest in fuel economy. Well over 3,120,642 Europeans and people in other parts of the world are using the F.K. 101 not only as a true fuel saver but also as a precision component that they can trust in. They know that it has a perfect blend of technology and craftsmanship making it a work of art in itself.

## THE 200 MPG PAPER MIRACLE

It happened a few months ago. There was a big promotion about an old 200 mpg carburetor. It said the patents had just run out, and probably would be available soon. While checking into it, it turned out that the patents on the PROGUE CARBURETOR had expired many, many years ago. This would cause anyone to have second thoughts about it. If it is so great, why isn't someone selling it? Why isn't any car manufacturer using that technology? I'm sure it would be a great boost to their sales program to have a car that gets 200 mpg, when everyone else is bragging about getting 35-40 mpg. But then again,

maybe by accident, someone DID get 200 mpg. Not all of us are mechanical engineers who want to spend our lives under the hood of a car. The point is, we do not offer a miracle on paper, we offer a proven econo miser.

To our understanding F.K. 101 is the only true gas saver in the entire world used by a car manufacturer. It has been and still is currently being used by Ferrari, Lotus, Lamborghini, Maserati, Alfa Romeo, Lancia and others. Some of the very best and most expensive cars in the world today use F.K. 101 because it works, and because it meets the high standard of quality and performance demanded by the leading sports car companies in the world. This would make any owner proud to have one on his own vehicle. With well over 3 million F.K. 101's sold in Europe and other parts of the world the reputation of performance and saving money is well proven.

If you now get:	Filter King will guarantee at least:	Certified Tests show you'll probably get:	Actual Experience indicates you might get up to:
15	16.5	17.4	19.5
16	17.6	18.6	20.8
17	18.7	19.7	22.1
18	19.8	20.9	23.4
19	20.9	22.0	24.7
20	22.0	23.2	26.0
21	23.1	24.4	27.3
22	24.2	25.5	28.6
23	25.3	26.7	29.9
24	26.4	27.8	31.2
25	27.5	29.0	32.5
26	28.6	30.2	33.8
27	29.7	31.3	35.1
28	30.8	32.5	36.4
29	31.9	33.6	37.7
30	33.0	34.8	39.0
31	34.1	36.0	40.3
32	35.2	37.1	41.6
33	36.3	38.3	42.9
34	37.4	39.4	44.2
35	38.5	40.6	45.5
36	39.6	41.8	46.8
37	40.7	42.9	48.1
38	41.8	44.1	49.4
39	42.9	45.2	50.7
40	44.0	46.4	52.0

Many people that are using F.K. 101 talk about not only dollar savings, but also better engine performance. They mention things such as smoothness in cruise and idling, and a more even acceleration. These are just some of the nice by-products of saving money with F.K. 101.

## AUNT TILLIE'S ACID TEST

We would like you to see for yourself, why the top car companies in the world use F.K. 101 on their superb automobiles, where performance and quality take first place. These also have to be your reasons for wanting to own your own F.K. 101.

We invite you to participate in this exciting program, where you can give F.K. 101 your own acid test, absolutely risk free for 30 days. Simply order F.K. 101 for only \$67.95 and put it in your car. Drive around town for a while and then do something real nice. Go visit your favorite Aunt Tillie, way out in the country. I'm sure she would be glad to see you, plus, you will get to experience first hand, how much the F.K. 101 saves on the long hauls.

If you find that you didn't get at least 10% increase in your mileage, simply return it in its original box within 30 days for a courteous refund.

A five cent per gallon increase is on the way even the government is making sure of that. But, don't worry, your own answer to the terribly high price of gasoline is the F.K. 101. Place your order now.

NOTE: FK101 DOES NOT WORK ON DIESEL OR FUEL INJECTED ENGINES.

To speed delivery of this product to your home or office, fill in this coupon & mail to:  
**ODYSSEY PRODUCTS**  
 DEPT S-604, BOX 1115, OROVILLE, WA 98844

### PLEASE PRINT CLEARLY

Please rush me . . . . . units at \$67.95, plus \$3.00 for shipping and handling.  
 All shipments made UPS unless other instructions given. NO COD'S PLEASE.  
 Charge my  VISA  MASTERCARD

Acct. No. . . . .

NAME: . . . . .

ADDRESS: . . . . .

CITY: . . . . .

STATE: . . . . . ZIP CODE . . . . .

TO CANADA: Cheque or money order must be made payable in US dollars & \$1.00 added to cover postage.



# CLASSIFIED ADVERTISEMENTS

**Sophie Gronowicz, Classified Sales Manager**

Rate: \$5.70 per word payable in advance each insertion. Minimum insertion ten words. Bold face capitalized words—\$1.00 per word additional (First word set in Bold Face at no extra charge, Zip Code Free.) The next available issue to place an advertisement in America's No. 1 Classified Section is **MAY**. The closing is **MARCH 4th**.

Send remittance payable and order to Popular Mechanics, Classified Department, 224 West 57th Street, New York, New York 10019. Please indicate Heading under which ad is to appear. As a consumer service and in cooperation with our mail-order advertisers who use post office box addresses for their convenience in handling your order, Popular Mechanics maintains a register of such mail-order advertisers containing their complete names and street addresses.

**Advertisers using P.O. Box number must furnish complete name and street address for our records. To avoid delay in the publication of your ad, please send descriptive materials with your request.**

## AUTOMOBILES

**SAVE Gasoline 10 Ways, FREE Details.** 1285 Claremont, Boulder, CO 80303

**CAR Salesman's Secrets—You Must Feel This Booklet Will Save You 50 Times Its Cost Or We'll Return Your Money To You!** Send \$2.95 To: Phoenix Publications, 1101 Georgia, Big Lake, Texas 76932

**SECRETS of Buying A Used Car Revealed by Ex-Dealer.** Send for Free Valuable Report. Baldwin, 10149 Hammerly, #62, Houston, TX 77080

**RUN your Car on Wood, Coal, Sawdust, High Mileage.** Info: \$3.00. Woods, Box 6263, Olympia, WA. 98502

**HOW to Inspect and Select a Used Vehicle.** Read used car dealer's amazing revelations. Tells all. Send \$3.00 plus 50¢ handling. Wilarene Publishing Co., Box 31506, Amarillo, TX 79104

**FIBERGLASS FENDERS, NOVA, VOLARE, GRANADA, MUSTANG II, HORNET \$135.00 EACH.** 3:30-7:30 pm. (216) 243-3388. OHIO-MADDEN SALES-44017

**SAVE on Expensive Auto Service!!** Home Auto Maintenance Manual. \$5.95. R.+B. Enterprises, 4880 Galley, Colorado Springs, CO 80915

**SAVE GASOLINE!!** Bypass pollution devices - - easily, reversibly! Posco (GB-3), LaGrangeville, NY 12540

**PROPANE/GASOLINE DUAL-FUEL AUTO!** Conversion Plans and Instructions, Parts Sources. Only \$10.00! RDA, Box 873, Concord, NC 28025

**HIGH Mileage Carburetors.** Free Details. Box 89, Draper, Utah 84020-0589.

**NEW STEEL REPLACEMENT PANELS,** Hoods, Fenders, Grilles and Bumpers for many foreign and domestic cars and trucks. 1,000 of parts in stock. Send \$4.25 for your 40 page catalog. **DEALERS INQUIRIES INVITED.** JR Auto Parts, 677 Central Avenue, Albany, New York 12206

**DISCOVER SECRETS OF 8 MILEAGE IMPROVING DEVICES.** How they work, how they're built. Diagrams, working descriptions. **ALL 6, \$3.00.** HERC DESIGN, P.O. Box 10, Concord, MA. 01742

**OLD CAR FANS:** subscribe to **HEMMINGS MOTOR NEWS**, world's largest old car marketplace since 1954. Over 450 pages of ads each month, crammed with thousands of old cars for sale—plus parts, literature, restoration shops and more. Only \$15.50 for 12 giant issues. Subscribe to the 'bible' of old car nuts today. Send to: Hemmings Motor News, Dept. 14B, Box 100, Bennington, Vermont 05201

**PROPANE/GASOLINE DUAL-FUELED AUTOMOBILE!** Complete Plans, Instructions and Parts Sources for converting your car. \$10.00. RDA, Box 873, Concord, NC 28025

**RUN YOUR CAR ON AIR!!** Exciting new book reveals live inventors, their systems, diagrams. Only \$9.95! Robert Schafer, 2440 Monaco, Tallahassee, FL 32308

**VAPOKARBII - FANTASTIC New Vapor Carburetor!** - Details **FREE** - Karbs B3, 720 Jordan, Rockford, Illinois 61108

**WHEEL ALIGNMENT, Do-It-Yourself.** Free Details! DIPCO, Box 39274, Detroit, MI 48239-0274

**CRACKED Engine blocks or heads repaired in car by you.** Send \$1.95 with SASE to: Box 37785, Phoenix, AZ 85021

**NEW Chrysler Stern Drives Series 300HA** Including Transom Shield \$750.00. Details: Rick Pearson, P.O. Box 24467, Seattle, WA 98134. (206) 435-5571.

**FREE CATALOG!** Ubuilt Gadgets: Automobile/Workshop/Recreation . . . Alternatives, Box 41300, Tucson, Arizona 85717

**HOW TO SAVE \$1000** When Buying New or Used Cars Plus Other Tips. Complete Details \$3.98. Woodbridge House, 11480 Woodbridge Lane, Baltimore, Ohio 43105

**INSTALL TURBOCHARGED DIESEL** in car, PU, RV for under \$1500. Get 30 MPG. Overlooked source US diesels, 550#., 6 cylinders. Thousands cheaper than Perkins, Deutz or Murphy. Send self Addressed Stamped Envelope for free info. Diesel Department, Box 1933, Walla Walla, WA 99362

**67 MPG in CHRYSLER 400 Cid HIGH MILEAGE CARBURETOR.** Complete Working Plans. KNISS, R2PM, Bowling Green, Missouri 63334

**AMAZING! 78 MPG,** Simple Instructions \$9.95. R. Baumier, P.O. Box 20346, St. Petersburg, FL 33742

**WATER Injector—Build Easily, Inexpensively!!** Free Information—Stamped Envelope. U&I, Box 4873PM33, Boise, Idaho 83704

**SATISFACTION GUARANTEED** Or refund M.P.G. Increase 70%. 80% in most application fits all. State Engine Size patterned pending \$42.50 Check or M.O. to: Mestro Nardi Q, 73 Glamis Drive S.W. #408, Calgary, Alberta, Canada T3E-6F9.

## ELECTRIC VEHICLES

**EVER THOUGHT OF BUILDING AN ELECTRIC CAR?** Complete Catalog of Parts and Theory. Send \$3.00 to: EVC, Box 25PM, Mechanicsburg, PA. 17055

## AUTO SUPPLIES & EQUIPMENT

**SHOCK ABSORBERS REBUILT: KONI, ARMSTRONG,** McAfee-McKenzie Ent., 7550 San Fernando Road, Sun Valley, Cal. 91352. 213-845-8525

**ALTERNATOR Generator Rebuilding Book.** Price: Hedelund Engineering, Box 26024, Las Vegas, NV. 89126.

**PARTS: Army Jeep and truck parts.** Spare Parts & Equipment Co., P.O. Box 751, Lexington, Kentucky 40501-0751

**IGNITION MONITOR- LIGHTS INDICATE** many PROBLEM AREAS. **EASILY BUILT,** installed. Under \$10. Plans \$3.00. A. Talvo, Box 163, Depew, NY 14043

**TIRE Changer - Plans, Parts, Complete Units Available.** Write: M-K-1, 2520 Tryon Road, Ashtabula, Ohio 44004

**GASKET IN A TUBE:** Replaces Material Gaskets, Stops Leaks, Prevents Rust, Creates a Strong, Dependable Seal. Quality and Consistency throughout. Send \$19.95 (CK. or M.O.) to: Stick It, Inc., 4029 West 99th Street, Oak Lawn, IL 60453. Order Today!

**THE FANTASTIC CAR-COP.** Allows you to start your car. Recommended by authorities. Satisfaction guaranteed. Send \$9.95 to: TMT Distributing, P.O. Box 41577, Sacramento, CA 95841. Calif. Residents add 6% tax.

**FREE Sample, Auto Glass Treatment for Better Visibility** in Rain or Snow. SASE. Rain-X, 103 Potter, Belleville, MI 48111.

**PICKUP OWNERS, SAVE \$.** No Trailer Needed. Haul Fishing Boat in Truck. Easy Plans. Send \$2.00 SASE, Heartland Publications, P.O. Box 1209, Florissant, MO. 63031.

## MOTORCYCLES, BICYCLES, MOTORSCOOTERS & SUPPLIES

**GO KART, MINI-BIKE, MOTORBIKE PARTS.** Tires, Clutches, Motors and Complete Carts and Mini-Bikes at Discount Prices. 3 1/2 Hp. motors \$106, 5 Hp. \$123. Send \$1.00 for Booklet. Northern Hydraulics, P.O. Box 1261, Dept. PM-MB, Burnsville, MN 55337

**GO KARTS, Minibikes, ATV's, Kits, Parts.** Lowest Prices. Catalog \$2.00 Refundable. Kart World, Dept. C, 1488 Mentor Ave., Painesville, Ohio 44077

**BICYCLE ENGINE, 175 MPG, 4.5 Lbs.** \$49.95. Send \$1.00. Yost, RR1, Box 37, Sauk City, WI 53583

**BICYCLE SUPPLIES.** Free bargain catalog. **BIKERY,** 1800 Beryl, Newport Beach, CA 92660

## HANG GLIDING, AVIATION

**DESIGN Build Airplanes, Hang Gliders, Simplified Publications.** Brochure 20¢. McCoy Aircraft, 12820 S. Figueroa, Los Angeles, CA 90061.

**"ON FINAL"** 5th dimensional aviation art by Jim Dungey a stunning perspective from the left seat in beautiful color, the buffs delight!! 22x37 poster \$3.50 plus \$1.50 p.h. Check or Money Orders to: 5D Art, Box 474, Mt. Vernon, N.Y. 10550

**OVER 55 PLANS-BUILT ULTRA LIGHTS;** Catalog \$5.00. AeroFun-M, Salida, California 95368

**THE WORLD OF SPORT AVIATION** a most comprehensive book to date on the fast-growing field of sport aviation. Focus is on 4 basic types of aircraft-homebuilts, antique and classics, warbirds and ultralights. Covers the skills needed to build a plane, types of materials used, space requirements, engines, certification and safety. Profusely illustrated. Send \$24.00 to: Popular Mechanics, Dept. PMC3, Box 1014, Radio City Station, New York, NY 10101.

## SPACE & ASTRONAUTS

**ANTIgravity Propulsion Device.** Free Brochure! RDA, Box 873N, Concord, NC 28025

## HOVERCRAFT

**AERO-CAR Amazing Hovercraft** built easily with ordinary tools. Lawnmower engine power. Carries one man plus. Hovers, flies forward, backward. Sideways over land/snow/water. Complete construction plans and brochure. \$9.95. Aero-Projects, Box 5118PM, Clinton, New Jersey 08809.

**HOVERCRAFT Plan All Sizes.** Catalog \$1.00. Universal Hovercraft, Box 281, Cordova, Illinois 61242

**BOOMERANGS— INCREDIBLE RETURNS!** You can do it. Exciting sport! Order **FREE CATALOG** today. BoomerangMan, 306 Park, Monroe, LA 71201

## CB-RADIO, TV & HAM EQUIPMENT

**POLICE Scanners, Crystals, Antennas, CBs, HPR.** Box 19224, Denver, CO 80219

**LINEARS - Send Stamp for Details - MATCO Electronics,** Box 316C, Cadillac, MI 49601

**IMPROVE CB PERFORMANCE!** Modification hardware, books, plans. Catalog \$2.00. CBC International, Box 31500M, Phoenix, AZ 85046

**AMATEUR Television Converter Kits.** Catalogue: \$2.00 (refundable). NDSO, Box 12852, Dallas, Texas 75225.

**NEW Two-Way radio, VOX, 8 1/4 oz., Four models, brochure.** Box 15798, Phoenix, 85060

**NOW! BRILLIANT LIVING STEREO SOUND FROM ANY TELEVISION SET!!** Amazing New Low Cost Method. Free information - Marcel, Box 7557AC, Monroe, LA 71211

**BEARCAT Scanners. Discounted. CRYSTALS \$2.75.** **RADIOSALES,** 3462 Oakland, Oshkosh, Wis. 54901

## ELECTRONICS

**GOVERNMENT Surplus receivers, transmitters, snooperscoopers, parts.** Catalog 25¢. Meshna, Nahant, Mass. 01906.

**SECURITY ALARM INDUSTRY BOOMING. TREMENDOUS DEMAND. GET IN NOW. EMPLOYMENT-BUSINESS TERRIFIC. INFORMATION \$1.00.** **SECURITY ELECTRONICS INTERNATIONAL, P.O. BOX 1456-JG, GRAND RAPIDS, MICHIGAN 49501**

## COMPUTERS

**HAVE your computer pay its own way.** Sample newsletter \$1. Compu-Profit, Dept. PM2, Fairfax Station, VA 22039-0332.

**US\$600.00 build 48K Apple Compatible** including Housings, Details US\$1.00. Reliant, P.O. Box 33610, Sheungwan, Hongkong.

**BASIC Language Program to Handicap Race Horses.** Order C.O.D. or Send \$14.95 To: Handi-Caper, P.O. Box 4896, Framingham, MA 01701.

**TRS-80 COMPUTER DISCOUNTS.** Lowest prices anywhere. Free price list. Radio Shack, 175B N. Delsea Dr., Vineland, NJ 08360. 800-257-0426.

**ATARI Game Kit, Build Your Own And Save.** Plans, Diagram, Resistors, Transistors and diodes included. Also where to get other parts. \$10.00 name and address to: Nutritronics, 212 W. Hill #2, Chicago, IL 60610.

**SINCLAIR, TIMEX, COMPUTER Owners.** Eight Program Cassette (Entertainment, Household, Others) \$5. ZX81H Club, P.O. Box 22446, Baltimore, MD. 21203

**TRS-80\* GAMES** diskette for Model III. Chinese Solitaire, Boxes, Four in a Row. \$19.95. Martian Software, Box 936, Pinellas Park, FL 33565. (\*TRS-80 is TM of Trademark Corporation).

## TV-VIDEO EQUIPMENT

**VIDEO MOVIES.** Sold, Exchanged, Membership, catalogues—mail \$10.00. Tower, Dunkirk, MD 20754-0213



## STEREO, CASSETTE TAPES, ETC.

**RECORD-TAPES!** Discounts to 73%; all labels; no purchase obligations; newsletters; discount dividend certificates; 100% guarantees. Free details. Discount Music Club, 650 Main St., P.O. Box 2000, Dept 1-0383, New Rochelle, New York 10901.

## BOATS, OUTBOARDS, TRAILERS & KITS

**BOATKITS - PLANS - PATTERNS - FRAMEPACKS - LARGEST CATALOG - 300 Designs 8'80" - Plywood - Fiberglass - Steel - Strip Planing - POWERBOATS - Inboards - Outboards - Cruisers - Sportfishers - Hydroplanes - Runabouts (KAYAKS CANOES - Large Selection - Plywood - Fiberglass) - SAILBOATS - Daysailers - Trailersailers - Multihulls - FIBERGLASS MATERIALS - Cloth - Resins - Foam - CATALOG \$2.00 - "Includes FREE Materials Brochure - Equipment - Rigging sails - (Book "AMATEUR BOATBUILDING" - Fiberglass - Plywood - Wood/Epoxy - \$6.00). CLARKCRAFT, 16P Aqualane, Tonawanda, NY 14150**

**BUILD Your Dream Steel Boat.** We teach you how. Free details. North Carolina Steel Boats, Route 1, Box 400, Bayboro, NC 28515.

**EVINRUDE 1982 Bargains . . . all sizes . . . Scott McCulloch parts . . . \$1. handling . . . Electra Marine, 610 Merrick Road, Lynbrook, New York 11563**

**BOAT PLANS - Frame Kits - Patterns - Hundreds of designs - Wood - Fiberglass - Steel - Powerboats - Sailboats - Outboards - Canoes - Kayaks - Rowboats - Houseboats - Duckboats - Sportfishers. Easy, proven methods include instructions especially for amateurs to assure professional results. No Lifting! "Supplies" - Fastenings - Fiberglass - Resins - Glues - Spars - Books. Send \$2.00 for Huge 144-page catalog or \$4.00 Airmail. Includes Free "Boatbuilding Supplies" brochure. GLEN-L Marine, 9152 Rosecrans, Box 758MP, Bellflower, CA 90706.**

**FIBERGLASS - RESINS - Foams - cloth - epoxies - mat - etc. Factory prices - CATALOGUE \$1.00 - (Book "COMPLETE FIBERGLASSING" \$6.00) - Clarkcraft, 16-PI Aqualane, Tonawanda, NY 14150**

**BOAT KITS - 27 trailerable models - POWER and SAIL - 8'-30". Molded fiberglass hulls and decks come factory assembled - you install factory supplied interior. Save half factory-built cost. No experience required. 48-page catalog - \$1.00. Luger, Dept. BC-83, 3800 West Highway 13, Burnsville, Minnesota 55337. 612-890-3000**

**BOATBUILDER'S PLANS, Patterns - Kayaks, Canoes, Sailboats, Progues, Fishing Boats, Duckboats, 40 models. Catalog 25c. Outdoor Sports, Box 871C, Brentwood, TN 37027**

**TRAILER PLANS— Hand Pulled, Laser, Sailfish, Rowboats & 100 other Uses. Weighs 50 lbs. & Hauls 300 lbs. Use Bicycle Wheels & our Ideas. Full Descriptive Drawings in Fine Detail. Welding Necessary. Very Durable, Thoroughly Tested. Send \$6.50 check— Ralph Mason, 11 Eagle St., Scotia, N.Y. 12302**

## ATHLETIC & BODY BUILDING COURSES

**BIGGER, More Powerful Muscles - faster! Free Booklet! Universal, Box 6694A, Detroit, Michigan 48240**

**KUNG-FU Free Lessons. Send \$1.00 for Postage. McLisa, Box 1755, Dept. PM83C, Honolulu, Hawaii 96806**

## SPORTING GOODS & EQUIPMENT

**LEARN FROM THE PRO'S.** Be better at your favorite sport. Sixty minute cassettes. All sports. Free list. Associated Executives, 4015 Georgia, West Palm Beach, Fla. 33405

## BATTERIES, GENERATORS

**SENTRY Generators With/Without engine. Big discount. JJ Enterprises, Box 693, Oshkosh, WI 54902**

## BATTERY REBUILDING SCHOOL

**TOOLS And Instructions \$326.00. Training available. Tested and proven method. Instructor has 32 years experience. Sun Battery Inc., 10415 U.S. 98, Sebring, FL 33870. (813-655-1314).**

## ENGINES, MOTORS, MAGNETS

**REPAIR ELECTRIC MOTORS! ILLUSTRATED INSTRUCTIONS! Modetrip, Box 7266, Kansas City, Missouri 64113**

**SMALL ENGINES Large Discounts. Send Stamped Business Envelope To: Engines, Box 166-PM, Ashland, MO. 65010**

## TOOLS FOR SALE

**DISCOUNT TOOL Catalogue - \$1.00. Hoosier Distributing, 3009 Sample, South Bend, Indiana 46619**

**COMPLETE LINE of high quality, low-priced CUTTING TOOLS, HOLDING FIXTURES, PRECISION INSTRUMENTS AND TOOLS, TOOL STEEL, PORTABLE ELECTRIC- AND AIR-TOOLS, HAND TOOLS AND MUCH MORE. Most items delivered free. Send \$4.00 for 368 page 1983 catalog, refundable with first order. KBC TOOLS, P.O. Box 343, Sterling Heights, Michigan 48078**

**AUTOMOTIVE Speciality Tools. Top Quality. Catalogue \$2.00. EHT, P.O. Box 7254, Orlando, FLA 32854**

**"TOOL APRON GENUINE LEATHER 12 Pocket" \$24.99. Jacomo Tool, 1019 Woods Chapel Road, Blue Springs, Missouri 64015**

**MAKITA GRINDERS 4 Inch (8501BKIT) only \$89.95 White Supplies Last. (Visa/Master Charge/American Express). Tel-Sel, 2814 Washington Avenue North, Minneapolis, MN 55411. Or Call 800-328-4560.**

## UPHOLSTERY SEWING MACHINES

**UPHOLSTERY Sewing Machines with Walking Feet, complete ready to use—only \$459.00. Thompson Model PW103-AGBP AVAILABLE FROM YOUR LOCAL DEALER, or order direct. (Master Charge-Visa). Datho Mfg., Inc., P.O. Box 12110, Lubbock, Texas 79452—Phone: (806) 744-6774**

## MACHINERY, TOOLS & SUPPLIES

**REPAIR Parts for chainsaws, lawnmowers and small engines combine top quality and low prices. Shop tools. Guaranteed. Free Catalog. For special dealer information also give tax no. and company name. Repair Parts, Dept. 40803, Box 10308, Erie, PA 16515**

**SILVO Hardware, 188 page Hand & Power Tool Catalog \$1.00, Dept PM3-3, 2205 Richmond St., Philadelphia, PA 19125**

**FREE Industrial Buyers catalog for home craftsmen. Buy equipment at same LOW prices as large industrial plants. Turnkey, 36PO, Letchworth St. Buffalo, NY 14213**

**BANDSAW BLADES, Carbide Tipped Saws, Any Size, Free literature. King Saw, 6541 Tidewater Drive, Norfolk, Virginia 23509**

**1400 Catalogs Listed and Described. Sources for Everything Imaginable. \$4.00. Masterlog, Box 879-B, Fairfax, CA 94930.**

**SMALL FOUNDRY Furnaces, Supplies. Free literature. Pyramid Products, 3736 South 7th Avenue, Phoenix, Arizona 85041**

**LATHES—Unimat—Maximat—Sherline Enco. Catalog \$1.00. Shop Supplies \$1.00. Campbell, 21000 Selma Road, Springfield, OH 45505. (513) 322-8562.**

**STEEL, Aluminum, Brass—Sheet, Bar, Shop Supplies, Plans. Write: CEI, RR1, Box 163, Cameron, IL 61423.**

**4" METAL Cutting Lathe \$83.50. Taig, 15048 Proctor, Industry, CA 91746**

**BRASS, Aluminum, Stainless Steel. No minimum. Write: METALS, Box 11204, Clayton, MO 63105**

## BLACKSMITH SUPPLIES

**FORGES: gas, coal — hammers — tongs — anvils — anvil benches—all blacksmith supplies. Catalog \$2.00 (refund first order) Mankel Blacksmith Shop, 7836 Cannonsburg, Cannonsburg, MI 49317.**

**AMAZING NEW ABRASIVE WHEEL FOR GRINDING ALUMINUM. Available in 4 1/2 Inch & 7 Inch Depressed Center Sizes. Send \$5.00 For 4 1/2 Inch Sample. (Visa/Master Charge/American Express.) Tel-Sel, 2814 Washington Avenue North, Minneapolis, MN 55411. Or Call 800-328-4560.**

## WELDING, SOLDERING, PLATING

**WELDING AND SAFETY: Everything to fit the Welders needs - major brands, at discount prices. Catalog \$1.00. City Welders Supply, 321 E. Highway 20, Michigan City, IN 46360.**

## ENERGY SAVING

**DO-IT-YOURSELF Solar Heating System - inexpensive, simple proven design, uses ordinary building materials, heats entire home. Plans \$8.50 - SCC, 118 Naylor Avenue, Livingston, NJ 07039**

**PROVEN JAPANESE ENERGY SAVINGS APPROACHES CAN SAVE 50+% !!! Send \$6.95 for New 1983 Report/Guide to: JAPAN RESEARCH, Box 42361-PM, Cincinnati, Ohio 45242**

**WATER HEATER TIMER Smashes Electric Bills. Free Information. MATTINGLY'S, Dept. PM, Box 704, Newton, Iowa 50208**

## SOLAR & ALTERNATE ENERGY

**SOLAR AND ENERGY SAVING PRODUCTS CATALOG! MATERIALS; Components: Complete System. 80 Pages, 18 Sections. Our 10th year! Order from one expert source—the country's largest energy saving mail order house! Call us at 603-668-8186 or send \$1.00 p.p.d. SOLAR COMPONENTS CORPORATION, Dept. M, P.O. Box 237, Manchester, NH 03105**

**AERMOTOR and Bowjon Windmills Make Sense!! Pump Water . . . Air to 125 PSI!! Brochures/System \$3.00 (Refundable). Sam's Windmill Service, R. 1, Box 563, Shipshewana, Indiana 46565**

**WIND Generator, build your own for about \$300. Free information. Send 25c to cover postage: Wind Energy, PM, P.O. Box 841, Paradise, CA 95969**

**ENERGY PRODUCTS Catalog \$1. Our 15th Year. MATTINGLY'S, Dept. MP, Box 704, Newton, Iowa 50208**

## HOME HEATING, FUEL SAVERS

**GAS WATER HEATING- Up to 40% Savings and More! New Timer. Excellent! Free Details: Perry Marketing, Box 303-PM3, New York, N.Y. 10021**

**FIREWOOD LOGS FROM SAWDUST Easy to make simple instructions. \$10.00. Today's Ideas, Box 22304C, San Francisco, CA. 94122**

**INEXPENSIVE Weekend Project reduces Home Heating Costs. Illustrated Solar Air Heater Construction Manual. Proven design offered by non-profit organization. Plans approved by Arkansas FmHA. \$5.95 postpaid. Components also available. Office of Human Concern, P.O. Box 756PM, Rogers, AR 72756.**

## HOME CRAFTSMAN

**UNIQUE BAR: Stor'n'Serve. Hangs On Wall. \$6.00. Wooden Hangups, 4136 Home Ave., Cincinnati, Ohio 45236**

**35 WOODEN TOY PATTERNS - Cars, Trucks, Train, Airplanes, Earthmovers - Only \$5.00 - FRANKS, 1202P5 Second, Booneville, MS 38829**

**WOODWORKERS, Hobbyists. 1983 catalog containing Chair Cane, Wooden Wheels, Lamp Parts, Tools, Finishing Materials, Hardware, Plans, etc. Send \$1.00. Barap Specialties, PM383, 835 Bellows, Frankfort, MI 49635**

**OVER 75 PATTERNS! Enjoy making profitable wooden gifts, toys, household accessories. PLUS "Shop Secrets". Only \$5.00. Accents (P-33), Box 262, Danvers, MA 01923**

**COUNTRY DESIGN Sketch Book. Measured Drawings 10 items, Wall Boxes Scones 8 1/2 x 11 Booklet. \$6.00. Window House, P.O. Box 81PM, Springfield, TN 37172**

**LARGE Selection of Plans. Furniture Designs, Loom, Spinning Wheel, Clocks, Dollhouses, Cradles, Toys, Alphabets, Bird Houses, Weather-vanes, Kites and More. Catalog 50c. Craftplans Co., Rogers, Minnesota 55374**

**UNFINISHED picture frame moulding. Factory closeout. 50% discount. 200 styles. Write: Japs, 126-PF Seventh North, Hopkins, MN 55343**

**MAKE TOYS- Plans, Kits- Hardwood Wheels, Parts, Dowels- Catalog \$1.00- Cherry Tree Toys, Belmont, Ohio 43718.**

**CATALOG FULL-SIZE FURNITURE PLANS — \$2.00. Refunded with first order. Traditional, Early American, over 170! Furniture Designs, 1425 Sherman, Dept. CP-83, Evanston, Illinois 60201.**

**PLANS & Supplies for toys, clocks, furniture and accessories. Catalog \$1.00. Armor Products, Box 290, Dept. CT., Dear Park, NY 11729**

**WOODEN Toys Are Better. List Of Plans \$1.00 U.S. Currency Only. Woodbutchers Toys, Box 514, Leslie, Mich. 49251**

**CHANGE Color Of Vinyl Or Leather Upholstery. Easy, Inexpensive. For Information SASE TO: Clausen, P.O. Drawer 140-N, Fords, NJ 08863.**

**WORLD'S LARGEST CATALOG? Three pounds 704 pages. Every Tool, Supply, Machine Imaginable \$5.00. Refundable. McKiligan, PM-383, Johnson City, New York 13790**

**BATTERY CLOCK MOVEMENTS. Hands: Hardware, Finest Quality. Discount Prices. Catalog \$1.00. Refundable. Yankee, Box 26, Thompson, Connecticut 06277**

**WALNUT Lumber cabinet grade. Squares, Gunstock blanks, Veneer. Iowa-Missouri Walnut Co., Dept. M, Station A, Box 66, St. Joseph, MO 64503**

**GRAVITY "BOOTS", Plans \$5.00. Upside Down, P.O. Box 66, Lowndesville, S.C. 29659**

**EXTREMELY SIMPLE wooden doll furniture-toys. lucrative, new (year around) market. Plans \$2.00. "Charly", Box 301, Collierville, Tenn. 38017**

**ALASKAN ESKIMO ULU A unique knife from a unique culture, complete plans and information, \$5.00. Channel Supply, Box 8, Pedro Bay, Alaska 99647**

**"WOODWORKERS" BUILD THIS "ELECTRONIC INSECT KILLER". Easy, Inexpensive To Build. Full Size Patterns, Photo Section. Free Details. Britton, 15835 Brookhurst, 46MI, Westminster, California. 92683.**

**COUNTRY FURNITURE PLANS Hutch, Corner Cabinet and more. Send 75 cents (refundable with first order) for our product sheet. Hammemark Associates, Box 201PM, Floral Park, NY 11002.**

**MINIATURE car wall rack (suitable for Hot Wheel style) Simple, inexpensive. Holds 96. Plans \$1.00, Rack Plans, Box 105, Jamestown, MI 49427**

(Continued on next page)



## HOME CRAFTSMAN

(Continued from preceding page)

**KIENZLE Quartz Clock Movements.** (Battery operated). From \$4.80. Also accessories. Free price list. North American, Box 77-ACK, Fox River Grove, Illinois 60021.

**DRIFTWOOD** from the Pacific, 5 lbs. Send \$6.75. Blair, Box 1244, Brookings, OR 97415

**CHILDREN'S ROOM MESSY?** Use valuable space under bed! Build three drawer twin bed frame. Order easy new plans, \$4. Althaus, PM383, 10309 Golden Quail, Austin, Texas 78758.

**PLANS** — Build Home Arcade Cabinet under \$30. Holds TV plus Atari, Intellivision. Send \$6.95. OWOOD Designs, Box 2366, Topeka, Kansas 66601

**UNUSUAL** Homemade toys, games, \$5.50; R&L Enterprise, P.O. Box 1580, Pittsburg, Kansas 66762

**CATALOG FURNITURE PLANS** \$1.00 (refundable) Bedroom, Living Room, Family Room, Early American, Mediterranean, Scandinavian over 200. VINESS, Box 945, N. Chelmsford, MA 01863

**CHILD'S PLAY HOUSE** Plans. Indoor/Outdoor \$2.00. Duet Enterprises, Dept. PM-2, 9514-9 Reseda Blvd., #464, Northridge, CA 91324

**NEW**—\$500.00 From one sheet of Plywood. Guaranteed. Oakstump Woodcraft, 3630-P1 Pacific Way, Longview, Wash. 98632

**YOU CAN BUILD** Furniture, Toys, Accessories and Shop Equipment. Five Free Plans with Illustrated Catalog 700 Items. Send \$1.00 for Details. Mayco Sales, Box 2931PM, Mesa, Arizona 85204

**FAVORITE WOOD TOYS,** Patterns, Parts, Wheels, Catalog \$1. Toys And Joys, Box 628M, Lynden, Wash. 98264

**PM'S GREAT, NEW MASTER HOME CARE GUIDE.** The latest and greatest in the Popular Mechanics Master Guide Series. Lays out all you need to know about home repairs, from basement waterproofing to roof repair. 24 laminated, wipe-clean sheets on 12 stand-up, hang-up boards. 150 charts and illustrations. Properly used, it can save thousands of dollars. \$4.95 + 50¢ to cover postage and handling. PM Master Home Care Guide, Dept. PMC3, Box 1014, Radio City Sta., New York, N.Y. 10101.

## CONSTRUCTION PLANS, BLUEPRINTS

**COMPLETE GARAGE PLANS.** Specify 1½ or 2-Car. Materials list, Instructions, Sectional Diagrams Included. \$14.95 Postpaid. FREE Blueprint Takeoff Guide. ROP, Box 35147, Station D, Albuquerque, New Mexico, 87178.

**PATIO SWING** Unique design enjoy a lifetime—Complete blueprint, send today \$9.95. Crawford Designers, Route 4, Mayfield, Kentucky 42066

## LOG CABINS AND "A" FRAMES

**ROUGH, RUGGED & RUSTIC. LOG PROJECTS!** Make chairs, benches, tables, gates, fences. A summer house, birdhouses, signs and house numbers, lamps, tables, shelves, bookends. Photocopy of articles as they appeared in Popular Mechanics available for \$4.00. Send order to: PM, Dept. PMC3, Box 1014 Radio City Sta., New York, N.Y. 10101

## HOME BUILDING & REMODELING

**CARPENTER'S** Leverage Tool, Little PeeVee: Holds partitions for nailing. Pushes/pulls sill plates. \$13.00 plus freight. **FRAMER'S** Wall Brace: Threaded end for fast alignment and bracing of walls, beam-supports. \$34.00 plus freight. Proctor Products, Box F, Kirkland, WA 98033.

**THOUSANDS** Served with homebuilders guide the UNHANDYMAN way. Large SASE / information. Owner Builder Consultants, 557 California St., Boulder City, NV. 89005

**HI-TECH LOFTS** Made Easy. UTILIZE WASTED SPACE. Four Easy To Understand Designs. Send \$2.95 To: LOFTS UNLIMITED, 16 Sunnyside Lane, Westport, CT 06880. Plus FREE Energy Saving Tips.

**SAVE 50% BUILDING** Remodeling—Free Information. Consumeraction, Box 13257-BK, Pittsburgh, 15243

**HOME REPAIR GUIDE** First comprehensive collection proven money savings, easy instructions, hundreds of photos and diagrams. Only \$4.95. The Porch, 4527 60th Street West, Bradenton, Florida 33507

## PLASTICS

**CASTOLITE** Liquid Plastics. Crystal clear, colors. For casting, embedding, coating, fiberglassing; in industry, laboratories, craft work. Reproduce your designs with our mold materials. Profitable. Illustrated Catalog \$1.00. CASTOLITE, Dept. 83C/PM, Box 391, Woodstock, IL 60098.

## DO-IT-YOURSELF

**LOCKSMITH** reveals "Secrets of Locks" — illustrated booklet. \$1.00. Rogers Alan, Box 16434M3, Memphis, TN 38116

**BUILD YOUR OWN BEHIVES.** An excellent copyrighted 150 page book. Complete procedures with 22 drawings and illustrations. A must for hobbyists and beekeepers. Build hives and sell for profit. \$13.95 Post Paid: Blue Ridge Publishers, P.O. Box 606, Dublin, Virginia 24064

**SAVE MONEY** By Doing Your Own Plumbing. 2 Fully Illustrated & Easy To Understand Booklets. Make Extra Money Doing Repairs For Others. Send \$3. C&A Enterprises, P.O. Box 596, Lombard, IL. 60148

**SURVIVE!!!** — Three Dozen Controversial Survival Publications — Energy, Banking, Firearms, Medical. "AUTOMATIC TELLER MACHINES" (\$20.00), "GAS FO' ALL!" (\$16.00), "SURVIVAL GUNS & AMMO!" (\$16.00), . . . Super-Survival Brochure (\$1.00). INTERVIEWED by CBS "60 MINUTES". WILLIAMS, MSEE, P.O. Drawer 537M, Alamogordo, NM 88310

**PLANTER** Boxes, 10 Plans \$5.00. Ashmore, Box 771, Grass Valley, CA 95945

**NEW! . . . REPAIR ANY TV . . . EASY.** Write: Research, Box 517X, Brea, CA 92621

**ELECTROPLATING.** Complete amateur's textbook. All metals Electroplate metallic/nonmetallic items \$11.95. Details free. Tropic, Box 95-P3, Palm Bay, Florida 32905.

**1400** Catalogs Listed and Described. Sources for Everything Imaginable \$4.00. Masterlog, Box 879-F, Fairfax, CA 94930.

**SAVE** on parts for Lawnmowers, Minibikes, Karts, Chainsaws, Small Engines. THOUSANDS OF PARTS. Send \$3.00 For Catalog. Sav-On-Parts, P.O. Box 231, Somerville, Mass. 02143

**WATERBEDS!** Plan And Accessory Catalogue \$1.00. Waterbeds, 1210A "Z" Street, Vancouver, Washington 98661

**DRAW YOUR OWN HOUSE PLANS** Step by Step Simplified Illustrated Booklet. Send \$5.00. Schwab, 2950 NE 23rd #131, Gresham, OR. 97030

**SURVEILLANCE ELECTRONICS.** Build your own. Details Free. Lextek Laboratories, Box 8485B, Silver Spring, MD 20907

**SILVER,** Dead Batteries Contain It: You Can Reclaim It. \$5.00. Goldbond Ltd., Box 10669, Pittsburgh, PA. 15235

**PROJECTION TV . . .** Convert your TV to project 7 Foot picture . . . Results Comparable to \$2,500 projector . . . Total cost less than \$200 . . . **PLANS & LENS** \$17.50 . . . Illustrated Information FREE . . . Macrocomb, Washington Crossing, Pennsylvania 18977, Creditcard Orders 24Hrs. 1-215-736-3979.

**HOMEOWNERS** Guide To Plumbing. Book Has Complete Step By Step Instructions, Detailed Diagrams and Photographs, \$5.95 Postpaid. Faulhouse, Suite 401, 16527 Stony Plain Road, Edmonton, Alberta, Canada T5P 4E7

**REPAIR,** Air Conditioning - Refrigerators - Illustrated - Manual \$10.00. Doves Inc., Box 771B, Hammond, Louisiana 70404

**SEAL** Backs of Picture Frames Drum Tight, Instructions \$2.00. Montgomery Specialty Products, P.O. Box 441, Yardley, PA 19067

**BELT** buckles for coins or stones, specialty buckles, jewelry mountings, cut stones, clock works. Wholesale catalog 25¢. Eloixte Corp., 806½ 10th Street, Wheatland, Wyoming 82201

**FREE DETAILS.** Build a Professional in-ground swimming pool. . . Easy. . . Inexpensive. . . Leisure King Products, Box 12763, Lake Charles, Louisiana 70612

**TELEPHONE KITS** easy. Free Brochure. Telesales, Box 114, Hope, ND 58046

**LEARN GLASS ETCHING** Complete starter kit \$4.95 ppd. Guaranteed! Eastern Art Glass, Greenwood Ave., Box 341, Wyckoff, NJ 07481

**FIX** your own washer—dryer—dishwasher! Easy photo-drawings reveal how to save money! Write: Kings, #pmc, 406 West Camino Real, Arcadia, California, 91006

**HOMEOWNER'S GUIDE TO PLUMBING** Complete Instructions. Detailed Diagrams. \$4.95. Sharon Elaine, 124-A Brown Street, Davenport, Iowa 52802

**PLANS** List \$1. **GENERATE** 12V and 110V Using Auto Alternator And Lawn Edger \$5, Hi-Intensity Camper Lamp \$5.00, Solar Enterprises, Suite 14M, 18677 West Dixie Highway, North Miami Beach, Fla. 33180

**LADDER HELPER** Rungs Hurt your Feet-No More. Movable Rung Extension Moves to Desired Rung without Leaving Ladder. Plans \$3.00. Orsino, P.O. Box 71, DPT3MP, Dresher, PA. 19025

**SECRET INVENTION—LETS YOU TURN ANY BED INTO . . . AUTOMATIC ADJUSTABLE BED.** Plans - \$3 - Guaranteed. Olymperial, Box 3102P, Wallington, New Jersey 07057

**SOLAR DOG HOUSE!** Keeps best friend warm, winter-cool, summer! Illustrated plans (adaptable size dog), \$1.95. Bonilla, 671AD3 Ninth, NY 10036.

**HOW TO GO INTO BUSINESS AND SUCCEED.** Free Literature, Write: PRS, Box 3145, Laval, MD 21502

**BUILD YOUR OWN EFFICIENT PYRAMID HOUSE FOR \$7,000.00!** Wind Proof, Snow resistant, Energy efficient, Maintenance free! House Plans . . . \$25.00 — Information Only . . . \$1.00. Patt Latham, P.O. Box 92, Midway, GA. 31320

## ARTS & CRAFTS

**"GETTING STARTED IN SANDBLASTING GLASS",** \$1.00 refundable. TA Associates, P.O. Box 6840, Laguna Niguel, CA 92687.

**"GETTING Started in Stained Glass" \$1.00.** Whitmore, Box 2065T, Hanover, Mass. 02339.

**CRAFT** Jewelry Supplies. (Wholesale Catalog .25¢). Roussels, 107-1630 Dow, Arlington, MA 02174

**STAINED GLASS SUPPLIES** Complete Catalog \$1.50 (refundable). Sunshine Glassworks, 785 Millersport, Dept. CT, Amherst, NY 14226

**LEATHERCRAFT** Catalog, Tools, Leather, Dyes, Dressings, Saddle Stamps, Buckles much more. Send \$2.00 (refundable with order) to: MacPherson Bros., P.O. Box 99442, San Francisco, Calif. 94109

**COMPLETE ASSORTMENT** of quality Leather, Tools, Belts, Dyes, Kits. Full-color catalog. Only \$1.00, refundable. Berman Leathercraft, Dept. 3372, 145 South Street, Boston, MA 02111.

**STAINED GLASS** Catalogue-P. \$1.00. Supplies, Kits, Books, Tools, Glass. Saylescrafs, 171 Main, Nyack, N.Y. 10960

## CARTOONING, COMMERCIAL ARTS & SIGN PAINTING

**MODERN** Cartooning taught by mail. Write for free brochure. Cartoonorama—Box 263-30, Branford, Conn. 06405.

**SIGN** Painting — Easy method. Free catalogue. Kaufmann Company, Centertown, Missouri 65023

**CARTOON** for Fun and Money!!! Free booklet!!! Cartoons, Box 40614A, Detroit, Michigan 48240

**35 LESSON** cartooning course. Cartoonist's Magazine, both \$4.00. Hartman, Box 30367, Lincoln, Nebraska 68503-0367

**LEARN** Sign Painting! Highly Profitable! One-Stroke Technique! Write: Eureka Press, Box 931, Fitzgerald, GA 31750.

**FREE** Pinups! Free with your order of 100 methods/markets list on pinups—creating, selling. \$1.00. LCU, P.O. Box 507, Lancaster Pa. 17603

## MODELS-CARS, SHIPS, TRAINS, PLANES, ETC.

**RADIO CONTROL** - Airplanes, Boats, Helicopters, Systems, Supplies. Big Discount Catalog-\$4.00 (Refundable). Modelers Supply, Box 7185, Montgomery, AL 36107

**FIRING CIVIL WAR** Model CANNON Plans: Catalog free. Green—PM-33, Box 892, Shalimar, Fla. 32579

**MODEL MAGIC:** Exceptional Product, Advanced Adhesive Technology Essential for Reliable Model Assembly. Superior bonds, consistent results, fast setting, eliminates clamps, saves time, efficient. Bonds woods, plastics and metals. Send \$19.95 (CK. or M.O.) to: Stick It, Inc., 4029 West 99th Street, Oak Lawn, IL 60453. Order Today!

## MAGIC TRICKS, JOKES, VENTRILOQUISM

**FREE!** World's Leading Novelty Catalog. 1600 Jokes, Tricks, Science, Sports, Hobbies. Johnson-Smith, C-6013, Mt. Clemens, MI 48043

**FREE!** Illustrated Ventriloquism/Puppetry Catalog. Maher, Box 420PM, Littleton, Colorado 80160

**LEARN MAGIC.** \$2.00 for Catalog. Same Day Service. 1512 Fremont, Las Vegas, Nevada 89101

## HOBBIES AND COLLECTIONS

**QUACK** Electro-Medical Devices. Literature. Describe, Price. Lindan, 1404 Dorsh Road, Cleveland, OH. 44121

**MILITARY** Medals Catalogue 50¢. Yearly Subscription \$4.50. Vernon, Box 387PM, Baldwin, NY 11510.

**NAZI** war souvenirs. FREE illustrated catalog. Delta, Box 31224PS, Honolulu, Hawaii 96820

**TOY SOLDIER, CHESS FIGURE MOLDS** — Free Information — Special Offering. Castings - PM, P.O. Box 3482, Longwood, FL 32750

## DECALS, EMBLEMS, PATCHES

**PATCHES,** Decals, Custom Made. Free Catalog - Emblems, Box 35, Tappan, New York 10983

**CUSTOM BUMPER STICKERS** - your message - \$3.00 each. FRITZWILLIE, Box 7276-P, Eugene, OR 97401

**SAVE** Big. Buy Patches, Decals, Pins & Caps Factory Direct. Free Catalog. Free Pricing. Eastern Emblem Co., Box 828-PM, Union City, N.J. 07087

## ANTIQUES, RELICS, INDIAN GOODS AND CURIOS

**FREE** List to Serious Collectors. 30,000 Indian Artifacts, Pots, Spears, Axes, Slate, Beadwork. Caddo Trading, Box 669, Murfreesboro, AR 71958

## STAMP COLLECTING

**50 YEARS** Old fifteen different United States, over fifty years old—25¢ with approvals. Jaxon, Box C11-P, New Rochelle, New York 10804

(Continued on next page)



## STAMP COLLECTING

(Continued from preceding page)

**U.S. 25 Different mint Including Souvenir Sheet \$1.00.** Free list. Brooks, Box 62, Brooklyn, NY 11229

**50 MINT** or 200 used all different US \$1.00 approvals. Stamps, Box 1427PM, Bellflower, CA 90706

**FREE!** Big Bargain Catalog - New Edition listing thousands of bargains including U.S. & B.N.A. stamps, packets, albums, accessories and supplies. Also fine stamps from our approval service. Buy only what you like. Return balance promptly. Thank you. Jamestown Stamp Co., Dept. E33PM, Jamestown, NY 14701

**SEND** Only 25¢ for nice collection of U.S. Stamps including \$5.00 issue and scarce mint Sipek Souvenir Sheet. Attractive price lists of other beautiful stamps and collectors supplies included. Mystic Stamps, SS-1, Camden, New York 13316

**U.S. 6 Commemorative Plate Blocks \$1.00!** Approvals. Gordon Davison, 56C, Nokomis, FL 33555

**"WHOLESALE" U.S.**—Foreign Pricelist and catalog Free! Everything Guaranteed. Schneider, Box 1240, Grand Rapids, Michigan 49501

**1,000 U.S.A. Mixture \$2.95.** St. Johns Stamps, Box 248P, Milford, CT. 06460

**FREE Gift** With Quality Approvals. Chapmans, Box 487-G, Galesburg, Michigan 49053

**GREAT Gift** free with 1st purchase—fine United States approvals and want list service. Send 15¢ for handling. The Stamp Boutique, P.O. Box 456, Madison, NJ 07940

**FREE Wholesale** Singles and Plate Block Price Lists. Five-5¢ Plate Blocks \$1.00. AMPBCO, Box 26066P, St. Louis, MO 63136

**BREATHTAKING** Beautiful, 50 Different mint Monaco pictorials commemoratives only \$1.50 with mint complete set approvals. Pagoda, Box 132P, Sidney, Ohio 45365.

**PENNY!** Approvals! Regardless catalogue! Kloster, 4164 52nd St., San Diego, Calif. 92105.

**UNITED NATIONS 3** Complete Mint Sets 25¢. Approvals. Cornetta, POB 1509-M, Lake Placid, Florida, 33852

**50 DIFFERENT** Old U.S. between 1861 and 1939 - \$1.00. Ed Roush, 423 Shepard, Mansfield, Ohio 44907.

**OLD U.S. Stamps** on Approval. Chester, Box 15355G, Philadelphia, PA 19111.

**WORLD Wide** Stamps mounted in books on approval 2¢ and up. **TRUST STAMP COMPANY**, P.O. Box 100-P, Jamaica, N.Y. 11435

**FREE Surprise** collection sent with approvals. Gould, 1784 Union, San Francisco, 94123.

**100 Different U.S. 25¢.** Approvals. Bradley, Box 425P, Midlothian, VA 23113

**BARGAIN 100** World-wide Stamps 25¢. Quality Approvals. R. Parker, Box 143, West Brookfield, MA 01585

**2,000,000** Stamps—150 Countries—2¢ Each. Belden, Box 4149, Dearborn, 48126

**STUNNING! 100 BEAUTIFUL MINT PICTORIALS.** All Different Only 25 Cents with Attractive Worldwide Approvals. **VANSTAM**, Dept. PM-383, P.O. Box 11272, Chicago, Illinois 60611

**"INVERTED ERROR"** + 100 Different United States, 50¢ with approvals. Luray, P.O. Box 7088, Silver Spring, MD 20907

**50 TOPICALS** 25¢ when requesting low priced approvals. Stewart Kent, Box 2398-F, Bellingham, WA 98227

**PENNY Approvals.** 1 - 2 - 3¢. CK Stamps, 17902 Marklee Drive, Jamul, CA 92035

**FREE 100** Canada with request of World Wide Approvals. Briner's, P.O. Box 5607, San Mateo, Calif. 94402

**300 Different** Worldwide Stamps 50¢ With Approvals. R.G. Sales, Box 1065, Jamaica, N.Y. 11431

**200 DIFFERENT WORLD WIDE \$1.00** when requesting approvals. Rail 'n Mail Stamp Mart, Box 325M, Okemos, MI 48864

**FREE - U.S. Discount Catalogue.** Shelton, Box 547B, North Miami, Fla. 33161.

**ABSOLUTELY FREE-** 50 different British Colonies **COMMEMORATIVES.** Approvals. Gobestamps, Box 690, Saco, ME 04072

**WOW!** Surprise Lot 10¢ With Approvals. Tarheel Philatelics, Siler City, North Carolina 27344

**FREE 100** Foreign, Request Approvals. Alpaugh, Box 225, High Bridge, NJ 08829

**COMPLETE set FREE** when requesting worldwide approvals. Benet, P.O. Box 210244, Dallas, Texas, 75211

**CANADA.** 50 different 25¢. Approvals. Oroszky, Box 1-C, Sarnia, Ontario, Canada N7T 7H8

**BREATHTAKING. 120 SPECTACULAR PICTORIALS INCLUDING 4 COMPLETE BEAUTIFUL SETS,** 25¢. Plus Attractive Approvals. Sharvin-7, Box 982F, Toronto, Canada M4Y 2N9.

**FREE!** 55 Different. Including Triangles, Space, Others! Approvals. Baird, PM60, Box 6128, Portland, OR. 97207-8128

**BRITISH EMPIRE 104** Different Includes Mint Pictorial Colonies 10¢ with Approvals. Kamco, Box 338M, Flushing, N.Y. 11367

**SEVEN** Different Canal Zone 25¢. Approvals. Merkel, 30 Grandview, South Hadley Falls, Mass. 01075

**100 Turkey 50¢.** No Approvals. Gibson, Box T, Williamstown, N.J. 08094

**ISRAEL 15** Different 10¢ Approvals. Sam Chazen, Box 666, Delray Beach, Florida 33444

**DISCOUNTS 50% I —** Approvals, any country. Gains, 716-S Sixteenth, Mattoon, IL 61838

**BETTER U.S. STAMPS ON APPROVAL. WRITE: PALISADES INTERNATIONAL, P.O. BOX 828, FORT LEE, NEW JERSEY 07024**

**100** different, Foreign British Colonies 10¢ Plus Bargain Approvals. City Stamp Co., Box 216, Station "W", Toronto, Canada M6M 4Z2

**FREE U.S. Mint Set.** Approvals. Hildebrand, Box 4867, Santa Clara, California 95054

**CANADA Ten** Late Commemoratives 10¢ Canadian Approvals. Harley Boardman, Little Valley, New York 14755

**FREE INCREDIBLE STAMP OFFER!** Giant Worldwide Collection: 125 different genuine postage stamps including beautiful large colorful pictorials, Savage Animals, Nudes, Olympics, Space, Disney and much more, absolutely **FREE** when requesting exciting "Stamps on Approval" selection for examination at home. Buy any or none, cancel service anytime. **SEND TODAY!** Mission D28, Piacentia, CA 92670-0009

**107** Different Triangles, Space, Animals, Etc. \$4.00 Value. Only 10¢. Approvals. Fayette Stamps, Dept. 418M, Fayetteville, NY 13066

**LOOK!** 358 World Stamps \$1.00 Worldwide Approvals. Kiordike, Harrisburg, IL 62946

**ICELAND** Collection 20 Different. \$1.00. Approvals. Sandell, Box 6664, St. Paul, 55106

**U.S. Stamp collectors** regard **LOWELL P. DONALD** Company as **THE** source for better issues prior to year 1940. **BELOW WHOLESALE PRICES!** Send 20¢ for complete price list. Box 729, Rutland, Vermont 05701

## COINS, TOKENS, CURRENCY

**FREE:** Worldwide Listing of Beautiful Collectors Currency. Tom Knebl, P.O.D. 3949, San Bernardino, Calif. 92413

## PHOTOS & PHOTO SUPPLIES

**GET THE MOST FROM YOUR CAMERA** "20 Hints For Better Pictures" Send \$1.00 To: Johnson's Photo Co., P.O. Box 402, Davison, Michigan 48423

**BARGAIN BOOK:** Send 25¢ credited on \$5.00 order. **CENTRAL CAMERA CO.**, Dept. #3223, 230 So. Wabash Ave., Chicago, Ill. 60604., **PHOTOGRAPHIC HEADQUARTERS SINCE 1899.**

## BOOK BINDING

**REBIND YOUR DAMAGED BOOKS.** With a few common tools and a homemade book press (plan included) you'll be able to handle anything from a torn hinge to a complete re-binding. Photocopy of article as it appeared in P.M. available for \$4.00. Send orders to: Popular Mechanics, Dept. PMC3, Box 1014, Radio City Sta., New York, N.Y. 10101

## BOOKS & PUBLICATIONS

**FREE** Book. Prophet Elijah Coming Before Christ. Megiddo Mission, Dept. 63, 481 Thurston Road, Rochester, N.Y. 14619.

**PUBLISH** Your Book! Join our successful authors. Publicity, advertising, beautiful books. All subjects invited. Send for fact-filled booklet and free manuscript report. Carlton Press, Dept. PMO, 84 Fifth Avenue, New York 10011.

**PUBLISHERS' OVERSTOCKS, BARGAIN BOOKS.** 2,000 Titles, all Subjects! Free Catalog: Hamilton's, 98-51 Clapboard, Danbury, CT 06810

**OUT-Of-Print** Books Found. Send Wants. Booklook, 51 Maple Ave., Warwick, N.Y. 10990

**FREE** Fascinating, Interesting, Illustrated, Self Improvement Book Catalog. Venus, Box 6351, Arlington, VA 22206

**LEARN ARC WELDING AT HOME** - Easy - Inexpensive - Instruction manual \$3.95, details free. Moneyback Guarantee. Box 2067MI, Cridersville, OH 45806

**McCARTNEY LAW LETTER.** Newsletter Covering Topics of Everyday Legal Matters. Written by Former Judge. \$16.00 Yearly (10 Issues). Send no money. Billed with First Issue, June '83. Box 45, Heron, Montana 59844

**BE SUCCESSFUL!** Achieve anything you desire. \$4 booklet reveals simple technique for Self-Improvement. C. C. Enterprises, 361 S. 100M W., Cedar City, UT 84720

**FISHING BEGINNERS SAVE \$** While Learning. Book "Family Fishing on a Budget" \$4.95 plus 60¢ handling. (Missouri residents include 28¢ sales tax). Heartland Publications, P.O. Box 1209, Florissant, MO. 63031

## PLAYS, SONGS, MANUSCRIPTS

**WANT** Your book published? Learn how we publish, advertise, promote, distribute. All subjects. Free booklet PM. Vantage, 516 W. 34th Street, New York City, 10001.

## MUSIC INSTRUCTIONS & INSTRUMENTS

**VIOLIN,** Guitar, Banjo, Mandolin Making Materials. Accessories, Books, Piano Tuning Kits, Catalog \$1.00. International Luthiers Supply, Box 15444, Tulsa, OK 74112

**ELECTRIFY** Player Pianos, Pump Organs Quickly. Inexpensively with Lee Silent Suction Units. Write: Lee Music, P.O. Box 308F, Culver, Oregon 97734

**FREE** Catalog! Kits and Completed. Harpsichords, Hammered and Appalachian dulcimers, guitars, banjos, mandolins. Hughes Dulcimers, 4419 West Colfax, PM, Denver, Colo. 80204.

**PLAY GUITAR FAST**—Details Free! Tollersongs, 209 Triunfo, 178PM4, Westlake, CA 91361

**POEMS** Set To Music. Nashville Music Productions, Box 40001-PM, Nashville, Tennessee 37204.

**PIANOS, PLAYERS, PUMP ORGANS.** Rebuild and repair. Catalog of "How-To" books, \$2.00 (refundable). Vestal Press, Vestal 11, New York 13850.

**SUPER-SAVINGS** Guitar Strings, Accessories, Effects Pedals, Microphones, etc. Free Catalog. Super-Save Music, Box 944, Morganton, N.C. 28655

**ACCORDION** Top Brands, Cordovox, Buy Direct. Tremendous Discounts. Trades accorded. Free brochure. PM, Accordion-O-Rama, 16 West 19th Street, New York, NY 10011

**CATALOG** for makers, repairers of stringed instruments. Imported tonewood, tools, parts, accessories, strings, cases. Fine European instruments and bows. Catalog 50¢, includes 10% discount certificate. International Violin Company, Ltd., Dept. FO, 4026 W. Belvedere Ave., Baltimore, Md. 21215.

**PLAY MUSIC BETTER** through understanding Chords as used to create "Musical Ideas". - **FREE INFORMATION** - Music Learning Systems Publishing (3PM), RD3, Box 142, Olean, NY 14760

**ACCORDIONS!** Famous Italian makes. Piano or button-style keyboards. Free information. L'ACCORDION, 1920 Medi-Park #1, Amarillo, TX 79106. Phone (806) 359-3193.

## SELF-IMPROVEMENT

**THE ULTIMATE SECRET** to getting everything you want. Amazing booklet reveals key to success. Send \$1.50: Secret Library, 2761 State, San Diego, CA 92103

**LONELY? BORED? POOR?** — Never again. Free details on how to make a comeback. Edlin Associates, Dept. PM3, 15 Wooster Street, Seymour, CT 06483.

**FREE** Catalog. Self Improvement Books. ADS Enterprises, 63(M) Monhegan Ave., Oakland, N.J. 07436

## EDUCATION & INSTRUCTIONS

**WELDING TRAINING.** Basic and Advanced for Major Processes—SMAW, GMAW, FCAW, GTAW, OAW, Pipe all processes. A non-profit school. Approved for eligible veterans. Accredited member NATTS. Approved Ohio 70-12-0064 HT. Write for school bulletin and course schedule. **HOBBART SCHOOL OF WELDING TECHNOLOGY**, Box 83, Troy, Ohio 45373.

**ELECTRICIAN.** Learn at home in spare time with no previous experience. Installation, maintenance, construction, lighting, heating, air conditioning applications. Get free facts. Write: ICS Electrician School, Dept. PBC23, Scranton, Pennsylvania 18515.

**DRAFTING** is a great career! Men, women. No previous experience or special talent needed. We train you at home in spare time. Get free facts. Write: North American School of Drafting, Dept. PBCC2, 4500 Campus, Newport Beach, CA 92660

**BE A DETECTIVE.** You Learn Quickly and Easily at Home. No College or Experience Required. Diploma. Equipment. Global School of INVESTIGATION, Box 191M, Hanover, MA 02339

**PIANO TUNING PAYS** - Piano tuning - Electronic organ servicing. Learned easily at home. Free booklet. Niles Bryant School, P.O. Box 20153, Sacramento, CA 95820

**BOOKKEEPING** Or Accounting! Easy home-study plan prepares you quickly to do your own books . . . or others. Approved for Veterans. Free "Accounting Career Kit." Write: Accounting School, Dept. PBCC2, Newport Beach, CA 92660

**"JET/GAS TURBINE CAREERS!"** Homestudy courses — theory, maintenance, overhaul — Established 1957. **AMERICAN JET SCHOOL**, Department PM-3, Darby, Montana 59829. (406) 349-2100

**REISCH WORLD WIDE COLLEGE OF AUCTIONEERING, INC.** World's Largest-48 Years. Term soon, Free Catalog. Approved for VA. Modern Auction Library "FREE" with enrollment. 515-423-5242 - Col. Gordon E. Taylor, P O Box 949, Dept. 19, Mason City, IA 50401

**BARTENDING** - Bar Management Home Study. Bartending Training. 3843-C San Fernando Road, Glendale, CA 91204

**UNIVERSITY DEGREES BY MAIL** Programs! Bachelors, Masters, Ph.D.'s . . . Free revealing details. Counseling, Box 317-PM3, Tustin, California 92680.

(Continued on next page)



## EDUCATION & INSTRUCTIONS

(Continued from preceding page)

**EXTENSION** And Post-Graduate Awards in Philosophy, Art, Science, Botanic, Medicine, Homeopathy, Radionics, and others. 30 subjects Curricular free (airmail \$1.00 refundable). Registrar, Sussex College of Technology, Highfield, Danehill, Sussex, England.

**RADIESTHESIA**, Radionics, Dowling E.S.P. Courses and Equipment Illustrated Catalog \$1.00 (refundable) Established 27 years. Dept. PM/R, Bruce Copen, Highfield, Danehill, Sussex, England RH17 7EX.

**LEARN** Asleep or awake. Records, tapes, equipment! Free catalog! Drawer PM-400, Ruidoso, New Mexico 88345

**AUTOSUGGESTION**. Sleep-learning headquarters! Tapes, records, books, Gigantic catalog free. Research Association, Box 24PM, Olympia, Washington 98501.

**DETECTIVE** Profession, Easy home study; free tie-tack or lapel pin, certificate, future. Professional investigators Training School, Dept. CP, P.O. Box 41256, Los Angeles, CA 90041

**INSTANT MEMORY . . . NEW WAY TO REMEMBER**. No memorization. Release "photographic" memory. Forget nothing! Liberates extraordinary knowledge, talents, ESP. Immediate results! Free information. Institute of Advanced Thinking, 845PM ViaLapaz, Pacific Palisades, California 90272.

**LEARN** Sewing Machine repairing. A profitable Trade. Easy to learn. Free details. Sewing Center, 187 FR, Rochelle, GA 31079.

**USED** Courses! Books! Lists 25c. Smith's, 124 Marlborough, Salem, Massachusetts 01970

**UNIVERSITY DEGREES BY SPECIAL EVALUATION OF EXISTING** Job Experience, Education, Achievement. Fast, Inexpensive. Call (614-863-1791). Or Write: Box 13151-M3, Columbus, OH 43213

**FINGERPRINT TECHNICIAN**. Training now available. You learn easily and quickly at home. No college or experience required. Diploma. Equipment. Global School of Fingerprinting, Box 191-MB, Hanover, MA 02339

**HIGH** School at home, no classes. Diploma awarded Information Free, Phone Free Anytime 1-800-228-5600, or write: American School, Dept 30345, 850 E. 58th St., Chicago, IL 60637.

**SHOE REPAIRING**-Secrets of the Trade - Learn Basics with Step-By-Step Illustrated Manual. \$11.95. Shoe Doctor, Box 458, Forest Lake, MN 55025

**UNIVERSITY** Degrees! Economical home study for Bachelor's, Master's, Doctorate. Prestigious faculty counsels for independent study and life experience credits. Free proof — Richard Crews, M.D. (Harvard), President, Columbia Pacific University, 150 Shoreline, Suite A503, Mill Valley, CA 94941; (800) 227-1617, Ext. 480; California: (800) 772-3545, Ext. 480.

**HANDLE YOUR OWN LEGAL AFFAIRS**. Be a Paralegal. Accredited Attorney Instruction. Home Study. Free Catalog. Southern Career Institute, Drawer 338-2158, Boca Raton, Florida 33427. (305) 368-2522.

**COLLEGE DEGREES** By Mail. Accredited Bachelors, Masters, Ph.D.'s. Free Facts Revealed. Careers-PM3, Box 45886, Tulsa, OK 74145.

**FREE CATALOG—LEARN AUCTIONEERING!** Full and partial scholarships available. Nashville Auction School, 233 E. Gaines St., Box 190, Department 2, Lawrenceburg, TN 38464

**LEARN BOOKKEEPING/ACCOUNTING**. Great opportunities for men/women. Write: ACI, Dept. SA308, Box 11704, Santa Ana, CA. 92701

**FREE** 120 page Career Opportunities Guide - shows how to train at home for top paying jobs. Granton Institute, 263A Adelaide Street West, Toronto, Canada M5H 1Y3.

**TEST** yourself at home. Check your math and reading skills. Write now for free details. Hadley Press, Box 147A, Hadley, MA 04840.

**SUCCESS** Is POWER. Outthink the Thinkers. \$7pp. "Philosophy", P.O. Box 120A, Kew Gardens, NY 11415

**HOW TO** Video Tapes by INSTRUCTOVISION. Mechanics, Sports, Home Improvement. 100 Programs Catalog \$2.00. WE, 15500 W Telegraph A7, Santa Paula, California 93060

**"PROCEDURE TO MANUFACTURING"** essential Know how. Only \$12.50. JHS-Co, Hustisford, Wis. 53034

**EARN** While You LEARN. Business of Your Choice Quickly Learned With Home Study Course. Unique Plan. Belong Teaching Systems, 1013 Springmill Road, P.O. Box 260-MP1, Ontario, Ohio 44862

**ACCREDITED** College Degrees By Mail. Details. GRADUATE REFERRAL SERVICE, 3010 Santa Monica Blvd., Suite 173-PM, Santa Monica, CA 90404

**HELPED** JER.32:40; Acts 2:43; Luke 1:50. 1127 NE Fifth St., Ocala, FL 32670

**"ENGINEERING OPPORTUNITIES!"** ELECTRIC UTILITIES! EXPERIENCE/DEGREE UNNECESSARY! ENGINEERS, 3 ROSWELL, NEW BEDFORD, MA. 02740

## EMPLOYMENT INFORMATION

**"ENGINEERING OPPORTUNITIES!"** "Degree Unnecessary!" Electric Utilities. Engineer, 3 Roswell, New Bedford, Mass. 02740

**SUNBELT JOBS - SOUTHEAST STATES**. Supervisors, office, sales EDP, engineers, more. Over 500 jobs briefly described, with addresses. Updated monthly. **MONEY BACK GUARANTEE**. Current list \$5.95. Southeast, 227-H Lynn, Danville, VA 24541

**JOBS OVERSEAS** . . . (Including Alaska). Free Details. Global Employment, Box 81933PM, San Diego, California 92138

**AUSTRALIA** - The World! 50,000 Jobs! Top pay. Transportation. Computerized reports \$2.00. Jobworld, Box 681E, Cypress, CA 90630.

**JOBS: COLORADO, WYOMING, UTAH, IDAHO, MONTANA!** Computerized newsletter with 200+ new jobs each week. Free details. **MOUNTAINWEST**, 925-PM Canyon, Logan, UT 84321.

**FLORIDA EMPLOYMENT NEWSLETTER**. Complete Sunshine State Coverage Weekly. Free Details. FEN, Box 845PM, Jupiter, Florida 33458

**JOBS** Overseas - Big money fast. \$20,000 to \$50,000 plus per year. Call 1-716-842-6000. Ext. 360.

**OVERSEAS JOBS** \$20,000 to \$60,000 plus bonus. Doycorp, Personnel, Box 697-SZ, Pocatello, ID 83201

**HOW TO GET INTO ENGINEERING AND SUCCEED WITHOUT REALLY TRYING**. Free information: Roman Press, Box 131PM, 450 Lakoville, Petaluma, CA 94952

**OVERSEAS** Jobs! \$20,000-\$60,000 and up! Call now! (317)-839-1712 Ext. 24

**MOVE** Abroad! Excitement/money overseas! Information-Call - Anita Lucas 312-262-9030.

**JOB HUNTING SECRETS!** Guaranteed, Taught by Top Expert, \$5.00 Order Now! Novel, 3517M, Division, Manitowoc, WI 54220

**ROCKY MOUNTAIN EMPLOYMENT NEWSLETTER!!** Colorado, Idaho, Montana, Wyoming!! Current Openings — All Occupations!! Free Details . . . . . Intermountain-L, P.O. Drawer 809, Grand Lake, CO 80447-0809

**RESUMES BY MAIL**. I maximize your abilities. Master wordsmith. 25 years experience. Frank Middleton, Suite 401, 4331 North Federal Highway, Fort Lauderdale, Florida 33308.

**DISCOVER** Exam secrets to get \$9.95/Hour Post Office Jobs. Free information. National, Box 1024, Dept. M, Norfolk, VA 23501

**JOBS ABROAD** All Countries. All Categories, including **CRUISE-SHIP, ACT FAST**. 1-716-885-3242. EX-101.

## HELP WANTED

**AUSTRALIA WANTS YOU!** Jobs! Big Pay! Transportation! Newest Handbook — \$2.00. **AUSTRALIAN INTERNATIONAL**, Box 19107-AC, WASHINGTON, DC 20036.

**OVERSEAS** Employment . . . \$20,000 - \$60,000+. Free Report! Employment, Box 19760-AC, Indianapolis, Indiana 46219.

**ELECTRONIC** Firm is Looking for Assemblers interested in Working at Home. Send \$3.00 Application Fee: IRDC. (I), Joppa Hill Rd., Manchester, N.H. 03102

## FOR INVENTORS

**INVENTORS:** Free information on offering your invention for sale. Kessler Sales Corporation, C-5-F1, Fremont, Ohio 43420

**PATENT AND DEVELOP** Your Invention. Registered Patent Agent and Licensed Professional Engineer. Send for **FREE PATENT INFORMATION** Every Inventor Should Have. Richard L. Miller, Woolworth Building, 233 Broadway, Suite 3612-M, New York, N.Y. 10007. (212) 267-5252.

**NONPROFIT** Foundation helps inventors. Widest range of services. Free recording forms. Free evaluation. Affiliated Inventors Foundation, 501-B, Iowa, Colorado Springs, CO 80909

**PROTECT** Your Invention. Registered Patent Attorney. Many Years Experience, all Fields. Individual Inventor's Problems Given Special Consideration. Very Reasonable Charges. Write for Free information. Paul H. Gallagher, 2530 Crawford Ave., Evanston, Illinois 60201

**REGISTERED PATENT ATTORNEY** Washington D.C. Suburb. Donald A. Kettlestrings, 414 Hungerford Drive, Rockville, Maryland 20850

**PATENT IT ECONOMICALLY!** Free Details. N. Raner, 2008 Fondulac, Richmond, VA 23229

**PROTECT YOUR INVENTION**. Registered Patent Attorney. **FREE** Preliminary Review Of Your Description. Box 392PM, Millwood, NY 10546

**WHY** let others make money off your invention? Start your own company! 1983 **VENTURE CAPITAL DIRECTORY** lists nearly 500 known investors. Includes money getting tips. Send \$12.95 plus \$1.50 shipping (90c tax, California residents). Quorum Publishing, 280-M12 Hegenburger Road, Oakland, California 94621

## INVENTIONS WANTED

**INVENTORS:** If you have an invention for sale or license, write for free booklet explaining how we can help you. Kessler Sales Corp., C-5-1W, Fremont, Ohio 43420

**IDEAS, INVENTIONS, NEW PRODUCTS WANTED** FOR Presentation to Industry. Call free 1-800-528-6060. Arizona, 1-800-352-0458. Extension 831. Or Write:

**INVENTION MARKETING INC., KIT PM**,  
701 Smithfield,  
Pittsburgh, PA 15222

**WE ARE** A manufacturer seeking inventions. Pac Trade, 618 Seattle First Bank Building, Aberdeen, WA 98520

**INVENTIONS WANTED. FREE CONSULTATION. NO IDEA TOO SMALL.** Disclosure registration. Potential cash or royalties from manufacturers seeking new ideas. For free information on how to register your idea, call or write: **AMERICAN INVENTORS CORPORATION**, 82 Broad Street, Dept. PM, Westfield, MA 01086. (413) 737-5376. A Fee Based Marketing Company. Offices Coast to Coast.

**INVENTORS** Free information How To Sell - F-M Service, 7345 Harlem, Niles, Ill. 60648

**HONGKONG** Factory needs Several New Products every Month to Satisfy their Oversea Buyers. Particularly Interested Household Items, Toys, Games, Gadgets. Please send Sketches or Detailed Explanation for Evaluation and Cash Royalty Purchase. If you have an Article/Accessory cannot Produce Domestically because of Quantity, Price, or Labour; Please try us. Hongkong Plastic & Metal Products Company, P.O. Box 9627, Kwun Tong, Hongkong.

## REAL ESTATE & FARMS

**FREE!** Big Spring Catalog! Over 5000 best farms, homes, businesses, recreation, retirement values All Across America! **STROUT REALTY**, Plaza Towers, Dept. 5800, Springfield, MO 65804. Toll free: 1-800-641-4266. In Missouri call collect: (417)862-4402.

**CANADIAN** Country Properties. Our 67th Year. Terms available. Moneyback guarantee. Catalog airmailed \$1.00. Dignam Corp., Ltd. Suite 496, 85 Bloor Street East, Toronto, Ontario, Canada M4W 1B5

**PROPERTY** And Lake Frontage from \$47 per acre. Investment Potential. Exchange Privilege. Free Catalog. Canadian Estate Land, Dept. 23C, 2411 Yonge St. #303, Toronto, Canada. M4P-221. (416) 488-0444

**COUNTRY LAND**, Complete Guide for Proper Choice. Anywhere. Details. Al Johnson, P.O. Box 53, Laporte, Minn. 56461

## BUYING & SELLING

**BUYING** B.M.W., Mercedes Benz, Harley Davidson, 1975-1981. Send the **DETAILS** and **PICTURES** To: Eiki Corp., No.407, 5-10, Tenjin 4-Chome, Chuo-ku, Fukuoka, Japan 810

## EXPORT-IMPORT

+2500 "Fast-Sellers." Free brochures! Allrightpro, Box 91309-B3, Cleveland, Ohio 44101

## PLASTIC BAGS

**ALL** Sizes. Buy Small Quantities. Free Catalog. SAKet, 6151-C Colbath, Van Nuys, Calif. 91401

**HUNDREDS** of Sizes, plain & Ziplock. Lowest Prices! Immediate Delivery! Free Catalog. Action Plastics, 14600, 93rd Lane N.E., Minneapolis, Minn. 55434. (612) 786-4144.

## BUY IT WHOLESALE

**WORLDWIDE BARGAINS:** Imports . . . Dropship . . . Closeouts . . . Surplus . . . Freebies . . . 25c/Stamp . . . Mamees, Box 1717PM, Highland, Indiana 46322

**BELOW** Wholesale: Clothing, Jewelry, Closeouts, Catalog \$1.00. Torrow Mac, P.O. Box 3333PM, Anderson, S.C. 29621

**BELTS** and Buckles. Complete line fast sellers, including truckers, motorcycles, wildlife, westerns etc. Big Profits. Complete dealer set up. Catalog \$1.00. Anchor Specialties, Box 3958-BPM, North Providence, RI 02911

**400,000 BARGAINS** Below Wholesale: Many Free! Liquidations . . . Closeouts . . . Job Lots . . . Single Samples. Free Details. Bargainhunters Opportunities, Box 730-A, Holland, Michigan 49423.

**CLOSEOUT** Jewelry 55c dozen. (Catalog 25c). Roussels, 107-1631 Dow, Arlington, MA 02174

**CLOSEOUTS!** Discounts! Below wholesale! Freebies! Samples! DDN, Box 20152-PM, Ferndale, Michigan 48220.

**EARN** Money selling rings, jewelry, buckles, watches—buy direct. 130% below retail. Catalog \$1.00 (refundable). Anka-PM, Box 89, West Warwick, RI 02893.

**FREE CATALOG!** Chainsaw, Motorcycle, ATC, Snowmobile, Small Engine, Parts, Woodstoves, Splitters, Energy Items. Manufacturer's Supply, Box 157-PM4, Dorchester, WI 54425.

**HOW** To Wholesale—\$10.00. JACO, P.O. Box 120711, Arlington, Texas 76012



## ADVERTISING AGENCIES, ADV. SERVICES, MAILING LISTS

**INEXPENSIVE** Custom Radio Commercials. **RADIOPRO**, 29 Scenic Drive, Freehold, NJ 07728

**REACH 200,000 HOT PROSPECTS ON RADIO!!** Under \$1.00 each commercial. Information: Astroradio, Box 199, Hope Valley, RI 02832.

## BUSINESS SERVICES

**STATIONERY: SATISFACTION GUARANTEED!** 100 Envelopes And Letterheads (\$32.95) Plus 100 Business Cards And Mailing Labels (\$47.50). Free Memo Pad! Send Check Or Visa/Mastercard Number, Signature And Expiration Date And Clear Copy Of Address Format. Quality House, Box 887-P, Minneapolis, MN 55410.

## RUBBER STAMPS

**BARCO** Type Founders. Type and Rubber Stamps catalogue. Mail \$1.00 refundable on first order. 237 S. Evergreen, Bensenville, 60106.

## MULTIGRAPH, MIMEOGRAPH

**NEED AN INEXPENSIVE COPY MACHINE.** Make a dry printer yourself. Buy a photocopy of the plans as they appeared in P.M. Price \$1.50. Send orders to: Popular Mechanics, Dept. PMC3, Box 1014, Radio City Sta., New York, N.Y. 10101

## PRINTING PRESSES, RUBBER STAMP OUTFITS

**PRINT YOUR OWN** - Printing Presses, Type, Supplies Direct from Factory. Send \$1.00 for Catalog and Samples to: Kelsey Company, B3, Meriden, CT 06450.

**TYPE** Fonts. Hand Printing Presses, Supplies. 120 Pages. \$1.00 Deductible first order. Acme Type, 1720 N. Marshfield, Chicago, 60622

**TYPE** for printing. Catalog \$1.00/deductible 1st order. Quaker City Type, R.D. 3, Box 134, Honeybrook, PA 19344

**MANUFACTURE** Rubber Stamps. Regular and Pre-inked. Catalog 1-800-851-4945. Jackson, Brownsville Rd., S110, Mt. Vernon, IL 62864.

**COMPLETE** Rubber Stamp Outfits, Supplies. Same day shipment. Sign Engraving Machines, Wholesale Catalog \$1.00 Deductible. Star Stamp, 1720 N. Marshfield, Chicago, 60622

## PRINTING AND SUPPLIES

**1983-84 GRAPHIC ARTS CATALOG.** 250 pages of printing presses, gold stamping presses, rubber stamp presses, wood type, foundry type, bookbinding equipment. The most complete catalog in U.S.A. Send \$5.00. American Printing Equipment & Supply, 42-25 Ninth St., Long Island City, NY 11101

**THERMOGRAPHED** Business Cards, Free Samples. BG, 2501 Sapling, Glenshaw, PA 15116

**QUICK** Copy Printing. Low Prices. Write: Nationwide, 614 North Main, Bloomington, Illinois 61701

**BUSINESS CARDS,** Low prices, Free samples, P.J. Box 134, Barberton, Ohio 44203.

**MAGIC CLIP** -eliminates paper clips \$3.95 to: House of Lori, Box 2469, Dearborn, MI. 48124. Money Back Guarantee.

**QUALITY** Printing Letterpress and offset Low, Low Prices. Free Catalog. Dunn's Distributor's, Box 21083, Lansing, MI. 48909

## GIFT SHOPPING

**LCD** Watch \$2.50, Penwatch \$3.50. Catalogue \$1.00. Reliant, P.O. Box 33610, Sheungwan, Hongkong.

**DISTINCTIVE** Gifts Catalog Free. Sporting Goods, Fishing Tackle, Archery, Etc. Maude Goins, 1316 Hollywood St., Tampa, FL 33604

**FREE** Mailorder Catalog Of Quality Gifts. Van's Gifts, 801 Highland Rd., Street, MD 21154

## CLOCKS, WATCHES, OLD GOLD, JEWELRY

**HIGHEST CASH** for Gold, Jewelry, Gold Teeth, Rings, Diamonds, Watches, Silver, Platinum. Mail Articles Today. Free gift with information. Chicago Gold & Precious Metals, 8 E. Monroe, Dept. 758, Chicago, 60603.

**TAKE NO CHANCES.** Deal with oldest, most reliable firm in old gold business. Established 1934. We buy Gold, Silver, Platinum, Diamonds. Highest Cash. Free Information. Rose Industries, 29-A East Madison, Chicago 60602

**MUSICAL** Instrument Clocks Send \$1.00 For Catalog. Gilbert's Music, 37070 Fremont Blvd., #114, Fremont, CA 94536

**WATCH** And Clock repairing books, tools, materials. Free Catalogs. North American, Box 77-AC, Fox River Grove, Illinois 60021

## PRECIOUS STONES & MINERALS

**GET** Free catalog no serious rockhound, gem cutter, jewelry maker, hobbyist or craftsman can be without. Full of bargains, exclusive items, low prices from largest suppliers and authorities in the field. Free new catalog just off the press, yours for the asking. Write: Grieger's, Dept. 1, 900 South Arroyo Pkwy., Pasadena, California 91109

## TREASURE FINDERS

**TREASURE** Hunters. Complete line. Electronic Detectors. Pendulums. Books. Hobby or profit. Free catalogue. Detectores, Apartado 7-905, 08700 Mexico.

**FIND** Lost coins, jewelry, buried treasure, gold nuggets, relics. New revolutionary patented detector analyzes objects, tremendous range, no ground pickup. Free catalog. Gardiner, 4729M N. 7th Ave., Phoenix, Arizona 85013

**TREASURE-** Locate quarter mile away with ultra sensitive locator - brochure free. Research Products, Box 270270 - AMC, Tampa, Florida 33688

**SAVE** up to 40% on new metal detectors. All major brands including White's and Garrett. **FREE** discount price list. Northwoods General Store, P.O. Box 9874PM3, Madison, WI 53715. (608) 274-4690.

## PROFITABLE OCCUPATIONS

**MECHANICALLY INCLINED? ASSEMBLED ELECTRONIC DEVICES, YOUR HOME. KNOWLEDGE, EXPERIENCE NOT NECESSARY. SPARE/FULL TIME. NO INVESTMENT. FREE DETAILS WRITE: ELECTRONIC DEVELOPMENT LAB, BOX 1560PM, PINELLAS PARK, FL. 33665.**

**FREE** Catalogs. Repair air conditioning Refrigeration. Tools, supplies, full instructions. Doolin, 2018 Canton, Dallas, Texas 75201.

**FT. SMITH** Auction School, Ft. Smith, Ark. 72903. Resident & Home study. Veteran Approved.

**REPAIR** Lawnmowers thousands of parts and tools. Wholesale list 35c. Eilwanger's, 15 Canal St., Port Jervis, NY 12771.

**TECHNICAL WRITERS** make big money! Free details. TekPubs, Box 2458-P, Oroville, CA 95965

**PLASTERCRAFT!!!** Profitable home business. Molds available. Details: Lynette, 6251C Mentor Park, Mentor, Ohio 44060

## SALESMEN-DISTRIBUTORS

**MAKE EXTRA MONEY DURING YOUR SPARE TIME!** Show our New Line of Calendars, Pens and Popular Advertising Gifts to local firms. Prompt, friendly service from small town AAA-1 Company in our 74th year. No investment or collections. Weekly commissions. Be your own boss. Full time potential. No experience necessary. Write to: Frank Buckley, **NEWTON MFG. CO.**, Dept. PMC-3, Newton, Iowa 50208

**SELL SENSATIONAL LOW-COST BURGLAR ALARM.** Lightning seller. Exceptional margin. Samples for trial. Northwest Electric-PM-3, Box 1046, Mitchell, SD 57301.

## AGENTS WANTED

**WITH** Mason Shoes, pay day is when you want it! Take orders from friends and neighbors. Watch your business build, without risk or investment. Call Toll Free 1-800-826-7030, Ext. 66; in WI 1-800-472-7003, Ext. 66, or write: Mason Shoes, K-700, Chippewa Falls, WI 54774.

**MONEYMAKING** Opportunity. Sell our Books by Mail From your Home. Details \$1.00. Baldwin, 10149 Hammerly #62, Houston, TX 77080

**SPARE TIME CASH.** Sell Famous Hanover Shoes. Samples, sales kit free. No experience needed. No age limit. Big commissions. Hanover Shoe, Dept. 3538, Hanover, PA 17331.

**AGENTS WANTED:** Sell "How To Books" by Mail. **AMAZING RESULTS.** Full Details, Send \$1.00. Bern-Al Books, 9614P, Brookfield, Livonia, MI. 48150

**SELL FINANCIAL OPPORTUNITY BOOKS BY MAIL** Fantastic part or full time home business. No experience needed. Details \$1.00. **ACT NOW!** MSE, Dept. PMC03, 325 Westgate Drive, West Columbia, S.C. 29169

**FOR** Fast Big Profits Sell How To Make Money Books By Mail. Unusual Opportunity, Full Details \$1.00. PM-3, 7701 NW 28 Terrace, Bethany, OK 73008

**RETIRED,** Out Of Work, Need Extra Income? Hydraulic Tool Company Needs Direct Sales Persons. No Experience Needed. Background In Body Shop or Aircraft Tools Helpful. Write: Gregory Hydraulics, 21707 8th St. East, Sonoma, CA 95476

## BUSINESS OPPORTUNITIES

**IMPORT-Export** opportunity, profitable world-wide, mail order business from home, without capital. We ship plan for no risk examination. Experience unnecessary. Free Report. Mellinger, Dept. H2703, Woodland Hills, California 91367

**PIANO** Tuning learned quickly at home! Free information. Empire School, Box 1014, Jupiter, Florida 33458

**MAILORDER** Opportunity! Start profitable home business without experience or capital. Write for free book, plus details. Mail Order Associates, Dept. 662, Montvale, NJ 07845.

**MAKE HOMEMADE BOOKLETS.** I've earned \$187,000 with mine. Free information: Falcon, Box 548, Woodville, Texas 75979

**LEARN** the Secrets of Profitable Mailorder Business. Details free! **M3MDOB**, Box 6707, Torrance, CA 90504

**PREPARE** Tax Returns - Housewife Jo Ann Netzley made \$5,500 last season. Train at home. VA Approved. National Tax School, Monsey 2CQ, New York 10952

**MILLIONAIRE** - Author's Easy Start Businesses can make you Wealthy **FAST!** Free details! Moneytalks, 3122 Edgemere, Appleton, WI 54915.

**\$700** Per month earnings possible filling out income tax forms at home or tax office during tax season. We show you how. Simple, quickly learned. Details mailed free. No salesmen. Hurry. Big Demand. Federated Tax, 2065 Montrose, Chicago, 60618.

**MAKE MONEY WOODWORKING** - Easy profits making unusual gifts, toys, novelties. Free details. Williams, 32K Titus, Glen Cove, NY 11542

**WOODWORKERS:** Make Unique Wooden Products for **BIG PROFITS.** Free Details. Dunning, 3727-P Joan Dr., Waterloo, Iowa 50702.

**\$300 WEEKLY** possible. Show world-famous weather-proof yellow pocket camera to friends, relatives, swimmers, skiers, hikers, etc. Retailers for \$70 to \$90. Your cost \$29.95. We drop ship. Money-back guarantee. Send check, M.O., Visa, Master. **FREE** Catalog. Import Clearing House, Box 8006, Saddlebrook, NJ 07662

**FROST** Air School of Air Condition and Heating, Box 27211, San Antonio, Texas 78227

**BIG** Profit, Fast Money Making Catalog \$1.00. Chazy Mail Order, Chazy, N.Y. 12921

**SOLAR** Heating learned quickly at home! Free information. Empire School, Box 193, Rockville, IN 47872

**WANT** Money? Try Selling Our Books. Free information. Poindexterco, 1011 Trevor, Detroit, Michigan 48207

**MAKE MILLIONS** MANUFACTURING Batteries. Supplies Available. Everlast, Box 366, Bogota, NJ 07603.

**ASSEMBLE PRODUCTS AT HOME.** Many opportunities paying High Weekly Profits presently available without investment. Write: Businesses, 92B Brighton 11th, Brooklyn, New York 11235.

**VINYL'S** Where the money is! Professionally repair, re-finish, recolor furniture, luggage, car tops. Quick, easy. Two small \$20 jobs a day earn you \$1,000 a month. Homes, cars, offices, restaurants, unlimited customers. Start earning after a few days practice. Sensational details free. VIP, 2007 Montrose, Chicago, 60618

**MAKE WOOD TOYS FOR PROFIT.** Toy parts, patterns wholesale. Lovebuilt Toys, PM-3, Tahoe City, CA 95730-5459

**MAKE** Rubber Stamps. Highly Profitable Business. Free Details. Stamper, POB 22808 (GE), Tampa, FL 33622.

**PIANO** Tuning quickly learned with home study courses. Diploma granted. American Tuning School, 17050 Teller Drive, Morgan Hill, Calif. 95037.

**PICTURE** Framing—Profitable full or spare-time business. Easy to learn with handbook-course "Guide To Picture Framing Profits." \$3.00 Guaranteed. Free framing-supplies catalog included. Japs, 126-PM Seventh North, Hopkins, Minnesota 55343.

**REPAIR HYDRAULIC JACKS — DETAILS FREE.** WRITE: **HYDRAULIC PARTS SUPPLY, BOX 4157, BROWNSVILLE, TEXAS 78520.**

**DEBTS WIPED OUT** with secret Federal Law!! Fortune building **FREE REPORT!** Moneywise #B-3, LaGrange, NY 12540

**FREE BOOK** 2042 Unique Proven Enterprises. Fabulous "unknowns." Second Inflation Income. **HAYLINGS**, Carlsbad, CA 92008

**LEARN** Sewing Machine Repairing. Men. Women. Lucrative Profits. Gresslin Correspondence School, Box 5104, Spencer, Iowa 51301.

**\$480** Weekly. Home mailing program. Goodworld, Box 26233-R, Tamarac, Florida 33320

**\$92.00** From Square Foot Plywood. (Huge Demand). Revealing Profit 25c. (Refundable). Woodwin, Bridgewater, Mass. 02324

**CONCRETE** Block Machines: Catalog \$1.00. Route One, Box 95, Rapid City, South Dakota 57701

**SELL** Books By Mail. Free Dealership. Midwest, Box 44R2-PM, Shawano, Wis. 54166

**GET RICH** using **OTHER PEOPLE'S MONEY!!** Unique — amazing business! Details **FREE!!** Finance Consultants, 5B-3, Billings, NY 12510

(Continued on next page)



## BUSINESS OPPORTUNITIES

(Continued from preceding page)

**NEW Discovery in Battery Reconditioning** . . . Eighteen Months Guarantee Means "Big Profits Fast." Electone, 7415 Gable Drive, Little Rock, AR 72205

**BUMPER STICKER PRINTING DEVICE.** Cheap, Simple, Portable. Free Details. Bumper, POB 22791 (GE), Tampa, FL 33622

**I MADE \$40,000 Year by Mailorder!** Helped others make money! Details 25c. Torrey, Box 318YY, Ypsilanti, Michigan 48197.

**CLIP newspaper items — \$2 - \$25 EACH!! FREE Report!** Clippings-KB-3, Billings, NY 12510

**PROFITABLE GOLD FOIL PRINTER.** Personalize business cards, pencils, matches. Free Details. Gold, POB 24986 (GE), Tampa, FL 33623.

**LEARN The secrets of repairing junk batteries** "Fabulous Profits." **FIRST ESTABLISHED COURSE.** Apex Engineering, 5454 Bolsa, Atascadero, Calif. 93422

**MONEY SECRETS!** Help People and businesses get money. Easy home business. Fantastic Profits. No Experience—Own Hours. Continuous Assistance. Free Details: DFC, Dept. 10-G-3, 1145 Reservoir Avenue, Cranston, Rhode Island, 02920

**VENDING MACHINES.** No selling. Routes earn amazing profits. "Big Catalogue FREE." Parkway Corporation, 1930 PMB Greenspring Drive, Timonium, Maryland 21093

**ARAB BUSINESSMEN** Have Money to Buy & Invest. Top Finders Fees Paid. Int. MiddleEast Assoc., 383PM1, 8291 Flaxman, Huntington Beach, CA 92646

**GET RICH!!** Secret Law smashes debts—brings cash and credit!! Details FREE! WealthKt-WB-3, Billings, NY 12510

**RECONDITION JUNK AUTOMOTIVE BATTERIES.** Huge demand creates profitable home business! Free report. J&M, 771PM, Battle Ground, Washington 98604

**MAKE \$15.00 Hourly building custom luggage/cases at home.** Huge nationwide demand. Fill mail orders. We supply materials, instructions, everything! Free details. Custom Case, 6067 De Soto Ave., Dept. C20-27, Woodland Hills, CA 91385.

**\$1,000 Weekly Home Business Directory.** Box 2019-PM, New York, New York 10163.

**HUNDREDS Weekly Possible For Ten Hour Work Week!** Guaranteed Home Business . . . Start Immediately!! Free Information - AHV, Box 1028-A3, Kalaheo, Hawaii 96741

**14K Gold, Sterling Silver Jewelry.** Make 300% Profit. Catalog \$1.00 (Refundable). Courtico, 1634 Bogart, Bronx, NY 10462

**HANDYMAN'S DREAM! DIE-MAKING SIMPLIFIED!** New manual explains easiest methods. You can quickly master this extremely profitable profession. Postcard brings information. Director, Trimex Building, Moores, N.Y. 12958

**SELL Profitable Mail Order Books.** Complete Details, \$1.00. Home Products Company, 14-A012 Chelsea Circle, Lacey's Spring, Alabama 35754.

**RELAX And Get Rich.** Free Details. Education Plus, PM, 1753 S. Orange Grow Avenue, Los Angeles, CA 90019

**GET RICH!!** Secret law generates cash - credit!! Smashes debts!! Wealthpak, Box 843, Lancaster, S.C. 29720.

**ALUMINUM SCRAP - Recycle - SELL FOR \$25.00/ POUND!** Free information! Industrial Scrap Yard, Box 127, Alexandria Bay, New York 13607

**FREE! EASIEST Most SUCCESSFUL of all HOME BUSINESSES.** Vaught, Rt. 2, Box 457, Helms City, FL 33844

**\$50 to \$200 Daily.** Easy for anyone. Send \$12 TO: V. Wafer, Suite 101, 2116 Greenbriar Clny Dr., Houston, TX 77032

**TAKE Catalog Orders.** We drop-ship 2500 best-selling specialty products. Lowest below wholesale prices. Immediate delivery. Spectacular home business opportunity. Free Book. SMC, 8061 De Soto Ave., Dept. 20-27, Woodland Hills, CA 91365.

**MANUFACTURE at home!** Cleaners . . . Polishes . . . Adhesives . . . Cosmetics. Professional Formulas. Business Plans. Frontier, Box 44179, Tucson, Arizona 85733.

**WOODWORKERS - IDEAL HOME BUSINESS.** Free brochure! Pine Shop, West Peterboro, NH 03468

**HONG KONG, Taiwan,** Buy Direct, Information. Long Sase, Birch, P.O. Box 142, Willow Springs, Ill 60490

**HOW to Start and Operate your own Profitable Business at Home.** Free Details. Rainbow Assoc., West 2203 Mission, Spokane, Wash. 99201

**NEW LUXURY CAR** without cost! Write: AMCO 9, 1801 Main, Plainfield, IN 46168

**\$2,000.00** every week possible !!! Build and sell "PROFESSIONAL" GIANT SCREEN PROJECTION TVs . . . "Don't be fooled with cheap imitations!" . . . "Use EXACT SAME TYPE LENSES and SCREENS utilized by Sony, Zenith, Pioneer, and Magnavox!" . . . Simple construction! . . . Illustrated dealers information and complete parts catalog \$2.00 . . . Money Back Guarantee! . . . POLI-VISION, 168-B Dunmore St., Troop, Pa. 18512

**SCREEN PRINT T-SHIRTS.** Inexpensive kits. Free Details. "T-Printer," POB 23991(GC), Tampa, FL 33623.

**MAKE Big Money Repairing Windshields And Plate Glass!** Earn up to \$50,000 yearly. Send for Valuable Free Report. Glas-Weld Systems, Box 87D, Hillsboro, OR 97123. 503-640-2278

**HUNDREDS Dollars Weekly Selling Money Making Books.** We Supply Everything. Send \$1.00. Dodge Publishing, Box 06164P, Ft. Myers, FL 33906

**GLASS TINTING Book** — The whole story, cars to skyscrapers, hobby or big profits. \$10.95. KIS Window Glass Tinting, 1149 East Commercial Blvd., Ft. Lauderdale, Florida 33334

**PROJECTION TV . . . Make \$\$\$'s assembling Projectors . . . Easy . . . Results comparable to \$2,500 Projectors . . . Your total cost less than \$17.00 . . . PLANS, LENS & Dealer Information \$15.50. Illustrated information FREE . . . Macrocombgx, Washington Crossing, Pennsylvania 18977. Creditcard Orders. 24Hrs. 215-736-2880**

**2000+ Best-Selling Products For Spring Flea Markets.** Catalog, \$3.00 (Refundable). Wiegand, 109 South Park Street, Michigan City, Indiana 46360.

**1000% Profit Bronzing or Chinakoting Baby Shoes.** Free Literature. NBSPM, 398 Airport, Sebring, Fla. 33870—(813-655-0346)

**FREE DETAILS.** Getting ripped off buying office supplies and furniture? Send SASE. Wincoft Company, 9071 Metcalf, Suite 107PM, Overland Park, KS 66212.

**FREE Directory!** 3,408 Money-making Opportunities! Dynamic, Box 1306G, Stow, OH 44224

**INCOME Tax Consultants Make Excellent Money.** \$1,000 Monthly Possible At Home Or Office. Part/Fulltime. Easily Learned. Home Training. Free Information. Nationwide Tax School, 14507 Warren, Dearborn A205, MI 48126.

**HOMEWORKERS Needed!** Receive 35c each name & address you send us. Details Free. Quality, Box 431 - PH, Lynbrook, New York 11563.

**BIG PROFITS DOING HOUSEHOLD CLEANING.** Sunshine, Box 3712, St. Augustine, FL 32085

**EASIEST business on earth.** Make us prove it. Free details. Wealth Secrets, Box 15137M, Pinellas Park, FL 33565

**REPAIR BOOKS & BIBLES.** I earn \$28,000 yearly. Free information: Peeler, Box 632-PM, Bonham, Texas 75418

**MAILORDER Success Means Big Profits!** Learn The Secrets; Join The Pros. Write: Jean, Box 5CN, Union, MO 63084.

**WOODCRAFTING BUSINESS!** Home "Money-making" Disclosure 50c. MLK, Box 468A, Springfield, Oregon 97477

**MAKE - Sell Attractive Personalized License Plates and Frames.** Inexpensive. Sizeable profits. Pro-Plate, POB 22809 (GE), Tampa, FL 33622

**101 BUSINESSES YOU CAN START & RUN WITH LESS THAN \$1000.** 240 page guideline, only \$3.95. Modac, Box 26D, Seabrook, Maryland 20706

**BUSINESS FINANCING CONSULTANTS NEEDED!** Full Training. PMG-Financial, 3109 Carriageway, Arlington Heights, Illinois 60004.

**HIGH PROFITS - Sell Books By Mail,** Best System Available. Details \$1.00. J.R. Publishing, Box 371, Medford, N.J. 08055

**GUARANTEED HUNDREDS Weekly!** Earned at Home!!! Don't Delay . . . Start Now . . . Paid Daily . . . Free information . . . Stewart Associated Enterprise, P.O. Box 392, Forest, MS 39074

**HOW TO GET RICH IN MAIL ORDER.** No Experience Or Capital Needed. Details FREE. Case Histories. T.A. Nielsen, 16400 Ledgemont, A220, Dallas, TX 75248

**FREE Details.** How to Start and Operate your Profitable Business. Write: Bodam Publishing, 269-PM/33 Glenbe, Grants Pass, OR. 97526

**EXTRA Cash.** Start Your Own Cleaning Service. Write: E-Zee Clean, P.O. Box 907, Nokomis, FLA. 33555

**LET Me Help You Make Nice.** Monthly, Mail Order Income—Just As I Do! Details \$1.00. Timberhill, Box 51, East Aurora, NY 14052

**CAR-COP™** Theft Preventor delivers America's biggest profit (\$14.00)! Hot \$19 seller! Sample \$9.95. Information FREE! Almost Manufacturing Ltd., Dept. GT3G, Milford, PA 18337.

**FAST IMMEDIATE PROFITS** Make 2 to 3 Times Your Cost. Over 2500 Gift Items, Novelties, Carded Merchandise. Free Details. R. D. Distributing, Dept. 23, P.O. Box 342, Graettinger, Iowa 51342

**MAILORDER OPPORTUNITY: 1000% PROFIT GUARANTEED! FREE PROOF.** VBD, Box 336, Riviera, AZ 86442.

**MAKE MONEY!!** Selling mailorder information!! ESP - 132, 377 Antenor, Pittsburgh, Penna. 15210

**TAKE PICTURES** for profit. Photomoney, 14569K West 32nd, Golden, CO 80401.

**YOU Can Make Money Wholesaling.** Free Details. Brokerage, 109D Circle, Burns, Tenn. 37029

**MAKE MONEY REPAIRING HYDRAULIC EQUIPMENT** . . . Write . . . Hydraulic Training Institute, 2840 Greeley, PM3, Erie, Pennsylvania 16506

**MAKE MONEY-2 to 3 Times Your Cost On Gifts, Novelties, Toys, Thousands of Products.** Big Catalog \$2.00 Refundable. Arnett Enterprises, Dept. PM3, 12383 10th St., Yucaipa, CA 92399.

**SELL Books By Mail.** 400% profit. Literature Free. Paragon, 344PM, Cass Lake, Minnesota 56633

**FREE directory - 1000 money-making opportunities - Newville, Box 85041/83 - Los Angeles, Ca. 90072**

**STEADY INCOME!** Earn To \$500.00 - \$1000.00 Weekly. Experience Unnecessary. Own Hours. Manual \$2.00. Progressive Finances, 1012 Hamilton St., PMC, Allentown, PA. 18105

**START and operate your own Profitable Business at Home.** Free details. Gray Books, Dept. PM, 635 Talwood Cir., Apt. B, Brandon, FL 33511

**SECRETS** behind successful products and ideas reveal how to find your fortune! Free information — Fortune Maker, 425PM1 Clayton, Denver, Colorado 80206

**BUILD Own Business.** Marketing Card Which Gives 10-25% Discount Nationwide. Multi-Level Plan. Albert Harmon, Rt. 5, Box 383, Simpsonville, S.C. 29681. 1(803) 288-2459

**MULTI-LEVEL MAIL ORDER.** No Investment Start Now FREE Package. MCKINLEY, 6913 Mexico, Concord, N.C. 28025

**PROFITABLE MAILORDER OPPORTUNITY!** Free Information. Frank Britton, PM3, 9103 Dentana Court, Richmond, VA. 23228

**AERIAL PHOTOGRAPHY Business.** Pilot, Non-Pilot. Profitable, Non-Competitive. Eastern Aerial, Box 9587J, Baltimore, MD. 21237

**ARE YOU TIRED OF JUST GETTING BY ON YOUR SALARY? START YOUR OWN BUSINESS. I MADE \$70,000 MY 1ST YEAR. NO SELLING, JUST SERVICE. VERY LITTLE TO GET STARTED. SEND \$2.00 TO: BUSINESS, INC., P.O. BOX 695, BARTLESVILLE, OKLA. 74005**

**OUT OF WORK? NEED MONEY?** \$1.00 booklet shows you how to start your own business through classified advertising. Popular Mechanics, Dept. KC, 224 W. 57th St., New York, NY 10019.

## MONEYMAKING OPPORTUNITIES

**EARN Tutoring Children!** Teaching Certificate, Procedures, \$2.00! Castle's, 19009-PM, Biscayne, Miami 33180.

**SAVE TAX MONEY!** Comprehensive checklist of 1982 tax-saving deductions prepared by Tax Specialists. Send \$3.95 now to: SRK&H, 213 W. Wesley, Suite 2020, Wheaton, IL 60187.

**\$400.00 Or More Weekly Taking Snapshots.** Part/Full Time. No Experience Or Selling Necessary. Write: Gerry Lobyoc, 689 Clouser Drive, Milpitas, CA 95035.

**ATTRACTIVE WOODEN COAT RACKS.** Amazing Opportunities. Send \$3.00 To: Coat Racks, 516 Marlan Ave., Lima, Ohio 45801

**\$50,000 - LAZY WAY.** Details! Free booklet - "Make money with Classified Ads." SEND \$2.00 for postage/handling. Lewis, Box 19500, Oakland, California 94619-0500

**BIG Money Selling Information.** Sample \$2.00. Vern Hover, Box 903, Lemon Grove, CA 92045

**SALARIES** may be hazardous to your wealth! Send for easy low-cost plan for financial freedom — Waterworth Publications, 1820 Park Newport Drive, Suite 414-033, Newport Beach, California 92660

**MAILORDER "OPPORTUNITIES"**. Small investment ideas with Good Returns. Work At Home. Send \$1.00 For Copy. Moneyback Guarantee. Acme Sales, PO Box 353P, Racine, WI 53401.

**LEARN** Landscaping and the growing of plants at home. Start business or hobby. Free booklet. Lifetime Career Schools, Dept. A-49, 2251 Barry Avenue, Los Angeles, California 90084.

**RELAX And Get Rich** — Millionaires Secrets to Wealth. Free Details. Mason Book Co., 2427 S. Beverly Drive, PM, Los Angeles, CA 90034

**EXTRA CASH** — You can earn it! Your FREE subscription to Opportunity Magazine shows you how with success stories of today's entrepreneurs. Write: Opportunity, Dept. 897, 8 N. Michigan, Chicago, 60602.

**400,000 BARGAINS** Below Wholesale! Many Free! Liquidations . . . Closeouts . . . Job Lots . . . Single Samples. Free Details. Worldwide Bargainhunters, Box 730-A, Holland, Michigan 49423.

**SPARE** time fortune in Vinyl Repair. Huge demand creates exceptional profits. We supply everything. Details free. VIP, 2062 Montrose, Chicago, 60618

(Continued on next page)



## MONEYMAKING OPPORTUNITIES

(Continued from preceding page)

**700,000 BARGAINS BELOW WHOLESALE**, Bankruptcy Merchandise, Free Samples, Closeouts, Imports, Surplus, Mail Order, 121 Home Businesses, Free Details. **AMERICAN MONEYMAKERS**, Box 8356PM, Tampa, FL 33674

**GET RICH!!** Secret law smashes debts — brings Cash, Credit! **FREE** report!! **WealthKit-WBM-3**, Billings, NY 12510

**FANTASTIC** earnings mailing from home!! Offer: Rush Stamped Addressed Envelope. Imperial, P-8 X17410, Fort Lauderdale, FL 33318

**BUMPER STICKER PRINTING DEVICE**. Cheap, Simple, Portable. Free details. Bumper, POB 22791 (GH), Tampa, FL 33622

**MAKE PVC PIPE FURNITURE**. Begin profitable home business without experience! Free report. J&M, 771PF, Battle Ground, Washington 98604

**UNEMPLOYED?** Hundreds of Money-making Opportunities. Free Information: BMO Enterprises, Box 8129, Kitchener, Ontario, N2K 2B6

**\$500.00** Weekly Recycling Discarded Tires. Send **SASE**. LeValleys, Fountain, FL 32438

**LIFETIME** income. Yes, you can! Find out how. Information \$1.00. Wilk, PM123, Box 5049, Clearwater, FL 33518-5049

**EXCITING 10- \$25 HOURLY** income. Unusual opportunity making, assembling products at home. Merritt, Drawer 428P, Richardson, TX 75080

**SALARIES** may be hazardous to your wealth! Send for easy low-cost plan for financial freedom — Waterworth Publications, 1820 Park Newport Drive, Suite 414-023, Newport Beach, California 92660

**MAIL** Order!! \$20,000 Guaranteed!! Or, Double Money Back!! Mailco, 671AB1 Ninth, NY 10036.

**SPARE TIME CASH**. Sell Famous Hanover Shoes. Samples, sales kit free. No experience needed. No age limit. Big commissions. Hanover Shoe, Dept. 3541, Hanover, PA 17331.

**WEALTH WITHOUT PERSPIRATION** Self Made Millionaire Explains Proven Steps. Details free. BM1PM, 2600 Woodward, Muncie, IN 47304

**EARN** Wealth! Experts shows amazing opportunities to wealth. Learn the amazing home business. **FREE** Details. Wealthscope, P.O. Box PM, Amherst, Mass. 01059

**FREE** details on business opportunities and wealth-producing secrets — Woodbine Distributors, Five Larkspur Way, #3PM2, Natick, Massachusetts 01760

**\$100,000**. Annual income. Details \$2.00. Binggely, Box 31401, El Paso, TX 79931

**EARN** \$2,000/month offering loans, starting part time. Prestigious opportunity. PFA, Box 84068P, Los Angeles, CA 90073

**\$500.00 WEEKLY**, Work at home, complete setup. **RUSH** \$5.00 To: Dunne, 79 South Street, Cambridge, Ontario, Canada N1R 2N9

**51 MOST POWERFUL MONEY MAKING TOOLS AVAILABLE SEND \$6.95 FOR COMPLETE PACKAGE**. WRA, DEPT. PM3, P.O. BOX 1090, WESTMONT, IL. 60559

**MAKE 1,000% PROFIT!** Buy for \$200. Sell for \$2000! Late-model vehicles. Government confiscated. Details \$3.00. Cantrell, Dept. 12-7, 550 Robinhood, Watkinsville, Georgia, 30677

**CANVASSERS WANTED**. \$1,000 month average. No selling. Details, 234 Club, San Antonio, TX 78201.

**MONEYMAKING OPPORTUNITY** Start and Operate Profitable Business at Home. Free Details. Cook's Publications, 3PS1, 18314 School, Lansing, IL 60438

**BIG** Profits! Miracle Product! Free Details: Walker Enterprises, Box 371077-PM, Decatur, GA., 30037-1077.

**HOME** Business, make 2 to 3 times cost on 3,635+ items. K-Bell, Box 116, Baltimore, OH 43105

**\$35.00** Per Hour "STEAM" Cleaning Carpets & Upholstery, Systems Breakthrough Worked Out on over 20 Thousand Jobs. No need to invest Thousands in Equipment or Franchise fees. Start making **BIG** Money with less than \$50.00. Easy to learn. Train at home. Exciting Details **FREE**. Rogerson "STEAM" Carpet Upholstery Cleaning Institute, 676 Squaw Rock Road, Danielson, CT 06239

**BIG** profits! Buy directly from HongKong/Taiwan Manufacturers at lowest prices without leaving home. Free information! Chan's, 39 Bowery, New York, NY 10002.

**PROFITABLE VACATION** Send \$10 SASE To: Profitable Vacation, Box 244, Boody, IL 62514

**700,000 BARGAINS**, Mail Order, Imports, Home Businesses, Free Details. American Money-makers, Box 8356PM, Tampa, FL 33674

**FANTASTIC**, Easy To Use Guide To Earn, Save Money. Must For Everyone. Now \$3.00. Dr. Almida, 2105 Moore, Las Vegas, Nevada 89104

**EXTRA MONEY** Make money in your spare time. Report shows how you can turn a hobby into a money making venture. Send \$2.50. M. L. Peters Enterprises, 155 N. Tulare Way, Upland, CA 91786

**PROFITABLE HOME BUSINESSES!** 105 Complete Plans—\$2.00. Mitchell, Route 1, Box 2608P, Stevensville, Montana 59870

**SCOTE** Patented Aluminum Guide For Power Saws. Personal Use or Quantity Discounts for Sales. \$1.00 for Details, Refundable with First Order. Scote, 6791 Versailles Rd., Lakeview, N.Y. 14085

**EARN EXTRA MONEY!!!** Sell **MILITARY SURPLUS** . . . **CAMPING SUPPLIES** . . . Details \$2.00 (\$4.00 Coupon Refundable First Order). Hill's General Store, 12841 Hawthorne, Suite 527B, Hawthorne, California 90250

**GOOD HOME INCOME** . . . Forwarding Mail! Details, rush stamped, add/env. Distributors, B1296-PM, Makawao, Hawaii 96768

**\$300** Weekly Sparetime, Mailing Salesletters, Mailworld, Box 805M, Pineville, NC 28134

**"FANTASTIC OPPORTUNITY"** Money Making Catalog \$1.00. Box 86007PM, San Diego, CA 92138-6007

**YOU'VE** Got to Believe! Make \$10,000 Using Our Quick, Easy, Proven Method, Money-Back Guarantee. Send \$10 Today To: P.A.P.A., P.O. Box 15056, Dept. F, Ft. Wayne, Indiana 46885. **YOU'LL BE GLAD YOU DID!**

**12 MONEYMAKING HOMEWORK PROJECTS!** Complete report. \$1.50. Professional Consultants Inc., Dept. A13, RD1 Box 386K, Williamsport, PA 17701

**PROVEN** Wealth Producer—Distribute Information By Mail—"Free Details!" Marketex, PM3, 5924 Catalina, Fairway, Kansas 66205

**BIG** Money in Garage Sales \$4.00. P&A Publications, Rt. 3, Box 353, Morristown, TN. 37814

**DON'T** Answer Another Opportunity Ad Until You've Read Our Report. Write: Consumer Operations, 1707 N. Harding, Chicago, Ill. 60647

**STOP** wasting time and money answering worthless ads. Now one source which examines over 1200 opportunities. Free details! Edlin Associates, Dept. PM3, 15 Wooster Street, Seymour, CT 06483

**MAKE MONEY IN SPARE TIME**. Earn generous commissions as a subscription representative for leading magazines. For free details, send this ad with your name and address to: **POPULAR MECHANICS**, Dept. AB-S, 250 W. 55th St., New York, NY 10019

## RABBITS-CHINCHILLAS-FUR BEARING ANIMALS

**AMAZING** Profits! \$10,000 Yearly Raising Rabbits for Wool and Breeding. Details—\$2.00. American Angora, Malta 12, Montana 59538.

**RAISE RABBITS SUCCESSFULLY** 68 Page Booklet Tells How. \$1.00. American Rabbit Assn., H1, P.O. Box 426, Bloomington, Illinois 61701

**\$500-\$1000** Month Plan raising rabbits for us. Free details. White's Rabbits, Box 1388PM, Hudson, Ohio 44236

**GUARANTEED** income. \$10.00 (refundable) for literature. Chinchillas, Box 8294, Mesa, Arizona 85204.

## PETS—BIRDS, CATS, HAMSTERS, ETC

**RARE** Tropical Fish. Guaranteed Live Delivery Anywhere. Free Details. Northeast Tropical Fish Hatchery, 38 Montvale Avenue, Stoneham, MA 02180

## EARTHWORMS, LIVE BAIT

**FREE** Literature. Raise Fishworms, Crickets, Redworms—1000-\$8.95, 5000-\$42.50. Book on How and Where to Sell with Order. Carter Fishworms, Plains, GA. 31780.

**GREY** Nightcrawlers - "Action Worm" - Free Literature - Telephone 912-835-2542. - Fain's Earthworms, Edison, GA 31746

## OF INTEREST TO ALL

**RADIATION WARNING!** Many televisions produce dangerous radiation. Find out about yours. **HEALTHWATCH**, 8B Oakpark Drive, Morristown, New Jersey 07961

**FREE** Promotional Albums, Concert Tickets, Stereo, etc. Information: Barry Publications, 477 82nd Street, Brooklyn, NY 11209

**NEED CREDIT?** Get MasterCard, others, w/no credit check. Guaranteed! Simple, Legal. Plus other credit secrets. Free details! Send SASE to: **INFLATION REPORTS, PM-N, BOX 60148, LOS ANGELES, CA 90060**

**VACUUM** Cleaners "Discount Prices" "New" Rainbow \$349.95, Kirby, Filter Queen, Compact, Details: ABC Vacuum Warehouse, 7021 Burnet - PM, Austin, Texas 78757

**COMFORT** while gardening, cleaning floors, etc. Soft, durable sponge rubber knee pads. Adjustable straps. Money back guarantee. \$6.88. Send for free catalogue. Ipswich House, Dept. PM3, R.R. 1, Main St., New Ipswich, NH 03071

**PROTECT** yourself, home. Booklet explains confusing products. Free safety tips. Write now! Safety, Box 9767BC, Minneapolis, MN 55440

**PLANNING A GARAGE SALE?** Useful Organizing Information Send \$4.00. Rod Faker, 105A Skyline, Rock Springs Wyoming 82901

**INCREDIBLE POLISH!** Cleans-Polishes-Protects. . . . . **ONE** Easy STEP! almost every metal - Send Only \$6.00 (refundable) for 8 oz bottle - Independence, 580 East 1000 Oaks, #150PM, Thousand Oaks, Calif. 91360.

**SEE** inside your own eye! Free information. Black Horse Enterprises, Dept. PM, 4918 1/2 Cahuenga Blvd., North Hollywood, Calif. 91601

**"TAX INFORMATION ORGANIZER"-SAVE TIME AND MONEY PREPARING YOUR FEDERAL TAX (1040). MANY HELPFUL HINTS. SEND \$1.00. ACCREDITED PRESS, BOX 6038, JACKSONVILLE, FLORIDA 32238**

**FREE CATALOG!** Privacy, Credit, Divorce, Employment, Tax Problems? Our books have the solutions. Write to: Eden Press, 11623 Slater, Box 8410-PG, Fountain Valley, CA 92708.

**ROGER ANDREWS** Obtained A \$225,000.00 Castle On An Average Income. \$10.00 Buys His Book, "HOW TO SURPASS THE AMERICAN DREAM." Andrews Enterprises, Box 2020PM, Sandusky, Ohio 44870

**NOW**, You can draw. **FREE** - Complete details plus first easy lesson from Disney artist. Bruce McIntyre - PM-12, 3471 Crownsworth, Corona, CA 91720. (714) 953-7452

**RETIREMENT PLANNING** Information You Must Consider Before Opening Or Continuing An Individual Retirement Account. Send \$7.50 Check To: Veers Press, 74 Baker Drive, Haw River, NC 27258

## OF INTEREST TO WOMEN

**SEWING** Easy Pattern Alteration - \$2.00 - Sewing, Box 3824, Youngstown, Ohio 44512.

**CALLING CARDS FOR SINGLES** Wallet Size, Space For Name, Phone, Address. **REVERSE SIDE** Fill In For Compatibility. 40 Card Pack \$2.00 plus 50¢ handling. Marigold Supply, Box 3098C, Dept. A, Warren, Ohio 44485

## GOVERNMENT SURPLUS

**1983** Surplus Army, Navy store 64 pages illustrated catalog. Send \$2.00. Ruvel, 3037 N. Clark, Dept. J-3, Chicago, IL 60657.

**J-E-E-P-S, T-R-U-C-K-S** from \$30.00. Millions of Items In Government Surplus; Typewriters, Boats, Clothing. Complete Directory On How And Where To Buy In Your Area - \$2.00. Surplus Bargains, Box 913-A, Holland, Michigan 49423.

**MOTORCYCLES — JEEPS — HELICOPTERS — AUTOMOBILES . . . GOVERNMENT SURPLUS DIRECTORY — MONEYBACK GUARANTEE—** How, where—\$2.00. GS Information, Department 13, Federal Building, Box 3913, Springfield, Massachusetts 01101

**GOVERNMENT SURPLUS** . . . Millions of items (including Jeeps) . . . low as 1¢ on dollar! Most complete Directory available — \$2.00 (guaranteed). **DISPOSAL**, Box 19107-AC, WASHINGTON, DC 20036.

**GOVERNMENT LANDS FROM \$7.50 ACRE!** Homesites, farming, vacationing, investment! "Land Buyer's Guide" plus nationwide listings - \$2.00. Lands, Box 19107-AC, Washington, DC 20036

**IS IT** True you can buy jeeps for \$44 through the U.S. Government? Get the facts today! Call 312-742-1143. Ext. 7133.

**"GOVERNMENT SURPLUS" JEEPS \$30.00!** 800,000 Items! Complete Information Your Area. **LARGEST OFFICIAL DIRECTORY**. \$2.00 (Guaranteed). **SURPLUS (A371)**, 4620 Wisconsin Northwest, WASHINGTON, D.C. 20018

**GOVERNMENT SURPLUS . . . JEEPS - AUTOMOBILES - \$30.00!** 900,000 Items! Complete Information—Your Area **GUARANTEED DIRECTORY - \$2.00. DISPOSAL**, Box 392MC, VALLEY FORGE, PENNSYLVANIA 19481

**GOVERNMENT** Surplus Rifles, Machine Gun Report, \$5. Edgar, 1604 Argonne No., Sterling, VA 22170.

## LOANS BY MAIL

**BORROW** \$30,000 without interest! All eligible. Repay anytime. Free details! Infohouse, 533 Sutter, Suite 508PM, San Francisco, CA 94102.

**BORROW** \$25,000 "overnight." Any Purpose. Keep Indefinitely! Free Report! Success Research, Box 19739-AC, Indianapolis, Indiana 46219.

(Continued on next page)

\*Материал, защищенный авторским правом



## LOANS BY MAIL

(Continued from preceding page)

**MONEY Problems?** Free Book describes Loans, Cash, Government Grants, Other benefits, available to individuals. Write: Associates, Box 98-A4, Brooklyn, New York 11235

**BORROW FROM HOME!** Any amount, any worthwhile purpose, within 30 days. Competitive Rates. Also, you can earn substantial income as a Money Agent. No Experience—Own Hours. National Company to assist every way possible. No Gimmicks! Free Details: DFC, Dept. 10-C-3, 1145 Reservoir Avenue, Cranston, Rhode Island 02920

**CASH Loans—Borrow by Mail \$500.00 to \$25,000!** Free details. Application! LTD-PM, Box 937, Ft. Lauderdale, FL 33302

**GET cash grants—**from Government. (Never repay.) Also, loans. All ages eligible. Information, \$2.00 (refundable). Surplus Funds-PM, 1629 K. St., Washington, D.C. 20006

**BORROW \$100-\$100,000!** Instant Reply! No Co-signers! Rush Stamped Envelope! Financial, Box 5487(P), Richardson, TX 75080

**BORROW \$300 - \$30,000 QUICKLY!** All qualified. Repay anytime. Details FREE! Financial Success, Box 1432 - MC, Upland, CA 91786.

## DIVORCE

**WINNING Information, \$1.00. MEN'S RIGHTS ASSOCIATION, 189B, Forest Lake, MN 55025-0189**

## PERSONAL

**BIBLE Questions answered.** Stamped envelope. Bylon, 17167 Bentler, Detroit, Michigan 48219

**COLLEGE DEGREES BY MAIL.** Renowned Universities offer fully-accredited Bachelors, Masters, PH.D's . . . Free revealing details. Counseling, Box 317-MP-3, Tustin, California 92680.

**UNIVERSITY DEGREES BY SPECIAL EVALUATION OF EXISTING Job Experience, Education, Achievement.** Fast, inexpensive. Call (614-863-1791). Or Write: Box 13151-T3, Columbus, OH 43213

**FINANCE YOUR DREAMS** with Government and Foundation Grants. Free Details. TOU-PM3, 432 PCH, Hermosa Beach, California 90254.

## REMAILING SERVICE

**COLORADO Remails; \$1.00 Each.** Box 21575, Denver, Colorado 80221

**CONFIDENTIAL Mail Receiving/Forwarding.** Mail Drop, Box 18039PM, Orlando, FL 32860

**PRIVATE ADDRESS.** Dependable. Professional Mail Forwarding, Box 561A, Milton, Mass. 02186

**SASKATCHEWAN Remailing.** Central, Box 101, Foam Lake, Saskatchewan, Canada S0A 1A0

**UNLISTED ADDRESS.** Discreet and confidential. Remail \$1.00 Single. Mail Forwarding Service, 8050 S. Main, Houston, Texas 77025

**REMAILING 20¢.** Forwarding \$18.00 yearly. "Ecomail", Box 541, Ephrata, Washington 98823

**DEPENDABLE Remail, Messages Daily.** Central, 430 Lakeside, North East, MD 21901

**FLORIDA REMAILS Receiving-Forwarding.** Allen, 6328 Autlan Drive, Jacksonville, Florida 32210

**CONFIDENTIAL New York Mailing Address. NEWYORK EXPRESS, 116-15 147 St., New York, N.Y. 11436**

**LOS ANGELES Remails—Receiving—Forwarding—Confidential.** Free Brochure. Stamped Envelope. Mail Headquarters, 18533 Burbank, Tarzana, CA 91356

**MID-AMERICA REMAILS.** Confidential. Overnight Receiving - Forwarding. Heartland, Box 7243, Shawnee Mission, Kansas 66207

**PRIVACY PROTECTED** completely. Intriguing address. Helen's Hideaway, PM163, Box 346, Diamond Springs, CA. 95619.

## MISCELLANEOUS

**PHOTO ID.** Sealed in plastic. All states, provinces. 24-hours. **GUARANTEED.** Send \$6.00 (2/\$10.00), photo, name, address, height, weight, hair, eyes, birthdate. **CARDINAL, 2071-46 Emerson, Jacksonville, Florida 32207.**

**PHOTO IDENTIFICATION CARDS . . . Certificates . . . GUARANTEED!!** Samples 25¢ . . . Bascoo, Box 3461-PM-83, Providence, R.I. 02909.

**ORNAMENTAL Iron Designs.** Book of 1600 beautiful practical designs for railings, columns, etc. Free Literature. Cunningham, Box 20005, Salt Lake City, Utah 84120-0005 — (3881 South 3200 West)

**COLLEGE STUDENTS!**—Improve your grades! — Research catalog—306 pages—10,278 topics—Rush \$1.00—Research, Box 25918K, Los Angeles, 90025. (213) 477-8226.

**CENTRAL VACUUM SYSTEM.** Two Motors. Wholesale. Details. Vacu-Kleen, P.O. Box 913, Inman, SC 29349

**INVENTION PATENT FOR SALE.** Renewable Filter Cigarette Holder. Smith, 757 NW Coast St., Newport, OR 97365

## WANTED MISCELLANEOUS

**UNIQUE 12V. Fluorescent Light Goes Anywhere.** Details Free. Gilman Auto Parts, 126 So. Main, Gilman, Ill. 60938

**GOLD, Silver, Platinum, Mercury, Tantalum wanted.** Ores assayed. Free circular. Wholesale Terminal, P.O. Box 191, Norwood, MA 02062.

**SCRAP SILVER CONTACTS, FORKLIFT CONTACTS, Silver Solder, Sterling, Gold Plated.** Robert Leszczak, 652 Myrtle St., Elizabeth, NJ 07202

## FOR SALE-MISCELLANEOUS

**ORIGINAL ART PRINTS!** Detailed C&O steam locomotives. 8" x 10", black ink on grey parchtex. \$5 each, six for \$25. Check or money order to: A Shye Touch, Dept. PM, P.O. Box 3247, Cocoa, Florida 32922-1902

## HEARING AIDS

**HUGE SAVINGS** Eliminate Dealer Markups. Free Trial. Batteries Wholesale. Terms Arranged. Call Toll Free 1-800-323-1212. Or Write: Lloyds-PMC, Rockford, IL 61110

**MAIL ORDER** buying saves half on hearing aids. Month's trial. Rea Company Inc., Box 364, Bridgeport, OH 43912

**FREE HEARING AID CATALOG - Save 1/2 by mail!** Write: "MoneySavers", 9530-PM-3, Langdon, Sepulveda, California 91343. **NOT sold in California.**

**NEW All-in-the-ear Hearing Aids.** Huge Savings. Batteries - other aids. Free catalog. No salesman. Rhodes, Dept. 132E, Brookport, Illinois 62910

## TOBACCO

**MAKE Pipes.** Information: Pimo, Inc., P33, Box 58211, Chicago, Illinois 60659

## SCIENCE & CHEMISTRY

**CATALOG \$1.00.** Surplus Lists. Lab. Supplies, Box 161, Brighton, Mass. 02135

**LABORATORY Chemicals, Glassware—Apparatus.** Catalogue \$1.00. Deluxe Scientific, 934 S. 13 Street, Manitowoc, Wisconsin 54220

## FORMULAS, PLANS, ETC.

**LAUGHING GAS.** Make your own using only Household Items. Instructions \$1.00: Stamper Publishing, Box 1063, Knoxville, TN 37901

**ANY FORMULA \$10.00.** Catalog \$1.00. J. Bellfort, Box 568, Chicago, 60690

**MONEYMAKING CHEMICAL FORMULAS — THOUSANDS! CATALOG \$3.00 (REFUNDABLE):** GWA3, Box 193, Brookfield, Wisconsin 53005-0193

## SPECIAL SERVICES

**INFORMATION** On anything. Ferguson Research Specialists, 60-15 Woodside, Woodside, New York 11377.

## BETTER HEALTH

**NEGATIVE ION GENERATORS** Guaranteed not to Soil Walls or Furnishings. Free Brochure. **ENERGEN,** Box 45222M, Dallas, Texas 75235.

**LOSE Weight, Better Health,** Worlds Simplest Exerciser. Illustrated Manual. \$6.00. Gene McLeod, Box 27A, Dixie, GA. 31629

**WORLD'S MOST ADVANCED VITAMIN!** Complete, balanced nutritional insurance for pennies a day. Month's supply \$15.95 postpaid (Check/M.O.) S.J.M. International, Dept. PM383, P.O. Box 805, Northville, Michigan 48167

**VITAMIN C the EASY, ECONOMICAL WAY.** FREE information on adding to foods and drinks. **C SHAKER,** P.O. Box 215, Algonquin, IL 60102.

**DMSO 100% Pure - 16 oz. \$19.95, 8 oz. \$13.95, 4 oz. \$8.95.** Info. Book \$2.95. Encore, Box 2027, Breckenridge, CO 80424

**PROSTATITIS** (An infection of the prostate gland), the scourge of the over-40 adult male, signals pain, discomfort, worry and misery. Send for free valuable information describing this prostate problem and a nutritional approach for relief. Don't hesitate-do it now. Send to: Bio-Vim, Inc., Dept. PM, P.O. Box 7369, Naples, FL 33941.

## FOR THE HOME

**JUMBO THERMOMETERS 12" diameter.** Decorative fun with 45 colorful selections of outdoor scenes, cartoon characters or sports. Send 50¢ for catalogue, refundable with purchase. **METT'S Specialties,** P.O. Box 356, Worthington, Ohio 43085

## WEARING APPAREL

**SATIN BASEBALL JACKETS . . . T-SHIRTS** Printing Available!! Info \$1.00: **BARKER JACKET - PMA,** 1000 Washington, St. Louis, MO. 63101. (314) 231-3339.

## FLOWERS, PLANTS & NURSERY SUPPLIES

**GROW GINSENG.** Very Profitable. Have seeds, roots. Goldenseal. Complete information. K. Collins, Viola, Iowa 52350

## HYDROPONICS

**NEW Hydroponic Home Planter.** Send \$1.00 for Report. Richard L. Zygmont Specialty, 400-J Davisville Rd., Willow Grove, PA 19090

## GARDENING AND LAWN CARE

**BUILD A WINDOW GREENHOUSE—**Converting a window in your home to a mini-greenhouse amounts to little more than attaching a box-like plexiglass enclosure to the outside. The beauty is that you don't do a thing to the window other than add screweyes to the frame—the window stays intact. No drafts in winter, no need for caulking. For plans send \$2.95 to: Popular Mechanics, Dept. PMC3, Box 1014, Radio City Sta., New York, N.Y. 10101

## RECIPES, COOKING, ETC

**NO ADDITIVES, NO PRESERVATIVES,** 14 Traditional English Chutney Recipes \$2.99 and Self Addressed Envelope to: Ginger Pig Enterprises, P.O. Box 927, Racine, WI 53405

**DELICIOUS MEAL** in Skillet, \$2.00 Bonus. Newton Burke Co., 1264 Lawndale Ct., Decatur, GA. 30032

**BLACKBERRY Jam Cake,** Unpublished Old Recipe, \$1.50. Box 381, Hurley, Mississippi, 39555

**FLAKEY Pie Crust** hors d'oeuvres, Entrees, Desserts. Recipe Booklet, \$3.00. Montgomery Specialty Products, P.O. Box 441, Yardley, PA 19067

**HAWAIIAN Imu Cooking-Info.** \$2.00 & SASE. Kanaka Keola, 127 Haakea Drive, Kailua, Hawaii 96734

**BAILEYS Irish Cream \$2.00.** 8690 Aero Drive, M-184, San Diego, California 92123

**NEW Introducing** Mama Gerry's Old World Gourmet Spaghetti Sauce. Rich, thick, delicious. Bonus recipe included. Send \$2.50. B & G Enterprises, P.O. Box 30398 BM-2, Santa Barbara, CA. 93105

**CHICKEN-10 DELICIOUS,** Easy, Fantastic Recipes-\$3.00. K&S, P.O. Box 387, Rossville, GA 30741

**CHICKEN Lovers!** 100 Delicious Recipes, \$4.95. 40 Authentic Mexican Recipes, \$2.00. Corey, Box 68, Redding, CA 96089.

## WINEMAKING, BEERMaking & OTHER RECIPES

**WINEMAKING-BEERMaking-GASOHOL.** Free Supply Catalog. Yeast Equipment. Continental, Box 188PM, Casselberry, FL 32707

**BORNEO Ricewine Kit.** \$9.00 Postpaid from: Intercity Marketing, W.D.T. 79, Kota Kinabalu, Sabah, Malaysia.

**WINTER: Try WINE CONCENTRATES.** B&J Enterprises, 1845 South 19th, Springfield, IL 62703

**MAKE QUALITY BEER,** Wine. Free catalog. Village Store, Box C-51PM, Westport, MA 02790

**WINEMAKERS-BEERMakers—** Free Catalog—Fast Service—Large Selection: Kraus, Box 7850-L, Independence, Missouri 64053.

**BEERLOVERS!** Brew American and European beer. Complete kits, Equipment, Supplies. FREE details. Duane Imports Inc., Department PM, P.O. Box 433, Hershey, PA. 17033

**BEER LOVERS —** Brew your own. Delicious! Inexpensive! Free Catalog. Beer Gear, Box 25093M, Lansing, Michigan 48909

**FREE BEERMaking BOOK** Plus Catalog. Finest Equipment, Ingredients. Fully Guaranteed. SPI, Box 784-M, Chapel Hill, NC 27514

**FREE ENCYCLOPEDIA** Winemaking, Beermaking, Supplies, Equipment Ingredients. Vynox, P.O. Box PM7498, Rochester, NY 14615

**WINEMAKERS-BEERMakers** Fresh Stocks, Fast Service, Free Catalog. O'Brien's, Box 284D, Wayne, IL 60184

**WINEMAKERS-Beermakers:** Free illustrated catalog of supplies. Semplex, Box 12276R, Minneapolis, Minnesota 55412-027

**WINEMAKERS- Beermakers-Free-Catalog-Free-Recipe.** Vinearts, Box 35B, Grain Valley, Missouri 64029

**WHISKEY, GIN, VODKA MAKING.** Illustrated Manual, \$2.00: Homebrewer, 723A Disston, Philadelphia, PA. 19111.

**BEERMakers ONLY!** Free Catalog/Newsletter. William's, Box 461M, Oakland, California 94604.

**FREE BEERMaking CATALOG.** Lowest prices. Home Brew, Inc., Box 158, Haslett, Michigan 48840

## BURGLAR ALARMS & HOME PROTECTIONS

**SUPERIOR SYSTEMS!** Catalog 50¢ (Refundable). AAS, 4148 Lorna Square, Birmingham, AL 35216



# 1 Million of the World's Slimmest Calculator/Watches To be Sold For Only \$15 Apiece In A Mammoth Publicity Drive

---

NEW YORK—One million of the world's slimmest, famous "micro-chip" quartz calculator/watches will be sold as part of a publicity campaign for only \$15 apiece to the first one million persons who apply in writing to the company before Midnight, May 31, 1983.

These are the same nationally publicized LCD Quartz "micro-chip" calculator/watches to be featured in *The New York Times*, *Cosmopolitan*, *Playboy* and other leading publications. The slimmest calculator/watches in the world, they are so powerful they never need winding, and accurate to within seconds per month.

The digital display shows year, month, date and day of the week (as well as hour, minute and second) in full quartz digital mode. A built-in "melody" alarm wakes you in the morning, reminds you of appointments during the day, and even tells you when it's time to put another coin in the parking meter. (It also chimes on the hour.)

The calculator is accurate to 8 places, features a sophisticated 16-pad keyboard with full computer memory, and performs all standard operations such as addition,



subtraction, multiplication, division, percentages, square roots, etc. It will even balance your checkbook and prepare your Income Tax Return.

These famous LCD quartz calculator/watches will not be sold at this price by the company in any store. To obtain one at this price, apply in writing to the com-

pany address (below) before Midnight, May 31, 1983.

Each calculator/watch carries a full one-year money-back guarantee and will be replaced by the company, free of charge, if it ever fails to function.

There is a limit of two (2) watches per address at this price, but requests which are mailed early enough (before May 25) are permitted to order up to 5 watches.

To apply for an LCD quartz calculator/watch, mail your name and address *and this original printed notice* together with \$15 for each watch desired. Add only \$2 shipping and handling no matter how many watches you are requesting. Mail to:  
**Carter & Van Peel, Ltd., Calculator/  
Watch, Dept. 114-5, Box 1230,  
Westbury, New York 11595.**

© 1983 Carter & Van Peel, Ltd.

(V21220)





## Mazda B2000 Sundowner. Today's lowest-priced truck is also today's best truck value.

1983 Mazda B2000 Sundowner **\$5795\***

It's not hard to find a low-priced truck these days. The trouble is, most of them don't have the features you're looking for.

On the other hand, consider the Mazda B2000 Sundowner—the lowest-priced truck in America. Its price alone makes it worth looking at. But when you also realize how well-equipped it is, it's almost irresistible.

For example, the B2000 is priced below Toyota's and Datsun's economy trucks. Yet it comes with many standard features they don't even offer.

These features include 5-speed overdrive, steel-belted radials, full carpeting, tinted glass, trip odometer, intermittent windshield wipers, swing-out side vent windows, dual



*Standard features include 5-speed overdrive and steel-belted radials. Neither is available on Toyota's or Datsun's economy truck.*



*Handsomely appointed interior includes full carpeting and three-passenger seat detailed in textured vinyl.*

door armrests, and more.

The B2000 also has wider wheels, a longer bed, a larger gas tank, and gets better fuel economy.

Further—**38** EST. HWY. MPG **27** EST. MPG more, the B2000 is built to haul a heavy payload of 1400 pounds. Its body and frame are strong, and so is its 2-litre overhead cam engine.

If you're looking for an economy pickup, you'll appreciate the astonishing value of the Mazda B2000 Sundowner. With its long list of standard features and superb gas mileage, today's lowest-priced truck is more than inexpensive. Much more.

# mazda

The more you look,  
the more you like.

\*Manufacturer's suggested retail price for B2000 Shortbed. Actual price set by dealer. Taxes, license, freight, options and other dealer charges extra. Price may change without notice. Comparisons based on '82 information. For '83 they may vary, as may availability of vehicles with specific features. \*\*EPA estimates for comparison. Your mileage may vary with trip length, speed and weather. Highway mileage will probably be less. Calif. 36 Est. hwy. mpg. 26 Est. mpg.



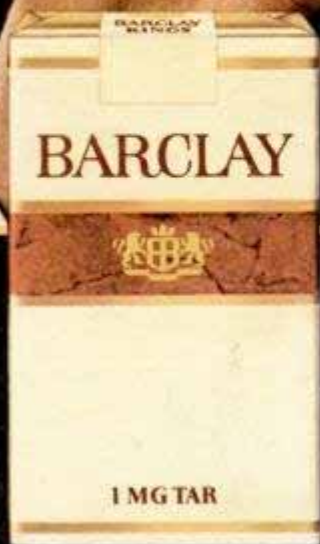

*The pleasure is back.*  
**BARCLAY**

*99% tar free.* <sup>TM</sup>

Warning: The Surgeon General Has Determined That Cigarette Smoking Is Dangerous to Your Health.